

cooling tower parts reference guide

OEM PARTS FOR MARLEY COOLING TOWERS AND FLUID COOLERS



SPX®

LENNTECH bv

Current Brands

Marley®
Recold®
Hamon Dry Cooling



Legacy Brands

Balcke®
Ceramic®
Custodis-Ecodyne
Davenport
Head Wrightson
Heenan Coolers
Pritchard
Zurn Balcke-Dürr

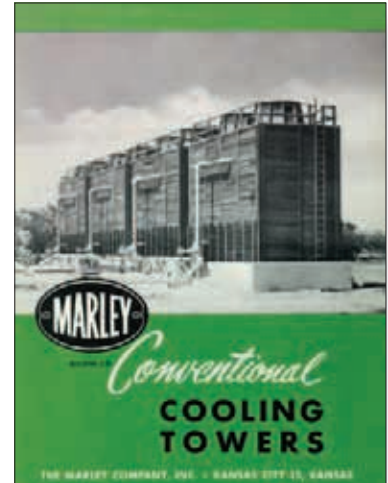

RECOLD

Water Distribution		Drift Eliminators	32
Crossflow Nozzles.....	5	Fans and Drives	
Counterflow Nozzles.....	7	Single Reduction Geareducer.....	34
Counterflow Distribution System.....	9	Double Reduction Geareducer.....	36
Legacy Nozzles.....	10	Geareducer Oil.....	38
HC Crossflow Valves.....	11	Geareducer Sound Levels.....	39
Make-Up Float Valves.....	12	Sprag Clutch Backstop.....	40
Fiberglass Hot Water Basin.....	13	Reflex RTM Fan Cylinder.....	41
Counterflow Film Fill		H3 Fan.....	42
DF254 Fill.....	14	X7 Fan.....	43
DF381 Fill.....	15	Ultra Quiet Fan.....	44
MVC20 Fill.....	16	HP7i Fan.....	45
MC120 Fill.....	17	HP7000 Fan.....	46
FB20 Fill.....	18	Series 400 Driveshaft.....	47
Cleanflow (AAFNCS) Fill.....	19	Driveshaft Specs.....	48
MC75 Film Fill.....	20	Comp-DS Driveshaft.....	49
MCR Film Fill.....	21	Close Coupling.....	50
Crossflow Film Fill		Cooling Tower Motors.....	51
MX Fill.....	22	Controls	
MBX Fill.....	23	Can-Do Fan Motor Control Panel.....	52
M106 Film Fill.....	24	Variable Speed Drive.....	53
Crossflow Splash Fill		Basin Heaters.....	54
Alpha Fill.....	25	Multicell Motor Sequence.....	55
Mesa Fill.....	26	Water Level Control.....	56
Ladder Fill.....	27	M-5 Vibration Switch.....	58
Omega Fill.....	28	Rental Cooling Towers	59
Counterflow Splash Fill		Aftermarket Services/Reconstruction	60
Permagrid Fill.....	29	Cooling Tower Fundamentals	61
TrickleBloc Fill.....	30	Maintenance Schedule	62
GridLoc Splash-Fill Support	31		

SPX®

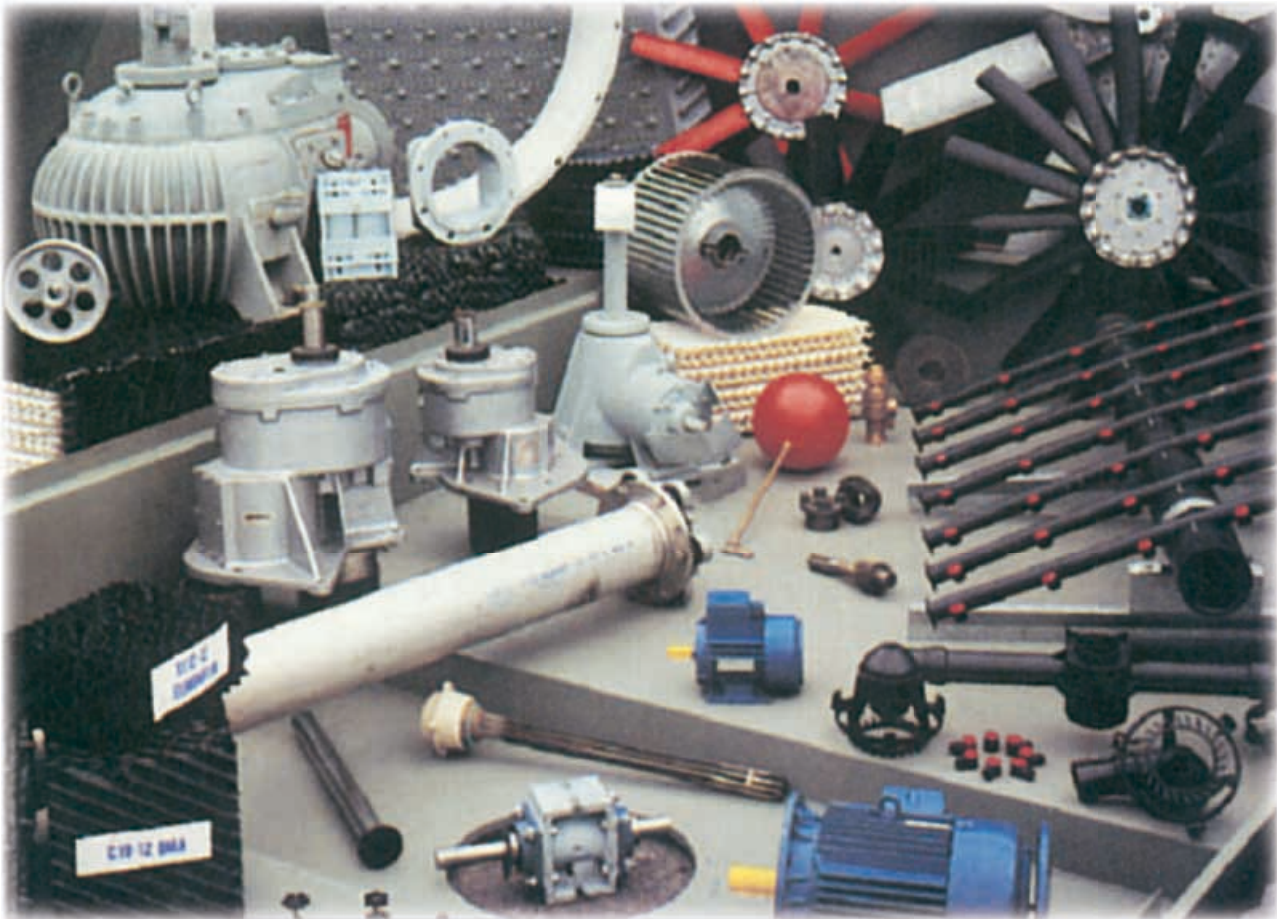

SpiralTarget™ Crossflow Nozzles

- Patented design
- The standard in crossflow nozzle design
- Available in 3 lengths to fit virtually every structural configuration
- 13 orifice diameters available for optimum performance adjustments
- No moving parts
- Wide range of adjustments in water flow rate

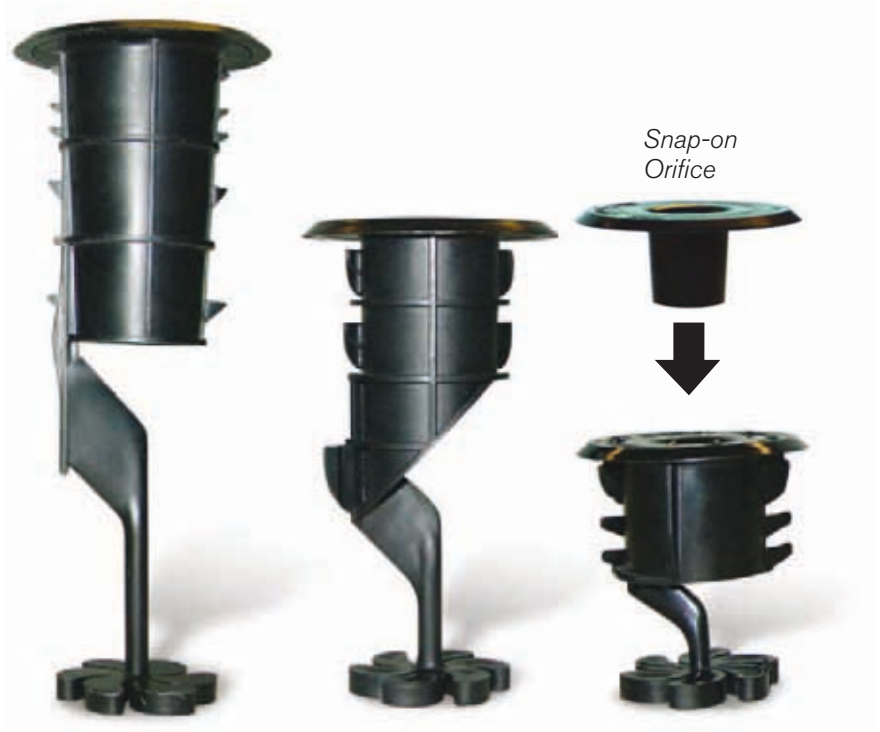

The Marley SpiralTarget nozzle is an injection molded polypropylene unit consisting of two parts—the main body with integral target diffuser and a snap-on insert or orifice cap.

The orifice cap is available in 13 diameters ranging from .362" through 1.099". This amount of flexibility allows for a wide range of adjustment in water flow rates and basin water levels.

The Spiral Target nozzle is available in three lengths. The 2.625" nozzle is used on wood, steel, and fiberglass cooling towers where basin support structure does not obstruct the release of water. The 4.875" nozzle is used on larger industrial wood and concrete cooling towers and on applications where clogging might be a concern. The 6.875" nozzle is used on towers where the release of the water has to clear obstructions within the tower structure.

In every application the target portion of the nozzle should be located at the correct distance above the top of the cooling tower fill to obtain maximum water distribution over the fill area.

Maintenance Know How

When cleaning basins avoid using a round dowel to clean nozzles. In most cases the "daisy" at the end of the nozzle will be knocked off which will destroy the distribution performance of the nozzle. Best practice is to remove the nozzle for cleaning.

NX™ Crossflow Nozzle



- A truly “clog-resistant” crossflow nozzle
- Nozzles are spaced on nominal 2'-0" centers
- 1.875" and 2.5" orifice diameters available

The Marley NX nozzle is used only on splash-fill crossflow towers where objects in the water supply create blockage in smaller nozzles.

NX nozzles are injection-molded, high-impact black polypropylene. Each nozzle is a single assembly with no moving parts.

The NX nozzle is the ideal solution for overflowing basin problems due to clogged nozzles in splash-fill, industrial crossflow cooling towers.

NS7™ Counterflow Nozzles

- Available in two sizes
- Easily removed for cleaning
- No moving parts
- Wide range of adjustments in water flow rate



NS7 Nozzle with Turbulator installed

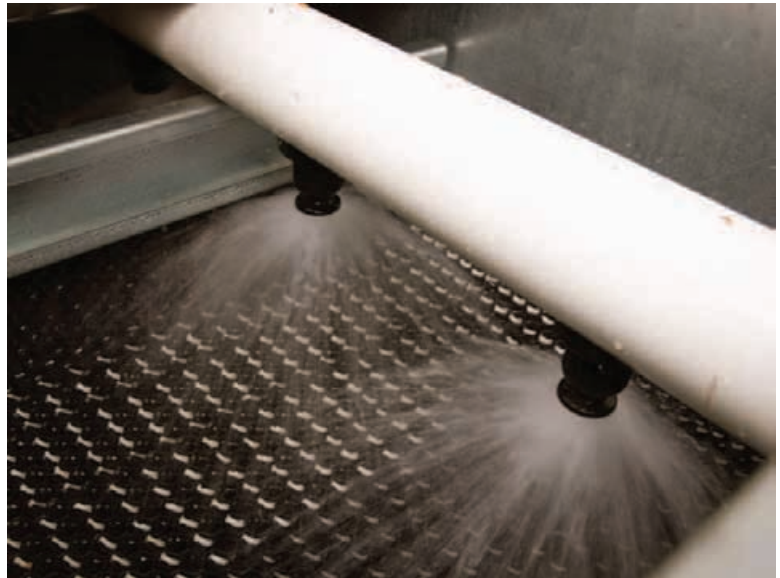

The Marley NS7 counterflow nozzle is an injection molded polypropylene unit consisting of two parts—the main assembly with integral turbulator and an EDPM rubber grommet. NS7 nozzles are designed to economically provide desired thermal performance at low spray heights typical of factory assembled cooling towers.

NS7 nozzles are produced in two sizes. The NS7-150 has a nominal insert OD of 1½" and the NS7-200 has a nominal insert OD of 2". Recommended spray height above the fill is between 7" and 15". NS7 grommets are made from EDPM rubber with a durometer rating between 45 and 50.



NS7 EDPM Grommet

NS5™ and NS6™ Counterflow Nozzles

- Patented design
- Easy to install—no tools required to install into adaptor pipes
- Clog resistant
- No moving parts
- Self draining



Marley NS5A Nozzle



Marley NS6 Nozzle

Cooling Tower Know How

Q Why are there two styles of counterflow NS nozzles?

A Typically the NS5 is used in most locations. The NS6 will handle higher GPMs and is used in areas where obstructions limit the use of NS5 nozzles.

The orifice sizes (1"-3.5") of Marley NS nozzles are large enough that many competitive nozzles will actually fit inside a Marley nozzle. Marley counterflow nozzles have no internal parts or narrow passageways. The attached diffusion ring will not retain even fibrous debris.

"Full cone" distribution pattern assures uniform water distribution for all film fills. Minimal spray overlap is required, providing uniform water distribution even near spray boundaries. Marley NS counterflow nozzles develop uniform water distribution over a wide range of operating water pressures.

Counterflow Distribution Assembly

- Self Draining
- Economical Installation
- Economical Operation
- Easy disassembly and Reassembly
- Larger pipe spacing
- Easily adapts to a variety of nozzle spacings

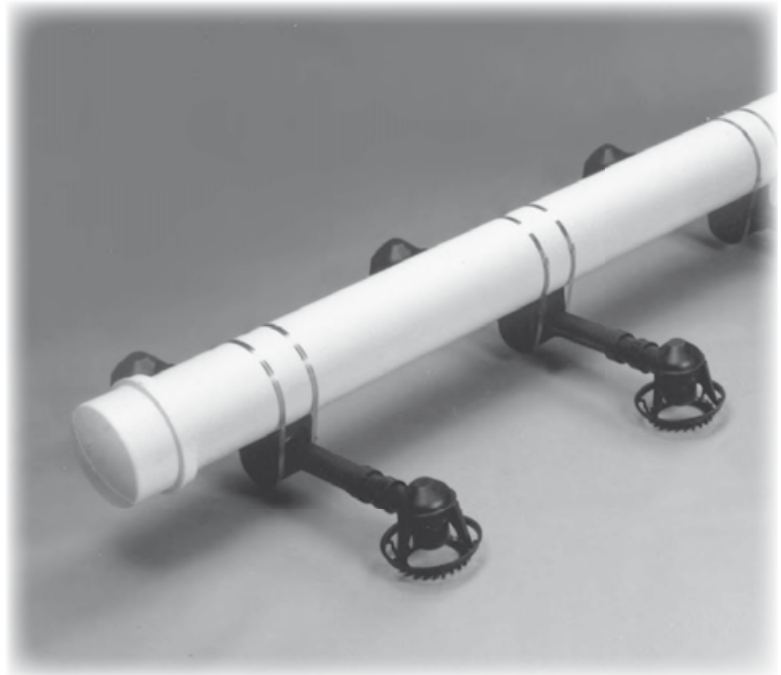

Spray Arm Extender Adapter



EPDM Grommet

Assembly of the entire system requires only a few simple hand tools. All connections are positive—yet the design allows repeated disassembly and reassembly.

Nozzles are installed in pairs—each supply pipe serving multiple pairs of nozzles. Multiple nozzle pairs per supply pipe mean larger pipe spacing and, therefore, lower installed cost than most other systems. The adaptor allows nozzle spacing on 3'-0" centers.

The nozzle outlet is always the lowest elevation in the distribution system. This arrangement is self draining when the supply water is shut off. There are no special valves to open or close.

The nozzle assembly is attached to the header/lateral using a unique design EPDM grommet that is inserted into the pipe—the entire assembly is attached with stainless steel strapping.

Legacy Product Nozzles



Cooling Tower Know How

In most cases it makes sense to replace older design nozzles with modern current designs.

HC™ Crossflow Valves

The HC Valve has inspired many imitators—only Marley can offer you the original:

- Cast iron body
- Cast iron operating bar
- Cast iron locking bar
- Stainless steel stem
- Neoprene joint gasket and set for floating valve disc
- Economical compared to a separate valve and elbow

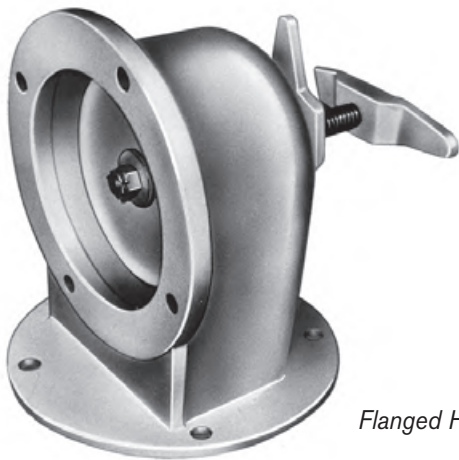

Flanged HC Valve

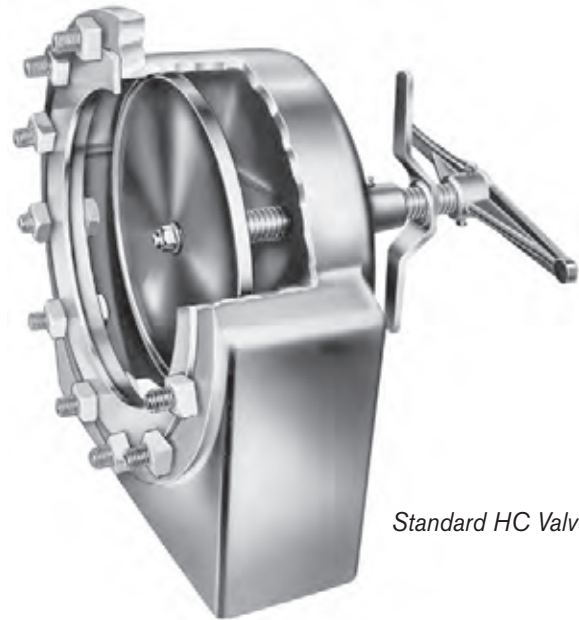

Standard HC Valve

Valve Size	Capacity GPM	
	@ 5 FPS	@10 FPS
6" Diameter	425	850
8" Diameter	750	1500
10" Diameter	1200	2400
12" Diameter	1750	3500
14" Diameter	2350	4700
16" Diameter	3000	6000
18" Diameter	4000	8000
20" Diameter	5000	10000

HC valve body proportions and the arrangement of internal parts provide a low discharge velocity and confine splash, resulting in low pressure drop.

The valve closure disc has a machined lip which closes on a heavy neoprene gasket, avoiding maintenance of expensive metal seats. In a shut-off position, the stem and yoke are external to the water, eliminating the necessity of valve stem packing.

The greatly simplified design ensures long trouble-free operation with no costly repairs or maintenance.

Water Make-Up Float Valves

- Heavy duty red brass body construction
- Buna rubber seal disc assures positive shut-off
- Free flow outlet
- Fully adjustable
- Available from 3/8" through 2" diameters
- Floats available in polypropylene or copper

Designed specifically for cooling tower duty, Marley make-up water float valves provide long life with little maintenance. Typically, valves are available in complete kits which include valve, float arm and float in kits to fit a specific application.

When installed some trial and error adjustment of the float valve may be required to balance the makeup water with tower operation. Ideally, the float valve setting will be such that no water is wasted through the overflow at pump shutdown. However, the water level after pump start-up must be deep enough to assure positive pump suction.



Maintenance Know How

Maintain inlet water pressure at or below 50 psig to ensure long valve seal life.

DuraLast™ FRP Hot Water Basin

Marley DuraLast FRP Basins offer many advantages compared to wood basins:

- Corrosion resistant
- Extremely stable
- Fire resistant
- Easy installation—ideal replacement for wood basins
- High strength
- Light Weight
- No preservative treatment chemicals
- Fasteners hidden by successive interlocking panels

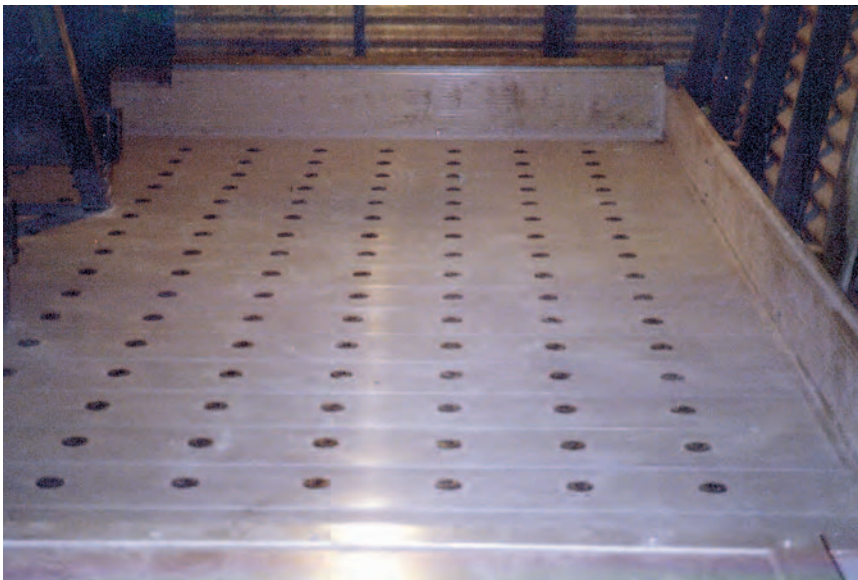

Your hot water basin can be a rugged, light weight basin of Marley DuraLast fiberglass composite material.

Pultruded fiberglass composite is an ideal material for the wet, corrosive cooling tower environment. It's strong and lightweight. Yet, it will not corrode from chemical exposure or moisture, and it resists deterioration from sunlight.

Our experience with composites dates back to the early 1950s. Now, the pultrusion process produces a product with definite, predictable and measurable performance. Extensive laboratory, university and field testing for long-term effects of deflection, bending, shear, buckling and temperature has enabled us to simulate and evaluate DuraLast's performance.

DF254™ Counterflow Film Fill

- High-performance low-clog design
- Bottom supported
- Requires minimum number of supports
- Log configuration

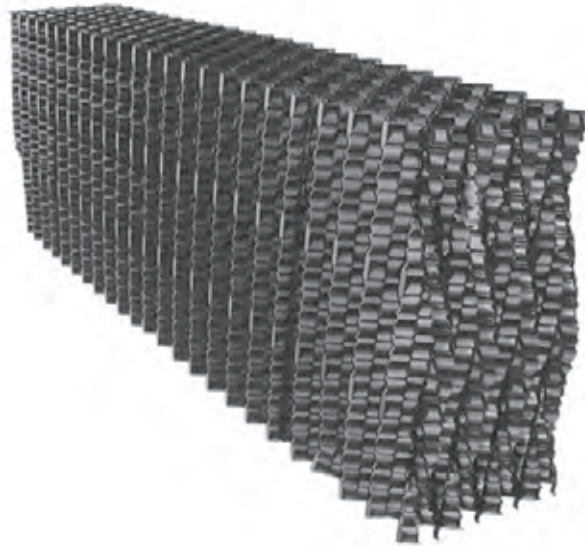

Marley DF254 is a film fill system designed to significantly reduce the risk of biological fouling without sacrificing high-performance heat transfer.

DF254 is a bottom supported low-clog log fill configuration. Open, angular cross-corrugations allow debris and biological growth foulant to pass, while providing maximum surface area and turbulence to develop efficient heat transfer.

Texturing creates thermal capability improvement with little effect on fouling. DF254 offers low pressure drop in an aerodynamic, durable design.

DF254 is easily adapted to any tower's configuration. To accommodate for various fill heights and/or desired duties, DF254 may be installed in multiple layers. DF254 fill is thermoformed from .020" thick, UV inhibited, chemically-resistant PVC (polyvinyl chloride). The material is extruded and manufactured to rigid specifications before forming, at one of Marley's plastics facility.

Cooling Tower Know How

Q *What is the difference between DF254 and DF381?*

A DF254 is a higher performing low-clog fill. DF381 should be used where there is a greater risk of clogging or fouling.

DF381™ Counterflow Film Fill

- High-performance low-clog design
- Bottom supported
- Requires minimum number of supports
- Log configuration

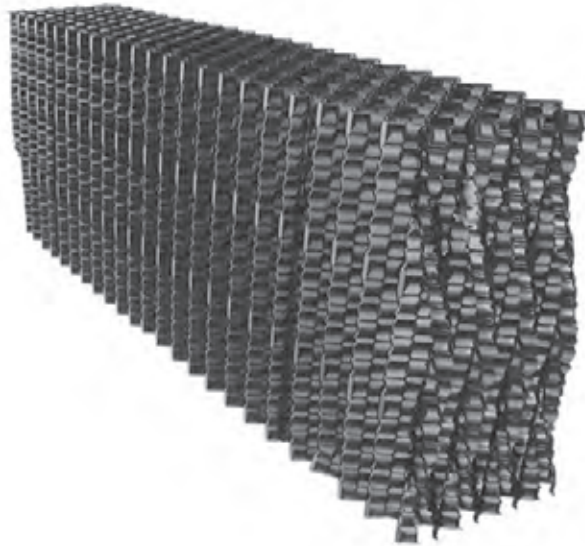

Marley DF381 is a film fill system designed to significantly reduce the risk of biological fouling without sacrificing high-performance heat transfer.

DF381 is a bottom supported low-clog log fill configuration. Open, angular cross-corrugations allow debris and biological growth foulant to pass, while providing maximum surface area and turbulence to develop efficient heat transfer. Texturing creates thermal capability improvement with little effect on fouling. DF381 offers low pressure drop in an aerodynamic, durable design.

DF381 is easily adapted to any tower's configuration. To accommodate for various fill heights and/or desired duties, DF381 may be installed in multiple layers. DF381 fill is thermoformed from .020" thick, UV inhibited, chemically-resistant PVC (polyvinyl chloride). The material is extruded and manufactured to rigid specifications before forming, at one of Marley's plastics facility.

In service now for over ten years at numerous installations throughout Europe, DF381 is now available globally for any counterflow cooling tower, regardless of a cooling tower's age, design or manufacturer.

Cooling Tower Know How

Continuous water temperatures for most PVC Film Fills should never exceed 125°F. Special high temperature PVC formulations and thicknesses are available for water temperatures as high as 165°F.

MVC20™ Counterflow Film Fill

- High-performance low-clog design
- Bottom supported
- Requires minimum number of supports



Marley MVC20™ anti-fouling film type fill consists of thermoformed corrugated sheets made of rigid polyvinyl chloride (PVC), impervious to decay, fungus and biological attack. The sheets are bonded to form modules which can be dimensioned to fit any application.

Marley MVC20 fill combines properties related to a media's ability to allow substances to migrate through it, while maintaining thermal efficiency—this then allows for the use of film fill where fouling risks occur.

Each module consists of vertically channeled flat and corrugated surfaces, which essentially avoids contact between the sheets, thus eliminating water concentration. The horizontal corrugations and their location within the sheet promote optimum mixing of air and water. The flutes in the MVC20 fill are vertically and aerodynamically shaped resulting in a reduction of pressure drop.

MC120™ Counterflow Film Fill

- High-performance design
- Bottom supported
- Requires minimum number of supports
- Log configuration
- Ideal replacement for Marley MC47 counterflow fill

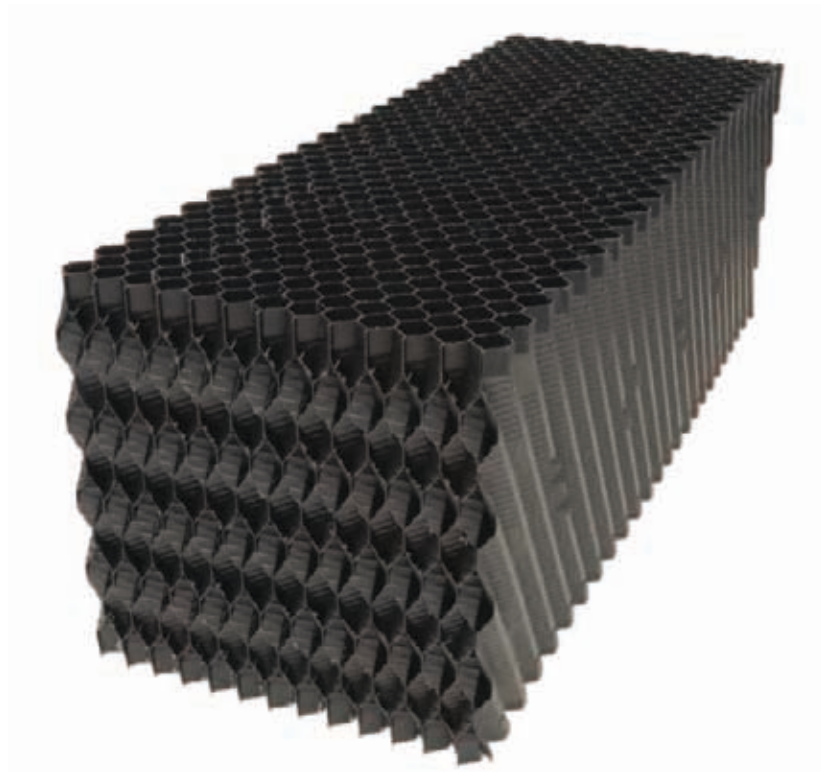

Marley MC120 is a high performance film fill system designed for factory-assembled counterflow towers offering you several distinct advantages.

Textured crossed corrugations provide the surface area and turbulence to develop efficient heat transfer. The corrugations inherently establish uniform fill sheet spacing at 0.45".

MC120 fill is thermoformed from .015" thick, UV inhibited, chemically-resistant polyvinyl chloride (PVC). The flame spread rating is less than 25 per ASTM E-84 and is considered self-extinguishing. The material is extruded and manufactured to rigid specifications before forming.

Log packs are nominally 12" in air travel height and 12" deep. Normal pack length is 72" but packs are available up to 120". Maximum air travel height is 48".

Packs have a 1/2" staggered edge on the air inlet side of the pack that enhances performance and air distribution.

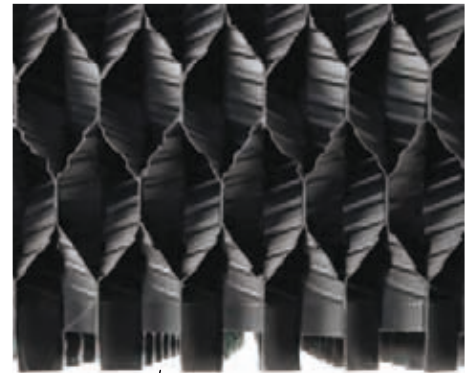

Staggered edge

FB20™ Counterflow Film Fill

- Vertical-flute film fill
- Efficient thermal performance
- Low clog design
- Low maintenance
- Withstands foot traffic
- Resists erosion from water spray



Marley's FB20 clog-resistant film fill is constructed of fire-retardant PVC sheets bonded to form blocks of cooling media. The surface microstructure facilitates air/water mixing and increases the surface cooling area. The offset vertical flutes provide directional changes in air and water flow to increase cooling and promote thermal efficiency while substantially reducing the occurrence of fouling.

Cooling Tower Know How

Continuous water temperatures for most PVC Film Fills should never exceed 125°F. Special high temperature PVC formulations and thicknesses are available for water temperatures as high as 165°F.

Cleanflow™ (AAFNCS) Counterflow Film Fill

- Vertical-flute film fill
- Low maintenance
- Low clog design
- Low pressure drop

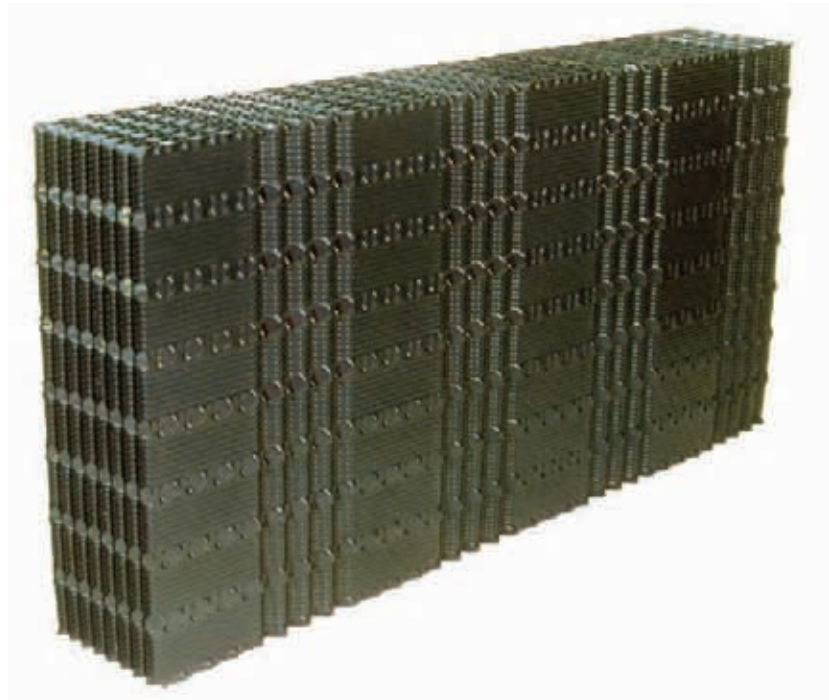

Marley's Cleanflow™ anti-fouling film type fill consists of thermoformed corrugated sheets made of rigid polyvinyl chloride (PVC), impervious to decay, fungus and biological attack. The sheets are bonded to form modules which can be dimensioned to fit any application.

Cleanflow fill combines properties related to a media's ability to allow substances to migrate through it, while maintaining thermal efficiency—this then allows for the use of film fill where fouling risks occur.

Each module consists of vertically channeled flat and corrugated surfaces, which essentially avoids contact between the sheets, thus eliminating water concentration. The horizontal corrugations and their location within the sheet promote optimum mixing of air and water. The flutes in the Cleanflow fill are vertically and aerodynamically shaped resulting in a reduction of pressure drop.

MC75™ Counterflow Film Fill

- High Performance
- Hanging or bottom support design
- Variable air-travel sizes
- Cross-corrugated design

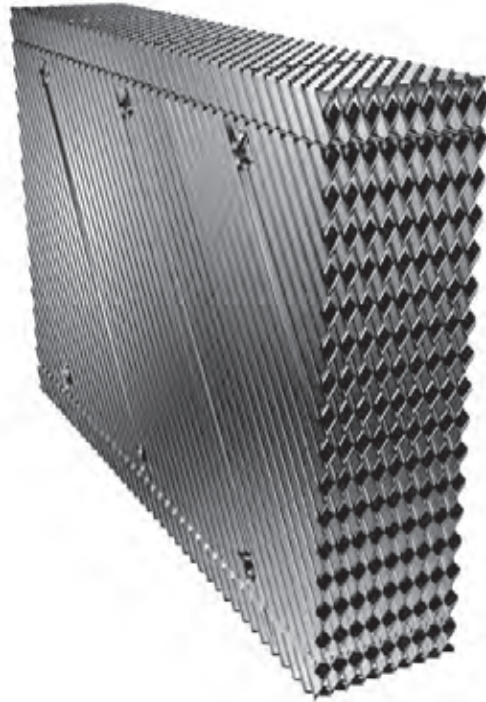

Marley MC75 is a film fill system designed for counterflow towers offering you several distinct advantages.

Crossed corrugations provide the surface area and turbulence to develop efficient heat transfer. The corrugations inherently establish uniform fill sheet spacing at 0.75 .

MC75 fill is thermoformed from .015 thick, UV inhibited, chemically-resistant polyvinyl chloride (PVC). The flame spread rating is less than 25

per ASTM E-84 and is considered self-extinguishing. The material is extruded and manufactured to rigid specifications before forming.

Using Marley MC75 film fill in place of existing splash type fill in counterflow towers usually means reduced fill height, which translates into reduced pumping head. MC75 will also provide greater cooling tower capacity, which means your current performance level will require less fan energy.

The fill pack depth (air travel) is variable to provide the proper heat transfer area within a single fill layer. If another layer of fill is necessary for situations where additional air travel is required, it will be limited to only one. Limiting the number of interfaces between packs minimizes restrictions that usually cause fill clogging. MC75 counterflow fill can be hung from structural members or it can be bottom-supported in virtually all counterflow cooling towers, regardless of a cooling tower's age or manufacturer.

MCR™ Counterflow Film Fill

- Vertical-flute film fill
- Hanging or bottom support design
- Efficient thermal performance
- Low maintenance
- Low clog design

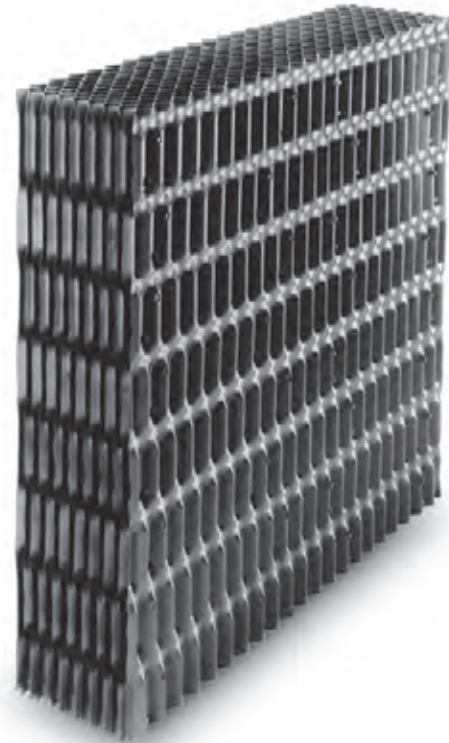

Marley MCR is a film fill system designed to significantly reduce the risk of biological fouling while minimizing the loss of high-performance heat transfer.

Open, offset vertical corrugations allow debris and biological growth foulant to pass, while providing maximum surface area and turbulence to develop evaporative heat transfer. Smooth surfaces without sharp intersections maintain water velocities and reduce

the number of restrictions where biological growth begins.

MCR fill is thermoformed from .015" thick, chemically-resistant PVC (polyvinyl chloride). Material thicknesses of .020" and thicker are also available.

MCR is easily adapted to any tower's configuration. The fill pack depth

(fill height) is variable to provide the proper heat transfer area within a single fill layer. MCR counterflow fill can be hung from structural members or it can be bottom-supported in virtually all counterflow cooling towers, regardless of a cooling tower's age or manufacturer.

MX™ Crossflow Film Fill

- High Performance
- Hanging fill design
- Integral louvers
- Integral triple-pass eliminators

Cooling Tower Know How

Always replace MX fill with genuine Marley MX fill in order to maintain your FM approval rating. Knock-off fill designs may reduce performance and void FM approval.

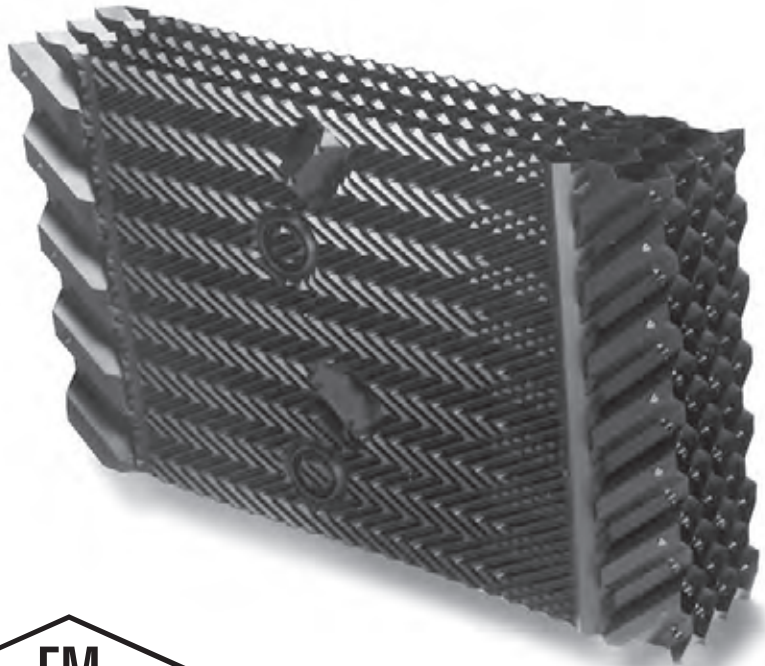

FM

Marley MX Fill is available in MX75 configuration and higher-performing MX625 configuration. MX is a hanging film type cooling tower fill which spreads the water into a thin film, flowing over large vertical surfaces, promoting maximum exposure to air flow. This type of fill provides much more water surface exposure per cubic foot than splash type fill.

MX fill incorporates highly efficient cellular drift eliminators, integrally molded within the fill sheets. Compared

with previous designs, these eliminators reduce drift emissions from the tower by a factor of ten or more! Less drift means tower owners save on water and water treatment chemical expenses. This fill virtually eliminates the nuisance caused by drift spotting on adjacent buildings and property. For additional savings, the drift eliminators discharge air directly toward the fan. Discharge air, traveling in the right direction when it leaves the eliminators, translates to lower fan horsepower.

Louvers are also integrally molded within the fill sheets preventing water from escaping and assuring precise air distribution throughout wide variations in airflow. Unlike towers equipped with separate external louvers, this fill operates virtually ice-free even in extremely cold weather.

MX fill is thermoformed from PVC with a flame spread rating less than 25 per ASTM E-84 and is considered self-extinguishing. Therefore, the risk of fire damage is minimal.

MBX™ Crossflow Film Fill

- High efficient replacement crossflow film-fill
- Single piece, full height design
- Durable design adaptable to any crossflow fill configuration
- Thermoformed from 20 mil (.020") thick PVC

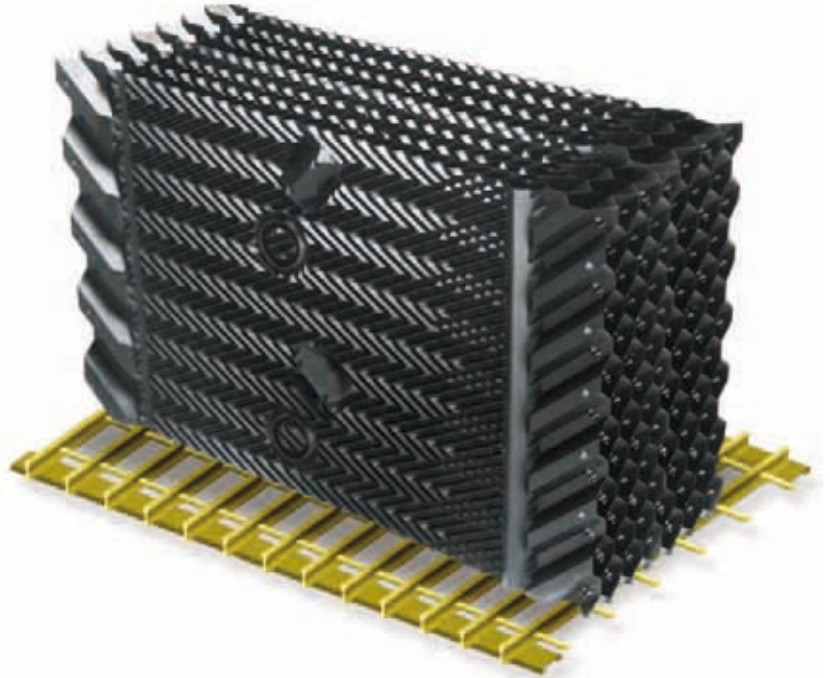

Marley MBX fill is a high performing, bottom supported PVC pack fill with integral louvers and drift eliminators, specifically designed for the Aftermarket. This fill will make installation easier and faster, while at the same time offering great cooling efficiency without major tower modifications.

MBX fill incorporates highly efficient cellular drift eliminators, integrally molded within the fill sheets. These eliminators may reduce drift emissions from the tower by a factor of 10 or more.

Louvers are also integrally molded within the fill sheets preventing water from escaping and ensuring precise air distribution throughout wide variations in airflow.

MBX fill packs are available in various heights and air travels from 24" to 48" and can be installed in almost any crossflow cooling tower regardless of tower age or manufacturer. Retrofit kits including MBX fill packs, fiberglass supports, stainless steel hardware and installation instructions are available.

MBX fill is manufactured from inert material, thus ensuring a long operating life with minimal maintenance. The wide sheet spacing prevents clogging and the integral drift eliminators do not require extra frames or retainers.

MBX is thermoformed from 20 mil (.020") thick PVC with a flame spread rating less than 25 per ASTM E-84 and is considered self-extinguishing. Therefore, the risk of fire damage is minimal.

M106™ Crossflow Film Fill

- High Performance
- Bottom supported fill design
- Integral triple-pass eliminators
- Available with or without eliminators
- Easily installed as a replacement fill in non-Marley products

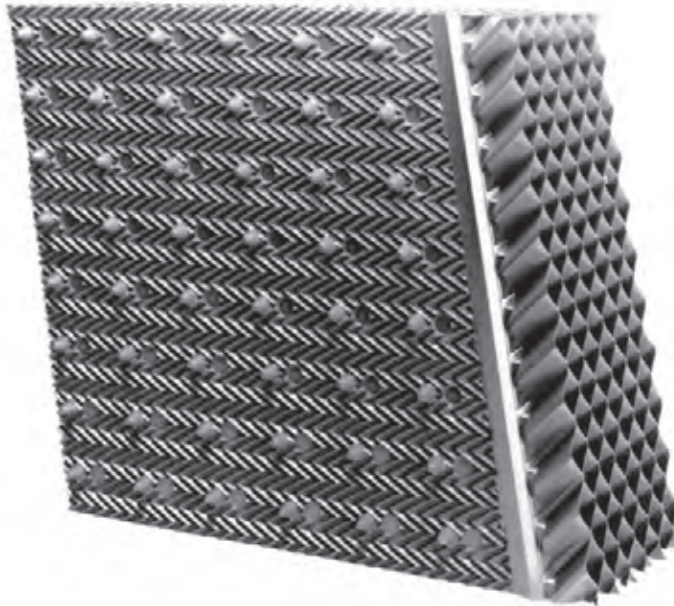

Marley M106 is a film-type cooling tower fill. Water flowing down the fill sheets forms a thin film on the surface of the sheets. This type of fill provides much more water surface exposure per cubic foot than does splash-type fill.

This fill offers greater cooling efficiency, which translates to colder water from present systems without an increase in fan horsepower. Or, this improved efficiency can be used to save horsepower and produce the same cold water temperature.

M106 fill is also available with highly efficient drift eliminators molded right into the fill sheets. Compared with older designs, these eliminators reduce water carryover (drift) from the tower by a factor of ten or more! Reduced drift means lower water and

treatment chemical costs. The nuisance of spotting adjacent buildings and property due to cooling tower drift is virtually eliminated.

Options include eliminators for both vertical and horizontal discharge cooling towers. Guiding the discharge air in the right direction further increases savings in fan horsepower.

M106 is thermoformed from PVC sheets with a maximum flame spread rating of 25 per ASTM E-84. Therefore, the risk of fire damage is minimal.

M106 fill is impervious to rot, corrosion, and decay. The wide sheet spacing prevents clogging ensuring minimal maintenance and long service life.

M106 is easy and inexpensive to install in almost all crossflow cooling towers. It requires minimal structural modification because it is bottom supported. The integral drift eliminators don't need extra frames or retainers. M106 provides more cooling capacity and improved drift elimination in one easily installed pack.

Alpha™ Crossflow Splash Fill

- High performance
- Heavy duty
- Easy cleaning
- Direct replacement for wood lath fill



Marley Alpha fill will increase cooling tower thermal performance capacity (compared with wood lath on similar spacing). Variable fill bar spacing is available to provide the required thermal performance.

Alpha fill bars are corrosion resistant PVC extrusions which are supported by FRP (fiberglass reinforced polyester) grids.

FRP fill grids are extremely inert and tough. Each fill bar is firmly attached to the FRP grid to prevent premature wear on either the grid or the fill bars. The fill bars are designed to prevent sagging, even after prolonged exposure to a cooling tower environment.

Alpha fill is a direct replacement for many types of wood lath fill. The FRP grid can be manufactured to fit virtually any cooling tower regardless of its age or manufacturer.

The rounded upper surface of the fill bars and the smooth surface finish facilitate cleaning.

Mesa™ Crossflow Splash Fill

- High performance
- Perpendicular and Parallel configurations
- Easy cleaning
- Exceeds CTI Standard 136 for strength, flammability and impact

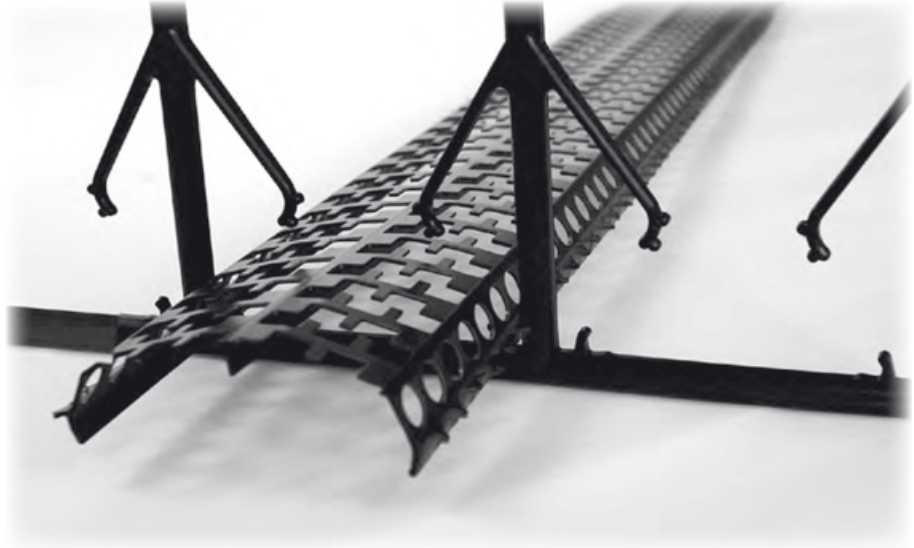

Marley Mesa splash-fill advances the state of the art in cooling tower splash fill.

The enhanced thermal performance of Mesa fill increases cooling tower capacity in most cases. Variable fill bar spacings provide the required thermal performance with the minimal fill material and installation time. Mesa fill is installed parallel or perpendicular to the air flow depending on thermal performance requirements or existing cooling tower configuration.

Mesa fill bars are extruded of corrosion resistant PVC (polyvinyl chloride) manufactured at SPX's Kansas plastics manufacturing facility. The unique material formula used in the Mesa bar meets or exceeds CTI Standard 136 for strength, flammability and impact. Each bar is firmly attached to the Marley GridLoc™ polypropylene injection molded support for use in crossflow towers. GridLoc provides a nonabrasive support that eliminates the need for bench supports.

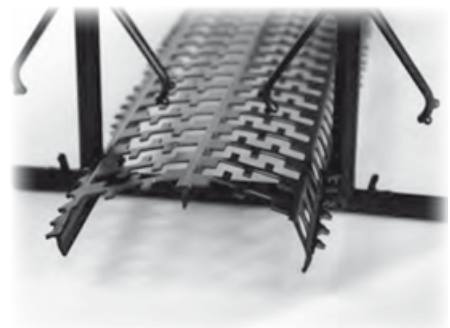

Ladder™ Crossflow Splash Fill

- High Performance
- High temperature capability
- Variable spacing
- Unique injection molded polypropylene design

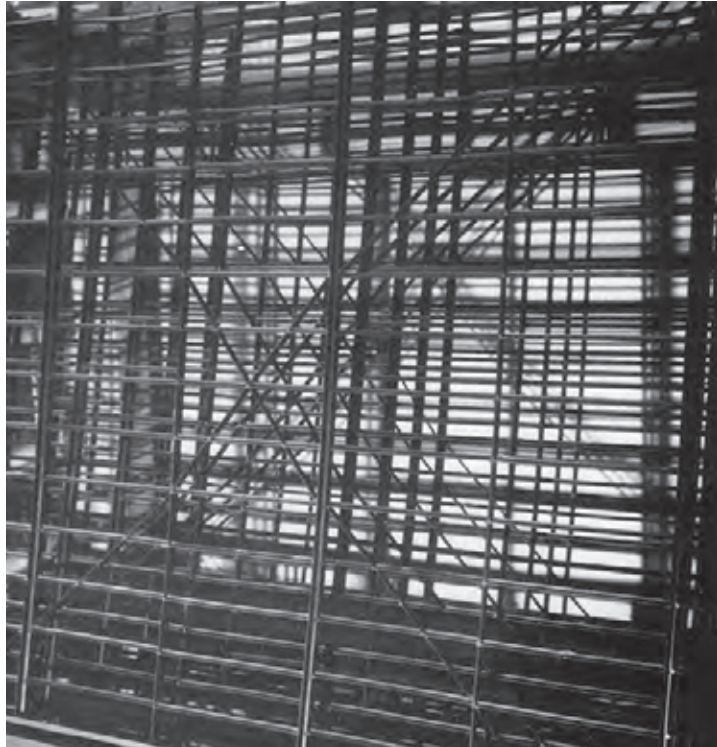

Marley Ladder fill provides highly efficient water breakup to develop excellent heat transfer with low resistance to airflow. The horizontal spacing is variable to meet thermal performance requirements.

Injection molded polypropylene Ladder fill is extremely inert to chemical reaction.

Ladder fill is capable of 150°F water temperature operation.

Ladder fill can be installed in virtually any crossflow cooling tower regardless of its age or manufacturer.

Omega™ Crossflow Splash Fill

- High performance
- Perpendicular and Parallel configurations
- Easy cleaning
- Exceeds CTI Standard 136 for strength, flammability and impact



Marley Omega splash fill advances the state of the art in cooling tower splash fill.

Enhanced thermal performance of Omega fill increases cooling tower capacity in most all cases. Variable fill bar spacings provide the required thermal performance with the minimum amount of fill material and installation time. Omega fill is installed parallel or perpendicular to the air flow depending on thermal performance requirements or existing cooling tower configuration.

Omega fill bars are extruded of corrosion resistant PVC (polyvinyl chloride) manufactured at SPX's Kansas plastics manufacturing facility. The unique material formula used in the Omega bar meets or exceeds CTI Standard 136 for strength, flammability and impact. Each bar is firmly attached to FRP or stainless steel fill grids with unique injected molded polypropylene benches designed to prevent premature wear on the fill bar and the grid.

Omega bar's classic arch shape enhances structural characteristics which prevents sagging, even after prolonged exposure to cooling tower environments.

Omega fill and its support system are designed to be used in virtually all cooling towers regardless of a cooling tower's age or manufacturer.

Permagrid® Counterflow Splash Fill

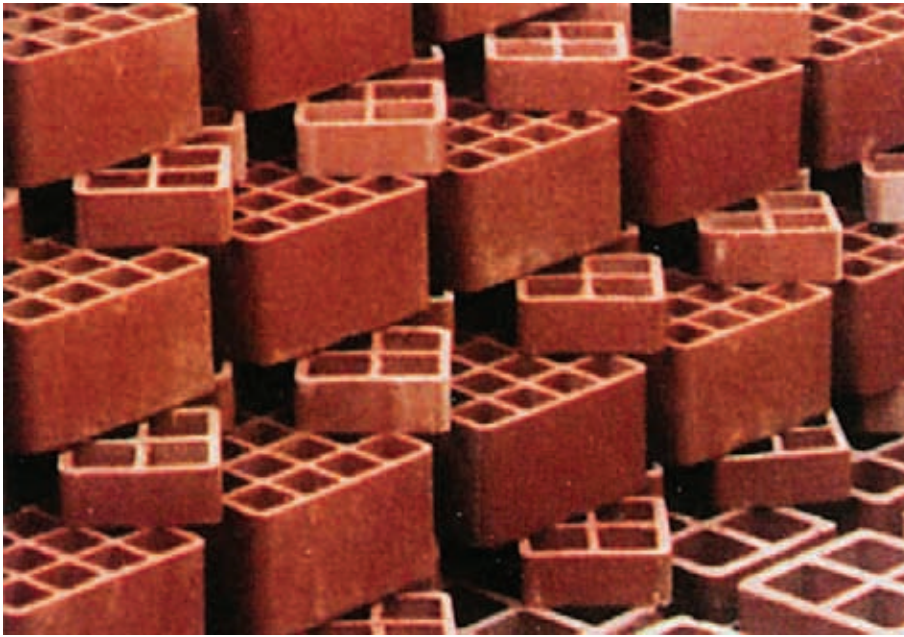

- Extremely durable
- 25 year guarantee
- Easy cleaning
- Dirty water application

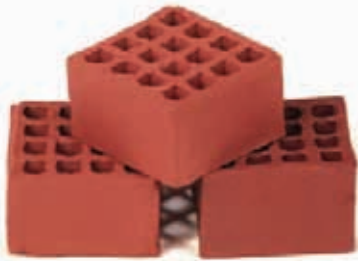

Ceramic® Permagrid tile fill is the most durable fill in the industry with a guaranteed minimum of 25 years of service. Molded from domestic clay to strict specifications, the clay is heat fired to create a fill that is immune to traditional fill deterioration problems. Because this revolutionary tile fill is not affected by ultraviolet exposure and fungal attack, cooling towers with Permagrid tile fill are perfectly suited for harsh operating environments involving temperature extremes. This tile fill exhibits low water absorption such that it will withstand extreme freeze-thaw environments common in cold weather climates or free-cooling applications.

Characterized by large openings, Permagrid tile is an excellent performer in the high-solid contents environment of dirty water applications. Permagrid is set without mortar, adhesive or mechanical connections so no regular maintenance is necessary. The installed system is placed in a pattern designed to provide optimal thermal performance.

TrickleBloc™ Counterflow Splash Fill

- High Performance
- High density counterflow design
- Withstands foot traffic
- Unique extruded heat-fused polypropylene design

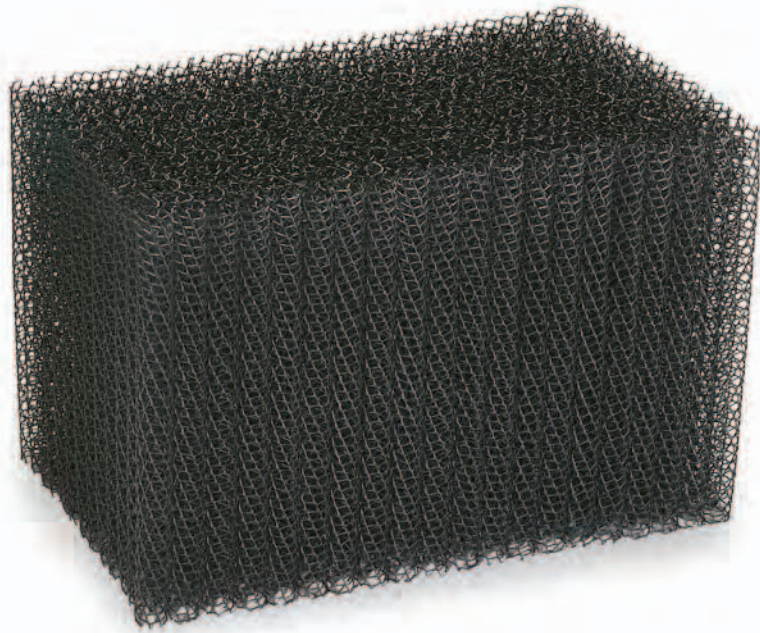

SPX's patented TrickleBloc™ clog-resistant splash fill is comprised of extruded polypropylene cylinders, heat-fused to form blocks of splash media. The open weave of the vertical cylinders provides even water flow and promotes thermal efficiency. The lattice design promotes splashing to help facilitate self-cleaning.

GridLoc™ Splash-Fill Support

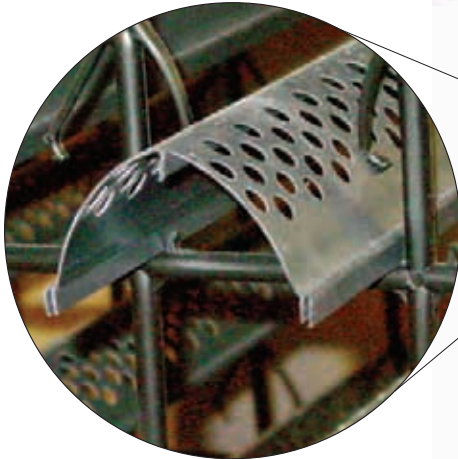

Splash bars are easily inserted into the grid and snapped into place.

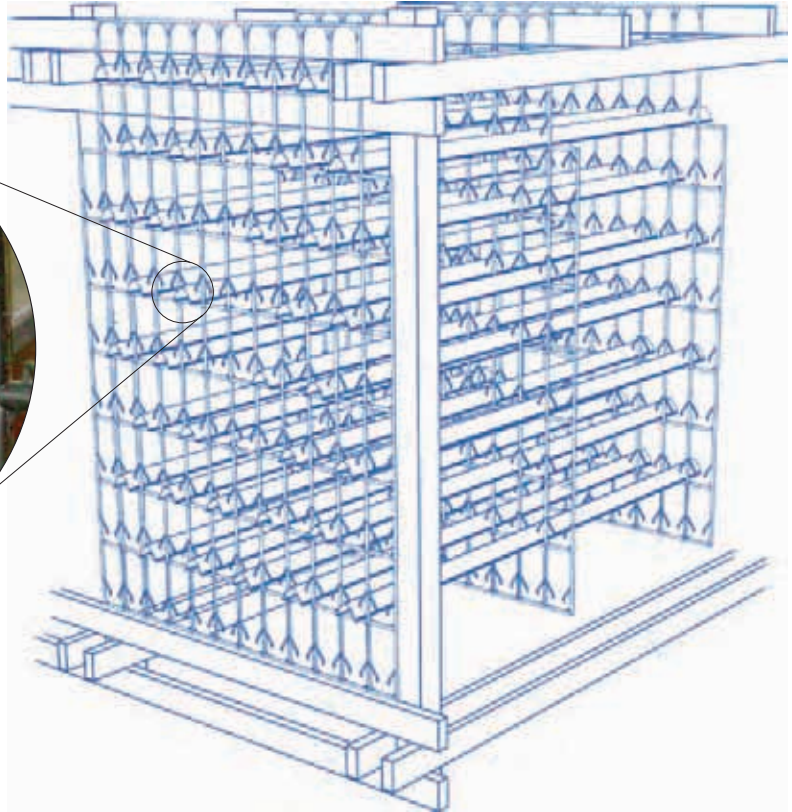

Marley GridLoc splash-fill support is a polypropylene injection molded support for use in crossflow towers. The GridLoc design has a pair of integral, opposing, downward sloping splash bar grips attached to the vertical strands in each window to secure splash bars. The lower horizontal strand has a short pair of vertical nubs to center splash bars and provide a nonabrasive support that eliminates the need for bench supports.

The GridLoc design has a molded in shelf support at the top of the grid for attaching the grid to the structural members. The grid can be either nailed or screwed to the support member to avoid movement of the grid in the horizontal plane.

The typical GridLoc arrangement will be in 4' x 6' bays with bars parallel to air flow. The nominal window opening for bar spacing is 4" horizontal by 8" vertical. The GridLoc splash bar grips are compatible with many Marley splash bar designs as well as commercially available bars. GridLoc will retrofit on historic Marley Class 600 as well as other manufacturer's crossflow cooling towers.

XCEL® TU Eliminators

- Cellular design
- Low pressure drop
- Very low drift rates
- Counterflow and crossflow designs

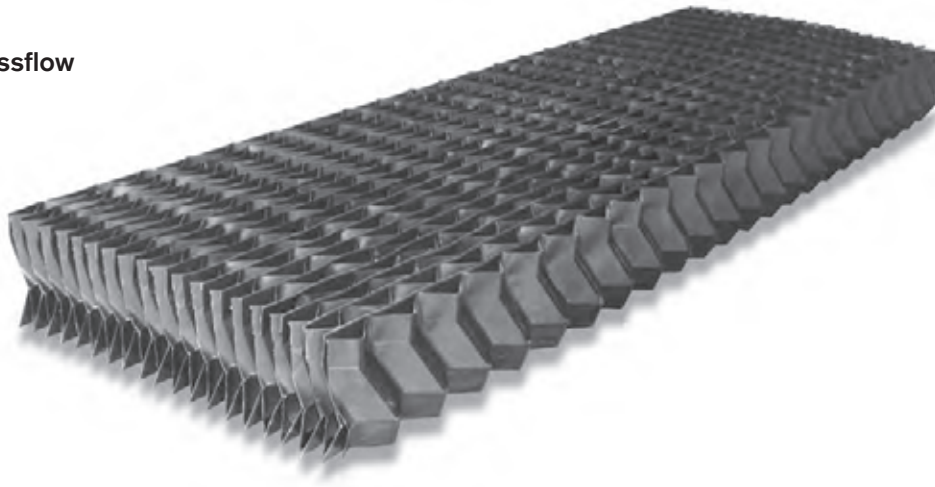

Marley developed the first cellular drift eliminator in the 1970s when eliminator designs were primarily ineffective blade type configurations. Next, Marley patented the XCEL generation of eliminators in the early 80s. No other eliminator could come close to XCEL eliminator's low drift rate and low pressure drop. Now, virtually every eliminator is a nesting cellular PVC type design.

XCELplus is a more advanced design that meets or exceeds today's demanding specifications for drift emissions without sacrificing fan horsepower. Drift rates are currently half that of the original XCEL design with equivalent pressure drop.

The eliminator discharge angle is important enough to warrant two separate eliminator designs—one for crossflow and one for counterflow towers. Tests show the air direction leaving the eliminator is extremely important—imperfect designs create additional work for the fan. This means either increased fan horsepower—or reduced cooling tower performance. The crossflow version features drainage slots within the eliminator pack to ensure trapped drift is returned to the wet side of the cooling tower.

Low drift rate is the primary goal of eliminator design. XCELplus boasts typical drift rates of .001% of the total GPM. Lower drift rates are available depending upon tower configuration.

XCEL eliminators require little or no maintenance. If it becomes necessary to clean them, care must be taken not to physically damage the PVC eliminator packs. For loose deposits of silt, fibers, etc., a water spray can be used, provided the spray nozzle is kept moving continually and the water pressure is not excessive (recommend less than 30 psi). Chemical cleaning can also be done. If an acid product such as inhibited sulfamic acid or glycolic acid is used for chemical cleaning of a scale deposit (e.g., calcium carbonate), care must be taken that the acid does not attack other materials in the cooling tower or system, such as steel. The acid should be quickly and thoroughly rinsed off all metal surfaces. Do not use cleaning agents which contain hydrocarbon solvents.

A Turn For The Better

It is widely accepted throughout the air-handling industry that turning vanes significantly enhance the performance of any system that includes a major change in air flow direction. A crossflow cooling tower is such a system. Air enters the tower horizontally and must turn to the vertical before it can exit through the fan stack.

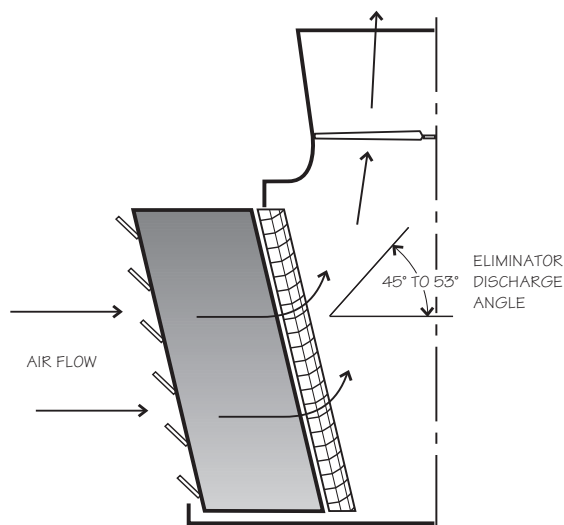

Marley XCEL Drift Eliminators

Marley XCEL drift eliminators discharge air at an angle of 45° to 53° with respect to the horizontal. The exact angle depends on the specific eliminator and on the slope of the tower frame.

The directional changes incorporated in Marley's three-pass drift eliminator act as turning vanes to induce the discharge air flow through a gentle turn from the horizontal toward the vertical.

To be sure of efficient cooling tower performance, always demand that drift eliminators in large crossflow towers must provide a discharge angle (as defined by the angle of the last section of the eliminator itself) at least 40° from the horizontal. Otherwise, unnecessary and costly turning losses will occur in the plenum.

Some drift eliminator manufacturers overlook this fact and do not include turning vanes on their cellular drift eliminators. Serious performance problems can occur because of this oversight.

R & D investigations have demonstrated that some cellular drift eliminators in crossflow towers actually reduce thermal performance by 4% to 8%, because they direct the discharge air inefficiently.

Discharge air from some cellular drift eliminators actually enters the fan plenum at an angle below or near the horizontal.

The fan energy is wasted because it must force the air stream through a turn of more than 90°. This resultant increase in pressure loss reduces the total air flow through the tower. Reduced air flow means reduced thermal performance.

R & D studies have determined that these eliminators can increase the fan horsepower required for a given cold water temperature by as much as 25%—or the owner will be forced to accept an increase of up to 2°F in cold water temperatures.

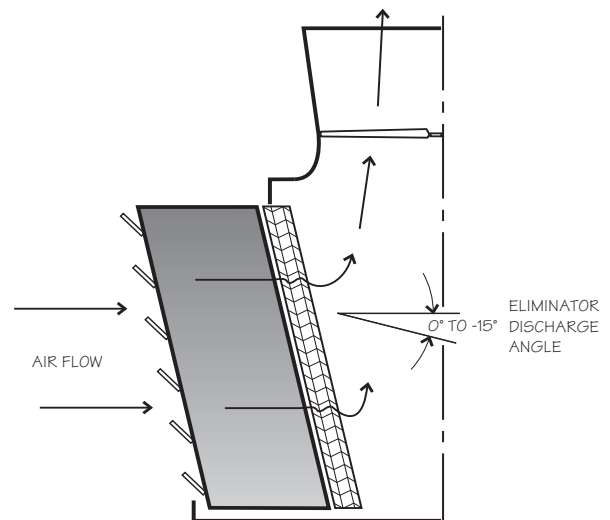

Other Cellular Drift Eliminators

Geareducer® – Single Reduction

- Outstanding durability
- Designed specifically for cooling tower duty
- 5 year oil change interval
- Minimum L_{10A} service life of 100,000 hours on both input and output shafts
- Gear sets meet or exceed the requirements of AGMA Quality No. 9
- Input shaft nitrile lip seals
- Premium seals available
- Output shaft sealed with a maintenance-free labyrinth ring
- Timken® tapered roller bearings

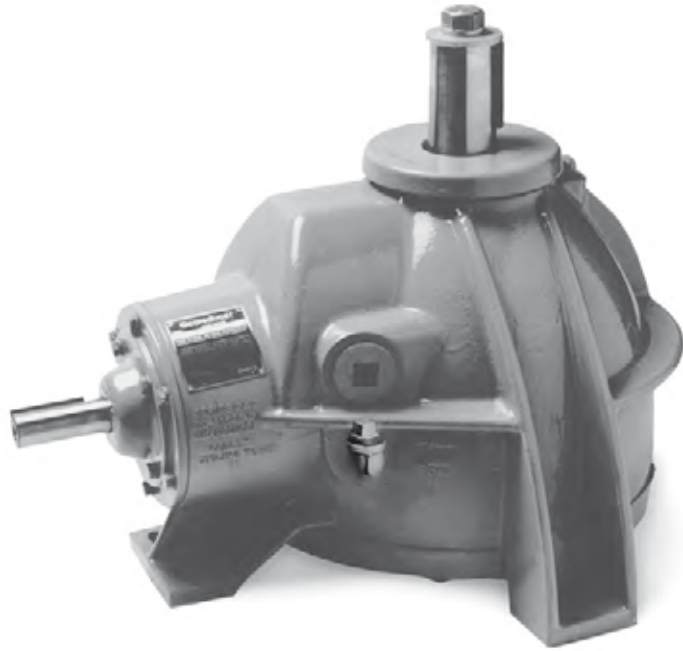

For over 40 years, the Marley Geareducer has been one of the most reliable geared speed reducers—designed specifically for cooling tower service.

The reliability of the Geareducer comes from more than 100,000 units of experience, and from Marley's attention to exacting quality standards of design and manufacturing. Today, every Marley Geareducer is tested under load at our factory. Then, it's inspected and adjusted before shipment.

Outstanding Geareducer engineering is only as good as the lubricant that protects it. That's why we took the next step and filled every System 5 Geareducer with Marley Gearlube™ lubricant.

In addition, several improvements to the System 5 Geareducer have been made to take advantage of the extraordinary lubricating properties of Gearlube. We've equipped it with a strong magnet in the sump to trap metal particles generated during the initial break-in period.

Rebuild Kits Available

Marley Geareducer kits offer a single consolidated shipment of all the materials you need for repair/rebuild including: gears, bearings, oil seals, O-ring seals, shims and oil

Geareducer – Single Reduction

Model	Reduction Ratio	Output RPM*		Input hp Limitations**		Empty Weight lb	Oil Capacity US gallon
		60 Hz	50Hz	60 Hz	50Hz		
10.1	2.13:1	832	692	7.5	7.5	67	.375
	2.61:1	679	564	7.5	7.5		
	3.27:1	543	451	7.5	7.5		
	3.77:1	471	391	7.5	7.5		
1800	2.71:1	655	544	34	28	210	2.4
	3.27:1	543	451	30	25		
	3.75:1	473	393	25	19		
	4.09:1	434	361	21	17		
2000	4.80:1	370	307	15	12	210	2.4
	2.71:1	655	544	57	49		
	3.27:1	543	451	51.5	44		
	3.75:1	473	393	41.5	35.5		
2200	4.09:1	434	361	34.5	30	350	2.5
	4.80:1	370	307	27	23.5		
	3.45:1	514	428	70	60		
	3.79:1	469	390	70	60		
	4.10:1	433	360	70	60		
	4.56:1	389	323	70	60		
	5.11:1	347	289	70	60		
	5.50:1	323	268	61	53		
	6.12:1	289	240	50	43		
	6.50:1	272	226	47	41		
2400	7.33:1	241	201	32	28	350	2.5
	8.67:1	204	170	29	25		
	3.45:1	514	428	143	121		
	3.79:1	469	390	133	110		
	4.10:1	433	360	103	90		
	4.56:1	389	323	88	75		
	5.11:1	347	289	80	70		
	5.50:1	323	268	75	60		
3000	6.12:1	289	240	60	50	1250	16.5
	6.50:1	272	226	55	45		
	7.33:1	241	201	40	30		
	8.67:1	204	170	31	27		
	5.06:1	351	292	150	125		
	5.44:1	326	271	150	125		
	6.14:1	289	240	150	125		
	6.85:1	259	215	150	125		
3000	7.91:1	224	186	150	125	1250	16.5
	8.80:1	202	168	131	110		
	9.60:1	185	154	113	94		

*Nominal input speed is assumed to be 1775 RPM at 60 Hz and 1475 RPM at 50 Hz

**Rated at AGMA 2.0 Service Factor

Geareducer – Double Reduction

- Outstanding durability
- Designed specifically for cooling tower duty
- Designed to meet or exceed the requirements of CTI Std. 111
- Gear sets meet or exceed the requirements of AGMA Quality No. 9 to 11
- Minimum L_{10A} service life of 100,000 hours on both input and output shafts
- Input shaft nitrile lip seals
- Premium seals available
- Output shaft sealed with a maintenance-free labyrinth ring
- Timken® tapered roller bearings
- Two-stage (spiral bevel/helical) gear reduction for efficient power transmission

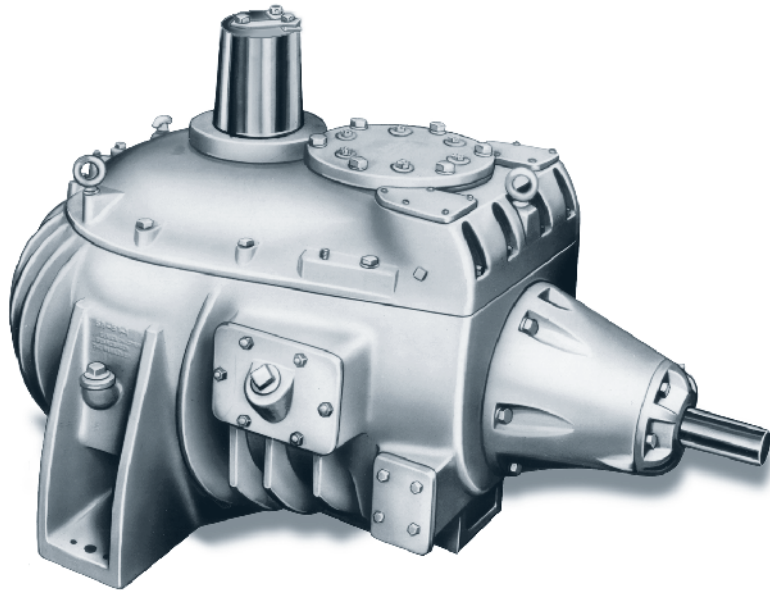

Marley Industrial Geareducers are manufactured and designed specifically for cooling towers in large industrial and power plant applications. In shape and function, their design goes beyond normal AGMA requirements—both to maximize air movement through the tower, and to minimize the impact of maintenance.

Although the primary function of a Geareducer is to reduce the speed of the driver (usually an electric motor) to a speed which is conducive to good fan performance, it must satisfy other criteria as well. For example, it must provide primary support for the fan—withstanding the shock loads imposed at

start-up and during subsequent speed changes—anchor the fan against lateral movement in response to rotational forces—and contribute as little as possible to power transmission losses as well as the generation of noise.

Given these requirements, many manufacturers of mechanical equipment provide acceptable speed reducers. Designed for more forgiving commercial applications, these units are often unprepared for the rigors and peculiarities of cooling tower service, such as the corrosive effects of operation (often intermittent) within an exceedingly humid environment. As a result, both the life expectancy of

these commercial speed reducers—and the thermal performance of the cooling towers on which they are installed—often suffer.

SPX Cooling Technologies is the only major manufacturer whose gearboxes are designed uniquely for cooling tower service. And, since we warrant not only the Geareducer, but the thermal performance of the cooling towers on which they operate as well, development, design, and manufacture are taken very seriously. This has resulted in an unequalled history of trouble-free operation.

Geareducer – Double Reduction

Model	Reduction Ratio	Output RPM*		Input hp Limitations**		Empty Weight lb	Oil Capacity US gallon
		60 Hz	50Hz	60 Hz	50Hz		
32.2	7.89:1	225	187	125	100	1700	9.0
	8.80:1	202	168	150	150		
	9.62:1	185	153	150	150		
	10.16:1	175	145	150	125		
	11.18:1	159	132	150	150		
	12.93:1	137	114	150	125		
	14.64:1	120	100	150	125		
3400	9.93:1	179	149	150	125	2810	18.5
	10.35:1	171	143	125	100		
	11.16:1	159	132	150	125		
	12.97:1	137	114	150	125		
3600	9.64:1	184	153	257	217	3000	18.5
	10.83:1	164	136	251	212		
	11.55:1	154	128	218	184		
	12.98:1	137	114	213	180		
	14.84:1	119	99	188	159		
4000	9.64:1	184	153	316	272	3200	18.5
	10.83:1	164	136	316	272		
	11.55:1	154	128	304	263		
	12.18:1	146	121	326	274		
	12.98:1	137	114	304	263		
	13.24:1	134	111	251	217		
	13.81:1	129	107	290	244		
	14.88:1	119	99	251	217		
	15.84:1	112	93	251	214		
	16.49:1	108	89	204	175		
	18.54:1	96	80	204	175		
19.72:1	90	75	204	174			

*Nominal input speed is assumed to be 1775 RPM at 60 Hz and 1475 RPM at 50 Hz

**Rated at AGMA 2.0 Service Factor

Geareducer Oil

Filled with Reliability

It is critical to the operational life of a transmission to utilize a satisfactory lubricant that includes the correct viscosity grade and additives. Additionally, it should be within the specific limitations of contaminants and fill volume throughout the machine's lifetime.

Marley Gearlube™ is a premium quality synthesized hydrocarbon lubricant that is specially formulated to deliver extended life without oxidation or loss of lubricity. It is free of undesirable elements that can produce sludge, deposits and corrosion—and a superior extended life lubricant than normal petroleum oil.



The advanced formulation of Gearlube can extend the service life of any gear box, especially the System 5 Geareducer.

Also available, non-synthetic Marley Turbine mineral oil is in accordance with the most recent edition of AGMA 9005 requirements for rust and oxidation inhibited gear oils.

Cooling Tower Know How

If lubricants, other than Marley oils are used, they must not contain any additives—such as detergents or E.P. additives—which are adversely affected by moisture and could reduce the service life of the Geareducer.

Geareducer Sound Levels

More Than Quiet

Although the primary function of a cooling tower speed reducer is to reduce the speed of the driver (usually an electric motor) to a speed which is conducive to good fan performance, it must satisfy other criteria as well. For example, it must provide support for a large fan, withstand the shock loads imposed at start-up and during subsequent speed changes, and anchor the fan against lateral movement in response to rotational forces. Plus it must contribute as little as possible to power transmission losses as well as the generation of noise.

SPX Cooling Technologies is the only major manufacturer whose gearbox is designed uniquely for cooling tower duty. Since SPX warrants not only its Geareducer, but the thermal performance of the cooling tower as well, design and manufacturing is taken very seriously. This has resulted in a history of trouble-free operation unequalled in the cooling tower industry.

Marley vs Amarillo®

Sound measurement testing of cooling tower gear speed reducers was conducted by National Technical Systems (NTS) in 1998. Concurrent testing was conducted on Marley and Amarillo gear speed reducers in accordance with SAE J2101 at various speeds and loads.

Lower sound levels were measured for Marley gear speed reducer products in both comparison groupings tested.

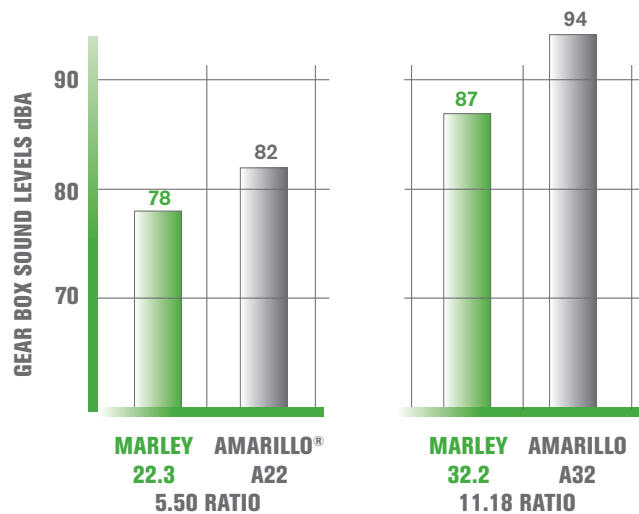

Sound Check

The Marley Series 22.3 was up to 4 dBA quieter than the Amarillo Series A22. Both products having the same gear ratio.

The Marley Series 32.2 was 7 to 10 dBA quieter than the Amarillo Series A32. Both products having the same gear ratio.

These sound levels were recorded under fully loaded conditions.

Sprag-Clutch Backstop

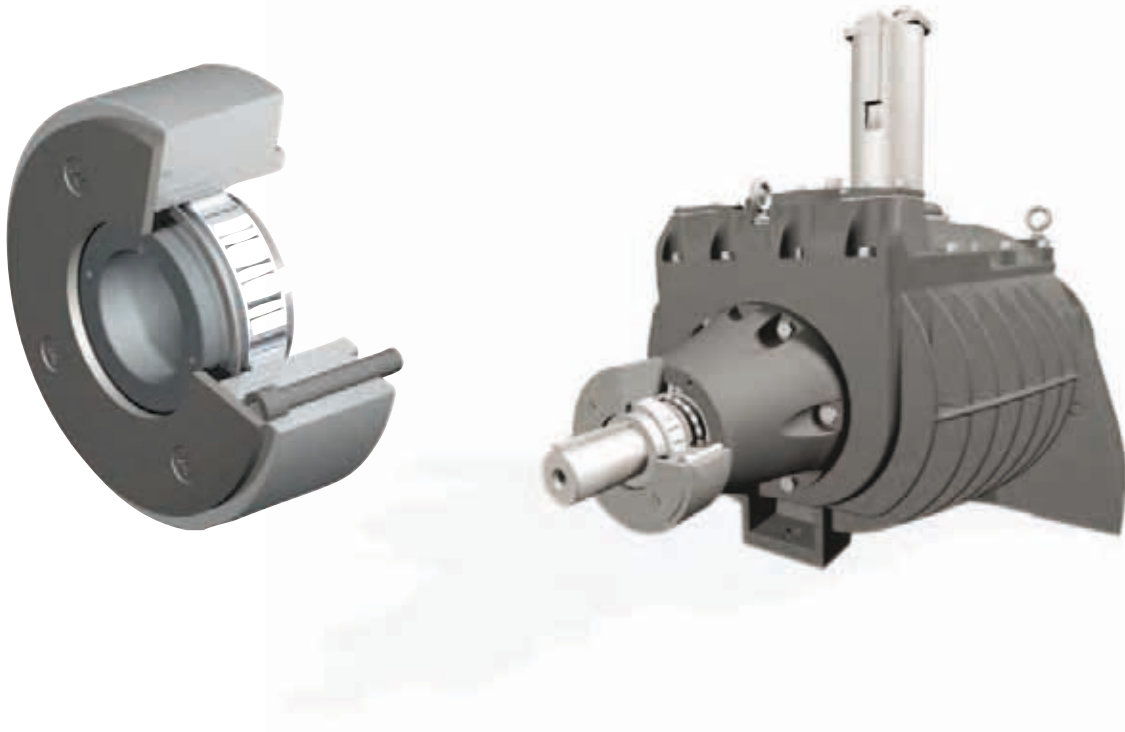

The Marley integral Sprag-Clutch Backstop is custom designed and configured specifically for a Marley Geareducer® with input shaft diameters of 2.375" and 2.625". Also referred to as a sprag clutch anti-rotation device, these units are designed to prevent reverse rotation of the fan, Geareducer and motor. Designed specifically for use with the current 32.2, 3400, 3600 and 4000 Geareducer models, they can also be utilized to fit legacy 32.1T, 34.3T, 34.4, 36 and 38 Geareducer models.

When operating, the outer race is stationary and the inner race is rotating. When facing the input shaft of the Geareducer, the forward (over-running) direction is clockwise.

In contrast to conventional sprag clutch devices which may continuously wear, this device utilizes a "Lift-off" sprag functionality which alleviates the wear issue once typical rotation speeds are reached.

This feature greatly diminishes the friction and heat generated, thus promoting longevity for both the clutch unit and the Geareducer itself.

Specifications

The backstop shall have a torque capacity of at least 1100 ft·lb_f (1490 N.m) and shall be capable of continuous overrunning operation at 1800 rpm

Reflex™ RTM Fan Cylinder



Having designed and manufactured cooling tower fan cylinders since the 1930s, Marley began producing FRP (fiberglass) fan cylinders in 1958, which quickly became the accepted standard within two years' time. With considerable modeling and full scale testing, this experience led to the development of several new fan cylinder designs for a variety of tower types and fan sizes. One such development resulted in the Reflex velocity recovery cylinder in the 1980s, and is the standard design still in use today for 10' diameter and larger fans.

21st century manufacturing technology has enabled further advancement and the introduction of the new Marley Reflex RTM industrial fan cylinder, offering a more dimensionally accurate, high quality surface finish, better fit and robust structural integrity. A light RTM (resin transfer molding) closed-molding process lends itself to increased durability for the final product, and ensures laminate thickness and weight consistency. Because the cavities are infused using rigid forms in the ribs, there is no porosity or potential sites for delamination or structural fracture to begin. Therefore, the cylinder load capacity is greatly enhanced.

The "green" benefit of the closed-molding process is the virtual elimination of VOC emissions because the resin is injected and cured in a sealed, closed mold. And because the lay-up process is now dry, a more precise laminate can be achieved, with no hand-working of resin-soaked materials, no cleaning requirements for application equipment, no hand tools using hazardous chemicals and no chemical disposal concerns.

H3™ Fan

- True “twisted” airfoil design
- Solid cast aluminum alloy
- Infinite pitch adjustment
- Machined aluminum hub
- 54" through 216" diameter
- Stainless steel hardware standard



Marley H3 cast aluminum alloy fans are standard equipment on various Marley product lines. All H3 fan assemblies incorporate machined aluminum hubs with stainless steel hardware. All H3 fan blades are adjustable in pitch, to take full advantage of rated horsepower or to compensate for unusual job site restrictions.

A true airfoil blade, designed specifically for cooling towers offering efficient quiet operation and long service life. Available in 54" through 216" fan diameters.

Cooling Tower Know How

Axial fans require only half the operating horsepower of centrifugal blower fans

X7™ Fan

- True airfoil “quiet” design
- Lightweight extruded aluminum alloy
- Infinite pitch adjustment
- Galvanized ductile iron hub
- 66" through 168" diameter



Marley X7Fan with U-Style hub

The Marley X7 fan is designed for induced-draft cooling tower applications, offering distinct advantages over other fan designs. The Marley FlareTip™ blade enhancement provides increased performance overcoming tip clearance losses—aiding the movement of air next to the fan cylinder.

The wide chord blade design is well suited for low noise operation as well, delivering superior air flow and pressure capability at reduced speed. The high performance X7 airfoil is one of the most efficient in the industry today.

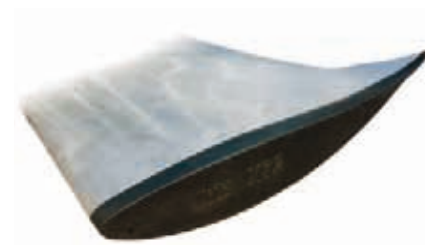

The blade end caps are injection molded impact-resistant, polypropylene with a section on the upper surface to allow for consistent fan pitch setting.

Additionally, all blades are match-moment weight balanced, allowing all X7 blades to be interchangeable without the need to rebalance the entire fan assembly.



Each blade is secured to the hub with two stainless U-bolts that allow blades to be easily rotated to adjust desired pitch angle, delivering precise utilization of fan horsepower.

Superior strength, excellent quality, light weight and outstanding performance makes the X7 fan an outstanding choice for cooling tower applications—and best of all it's a Marley fan.

Ultra Quiet Fan

- True airfoil “quiet” design
- FRP blades
- Infinite pitch adjustment
- Machined aluminum hub
- 84" through 168" diameter
- Stainless steel hardware standard

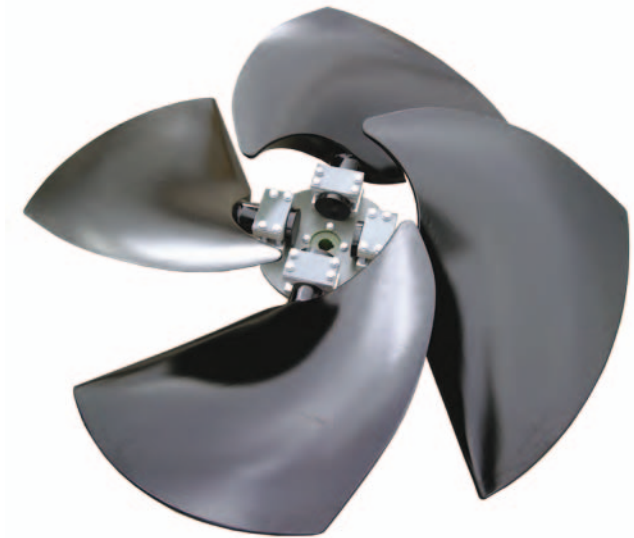

The Marley Ultra Quiet Fan represents the top-of-the-line of new generation in super quiet fans—the FRP blades have been developed to meet the most stringent noise limitations. The fans permit variable pitch adjustment and feature a simplified hub design.

Common Applications for Ultra Quiet Fans

Hospitals—Noise concerns may be paramount near medical facilities where quiet and rest are necessary.

Universities and Office Buildings—Whenever HVAC equipment is near people, unwanted noise may be a concern. For example, conducting a meeting or teaching a class in a room with cooling equipment outside is an unwelcome distraction.

Hotels and Residential Areas— At night ambient noise levels are lower which may make a cooling tower seem louder to anyone nearby. Hotel guests or residential neighbors shouldn't have to contend with a cooling tower fan cycling on and off at night.

HP7i Fan

- True “twisted” airfoil design
- Fiberglass vinyl ester laminate
- Single piece construction
- Heavy duty steel hub assembly
- 72" through 168" diameter
- Stainless steel hardware standard

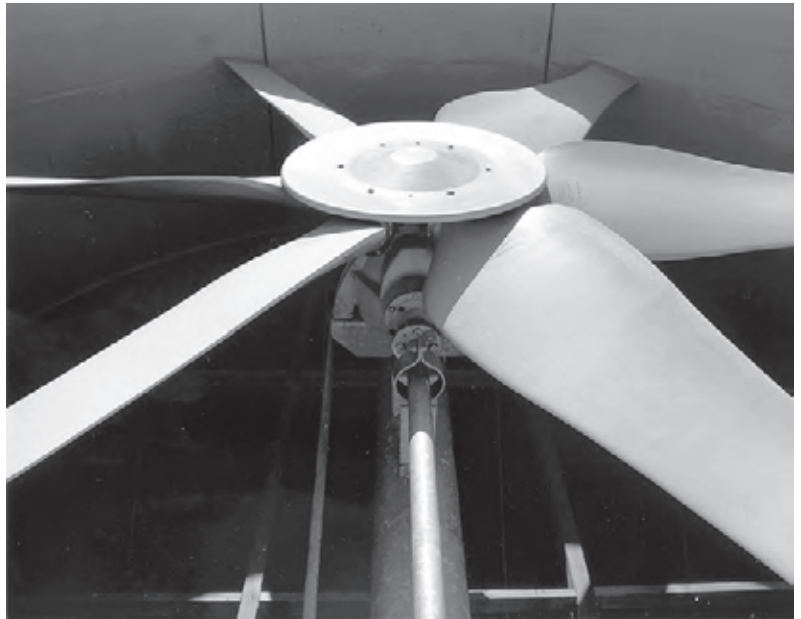

Marley HP7i fans are designed specifically for cooling tower applications, offering distinct advantages over other types of fans. The Marley FlareTip™ blade enhanced for low sound operation, delivers maximum air flow and pressure capability at reduced speed.

The HP7i blade is a single piece composite design ensuring structural integrity. Fan blades with bolted or glued connections between the blade shank and airfoil section introduce an additional mechanical joint under stress. The one piece composite design ensures the integrally molded leading-edge will not come off or fail and the blade will handle the toughest cooling tower applications.

The skin of the HP7i is made with top-quality fiberglass reinforced vinyl ester that is infused with pigment for even distribution across the laminate. There are multiple layers of surface veil on the blade surface leading to superior UV protection compared to fans with only a painted exterior.

Blades attach to the fan hub using a heavy-galvanized iron ring integrally molded with each fan blade. By loosening the hub attachment hardware, blades can easily be rotated to achieve desired pitch, permitting maximum utilization of fan horsepower.

HP7000™ Fan

- True “twisted” deep airfoil design
- Fiberglass reinforced vinyl ester laminate
- Single piece construction
- Heavy duty dual-plate heavy galvanized steel hub assembly
- 168" through 394" (10 meter) diameter
- Stainless steel hardware standard

Marley HP7000 fans are designed specifically for industrial cooling tower applications, offering distinct advantages over other types of fans. The Marley FlareTip™ blade enhancement provides increased performance overcoming tip clearance losses, aiding the movement of air next to the fan cylinder. The wide blade design is well suited for low sound operation, delivering superior air flow and pressure capability at reduced speed.

The skin of the HP7000 is made with top-quality fiberglass reinforced vinyl ester that is infused with pigment for even distribution across the laminate. There are multiple layers of surface veil on the blade surface leading to superior UV protection compared to fans with only a painted exterior.

Constructed in one continuous piece, with a consistent moment weight, HP7000 blades are interchangeable without the need to rebalance the fan assembly. A nylon leading edge erosion barrier is molded into each blade to ensure long service.

The hollow blade is designed with a deep section airfoil making the HP7000 strong, yet light and easy to handle.

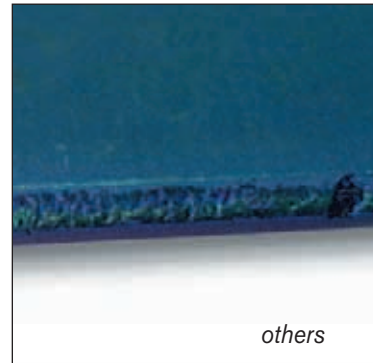

others

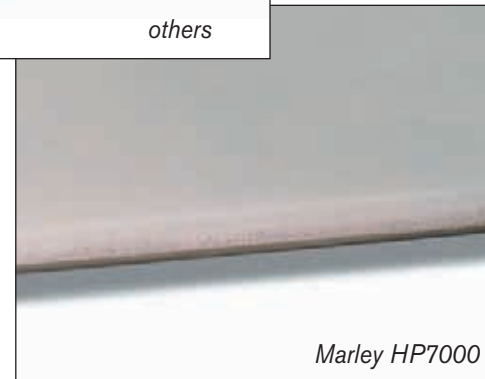

Marley HP7000

Close-up views of other manufacturer and Marley HP7000 fan blade samples after 300 hours in the same erosion test chamber.



Series 400™ Driveshaft

- Low maintenance
- Easy to install
- Easy to align
- Long service life
- Corrosion resistant
- Easily interchanged

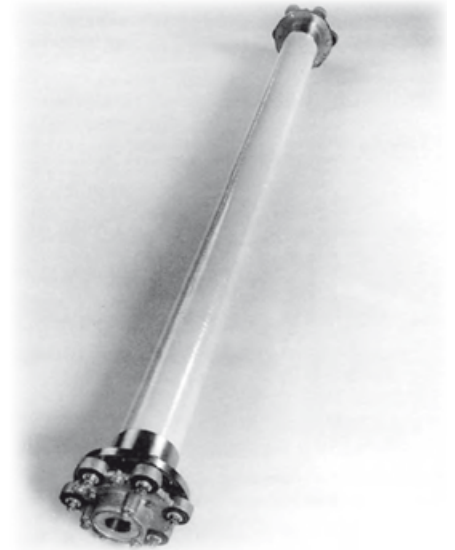

Series 400 carbon-fiber driveshafts provide a lightweight, low maintenance alternative to stainless steel driveshafts.

Marley neoprene flexible bushings are easier to install and align than others using stainless steel torque elements. Series 400 driveshafts are designed for fans up to 10 meters in diameter and for motors up to 300 hp.

The Marley Series 400 carbon fiber driveshafts offer you the following benefits:

Low maintenance—No intermediate couplings or bearings. You realize extensive savings in maintenance costs. The yoke and flange coupling design, featuring flexible bushings, has been proven for more than 30 years on the Marley Series 301 driveshaft. This system is more tolerant of misalignment, with lower thrust forces transmitted to motor and Geareducer® bearings, than conventional driveshafts.

Easy to install/easy to align—One-piece design eliminates hard-to-reach intermediate bearings. Installation requires fewer steps. The tube and flange is lightweight, easily handled by two workers.

Long service life—Rugged design includes carbon fiber/epoxy composite tube with stainless steel flanges and neoprene flexible elements. Also, vibration is internally dampened to

prolong alignment and transmit less vibration to the motor and gearbox. All materials are specially selected for cooling tower duty and longer life. The composite tube prevents transient start-up vibration.

Corrosion resistant—Materials such as composite carbon fiber, epoxy, stainless steel, and others help prevent corrosion.

Easily interchanged—Owners with Marley 301 stainless steel driveshafts can upgrade to the Series 400 simply by exchanging their existing driveshaft tube assembly with the new carbon fiber tube assembly and using the existing driveshaft yokes.

Marley Driveshaft Specs

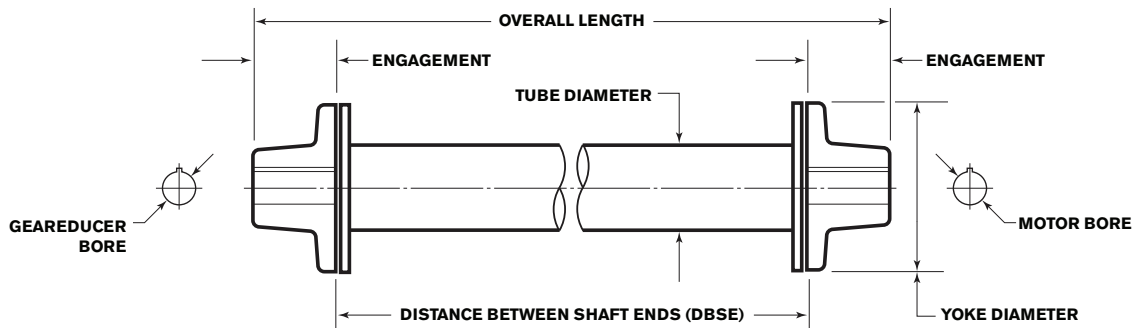

Driveshaft Series	Maximum Horsepower	Maximum Overall Length	Maximum DBSE	Yoke Diameter	Tube Diameter	Bore Range
Q1	7.5	48"	45.25"	5.625"	1.125"	1" - 1.5"
6Q	60	86.5"	80.75"	6"	2.5"	1" - 2.375"
175	75	115.5"	109.75"	8"	4"	1" - 3.125"
250	150	115.5"	109.75"	8"	4"	1" - 3.375"
301	300	143.5"	136.25"	12.375"	6.625"	1" - 3.9375"
400	300	180.5"	173.25"	12.375"	6.625"	1" - 3.9375"

Comp-DS™ Driveshaft

- Low maintenance
- Easy to install
- Modern construction
- Easy to align
- Long service life
- UV and corrosion resistant
- Easily interchanged



Carbon-fiber, unitized flexible element

Comp-DS composite driveshafts provide a high-performance, lightweight and low-maintenance alternative to steel driveshafts.

Marley's patent pending, unitized, carbon-fiber flexible elements with slip-fit, stainless steel hubs are easier to install and align than others using steel torque elements. Comp-DS driveshafts are designed for fans up to 10 meters in diameter and for motors up to 300 hp.

Marley's Comp-DS composite driveshafts offer the following benefits:

Low Maintenance - Ease of Installation—The full-floating design has no intermediate couplings or bearings. The simple hub design and corresponding unitized flex-elements, require less labor to install and maintain than previous designs.

Lightweight—The lightweight, permanently bonded, tube and flange assembly is easily handled by technicians without the need for lifting equipment. The reduction in rotating mass also results in lower radial loads on motor and Geareducer bearings.

Modern Construction—Robust composite design is comprised of high strength fiberglass and/or carbon-fiber reinforced tubes in a tough epoxy matrix along with fiberglass flanges and urethane encased, carbon-fiber flex-elements. Additionally, the quantity of components and hardware is minimized.

UV and Corrosion Resistant Materials—All materials are specially selected for cooling tower duty and are constructed to provide maximum protection against corrosion and UV attack.

Performance—The composite tube prevents transient start-up vibration and diminishes some of the initial, peak-torque impulse realized during hard-starting. High torque ratings allow the Comp-DS design to accommodate high motor power ratings in an expanded speed range.

Easily interchanged—Owners with Marley 301 stainless steel driveshafts or Series 400 composite tube driveshafts may directly replace their existing assembly with the Comp-DS series.

SofTork™ MC Coupling

- Quiet operation
- No axial separation of hubs
- Corrosion resistant materials and coatings
- Simple to install
- Balancing not required at 1800 rpm
- Fast and easy flexible element replacement
- Accommodates misalignment in the angular and parallel directions as well as end float

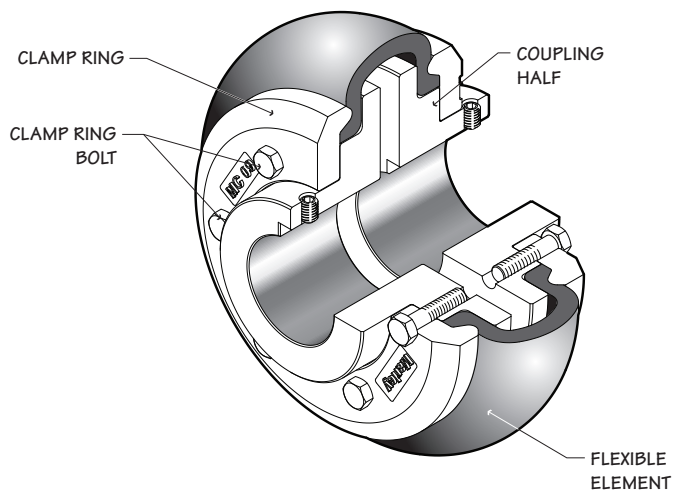

Flexible element, tire type coupling designed specifically for cooling tower applications. Couplings consist of two cast ductile-iron, electro-galvanized hubs and clamp rings with stainless steel fasteners.

- Outstanding vibration dampening characteristics
- Shock load cushioning ideal for VFD use
- High degree of flexibility to accommodate misalignment

Cooling Tower Duty Motors

- Three-part corrosion resistant epoxy paint coating on exterior and interior surfaces
- V-ring slingers on both end shields, plus an external water slinger/flinger
- Service factor: 1.25 up to 100 hp, 1.15 from 125 hp and up
- Automatic drain plugs—pressure compensated



Marley cooling tower duty motors utilize a double-dip and bake impregnation process for the insulation system to increase mechanical endurance and moisture resistance. Additionally, an epoxy paint coating system is used externally and internally to inhibit corrosion. Multiple end-bell drains allow for quick removal of condensation regardless of the motor mounting position. Automatic terminal box drain plugs, a rubber lead separator, V-ring slingers on both end-shields and an additional external water slinger all aid in increasing the motor's longevity.

Marley cooling tower motors meet or exceed all NEMA Premium and CEE requirements for energy efficiency. These TEFC motors are built according to NEMA specifications and designed for operation in moist or dusty atmospheric conditions without affecting useful life. Motors are NEMA Design "B" and maintain exceedingly high breakdown and locked rotor torque while providing the highest rated efficiency levels.

Cooling Tower Know How

TEFC motors offer additional benefits over TEAO motors whose only source of cooling is the flow of air produced by the cooling tower fan

Can-Do™ Fan Motor Control Panel

Electrical components:

- External disconnect handle with padlocking provisions to meet lockout tag-out safety requirements
- Main circuit breaker with thermal and magnetic overload protection
- Door mounted H-O-A selector switch. Speed selector switch for two speed applications
- Adjustable motor overload
- User terminal points for connecting field devices:
 - Two wire vibration switch interface for starter shut down if vibration switch trips
 - 1 N.O. motor overload trip contact for feedback to customers alarm system or BAS
 - Cold water temperature thermostat connections for starter ON – OFF control
- Wiring diagram laminated and mounted on inside of door
- UL and CUL listed assembly



NEMA 3R outdoor cabinet* with the following features:

- Rain shield
- Mounting flanges located top and bottom
- Piano hinge
- Lock off capabilities
- Hex head “screw type” hold downs for door
- Warning labels

* optional NEMA 4X fiberglass cabinet for corrosive locations

Options:

- Pilot lights
- Status contacts for BMS interface
- Solid-state temperature controller with readout display
- Integrated basin heater controls with temperature probe and heater contactor
- Integrated water level controls (Make-Up, Hi and Lo alarm contacts)
- GFI power receptacle (for trouble light and power tool)
- Factory installed and wired control panel on select towers
- DE-ICE reversing circuit for two-speed applications only

Variable Speed Drive

- 6 Pulse PWM drive with IGBT switching and integrated bypass design
- Main circuit breaker disconnect with thermal and short circuit protection
- Field selectable bypass mode of operation
- UL Listed



Marley fan motor Variable Speed Drive systems are designed to combine absolute temperature control with ideal energy management. The cooling tower user selects a cold water temperature and the drive system will vary the fan speed to maintain that temperature. Precise temperature control is accomplished with far less stress to the mechanical equipment components. The improved energy management provides fast payback to the user.

The standard VFD requires a speed reference input signal from a remote source such as a building automation system or RTD with 4–20mA transmitter. VFD will accept a 4–20mA, 0–20mA or 1–10VDC signal. Speed may also be controlled with the onboard keypad.

Marley Premium Variable Speed Drive features:

Automatic Bypass circuit standard. This feature transfers the fan motor from the drive to a temperature modulating bypass contactor if the VFD faults out on specific fault parameters allowing continuous operation of the tower.

De-icing function standard with auto canceling timed run of 20 minutes maximum

The Marley Premium VFD drive is not intended to be controlled by building or process automation systems. No external controller required. Included is an integrated temperature controller and RTD sensor for mounting into the tower outlet water piping.

Basin Heater

- Pre-engineered, UL Listed / CSA approved package for freeze protecting cooling tower basins
- Stainless steel heating elements
- Complete control package



Basin Heating Element

Basin Heater Control Panel with Low Water Safety Circuit

The system usually consists of one or more stainless steel electric immersion heaters installed in threaded couplings provided in the side of the basin. A NEMA 4 enclosure houses a magnetic contactor to energize heaters; a transformer to provide 24-volt control circuit power; and a solid-state circuit board for temperature and low water cut-off.

Cooling Tower Know How

Submerged in basin water, in which zinc ions are present, copper immersion heaters must not be used. Insist upon stainless steel.

Multicell Motor Sequencer

- Simple to install and operate
- Eliminate multiple fan thermostats
- Single set point stages multiple fans



Marley performance-matched sequencer—available in either 8 or 16 stage systems—will stage multiple fan cells of a cooling tower from a single temperature measurement location based upon a single temperature set point. Old mechanical thermostats with staggered set points on each cooling tower fan cell are no longer necessary.

Marley controls help extend the life of the fan motors with automatic lead stage rotation. The sequencing controllers prevent the same motor from always starting first in the normal sequence of operation. Every 24 hours a different motor becomes the lead stage equalizing the wear on all motors.

The sequencer can easily be configured for single or two speed motor systems. On two speed systems, the unit can be set to cycle through a Lo1-Lo2-Lo3-Hi1-Hi2-Hi3 or Lo1-Hi1-Lo2-Hi2-Lo3-Hi3 sequence. The controller recognizes the two speed motor settings and only uses low speed as a lead stage. Adjusting the temperature set point and activating cells can easily be accomplished at the unit.

Liquid Level Control

Marley liquid level controls provide you with state of the art systems to control and monitor the water level in your cooling tower collection basin. Relays operating in conjunction with suspended stainless steel electrode probes monitor basin water levels, providing simple solenoid-valve water makeup or discrete on/off signals to more sophisticated automation controls. Up to seven probes may be provided in a single head unit. Optional configurations might include any configuration of the following combinations:

- Water level make-up with a solenoid valve
- High and low alarming back to a BMS
- High level cut-off for pump control
- Low level cut-off for pump control



Each probe is furnished with 20 feet of wire



Electrode Probe installed in a Marley NC[®] crossflow cooling tower

Stainless steel 303 conductivity probe tips are suspended from a PVC conduit box using flexible wire providing a means to monitor water level when used with a Marley LLC control panel. Each probe is furnished with 20 feet of wire for connection to the Marley LLC control panel. If longer wire is required the probe wire may be spliced in the field. Each probe is furnished with a cord grip which may be loosened allowing probe height adjustment.



Adjustable electrode probe system (stilling chamber removed)

LLC™ Water Level Control Panel



LLC Control Panel Features:

- NEMA 4X Fiberglass Enclosure
- Mounting flanges located top and bottom
- Outdoor rated
- Stainless steel continuous hinge
- Swing out lid with stainless steel clamps
- Lock-off capabilities
- 14" high x 12" wide enclosure for configurations up to 4 cards
- 18" high x 16" wide enclosure for configurations up to 6 cards

Electrical Components:

- Main breaker disconnect
- HAND-OFF-AUTO selector switch for manual fill control when makeup card is used
- Output contact for makeup card is internally powered with 120 VAC for use by customer
- User terminal points for connecting field devices e.g. solenoid, water level probes and alarm devices
- Terminal strip raised for easy access
- Wiring diagram and User Manual secured in literature pocket inside the panel door
- Built to UL and CUL standards
- Single enclosure for all control cards
- Level cards as required for following conditions:
 - Make up
 - Hi alarm
 - Lo alarm
 - Hi level cutout
 - Lo level cut out



M-5™ Vibration Switch

- Meets all requirements for mechanical switches on one package
- Weatherproof and optional hazardous area rating
- Local and optional remote reset with startup delay
- SPDT or (2)SPDT switch output contacts



The Marley M-5 vibration switch is designed to meet all requirements for mechanical switches in a single, affordable package. This unit provides economical vibration protection for cooling tower mechanical equipment. An inertia sensitive mechanism activates a snap-action switch with SPDT output contacts if the vibration exceeds an adjustable setpoint.

The M-5 contacts can be used to activate an alarm or initiate equipment shutdown. The housing is weatherproof with an optional hazardous area rating.

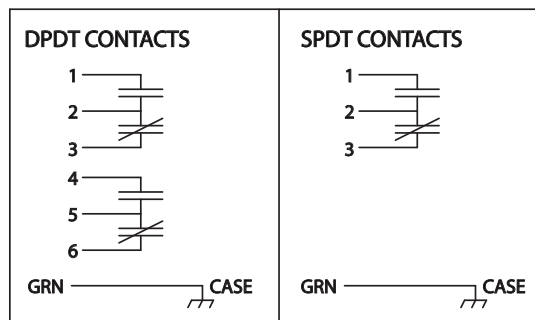

User Wiring Diagrams

Temporary Cooling

- Disaster response
- Maintenance outages
- Repair/replacement cooling

A sense of urgency that gives new meaning to the word "fleet."

In this business, every minute of cool water flow, and every minute variation in water temperature counts, regardless of whether you provide emergency backup or increase production capacity.

Because it all equates to profits.

Marley Temporary Cooling Solutions is geared entirely toward making your performance our priority—including a fleet of ultra-efficient induced-draft towers, and regional support teams who are on the ground and ready to move.



Aftermarket Services

- **Repair and reconstruction**
- **Inspection and condition reports**
- **Performance testing**
- **Maintenance plans**

Whether investing in a new plant or operating an existing system, cooling tower maintenance is critically important to operational efficiency, equipment longevity, and regulatory compliance. Regular service by experienced teams helps ensure your cooling system—and your bottom line—is not compromised by unexpected failure, giving you the peace of mind to focus on your business.

For many older towers, reconstruction is a cost-effective alternative to replacement. Our reconstruction experts work with our engineering staff to make old towers as good as new—if not better!

Our reconstruction specialists have been trained to analyze the condition of your cooling equipment—and its capability to be successfully repaired, rebuilt, or upgraded. Your SPX Cooling Technologies sales representative can arrange an inspection of your cooling system.



Let our cooling system experts help your maintenance experts. We can contract with you to provide as much “hands-on” maintenance assistance as you need.

Performance Testing—you can't know how much any reconstruction effort has improved your tower unless you know how your tower is performing now. Our staff of Testing and Ratings Engineers can help you to gain that vital information.



Cooling Tower Fundamentals

Cooling Tower Fundamentals is devoted to the implementation of water cooling systems which satisfy design and environmental requirements with sound engineering and responsible cost. Over 100 pages devoted to design, components, usage and testing. First published in 1967, Fundamentals has evolved to one of the most popular cooling tower reference guides available. Now you can own the latest edition for free. Contact your sales representative for a copy or download at spxcooling.com.

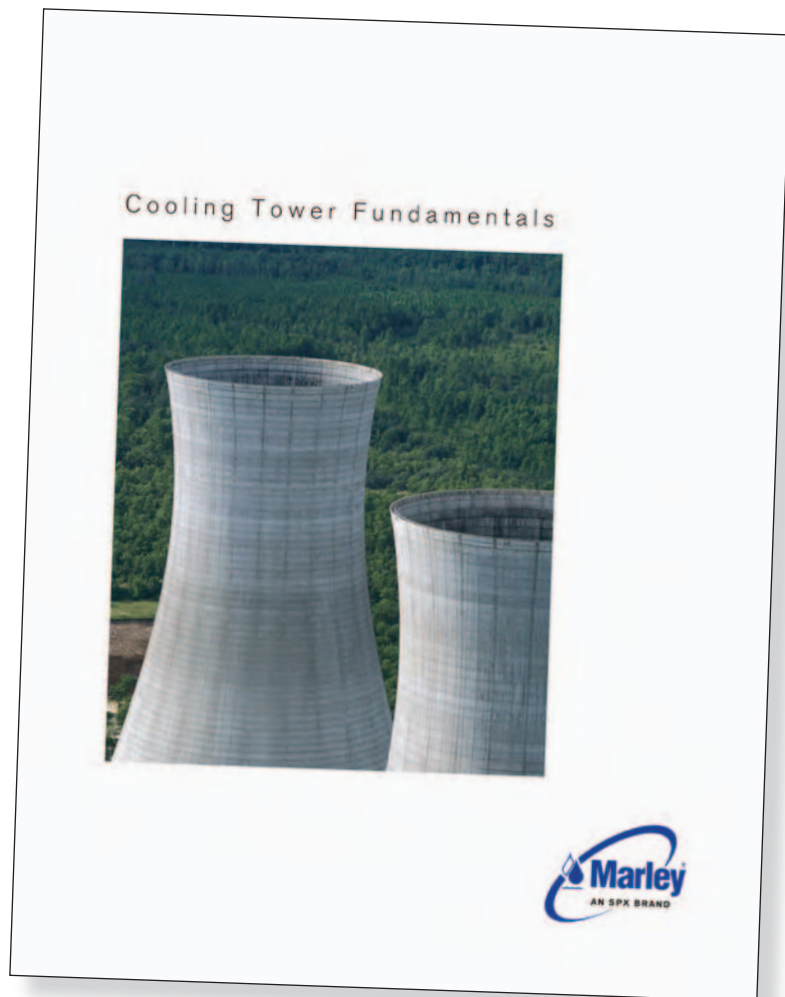

Maintenance Service	Monthly	Semi-annually	Seasonal Startup or Annually
Inspect General Condition and Operation	x		x
Observe Operation of:			
Mechanical—motor, fan and drive mechanism	x		x
Makeup valve (if equipped)	x		x
Inspect for unusual noise or vibration	x		x
Inspect and Clean:			
Air inlet	x		x
PVC drift eliminators	x		x
Distribution basin, nozzles and collection basin	x		x
Fan motor exterior	x		x
Check:			
Collection water basin level	x		x
Blowdown—adjust as required	x		x
Geareducer Drive (if equipped):			
Check for loose fasteners including oil drain plug			x
Check for / repair oil leaks	x		x
Check oil level	x		x
Change oil		R	
Make sure vent is open		x	x
Check driveshaft or coupling alignment			x
Check for loose driveshaft or coupling fasteners			x
Check driveshaft or coupling bushings or flex element for unusual wear		x	x
Lube lines (if equipped):			
Check for oil leaks in hoses or fittings	x	R	x
Belt drive (if equipped):			
Fan shaft bearing lubrication (every 3 mo.)		every 3 months	every 3 months
Check and tighten support fasteners			x
Check shaft, sheave and belt alignment			x
Check belt tension and condition		x	x
Check sheave bushing fastener torque			x
Fan:			
Check and tighten blade and hub fasteners			x
Check fan blade pitch and tip clearance			x
Check fan cylinder for loose fasteners			x
Motor:			
Lubricate (grease as required)			R
Check mounting bolts for tightness			x
Operate at least	3 hours a month	3 hours a month	3 hours a month
Basin Heater (if equipped):			
Check for proper operation of temp/low water level sensor			x
Inspect/clean buildup of contaminant from sensor		x	x
Structure:			
Inspect/tighten all fasteners		x	x
Inspect and touch up all metal surfaces			x

cooling tower parts reference guide

AUTUMN 2011



SPX COOLING TECHNOLOGIES, INC.

7401 W 129 STREET
OVERLAND PARK, KANSAS USA
P: 913 664 7400
F: 913 664 7439
E: spxcooling@spx.com
spxcooling.com

In the interest of technological progress, all products are subject to design and/or material change without notice

ISSUED 11/2011 PRG-11B
COPYRIGHT © 2011 SPX Corporation

LENNTECH

info@lennotech.com Tel. +31-152-610-900
www.lennotech.com Fax. +31-152-616-289