

Thermo Top

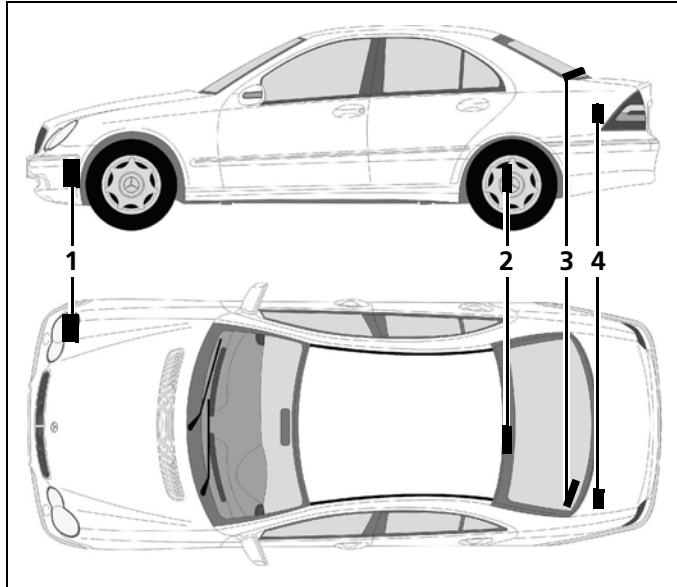

Mercedes C Class

3.2 Liter V 6

Beginning Model Year: 2004

Special instructions for these models

Part locations may differ slightly dependent on the vehicle model.

Be sure to check WWW.techwebasto.com for the latest addition of this manual.

Legend

- 1 BlueHeat Coolant Heater, Exhaust Muffler, and Combustion Air Intake Silencer
- 2 Fuel Pump
- 3 Remote Antenna
- 4 Remote Module

Special Tools

- Hose Clamping pliers
- Torque Wrench (1/4' Drive)

Table of Contents

Foreword

Parts List	3
Vehicle Information	3
Scope and Purpose	3
Symbol Identification	4
General References	5
Preparations	5
Heater Installation Site	5

Installation

Electrical - Overview	6
Electrical Harness Routing / Installation	7
Ground Location	7
Power Connection	7
CAN-BUS Connector	7
Harness Ground	8
Fuse / Relay Center Connection	8

Remote Control Installation	8
Fuel Pump Harness Connection	9
Remote Antenna Installation	9
Heater Mounting	10
Integration Into The Fuel System	11
Fuel Pump Mounting	11
Fuel Line Connection at Tank	12
Fuel Line Routing	12
Fuel Line Connection at Heater	13
Integration into Coolant System	14
Coolant Hose Connections (without boost pump)	15
Coolant Hose Connections (with boost pump)	16
Concluding Work	17
Heater Activation	17
Activating the Timer Function	17
Final Inspection	18
Heater Lockout Reset Procedure	18



Warning

- *Improper installation or repair of Webasto heating and cooling systems can cause fire or the leakage of deadly carbon monoxide leading to serious injury or death.*
- *Installation and repair of Webasto heating and cooling systems requires special Webasto training, technical information, special tools and special equipment.*
- *NEVER attempt to install or repair a Webasto heating or cooling system unless you have successfully completed the factory training course and have the technical skills, technical information, tools and equipment required to properly complete the necessary procedures.*
- *ALWAYS carefully follow Webasto installation and repair instructions and heed all WARNINGS.*
- *Webasto rejects any liability for problems and damage caused by the system being installed by untrained personnel or by improper installation.*
- *Improper installation or installation by untrained personnel voids all warranties on this product.*

If there are any questions regarding the installation or maintenance of this product, please call technical support at **1-800-555-4518**.

Parts List

Quantity	Part	Part Number
1	Heater Kit	9010977A
1	Installation Kit	5001068A

Vehicle Information

Manufacturer	Model	Year	Engine Type
Mercedes Benz	C-Class	Beginning 2004	Gas and Diesel

Foreword

The installation and service of Webasto Thermo Top series (BlueHeat) heaters requires special expertise and training. Installations and servicing of Webasto products by untrained, unauthorized personnel and end-users voids all warranties and releases Webasto Product North America, Inc. and Webasto authorized distributors, dealers and their personnel from responsibility for damage to Webasto products, any resulting collateral property damage and personal injury.

Any use, operation, installation, modification or application of the product not described in Webasto manuals, or subjecting the product to extreme or unusual conditions beyond the limits of specified performance characteristics is misuse of the product.

Failure to comply with all installation instructions is a misuse of Webasto products. The same applies for repairs without using genuine Webasto service parts. This will void the coolant heaters "official Marks of Conformity."

Scope and Purpose

These installation instructions are intended to support Webasto trained and authorized distributors and dealers in the installation of the Thermo Top series (BlueHeat) Coolant Heaters. These instructions are not intended for use by untrained or unauthorized personnel.

The directives in the "installation manual" and "operating manual" for the Thermo Top series heater must be followed. Acknowledged engineering conventions must be observed for the installation work.

ATTENTION

All relevant state and provincial licensing regulations if any, governing the installation and use of auxiliary heating devices must be observed!



CAUTION

Location of heater, installation of coolant lines, fuel system and components, wiring and control devices are important for proper operation. Failure to comply with the installation instructions provided may result in poor operation or damage to heater and vehicle components.



Symbol Identification

Symbols that define sections in manual



Mechanical Preparation



Fuel



Electrical



Exhaust



Coolant



Combustion Air Intake

General Symbol Descriptions



Warning



Refer to Webasto or Manufacturer Manual



Caution



Attention



Flammable or Combustible

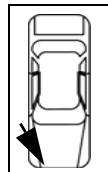

Part Location on Vehicle

General References

- Bare body parts, for example around drilled holes, must be treated with anti-corrosive coating.
- Secure hoses, cables and wiring harnesses with cable ties and fit protective hoses around them at chafing points.
- Fit edge protectors (opened fuel hose) to sharp edges.

Preparation

- Remove cabin air filter
- Remove battery and battery holder
- Relieve coolant system pressure
- Open and close fuel cap
- Remove front right wheel and wheel skirt
- Remove tow hook cover
- Remove engine splash shield
- Remove A pillar covers (both sides)
- Remove passenger side under dash cover
- Remove fuse block cover
- Remove accelerator pedal
- Remove front carpet (both sides)
- Remove wiring harness channel cover behind rear seat
- Remove inside trunk cover on driver's side
- Loosen fuse / relay box in trunk

Heater Kit

- Verify and identify all contents of kit.

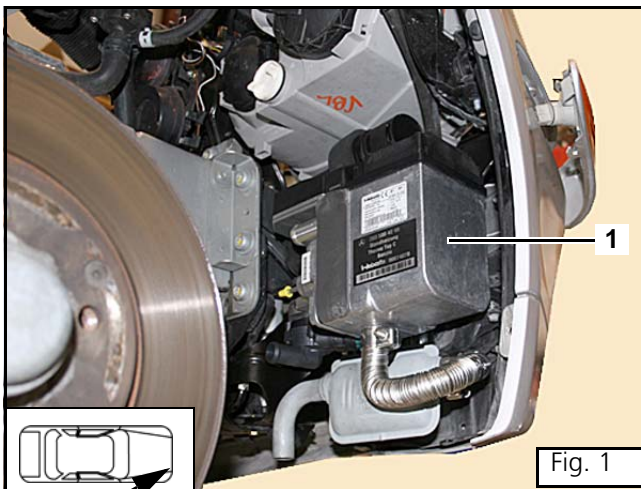

Heater Installation Site

- (1) Webasto Auxiliary Coolant Heater and Bracket (Heater is located on the lower right-hand corner of the vehicle behind the front bumper.)



Installation

Electrical Overview

Heater Ground

- (1) Heater Ground
- (2) Vehicle Ground

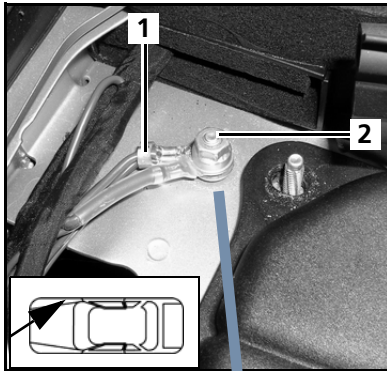

Harness Routing

- (1) Harness Pass-through
- (2) Bulkhead
- (3) Heater Harness

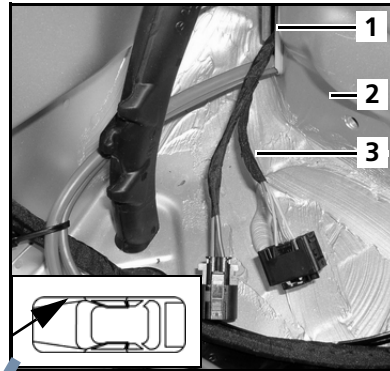

Fuse/Relay Module and Control Unit

- (1) Fuse/Relay Module
- (2) Connection at Control Unit

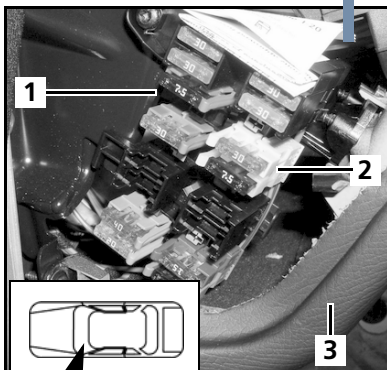
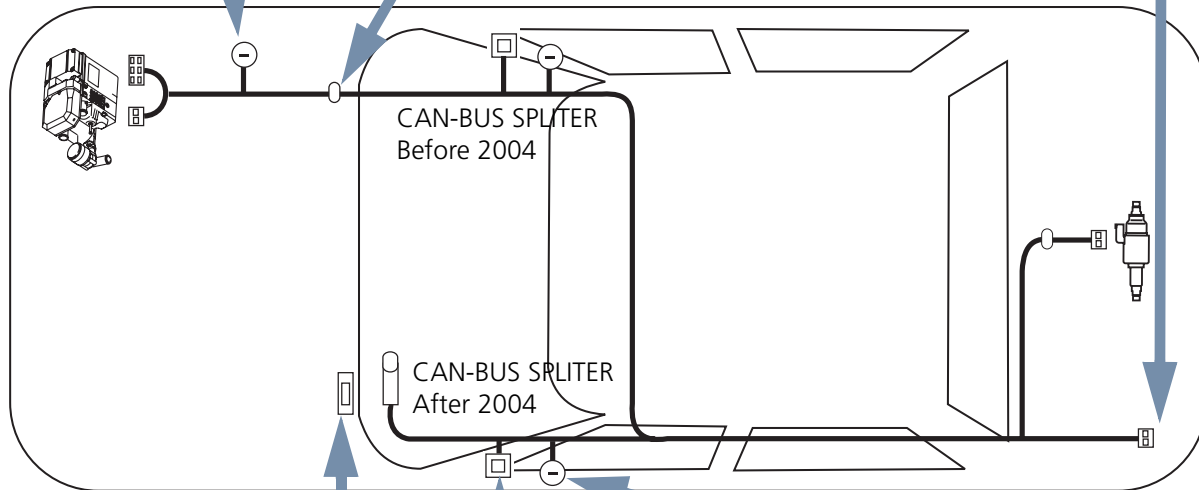
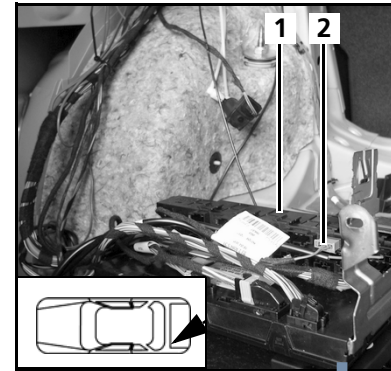

Fuse Block

- (1) Fuse Block
- (2) Fuse Holder
- (3) Dashboard

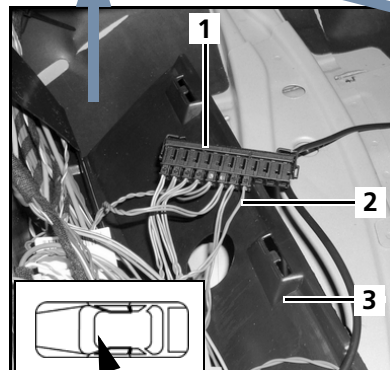

CAN - BUS Connection

- (1) CAN Connector
- (2) CAN Harness
- (3) Wire Harness Channel

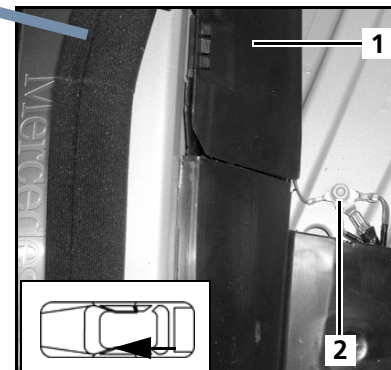

Ground Connection

- (1) Wire Harness Channel
- (2) Ground

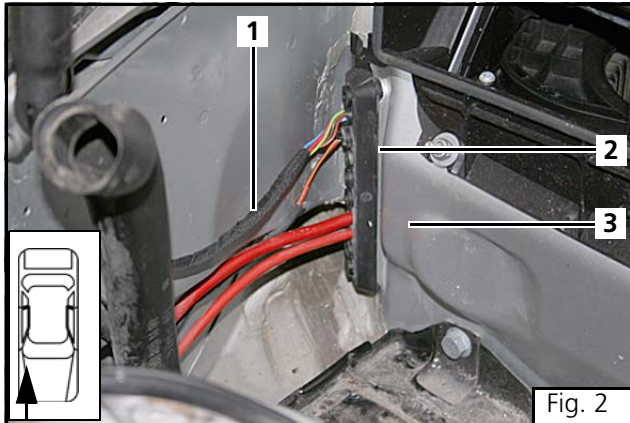

Electrical Harness Routing / Installation

ATTENTION

The pass-through grommet may look different from the one shown in Figure 2 depending on the model year of the vehicle.

Route heater harness through bulkhead grommet.

- (1) Heater harness
- (2) Bulkhead grommet (passenger side)
- (3) Bulkhead

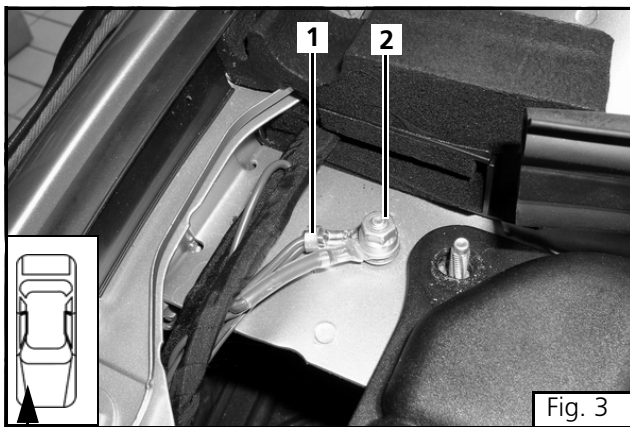

Ground location

Connect heater harness ground to existing vehicle ground.

- (1) Heater harness ground
- (2) Existing vehicle ground

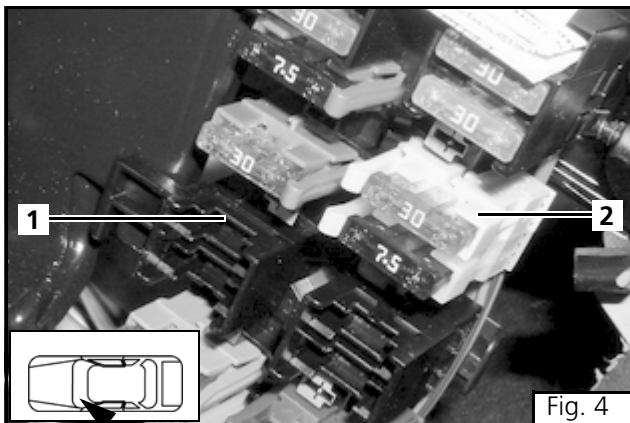

Power Connection

ATTENTION

The fuse holder may only contain the 30 amp fuse.

Match color of fuse holder to existing slot on fuse block and insert fuse holder.

- (1) Interior fuse block
- (2) Webasto fuse holder and 30 amp fuse

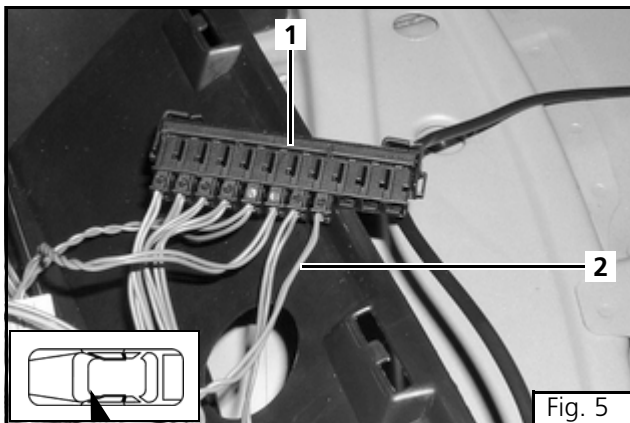

CAN-BUS Connector

Route heater harness from bulkhead pass-through to the driver's side of the vehicle through harness channel located under the front carpet (not shown).

Access CAN-BUS connector. Plug connector from heater harness into empty slot in CAN-BUS connector.

- (1) CAN-BUS connector
- (2) Wire from heater harness

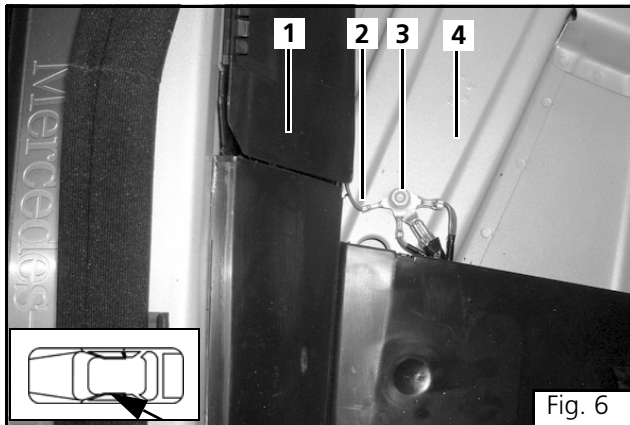

Harness Ground

Install ground wire on existing vehicle ground located under carpet in driver's footwell area.

- (1) Driver's side harness channel
- (2) Heater harness ground
- (3) Existing vehicle ground
- (4) Driver's footwell area

Route the heater harness through the driver's side harness channel to the rear of the vehicle.

Route the heater harness into the trunk of the vehicle through the passage alongside the rear seat back (not shown).

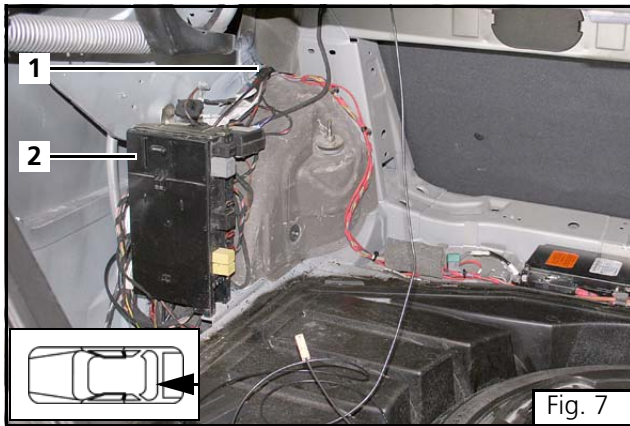

Rear Fuse / Relay Center Connection

ATTENTION

Do not disconnect fuse / relay center.

Remove the fuse / relay center from its mounting location.

- (1) Heater harness routed into trunk
- (2) Fuse / relay center

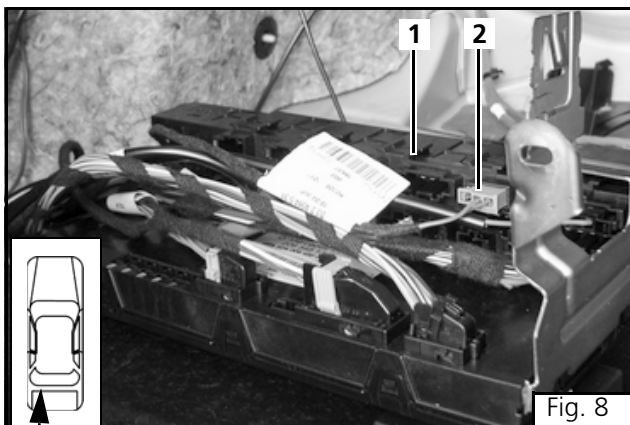

Connect the heater harness blue connector in the color matched female housing on the fuse / relay center.

- (1) Fuse / relay center
- (2) Blue heater harness connector

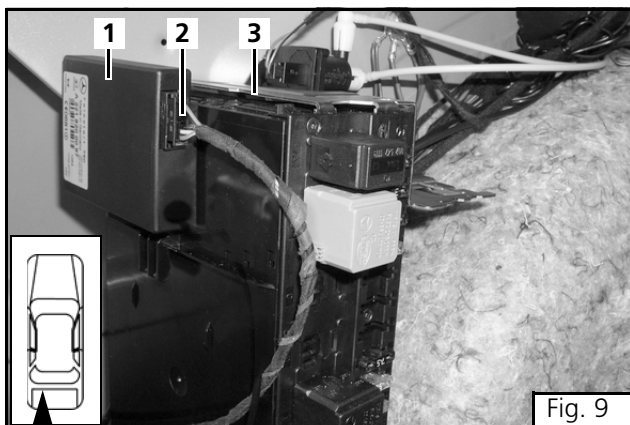

Remote Control Installation

Install the remote control receiver on the side of the fuse / relay center as shown in Figure 9.

Install the SPAL remote control module in the trunk area (not shown). Splice power and ground wires from the remote control module to power and ground at the remote receiver.

Connect the "power on" (black) wire from the SPAL remote control module to **Pin 4** of the remote control receiver (not shown).

- (1) Remote control receiver
- (2) Pin 4
- (3) Fuse / relay center

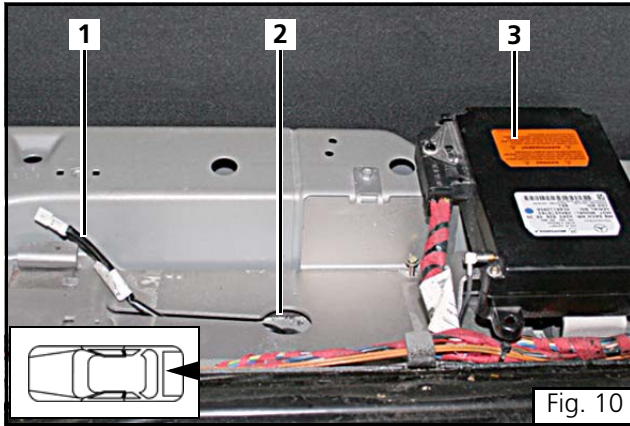

Fuel Pump Harness Connection

ATTENTION

Do not disconnect module.

Remove vehicle module mounting hardware and set module aside.

Route fuel pump harness through access hole in trunk and slide to the left as shown in Figure 10.

- (1) Fuel pump harness
- (2) Access hole
- (3) Vehicle module

Fig. 10

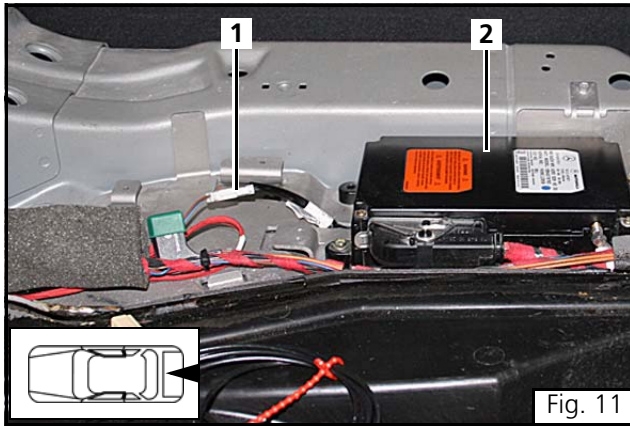

Re-install the vehicle module.

Connect the fuel pump harness to the heater harness.

- (1) Fuel pump harness
- (2) Vehicle module

Fig. 11

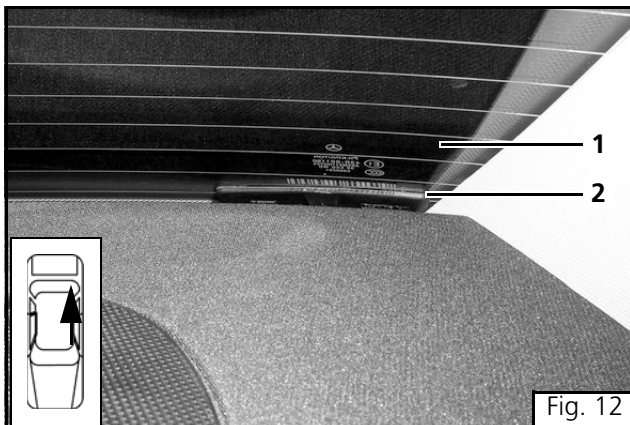

Remote Antenna Installation

Mount the remote control antenna on the rear window.

Route the antenna wire to the remote control module in the trunk (not shown).

- (1) Rear window
- (2) Remote control antenna

Fig. 12

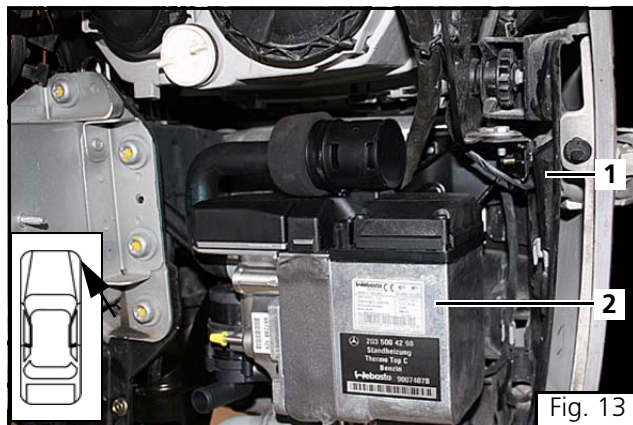

Heater Mounting

Position heater in mounting location as shown in Figure 13.

- (1) Front-right-side of vehicle
- (2) Webasto heater and mounting bracket

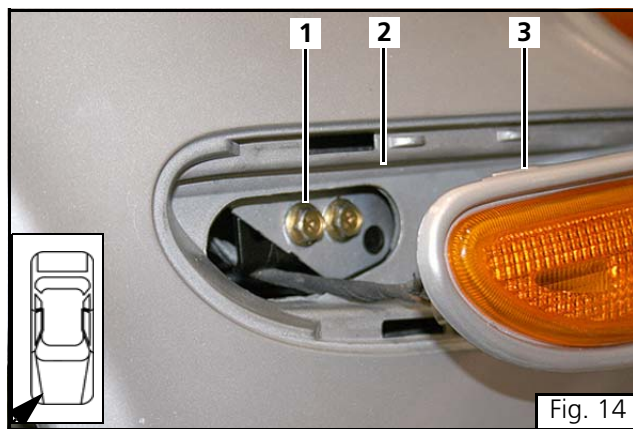

Secure heater with two M6 x 16 mounting bolts.

- (1) M6 x 16 mounting bolts (2 ea.)
- (2) Front-right-side of vehicle
- (3) Side marker light

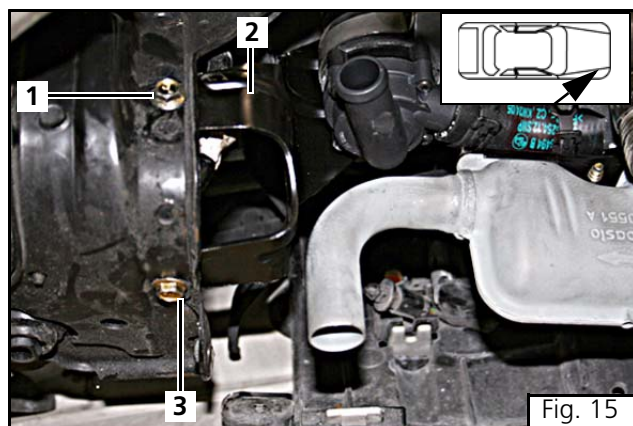

Secure heater mounting bracket to vehicle with two M6 x 16 bolts and a washer as shown in Figure 15.

- (1) M6 x 16 bolt
- (2) Heater mounting bracket
- (3) M6 x 16 bolt and washer

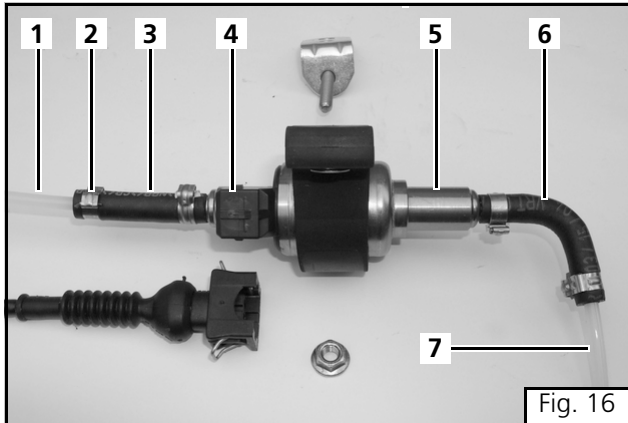

Fig. 16

Integration Into The Fuel System

Fuel Pump Preparation

ATTENTION

Prepare fuel pump for installation.

- (1) Fuel line to heater
- (2) Fuel line clamp (4 ea.)
- (3) Fuel line coupler
- (4) Harness connector
- (5) Fuel pump
- (6) 90° fuel line coupler
- (7) Suction side Fuel line (cut to 900 mm or 35.4 inches)

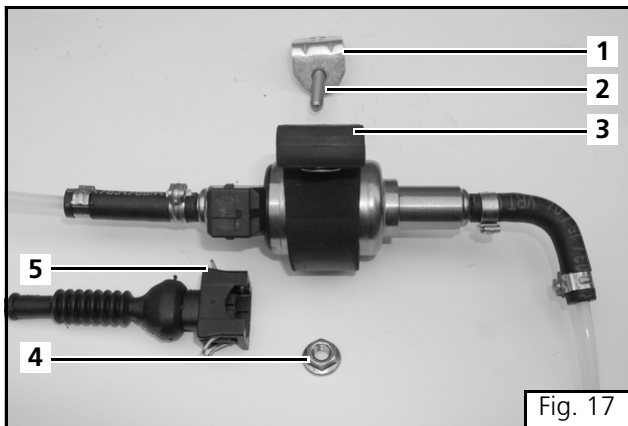

Fig. 17

- (1) Angle bracket
- (2) M6 x 30 bolt
- (3) Fuel pump mounting bracket
- (4) M6 nut
- (5) Fuel pump harness connector

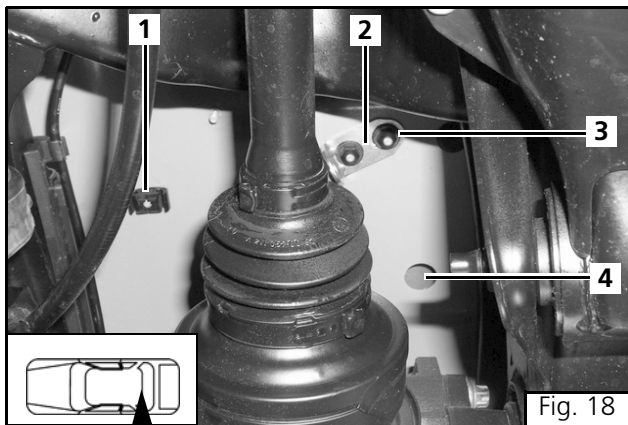

Fig. 18

Fuel Pump Mounting

ATTENTION

The fuel pump is mounted on the left side of the vehicle above the rear axle.

Attach two clips (fuel line holder) to existing studs located to the right and left of the differential.

Install angle bracket with nylon nuts.

Remove grommet.

- (1) Clip (2 ea.)
- (2) Angle bracket
- (3) Nylon nut (2 ea.)
- (4) Hole / Grommet

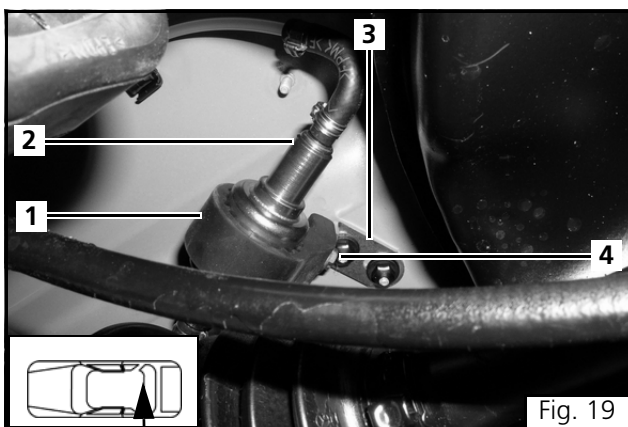
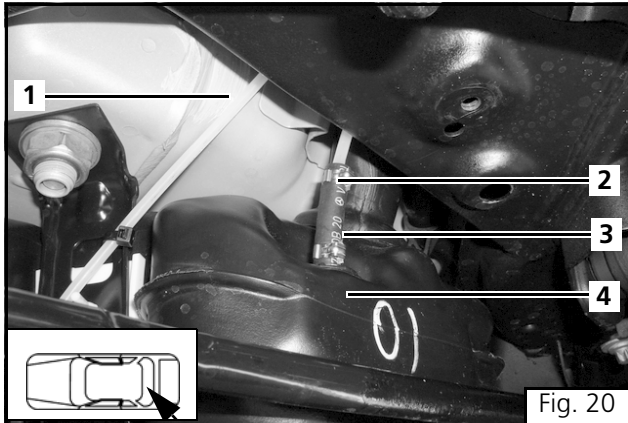

Fig. 19

Mount the fuel pump to the angle bracket as shown in Figure 19.

- (1) Fuel pump mounting bracket
- (2) Fuel pump
- (3) Angle bracket
- (4) M6 x 25 bolt



Fuel Line Connection at Tank

ATTENTION

Cut the tip off the existing plastic fuel pickup tube with a sharp razor knife or equivalent tool. Cut off just enough to allow for proper fuel flow.

Connect fuel line from fuel dosing pump to fuel pickup tube with fuel line coupler and two clamps.

- (1) Fuel line to heater fuel pump
- (2) Fuel line clamp (2 ea.)
- (3) Fuel line coupler
- (4) Vehicle fuel tank

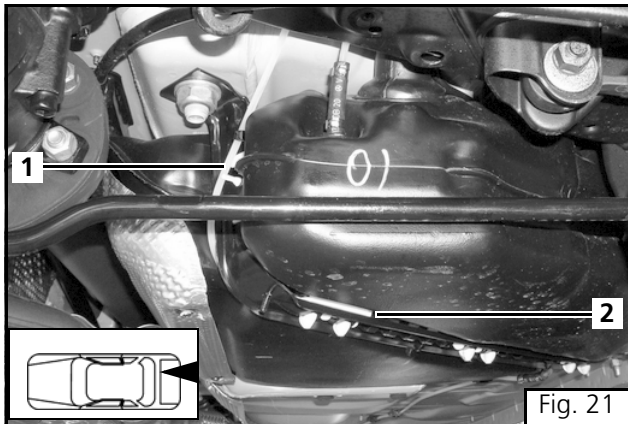

Fuel Line Routing

Secure fuel line to fuel tank / vehicle with cable ties.

- (1) Fuel line to fuel pump
- (2) Cable tie

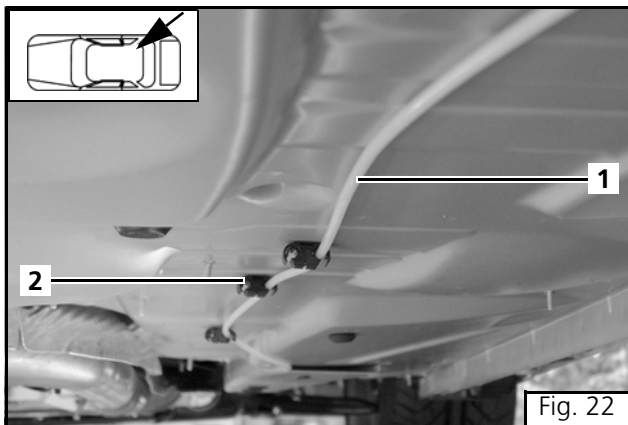

Install fuel line clips on existing studs to secure fuel line to vehicle underbody.

- (1) Fuel line to heater
- (2) Fuel line clips (3 ea.)

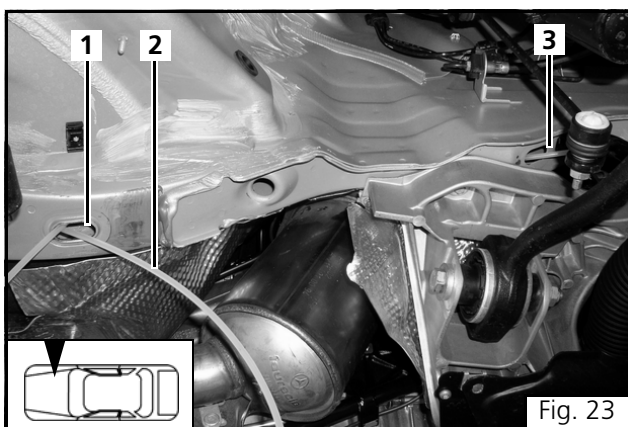

Remove two oval plastic grommets from vehicle underbody.

Drill a 5mm (13/64 in.) hole through both oval grommets in order to pass fuel line through and re-install on underbody.

Route fuel line through grommet and rear opening towards the front of the vehicle.

- (1) Oval opening - rear
- (2) Fuel line to heater
- (3) Oval opening - front

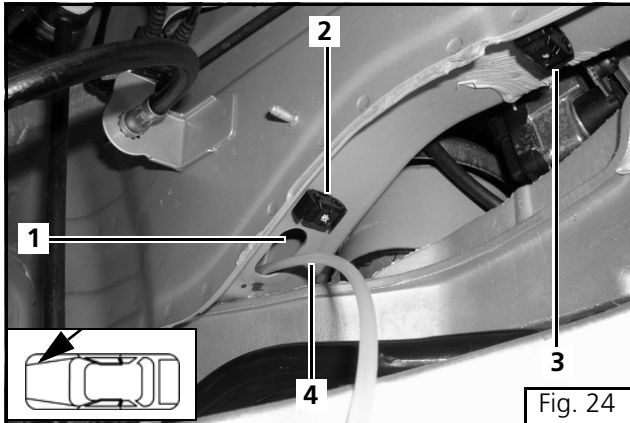

Pull fuel line through front oval opening and grommet.

Re-install oval grommets.

Install fuel line clips where shown in Figure 24.

- (1) Oval opening - front
- (2) Fuel line clip
- (3) Fuel line clip
- (4) Fuel line to heater

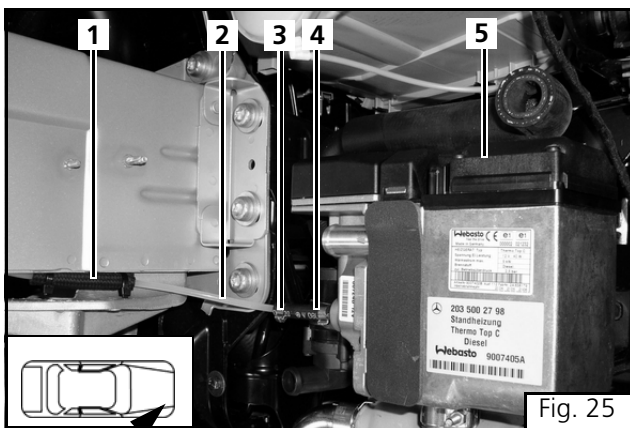

Fuel Line Connection at Heater

Cut fuel line to the appropriate length at the heater.

Protect heater fuel line with section of rubber hose provided.

Connect fuel line to heater with fuel line coupler and two clamps.

- (1) Rubber hose - used to protect fuel line
- (2) Heater fuel line
- (3) Fuel line clamps (2 ea.)
- (4) Fuel line coupler
- (5) Webasto heater



Integration into Coolant System

ATTENTION

Torque hose clamps to 2.0 - 2.5 Nm (18 - 22 lb-in.)

Avoid sharp bends and kinks when installing coolant hoses.

Position hose clamps in such a way to avoid cutting or damaging adjacent components.

ATTENTION

Clamp vehicle coolant hose with hose clamping pliers prior to cutting to prevent coolant spillage.

The coolant heater integration into the vehicle heater circuit is done in an "INLINE" fashion. Refer to Figure 26.

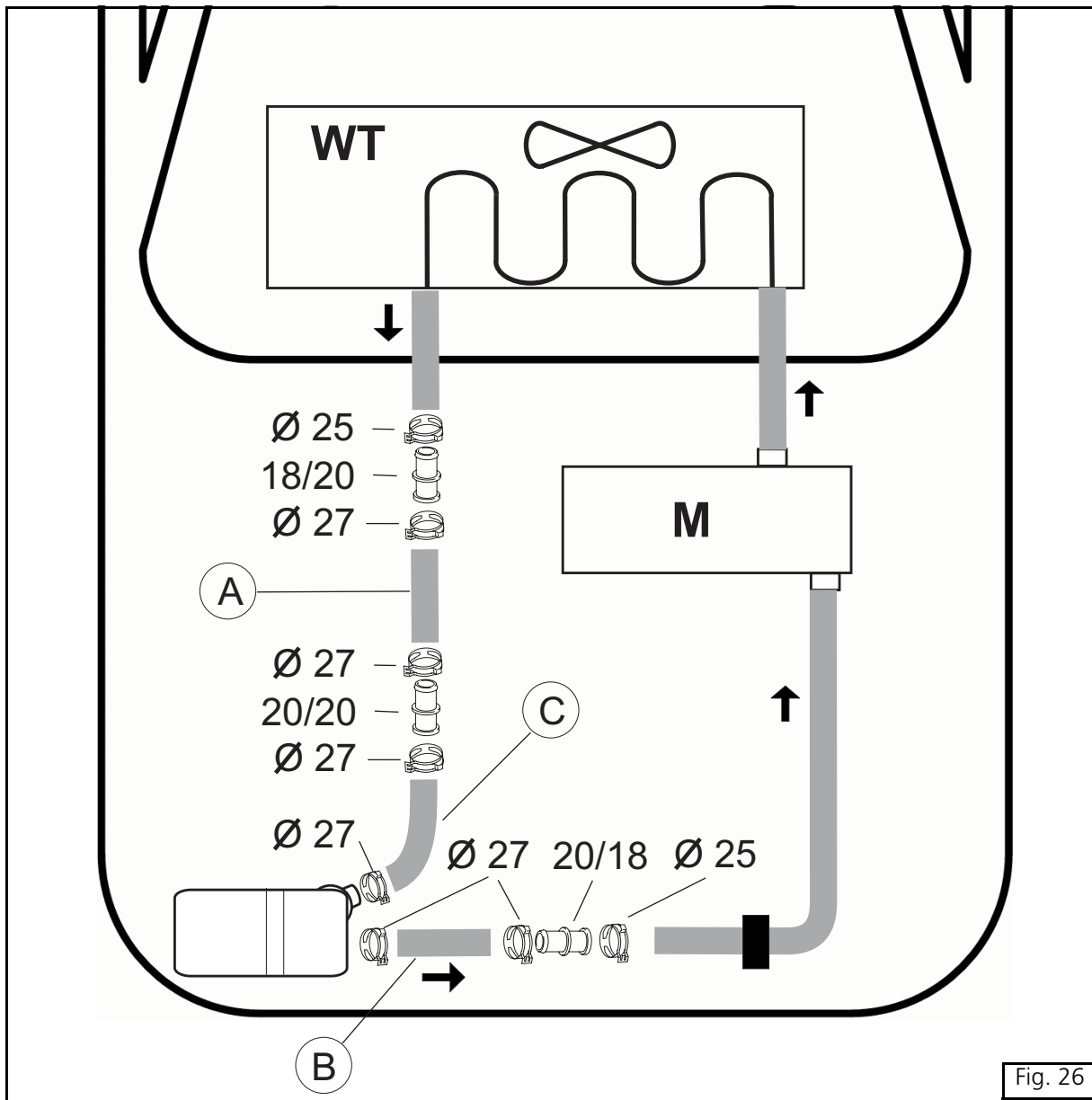
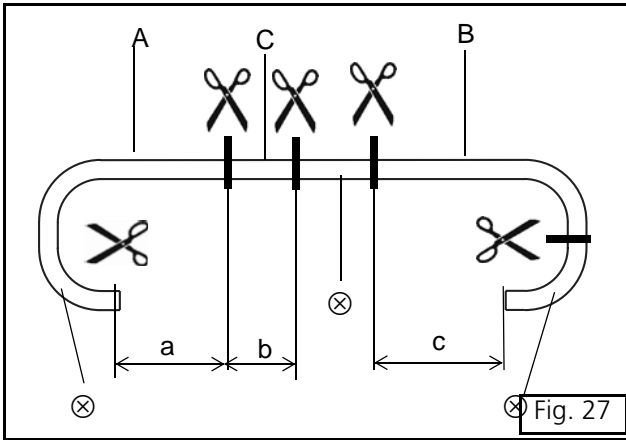

Fig. 26



Coolant Hose Connections (without boost pump)

Cut supplied coolant hose as shown in Figure 27.

A = 360 mm (14 inches)

B = 170 mm (6 3/4 inches)

C = 200 mm (8 inches)

X = Discard

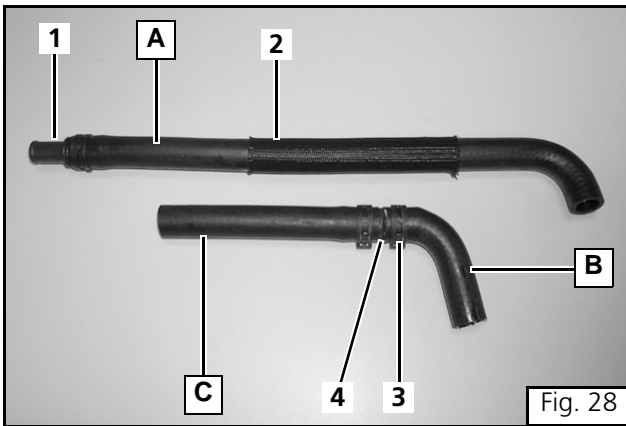

Pre-assemble coolant hoses as shown in Figure 28.

- (1) Coolant hose adapter 18-20
- (2) Protective loom
- (3) Clamp (3 ea.)
- (4) Coolant hose adapter 20-20

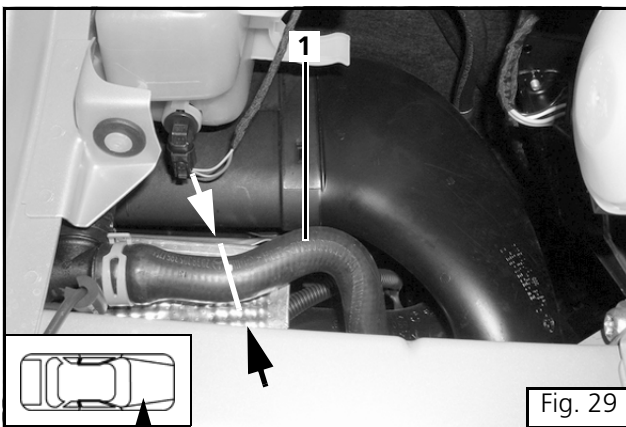

ATTENTION

Figure 29 shows the recommended location to cut into the vehicle's coolant circuit. Remember to install hose clamp pliers prior to cutting coolant hose.



Cut coolant hose going to the engine where shown in Figure 29.

- (1) Vehicle coolant hose (towards engine)

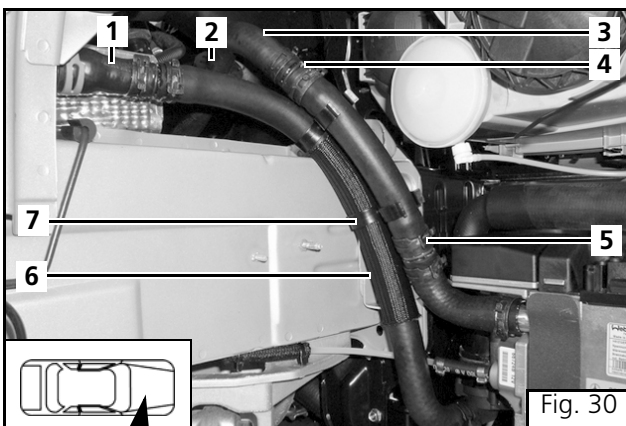

Install coolant hoses as shown in Figure 30.

- (1) Vehicle coolant hose from heat exchanger
- (2) Rubber insulator
- (3) Vehicle coolant hose to engine
- (4) 25 mm clamp (2 ea.)
- (5) 27 mm clamp (6 ea.)
- (6) Protective loom
- (7) Coolant hose holder (2 ea.)

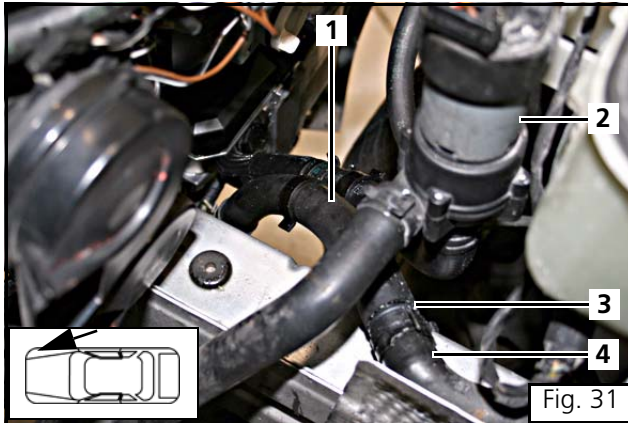

Coolant Hose Connections (with boost pump)

ATTENTION

Use hose clamp pliers to prevent coolant loss.

Disconnect coolant hose going to the bottom of the boost pump and cut off the 90° end.

Connect the Webasto heater coolant inlet hose to the cut end of the vehicle coolant hose using adapter and clamps provided.

- (1) Vehicle coolant hose from heat exchanger
- (2) Boost pump
- (3) Coolant adapter 18-20 and clamps
- (4) Webasto heater inlet hose

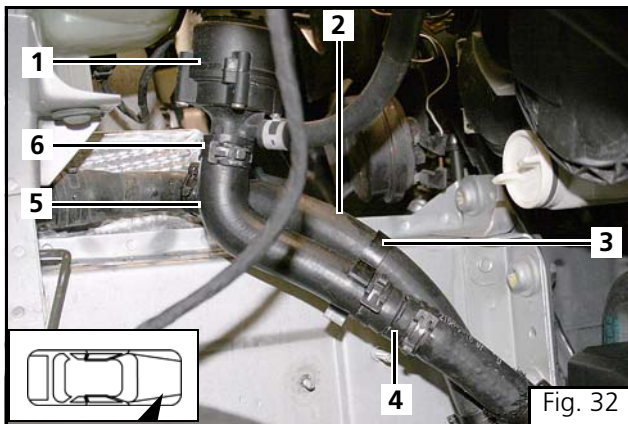

Install coolant hoses as shown in Figure 32.

- (1) Boost pump
- (2) Webasto heater inlet hose
- (3) Coolant hose holder
- (4) Coolant hose adapter 20-20 and clamps
- (5) Webasto heater outlet hose
- (6) Clamp

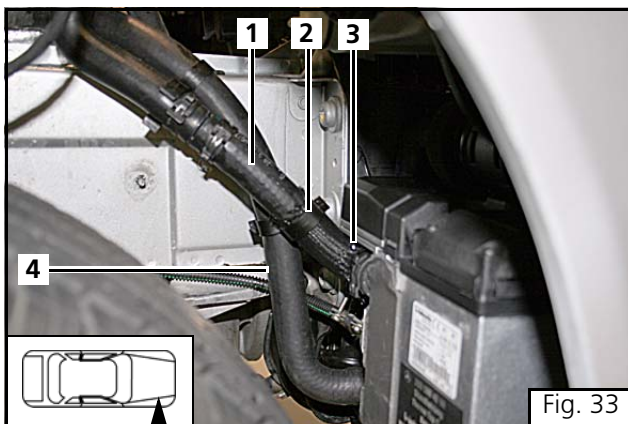

Install protective loom on Webasto heater outlet hose.

Connect Webasto heater outlet and inlet hoses to heater with clamps provided.

Secure coolant hoses with holder where shown in Figure 33.

- (1) Webasto heater outlet hose
- (2) Coolant hose holder
- (3) Protective loom
- (4) Webasto heater inlet hose



Concluding Work

- Install all vehicle parts, panels and components removed during heater installation.
- Check that all hose lines, hose clamps, pipe clips and electrical connections are secure.
- Secure all loose lines and cables with nylon cable ties.
- Spray the heater components and electrical connections with an anti-corrosive wax coating.
- Top off cooling system with coolant per engine/vehicle manufacturers recommendations.
- Set interior heater control to maximum heat position (hot) and switch off air conditioning system.
- Start the vehicle engine and run on fast idle for 5 minutes to purge any remaining air from the Webasto heater and coolant system. While the engine is running check:
 - Hose connections for leaks.
 - Coolant level in expansion tank. (Add coolant as needed)
 - Switch off the engine.

Heater Activation

ATTENTION

Heater activation is limited to the remote control until the vehicle is programmed via STAR Diagnostics. Programming the vehicle enables the operator to set desired heater On and Off times. Only a certified Mercedes dealership has the necessary information and equipment to properly set up these heater functions.

ATTENTION

More than one start-up attempt of the heater may be required to purge air from fuel system before heater will start. Cycle heater Off and On after each failed start attempt until heater starts successfully. After 3 consecutive unsuccessful start attempts, the Webasto control unit enters into Heater lockout. See Heater Lockout section for reset instructions.

1. Using the remote control, switch on the Webasto heater and check:
 - Circulating pump in operation.
 - Initiation of start-up sequence.
 - Successful start-up and operation.
2. Allow heater to run for 20 minutes or until coolant is heated to temperature.

ATTENTION

Engine coolant temperature gauge may read lower than actual Webasto heater output temperature. This is due to the location of the temperature gauge sensor on engine.

Activating the Timer Function

ATTENTION

The vehicle must be programmed via STAR Diagnostics to set up timer functions. Only a certified Mercedes dealership has the necessary information and equipment to properly set up these heater functions.

Refer to "Auxiliary heating / ventilation" in the vehicle's owners manual for specific instructions on how to set heater On / Off times.





Final Inspection

Inspect installation for:

- Loose fasteners.
- Exhaust system routing and clamp tightness.
- Combustion air intake tube routing and clamp tightness.
- Loose coolant line clamps.
- Pinched coolant lines.
- Routing of coolant lines and coolant lines securely tied and protected against chafing and related damage.
- Loose fuel line clamps.
- Routing of fuel lines and fuel lines securely tied and protected against chafing and related damage.
- Loose wiring connections and battery connections.
- routing of wiring harness and wiring harness securely tied and protected against chafing and related damage.
- Check operation of vehicle heater fan with Webasto heater OFF.

Heater Lockout Reset Procedure

The BlueHeat is designed with a lockout safety feature built into the control unit. After 3 consecutive unsuccessful startup attempts, the heater will lock itself out from any further start attempts. The heater may also enter the lockout mode after experiencing an overheat condition.

Reset Heater “Lockout” mode by performing the following procedure:

1. Ensure timer or switch is in the “OFF” position. Turn timer or switch to the “On” position. Remove main fuse F2 (20 Amp), reinsert after 5 seconds.
2. Cycle timer or switch off and then back on once more. Remove fuse F2 once again and reinsert after 5 seconds. Heater should attempt to start after inserting fuse.

ATTENTION

- Coolant temperature must be below the lower threshold before heater will attempt to start.
- The engine coolant must reach 86 °F (30 °C) before the Webasto heater will attempt to start vehicles blower fan.
- Should the heater fail to start or operate correctly, call your Webasto technical representative at:
1-800-555-4518



Documentation Feedback Form

Detailed user feedback is extremely valuable to us in producing accurate, comprehensive, and useful documentation. Please complete the relevant parts of the form below; your comments and suggestions will help us improve our documentation. Thank you.

	Unsatisfactory			Excellent	
Please rate the overall usefulness of the documentation.	1	2	3	4	5
Rate the completeness and clarity of the instructions: did the procedures provide enough detail?	1	2	3	4	5

What could be added or clarified? _____

Please list any other comments, concerns, or suggestions. _____



Please provide contact information below.

Name: _____

Company Name: _____

City/State: _____

Phone: _____

Email: _____

Mail to:
Webasto Product N. A., Inc.
15083 North Road
Fenton, MI 48430
Attention: Documentation Group
or
Fax to: (810) 593-6137



Webasto Product N.A., Inc.

Technical Assistance Hotline

USA: (800) 555-4518

Canada: (800) 667-8900