

MERIDIAN

OPERATOR'S MANUAL

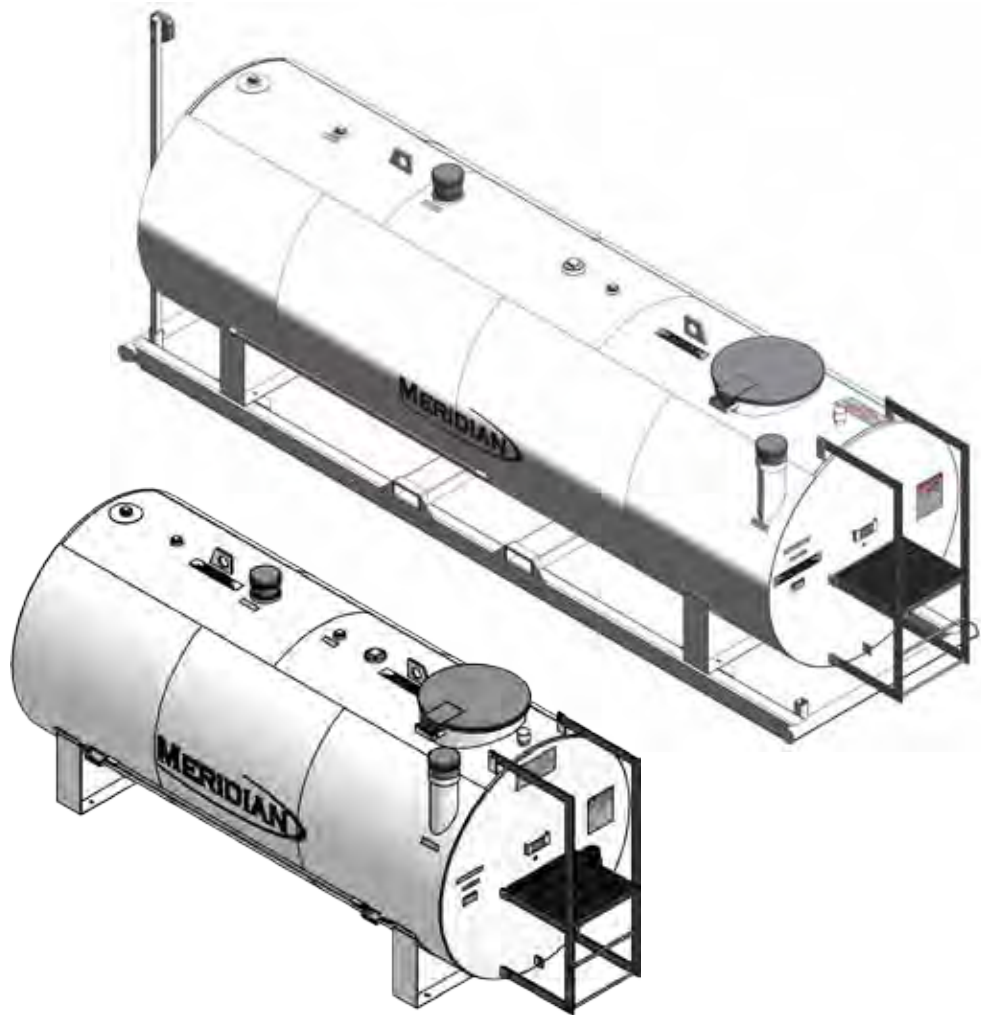

7,400L & 10,000L DW Fuel Tanks

CAN-ULC-S601-07

This page intentionally left blank.



ATTENTION DEALERS:

You can register your products online through the
Dealer Login: <http://dealers.meridianmfg.com/login/>

“Warranty Registration Form”:

It is mandatory to complete this form and return to the manufacturer in order to qualify for future warranties that may arise; knowingly falsifying information on this form will result in the voiding of the product warranty.

Dealer Information
Name: _____
Address: _____
City, State, Code: _____
Phone: _____

Customer Information
Name: _____
Address: _____
City, State, Code: _____
Phone: _____

Note; registering a product in multiple entry format is only allowed when; the product has the same Model # and the same dealer, however **each serial number must be legibly listed for each unit.** Delivery dates for a multiple entry must be within a 1 month time frame.

Product Information: _____

Model #: _____

Serial #: _____

Invoice Date: _____

***Warranty Acknowledgement ***

The “**Product Warranty**” along with the “**Operator’s Manual**” for this product purchase has been reviewed and understood by the end user.

Date: _____

Signature: _____

Important: Please send this form to the Meridian Manufacturing Location which built this product being registered; if you require further assistance call your Dealer or the Meridian Manufacturing outlet nearest to your location.

We want to thank you for purchasing a Meridian manufactured product. Whether this is your first Meridian purchase or you have been a customer for years; you are now part of the Meridian community of customers and we appreciate your business.

It is important that you now complete the product registration information and this form indicating you have received delivery. This registration and information is necessary to ensure you have access to warranty and product updates in the event it be required in the future.

Registration can be completed by using this form or visiting your dealer who will complete the form online. You will be given access to the Meridian Community and become eligible for updates, special offers and prizes.

Again thank you for choosing Meridian.

This page intentionally left blank.

Table of Contents

Thank You! 2
Codes, Regulations and Guidelines 2
Introduction 3
 Standard Features 3
 Specifications 3
 Safety Decals 4
Personal Safety 7
 Machine Safety 7
 General Notes 7
Installing The Tank 8
 Installation 8
 Choosing a Location 8
 Installing the Fuel Tank Base 8
 Lifting and Transporting Fuel Tanks 9
 Inspecting Fuel Tanks 9
 Installation of Tank Venting 9
 Inspecting the Fuel Tank Containment System 9
 Environmental Regulations 9
 Protect Fuel Tank Against Vehicle Traffic 9
 Regular Inspection and Maintenance 9
7,400L Vent & Port Locations 10
10,000L Vent & Port Locations 11
Measuring Fuel Tank Levels 12
Fuel Transfer Safety 13
 Top Fill Fuel Transfer (7400L & 10,000L) 14
Pump Operations 15
 Dispensing Fuel (general) 15
 Locking The Pump 15
 Trouble Shooting 16
Limited Warranty 18
 Warranty Claim Procedure 18
Fuel Tank Warranty Order Request 20
7,400L Fuel Tank Dip Chart 22
10,000L Fuel Tank Dip Chart 23
Index 24

Thank You!

Thank you for purchasing a Meridian Fuel Tank and putting your trust in our hands. Setting the standard for excellence in the storage and fuel handling industry our double wall fuel tanks meet and exceed all safety and environmental standards. Built with meticulous attention to detail by an enthusiastic and skilled production team our best references are thousands of customers, like you, who have placed their trust in our superior design and technology.

Codes, Regulations and Guidelines

Built to exacting standards your Fuel Tank is designed to give years of trouble free use. To ensure it provides that service, **it is critical all operators read this entire manual before attempting to install or operate your new tank.** If you become familiar with all maintenance and safety procedures, pay close attention to safety labels and diagrams, your Fuel Tank will provide years of environmentally safe trouble free service.

Fuel storage tanks fall under a variety of governmental jurisdictions; therefore the following references in this manual are provided only as a general outline. You may be subject to different legislation and governing bodies in your specific location.

IT IS THE TANK OWNER'S RESPONSIBILITY TO DETERMINE WHAT CODES AND REGULATIONS MUST BE FOLLOWED IN YOUR LOCAL AREA

Meridian Manufacturing assumes no responsibility for any errors that may appear in this manual and shall not be liable under any circumstances for incidental, consequential or punitive damages in connection with, or arising from, the use of this manual. Meridian Manufacturing reserves the right to make changes to this manual at any time without obligation or notice.

Introduction

The 7,400L & 10,000L DW model fuel tanks are designed to meet ULC S601-07 standards for strength and durability. These tanks can accommodate a variety of fuel types and feature a 100% containment system designed to prevent costly leaks.

These double walled steel lined tanks are finished with long lasting durable powder coat paint finish. With proper care and handling these tanks will provide many years of environmentally safe fuel storage.

Standard Features

- CAN-ULC-S601-07 APPROVED
- 100% SECONDARY CONTAINMENT
- HEAVY GAUGE CONSTRUCTION
- LIFTING LUGS
- EMERGENCY VENTS
- SPARE FITTINGS PORTS
- STURDY FULLY WELDED SKID
- CLIMBING LADDER
- PREMIUM POWDER COAT FINISH

Specifications	7400L DW		10,000L DW	
	Metric	Imperial	Metric	Imperial
Volume (Total)	7400 liters	1954.87 gallons	10000 liters	2193 gallons
Diameter	162.08 cm	63 13/16 "	161.5 cm	63 5/8 "
Tank Length	368.3 cm	145 "	535.9 cm	211 "
Length (with Ladder)	438.46 cm	172 5/8 "	615.9 cm	242 1/2"
Weight (empty)	1,270 kg	2799.87 lb.	2053 kg	4528 lb

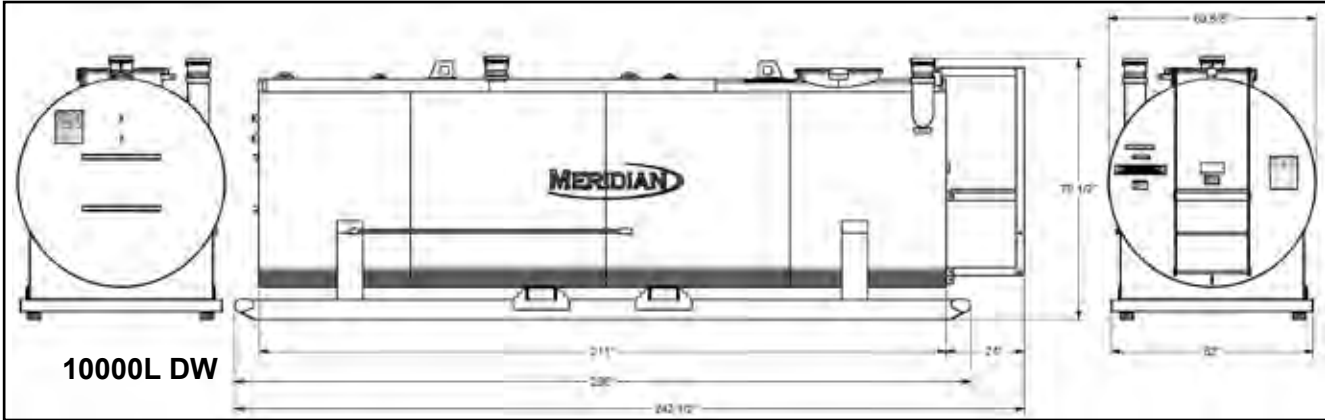
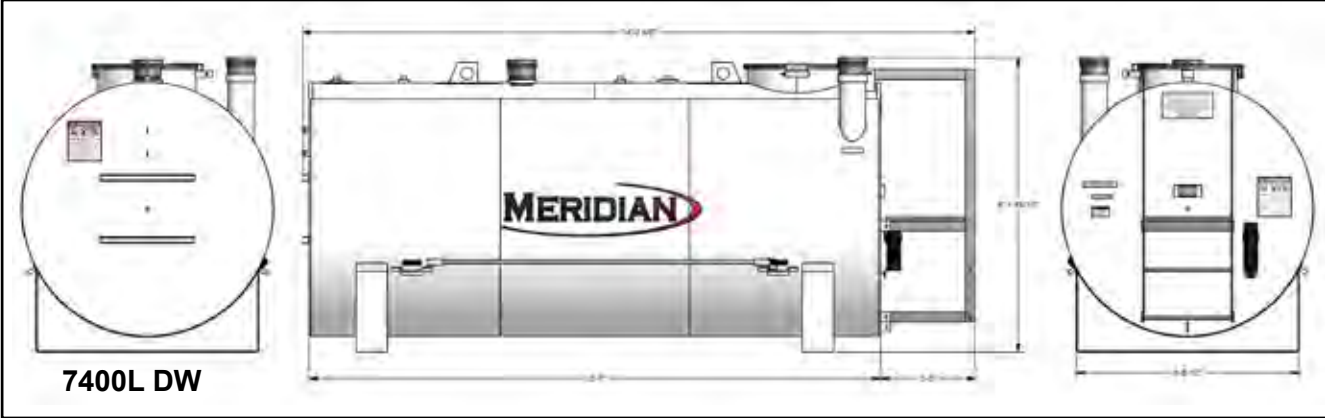

7,400L & 10,000L DW Fuel Tanks

Safety Decals





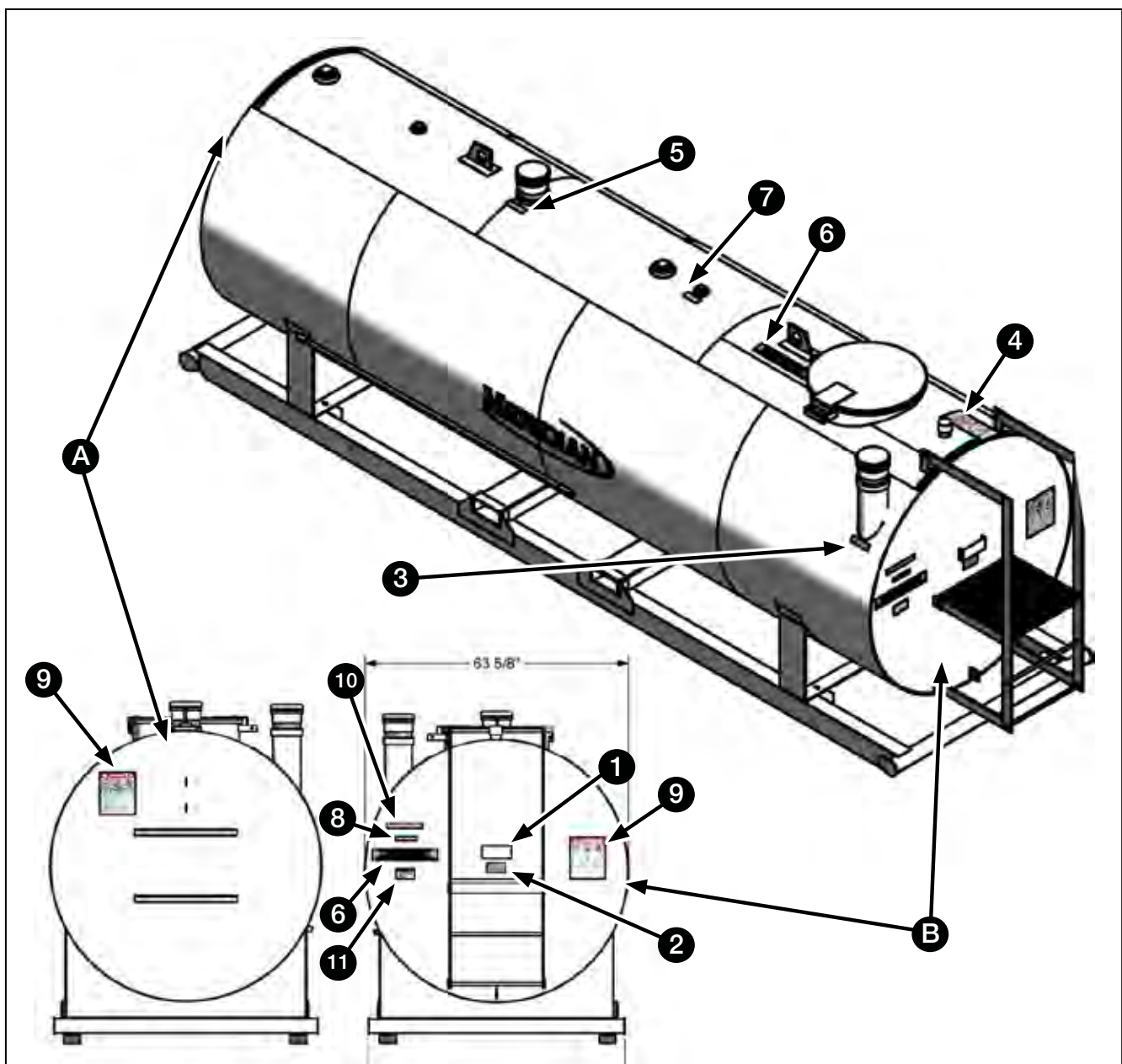

Safety Decals

The following warning decals (see table next page) are installed on the tank at the indicated areas. Decals will vary dependent on the options associated with the selected model. They are intended for your safety and the safety of those working with you. Please become familiar with the location of these warning decals and the information contained on them.





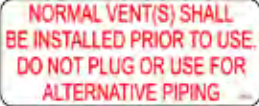

If the safety decals become damaged or cannot be clearly or easily read they must be replaced.



Decal Number	Description, Part Number and Location	Image
1	ULC Plate (P/N 20027) located on rear of tank.	
2	Serial Number Decal	
3	Emergency Vent Warning (P/N 20105) Located below Emergency Vent.	
4	Containment Inspection Warning. (P/N 20045) Located below Containment Inspection Port	
5	Emergency Vent Warning (P/N 20105) Located below Emergency Vent.	
6	Lifting Lug Warning (P/N 19042) Located Below Lifting Lug.	
7	Vent Warning. (P/N 20026) Located below 2" Port	

7,400L & 10,000L DW Fuel Tanks
Safety Decals

Decal Number	Description, Part Number and Location	Image
8	<p>Fill Warning (P/N 20022) Located below Vented Fill Cap.</p>	
9	<p>Danger Safety Decal (P/N 20048) Located on both ends of the tank.</p>	
10	<p>Jurisdictional Warning (P/N 20046) Located on dispensing end of tank.</p>	
11	<p>Warning Falling Hazard (P/N 19961) Located next to climbing ladder.</p>	

Personal Safety

Throughout this manual and on fuel tank decals, in accordance with ISO standards, you will find the signal words “**DANGER**”, “**WARNING**”, and “**CAUTION**” followed by specific instructions. These instructions are there to protect your personal safety and the personal safety of those working with you. Take the time to read these statements and follow the instructions.



Indicates an imminently hazardous situation which, if not avoided, **WILL** result in death or serious bodily injury.



Indicates a potentially hazardous situation which, if not avoided **COULD** result in minor or severe bodily injury.



Indicates a potentially hazardous situation which, if not avoided, **MAY** result in minor or moderate bodily injury.



Machine Safety

In addition to notes on personal safety the following text notes on Machine Safety will appear as related to machine safety. Following these instructions will help the user avoid possible machine damage.

IMPORTANT: indicates a situation which, if not followed, **WILL** involve deterioration or damage to equipment.

General Notes

The following general notices also appear in the manual. These notices draw attention to correct procedures that will assist the operator.

NOTE: Indicates an important installation, operation and/or maintenance procedure which if not followed **MAY** result in deterioration or damage to the equipment.

ATTENTION: Indicates important procedures which should be followed.

7,400L & 10,000L DW Fuel Tanks

Installing The Tank

Installing The Tank

This document only covers general installation instructions. Consult the correct authority having jurisdiction in your area prior to tank installation.

NOTE: This tank must be installed by a qualified tank installer who shall consult with the proper authorities with jurisdiction to ensure all requirements of CAN/ULC-S60 1-07 and all Federal, Provincial and Local codes are being met prior to installation. Failure to do so, could void your warranty.

Installation

All timber/crates used in shipping must be completely removed from the tank prior to installation of tank.

Choosing a Location

The tank shall be placed at a safe distance from buildings, other tanks, roadways, waterways, property lines and all public paths (1). Refer to local authorities for applicable codes.

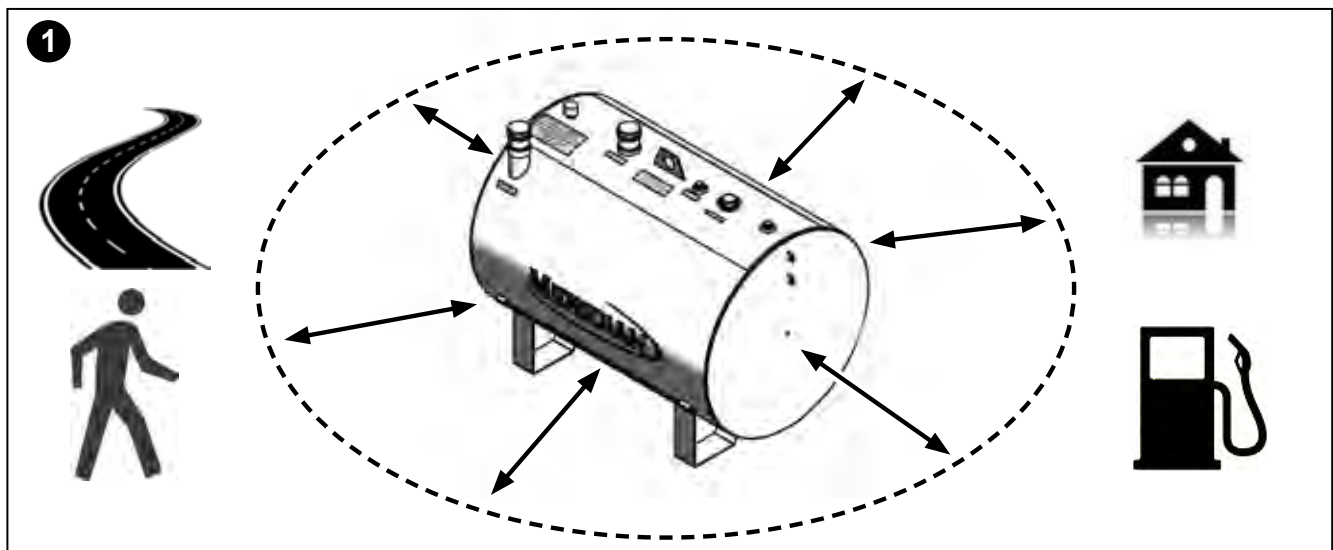

Installing the Fuel Tank Base

The tank shall be installed on a level base (2) designed to support the tank weight plus 100% liquid loading.

The tank skid, saddle or cradle shall be the only part of the tank in contact with the foundation or base.

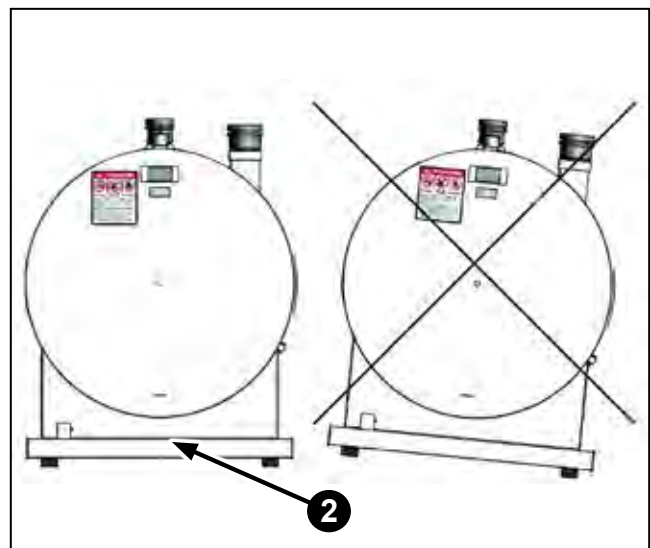

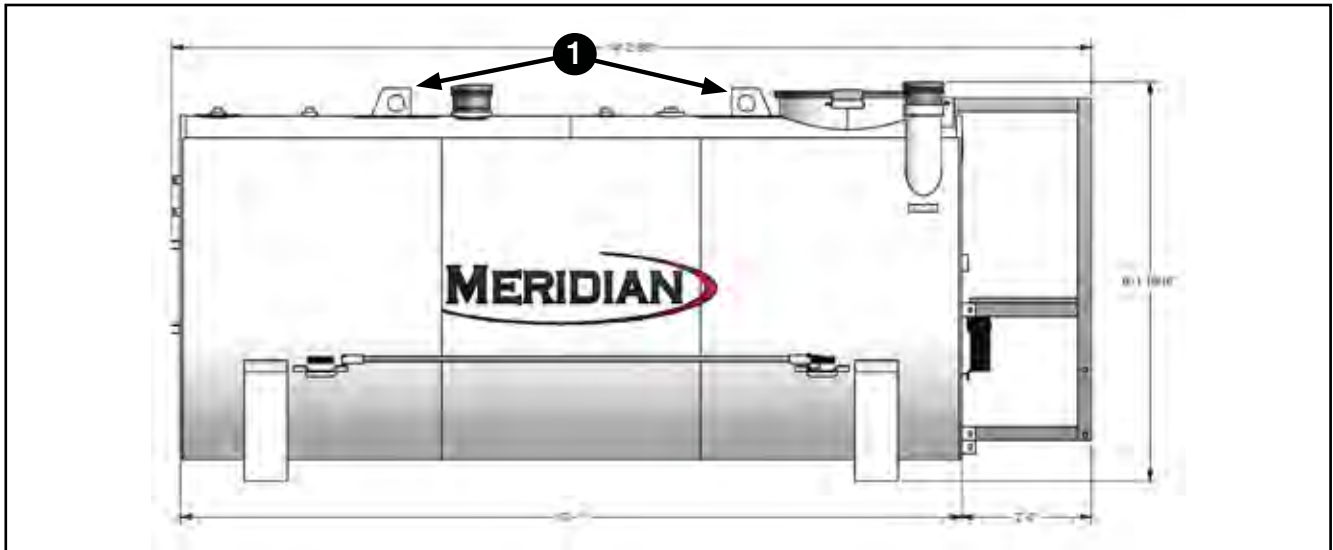

Lifting and Transporting Fuel Tanks

Only the lifting lugs (1) or the fork pockets on the skid if equipped, shall be used for unloading or transporting the empty fuel tank. Do not lift or transport tanks containing fluid at any time.

Inspecting Fuel Tanks

The tank installer shall ensure that all fittings, have not loosened during transportation and that they are sealed and tight.



Check all painted areas of tank for damage due to shipping and also at final installation. All scratched or scuffed areas must be touched up with paint prior to use. If the damages are deemed to affect the integrity of the tank, contact your distributor or dealer prior to putting any product in the tank.

Installation of Tank Venting

All primary and secondary normal and emergency vents are to be installed before the tank is placed into service and the design of the normal vent shall not allow flame impingement onto the surface of the tank in the event of vapor ignition.

Inspecting the Fuel Tank Containment System

The containment should be checked on a regular basis, to confirm that neither product nor water has accumulated therein. Take immediate remedial action if product or water is found. The disposal of any liquid found in the containment shall be disposed of in accordance with the requirements of the authority having jurisdiction.

—  **DANGER**  —

DO NOT lift or attempt to transport tanks containing fluid at any time.

Environmental Regulations

The fuel tank installer shall ensure that all environmental requirements are taken and implemented in accordance with the local authority having jurisdiction.

Protect Fuel Tank Against Vehicle Traffic

The installer is to ensure that the fuel tank is adequately protected against damage from vehicular traffic in compliance with all Federal, Provincial and Local Codes.

Regular Inspection and Maintenance

The fuel tank is to be inspected annually and any repairs to the exterior coating shall be made at the time of inspection in accordance with the coating manufacturer's instructions.

7,400L & 10,000L DW Fuel Tanks
Installing The Tank

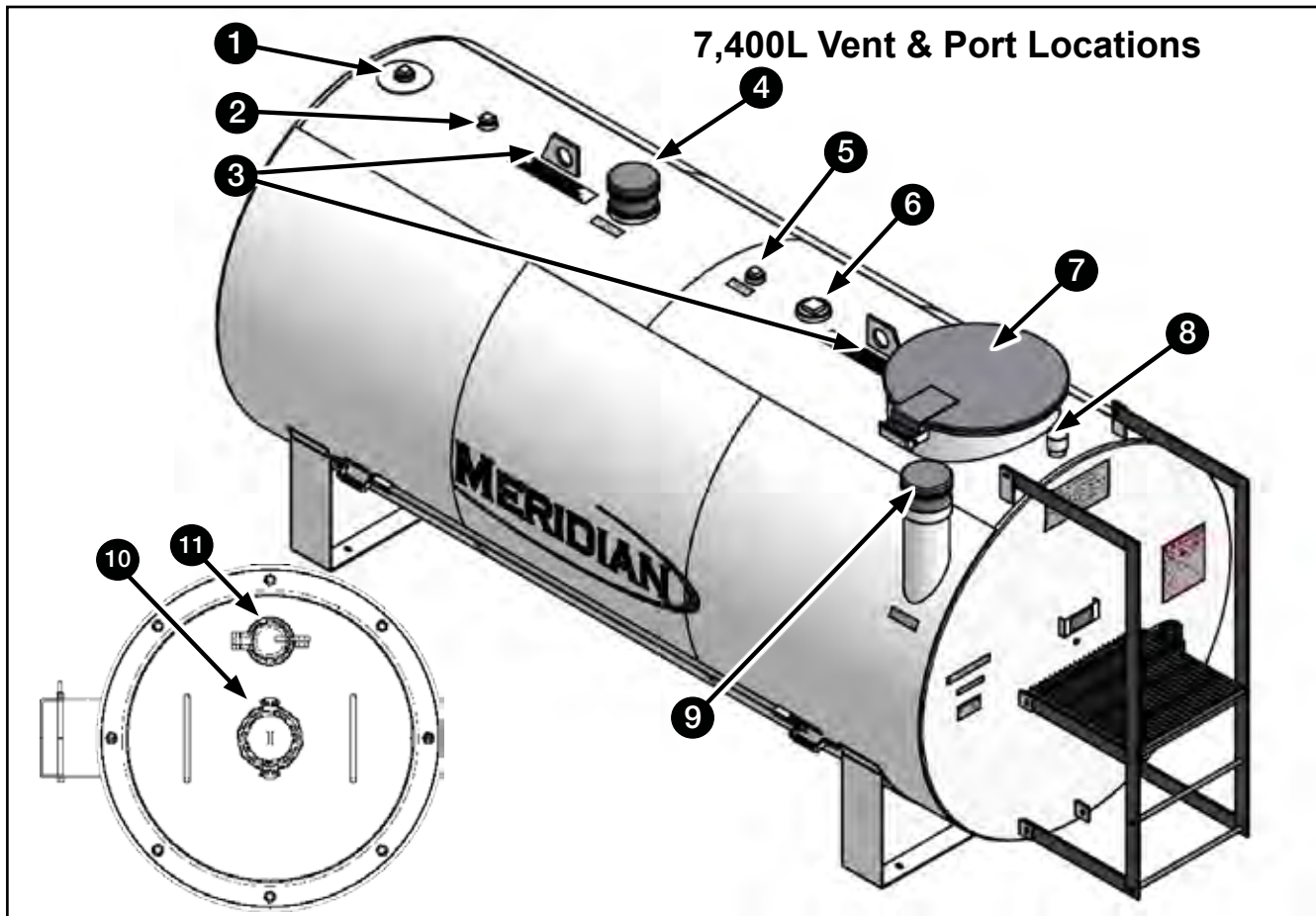

7,400L Vent & Port Description			
#	Description	#	Description
1	2" Port	7	25" Spill Box Cover
2	2" Port	8	2" Containment Inspection Port
3	Lifting Lugs	9	6" Emergency Vent (Containment)
4	6" Emergency Vent (Primary)	10	3" Camlock Coupler
5	2" Port	11	2" Dip Port (Lockable Hinged)
6	4" Port		

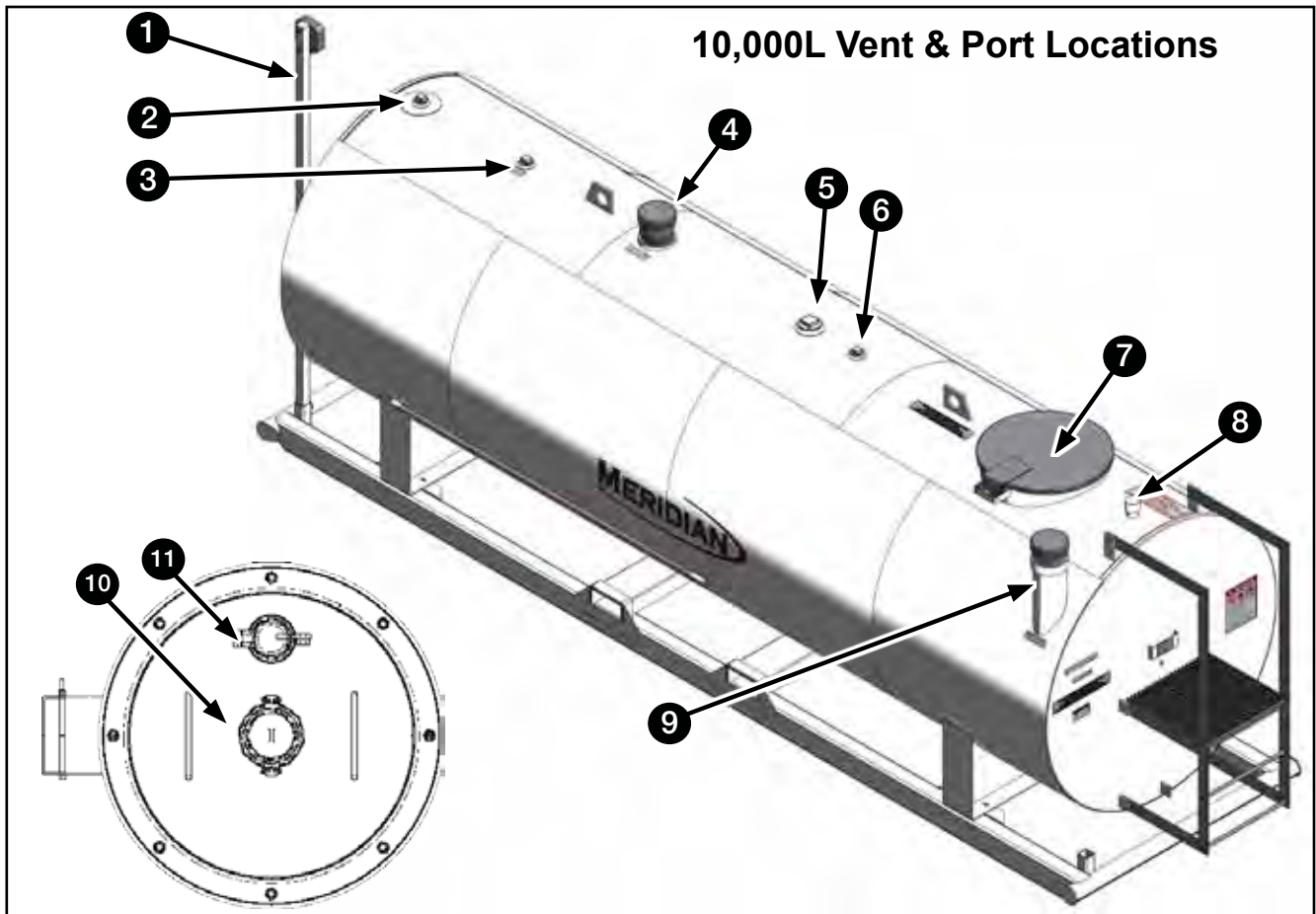

10,000L Vent & Port Description			
#	Description	#	Description
1	Hose Retractor	7	25" Spill Box Cover
2	2" Pump Port	8	2" Containment Inspection Port
3	2" Port	9	6" Emergency Vent (Containment)
4	6" Emergency Vent (Primary)	10	3" Camlock Coupler
5	4" Port	11	2" Dip Port (Lockable Hinged)
6	2" Port		

7,400L & 10,000L DW Fuel Tanks

Measuring Fuel Tank Levels



DANGER



Never smoke around the fuel tank or expose the tank to direct flame!

Measuring Fuel Tank Levels

NOTE: For greater accuracy wait 30 - 60 mins then dip check the tanks. This allows fuel to settle and will give more accurate readings.

1. Remove the dip stick (1) from its position at the side of the tank.
2. Carefully mount climbing ladder (2). Lift the Hinged Spill Box Cover (3).
3. Locate the Dip Port (4) and remove the pins securing the lid. Lift to open.
4. Insert the dip stick into the tank until it reaches the bottom.

NOTE: Ensure the dip stick is inserted with the lowest number on the dip stick placed toward the bottom of the tank.

5. Remove the dip stick (1) and take note of the amount of fuel in centimeters (cm) that is showing on the stick.
6. Compare the number of centimeters on the dip stick with the Fuel Tank Depth Chart in this manual to determine the amount of fuel in the tank.
7. Close the Dip Port Lid (4) and secure.
8. Close and secure Hinged Spill Box Cover (3).
9. Carefully dismount climbing ladder.

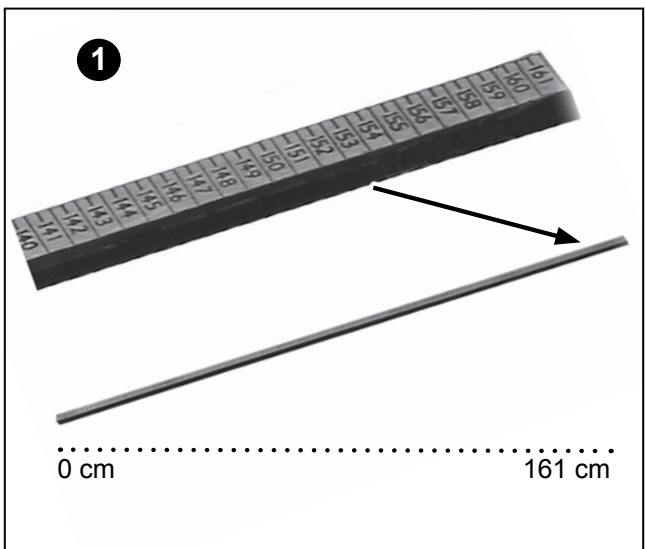
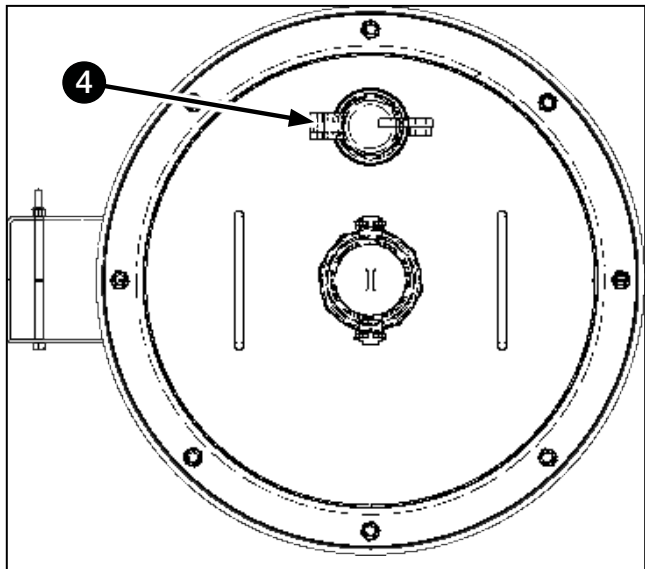
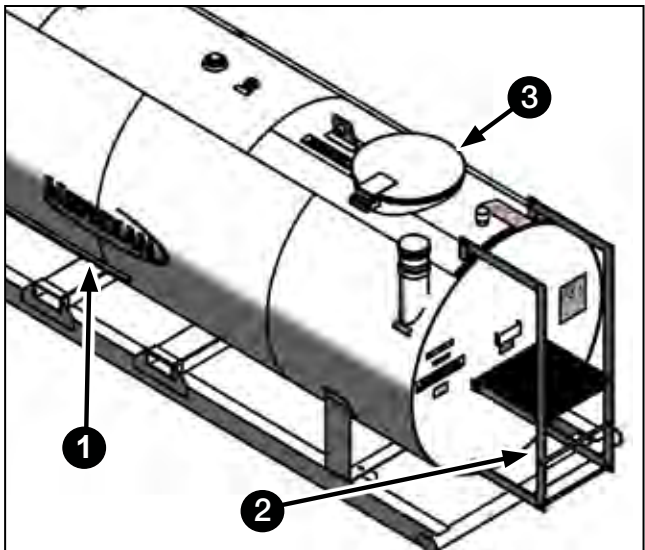

Fuel Transfer Safety

Transfer procedures are to be used when transferring fuel from a delivery vehicle to the tank. Although some transfer procedures are unique to some facilities the following general safety procedures **MUST ALWAYS BE FOLLOWED**:

- Read the Operator Manual before using the fuel tank.
- **DO NOT** smoke when operating or refueling the fuel tank.
- Keep sparks, flames & hot material away from the fuel tank.
- Turn Vehicle ignition off and remove key from ignition before refueling.
- Keep vehicles at least 1.5 m (5') away from the fuel tank at all times.
- Never leave the tank unattended while refueling is in process.
- **DO NOT** overfill. 95% capacity is the maximum legal limit.
- Always turn pump off when finished fueling operations.
- Always store pump nozzle in drip pot when not in operation.



ALWAYS determine how much fuel your tank can safely hold. Over filling the tank will cause spills. Check the fuel level by dip checking the tank prior to any fuel transfer. Instructions on the correct procedure for dip checking a tank can be found in this manual.



ALWAYS start the fuel transfer at a reduced rate. This reduces the potential for the build up of static electricity



DO NOT OVERFILL. Determine a Safe Gauge Height (SGH) this is how much fuel a tank can hold allowing for expansion due to temperature variations. A good rule of thumb is in summer months the tank should not be more than 90% full and in winter the tank should not be more than 95% full.



DO NOT dispense fuel during transfer procedures.



ALWAYS maintain good communications with the driver of the delivery vehicle. Poor communication between the tank operator and the delivery driver often leads to spills and accidents.

7,400L & 10,000L DW Fuel Tanks

Fuel Transfer Safety

Top Fill Fuel Transfer (7400L & 10,000L)

1. Have a pre-transfer meeting with the operator of the delivery vehicle to determine the correct product is being transferred into the correct tank.
2. Mount the tank ladder, open spill box cover.
3. Open Dip Port (1) and confirm the amount of fuel to be added.
4. Inspect transfer hose for visible leaks, cracks or damage in the line (2). If leaks are present or later appear do not continue with transfer. Repair as necessary.
5. Wipe area around the 3" Camlock (3) with a clean cloth or rag to remove risk of fuel contamination.
6. Open 3" Camlock (3) and place cap in a clean secure location. Attach delivery nozzle to 3" Camlock (3).

NOTE: The 2300L, 4600L, & 4595L models operate with a fill port. On models over 7,400L this is replaced with a 3 inch male cam and drop tube.

7. Start delivery vehicle pump, depress delivery nozzle handle and slowly begin fuel transfer. Only increase the flow of the product from the delivery vehicle when you are sure there are no problems.
8. **DO NOT WALK AWAY DURING A TRANSFER.** Continuously monitor the transfer of fuel. At all times keep in open communication between the delivery vehicle and tank operator.
9. Regularly check fuel tank levels. Reduce fuel transfer rates when nearing the top of the tank to avoid overfilling the tanks. Notify the delivery vehicle operator when the transfer procedure is almost complete.
10. Release the handle on the delivery nozzle.
11. Turn off the delivery vehicle delivery pump.
12. Remove the delivery nozzle from the fill port and secure hose and nozzle on the delivery vehicle
13. Conduct a post-transfer meeting between the delivery operator and tank operator.
14. Dip tanks and record amount of fuel delivered.
15. Secure 3" Camlock (3) and Dip Port (1) lids.

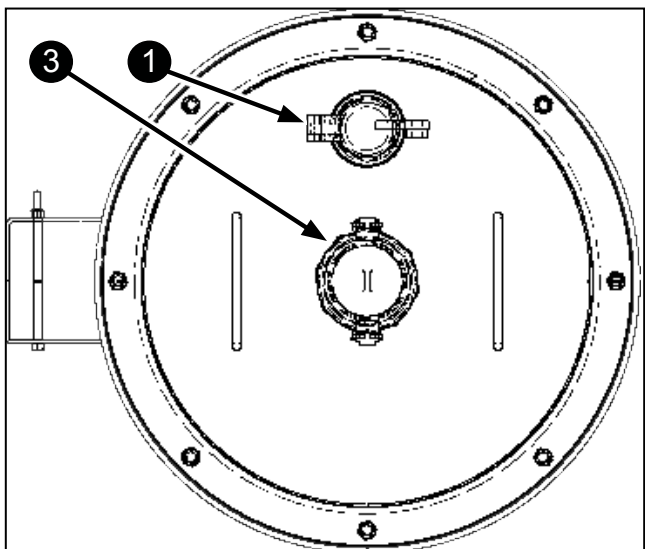
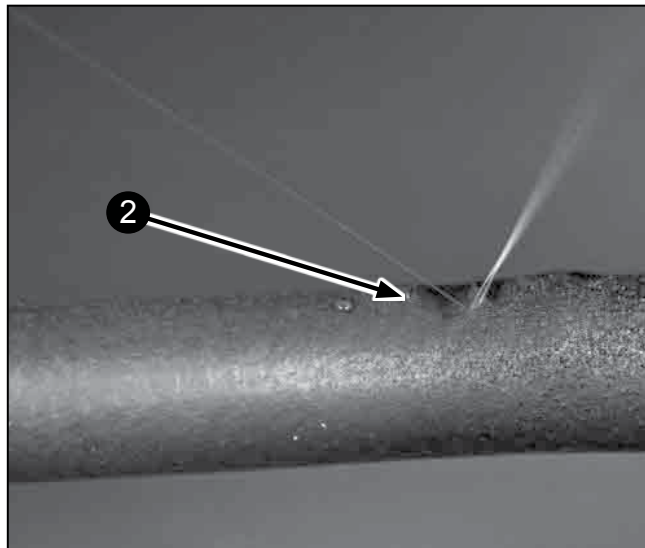
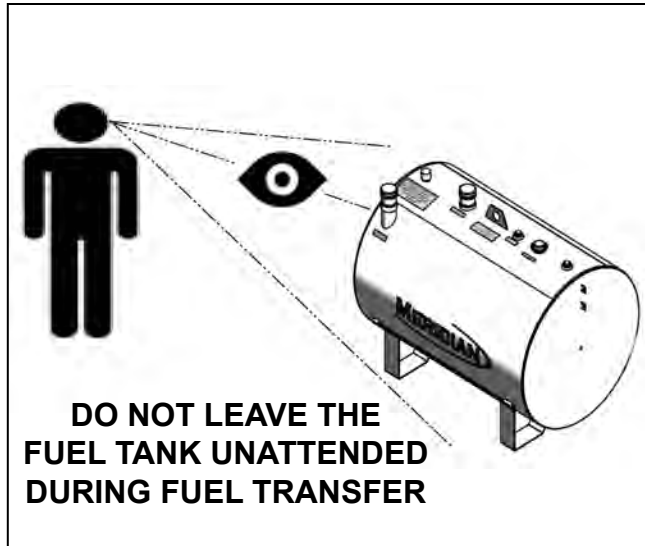



WARNING



Always keep the nozzle in contact with the container being filled during the filling process to minimize the possibility of static electricity build up.

Pump Operations

The 7,400L & 10,000L Fuel Tanks come with three different pump options. A different or similar pump can be installed for each tank compartment. Dependent on the pump option associated with your tank consult the correct Installation and Operator manual provided at time of purchase for detailed pump installation, operation and maintenance procedures.

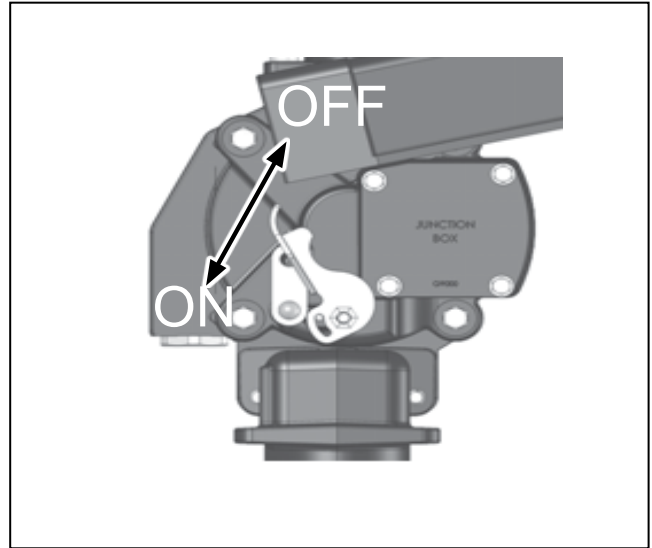

Dispensing Fuel (general)

1. Reset Meter to "0" (if applicable). (Do not reset meter while dispensing fuel.)
2. Remove dispensing nozzle from the nozzle boot or Drip pot.
3. Move the switch lever to the "ON" position to power the pump.
4. Insert the dispensing nozzle into the container to be filled.
5. Operate the nozzle to dispense fluid; release nozzle when the desired amount of fluid has been dispensed.
6. Move switch lever to the "OFF" position to stop the pump.
7. Remove the dispensing nozzle from the container and store it in the nozzle boot or drip pot.

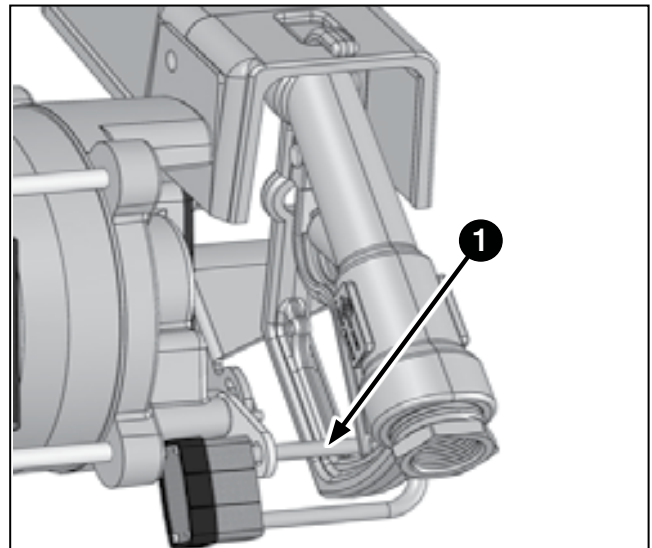

Locking The Pump

Dependent on the pump options selected, the pump nozzle can be pad locked (1) for added security. With the pump turned off, and the nozzle in the stored position, a pad lock can be inserted through the locking link and the nozzle handle opening. This configuration prevents the nozzle from being removed from the nozzle cover.

Optional drip pots (2) and chains (3) are also available. The chain can be wrapped around the nozzle and secured with a padlock. This secures the nozzle when not in use or when the tank is left unattended for long periods of time.

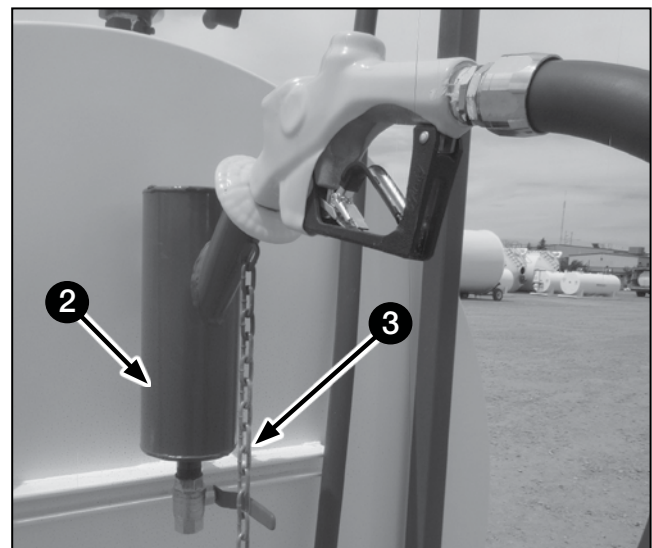

7,400L & 10,000L DW Fuel Tanks

Pump Operations

Trouble Shooting

The following Trouble Shooting guide is provided to offer basic diagnostic assistance in the event you encounter pump problems. For detailed instructions consult the pump installation and operation manuals that were provided with the pump at the time of sale.



WARNING



DO NOT open or attempt to repair the motor. Opening the motor will compromise the integrity of the Explosion Proof Construction and will void any existing warranty and certification (UL listing).



WARNING



Make Sure all power to the pump is turned off prior to performing any service or maintenance.

NOTE: Consult your local Meridian Dealer for replacement parts.



WARNING



In "Skid Tank" applications, make sure the tank is properly secured so it cannot shift or move when the tank is empty or full..

Symptom	Cause	Cure
Pump Won't Prime	Suction line problem	Check for leaks in suction line
	Bypass valve open.	Remove and inspect valve: Must move freely & be free of debris
	Vanes sticking.	Check vanes and slots for nicks, burrs and wear.
	Excessive rotor or vane wear.	Inspect rotor & vanes for excessive wear or damage; replace if necessary.
	Outlet blocked.	Check pump outlet, hose, nozzle & filter for blockage.
	Vapor Lock	Reduce vertical and horizontal distance from pump to liquid; remove automatic nozzle
Low Capacity	Excessive dirt in screen.	Remove and clean screen.
	Suction line problem.	Check suction line for leaks or restrictions; it may be too small, too long or not airtight.
	Bypass valve sticking.	Remove and inspect valve; must move freely & be free of debris
	Vanes sticking.	Check vanes and slots for wear.
	Excessive rotor or vane wear.	Inspect rotor & vanes for excessive wear or damage; replace if necessary.
	Hose or nozzle damage	Replace hose or nozzle.
	Plugged filter	Replace filter.
Low fluid level.	Fill tank.	
Pump runs slowly.	Incorrect voltage.	Check incoming line voltage while pump is running.
	Vanes sticking.	Inspect vanes and slots for nicks, burrs and wear.
	Wiring problem.	Check for loose connections.
	Motor problem.	Return to place of purchase.

Symptom	Cause	Cure
Motor stalls.	Bypass valve sticking.	Remove and inspect valve; must move freely & be free of debris.
	Low voltage	Check incoming line voltage while pump is running.
	Excessive rotor or vane wear.	Check rotor & vanes for excessive wear or damage.
	Debris in pump cavity.	Clean debris from pump cavity.
Motor overheats.	Pumping high viscosity fluids.	These fluids can only be pumped for short periods of time (less than 30 minutes duty cycle).
	Clogged screen.	Remove and clean screen.
	Restricted suction pipe.	Remove and clean pipe.
	Motor failure.	Return to place of purchase.
Motor Inoperative.	Pump rotor lock-up.	Clean and check pump rotor and vanes.
	No power	Check incoming power.
	Switch failure.	Return to place of purchase.
	Motor failure.	Return to place of purchase.
	Thermal protector failure.	Return to place of purchase.
Fluid Leakage	Incorrect/loose wiring.	Check wiring
	Bad O-Ring casket	Check all o-ring gaskets.
	Dirty Shaft Seal	Clean seal & seal cavity
	bad Shaft Seal	Replace seal.
	Incompatible Fluid	Refer wetted parts list to fluid manufacturer.
Pump hums but will not operate	Loose fasteners	Tighten fasteners.
	Dirt in Pump cavity	Clean out pump cavity.
	Motor failure.	Return to place of purchase.
	Broken Key	Remove all debris & replace key.

7,400L & 10,000L DW Fuel Tanks Limited Warranty

Limited Warranty

Meridian Manufacturing Inc., (hereinafter referred to as the Manufacturer) hereby warrants the tank(s) sold by it to be free from any defect in material or workmanship under normal use and service for a period of two (2) years from the date of shipment. The Manufacturer also warrants the structural integrity of the tanks(s) for a period of ten (10) years from the date of shipment. The Manufacturer's obligation under this warranty shall be limited to the repair or replacement only, FOB the original point of shipment, of any defective parts or portions of the tank or accessories manufactured by Meridian. Any warranty claim must be reported to the Manufacturer within two (2) years for general and coating claims or ten (10) years for structural claims, from the date of shipment and in the manner as referred to in paragraph 2 herein.

THIS WARRANTY IS SUBJECT TO THE FOLLOWING LIMITATIONS, PROVISIONS AND CONDITIONS

1. This warranty does not apply to:
 - a. Any product sold by the Manufacturer where it is used in areas exposed to corrosive or aggressive conditions including salt water, acids, alkaloid, ash, cement dust, animal waste or other corrosive chemicals.
 - b. Failures or defects arising out of damage during shipment or during storage on site.
 - c. Materials replaced or repaired under this warranty except to the extent of the remainder of the applicable warranty.
 - d. Damage resulting from misuse, negligence, accident or improper site preparation by others.
 - e. Products that have been altered or modified by others.
 - f. (in the case of coating failures) failure as the result of damage, lack of proper maintenance or failure to remove road salt or other contaminants that may have come in contact with the tank surface.
 - g. Products that have not been installed strictly in accordance with the Manufacturer's manuals and instructions.
2. The obligation of the Manufacturer under this warranty shall not arise unless the Manufacturer is notified and this warranty is presented together with a written statement specifying the claim or defect within thirty (30) days after the failure is first detected or made known to the owner and within two (2) years for general and coating claims and ten (10) years for structural claims, from the shipment date. The Manufacturer in its sole discretion shall determine if the claim is valid and whether correction of the defect or failure shall be made by repair or replacement of the materials.
3. The coating warranty is based on the Manufacturer's performance specification for polyester powder finishes and does not include repair of minor blemishes or rusting that is normally part of the general maintenance of the tank.
4. The obligation of the Manufacturer hereunder extends only to the original owner and to the Meridian dealer to whom the materials may have been initially sold. This warranty shall not be subject to any assignment or transfer without the written consent of the Manufacturer.
5. The customer shall acknowledge that it has made its own independent decision to approve the use of the supplied materials and also the specific fabrication and construction procedures utilized to complete the tank, and has satisfied itself as to the suitability of these products for this particular application.
6. The foregoing sets forth the only warranties applicable to said materials and said warranties are given expressly and in lieu of all other warranties, expressed or implied, statutory or otherwise, of merchantability or fitness for a particular purpose and all warranties which exceed or differ from said warranties herein are disclaimed by the Manufacturer.
7. The owners sole and exclusive remedy against the Manufacturer shall be limited to the applicable warranty set forth herein and the endorsements, if any, issued together with this document and no other remedy (including but not limited to the recovery of assembly or disassembly costs, shipping costs, direct, incidental, special, indirect or consequential damages for lost profits, lost sales, injury to person or property or any other loss, whether arising from breach of contract, breach of warranty, tort, including negligence, strict liability or otherwise) shall be available to the owner or Meridian Dealer or any other person or entitles whether by direct action or for contribution or indemnity or otherwise.
8. The financial obligation of the Manufacturer under this warranty shall be limited to the repair or replacement of the product as originally supplied and in no event shall exceed the original cost of the product supplied.
9. The Manufacturer shall not have any obligation under any warranty herein until all accounts for materials, installation and erection of the said product thereof and for labor and other work performed by the Manufacturer or its dealers have been paid in full by the owner.

Warranty Claim Procedure

- a. Advise the Dealer or Manufacturer immediately upon discovery of any defects.
- b. Complete the Fuel Tank Warranty Order Request found in the back of this manual in its entirety then mail or e-mail the form to tankwarrantyca@meridianmfg.com
- c. When the warranty claim form is received by the Manufacturer you will be contacted by our customer service department.
- d. Claims will be adjudicated at the sole discretion of the Manufacturer and in accordance with the terms and conditions of the applicable limited warranty.

This page intentionally left blank.

Fuel Tank Warranty Order Request

IMPORTANT!

- Advise the dealer or manufacturer immediately upon discovery of any defects.
- Complete the Fuel Tank Warranty Order Request found in the back of this manual in its entirety and e-mail the form to tankwarrantyca@meridianmfg.com or mail this form to: Meridian Manufacturing Fuel Tank Warranty Request, Lethbridge, AB Office 3125 24th Ave North. Lethbridge, AB T1H 5G2 (1-800-661-1436)
- When the warranty claim form is received by the manufacturer you will be contacted by our customer service department.
- Claims will be adjudicated at the sole discretion of the manufacturer and in accordance with the terms and conditions of the applicable limited warranty.

Tank Information

Current Tank Location MMG Yard Dealer Yard Customer Yard

Model Number _____ Date Reported to MMG _____

Tank Serial Number _____ Repair On Site Repair Off Site

Describe Warranty Issue in Detail	
--	--

Directions to Site _____

Customer Information

Customer Name _____ Customer Contact _____

Address _____ City _____ Province _____

Postal Code _____ Phone _____ Cell _____

Dealer Information

Dealer Name _____ Dealer Contact _____

Address _____ City _____ Province _____

Postal Code _____ Phone _____ Cell _____

Company Use Only

Net Price to Charge on Invoice _____

Part Numbers Used in Repair _____

Directions	
-------------------	--

Claim Disposition Claim Approved Pending Inspection Claim Denied

This page intentionally left blank.

7,400L Fuel Tank Dip Chart

Depth cm	Vol L
1	6
2	17
3	32
4	49
5	69
6	90
7	114
8	138
9	165
10	193
11	222
12	252
13	284
14	317
15	351
16	385
17	421
18	458
19	496
20	534
21	574
22	614
23	655
24	697
25	739
26	782
27	826
28	870
29	916
30	961
31	1008
32	1055
33	1102
34	1150
35	1198
36	1247
37	1297
38	1347
39	1397
40	1448

Depth cm	Vol L
41	1499
42	1551
43	1603
44	1656
45	1709
46	1762
47	1815
48	1869
49	1923
50	1978
51	2033
52	2088
53	2143
54	2199
55	2255
56	2311
57	2368
58	2424
59	2481
60	2538
61	2595
62	2653
63	2710
64	2768
65	2826
66	2884
67	2942
68	3001
69	3059
70	3118
71	3176
72	3235
73	3294
74	3353
75	3412
76	3471
77	3530
78	3589
79	3648
80	3707

Depth cm	Vol L
81	3766
82	3825
83	3884
84	3943
85	4002
86	4061
87	4120
88	4179
89	4238
90	4296
91	4355
92	4414
93	4472
94	4530
95	4588
96	4647
97	4704
98	4762
99	4820
100	4877
101	4934
102	4992
103	5048
104	5105
105	5161
106	5218
107	5273
108	5329
109	5385
110	5440
111	5494
112	5549
113	5603
114	5657
115	5711
116	5764
117	5817
118	5869
119	5921
120	5973

Depth cm	Vol L
121	6024
122	6075
123	6126
124	6175
125	6225
126	6274
127	6322
128	6370
129	6418
130	6465
131	6511
132	6557
133	6602
134	6646
135	6690
136	6733
137	6776
138	6817
139	6858
140	6898
141	6938
142	6976
143	7014
144	7051
145	7087
146	7121
147	7155
148	7188
149	7220
150	7250
151	7279
152	7307
153	7333
154	7358
155	7381
156	7403
157	7422
158	7439
159	7454

10,000L Fuel Tank Dip Chart

Depth cm	Vol L
1	9
2	25
3	46
4	71
5	99
6	130
7	163
8	199
9	237
10	277
11	319
12	363
13	408
14	455
15	504
16	554
17	605
18	658
19	712
20	768
21	824
22	882
23	941
24	1001
25	1062
26	1124
27	1187
28	1251
29	1316
30	1381
31	1448
32	1515
33	1584
34	1652
35	1722
36	1792
37	1864
38	1935
39	2008
40	2081

Depth cm	Vol L
41	2154
42	2229
43	2303
44	2379
45	2455
46	2531
47	2608
48	2685
49	2763
50	2842
51	2920
52	2999
53	3079
54	3159
55	3239
56	3320
57	3401
58	3482
59	3564
60	3646
61	3728
62	3810
63	3893
64	3976
65	4059
66	4142
67	4226
68	4309
69	4393
70	4477
71	4561
72	4645
73	4730
74	4814
75	4899
76	4983
77	5068
78	5152
79	5237
80	5322

Depth cm	Vol L
81	5407
82	5491
83	5576
84	5660
85	5745
86	5830
87	5914
88	5998
89	6083
90	6167
91	6251
92	6334
93	6418
94	6502
95	6585
96	6668
97	6751
98	6834
99	6916
100	6998
101	7080
102	7162
103	7243
104	7324
105	7405
106	7485
107	7565
108	7644
109	7724
110	7802
111	7881
112	7958
113	8036
114	8113
115	8189
116	8265
117	8341
118	8415
119	8490
120	8563

Depth cm	Vol L
121	8636
122	8709
123	8781
124	8852
125	8922
126	8992
127	9061
128	9129
129	9196
130	9263
131	9329
132	9394
133	9458
134	9521
135	9583
136	9644
137	9704
138	9763
139	9820
140	9877
141	9933
142	9987
143	10040
144	10091
145	10141
146	10190
147	10237
148	10283
149	10327
150	10369
151	10409
152	10447
153	10483
154	10516
155	10547
156	10575
157	10600
158	10621
159	10638

7,400L & 10,000L DW Fuel Tanks
Fuel Tank Warranty Order Request

Index

CAN/ULC-S601-07	8	Standard Features	3
Coating Warranty	18	Structural Integrity	18
Codes	2	Top Fill Fuel Transfer	14
Containment Inspection Warning	5	Transporting Fuel Tanks	9
Containment System	3, 9	Trouble Shooting	16
Danger Safety Decal	6	ULC Plate	5
Decals	4, 5	Vehicle Traffic	9
Diameter	3	VENT & PORT LOCATIONS	10
Dip Stick	12	Vent Warning.	5
Dispensing Fuel (general)	15	Volume	3
Emergency Venting	9	Warning Falling Hazard	6
Emergency Vent Warning	5	Warranty	18
Environmental Regulations	9	Warranty Order Request	18
Fill Warning	6	Weight (empty)	3
Fuel Tank Base	8		
Fuel Tank Depth Chart	12, 22, 23		
Fuel Tank Venting	9		
Fuel Transfer Safety	13		
General Notes	7		
Guidelines	2		
Inspecting Fuel Tanks	9		
Inspection and Maintenance	9		
Installation	8		
Jurisdictional Warning	6		
Length (without Skid)	3		
Length (with Skid)	3		
Lifting Fuel Tanks	9		
Lifting Lug Warning	5		
Limited Warranty	18		
Machine Safety	7		
Measuring Fuel Tank Levels	12		
Personal Safety	7		
Qualified Installer	8		
Regulations	2		
SAFETY ALERT SYMBOL	7		
Safety Decals	4		
Serial Number Decal	5		
Site Location	8		
Specifications	3		

MERIDIAN MANUFACTURING INC.

With over 65 years of experience,
Meridian is your storage and handling expert.



AGRICULTURAL



INDUSTRIAL



OIL & GAS

Cambridge Office

605 Sheldon Drive
Cambridge, ON N1T 2K1
PH: 519.620.6004
TF: 855.346.3712
FX: 519.620.6041

Camrose Office

4232 - 38 St.
Camrose, AB T4V 4B2
PH: 780.672.4516
TF: 800.830.2467
FX: 780.672.4759

Lethbridge Office

3125 - 24 Ave. N.
Lethbridge, AB T1H 5G2
PH: 403.320.7070
TF: 800.661.1436
FX: 403.320.7579

Regina Office

PO Box 1996
Regina, SK S4P 3E1
PH: 306.545.4044
TF: 800.667.5904
FX: 306.545.4216

Storm Lake Office

2902 Expansion Blvd.
Storm Lake, IA 50588
PH: 712.732.1780
TF: 800.437.2334
FX: 712.732.1028

Winkler Office

Box 760, 275 Hespler Ave.
Winkler, MB R6W 4A8
PH: 204.325.7883
TF: 800.665.7259
FX: 204.325.5556

MERIDIAN

www.meridianmfg.com