

MERIDIAN

OPERATOR'S MANUAL



FOR FUEL TRAILERS

www.MeridianMFG.com



PRODUCT WARRANTY REGISTRATION FORM



www.meridianmfg.com

WARRANTY REGISTRATION

This form must be filled out by the dealer and signed by both the dealer and the customer at the time of delivery. Please mail or fax the completed form for validation of the equipment registration.

Customer's Name _____

Address _____

City, State, Postal Code _____, _____, _____

Phone Number (_____) _____ - _____

PRODUCT INFORMATION

Fuel Trailer Model # _____

Serial Number # _____

I have thoroughly instructed the buyer on the above-described equipment, including review of the Operator's Manual content, equipment care, adjustments, operational use, safety procedures, and applicable warranty policy.

Dealer/Company Name _____

City, State, Postal Code _____, _____, _____

Dealer's Signature _____ Date ____/____/____

The above equipment and Operator's Manual have been received by me, and I have been thoroughly instructed as to care, adjustments, safe operation, and applicable warranty policy.

Owner's Signature _____ Date ____/____/____

2902 Expansion Blvd. Storm Lake, Iowa 50588 Phone: 800-437-2334 Fax: 712-732-1028 Email: iowa_warranty@meridianmfg.com

Cut Here to Remove Page

PRODUCT WARRANTY

REGISTRATION FORM



www.meridianmfg.com

DEALER INSPECTION REPORT

- If equipped, check gasoline engine fuel level
- If equipped, check gasoline engine oil level
- If equipped, start gasoline engine
- Inspect brake and lighting wiring harness connection
- Check air pressure in tires
- Make sure electric brakes are in working condition
- Make sure all guards/shields are installed correctly
- Make sure all safety signs are installed and legible
- Make sure all four 1993 Diesel Fuel Placards are installed
- Reflectors and lights must be clean and working
- Inspect customer's hitch for 2 -5/16" ball
- Verify receipt of all options ordered
- Make sure hitch-to-tongue bolts are tight
- Make sure safety chains are properly attached and are in good working condition
- Wheel nuts/bolts must be tightened to proper torque on all wheels
- Wiring harness plug must be in working condition and fit into tow vehicle's receptacle
- Make sure breakaway cable and pin is supplied with trailer
- Make sure battery is fully charged and in good working order
- Make sure license plate light is operating
- Make sure turn signal lights are operating
- Make sure brake lights are operating
- Verify that tow vehicle is large enough to safely tow the trailer
- Make sure owner is instructed to check wheel bolt/nut torque at 5, 10, 25, and 50 miles; then check annually
- Review safety and operating instructions with owner



www.meridianmfg.com

2902 Expansion Blvd.
Storm Lake, IA 50588
Phone: 712-732-1780
Fax: 712-732-1028

CERTIFICATE OF ORIGIN

LICENSING INFORMATION

Date: ____/____/____

DEALER:

Business

Contact

Address

City, State, Zip

SOLD TO:

Business

Contact

Address

City, State, Zip

FUEL TRAILER MODEL # _____

FUEL TRAILER WEIGHT _____

- Fuel Trailer Bone White
- Fuel Trailer Red
- Fuel Trailer Grey

Cut Here to Remove Page

IMPORTANT INFORMATION

SERIAL NUMBER LOCATION

Please provide the serial number of your Meridian Fuel Trailer and engine when ordering parts or requesting service or other information.

The serial number plates are located where indicated. Please record the numbers in the space provided below for easy reference.

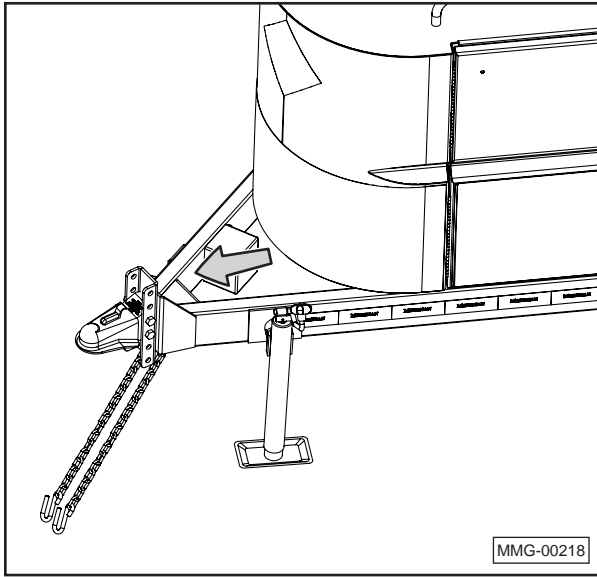

Fuel Trailer

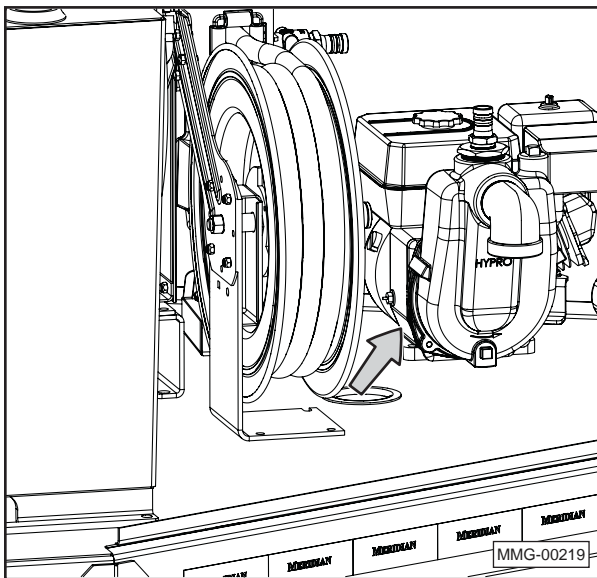

Engine

Model Number: _____

Serial Number: _____

Engine Serial Number: _____

PATENT INFORMATION



Meridian continuously enhances its product offering through product improvements and new product innovations. Marketplace feedback, technological innovation, new materials and manufacturing methods, and a philosophy of continuous improvement constantly challenge the company to develop new and better ways of addressing market needs. Meridian is committed to innovation and reinvestment and as a result, the company maintains a portfolio of patents and intellectual property. For more information on our patents please see our website: www.meridianmfg.com/patents

CONTENTS

1. INTRODUCTION	11
1.1 Congratulations	11
1.2 Operator Orientation	11
1.3 Owner/Operator	11
1.4 Disposal of Equipment at End of Useful Life	11
1.5 Continuous Improvement Process	11
1.6 Before Starting Gas Engine	12
2. SAFETY	13
2.1 Additional Safety Words	14
2.2 Safety Training	14
2.3 Safety Icon Nomenclature	15
2.3.1 Personal Protection/Important Information	15
2.3.2 Prohibited Actions	15
2.3.3 Hazard Avoidance	15
2.4 General Safety	16
2.5 Safety Signs	16
2.6 Preparation	16
2.7 Operating Safety	16
2.8 Transport Safety	17
2.9 Storage Safety	17
2.10 Maintenance Safety	17
2.11 Diesel Fuel Safety	17
2.11.1 Inhalation Hazard	17
2.11.2 Fire and Explosion Hazards	17
2.11.3 Ingestion	17
2.11.4 Eye Protection	17
2.11.5 Skin Protection	18
2.11.6 Storage Precautions	18
2.11.7 U.S. Federal, State, and Local Regulatory Information	18
2.12 Battery Safety	18
2.12.1 General Hazards	18
2.12.2 Ventilation Hazard	18
2.12.3 Shock Hazards	19
2.12.4 Explosion Hazards	19
2.13 Sign-Off Form	20
3. SAFETY SIGN LOCATIONS	21
3.1 General Information	21
3.2 How to Install Safety Signs	21
3.3 Decal Locations	21
3.4 Installing 1993 Diesel Fuel Placards	23
4. SPECIFICATIONS	24
4.1 Overall Dimensions	24
4.2 Specifications	24
4.2 Bolt Specifications	25
4.2.1 Bolt Torque Values	25
4.2.2 Grade Markings Chart	25
5. EQUIPMENT COMPONENTS AND CONTROLS	26
5.1 Component Nomenclature and Location	26
5.2 Electric Pump (12 Volt)	27
5.3 Gasoline Engine and Controls	27
5.4 Gasoline Engine Safety Signs	28

6. PRE-OPERATING INSTRUCTIONS	29
6.1 Equipment Break-In Period	29
6.1.2 Inspections for 1/2, 5, and 10 Hours	29
6.2 Daily Pre-Operation Checklist	30
7. TOWING	31
7.1 Transport Safety	31
7.1 Transport Safety (continued)	32
7.2 Connecting the Trailer	32
8. OPERATION	34
8.1 Operating Safety	34
8.2 Fire Extinguisher	35
8.3 Pre-operation Checks	35
8.4 DEF and Diesel Fuel Tanks	36
8.4.1 Filling the Fuel Trailer with Diesel Fuel	36
8.4.2 Filling Machinery Using 12 Volt Electric Diesel Fuel Pump	36
8.4.3 Filling Machinery Using Gasoline Diesel Fuel Pump	38
8.4.4 Filling the Trailer's DEF Tank	40
8.4.5 Filling the DEF Tank on Machinery	40
8.5 DEF Solution	42
8.5.1 DEF Solution Safety Practices	42
8.5.2 First Aid Measures	43
8.5.3 General Information.	43
8.5.4 Storage	43
8.5.5 Using DEF	43
8.5.6 DEF Disposal	43
9. STORAGE	44
9.1 General Information	44
9.2 Placing in Storage	44
9.3 Removing from Storage	44
9.4 Winterizing the DEF System	44
10. MAINTENANCE	45
10.1 Safety	45
10.1.1 General Safety.	45
10.2 Wheel Bearings	45
10.3 Battery	46
10.3.1 Battery Safety	46
10.3.2 Battery Replacement and Maintenance Tips	46
10.3.3 Battery Maintenance.	46
10.4 Gasoline Engine (Optional)	47
10.4.1 Approved Fuel	47
10.4.2 Engine Oil	47
10.4.3 Change Engine Oil	47
10.4.4 Air Filter Inspection	48
10.5 Engine Circuit Protection	48
10.6 Engine to Pump Connection (Gasoline Engine Option Only).	49
10.7 Trailer Breakaway System	49
10.7.1 Testing the Battery.	49
10.7.2 Changing Battery	49
10.7.3 Replacing Battery	49
10.8 Wheel Bolt Torque Requirements.	50
10.9 Axle Bolts, Trailer Hitch Bolts, and tank Hold-Down Bolts	50

11. SERVICE	51
11.1 Service Record Chart	51
11.2 Service Checks	52
11.2.1 Daily (8 Hours).	52
11.2.2 Weekly (50 Hours).	52
11.2.3 Semiannual (200 Hours).	52
11.2.4 Annually (400 Hours)	52
11.3 Axle Maintenance	53
11.3.1 First 200 Miles	53
11.3.2 3,000 Miles or 3 Months	53
11.3.3 6,000 Miles or 6 Months	53
11.3.4 12,000 Miles or 12 Months	53
11.4 Tires.	53
11.5 Welding Repairs	53
12. OEM LITERATURE	54
12.1 Engine and DEF Pump	54
12.3 Diesel Fuel Pump.	55
12.3.1 Electric Diesel Fuel Pump	55
12.3.2 Gasoline Diesel Fuel Pump	55
13. TROUBLESHOOTING	56
13.1 Troubleshooting Chart	56
14. WARRANTY	59
14.1 Warranty Statement.	59
15. PARTS	61
15.1 Fuel Trailer Compartment (Drivers Side)	62
15.2 Fuel Trailer Compartment (Passenger Side)	64
15.3 Fuel Trailer Caps and Gauges	65
15.4 Fuel Trailer Lower Piping	66
15.5 Wheel and Fender	67
15.6 Axle and Mounting Hardware	68
15.7 Lighting and Spare Tire Option	69
15.8 Decals and Safety Signs	70
15.9 Front Engine/Pump Compartment	71

1. INTRODUCTION

1.1 CONGRATULATIONS

Congratulations on your choice of a Meridian Manufacturing Inc. Fuel Trailer to complement your farming operation. This equipment has been designed and manufactured to meet the exacting standards for such equipment in the agricultural industry and will keep your operation running at optimum efficiency.



The Fuel Trailer is designed to transport diesel fuel and diesel exhaust fluid (DEF) to your machinery.

Safe, efficient, and trouble-free operation of your Fuel Trailer requires that you, and anyone else who will be operating or maintaining the equipment, read and understand the Safety, Operation, Maintenance, and Troubleshooting information contained within this Operator's Manual.

This manual covers all Fuel Trailer models manufactured by Meridian Manufacturing Inc. Use the Table of Contents as a guide to locate required information.

⚠ WARNING

 **Do not fill or tow the unit until you read and understand the information contained in this manual.**

1.2 OPERATOR ORIENTATION

The directions left, right, front, and rear, as mentioned throughout this manual, are as seen from the truck drivers' seat and facing in the direction of travel.

1.3 OWNER/OPERATOR

It is the responsibility of the owner or operator to read this manual and to train all other operators before they start working with the equipment. Follow all safety instructions exactly. Safety is everyone's business. By following recommended procedures, a safe working environment is provided for the operator, bystanders, and the area around the work site. Untrained operators are not qualified and must not operate the equipment.

In addition to the design and configuration of equipment, hazard control and accident prevention are dependent upon the awareness, concern, prudence, and proper training of personnel involved in the filling, operation, transport, maintenance, and storage of this equipment. It is the responsibility of the owner or operator to read this manual and to train all operators before they start working with the equipment. Follow all safety instructions as laid out in this manual.

Keep this manual handy for easy reference and to pass on to new operators or owners. Call your Meridian Manufacturing Inc. dealer if you need assistance, information, or additional copies of the manuals.

The information, specifications, and illustrations in this manual are those in effect at the time of printing. We reserve the right to change specifications or design at any time without notice.

1.4 DISPOSAL OF EQUIPMENT AT END OF USEFUL LIFE

The Fuel Trailer has been designed for the specific purpose of transporting diesel fuel and diesel exhaust fluid (DEF) to your machinery using country roads, local highways, and on agricultural farm land. When this unit is no longer capable of performing its designed purpose, it should be dismantled and scrapped. Do not use any materials or components from this unit for any other purpose.

1.5 CONTINUOUS IMPROVEMENT PROCESS

Meridian's desire is to manufacture, for our customers, the best equipment possible. Because of our continuous improvement process, some images may be different than the actual product.

1.6 BEFORE STARTING GAS ENGINE

Before starting the gasoline engine for the first time, check the engine oil level. Add oil as necessary. Operating the engine without oil will damage the engine and void the warranty.

NOTICE

Check the engine oil level and add as needed.

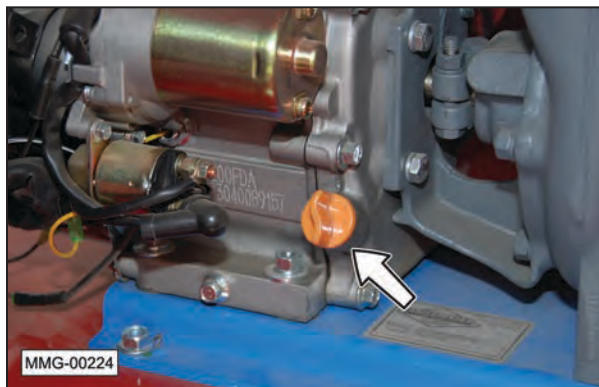

2. SAFETY

SAFETY ALERT SYMBOL

This Safety Alert symbol means
ATTENTION! BECOME ALERT!
YOUR SAFETY IS INVOLVED!



The Safety Alert symbol identifies important safety messages on the Meridian Fuel Trailer Models and in the manual. When you see this symbol, be alert to the possibility of personal injury or death. Follow the instructions in the safety message.

WHY IS SAFETY IMPORTANT TO YOU?

3 Big Reasons

- Accidents Disable and Kill •
- Accidents Cost •
- Accidents Can Be Avoided •

SIGNAL WORDS:

Note the use of the signal words **DANGER**, **WARNING**, and **CAUTION** with the safety messages. The appropriate signal word for each message has been selected using the following guidelines:



CAUTION - Indicates a potentially hazardous situation that, if not avoided, may result in minor or moderate injury. It may also be used to alert against unsafe practices.



WARNING - Indicates a potentially hazardous situation that, if not avoided, could result in death or serious injury, and includes hazards that are exposed when guards are removed. It may also be used to alert against unsafe practices.



DANGER - Indicates an imminently hazardous situation that, if not avoided, will result in death or serious injury. This signal word is to be limited to the most extreme situations typically for equipment components which, for functional purposes, cannot be guarded.

If you have any questions not answered in this manual, require additional copies of the manual, or the manual is damaged, please contact your dealer or Meridian Manufacturing Group, 2902 Expansion Blvd., Storm Lake, Iowa, 50588, toll free 1-800-437-2334, phone (712) 732-1780, or fax (712) 732-1028.

2.1 ADDITIONAL SAFETY WORDS

NOTICE

Indicates that equipment or property damage can result if instructions are not followed.

SAFETY INSTRUCTIONS

Safety instructions (or equivalent) signs indicate specific safety-related instructions or procedures.

Note: Contains additional information important to a procedure.

2.2 SAFETY TRAINING

1. Safety is a primary concern in the design and manufacture of our products. Unfortunately, our efforts to provide safe equipment can be wiped out by a single careless act of an operator or bystander.
2. Know your controls and how to immediately stop the equipment in an emergency. Read this manual and the one provided with all auxiliary equipment.

YOU are responsible for the **SAFE** operation and maintenance of your Meridian Manufacturing Inc. Fuel Trailer. **YOU** must ensure that you and anyone else who is going to operate, maintain, or work around the Fuel Trailer be familiar with the operating and maintenance procedures and related **SAFETY** information contained in this manual. This manual will take you step-by-step through your working day and alert you to all good safety practices that should be adhered to while operating the Fuel Trailer system.

Remember, **YOU** are the key to safety. Good safety practices not only protect you but also the people around you. Make these practices a working part of your safety program. Be certain that **EVERYONE** operating this equipment is familiar with the recommended operating and maintenance procedures and follow all the safety precautions. Most accidents can be prevented. Do not risk injury or death by ignoring good safety practices.

- Fuel Trailer owners must give operating instructions to operators or employees before allowing them to operate the equipment, and then annually thereafter per OSHA (Occupational Safety and Health Administration) regulation 1928.57.
- The most important safety feature on this equipment is a **SAFE** operator. It is the operator's responsibility to read and follow **ALL** Safety and Operating instructions in the manual. Most accidents can be avoided.
- A person who has not read and understood all operating and safety instructions is not qualified to operate the equipment. An untrained operator exposes himself and bystanders to possible serious injury or death. Always be and stay alert to any possible unsafe operating or maintenance procedures or conditions.
- Do not modify the equipment in any way. Unauthorized modification may impair the function and/or safety of the components and systems and could affect the life of the equipment, possibly invalidating the warranty coverage.
- Think SAFETY! Work SAFELY!

2.3 SAFETY ICON NOMENCLATURE

Pictorial icons signal a type of hazard and warn of personal protection issues, prohibited actions, and hazard avoidance.

2.3.1 Personal Protection/Important Information

-  Read the manual
-  Damaged safety signs
-  Eye protection
-  Fire extinguisher
-  First aid kit
-  Hand protection
-  Head protection
-  Hearing protection
-  Inspect equipment
-  OEM parts only
-  Protective shoes
-  Remove key
-  Set parking brake
-  Stop engine
-  Think safety
-  Transmission in park
-  Use proper support
-  Use proper tools
-  Visibility
-  Weight rating

2.3.2 Prohibited Actions

-  Do not alter or modify
-  Do not ride
-  Do not weld
-  No alcohol
-  No drugs
-  No young children

2.3.3 Hazard Avoidance

-  Crush hazard
-  Crush hazard (chock wheels)
-  Defective or broken part
-  Entanglement hazard
-  Explosive force hazard
-  Fall hazard
-  Safety alert symbol
-  Slipping hazard
-  Tire pressure (maintain)
-  Tripping injury









2.4 GENERAL SAFETY







Read and understand the Operator's Manual and all safety signs before operating, maintaining, adjusting, filling, or towing the Fuel Trailer.

This trailer was designed for a specific application; transporting diesel fuel and diesel exhaust fluid (DEF). DO NOT modify or use this trailer for any application other than which it was designed.

Trailers that are filled or operated improperly or by untrained personnel can be dangerous, exposing themselves and/or bystanders to possible serious injury or death.

-  Have a first aid kit available for use should the need arise and know how to use it.
-  Have a fire extinguisher available for use should the need arise and know how to use it.
-  Do not allow riders.
- When working around or operating this equipment, wear appropriate personal protective equipment. This list includes but is not limited to:

 - A hard hat.
 - Protective shoes with slip resistant soles.
 - Protective goggles, glasses, or face shield.
 - Heavy gloves and protective clothing.
 - Respirator, if necessary.
-  Do not allow long hair, loose fitting clothing, or jewelry around equipment with rotating parts.
-  Securely latch compartment doors before towing.
-  Stop engine, remove ignition key, and wait for all moving parts to stop before servicing, repairing, adjusting, filling, or towing.
-  Clear the area of people, especially small children, before refueling machinery.

-  Review safety related items annually with all personnel who will be operating, using, or maintaining the Fuel Trailer.
-  Provide the end user with the owner/operator literature. Fuel Trailer owners must provide operating instructions to anyone using the trailer.
-  Under no circumstances should young children be allowed to work with or around the Fuel Trailer.
-  Do not attempt to fill, tow, or operate this trailer under the influence of drugs or alcohol. Consult your doctor before using this trailer while taking prescription medications.

-  **Hearing Loss – Prolonged Exposure To Loud Noise May Cause Permanent Hearing Loss!**

Working environments with noise-producing equipment can cause partial to permanent hearing loss. We recommend using hearing protection any time noise levels exceed 80db. Noise levels over 85db, on a long-term basis, can cause severe hearing loss. Noise levels over 90db over a period of time can cause permanent and even total hearing loss.

Hearing loss from loud noise is cumulative over a lifetime without hope of natural recovery.

Note: In order to provide a better view, certain photographs or illustrations in this manual may show an assembly with a safety shield removed. However, equipment should never be operated in this condition. Keep all shields in place. If shield removal becomes necessary for repairs, replace the shield prior to use.

2.5 SAFETY SIGNS

Refer to the Safety Signs Locations section for safety information.

2.6 PREPARATION

Refer to the Pre-Operating Instructions section for safety information.

2.7 OPERATING SAFETY

Refer to the Operation section for safety information.

2.8 TRANSPORT SAFETY

Refer to the Towing section for safety information.

2.9 STORAGE SAFETY

Refer to the Storage section for safety information.

2.10 MAINTENANCE SAFETY

Refer to the Maintenance section for safety information.

2.11 DIESEL FUEL SAFETY

2.11.1 Inhalation Hazard

DANGER

 Always avoid breathing fuel vapors or mists which may cause dizziness, drowsiness, moderate eye irritation, and/or skin irritation (rash). Excessive exposure may cause irritations to the nose, throat, lungs, and respiratory tract. Central nervous system (brain) effects may include headache, dizziness, loss of balance and coordination, unconsciousness, coma, respiratory failure, and death.

In case of inhalation, remove person to fresh air. If person is not breathing, provide artificial respiration. If necessary, provide additional oxygen once breathing is restored if trained to do so. Seek medical attention immediately.

2.11.2 Fire and Explosion Hazards

WARNING

 Diesel fuel presents a moderate fire hazard. Vapors may be ignited rapidly when exposed to heat, spark, open flame, or other source of ignition. When mixed with air and exposed to an ignition source, flammable vapors can burn in the open or explode in confined spaces. Being heavier than air, vapors may travel long distances to an ignition source and flash back. Runoff to sewer may cause fire or explosion hazard.

2.11.3 Ingestion

WARNING

 The major health threat of ingestion occurs from the danger of aspiration (breathing) of liquid drops into the lungs, particularly from vomiting. Aspiration may result in chemical pneumonia (fluid in the lungs), severe lung damage, respiratory failure, and even death. Ingestion will cause gastrointestinal disturbances, including irritation, nausea, vomiting and diarrhea, and central nervous system (brain) effects similar to alcohol intoxication. In severe cases, tremors, convulsions, loss of consciousness, coma, respiratory arrest, and death may occur.

In case of ingestion **DO NOT INDUCE VOMITING**. Do not give liquids. Obtain immediate medical attention. If spontaneous vomiting occurs, lean victim forward to reduce the risk of aspiration. Monitor for breathing difficulties.

Small amounts of material which enter the mouth should be rinsed out until the taste is dissipated.

2.11.4 Eye Protection

WARNING

 Safety glasses or goggles are recommended where there is a possibility of splashing or spraying. Contact with liquid or vapor may cause mild irritation.

In case of contact with eyes, immediately flush with clean, low-pressure water for at least 15 minutes. Hold eyelids open to ensure adequate flushing. Seek medical attention.

2.11.5 Skin Protection

CAUTION



Contact with diesel fuel may cause skin irritation with prolonged or repeated contact. Wearing gloves constructed of nitrile, neoprene, or PVC are recommended when in close contact with diesel fuel. Chemical protective clothing should also be worn. Long-term, repeated exposure to diesel fuel may cause skin cancer.

In case of contact with skin, remove contaminated clothing. Wash contaminated areas thoroughly with soap and water or waterless hand cleanser. Obtain medical attention if irritation or redness develops.

2.11.6 Storage Precautions

CAUTION



Keep away from flame, sparks, excessive temperatures, and open flame. Keep trailer fill port closed because an empty tank may contain explosive vapors. Do not pressurize, cut, heat, weld, or expose tanks to sources of ignition.



Store the trailer in a well-ventilated area. Avoid storage near incompatible materials.

2.11.7 U.S. Federal, State, and Local Regulatory Information

SAFETY INSTRUCTIONS



Diesel fuel is on the EPA TSCA Inventory. Any spill or uncontrolled release of this product, including any substantial threat of release, may be subject to federal, state and/or local reporting requirements. This product may also be subject to other regulations at the state and/or local level. Always consult the regulations applicable to your area prior to operation.

2.12 BATTERY SAFETY

2.12.1 General Hazards

SAFETY INSTRUCTIONS

Wear protective eye wear and gloves.

DO NOT attempt to recharge a frozen battery. Remove the battery from the vehicle/equipment, bring it into a warm room, and let it thaw before charging or testing.

Inspect the battery cables to make sure they are free of rust and corrosion and have no exposed wires. Never use electrical tape to cover exposed wires.

Automotive lead-acid batteries contain sulfuric acid in the electrolyte. The acid inside the battery is highly corrosive and can burn your skin if it leaks out of the battery and gets on your skin. Acid may leak out of the battery if the case is cracked or damaged.

Maintenance-free batteries should always remain in an upright position (do not turn it sideways or upside down).

On equipment with a battery designed into the fuel trailer, it is usually a good idea to disconnect the battery before doing electrical repairs. Disconnect the negative battery cable from the battery to prevent accidental damage to onboard electronics or wiring to prevent a short circuit.

2.12.2 Ventilation Hazard

SAFETY INSTRUCTIONS

Whenever servicing a battery, work in a well ventilated area to prevent gas buildup.

2.12.3 Shock Hazards

**SAFETY
INSTRUCTIONS**

Batteries only produce 12 Volts so there is NO danger of being shocked. However, 12 Volt batteries can generate several hundred amps of current, which is roughly the amount of current used by a welding arc. Do not short the battery by touching the positive or negative terminals with a metal tool. This current is capable of damaging tools, equipment, and causing personal injury. It can also cause the battery to explode.

Before working around a battery, remove all jewelry, particularly rings and necklaces. The electrical charge from a battery can be transmitted through a metal tool and into a metal ring or watch.

NEVER disconnect a battery when the ignition is ON in the tow vehicle, or while the engine is idling or running, as this can damage electrical and/or electronic components in the tow vehicle.

2.12.4 Explosion Hazards

**SAFETY
INSTRUCTIONS**

Always remove the battery's ground cable (black) before removing the positive (red). If the negative cable is removed first, it will not be possible to inadvertently complete a circuit, thus causing electrical shock.

A short circuit can occur if the positive terminal is connected to the battery and the person working with the battery comes into contact with a grounded object. Always remove the ground cable first.

Do not smoke around a battery, or use anything that produces an open flame or spark.

Batteries can explode. Batteries give off hydrogen gas, which is flammable and can explode if a spark occurs near the battery (as when connecting a jumper cable).

3. SAFETY SIGN LOCATIONS

3.1 GENERAL INFORMATION

The types of safety signs and locations on the equipment are shown in the following pages. Good SAFETY AWARENESS requires that you familiarize yourself with the various safety signs, the type of warning and the area, or a particular function related to that area.

- 
 If safety signs have been damaged, removed, become illegible, or parts replaced without signs, new signs must be applied.
- Replacement parts that displayed a safety sign should also display the current sign.
- Replacement safety signs (labels) are available from your authorized Dealer Parts Department or the factory at no cost.

3.2 HOW TO INSTALL SAFETY SIGNS

- Be sure that the installation area is clean and dry.
- Be sure the temperature is above 50°F (10°C).
- Determine the exact position before you remove the backing paper.
- Remove the smallest portion of the split backing paper.
- Align the sign over the specified area and carefully press the small portion with the exposed sticky backing in place.
- Slowly peel back the remaining paper and carefully smooth the remaining portion of the sign in place.
- Small air pockets can be pierced with a pin and smoothed out using a piece of sign backing paper.

3.3 DECAL LOCATIONS





1. Product Serial Number Decal (#19984)





2. WARNING — Read and Understand (#17731) (located inside driver's side compartment door)

⚠ WARNING
<p>To prevent serious injury or death:</p> <ul style="list-style-type: none"> • Read and understand Operator's Manual before using. Review safety instructions annually. • Do not use fuel trailer for any purpose other than its intended use; transporting diesel fuel and DEF solution. • Keep working area clean and free of spills and debris to prevent slipping or tripping. • Do not allow riders on trailer or fuel tank when transporting. • Do not place hands, arms, or body between stationary and moving objects. • Do not stand on any part of trailer. Do not use fuel tank as a work platform. • Do not allow compartment doors to swing open freely. • Do not smoke when refuelling gasoline engine, filling trailer's diesel fuel tank, or refuelling machinery. • Stop and turn off machinery before refuelling. • Do not weld on any part of fuel trailer. Welding sparks can cause an explosion. • Make sure fuel tank and DEF tank shutoff valves are in closed position when not in use or before towing. • Do not tow fuel trailer with gasoline engine running. • Follow all State/Federal health and safety laws and/or local regulations when filling machinery or transporting diesel fuel. • Before towing, securely attach hitch to tow vehicle, install hitch retainer clip, connect safety chains, attach breakaway brake cable, connect wiring harness, and make sure taillights are functioning.

⚠ WARNING
<p>To prevent serious injury or death:</p> <ul style="list-style-type: none"> • Stop gasoline engine, remove start key, and wait for all moving parts to stop before servicing, repairing, adjusting, or towing trailer or refueling gasoline engine. • Obey all local regulations for the use and disposal of diesel fuel and/or DEF solution. • Flammable fluid (gasoline, diesel fuel, or engine oil) leaked or spilled onto hot surfaces can cause a fire. Clean up all leaked or spilled fluid immediately. Sparks or open flames can cause flammable fluid to ignite. DO NOT smoke while working on or near any flammable fluid. • Do not store flammable or caustic substances inside engine compartment. • Keep sparks, lighted matches, and/or open flames away from top of battery, because battery gas can explode. Always follow safety recommendations when working near battery. • Automotive batteries contain sulfuric acid and can produce explosive gases. To prevent ignition of these gases, keep sparks, open flames, lighted tobacco, or any other ignition sources away from battery at all times. DO NOT allow jumper cables to contact each other or any metal surface. Battery fumes can ignite resulting in an explosion and personal injury or death. • Engine does not recharge battery. Manually recharge battery periodically. • Inspect hoses and pipes for leaks prior to each use. If found, immediately discontinue use of trailer until leak is repaired.

⚠ WARNING
<p>EXHAUST FUMES HAZARD</p>   <p>Engine exhaust contains products of combustion which are harmful to your health and can cause death. Always start and operate engine in a well ventilated area. Do not operate engine inside of an enclosed area or building.</p>

⚠ WARNING
<p>COMBUSTIBLE FUMES HAZARD</p>   <p>Take precautions to avoid sparks from battery coming into contact with fuel or fumes from gasoline engine's fuel tank or the trailer's fuel tank. Sparks will cause an explosion of combustible fuel/fumes, resulting in serious injury or death.</p>

17731

WARNING

To prevent serious injury or death:

- Read and understand Operator's Manual before using. Review safety instructions annually.
- Do not use fuel trailer for any purpose other than its intended use; transporting diesel fuel and DEF solution.
- Keep working area clean and free of spills and debris to prevent slipping or tripping.
- Do not allow riders on trailer or fuel tank when transporting.
- Do not place hands, arms, or body between stationary and moving objects.
- Do not stand on any part of trailer. Do not use fuel tank as a work platform.
- Do not allow compartment doors to swing open freely.
- Do not smoke when refuelling gasoline engine, filling trailer's diesel fuel tank, or refueling machinery.
- Stop and turn off machinery before refueling.
- Do not weld on any part of fuel trailer. Welding sparks can cause an explosion.
- Make sure fuel tank and DEF tank shutoff valves are in closed position when not in use or before towing.
- Do not tow fuel trailer with gasoline engine running.
- Follow all State/Federal health and safety laws and/or local regulations when filling machinery or transporting diesel fuel.
- Before towing, securely attach hitch to tow vehicle, install hitch retainer clip, connect safety chains, attach breakaway brake cable, connect wiring harness, and make sure taillights are functioning.

WARNING

To prevent serious injury or death:

- Stop gasoline engine, remove start key, and wait for all moving parts to stop before servicing, repairing, adjusting, or towing trailer or refueling gasoline engine.
- Obey all local regulations for the use and disposal of diesel fuel and/or DEF solution.
- Flammable fluid (gasoline, diesel fuel, or engine oil) leaked or spilled onto hot surfaces can cause a fire. Clean up all leaked or spilled fluid immediately. Sparks or open flames can cause flammable fluid to ignite. **DO NOT** smoke while working on or near any flammable fluid.
- Do not store flammable or caustic substances inside engine compartment.
- Keep sparks, lighted matches, and/or open flames away from top of battery, because battery gas can explode. Always follow safety recommendations when working near battery.
- Automotive batteries contain sulfuric acid and can produce explosive gases. To prevent ignition of these gases, keep sparks, open flames, lighted tobacco, or any other ignition sources away from battery at all times. **DO NOT** allow jumper cables to contact each other or any metal surface. Battery fumes can ignite resulting in an explosion and personal injury or death.
- Engine does not recharge battery. Manually recharge battery periodically.
- Inspect hoses and pipes for leaks prior to each use. If found, immediately discontinue use of trailer until leak is repaired.

WARNING

EXHAUST FUMES HAZARD



Engine exhaust contains products of combustion which are harmful to your health and can cause death. Always start and operate engine in a well ventilated area. Do not operate engine inside of an enclosed area or building.

WARNING

COMBUSTIBLE FUMES HAZARD



Take precautions to avoid sparks from battery sparks coming into contact with fuel or fumes from gasoline engine's fuel tank or the trailer's fuel tank. Sparks will cause an explosion of combustible fuel/fumes, resulting in serious injury or death.

3.4 INSTALLING 1993 DIESEL FUEL PLACARDS



SAFETY INSTRUCTIONS



Before transporting fuel, make sure the diesel fuel placards are displayed on all four sides of the trailer. It is the responsibility of the owner to properly install and display these placards.

Fuel trailers are shipped with four diesel fuel placards that are not installed. Federal regulations require that the placards be installed before filling the tank with diesel fuel.

Install one placard on each of the four sides.

Note: Install the placards prior to filling the fuel tank with diesel fuel. Trailers that have never been filled with fuel do not require the placards in order to be towed.

4. SPECIFICATIONS

4.1 OVERALL DIMENSIONS

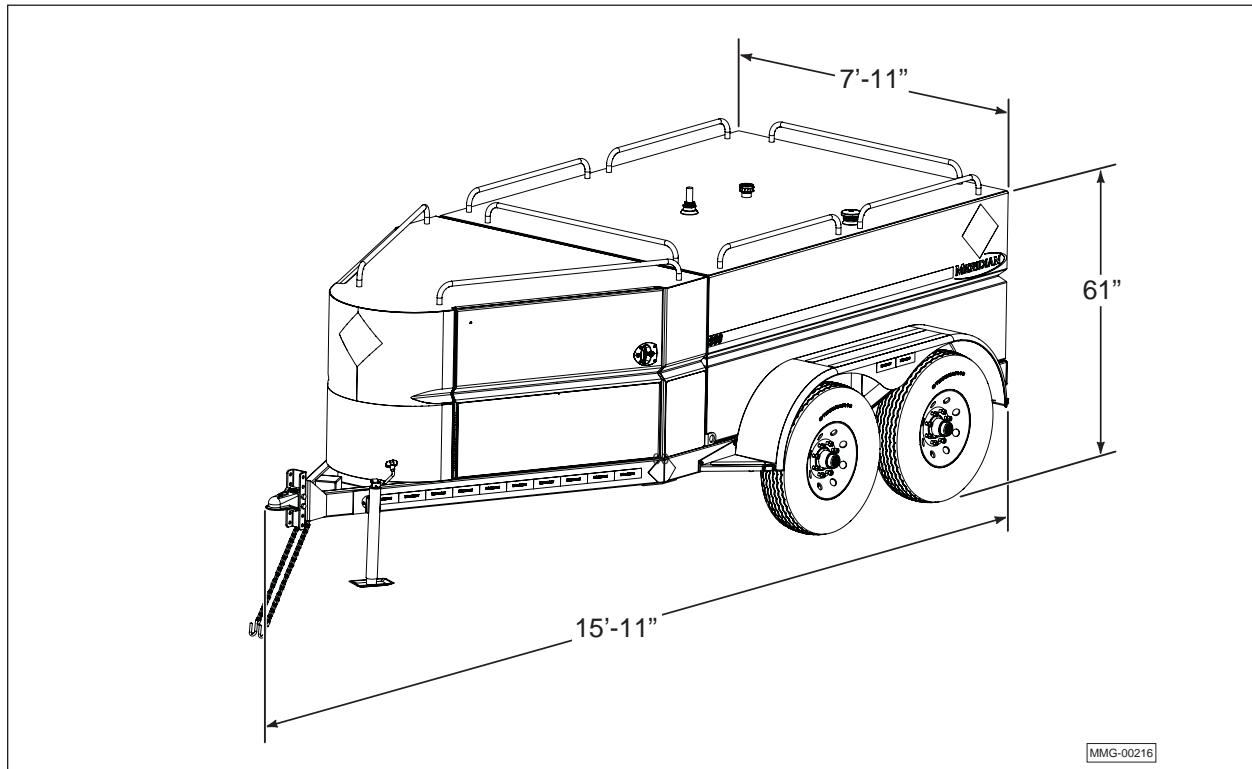

4.2 SPECIFICATIONS

Description	Specification
Gasoline Engine Option	Size 6.5 horsepower Electric start Low-oil sensor One-year manufacturers warranty from OEM
Diesel Fuel Pump	Rated for diesel fuel only Flow — 25 gpm standard Flow — 40 gpm optional
Diesel Fuel Hose Length	35' long hose on retracting reel
Filter (diesel fuel)	10 Micron
Diesel Fuel Tank Capacity	990 gallons
Shut-off Valve	2" ball type (located under tank)
Fill Opening	2" with vented and lockable fill cap
Electric (12 Volt) Pump Option	Power — DC 12 Volt Size — 1/2 horsepower Duty cycle — 30 minutes Thermal protection switch Circuit protection fuse Flow — 25 gpm

Description	Specification
DEF Solution Pump	Power — 12 Volt Flow — 12 gpm
DEF Hose Length	25' long hose on retracting reel
DEF Heater (optional)	110 Volt
DEF Solution Tank Capacity	55 or 110 gallons
Electrical System	Battery (12 Volt) for engine's electric start and DEF pump
Breakaway Brake System	Standard
Wiring Harness	Standard 7-pin automotive connector
Axles and Tires	7000 pound axle with electric drum brakes (each axle) 16" x 10-ply tires



4.2 BOLT SPECIFICATIONS

WARNING

EQUIPMENT FAILURE

The torque value for bolts and capscrews are identified by their head markings. Replacing higher "Grade" bolts (Grade 8) with lower Grade bolts (Grade 5) will lead to equipment failure and can result in injury or death. Always use replacement bolts with the same Grade markings as the removed bolt.

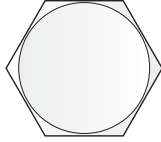
4.2.2 Grade Markings Chart

 No Marking	Grade 2 Low or Medium Carbon Steel
 3 Radial Lines	Grade 5 Medium Carbon Steel Quenched and Tempered
 6 Radial Lines	Grade 8 Medium Carbon Alloy Steel, Quenched and Tempered

4.2.1 Bolt Torque Values

Torque figures indicated above are valid for non-greased or non-oiled threads and heads unless otherwise specified. Therefore, do not grease or oil bolts or capscrews unless otherwise instructed in this manual. When using locking elements, increase torque values by 5%.

Bolt Diameter "A"	SAE Grade 2		SAE Grade 5		SAE Grade 8	
	N·m	(ft-lbs)	N·m	(ft-lbs)	N·m	(ft-lbs)
1/4"	8	(6)	12	(9)	17	(12)
5/16"	13	(10)	25	(19)	36	(27)
3/8"	27	(20)	45	(33)	63	(45)
7/16"	41	(30)	72	(53)	100	(75)
1/2"	61	(45)	110	(80)	155	(115)
9/16"	95	(70)	155	(115)	220	(165)
5/8"	128	(95)	215	(160)	305	(220)
3/4"	225	(165)	390	(290)	540	(400)
7/8"	230	(170)	570	(420)	880	(650)
1"	345	(225)	850	(630)	1320	(970)

5. EQUIPMENT COMPONENTS AND CONTROLS

5.1 COMPONENT NOMENCLATURE AND LOCATION

The Fuel Trailer is designed to transport diesel fuel and diesel exhaust fluid (DEF) to your machinery.

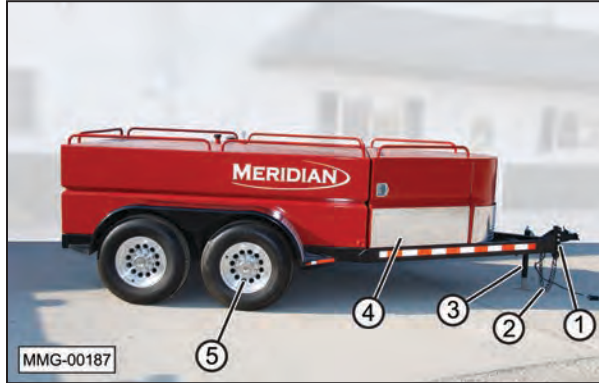

(1) Adjustable height hitch for 2-5/16" ball. (2) Safety towing chains. (3) Jack. (4) Gasoline or electric diesel fuel pump and DEF solution pump. (5) 7000 lb axles with standard or aluminium wheels.

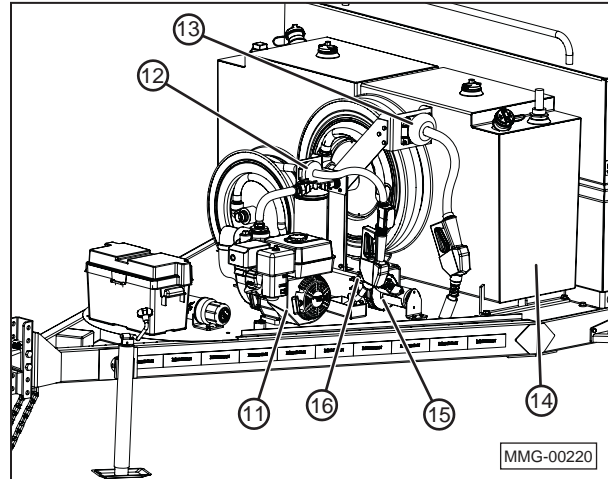

(11) Optional gasoline engine and diesel fuel pump shown. (12) 12 Volt electric pump is standard. (12) DEF solution hose and retractable reel with auto shut-off nozzle. (13) Diesel fuel hose and retractable reel with auto shut-off nozzle. (14) DEF solution tank (55 or 110 gallons). (15) DEF solution pump. (16) DEF tank shut-off valve.



(6) Fuel tank fill opening with vented and lockable cap. (7) Fill level indicator. (8) Tank vent.



(17) Breakaway Brake System.



(9) DOT compatible taillights and turn signals. (10) License plate holder and light.

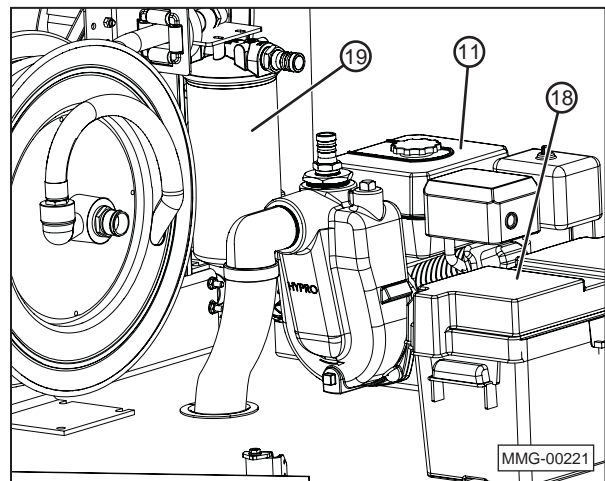

(11) Gasoline engine and diesel fuel pump. (18) 12 Volt battery and battery box. (19) Diesel fuel filter.

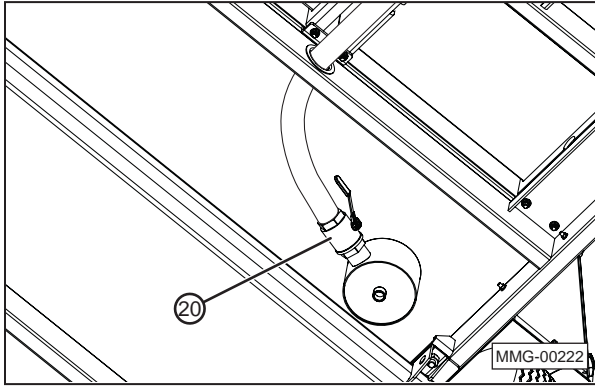

(20) Fuel tank shut-off valve.

5.2 ELECTRIC PUMP (12 VOLT)

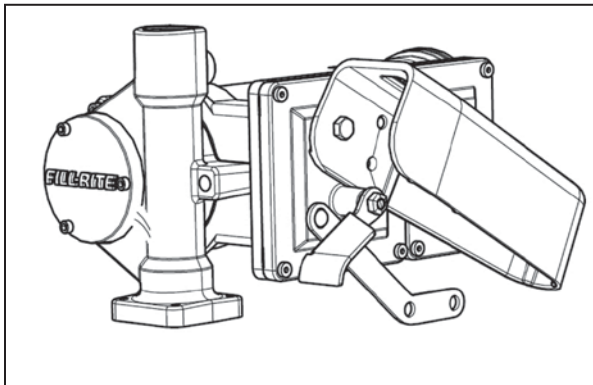

The standard fuel trailer is equipped with a 12 Volt electric fuel pump. The fuel pump is powered by a 12 Volt battery located in the front compartment of the fuel trailer.

5.3 GASOLINE ENGINE AND CONTROLS

An optional gasoline engine may be used with this unit. Always read the OEM engine Operator's Manual supplied with the fuel trailer for the detailed engine operating procedures.

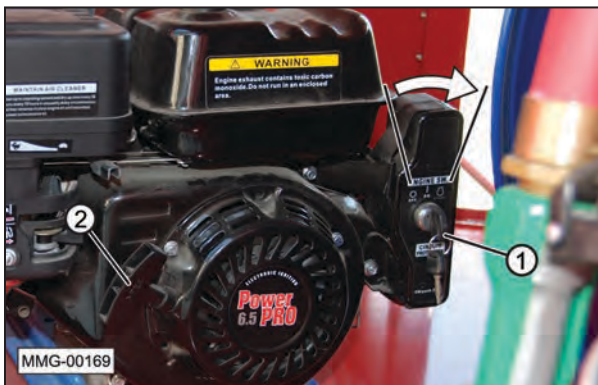

1. Engine Key Switch

Turn the key switch to the START position to start the engine. When the engine starts, then release the key and allow it to return to the ON position.

2. Starting Rope

This retracting rope and T-bar is an optional method used to start the engine. Grasp the T-bar firmly and pull the rope sharply to start the engine. The key on the master control must be ON for the engine to start.

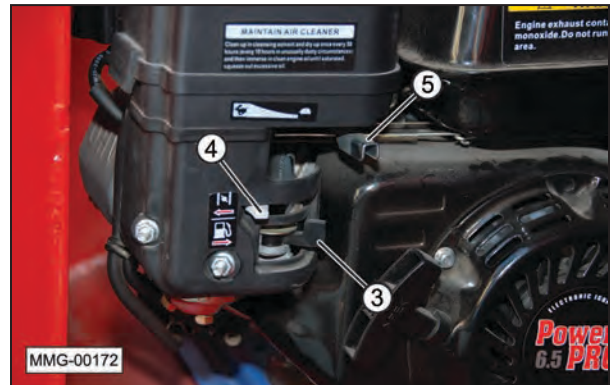

3. Fuel Shut-Off Lever

Each engine is equipped with a fuel valve between the fuel tank and the carburetor. The fuel valve lever must be in the ON position (to the right) for the engine to run. Slide the fuel valve toward the engine to turn ON and away for OFF (to the left).

Before transporting or when the engine is not in use, move the fuel valve lever to the OFF position to prevent carburetor flooding and to reduce the possibility of fuel leakage.

4. Choke Lever

The choke lever controls the fuel/air mixture to the engine. Close the choke when starting if the engine is cold. Open the choke as the engine warms. Always open the choke fully during operation.

5. Throttle Lever

This lever controls the engine RPM. Move the lever to increase or decrease the RPM. Always run at maximum throttle while operating the auger.



6. Engine Circuit Protection

The circuit protector protects the battery charging circuit. A short circuit, or a battery connected with reverse polarity, will trip the circuit breaker. The green indicator inside the circuit protector will pop out to show that the circuit protector has switched off.

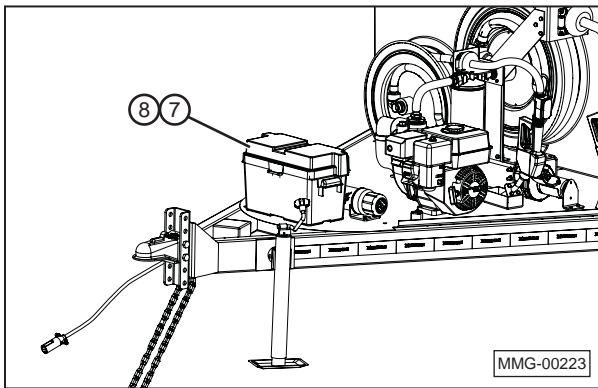

7. Battery (12 Volt)

A 12 Volt battery supplies the power to start the gasoline engine or operate the 12 Volt electric diesel pump. If the tow vehicle is properly wired, the battery receives a trickle charge during whenever the vehicle is running. Depending on the amount of use, the battery may still need to be periodically recharged from an external source to keep it fully charged.

8. Fuse

A 7.5 amp fuse protects the electrical system of the trailer.

5.4 GASOLINE ENGINE SAFETY SIGNS

1. Maintain Air Cleaner — (contact OEM manufacturer for replacement of this decal)

MAINTAIN AIR CLEANER

Clean up in cleansing solvent and dry up once every 50 hours (every 10 hours in unusually dusty circumstances) and then immerse in clean engine oil until saturated, squeeze out excessive oil.

2. CAUTION — Fill With Oil Before Operating (contact OEM manufacturer for replacement of this decal)



3. WARNING — Carbon Monoxide Hazard (contact OEM manufacturer for replacement of this decal)

! WARNING

Engine exhaust contains toxic carbon monoxide. Do not run in an enclosed area.

4. Read Operating Manual Before Using Engine (contact OEM manufacturer for replacement of this decal)

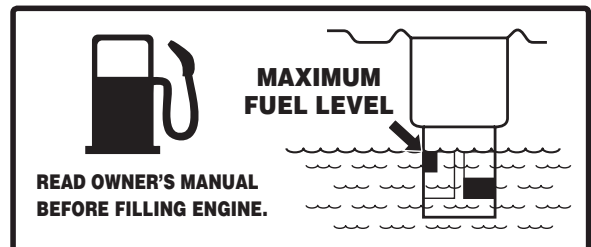

6. PRE-OPERATING INSTRUCTIONS

6.1 EQUIPMENT BREAK-IN PERIOD

A special break-in procedure has been developed to ensure the integrity of the fuel trailer when first put into service. Follow the instructions and then follow the Inspections for 1/2, 5, and 10 hour instructions at the appropriate interval.

After completing these instructions, follow the normal service schedule in the Maintenance and Service sections and engine manual.

1. Read and follow the instructions in the OEM engine, DEF pump, and the Meridian Operator's Manuals.
2. Before starting the gasoline engine for the first time, check the engine oil level. Add oil as necessary. Operating the engine without oil will damage the engine and void the warranty.

NOTICE

Check the engine oil level and add as needed.

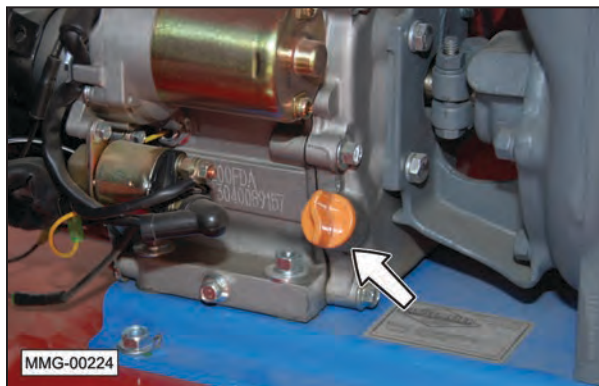

3. Make sure the fuel pump is primed.
4. Start the engine and check the controls. Be sure that they function properly.
5. Review and follow the Daily Pre-operation Checklist before starting the equipment.

6. Initially check the wheel bolt torque and then again at 10, 25, and 50 miles. Refer to the Wheel Bolt Torque Requirements section in this manual for tightening instructions.



6.1.2 Inspections for 1/2, 5, and 10 Hours

1. On gasoline engine/pump combinations, recheck the engine to pump shaft connection after 1/2 hour and again after 4 hours.



2. Recheck all hardware and fasteners after 4 hours of operation. Tighten to specified torque.
3. At 10 hours, change the engine oil with the specified oil. Remove plug (2) to drain the oil and check the level with fill cap/gauge (1).

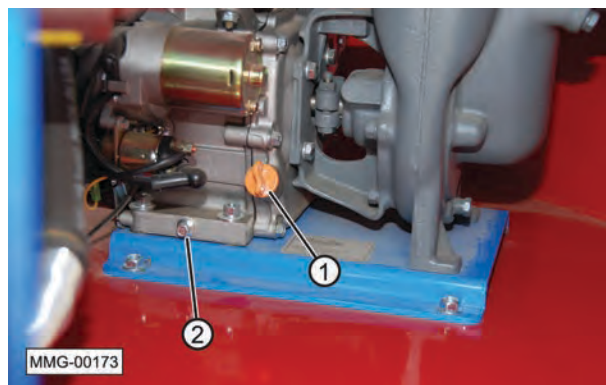

6.2 DAILY PRE-OPERATION CHECKLIST

Efficient and safe operation of the Fuel Trailer requires that each operator reads and follows the operating procedures and all related safety precautions outlined in this section.

A pre-operational checklist is provided for the operator. It is important for both personal safety and maintaining the efficient operation of the delivery system that this checklist be followed.

Before operating and each time thereafter, the following areas should be checked:

1. Use only a truck or tractor of adequate power and weight to pull the trailer.
2. Make sure the trailer is positively hitched to the tow vehicle.
3. Attach safety chains from the trailer to the tow vehicle. Crisscross chains under the hitch to support it should an unplanned separation occur.
4. Inspect wiring harness and plug for damage. Do not use trailer if damage is found.
5. Check the engine oil and fuel levels. Add, as required.

IMPORTANT

The engine warranty is void if the engine is run without oil.

6. Make sure the fuel level in the tank is sufficient enough to prime the fuel pump and provide a steady flow of fuel. Do not run the pump dry.
7. Visually check all hardware and fasteners for missing parts and make sure the fasteners are properly tightened.
8. Make sure the wheel bolt lug nuts are properly tightened.
9. Check the tires and ensure they are inflated to their specified pressure. Correct under-inflation or over-inflation pressures. The specified inflation pressure is on the tires.
10. Remove any entangled crop material from under the trailer.

11. Test the breakaway brake unit and the trailer brakes.
 - a. Make sure the trailer brakes are operating properly.
 - b. Make sure the trip wire to the breakaway switch is connected to the tow vehicle.
 - c. Make sure the key is correctly installed in the breakaway switch.
 - d. Press the Test button. The indicator should illuminate green. If the red light illuminates, the battery charge is low. Refer to the Trailer Breakaway System in the Maintenance section for instructions on charging the battery.

Note: The breakaway brake system is standard equipment. This system applies the brakes automatically and immediately whenever the breakaway cable is properly connected and the trailer separates from the tow vehicle.

12. Make sure lights, reflectors, Diesel Fuel Placards, and SMV/SIS emblem required by local highway authorities are installed.
13. Clean and make sure taillights, signal lights, and side running lights are working properly.

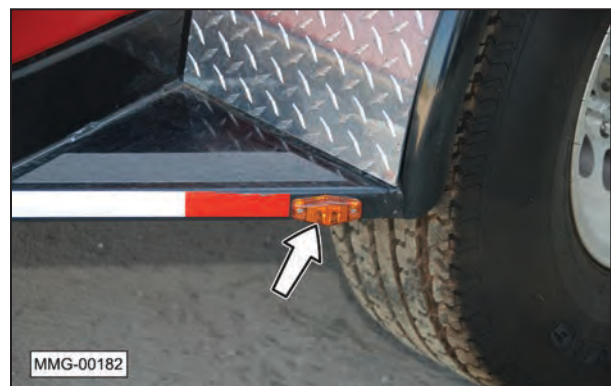





















7. TOWING

7.1 TRANSPORT SAFETY

SAFETY INSTRUCTIONS



The following safety instructions are provided to help prevent injury or limit equipment damage.

-  Comply with local, state, and federal laws governing safety and conveyance of farm related equipment on public roads.
-  Always refer to the tow vehicle owner's manual Trailer Towing section to determine the vehicle's towing capacity and to ensure compatibility and maximum safety.
-  Before attaching the trailer to the tow vehicle, be familiar with its controls and how to stop it quickly in the event of an emergency. Read and understand this manual and the one provided with your tow vehicle before towing the trailer.
- Ensure that the trailer is equipped with brakes that are in good working order. Be familiar with their operation.
-  Make sure the diesel fuel tank is securely fastened to the trailer before transporting.
- Be sure the trailer is securely hitched to the tow vehicle and a retainer clip is inserted through the hitch. Always attach safety chains between the hitch and the tow vehicle.
-  Stay away from electrical power sources. Electrocutation can occur without direct contact.
- Plan your route to avoid heavy traffic.
-  Do not drink and drive.
- Be a safe and courteous driver. Yield to oncoming traffic in all situations, including narrow bridges, intersections, etc. Watch for traffic when operating near or crossing roadways.
-   Never allow riders on the fuel trailer.
-   Under no circumstances should young children be allowed to work with or around the Fuel Trailer. When moving the trailer, make sure all bystanders, especially small children, stay clear of the working area.
-  Do not exceed a maximum safe travel speed, which may be lower than the recommended or posted speed. Slow down for corners and rough terrain.
-  Shift towing vehicle to a lower gear before going down steep downgrades to use engine as a retarding force. Keep towing vehicle in gear at all times.
-   If equipped, clean reflectors, SMV or SIS sign, and lights before towing. Make sure all the lights and reflectors required by highway and transport authorities are in place and can be seen clearly by all overtaking and oncoming traffic.
-  Make sure all local, state, and federal regulations, regarding the transport of equipment on public roads and highways, are met. Check with the local authorities regarding trailer transport on public roads. Obey all applicable laws and regulations.
-  Make sure the hitch and hitch ball on the towing vehicle are rated greater than the trailer's "gross vehicle weight rating" (GVWR).
-  Inspect the hitch and hitch ball for wear or damage. Make sure the hitch and coupling are compatible. **DO NOT** tow the trailer using a defective hitch or coupling.
-  Connect and crisscross the chains under the hitch to support the hitch should an unplanned separation occur.
-  If equipped, attach the breakaway cable to the rear of the towing vehicle. Do not attach the cable to the trailer hitch.
-  Check the tires for high/low pressure, cuts, bubbles, damaged rims, or missing lug nuts. Do not use the trailer if any damage is found.

7.1 TRANSPORT SAFETY (CONTINUED)

SAFETY INSTRUCTIONS

The following safety instructions are provided to help prevent injury or limit equipment damage.

22.  Make sure the directional and brake lights on the trailer are connected and working properly.
23. Department of Transportation (DOT) requires that all highway safety devices, such as fenders, mud flaps, and lighting, are properly installed and in working condition before using the trailer.
24.  A 3/4 ton or larger capacity truck should be used for towing.

7.2 CONNECTING THE TRAILER

WARNING



Ensure that all bystanders, especially small children, are clear of the working area. Ensure there is enough room and clearance to safely back up to the trailer.

1. On a flat surface, use the trailer jack to level the trailer.

WARNING



Towing the fuel trailer with diesel fuel, when it is not in a level position, could cause an upward force on the tongue, separating the trailer from the tow vehicle. Make sure the trailer is set up with downward pressure on the tongue assembly.

2. Adjust the height of the receiver to align with the tow ball or be lower than the tow ball. Once aligned, tighten both bolts to 70 ft-lb (95 N·m).

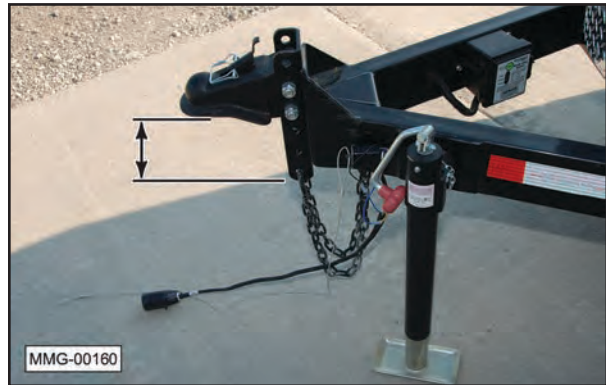

WARNING



The receiver must be bolted to the frame with two bolts. The use of only one bolt could cause the receiver assembly to separate from the trailer, resulting in injury or death to bystanders. Do not use the trailer if only one bolt is installed.

3. Remove retainer clip (1). Release or open the receiver by lifting locking lever (2) into the open position.

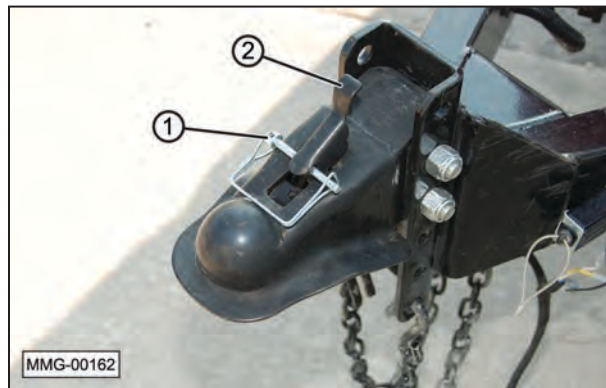

4. Using the jack, raise the hitch above the ball on the tow vehicle.
5. Slowly back the tow vehicle until the hitch and ball are aligned.

6. Lower the hitch onto the ball.
7. Raise the jack and place it in its stowed position.

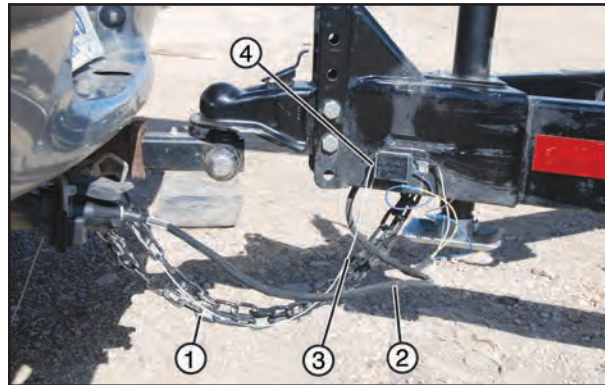

(The photo reflects a different trailer model; however, the hookup method is the same).

8. Close the receiver lock lever and install the retainer clip to prevent unwanted opening of the receiver.

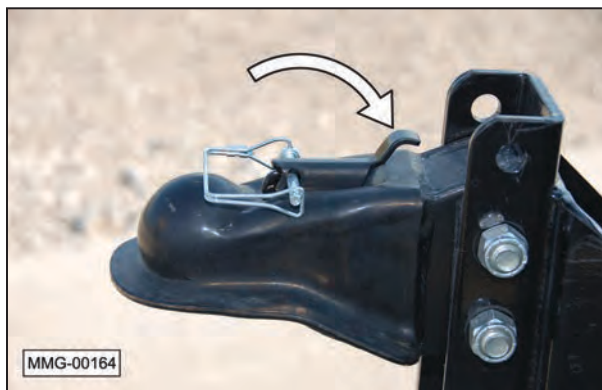

(The key must be completely plugged into the socket for the system to operate properly).

12. Route the wiring harness and breakaway brake cable in a manner that will prevent them from dragging. Be sure to provide enough slack for turning.

⚠ WARNING

⚠ If the safety chains are damaged in any way, do not use the trailer until proper chains are installed. Substandard or damaged safety chains could allow the trailer to separate from the tow vehicle, resulting in equipment damage, personal injury, or death.

9. Attach safety chains (1) securely to the tow vehicle to prevent unexpected separation. Cross the chains when attaching.
10. Connect wiring harness (2) with the seven-pin connector for the lights and brakes.
11. Connect breakaway system cable (3) to the tow vehicle. Make sure key (4) on the end of the cable is properly plugged into the receiving unit.

SAFETY INSTRUCTIONS

Before towing the trailer, make sure:

1. The trailer lights and brakes are working properly. If the trailer's electrical equipment is not functioning properly, it may be due to incompatible or crossed wiring from the tow vehicle to the trailer.
2. The trailer brakes apply when the brake pedal is depressed.
3. The breakaway brake system activates and applies the brakes when the cable key is pulled from its socket.
4. Make sure the diesel tank shutoff and DEF tank shutoff valves are in the closed position before towing.

8. OPERATION

8.1 OPERATING SAFETY

DANGER



Explosion/Fire Hazard

The Fuel Trailer is only intended for use with diesel fuel or non-hazardous liquids such as diesel exhaust fluid (DEF). DO NOT use this trailer with any flammable liquid, such as gasoline or kerosene. Transporting any other flammable or combustible liquid could result in a fire and explosion causing serious injury or death.

WARNING























Read And Understand Manual







To prevent personal injury or even death, be sure you read and understand all of the instructions in this manual and other related OEM equipment manuals! The Fuel Trailer, if not used and maintained properly, can be dangerous to users unfamiliar with its operation. Do not allow filling, towing, refueling, maintaining, adjusting, or cleaning of this trailer until the user has read this manual and has developed a thorough understanding of the safety precautions and functions of the trailer.

DO NOT modify or use this trailer for any application other than which it was designed.

Trailers that are filled or operated improperly or by untrained personnel can be dangerous; exposing themselves and/or bystanders to possible serious injury or death.

-  Make sure that anyone who will be operating the Fuel Trailer or working on or around the unit reads and understands all the operating, maintenance, and safety information in the operator's manual.
-  Keep all bystanders, especially children, away from the equipment when filling or refueling.
-  Keep working area clean and free of debris to prevent slipping or tripping.
-  Keep hands, feet, hair, and clothing away from rotating parts on the machinery being refueled.

-  Do not place hands, fingers, or arms between moving parts.
-  Stay away from overhead power lines. Electrocutation can occur without direct contact.
-  Use care when climbing on machinery to prevent slipping or falling.
-  Know and follow applicable national, state, and local safety codes concerning safe handling of petroleum fuels.
-    Gasoline is a highly flammable fuel. The improper use, handling, or storage of gasoline can be dangerous. Never fill a hot engine. DO NOT fill the engine's fuel tank near an open flame while smoking or while engine is running. DO NOT fill tank in an enclosed area with poor ventilation. Clean up any gasoline spills immediately.
-     Before filling the trailer, make sure the engine of the tow vehicle is stopped, the transmission is placed in park, the key is removed, and the parking brake is set.
-  Only store gasoline in containers with approved labels, as required by federal or state authorities. Never store gasoline in the front compartment of the trailer.
- Manually control the nozzle valve throughout the filling process. Keep your face away from the nozzle or fuel tank opening.
-  Avoid prolonged breathing of gasoline vapors.
-  Keep gasoline away from your eyes and skin, because it may cause irritation.
-  Use gasoline only in open areas that get plenty of fresh air. Never use gasoline to wash your hands. Remove gasoline-soaked clothing immediately.
-  Fill fuel tanks no more than 95 percent full to allow for expansion. Replace and tighten the machine's fuel cap.

17.  Never dispose of gasoline by pouring it onto the ground or into a sewer, street drain, stream or other body of water, or putting it into the trash. These actions are environmentally harmful and may result in a fire, explosion, or soil, surface or groundwater contamination. Fines and criminal penalties may be associated with improper disposal.
18.  The muffler becomes very hot during operation and remains hot for a while after stopping the engine. Be careful not to touch the muffler while it is hot. Let the engine cool before storing it indoors.
19.   Exhaust gas contains poisonous carbon monoxide. Avoid inhalation of exhaust gas. Never run the engine in a closed garage or confined area.
20.  Never exceed the weight limits of this trailer. Refer to the Specifications section in this manual for maximum load ratings.
21.  An ignition source is always a concern in refueling. Gasoline for the gas powered engine is very explosive, especially the fumes. The most common source of electrostatic discharge (spark) is from the operator. The person refueling the equipment should always make a point of touching something nearby to ground and discharge themselves before refueling the gas engine.

3. Review the OEM instructions provided with all equipment used on the fuel trailer for operating and safety precautions.
4. When towing the trailer with a truck, the 12 Volt electrical system is designed so the vehicle's charging system will charge the trailer's battery. Charging will only occur when the tow vehicle's engine/alternator is running and the wiring harness is properly configured.

This system will not recharge a depleted or dead battery; only help to maintain its current charge state. Use the following to make sure the tow vehicle is compatible with the fuel trailer:

- a. Make sure the tow vehicle is equipped with a standard 7-way automotive wiring harness socket. If the tow vehicle is not equipped with a 7-way connector which is properly configured, the trailer battery will not be charged without custom wiring from the tow vehicle's alternator/charging system.
- b. If equipped, check the 7-way socket on the tow vehicle, using a Volt meter, to make sure Pin 4 and 7 are supplying 12 Volts of power. If any other pin has the 12 Volt supply the battery will not be recharged.

Note: To properly charge the battery, the tow vehicle's socket must be configured with Pin 4 (black) along with center Pin 7 (red/orange) connected to the 12 Volt supply.

8.2 FIRE EXTINGUISHER

A user-supplied fire extinguisher is recommended whenever using the fuel trailer.

The extinguisher bracket should be mounted in an accessible location on the trailer. Do not install the fire extinguisher onto the diesel fuel tank.

Follow the manufacturer's instructions to periodically check and maintain the fire extinguisher.

8.3 PRE-OPERATION CHECKS

1. The gasoline engine may not be shipped with oil. Please add oil to the gasoline engine prior to starting for the first time.
2. Make sure the diesel fuel pump is properly primed before attempting to refuel any machinery.

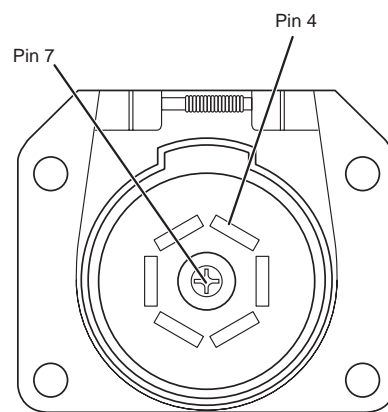

MMG-00238

- c. If there is no voltage on any of the pins, check the fuse in the truck's fuse panel. The fuse for the charge line may not be installed or is blown.

Note: If the tow vehicle's wiring connections do not correspond to the fuel trailer's wiring harness, the breakaway brake system battery will also not be charged during normal operation.

5. Always make sure the trailer lights and brakes are working properly before towing the trailer. Do not tow a trailer that is not operating properly.
6. The fuel trailer can be towed with a tractor, however it is electrically wired for a 7-way automotive wiring harness application. An ag tractor will not properly operate the trailer's brake, battery charging system, or lights without special wiring modification. Do not tow the fuel trailer on public roads without proper brakes and lighting.

8.4 DEF AND DIESEL FUEL TANKS

8.4.1 Filling the Fuel Trailer with Diesel Fuel

1. Before filling the fuel tank, follow all the safety recommendation, such as attaching the fuel trailer to the tow vehicle, placing the fuel trailer on a level surface, blocking both sides of the wheels to prevent unexpected movement, etc.



2. If not already closed, close the fuel valve located under the front of the trailer.

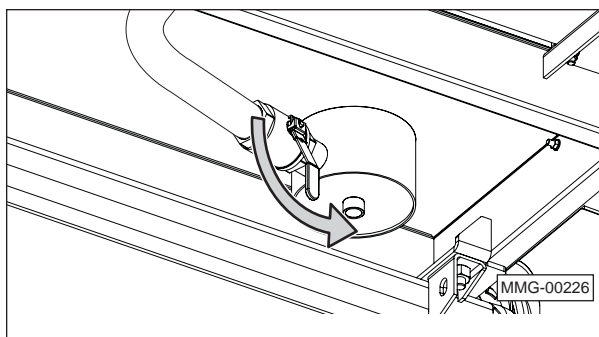

3. Fill the trailer with diesel fuel using fill spout (1). Use sight gauge (2) on top of the tank to prevent overfilling. Never obstruct breather (3) at any time.

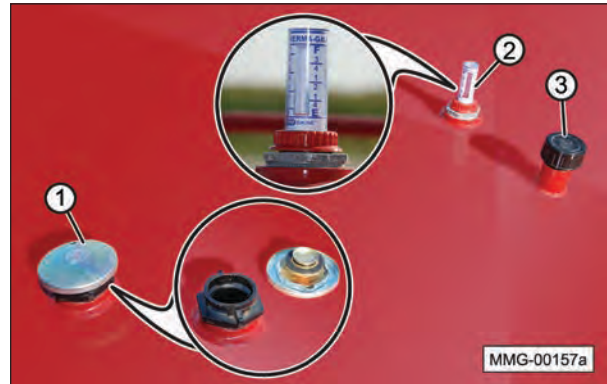

8.4.2 Filling Machinery Using 12 Volt Electric Diesel Fuel Pump

⚠ WARNING



Do not use fuel tank as a work platform. Do not stand on fenders. Do not ride on trailer or allow others to ride on trailer.

1. Position the fuel trailer near the machinery being refueled.
2. Open the shutoff valve on the underside of the fuel tank, as shown.

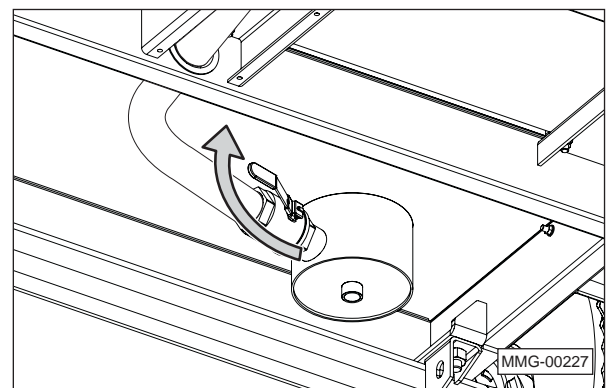

3. Extend the hose to easily reach the fill spout of the machinery being refueled.

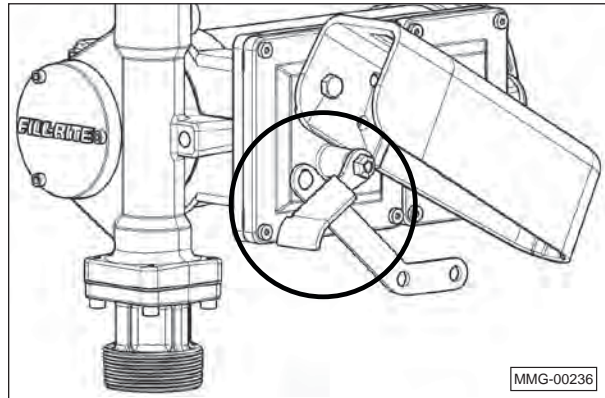

Fuel Pump Lever in "OFF" Position.

⚠ CAUTION

Once the pump is turned ON, the fuel hose is pressurized and will pump fuel. Do not squeeze the handle on the fuel nozzle until it is inside the fuel tank of the machinery being refueled.

7. Remove the dispensing nozzle from the machinery being refueled and retract the hose onto the hose reel.

4. Move the ON/OFF lever upward to the "ON" position to apply power to the pump.

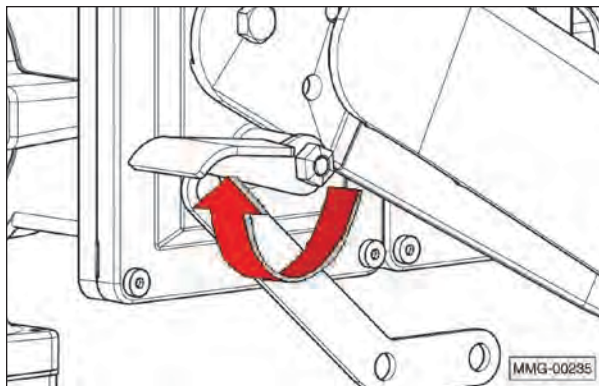

Fuel Pump Lever in "ON" Position.

5. Refuel the machinery. Release the nozzle when the desired amount of fuel has been dispensed.
6. Move the ON/OFF lever downward to the "OFF" position to turn off the pump.

8.4.3 Filling Machinery Using Gasoline Diesel Fuel Pump

WARNING



Do not use fuel tank as a work platform. Do not stand on fenders. Do not ride on trailer or allow others to ride on trailer.

This petroleum pump is a self-priming centrifugal pump and only requires priming prior to its initial start. The pump will retain sufficient liquid for self-priming thereafter.

To prime the pump:

1. Remove the fill plug on top of the pump housing.
2. Fill the pump housing with the fluid to be pumped.
3. Replace the plug.

To fill the machinery:

1. Position the fuel trailer near the machinery being refueled.
2. Open the shutoff valve on the underside of the fuel tank, as shown.

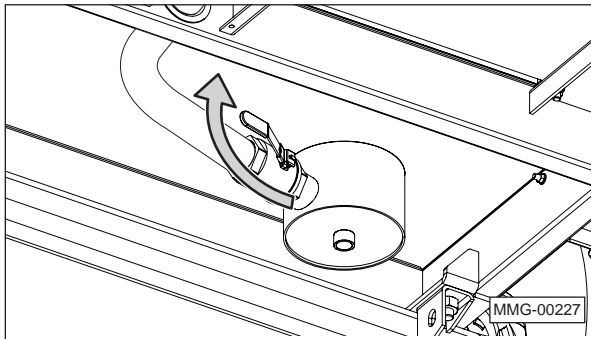

3. Extend the hose to easily reach the fill spout of the machinery being refueled.



If using the optional gasoline engine, start the engine.

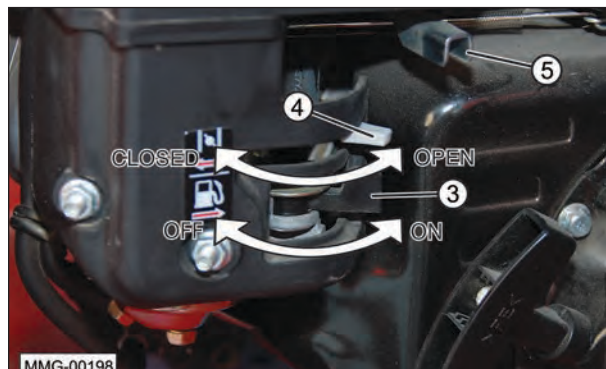

- a. Turn engine fuel lever (3) to the ON position.



- b. To start a cold engine, move choke lever (3) to the left (closed). In warm weather, start the engine with the choke in the middle position. To restart a hot engine, move the choke lever to the closed position.



- c. Move throttle lever (5) away from the SLOW position to the FAST position.

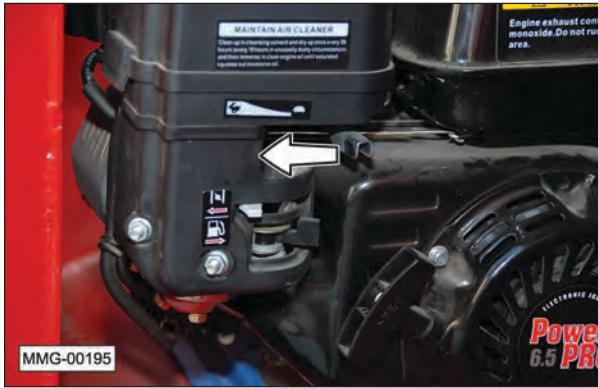

- d. Use engine pull cord (2) or electric start (1) and start the engine.



- e. If the choke lever is in the CHOKE position, gradually move it to the right (OPEN) position as the engine starts to run.



⚠ CAUTION

Once the pump is started, the fuel hose is pressurized and will pump fuel. Do not squeeze the handle on the fuel nozzle until it is inside the fuel tank of the machinery being refueled.

4. Place the fuel nozzle into the receiving tank and squeeze the handle to start fuel flow. When the tank is full, the nozzle will

automatically shut off the flow.

Note: If an electronic fuel meter is attached to the hose, a specific amount of fuel can be added.

NOTICE

When filling machinery from the fuel trailer, never allow the pump to run dry. Operating the pump without fuel can cause damage to pump and/or gasoline engine.

5. When fueling is complete, turn the gasoline engine off.
6. Rewind the fuel hose onto the fuel reel and place the nozzle back into the nozzle holder.



7. Place the engine's fuel lever in the OFF position before towing the fuel trailer on the open road.



- Allow the engine to cool for at least 15 minutes, with both compartment doors open, before towing.

⚠ WARNING



To prevent a fire, which could lead to personal injury or death, allow the engine to cool before closing the engine compartment doors. A hot engine and exhaust system could ignite various materials within the front compartment.

- Before towing, close the shutoff valve on the fuel tank.

8.4.4 Filling the Trailer's DEF Tank

Review the section on DEF Solution in this manual before filling the DEF tank or servicing the machinery. **Because of our continuous improvement process, some images may be different than the actual product.**

- Make sure the DEF tank shutoff nozzle is closed.
- Fill the DEF tank using filler spout (1). Use the fluid level indicator (2) to determine when the tank is full.

Note: To prevent contamination of the DEF fluid, keep the DEF nozzle and the fill port on the tank clean and free of dust and dirt.

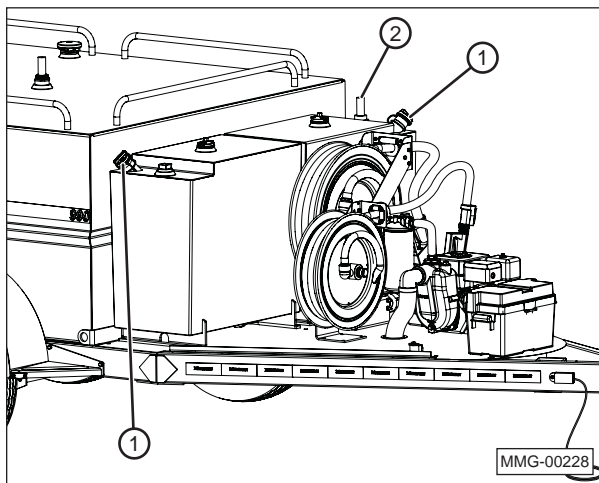

NOTICE

Use the fluid level indicator located on top of the tank and do not overfill the tank.

8.4.5 Filling the DEF Tank on Machinery

The DEF transfer pump is a 12 Volt DC, self-priming, positive-displacement diaphragm pump. The pump is equipped with a 20' power cord with alligator clips to connect to the battery on the fuel trailer or to the tow vehicle.

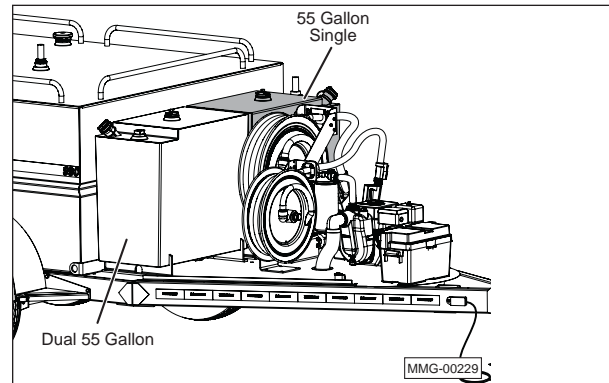

The 110 gallon option is shown here. The 55 gallon option uses only the left side tank.

Note: If the pump does not operate, make sure the in-line fuse is working.

SAFETY INSTRUCTIONS

This pump should only be used to pump DEF solution from the fuel trailer to the machinery being serviced. Do not pump any other type of fluid.

- Ensure the power switch on the DEF pump is in the OFF position.

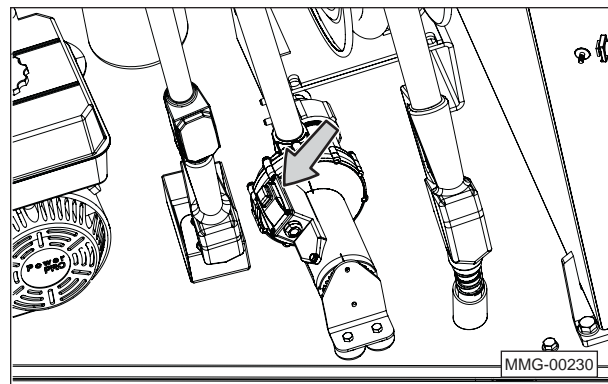

WARNING



12 Volt batteries can present a hazardous, explosive environment. Before making any battery connections, ensure the pump's ON/OFF switch is in the OFF position. Also make sure the pump's battery connections are tight before operating the pump.

2. Connect the clamps of the electrical cables for the DEF pump to a 12 Volt power source; either the fuel trailer battery or the tow vehicle.
 - a. Connect the end of the RED jumper cable to the POSITIVE (+) post on the battery (power source). Make sure the NEGATIVE (-) cable is not touching a grounded surface.

Note: In many cases the POSITIVE battery post is slightly larger than the NEGATIVE post and will be marked with a PLUS (+) sign. There may also be a RED plastic protective cover over the positive battery post.

- b. Connect the end of the BLACK jumper cable NEGATIVE (-) to a heavy metal ground on the frame of the trailer or tow vehicle.

SAFETY INSTRUCTIONS

If the cable must be connected to the NEGATIVE (-) post on the battery itself, be extremely careful to prevent any sparks that can ignite hydrogen fumes around or on top of the dead battery, causing it to explode.

NOTICE

To avoid contaminating the DEF solution and possible nozzle malfunction, keep the nozzle clean. Always store the nozzle in the nozzle holder when not in use.

3. Extend the DEF hose to easily reach the fill opening of the machinery being serviced



4. Open the DEF tank shutoff nozzle by depressing the nozzle lever.

CAUTION

Once the pump is turned ON, the DEF hose is pressurized and will pump DEF solution. Do not squeeze the handle on the nozzle until it is inside the DEF tank of the machinery being serviced.

5. Turn the power switch to the ON position to start the DEF pump.

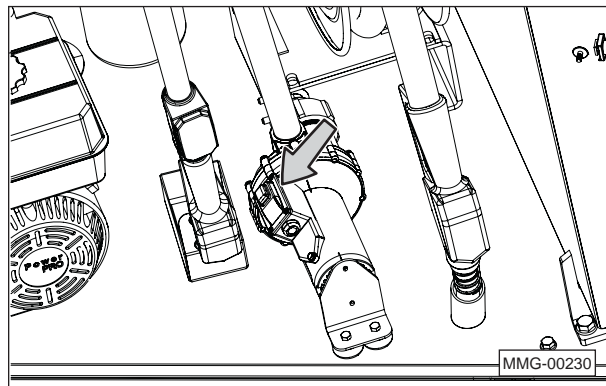

6. Fill the DEF tank on the machine.

SAFETY INSTRUCTIONS

Even though the nozzle is equipped with an automatic shutoff, do not leave the nozzle unattended during filling. Be prepared to manually shut off flow at the nozzle, if necessary.

7. Fill the machine's DEF tank. Once the DEF tank is filled, turn the pump OFF. Do not run the pump any longer than necessary.
8. Replace the nozzle in its holder.
9. Place the shut off valve for the DEF tank in the closed position.

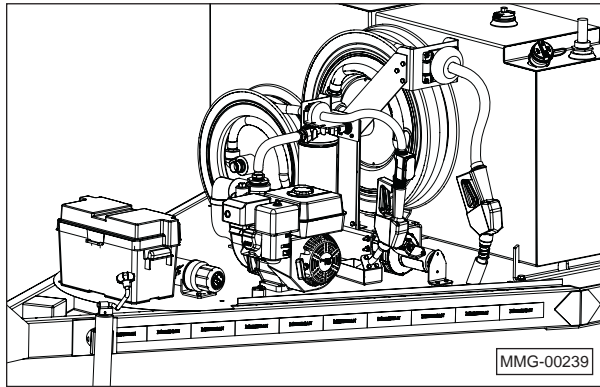

10. Remove the battery cables.
 - a. Remove the BLACK cable NEGATIVE (-) from the metal ground on the frame of the tow vehicle.
 - b. Remove the RED jumper cable from the POSITIVE (+) post on the battery (power source). Make sure the NEGATIVE (-) cable is not touching a grounded surface.

8.5 DEF SOLUTION

The information concerning DEF provided in this manual has been obtained from sources considered technically accurate and reliable. Review the safety information concerning potential product hazards. Since the actual product use is beyond our control, it is assumed that the user has been fully trained to meet any local, state, or federal regulations.

8.5.1 DEF Solution Safety Practices

SAFETY INSTRUCTIONS



Respiratory protection is not usually required. If significant spray or mist occurs, wear a NIOSH approved or equivalent dust respirator.



The use of gloves, impermeable to the specific material handled, is advised to prevent skin contact, possible irritation, or absorption.



Approved eye protection to safeguard against potential eye contact, irritation, or injury is recommended. Depending on the conditions of use, a face shield may be necessary.



A source of clean water should be available in the work area for flushing eyes and skin. Impervious clothing should be worn, as needed.



DO NOT operate the pump at voltages which exceed the 12 Volt rating indicated on the name plate. Operating the pump with more than 12 Volts will cause the motor to overheat.

8.5.2 First Aid Measures

Eye: If irritation or redness develops, move away from exposure and into fresh air. Flush eyes with clean water immediately for at least 15 minutes. If symptoms persist, seek medical attention.

Skin: Remove contaminated shoes and clothing and cleanse affected area(s) thoroughly by washing with mild soap and water. If irritation or redness develops and persists, seek medical attention.

Inhalation (Breathing): If respiratory conditions develop, move away from source of exposure and into fresh air. If symptoms persist, seek medical attention. If victim is not breathing, clear airway and immediately begin artificial respiration. If breathing difficulties develop, oxygen should be administered by qualified personnel. Seek immediate medical attention.

Ingestion (Swallowing): First aid is not normally required; however, if swallowed and symptoms develop, seek medical attention.

8.5.3 General Information

1. DEF has not been shown to be harmful to humans or animals.
2. DEF is not explosive, does not burn, and will not aid in combustion.
3. DEF is non-toxic. If you get it on your skin or clothes, rinse with plenty of water.
4. DEF is a colorless liquid. However, it is best to avoid spilling on clothing or vehicle upholstery as it may leave a stain.

NOTICE

DEF is very corrosive to certain types of material. Care should be taken when filling the trailer or the machinery.

8.5.4 Storage

1. Keep DEF containers tightly closed.
2. To avoid solidification, do not store DEF at temperatures below 23°F (-5°C). Solidified DEF, which has been warmed up carefully at temperatures not exceeding 86°F (30°C), will not be impaired in quality and can be used as soon as the warmed up solution is free from solids. Frozen DEF can be thawed and used without concerns of product degradation; however, damage to the container or equipment will likely occur.

3. Store only in approved containers.
4. Protect containers against physical damage.
5. In order to prevent decomposition of the urea, as well as the evaporation of water in the case of vented containers, prolonged transportation or storing above 77°F should be avoided. (See Table Below).

Constant Ambient Storage Temperature (°F)	Minimum Shelf Life (Months)
≤50°F	36
≤77°F*	18
≤86°F	12
≤95°F	6
>95°F	**

* To prevent decomposition of the DEF solution, prolonged transportation or storage above 77°F should be avoided.
** Significant loss of shelf life. Check every batch before use.
Source: ISO 22241-3:2008(E)

8.5.5 Using DEF

1. Only fill the DEF tank with ISO certified DEF that has been delivered in dedicated, sealed DEF packages.
2. Wear appropriate protective clothing and equipment, such as safety glasses, gloves, etc. while pumping DEF.
3. Wash thoroughly after handling DEF.
4. Never add DEF into the diesel fuel tank.
5. Never add diesel fuel into the DEF tank.
6. Avoid contact with DEF on eyes, skin, and clothing.
7. If spilled, rinse the area with water.
8. Do not use DEF that has been diluted with water or other substances.

8.5.6 DEF Disposal

For proper disposal of waste DEF, as a non-hazardous liquid waste, it should be solidified with stabilizing agents such as sand, fly ash, or clay absorbent, so that no free liquid remains before disposal in an industrial waste landfill.

9. STORAGE

9.1 GENERAL INFORMATION

When the fuel trailer will not be used for an extended period of time, perform a complete inspection. Replace or repair any worn or damaged components to prevent unnecessary downtime at the beginning of the next season.

9.2 PLACING IN STORAGE

CAUTION



Store the trailer in an area away from human activity. To prevent the possibility of serious injury, do not permit children to play on or around the stored equipment.

1. Remove all fuel from the fuel trailer.
2. Place the gasoline engine fuel valve in the OFF position.
3. Drain the gasoline engine fuel tank and carburetor for seasonal or long term storage. If this is not possible, add a fuel additive to the gas tank.
4. Thoroughly wash the equipment with a pressure washer or water hose to remove all dirt, mud, or debris.
5. Remove any entangled material from the underside of the trailer.
6. Check the condition of the fuel pump and DEF pump. Replace or adjust, as required.
7. Touch up paint nicks and scratches to prevent rusting.
8. If the engine has been running, allow it to cool for at least half an hour before closing the compartment doors.
9. Remove the engine's ignition key and store in a secure place.
10. Remove the battery and store it in a cool, dry area on wooden blocks or a wooden pallet. Charge it monthly to maintain an adequate charge. This will help to extend the service life of the battery
11. It is best to store the equipment inside. If possible, avoid any area with high humidity. Humidity promotes rust and corrosion.

9.3 REMOVING FROM STORAGE

When removing the equipment from storage, follow this procedure:

1. Install and connect the battery.
2. Add new fuel to the gasoline engine's fuel tank.
3. Review and follow the Daily Pre-Operation Checklist.
4. Review and follow the service checks in the Services section.

IMPORTANT

If the equipment has been stored for more than 12 months, warm the engine by running it for two to three minutes and then drain the oil. Change the oil while the oil is warm to remove any condensation. Refer to the Change Engine Oil section in the Maintenance section.

9.4 WINTERIZING THE DEF SYSTEM

Since the majority of the DEF solution is water, freezing of this solution can cause damage to the components of the DEF system. It is recommended that the solution be removed from the DEF tank and stored in a DEF compatible container.

NOTICE









Do not allow DEF fluid to freeze in the tank. Since DEF solution is mostly water, freezing and expansion of the solution will cause damage to the tank and the pump. The warranty is void if freezing occurs.

Note: In colder climates, a 110 Volt DEF solution heater (part number 68712) can be installed.

10. MAINTENANCE

10.1 SAFETY

10.1.1 General Safety

1. Good maintenance is your responsibility. Poor maintenance is an invitation for trouble.
2. Follow good shop practices. Keep service area clean and dry. Be sure electrical outlets and tools are properly grounded. Use adequate light.
3.  Ensure proper ventilation. Never operate the engine in a closed building. The exhaust fumes may cause asphyxiation.
4.  Before working on this equipment, shut off the engine and remove the ignition keys.
5.  Never work under equipment unless it is securely blocked.
6.  Always use personal protection devices, such as eye, hand, and hearing protectors, when performing any service or maintenance.
7.  Where replacement parts are necessary for periodic maintenance and servicing, genuine factory replacement parts must be used to restore your equipment to the original specifications. The manufacturer will not be responsible for injuries or damages caused by use of unapproved parts and/or accessories.
8.   A fire extinguisher and first aid kit should be readily accessible while performing maintenance on this equipment.
9.  Periodically tighten all bolts, nuts, and screws and ensure all cotter pins are properly installed to ensure the unit is in safe condition.
10.  When completing a maintenance or service function, make sure all safety shields and devices are installed before placing the unit in service.



DO NOT operate the engine with the fuel tank cap loose or missing.



DO NOT clean engine air filter with gasoline or other types of low flash point solvents.



DO NOT operate the unit without a functional exhaust system. Prolonged exposure to sound levels in excess of 85 dBA can cause permanent hearing loss. Wear hearing protection when working around a running engine.



Keep hands, feet, and loose clothing away from moving parts on the engine.



Keep area around exhaust free of debris to reduce the chance of an accidental fire.



Do not operate the gas engine if any of the following conditions exist during operation:

1. Noticeable change in engine speed.
2. Sparking occurs.
3. Engine misfires or there is excessive engine vibration.

10.2 WHEEL BEARINGS

Each axle is equipped with a grease zerk under the center dust cap of the wheel. Add grease sparingly to the wheel bearings, using only wheel bearing grease. The wheel bearings should be repacked annually. Check for excessive end play and tighten, if necessary.

IMPORTANT

Over-greasing wheel bearings can cause them to overheat, resulting in damage and/or failure.



SAFETY INSTRUCTIONS



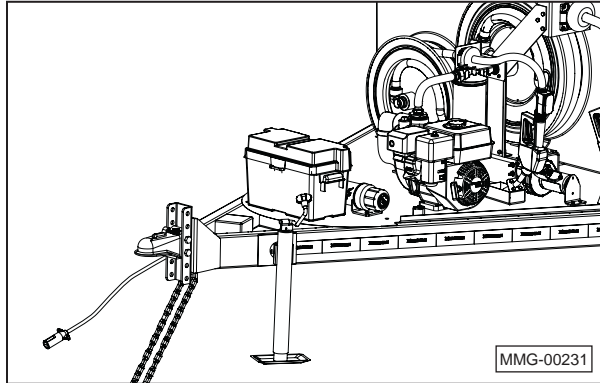

The following safety instructions are provided to help prevent injury or limit equipment damage.

10.3 BATTERY

Inspect the battery at least once every six months and before using the fuel trailer at the beginning of the season. Always follow the safety instructions when servicing a battery.



10.3.1 Battery Safety

-  Keep all sparks and flames away from batteries, as gas given off by electrolyte is explosive.
-  Avoid contact with battery electrolyte: wash off any spilled electrolyte immediately because battery acid can cause severe chemical burns.
-  Wear safety glasses when working near batteries.
- Do not tip batteries more than 45 degrees, to avoid electrolyte loss.
-  To avoid injury from spark or short circuit, disconnect the battery ground cable before servicing any part of the electrical system. Never short circuit the battery; it may explode.
-  Protect battery terminals, battery-charger terminals, and cables against accidental contact which can cause sparks, explosions, or component damage.
- Never attempt to jump-start a frozen battery.

10.3.2 Battery Replacement and Maintenance Tips

- Check the batteries at least every six months for low Voltage, leakage, etc.
- Always use the correct size and type of battery. Replace old batteries with a new 12 Volt automotive type battery.
- Do not install the battery cable to the wrong terminal. Make sure the RED cable is connected to the + (plus) terminal and the BLACK cable is connected to the – (minus) terminal.
- Remove the batteries from the fuel trailer if not expected to be in use for several months.
- Use recommended practices when recharging a dead battery.
- Remove any corrosion from the battery post using a wire brush terminal cleaner. Corrosion can also be removed using a baking soda paste and water to neutralize and remove the acid from the battery terminals.
- Dispose of old batteries properly.

10.3.3 Battery Maintenance

- Make sure the top of the battery box is installed and in good condition (not cracked, cut, or damaged).

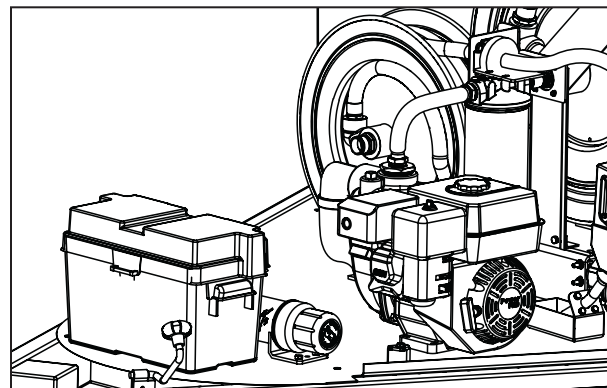

- The battery is not charged when the engine is operating. If the battery is not charging using an external charger, check the fuse. Replace the fuse if necessary.

10.4 GASOLINE ENGINE (OPTIONAL)

Gasoline engines are not typically shipped with oil. Check and add oil to engine prior to operating, as needed.

For any questions concerning the gasoline engine not provided in this manual, refer to the OEM manual that was provided with the fuel trailer.

For contact information on the manufacturer, refer to the OEM Literature section in this manual.

10.4.1 Approved Fuel

Use a regular unleaded automotive gasoline for all operating conditions. The fuel tank capacity is approximately 1.0 gallons.

The fuel trailer engines are designed for good performance and efficient operation using gasoline containing from 0 to 10% ethanol.

NOTICE

E85 is an alternative fuel and Meridian's equipment is not designed for this type of fuel. E85 is not gasoline. It is made by combining 85% ethanol with 15% gasoline. The fuel trailer engine is not currently certified or designed to run on E85 or any other alternative fuel.

Always refer to the OEM Owner's manual for a list of recommended fuel and the current approved additives.

10.4.2 Engine Oil

Use a typical SAE 10W-30 or 10W-40 multi-viscosity motor oil for normal operating conditions. Consult your engine manual for the recommended oil in cold temperatures. The crankcase capacity is 1.1 liters (1.16 US qt.).

10.4.3 Change Engine Oil

1. Review the Operator's Manual for the engine.
2. Allow the engine to cool before changing the oil. Draining works best when the oil is warm.

CAUTION



BURN HAZARD
Hot engine oil can burn skin.

3. Be sure the engine key switch is in the OFF position and the fuel valve is turned OFF.
4. Remove the drain plug and allow the oil to drain for ten minutes.

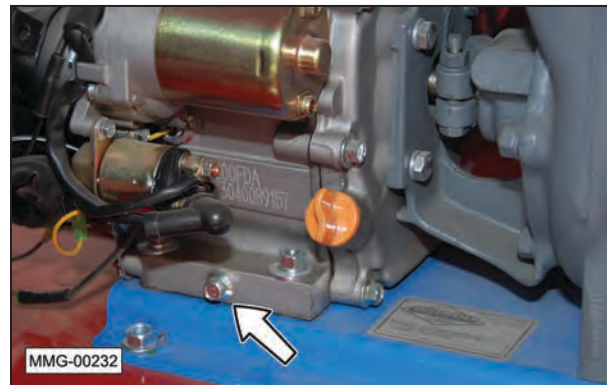

5. Reinstall the drain plug and tighten.
6. Dispose of the oil in an approved container. Follow industrial disposal regulations.
7. Fill the engine case (less than 1 quart) with SAE 10W-30 oil for general usage. If the engine is operated in more extreme conditions, refer to the OEM manual for oil recommendations.
8. Run the engine for one minute and recheck both oil levels. Add oil, as needed.

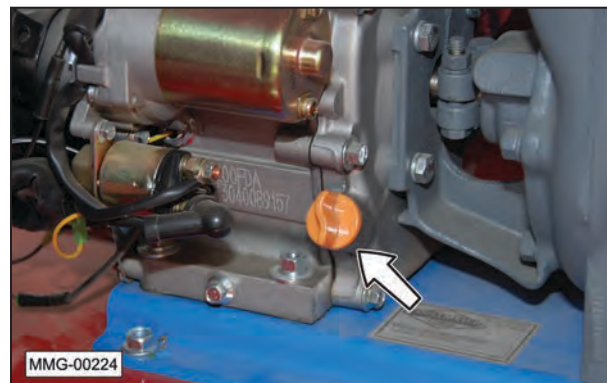

10.4.4 Air Filter Inspection

A dirty air filter will restrict air flow to the carburetor, reducing engine performance. If you operate the engine in very dusty areas, clean the air filter more often than specified in the maintenance schedule.

1. Remove the air cleaner cover and inspect the filter and foam cover weekly.



2. Remove any debris from the foam cover. Thoroughly clean or replace the foam cover every three months or 50 hours of operation (clean it more frequently when used in dusty conditions).
3. Clean or replace dirty filter elements. Always replace damaged filter elements.



NOTICE

Operating the engine without an air filter, or with a damaged air filter, will allow dirt to enter the engine, causing rapid engine wear. This type of damage is not covered by any warranty.

4. Replace the cover.



10.5 ENGINE CIRCUIT PROTECTION

The circuit protector protects the battery charging circuit. A short circuit, or a battery connected with reverse polarity, will trip the circuit breaker.

The green indicator inside the circuit protector will pop out to show that the circuit protector has switched off. If this occurs, determine the cause of the problem and correct it before resetting the circuit protector.

Push the circuit protector button to reset.

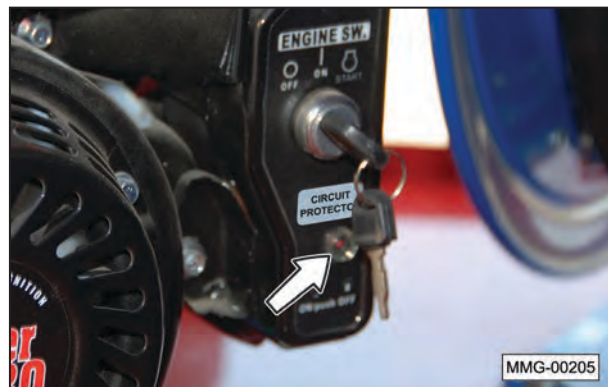

10.6 ENGINE TO PUMP CONNECTION (GASOLINE ENGINE OPTION ONLY)

Check the coupling between the pump and engine annually.



10.7 TRAILER BREAKAWAY SYSTEM



10.7.1 Testing the Battery

1. Disconnect the trailer plug from the tow vehicle; otherwise, you are testing the tow vehicle's battery.
2. Press the green TEST button on the control box located inside the frame of the trailer. The green indicator light should illuminate if the battery is fully charged. If the yellow or red indicator lights illuminate, the unit's battery should be charged before towing the trailer.

IMPORTANT

If the battery is weak or dead (red indicator, even after charging), as indicated by the indicator light, the battery must be replaced.

3. Plug the trailer into the tow vehicle. The yellow "Charging" light should be ON.
4. Test the system by pulling the pin out of the breakaway switch. The battery will activate the brakes. (**Note:** Do not use this kit as a parking brake). The battery should be charged and tested prior to each trailer outing.



10.7.2 Changing Battery

The battery in the breakaway system is rechargeable. If the battery will not hold a charge, replace the battery.

10.7.3 Replacing Battery

The battery in the breakaway system is replaceable. If the battery will not hold a charge, replace the battery. Contact the OEM supplier for a replacement battery.



10.8 WHEEL BOLT TORQUE REQUIREMENTS



1. Initially check the wheel bolt torque at 10, 25, and 50 miles and after each wheel removal. Refer to the Wheel Bolt Torque Requirements section in this manual for tightening instructions.

Note: Torque wrenches are the best method to ensure the proper amount of torque is being applied to a wheel nut.

CAUTION



EXPLOSIVE FORCE HAZARD

To prevent injury due to possible dangerous separation of wheels from the axle, the wheel nuts must be maintained at the proper torque levels. Properly maintained wheel nuts prevent loose wheels and broken studs.

2. Tighten the wheel nuts in three stages.
 - First stage: 20 to 25 foot pounds.
 - Second stage: 50 to 60 foot pounds.
 - Third stage: 90 to 120 foot pounds.
3. Tighten the wheel nuts in a clockwise, cross-axle alternating pattern.

10.9 AXLE BOLTS, TRAILER HITCH BOLTS, AND TANK HOLD-DOWN BOLTS

Check the torque on the axle to frame bolts, tank hold-down bolts, and trailer hitch bolts at least once per year.

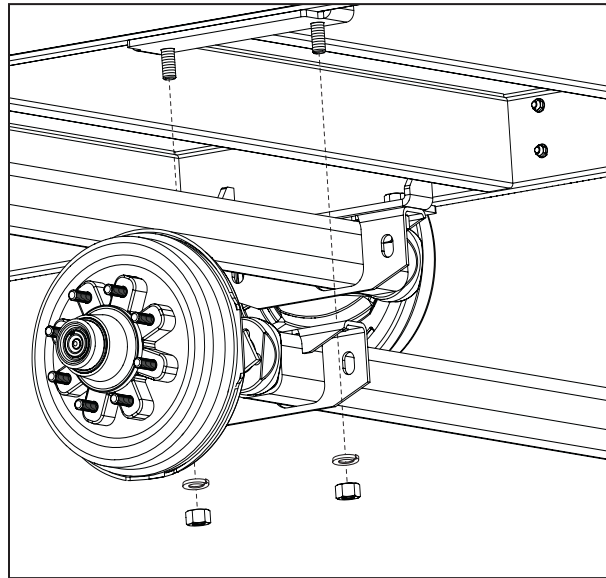

11. SERVICE

11.1 SERVICE RECORD CHART

The chart on the following page should be copied and filled out as maintenance is performed on the equipment. Refer to the Lubrication, Maintenance, and Service sections for additional instructions.

Date																				
Serviced by																				
8 hours or daily																				
Check Engine Fluid Levels																				
Test Breakaway Brake System																				
Inspect Tires and Check Wheel Bolt Torque																				
Inspect Taillights and Running Lights																				
Inspect 7-pin Connector Plug																				
50 Hours or Weekly																				
Clean Engine Air Intake Filter																				
Check Tire Pressure																				
200 Hours or Semiannual																				
Adjust Brakes																				
Inspect Brake Magnets																				
Make sure the battery box is securely holding battery onto frame, check electrolyte levels in the cells, clean terminals to remove any dirt or corrosion.																				
Check and/or Replace Diesel Fuel Filter																				
400 hours or annually																				
Change Engine Oil																				
Check Wheel Bolt Torque																				
Check Frame Hold-Downs																				
Check Bolt-On Hitch Tongue Bolts																				
Inspect Brake Lining Wear, Brake Cylinder, and Brake Wiring																				
Repack Wheel Bearings and Check Hub for Wear																				
Inspect Axle Grease Seal																				
Inspect Diesel Fuel Pump																				
Inspect DEF Solution Pump																				
Inspect all electrical wiring connections for looseness or corrosion. Tighten and/or seal, as necessary.																				
Thoroughly Clean Equipment																				

11.2 SERVICE CHECKS

11.2.1 Daily (8 Hours)

WARNING



Gasoline is a highly combustible fuel. Improper use, handling, or storage of gasoline can be dangerous. Never touch or fill a hot engine. **DO NOT** fill the engine's fuel tank near an open flame while smoking or while engine is running. **DO NOT** fill tank in an enclosed area with poor ventilation. Wipe up spills immediately.

1. Check engine oil and fuel levels and fill, as needed.

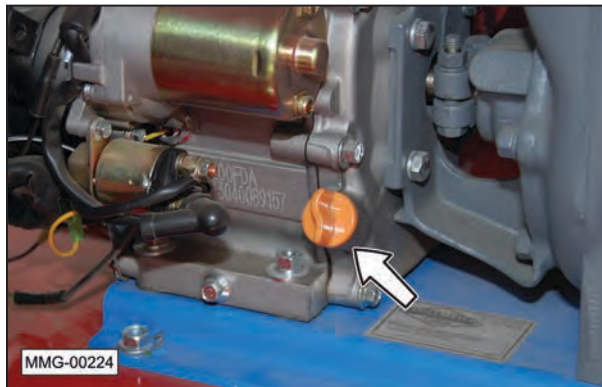

2. Test the trailer breakaway brake system.
3. Inspect the tires for wear or damage and check wheel bolt torque.
4. Inspect the taillights and running lights to make sure they are working properly.
5. Inspect the 7-pin wiring harness connector for damage.

11.2.2 Weekly (50 Hours)

1. Clean or replace the foam filter element. Replace the paper air filter, as required.



2. Check the tire pressure. Inflate the tires to the recommended pressure stated on the tire.
3. Check and/or replace diesel fuel filter.

11.2.3 Semiannual (200 Hours)

1. Adjust the brakes.
2. Inspect the brake magnets.
3. Make sure the battery box is securely holding battery onto frame, check electrolyte levels in the cells, clean terminals to remove any dirt or corrosion.
4. Check and/or replace the diesel fuel filter.

11.2.4 Annually (400 Hours)

1. Check the wheel bolt torque.
2. Repack the wheel bearings and check for excessive end play in the bearings.
3. Check the frame and tank hold-down bolts.
4. Check the trailer hitch tongue bolts.
5. Thoroughly clean the fuel trailer.
6. Check the tires for wear, and replace if needed.
7. Check the red taillights to make sure they are working properly.



11.3 AXLE MAINTENANCE

11.3.1 First 200 Miles

1. Adjust brakes. Refer to OEM manual for procedure.

11.3.2 3,000 Miles or 3 Months

1. Adjust brakes. Refer to OEM manual for procedure.
2. Check torque on wheel nuts. Refer to the section in this manual.
3. Inspect tires for wear. Refer to OEM manual for procedure.

11.3.3 6,000 Miles or 6 Months

1. Inspect brake magnets for wear. Refer to OEM manual for procedure.
2. Inspect suspension parts for wear. Refer to OEM manual for procedure.

11.3.4 12,000 Miles or 12 Months

1. Inspect brake lining wear, check brake cylinder for leaks, and inspect brake wiring for damage. Refer to OEM manual for procedure.
2. Grease the wheel bearings and check the hub for wear. Refer to OEM manual for procedure.
3. Inspect grease seal for leakage. Refer to OEM manual for procedure.

11.4 TIRES

Check the tires for normal and/or abnormal tire wear. Replace tires that are damaged or worn beyond normal tread life. Refer to the axle OEM manual for a Tire Wear Diagnostic Chart.

Replace the tires with Meridian part number 18131 or an equivalent tire:
3T235/80R16
TR643
Load Range E
For Trailer Service Only

11.5 WELDING REPAIRS



Repair welding must be done with care and with procedures that may be beyond the capabilities of the ordinary welder.

Before performing any type of welding repair to the fuel trailer, contact Meridian for approval.

WARNING



PERSONAL INJURY HAZARD
Repairs or modifications to the trailer, trailer tongue, or trailer hitch can result in serious injury or death should these repairs fail.

IMPORTANT NOTICE

Anyone performing a welding repair should be certified in accordance to the American Welding Society (AWS) standards.

12.3 DIESEL FUEL PUMP

12.3.1 Electric Diesel Fuel Pump

Fill-Rite Electric Fuel Pumps
Tuthill Corporation
8825 Aviation Drive
Ft. Wayne, IN 46809

Toll Free: 800-634-2695



12.3.2 Gasoline Diesel Fuel Pump

Flow Max Diesel Fuel Pumps
MP Pumps, Inc.
34800 Bennett
Fraser, MI, 48026-1686

Phone: 586-293-8240
Toll Free: 800-563-8006
Fax: 586-293-8469

PETROLEUM SELF-PRIMING CENTRIFUGAL PUMPS
INSTRUCTION BULLETIN

Read this bulletin in full before installing, operating or servicing this pump. If any of the warnings of this bulletin are ignored serious injury or death could occur.

WARNING!

This pump was designed to handle volatile and flammable fluids. To reduce the risk of fire or explosion keep pump in well ventilated area free of explosive atmosphere. Do not smoke where the fuel is being handled, also keep away from any sparks or open flame. Do not operate pump with either the suction or discharge valves fully closed as this will over heat the pump. If pump becomes overheated allow to cool before next use.

<p>Do not operate the pump in a manner that it was not intended to be used.</p>	<p>Do not continue to operate the pumping system when a known leak exists or the system starts to smoke.</p>
<p>Do not install a piping system that does not allow for any flex due to expansion from heat generated by the pumping system.</p>	<p>Do not continue to operate the pumping system when unusual noise or vibration occurs.</p>
<p>Do not allow severe temperature changes to occur in a short time period within the pumping system.</p>	<p>Do not perform service or maintenance when the pumping system is pressurized or hot.</p>
<p>Drain pump completely before switching fuel type that is to be pumped.</p>	<p>Do not mount pump in conditions that high piping loads exist on the pump flanges.</p>

MODELS:

PO Biodiesel, Diesel and Fuel Oil.	
PG Gasoline, Kerosene, Avgas Jet A and JP 8 Fuel.	
PE Ethanol and E-85.	



MP PUMPS, Inc.
34800 Bennett
Fraser, MI 48026-1686
Phone: 586-293-8240
Fax: 586-293-8469

FORM 3074-A (2/08)
PRINTED IN THE U.S.A.

13. TROUBLESHOOTING

13.1 TROUBLESHOOTING CHART

PROBLEM	CAUSE	SOLUTION
Gasoline engine will not start.	No fuel.	Fill the fuel tank.
	Low engine oil.	Fill the crankcase with oil.
	Cold engine.	Open choke.
	Ignition key switch off.	Turn ignition key switch on.
	Battery dead.	Recharge or replace battery.
	Engine problem.	Refer to engine manual.
	Wrong fuel type.	Do not use gasoline containing more than 10% ethanol.
	Poor fuel quality.	Store gasoline in a clean, plastic, sealed container approved for fuel storage. Close vent cap (if equipped) when not in use and store container away from direct sunlight. If fuel is stored longer than three months, adding a fuel stabilizer is recommended.
Electrical functions are not working properly.	Dirty air filter.	Clean or replace the filter.
	Battery cable or battery.	Check battery cable and make sure battery is fully charged.
DEF pump is not working properly.	Improper ground.	Check for proper grounding of electrical circuit.
	Pump is not working.	The DEF pump is for intermittent duty only. Once the maximum thermal limit is reached, the motor must be allowed to return to ambient temperature before resuming operation.
		Pump will not start.
	Pump will not prime. (no discharge but motor runs)	DEF tank is empty.
		Inlet or outlet pipes and/or hose are blocked with debris.
		Check for severe vacuum leak.
		Check for proper Voltage with the pump operating ($\pm 10\%$).
	Pump leaks.	Check pump for damage.
		Diaphragm may be ruptured, pinched, or punctured. Contact OEM for repair options. Check for loose pump head or drive screws.

PROBLEM	CAUSE	SOLUTION
Electric diesel fuel pump will not prime.	Suction line is damaged.	Check for leaks in suction line
	Fuel level in tank is below the pump inlet.	Maintain the fuel level above the height of the fuel pump inlet.
	Bypass valve open.	Valve problems; must move freely and be free of debris. Contact OEM for cleaning and/or repair options.
	Vanes sticking.	Vanes and slots may have nicks, burrs or wear. Contact OEM for repair options.
	Excessive rotor or vane wear.	Rotor and vane wear or damage. Contact OEM for repair options.
	Outlet blocked.	Check pump outlet, hose, nozzle, and filter for blockage.
	Vapor lock.	Check breather on top of tank for obstruction.
Electric diesel fuel pump low capacity.	Excessive dirt in screen.	Remove and clean screen.
	Suction line problem.	Check suction line for leaks or restrictions or air leaks (not airtight).
	Bypass valve sticking.	Valve problems; must move freely and be free of debris. Contact OEM for cleaning and/or repair options.
	Vanes sticking.	Vanes and slots may have nicks, burrs or wear. Contact OEM for repair options.
	Excessive rotor or vane wear.	Rotor and vane wear or damage. Contact OEM for repair options.
	Hose or nozzle damage.	Replace hose or nozzle.
	Plugged filter.	Replace filter.
	Low fluid level.	Fill tank.
Electric diesel fuel pump runs slowly.	Incorrect voltage.	Check incoming line voltage while pump is running. Must be 12 Volts.
	Vanes sticking.	Vanes and slots may have nicks, burrs or wear. Contact OEM for repair options.
	Wiring problem.	Check for loose connections.
	Motor problem.	Contact OEM for replacement options.
Electric diesel fuel pump stalls, fuse blows, or circuit breaker trips repeatedly.	Bypass valve sticking.	Valve problems; must move freely and be free of debris. Contact OEM for cleaning and/or repair options.
	Low voltage.	Check incoming line voltage while pump is running. Must be 12 Volts.
	Excessive rotor or vane wear.	Rotor and vane wear or damage. Contact OEM for repair options.
	Debris in pump cavity.	Clean debris from pump cavity.
Electric diesel fuel pump overheats.	Diesel fuel may be too viscose (too thick).	Viscous fluids can only be pumped for short periods of time (less than 30 minutes).
	Clogged screen.	Remove and clean screen.
	Restricted suction pipe.	Remove restriction.
	Motor failure.	Contact OEM for replacement options.
	Pump rotor lock-up.	Contact OEM for cleaning and/or repair options.

PROBLEM	CAUSE	SOLUTION
Electric diesel fuel pump does not operate.	No power.	Check incoming 12 Volt power source.
	Switch failure.	Replace switch with OEM parts.
	Motor failure.	Contact OEM for replacement options.
	Thermal protector failure.	Contact OEM for replacement options.
	Incorrect or loose wiring.	Repair wiring.
Electric diesel fuel pump leaks.	Bad O-ring gasket.	Replace all O-ring gaskets.
	Dirty shaft seal.	Clean seal and seal cavity.
	Bad shaft seal.	Replace seal.
	Incompatible fluid.	Do not pump any fluid other than diesel fuel.
	Loose fasteners.	Tighten fasteners.
Electric diesel fuel pump hums but will not operate.	Motor failure.	Contact OEM for replacement options.
	Broken key.	Remove all debris and replace key.
Notes:	Notes:	Notes:

14. WARRANTY

14.1 WARRANTY STATEMENT

Limited Materials and Workmanship Warranty For Fuel Trailers

Meridian Manufacturing Inc. (hereinafter referred to as the Manufacturer) hereby warrants the Fuel Trailer(s) sold by it to be free from any defect in material or workmanship under normal use and service for a period of one (1) year from the date of shipment. The Manufacturer's obligation under this warranty shall be limited to the repair or replacement only, FOB the original point of shipment, of any defective parts or portions of the fuel trailer or accessories manufactured by Meridian. Any warranty claim must be reported to the Manufacturer within one (1) year from the date of shipment.

THIS WARRANTY IS SUBJECT TO THE FOLLOWING LIMITATIONS, PROVISIONS AND CONDITIONS:

1. This warranty does not apply:
 - a) To any product sold by the Manufacturer where it is used in areas exposed to corrosive or aggressive conditions including salt water, acids, alkaloid, ash, cement dust, animal waste or other corrosive chemicals from either inside or outside the bin.
 - b) For failures or defects arising out of damage during shipment or during storage on site.
 - c) To materials replaced or repaired under this warranty except to the extent of the remainder of the applicable warranty.
 - d) To damage resulting from misuse, negligence, accident or improper site preparation by others.
 - e) If the product has been altered or modified by others.
 - f) If in the case of coating failures the failure is the result of damage, lack of proper maintenance or failure to remove road salt or other contaminants that may have come in contact with the bin surface.
 - g) To loss of time, inconvenience, loss of material, down time or any other consequential damage.
 - h) For a function that is different than original designed intent.
2. The obligation of the Manufacturer under this warranty shall not arise unless the Manufacturer is notified and this warranty is presented together with a written statement specifying the claim or defect within thirty (30) days after the failure is first detected or made known to the owner and within one (1) year from the shipment date. The Manufacturer in its sole discretion shall determine if the claim is valid and whether correction of the defect or failure shall be made by repair or replacement of the materials.
3. The coating warranty is based on the manufacturer's performance specification for Polyester Powder finishes and does not include repair of minor blemishes or rusting that is normally part of the general maintenance of the fuel trailer. This warranty does not cover excessive wear on interior coatings. See attachment for full Performance Specification details on Polyester Powder Finishes.
4. The obligation of the Manufacturer hereunder extends only to the original owner and to the Meridian dealer to whom the materials may have been initially sold. This warranty shall not be subject to any assignment or transfer without the written consent of the Manufacturer.
5. The customer shall acknowledge that it has made its own independent decision to approve the use of the supplied materials and also the specific fabrication and construction procedures utilized to complete the fuel trailer, and has satisfied itself as to the suitability of these products for this particular application.
6. The foregoing sets forth the only warranties applicable to said materials and said warranties are given expressly and in lieu of all other warranties, expressed or implied, statutory or otherwise, of merchantability or fitness for a particular purpose and all warranties which exceed or differ from said warranties herein are disclaimed by the Manufacturer.
7. The owners sole and exclusive remedy against the Manufacturer shall be limited to the applicable warranty set forth herein and the endorsements, if any, issued together with this document and no other remedy (including but not limited to the recovery of assembly or disassembly costs, shipping costs, direct, incidental, special, indirect or consequential damages for lost profits, lost sales, injury to person or property or any other loss, whether arising from breach of contract, breach of warranty, tort, including negligence, strict liability or otherwise) shall be available to the owner or Meridian Dealer or any other person or entitles whether by direct action or for contribution or indemnity or otherwise.
8. The financial obligation of the Manufacturer under this warranty shall be limited to the repair or replacement of the product as originally supplied and in no event shall exceed the original cost of the product supplied.
9. The Manufacturer shall not have any obligation under any warranty herein until all accounts for materials, installation and erection of the said product thereof and for labor and other work performed by the Manufacturer or its dealers have been paid in full by the owner.

Warranty Claim Procedure

1. Registering product with Meridian Manufacturing.
2. Contact the dealer unit was purchased from upon discovery of any defects.
3. A completed warranty claim form submitted by dealer to Meridian warranty representative for review and course of action.
4. Warranty repair work will only be performed by Meridian, the dealer or an approved representative. No warranty work completed prior to approval. Failure to follow procedure may affect any or all reimbursement.
5. Claims will be adjudicated at the sole discretion of the manufacturer and in accordance with the terms and conditions of the applicable limited warranty.
6. A complete list of warranty procedures can be procured from the Warranty Department or found in your owner's manual.

Effective July 1, 2009

NOTES

15. PARTS

The following pages contain a list of serviceable parts for the Fuel Trailer unit.

Parts are available from your authorized Dealer Parts Department.

15.1 FUEL TRAILER COMPARTMENT (DRIVERS SIDE)

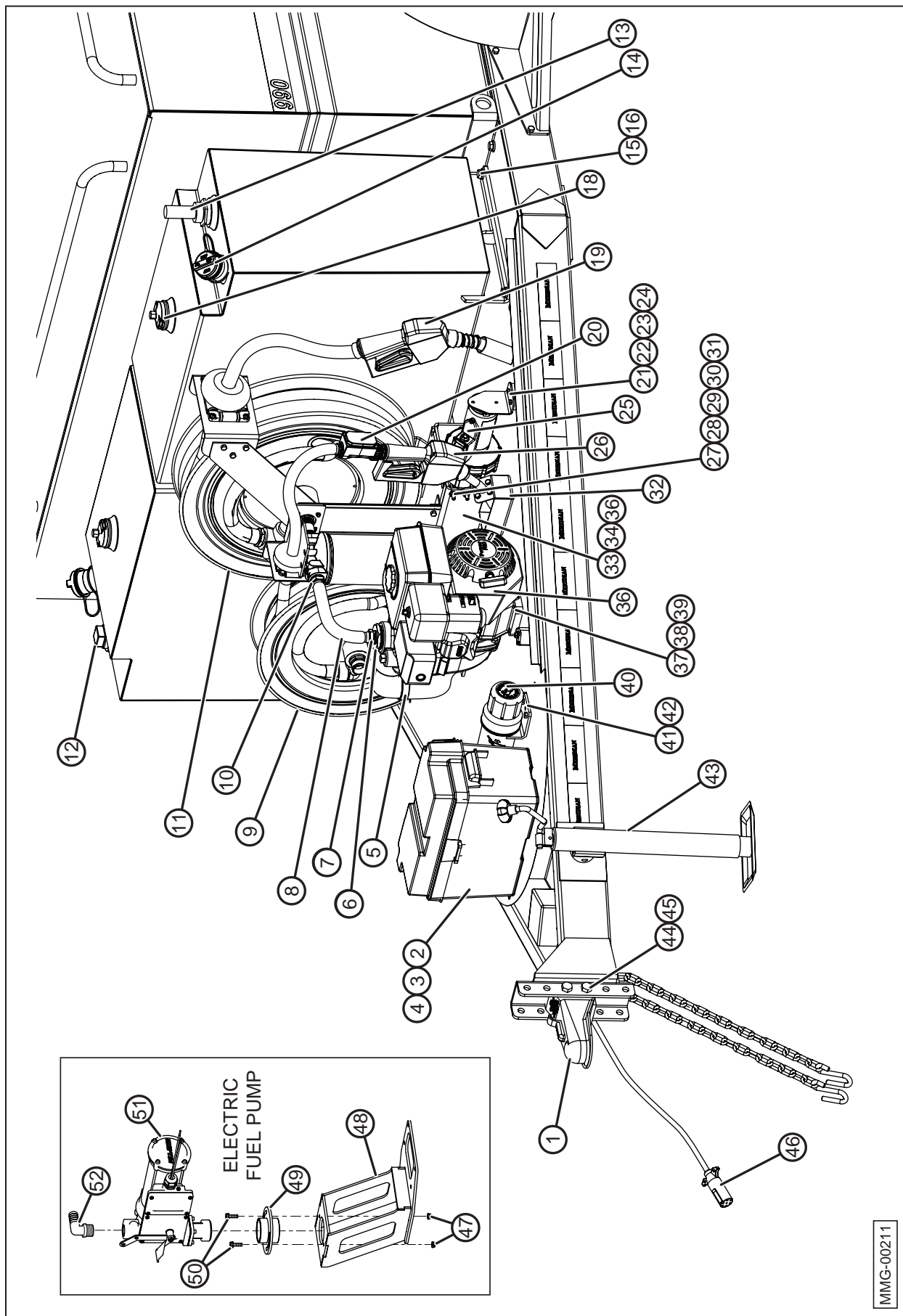

MMG-00211

Item	Qty.	Part No.	Description
1	1	19298	2-5/16" ADJUSTABLE HITCH COUPLER
2	1	11218	LARGE BATTERY BOX
3	1	19688	BATTERY
4	1		CABLE, BATTERY
5	1	11509	2" NPT TO 1" NPT BLK POLY REDUCING COUPLER
6	1	11517	2" NPT M x 1" NPT F 304 SS REDUCING BUSHING
7	1	11524	1" NPT X 1" NIPPLE/ADAPTER-POLYPR-BLK
8	1	24687	HOSE
9	1	11502	DEF HOSE REEL 25' [COX REEL]
10	1	11511	1" NPT X 1" BARB ELBOW-POLYPR-BLK
11	1	11205 25178 17900 19128	DIESEL HOSE REEL 35' [COX REEL] DIESEL REEL MOUNT BOLT, HEX, 1/4-20 UNC X 1.25 STEEL, MILD Ø1/4"-20 UNC NYLON HEX NUT
12	1	11226	2" SS STEEL PLUG
13	1	11210	KRUEGER SENTRY THERMA GAUGE (H-2-28-All SS)
14	1	11221	VENTED DEF CAP
15	4	19595	1/2-13 UNC FLANGED NUT
16	4	19570	1/2-13 x 2" FLANGED HEX SCREW
17	—	—	—
18	1	11213	Ø2" NPS DUAL ACTION VENT (4 psi)
19	1	21020	DIESEL NOZZLE 1" OUTLET [FILL-RITE] GREEN
20	1	11227 68711	DEF DIGITAL METER (GPI 113255-24) METER, DIGITAL DEF (OPTIONAL)
21	3	19128	LOCKNUT 1/4-20 UNC
22	3	17900	1/4-20 UNC x 1 1/4" HHCS
23	3	19133	RUBBER BUMPER
24	1	25181	ELECTRIC DEF PUMP MOUNT
25	1	11501	DEF PUMP 12V DC [HYPRO/SHURFLO 7-10 GPM]
26	1	11207	DEF NOZZLE 3/4" OUTLET
27	1	19575	BOLT, HEX, FLANGED, 1/2-13 UNC X 1.5
28	1	11516	1" SCH 40 NIPPLE - 3" LONG 304 SS
29	2	19318	NUT, HEX, FLANGED, 5/16-18 UNC
30	1	19323	Ø5/16"-18 UNC x 3/4" PIPE U-BOLT
31	2	19128	Ø1/4"-20 UNC NYLON HEX NUT
32	1 1 1 4 4 8	32430 24912 11214 18321 17768 17767	DEF NOZZLE HOLSTER ASSEMBLY DEF NOZZLE HOLSTER PAN DEF NOZZLE WIPER Ø1/4"-20 UNC NYLON SS HEX NUT 1/4"-20 UNC x 3/4" SS H.H.C.S. 1/4" SS FLAT WASHER
33	4	19570	BOLT, HEX, FLANGED, 1/2-13 UNC x 2
34	1	25178	DIESEL REEL MOUNT
35	4 2	19595 19128	NUT, HEX, FLANGED, 1/2-13 UNC Ø1/4"-20 UNC NYLON HEX NUT
36	1	17767	6.5 HP, ELECTRIC STATR ENGINE - 40 GAL/MIN FUEL PUMP
37	4	19626	BOLT, HEX, FLANGED, 3/8-16 x 1-3/4"
38	4	19348	WASHER, FLAT, 3/8"
39	4	19347	NUT, LOCK, 3/8-16 NYLON

Item	Qty.	Part No.	Description
40	1	18128	HOLDER FOR MANUAL OMC-1
41	3	19560	BOLT, HEX, Ø1/4"-20 x 3/4" HHCS
42	3	19128	NUT, LOCK, NYLON 1/4-20 UNC
43	1	18120	5K, 15" STROKE, TOP WIND JACK
44	2	19380	5/8-11 x 4 1/2" GRADE 5 HHCS
45	2	2688221	LOCKNUT
46	1	14065	990 FUEL TRAILER WIRE HARNESS
47	2	19318	NUT, HEX, FLANGED, 5/16-18 UNC
48	1	32440	MOUNT WELDMENT
49	1	32439	COUPLER WELDMENT
50	1	19581	BOLT, HEX, FLANGED, 5/16-18 X 1
51	1	11500	DIESEL PUMP - 12V DC 25 GPM [FILL RITE]
52	1	11523	1" HOSE NIPPLE - 90 DEG 1" NPT F ELBOW - 304 SS

15.2 FUEL TRAILER COMPARTMENT (PASSENGER SIDE)

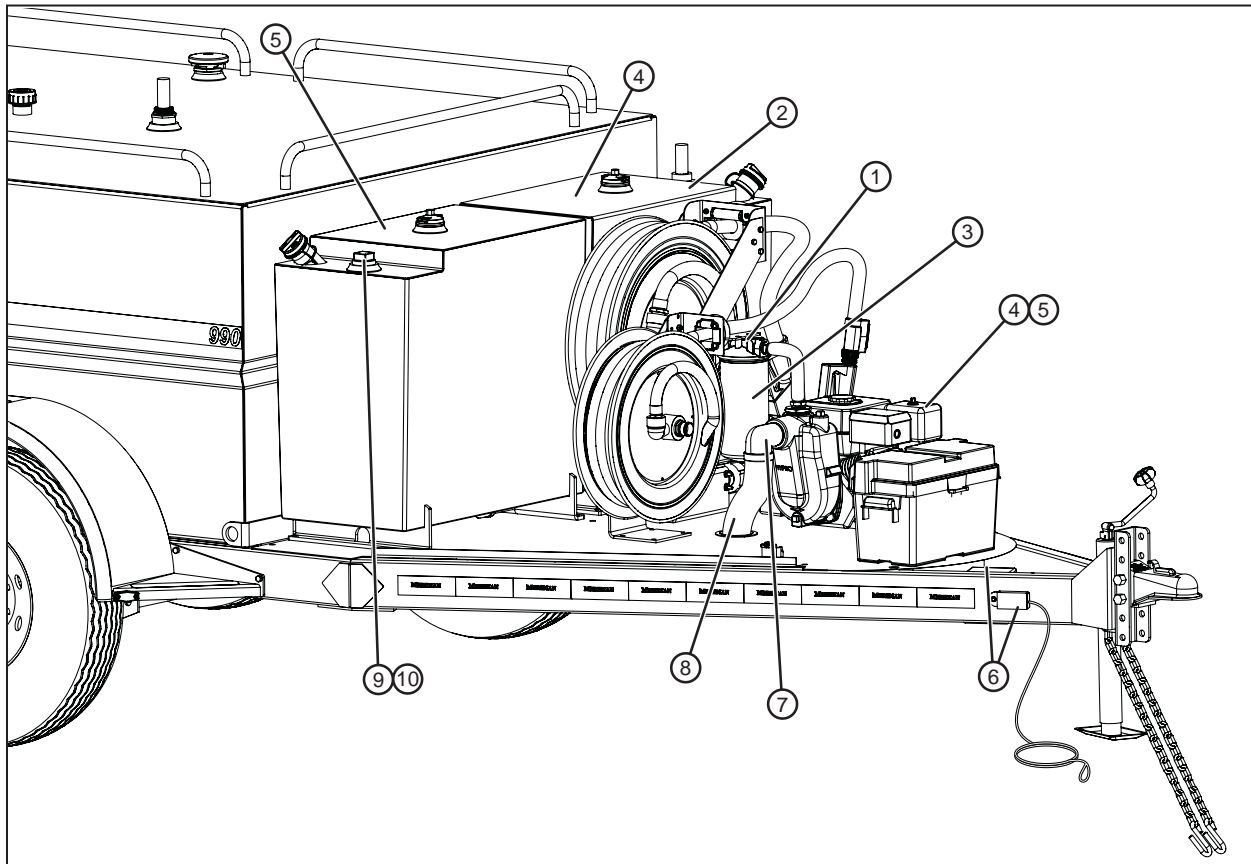

Item	Qty.	Part No.	Description
1	1	25176	FILTER HEAD MOUNT
2	1	25173	TANK, 55 GALLON WITH PUMP (FACTORY INSTALLED)
3	1	11220	DIESEL FILTER - 40 GPM-50 PSI 10 MICRON
4	1	68708	TANK, 55 GALLON WITH PUMP (FACTORY INSTALLED)
	1	68709	TANK, 55 GALLON (FIELD INSTALLED)
5	1	68710	TANK, 110 GALLON (FACTORY INSTALLED)
6	1	19275	BREAKAWAY SYSTEM, BATTERY BA10-150
7	1	17790	ELBOW 2 NPT 304SS 90 FEMALE x MALE
8	1	24686	HOSE
9	1	11226	2" SS STEEL PLUG
10	1	68712	HEATER, DEF 110 VOLT (OPTIONAL)

15.3 FUEL TRAILER CAPS AND GAUGES

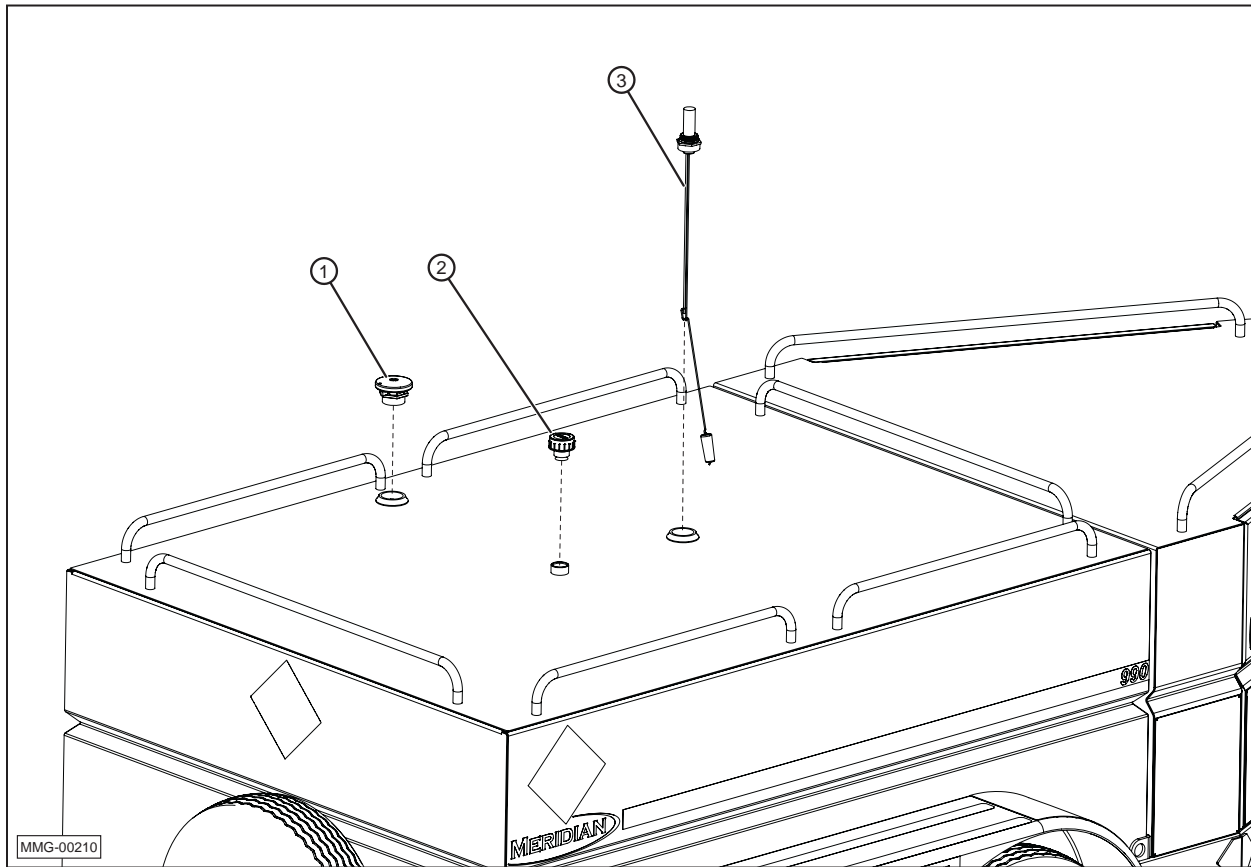

Item	Qty.	Part No.	Description
1	1	11527	2" NPT VAPOR CONTROL CAP (60001 CIM TEK)
2	1	11212	BREATHER CAP (AS-NY-7-20-10M)
3	1	11211	KRUEGER SENTRY THERMA GAUGE (H-2-36-SSR)

15.4 FUEL TRAILER LOWER PIPING

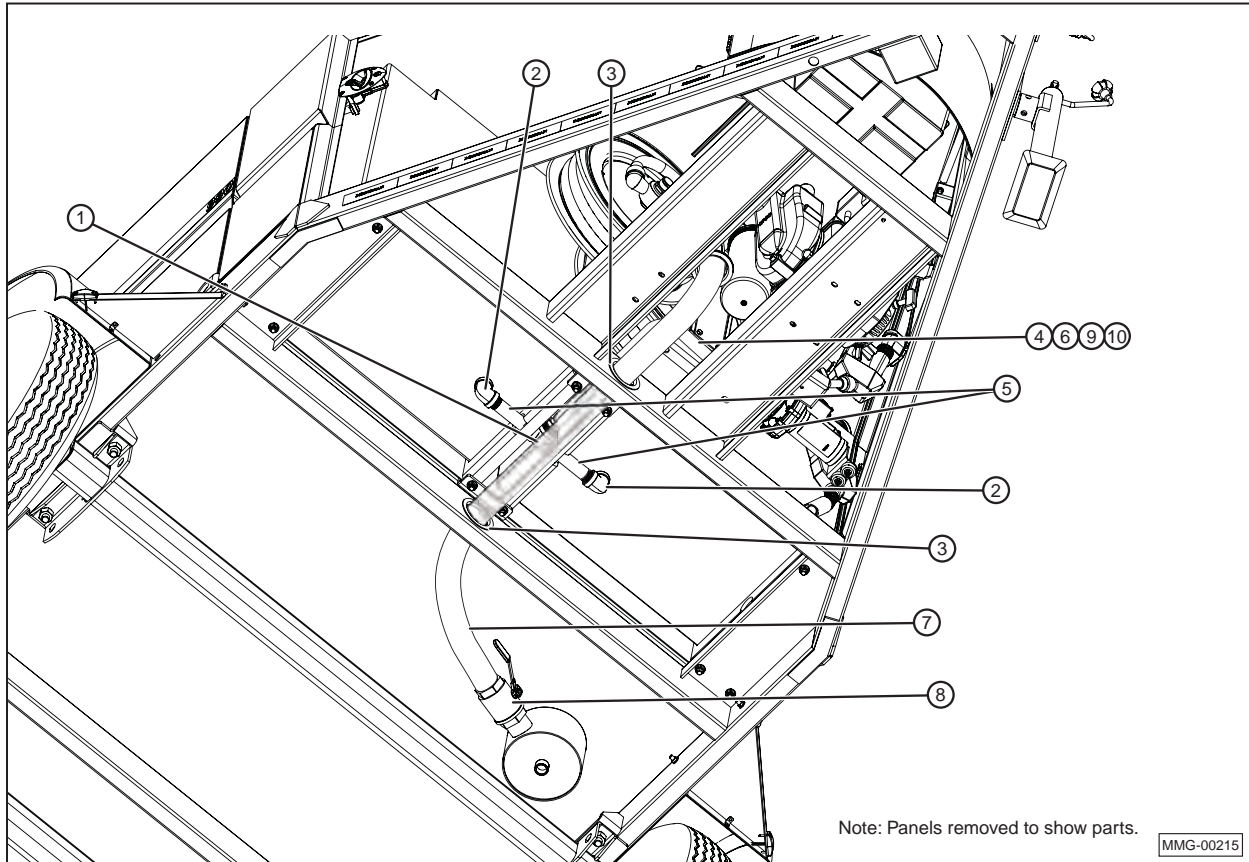

Item	Qty.	Part No.	Description
1	1	11508	1" NPT F 90 DEG ELBOW 304 SS
	1	11515	1" NPT T-FITTING - 304 SS
2	3	11506	1" HOSE NIPPLE W 1" M NPT THD 304 SS
3	1	14062	NEOPRENE EDGING - FOR SUCTION HOSE TO PASS THROUGH
4	1	24685	HOSE
5	1/2	11507	1" NPT X 6" L DBL THD PIPE NIPPLE 304 SS
6	1	11510	1" NPT X 1" BARB ADAPTER-POLYPR-BLK
7	1	24686	HOSE
8	1	11224	2" BRASS BALL VALVE
9	1	11524	1" NPT X 1" NIPPLE/ADAPTER-POLYPR-BLK
10	1	11511	1" NPT X 1" BARB ELBOW-POLYPR-BLK

15.5 WHEEL AND FENDER

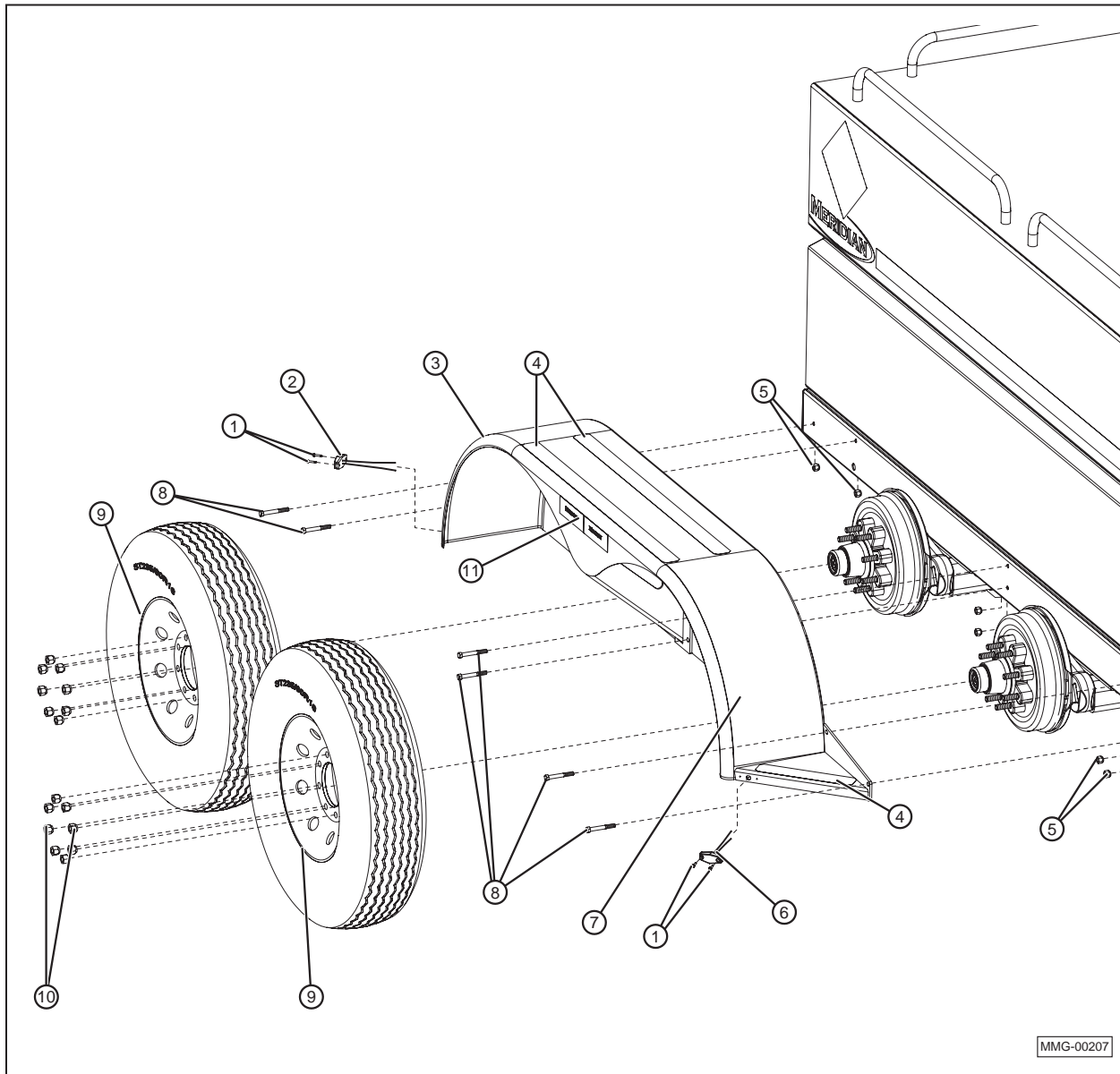

MMG-00207

Item	Qty.	Part No.	Description
1	21	19779	#8-18 X 3/4" SELF DRILLING ZINC SCREW
2	2	18229	RED CLEARANCE LIGHT
3	2	32443	BOLT ON FENDER WELDMENT-TANDEM AXLE
4	4	18118	ANTI-SLIP TAPE
5	13	19564	NUT, HEX, FLANGED, 3/8-16 UNC
6	2	18151	AMBER CLEARANCE LIGHT
7	2	25180	ALUMINUM ROCK GUARD - FENDER
8	12	19330	BOLT, HEX, 3/8-16 UNC X 3 STEEL, MILD
9	4	18131 17756	ST235/80R16, TIRE AND STEEL RIM ST235/80R16-E, TIRE, ALUMINUM RIM ASSEMBLY
10	3	18991	Ø9/16-18 UNF x 3/4" LUG NUT
11	—	18096	TAPE REFLECTIVE MERIDIAN 2X6X6

15.6 AXLE AND MOUNTING HARDWARE

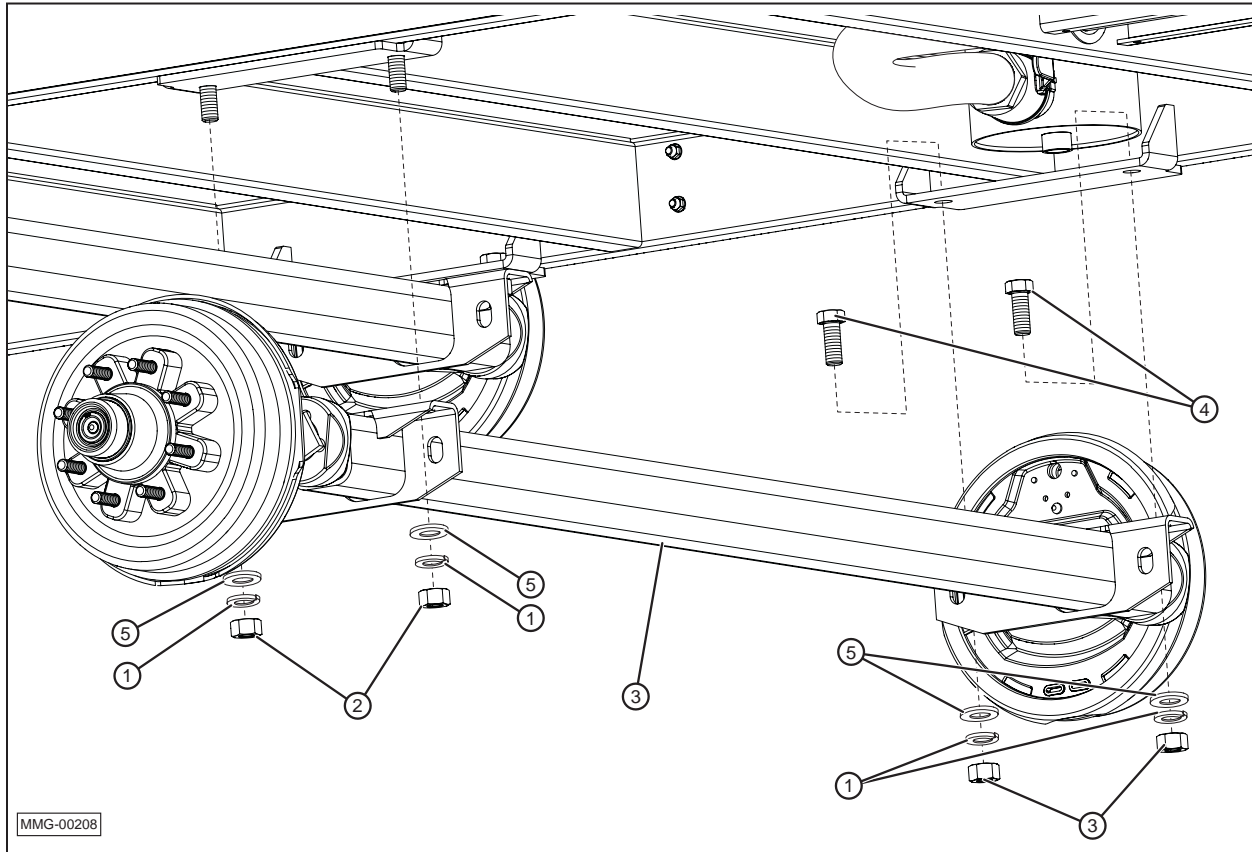

Item	Qty.	Part No.	Description
1	8	19396	3/4" HELICAL SPRING LOCK WASHER
2	8	19652	NUT, HEX, HEAVY 3/4 - 10
3	2	17755	7000 lb AXLE
4	8	19388	BOLT, HEX, 3/4-10 UNC X2
5	8	18097	WASHER, NARROW 3/4"

15.7 LIGHTING AND SPARE TIRE OPTION

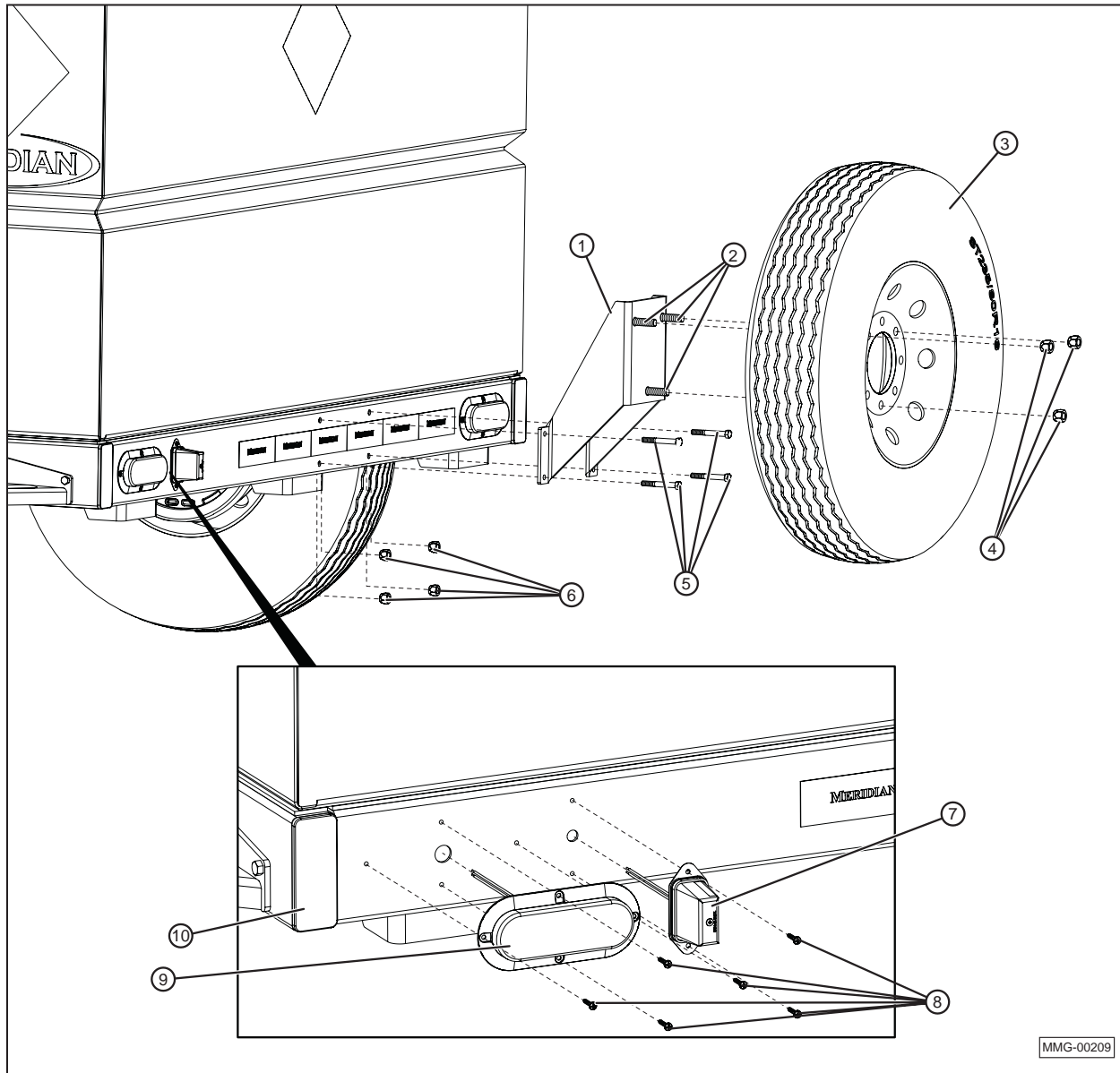

MMG-00209

Item	Qty.	Part No.	Description
1	1	24109	BOLT ON SPARE TIRE MOUNT
2	3	18992	Ø9/16"-18 UNF X 2" H.H.C.S.
3	1	18131 17756	ST235/80R16, TIRE AND STEEL RIM ST235/80R16-E TIRE, ALUMINUM RIM ASSEMBLY
4	3	18991	Ø9/16-18 UNF x 3/4" LUG NUT
5	4	19330	BOLT, HEX, 3/8-16 UNC X 3 STEEL, MILD
6	4	19564	NUT, HEX, FLANGED, 3/8-16 UNC
7	1	17209	CHROME, LED LICENSE PLATE LIGHT (5 DIODES)

Item	Qty.	Part No.	Description
8	21	19779	#8-18 x 3/4" SELF DRILLING ZINC SCREW
9	2	18117	TAIL LIGHT WITH 10 DIODES (LED STL-78RB)
10	2	19619	5" x 2" TUBE PLUG
11	1	14065	HARNES, WIRING (NOT SHOWN)
—	—	68706	SPARE TIRE KIT (STEEL)
—	—	68707	SPARE TIRE KIT (ALUMINIUM)

15.8 DECALS AND SAFETY SIGNS

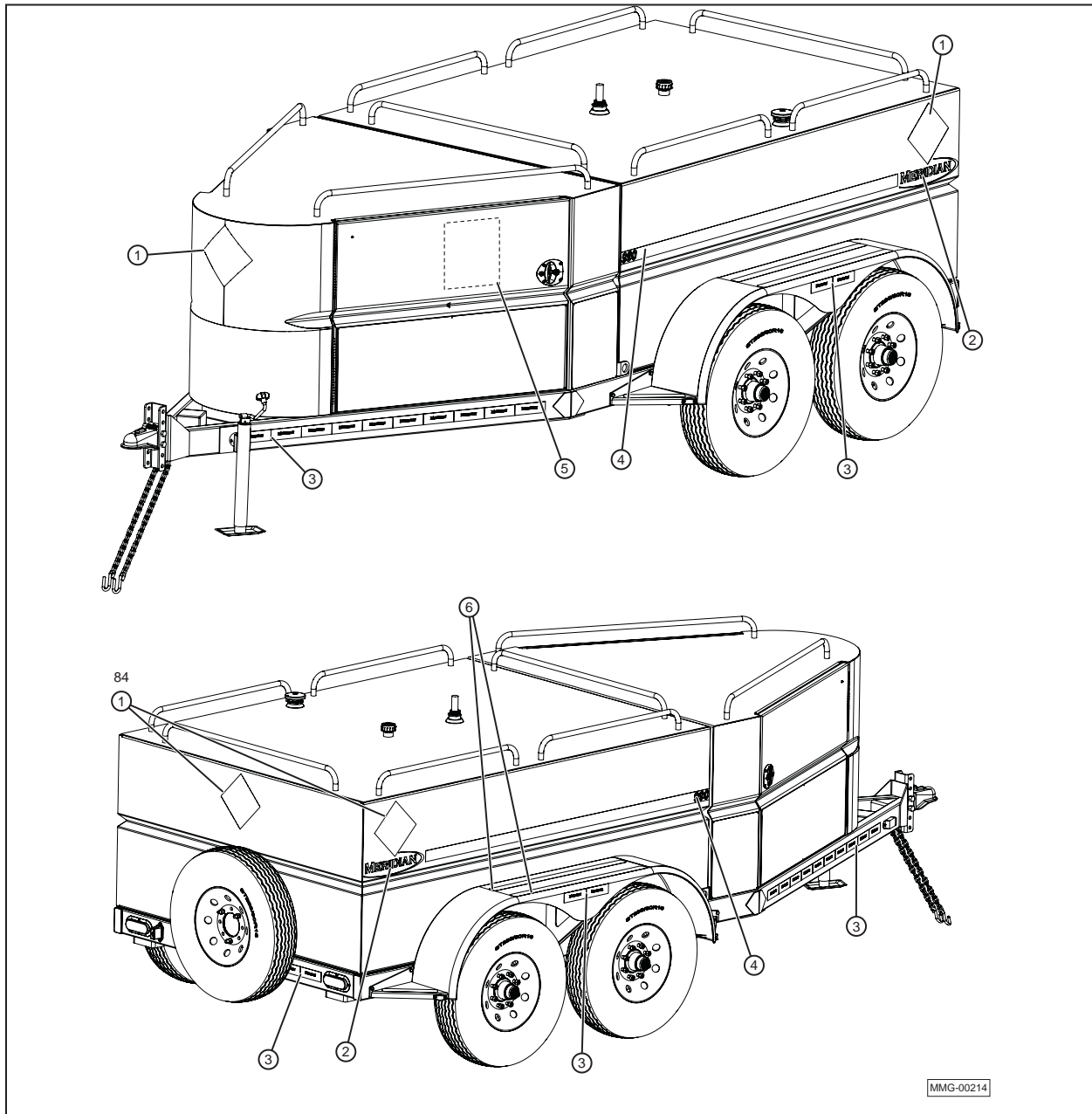

Item	Qty.	Part No.	Description
1	4	11514	1993 PLACARD
2	2	19911	MERIDIAN TRAILER WHITE DECAL
3	—	18096	TAPE REFLECTIVE MERIDIAN 2X6X6
4	2	11528	990 FUEL TRAILER DECAL
5	1	17731	DECAL, WARNING (inside door)
6	4	18118	TAPE, FENDER ANTISLIP

15.9 FRONT ENGINE/PUMP COMPARTMENT

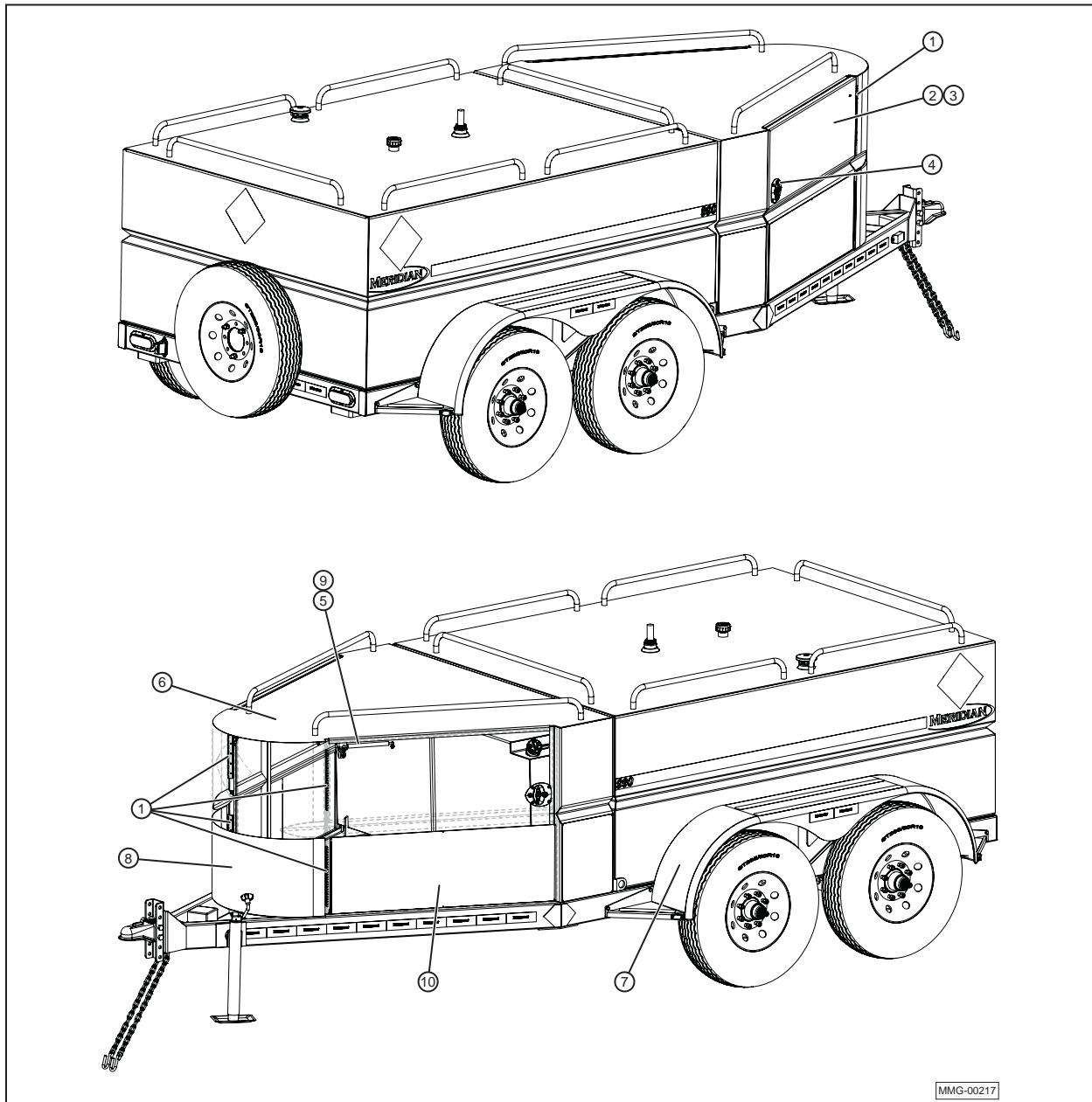

MMG-00217

Item	Qty.	Part No.	Description
1	4	11222	SS HINGE ASSY (1" X 12" L DRILLED)
	48	17042	CAPSCREW #6-32 X 5/8" 18-8 SS FHSS
	48	17043	#6 WASHER X 5/16" OD 18-8 SS
	48	17044	NUT HEX # 6-32 18-8 SS NYLON LOCKNUT
2	1	32436	DS DOOR WELDMENT
3	1	32435	PS DOOR WELDMENT
4	2	11223	VECTOR T-HANDLE - ZINC HANDLE FINISH
5	4	11206	30lb GAS SHOCK/SPRING 15.24" EXT

Item	Qty.	Part No.	Description
6	2	24990	BUTTON SWITCH MOUNT
	2	11526	BUTTON SWITCH
	1	11505	36" - SELF-ADHESIVE, LED STRIP
	1	11525	COWLING WIRE HARNESS
7	2	24956	ALUM. ROCK GUARD - SIDE PANEL
8	1	24954	ALUM. ROCK GUARD - NOSE
9	8	19318	NUT, HEX, FLANGED, 5/16-18 UNC
10	2	24955	ALUM. ROCK GUARD - DOOR

NOTES

NOTES

NOTES

MERIDIAN MANUFACTURING INC.

With over 65 years of experience,
Meridian is your storage and handling expert.



AGRICULTURAL



INDUSTRIAL



OIL & GAS

Cambridge Office
605 Sheldon Drive
Cambridge, ON N1T 2K1
PH: 519.620.6004
TF: 855.346.3712
FX: 519.620.6041

Camrose Office
4232 - 38 St.
Camrose, AB T4V 4B2
PH: 780.672.4516
TF: 800.830.2467
FX: 780.672.4759

Lethbridge Office
3125 - 24 Ave. N.
Lethbridge, AB T1H 5G2
PH: 403.320.7070
TF: 800.661.1436
FX: 403.320.7579

Regina Office
PO Box 1996
Regina, SK S4P 3E1
PH: 306.545.4044
TF: 800.667.5904
FX: 306.545.4216

Storm Lake Office
2902 Expansion Blvd.
Storm Lake, IA 50588
PH: 712.732.1780
TF: 800.437.2334
FX: 712.732.1028

Winkler Office
Box 760, 275 Hespler Ave.
Winkler, MB R6W 4A8
PH: 204.325.7883
TF: 800.665.7259
FX: 204.325.5556



www.meridianmfg.com