

Cat. No. 22-185A

OWNER'S MANUAL

Please read before using this equipment

LCD DIGITAL MULTIMETER

RADIO SHACK
A Division of Tandy Corporation
Fort Worth, Texas 76102

Printed in Taiwan
811018440E

7A8

MICRONTA®

FEATURES

The MICRONTA[®] LCD Digital Multimeter is a portable 3-2/3 digit, compact-sized multimeter ideally suited for field, lab, shop, bench and home applications. Here is a review of some of the features that qualify your new digital multimeter as real "pro"

- The latest IC and display technology is used to achieve the lowest possible component count. This, in turn, ensures reliability, accuracy, stability and a really rugged, easy-to-handle instrument. Two analog-to-digital converters are used for many special features.

- Conveniently positioned range and function switch knobs for one-hand range/function control.
- Colored indication of the referential ranges to the selected function.
- Effective overload and transient protection on all ranges except DC/AC 10A range.
- Continuity function for quick continuity check — buzzer sounds when circuit resistance is approximately 300 ohms or less.

©1988 Tandy Corporation
All Rights Reserved.

Micronta is a registered trademark of Tandy Corporation.

CONTENTS

- Diode check function lets you safely check semiconductor junctions for open, short or normal.
- Over-range indication on each range.
- Full auto-polarity operation.
- Low battery voltage is automatically detected and a caution is displayed.
- Fold-out stand for bench-top use or for hanging-up.

FEATURES	2
SPECIFICATIONS	4
CONTROLS AND FUNCTIONS	8
PREPARING FOR OPERATION	12
CHECK BEFORE OPERATION	16
MAKING MEASUREMENTS	18
FUSE REPLACEMENT	34
MAINTENANCE.....	36
A WORD ABOUT SAFETY	38
SCHEMATIC DIAGRAM	42

Warning: Use extreme caution in the use of this device. Improper use of this device can result in injury or death. Follow all safeguards suggested in this Owner's Manual in addition to normal safety precautions in dealing with electrical circuits. Do not use this device if you are unfamiliar with electrical circuits and testing procedures.

SPECIFICATIONS

Ranges & Accuracy

DC VOLTS

300 mV-3-30-300-3000 V
(Maximum Measurement
= 1000 Volts)

$\pm 0.8\%$ of reading and
 $\pm 0.2\%$ of full scale,
 ± 1 in last digit

AC VOLTS

3-30-300-3000 V
(Maximum Measurement
= 750 Volts RMS)
at 50/60 Hz

$\pm 1\%$ of reading and
 $\pm 0.5\%$ of full scale,
 ± 1 in last digit

45 Hz to 500 Hz
at 30 Volt Range

$\pm 1.5\%$ of reading and
 $\pm 0.5\%$ of full scale,
 ± 1 in last digit

500 Hz to 10 kHz
at 30 Volt Range

$\pm 10\%$ of reading and
 $\pm 0.5\%$ of full scale,
 ± 1 in last digit

Specifications

DC CURRENT

3-30-300 mA-30 A
(Maximum measurement = 10A)

$\pm 1.5\%$ of reading and
 $\pm 0.2\%$ of full scale,
 ± 1 in last digit

AC CURRENT

3-30-300 mA-30 A
(Maximum measurement = 10A)

$\pm 1.5\%$ of reading and
 $\pm 0.5\%$ of full scale,
 ± 1 in last digit

RESISTANCE

300 ohm-3-30-300-3000 kohm

$\pm 1.5\%$ of reading and
 $\pm 0.2\%$ of full scale,
 ± 1 in last digit
+5 digits maximum at
300 ohm range

30 Megohm

$\pm 3\%$ of reading and
 $\pm 0.2\%$ of full scale,
 ± 1 in last digit

<i>Specifications</i>	
Continuity Function:	Continuity buzzer sounds at less than 295 ohm (± 20 ohm) input resistance. Buzzer sounds 100 ms — 150 ms (typical) after input is shorted.
Diode Check Function:	For checking semiconductors open, short or normal.
Input Impedance:	10 Megohm (DCV/ACV). More than 100 Megohm on 300 mV DC
Range Selection:	Manual range
Power Source:	Four "AA" size 1.5V batteries, providing $\pm 3V$
Power Consumption:	10 mW typical
Low Battery Indication:	"BATT" on the left of display indicates when + or - supply is below 2.4V — 2.6V.

	<i>Specifications</i>
Polarity:	Automatic polarity
Overrange Indication:	3000 with blinking "3". When the measured value exceeds the maximum value, all digits on display will blink.
Operating Temperature:	32°F to 122°F (0°C to 50°C)
Storage Temperature:	-4°F to 140°F (-20°C to 60°C)
Weight:	11.6 oz. (330g)
Size:	6-3/4" \times 3-1/16" \times 1-1/4" (170 mm \times 78 mm \times 32 mm)
Accessories:	Fuse (0.5 A/250 V) Banana type test leads (Cat. No. 278-704)

CONTROLS AND FUNCTIONS

①

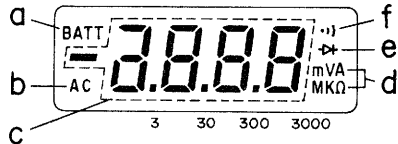

1. Digital display:

- a. **Low BATTERY indicator** — lights when batteries are weak and need replacing.
- b. **AC indicator** — lights when you select the AC voltage/current measurement.
- c. **Measured input values** — shows the measured value with decimal point and minus polarity indication (2999 maximum.)
- d. **Measuring unit indicators** — lights to show the current measuring unit.
- e. **Diode check indicator** — lights in the diode check mode.
- f. **Continuity indicator** — lights during the CONTINUITY check mode.

Controls and Functions

2. **Power switch:** Turns the meter ON and OFF. Set to CONTINUITY for continuity check.

3. **Range switch:** Used for selecting ranges:

Voltage: DC V 300mV, 3V, 30V, 300V, 3000V
(Maximum measurable voltage is 1000V.)

AC V 3V, 30V, 300V, 3000V (Maximum measurable voltage is 750V.)

Current: 3mA, 30mA, 300mA, 10A

Resistance: 300ohm, 3kohm, 30kohm, 300kohm, 3000kohm, 30 Mohm

Diode Check

4. **Function switch:** Used for selecting functions: DC V, AC V, Diode CHECK, kohm, DCmA and ACmA.

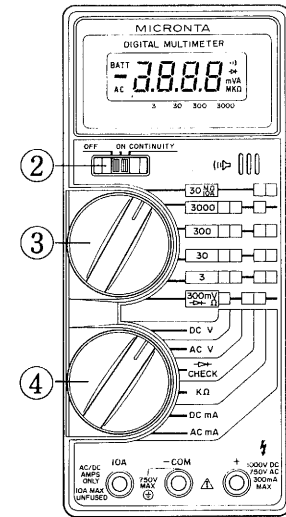

Controls and Functions

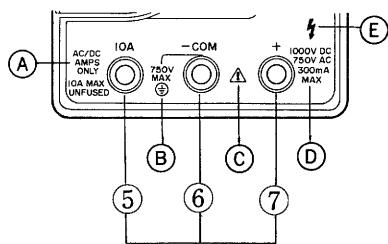

5. Input (10A) jack: Connect (+) red lead for current measurement with the 10A setting of the range switch.

6. Input (-) jack: Connect (-) black lead for all measurements.

7. Input (+) jack: Connect (+) red lead here for all measurements except 10 A range.

8. Battery/fuse Compartment : Open to install/replace fuse and/or batteries.

9. Fold-out Stand: Use to support the multimeter at a convenient viewing angle for benchtop use or to hang it up.

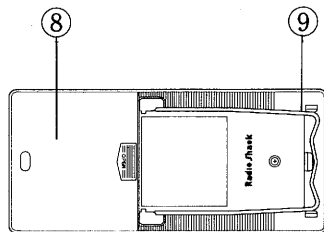

Special Panel Markings

Controls and Functions

Ⓐ	AC/DC AMPS ONLY 10A MAX UNFUSED	Special markings has been added to the panel to remind you of the measurement limitations and safety. The maximum current that can be measured is DC/AC 10A. 10A range is not fuse-protected.
Ⓑ	750V MAX ⊕	To avoid electrical shock and/or instrument damage, do not connect the common input terminal (-jack) to any source of more than 750V with respect to earth/ground.
Ⓒ	⚠	Refer to complete operating instructions.
Ⓓ	1000V DC 750V AC 300mA MAX	The maximum voltage that can be measured is 1000V DC or 750V AC. The maximum current measurement at this terminal is 300 mA.
Ⓔ	⚡	Be extra careful when making measurements for high voltage; DO NOT TOUCH TERMINALS OR PROBE ENDS.

PREPARING FOR OPERATION

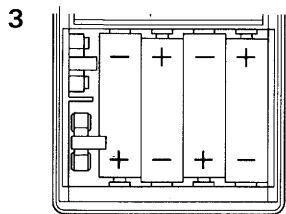
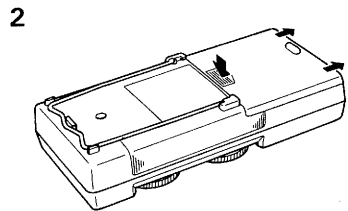
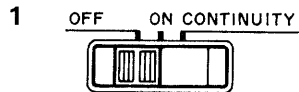

Installing Batteries

All you need to do is load four 1.5V "AA" batteries. We recommend that you use the alkaline type — such as our 23-552.

1. Be sure POWER is OFF and test leads are disconnected.
2. Push the arrow on the battery/fuse compartment cover and press in the direction of the arrow.
3. Snap the batteries in place — watch polarity!
4. Press the cover back into place.

Preparing For Operation

When the batteries become weak, "BATT" will be displayed on the left part of the display. Replace all the batteries. **NEVER LEAVE WEAK OR DEAD BATTERIES IN YOUR UNIT.** Even "leak-proof" types can leak and cause damage to the circuitry.

When you are not going to use your unit for a few weeks, remove the batteries.

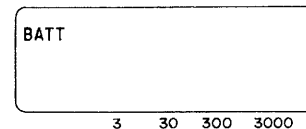

NOT IN USE

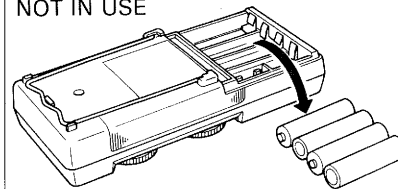

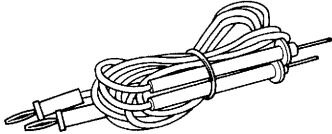
<i>Preparing For Operation</i>	Using Test Leads
<p>Test Leads (Cat. No. 278-704)</p> 	<p>Use only the same type of the test leads as are supplied with your unit. These test leads are rated for 1200 volts; replacements are available from your local Radio Shack store (Radio Shack Cat. No. 278-704).</p> <p>Caution: Although these test leads are rated for 1200 volts, the maximum rating of this meter is 1000 volts DC/750 volts AC. You should not attempt to measure any voltage more than 1000 volts DC/750 volts AC. Use extreme care when using these high voltage ranges.</p>
	<p>Using Stand</p> <p>The fold-out stand allows you to use your unit on the benchtop or hang from a hook.</p>

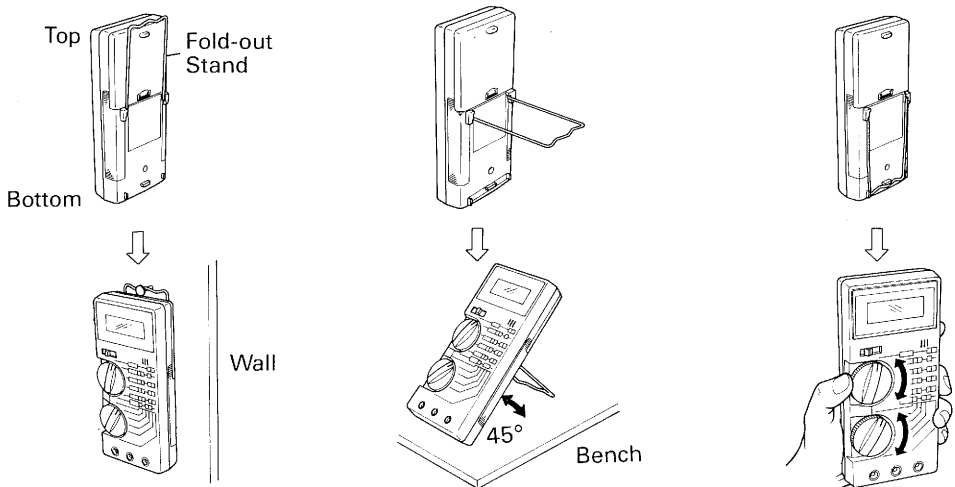
		<i>Preparing For Operation</i>
<p style="text-align: center;">Stand Positions and Their Usage</p>  <p>Note: To fold the stand upwards from the middle position, press at the lower parts on both sides slightly, then turn upwards. The stand can be removed by pressing the lower parts strongly.</p>		

CHECK BEFORE OPERATION

1



2

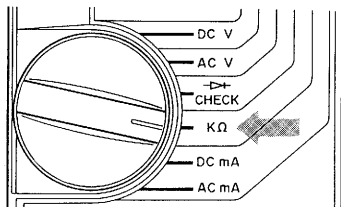

3

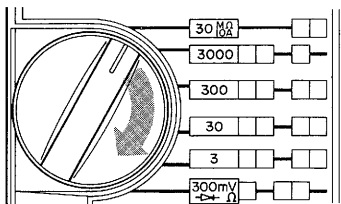

1. Set the power switch to ON. All the elements of the display will appear on the LCD briefly as a self test. The display will soon revert to normal.

2. Set the function switch to kΩ.

3. Rotate the range switch, starting at the top (30 MΩ). The decimal point in the display should be positioned as described in the chart on next page:

Notes:

1. In low voltage ranges, with leads unconnected to any circuit, the display may show some "phantom" readings. This is normal and is caused by the high sensitivity and high input impedance of the meter's circuitry. As soon as a circuit is connected, normal accurate measurements are performed.

Check Before Operation

Functions	Range	Display	Functions	Range	Display
k Ohm	30 Megohm 3000 kohm 300 kohm 30 kohm 3 kohm 300 ohm	dd.dd MΩ dddd kΩ ddd.d kΩ dd.dd kΩ d.ddd kΩ ddd.d Ω	DCmA/ ACmA	10 A 300 mA 30 mA 3 mA	dd.dd A ddd.d mA dd.dd mA d.ddd mA
DCV/ACV	3000 V 300 V 30 V 3 V 300 mV (DCV only)	dddd V ddd.d V dd.dd V d.ddd V ddd.d mV		Continuity	320 ohm (Fixed range)
			Diode Check	3.000 (Fixed range)	d.ddd

2. See the measuring unit on the display to distinguish the range when two ranges have a decimal in the same position. For example, on the 300 mV range the unit display is "mV" against "V" on the 300 V range.

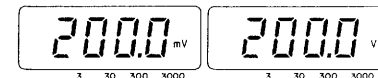

MAKING MEASUREMENTS

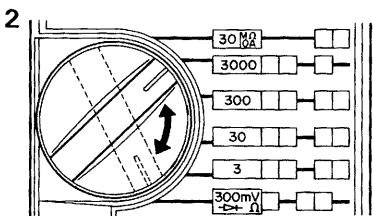
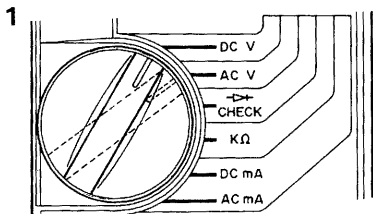

DC/AC Voltage Measurements

Important: The maximum input limit for voltage measurement is 1000 V/DC and 750 V/AC (RMS). If you attempt to measure DC voltages above 1000 volts or AC volts above 750 volts RMS, your unit may be damaged. All the figures on the display will blink when more than the maximum rate (DC 1000 V/AC 750 V) is supplied: **DISCONNECT PROBES IMMEDIATELY.**

1. Set the function switch to DC V or AC V.
2. Set the range switch as required for the voltage level to be measured. If you do not know the voltage level, start with the range switch set to the highest position and reduce the setting as required to obtain a satisfactory reading.

3. Plug the red lead into the + jack and the black lead into the - COM jack.

4. Connect the probes to the circuit to be tested. In DCV, the minus sign will appear if voltage is negative.

5. Read the range by the position of the decimal point.

Making Measurements

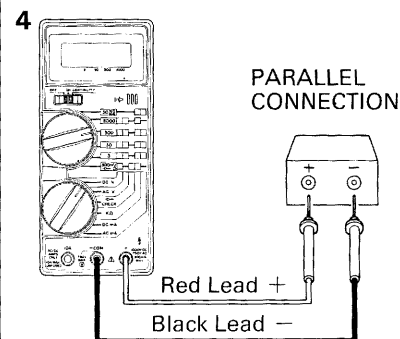
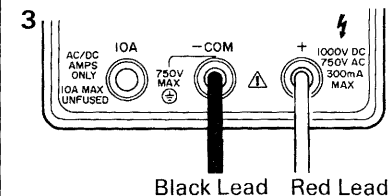

Making Measurements

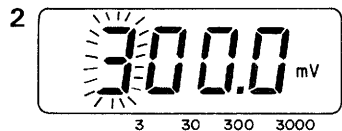
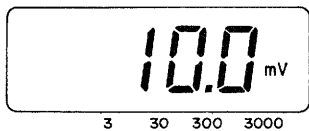
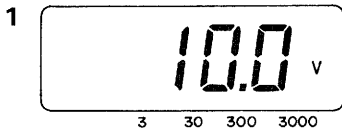

Notes:

1. On 300 V and 300 mV ranges, the decimal point will appear in the same position (one place to the left), but if the 300 mV range is selected, "mV" will appear on the display.
2. If the function switch is rapidly shifted from Kohm to DCV with the range switch set to the 300 mV position, the display might show the over-range indication because of the high input impedance. Short the test leads to remove this condition.
3. When measuring DCV or ACV with no circuit under test the display may show small changes in the lower ranges. This is normal. A high input impedance produces this "wandering" effect. As soon as a circuit is connected, normal accurate measurement is performed.

Making Measurements

HINTS: When you are using the meter to probe for a voltage in a high voltage circuit, we recommend that you do not try to position both of the probes at once. Instead, you should clamp one of the leads to the neutral or ground lead of the circuit (usually a bare, green or white lead, in AC wiring circuits) using our insulated Slip-On Alligator Clips (Cat. No. 270-354), and then probe for voltages with the other probe. This helps to prevent you from accidentally touching a "hot" wire, since you need only concentrate on one test probe. Never clamp on to a "hot" wire, (usually red, black or blue, in AC wiring circuits), since if you did so and then touched the other probe connected to the meter, you could receive an electric shock.

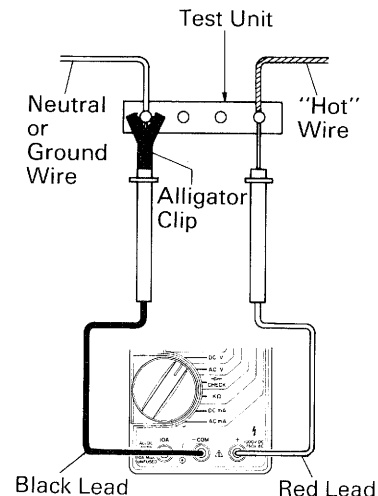

Making Measurements

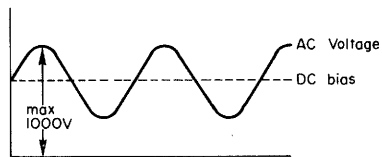

AC Voltage Riding on a DC Source Bias Measurement

You can measure an AC voltage superimposed on a DC voltage source bias. Set the function switch to ACV. However, **NEVER ATTEMPT TO MEASURE ANY CIRCUIT OVER 750V AC** with respect to earth ground.

Measuring 3-Phase AC Voltages

This meter is designed primarily to measure household AC voltages. When measuring 3-phase circuits line-to-line, the value of the voltage will actually be higher than the rated line-to-ground 3-phase voltage. It is important that you do not exceed the maximum RMS AC rating of this meter, which is 750V AC. To determine the highest possible voltage on a 3-phase line, multiply the stated voltage by the square root of three (approximately 1.75). Severe damage as well as a dangerous shock hazard could result if the meter is connected to a circuit that exceeds the voltage rating of the meter.

Making Measurements

Making Measurements

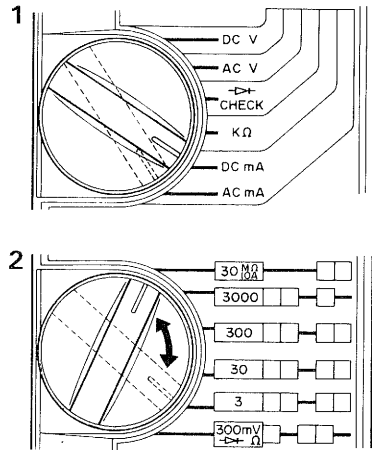

DC/AC Current Measurements

To measure current, you must break the circuit and connect the leads to two circuit connection points. **Never connect the leads across a voltage source;** doing so will blow the fuse or damage the circuit under test. The maximum input limit for DC current/AC current measurement is 10A (with red lead plugged to 10A jack).

1. Set the function switch to DCmA or ACmA.
2. Set the range switch to the desired position.

3. For 300 mA max., plug the red lead into the + jack, and the black lead into the - COM jack.

For 10A max., plug the red lead into the 10A jack, and the black lead into the - COM jack.

4. Remove power from the circuit under test and then break the circuit at the appropriate point.

Making Measurements

- 3 (300 mA Measurement)

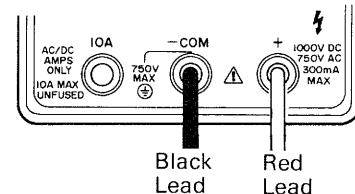

- (10A Measurement)

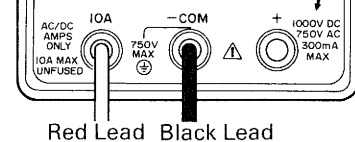

- 4

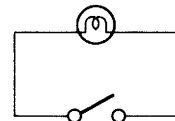

Making Measurements

5. 6

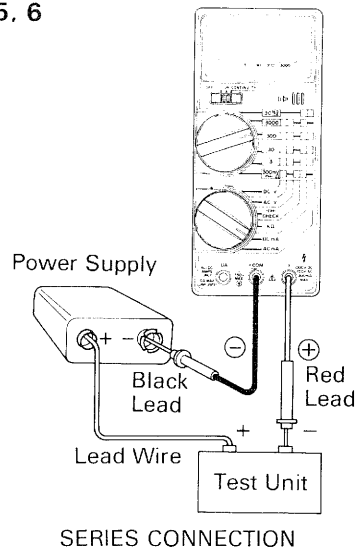

5. Connect probes to the circuit in series.

6. Apply power and read current.

7. If the polarity of the current being measured is negative in DC measurement, the value displayed will be preceded by a minus (–) sign (Figure (a)). Input of more than the maximum rate (DC/AC 10A) will cause the display to blink on and off as a warning (Figure (b)).

(a)

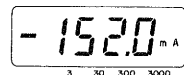

(b)



Note: All current ranges except the 10A are fuse-protected. If inoperative, check the fuse.

Resistance Measurements

Note: The resistance measuring circuit compares the voltage which is gained through a known resistance (internal) with the voltage developed across the unknown resistance. Thus when checking “in-circuit” resistance, be sure the circuit under test has all power removed (are all capacitors fully discharged?).

1. Set the function switch to the $k\Omega$ position.
2. Set the range switch to the desired position.

3. Plug the red test lead into the + jack and the black lead into the – COM jack.

Making Measurements

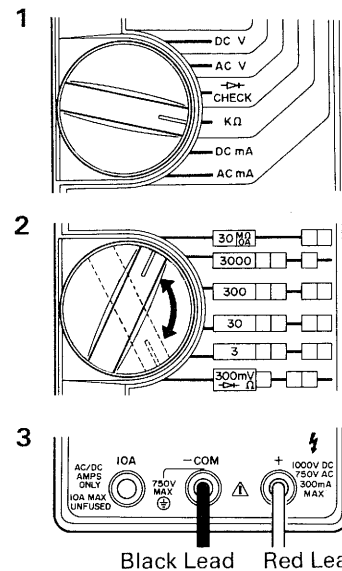

Making Measurements

4

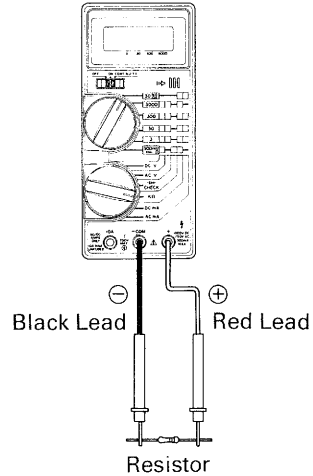

PARALLEL CONNECTION

4. Connect the probes across the circuit to be measured.
5. For resistances of approximately 1 megohm and above, the display may take a few seconds to stabilize. This is normal for high resistance readings.

Use the measuring unit display to see the range you are in. " Ω " or " $k\Omega$ " to distinguish between 300 ohm and 300 kohm, " $M\Omega$ " or " $k\Omega$ " for 30 Megohms vs. 30 kohms.

Notes:

1. Your unit has a circuit to protect the resistance ranges from over-voltage (500V AC 1 minute). To prevent accidentally exceeding the rating of the protection circuit and to ensure the correct measurement, never connect the probes to a source of voltage when the function switch is set to the $k\Omega$ or diode check position.

Making Measurements

2. Some devices could be damaged by the current applied during resistance measurements. The table below lists the voltage and current available for each range.

3. When you short the test leads in the 300 ohm range, a small value (no more than 0.3 ohms) will be displayed. This is due to internal circuit and test leads resistance. You may need to take note of this value and deduct it from the measured value when you measure very small resistances.

Range	A	B	C
300 ohm	3.0 V	180 mV	700 μA
3 k	1.3 V	310 mV	140 μA
30 k	1.3 V	400 mV	20 μA
300 k	1.3 V	460 mV	2 μA
3000 k	0.7 V	440 mV	0.4 μA
30 M	0.7 V	440 mV	0.04 μA

- * A is the open circuit voltage at the jacks in volts.
- * B is the voltage across a resistance equal to full scale value.
- * C is the current through a short circuit at the input jacks. All values are typical.

Making Measurements

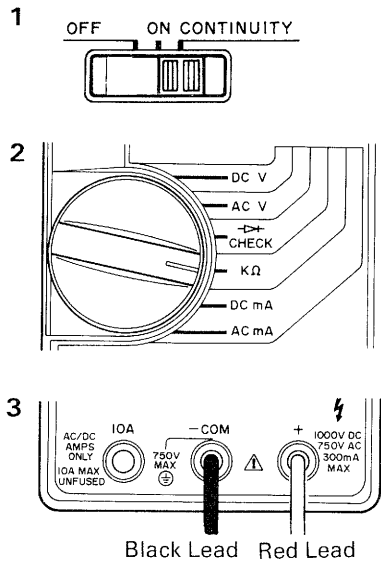

Continuity Function

This tester has a built-in audible continuity function.

1. Set the power switch to the CONTINUITY position.
2. Set the function switch to kΩ.
The range is automatically set to 320 ohm.
3. Connect the red lead into the + jack and the black lead into the - COM jack.

4. Connect the probes to the circuit you want to check.

5. If the circuit resistance is 300 ohms or less, the buzzer will sound.

Note: When the switch is in the CONTINUITY position, the buzzer will also sound when:

1. the function or range switch setting is changed.
2. over-range takes place (except in kohm and diode check functions).

Making Measurements

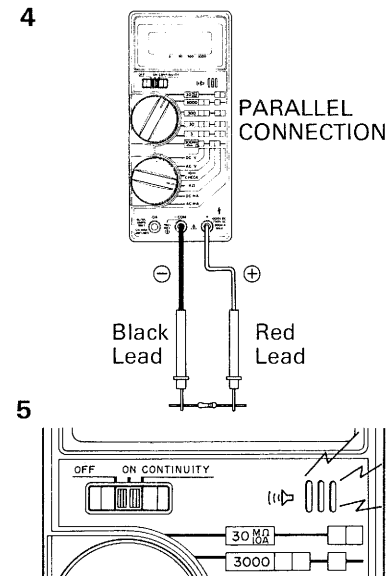

Making Measurements

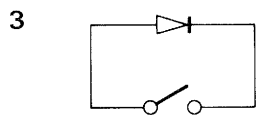
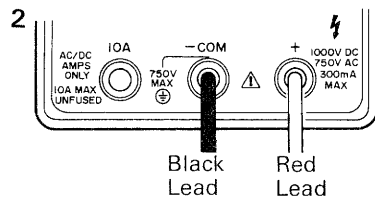
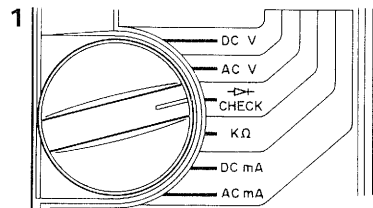

Diode Check

1. Set the function switch to the diode check position. The range is automatically set to 3V.

2. Plug the red test lead into the + jack and the black lead into the - COM jack.

3. Remove power from the circuit under test.

4. Connect the probe to the semiconductor device you want to check and note the meter reading.

5. Reverse the probes and note the second reading. If the first reading shows some value and second is overrange, the device is good. If both are overrange, the device is open. If the readings are both very small or zero, the device is shorted.

Note: The values indicated on the display during the diode check operation shows the actual forward voltage (max. 2V). If the value is around 0.400 the device is germanium type: if it is around 0.600 the device is silicon type. An LED will make the meter display a value of about 1.800.

Making Measurements

4

PARALLEL CONNECTION

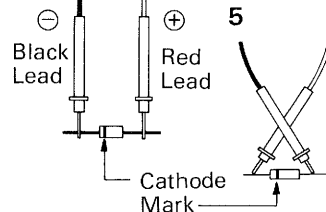
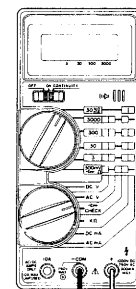

FUSE REPLACEMENT

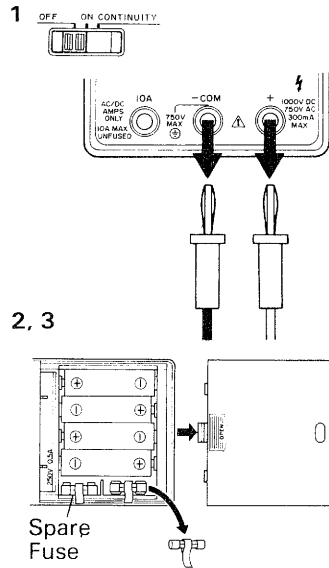

WARNING: TO AVOID ELECTRIC SHOCK, DISCONNECT THE TEST PROBES BEFORE REMOVING BATTERIES OR FUSE. REPLACE ONLY WITH SAME TYPE OF BATTERIES OR FUSE. THIS INSTRUMENT CONTAINS NO USER SERVICEABLE PARTS. SERVICE SHOULD BE PERFORMED ONLY BY QUALIFIED PERSONNEL.

CAUTION: FOR CONTINUED PROTECTION AGAINST FIRE, REPLACE ONLY WITH 0.5A, 250V FUSES (Cat. No. 270-1241).

1. Be sure POWER is OFF and test leads are disconnected.
2. Open the battery/fuse compartment cover.
3. Pull the red ribbon in the fuse compartment; the fuse will pop out.

Fuse replacement

Note: The fuse in your digital multimeter is a special size and type. One spare fuse comes supplied with your unit.

4. Insert a new fuse on the ribbon ring. Use only a fuse of the same type/rating (0.5A, 250V, 5 × 20 mm miniature fuse; Radio Shack Cat. No. 270-1241).
5. Install the new fuse with ribbon in the fuse compartment.
6. Close the battery/fuse compartment cover.

WARNING: DO NOT OPERATE YOUR UNIT UNTIL THE BATTERY/FUSE COVER IS IN PLACE AND FULLY CLOSED.

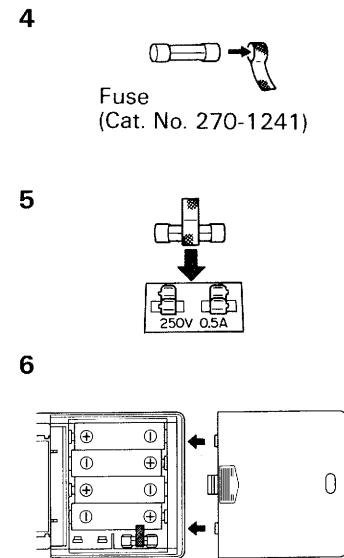

MAINTENANCE



Your MICRONTA LCD DIGITAL MULTIMETER is an example of superior design and craftsmanship, and should be treated with care. The suggestions below will help you enjoy this product for many years.

Keep it dry. If water should get on it, wipe it off. Water contains minerals that can corrode electronic circuits.



Do not store in hot areas. High temperatures can shorten the life of electronic devices, damage batteries, and warp or melt certain plastics.



Do not drop it. This might cause permanent damage. The circuit boards and case can be broken.

Maintenance

Do not use or store it in dusty, dirty areas. This will cause premature wear of moving parts.



Do not use harsh chemicals, cleaning solvents, or strong detergents to clean it. Wipe it with a soft cloth dampened in a mild soap-and-water solution.



Be sure batteries are the correct type—do not use general purpose batteries if alkaline batteries are recommended. Remove old, weak batteries—they can leak chemicals that damage electronic circuits.



If the unit is not working properly, take it to your local Radio Shack. The personnel there will assist you and, if necessary, arrange service.



A WORD ABOUT SAFETY

1

~~ABOVE 1000V DC
ABOVE 750V RMS AC~~

2

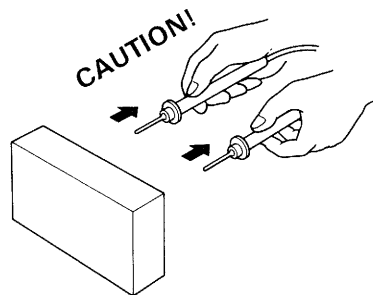

ABOVE 100V

Every precaution has been taken in the design of your meter to ensure that it is as safe as we can make it. However, safe operation depends on you, the operator. We recommend that you follow these simple safety rules:

1. Never apply voltages to the meter that exceed the limits given in the specifications. Never apply more than 1000V DC or 750V RMS AC between input jacks and/or ground.
2. Use extreme caution when working with voltages above 100V. Always disconnect power from the circuit being measured before connecting test leads to high-voltage points.

3. Never connect to a source of voltage when the $K\Omega$ or diode check function is selected.

4. Always discharge filter capacitors before attaching test leads to a power supply.

A Word About Safety

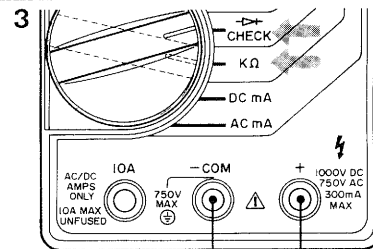

4

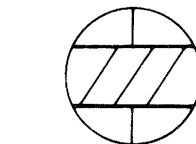

DISCHARGE!

A Word About Safety

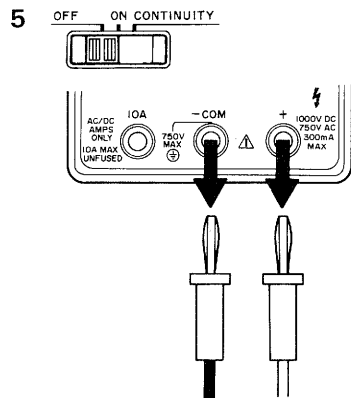

5. Battery and/or fuse replacements should only be performed after the test leads have been disconnected and POWER is OFF.

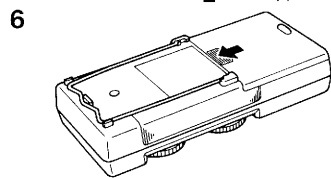

6. Never operate unless the battery cover is in place and fully closed.

A Word About Safety

7. Since many AC-DC sets have a potentially "hot" chassis, be sure that the top of your workbench and the floor underneath it are made of non-conductive materials.

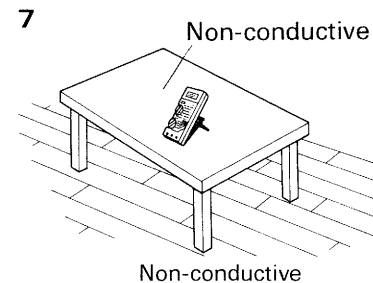

The MICRONTA digital multimeter comes to you fully calibrated and tested. Under normal use, no further adjustment should be necessary. In case the meter should require repair, do NOT try to adjust yourself; bring it to your nearest Radio Shack store. **SERVICE BY UNAUTHORIZED PERSONNEL WILL VOID THE WARRANTY.**

SCHEMATIC DIAGRAM

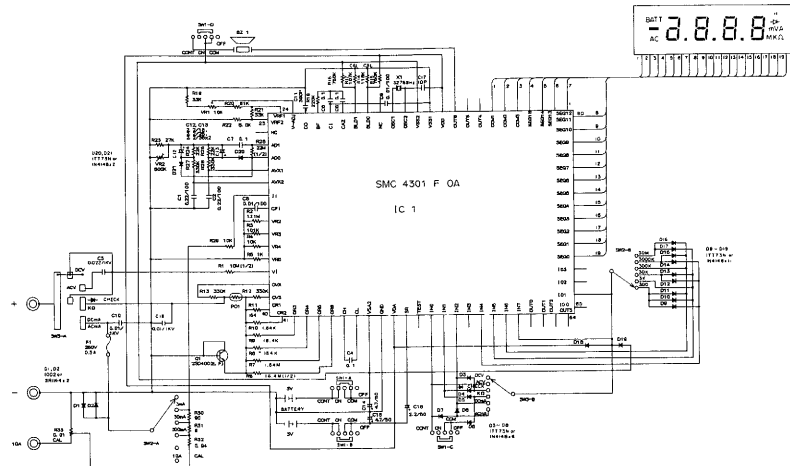

NOTES: (1) ALL RESISTANCE VALUES ARE IN OHM (K=10³ OHM, M=10⁶ OHM)
 (2) ALL CAPACITANCE VALUES ARE IN pF (P=10⁻¹² F)
 (3) SWITCHES:
 SW1 POWER SW WITH CONTINUITY (SLIDE)
 SW2 RANGE SW (ROTARY)
 SW3 FUNCTION SW (ROTARY)

RADIO SHACK LIMITED WARRANTY

This product is warranted against defects for 90 days from date of purchase from Radio Shack company-owned stores and authorized Radio Shack franchisees and dealers. Within this period, we will repair it without charge for parts and labor. Simply **bring your Radio Shack sales slip** as proof of purchase date to any Radio Shack store. Warranty does not cover transportation costs. Nor does it cover a product subjected to misuse or accidental damage.

EXCEPT AS PROVIDED HEREIN, RADIO SHACK MAKES NO WARRANTIES, EXPRESS OR IMPLIED, INCLUDING WARRANTIES OF MERCHANTABILITY AND FITNESS FOR A PARTICULAR PURPOSE. Some states do not permit limitation or exclusion of implied warranties; therefore, the aforesaid limitation(s) or exclusion(s) may not apply to the purchaser.

This warranty gives you specific legal rights and you may also have other rights which vary from state to state.

We Service What We Sell