



**MOTOROLA**

# *MTM800 Enhanced TETRA Mobile Terminal Installation Manual*



**American Communication Systems**

*Discover the Power of Communications™*

***TO ORDER—VISIT <http://www.ameradio.com>***

Publication Number  
6866539D30-L



When printed by Motorola





# COPYRIGHT

---

## Copyrights

© 2007 - 2010 by Motorola Inc.  
All rights reserved.

No part of this manual may be reproduced, transmitted, stored in a retrieval system, or translated into any language or computer language, in any form or by any means, without the prior written permission of Motorola Inc.

---

## Computer Software Copyrights

The Motorola products described in this manual may include copyrighted Motorola computer programs stored in semiconductor memories or other media. Laws in the United States and other countries preserve for Motorola certain exclusive rights for copyrighted computer programs including, but not limited to, the exclusive right to copy or reproduce in any form the copyrighted computer program. Accordingly, any copyrighted Motorola computer programs contained in the Motorola products described in this manual may not be copied, reproduced, modified, reverse-engineered, or distributed in any manner without the express written permission of Motorola. Furthermore, the purchase of Motorola products shall not be deemed to grant either directly or by implication, estoppel, or otherwise, any license under the copyrights, patents or patent applications of Motorola, except for the normal non-exclusive royalty-free license to use that arises by operation of law in the sale of a product.

---

## Trademarks

Motorola, the Motorola Logo and all other trademarks identified as such herein are trademarks of Motorola Inc. All other product or service names are the property of their respective owners.

**THIS PAGE INTENTIONALLY LEFT BLANK**

# IMPORTANT SAFETY INFORMATION

## Icon Conventions

**WARNING**

The signal word **Warning** with the associated safety icon implies information that, if disregarded, could result in death or serious injury, or serious product damage.

**CAUTION**

The signal word **Caution** with the associated safety icon implies information that, if disregarded, may result in minor or moderate injury, or serious product damage.

**CAUTION**

The signal word **Caution** may be used without the safety icon to state potential damage or injury that is not related to the product.

**NOTE**

Notes contain information more important than the surrounding text, such as exceptions or preconditions. They also refer the reader elsewhere for additional information, remind the reader how to complete an action (when it's not part of the current procedure, for instance), or tell the reader where something is located on the screen. There is no warning level associated with a Note.

## Installation Requirements for Compliance with Radio Frequency (RF) Energy Exposure Safety Standards

### ATTENTION!

**This radio is intended for use in occupational/controlled conditions, where users have full knowledge of their exposure and can exercise control over their exposure to meet FCC limits. This radio device is NOT authorized for general population, consumer, or any other use.**

To ensure compliance to RF Energy Safety Standards:

- Install only Motorola approved antennas and accessories.
- Be sure that Product Safety and RF Safety Booklet enclosed with this radio is available to the end user upon completion of the installation of this radio.

Before using this product, the operator must be familiar with the RF energy awareness information and operating instructions in the Product Safety and RF Exposure booklet enclosed with each radio (Motorola Publication part number 6866537D37) to ensure compliance with Radio Frequency (RF) energy exposure limits.

For a list of Motorola-approved antennas and other accessories, visit the following web site which lists approved accessories for your radio model:

<http://www.motorola.com/governmentandenterprise>

## ADDITIONAL IMPORTANT INFORMATION FOR SERVICING AND INSTALLING THE TERMINAL

Only specialized workshops should be contacted for installation, maintenance and repair work. This unit is equipped with protection fuses in the Power and Ignition Sense Cable. Replace these fuses only with the original ratings!

**CAUTION**

**Failure to use correct manufacturer-approved parts may result in physical damage to this unit.**

Fuse for Power Cable GKN6270/GKN6274: 10A (Motorola Part Number: 6500139767)  
Fuse for Ignition Sense Cable HKN9327: 4A (Motorola Part Number: 6580283E02)

## DOCUMENT HISTORY

The following major changes have been implemented in this manual since the previous edition:

<b>Edition</b>	<b>Description</b>	<b>Date</b>
6866539D30-A	Initial edition	Mar 2007
6866539D30-B	Ferrite Clamp included	Mar 2007
6866539D30-C	Legacy errors corrections	May 2007
6866539D30-D	Changes in ferrite clamp installation Accessory part numbers updated	Aug 2007
6866539D30-E	Note regarding installation PIN 12 description corrections	Jul 2008
6866539D30-F	Toroids added for Remote Mount Installation	Mar 2009
6866539D30-G	Data Box solution included	May 2009
6866539D30-H	Rated Power and Distance table corrected	May 2009
6866539D30-J	Dual Control Head installation	Jul 2009
6866539D30-K	Ferrite Clamps for Dual Control Head cable added	Sep 2009
6866539D30-L	Dual Control Head installation removed	May 2010

**THIS PAGE INTENTIONALLY LEFT BLANK**

# CONTENTS

<b>COPYRIGHT</b> .....	<b>3</b>
<b>Copyrights</b> .....	<b>3</b>
<b>Computer Software Copyrights</b> .....	<b>3</b>
<b>Trademarks</b> .....	<b>3</b>
<b>IMPORTANT SAFETY INFORMATION</b> .....	<b>5</b>
<b>Icon Conventions</b> .....	<b>5</b>
<b>Installation Requirements for Compliance with Radio Frequency (RF) Energy Exposure Safety Standards</b> .....	<b>5</b>
<b>Additional Important Information for Servicing and Installing the Terminal</b> . . . .	<b>6</b>
<b>DOCUMENT HISTORY</b> .....	<b>7</b>
<b>CONTENTS</b> .....	<b>9</b>
<b>SCOPE</b> .....	<b>13</b>
<b>Scope of This Manual</b> .....	<b>13</b>
MTM800 Enhanced Manuals and User Guides .....	14
Warranty and Service Support .....	15
<b>Service Information</b> .....	<b>16</b>
Europe, Middle East and Africa Region .....	16
EMEA Systems Support Centre (ESSC) .....	16
EMEA Systems Component Centre (ESCC) .....	16
Parts Identification and Ordering .....	17
EMEA Test Equipment Support .....	17
Your Input .....	17
Updated Versions of this Manual .....	17
Asia, Pacific Region .....	18
Piece Parts .....	18
Technical Support .....	18
Further Assistance from Motorola .....	18
Parts Identification and Ordering .....	18
Latin America Region .....	19
<b>MODEL INFORMATION &amp; ACCESSORIES</b> .....	<b>21</b>
<b>MTM800 Enhanced Mobile Terminal Model Information</b> .....	<b>21</b>
<b>Sales Model Nomenclature</b> .....	<b>21</b>

Model Specifications\* .....22  
 Model Descriptions\*\* .....23  
 Accessories-to-Model Chart .....24

**INSTALLATION ..... 27**

**Introduction .....27**

General Information .....27

**DC Power Cable Installation .....28**

Installation Planning .....28

Installation Procedure .....29

**Ignition Sense Cable Installation .....31**

**Terminal Installation .....32**

Enhanced Control Head Installation .....32

Trunnion Installation .....33

Installation Planning .....33

Installation Procedure .....34

Dashboard Installation .....35

Installing the Radio in an Automotive Dashboard .....35

Mounting the Radio in the Frame .....35

Remove the Radio from the Frame .....37

Desktop Installation .....38

Planning .....38

Installation .....38

Remote Mount Installation .....40

Installing the Remote Mount Enhanced Control Head onto the Remote Mount Trunnion  
41

Installing the Remote Mount Enhanced Control Head in a DIN Mount Bracket .....42

Inserting the Remote Mount Enhanced Control Head with the DIN Mount Bracket into the  
DIN Frame .....43

Adding Extra Connectivity to the Remote Head .....44

Installing the Accessories Expansion Cable .....44

Motorcycle Mount Enhanced Control Head Installation .....45

Planning .....45

Installing the Motorcycle Mount Enhanced Control Head .....46

Mechanical Parts .....48

Installation of the Motorcycle Mount TELCO Cable (PMKN4030) .....48

Adding Extra Connectivity to the Motorcycle Mount Enhanced Control Head .....48

**Data Expansion Head Enhanced Installation .....49**

Data Expansion Head Enhanced Radio without Control Head .....49

Data Expansion Head Enhanced with 3rd Party Control Head .....50

Data Box Radio .....51

Junction Box Installation .....52

General .....52

Installation .....52

Service . . . . .	53
Connections . . . . .	53
Connection Plan for the Junction Box Accessory Terminal . . . . .	54
Connection Plan for Accessory Connector Kit (GMBN1021) . . . . .	57
<b>Connectors and Pin Assignment of the Radio . . . . .</b>	<b>59</b>
Transceiver Rear Side - Pin Function . . . . .	59
Accessory Connection Plan . . . . .	61
<b>Connectors and Pin Assignment of Data Expansion Head Enhanced and Remote Head Enhanced . . . . .</b>	<b>62</b>
10-Pin TELCO Connector . . . . .	62
25-Pin subD Connector . . . . .	63
9-Pin subD Connector . . . . .	65
<b>Connector and Pin Assignment of the Enhanced Control Head . . . . .</b>	<b>66</b>
<b>Connecting Cables . . . . .</b>	<b>69</b>
Motorcycle Mount Enhanced Control Head-to-Remote Head Enhanced/Data Expansion Head Enhanced (Motorcycle Mount TELCO Cable) . . . . .	69
Remote Mount Enhanced Control Head/Motorcycle Mount Enhanced Control Head-to-Accessories (Accessories Expansion Cable) . . . . .	70
Radio-to-Junction Box . . . . .	71
Data Expansion Head Enhanced Radio-to-Data Device . . . . .	72
Data Expansion Head Enhanced Radio-to-Fist Microphone . . . . .	73
Operation . . . . .	73
Making Connections . . . . .	73
Removing the Existing Coiled Cord Cable . . . . .	73
Radio-to-Data Device: Active Data Cable . . . . .	74
Cable Connectivity . . . . .	74
<b>Vehicle Antenna Installation . . . . .</b>	<b>75</b>
Mobile Radio Operation and EME Exposure . . . . .	75
Selecting an Antenna Site . . . . .	75
Antenna Installation Procedure . . . . .	76
Completing the Installation . . . . .	76
<b>External Speaker Installation . . . . .</b>	<b>77</b>
<b>UPGRADING THE TERMINAL . . . . .</b>	<b>85</b>
<b>Upgrade Procedure from MTM800 to MTM800 Enhanced . . . . .</b>	<b>85</b>
From an MTM800 Dash/Desk Radio to an MTM800 Enhanced Dash/Desk Radio . . . . .	85
From an MTM800 Remote Radio to an MTM800 Enhanced Remote Radio . . . . .	86
From an MTM800 Motorcycle Radio to an MTM800 Enhanced Motorcycle Radio . . . . .	87
Using the MR7.4 or Subsequent Software . . . . .	88
<b>APPENDIX . . . . .</b>	<b>91</b>
<b>Product Specific Information . . . . .</b>	<b>91</b>

Equipment Electrical Ratings . . . . . 91  
Normal Load Conditions . . . . . 91  
Fuse Identification . . . . . 92

# SCOPE

## Scope of This Manual

This manual is intended for use by service technicians familiar with similar types of equipment. It contains information required for the installation of the equipment described and is current as of the printing date. Changes which occur after printing date may be incorporated by a complete Manual revision or alternatively as additions.



### NOTE

**The mobile terminal has to be installed by trained service personnel only.**

**All installations should take place in accordance with the requirements of the vehicle and antenna manufacturer/supplier.**

This manual is divided into the following sections:

- Safety and General Information
- Document History
- Contents
- Scope of this manual
- Model Information
- Installation
- APPENDIX Product Specific Information

---

## MTM800 Enhanced Manuals and User Guides

### Installation Instructions

6866539D30 MTM800 Enhanced Installation Manual (English)

### Service Manual

6866539D28 MTM800 Enhanced Basic Service Manual (English)

### Quick Start Guides

68015000276 MTM800 Enhanced Quick Start Guide (English)  
68015000277 MTM800 Enhanced Quick Start Guide (Spanish)  
68015000278 MTM800 Enhanced Quick Start Guide (Norwegian)  
68015000279 MTM800 Enhanced Quick Start Guide (Dutch)  
68015000280 MTM800 Enhanced Quick Start Guide (German)  
68015000281 MTM800 Enhanced Quick Start Guide (Polish)  
68015000275 MTM800 Enhanced Quick Start Guide (Italian)  
68015000274 MTM800 Enhanced Quick Start Guide (French)  
68015000244 MTM800 Enhanced Quick Start Guide (Danish)  
68015000241 MTM800 Enhanced Quick Start Guide (Swedish)  
68015000234 MTM800 Enhanced Quick Start Guide (Traditional Chinese)  
68015000227 MTM800 Enhanced Quick Start Guide (Simplified Chinese)  
68015000224 MTM800 Enhanced Quick Start Guide (Korean)  
68015000221 MTM800 Enhanced Quick Start Guide (Arabic)  
68015000222 MTM800 Enhanced Quick Start Guide (Lithuanian)  
68015000303 MTM800 Enhanced Quick Start Guide (Portuguese)  
68015000304 MTM800 Enhanced Quick Start Guide (Russian)  
68015000305 MTM800 Enhanced Quick Start Guide (Greek)  
68015000312 MTM800 Enhanced Quick Start Guide (Romanian)

### User Guides

6866539D25 MTM800 Enhanced Feature User Guide (English)  
6871075M01 MTM800 Enhanced Feature User Guide (Simplified Chinese)  
6871076M01 MTM800 Enhanced Feature User Guide (Traditional Chinese)  
6871077M01 MTM800 Enhanced Feature User Guide (Korean)  
6866539D49 MTM800 Enhanced Feature User Guide (Hungarian)  
6866539D78 MTM800 Enhanced Feature User Guide (German)  
6866539D77 MTM800 Enhanced Feature User Guide (Danish)  
6866539D80 MTM800 Enhanced Feature User Guide (Croatian)  
6866539D79 MTM800 Enhanced Feature User Guide (Macedonian)

### Safety Leaflets

6804112J96 Mobile Safety Leaflet (APAC & LACR) or  
6804113J25 Mobile Safety Leaflet (APAC & LACR) especially for TETRA Mobiles  
6866537D37 Mobile Safety Leaflet (EMEA)

## Warranty and Service Support

Motorola offers long term support for its products. This support includes full exchange and/or repair of the product during the warranty period, and service/ repair or spare parts support out of warranty. Prior to shipping any terminal back to the appropriate Motorola warranty depot, please contact Customer Resources or your Motorola dealer, distributor or reseller.

All returns must be accompanied by a Warranty Claim Form, available from your Customer Service representative or Motorola Online Extranet (MOL) or your Motorola dealer, distributor or reseller.

### Warranty Period and Return Instructions

The terms and conditions of warranty are defined fully in the Motorola Customer, Dealer or Distributor or Reseller contract. These conditions may change from time to time and the following notes are for guidance purposes only.

In instances where the product is covered under a "return for replacement" or "return for repair" warranty, a check of the product should be performed prior to shipping the unit back to Motorola. This is to ensure that the product has been correctly programmed or has not been subjected to damage outside the terms of the warranty.

Prior to shipping any terminal back to the appropriate Motorola warranty depot, please contact Customer Resources (please refer to following pages). All returns must be accompanied by a Warranty Claim Form, available from your Customer Services representative. Products should be shipped back in the original packaging, or correctly packaged to ensure no damage occurs in transit.

### After Warranty Period

After the Warranty period, Motorola continues to support its products in two ways.

- Motorola's Regional Radio Support Centres offer a repair service to both end users and dealers at competitive prices.
- AAD supplies individual parts and modules that can be purchased by dealers who are technically capable of performing fault analysis and repair.

## Service Information

### Europe, Middle East and Africa Region

#### EMEA Systems Support Centre (ESSC)

The EMEA Systems Support Centre provides a remote Technical Support Service to help customers resolve technical issues and quickly restore networks and systems. This team of highly skilled professionals is available to customers with current service agreements in place that include the Technical Support Service. The ESSC technical experts may be accessed through the EMEA Integrated Call Center either electronically or using the telephone numbers listed below. If you are unsure as to whether or not your current service agreement entitles you to benefit from this service, or if you would like more information about the Technical Support Service, please contact your local customer support or account manager for further information.

Contact details:

Email: [ESSC@motorola.com](mailto:ESSC@motorola.com)

List of Telephone Numbers:

Country	In Country Number to Dial
Austria	01206091087
Denmark	043682114
France	0157323434
Germany	06950070204
Italy	0291483230
Lithuania	880 030 828
Netherlands	0202061404
Norway	24159815
Portugal	0217616160
Spain	0912754787
Russia	810 800 228 41044 (Alternative 810 800 120 1011)
Saudi Arabia	800 844 5345
United Kingdom (except for Thales/LUL Connect)	02030 277499
Thales/LUL Connect	02030 277500

It is recommended that access from any other country uses: +44 2030 277499

#### EMEA Systems Component Centre (ESCC)

The European Systems Component Centre provides a repair service for infrastructure equipment. Customers requiring repair service should contact the Customer Information Desk to obtain a Return

Material Authorisation number. The equipment should then be shipped to the following address unless advised otherwise.

Motorola GmbH, European Systems Component Centre, Am Borsigturm 130, 13507 Berlin, Germany

Contact details:

Email: [ESCC.admin@motorola.com](mailto:ESCC.admin@motorola.com)

Telephone Number: +49 30 66861555

Fax: +49 30 66861426

Mon - Fri 08:00 am to 06:00 pm (CET)

## Parts Identification and Ordering

Request for help in identification of non-referenced spare parts should be directed to the Customer Care Organization of Motorola's local area representation. Orders for replacement parts, kits and assemblies should be placed directly on Motorola's local distribution organization or via the Extranet site Motorola Online at <https://emeaonline.motorola.com>.

## EMEA Test Equipment Support

Information related to support and service of Motorola Test Equipment is available by calling the Motorola Test Equipment Service Group in Germany at +49 (0) 6128 702179, Telefax +49 (0) 6128 951046, through the Customer Care Organization of Motorola's local area representation, or via the Internet at <http://www.gd-decisionssystem.com/cte/>.

## Your Input

...is much appreciated. If you have any comments, corrections, suggestions or ideas for this publication or any other requirements regarding Motorola publications, please send an e-mail to [doc.emea@motorola.com](mailto:doc.emea@motorola.com).

## Updated Versions of this Manual

...are available at our Extranet site Motorola Online. Contact us at [doc.emea@motorola.com](mailto:doc.emea@motorola.com) for access.

---

## Asia, Pacific Region

### Piece Parts

Some replacement parts, spare parts, and/or product information can be ordered directly. If a complete Motorola part number is assigned to the part, it is available from Motorola Radio Aftermarket and Accessory Division (AAD). If no part number is assigned, the part is not normally available from Motorola. If a parts list is not included, this generally means that no user-serviceable parts are available for that kit or assembly.

Note on this digital TETRA Terminal: **The CPS has no capability to tune the terminal. Tuning the terminal can only be performed at the factory or at the appropriate Motorola Repair Centre. Component replacement can affect the terminal tuning and must only be performed by the appropriate Motorola Repair Centre.**

All orders for parts/information should include the complete Motorola identification number. All part orders should be directed to your local AAD office. Please refer to your latest price pages.

### Technical Support

Technical support is available to assist the dealer/distributor in resolving any malfunction which may be encountered. Initial contact should be by telephone wherever possible.

When contacting Motorola Technical Support, be prepared to provide the product model number and the unit's serial number.

### Further Assistance from Motorola

You can also contact the Customer Help Desk through the following web address:

<http://www.motorola.com/governmentandenterprise/contactus>.

### Parts Identification and Ordering

Request for help in identification of non-referenced spare parts should be directed to the Customer Care Organization of Motorola's local area representation. Orders for replacement parts, kits and assemblies should be placed directly on Motorola's local distribution organization or via Motorola Online (Extranet).

---

## Latin America Region

Latin America Radio Support Centres  
The Customer Support is available through the following service centres:

### Warranty and Repairs:

#### **MOTOROLA DE COLOMBIA SERVICE CENTRE**

Torre Banco Ganadero  
Carrera 7 No. 71-52  
Torre B piso 13  
Oficina 1301  
Bogota - Colombia  
(571) 376-6990

#### **MOTOROLA DE MEXICO SERVICE CENTRE**

Bosques de Alisos #125  
Col. Bosques de las Lomas  
CP 05120 Mexico DF  
5252576700

### Piece Parts:

To order parts in Latin America and the Caribbean contact your local Motorola CGISS representative.

#### **MOTOROLA, INC.**

Latin American Countries Region  
789 International Parkway  
Sunrise, FL 33325  
USA 954-723-8959

#### **MOTOROLA DE ARGENTINA**

Ave. del Libertador 1855  
B1638BGE, Vicente Lopez  
Buenos Aires, Argentina  
5411-4317-5300

#### **MOTOROLA DE LOS ANDES C.A.**

Ave. Francisco de Miranda  
Centro Lido, Torre A  
Piso 15, El Rosal  
Caracas, 1060 Venezuela  
58212-901-4600

#### **MOTOROLA DO BRASIL LTDA.**

Av. Chedid Jafet  
222 Bloco D Conjuntos 11,12,21,22 E 41  
Condominio Millennium Office Park  
04551-065- Vila Olimpia, Sao Paulo  
Brasil  
5511-3847-668

#### **MOTOROLA CHILE**

Ave. Nueva Tajarar 481  
Edif. World Trade Center  
Of. 1702, Torre Norte  
Las Condes  
Santiago, Chile  
562-338-9000

#### **MOTOROLA DE COLOMBIA, LTDA.**

Carrera 7 #71-52  
Torre A, Oficina 1301  
Bogotá, Colombia  
571-376-6990

#### **MOTOROLA DE COSTA RICA**

Parque Empresarial Plaza Roble  
Edificio El Portico, 1er Piso  
Centro de Negocios Internacional  
Guachepelin, Escazu  
San Jose, Costa Rica  
506-201-1480

#### **MOTOROLA DEL ECUADOR**

Autopist Gral. Rumiñahui, Puente 2  
Conjunto Puerta del Sol Este-Ciudad Jardin  
Pasa E, Casa 65  
Quito, Ecuador  
5932-264-1627

#### **MOTOROLA DE MEXICO, S.A.**

Calle Bosques de Alisos #125  
Col. Bosques de Las Lomas  
05120 México D.F.  
México  
52-555-257-6700

#### **MOTOROLA DEL PERU, S.A.**

Ave. República de Panama 3535  
Piso 11, San Isidro  
Lima 27, Peru  
511-211-0700

### Technical Support:

<https://businessonline.motorola.com>, go to Contact Us to request technical support

Some replacement parts, spare parts, and/or product information can be ordered directly. If a complete Motorola part number is assigned to the part, it is available from Motorola. If no part number is assigned, the part is not normally available from Motorola. If the part number is appended with an asterisk, the part is serviceable by Motorola Depot only. If a parts list is not included, this generally means that no user-serviceable parts are available for that kit or assembly.

**THIS PAGE INTENTIONALLY LEFT BLANK**

# MODEL INFORMATION & ACCESSORIES

## MTM800 Enhanced Mobile Terminal Model Information

This manual applies to the following Mobile Terminal Models

Type No.	Sales Model No.	Short Description	Model
MT512M MT712M MT812M MT912M	M80RCS6TZ5AN M80UCS6TZ5AN M80NCS6TZ5AN M80PCS6TZ5AN	MTM800 ENH 410-470 MHz, DASH MTM800 ENH 806-870 MHz, DASH MTM800 ENH 350-390 MHz, DASH MTM800 ENH 380-430 MHz, DASH	M1
MT512M MT712M MT812M MT912M	M80RCS6TZ4AN M80UCS6TZ4AN M80NCS6TZ4AN M80PCS6TZ4AN	MTM800 ENH 410-470 MHz, DESK MTM800 ENH 806-870 MHz, DESK MTM800 ENH 350-390 MHz, DESK MTM800 ENH 380-430 MHz, DESK	M2
MT512M MT712M MT812M MT912M	M80RCS6TZ6AN M80UCS6TZ6AN M80NCS6TZ6AN M80PCS6TZ6AN	MTM800 ENH 410-470 MHz, REMOTE MTM800 ENH 806-870 MHz, REMOTE MTM800 ENH 350-390 MHz, REMOTE MTM800 ENH 380-430 MHz, REMOTE	M3
MT512M MT712M MT812M MT912M	M80RCS6TZ2AN M80UCS6TZ2AN M80NCS6TZ2AN M80PCS6TZ2AN	MTM800 ENH 410-470 MHz, M'CYCLE MTM800 ENH 806-870 MHz, M'CYCLE MTM800 ENH 350-390 MHz, M'CYCLE MTM800 ENH 380-430 MHz, M'CYCLE	M4
MT512M MT712M MT812M MT912M	M80RCA6TZ5AN M80UCA6TZ5AN M80NCA6TZ5AN M80PCA6TZ5AN	MTM800 ENH 410-470 MHz, DATA MTM800 ENH 806-870 MHz, DATA MTM800 ENH 350-390 MHz, DATA MTM800 ENH 380-430 MHz, DATA	M5

## Sales Model Nomenclature

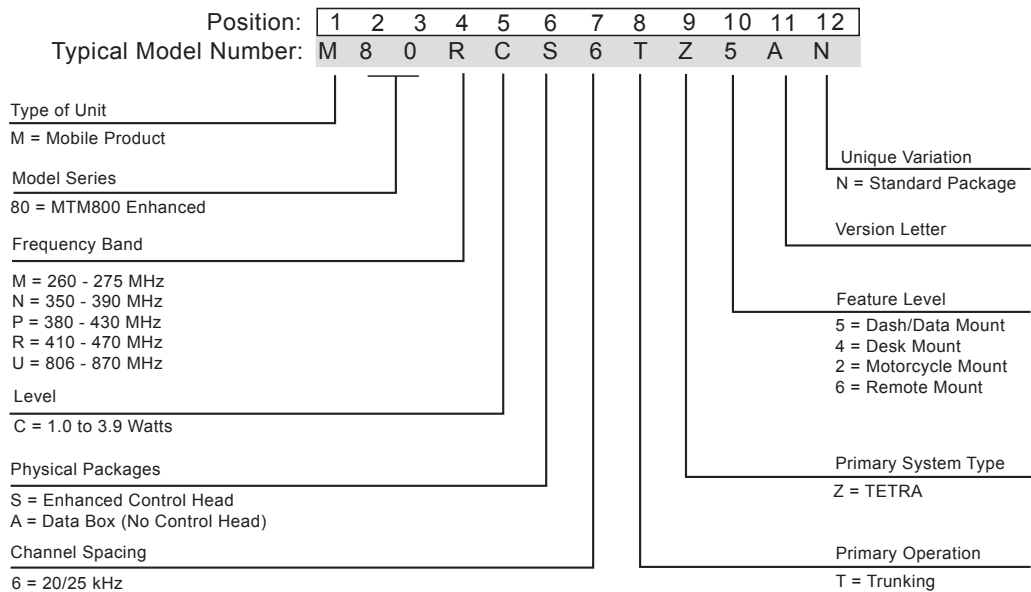

## Model Specifications\*

GENERAL		RECEIVER		TRANSMITTER	
<b>ETSI:</b>	ETS 300 394-1	<b>Receiver Type:</b>	Superheterodyne	<b>Modulation Type:</b>	$\pi/4$ DQPSK
<b>Type Number:</b>		<b>Frequency Range:</b>		<b>RF Power:</b>	
MTM800 ENH 410-470 MHz	MT512M	MTM800 ENH		TMO	
MTM800 ENH 806-870 MHz	MT712M	MTM800 ENH	380-430 MHz	DMO	
MTM800 ENH 350-390 MHz	MT812M	MTM800 ENH	851-870 MHz		
MTM800 ENH 380-430 MHz	MT912M	MTM800 ENH	350-390 MHz		
			410-470 MHz		
<b>Temperature Range for Transceiver:</b>		<b>Channel Spacing:</b>	25 kHz	<b>Frequency Range TMO:</b>	
Operating	-30°C to +60°C	<b>Sensitivity (3.5%) BER:</b>	-112 dBm	MTM800 ENH	380-430 MHz
Storage:	-40°C to +85°C			MTM800 ENH	806-825 MHz
				MTM800 ENH	350-390 MHz
				MTM800 ENH	410-470 MHz
<b>Power Supply:</b>		<b>Intermodulation:</b>	-47 dBm	<b>Frequency Range DMO:</b>	
Minimum:	10.8 Vdc	<b>Blocking (50-100 kHz):</b>	-40 dBm	MTM800 ENH	380-430 MHz
Nominal:	13.2 Vdc			MTM800 ENH	851-870 MHz
Maximum:	15.6 Vdc	<b>Spurious Rejection:</b>	-45 dBm	MTM800 ENH	350-390 MHz
Max. Current	Approx. 3.5 A	<b>Adjacent Channel Interference Ratio:</b>	-45 dB	MTM800 ENH	410-470 MHz
<b>Dimensions (HxWxD) in mm:</b>		<b>Frequency Stability:</b>		<b>Frequency Stability:</b>	
Transceiver with		Locked to Base	+/-100 Hz	Locked to Base	+/-100 Hz
Enhanced Control Head,		Unlocked to Base	+/- 1 kHz	Not Locked to Base	+/- 1 kHz
Dash Mount	60 x 185 x 175	<b>Audio Rated (@4 Ohms):</b>		<b>Spurious Emissions:</b>	
		For External Speaker:	10 W	Conducted/Radiated	- 36 dBm <=1GHz
<b>Weight in grams:</b>		Distortion at Rated Audio:	5% Max.		- 30 dBm > 1GHz
Transceiver with				<b>Adjacent Channel Power Ratio (@ ± 25kHz)</b>	
Enhanced Control Head,				350-390 MHz	
Dash Mount	1430			380-430 MHz	
				806-870 MHz	
				410-470 MHz	- 60 dBc

\*) Technical information may be subject to change without further notice.

## Model Descriptions\*\*

Model	Description
M1	Dash Mount with Mobile Terminal with Direct Mount Enhanced Control Head, Speaker, Microphone or Handset, Standard User Guide, and Installation Accessories.
M2	Desk Mount with Mobile Terminal with Direct Mount Enhanced Control Head, Speaker, Microphone or Handset, Standard User Guide, Installation Accessories and Tray with a Power Supply.
M3	Remote Mount with Mobile Terminal with Remote Mount Enhanced Control Head, optional either with Remote Head Enhanced or Data Expansion Head Enhanced, Speaker, Microphone or Handset, Remote Mount cables, Standard User Guide, and Installation Accessories.
M4	Motorcycle Mount with Mobile Terminal with Motorcycle Mount Enhanced Control Head, optional either with Remote Head Enhanced or Data Expansion Head Enhanced, Speaker, Microphone or Handset, Motorcycle cables, Standard User Guide, and Installation Accessories; Audio Accessories, Standard User Guide, and Installation Accessories.
M5	Data Box - Remote Mount Configuration with Expansion Head Enhanced, without Enhanced Control Head, Remote Mount cables, Standard User Guide, Installation Accessories, and a Power Supply.

\*\*) Other combinations are not recommend or not possible.

## Accessories-to-Model Chart

ACCESSORIES						
Control Heads	Part Number	M1	M2	M3	M4	M5
Enhanced Control Head, English Keypad	GMWN4298	X	X			
Enhanced Control Head, Chinese Keypad	GMWN4299	X	X			
Enhanced Control Head, Korean Keypad	GMWN4300	X	X			
Enhanced Control Head, Arabic Keypad	GMWN4301	X	X			
Enhanced Control Head Bopomofo Keypad	GMWN4302	X	X			
Enhanced Control Head Cyrillic Keypad	GMWN4303	X	X			
Enhanced Control Head, English Keypad - Hungarian	GMWN4608	X	X			
Remote Mount Enhanced Control Head, English Keypad	GMWN4304			X	X	
Remote Mount Enhanced Control Head, Chinese Keypad	GMWN4305			X		
Remote Mount Enhanced Control Head, Korean Keypad	GMWN4306			X		
Remote Mount Enhanced Control Head, Arabic Keypad	GMWN4307			X		
Remote Mount Enhanced Control Head, Bopomofo Keypad	GMWN4308			X		
Remote Mount Enhanced Control Head, Cyrillic Keypad	GMWN4309			X		
Remote Mount Enhanced Control Head, English Keypad - Hungarian	GMWN4606			X		
Motorcycle Mount Enhanced Control Head, English Keypad	GMWN4600				X	
Motorcycle Mount Enhanced Control Head, Chinese Keypad	GMWN4601				X	
Motorcycle Mount Enhanced Control Head, Korean Keypad	GMWN4602				X	
Motorcycle Mount Enhanced Control Head, Arabic Keypad	GMWN4603				X	
Motorcycle Mount Enhanced Control Head, Bopomofo Keypad	GMWN4604				X	
Motorcycle Mount Enhanced Control Head, Cyrillic Keypad	GMWN4605				X	
Motorcycle Mount Enhanced Control Head, English Keypad - Hungarian	GMWN4607				X	
Expansion & Remote Head Kits	Part Number	M1	M2	M3	M4	M5
Data Expansion Head	PMLN4908				X	X
Remote Head	PMLN4904			X	X	
Microphones	Part Number	M1	M2	M3	M4	M5
Desktop Microphone, Mobile Microphone Port	RMN5106	X	X	X	X	
Compact Fist Microphone	RMN5107	X	X	X	X	
Compact Fist, Mobile Microphone Port	RMN5052	X	X	X	X	
Heavy Duty Fist Microphone, Mobile Microphone Port	RMN5053	X	X			
Heavy Duty Fist Microphone	RMN5111	X	X	X	X	
Fist Microphone	GMMN4063				X	
Visor Microphone	GMMN4065	X	X	X	X	
Loudspeakers	Part Number	M1	M2	M3	M4	M5
Small Loudspeaker, 5W	GMSN4078	X	X	X	X	

ACCESSORIES						
Speaker, 13W	GMSN4066	X	X	X	X	
Speaker Extension Cable	GMKN4084	X	X	X	X	
<b>Handset</b>	<b>Part Number</b>	<b>M1</b>	<b>M2</b>	<b>M3</b>	<b>M4</b>	<b>M5</b>
Telephone-Style Handset <sup>2</sup>	GMUN1006	X	X	X	X	
Impress GCAI Handset <sup>3</sup>	HLN7016				X	
<b>PTT Switches</b>	<b>Part Number</b>	<b>M1</b>	<b>M2</b>	<b>M3</b>	<b>M4</b>	<b>M5</b>
External PTT with Emergency Footswitch	RLN4836	X	X	X	X	
Footswitch with Remote PTT	RLN4856	X	X	X	X	
Pushbutton with Remote PTT	RLN4857	X	X	X	X	
<b>Desktop &amp; Data Box Mount</b>	<b>Part Number</b>	<b>M1</b>	<b>M2</b>	<b>M3</b>	<b>M4</b>	<b>M5</b>
Power Cable (For Supply to Desktop Mobile)	GKN6266		X			X
Desktop Tray without Loudspeaker	GLN7318		X			
Desktop Tray with Loudspeaker	GLN7326		X			
Desktop Power Supply	GPN6145		X			X
<b>Power Cable (For Desktop Power Supply GPN6145)</b>	<b>Part Number</b>	<b>M1</b>	<b>M2</b>	<b>M3</b>	<b>M4</b>	<b>M5</b>
US Linecord (3060665A04) Packed	NTN7373		X			X
Euro Linecord (3060665A05) Packed	NTN7374		X			X
UK Linecord (3002120F02) Packed	NTN7375		X			X
Argentina Linecord	NTN9246		X			
<b>Cables</b>	<b>Part Number</b>	<b>M1</b>	<b>M2</b>	<b>M3</b>	<b>M4</b>	<b>M5</b>
Remote Mount Cable (Terminal to C/H), 3m	RKN4077			X	X	
Remote Mount Cable (Terminal to C/H), 5m	RKN4078			X	X	
Remote Mount Cable (Terminal to C/H), 7m	RKN4079			X	X	
Remote Mount Cable (Terminal to C/H), 10m	PMKN4020			X	X	
Accessories Expansion Cable, 2.3m	PMKN4029			X	X	
Motorcycle Mount TELCO Cable, 2.3m	PMKN4030				X	
Accessories Expansion Cable, 4m	PMKN4056			X	X	
<b>Junction Box</b>	<b>Part Number</b>	<b>M1</b>	<b>M2</b>	<b>M3</b>	<b>M4</b>	<b>M5</b>
Junction Box	GMLN3002	X	X	X	X	
Cable 6m Transceiver to Junction Box	GMKN4192	X	X	X	X	
Cable 4m Transceiver to Junction Box	GMKN4193	X	X	X	X	
Cable 2m Transceiver to Junction Box	GMKN4194	X	X	X	X	
<b>Power Cables (to Mobile Terminal)</b>	<b>Part Number</b>	<b>M1</b>	<b>M2</b>	<b>M3</b>	<b>M4</b>	<b>M5</b>
12V Power Cable to Battery, 3m with Fuse (10 A)	GKN6270	X		X	X	
12V Power Cable to Battery, 6m with Fuse (10 A)	GKN6274	X		X	X	
Ignition Sense Cable, 3m with Fuse (4 A)	HKN9327	X		X	X	

<b>ACCESSORIES</b>						
<b>Installation</b>	<b>Part Number</b>	<b>M1</b>	<b>M2</b>	<b>M3</b>	<b>M4</b>	<b>M5</b>
External Alarm Relay	GKN6272	X	X	X	X	
Accessory Connector Kit	GMBN1021	X	X	X	X	
Buzzer Kit	GLN7282	X	X	X	X	
<b>Mounting (Transceiver)</b>	<b>Part Number</b>	<b>M1</b>	<b>M2</b>	<b>M3</b>	<b>M4</b>	<b>M5</b>
Key Lock Mount	RLN4779	X	X	X	X	X
High Profile Mounting Bracket	GLN7317	X	X	X	X	X
Low Profile Mounting Bracket	GLN7324	X	X	X	X	X
Mounting Frame to Install Transceiver in DIN-A Slot	PMLN5094	X	X	X	X	X
<b>Mounting (Control Head)</b>	<b>Part Number</b>	<b>M1</b>	<b>M2</b>	<b>M3</b>	<b>M4</b>	<b>M5</b>
Remote Mount Trunnion Kit	PMLN4912			X		
Motorcycle Mount Trunnion Kit	PMLN5092				X	
DIN Mount Bracket	PMLN5093			X		
<b>Programming/Data</b>	<b>Part Number</b>	<b>M1</b>	<b>M2</b>	<b>M3</b>	<b>M4</b>	<b>M5</b>
Programming Cable	GMKN4067	X	X	X	X	
Active Data Cable	GMKN1022	X	X <sup>4</sup>	X	X	
USB Programming Cable (Mobile Microphone Port)	HKN6184	X	X	X	X	
I85 USB Data Cable with Inline Power	NNTN4007	X	X	X	X	

- 1) Keep the GCAI connector cover supplied with the new Control Head.
- 2) Requires Junction Box, GMLN3002.
- 3) The GCAI handset is only approved for Remote and Motorcycle installations used with Toroid EMC Suppression kit (P/N: 01015001001). The handset is certified to 350–390 MHz and 380–430 MHz frequency ranges only. The handset is not certified for 410–470 MHz and 806–870 MHz with any installation type.
- 4) The cable, GMKN1022, is only compatible when an Data Expansion Head Enhanced is not fitted as part of a remote mount configuration. In this configuration access to the Tetra PEI for IP Packet Data and SDS services is available on the Data Expansion Head Enhanced and the Active Data Cable GMKN1022 is not required.

# INSTALLATION

## Introduction

## General Information

**NOTE**

**This product must be installed in a vehicle in accordance with the vehicle manufacturer's guidelines and the instruction detailed in this manual.**

**Only the specified Motorola parts in this manual should be used. Failure to do so could result in non compliance to the Automotive Directive (72/245/EEC, as amended by 95/54/EC).**

**For products fitted to two and three wheeled vehicles, Directive 97/24/EC applies.**

**This Terminal is only designed and certified to be used for terrestrial use only.**

There are two methods of installing the mobile terminal in a vehicle:

1. Using the direct mounting trunnion and power cables supplied with a standard radio package.
2. Remote mounted in the car radio cut-out (using the required DIN mounting kit PMLN5094), per ISO7736.

An accessory connector on the rear of the terminal enables you to attach different accessories (see section "Accessory Connection Plan").

A mobile microphone port on the front control head panel (see page 66) provides for the connection of various types of microphones (Desktop Microphone RMN5106, fist microphone RMN5053).

**NOTE**

**This terminal is ONLY made for 12 V power supply connection. In vehicles with 24 V power supply, a DC/DC converter is required.**

**Please be aware when planning the installation that there is a current consumption of approx. 3.5 A during PTT and up to 30 mA when terminal is switched off.**

1. Mount the terminal horizontally near the driver, so the driver can easily view, access and operate the controls and accessories.
2. Ensure that the location is not exposed to dirt and moisture.
3. Verify that there will be sufficient space around the mobile unit for air flow and installation.
4. Check that there is enough routing space for the power cable connector and the antenna coaxial cable.
5. Plan the best place to run connections to minimize pinching, crushing, and overheating of wires and cables.



**NOTE**

In a vehicle with an airbag, make sure that the mounting location of the mobile terminal, or of any terminal accessory, is not in the deployment path of the air bag.

**CAUTION**

**Uninstalling the radio**

**OPTION 1:**

Before disconnecting the 13.2 V main power supply from the radio:

1. Switch off the radio.
2. Wait for a minimum of 4 seconds after the radio switch is released.
3. Disconnect the 13.2 V main power supply.

**OPTION 2:**

Turn off the main power supply **WITHOUT** switching OFF the radio.

## DC Power Cable Installation

### Installation Planning

**CAUTION**

This terminal must be operated only in negative ground electrical systems. Operating the terminal on a positive ground system will cause the cable fuse to short-circuit. Check the vehicle ground polarity before you begin the installation.

The 3-meter (10-foot) DC power cable shipped with the terminal should be long enough to be installed in most vehicles. Take the following precautions before you begin:

1. Whenever possible, avoid routing the cable above the catalytic converter.
2. Make sure that the power cable never rests on sharp edges.
3. Use grommets whenever a cable has to pass through a hole in a metal panel.

The following table lists power cables available for this terminal:

Table 1 DC Power Cables

Number	Description	Rating
GKN6270	Power Cable to battery with fuse 10 A	12V Power Cable to Battery, Length: 3 m
GKN6274	Power Cable to battery with fuse 10 A	12V Power Cable to Battery, Length: 6 m
HKN9327 *	Ignition Sense Cable with fuse 4 A	Ignition Sense Cable, Length: 3 m
6500139767	Fuse 10 A for Power Cable	
6580283E02 *	Fuse 4 A for Ignition Sense Cable	

\* For more information refer to section "Ignition Sense Cable Installation". The Ignition Sense Cable allows the terminal to be turned on and off by the vehicle ignition switch.

**CAUTION**

**In cases of blown fuses, replace ONLY with those of identical value.  
NEVER insert ones of different values.**

## Installation Procedure

Begin the DC power cable installation as follows:

1. Determine a routing plan, keeping in mind where the terminal is to be mounted and make sure that the cable does not rest on sharp edges.

**CAUTION**

**Improper handling with the power cable may cause shorting to ground. Ensure that during terminal installation the power cable fuse is removed.**

**CAUTION**

**Make sure your power cable is not placed with the antenna in parallel. Interference can cause radio to hang.**

2. Locate an existing hole with grommet in the vehicle fire wall, or use a 9.5 mm (3/8-inch) bit to drill an access hole in the fire wall. Install a grommet with a 5 mm (3/16-inch) inside diameter into the hole to protect the power cable.

**CAUTION**

**Be very careful not to damage existing wires.**

3. From inside the vehicle, feed the red and black leads (without the lugs attached) through the access hole and into the engine compartment. (see Figure 1)

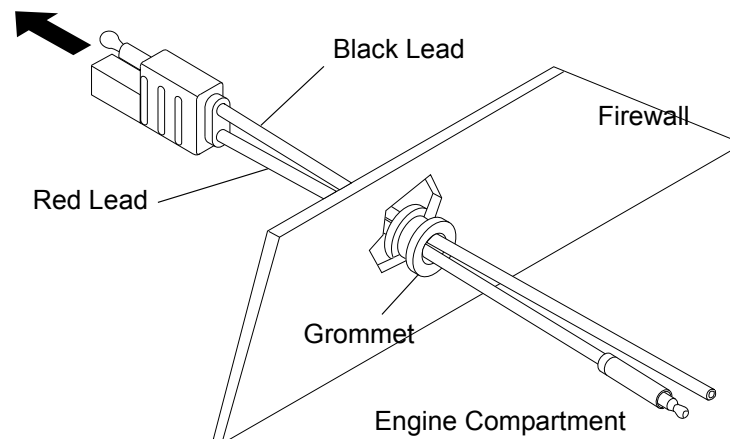

Figure 1 Power Cable Routing into the Engine Compartment

4. Connect the black lead of the DC power cable to the nearest vehicle chassis ground point (using the provided ring lug if necessary). Shorten the black lead to remove any excess cable. (see Figure 2).



**NOTE**

**Locate a good vehicle ground point. The vehicle frame provides the best ground. Optimum terminal performance can only be achieved with a very low resistance ground connection. Verify that the connections between the battery negative terminal, vehicle chassis, and engine block have low resistance.**

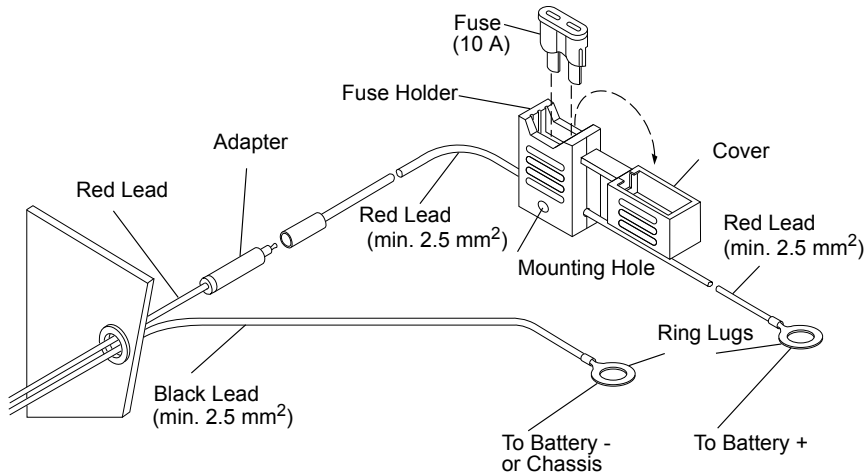

Figure 2 Power Cable Assembly

5. Place the fuse holder close to the battery. Ensure that it is not near any hot engine component. Mount the fuse holder using its mounting hole and dress the wires as required.
6. Insert the stripped end of the red lead of the fuse holder into the ring lug hole and crimp it. Connect the fuse holder red adapter lead plug to the mating receptacle on the red lead of the power cable.
7. Connect the red lead ring lug from the fuse holder to the positive (+) battery terminal. Make sure the adapter cable is connected to the main power cable red lead.
8. Carefully check that all connections are proper. Insert the fuse into the fuse holder and close the cover.

## Ignition Sense Cable Installation

Table 2 Ignition Sense Cable

Number	Description	Rating
HKN9327	Ignition Sense Cable with fuse 4 A	Ignition Sense Cable, Length: 3 m
6580283E02	Fuse 4 A for Ignition Sense Cable	

The HKN9327 Ignition Sense Cable allows the terminal to be turned on and off by the vehicle ignition switch.

The ignition sense cable kit contains a thin cable and a fuse holder. To install the cable, carry out the following steps.

**CAUTION**

**In cases of blown fuses, replace ONLY with those of identical value. NEVER insert ones of different values.**

**Ensure that the fuse is removed during cable installation.**

1. Plug the lead of the Ignition Sense Cable with the crimped on terminal into #10 socket of the accessory plug.
2. Route and secure the cable with attached tie wrap.
3. Connect the other lead of the accessory cable to the ignition switch of the vehicle.
4. Insert the fuse into the fuse holder and close the cover.

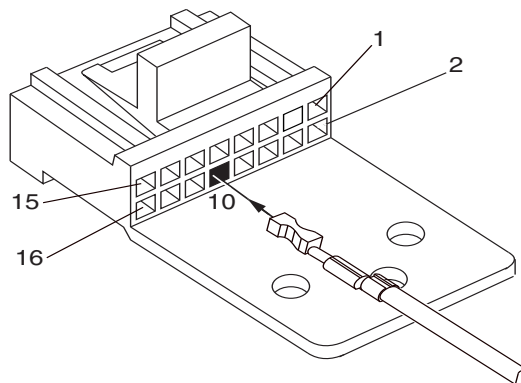

Figure 3 Accessory Connector with Ignition Sense Cable

**CAUTION**

**If the ignition line is not used, it needs to be grounded. Interference can cause radio to hang.**

## Terminal Installation

### Enhanced Control Head Installation

The Enhanced Control Head can be removed from the housing and turned to any position within a 180° radius. This provides multiple mounting options for the terminal. For example, the terminal may be mounted on either side of the vehicle to facilitate the safest and most ergonomically ideal position. The Enhanced Control Head may then be turned to provide the most convenient access.

To reposition the Enhanced Control Head:

1. Insert the Dismantling tool (Motorola P/N 6686119B01) in the groove between the Enhanced Control Head and the terminal assembly as shown in the figure below.
2. Press on the dismantling tool until the snap connectors on the side of the Enhanced Control Head release from the terminal assembly.
3. Pull the Enhanced Control Head away from the terminal assembly.

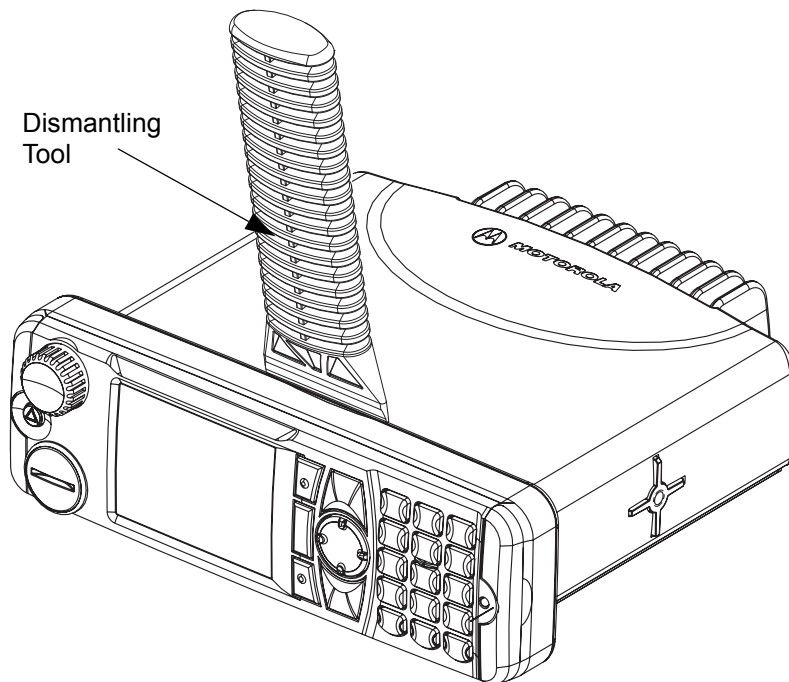

Figure 4 Typical Control Head Removal

## Trunnion Installation

### Installation Planning

The trunnion allows the terminal to be mounted to a variety of surfaces.

1. The trunnion must be **securely fixed** to the vehicle chassis.
2. Ensure the surface can support the weight of the terminal.
3. Although the trunnion can be mounted to a plastic dashboard, it is recommended that the mounting screws be located so they penetrate the supporting metal frame of the dashboard.

2x Wingscrews  
0305760W02

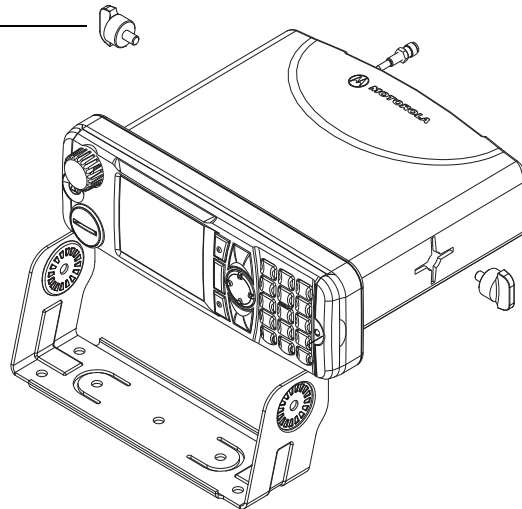

Figure 5 Terminal into High Profile Trunnion (GLN7317)

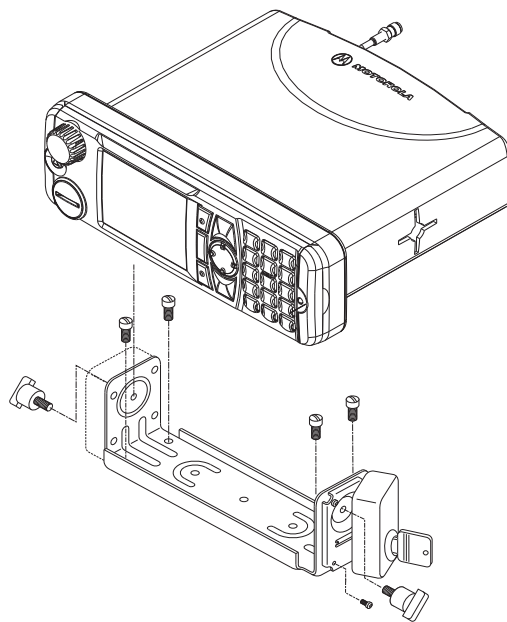

Figure 6 Terminal into Key Locked Mount Trunnion (RLN4779A)

### Installation Procedure

1. Select either the transmission hump or an open underneath portion of the dash to mount your terminal (see Figure 7). When mounting the trunnion on the transmission hump, be careful that the transmission housing is not affected.
2. Use the trunnion mounting bracket as a template, to mark the hole positions on the mounting surface. Use the innermost three holes for a curved mounting surface, such as the transmission hump, and the three outermost holes for a flat surface such as under the dash.
3. Centre-punch the spots you marked and use a 4 mm (5/32-inch) bit to drill a hole at each location.
4. Secure the trunnion mounting bracket to the mounting surface with the three self-tapping screws provided. (See Figure 7.)
5. Slide the terminal into the trunnion. Secure the terminal with the two wing screws provided.



**NOTE**

The keypad labelling of the control head may vary according to the specific customer/country concerns.

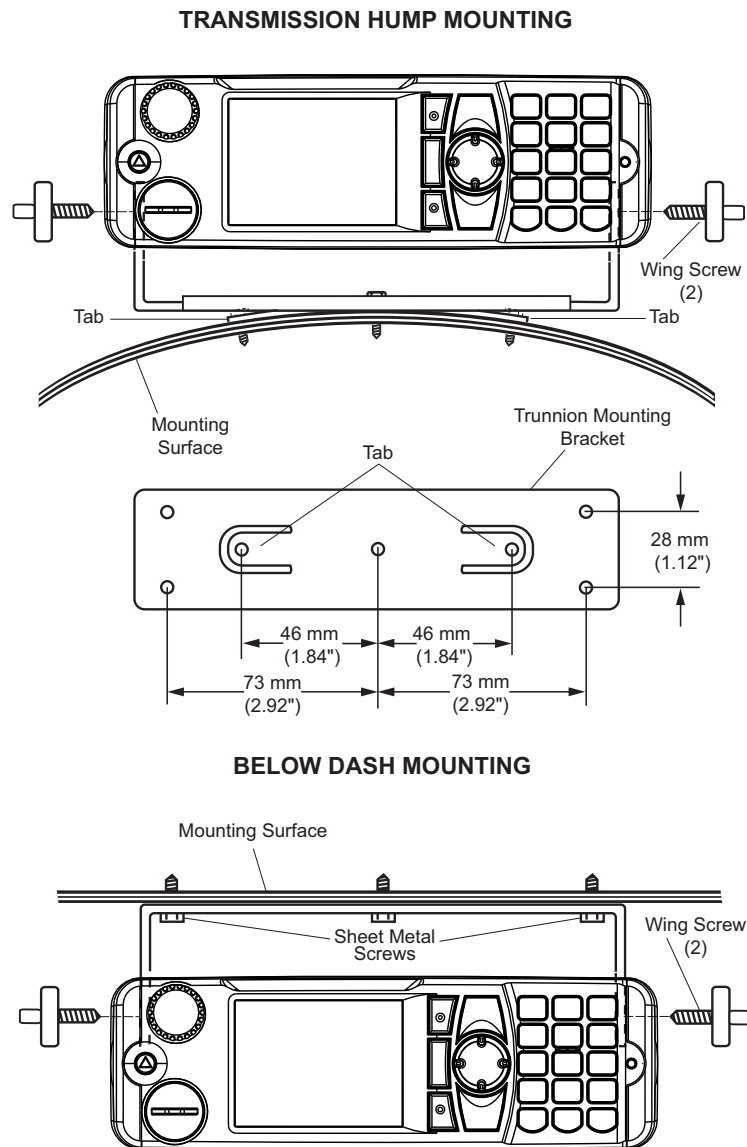

Figure 7 Transmission Hump Mounting (Top) and Below Dash Mounting (Bottom)

---

## Dashboard Installation

### Installing the Radio in an Automotive Dashboard

1. Open out the radio cut-out in the dashboard.
2. Remove the top plastic cover off the radio.
3. Insert the mounting frame into the cut-out and retain it by bending back the relevant fixing tabs, using all 6 where possible, to hold it in place.

**NOTE**

**The tabs are easily bent back by twisting a large flat-bladed screwdriver into the slot behind the tabs.**

**For a more secure installation the top and rear of the frame should also be secured with screws.**

**The demount tool can be used as an aid to mounting as well as demounting.**

### Mounting the Radio in the Frame

1. Provide the electrical connections to the radio for power, antenna and accessories.
2. Plug in all the connectors and push the radio with its Remote Head Enhanced, or alternatively the Data Expansion Head Enhanced, firmly onto the mounting frame until the two springs snap into place.

**NOTE**

**The fixing tabs should be checked for tightness each time the radio is removed. The tabs are easily tightened by twisting a large flat-bladed screwdriver in the slot behind the tabs. The frame is not designed for daily mounting and demounting.**

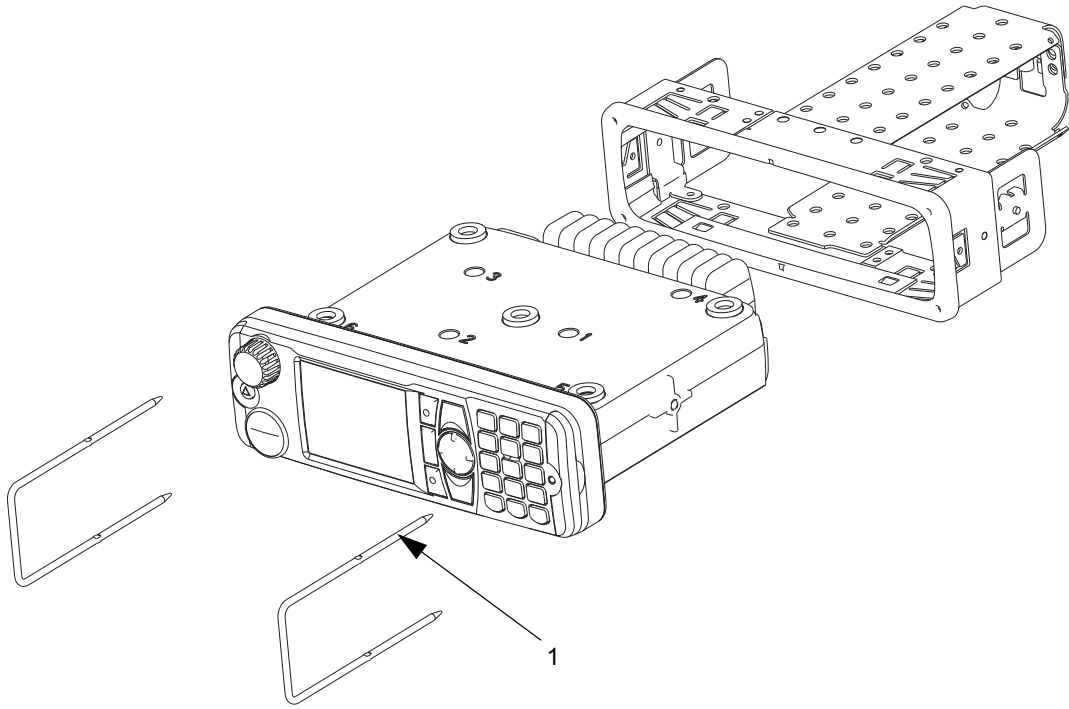

Figure 8 Mounting the Radio into the Frame (Shown with Enhanced Control Head)

Table 3 DIN Mount Kit Components

Item	Description	Part Number
	DIN Mount Kit	PMLN5094
1	Demount Tool	8166514A01

## Remove the Radio from the Frame

1. Remove both rubber side caps from the Enhanced Control Head.
2. Insert the demount tool into the two openings as shown in Figure 9 below.

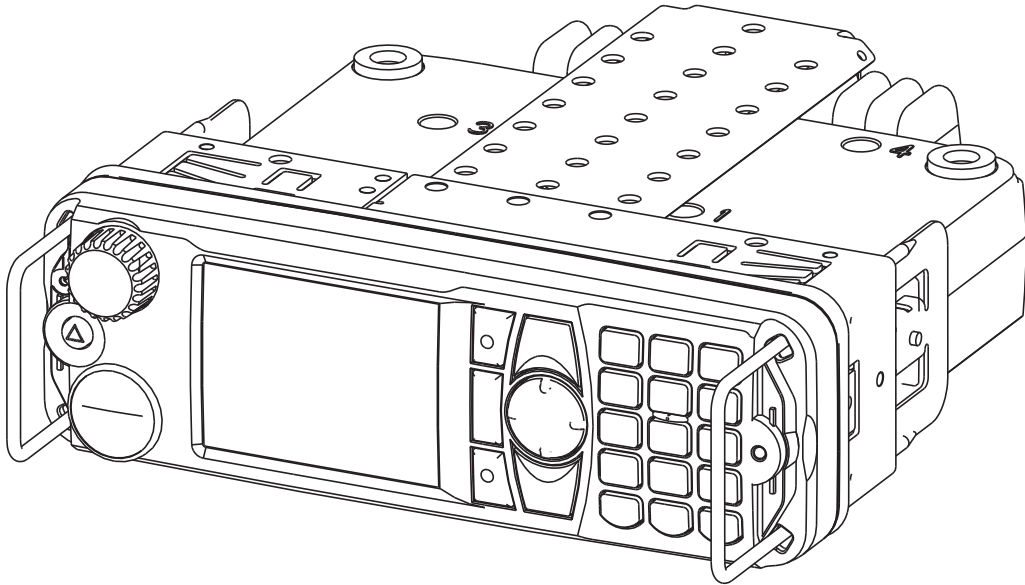

Figure 9 Removing the Radio from the Frame

3. Push the demount tools through the openings in the frame.
4. Slide out the radio.

---

## Desktop Installation

The MTM800 Enhanced may be desktop mounted. The Desktop Station option provides the terminal with the desk microphone, power supply, desk top tray (without speaker) and external loudspeaker.

**CAUTION**

**If an outdoor antenna is used a proper grounded Lightning Protector with Quarter-Wave Shorting Stub must be inserted between the outdoor antenna and the transceiver antenna input. The line voltage power supply shall have a proper ground connection (refer to IEC61312-1). The installation must meet the requirements of any and all applicable local codes and regulations.**

## Planning

Planning is the key to fast, easy terminal installation. Before a hole is drilled or a wire is run, inspect the location and determine how and where you intend to mount the antenna, terminal and accessories. Plan wire and cable runs to provide maximum protection from pinching, crushing, and overheating. The installation planning should only be undertaken by persons who are competent and able to ensure that the complete installation fulfils its regulatory requirements, such as EMC (Electro Magnetic Compatibility) and IEC (International Electrotechnical Commission).

## Installation

1. Be sure line voltage power is available.
2. Make sure sufficient air can flow around the terminal to permit adequate cooling.
3. Choose a flat surface for the desktop tray and external loudspeaker.
4. Be sure the mounting surface is able to adequately support the weight of the terminal and tray.
5. If an outdoor antenna is used choose a location for the terminal as close as possible to the antenna cable inlet of the building. Make sure that the installation of the surge protector is in accordance with the manufacturer's specifications and safety hints. The line voltage power supply shall be grounded properly.

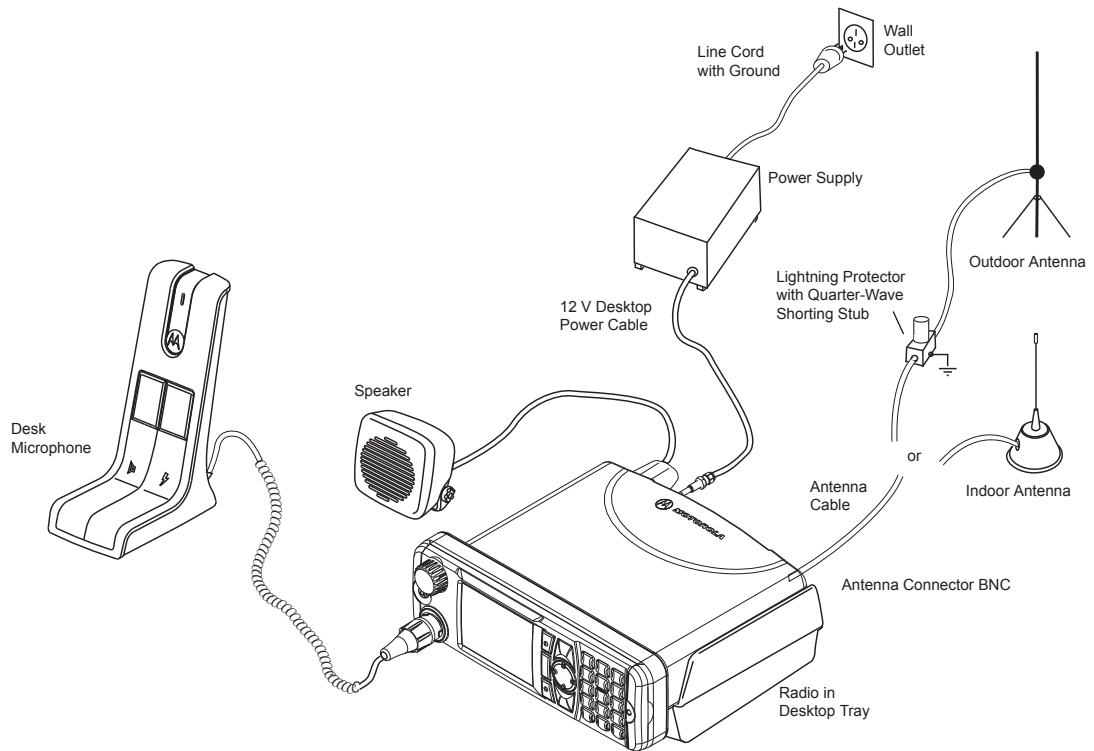

Figure 10 Desktop Mounting (See Table 4 for Part Numbers)

Table 4 Associated Components

Item	Description	Part Number
1	Desktop Microphone	RMN5106
2	External Speaker 13 W	GMSN4066
3	Small Loudspeaker 5 W	GMSN4078
4	Desktop Tray w/o speaker	GLN7318
5	12 V Desktop Power Cable	GKN6266
6	Power Supply Unit PSU	GPN6145
7	110 V PSU Line Cord US	NTN7373R
8	230 V PSU Line Cord Euro	NTN7374R
9	240 V PSU Line Cord UK	NTN7375R
10	220 V PSU Line Cord Argentina	NTN9246
11	Lightning Protector with Quarter-Wave Stub Protector in the appropriate frequency range (for example, HUBER+SUHNER® : type 3400.17.0389 (UHF) or type 3400.17.0277 (800 MHz))	

**CAUTION**

**5W speaker (GMSN4078B) cannot sustain the maximum audio output power of 13 W coming from the radio when the volume is set to the maximum in Loudspeaker Volume Max code plug. This causes the speaker cone to dislocate.**

## Remote Mount Installation

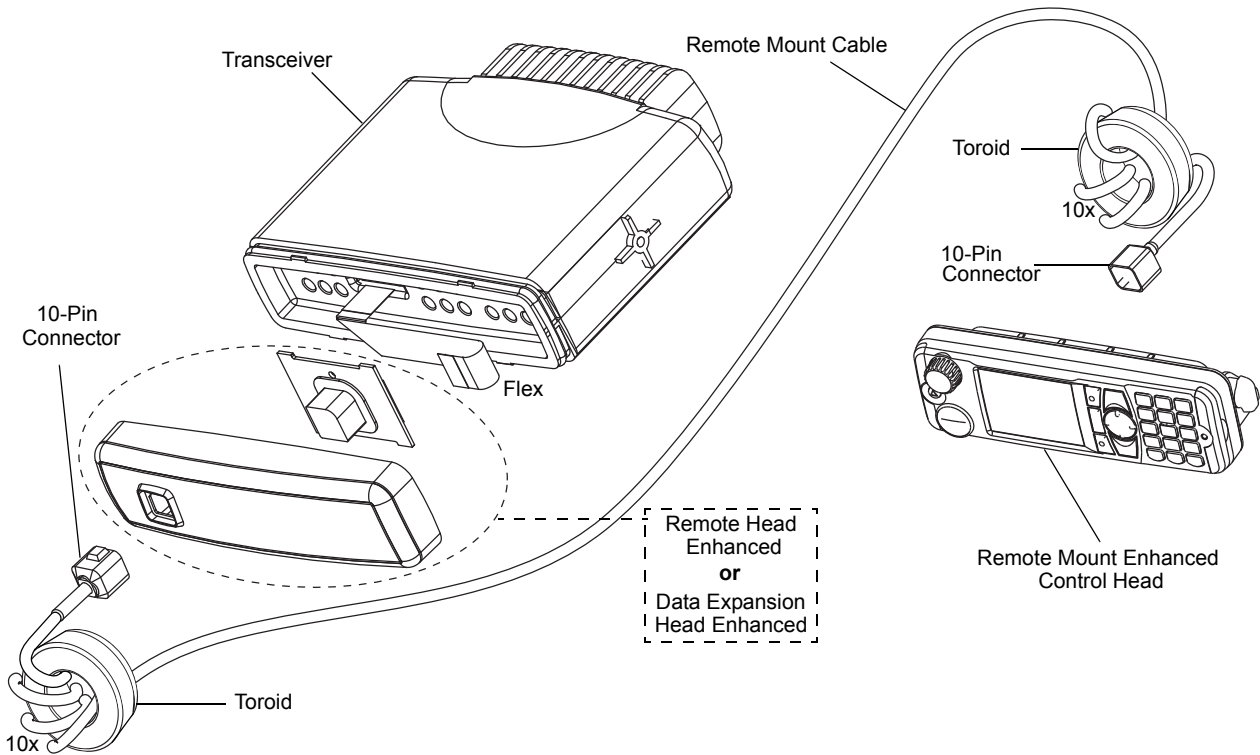

Figure 11 Remote Mount Installation with Remote Head Enhanced/Data Expansion Head Enhanced

Table 5 Associated Components for Remote Mount

Item	Description	Part Number
1	Remote Mount Cable, 3 m	RKN4077
2	Remote Mount Cable, 5 m	RKN4078
3	Remote Mount Cable, 5 m	RKN4079
4	Remote Mount Cable, 10 m	PMKN4020
5	Speaker Extension Cable	GMKN4084
6	Remote Head Enhanced	PMLN4904
7	Data Expansion Head Enhanced	PMLN4908
8	Toroid EMC Suppression Kit	01015001001



**NOTE**

The Remote Mount Cable have to be wound 10 times around each toroid.

Each toroid have to be placed 30.0±2.5 cm respectively from the expansion head and the control head.

Winding at both ends reduces the effective cable length approximately by 0.8 m.

Fix the toroids firmly to a stable surface once the Remote Mount Cable is connected.

### Installing the Remote Mount Enhanced Control Head onto the Remote Mount Trunnion

1. Slide the Remote Mount Enhanced Control Head onto the mounting trunnion until it snaps into place.
2. Tighten the screws at both sides of the trunnion. After a few turns, tilt the control head for an optimum view of the display. Then, complete the tightening of the screws.

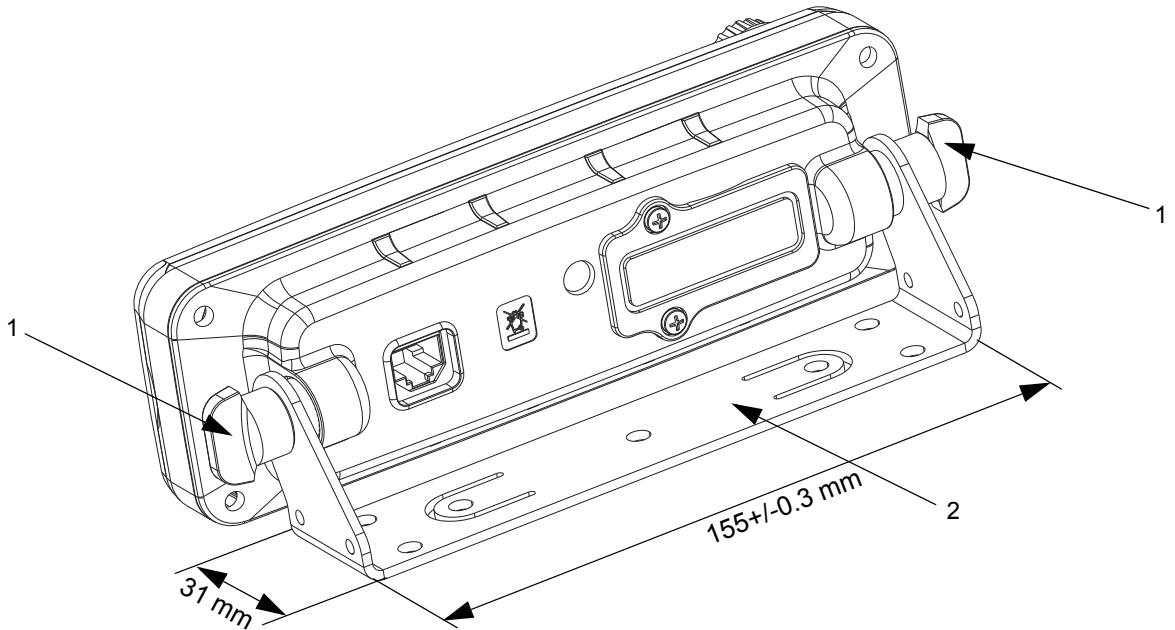

Figure 12 Remote Mount Enhanced Control Head Installation with Remote Mount Trunnion

Table 6 Remote Mount Enhanced Control Head Installation with Remote Mount Trunnion  
- Mechanical Parts List for Installation

Item	Description	Part Number
1 & 2	Remote Mount Trunnion Kit	PMLN4912

### Installing the Remote Mount Enhanced Control Head in a DIN Mount Bracket

1. Slide the Remote Mount Enhanced Control Head onto the DIN Mount Bracket until it snaps into place.
2. Tighten the screws at both sides of the DIN Mount Bracket.

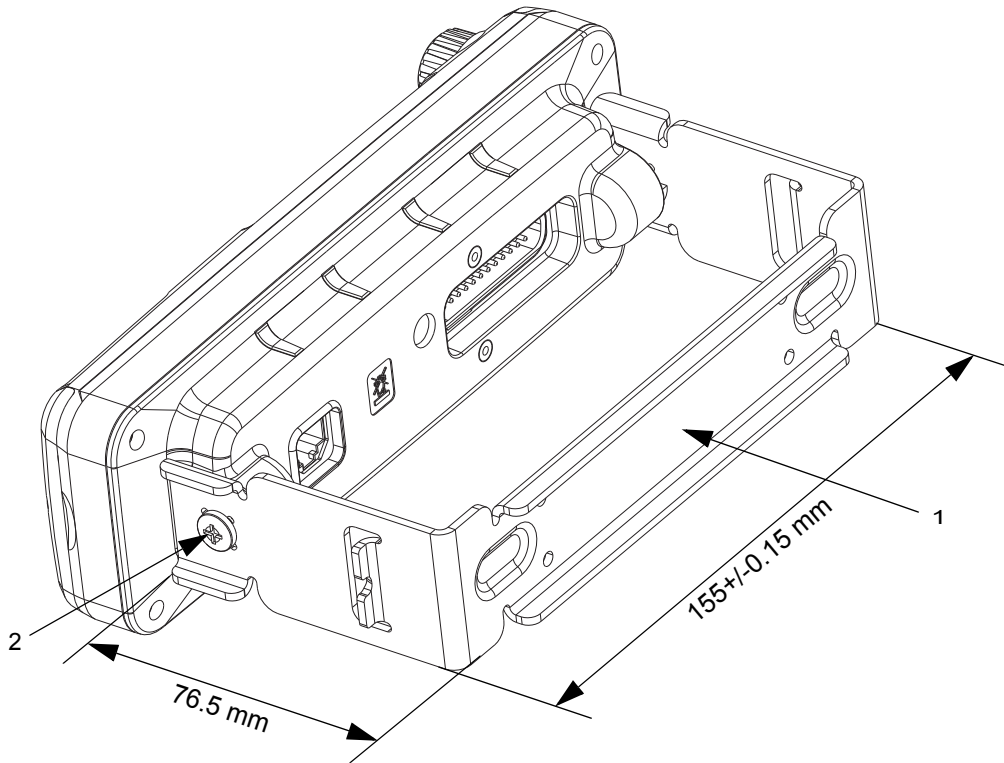

Figure 13 Remote Mount Enhanced Control Head Installation with DIN Mount Bracket

Table 7 Remote Mount Enhanced Control Head Installation with DIN Mount Bracket  
- Mechanical Parts List for Installation

Item	Description	Part Number
1 & 2	DIN Mount Bracket Kit	PMLN5093

## Inserting the Remote Mount Enhanced Control Head with the DIN Mount Bracket into the DIN Frame

1. Insert the mounting frame into the DIN Mount Bracket and retain it by bending back the relevant fixing tabs. Use all 6 tabs, if necessary, to hold it in place.



### NOTE

The tabs are easily bent back by twisting a large flat-bladed screwdriver into the slot behind the tabs.

For a more secure installation the top and rear of the frame should also be secured with screws.

The demount tool can be used as an aid to mounting as well as demounting.

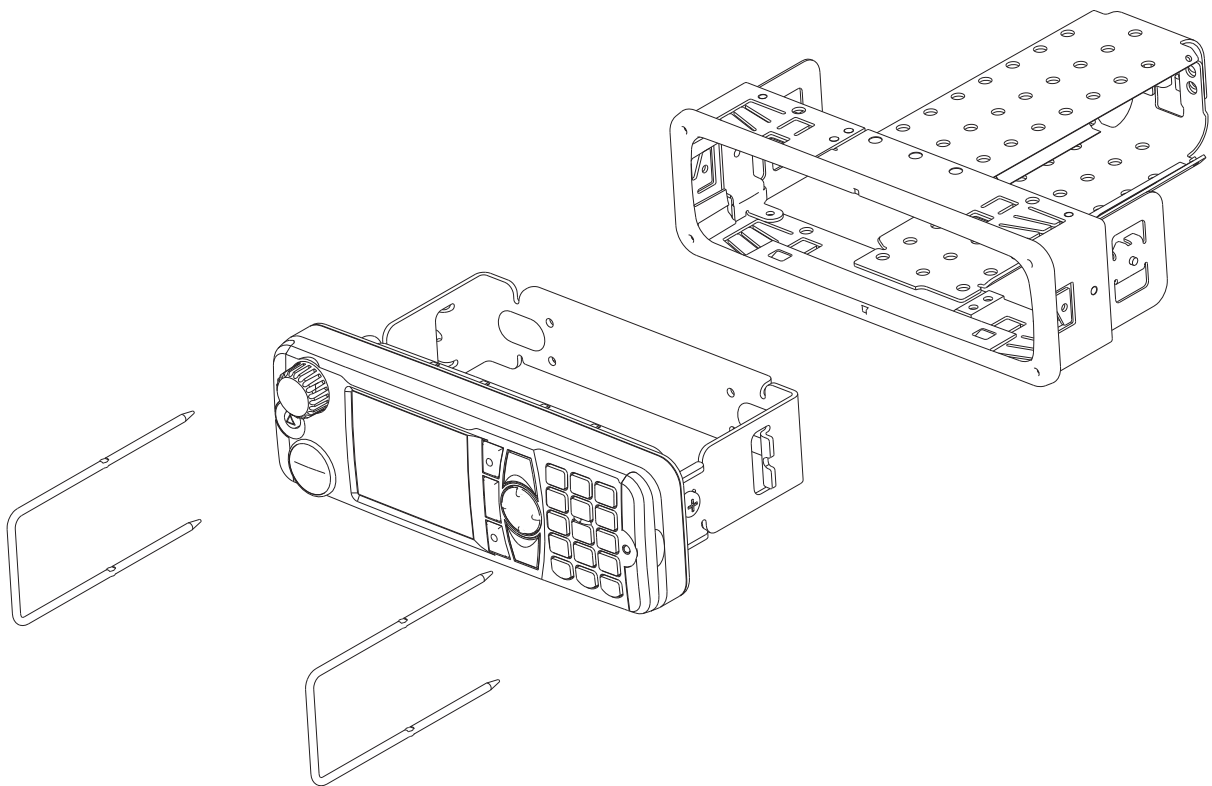

Figure 14 Mounting the Remote Mount Enhanced Control Head with the DIN Mount Bracket into the DIN Frame

## Adding Extra Connectivity to the Remote Head

The Accessories Expansion Cable (PMKN4029/PMKN4056) allows users to have extra connectivity to accessories via the Mobile Microphone Port (MMP) and USB port.

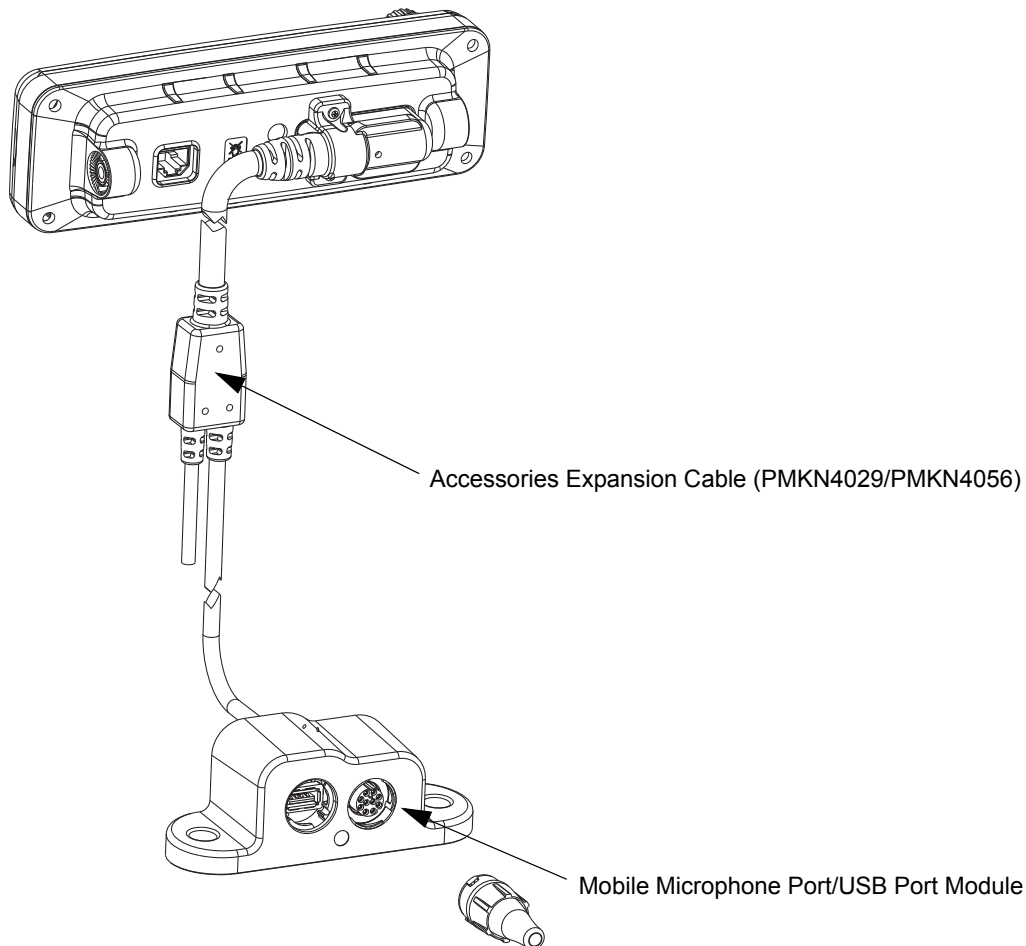

Figure 15 The Accessories Expansion Cable with the Mobile Microphone Port (MMP)/USB Port Module

### Installing the Accessories Expansion Cable

1. Plug in the Accessories Expansion Cable to the subD Port of the Remote Mount Enhanced Control Head.
2. Tighten the screws at the subD connector to secure the Accessories Expansion Cable in place.
3. The Mobile Microphone Port (MMP)/USB port module can be mounted to a variety of surfaces. Tighten the two screws at both sides of the module to fix it securely in place.

\* For more information on the connector pin functions of the Accessories Expansion Cable and the Mobile Microphone Port (MMP)/USB Port Module, please see Table 17 on page 70.

## Motorcycle Mount Enhanced Control Head Installation

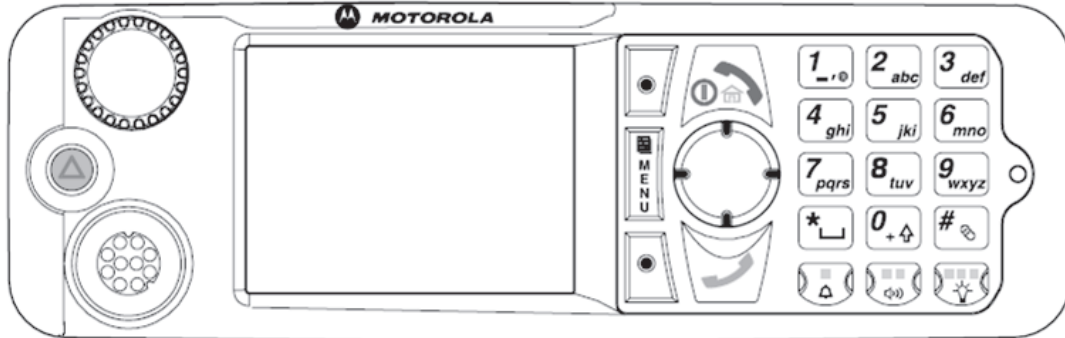

Figure 16 Motorcycle Mount Enhanced Control Head - Front Side



### NOTE

The keypad labelling of the control head may vary according to the specific customer/country concerns.

## Planning

Planning is the key to fast, easy radio installation. Before a hole is drilled or a wire is run, inspect the vehicle and determine how and where you intend to mount the antenna, radio, and accessories. Plan wire and cable runs to provide maximum protection from pinching, crushing, and overheating.

The installation planning should only be undertaken by persons who are competent and able to ensure that the complete installation fulfils its regulatory requirements, such as EMC (ElectroMagnetic Compatibility).

The following list of considerations should, as a minimum, be checked during installation planning:

1. The recommended place for the transceiver is to place it in the box at the back of the motorcycle.
2. Mount the Motorcycle Mount Enhanced Control Head horizontally at a position which enables the driver to view the controls and operate them easily.
3. Be sure the Motorcycle Mount Enhanced Control Head is close enough to the vehicle operator to permit easy access to operating controls.
4. It is recommended to mount the Motorcycle Mount Enhanced Control Head directly on the chassis or handle part.
5. Ensure that the units mounted in the motorcycle box are protected from dirt and moisture.
6. Verify that there is sufficient space around the units to allow air flow and removal.
7. Verify that the cable from a handlebars mounted Motorcycle Mount Enhanced Control Head and to the radio unit is long enough to allow for the handles to be turned.
8. Verify that the antenna cable is routed in the shortest way to minimize power loss over the cable.
9. Check that the mounting surfaces are able to support the weight of the units.



**NOTE**

If an additional GPS antenna or a combined TETRA/GPS antenna is used, the antenna housing carries the GPS receiver. Take care not to cover the antenna housing with metal or other radio wave absorbing material.

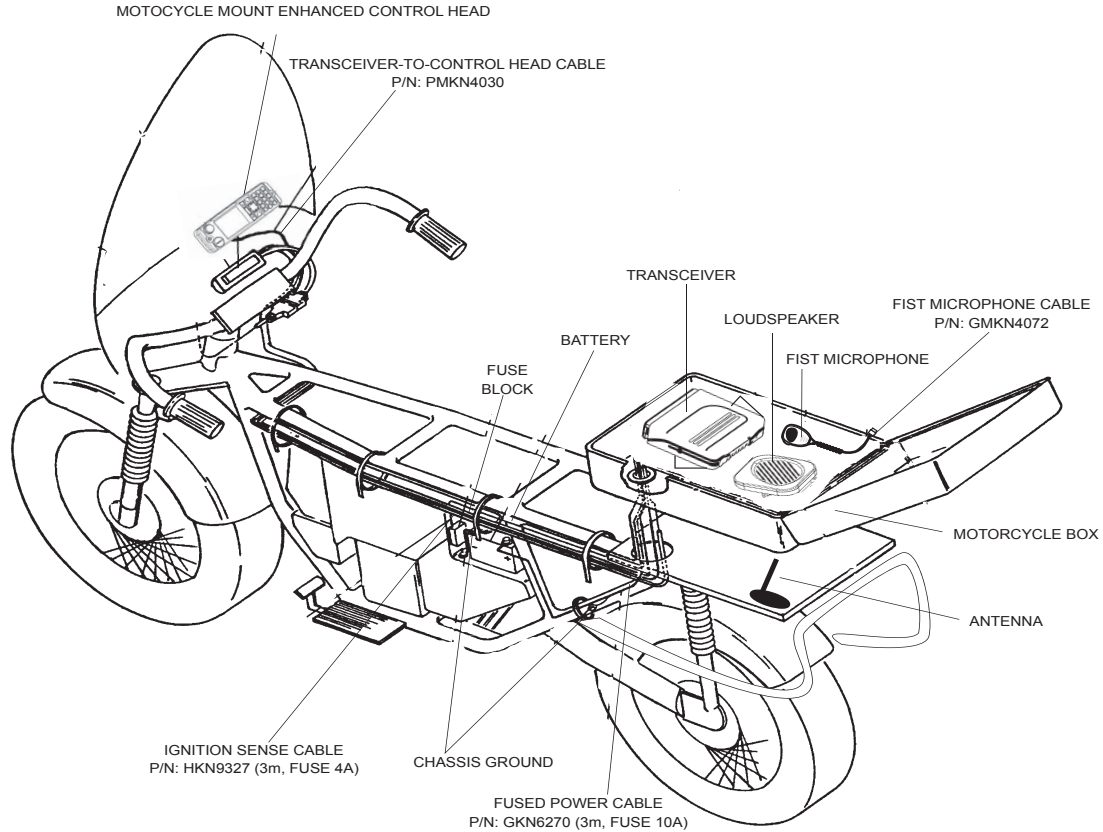

Figure 17 Motorcycle Installation

### Installing the Motorcycle Mount Enhanced Control Head

1. Slide the Motorcycle Mount Enhanced Control Head onto the mounting trunnion until it snaps into place.
2. Tighten the screws at both sides of the trunnion. After a few turns, tilt the Motorcycle Mount Enhanced Control Head for an optimum view of the display. Then, complete the tightening of the screws.
3. There are two ways to mount the motorcycle trunnion, each limited to a 77 degree of allowable movement, as shown in Figure 18 and Figure 19:

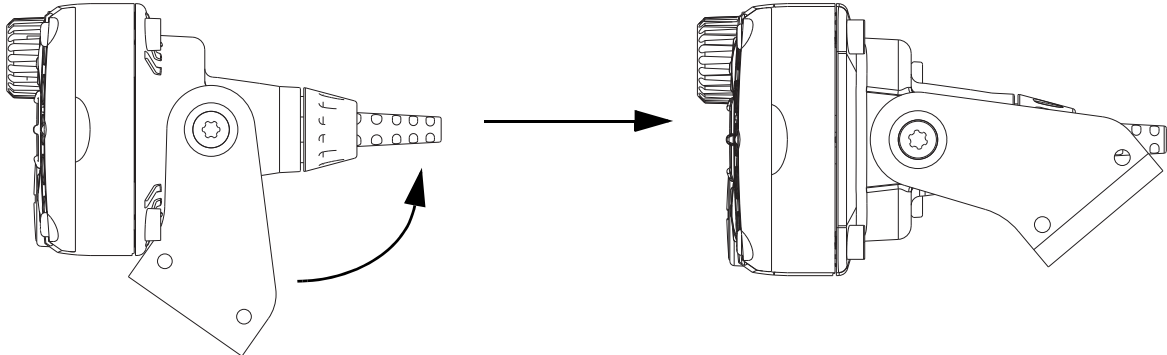

Figure 18 Upward Movement

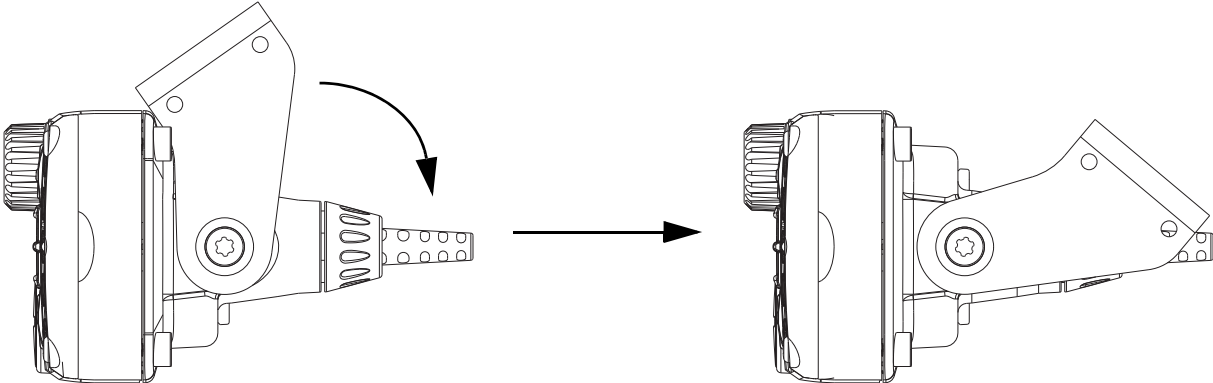

Figure 19 Downward Movement

**Mechanical Parts**

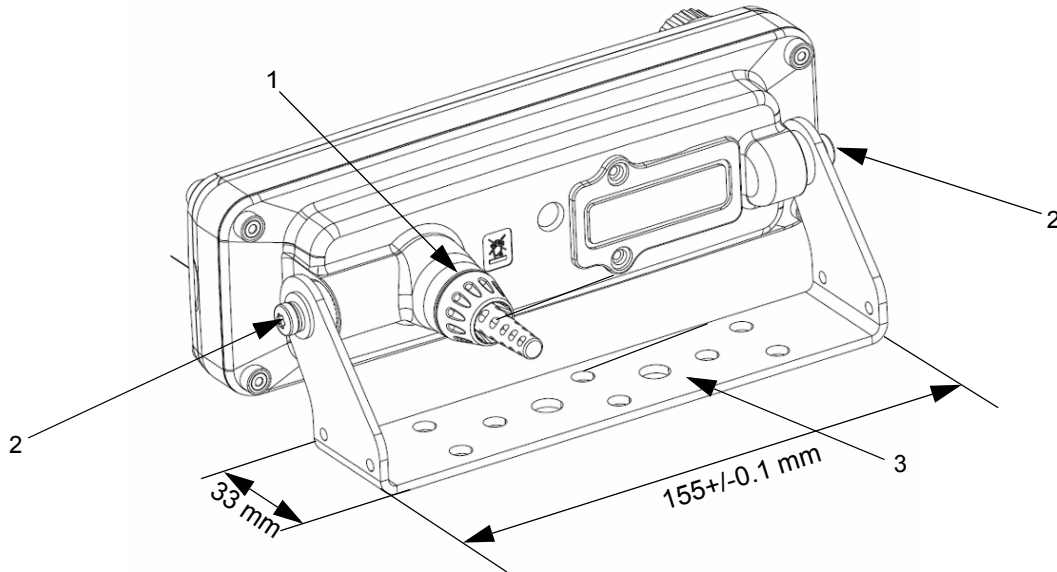

Figure 20 Motorcycle Mount Enhanced Control Head Mounted in a Trunnion

Table 8 Motorcycle Mount Enhanced Control Head - Mechanical Parts List for Installation

Item	Description	Part Number
1	Motorcycle Mount TELCO Cable	PMKN4030
2 & 3	Motorcycle Trunnion Kit	PMLN5092

**Installation of the Motorcycle Mount TELCO Cable (PMKN4030)**

1. Plug the TELCO connector to the TELCO socket of the Remote Head Enhanced/Data Expansion Head Enhanced connected to the transceiver.
2. Plug the other side of TELCO connector to the TELCO socket of Motorcycle Mount Enhanced Control Head.

**Adding Extra Connectivity to the Motorcycle Mount Enhanced Control Head**

Please see “Adding Extra Connectivity to the Remote Head” on page 44 for more information on adding extra connectivity using the Accessories Expansion Cable and the Mobile Microphone Port (MMP)/USB Port module.

---

## Data Expansion Head Enhanced Installation

---

---

### Data Expansion Head Enhanced Radio without Control Head

---

The Data Expansion Head Enhanced can be used without a control head.

This configuration allows the use of the radio without any control head, allowing the radio to be powered on via the ignition switch.

The packet data/SDS via the AT commands are available from the 9-pin subD connector (PEI).

The Remote PTT can be connected via the 20-pin rear connector. Only one talkgroup is available, and that talkgroup is the first one on the CPS list.

## Data Expansion Head Enhanced with 3rd Party Control Head

The Data Expansion Head Enhanced can be used with a “virtual head” on a PC or a third party control head.

This configuration allows the controlling of the radio (Transceiver Box) with a Control Terminal (for example: Personal Computer, Laptop, Console, and so forth). In this configuration, the Control Terminal is a substitute for the Enhanced Control Head. The Control Terminal is connected to the 25-pin socket of the Data Expansion Head Enhanced via the GMKN4079 cable (see section “Connecting Cables” on page 69 for more information).

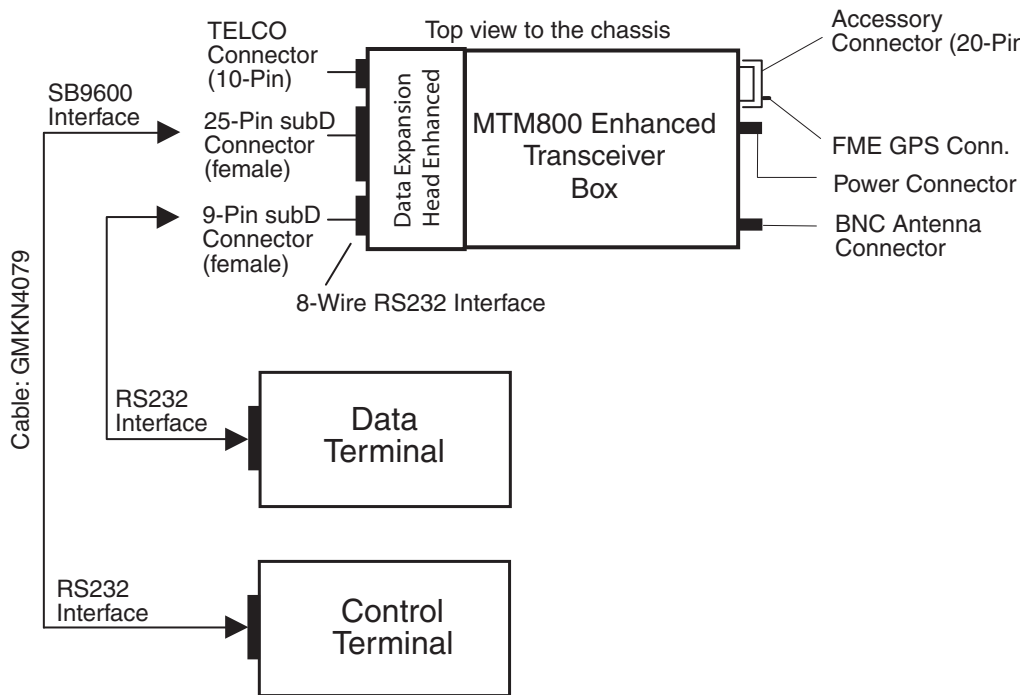

Figure 21 Configuration with Remote Control Terminal and Data Terminal

## Data Box Radio

This configuration allows the controlling of the radio (Transceiver Box) via PEI (for example: Personal Computer, Laptop, Console, and so forth) with AT Commands (recommended) or TNP1 protocol from a Control Terminal.

In this configuration, the Data Terminal is a substitute for the Enhanced Control Head. The Data Terminal is connected to either the 9-pin socket of the Data Expansion Head Enhanced via the RS232 cable or to the 20-pin accessory connector via the active data cable (see section "Connecting Cables" on page 69 for more information).

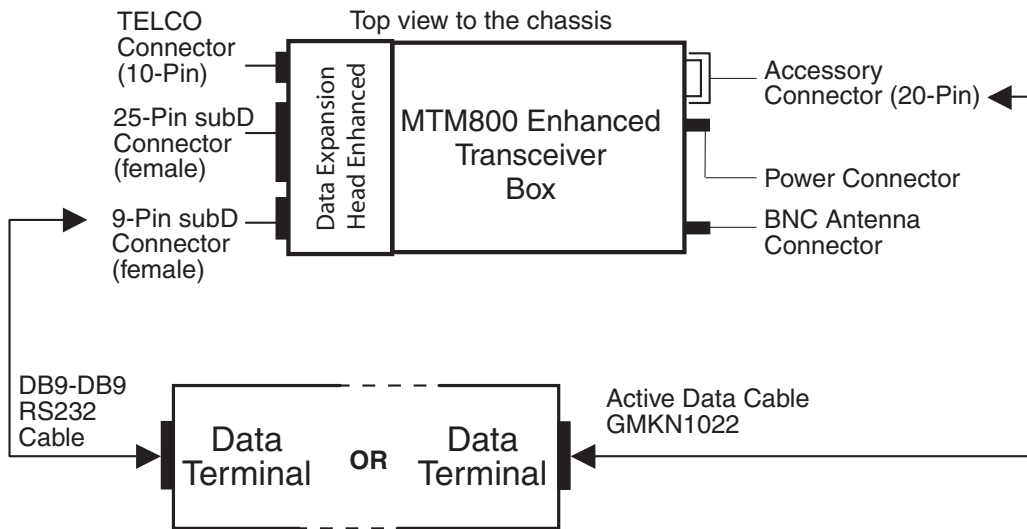

Figure 22 Data Box Radio Configuration

## Junction Box Installation

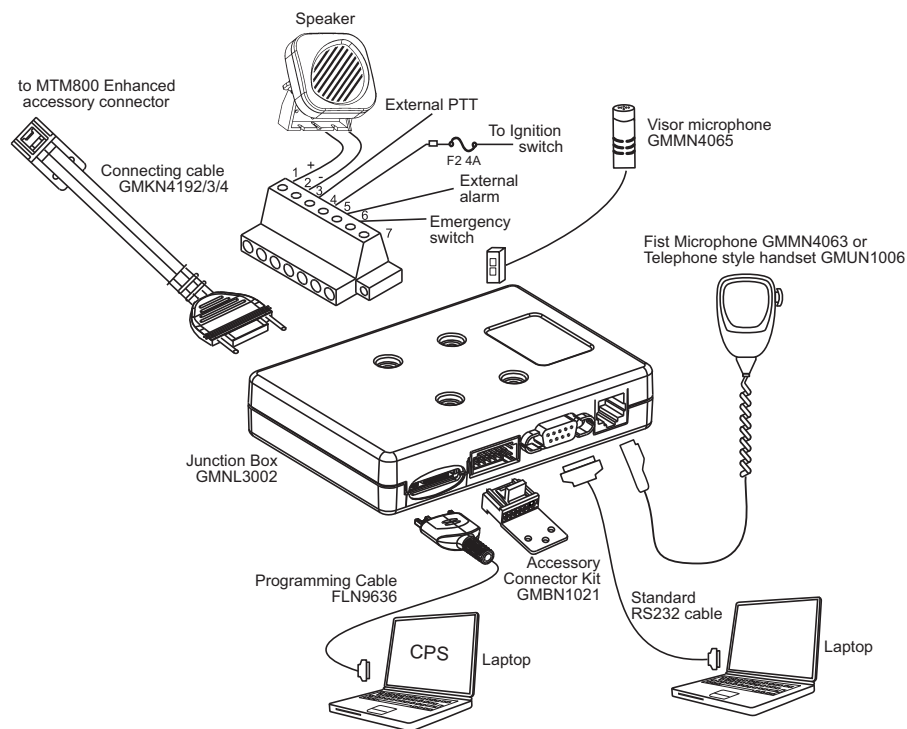

Figure 23 Remote Mount Installation with Junction Box

### General

The junction box (GMLN3002) assists the easy installation for dash and remote mount configurations. It furthermore provides access to the radio for flashing and keyloading of Universal Crypto Module (UCM) encryption keys.

The junction box enables the customer adding a laptop to the remote configuration, connecting a visor microphone, various accessories or fist microphone.

### Installation

The junction box can be installed horizontally and vertically. Secure the junction box by screwing the four supplied screws straight into the location as shown in the figure below. Use the connecting cable (1) for installation purposes.

Ingress Protection (IP) Code: IP30

The junction box has no connector sealing and is designed for use in dust and water protected location only.

1. Secure the junction box (GMLN3002) with the four screws supplied with kit.
2. Connect the connection cable GMKN4192 (length = 6 m), GMKN4193 (length = 4 m) or GMKN4194 (length = 2 m) from the junction box to the accessory connector on the rear side of the transceiver and fasten it with the plug-screws.  
The cable which will be used for installation purposes only must be ordered separately.
3. All other devices should be adapted as shown in Figure 23.

## Service

The junction box PCB is not repairable. Please order a new junction box as necessary.

## Connections

1. Connect all accessories to the junction box.
2. Connect the mobile-terminal-to-Junction box cable to the junction box.
3. Connect the programming cable to the junction box (if required).

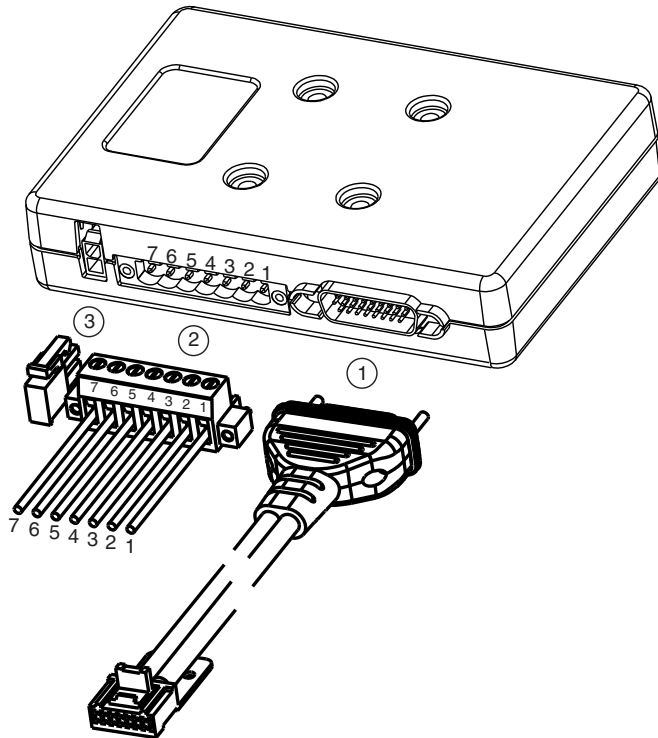

1 = Connecting cable from Junction Box to MTM800 Enhanced (rear side accessory connector) for installation purpose only.

GMKN4192 (length 6 m)  
GMKN4193 (length 4 m)  
GMKN4194 (length 2 m)

2 = Connector for accessory terminal  
pin 1 SPEAKER +  
pin 2 SPEAKER -  
pin 3 EXT\_PTT  
pin 4 IGNITION SENSE  
pin 5 EXT\_ALARM  
pin 6 EMERGENCY  
pin 7 GND

3 = Connector for visor microphone

Figure 24 Connectors on the Junction Box - Front Panel

### CAUTION

**PIN 4: Use an adapter between the radio and the accessory connector to short the ignition to ground. Interference can cause radio to hang.**

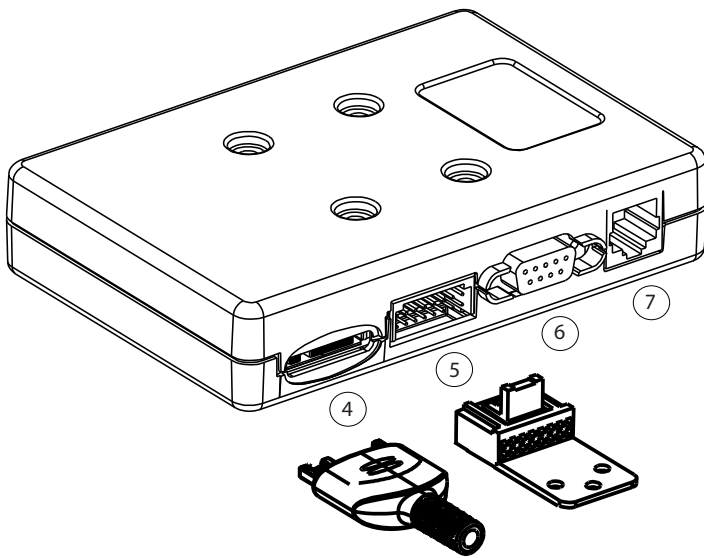

4 = Connector for programming cable FLN 9636

5 = Connector for accessory connector kit GMBN1021

6 = Connector for adapting a laptop via RS232 cable

7 = TELCO-connector for fist microphone (GMMN4063) or telephone style handset (GMUN1006)

Figure 25 Connectors on the Junction Box - Rear Panel

### Connection Plan for the Junction Box Accessory Terminal

#### Connection Plan for the Speaker

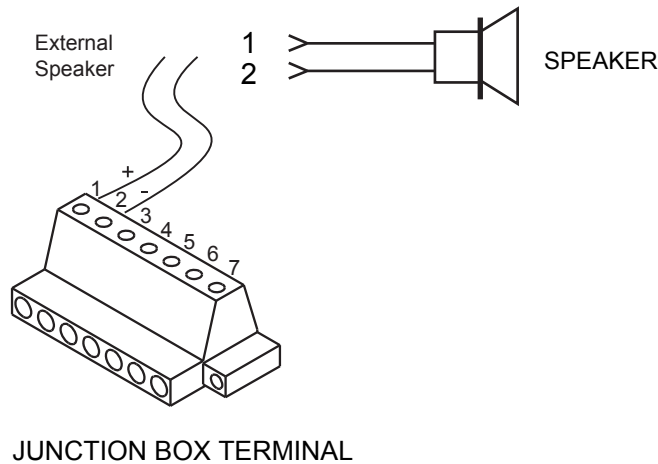

JUNCTION BOX TERMINAL

**Connection Plan for the Alarm Relay**

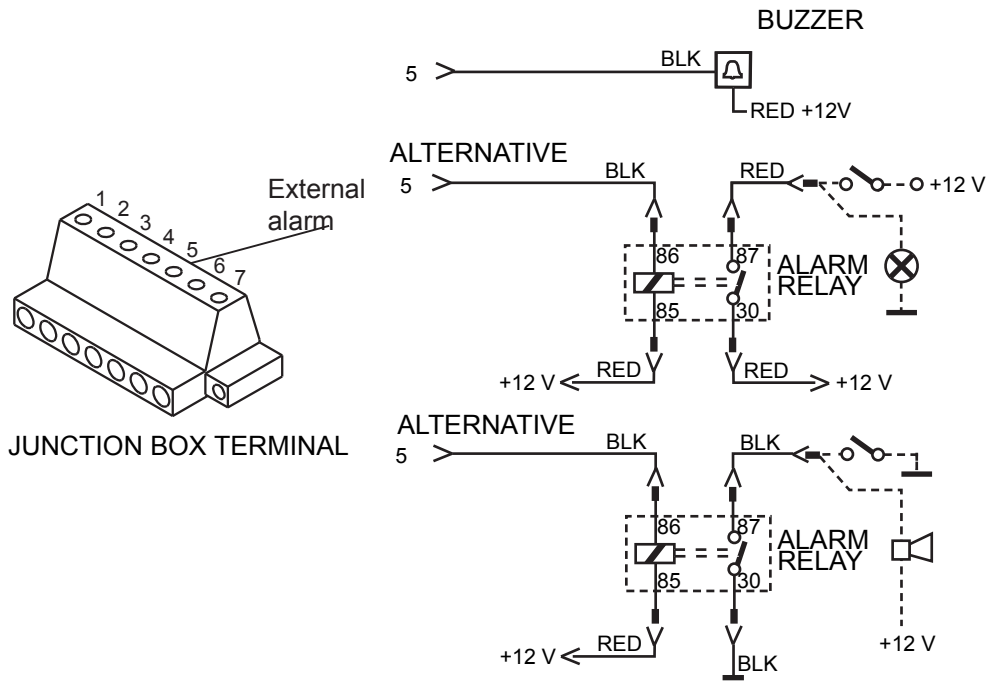

**Connection Plan for the Emergency Switch**

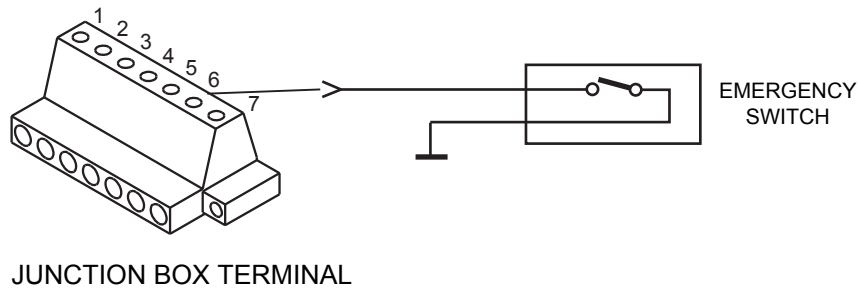

**Connection Plan for the Ignition Sense Cable**

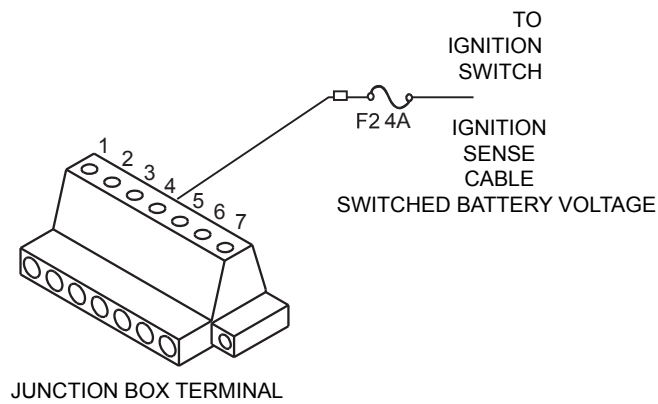

The ignition sense cable HKN9327 allows the MTM800 Enhanced to be turned on and off by the vehicle ignition switch.

To install the cable, carry out the following steps.

1. Connect the stripped lead of the fuse holder cable only to an ignition switched terminal of the fuse block. Use the supplied terminal or any other suitable terminal.
2. Mount the fuse holder using the mounting hole, and dress wires as required.
3. Cut the thin cable to the required length, crimp the supplied red lead to the stripped lead of the thin cable, and connect it to the blue terminal of the fuse holder cable.
4. Connect the other end of the ignition sense thin cable to pin 4 of the junction box terminal.
5. Insert the provided fuse into the fuse holder and close the cover.

**CAUTION** PIN 4: If the ignition line is not used, it needs to be grounded. Interference can cause radio to hang.

**Connection Plan for External PTT**

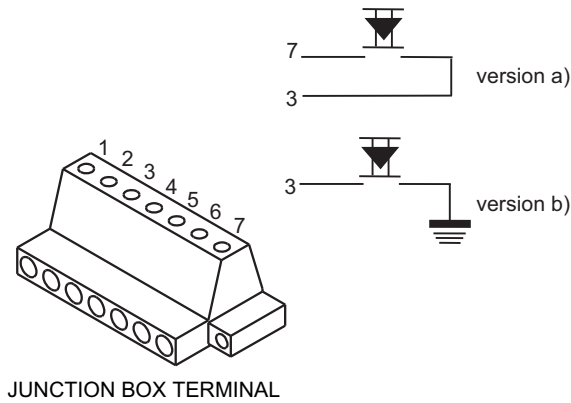

### Connection Plan for Accessory Connector Kit (GMBN1021)

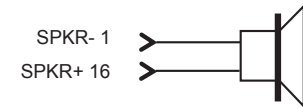
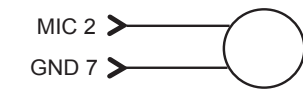
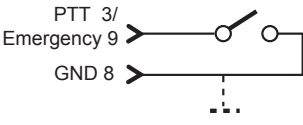
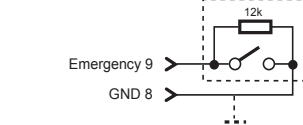
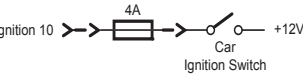
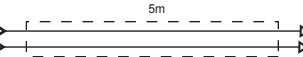
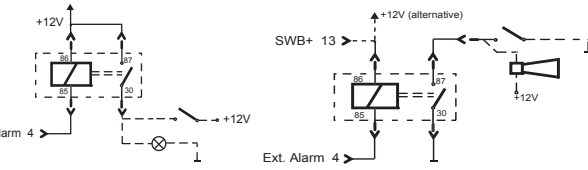
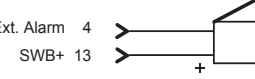
Part Number/Description	Cable Connectivity
<b>GMSN4066</b> Speaker 13W <b>GMSN4078</b> Speaker 5W	SPKR- 1 SPKR+ 16 
<b>GMMN4065</b> Visor Microphone <i>Cannot be used if connector 7 (TELCO) is in use.</i>	MIC 2 GND 7 
<b>RLN4856</b> Footswitch PTT <b>RLN4857</b> Push button PTT <b>RLN4858</b> Gooseneck PTT <i>These accessories can be used for PTT or Emergency function.</i>	PTT 3/ Emergency 9 GND 8 
<b>RLN4836</b> Tri-State Emergency Footswitch and Cable	Emergency 9 GND 8 
<b>HKN9327</b> Ignition Sense Cable	Ignition 10 
<b>GMKN4084</b> Speaker Extension Cable	1 16 
<b>GKN6272</b> External Alarm Relay and Cable	+12V SWB+ 13 Ext. Alarm 4 
<b>GLN7282</b> Buzzer	Ext. Alarm 4 SWB+ 13 

**CAUTION**

**HKN9327 Ignition Sense Cable: If the ignition line is not used, it needs to be grounded. Interference can cause radio to hang.**

#### Radios with Data Expansion Head Enhanced

To use a junction box with one of the MTM800 Enhanced mobile terminals fitted with a Data Expansion Head Enhanced, always use the 9-pin RS232 port on the Data Expansion Head Enhanced for PEI instead of the 9-pin RS232 port on the junction box (connector 6). Ensure to fit a jumper between pins 6 and 15 of the Junction Box (connector 5) for the PEI to operate correctly in this configuration.

**Standard Radios without Data Expansion Head Enhanced**

For standard MTM800 Enhanced mobile terminals without a Data Expansion Head Enhanced, the jumper between pins 6 and 15 of the junction box (connector 5) should be removed.

Table 9 Jumper on Accessory Connector

<b>MTM800 Enhanced Mobile Terminal</b>	<b>Fit Jumper Pins 6-15?</b>	<b>Use Junction Box RS232 PEI?</b>
With Data Expansion Head Enhanced	Yes	No Use the Data Expansion Head Enhanced 9-pin PEI instead.
Without Data Expansion Head Enhanced	No	Yes

## Connectors and Pin Assignment of the Radio

### Transceiver Rear Side - Pin Function

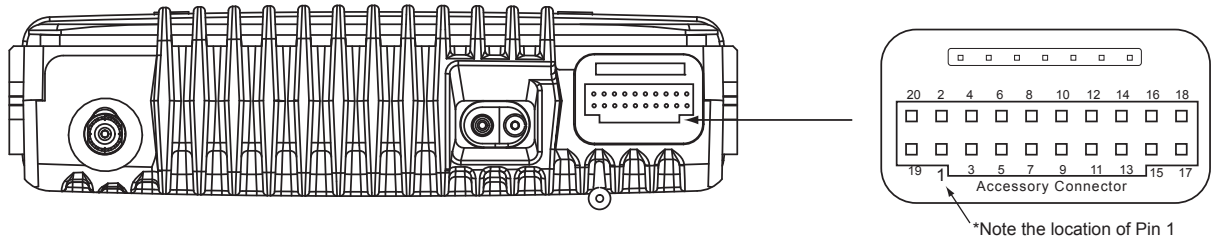

Figure 26 Location of Accessory Connector - Rear Side

This section gives a description of the Accessory Connector pin functions.

**CAUTION**

**The accessory connections shown are not compatible to some other models of Motorola radios. Check the appropriate accessory or technical manual for further information.**

Table 10 20-Pin Accessory Connector

Pin	Function	Description
1	EXTERNAL SPEAKER -	Speaker - and Speaker + (Pin 16) are used to connect an external speaker. The audio PA is a bridge amplifier with a minimum load resistance of 3.2 ohms.
2	EXTERNAL MIC AUDIO	External-, Emergency-, or Hot-Microphone; depends on CPS programming. This microphone signal is independent of the microphone signal on the microphone connector. The DC impedance is 660 ohms and the AC impedance is 560 ohms.
3	EXTERNAL PTT	This is a digital input to trigger external PTT; active low; non active high
4	EXTERNAL ALARM	This is a digital output for External Alarm/Fault Indication; active low; open collector with 4k7 Ohms pull up to B+.
5	TX_AUDIO	This input is intended for injecting signals into the transmit path. Input impedance > 10 k Ohms; Input level = 775mV <sub>RMS</sub>
6	KEYFAIL/FLASH	This line supports the encryption module and the flash mode. Service Aids: 12 volts at this pin during power up/on brings the radio into the flash mode.
7	ANALOG GROUND	Analogue Ground (the same as pin 8)
8	DIGITAL_GROUND	Digital Ground (the same as pin 7)
9	EMERGENCY	To activate this functionality the pin has to be connected to ground. This will turn on the radio.
10	IGNITION	Connecting this pin to the ignition line of the vehicle that will automatically turn on the radio if ignition of the vehicle is turned on. High active.

Table 10 20-Pin Accessory Connector

Pin	Function	Description
11	RX_AUDIO	This is the received RX signal. Output impedance approximate 600 Ohms; unsymmetrical; Output level = 775mV <sub>RMS</sub>
12	AUDIO_PA_ENABLE	This is a digital input. High level or pin enables the audio PA. Low level disables the audio PA.
13	SWB +	This voltage is available when the radio is switched on. The max. current is 1.0A w/o GPS board and 0.8A with GPS board mounted.
14	HOOK	This is a high active digital input. Low = On hook; High = Off hook
15*	SCI_DTR	Data Terminal Ready, used for clock input for high speed flashing. <i>Reserved for Service Aids.</i>
16	SPEAKER +	Positive output of radio's audio PA (see Pin 1).
17*	SCI_CTS	Radio OUTPUT: Clear To Send. <i>Reserved for Service Aids</i>
18*	SCI_RTS	Radio INPUT: Request To Send. <i>Reserved for Service Aids</i>
19*	SCI_RXD	Radio OUTPUT: Receive Data. <i>Reserved for Service Aids</i>
20*	SCI_TXD	Radio INPUT: Transmit Data. <i>Reserved for Service Aids</i>

**NOTE**

The 4-wire 3 Volts SCI interface on the accessory connector (pins 17 -20) can only be used for flashing of radio firmware and programming software features. It can **NOT** be used for communication during normal radio operation.

**CAUTION**

**PIN 10:** If the ignition line is not used, it needs to be grounded for example connected to pin 7 or 8. Interference can cause radio to hang.

# Accessory Connection Plan

**CAUTION**

The accessory connections shown are not compatible to some other models of Motorola radios. Check the appropriate accessory or technical manual for further information. Ensure correct position of the accessory connector.

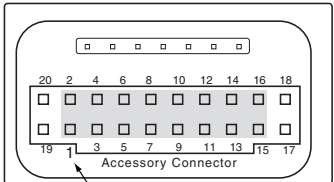
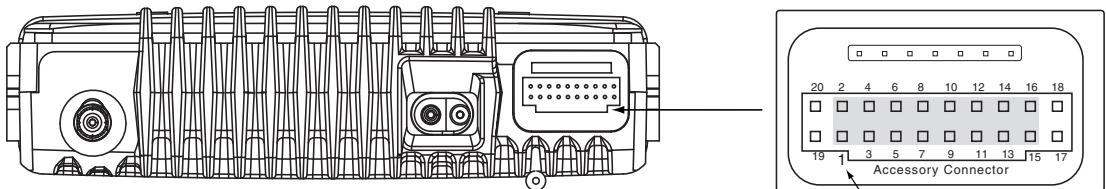

\*Note the location of Pin 1

### 16-pin Accessory Connector

The 16-pin connector, Part Number: 1580922V01 (delivered with the accessory connector kit, Part Number: GMBN1021) plugs into the centre of the 20-pin accessory connector. The four outside pins are not connected, see grey square at figure above.

(Alternatively, a 20-pin connector can be used as well, Part Number: 1586184B01).

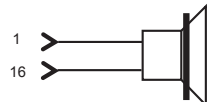
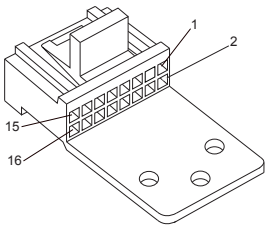

- GMSN4066 Speaker 13W
- GMSN4078 Speaker 5W

GMBN1021 Accessory connector kit containing:  
 Seal, Part No 3202606Y02  
 Accessory Connector Housing 16-Pin, Part No 1580922V01  
 Crimp Contact, Part No 2984249N01

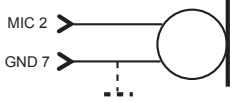

- GMMN4065 Visor Microphone
- GMMN1033 Visor Mic, omni directional

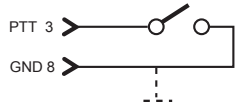

- RLN4856 Footswitch
- RLN4857 Pushbutton w/Remote PTT
- RLN4858 Gooseneck PTT

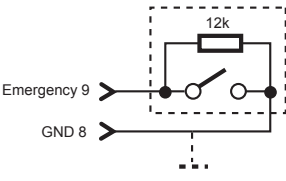

- RLN4836 Tri-state Emergency Footswitch and Cable

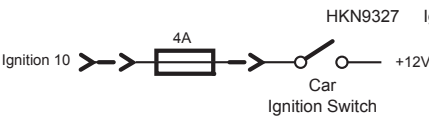

- HKN9327 Ignition Sense Cable

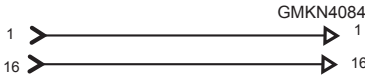

- GMKN4084 Speaker Extension Cable

### GKN6272 External Alarm, Relay and Cable

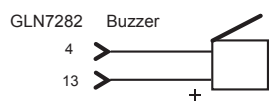
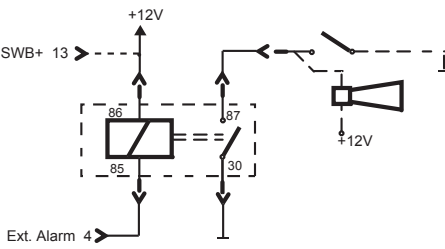
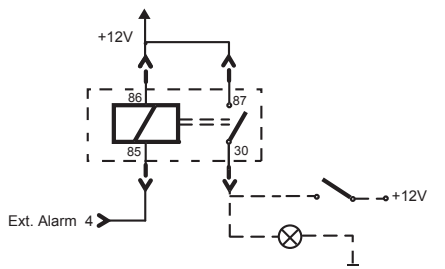

- GLN7282 Buzzer

**CAUTION**

DO NOT short pin 16 or pin 1 on the accessory connector to ground; this may damage the radio.

If the ignition line is not used, it needs to be grounded. Interference can cause radio to hang.

# Connectors and Pin Assignment of Data Expansion Head Enhanced and Remote Head Enhanced

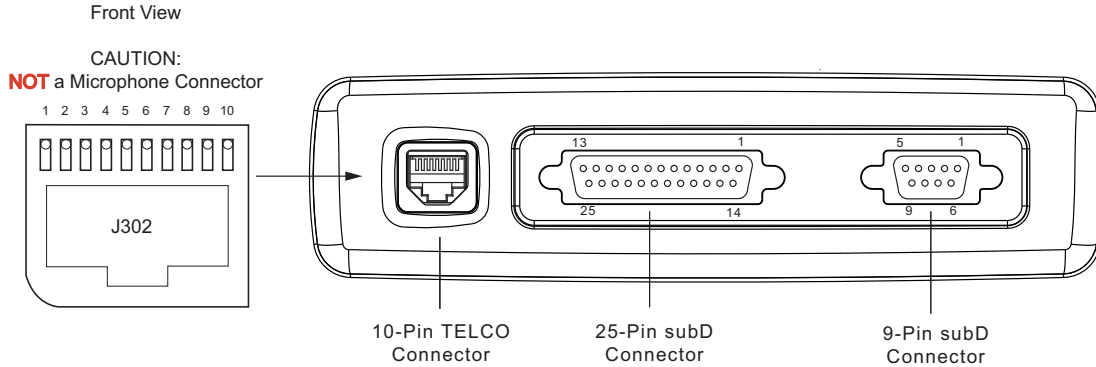

Figure 27 Data Expansion Head Enhanced - Front View and Connector Location

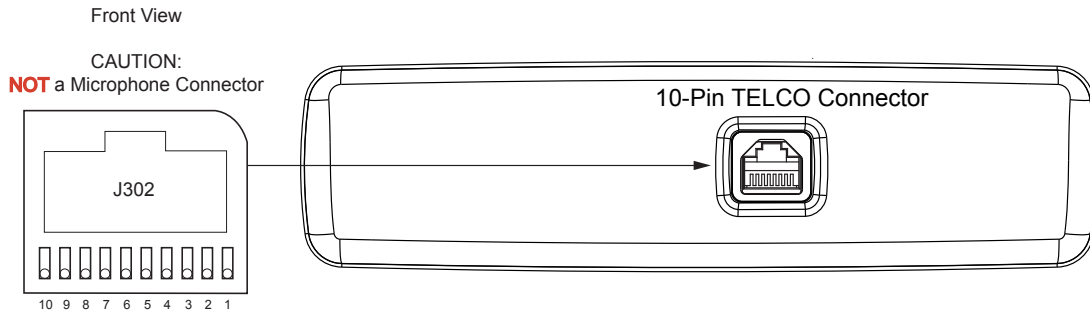

Figure 28 Remote Head Enhanced - Front View and Connector Location

## 10-Pin TELCO Connector

### Data Expansion Head Enhanced:

a) The 10-pin TELCO connector can be used to connect a customized adapter, for example, for connecting the helmet including microphone/earpiece (non-Motorola accessory) or an external PTT. The customized adapter will be connected via the cable RKN4077.

b) The 10-pin TELCO connector can be used to connect a remote mount Enhanced Control Head.

DO NOT connect any other accessories (for example, microphone). This might result in malfunctioning hardware failure.

### Remote Head Enhanced:

The 10-pin TELCO connector of the Remote Head Enhanced can be used in the same way as described on b).

Table 11 10-Pin TELCO Connector

Pin	Function	Description
10	Analog Ground	Analog Ground
9	FLT_A+	This voltage is at battery voltage level and is available as long as the radio is connected to the supply voltage. The maximum current is 300mA. A fuse in the radio prevents further circuit damage in case of shorting this pin to ground.
8	SCI_TX	This is for communication between the radio and the Enhanced Control Head.
7	Radio On/Off Control	This is the Enhanced Control Head service request input. A level of 5 volts indicates that the Enhanced Control Head needs to communicate with the radio. In addition it switches on the radio's voltage regulators. The idle state is a level below 0.6V.
6	Ground	Ground
5	Speaker -	Negative output of the radio's audio PA.
4	Audio-	Balanced Audio - (Bidirectional)
3	BUS+	This is used for communication between the radio and an Enhanced Control Head.
2	Speaker +	Positive output of the radio's audio PA.
1	Audio +	Balanced Audio + (Bidirectional)

## 25-Pin subD Connector

### Data Expansion Head Enhanced:

The radio must be turned ON/OFF via the Ignition Sense Cable HKN9327, which has to be connected on Pin 10 of the Accessory Connector on the rear side of the radio.

Table 12 25-Pin subD Connector

Pin	Function	Description
1	GND	Ground
2	RS232_SCI_TX	Transmit Data (4-wire RS232 with RS232 level)
3	RS232_SCI_RX	Receive Data (4-wire RS232 with RS232 level)
4	RS232_RTS	Request to Send (4-wire RS232 with RS232 level)
5	RS232_CTS	Clear to Send (4-wire RS232 with RS232 level)
6	FLT_A+	This voltage is at battery voltage level and is available as long as the radio is connected to the supply voltage. A fuse in the radio prevents further circuit damage in case of shorting this pin to ground. This pin is only used together with the pins 14, 20, and 23 to select flashing and programming mode, or to switch the radio on.
7	Ground	Ground for RS232
8	SB9600_BUSY	SB9600 Busy
9	NC	Not Connected

Table 12 25-Pin subD Connector

Pin	Function	Description
10	NC	Not Connected
11	NC	Not Connected
12	SW_B+	Switched $U_B$ +/-100mA
13	SB9600_BUS-	SB9600 BUS-
14	ON_OFF_CONTROL/ FLASH_MODE	This input is intended to switch the terminal into flashing & programming mode. When the terminal is switched off and this pin is connected with pin 6 (FLT A+), the terminal switches on and enters flashing & programming mode. This is also On/Off control for Std. Control Head.
15	SB9600_BUS+	SB9600 BUS+.
16	Internal Mic Audio	This input depends on radio programming mode. This microphone signal is independent of the microphone signal on the accessory connector. The nominal input level is 80 mV. The DC impedance is 660 ohms and the AC impedance is 560 ohms.
17	SB9600-Reset	This output can be used to reset a SB9600 device.
18	NC	Not Connected
19	GROUND	Ground
20	IGNITION	The radio can be switched on by connecting this pin with pin 6 (FLT A+). As long as both pins are connected, the radio will be switched on.
21	ON_OFF_GND	This is On/Off control for the old Control Head "J" (MTM300 Control Head)
22	EXPANSION- PTT	When this input is used to key up the transmitter, the internal Mic Audio input (pin 16) is selected.
23	SB9600_SW	This input is intended to switch into SB9600 mode. The terminal must be switched off and then this input must be connected to pin 6 (FLT A+). When the radio is switched on again, the SB9600 mode will be active.
24	HANDSET_AUDIO	This is a low power audio output primarily intended for a connected handset. the Dc level is 4.6 V and the AC level depends on the volume setting.
25	NC	Not Connected

## 9-Pin subD Connector

The pin assignment of this 9-pin subD connector will follow the requirements of an RS232 standard interface with RS232 voltage level. The cable (see section "Connecting Cables" on page 69) which has to be used is a standardized serial interface cable which allows to connect a data device with an RS232 Interface such as for example PC, Laptop, Console.

Table 13 9-Pin subD Connector

Pin	Function	Description	PC Direction
1	DCD	Data Carrier Detect	Input
2	RXD	Received Data	Serial IN
3	TXD	Transmitted Data	Serial OUT
4	DTR	Data Terminal Ready	Output
5	GND	Ground	Output
6	DSR	Data Set Ready	Input
7	RTS	Request to Send	Output
8	CTS	Clear to Send	Input
9	RI	Ring Indicator	Input

# Connector and Pin Assignment of the Enhanced Control Head

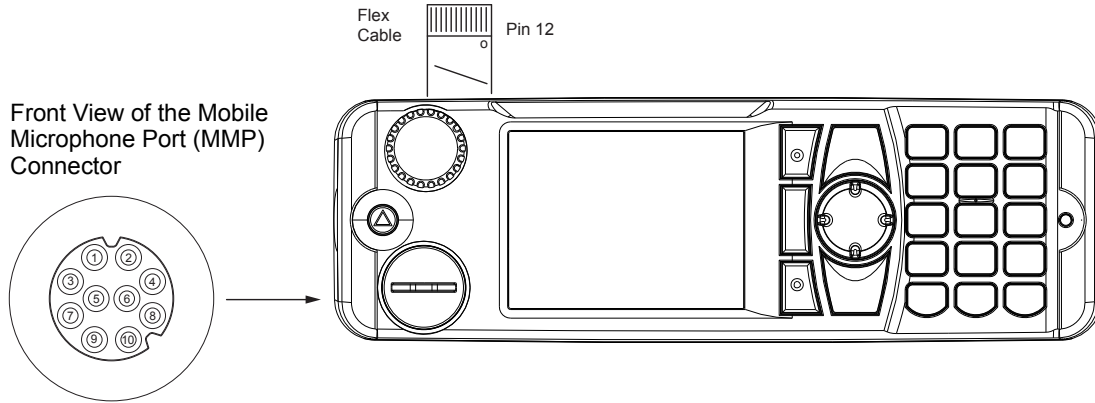

Figure 29 View of the Enhanced Control Head’s Mobile Microphone Port Connector and Flex Cable



**NOTE**

The keypad labelling of the control head may vary according to the specific customer/country concerns.

Table 14 10-Pin Mobile Microphone Port (MMP) Connector

Mobile Microphone Port Pin	Default Functions	Alternative Functions	USB Functions	RS232 Functions
1	1-WIRE	1-WIRE	1-WIRE	1-WIRE
2	GPIO_3	PTT	GP Input or Output	RS-232-RTS
3	SPEAKER	SPEAKER	SPEAKER	SPEAKER
4	GPIO_2	GPIO_2 INPUT	GP Input or Output	DATA -
5	GND	GND	GND	GND
6	OPT 5V	HIGH Impedance	OPT 5V	VBUS
7	MIC +	MIC +	MIC +	MIC +
8	GPIO_1	GPIO_1 INPUT	GP Input or Output	DATA +
9	GPIO_4	HOOK	GP Input or Output	RS-232-CTS
10	GPIO_0	GPIO_0 INPUT	GP Input or Output, PWR ON	GP Input or Output, PWR ON

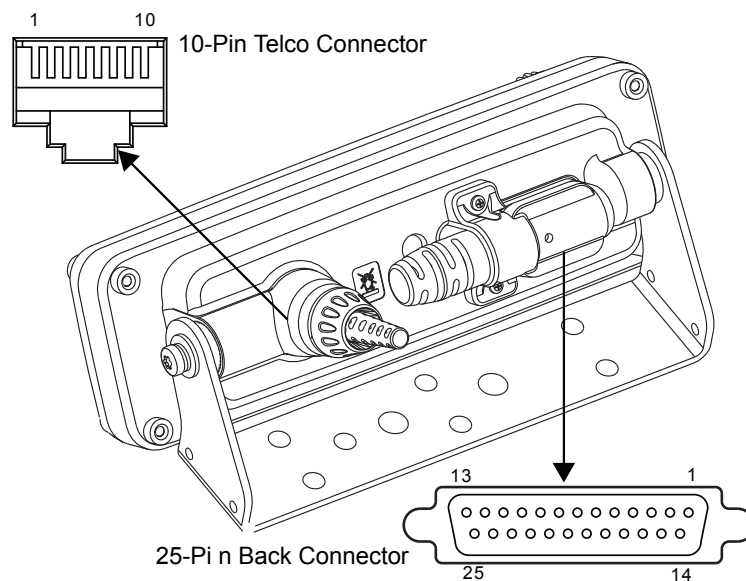

Figure 30 View of the Enhanced Control Head's rear connectors

Table 15 10-Pin Telco Connector

Telco Connector Pin	Function	Description
1	AUDIO +	Balanced Audio + (Bidirectional)
2	SPKR +	Speaker +
3	BUS +	Serial Bus, Data sent from the Enhanced Control Head
4	AUDIO -	Balanced Audio - (Bidirectional)
5	SPKR -	Speaker -
6	GND	Ground
7	ON_OFF_CONTROL	Radio Turn-On Signal
8	SCI_TX	Serial Bus, Data sent to the Enhanced Control Head
9	FLT_A +	Supply voltage
10	GND	Ground

Table 16 25-Pin Back Connector

Back Connector Pin	Function	Description	Default
1	GPIO_9	GPIO	Output: Active for duration of call (car radio mute)
2	GPIO_6	GPIO	PTT Input, TX audio from MIC_REAR_2
3	GPIO_8	GPIO	Disabled
4	GPIO_3	GCAI PIN 2	PTT Input, TX audio from MIC_REAR_1

Table 16 25-Pin Back Connector

Back Connector Pin	Function	Description	Default
5	VBUS_1B	GCAI PIN 6: 5V Supply	Disabled
6	REAR_D -	GCAI PIN 4: USB D -, GPIO_2 (Shared with the front MMP)	Disabled
7	REAR_D +	GCAI PIN 8: USB D +, GPIO_1 (Shared with the front MMP)	Disabled
8	GPIO_0	GCAI PIN 10: GPIO	Input: GCAI detection / Select Line
9	VBUS_2	Second USB 5 V Supply	Disabled
10	TX	4-wire RS232 TX	
11	RX	4-wire RS232 RX	
12	MIC_REAR_2	Second Rear Microphone	Disabled
13	GND	Ground	
14	GPIO_5	GPIO	Disabled
15	GPI_7	4-Level Analogue Input	Enabled
16	1_WIRE	GCAI PIN 1: Bi-directional Serial Bus	Disabled
17	HANDSET	GCAI PIN 3: Handset Audio Output	Parallel to front GCAI
18	GND	GCAI PIN 5: Ground	
19	MIC_REAR_1	GCAI PIN 7: Microphone Input	Disabled
20	GPIO_4	GCAI PIN 9: GPIO	Hook Input
21	USB_D +	Second USB D +	
22	USB_D -	Second USB D -	
23	RTS	4-wire RS232 RTS	
24	CTS	4-wire RS232 CTS	
25	PWR_ON	Enhanced Control Head Power On Input	

---

## Connecting Cables

---

### Motorcycle Mount Enhanced Control Head-to-Remote Head Enhanced/Data Expansion Head Enhanced (Motorcycle Mount TELCO Cable)

**Part Number:** PMKN4030

**Length:** 2.3 m (7.55 feet)

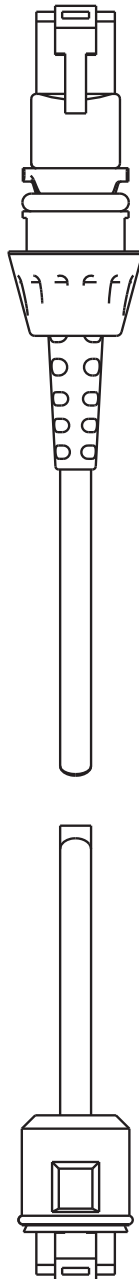

Figure 31 Connecting Cable - Motorcycle Mount TELCO Cable

## Remote Mount Enhanced Control Head/Motorcycle Mount Enhanced Control Head-to-Accessories (Accessories Expansion Cable)

**Part Number:** PMKN4029/PMKN4056

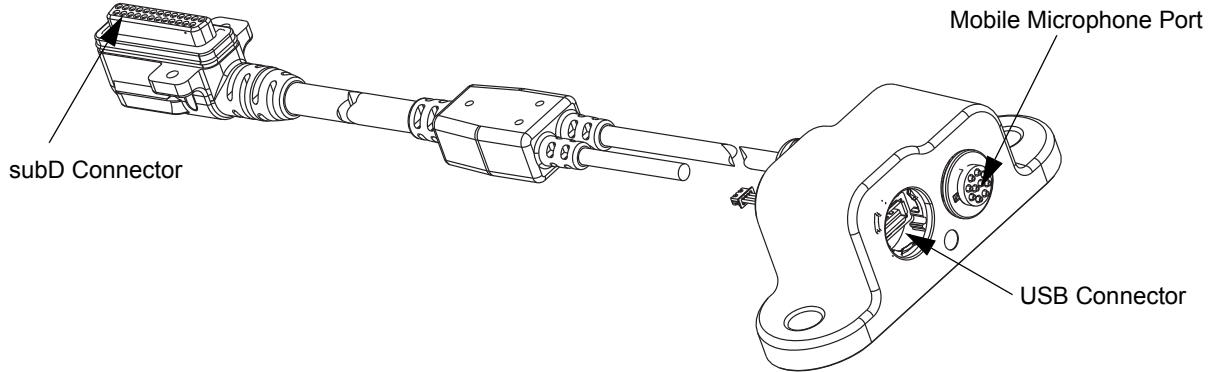

Figure 32 Connecting Cable - Accessories Expansion Cable

Table 17 Accessories Expansion Cable, Connector Pin Function

USB A JACK	Signal	subD 25 Pos
1	VBUS	9
2	D-	22
3	D+	21
4	Ground	18
<b>Mobile Microphone Port (MMP)</b>		
1	1_WIRE	16
2	GPIO_3 (PTT)	4
3	Speaker to Headset	17
4	GPIO_2 (D-)	6
5	GPIO_1 (D+)	7
6	Ground	-
7	VBUS	5
8	MIC	19
9	GPIO_4 (HOOK)	20
10	GPIO_0	8
<b>Customised Wire Color</b>		
BROWN / BLACK	GPIO_9	1
ORANGE / BLACK	GPIO_6	2
YELLOW / BLACK	GPIO_8	3
GREEN / BLACK	TX	10
BLUE / BLACK	RX	11
GRAY / BLACK	MIC_2	12
BLUE	Ground	13
PINK / BLACK	GPIO_5	14
BLACK / WHITE	GPI_7	15
BROWN / WHITE	RTS	23
RED / WHITE	CTS	24
ORANGE / WHITE	Power On	25
RED / BLACK	Headset	17
YELLOW / WHITE	Ground	-

# Radio-to-Junction Box

**Part Number:** 3066537B01  
**Length:** 6 m (19.69 feet)

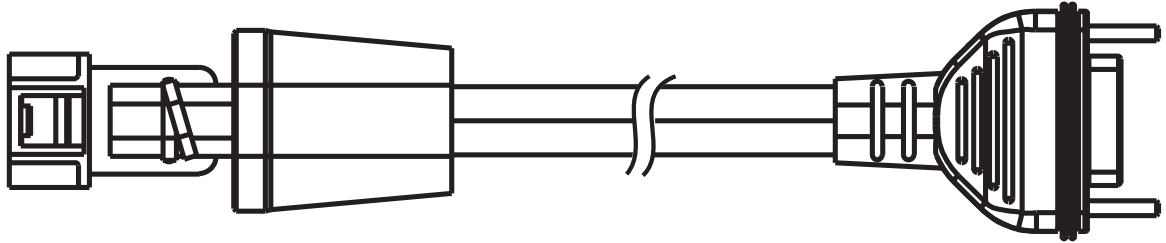

MTM800 ACCESSORY CONNECTOR  
20-Pin AMP

JUNCTION BOX CONNECTOR  
26-Pin subD

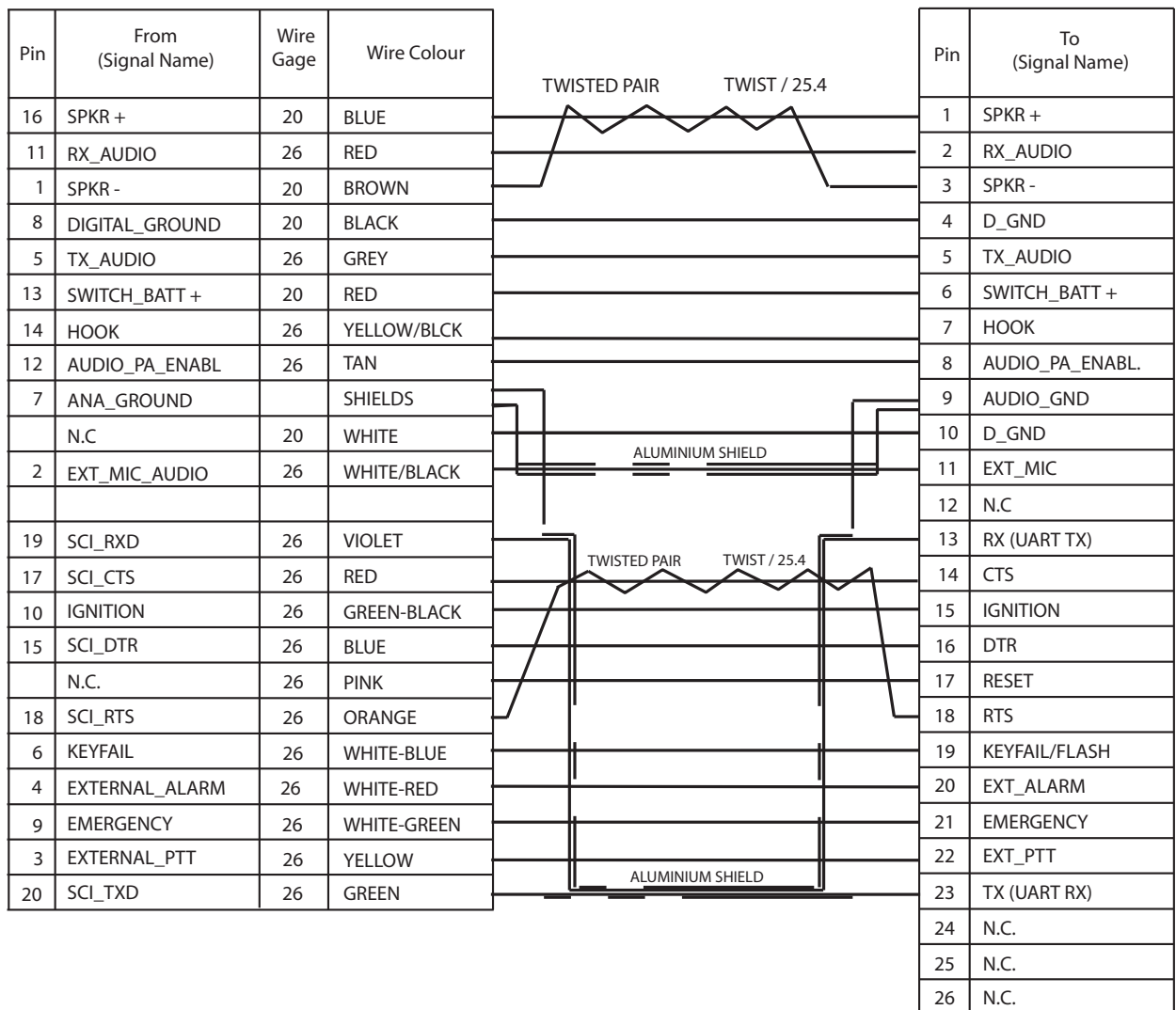

Figure 33 Connecting Cable - Radio-to-Junction Box

## Data Expansion Head Enhanced Radio-to-Data Device

This is a standardized RS232 cable (will not be provided by Motorola). Use the 9-pin socket on the front side of the Data Expansion Head Enhanced Radio to connect this cable with the data device.

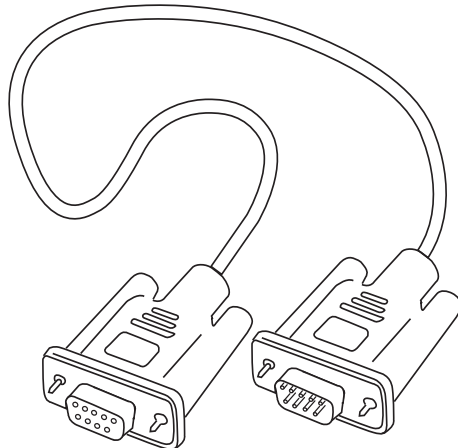

Figure 34 Standardized RS232 Cable



### NOTE

**The Data Expansion Head Enhanced has a protection grade of IP54.**

**To maintain IP54 sealing when connecting an RS232 data cable make sure to use an IP54 specified cable (example: ROLINE AT-Modem cable ST-BU 1.8m order no. 11.01.4518).**

## Data Expansion Head Enhanced Radio-to-Fist Microphone

The GMKN4072 Connecting Cable replaces the existing coiled cord cable of the fist microphone (Motorola P/N: GMMN4063).

### Operation

The crimped wires of the cable have to be connected into the 16-pin Accessory Connector (delivered with speaker GMSN4066) and then plugged into the 20-pin connector on the rear side of the radio. The other end has a connector which fits into the fist microphone's housing.

### Making Connections

First connect the exposed four wires to the 16-pin Accessory Connector as shown in Figure 1 and then plug the connector block into the 20-pin accessory socket on the rear side of the radio. The connector block plugs into the center of the 20-pin accessory connector (four outside pins do not connect).

### Removing the Existing Coiled Cord Cable

1. Rotate the locking collar at the base of the microphone in a counterclockwise direction until it stops.
2. Pull the cord out and away from the base of the of the microphone.

Install the new coiled cord GMKN4072 in a reverse order of removal.

**Part Number:** GMKN4072

**Length:** 65 cm (2.2 feet)

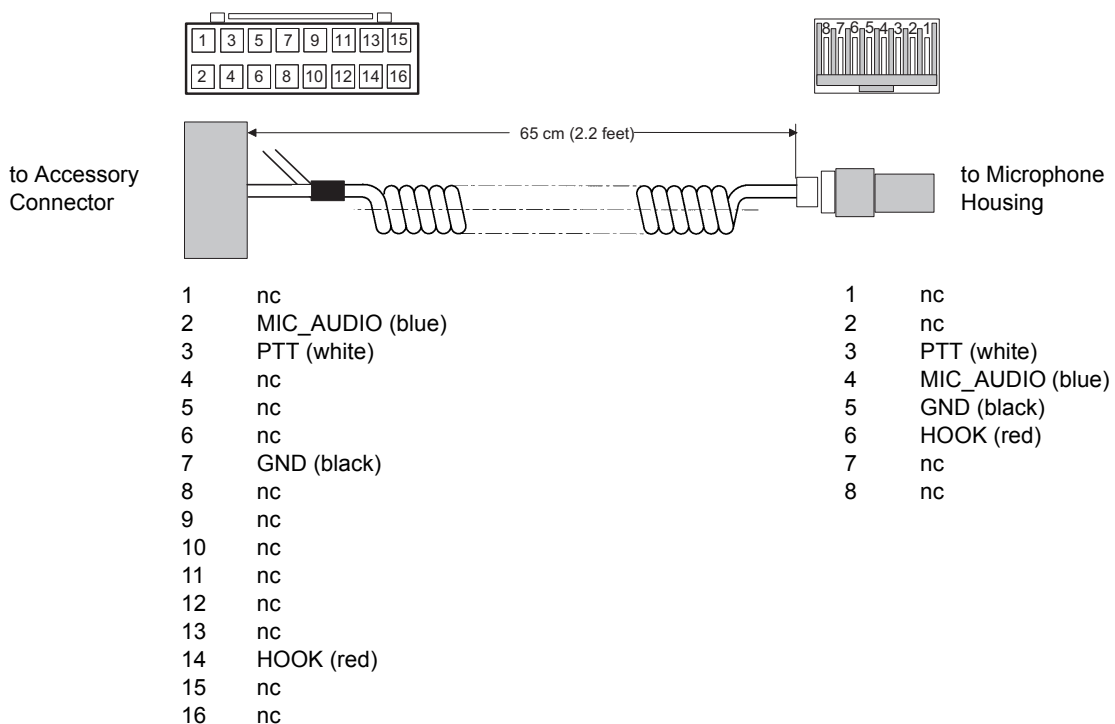

Figure 35 Pin Assignment of Cable from Accessory Connector to Microphone Housing

## Radio-to-Data Device: Active Data Cable

The GMKN1022 Active Data Cable provides a 5-wire RS232 interface (for example, RxD, TxD, CTS, RTS, DTR) between a computer and a mobile radio. The cable has to be connected to the 20-pin Accessory Connector on the rear side of the radio and into the 9-pin connector of a Data Device (for example, PC, Laptop, console)

The GMKN1022 Active Data Cable is not repairable. Order a replacement cable as necessary.

**Length:** 2.0 m (6.56 feet)

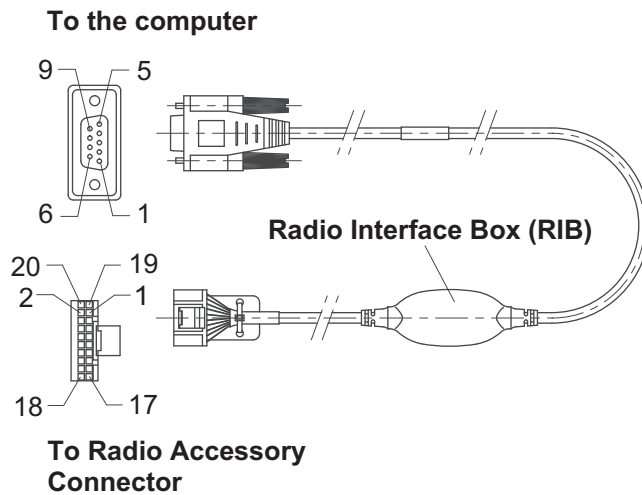

Figure 36 Active Data Cable GMKN1022

### Cable Connectivity

Table 18 Pin Assignment - Active Data Cable GMKN1022

9-Pin Connector	Function	20-Pin Connector	Function
1	DCD	3	External PTT
2	RXD	8	GND
3	TXD	13	SWB +
4	DTR	15	DTR
5	GND	17	CTS
6	DSR	18	RTS
7	RTS	19	TXD
8	CTS	20	RXD
9	RI		

## Vehicle Antenna Installation

### Mobile Radio Operation and EME Exposure

To assure optimal radio performance and that human exposure to radio frequency electromagnetic energy is within the guidelines referenced in this document, transmit *only* when people inside and outside the vehicle are at least the minimum distance away from a properly installed, externally-mounted antenna. The table below lists the minimum distance for several different ranges of rated radio power.

**Table 19 Rated Power and Distance**

Mobile Radio Rated Power (see Note below)	Minimum Lateral Distance from Vehicle Body
Less than 7 Watts	20 Centimetres (8 inches)
7 to 15 Watts	30 Centimetres (1 Foot)
16 to 39 Watts	60 Centimetres (2 Feet)
40 to 110 Watts	90 Centimetres (3 Feet)



**NOTE**

**If you are not sure of the rated power of your radio, contact your Motorola representative or dealer and supply the radio model number found on the radio model label. If you cannot determine the rated power out, then assure 90 cm (3 feet) separation from the body of the vehicle.**

### Selecting an Antenna Site

1. Install the vehicle antenna external to the vehicle and in accordance with:
  - a. **The requirements of the antenna manufacturer/supplier**
  - b. **The requirements of the vehicle manufacturer**
2. The best mounting location for the antenna is in the centre of a large, flat conductive surface. In almost all vehicles, mounting the antenna in the centre of the roof will satisfy these requirements. A good alternate location is in the centre of the trunk lid. If you use the trunk lid, ensure that the trunk lid is grounded by connecting grounding straps between the trunk lid and the vehicle chassis.
3. Ensure the antenna cable can be easily routed to the radio. Ensure that the antenna cable is routed separately and not in parallel to any other vehicle wiring or mobile radio cable wiring.

**CAUTION**

**It is recommended to mount the antenna outside the vehicle. Also make sure your power cable is not placed with the antenna in parallel. Interference can cause radio to hang.**

4. Check the antenna location for any electrical interference according to vehicle manufacturer requirements.
5. Make sure the mobile radio antenna is installed at least 30 centimeters (1 foot) away from any other antenna on the vehicle.



**NOTE**

**Any two metal pieces rubbing against each other (such as seat springs, shift levers, trunk and hood lids, exhaust pipes, and so forth) in close proximity to the antenna can cause severe receiver interference.**

6. The MTM800 Enhanced mobile terminal has the option of a GPS board. If a GPS or combined TETRA/GPS antenna is used, make sure that the antenna has a clear view to the sky and that the antenna base which carries the GPS receiver is not covered with any metallic or radio frequency absorbing material.

---

## Antenna Installation Procedure

1. Mount the antenna according to the instructions provided with the antenna kit. Run the coaxial cable to the radio mounting location. If necessary, cut off the excess cable and install the cable connector.
2. Connect the antenna cable connector to the radio antenna connector on the rear of the radio.
3. In case of an installed GPS board, connect the GPS antenna to the GPS antenna connector on the rear side of the radio.

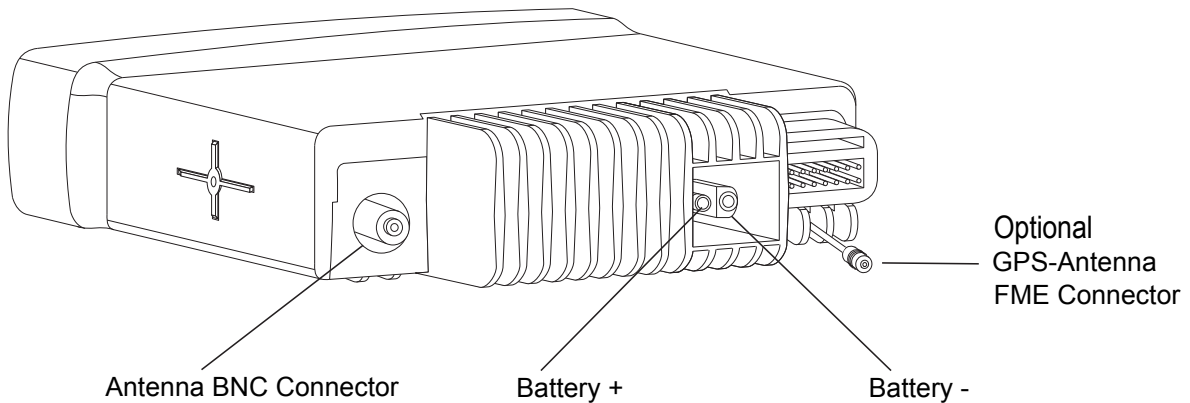

Figure 37 Connections to the Back of the Radio

---

## Completing the Installation

1. Mount the microphone clip to a convenient spot near your radio.
2. If your microphone has a telephone-type connector at the end of its cord, plug this connector into the 10-pin TELCO connector of your Junction Box.

**CAUTION**

**DO NOT use the 10-pin TELCO connector of Data Expansion Head Enhanced or Remote Head Enhanced to plug in a microphone.**

3. To complete your radio installation, plug the power cable into the radio power connector.

## External Speaker Installation

1. Remove the speaker from the trunnion bracket by loosening the two wing screws.
2. Choose a place to mount the speaker. When mounting the trunnion on the transmission hump, be careful that the transmission housing is not affected.
3. Use the trunnion bracket as a template to mark the positions of the mounting holes.
4. Centre-punch the spots you marked and drill a 4 mm (5/32-inch) diameter hole at each location.
5. Mount the trunnion bracket with the screws supplied (see Figure 38).
6. Insert the speaker into the trunnion bracket and tighten the two wing screws.
7. Insert the external speaker accessory plug into the accessory connector of the radio.

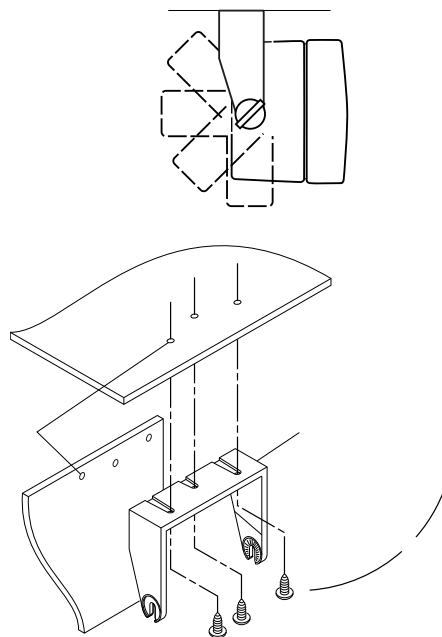

Figure 38 Mounting the Speaker under the Dashboard













**THIS PAGE INTENTIONALLY LEFT BLANK**

# UPGRADING THE TERMINAL

## Upgrade Procedure from MTM800 to MTM800 Enhanced

Existing users of the MTM800 can upgrade their equipment with the Enhanced Control Head. The different procedures below detail the software upgrade as well as the hardware changes required.

### From an MTM800 Dash/Desk Radio to an MTM800 Enhanced Dash/Desk Radio

1. Upgrade the software on the transceiver. To use the software upgrade feature on the CPS, choose MR7.4 SW or subsequent (see "Using the MR7.4 or Subsequent Software" on page 88).
2. Replace the control head with an Enhanced Control Head:

Description	Part Number
Enhanced Control Head (English Keypad)	GMWN4298
Enhanced Control Head (Chinese Keypad)	GMWN4299
Enhanced Control Head (Korean Keypad)	GMWN4300
Enhanced Control Head (Arabic Keypad)	GMWN4301
Enhanced Control Head (Bopomofo Keypad)	GMWN4302
Enhanced Control Head (Cyrillic Keypad)	GMWN4303
Enhanced Control Head (English Keypad) - Hungarian	GMWN4608

3. Replace the fist microphone/desk microphone with a new accessory:

Description	Part Number
Desk Microphone (Mobile Microphone Port)	RMN5106
Compact Fist Microphone	RMN5107
Fist Microphone, Compact (Mobile Microphone Port)	RMN5052
Fist Microphone, Heavy Duty (Mobile Microphone Port)	RMN5053
Heavy Duty Fist Microphone	RMN5111

## From an MTM800 Remote Radio to an MTM800 Enhanced Remote Radio

1. Upgrade the software on the transceiver. To use the software upgrade feature on the CPS, choose MR7.4 SW or subsequent (see "Using the MR7.4 or Subsequent Software" on page 88).
2. Replace the control head with a Remote Mount Enhanced Control Head:

Description	Part Number
Remote Mount Enhanced Control Head (English Keypad)	GMWN4304
Remote Mount Enhanced Control Head (Chinese Keypad)	GMWN4305
Remote Mount Enhanced Control Head (Korean Keypad)	GMWN4306
Remote Mount Enhanced Control Head (Arabic Keypad)	GMWN4307
Remote Mount Enhanced Control Head (Bopomofo Keypad)	GMWN4308
Remote Mount Enhanced Control Head (Cyrillic Keypad)	GMWN4309
Remote Mount Enhanced Control Head (English Keypad) - Hungarian	GMWN4606



### NOTE

The cable from the control head to the transceiver remains the same.

3. Replace the remote head kit/expansion head kit on the transceiver with a new version of the Remote Head Enhanced/Data Expansion Head Enhanced:

Description	Part Number
Remote Head Enhanced	PMLN4904
Data Expansion Head Enhanced	PMLN4908

4. Replace the fist microphone/desk microphone with a new accessory:

Description	Part Number
Desk Microphone (Mobile Microphone Port)	RMN5106
Fist Microphone, Compact (Mobile Microphone Port)	RMN5052
Heavy Duty Fist Microphone	RMN5111
Compact Fist Microphone	RMN5107

## From an MTM800 Motorcycle Radio to an MTM800 Enhanced Motorcycle Radio

1. Upgrade the software on the transceiver. To use the software upgrade feature on the CPS, choose MR7.4 SW or subsequent (see "Using the MR7.4 or Subsequent Software" on page 88).
2. Replace the control head with a Motorcycle Mount Enhanced Control Head:

Description	Part Number
Motorcycle Mount Enhanced Control Head (English Keypad)	GMWN4600
Motorcycle Mount Enhanced Control Head (Chinese Keypad)	GMWN4601
Motorcycle Mount Enhanced Control Head (Korean Keypad)	GMWN4602
Motorcycle Mount Enhanced Control Head (Arabic Keypad)	GMWN4603
Motorcycle Mount Enhanced Control Head (Bopomofo Keypad)	GMWN4604
Motorcycle Mount Enhanced Control Head (Cyrillic Keypad)	GMWN4605
Motorcycle Mount Enhanced Control Head (English Keypad) - Hungarian	GMWN4607

3. Replace the expansion head kit on the transceiver with a new version of the Remote Head Enhanced/Data Expansion Head Enhanced:

Description	Part Number
Remote Head Enhanced	PMLN4904
Data Expansion Head Enhanced	PMLN4908

4. Replace the motorcycle remote mount cable with the following:

Description	Part Number
Motorcycle Mount TELCO cable, 2.3m	PMKN4030

5. Replace the fist microphone/desk microphone with a new accessory:

Description	Part Number
Desk Microphone (Mobile Microphone Port)	RMN5106
Fist Microphone, Compact (Mobile Microphone Port)	RMN5052
Heavy Duty Fist Microphone	RMN5111
Compact Fist Microphone	RMN5107



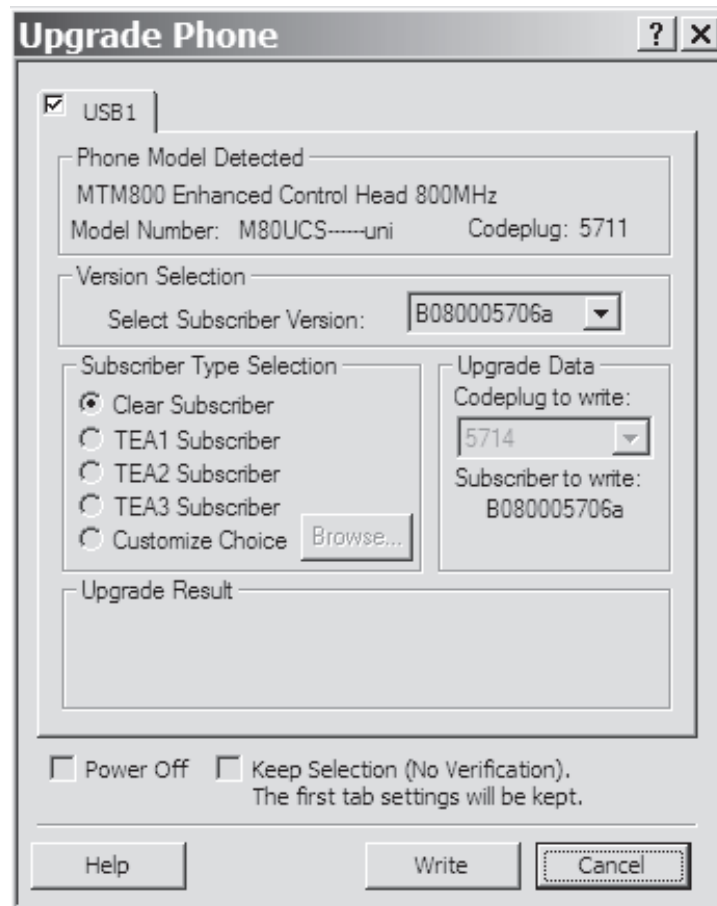

6. Power off the MTM800.



# APPENDIX

## Product Specific Information for Digital Terminals Type MT912M/MT812M/MT712M/MT512M

This section gives the Service Personnel an overview about product specific notes. This is necessary to take special precautions to avoid the introduction of hazards when operating, installing, servicing or storing equipment. This terminal meets the applicable safety standards if it is used as described. All operating and safety instructions are to be followed carefully.

### Equipment Electrical Ratings

**Rated Voltage:** 12 Volt DC

**Rated Voltage Range:** 10.8 to 15.6 V DC

**Rated Current:**

MT912M (380-430 MHz), MT812M (350-390 MHz), MT512M (410-470 MHz),  
MT712M (806-870 MHz): 3 Amps @ 3 Watts RF power

Please be aware when planning the installation that there is a current consumption of approx. 3.5A during PTT and even 30mA when terminal is switched off.

**Transmitter Frequency Range:**

TMO: 380-430 MHz (MT912M), 350-390 MHz (MT812M), 806-825 MHz (MT712M),  
410-470 MHz (MT512M)

DMO: 380-430 MHz (MT912M), 350-390 MHz (MT812M), 851-870 MHz (MT712M),  
410-470 MHz (MT512M)

**Receiver Frequency Range:**

380-430 MHz (MT912/MT912M), 350-390 MHz (MT812M), 851-870 MHz (MT712/MT712M),  
410-470 MHz (MT512M)

### Normal Load Conditions

**Rated RF Power:** 3 Watts

**Rated Audio Power:** 10 Watts @ 4 Ohms; 6 Watts @ 8 Ohms

**Antenna Impedance:** 50 Ohms

**Operating Temp. Range:** -30 to +60°C

**Operating Time:** Continuous/Intermittent



#### NOTE

In general, the terminal transmit and receive time (operating cycle time) is determined by the communication system. On overload, respectively on extensive use beyond the systems specifications at high ambient temperatures, the terminal is protected by its thermal control, which cuts down the RF output power, thus reducing the terminal coverage range.

## Fuse Identification

In case of blown fuses during the installation replace **ONLY** with those of identical value.  
**Never insert ones of different values.**

**Fuse for Power Cable GKN6270/GKN6274:**

10 A (Motorola Part Number: 6500139767)

**Fuse for Ignition Sense Cable HKN9327:**

4 A (Motorola Part Number: 6580283E02)