



Poultry Production Systems

Standard Nipple & RELIA-FLOW[®]

Watering

Installation and Operators Manual

Installation and Operators Manual

Installation and Operators Manual

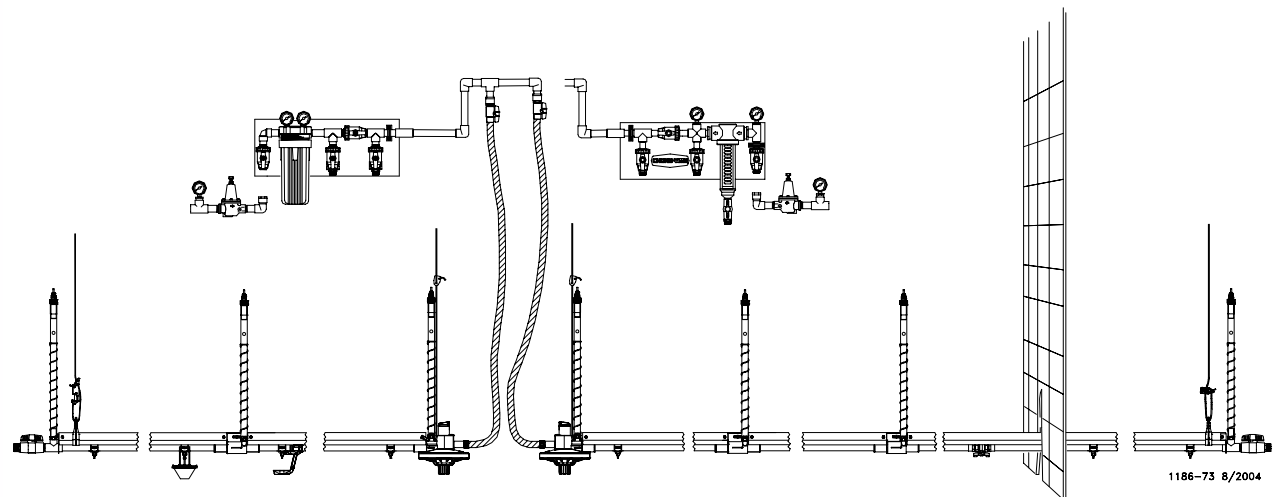

1186-73 8/2004

Warranty

Chore-Time Poultry Production Systems, a division of CTB, Inc., (“Chore-Time”), warrants each new CHORE-TIME® product manufactured by it to be free from defects in material or workmanship for one (1) year from and after the date of initial installation by or for the original purchaser. If such a defect is found by Chore-Time to exist within the one-year period, the Chore-Time will, at its option, (a) repair or replace such product free of charge, F.O.B. the factory of manufacture, or (b) refund to the original purchaser the original purchase price, in lieu of such repair or replacement. Labor costs associated with the replacement or repair of the product are not covered by the Manufacturer.

Conditions and Limitations

1. The product must be installed by and operated in accordance with the instructions published by the **Manufacturer or Warranty will be void.**
2. Warranty is void if **all components** of the system are not original equipment supplied by the **Manufacturer.**
3. This product must be purchased from and installed by an authorized distributor or certified representative thereof or the Warranty will be void.
4. "Malfunctions or failure resulting from misuse, abuse, mismanagement, negligence, alteration, accident, or lack of proper maintenance, or from lightning strikes, electrical power surges or interruption of electricity shall not be considered defects under the Warranty. Corrosion, material deterioration and/or equipment malfunction caused by or consistent with excessive additions of chemicals, minerals, sediments or other foreign elements with the product shall not be considered defects under the Warranty."
5. This Warranty applies only to systems for the care of poultry and livestock. Other applications in industry or commerce are not covered by this Warranty.

Chore-Time shall not be liable for any **Consequential or Special Damage** which any purchaser may suffer or claim to suffer as a result of any defect in the product. **“Consequential” or “Special Damages” as used herein include, but are not limited to, lost or damaged products or goods, costs of transportation, lost sales, lost orders, lost income, increased overhead, labor and incidental costs and operational inefficiencies.**

THIS WARRANTY CONSTITUTES THE MANUFACTURER’S ENTIRE AND SOLE WARRANTY AND THIS MANUFACTURER DISCLAIMS ANY AND ALL OTHER WARRANTIES, INCLUDING, BUT NOT LIMITED TO, EXPRESS AND IMPLIED WARRANTIES AS TO MERCHANTABILITY, FITNESS FOR PARTICULAR PURPOSES SOLD AND DESCRIPTION OR QUALITY OF THE PRODUCT FURNISHED HEREUNDER.

Chore-Time Distributors are not authorized to modify or extend the terms and conditions of this Warranty in any manner or to offer or grant any other warranties for CHORE-TIME® products in addition to those terms expressly stated above. An officer of CTB, Inc. must authorize any exceptions to this Warranty in writing. Chore-Time reserves the right to change models and specifications at any time without notice or obligation to improve previous models.

Effective: **August 2008**

Chore-Time Poultry Production Systems
A Division of CTB, Inc.
410 N. Higbee Street • Milford, Indiana 46542 • U.S.A.
Phone (574) 658-4101 • Fax (877) 730-8825
E-mail: poultry@choretime.com • Internet: www.choretimepoultry.com

Thank You

The employees of CTB, Inc. would like to thank your for your recent Chore-Time purchase. If a problem should arise, your Chore-Time distributor can supply the necessary information to help you.

Contents

| Topic | Page |
|--|-------------|
| Warranty | 1 |
| Conditions and Limitations | 1 |
| About This Manual | 4 |
| Safety Information | 4 |
| Safety Instructions | 5 |
| Follow Safety Instructions..... | 5 |
| Decal Descriptions | 5 |
| DANGER: Moving Auger | 5 |
| DANGER: Electrical Hazard | 5 |
| CAUTION:..... | 5 |
| General | 5 |
| Support Information | 5 |
| Tools for Installation | 6 |
| General Information | 6 |
| Manufacturer's Recommendations: Birds per Nipple..... | 7 |
| Planning the System layout | 8 |
| Preferred Layout..... | 8 |
| Alternate Layout #1 | 8 |
| Alternate Layout #2..... | 9 |
| Suspension System Installation | 10 |
| Assembling and Hanging the Water Line | 12 |
| Operation | 13 |
| Filter Control Panel Installation | 17 |
| Flushable Filter Control Panel Installation | 17 |
| Anti-Roost Installation | 19 |
| Installing the Flush System | 21 |
| Parts Listing | 23 |
| Filter Control Panel with Step Regulator | 23 |
| Flushable Filter Control Panel..... | 24 |
| Manual Adjustment Nipple Inlet Assembly | 25 |
| PDS™ Controlled Nipple Inlet Assembly | 27 |
| Slope Compensator Assembly..... | 29 |
| Mid Line Stand Tube Assembly..... | 29 |
| Stand Tube Outlet Assembly..... | 30 |
| Nipple Line Assembly and Components | 31 |
| Nipple Waterer Miscellaneous Components..... | 33 |
| Nipple Waterer Mini Drinker Part Number 35412 | 33 |
| Miscellaneous Kits and Components | 34 |
| Flush Manifold Kit Part Number 34532 | 34 |
| Miscellaneous Hose Components | 34 |
| Mid Line Shut-Off Kit Part Number 29658..... | 34 |
| Mid Line Shut-Off Kit with Flush | 34 |

Contents - continued

| Topic | Page |
|---|-------------|
| Water Medicator..... | 34 |
| Water Meters..... | 34 |
| Suspension System Components..... | 35 |
| CHORE-TIME Nipple Watering Quick Reference Sheet | 36 |
| Operational Guidelines | 37 |
| Troubleshooting Guidelines..... | 37 |
| Guide to Cleaning Water Lines..... | 38 |
| Standard Cleaning Procedure | 38 |
| Regular Maintenance..... | 38 |
| End of Grow Out Cleaning..... | 38 |
| After Administering Vitamins, Medication or other Chemicals | 38 |
| Between Flocks | 38 |
| Water Quality | 39 |
| Hardness | 39 |
| Iron | 39 |
| Iron Bacteria | 39 |
| Acid Water | 39 |
| Aggressive/Corrosive Water | 39 |
| Taste and Color | 39 |
| Hydrogen Sulfide | 39 |
| Sand, Silt or Sediment..... | 39 |

About This Manual

The intent of this manual is to help you in two ways. One is to follow step-by-step in the order of assembly of your product. The other way is for easy reference if you have questions in a particular area.

Important: Read ALL instructions carefully before starting construction.

Important: Pay particular attention to all SAFETY information.

- *Metric measurements are shown in millimeters and in brackets, unless otherwise specified. “ ” equals inches and “ ’ ” equals feet in English measurements.*

Examples:

1" [25.4]

4' [1 219]

- Optional equipment contains necessary instructions for assembly or operation.
- Very small numbers near an illustration (*i.e.*, 1257-48) are identification of the graphic, not a part number.

Note: The original, authoritative version of this manual is the English version produced by CTB, Inc. or any of its subsidiaries or divisions, (hereafter collectively referred to as "CTB"). Subsequent changes to any manual made by any third party have not been reviewed nor authenticated by CTB. Such changes may include, but are not limited to, translation into languages other than English, and additions to or deletions from the original content. CTB disclaims responsibility for any and all damages, injuries, warranty claims and/or any other claims associated with such changes, inasmuch as such changes result in content that is different from the authoritative CTB-published English version of the manual. For current product installation and operation information, please contact the customer service and/or technical service departments of the appropriate CTB subsidiary or division. Should you observe any questionable content in any manual, please notify CTB immediately in writing to: CTB Legal Department, P.O. Box 2000, Milford, IN 46542-2000 USA.

Safety Information

Caution, Warning and Danger Decals have been placed on the equipment to warn of potentially dangerous situations. Care should be taken to keep this information intact and easy to read at all times. Replace missing or damaged safety decals immediately.

Using the equipment for purposes other than specified in this manual may cause personal injury and/or damage to the equipment.

Safety–Alert Symbol



This is a safety–alert symbol. When you see this symbol on your equipment, be alert to the potential for personal injury. This equipment is designed to be installed and operated as safely as possible...however, hazards do exist.

Understanding Signal Words

Signal words are used in conjunction with the safety–alert symbol to identify the severity of the warning.



DANGER indicates an imminently hazardous situation which, if not avoided, **WILL** result in death or serious injury.



WARNING indicates a potentially hazardous situation which, if not avoided, **COULD** result in death or serious injury.



CAUTION indicates a hazardous situation which, if not avoided, **MAY** result in minor or moderate injury.

Safety Instructions

Follow Safety Instructions

Carefully read all safety messages in this manual and on your equipment safety signs. Follow recommended precautions and safe operating practices.

Keep safety signs in good condition. Replace missing or damaged safety signs.

Decal Descriptions

DANGER: Moving Auger

This decal is placed on the Panel Weldment.

Severe personal injury will result, if the electrical power is not disconnected, prior to servicing the equipment.

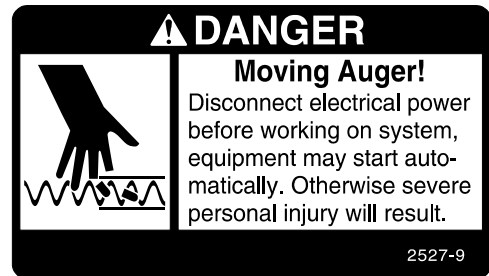

DANGER: Electrical Hazard

Disconnect electrical power before inspecting or servicing equipment unless maintenance instructions specifically state otherwise.

Ground all electrical equipment for safety.

All electrical wiring must be done by a qualified electrician in accordance with local and national electric codes.

Ground all non-current carrying metal parts to guard against electrical shock.

With the exception of motor overload protection, electrical disconnects and over current protection are not supplied with the equipment.

CAUTION:

Use caution when working with the Auger—springing Auger may cause personal injury.

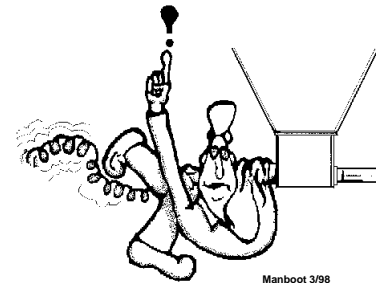
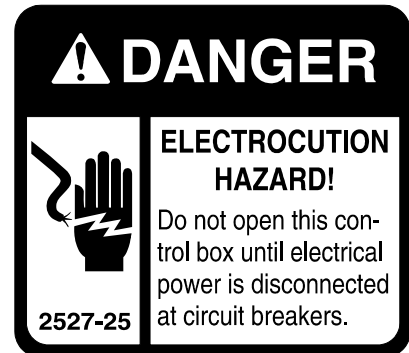

General

Support Information

The Chore-Time Nipple Watering Systems are designed to provide water to poultry types. Using this equipment for any other purpose or in a way not within the operating recommendations specified in this manual will void the warranty and may cause personal injury.

This manual is designed to provide comprehensive planning and installation information. The Table of Contents provides a convenient overview of the information in this manual.

Tools for Installation

- | | | | |
|---|----------------------|---|---------------------------------|
| 1 | Regular Screwdriver | 6 | Bolt Cutters or Hack Saw |
| 2 | Locking Pliers | 7 | PVC Cleaning Solvent |
| 3 | File | 8 | Electrical Drill and Drill Bits |
| 4 | Saw to cut PVC Tubes | 9 | Another Person to help |
| 5 | Screw-Hook Driver | | |

General Information

It is extremely important to maintain good water quality. Good water quality maximizes performance of the equipment, minimizes maintenance and repair, and increases the life of the system. The water should be free of foreign particles.

Pump the well prior to hookup of the system to clear sand, mud, or debris. CHORE-TIME recommends a water test by a reputable water treatment company in the area. Water treatment and/or extra filtration may be required, depending on the water test results.

CHORE-TIME recommends an incoming water pressure between 40 p.s.i. [2.9 kg/cm^2] minimum and 125 p.s.i. [8.8 kg/cm^2] maximum for use with the 9275, 36802-1 or 36802-2 Control Panel and 35308 Step Regulator. A pressure of 45 p.s.i. [3.2 kg/cm^2] is best. It is recommended to use the Step Regulator for regulating the water pressure through the Control Panel at 25 p.s.i. [1.8 kg/cm^2] a maximum of 35 p.s.i. [2.5 kg/cm^2].

CHORE-TIME recommends a minimum incoming water pressure of 3 p.s.i. [0.2 kg/cm^2] for gravity feed systems. To obtain this minimum pressure the water level in the water tank should be maintained 8' [2.4 m] above the nipple line. CHORE-TIME recommends a Maximum line length of 250' [76 m] for a gravity feed system.

For every 28" [711 mm] drop in height, water pressure increases one pound. Measure the operating pressure at the water line height.

Incoming water supply should be at least a 1" [25 mm] diameter incoming line (preferably PVC) from a single well. If there are two or more supply wells, the supply line should be larger. Other factors such as, the distance from the well(s) to the Filter Control Panel and other equipment which requires water could demand larger lines.

The suspension system must be correctly installed to insure proper operation of the system. This manual includes the suspension installation information.

The CHORE-TIME Nipple Drinker is available with Nipples spaced 6" [150 mm], 8" [200 mm], 10" [250 mm], 12" [300 mm], 15" [380 mm], 20" [508 mm], or 24" [610 mm] on the 10' [3 m] pipe.

Water lines up to 500' [152 m] may be supplied using (1) Inlet Assembly. Water lines over 500' [152 m] must be split in the center of the house and supplied with (2) Inlet Assemblies. However the management of the lines over 250' [76 m] becomes more critical. They must be kept very level, flushed, and cleaned several times per flock.

The CHORE-TIME Nipple Drinker is available with the standard Support Channel for broiler applications. The Chore-Time Nipple Drinker is also available with the heavy Support Channel for pullets and breeders. **Figure 1** shows the difference between the standard and heavy Support Channel with the standard and Button Nipple Assemblies. **Figure 2** shows the difference between the standard and heavy Support Channel and Button Nipple Assemblies in the Relia-Flow® drinkers.

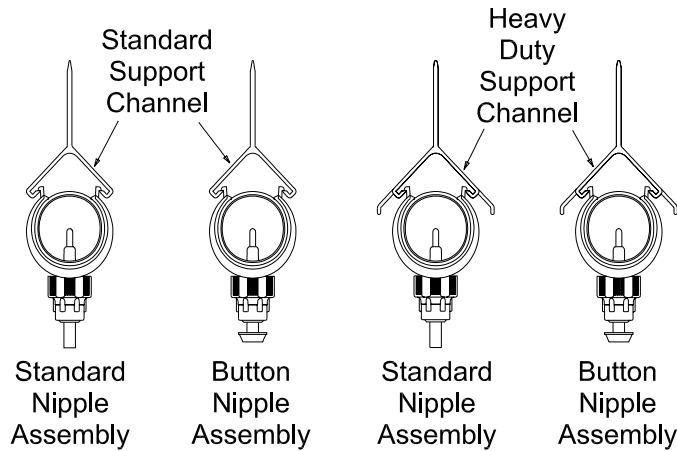

Figure 1. Various Drinker Styles

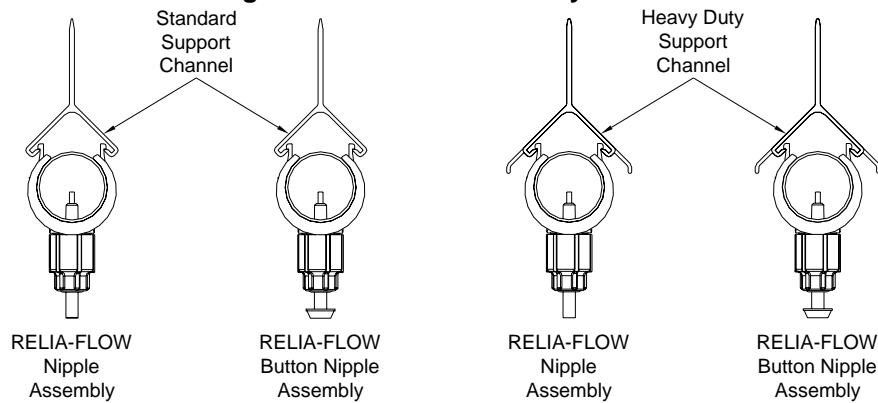

Figure 2. Various RELIA-FLOW® Drinker Styles

Manufacturer’s Recommendations: Birds per Nipple

| Type | Recommended Number birds per Nipple | Recommended Options |
|---------|--|--|
| Broiler | 30 for day old chicks 10-15 for grow-out | Standard channel-Standard Flow (Button options) or Standard channel-Hi Flow w/drip cup (Button options) |
| Breeder | 8-10 for hot to warm climates 10-12 for warm to cool climates | Heavy Duty channel-standard-flow or Heavy Duty channel High Flow w/drip cup (Hot climates Only) |
| Pullets | 16-24 for day-old chicks 8-12 for grow out | Standard channel-Standard Flow |
| Poult | 10-15 after brooding | 6 wks or less-Standard channel-Standard flow 7-9 wks-Heavy Duty channel (Hi Flow w/Buttons recommended) |

For breeders, place the water line INSIDE The ULTRAFLO® Breeder Feeder Loop.

For a Pan Feeder System, place the water line within three feet(1m) of the feed line.

For Pullets, it is ideal to place water lines on either side of the feed lines within 3 ft. (1m).

In areas where house temperature will reach 100°F (40°C) for sustained periods and no evaporative cooling or tunnel ventilation is used, an anti-roost is needed.

Recommended incoming pressure of 25 psi.

Planning the System layout

The diagrams below reflect approved system layouts. Use these diagrams as guidelines. Your system layout may be different.

Preferred Layout

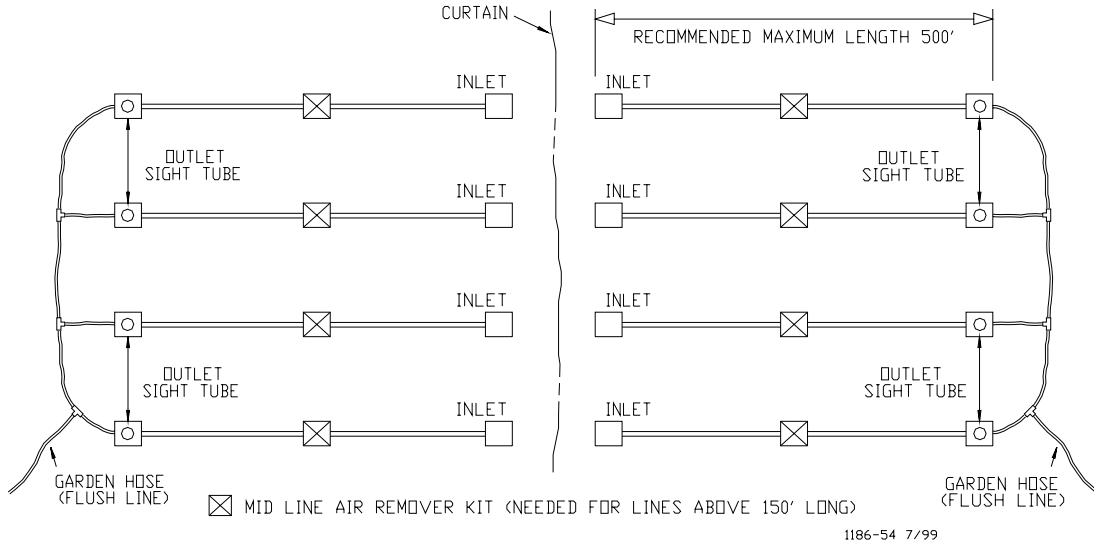

Alternate Layout #1

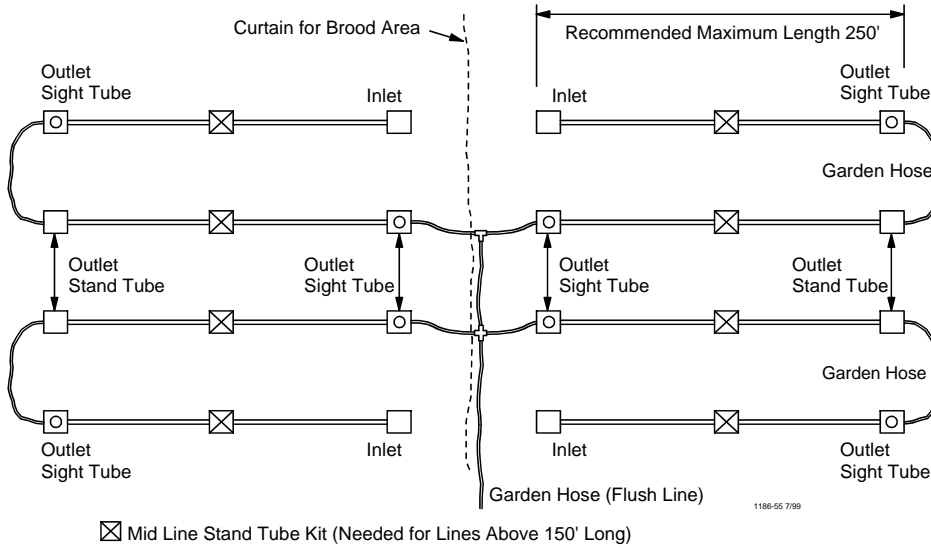

Alternate Layout #2

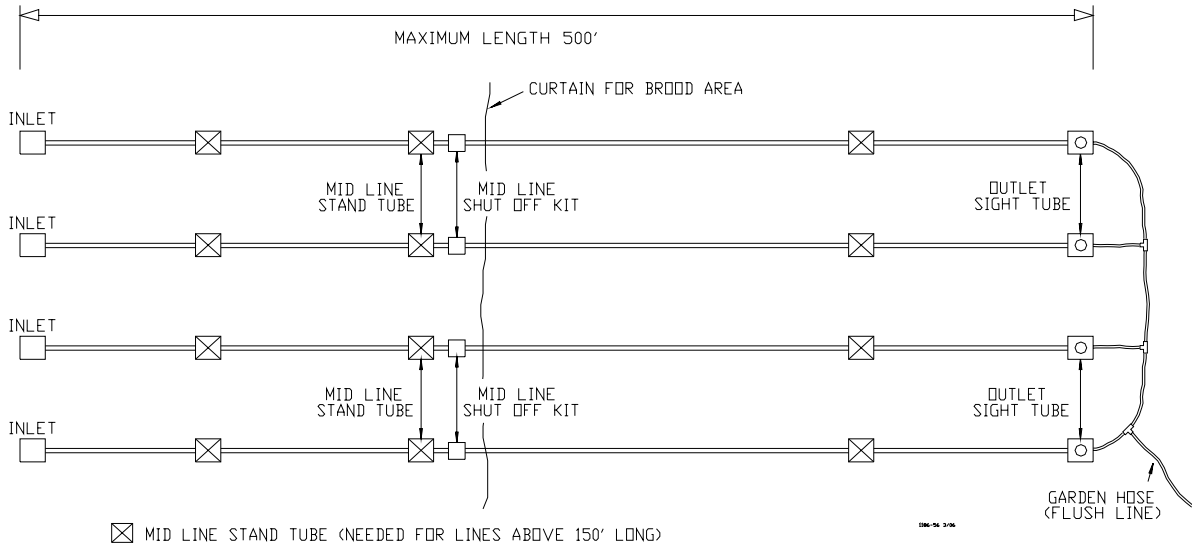

Suspension System Installation

The following installation instructions are for standard installations. For Partial House Brooding, the sections can be winched separately or together. Install each section as a separate section.

1. Determine where the water line is to be installed. Mark a straight line on the ceiling or rafters at this point using string or chalk line, or winch cable temporarily attached with staples or nails.
2. For installations using wood trusses, the standard screw hook or the optional Ceiling Hook may be used to hold the pulley Assemblies.

For installations using steel trusses, the Ceiling Hooks are available to hold the pulley Assemblies.

Screw Hook Installations: Install screw hooks along the line at 8' [2.4 m] or 10' [3 m] intervals.

Screw the threads all the way in to prevent bending. The opening of the hooks must point away from the direction the cable pulls. See **Figure 3**

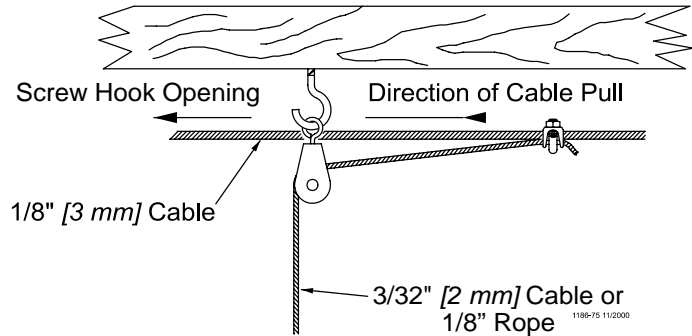

Figure 3. Screw Hook Installation

Ceiling Hook Installations: Install Ceiling Hooks along the line at 8' [2.4 m] or 10' [3 m] intervals. If the Ceiling Hook is to be secured with bolts or self-tapping screws, install as shown in **Figure 4**. The Ceiling Hooks may be welded in place, if desired, instead of bolting.

Note: If the distance the waterer is to be raised is greater than the distance between the pulleys, offset the pulleys from each other approximately 3" [75 mm].

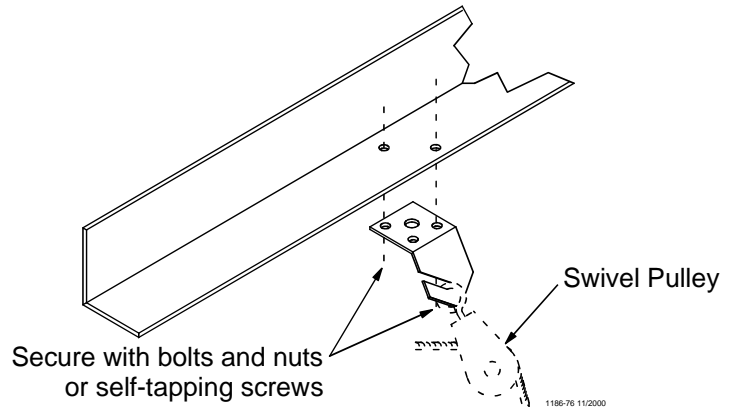

Figure 4. Ceiling Hook Installation

3. After the Screw Hooks or Ceiling Hooks have been secured to the trusses, install the pulley assemblies as shown in **Figures 3 & 4**. Make sure the Screw Hooks or Ceiling Hooks are pointing in the proper direction (opposite the winch).

4. Mount the Split Drum Winch as shown in **Figure 6**. Mount the winch to the ceiling or on a 2 x 8" [50x200 mm] board spanning at least two rafters for support. Use at least (4) 1/4" lag screws (not supplied) to secure winch to support.

For systems less than 150' [46 m], the manual winch may be used in place of the split drum winch.

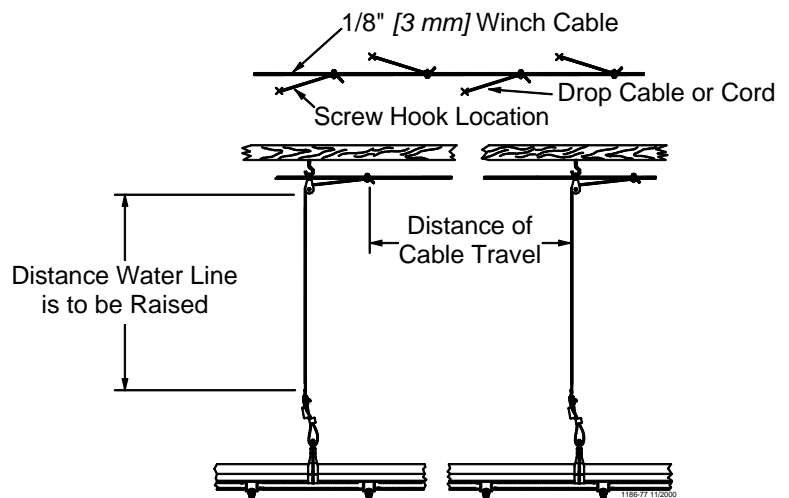

Figure 5. Offset the Screw/Ceiling Hooks

- Bolt the winch to the bracket, as shown in **Figure 6**.

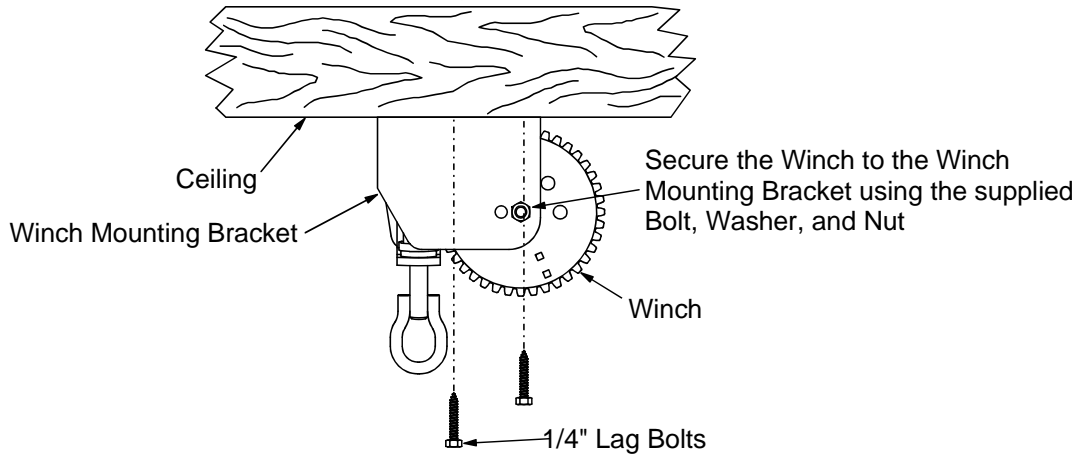

Figure 6. Winch Mounting

- Attach one end of the 3/16" [4.8 mm] cable to the winch as shown in **Figure 7**. Unroll the cable along the length of the water line.

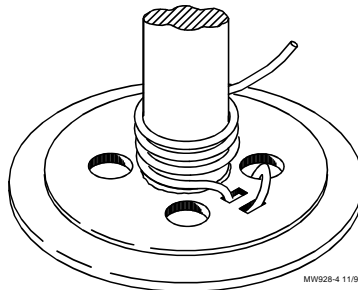

Figure 7. Cable Wrap on Drum

- Cut a section of the 3/32" [2.3 mm] cable or cord for each suspension drop. The cable or cord should be approximately three feet [91 cm] longer than the distance from the floor to the ceiling so that it can be attached at the top and bottom.
Route the cable or cord around the Swivel Pulley and attach to the main cable, using a clamp.
- Cable drop installations: Install an Adjustment Leveler on each drop line. See **Figure 8**.
Cord drop installations: Install a Cord Adjuster on each drop line. See **Figure 8**.

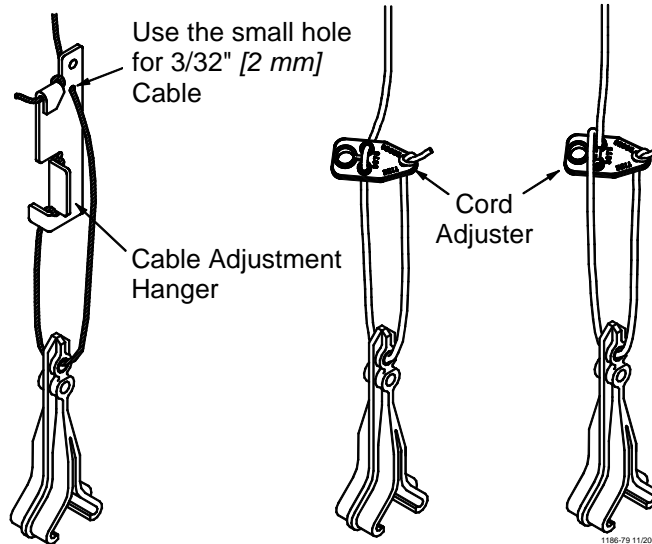

Figure 8. Cable Drop Installation

Helpful Hint: It may be necessary to fasten a weight to the end of the main cable to maintain tension while connecting the drop lines, etc.

Assembling and Hanging the Water Line

Raise the suspension to a convenient working height.

A nail apron may be used to carry Hangers, Connectors, Expansion Joints, Keys, Adjustment Levelers, or Cord Adjusters.

Figure 9 identifies several of the primary components used with the Nipple Waterer.

Assemble and install the Inlet Assembly, as shown in **Figure 10**.

1. Glue the included NH Male Adapter Fitting or optional Street Ell and NH Male Adapter Fitting to the Inlet. **Be careful not to get glue inside the Inlet.**
2. Slide the Outlet end over the watering pipe, **it helps to wet the black outlet liner**, and into the end of the channel.
3. Slide the Regulator Bracket into the hole provided in the regulator and fasten into the hole provided in the channel with the included #10-24 x 5/8" Hex Washer Head Screw and #10-24 Hex Nut.
4. Assemble the Stand Tube and Clamp to the Stand Tube Outlet by sliding the tube over the barbs and tightening the hose clamp. Now push and twist the stand tube spring over the tube and barbs. **DO NOT USE LUBRICANT.**

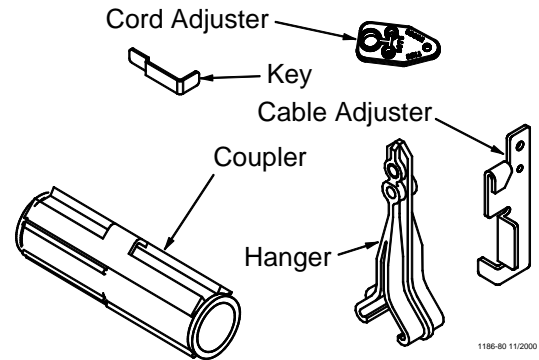
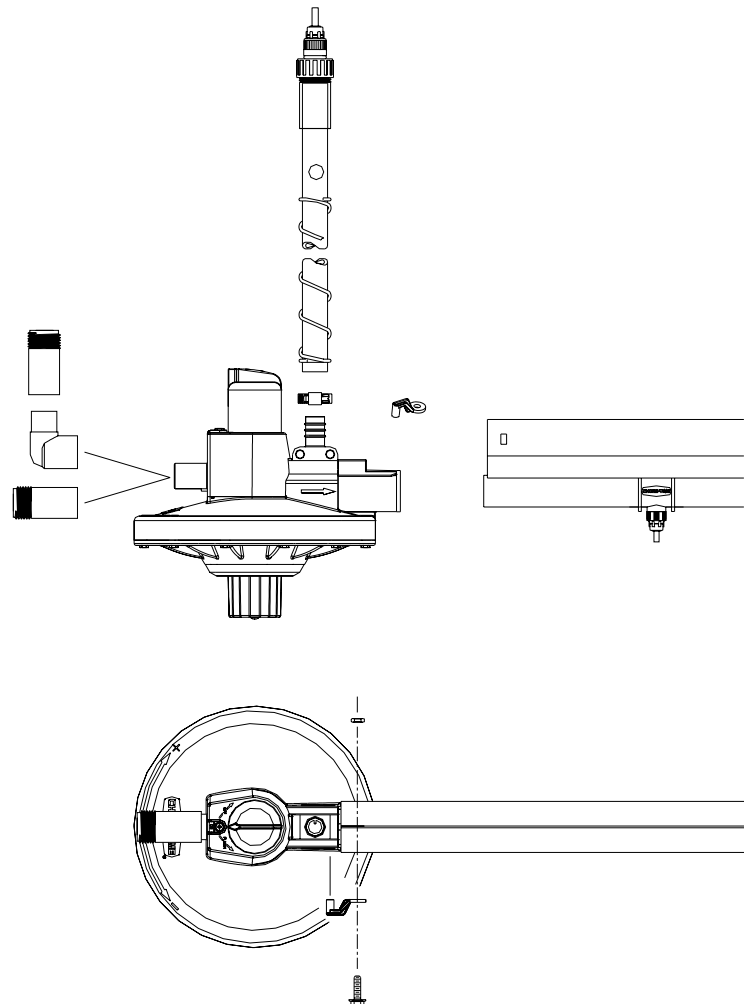

Figure 9. Nipple Waterer Components



1186-88 3/2006

Figure 10. Inlet End Components

Operation

The VOLUMATIC™ Water Regulator can be shut off by turning the Selector Knob clockwise until it stops. To turn on the regulator, turn the Selector Knob until it points to the ON position indicated on the regulator. To activate the Flush mode turn the Selector Knob fully counter-clockwise until it stops.

Optimum incoming pressure is 25 - 35 psi [172 - 241 kPa]. The VOLUMATIC Water Regulator can operate at pressures as high as 50 psi [345 kPa] however the life of the regulator seat and diaphragm will be shortened. Also, the supply hose must be of high quality and rated for the increased pressure.

When flushing, make sure the outlet line is clear of restrictions. Excessive back pressure can damage the Regulator.

When using the Manual Adjustment version of the regulator, the water column is set by turning the Manual Adjustment Knob on the bottom of the regulator in the direction shown on the regulator.

Important: When increasing the water column, as soon as resistance is noticed, stop turning the Manual Adjustment Knob or damage will occur.

Install Coupling Liner Assembly on the end of the water pipe, as shown in **Figure 11**. Insert the pipe until it contacts the Stop Rib inside the Coupling Liner Assembly.

Note: It may be necessary to lubricate the inside of the Coupler Liner with soapy water to allow for easy installation.

Insert the next pipe into the other end of the Coupling Liner Assembly until the Support Channels meet.

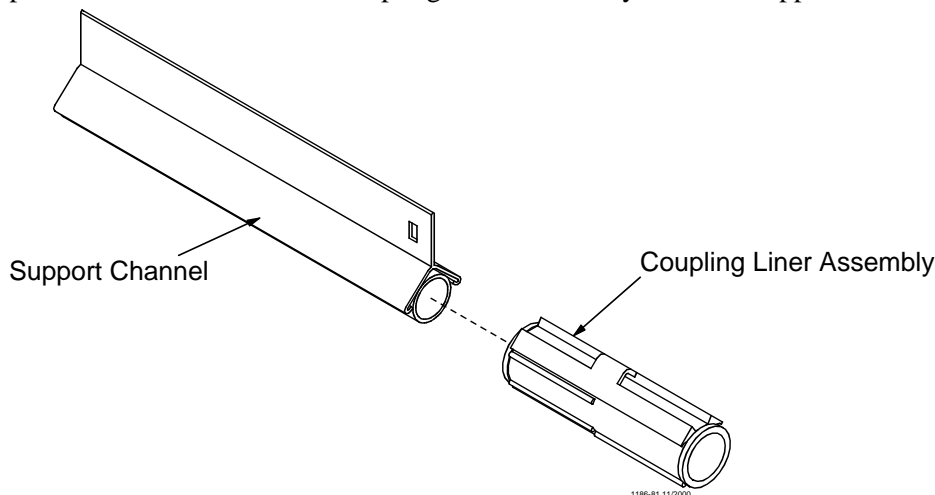

Figure 11. Coupling Liner Assembly Installation

Make sure the water pipes are fully inserted into the Coupling Liner Assembly.

Note: The Support Channels will be butted against each other when the Coupling Liner is properly installed.

Insert the Key into the first Support Channel, as shown in **Figure 12**. Insert the tab of the Key through the hole in the second Support Channel. Once installed, bend the tab to secure it in place. This will prevent the water lines from separating at the joints.

Note: When an Anti-Roost system is to be installed it is recommended to use 46209-40 Channel Bracket Kit (40 brackets per kit) in place of the Key.

Install a Hanger, as shown in **Figure 12**, at each Drop Line location.

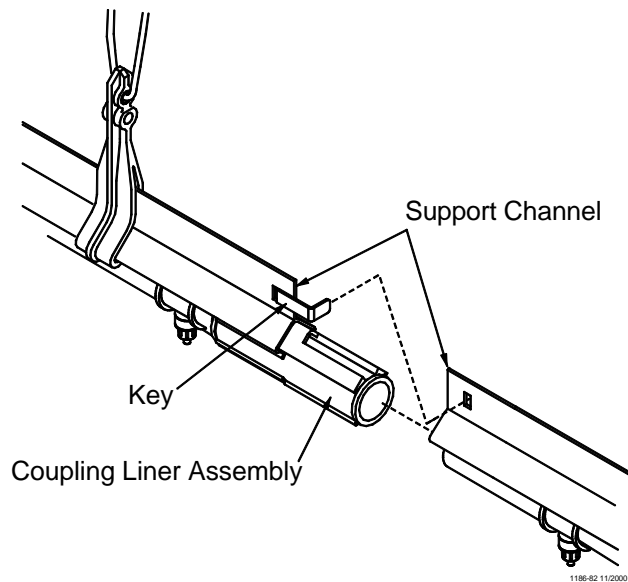

Figure 12. Securing the Water Line together

One Mid-Line Stand Tube is required for every 150' [46 m] of Nipple Waterer Line. See **Figure 13**.

Insert the water pipe into the Body. The Support Channel should slide into the channels on the top of the Body. Secure the Body to the Support Channel using the 10-24 stainless steel truss head screw and lock nut, supplied. Repeat this procedure on the opposite side of the Mid-Line Stand Tube Kit.

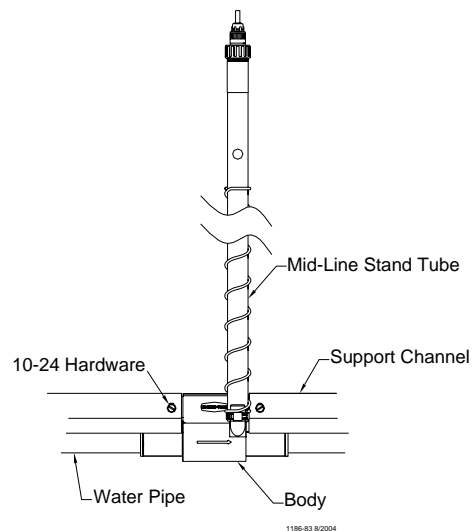

Figure 13. Mid Line Stand Tube Installation

The Outlet Assembly is shipped completely assembled except for the Stand Tube.

The outlet end must be located directly under a suspension drop line. This may require adding an additional suspension drop line or cutting the last section of water line to stop directly under an existing drop line.

Install the Outlet Assembly, as shown in **Figure 14**. Make sure the Hanger is properly oriented on the Outlet Assembly Tee prior to securing the water line with PVC cement.

Secure the Hanger to the Support Channel, as shown in **Figure 14**. If the water line was shortened to terminate under a suspension drop line, it may be necessary to drill a hole in the Support Channel for the 10-24 stainless steel truss head screw and lock nut. The Hanger may be used as a template to determine proper hole location.

Assemble the Stand Tube and Clamp to the Stand Tube Outlet by sliding the tube over the barbs and tightening the hose clamp. Now push and twist the stand tube spring over the tube and barbs. **DO NOT USE LUBRICANT.**

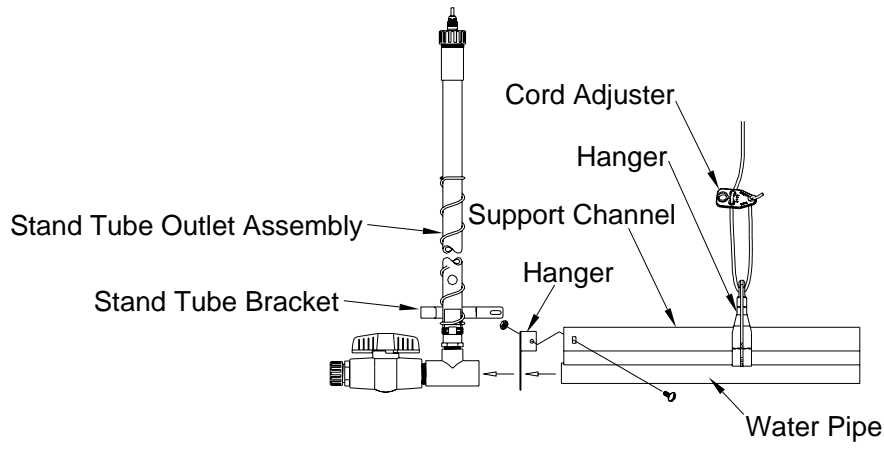

Figure 14. Outlet Assembly Installation

Optional Equipment: The Mid-Line Shut-Off Valve may be located at any convenient location along the water line, except next to a joint.

Determine the desired location for the Mid-Line Shut-Off Valve.

Use a flat screw driver to carefully pry 3 or 4 Saddles away from the Support Channel. This will allow easy access to the water pipe for cutting.

Use PVC pipe cutters to cut a section out of the water pipe. See **Figure 15**. The Shut-Off Valve may be used as a template to determine the required size of the cut.

Apply PVC cement to the couplers on the Mid-Line Shut-Off Valve Assembly.

Install the Mid-Line Shut-Off Valve on the water line.

Reinstall the Saddles, previously loosened, in the Support Channel.

Note: **Chore-Time recommends installing a Mid-Line Stand Tube at the first joint preceding a Mid-Line Shut-Off Valve to insure proper air removal from the water line.**

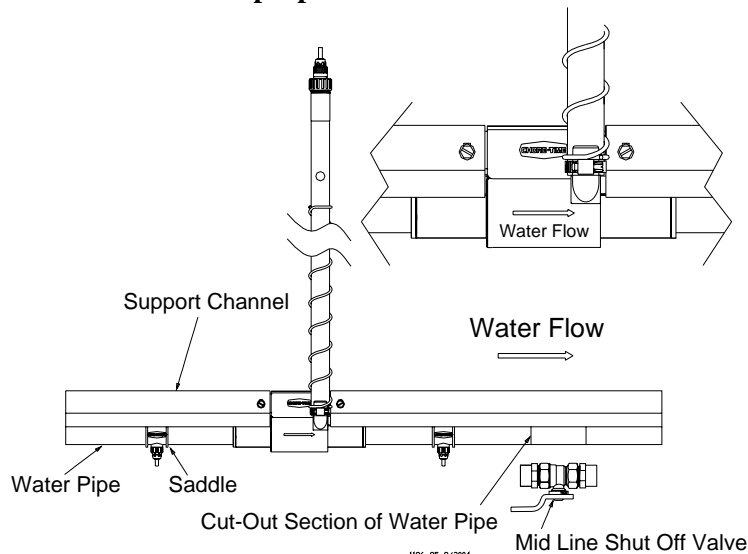

Figure 15. Mid-Line Shut-Off Valve Installation

Optional Equipment: The *Slope Compensator* is used in houses that have a gradual slope over the length of the system. The *Slope Compensator* allows the water pressure to be re-adjusted along the line.

The inlet end of the *Slope Compensator* must be at the top of the slope. Arrow must point in direction of water

flow. Do not attempt to push water uphill.

The maximum amount of drop between the Inlet Assembly and the Slope Compensator, or between two Slope Compensators, or between the Slope Compensator and the Outlet Assembly is 4 inches [100 mm]. See **Figure 16**.

The maximum number of Slope Compensator used on any one water line is six.

The maximum amount of slope over any water line is 28 inches [71 cm] of drop. See **Figure 16**.

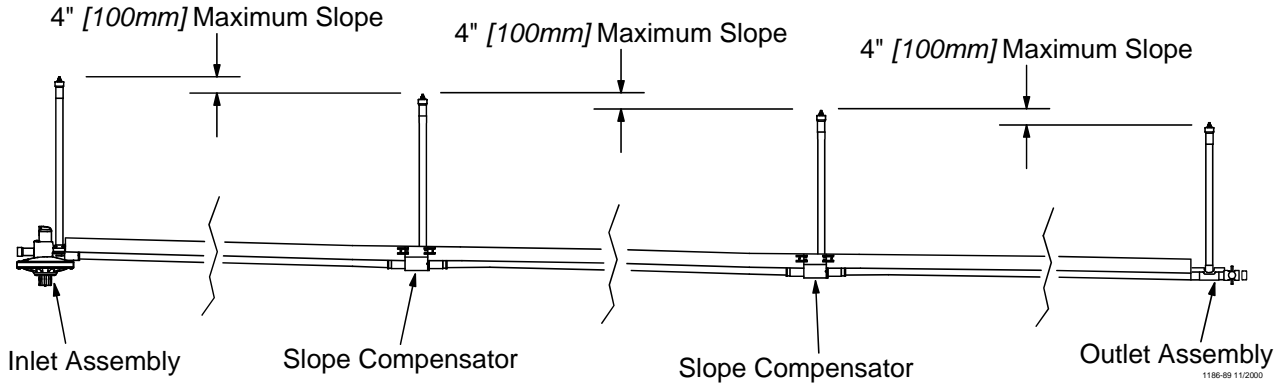

Figure 16. Slope Compensator Assembly Installation

Filter Control Panel Installation

The Filter Control Panel is used to remove foreign material from the incoming water, and, if necessary, add medication to the water.

The Step Down Regulator and Gauge Assembly is used to reduce the water pressure supplying the Filter Control Panel. Adjust the operating pressure as recommended in the Nipple Waterer Quick Reference Sheet. **See page 36.**

The Filter Control Panel and Step Down Regulator should be installed in a convenient location where incoming and outgoing water supply lines can be easily run. The control panel must be out of the reach of birds.

The Filter Control Panel is shipped secured to a Mounting Board. The Mounting Board and Filter Control Panel should be secured to wall or post using lag bolts (not supplied).

The Step Down Regulator and Gauge Assembly is shipped un-assembled. Assemble the Step Down Regulator and Gauge Assembly components as specified in the instruction (MW1052) shipped with the kit.

Connect the Step Down Regulator and Gauge Assembly to the Filter Control Panel, as shown in **Figure 17.**

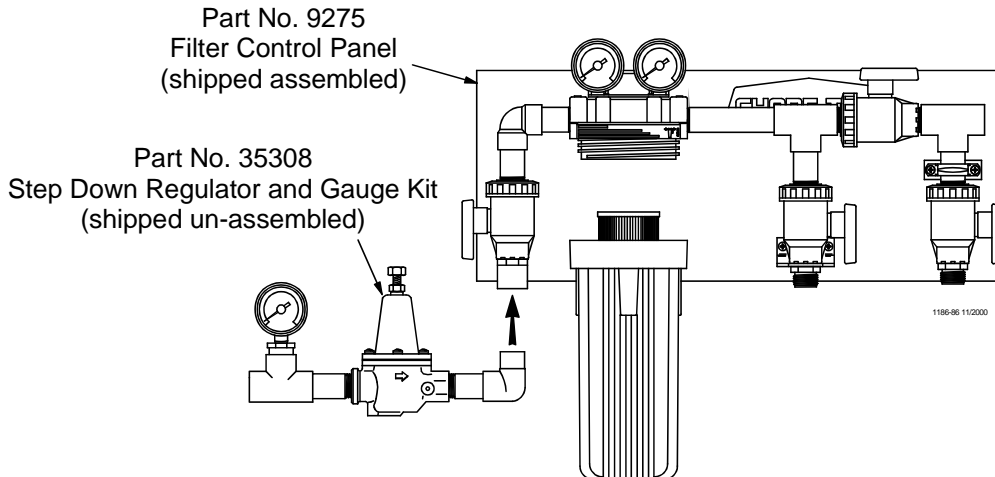

Figure 17. Control Panel Installation

Flushable Filter Control Panel Installation

(optional alternative to the standard Filter Control Panel)

The Flushable Filter Control Panel is used to remove foreign material from the incoming water, and, if necessary, add medication to the water. This Control Panel features a filter that may be removed, cleaned, then reinstalled.

Two versions of the Filter Control Panel are available.

The low pressure version is designed to accommodate gravity flow systems with 5 - 10 p.s.i. [34.5 - 69.0 kPa]. Do not exceed 15 p.s.i. [103.4 kPa] with this Control Panel, or damage will occur to the gauges.

Systems with 11+ p.s.i. [75.8+ kPa] should use the high pressure Control Panel and a Step Down Regulator (order separately).

The Filter Control Panel should be installed in a convenient location where incoming and outgoing water supply lines can be easily run. The control panel must be out of the reach of birds.

The Filter Control Panel is shipped secured to a Mounting Board. The Mounting Board and Filter Control Panel should be secured to wall or post using lag bolts (not supplied).

The Gauge Assembly is shipped un-assembled. Assemble the Gauge Assembly components as specified in the instruction (MW1052) shipped with the kit.

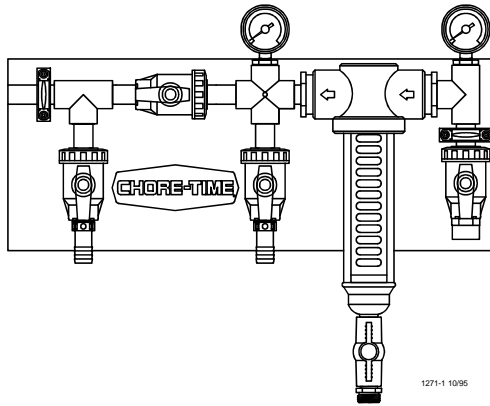

Low Pressure Control Panel
Part Number 36802-1
(5-10 p.s.i. [34.5 - 69.0 kPa])

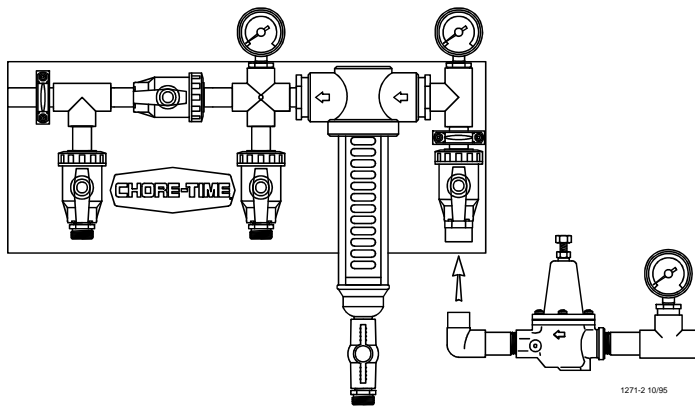

High Pressure Control Panel
Part Number 36802-2
(11+ p.s.i. [75.8+ kPa])

Anti-Roost Installation

Pullet and breeder applications require the Anti-Roost System to be installed. This prevents the birds from setting on the water line. **Figure 18** shows an overview of the Anti-Roost System.

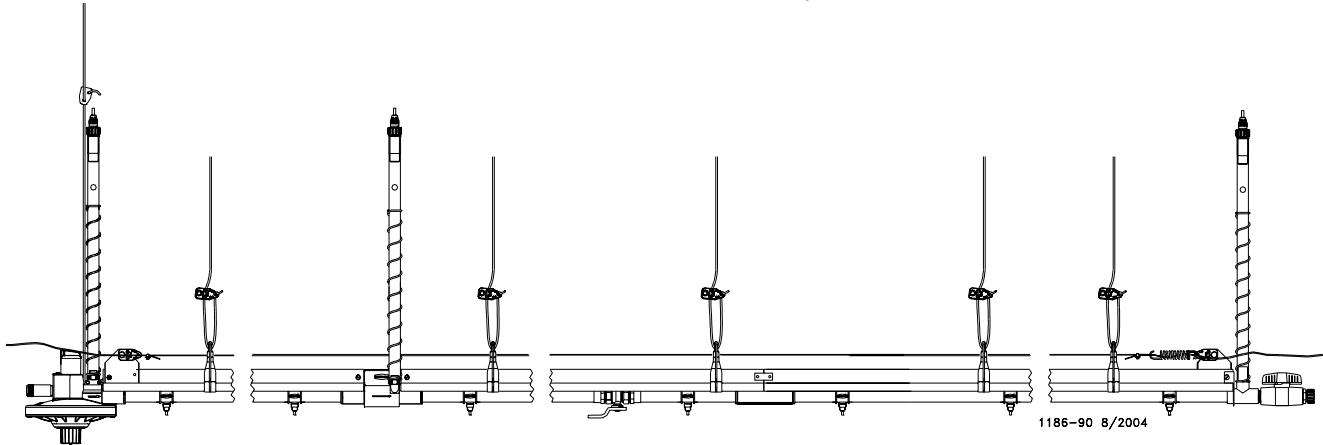

Figure 18. Anti-Roost System Overview

1. Make certain that an Anchor Plate with Adjustment Leveler is installed at the beginning and end of each anti-roost line. See **Figure 19**.
2. When an Anti-Roost system is to be installed the 46209-40 Channel Bracket Kit (40 brackets per kit) must be used in place of the Key to connect the channels together.
3. Install a Hanger every 24" [610 mm]
4. Beginning at the first Hanger, thread the training cable the full length of the anti-roost line. Allow approximately 24" [610 mm] extra and cut the cable.
5. Create a small loop with the cable and a cable clamp.
6. Connect the cable loop to the Adjustment Leveler/Anchor Plate.
7. Install a spring on the Adjustment Leveler/Anchor Plate near the Inlet Assembly.
8. Pull the cable taught and create a small loop with the cable and a cable clamp.
9. Connect the cable to the spring.
10. The spring should be stretched to an overall length of approximately 8" [203 mm]. Adjust as required.
11. Repeat the above procedure on each of the anti-roost lines.
12. Secure the Poultry Trainer to a wall or post near the water line.
Chore-Time recommends wiring the Poultry Trainer into separate electrical circuit that can be switched at the door.
Refer to the instructions supplied with the Poultry Trainer for wiring information.
Note: Make sure that the Support Channel is attached to ground (to insure proper operation of the Poultry Trainer). See **Figure 19**.
It will be necessary to install a jumper wire at Stand Tube, Inlet Assemblies, etc., to insure the ground circuit. See **Figure 19**.

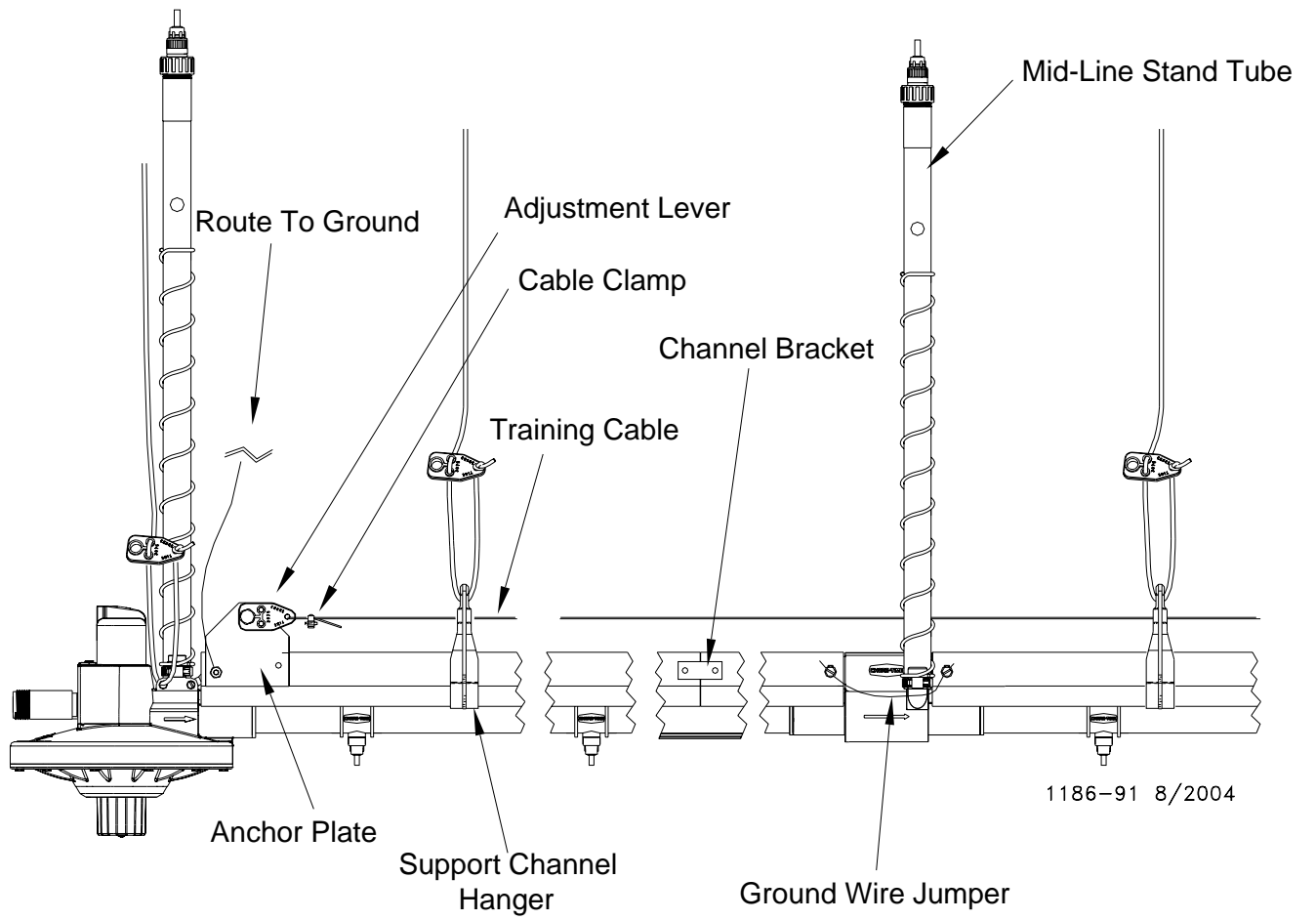

Figure 19. Anti-Roost Components

Installing the Flush System

The flush system provides convenient one-man system purging.

CHORE-TIME recommends flushing one line at a time to most thoroughly clean each line.

The Flush Kit includes the required components to flush (4) water lines. The hose must be purchased locally.

Install the Flush components as shown in **Figure 20**.

1. Measure and cut the hose to the required lengths for your individual system. Notice that the hose must exit through the building wall between 48" [121 cm] and 60" [152 cm] above floor level. Sloped houses require exiting at approximately 60" [152 cm].

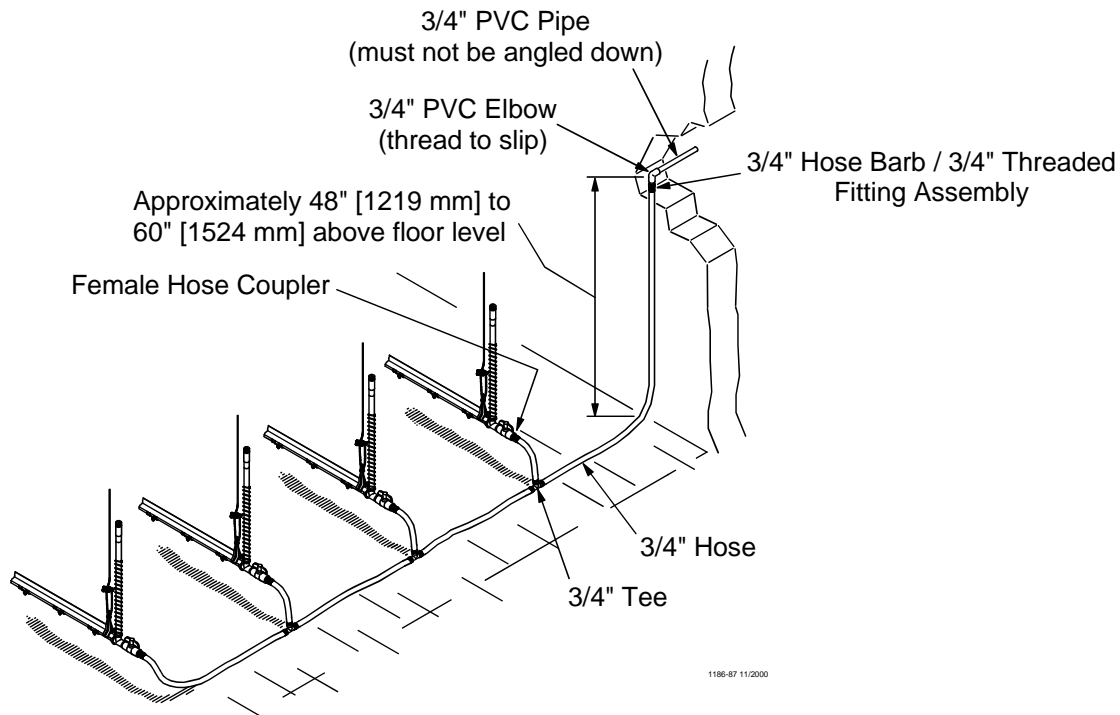

Figure 20. Flush System Component Layout Diagram

2. Slide Female Hose Couplers into the end of the (4) hoses to be directly connected to the Outlet Assembly. Secure with hose clamps. See **Figure 21**.
3. Install the (3) Tees at the locations shown using hose clamps supplied. See **Figure 21**.

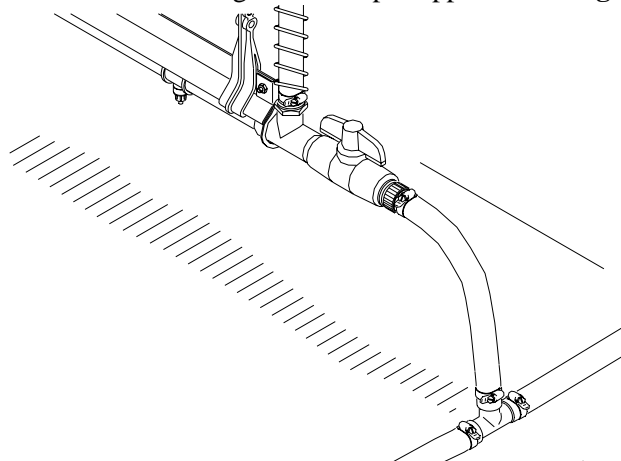

Figure 21. Flush System Component Connection Diagram

4. Install the 3/4 in. Hose Barb to 3/4 in. Pipe Thread Fitting in the end of the drain hose exiting up the side wall of the building. See **Figure 22**.
5. Thread the 3/4 in. Elbow onto the 3/4 in. Fitting. See **Figure 22**.
6. Slip a straight 3/4 in. PVC Pipe into the 3/4 in. Elbow. Secure using PVC cement.

Note: A siphon will be created if the 3/4 in. PVC pipe is angled down after exiting the building. Do not install a pipe or hose outside the building.

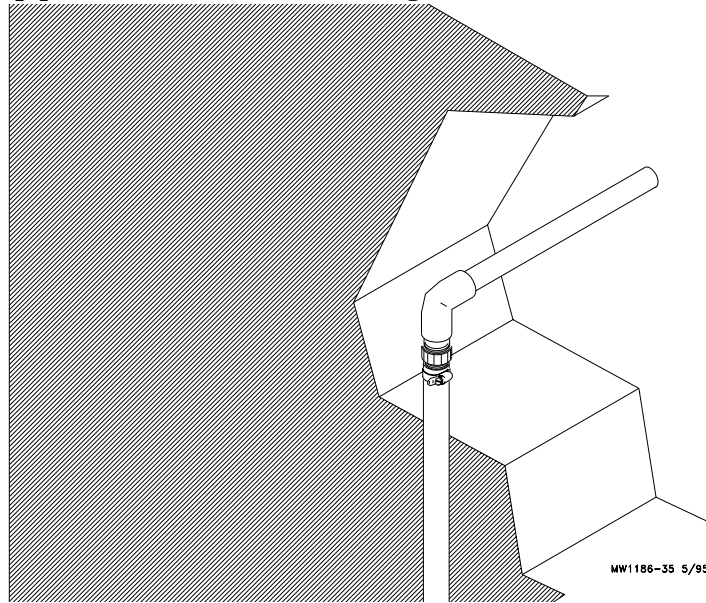
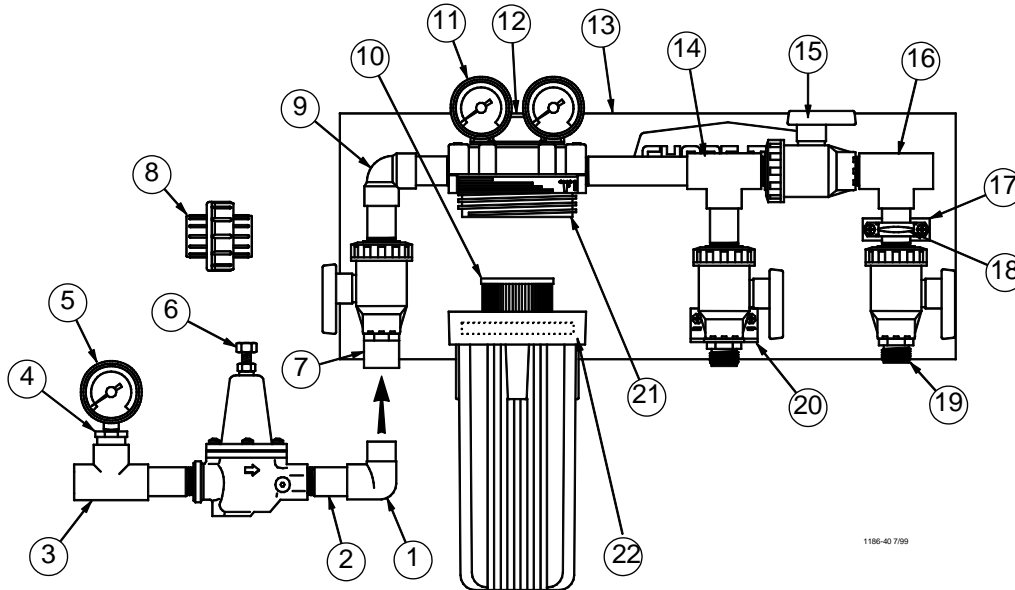

Figure 22. Flush System Component Connection Diagram

Parts Listing

Filter Control Panel with Step Regulator



| Item | Description | Part No. |
|------|--|-----------------------|
| 1* | 3/4" PVC Street Ell | 30138 |
| 2* | 3/4" Threaded PVC Nipple | 7531-1 |
| 3* | 3/4" PVC Tee | 7538 |
| 4* | 3/4x1/4 Reducer Bushing | 7789 |
| 5* | High Press. Water Gauge | 7191 |
| 6* | Regulator | 29951 |
| 7** | 3/4" PVC Male Adapter | 9229 |
| 8* | Union | 8137 |
| 9** | Filter Inlet Assembly | 35306 |
| 10** | 10 Micron Filter Cartridge (optional) 20 Micron Filter Cartridge (standard) 100 Micron Filter Cartridge (optional) | 13145 7723 9278 |
| 11** | High Press. Water Gauge | 7191 |
| 12** | Filter Mounting Bracket | 35302 |
| 13** | Mounting Board | 35303 |
| 14** | Filter Outlet Assembly | 35304 |
| 15** | 3/4" Quarter Turn Valve | 36720 |
| 16** | Medicator Outlet Assembly | 35305 |
| 17** | Standoff Block | 35300 |
| 18** | Plastic Conduit Clamp | 35301 |
| 19** | 3/4" Nylon Adapter | 7543 |
| 20** | Medicator Connector Brace | 35307 |
| 21** | Water Filter | 35309 |
| 22 | "O" Ring | 9191 |

*These components may be ordered as an assembly under Part No. 35308.

**These components may be ordered as an assembly under Part No. 9275.

Flushable Filter Control Panel

(Low Pressure Part No.: 36802-1 • High Pressure Part No.: 36802-2)

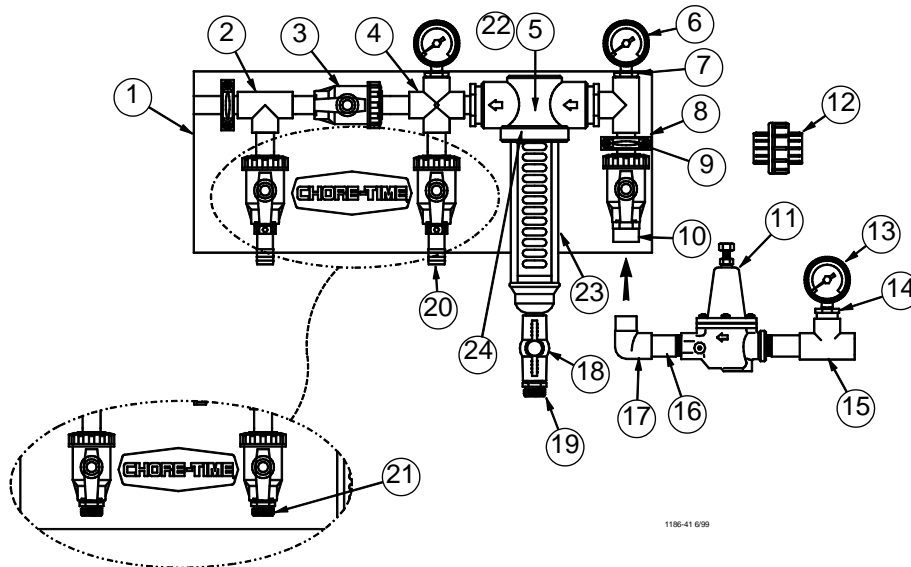

| Item | Description | Low Press. Part No. | High Press. Part No. | Item | Description | Low Press. Part No. | High Press. Part No. |
|------|-----------------------------------|---------------------|----------------------|------|-------------------------------------|---------------------|----------------------|
| 1 | Mounting Board | 35303 | 35303 | 13* | High Pressure Gauge | 7191 | ---- |
| 2 | Medicator Outlet Assembly | 36805 | 36805 | 14* | 3/4 in. x 1/4 in. Reducer Bushing | 7789 | ---- |
| 3 | 3/4 in. Valve | 36720 | 36720 | 15* | 3/4 in. PVC Tee (SxSxS) | 7538 | ---- |
| 4 | 3/4 in. Cross | 7536 | 7536 | 16 | 3/4 in. Threaded PVC Nipple | 7531-1 | ---- |
| 5 | Filter Inlet Assembly | 36803 | 36803 | 17 | 3/4 in. PVC Street Ell | 30138 | ---- |
| 6 | Pressure Gauge | 27722 | 7191 | 18 | 1/2 in. Ball Valve | 34961 | 34961 |
| 7 | 3/4 in. x 1/4 in. Reducer Bushing | 7789 | 7789 | 19 | Nylon Adapter | 29141 | 29141 |
| 8 | Standoff Block | 35300 | 35300 | 20 | 3/4 in. Barb x 3/4 in. Pipe Adapter | 29422 | ---- |
| 9 | 3/4 in. Plastic Conduit Clamp | 35301 | 35301 | 21 | 3/4 in. Male Adapter (Nylon) | ---- | 7543 |
| 10 | 3/4 in. PVC Male Adapter | 9229 | 9229 | 22 | Filter, Flushable | 36806 | 36806 |
| 11* | Step Regulator | 29951 | ---- | 23 | Filter, Cover | 46993 | 46993 |
| 12* | Union | 8137 | ---- | 24 | "O" Ring Kit | 36807 | 36807 |

These parts may be ordered separately, if needed:

| Description | Part No. |
|-----------------------------|----------|
| 1/2 Pint PVC Cement | 6303-3 |
| Replacement 140 Mesh Filter | 36809 |
| Flushable Filter Assembly | 36810 |

*Items 11 - 15 are not included with the Flushable Filter Control Panel. They may be ordered separately as an assembly under Part No. 35308.

Manual Adjustment Nipple Inlet Assembly

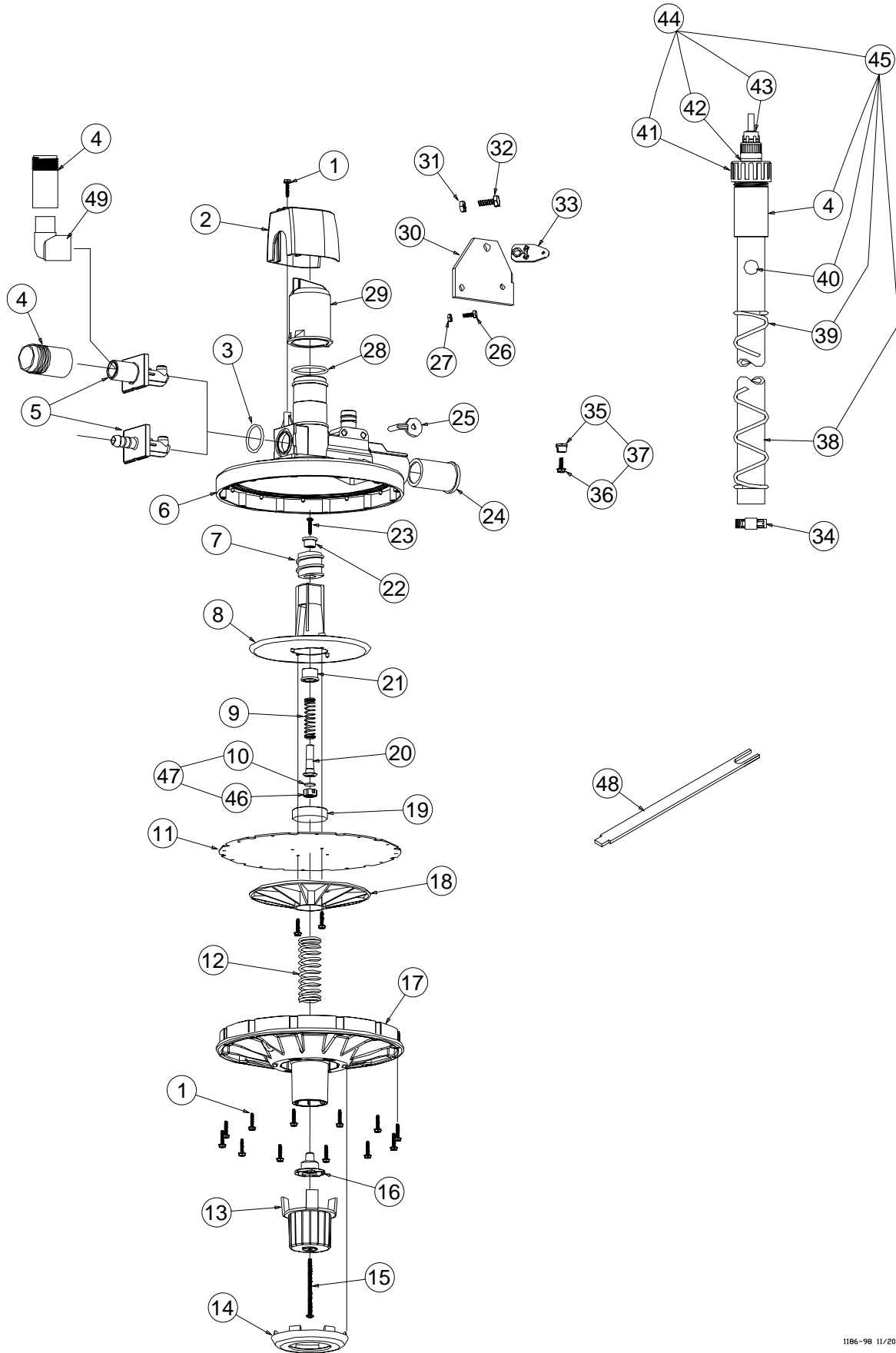

| Item | Description | Manual Adjustment Standard Inlet Part No. 42400-1 | Manual Adjustment Standard Inlet Anti-Roost Part No. 42400-21 | Manual Adjustment Hose Barb Inlet Part No. 42400-3 | Manual Adjustment Hose Barb Inlet Anti-Roost Part No. 42400-23 |
|------|------------------------------------|---|---|--|--|
| 1 | #6-20 x 5/8" Hex Washer Head Screw | 44946 | 44946 | 44946 | 44946 |
| 2 | Shroud | 42390 | 42390 | 42390 | 42390 |
| 3 | O-Ring | 29118 | 29118 | 29118 | 29118 |
| 4 | NH Male Adapter Fitting | 25098 | 25098 | _____ | _____ |
| 5 | Inlet Orifice | 42190 | 42190 | 42185 | 42185 |
| 6 | Top Half Regulator | 42174 | 42174 | 42174 | 42174 |
| 7 | Barrel | 42172 | 42172 | 42172 | 42172 |
| 8 | Top Diaphragm Plate | 42182 | 42182 | 42182 | 42182 |
| 9 | .375" ID x 1.750" Spring | 42392 | 42392 | 42392 | 42392 |
| 10 | Seat | 48225 | 48225 | 48225 | 48225 |
| 11 | Diaphragm | 42181 | 42181 | 42181 | 42181 |
| 12 | .780" ID x 2.800" Spring | 42393 | 42393 | 42393 | 42393 |
| 13 | Adjustment Knob | 42184 | 42184 | 42184 | 42184 |
| 14 | Knob Retainer | 42173 | 42173 | 42173 | 42173 |
| 15 | #8-18 x 2-1/2" Pan Head Screw | 42387 | 42387 | 42387 | 42387 |
| 16 | Follower | 42183 | 42183 | 42183 | 42183 |
| 17 | Bottom Regulator Half | 42180 | 42180 | 42180 | 42180 |
| 18 | Diaphragm Plate | 42177 | 42177 | 42177 | 42177 |
| 19 | Diaphragm Center Support | 42186 | 42186 | 42186 | 42186 |
| 20 | Seat Holder | 42189 | 42189 | 42189 | 42189 |
| 21 | Seat Holder Sleeve | 42187 | 42187 | 42187 | 42187 |
| 22 | Seat Holder Cap | 42176 | 42176 | 42176 | 42176 |
| 23 | #6-20 x 5/8 Pan Head Screw | 42386 | 42386 | 42386 | 42386 |
| 24 | Half Liner | 36501 | 36501 | 36501 | 36501 |
| 25 | Regulator Bracket | 44866 | 44866 | 44866 | 44866 |
| 26 | #10-24 x 5/8" Hex Nut | 313 | 313 | 313 | 313 |
| 27 | #10-24 Hex Head Screw | 1876 | 1876 | 1876 | 1876 |
| 28 | O-Ring | 42389 | 42389 | 42389 | 42389 |
| 29 | Selector Knob | 42178 | 42178 | 42178 | 42178 |
| 30 | Anchor Plate | | 42807 | | 42807 |
| 31 | 5/16" Nut | | 2145 | | 2145 |
| 32 | 5/16" Bolt | | 2046 | | 2046 |
| 33 | Adjustment Leveler | | 3075 | | 3075 |
| 34 | Hose Clamp | 49529 | 49529 | 49529 | 49529 |
| 35 | #10-24 Slotted Nut | | 1840 | | 1840 |
| 36 | #10-24 Hex Head Screw | | 1951 | | 1951 |
| 37 | Cable Clamp | | 1826 | | 1826 |
| 38 | Flexible Tube | 36840-1 | 36840-1 | 36840-1 | 36840-1 |
| 39 | Stand Tube Spring | 36839-1 | 36839-1 | 36839-1 | 36839-1 |
| 40 | Blue Ball | 37142 | 37142 | 37142 | 37142 |
| 41 | Hose Cap | 9811 | 9811 | 9811 | 9811 |
| 42 | O-Ring | 8598 | 8598 | 8598 | 8598 |
| 43 | Breather Valve | 46487-1 | 46487-1 | 46487-1 | 46487-1 |
| 44 | Breather Cap Assembly | 45703 | 45703 | 45703 | 45703 |
| 45 | Stand Tube Assembly | 39245 | 39245 | 39245 | 39245 |
| 46 | Seat Cup | 48199 | 48199 | 48199 | 48199 |
| 47 | Seat Cup and Seat | 42188 | 42188 | 42188 | 42188 |
| 48 | Seat Installation Tool (optional) | 48688 | 48688 | 48688 | 48688 |
| 49 | 1/2" Street Elbow (optional) | 33895 | 33895 | 33895 | 33895 |

PDS™ Controlled Nipple Inlet Assembly

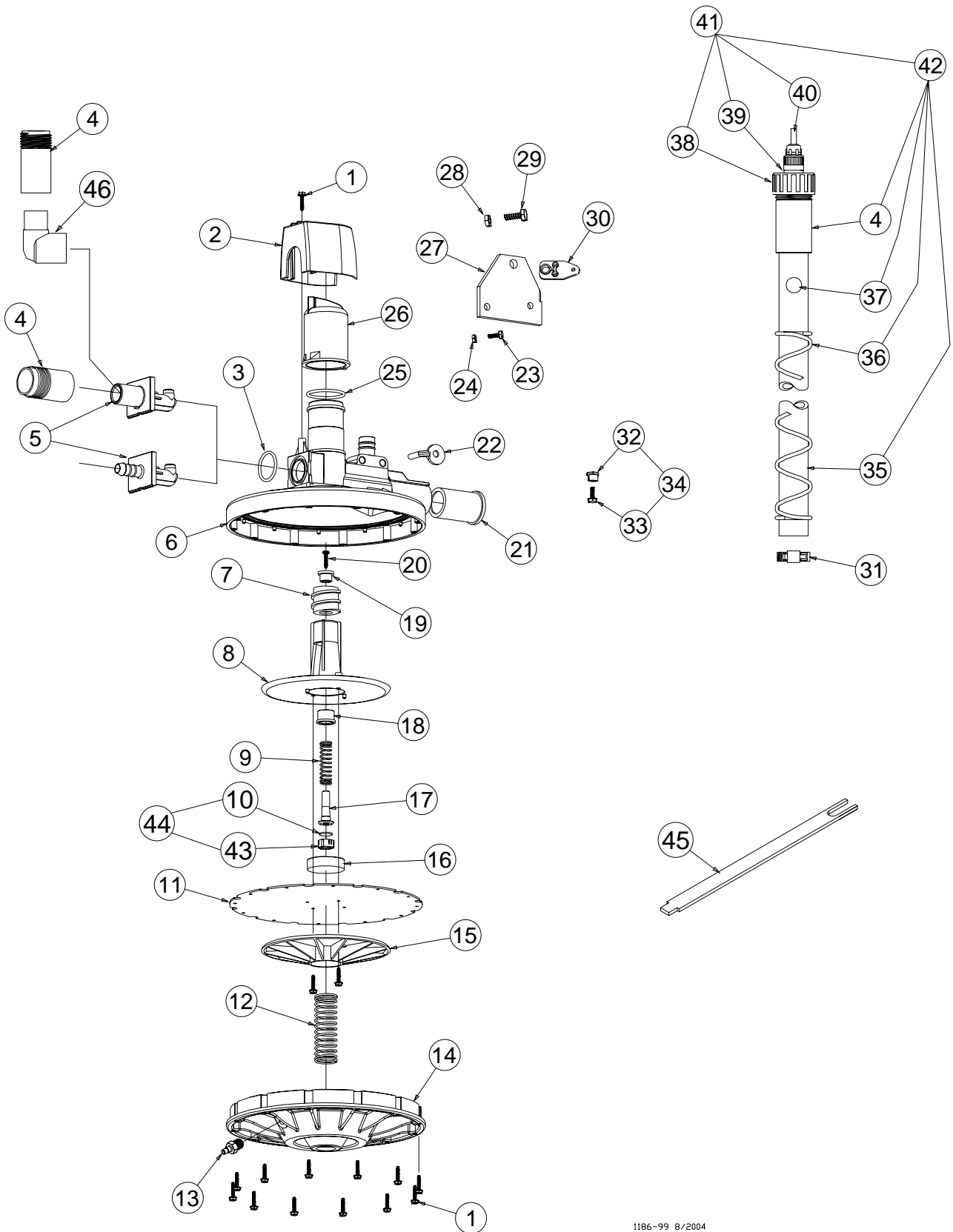

1186-99 8/2004

| Item | Description | PDS Control Standard Inlet Part No. 42400-2 | PDS Control Standard Inlet Anti-Roost Part No. 42400-22 | PDS Control Hose Barb Inlet Part No. 42400-4 | PDS Control Hose Barb Inlet Anti-Roost Part No. 42400-24 |
|------|------------------------------------|--|---|---|--|
| 1 | #6-20 x 5/8" Hex Washer Head Screw | 44946 | 44946 | 44946 | 44946 |
| 2 | Shroud | 42390 | 42390 | 42390 | 42390 |
| 3 | O-Ring | 29118 | 29118 | 29118 | 29118 |
| 4 | NH Male Adapter Fitting | 25098 | 25098 | ———— | ———— |
| 5 | Inlet Orifice | 42190 | 42190 | 42185 | 42185 |
| 6 | Top Half Regulator | 42174 | 42174 | 42174 | 42174 |
| 7 | Barrel | 42172 | 42172 | 42172 | 42172 |
| 8 | Top Diaphragm Plate | 42182 | 42182 | 42182 | 42182 |
| 9 | .375" ID x 1.750" Spring | 42392 | 42392 | 42392 | 42392 |
| 10 | Seat | 48225 | 48225 | 48225 | 48225 |
| 11 | Diaphragm | 42181 | 42181 | 42181 | 42181 |
| 12 | .780" ID x 2.800" Spring | 42394 | 42394 | 42394 | 42394 |
| 13 | Hose Barb | 44759 | 44759 | 44759 | 44759 |
| 14 | Bottom Regulator Half | 44784 | 44784 | 44784 | 44784 |
| 15 | Diaphragm Plate | 42177 | 42177 | 42177 | 42177 |
| 16 | Diaphragm Center Support | 42186 | 42186 | 42186 | 42186 |
| 17 | Seat Holder | 42189 | 42189 | 42189 | 42189 |
| 18 | Seat Holder Sleeve | 42187 | 42187 | 42187 | 42187 |
| 19 | Seat Holder Cap | 42176 | 42176 | 42176 | 42176 |
| 20 | #6-20 x 5/8 Pan Head Screw | 42386 | 42386 | 42386 | 42386 |
| 21 | Half Liner | 36501 | 36501 | 36501 | 36501 |
| 22 | Regulator Bracket | 44866 | 44866 | 44866 | 44866 |
| 23 | #10-24 x 5/8" Hex Nut | 313 | 313 | 313 | 313 |
| 24 | #10-24 Hex Head Screw | 1876 | 1876 | 1876 | 1876 |
| 25 | O-Ring | 42389 | 42389 | 42389 | 42389 |
| 26 | Selector Knob | 42178 | 42178 | 42178 | 42178 |
| 27 | Anchor Plate | ———— | 42807 | ———— | 42807 |
| 28 | 5/16" Nut | ———— | 2145 | ———— | 2145 |
| 29 | 5/16" Bolt | ———— | 2046 | ———— | 2046 |
| 30 | Adjustment Leveler | ———— | 3075 | ———— | 3075 |
| 31 | Hose Clamp | 49529 | 49529 | 49529 | 49529 |
| 32 | #10-24 Slotted Nut | ———— | 1840 | ———— | 1840 |
| 33 | #10-24 Hex Head Screw | ———— | 1951 | ———— | 1951 |
| 34 | Cable Clamp | ———— | 1826 | ———— | 1826 |
| 35 | Flexible Tube | 36840-1 | 36840-1 | 36840-1 | 36840-1 |
| 36 | Stand Tube Spring | 36839-1 | 36839-1 | 36839-1 | 36839-1 |
| 37 | Blue Ball | 37142 | 37142 | 37142 | 37142 |
| 38 | Hose Cap | 9811 | 9811 | 9811 | 9811 |
| 39 | O-Ring | 8598 | 8598 | 8598 | 8598 |
| 40 | Breather Valve | 46487-1 | 46487-1 | 46487-1 | 46487-1 |
| 41 | Breather Cap Assembly | 45703 | 45703 | 45703 | 45703 |
| 42 | Stand Tube Assembly | 39245 | 39245 | 39245 | 39245 |
| 43 | Seat Cup | 48199 | 48199 | 48199 | 48199 |
| 44 | Seat Cup and Seat | 42188 | 42188 | 42188 | 42188 |
| 45 | Seat Installation Tool (optional) | 48688 | 48688 | 48688 | 48688 |
| 46 | 1/2" Street Elbow (optional) | 33895 | 33895 | 33895 | 33895 |

Slope Compensator Assembly

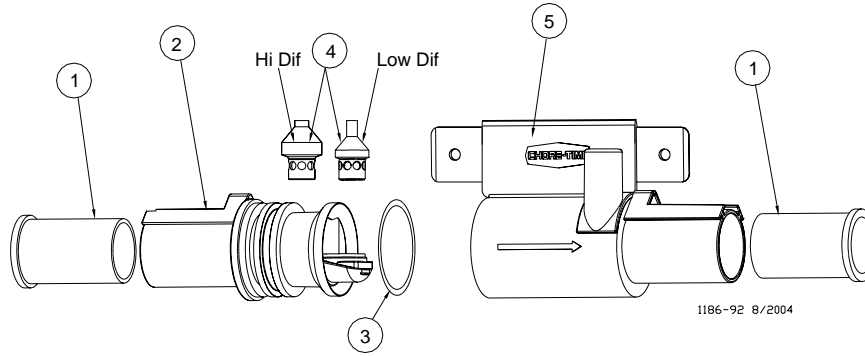

| Item | Description | Low Dif Part No. 36500-3L | Hi Dif Part No. 36500-3H |
|------|-----------------------------------|------------------------------|-----------------------------|
| 1 | Half Liner | 36501 | 36501 |
| 2 | Inlet Assembly | 46472 | 46472 |
| 3 | O - Ring | 44015 | 44015 |
| 4 | Plunger | 46450 | 46451 |
| 5 | Compensator Outlet | 40902-1 | 40902-1 |
| - | Stand Tube Assembly (Shown below) | 39245 | 39245 |

Mid Line Stand Tube Assembly

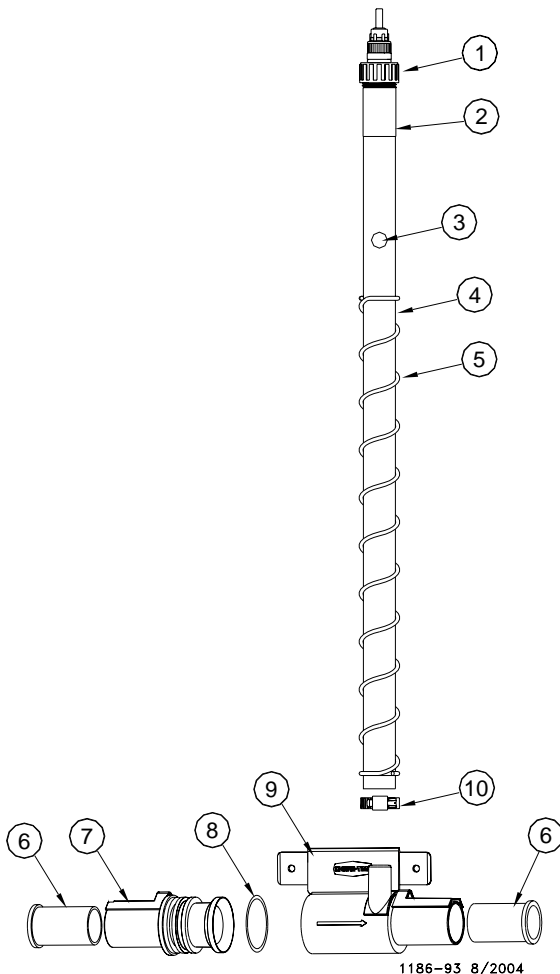

| Item | Description | Part No. |
|------|-----------------------|----------|
| 1 | Breather Cap Assembly | 45703 |
| 2 | 3/4 in. Male Adapter | 25098 |
| 3 | Blue Ball | 37142 |
| 4 | Flexible Tubing | 36840-1 |
| 5 | Stand Tube Spring | 36839-1 |
| 6 | Half Liner | 36501 |
| 7 | Inlet Assembly | 46464 |
| 8 | O-Ring | 44015 |
| 9 | Compensator Outlet | 40902-1 |
| 10 | Hose Clamp | 49529 |
| -- | Ground Wire Jumper | 36500W |

*These components may be ordered as an Assembly under Part No. 49607-1 for standard length(20") stand tube & 49607-2 for longer length(35.4") stand tube.

Stand Tube Outlet Assembly

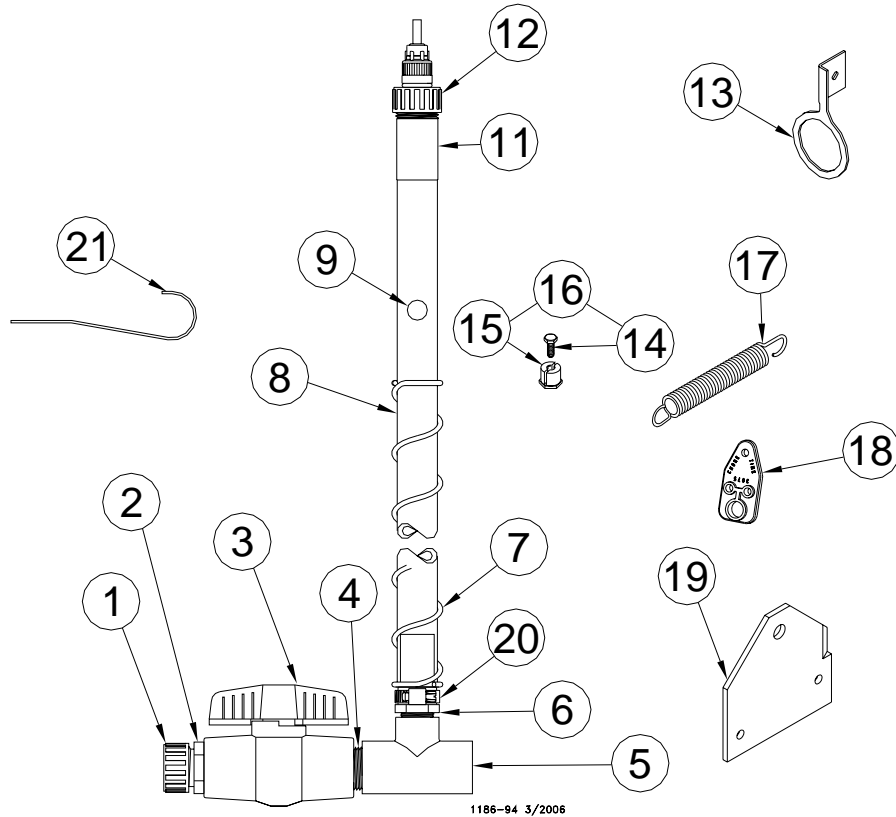

1186-94 3/2006

| Item | Description | 35779-4 Part No. | 35779-5 Part No. |
|------|-------------------------------------|------------------|------------------|
| 1 | Hose Cap (incl. washer) | 9811 | 9811 |
| 2 | 3/4 in. Nylon Adapter | 7543 | 7543 |
| 3 | 3/4 in. Valve | 35781 | 35781 |
| 4 | Threaded Pipe | 7531-4 | 7531-4 |
| 5 | Reducing Tee | 34777 | 34777 |
| 6 | Adapter 1/2 male | 47881 | 47881 |
| 7* | Spring | 36839-1 | 36839-1 |
| 8* | Flexible Tubing | 36840-1 | 36840-1 |
| 9* | Stand Tube Float | 37142 | 37142 |
| 10 | | | |
| 11* | Male Adapter Fitting | 25098 | 25098 |
| 12* | Breather Cap Assembly | 45703 | 45703 |
| 13 | Hanger | 35481 | 35481 |
| 14 | #10-24 x 3/8 Hex Head Machine Screw | ---- | 1951 |
| 15 | #10-24 Slotted Nut | ---- | 1840 |
| 16 | Cable Clamp | ---- | 1826 |
| 17 | Extension Spring | ---- | 25353 |
| 18 | Adjustment Leveler | 3075 | 3075 |
| 19 | Anchor Plate | ---- | 42807 |
| 20 | Hose Clamp | 49529 | 49529 |
| 21 | Stand Tube Bracket | 33900 | 33900 |

*These components may be ordered as a Stand Tube Assembly under Part No. 39245 for standard length(20") stand tube & 39245-1 for longer length(35.4") stand tube.

Standard Equipment: Use the 35779-4 Stand Tube Outlet Assembly.

Heavy Channel applications: Use the 35779-5 Stand Tube Outlet Assembly. This includes components required for the anti-roost system.

Nipple Line Assembly and Components

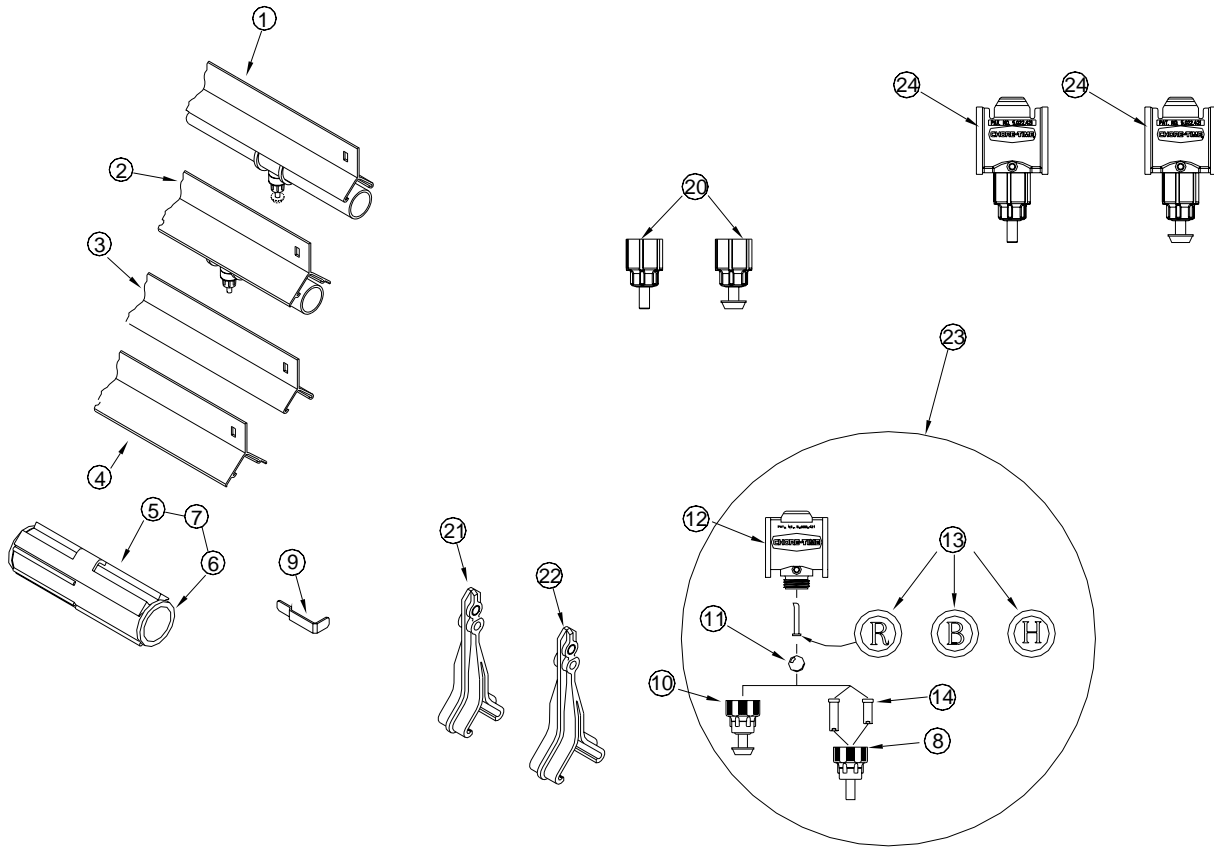

| Item | Description | Standard Flow Part No. | High Flow Part No. | Regulated Flow Part No. | Lift Trigger |
|-----------------------------------|--|------------------------|--------------------|-------------------------|--------------|
| 1 | Standard Channel Nipple Drinker Assembly | | | | |
| | 6 in. spacing (20 Nipples) | 46681-1 | 46683-1 | 46685-1 | 47642-1 |
| | 8 in. spacing (15 Nipples) | 46681-2 | 46683-2 | 46685-2 | 47642-2 |
| | 10 in. spacing (12 Nipples) | 46681-3 | 46683-3 | 46685-3 | 47642-3 |
| | 12 in. spacing (10 Nipples) | 46681-4 | 46683-4 | 46685-4 | 47642-4 |
| | 15 in. spacing (8 Nipples) | 46681-5 | 46683-5 | 46685-5 | 47642-5 |
| | 20 in. spacing (6 Nipples) | 46681-6 | 46683-6 | 46685-6 | 47642-6 |
| | 24 in. spacing (5 Nipples) | 46681-7 | 46683-7 | 46685-7 | 47642-7 |
| | 6 in. spacing (20 Button Nipples) | 46681-1B | 46683-1B | 46685-1B | |
| | 8 in. spacing (15 Button Nipples) | 46681-2B | 46683-2B | 46685-2B | |
| | 10 in. spacing (12 Button Nipples) | 46681-3B | 46683-3B | 46685-3B | |
| | 12 in. spacing (10 Button Nipples) | 46681-4B | 46683-4B | 46685-4B | |
| | 15 in. spacing (8 Button Nipples) | 46681-5B | 46683-5B | 46685-5B | |
| | 20 in. spacing (6 Button Nipples) | 46681-6B | 46683-6B | 46685-6B | |
| | 24 in. spacing (5 Button Nipples) | 46681-7B | 46683-7B | 46685-7B | |
| | Standard Channel RELIA-FLOW Drinker Assembly | | | | |
| | 6 in. spacing (20 Nipples) | 49575-1 | 49578-1 | | |
| | 8 in. spacing (15 Nipples) | 49575-2 | 49578-2 | | |
| | 10 in. spacing (12 Nipples) | 49575-3 | 49578-3 | | |
| | 12 in. spacing (10 Nipples) | 49575-4 | 49578-4 | | |
| | 15 in. spacing (8 Nipples) | 49575-5 | 49578-5 | | |
| | 20 in. spacing (6 Nipples) | 49575-6 | 49578-6 | | |
| | 24 in. spacing (5 Nipples) | 49575-7 | 49578-7 | | |
| | 6 in. spacing (20 Button Nipples) | 49575-1B | 49578-1B | | |
| | 8 in. spacing (15 Button Nipples) | 49575-2B | 49578-2B | | |
| | 10 in. spacing (12 Button Nipples) | 49575-3B | 49578-3B | | |
| | 12 in. spacing (10 Button Nipples) | 49575-4B | 49578-4B | | |
| | 15 in. spacing (8 Button Nipples) | 49575-5B | 49578-5B | | |
| 20 in. spacing (6 Button Nipples) | 49575-6B | 49578-6B | | | |
| 24 in. spacing (5 Button Nipples) | 49575-7B | 49578-7B | | | |

| Item | Description | Standard Flow Part No. | High Flow Part No. | Regulated Flow Part No. | Lift Trigger |
|-----------------------------------|---|------------------------|--------------------|-------------------------|---------------|
| 2 | Heavy Channel Nipple Drinker Assembly | | | | |
| | 6 in. spacing (20 Nipples) | 46682-1 | 46684-1 | | 45704-1 |
| | 8 in. spacing (15 Nipples) | 46682-2 | 46684-2 | | 45704-2 |
| | 10 in. spacing (12 Nipples) | 46682-3 | 46684-3 | | 45704-3 |
| | 12 in. spacing (10 Nipples) | 46682-4 | 46684-4 | | 45704-4 |
| | 15 in. spacing (8 Nipples) | 46682-5 | 46684-5 | | 45704-5 |
| | 20 in. spacing (6 Nipples) | 46682-6 | 46684-6 | | 45704-6 |
| | 24 in. spacing (5 Nipples) | 46682-7 | 46684-7 | | 45704-7 |
| | 6 in. spacing (20 Button Nipples) | 46682-1B | 46684-1B | | |
| | 8 in. spacing (15 Button Nipples) | 46682-2B | 46684-2B | | |
| | 10 in. spacing (12 Button Nipples) | 46682-3B | 46684-3B | | |
| | 12 in. spacing (10 Button Nipples) | 46682-4B | 46684-4B | | |
| | 15 in. spacing (8 Button Nipples) | 46682-5B | 46684-5B | | |
| | 20 in. spacing (6 Button Nipples) | 46682-6B | 46684-6B | | |
| | 24 in. spacing (5 Button Nipples) | 46682-7B | 46684-7B | | |
| | Heavy Channel RELIA-FLOW Drinker Assembly | | | | |
| | 6 in. spacing (20 Nipples) | 49576-1 | 49579-1 | | 49626-1 |
| | 8 in. spacing (15 Nipples) | 49576-2 | 49579-2 | | 49626-2 |
| | 10 in. spacing (12 Nipples) | 49576-3 | 49579-3 | | 49626-3 |
| | 12 in. spacing (10 Nipples) | 49576-4 | 49579-4 | | 49626-4 |
| | 15 in. spacing (8 Nipples) | 49576-5 | 49579-5 | | 49626-5 |
| | 20 in. spacing (6 Nipples) | 49576-6 | 49579-6 | | 49626-6 |
| | 24 in. spacing (5 Nipples) | 49576-7 | 49579-7 | | 49626-7 |
| | 6 in. spacing (20 Button Nipples) | 49576-1B | 49579-1B | | |
| | 8 in. spacing (15 Button Nipples) | 49576-2B | 49579-2B | | |
| | 10 in. spacing (12 Button Nipples) | 49576-3B | 49579-3B | | |
| | 12 in. spacing (10 Button Nipples) | 49576-4B | 49579-4B | | |
| | 15 in. spacing (8 Button Nipples) | 49576-5B | 49579-5B | | |
| 20 in. spacing (6 Button Nipples) | 49576-6B | 49579-6B | | | |
| 24 in. spacing (5 Button Nipples) | 49576-7B | 49579-7B | | | |
| 3 | Support Channel (standard) | 35482-1 | | | |
| 4 | Support Channel (heavy) | 35483-1 | | | |
| 5 | PVC Coupling | 34318 | | | |
| 6 | Coupling Liner | 34319 | | | |
| 7 | Coupling Liner Assembly | 35763 | | | |
| 8 | Nipple Valve Assembly | 29463 | 29463 | 29463 | 45746 |
| 9 | Support Channel Key | 35480 | | | |
| 10 | Trigger Button Cap Assembly | 33623 | | | |
| 11 | Stainless Steel Ball | 29117 | | | |
| 12 | Saddle Body | 41228 | | | |
| 13 | Flow Control Pin | 34799 | 34889 | 36860 | |
| | Flow Control Pin - Relia-Flow | 49317 | | 49624 | 49317 |
| 14 | Nipple Stem - Standard | 29119 | 29119 | 29119 | 29119 |
| | Nipple Stem - Lift Trigger | 46470 | | | |
| 15 | Nipple Insert - Standard | 29470 | | | |
| | Nipple Insert - Lift Trigger | 46411 | | | |
| 16 | Low Pressure Cap | 29121 | | | |
| 17 | RELIA-FLOW Flow Control Insert | 48876 | | | 48876 |
| 18 | RELIA-FLOW Flow Control Cap | 48877 | | | 48877 |
| 19 | RELIA-FLOW Cap and Button Assembly | 49798 | | | |
| 20 | RELIA-FLOW Valve Assembly | 49547-1 & -1B | 49547-2 & -2B | 49547-4 & -4B | 49547-5 |
| 21 | Support Channel Hanger (standard, gray) | 33824-1 | | | |
| 22 | Support Channel Hanger (heavy, gray) | 33824-2 | | | |
| 23 | Nipple Saddle Assembly | 46073-1 & -1B | 46073-2 & -2B | 46073-4 & -4B | 46073-5 & -5B |
| 24 | RELIA-FLOW Saddle Assembly | 49584-1 & -1B | | | 49584-5 |

Nipple Waterer Miscellaneous Components

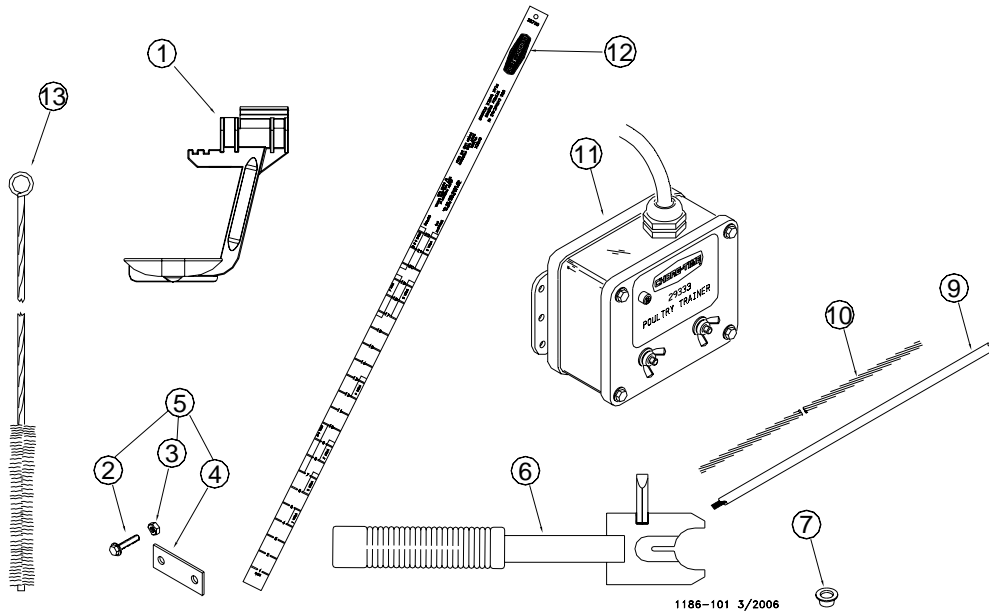

| Item | Description | Part No. |
|------|---|------------------------|
| 1 | Catch Cup | 36591 |
| 2 | #10-24 x 3/8" Hex Washer Head Screw | 25124 |
| 3 | #10-24 Kepnut | 27725 |
| 4 | Channel Bracket | 46208 |
| 5 | Channel Bracket Kit(40/kit) | 46209-40 |
| 6 | Assembly Tool | 41247 |
| 7 | Cap Plug (qty of 100) | 42679-100 |
| 8 | --- | --- |
| 9 | Training Wire (165 ft.) Training Wire (330 ft.) | 28994-165 28994-330 |
| 10 | 1/16 in. Training Cable (1 ft.) 1/16 in Training Cable (5000ft.) | 1922 1922-5000 |
| 11 | Poultry Trainer | 29333 |
| 12 | Broiler Management Stick | 35750 |
| 13 | Pipe Brush | 29465 |

Item 7 is used to cap off nipples

Nipple Waterer Mini Drinker Part Number 35412

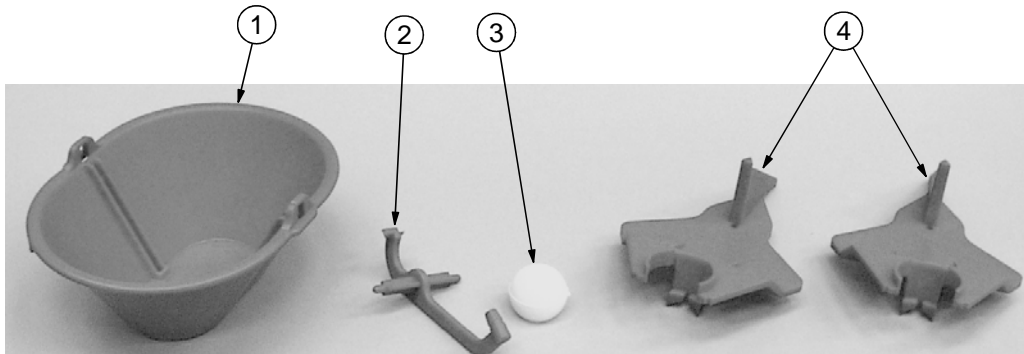

| Item | Description | Part No. |
|------|----------------------------|----------|
| 1 | Mini Drinker Bowl | 34790 |
| 2 | Pivot Arm | 34791 |
| 3 | Float Ball (small) | 25026 |
| 4 | Mounting Bracket (2 req'd) | 34792 |

Miscellaneous Kits and Components

Flush Manifold Kit Part Number 34532

Only one kit is required for every four water lines

| Description | Part No. | Qty |
|--------------------------|----------|-----|
| Ell, PVC .75 SXT | 7558 | 1 |
| Pipe, .75x6 PVC Gray | 29107-3 | 1 |
| 3/4" Adapter Assembly | 34534 | 1 |
| 3/4" Insert Tee | 34535 | 3 |
| Rubber Washer | 7147 | 4 |
| 3/4" Hose Barb | 40649 | 4 |
| 3/4" Hose Female Fitting | 40648 | 4 |
| Hose Clamp | 7187 | 4 |

Miscellaneous Hose Components

| Description | Part No. | Qty |
|---------------------------------------|----------|------------|
| Hose Coupling Kit Female 3/4" Hose | 7812 | 4 sets |
| 3/4" NPT x 3/8" Hose Barb | 37141 | 1 |
| 3/8" Nylon Hose Clamp | 37144 | 1 |
| 3/4" I.D. Rubber Hose | *47820-0 | *See note. |

*47820-0 is available in lengths of 50', 100', 150' and 200'.

The numbers following the dash represent the length of hose (47820-50 is 50' of hose).

Mid Line Shut-Off Kit Part Number 29658

| Description | Part No. | Qty |
|-------------------------|----------|-----|
| 3/4" Quarter Turn Valve | 29623 | 1 |
| 3/4" PVC Male Adapter | 9229 | 2 |

Mid Line Shut-Off Kit with Flush

Part Number 34939-2

Water Medicator

| Description | Part No. |
|----------------------------|----------|
| Chemilizer (1 - 100 Ratio) | 41778-1 |

Water Meters

Important: Line must be flushed out before installing Water Meters. Bleed air out of the water line, running air through the Water Meter will damage it.

| Description | Part No. | Replacement Head |
|--|----------|------------------|
| 3/4" Water Meter with Connectors (Liter) | 13228-L | 47634-6 |
| 3/4" Water Meter with Connectors (Gallon) | 13228-G | 47634-G |
| 3/4" Water Meter with Pulser and Connectors (Liter) | 13228-LP | 47634-LP |
| 3/4" Water Meter with Pulser and Connectors (Gallon) | 13228-GP | 47634-GP |

Suspension System Components

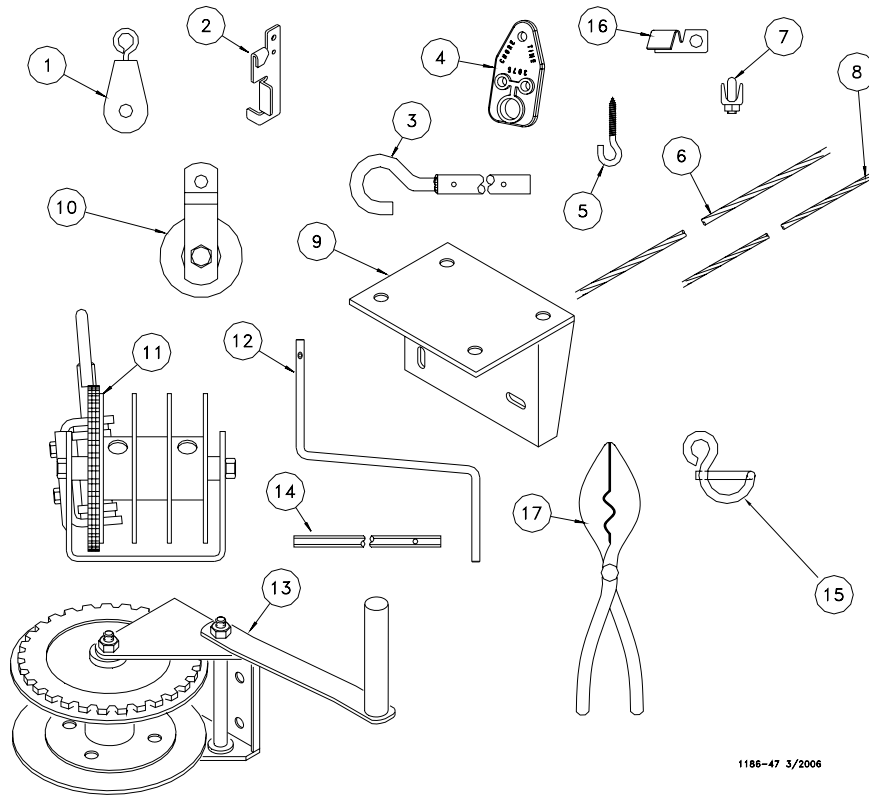

1186-47 3/2006

| Item | Description | Part No. |
|-------|--|------------------|
| 1 | Pulley with Swivel Hook | 44577 |
| 2 | Cable Lock (for cable) | 14337 |
| 3 | Winch Drive Tube (4 ft.) Winch Drive Tube (8 ft.) | 2884-1 2884-2 |
| 4 | Adjustment Leveler (for rope) | 3075 |
| 5 | Screw Hook (standard) Screw Hook (large) | 1214 2041 |
| 6 | 1/8 in. Overhead Cable | 27975 |
| 7 | 1/8 in. Cable Clamp | 14898 |
| 8 | 3/32 in. Drop Cable | 4973 |
| 9* | Winch Bracket with hardware | 1193 |
| 10 | Pulley | 44596 |
| 11 | Split Drum Winch | 29428 |
| 12 | Handle Shank | 3148 |
| 13** | Hand Winch | 1212 |
| 14 | Drill Adapter Shaft | 3151 |
| 15 | Winch Handle Pin | 3761 |
| 16*** | Open .125" Cable Eyelet | 44598-100 |
| 17 | Crimping Tool | 44599 |
| -- | 1/8 in. Rope | 9247 |

*Winch Bracket to be used with Hand Winch only.

**Hand Winch is recommended for systems up to 150 ft. (46 m) only.

***This Item consists of 100 pcs of the Open Cable Eyelets.

Operational Guidelines

| Topic | Recommendations |
|--------------------------------|--|
| Initial Start-Up Procedure | <ol style="list-style-type: none"> 1. Thoroughly flush the water lines. 2. Set incoming water pressure to 35 p.s.i. [172 kPa] at the Step Regulator on the Filter Control Panel. 3. Level the shavings under the water line to eliminate high/low spots. 4. Adjust the Inlet Regulators on the lines so the Stand Tube Float corresponds to the drawing on page 36. Make sure there is water at the Outlet Sight Tube and air is bled from the line. Indicator Ball should be visible during operation. 5. Check Outlet Assemblies and Stand Tubes to make sure water is passing throughout the system. |
| Bird Placement Procedure | Immediately before birds are housed, brush the Nipples with a broom to form water droplets on the Nipples |
| Operation During Bird Grow Out | If wet floors begin to develop under the drinker lines, increase ventilation and add additional heat to dry the litter. The floor conditions are a good indication of adequate or deficient water supply. If the floors are wet, the water column may be too high. If the floors are dry, the water column may be set to low. |
| Maintenance Between Batches | <p>Flush each line at full pressure for 5 minutes to remove deposits and sediments.</p> <p>Check pressure drop across water filter - clean or replace if necessary.</p> <p>Check Regulator, Shut-Off Valves, Stand Tube(s), and Coupling Liner Assemblies for proper operation.</p> <p>Adjust the Cable Levelers so that the water lines are level.</p> <p>Maintain house temperature above freezing or drain the lines thoroughly. Drain Inlet(s).</p> |
| Precautions | <p>Do not over Chlorinate. The maximum concentration is 2.5 ppm (parts per million) for extended periods and 5 ppm for flushing only.</p> <p>If medication or other chemicals are added to the water, flush the lines immediately after use, then chlorinate, as specified. Allow at least 24 hours before adding additional chemicals (such as iodine, citric acid, etc.) or vitamins to the water.</p> |

Troubleshooting Guidelines

| Problem | Cause | Solution |
|-------------------------------------|--|---|
| Nipples are leaking | Internal parts improperly assembled. | Disassemble and reassemble parts correctly. |
| | Foreign material preventing proper valve operation. | Trigger Nipple a few times to see if leak stops. If leak persists, disassemble valve, clean, and reassemble. Replace Valve components and Saddle if leaks persist. |
| Leaking above Cap Assembly | Cap not properly tightened. | Tighten Cap on Saddle. |
| | Damaged Saddle. | Replace Saddle, Nipple may not need to be replaced. |
| Leaking between Saddle and PVC Pipe | Damaged Saddle. | Replace Saddle, Nipple may not need to be replaced. |
| Leaking at Coupler Liner Assembly | Damaged (flexible) Coupler Liner or PVC Coupler. | Replace Coupler Liner and/or PVC Coupler. |
| Leaking or damaged Inlet Assembly | Damaged component or improperly glued component. | Replace damaged or defective component(s). It may be necessary to order a union to reconnect the Inlet components. |
| Stand Tube not working properly | Depending on water quality and management techniques, the Stand Tube may require more frequent cleaning. | <ol style="list-style-type: none"> 1. Remove Hose Cap on top of Stand Tube. 2. Use a brush (available through Chore-Time) to thoroughly clean the Stand Tube. 3. Bend the flexible tube to allow the water and/or foreign material to exit the tube. 4. Clean and reassemble the components and check for proper water level. |

Guide to Cleaning Water Lines

Important: Chore-Time strongly recommends a regular cleaning program to eliminate water line contaminants.

Standard Cleaning Procedure

1. Mix the cleaning solution as indicated below.
2. Fill watering system with solution.
3. Allow solution to remain in lines 1 to 3 hours.
4. Flush system with clean water using high pressure.
5. Check filters, valve, and nipples for clogging from debris.
6. Adjust regulator pressure to normal operating pressure.

Regular Maintenance

The Watering System should be cleaned one day every two weeks during the production cycle using a proportioner and one of the following stock solutions. Set the proportioner at 1 oz. (30 ml.) stock solution to 128 oz. (3785 ml.) of water.

1. Vinegar stock solution = 64 fl. oz. (1893 ml.) white household vinegar + 64 fl. oz. (1893 ml.) water
2. Citric Acid stock solution = 1 pack (205 gm) citric acid + 128 fl. oz. (3785 ml.) water.

End of Grow Out Cleaning

A chlorine solution should run through the watering system, using a proportioner, at 1 fl. oz. (30 ml.) stock solution to 128 fl. oz. (3785 ml.) water. The solution should be administered during one of the last 3 days of the grow out. This cleans the whole system including the Nipple Drinkers and sterilizes the entire system for the next grow out cycle.

1. Chlorine stock solution = 1 fl. oz. (30 ml.) 5-1/4% bleach (or similar source of 5-1/4% sodium hyperchlorite) + 128 fl. oz. (3785 ml.) water. This solution will yield about 2 PPM chlorine in the drinkers with average water. **Do not** exceed this level for an extended period of time (otherwise, damage to the system may occur).

After Administering Vitamins, Medication or other Chemicals

Chore-Time recommends flushing and Chlorinating lines immediately after administering Vitamins, Medication or other Chemicals. Failure to flush and chlorinate can result in bacteria build-up which can reduce or prevent water flow.

Between Flocks

The Watering System should thoroughly cleaned between flocks. A stronger cleaning solutions may be used since birds will not be drinking the water. It is important to thoroughly flush the system (after 1 to 3 hours) with clean water to prevent storing high concentrates of cleaning solution in the watering system until the next flock is placed.

Use one of the following stock solutions for cleaning the system between flocks. Set the proportioner at 1 oz. of stock solution to 128 oz. (3785 ml.) water.

1. Vinegar stock solution = 128 fl. oz. (3785 ml.) white household vinegar.
2. Citric Acid stock solution = 4 pack (205 gm) citric acid + 128 fl. oz. (3785 ml.) water.

Water Quality

Hardness

Hardness is the calcium and magnesium content of a water supply. These minerals are responsible for scaling that forms in hot water heaters, plumbing lines, humidifiers, dishwashers and all other water using appliances. Waters containing hardness minerals are generally classified as:

| | |
|-----------------------|---------------------|
| Soft Water | 0 to 1.0 GPG |
| Slightly Hard Water | 1.1 to 3.5 GPG |
| Moderately Hard Water | 3.6 to 7.0 GPG |
| Hard Water | 7.1 to 10.5 GPG |
| Very Hard Water | 10.6 GPG or greater |

Iron

Iron, when present in amounts of 0.3 ppm or higher, can cause a yellow or rusty appearance in water. It can also cause staining of clothing and water fixtures. Iron is to be found in two forms, clear (dissolved) or red (oxidized) water iron. Water refiners are capable of removing both types of iron. Higher amounts of iron may require Further treatment.

Iron Bacteria

Iron bacteria are found in water supplies containing clear water iron. They use the clear water iron as a source of energy, and at the same time, convert the iron to the red water state. These bacteria are not considered a health hazard, but can plug plumbing lines, fixtures and appliances, and promote localized corrosion and impart a taste and/or color to water. Effective treatment requires shock chlorination of all plumbing lines prior to the installation of any equipment. This is followed by the installation of a chemical feed pump feeding chlorine to eliminate the bacteria, and a clarifying filter to remove the residue.

Acid Water

The acid content of a water supply is measured and reported to terms of pH units. Acid waters cause staining of plumbing fixtures and corrosion of plumbing systems which may necessitate expensive repairs. Waters having a pH of less than 6.8 are considered acidic. A pH of 6.0 to 6.7 indicates a moderately acidic supply and should be treated with a neutralizing filter. A pH of 4.0 to 5.9 is considered extremely acidic and should be treated with a chemical feed pump feeding neutralizing compound.

Aggressive/Corrosive Water

Aggressiveness of water is measured by the stability index (a calculation from several factors in a water supply). A stability index of 7.5 or higher indicates the water may have corrosive tendencies. This type of corrosion may attack plumbing and fixtures causing rusty or blue/green stains. The use of a phosphate crystal cartridge will help to eliminate this problem.

Taste and Color

Objectionable tastes and/or odors can be dissolved minerals and gases, organic contamination, or from chlorination. Treatment requires the installation of taste and odor tank filter for the whole house or a taste and odor cartridge filter for individual faucets.

Hydrogen Sulfide

Hydrogen sulfide is a dissolved gas common to some water supplies. It is detected by a rotten egg taste and/or odor of the water. Proper treatment requires the installation of a chemical feed pump system feeding household chlorine bleach, followed by a sediment filter to remove the precipitation.

Sand, Silt or Sediment

Sand, silt or sediments are found in many water supplies. It is usually detected by a cloudy or hazy appearance when the water is first drawn. Treatment requires the installation of a sediment filter to remove the particles.

This page left blank for notes.



MADE TO WORK.

BUILT TO LAST.®

Contact your nearby Chore-Time distributor or representative for additional parts and information.

**Chore-Time Poultry Production Systems
A Division of CTB, Inc.
P.O. Box 2000 • Milford, Indiana 46542-2000 • U.S.A.
Phone (574) 658-4101 • Fax (877) 730-8825
E-mail: poultry@choretime.com • Internet: www.choretimepoultry.com**

Printed in the U.S.A.