

GOVERNMENT GAZETTE

OF THE

REPUBLIC OF NAMIBIA

N\$12.20

WINDHOEK - 31 March 2003

No.2945

CONTENTS

	<i>Page</i>
GOVERNMENT NOTICES	
No. 67 Namibian Civil Aviation Technical Standards: NAM-CATS-GMR "General Maintenance Rules"	2
No. 68 Namibian Civil Aviation Technical Standards: NAM-CATS-ENVIRO "Noise certification"	41

Government Notices

MINISTRY OF WORKS, TRANSPORT AND COMMUNICATION

No. 67

2003

NAMIBIAN CIVIL AVIATION TECHNICAL STANDARDS: NAM-CATS-GMR "GENERAL MAINTENANCE RULES"

The Director: Civil Aviation has under regulation 11.03.5 of the Namibian Civil Aviation Regulations, 2001 and in consultation with the Civil Aviation Regulations Committee issued the technical standards in the Schedule. These technical standards shall come into operation on 31 March 2003.

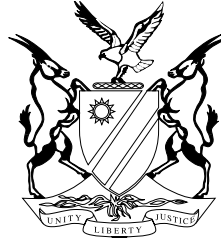

REPUBLIC OF NAMIBIA

CIVIL AVIATION

**DOCUMENT NAM-CATS-GMR
(GENERAL MAINTENANCE RULES)**

NAMIBIAN CIVIL AVIATION TECHNICAL STANDARDS RELATING TO THE GENERAL MAINTENANCE RULES

1 GENERAL

Section 22A of the Aviation Act, 1962 (as amended by section 5 of the Aviation Amendment Act, 1998) empowers the Director: Civil Aviation to issue technical standards for civil aviation on the matters which are prescribed by regulation.

The Director: Civil Aviation has pursuant to the empowerment mentioned above, on 31 March 2003 issued technical standards relating to general maintenance rules to be known as Document NAM-CATS-GMR.

2. PURPOSE

Document NAM-CATS-GMR contains the standards, rules, requirements, methods, specifications, characteristics and procedures which are applicable in respect of general maintenance rules.

Each reference to a technical standard in this document, is a reference to the corresponding regulation in the Namibian Civil Aviation Regulations, 2001, for example, technical standard 43.02.18 refers to regulation 18 of Subpart 2 of Part 43 of the Regulations.

The abbreviation "CAR" is used throughout this document when referring to any regulation.

The abbreviation "TS" refers to any technical standard.

3. SCHEDULES AND NOTES

Guidelines and recommendations in support of any particular technical standard, are contained in schedules to, and/or notes inserted throughout the technical standards.

LIST OF TECHNICAL STANDARDS

43.02.1 PERSONS TO CARRY OUT MAINTENANCE

1. Pilots

43.02.4 MAINTENANCE FOR IFR OPERATIONS

1. Abbreviations
2. Aircraft radio station inspection

43.02.6 MANDATORY PERIODIC INSPECTIONS

1. Approved Maintenance Schedule for powered aircraft with a maximum certificated mass of 5 700 kg or less
2. Minimum requirements for mandatory periodic inspections
3. Minimum requirements for an annual inspection for amateur-built aircraft
4. Minimum requirements for an annual inspection for manned free balloons

43.02.7 ALTIMETER SYSTEM TESTS AND INSPECTIONS

1. The static pressure system test
2. The altimeter test
3. The automatic pressure altitude reporting equipment and ATC transponder system integration test

43.02.8 AVIATION TRANSPONDER TESTS AND INSPECTIONS

1. General
2. Radio reply frequency test
3. Suppression test

4. Receiver sensitivity test
5. RF peak output power test
6. Mode S diversity transmission channel isolation test
7. Mode S address test
8. Mode S formats test
9. Mode S all-call interrogations test
10. ATCRBS-only all-call interrogation test
11. Squitter test

43.02.9 EMERGENCY LOCATOR TRANSMITTER TESTS AND INSPECTIONS

43.02.11 NON-DESTRUCTIVE TESTING

43.02.15 RECORDING OF MAJOR REPAIRS AND MODIFICATIONS

1. Manner of recording

43.02.17 TEMPORARY AND PERMANENT REPAIRS AFTER ACCIDENTS OR INCIDENTS

1. Requirements

43.02.18 AIRCRAFT COMPASS REQUIREMENTS

1. Compass swing requirements
2. Deviation cards
3. Logbook entries
4. Compass swing areas and equipment

43.03.3 CERTIFYING AFTER INSPECTION

1. Statement

43.03.4 CERTIFYING AFTER MAINTENANCE

1. Statement
2. Form of certificate of release to service

43.03.5 DISCREPANCIES

1. Statement

43.04.1 CERTIFYING REVIEW

1. Statement

APPENDICES

APPENDIX 1 : TIME BETWEEN OVERHAULS AND LIFE-LIMITED PARTS

APPENDIX 2 : INSPECTION REMINDER

ANNEXURES

ANNEXURE A : AUTHORISED RELEASE CERTIFICATE

ANNEXURE B : AIRCRAFT RELEASE CERTIFICATE

ANNEXURE C : CERTIFICATE OF RELEASE TO SERVICE

43.02.1 PERSONS TO CARRY OUT MAINTENANCE**1. Pilots**

- (1) The maintenance referred to in CAR 43.02.1(2), which a licensed pilot, other than a student pilot, may carry out on an aircraft with a maximum certificated mass of 5 700 kg or less for which the pilot is rated, and all its equipment, is as follows, provided that only approved materials, parts and components are used:
 - (a) Changing tyres and tubes and repairing punctures;
 - (b) servicing landing gear shock struts by adding air, oil or both;
 - (c) replacing defective locking wire and split pins;
 - (d) replenishing hydraulic fluid in the hydraulic fluid reservoir;
 - (e) small simple repairs to fairings, non-structural cover plates and cowlings by means of stop drilling cracks and fitting small patches or reinforcements which will not change contours or interfere with proper airflow;
 - (f) temporary repairs to side windows;
 - (g) replacing safety belts;
 - (h) replacing seats or seat parts where such work does not involve any removal, dismantling or interference with a primary structure or system;
 - (i) replacing prefabricated fuel and oil lines;
 - (j) replacing any electrical bulb, reflector, lens or fuse of navigation and landing lights;
 - (k) replacing or cleaning spark plugs and setting spark plug gaps;
 - (l) cleaning fuel and oil strainers;
 - (m) replacing batteries and checking fluid level and specific gravity;
 - (n) replacing tailwheels and tailwheel springs;
 - (o) changing engine oil; and
 - (p) removing and installing such dual controls as are designed for easy removal and installation.
- (2) Whenever it is necessary to carry out maintenance of this nature, the pilot must -
 - (a) notify the aircraft maintenance organisation or aircraft maintenance engineer normally responsible for the maintenance of the aircraft, to assist in -
 - (i) supplying parts, if required;
 - (ii) giving technical advice; and
 - (iii) supplying maintenance publications, where required; and

- (b) ensure that any maintenance work done, is correctly recorded in the aircraft flight folio, including particulars of -
 - (i) maintenance publications referred to;
 - (ii) parts replaced (serial where applicable);
 - (iii) parts repaired; and
 - (iv) tests carried out (if applicable).
- (3) Entries in the aircraft flight folio must be accompanied by the pilots signature, licence number and the date of entry.
- (4) Unless the pilot is an appropriately rated aircraft maintenance engineer, such pilot may on no account sign an aircraft logbook in the column intended for the signature of the appropriately rated aircraft maintenance engineer or approved aircraft maintenance organisation.
- (5) All the maintenance listed in this technical standard, must be inspected and signed out by an appropriately rated aircraft maintenance engineer at an appropriate maintenance facility, at the first opportunity after such maintenance has been carried out.

43.02.4 MAINTENANCE FOR IFR OPERATIONS

1. Abbreviations

In this technical standard -

- (1) VSWR means voltage standing wave ratio;
- (2) VHF Comm means very high frequency communication;
- (3) HF Comm means high frequency communication;
- (4) ADF means automatic direction-finder;
- (5) ILS means instrument landing system;
- (6) VOR means VHF omnidirectional radio range;
- (7) Hz means Hertz;
- (8) DME means distance measuring equipment.

2. Aircraft radio station inspection

- (1) Examine the maintenance records for service history and compliance with the applicable maintenance rules.
- (2) Inspect and test the bonding of mounting racks and shock mounts for a maximum resistance of 0.05 ohms.
- (3) Check the VSWR of the transmission lines and aerials of the following:
 - (a) VHF Comm;
 - (b) HF Comm (T/R to antenna coupler).

(VSWR less than 1.5:1 is desirable but must not exceed 3:1.)

- (4) Inspect and test the ADF sense antenna for insulation resistance.
- (5) Inspect and test the HF antenna for integrity and insulation resistance.
- (6) Inspect and test the operation of ILS receivers with an approved field test set, including -
 - (a) testing flag warnings for modulation failure, centre line accuracies, sense and course widths; and
 - (b) testing the audio function.
- (7) Inspect and test the operation of VOR with an approved field test set, including -
 - (a) testing flag warnings for modulation failure; and
 - (b) omni-radial resolving, and radio magnetic indicators, accuracy at 30° intervals; and
 - (c) carrying out "1° test for freedom of meter movement, sense and course width; and
 - (d) testing the audio function.
- (8) Inspect and test the operation of marker receiver with an approved field test set including -
 - (a) testing operations of 400, 1 300 and 3 000 Hz tones and associated lamps; and
 - (b) where fitted, operation of hi/lo sensitivity.
- (9) Inspect and test the operation of DME with an approved field test set, including -
 - (a) testing range accuracy and ground speed readings; and
 - (b) testing the audio function.

43.02.6 MANDATORY PERIODIC INSPECTIONS

1. Approved Maintenance Schedule for powered aircraft with a maximum certificated mass of 5 700 kg or less

1.1 Definitions and abbreviations

- (1) Any word or expression to which a meaning has been assigned in the Aviation Act, 1962, and the Namibian Civil Aviation Regulations, 2001, bears, when used in this technical standard, the same meaning unless the context indicates otherwise, and -

“Aircraft” for the purposes of this technical standard includes the airframe, power plant(s), propeller(s) where applicable, rotors where applicable, components, parts, accessories, instruments, avionics and equipment when installed in or on the aircraft;

“Equipment” includes emergency equipment, placards, flight or operations manuals or equivalent, when these are required to be carried, and such written, diagrammatic or pictorial instructions as are necessary or required for the safe operation and navigation of the aircraft and for the safety of its occupants;

“Airworthy” means, when used in relation to an aircraft, that the aircraft is serviceable, is in conformity with its type design and meets all the requirements prescribed for the issuing of a certificate of airworthiness, and such other requirements as have been prescribed for the continuing validity of such certificate;

“check for condition” means that the part, component or other item referred to must be inspected for cleanliness, corrosion, wear, deterioration, delamination, cracks, dents, scores, cuts, scratches, distortion, bowing, evidence of overheating, freedom from obstruction, fouling, leaks, correct locking and any other unacceptable feature not specifically mentioned herein;

“Inspect for condition” and “Examine for condition” have corresponding meanings;

“direct supervision” means, in relation to the maintenance, overhaul and inspection of an aircraft, that the person exercising the supervision personally maintains such surveillance of the work being performed as is necessary to ensure that it is being properly carried out and that such person is readily available for consultation with the person doing the work;

“maintenance” means all work carried out in accordance with manufacturer’s recommendations and approved maintenance schedules and includes cleaning, inspection, adjustment, rectification, repair, modification, overhaul and testing;

“serviceable” means that the aircraft has been maintained and inspected in accordance with the requirements of the approved maintenance schedules, and that all adjustments and rectifications found to be necessary have been satisfactorily made.

(2) In this technical standard -

ADs means Airworthiness Directives

AIC means Aeronautical Information Circular

AME means Aircraft Maintenance Engineer

AMO means Aircraft Maintenance Organisation

C of A means Certificate of Airworthiness

C of R means Certificate of Registration

CRS means Certificate of Release to Service

CRMA means Certificate Relating to Maintenance of an Aircraft

DCA means Directorate of Civil Aviation

HRS means Hours

MPI means Mandatory Periodic Inspection

PI means Progressive Inspection

P/N means Part Number

SBs means Service Bulletins

SIs means Service Instructions

SLs means Service Letters

S/N means Serial Number

TBO means Time Between Overhaul

IP means Inspection Program.

1.2 General instructions

- (1) Unless the Director has granted written exemption from compliance with any of the requirements contained in this schedule, no aircraft to which this schedule relates is to be flown unless it is serviceable or airworthy and all the mandatory maintenance required by this Schedule and that of the manufacturer has been carried out when due and has been certified by an appropriately rated AME. The owner or operator of an aircraft is solely responsible for the maintenance. It is the duty and responsibility of the pilots who fly the aircraft to ensure that all unusual occurrences, defects or suspected faults coming to their notice during operations and which may affect the service ability of the aircraft, are recorded in the aircraft's flight folio as and when they occur and are reported to the maintenance personnel responsible for the maintenance of the aircraft.
- (2) The maintenance requirements contained in this schedule constitute the minimum requirements considered necessary for the satisfactory maintenance of the aircraft to which the schedule applies. In performing maintenance work on an individual aircraft, due regard must be given to its age, type of operations, climatic and housing conditions and any other factors which may affect the airworthiness of such an aircraft. Consequently, this schedule must not be construed as absolving the owner, the appropriately rated AME or the approved AMO from ensuring that any additional maintenance found to be necessary or required by the Director is carried out.
- (3) Nothing in this schedule is to be construed as relieving the pilot-in-command of the aircraft from his/her responsibility regarding flight preparation as prescribed in CAR 91.02.7.
- (4) All maintenance required to be carried out in accordance with the provisions of this schedule must be accomplished under such working conditions and with the use of such tools, equipment, test apparatus and technical information as will ensure completion to standards acceptable to the Director. Whenever the tools, equipment or test apparatus referred to in this subparagraph are used, it must be ensured that they are in good working order and condition and that the person using them is familiar with their use. Precision measuring tools, equipment, test apparatus and items such as gauges and indicators must be periodically checked and, as often as deemed necessary or once annually, whichever is the shorter, or as required by the Director. Where the security or tightness of nuts, unions and other fasteners is required to be checked, such checking must be done with the aid of the appropriate tools.
- (5) Nothing contained in this schedule is deemed to require any maintenance to be done on an aircraft withdrawn from service for storage, repair or any other reasons. Owners of aircraft and maintenance personnel must ensure that the preservation requirements of the various manufacturers as outlined in maintenance manuals, SLs and/or SBs be strictly adhered to for the various categories of inoperative periods. Before such aircraft is released to service, it must be ensured that all maintenance due is carried out.

- (6) Failure to comply with any applicable mandatory requirement of this schedule invalidates the validity of certificates of airworthiness unless exemption has been obtained from the Director in terms of Part 11 of the CARs.
- (7) If any requirement in this schedule does not apply to the aircraft being inspected, it may be ignored.

1.3 Inspections

Periodic inspections consist of the following:

- (1) Inspections as recommended by the manufacturer.
- (2) Mandatory Periodic Inspections (scheduled inspections).

1.4 Recommended inspections

The inspections referred to in paragraph 1.3(1) are recommended and must be complied with whenever the contents of the recommended inspections indicate that the serviceability of the aircraft may be effected.

1.5 Mandatory periodic inspections

- (1) The MPIs referred to in paragraph 1.3(2) are mandatory and must be accomplished in order to validate or revalidate the Certificate of Airworthiness -
 - (a) on all aircraft imported into Namibia, for the purpose of registration, before such may be put into service;
 - (b) on newly Namibian registered aircraft, on completion of the manufacturer's service interval after the first flight of the aircraft;
 - (c) at the manufacturer's service interval, hours or calendar, since the last MPI, whichever comes first. This means that if an aircraft is operated for less than the manufacturer's service interval hours of flight time per annum, it will undergo an MPI at the manufacturer's service calendar period, regardless of the hours flown. However, if the Director has approved another inspection program, the conditions laid down in that program are to be adhered to;
 - (d) when an aircraft sustained damage as set out in paragraph 1.11(2);
 - (e) at any time before the next routine inspection is due, should circumstances warrant such action.

(2) MPI extensions

An extension of 10 % is allowed on flight hours between two particular MPIs. The intention is to assist owners or operators in conveniently executing the maintenance, for example, should the flight hours between MPIs be exceeded by 4 hours, the next ensuring MPI must be executed at 96 flight hours.

(3) General

In carrying out a MPI, the following requirements must be observed:

- (a) No MPI may be attempted without the use of a check list as outline in paragraph 1.3(1) and 1.3(2). Such check list may have been com-

plied by the aircraft manufacturer, provided it is sufficiently comprehensive to cover the complete aircraft and installed equipment. The check list used during an inspection must be retained by the certifying AME for the appropriate period as pre-scribed in the CARs.

- (b) The relevant logbooks, component logcards and flight folio must be available during a MPI.
- (c) It is the responsibility of the AMO/AME concerned to open the flight folio and record all details. When reaching the flight time between scheduled inspections, the flying times must be transferred to the appropriate logbooks. After the inspection a new page must be opened with all the relevant details recorded and inspections signed for.
- (d) Before commencing an inspection, the necessary panels must be removed in the areas to be inspected.
- (e) Serviceability of the aircraft must be determined by an inspection in accordance with the manufacturer's recommendations and standard inspection practices and procedures.
- (f) It must be ascertained that the requirements of all mandatory repairs, and replacements, modifications and special inspections have been met and that the mandatory replacements of products and parts have been complied with.
- (g) A copy of the certificate of release to service must be completed and forwarded to the Director within 48 hours after completion of each MPI.

1.6 Other inspections

(1) Progressive inspections

Notwithstanding anything to the contrary contained in paragraph 1.5, it is permissible for an owner or operator to introduce a system of progressive inspections which will enable the work required by the mandatory periodic inspections to be spread over the intervals between successive mandatory inspections. However, prior to introducing a progressive inspection system, the owner or operator must submit in writing to the Director for approval, full details of the manner in which he/she proposes to implement the system.

(2) Duplicate inspection

A duplicate inspection of all control systems must be carried out after the initial assembly and at any time the systems are disturbed in any way. The purpose of the duplicate inspection is to verify that the manufacturer's specifications and requirements have been met. An initial inspection of the control systems must be made and certified immediately after the maintenance was completed and before the aircraft is flown, by an appropriately rated AME who has been designated by the Director as an approved person in the organisation. A duplicate inspection of the controls being worked on must be made prior to the first flight and certified. Persons qualified to perform and certify duplicate inspections are -

- (a) an appropriately rated AME; and
- (b) a commercial pilot licensed and rated on the type concerned.

- (3) Non-scheduled maintenance inspections
- (a) During operations an aircraft may be subject to -
- (i) hard/overweight landing;
 - (ii) operations outside the normal flight envelope, including power limitations;
 - (iii) severe air turbulence or abnormal manoeuvres;
 - (iv) lightning strikes;
 - (v) foreign object damage; or
 - (vi) towing - involving high drag/ side loads due to ground handling.
- (b) If any of the foregoing occurs, the manufacturer's recommendations must be followed. If no specific procedures are prescribed for a particular aircraft, the DCA must be approached for guidance.
- (c) Propeller/rotor strikes
- To be carried out in accordance with the requirements prescribed in paragraph 1.11(2)(a).

(4) Fuel flow checks

Fuel flow checks must be carried out and the results recorded as follows:

- (a) At each MPI on all aircraft.
- (b) After any work has been done on the fuel system.
- (c) At any time the operator encounters fuel system problems.

1.7 Rectification of unsatisfactory items

When, during any inspection or at any other time, any part, product, component or item is found to be unserviceable or, in the opinion of the supervising approved person in the aircraft maintenance organisation, is unlikely to remain serviceable under normal operating conditions during the period preceding the next MPI, such rectification action as the supervising approved person considers to be necessary must be taken to restore the serviceability of the part, product or item prior to releasing the aircraft to service. All deferred defects must be transferred from the Flight Folio and all work involved in restoring the serviceability of any part, product or item must be clearly recorded in the relevant logbook and be certified by an appropriately rated AME.

1.8 Associated documents

- (1) During the maintenance of aircraft to which this schedule applies, special attention must be given to -
- (a) the contents, recommendations or requirements of the relevant manuals, service bulletins or other similar technical information produced by the manufacturer of the airframe, engine, propeller and installed equipment; and
 - (b) additional requirements issued by the Director and by the authorities of the country of origin of the aircraft, which may prescribe or amplify

techniques to be followed in the maintenance of aircraft, eg. British Civil Aircraft Inspection Procedures and United States of America Federal Aviation Administration handbooks AC. 43.13-1A and -2A (Acceptable Methods, Techniques and Practices - Aircraft Inspection and Repair) and AC. 43.13-2 (Acceptable methods, Techniques and Practices - Aircraft Alterations), or their successor publications.

- (2) All relevant information and requirements referred to in subparagraphs (1)(a) and (1)(b) must be either contained in, listed or otherwise associated with the check list required to be used in terms of paragraph 1.5(3)(a)(i) for each specific aircraft.
- (3) In the event of any conflict between the requirements or instructions issued by a manufacturer and those of the Director, the provisions of the latter prevail.
- (4) It is required that all relevant aircraft documents be available at the time of inspection and that such documents be current and up to date, and that no inspection be certified unless all requirements in respect thereof have been satisfied.

1.9 Recording and certification of inspections

- (1) Whenever any inspection referred to in paragraph 1.3 is carried out, it must be recorded in the appropriate logbook(s) and certified as follows:
 - (a) A recommended inspection of an aeroplane - by an appropriately rated AME;
 - (b) a MPI of an aeroplane and its engine(s) but without a Category (a) endorsement (Public Transport Category) on the Certificate of Airworthiness, by an appropriately rated AME;
 - (c) a MPI for an aeroplane with a Category (a) endorsement (Public Transport Category) on the Certificate of Airworthiness, by an appropriately approved AMO.
- (2) Before any aircraft not classified under Category (a) (Public Transport Category), and on which the last MPI was certified by an appropriately rated AME, can be reclassified for operation under Category (a) (Public Transport Category), it must be inspected and certified by an approved AMO. In addition, any overhauls classed as mandatory for aircraft classified under Category (a) (Public Transport Category), must be carried out if found to be due or overdue and be certified in the prescribed manner.
- (3) It is required that all additional work performed during an inspection be recorded on a check list and certified in the relevant logbooks by the AME or AMO concerned.
- (4) It is of utmost importance that records pertaining to life - limited parts be available and traceable as required.

1.10 Issue of certificate of release to service

- (1) A certificate of release to service must be issued by an appropriately rated AME who has been designated by the Director as an approved person in the organisation concerned, immediately on completion and certification of scheduled inspections.

- (2) A certificate of release to service is valid for a period not exceeding the manufacturer's service interval of flight time or calendar time, whichever occurs first.
- (3) When a Certificate of Airworthiness becomes invalid, the validity of the certificate must be restored when the defect has been rectified and certified.

1.11 Overhauls and repairs

- (1) All Class I product overhauls and repairs to the major primary structure of an aircraft must be undertaken by AMOs only. For overhauls and replacement of life-limited parts, refer to Appendix 1 to this schedule and all manufacturer's recommendations.
- (2) The Certificate of Airworthiness is deemed suspended when an aircraft has been involved in an accident. To reinstate the validity of such Certificate of Airworthiness the following apply:
 - (a) Such maintenance as is necessary must be carried out as laid down in approved publications, the latest manufacturer's service bulletins, service letters and service instructions, or as determined by the Director.
 - (b) A Mandatory Periodic Inspection must be carried out if so required by the Airworthiness Inspector.
 - (c) A test flight must be carried out by an appropriately rated pilot for such purpose, and the performance recorded, when applicable.
 - (d) After the repairs or maintenance as required, have been effected and certified by the AMO concerned, the aircraft must be made available for an inspection by an Airworthiness Inspector of the DCA or a person approved by the Director.
 - (e) Copies of CRMA's in respect of all repairs effected must be submitted to the Director.
- (3) The overhauled Class II products installed on aircraft classified exclusively under Category (f) (Private Category), must be executed at such times as is found necessary: Provided that when such aircraft are upgraded to a higher category, all the requirements prescribed in respect of such higher category, must be complied with.
- (4) The engine overhauls specified in Appendix 1 of this schedule are mandatory for all aircraft not classified exclusively under Category (f) (Private Category), and must be executed in accordance with the manufacturer's current manuals and recommendations, not later than the times shown.
- (5) All propellers must be overhauled at the times and according to the provisions specified in Appendix 1 of this schedule irrespective of the category in which the aircraft is classified.
- (6) All Class I and Class II product overhauls must be done by an approved AMO.
- (7) Notwithstanding the requirements, relating to mandatory overhaul times and referred to in paragraph 1.11(4), it will be permissible for an appropriately rated AME or approved AMO, to authorise extensions to the times between overhauls specified for any engine or propeller, subject to compliance with the following conditions:

- (a) The person authorising any extension may, on being satisfied from the logbook history and the performance of the engine or propeller, extend the overhaul time up to the next MPI due with the approval of the Director;
- (b) turbine engines that have been granted TBO escalation by the engine manufacturer and the Director, may not be granted a further extension over and above the TBO escalation;
- (c) on each occasion that an extension to the TBO of a Class I product referred to in (a), is granted, the person authorising such extension must ensure that a test flight has been carried out and that the performance of the product under test is in accordance with the performance given in the appropriate flight manual. Such person must certify in the appropriate logbook an entry to the following effect:

“I hereby certify that I have satisfied myself that the performance, conditions and record history of (name the product or component concerned giving a description and quoting part and serial number) since new or last overhaul is such that it can be operated with safety for a further hours of flight time and I hereby authorise such extension.”

Signature :

Licence No :

Date :

Note: Before presenting the relevant logbook and flight folio to the AME to authorise the extension of overhaul time, the owner or operator must ensure that the documents are up to date.

- (8) Where no manufacturer’s instructions or recommendations have been issued, such units or equipment must be overhauled as and when their condition shows that this is necessary to keep the aircraft airworthy. The work involved must be executed in accordance with good aeronautical practices and procedures acceptable to the Director.
- (9) The foregoing notwithstanding, all components specified in the engine type certificate such as components of the fuel system, the ignition system and (if applicable) the turbocharging system, must be overhauled concurrently with the engine and tested as a Class I product, unless the Director determines otherwise.
- (10) Tubular engine mountings must be inspected and certified at intervals not exceeding the TBO of an engine or when involved in a propeller/rotor strike or as per an AD, for signs of external and internal corrosion, cracks and other damage. The X-ray method of inspection is recommended for the purpose of detecting internal corrosion.

1.12 Airworthiness directives, modifications and special inspections

- (1) In the event of any conflict between the modifications and special inspections classified as essential and mandatory by the manufacturer, and airworthiness directives issued by the State of Design, and airworthiness directives issued by the Director, the provisions of the latter prevail. Such modifications and special inspections must be accomplished not later than the time or date specified against each item. Should the certifying AME/AMO find that due to circumstances beyond its control, it is unable to comply with the

manufacturer's instructions regarding the specified time or date, it may be extended by written authority from the Director. Deferred modifications or special inspections must be accomplished as soon as the circumstances requiring the postponement no longer exist, but in any event not later than the extension granted by the Director. The Director must be advised accordingly. An alternate method of compliance may be considered by the Director, on application.

- (2) Modifications and special inspections required by the manufacturer of the airframe, engine, propeller, component or installed equipment are made known by way of service bulletins, service letters, modification bulletins or other similar technical information. Such information is generally classified by the manufacturer's to indicate the degree of essentiality. AMEs/AMOs who certify the inspections required by this schedule, must ensure that they possess and keep up-to-date all such information which is to be brought to the notice of the aircraft owner as well as the operator.
- (3) All modifications and special inspections classified by the manufacturer as essential or mandatory must be carried out in accordance with the manufacturer's instructions not later than the time or date specified: but in the event of any difficulties in complying therewith, the requirements of the provisions contained in subparagraph (1) apply.
- (4) The accomplishment of any modification or special inspection must be recorded where provided for in the appropriate logbook and certified by appropriately rated AMEs or approved AMOs as required by this schedule.

1.13 Replacement of products and parts

- (1) The replacement of products and parts which the manufacturer of the product or part considers to be desirable after a specified time in service, must be effected at the times recommended by the manufacturer in its applicable manuals, service bulletins, service letters or other similar technical information, and certified in the appropriate logbook.
- (2) Products and parts, the replacement of which the manufacturer has classified as being essential or mandatory after a specified time in service, must be replaced not later than the times stipulated. Where a manufacturer bases the life of any items on factors other than flight times, eg. number of flights, number of landings, cycles or calendar times, such records must be kept in the flight folio in respect of such items to ensure that service life is not exceeded.
- (3) The replacements shown in Appendix 1 of this schedule are those which the Director considers to be mandatory. Such replacements must be effected not later than the times specified.
- (4) All replacements must be recorded, together with serial and part numbers where applicable. Where the part is being replaced by a used part, the time the latter has been in service since new or overhaul, must be recorded. Replacements must be certified appropriately rated AMEs or approved AMOs.

2. Minimum requirements for mandatory periodic inspections

- Notes:*
1. *The minimum requirements for the Mandatory Periodic Inspections are those of manufacturers contained in their check sheets and service manuals and supplemented by those prescribed by the Director.*
 2. *AMOs must draw up check sheets for individual aircraft models in accordance with the format that follows.*

- 3. *The serviceability of an item is to be indicated by initialling the block against the item. Where an item is not applicable, NA must be inserted in the blocks.*

2.1 General

Verify if Class I and Class II products correspond with the aircraft documentation and determine if the correct data plates are affixed to these products as applicable. If data plates are omitted the Airworthiness Inspector must be notified prior to releasing the aircraft to service.

43.02.6 MANDATORY PERIODIC INSPECTIONS

Aircraft type Registration

Engine type (give full designation).....

Engine serial number(s)

Propeller/rotor type (as applicable).....

Propeller/rotor serial number(s).....

Tacho : Reading(s).....

Hobbs: Reading(s).....

Hours and/or cycles of operation

Airframe T.T HOUR METER TIME

Engine(s) since new or last overhaul

Propeller(s) since new or last overhaul/half life inspection as applicable.

1.	Mass and balance. Date last established	
2.	Component overhauls due.	
3.	Aircraft documentation	C. of A. No.
	Available and current	C. of R. No.
		Radio Station Licence No.

4. Record of avionics equipment installed (name and type)

VHF..... ADF..... RADAR

HF DME GPS

TXPDR..... STORMSCOPE OTHER

Special attention must be given to the following and be integrated with the manufacturer check sheets in the appropriate places.

	TECH	INSP
1. Test fabric tensile strength in accordance with the provisions contained in AC 43.13-A1 or as prescribed by the manufacturer and record the findings in the airframe logbook on an annual basis. Inspect the wing rib lacing cords for proper tightness or failure and correct as necessary.		
2. Inspect registration and other markings for conformity.		
3. Where applicable ensure that all water drain holes are open.		
4. Inspect area beneath floor including, lines, hoses, wires, control cables and pulleys for condition, cleanliness, security, routing and proper functioning.		
5. Test Pitot and static systems for freedom from obstructions and leaks. Drain water traps.		
6. Inspect compass for discolouration and bubbles, check for freedom or rotation and ensure that compass has been swung in accordance with the requirements and periods specified in TS 43.02.18.		
7. Check altimeters and airspeed indicators for accuracy. Carry out a Pitot static check.		
8. Inspect general condition of all bungy cords for wear, serviceability and correct colour coding. Bungy cords should be replaced on condition or every five years, whichever occurs first, or in accordance with the manufacturer's recommendation.		
9. Operate landing gear through five fault free cycles or follow the manufacturer's recommendations and record findings.		
10. Check aileron travel and aileron trim tab(s) and record. Right Aileron Up..... down..... Left Aileron Up..... down..... Trim tab L.H..... R.H..... Up..... down.....		
11. Check flap travel and record Up..... intermediate..... Down..... (as applicable).		
12. Inspect and record rudder and elevator or stabilizer travels and correct sense. Rudder left..... right..... Elevator up..... down..... Rudder trim tab: L..... R..... Elevator trim tab: Up..... Down.....		
13. Carry out fuel flow checks and record. Left: Right:		

14.	Check that the propeller has been overhauled within the time limit specified by the manufacturer or that the provisions in Appendix 1 have been met.		
15.	Cylinder blowbys for each engine		
	Left Hand Engine	/80	/80
		/80	/80
		/80	/80
		/80	/80
	Right Hand Engine	/80	/80
		/80	/80
		/80	/80
		/80	/80
16.	Inspect wooden propellers for condition. Check that propeller hub bolts are correctly torqued and bolt holes for excessive compression of the front and rear faces due to over tightening.		
17.	Carrying out a test flight, and operationally check all systems. Pilot's Name: Licence No: Signature:		
18.	All flexible hoses must be renewed as prescribed by the manufacturer. In cases where the manufacturer does not specify the replacement of hoses, all fluid carrying flexible hoses must be renewed every 8 years. Record part numbers of any hoses replaced in the appropriate logbook(s).		
19.	Ensure that the aircraft empty mass has been established.		
20.	An aircraft may not be released for service unless the following documentation has been checked for availability, applicability and that it is up to date.		
	Certificate of registration.	No.	
	Certificate of airworthiness.	No.	
	Radio Station licence.	No.	
	A certificate of release to service.		
	An approved flight manual or equivalent.		
	An approved mass and balance data and equipment list.		
	An approved flight folio.		
	An approved minimum equipment list, if applicable.		
	Inspection reminder.		
	Airframe, engine(s) and propeller logbook(s).		
21.	Record all Service Bulletins, Airworthiness Directives, Service Letters, Modifications of other instructions embodied during this inspection.		
22.	I hereby certify that in carrying out the foregoing specified maintenance, all the requirements prescribed in the Civil Aviation Regulations, 2001, which are applicable thereto, have been complied with.		
	Date	Signature	
	LICENCE OR OTHER APPROVAL NO:		
	Name of Organisation or employer		

- 3. Minimum requirements for an annual inspection for amateur-built and microlight aircraft**
- 3.1 Airframe and installed equipment**
 - (1) Fuselage or hull
 - (a) Carefully inspect the fuselage or hull for general condition.
 - (b) Check the fabric and dope or other skin covering, for condition and security.
 - (c) Check installed systems and components for proper installation, security, defects and satisfactory functioning.
 - (2) Cabin or cockpit
 - (a) Inspect the cabin or cockpit for cleanliness and loose or displaced articles that may interfere with the operation of controls.
 - (b) Check seats, safety harness, flooring and tie down fittings for security and condition.
 - (c) Check windscreens and windows for security, condition and, where applicable, for satisfactory operation.
 - (d) Check emergency exits for proper installation, condition, legibility of operating instructions and other markings and for satisfactory functioning.
 - (e) Check flight, engine and propeller controls for correct installation, security of connections, condition, proper operation and, where applicable, legibility of markings.
 - (f) Check all systems and their controls in the cockpit or cabin for proper installation, security, satisfactory operation and legibility of markings.
 - (g) Ensure that all required placards and registration letters are correctly installed and positioned, are legible and in good condition.
 - (3) Instruments and instrument systems
 - (a) Check instruments for proper installation, security, obvious defects and legibility and correctness of markings.
 - (b) Check instrument operating systems for proper installation, security and condition. Pay particular attention to pitot-static systems for freedom from obstructions and absence from leakage.
 - (c) Check that filter elements of vacuum operated instruments are cleaned or replaced in accordance with the manufacturer's recommendations.
 - (d) Check altimeters and airspeed indicators for accuracy.
 - (4) Landing gear
 - (a) Check the landing gear for general condition and security of attachment of all components.
 - (b) Inspect the shock absorbing devices for correct fluid levels and pressures.
 - (c) Check linkages, trusses and other members for condition and security of attachments.

- (d) Check retracting and locking mechanisms for condition and satisfactory operation.
 - (e) Check hydraulic lines and retraction jacks for condition and any leakage of fluid.
 - (f) Check electrical items for condition, chafing of cables and satisfactory operation of motors, switches and indicators.
 - (g) Check mechanical indicators for condition and satisfactory operation.
 - (h) Check steering mechanisms for condition and bearings for condition, lubrication and correct adjustment.
 - (i) Check tyres for condition and creep. Check tyre pressures.
 - (j) Check brakes for condition, correct adjustment and operation.
 - (k) Check floats, skis or skids for additional security.
- (5) Wings and centre sections
- (a) Check the entire assembly, including any external bracing for general conditions.
 - (b) Check fabric and dope, or other skin covering, for condition and security.
 - (c) Check wing attachments and bracings for security, condition, correct assembly and, where applicable, correct torquing of attaching bolts.
 - (d) Check movable surfaces for condition, security, proper attachment, correct operation and security of all control connections.
 - (e) Check installed systems and components for proper installation, condition and satisfactory functioning.
- (6) Empennage
- (a) Check the entire assembly, including external bracing for general condition.
 - (b) Check fabric and dope, or other skin covering, for condition and security.
 - (c) Check attachment of all components for security and correct assembly.
 - (d) Check movable surfaces for condition, security, proper attachment, correct operation and security of all control connections.
 - (e) Check installed systems and components for proper installation, security, condition and satisfactory functioning.
- (7) Electrical and radio equipment installations
- (a) Inspect batteries for condition and correct installation and check specific gravity and level of electrolyte.
 - (b) Check electrical installations and components for condition, security of mounting, correct installation and functioning.
 - (c) Check electrical wiring and conduits for condition and security of mounting.
 - (d) Check bonding and shielding for correct installation, security and condition.

- (e) Check radio equipment for correct functioning and for correct installation and security of mountings.
- (f) Check radio antenna systems for condition, correct installation and security and trailing aerials for satisfactory operation.
- (g) Check for unacceptable interference from electrical and ignition systems on applicable radio equipment.

(8) Fuel systems

Check fuel tanks and fuel systems for the presence of water or other foreign matter, condition, security, correct installation, freedom from leaks and satisfactory functioning of components.

(9) Rotorcraft

In addition to applicable items under subparagraphs (1) to (8) above, the following items on rotorcraft must be checked for condition, security, correct installation and, as applicable, alignment:

- (a) Drive shaft assemblies or similar systems;
- (b) main rotor transmission gear box;
- (c) rotary wings (rotors) and centre section or equivalent area;
- (d) tail rotor assembly where applicable; and
- (e) tracking of main rotors.

(10) Miscellaneous

Check any systems, assemblies and items not specifically mentioned under subparagraphs (1) to (9) above, for connection, correct installation, security and satisfactory operation.

3.2 Power plants and instruments relating thereto

(1) Engine and engine installations

- (a) Inspect each entire engine for evidence of fuel, oil and other fluid leaks and for the sources of any such leaks.
- (b) Check all studs, nuts and other fasteners for security, condition and correct torquing.
- (c) Check the internal conditions of engines by means of cylinder compression checks and oil filters and sump drain plugs for evidence of metal particles or other foreign matters.
- (d) Check engine shock mounts for condition, security and correct installations.
- (e) Check engine controls for correct installation, operation, condition and security.
- (f) Check fluid carrying lines for security, correct installation and condition.
- (g) Check systems of security of condition. Pay particular attention to exhaust manifold assemblies, heater mufflers and heat exchangers.

- (h) Check engine driven accessories for condition and security of mountings.
- (i) Check carburettor air intake filters for cleanliness, condition, security and correct installation.
- (j) Check engine mountings for condition and security of attachment to the main structure.
- (k) Check cooling baffles and seals for condition, security and correct installation.
- (l) Check engine cowling for condition, security and correct installation.
- (m) Check cooling gills or other cooling devices for condition, security, correct installation and operation.
- (n) Check ignition systems for condition and correct timing of magnetos. Pay particular attention to the condition and assembly at terminal points of ignition switch wiring and ensure that ignition switch(es) function satisfactorily.
- (o) Where practicable, ensure that fuel flow at the carburettor, or equivalent component, from all tanks meets at least the minimum prescribed flow requirements.

(2) Propellers

- (a) Check metal and composite propeller blades, metal hubs and counterweights where applicable for condition.
- (b) Check wooden propellers for condition. Check that propeller hub bolts are correctly torqued.
- (c) Check security of attachment of propeller to the engine.
- (d) Check propeller, where applicable, for oil leaks and for satisfactory operation.
- (e) Check propeller control systems for condition and satisfactory operation.
- (f) Check that propeller track is within specified limits.
- (g) Check any anti-icing systems for condition, security and satisfactory operation.

(3) Powerplant instruments and instrument systems

- (a) Check instruments or proper installation, security, obvious defects and legibility and correctness of markings.
- (b) Where practicable, check powerplant instrument for satisfactory functioning before and during engine run-up.

(4) Miscellaneous

Check any other power plant system, assemblies and items not specifically mentioned under subparagraphs (1) to (3) above, for condition, correct installation, security and satisfactory operation.

(5) Engine operation

On completion of an annual inspection each engine must be run in accordance with the manufacturer's recommendations to determine in respect of the following:

(a) Piston engines

- (i) Power output (static and idle r.p.m.);
- (ii) engine r.p.m. drop on each magneto;
- (iii) fuel and oil pressures;
- (iv) cylinder and oil temperatures; and
- (v) satisfactory operation of any engine driven accessories or other items not specifically mentioned above.

(b) Gas turbine engines

Satisfactory operation of the engine and engine-driven accessories.

4. Minimum requirements for an annual inspection for manned free balloons

4.1 Envelope fabric and load tape

- (1) Check that the temperature link is still in place.
- (2) Check temperature label, if overheating is indicated (above 120EC), install a new label alongside, and note temperature indication in logbook. See paragraph 4.12 for procedures.
- (3) Inspect for holes, tears and abrasions. Holes or tears smaller than 25 mm (1") are acceptable, but all other damage must be repaired using prescribed methods.
- (4) Check fabric porosity by attempting to blow through it. If substantial porosity is suspected, perform a flight test.
- (5) Check envelope fabric strength by a 1" grab test. Minimum strength is 14 kg (30 lbs). Perform the test three times; the lowest value is disqualifying. Perform test on the top section of the envelope, and make sure original fabric is tested. Also look for discoloration as sign of overheating or exposure.
- (6) Check both vertical and horizontal tapes for security or stitching. Check especially the stitching of the crown ring and the joints between overlying tapes and top rim tape.
- (7) Check the flying wire loops for friction and burn damage. Check that the pockets are in place.

4.2 Parachute deflation systems

- (1) Check control line for wear and burn damage.
- (2) Check that knots are secure.
- (3) Check that pulleys are in good condition and not jammed with loose thread or other foreign material.
- (4) Check stitching of control line tie off loops and pulley fixings.

- (5) Check that retaining cords and release cords are in good condition. Stiffness indicates overheating.
- (6) Check knots and stitching of loops to both parachute and balloon. If there are doubts about the sealing of the parachute, the balloon should be inflated. The parachute overlap should be equal all the way round with no daylight showing and no excessive stress in the retaining lines. Excessive stress is indicated by stress wrinkles in the edge of the parachute.

4.3 **Combination tops**

- (1) Check parachute as above.
- (2) Check velcro control line as above.
- (3) Check that capewells operate correctly.
- (4) Check fixing of capewells. The fixing of the female half to the velcro panel is particularly important.
- (5) Check condition of velcro.
- (6) Check fit of velcro. The velcro panel edge must not be shorter at all, or significantly longer than, the velcro on the balloon. On velcro balloons the overlying tapes are gated to a top rim tape. The length of free tape below this rim tape should be 22 - 5% shorter than the corresponding seam length on the velcro panel. Any errors here should be reported to the manufacturer so that the correct repair can be specified.

4.4 **Triangular velcro rip**

This is only used on certain special shapes. With one person stretching each corner of the triangular aperture, the fitted velcro panel should be loose below the mesh of overflying tapes. Check rigging and capewell as for parachute/velcro balloons. Check the condition of the side vent. Check the attachment of release and closing lines as for parachutes (above). Check that the elastic closing lines are in good condition.

4.5 **Load bearing attachments**

- (1) Flying wires must be stainless steel. There should be no exposed strands in the wire and no severe kinks. Slight discoloration is permissible.
- (2) Check thimbles and copper ferrules. Damage to the colour coded plastic sleeving at the carabiner end of the cable is not important.
- (3) Carabiners should be free of distortion with fully operational screw gates. There should be no serious corrosion.
- (4) Basket wires : Check for abrasion damage. Check thimbles and copper ferrules.
- (5) Burner frame : Check for condition of welds, particularly if the frame shows signs of distortion.
- (6) Nylon rods are not critical for flight safety. Replace if cracked.

4.6 **Burner and fuel system**

- (1) Burner

- (a) Check for external signs of damage.
 - (b) Check tightness of main jets.
 - (c) Check blast valves for signs of wear or leakage.
 - (d) Check that all joints and connections are leak proof.
 - (e) Carry out a burner test using each cylinder; observe function of pressure gauge, blast valves and cylinder valves. Cylinders should be vertical for this test.
 - (f) Pilot light : Check by sound and appearance of flame.
 - (g) If blockage is suspected check hose and jet by removing them and cleaning as necessary. Reassemble with PTFE tape.
 - (h) Check operation of pilot valves on burner (if fitted).
 - (i) Hoses : Should be wire braided type. Check for wear, cuts or excessive bends. Liquid hoses should be pinpicked on the outer cover. Hose inspection should include fuel manifolds if these are fitted.
- (2) Fuel cylinders
- (a) Check for external damage.
 - (b) Check self seal on couplings by opening the valves with no hoses connected. No leakage should occur. After closing the liquid valve, release the pressure in the coupling by depressing the central pin.
 - (c) Check operation of contents gauge.
 - (d) Fuel tanks should be treated with 4 oz of methanol/10 gallons propane.

4.7 **Baskets**

- (1) Check for wear or excessive distortion in weave.
- (2) Check the floor where (and if) the cane passes through it.
- (3) Check integrity of wooden floor.
- (4) Check rod socket condition.
- (5) Check integrity of tank straps. No more than 30% cross sectional damage is acceptable.

4.8 **Inflation or flight test**

A test inflation is recommended, as this makes detailed fabric inspection much simpler and allows control lines to be checked. If fabric porosity or leaking parachute is suspected, a carefully monitored test flight should be made to assess fuel consumption. High fuel consumption itself is not dangerous, but if the leakage is such that exceptional skill is required to fly the balloon, then the balloon is not airworthy.

4.9 **Instruments**

Check instruments for proper operation, security and that it has been annually calibrated.

4.10 Fire extinguisher

Check by weighing.

4.11 250 Hour test and subsequent 100 hour test

Perform grab test.

4.12 Procedure after overheating

If the temperature flag descends (i.e. the fusible link melts), the maximum allowable temperature has been exceeded. The flag will separate at approximate 127EC and maximum allowable temperature is 120EC. Then inspect the two temperature indicating tags if stitched onto the inside surface of the parachute. These tags register service temperature (i.e. direct fabric temperature) which always will be somewhat less than inside air temperature.

If after flag separation the temperature tags show:

- (1) up to 120EC. No further action needed. Replace flag link.
- (2) 120EC to 127EC. Carefully inspect top of envelope for signs of overheating. Especially parachute and its retaining lines. Look for discoloration and undue stiffness in materials. If any is visible, perform fabric test as per 250 hour inspection. If no signs of overheating are apparent, replace the temperature tags and flags but always enter into the log/maintenance manual that an overheating has occurred and what the tags had registered.
- (3) 127EC or higher reading. Perform fabric test and enter result of same and temperature reading into flight log.

Do not try to resolder the temperature flag link - always replace with a new item.

43.02.7 ALTIMETER SYSTEM TESTS AND INSPECTIONS

The tests and inspections referred to in CAR 43.02.7(a) are as follows:

1. The static pressure system test

- (1) Ensure freedom from entrapped moisture and restrictions.
- (2) Ensure the leakage is within the following established tolerances:
 - (a) For unpressurised aeroplanes, evacuate the static pressure system to a pressure differential of approximately 1 inch of mercury or to a reading, on the altimeter, 1 000 feet above the aircraft elevation at the time of the test. Without additional pumping for a period of 1 minute, the loss of indicated altitude must not exceed 100 feet on the altimeter;
 - (b) for pressurised aeroplanes, evacuate the static pressure system until a pressure differential equivalent of the maximum cabin differential for which the aeroplane is type certificated is achieved. Without additional pumping for a period of 1 minute, the loss of indicated altitude must not exceed 2 per cent of the equivalent altitude of the maximum cabin differential pressure or 100 feet, whichever is the greater.
- (3) Determine that the static port heater, if installed, is operative.

- (4) Ensure that no alterations or deformations of the airframe surface have been made that would affect the relationship between air pressure in the static pressure system and true ambient static air pressure for any flight condition.

2. The altimeter test

- (1) Unless otherwise specified, each test for performance may be conducted with the instrument subjected to vibration. When tests are conducted with the temperature substantially different from an ambient temperature of approximately 25 degrees Celsius, allowance must be made for the variation from the specified condition.
- (2) Altimeter tests must be carried out by an appropriately rated aircraft maintenance organisation approved under Part 145 in accordance with the following:

- (a) **Scale Error.** The altimeter must, with the barometric pressure scale at 1013.25 millibars, be subjected successively to pressures corresponding to the altitude listed in Table I up to the maximum normally expected operating altitude of the aircraft in which the altimeter is to be installed.

The reduction in pressure must be made at a rate not exceeding 20 000 feet per minute to within approximately 2 000 feet of the test point.

The test point must be approached at a rate compatible with the test equipment.

The altimeter must be kept at the pressure corresponding to each test point for at least 1 minute, but not more than 10 minutes, before a reading is taken.

The error at all test points must not exceed the tolerances listed in Table I.

- (b) **Hysteresis.** The hysteresis test must begin not more than 15 minutes after the altimeter's initial exposure to the pressure corresponding to the upper limit of the scale error tests prescribed in subparagraph (2)(a) and the hysteresis test must commence while the altimeter is at this pressure.

Pressure must be increased at a rate simulating a descent in altitude at the rate of 5 000 to 20 000 feet per minute until within 3 000 feet of the first test point (50 percent of maximum altitude).

The test point must then be approached at a rate of approximately 30 000 feet per minute.

The altimeter must be kept at this pressure for at least 5 minutes, but not more than 15 minutes, before the test reading is taken.

After the reading has been taken, the pressure must be increased further, in the same manner as before, until the pressure corresponding to the second test point (40 percent of maximum altitude) is reached.

The altimeter must be kept at this pressure for at least 1 minute, but not more than 10 minutes, before the test reading is taken.

After the reading has been taken, the pressure must be increased further, in the same manner as before, until atmospheric pressure is reached.

The reading of the altimeter at either of the two test points may not differ by more than the tolerance specified in Table II from the reading of the altimeter for the corresponding altitude recorded during the scale error test prescribed in subparagraph (2)(a).

- (c) After effect. Not more than 5 minutes after the completion of the hysteresis test prescribed in subparagraph (2)(b), the reading of the altimeter, corrected for any change in atmospheric pressure, may not differ from the original atmospheric pressure reading by more than the tolerance specified in Table II.
 - (d) Friction. The altimeter must be subjected to a steady rate of decrease of pressure approximating 750 feet per minute. At each altitude listed in Table III, the change in reading of the pointers after vibration may not exceed the corresponding tolerance listed in Table III.
 - (e) Case Leak. The leakage of the altimeter case, when the pressure within it corresponds to an altitude of 18 000 feet, may not change the altimeter reading by more than the tolerance shown in Table II during an interval of 1 minute.
 - (f) Barometric Scale Error. At constant atmospheric pressure, the barometric pressure scale must be set at each of the pressures, falling within its range of adjustment, that are listed in Table IV, and must cause the pointer to indicate the equivalent altitude shown in Table IV with a tolerance of 25 feet.
- (3) Altimeters which are of the air data computer type with associated computing systems, or which incorporate air data correction internally, may be tested in a manner and to specifications developed by the manufacturer which are acceptable to the Director.

3. The automatic pressure altitude reporting equipment and ATC transponder system integration test

- (1) Conduct each test in accordance with paragraph 2.
- (2) Measure the automatic pressure altitude at the output of the installed ATC transponder when interrogated on Mode C at a sufficient number of test points, to ensure that the altitude reporting equipment altimeters, and ATC transponders perform their intended functions as installed in the aircraft.
- (3) The difference between the automatic reporting output and the altitude displayed at the altimeter may not exceed 125 feet.

43.02.7 ALTIMETER SYSTEM TESTS AND INSPECTIONS

TABLE I: SCALE ERROR

Altitude	Equivalent pressure (millibars)	Tolerance ∇ (feet)	Altitude	Equivalent pressure (millibars)	Tolerance ∇ (feet)
1 000	1050.36	20	14 000	595.21	100
0	1013.25	20	16 000	549.12	110
500	995.06	20	18 000	505.98	120
1 000	977.15	20	20 000	465.62	130
1 500	959.51	25	22 000	427.89	140
2 000	942.10	30	25 000	376.01	155
3 000	908.10	30	30 000	300.87	180
4 000	875.09	35	35 000	238.43	205
6 000	811.97	40	40 000	187.53	230
8 000	752.61	60	45 000	147.47	255
10 000	696.12	80	50 000	115.98	280
12 000	644.38	90			

TABLE II : TEST TOLERANCES

Test	Tolerance V(feet)
Case Leak Test	100
First test point (50% of maximum altitude)	75
Second test point (40% of maximum altitude)	75
After effect test	30

TABLE III: FRICTION

Altitude (feet)	Tolerance V(feet)
1 000	70
2 000	70
3 000	70
5 000	70
10 000	80
15 000	90
20 000	100
25 000	120
30 000	140
35 000	160
40 000	180
50 000	250

TABLE IV: PRESSURE ALTITUDE

Pressure in Millibars	Altitude (feet)
951.55	- 1 727
965.10	- 1 340
982.03	- 863
998.96	- 392
1013.25	0
1032.82	+ 531
1046.37	+ 893
1049.41	+ 974

43.02.8 AVIATION TRANSPONDER TESTS AND INSPECTIONS**1. General**

- (1) In this technical standard, ATCRBS means air traffic control radio beacon system.
- (2) The aviation transponder functional tests may be conducted using either a bench check or portable test equipment.
- (3) If portable test equipment with appropriate coupling to the aircraft antenna system is used, operate the test equipment for ATCRBS transponders at a nominal rate of 235 interrogations per second to avoid possible ATCRBS interference.
- (4) For Mode S, operate the test equipment at a nominal rate of 50 Mode S interrogations per second.
- (5) An additional 3 dB loss is allowed to compensate for antenna coupling errors during receiver sensitivity measurements conducted in accordance with paragraph 4 below when using portable test equipment.

2. Radio reply frequency test

- (1) For all classes of ATCRBS transponders, interrogate the transponder and verify that the reply frequency is 1090 \pm 3 MHz.
- (2) For classes 1B, 2B and 3B Mode S transponders, interrogate the transponder and verify that the reply frequency is 1090 \pm 3 MHz.

- (3) For classes 1B, 2B and 3B Mode transponders that incorporate the optional 1090 \pm 1 MHz reply frequency, interrogate the transponder and verify that the reply frequency is correct.
- (4) For classes 1A, 2A, 3A and 4 Mode S transponders, interrogate the transponder and verify that the reply frequency is 1090 \pm 1 MHz.

3. Suppression test

When Classes 1B, 2B ATCRBS transponders, or classes 1B, 2B and 3B Mode S transponders are interrogated at a rate between 230 and 1 000 Mode 3/A interrogations per second or when Classes 1A and 2A ATCRBS Transponders, or Classes 1, 2A, 3A and 4 Mode S transponders are interrogated at a rate between 230 and 1 200 Mode 3/A interrogations per second -

- (1) verify that the transponder does not respond to more than 1 percent of ATCRBS interrogations when the amplitude of P2 pulse is equal to the P1 pulse; and
- (2) verify that the transponder replies to at least 90 percent of ATCRBS interrogations when the amplitude of the P2 pulse is 9 dB less than the P1 pulse. If the test is conducted with a radiated test signal, the interrogation rate shall be 235 \pm 5 interrogations per second unless a higher rate has been approved for the test equipment used at that location.

4. Receiver sensitivity test

- (1) Verify that, for any class of ATCRBS Transponder, the minimum triggering level of the receiver for the system is - 73 \pm 4 dbm, or that for any class of Mode S transponder, the minimum triggering level of the receiver for Mode S format (P6 type) interrogations is - 74 \pm 3 dbm by use of a test set -
 - (a) connected to the antenna end of the transmission line; or
 - (b) connected to the antenna terminal of the transponder with a correction for transmission line loss; or
 - (c) utilising radiated signals.
- (2) Verify that the difference in Mode 3/A and Mode C receiver sensitivity does not exceed 1 db for either any class of ATCRBS transponder or any class of Mode S transponder.

5. RF peak output power test

Verify that the transponder RF output power is within the following specifications for the class of transponder using the conditions prescribed in paragraph 4(1):

- (1) For class 1A and 2A ATCRBS transponders, the minimum RF peak output power is at least 21.0 dbw (125 watts);
- (2) for class 1B and 2B ATCRBS transponders, the minimum RF peak output power is at least 18.5 dbw (70 watts);
- (3) for class 1A, 2A, 3A and 4 and those Class 1B, 2B and 3B Mode S transponders that include the optional high RF peak output power, the minimum RF peak output power is at least 21.0 dbw (125 watts);
- (4) for class 1B, 2B and 3B Mode S transponders, the minimum RF peak output power is at least 18.5 dbw (70 watts);

- (5) for any class of ATCRBS or any class of Mode S transponders, the maximum RF peak output power does not exceed 27.0 dbw (500 watts).

6. Mode S diversity transmission channel isolation test

For any class of Mode S transponder that incorporates diversity operation, verify that the RF peak output power transmitted from the selected antenna exceeds the power transmitted from the non-selected antenna by at least 20 db.

7. Mode S address test

Interrogate the Mode S transponder using the correct address and at least two incorrect addresses and making the interrogations at a nominal rate of 50 interrogations per second and verify that it replies only to its assigned address.

8. Mode S formats test

Interrogate the Mode S transponder with UF for which it is equipped and verify that the replies are made in the correct format using the surveillance formats UF=4 and 5. Verify that the altitude reported in the replies to UF=4 are the same as that reported in a valid ATCRBS Mode C reply. Verify that the identity reported in the replies to UF=5 are the same as that reported in a valid ATCRBS Mode 3/A reply, if the transponder is so equipped, using the communication formats UF=20, 21 and 24.

9. Mode S all-call interrogations test

Interrogate the Mode S transponder with the Mode S-only all-call format UF=11, and the ATCRBS/Mode S all-call formats (1,6 microsecond P4 pulse) and verify that the correct address and capability are reported in the replies (downlink format DF=11).

10. ATCRBS-only all-call interrogation test

Interrogate the Mode S transponder with the ATCRBS-only all-call interrogation (0.8 microsecond P4 pulse) and verify that no reply is generated.

11. Squitter test

Verify that the Mode S transponder generates a correct squitter approximately once per second.

(The tests in paragraphs 6 to 11 inclusive, apply only to Mode S transponders.)

43.02.09 EMERGENCY LOCATOR TRANSMITTER TESTS AND INSPECTIONS

(Reserved.)

43.02.11 NON-DESTRUCTIVE TESTING

(Reserved.)

43.02.15 RECORDING OF MAJOR REPAIRS AND MODIFICATIONS

1. Manner of recording

The manner referred to in CAR 43.02.15, in which a major repair or a major modification must be recorded, is -

- (1) in the case of a major repair or modification of an aircraft component an authorized release certificate contained in Annexure A.

- (2) in the case of a major repair or modification to an aircraft a Certificate Relating to the Maintenance of an Aircraft (CRMA) contained in Annexure B.

43.02.17 TEMPORARY AND PERMANENT REPAIR AFTER ACCIDENTS OR INCIDENTS

1. Requirements

The following procedures must be followed whenever temporary or permanent repairs become necessary after an accident or incident, irrespective of the extent of the damage to a Class I product:

- (1) The aircraft maintenance organisation (AMO) or aircraft maintenance engineer (AME) concerned must advise the Director of -
 - (a) in the case of an aircraft, the registration marks thereof;
 - (b) the extent of the damage; and
 - (c) the name(s) of appropriately rated AMEs who will be responsible for the carrying out of such repairs.
- (2) The AMO or AME concerned must, in addition to (1), advise the Director when all the repairs have been completed and arrange for an inspection by an inspector of the DCA.

43.02.18 AIRCRAFT COMPASS REQUIREMENTS

1. Compass swing requirements

- (1) All compasses fitted to Namibian registered aircraft must be swung as follows:
 - (a) On installation.
 - (b) At 12 monthly intervals thereafter.

Note: Whilst under the most favourable conditions an annual check is sufficient, it is recommended that owners of aircraft carry out a check swing every six months.
 - (c) Before a newly registered aircraft is placed into service in the country.
 - (d) Immediately after material or equipment which may effect the compass is installed, removed or replaced.
 - (e) After an aircraft has been struck by lightning.
 - (f) After each engine change, except where it has been established that non-compliance with this requirement will not affect the compass readings. The Director must be advised accordingly.
 - (g) In the case of "cargo only" aircraft, whenever cargo which is likely to affect the compass reading is carried. In such cases a check must be made on the cardinal headings and headings to be flown and a temporary deviation card installed. The original card must be replaced when such cargo is unloaded.

2. Deviation cards

- (1) A deviation card must be installed on or in close proximity to each compass or, for remote-reading compasses, the main indicator or repeaters and must contain the following information:

- (a) The readings at intervals not greater than 45 degrees.
- (b) Whether the compass was swung with radio and/or navigation aid equipment on or off as applicable. The space marked A as shown on the examples of the deviation cards referred to in subparagraph (f) below, may be used for this purpose.

Note: Under certain conditions radio contact must be maintained with one aeronautical station at all times and if the radio receiver affects the compass, it will be necessary to install a card which will indicate the readings with such receiver on.

- (c) The signature and licence number of the person responsible for the swing and the date it was done.
- (d) After the magnetic compass has been compensated the reading must be such that the residual deviation in level flight does not exceed 10 degrees on any heading.
- (e) Remote-reading compasses must be adjusted to obtain minimum deviations, but where the construction of the compasses is such that all deviation can be adjusted for, no deviation card will be necessary.
- (f) The compass deviation card must be completed in a manner similar to the examples shown below:

A								
FOR	000	045	090	135	180	225	270	315
STEER	001	046	090	134	179	225	272	316
A								
FOR	STEER	FOR	STEER					
000	001	180	179					
045	046	225	225					
090	090	270	272					
135	134	315	316					

- (g) Deviation cards must be placed in holders provided for this purpose.

3. Logbook entries

The date on which the compass was swung must be entered in the airframe logbook and certified by an appropriately rated aircraft maintenance engineer or approved aircraft maintenance organisation, or by a flight navigator or a commercial pilot or airline transport pilot.

43.02.18 AIRCRAFT COMPASS REQUIREMENTS**4. Compass swing areas and equipment**

- (1) Before any compass is swung it must be established that the swinging area is free from unwanted magnetic effects and that the landing compass is serviceable.
- (2) Where the landing compass is replaced by a permanent base it must be borne in mind that the magnetic north on the base is not a fixed point but is a point which moves due to local magnetic variations. The magnetic bearings of the compass base must therefore be checked at periods not exceeding 4 years.

43.03.3 CERTIFYING AFTER INSPECTION**1. Statement**

- (1) After a progressive inspection:

I certify that Phase of the progressive inspection programme of aircraft (description) was performed in accordance with its progressive inspection programme and in accordance with the Civil Aviation Regulations, 2001, and is fit for release to service.

- (2) After any other inspection:

I certify that aircraft (description) has been inspected in accordance with a (identify inspection) inspection and in accordance with the Civil Aviation Regulations, 2001, and is fit for release to service.

43.03.4 CERTIFYING AFTER MAINTENANCE**1. Statement**

The statement referred to in CAR 43.03.4(1)(a) is as follows:

The work recorded above has been carried out in accordance with the Civil Aviation Regulations, 2001, and in respect of that work the aircraft is fit for release to service.

Signature :

Licence number :

Date of entry :

2. Form of certificate of release to service

The form referred to in CAR 43.03.4(2), in which the release to service of an aircraft is certified, is contained in Annexure C.

43.03.5 DISCREPANCIES**1. Statement**

- (1) After a progressive inspection:

I certify that Phase of the progressive inspection programme of aircraft (description) was performed in accordance with its progressive inspection programme and is not released to service. A list of discrepancies and non-airworthy items dated (date) has been provided to the aircraft owner or operator.

- (2) After any other inspection:

I certify that aircraft (description) has been inspected in accordance with a (identify inspection) inspection and is not released to service. A list of discrepancies and non-airworthy items dated (date) has been provided to the aircraft owner or operator.

43.04.1 CERTIFYING REVIEW

1. Statement

The statement referred to in CAR 43.04.1(a), is as follows:

I hereby certify that a review of maintenance has been carried out and that the requirements of Part 91 (General operating and flight rules) and Part 43 (General maintenance rules) of the Civil Aviation Regulations, 2001, have been complied with.

APPENDIX 1: TIME BETWEEN OVERHAULS AND LIFE-LIMITED PARTS

The time between overhauls for engines, propellers and other life limited parts shall be determined by the relevant manufacturer of such engine, propeller or other life limited part.

ANNEXURE A

AUTHORISED RELEASE CERTIFICATE

1. Country of national authority	2. National Authority		3. Certificate Ref. No.			
4. Organisation	5. Work Order/Contract/Invoice					
6. Item	7. Description	8. Part No.	9. Eligibility	10. Qty	11. Serial/Batch	12. Status/
13. Remarks						
Released to Service in accordance with the Namibian Civil Aviation Regulations, 2001.						
Certifies that the work specified in block 13 (or attached) was carried out in accordance with the Namibian Civil Aviation Regulations, 2001, and in respect of the work performed, the part(s) is (are) approved for release to service.						
Limited life parts must normally be accompanied by maintenance history including life used.						
14. New Parts <input type="checkbox"/> Airworthiness <input type="checkbox"/> Conformity		19. Namibian Regulations Release to service <input type="checkbox"/> other regulations specified in block				
Certifies that the part(s) identified above, except as otherwise specified in block 13, was (were) manufactured/inspected in accordance with the applicable design data and with the		Certifies that the work specified above, except as otherwise specified in block 13, was carried out in accordance with the Namibian Civil Aviation Regulations, 1999, and in respect of that work, the part(s)				
15. Signature	16. Approval Reference	20. Signature	21. Approval Reference Number			
17. Name	18. Date (d/m/y)	22. Name	23. Date (d/m/y)			

Notes:

1. Installer must cross check eligibility with applicable technical data.
2. It is important to understand that the existence of the Document alone does not automatically constitute authority to install the part/component/assembly.
3. Where the user/installer works in accordance with the national regulations of an Airworthiness Authority different than the Airworthiness Authority specified in block 2 it is essential that the user/installer ensures that his/her Airworthiness Authority accepts parts/components/assemblies from the Airworthiness Authority specified in block 2.
4. Statements 14 and 15 do not constitute installation certification. In all cases the aircraft maintenance record must contain an installation certification issued in accordance with the national regulations by the user/installer before the aircraft may be flown.

Annexure B

AIRCRAFT RELEASE CERTIFICATE

COMPANY:

REF:

1. Details of aircraft:

V5-	Airframe	Engine	Propeller	Equipment
Make
Model
Serial No.

2. Detail of work carried out:

.....

.....

.....

.....

3. Details of equipment to be installed and/or removed:

	Make	Model/Serial number	Description	Mass	Station	Position Installed
a						
b						
c						
d						
e						
f						
g						
h						

4. Applicable manuals and revision status of manuals used:

a. b. c. d.

5. Mass and moment change:

6. Mass and Balance record and equipment list amended as applicable.

YES		NO	

7. I hereby certify that, in carrying out the maintenance specified above, all the requirements prescribed in the Namibian Civil Aviation Regulations, 2001, which are applicable thereto, have been complied with.

DATE:

SIGNED:

AMO APPROVAL/AME LICENCE NO. (STAMP):

*Annexure C***CERTIFICATE OF RELEASE TO SERVICE**

Nationality and registration marks
 Aircraft type Serial No

I hereby certify that I am satisfied that the abovementioned aircraft and all its equipment are in every way serviceable for flight and that all maintenance has been carried out in accordance with the Namibian Civil Aviation Regulations, 2001, and its Approved Maintenance Schedule.

This certificate lapses at a total of hours of flight time or on (expire date), whichever occurs first, unless the aircraft is involved in an accident or otherwise becomes unserviceable, in which case the certificate is invalid for the duration of the period.

Subject to the following maintenance activity carried out:

Maintenance activity:

Due at: (flight time/date)

Due at: (hours)

Compliance:

Signed: AMO Approval No.

Date Time

Signed Licence No.

*Aircraft maintenance engineer/organisation:

Date Time

*Delete whichever is not applicable

MINISTRY OF WORKS, TRANSPORT AND COMMUNICATION

No. 68

2003

**NAMIBIAN CIVIL AVIATION TECHNICAL STANDARDS
NAM-CATS-ENVIRO "NOISE CERTIFICATION"**

The Director: Civil Aviation has under regulation 11.03.5 of the Namibian Civil Aviation Regulations, 2001 and in consultation with the Civil Aviation Regulations Committee issued the technical standards in the Schedule. These technical standards shall come into operation on 31 March 2003.

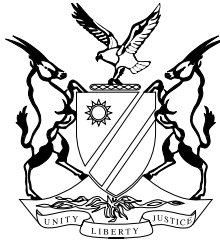

REPUBLIC OF NAMIBIA

CIVIL AVIATION

**DOCUMENT NAM-CATS-ENVIRO
(ENVIRONMENT PROTECTION)**

NAMIBIAN CIVIL AVIATION TECHNICAL STANDARDS RELATING TO ENVIRONMENT PROTECTION

1. GENERAL

Section 22A of the Aviation Act, 1962 (as amended by section 5 of the Aviation Amendment Act, 1998) empowers the Director: Civil Aviation to issue technical standards for civil aviation on the matters which are prescribed by regulation.

The Director: Civil Aviation has pursuant to the empowerment mentioned above, on 31 March 2003 issued technical standards relating to environment protection to be known as Document NAM-CATS-ENVIRO.

2. PURPOSE

Document NAM-CATS-ENVIRO contains the standards, rules, requirements, methods, specifications, characteristics and procedures which are applicable in respect of environment protection.

Each reference to a technical standard in this document, is a reference to the corresponding regulation in the Namibian Civil Aviation Regulations, 2001, for example, technical standard 34.02.5 refers to regulation 5 of Subpart 02 of Part 34 of the Regulations.

The abbreviation "CAR" is used throughout this document when referring to any regulation.

The abbreviation "TS" refers to any technical standard.

3. SCHEDULES AND NOTES

Guidelines and recommendations in support of any particular technical standard, are contained in schedules to, and/or notes inserted throughout the technical standards.

4. INCORPORATION OF INTERNATIONAL AVIATION STANDARDS

Section 22A(3) of the Aviation Act, 1962 (as amended by section 5 of the Aviation Amendment Act, 1998) empowers the Director: Civil Aviation to incorporate by reference into a technical standard, any international aviation standard.

The current edition of the international aviation standard known as Annex 16 (Environmental protection) Volume I (Aircraft Noise) to the Convention on International Civil Aviation, is incorporated into the technical standards contained in this document.

The current edition of the international aviation standard known as Annex 16 (Environmental protection) Volume II (Aircraft engine emissions) to the Convention on International Civil Aviation, is incorporated into the technical standards contained in this document.

LIST OF TECHNICAL STANDARDS

PART 34: ENGINE EMISSION CERTIFICATION

34.02.1 FUEL VENTING STANDARDS

1. Fuel venting standards

34.02.2 RECOGNITION OF FOREIGN FUEL VENTING CERTIFICATION

1. Standards

34.02.3 APPLICATION FOR FUEL VENTING CERTIFICATE

1. Form of application

- 34.02.5 FORM OF FUEL VENTING CERTIFICATE**
1. Form of certificate
- 34.03.1 ENGINE EMISSION STANDARDS**
1. Engine emission standards
- 34.03.2 RECOGNITION OF FOREIGN ENGINE EMISSION CERTIFICATION**
1. Standards
- 34.03.3 APPLICATION FOR ENGINE EMISSION CERTIFICATE**
1. Form of application
- 34.03.5 FORM OF ENGINE EMISSION CERTIFICATE**
1. Form of certificate

PART 36: NOISE CERTIFICATION

- 36.00.2 NOISE STANDARDS**
1. General
2. Noise standards for microlight aeroplanes
- 36.00.3 RECOGNITION OF FOREIGN NOISE CERTIFICATION**
1. Standards
- 36.00.5 APPLICATION FOR NOISE CERTIFICATE**
1. Form of application
- 36.00.7 FORM OF NOISE CERTIFICATE**
1. Form of certificate

FIGURES

FIGURE 1: MICROLIGHT AEROPLANE FLIGHT PROCEDURE

ANNEXURES

- ANNEXURE A : APPLICATION FOR FUEL VENTING CERTIFICATE
ANNEXURE B : FUEL VENTING CERTIFICATE
ANNEXURE C : APPLICATION FOR ENGINE EMISSION CERTIFICATE
ANNEXURE D : ENGINE EMISSION CERTIFICATE
ANNEXURE E : APPLICATION FOR NOISE CERTIFICATE
ANNEXURE F : NOISE CERTIFICATE

PART 34
ENGINE EMISSION CERTIFICATION

34.02.1 FUEL VENTING STANDARDS**1. Fuel venting standards**

The fuel venting standards referred to in CAR 34.02.1 are the appropriate fuel venting standards contained in Part II of the current edition of Annex 16, Volume II.

34.02.2 RECOGNITION OF FOREIGN FUEL VENTING CERTIFICATION**1. Standards**

The standards that apply for the recognition of a foreign fuel venting certificate are the appropriate fuel venting standards referred to in TS 34.02.1.

34.02.3 APPLICATION FOR FUEL VENTING CERTIFICATION**1. Form of application**

The form referred to in CAR 34.02.3(a), in which application for the issuing of a fuel venting certificate must be made, is contained in Annexure A.

34.02.5 FORM OF FUEL VENTING CERTIFICATE**1. Form of certificate**

The form referred to in CAR 34.02.5, on which a fuel venting certificate is issued, is contained in Annexure B.

34.03.1 ENGINE EMISSION STANDARDS**1. Engine emission standards**

The engine emission standards referred to in CAR 34.03.1 are the appropriate engine emission standards contained in Part III of the current edition of Annex 16, Volume II.

34.03.2 RECOGNITION OF FOREIGN ENGINE EMISSION CERTIFICATION**1. Standards**

The standards that apply for the recognition of a foreign engine emission certificate are the appropriate engine emission standards referred to in TS 34.03.1.

34.03.3 APPLICATION FOR ENGINE EMISSION CERTIFICATE**1. Form of application**

The form referred to in CAR 34.03.3(a), in which application for the issuing of an engine emission certificate must be made, is contained in Annexure C.

34.03.5 FORM OF ENGINE EMISSION CERTIFICATE**1. Form of certificate**

The form referred to in CAR 34.03.5, on which an engine emission certificate is issued, is contained in Annexure D.

PART 36
NOISE CERTIFICATION

36.00.2 NOISE STANDARDS

1. General

The noise standards referred to in CAR 36.00.2 are the appropriate noise standards contained in the current edition of Annex 16, Volume I.

2. Noise standards for microlight aeroplanes

The average noise emittance limit of a microlight aeroplane at full power and a height of 500 ft AGL may not exceed 78 dBA when measured under the following conditions and procedures:

2.1 Environmental conditions

- (1) Wind speed may not exceed 15 km/h at any time during test.
- (2) Cloud base to be 5 000 ft AGL minimum.
- (3) Cloud cover to be 4/8 maximum.
- (4) No other air traffic is allowed in a 4 000 meter radius from the measurement position during any measurements.
- (5) The test must be conducted during normal daylight hours.

2.2 Test equipment

- (1) The equipment to be used, must consist of a sound level meter capable of giving an indication in dBA with a fast time response. The test equipment must be supplied with a separate sound calibrated and a wind screen.
- (2) The test equipment must comply with the characteristics specified for Type 1 instruments in the publication No. 651 of the International Electrotechnical Commission.
- (3) The equipment must be verified for compliance with the relevant specifications by the supplier on delivery of the equipment. The equipment must be calibrated annually thereafter.

2.3 Certification

- (1) All tests must be conducted by a person qualified in the use of test equipment, in the presence of an authorised officer or inspector of the Directorate of Civil Aviation and/or a person approved by the body or institution designated by the Director in terms of Part 149 of the CARs.
- (2) Depending on the results, a noise certificate may be issued by the person conducting the test. All documentation must be completed in triplicate, a copy to be handed to the persons referred to in subparagraph (1) and the original to be kept by the manufacturer/owner. All microlight aeroplanes certified for production must have a copy of the noise certificate attached to the airframe logbook before delivery to the prospective owner.
- (3) Approved manufacturers must supply all the relevant information on the noise certificate e.g. powerplant (type, horse-power), propeller (type, number of blades, diameter, pitch), gearbox ratio, noise reduction equipment, etc.
- (4) Attached to the above certificate must be the following information regarding the test equipment:

- (a) Make
- (b) Model
- (c) Serial number of the equipment
- (d) Serial number of the microphone
- (e) Serial number of the calibrator and the sound pressure level value and frequency of the calibrator
- (f) The certificate number and date of the last verification.

2.4 **Compliance by similarity**

Manufacturers/owners may obtain compliance by proving similarity to aeroplanes already tested and passed as described. When requesting compliance by similarity, proof must be submitted, in writing, to show aircraft configuration, engine, propeller arrangement, noise reduction equipment, etc, to be identical to the model previously approved.

2.5 **Compliance date**

All microlight aeroplanes registered in terms of Part 47 of the CARs on or after its date of commencement, must comply with the above noise requirements. All microlight aeroplanes registered before this date must prove compliance with the noise requirements within three (3) years after Part 36 of the CARs comes into operation.

2.6 **Extensions**

Manufacturers/owners of microlight aeroplanes which cannot comply with the limits as stated, may request written extension for a maximum period of six (6) months, during which period a second test may be conducted to prove compliance. No further extension will be granted.

2.7 **Validity**

Microlight aeroplanes tested in accordance with this standard, will remain legal unless the test configuration is altered. This includes items such as changing the propeller pitch, propeller diameter, propeller make and exhaust. Any change will require a re-test. Approved persons will certify that the aircraft configuration has not been changed, as per the noise certificate attached to the aircraft logbook during annual inspections.

2.8 **Test procedure**

- (1) Test equipment:
 - (a) The equipment must be set up with its measurement microphone between 1.2 and 1.5 meters AGL. It must be fitted with a wind screen of which the sound attenuation characteristics are such that it will not affect the accuracy of the measurement.
 - (b) The equipment must be set to “weighting” and “FAST” response.

Before and after each set of readings, the calibration of the equipment must be checked by means of the sound calibrator in accordance with the instructions of the manufacturer. If the calibration readings of the equipment before and after each set of readings does not coincide to within 1.5 dB, the readings obtained must be discarded

and the calibration of the equipment controlled before the test is proceeded with.

- (c) The equipment must be operated strictly in accordance with the instructions from the manufacturer.

(2) Test site:

- (a) The test site must consist of a level piece of hard ground surface of radius of at least 10 meters. The surface may consist of hard ground free from any vegetation, compacted gravel, asphalt or concrete.
- (b) No buildings, trees or other obstacles may be within 250 meters from the measurement position.

(3) Flight procedure:

The aeroplane must be flown in the test pattern as per Figure 1. All tests must be conducted at full power and at a height of 500 ft AGL. The flight path must pass directly over the measurement microphone position while a height of 500 ft AGL is maintained over the measurement microphone. Four traverses must be made, each from a different direction.

(4) Measurements:

- (a) Readings must be taken of the maximum value indicated by the test equipment during the particular overflight. Note must be taken that the difference between the minimum reading with the aeroplane at the furthest position from the test site and the maximum reading during the overflight must be at least 10 dB. Less than that is an indication that the environmental back-ground noise level cause an error in the readings of more than 1 dB.
- (b) The differences between the four readings must not exceed 3 dB. If the differences exceed 3 dB, then the test must continue until four consecutive readings are obtained of which the largest difference between the readings does not exceed 3 dB.
- (c) The four readings must be combined by taking the arithmetic average. The average value shall not exceed 78 dBA.

36.00.3 RECOGNITION OF FOREIGN NOISE CERTIFICATION

1. Standards

The standards that apply for the recognition of a foreign noise certificate are the appropriate noise standards referred to in TS 36.00.2.

36.00.5 APPLICATION FOR NOISE CERTIFICATION

1. Form of application

The form referred to in CAR 34.00.5(a), in which application for the issuing of a noise certificate must be made, is contained in Annexure E.

36.00.7 FORM OF NOISE CERTIFICATE

1. Form of certificate

The form referred to in CAR 36.00.7, on which a noise certificate is issued, is contained in Annexure F.

FIGURE 1: MICROLIGHT AEROPLANE FLIGHT PROCEDURE

Figure 1 : Test pattern to be flown as shown.
Maximum radius from test point to be 1 000 meters at any time during test

Annexure A**REPUBLIC OF NAMIBIA****CIVIL AVIATION****APPLICATION FOR FUEL VENTING CERTIFICATE****Notes:**

- (i) *An application for the issuing of a fuel venting certificate, must comply with the provisions of CAR 34.02.3.*
- (ii) *The original application must be submitted to the Director: Civil Aviation.*
- (iii) *Where the required information cannot be furnished in the space provided, the information must be submitted as a separate memorandum and attached hereto.*
- (iv) *Please delete if not applicable.*

1. PARTICULARS REGARDING THE APPLICANT

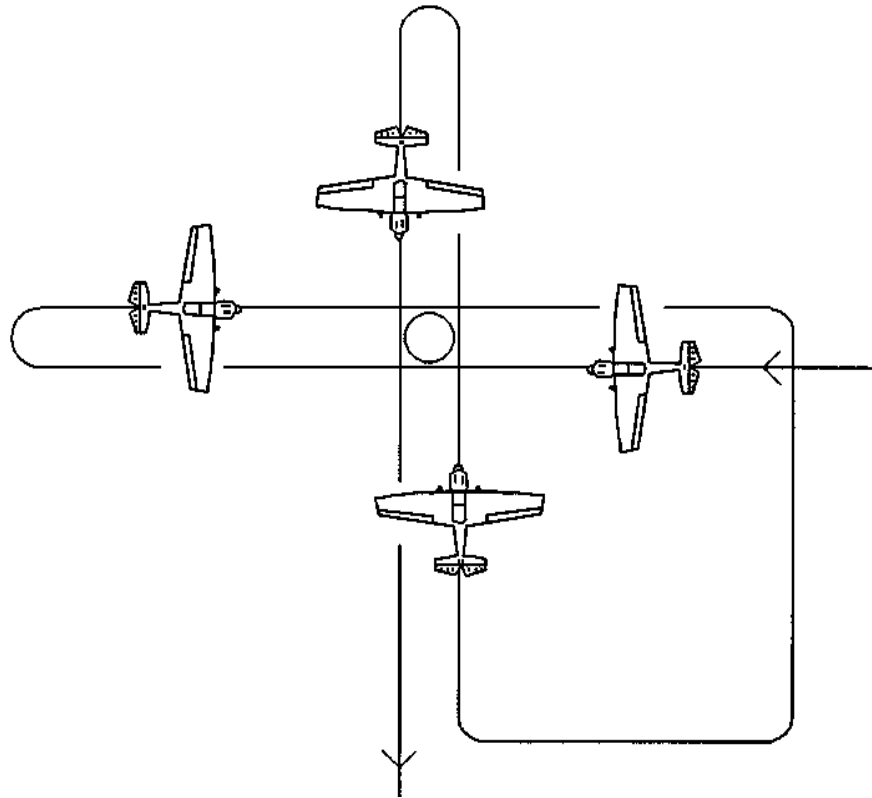
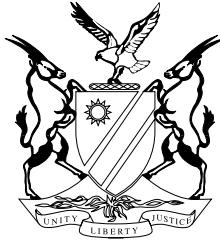
1.1	Full name:
-----	------------------

1.2	Trade name:.....
-----	------------------

1.3	Full business / residential address:	1.4	Postal address: Postal code :
-----	--	-----	---

1.5	Telephone number:	1.6	Telefax number:
-----	-------------------------	-----	-----------------------

1.7	Cellular phone number:	1.8	E-mail address :.....
-----	------------------------------	-----	-----------------------

1.9	SITA code (if any):	1.10	Telex number:
-----	---------------------------	------	---------------------

1.11	Legal status of applicant/holder (individual/close corporation/company/trust/other -specify):
------	--

1.12 Registration number in the case of a close corporation/company/trust:

1.13 Full particulars in respect of the individual/each responsible director/shareholder/partner/member/office bearer:

Name	Position	Identity Number	Nationality	Country of permanent residence
.....
.....
.....
.....
.....
.....
.....
.....

1.14 The applicant/holder declares hereby that the particulars provided in this application are true in every respect.

.....
 Signature

.....
 Date

2. PARTICULARS REGARDING THE AIRCRAFT

2.1 Aircraft registration:	2.2 Aircraft manufacturer:
----------------------------------	----------------------------------

2.3 Aircraft model:	2.4 Aircraft serial number:
---------------------------	-----------------------------------

2.5 Engine manufacturer:	2.6 Engine model:
--------------------------------	-------------------------

2.7 Engine serial number:	2.8 Date of manufacture:
---------------------------------	--------------------------------

3. ATTACHED DOCUMENTS

- Proof of compliance with fuel venting standards

Annexure B

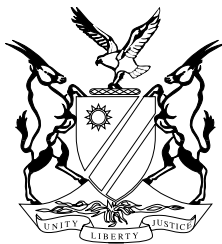

REPUBLIC OF NAMIBIA

CIVIL AVIATION

FUEL VENTING CERTIFICATE

1. Certificate number:

2. Name of holder:

3. Physical address of holder:	4. Postal address of holder: Postal code:
---	--

5. Aircraft registration:	6. Aircraft model:
---------------------------------	--------------------------

7. Aircraft serial number:	8. Engine model:
----------------------------------	------------------------

8. Engine serial number:

10. I hereby certify that the holder of this certificate has shown compliance with the fuel venting standards prescribed in Part 34 of the Namibian Civil Aviation Regulations, 2001.

11. Conditions:
--

.....
Date of issue

.....
Director: Civil Aviation

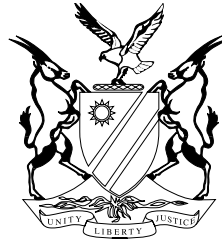
Annexure C**REPUBLIC OF NAMIBIA****CIVIL AVIATION****APPLICATION FOR ENGINE EMISSION CERTIFICATE****Notes:**

- (i) *An application for the issuing of a fuel venting certificate, must comply with the provisions of CAR 34.03.3.*
- (ii) *The original application must be submitted to the Director: Civil Aviation.*
- (iii) *Where the required information cannot be furnished in the space provided, the information must be submitted as a separate memorandum and attached hereto.*
- (iv) *Please delete if not applicable.*

1. PARTICULARS REGARDING THE APPLICANT

1.1	Full name:
-----	------------------

1.2	Trade name:.....
-----	------------------

1.3 Full business / residential address:	1.4 Postal address: Postal code :
--	---

1.5 Telephone number:	1.6 Telefax number:
-----------------------------	---------------------------

1.7 Cellular phone number:	1.8 E-mail address :
----------------------------------	----------------------------

1.9 SITA code (if any):	1.10 Telex number:
-------------------------------	--------------------------

1.11	Legal status of applicant (individual/corporation/company/trust/other -specify):
------	---

1.12	Registration number in the case of a close corporation/company/trust:

1.13 Full particulars in respect of the individual/each responsible director/shareholder/partner/member/office bearer:				
Name	Position	Identity Number	Nationality	Country of permanent residence
.....
.....
.....
.....
.....
.....
.....

1.14 The applicant/holder declares hereby that the particulars provided in this application are true in every respect.	
.....
Signature	Date

2. PARTICULARS REGARDING THE AIRCRAFT

2.1 Aircraft registration:	2.2 Aircraft manufacturer:
----------------------------------	----------------------------------

2.3 Aircraft model:	2.4 Aircraft serial number:
---------------------------	-----------------------------------

2.5 Engine manufacturer:	2.6 Engine model:
--------------------------------	-------------------------

2.7 Engine serial number:	2.8 Date of manufacture:
---------------------------------	--------------------------------

3. ATTACHED DOCUMENTS

<ul style="list-style-type: none"> • Proof of compliance with engine emission standards
--

Annexure D

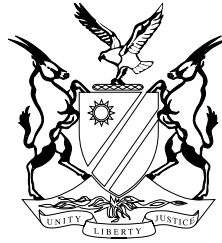

REPUBLIC OF NAMIBIA

CIVIL AVIATION

ENGINE EMISSION CERTIFICATE

1. Certificate number:

2. Name of holder:

3. Physical address of holder:	4. Postal address of holder: Postal code:
--	---

5. Aircraft registration:	6. Aircraft model:
---------------------------------	--------------------------

7. Aircraft serial number:	8. Engine model:
----------------------------------	------------------------

8. Engine serial number:

10. I hereby certify that the holder of this certificate has shown compliance with the engine emission standards prescribed in Part 34 of the Namibian Civil Aviation Regulations, 2001.
--

11. Conditions:
--

.....
Date of issue

.....
Director: Civil Aviation

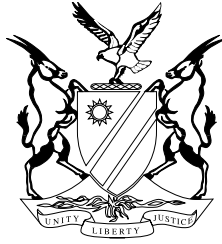
Annexure E**REPUBLIC OF NAMIBIA****CIVIL AVIATION****APPLICATION FOR NOISE CERTIFICATE****Notes:**

- (i) *An application for the issuing of a noise certificate, must comply with the provisions of CAR 36.00.5.*
- (ii) *The original application must be submitted to the Director: Civil Aviation*
- (iii) *Where the required information cannot be furnished in the space provided, the information must be submitted as a separate memorandum and attached hereto.*
- (iv) *Please delete if not applicable.*

1. PARTICULARS REGARDING THE APPLICANT

1.1	Full name:
-----	------------------

1.2	Trade name:.....
-----	------------------

1.3	Full business / residential address:	1.4	Postal address: Postal code :.....
-----	--	-----	--

1.5	Telephone number:	1.6	Telefax number:
-----	-------------------------	-----	-----------------------

1.7	Cellular phone number:	1.8	E-mail address :
-----	------------------------------	-----	------------------------

1.9	SITA code (if any):	1.10	Telex number:
-----	---------------------------	------	---------------------

1.11	Legal status of applicant (individual/corporation/company/trust/other -specify):
------	---

1.12 Registration number in the case of a close corporation/company/trust:

.....

1.13 Full particulars in respect of the individual/each responsible director/shareholder/partner/member/office bearer:

Name	Position	Identity Number	Nationality	Country of permanent residence
.....
.....
.....
.....
.....
.....
.....

1.14 The applicant/holder declares hereby that the particulars provided in this application are true in every respect.

.....

Signature Date

2. PARTICULARS REGARDING THE AIRCRAFT (OTHER THAN A MICROLIGHT AEROPLAN)

2.1 Aircraft registration:	2.2 Aircraft manufacturer:.....
----------------------------------	---------------------------------

2.3 Aircraft model:	2.4 Aircraft serial number:
---------------------------	-----------------------------------

2.5 Engine manufacturer:	2.6 Engine model:
--------------------------------	-------------------------

2.7 Engine serial number:	2.8 Date of manufacture:
---------------------------------	--------------------------------

2.9 Attached documents:

- Proof of compliance with noise standards

3. PARTICULARS REGARDING THE MICROLIGHT AEROPLANE

3.1 Aircraft registration:	3.2 Aircraft manufacturer:
----------------------------------	----------------------------------

3.3 Aircraft model:	3.4 Aircraft serial number:
---------------------------	-----------------------------------

3.5 Engine manufacturer:	3.6 Engine model:
--------------------------------	-------------------------

3.7 Engine serial number:	3.8 Date of manufacture:
---------------------------------	--------------------------------

3.9 Number of propeller blades:	3.10 Adjustable pitch: Yes/No
---------------------------------------	-------------------------------

3.11 Propeller diameter:	3.12 Pitch setting:
--------------------------------	---------------------------

3.13 Inlet silencer: Ues/No	3.14 Exhaust silencer: Yes/No
-----------------------------	-------------------------------

I, the undersigned, hereby certify that the above microlight aeroplane was tested by me in accordance with the noise requirements prescribed in paragraph 2 of TS 36.00.2 on (date) at The microlight aeroplane passed/failed.

.....
Signature

.....
Date

Full name of authorised officer/inspector/approved person:

Annexure F

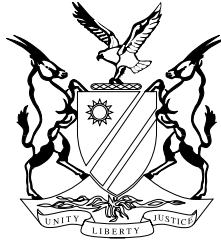

REPUBLIC OF NAMIBIA

CIVIL AVIATION

NOISE CERTIFICATE

1. Certificate number:

2. Name of holder:

3. Physical address of holder:	4. Postal address of holder: Postal code:
--	---

5. Aircraft registration:	6. Aircraft model:
---------------------------------	--------------------------

7. Aircraft serial number:	8. Engine model:
----------------------------------	------------------------

9. Engine serial number:

10. I hereby certify that the holder of this certificate has shown compliance with the noise standards prescribed in Part 36 of the Namibian Civil Aviation Regulations, 2001.

11. Conditions:
.....
.....
.....

.....
Date of issue

.....
Director: Civil Aviation
