

**HENNY PENNY™**

*Global Foodservice Solutions*

## **Henny Penny Open Fry Station**

**Model OFE/OFG-323**

**Model OFE/OFG-322**

**Model OFE/OFG-321**

**Model OFE/OFG-324**

**Model OEA/OGA-321**

**Model OEA/OGA-322**

**Model OEA/OGA-323**

---

# **SERVICE MANUAL**

---

**WARNING**

This manual should be retained in a convenient location for future reference.

A wiring diagram for this appliance is located on the inside of the right side panel.

Post in a prominent location, instructions to be followed in event user smells gas. This information shall be obtained by consulting the local gas supplier.

**FOR YOUR SAFETY**

**DO NOT STORE OR USE GASOLINE OR OTHER FLAMMABLE VAPORS AND LIQUIDS IN THE VICINITY OF THIS OR ANY OTHER APPLIANCE.**

Keep appliance area free and clear from combustibles.

Do not obstruct the flow of combustion and ventilation air. Adequate clearance must be left all around appliance for sufficient air to the combustion chamber.

**NOTE**

The Model OFG/OGA-32X Fryer is equipped with a continuous pilot. But Fryer can not be operated without electric power. Fryer will automatically return to normal operation when power is restored.

**WARNING**

**WARNING: Improper installation, adjustment, alteration, service or maintenance can cause property damage, injury or death. Read the installation, operating and maintenance instructions thoroughly before installing or servicing this equipment.**

Provided by  
DAVISWARE

## **LIMITED WARRANTY FOR HENNY PENNY APPLIANCES**

Subject to the following conditions, Henny Penny Corporation makes the following limited warranties to the original purchaser only for Henny Penny appliances and replacement parts:

**NEW EQUIPMENT:** Any part of a new appliance, except lamps and fuses, which proves to be defective in material or workmanship within two (2) years from date of original installation, will be repaired or replaced without charge F.O.B. factory, Eaton, Ohio, or F.O.B. authorized distributor. To validate this warranty, the registration card for the appliance must be mailed to Henny Penny within ten (10) days after installation.

**REPLACEMENT PARTS:** Any appliance replacement part, except lamps and fuses, which proves to be defective in material or workmanship within ninety (90) days from date of original installation will be repaired or replaced without charge F.O.B. factory, Eaton, Ohio, or F.O.B. authorized distributor.

The warranty for new equipment and replacement parts covers only the repair or replacement of the defective part and does not include any labor charges for the removal and installation of any parts, travel or other expenses incidental to the repair or replacement of a part.

**EXTENDED FRYPOT WARRANTY:** Henny Penny will replace any frypot that fails due to manufacturing or workmanship issues for a period of up to seven (7) years from date of manufacture. This warranty shall not cover any frypot that fails due to any misuse or abuse, such as heating of the frypot without shortening.

**0 TO 3 YEARS:** During this time, any frypot that fails due to manufacturing or workmanship issues will be replaced at no charge for parts, labor, or freight. Henny Penny will either install a new frypot at no cost or provide a new or reconditioned replacement fryer at no cost.

**3 TO 7 YEARS:** During this time, any frypot that fails due to manufacturing or workmanship issues will be replaced at no charge for the frypot only. Any freight charges and labor costs to install the new frypot as well as the cost of any other parts replaced, such as insulation, thermal sensors, high limits, fittings, and hardware, will be the responsibility of the owner.

Any claim must be represented to either Henny Penny or the distributor from whom the appliance was purchased. No allowance will be granted for repairs made by anyone else without Henny Penny's written consent. If damage occurs during shipping, notify the sender at once so that a claim may be filed.

THE ABOVE LIMITED WARRANTY SETS FORTH THE SOLE REMEDY AGAINST HENNY PENNY FOR ANY BREACH OF WARRANTY OR OTHER TERM. BUYER AGREES THAT NO OTHER REMEDY (INCLUDING CLAIMS FOR ANY INCIDENTAL OR CONSEQUENTIAL DAMAGES) SHALL BE AVAILABLE.

The above limited warranty does not apply (a) to damage resulting from accident, alteration, misuse, or abuse; (b) if the equipment's serial number is removed or defaced; or (c) for lamps and fuses. THE ABOVE LIMITED WARRANTY IS EXPRESSLY IN LIEU OF ALL OTHER WARRANTIES, EXPRESS OR IMPLIED, INCLUDING MERCHANTABILITY AND FITNESS, AND ALL OTHER WARRANTIES ARE EXCLUDED. HENNY PENNY NEITHER ASSUMES NOR AUTHORIZES ANY PERSON TO ASSUME FOR IT ANY OTHER OBLIGATION OR LIABILITY.

## TABLE OF CONTENTS

<b>Section</b>		<b>Page</b>
Section 1.	INTRODUCTION .....	1-1
	1-1 Introduction .....	1-1
	1-2 Model Variations.....	1-1
	1-3 Features .....	1-1
	1-4 Safety.....	1-1
	1-5 Assistance.....	1-2
Section 2.	INSTALLATION .....	2-1
	2-1 Introduction .....	2-1
	2-2 Unpacking.....	2-1
	2-3 Selecting the Location.....	2-2
	2-4 Leveling the Fry Station.....	2-2
	2-5 Ventilation of Fry Station.....	2-2
	2-6 Gas Supply.....	2-3
	2-7 Gas Leak Test.....	2-5
	2-8 Gas Pressure Regulator .....	2-6
	2-9 Electrical Requirements OFE-320 Series.....	2-6
	2-10 Testing the Fry Station .....	2-7
	2-11 Joining Instructions .....	2-7
Section 3.	OPERATION.....	3-1
	3-1 Introduction .....	3-1
	3-2 Operating Controls .....	3-1
	3-3 Filling or Adding Shortening.....	3-5
	3-4 Basic Operations and Procedures (6 Product Controls).....	3-5
	3-5 Basic Operations and Procedures (Electro-Mechanical).....	3-7
	3-6 Basic Operations and Procedures (12 Product Controls/Auto-lift).....	3-9
	3-7 Filtering of Shortening .....	3-12
	3-8 Filter Pump Problems .....	3-14
	3-9 Filter Pump Motor Protector .....	3-14
	3-10 Changing the Filter Envelope.....	3-15
	3-11 Cleaning the Cookpots .....	3-16
	3-12 Lighting and Shutdown of Burners .....	3-19
	3-13 Regular Maintenance.....	3-20
Section 4.	PROGRAMMING .....	4-1
	4-1 Introduction .....	4-1
	4-2 Product Program Mode .....	4-1
	4-3 Special Program Mode.....	4-4
Section 5.	TROUBLESHOOTING.....	5-1
	5-1 Introduction .....	5-1
	5-2 Troubleshooting .....	5-1
Section 6.	MAINTENANCE.....	6-1
	6-1 Introduction .....	6-1
	6-2 Maintenance Hints .....	6-1

**TABLE OF CONTENTS**

<b>Section</b>		<b>Page</b>
Section 6.	MAINTENANCE (Continued)	
6-3	High Temperature Limit Control (Gas Units).....	6-1
6-4	Complete Control Panel Replacement .....	6-4
6-5	Power Switch.....	6-4
6-6	Temperature Probe Replacement .....	6-5
6-7	Flame Sensor (Gas Units) .....	6-6
6-8	Pilot/Ignitor Assembly .....	6-7
6-9	Ignition Module.....	6-8
6-10	Transformer.....	6-8
6-11	I/O Power Supply Board Assembly .....	6-9
6-12	Airflow Switch .....	6-9
6-13	Speaker Assembly (Gas Units) .....	6-10
6-14	Drain Microswitch .....	6-11
6-15	Filter Switch.....	6-11
6-16	Gas Valve Assembly .....	6-12
6-17	Blower Motor Assembly .....	6-14
6-18	Heating Elements (Electric Only) .....	6-16
6-19	Heating Contactors (Electric Only).....	6-19
6-20	Speaker Assembly (Electric Units).....	6-21
6-21	High Temperature Limit Control (Electric Units) .....	6-21
Section 7.	PARTS INFORMATION.....	7-1
7-1	Introduction .....	7-1
7-2	Genuine Parts .....	7-1
7-3	When Ordering Parts.....	7-1
7-4	Prices .....	7-1
7-5	Delivery .....	7-1
7-6	Warranty.....	7-1
	120V/60Hz/1Ph (OFG-32X Gas) Wiring Diagram.....	7-13
	208-240V/60Hz/1Ph (Domestic-OFE-32X Electric) Wiring Diagram.....	7-14
	120V/50/60Hz/1Ph (OFG-322) Wiring Diagram.....	7-15
	230V/50Hz/1 Ph (OFG-321) Wiring Diagram.....	7-16
	208-240V/50-60 Hz/3Ph (OFE-321/2/3 Electric) Wiring Diagram.....	7-17
	120V/50-60Hz/1Ph (OFG-321) Wiring Diagram .....	7-18
	380-415V/50-60Hz/3Ph (OFE-321/2/3) Wiring Diagram .....	7-19
	120V/50-60Hz/1Ph (OGA-323) Wiring Diagram.....	7-20
	120V/50-60/1Ph (OGA-321) Wiring Diagram .....	7-21
	380-480V/50-60Hz/3Ph (OFE-321/2/3) Wiring Diagram .....	7-22
	230V/50Hz/1Ph (OFG-323) Wiring Diagram.....	7-23
	120V/50-60Hz/1Ph (ODG-323) Wiring Diagram.....	7-24
	230V/50Hz/1Ph (OFG-322) Wiring Diagram.....	7-25
	120V/50-60Hz/1Ph (OFG-323) Wiring Diagram .....	7-26
	208-240V/50-60Hz/3Ph (OFE-321/2/3) Wiring Diagram .....	7-27
	208-240V/50-60Hz/3Ph (OEA-321/2/3) Wiring Diagram.....	7-28

## SECTION 1. INTRODUCTION

### 1-1. INTRODUCTION.

The Henny Penny Open Fry Station is a basic unit of food equipment designed to cook foods better and easier. The microcomputer based design helps make this possible. This unit is used only in institutional and commercial food service operations.

### 1-2. MODEL VARIATIONS

This manual covers the following variations of the Henny Penny Open Fry Station:

- Model OFG/OFE-323
- Model OFG/OFE-322
- Model OFG/OFE-321
- Model OFG/OFE-324
- Model OGA/OEA-323
- Model OGA/OEA-322
- Model OGA/OEA-321

### 1-3. FEATURES

- Easily cleaned.
- 55 lb. (24.94 kg.) shortening capacity
- 2 Half size baskets per well (or full size baskets).
- Microcomputer control.
- Stainless steel construction.
- Manual reset high limit control.
- Self-diagnostic system built into controls.
- Built in filter (handles all 3 wells).
- Propane or Natural Gas; 85,000 BTU/pot (26.38 kW)

### 1-4. SAFETY

The Henny Penny Fry Station has many safety features incorporated. However, the only way to ensure safe operation is to fully understand the proper installation, operation, and maintenance procedures. The instructions in this manual have been prepared to aid you in learning the proper procedures. Where information is of particular importance or is safety related, the words DANGER, WARNING, CAUTION, or NOTE are used. Their usage is described below:



The word DANGER indicates an imminent hazard which will result in highly serious injury such as second or third degree burns.

**1-4. SAFETY  
(Continued)**

**WARNING**

The word WARNING is used to alert you to a procedure that if not performed properly, might cause personal injury.

**CAUTION**

The word CAUTION is used to alert you to a procedure that, if not performed properly, may damage the fry station.

**NOTE**

The word NOTE is used to highlight especially important information.

**1-5. ASSISTANCE**

Should you require outside assistance, just call your local independent distributor maintained by Henny Penny Corporation.

In addition, feel free to contact our corporate headquarters in Eaton, Ohio. Dial 1-800-417-8405 toll free, or 937-456-8405.

## SECTION 2. INSTALLATION

### 2-1. INTRODUCTION

This section provides the installation instructions for the Henny Penny Fry Station.

#### NOTE

Installation of the unit should be preformed only by a qualified service technician.

#### WARNING

Do not puncture the unit with any objects such as drills or screws as component damage or electrical shock could result.

### 2-2. UNPACKING

The Henny Penny Fry Station has been tested, inspected, and expertly packed to ensure arrival at its destination in the best possible condition. The unit is banded to a wooden skid and then packed inside a heavy cardboard carton with sufficient padding to withstand normal shipping treatment.

#### NOTE

Any shipping damage should be noted in the presence of the delivery agent and signed prior to his or her departure.

1. Carefully cut bands from cardboard carton.
2. Lift carton from fryer.

#### WARNING

This manual should be retained in a convenient location for future reference.

Wiring diagram for this appliance is located on the inside of the Service and Operation Manual. Post in a prominent location, instructions to be followed in event user smells gas. This information shall be obtained by consulting the local gas supplier.



### 2-3. SELECTING THE LOCATION

The proper location of the Fry Station is very important for operation, speed, and convenience. The location of the fry station should allow clearances for servicing and proper operation. Choose a location which will provide easy loading and unloading without interfering with the final assembly of food orders. Operators have found that frying from raw to finish, and holding the product in warmers provides fast continuous service. Keep in mind the best efficiency will be obtained by a straight line operation, i.e. raw in one side and finished out the other side. Order assembly can be moved away with only a slight loss of efficiency.

#### NOTE

The fryer should be installed in such a way as to prevent tipping or movement causing splashing of hot liquid shortening. This may be accomplished by the location the fry station is in, or by restraining ties.

#### CAUTION

The gas Model OFG-320 Series Fry Station is designed for installation on combustible floors and adjacent to combustible walls. Fry Station must be installed with a minimum clearance from all combustible materials, 4 inches (10.16 cm) from side and 4 inches (10.16 cm) from the back.

### 2-4. LEVELING THE FRY STATION

For proper operation, the fry station should be level from side to side and front to back. Using a level place on the flat areas around the frypot collar, on the middle well, adjust the casters until the unit is level.

### 2-5. VENTILATION OF FRY STATION

The fry station should be located with provision for venting into an adequate exhaust hood or ventilation system. This is essential to permit efficient removal of the steam exhaust and frying odors. Special precaution must be taken in designing an exhaust canopy to avoid interference with the operation of the fry station. We recommend you consult a local ventilation or heating company to help in designing an adequate system.

#### NOTE

Ventilation must conform to local, state, and national codes. Consult your local fire department or building authorities.

## 2-5. VENTILATION OF FRY STATION (Continued)

**WARNING**

When installing the gas fry station do not attach an extension to the gas flue exhaust stack. This may impair proper operation of the burner, causing malfunctions and possible negative back draft.

## 2-6. GAS SUPPLY

The gas fry station is factory available for either natural or propane gas. Check the data plate inside the front door of the cabinet to determine the proper gas supply requirements.



Do not attempt to use any gas other than that specified on the data plate. Incorrect gas supply could result in a fire or explosion.

Please refer to the illustration on the following page for the recommended hookup of the fry station to the main gas line supply.

**WARNING**

To avoid possible serious personal injury:

- Installation must conform with local, state, and national codes.
- Installation must conform with American National Standard Z223.1-Latest Edition National Fuel Gas Code and the local municipal building codes. In Canada, installation must be in accordance with Standard CAN/CGA B 149.1 & Installation Codes - Gas Burning Appliances and local codes.
- The fry station must be isolated from the gas supply piping system by closing its individual manual shut off valve during any pressure testing of the gas supply piping system at test pressures equal to or less than 1/2 PSIG (3.45 KPA) (34.47 mbar).

Provided by  
DAVIS

**GAS PIPING**

**RIGHT**

MINIMUM PULL of equipment away from wall permissible for accessibility to Quick Disconnect Device.

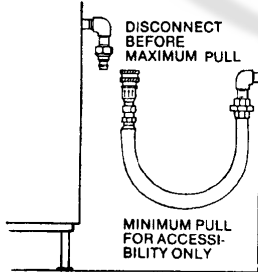

**WRONG**

AVOID SHARP BENDS AND KINKS when pulling equipment away from wall. (Maximum pull will kink ends, even if installed properly, and reduce Connector life.)

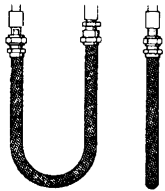
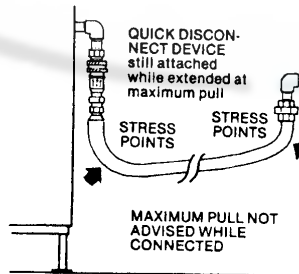

**RIGHT**

Couplings and hose should be installed in the same plane as shown at left. DO NOT OFFSET COUPLINGS—this causes torsional twisting and undue strain causing premature failure.

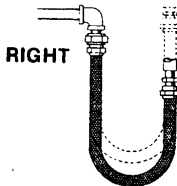
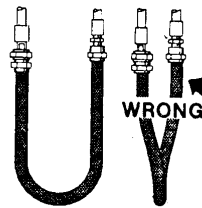

This is the correct way to install metal hose for vertical traverse. Note the single, natural loop.

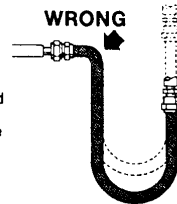

Allowing a sharp bend, as shown at right, strains and twists the metal hose to a point of early failure at the coupling.

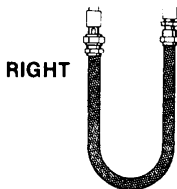

Maintain the minimum or larger bending diameter between the couplings for longest life.



Closing in the diameter at the couplings, as shown at right, creates double bends causing work fatigue failure of the fittings.

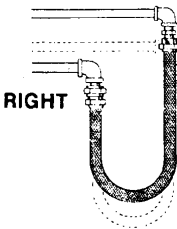

In all installations where "self-draining" is not necessary, connect metal hose in a vertical loop.

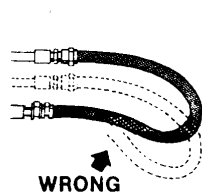

DO NOT CONNECT METAL HOSE HORIZONTALLY... unless "self-draining" is necessary, then use support on lower plane as shown at left.

**CABLE RESTRAINT**

Please refer to the illustration below when installing cable restraint on all moveable gas fryers.

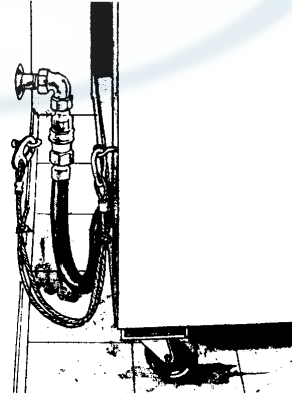

I-bolt is to be secured to the building using acceptable building construction practices.

**CAUTION**

**DRY WALL CONSTRUCTION**

Secure I-bolt to a building stud. DO NOT attach to dry wall only. Also, locate the I-bolt at the same height as the gas service. Preferred installation is approximately six inches to either side of service. Cable restraint must be at least six inches shorter than flexible gas line.

**CAUTION**

Utilize elbows when necessary to avoid sharp kinks or excessive bending. For ease of movement, install with a "lazy" loop. Gas appliance must be disconnected prior to maximum movement. (Minimum movement is permissible for hose disconnection).

## 2-6. GAS SUPPLY (Continued)

- A standard one inch, black steel pipe and malleable fittings should be used for gas service connections.
- Do not use cast iron fittings.
- Although one inch (2.54 cm) size pipe is recommended, piping should be of adequate size and installed to provide a supply of gas sufficient to meet the maximum demand without undue loss of pressure between the meter and the fry station. The pressure loss in the piping system should not exceed 0.3 inch water column (.747 mbar).
- Do not adjust the vacuum pressure switch. It is factory set for the most efficiency.

Provisions should be made for moving the fry station for cleaning and servicing. This may be accomplished by:

1. Installing a manual gas shut off valve and a disconnect union, or
2. Installing a heavy-duty design A.G.A. certified connector. In order to be able to service this appliance, which is provided with casters, a connector complying with ANSI Z21.69 or CAN 1-6.10m88 and a quick-disconnect device, complying with ANSI Z21.41 or CAN 1-6.9m70, must be installed. It must also be installed with restraining means to guard against transmission of strain to the connector as specified in the appliance manufacturer's instruction.
3. Refer to the cable restraint instructions, on preceding page, on how and where to attach the restraining devices to the wall and fryer.

## 2-7. GAS LEAK TEST

### NOTE

Upon initial installation, and after moving the unit, be sure the gas dial cock on fry station gas valve is in the OFF position. After the piping and fittings have been installed, check for gas leaks. A simple checking method is to turn on the gas and brush all connections with a soap solution. If bubbles occur, it indicates escaping gas. In this event, the piping connection must be redone.



Never use a lighted match or open flame to test for gas leaks. Escaping gas could cause an explosion resulting in severe personal injury.

**2-8. PRESSURE REGULATOR**

The gas pressure regulator on the automatic gas valve is factory set as follows:

- Natural: 3.5 inches water column (8.7 mbar).
- Propane 10.0 inches water column (24.9 mbar).

**2-9. ELECTRICAL REQUIREMENTS OFG-320 SERIES**

- 120 V, 50/60 Hz., 12 A, 1 PH
- 230 V, 50 Hz., 1 PH

The 120 V gas fry station requires a 3 wire grounded (Earthed) service and is supplied with a grounded cord and plug. Any 230 volt plug used on the 230 volt unit must conform to all local, state, and national codes.

**WARNING**

DO NOT DISCONNECT THE GROUND (EARTH) PLUG. This fry station MUST be adequately and safely grounded or electrical shock could result. Refer to local electrical codes for correct grounding (Earthing) procedures or in absence of local codes, with the National Electrical Code, ANSO/NFPA No. 70 Latest Edition. Canadian models are supplied with a terminal box, suitable for conduit connection. In Canada, all electrical connections are to be made in accordance with CSA C221, Canadian Electrical Code Part 1, and/or local codes.

Servicing of the filter pump is done at the rear of the unit. If service is required, disconnect the fry station from the electrical power source. The fry station will have to be pulled out from the wall to gain access to rear.

**2-9. ELECTRICAL REQUIREMENTS OFE-320 SERIES**

Refer to the table below for supply wiring and fusing.

(Per Well)			
Volts	Phase	Kw	Amps
200-208	3	14.4	40
220/240	3	14.4	40
440-480	3	14.4	17
380-415	3	14.4	20

**WARNING**

This fry station must be adequately and safely grounded. Refer to local electrical codes for correct grounding procedures. If fry station is not adequately grounded, electrical shock could result.

A separate disconnect switch with proper capacity fuses or breakers must be installed at a convenient location between the fry station and the power switch.

**NOTE**

CE units require a minimum wire size of 6mm to be wired to the terminal block.

**2-10 TESTING THE FRY STATION**

Each Henny Penny Fry Station was completely checked and tested prior to shipment. However, it is good practice to check the unit again after installation.

**2-11 JOINING INSTRUCTIONS**

The following instructions are for joining two units together. The instructions have part numbers in them. Please refer to figure 2-1 on the following page to visually match the numbers in the instructions to the illustration.

1. Remove all hardware from the sides of the two fryers.
2. Remove the right control panel assembly from the left unit and the left control panel assembly from the right unit.

## 2-11 JOINING INSTRUCTIONS (Continued)

3. Move the two units side by side with minimal gap.
4. Remove the right front caster from the left unit and the left rear caster from the right unit. Fasten both casters to the rear of the unit with wire ties (EF02-041).
5. Position the two fryers by inserting bolts (SC01-227) thru the holes in top cover and the pot sides. Use washer (WA01-017) on both sides of the bolt when installing. DO NOT TIGHTEN!
6. Position front spacer (60554) between the front of the two fryers. Place bolt (SC01-215), backed by washers (55350 & WA01-016), thru three holes in the frame capturing the spacer between the frames. Place washers ( 55350& WA01-016) on bolt before installing nuts (NS02-010). DO NOT TIGHTEN!
7. Repeat with rear spacer (60555).
8. Tighten all fasteners securely.
9. Place cover (60593) over gap between fryers.
10. Drill out dimples on rear shroud to 0.250 diameter holes.
11. Apply silicon around edge of unfinished side of rear cover (60599). Install rear cover (60599) with #8 nuts (NS02-007).
12. Apply silicon around edge of unfinished side of front cover (60601). Install front cover (60601) using #8 self drilling screws (SC03-005).
13. Apply silicon around edge of unfinished side of top cover (60590) and basket rest cover ( 60591). Position top cover (60590) on fryer top cover and install basket rest cover ( 60591) using #8 screws and nuts (Sc01-013 & Ns02-007).
14. Apply silicon to any gaps that may be left.

2-11 JOINING INSTRUCTIONS  
( Continued)

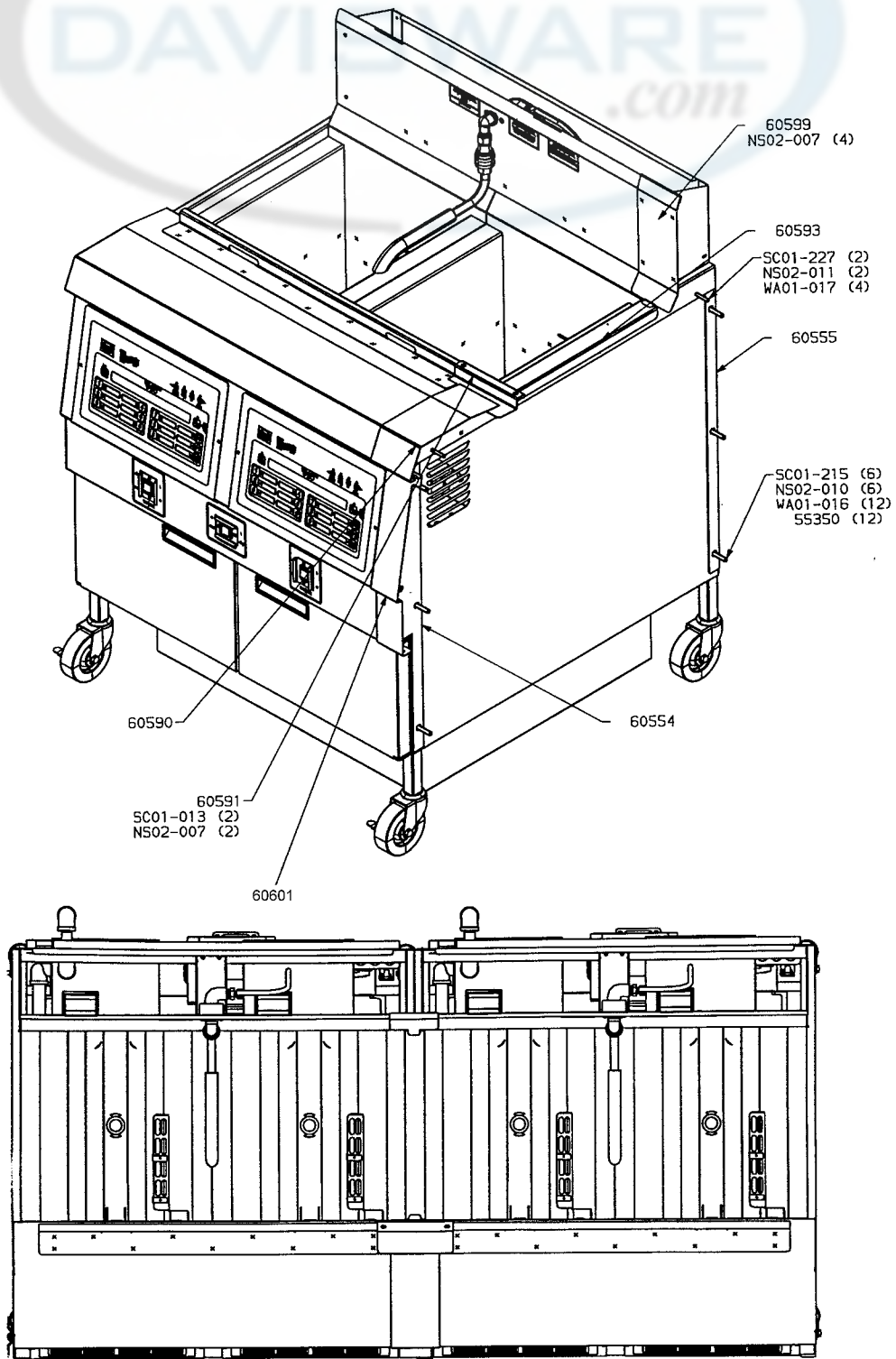

Figure 2-1







### SECTION 3. OPERATION

#### 3-1. INTRODUCTION

This section provides operating procedures for the Henny Penny OFG/OFE-320 series open fryer with both 6 and 12 button timer controls. Sections 1, 2, and 3 should be read and all instructions should be followed before operating the fryer.

#### 3-2. OPERATING CONTROLS

Figure 3-1 shows the function of the 12 button timer control, and Figure 3-2, shows the function of the 6 timer control.

Fig. No.	Item No.	Description	Function
3-1 3-2	1	 HEAT ON	The Heat-On LED will light when the control calls for heat, and the burners should come on and heat the shortening.
3-1 3-2	2	Digital Display	The digital display is to show the shortening temperature, the timer countdown in the frying cycle, and the selections in the Program mode. The temperature of the shortening can be shown by depressing the INFO button. If the temperature exceeds 425°F (218°C), the display will read "E-5", "FRYER TOO HOT".
3-1 3-2	3	Wait LED	Once the fryer is out of the Melt mode, the Wait LED will light, signaling the operator that the shortening temperature is NOT at the proper temperature for dropping product into the cookpot.
3-1 3-2	4	Ready LED	The Ready LED will light when the shortening temperature is within 5° of the setpoint temperature, signaling the operator that the shortening temperature is now at the proper temperature for dropping product into the cookpot.
3-1 3-2	5	 INFO	The INFO button can display the current shortening temperature, the setpoint temperature, as well as cooking performance. It will also show the amount of time left in a hold mode. Also, in the program mode, it will step back to the previous parameter.
3-1 3-2	6 & 7	  DOWN UP	The Up and Down buttons are used to adjust the value of the currently displayed setting in the Program mode.

**3-2. OPERATING CONTROLS**  
(Continued)

Fig. No.	Item No.	Description	Function
3-1 3-2	8		<p>The PROG button is used access the program modes. Also, once in the program mode, it is used to advance to the next parameter.</p>
3-1 3-2	9	Start/Stop Button	<p>The Start/Stop buttons are used to start and stop cooking cycles. They will also de-activate the quality timer at the end of a hold mode.</p>
3-1 3-2	10	Menu Card Window	<p>The name of the food product associated with each Product Selection button below. The menu card strip is located Behind the decal.</p>
3-1 3-2	11	Product Select Buttons	<p>The Product Select buttons are used to select which food products are to be cooked. (On Auto-lift fryers, the 6 and 12 product buttons are basket lift buttons.)</p>

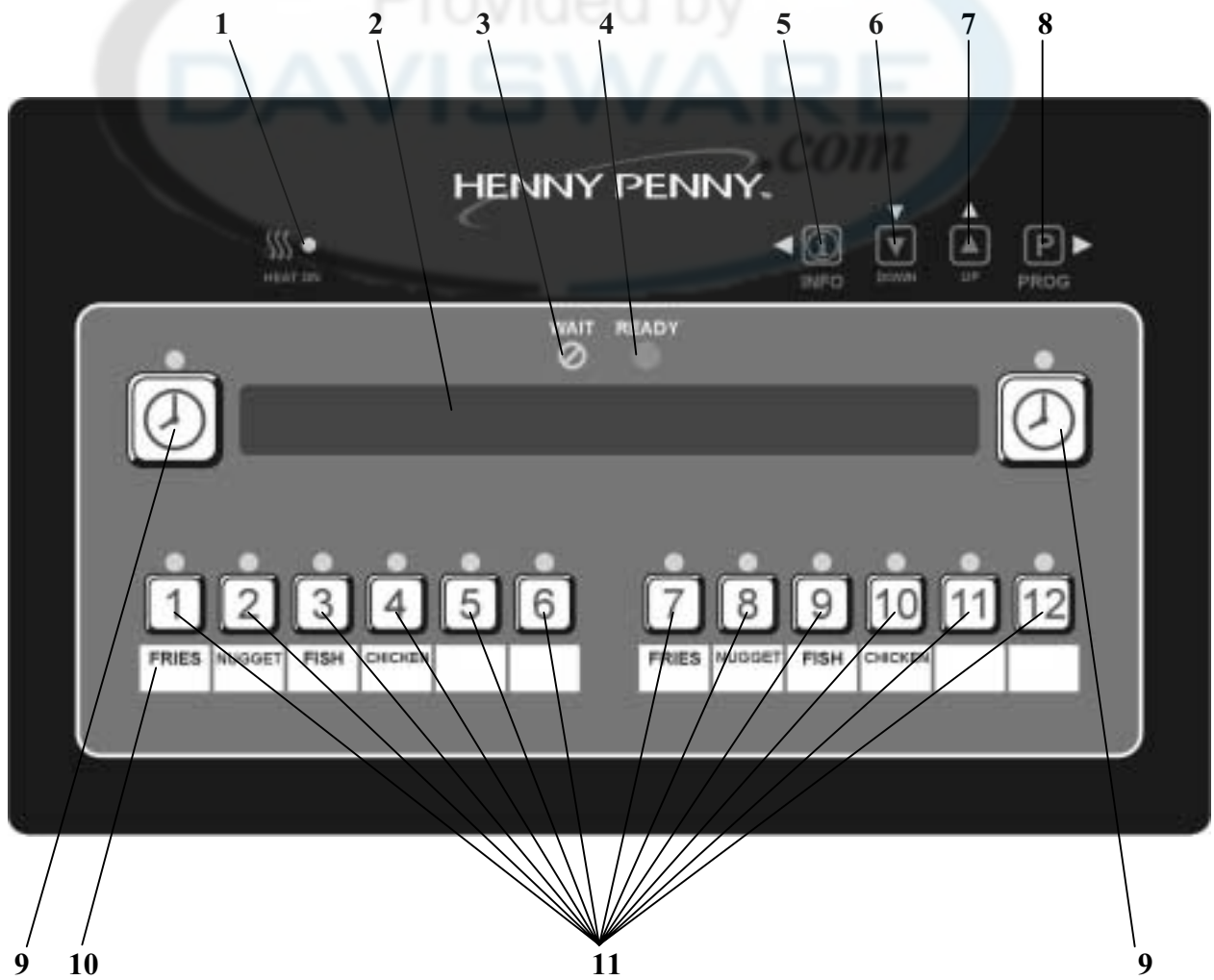

Figure. 3.1

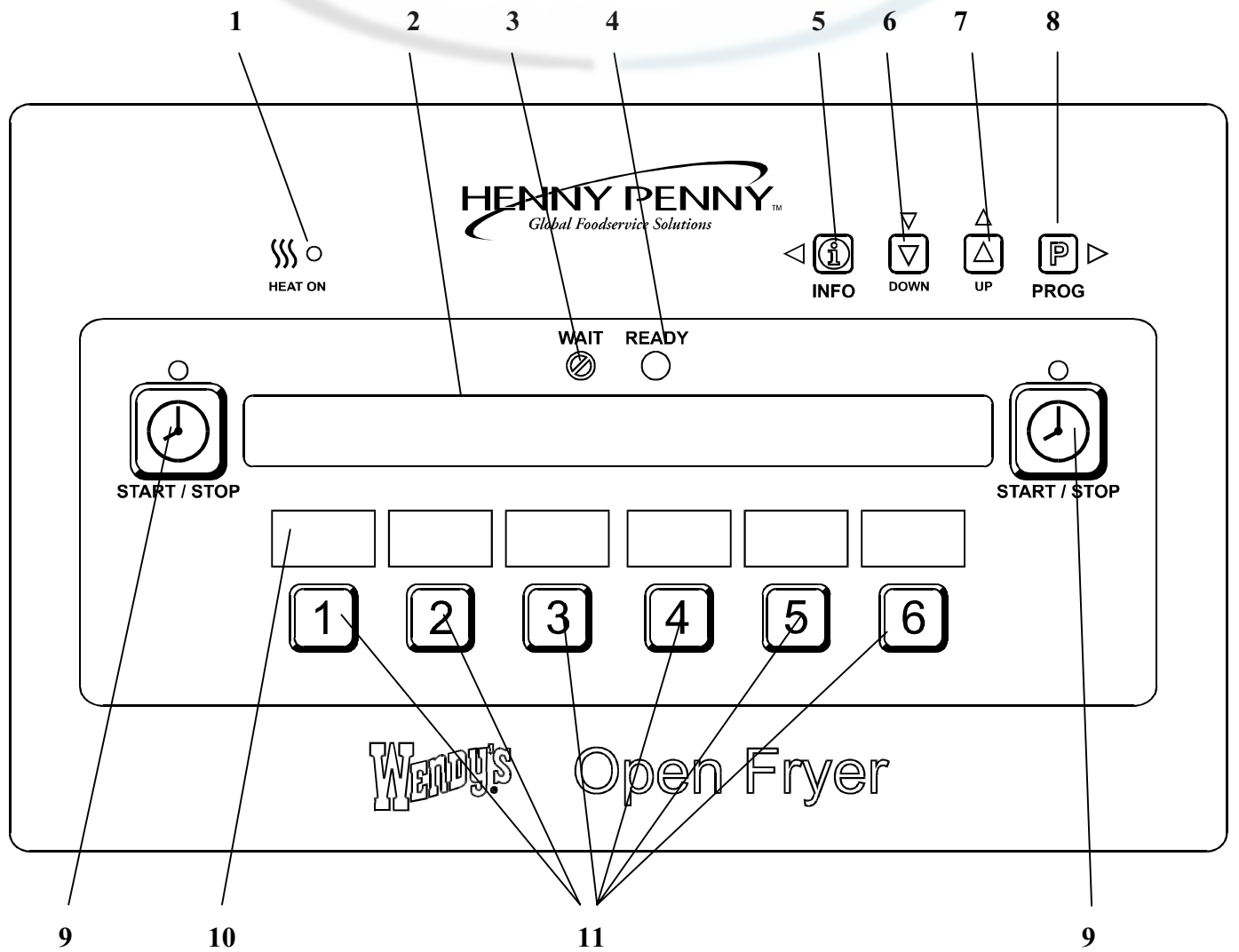

Figure. 3.2

### 3-3. FILLING OR ADDING SHORTENING

It is recommended that a high quality frying shortening be used in the OFG/OFE-320 fry stations. Some low grade shortenings have a high moisture content causing foaming and boiling over. The Henny Penny OFG-320 requires 55 pounds (24.94 kg) of shortening per cookpot. All cookpots have two level indicators inscribed on the rear of the cookpot wall. The top indicator shows when the heated shortening is at the proper level. Cold shortening should be at the bottom indicator, since the shortening will expand when heated.

**WARNING**

Hot shortening must be maintained at the level indicator on each cookpot, or fire could result. It is also recommended to use gloves when in contact with hot shortening. Shortening and all metal parts that are in contact with the shortening are extremely hot and severe burns could result.

Moving the fryer with hot shortening in the cookpots or filter pan is not recommended. Hot shortening can splash out and severe burns could result.

### 3-4. BASIC OPERATIONS AND PROCEDURES (6 Product Controls)

The Henny Penny Open Fry Station has electronic controls for each cookpot. The following is brief description of the operating procedures for controls with 6 Product Buttons.

1. Be sure the drain valve is in the closed position.
2. Place basket support inside of cookpot.
3. Fill the cookpot with shortening.

**WARNING**

When using solid shortening, it is recommended to melt the shortening on an outside heating source before placing it in the cookpots. The heating tubes of the gas cookpot or the elements of the electric pot must be completely submerged in shortening. Fire could result, or damage to the cookpot could result.

**3-4. BASIC OPERATIONS  
AND PROCEDURES  
(6 Product Controls)  
(Continued)**

4. Move power switch to the "ON" position. Unit will automatically go into the melt cycle. When the temperature reaches 230°F (110°C) the control will go into the heat cycle. The shortening will be heated until the temperature setting is reached.

**NOTE**

The OFG-320 series fryer has several safety devices which shuts down the gas supply when they are activated. The above procedures should be followed to restart the cooker and if the shut down is repeated, a qualified technician should be notified.

**NOTE**

The melt cycle may be bypassed, if desired, by pressing a Product button and holding it for five seconds.

**WARNING**

Do not bypass the melt cycle unless enough shortening has melted to completely cover all of the heating tubes. If melt cycle is bypassed before all heating tubes are covered, excessive smoking of the shortening, or a fire will result.

5. Once out of the Melt cycle, the Wait LED will flash until the setpoint temperature has been reached. Then the Ready LED will light, and the selected product will display on the left and right side of the display.

**NOTE**

The timing operation of the two sides of the control is entirely independent. They may be set, started, or stopped without affecting each other.

6. Thoroughly stir shortening to stabilize the temperature throughout the cookpots.
7. Once the shortening temperature has stabilized at the setpoint temperature, the operator can then lower the basket with product into the cookpot.

**WARNING**

Do not overload, or place product with extreme moisture content into the basket. 12.5 lbs. (5.7 kgs.) is the maximum amount of product per cookpot, (15 lbs. (6.75 kgs.) maximum for Auto-lift fryers). Failure to follow these directions can result in shortening overflowing the cookpot. Serious burns or damage to the cookpot could result.

**3-4. BASIC OPERATIONS  
AND PROCEDURES  
(6 Product Controls)  
(Continued)**

8. If the right basket was dropped into the shortening, then the right START/STOP button should be pressed. If the left basket was dropped, then the left START/STOP button should be pressed.
9. Once the START/STOP button has been pressed, the timer on the appropriate side (right or left) will start counting down.
10. At the end of the cook cycle a tone will sound the Display will flash 'DONE'. Press the START/STOP button and lift the basket from the shortening.
11. The display will show which product it is ready to time down. If a HOLD time was programmed, the controller will automatically start the hold timer. The display will alternately show the product selected and the quality time remaining in minutes. If a different product is selected during the hold cycle, the display will only show the product selected. To view the hold time remaining, push the INFO button.
11. At the end of the Hold mode, a tone will sound and the display will flash "QUALITY" and the product it was timing. Press and release the START/STOP button. The display will show the product it is ready to start timing for frying.

**3-5. BASIC OPERATIONS  
AND PROCEDURES  
(Electro-Mechanical)**

The Henny Penny Open Fryer models OFE/OFG are available with electro-mechanical controls. The electro-mechanical controls consist of one timer and one thermostat per well.

1. Be sure the drain valve is in the closed position.
2. Place basket support inside of cookpot.
3. Fill the cookpot with shortening.

**3-5. BASIC OPERATIONS  
AND PROCEDURES  
(Electro-Mechanical)  
(Continued)**

**WARNING**

When using solid shortening, it is recommended to melt the shortening on an outside heating source before placing it in the cookpots. The heating tubes of the gas cookpot or the elements of the electric pot must be completely submerged in shortening. Fire could result, or damage to the cookpot could result.

4. Turn the POWER switch to the On position.
5. Determine the time and temperature settings according to the type of product to be fried.
6. Set the thermostat to the desired temperature.
7. Set the TIMER dial, but do not turn on yet.

**NOTE**

Before placing the product into the basket, make certain the shortening temperature is at the correct frying temperature for the type of product. Also check that the TEMPERATURE light is off.

8. Place the product into the basket. Lower the basket into the shortening. Lift the basket slightly out of the shortening and shake it, causing the pieces to separate. Doing this will prevent white spots on the finished product.

**WARNING**

Do not overload, or place product with extreme moisture content into the basket. 12.5 lbs. (5.7 kgs.) is the maximum amount of product per cookpot, (15 lbs. (6.75 kgs.) maximum for Auto-lift fryers). Failure to follow these directions can result in shortening overflowing the cookpot. Serious burns or damage to the cookpot could result.

9. Turn the TIMER ON/OFF switch to ON.
10. At the end of the frying cycle (the TIMER reaches zero), the TIMER buzzer will sound, and the Timer light will go off.



**3-5. BASIC OPERATIONS  
AND PROCEDURES  
(Electro-Mechanical)  
(Continued)**

11. Turn the TIMER switch to OFF. The TIMER will automatically reset to the previously selected time setting.
12. Lift the basket and hang it on the front of the frypot to drain. Allow the product to drain for approximately 15 seconds before dumping the product onto a tray.
13. Place the product into a warming cabinet immediately.
14. Before frying the next load, allow time for the shortening to reheat. (Wait until the TEMPERATURE light goes off.)

**3-6. BASIC OPERATIONS  
AND PROCEDURES  
(12 Product Controls/Auto-lift)**

The Henny Penny Open Fryer models OFE/OFG are available with 12 product button controls. Also, models OEA/OGA, are available with 12 button controls, equipped with Auto-Lift features. The Auto-lift controls, allows the baskets to be automatically lowered into the shortening, at the beginning of the cook cycle, and raised from the shortening at the end of the cycle.

1. Be sure the drain valve is in the closed position.
2. Fill the cookpot with shortening.

**WARNING**

When using solid shortening, it is recommended to melt the shortening on an outside heating source before placing it in the cookpots. The heating tubes of the gas cookpot or the elements of the electric pot must be completely submerged in shortening. Fire could result, or damage to the cookpot could result.

**3-6. BASIC OPERATIONS  
AND PROCEDURES  
(12 Product Controls/Auto-lift)  
( Continued)**

3. Move power switch to the "ON" position. Unit will automatically go into the melt cycle. When the temperature reaches 250°F (121°C) the control will go into the heat cycle. The shortening will be heated until the temperature setting is reached.

**NOTE**

The OFG-320 series fryer has several safety devices which shuts down the gas supply when they are activated. The above procedures should be followed to restart the cooker and if the shut down is repeated, a qualified technician should be notified.

**NOTE**

The melt cycle may be bypassed, if desired, by pressing

**WARNING**

Do not bypass the melt cycle unless enough shortening has melted to completely cover all of the heating tubes. If melt cycle is bypassed before all heating tubes are covered, excessive smoking of the shortening, or a fire will result.

4. Once out of the Melt cycle, the Wait LED will flash until the setpoint temperature has been reached. Then the Ready LED will illuminate.

**NOTE**

The timing operation of the two sides of the control can be programmed entirely independent from each other for 2 half baskets, or as one timer for a single full sized basket which will set on both lifts. The default setting from the factory is for two half sized baskets. To change to a single full size basket setting, push and hold the #1 product button while turning on the "POWER" switch. To change back to the two basket mode, push and hold the #2 product button while turning on the "POWER" switch.

5. Thoroughly stir shortening to stabilize the temperature throughout the cookpots.

**3-6. BASIC OPERATIONS  
AND PROCEDURES  
(12 Product Controls/Auto-lift)  
( Continued)**

6. Once the shortening temperature has stabilized at the setpoint temperature, the operator may now place the baskets into the shortening, (or for Auto-lift fryers, lift basket onto the hangers,). Place product into the basket.

**WARNING**

Do not overload, or place product with extreme moisture content into the basket. 12.5 lbs. (5.7 kgs.) is the maximum amount of product per cookpot, (15 lbs. (6.75 kgs.) maximum for Auto-lift fryers). Failure to follow these directions can result in shortening overflowing the cookpot. Serious burns or damage to the cookpot could result.

7. If the right basket is to be lowered into the shortening, then one of the right product buttons should be pressed. If the left basket is to be lowered, then one of the left product buttons should be pressed.
8. The timer on the appropriate side will start counting down. (On Auto-lift fryers, the basket will automatically lower into the shortening.)
9. At the end of the cook cycle, a tone will sound and the display will show "DONE". Lift the basket from the shortening. (On Auto-lift fryers, the basket will automatically raise out of the shortening.) To stop the "DONE" beeper, either press the "TIMER" button, or the product button.

**NOTE**

A different product can be selected during the first minute of cooking.

10. The display will show which product it is ready to time down. If a HOLD time was programmed, the controller will automatically start the hold timer. The display will alternately show the product selected and the hold time remaining in minutes. If a different product is selected during the hold cycle, the display will only show the product selected.

### 3-6. BASIC OPERATIONS AND PROCEDURES

(12 Product Controls/Auto-lift)  
( Continued)

11. At the end of the Hold mode, a tone will sound and the display will flash "QUALITY" and the product it was timing. Press and release the TIMER button.

#### NOTE

In the Cook mode, when "FILTER SUGGESTED," shows in the display, the operator has the option to filter at this time, or to continue cooking. But, if the operator continues cooking, a Filter Lockout will occur within the next cook cycle, or two.

When "**FILTER LOCKOUT**", then "**YOU \*MUST\* FILTER NOW.....**" shows in the display, the PROG button is the only button that will function, until the unit is filtered.

### 3-7. FILTERING OF SHORTENING

Frying breaded food requires frequent filtering. Taste the cold shortening every day for flavor. Watch the shortening for foaming during the frying cycle. Discard the shortening as soon as it shows sign of foaming. Clean the cookpot as follows each time the shortening is changed or filtered.

1. Turn the main switch to the OFF position. Remove and clean the fry basket in soap and water. Rinse thoroughly.

#### NOTE

Best results are obtained when shortening is filtered at the normal frying temperature.

2. Use a metal spatula to scrape any build up from the sides of the cookpot. Do not scrape heating tubes on the gas models, or heating elements on electric models.

#### WARNING

Position the filter pan properly, under the drain valve, to prevent splashing of hot shortening. Severe burns could result.

### 3-7. FILTERING OF SHORTENING (Continued)

3. Open door(s) under unit, and slowly turn drain valve handle a half turn. Leave for a few minutes, then slowly, fully open drain valve. This prevents much splashing of the hot shortening as it drains.
4. As the shortening drains from the cookpot, use brushes to scrape and clean the sides of the cookpot and the heat tubes or heating elements. If the drain fills with breading, use straight white brush to push excess breading into the drain pan.
5. When all of the shortening has drained, scrape or brush the sides and the bottom of the cookpot.
6. Rinse the cookpot as follows:
  - Standard fryers**
    - a. Close the drain valve.
    - b. Position return line over empty cookpot.
    - c. Move the pump switch to the pump position.
    - d. Fill the cookpot 1/3 full, then turn off pump.

**Figure 3-3**  
**Filter Handle**



#### **Autolift fryers**

- a. Close the drain valve.
- b. Turn filter handle to the on position. Figure 3-3.
- c. Fill the cookpot 1/3 full.
- d. Turn filter handle to the off position.

**WARNING**

Use care when reaching across a cookpot of hot shortening. Severe burns could result.

- e. Wash down and scrub the sides of the frypot with the brushes.
- f. After the sides and bottom are cleaned, open the drain valve.

**WARNING**

If shortening flow is slow from faucet, use gloves to tighten the filter union. This union will be hot, and severe burns could result.

### 3-7. FILTERING OF SHORTENING (Continued)

7. Pump all of the shortening out of the filter pan and back into the cookpot.
8. When the pump is pumping air only, move the pump switch from PUMP to OFF, or on autolift fryers, turn filter handle to OFF.
9. Check the level of the shortening in the cookpot. Add fresh shortening if necessary, until it reaches the top level indicator line on the rear wall of the cookpot.

#### NOTE

About 10 to 12 filterings can be made with one filter paper envelope, depending on:

- the quantity and type of product fried and filtered
- the type of breading used
- the amount of crumbs left inside the filter drain pan

When the filter screen assembly and filter paper become clogged, and the pumping flow slows, clean the screen assembly and change the filter envelope.

10. To continue cooking, move the main power switch to the "ON" position, and shortening reheats.

### 3-8. FILTER PUMP PROBLEMS

To help prevent filter pump problems:

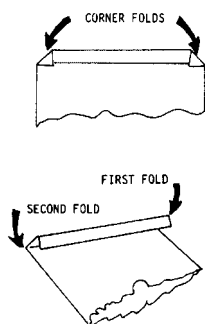

1. Properly install paper envelope over the filter screens. Fold the open end of the envelope, and clamp With retaining clips so that crumbs cannot enter.
2. Pump shortening, until no shortening is coming from nozzle.

### 3-9. FILTER PUMP MOTOR PROTECTOR

The filter pump motor is equipped with a manual reset button in the event the motor's thermal protector actuates. This reset button is located on the rear of the motor. Wait approximately 5 minutes before attempting to reset this protector device.

### 3-9. FILTER PUMP MOTOR PROTECTOR (Continued)

**WARNING**

To prevent burns caused by splashing shortening, the unit's filter pump switch must be in the OFF position before resetting the filter pump motor's manual reset protector device.

**NOTE**

The reset button will take some effort to reset. A screwdriver could be used to press against the reset button to aid in resetting the protector device.

### 3-10. CHANGING THE FILTER ENVELOPE

The filter envelope should be changed after 10-12 filterings or whenever it becomes clogged with crumbs. Proceed as follows:

1. Move the main power switch to the OFF position.
2. Disconnect the filter union and remove the filter drain pan from beneath the cookpot.

**WARNING**

This unit maybe hot. Use protective gloves or cloth to prevent burns. Also use care to prevent burns caused by splashing of hot shortening.

3. Remove drain pan cover from drain pan and lift the screen assembly from the drain pan.
4. Wipe the shortening and crumbs from the drain pan. Clean the drain pan with soap and water. Thoroughly rinse with hot water.
5. Unthread the suction standpipe from the screen assembly.
6. Remove the crumb catcher and clean thoroughly with soap and water. Rinse thoroughly with hot water.
7. Remove the filter clips and discard the filter envelope.

**3-10. CHANGING THE FILTER ENVELOPE (Continued)**

8. Clean the top and bottom filter screen with soap and water. Rinse thoroughly with hot water.

**CAUTION**

Be sure that the filter screens, crumb catcher, filter clips and the suction standpipe are thoroughly dry before assembly of filter envelope or water will dissolve the filter paper.

9. Assemble the top filter screen to the bottom filter screen.
10. Slide the screen into a clean filter envelope.
11. Fold the corners in and then double fold the open end.
12. Clamp the envelope in place with the two filter retaining clips.
13. Replace the crumb catcher screen on top of the filter paper. Screw on the suction standpipe assembly.
14. Place complete filter screen assembly back into filter drain pan, replace cover, and slide pan back into place beneath the fryer.
15. Connect the filter union by hand. Do not use a wrench to tighten.
16. The fryer is now ready to operate.

**3-11. CLEANING THE COOKPOTS**

After the initial installation of the fryer, as well as before every change of shortening, the cookpot should be thoroughly cleaned as follows:

1. Turn the main power switch OFF.

**WARNING**

The filter drain pan must be in position under the drain valves to prevent splashing or spilling of hot liquids which can cause serious burns.



### 3-11. CLEANING THE COOKPOTS (Continued)

2. If hot shortening is present in the cookpot, it must be drained by slowly opening the drain valve handle one half turn. Leave for a few minutes, then slowly open the valve to full open position.
3. Close the drain valve. Discard the shortening in the filter pan using the shortening shuttle. Then install the filter drain under the fryer, leaving out the filter screen assembly.

**WARNING**

Moving the fry station, or drain pan, with hot shortening in them is not recommended. Hot shortening can splash out, and severe burns could result.

4. Fill the cookpot to the level indicator with hot water. Add 4 ounces (.12 l) of fryer cleaner to the water and mix thoroughly. The fry basket can be placed inside the cookpot for cleaning.

**WARNING**

**Always wear chemical splash goggles or face shield and protective rubber gloves when cleaning the cookpot as the cleaning solution is high in alkaline. Avoid splashing or other contact of the solution with your eyes or skins. Severe burns may result. Carefully read the instructions on the cleaner. If the solution comes in contact with your eyes rinse thoroughly with cool water and see a physician immediately.**

5. Turn the main POWER switch to the POWER position and set temperature to 200° F.
6. When the solution reaches 200° F, turn the main power switch to the OFF position.

**CAUTION**

Watch cleaning solution constantly to make sure it does NOT boil over, and **do not** spray the unit with water, such as, with a garden hose. Failure to follow these directions could cause component failure.

**3-11. CLEANING  
THE COOKPOTS  
(Continued)**

7. Let the cleaning solutions stand for 15 to 20 minutes with the power off.
8. Using the fryer brush (never use steel wool), scrub the inside of the cookpot.

**CAUTION**

**DO NOT** use harsh abrasive cleaners, or cleaners containing chlorine, bromine, iodine, or ammonia chemicals on the stainless steel, as these will deteriorate the stainless steel.

9. After cleaning, open the drain valve and drain cleaning solution from the cookpot into the drain pan and discard.
10. Replace the empty drain pan, close the drain valve, and refill the cookpot with plain hot water to the proper level.
11. Add approximately 8 ounces (.24 l) of distilled vinegar and bring the solution back up to 200°F (93° C).
12. Using a clean brush, scrub the interior of the cookpot. This will neutralize the alkaline left by the cleaning compound.
13. Drain the vinegar rinse water and discard.
14. Rinse down the cookpot using clean, hot water.
15. Thoroughly dry the drain pan and the cookpot interior.

**NOTE**

Make sure the inside of the cookpot, the drain valve opening, and all the parts that will come in contact with new shortening are as dry as possible.

16. Replace the clean filter screen assembly in the drain
17. Refill the cookpot with fresh shortening.

### 3-12. LIGHTING AND SHUTDOWN OF THE BURNERS

1. Turn the Power Switch to the OFF position.
2. Rotate the gas valve knob clockwise to the OFF position and wait at least five(5) minutes before continuing to the next step.
3. Rotate gas valve counter clockwise to the ON position.
4. Place the Power Switch to the ON position.
5. The burner will light and operate in a melt cycle mode until the shortening reaches a preset temperature.
6. Press the desired Product button after the display and LED shows READY.

To Shutdown burner:

1. Turn the Power Switch to the OFF position.
2. Rotate gas valve knob to the OFF position.

This fryer is equipped with a grounded cord and plug for your protection against electrical shock, and should be plugged into a 3 prong grounded receptacle. DO NOT cut or remove the grounding prong.

**WARNING**

Before servicing the fryer, the burner should be shut down and the electrical supply removed from the unit. The fryer should be unplugged or the wall circuit breaker turned off, or electrical shock could result.

**3-13. REGULAR MAINTENANCE**

As in all food service equipment, the Henny Penny Open Fryer does require care and proper maintenance. The table below provides a summary of scheduled maintenance procedures to be performed by the operator.

<b>Procedure</b>	<b>Frequency</b>
Filtering of shortening	Daily (3-4 loads) See section 3-5
Changing of shortening	When shortening smokes, foams up violently, or tastes bad.



The shortening should be changed regularly. With prolonged use, the flashpoint of shortening is reduced and it tends to foam up more, which could cause serious burns, personal injury, fire and property damage.

Changing the filter envelope	After 10-12 filterings, or when envelope is clogged with crumbs. See section 3-8
Cleaning the cookpot	Every change of shortening. See section 3-9

## SECTION 4. PROGRAMMING

### 4-1. INTRODUCTION

The controls are preset from the factory, but desired functions can be programmed in the field. Press and hold the PROG button for one second to access the Product Programming Mode. By continuing to hold the PROG button for five seconds, you may access Level 2 programming.

### 4-2. PRODUCT PROGRAM MODE

This mode allows the operator to change and set various parameters for each product.

1. Press and hold the PROG button for one second. "PROG" will show in the display.
2. After 5 seconds, "ENTER CODE" will scroll through the display.
3. Enter code 1,2,3. "SELECT PROG PRODUCT" now scrolls across the display.
4. Press and release the desired Product button (1 thru 12, - 12 timer controls or, 1 thru 6, - 6 timer controls).
5. Press and release the PROG button. The present name of that product will show in the display. Ex. "NAME" "FRIES".  
**Change Product Names**
  - a. Press and release the the Up or Down arrows and the first letter, or digit, will start flashing.
  - b. Press and release the Up or Down arrows to change the flashing letter.
  - c. To continue to the next letter, press the PROG button. Then press the Up or Down buttons to change this letter.
6. Press and release the PROG button and "COOK TIME" shows in the display along with the preset time in the right side of the display. Press the Up or Down buttons to change the time. The time will show in minutes and seconds. Press and hold the buttons, and the time will jump by 5 second increments to a maximum of 59:59.

**4-2. PRODUCT PROGRAM  
(Continued)**

7. Press and release the PROG button a second time and "TEMP" shows in the display, along with the preset temperature on the right side of the display. Press the Up or Down button to change the temperature. Press and hold the buttons and the temperature will jump by 5 degree increments to a maximum of 390°F (200°C), and a minimum of 200°F (100°C).
8. Press and release the PROG button a third time and "COOK ID" shows in the display along with the product ID. For example, "FF" would be the ID for french fries And "NU" would be the ID for nuggets. Press the Up and Down arrows to change the ID letters.
9. Press and release the PROG button a fourth time and "LOAD COMP" shows in the display along with the load compensation value on the right side of the display. Press and release the Up and Down arrows to change this value to a maximum of 20 and a minimum of 0.
10. Press and release the PROG button a fifth time and "LCOMP AVG" shows in the display along with the load compensation average temperature on the right side of the display. Press and release the Up and Down arrows to change this value to a maximum of 50 degrees below the setpoint temperature.
11. Press and release the PROG button a sixth time and "ALARM – 1 AT 0:00" shows in the display. Press and release the Up and Down arrows to set a time an alarm is to sound. Ex : If a cook cycle was set at 3 minutes, and an alarm was to go off after 30 seconds into the cook cycle, "2:30" would be set in the display at this time. When the timer counts down to 2:30 the alarm will sound.

**NOTE**

Up to 4 alarms can be programmed. After the first one is set, the other alarms can be accessed by pressing the PROG button again.

## 4-2. PRODUCT PROGRAM (Continued)

### NOTE

On 12 button controls, additional prompts will show in the display. These will be “NONE”, “SHAKE”, “STIR”, “ADD”, or “PAUSE”. Use the “UP” and “DOWN” buttons to select the word to show in the display if an alarm is programmed. If the “PAUSE” mode is selected, on Auto-lift fryers, the basket will automatically raise out of the shortening and timer will stop the countdown. The TIMER button must be pressed to lower the basket back into the shortening and resume the timer.

12. Press and release the PROG button until "QUALITY TMR" shows in the display along with the preset holding time on the right side of the display. Press and release the Up and Down buttons to adjust the holding time.

### NOTE

To exit the Program mode at any time, press and hold PROG button for 2 seconds.

### Filter Cycle Mode (Optional)

For "2,MIXED", or "3,GLOBAL" to appear in the Product Program mode, the Filter Tracking must be enabled in the Special Program Mode. (See section 4-3.)

13. Press the PROG button.
  - "2,MIXED"**
    - a. "FILTER AFTER" shows in the display, along with the preset number of cook cycles on the right side of the display.
    - b. Press and release the Up and Down buttons until the desired number of cook cycles between filters shows in the display. For example, if 4 is set for a product, each time that product is selected, it count 1/4, or 25%. Then each time a product is selected, the percentages add up until 100%, or more is reached. Then the display shows "FILTER SUGGESTED".
  - "3,GLOBAL"**
    - a. "FILTER INCL" shows in the display, along with "NO" or "YES"
    - b. Press and release the Up and Down buttons to "YES" if that product is to be included in the filter count, or "NO" if is not.

### 4-3. SPECIAL PROGRAM MODE

The Special Program mode is used to set more detailed parameters listed below.

- SP-1** • Degrees Fahrenheit or Celsius
- SP-2** • Language: English, French, German, Spanish and Portuguese.
- SP-3** • System Initialization (Factory Presets)
- SP-4** • Audio Volume
- SP-5** • Audio Tone
- SP-6** • Audio Effect
- SP-7** • Type of Shortening to be Melted - Liquid, Solid
- SP-8** • Idle Mode
- SP-9** • Filter Tracking
- SP-10** • Product Buttons
- SP-11** • Cooking Display
- SP-12** • Quality Timer Display
- SP-13** • Baskets - 1 or 2 (12 Product Controls Only)
- SP-14** • Auto-lift Detection (12 Product Controls Only)

1. Press and hold the PROG button for 5 seconds until "L-2" and "LEVEL 2", followed by, "SP PROG" and "ENTER CODE" shows in the display.
2. Enter code 1,2,3, and "SP- 1 ", "TEMP, UNITS" shows in the display.

#### **NOTE**

If a bad code is entered, a tone will sound and "BAD CODE" will show on the display. Wait a few seconds, the control will revert back to the cook mode, and repeat the above steps.

To exit from the Special Program mode at any time, press and hold the PROG button for 2 seconds.

#### **Degrees Fahrenheit or Celsius (SP-1)**

- a. Follow steps 1 and 2 above.
- b. The display will flash "SP- 1" and "TEMP, UNITS", along with "°F" or "°C" in the right side of the display. Press the Up or Down buttons to toggle from "°F" to "°C", or vice versa.



### 4-3 SPECIAL PROGRAM MODE (Continued)

#### Language (SP-2)

- a. Follow steps 1 and 2 above.
- b. Press and release the PROG button. "SP-2" and "LANGUAGE" will flash on the display, along with the language type in the right side of the display (Ex: " 1.ENGL")
- c. To toggle to the desired language, press and release the Up and Down buttons.

#### System Initialization (SP-3)

This step will reset the cook programs to factory settings.

- a. Follow steps 1 and 2 above.
- b. Press and release the PROG button twice. "SP-3" and "DO SYSTEM INIT" will flash on the display, along with "INIT" on the right side of the display.
- c. Press and hold the Down button. "INIT" will show on the display, a tone will sound, and "IN 3", "IN 2", "IN 1" will flash on the right side of the display. When "INIT" starts flashing on the left side of the display, release the Up or Down button. When "DONE" shows on the display, the initialization is complete, and the controls now have factory preset parameters.

#### Audio Volume (SP-4)

The volume of the speaker can be adjusted.

- a. Follow steps 1 and 2 above.
- b. Press the PROG button 3 times. "SP-4" and "AUDIO VOLUME" will flash on the display, along with the volume value on the right side of the display.
- c. Press the Up and Down buttons to adjust the volume of the speaker, 10 being the maximum value and 1 the minimum.

#### Audio Tone (SP-5)

The tone of the speaker can be adjusted.

- a. Follow steps 1 and 2 above.
- b. Press the PROG button 4 times. "SP-5" and "AUDIO TONE (HZ)" flashes on the display, along with the tone value on the right side of the display.
- c. Press the Up and Down buttons to adjust the tone of the speaker, 2000 being the maximum, 50 being the minimum.

### 4-3. SPECIAL PROGRAM MODE (Continued)

#### Audio Effect (SP-6)

This setting lets you add an “audio effect”- i.e. a pulsed or “warble” sound effect – to the beeps generated in the cook mode.

- a. Follow steps 1 and 2 above.
- b. Press the PROG button 5 times. “SP-6” and “Audio Effect” will show in the display, along with the effect Value in the right of the display.
- c. Press the Up and Down buttons to change the sound effect of the tone. The numbers correspond as follows:
  - 0 = Normal Tone
  - 1 = Fast-Pulsed Tone
  - 2 = Slow Pulsed Tone
  - 3 = Warble Tone

#### Type of shortening to be melted - Liquid or Solid (SP-7)

The Melt cycle can be set to the type of shortening being used.

- a. Follow steps 1 and 2 above.
- b. Press and release the PROG button 6 times. "SP-7" and "MELT CYCLE SELECT" will flash on the display, along with "1=LIQ" or "2=SOLID" will show on the right side of the display.
- c. Press the Up or Down buttons to toggle from one type to another.

**WARNING**

The type of shortening being used in the cooker determines the amount of heat applied during the Melt cycle. If the controls are set to the Solid setting, less heat is applied to the shortening, than if the controls were set to Liquid. Too much heat applied to solid shortening will cause much smoking, and could cause a fire. This setting should match the type of shortening being used at the time.

### 4-3. SPECIAL PROGRAM MODE (Continued)

**WARNING**

When using solid shortening, it is recommended to melt some of the shortening on an outside heating source before placing the shortening in the cookpots. The heat exchange tubes must be completely surrounded by **liquid** shortening. Fire or damage to the cookpot could result.

#### Idle Mode (SP-8)

An Idle mode can be programmed to allow the shortening temperature to drop to a lower temperature when not in use. This will be a savings on the shortening and utilities.

- a. Follow steps 1 and 2 above.
- b. Press and release the PROG button 7 times.  
"SP-8" and "IDLE MODE ENABLED?" flashes in the display, along with "NO" or "YES" on the right side of the display.
- c. Press and release the Up or Down buttons to toggle from NO to YES, or vice versa.
- d. With "YES" in the display, the Idle mode is enabled.  
Press and release the PROG button. "SP-8A" and "IDLE SETPT TEMP" shows in the display, along with the preset temperature in the right side of the display.
- e. The setpoint, at which the temperature the shortening will stay idle at, can be changed at this time by pressing the Up or Down buttons.
- f. Press and release the PROG button. "SP-8B" and "AUTO-IDLE MINUTES" shows in the display, along with the preset time on the right side of the display.
- g. Press the Up and Down buttons to set the minutes the cooker stays idle before the Auto-idle is enabled, 60 being the maximum, OFF the minimum. Ex: "30" in the display means, if product is not cooked in that particular cookpot for 30 minutes, the control will automatically cool the shortening down to the idle setpoint temperature, programmed above.
- h. To use Product button number 6 (P6) as the Idle button (P12 for 12 button controllers), press the PROG button. "SP8C" and "USE P 6 FOR IDLE (12 for 12 button controllers), shows in the display, along with "NO" or "YES" on the right side of the display.

### 4-3. SPECIAL PROGRAM MODE (Continued)

- i. Press the Up or Down buttons to toggle from NO to YES. If "YES" is in the display, then during a time of low volume, the operator can press the P6 button (or P12) to manually enter the Idle mode.

#### **NOTE**

Programming the Idle on Auto-lift fryers, disables the basket lift function of the P12 button.

#### **Filter Tracking Enabled (Sp-9 - 6 Product Controls)**

The controls can be set to signal the operator when the shortening needs filtering. The Filter Tracking must be enabled to program the number of cook cycles between filtering procedures. (See Filter Cycles section 4-2.)

- a. Follow steps 1 and 2 above.
- b. Press and release the PROG button until "SP" and "FILTER TRACKING ENABLED" flashes on the display, along with "YES" or "NO" on the right side of the display.
- c. To enable the filter tracking, press either the Up or Down buttons to toggle the display from "NO" to "YES".
- d. Press the PROG button and "SP-10A" will show in the display followed by "SUGGEST FILTER AT ..." and a value between 75% and 100% on the right display. Press and release the Up and Down arrows to change this value.
- e. Press the PROG button and "SP10B" will show in the display followed by "FILTER LOCKOUT AT..." AND a value between 100% and 200% in the right display. Press and release the Up and Down arrows to change this value.
- f. Now, go back to the Product Program mode, to the Filter Cycle, and program in the number of cook cycles

#### **Filter Tracking Enabled (Sp-9 - 12 Product Controls)**

The controls can be set to signal the operator when the shortening needs filtering. The Filter Tracking must be enabled to program the number of cook cycles between filtering procedures. (See Filter Cycles section 4-2.)

- a. Follow steps 1 and 2 above.
- b. Press and release the PROG button until "SP-9" and "FILTER TRACKING ENABLED" flashes on the display, along with "1,OFF" on the right side of the display.

### 4-3. SPECIAL PROGRAM MODE (Continued)

- c. To enable the filter tracking, press either the Up or Down buttons to toggle the display from "1,OFF", to "2,MIXED", or, "3,GLOBAL".

#### NOTE

The Mixed setting allows the operator to set different amounts of cook cycles, between filters, for each product. If the operator wants to have one setting for all products, go to **step g**.

- d. If "2,MIXED" is selected, press the PROG button and "SP-9A" will show in the display followed by "SUGGEST FILTER AT ..." and a value between 75% and 100% on the right display. Press and release the Up and Down arrows to change this value.
- e. Press the PROG button and "SP-9B" will show in the display followed by "FILTER LOCKOUT AT..." and a value between 100% and 200% in the right display. Press and release the Up and Down arrows to change this value.
- f. Now, go back to the Product Program mode, to the Filter Cycle, and program in the number of cook cycles between filtering.
- g. If "3,GLOBAL" is selected, "SP-9A" shows in the display, and followed by "GLOBAL FILTER CYCLES". The right side of the display will show a digit, 1 to 99. Press the Up or Down buttons to set the desired amount of cook cycles between filters.

#### NOTE

When the unit is on, the number of global cook cycles remaining, before Filter Lockout occurs, shows in the center of the display.

Ex: "----- 5x -----".

- h. Now, go back to section 4-2 and enter the Program mode. Press the PROG until "FILTER INCL" shows in the display (step 13). Each product must be set to "YES" to be included in the filter tracking.

### 4-3. SPECIAL PROGRAM MODE (Continued)

#### Product Buttons (Sp-10)

This mode allows you set up the way the product buttons are displayed in the cook mode.

- a. Follow steps 1 and 2 above.
- b. Press and release the PROG button until “SP-10” and “PRODUCT BUTTONS” flashes in the display.
- c. The first option, “1,COOK”, will display only the product button that is selected. When nothing is cooking, no product will be displayed. Products 1,2,and 3 will display on the left timer only, and products 4,5, and 6 will display on the right timer only. (1 to 6 on the left timer only, and 7 to 12, for 12 product controls)
- d. The second option, “2,L+R” (“2,SELECT” for 12 product controls), will automatically display the product button selected in both timer displays. The TIMER buttons start the cook cycle.
- e. **(6 Product Controls Only)** The third option, , “3,L/R”, will make the operator determine which timer the product selected goes to. If no timer switch is selected, then the product selected will automatically display in both timers. The TIMER buttons start the cook cycle.

#### Cooking Display (Sp-11)

This mode lets the operator set up the display during a cook cycle.

- a. Follow steps 1 and 2 above.
- b. Press the PROG button until “SP-11” and “COOKING DISPLAY” shows in the display.
- c. The first option, “1,TIME”, will set the display to read only the time remaining in the cook cycle during a cook mode.
- d. The second option, “2,TM+ID”, will set the display to read both the time remaining in the cook cycle and also the product ID.(ie. FF=French Fries)
- e. The third option, “3,NM+TM”, will set the display to alternate between showing the name of the product being timed, and the time remaining in the cook cycle.

### 4-3. SPECIAL PROGRAM MODE (Continued)

#### Quality Timer Display (SP-12)

This mode lets the operator set up the display during the quality timer countdown.

- a. Follow steps 1 and 2 above
- b. Press the PROG button until “SP-12” and “QUALITY TMR DISPLAY” shows in the display.
- c. The first option, “1,NONE”, means that the display will not show the quality time remaining after a cook cycle. The only way to view the quality time remaining is to push the INFO button.
- c. The second option, “2,QT+ID”, will set the display to constantly show the quality time remaining and the product ID that the quality time is holding for after a cook cycle.
- d. The third option, “3,NM+QT”, will set the display to alternate between the name of the product the timer is ready to count down for, and the quality time remaining for the product just cooked.

#### 6 Product Controls Only

##### Enable 2 products Per Button (SP-13)

This mode is an option that will allow the operator to be Able to program 2 product times on each button.

- a. Follow steps 1 and 2 above.
- b. Press the PROG button until “SP-13” an “ENABLE 2 PRODS PER BTN?” shows in the display. “YES” or “NO” will show on the right side of the display.
- c. Press and release the UP and DOWN arrows to toggle between “YES and “NO”. If “NO” is displayed, only one product may be programmed per each product button. If “YES” is displayed, two products may be programmed per each product button. They will be displayed as “1A”, “1B”-“2A”, “2B” Etc.

#### 12 Product Controls Only

##### Number of Baskets (SP-13)

This allows the operator to set the controls for use of 1 basket or 2.

- a. Follows steps 1 and 2 above.
- b. Press PROG until "SP-13" and "NUMBER OF BASKETS" shows in the display.
- c. Press the UP or DOWN buttons to toggle between "1,BSKT", or "2,BSKT".

**4-3. SPECIAL PROGRAM  
MODE (Continued)**

**12 Product Controls Only  
Auto-lift Detection (SP-14)**

- a. Follows steps 1 and 2 above.
- b. Press PROG until "SP-14" and "AUTOLIFT" shows in the display.
- c. Keep the controls set at "1,DETECT" for the controls to automatically detect the autolift or not.
- d. Press the Up or Down buttons to select "2,\*OFF\*", to disable the auto-lift. This can be used to bypass the auto-lift mechanism, if the auto-lift becomes disabled.
- e. Press the Up or Down buttons to select "3,\*ON\*", to force the auto-lift feature, if the controls are not detecting the auto-lift.

**4-4. DATA LOGGING, HEAT  
CONTROL, TECH MODE,  
AND STAT MODE**

The Data Logging, Heat Control, Tech and Stat modes are advanced diagnostic and program modes, mainly for Henny Penny use only. For more information on these Modes, contact the Service Department at 1-800-417- 8405, or 937-456-8405.



**SECTION 5. TROUBLESHOOTING**

**5-1. INTRODUCTION**

This section provides troubleshooting information in the form of an easy-to-read table.

If a problem occurs during the first operation of a new fryer, recheck the installation per Section 2 of this manual.

Before troubleshooting, always recheck the operating procedure per Section 3 of this manual.

**5-2. TROUBLESHOOTING**

In the event of a control system failure, the digital display will show an "Error Message." These messages are coded: E4, E5, E6, E10, E15, E20, E41, E46, and E92. A constant tone is heard when an error code is displayed, and to silence this tone, press any button.

<b>DISPLAY</b>	<b>CAUSE</b>	<b>PANEL BOARD CORRECTION</b>
E4	Control Board Overheating	Turn switch to OFF position, then turn switch back to ON. If display shows E4, the control board is getting too hot. Check the louvers on each side of the unit for obstructions.
E5	Shortening Overheating	Turn switch to OFF position, then turn switch back to ON. If display shows E5, the heating circuits and temperature probe should be checked.
E6-A	Thermal Sensor Open	Turn switch to OFF position, then turn switch back to ON. If display shows E6 the thermal sensor should be checked. To replace, refer to section 6-6.
E6-B	Thermal Sensor Shorted	Turn switch to OFF position, then turn switch back to ON. If display shows E6 the thermal sensor should be checked. To replace, refer to section 6-6.
E10	High Limit	Reset the high limit by manually pushing up on the red reset button. If high limit does not reset, high limit must be replaced per section 6-3.
E15	Drain Switch Failure	Close drain, using the drain valve handle. If display still shows E-15, check the drain microswitch per section 6-14.

## 5-2. TROUBLESHOOTING (Continued)

DISPLAY	CAUSE	PANEL BOARD CORRECTION
E41, E46	Programming Failure	Turn switch to OFF, then back to ON. If display shows any of the error codes, try to reinitialize the control (Section 4-3). If error code persists, replace the control board per section 6-4.
E-20 A	Air Pressure Switch Failure (stuck closed)	Press the Timer button to try the ignition process again, and if E-20 A persists check the air switch per section 6-12.
E-20 B	Draft Fan or Air Pressure Switch Failure (stuck open)	Press the Timer button to try the ignition process again, and if E-20 B persists, check the air switch per section 6-12 or the blower motor per section 6-17.
E-20 C	Ignition Modules Not Responding	Press the timer button to try the ignition process again. If E-20 C persist, check the ignition module per section 6-9, or the spark ignitor per section 6-8, or the I/O board per section 6-11.
E-20 D	Pilots Not Lit or No Flame Sense	Press the timer button to try the ignition process again. If E-20 D persist, check the ignition module per section 6-9, or the I/O board per section 6-11, or the flame sensor per section 6-7.
E-92	24 VAC Fuse On I/O Open	24 VAC fuse on I/O Board open. Check for shorted component in 24 volt circuit. (I.E., Hi Limit, Drain Switch, Air Switch).

**5-2. TROUBLESHOOTING  
(Continued)**

PROBLEM	CAUSE	POWER CORRECTION
<p>With the switch in the POWER position, fryer is completely inoperative.</p>	<p>Open Circuit</p>	<ul style="list-style-type: none"> <li>• Check to see if unit is plugged in.</li> <li>• Check breaker or fuse at supply box.</li> <li>• Check POWER switch per section 6-5. Replace if defective.</li> <li>• Check voltage at wall receptacle.</li> <li>• Check cord and plug.</li> </ul>
<p>Shortening will not heat but lights are on.</p>	<p>Faulty Contactor (elec. model)</p> <p>Faulty Gas Valve (gas model)</p> <p>Faulty Probe</p> <p>Faulty High Limit</p> <p>Faulty Drain Switch</p>	<ul style="list-style-type: none"> <li>• Check contactor per Section 6-19.</li> <li>• Check gas valve per Section 6-16.</li> <li>• Check probe per Section 6-6. “Error message” E6.</li> <li>• Check High Limit per Section 6-3 or 6-12. “Error message” E10.</li> <li>• Check drain switch per Section 6-14. “Error Message E15)</li> </ul>
<p>Heating of shortening too slow</p>	<p>Low or improper voltage (elec. unit)</p> <p>Weak or burnt out elements (elec. model)</p> <p>Wire(s) loose</p> <p>Burnt or charred wire connection</p> <p>Faulty contactor</p> <p>Supply line too small - low gas volume (gas unit)</p> <p>Improper ventilation system (gas unit)</p>	<ul style="list-style-type: none"> <li>• Use a meter and check the receptacle voltage against the data plate.</li> <li>• Check heating elements per Section 6-18.</li> <li>• Tighten</li> <li>• Replace wire and clean connectors.</li> <li>• Check contactor per Section 6-19.</li> <li>• Increase supply line size. Refer to installation instructions.</li> <li>• Refer to Section 2-5.</li> </ul>

**5-2. TROUBLESHOOTING  
(Continued)**

PROBLEM	CAUSE	POWER CORRECTION
Shortening overheating	Check probe calibration  Check mercury contactor for not opening. (elec. unit)  Bad controller	<ul style="list-style-type: none"> <li>• Calibrate probe if <math>\pm 10^{\circ}\text{F}</math> or <math>^{\circ}\text{C}</math> off. If more than <math>\pm 10^{\circ}\text{F}</math> or <math>^{\circ}\text{C}</math> off, replace probe.</li> <li>• Replace control board if heat indicator stays on past ready temperature.</li> </ul>
Foaming or boiling over of shortening	Water in shortening  Improper or bad shortening  Improper filtering  Improper rinsing after cleaning the fryer	<ul style="list-style-type: none"> <li>• At end of frying cycle, drain shortening and clean</li> <li>• Use recommended shortening.</li> <li>• Refer to the procedure covering filtering the shortening.</li> <li>• Clean and rinse the frypot. Then dry thoroughly.</li> </ul>
Shortening will not drain from frypot	Drain valve clogged with crumbs  Drain valve will not open by turning handle	<ul style="list-style-type: none"> <li>• Open valve, force cleaning brush through drain</li> <li>• Replace cotter pins in valve coupling.</li> </ul>
Filter motor runs but pumps shortening slowly	Pump clogged  Filter line connection loose.  Solidified shortening in lines	<ul style="list-style-type: none"> <li>• Remove pump cover and clean.</li> <li>• Tighten all filter line connections.</li> <li>• Clear all filter lines of solidified shortening.</li> </ul>

**5-2. TROUBLESHOOTING  
(Continued)**

<b>PROBLEM</b>	<b>CAUSE</b>	<b>POWER CORRECTION</b>
Filter switch on, motor does not run	Defective switch  Defective motor  Motor thermal protector tripped	<ul style="list-style-type: none"> <li>• Check/replace switch per Section 6-15.</li> <li>• Check/replace motor.</li> <li>• Reset thermal switch per Section 3-7.</li> </ul>
Motor hums but will not pump	Clogged lines or pump	<ul style="list-style-type: none"> <li>• Remove and clean pump and lines.</li> <li>• Replace pump seal, rotor and rollers.</li> </ul>

**SECTION 6. MAINTENANCE**

**6-1. INTRODUCTION**

This section provides procedures for the check out and replacement of the various parts used within the fryer. Before replacing any parts, refer to the Troubleshooting section. It will aid you in determining the cause of the malfunction.

**6-2. MAINTENANCE HINTS**

1. You may need to use a multimeter to check the electric components.
2. When the manual refers to the circuit being closed, the multimeter should read zero unless otherwise noted.
3. When the manual refers to the circuit being open, the multimeter will read infinity.

**6-3 HIGH TEMPERATURE LIMIT CONTROL (Gas Units)**



This high temperature control is a safety, manual reset control, which senses the temperature of the shortening. If the shortening temperature exceeds 425°F (218°C), this switch will open and shut off heat to the cookpot. When the temperature of the shortening drops to a safe operation limit, the control must be manually reset by pressing the red reset button. The red reset button is located under the control panel, in the front of the fryer. This will allow heat to be supplied to the cookpot once again.

Before replacing a high temperature limit control, check to see that its circuit is closed.

**NOTE**

The shortening temperature must be below 380°F (193°C) to accurately perform this check.

1. Remove electrical power supplied to fryer.

**WARNING**

Remove electrical power supplied to the fryer by unplugging the unit, or by turning off the wall circuit breaker or electrical shock could result.

2. Remove the control panel.

### 6-3 HIGH TEMPERATURE LIMIT CONTROL (Continued)



3. Remove the two nuts securing the high limit bracket to the unit and pull the bracket from the unit.
4. Remove the two screws securing the high limit to the bracket, and remove the high limit from the bracket.
5. Remove the two electrical wires from the high temperature limit control.
6. Manually reset the control, then check for continuity between the two terminals after resetting the control. If the circuit is open, replace the control, then continue with this procedure. (If the circuit is closed, the high limit is not defective. Re-connect the two electrical wires.)

#### WARNING

Remove electrical power supplied to the fryer by unplugging the unit, or by turning off the wall circuit breaker or electrical shock could result.

1. If the tube is broken or cracked, the control will open , shutting off electrical power to the heat circuit. The control cannot be reset, and it will continuously click when pushed.
2. Drain the shortening from the cookpot and discard. A substance in the tube could contaminate the shortening.
3. Remove the control panel.
4. Loosen small inside screw nut on capillary tube.

### 6-3 HIGH TEMPERATURE LIMIT CONTROL (Continued)



5. Remove the bracket from the heat tube covering the high limit bulb.
6. Straighten the capillary tube behind the pot wall.
7. Pull the high limit bulb through the retainers on the heat tube.
8. Remove the larger outside nut that threads into the pot wall.
9. Remove the defective high limit from the control panel area.
10. Insert new high limit into bracket and replace wires.
11. Uncoil capillary line, starting at capillary tube, and insert through cookpot wall.

**WARNING**

To avoid electrical shock or other injury, the capillary line must run under and away from all electrical power wires and terminals. The tube must NEVER be in such position where it could accidentally touch the electrical power terminals.

12. Insert capillary line through brackets on heat tube, and then pull back through pot wall until capillary bulb is secure in brackets.
13. Pull excess capillary line from pot and tighten nut into cookpot wall.
14. With excess capillary line pulled out, tighten smaller nut.
15. Replace bracket on heat tube covering the high limit bulb.
16. Replace front panel.
17. Refill cookpot with shortening.



#### 6-4. COMPLETE CONTROL PANEL REPLACEMENT



Should the control board become inoperative, follow these instructions for replacing the board.

1. Remove electrical power supplied to the unit.

**WARNING**

Place the power switch in the “OFF” position, and unplug the power cord and/or turn the wall circuit breaker off or electrical shock could result.

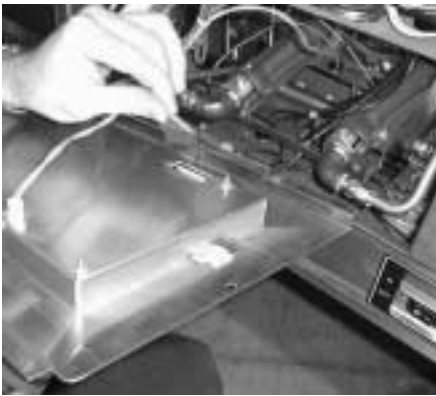

2. Remove the four screw securing the control panel and lift out.
3. Unplug the wire connectors going to the control board.
4. Install new control panel in reverse order.

**WARNING**

When plugging connectors onto new control panel, be sure the connectors are inserted onto all of the pins. Also, be sure the connectors are not forced onto the pins backwards, or damage to the board could result.

#### 6-5. POWER SWITCH

1. Remove electrical power supplied to fryer.

**WARNING**

Place the power switch in the off position, and remove power to the fryer by unplugging the unit or turning off the wall circuit breaker. Failure to do so could result in electrical shock.



2. Remove control panel.
3. Label and remove the wires from the switch. With test instrument check across the terminals of the switch with the switch in the on position, then in the off position. With the switch in the on position, the circuit should be closed. With the switch in the off position, the circuit should be open. If the switch checks defective, replace by continuing with this procedure.

### 6-5. POWER SWITCH (Continued)

4. With control panel removed, and the wires off the switch, push in on tabs on the switch to remove from panel.
5. Replace with new switch, and reconnect wires to switch.
6. Replace the control panel.

### 6-6. TEMPERATURE PROBE REPLACEMENT

The Temperature Probe relays the actual shortening temperature to the control board. If it becomes disabled, “E06” will show in the display. Also, if the shortening temperature is out of calibration more than 10°F or C°, the probe should be replaced as follows:

1. Remove electrical power supplied to the fryer.

**WARNING**

Place the Power switch in the “OFF” position, and unplug the power cord or turn the wall circuit breaker off or electrical shock could result.

2. Drain the shortening from the cookpot.
3. Remove the control panel.
4. Using a ½ inch wrench, remove the nut on the compression fitting.
5. Remove the probe from the cookpot, and disconnect wire connector from the control panel.
6. Place the nut and new ferrule on the probe on the new probe and insert the probe into the compression fitting until it extends one (1) inch (2.54cm) into the cookpot.
7. Tighten hand tight and then a half turn with wrench.



## 6-6. TEMPERATURE PROBE REPLACEMENT (Continued)



### WARNING

Excess force will damage probe.

8. Connect new probe to PC board and replace Control Panel.
9. Replace shortening.
10. Turn power "ON" and check out fryer.

## 6-7. FLAME SENSOR (Gas Units)

The flame sensor recognizes the pilot flame and allows gas to continue to the pilot. The flame sensor must send a minimum of two (2) micro amps to the ignition module. The pilot flame should be split in two by the flame sensor, causing the flame sensor to be bright red in color.

1. Remove electrical power supplied to the unit.

### WARNING

Remove electrical power supplied to the unit by unplugging the power cord, or by turning off the wall circuit breaker or electrical shock could result.



2. To access flame sensor, open the filter doors in the front of the unit. Follow the small gauge yellow wire running to the sensor behind the pilot assembly.
3. Disconnect the flame sense wire from the flame sensor.
4. Using a pair of needle nosed pliers, pull the flame sensor out of the pilot assembly bracket.
5. Insert new flame sensor and reconnect flame sensor wire.
6. Turn power "ON" and check fryer.

## 6-8. PILOT / IGNITOR ASSEMBLY



The Henny Penny Open Fryer (Gas) has electronic spark ignition that lights a standing pilot. The gap between the spark electrode and the pilot hood should be set at 1/8 of an inch.

1. Remove electrical power supplied to the unit.

### WARNING

Remove electrical power supplied to the unit by unplugging the unit , or by turning off the wall circuit breaker, or electrical shock could result.



To avoid injury or property damage, before starting this procedure, move the power switch to the “OFF” position. Disconnect the main circuit breaker at the circuit breaker box, or unplug the power cord at the receptacle. Turn off the main gas supply to the fryer and disconnect, and cap, the the supply line to the fryer, or possible explosion could result.

2. Remove the control panel as discussed in section 6-4.
3. Disconnect the pilot gas line fitting at the pilot assembly with a ½ inch wrench.
4. With a phillips screwdriver, remove the two screws securing the pilot assembly to the mounting bracket.
5. Remove the flame sensor wire from the flame sensor.
6. Follow the wire from the spark ignitor back to the module, and remove wire from module.
7. After removing assembly from unit, pull the flame sensor out of the bracket as discussed in section 6-7. Insert flame sensor into new pilot/ignitor assembly.
8. Reinstall the new pilot/ignitor assembly in reverse order. Be extremely careful not to cross thread the pilot gas line fitting.

**6-9. IGNITION MODULE**

During normal operation, the ignition modules send 24 volts to the ignitors and gas valve. If a module does not sense a pilot flame, the module starts the ignition process again. But, if a pilot light goes out for longer than 10 seconds, or it goes out 3 times within 10 seconds, the module keeps the 24 volts from reaching the gas valve. The burners shut down.

1. Remove electrical power supplied to the unit.

**WARNING**

Remove electrical power supplied to the unit by unplugging the unit or by turning off the wall circuit breaker or electrical shock could result.



2. Remove the control panel as discussed in section 6-4.
3. Label and remove the wires at module.
4. Using a 3/8 inch nut driver, remove the keps nuts securing the module to the shroud.
5. Install new module in reverse order.

**6-10. TRANSFORMER**

The transformer reduces voltage down (120V to 24V ) to accommodate those components with low voltage.

1. Remove electrical power supplied to the unit.

**WARNING**

Remove electrical power supplied to the unit by unplugging the unit, or by turning off the wall circuit breaker, or electrical shock could result.



2. Remove the control panel as discussed in section 6-4.
3. Squeeze on the wire connector at the I/O Board assembly to disconnect the wires from the transformer.
4. Using a phillips screwdriver, remove the two screws securing the transformer to the shroud.
5. Install the new transformer in reverse order.

### 6-11. I/O POWER SUPPLY BOARD ASSEMBLY



The Input/Output Power Supply Board Assembly distributes voltage to the various components in the fryer. The board also receives information from components in the fryer.

1. Remove electrical power supplied to the unit.

**WARNING**

Remove electrical power supplied to the fryer by unplugging the unit, or by turning off the wall circuit breaker, or electrical shock could result.

2. Remove the control panel as discussed in section 6-4.
3. Disconnect the wire assemblies from the board.
4. Using a nut driver or wrench, remove the four keps nuts securing the board to the shroud.
5. Install the new I/O Board Assembly in reverse order.

### 6-12. AIRFLOW SWITCH

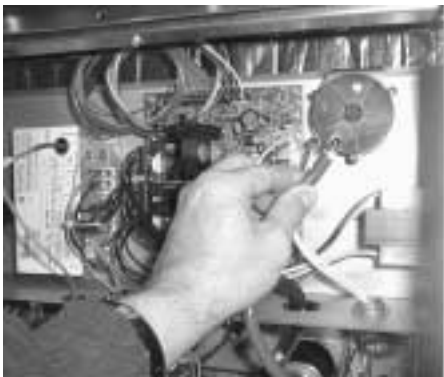

The airflow switch senses the airflow from the induction blower. If the airflow is reduced below a set amount, the switch will open and the I/O board will cut power to the gas control valve, which will shut the pilot flame off.

1. Remove electrical power supplied to the unit.

**WARNING**

Remove electrical power supplied to the unit by unplugging the unit, or by turning off the wall circuit breaker, or electrical shock could result.

2. Remove the control panel as discussed in section 6-4.
3. Remove the air hose from the air switch.
4. Label and remove wires from air switch.

### 6-12. AIRFLOW SWITCH (Continued)

5. Using a phillips screwdriver, remove the screws securing the air switch to the shroud.
6. Install the new air switch in reverse order.

**WARNING**

Do not tamper with, or disassemble this component. It is set and sealed from the factory and is not to be adjusted.

### 6-13. SPEAKER ASSEMBLY (Gas Units)

The speaker assembly emits audible signals to let the operator know when cooking and hold times are finished.

1. Remove electrical power supplied to the unit.

**WARNING**

Remove electrical power supplied to the unit by unplugging the unit, or by turning off the wall circuit breaker, or electrical shock could result.

2. Remove the control panel as discussed in section 6-4.
3. Using a phillips screwdriver, remove the four screws securing the speaker to the shroud.
4. Install new speaker in reverse order. When plugging connector into control board, be sure to align pins into connector correctly.



**6-14. DRAIN MICROSWITCH**

Upon turning the drain handle, the drain microswitch should “open”, cutting off the pilot flame. This will prevent the fryer from heating while shortening is being drained from the cookpot.

1. Remove electrical power supplied to the unit.

**WARNING**

Remove electrical power supplied to the unit by unplugging the unit, or by turning off the wall circuit breaker, or electrical shock could result.

2. The following check should be made to determine if the drain microswitch is defective.
  - a. Remove the two screws securing the microswitch to the drain rod valve bracket.
  - b. Remove wires from the switch.
  - c. Check for continuity across the two outside terminals of the drain switch. If the circuit is open, the drain switch is defective. The circuit should only be opened by pressing on the actuator of the drain switch.
3. Replace switch in reverse order.

**6-15. FILTER SWITCH**

1. Remove electrical power supplied to the unit.

**WARNING**

Remove electrical power supplied to the unit by unplugging the unit, or by turning off the wall circuit breaker, or electrical shock could result.



### 6-15. FILTER SWITCH (Continued)



2. According to the amount of wells in the unit, remove the control panel above the switch.
3. Label and remove the wires from the switch. With test instrument check across the terminals of the switch with the switch in the on position and then in the off position. With the switch in the on position, the circuit should be closed. With the switch in the off position, the circuit should be open. If the switch checks defective, replace by continuing with this procedure.
4. With wires removed from the switch, push in on tabs on the switch and remove switch from the panel.
5. Push new switch into panel and reconnect wires.

### 6-16. GAS VALVE ASSEMBLY

The gas valve assembly controls the flow of gas to the pilot and the main burner. The valve has two 24 volt coils, which are regulated by the P and M terminals on the valve. The C terminal is the common terminal. For gas flow to the pilot, 24 VAC must be present between the P and C terminals. For gas flow to the main burner, 24 VAC must be present between the M and C terminals.



To avoid injury or property damage, before starting this procedure, move the POWER/PUMP switch to the "OFF" position. Disconnect the main circuit breaker at the circuit breaker box, or unplug the service cord at the receptacle. Turn off the main gas supply to the fryer and disconnect and cap the supply line to the fryer, or possible explosion could result.



1. Remove control panel assembly.
2. Remove wires from gas valve.

**6-16. GAS VALVE  
ASSEMBLY  
(Continued)**



3. Using a 7/16 wrench, remove the pilot line from the gas valve.



4. Using a 1 inch wrench, loosen the nut securing the main gas inlet line to the gas valve.



5. Using 5/8 wrench, remove the two burner gas line fittings at the black "T" located behind the control panel area.



6. Using a phillips screwdriver, remove the three screws securing the gas valve bracket to the frame of the fryer behind the control panel area.

### 6-16. GAS VALVE ASSEMBLY (Continued)



7. With the bracket dropped down, remove the two screws behind the bracket securing the gas valve to the bracket.

8. Install the new gas valve in reverse order.

### 6-17. BLOWER MOTOR ASSEMBLY

The blower motor assembly induces the draft for the burners. If the blower motor fails, the air switch will fail to close, causing an “E-20B” error code in the display.

1. Remove electrical power supplied to the unit.

**WARNING**

Remove electrical power supplied to the unit by unplugging the unit, or by turning off the wall circuit breaker, or electrical shock could result.

2. Remove screws securing the two rear covers to the unit.



3. Remove the wire cover from the blower motor housing.

**6-17. BLOWER MOTOR  
ASSEMBLY  
(Continued)**



4. Remove wire nuts connecting blower motor wires to wires in conduit.



5. Loosen conduit from blower motor.



6. Remove screws connecting flue to bracket in upper frame.

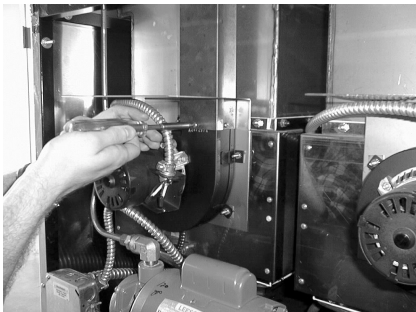

7. Remove screws connecting flue to blower.

### 6-17. BLOWER MOTOR ASSEMBLY (Continued)



8. Using 3/8 inch nut driver, remove nuts securing blower to the unit. Pull blower from unit.

9. Install new blower in reverse order.

### 6-18. HEATING ELEMENTS (ELECTRIC ONLY)

#### Checkout

#### NOTE

Heating elements are available for 208 and 230 voltage. Check data plate to determine correct voltage.

If the shortenings temperature recovery is very slow or at a slower rate than required, this may indicate defective heating element(s). An ohmmeter will quickly indicate if the elements are shorted or open.

1. Remove electrical power supplied to the cookpot to be worked on.

#### WARNING

Place power switch to the OFF position and unplug the power cord or open the wall circuit breaker, for the cookpot to be worked on. Be aware the other controls will have power, or electrical shock could result.

2. Remove control panel per section 6-4.

**6-18. HEATING ELEMENTS  
(ELECTRIC ONLY)  
Continued**

3. Perform an ohm check on one element at a time, with wires disconnected from element. If the resistance is not within tolerance, replace the element.

Voltage	Wattage	Resistance Ohms (cold)
208	4800	9
230	4800	11

**Replacement**

**NOTE**

Refer to figure 6-2

1. Drain the shortening from the cookpot.
2. Remove the High Limit bulb holder from the heating element inside the cookpot.
3. Remove the heating element wires from the terminals by removing the nuts and washers. Label each so it can be replaced on the new element in the same position.
4. Remove the bolts from the five element spreaders. The element spreaders will now pull off the elements.
5. Remove the brass nuts and washers which secure the ends of the elements through the frypot wall.
6. Remove the heating elements from the frypot as a group by lifting the far end and sliding them up and out toward the rear of the cookpot.

**NOTE**

Always install new rubber O rings when installing heater elements.

7. Install new heating elements with the new O rings, terminal end first at approximately a 45° angle, slipping the terminals through the front wall of the cookpot.
8. Replace the brass nuts and washers on the element terminals. Tighten the brass nuts to 30 foot lbs. of torque.

**6-18. HEATING ELEMENTS  
(ELECTRIC ONLY)  
Continued**

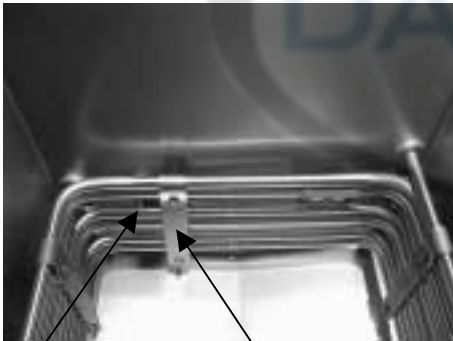

Probe

Spreader

**Fig. 6-1**

9. Evenly space the element spreaders on the sides of the elements and reinstall bolts. Place the fifth spreader in the front of the elements as to protect the probe. (Fig. 6-1)
10. Replace the high limit bulb holder on the top element, and position the bulb between the top and second element midway from side to side, and tighten screw that holds the bulb in place.
11. Reconnect the wires to the appropriate terminal as labeled when they were removed.
12. Replace the front control panel.
13. Connect the power cord to the wall receptacle or close wall circuit breaker.

**CAUTION**

Heating elements should never be energized without shortening in the frypot, or damage to the elements could result.

14. Replace the shortening in the frypot.

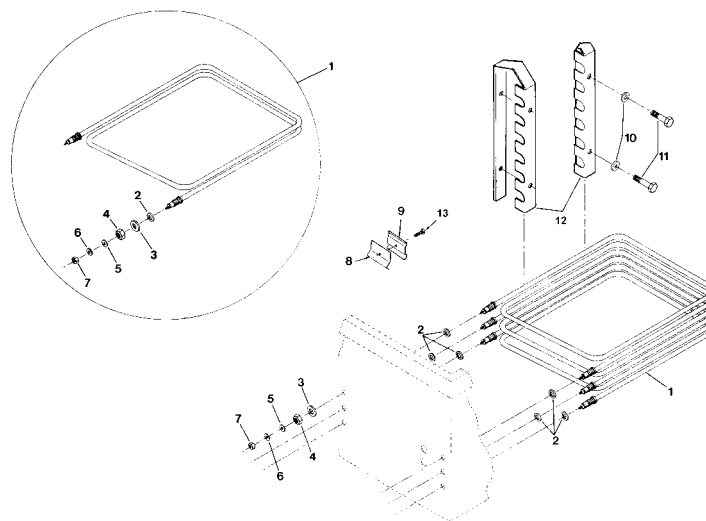

**Fig. 6-2**

**6-19. HEATING CONTACTORS (ELECTRIC ONLY)**

Each well of an electric fryer requires two switching contactors. the first in line is the primary contactor and the second in line is the heat contactor. When open, the primary contactor does not allow power to flow to the heat contactor. When closed, the primary supplies voltage to the heat contactor. When the heat contactor is open, no voltage is supplied to the heating elements. When the heat contactor closes, voltage is supplied to the heating elements.

**Checkout (Power Removed)**

1. Remove electrical power supplied to the cookpot to be worked on.

**WARNING**

Place POWER switch to the OFF position, and unplug the power cord or open the wall circuit breaker, or electrical shock could result. Be aware that the other controls will still have power.

2. Remove the control panel per section 6-4.
3. Perform a check on the contactor as follows:

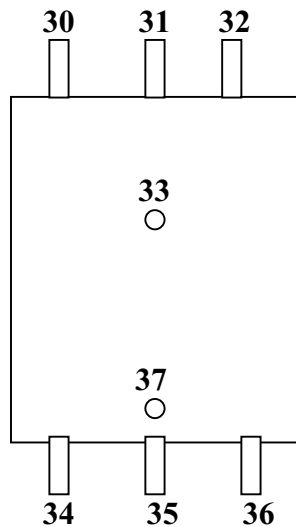

**Mercury Contactor**

<u>Test Points</u>	<u>Results</u>
From 30 to 34	open circuit
From 31 to 35	open circuit
From 32 to 36	open circuit
From 33 to 37	ohm reading 1700

**NOTE**

Wires should be removed and labeled to obtain an accurate check of contactors.



**6-19. HEATING CONTACTORS (ELECTRIC ONLY) (Continued)**

**Checkout (power supplied)**

**WARNING**

The following checks are performed with the wall circuit breaker closed and the POWER switch in the ON position. Extreme caution should be taken. Make connections before applying power, take reading, and remove power before removing meter leads, or electrical shock could result.

1. Re-apply power to unit and turn POWER switch "ON".
2. Using illustrations from previous page, check voltage as follows:

Test Points

From terminal 34 to 35  
 From terminal 35 to 36  
 From terminal 34 to 36

Results

The voltage should read the same at each terminal

**Replacement**



If either contactor is defective it must be replaced as follows:

**WARNING**

Remove electrical power supplied to the cookpot to be worked on, by unplugging the power cord from the receptacle or opening the wall circuit breaker, or electrical shock could result. Be aware the other controls will have power.

1. Remove only the wires directly connected to the contactor being replaced. Label the wires for replacement.
2. Loosen the screws securing the contactor bracket to the shroud.
3. Remove the contactor from the bracket.
4. Reinstall in reverse order.

## 6-20. SPEAKER ASSEMBLY (Electric Units)



The speaker assembly emits audible signals to let the operator know when cooking and hold times are finished.

1. Remove electrical power supplied to unit.

**WARNING**

Remove electrical power supplied to the unit by unplugging the unit, or by turning off the wall circuit breaker, or electrical shock could result.

2. Remove control panel per section 6-4.
3. Follow the speaker wire and disconnect from control board.
4. Remove the screws securing the speaker bracket to the shroud.
5. Remove the speaker from the bracket.
6. Reinstall in reverse order.

## 6-21. HIGH TEMPERATURE LIMIT CONTROL (Electric Units)

### Checkout

### Replacement

The electric units, model OFE-321/2/3/4, use the same high temperature control limits as the gas units, OFG-321/2/3/4, but the mounting of the capillary tube is different on the electric units compared to the gas units.

Use the same procedure as in section 6-3.

**WARNING**

Before following these steps, place the POWER switch in the OFF position, and unplug the power cord or open the wall circuit breaker, or electrical shock could result. Be aware the other controls will have power.

**6-21. HIGH TEMPERATURE  
LIMIT CONTROL  
(Electric Units)  
(Continued)**



1. Drain the shortening from the cookpot.
  2. Remove control panel per section 6-4.
  3. Loosen small inside screw nut on capillary tube.
  4. Remove capillary bulb from bulb holder inside the frypot.
  5. Straighten the capillary tube.
  6. Remove larger outside nut that threads into pot wall.
  7. Remove the two screws that secure the high limit to the high limit bracket.
  8. Remove the defective control from the control panel area.
  9. Insert new control and replace screws.
  10. Uncoil capillary tube, starting at control, and insert through pot fitting.
- WARNING**
- To avoid electric shock or other injury, the capillary line must run under and away all electrical power wires and terminals. The tube must never be in a position where it could accidentally touch the electrical power terminals.
11. Carefully bend the capillary bulb and tube toward bulb holder on heating elements.
  12. Slip capillary bulb into bulb holder on heating elements. Pull excess capillary line from pot and tighten nut into frypot wall.

**6-21. HIGH TEMPERATURE  
LIMIT CONTROL  
(Electric Units)  
(Continued)**

**CAUTION**

Be sure capillary bulb of high limit is located behind front edge of heating elements. Capillary bulb and bulb holders should be positioned as not to interfere with basket or when cleaning the frypot wall, or damage to the capillary bulb could result.

13. With excess capillary line pulled out, tighten smaller nut hand tight, then  $\frac{1}{4}$  turn with wrench.
14. Replace front panel.
15. Refill with shortening.

**SECTION 7. PARTS INFORMATION**

**7-1. INTRODUCTION**

This section list the replaceable parts of the Henny Penny OFE/OFG- 32x Open Fryers.

**7-2. GENUINE PARTS**

Use only genuine Henny Penny parts in your fryer. Using a part of lesser quality or substitute design may result in damage to the unit or personal injury.

**7-3. WHEN ORDERING PARTS**

Once the parts that you want to order have been found in the parts List, write down the following information:

Item Number	<u>8</u>	Example:
Part Number	<u>31561</u>	
Description	<u>On/Off Switch</u>	

From the data plate, list the following information:

Product Number	<u>01400</u>	Example:
Serial Number	<u>0001</u>	
Voltage	<u>208</u>	

**7-4. PRICES**

Your distributor has a price parts list and will be glad to inform you of the cost of your parts order.

**7-5. DELIVERY**

Commonly replaced items are stocked by your distributor and will be sent to you when your order is received. Other parts will be ordered, by your distributor, from Henny Penny Corporation. Normally, these will be sent to your distributor within three working days.

**7-6. WARRANTY**

All replacement parts (except lamps and fuses) are warranted for 90 days against manufacturing defects and workmanship. If damage occurs during shipping, notify the carrier at once so that a claim may be properly filed. Refer to warranty in the front of this manual for other rights and limitations.

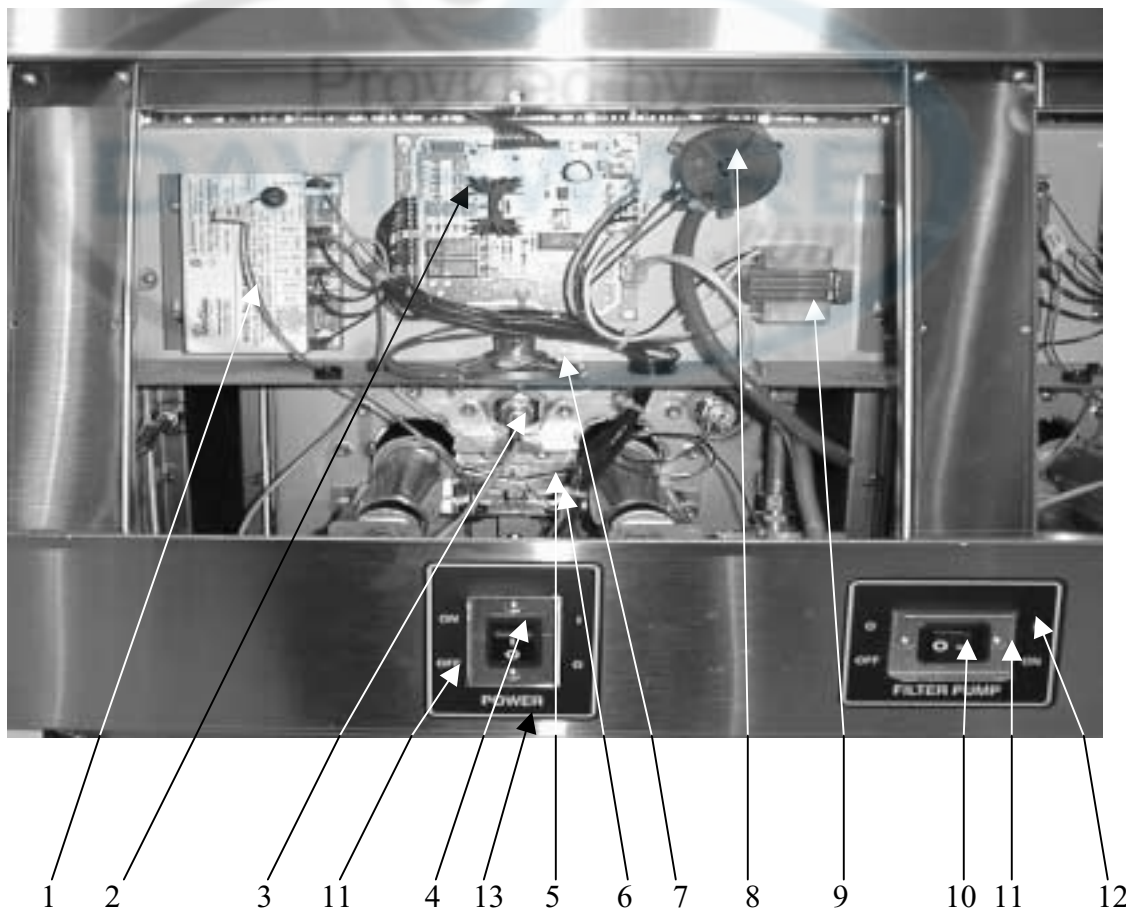

Item No.	Part No.	Description	Qty. per Well
1	54924	Ignition Module – CE only	1
1	21347	Ignition Module	1
2	60430RB	I/O Board Assy	1
3	55168	Probe Assy	1
4	43768	Power Switch Assy	1
4	52224	Covered Power Switch – CE	1
5	60266	Tee Style Pilot Assy (Gas Only)	1
6	60292	Pilot Flame sensor (Gas Only)	1
7	60206	Speaker Assy	1
8	60783	Vacuum Switch (Gas Only)	1
9	60207	120v to 24v Transformer (Gas Only)	1
10	43768	Filter Switch (One Per Unit)	-
11	60844	Switch Guard – Power Switch	1
11	60844	Switch Guard – Filter Switch	1 (per unit)
12	60609	Decal – Filter Power Switch	1 (per unit)
13	60608	Decal – Main Power Switch	1

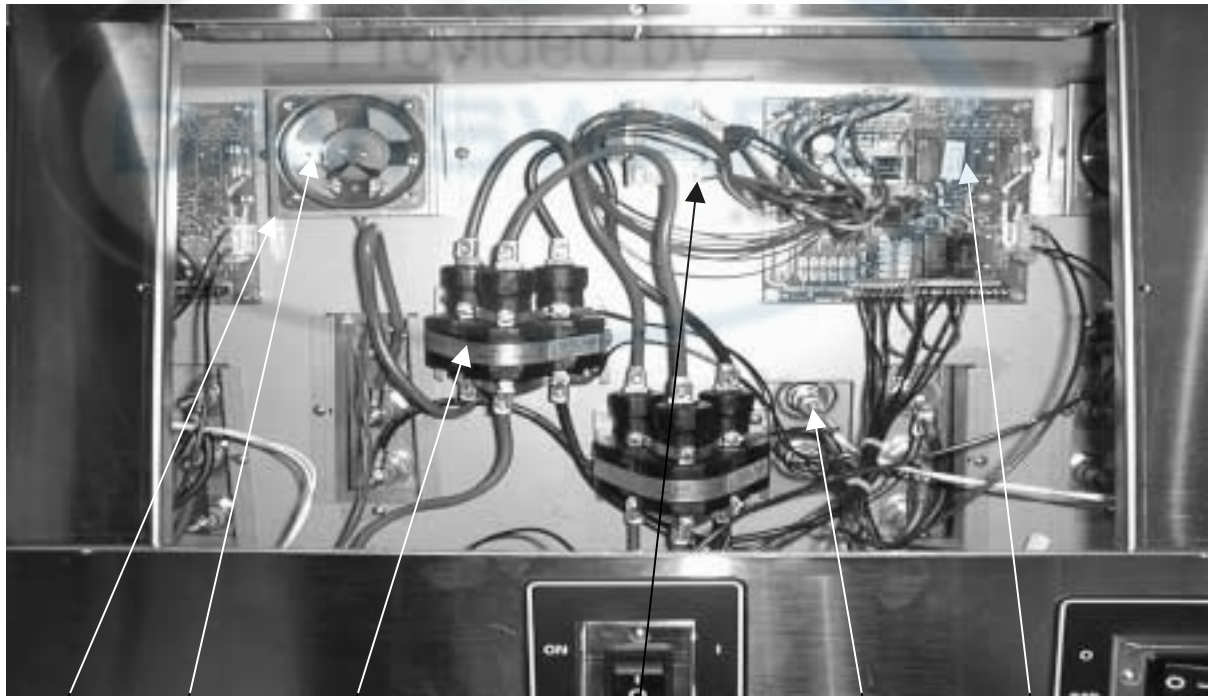

1                      2                      3    4    5    6

Item No.	Part No.	Description	Qty. per Well
1	60781	Speaker Bracket Assy (Elec. Only)	1
2	60206	Speaker Assy	1
3	29510	24v Mercury Contactor (Elec. Only)	1
*	51795	24v Mechanical Contactor (Elec. Only)	1
4	60536	24v/230v Transformer Assy (Elec. Only)	1
5	55168	Probe Assy	1
6	60430RB	I/O Board Assy	1
*	60838	Transformer 480V to 240V	1
*	60810	I/O to Control Cable – 3 Pin	1

\* Not Shown

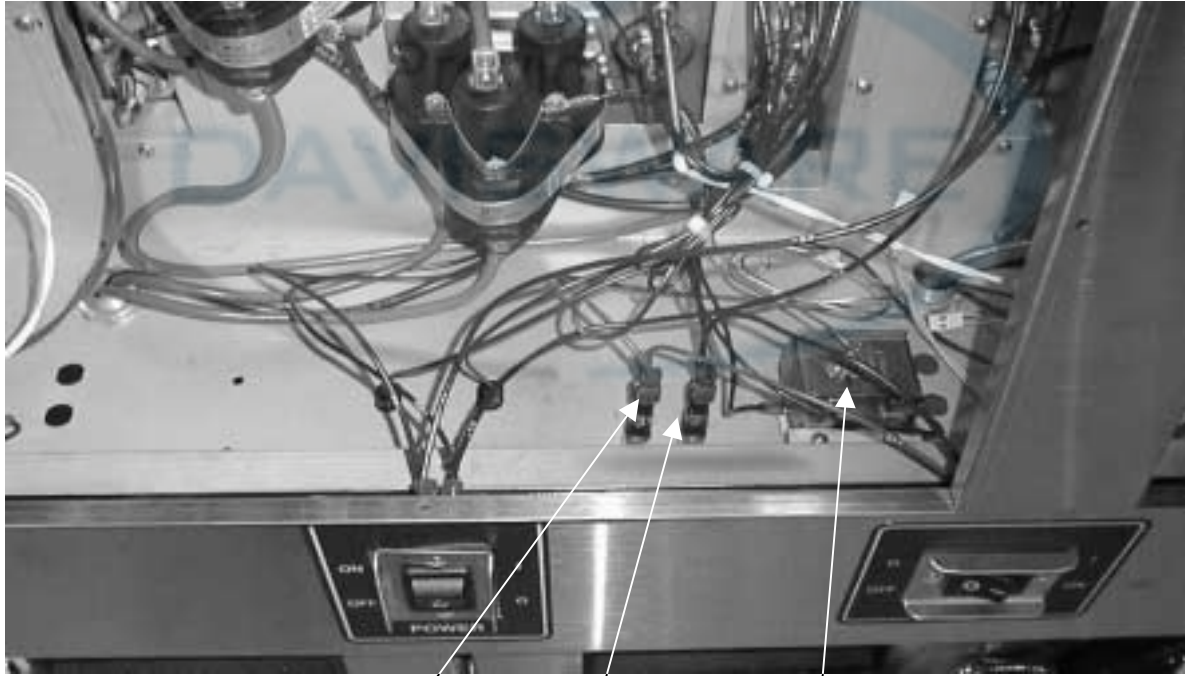

1

2

3

Item No.	Part No.	Description	Qty. per Well
1	EF02-006	20A 250v Fuse Holder (Elec. Only)	2
1	EF02-104	20A 250v Fuse Holder (Elec. Only) - CE	2
2	EF02-007	15 Amp Fuse (Elec. Only)	2
2	EF02-105	15 Amp Fuse (Elec. Only) - CE	2
3	60241	425° High limit Assy	1
*	60838	Transformer – 480-240 Volt (480 Volt fryers)	1
*	60847	Transformer Mounting Bracket (480 Volt fryers)	1

\* not shown



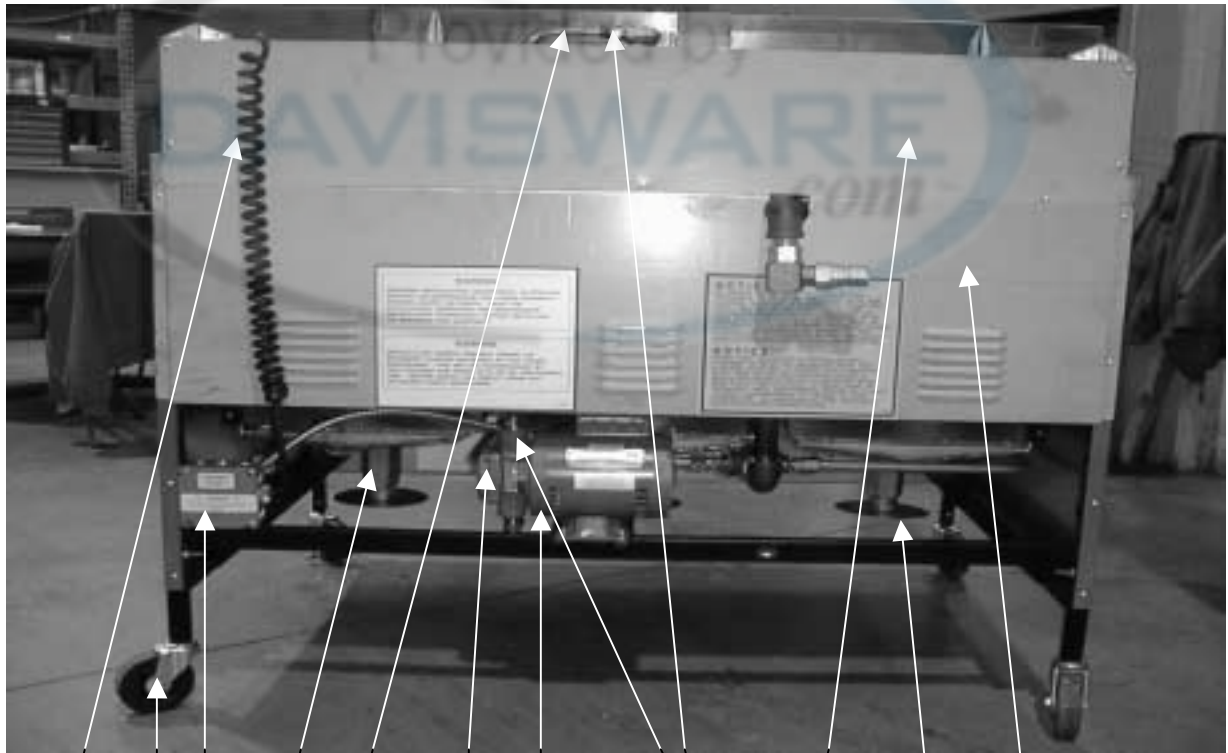

1 2 8 3 11 4 5 12 6 13 7

Item No.	Part No.	Description	Qty. per Unit
1.	33353	120v Coiled Power Cord (Gas Only)	1
2.	60312	Caster 4in. w/o Brake	2
3.	55152	Drain Valve & Coupling Assy	1
4.	17437	Filter Pump	1
5.	46854	Filter Pump Motor, ½ hp.	1
6.	60368	Top Rear Cover (3 Well)	1
6.	60471	Top Rear Cover (2 Well)	1
7.	60369	Bottom Rear Cover (3 Well)	1
7.	60472	Bottom Rear Cover (2 Well)	1
8.	ME50-021	Terminal Block – Gas	1
9*	18127	Terminal Block – Electric	12
10*	52078	Blower Motor Assy. (Gas Only)	1 per well
11.	60293	Tube-Oil Return Line	1
11.	60504	Tube-Oil Return Line–OFG-322 & 324 only	1
12.	FP01-082	Connector – 3/8 tube to ½ NPT SS	2
13	60736	Drain Valve Extension – Electric	1 per well
13	60388	Drain Valve Extension – Gas	1 per well
*	60618	Gas Line-1/2” w/Double Swivel - 321	1
*	33501	Gas Line-3/4” w/Double Swivel – 322	1
*	33167	Gas Line-1” w/Double Swivel – 323	1

\* Not Shown

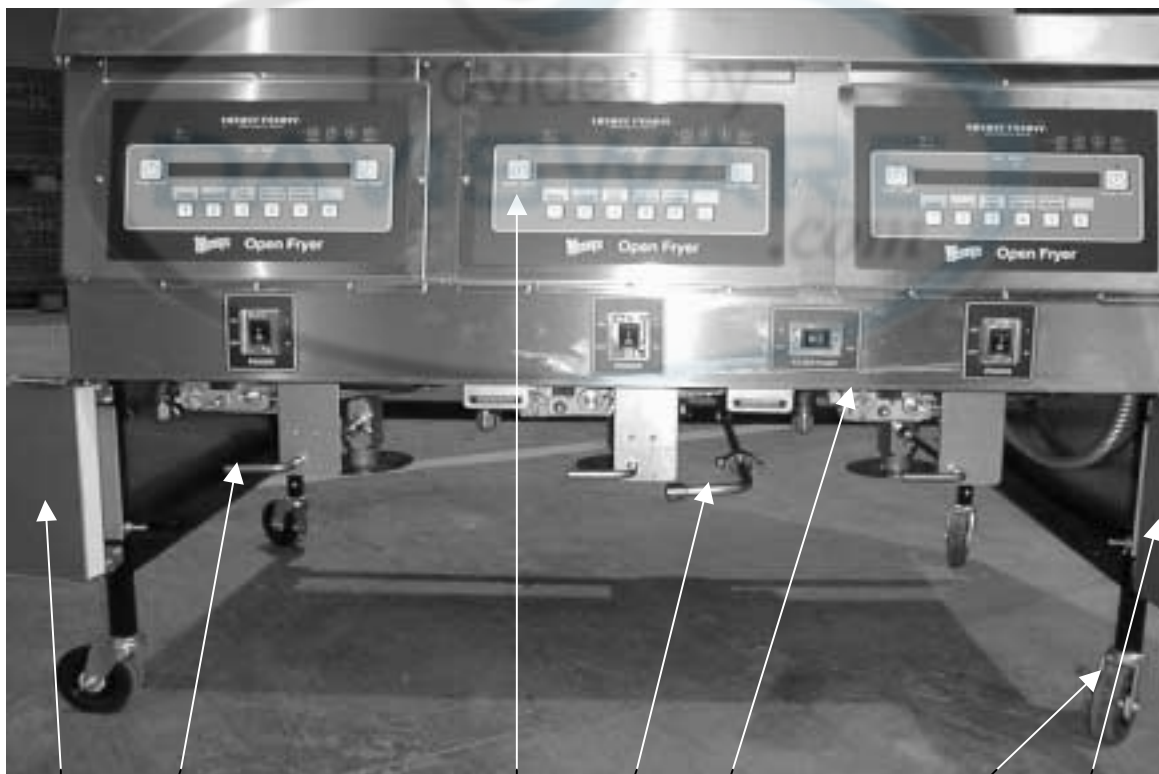

Item No.	Part No.	Description	Qty. per Well
1.	60490	Left Door Assy (3 Well)	1
1.	60502	Left Door Assy (2 Well)	1
*	60542	Door Assy ( 1 Well )	1
2.	18818	Drain Valve Extension Rod	1
3.	60603RB	6 Timer Control Board Assy	1
3.	60803BB	12 Timer Control Board Assy.	1
*	60682	Wendys Menu Card	-
*	61724	CFA Menu Card	-
*	59565	GM Menu Card	-
*	59566	Blank Menu Card	-
4.	52129	24v Natural Gas Valve	1
4	60632	24v Natural Gas Valve - CE	1
4.	60363	24v LP Gas Valve	1
4.	60633	24v LP Gas Valve – CE	1
5.	52064	4 Inch Swivel Caster W/ Brake	2
6.	60485	Right Door Assy (3 Well)	1
6.	60501	Right Door Assy (2 Well)	1
7.	60442	Filter to Pump Tube Assy. – Gas 323 & 322/324	1
*	14260	OFG Natural to LP Conv. Kit	1
*	14261	OFG LP to Natural Conv. Kit	1
*	18227	Drain Microswitch	1
*	60370	Drain Switch Cover	1
*	59224	Drain Switch Cover- CE	1

\* Not Shown

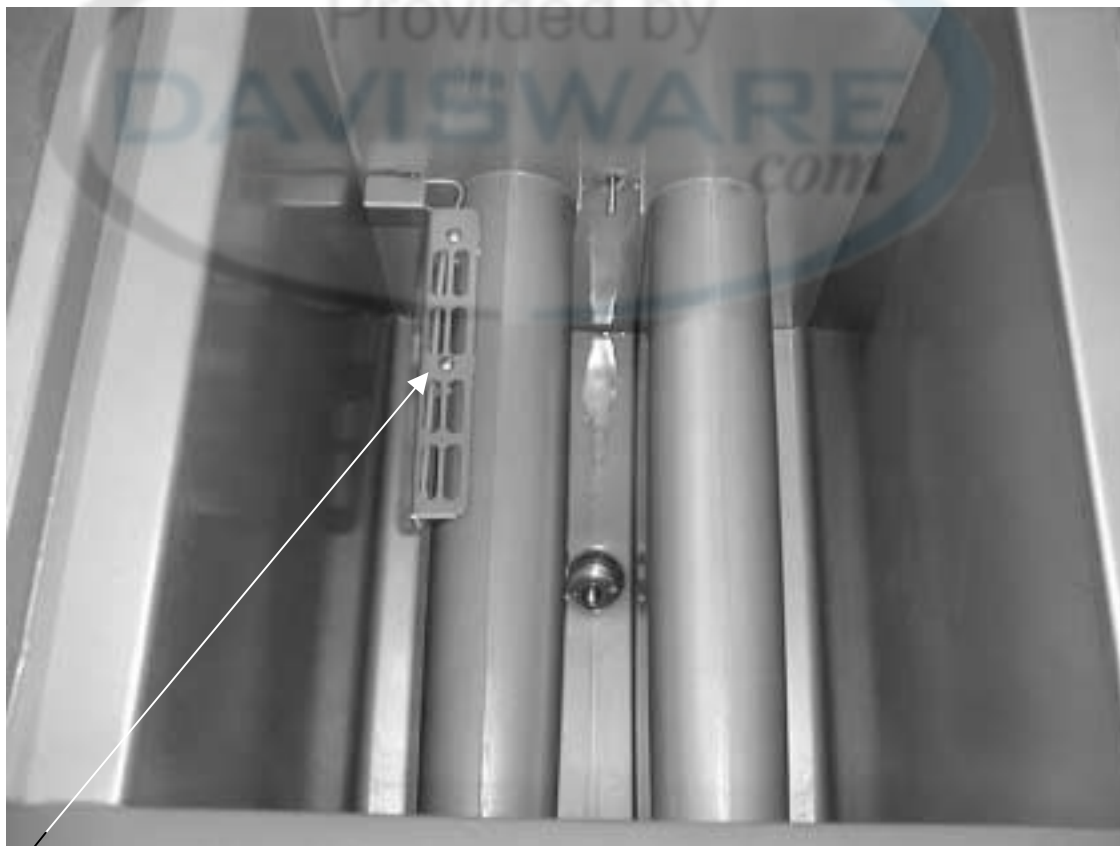

1

**(Gas Models)**

Item No.	Part No.	Description	Qty. per Well
1.	60367	High Limit Guard	1
*	60120	OFG Fry Basket Support	1
*	33102	Half Size Fry Basket	2
*	59078	Third Size Fry Basket	3
*	33824	Full Size Fry Basket	1

\* Not Shown

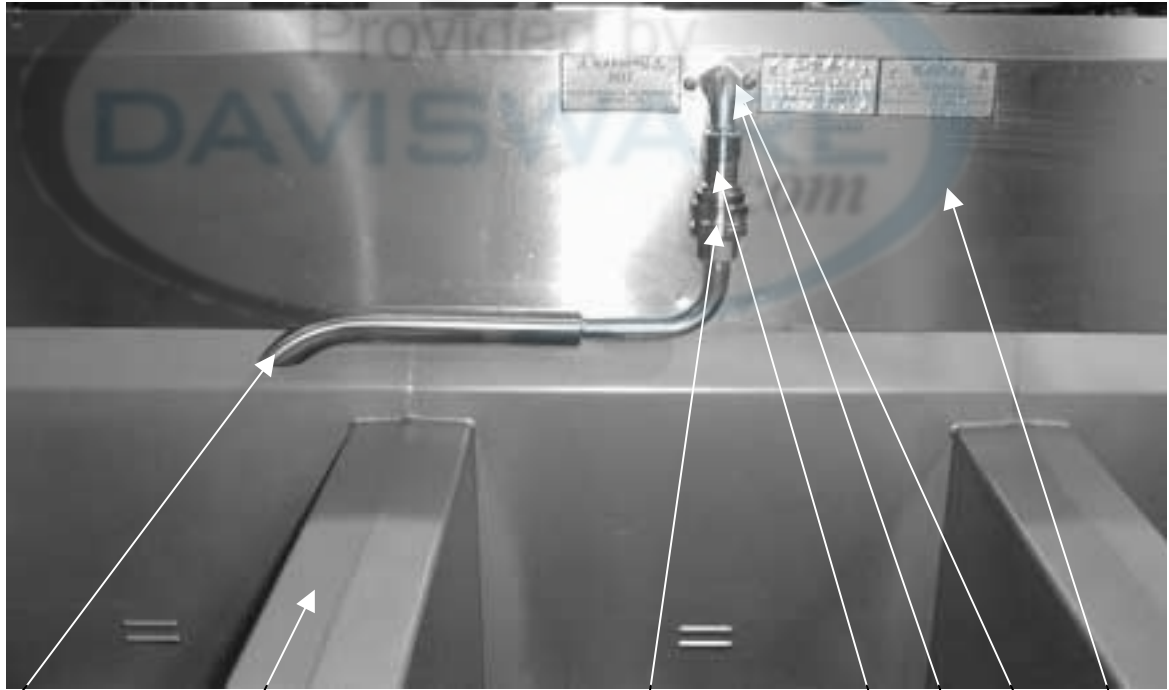

1                      7                                      2                                      3                      4                      5                      6

Item No.	Part No.	Description	Qty. per Unit
1.	45402	Return Faucet Only (without 17333) - 322, 323, & 324	1
1	60611	Return Faucet Assy. (with 17333)-321 & <b>Auto-lift (1 per well)</b>	1
2.	17333	Female Disconnect	1
3.	17334	Male Disconnect	1
4.	FP01-087	Elbow, Male-3/8 in.	1
5*	50715	3/8 x 1 1/8 Nipple	1
6.	60441	Front Shroud Assy. (3 Well)	1
6.	60470	Front Shroud Assy. (2 Well)	1
7.	60686	Pot & Countertop Assy. – OFE-321	1
7.	60687	Pot & Countertop Assy. – OFE-322	1
7.	60688	Pot & Countertop Assy. – OFE-323	1
8.	60843	Frypot Cover	1 per well

\* Not Shown



1

2

3

4

**(Electric Models)**

Item No.	Part No.	Description	Qty. per Well
1	60744-3	Heater – 230V 4800W	3
1	60744-4	Heater – 208V 4800W	3
1	60744-5	Heater – 480V 4800W	3
1	60744-2	Heater – 380V 4800W	3
1	60744-1	Heater – 460V 4800W	3
2	60747	OFE Fry Basket Support	1
3	18720	Hi Limit Rear Clamp	1
3	18248	Hi Limit Front Clamp	1
3	SC01-053	Clamp Screw #8-32x1/2	1
4	51931	Spreader Bar Assy	5
4	SC01-055	Spreader Screw #10-32x3/4	10
4	LW02-005	Lockwasher #10 Internal	10

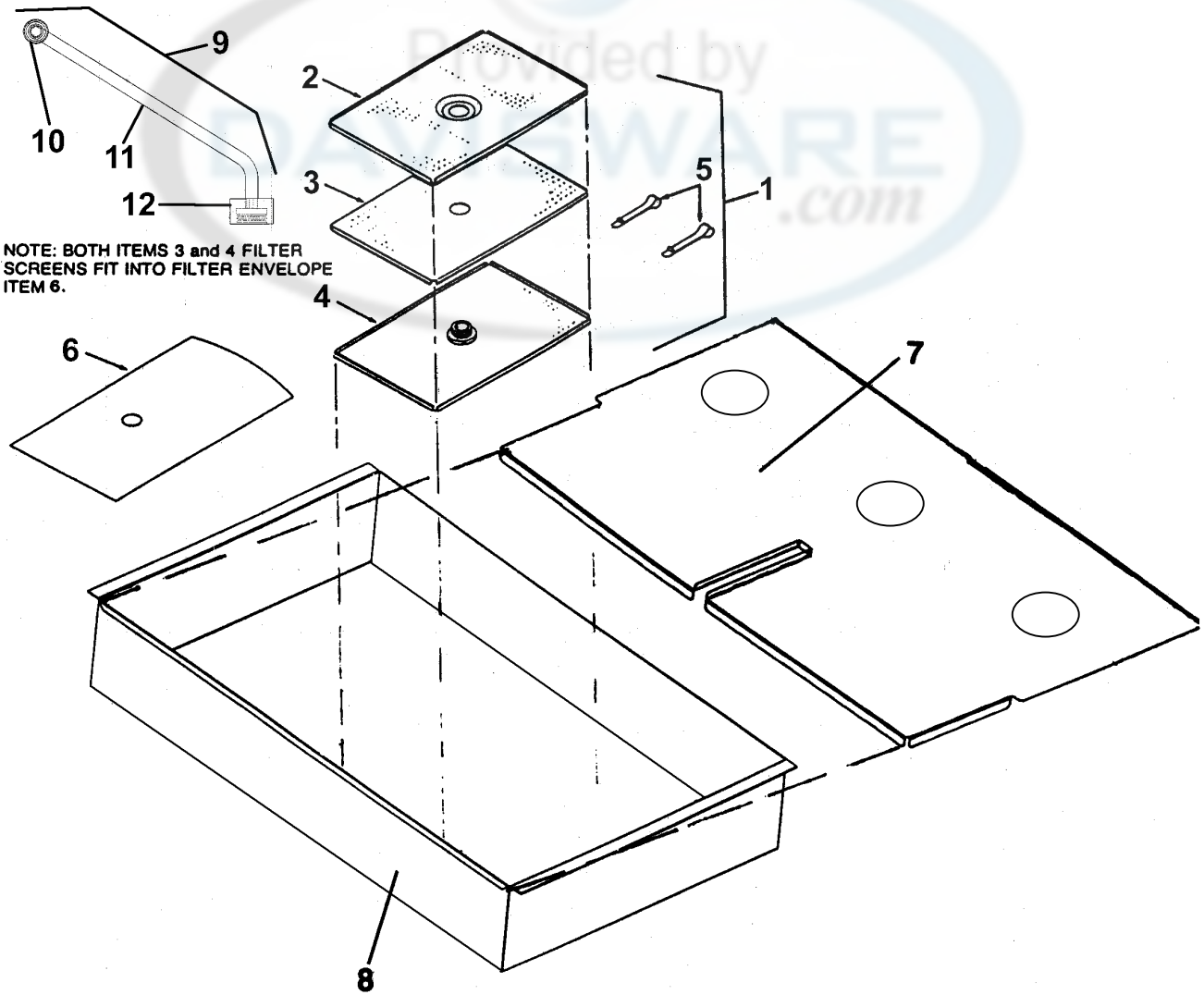

NOTE: BOTH ITEMS 3 and 4 FILTER SCREENS FIT INTO FILTER ENVELOPE ITEM 6.

Item No.	Part No.	Description	Qty. per Unit
1	17510	Screen Assembly, Filter	1
2	17501	Crumb Catcher	1
3	17502	Top Filter Screen	1
4	17503	Bottom Filter Screen	1
5	17505	Filter Envelope Clips	2
6	12102	Filter Envelope Paper (100 per Carton)	1
7	60512	Drain Pan Cover – 321	1
7	60460	Drain Pan Cover – 322	1
8	60510	Drain Pan – 321	1
8	60458	Drain Pan – 322	1
9	60378	Filter Standpipe Assembly	1
10	17430	Union – Female Fitting	1
11	60377	Standpipe Tube	1
12	17403	Nut – Filter	1

Main Gas Lines

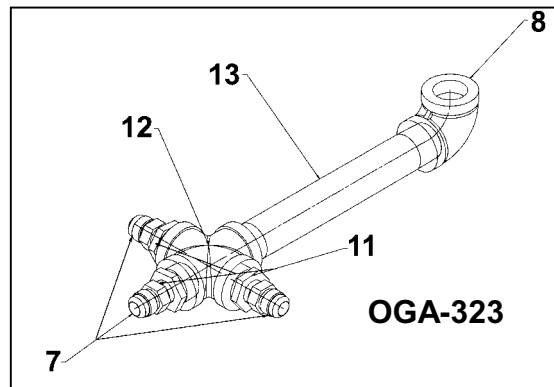
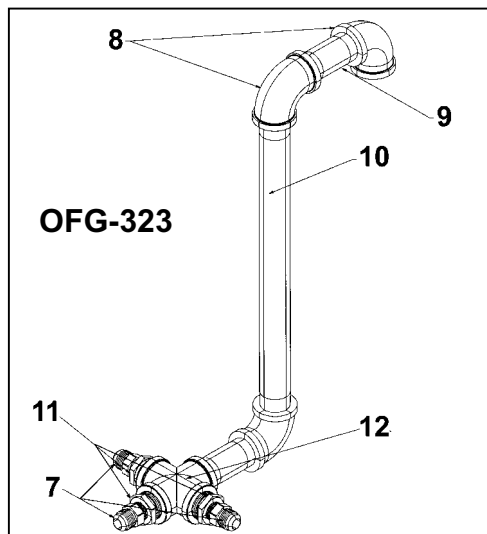
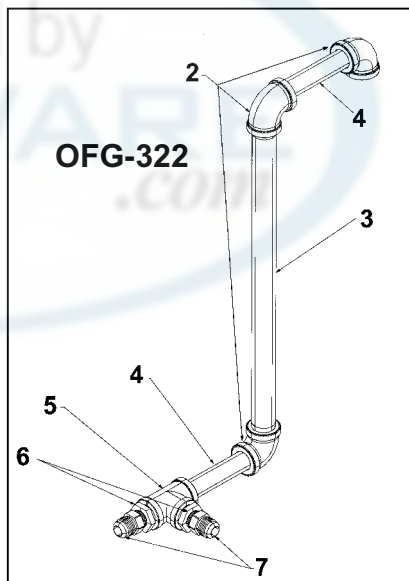
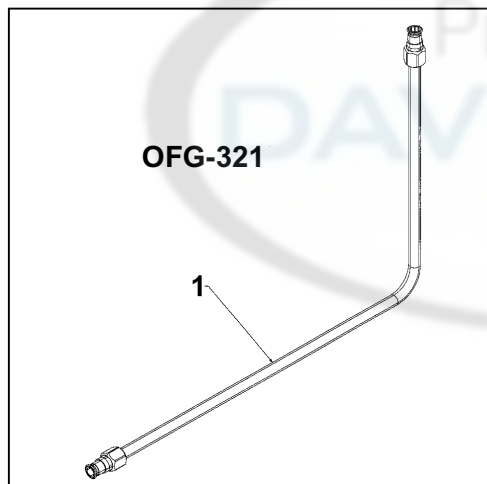

Item No.	Part No.	Description	Qty. per Unit
1	60621	Main Gas Line Assy	1
2	FP01-098	Elbow 3/4 NPT x 90 Female Bi	3
3	FP02-032	Nipple - 3/4 NPT x 17 in. Lg. Bi	1
4	FP02-033	Nipple - 3/4 NPT x 4 in. Lg. Bi	2
5	FP01-097	Tee 3/4 NPT Female Pip Bi	1
6	FP01-089	Bushing-Reducing 3/4M to 1/2F BI	1
7	16335	Male Connector 37 Flare	5
8	FP01-093	Elbow 1 in. NPT x 90 Female Bi	3
9	FP01-094	Nipple 1 in. NPT x 3 1/2 Lg. Bi	2
10	FP02-031	Nipple 1 in. NPT x 16 in Lg. Bi	1
11	FP01-085	Bushing-Reducing 1M to 1/2F BI	3
12	FP01-092	Cross Tee 1 in. NPT Female Bi	1
13	FP02-034	Nipple 1 in. NPT x 9 in. Lg. Bi	1

Provided by  
**AUTO-LIFT PARTS LIST**

Part Number	Description	Quantity		
		321	322	323
TS22-012	Transformer	1	2	3
60241	High Limit - 425° F	1	2	3
60206	Speaker Assembly	1	2	3
29510	Mercury Contactor - <b>Electic Units</b>	2	4	6
30614	Transformer - 208/240V-Pri, 24V Sec. - <b>Electic Units</b>	1	2	3
EF02-006	Fuse Holder - <b>Electic Units</b>	2	4	6
EF02-007	Fuse - 15 amp - <b>Electic Units</b>	2	4	6
50703	Full Size Basket	1	2	3
50704	1/2 Size Basket	2	4	6
50716	Actuator-Auto-lift-24V (motor)	1	2	3
50719	Basket Hanger Assembly	2	4	6
50750	Filter Valve-Oil Return	1	2	3
60796RB	GM 12 Button Control-321	1	-	-
60797RB	GM 12 Button Control-322	-	2	-
60798RB	GM 12 Button Control-323	-	-	3
60430RB	I/O PCB W/ Power Supply	1	2	3
50290	Basket Lift PCB Assembly	1	2	3
50764	Microswitch-Rigid Lever	1	2	3
60292	Pilot Flame Sensor - <b>Gas Units</b>	1	2	3
21347	Ignition Module - <b>Gas Units</b>	1	2	3
60363	Gas Valve Assembly - 24V-LP- <b>Gas Units</b>	1	2	3
60397	Gas Valve Assembly - 24V-Nat. - <b>Gas Units</b>	1	2	3
60783	Vacuum Switch - <b>Gas Units</b>	1	2	3
43768	Power Switch	1	2	3
52224	Covered Power Switch – CE	1	2	3
52078	Blower Motor Assembly - <b>Gas Units</b>	1	2	3
55168	Probe Assembly	1	2	3
46854	Filter Pump Motor - 1/2 Horse	1	1	1
61562	Menu Card – Auto-lift	2	4	6
59721	Return Valve Handle	1	2	3
50814	Frypot Cover – Auto-lift	1	2	3

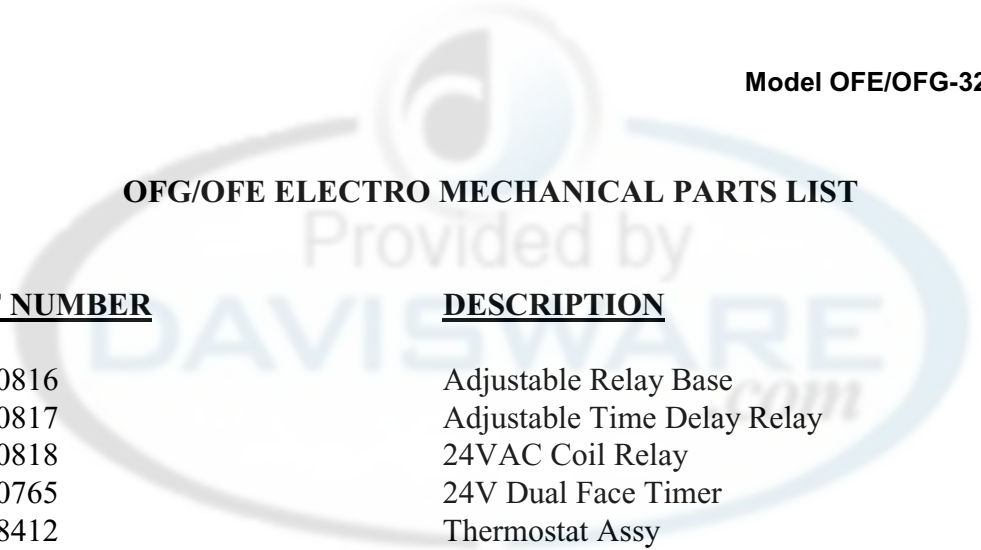

**OFG/OFE ELECTRO MECHANICAL PARTS LIST**

<b><u>PART NUMBER</u></b>	<b><u>DESCRIPTION</u></b>
60816	Adjustable Relay Base
60817	Adjustable Time Delay Relay
60818	24VAC Coil Relay
60765	24V Dual Face Timer
18412	Thermostat Assy
60814	E/M Bulb Mounting Clip
35916	Transformer 120V to 24V (Gas)
60536	Transformer 24V/230V (Electric)
60792	Indicator Light – 24 V

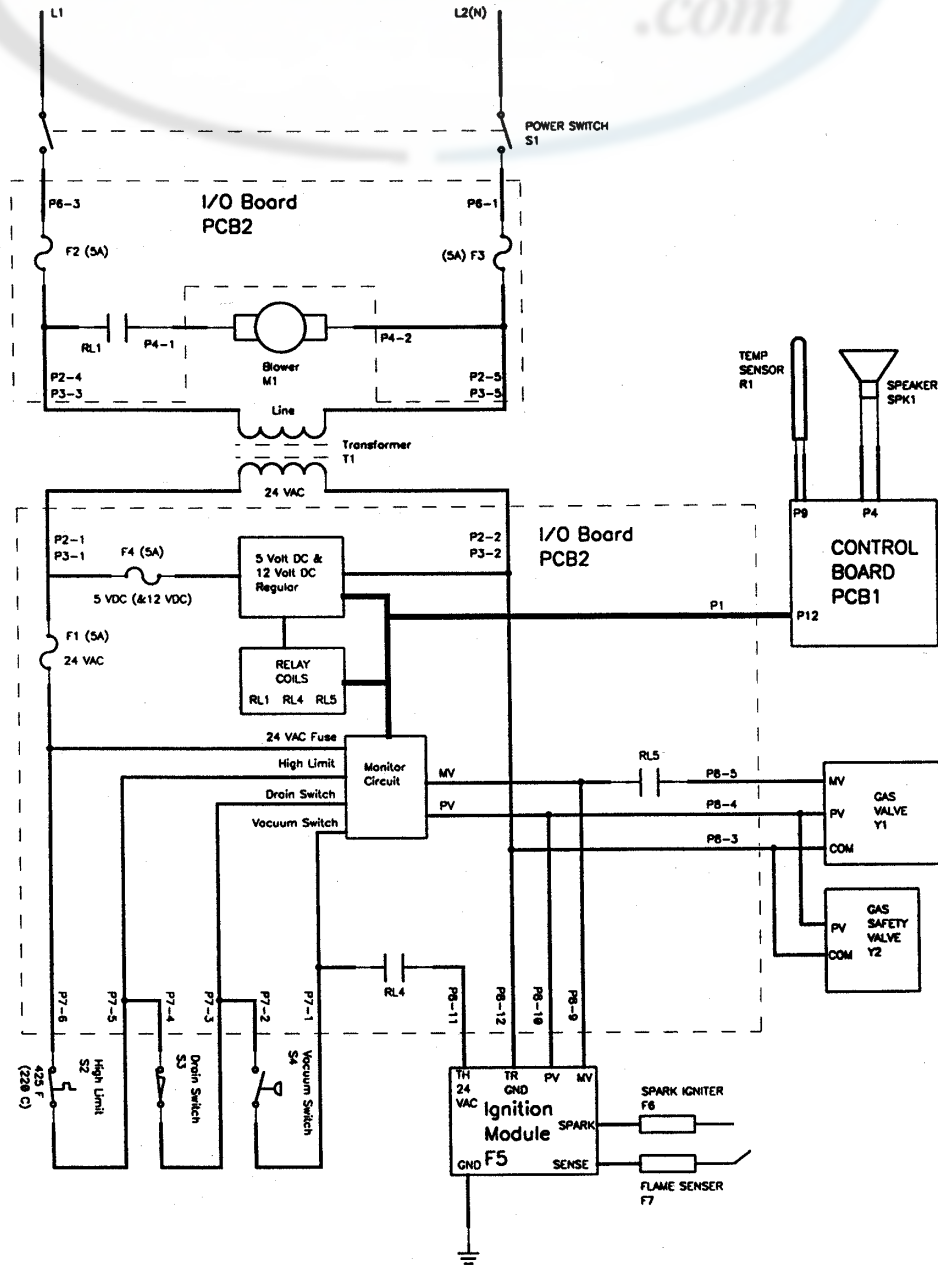

OFG-32X Gas Open Fryer

120 Volt

Provided by  
DAVISWARE.com

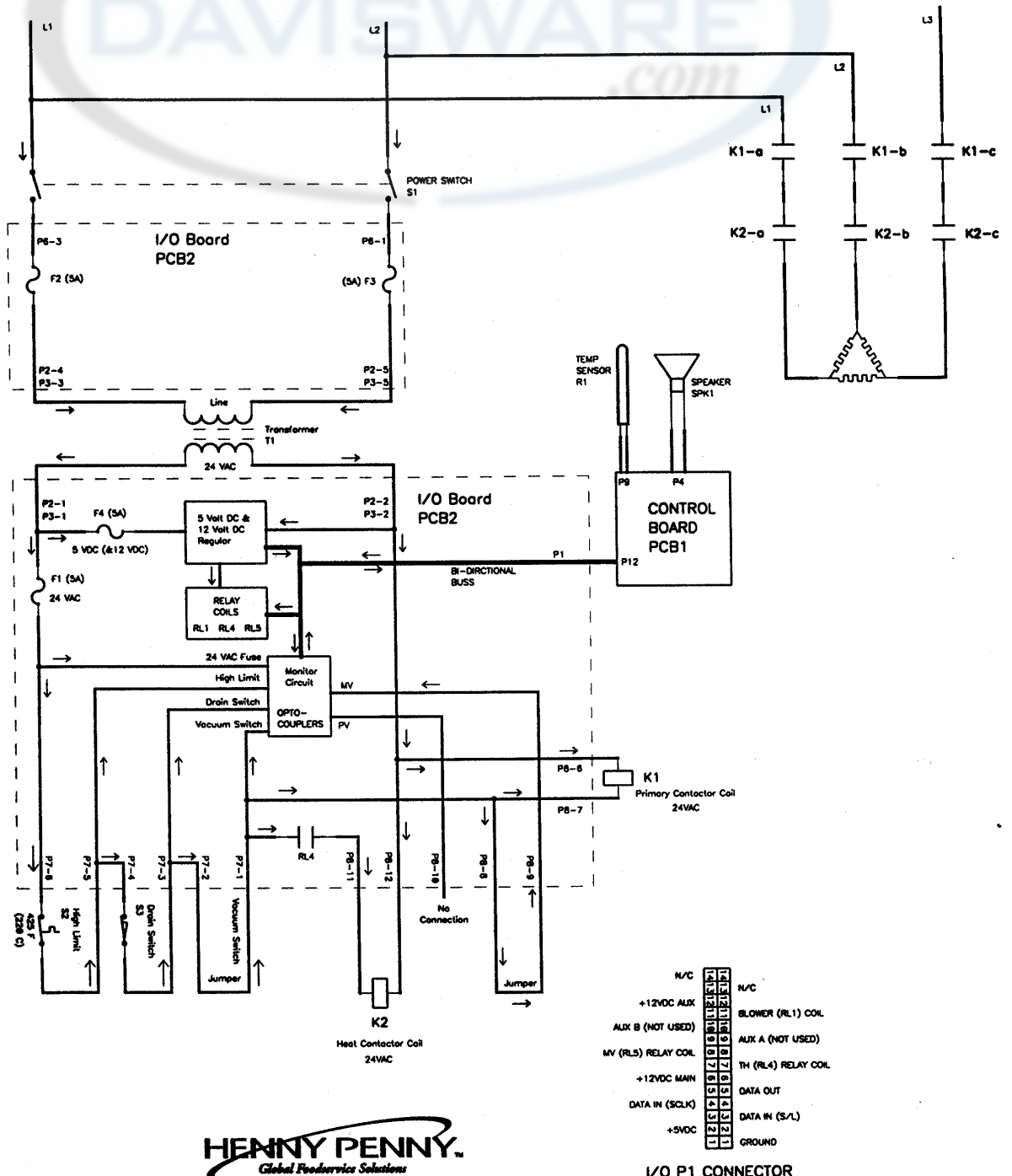

OFE-32X Electric Open Fryer

208/240 Volt (Domestic)

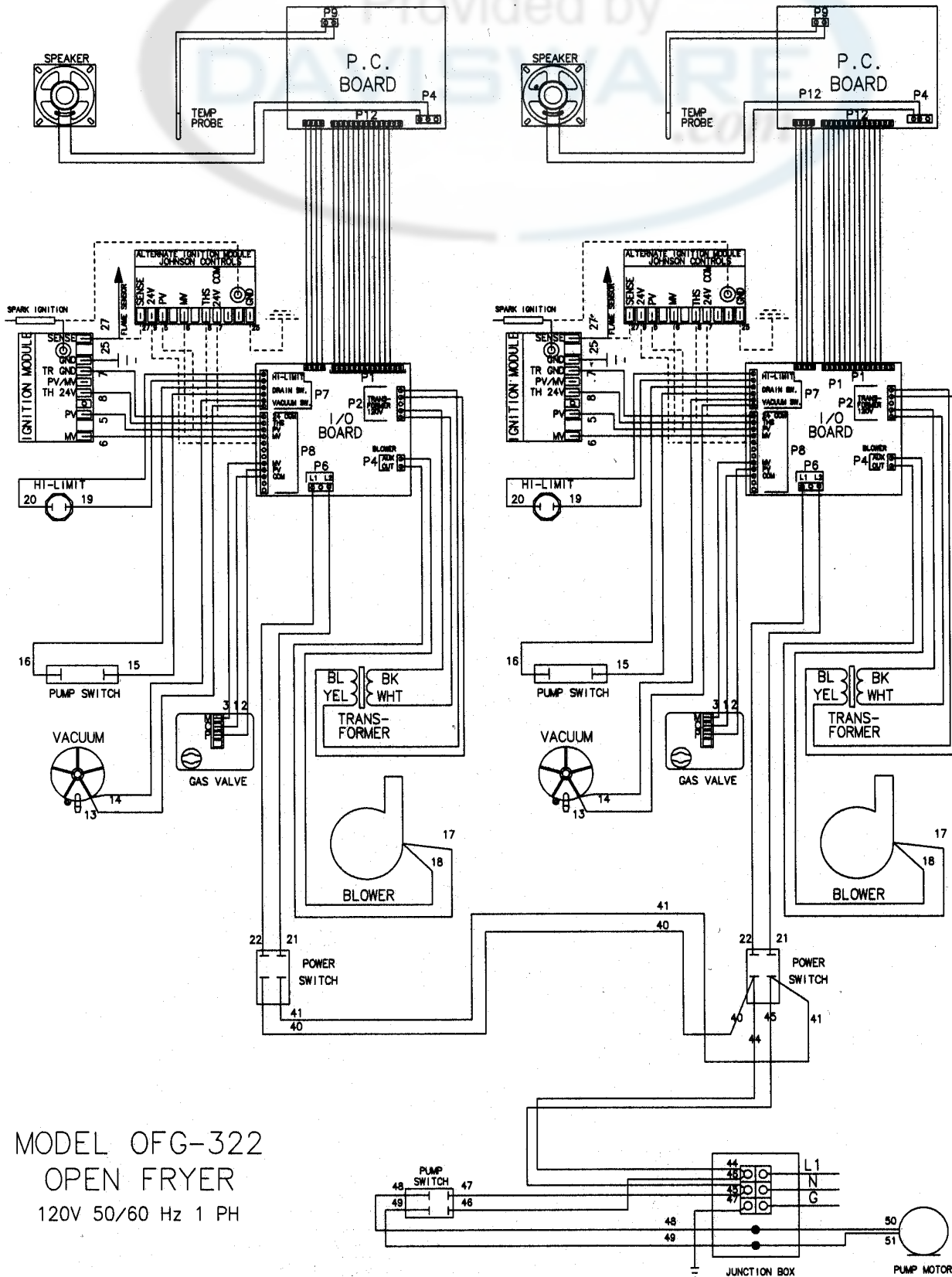

MODEL OFG-322  
OPEN FRYER  
120V 50/60 Hz 1 PH

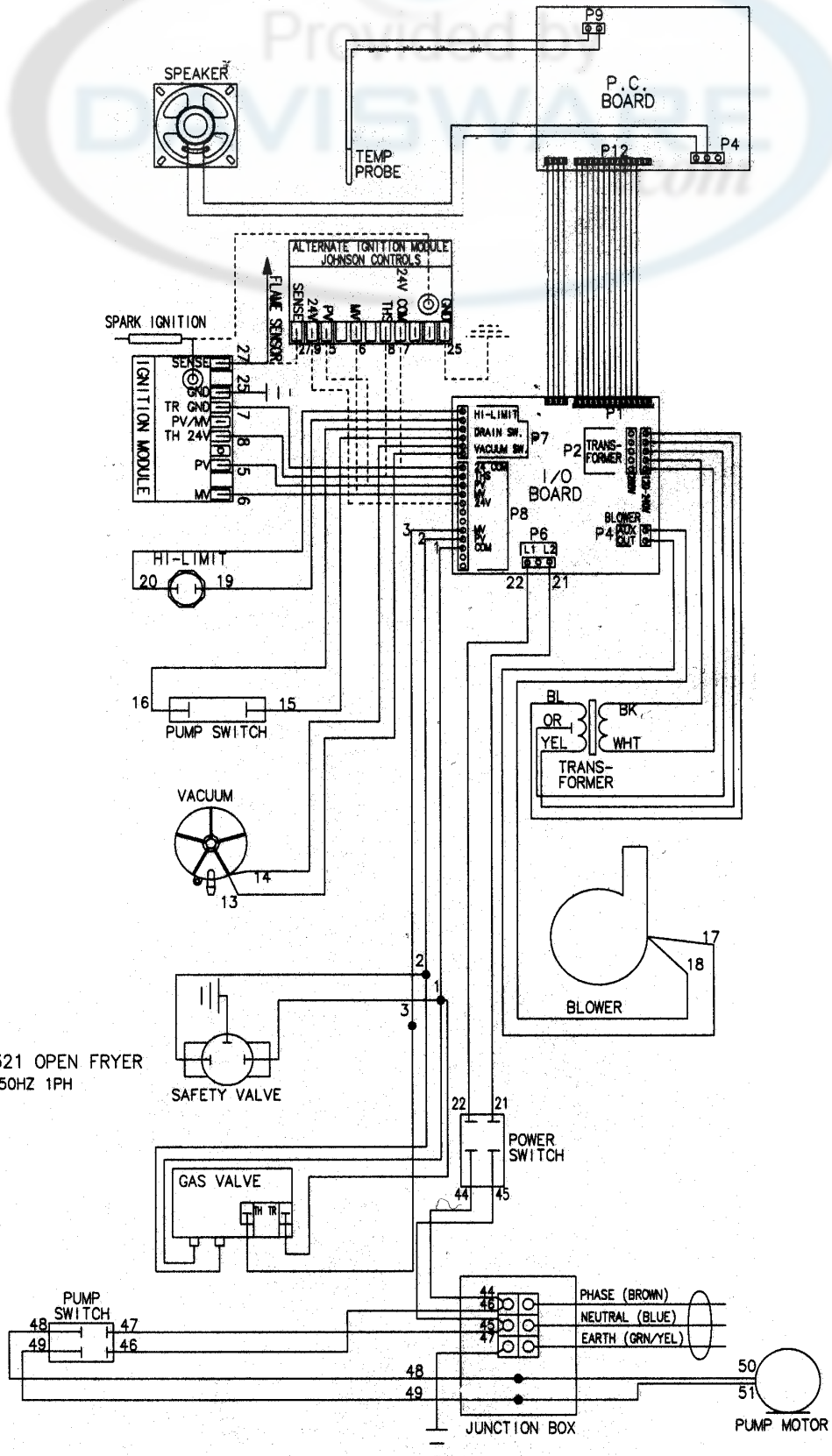

MODEL OFG-321 OPEN FRYER  
230V 50HZ 1PH

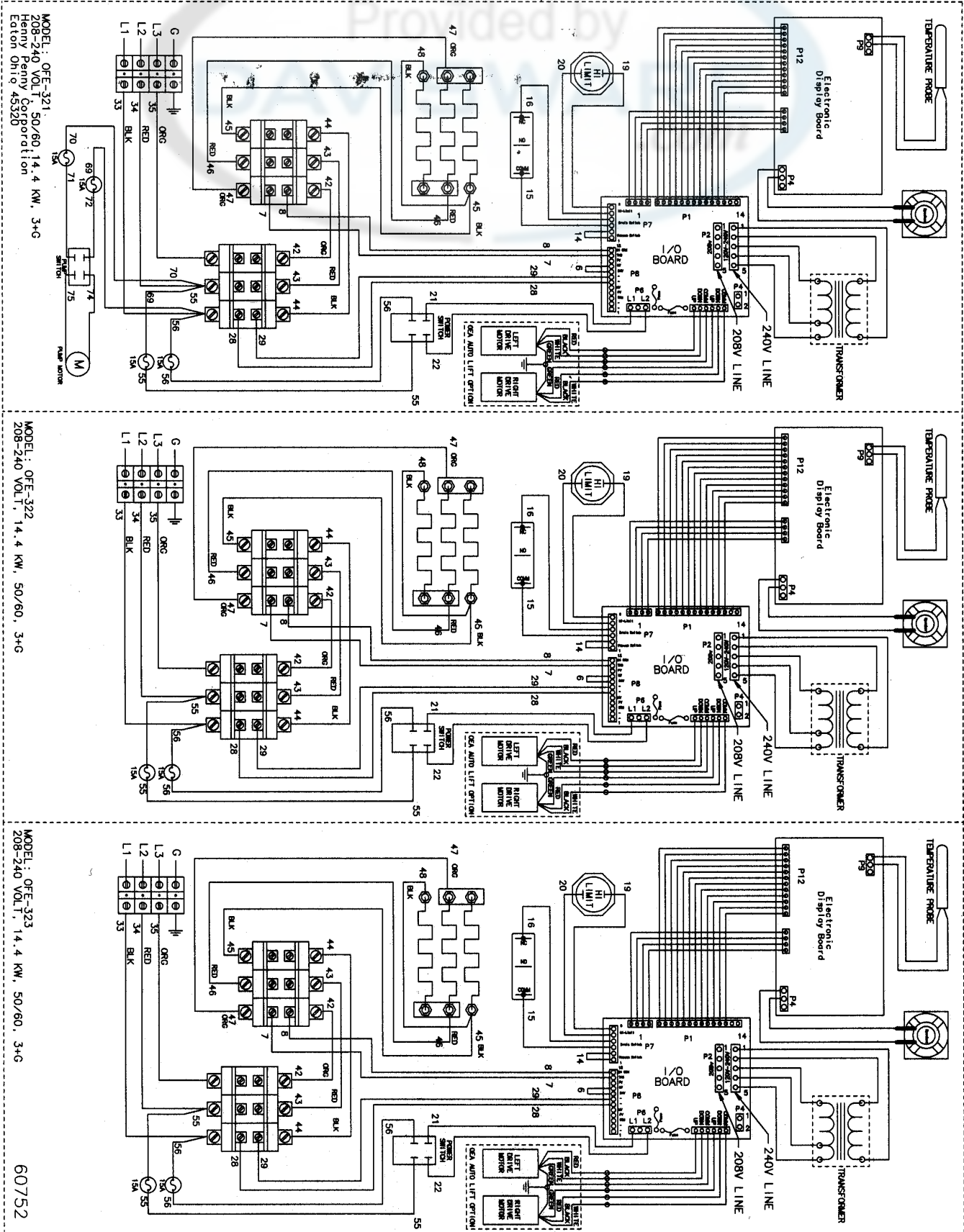

MODEL: OFE-321.  
208-240 VOLT, 50/60, 14.4 KW, 3+G  
Henny Penny Corporation  
Eaton Ohio 45320

MODEL: OFE-322  
208-240 VOLT, 14.4 KW, 50/60, 3+G

MODEL: OFE-323  
208-240 VOLT, 14.4 KW, 50/60, 3+G

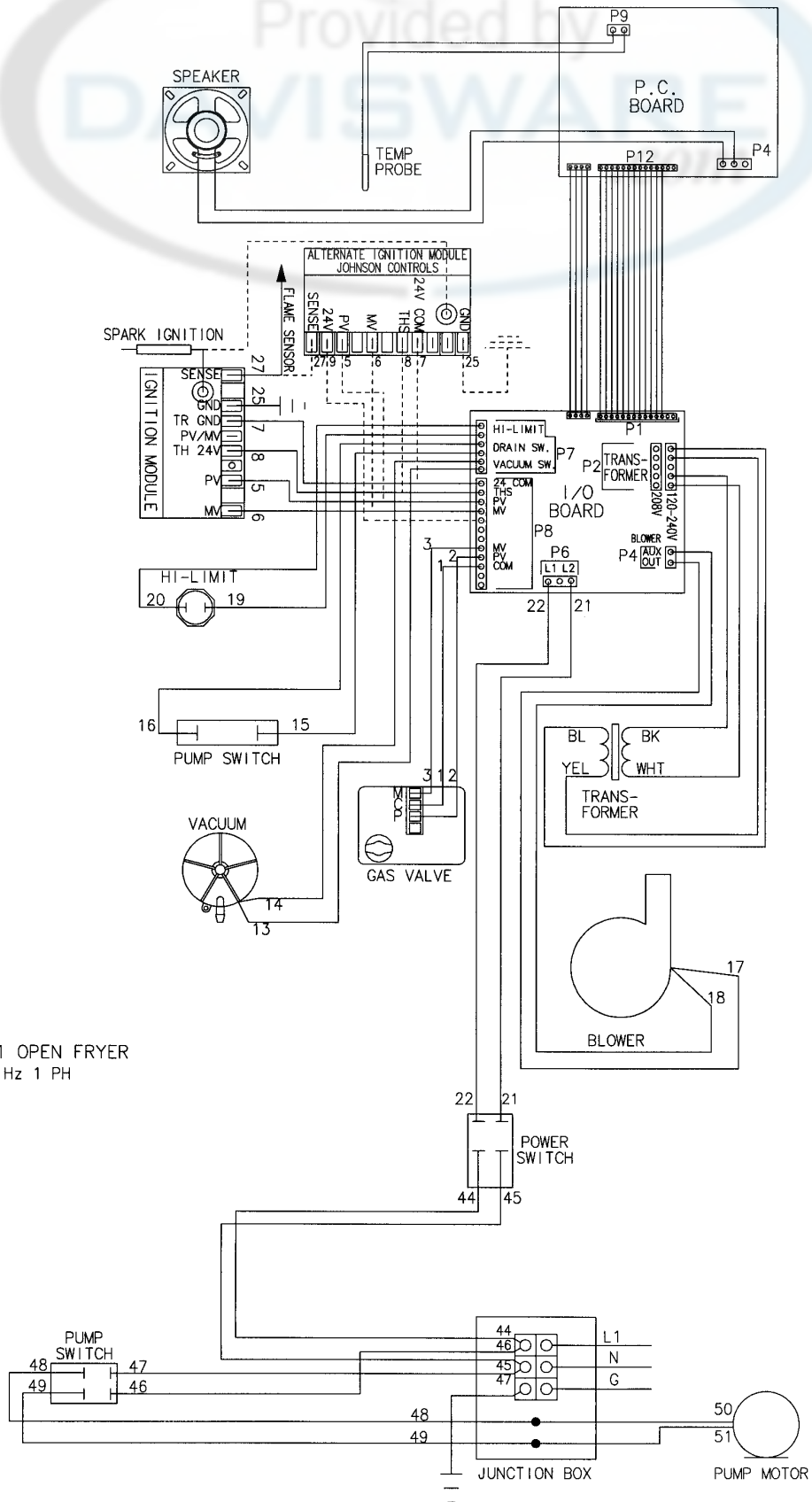

MODEL OFG-321 OPEN FRYER  
120V 50/60 Hz 1 PH

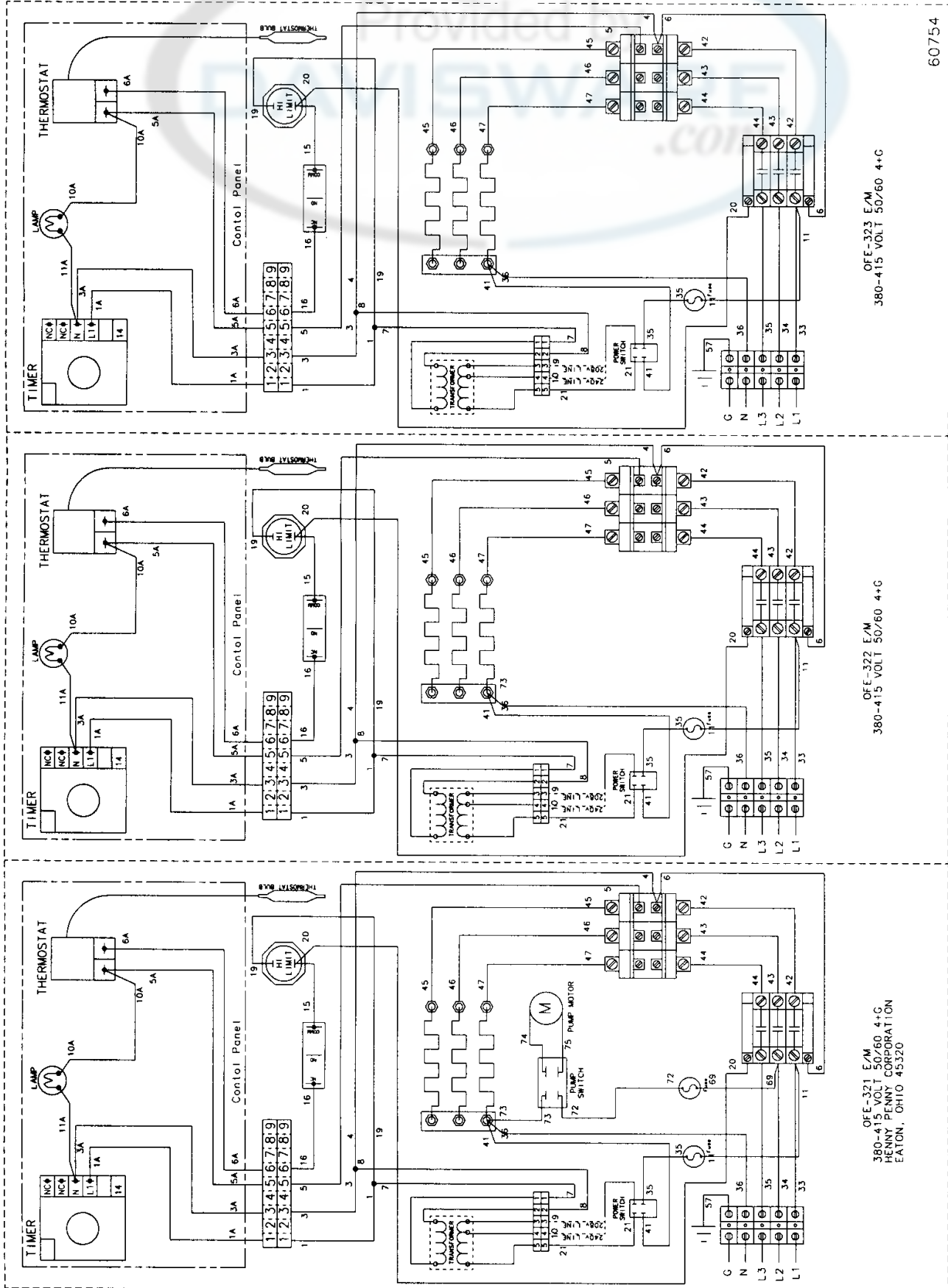

OFE-323 E/M  
380-415 VOLT 50/60 4+C

OFE-322 E/M  
380-415 VOLT 50/60 4+C

OFE-321 E/M  
380-415 VOLT 50/60 4+C  
HENNY PENNY CORPORATION  
EATON, OHIO 45320

60754



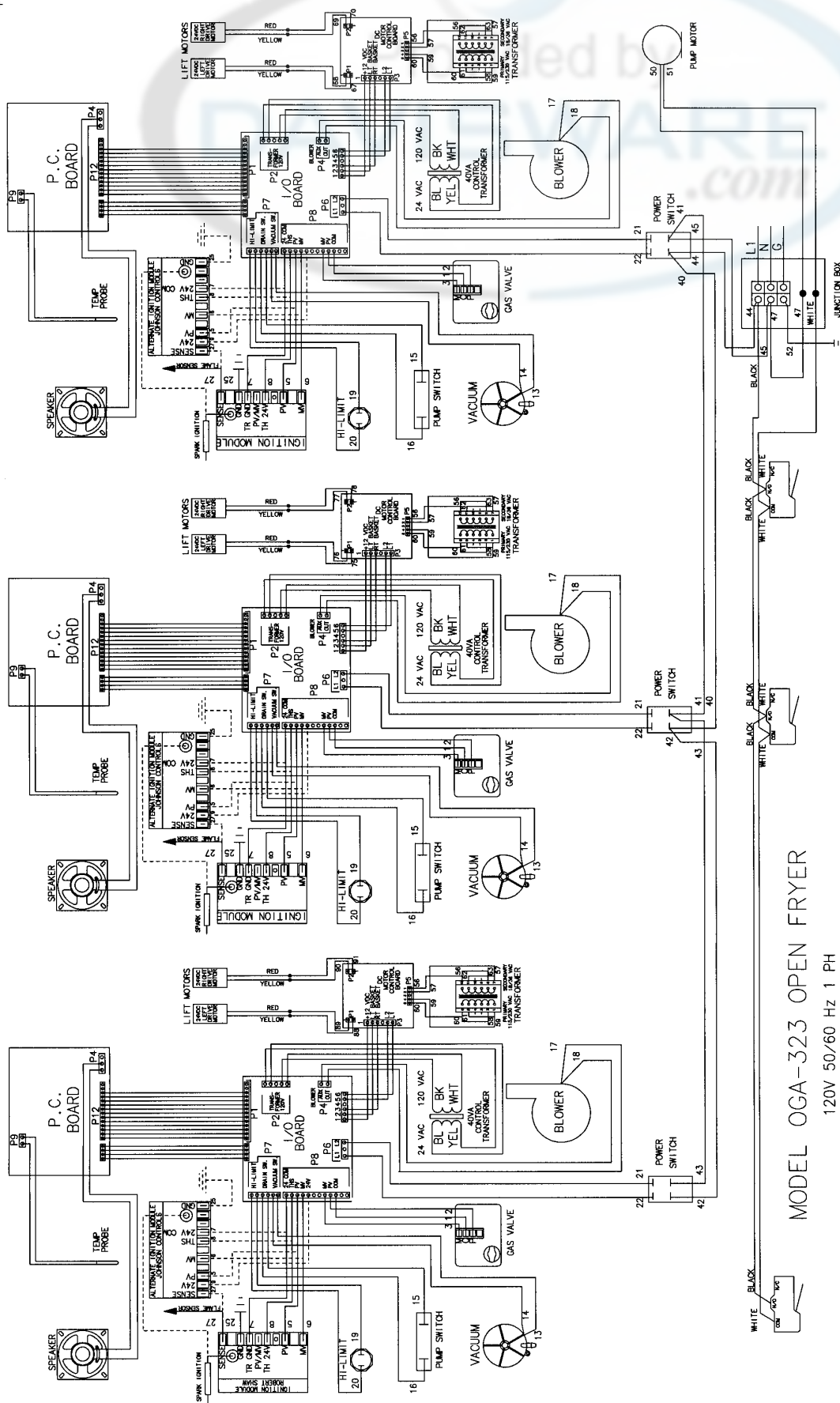

59523 +

MODEL OGA-323 OPEN FRYER  
120V 50/60 Hz 1 PH

+

+

+

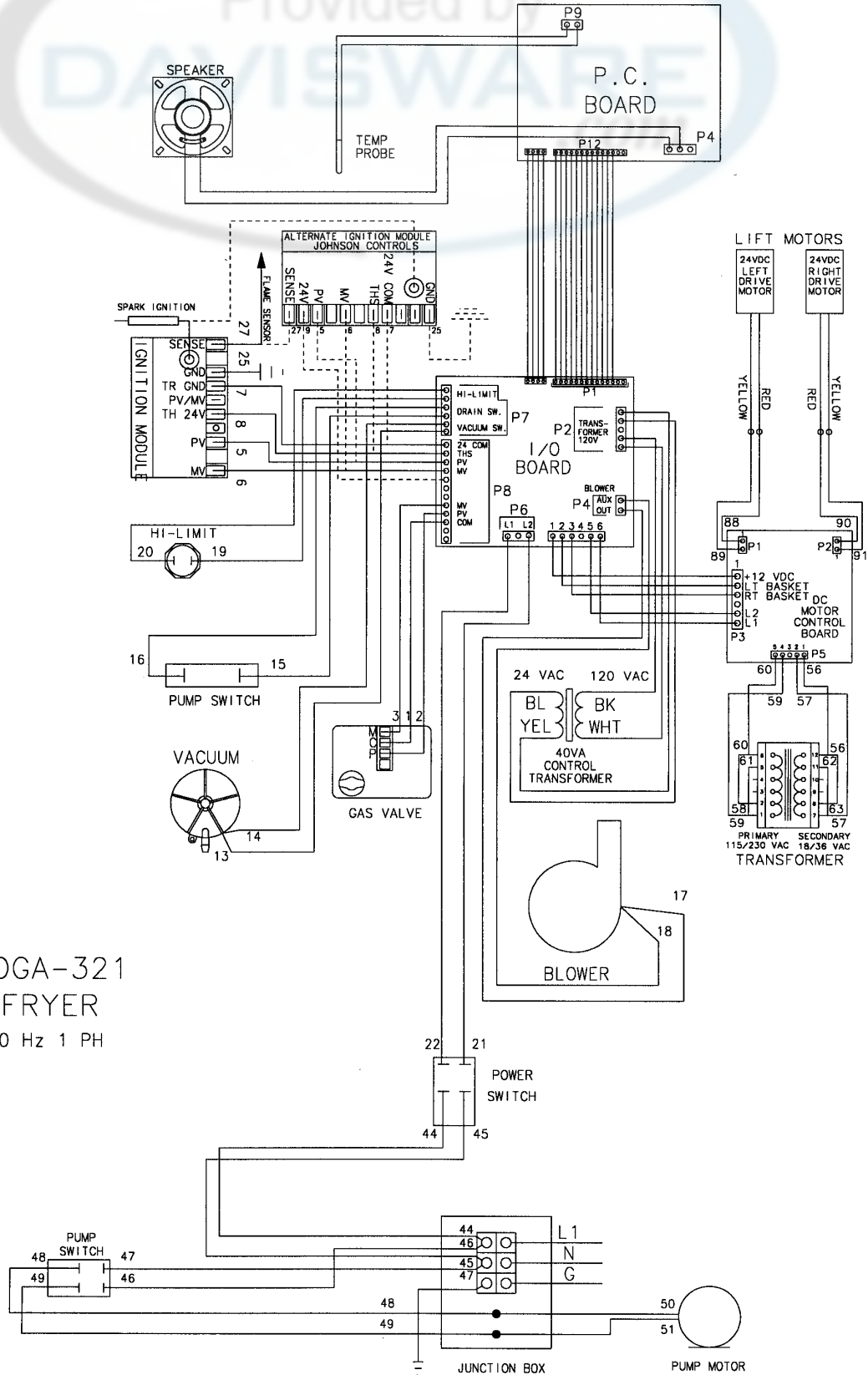

MODEL OGA-321  
OPEN FRYER  
120V 50/60 Hz 1 PH

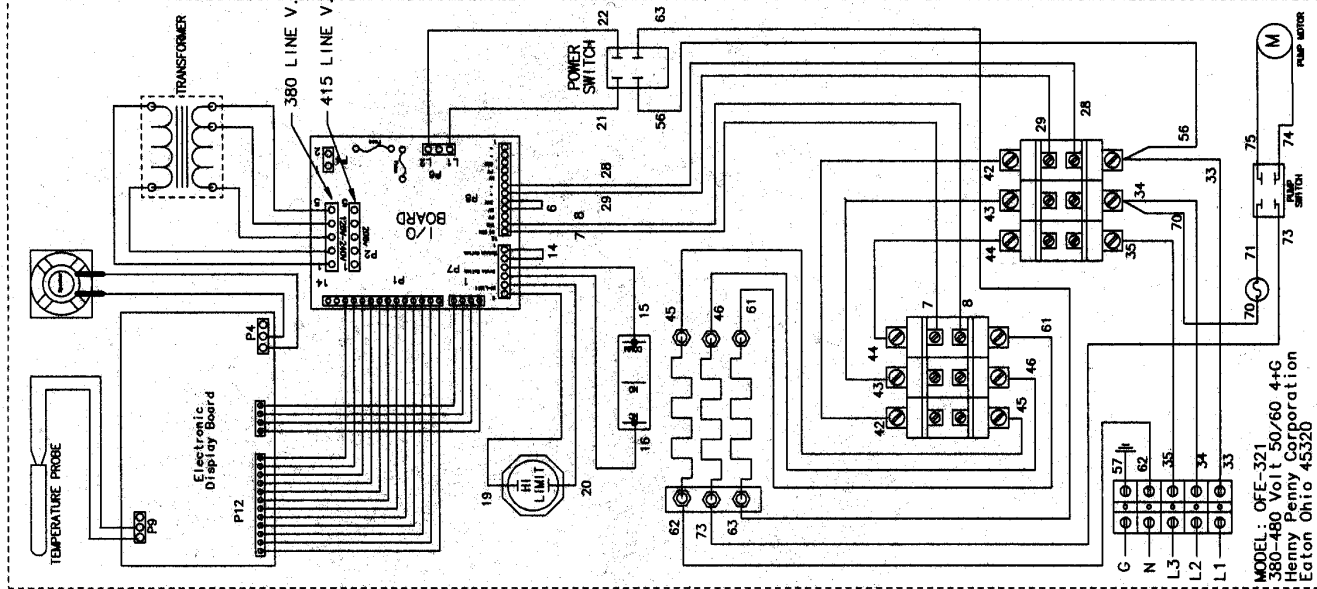
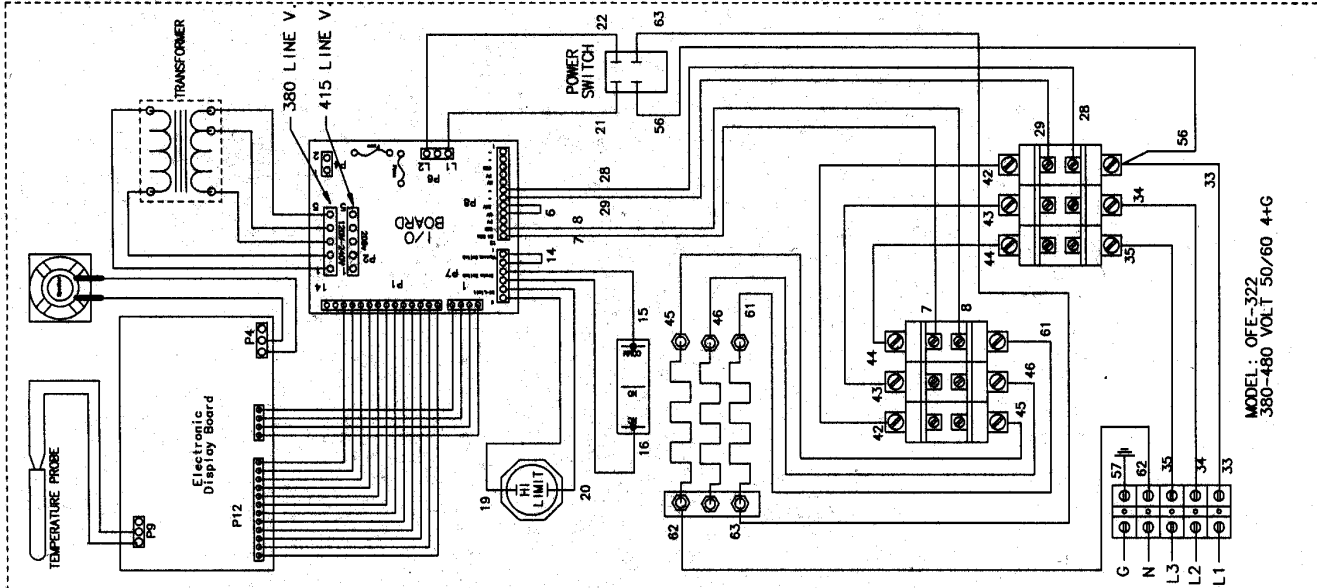
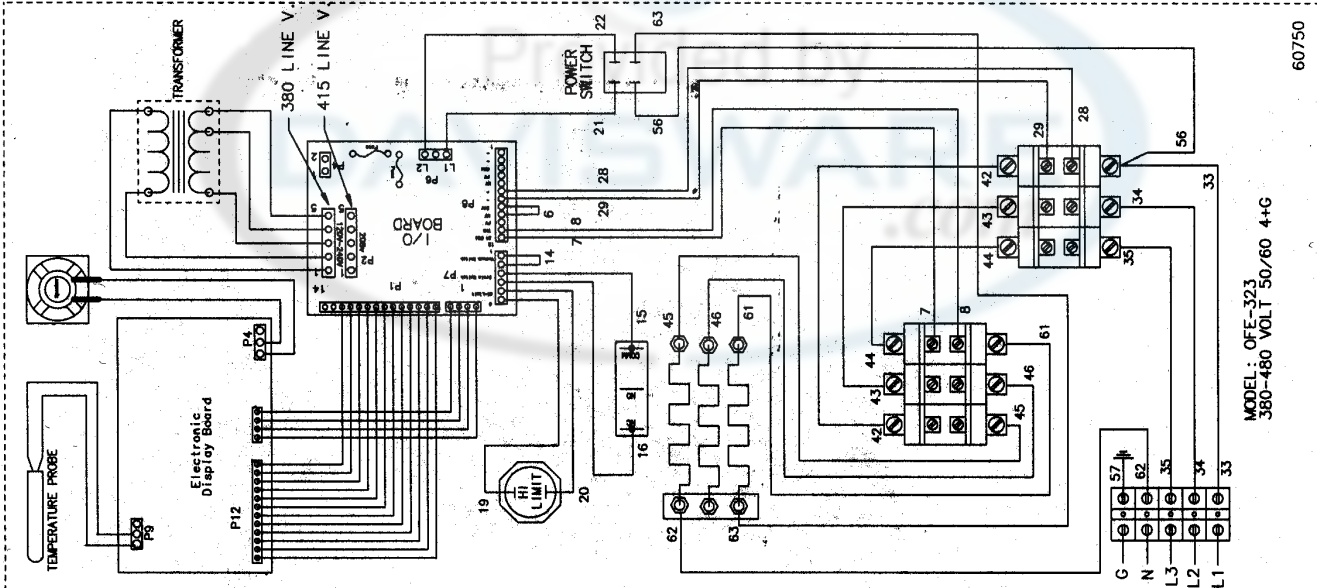

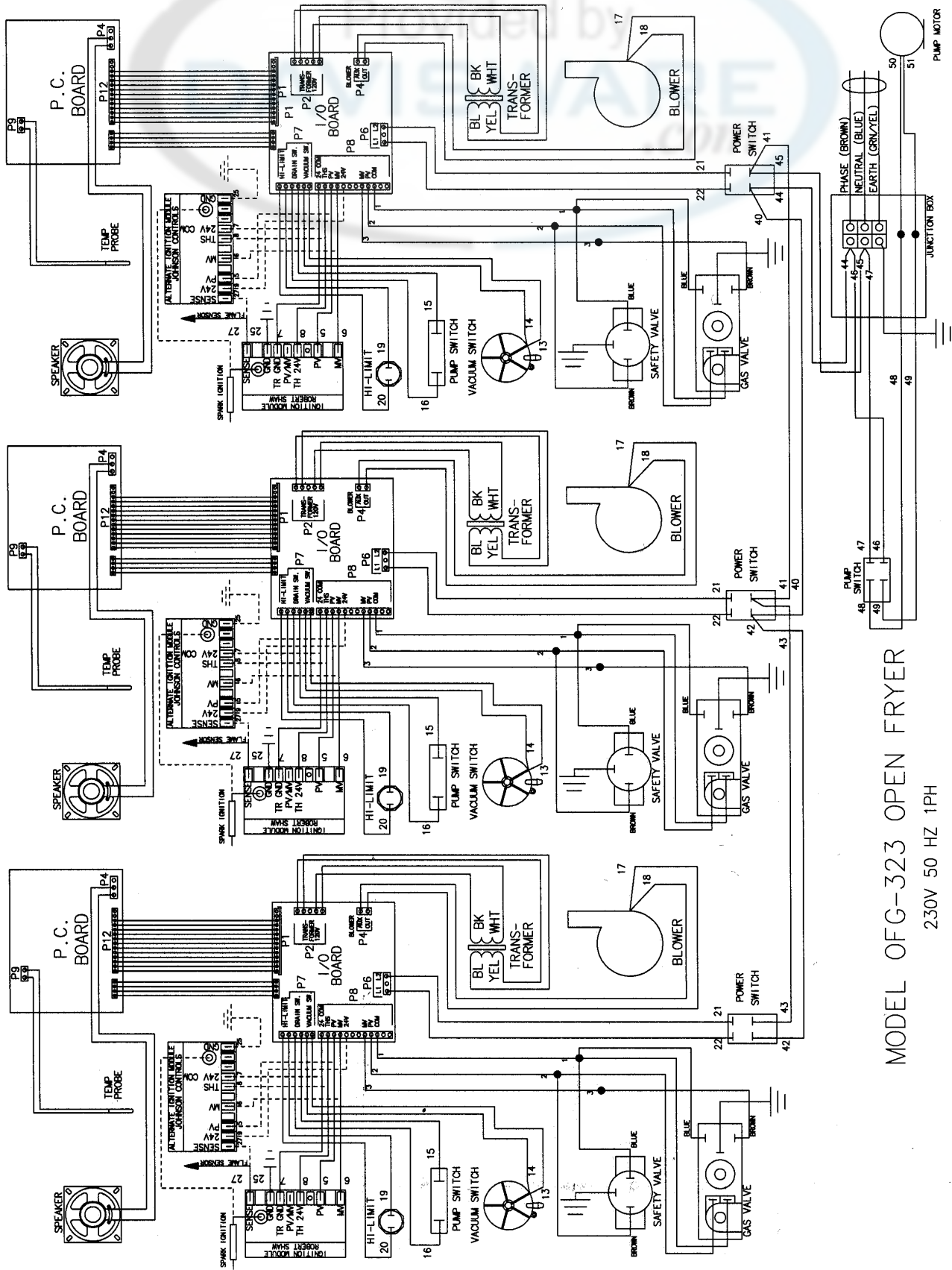

MODEL OFG-323 OPEN FRYER

230V 50 HZ 1PH

60236

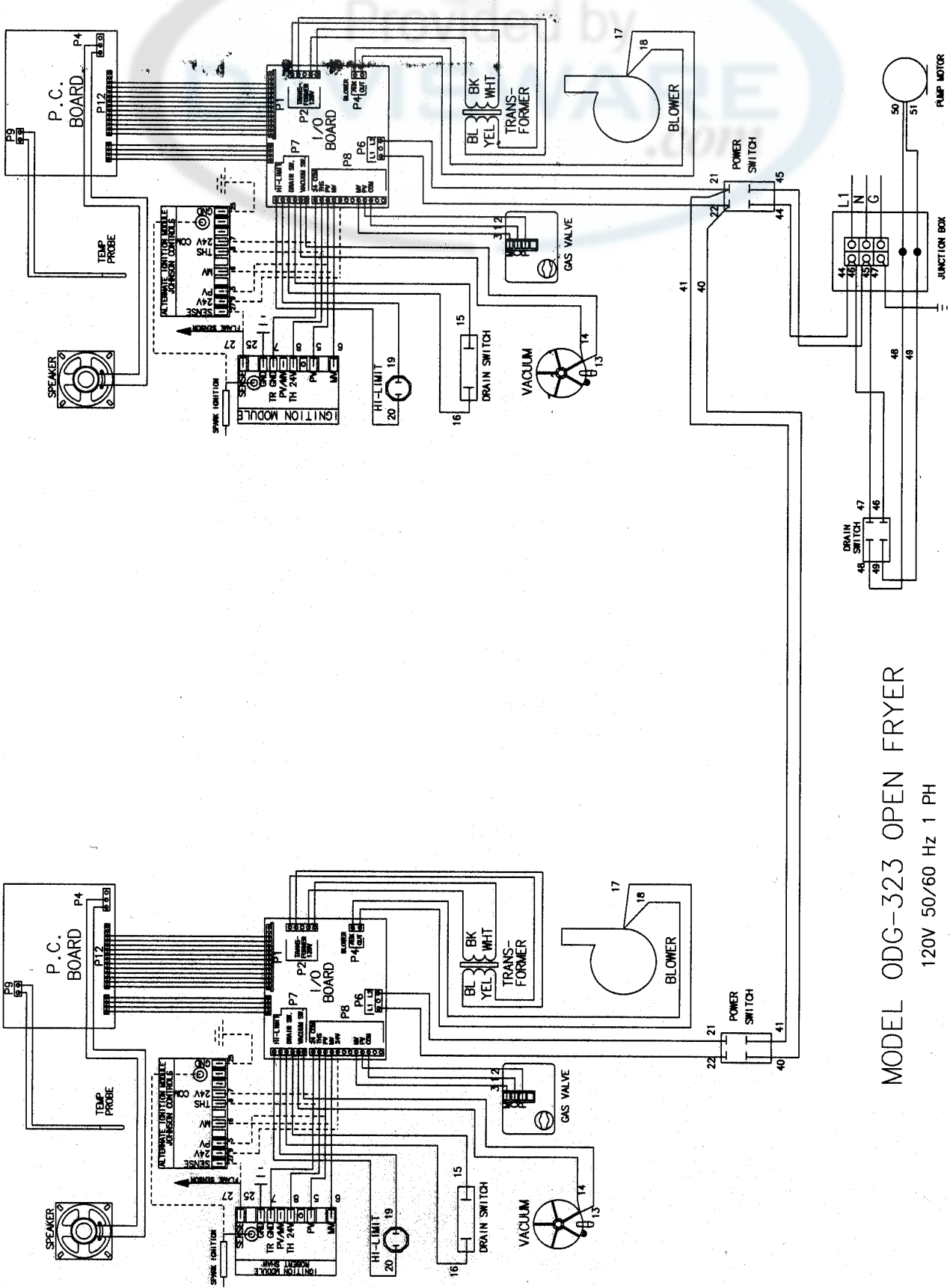

MODEL ODC-323 OPEN FRYER

120V 50/60 Hz 1 PH

60626



MODEL OFG-322 OPEN FRYER  
230V 50 HZ 1PH

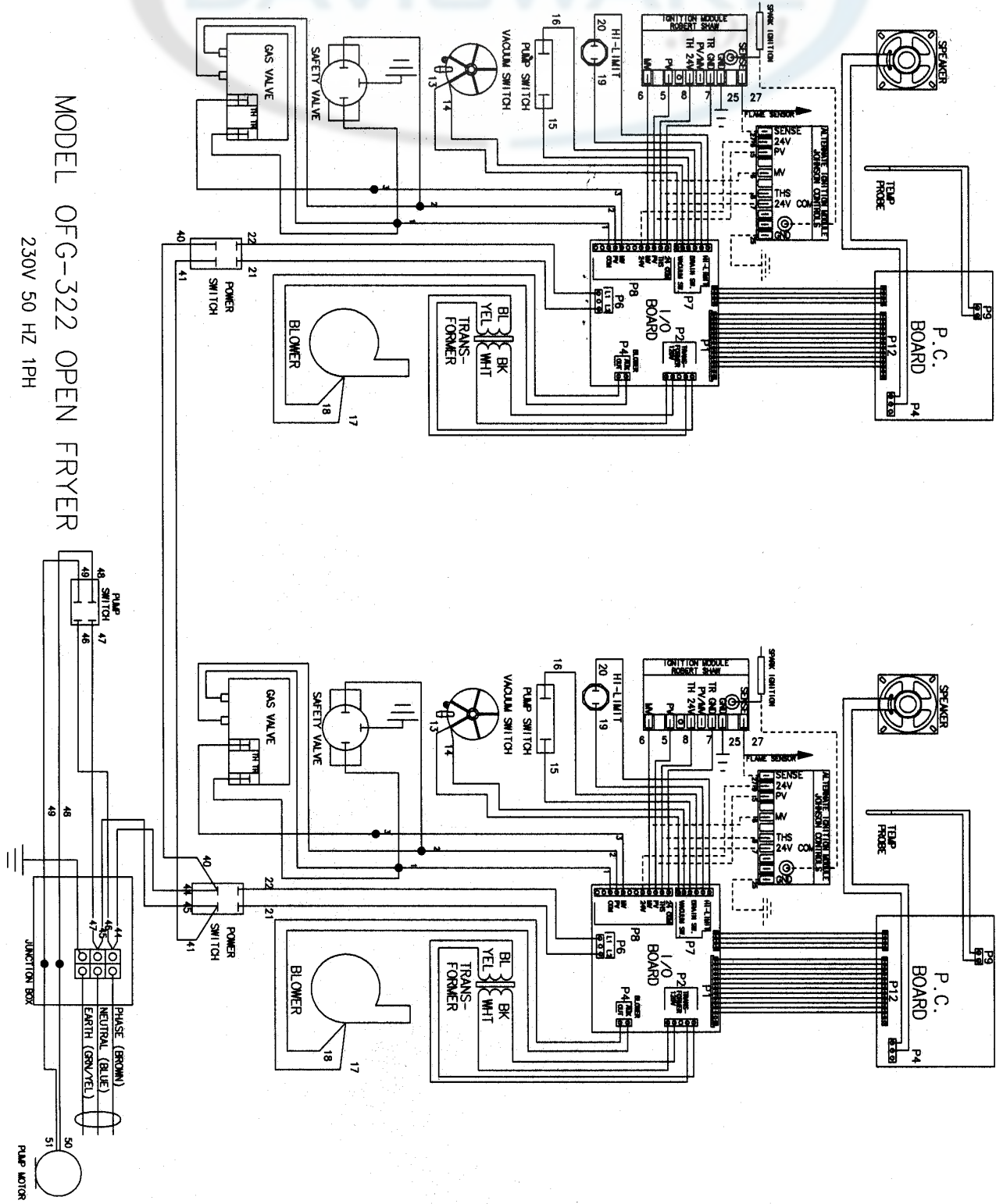

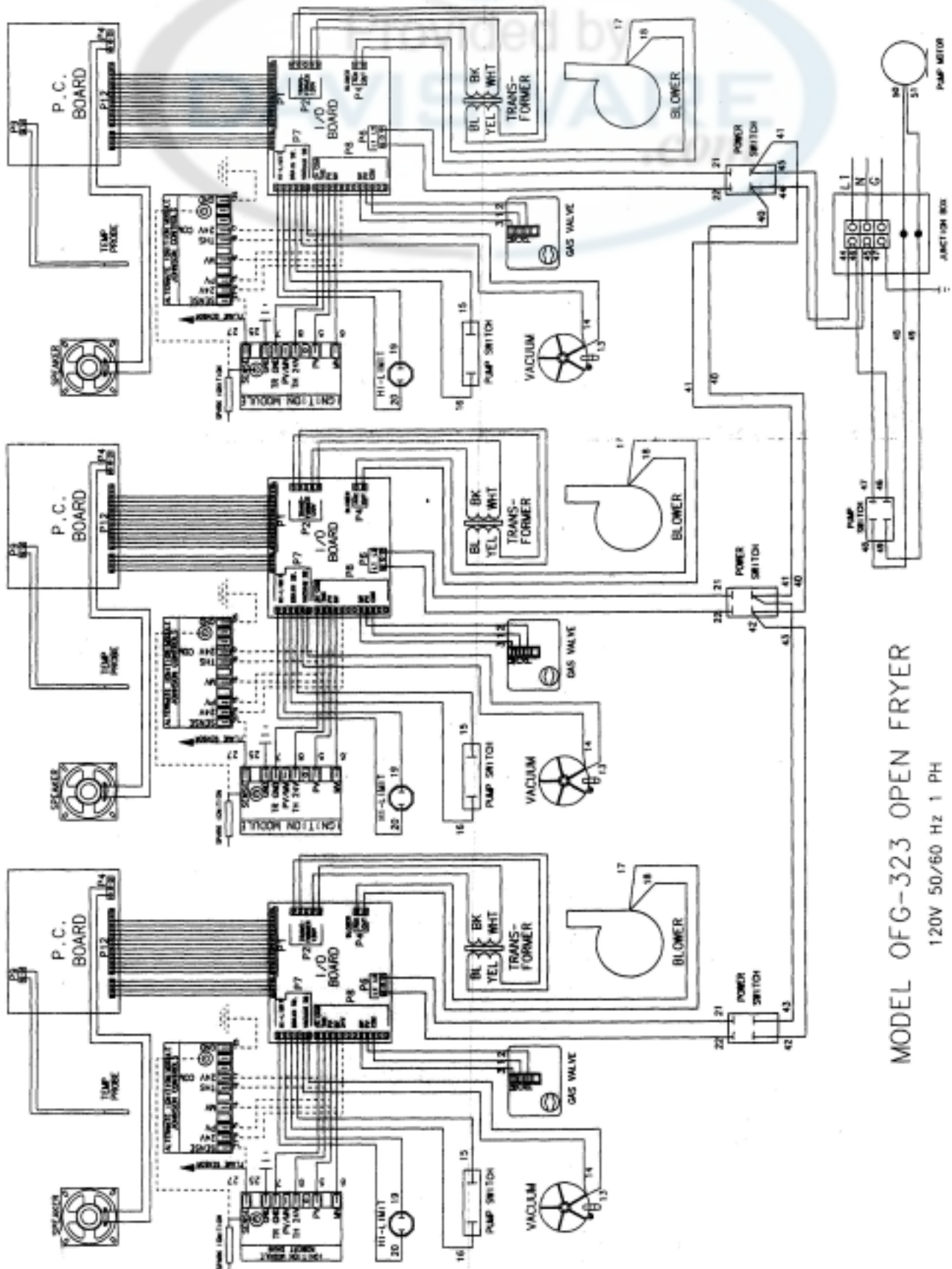

MODEL OFG-323 OPEN FRYER

120V 50/60 Hz 1 PH

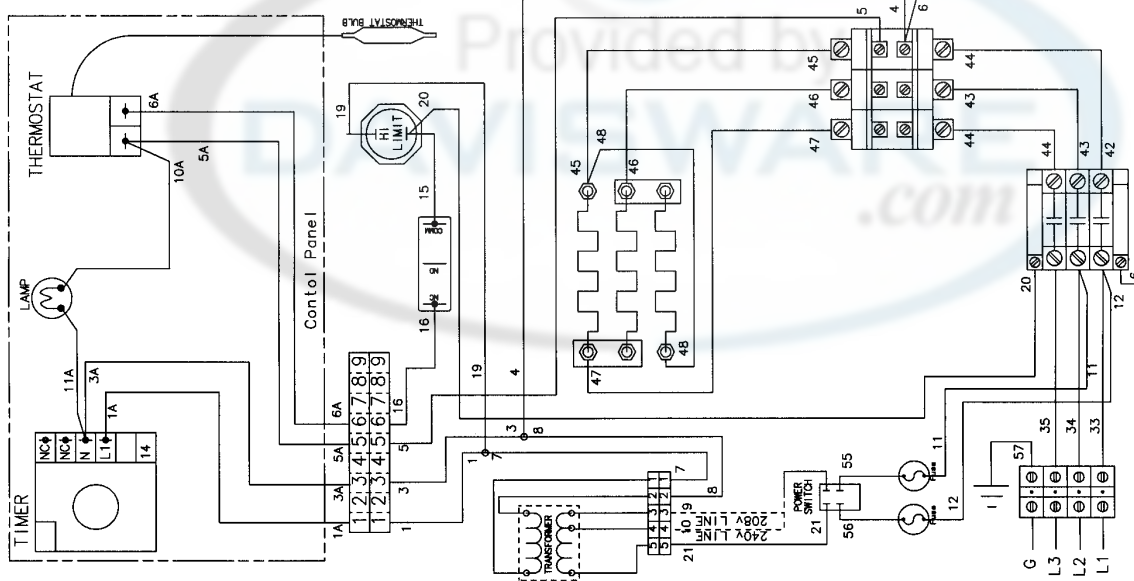

OFE-323 E/M  
208-240 VOLT 50/60 3+G

60753

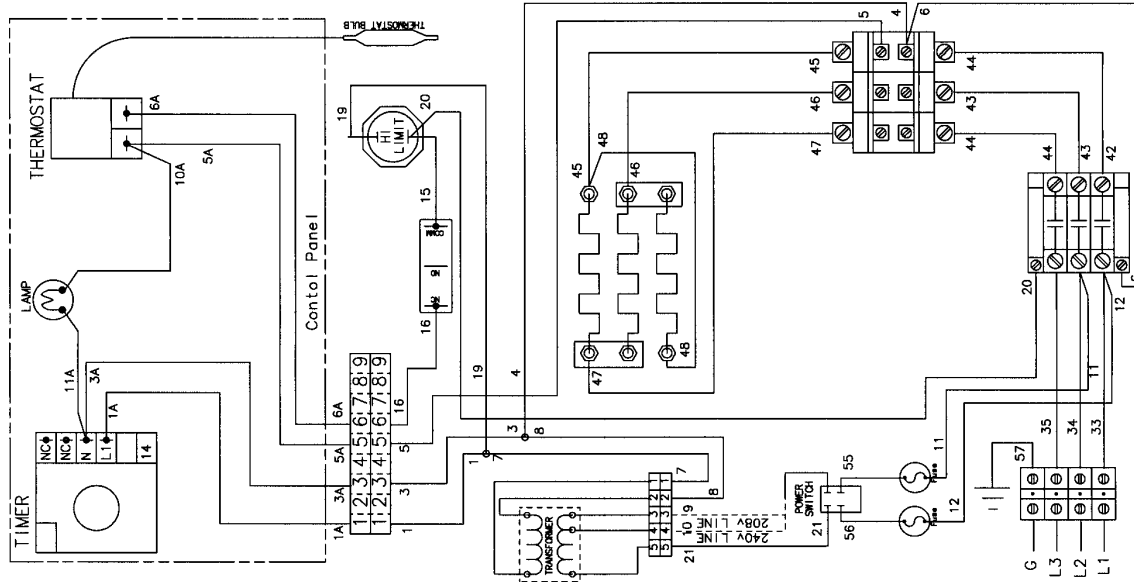

OFE-322 E/M  
208-240 VOLT 50/60 3+G

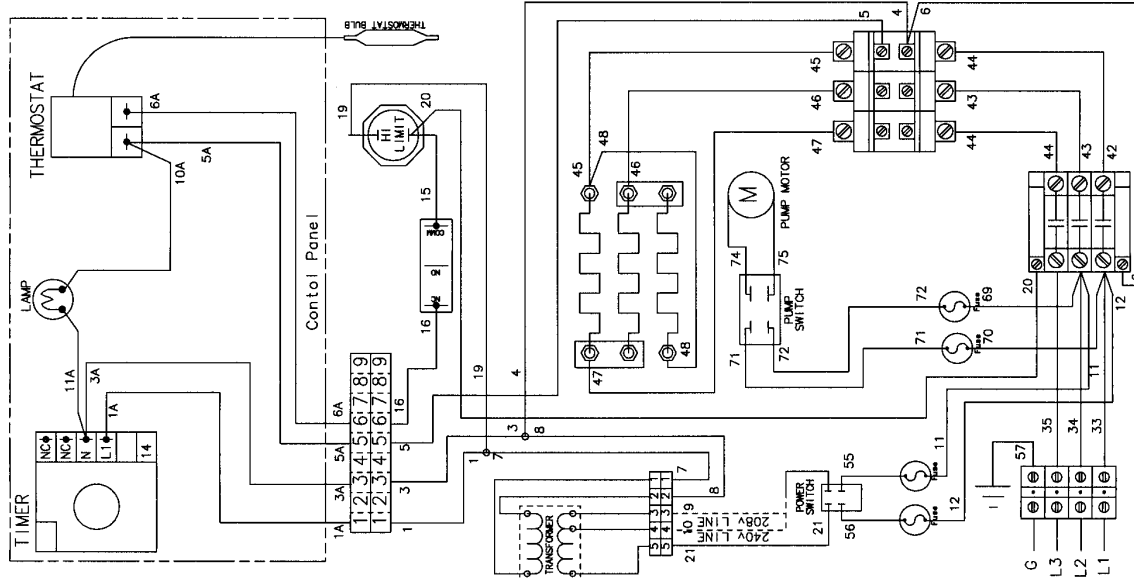

OFE-321 E/M  
208-240 VOLT 50/60 3+G  
HENNY PENNY CORPORATION  
EATON, OHIO 45320



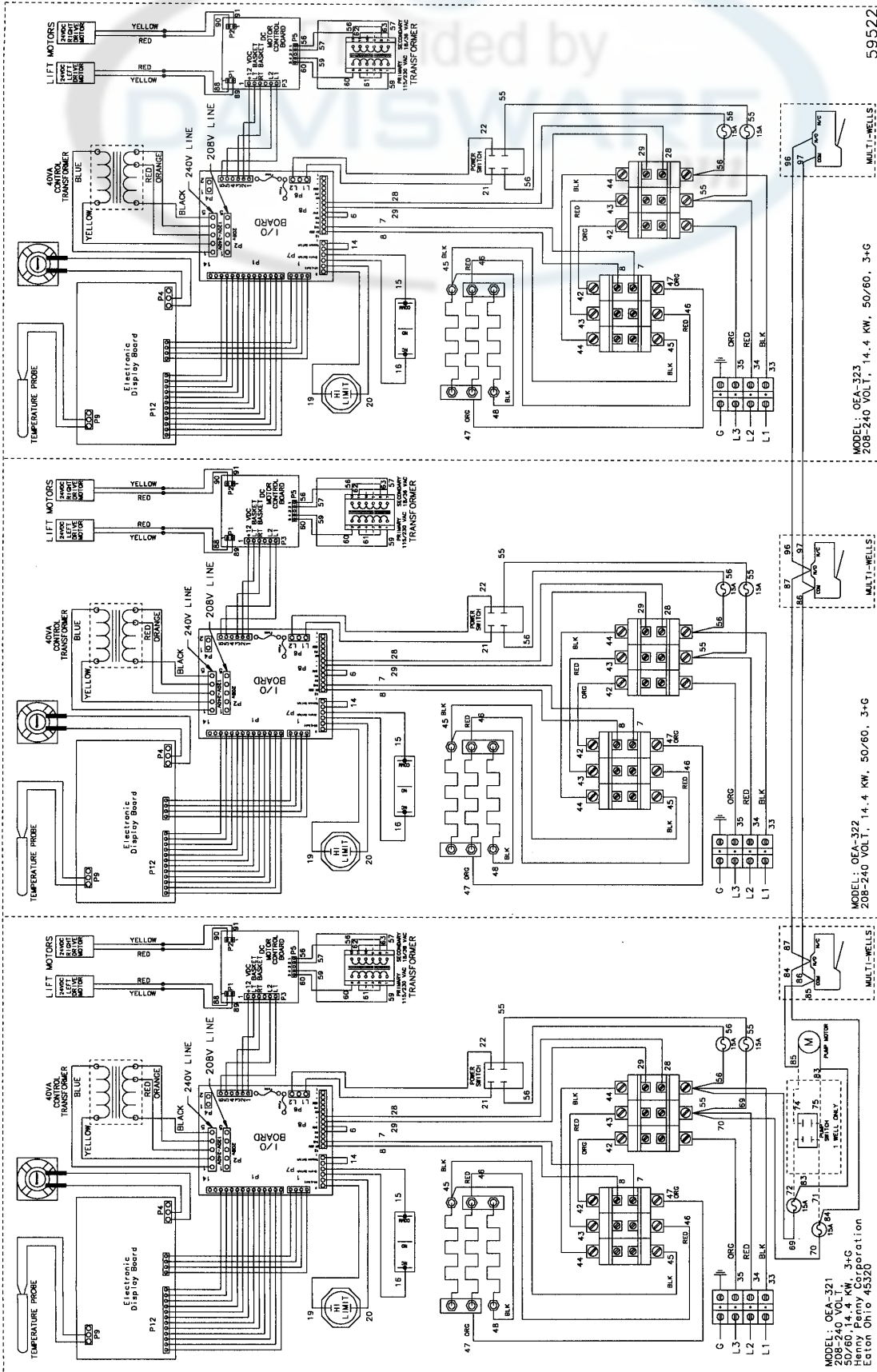

59522

MODEL: OFE-323  
208-240 VOLT, 14.4 KW, 50/60, 3+G

MODEL: OFE-322  
208-240 VOLT, 14.4 KW, 50/60, 3+G

MODEL: OFE-321  
208-240 VOLT,  
50/60, 14.4 KW, 3+G  
Henny Penny Corporation  
P.O. Box 45570  
Chicago, IL 60645

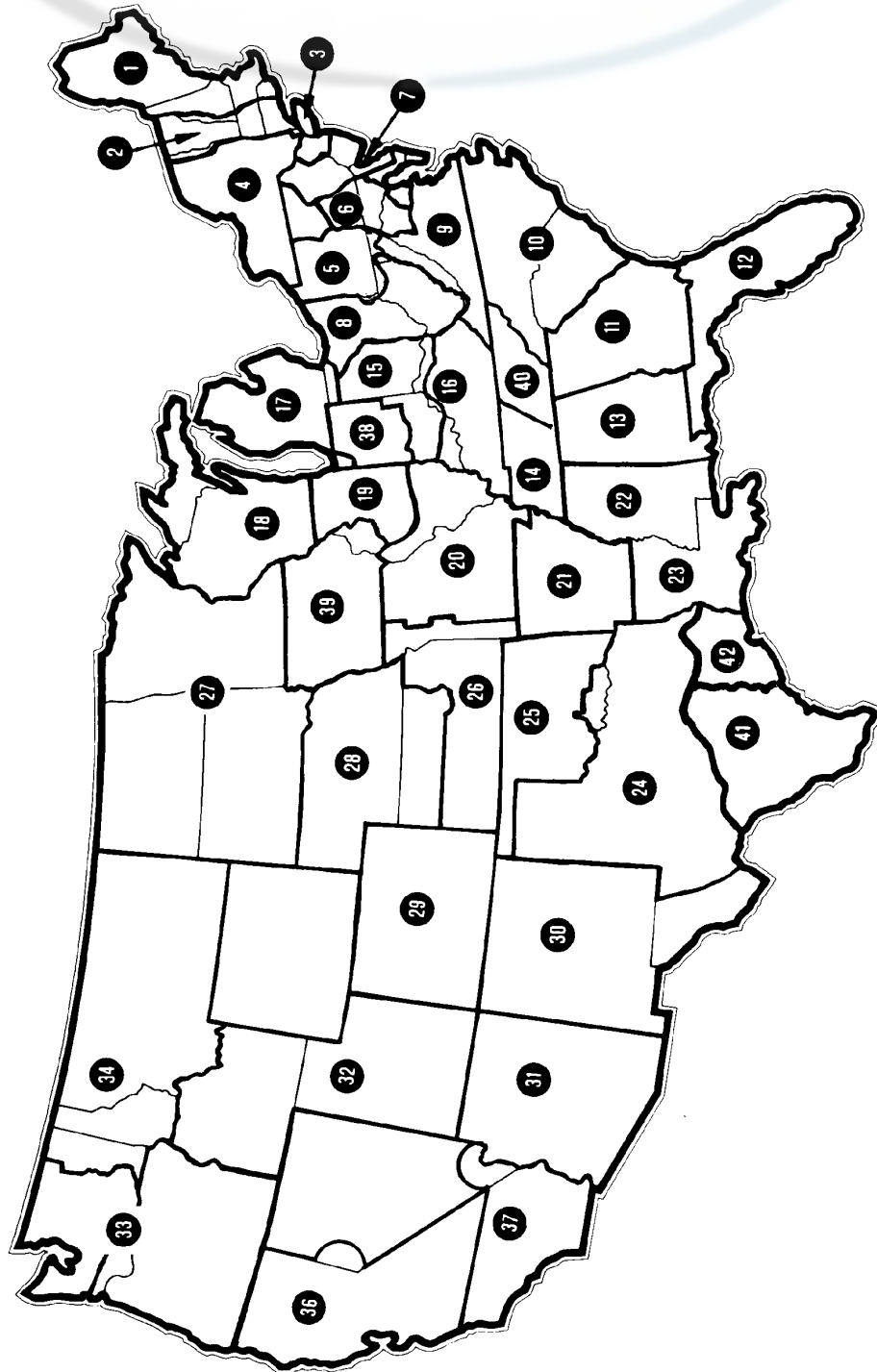

**For Sales or Service Please Contact  
The Nearest Henny Penny Distributor**

- |   |   |  |   |
|---|---|--|---|
| <p><b>1. General Services</b><br/>100 Hicks Ave.<br/>Medford, MA 02155<br/>(800) 233-1033</p>   | <p><b>14. Barnett Supply</b><br/>2089 York Ave.<br/>Memphis, TN 38104<br/>(901) 278-0440<br/>Nashville, TN<br/>(615) 242-6451<br/><b>Scotsman Supply</b><br/>516 5th Ave., South<br/>Nashville, TN 37203<br/>(615) 242-6451</p> | <p><b>27. PHT Systems</b><br/>1801 Highway 8<br/>Suite 120<br/>New Brighton, MN 55112<br/>(651) 639-0368</p>   | <p><b>42. Top-Line Distributors</b><br/>1501 College Ave.<br/>Houston, TX 77585<br/>(713) 946-6008</p>  |
| <p><b>2. Art Cole Associates</b><br/>Golden Street<br/>Industrial Park<br/>Meriden, CT 06450<br/>(203) 237-7177</p>   | <p><b>15. St. Clair Supply Company</b><br/>231 East Main Street<br/>Eaton, OH 45320<br/>(937) 456-5500<br/>(800) 762-2968</p>   | <p><b>28. Mid-Nebraska Restaurant Supply Co.</b><br/>1415 S. Webb Road<br/>Grand Island, NE 68802<br/>(308) 384-5780</p>                             | <p><b>43. DSL Inc., Canada</b><br/>14520 128th Ave.<br/>Edmonton, Alberta<br/>Canada T5L3H6<br/>(403) 452-7580<br/>(Alberta, British Columbia, Manitoba, Saskatchewan, Yukon, &amp; N.W. Territories)</p> |
| <p><b>3. Globe-Monte Metro, Inc.</b><br/>47-02 Metropolitan Avenue<br/>Ridgewood, NY 11385<br/>(718) 786-5760</p>   | <p><b>16. Dine Equipment Co.</b><br/>3110 Preston Hwy.<br/>P.O. Box 34038 zip 40232<br/>Louisville, KY 40213<br/>(502) 637-3232<br/>FAX (502) 637-5177</p>  | <p><b>29. Robert G. Wood &amp; Co.</b><br/>2080 W. Cornell Ave.<br/>Englewood, CO 80110<br/>(303) 761-0500<br/>(800) 358-3061</p>                    | <p><b>44. Taylor Freezers, Inc.</b><br/>52 Armthorpe Rd.<br/>Brampton, Ontario<br/>Canada L6T5M4<br/>(905) 790-2211<br/>(Ontario, Montreal, and Maritime Provinces)</p>                                   |
| <p><b>4. Guertin Dist. Inc.</b><br/>5 Technology Drive<br/>East Syracuse, NY 13057-9713<br/>(315) 437-4928<br/>(800) 468-6336</p>   | <p><b>17. United Marketing Assoc.</b><br/>11877 Belden Court<br/>Livonia, MI 48150<br/>(734) 261-5380</p>   | <p><b>30. Open Territory</b></p>   | <p><b>45. Bazinet Taylor Ltee.</b><br/>4750 Rue Bourg<br/>Ville St. Laurent<br/>Quebec, Canada H5T 1J2<br/>(514) 735-3627<br/>(Quebec only)</p>   |
| <p><b>5. Kreiser Distributing Co.</b><br/>13800 Lincoln Highway<br/>N. Huntingdon, PA 16652<br/>(724) 863-3360</p>  | <p><b>18. T&amp;H Distributors</b><br/>1235 Parkview<br/>Green Bay, WI 54304<br/>(920) 339-9838</p>   | <p><b>31. CPE-USALCO</b><br/>1310 West Drivers Way<br/>Tempe, AZ 85284<br/>(480) 496-6995</p>  |   |
| <p><b>6. AFS Equipment Company</b><br/>9130-X Red Branch Road<br/>Columbia, MD 21045<br/>(410) 964-3770<br/>(800) 969-3770</p>  | <p><b>19. Food Service Solutions, Inc.</b><br/>1682 Barclay Blvd.<br/>Buffalo Grove, IL 60089<br/>(847) 459-8040<br/>(847) 459-7942</p>   | <p><b>32. National Equipment Corp.</b><br/>242 West-3680 South<br/>Salt Lake City, UT 84115<br/>(800) 266-5824<br/>(800) 955-9202</p>                |   |
| <p><b>7. HP Sales &amp; Service Co.</b><br/>200 Rittenhouse Circle, 4-East<br/>Bristol, PA 19007<br/>(215) 785-3250<br/>NJ Watts (800) 477-4379</p>   | <p><b>20. MEC</b><br/>2511 Cassens Dr.<br/>Fenton, MO 63026-2547<br/>(636) 343-0664<br/>(800) 397-1515</p>  | <p><b>33. The Nicewonger Co.</b><br/>19219 West Valley Hwy<br/>Suite M103<br/>Kent, WA 98032<br/>(800) 426-5972<br/>(425) 656-0907 FAX</p>           |   |
| <p><b>8. Astro Food Equipment</b><br/>7901 Old Rockside Rd.)<br/>Independence, OH 44131<br/>(216) 619-8821<br/>(800) 367-4237</p>   | <p><b>21. Delta Supply Co., Inc.</b><br/>3315 W. Roosevelt Rd.<br/>Little Rock, AR 72204<br/>(501) 664-4326</p>   | <p><b>34. Tri-State Market Supply</b><br/>11115 E. Montgomery, Suite A<br/>Spokane, WA 99206<br/>(509) 928-8815<br/>(877) 828-4268</p>               |   |
| <p><b>9. Carlisle Food Systems, Inc.</b><br/>11020 Lakeridge Pkwy.<br/>Ashland, VA 23005<br/>(804) 550-2169</p>   | <p><b>22. Dixie Supply</b><br/>490 Julianne St.<br/>Bldg. A-2<br/>Jackson, MS 39201<br/>(601) 354-3025</p>  | <p><b>35. Western Pacific Distributors, Inc.</b><br/>19422 Cabot Boulevard<br/>Haywood, CA 94545<br/>(510) 732-0100</p>                              |   |
| <p><b>10. Price-Davis, Inc.</b><br/>Route 1, Highway 27<br/>Iron Station, NC 28080<br/>(509) 928-8815<br/>(704) 732-2236<br/>(800) 456-1014</p>   | <p><b>23. Beaulieu Refrigeration Inc.</b><br/>200 North Luke St.<br/>Lafayette, LA 70506<br/>(337) 235-9755</p>   | <p><b>36. Don Walters Company</b><br/>2121 S. Susan Street<br/>Suite A<br/>Santa Ana, CA 92704<br/>(714) 979-5863</p>                                |   |
| <p><b>11. Big A Distributors, Inc.</b><br/>P.O. Box 1283<br/>Forest Park, GA 30051<br/>(404) 366-6510<br/>(800) 222-0298</p>  | <p><b>24. S.L.E. Corporation</b><br/>1110 Avenue "H" East<br/>Arlington, TX 76011<br/>(817) 640-7999</p>  | <p><b>37. Troyer Foods, Inc.</b><br/>17141 State Route 4<br/>Goshen, IN 46526<br/>(219) 533-0302</p>   |   |
| <p><b>12. W.H. Reynolds Distributors, Inc.</b><br/>4817 Westshore Blvd.<br/>Tampa, FL 33609<br/>(813) 873-2402<br/>Miami-(954) 845-0841<br/>Jacksonville-(904) 781-9054<br/>FL Watts (800) 282-2733</p> | <p><b>25. Brooks Industries</b><br/>4420 S.W. 29th St.<br/>Oklahoma City, OK 73119<br/>(405) 685-7200</p>   | <p><b>38. Tri-City HP, Inc.</b><br/>527 West Fourth St.<br/>Davenport, IA 52801<br/>(319) 322-5382</p>   |   |
| <p><b>13. Ber-Vel Distributing Co. Inc.</b><br/>P.O. Box 9943<br/>Birmingham, AL 35220<br/>(205) 681-1855</p>   | <p><b>26. B &amp; D Dist.</b><br/>19915 W. 161st St.<br/>Suite D<br/>Olathe, KS 66062<br/>(913) 768-8588<br/>FAX 913-768-8855</p>   | <p><b>39. Certified Commercial Service &amp; Equipment (CCSE)</b><br/>6031-A Industrial Heights Drive<br/>Knoxville, TN 37909<br/>(865)-546-8778</p> |   |
|   |   | <p><b>40. Gower Distributors, Inc.</b><br/>P.O. Box 4804<br/>Box 216K Rt. -4<br/>Victoria, TX 77903<br/>(361) 573-9777</p>                           |   |

**If Further Assistance Is Needed Please Contact: Henny Penny Corporation  
1219 U. S. Route 35 West  
Eaton, Ohio 45320  
1-800-417-8417  
Fax 1-800-417-8402**

Provided by  
**DAVISWARE**

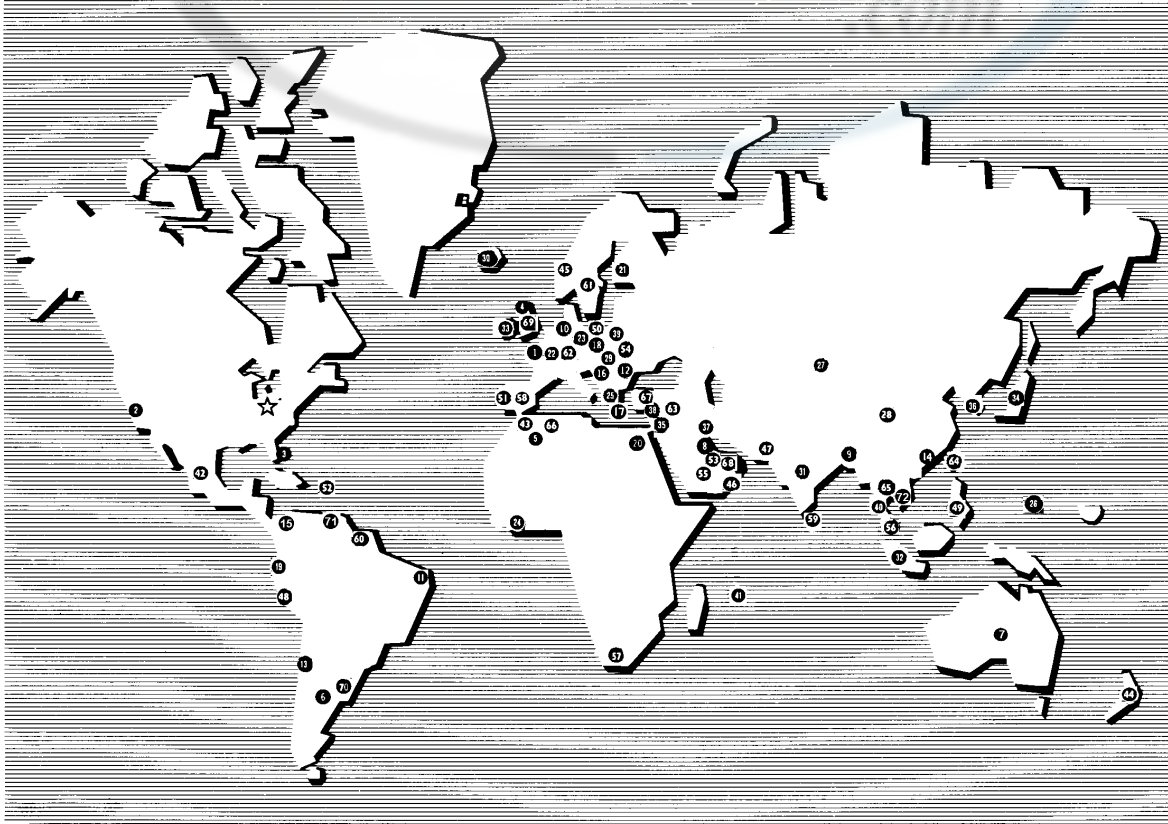

## **Henny Penny International Distributor Network**

## Henny Penny International Distributor Network

- U.S. Headquarters**  
Henny Penny Corporation  
1219 U.S. Route 35 West  
Eaton, OH 45320 USA  
Telephone: 937-456-8417  
Fax: 937-456-1860
- Representative Office**  
1. Henny Penny Corporation  
Representative Office  
Parc d'Entreprises de  
l'Esplanade  
2bis Rue Paul Henri Speak  
Saint Thibault des Vignes  
77462 Lagny sur Mame Cedex,  
France  
Telephone: 33 (1) 60075600  
Fax: 33 (1) 60071489
- U.S. Export Centers**  
2. Feco International Company  
20 North San Mateo Drive,  
Suite 9  
San Mateo, CA 94401 USA  
Telephone: 415-348-3499  
Fax: 415-348-3575
- Caribbean Islands & Central America** (excluding Puerto Rico)  
Total Equipment Suppliers  
9550 NW 41<sup>st</sup> St.  
Miami, FL 33178  
Telephone: 305-718-9550  
Fax: 305-718-9505
- Algeria**  
4. SOMAB  
Y1 Rue Mahmoud Boudjattit  
(Oasis) Ager, Algeria  
Tel: 213-21-23-3051/3052  
Fax: 213-21-23-3161
- Argentina**  
5. Oditec S.A.  
Augustin Alvarez 2128  
1602 Florida  
Buenos Aires, Argentina  
Telephone: (541) 796-0820  
Fax: (541) 796-2009
- Australia**  
6. J.L. Lennard Pty. Ltd.  
937-941 Victoria Rd.  
West Ryde NSW 2114  
Sydney, Australia  
Telephone: 617-3272-4744  
Fax: 617-3272-4799
- Bahrain**  
7. Mohammed Jalal Catering  
Old Palace Road  
P.O. Box 1335  
Manama, State of Bahrain  
Telephone: 973-53-45-39  
Fax: 973 53-14-78
- Bangladesh**  
8. Puffin International Ltd.  
3691B Elephant Rd.  
Swarankika Plaza  
4th Floor-Dhaka 1205  
Dhaka, Bangladesh  
Telephone: 8802-863117  
Fax: 880-2-867563
- Belgium**  
9. Engelen-Heere N.V.  
Industrialpark Terbekehof  
Fotografieaan 14  
B-2610 Antwerpen (Wilrijk)  
Telephone: 323-825-5577  
Fax: 323-825-3702
- Brazil**  
10. Pesin Equipment Food Service  
R. Olavo Bilac 188/198  
Sao Caetano Do Sul - SP  
Brazil  
Telephone: 55-11-7690-1470  
Fax: 55-11-7690-1466
- Bulgaria**  
11. E.C.E. - CAIX  
23A Rue Oborichte  
Sofia 1604, Bulgaria  
Telephone: 19-359-2-946-1479  
Fax: 19-359-2-946-1669
- Chile**  
12. IMAHE  
Manuel Montt 1154 Providencia  
Santiago, Chile  
Tel: 562-341-4953/5707  
Fax: 562-274-8567
- China**  
13. Bonny Foodservice Products  
Flat C, 8/F, Yeung Yiu Chung  
Industrial Bldg., No. 20  
Wang Hoi Rd.  
Kowloon Bay, Kowloon Hong Kong  
Telephone: 852-796-5616  
Fax: 852-799-8490
- Colombia**  
14. Industrial Taylor Ltda.  
Transversal 93, Numero 64-24  
Apartado Aereo 95075  
Bogota D.E., Colombia  
Telephone: 57 (1) 4340016  
Fax: 571-223-2642
- Croatia**  
15. New Rok  
Opatija M. Tita 15  
51410 Opatija, Croatia  
Telephone: 385-51-701-251  
Fax: 385-51-701-251
- Cyprus**  
16. AMF Chistofides Ltd.  
104A Prodomos Str.  
P.O. Box 25100  
Nicosia, Cyprus  
Telephone: 357-2-454-380  
Fax: 357-2-454-088
- Czech Republic**  
17. Citus  
Argentinska 20  
CZ 4170 00 Pragues 7  
CZECH REPUBLIC  
Telephone: 420-2-667-10-561  
Fax: 420-2-667-10-557
- Denmark**  
18. Inter-Gastro A.S.  
Midtager 18  
2605 Brondby  
Denmark DK2605  
Telephone: 45-43292000  
Fax: 45-43292001
- Ecuador**  
19. Equindeca Cia. Ltda.  
Hotel El Conquistador  
Gran Colombia 6-65  
Cuenca, Ecuador  
Telephone: 593-7-831788  
Fax: 593-7-843221
- Egypt**  
20. Con Trade Centre  
3A Ramsis Street  
Maarof Building #83 & #62  
Cairo, Egypt  
Telephone: 20 (2) 770642/762551  
Fax: 20 (2) 756258
- Estonia**  
21. Sisustaja As  
Tihniku 5  
11625 Tallinn, Estonia  
Telephone: 372-6502300  
Fax: 372-6502301
- Finland**  
22. Monilaite Oy  
P.O. Box 27  
Salpakuja 6  
SF-01200 Vantaa, Finland  
Telephone: 358-9-877-0100  
Fax: 358-9-877-01099
- France**  
23. Diffusion International de  
Materiel (DIM)  
Parc d'activite Clemenceau  
Chemin du Chateau d'Eau  
B.P. 4009  
59704 Marcq-En-Baroeuil  
Cedex, France  
Telephone: (33) 20890000  
Fax: (33) 20727355
- Germany**  
24. Sesjak KG  
Wullener Feld 9a  
D-58454 Witten  
Germany  
Telephone: 49-2302-697077  
Fax: 49-2302-698451
- Ghana**  
25. DRT Ghana  
E6619 Ablade Road  
Kanda Estate  
P.O. Box C2074  
Accra-Cantonments, Ghana  
Telephone: 233-2123-3949  
Fax: 233-2123-1380
- Greece**  
26. Domestica S.A.  
65 Stournara Str.  
Athens 10432, Greece  
Telephone: 30-15-24-30-14/15  
Fax: 30-15-22-91-58
- Guam**  
27. Pacific Technical Service, Inc.  
New Commercial Building  
#979 Rt. 16, Suite B-3  
Barrigada, Guam 96913  
Telephone: 6710632-5000  
Fax: 671-632-3333
- Holland**  
28. Englelen-Heere B.V.  
Straatveg 85, Postbus 35020  
3005 DA Rotterdam, Holland  
Telephone: 311-042-23077  
Fax: 311-042-23435
- Hong Kong**  
29. Bonny Foodservice Products  
Flat C, 8/F, Yeung Yiu Chung  
Industrial Building #20  
Wang Hoi Road  
Kowloon Bay, Kowloon,  
Hong Kong  
Telephone: 852-796-5616  
Fax: 852-799-8490
- Hungary**  
30. Hotex Service  
H-2094 Nagykovacsi  
Kossith Lajos u. 1.  
Hungary  
Telephone: 36-263-56653/89463  
Fax: 36-26389463
- Iceland**  
31. A. Karlsson H. F.  
Brautarholt 28  
105 Reykjavik, PO Box 167  
Iceland  
Telephone: 354-560-0900  
Fax: 354-560-0901
- India**  
32. AISHWARYA  
Trust Complex, 10 OVG Rd  
Basavanagudi  
Bangalore 560004, India  
Telephone: 91-80-667-7576  
Fax: 91-80-667-7576
- Int'l. Refrigeration Corp**  
7 Netaji Subhash Marg  
Darya Ganj  
New Delhi 110002, India  
Telephone: 91-11-4532077  
Fax: 91-11-6221827
- Indonesia**  
33. P.T. Gema  
JL. Raya Boulevard Raya  
Block IOA 2 No. 27  
Kelapa Gading Permai  
Jakarta 14240, Indonesia  
Telephone: 62-21-4532077  
62-21-4508910  
Fax: 62-21-4532586/4530777
- Ireland**  
34. Martin Food Equipment Ltd.  
Gaskin Business Park  
Coes Road  
Dundalk, Louth County  
Ireland  
Telephone: 353-42-30366  
Fax: 353-42-30370
- Italy**  
35. Allegra SRL  
Corso Matteotti, 5 - 10121  
Torino, Italy  
Telephone: 39-011-540264  
Fax: 39-011-533779
- Japan**  
36. Toei Kogyo Co. Ltd.  
4F, Nissay Nishi-Gotanda  
Building 24-5  
Nishi-Gatanda 7-Chome  
Shinagawa-ku, Tokyo 141-0031  
Japan  
Telephone: 813-3779-1081  
Fax: 813-3779-1638
- Jordan**  
37. Awar Trading Est  
PO Box 962227  
Amman 11196, Jordan  
Telephone: 962-6-55-19-610  
Fax: 962-6-55-19-605
- Korea**  
38. Ohjin Corporation  
3rd Floor, Hee Jung Building  
1635-0 Seocho-dong  
Seocho-ku  
C.P.O. Box 3252  
Seoul 137-070, Korea  
Telephone: 82-2-5850441  
Fax: 82-2-5874197
- Kuwait**  
39. Mabrook Hotel Supplies Co.  
PO Box 43832 Hawalli  
32053 Kuwait  
Telephone: 965-481-8242  
965-483-01648  
Fax: 965-483-4314

- Lebanon**  
40. Pro Kitchen  
Cahfoun Building  
Kaslik - Main Road  
PO Box 1066 Jounieh  
Lebanon  
Telephone: 961-9-635-077  
Fax: 961-9-635-059
- Lithuania**  
41. Master Group Baltic Master  
Darius Ir Girena 175  
2038 Vilnius, Lithuania  
Telephone: 3702-306-528/529  
Fax: 3702-306-533
- Malaysia**  
42. SCC Corp. Sdn. Bhd.  
19-21 Jalan Hujan  
Taman Overseas Union  
58200 Kuala Lumpur,  
Malaysia  
Telephone: 60-3-77828384  
Fax: 60-3-77818561
- Malta**  
43. C & H Bartoli Ltd.  
232 The Strand  
Gzira Gzros, Malta  
Telephone: 356-342-584  
Fax: 356-342-569
- Mauritius Island**  
44. (Mauritius, Reunion Island,  
Seychelles)  
Hassam Moussa Rawat  
10 Bourbon Street  
P.O. Box 492  
Port Louis, Mauritius Island  
Telephone: 160 (230) 2080024  
Fax: 160-230-2080147
- Mexico**  
45. Central Mexico Metro Mexico City  
Cavimex S.A. de C.V.  
Revillagigedo No. 61 Col Centro  
Mexico, D.F. 06070  
Mexico  
Telephone: 525-521-4200  
Fax: 525-510-2791
- Pacific**  
Micro Herros De Occidente,  
S.A. de C.V.  
Av. Juan Palamar y Arias  
#83 Col. Jardines Vallarta  
Zapopan, Jalisco, Mexico  
C.P.45020  
Telephone: 52-3-629-54-05  
Fax: 52-3-673-29-43
- Southeast**  
Equipo Para El Mercado  
S.A. de C.V  
Calle 55 No. 501-B por 60 y 62  
Merida, Yucatan,  
Mexico C.P. 97000  
Telephone: 52-99-236500  
Fax: 52-99-286649
- Morocco**  
46. Electra  
Boulevard AHL Loughlam  
BP 25698  
Sidi Bernoussi - Ain-Sebaa  
Casablanca Morocco  
Telephone: 212-22-753-531  
Fax: 212-22-753-554
- New Zealand**  
47. Taylor Equipment Limited  
4 Ponuz Place  
Mt. Wellington  
Auckland, New Zealand  
Telephone: 64 (9) 5733377  
Fax: 64 (9) 5730841
- Norway**  
48. Grillfagmannen A.S.  
Ostensjoveien 44  
N-0667 Oslo 6, Norway  
Telephone: 47 (2) 651410  
Fax: 47 (2) 720017
- Oman**  
49. Mohsin Haider Darwish LLC  
P.O. Box 880  
Ruwi, Code 112  
SULTANATE OF OMAN  
Telephone: 968-703411  
Fax: (968) 789927
- Pakistan**  
50. The Equipment Company  
Ground Floor, Dadabhoy Centre  
Sharea Faisai, Karachi 75530  
Pakistan  
Telephone: 922-1-778-1778/2778  
Fax: 922-1-587-0456/778-2777
- Peru**  
51. Importadora Tecnica  
Comercial C.R. Ltda.  
Jr. Marcos de Aramburu #595  
Lima 17, Peru  
Telephone: 51-1-226-2124  
Fax: 51-1-275-2689
- Philippines**  
52. HKR Equipment Corp.  
2nd Floor, THC Bldg.  
2176 Primo Rivera St.  
La Paz, Makati City, Philippines  
Telephone: 632-899-4511  
Fax: 632-899-4541
- Poland**  
53. I. F. E.  
Rydygiera 12  
01 793 Warsaw, Poland  
Telephone: 48-3912-3373  
42-22-663-4820/4069  
Fax: 48-3912-3373
- Portugal**  
54. Restautotel  
AV Da Republica  
83 C 1050  
243 Lisboa  
Portugal  
Telephone: 351 7967116/7/8/9  
FAX: 351 7933982
- Puerto Rico**  
55. Progressive Sales and Service  
PO Box 10876  
Caparra Heights Station  
San Juan, Puerto Rico 00922-0876  
Telephone: 787-782-7474  
Fax: 787-793-6479
- Qatar**  
56. Tristar Group  
C.R. No. 6778  
P.O. Box 4746  
Doha, Qatar  
Telephone: 974-4664433  
Fax: 974-4365365
- Romania**  
57. Delta Technologies Romani S.A.  
Sector 6, 20 Constructorilor Blvd.  
Bloc 20 A, sc. B 7th Floor  
Apt. 64  
Bucharest, D599 Romania  
Telephone: 401-220-4261  
Fax: 401-220-3990  
US Address:  
115 Main St.  
Mishawaka, In. 46544  
Telephone: 219-256-3783  
Fax: 219-256-7130
- Saudi Arabia**  
58. Commercial Center  
Development & Economy  
P.O. Box 1210  
Jeddah 21431, Saudi Arabia  
Telephone: 966 (2) 629-1857  
Fax: 966 (2) 629-1860
- Senegal**  
59. Breeding Systems Co.  
C/ Ripoché,14  
35007 Las Palmas  
Spain  
Telephone: 34-9-28-22-43-86  
Fax: 34-9-28-27-56-90
- Singapore**  
60. Simplex Pte. Ltd.  
Block 1, Lorong 8  
Toa Payoh Industrial Park 01-1383  
Singapore 319053  
Telephone: 65-251-6241  
Fax: 65-253-8814
- Shopfit (S) Pte. Ltd.**  
Blk 623 Aljunied Industrial Complex  
Unit 02-09  
Singapore 389835  
Telephone: 65-7410911  
Fax: 65-7438911
- South Africa**  
61. Foodserv "CC"  
PO Box 55269  
Northlands 2116,  
Republic of South Africa  
Telephone: 27 (11) 616-5183,  
Fax: 27 (11) 616-8287
- Spain**  
62. Adisa  
Tuset, 8-10  
08006 Barcelona, Spain  
Telephone: 34-93-415-0018  
Fax: 34-93-218-1782
- Sri Lanka**  
63. Sperrys Commercial Equipment  
1014 Parliament Road  
Etul Kotte  
Kotte/Colombo, Sri Lanka  
Telephone: 941-873-0561  
Fax: 941-863-8361
- Suriname**  
64. Tessco N.V.  
Oude Charlesburgweg #47  
Paramaribo Suriname  
Telephone: 597-473366/477388  
Fax: 597-473366
- Sweden**  
65. Eurospice AB  
Box 5050  
Hejargatan 6  
632 29 Eskilstuna, Sweden  
Telephone: 46 (16) 125600  
Fax: 46 (16) 131390
- Switzerland**  
66. Stuppen Fast Food GmbH  
Oberneuhofstrasse 8  
CH-6340 Baar, Switzerland  
Telephone: 41-41-761-5052  
Fax: 41-41 761-7210
- Syria**  
67. Lahham Trading & Contracting  
Hamra Str. Omyad Building  
P.O. Box 2960  
Damascus Syria  
Telephone: 963-11-331-2251  
Fax: 963-11-331-2252
- Taiwan**  
68. Feco Corporation  
420, 11 F Keelung Rd.  
Sec. 1 Postal Code 110  
Taipei, Taiwan  
Republic of China  
Telephone: 886-2-2758-2288  
Fax: 886 (2) 2758-2297
- Thailand**  
69. Fieco Company Ltd.  
43/524-526 Amarinnivej 1  
Anusaovari Laksi  
Phaholoyothin Road  
Bangkok 10220  
Thailand  
Telephone: 66-2-521-3824/3878  
Fax: 66-2-552-0833
- Tunisia**  
70. Senci  
16, Rue Aziz Taj  
1101 Tunis RP, Tunisia  
Telephone: 216 -133-1501  
Fax: 216-133-0698
- Turkey**  
71. Klimatek  
Inonu Caddesi, Opera Palas 73/5  
80090 Gumussuyu  
Istanbul, Turkey  
Telephone: 90-212-245-1812  
90-212-293-7892  
Fax: 90-212-293-3903
- United Arab Emirates**  
72. Habtoor International  
P.O. Box 55332  
Dubai, United Arab Emirates  
Telephone: 971-4-272-1212  
Fax: 971-4-272-2255
- United Kingdom**  
73. Servequip Products Ltd.  
214 Purley Way  
GB-Croyden CRO 4XG, England  
Telephone: 44-208-6868855  
Fax: 44-208-6817509
- Uruguay**  
74. Tecnoland S.A.  
Dr. José Scorsería 2740  
CP 11300 Montevideo, Uruguay  
Telephone: 598-2-7105900  
Fax: 598-2-7105900
- Venezuela**  
75. Prefer, C.A.  
Avenida Presidente Medina  
Edificio Prefer, Local No. 44  
Entre Calles Chile y Progreso  
urb. Los Acacias  
Caracas 1040, Venezuela  
Telephone: 58-212-633-6933/2801  
Fax: 58-212-632-6711
- Vietnam**  
76. Cao Sinh Pte  
Block 1, Lorong 8  
Toa Payoh Industrial  
Estate #01-1383  
Singapore 319053  
Telephone: 65-2516241  
Fax: 84-2538814
- Yemen**  
77. Mukiriani Sana'a  
PO Box 8150 Sana'a  
Yemen  
Telephone: 967-1-230-675  
Fax: 967-1-230-929