

Introduction

This manual explains the operation of the Navigation System. Please read this manual carefully to ensure proper use. Keep this manual in your vehicle at all times.

The Navigation System is one of the most technologically advanced vehicle accessories ever developed. The system receives satellite signals from the Global Positioning System (GPS) operated by the U.S. Department of Defense. Using these signals and other vehicle sensors, the system indicates your present position and assists in locating a desired destination.

The navigation system is designed to select efficient routes from your present starting location to your destination. The system is also designed to direct you to a destination that is unfamiliar to you in an efficient manner. The system uses DENSO maps. The calculated routes may not be the shortest nor the least traffic congested. Your own personal local knowledge or "short cut" may at times be faster than the calculated routes.

The navigation system's database includes Point of Interest categories to allow you to easily select destinations such as restaurants and hotels. If a destination is not in the database, you can enter the street address or a major intersection close to it and the system will guide you there.

The system will provide both a visual map and audio instructions. The audio instructions will announce the distance remaining and the direction to turn in approaching an intersection. These voice instructions will help you keep your eyes on the road and are timed to provide enough time to allow you to maneuver, change lanes or slow down.

Please be aware that all current vehicle navigation systems have certain limitations that may affect their ability to perform properly. The accuracy of the vehicle's position depends on the satellite condition, road configuration, vehicle condition or other circumstances. For more information on the limitations of the system, refer to pages 406 through 407.

TOYOTA MOTOR CORPORATION

Important information about this manual

For safety reasons, this manual indicates items requiring particular attention with the following marks.

 CAUTION
This is a warning against anything which may cause injury to people if the warning is ignored. You are informed about what you must or must not do in order to reduce the risk of injury to yourself and others.

NOTICE
<i>This is a warning against anything which may cause damage to the vehicle or its equipment if the warning is ignored. You are informed about what you must or must not do in order to avoid or reduce the risk of damage to your vehicle and its equipment.</i>

INFORMATION
<i>This provides additional information.</i>

Safety Instruction

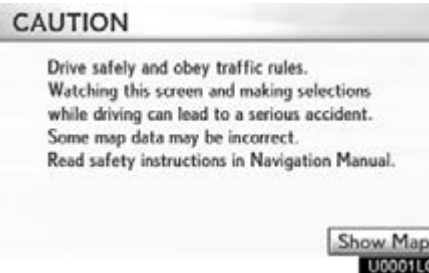

To use this system in the safest possible manner, follow all the safety tips shown below.

This system is intended to assist in reaching the destination and, if used properly, can do so. The driver is solely responsible for the safe operation of your vehicle and the safety of your passengers.

Do not use any feature of this system to the extent it becomes a distraction and prevents safe driving. The first priority while driving should always be the safe operation of the vehicle. While driving, be sure to observe all traffic regulations.

Prior to the actual use of this system, learn how to use it and become thoroughly familiar with it. Read the entire Navigation System Owner's Manual to make sure you understand the system. Do not allow other people to use this system until they have read and understood the instructions in this manual.

For your safety, some functions may become inoperable when driving. Unavailable screen buttons are dimmed. Only when the vehicle is not moving, can the destination and route selection be done.



CAUTION

- For safety, the driver should not operate the navigation system while he/she is driving. Insufficient attention to the road and traffic may cause an accident.
- While driving, be sure to obey the traffic regulations and maintain awareness of the road conditions. If a traffic sign on the road has been changed, route guidance may not have the updated information such as the direction of a one way street.

While driving, listen to the voice instructions as much as possible and glance at the screen briefly and only when it is safe. However, do not totally rely on voice guidance. Use it just for reference. If the system cannot determine the current vehicle position correctly, there is a possibility of incorrect, late, or non-voice guidance.

The data in the system may occasionally be incomplete. Road conditions, including driving restrictions (no left turns, street closures, etc.) frequently change. Therefore, before following any instruction from the system, look to see whether the instruction can be done safely and legally.

This system cannot warn about such things as the safety of an area, condition of streets, and availability of emergency services. If unsure about the safety of an area, do not drive into it. **Under no circumstances is this system a substitute for the driver's personal judgement.**

Use this system only in locations where it is legal to do so. Some states/provinces may have laws prohibiting the use of video and navigation screens next to the driver.

Table of Contents

Quick guide —	
— Overview buttons and guidance screen	10
— Registering home	12
— Registering preset destinations	14
— Operation flow: guiding the route	16
— Setting home as the destination	17
Navigation system function index	18
Quick reference (“Destination” screen)	20
Quick reference (“Setup” screen)	22
Quick reference (“Information” screen)	23
1 Navigation System: Basic Functions	
〈Basic information before operation〉	
Initial screen	26
Touch screen operation	27
Inputting letters and numbers/List screen operation	28
Screen adjustment	31
Help icon	33
Map screen operation	33
Current position display	33
Screen scroll operation	34
Switching the screens	39
Map scale	42
Foot print map	42
Orientation of the map	43
Standard map icons	44
Voice command system	44
Natural speech information	47
Command list	49

2	Navigation System: Destination Search	
	Destination search	62
	Selecting the search area	62
	Destination search by Home	64
	Destination search by Preset destinations	64
	Destination search by "Address"	65
	Destination search by "Point of Interest"	69
	Destination search by "Destination Assist"	76
	Destination search by "Previous Destinations"	76
	Destination search by "Address Book"	77
	Destination search by "Emergency"	77
	Destination search by "Intersection & Freeway"	78
	Destination search by "Map"	81
	Destination search by "Coordinates"	82
	Deleting set destinations	82
	Starting route guidance	83
3	Navigation System: Route Guidance	
	Route guidance screen	88
	Typical voice guidance prompts	91
	Distance and time to destination	93
	Setting and deleting destinations	94
	Adding destinations	94
	Reordering destinations	94
	Deleting destinations	95
	Setting route	96
	Detour setting	96
	Route overview	97
	Route preference	99
	Pausing and resuming guidance	101
	Show on map	102
	Display POI* icons	102
	Route trace	106

*: Point of Interest

4	Navigation System: Memory Points	
	Navigation settings	110
	Setting up the “Home”	111
	Setting up the “Preset Destinations”	113
	Setting up the “Address Book”	116
	Setting up the “Areas to Avoid”	122
	Deleting previous destinations	127
5	Telephone and Information	
	Telephone (Hands-free system for cellular phone)	130
	Enter a Bluetooth® phone	134
	Call on the Bluetooth® phone	139
	Receive on the Bluetooth® phone	146
	Talk on the Bluetooth® phone	146
	Fuel consumption	149
	Past record	149
	Consumption	150
	Calendar	151
6	Lexus Enform with Safety Connect	
	Lexus Enform with Safety Connect–Overview	154
	Destination Assist	157
	eDestination	160
	XM® Sports and Stocks	163
	XM NavWeather™	168
	XM® NavTraffic	173
	Lexus Insider	175

7	Audio/video System	
	Quick reference	184
	Using your audio/video system	187
	Some basics	187
	Radio operation	196
	Radio operation (XM® Satellite Radio broadcast)	200
	CD changer operation	206
	DVD changer operation	220
	Bluetooth® audio operation	245
	USB memory/iPod operation	253
	Audio/video remote controls (steering switches)	261
	Rear seat entertainment system features	263
	Using the radio	269
	Using the DVD changer	270
	Playing an audio CD/CD text	270
	Playing MP3/WMA discs	271
	Playing DVD video/audio	271
	Using the video mode	284
	Changing other settings	285
	Audio/video system operating hints	287
8	Air Conditioning	
	Automatic air conditioning controls	296
9	Wide View Front & Side Monitor	
	Wide view front & side monitor	314
10	Intuitive Parking Assist	
	Intuitive parking assist	322

11 Setup	
General settings	330
Clock settings	335
Voice settings	337
Navigation settings	340
Detailed navigation settings	340
Telephone settings	349
Volume setting	350
Manage phone	351
Phonebook	359
Setting the phonebook	360
Speed dials setting	368
Deleting call history	375
Setting the voice tag	376
Bluetooth®	380
Details	385
Audio settings	388
Select portable player	388
Setting Bluetooth® audio	390
Vehicle settings	395
Maintenance	395
Vehicle customization	400
Intuitive parking assist setting	401
Other settings	403
12 Appendix	
Limitations of the navigation system	406
Map database information and updates	408
Index	419

Quick guide — — Overview buttons and guidance screen

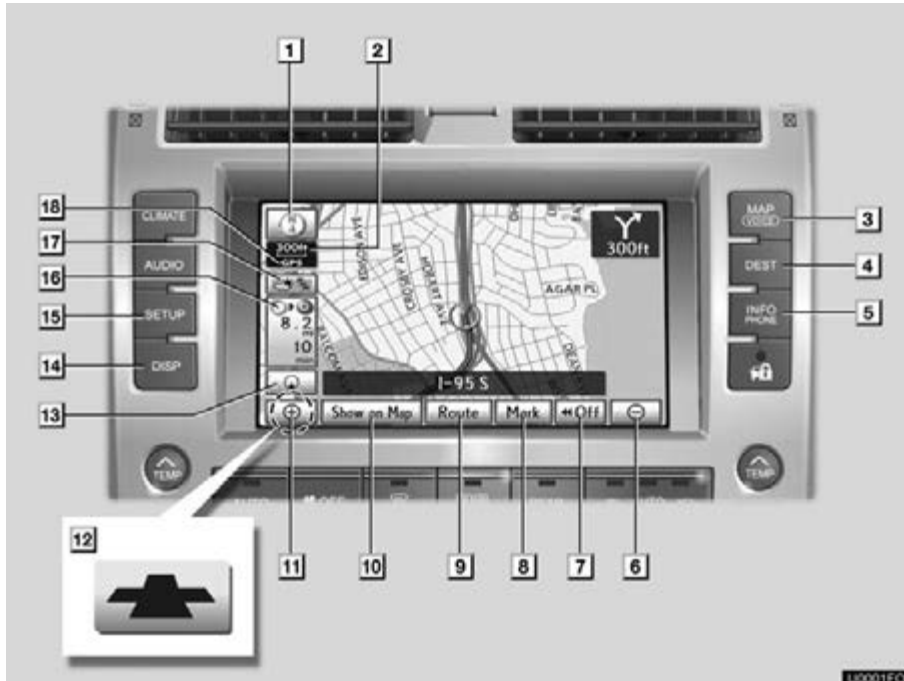

No.	Name	Function	Page
1	North-up or heading-up symbol	This symbol indicates a map view with north-up or heading-up. Touching this symbol changes the map orientation.	43
2	Scale indicator	This figure indicates the map scale.	42
3	“MAP/VOICE” button	Push this button to repeat a guidance voice, cancel the map scroll, start guidance and display the current position.	33
4	“DEST” button	Push this button to display the “Destination” screen.	12, 14, 16, 17, 20, 62
5	“INFO/PHONE” button	Push this button to display the “Information” screen.	23, 134, 149, 151, 163, 169, 176, 417
6	Zoom out button	Touch this button to reduce the map scale.	42

No.	Name	Function	Page
7	“◀◀Off”	Touch this button to obtain a broader view. Some of the buttons on the screen are not displayed. They are displayed again by touching “On▶▶”.	346
8	“Mark”	Touch this button to register the current position or the cursor position as an address book entry.	35
9	“Route”	Touch this button to change the route.	94, 96
10	“Show on Map”	Touch this button to browse information about guidance route, to set the Points of Interest to be displayed on the screen, or to record the route.	102, 173
11	Zoom in button	Touch this button to magnify the map scale.	42
12	Foot print map button	Touch this button to display the foot print map and the building information.	42
13	Screen configuration button	Touch this button to change the screen mode.	39
14	“DISP” button	Push this button to display the “Display” (quality control) screen.	31
15	“SETUP” button	Push this button to display the “Setup” screen. You can change the language from this screen. (See “● Selecting a language” on page 331.)	22, 110, 179, 330, 335, 337, 340, 349, 388, 395, 403
16	Distance and time to destination	Displays the distance, the estimated travel time to the destination, and the estimated arrival time at the destination.	93
17	XM® indicator	This mark is displayed when XM® information is received.	173
18	“GPS” mark (Global Positioning System)	Whenever the vehicle is receiving signals from the GPS, this mark is displayed.	406

— Registering home



1 Push the “DEST” button.



2 Touch “Go Home”.

If home has not been registered, you can register it by touching “Go Home”.



3 Touch “Yes”.



4 There are 4 different methods to search your home.

See “Destination search” on page 62.



5 Touch "Enter".

The "Edit Home" screen is displayed.



6 Touch "OK".

Registration of home is complete.

You can also register home by pushing the "SETUP" button. (See "(a) Registering home" on page 111.)

You can change the name, location, phone number and icon. (See "(b) Editing home" on page 112.)

— Registering preset destinations



1 Push the “DEST” button.



2 Touch one of the preset destination buttons.

You can set a preset destination to any preset destination button that has not yet been set.



3 Touch “Yes”.



4 There are 4 different methods to search preset destinations.

See “Destination search” on page 62.



5 Touch "Enter".

The "Edit Preset Destination" screen is displayed.



6 Touch "OK".

Registration of preset destinations is complete.

You can also register preset destinations by pushing the "SETUP" button. (See "(a) Registering preset destinations" on page 114.)

You can change the name, location, phone number and icon. (See "(b) Editing preset destinations" on page 115.)

The registered points can be used on the "Destination" screen. (See "— Destination search by Preset destinations" on page 64.)

— Operation flow: guiding the route



1 Push the “DEST” button.



2 There are 11 different methods to search destinations.

See “Destination search” on page 62.



3 Touch “Go to”.

The navigation system performs a search for the route.

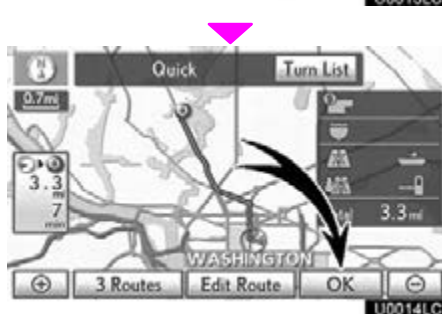

4 Touch “OK”, and start driving.

Routes other than the one recommended can also be selected. (See “Starting route guidance” on page 83.)

5 Guidance to the destination is given via voice and on the guidance screen.

— Setting home as the destination



1 Push the “DEST” button.



2 Touch “Go Home”.

“Go Home” can be used if your home has been registered. (To register “Home”, see “(a) Registering home” on page 111.)



3 Touch “Go to”.

The navigation system performs a search for the route.



4 Touch “OK”, and start driving.

Routes other than the one recommended can also be selected. (See “Starting route guidance” on page 83.)

5 Guidance to the destination is given via voice and on the guidance screen.

Navigation system function index

〈Map〉

Displaying maps	Page
Viewing the map screen	10
Displaying the current vehicle position	33
Viewing the current position vicinity map	34
Changing the scale	42
Changing the map orientation	43
Displaying Point of Interest	102
Displaying the estimated travel/arrival time to the destination	93
Selecting the dual map screen	39
Viewing foot print map	42
Deleting map screen buttons	346
Searching destination	Page
Searching the destination (by home, Point of Interest, phone #, etc.)	62
Changing the selected search area	62
Operating the map location of the selected destination	83

〈Route guidance〉

Before starting route guidance	Page
Setting the destination	83
Viewing alternative routes	83
Starting route guidance	83
Before starting or during route guidance	Page
Viewing the route	83
Adding destinations	94
Changing the route	96
Displaying the estimated travel/arrival time to the destination	93

During route guidance	Page
Pausing route guidance	101
Adjusting route guidance volume	338
Deleting the destination	82, 95
Displaying the entire route map	97

⟨ Useful functions ⟩

Address book	Page
Registering your own address book entries	116
Marking icons on the map	118
Information	Page
Displaying vehicle maintenance	395
Displaying the calendar	151
Hands-free system (for cellular phone)	Page
Initiating Bluetooth®	134
Making a call on the Bluetooth® phone	139
Receiving a call on the Bluetooth® phone	146
Voice command system	Page
Operating the system with your voice	44

Quick reference (“Destination” screen)

The “Destination” screen allows you to search for a destination. To display the “Destination” screen, push the “DEST” button.

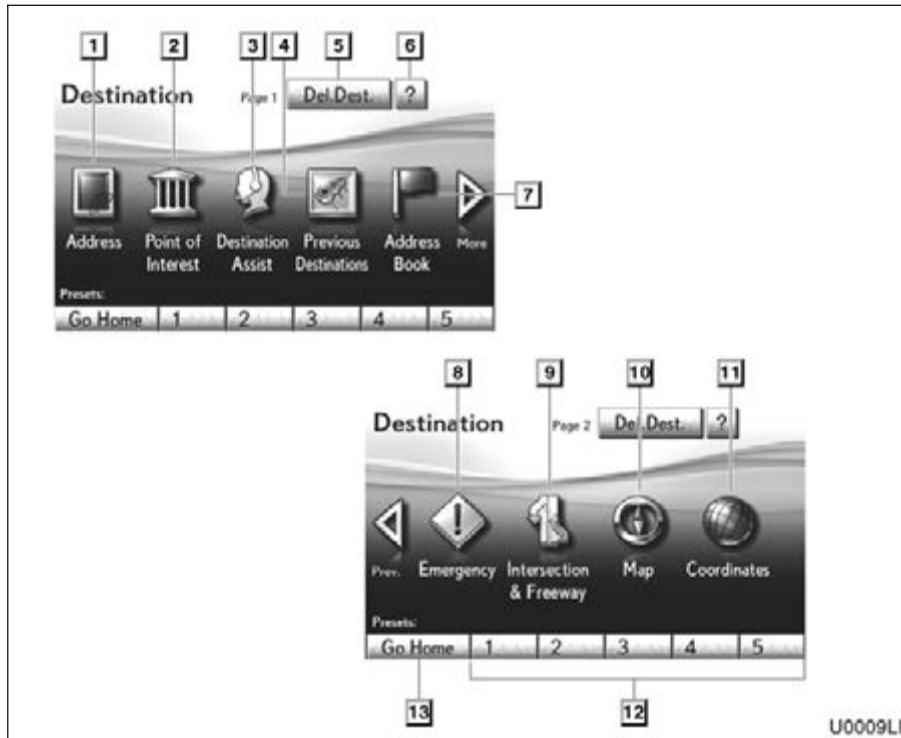

1 “Address”

A house number and the street address can be input by using the input keys. 65

2 “Point of Interest”

Select one of the many Points of Interest that have already been stored in the system’s database. 69

3 “Destination Assist”

Provides you with live assistance finding destinations via the Lexus Enform response center. 76, 157

4 “Previous Destinations”

A destination can be selected from any of the last 100 previously set destinations and from the previous starting point. 76

5 “Del. Dest.”

Set destinations can be deleted. 82

6 “?”

Function help for the “Destination” screen can be viewed on this screen. 33

7 “Address Book”

The desired location can be selected from a registered entry in the “Address book”. (To register address book entries, see “(a) Registering address book entries” on page 117.) 77

8 “Emergency”

One of the four categories of emergency service points that are already stored in the system’s database can be selected. 77

9 “Intersection & Freeway”

The names of two intersecting streets or a freeway (interstate) entrance or exit can be entered. This is helpful if only the general vicinity, not the specific address, is known. 78

10 “Map”

A destination can be selected simply by touching the location on the displayed map. 81

11 “Coordinates”

A destination can be set using latitudes and longitudes as coordinates. 82

12 Preset destination buttons

One of 5 preset destination points can be selected by touching the screen directly. If a preset destination point has not been registered, a message will be displayed and the setting screen will automatically appear. To use this function, it is necessary to set the “Preset Destination”. (To register a “Preset Destination”, see “(a) Registering preset destinations” on page 114.) 64

13 “Go Home”

A personal home address can be selected without entering the address each time. If “Home” has not been registered, a message will be displayed and the setting screen will automatically appear. To use this function, it is necessary to set a “Home” address. (To register “Home”, see “(a) Registering home” on page 111.) 64

Quick reference (“Setup” screen)

The items shown on the “Setup” screen can be set. To display the “Setup” screen, push the “SETUP” button.

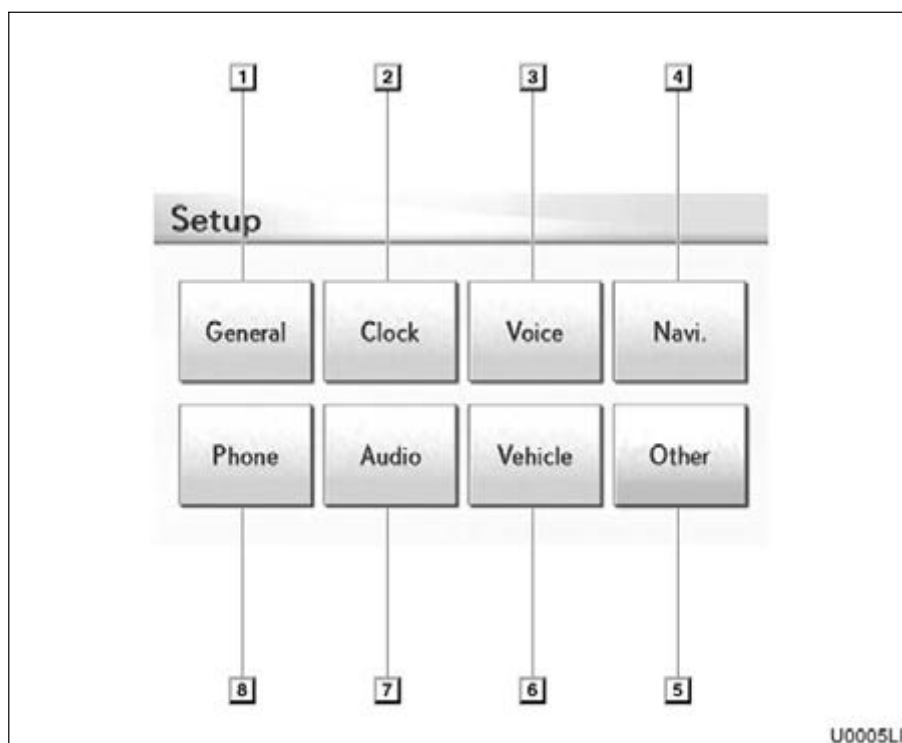

- 1** “General”
Settings are available for language selection, operation sounds, automatic screen change, etc. 330
- 2** “Clock”
Used for changing settings for time zones, daylight saving time, etc. 335
- 3** “Voice”
Voice guidance can be set. 337
- 4** “Navi.”
Settings are available for average cruising speed, displayed screen contents, POI icon categories, etc. 340

- 5** “Other”
Settings are available for Lexus Insider, XM® Sports and Stocks. 403
- 6** “Vehicle”
Settings are available for vehicle information such as maintenance information. 395
- 7** “Audio”
Settings are available for portable audio devices, Bluetooth® audio devices, etc. 388
- 8** “Phone”
Bluetooth® phones and phone numbers can be registered, and the receiver volume can be adjusted. 349

Quick reference (“Information” screen)

This screen can be used to display the calendar and information on operation of the hands-free phone, etc. To display the “Information” screen, push the “INFO/PHONE” button.

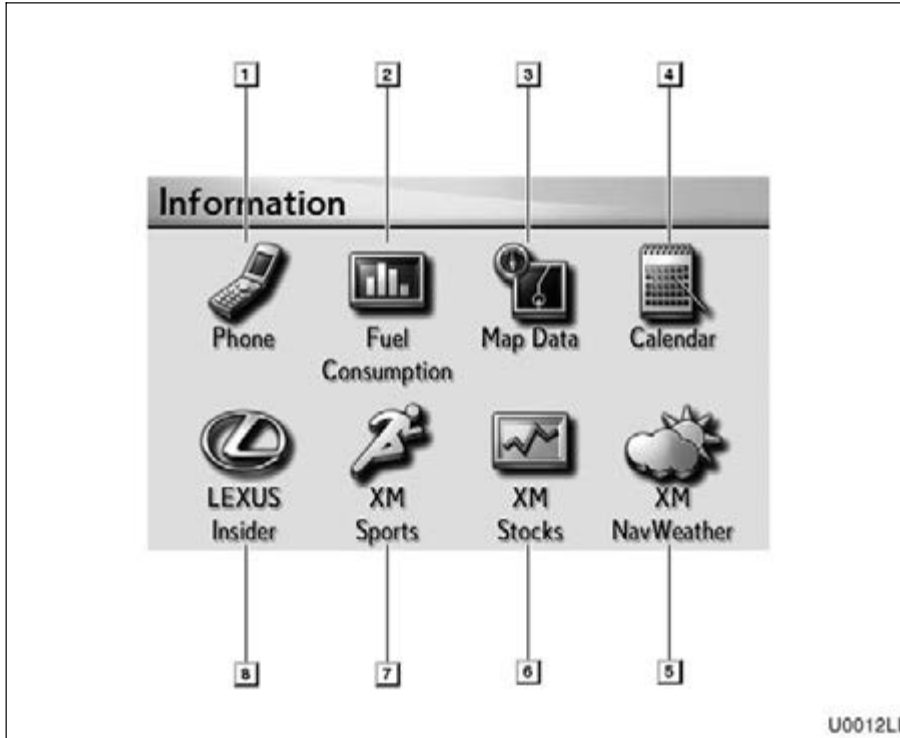

1 “Phone” To view hands free phone information. 134	5 “XM NavWeather” To display the “XM NavWeather” screen. 168
2 “Fuel Consumption” Fuel consumption is displayed. 149	6 “XM Stocks” To display the “XM Stocks” screen. 163
3 “Map Data” Displays information regarding the map data disc version or coverage area. 417	7 “XM Sports” To display the “XM Sports” screen. 163
4 “Calendar” To view calendar. 151	8 “LEXUS Insider” To display the “LEXUS Insider” screen. 175

SECTION 1

NAVIGATION SYSTEM: BASIC FUNCTIONS

Basic information before operation

- Initial screen 26
- Touch screen operation 27
- Inputting letters and numbers/List screen operation 28
- Screen adjustment 31
- Help icon 33
- **Map screen operation** 33
 - Current position display 33
 - Screen scroll operation 34
 - Switching the screens 39
 - Map scale 42
 - Foot print map 42
 - Orientation of the map 43
 - Standard map icons 44
- **Voice command system** 44
 - Natural speech information 47
 - Command list 49

Initial screen



When the "ENGINE START STOP" switch is in ACCESSORY or IGNITION ON mode, the initial screen will be displayed and the system will begin operating.



After a few seconds, the "CAUTION" screen will be displayed.

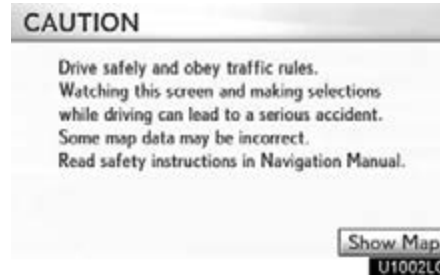

After about 5 seconds, the "CAUTION" screen automatically switches to the map screen. When touching "Show Map" or pushing the "MAP/VOICE" button, the map screen is displayed.

While the "CAUTION" screen is displayed, the "DEST" or "SETUP" button cannot be operated. And if the "Calendar" button on the "Information" screen is touched, the screen will change back to the "CAUTION" screen. In about 5 seconds, or when the "MAP/VOICE" button is pushed or the "Show Map" is touched, the "CAUTION" screen will change to the map screen.

● **Maintenance information**

This system informs about when to replace certain parts or components and shows dealer information (if registered) on the screen.

When the vehicle reaches a previously set driving distance or date specified for a scheduled maintenance check, the “Information” screen will be displayed when the navigation system is in operation.



To disable this screen, touch “Do Not Display This Message Again”. This screen goes off if the screen is not operated for several seconds.

To prevent this information screen from being displayed again, touch “Do Not Display This Message Again”.

To register “Maintenance information”, see “—Maintenance” on page 395.

Touch screen operation

This system is operated mainly by the touch screen buttons on the screen.

To prevent damage to the screen, lightly touch buttons on the screen with the finger. When a button on the screen is touched, a beep sounds. (To set a beep sound, see page 330.)

Do not use objects other than the finger to touch the screen.

INFORMATION
<ul style="list-style-type: none"> ● <i>If the system does not respond to a touch on a touch screen button, move the finger away from the screen and then touch it again.</i> ● <i>Dimmed touch screen buttons cannot be operated.</i> ● <i>Wipe off fingerprints using a glass cleaning cloth. Do not use chemical cleaners to clean the touch screen.</i> ● <i>The displayed image may become darker and moving images may be slightly distorted when the display is cold.</i> ● <i>Under extremely cold conditions, the map may not be displayed and the data input by a user may be deleted. Also, the touch screen buttons may be harder than usual to depress.</i> ● <i>When you look at the screen through polarized material such as polarized sunglasses, the screen may be dark and hard to see. If so, look at the screen from different angles, adjust the screen settings on the “Display” screen, or take off your sunglasses.</i>

Inputting letters and numbers/List screen operation

When searching for an address or a name, or entering, letters and numbers can be input via the screen.

INFORMATION

*Keyboard layout can be changed.
(See page 332.)*

- **To input letters and numbers**

To display the alphabet keys, touch "A-Z".

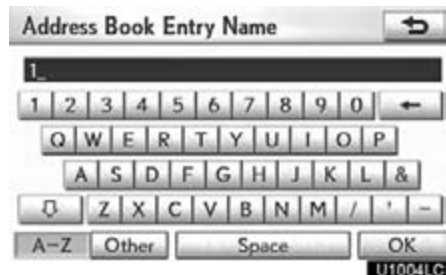

Enter letters by touching the keys directly.

 : Touching this button erases one letter. By holding this button, letters will continue to be erased.

On certain letter entry screens, letters can be entered in upper or lower case.

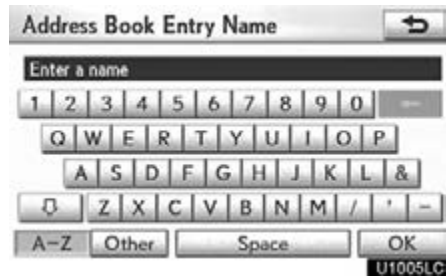

 : To enter in lower case.

 : To enter in upper case.

- **To input symbols**

To display symbol keys, touch “Other”.

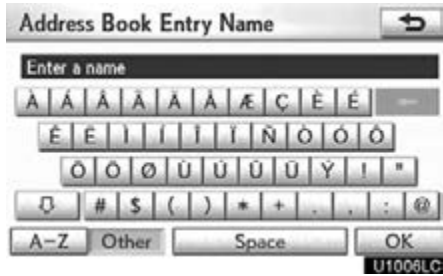

Enter symbols by touching the symbol keys directly.

 : Touching this button erases one letter. By holding this button, letters will continue to be erased.

- **To display the list**



To search for an address or a name, touch “OK”. Matching items from the database are listed even if the entered address or name is incomplete.

If the number of matches is five or less, the list is displayed without touching “OK”.



INFORMATION

*The number of matching items is shown to the right side of the screen. If the number of matching items is more than 999, the system displays “***” on the screen.*

NAVIGATION SYSTEM: BASIC FUNCTIONS

- **List screen operation**





When a list is displayed, use the appropriate button to scroll through the list.



 To shift to the next or previous page.

 Touch  or  to scroll through the displayed list.

 This expresses a displayed screen position.

 If  appears to the right of the item name, the complete name is too long for the display. Touch  to scroll to the end of the name. Touch  to scroll to the beginning of the name.

- **Sorting**

The order of a list displayed on the screen can be rearranged.

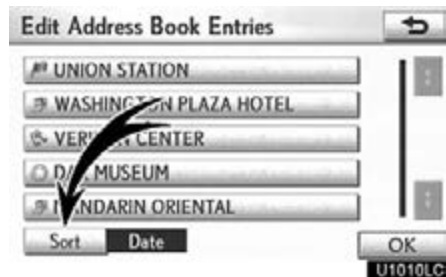

1. Touch "Sort".



2. Touch the desired sorting criteria.

Sorting criteria are as follows:

“**Distance**”: To sort in the order of distance from your current location.

“**Date**”: To sort in the order of the date.

“**Category**”: To sort in the order of the category.

“**Icon**”: To sort in the order of the icons.

“**Name**”: To sort in order by name.

Screen adjustment

You can adjust the contrast, brightness, color and tone of the screen. You can also turn the display off, and change the screen to either day or night mode.

- **Contrast, brightness, color and tone adjustment**

The contrast, brightness, color and tone of the screen can be adjusted depending on the brightness of your surroundings. You can also turn the display off.



1. Push the “DISP” button.

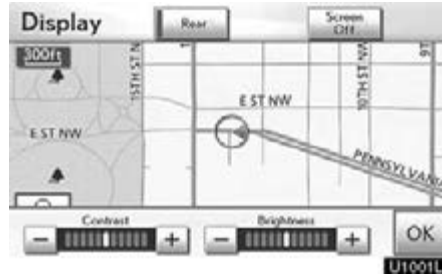

Contrast and brightness adjustment

2. Touch the desired button to adjust contrast and brightness.

“Contrast” “+”: Strengthens the contrast of the screen.

“Contrast” “-”: Weakens the contrast of the screen.

“Brightness” “+”: Brightens the screen.

“Brightness” “-”: Darkens the screen.

3. After adjusting the screen, touch “OK”.

If your vehicle is equipped with the rear seat entertainment system, the rear screen turns on or off when “Rear” is touched.

The screen goes off when “Screen Off” is touched. To turn the display screen back on, push the “DISP” button again.

INFORMATION

When you do not touch any button on the “Display” screen for 20 seconds, the previous screen will be displayed.

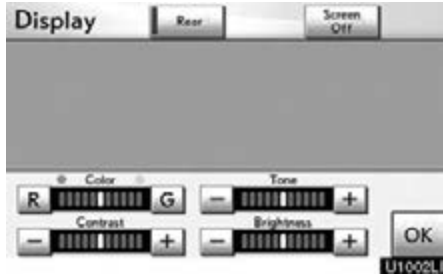

Color and tone adjustment

1. Touch the desired button to adjust color and tone.

You can adjust the color and the tone while the DVD video, DVD audio and video CD are being played.

“Color” “R”: Strengthens the red color of the screen.

“Color” “G”: Strengthens the green color of the screen.

“Tone” “+”: Strengthens the tone of the screen.

“Tone” “-”: Weakens the tone of the screen.

2. After adjusting the screen touch “OK”.

If your vehicle is equipped with the rear seat entertainment system, the rear screen turns on or off when “Rear” is touched.

The screen goes off when “Screen Off” is touched. To turn the display screen back on, push the “DISP” button again.

INFORMATION

When you do not touch any button on the “Display” screen for 20 seconds, the previous screen will be displayed.

● **Changing between day mode and night mode**

Depending on the position of the headlight switch, the screen changes to day mode or night mode.



To display the screen in day mode even with the headlight switch on, touch “Day Mode” on the adjustment screen for brightness and contrast control.

If the screen is set in day mode with the headlight switch turned on, this condition is memorized in the system even with the engine is turned off.

In the following conditions, the displays condition is not changed to night mode even if headlight switch is turned on.

- The instrument panel light control switch is adjusted full brightness.
- The vehicle is in a bright area such as daytime.

Help icon

When  appears on the screen, an explanation of the function can be displayed.



1. Touch  .



2. Touch the button of the desired function.





Map screen operation — — Current position display

When starting the navigation system, the current position is displayed first.

This screen displays the current vehicle position and a map of the surrounding local area.



The current vehicle position mark () appears in the center or bottom center of the map screen.

A street name will appear on the bottom of the screen, depending on the scale of the map () .

You can return to this map screen that shows your current position at any time from any screen by pushing the “MAP/VOICE” button.

While driving, the current vehicle position mark is fixed on the screen and the map moves.

The current position is automatically set as the vehicle receives signals from the GPS (Global Positioning System). If the current position is not correct, it is automatically corrected after the vehicle receives signals from the GPS.

INFORMATION

- **After the battery disconnection, or on a new vehicle, the current position may not be correct. As soon as the system receives signals from the GPS, the correct current position is displayed.**
- **To correct the current position manually, see page 346.**

— Screen scroll operation

When any point on the map is touched, that point moves to the center of the screen and is shown by the cursor mark (1).



Use the scroll feature to move the desired point to the center of the screen for looking at a point on the map that is different from the current position of the vehicle.

If the finger is continuously held on the screen, the map will continue scrolling in that direction until the finger is removed.

A street name, city name, etc. of the touched point will be shown, depending on the scale of the map (2). Distance from the current position to the cursor mark will also be shown (3).

After the screen is scrolled, the map remains centered at the selected location until another function is activated. The current vehicle position mark will continue to move along your actual route and may move off the screen. When the "MAP/VOICE" button is pushed, the current vehicle position mark returns to the center of the screen and the map moves as the vehicle proceeds along the designated route.

- To set the cursor position as a destination

A specific point on the map can be set as a destination using the scroll function.



Touch "Enter".

The screen changes and displays the map location of the selected destination and the route preference. (See "Starting route guidance" on page 83.)

INFORMATION

When the scroll feature is used, the current vehicle position mark may disappear from the screen. Move the map with a scroll again or push the "MAP/VOICE" button to return to the current vehicle position map location display.

- **To register the cursor position as an address book entry**

Address book entry registration enables easy access to a specific point.



Touch “Mark”.

When you touch “Mark”, the following screen appears for a few seconds, and then the map screen returns.



The registered point is shown by  on the map.

To change the icon or name, etc., see “(b) Editing address book entries” on page 118.

Up to 100 address book entries can be registered. If there is an attempt to register more than 100 address book entries, an error message will appear.



NAVIGATION SYSTEM: BASIC FUNCTIONS

- To see information about the icon where the cursor is set



To display information about an icon, set the cursor on it.

POI INFORMATION

When the cursor is set on a POI icon, the name and “Info.” are displayed at the top of the screen.



Touch “Info.”.

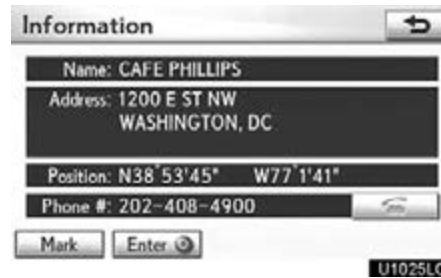

Information such as the name, address, and phone number are displayed.

If “Enter” is touched, the position of the cursor is set as a destination.

If there is already a set destination, “Go to” and “Add to Route” are displayed.

“Go to”: To delete the existing destinations and set a new one.

“Add to Route”: To add a destination.

To register this POI as an address book entry, touch “Mark”. (See page 117.)

If  is touched, the registered telephone number can be called.

INFORMATION

The desired Point of Interest can be displayed on the map screen. (See “ — Display POI icons” on page 102.)

ADDRESS BOOK ENTRY INFORMATION

When the cursor is set on an address book entry icon, the name and “Info.” are displayed at the top of the screen.



Touch “Info.”.

NAVIGATION SYSTEM: BASIC FUNCTIONS

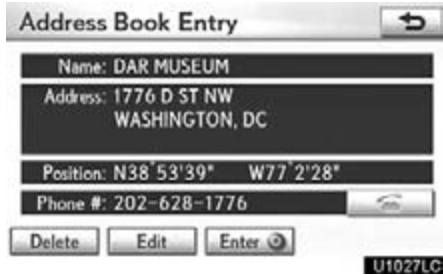

Information such as the name, address, and phone number are displayed.

If “Enter” is touched, the position of the cursor is set as a destination.

If there is already a set destination, “Go to” and “Add to Route” are displayed.

“Go to”: To delete the existing destinations and set a new one.

“Add to Route”: To add a destination.

To edit an address book entry, touch “Edit”. (See “(b) Editing address book entries” on page 118.)

To delete an address book entry, touch “Delete”.

If  is touched, the registered telephone number can be called.

DESTINATION INFORMATION

When the cursor is set on a destination icon, the name and “Info.” are displayed on the top of the screen.

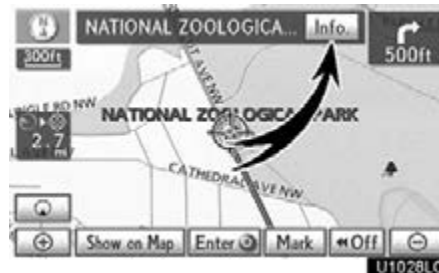

Touch “Info.”.

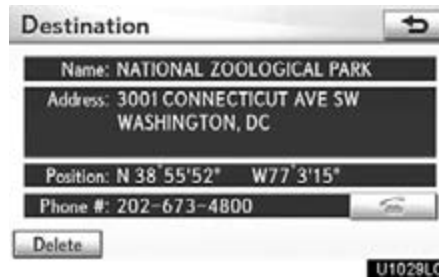

Information such as the name, address, and phone number are displayed.

To delete a destination, touch “Delete”.

If  is touched, the registered telephone number can be called.

XM® NavTraffic TEXT INFORMATION

When you touch the XM® NavTraffic icon on the map, the XM® NavTraffic info. bar will appear on the upper part of the screen.



Touch "Info.".

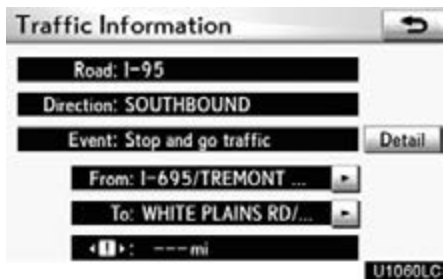

Traffic information is displayed on the screen.

Touch "Detail" to display detailed traffic event information.

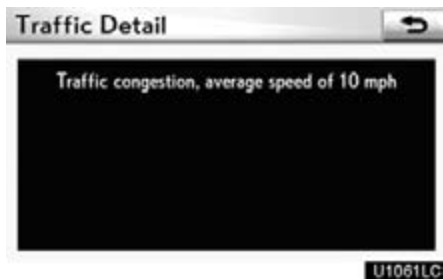

— Switching the screens

Any one of the screen configurations can be selected.

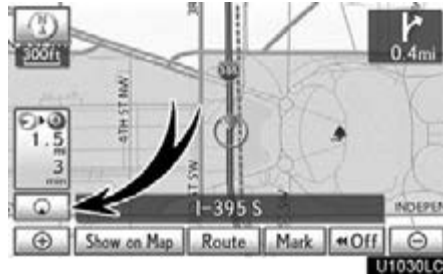

1. Touch this button to display the following screen.



2. To select the desired screen configuration, touch one of the following buttons.

NAVIGATION SYSTEM: BASIC FUNCTIONS

Depending on the conditions, certain screen configuration buttons cannot be selected.

 **Single Map** :
To display the single map screen.
(See page 40.)

 **Dual Map** :
To display the dual map screen.
(See page 41.)

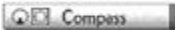
 **Compass** :
To display the compass mode screen. (See page 41.)

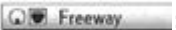
 **Freeway** :
To display the freeway screen.
(See page 88.)

 **Turn List** :
To display the turn list screen.
(See page 90.)

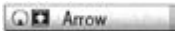
 **Arrow** :
To display the arrow screen. (See page 90.)

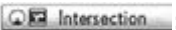
 **Intersection** :
To display the intersection guidance screen or the guidance screen on the freeway. (See page 89.)

● Screen configurations

SINGLE MAP

This is a regular map screen.

While on a different screen, touching  will display the single map screen.

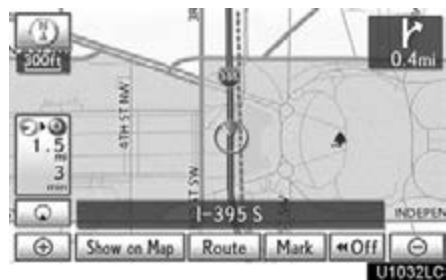

The screen shows the single map.

DUAL MAP

A map can be displayed split in two. While on a different screen, touching  will display the dual map screen.



The screen shows the dual map. The map on the left is the main map.

The right side map can be edited by touching any specific point on the right side map.



This screen can perform the following procedures:

1. Changing the map scale
2. Displaying the POI icon
3. Show XM® NavTraffic Info. (See page 173.)
4. Changing the orientation of the map

Touch “OK” when you complete editing.

The screen returns to the dual map screen.

COMPASS MODE

Current vehicle position is indicated with a compass.

While on a different screen, touching  will display the compass mode screen.

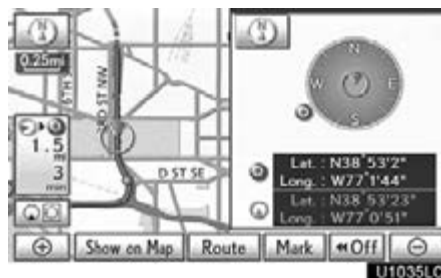

Information about the destination and current position, as well as a compass, is displayed on the screen.

The destination mark is displayed in the direction of the destination. When driving refer to the longitude and latitude coordinates, and the compass, to make sure that your vehicle is headed in the direction of the destination.

INFORMATION

When the vehicle travels out of the coverage area, the guidance screen changes to the compass mode screen.

— Map scale



Touch or to change the scale of the map display. The scale bar and indicator at the bottom of the screen indicates the map scale menu. The scale range is 150 feet (50 m) to 250 miles (400 km).

Touch or until the scale bar changes normally. By continuing to touch the button, the scale bar changes smoothly.

The scale of the map display can be changed by touching the scale bar directly. It is not available while driving.

The map scale is displayed under the north-up symbol or heading-up symbol at the top left of the screen.

INFORMATION

When the map scale is at the maximum range of 250 miles (400 km), is not shown. When the map scale is at the minimum range of 150 feet (50 m), is not shown. In areas where the foot print map is available the map scale changes from to when at the minimum range.

— Foot print map

For the area which is covered by the foot print map (Some areas in the following cities: Detroit, Chicago, N.Y., L.A), you can switch to the foot print map on a scale of 75 feet (25 m).

● To switch to the foot print map

changes into when the map is scaled down to 150 feet (50 m).



To display the foot print map, touch



To delete the foot print map display, touch



INFORMATION

- If the map or the current position is moved to the area which is not covered by the foot print map, the screen scale automatically changes to 150 feet (50 m).
- On the foot print map, a one way street is displayed by .
- It is not possible to perform scrolling on the foot print map while driving.

Building footprints in the database were created and provided by MAPMASTER.

● **To display building information**

Information is available only for buildings for which information is recorded on the map data.



Touch “Info.” while the foot print map is displayed.

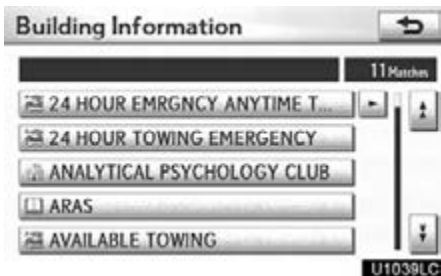

Details of POIs in some buildings may be displayed.

For detailed POI information, touch the building name. You can see details of the selected POIs.

— **Orientation of the map**

The orientation of the map can be changed from North-up to Heading-up by touching the orientation symbol at the top left of the screen.

Touch  or .



► **North-up screen**



► **Heading-up screen**











 **North-up symbol**

Regardless of the direction of vehicle travel, North is always up.

 **Heading-up symbol**

The direction of vehicle travel is always up. A red arrow indicates North.

— Standard map icons

Icon	Name
	Island
	Park
	Industry
	Business facility
	Airport
	Military
	University
	Hospital
	Stadium
	Shopping mall
	Golf

Voice command system —

The voice command system enables you to operate the navigation system, audio/video system, air conditioning system and hands-free system by giving a command.



1. Push the talk switch.

After a beep sounds, the “Voice Menu” screen is displayed.

INFORMATION

Voice guidance for the voice command system can be skipped by pushing the talk switch.



2. After a beep sounds, say the command of your choice.

Voice commands are marked with . Some commonly used commands are displayed on the screen. Speak the commands as displayed on the screen.

If you want to check the all command list, say **“Command list”** to display the command list screen. (See “— Command list” on page 49.)

3. Following voice guidance, say the command displayed on the screen.

If a desired outcome is not shown, or if no choices are available, say **“Go back”** or touch **“Go Back”** to return to the previous screen.

To cancel voice command recognition, say **“Cancel”**, touch **“Cancel”**, or push and hold the talk switch.

If the navigation system does not respond or the confirmation screen does not disappear, please push the talk switch and try again.

If a voice command cannot be recognized within 6 seconds, the voice guidance system will say “Pardon?” (“Command not recognized.” will be displayed on the screen) and voice command reception will restart.

If a voice command cannot be recognized two consecutive times, the voice guidance system will say “Paused. To restart voice recognition, push the talk switch.”, then be suspended.



► **Microphone**

It is unnecessary to speak directly into the microphone when giving a command.

INFORMATION

- *Wait for the confirmation beep before speaking a command.*
- *Voice commands may not be recognized if :*
 - *Spoken too quickly*
 - *Spoken at a low or high volume*
 - *The windows or moon roof are open*
 - *Passengers are talking while voice commands are spoken*
 - *The air conditioning speed is set high*
 - *Turning the air conditioning vents towards the microphone*
- *In the following conditions, the system may not recognize the command properly and using voice commands may not be possible.*
 - *The command is not correct or clear.*

Note that certain words, accents, or speech patterns may be difficult for the system to recognize.

- *There are some noises such as wind noise, etc.*

● **Voice command example: Searching for a route to your home.**

1. **Push the talk switch.**
2. **Say “Go home”.**

If a home address is not registered, the voice guidance system will say “Your home is not set” and you will be prompted to enter a home address. (See page 111.)

When the voice command is recognized, a map of the area around your home is displayed.



3. **Touch “Enter” or say “Enter”, and the system starts searching for a route to your home.**

To return to the “Voice Menu” screen, say “Go back” or touch “Go Back”.

Touch “Cancel” or say “Cancel”, and the voice command system will be canceled.

— **Natural speech information (English only)**

Due to natural language speech recognition technology, this system enables recognition of a command when spoken naturally. However, the system cannot recognize every variation of each command. In some situations, it is possible to omit the command for the procedure and directly state the desired operation.

● **Voice recognition top screen expression examples**

Command	Expression examples
Go Home	<i>Take me home. Let's go home.</i>
Destination	<i>I'd like to set a destination.</i>
Phone	<i>I'd like to make a call. I need to use the phone. Bring up the phone menu.</i>
Audio	<i>Audio menu, please.</i>
Information	<i>Let me see the information menu. Give us the information menu, please.</i>
Command List	<i>Show me the voice command list.</i>

- **Expression examples for each function**

In some situations, It is possible to omit a command for each procedure and to say the desired operation directly.

EXPRESSION EXAMPLES WITH THE “Destination” SCREEN

Normal command recognition —

Destination>Point of Interest>Near Here>Gas> The gas stations near the current location will be listed.

Natural speech recognition —

Destination> What gas stations are nearby?> The gas stations near the current location will be listed.

INFORMATION

Natural speech example:

“Where’s the nearest Mexican restaurant?”

“Where is the closest ATM?”

EXPRESSION EXAMPLES WITH THE “Phone Menu” SCREEN (when making a call using a phonebook)

Normal command recognition —

Phone>Dial by Name>Bob>mobile> The phone number will be displayed.

Natural speech recognition —

Phone>Call to Bob on his mobile.> The phone number will be displayed.

INFORMATION

Natural speech example:

“Get me Rob Brown on the phone.”

“Please place a call to John on his mobile.”

EXPRESSION EXAMPLES WITH THE “Phone Menu” SCREEN (when making a call by saying a phone number)

Normal command recognition —

Phone>Dial by Number>123-456-789> The phone number will be displayed.

Natural speech recognition —

Phone>Call to 123-456-789.> The phone number will be displayed.

INFORMATION

The above mentioned command for making a call can also be recognized on the voice recognition top screen.

Natural speech example:

“I’d like to place a call to 123-456-789.”

“I want to buzz 123-456-789, please.”

EXPRESSION EXAMPLES WITH THE “Information Menu” SCREEN

Normal command recognition —

Information>XM Nav Weather>Los Angeles, California> The weather information will be displayed.

Natural speech recognition —

Information>Give me a weather report for Los Angeles, California.> The weather information will be displayed.

INFORMATION

Natural speech example:

“How about Detroit, Michigan?”

EXPRESSION EXAMPLES WITH THE “Audio Menu” SCREEN (when the audio source is in satellite radio mode)

Normal command recognition —

Audio>Select Channel Number>90> The channel will be changed to the one selected.

Natural speech recognition —

Audio>Play channel ninety, please> The channel will be changed to the one selected.

INFORMATION

Natural speech example:

“Switch the channel to XM one seventy five.”

VOICE RECOGNITION TOP SCREEN EXPRESSION EXAMPLES

Normal command recognition —

Command List>Dual Map> The map will be displayed in dual map mode.

Natural speech recognition —

Switch to dual map mode.> The map will be displayed in dual map mode.

— Command list

The system has a voice recognition command list. You can operate the voice recognition system by saying any command from the displayed command list.



1. Push the talk switch.

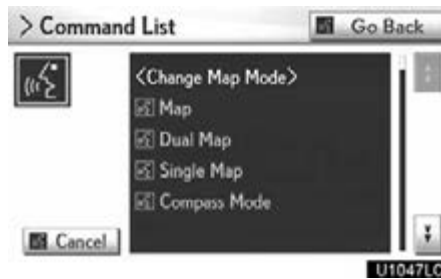

2. Say “Command list”.



3. Say the command of your choice to operate the system.

To confirm commands on the screen, touch  or  to scroll through the command list. This function is available only when the vehicle is not moving.

INFORMATION

When the “Voice Menu” screen is displayed, all the commands in the voice recognition command list can be recognized.



NAVIGATION SYSTEM: BASIC FUNCTIONS



- Voice command example: Changing map screen

1. Push the talk switch.
2. Say "Command list".



3. Say "Dual map".

To confirm commands on the screen, touch  or  to scroll through the command list. This function is available only when the vehicle is not moving.

When  or  is touched, push the talk switch again and say the command.





The screen shows the dual map.

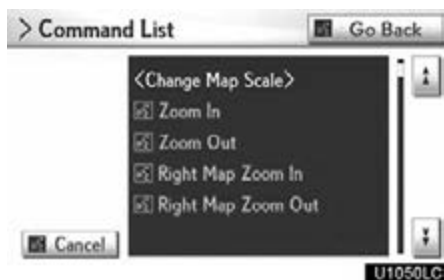

- Voice command example: Changing map scale

1. Push the talk switch.
2. Say "Command list".



3. Say "Zoom in" or "Zoom out".

To confirm commands on the screen, touch  or  to scroll through the command list. This function is available only when the vehicle is not moving.

When  or  is touched, push the talk switch again and say the command.

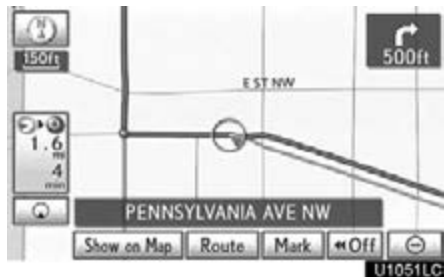

The scale of the map display is changed.

NAVIGATION SYSTEM: BASIC FUNCTIONS

COMMAND LIST

Change map mode	
Command	Action
Map	Shows current position map.
Dual map	Changes map to dual mode.
Single map	Changes map to single mode.
Compass mode	Changes map to compass mode.
Change map scale	
Command	Action
Zoom in	Zoom in.
Zoom out	Zoom out.
Right map zoom in	Zooms right map in.
Right map zoom out	Zooms right map out.
Change map orientation	
Command	Action
North up	Changes map bearing to north up.
Heading up	Changes map bearing to heading up.
Map direction	Changes map bearing to another direction.
Right map north up	Changes right map bearing to north up.
Right map heading up	Changes right map bearing to heading up.
Right map direction	Changes right map bearing to another direction.
Change guidance mode	
Command	Action
Arrow mode	Changes guidance screen to arrow mode.
Turn list mode	Changes guidance screen to turn list mode.

NAVIGATION SYSTEM: BASIC FUNCTIONS

Change guidance mode	
Command	Action
Freeway mode	Changes guidance screen to freeway mode.
Intersection mode	Changes guidance screen to Intersection mode.
Set a destination	
Command	Action
Previous start point	Calculates route to previous start point.
Save a point on the map	
Command	Action
Mark this point	Marks the point on the map.
Change route	
Command	Action
Quick route	Changes route to quick route.
Short route	Changes route to short route.
Alternate route	Changes route to alternate route.
Detour	Calculates detour route.
Detour entire route	Calculates detour entire route.
Review route	
Command	Action
Route overview	Shows entire route.
Next destination map	Shows position of next destination.
First destination map	Shows position of first destination.
Second destination map	Shows position of second destination.
Third destination map	Shows position of third destination.
Fourth destination map	Shows position of fourth destination.
Fifth destination map	Shows position of fifth destination.
Final destination map	Shows position of final destination.

NAVIGATION SYSTEM: BASIC FUNCTIONS

Delete destination	
Command	Action
Delete next destination	Deletes position of next destination.
Delete final destination	Deletes position of final destination.
Delete all destinations	Deletes position of all destination.
Guidance options	
Command	Action
Pause guidance	Pauses the guidance.
Resume guidance	Resumes the guidance.
Repeat guidance	Repeat voice guidance.
Louder	Turns volume up 1 level.
Softer	Turns volume down 1 level.
Traffic information	
Command	Action
Traffic information	Displays traffic information.
Show POI icons	
Command	Action
SHOW GAS	Displays GAS STATION icons.
SHOW PARKING	Displays PARKING icons.
SHOW SERVICE AND MAINTENANCE	Displays SERVICE & MAINTENANCE icons.
SHOW DEALERSHIPS	Displays DEALERSHIP icons.
SHOW LEXUS	Displays LEXUS DEALERSHIP icons.
SHOW TOYOTA	Displays TOYOTA DEALERSHIP icons.
SHOW PARTS STORES	Displays PARTS STORE icons.
SHOW ROADSIDE ASSISTANCE	Displays ROADSIDE ASSISTANCE icons.
SHOW AUTOMOBILE CLUBS	Displays AUTOMOBILE CLUB icons.
SHOW CAR RENTAL AGENCIES	Displays CAR RENTAL AGENCY icons.
SHOW CAR WASHES	Displays CAR WASH icons.
SHOW OTHER AUTOMOTIVE	Displays OTHER AUTOMOTIVE STORE icons.
SHOW DINING	Displays DINING icons.

NAVIGATION SYSTEM: BASIC FUNCTIONS

Show POI icons	
Command	Action
SHOW AMERICAN DINING	Displays AMERICAN RESTAURANT icons.
SHOW BAKERIES AND DELIS	Displays BAKERY & DELI icons.
SHOW BARBECUE AND GRILL DINING	Displays BARBECUE & GRILL RESTAURANT icons.
SHOW CAJUN AND CARIBBEAN DINING	Displays CAJUN & CARIBBEAN RESTAURANT icons.
SHOW CHINESE DINING	Displays CHINESE RESTAURANT icons.
SHOW COFFEE HOUSES	Displays COFFEE HOUSE icons.
SHOW FAST FOOD	Displays FAST FOOD icons.
SHOW FRENCH DINING	Displays FRENCH RESTAURANT icons.
SHOW GREEK DINING	Displays GREEK RESTAURANT icons.
SHOW INDIAN DINING	Displays INDIAN RESTAURANT icons.
SHOW ICE CREAM AND CANDY	Displays ICE CREAM & CANDY icons.
SHOW ITALIAN DINING	Displays ITALIAN RESTAURANT icons.
SHOW JAPANESE DINING	Displays JAPANESE RESTAURANT icons.
SHOW KOREAN DINING	Displays KOREAN RESTAURANT icons.
SHOW LATIN AND SOUTH AMERICAN DINING	Displays LATIN & SOUTH AMERICAN RESTAURANT icons.
SHOW MIDDLE EASTERN DINING	Displays MIDDLE EASTERN RESTAURANT icons.
SHOW MEXICAN DINING	Displays MEXICAN RESTAURANT icons.
SHOW PIZZA	Displays PIZZERIA icons.
SHOW SEAFOOD DINING	Displays SEAFOOD RESTAURANT icons.
SHOW SPANISH DINING	Displays SPANISH RESTAURANT icons.
SHOW STEAK HOUSES	Displays STEAK HOUSE icons.
SHOW THAI DINING	Displays THAI RESTAURANT icons.

NAVIGATION SYSTEM: BASIC FUNCTIONS

Show POI icons	
Command	Action
SHOW VIETNAMESE DINING	Displays VIETNAMESE RESTAURANT icons.
SHOW OTHER DINING	Displays OTHER RESTAURANT icons.
SHOW GROCERIES	Displays GROCERY STORE icons.
SHOW SHOPPING MALLS	Displays SHOPPING MALL icons.
SHOW CONVENIENCE STORES	Displays CONVENIENCE STORE icons.
SHOW HOME IMPROVEMENT	Displays HOME IMPROVEMENT icons.
SHOW OFFICE AND ELECTRONICS	Displays OFFICE & ELECTRONICS icons.
SHOW RETAIL AND DEPARTMENT STORES	Displays RETAIL & DEPARTMENT STORE icons.
SHOW DEPARTMENT STORES	Displays DEPARTMENT STORE icons.
SHOW BOOK STORES	Displays BOOK STORE icons.
SHOW CLOTHING AND SHOE STORES	Displays CLOTHING & SHOES STORE icons.
SHOW HOBBY AND CRAFTS	Displays HOBBY & CRAFT icons.
SHOW JEWELRY	Displays JEWELRY icons.
SHOW SPORTING EQUIPMENT	Displays SPORTING EQUIPMENT icons.
SHOW RECREATIONAL VEHICLES	Displays RECREATIONAL VEHICLE icons.
SHOW OTHER RETAIL STORES	Displays OTHER RETAIL STORE icons.
SHOW POLICE STATIONS	Displays POLICE STATION icons.
SHOW FIRE STATIONS	Displays FIRE STATION icons.
SHOW HOSPITALS	Displays HOSPITAL icons.
SHOW PHARMACIES	Displays PHARMACY icons.
SHOW OTHER MEDICAL FACILITIES	Displays OTHER MEDICAL FACILITY icons.
SHOW HOTELS	Displays HOTEL icons.
SHOW REST AREAS	Displays REST AREA icons.
SHOW AIRPORTS	Displays AIRPORT icons.
SHOW BUS STATIONS	Displays BUS STATION icons.

NAVIGATION SYSTEM: BASIC FUNCTIONS

Show POI icons	
Command	Action
SHOW TRAIN STATIONS	Displays TRAIN STATION icons.
SHOW PORTS AND FERRIES	Displays PORT & FERRY icons.
SHOW TAXIS AND SHUTTLES	Displays TAXI & SHUTTLE icons.
SHOW FULL SERVICE BANKS	Displays FULL-SERVICE BANKS icons.
SHOW ATMS	Displays ATM icons.
SHOW ATTRACTIONS	Displays ATTRACTIONS icons.
SHOW ENTERTAINMENT	Displays ENTERTAINMENT icons.
SHOW TOURIST INFORMATION	Displays TOURIST INFORMATION icons.
SHOW PARKS AND BEACHES	Displays PARK & BEACH icons.
SHOW SPORTS AND FITNESS	Displays SPORTS & FITNESS icons.
SHOW BOWLING CENTERS	Displays BOWLING icons.
SHOW GOLF COURSES	Displays GOLF COURSE icons.
SHOW HORSE RACING	Displays HORSE RACING icons.
SHOW HEALTH AND FITNESS CLUBS	Displays HEALTH & FITNESS CLUB icons.
SHOW MARINAS	Displays MARINA icons.
SHOW MOTOR SPORTS	Displays MOTOR SPORTS icons.
SHOW SKI RESORTS	Displays SKI RESORT icons.
SHOW SPORTS COMPLEXES	Displays SPORTS COMPLEX icons.
SHOW NIGHTLIFE	Displays NIGHTLIFE icons.
SHOW PERFORMING ARTS	Displays PERFORMING ART icons.
SHOW CITY CENTERS	Displays CITY CENTER icons.
SHOW GOVERNMENT	Displays GOVERNMENT icons.
SHOW SCHOOLS	Displays SCHOOL icons.
SHOW DRY CLEANERS	Displays DRY CLEANING icons.
SHOW FLORISTS	Displays FLORIST icons.
SHOW LIBRARIES	Displays LIBRARY icons.
SHOW PERSONAL GROOMING	Displays PERSONAL GROOMING icons.

NAVIGATION SYSTEM: BASIC FUNCTIONS

Show POI icons	
Command	Action
SHOW SHIPPING AND COPIES	Displays SHIPPING & COPY icons.
SHOW POST OFFICES	Displays POST OFFICE icons.
SHOW OTHER SERVICES	Displays OTHER SERVICE icons.
Delete POI icons	
Command	Action
Clear all icons	Deletes all POI icons.
Select audio mode	
Command	Action
Radio	Selects audio mode to radio.
AM	Selects audio mode to AM.
FM	Selects audio mode to FM.
FM1	Selects audio mode to FM1.
FM2	Selects audio mode to FM2.
Satellite radio	Selects audio mode to satellite radio.
Satellite radio 1	Selects audio mode to satellite radio 1.
Satellite radio 2	Selects audio mode to satellite radio 2.
Satellite radio 3	Selects audio mode to satellite radio 3.
CD	Selects audio mode to CD.
DVD	Selects audio mode to DVD.
CD changer	Selects audio mode to CD changer.
DVD changer	Selects audio mode to DVD changer.
Auxiliary	Selects audio mode to auxiliary.
Bluetooth audio	Selects audio mode to Bluetooth® audio.
iPod	Selects audio mode to iPod.
USB audio	Selects audio mode to USB audio.
Audio On/Off	
Command	Action
Audio on / Audio off	Turns audio system on and off.

NAVIGATION SYSTEM: BASIC FUNCTIONS

Radio operation	
Command	Action
Seek up	Seeks up for a radio station.
Seek down	Seeks down for a radio station.
Type up	Seeks up for program type.
Type down	Seeks down for program type.
Disc operation	
Command	Action
Track up	Tracks up for a track number.
Track down	Tracks down for a track number.
Previous track	Selects previous track.
Disc up	Disc up.
Disc down	Disc down.
Climate command	
Command	Action
Automatic climate control	Turns air conditioner on and off.
Raise temperature	Turns temperature up.
Lower temperature	Turns temperature down.
?? degrees (?? is 65 to 85)	Selects temperature from 65 to 80 degrees.
Phone	
Command	Action
Dial by number	Calls by phone number.
Dial by name	Calls by giving a voice tag in the phonebook.
Select phone	Selects phone.

INFORMATION

- *The function that cannot be used according to the vehicle is provided.*
- *Voice recognition language can be changed. (See “● Selecting a language” on page 331.)*

NAVIGATION SYSTEM: BASIC FUNCTIONS

SECTION 2

NAVIGATION SYSTEM: DESTINATION SEARCH

- **Destination search** 62
 - Selecting the search area 62
 - Destination search by Home 64
 - Destination search by Preset destinations 64
 - Destination search by “Address” 65
 - Destination search by “Point of Interest” 69
 - Destination search by “Destination Assist” 76
 - Destination search by “Previous Destinations” 76
 - Destination search by “Address Book” 77
 - Destination search by “Emergency” 77
 - Destination search by “Intersection & Freeway” 78
 - Destination search by “Map” 81
 - Destination search by “Coordinates” 82
 - Deleting set destinations 82
- **Starting route guidance** 83

Destination search —



Push the “DEST” button.



You can use one of 11 different methods to search your destination. (See pages 64 through 82.)

INFORMATION

When searching the destination, the response to the screen button may be slow.

— Selecting the search area

Change the selected region in order to set a destination from a different region by using “Address”, “Point of Interest” or “Intersection & Freeway”.



1. Touch “Search Area” to display a map of the United States and Canada divided into 15 regions. (For map database information and updates, see “Map database information and updates” on page 408.)

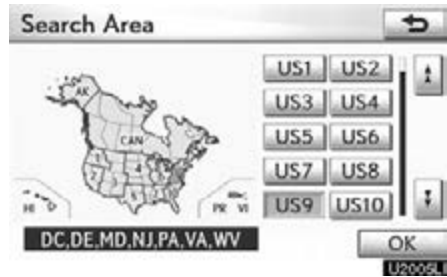

2. Touch one of “US1” through “CAN” to select a region to search.
3. Touch “OK” and the previous screen returns.

NAVIGATION SYSTEM: DESTINATION SEARCH

U.S.A.	
Button	States included in the search region
"US1"	Idaho Oregon Washington
"US2"	California Nevada
"US3"	Arizona Colorado Montana New Mexico Utah Wyoming
"US4"	Iowa Kansas Minnesota Missouri North Dakota Nebraska South Dakota
"US5"	Oklahoma Texas
"US6"	Illinois Indiana Kentucky Michigan Ohio Wisconsin
"US7"	Arkansas Alabama Louisiana Mississippi Tennessee
"US8"	Connecticut Massachusetts Maine New Hampshire New Jersey New York Rhode Island Vermont

"US9"	Washington, D.C. Delaware Maryland New Jersey Pennsylvania Virginia West Virginia
"US10"	Florida Georgia North Carolina South Carolina
"HI"	Hawaii
"AK"	Alaska
"PR"	Puerto Rico
"VI"	US Virgin Islands

Canada	
Button	Provinces and regions included in the search region
"CAN"	All provinces and regions in Canada included in this button.

— Destination search by Home

1. Push the “DEST” button.



2. Touch “Go Home”.

The screen changes and displays the map location for home and the route preference. (See “Starting route guidance” on page 83.)

If home has not been registered, a message will be displayed and the setting screen will automatically appear.

To use this function, it is necessary to set a “Home” address. (To register “Home”, see page 111.)

INFORMATION

Guidance starts from the current vehicle position to your home if “OK” is touched even while driving.

— Destination search by Preset destinations

1. Push the “DEST” button.



2. Touch any of the preset destination buttons on the “Destination” screen.

The screen changes and displays the map location of the preset destination point and the route preference. (See “Starting route guidance” on page 83.)

If a preset destination point has not been registered, a message will be displayed and the setting screen will automatically appear.

To use this function, it is necessary to set “Preset Destinations”. (To register “Preset Destinations”, see page 113.)

INFORMATION

Guidance starts from the current vehicle position to the preset destination point if “Go to Ⓞ” is touched even while driving.

— Destination search by “Address”

There are 2 ways to search a destination by address.

- (a) Search by city
- (b) Search by street address

1. Push the “DEST” button.
2. Touch “Address” on the “Destination” screen.

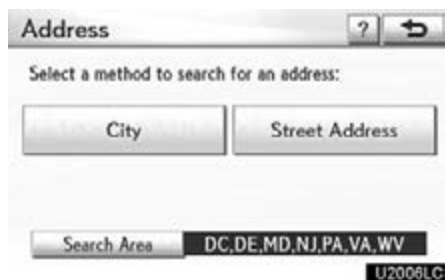

3. Touch the button for the desired method.

(a) Selecting a city to search

1. Push the “DEST” button.
2. Touch “Address” on the “Destination” screen.



3. Touch “City”.



4. Input a city name.



5. Touch the button of the desired city name from the displayed list.

NAVIGATION SYSTEM: DESTINATION SEARCH



6. Input the street name and touch "OK".

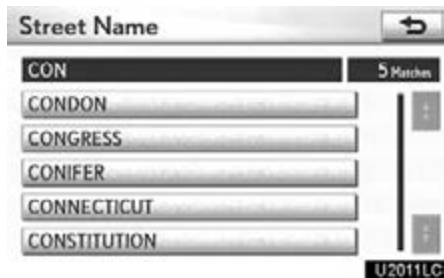

7. When the desired street name is found, touch the corresponding button.

The screen changes and displays the map location of the selected destination and the route preference. (See "Starting route guidance" on page 83.)



8. Input a house number.

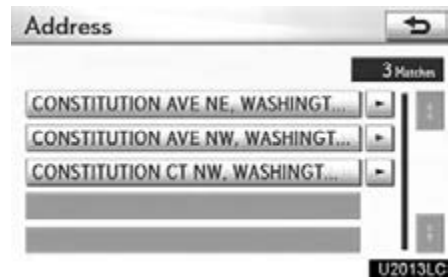

If the same address exists in more than one city, the current screen changes to the address list screen.

SELECTING FROM THE LAST 5 CITIES



1. Touch "Last 5 Cities".



2. Touch the button of the desired city name.

If the navigation system has never been used, this function will not be available.

The current screen changes to the screen for inputting a street name. (See "(a) Selecting a city to search" on page 65.)

(b) Search by street address

1. Push the "DEST" button.
2. Touch "Address" on the "Destination" screen.



3. Touch "Street Address".

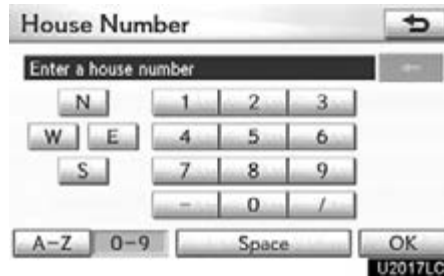

4. Touch numbers directly on the screen to input a house number.

After inputting a house number, touch "OK" to display the screen for inputting a street name.



5. Input the street name and touch "OK".

NAVIGATION SYSTEM: DESTINATION SEARCH

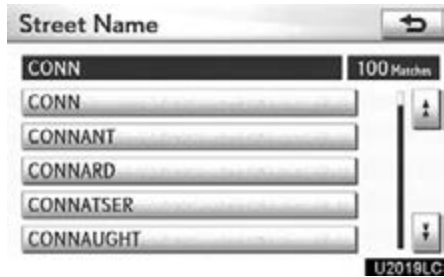

6. When the desired street name is found, touch the corresponding button.

The screen changes and displays the map location of the selected destination and the route preference. (See "Starting route guidance" on page 83.)

If the same address exists in more than one city, the current screen changes inputting the city name or to the address list screen.



7. Input a city name.



8. Touch the button of the desired city name from the displayed list.

INFORMATION

You can search for a street name using just the body.

Example : S WESTERN AVE

You can input "S WESTERN AVE", "WESTERN AVE" or "WESTERN"

— Destination search by “Point of Interest”

There are 4 ways to search by Points of Interest.

- (a) Search by name
- (b) Search by category
- (c) Search by phone #
- (d) Search by eDestination

1. Push the “DEST” button.
2. Touch “Points of Interest” on the “Destination” screen.

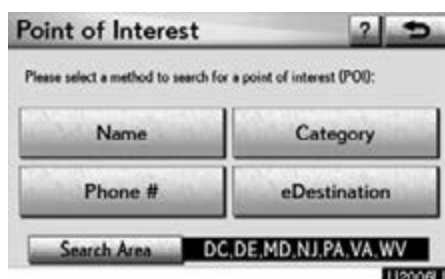

3. Touch the button for the desired method.

(a) Search by “Name”

1. Push the “DEST” button.
2. Touch “Point of Interest” on the “Destination” screen.
3. Touch “Name” on the “Point of Interest” screen.



4. Input the name of the Point of Interest.

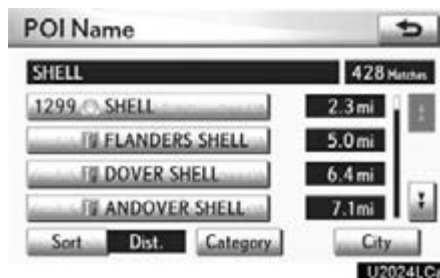

5. Touch the button of the desired destination.

The screen changes and displays the map location of the selected destination and the route preference. (See “Starting route guidance” on page 83.)

When inputting the name of a specific Point of Interest, and there are two or more sites with the same name, the list screen is displayed.

INFORMATION

To search for a facility name using multiple search words, put a space between each word.

NAVIGATION SYSTEM: DESTINATION SEARCH

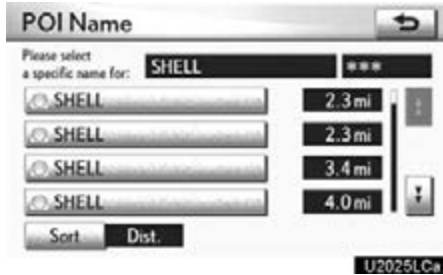

Touch the button of the desired destination.

If the same name exists in more than one city, a search can be performed more easily with “City” and “Category”. (See “● Selecting a city to search” on page 70 and “● Selecting from the categories” on page 71.)

INFORMATION

The desired Point of Interest can be displayed on the map screen. (See “ — Display POI icons” on page 102.)

● Selecting a city to search

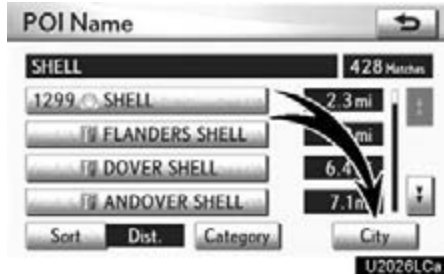

1. Touch “City”.



2. Input the city name.



3. Touch the button of the desired city name from the displayed list.

INFORMATION

To cancel the city setting, touch “Any City”.

● **Selecting from the categories**

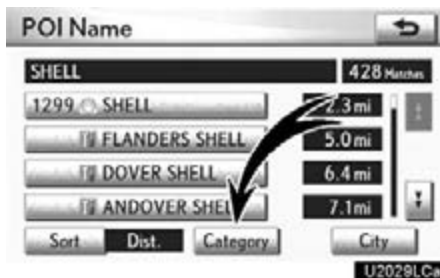

Touch “Category”.



If the desired POI category is on the screen, touch the name to display a detailed list of the POI category.

If the desired POI category is not on the screen, touch “List All Categories” to list all POI categories.



When the desired category is touched, the POI name list screen is displayed.

(b) **Search by “Category”**

The destination can be set by touching the search point and the POI category.

1. Push the “DEST” button.
2. Touch “Point of Interest” on the “Destination” screen.
3. Touch “Category” on the “Point of Interest” screen.



Set the search point by the following method:

1. Set the search point from near the vehicle’s current position
2. Set the search point from along the chosen route
3. Set the search point from near a city center
4. Set the search point from near a destination

It is possible to display the names of POIs located within approximately 200 miles (320 km) from the selected search point.

NAVIGATION SYSTEM: DESTINATION SEARCH

SETTING THE SEARCH POINT FROM NEAR HERE

Touch "Near Here".

The search point is set at the current position, and the "POI Category" screen will be displayed. (See page 74.)

SETTING THE SEARCH POINT FROM ALONG MY ROUTE

Touch "Along My Route".

The search point is set and the "POI Category" screen will be displayed. (See page 74.)

SETTING THE SEARCH POINT FROM NEAR CITY CENTER

1. Touch "Near City Center".



2. Input the city center name.



3. Touch the button of the desired city center name.

The search point is set and the "POI Category" screen will be displayed. (See page 74.)

SELECTING FROM THE LAST 5 CITIES

1. Touch "Near City Center".



2. Touch "Last 5 Cities".



3. Touch the button of the desired city center name.

The search point is set and the "POI Category" screen will be displayed. (See page 74.)

SETTING THE SEARCH POINT FROM NEAR A DESTINATION

1. Touch "Near a Destination".

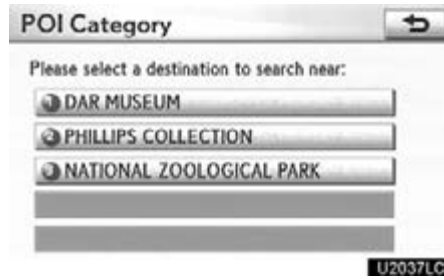

2. Touch the button of the desired destination.

The search point is set and the "POI Category" screen will be displayed. (See page 74.)

NAVIGATION SYSTEM: DESTINATION SEARCH

- To search POIs near the search point

When the search point is set, the “POI Category” screen will be displayed.



Touch the desired POI category.

If the desired POI category is not on the screen, touch “List All Categories” to list all POI categories.



Touch the desired POI category from the list.



By touching the button of the desired item, the screen changes and displays the map location of the selected destination and the route preference. (See “Starting route guidance” on page 83.)

(c) Search by “Phone #”

1. Push the “DEST” button.
2. Touch “Point of Interest” on the “Destination” screen.
3. Touch “Phone #” on the “Point of Interest” screen.



4. Input a telephone number.
5. After inputting a telephone number, touch “OK”.

The screen changes and displays the map location of the selected destination and the route preference. (See “Starting route guidance” on page 83.)

If there is more than one site with the same number, the following screen will be displayed.



INFORMATION

- *If there is no match for the telephone number inputted, a list of identical numbers with different area codes will be displayed.*
- *To set an address book entry as a destination using the phone number, the number must already be registered. (See page 121.)*

(d) Search by “eDestination”

1. Push the “DEST” button.
2. Touch “Point of Interest” on the “Destination” screen.
3. Touch “eDestination” on the “Point of Interest” screen.

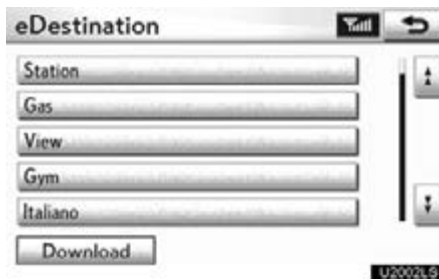

With the eDestination feature, you can go online, via the Lexus.com owner’s Web site, to select and organize destinations of your choice and then wirelessly send them to your vehicle’s navigation system. You can store up to 200 locations online to access and update at any time. Your locations can be organized into up to 20 folders. (See “eDestination” on page 160.)

— Destination search by “Destination Assist”

1. Push the “DEST” button.
2. Touch “Destination Assist” on the “Destination” screen.
3. Touch “Call Dest. Assist” on the “Destination Assist” screen.



Destination Assist provides you with live assistance for finding destinations via the Lexus Enform response center. You can request either a specific business, address, or ask for help locating your desired destination by category, such as restaurants, gas stations, shopping centers or other points of interest (POI). After you tell the agent your choice of destination, its coordinates are sent wirelessly to your vehicle’s navigation system. (See “Destination Assist” on page 157.)

— Destination search by “Previous Destinations”

1. Push the “DEST” button.
2. Touch “Previous Destinations” on the “Destination” screen.



The previous starting point and up to 100 previously set destinations are displayed on the screen.

3. Touch the button of the desired destination.

“Delete”: To delete the previous destination. (To delete previous destinations, see page 127.)

The screen changes and displays the map location of the selected destination and the route preference. (See “Starting route guidance” on page 83.)

INFORMATION

The list of previous destinations can also be deleted by touching “Delete Previous Dest.” on the “Navigation Settings” screen when the vehicle is stopped. (See “ — Deleting previous destinations” on page 127.)

— Destination search by “Address Book”

1. Push the “DEST” button.
2. Touch “Address Book” on the “Destination” screen.

A list of registered address book entries is displayed.

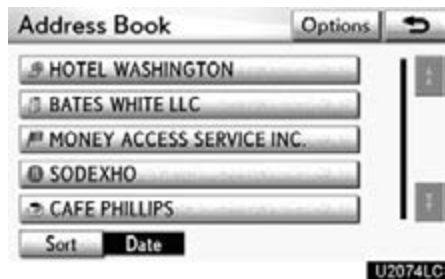

3. Touch the button of the desired address book entry.

“Options”: To register or edit address book. (See page 116.)

The screen changes and displays the map location of the selected destination and the route preference. (See “Starting route guidance” on page 83.)

— Destination search by “Emergency”

1. Push the “DEST” button.
2. Touch “Emergency” on the second page of the “Destination” screen.

The display changes to a screen to select police stations, dealers, hospitals or fire stations. While driving, only nearby police stations, dealers, hospitals, or fire stations are shown. The current position is shown with an address, and the latitude and longitude at the top of the screen.



3. Touch the desired emergency category.

The selected emergency category list is displayed.



4. Touch the button of the desired destination.

The screen changes and displays the map location of the selected destination and the route preference. (See “Starting route guidance” on page 83.)

INFORMATION

The navigation system does not guide in areas where route guidance is unavailable. (See page 407.)

— Destination search by “Intersection & Freeway”

There are 2 ways to search.

- (a) Search by intersection
- (b) Search by Freeway Entrance/Exit

1. Push the “DEST” button.
2. Touch “Intersection & Freeway” on the second page of the “Destination” screen.

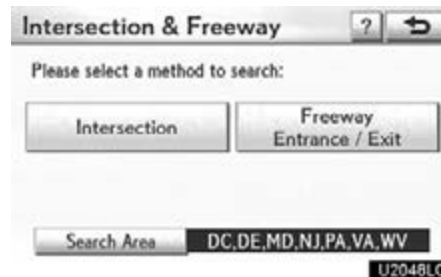

3. Touch the button for the desired method.

(a) Search by “Intersection”

1. Push the “DEST” button.
2. Touch “Intersection & Freeway” on the second page of the “Destination” screen.
3. Touch “Intersection” on the “Intersection & Freeway” screen.



4. Input the name of the first intersecting street which are located near the destination to be set.
5. Touch “OK”.



6. Touch the button of the desired item.



7. Input the name of the second intersecting street.

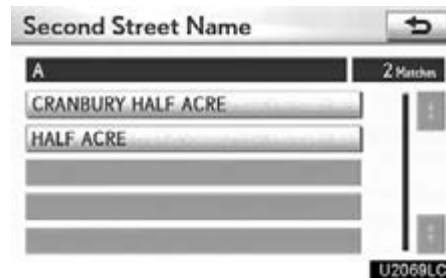

8. Touch the button of the desired item.

After inputting the two intersecting streets, the screen changes and displays the map location of the selected destination and the route preference. (See “Starting route guidance” on page 83.)

NAVIGATION SYSTEM: DESTINATION SEARCH

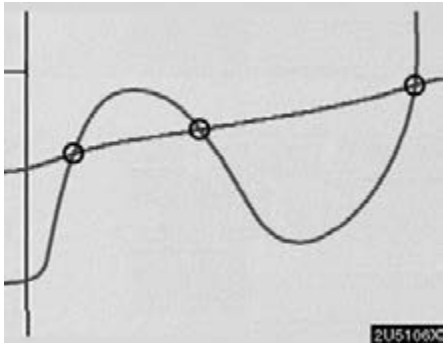

If the same two streets cross at more than one intersection, the screen changes and displays the menu to select the city name where the streets intersect. Select the city, and the map location of the selected destination and the route preference. (See “Starting route guidance” on page 83.)

(b) Search by “Freeway Entrance/Exit”

1. Push the “DEST” button.
2. Touch “Intersection & Freeway” on the second page of the “Destination” screen.
3. Touch “Freeway Entrance/Exit” on the “Intersection & Freeway” screen.



4. To input a freeway name.

Be sure to use the complete name of the freeway or highway, including the hyphen, when entering the destination. Freeways and interstates use an “I” (I-405). US highways use the state designation before the number (CA-118).

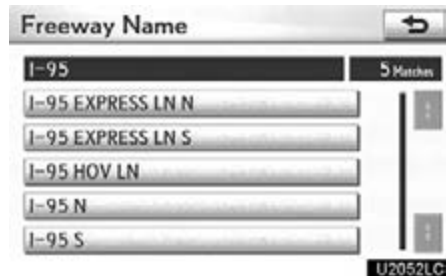

5. Select the desired freeway by touching the button.

— Destination search by “Map”

1. Push the “DEST” button.
2. Touch “Map” on the second page of the “Destination” screen.



6. Either a freeway “Entrance” or “Exit” can be selected.

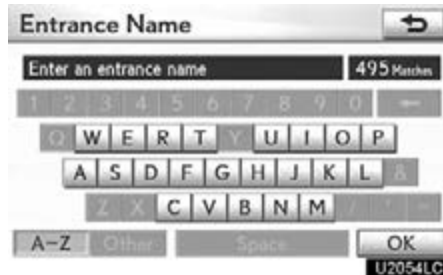

7. Input a freeway entrance or exit name.
8. Touch “OK”.

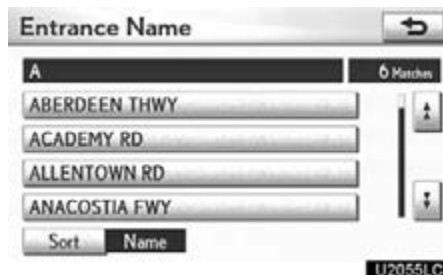

9. Touch the button of the desired entrance or exit name.

The screen changes and displays the map location of the selected destination and the route preference. (See “Starting route guidance” on page 83.)



The screen changes and displays the map location that was previously displayed just before the destination input operation and the route preference. (See “Starting route guidance” on page 83.)

INFORMATION
<i>Guidance starts if “OK” is touched even while driving. However, the cursor cannot be moved.</i>

— Destination search by “Coordinates”

1. Push the “DEST” button.
2. Touch “Coordinates” on the second page of the “Destination” screen.

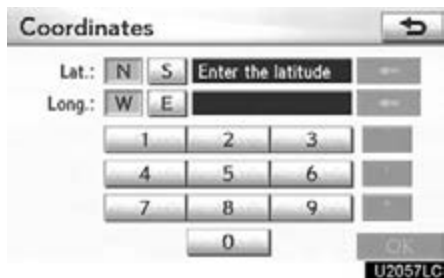

3. Input the latitude and the longitude.
4. When the input is finished, touch “OK”.

By touching the button of the desired point, the screen changes and displays the map location of the selected destination and the route preference. (See “Starting route guidance” on page 83.)

— Deleting set destinations

A set destination can be deleted.

1. Push the “DEST” button.
2. Touch “Del. Dest.” on the “Destination” screen.

When more than one destination is set, a list will be displayed on the screen.



3. Touch the destination for deletion.

“Select All”: To select all destinations on the list.

“Unselect All”: To unselect all of the selected destinations.

4. Touch “Delete”.



A message appears to confirm the request to delete.

5. To delete the destination(s), touch “Yes”.

If “Yes” is touched, the data cannot be recovered.

If “No” is touched, the previous screen will return.

The system searches for the guidance route again, and displays the entire route.

INFORMATION

Set destinations can also be deleted by touching “Route”. (See “— Deleting destinations” on page 95.)

Starting route guidance

After inputting the destination, the screen changes and displays the map location of the selected destination and the route preference.



1. Scroll the map to the desired point.

“Adjust Location”: To adjust the position in smaller increments.



When an arrow facing the desired point is touched, the map scrolls in that direction.

The scroll stops when the selection of the arrow is released.

2. Touch “Go to”.

The system starts route search and displays recommended routes.

If there is already a set destination, “Go to” and “Add to Route” are displayed.

“Go to”: To delete the existing destinations and set a new one.

“Add to Route”: To add a destination.

“Info.”: If this button is displayed on the top of the screen, touch it to view items such as name, address, and phone number.



- 1 Current position
- 2 Destination point
- 3 Type of the route and the distance
- 4 Distance of the entire route

3. To start guidance, touch "OK".

"Turn List": The following screen displays the list of the roads up to the destination.

"3 Routes": To select the desired route from 3 possible routes. (See page 85.)

"Edit Route": To change the route. (See page 86.)

INFORMATION

- Guidance can be paused or resumed. (See "— Pausing and resuming guidance" on page 101.)
- If "OK" is touched until a beep sounds, demo mode will start. Push the "MAP/VOICE" button to finish Demo mode.
- The route for returning may not be the same as that for going.
- The route guidance to the destination may not be the shortest route nor a route without traffic congestion.
- Route guidance may not be available if there is no road data for the specified location.
- When setting the destination on a map with a scale larger than 0.5 miles (800 m), the map scale changes to 0.5 miles (800 m) automatically. Set the destination again.
- If a destination is entered, the road nearest to the point you selected is set as the destination.

CAUTION

Be sure to obey traffic regulations and keep road conditions in mind while driving. If a traffic sign on the road has been changed, the route guidance may not indicate such changed information.

3 ROUTES SELECTION



1. To select the desired route from 3 routes, touch “3 Routes”.



2. Touch “Quick”, “Alt.” or “Short” to select the desired route.

“Quick”: Recommended route.
This route is indicated by an orange line.

“Alt.”: Alternative route.
This route is indicated by a purple line.

“Short”: A route by which you can reach the destination in the shortest distance.
This route is indicated by a green line.

“Info.”: To display the following information about each of the 3 routes.

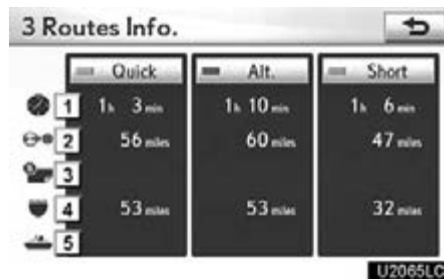

- 1 Time necessary for the entire trip
- 2 Distance of the entire trip
- 3 Toll road
- 4 Freeway
- 5 Ferry

● **Edit route**

You can again designate the conditions of the route to the destination.



INFORMATION

- *Even if the “Freeways” indicator is dimmed, the route cannot avoid including a freeway in some cases.*
- *If the calculated route includes a trip by ferry, the route guidance shows a sea route. After you travel by ferry, the current vehicle position may be incorrect. Upon reception of GPS signals, it is automatically corrected.*

Touch “Edit Route”.



“**Add**”: To add destinations. (See page 94.)

“**Delete**”: To delete destinations. (See page 95.)

“**Reorder**”: To reorder destinations. (See page 94.)

“**Preferences**”: A number of choices are provided on the conditions which the system uses to determine the route to the destination. (See page 99.)

SECTION 3

NAVIGATION SYSTEM: ROUTE GUIDANCE

- Route guidance screen 88
- Typical voice guidance prompts 91
- Distance and time to destination 93
- **Setting and deleting destinations** 94
 - Adding destinations 94
 - Reordering destinations 94
 - Deleting destinations 95
- **Setting route** 96
 - Detour setting 96
 - Route overview 97
 - Route preference 99
 - Pausing and resuming guidance 101
- **Show on map** 102
 - Display POI* icons 102
 - Route trace 106

*: Point of Interest

Route guidance screen

During route guidance, various types of guidance screens can be displayed depending on conditions.

- **Screen layout**



- 1 Distance to the next turn and the arrow indicating turning direction
- 2 Current street name
- 3 Distance and travel/arrival time to the destination
- 4 Current position
- 5 Guidance route

INFORMATION

- *If the vehicle goes off the guidance route, the route is searched again.*
- *For some areas, the roads have not been completely digitized in our database. For this reason, the route guidance may select road that should not be traveled on.*
- *When you arrive at your destination, the destination name will be displayed on the top of the screen. Touching "Off" clears the display.*

- **During freeway driving**

During freeway driving, the freeway exit information screen will be displayed.

This screen displays the distance to the next junction and exit, or POIs in the vicinity of the freeway exit.

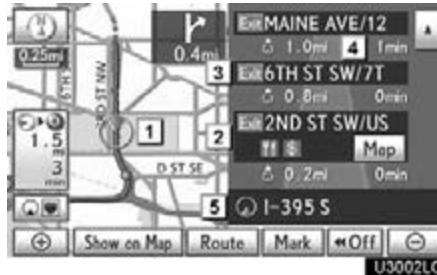

- 1 Current position
- 2 Points of Interest that are close to a freeway exit
- 3 Exit number and junction name
- 4 Distance from the current position to the exit or junction
- 5 Current street name

"Map": To display the selected map of the exit vicinity.

- ▲ : To scroll for farther junctions or exits.
- ▼ : To scroll for closer junctions or exits.
- 🔄 : To scroll for the closest 3 junctions or exits.

- **When approaching a freeway exit or junction**

When the vehicle approaches an exit or junction, the guidance screen for the freeway will be displayed.



- 1 Next street name
- 2 Distance from the current position to the exit or junction
- 3 Current position

“Off”: The guidance screen on freeway disappears and the map screen appears.

When touching  or pushing the “MAP/VOICE” button, the guidance screen on freeway reappears.

- **When approaching an intersection**

When the vehicle approaches an intersection, the intersection guidance screen will be displayed.

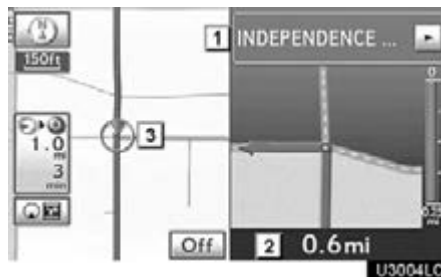

- 1 Next street name
- 2 Distance to the intersection
- 3 Current position

“Off”: The intersection guidance screen disappears and the map screen appears.

When touching  or pushing the “MAP/VOICE” button, the intersection guidance screen reappears.

NAVIGATION SYSTEM: ROUTE GUIDANCE

- Other screens

TURN LIST SCREEN

On this screen, the list of turns on the guidance route can be viewed.

Touching  during guidance displays the turn list.

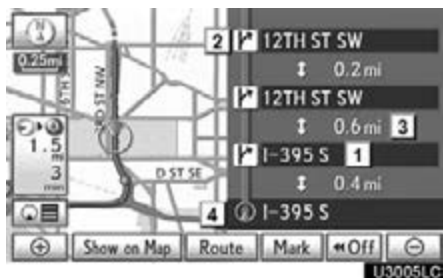

- 1 Next street name or destination name
- 2 Turn direction
- 3 Distance between turns
- 4 Current street name

ARROW SCREEN

On this screen, information about next turns on the guidance route can be viewed.

Touching  during guidance displays the arrow screen.

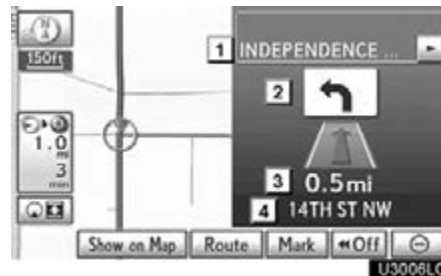

- 1 Exit number, street name containing number or next street name
- 2 Turn direction
- 3 Distance to the next turn
- 4 Current street name

Typical voice guidance prompts

The voice guidance provides various messages as you approach an intersection, or other point where you need to maneuver the vehicle.

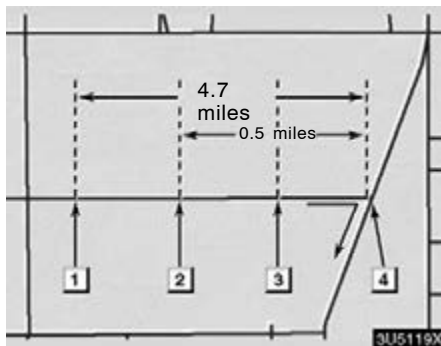

- 1 "Proceed about 5 miles to Main street."
- 2 "In half of a mile, right turn onto Main street."
- 3 "Right turn."
- 4 (Beep sound only)

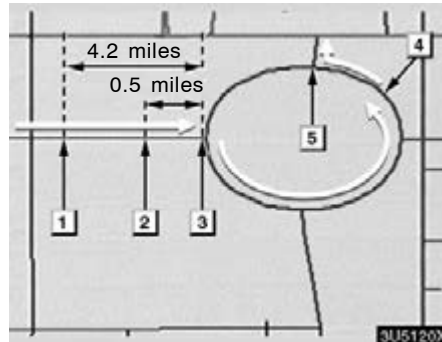

- 1 "Proceed about 4 miles to the traffic circle."
- 2 "In half of a mile, traffic circle ahead, and then 3rd exit ahead onto Main street."
- 3 "The 3rd exit ahead."
- 4 "The exit ahead."
- 5 (Beep sound only)

INFORMATION

- *The street names may not be pronounced correctly or clearly due to text-to-speech function.*
- *On freeways, interstates or other highways with higher speed limits, the voice guidance will be made at earlier points than on city streets in order to allow time to maneuver.*

NAVIGATION SYSTEM: ROUTE GUIDANCE

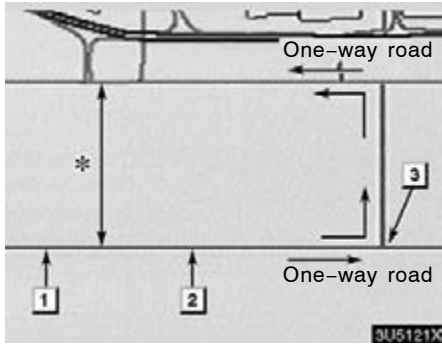

*: The system indicates a U-turn if the distance between two one-way roads (of opposite directions) is less than 50 feet (15 m) in residential areas or 164 feet (50 m) in non-residential areas.

- 1 🎵 "In half of a mile, make a legal U-turn."
- 2 🎵 "Make a legal U-turn ahead."
- 3 🎵 (Beep sound only)

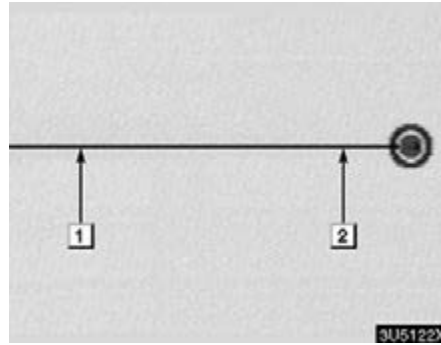

The system announces the approach to the final destination.

- 1 🎵 "Your destination is ahead."
- 2 🎵 "You have arrived at your destination. The route guidance is now finished."

INFORMATION

- *If the system cannot determine the current vehicle position correctly (in cases of poor GPS signal reception), the voice guidance may be made early or delayed.*
- *If you did not hear the voice guidance command, push the "MAP/VOICE" button to hear it again.*
- *To adjust the voice guidance volume, see "• Voice volume" on page 338.*

Distance and time to destination



The distance, the estimated travel time and the estimated arrival time from the current position to the selected destination are displayed.



Estimated travel time is displayed.



Estimated arrival time is displayed.



To switch to estimated arrival time.



To switch to estimated travel time.



Displayed while driving off the guidance route. The destination direction is indicated by an arrow.

When the vehicle is on the guidance route, the distance and the estimated travel/arrival time to the destination are displayed. When the vehicle is not on the guidance route, the distance and the direction of the destination are displayed.

When driving on the guidance route and more than one destination is set, the distance and the estimated travel/arrival time from the current position to each destination are displayed.

1. Touch this button to display the following screen.



2. Touch the number button to display the desired destination.

INFORMATION

When the vehicle is on the guidance route, the distance measured along the route is displayed. Travel time and arrival time is calculated based on the set vehicle speed information. (See page 342.) However, when the vehicle is not on the guidance route, the distance is the linear distance between the current position and the destination.

**Setting and deleting destinations —
— Adding destinations**

You can add destinations and search again for the routes.



1. Touch “Route”.



2. Touch “Add”.

3. Input an additional destination in the same way as the destination search. (See “Destination search” on page 62.)

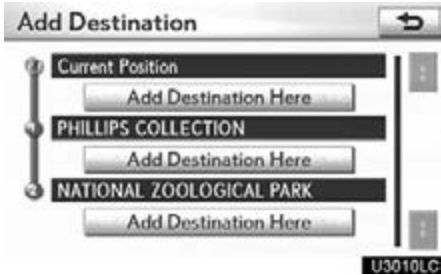

4. Touch the desired “Add Destination Here” to determine the arrival order of the additional destination.

— Reordering destinations

When more than one destination is set, you can change the arrival order of the destinations.



1. Touch “Route”.



2. Touch “Reorder”.

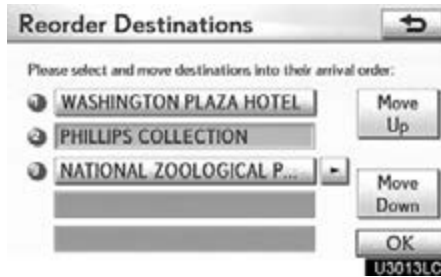

3. Touch the desired destination and touch “Move Up” or “Move Down” to change the arrival order.

4. Touch “OK”.

5. After selecting the destinations, touch “OK”.

The system searches for the guidance route again, and displays the entire route.

— Deleting destinations

A set destination can be deleted.



1. Touch “Route”.



2. Touch “Delete”.

When more than one destination is set, a list will be displayed on the screen.



3. Touch the destination for deletion.

“Select All”: To select all destinations on the list.

“Unselect All”: To unselect all of the selected destinations.

A message appears to confirm the request to delete.

4. To delete the destination(s), touch “Yes”.

If “Yes” is touched, the data cannot be recovered.

If “No” is touched, the previous screen will return.

The system searches for the guidance route again, and displays the entire route.

Setting route — — Detour setting

While the route guidance is operating, you can change the route to detour around a section of the route where a delay is caused by road repairs, or an accident, etc.



1. Touch “Route”.



2. Touch “Detour”.



3. Touch the button below to select the desired detour distance.

“1 mile (km)”, “3 miles (km)” or “5 miles (km)”: Touch one of these buttons to start the detour process. After detouring, the system returns to the original guidance route.

“Whole Route”: By touching this button, the system will calculate an entire new route to the destination.

“Around Traffic”: If you touch this button, the system will search for the route based on the traffic congestion information received from XM® NavTraffic. For details, see “XM® NavTraffic” on page 173.

— Route overview

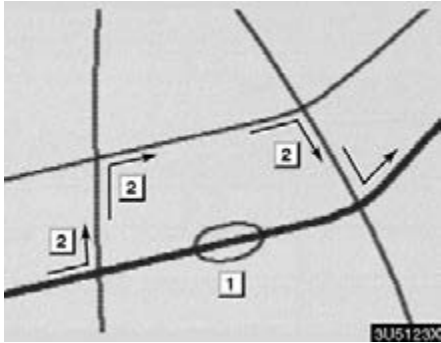

This picture shows an example of how the system would guide around a delay caused by a traffic jam.

- 1 This position indicates the location of a traffic jam caused by road repairs or an accident.
- 2 This route indicates the detour suggested by the system.

INFORMATION
<ul style="list-style-type: none"> ● <i>When your vehicle is on a freeway, the detour distance selections are 5, 15, and 25 miles (km).</i> ● <i>The system may not be able to calculate a detour route depending on the selected distance and surrounding road conditions.</i>



1. Touch "Route".



2. Touch "Overview".



The entire route from the current position to the destination is displayed.



"OK": To start guidance.



"Turn List": The following screen displays the list of the roads up to the destination.

"Preview": To preview the route.

NAVIGATION SYSTEM: ROUTE GUIDANCE



You can scroll through the list of roads by touching  or . However, not all road names in the route may appear on the list. If a road changes its name without requiring a turn (such as on a street that runs through two or more cities), the name change will not appear on the list. The street names will be displayed in order from the starting point, along with the distance to the next turn.

-  These marks indicate the direction in which you should turn at an intersection.
- 

Touch "Map" on the "Turn List" screen. The point which you choose is displayed on the map screen.



• Route preview



1. Touch "Route".









2. Touch "Overview".



3. Touch "Preview".



-  : To indicate the next destination.
-  : To preview the route to the next destination.
-  : To preview the route to the next destination in fast-forward mode.
-  : To stop the preview.
-  : To review the route to the previous destination or starting point.
-  : To review the route to the previous destination or starting point in fast-forward mode.
-  : To indicate the previous destination or starting point.

— Route preference

- **To select route type**

You can designate the route conditions of the route to the destination.



1. Touch “Route”.

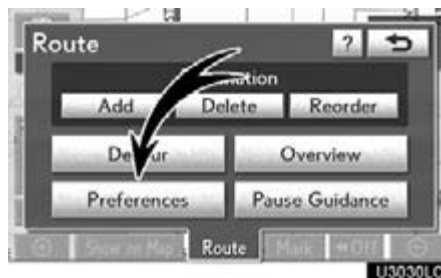

2. Touch “Preferences”.

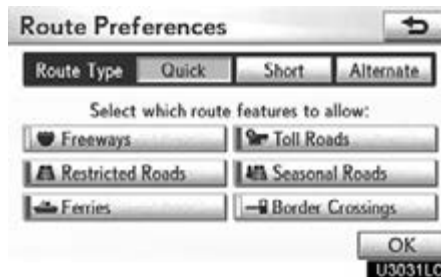

3. Touch “Quick”, “Short” or “Alternate” and touch “OK”.

NAVIGATION SYSTEM: ROUTE GUIDANCE



The entire route from the starting point to the destination is displayed.

“OK”: To start guidance.

“Edit Route”: To change a route. (See page 86.)

- **To select route features**

A number of choices are provided on the conditions which the system uses to determine the route to the destination.

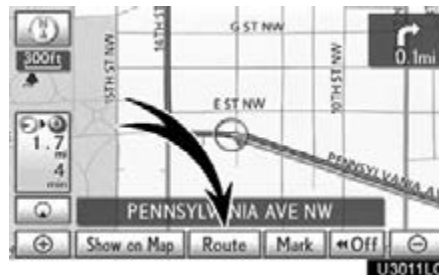

1. Touch “Route”.

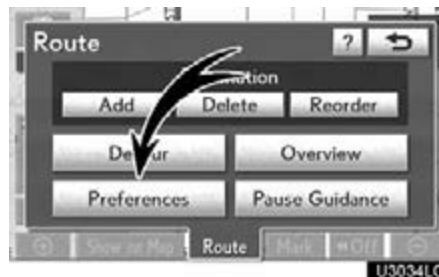

2. Touch “Preferences” to change the conditions that determine the route to the destination.



3. Select the desired route preference by touching the button.

When searching for a route, the system will avoid routes when the indicator is off.

4. After choosing the desired route preference, touch “OK”.

- **Starting route from adjacent road**

You can start the route guidance from the adjacent road.

(ex. When route guidance is set on the freeway, but the vehicle is driven parallel along the freeway.)



1. Touch "Route".



2. Touch "Preferences".



3. Touch "Start from Adjacent Road".

When there is no adjacent road, this button will not be displayed.

— Pausing and resuming guidance

- **To pause guidance**



1. Touch "Route".



2. Touch "Pause Guidance".



The screen will return to the current position map without route guidance.

INFORMATION

Without route guidance, "Pause Guidance" cannot be used.

- To resume guidance



1. Touch "Route".



2. Touch "Resume Guidance".



The screen will change to the current position map with route guidance.

Show on map — — Display POI icons

Points of Interest such as gas stations and restaurants can be displayed on the map screen. You can also set their location as a destination and use them for route guidance.



1. Touch "Show on Map".



2. Touch "Select POI" to display a particular type of Point of Interest on the screen.

When the Points of Interest to be displayed on the map screen have already been set, "Change POI" is displayed.

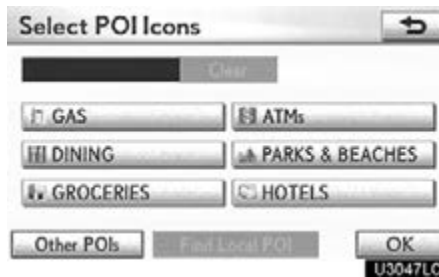

A screen with a limited choice of Points of Interest will be displayed. (To change the displayed POI, see page 345.)

● **Selecting POIs to be displayed**

Up to 5 categories of icons can be displayed on the screen.



Touch the desired Point of Interest category to display POI location symbols on the map screen.

By touching the desired POI category and then touching “OK”, the selected POI icons are displayed on the map screen.

To turn off the Points of Interest icons on the map screen, touch “Clear”.

“**Other POIs**”: If the desired Point of Interest can not be found on the limited choice screen, touch this button.

“**Find Local POI**”: When searching for the nearest Point of Interest, touch this button. Then choose one of the categories. The system will list the points within 200 miles (320 km). (See page 104.)

Touch “Other POIs” on the “Select POI Icons” screen.

When a Point of Interest category is selected from either the limited list or the complete list, the screen will display symbols of those locations on the map screen.



Touch the desired POI categories.

The selected category icon appears on the top left of the screen.

By touching the desired POI category and then touching “OK”, the selected POI icons are touching on the map screen.

If the desired POI category is not on the screen, touch “**List All Categories**” to list all POI categories.

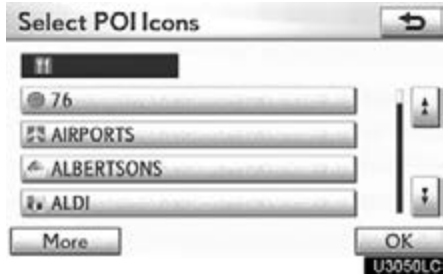

Touch the desired POI categories from the list.

The selected category icon appears on the top left of the screen.

By touching the desired POI category and then touching “OK”, the selected POI icons are displayed on the map screen.

To return to the POI category selection screen, touch “More”.

● To display the local POI list

Points of Interest that are within 200 miles (320 km) of the current position will be listed from among the selected categories.



1. Touch “Find Local POI” on the “Select POI Icons” screen.



2. Touch the button of the desired Point of Interest.

The selected Points of Interest are displayed on the map screen.

“Near...”: To search for Points of Interest near the current position or along the route.



“Near Here” : When **“Near Here”** is touched, the list of Points of Interest near the current position will be displayed.

“Along My Route” : When **“Along My Route”** is touched, the list of Points of Interest along the route will be displayed.

● **To set a POI as a destination**

You can select one of the Points of Interest icons on the map screen as a destination and use it for route guidance.



1. Directly touch the Point of Interest icon that you want to set as a destination.

The map will shift so that the icon is centered on the screen and overlaps with the cursor. At this time, the distance from the current position is displayed on the screen. The distance shown is measured as a straight line from the current vehicle position to the POI.

2. When the desired Point of Interest overlaps with the cursor, touch “Enter”.

The screen changes and displays the map location of the selected destination and route preference. (See “Starting route guidance” on page 83.)

- To hide POI icons



1. Touch "Show on Map".



2. Touch "POI Icons".

The "POI Icons" indicator is dimmed.

The map screen will be displayed with the POI icons hidden.

To display the POI icons again, touch "POI Icons" on the "Show on Map" screen.

— Route trace

It is possible to store the traveled route up to 124 miles (200 km) and retrace the route on the display.

INFORMATION

This feature is available on the map with more detailed map scale than 30 miles (50 km).

- To start recording the route trace



1. Touch "Show on Map".



2. Touch "Route Trace". "Route Trace" indicator is highlighted.

- To stop recording the route trace



1. Touch "Show on Map".



2. Touch "Route Trace". The following screen will be displayed.



Touching "Yes" stops recording and the route trace remains displayed on the screen.

Touching "No" stops recording and the route trace is erased.

NAVIGATION SYSTEM: ROUTE GUIDANCE

SECTION 4

NAVIGATION SYSTEM: MEMORY POINTS

- **Navigation settings** 110
 - Setting up the “Home” 111
 - Setting up the “Preset Destinations” 113
 - Setting up the “Address Book” 116
 - Setting up the “Areas to Avoid” 122
 - Deleting previous destinations 127

Navigation settings —

Points or areas on the map can be registered.

The registered points can be used on the “Destination” screen. (See “— Destination search by Home” on page 64, “— Destination search by Preset destinations” on page 64 and “— Destination search by “Address Book”” on page 77.)

Registered areas are avoided at the time of route search.



On this screen, the following operations can be performed.

No.	Function
1	Sets home (See page 111.)
2	Sets preset destinations (See page 113.)
3	Sets address book (See page 116.)
4	Sets area to avoid (See page 122.)
5	Deletes previous destinations (See page 127.)
6	Detailed navigation settings (See page 340.)



1. Push the “SETUP” button.



2. Touch “Navi.”.

— Setting up the “Home”

If home has been registered, that information can be recalled by using “Go Home” on the “Destination” screen. (See “— Destination search by Home” on page 64.)

1. Push the “SETUP” button.
2. Touch “Navi.” on the “Setup” screen.



3. Touch “Home”.



- Registering home (See page 111.)
- Editing home (See page 112.)
- Deleting home (See page 113.)

(a) Registering home

1. Push the “SETUP” button.
2. Touch “Navi.” on the “Setup” screen.
3. Touch “Home” on the “Navigation Settings” screen.



4. Touch “Set Home”.



5. Enter the location in the same way as for a destination search. (See “Destination search” on page 62.)

NAVIGATION SYSTEM: MEMORY POINTS

When registration of home is completed, the "Edit Home" screen will be displayed.



6. Touch "OK".

To edit registered information, see "(b) Editing home" on page 112.

(b) Editing home

1. Push the "SETUP" button.
2. Touch "Navi." on the "Setup" screen.
3. Touch "Home" on the "Navigation Settings" screen.



4. Touch "Edit".



5. Touch "Edit" for the item you want to change.

"Name": To edit home name. The names can be displayed on the map. (See page 120.)

"Location": To edit location information. (See page 121.)

"Phone #": To edit telephone numbers. (See page 121.)

"Icon": To select icons to be displayed on the map. (See page 119.)

6. Touch "OK".

(c) Deleting home

1. Push the “SETUP” button.
2. Touch “Navi.” on the “Setup” screen.
3. Touch “Home” on the “Navigation Settings” screen.



4. Touch “Delete”.
5. To delete home, touch “Yes”. To cancel the deletion, touch “No”.

— Setting up the “Preset Destinations”

If preset destination has been registered, that information can be recalled by using “Preset Destination” on the “Destination” screen. (See “— Destination search by Preset destinations” on page 64.)

1. Push the “SETUP” button.
2. Touch “Navi.” on the “Setup” screen.



3. Touch “Preset Destinations”.



- Registering preset destination (See page 114.)
- Editing preset destination (See page 115.)
- Deleting preset destination (See page 116.)

NAVIGATION SYSTEM: MEMORY POINTS

(a) Registering preset destinations

1. Push the "SETUP" button.
2. Touch "Navi." on the "Setup" screen.
3. Touch "Preset Destinations" on the "Navigation Settings" screen.



4. Touch "Set".



5. Enter the location in the same way as for a destination search. (See "Destination search" on page 62.)

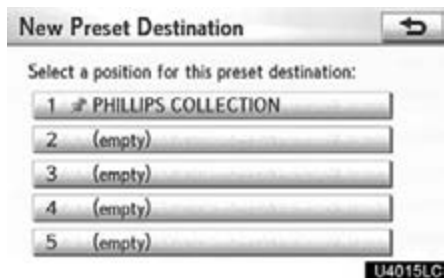

6. Touch a position for this preset destination.

When registration of preset destination is completed, the "Edit Preset Destination" screen will be displayed.



7. Touch "OK".

To edit registered information, see "(b) Editing preset destinations" on page 115.

(b) Editing preset destinations

1. Push the "SETUP" button.
2. Touch "Navi." on the "Setup" screen.
3. Touch "Preset Destinations" on the "Navigation Settings" screen.



4. Touch "Edit".

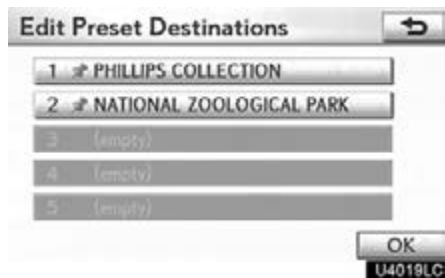

5. Touch the button of the desired preset destination.



6. Touch "Edit" for the item you want to change.

"Name": To edit preset destination names. The names can be displayed on the map. (See page 120.)

"Location": To edit location information. (See page 121.)

"Phone #": To edit telephone numbers. (See page 121.)

"Icon": To select icons to be displayed on the map. (See page 119.)

7. Touch "OK".

(c) Deleting preset destinations

1. Push the "SETUP" button.
2. Touch "Navi." on the "Setup" screen.
3. Touch "Preset Destinations" on the "Navigation Settings" screen.



4. Touch "Delete".

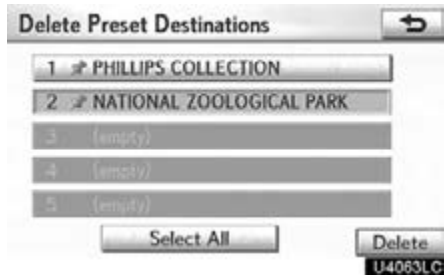

5. Touch the preset destination for deletion.

"Select All": To select all preset destinations on the list.

"Unselect All": To unselect all of the selected preset destinations.

6. Touch "Delete".

7. To delete preset destination, touch "Yes". To cancel the deletion, touch "No".

— Setting up the "Address Book"

Points or areas on the map can be registered.

1. Push the "SETUP" button.
2. Touch "Navi." on the "Setup" screen.



3. Touch "Address Book".

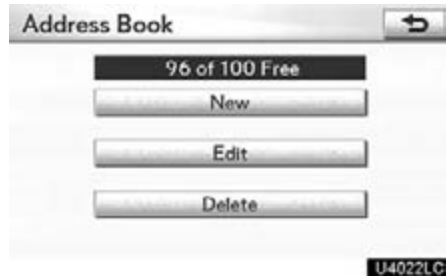

- Registering address book entries (See page 117.)
- Editing address book entries (See page 118.)
- Deleting address book entries (See page 122.)

(a) Registering address book entries

1. Push the "SETUP" button.
2. Touch "Navi." on the "Setup" screen.
3. Touch "Address Book" on the "Navigation Settings" screen.



4. Touch "New".

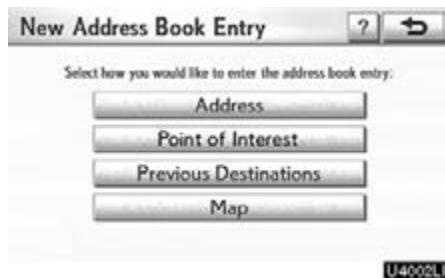

5. Enter the location in the same way as for a destination search. (See "Destination search" on page 62.)

After the address book entry has been registered, the "Edit Address Book Entry" screen will be displayed.

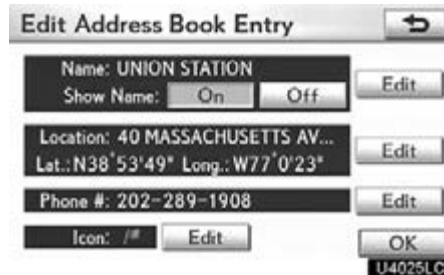

6. Touch "OK".

To edit registered information, see "(b) Editing address book entries" on page 118.

INFORMATION
<i>Up to 100 address book entries can be registered.</i>

NAVIGATION SYSTEM: MEMORY POINTS

(b) Editing address book entries

The icon, name, location and/or telephone number of a registered address book entry can be edited.

1. Push the “SETUP” button.
2. Touch “Navi.” on the “Setup” screen.
3. Touch “Address Book” on the “Navigation Settings” screen.

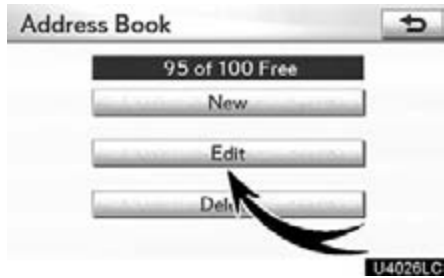

4. Touch “Edit”.

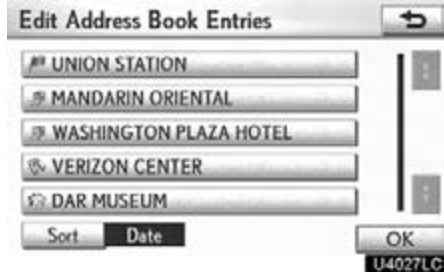

5. Touch the button of the desired address book entry.

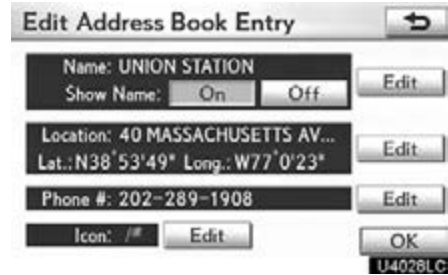

6. Touch “Edit” for the item you want to change.

“Name”: To edit address book entry names. The names can be displayed on the map. (See page 120.)

“Location”: To edit location information. (See page 121.)

“Phone #”: To edit telephone numbers. (See page 121.)

“Icon”: To select icons to be displayed on the map. (See page 119.)

7. Touch “OK”.

- To change “Icon”

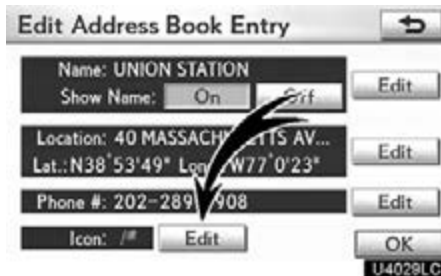

1. Touch “Edit” of “Icon”.

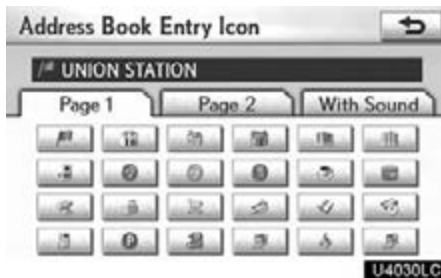

2. Touch the desired icon.

Change pages by touching “Page 1”, “Page 2” or “With Sound” tab.

SOUND ICONS

You can set a sound for some address book entries. When the vehicle approaches the location of the address book entry, the selected sound will be heard.

1. Touch “With Sound” on the “Address Book Entry Icon” screen.

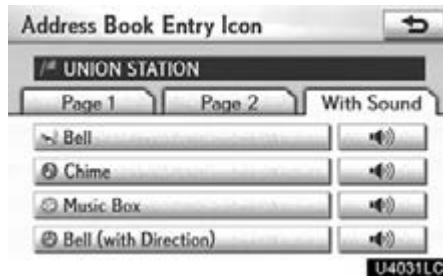

2. Touch the desired sound icon.

The next screen appears when “Bell (with Direction)” is touched.



Touch either  or  to adjust the direction. Touch “OK”.

The bell sounds only when the vehicle approaches this point in the direction that has been set.

- To change “Name”

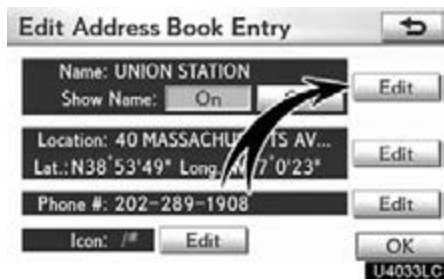

1. Touch “Edit” of “Name”.

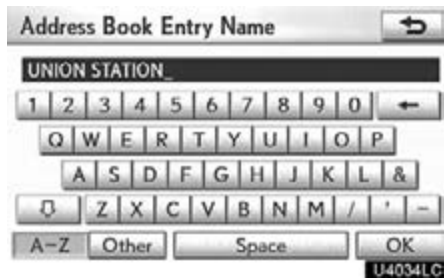

2. Enter the name using the alphanumeric keys.

Up to 32 characters can be entered.

3. Touch “OK”.

The previous screen will be displayed.

DISPLAYING MEMORY POINT NAMES

The name of an address book entry can be set to display on the map.

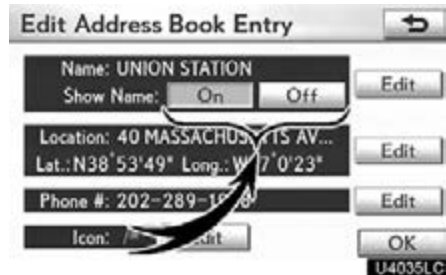

To show the name, touch “On” on the “Edit Address Book Entry” screen. To not show it, touch “Off”.

- To change “Location”

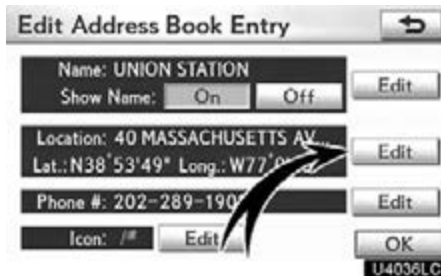

1. Touch “Edit” of “Location”.



2. Touch one of the 8 directional buttons to move the cursor to the desired point on the map.
3. Touch “OK”.

The previous screen will be displayed.

- To change “Phone #” (telephone number)

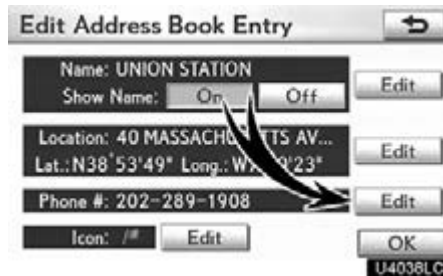

1. Touch “Edit” of “Phone #”.

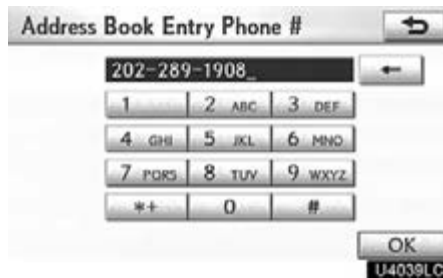

2. Enter the number using number keys.
3. Touch “OK”.

The previous screen will be displayed.

(c) Deleting address book entries

1. Push the “SETUP” button.
2. Touch “Navi.” on the “Setup” screen.
3. Touch “Address Book” on the “Navigation Settings” screen.

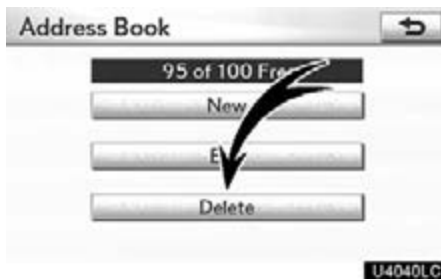

4. Touch “Delete”.

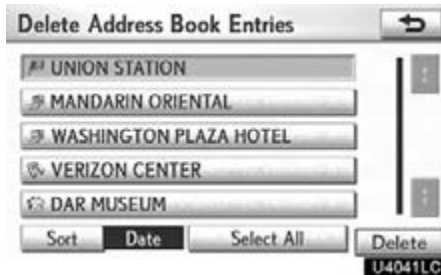

5. Touch the button to be deleted.
 “Select All”: To select all addresses in the address book.
 “Unselect All”: To unselect all of the selected addresses.
6. Touch “Delete”.
7. To delete the address book entry, touch “Yes”. To cancel the deletion, touch “No”.

— Setting up the “Areas to Avoid”

Areas you want to avoid because of traffic jams, construction work or other reasons can be registered as areas to avoid.

1. Push the “SETUP” button.
2. Touch “Navi.” on the “Setup” screen.



3. Touch “Areas to Avoid”.



- Registering areas to avoid (See page 123.)
- Editing areas to avoid (See page 124.)
- Deleting areas to avoid (See page 127.)

(a) Registering areas to avoid

1. Push the “SETUP” button.
2. Touch “Navi.” on the “Setup” screen.
3. Touch “Areas to Avoid” on the “Navigation Settings” screen.



4. Touch “New”.





5. Enter the location in the same way as for a destination search, or display the map of the area to be avoided. (See “Destination search” on page 62.)



6. Scroll the map to the desired point. “Adjust Location”: To adjust the position in smaller increments.

7. Touch “Enter”.



8. Touch either  or  to change the size of the area to be avoided.

9. Touch “OK”.

INFORMATION

- If a destination is input in the area to avoid or the route calculation cannot be made without running through the area to avoid, a route passing through the area to be avoided may be shown.
- Up to 10 locations can be registered as points/areas to avoid.

NAVIGATION SYSTEM: MEMORY POINTS

(b) Editing area to avoid

The name, location and/or area size of a registered area can be edited.

1. Push the “SETUP” button.
2. Touch “Navi.” on the “Setup” screen.
3. Touch “Areas to Avoid” on the “Navigation Settings” screen.



4. Touch “Edit”.

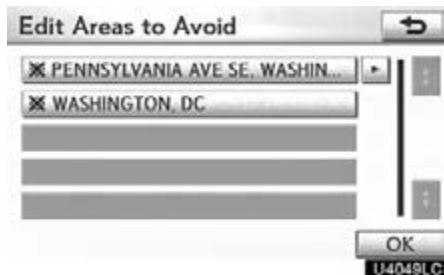

5. Touch the desired area button.

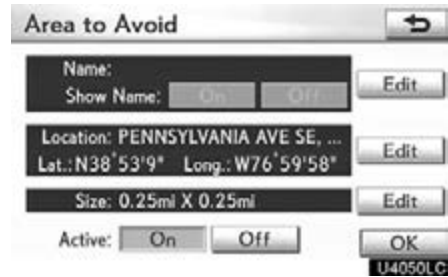

6. Touch “Edit” for the item you want to change.

“Name”: To edit the name of the area to avoid. The names can be displayed on the map. (See page 125.)

“Location”: To edit area location. (See page 126.)

“Size”: To edit area size. (See page 126.)

“Active”: To turn on or off the area to avoid feature. To turn on the feature, touch “On” on the “Area to Avoid” screen. To turn off the feature, touch “Off” on the “Area to Avoid” screen.

7. Touch “OK”.

- To change “Name”

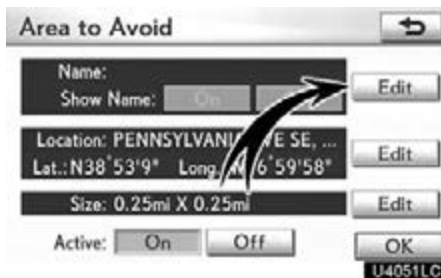

1. Touch “Edit” of “Name”.



2. Enter the name using alphanumeric keys.

Up to 32 characters can be entered.

3. Touch “OK”.

The previous screen will be displayed.

DISPLAYING NAMES OF AREAS TO BE AVOIDED

The name of an area to be avoided that may be displayed on the map can be set.

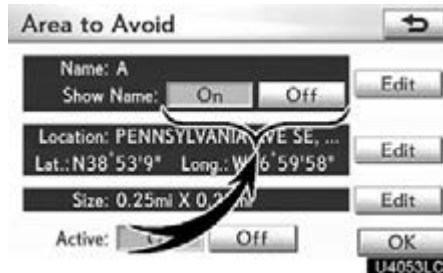

To show the name, touch “On” on the “Area to Avoid” screen. To not show it, touch “Off”.

NAVIGATION SYSTEM: MEMORY POINTS

- To change “Location”

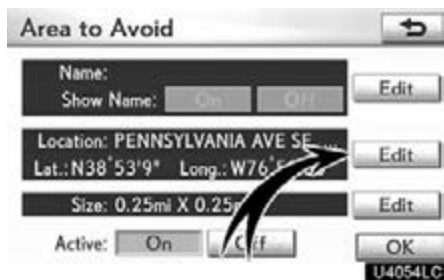

1. Touch “Edit” of “Location”.



2. Touch the 8 directional button to move the cursor  to the desired point on the map.

3. Touch “OK”.

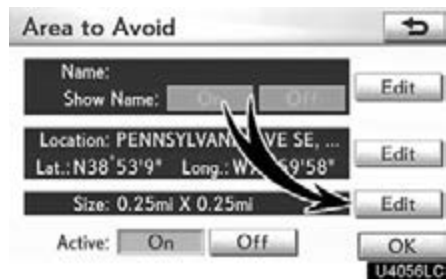

The previous screen will be displayed.

- To change “Size”



1. Touch “Edit” of “Size”.



2. Touch either  or  to change the size of the area to be avoided.

3. Touch “OK”.

The previous screen will be displayed.

(c) Deleting areas to avoid

1. Push the “SETUP” button.
2. Touch “Navi.” on the “Setup” screen.
3. Touch “Areas to Avoid” on the “Navigation Settings” screen.



4. Touch “Delete”.

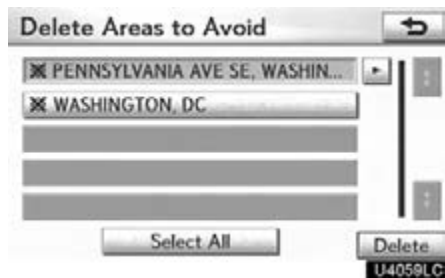

5. Touch the button to be deleted.

“**Select All**”: To select all registered areas to avoid in the system.

“**Unselect All**”: To unselect all registered areas to avoid in the system.

6. Touch “Delete”.

7. To delete the area, touch “Yes”. To cancel the deletion, touch “No”.

— Deleting previous destinations

The previous destination can be deleted.

1. Push the “SETUP” button.
2. Touch “Navi.” on the “Setup” screen.



3. Touch “Delete Previous Dest.”.

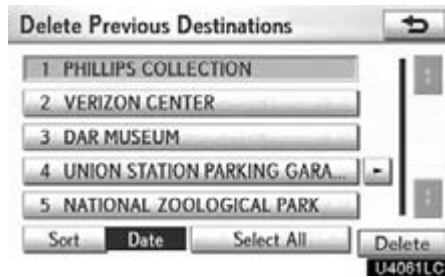

4. Touch the button you want to delete.

“**Select All**”: To select all previous destinations in the system.

“**Unselect All**”: To unselect all previous destinations in the system.

5. Touch “Delete”.

NAVIGATION SYSTEM: MEMORY POINTS



6. To delete the destination, touch "Yes". To cancel the deletion, touch "No".

SECTION 5

TELEPHONE AND INFORMATION

- **Telephone (Hands-free system for cellular phone)** 130
 - Enter a Bluetooth® phone 134
 - Call on the Bluetooth® phone 139
 - Receive on the Bluetooth® phone 146
 - Talk on the Bluetooth® phone 146
- **Fuel consumption** 149
 - Past record 149
 - Consumption 150
- **Calendar** 151

Telephone (Hands-free system for cellular phone)

Hands-free system allows you to make or receive a call without taking your hands off the steering wheel by connecting your cellular phone.

This system supports Bluetooth®. Bluetooth® is a wireless data system by which you can call without your cellular phone being connected with a cable or placed on a cradle.

If your cellular phone does not support Bluetooth®, this system can not function.

The operating procedure of the phone is explained here.

For registering and setting of the phone, see "Telephone settings" on page 349.



CAUTION

While driving, do not use a cellular phone or connect the Bluetooth® phone.

NOTICE

Do not leave your cellular phone in the car. The temperature inside may be high and damage the phone.

INFORMATION

- *In the following conditions, the system may not function.*
 - *The cellular phone is turned off.*
 - *The current position is outside the communication area.*
 - *The cellular phone is not connected.*
 - *The cellular phone has a low battery.*
- *Even if your cellular phone supports both hands-free and audio Bluetooth® connections, it may not be able to connect to the hands-free connection at the same time.*
- *When using Bluetooth® audio and hands-free at the same time, the following problems may occur.*
 - *The Bluetooth® connection may be cut.*
 - *Noise may be heard on the Bluetooth® audio playback.*



Bluetooth is a registered trademark of Bluetooth SIG, Inc.

INFORMATION

This system supports the following service.

- **Bluetooth® Specification**
Ver.1.1 or higher
(Recommended: Ver. 2.0 + EDR or higher)
- **Profiles**
 - **HFP (Hands Free Profile)**
Ver.1.0 or higher
(Recommended: Ver.1.5 or higher)
 - **OPP (Object Push Profile) Ver.1.1**
 - **PBAP (Phone Book Access Profile) Ver.1.0**

If your cellular phone does not support HFP, you cannot enter the Bluetooth® phone, and take OPP or PBAP service individually.

Please go to "<http://www.lexus.com/>" to find approved Bluetooth® phones for this system.



By pushing the telephone switch above, you can receive a call or hang up without taking your hands off the steering wheel.



► **Microphone**

You can use the microphone above when talking on the phone.

The other party's voice outputs from the front speaker. When the received calls or received voice outputs, the audio from the audio system or voice guidance from the navigation system will be muted.

INFORMATION

- *Talk alternately with the other party on the phone. If you talk at the same time, the voice may not reach each other. (It is not a malfunction.)*
- *Keep the volume of receiving voice down. Otherwise, an echo will be heard and receiving voice can be heard outside of the vehicle. When you talk on the phone, speak clearly towards the microphone.*
- *In the following situations, your voice may not reach the other party.*
 - *Driving on unpaved road. (Making a traffic noise.)*
 - *Driving at the high speed.*
 - *The windows or moon roof are open.*
 - *Turning the air-conditioning vents towards the microphone.*
 - *The sound of the air-conditioning fan is loud.*
 - *There is an effect from the network of the cellular phone.*



1 Indicates the condition of Bluetooth® connection.

“Blue” indicates an excellent connection to Bluetooth®.

“Yellow” indicates a bad connection to Bluetooth®, resulting in possible deterioration of voice quality.

: No connection to Bluetooth®.

2 Indicates the amount of battery charge left.



Empty ← → Full

This is not displayed when the Bluetooth® is not connected.

The amount left does not always correspond with the one of your cellular phone. The amount of battery charge left may not be displayed depending on the phone you have. This system doesn't have a charging function.

3 Indicates the receiving area.

“Rm” is displayed when receiving in Roaming area.

“Hm” is displayed when receiving in Home area.

The receiving area may not be displayed depending on the phone you have.

4 Indicates the level of reception.



The level of reception does not always correspond with the one of your cellular phone.

The level of reception may not be displayed depending on the phone you have.

When you are out of the service area or in a place inaccessible by radio waves, "No Service" is displayed.

An antenna for the Bluetooth® connection is built in the display. The indication of the Bluetooth® connection may turn yellow and the system may not function when you use the Bluetooth® phone in the following conditions and places.

- Your cellular phone is hiding behind the display (behind the seat or in the glove box and console box).
- Your cellular phone touches or is covered with metal materials.

Leave the Bluetooth® phone on the place where "Blue" indication is displayed.

About the phonebook in this system

The following data is stored for every registered phone. When another phone is connecting, you cannot read the registered data.

- Phonebook data
- Voice tag
- All of call history
- Speed dial

When you delete the phone, the above-mentioned data is also deleted.

When you release your car:

A lot of personal data is registered when you use the Hands-free system. When you release your car, initialize your data. (See "● Delete personal data" on page 334.)

If you initialize it, the former state will never come back again. Pay much attention when initializing the data.

You can initialize the following data in the system.

- Phonebook data
- Call history data
- Speed dial data
- Voice tag data
- Bluetooth® phone data
- Volume setting
- Details setting

FCC ID : AJDK021
IC ID : 775E-K021

This device complies with Part 15 of the FCC Rules and RSS-Gen and RSS-210 of IC Rules. Operation is subject to the following two conditions : (1) This device may not cause harmful interference, and (2) this device must accept any interference received, including interference that may cause undesired operation.

CAUTION

FCC WARNING: Changes or modifications not expressly approved by the party responsible for compliance could void the user's authority to operate the equipment.

CAUTION: Radio Frequency Radiation Exposure

This equipment complies with FCC radiation exposure limits set forth for uncontrolled equipment and meets the FCC radio frequency (RF) Exposure Guidelines in Supplement C to OET65. This equipment has very low levels of RF energy that it deemed to comply without maximum permissive exposure evaluation (MPE). But it is desirable that it should be installed and operated with at least 20 cm and more between the radiator and person's body (excluding extremities: hands, wrists, feet and ankles).

Co-location: This transmitter must not be co-located or operated in conjunction with any other antenna or transmitter.

— Enter a Bluetooth® phone

To use the hands-free system, you need to enter your phone into the system. Once you have registered it, you can make a hands-free call.

If you haven't yet registered any Bluetooth® phones, you must first register your phone according to the following procedure.

Please see “● Registering a Bluetooth® phone” on page 352 of additional registration when registering.



1. Push the “INFO/PHONE” button.



2. Touch “Phone”.



3. Touch “Yes” to connect your phone.



4. When this screen is displayed, input the passcode displayed on the screen into the phone.

For the operation of the phone, see the manual that comes with your cellular phone.

If you want to cancel it, touch “Cancel”.



5. When the connection is completed, this screen is displayed.

You do not need to enter the phone in case of using the same one.



When this screen is displayed, follow the guidance on the screen to try again.

● Connecting a Bluetooth® phone
AUTOMATICALLY



When you register your phone, auto connection will be turned on. Always set it to this mode and leave the Bluetooth® phone in a condition where connection can be established.



When the “ENGINE START STOP” switch is in ACCESSORY or IGNITION ON mode, a nearby cellular phone you have registered is searched for.

Next, the system automatically connects with the latest of the phones connected to in the past.

Then, the connection result is displayed.

This screen appears when the Bluetooth® phone is first connected after the “ENGINE START STOP” switch is in ACCESSORY or IGNITION ON mode.

INFORMATION

It may take time, the phone connection is carried out during Bluetooth® audio play.

MANUALLY

When the auto connection has failed or “Handsfree Power” is turned off, you have to connect Bluetooth® manually.

1. Push the “INFO/PHONE” button.
2. Touch “Phone”.



3. Touch “Connect Phone”.



4. Touch “Handsfree Power”, or select the phone to connect.



5. The “Connect Bluetooth” screen is displayed.

*: Bluetooth is a registered trademark of Bluetooth SIG.Inc.



6. When the connection is completed, this screen is displayed.

Now you can use the Bluetooth® phone.

When you connect the phone while Bluetooth® audio is playing



This screen is displayed, and the Bluetooth® audio will stop temporarily.

- **Reconnecting the Bluetooth® phone**

If the Bluetooth® phone is disconnected with a poor reception from the Bluetooth® network when the “ENGINE START STOP” switch is in ACCESSORY or IGNITION ON mode, the system automatically reconnects the Bluetooth® phone. In this case, the connection result is not displayed.

If the Bluetooth® is disconnected on purpose such as you turned your cellular phone off, this does not happen. Reconnect it by the following methods.

- Select the Bluetooth® phone again.
- Enter the Bluetooth® phone.

— Call on the Bluetooth® phone

After you enter the Bluetooth® phone, you can call by using hands-free system. You can call using the 6 methods described below.

- By dial

You can call by inputting the phone number.

This cannot be operated while driving.

1. Push the “INFO/PHONE” button.

You can also push  of the steering wheel to display the “Phone” screen.





2. Touch “Phone”.



3. Touch the desired key to input the phone number.

Each time you touch , an inputted digit is deleted.

When you touch “Redial”, the number you called last is inputted.

Touch  or push  of the steering wheel.

TELEPHONE AND INFORMATION

- **By phonebook**

You can call by phonebook data which is transferred from your cellular phone.

The system has one phonebook for each telephone. You can register up to 1000 numbers in total of phonebooks.

This cannot be operated while driving.



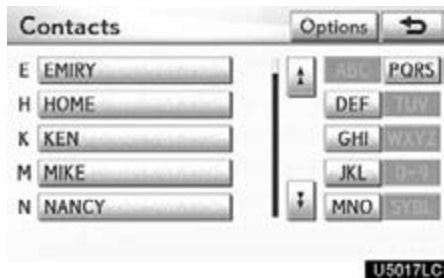

1. Touch "Contacts".

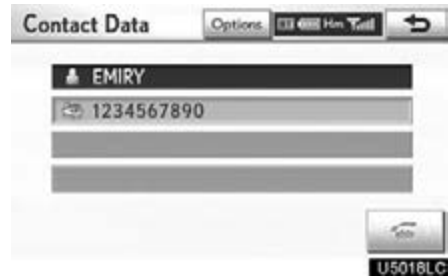

2. Select the desired data from the list.



3. Select the desired number from the list.

Touch  or push  of the steering wheel.

When the phonebook is empty



1. Touch "Contacts".



2. Touch "Yes" if you want to transfer new contacts from a cellular phone. Touch "No" if you want to edit the phonebook.

- By speed dial

You can call using registered phone numbers which can be selected from a phonebook. (See "• Registering the speed dial" on page 369 for registering the speed dial.)

This can be done while driving.



1. Touch "Speed Dials".



2. Touch the desired number to call. You can change the page by touching "Speed Dial 2" or "Speed Dial 3" tab.

TELEPHONE AND INFORMATION

- **By call history**

You can call by call history which has 4 functions below.

All:

All the numbers above which were memorized

Missed:

Calls which you missed

Incoming:

Calls which you received

Outgoing:

Numbers which you called

You can call using the latest 5 call history items shown by “All” while driving.



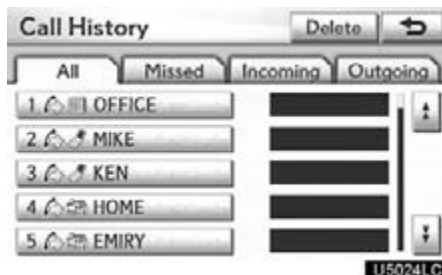

1. Touch “Call History”.







2. Select the desired data from the list.

When the list is switched, touch “All”, “Missed”, “Incoming” or “Outgoing” tab.



3. Touch  or push  of the steering wheel.

You can call using the latest call history item.

1. Push  of the steering wheel to display the “Phone” screen.
2. Push  of the steering wheel to display the “Call History” screen.
3. Push  of the steering wheel to select the latest history item.
4. Touch  or push  of the steering wheel to call the latest history item.
 - When you call by phonebook, the name (if registered) is displayed.
 - When you call the same number continuously, only the newest number is registered.
 - When a phone number registered in the phonebook is received, the name and the number are displayed.
 - Number-withheld calls are also memorized in the system.
 - A international phone call may not be made depending on the cellular phone which you have.

- By voice recognition



You can call by giving a command. (For the operation and command of voice recognition, see “Voice command system” on page 44.)

This can be operated while driving.

The “Dial by Name” operating procedure is explained here.

Other operating procedures are also similar.

DIALING BY NAME

You can call by giving a voice tag registered in the phonebook. For setting the voice recognition, see “—Setting the voice tag” on page 376.

When you select “English” of “Language”, you can call by giving a name registered in the phonebook.

For setting the voice recognition, see “● Registering the phonebook data” on page 363.

Example: Call MIKE.



- You: Push the talk switch.
- System: “After the beep, please say a command.” “Such as “Go Home”, “Destination”, “Phone”, “Audio”, “Information” or “Command List”.”
“(beep)”
- You: “Phone.”
- System: “Phone.”
“Say a command.” “Such as “Dial by Number”, “Dial by Name”, “Redial”, “Call Back” or “Connect Phone”.”
“(beep)”
- You: “Dial by Name.”
- System: “Dial by Name.” “Say a name from your contact list.”
“(beep)”
- You: “MIKE.”
- System: “MIKE.” “Say the type of number.” “Such as “Mobile”, “Home”, “Work” or “Other”.”
“(beep)”
- You: “Home.”
- System: “MIKE.” “Home.”
“Push the off-hook switch to dial or say “Dial”.”
“(beep)”
- You: “Dial.”
- System: “Dial.”
- Now, you can call MIKE.

Calling without the voice recognition

After the entry number is displayed, you can also call by pushing  of the steering wheel or touching “Dial”.

Cancelling the voice recognition

The voice recognition will be cancelled when you do the following.

- Keep on pushing the talk switch.
- Push  of the steering wheel.
- Touch “Cancel”. (Except for recognizing the command.)
- Say “Cancel”.

● **By POI* call**

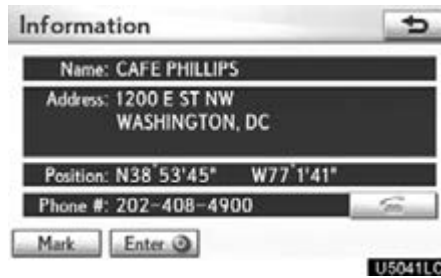



You can call by touching  when it is displayed on the screen from navigation system. (See “POI INFORMATION” on page 36 for details.)



*: Point of Interest

— Receive on the Bluetooth® phone



When a call is received, this screen is displayed with a sound. Touch  or push  of the steering wheel to talk on the phone.

To refuse to receive the call:

Touch  or push  of the steering wheel.

To adjust the volume of received call:

Touch “-” or “+” or use the volume switch of the steering wheel.

On the international phone call, the other party’s name may not be displayed correctly depending on the cellular phone which you have.

— Talk on the Bluetooth® phone





While you are talking on the phone, this screen is displayed. You can do the operation below on the screen.

To adjust the volume of the other party’s voice:

Touch “-” or “+” or use the volume switch of the steering wheel.

To hang up the phone:

Touch  or push  of the steering wheel.

To mute your voice:

Touch “Mute”.

To input a Key:

Touch “0-9”.

To transfer the call:

Touch “Call Transfer”.

You cannot change from Hands-free call to cellular phone call while driving.

When you change from cellular phone call to Hands-free call, the Hands-free screen will be displayed and you can operate it on the screen.

Transferring method and behavior are different depending on the cellular phone which you have.

For the operation of the phone, see the manual that comes with your cellular phone.

When you select “0-9”



Touch the desired number to input the key.

To hang up the phone:

Touch or push of the steering wheel.

This cannot be operated while driving.



If the continuous tone signal is registered in a phonebook, this screen appears. (If not registered, “Send” and “Exit” are not displayed.)

Confirm the number displayed on the screen and touch “Send”. The number before marked sign will be sent.

When you touch “Exit”, this function will be finished and normal tone screen appears.

To hang up the phone:

Touch or push of the steering wheel.

The continuous tone signal is the marked sign (p or w) and the number following phone number. (ex. 056133w0123p#1*)

You can do this operation when you want to operate an answering machine or use a telephone service in bank for example. You can register the phone number and the code number in the phonebook.

TELEPHONE AND INFORMATION

- By voice recognition





You can operate “Mute” and “Send Tones” by giving a command during a call.



The operating procedure is similar to other voice recognition. (For the operation of voice recognition, see “Voice command system” on page 44.)

- Interrupt call



When a connected call is interrupted by a third party, this screen is displayed.

Touch  or push  of the steering wheel to start talking with the other party.

Touch  or push  of the steering wheel to refuse the call.

Fuel consumption — — Past record

Fuel consumption information from recent resets will be displayed.



Everytime you touch or push of the steering wheel while interrupt call, the other party will be switched.

If your cellular phone is not accepted for HFP Ver. 1.5, this function can not be used.

INFORMATION

Interrupt call operation may differ depending on your phone company and cellular phone.



1. Push the “INFO/PHONE” button.

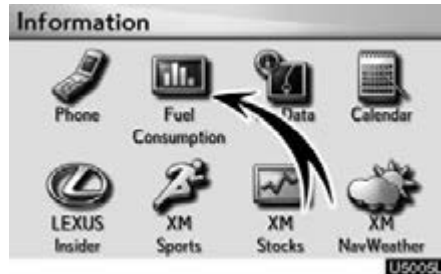

2. Touch “Fuel Consumption”.

If the “Past Record” screen does not appear, touch “**Past Record**”.



“Past Record” screen will be displayed.

- 1 Fuel economy since the last reset (blue)
- 2 Current fuel economy (light blue)
- 3 Best recorded fuel economy

The average fuel consumption history is divided by color into past averages and the average fuel consumption since the last reset. Reset the average fuel consumption to measure the current fuel consumption again. For more information on resetting fuel consumption, see the vehicle owner’s manual.

Past record data can be deleted by touching “**Clear**”.

— Consumption

The average fuel consumption of the last 30 minutes will be shown in one-minute blocks.

1. Push the “**INFO/PHONE**” button.
2. Touch “**Fuel Consumption**” on the “**Information**” screen.

If the “Consumption” screen does not appear, touch “**Consumption**”.

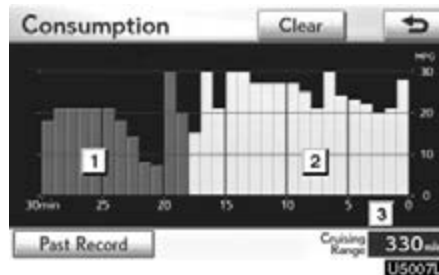

“Consumption” screen will be displayed.

- 1 Fuel consumption in the past 30 minutes (blue)
- 2 Fuel consumption in the past 30 minutes (light blue)
- 3 Cruising range

Average fuel consumption is divided by color into past averages and averages attained since the “ENGINE START STOP” switch was last turned to the ACCESSORY or IGNITION ON mode.

Consumption data can be deleted by touching “**Clear**”.

Calendar

To view calendar.



1. Push the "INFO/PHONE" button.



2. Touch "Calendar".



On this screen, a blue line appears under the current date.

▲ M or **▼ M**: To change month.

▲ Y or **▼ Y**: To change year.

"Today": To display the current month calendar (if another month will be displayed).

TELEPHONE AND INFORMATION

SECTION 6

LEXUS ENFORM WITH SAFETY CONNECT

- Lexus Enform with Safety Connect–Overview 154
- Destination Assist 157
- eDestination 160
- XM® Sports and Stocks 163
- XM NavWeather™ 168
- XM® NavTraffic 173
- Lexus Insider 175

Lexus Enform with Safety Connect—Overview

Lexus Enform and Safety Connect are subscription-based telematics services that use Global Positioning System (GPS) data, embedded cellular technology and XM® satellite data services to provide safety and security as well as convenience features to subscribers.

Lexus Enform and Safety Connect services are supported by Lexus' designated response center, which operates 24 hours per day, 7 days per week.

Lexus Enform service is available by subscription on select, telematics hardware-equipped vehicles.

With an active Lexus Enform subscription, the following features are available:

- **Safety Connect features** (See your vehicle Owner's Manual, Section 3 for details.)
 - Automatic collision notification*1
 - Stolen vehicle location
 - Emergency assistance button (SOS)
 - Enhanced roadside assistance
- **Destination Assist** (See page 157.)
- **eDestination** (See page 160.)
- **XM® Sports and Stocks***2 (See page 163.)
- **XM NavWeather**™*3 (See page 168.)
- **XM® NavTraffic***3 (See page 173.)

The following navigation-based Lexus Enform features are available without a subscription:

- **Lexus Insider** (See page 175.)
- **Voice Command** (See page 44.)

*1: U.S. Patent No. 7,508,298 B2

*2: Available at no extra charge with an active XM® satellite radio subscription.

*3: Available via separate XM® subscription(s).

● **Subscription**

After you have signed the Telematics Subscription Service Agreement and are enrolled, you can begin receiving services. A variety of subscription terms is available for purchase. Contact your Lexus dealer, call 1-800-25-LEXUS (1-800-255-3987), or touch the "Destination Assist" button (see page 157) in your vehicle for further subscription details.

XM® NavTraffic and XM NavWeather™ require separate XM® subscription(s). XM® Sports and Stocks is available with an XM® Satellite Radio subscription. After a 90-day free trial, you must set up the appropriate XM® subscription(s) to continue receiving these services.

● **Availability of service(s)**

Lexus Enform premium services Destination Assist and eDestination will function in the contiguous 48 states and D.C. These services may also function in Hawaii and limited areas of Alaska for vehicles that contain map data for those states. They will not function in Canada or in other countries outside the United States.

Lexus Insider and XM® services will function in the contiguous 48 states and Canada. They will not function in Hawaii, Alaska, or countries outside of the U.S other than Canada.

The XM® NavTraffic, XM NavWeather™, and XM® Sports and Stocks services are available in the contiguous 48 U.S. states and Canada. For details about the XM® service coverage areas, refer to www.xmradio.com or call XM® Listener Care Center at 1-877-515-3987.

● **Activation of service(s)**

Enrollment in Lexus Enform with Safety Connect (via your dealership) is required to activate all Enform services.

To receive XM® NavTraffic, XM NavWeather™, and XM® Sports and Stocks services, the XM® service must be activated. To activate the service, call the XM® Listener Care Center at 1-877-515-3987.

Customers should have their radio ID ready. The radio ID can be found by selecting "channel 000" on the radio. For details, see "(b) Displaying the radio ID" on page 201.

XM® Satellite Radio is responsible for all fees and services, which are subject to change.

■ **Certification for Lexus Enform with Safety Connect**

FCC ID: O9EGTM1
FCC ID: O6Y-CDMRF101

NOTE

This device complies with part 15 of the FCC Rules. Operation is subject to the following two conditions: (1) This device may not cause harmful interference, and (2) this device must accept any interference received, including interference that may cause undesired operation.

FCC WARNING

Changes or modifications not expressly approved by the party responsible for compliance could void the user's authority to operate the equipment.



CAUTION

Exposure to radio frequency signals: The Lexus Enform with Safety Connect system installed in your vehicle is a low power radio transmitter and receiver. The system receives and also sends out radio frequency (RF) signals.

In August 1996, the Federal Communications Commission (FCC) adopted RF exposure guidelines with safety levels for mobile wireless phones. Those guidelines are consistent with the safety standards previously set by both U.S. and international standards bodies.

- ANSI (American National Standards Institute) C95.1 [1992]
- NCRP (National Council on Radiation Protection and Measurement) Report 86 [1986]
- ICNIRP (International Commission on Non-Ionizing Radiation Protection) [1996]

Those standards were based on comprehensive and periodic evaluations of the relevant scientific literature. Over 120 scientists, engineers, and physicians from universities, government health agencies, and industry reviewed the available body of research to develop the ANSI Standard (C95.1).

The design of Lexus Enform with Safety Connect complies with the FCC guidelines in addition to those standards.

INFORMATION

- *Available beginning Fall 2009 on select Lexus models. Contact with the Lexus Enform response center is dependent upon the telematics device being in operative condition, cellular connection availability, navigation map data, and GPS satellite signal reception, which can limit the ability to reach the response center or receive support. Enrollment and Telematics Subscription Service Agreement required. A variety of subscription terms is available; charges vary by subscription term selected.*
- *The Lexus Enform response center will offer support in multiple languages.*
- *Select Lexus Enform-subscribed vehicles are capable of communicating vehicle information, triggering owner reminder notifications.*
Owners who do not wish to have their vehicle transmit this information can opt out of the service at the time of enrollment or by calling 1-800-255-3987 and follow the prompt for Safety Connect/Lexus Enform.
- *For further details about the service, contact your Lexus dealer.*
- *Lexus Enform with Safety Connect services are not subject to section 255 of the Telecommunications Act and the device is not TTY compatible.*

Destination Assist

Destination Assist provides you with live assistance for finding destinations via the Lexus Enform response center. You can request either a specific business, address, or ask for help locating your desired destination by category, such as restaurants, gas stations, shopping centers or other points of interest (POI).

After you tell the agent your choice of destination, its coordinates are sent wirelessly to your vehicle's navigation system.

- **Make a call with Destination Assist**



1. Push the "DEST" button.

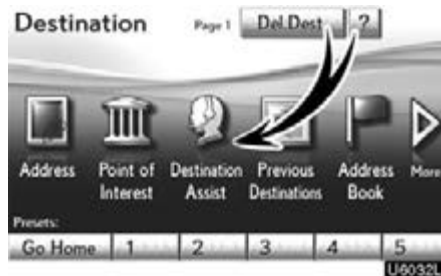

2. Touch "Destination Assist".

"Destination Assist" screen is displayed on the screen.



3. Touch "Call Dest. Assist" to contact an agent.

LEXUS ENFORM WITH SAFETY CONNECT



4. When an agent comes on the line, tell the agent the address, business name, or the type of POI or service you would like to locate.

To adjust the call volume, touch “-” or “+” on the “Destination Assist” screen, or use the volume switch on the steering wheel during the call.

You can end the call at any time by touching the “**Disconnect**” button on the “Destination Assist” screen or the steering-wheel phone on-hook (hang-up) switch.

After the agent helps you determine your location of choice, he or she will place you on hold briefly and wirelessly send the POI to your vehicle’s navigation system. The agent will then instruct you to either touch “**Go to**” or “**Enter**” on the navigation screen in order to save the destination. The agent will then end the call.

5. Touch “Go to” or “Enter” to set the location as a destination, receive navigation guidance via your navigation system and to save the destination to Destination Assist folder for future reference.

● **Destination Assist History**

Locations you receive via Destination Assist will be saved to the navigation system. Up to 100 destinations can be stored in the Destination Assist history.

1. Push the “DEST” button.
2. Touch “Destination Assist” on the “Destination” screen.



3. Touch “Dest. Assist History”.



4. Select the desired location in order to display its data and be able to be set it as a destination.

Touch “Sort” to sort the locations by either date or name.

DELETE DESTINATION ASSIST HISTORY

You can delete destinations from your history.



1. Touch “Delete” on the “Destination Assist History” screen.



2. Touch the individual destination you would like to delete or “Select All”.
3. Touch “Delete” on the screen.

eDestination

With the eDestination feature, you can go online, via the Lexus.com owner's Web site, to select and organize destinations of your choice and then wirelessly send them to your vehicle's navigation system. You can store up to 200 locations online to access and update at any time.

Your locations can be organized into up to 20 personalized folders.

You must first go online at www.lexus.com and go to the "Owners" section where you will need to register and log in. After this, you can create your personalized folders containing the locations you wish to send to your vehicle. (See Lexus Enform Guide for more information.)

- **Download eDestinations**

After updating your eDestination folders online, you will need to download the information to update the data in the vehicle.



1. Push the "DEST" button.



2. Touch "Point of Interest".

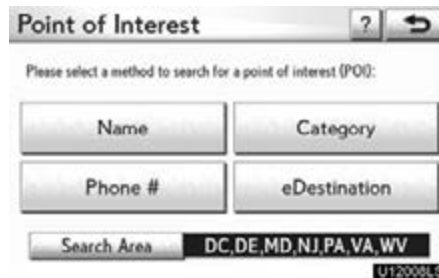

3. Touch "eDestination".

"eDestination" screen is displayed on the screen.

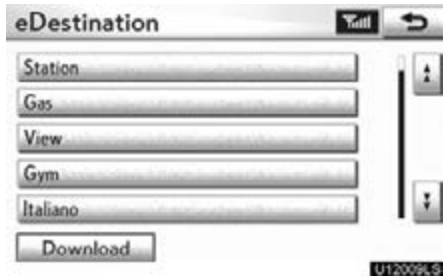

4. Touch "Download".



5. Touch "Yes" to confirm or "No" to cancel download.



When "Yes" is touched, your most recent online eDestination data will be loaded to the navigation system.

- Set an eDestination in the navigation system for guidance

1. Push the "DEST" button.
2. Touch "Point of Interest" on the "Destination" screen.
3. Touch "eDestination" on the "Point of Interest" screen.

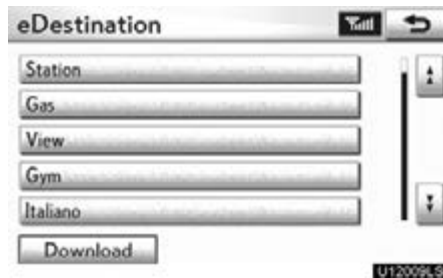

4. Touch the desired eDestination folder.

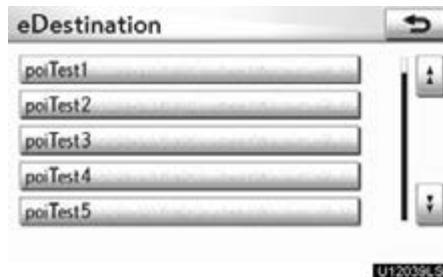

5. Touch the desired location.



The POI will be shown on the map. You can touch the “Go to” button to set the POI as a destination with route directions.

You can also touch the “Info.” button to display more information about the POI.



“Mark”: To mark the POI on the navigation map.

“Go to”: To set the POI as a destination with route directions.

“Detail”: To read the POI notes you entered online, if any.

● Show eDestination icons

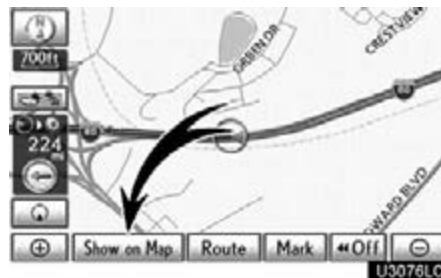

1. Touch “Show on Map”.



2. Touch “eDest. Icons”.
“eDest. Icons” indicator is highlighted.

XM® Sports and Stocks

XM® Sports and Stocks is a service included with XM® satellite radio subscriptions for Lexus Enform vehicles. With this service, you can receive updates via the navigation system on your personally selected sports teams and stocks.

The following operations can be performed.

(a) XM Sports

- **Receive sports information** (See page 164.)
- **XM Sports settings** (See page 164.)

(b) XM Stocks

- **Receive stock data** (See page 166.)
- **XM Stocks settings** (See page 167.)



1. Push the “INFO/PHONE” button.



2. Touch “XM Sports” or “XM Stocks”.
“XM Sports” or “XM Stocks” screen is displayed on the screen.

(a) XM Sports

You must first add your desired teams prior to receiving information. (See page 165.)

● **Receive sports information**

1. Push the “INFO/PHONE” button.
2. Touch “XM Sports” on the “Information” screen.

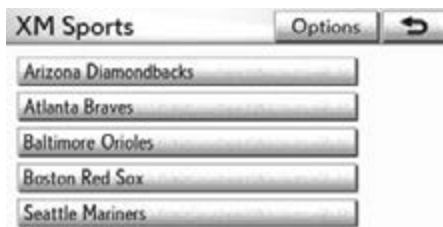

U12024L9

3. Touch the desired team for which you would like to receive information.

Teams for which there is no current data available will be shaded out and you will not be able to select them.



U12025L6

4. Touch the specific information you would like to receive or touch “Read All” to receive all available information for that team.

The selected information will be read in its entirety.

● **XM Sports settings — Add or delete teams**

To input your personalized XM Sports team.

1. Push the “INFO/PHONE” button.
2. Touch “XM Sports” on the “Information” screen.



U12026L9

3. Touch “Options”.



U12027L9

Please refer to the following pages for each setting.

You can also input your personalized XM Sports team from the “Setup” screen. (See “Other settings” on page 403.)

ADD SPORTS TEAM



U12027L5

1. Touch "Add Sports Team".

Up to 5 teams can be added and saved in the system for which you will receive information. You can change your teams at any time. Teams must be added one at a time.



U12044L5

4. Touch "Yes" to confirm or "No" to cancel.

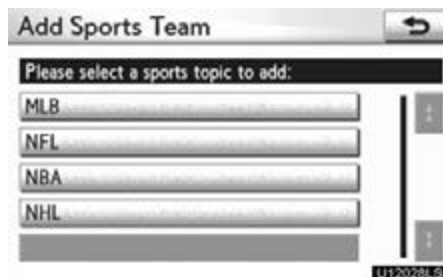

U12028L5

2. Touch the sporting league of the team you would like to enter.

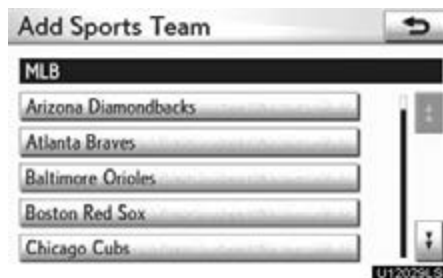

U12029L5

3. Touch the name of the team you would like to add from the list that appears.

DELETE SPORTS TEAMS



1. Touch "Delete Sports Teams".



2. Touch the sports team that you would like to delete or touch "Select All" to delete all teams.

3. Touch "Delete".



4. Touch "Yes" to confirm or "No" to cancel.

(b) XM Stocks

You must first add your desired stocks prior to receiving data. (See page 167.)

● **Receive stock data**

1. Push the "INFO/PHONE" button.
2. Touch "XM Stocks" on the "Information" screen.



3. Touch the individual stock for which you would like to receive verbal data or touch "Read All".

The available chosen data will be read in its entirety.

Stock data may be delayed by up to 15 minutes.

- **XM Stocks settings — Add or delete stocks**

To input your personalized XM Stocks settings.

1. Push the “INFO/PHONE” button.
2. Touch “XM Stocks” on the “Information” screen.

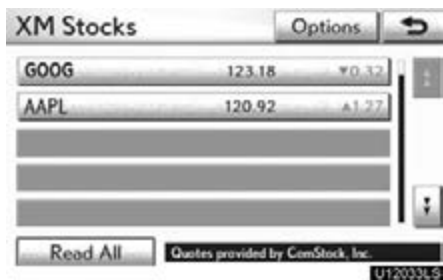

3. Touch “Options”.



Please refer to the following pages for each setting.

You can also input your personalized XM Stocks settings from the “Setup” screen. (See “Other settings” on page 403.)

ADD STOCK



1. Touch “Add Stock”.

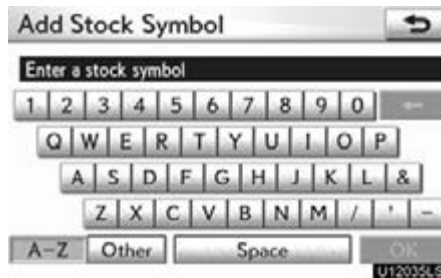

2. Input the stock symbol you would like to add.

3. When finished, touch “OK” to enter.

You can enter and save up to 10 individual stock symbols for which you would like to receive data. Stocks must be input one at a time. You must know the symbol of the stock you wish to enter.

DELETE STOCKS



1. Touch "Delete Stocks".



2. Touch the stock you would like to delete or touch "Select All".

3. Touch "Delete".



4. Touch "Yes" to confirm or "No" to cancel.

XM NavWeather™

The subscription-based XM NavWeather™ service allows the navigation system to display weather information on the map.

See page 155 for subscription information.

The following operations can be performed.

- **Show XM NavWeather™ information**

Weather forecast information is displayed on the map. (See page 169.)

- **Weather information**

Weather information for the selected city is displayed. (See page 171.)

- **Weather warnings**

Weather warnings issued within an approximately 15.5 miles (25 km) radius around the vehicle are displayed on the warning screen. (See page 172.)

- Show XM NavWeather™ information



1. Push the “INFO/PHONE” button.



2. Touch “XM NavWeather”.

“XM NavWeather” screen is displayed on the screen.

XM NavWeather™ SCREEN



1 “Info.” button

When the city icon button is touched, the “Info.” button will be displayed on the screen. Touching this button displays the “Forecast” screen. (See page 171.)

2 City icon

When this button is touched, city names and the “Info.” button will be displayed on the upper part of the screen.

3 “Forecast” button

When this button is touched, the city selection screen will be displayed.



Touch a city to display weather information. Weather information of the selected city will be displayed. (See page 171.)

LEXUS ENFORM WITH SAFETY CONNECT

4 “Current Location” button







When the “**Current Location**” button is touched, a map of the vehicle’s current location will be displayed.





5 Zoom in/out button

The scale of the map can be changed. Three zoom levels can be selected; 16 miles (26 km), 30 miles (48 km) and 60 miles (97 km).

6 Weather icons and grids

Incident weather information is displayed on the map using weather icons and grids. Touching an icon shows the related information at the top of the screen.

Icon	Weather
	Tornado
	Hurricane
	Storm
	Flood
	Winter
	Wind
	Extremes
	Other

Icon	Weather
	Hail storm
	Shear storm
	Heavy fog
	Heavy freezing rain/ice
	Heavy snow
	Heavy rain

● Weather information



- 1 Received time
- 2 City name
- 3 Today's date
- 4 Current weather
- 5 Current temperature
- 6 Today's weather
- 7 Tomorrow's weather
- 8 Day after tomorrow's weather
- 9 Observed time
- 10 Specified day's weather

- 1 Daytime weather
- 2 Nighttime weather
- 3 Maximum temperature
- 4 Minimum temperature
- 5 Precipitation probability

When this button is touched, weather information for a specified day will be displayed.

LEXUS ENFORM WITH SAFETY CONNECT

- **Weather warnings**

Weather warnings issued within an approximately 15.5 miles (25 km) radius around the vehicle are displayed on the warning screen.



“Show Map”: When this button is touched, the “XM NavWeather” screen will be displayed.

“OK”: When this button is touched, the screen will return to the map of the current location.

This severe weather warning will display again if the severe weather is within an approximate 7.8 miles (12.5 km) radius around the vehicle.

- **XM NavWeather™ indicator**



When an XM NavWeather™ Warning is issued within the vicinity, the XM NavWeather™ indicator will appear on the screen.

XM® NavTraffic

The subscription-based XM® NavTraffic service allows the navigation system to display traffic information on the map.

See page 155 for subscription information.

The following operations can be performed.

- **Show XM® NavTraffic Information**

Traffic information is displayed on the map. (See page 173.)

- **Auto Avoid Traffic**

If any heavy congestion or moderate traffic has been detected on the guidance route, it may be possible for you to select another route offered by the system. (See page 343.)

- **Traffic Voice Guidance**

Traffic information is provided using voice guidance. (See page 339.)

- **Show Free Flowing Traffic**

Freely flowing traffic is shown by the arrow on the map. (See page 344.)

- **Show XM® NavTraffic information**

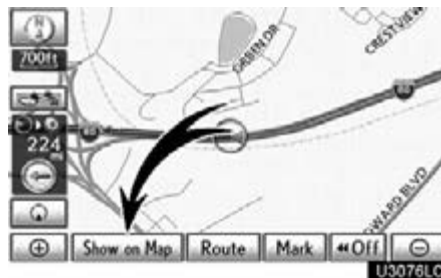

1. Touch “Show on Map”.



2. Touch “Traffic Information”.

“Traffic Information” indicator is highlighted.

INFORMATION

- *Traffic voice guidance is available only in English. To select English, see “● Selecting a language” on page 331.*
- *When the “Traffic Information” indicator is dimmed, “Auto Avoid Traffic”, “Traffic Voice Guidance” and “Show Free Flowing Traffic” will not operate.*

XM® NavTraffic information is displayed on the map.

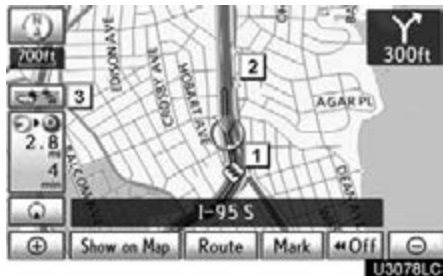

► On Map screen

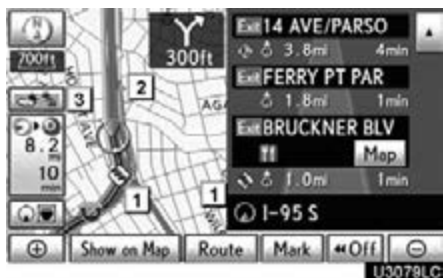

► On Freeway information screen

1 XM® NavTraffic icon

When any traffic information has been received, the XM® NavTraffic icon will appear on the map screen. Touching the XM® NavTraffic icon on the screen will start voice guidance for the traffic information. (See page 39.)

INFORMATION

When the XM® NavTraffic icon is selected, voice guidance for the traffic information will start even if "Off" for "Traffic Voice Guidance" is selected.

2 XM® NavTraffic information arrow

When any XM® NavTraffic information has been received, the XM® NavTraffic information arrow will appear on the map screen. The color of the arrow changes depending on the traffic information received.

"Orange": Heavy congestion

"Yellow": Moderate traffic

"Green": Freely flowing traffic

3 XM® NavTraffic indicator

When any XM® NavTraffic information has been received, the XM® NavTraffic indicator will appear on the screen. The color of the indicator changes depending on the traffic information received.

“White”: Traffic information has been received.

“Yellow”: Traffic restriction information on the guidance route has been received (screen button*).

“Orange”: Congestion information on the guidance route has been received (screen button*).

*: Touching the XM® NavTraffic indicator will start voice guidance.

Lexus Insider

Lexus Insider is an optional service that can send audio messages, or articles, to participating owners' vehicles via the navigation system. Potential Lexus Insider subjects might include, for example, Lexus vehicle technology tips, updates on regional Lexus events, or audio excerpts from Lexus Magazine articles. Up to 20 articles can be stored at a time.

You may opt out of receiving Lexus Insider messages at any time. (See page 178.)

LEXUS ENFORM WITH SAFETY CONNECT

- View and play received Lexus Insider messages



1. Push the “INFO/PHONE” button.



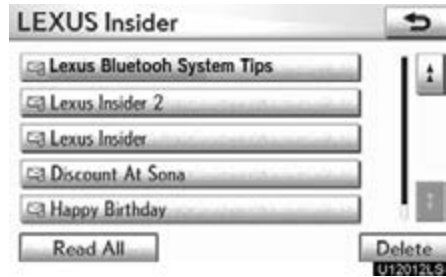

2. Touch “LEXUS Insider”.
“LEXUS Insider” screen is displayed on the screen.



3. Touch the desired article title from the Lexus Insider menu to play that broadcast or touch “Read All” to listen to all stored Lexus Insider broadcasts.

To disrupt the audio read of Lexus Insider, push the “MODE” switch on the steering wheel or push the “AM-FM”, “SAT”, “DISC” or “AUX-USB” button on the audio system.

Icons appear at the left of the Lexus Insider story titles and indicate the following:

Icon	Article
	Unread article
	Previously read article
	Article with downloadable Point of Interest (POI)

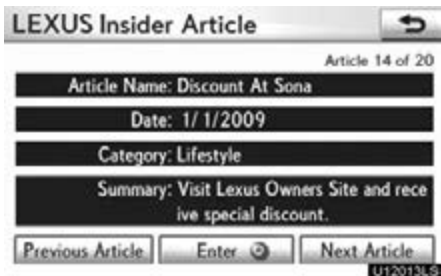

After selecting an individual article, you can then touch **“Next Article”** or **“Previous Article”** to listen to another article.

You can also use the “^” or “v” switch on the steering wheel to move to the previous or next article.

Some Lexus Insider stories will contain a downloadable POI relevant to the content. If it contains a POI, you can touch **“Enter”** to download it to the navigation system.

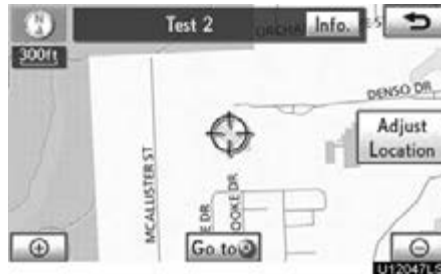

You can touch the **“Go to”** button to set the POI as a destination with route directions.

DELETE LEXUS INSIDER ARTICLE

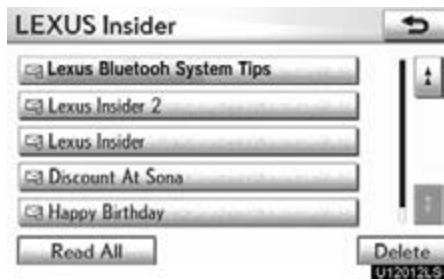

1. Touch "Delete" on the "LEXUS Insider" screen.

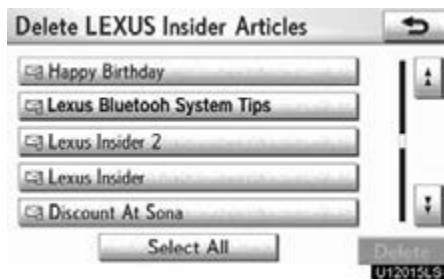

2. Touch the individual article title that you would like to delete or "Select All".

3. Touch "Delete" on the screen.

● **New article notification**

When the vehicle is first powered on and a new Lexus Insider article is available, a notification will appear on the navigation screen.

The notice will appear for only approximately 6 seconds unless you choose one of the options listed.



When the new article notification appears, you can select any of the following options.

"Listen Now":

Plays newly received Lexus Insider article(s).

"Ignore":

Removes notification screen without playing new articles.

"Remind Me Later":

Removes notification screen without playing articles. Notification will be displayed again when the vehicle is next powered on.

- **Lexus Insider settings**

To change Lexus Insider settings, notification, and opt in or out of article receipt.



1. Push the “SETUP” button.



2. Touch “Other”.



3. Touch “LEXUS Insider”.

“LEXUS Insider Settings” screen is displayed on the screen.

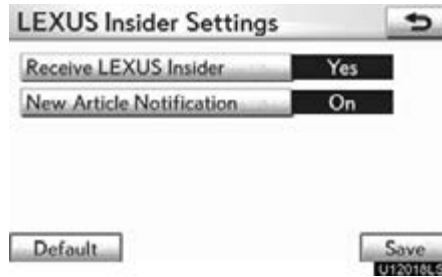

Please refer to the following pages for each setting.

RECEIVE/OPT OUT OF LEXUS INSIDER



1. Touch "Receive LEXUS Insider".
2. Touch "Yes" to receive Lexus Insider articles or "No" to opt out of receiving articles.
3. Touch "Save".

NEW ARTICLE NOTIFICATION

Automatic notification of new Lexus Insider articles is available and is the default setting.

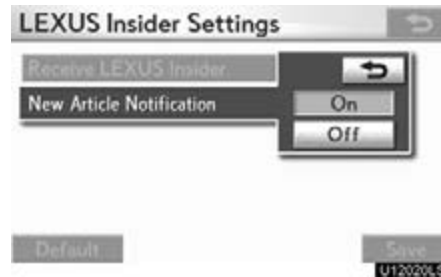

1. Touch "New Article Notification".
2. Touch "On" or "Off".
3. Touch "Save".

RESTORE THE DEFAULT LEXUS INSIDER SETTINGS

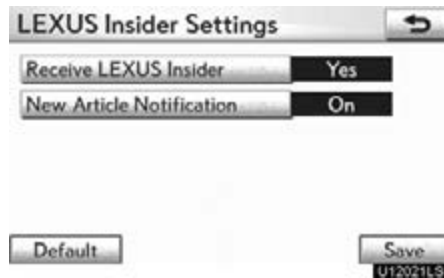

1. Touch "Default".



2. Touch "Yes" to confirm or "No" to cancel.

LEXUS ENFORM WITH SAFETY CONNECT

SECTION 7**AUDIO/VIDEO SYSTEM**

- Quick reference 184
- **Using your audio/video system** 187
 - Some basics 187
 - Radio operation 196
 - Radio operation (XM® Satellite Radio broadcast) 200
 - CD changer operation 206
 - DVD changer operation 220
 - Bluetooth® audio operation 245
 - USB memory/iPod operation 253
- Audio/video remote controls (steering switches) 261
- **Rear seat entertainment system features** 263
 - Using the radio 269
 - Using the DVD changer 270
 - Playing an audio CD/CD text 270
 - Playing MP3/WMA discs 271
 - Playing DVD video/audio 271
 - Using the video mode 284
 - Changing other settings 285
- Audio/video system operating hints 287

Quick reference

Operations such as selecting a preset station and adjusting the sound balance are carried out on the screen. To display the audio screen, push the “AUDIO” button.

► DVD changer

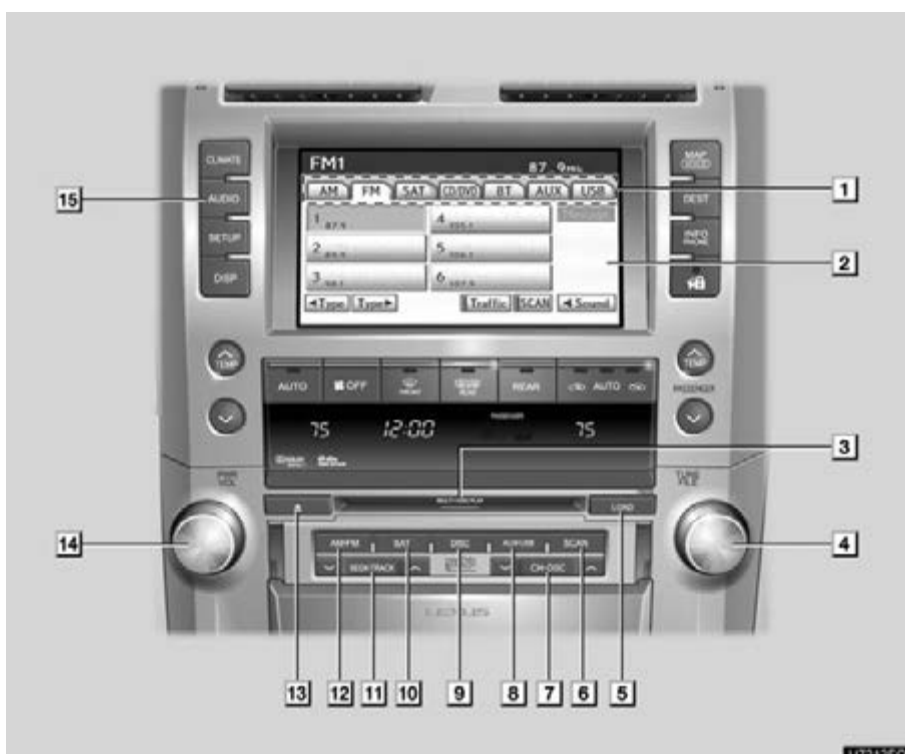

- | | |
|---|---|
| <p>1 Function menu tab
To control the radio, DVD changer, Bluetooth® audio player, AUX, USB memory or iPod, touch the screen tabs. For details, see page 190.</p> <p>2 Function menu display screen
To control the radio, DVD changer, Bluetooth® audio player, AUX, USB memory or iPod, touch the screen buttons. For details, see page 190.</p> <p>3 Disc slot
Insert discs into the slot after pushing “LOAD” button. For details, see page 220.</p> | <p>4 “TUNE/FILE” knob
Turn this knob to move the station band and files up or down. For details, see pages 196, 201, 216 and 257.</p> <p>5 “LOAD” button
Push this button to insert the discs. For details, see page 220.</p> <p>6 “SCAN” button
Push this button to scan radio stations or scan the files or tracks. For details, see pages 197, 203, 213, 217, 218 and 259.</p> <p>7 “CH-DISC” button
Push the “^” or “X” button to select a preset station or a selected disc. For details, see pages 197, 203, 223 and 225.</p> |
|---|---|

- 8** **“AUX-USB” button**
Push this button to turn the Bluetooth® audio player, AUX, USB memory or iPod on. For details, see pages 190, 195, 245 and 253.
- 9** **“DISC” button**
Push this button to play a DVD. For details, see pages 190 and 225.
- 10** **“SAT” button**
Push this button to choose a SAT station. For details, see pages 190, 196 and 200.
- 11** **“SEEK-TRACK” button**
Push the “^” or “X” button to seek up or down for a station, or to access a desired track, file or chapter. For details, see pages 197, 203, 212, 215, 231, 232, 242, 251 and 257.
- 12** **“AM-FM” button**
Push this button to choose a radio station. (AM, FM1, FM2)
For details, see pages 190 and 196.
- 13** **“▲” button**
Push this button to eject the discs. For details, see page 223.
- 14** **“PWR/VOL” knob**
Push this knob to turn the audio system on and off, and turn it to adjust the volume. For details, see page 189.
- 15** **“AUDIO” button**
Push this button to display the audio control screen. For details, see page 189.

► CD changer

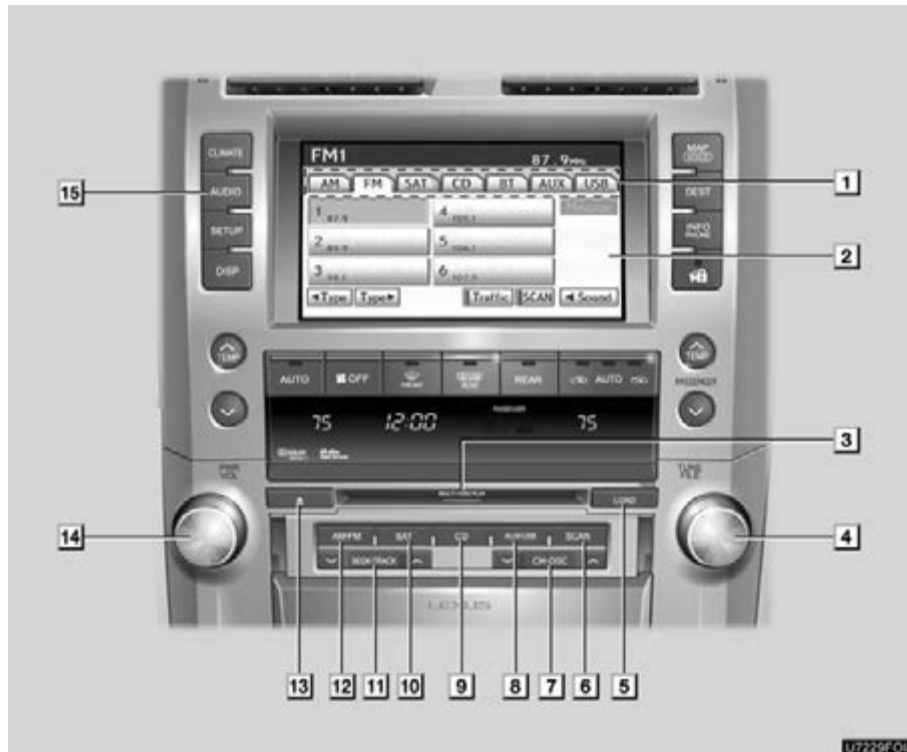

- | | |
|---|---|
| <p>1 Function menu tab
To control the radio, CD changer, Bluetooth® audio player, AUX, USB memory or iPod, touch the screen tabs. For details, see page 190.</p> <p>2 Function menu display screen
To control the radio, CD changer, Bluetooth® audio player, AUX, USB memory or iPod, touch the screen buttons. For details, see page 190.</p> <p>3 Disc slot
Insert discs into the slot after pushing “LOAD” button. For details, see page 206.</p> | <p>4 “TUNE/FILE” knob
Turn this knob to move the station band and files up or down. For details, see pages 196, 201, 216 and 257.</p> <p>5 “LOAD” button
Push this button to insert the discs. For details, see page 206.</p> <p>6 “SCAN” button
Push this button to scan radio stations or scan the files or tracks. For details, see pages 197, 203, 213, 217, 218 and 259.</p> <p>7 “CH-DISC” button
Push the “^” or “X” button to select a preset station or a selected disc. For details, see pages 197, 203, 208 and 211.</p> |
|---|---|

Using your audio/video system — — Some basics

- 8** **“AUX-USB” button**
Push this button to turn the Bluetooth® audio player, AUX, USB memory or iPod on. For details, see pages 190, 195, 245 and 253.
- 9** **“CD” button**
Push this button to play a CD. For details, see pages 190 and 210.
- 10** **“SAT” button**
Push this button to choose a SAT station. For details, see pages 190, 196 and 200.
- 11** **“SEEK-TRACK” button**
Push the “^” or “X” button to seek up or down for a station, or to access a desired track or file. For details, see pages 197, 203, 212, 215, 251 and 257.
- 12** **“AM-FM” button**
Push this button to choose a radio station. (AM, FM1, FM2)
For details, see pages 190 and 196.
- 13** **“▲” button**
Push this button to eject the discs. For details, see page 208.
- 14** **“PWR/VOL” knob**
Push this knob to turn the audio system on and off, and turn it to adjust the volume. For details, see page 189.
- 15** **“AUDIO” button**
Push this button to display the audio control screen. For details, see page 189.

This section describes some of the basic features of your audio/video system. Some information may not pertain to your system.

Your audio/video system works when the “ENGINE START STOP” switch is turned to ACCESSORY or IGNITION ON mode.

FCC ID : AJDK021
IC ID : 775E-K021

This device complies with Part 15 of the FCC Rules and RSS-Gen and RSS-210 of IC Rules. Operation is subject to the following two conditions : (1) This device may not cause harmful interference, and (2) this device must accept any interference received, including interference that may cause undesired operation.



CAUTION

FCC WARNING: Changes or modifications not expressly approved by the party responsible for compliance could void the user's authority to operate the equipment.

CAUTION: Radio Frequency Radiation Exposure

This equipment complies with FCC radiation exposure limits set forth for uncontrolled equipment and meets the FCC radio frequency (RF) Exposure Guidelines in Supplement C to OET65. This equipment has very low levels of RF energy that it deemed to comply without maximum permissive exposure evaluation (MPE). But it is desirable that it should be installed and operated with at least 20 cm and more between the radiator and person's body (excluding extremities: hands, wrists, feet and ankles).

Co-location: This transmitter must not be co-located or operated in conjunction with any other antenna or transmitter.

● **Laser products**

- Do not take this unit apart or attempt to make any changes yourself. This is an intricate unit that uses a laser pickup to retrieve information from the surface of compact discs. The laser is carefully shielded so that its rays remain inside the cabinet. Therefore, never try to disassemble the player or alter any of its parts since you may be exposed to laser rays and dangerous voltages.
- This product utilizes a laser. Use of controls or adjustments or performance of procedures other than those specified herein may result in hazardous radiation exposure.

(a) Voice command system



By pushing the switch above, you can operate the voice command system.

For the operation of the voice command system and the list of commands, see pages 44 and 49.

NOTICE

To prevent the battery from being discharged, do not leave the audio/video system on longer than necessary when the engine is not running.

(b) Turning the system on and off



“**AUDIO**”: Push this button to display touch–screen buttons for audio system (audio control mode).

“**PWR/VOL**”: Push this knob to turn the audio system on and off. Turn this knob to adjust the volume. The system turns on in the last mode used.

You can select the function that enables automatic return to the previous screen from the audio screen. See page 330 for details.

(c) Open the lid



Push the back part of the lid to open.
Push the lid again to close.

(d) Switching between functions



► DVD changer image

Push the “AM-FM”, “SAT”, “DISC”, “CD” or “AUX-USB” button to turn on the desired mode.

1. Push the “AUDIO” button.

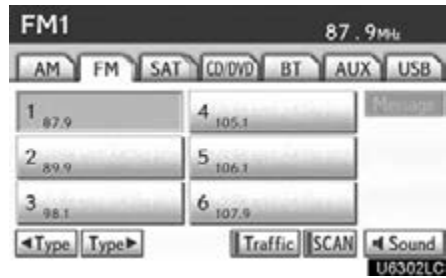

2. Touch “AM”, “FM”, “SAT”, “CD”, “CD/DVD”, “BT”, “AUX” or “USB” tab to turn on the desired mode.

Push these buttons or tabs if you want to switch from one mode to another.

If the disc is not set, the CD changer/DVD changer does not turn on.

You can turn off the CD changer/DVD changer by ejecting a disc.

AUDIO/VIDEO SYSTEM

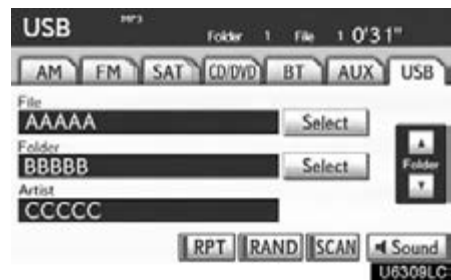
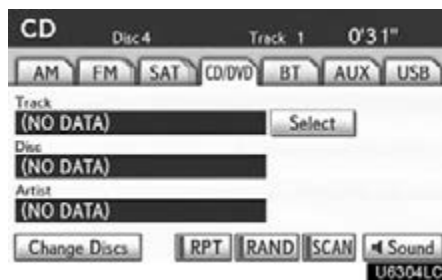
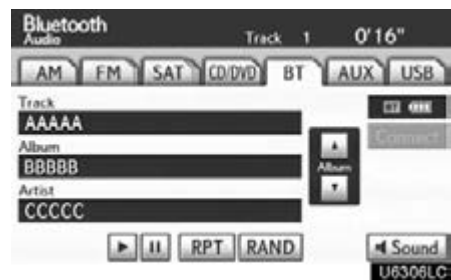
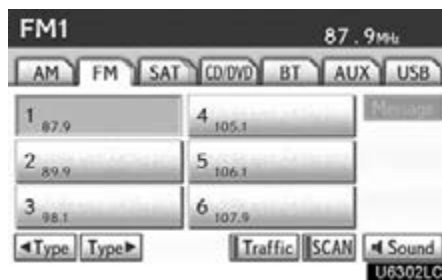

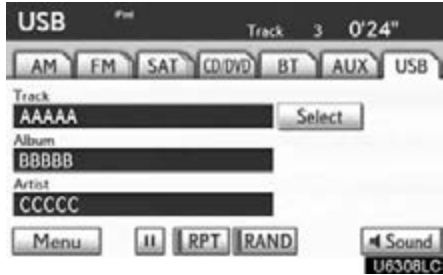

The screen buttons for radio, CD changer, DVD changer, Bluetooth® audio player, AUX, USB memory and iPod operation are displayed on the screen when the audio control mode is selected.

Touch the tab to select the desired mode when the audio control mode is selected.

INFORMATION

- If the system does not respond to a touch of a touch screen button, move your finger away from the screen and then touch it again.
- You cannot operate dimmed touch-screen buttons.
- Wipe off fingerprints using a glass cleaning cloth. Do not use chemical cleaners to clean the touch screen.

(e) DSP control

1. Push the “AUDIO” button.

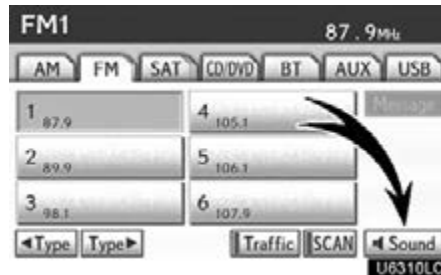

2. Touch “Sound” to display the sound adjustment screen.

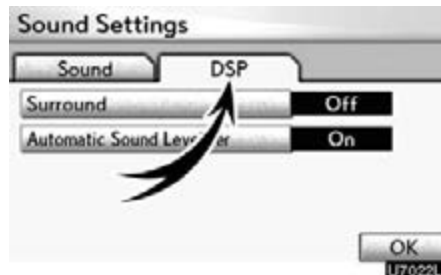

3. Touch “DSP” tab to display this screen.

4. Touch the desired button.

Surround function:
Touch “On” of “Surround” and touch “OK”.

The surround function will turn on.

Automatic sound levelizer (ASL):
When the audio sound becomes difficult to hear due to road noise, wind noise or other noises while driving, touch “On”. The system adjusts to the optimum volume and tone quality according to the speed of car, wind noise or other noise.

5. Touch “OK”.

(f) Tone and balance**Tone**

How good an audio program sounds to you is largely determined by the mix of the treble, mid and bass levels. In fact, different kinds of music and vocal programs usually sound better with different mixes of treble, mid and bass.

Balance

A good balance of the left and right stereo channels and of the front and rear sound levels is also important.

Keep in mind that if you are listening to a stereo recording or broadcast, changing the right/left balance will increase the volume of one group of sounds while decreasing the volume of another.

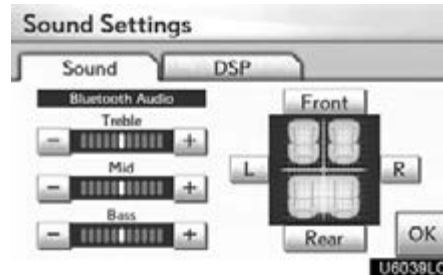

1. Touch “Sound” tab to display this screen.

2. Touch the desired button.

“**Treble**” “+” or “-”: Adjust high-pitched tones.

“**Mid**” “+” or “-”: Adjust mid-pitched tones.

“**Bass**” “+” or “-”: Adjusts low-pitched tones.

“**Front**” or “**Rear**”: Adjusts sound balance between the front and rear speakers.

“**L**” or “**R**”: Adjusts sound balance between the left and right speakers.

3. Touch “OK”.

The tone of each mode (for such as AM, FM, CD changer and DVD changer) can be adjusted.

(g) Selecting screen size (DVD changer only)

Before selecting screen size, it is necessary to insert a DVD disc and select DVD mode.

1. Push the "AUDIO" button.
2. Touch "CD/DVD" tab.



3. Touch "Settings".



4. Touch "Wide".



5. Touch the desired button.

- "Normal": Displays a 3 : 4 screen, with either side in black.
- "Wide 1": Widens the 3 : 4 screen horizontally to fill the screen.
- "Wide 2": Widens the 3 : 4 screen vertically and horizontally, in the same ratio, to fill the screen.

When you touch , the previous screen returns.

6. Touch "OK".

(h) Your CD or DVD changer

When you insert a disc, push the “LOAD” button and gently push the disc in with the label side up. This CD or DVD changer can store up to six discs.

The changer is intended for use with 4.7 in. (12 cm) discs only.



(i) AUX port

The sound of portable audio players connected to the AUX port can be enjoyed. Push the “AUX-USB” button, or push the “AUDIO” button to display audio screen and touch “AUX” tab to switch to AUX mode. When the portable audio player is not connected to the AUX port, the tab will tone down. For details, refer to the “Owner’s Manual”.

(j) USB port

It is available to connect a USB memory/iPod device with the USB port. When the USB memory/iPod is not connected to the USB port, the tab will tone down. For details, see “(a) Connecting a USB memory or iPod” on page 254.

NOTICE

- *Do not stack up two discs for insertion, or it will cause damage to the changer. Insert only one disc into the slot at a time.*
- *Never try to disassemble or oil any part of the changer. Do not insert anything other than a disc into the slot.*

— Radio operation

(a) Listening to the radio



Push the “AM-FM” button, or push the “AUDIO” button to display audio screen and touch “AM” or “FM” tabs to choose either an AM or FM station.

“AM”, “FM1” or “FM2” appears on the screen.

If your vehicle is equipped with a satellite radio broadcast system, when you push the “SAT” button or touch “SAT” tab on audio screen, “SAT1”, “SAT2”, “SAT3” station appears on the display. For details about satellite radio broadcast, see “— Radio operation (XM® Satellite Radio broadcast)” on page 200.



Turn the knob clockwise to step up the station band or counterclockwise to step down.

Your radio automatically changes to stereo reception when a stereo broadcast is received. “ST” appears on the screen. If the signal becomes weak, the radio reduces the amount of channel separation to prevent the weak signal from creating noise. If the signal becomes extremely weak, the radio switches from stereo to mono reception. In this case, “ST” disappears from the screen.

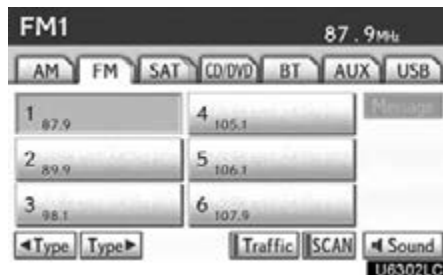
(b) Presetting a station

1. Tune in the desired station.
2. Touch one of the buttons (1 — 6) you want and hold it until a beep is heard. This sets the station to the button and the frequency appears on the button.

Each radio mode (AM, FM1 or FM2) can store up to 6 stations. To change the preset station to a different one, follow the same procedure.

The preset station memory is cancelled when the power source is interrupted by battery disconnection or a blown fuse.

(c) Selecting a station

Tune in the desired station using one of the following methods.

Preset tuning: Touch the button (1 — 6) or push the “^” or “X” button of “CH-DISC” for the station you want. The button is highlighted and the station frequency appears on the screen.

Seek tuning: Push the “^” or “X” button of “SEEK-TRACK”. The radio will begin seeking up or down for a station of the nearest frequency and will stop on reception. Each time you push the button, the stations will be searched automatically one after another.

To scan all the frequencies: Push the “SCAN” button or touch “SCAN” on the screen briefly. “SCAN” appears on the screen. The radio will find the next station and stay there for a few seconds, and then scan again. To select a station, push the “SCAN” button or touch “SCAN” again.

To scan the preset stations: Push the “SCAN” button or touch “SCAN” on the screen for longer than a second. “P. SCAN” appears on the screen. The radio will tune in the next preset station, stay there for a few seconds, and then move to the next preset station. To select a station, push the “SCAN” button or touch “SCAN” again.

AUDIO/VIDEO SYSTEM

(d) Radio Data System (if equipped)

Your audio system is equipped with Radio Data Systems (RDS). RDS mode provides you to receive text messages from radio stations that utilize RDS transmitters.

When RDS is on, the radio can

- only select stations of a particular program type,
- display messages from radio stations,
- search for a stronger signal station.

RDS features are available for use only on FM stations which broadcast RDS information.

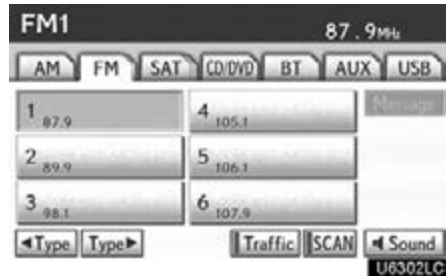

“Type ◀ ▶”

If the system receives no RDS stations, “NO-PTY” appears on the display.

Each time you touch “◀ Type ” or “Type ▶”, the program type changes as in the following:

- ROCK
- MISC (Miscellaneous)
- INFORM (Information)
- EASY LIS (Easy listening)
- CLS/JAZZ (Classical music and Jazz)
- R & B (Rhythm and Blues)
- RELIGION
- ALART (Emergency message)



“Message”

If the system receives a radio text from RDS station, “MSG” appears on the display. Touch **“Message”**, and a text message is displayed on the screen. This function is available only when the vehicle is not moving.

When you touch **“Message Off”**, the display returns.

“TypeSeek”

When a program is set, “Type Seek” appears. Touch the button and the system starts to seek the station in the relevant program type.

If any type program station is not found, “Nothing” appears on the display.

**(e) Traffic announcement
(if equipped)**

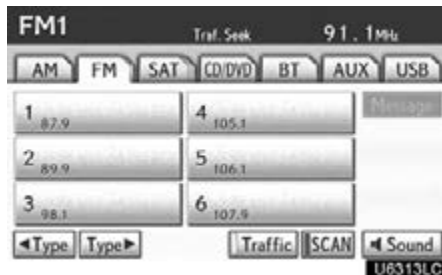

“Traffic”

A station that regularly broadcasts traffic information is automatically located.

When you touch **“Traffic”**, **“Traf. Seek”** appears on the display and the radio will start seeking any traffic program station.

If no traffic program station is found, **“Nothing”** appears on the display.

If a traffic program station is found, the name for traffic program station is displayed for a while until a traffic announcement is received.

**—Radio operation
(XM® Satellite Radio
broadcast) (if equipped)**

To listen to a satellite radio broadcast in your vehicle, a subscription to the XM® Satellite Radio service is necessary.

(a) How to subscribe to an XM® Satellite Radio

An XM® Satellite Radio is a tuner designed exclusively to receive broadcasts provided under a separate subscription. Availability is limited to the 48 contiguous U.S. states and some Canadian provinces.

How to subscribe:

You must enter into a separate service agreement with the XM® Satellite Radio in order to receive satellite broadcast programming in the vehicle. Additional activation and service subscription fees apply that are not included in the purchase price of the vehicle and optional digital satellite tuner.

For complete information on subscription rates and terms, or to subscribe to the XM® Satellite Radio.

U.S.A. —

Visit on the web at www.xmradio.com or call 1-877-515-3987.

Canada —

Visit on the web at www.xmradio.ca or call 1-877-515-3987.

The XM® Satellite Radio is solely responsible for the quality, availability and content of the satellite radio services provided, which are subject to the terms and conditions of the XM® Satellite Radio customer service agreement.

Customers should have their radio ID ready; the radio ID can be found by tuning to “channel 000” on the radio. For details, see “(b) Displaying the radio ID” below.

All fees and programming are the responsibility of the XM® Satellite Radio and are subject to change.

Satellite tuner technology notice:

Lexus’s satellite radio tuners are awarded Type Approval Certificates from XM® Satellite Radio Inc. as proof of compatibility with the services offered by the XM® Satellite Radio.

(b) Displaying the radio ID

Each XM® tuner is identified with a unique radio ID. You will need the radio ID when activating XM® service or when reporting a problem.

If you select the “CH 000” using the “TUNE/FILE” knob, the ID code of 8 alphanumeric characters appears. If you select another channel, display of the ID code is canceled. The channel(000) alternates the display between the radio ID and the specific radio ID code.

(c) Listening to satellite radio



Push the “SAT” button, or push the “AUDIO” button to display audio screen and touch “SAT” tab to choose a SAT channel.

“SAT1”, “SAT2” or “SAT3” appears on the screen.



Turn this knob to select the next or previous channel.

If you turn continuously, you can rapidly scroll forward or down through the channels.

(d) Channel category



Touch either “◀Type” or “Type▶” to go to the next or previous category.

(e) Presetting a channel

1. Tune in the desired channel.

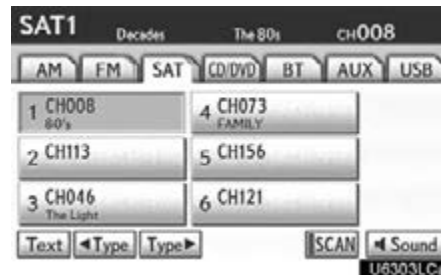

2. Touch one of the channel selector buttons (1 — 6) and hold it until a beep is heard.

This sets the channels to the button and the name and number of the channel appears on the button.

Each button can store three SAT channels. To change the preset channel to a different one, follow the same procedure.

The preset channel memory is cancelled when the power source is interrupted by battery disconnection or a blown fuse.

(f) Selecting a channel

Tune in the desired channel using one of the following methods.

Preset tuning: Touch the channel selector button (1 — 6) or push the “^” or “X” button of “CH-DISC” for the channel you want. The button (1 — 6) is highlighted and channel number appears on the display.

To select channel within the current category: Push the “^” or “X” button of “SEEK-TRACK”. The radio will step up or down the channel within the current channel category.



To scan the currently selected channel category: Touch “SCAN” or push the “SCAN” button briefly. “SCAN” appears on the display. The radio will find the next channel in the same channel category, stay there for a few seconds, and then scan again. To select a channel, touch “SCAN” or push the “SCAN” button a second time.

To scan the preset channels: Touch “SCAN” or push the “SCAN” button and hold it until you hear a beep. “P.SCAN” appears on the display. The radio will find the next preset channel, stay there for a few seconds, and then move to the next preset channel. To select a channel, touch “SCAN” or push the “SCAN” button a second time.

(g) Displaying the title and name

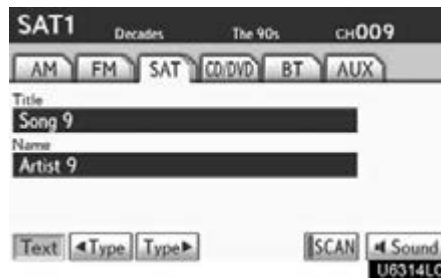

When you touch “Text”, the song/program title and the artist name/feature are displayed.

Up to 16 alphanumeric characters can be displayed. (Some information will not be fully displayed.)

When you touch “Text” again, the display returns.

AUDIO/VIDEO SYSTEM

(h) If the satellite radio tuner malfunctions

When problems occur with the XM® tuner, a message will appear on the display. Referring to the table below to identify the problem, take the suggested corrective action.

ANTENNA	The XM® antenna is not connected. Check whether the XM® antenna cable is attached securely.
	A short circuit occurs in the antenna or the surrounding antenna cable. See a Lexus certified dealer for assistance.
UNAUTH	You have not subscribed to the XM® Satellite Radio. The radio is being updated with the latest encryption code. Contact the XM® Satellite Radio for subscription information. When a contract is canceled, you can choose the "CH000" and all free-to-air channels.
	The premium channel you selected is not authorized. Wait for about 2 seconds until the radio returns to the previous channel or "CH001". If it does not change automatically, select another channel. If you want to listen to the premium channel, contact the XM® Satellite Radio.
NO SIGNAL	The XM® signal is too weak at the current location. Wait until your vehicle reaches a location with a stronger signal.
LOADING	The unit is acquiring audio or program information. Wait until the unit has received the information.
OFF AIR	The channel you selected is not broadcasting any programming. Select another channel.
-----	There is no song/program title or artist name/feature associated with the channel at that time. No action needed.
CH UNAVL	The channel you selected is no longer available. Wait for about 2 seconds until the radio returns to the previous channel or "CH001". If it does not change automatically, select another channel.

Contact the XM® Listener Care Center at 1-877-515-3987.

NOTICE

This equipment has been tested and found to comply with the limits for a class B digital device, pursuant to Part 15 of the FCC Rules. These limits are designed to provide reasonable protection against harmful interference in a residential installation. This equipment generates, uses and can radiate radio frequency energy and, if not installed and used in accordance with the instructions, may cause harmful interference to radio communications. However, there is no guarantee that interference will not occur in a particular installation.

If this equipment does cause harmful interference to radio or television reception, which can be determined by turning the equipment off and on, the user is encouraged to try to correct the interference by one or more of the following measures:

- *Reorient or relocate the receiving antenna.*
- *Increase the separation between the equipment and receiver.*
- *Connect the equipment into an outlet on a circuit different from that to which the receiver is connected.*
- *Consult the dealer or an experienced radio/TV technician for help.*

Information to user

Alteration or modifications carried out without appropriate authorization may invalidate the user's right to operate the equipment.

INFORMATION

This XM® tuner supports "Audio Services" (Music and Talk) of only XM® Satellite Radio and "Text Information" linked to the respective "Audio Services".*

**: Text Information includes, Station Name, (Artist) Name, (Song) Title and Category Name.*

— CD changer operation

(a) Inserting discs

The “ENGINE START STOP” switch must be in ACCESSORY or IGNITION ON mode.

Your CD changer can store up to 6 discs.

You can set a disc at the lowest empty disc number.

- **Setting a single disc:**



- 1. Push the “LOAD” button briefly.**

The orange indicators at both ends of the slot start blinking. After the orange indicators change to green and stay on, the CD changer door will open.



2. Insert only one disc while the CD changer door is open.

You can set a disc at the lowest empty disc number.

After insertion, the set disc is automatically loaded.

If the label faces down, the disc cannot be played. In this case, "Check CD" appears on the screen.

If you do not insert the disc within 15 seconds after pushing the "LOAD" button, a beep will sound and the operation will be canceled automatically.

If you need to insert the next disc, repeat the same procedure to insert another disc.

● **Setting all the discs:**



1. Push the "LOAD" button until you hear a beep.

The orange indicators at both ends of the slot start blinking. After the orange indicators change to green and stay on, the CD changer door will open.



2. Insert only one disc while the CD changer door is open.

The CD changer door closes and the orange indicators start blinking.

3. Insert the next disc after the orange indicators change to green and stay on and the CD changer door opens.

4. Repeat this procedure until you insert all the discs.

To cancel the operation, push the “LOAD” button briefly.

If you do not insert the discs within 15 seconds after pushing the “LOAD” button, the beep will sound and the operation will be canceled automatically.

NOTICE

Do not insert one disc stacked on top of another one or feed them in continuously, to prevent discs from getting stuck in the changer.

INFORMATION

Under extremely cold conditions, the display may react slowly.

(b) Ejecting discs

- A single disc alone:



1. Push the “^” or “X” button of “CH-DISC” or touch the disc number button on the “Change Discs” screen to highlight the disc number you want to eject.

To display the “Change Discs” screen, touch “Change Discs” on each audio control screen.



2. Push the “▲” button for the disc briefly.

At this time, the orange indicators of the slot start blinking and the disc is ejected.

3. After the blinking indicators stay on, remove the disc.

● **Ejecting all the discs:**



1. Push the “▲” button for the disc until you hear a beep.

At this time, the orange indicators of the slot start blinking and a disc is ejected.

2. After the blinking indicators stay on, remove the disc.

The indicators start blinking again and the next disc is ejected.

If you do not remove the disc within 15 seconds after it is ejected, the beep will sound and the operation will be canceled automatically.

When all the discs are removed, the indicators go out.



The numbers of the trays where the disc is not set are dimmed.

(c) Playing a disc



Push the “CD” button, or push the “AUDIO” button to display audio screen and touch “CD” tab if the discs are already loaded in the changer.

The discs set in the changer are played continuously, starting with the last disc you inserted. The disc number of the disc currently being played, the track number and the time from the beginning of the program appear on the screen.

When play of one disc ends, the first track of the following disc starts. When play of the final disc ends, play of the first disc starts again.

The changer will skip any empty disc trays.

(d) Selecting a desired disc



On the screen:

Touch “CD” tab, then touch “Change Discs”.

The selected disc number is highlighted.

The changer will start playing the selected disc from the first track.

On the audio panel:

Push the “^” or “X” button of “CH-DISC”.

When you release the button, the changer will start playing the selected disc from the first track.

(e) Playing an audio disc

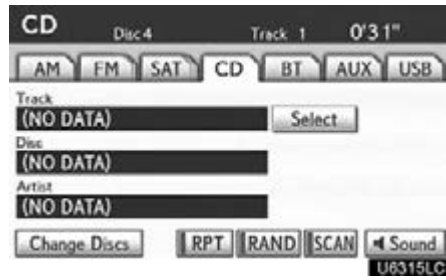

Touch “CD” tab, then touch “Change Discs”. Choose an audio disc number to display this screen.

SELECTING A DESIRED TRACK

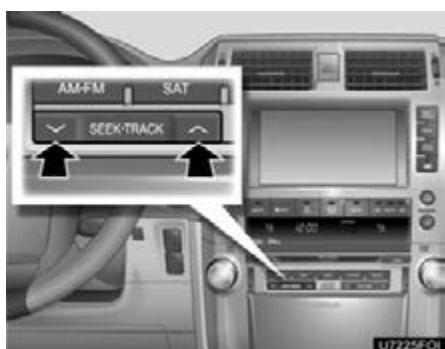

“SEEK-TRACK” button: Use for direct access to a desired track.

Push the “^” or “X” button of “SEEK-TRACK” and repeat it until the desired track number appears on the screen. As you release the button, the changer will start playing the selected track from the beginning.

“Select” for Track: The desired track can be selected from a list. This function is available only when the vehicle is not moving.



Touch **“Select”**. The track list is displayed.





Touch the desired track number. The changer will start playing the selected track from the beginning.

 : By touching this button, the list moves up by 5 track groups. If this button is touched when the top page of the list is displayed, the last page is displayed.

 : By touching this button, the list moves down by 5 track groups. If this button is touched when the last page of the list is displayed, the top page is displayed.

 ,  : If  appears to the right of the item name, the complete name is too long for the display.

Touch  to scroll to the end of the name. Touch  to scroll the beginning of the name.

Fast forward: Push the “^” button of “SEEK-TRACK” and hold it to fast forward the disc. When you release the button, the changer will resume playing from that position.

Reverse: Push the “X” button of “SEEK-TRACK” and hold it to reverse the disc. When you release the button, the changer will resume playing.

SEARCHING FOR A DESIRED TRACK OR DISC

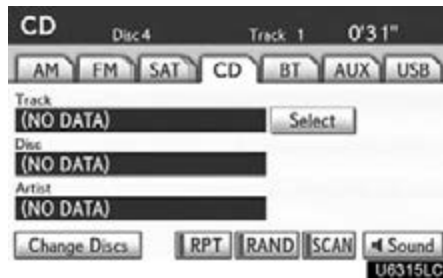

Searching for a desired track —

Touch **“SCAN”** on the screen or push the **“SCAN”** button briefly while the disc is playing.

“SCAN” appears on the screen. The changer will play the next track for 10 seconds, then scan again. To select a track, touch **“SCAN”** on the screen or push the **“SCAN”** button a second time. If the changer reaches the end of the disc, it will continue scanning at track 1.

After all the tracks are scanned in one pass, normal play resumes.

Searching for a desired disc —

Touch **“SCAN”** on the screen or push the **“SCAN”** button for longer than a second while the disc is playing.

“D.SCAN” appears on the screen. The program at the beginning of each audio disc will be played for 10 seconds. To continue listening to the program of your choice, touch **“SCAN”** on the screen or push the **“SCAN”** button a second time.

After all the audio discs are scanned in one pass, normal play resumes.

OTHER FUNCTIONS

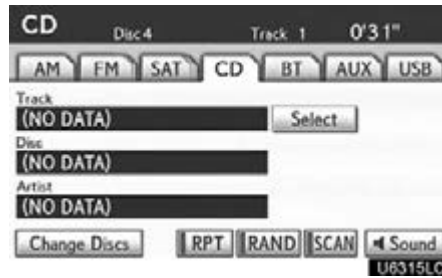

“RPT”: Use it for automatic repeat of the track or disc you are currently listening to.

Repeating a track —

Touch **“RPT”** briefly while the track is playing. “RPT” appears on the screen. When the track is finished, the changer will automatically go back to the beginning of the track and play the track again. To cancel it, touch **“RPT”** once again.

Repeating a disc —

Touch **“RPT”** for longer than a second while the disc is playing. “D.RPT” appears on the screen. When the disc is finished, the changer will automatically go back to the beginning of the disc and play the disc again. To cancel it, touch **“RPT”** once again.

“**RAND**”: Use it for automatic and random selection.

Playing the tracks on one disc in random order —

Touch “**RAND**” briefly while the disc is playing. “**RAND**” appears on the screen. The system selects a track on the disc being listened to in random order. To cancel it, touch “**RAND**” once again.

Playing the tracks on all the audio discs in random order —

Touch “**RAND**” for longer than a second while the disc is playing. “**D.RAND**” appears on the screen. The system selects a track on all the audio discs in the changer in random order. To cancel it, touch “**RAND**” once again.

If a CD-TEXT disc is inserted, the title of the disc and track will be displayed. Up to 32 letters can be displayed.

(f) Playing a MP3/WMA disc

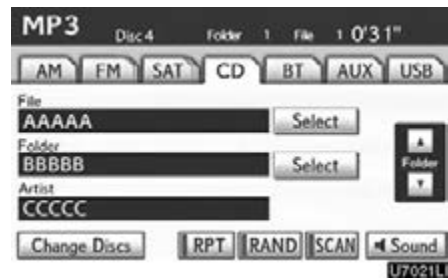

Touch “**CD**” tab, then touch “**Change Discs**”. Choose an MP3/WMA disc number to display this screen.

SELECTING A DESIRED FOLDER

“Folder▲”: Touch this button to go to the next folder.

“Folder▼”: Touch this button to go to the previous folder.

“Select” for Folder: The desired folder can be selected in a list. This function is available only when the vehicle is not moving.

Touch **“Select”**. The folder list is displayed.



Touch the desired folder number. The changer will start playing the first file of the selected folder.

 : By touching this button, the list moves up by 5 folder groups. If this button is touched when the top page of the list is displayed, the last page is displayed.

 : By touching this button, the list moves down by 5 folder groups. If this button is touched when the last page of the list is displayed, the top page is displayed.

SELECTING A DESIRED FILE

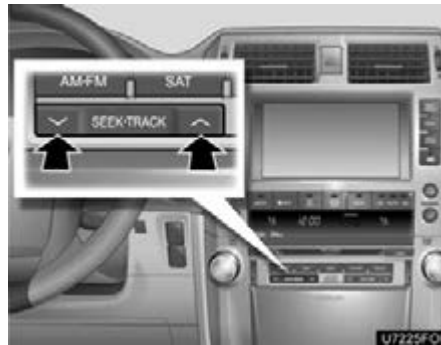

“SEEK-TRACK” button: Use for direct access to a desired file.

Push the “^” or “X” button of “SEEK-TRACK” and repeat it until the desired file number appears on the display. As you release the button, the changer will start playing the selected file from the beginning. When “RAND” or “FLD.RPT” is on, the file number within the folder you are currently listening to appears.

Fast forward: Push the “^” button of “SEEK-TRACK” and hold it to fast forward the disc. When you release the button, the changer will resume playing from that position.

Reverse: Push the “X” button of “SEEK-TRACK” and hold it to reverse the disc. When you release the button, the changer will resume playing.

AUDIO/VIDEO SYSTEM



“TUNE/FILE” knob: Use for direct access to a desired file in the disc.

Turn the **“TUNE/FILE”** knob to step up or down all the files in the disc you are currently listening to. The file number appears on the display. When **“RAND”** or **“FLD.RPT”** is on, all the files in the folder you are currently listening to can be stepped up or down.

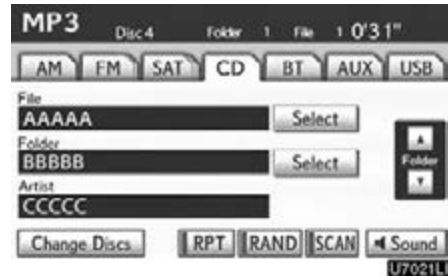

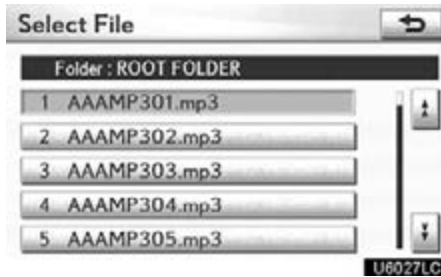

“Select” for File: The desired file can be selected in a list. This function is available only when the vehicle is not moving.

Touch **“Select”**. The file list is displayed.



Touch the desired file number. The changer will start playing the selected file from the beginning.

 : By touching this button, the list moves up by 5 file groups. If this button is touched when the top page of the list is displayed, the last page is displayed.

 : By touching this button, the list moves down by 5 file groups. If this button is touched when the last page of the list is displayed, the top page is displayed.

SEARCHING FOR A DESIRED FILE

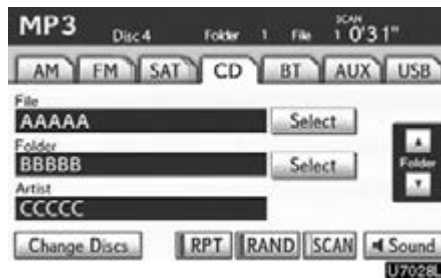

Touch “SCAN” on the screen or push the “SCAN” button briefly while the disc is playing.

“SCAN” appears on the screen. The changer will play the next file in the folder for 10 seconds, then scan again. To select a file, touch “SCAN” on the screen or push the “SCAN” button a second time. If the changer reaches the end of the folder, it will continue scanning from file 1.

After all the files are scanned in one pass, normal play resumes.

SEARCHING FOR A DESIRED FOLDER

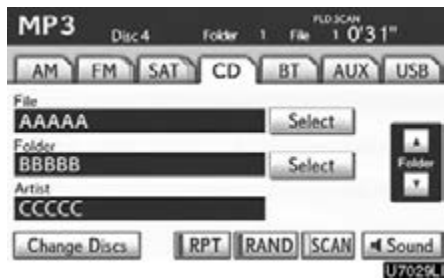

Touch **“SCAN”** on the screen or push the **“SCAN”** button for longer than a second while the disc is playing.

“FLD.SCAN” appears on the screen. The program at the beginning of each folder will be played for 10 seconds. To continue listening to the program of your choice, touch **“SCAN”** on the screen or push the **“SCAN”** button a second time.

After all the folders are scanned in one pass, normal play resumes.

OTHER FUNCTIONS

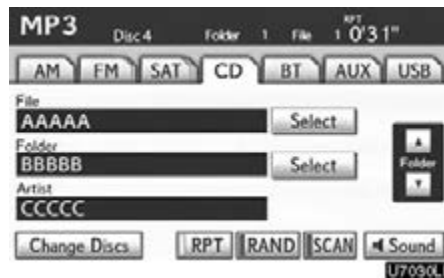

“RPT”: Use it for automatic repeat of the file or folder you are currently listening to.

Repeating a file —

Touch **“RPT”** briefly while the file is playing. **“RPT”** appears on the screen. When the file is finished, the changer will automatically go back to the beginning of the file and play the file again. To cancel it, touch **“RPT”** once again.

Repeating a folder —

Touch **“RPT”** for longer than a second while the folder is playing. **“FLD.RPT”** appears on the screen. When the folder is finished, the changer will automatically go back to the beginning of the folder and play the folder again. To cancel it, touch **“RPT”** once again.

“RAND”: Use it for automatic and random selection of the folder or the disc which you are currently listening to.

Playing the files in one folder in random order —

Touch **“RAND”** briefly while the disc is playing. **“RAND”** appears on the screen. The system selects a file in the folder you are currently listening to. To cancel it, touch **“RAND”** once again.

Playing the files in all the folders on one disc in random order —

Touch **“RAND”** for longer than a second while the disc is playing. **“FLD.RAND”** appears on the screen. The system selects a file in all the folders. To cancel it, touch **“RAND”** once again.

When a file is skipped or the system is inoperative, touch **“RAND”** to reset.

(g) If the changer malfunctions

If **“CD error”** appears on the screen, audio signals of the disc cannot be read or the system has trouble. Push the **“CD”** button once again.

If the changer does not operate, check that the disc surface is not soiled or damaged. If the disc is O.K., the temperature of the changer’s internal mechanism may be raised because of high external temperature. Remove the disc from the changer to cool it.

If the changer still does not operate, have it checked by your dealer.

If an MP3/WMA disc contains CD-DA files, only CD-DA files are played. If an MP3/WMA disc contains files other than CD-DA, only MP3/WMA files are played.

— DVD changer operation

For safety reasons, you can enjoy DVD video discs, DVD audio discs and video CDs only when the vehicle is completely stopped with the “ENGINE START STOP” switch is in ACCESSORY or IGNITION ON mode and the parking brake applied. While you are driving, you can hear audio alone even in the DVD video, DVD audio or video CD mode.

(a) Inserting discs

The “ENGINE START STOP” switch must be in ACCESSORY or IGNITION ON mode.

Your DVD changer can store up to 6 discs.

You can set a disc at the lowest empty disc number.

● **Setting a single disc:**



1. Push the “LOAD” button briefly.

The orange indicators at both ends of the slot start blinking. After the orange indicators change to green and stay on, the DVD changer door will open.



2. Insert only one disc while the DVD changer door is open.

You can set a disc at the lowest empty disc number.

After insertion, the set disc is automatically loaded.

If the label faces down, the disc cannot be played. In this case, “Check disc ×” appears on the screen.

If you do not insert the disc within 15 seconds after pushing the “LOAD” button, a beep will sound and the operation will be canceled automatically.

If you need to insert the next disc, repeat the same procedure to insert another disc.

● **Setting all the discs:**



1. Push the “LOAD” button until you hear a beep.

The orange indicators at both ends of the slot start blinking. After the orange indicators change to green and stay on, the DVD changer door will open.



2. Insert only one disc while the DVD changer door is open.

The DVD changer door closes and the orange indicators start blinking.

3. Insert the next disc after the orange indicators change to green and stay on and the DVD changer door opens.

4. Repeat this procedure until you insert all the discs.

To cancel the operation, push the “LOAD” button briefly.

If you do not insert the discs within 15 seconds after pushing the “LOAD” button, the beep will sound and the operation will be canceled automatically.

NOTICE

Do not insert one disc stacked on top of another one or feed them in continuously, to prevent discs from getting stuck in the changer.

INFORMATION

Under extremely cold conditions, the display may react slowly.

(b) Ejecting discs

- A single disc alone:



2. Push the “▲” button for the disc briefly.

At this time, the orange indicators of the slot start blinking and the disc is ejected.

3. After the blinking indicators stay on, remove the disc.

1. Push the “^” or “X” button of “CH-DISC” or touch the disc number button on the “Change Discs” screen to highlight the disc number you want to eject.

To display the “Change Discs” screen, touch “Change Discs” on each audio control screen.

- **Ejecting all the discs:**



The numbers of the trays where the disc is not set are dimmed.

- 1. Push the “▲” button for the disc until you hear a beep.**

At this time, the orange indicators of the slot start blinking and a disc is ejected.

- 2. After the blinking indicators stay on, remove the disc.**

The indicators start blinking again and the next disc is ejected.

If you do not remove the disc within 15 seconds after it is ejected, the beep will sound and the operation will be canceled automatically.

When all the discs are removed, the indicators go out.

(c) Playing a disc



Push the “DISC” button, or push the “AUDIO” button to display audio screen and touch “CD/DVD” tab if the discs are already loaded in the changer.

The discs set in the changer are played continuously, starting with the last disc you inserted. The disc number of the disc currently being played, the track or title and chapter number and the time from the beginning of the program appear on the screen.

Audio CD only —

When play of one disc ends, the first track of the following disc starts. When play of the final disc ends, play of the first disc starts again.

The changer will skip any empty disc trays.

(d) Selecting a desired disc

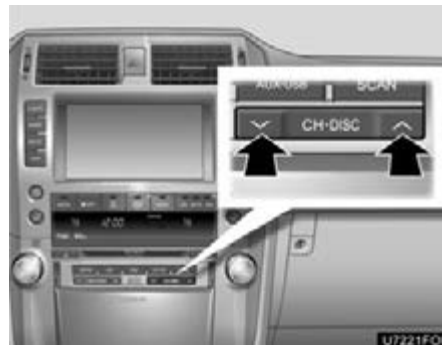
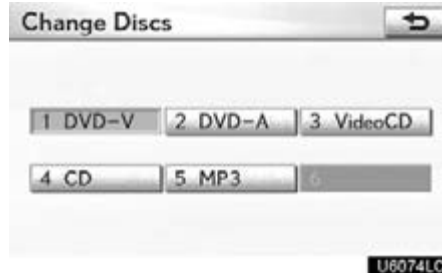

On the screen:

Touch “CD/DVD” tab, then touch “Change Discs”.

The selected disc number is highlighted.

The changer will start playing the selected disc from the first track.

On the audio panel:

Push the “^” or “X” button of “CH-DISC”.

When you release the button, the changer will start playing the selected disc from the first track.

(e) Operating a DVD disc

NOTE: The playback condition of some DVD discs may be determined by a DVD software producer. This DVD changer plays a disc as the software producer intended. So some functions may not work properly. Be sure to read the instruction manual for the DVD disc separately provided. For the detailed information about DVD video discs, see “(h) DVD player and DVD video disc information” on page 243.

Precautions on DVD video disc

When recording with a DVD video or video CD, audio tracks may not record in some cases while the menu is displayed. As audio will not play in this case, verify that the video tracks are playing and then activate playback.

When playback of a disc is completed:

- If an audio CD or MP3 disc is playing, the first track or file starts.
- If a DVD video or video CD is playing, playback will stop or the menu screen will be displayed.

The title/chapter number and playback time display may not appear while playing back certain DVD video discs.

 **CAUTION**

Conversational speech on some DVDs is recorded at a low volume to emphasize the impact of sound effects. If you adjust the volume assuming that the conversations represent the maximum volume level that the DVD will play, you may be startled by louder sound effects or when you change to a different audio source. The louder sounds may have a significant impact on the human body or pose a driving hazard. Keep this in mind when you adjust the volume.



This screen appears when the video screen is first displayed after “ENGINE START STOP” switch is in ACCESSORY or IGNITION ON mode.

PLAYING A DVD DISC



Touch “CD/DVD” tab to display this screen.

Touch “Settings” on “DVD” screen, then touch “Wide” on “Settings” screen. The screen mode can be changed.

If you touch “Full Screen” when the vehicle is completely stopped and the parking brake is applied, the video screen returns.

DVD SETTINGS



► DVD video



► DVD audio

If you touch **“Settings”** on **“DVD”** screen, **“Settings”** screen appears.

DESCRIPTION OF DVD VIDEO SETTINGS

“DVD Video Settings”: The initial set up screen appears. (See page 235.)

“Search”: The title search screen appears. (See page 231.)

“Return”: Touching this will display the predetermined scene and start playing from there.

“Audio”: The audio changing screen appears. (See page 234.)

“Subtitle”: The subtitle changing screen appears. (See page 233.)

“Angle”: The angle selection screen appears. (See page 235.)

“Wide”: The screen mode screen appears. (See page 194.)

DESCRIPTION OF DVD AUDIO SETTINGS

“**DVD Audio Settings**”: The initial set up screen appears. (See page 235.)

“**Search**”: The group search screen appears. (See page 232.)

“**Return**”: Touching this will display the predetermined scene and start playing from there.

“**Audio**”: The audio changing screen appears. (See page 234.)

“**Subtitle**”: The subtitle changing screen appears. (See page 233.)

“**Angle**”: The angle selection screen appears. (See page 235.)

“**Wide**”: The screen mode screen appears. (See page 194.)

“**Prev. Page**”: Touch this button to reverse the pages. (See page 233.)

“**Next Page**”: Touch this button to forward the pages. (See page 233.)

“**Select Number**”: The track or number search screen appears. (See page 242.)

“**RPT**”: Touch this button to repeat a track.

“**RAND**”: Touch this button to play the track in one group in random order.

“**SCAN**”: Touch this button to play the next track in the group for 10 seconds, then scan again.

DISPLAYING DVD CONTROLS



► DVD video









► DVD audio

If you touch , while watching video, DVD controls will appear.

If “” appears on the screen when you touch a control, the operation relevant to the control is not permitted.







DESCRIPTION OF DVD VIDEO CONTROLS

“Menu” and “Top Menu”: If you touch any of the above controls, the menu screen for DVD video appears. (For the operation, see the manual that come with the DVD video disc provided separately.)

-  : The menu control key appears on the screen. (See page 231.)
-  : Touching this will pause the video screen.
-  : Touching this will fast reverse during playback.
-  : Touching this will stop the video screen.
-  : Touching this will resume normal play during pause.
-  : Touching this will fast forward during playback and forward frame by frame during pause.





DESCRIPTION OF DVD AUDIO CONTROLS

“Top Menu”: If you touch this button, the menu screen for DVD audio appears. (For the operation, see the manual that come with the DVD audio disc provided separately.)

-  : The menu control key appears on the screen. (See page 231.)
-  : Touching this will pause the disc.
-  : Touching this will fast reverse during playback.
-  : Touching this will stop the disc.
-  : Touching this will resume normal play during pause.
-  : Touching this will fast forward during playback and forward frame by frame during pause.

SELECTING A MENU ITEM



Enter the menu item using , ,  or , and touch "Enter". The player starts playing disc for that menu item. Menu items can also be touched using the pointer. (For details, see the manual that comes with the DVD disc provided separately.)

When you touch the any point on the screen, the controls will disappear. To display them again, touch the any point on the screen.

When you touch , the previous screen returns.

SEARCHING BY TITLE

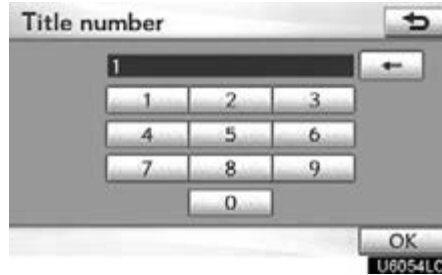

DVD video only —

Enter the title number and touch "OK". The player starts playing video for that title number.

When you push the "∧" or "×" button of "SEEK-TRACK", you can select a chapter.

If you enter the wrong numbers, touch  to delete the numbers.

When you touch , the previous screen returns.

SEARCHING BY GROUP



DVD audio only —

Enter the group number and touch “OK”. The player starts playing the disc for that group number.

When you push the “^” or “X” button of “SEEK-TRACK”, you can select a track.

If you enter the wrong numbers, touch  to delete the numbers.

When you touch , the previous screen returns.

SELECTING THE BONUS GROUP

DVD audio only —

Enter the bonus group number on the searching group screen and touch “OK”.

The “Key Code” screen will appear. To enter the number of the group you want to play, touch the group number.

If you enter the wrong numbers, touch  to delete the numbers.

When you touch , the previous screen returns.

Touch “OK” on the screen.

The player starts playing the disc from the selected bonus group number.

CHANGING THE PAGE



DVD audio only —

Touch “Prev. Page” or “Next Page” on the screen to forward or reverse the pages.

CHANGING THE SUBTITLE LANGUAGE

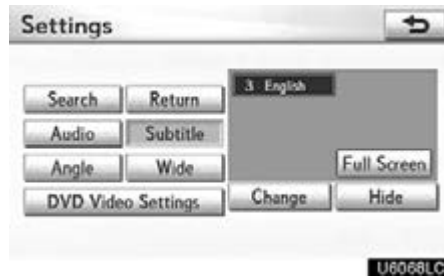

Each time you touch “Change”, the language is selected from the ones stored in the discs and changed.

When you touch “Hide”, the subtitle can be hidden.

When you touch , the previous screen returns.

CHANGING THE AUDIO LANGUAGE

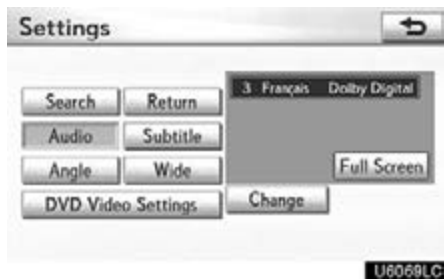

DVD video only —

Each time you touch “Change”, the language is selected from the ones stored in the discs and changed.

When you touch , the previous screen returns.

CHANGING THE AUDIO FORMAT



DVD audio only —

Each time you touch “Audio”, another audio format stored on the disc is selected.

When you touch , the previous screen returns.

CHANGING THE ANGLE



The angle can be selected for discs that are multi-angle compatible when the angle mark appears on the screen.

Each time you touch “Change”, the angle is selected from the ones stored in the discs and changed.

When you touch , and the previous screen returns.

SETUP MENU

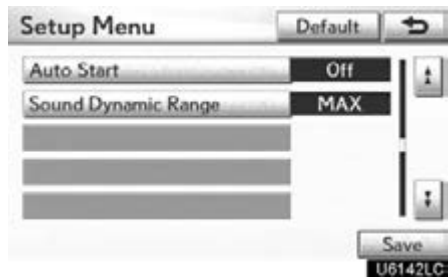
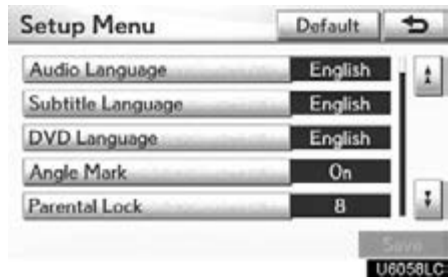

There are initial setting buttons on the “Setup Menu” screen.

After you change the initial setting, touch . The initial setting screen will be turned off and return to the picture previously.

When “Default” is touched, all menus are initialized.

The initial setting can be changed.

- **Audio language (DVD video only)**

You can change the audio language.

1. Touch “Audio Language”.
2. Touch the language you want to hear on the “Audio Language” screen.

If you cannot find the language you want to hear on this screen, touch “Other” and enter a language code. For the entry of language code, see the following “ENTER AUDIO LANGUAGE CODE”.

To return to the “Setup Menu” screen, touch .

- **Subtitle language**

You can change the subtitle language.

1. Touch “Subtitle Language”.
2. Touch a language you want to read on the “Subtitle Language” screen.

If you cannot find the language you want to read on this screen, touch “Other” and enter a language code. For the entry of language code, see the following “ENTER AUDIO LANGUAGE CODE”.

To return to the “Setup Menu” screen, touch .

- **DVD language**

You can change the language on the DVD video menu.

1. Touch “DVD Language”.
2. Touch the language you want to read on the “DVD Language” screen.

If you cannot find the language you want to read on this screen, touch “Other” and enter a language code. For the entry of language code, see the following “ENTER AUDIO LANGUAGE CODE”.

To return to the “Setup Menu” screen, touch .

- **Angle mark**

The multi-angle mark can be turned on or off on the screen while the disc which is multi-angle compatible is being played.

1. Touch “Angle Mark”.
2. Touch “On” or “Off”.

- **Parental lock (DVD video only)**

The level of viewer restrictions can be changed.

1. Touch “Parental Lock”.
2. Enter the 4-digit personal code on the “Key code” screen.

If you enter the wrong numbers, touch  to delete the numbers.

To return to the “Setup Menu” screen, touch .

3. Touch a parental level (1 — 8) on the “Select Restriction Level”. Touch  to return to the “Setup Menu” screen.

- **Auto start**

Discs that are inserted while the vehicle is in motion will automatically start playing. Certain discs may not play.

1. Touch “Auto Start”.
2. Touch “On” or “Off”.

- **Sound dynamic range (DVD video only)**

The difference between the lowest volume and the highest volume can be adjusted.

1. Touch “Sound Dynamic Range”.
2. Touch “MAX”, “STD” or “MIN”.

ENTER AUDIO LANGUAGE CODE

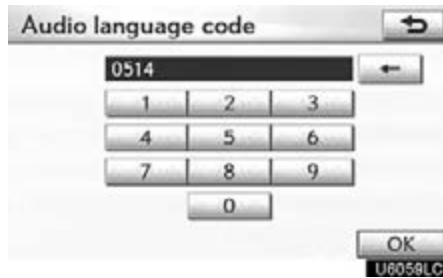

If you touch “Other” on the “Audio Language” screen, “Subtitle Language” screen or “DVD Language” screen, you can select the language you want to hear or read by entering a language code.

1. Enter the 4–digit language code.

If you enter the wrong numbers, touch



to delete the numbers.

2. Touch “OK”.

Code	Language
0514	English
1001	Japanese
0618	French
0405	German
0920	Italian
0519	Spanish
2608	Chinese
1412	Dutch
1620	Portuguese
1922	Swedish
1821	Russian
1115	Korean
0512	Greek
0101	Afar
0102	Abkhazian

0106	Afrikaans
0113	Amharic
0118	Arabic
0119	Assamese
0125	Aymara
0126	Azerbaijani
0201	Bashkir
0205	Byelorussian
0207	Bulgarian
0208	Bihari
0209	Bislama
0214	Bengali
0215	Tibetan
0218	Breton
0301	Catalan
0315	Corsican
0319	Czach
0325	Welsh
0401	Danish
0426	Bhutani
0515	Esperanto
0520	Estonian
0521	Basque
0601	Persian
0609	Finnish
0610	Fiji
0615	Faroese
0625	Frisian
0701	Irish
0704	Scots–Gaelic
0712	Galician
0714	Guarani

AUDIO/VIDEO SYSTEM

0721	Gujarati
0801	Hausa
0809	Hindi
0818	Croatian
0821	Hungarian
0825	Armenian
0901	Interlingua
0905	Interlingue
0911	Inupiak
0914	Indonesian
0919	Icelandic
0923	Hebrew
1009	Yiddish
1023	Javanese
1101	Georgian
1111	Kazakh
1112	Greenlandic
1113	Cambodian
1114	Kannada
1119	Kashmiri
1121	Kurdish
1125	Kirghiz
1201	Latin
1214	Lingala
1215	Laothian
1220	Lithuanian
1222	Latvian
1307	Malagasy
1309	Maori
1311	Macedonian
1312	Malayalam
1314	Mongolian

1315	Moldavian
1318	Marathi
1319	Malay
1320	Maltese
1325	Burmese
1401	Nauru
1405	Nepali
1415	Norwegian
1503	Occitan
1513	(Afan)Oromo
1518	Oriya
1601	Panjabi
1612	Polish
1619	Pashto, Pushto
1721	Quechua
1813	Rhaeto-Romance
1814	Kirundi
1815	Romanian
1823	Kinyarwanda
1901	Sanskrit
1904	Sindhi
1907	Sangho
1908	Serbo-Croatian
1909	Sinhalese
1911	Slovak
1912	Slovenian
1913	Samoaan
1914	Shona
1915	Somali
1917	Albanian
1918	Serbian
1919	Siswati

1920	Sesotho
1921	Sundanese
1923	Swahili
2001	Tamil
2005	Telugu
2007	Tajik
2008	Thai
2009	Tigrinya
2011	Turkmen
2012	Tagalog
2014	Setswana
2015	Tonga
2018	Turkish
2019	Tsonga
2020	Tatar
2023	Twi
2111	Ukrainian
2118	Urdu
2126	Uzbek
2209	Vietnamese
2215	Volapük
2315	Wolof
2408	Xhosa
2515	Yoruba
2621	Zulu

SETUP OPERATION FROM THE REAR SEAT



This screen appears when a rear passenger selects the setup menu. If you want to cancel the setup operation from the rear seat, select **“Play”**. The player will resume normal play. Under the same condition, the rear passenger can cancel the setup operation from the front seat. To lock the operation of the player from the rear seat, see **“● Rear system lock”** on page 332.

(f) Operating a video CD
PLAYING A VIDEO CD



Touch **“CD/DVD”** tab to display this screen.

When you touch **“Wide”** on **“Settings”** screen, the screen mode can be changed.

If you touch **“Full Screen”** when the vehicle is completely stopped and the parking brake is applied, the video screen returns.

DISPLAYING VIDEO CD SETTINGS



If you touch **“Settings”** on **“Video CD”** screen, **“Settings”** screen appears.

DESCRIPTION OF VIDEO CD SETTINGS

- **Controls on top page**

“Select Number”: The track or number search screen appears. (See “SEARCHING BY TRACK” on page 242.)

“Prev. Page”: When you touch this while the disc menu is displayed, the previous page appears on the screen. If you touch this while the player is playing video, the previous track is searched and played.

“Next Page”: When you touch this while the disc menu is displayed, the next page appears on the display. If you touch this while the player is playing video, the next track is searched and played.

“Main/Sub”: A multiplex transmission changing control. The mode changes from Main/Sub to Main, to Sub and back to Main/Sub by touching this control.

“Return”: Touching this will display the predetermined scene and start playing from there.





“Wide”: The screen mode screen appears.

DISPLAYING VIDEO CD CONTROLS

If you touch the part where controls are not located while you are watching video on the video CD, video CD controls will appear.

If “” appears on the display when you touch a control, the operation is not permitted.

DESCRIPTION OF VIDEO CD CONTROLS

-  : Use this to pause the video screen.
-  : Touch this to fast reverse during playback.
-  : Touch this to stop the disc.
-  : Touch this to resume playing during pause.
-  : Touch this to fast forward during the playback and start playing frame by frame during pause.

SEARCHING BY TRACK



Enter the track numbers and touch "OK". The player starts playing video for that title number.

You can select a track number by pushing the "**^**" or "**×**" button of "**SEEK-TRACK**".

If you enter the wrong numbers, touch  to delete the numbers.

Touch , and the previous screen returns.

(g) If the changer malfunctions

If the changer or another unit equipped with the changer malfunction, your audio/video system will display following messages.

If “Check disc ×” appears on the display: It indicates that the disc dirty, damaged, or it was inserted upside down. Clean the disc or insert it correctly. If a disc which is not playable is inserted, “Check disc ×” will also appear on the screen. For appropriate discs for this changer, see “Audio/video system operating hints” on page 287.

If “Region code error” appears on the display: It indicates that the DVD region code is not set properly.

If “DVD error” appears on the display: It indicates that the inside of the player unit may be too hot due to the very high ambient temperature. Remove the disc from the player and allow the player to cool down.

If the malfunction is not rectified: Take your vehicle to your dealer.

If an MP3 disc contains CD-DA files, only CD-DA files are played. If an MP3 disc contains files other than CD-DA, only MP3 files are played.





(h) DVD player and DVD video disc information

DVD VIDEO DISCS

This DVD player conforms to NTSC color TV formats. The DVD video disc conforming to another formats such as PAL or SECAM cannot be used.

Region codes: Some DVD video discs have a region code indicating a country where you can use the DVD video disc on this DVD player. If the DVD video disc is not labeled as “ALL” or “1”, you cannot use it on this DVD player. If you attempt to play an inappropriate DVD video disc on this player, “Region code error” appears on the screen. Even if the DVD video disc does not have a region code, there is a case that you cannot use it.

Marks shown on DVD video discs:

NTSC	Indicates NTSC format of color TV.
	Indicates the number of audio tracks.
	Indicates the number of language subtitles.
	Indicates the number of angles.
	Indicates the screen to be selected. Wide screen: 16:9 Standard: 4:3
	Indicates a region code by which this video disc can be played. ALL: in all countries Number: region code

DVD VIDEO DISC GLOSSARY

DVD video discs: Digital Versatile Disc that holds video. DVD video discs have adopted “MPEG2”, one of the world standards of digital compression technologies. The picture data is compressed by 1/40 on average and stored. Variable rate encoded technology in which the volume of data assigned to the picture is changed depending on the picture format has also been adopted. Audio data is stored using PCM and Dolby Digital, which enables higher quality of sound. Furthermore, multi-angle and multi-language features will also help you enjoy the more advanced technology of DVD video.

Viewer restrictions: This feature limits what can be viewed in conformity with a level of restrictions of the country. The level of restrictions varies depending on the DVD video disc. Some DVD video discs cannot be played at all, or violent scenes are skipped or replaced with other scenes.

Level 1: DVD video discs for children can be played.

Level 2 – 7: DVD video discs for children and G-rated movie can be played.

Level 8: All types of the DVD video discs can be played.

Multi-angle feature: You can enjoy the same scene at different angles.

Multi-language feature: You can select a language of the subtitle and audio.

Region codes: The region codes are provided on DVD players and DVD discs. If the DVD video disc does not have the same region code as the DVD player, you cannot play the disc on the DVD player. For region codes, see page 244.

Audio: This DVD player can play liner PCM, Dolby Digital and MPEG audio format DVD. Other decoded type cannot be played.

Title and chapter: Video and audio programs stored in DVD video disc are divided in parts by title and chapter.

Title: The largest unit of the video and audio programs stored on DVD video discs. Usually, one piece of movie, one album, or one audio program is assigned as a title.

Chapter: The unit smaller than that of title. A title comprises plural chapters.

Manufactured under license from Dolby Laboratories. “Dolby”, “Pro Logic”, and the double-D symbol are trademarks of Dolby Laboratories.

This product incorporates copyright protection technology that is protected by method claims of certain U.S. patents and other intellectual property rights owned by Macrovision Corporation and other rights owners. Use of this copyright protection technology must be authorized by Macrovision Corporation, and is intended for home and other limited viewing uses only unless otherwise authorized by Macrovision Corporation. Reverse engineering or disassembly is prohibited.

“DTS” and “DTS Digital Surround” are registered trademarks of Digital Theater Systems, Inc.

Manufactured under license under U.S. Patent #'s: 5,451,942; 5,956,674; 5,974,380; 5,978,762; 6,487,535 & other U.S. and worldwide patents issued & pending. DTS and the Symbol are registered trademarks & DTS Digital Surround and the DTS logos are trademarks of DTS, Inc. Product includes software. © DTS, Inc. All Rights Reserved.

— Bluetooth® audio operation

The Bluetooth® audio system enables users to enjoy music played on a portable player from the vehicle speaker via wireless communication.

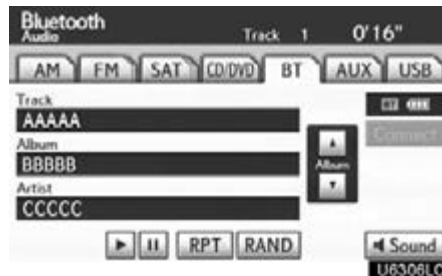

This audio system supports Bluetooth®, a wireless data system capable of playing portable audio music without cables. If your portable player does not support Bluetooth®, the Bluetooth® audio system will not function.

INFORMATION

Portable players must correspond to the following specifications in order to be connected to the Bluetooth® audio system. However, please note that some functions may be limited depending on the type of portable player.

- **Bluetooth® Specification Ver.1.1 or higher**
(Recommended: Ver. 2.0+EDR or higher)
- **Profile**
 - **A2DP (Advanced Audio Distribution Profile) Ver.1.0 or higher**
 - **AVRCP (Audio/Video Remote Control Profile) Ver.1.0 or higher**
(Recommended: Ver.1.3 or higher)

Please go to "<http://www.lexus.com/>" to find approved Bluetooth® phones for this system.



Bluetooth is a trademark owned by Bluetooth SIG, Inc.

CAUTION

Do not operate the player's controls or connect to the Bluetooth® audio system while driving.

NOTICE

Do not leave your portable player in the car. In particular, high temperatures inside the vehicle may damage the portable player.

INFORMATION

- **In the following conditions, the system may not function.**
 - **The portable player is turned off.**
 - **The portable player is not connected.**
 - **The portable player has a low battery.**
- **It may take time, the phone connection is carried out during Bluetooth® audio play.**

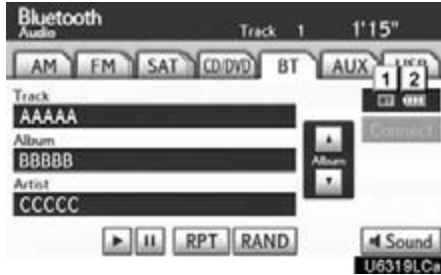

1 Indicates the condition of the Bluetooth® connection.

“Blue” indicates an excellent connection to Bluetooth®.

“Yellow” indicates a bad connection to Bluetooth®, resulting in possible deterioration of audio quality.

BT : No connection to Bluetooth®.

2 Indicates the amount of battery charge left.



Empty ←————→ Full

Remaining charge is not displayed while the Bluetooth® is connecting.

The amount left does not always correspond with the one of your portable player.

This system doesn't have a charging function.

An antenna for the Bluetooth® connection is built in to the instrument panel. The indication of the Bluetooth® connection may turn yellow and the system may not function when you use the Bluetooth® portable player in the following conditions.

- Your portable player is hiding behind from the display (behind the seat or in the glove box or console box).
- Your portable player touches or is covered with metal materials.

Leave the Bluetooth® portable player in a place where the “Blue” indication is displayed.

The portable player information is registered when the Bluetooth® audio system is connected. When you release possession of your vehicle, remove your portable player. (See “(a) Removing a Bluetooth® audio” on page 392.)

FCC ID : AJDK021
IC ID: 775E-K021

This device complies with Part 15 of the FCC Rules and RSS-Gen and RSS-210 of IC Rules. Operation is subject to the following two conditions : (1) This device may not cause harmful interference, and (2) this device must accept any interference received, including interference that may cause undesired operation.

 **CAUTION**

FCC WARNING: Changes or modifications not expressly approved by the party responsible for compliance could void the user's authority to operate the equipment.

CAUTION: Radio Frequency Radiation Exposure

This equipment complies with FCC radiation exposure limits set forth for uncontrolled equipment and meets the FCC radio frequency (RF) Exposure Guidelines in Supplement C to OET65. This equipment has very low levels of RF energy that it deemed to comply without maximum permissive exposure evaluation (MPE). But it is desirable that it should be installed and operated with at least 20 cm and more between the radiator and person's body (excluding extremities: hands, wrists, feet and ankles).

Co-location: This transmitter must not be co-located or operated in conjunction with any other antenna or transmitter.

(a) **Connecting Bluetooth® audio player**

To use the Bluetooth® audio system, you need to enter your portable player into the system. Once you have registered it, you can enjoy your music on the vehicle's audio system. (See "—Setting Bluetooth® audio" on page 390.)

For the operation procedure for the portable player, see the instruction manual that comes with it.

- When the connection method is "From Vehicle".
 - When the auto connection is on
When the portable player is standby for the connection, it will be automatically connected whenever the "ENGINE START STOP" switch is in either ACCESSORY or IGNITION ON mode.
 - When the auto connection is off
Manually connect the portable player in accordance with the following procedure.



Touch "Connect".



When the connection is completed, this screen is displayed. Now you can use the portable player.



This screen will appear when the connection has failed.

- When the connection method is "From Portable Player"

Operate the portable player and connect it to the Bluetooth® audio system. For the operation procedure for the portable player, see the instruction manual that comes with it.



Touch "Connect".



Connect the portable audio player to the Bluetooth® audio system.



This screen will appear when the connection has been successfully established.

- **Reconnecting the portable player**

If the portable player is disconnected with a poor reception from the Bluetooth® network when the “ENGINE START STOP” switch is in ACCESSORY or IGNITION ON mode, the system automatically re-connects the portable player.

If the Bluetooth® is disconnected on purpose such as you turned your portable player off, this does not happen.

Reconnect it by the following method.

- **Select the portable player again.**
- **Enter the portable player.**

(b) Playing a Bluetooth® audio

- **Playing and pausing a Bluetooth® audio**

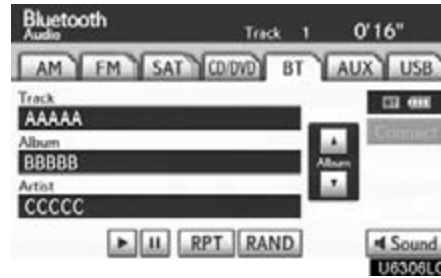



Touch “BT” tab if the Bluetooth® audio player is already connected.

Touch  and the music will start playing.

Touch  and the music will pause.

Touch  and the music will start playing again.

Depending on the portable player that is connected to the system, the music may start playing when touching  while it is paused. On the other hand, the music may pause when touching  while it is playing.



Some titles may not be displayed depending on the type of portable player.

● **Selecting a desired track**

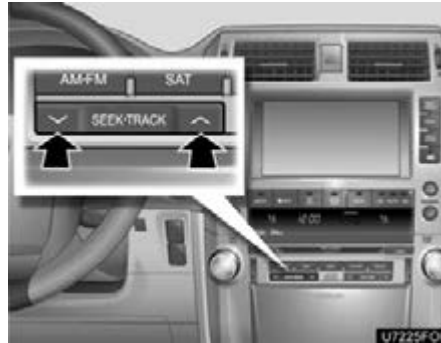

“SEEK-TRACK” button: Use for direct access to a desired track.

Push the “^” or “v” button of “SEEK-TRACK” and repeat it until the desired track number appears on the screen. As you release the button, the portable player will start playing the selected track from the beginning.

Fast forward:

Push and hold the “^” button of “SEEK-TRACK” to fast forward the player. When you release the button, the portable player will resume playing from that position.

Reverse:

Push and hold the “v” button of “SEEK-TRACK” to reverse the player. When you release the button, the player will resume playing.

INFORMATION

Depending on the portable player that is connected to the system, certain functions may not be available.

AUDIO/VIDEO SYSTEM

- **Selecting a desired album**

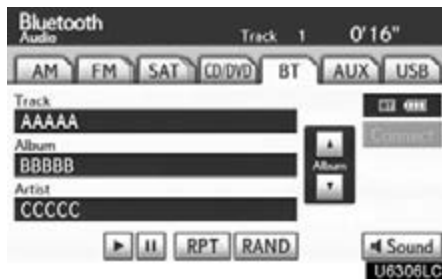

“Album ▲”: Touch this button to go to the next album.

“Album ▼”: Touch this button to go to the previous album.

INFORMATION

Depending on the portable player that is connected to the system, certain functions may not be available.

- **Other function**

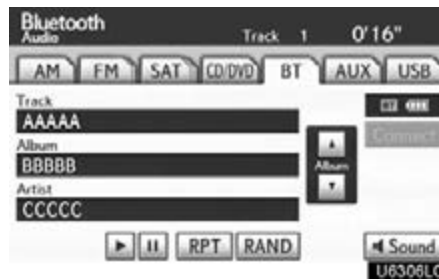

“RPT”: Use this control to automatic replay the track you are currently listening to.

Repeating a track —

While the track is playing, touch “RPT” briefly.

“RPT” appears on the screen. When the track is finished, the player will automatically play it again. To cancel the repeat, touch “RPT” once again.

“**RAND**”: Use this for automatic and random selection of tracks on the album that you are currently listening to.

Playing the tracks in the album in random order —

While the track is playing, touch “RAND” briefly.

“RAND” appears on the screen. The system selects a track in the album you are currently listening to. To cancel this function, touch “RAND” once again.

INFORMATION

Depending on the portable player that is connected to the system, certain functions may not be available.

— USB memory/ iPod operation

Connecting a USB memory or iPod enables you to enjoy music from the vehicle speakers.



CAUTION

Do not operate the player's controls or connect the USB memory or iPod while driving.

NOTICE

- *Do not leave your portable player in the car. In particular, high temperatures inside the vehicle may damage the portable player.*
- *Do not push down on or apply unnecessary pressure to the portable player while it is connected as this may damage the portable player or its terminal.*
- *Do not insert foreign objects into the port as this may damage the portable player or its terminal.*

(a) Connecting a USB memory or iPod

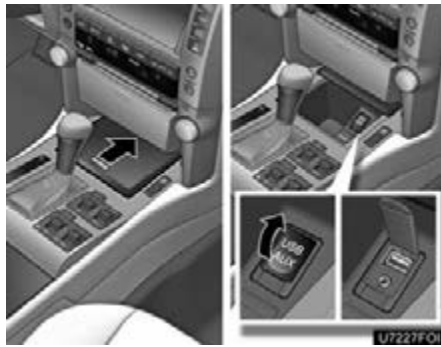

Open the cover and connect a USB memory or iPod using an iPod cable.

Turn on the power of the USB memory or iPod if it is not turned on.

(b) Playing a USB memory or iPod

- Playing and pausing a file or track

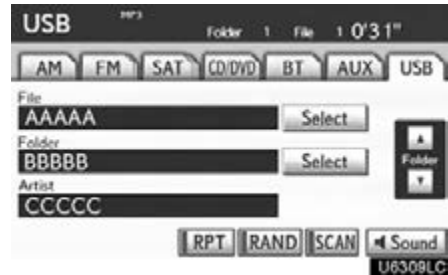

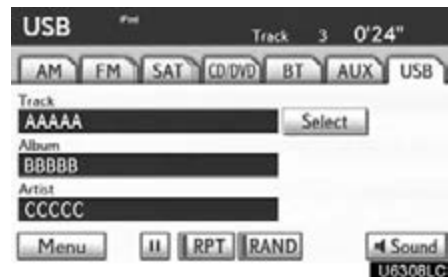

► USB memory



► iPod

Push the “AUX-USB” button or push the “AUDIO” button to display this screen and touch the “USB” tab to display this screen if the USB memory or iPod are already connected.

Touch  and the music will start playing.

Touch  and the music will pause.

Touch  and the music will start playing again.

INFORMATION

- When an iPod is connected and the audio source is changed to iPod mode, the iPod will resume play from the same point in which it was last used.
- When the USB memory is connected and the audio source is changed to USB memory mode, the USB memory will start playing the first file in the first folder. If the same device is removed and reinserted (and the contents have not been changed), the USB memory will resume play from the same point in which it was last used.
- Depending on the iPod or USB memory that is connected to the system, certain functions may not be available.

- Selecting a play mode (iPod only)



1. Touch "Menu".



2. Touch the desired play mode.

- **Selecting a desired folder (USB memory only)**

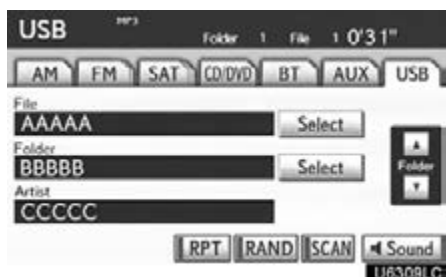

“**Folder▲**” : Touch this button to go to the next folder.

“**Folder▼**” : Touch this button to go to the previous folder.

“**Select**” for Folder: The desired folder can be selected in a list. This function is available only when the vehicle is not moving.

Touch “**Select**”. The folder list is displayed.



Touch the desired folder number. The system will start playing the first file of the selected folder.

 : By touching this button, the list moves up by 5 folder groups. If this button is touched when the top page of the list is displayed, the last page is displayed.

 : By touching this button, the list moves down by 5 folder groups. If this button is touched when the last page of the list is displayed, the top page is displayed.

● **Selecting a desired file or track**

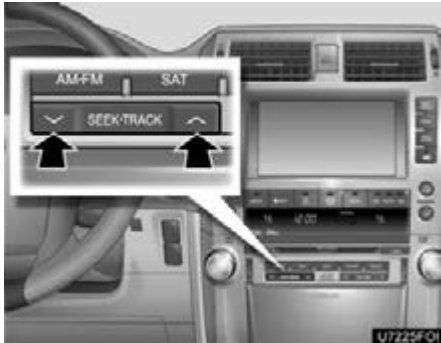

“SEEK-TRACK” button: Use for direct access to a desired file or track.

Push the “^” or “X” button of “SEEK-TRACK” and repeat it until the desired file or track appears on the screen. As you release the button, the USB memory or iPod will start playing the selected file or track from the beginning.

Fast forward:

Push and hold the “^” button of “SEEK-TRACK” to fast forward the player. When you release the button, the player will resume playing from that position.

Reverse:

Push and hold the “X” button of “SEEK-TRACK” to reverse the player. When you release the button, the player will resume playing.



“TUNE/FILE” knob: Use for direct access to a desired file or track in the player.

Turn the “TUNE/FILE” knob to step up or down all the files or tracks in the player you are currently listening to.

AUDIO/VIDEO SYSTEM

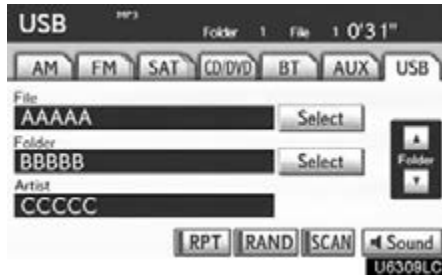

► USB memory

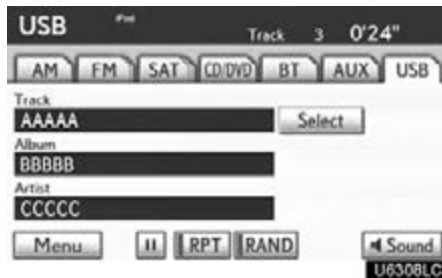

► iPod

“Select” for File or Track: The desired file or track can be selected in a list. This function is available only when the vehicle is not moving.

Touch **“Select”**. The file or track list is displayed.

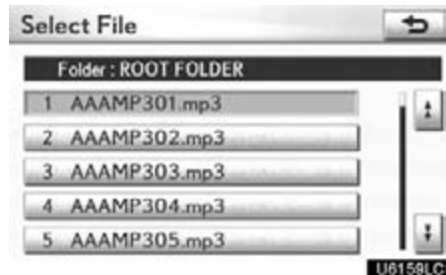

Touch the desired file or track number. The changer will start playing the selected file or track from the beginning.

 : By touching this button, the list moves up by 5 file or track groups. If this button is touched when the top page of the list is displayed, the last page is displayed.

 : By touching this button, the list moves down by 5 file or track groups. If this button is touched when the last page of the list is displayed, the top page is displayed.

- Searching for a desired file (USB memory only)

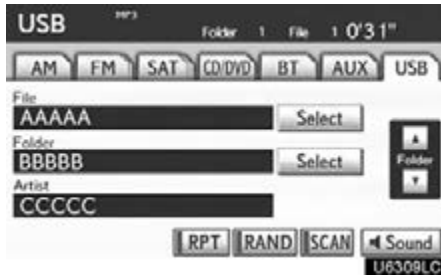

Touch "SCAN" on the screen or push the "SCAN" button briefly while the music is playing.

"SCAN" appears on the screen. The player will play the next file for 10 seconds, then scan again. To select a file, touch "SCAN" on the screen or push the "SCAN" button a second time. If the player reaches the end of the memory, it will continue scanning at file 1.

After all the files are scanned in one pass, normal play resumes.

- Searching for a desired folder (USB memory only)

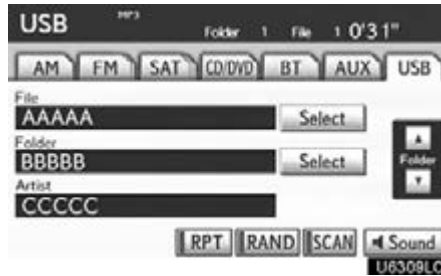

Touch "SCAN" on the screen or push the "SCAN" button for longer than a second while the music is playing.

"FLD.SCAN" appears on the screen. The program at the beginning of each folder will be played for 10 seconds. To continue listening to the program of your choice, touch "SCAN" on the screen or push the "SCAN" button a second time.

After all the folders are scanned in one pass, normal play resumes.

• Other function

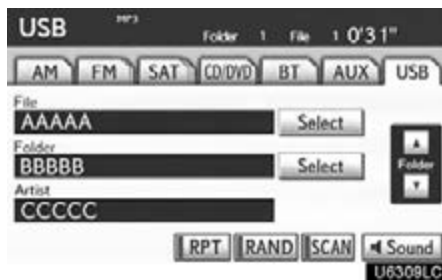

► USB memory

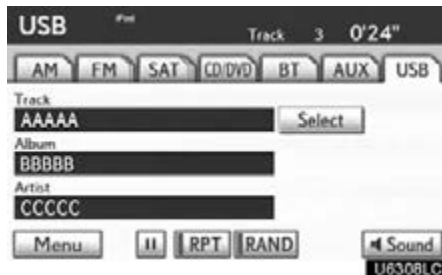

► iPod

“RPT”: Use this control to automatic re-play the file or track you are currently listening to.

Repeating a file or track —

While the file or track is playing, touch “RPT” briefly.

“RPT” appears on the screen. When the file or track is finished, the player will automatically play it again. To cancel the repeat, touch “RPT” once again.

Repeating a folder (USB memory only) —

While the folder is playing, touch “RPT” for longer than a second.

“FLD.RPT” appears on the screen. When the folder is finished, the changer will automatically go back to the beginning of the folder and play the folder again. To cancel it, touch “RPT” once again.

“RAND”: Use this for automatic and random selection of files or tracks on the album that you are currently listening to.

Playing the file or track in random order —

While the file or track is playing, touch “RAND” briefly.

“RAND” appears on the screen. The system selects a file or track you are currently listening to. To cancel this function, touch “RAND” once again.

Playing the files in all files in random order —

Touch “RAND” for longer than a second while the music is playing. “FLD.RAND” appears on the screen. The system selects a file in all files. To cancel it, touch “RAND” once again.

When a file is skipped or the system is inoperative, touch “RAND” to reset.

Audio/video remote controls (steering switches)



Some parts of the audio system can be adjusted using the switches on the steering wheel.

Details of the specific switches, controls, and features are described below.

- 1** Volume control switch
- 2** “^ X” switch
- 3** “MODE” switch

1 Volume control switch

Push “+” side to increase the volume. The volume continues to increase while the switch is being pressed.

Push “-” side to decrease the volume. The volume continues to decrease while the switch is being pressed.

2 “^ X” switch

Radio

This switch has the following features —

To select a preset station:

Quickly push and release the “^” or “X” side of the switch. Do this again to select the next preset station.

To seek a station:

Push and hold the “^” or “X” side of the switch until you hear a beep. Do this again to find the next station. If you push the switch on either side during the seek mode, seeking will be cancelled.

To step up or down the frequency, push and hold the switch even after you hear a beep. When you release from the switch, the radio will begin seeking up or down for a station. Do this again to find the next station.

XM® Satellite Radio (if equipped) —

To select a preset channel, push the “^” or “X” side of the switch. Repeat until a desired channel is found.

CD changer or DVD changer

Use this switch to skip up or down to a different track, file or chapter in either direction.

To select a desired track, file or chapter: Quickly push and release the “^” or “X” side of the switch until the track, file or chapter you want to play is set. If you want to return to the beginning of the current track, file or chapter, push the “X” side of the switch once, quickly.

To select a desired disc:

Push and hold the “^” or “X” switch until you hear a beep to change to the next or the previous disc. Repeat this operation until you reach the disc you want to listen to.

Bluetooth® audio player

Use this switch to skip up or down to a different track or album in either direction.

To select a desired track:

Quickly push and release the “^” or “X” side of the switch until the track you want to listen to is set. If you want to return to the beginning of the current track, push the “X” side of the switch once quickly.

To select a desired album:

Push and hold “^” or “X” switch until you hear a beep to change to the next or the previous album. Repeat this operation until you reach the album you want to listen to.

USB memory/iPod

Use this switch to skip up or down to a different file or track in either direction.

To select a desired file or track:

Push the “^” or “X” side of the switch until the file or track you want to listen to is set. If you want to return to the beginning of the current file or track, push the “X” side of the switch once quickly.

To select a desired folder (USB memory only):

Push and hold “^” or “X” switch until you hear a beep to change to the next or the previous folder. Repeat this operation until you reach the folder you want to listen to.

3 “MODE” switch

Push “MODE” switch to select an audio mode. Each push changes the mode sequentially if the desired mode is ready to use.

To turn the audio/video system on, push the “MODE” switch.

To turn the audio/video system off, push and hold the “MODE” switch until you hear a beep.

Rear seat entertainment system features (if equipped) —

The rear seat entertainment system is designed for the rear passengers to enjoy audio and DVD video.

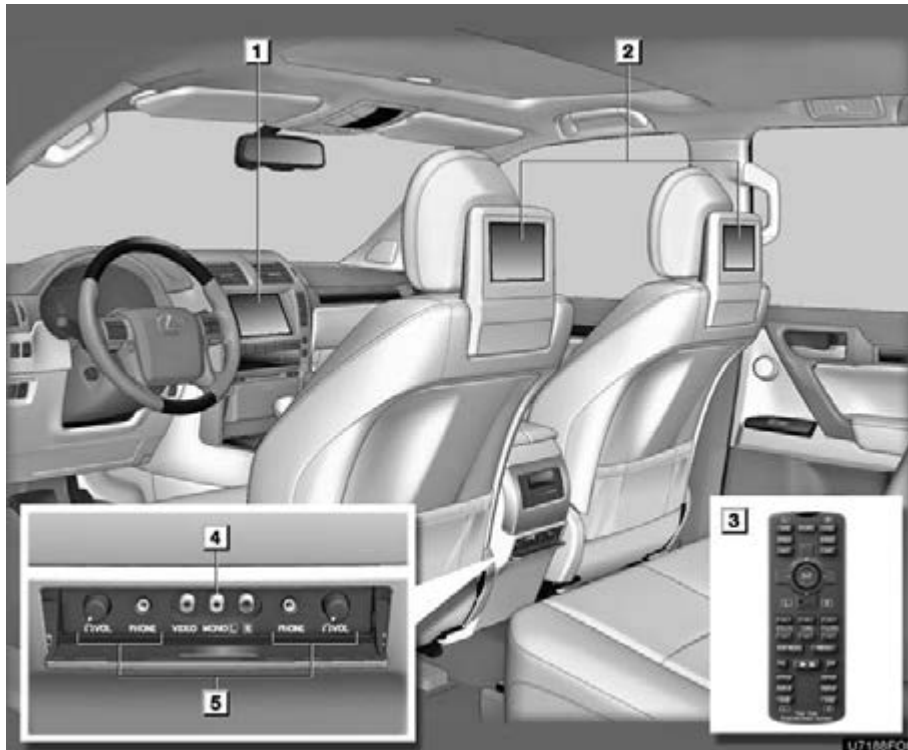

- 1** Front audio system
- 2** Displays
- 3** Rear seat entertainment system controller
- 4** A/V input port
- 5** Headphone volume control dials and headphone jacks

AUDIO/VIDEO SYSTEM

The rear seat entertainment system can be used when the “ENGINE START STOP” switch is in ACCESSORY or IGNITION ON mode.

- **Displays**



A display is installed in the back of each front seat. When audio–video equipment is connected to the A/V input port, rear passengers can enjoy different audio sources on each display. See “—Using the video mode” on page 284.

- **Rear seat entertainment system controller**

Use the controller to operate both the left and right side displays. Some controller buttons are shared between the left and right side displays. When operating those buttons, first select the desired display using the select display switch.

To operate, aim the controller at the desired display.



- 1 Controller buttons for the left side display
- 2 Controller buttons for the right side display
- 3 Turns display off
- 4 Selects the display to be operated (for some controller buttons only)

- Before using the controller (for new vehicle owners)



An insulating sheet is set to prevent the batteries from being discharged. Remove the insulating sheet before using the remote control.

- Replacing the controller batteries
Necessary item for replacing “3 AA batteries”.



1. Remove the cover.



2. Remove the depleted batteries and install the new ones.

If the batteries are discharged, the following symptoms may occur.

- The rear seat entertainment system controller will not function properly.
- The operational range is reduced.

When using 3 AA batteries

- Batteries can be purchased at your Lexus dealer, electric appliance shop, or camera stores.
- Replace only with the same or equivalent type recommended by a Lexus dealer.
- Dispose of used batteries according to the local laws.

- **Headphone jacks**



1 To use the headphones, connect them to the jack.

2 To adjust the volume

1. Push and release the lid.

2. Turn the knob clockwise to increase the volume. Turn the knob counterclockwise to decrease the volume.

- **Headphones**

With some headphones generally available in the market, it may be difficult to catch signals properly. Lexus recommends the use of Lexus genuine wireless headphones.

Please contact your Lexus dealer for further details.

- **Volume**

Adjust the volume when you connect the headphones to the jack. Loud sounds may have a significant impact on the human body.

- Caution screen



This screen appears for a few seconds when the “ENGINE START STOP” switch is in ACCESSORY or IGNITION ON mode.

- Changing the source



- 1 Turning on the audio source selection screen
- 2 Inputting the selected icon
- 3 Selecting an icon

Push “**SOURCE**” to display the audio source selection screen.



Select an audio source.

- Changing the speaker output



To play the rear audio over the speakers in the vehicle, turn **“Speaker Output”** on.

CAUTION

- **While driving**
 - Do not use headphones. Doing so may cause an accident, resulting in death or serious injury.
- **To prevent accidents and electric shock**
 - Do not disassemble or modify the remote control.
- **When the remote control is not used**
 - Stow the remote control. Injuries may result in the event of an accident or sudden braking.
- **Conversational speech on some DVDs is recorded at a low volume to emphasize the impact of sound effects. If you adjust the volume assuming that the conversations represent the maximum volume level that the DVD will play, you may be startled by louder sound effects or when you change to a different audio source. The louder sounds may have a significant impact on the human body or pose a driving hazard. Keep this in mind when you adjust the volume.**
- **Removed battery and other parts:**
 - Keep away from children.
 - These parts are small and if swallowed by a child they can cause choking.

— Using the radio

NOTICE

- **Cleaning the display**
Wipe the display with a dry soft cloth.
If the screen is wiped with a rough cloth, the surface of the screen may be scratched.
- **To prevent damage to the remote control**
Keep the remote control away from direct sunlight, temperature heat and high humidity.
Do not drop or knock the remote control against hard objects.
Do not sit on or place heavy objects on the remote control.
- **For normal operation after replacing the battery, observe the following precautions to prevent accidents:**
 - Always work with dry hands. Moisture may cause the battery to rust.
 - Do not touch or move any other components inside the remote control.
 - Do not bend either of the battery terminals.

INFORMATION

Rear seat entertainment system can be locked to prevent rear passengers from operating the entertainment system. (See “● Rear system lock” on page 332.)



Select radio mode on the source screen to display the control screen.



- 1 Selecting a preset station
- 2 Tuning the station

● **Selecting a preset station**

Push “^” or “X” of “DISC-CH” until the desired station band appears on the screen.

● **Tuning the station**

Push “^” or “X” of “TUNE” until the desired station appears on the screen.

Push “^” or “X” of “TUNE” and the stations will be searched automatically one after another.

— Using the DVD changer



- 1 Turning on DVD changer mode
- 2 Selecting a disc

● Selecting a disc



Push “^” or “X” of “DISC-CH” until the desired disc number appears on the screen.

- Audio CD, CD text 270
- MP3/WMA disc 271
- DVD video/audio 271
- Video CD 281

— Playing an audio CD/CD text

● Selecting a track



Push “^” or “X” of “TUNE” until the desired track number appears on the screen.

● Fast forwarding or reversing a track

Push and hold “^” or “X” of “TUNE”.

— Playing MP3/WMA discs

- Selecting a file



- 1 Selecting a file
- 2 Selecting a folder



Push “^” or “X” of “TUNE” until the desired file number appears on the screen.

- Selecting a folder

Push “^” or “X” of “FOLDER” until the desired folder number appears on the screen.

- Fast forwarding or reversing a file

Push and hold “^” or “X” of “TUNE”.

— Playing DVD video/audio

- Controller



AUDIO/VIDEO SYSTEM

- 1 Turning on the DVD mode
- 2 Inputting the selected icon
- 3 Selecting an icon
- 4 Turning on the menu screen
- 5 Playing/pausing a disc
- 6 Fast forwarding a disc
- 7 Turning on the control icon screen
- 8 Reversing a disc
- 9 Turning on the title selection screen
- 10 Push to select a chapter/track
Push and hold to fast forwarding or reversing a chapter/track

● DVD video and DVD audio

Push “**OPTION**” if no icons are shown while watching a DVD video or DVD audio, and following screens appear.

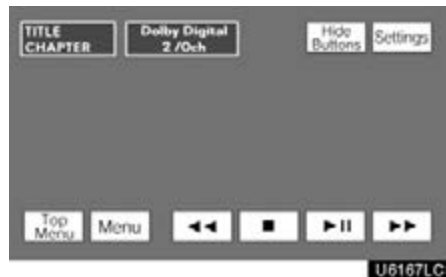

▶ DVD video

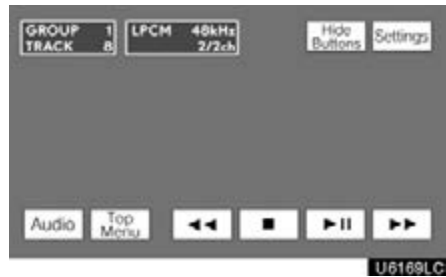

▶ DVD audio





“**Settings**”: Selecting this will display setting screen.

“**Hide Buttons**”: Selecting this will turn off the icons from the screen.

If “” appears on the screen when you select a control, the operation relevant to the control is not permitted.

DESCRIPTION OF DVD VIDEO CONTROLS





“Menu” and “Top Menu”: If you select any of the above controls, the menu screen for DVD video appears. (For the operation, see the manual that come with the DVD video disc provided separately.)

-  : Selecting this will fast reverse during playback.
-  : Selecting this will stop the video screen.
-  : Selecting this will pause/resume the video screen.
-  : Selecting this will fast forward during playback and forward frame by frame during pause.

DESCRIPTION OF DVD AUDIO CONTROLS

“Top Menu”: If you select this button, the menu screen for DVD audio appears. (For the operation, see the manual that come with the DVD audio disc provided separately.)

“Audio”: The audio changing screen appears. (See page 278.)

-  : Selecting this will fast reverse during playback.
-  : Selecting this will stop the disc.
-  : Selecting this will pause/resume the disc.
-  : Selecting this will fast forward during playback and forward frame by frame during pause.

DVD SETTINGS

When “Settings” is selected on the control icon screens, the following screens will appear according to audio mode.

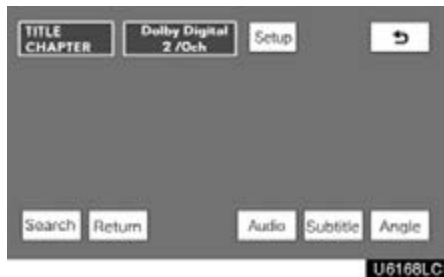

► DVD video



► DVD audio

DESCRIPTION OF DVD VIDEO SETTINGS

“Setup”: The initial set up screen appears. (See page 279.)

“Search”: The title search screen appears. (See page 275.)

“Return”: Selecting this will display the predetermined scene and start playing from there.

“Audio”: The audio changing screen appears. (See page 278.)

“Subtitle”: The subtitle changing screen appears. (See page 277.)

“Angle”: The angle selection screen appears. (See page 279.)

When you select , the previous screen returns.

DESCRIPTION OF DVD AUDIO SETTINGS

“Setup”: The initial set up screen appears. (See page 279.)

“Select Number”: The track or number search screen appears. (See page 277.)

“Search”: The group search screen appears. (See page 276.)

“Return”: Selecting this will display the predetermined scene and start playing from there.

“Prev. Page”: Select this button to reverse the pages.

“Next Page”: Select this button to forward the pages.

“Subtitle”: The subtitle changing screen appears. (See page 277.)

“Angle”: The angle selection screen appears. (See page 279.)

When you select , the previous screen returns.

SEARCHING BY TITLE

DVD video only—

Select “Search” on the settings screen. Enter the title number and select “OK”. The player starts playing video for that title number.

When you push “^” or “X” of “TUNE”, you can select a chapter.

If you enter the wrong numbers, select  to delete the numbers.

When you select , the previous screen returns.

SEARCHING BY GROUP



DVD audio only —

Select **“Search”** on the settings screen. Enter the group number and select **“OK”**. The player starts playing the disc for that group number.

When you push **“^”** or **“X”** of **“TUNE”**, you can select a track.

If you enter the wrong numbers, select

 to delete the numbers.

When you select , the previous screen returns.

SELECTING THE BONUS GROUP



DVD audio only —

Select **“Search”** on the settings screen. Enter the bonus group number on the searching group screen and select **“OK”**.

The **“Enter Key Code”** screen will appear. To enter the number of the group you want to play, select the group number.

If you enter the wrong numbers, select

 to delete the numbers.

When you select , the previous screen returns.

Select **“OK”** on the screen.

The player starts playing the disc from the selected bonus group number.

SELECTING THE MENU NUMBER

DVD audio only —

Select **“Select Number”** on the settings screen.

Enter the menu number and select **“OK”**.

If you enter the wrong numbers, select



to delete the numbers.

When you select , the previous screen returns.

CHANGING THE SUBTITLE LANGUAGE



Select **“Subtitle”** on the settings screen.

Each time you select **“Subtitle”**, the language is selected from the ones stored in the discs and changed.

When you select **“Hide”**, the subtitle can be hidden.

When you select , the previous screen returns.

AUDIO/VIDEO SYSTEM

CHANGING THE AUDIO LANGUAGE



DVD video only —

Select “Audio” on the settings screen.

Each time you select “Audio”, the language is selected from the ones stored in the discs and changed.

When you select , the previous screen returns.

CHANGING THE AUDIO FORMAT

DVD audio only —

Select “Audio” on the control icon screen.

Each time you select “Audio”, another audio format stored on the disc is selected.

When you select , the previous screen returns.

CHANGING THE ANGLE

Select “Angle” on the settings screen.

The angle can be selected for discs that are multi-angle compatible when the angle mark appears on the screen.

Each time you select “Angle”, the angle is selected from the ones stored in the discs and changed.

When you select , and the previous screen returns.

SETUP MENU



Select “Setup” on the settings screen.

There are initial setting buttons on the “Setup Menu” screen.

After you change the initial setting, select “OK”. The initial setting screen will be turned off and return to the picture previously.

When “Default” is selected, all menus are initialized.

The initial setting can be changed.

- **Audio language (DVD video only)**

You can change the audio language.

1. Select "Audio Language".
2. Select the language you want to hear on the "Audio Language" screen.

If you cannot find the language you want to hear on this screen, select "Other" and enter a language code. For the entry of language code, see the following "ENTER AUDIO LANGUAGE CODE".

To return to the "Setup Menu" screen, select .

- **Subtitle language**

You can change the subtitle language.

1. Select "Subtitle Language".
2. Select a language you want to read on the "Subtitle Language" screen.

If you cannot find the language you want to read on this screen, select "Other" and enter a language code. For the entry of language code, see the following "ENTER AUDIO LANGUAGE CODE".

To return to the "Setup Menu" screen, select .

- **DVD language**

You can change the language on the DVD video menu.

1. Select "DVD Language".
2. Select the language you want to read on the "DVD Language" screen.

If you cannot find the language you want to read on this screen, select "Other" and enter a language code. For the entry of language code, see the following "ENTER AUDIO LANGUAGE CODE".

To return to the "Setup Menu" screen, select .

- **Angle mark**

The multi-angle mark can be turned on or off on the screen while the disc which is multi-angle compatible is being played.

1. Select "Angle Mark".
2. Select "ON" or "OFF".

- **Parental lock (DVD video only)**

The level of viewer restrictions can be changed.

1. Select "Parental Lock".
2. Enter the 4-digit personal code on the "Key code" screen.

If you enter the wrong numbers, select  to delete the numbers.

To return to the "Setup Menu" screen, select .

3. Select a parental level (1 — 8) on the "Select Restriction Level". Select  to return to the "Setup Menu" screen.

- **Sound dynamic range (DVD video only)**

The difference between the lowest volume and the highest volume can be adjusted.

1. Select "Sound Dynamic Range".
2. Select "MAX", "STD" or "MIN".

ENTER AUDIO LANGUAGE CODE

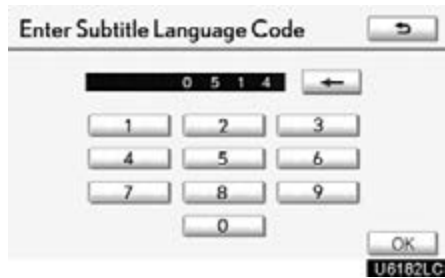

If you select “Other” on the “Audio Language” screen, “Subtitle Language” screen or “DVD Language” screen, you can select the language you want to hear or read by entering a language code. (See page 237.)

1. Enter the 4–digit language code.

If you enter the wrong numbers, select



to delete the numbers.

2. Select “OK”.

● **Video CD**

Push “OPTION” if no icons are shown while watching a video CD, and following screen appears.

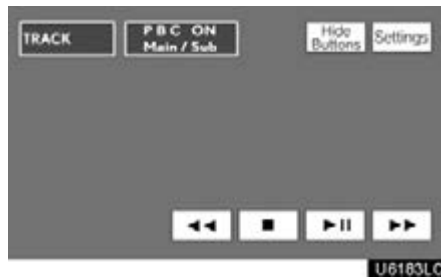





“Settings”: Selecting this will display setting screen.

“Hide Buttons”: Selecting this will turn off the icons from the screen.

If “” appears on the display when you select a control, the operation is not permitted.

AUDIO/VIDEO SYSTEM

DESCRIPTION OF VIDEO CD CONTROLS

-  : Select this to fast reverse during playback.
-  : Selecting this will stop the video screen.
-  : Use this to pause/resume the video screen.
-  : Select this to fast forward during the playback and start playing frame by frame during pause.

VIDEO CD SETTINGS

When “**Settings**” is selected on the control icon screen, the following screen will appear.

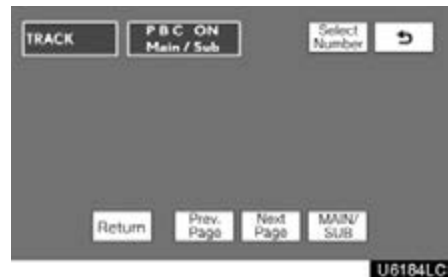

DESCRIPTION OF VIDEO CD SETTINGS

“Select Number”: The track or number search screen appears. (See “SEARCHING BY TRACK” on page 283.)

“Return”: Selecting this will display the predetermined scene and start playing from there.

“Prev. Page”: When you select this while the disc menu is displayed, the previous page appears on the screen. If you select this while the player is playing video, the previous track is searched and played.

“Next Page”: When you select this while the disc menu is displayed, the next page appears on the display. If you select this while the player is playing video, the next track is searched and played.

“MAIN/SUB”: A multiplex transmission changing control. The mode changes from Main/Sub to Main, to Sub and back to Main/Sub by selecting this control.

SEARCHING BY TRACK

Select **“Select Number”** on the settings screen.

Enter the track numbers and select “OK”. The player starts playing video for that title number.

You can select a track number by pushing **“^”** or **“X”** of **“TUNE”**.

If you enter the wrong numbers, select



to delete the numbers.

Select , and the previous screen returns.

— Using the video mode



Push “**VIDEO**” to select the video mode. Before switching to the video mode, connect the audio–video equipment to the A/V input port.

When “**Speaker Output**” is off, any audio–video source can be selected for the other rear display. See “● Changing the speaker output” on page 268.

● Using the port

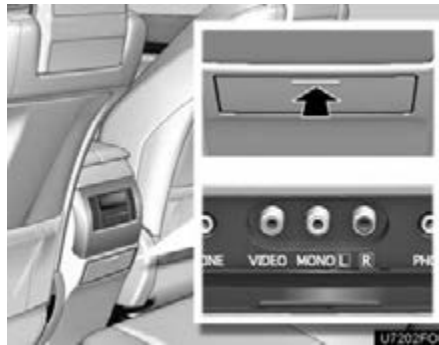

Push and release the lid.

The A/V input port is composed of 3 input ports.

Yellow: Image input port

White: Left channel audio input port

Red: Right channel audio input port

The rear seat entertainment system plays videos and sound when audio–video equipment is connected to the A/V input port. For details, refer to the manufacturer’s instructions.

NOTICE

When the A/V input port is not in use, keep the A/V input port cover closed. Inserting anything other than an appropriate plug may cause electrical failure or a short circuit.

— Changing other settings

- If the video is not correctly displayed



Push “DISPLAY”.

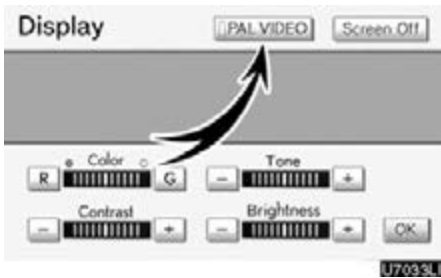

Select “PAL VIDEO”.

If the video is not correctly displayed, turn “PAL VIDEO” on or off.

- Setting the display mode



Pushing “SIZE” changes the display modes sequentially as follows:

Normal → “Wide 1” → “Wide 2”

● **Adjusting the screen**



Push **"DISPLAY"**.



Select the desired button to adjust color, tone, contrast and brightness. After adjusting the screen, touch **"OK"**.

"Color" "R":

Strengthens the red color of the screen.

"Color" "G":

Strengthens the green color of the screen.

"Tone" "+":

Strengthens the tone of the screen.

"Tone" "-":

Weakens the tone of the screen.

"Contrast" "+":

Strengthens the contrast of the screen.

"Contrast" "-":

Weakens the contrast of the screen.

"Brightness" "+":

Brightens the screen.

"Brightness" "-":

Darkens the screen.

The screen goes off when **"Screen Off"** is selected. To turn the display screen back on, push **"DVD"**, **"VIDEO"**, **"OFF"** or **"DISPLAY"** for the display. The selected screen appears.

Audio/video system operating hints

NOTICE

To ensure correct audio/video system operations:

- *Be careful not to spill beverages over the audio/video system.*
- *Do not put anything other than an appropriate discs into the CD changer or DVD changer.*
- *The use of a cellular phone inside or near the vehicle may cause a noise from the speakers of the audio/video system which you are listening to. However, this does not indicate a malfunction.*

● Radio reception

Usually, a problem with radio reception does not mean there is a problem with your radio — it is just the normal result of conditions outside the vehicle.

For example, nearby buildings and terrain can interfere with FM reception. Power lines or telephone wires can interfere with AM signals. And of course, radio signals have a limited range. The farther you are from a station, the weaker its signal will be. In addition, reception conditions change constantly as your vehicle moves.

Here are some common reception problems that probably do not indicate a problem with your radio:

FM

Fading and drifting stations — Generally, the effective range of FM is about 25 miles (40 km). Once outside this range, you may notice fading and drifting, which increase with the distance from the radio transmitter. They are often accompanied by distortion.

Multi-path — FM signals are reflective, making it possible for two signals to reach your antenna at the same time. If this happens, the signals will cancel each other out, causing a momentary flutter or loss of reception.

Static and fluttering — These occur when signals are blocked by buildings, trees, or other large objects. Increasing the bass level may reduce static and fluttering.

Station swapping — If the FM signal you are listening to is interrupted or weakened, and there is another strong station nearby on the FM band, your radio may tune in the second station until the original signal can be picked up again.

AM

Fading — AM broadcasts are reflected by the upper atmosphere — especially at night. These reflected signals can interfere with those received directly from the radio station, causing the radio station to sound alternately strong and weak.

Station interference — When a reflected signal and a signal received directly from a radio station are very nearly the same frequency, they can interfere with each other, making it difficult to hear the broadcast.

Static — AM is easily affected by external sources of electrical noise, such as high tension power lines, lightening, or electrical motors. This results in static.

AUDIO/VIDEO SYSTEM

XM®

Cargo loaded on the roof luggage carrier, especially metal objects, may adversely affect the reception of XM® Satellite Radio.

Alteration or modifications carried out without appropriate authorization may invalidate the user's right to operate the equipment.

iPod

About iPod —

- Apple is not responsible for the operation of this device or its compliance with safety and regulatory standards.
- iPod is a trademark of Apple Inc., registered in the U.S. and other countries.

Compatible models —

Model	Generation	Software version
iPod	5th generation	Ver. 1.2.0 or higher
iPod nano	1st generation	Ver. 1.3.0 or higher
	2nd generation	Ver. 1.1.2 or higher
	3rd generation	Ver. 1.0.0 or higher
iPod touch	1st generation	Ver. 1.1.0 or higher
iPod classic	1st generation	Ver. 1.0.0 or higher

Depending on differences between models or software versions etc., some models listed above might be incompatible with this system.

iPod 4th generation and earlier models are not compatible with this system.

iPhone, iPod mini, iPod shuffle and iPod photo are not compatible with this system.

USB memory

USB memories that can be used for MP3 and WMA playback.

- USB communication formats: USB 2.0 FS (12 MBPS)
- File formats: FAT 16/32 (Windows®)
- Correspondence class: Mass storage class

CARING FOR YOUR CD CHANGER, DVD CHANGER AND DISCS

- Your CD changer and DVD changer is intended for use with 4.7 in. (12 cm) discs only.
- Extremely high temperatures can keep your CD changer and DVD changer from working. On hot days, use the air conditioning to cool the vehicle interior before you use the changer and player.
- Bumpy roads or other vibrations may make your CD changer and DVD changer skip.
- If moisture gets into your CD changer and DVD changer, you may not play even though they appear to be working. Remove the discs from the changer and wait until it dries.

CAUTION

CD changer and DVD changer use an invisible laser beam which could cause hazardous radiation exposure if directed outside the unit. Be sure to operate the changers correctly.

CD changer



- Use only discs marked as shown above. The following products may not be playable on your changer.
SACD
Copy-protected CD
CD-ROM

DVD changer

Audio CDs	 
DVD video discs	 
DVD audio discs	 
DVD audio discs	
Video CDs	 

- Use only discs marked as shown above. The following products may not be playable on your changer.
SACD
Copy-protected CD
CD-ROM
DVD-R
DVD+R
DVD-RW
DVD+RW
DVD-ROM
DVD-RAM



► Special shaped discs

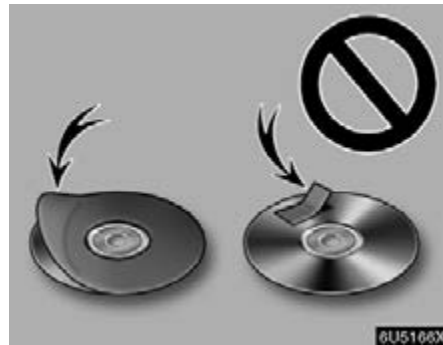

► Labeled discs



► Transparent/translucent discs

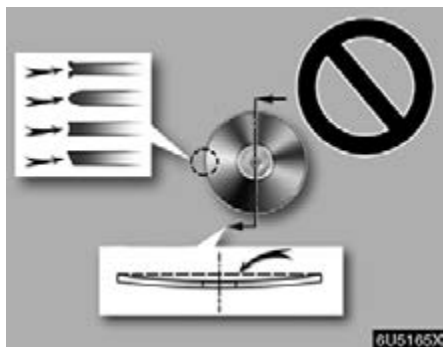

► Low quality discs

NOTICE

- Do not use special shaped, transparent/translucent, low quality or labeled discs such as those shown in the illustrations. The use of such discs may damage the player or changer, or it may be impossible to eject the disc.
- This system is not designed for use of Dual Disc. Do not use Dual Disc because it may cause damage to the changer.
- Do not use a disc with protection ring. The use of such disc may damage the changer, or it may be impossible to eject the disc.

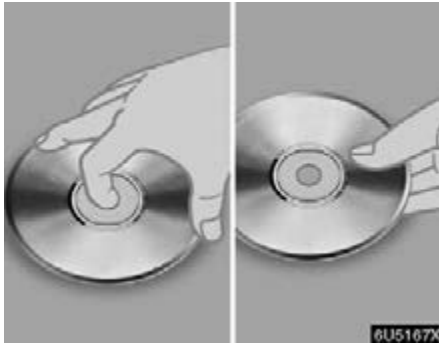

► Correct ► Wrong

- Handle discs carefully, especially when you are inserting them. Hold them on the edge and do not bend them. Avoid getting fingerprints on them, particularly on the shiny side.
- Dirt, scratches, warping, pin holes, or other disc damage could cause the player to skip or to repeat a section of a track. (To see a pin hole, hold the disc up to the light.)
- Remove discs from the players when you are not using them. Store them in their plastic cases away from moisture, heat, and direct sunlight.



To clean a disc: Wipe it with a soft, lint-free cloth that has been dampened with water. Wipe in a straight line from the center to the edge of the disc (not in circles). Dry it with another soft, lint-free cloth. Do not use a conventional record cleaner or anti-static device.

MP3/WMA FILES

- MP3 (MPEG Audio Layer 3) and WMA (Windows Media® Audio) are audio compression standards.
- The MP3/WMA player can play MP3 and WMA files on CD-ROM, CD-R and CD-RW discs.
 - The unit can play disc recordings compatible with ISO 9660 level 1, 2, (Romeo Joliet) and UDF (2.01 or lower) file system.
- When naming an MP3 or WMA file, add the appropriate file extension (.mp3 or .wma).
- The MP3/WMA player plays back files with .mp3 or .wma file extensions as MP3 or WMA files. To prevent noise and playback errors, use the appropriate file extensions.
- The MP3/WMA player can play only the first session using multi-session compatible CDs.
- MP3 player — MP3 files are compatible with the ID3 Tag Ver. 1.0, Ver. 1.1, Ver. 2.2, and Ver. 2.3 formats. The unit cannot display disc title, track title and artist name in other formats.
- USB memory — MP3 files are compatible with the ID3 Tag Ver. 1.0, Ver. 1.1, Ver. 2.2, Ver. 2.3 and Ver. 2.4 formats. The unit cannot display track title and artist name in other formats.
- WMA files can contain a WMA tag that is used in the same way as an ID3 tag. WMA tags carry information such as track title, artist name.
- The emphasis function is available only when playing MP3/WMA files recorded at 32, 44.1 and 48 kHz.

Sampling frequency

MP3 files for MP3 player:

MPEG 1 LAYER 3 — 32, 44.1, 48 kHz

MPEG 2 LSF LAYER 3 — 16, 22.05, 24 kHz

MP3 files for USB memory:

MPEG 1 AUDIO LAYER 2, 3 — 32, 44.1, 48 kHz

MPEG 2 AUDIO LAYER 2, 3 — 16, 22.05, 24 kHz

MPEG 2.5 — 8, 11.025, 12 kHz

WMA files for WMA player:

Ver. 7, 8, 9 CBR — 32, 44.1, 48 kHz

WMA files for USB memory:

Ver. 9 — HIGH PROFILE 32, 44.1, 48 kHz

- The sound quality of MP3/WMA files generally improves with higher bit rates. In order to achieve a reasonable level of sound quality, discs recorded with a bit rate of at least 128 kbps are recommended.

Playable bit rates

MP3 files for MP3 player:

MPEG1 LAYER3 — 64 to 320 kbps

MPEG2 LSF LAYER3 — 64 to 160 kbps

MP3 files for USB memory:

MPEG 1 AUDIO LAYER 2, 3 — 32 to 320 kbps

MPEG 2 AUDIO LAYER 2, 3 — 32 to 160 kbps

MPEG 2.5 — 32 to 160 kbps

WMA files for WMA player:

Ver. 7, 8 CBR — 48 to 192 kbps

Ver. 9 CBR — 48 to 320 kbps

WMA files for USB memory:

Ver. 9 CBR — 32 to 320 kbps

- M3u playlists are not compatible with the audio player.
- MP3i (MP3 interactive) and MP3PRO formats are not compatible with the audio player.
- The player is compatible with VBR (Variable Bit Rate).
- When playing back files recorded as VBR (Variable Bit Rate) files, the play time will not be correctly displayed if fast-forward or reverse operations are used.
- It is not possible to check folders that do not include MP3/WMA files.
- MP3/WMA files in folders up to 8 levels deep can be played. However, the start of playback may be delayed when using discs containing numerous levels of folders. For this reason, we recommend creating discs with no more than two levels of folders.

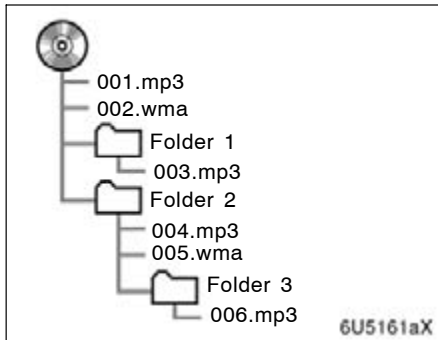

- The play order of the compact disc with the structure shown above is as follows:

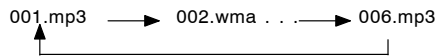

- MP3/WMA player — It is possible to play up to 192 folders or 255 files on one disc.
- USB memory — It is possible to play up to 999 folders, 255 files per folder or 65,025 files in device.
- The order changes depending on the PC and MP3/WMA encoding software you use.

CD-R and CD-RW discs

- CD-R/CD-RW discs that have not been subject to the “finalizing process” (a process that allows discs to be played on a conventional CD player) cannot be played.
- It may not be possible to play CD-R/CD-RW discs recorded on a music CD recorder or a personal computer because of disc characteristics, scratches or dirt on the disc, or dirt, condensation, etc. on the lens of the unit.
- It may not be possible to play discs recorded on a personal computer depending on the application settings and the environment. Record with the correct format. (For details, contact the appropriate application manufacturers of the applications.)
- CD-R/CD-RW discs may be damaged by direct exposure to sunlight, high temperatures or other storage conditions. The unit may be unable to play some damaged discs.
- If you insert a CD-RW disc into the MP3/WMA player, playback will begin more slowly than with a conventional CD or CD-R disc.
- Recordings on CD-R/CD-RW cannot be played using the DDCD (Double Density CD) system.

TERMS

Packet write —

This is a general term that describes the process of writing data on-demand to CD-R, etc., in the same way that data is written to floppy or hard discs.

ID3 Tag —

This is a method of embedding track-related information in an MP3 file. This embedded information can include the track title, the artist's name, the album title, the music genre, the year of production, comments and other data. The contents can be freely edited using software with ID3 tag editing functions. Although the tags are restricted to the number of characters, the information can be viewed when the track is played back.

WMA Tag —

WMA files can contain a WMA tag that is used in the same way as an ID3 tag. WMA tags carry information such as track title, artist name.

ISO 9660 format —

This is the international standard for the formatting of CD-ROM folders and files. For the ISO 9660 format, there are two levels of regulations.

Level 1:

The file name is in 8.3 format (8 character file names, with a 3 character file extension. File names must be composed of one-byte capital letters and numbers. The “_” symbol may also be included.)

Level 2:

The file name can have up to 31 characters (including the separation mark “.” and file extension). Each folder must contain fewer than 8 hierarchies.

m3u —

Playlists created using “WINAMP” software have a playlist file extension (.m3u).

MP3 —

MP3 is an audio compression standard determined by a working group (MPEG) of the ISO (International Standard Organization). MP3 compresses audio data to about 1/10 the size of that on conventional discs.

WMA—

WMA (Windows Media® Audio) is an audio compression format developed by Microsoft®. It compresses files into a size smaller than that of MP3 files. The decoding formats for WMA files are Ver. 7, 8, and 9.

SECTION 8

AIR CONDITIONING

- Automatic air conditioning controls 296

Automatic air conditioning controls

Operations such as changing the air outlets or fan speed are carried out on the screen. To display the air conditioning control screen, push the “CLIMATE” button.

► Without rear air conditioning system



- | | |
|--|---|
| <p>1 “CLIMATE” button
(Air conditioning operation screen display button) 299</p> <p>2 Outside temperature display
(In degrees Fahrenheit or Centigrade) 311</p> <p>3 Air flow control buttons 304</p> <p>4 Fan speed control buttons
..... 303</p> <p>5 Windshieled wiper de-icer button 309</p> <p>6 Micro dust and pollen filter button
..... 310</p> | <p>7 “A/C” 308</p> <p>8 “PASSENGER TEMP” buttons
(Passenger side temperature control button)
When you touch this button, the “DUAL” indicator light will be yellow, and then mode will be independent mode. 301, 304</p> <p>9 Air intake control button
..... 306</p> <p>10 “DUAL” button
(Temperature setting mode change button) 301, 304</p> <p>11 Rear window defogger button
..... 309</p> |
|--|---|

- 12** Windshield air flow button
..... 307
- 13** “OFF” button 301, 303
- 14** “AUTO” button 301
- 15** “TEMP” buttons
(Driver side temperature control button) 301, 304
- 16** Passenger side temperature display
(In degrees Fahrenheit or Centigrade)
- 17** Driver side temperature display
(In degrees Fahrenheit or Centigrade)

AIR CONDITIONING

► With rear air conditioning system

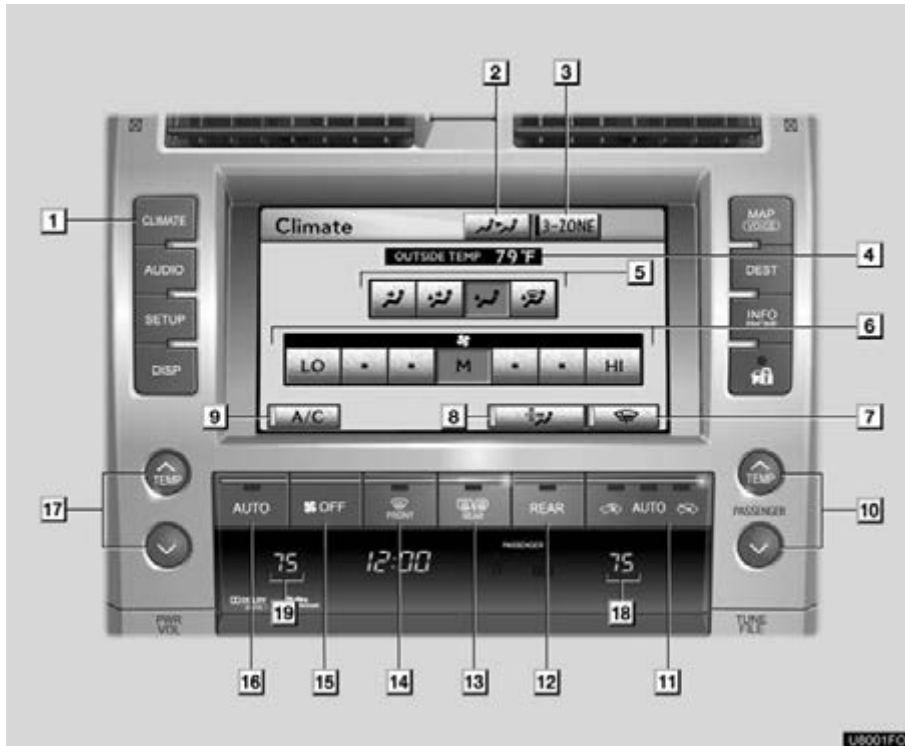

- | | |
|---|--|
| <p>1 “CLIMATE” button
(Air conditioning operation screen display button) 299</p> <p>2 Rear air conditioning control touch–screen button 306</p> <p>3 “3-ZONE”
(Temperature setting mode change touch–screen button) 301</p> <p>4 Outside temperature display
(In degrees Fahrenheit or Centigrade) 311</p> <p>5 Air flow control buttons 304</p> <p>6 Fan speed control buttons 303</p> <p>7 Windshield wiper de–icer button 309</p> <p>8 Micro dust and pollen filter button 310</p> | <p>9 “A/C” 308</p> <p>10 “PASSENGER TEMP” buttons
(Passenger side temperature control button)
When you touch this button, the “3-ZONE” indicator light will be yellow, and then mode will be independent mode. 301, 304</p> <p>11 Air intake control button 302, 306</p> <p>12 “REAR” button Owner’s manual</p> <p>13 Rear window defogger button 309</p> <p>14 Windshield air flow button 307</p> <p>15 “OFF” button 301, 303</p> <p>16 “AUTO” button 301</p> |
|---|--|

- 17** **“TEMP” buttons**
(Driver side temperature control button) 301, 304
- 18** **Passenger side temperature display**
(In degrees Fahrenheit or Centigrade)
- 19** **Driver side temperature display**
(In degrees Fahrenheit or Centigrade)

(a) Climate control

Air outlets and fan speed are automatically adjusted according to the temperature setting.

The “ENGINE START STOP” switch must be in IGNITION ON mode.



Push the “CLIMATE” button to display the air conditioning control screen.

INFORMATION

- *When the “ENGINE START STOP” switch is turned on, the air conditioning system settings will be set to those that were in use the last time the “ENGINE START STOP” switch was turned off. Air conditioning system settings are memorized individually on each electronic key, so the settings reproduced will be specific to the key that is used.*
- *During use, various odors from inside and outside the vehicle may enter into and accumulate in the air conditioning system. This may then cause odor to be emitted from the vents.*
- *To reduce potential odors from occurring:*
 - *It is recommended that the air conditioning system be set to outside air mode prior to turning the vehicle off.*
 - *The start timing of the blower may be delayed for a short period of time immediately after the air conditioning system is started in automatic operation mode.*



By pushing the switch above, you can operate the voice command system.

For the operation of the voice command system and the command, see pages 44 and 49.

NOTICE

To prevent the battery from being discharged, do not leave the air conditioning on longer than necessary when the engine is not running.

(b) Using automatic air conditioning system

- Switching to automatic operation mode



Push the "AUTO" button.

The air conditioning system begins to operate. Air outlets and fan speed are automatically adjusted according to the temperature setting.

Push "OFF" button to turn the air conditioning system off.

- Setting the vehicle interior temperature



Push the "∧" button on "TEMP" to increase the temperature and "∨" to decrease the temperature.

INFORMATION

- Turning cool box on also turns on front air conditioning system.
- When the outside temperature is 32° F (0° C) or below, the cool box may not operate.

AIR CONDITIONING

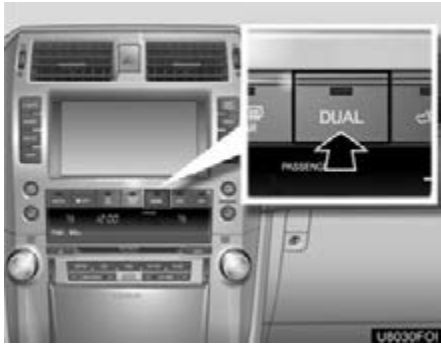

“DUAL” button (with out rear air conditioning system) —

This button is used to set the temperatures independently for the driver’s seat and front passenger seat.

When the “DUAL” button indicator is on, the temperature for the driver’s seat and front passenger seat can be adjusted separately.

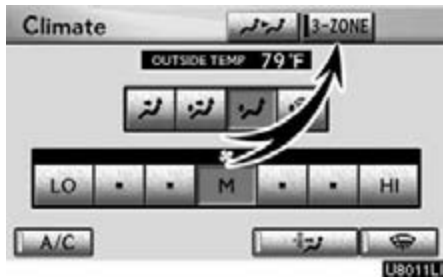

“3-ZONE” (with rear air conditioning system) —

This button is used to set the temperatures independently for the driver’s, front passenger’s and rear seats.

When the “3-ZONE” indicator is on, the temperature for the driver’s, front passenger’s and rear seats can be adjusted separately.

- Switching the air intake control to automatic mode (with rear air conditioning system)



Push the air intake control button to switch to automatic mode.

The air conditioning system automatically switches between outside air and recirculated air modes.

- **Adjusting the sensitivity of the air intake control in automatic mode (with rear air conditioning system)**

You can adjust smog sensor sensitivity.

The sensitivity level is set to be higher toward “+” and lower toward “-” on “Vehicle Customization” screen.

For “Vehicle Customization” screen, see “— Vehicle customization” on page 400.

- (c) Adjusting the settings manually
- **Setting the fan speed**

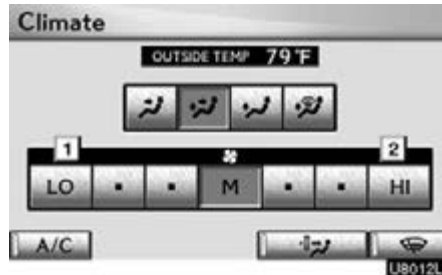

► **Without rear air conditioning system**

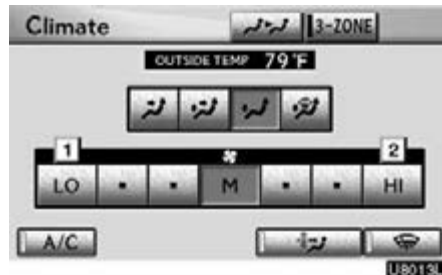

► **With rear air conditioning system**

- 1 **Fan speed at low**
- 2 **Fan speed at high**

The fan speed can be set to your desired speed by touching the appropriate fan speed control button.

Pushing the “OFF” button turns the fan off.

AIR CONDITIONING

- Setting the vehicle interior temperature



To adjust the temperature setting, push the “^” button on “TEMP” to increase the temperature and push the “v” button to decrease the temperature.

When the “DUAL” button indicator is on, the temperature for the driver’s seat and front passenger seat can be adjusted separately. (without rear air conditioning system)

When the “3-ZONE” indicator is on, the temperature for the driver’s, front passenger’s and rear seats can be adjusted separately. (with rear air conditioning system)

- Switching the air outlets

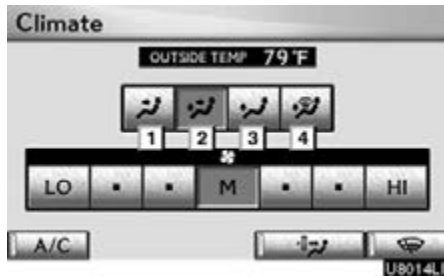

- ▶ Without rear air conditioning system

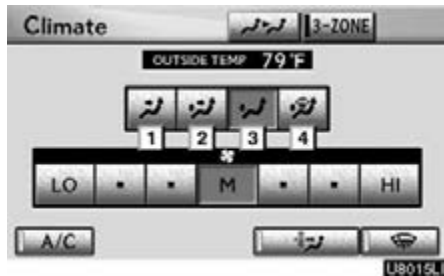

- ▶ With rear air conditioning system

- 1 Panel
- 2 Bi-level
- 3 Floor
- 4 Floor/windshield

The outlets from which air is delivered can be selected manually by touching the touch-screen button.

The air flow shown on the display indicates the following.

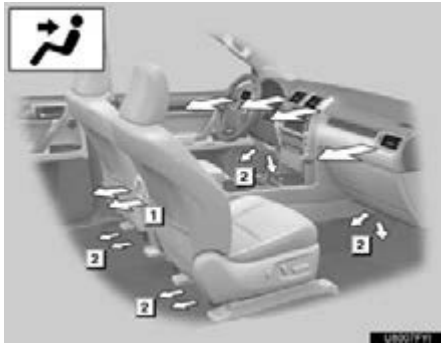

► Air flows to the upper body (Panel)



► Air flows to the feet and the windshield defogger operates (Floor/windshield)



► Air flows to the upper body and feet (Bi-level)

- 1 Without rear air conditioning system
- 2 Only in automatic mode (Air may not always flow.)

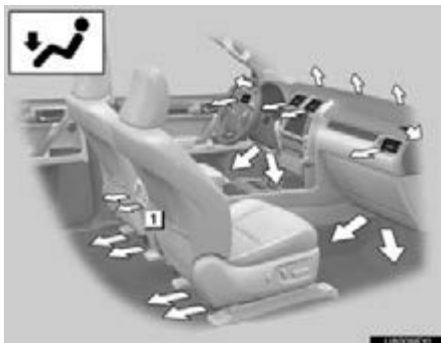

► Air flows to the feet (Floor)

AIR CONDITIONING

- Switching between outside air and recirculated air modes



- 1 Recirculated air mode
- 2 Automatic mode
- 3 Outside air mode

Push the air intake control button.

The mode switches between recirculated air mode, automatic mode (with rear air conditioning system) and outside air mode each time the button is pushed.

When the system is switched to automatic mode, the air conditioning system operates automatically.

- (d) Rear air conditioning controls (With rear air conditioning system)

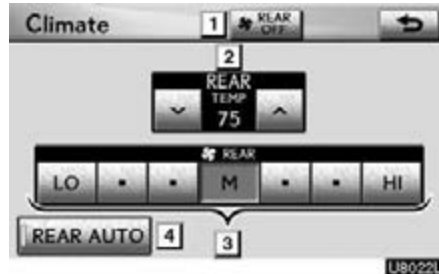

- 1 "REAR OFF" button
- 2 Temperature control
- 3 Fan speed control
- 4 "REAR AUTO" button

Touch the "REAR AUTO" button.

The air conditioning system will operate, and air outlets and fan speed will be adjusted automatically.

To adjust the temperature setting, push the "∧" button on "TEMP" to increase the temperature and push the "∨" button to decrease the temperature.

The fan speed can be set to your desired speed by touching the appropriate fan speed control button.

Touch "REAR OFF" to turn the fan off.

INFORMATION

When the "ENGINE START STOP" switch is turned on, the air conditioning system settings will be set to those that were in use the last time the "ENGINE START STOP" switch was turned off. Air conditioning system settings are memorized individually on each electronic key, so the settings reproduced will be specific to the key that is used.

(e) Defogging the windshield



The air conditioning system operates automatically.

Recirculated air mode will automatically switch to outside air mode. It is not possible to return to recirculated air mode when the switch is on.

CAUTION

To prevent the windshield from fogging up

Do not use the windshield air flow button during cool air operation in extremely humid weather. The difference between the temperature of the outside air and that of the windshield can cause the outer surface of the windshield to fog up, blocking your vision.

(f) Adjusting the position of and opening and closing the air outlets

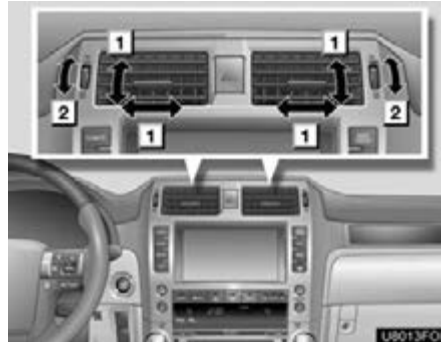

► Front center outlets

- 1 Direct air flow to the left or right, up or down
- 2 Turn the knob to open or close the vent

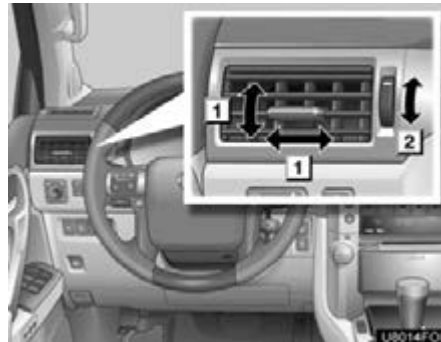

► Front side outlets

- 1 Direct air flow to the left or right, up or down
- 2 Turn the knob to open or close the vent

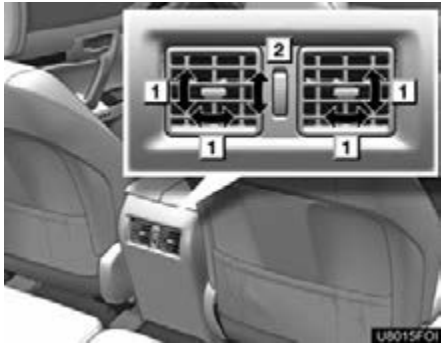

► Rear outlets (without rear air conditioning system)

- 1 Direct air flow to the left or right, up or down
- 2 Turn the knob to open or close the vent

INFORMATION

- **Using automatic mode**
Fan speed is adjusted automatically according to the temperature setting and ambient conditions. As a result, the following may occur:
 - Immediately after the button is pushed, the fan may stop for a while until warm or cool air is ready to flow.
 - Cool air may flow to the area around the upper body when the heater is on.
- **Using the system in recirculated air mode**
The windows will fog up more easily if recirculated air mode is used for an extended period.

- **Switching between outside air and recirculated air modes**

Recirculated air mode or outside air mode may be automatically switched to in accordance with the temperature setting and the inside temperature.

- **Window defogger feature**

Recirculated air mode may automatically switch to outside air mode in situations where the windows need to be defogged.

- **When outside air temperature is below 32° F (0° C)**

The cooling and dehumidification function may not operate even when "A/C" is on.

- **When the indicator light on "A/C" flashes**

Touch "A/C" to turn off the air conditioning system and turn it on again. There may be a problem in the air conditioning system if the indicator light continues to flash. Turn the air conditioning system off and have it inspected by your Lexus dealer.

- **Automatic air intake change mode (with rear air conditioning system)**

In automatic mode, the system automatically switches between recirculated air and outside air modes according to whether the system detects harmful substances such as exhaust gas in the air outside.

(g) Windshield wiper de-icer

This feature is used to prevent ice from building up on the windshield and wiper blades.

The windshield wiper de-icer can be operated when the "ENGINE START STOP" switch is in IGNITION ON mode.

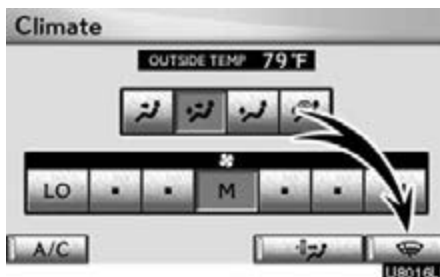

► **Without rear air conditioning system**

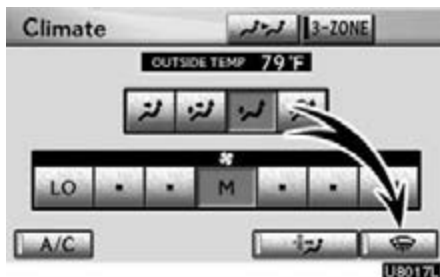

► **With rear air conditioning system**

Turns the windshield wiper de-icer on/off.

The windshield wiper de-icer will automatically turn off after approximately 15 minutes.

! CAUTION

When the windshield wiper de-icer is on
Do not touch the lower part of the windshield or the side of the front pillars, as the surfaces can become very hot and burn you.

(h) Rear window and outside rear view mirror defogging



To turn the electric rear window and outside rear view mirror defogger on, push the button above.

The "ENGINE START STOP" switch must be in IGNITION ON mode.

The thin heater wires on the inside of the rear window and the heater panels in the outside rear view mirrors will quickly clear the surface.

Keep your hands off the mirror faces when the system is on.

The indicator light is on when the defogger is operating.

! CAUTION

When the outside rear view mirror defoggers are on, do not touch the outside surface of the rear view mirror as it can become very hot and burn you.

AIR CONDITIONING

The defoggers will automatically turn off after 15 to 270 minutes. The operation time changes according to the ambient temperature and vehicle speed.

If further defrosting or defogging is desired, simply actuate the switch again. When the surface has cleared, push the button once again to turn the defogger off. Continuous use may cause the battery to discharge, especially during stop-and-go driving. The defogger is not designed to dry rain water or to melt snow.

If the outside rear view mirrors are heavily coated with ice, use a spray de-icer before operating the system.

NOTICE

- *When cleaning the inside of the rear window, be careful not to scratch or damage the heater wires or connectors.*
- *To prevent the battery from being discharged, turn the switch off when the engine is not running.*

(i) Micro dust and pollen filter

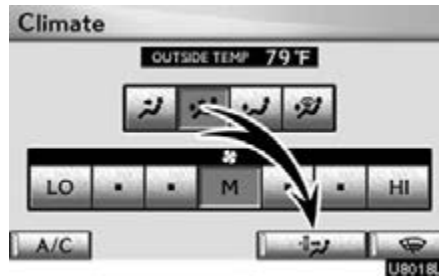

► Without rear air conditioning system

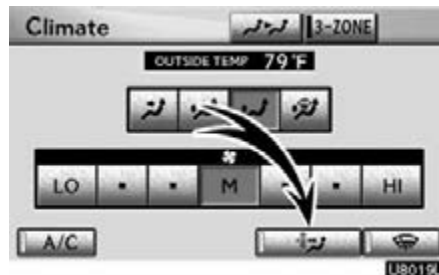

► With rear air conditioning system

Touch the micro dust and pollen filter button.

Outside air mode switches to recirculated air mode. Pollen is removed from the air flows to the upper part of the body.

Usually the system will turn off automatically after approximately 3 minutes.

To stop the operation, touch the micro dust and pollen filter button again.

INFORMATION

- In order to prevent the window from fogging up when the outside air is cold, the following may occur:
 - Outside air mode does not switch to recirculated air mode.
 - The air conditioning system operates automatically.
 - The operation cancels after 1 minute.
- In rainy weather, the windows may fog up. Push the windshield air flow button.

(j) Outside temperature display



► Without rear air conditioning system

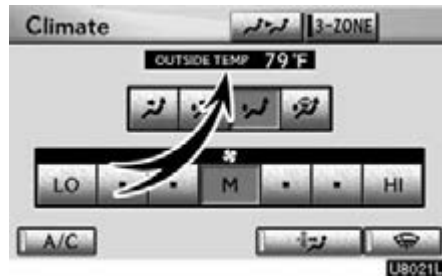

► With rear air conditioning system

Outside temperature is displayed on the screen.

The displayed temperature ranges from -40°F (-40°C) up to 122°F (50°C).

If the temperature shows “-” or “E”, take your vehicle to your Lexus dealer.

In the following situations, the correct outside temperature may not be displayed, or the display may take longer than normal to change.

- When stopped, or driving at low speeds (less than 15.5 mph [25 km/h])
- When the outside temperature has changed suddenly (at the entrance/exit of a garage, tunnel, etc.)

AIR CONDITIONING

SECTION 9

WIDE VIEW FRONT & SIDE MONITOR

- [Wide view front & side monitor](#) 314

Wide view front & side monitor —

This system can display the wide view front monitor and the side monitor separately or at the same time.

The wide view front monitor uses a super-wide angle lens to display on screen the areas to the left and right of the vehicle and the blind spots to the front of the vehicle. This system helps the driver check for approaching cars, bicycles and pedestrians when at intersections with poor visibility.

The side monitor uses a camera installed in the passenger's side outside rear view mirror to display on screen the area to the front-right of the vehicle, helping the driver check this area.

CAUTION

- When using the wide view front & side monitor system, observe these precautions to avoid an accident that could result in death or serious injuries.
 - Never depend solely on the monitor system.
 - Always check visually to confirm your intended path is clear.
 - Depicted distances between objects and flat surfaces differ from actual distances.
 - Do not use the system if the hood or the front passenger's door is not completely closed.
- The displayed image may be darker and moving images may be slightly distorted when the system is cold.
- Do not use the system in the following cases:
 - On icy or slick road surfaces, or in snow.
 - When using tire chains or emergency tires.
 - On roads that are not flat or straight, such as curves or slopes.

NOTICE

- *If the front of the vehicle or the passenger side outside rear view mirror is hit, the camera's position and mounting angle may change. Contact your Lexus dealer.*
- *As the camera has a water proof construction, do not detach, disassemble or modify it. This may cause incorrect operation.*
- *If the temperature changes rapidly, such as when hot water is poured on the vehicle in cold weather, the system may not operate normally.*
- *Do not strongly rub the camera lens. If the camera lens is scratched, it can not transmit a clear image.*
- *Do not allow organic solvent, car wax, window cleaner or glass coat to adhere to the camera. If this happens, wipe it off as soon as possible.*
- *When replacing the tires, please consult your Lexus dealer. If you replace the tires, the area displayed on the screen may change.*
- *Even if an obstacle is no longer visible on the side monitor, do not turn the steering wheel further in the direction the vehicle is turning until the vehicle has moved completely past the obstacle. If the steering wheel is turned to full lock, the vehicle will turn in the smallest possible turning circle, and may collide with the obstacle.*
- *When washing the vehicle, do not apply intensive bursts of water to the camera or camera area. Doing so may result in the camera malfunctioning.*

— Activating the wide view front & side monitor

INFORMATION

If the camera lens becomes dirty, it cannot transmit a clear image. If water droplets, snow, or mud adhere to the lens, rinse with water and wipe with a soft cloth. If the lens is extremely dirty, wash it with a mild cleanser and rinse.

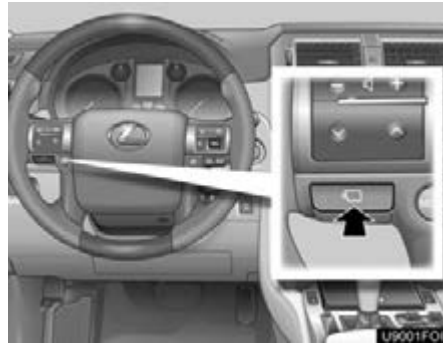

To display the front or side view, push the wide view front & side monitor switch with the “ENGINE START STOP” switch in IGNITION ON mode and vehicle speed at 7 mph (12 km/h) or less.

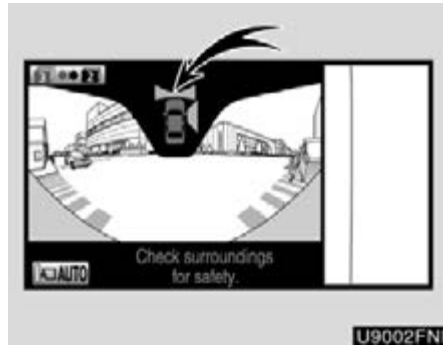

INFORMATION

If the wide view front & side monitor is switched to from the rear view monitor system, the icon display area will flash to inform the driver that the currently displayed area is the front and side. The icon display area will continue to flash until the screen is turned off.

— Display

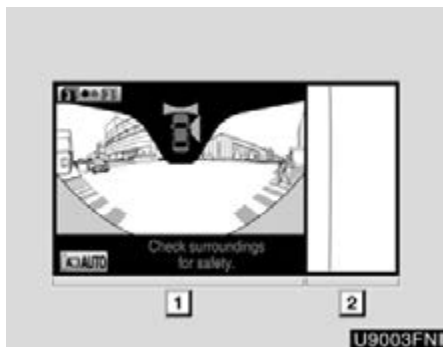

► Wide view front & side monitor simultaneous display

- 1 Wide view front monitor
- 2 Side monitor

Both the wide view front monitor and the side monitor are displayed on one screen. When switching to the wide view front & side monitors this screen is displayed first, regardless of the screen mode.

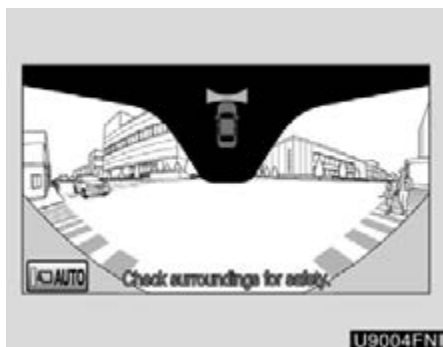

► Wide view front monitor

The image from the front camera is displayed. Use this monitor to help check the area in front of the vehicle for safety, for example in intersections with poor visibility.



► Side monitor

The image from the side camera is displayed. Use this monitor to help check the area to the passenger's side of the vehicle, for example when taking off and stopping, when turning right, etc.

INFORMATION

The side monitor screen can be displayed even if the outside rear view mirrors have been folded. In this case, there will be a slight difference between the image displayed when the outside rear view mirrors are extended and when the outside rear view mirrors have been folded. If the side monitor is displayed while the outside rear view mirrors are folded, you cannot check the area near the front edge of the vehicle as the base of the outside rear view mirrors will be in the way.

● Displayed area

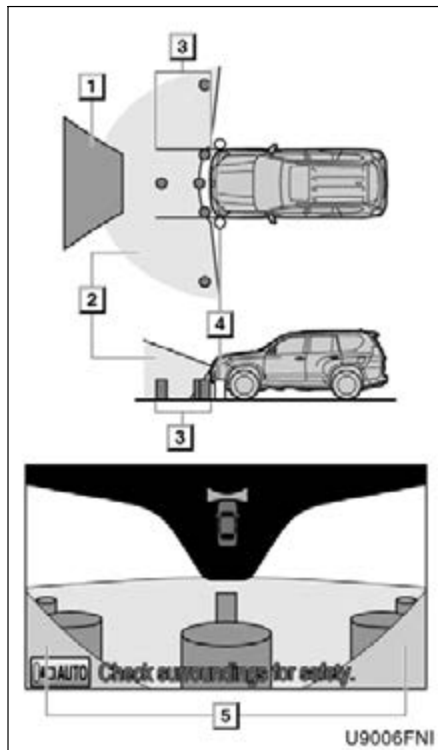

► Front camera

- 1 **Masking**
This section is masked to prevent the driver from moving the vehicle while only watching the wide view front monitor screen. The driver must visually confirm this area directly.
- 2 **Camera's field of view**
- 3 **Objects visible to the camera**
- 4 **Objects not visible to the camera**
- 5 **Parts of the vehicle (bumper*, grill, etc.)**

*: Corners of the bumper are not displayed.

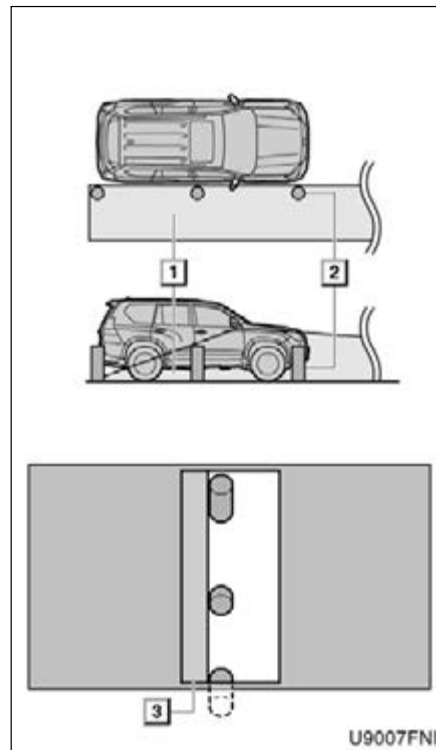

► Side camera

- 1 **Camera's field of view**
- 2 **Objects visible to the camera**
- 3 **Passenger's side of vehicle**

The area covered by the camera is limited. Objects which are close to either corner of the bumper or under the bumper cannot be seen on the screen.

The area displayed on the screen may vary according to vehicle orientation or road conditions.

WIDE VIEW FRONT & SIDE MONITOR

- **Wide view front & side monitor cameras**



- ▶ **1 Side camera**
- ▶ **2 Front camera**

When the camera is used under fluorescent lights, sodium lights, mercury lights etc., the lights and the illuminated areas may appear to flicker.

In the following cases, it may be difficult to see the images on the screen, even when the system is functioning correctly.

- In the dark (e.g. at night).
- If the temperature near the lens is extremely high or low.
- If water droplets get on the camera, or when humidity is high (e.g. when it rains).
- If the camera has scratches or dirt on it.
- If foreign matter (e.g. snow or mud) get on the camera lens.
- If the sun or headlights are shining directly into the camera lens.
- If the camera lens is damaged by flying stones.

- **Smear effect**

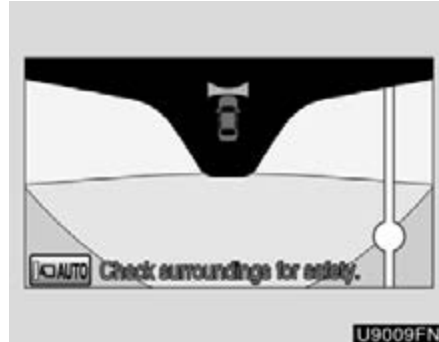

If a bright light (for example, sunlight reflected off the vehicle body) is picked up by the camera, a smear effect* peculiar to the camera may occur.

*: Smear effect — A phenomenon that occurs when a bright light (for example, sunlight reflected off the vehicle body) is picked up by the camera; when transmitted by the light source will appear to have streaks of light emanating from it. The streaks will also appear when the light source is in the masked area.

(a) Changing the screen mode

This system has a 2 screen mode and a 3 screen mode.

2 screen mode :

Only the wide view front & side monitor simultaneous display can be used.

3 screen mode :

The wide view front & side monitor simultaneous display or the individual display can be used. The display can be switched between the simultaneous display and the individual display by operating the wide view front and side monitor switch.

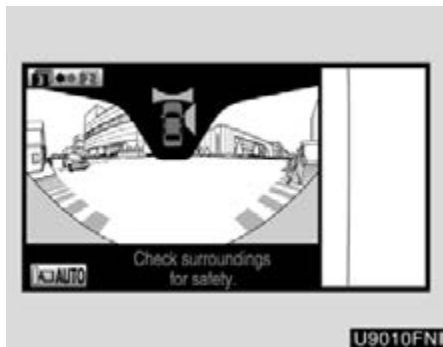

Touch **[3] [←] [2]** or **[3] [→] [2]** on the wide view front and side monitor simultaneous display screen.

If the screen is changed to the wide view front & side monitor simultaneous display screen while the rear view monitor system is activated, it is not possible to switch to the 3 screen mode. (The switch is not displayed.)

(b) Changing the display in 3 screen mode

When in 3 screen mode, you can change the display from the simultaneous display to each individual display.

The screen changes as follows with each press of the wide view front and side monitor switch.

► **When the multi-terrain monitor is not in use**

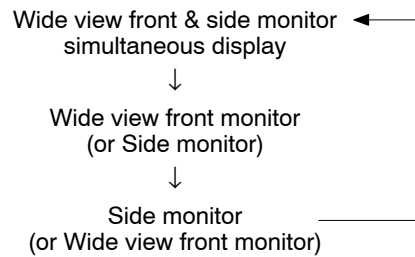

► **When the multi-terrain monitor is in use**

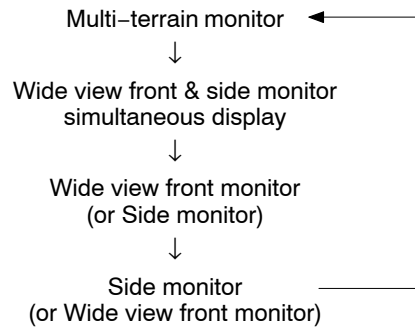

The wide view front monitor and side monitor individual displays are not accessible when the shift lever is in "R".

WIDE VIEW FRONT & SIDE MONITOR

(c) Automatic display mode

You can set the automatic display mode, which automatically changes the display.

Touch  .

When automatic display mode is on, you can have the system display automatically in the following situations:

- The shift lever is in “N”, “D” or “S”.
- The vehicle speed is approximately 6 mph (10 km/h) or less.

 will not be displayed when the shift lever is in “R”.

INFORMATION

In the following situations, the system is canceled automatically.

- *When the vehicle speed exceeds approximately 7 mph (12 km/h).*
- *When the shift lever is in “R”.*

SECTION 10

INTUITIVE PARKING ASSIST

- [Intuitive parking assist](#) 322

Intuitive parking assist —

The distance to obstacles measured by the sensors is communicated via the display and a buzzer when parallel parking or maneuvering into a garage. Always check the surrounding area when using this system.

• Types of sensors

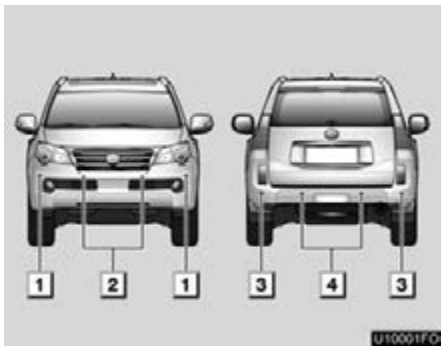

- 1 Front corner sensors
- 2 Front center sensors
- 3 Rear corner sensors
- 4 Rear center sensors

• Setting the intuitive parking assist mode

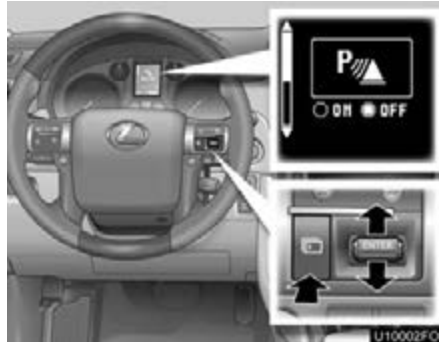

1. Push the menu switch.

The multi-information display will change modes to electronic features control mode.

2. Push the “ENTER” switch upwards or downwards until the intuitive parking assist mark appears in the multi-information display.

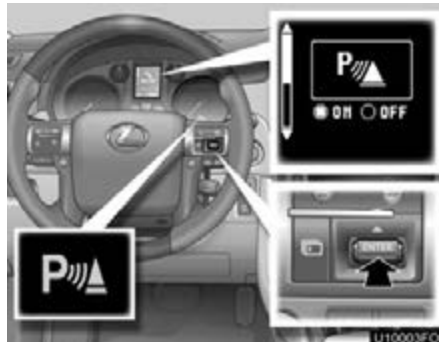

The intuitive parking assist indicator will be displayed.

Each pushing of the switch turns the intuitive parking assist on and off.

To turn on: Push the switch. The buzzer sounds to inform the driver that the system is operational.

To turn off: Push the switch again.

Push the menu switch to change to the normal display.

— Display

When the sensors detect an obstacle, the graphic is shown on the multi-information display and navigation display according to position and distance to the obstacle.

● Multi-information display

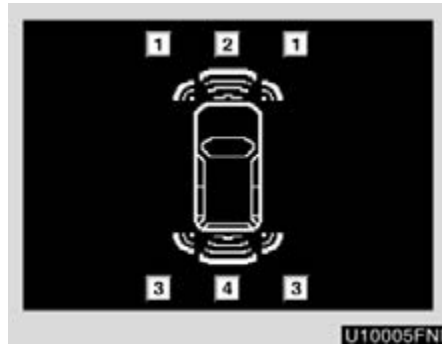

- 1 Front corner sensors operation
- 2 Front center sensors operation
- 3 Rear corner sensors operation
- 4 Rear center sensors operation

● Navigation display



The graphic is automatically displayed when an obstacle is detected. The screen can be set so that the graphic is not displayed. (See page 401.)

WHEN THE REAR VIEW MONITOR SYSTEM OR WIDE VIEW FRONT & SIDE MONITOR IS IN USE





A simplified image is displayed when an obstacle is detected.

INTUITIVE PARKING ASSIST





— The distance display and buzzer

When a sensor detects an obstacle, the direction of and the approximate distance to the obstacle are displayed and the buzzer sounds.

CORNER SENSORS

Level	1	2	3	4
Display example	–			
Buzzer	–	Medium	Fast	Continuous

CENTER SENSORS

Level	1	2	3	4
Display example				
Buzzer	Slow	Medium	Fast	Continuous

● Detection level and approximate distance to an obstacle

Level	1	2	3	4
Front corner sensors	–	2.0 to 1.6 ft. (60 to 47.5 cm)	1.6 to 1.1 ft. (47.5 to 35 cm)	1.1 ft. (35 cm) or less
Front center sensors	3.3 to 1.6 ft. (100 to 50 cm)	1.6 to 1.2 ft. (50 to 37.5 cm)	1.2 to 1.0 ft. (37.5 to 30 cm)	1.0 ft. (30 cm) or less
Rear corner sensors	–	1.8 to 1.2 ft. (55 to 37.5 cm)	1.2 to 0.8 ft. (37.5 to 25 cm)	0.8 ft. (25 cm) or less
Rear center sensors	4.9 to 2.1 ft. (150 to 65 cm)	2.1 to 1.6 ft. (65 to 50 cm)	1.6 to 1.3 ft. (50 to 40 cm)	1.3 ft. (40 cm) or less

INFORMATION

Settings (e.g. buzzer volume) can be changed. (See page 401.)

— Detection range of the sensors

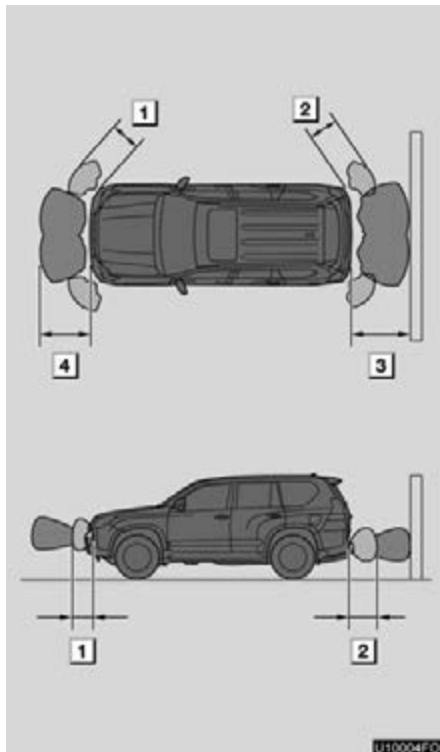

- 1** Approximately 2.0 ft. (60 cm)
- 2** Approximately 1.8 ft. (55 cm)
- 3** Approximately 4.9 ft. (150 cm)
- 4** Approximately 3.3 ft. (100 cm)

The diagram shows the detection range of the sensors. Note that the sensors cannot detect obstacles that are extremely close to the vehicle.

The range of the sensors may change depending on the shape of the object etc.

— Sensor detection information

- Certain vehicle conditions and the surrounding environment may affect the ability of a sensor to correctly detect an obstacle. Particular instances where this may occur are listed below.
 - There is dirt, snow or ice on a sensor.
 - A sensor is frozen.
 - A sensor is covered in any way.
 - The vehicle is leaning considerably to one side.
 - On an extremely bumpy road, on an incline, on gravel, or on grass.
 - The vicinity of the vehicle is noisy due to vehicle horns, motorcycle engines, air brakes of large vehicles, or other loud noises producing ultrasonic waves.
 - There is another vehicle equipped with parking assist sensors in the vicinity.
 - A sensor is coated with a sheet of spray or heavy rain.
 - The vehicle is equipped with a fender pole or radio antenna.
 - Towing eyelets are installed.
 - A bumper or sensor receives a strong impact.
 - The vehicle is approaching a tall or right-angled curb.
 - In harsh sunlight or intense cold weather.
 - A non-genuine Lexus suspension (lowered suspension, etc.) is installed.

In addition to the examples above, there are instances in which, because of their shapes, signs and other objects may be judged by a sensor to be closer than they are.

- The shape of the obstacle may prevent a sensor from detecting it. Pay particular attention to the following obstacles:
 - Wires, fences, ropes, etc.
 - Cotton, snow and other materials that absorb sound waves
 - Sharply-angled objects
 - Low obstacles
 - Tall obstacles with upper sections projecting outwards in the direction of your vehicle

— Intuitive parking assist failure warning

If an error is detected when the intuitive parking assist is turned on, the vehicle symbol comes on or flashes with beeping sounds.

However, the sensors functioning properly continue their obstacle detection.

The intuitive parking assist failure warning display is not given in either of the following operations:

- Changing to another screen
- Turning the intuitive parking assist mode off

 **CAUTION**

Caution when using the intuitive parking assist

Observe the following precautions.

Failing to do so may result in the vehicle being unable to be driven safely and possibly cause an accident.

- Do not use the sensor at speeds in excess of approximately 6 mph (10 km/h).
- Do not attach any accessories within the sensor range.

NOTICE

Notes when washing the vehicle

Do not apply intensive bursts of water or steam to the sensor area.

Doing so may result in the sensor malfunctioning.

System malfunction

- **An accident will affect the sensors, resulting in system failure.**
- **If the indicators remain on without a beeping sound, the system may be malfunctioning.**

Contact your Lexus dealer.

- When snowflakes or mud gets on the sensors



If the failure warning does not go off even after the foreign matter is removed, the intuitive parking assist may be malfunctioning. Have it checked by your Lexus dealer.

- When the sensor is malfunctioning



If this message appears, have the intuitive parking assist checked by your Lexus dealer.

As the intuitive parking assist might be malfunctioning in the following cases, have it checked by your Lexus dealer.

- The indicator in the instrument cluster does not come on and a beep does not sound even when the intuitive parking assist mode is turned on.
- The warning comes on despite no obstacle around the vehicle.

INTUITIVE PARKING ASSIST

- **Certification**

For vehicles sold in Canada.

This ISM device complies with Canadian ICES-001.
Cet appareil ISM est conforme à la norme NMB-001 du Canada.

SECTION 11

SETUP

- General settings 330
(Used for language selection and the on/off settings of operation sounds and automatic screen change.)
- Clock settings 335
(Used for changing time zones and the on/off settings of daylight saving time.)
- Voice settings 337
(Voice guidance can be set.)
- Navigation settings 340
(“Home” and “Preset Destinations” can be set and edited.)
- Detailed navigation settings 340
(Average cruising speed, displayed screen contents, and POI icon categories can be set.)
- Telephone settings 349
(Bluetooth® phones can be registered.)
- Audio settings 388
(Settings are available for portable audio devices and Bluetooth® audio devices players.)
- Vehicle settings 395
(Vehicle information can be set.)
- Other settings 403
(Used for changing settings for Lexus Insider and XM® Sports and Stocks.)

SETUP

General settings

Used for language selection and the on/off settings of operation sounds and automatic screen change.



1. Push the "SETUP" button.



2. Touch "General".

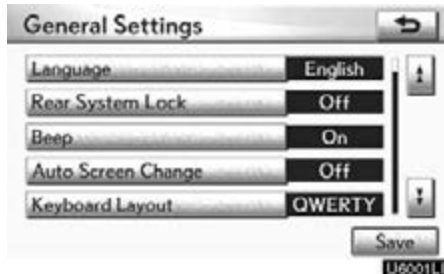

3. Touch the items to be set.
4. Touch "Save".

SCREENS FOR GENERAL SETTINGS

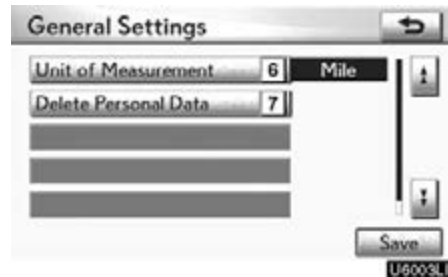
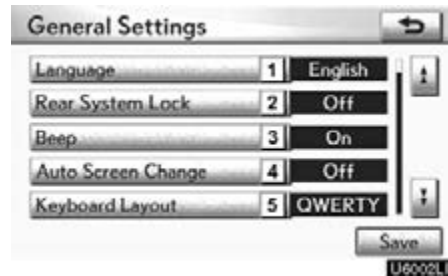

On this screen, the following functions can be performed.

No.	Function
1	You can change the language. (See “● Selecting a language” on page 331.)
2	Rear system lock* can be set to “On” or “Off”. (See “● Rear system lock” on page 332.) *: Vehicles with rear seat entertainment system
3	“On” or “Off” can be selected to sound beeps.
4	“On” or “Off” can be selected for automatic screen changes from the audio/air conditioner screen to the map. When “On” is selected, the screen will automatically return to the map from the audio/air conditioner screen after 20 seconds.
5	Keyboard layout can be changed. (See “● Selecting a keyboard layout” on page 332.)
6	Distance unit can be changed. (See “● Unit of measurement” on page 333.)
7	The personal data can be deleted. (See “● Delete personal data” on page 334.)

● **Selecting a language**

You can change the language.

1. Push the “SETUP” button.
2. Touch “General” on the “Setup” screen.

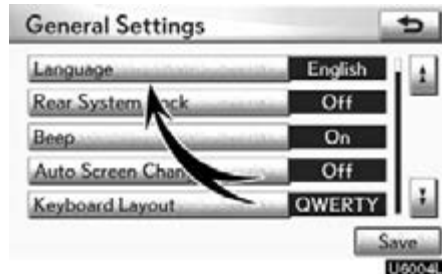

3. Touch “Language”.

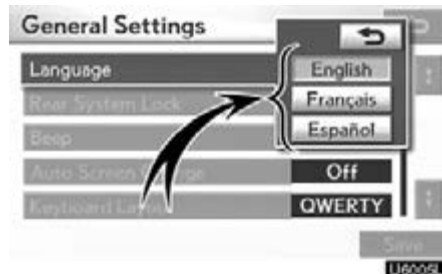

4. Touch the desired button.
The previous screen will be displayed.
5. Touch “Save”.

SETUP

- **Rear system lock (with rear seat entertainment system)**

If the vehicle is equipped with the rear seat entertainment system, the rear seat entertainment system can be locked to prevent rear passengers from operating the entertainment system.

1. Push the “SETUP” button.
2. Touch “General” on the “Setup” screen.

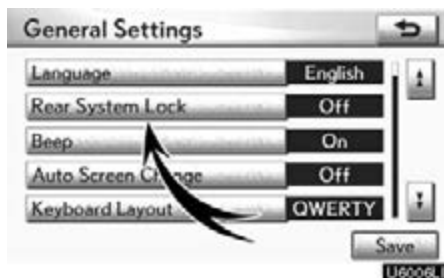

3. Touch “Rear System Lock”.

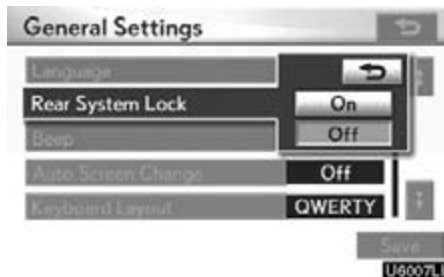

4. Select “On” or “Off” and then touch “Save”.

“On”: The rear passengers cannot operate the rear seat entertainment system. Only front passengers can operate the system.

“Off”: Both the front and rear passengers can operate the rear seat entertainment system.

- **Selecting a keyboard layout**

Keyboard layout can be changed.

1. Push the “SETUP” button.
2. Touch “General” on the “Setup” screen.

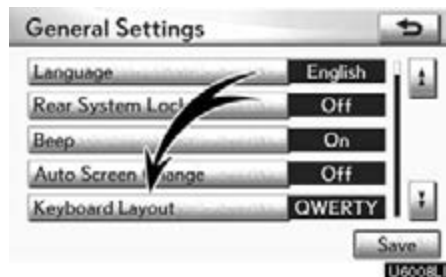

3. Touch “Keyboard Layout”.

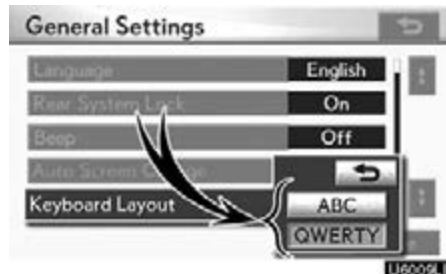

4. Touch “ABC” or “QWERTY” of “Keyboard Layout” to choose the keyboard layout.

5. Touch “Save”.

LAYOUT TYPE

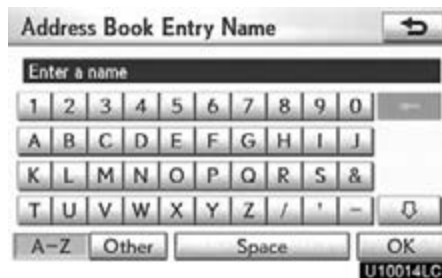

► “ABC” type

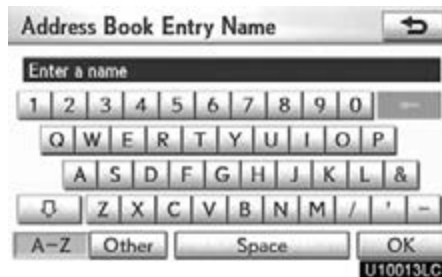

► “QWERTY” type

● **Unit of measurement**

Distance unit can be changed.

1. Push the “SETUP” button.
2. Touch “General” on the “Setup” screen.

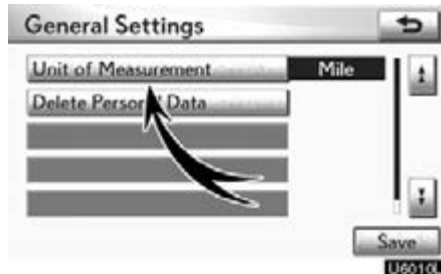

3. Touch “Unit of Measurement”.

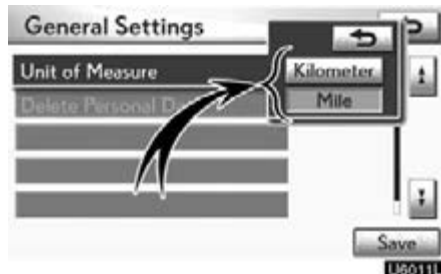

4. Touch “Kilometer” or “Mile”.
5. Touch “Save”.

INFORMATION

This function is available only in English or Spanish. To switch language, see “● Selecting a language” on page 331.

SETUP

- **Delete personal data**

The following personal data can be deleted or returned to their default settings:

- Maintenance conditions
- Maintenance information “off” setting
- Address book
- Areas to avoid
- Previous points
- Route guidance
- Route trace
- Phonebook data
- Call history data
- Speed dial data
- Voice tag data
- Bluetooth® phone data
- Phone volume setting
- Details phone setting

This function is available only when the vehicle is not moving.

1. Push the “SETUP” button.

2. Touch “General” on the “Setup” screen.

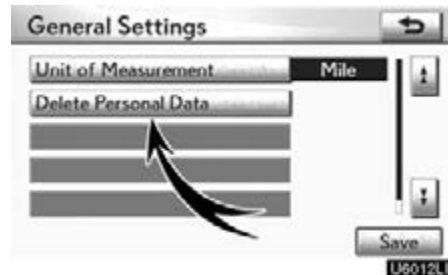

3. Touch “Delete Personal Data”.

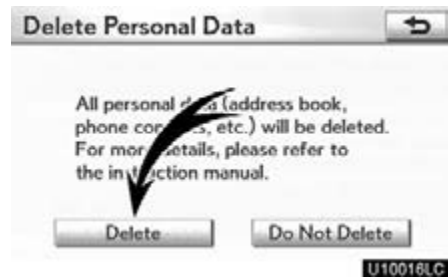

4. Touch “Delete”.

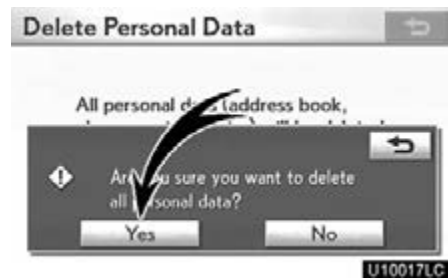

5. Touch “Yes”.

Clock settings

Used for changing time zones and the on/off settings of daylight saving time.



1. Push the “SETUP” button.



2. Touch “Clock”.

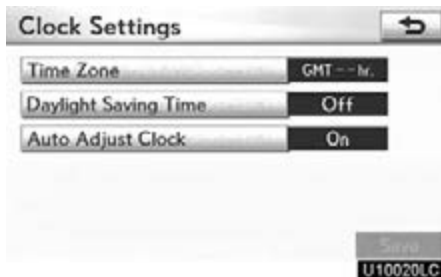

3. Touch the items to be set.

4. Touch “Save”.

SCREEN FOR CLOCK SETTINGS

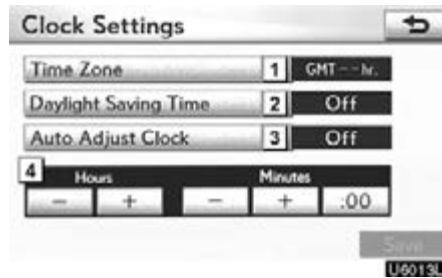

On this screen, the following functions can be performed.

No.	Function
1	Time zone can be changed. (See “● Time zone” on page 336.)
2	“On” or “Off” can be selected for daylight savings time.
3	“On” or “Off” can be selected for automatic adjustment of the clock.
4	When “Auto Adjust Clock” is turned “Off”, the clock can be manually adjusted. (See “● Manual clock setting” on page 336.)

SETUP

- **Time zone**

A time zone can be selected and GMT can be set.

1. Push the “SETUP” button.
2. Touch “Clock” on the “Setup” screen.

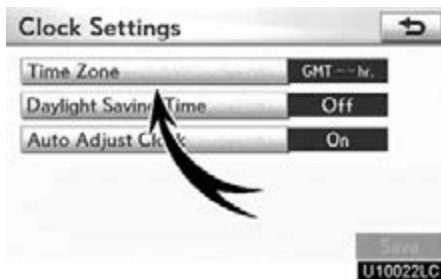

3. Touch “Time Zone”.



4. Touch the desired time zone.

If you touch “Other”, adjust the zone manually.



5. Touch “OK”.

- **Manual clock setting**

When “Auto Adjust Clock” is turned “Off”, the clock can be manually adjusted.

1. Push the “SETUP” button.
2. Touch “Clock” on the “Setup” screen.

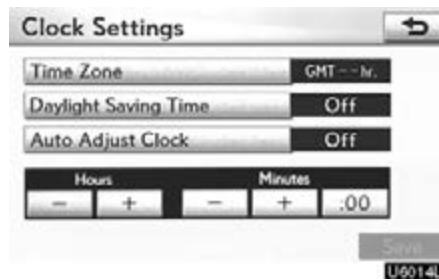

Hours “+”, “-”: Touch “+” to set the time forward one hour and “-” to set the time back one hour.

Minutes “+”, “-”: Touch “+” to set the time forward one minute and “-” to set the time back one minute.

Minutes “:00”: Rounds to the nearest hour.*

*: e.g. 1:00 to 1:29 → 1:00
1:30 to 1:59 → 2:00

3. Touch “Save”.

Voice settings

Voice guidance can be set.



1. Push the "SETUP" button.



2. Touch "Voice".

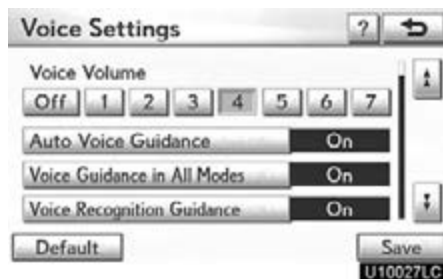

3. Touch the items to be set.

4. Touch "Save".

SCREEN FOR VOICE SETTINGS

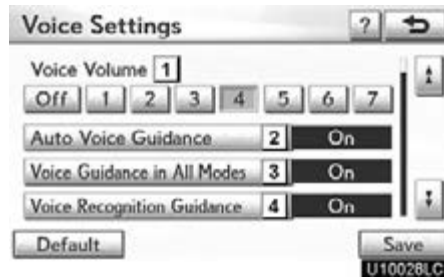

On this screen, the following functions can be performed.

SETUP

No.	Function
1	The voice guidance volume can be adjusted or switched off. (See “● Voice volume” on page 338.)
2	Voice guidance during route guidance can be set to “On” or “Off”.
3	Voice guidance during audio system use can be set to “On” or “Off”.
4	Voice recognition talkback can be set to “On” or “Off”.
5	When “On” is selected, the voice command system can be operated without pressing the talk switch more than once.
6	When using the traffic information function, voice guidance can be set to “On” or “Off”. (See “● Traffic voice guidance” on page 339.)
7	When using the XM NavWeather™ function, the severe weather warning can be set to “On” or “Off”.
8	Voice guidance projection can be set to the “Center” position or the “Driver” position. (See “● Voice guidance speaker” on page 339.)

● Voice volume

The voice guidance volume can be adjusted or switched off.

1. Push the “SETUP” button.
2. Touch “Voice” on the “Setup” screen.

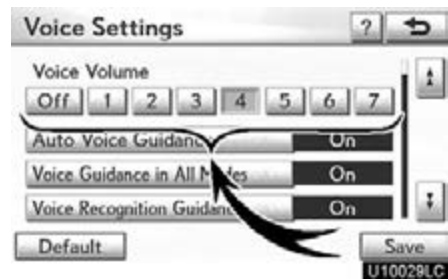

3. Select the desired level by touching the number.

If voice guidance is not needed, touch “Off” to disable the feature.

When selected, the number or “Off” will be highlighted.

4. Touch “Save”.

- **Traffic voice guidance**

You can receive congestion information through voice guidance while being guided to your destination.

To turn the "Traffic Voice Guidance" on:

1. Push the "SETUP" button.
2. Touch "Voice" on the "Setup" screen.



3. Touch "On" of the "Traffic Voice Guidance".
4. Touch "Save".

INFORMATION

- *This function is available only in English. To select English, see "● Selecting a language" on page 331.*
- *When the "Traffic Information" indicator is dimmed, "Auto Avoid Traffic", "Traffic Voice Guidance" and "Show Free Flowing Traffic" will not operate.*

- **Voice guidance speaker**

The projection position of voice guidance can be adjusted.

1. Push the "SETUP" button.
2. Touch "Voice" on the "Setup" screen.



3. Touch "Voice Guidance Speaker".

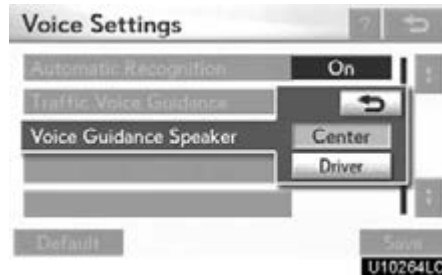

4. Touch "Center" or "Driver".
5. Touch "Save".

SETUP

Navigation settings

Points or areas on the map can be registered.



On this screen, the following operations can be performed.

No.	Function
1	Sets home (See page 111.)
2	Sets preset destinations (See page 113.)
3	Sets address book (See page 116.)
4	Sets area to avoid (See page 122.)
5	Deletes previous destinations (See page 127.)
6	Detailed navigation settings (See page 340.)

Detailed navigation settings

Average cruising speed, displayed screen contents, and POI icon categories can be set.



1. Push the "SETUP" button.

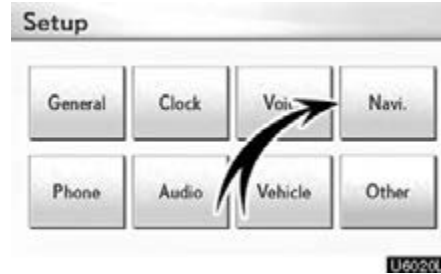

2. Touch "Navi.".



3. Touch "Detailed Navi. Settings".

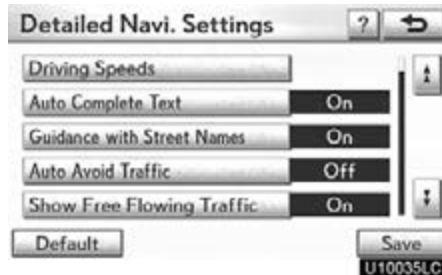

4. Touch the items to be set.
5. Touch "Save".

SCREENS FOR NAVIGATION SETTINGS

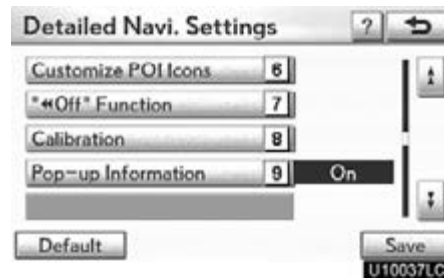
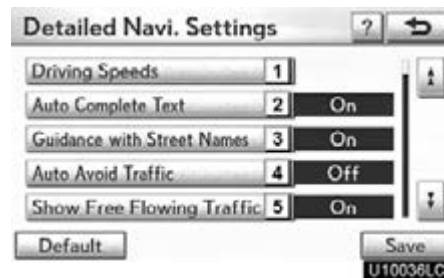

On this screen, the following functions can be performed.

No.	Function
1	Average cruising speed can be set. (See "● Driving speeds" on page 342.)
2	The automatic input function can be set to "On" or "Off".
3	During route guidance, voice guidance for the next street name can be set to "On" or "Off".
4	"On" or "Off" can be selected to display cautionary messages when the route includes traffic restrictions or seasonally restricted roads.
5	When "On" is selected, freely flowing traffic can be shown with the arrow.

No.	Function
6	Displayed POI icon categories can be set. (See “● POI category change (Select POI icons)” on page 345.)
7	Buttons displayed on the map screen when “◀◀Off” is selected can be set. (See “● Screen layout function (“◀◀Off” function)” on page 346.)
8	The current vehicle position mark can be adjusted manually. Miscalculation of the distance caused by tire replacement can also be adjusted. (See “● Current position/tire change calibration” on page 346.)
9	Display of pop-up information can be set to “On” or “Off”. (See “● Pop-up information” on the page 348.)

● **Driving speeds**

The speed that is used for the calculation of the estimated travel time and the estimated arrival time can be set.

1. Push the “SETUP” button.
2. Touch “Navi.” on the “Setup” screen.
3. Touch “Detailed Navi. Settings” on the “Navigation Settings” screen.

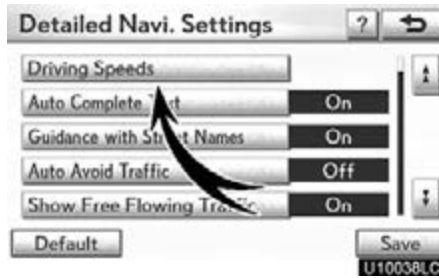

4. Touch “Driving Speeds”.



5. Touch ◀ or ▶ to set the average vehicle speeds for “Residential”, “Main Streets”, and “Freeways”.

To set the default speeds, touch “Default”.

6. After setting of the desired speeds is completed, touch “Save”.

INFORMATION

- *The displayed time to the destination is the approximate driving time that is calculated based on the selected speeds and the actual position along the guidance route.*
- *The time shown on the screen may vary greatly depending on progress along the route, which may be affected by conditions such as traffic jams and construction work.*
- *It is possible to display up to 99 hours 59 minutes.*

• **Auto avoid traffic**

The guidance route automatically changes to another route to avoid heavy congestion.

To turn the "Auto Avoid Traffic" on:

1. Push the "SETUP" button.
2. Touch "Navi." on the "Setup" screen.
3. Touch "Detailed Navi. Settings" on the "Navigation Settings" screen.

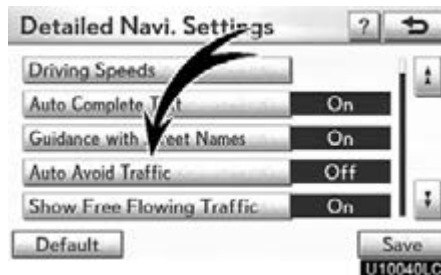

4. Touch "On" of the "Auto Avoid Traffic".
5. Touch "Save".



When congestion information about the guidance route has been received, a screen will appear to ask you whether to reroute to avoid the congestion.

If you wish to reroute, touch "Yes". Another route to allow you to avoid the congestion will appear.

If you do not wish to reroute, touch "No".

INFORMATION

When the “Traffic Information” indicator is dimmed, “Auto Avoid Traffic”, “Traffic Voice Guidance” and “Show Free Flowing Traffic” will not operate.

● **Show free flowing traffic**

Freely flowing traffic is shown with the arrow.

To turn the “Show Free Flowing Traffic” on:

1. Push the “SETUP” button.
2. Touch “Navi.” on the “Setup” screen.
3. Touch “Detailed Navi. Settings” on the “Navigation Settings” screen.

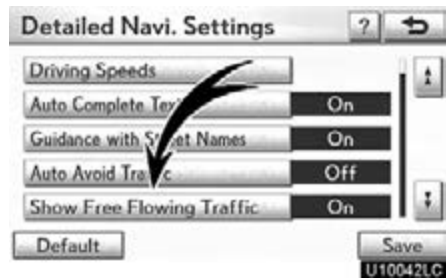

4. Touch “On” of the “Show Free Flowing Traffic”.
5. Touch “Save”.

INFORMATION

When the “Traffic Information” indicator is dimmed, “Auto Avoid Traffic”, “Traffic Voice Guidance” and “Show Free Flowing Traffic” will not operate.

- **POI category change (Select POI icons)**

Select from among the 6 icons displayed on the “Customize POI Icons” screen, so that setting of the icons to be displayed on the map screen can be done easily.

1. Push the “SETUP” button.
2. Touch “Navi.” on the “Setup” screen.
3. Touch “Detailed Navi. Settings” on the “Navigation Settings” screen.

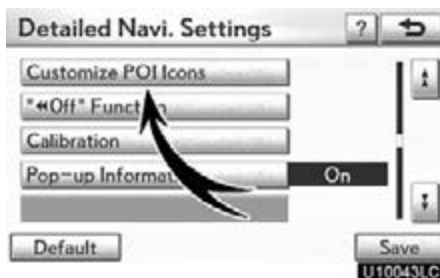

4. Touch “Customize POI Icons”.



5. Touch the category button to be changed.



6. Touch the desired group.

If the desired POI category is not on the screen, touch “List All Categories” to list all POI categories.



7. Touch the desired category.
8. Touch “OK”.

SETUP

- **Screen layout function**
(“◀◀Off” function)

Each screen buttons and current street name on the map screen can be displayed or hidden.

1. Push the “SETUP” button.
2. Touch “Navi.” on the “Setup” screen.
3. Touch “Detailed Navi. Settings” on the “Navigation Settings” screen.

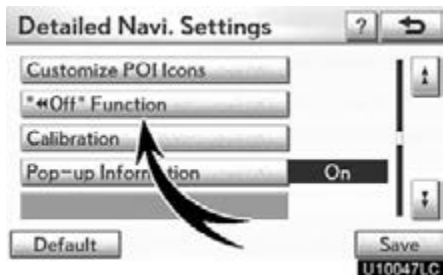

4. Touch “◀◀Off” Function”.



5. Touch the button to be turned off. The button becomes dimmed.

To set the default, touch “Default”.

6. Touch “Save”.

- **Current position/tire change calibration**

The current vehicle position mark can be adjusted manually. Miscalculation of the distance caused by tire replacement can also be adjusted.

1. Push the “SETUP” button.
2. Touch “Navi.” on the “Setup” screen.
3. Touch “Detailed Navi. Settings” on the “Navigation Settings” screen.

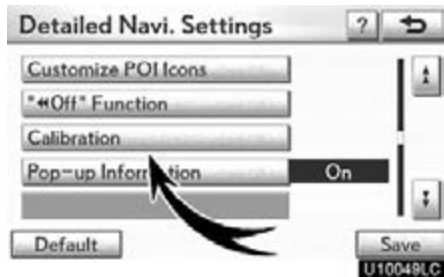

4. Touch “Calibration”.

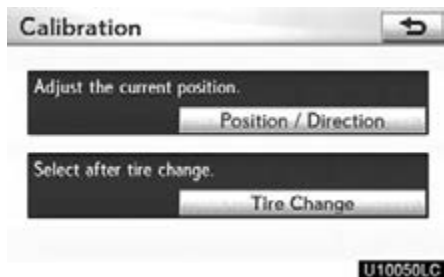

5. Touch the desired button.

INFORMATION

For additional information on the accuracy of a current vehicle position, see “Limitations of the navigation system” on page 406.

POSITION/DIRECTION CALIBRATION

When driving, the current vehicle position mark will be automatically corrected by GPS signals. If GPS reception is poor due to location, you can manually adjust the current vehicle position mark.

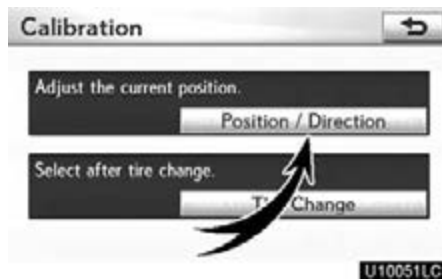

U10051LC

1. Touch "Position / Direction".





U10052LC

2. Touch the 8 directional button to move the cursor to the desired point on the map.

3. Touch "OK".



U10053LC

4. Touch either the  or  to adjust the direction of the current vehicle position mark.

5. Touch "OK".

The map will be displayed.

TIRE CHANGE CALIBRATION

The tire change calibration function will be used when replacing the tires. This function will adjust the miscalculation caused by the circumference difference between the old and new tires. If this procedure is not performed when the tires are replaced, the current vehicle position mark may be incorrectly displayed.

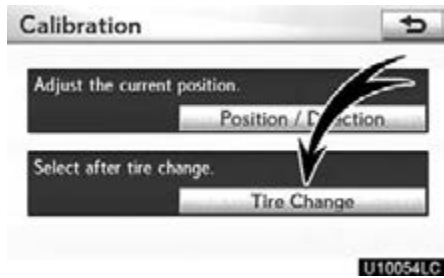

U10054LC

To perform a distance calibration procedure, touch “Tire Change” on the “Calibration” screen.

The message appears and the quick distance calibration is automatically started. A few seconds later, a map will be displayed.

● **Pop-up information**

When the “Pop-up information” is turned on, the pop-up information will be displayed.

1. Push the “SETUP” button.
2. Touch “Navi.” on the “Setup” screen.
3. Touch “Detailed Navi. Settings” on the “Navigation Settings” screen.

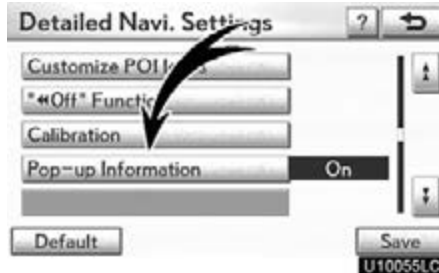

U10055LC

4. Touch “Pop-up Information”.

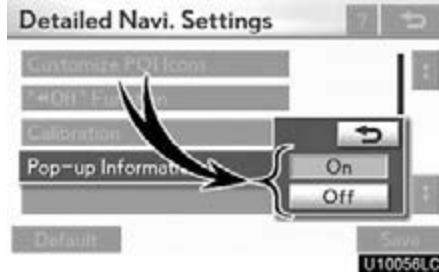

U10056LC

5. Touch “On” or “Off”.
6. Touch “Save”.

When the “Pop-up Information” is turned off, the following messages will not be displayed.



This message appears when the system is in the POI mode and the map scale is over 0.5 miles (800 m).



The message appears when the map is switched to the dual map screen mode.

Telephone settings —

“Telephone settings” can be changed on the “Phone settings” screen.



1. Push the “SETUP” button.



2. Touch “Phone”.

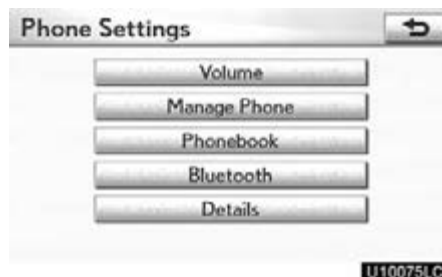

Please refer to the following pages for each setting.

— Volume setting

You can adjust the voice and ring volume.

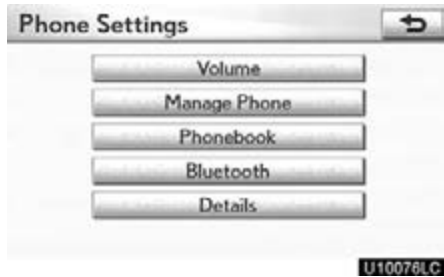

1. Touch "Volume".

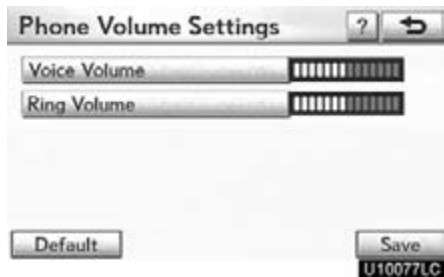

2. Change each setting according to the following procedures.
3. When you complete all settings, touch "Save".

Automatic volume settings for high speed

The system will automatically increase the volume by one step up when the speed exceeds 50 mph (80 km/h).

- Voice volume setting

1. Touch "Voice Volume".



2. Touch "-" or "+" to adjust the voice volume.
3. Touch "OK".

- Ring volume setting

1. Touch "Ring Volume".

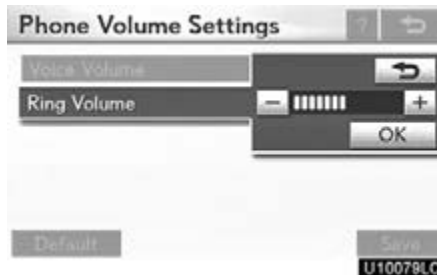

2. Touch "-" or "+" to adjust the ring volume.
3. Touch "OK".

- **Initializing the settings**

You can initialize the settings.

1. Touch "Default".



2. Touch "Yes".

— Manage phone

"Manage phone" is accessed from the "Connect Phone" screen.

1. Push the "SETUP" button.
2. Touch "Phone".

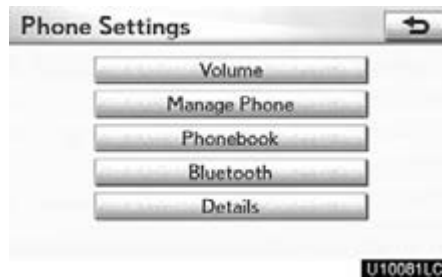

3. Touch "Manage Phone".



Please refer to the following pages for each setting.

SETUP

• Registering a Bluetooth® phone



1. Touch “(add new)” to register your cellular phone to the system.



2. When this screen is displayed, input the passcode displayed on the screen into the phone.

For the operation of the phone, see the manual that comes with your cellular phone.

If you want to cancel it, touch “Cancel”.



3. When the connection is completed, this screen is displayed.

You do not need to enter the phone in case of using the same one.



When this screen is displayed, follow the guidance on the screen to try again.

When another Bluetooth® device is connected



When another Bluetooth® device is currently connected, this screen is displayed. If you want to disconnect it, touch “Yes”.

INFORMATION

When you register your phone, Bluetooth® audio will disconnect. It will reconnect automatically when you finish registration. It will not be reconnected depending on the phone you are using.

You can also register a new Bluetooth® phone in the following way.

1. Push the “SETUP” button.
2. Touch “Phone”.
3. Touch “Manage Phone”.



4. Touch “Options”.



5. Touch “New Phone”.

SETUP

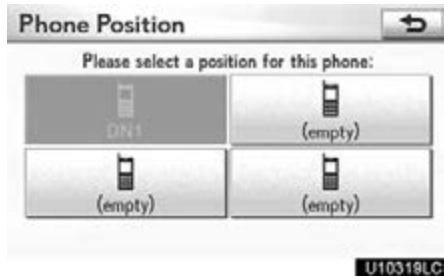

6. Touch “(empty)” to register your cellular phone to the system.

The following operations are the same as the operation after you touch “(add new)”.

- **Selecting a Bluetooth® phone**

In case you register more than one Bluetooth® phone, you need to choose a favorite one.

You can select the Bluetooth® phone from a maximum of 4 numbers.

“(add new)” is displayed when you have not registered a Bluetooth® phone yet.

Although you can register up to 4 Bluetooth® phones in the system, only one Bluetooth® phone can function at a time.



1. **Select the phone to connect.**

The Bluetooth® mark is displayed when you connect the phone.



2. The “Connect Bluetooth*” screen is displayed.

*: Bluetooth is a registered trademark of Bluetooth SIG, Inc.



3. When the result message is displayed, you can use the Bluetooth® phone.

When you connect the phone while Bluetooth® audio is playing



This screen is displayed, and the Bluetooth® audio will stop temporarily.

When another Bluetooth® device is connected



When another Bluetooth® device is currently connected, this screen is displayed. If you want to disconnect it, touch “Yes”.

Setting the handsfree power

You can select the state of “Handsfree Power”.



Changes between “On” and “Off” every time you touch “Handsfree Power”.

For the “Handsfree Power”, see “Changing the handsfree power” on page 381.

● **Editing the Bluetooth® phone**

You can see the information of the Bluetooth® phone on the system or edit.

“Device Name”

..... The name of Bluetooth® phone which is displayed on the screen. You can change it into a desired name.

If you change a device name, the name registered in your cellular phone is not changed.

“Device Address”

..... The address peculiar to the system. You cannot change it.

If you have registered two Bluetooth® phones with the same device name and you cannot distinguish one from the other, refer to it.



1. Touch “Options”.



2. Touch “Edit Phones”.



3. Select the phone to edit.



4. This screen is displayed.
If you want to change the device name, touch "Edit".



5. Use the software keyboard to input the device name.



6. Confirm the device name and touch "OK".

• Deleting a Bluetooth® phone



U10327LC

1. Touch “Options”.



U10104LC

2. Touch “Remove Phones”.

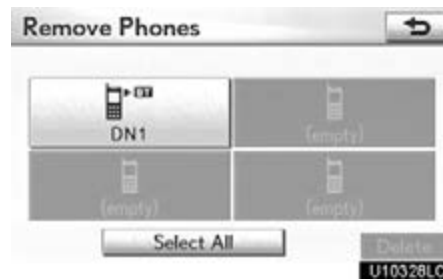

U10328LC

3. Select the desired phone or touch “Select All”, then touch “Delete”.

You can select multiple phones and delete them at the same time.



U10108LC

4. Touch “Yes”.

INFORMATION

When you delete a Bluetooth® phone, the phonebook data will be deleted at the same time.

- **By voice recognition**



You can operate “Connect Phone” by giving a command.

“Connect Phone” includes “Select Phone”, “Add New Phone” and “Handsfree Power Off” (On).

The operating procedure is similar to other voice recognition. (For the operation of voice recognition, see “Voice command system” on page 44.)

When you select the command of “Add New Phone”, you must carry out the following operation on the screen.

— Phonebook

INFORMATION

Phonebook data is managed for every registered phone. When another phone is connecting, you can not read the registered data.

“Phonebook” is accessed from the “Phonebook Settings” screen.

1. Push the “SETUP” button.
2. Touch “Phone”.

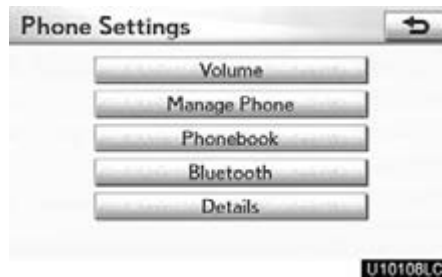

3. Touch “Phonebook”.

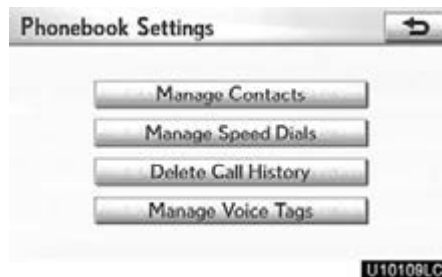

Please do each setting from this screen.

— Setting the phonebook

“Setting the phonebook” is accessed from the “Contacts” screen.

1. Push the “SETUP” button.
2. Touch “Phone”.
3. Touch “Phonebook”.



4. Touch “Manage Contacts”.



Please refer to the following pages for each setting.

You can also display the “Contacts” screen in the following way.

1. Push the “INFO/PHONE” button.
2. Touch “Phone”.
3. Touch “Contacts”.

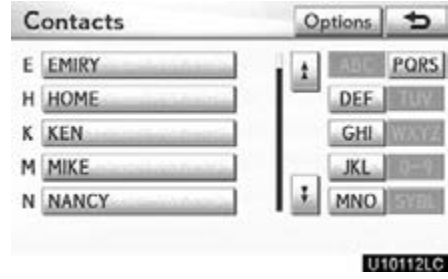

4. Touch “Options”.



5. Touch “Manage Contacts”.

- **Transferring a phone number**

You can transfer the phone numbers in your Bluetooth® phone to the system. The phonebook manages a maximum of 4 phonebooks in all. The data for 1000 contacts (up to 3 numbers per contact) can be registered in total of phonebooks.

Transfer it while the engine is running.



1. Touch "Transfer Contacts".



2. Touch "Replace Contacts" or "Add Contacts".

In case that the phonebook contains phonebook data, this screen is displayed.



3. Transfer the phonebook data to the system using the Bluetooth® phone.

This screen appears while transferring. To cancel it, touch "Cancel". If the transferring is interrupted on the way, the phonebook data transferred until then can be memorized in the system.

When you have touched "Replace Contacts":

If your cellular phone does not support PBAP or OPP service, you can not use this function.

If your phone supports PBAP service, you can transfer the phonebook data without operating your phone.

If your phone does not support PBAP service, you must transfer the phonebook data by operating your phone.

When you have touched "Add Contacts":

If your cellular phone does not support OPP service, you can not use this function.

You can transfer the phonebook data only by operating your phone.



4. In case that you have touched “Add Contacts”, this screen is displayed.

If you want to transfer another phonebook, touch “Yes”.

When another Bluetooth® device is connected



When another Bluetooth® device is currently connected, this screen is displayed. If you want to disconnect it, touch “Yes”.

INFORMATION

Bluetooth® audio will disconnect during transfer on phonebook data. In this case, it will reconnect automatically when data transfer finishes. (It will not be reconnected depending the phone you are using.)

- Registering the phonebook data
You can register the phonebook data.
Up to 3 numbers per person can be registered.



1. Touch "New Contact".



2. Use the software keyboard to input the name and touch "OK".



3. Input the phone number and touch "OK".

If you want to use the tone signal after the phone number, input the tone signal too.



4. Select the phone type.

SETUP



5. When two or less numbers in total are registered to this contact, this screen is displayed.

When you want to add a number to this contact, touch "Yes".

- **Editing the phonebook data**

You can register the phone number in "Phone#1", "Phone#2" and "Phone#3" separately.



1. Touch "Edit Contacts".

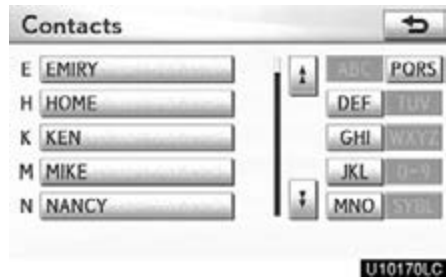

2. Select the data you want to edit.

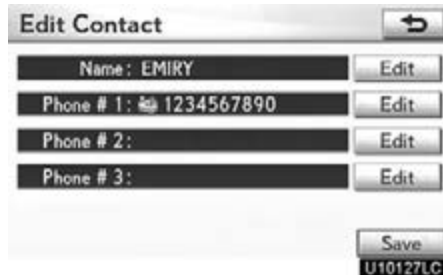

3. Touch "Edit" for the desired name or number.
4. Edit the name or the number. (See "• Registering the phonebook data" on page 363.)
5. When you complete the edit, touch "Save".

You can also display the "Edit Contact" screen in the following ways.

From "Contact Data" screen

1. Push the "INFO/PHONE" button.
2. Touch "Phone".
3. Touch "Contacts".
4. Select the desired data from the list.

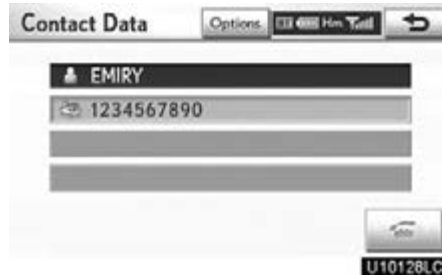

5. Touch "Options".



6. Touch "Edit Contact".

SETUP

From “Call History” screen

1. Push the “INFO/PHONE” button.
2. Touch “Phone”.
3. Touch “Call History”.
4. Select the desired number from the list.



5. Touch “Add Contact” or “Update Contact”.

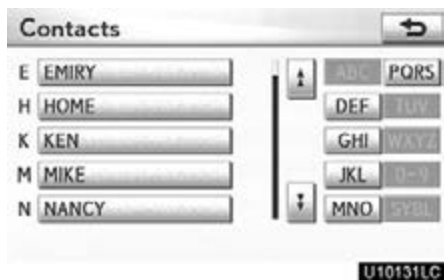

6. In case that you have touched “Update Contact”, this screen is displayed. Select the desired data from the list.

- Deleting the phonebook data

You can delete the data.

When you release your car, delete all your data on the system.



1. Touch “Delete Contacts”.



2. Select the desired data or touch “Select All”, then touch “Delete”.

You can touch multiple data and delete them at the same time.



3. Touch "Yes".

You can also delete it in the following way.

1. Push the "INFO/PHONE" button.
2. Touch "Phone".
3. Touch "Contacts".
4. Select the desired data from the list.

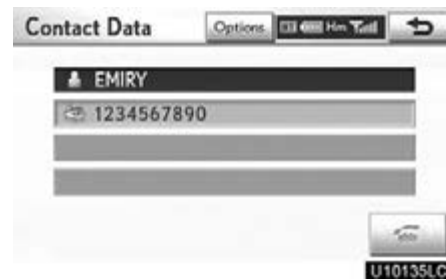

5. Touch "Options".



6. Touch "Delete Contact".



7. Touch "Yes".

INFORMATION

When you delete a Bluetooth® phone, the phonebook data will be deleted at the same time.

— Speed dials setting

"Speed dials setting" is accessed from the "Speed Dials" screen.

1. Push the "SETUP" button.
2. Touch "Phone".
3. Touch "Phonebook".



4. Touch "Manage Speed Dials".



Please refer to the following pages for each setting.

You can also display the “Speed Dials” screen in the following way.

1. Push the “INFO/PHONE” button.
2. Touch “Phone”.
3. Touch “Speed Dials”.



4. Touch “Options”.

• Registering the speed dial

You can register the desired phone number from phonebook. Up to 18 numbers per phone can be registered.



1. Touch “New Speed Dial”.



2. Select the data you want to register.

SETUP

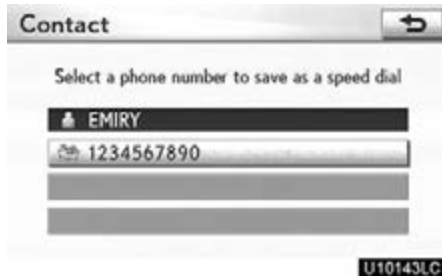

3. Touch the desired phone number.

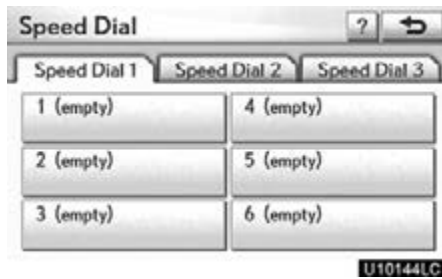

4. Touch the touch-screen button you want to register in.



5. If you select a touch-screen button you registered before, this screen is displayed.

Touch "Yes" if you want to replace it.

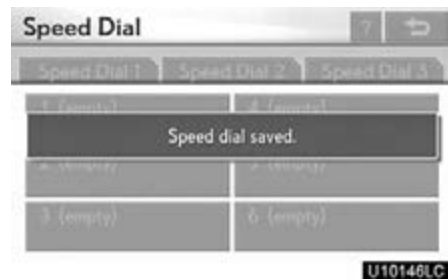

6. When this screen is displayed, the operation is complete.

You can also register the speed dial in the following ways.

From "Speed Dial" screen

1. Push the "INFO/PHONE" button.
2. Touch "Phone".
3. Touch "Speed Dials".

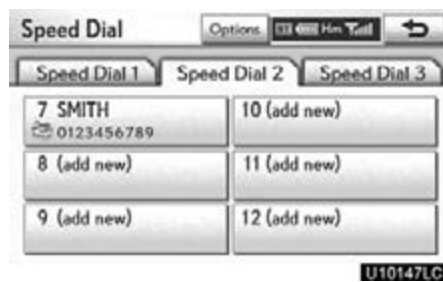

4. Touch "(add new)".



5. Touch "Yes" to set new speed dial.

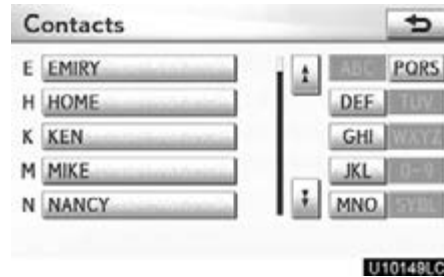

6. Select the data you want to register.

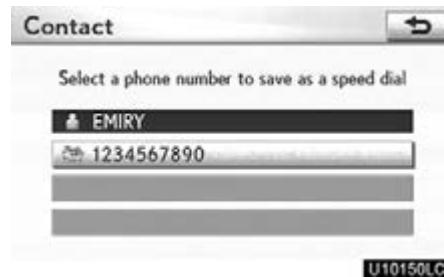

7. Touch the desired phone number.

SETUP

From "Contact Data" screen

1. Push the "INFO/PHONE" button.
2. Touch "Phone".
3. Touch "Contacts".
4. Select the desired data from the list.

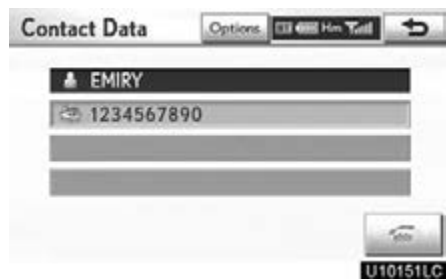

5. Touch "Options".



6. Touch "Set Speed Dial".

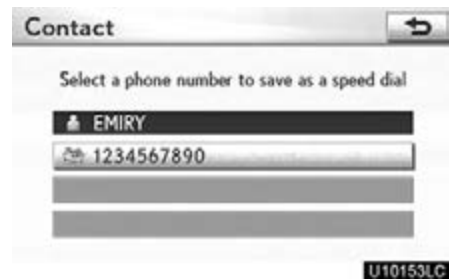

7. This screen is displayed.
The following operations are the same as the operation when you operate it from the "SETUP" button.

- **Editing the speed dial**
You can edit the speed dial.



1. Touch "Edit Speed Dials".



2. Touch the touch-screen button you want to edit.

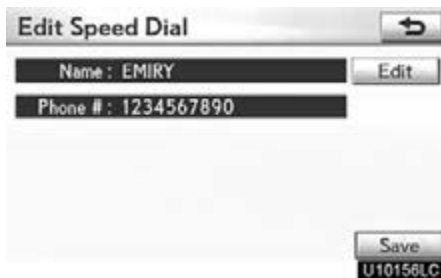

3. Touch "Edit".



4. Use the software keyboard to input the name.

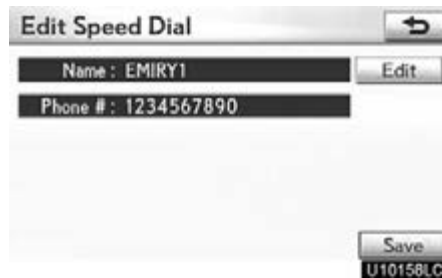

5. Touch "Save".

SETUP

- **Deleting the speed dial**

You can delete the speed dial.



3. Touch "Yes".

1. Touch "Delete Speed Dials".



2. Select the desired data or touch "Select All", then touch "Delete".

You can select multiple data and delete them at the same time.

— Deleting call history

You can delete the call history.



U10162LC

1. Touch “Delete Call History”.



U10163LC

2. Select the desired history to delete.

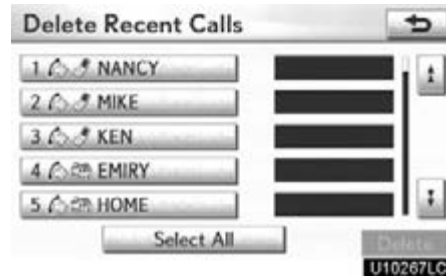

U10267LC

3. Select the desired data or touch “Select All”, then touch “Delete”.

You can select multiple data and delete them at the same time.



U10268LC

4. Touch “Yes”.

SETUP

You can also delete the call history in the following way.

1. Push the “INFO/PHONE” button.
2. Touch “Phone”.
3. Touch “Call History”.

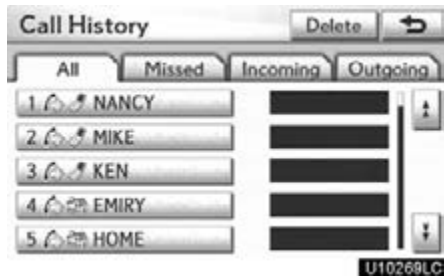

4. Touch “Delete”.

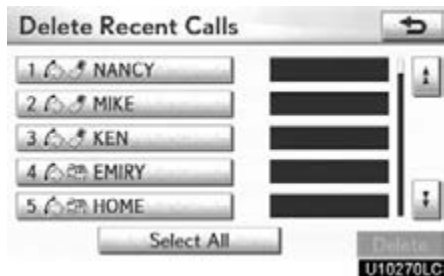

5. This screen is displayed.

The following operations are the same as the operation when you operate it from the “SETUP” button.

You can similarly operate other call history.

— Setting the voice tag

“Setting the voice tag” is done by displaying “Voice Tags” screen.

1. Push the “SETUP” button.
2. Touch “Phone”.
3. Touch “Phonebook”.



4. Touch “Manage Voice Tags”.



Please refer to the following pages for each setting.

You can also display “Voice Tags” screen in the following way.

1. Push the “INFO/PHONE” button.
2. Touch “Phone”.
3. Touch “Contacts”.

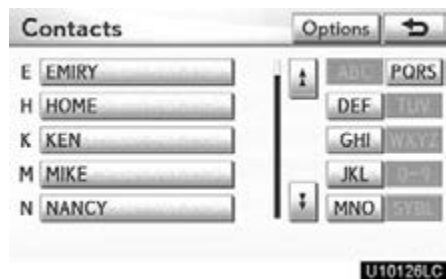

4. Touch “Options”.



5. Touch “Manage Voice Tags”.

● Registering the voice tag

You can register a voice tag for up to 20 numbers.



1. Touch “New Voice Tag”.



2. Select the data you want to register.

SETUP



3. Touch “● REC”, and record a voice tag.

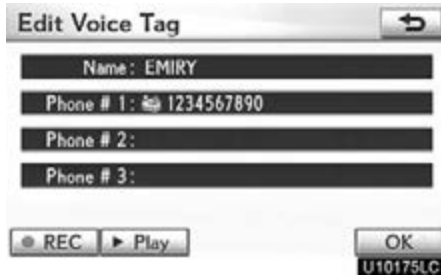

4. Touch “▶ Play” to play the voice tag.

When you complete the voice tag registration, touch “OK”.

INFORMATION

When you use the voice tag, do not change the language setting from the language setting used when registering.

If they are different, the voice recognition can't recognize the voice tag that you have registered.

You can also register the voice tag in the following way.

1. Push the “INFO/PHONE” button.
2. Touch “Phone”.
3. Touch “Contacts”.
4. Select the desired data from the list.

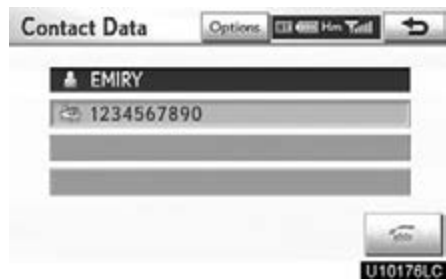

5. Touch “Options”.



6. Touch “Set Voice Tag”.

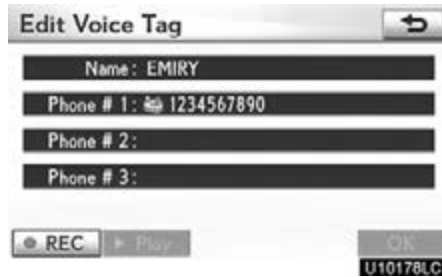

7. This screen is displayed.
The following operations are the same as the operation when you operate it from the "SETUP" button.

• Editing the voice tag



1. Touch "Edit Voice Tags".



2. Select the data you want to edit.



3. This screen is displayed.
The following operations are the same as the operation when you register the voice tag.

• Deleting the voice tag



U10182LC

1. Touch "Delete Voice Tags".



U10183LC

2. Select the desired data or touch "Select All", then touch "Delete".

You can select multiple data and delete them at the same time.



U10184LC

3. Touch "Yes".

— Bluetooth®

You can confirm and change the Bluetooth® settings.

1. Push the "SETUP" button.
2. Touch "Phone".



U10185LC

3. Touch "Bluetooth**".

*: Bluetooth is a registered trademark of Bluetooth SIG, Inc.



U10186LC

4. This screen is displayed.

The information displays the following items.

“Device Name”

..... The name in the Bluetooth® network. You can change it.

“Passcode”

..... The passcode when you used to register your cellular phone in the system. You can change it.

“Device Address”

..... The address peculiar to the system. You can not change it. If the same device name is displayed on the screen of your phone, refer to it.

If you want to change the settings, refer to the following pages.

When you change the settings, touch “Save” after changing them.

● **Changing the Bluetooth® settings**

You can change the Bluetooth® settings according to the following procedures.

Changing the handsfree power

The “Handsfree Power” display shows the following state.

When “Handsfree Power” is **“On”**:

The Bluetooth® phone is automatically connected when you turn the ignition to ACCESSORY or IGNITION ON mode.

When “Handsfree Power” is **“Off”**:

The Bluetooth® phone is disconnected, and the system will not connect to it next time.

You can select the state of “Handsfree Power”.

On: The auto connection is turned on.

Off: The auto connection is turned off.

You can not change the state from **“On”** into **“Off”** while driving.

SETUP



1. Touch "Handsfree Power".



2. Touch "On" or "Off".



3. Touch "Save".

In case that "Handsfree Power" is changed from "Off" into "On", Bluetooth® connection will begin.

When you connect the phone while Bluetooth® audio is playing



This screen is displayed, and the Bluetooth® audio will stop temporarily.

Editing the device name



1. Touch "Edit" of "Device Name".



2. Use the software keyboard to input the device name.

Editing the passcode



1. Touch "Edit" of "Passcode".



2. Input a passcode and touch "OK".

INFORMATION

The device names are common Bluetooth® audio and Bluetooth® phone.

If you change the device name of the phone, the device name of the audio will change at same time.

However, passcodes can be set separately.

SETUP

- **Initializing the Bluetooth® settings**
You can initialize the settings.



1. Touch "Default".



2. Touch "Yes".

If "Handsfree Power" is changed from "Off" into "On", Bluetooth® connection will begin.

If you connect a phone while Bluetooth® audio is playing



This screen is displayed, and the Bluetooth® audio will stop temporarily.

— Details

You can do the detail settings.

1. Push the “SETUP” button.
2. Touch “Phone”.

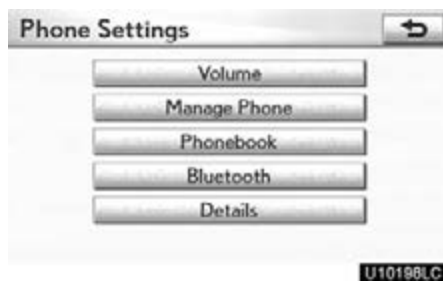

3. Touch “Details”.



4. Do each setting according to the following procedures.
5. When you complete each setting, touch “Save”.

● Incoming call display

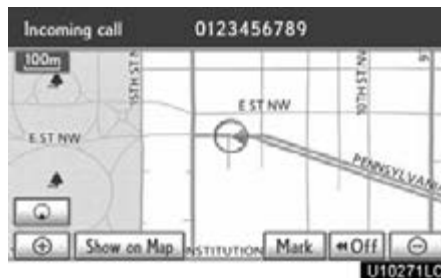

You can select the method of the incoming call display.

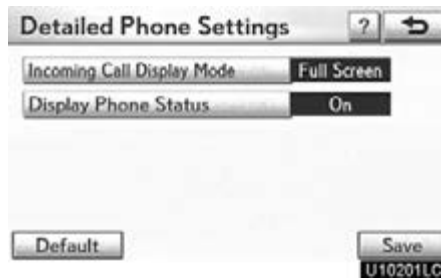

1. Touch “Incoming Call Display Mode”.

SETUP



2. Touch “Full Screen” or “Drop Down”.

“Full Screen” mode

- When a call is received, the Hands-free screen is displayed and you can operate it on the screen.

“Drop Down” mode

- The message is displayed on the upper side of the screen. You can only operate the steering switch.

- The Bluetooth® connection status at start up

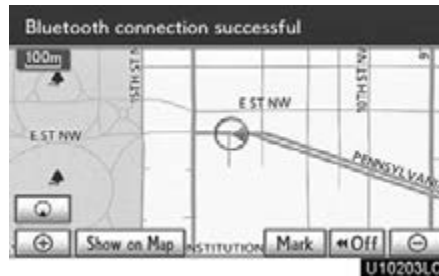

When the “ENGINE START STOP” switch is in ACCESSORY or IGNITION ON mode and the Bluetooth® is automatically connected, the connection check is displayed.

When “Display Phone Status” is “On”, this status is displayed.

When “Display Phone Status” is “Off”, this status is not displayed.

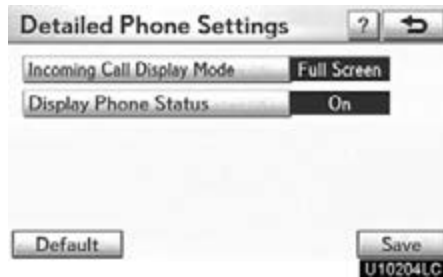

1. Touch "Display Phone Status".



2. Touch "On" or "Off".

- **Initializing the settings**

You can initialize the settings.

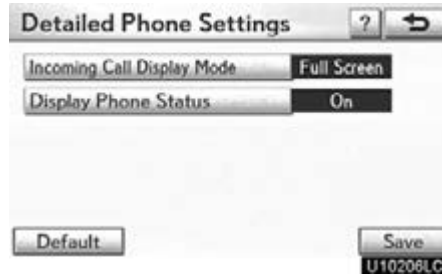

1. Touch "Default".



2. Touch "Yes".

SETUP

Audio settings — — Select portable player

The portable player to connect can be selected. The registered audio information can be confirmed and edited.

- **Selecting a portable player**

If you register a second portable player, either one can be selected for connection.



1. Push the “SETUP” button.



2. Touch “Audio” on “Setup” screen.

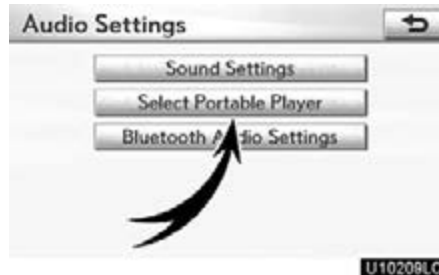

3. Touch “Select Portable Player” on “Audio Settings” screen.

You can select from a maximum of two Bluetooth® portable players.

“Empty” is displayed when you have not registered a portable player yet. The Bluetooth® mark is displayed when you choose the portable player.



4. Select desired portable player and then touch “OK”.

Although you can register up to two portable players in the system, only one portable player can function at a time.

- **Displaying Bluetooth® information**

You can see or change the information of the portable player on the system.

“Device Name”

... The name of Bluetooth® portable player which is displayed on the screen. You can change it into a desired name.

“Device Address”

... The address peculiar to the system. You cannot change it. If you have registered two Bluetooth® portable players with the same device name and you cannot distinguish one from the other, refer to it.

“Connection Method”

... The connection method can be switched between **“From Vehicle”** and **“From Portable Player”**.



Select the desired portable player and then touch “Portable Player Info”.

- **Changing a device name**

You can change a device name. Even if you change a device name, the name registered in your portable player is not changed.



1. Touch “Portable Player Info” on “Select Portable Player” screen.



2. Touch “Edit” for “Device Name” on “Portable Player Information” screen.



3. Use the software keyboard to input the device name.

- **Selecting Connection method**

The connection method can be selected.

From Vehicle: Connect the audio system to the portable player.

From Portable Player: Connect the portable player to the audio system.



Select desired connection method "From Vehicle" or "From Portable Player" and then touch "Save".

INFORMATION

If the connection method is set to "From Portable Player", "Auto Bluetooth Connect" cannot be selected.*

*: Bluetooth is a registered trademark of Bluetooth SIG.Inc.

— **Setting Bluetooth® audio**

The Bluetooth® audio settings can be set.

- **Registering your portable player**



1. Touch "Bluetooth* Audio Settings" on "Audio Settings" screen.



2. Touch "Register" of "Bluetooth* Audio" on "BT Audio Settings" screen.

*: Bluetooth is a registered trademark of Bluetooth SIG.Inc.



3. When this screen is displayed, enter the passcode displayed on the screen into the portable player.

For the operation of the portable player, see the manual that comes with it.

If you want to cancel the entry, touch “Cancel”.



4. When the connection is complete, this screen is displayed.

You do not need to enter the portable player in case of using the same one.



When this screen is displayed, follow the guidance on the screen to try connection again.

When another Bluetooth® device is connected



When the Bluetooth® device is currently connected, this screen is displayed.

If you want to disconnect it, touch “Yes”.

INFORMATION

If the device corresponds with both Bluetooth® phone and Bluetooth® audio, register and connect the Bluetooth® phone first or a connection failure may occur when registering the Bluetooth® audio.

SETUP

(a) Removing a Bluetooth® audio



1. Touch “Remove” of “Bluetooth* Audio” on “BT Audio Settings” screen.



2. Select the portable player you want to delete and touch “OK”.



3. Touch “Yes” to unregister the selected portable player.

*: Bluetooth is a registered trademark of Bluetooth SIG.Inc.



If the selected portable player is in use, this screen will appear. Touch “Yes”. The system will disconnect the portable player and remove it.

**(b) Connecting Bluetooth® audio
AUTOMATICALLY**

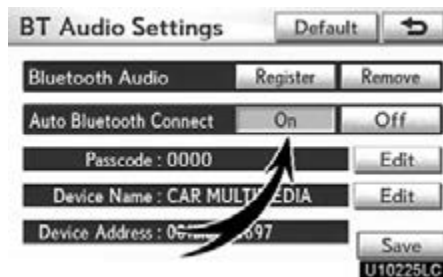

Touch “On” for “Auto Bluetooth* Connect” to activate the automatic connection for the Bluetooth®. Always set it to this mode and leave the Bluetooth® portable player in a condition where connection can be established. The “Auto Bluetooth* Connect” cannot be selected if the connection method is set to “**From Portable Player**”.

*: Bluetooth is a registered trademark of Bluetooth SIG.Inc.



When the “ENGINE START STOP” switch is in ACCESSORY or IGNITION ON mode, the selected portable player will be automatically connected and the connection result is displayed.

MANUALLY

When the auto connection failed or turned off, you have to connect Bluetooth® manually.

For the manual operation, see page 248.

SETUP

(c) Changing the passcode

The passcode for registering your portable player on the system. You can change this to 4 to 8 digit number of your choice. The default is "0000".



1. Touch "Edit" of "Passcode" on "BT Audio Settings" screen.



2. Enter the new 4–8 digits passcode and touch "OK".

Each time you touch , an input digit is deleted.

(d) Changing the device name

You can change a device name. Even if you change a device name, the name registered your portable player is not changed.



1. Touch "Edit" of "Device Name" on "BT Audio Settings" screen.



2. Enter the new device name and touch "OK".

INFORMATION

The device names are common Bluetooth® audio and Bluetooth® phone.

If you change the device name of the audio, the device name of the phone will change at same time.

However, passcodes can be set separately.

(e) Initializing the Bluetooth® audio settings

You can initialize the settings.

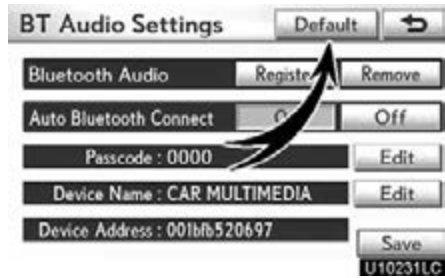

1. Touch “Default” on “BT Audio Settings” screen.



2. Touch “Yes”.

**Vehicle settings —
— Maintenance**

When the navigation system is turned on, the “Information” screen displays when it is time to replace a part or certain components. (See page 27.)



1. Push the “SETUP” button.

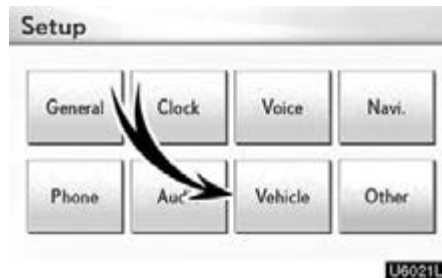

2. Touch “Vehicle”.

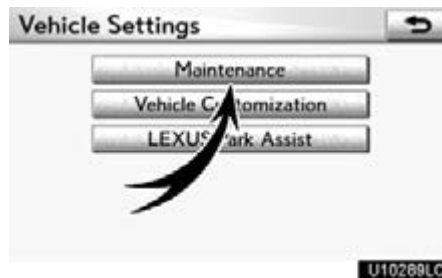

3. Touch “Maintenance”.

SETUP



- Setting maintenance information (See page 396.)
- Setting dealer (See page 398.)

(a) Maintenance information setting

1. Push the “SETUP” button.
2. Touch “Vehicle” on the “Setup” screen.
3. Touch “Maintenance” on the “Vehicle Settings” screen.



4. Touch the desired button.

For details of each button, see “INFORMATION ITEMS” on page 397.

“**Delete All**”: To cancel all conditions which have been inputted.

“**Reset All**”: To reset the item which has satisfied a condition.

“**Set Dealer**”: To register dealer information. (See “(b) Dealer setting” on page 398.)

“**Dealer Info.**”: To edit dealer information. (See “(b) Dealer setting” on page 398.)

“**Reminder**”: When this button is touched, the indicator is illuminated. The system is set to give maintenance information with the “Information” screen. (See page 27.)

When the vehicle needs to be serviced, the button color will change to orange.

INFORMATION ITEMS

- “**Engine oil**” : Replace engine oil
- “**Oil filter**” : Replace engine oil filter
- “**Rotation**” : Rotate tires
- “**Tires**” : Replace tires
- “**Battery**” : Replace battery
- “**Brake pad**” : Replace brake linings
- “**Wipers**” : Replace wiper blades
- “**Coolant**” : Replace engine coolant
- “**Brake oil**” : Replace brake fluid
- “**Trans. fluid**” : Replace transmission fluid
- “**Service**” : Scheduled maintenance
- “**Air filter**” : Replace air filter
- “**Personal**” : New information items can be created separately from provided ones.

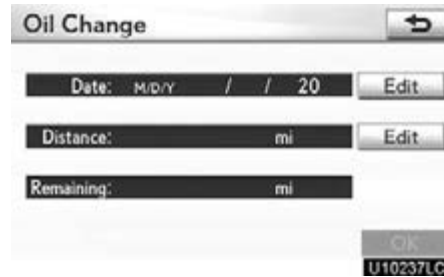

5. Input the conditions.

“Date”: The next maintenance date can be input.

“Distance”: The driving distance until the next maintenance check can be input.

“Delete”: To cancel the date and distance conditions.

“Reset”: To reset the date and distance conditions.

6. Touch “OK”.

The screen then returns to the “Maintenance” screen.

INFORMATION
<ul style="list-style-type: none"> ● <i>For scheduled maintenance information, please refer to the “Warranty and Services Guide/Owner’s Manual Supplement/Scheduled Maintenance”.</i> ● <i>Depending on driving or road conditions, the actual date and distance may differ from the stored date and distance in the system.</i>

SETUP

(b) Dealer setting

It is possible to register a dealer in the system. With dealer information registered, route guidance to the dealer is available.

1. Push the “SETUP” button.
2. Touch “Vehicle” on the “Setup” screen.
3. Touch “Maintenance” on the “Vehicle Settings” screen.



4. Touch “Set Dealer”.



5. If the dealer has not been registered, enter the location of the dealer in the same way as for a destination search. (See “Destination search” on page 62.)

When “Set Dealer” registration is finished, the “Dealer” screen will be displayed.



6. Touch “Edit” for the item you want to change.

“Dealer”: To enter the name of a dealer. (See page 399.)

“Contact”: To enter the name of a dealer member. (See page 399.)

“Location”: To set a location. (See page 399.)

“Phone #”: To set a telephone number. (See page 400.)

“Delete Dealer”: To delete the dealer information displayed on the screen.

“Enter” (location pin icon): To set the displayed dealer as a destination. (See “Starting route guidance” on page 83.)

● To edit “Dealer” or “Contact”

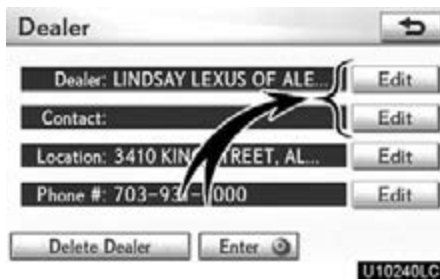

1. Touch “Edit” of “Dealer” or “Contact”.



2. Enter the name using the alphanumeric keys.
Up to 32 characters can be entered.
3. Touch “OK”.
The previous screen will be displayed.

● To edit “Location”



1. Touch “Edit” of “Location”.



2. Touch the 8 directional button to move the cursor to the desired point on the map.
3. Touch “OK”.
The previous screen will be displayed.

SETUP

- To edit “Phone #” (telephone number)

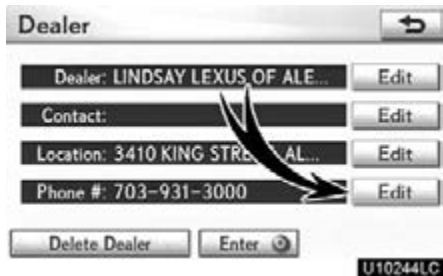

1. Touch “Edit” of “Phone #”.



2. Enter the number using number keys.

3. Touch “OK”.

The previous screen will be displayed.

— Vehicle customization

Vehicle settings can be changed.

1. Push the “SETUP” button.
2. Touch “Vehicle” on the “Setup” screen.

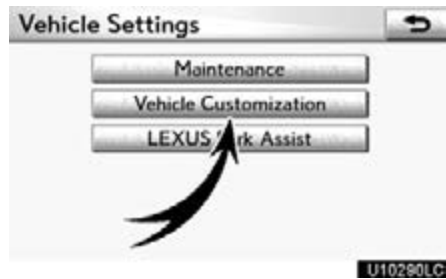

3. Touch “Vehicle Customization”.



4. Select the setting to be changed. Various settings can be changed. For a list of the settings that can be changed, see the vehicle owner’s manual.

5. After changing the settings, touch “Save”.

A message indicating that the settings are being saved will appear. Do not perform any other operations while this message is displayed.

CAUTION

When performing the customization procedure, ensure that there is sufficient ventilation in the vehicle and surrounding area. If there is insufficient ventilation, exhaust gases may collect and enter the vehicle. Exhaust gases include harmful carbon monoxide (CO) and inhaling them may lead to death or a serious health hazard.

INFORMATION

Stop the vehicle in a safe place, set the parking brake and put the shift lever in "P". To avoid discharging the battery, perform the customization procedure with the engine running.

— Intuitive parking assist setting

The volume of the beeps and turning on or off of the display can be set.

1. Push the "SETUP" button.
2. Touch "Vehicle" on the "Setup" screen.

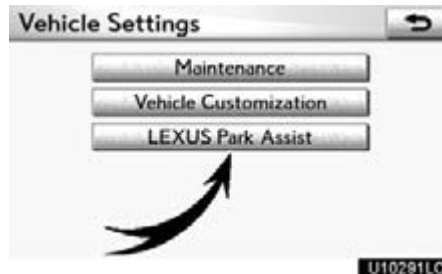

3. Touch "LEXUS Park Assist".



4. Touch the desired button.
5. Touch "Save".

SETUP

- **Setting an alert volume**

The alert volume can be adjusted.

1. Push the **“SETUP”** button.
2. Touch **“Vehicle”** on the **“Setup”** screen.
3. Touch **“LEXUS Park Assist”** on the **“Vehicle Settings”** screen.



4. Touch the desired button.

The volume has 5 levels, increasing with higher value or decreasing with lower value.

5. Touch **“Save”**.

- **Setting a parking sonar display**

“On” or **“Off”** can be selected for parking sonar display.

1. Push the **“SETUP”** button.
2. Touch **“Vehicle”** on the **“Setup”** screen.
3. Touch **“LEXUS Park Assist”** on the **“Vehicle Settings”** screen.



4. Touch the desired button.

5. Touch **“Save”**.

Although **“Off”** is selected, if the obstacle is detected while using rear view monitor system or wide view front & side monitor, the warning appears on the screen.

- **Setting a display and tone indication**

Front and back sensors display and tone indication can be set.

1. Push the “SETUP” button.
2. Touch “Vehicle” on the “Setup” screen.
3. Touch “LEXUS Park Assist” on the “Vehicle Settings” screen.

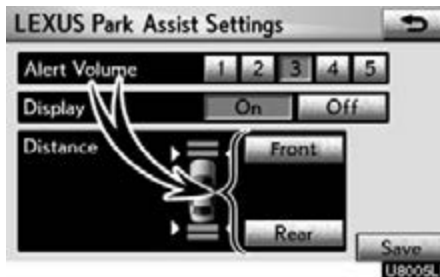

4. Touch “Front” or “Rear”.
Selecting “Front” or “Rear” to switch the distance for the front or back sensors display and tone indication, from long distance to short distance, or from short distance to long distance.
5. Touch “Save”.

Other settings

Used for changing settings for Lexus Insider and XM® Sports and Stocks.



1. Push the “SETUP” button.



2. Touch “Other”.

SETUP

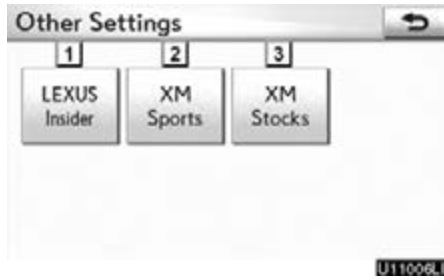

On this screen, the following functions can be performed.

No.	Function
1	Sets Lexus Insider (See page 175.)
2	Sets XM sports (See page 164.)
3	Sets XM stocks (See page 166.)

SECTION 12

APPENDIX

- [Limitations of the navigation system](#) 406
- [Map database information and updates](#) 408

Limitations of the navigation system

This navigation system calculates the current vehicle position using satellite signals, various vehicle signals, map data, etc. However, the accurate position may not be shown depending on the satellite condition, road configuration, vehicle condition or other circumstances.

The Global Positioning System (GPS) developed and operated by the U.S. Department of Defense provides an accurate current vehicle position, normally using 4 or more satellites, and in some case 3 satellites. The GPS system has a certain level of inaccuracy. While the navigation system will compensate for this most of the time, occasional positioning errors of up to 300 feet (100 m) can and should be expected. Generally, position errors will be corrected within a few seconds.



When your vehicle is receiving signals from the satellites, the "GPS" mark appears at the top left of the screen.

The GPS signal may be physically obstructed, leading to inaccurate vehicle position on the map display. Tunnels, tall buildings, trucks, or even the placement of objects on the instrument panel may obstruct the GPS signals.

The GPS satellites may not send signals due to repairs or improvements being made to them.

Even when the navigation system is receiving clear GPS signals, the vehicle position may not be shown accurately or inappropriate route guidance may occur in some cases.

NOTICE

The installation of window tinting may obstruct the GPS signals. Most window tinting contains some metallic content that will interfere with GPS signal reception of the antenna in the instrument panel. We advise against the use of window tinting on vehicles equipped with navigation systems.

(a) Accurate current vehicle position may not be shown in the following cases:

- When driving on a small angled Y-shaped road.
- When driving on a winding road.
- When driving on a slippery road such as in sand, gravel, snow, etc.
- When driving on a long straight road.
- When motorway and surface streets run in parallel.
- After moving by ferry or vehicle carrier.
- When a long route is searched during high speed driving.
- When driving without setting the current position calibration correctly.
- After repeating a change of direction by going forward and backward, or turning on a turntable in the parking lot.
- When leaving a covered parking lot or parking garage.
- When a roof carrier is installed.
- When driving with tire chains installed.
- When the tires are worn.
- After replacing a tire or tires.
- When using tires that are smaller or larger than the factory specifications.
- When the tire pressure in any of the four tires is not correct.

(b) Inappropriate route guidance may occur in the following cases:

- When turning at an intersection off the designated route guidance.
- If you set more than one destination but skip any of them, auto reroute will display a route returning to the destination on the previous route.
- When turning at an intersection for which there is no route guidance.
- When passing through an intersection for which there is no route guidance.
- During auto reroute, the route guidance may not be available for the next turn to the right or left.
- It may take a long time to operate auto reroute during high speed driving. In auto reroute, a detour route may be shown.
- After auto reroute, the route may not be changed.
- An unnecessary U-turn may be shown or announced.
- A location may have multiple names and the system will announce one or more.
- Some routes may not be searched.
- If the route to your destination includes gravel, unpaved roads or alleys, the route guidance may not be shown.
- Your destination point might be shown on the opposite side of the street.
- When a portion of the route has regulations prohibiting the entry of the vehicle that vary by time or season or other reasons.
- The road and map data stored in your navigation system may not be complete or may not be the latest version.

INFORMATION

If your vehicle cannot receive GPS signals, you can correct the current position manually. For information on setting the current position calibration, see page 346.

After replacing a tire, implement the operation described in the “TIRE CHANGE CALIBRATION”. (See page 348.)

This navigation system uses tire turning data and is designed to work with factory-specified tires for your vehicle. Installing tires that are larger or smaller than the originally equipped diameter may cause inaccurate display of the vehicle’s position. The tire pressure also affects the diameter of the tires so please make sure the tire pressure of all four tires is correct.

Map database information and updates

This system uses the maps of DENSO.

© 2009 DENSO CORPORATION
© 2008 NAVTEQ. All rights reserved.
© 2009 Tele Atlas North America, Inc. All rights reserved. This material is proprietary and the subject of copyright protection and other intellectual property rights owned by or licensed to Tele Atlas North America, Inc. The use of this material is subject to the terms of a license agreement. You will be held liable for any unauthorized copying or disclosure of this material.
Data by infoUSA Copyright © 2008, All Rights Reserved.
© 2008 VISA Corporation
Copyright © CoStar Realty Information, Inc.
The Bullseye Design is a registered trademark of Target Brands, Inc.

END USER LICENSE AGREEMENT

PLEASE READ THIS AGREEMENT CAREFULLY BEFORE USING THE NAVIGATION SYSTEM

THIS IS A LICENSE AGREEMENT FOR YOUR COPY OF THE SPATIAL MAP DATABASE, INCLUDING LOCATION CODES AND RELATED PRODUCTS (COLLECTIVELY, THE "DATABASE"), USED IN THE NAVIGATION SYSTEM. BY USING THE NAVIGATION SYSTEM AND THE DATABASE, YOU ACCEPT AND AGREE TO BE BOUND BY ALL TERMS AND CONDITIONS SET FORTH BELOW.

LICENSE GRANT

DENSO CORPORATION ("DENSO"), as a licensed distributor of the DATABASE, grants to you a non-exclusive, non-perpetual license to use your copy of the DATABASE for your personal use or for your use in your business' internal operations and not for any other purpose. This license does not include the right to grant sub-licenses.

OWNERSHIP

The DATABASE and the copyrights and intellectual property and neighboring rights therein are owned by Tele Atlas North America, Inc. ("TANA") and its licensors. This Agreement does not transfer any title or interest in the DATABASE, except for the license to use the DATABASE according and subject to the terms and conditions of this Agreement. You shall not alter, obscure or remove any copyright notices, trademark notices or other restrictive legends relating to the DATABASE.

The DATABASE comprises confidential and proprietary information and materials of TANA. Accordingly, you shall hold the DATABASE in confidence and trust. You shall take reasonable steps to protect the DATABASE from misappropriation or misuse. You shall not extract stand-alone data from or publish any part of the DATABASE without the prior written consent of TANA and its licensors.

LIMITATIONS ON USE

The DATABASE is restricted for use in the specific system for which it was created. Except to the extent explicitly permitted by mandatory laws, you may not extract or reutilize any portion of the contents of the DATABASE, nor reproduce, copy, duplicate, modify, adapt, translate, disassemble, decompile, or reverse engineer any portion of the DATABASE.

TRANSFER

You may not transfer the DATABASE to third parties, except together with the system for which it was created, provided that you do not retain any copy of the DATABASE, and provided that the transferee agrees to all terms and conditions of this AGREEMENT.

DISCLAIMER OF WARRANTY

THE DATABASE IS PROVIDED ON AN "AS IS" AND "WITH ALL FAULTS BASIS" AND DENSO AND TANA (AND THEIR LICENSORS AND SUPPLIERS) EXPRESSLY DISCLAIM ALL OTHER WARRANTIES, EXPRESS OR IMPLIED, INCLUDING BUT NOT LIMITED TO, THE IMPLIED WARRANTIES OF NON-INFRINGEMENT, MERCHANTABILITY, SATISFACTORY QUALITY, ACCURACY, TITLE AND FITNESS FOR A PARTICULAR PURPOSE. NO ORAL OR WRITTEN ADVICE OR INFORMATION PROVIDED BY DENSO OR TANA (OR ANY OF THEIR LICENSORS, AGENTS, EMPLOYEES OR THIRD PARTY PROVIDERS) SHALL CREATE A WARRANTY, AND YOU ARE NOT ENTITLED TO RELY ON ANY SUCH ADVICE OR INFORMATION. THIS DISCLAIMER OF WARRANTIES IS AN ESSENTIAL CONDITION OF THIS AGREEMENT.

LIMITATION OF LIABILITY

IN NO EVENT SHALL DENSO OR TANA (OR THEIR LICENSORS OR SUPPLIERS) BE LIABLE FOR ANY INCIDENTAL, CONSEQUENTIAL, SPECIAL, INDIRECT OR EXEMPLARY DAMAGES ARISING OUT OF THIS AGREEMENT OR YOUR USE OF THE DATABASE, INCLUDING, WITHOUT LIMITATION, LOST PROFITS OR COSTS OF COVER, LOSS OF USE OR BUSINESS INTERRUPTION OR THE LIKE, REGARDLESS OF WHETHER THE PARTY WAS ADVISED OF THE POSSIBILITY OF SUCH DAMAGES.

IN NO EVENT WILL THE TOTAL LIABILITY OF DENSO OR TANA (OR THEIR LICENSORS OR SUPPLIERS) EXCEED THE AMOUNTS PAID BY YOU FOR THE DATABASE.

WARNINGS

The DATABASE comprises facts and information from government and other sources reflecting circumstances in existence before you received the DATABASE, which may contain errors and omissions. Accordingly, the DATABASE may contain inaccurate or incomplete information due to the passage of time, changing circumstances, and due to the nature of the sources used. The DATABASE does not include or reflect information relating to, among other things, neighborhood safety; law enforcement; emergency assistance; construction work; road or lane closures; vehicle or speed restrictions; road slope or grade; bridge height, weight or other limits; road or traffic conditions; special events; traffic congestion; or travel time.

U.S. GOVERNMENT RIGHTS

If you are an agency, department, or other entity of the United States Government, or funded in whole or in part by the United States Government, then use, duplication, reproduction, release, modification, disclosure or transfer of this commercial product and accompanying documentation, is restricted in accordance with the LIMITED or RESTRICTED rights as described in DFARS 252.227-7014(a)(1) (JUN 1995) (DOD commercial computer software definition), DFARS 227.7202-1 (DOD policy on commercial computer software), FAR 52.227-19 (JUN 1987) (commercial computer software clause for civilian agencies), DFARS 252.227-7015 (NOV 1995) (DOD technical data - commercial items clause); FAR 52.227-14 Alternates I, II, and III (JUN 1987) (civilian agency technical data and noncommercial computer software clause); and/or FAR 12.211 and FAR 12.212 (commercial item acquisitions), as applicable. In case of conflict between any of the FAR and DFARS provisions listed herein and this Agreement, the construction that provides greater limitations on the Government's rights shall control.

Contractor/manufacturer is Tele Atlas North America, Inc., 11 Lafayette Street, Lebanon, NH 03766-1445. Phone: 603.643.0330. The DATABASE is ©1984-2009 by Tele Atlas North America, Inc. ALL RIGHTS RESERVED. For purpose of any public disclosure provision under any federal, state or local law, it is agreed that the DATABASE is a trade secret and a proprietary commercial product and not subject to disclosure.

If you are an agency, department, or other entity of any State government, the United States Government or any other public entity or funded in whole or in part by the United States Government, then you hereby agree to protect the DATABASE from public disclosure and to consider the DATABASE exempt from any statute, law, regulation, or code, including any Sunshine Act, Public Records Act, Freedom of Information Act, or equivalent, which permits public access and/or reproduction or use of the Licensed Products. In the event that such exemption is challenged under any such laws, this Agreement shall be considered breached and any and all right to retain any copies or to use of the DATABASE shall be terminated and considered immediately null and void. Any copies of the DATABASE held by you shall immediately be destroyed. If any court of competent jurisdiction considers this clause void and unenforceable, in whole or in part, for any reason, this Agreement shall be considered terminated and null and void, in its entirety, and any and all copies of the DATABASE shall immediately be destroyed.

END USER TERMS

The data ("Data") is provided for your personal, internal use only and not for resale. It is protected by copyright, and is subject to the following terms and conditions which are agreed to by you, on the one hand, and DENSO CORPORATION ("DENSO") and its licensors (including their licensors and suppliers) on the other hand.

© 2008 NAVTEQ. All rights reserved.

The Data for areas of Canada includes information taken with permission from Canadian authorities, including: © Her Majesty the Queen in Right of Canada, © Queen's Printer for Ontario, © Canada Post Corporation, GeoBase®.

NAVTEQ holds a non-exclusive license from the United States Postal Service® to publish and sell ZIP+4® information.

©United States Postal Service®2008. Prices are not established, controlled or approved by the United States Postal Service®. The following trademarks and registrations are owned by the USPS: United States Postal Service, USPS, and ZIP+4.

TERMS AND CONDITIONS

Personal Use Only. You agree to use this Data together with vehicle navigation system for the solely personal, non-commercial purposes for which you were licensed, and not for service bureau, time-sharing or other similar purposes. Accordingly, but subject to the restrictions set forth in the following paragraphs, you may copy this Data only as necessary for your personal use to (i) view it, and (ii) save it, provided that you do not remove any copyright notices that appear and do not modify the Data in any way. You agree not to otherwise reproduce, copy, modify, decompile, disassemble or reverse engineer any portion of this Data, and may not transfer or distribute it in any form, for any purpose, except to the extent permitted by mandatory laws. Multi-disc sets may only be transferred or sold as a complete set as provided by DENSO and not as a subset thereof.

Restrictions. Except where you have been specifically licensed to do so by DENSO, and without limiting the preceding paragraph, you may not (a) use this Data with any products, systems, or applications installed or otherwise connected to or in communication with vehicles, capable of vehicle navigation, positioning, dispatch, real time route guidance, fleet management or similar applications; or (b) with or in communication with any positioning devices or any mobile or wireless-connected electronic or computer devices, including without limitation cellular phones, palmtop and handheld computers, pagers, and personal digital assistants or PDAs.

Warning. The Data may contain inaccurate or incomplete information due to the passage of time, changing circumstances, sources used and the nature of collecting comprehensive geographic data, any of which may lead to incorrect results.

No Warranty. This Data is provided to you "as is," and you agree to use it at your own risk. DENSO and its licensors (and their licensors and suppliers) make no guarantees, representations or warranties of any kind, express or implied, arising by law or otherwise, including but not limited to, content, quality, accuracy, completeness, effectiveness, reliability, fitness for a particular purpose, usefulness, use or results to be obtained from this Data, or that the Data or server will be uninterrupted or error-free.

Disclaimer of Warranty: DENSO AND ITS LICENSORS (INCLUDING THEIR LICENSORS AND SUPPLIERS) DISCLAIM ANY WARRANTIES, EXPRESS OR IMPLIED, OF QUALITY, PERFORMANCE, MERCHANTABILITY, FITNESS FOR A PARTICULAR PURPOSE OR NON-INFRINGEMENT. Some States, Territories and Countries do not allow certain warranty exclusions, so to that extent the above exclusion may not apply to you.

Disclaimer of Liability: DENSO AND ITS LICENSORS (INCLUDING THEIR LICENSORS AND SUPPLIERS) SHALL NOT BE LIABLE TO YOU: IN RESPECT OF ANY CLAIM, DEMAND OR ACTION, IRRESPECTIVE OF THE NATURE OF THE CAUSE OF THE CLAIM, DEMAND OR ACTION ALLEGING ANY LOSS, INJURY OR DAMAGES, DIRECT OR INDIRECT, WHICH MAY RESULT FROM THE USE OR POSSESSION OF THE INFORMATION; OR FOR ANY LOSS OF PROFIT, REVENUE, CONTRACTS OR SAVINGS, OR ANY OTHER DIRECT, INDIRECT, INCIDENTAL, SPECIAL OR CONSEQUENTIAL DAMAGES ARISING OUT OF YOUR USE OF OR INABILITY TO USE THIS INFORMATION, ANY DEFECT IN THE INFORMATION, OR THE BREACH OF THESE TERMS OR CONDITIONS, WHETHER IN AN ACTION IN CONTRACT OR TORT OR BASED ON A WARRANTY, EVEN IF DENSO OR ITS LICENSORS HAVE BEEN ADVISED OF THE POSSIBILITY OF SUCH DAMAGES. Some States, Territories and Countries do not allow certain liability exclusions or damages limitations, so to that extent the above may not apply to you.

APPENDIX

Export Control. You agree not to export from anywhere any part of the Data provided to you or any direct product thereof except in compliance with, and with all licenses and approvals required under, applicable export laws, rules and regulations.

Entire Agreement. These terms and conditions constitute the entire agreement between DENSO (and its licensors, including their licensors and suppliers) and you pertaining to the subject matter hereof, and supersedes in their entirety any and all written or oral agreements previously existing between us with respect to such subject matter.

Governing Law. The above terms and conditions shall be governed by the laws of the State of Illinois, without giving effect to (i) its conflict of laws provisions, or (ii) the United Nations Convention for Contracts for the International Sale of Goods, which is explicitly excluded. You agree to submit to the jurisdiction of the State of Illinois for any and all disputes, claims and actions arising from or in connection with the Data provided to you hereunder.

Government End Users. If the Data is being acquired by or on behalf of the United States government or any other entity seeking or applying rights similar to those customarily claimed by the United States government, this Data is a "commercial item" as that term is defined at 48 C.F.R. ("FAR") 2.101, is licensed in accordance with these End-User Terms, and each copy of Data delivered or otherwise furnished shall be marked and embedded as appropriate with the following "Notice of Use", and shall be treated in accordance with such Notice:

NOTICE OF USE

CONTRACTOR (MANUFACTURER/
SUPPLIER) NAME: NAVTEQ

CONTRACTOR (MANUFACTURER/
SUPPLIER) ADDRESS:
425 West Randolph Street,
Chicago, Illinois 60606

This Data is a commercial item as defined in FAR 2.101 and is subject to these End-User Terms under which this Data was provided.

©2008 NAVTEQ – All rights reserved.

If the Contracting Officer, federal government agency, or any federal official refuses to use the legend provided herein, the Contracting Officer, federal government agency, or any federal official must notify NAVTEQ prior to seeking additional or alternative rights in the Data.

END USER NOTICE**PLEASE READ THIS NOTICE CAREFULLY BEFORE USING THIS NAVIGATION SYSTEM**

The Point Of Interest Data (“POI” Data) in the navigation system is in part provided by infoUSA Inc. (“infoUSA”). By using the POI Data, you accept and agree to all terms and conditions set forth below.

1. Ownership

All rights, title and interest to the infoUSA POI Data shall be retained by infoUSA.

2. Limitations on use

Except to the extent explicitly permitted by mandatory laws, you may not extract or reutilize any portion of the contents of the POI Data, nor reproduce, copy, modify, adapt, translate, disassemble, decompile, or reverse engineer any portion of the POI Data.

3. Transfer

You may not transfer the POI Data to third parties, except together with the system for which it was created, provided that you do not retain any copy of the POI Data.

4. Disclaimer of warranty

EXCEPT AS STATED HEREIN, INFOUSA MAKES NO EXPRESS OR IMPLIED WARRANTIES, INCLUDING, WITHOUT LIMITATION, ANY EXPRESS OR IMPLIED WARRANTY OF FITNESS FOR A PARTICULAR PURPOSE OR WARRANTY OF MERCHANTABILITY.

5. Limitation of liability

EITHER INFOUSA OR SUPPLIER OF POI DATA SHALL NOT BE LIABLE FOR ANY INDIRECT, CONSEQUENTIAL OR INCIDENTAL DAMAGES MADE OR ALLEGED IN CONNECTION WITH YOUR USE OF THE POI DATA.

END USER LICENSE AGREEMENT

Personal Use Only. You agree to use this information for solely personal, non-commercial purposes, and not for service bureau, time-sharing or other similar purposes. You may not modify the information or remove any copyright notices that appear on the information in any way. You may not decompile, disassemble or reverse engineer any portion of this information, and may not transfer or distribute it in any form, for any purpose. Without limiting the foregoing, you may not use this information with any products, systems, or applications installed or otherwise connected to or in communication with vehicles, capable of vehicle navigation, positioning, dispatch, real time route guidance, fleet management or similar applications.

No Warranty. This information is provided to you “as is,” and you agree to use it at your own risk. DENSO and its licensors (and their licensors and suppliers, collectively “DENSO”) make no guarantees, representations or warranties of any kind, express or implied, arising by law or otherwise, including but not limited to, and DENSO expressly disclaims any warranties regarding content, quality, accuracy, completeness, effectiveness, reliability, fitness for a particular purpose, non-infringement, usefulness, use or results to be obtained from this information, or that the information or server will be uninterrupted or error-free. Some states, territories and countries do not allow certain warranty exclusions, so to that extent, the above exclusion may not apply to you.

Disclaimer of Liability: DENSO SHALL NOT BE LIABLE TO YOU FOR ANY CLAIM, DEMAND OR ACTION, IRRESPECTIVE OF ITS NATURE, ALLEGING ANY LOSS, INJURY OR DAMAGES, WHETHER DIRECT, INDIRECT, INCIDENTAL, SPECIAL OR CONSEQUENTIAL DAMAGES, INCLUDING ANY LOSS OF PROFIT, REVENUE OR CONTRACTS ARISING OUT OF YOUR POSSESSION, USE OF OR INABILITY TO USE THIS INFORMATION, ANY DEFECT IN THE INFORMATION, OR THE BREACH OF THESE TERMS OR CONDITIONS, WHETHER IN AN ACTION IN CONTRACT OR TORT OR BASED ON A WARRANTY, EVEN IF DENSO OR ITS LICENSORS HAVE BEEN ADVISED OF THE POSSIBILITY OF SUCH DAMAGES. Some states, territories and countries do not allow certain liability exclusions or damages limitations, so to that extent the above may not apply to you.

Indemnity. You agree to indemnify, defend and hold DENSO and its licensors (including their respective licensors, suppliers, assignees, subsidiaries, affiliated companies, and the respective officers, directors, employees, shareholders, agents and representatives of each of them) free and harmless from and against any liability, loss, injury (including injuries resulting in death), demand, action, cost, expense, or claim of any kind or character, including but not limited to attorney's fees, arising out of or in connection with any use or possession by you of this information.

END USER NOTICE

The marks of companies displayed by this product to indicate business locations are the marks of their respective owners. The use of such marks in this product does not imply any sponsorship, approval, or endorsement by such companies of this product.

There are two types of areas available for route guidance. In one type of area, primarily around metropolitan centers, detailed route guidance is available for the entire area. In the other type of area, all roads are displayed on the map but route guidance is limited. The navigation route might lack precision because the data (no right turns, one-way traffic, etc.) is not complete. It is still possible to reach the destination by following the arrow direction and distance as shown on the bottom left of the screen. The arrow points in the direction of the destination. The distance shown is as measured in a straight line from the current vehicle position to the destination area.

In order to provide you with as accurate map information as possible, we are always gathering information such as on road repairs and carrying out on-site investigations. However, the names of roads, streets, facilities, and their locations frequently change. In some places, construction on roads may be in progress. For that reason, information on some areas in this system might be different from the actual location.

The map database is normally updated once a year. Contact your Lexus dealer for information about the availability and pricing of an update.

- To confirm the database version and map coverage area



1. Push the “INFO/PHONE” button.



2. Touch “Map Data”.



Make sure the version of the database on this screen.

To display the disc coverage area, touch “**Map Data Coverage**”. Confirm the covered area on the screen.

Contact your Lexus dealer to find out if there is a more recent update released.

- Certification

For vehicles sold in Canada.

Operation is subject to the following two conditions: (1) this device may not cause interference, and (2) this device must accept any interference, including interference that may cause undesired operation of the device. This Category II radiocommunication device complies with Industry Canada Standard RSS-310.

L'utilisation de ce dispositif est autorisée seulement aux deux conditions suivantes: (1) il ne doit pas produire de brouillage, et (2) l'utilisateur du dispositif doit être prêt à accepter tout brouillage radioélectrique reçu, même si ce brouillage est susceptible de compromettre le fonctionnement du dispositif. Ce dispositif de radiocommunication de catégorie II respecte la norme CNR-310 d'Industrie Canada.

APPENDIX

INDEX

For navigation system function, please also refer to the “Navigation system function index” on page 18.

INDEX

Numbers/Symbols

- ? button 20, 33
- 3 routes selection 85
- 3-ZONE button 298, 302

A

- A/C button 296, 298
- A/V input port 284
- Activating the wide view
 - front & side monitor 315
- Activation of service 155
- Adding destinations 94
- Address book button 20, 77
- Address book entries 117
- Address book entry information 37
- Address button 20, 65
- Adjusting the air conditioning
 - system settings manually 303
- Adjusting the air outlets 307
- Air conditioning controls 296
- Air flow control buttons 296, 298, 304
- Air intake control button
 - 296, 298, 302, 306
- Air outlets 304
- Alphabet key 28
- AM-FM button 184, 186, 196
- Angle mark 235, 279
- Areas to avoid 122
- Arrow screen 39, 90
- ASL 192
- AUDIO button 184, 186
- Audio button 22
- Audio language 235, 279
- Audio settings 388
- Audio/video remote controls 261
- Auto avoid traffic 173, 343
- AUTO button 296, 298
- Auto start 235
- Automatic air conditioning system 301
- Automatic mode 306
- Automatic sound levelizer 192
- AUX port 195
- AUX-USB button 184, 186

B

- Bass 193
- Before using the rear seat
 - entertainment system controller 265
- Bluetooth® 130, 349, 380, 388
- Bluetooth® audio operation 245
- Bluetooth® connection status ... 385, 386
- Brightness 31, 286
- Building information 43

C

- Calendar 151
- Calendar button 23
- Call by call history 142
- Call by dial 139
- Call by phonebook 140
- Call by POI 145
- Call by speed dial 141
- Call by voice recognition 143, 148
- Call on the Bluetooth® phone 139
- Categories 71
- CAUTION screen 26, 267
- CD button 186
- CD changer operation 206
- Cellular phone 130
- CH-DISC button 184, 186
- Change icon 119
- Change location 121, 126
- Change name 120, 125
- Change phone # 121
- Change size 126
- Changing a portable player name 389
- Changing the angle 235, 279
- Changing the audio format 234, 278
- Changing the audio language ... 234, 278
- Changing the Bluetooth® audio
 - passcode 394
- Changing the Bluetooth® audio
 - player name 394
- Changing the Bluetooth® settings 381
- Changing the page 233
- Changing the rear seat audio
 - source 267

Changing the speaker output	268
Changing the subtitle language	233, 277
Channel category	202
Chapter	244
City to search	65, 70
CLIMATE button	296, 298, 299
Clock button	22
Clock settings	335
Color	31, 286
Command list	49, 51
Compass mode screen	39, 41
Connecting a Bluetooth® phone	136
or iPod	254
Connecting Bluetooth® audio	393
Connecting Bluetooth® audio	
player	248
Consumption	150
Contrast	31, 286
Coordinates button	20, 82
Current position calibration	346
Current position display	33
Cursor position as a destination	34
Cursor position as	
an address book entry	35
D	
Dealer setting	398
Defogging the windshield	307
Delete destination button	20, 82
Delete personal data	334
Deletes previous destinations	110
Deleting a Bluetooth® phone	358
Deleting address book entries	122
Deleting areas to avoid	127
Deleting call history	375
Deleting destinations	82, 95
Deleting home	113
Deleting preset destinations	116
Deleting previous destinations	127
Deleting the phonebook data	366
Deleting the speed dial	374
Deleting the voice tag	380
DEST button	10
Destination Assist	157
Destination assist button	20, 76
Destination information	38
Destination screen	20
Destination search	62
Destination search by “Address”	65
Destination search by	
“Address Book”	77
Destination search by	
“Coordinates”	82
Destination search by	
“Destination Assist”	76
Destination search by “Emergency”	77
Destination search by	
“Intersection & Freeway”	78
Destination search by “Map”	81
Destination search by	
“Point of Interest”	69
Destination search by	
“Previous Destinations”	76
Destination search by home	64
Destination search	
by preset destinations	64
Detailed navigation settings	110, 340
Detection range of the sensors	325
Detour setting	96
Dialing by name	144
DISC button	184
Disc slot	184, 186
DISP button	10
Display POI icons	102
Displaying portable player	
information	389
Displaying the title and name	203
Distance and time to destination	10, 93
Download eDestinations	160
Driving speeds	342
DSP control	192
DUAL button	296
Dual map screen	39, 41
DVD audio controls	230, 273
DVD audio discs	226, 270
DVD audio settings	229, 275
DVD changer operation	220
DVD language	235, 279
DVD player and DVD video disc	
information	243
DVD setup menu	235, 279
DVD video controls	230, 273
DVD video discs	
226, 243, 244, 270	
DVD video settings	228, 274

INDEX

E

eDestination 160
Edit "Dealer" or "Contact" name 399
Edit "Location" 399
Edit "Phone #" 400
Edit route 86
Editing address book entries 118
Editing area to avoid 124
Editing home 112
Editing preset destinations 115
Editing the Bluetooth® phone 356
Editing the phonebook data 364
Editing the speed dial 373
Editing the voice tag 379
Eject button 184, 186, 208, 223
Ejecting discs 208, 223
Emergency button 20, 77
Enter a Bluetooth® phone 134
Estimated arrival time 93
Estimated travel time 93

F

Fan speed 303
Fan speed control buttons
..... 296, 298, 303
Foot print map 42
Foot print map button 10
Freeway exit information screen 88
Freeway screen 39
Fuel consumption 149
Function menu display
screen 184, 186
Function menu tab 184, 186

G

General button 22
General settings 330
Go home button 20
GPS information 406
GPS mark 10
Guidance screen for the freeway 89
Guidance screen on the freeway 39
Guiding the route 16

H

Hands-free system 130
Heading-up 10, 43
Headphone jacks 266
Help 33
HFP (Hands Free Profile) 130
Home 12, 17, 64, 111

I

If the changer malfunctions 219, 243
Incoming call display 385
INFO/PHONE button 10
Information about the icon 36
Information screen 23
Initial screen 26
Initializing the Bluetooth® audio
settings 395
Initializing the Bluetooth® settings 384
Initializing the detailed phone
settings 387
Initializing the phone volume
settings 350
Inputting letters and numbers 28
Inserting discs 206, 220
Interrupt call 148
Intersection & freeway button 20, 78
Intersection guidance screen 39, 89
Intuitive parking assist 322
Intuitive parking assist failure
warning 326
Intuitive parking assist setting 401
iPod operation 253

L

Language code 237, 281
Last 5 cities 67, 73
Lexus Enform 154
Lexus Insider 175
Lexus Insider settings 179
Limitations of
the navigation system 406
List 29
List all categories button 71, 74
List screen operation 28
Listening to satellite radio 201
Listening to the radio 196
LOAD button 184, 186, 206, 221
Local POI list 104

M

Maintenance 395
 Maintenance information 27
 Maintenance information items 397
 Maintenance information setting 396
 Manage phone 351
 Map button 20, 81
 Map coverage area 417
 Map data button 23
 Map database information 408
 Map database updates 408
 Map database version 417
 Map icons 44
 Map scale 42
 Map screen 10
 Map screen operation 33
 MAP/VOICE button 10, 33, 34
 Mark button 10
 Marks shown on DVD video discs 244
 Memory point names 120
 Message button 198
 Micro dust and pollen filter 310
 Micro dust and pollen filter button
 296, 298, 310
 Microphone 44, 130
 Mid 193
 MODE button 304
 MP3 214, 271

N

Names of areas to be avoided 125
 Natural speech information 47
 Navigation button 22
 Navigation settings 110, 340
 North-up 10, 43
 Number key 28

O

OFF button 296, 298
 Off function 10
 Operating a DVD disc 226, 270
 OPP (Object Push Profile) 130
 Orientation of the map 43
 Other settings 403
 Outside air mode 306
 Outside rear view mirror defogging ... 309
 Outside temperature display
 296, 298, 311

P

PAL format 243, 285
 Parental lock 235, 279
 Past record 149
 Pause guidance 101
 Phone button 22, 23
 Phonebook 140, 359, 360
 Playing a Bluetooth® audio 250
 Playing a disc 210, 225
 Playing a DVD disc 227, 271
 Playing a MP3/WMA disc 214, 271
 Playing a USB memory or iPod 254
 Playing a video CD 240
 Playing an audio disc 211, 270
 POI as a destination 105
 POI category change 345
 POI icons hidden 106
 POI information 36
 Point of interest button 20, 69
 POIs near the search point 74
 POIs to be displayed 103
 Pop-up information 348
 Portable audio players
 195, 245, 253, 388
 Preset destination buttons 20, 64
 Preset destinations 14, 64, 114
 Presetting a channel 202
 Presetting a station 197
 Previous destinations button 20, 76
 PWR/VOL knob 184, 186

R

Radio data system 198
 Radio ID 201
 Radio operation 196, 200, 269
 RAND button 213, 218, 252, 260
 RDS 198
 Rear air conditioning controls 306
 Rear seat entertainment system
 controller 264
 Rear seat entertainment system
 displays 264
 Rear seat entertainment system
 features 263
 Rear system lock 332
 Rear window defogger button ... 296, 298
 Rear window defogging 309
 Receive on the Bluetooth® phone ... 146
 Receive sports information 164
 Receive stock data 166

INDEX

- Recirculated air mode 306
- Reconnecting Bluetooth® audio
 - player 250
- Reconnecting the Bluetooth®
 - phone 138
- Region codes 243
- Registering a Bluetooth®
 - phone 352, 359
- Registering address book entries 117
- Registering areas to avoid 123
- Registering home 12, 111
- Registering portable player 390
- Registering preset destinations 14, 114
- Registering the phonebook data 363
- Registering the speed dial 369
- Registering the voice tag 377
- Removing a Bluetooth® audio 392
- Reordering destinations 94
- Replacing the rear seat entertainment
 - system controller batteries 265
- Resume guidance 102
- Ring volume 350
- Route button 10
- Route features 100
- Route guidance screen 88
- Route overview 97
- Route preference 99
- Route preview 98
- Route trace 106
- Route trace–start 107
- Route trace–stop 107
- Route type 99
- RPT button 213, 218, 252, 260

- S**
- Safety Connect 154
- SAT button 184, 186
- Satellite tuner 200
- Scale indicator 10
- SCAN button 213, 217, 218, 259
- Screen adjustment 31, 286
- Screen configuration button 10
- Screen layout function 346
- Screen off 31, 286
- Screen scroll operation 34
- Screen size 194, 285
- Screens for clock settings 335
- Screens for general settings 330
- Screens for navigation settings 341
- Screens for voice settings 337
- Search area 62
- Search by category 71
- Search by eDestination 75
- Search by freeway entrance/exit 80
- Search by intersection 79
- Search by name 69
- Search by phone # 74
- Search point from along my route 72
- Search point from
 - near a destination 73
- Search point from near city center 72
- Search point from near hear 72
- Searching by group 232, 276
- Searching by title 231, 275
- Searching by track 242, 283
- Searching for a desired file 217, 259
- Searching for a desired folder 218, 259
- Searching for a desired track
 - or disc 213
- SEEK-TRACK button 184, 186
- Select button 215, 256
- Select portable player 388
- Selecting a Bluetooth® phone 354, 359
- Selecting a desired album 252
- Selecting a desired disc 211, 225
- Selecting a desired file 215, 271
- Selecting a desired file or track 257
- Selecting a desired folder 215, 256
- Selecting a desired track 212, 251, 270
- Selecting a keyboard layout 332
- Selecting a language 331
- Selecting a play mode 255
- Selecting a satellite radio channel 203
- Selecting a station 197
- Selecting DVD disc menu item 231
- Selecting portable player
 - connection method 390
- Selecting the bonus group 232, 276
- Selecting the menu number 277
- Selecting the search area 62
- Sensor detection information 325
- Sets address book 110
- Sets areas to avoid 110
- Sets home 110
- Sets preset destinations 110
- Setting and deleting destinations 94
- Setting Bluetooth® audio 390
- Setting home as the destination 17
- Setting route 96
- Setting the phonebook 360
- Setting the vehicle interior
 - temperature 301, 304
- Setting the voice tag 376
- Setting up the address book 116
- Setting up the areas to avoid 122
- Setting up the home 111
- Setting up the preset destinations 113
- SETUP button 10
- Setup screen 22
- Show eDestination icons 162

Show free flowing traffic 344
 Show on map 102
 Show on map button 10
 Side monitor 316
 Single map screen 39, 40
 Sort 30
 Sound dynamic range 235, 279
 Sound icons 119
 Speed dial 141, 368
 Speed dials settings 368
 Starting route from adjacent road 101
 Starting route guidance 83
 Steering switches 261
 Street address 67
 Subscription 155
 Subtitle language 235, 279
 Surround function 192
 Switching between audio functions ... 190
 Switching the air intake control
 to automatic mode 302
 Switching the screens 39
 Symbol key 29

T

Talk on the Bluetooth® phone 146
 Talk switch 44, 143
 Telephone settings 349
 Telephone switch 130
 TEMP button 296, 298, 301, 304
 Temperature display 296, 298, 311
 Time zone 336
 Tire change calibration 346, 348
 Title 244
 Tone 31, 286
 Tone and balance 193
 Touch screen operation 27
 Traffic announcement 200
 Traffic button 200
 Traffic voice guidance 339
 Transferring a phone number 361
 Treble 193
 TUNE/FILE knob 184, 186
 Turn list screen 39, 90
 Turning the audio system
 on and off 189
 TypeSeek button 198
 Typical voice guidance prompts 91

U

Unit of measurement 333
 USB memory operation 253

V

Vehicle button 22
 Vehicle customization 400
 Vehicle settings 395
 Video CD 240, 281
 Video CD controls 242, 282
 Video CD settings 241, 282
 Video mode 284
 Viewer restrictions 244
 Voice button 22
 Voice command example 47, 50
 Voice command system 44
 Voice guidance speaker 339
 Voice settings 337
 Voice tag 144, 376
 Voice volume 338, 350

W

Wide view front & side monitor 314
 Wide view front & side monitor
 cameras 318
 Wide view front & side monitor
 simultaneous display 316
 Wide view front monitor 316
 Windshield air flow button
 296, 298, 307
 Windshield wiper de-icer 309
 WMA 214, 271

X

XM® indicator 10
 XM® NavTraffic 154, 173
 XM® NavTraffic icon 174
 XM® NavTraffic indicator 175
 XM® NavTraffic information arrow 174
 XM® NavTraffic text information 39
 XM NavWeather™ 168
 XM NavWeather button 23
 XM® Satellite Radio broadcast 200
 XM Sports 164
 XM Sports button 23
 XM Sports settings 164
 XM Stocks 166
 XM Stocks button 23
 XM Stocks settings 167

Z

Zoom in button 10
 Zoom out button 10