

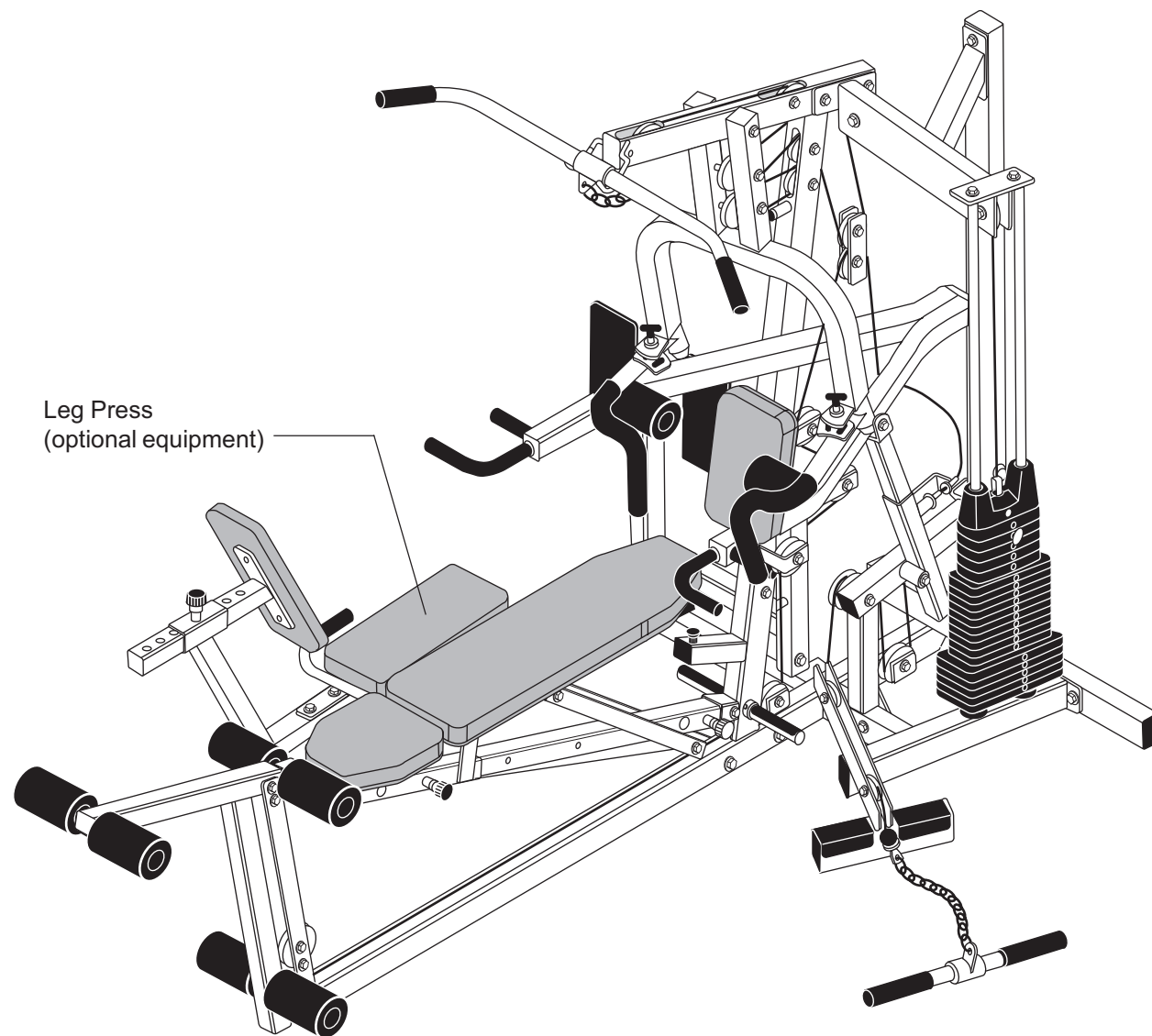

Solana

Strength-Training
Fitness Equipment



Leg Press
(optional equipment)

Assembly and Maintenance Guide

Important Safety Instructions for Using the Equipment

Before beginning any fitness program, you should obtain a complete physical examination from your physician.

Il est conseillé de subir un examen médical complet avant d'entreprendre tout programme d'exercice. Si vous avez des étourdissements ou des faiblesses, arrêtez les exercices immédiatement.

When using exercise equipment, basic precautions should always be taken, including the following:

- Read all instructions before using the Solana equipment. These instructions are written to ensure your safety and to protect the unit.
- Do not allow children on or near the equipment.
- Use the equipment only for its intended purpose as described in this manual. Do not use accessory attachments that are not recommended by the manufacturer: such attachments might cause injuries.
- Wear proper exercise clothing and shoes for your workout—no loose clothing.
- Use care when getting on or off the unit.
- Do not overexert yourself or work to exhaustion.
- If you feel any pain or abnormal symptoms, stop your workout immediately and consult your physician.

- Never operate the unit when it has been dropped or damaged. Return the equipment to a service center for examination and repair.
- Never drop or insert objects into any opening. Keep hands away from moving parts.
- Always check the unit and its cables before each use. Make sure that all fasteners and cables are secure and in good working condition.
- Do not use outdoors.

Personal Safety During Assembly

- It is strongly recommended that a qualified dealer assemble the equipment. **Assistance is required.**
- Read each step in the assembly instructions and follow the steps in sequence. Do not skip ahead. If you skip ahead, you may learn later that you have to disassemble components and that you may have damaged the equipment.
- Assemble and operate the Solana on a solid, level surface. Locate the unit a few feet from walls or furniture to provide easy access.

The Solana is designed for your enjoyment. By following these precautions and using common sense, you will have many safe and pleasurable hours of healthful exercise with your new equipment.

Obtaining Service

Do not attempt to service the Solana yourself except for the maintenance tasks described in this guide. This unit does not contain any user-serviceable parts.

For information about product operation or service, check out the Precor web site at **www.precor.com** or contact an authorized Precor dealer or a Precor factory-authorized service company. To locate the dealer or service person nearest you, call 1-800-4-PRECOR.

If you call or e-mail Customer Service, have the serial number and part numbers available.

You can find the serial number printed on a label affixed to the side of the Solana. For future reference, write the serial number in the space provided below.

Serial number: _____

IMPORTANT SAFETY INSTRUCTIONS

Table of Contents

	Important Safety Instructions for Using the Equipment	2
	Personal Safety During Assembly	2
	Obtaining Service	2
1	Before You Begin	5
	Unpacking the Equipment	5
	Optional Equipment	5
2	Preparations.....	6
	Required Tools	6
	Installation Requirements	6
	Assembly Tips	6
3	Assembly Instructions	7
	Open Box 1	8
	1. Assemble Main Structure	9
	2. Assemble Weight Stack.....	11
	Open Box 2.....	12
	3. Assemble Press Arm	13
	4. Assemble Chest Press/Pec Fly	17
	5. Assemble Seat Pads	18
	6. Install Seat Extension.....	21
	7. Assemble Leg Extension.....	22
	8. Install Main Cable and Pulley	23

4	Adjustments and Maintenance	30
	1. Cable Adjustments	30
	2. Selector Stem Adjustments	31
	Forward Angle Adjustment	31
	Backward Angle Adjustment	32
	Side-to-Side Vertical Adjustment	33
	5. Maintenance	33
	Warranty Card and Specifications	Back cover

1

Before You Begin

Thank you for purchasing the Solana. This unit is part of the Pacific Fitness line of quality strength training machines, which let you target specific muscle groups to achieve better muscle tone and overall body conditioning. To maximize your use of the equipment, please study this guide thoroughly.

Unpacking the Equipment

The Solana is carefully tested and inspected before shipment. Pacific Fitness ships the unit in several pieces that require assembly. Ask for assistance during the assembly process.

- Review the *Installation Requirements* found on the next page.
- When instructed to open a box, carefully unpack the pieces and lay them on the floor near the location where you plan to use the equipment.

Be careful to open boxes and assemble components in the sequence presented in this manual.

If any items are missing, contact the dealer from whom you purchased the unit or call 1-800-4-PRECOR for the dealer nearest you.

Optional Equipment

Optional equipment that you can purchase through your dealer includes the 250-lb Weight Stack and the Leg Press.

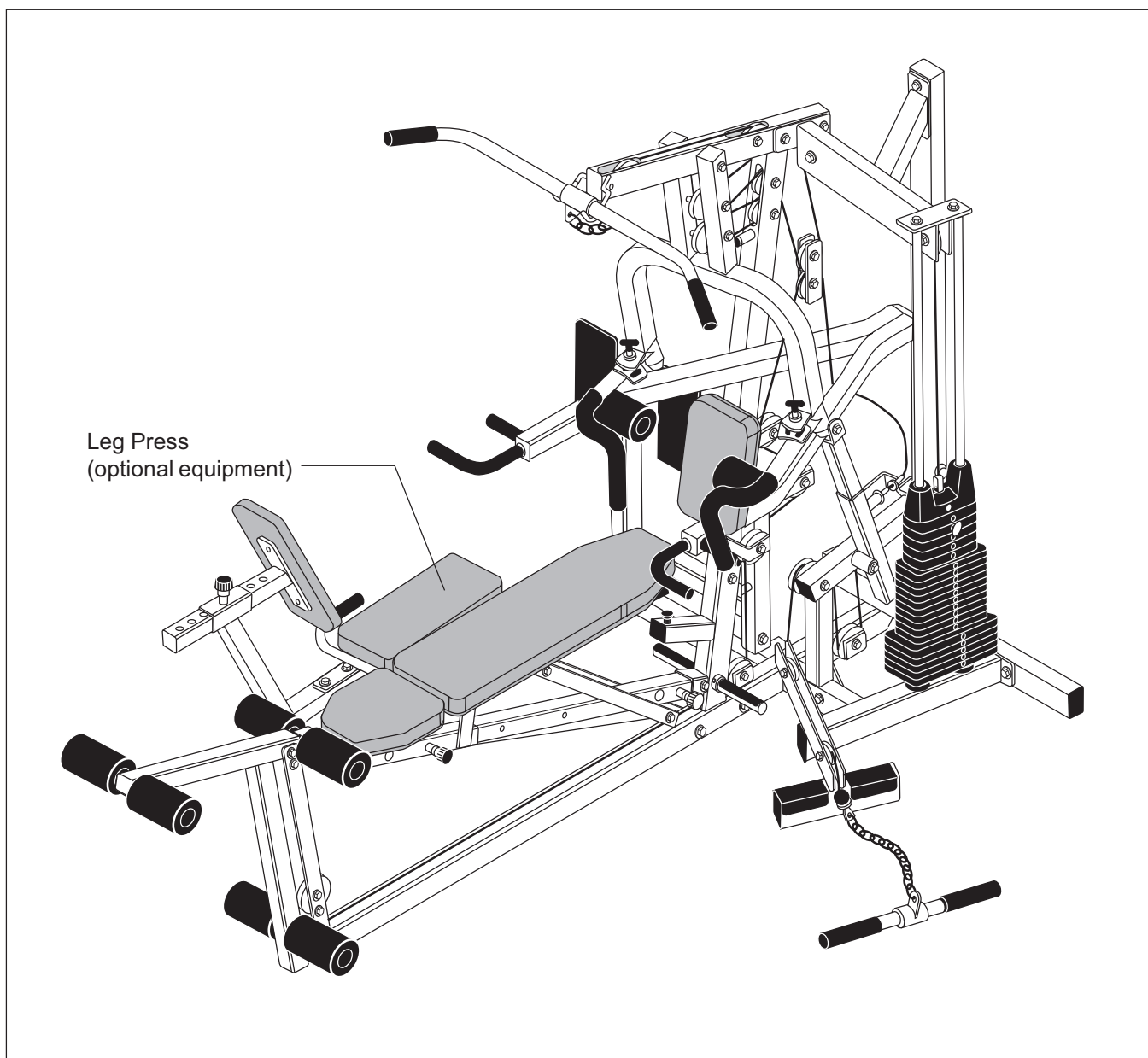

Before You Begin

2

Preparations

CAUTION: To set up this unit, you will need assistance. Do not attempt assembly by yourself.

You must review and follow the instructions in this guide. If you do not assemble and use the Solana according to the following guidelines, you could void the Precor limited warranty.

Required Tools

Tools that you need to obtain before assembling the unit include:

- 1/16-inch socket wrench
- 3/4-inch socket wrench
- 1/16-inch box wrench
- 3/4-inch box wrench
- Standard set of metric hex keys
- Two adjustable pliers or crescent wrenches
- Measuring tape
- Wire tie cutter (cuts plastic tie wraps)
- Rubber mallet
- Step stool

Installation Requirements

Follow these installation requirements when assembling the unit:

- **Fill out and mail the limited warranty card.** The warranty card is found on the back cover of this guide.
- **Set up the Solana on a solid, flat surface.** A smooth, flat surface under the unit helps keep it level. A level unit has fewer malfunctions.
- **Provide ample space around the machine.** Open space around the machine allows for easier access.
- **Insert all bolts in the same direction.** For aesthetic purposes, insert all the bolts in the same direction unless specified (in text or illustrations) to do otherwise.
- **Leave room for adjustments.** Tighten fasteners (such as bolts, nuts, and screws), so the unit is stable, but leave room for adjustments. **Do not** fully tighten fasteners until instructed (in the steps) to do so.

Assembly Tips

- A black 6-inch scale with white numbers is provided at the bottom of every assembly instruction page. Use this scale to identify the correct size bolts and spacers. The head of a bolt is not used in measuring the length of a bolt.

Note: A few of the bolts used to assemble the Solana are longer than 6 inches. You may want to use a measuring tape to accurately identify the correct sizes.

To find out the length of a particular bolt, measure its shank (the long, narrow part beneath the head). Refer to the following diagram:

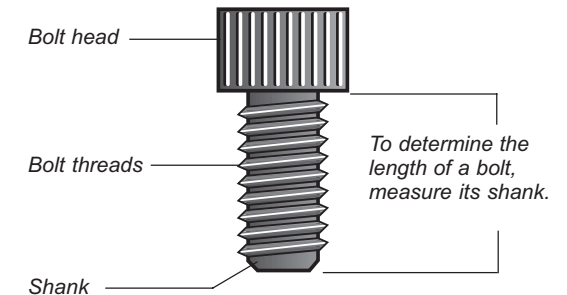

- Read all caution notes on each page before completing that step.
- Some pieces have extra holes that you will not use. Use only those holes indicated in the instructions and illustrations.
- While you may be able to assemble the Solana by reading the illustrations only, refer to the text for important safety cautions and notes.

3

Assembly Instructions

Assembly of the Solana takes professional installers about 2 hours to complete. If this is the first time you have assembled this type of equipment, plan on significantly more time.

Professional installers are highly recommended!

However, if you acquire the appropriate tools, obtain assistance, and follow the assembly steps sequentially, the process will take time, but is fairly easy.

CAUTION: Obtain assistance! Do not attempt to assemble the Solana by yourself. Review the *Installation Requirements* on page 6 before proceeding with the following steps.

The Solana comes in two boxes.

Be careful to open boxes and assemble components in the sequence presented in this manual.

Note: With so many assembled parts, proper alignment and adjustment is critical. While tightening the nuts and bolts, be sure to leave room for adjustments. **Do not fully tighten bolts until instructed to do so.**

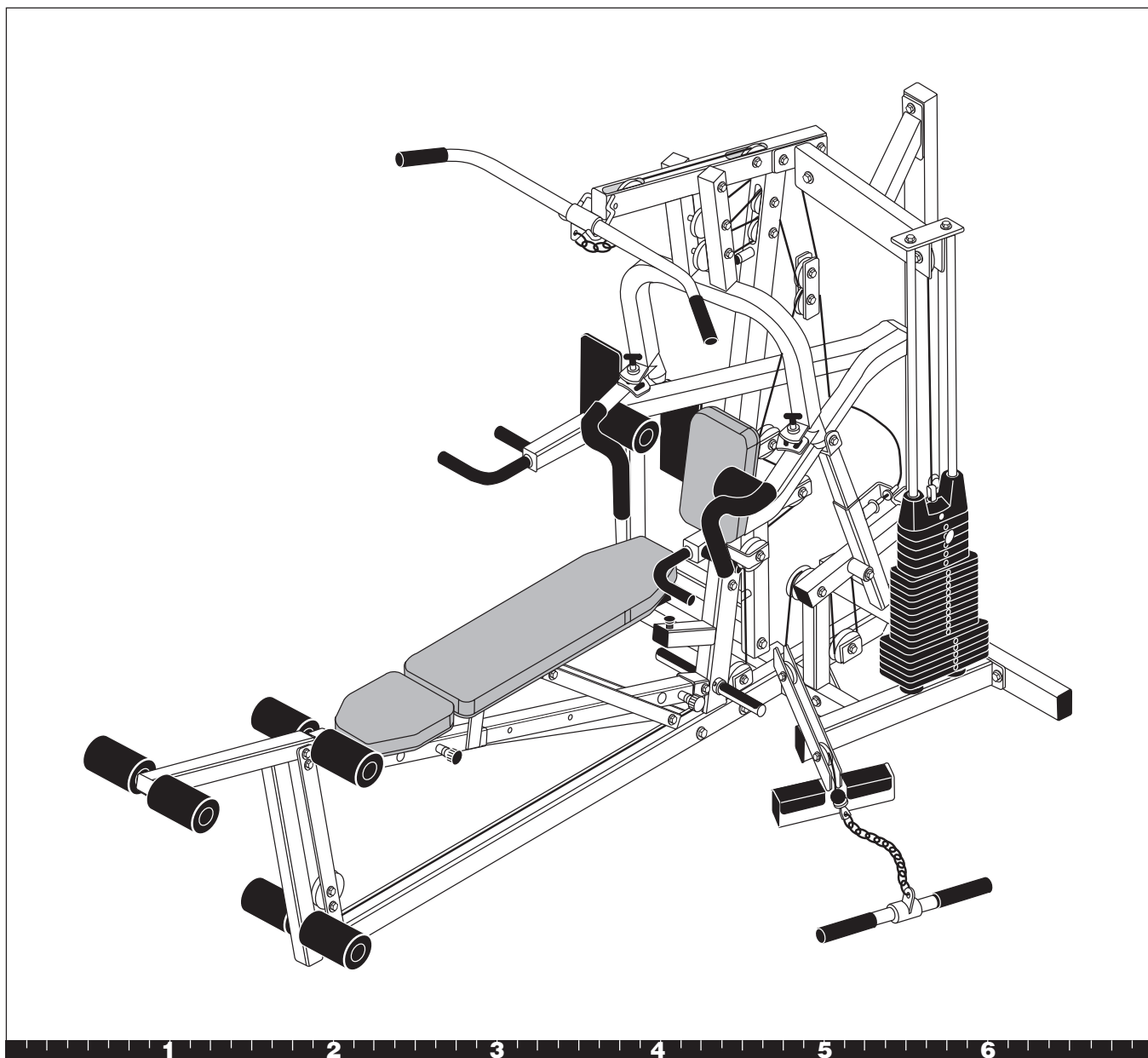

Open Box 1

Use tie cutters to open the boxes.

In this section, you will assemble the main structure of the Solana. The illustration shows the different parts that come in box 1.

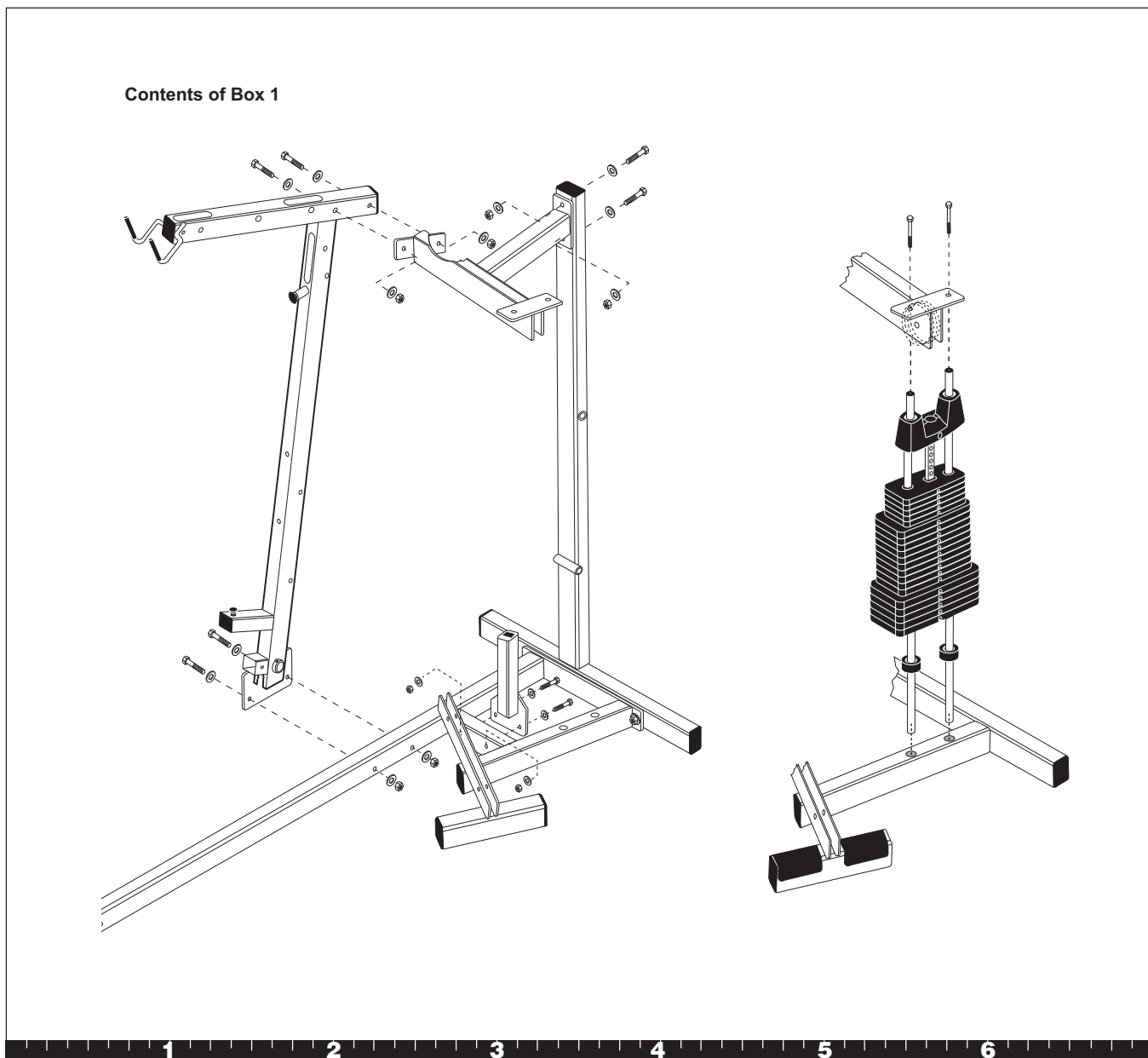

1. Assemble Main Structure

- A. Have an assistant hold the Main Upright steady while you align it with the Base Frame. Attach using
two 3-inch bolts
four washers
two locknuts

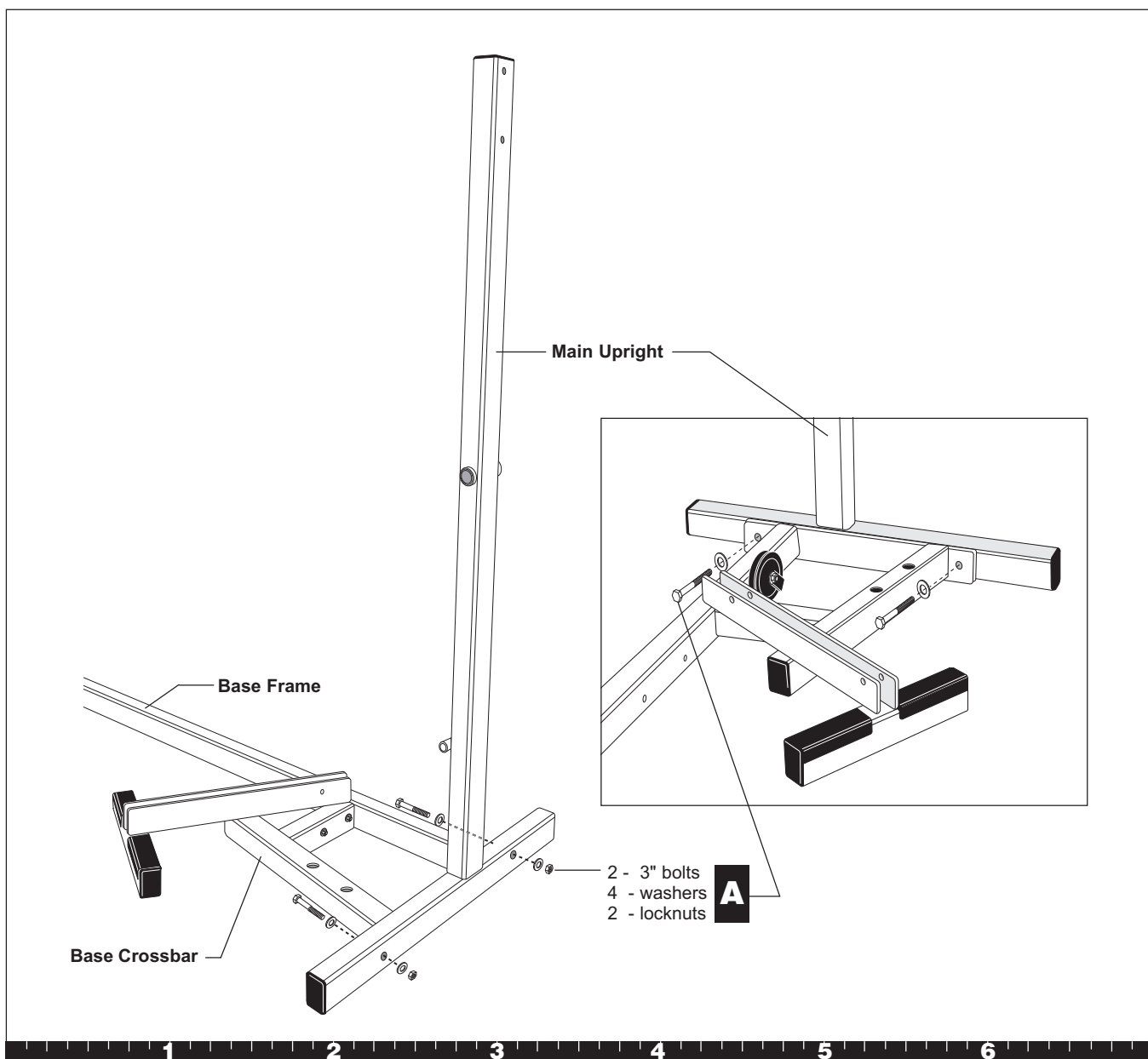

Step 1. Assemble Main Structure

- B. Attach the Chest Press Upright to the Base Frame using
 two 3-inch bolts
 four washers
 two locknuts

CAUTION: Tighten the bolts enough so that the Chest Press Upright is secure on the Base Frame. Make sure that the assembled parts are stable and balanced before your assistant lets go of the Main Upright.

- C. Insert the noncoated end of the Foot Support through the Foot Support Hole at the base of the Chest Press Upright until the black coated pad touches the bracket.
- D. Attach a black coated pad (found in the hardware bag) to the noncoated end of the Foot Support. Remove the adhesive backing from the black coated pad and attach it in the same manner as the factory-installed side. Tap a round end cap into the end of the Foot Support in the same manner as the factory-installed side.
- E. Tighten the set screws with an appropriate hex key when the Foot Support is positioned properly.
- F. Attach the Guide Rod Bracket to the Chest Press Upright using
 two 3-inch bolts
 four washers
 two locknuts
 Finger tighten.
- G. Attach the Guide Rod Bracket to the Main Upright using
 two 3-inch bolts
 four washers
 two locknuts
 Finger tighten.
- H. Attach the Rest Support to the crossbar of the Base Frame using
 two 2¾-inch bolts
 four washers
 two locknuts
 Wrench tighten.

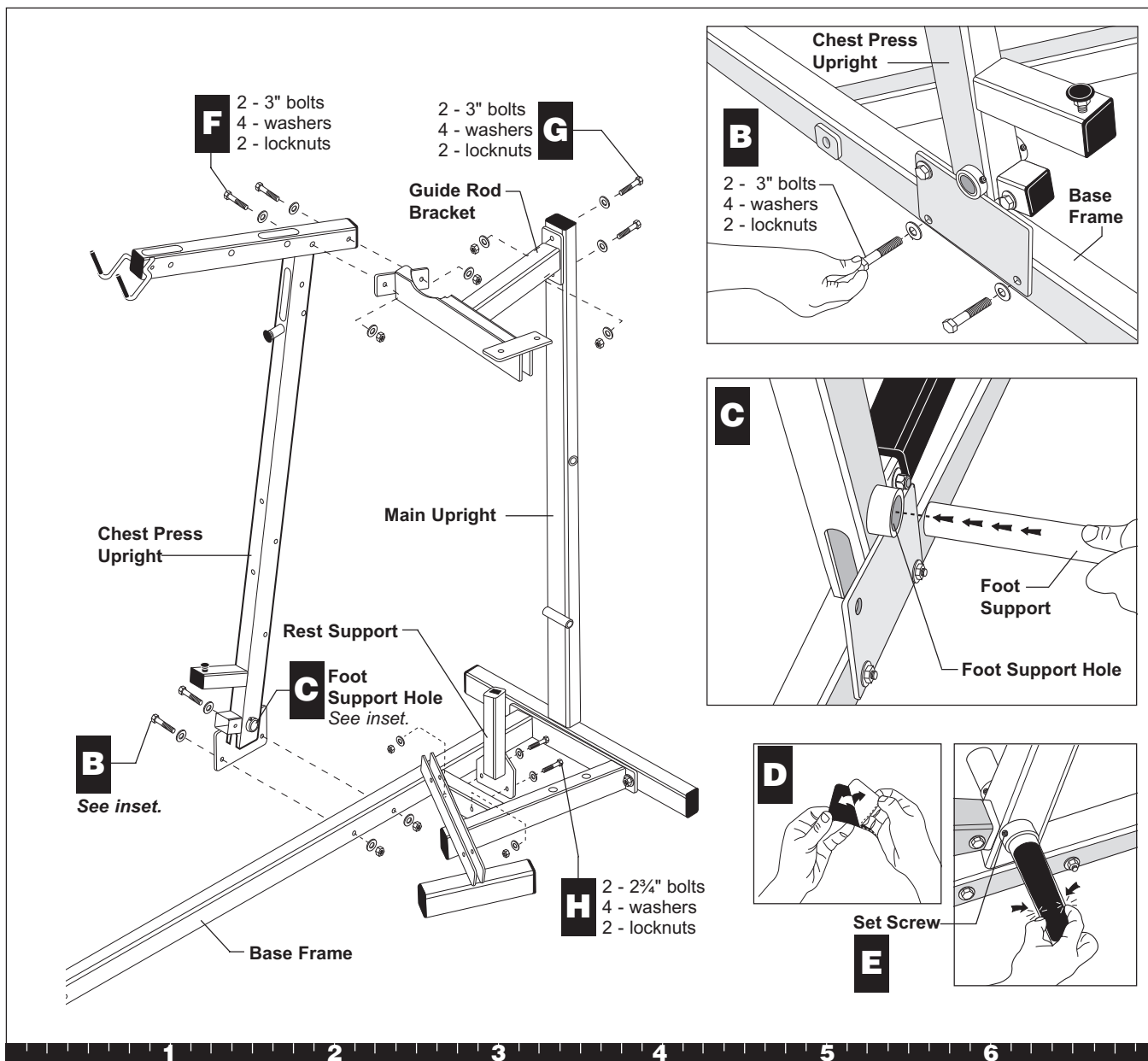

Step 1. Assemble Main Structure, Continued

2. Assemble Weight Stack

- A. Place two Guide Rods in the large holes on Base Frame. The Guide Rods will be unstable until you complete this step. Avoid getting lubricant from the Rods on your clothing or on other parts of the machine.
- B. Place one Weight Cushion on each Guide Rod and allow it to slide down to the top of the Base Frame.
- C. Add the five 15-lb weights, the ten 10-lb weights, and the five 5-lb weights. Note the tab location for the weight stickers (you will attach the stickers later). Hold your finger over the plastic bushing in each weight to prevent the bushing from popping out.

CAUTION: The weights are heavy! Handle the weights carefully so as not to drop them or injure yourself. Pick up and place one weight at a time on the Guide Rods. Have someone hold the Guide Rods in place while you slide the weights on the stack.

- D. Place the Top Cap Weight on the Guide Rods with the hole facing away from the Chest Press Upright. Place it on the weight stack.
- E. Attach the Guide Rods to the Guide Rod Bracket using two 1-inch bolts. Wrench tighten.
- F. Wrench tighten the bolts from step 1F and 1G.

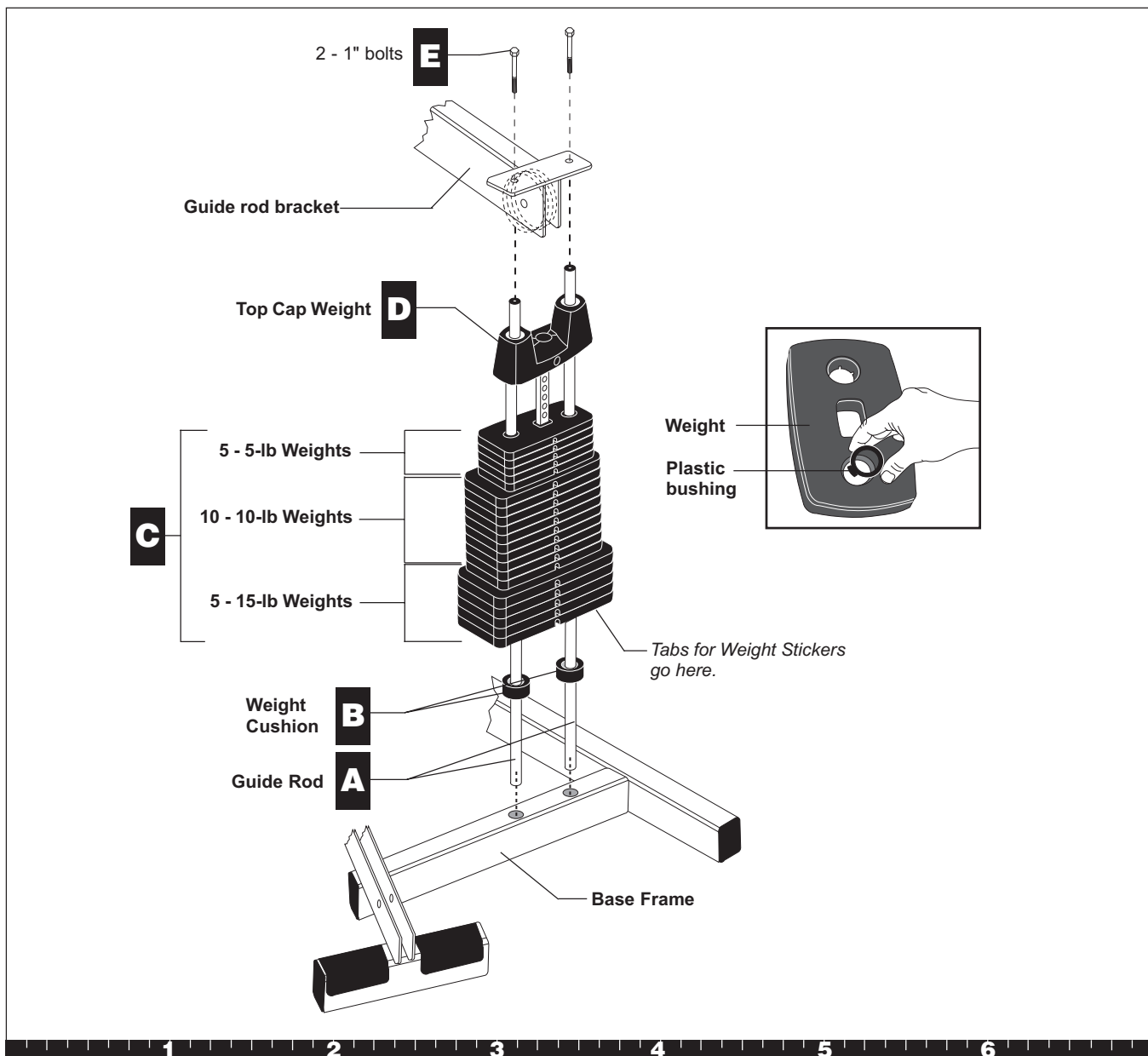

Step 2. Assemble Weight Stack

Open Box 2

Use tie cutters to open the box.

Box 2 includes the Seat Frame, Pec Fly Arm, Chest Press, Lat Bar and cable assemblies.

The illustration shows the entire Solana assembly once you have completed installing the contents of box 2.

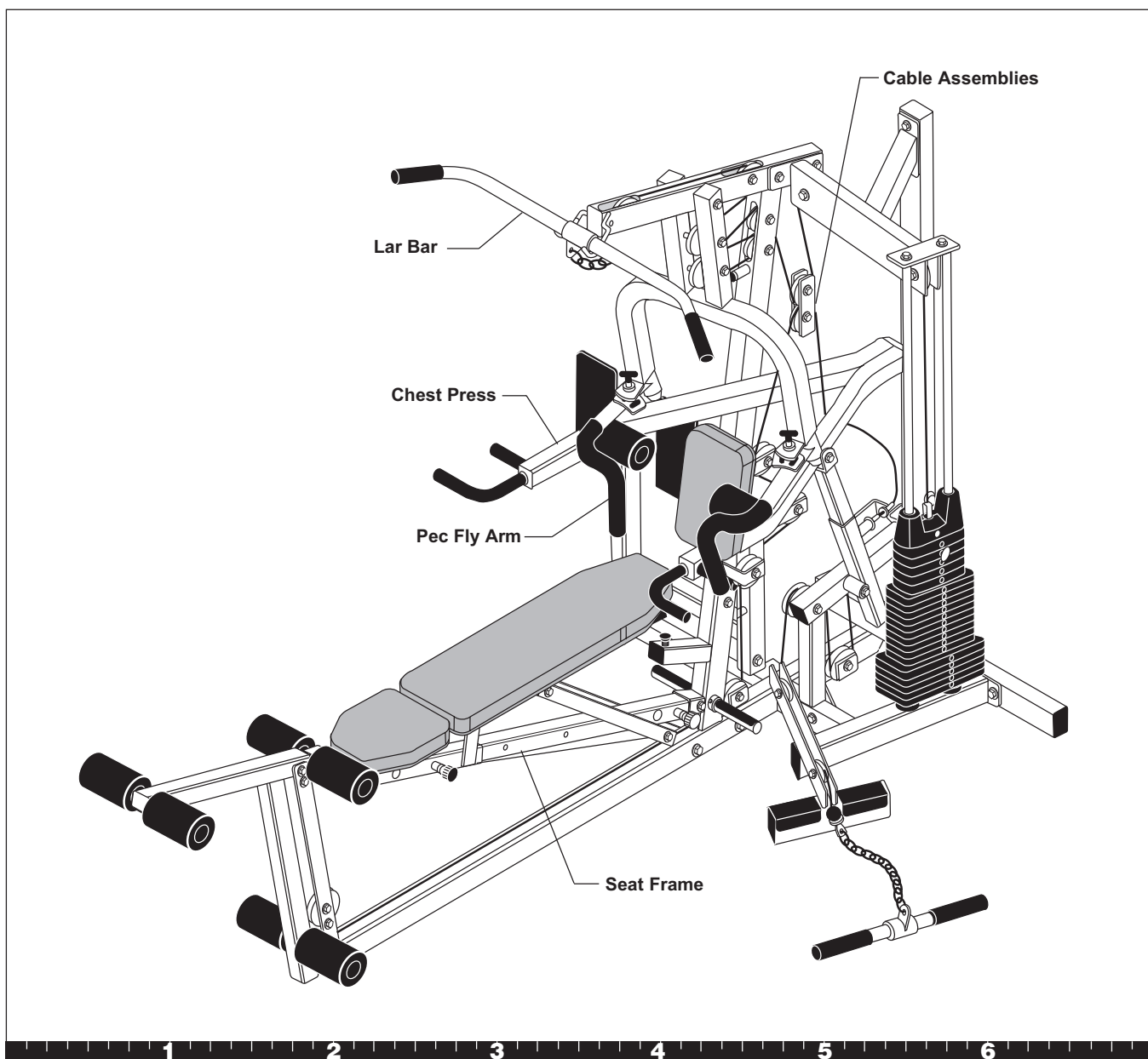

3. Assemble Press Arm

- A. On one end of the Threaded Shaft, attach one 1⁹/₁₆-inch washer, one cap washer, one 1/2-inch locknut, one dome cap.
- B. Insert the Threaded Shaft through the Main Upright.
- C. While someone supports the Press Arm, align it with the Threaded Shaft on the Main Upright and attach it using one 1⁹/₁₆-inch washer, one cap washer, one 1/2-inch locknut, one dome cap. Wrench tighten, still allowing movement. Lower the Press Arm slowly.

Note: The Handle will rest temporarily on the crossbar of the Base Frame. Place a protective towel underneath its pad until the Height Extender is assembled in the next step.

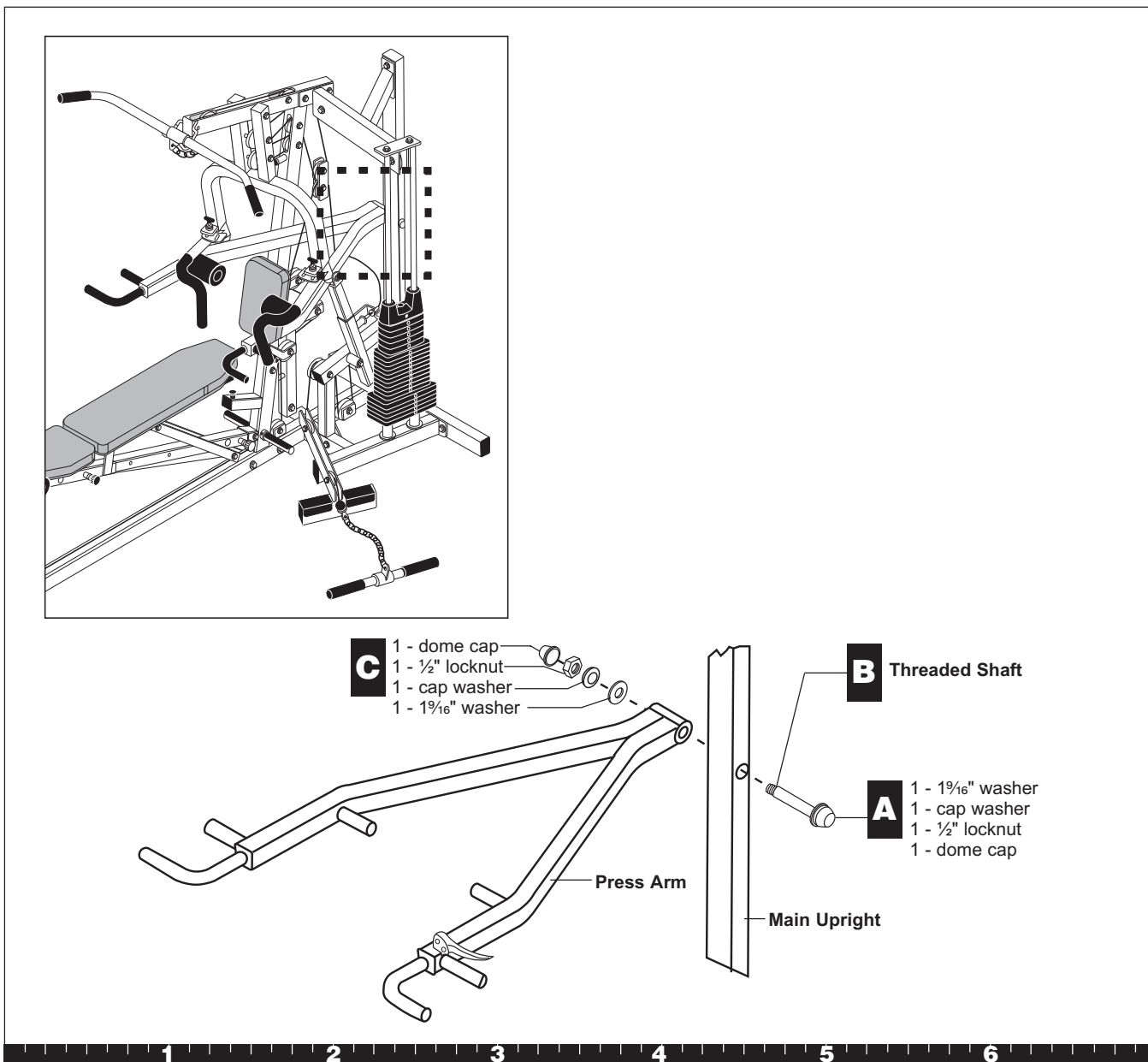

Step 3. Assemble Press Arm

- D. Slide the Height Extender through the Press Arm Bracket and attach them using a small hex head screw near the base of the Height Extender. Wrench tighten. The screw acts as a stop so that the extender cannot slide out of the Press Arm Bracket.

Note: Ensure that the flange on the Press Arm Bracket faces the Main Upright.

- E. While someone supports the Press Arm, attach the Height Extender to the Press Arm Mounting Flange using
one 1/2-inch by 5/4-inch bolt
two washers
one locknut.
Wrench tighten.

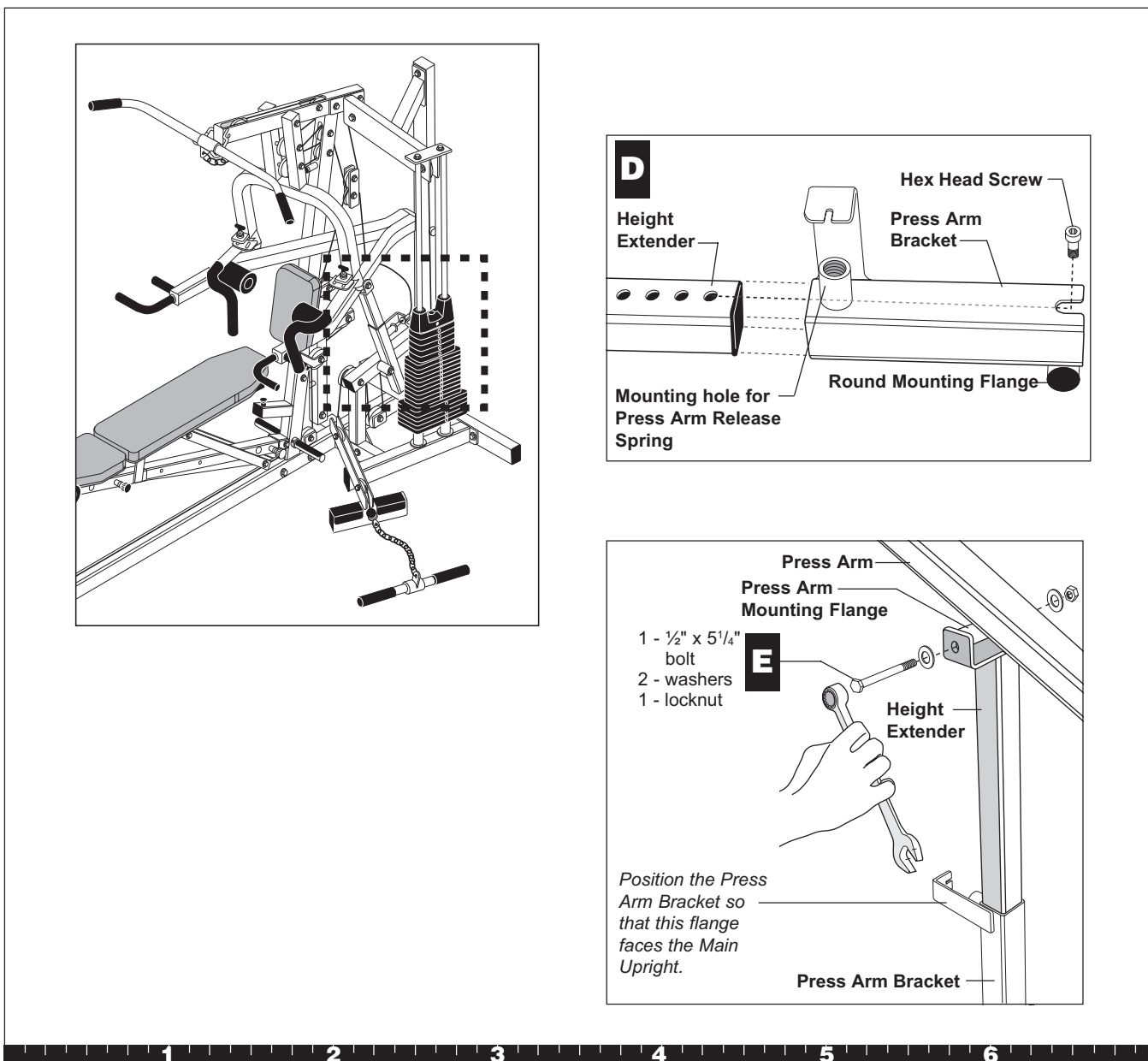

Step 3. Assemble Press Arm, Continued

F. Align one of the Height Extender holes with the mounting hole for the Press Arm Release Spring. Thread the Press Arm Release Spring (at the end of the Press Arm Cable) into the Press Arm Bracket.

CAUTION: Have someone hold the cable attached to the Press Arm Release Spring away from the following assembly. Cables pinched, crimped, or damaged during assembly are not covered by the warranty.

G. Attach the Support Bracket to the Main Upright using one 1/2-inch by 5/4-inch bolt two washers one locknut. Wrench tighten.

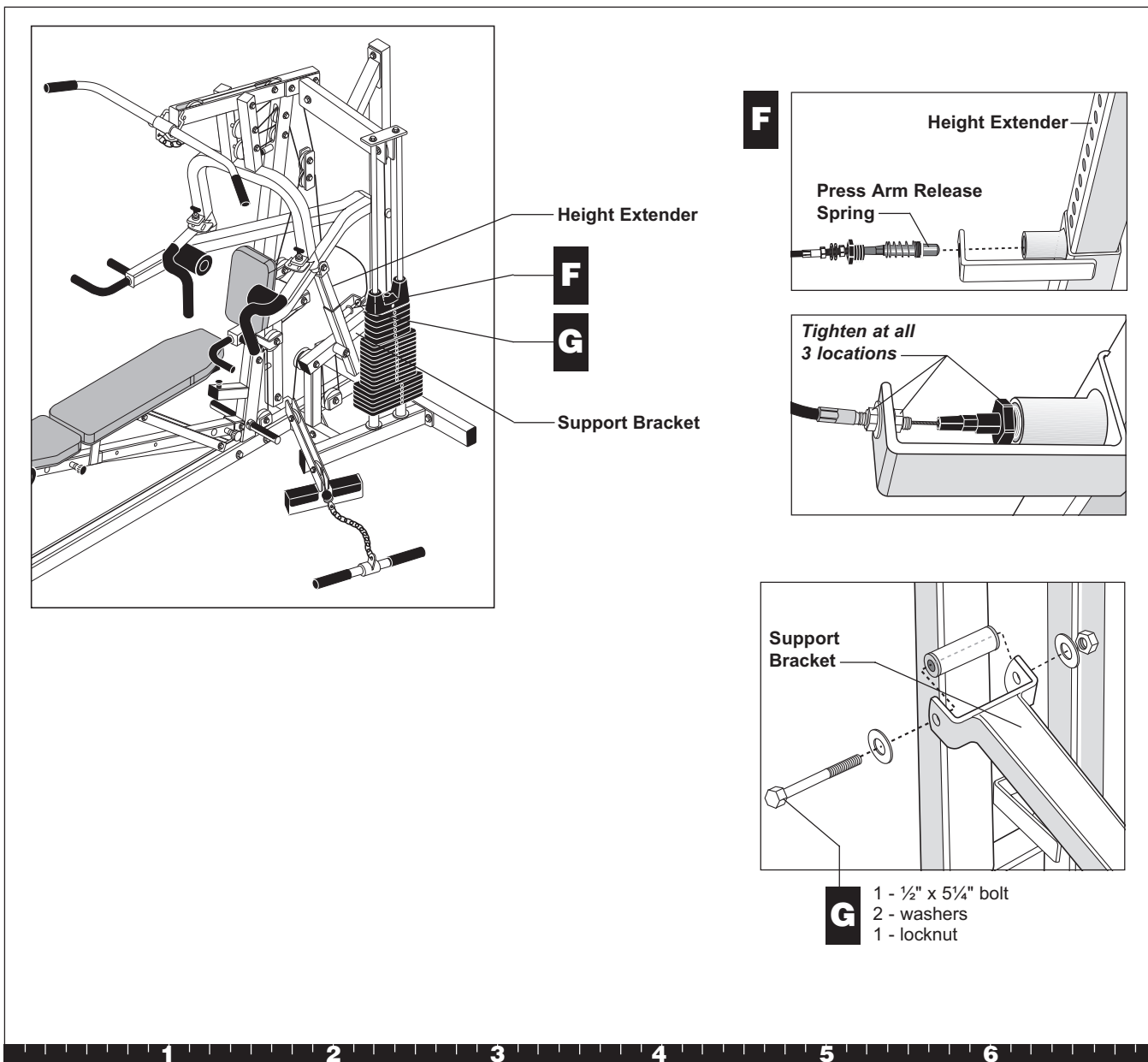

Step 3. Assemble Press Arm, Continued

- H. While someone holds the Quick Release Handle down, raise the Press Arm and align the Height Extender with the Round Mounting Flange on the Press Arm Bracket.
- I. Secure the Support Bracket using one ½-inch by 5-inch bolt two washers one locknut. Wrench tighten.
- J. Slide the Press Arm Roller Pads into place. The Pads are held in place by friction, so you may need to readjust them from time to time.

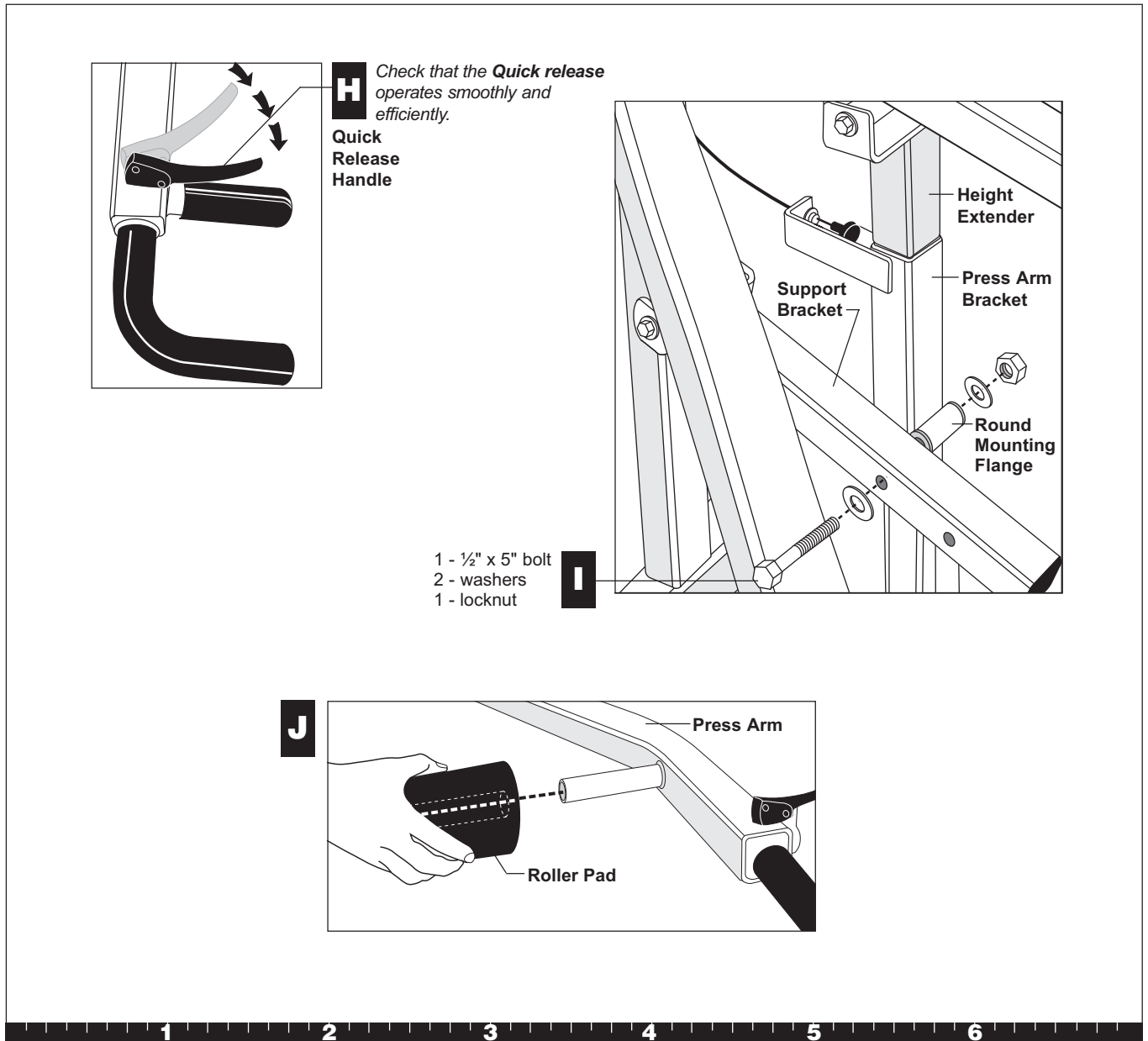

Step 3. Assemble Press Arm, Continued

4. Assemble Chest Press/Pec Fly

- A. To ease assembly, place the Chest Press flat on the floor. Attach two 3½-inch pulleys between the two uprights using two 7½-inch bolts four barrel spacers four washers two locknuts Wrench tighten.
- B. With someone helping you, lift the Chest Press into position. The Pec Fly Pin Holes point away from the Main Upright.

Note: A step stool might be useful.

- C. While someone holds the Chest Press, align it with the hole at the top end of the Chest Press Upright. Attach it using one ½-inch by 7½-inch pivot bolt two ½-inch washers one locknut Wrench tighten.

- D. One at a time, slide each Pec Fly Arm onto the Pivot Shaft. (The Pin Hole should face away from the Main Upright.) Attach them on the end of each Threaded Pec Fly Mount using two 1¼-inch washers two cap washers two locknuts

Note: Tighten the locknut until the Pec Fly Arms don't move. Then loosen the locknut about a half-turn until the arms pivot freely with no resistance. A few threads should show beneath the Pec Fly Mounts.

- E. Secure the Dome Caps on each Threaded Pec Fly Mount. A rubber mallet may be useful to lightly tap the Dome Caps into place.

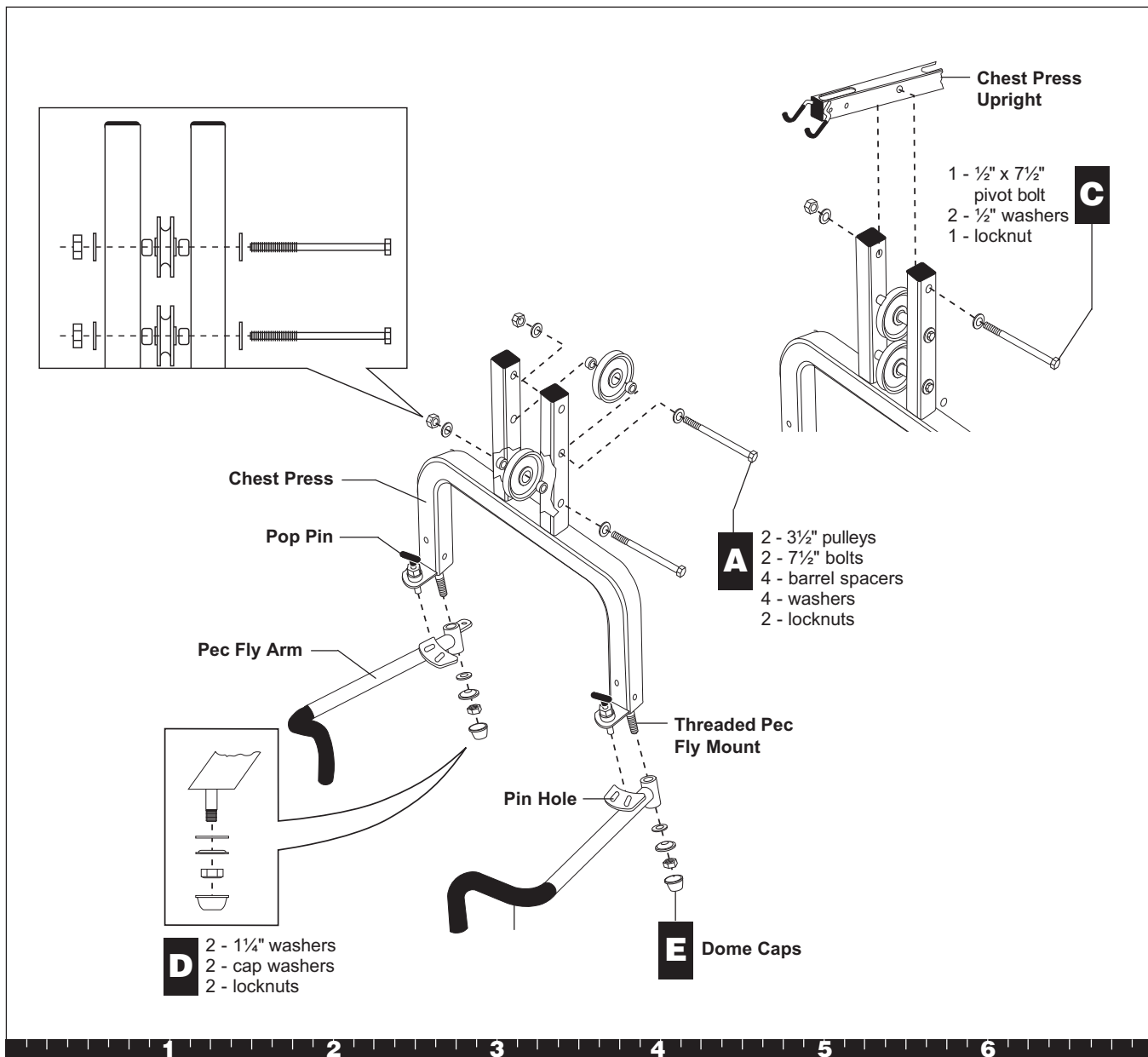

Step 4. Assemble Chest Press/Pec Fly

5. Assemble Seat Pads

Note: Lubricate the chrome Seat Extension with the supplied lubricant. The lubricant helps the two Seat Brackets slide more easily. To ease installation, assemble the Seat Brackets and Seat Pads on the Seat Extension before mounting it on the Chest Press Upright.

- A. Position the Seat Extension so that the letters on it will appear through the holes in the brackets.
- B. Slide the Long Seat Bracket on the Seat Extension with the flange pointing up.
- C. Slide the Short Seat Bracket on the Seat Extension with the flange pointing down.
- D. Align the Backpad Supports so that they extend off the bottom of the back side of the Backpad. Attach using
 - four 2 $\frac{3}{4}$ -inch bolts
 - four washers
 Wrench tighten.

CAUTION: Assistance is required for the next steps.

- E. With the Backpad still on the floor, have someone hold the Long Seat Bracket flange between the Backpad Supports close to the mounting holes. Attach using
 - two 2-inch bolts
 - six washers
 - two locknuts
 The sequence will be bolt, washer, Backpad Support, washer, Flange, washer, locknut. Wrench tighten, without overtightening.

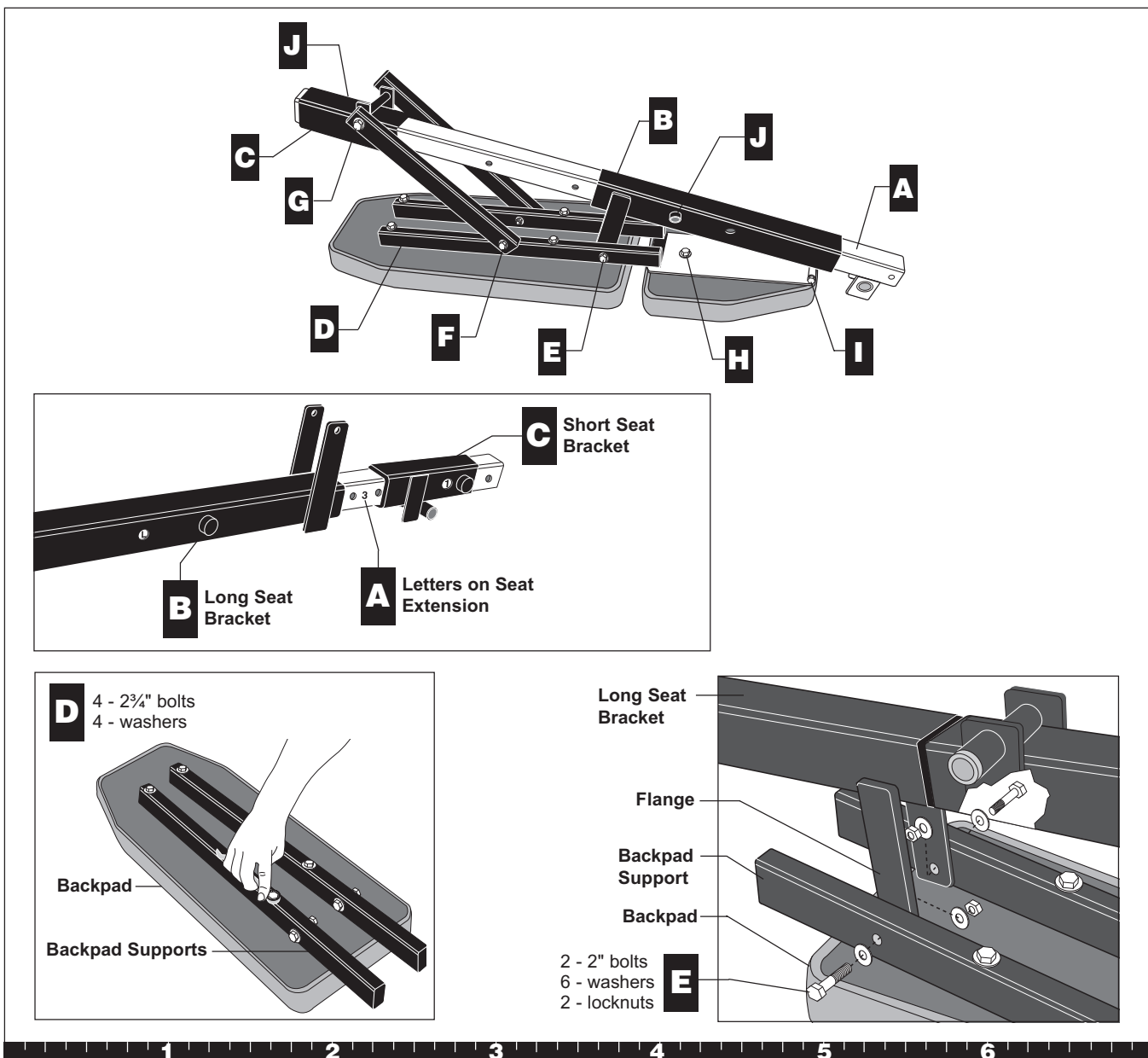

Step 5. Assemble Seat Pads

- F. Attach the Backpad Side Bars to the Backpad Supports using
 two 3/4-inch bolts
 four washers
 two 1/2-inch barrel spacers
 two locknuts
 The sequence will be bolt, washer, Side Bar, barrel spacer, Backpad Support, washer, locknut. Wrench tighten, without overtightening.
- G. Attach the other end of the Side Bars to the Short Seat Bracket flange using
 one 1/2-inch by 8 3/4-inch bolt
 two 1/2-inch washers
 one locknut
 The sequence will be bolt, washer, Side Bar, Seat Bracket Flange, washer, locknut. Wrench tighten.
- H. Attach the Seat Pad to the Seat Base Flange using
 two 1-inch bolts
 two washers
 Refer to the diagram for proper orientation.
 Wrench tighten.

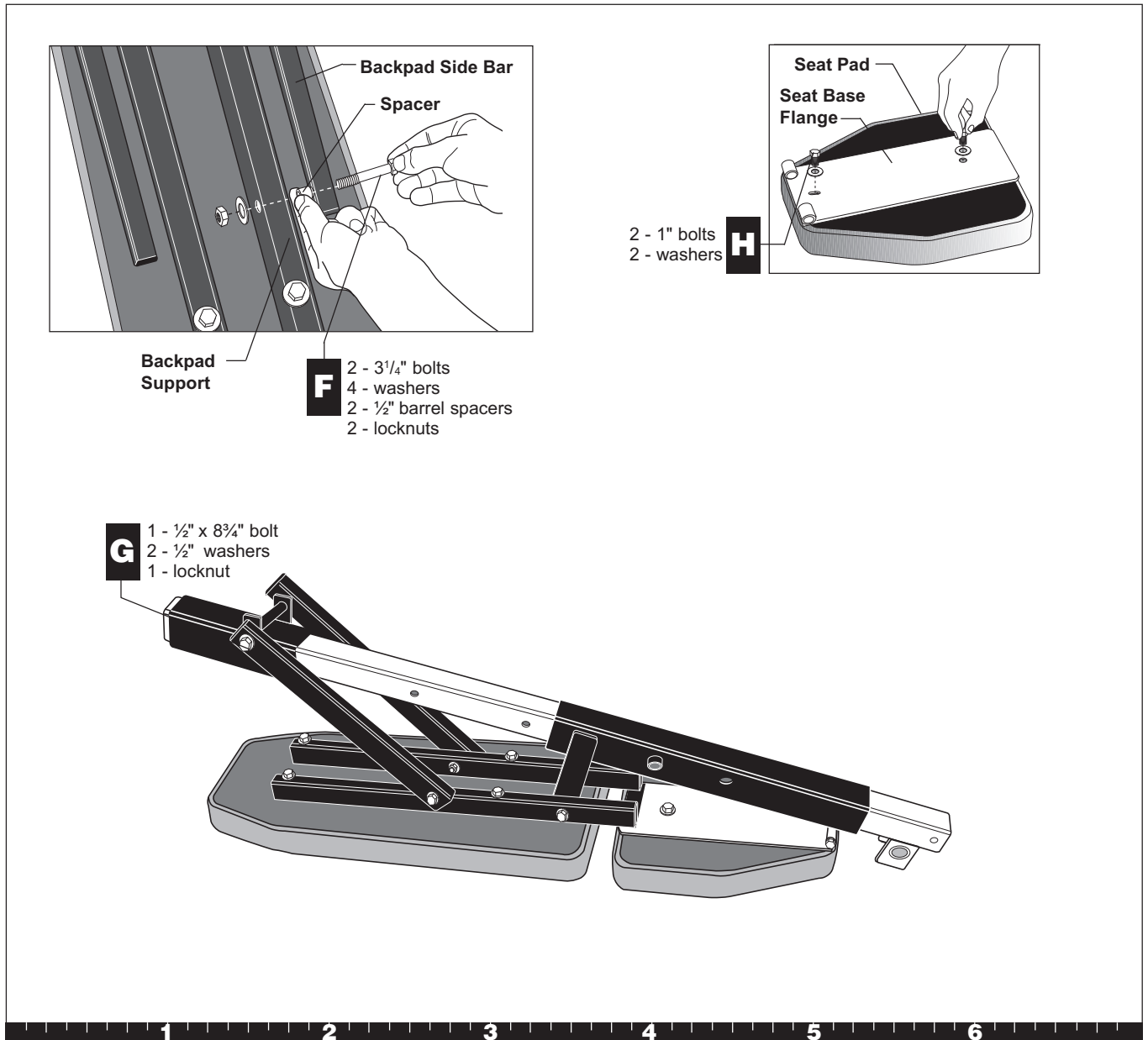

Step 5. Assemble Seat Pads, Continued

- I. Align the Seat Base Flange with the mounting bracket on the Long Seat Bracket. Attach using one 1/2-inch by 5/4-inch bolt two 1/2-inch washers one locknut Wrench tighten.
- J. Insert a Pop Pin into each Seat Bracket and wrench tighten.
- K. Attach the Back Rest Pad to the Chest Press Upright using two 3/4-inch bolts two washers Wrench tighten.

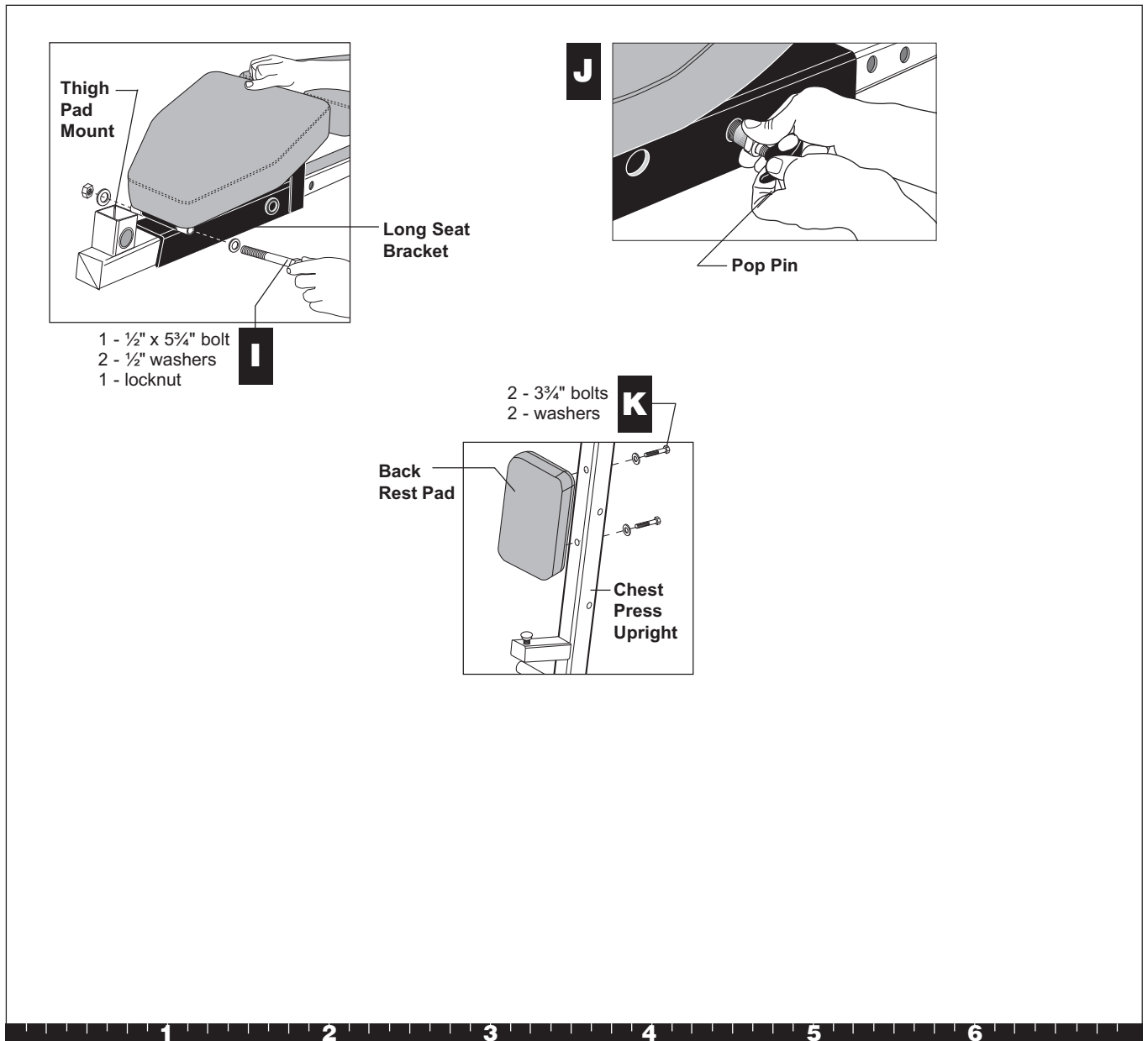

Step 5. Assemble Seat Pads, Continued

6. Install Seat Extension

CAUTION: Have an assistant help you install the Seat Extension to the Chest Press Upright.

- A. Attach two Flat Bars to the end of the Base Frame using
 one 3/4-inch bolt
 two washers
 one locknut
 Wrench tighten, leaving room for adjustment.

Note: See the diagram for the proper mounting location on the Flat Bar.

- B. In the third hole from the bottom, attach one 3/2-inch pulley to the Flat Bars using
 one 3/4-inch bolt
 two washers
 two 1/2-inch barrel spacers
 one locknut
 Wrench tighten, still allowing movement.

- C. Slide the Seat Extension on the mounting stub on the Chest Press Upright. Attach it using
 one 2 3/4-inch bolt
 two washers
 one locknut
 Wrench tighten.

- D. Align the other end of the Seat Extension with the Flat Bars. Attach it to the second mounting hole from the top using
 one 3/4-inch bolt
 two washers
 one locknut
 Wrench tighten, leaving room for adjustment.

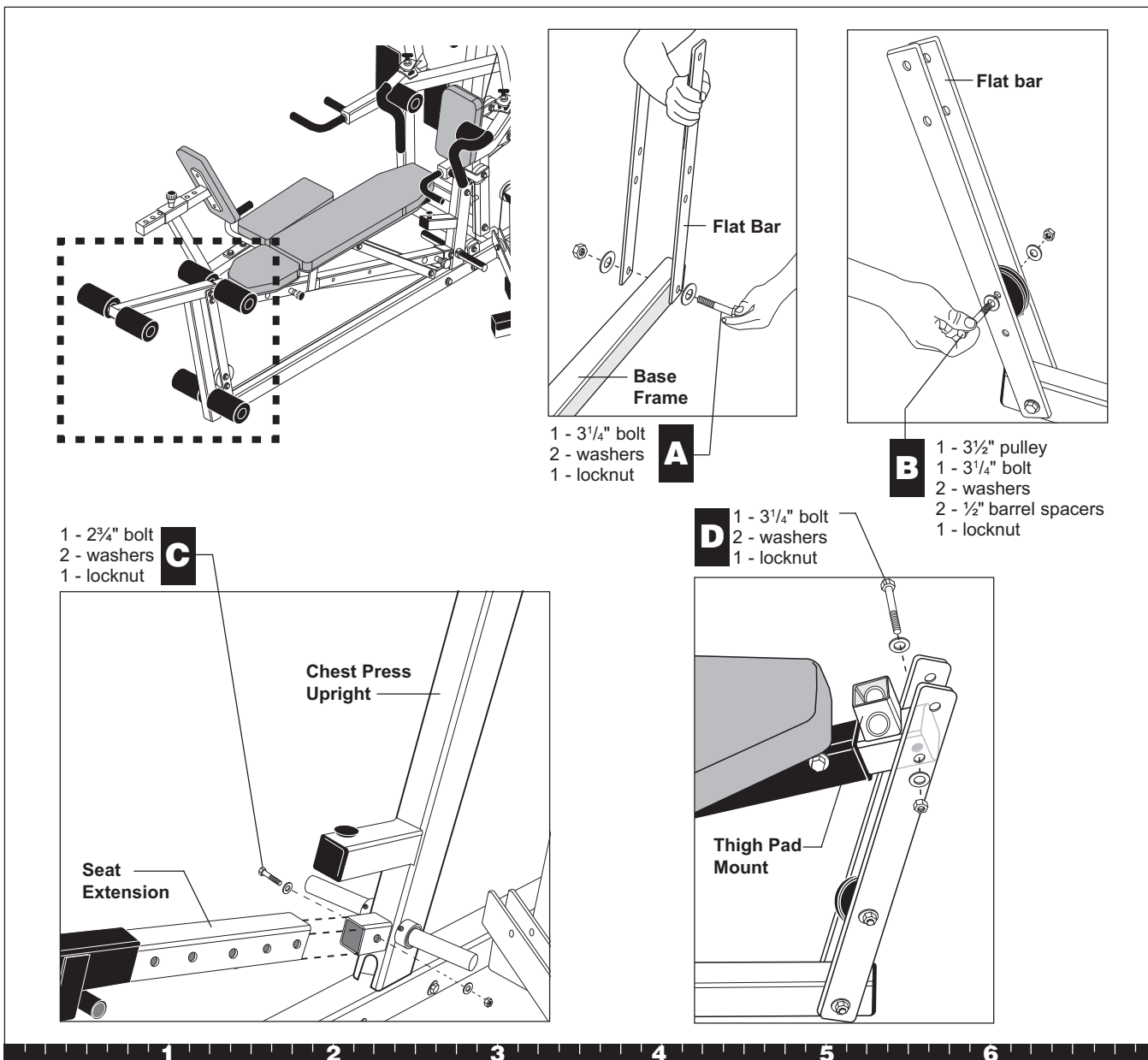

Step 6. Install Seat Extension

7. Assemble Leg Extension

- A. Attach the Leg Extension to the top mounting hole on the Flat Bars using one 1/2-inch by 3/4-inch bolt, two 1/2-inch washers, and one 1/2-inch locknut. Wrench tighten, still allowing movement.
- B. Center the Thigh Pad Rod in the Leg Curl Mount on the Seat Extension. Attach using two hex set screws. Place a large washer and Roller Pad on both ends of the Rod.
- C. Cover the set screws with the large square black cap on the Leg Curl Mount.
- D. Center the Knee Pad Rod in the mount at the end of the Leg Extension. Attach using two hex set screws. Place a large washer and Roller Pad on both ends of the Rod. Place the smaller square black cap into the end of the Leg Extension.
- E. Have someone hold the Leg Extension in an upward position while you assemble the Ankle Pads. Center the Ankle Pad Rod in the base of the Leg Extension. Attach using two hex set screws. Place a large washer and Roller Pad on both ends of the support tube.
- F. Tap the End Caps into all the Roller Pads using a rubber mallet.

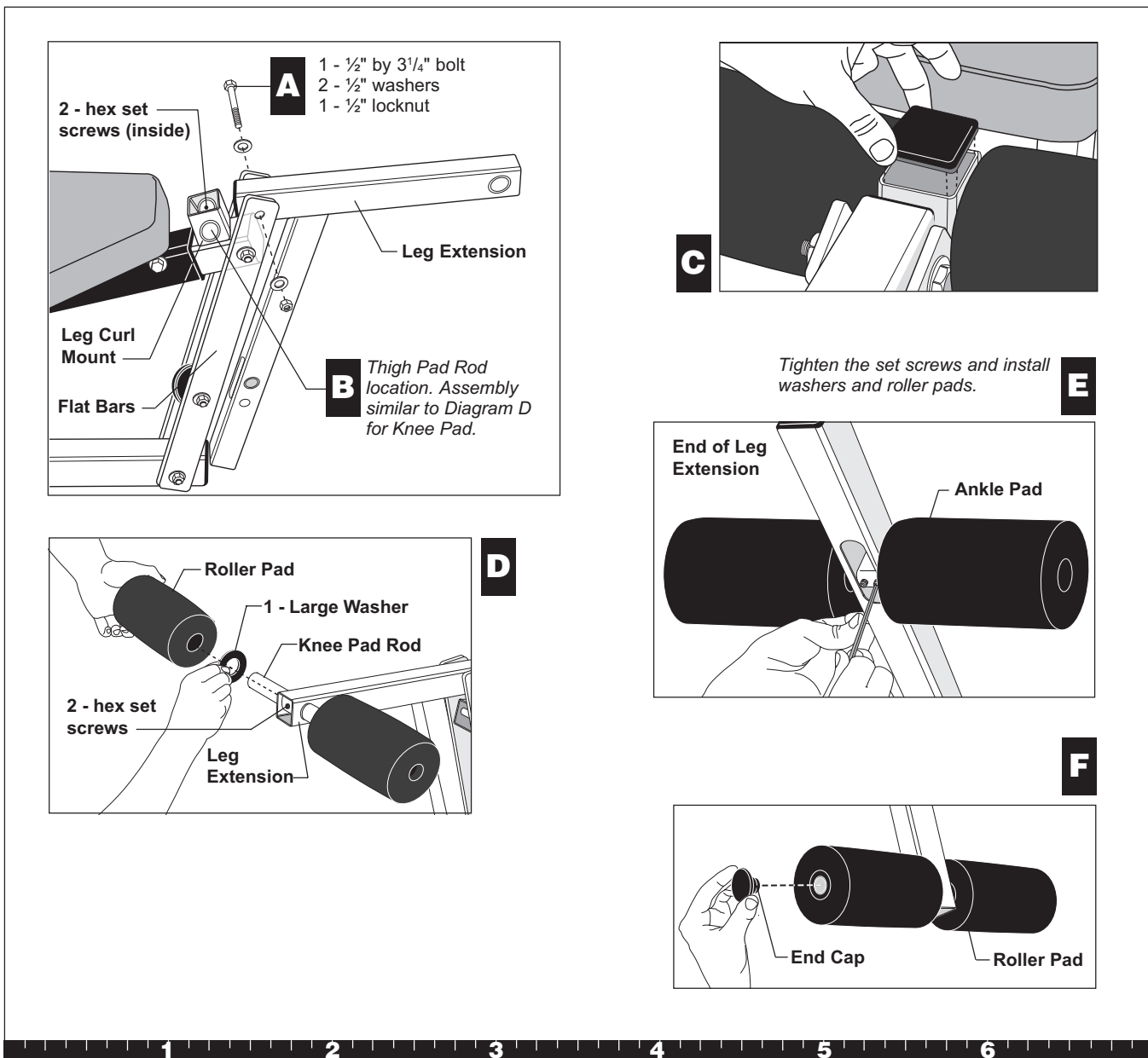

Step 7. Assemble Leg Extension

8. Install Main Cable and Pulley

- A. Insert the Selector Stem in the Weight Stack with the threaded hole at the top. Hold the Selector Stem approximately one foot above the Top Cap Weight.
- B. Insert the Weight Pin to suspend the Selector Stem.
- C. Place the loop end of the Weight Pin Lanyard into the U end of the Main Cable (#43746-101). Align the U end of the Main Cable, the top of the Selector Stem, and the Top Cap Weight. Attach using one 1½-inch socket cap bolt Wrench tighten.
- D. Remove the Weight Pin and lower the Top Cap Weight on the Weight Stack. Reinsert the Weight Pin into the Weight Stack.

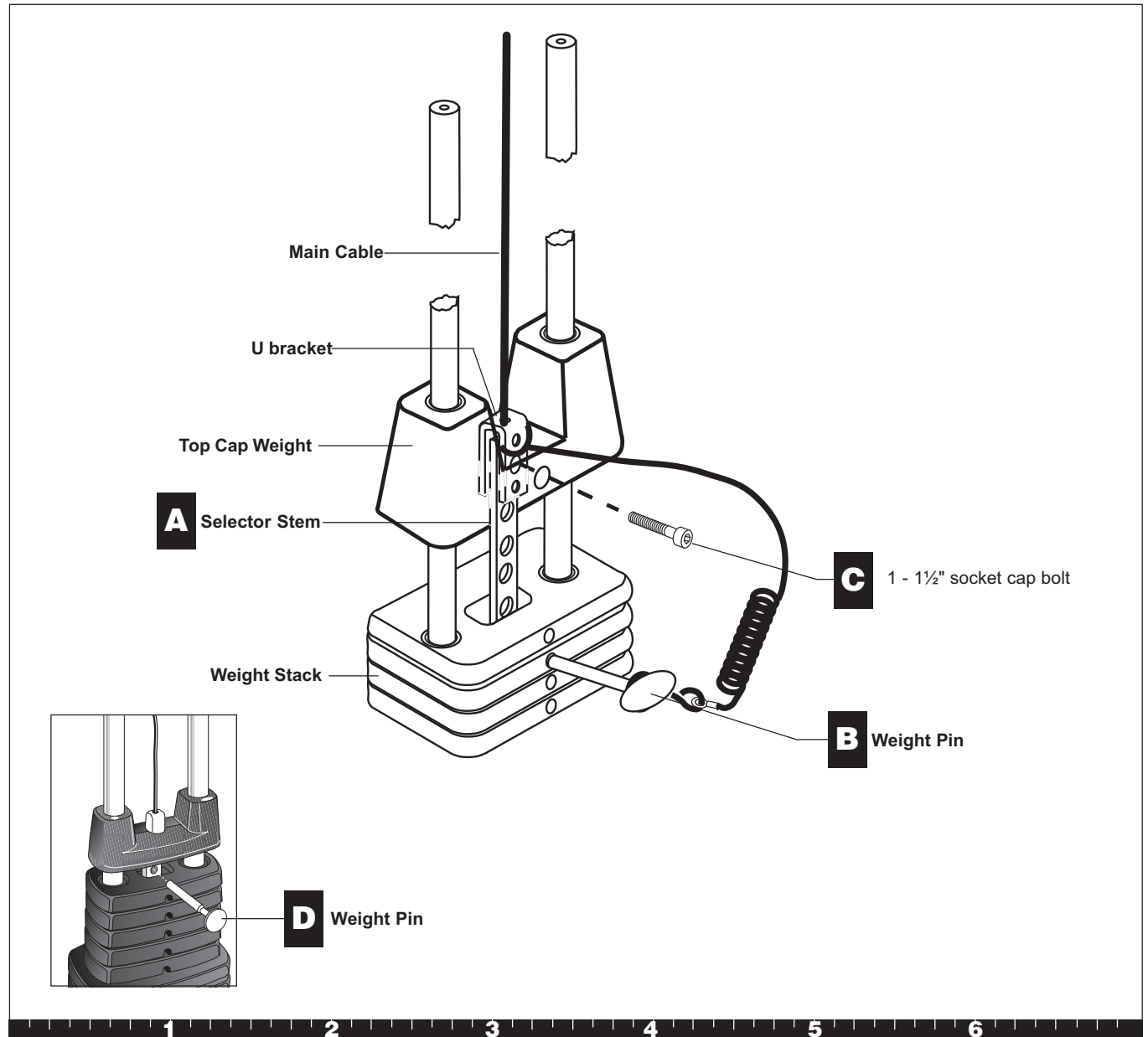

Step 8. Install Main Cable and Pulley

Note: As you feed the cable through the following steps, remove any twists in the cable before securing the pulleys. To remove a twist in the cable, rotate the cable end until the cable becomes straight. Always check that the pulleys can rotate freely after the nuts and bolts are wrench tightened.

- E. Feed the free end of the Main Cable over one 4½-inch pulley and attach it between the two upper plates that are welded to the Guide Rod Bracket using
 - one 2-inch bolt
 - two washers
 - one locknutCheck that the cable moves freely in the pulley and wrench tighten.
- F. Feed the Main Cable over a second 4½-inch pulley and attach it between the two upper plates at the other end of the Guide Rod Bracket using
 - one 2-inch bolt
 - two washers
 - one locknutCheck that the cable moves freely in the pulley and wrench tighten.
- G. Feed the cable under one 3½-inch pulley and attach it between the two Floating Pulley Plates using
 - one 2-inch bolt
 - two washers
 - one locknut
- H. Feed the cable over one 4½-inch pulley and attach it to the lower hole in the pulley window of the Chest Press Upright using
 - one 2¾-inch bolt
 - two ½-inch step spacers
 - one locknut
- I. Feed the cable under and then over the bottom pulley of the Chest Press Arm.
- J. Feed the cable under and then over one 3½-inch pulley and attach it to the upper hole in the pulley window of the Chest Press Upright using
 - one 2¾-inch bolt
 - two ½-inch step spacers
 - one locknut
- K. Feed the cable under and then over the upper pulley of the Chest Press Arm.
- L. Feed the cable under and then over one 3½-inch pulley and attach it to the pulley window toward the rear of the top beam of the Chest Press Upright using
 - one 2¾-inch bolt
 - two ½-inch step spacers
 - one locknut
- M. Feed the cable over (not through) the top beam of the Chest Press Upright and over one 4½-inch pulley and attach it to the pulley window at the end of the Chest Press Upright using
 - one 2¾-inch bolt
 - two ½-inch step spacers
 - one locknut
- N. Attach the Lat Bar to the end of the Main Cable using a Spring Clip.

Step 8. Install Main Cable and Pulley, Continued

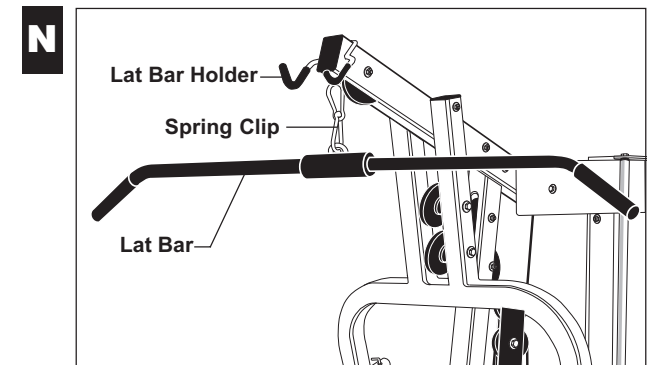
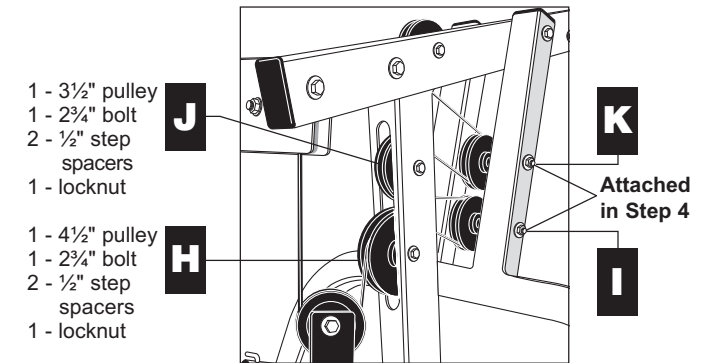
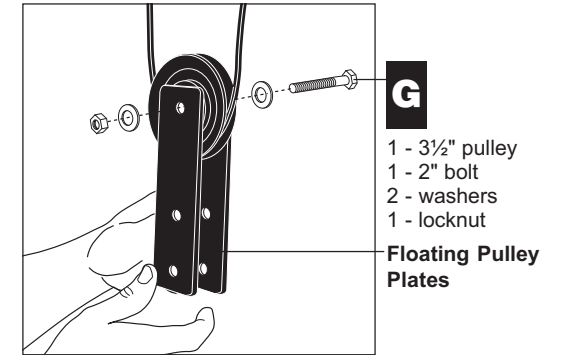
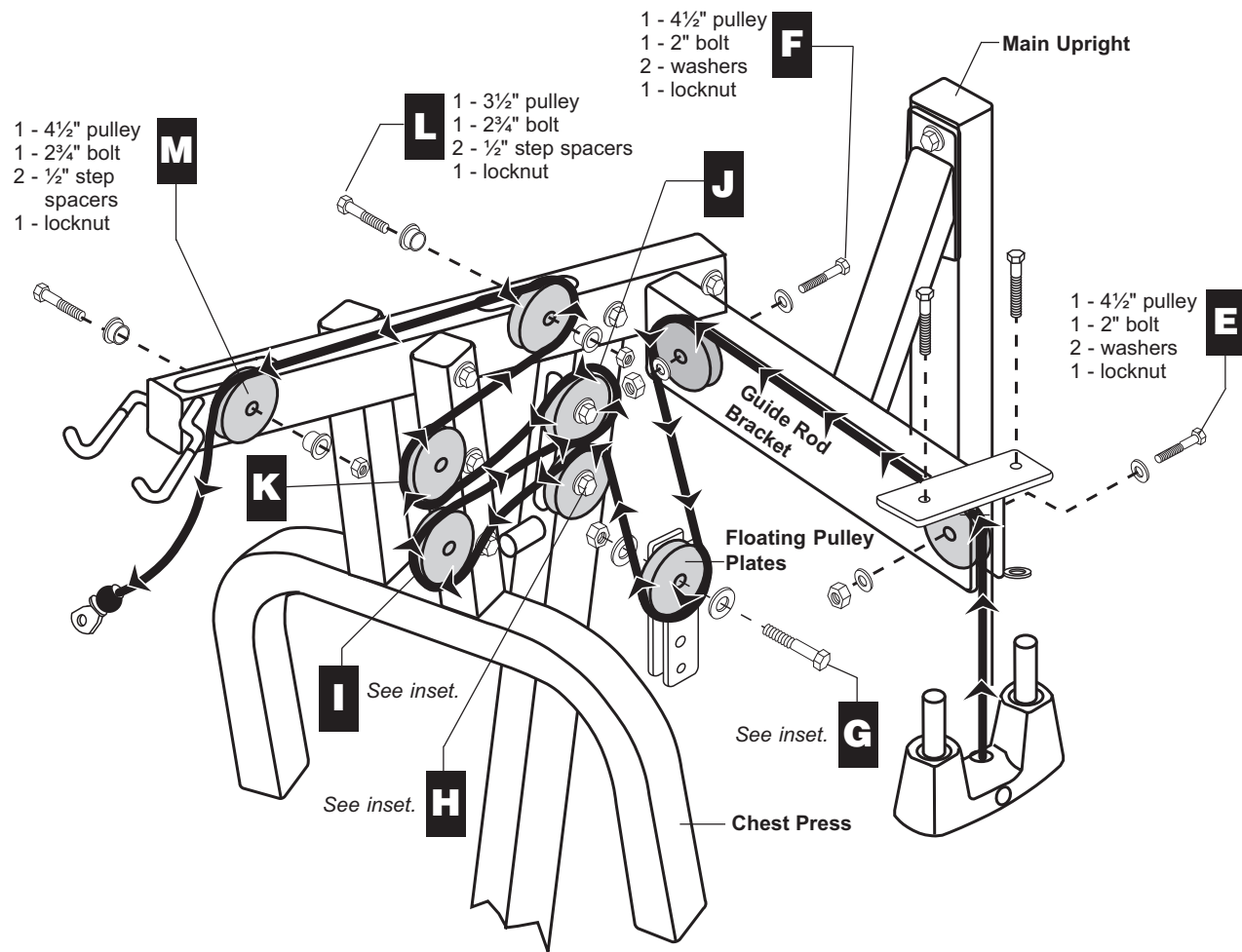

Step 8. Install Main Cable and Pulley, Continued

9. Install Lower Cable and Pulley

- A. Attach the lower cable (#43903-101) in the Pulley Window at the end of the Leg Extension using one 2½-inch bolt
two 13/16-inch step spacers
one locknut
Wrench tighten.
- B. Feed the cable along the base under the 3½-inch pulley attached to the Flat Bars and through the opening in the Chest Press Upright.
- C. Create a cable retainer in the hole under the pulley in the Flat Bars using one 3¼-inch bolt
two washers
one locknut
Ensure the cable runs between the Pulley and the bolt.
- D. Wrap the cable under one 3½-inch pulley and attach it to the flange at the base of the Chest Press Upright using one 2½-inch bolt
two washers
one ½-inch barrel spacer
one cable retainer
one locknut
The sequence will be bolt, washer, flange, barrel spacer, pulley, cable retainer, washer, locknut.
Wrench tighten.

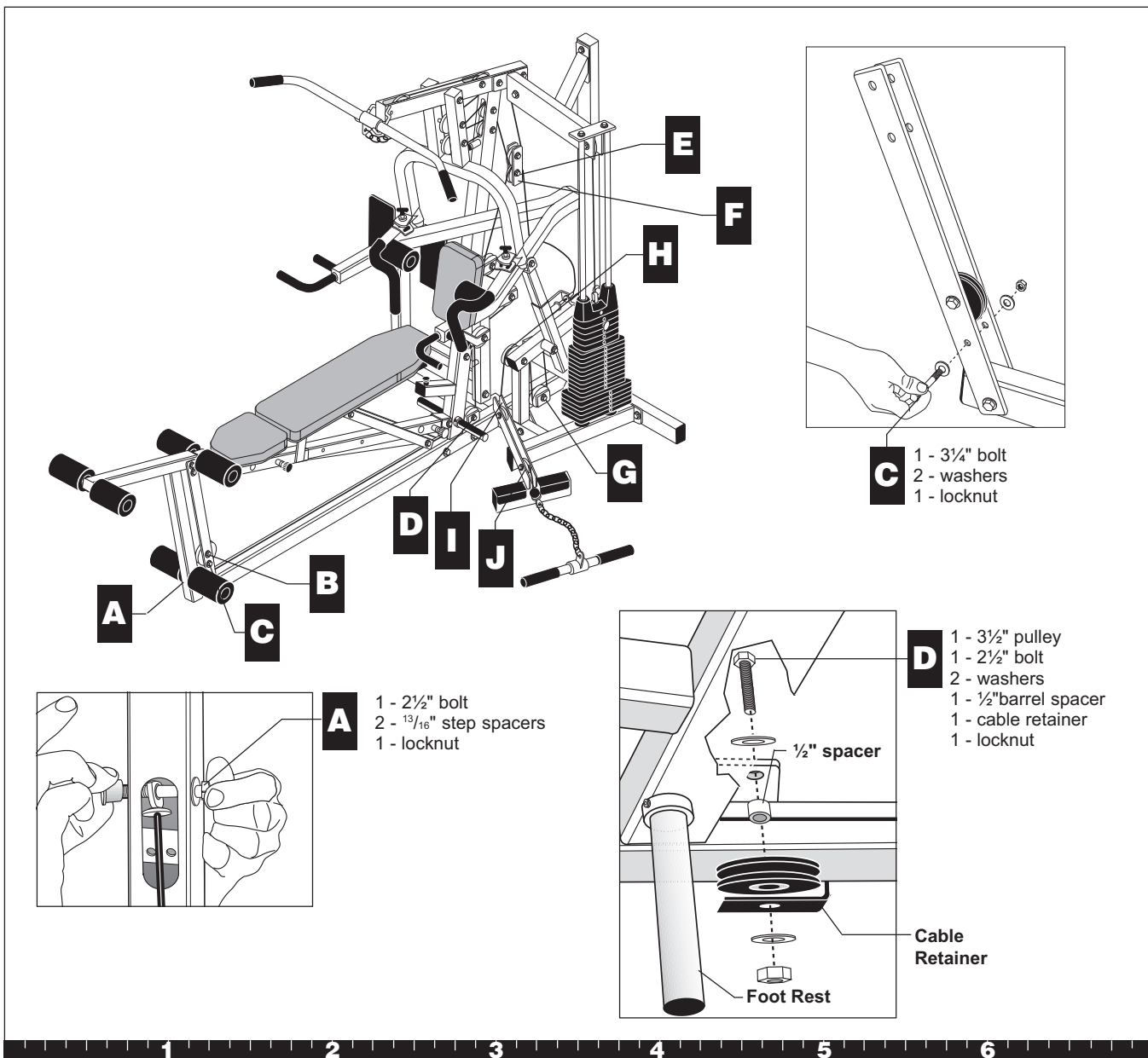

Step 9. Install Lower Cable and Pulley

- E. Feed the cable over one 3½-inch pulley and attach it to the Floating Pulley Plates (from step 8G) using one 2-inch bolt two washers one locknut. Wrench tighten.
- F. Create a cable retainer in the lower hole of the Pulley Plates using one 2-inch bolt two washers one locknut. Ensure the cable runs between the pulley and the bolt.
- G. Feed the cable under one 4½-inch pulley and attach it to the bracket on the Base Frame using one 4¼-inch bolt two washers one cable retainer one locknut. Wrench tighten.
- H. Feed the cable over one 4½-inch pulley and attach it to the mid-level bracket on the Main Upright using one 4¼-inch bolt two washers one ½-inch barrel spacer one cable retainer one locknut. The sequence will be bolt, washer, cable retainer, pulley, barrel spacer, bracket, washer, locknut. Wrench tighten.

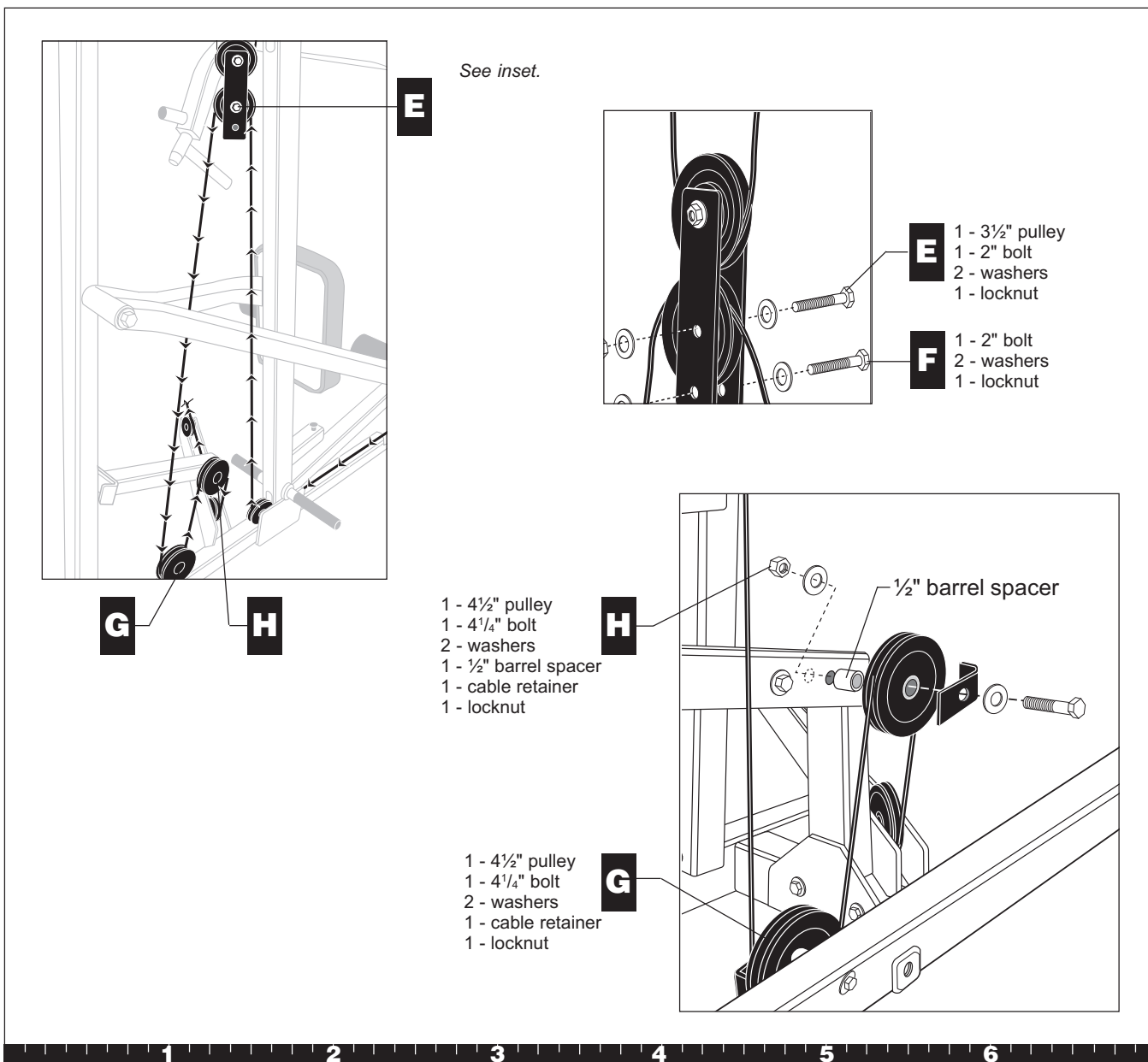

Step 9. Install Lower Cable and Pulley, Continued

- I. Feed the cable under one 3½-inch pulley and attach it between the two plates on the Base Frame using one 2¼-inch bolt, two washers, and one locknut. Wrench tighten.
- J. Wrap the cable under one 3½-inch pulley and attach it between the two plates at the other end of the foot support of the Base Frame using one 2¼-inch bolt, two washers, and one locknut. Wrench tighten.
- K. Attach the Curl Bar or Ankle Strap to the end of the cable using a Spring Clip.

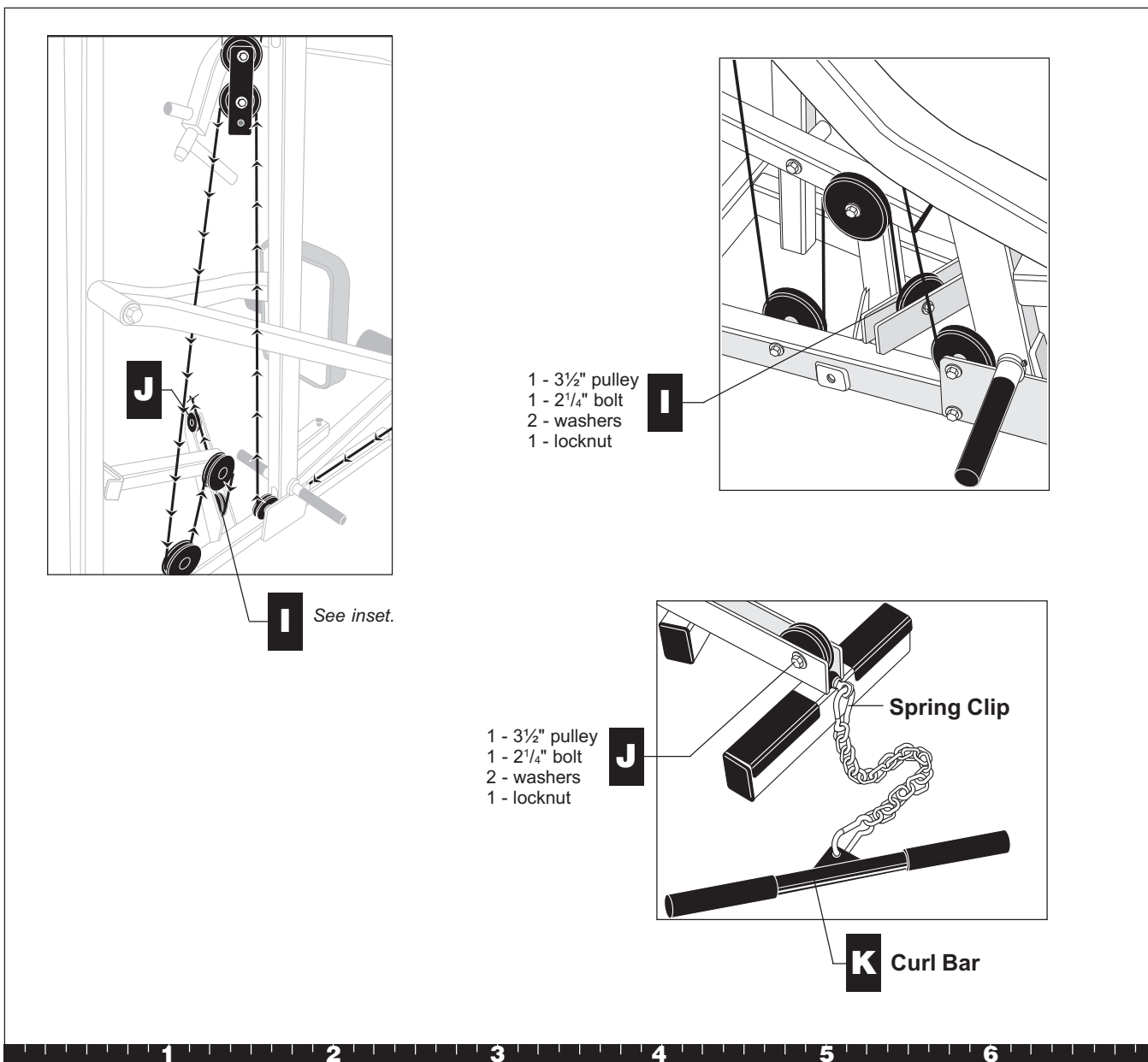

- 1 - 3½" pulley
- 1 - 2¼" bolt
- 2 - washers
- 1 - locknut

- 1 - 3½" pulley
- 1 - 2¼" bolt
- 2 - washers
- 1 - locknut

Spring Clip

Curl Bar

Step 9. Install Lower Cable and Pulley, Continued

10. Apply Weight Decals

- A. Remove the backing for the decals labeled “1–5.” Press the decals to the front surface of the top five weight plates in the tab location as indicated. Remove the front decal protector.
- B. Remove the backing for the decals labeled “6–15.” Press the decals to the front surface of the middle ten weight plates in the tab location as indicated. Remove the front decal protector.
- C. Remove the backing for the decals labeled “16–20.” Press the decals to the front surface of the bottom five weight plates in the tab location as indicated. Remove the front decal protector.

This completes the assembly of your Solana Strength-Training Fitness Equipment.

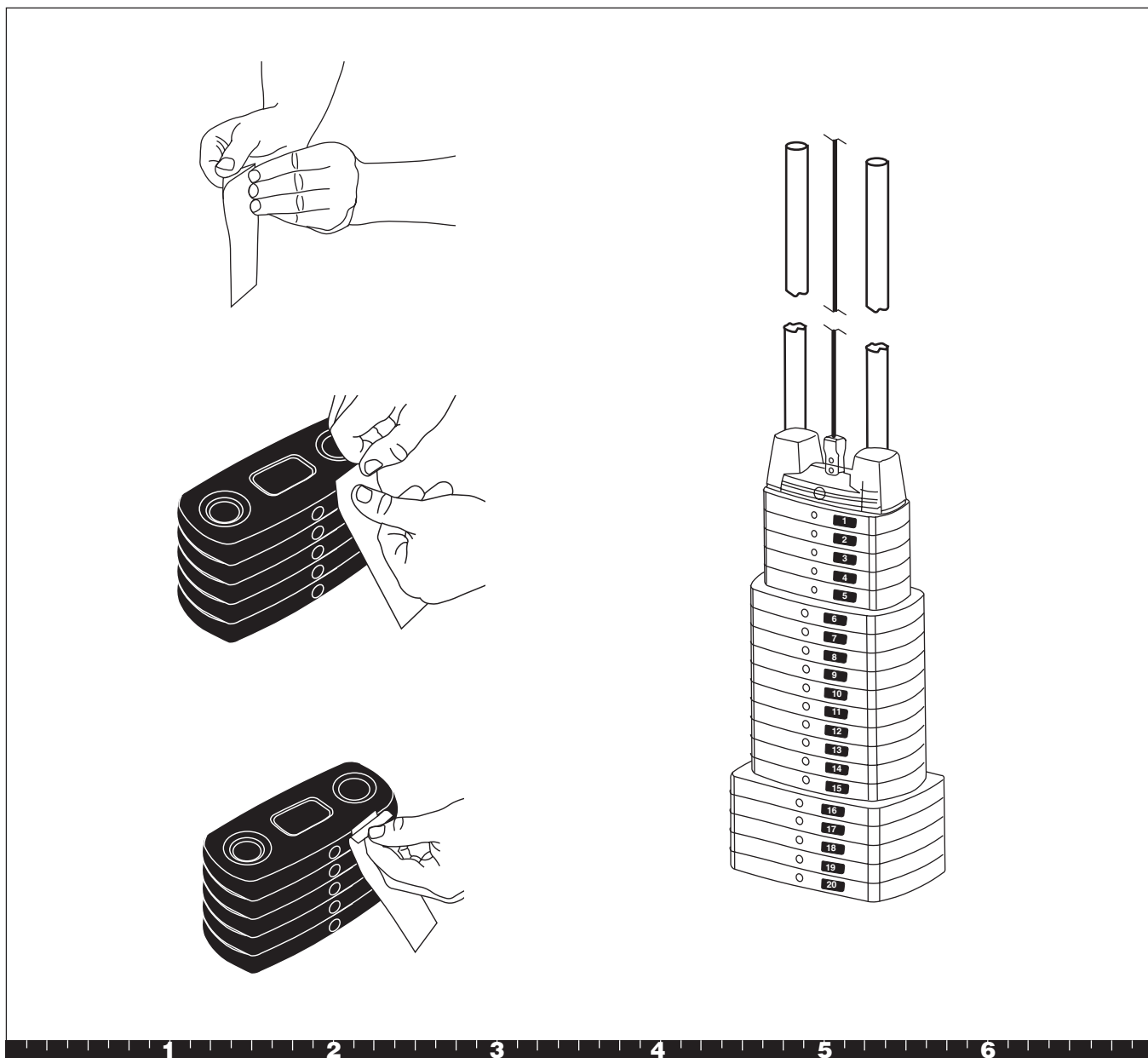

Step 10. Apply Weight Decals

4

Adjustments and Maintenance

1. Cable Adjustments

When the Solana is completely assembled, you need to check the cables for proper tension. Obvious signs that cable problems exist include:

- ✓ Top Cap Weight does not rest squarely on the top weight of the Weight Stack.
- ✓ Cable rubs the inside edges of the pulleys.
- ✓ Excess slack exists in the cable.

CAUTION: Take the time to perform the following steps. If the cables do not have the proper tension you could void the Precor Limited Warranty.

If you experience any of the above signs of cable problems, make the adjustment as follows:

- A. Place the Weight Pin in the Top Cap Weight to ensure the least cable resistance.
- B. Insert both Pec Fly Locking Pins so that the Pec Fly Arms are in the locked position.
- C. Pull up on the Pec Fly Arms and tighten or loosen the Press Arm Stop so that it rests on the Chest Press Upright.
- D. Lower the Pec Fly Arms.
- E. Make certain that the Weight Pin can be inserted into every hole in the Weight Stack.

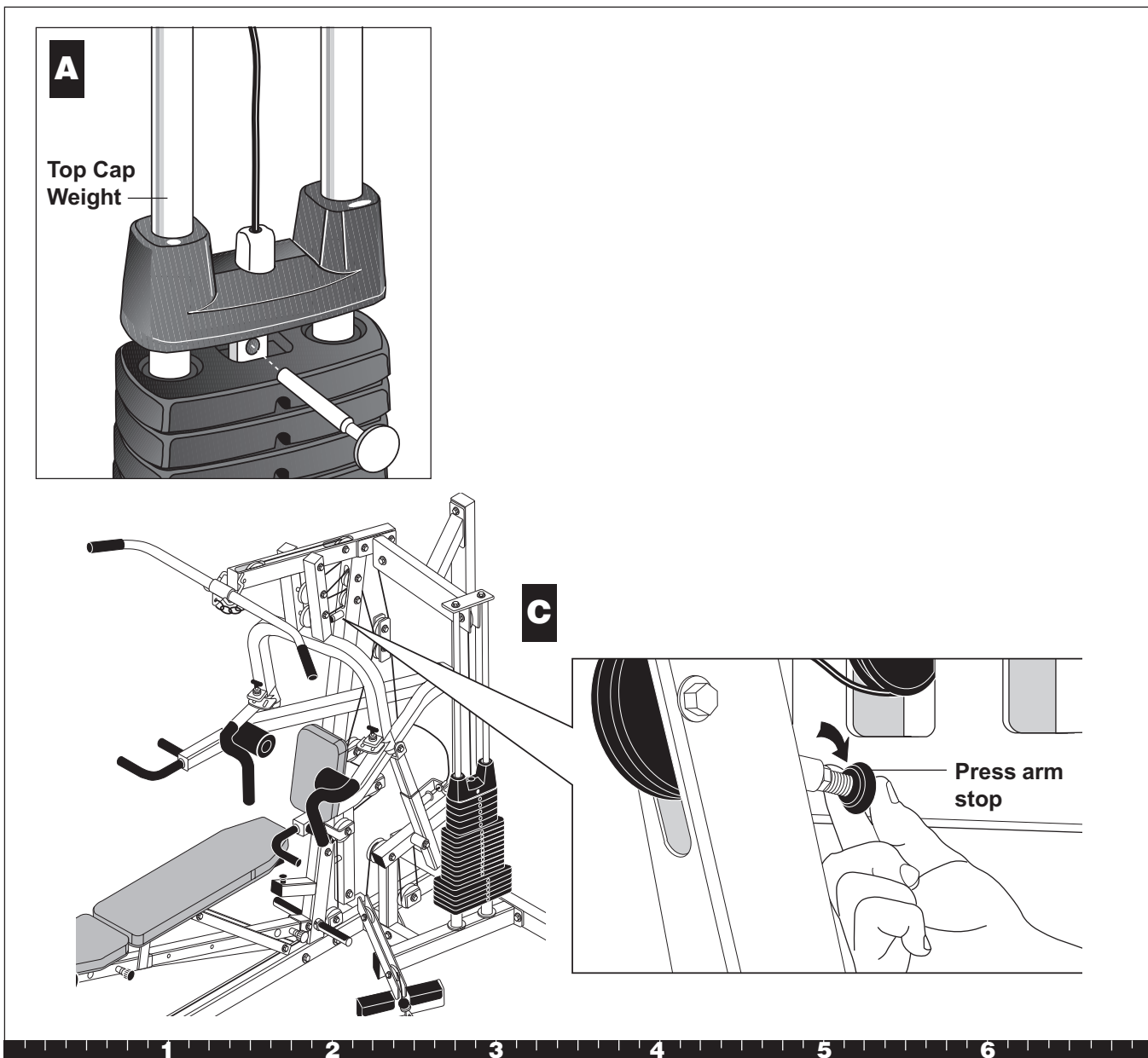

Step 1. Cable Adjustments

2. Selector Stem Adjustments

To prevent the Selector Stem from contacting the inside of the Weight Stack when the machine is in use, you need to check the vertical angle of the Selector Stem (steps A and B). If the stem slides smoothly without contacting the inside of the weight plates, assembly of the unit is complete.

CAUTION: Performing the following tasks requires two people.

- A. Remove the Weight Pin from the Weight Stack.
- B. Perform an exercise using each part of the Solana. When the base of the Selector Stem is clear of the Weight Stack, observe the position of the Selector Stem.

The following sections describe how to adjust the Selector Stem when contact does occur.

The Selector Stem can be adjusted forward, backward, and vertically depending on the area of contact.

Forward Angle Adjustment

When the Selector Stem angles forward (toward the seat) and contacts the inside of the Weight Stack during use, adjust it by following these steps:

CAUTION: This adjustment requires two people.

- A. Completely disassemble the Top Cap Weight, Selector Stem, and U bracket.
- B. Thread the Allen head set screw into the hole closest to the top of the U bracket and turn it clockwise until the end of the screw is flush with the inside surface of the U bracket.
- C. Turn the set screw clockwise another one-half turn (see diagram).

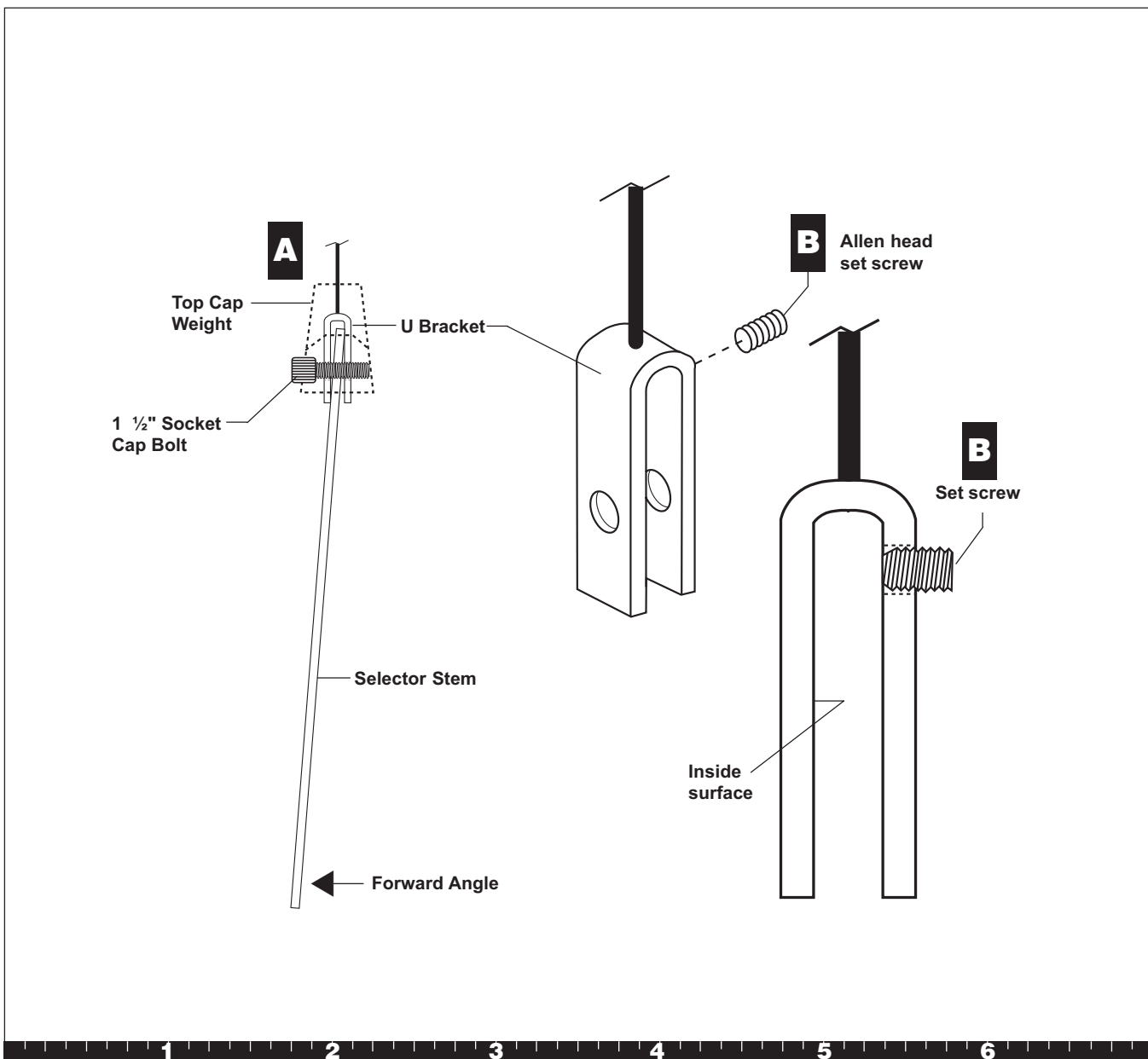

Step 2. Selector Stem Adjustments

- D. Reassemble the Top Cap Weight, Selector Stem, and U bracket.
- E. Test again the movement of the Selector Stem inside the Weight Stack.
- F. If the Selector Stem continues to contact the plates, repeat steps A through E until the Selector Stem slides through the Weight Stack without contacting the plates.

Backward Angle Adjustment

When the Selector Stem angles backward (away from the seat) and contacts the inside of the Weight Stack during use, adjust it by following these steps:

CAUTION: This adjustment requires two people.

- A. Completely disassemble the Top Cap Weight, Selector Stem, and U bracket.
- B. Thread an Allen head set screw into the hole closest to the top of the U bracket and turn it clockwise until the end of the screw is flush with the inside surface of the U bracket.
- C. Turn the set screw clockwise another one-half turn (see diagram).
- D. Reassemble the Top Cap Weight, Selector Stem, and U bracket.
- E. Test again the movement of the Selector Stem inside the Weight Stack.
- F. If the Selector Stem continues to contact the plates, repeat steps A through E until the Selector Stem slides through the Weight Stack without contacting the plates.

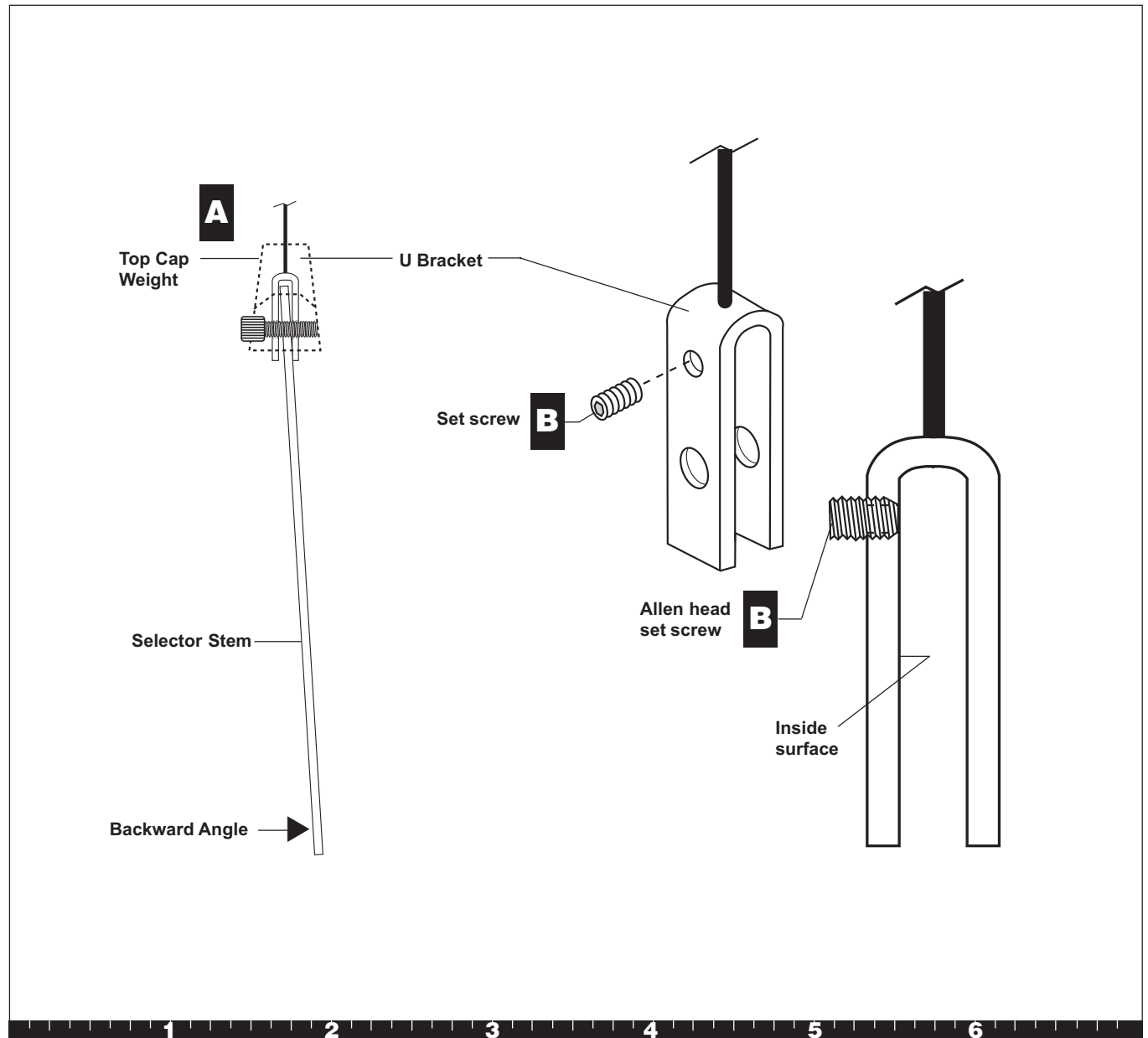

Step 2. Selector Stem Adjustments, Continued

Side-to-Side Vertical Adjustment

If the Selector Stem contacts the inside of the Weight Stack during use or the Weight Pin becomes difficult to insert in the Weight Stack, the Selector Stem may be out of alignment vertically side to side. Adjust the Selector Stem by following these steps:

CAUTION: This procedure requires two people.

- A. Pull the Selector Stem and Top Cap Weight up to expose at least five Selector Stem holes.
- B. Insert the Weight Pin near the base of the Selector Stem to hold it in place.
- C. To center the Selector Stem, loosen the socket cap bolt that attaches the Top Cap Weight to the U bracket.
- D. Once the Selector Stem is centered, retighten the socket cap bolt securely.
- E. Lower the Selector Stem into the Weight Stack. Test the movement of the Selector Stem inside the Weight Stack.
- F. Make certain that the Weight Pin can be inserted into every hole in the Weight Stack. If the Selector Stem continues to contact the plates, repeat steps A through E until the Selector Stem slides through the Weight Stack without contacting the plates.

After completing the adjustments, fill out the warranty card and mail it in.

3. Maintenance

Lubricate the Guide Rods every six months.

Use a silicon lubricant to lubricate the rods; you can purchase this lubricant from any hardware store.

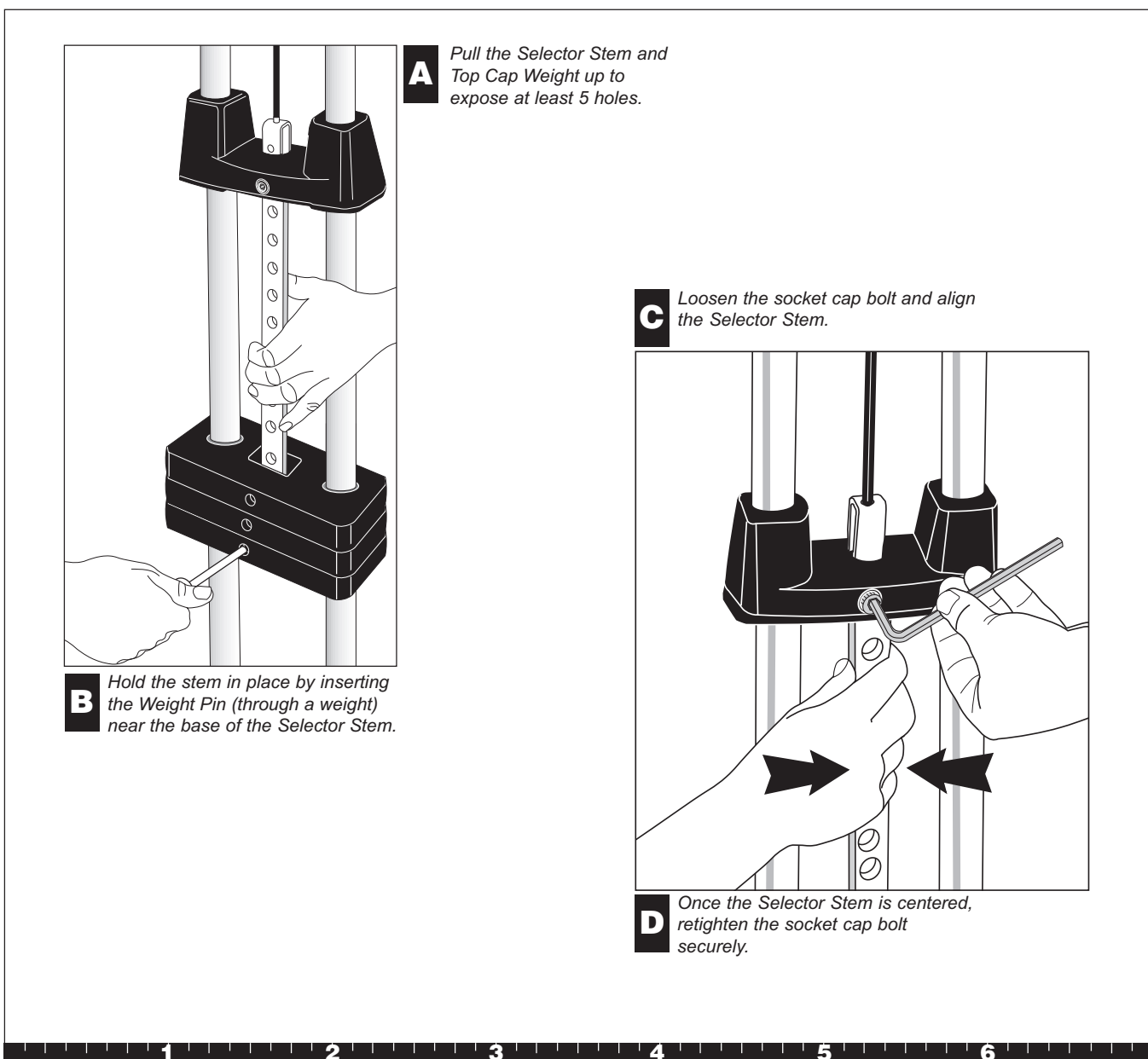

Step 2. Selector Stem Adjustments, Continued

Residential Equipment Limited Warranty

Precor Incorporated warrants that all new Precor products are free of manufacturing defects in workmanship and materials. Parts repaired or replaced under the terms of this warranty will be warranted for the remainder of the original warranty period only. This warranty becomes effective at the invoice date of the original purchase.

Elliptical Fitness Crosstrainers and Motorized Treadmills (excluding EFX5.17 and Treadmills: 9.2 and 9.4 series) — Labor is covered for one year, parts are covered for five years plus a lifetime frame weld warranty covering parts-only repair or replacement parts. (Labor is not covered on frame replacement after one year.)

Products (StretchTrainer, Strength Equipment — formerly Pacific Fitness) other than Elliptical Fitness Crosstrainer and Motorized Treadmills (except options)

StretchTrainer — Labor is covered for a period of 90 days, parts are covered for a period of one year plus a lifetime frame weld warranty covering parts-only repair or replacement parts. (Labor is not covered on frame replacement after one year.)

Pacific Fitness Branded Strength Products and Precor Strength Products S3.xx

This is a parts only warranty. Labor costs are not covered.

1. Frame & Welds: Defective parts pertaining to frame structure, including all welded assembly parts, will be warranted for Lifetime.
2. Bearings, Guide rods, Cams, Pulleys, Belts, Cables, Hand grips, and Miscellaneous parts will be warranted for a period of three years. **Note that for the Precor Strength Products S3.xx, and the Pacific Fitness Solana and Zuma, the warranted period is five years.**
3. Upholstery will be warranted for a period of one year. A three month warranty applies to Naugahyde upholstery for Pacific Fitness Branded Strength Products only.

Return Policy: Proof of purchase is required to determine whether service on a Precor Strength Product/ Pacific Fitness Product during its warranty period will commence. Claims should be made to the dealer from whom you purchased the product. The purchaser is responsible for all transportation and insurance costs on returned or replaced equipment or parts. The purchaser also assumes any costs associated with the disassembling or reassembling of the replacement parts. **WARRANTY BECOMES VOID IF PRECOR FINDS THE DEFECT A RESULT OF INCORRECT INSTALLATION, MISUSE, LACK OF PROPER MAINTENANCE OR ANY MODIFICATION NOT APPROVED BY PRECOR.**

Options / Accessories / Battery-powered or Self-Operated Devices

Many options or accessories have components that are connected internally or mounted inside the electronic console. The following guidelines determine the warranty for these components. If the internal components are installed by the factory or by an authorized dealer as part of the original sale and delivery, they have a warranty that is identical to the warranty of the equipment in which they are connected or mounted. If the internal components are not installed by the factory or by an authorized dealer as part of the original sale and delivery, they have a 90 days parts and labor limited warranty. All components that are not internally connected have a 90 days parts only limited warranty. Satisfactory proof of purchase is required in all cases.

PRECOR'S SOLE LIABILITY IS LIMITED TO REPAIR OR REPLACEMENT OF PARTS ACCORDING TO THE TERMS AND CONDITIONS OF THESE LIMITED WARRANTIES, AND ANY IMPLIED WARRANTIES OF MERCHANTABILITY OR FITNESS FOR A PARTICULAR PURPOSE ARE LIMITED TO THE DURATION OF THE ABOVE WRITTEN WARRANTIES. IN NO EVENT WILL PRECOR OR THE SELLING DEALER BE LIABLE FOR INCIDENTAL OR CONSEQUENTIAL DAMAGES SUCH AS INCONVENIENCE, COMMERCIAL LOSS, LOST PROFITS OR DAMAGE TO OTHER PROPERTY.

Some states do not allow the exclusion or limitation of incidental or consequential damages, so the above limitation may not apply to you. This warranty gives you specific legal rights, and you may also have other rights which vary from state to state.

Keep this for your records. Purchased From: _____

Phone Number: _____ Product/Model: _____

Serial #: _____

Conditions

This warranty is valid only in accordance with the conditions set forth below.

1. Warranty applies to the Precor product only while
 - A) it remains in the possession of the original purchaser and proof of purchase is demonstrated,
 - B) it has not been subjected to accident, misuse, abuse, improper service, or non-Precor modification and
 - C) claims are made within the warranty period.
2. Warranty of all Precor products applies to residential use only (unless specifically stated by the factory, in writing, to be warranted for commercial use) and is void when products are used in a non-residential environment or installed in a country other than where sold.
3. This warranty does not cover damage or equipment failure caused by residential wiring not in compliance with electrical codes or Precor owner's manual specifications, or failure to provide reasonable and necessary maintenance as outlined in the owner's manual.
4. During the labor period Precor compensates Servicers for warranty trips within their normal service area to repair motorized treadmills and elliptical fitness crosstrainers at the customer's location. You may be charged a trip charge outside the service area, or for on-site warranty repairs, or for on-site warranty repairs of strength products, within the service area.
5. Precor Limited Warranty service may be obtained by contacting the authorized dealer from where you purchased the equipment or by contacting a Precor Factory Authorized Service Center, or by calling 1-800-4-PRECOR (1-800-477-3267).
6. Except in Canada, Precor does not pay labor outside the United States. Equipment limited warranty is void when equipment is installed in a country other than where sold. For specific warranty details, contact a local Precor dealer.

This Limited Warranty shall not apply to:

1. Software (PROM) limitations or corrections.
2. Batteries or other consumables, or cosmetic items, grips, seats, labels, or wheels.
3. Repairs performed on Precor equipment missing a serial number or with a serial tag that has been altered or defaced.
4. Service calls to correct installation of the equipment or instruct owners on how to use the equipment.
5. Pick-up, delivery, or freight charges involved with repairs.
6. Any labor costs incurred beyond the applicable labor warranty period.

Please fill out the Warranty Registration and mail it to Precor.



Residential Equipment Limited Warranty

Thank you for purchasing a PRECOR product. In order that we may continue to serve you in the future, please take a few minutes to complete and return this warranty registration.

The undersigned hereby acknowledges receipt of the Precor Limited Warranty and affirms that the date of purchase was 20____, further that the undersigned has read and understands the conditions and terms of the Precor Limited Warranty in its entirety. For your protection, complete the Precor Limited Warranty registration card within 10 days from date of purchase and mail it to Precor. In the event of a safety modification or for other reasons Precor might deem necessary, we will contact you directly.

Name of Facility _____

Contact Person _____ Mr. Ms.

Phone Number _____ - _____

Address _____

City _____ State _____ Zip Code _____

Purchased From _____ State _____ Zip Code _____ - _____

Serial # _____ Serial number is located on the shipping box and on the product.

Purchaser's Signature _____

Please detach and return this portion.

Please fill out the Warranty Registration and mail it to Precor.

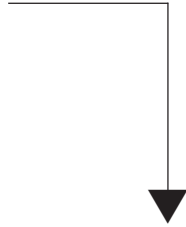

Solana Specifications

Length: 99 inches (252 cm)

Height: 82 inches (208 cm)

Width: 44 inches (112 cm) Leg press option adds 15 inches (38 cm)

Shipping weight: 320 lb (144 kg)

Warranty Registration Card

PRECOR[®]
USA
Precor Incorporated
20031 142nd Avenue NE
P.O. Box 7202
Woodinville, WA USA 98072-4002

PRECOR[®]
USA

Precor Incorporated
20031 142nd Avenue NE
P.O. Box 7202
Woodinville, WA USA 98072-4002

Precor and Pacific Fitness are registered trademarks of Precor Incorporated.
Specifications subject to change without notice.

Copyright 2001 Precor Incorporated. Precor web site: www.precor.com

NOTICE:

Precor is widely recognized for its innovative, award winning designs of exercise equipment. Precor aggressively seeks U.S. and foreign patents for both the mechanical construction and the visual aspects of its product design. Any party contemplating the use of Precor's product designs is hereby forewarned that Precor considers the unauthorized appropriation of its proprietary rights to be a very serious matter. Precor will vigorously pursue all unauthorized appropriation of its proprietary rights.

Literature Kit# 43682-106
Owner's Manual# 43684-106
Warranty Card# 36287-108
Exploded Views# 43683-103
Effective date: Oct 30, 2001

PLACE
STAMP
HERE