



INSTALLATION INSTRUCTIONS
COLD AIR INTAKE KIT
2005 JEEP GRAND CHEROKEE 5.7L V8
PART NUMBER P5153374

Bill of Materials for Part Number

1	2-P5153374	Inlet Pipe
1	20-8306	Heat Shield
1	1-3027	Washer, 1/4 x 1 1/4 Fender
1	21-209M	6.0x5.0 Filter Element
1	1-3028	Washer, 1/4 SAE Flat
1	1-2072	Bolt, 1/4-20-UNC x 1 3/4
1	1-2074	Lock Nut, '1/4-20
1	1-2073	Nut, '1/4-20
1	2-670	Heat Shield Spacer
1	K6857038	Instructions
13"	8-119	Gasket, Rubber Sponge
1	444.460.04	M6 Nylok Nut
1	784634	Grommet
2	5-351N	Hose, Silicone Blk 3.50X2.0
4	103-BLO-5620	Hose Clamp 3.5"
22"	65116	1/2" ID Hose
2	99024.032	1" Hose Clamps
1	9-P4510832	Air Horn
6"	8-143	Helical Bundle Wrap
2	1-2104	M8 Nuts
2	559960	M8 Washers
1	1228560	Rubber Mount 8MM
1	10-506B	BFS Box 36x12x10
1	1-3016	SS M6 Washer
1	10-MW	Mopar Warranty

Read and understand these instructions BEFORE attempting to install this product.

1) Getting Started

- a) Make sure vehicle is parked on a level surface.
- b) Set parking brake.
- c) If engine has run with in the past two hours let it cool down.
- d) Disconnect negative battery terminal.



**INSTALLATION INSTRUCTIONS
COLD AIR INTAKE KIT
2005 JEEP GRAND CHEROKEE 5.7L V8
PART NUMBER P5153374**

2) Removal of the stock intake system



a) Start by making sure the area around and on the oil filler cap is clear of debris. Remove oil filler cap.

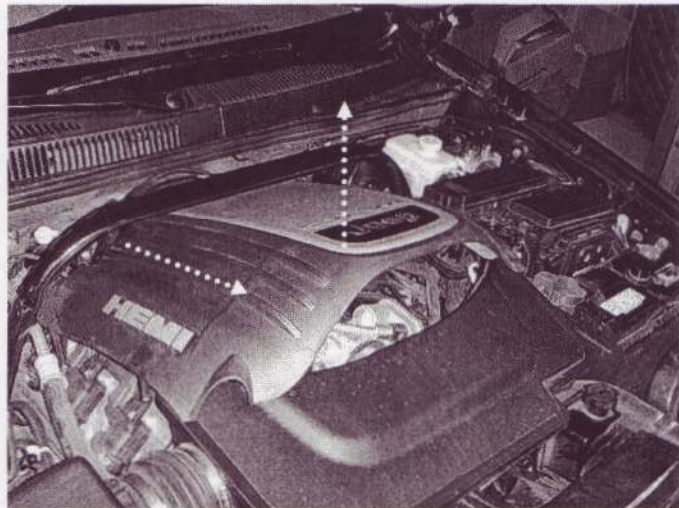

b) With the oil filler cap removed, remove the plastic engine cover. Pull up on the front and then out of the engine bay.

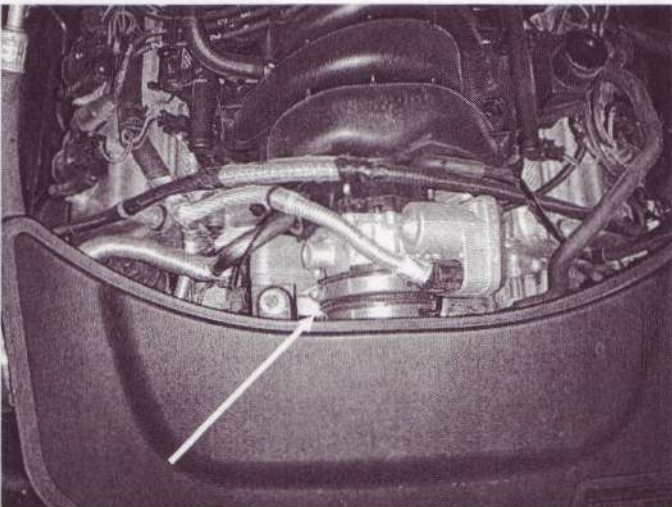

c) Loosen hose clamp at the throttle body.

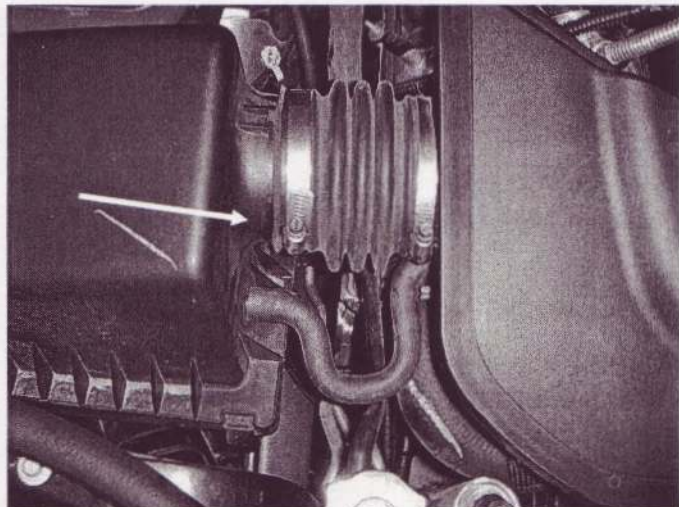

d) Loosen hose clamp at the air box.



INSTALLATION INSTRUCTIONS
COLD AIR INTAKE KIT
2005 JEEP GRAND CHEROKEE 5.7L V8
PART NUMBER P5153374

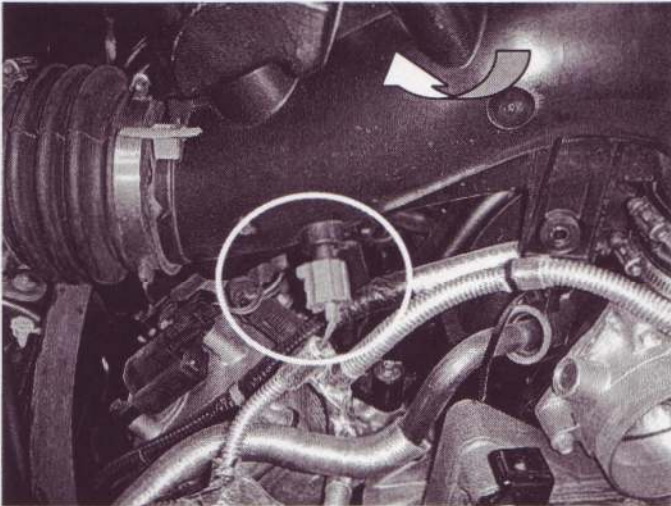

e) Rotate the inlet pipe up and away from the front side of the vehicle to access the IAT Sensor. Unplug the IAT sensor.

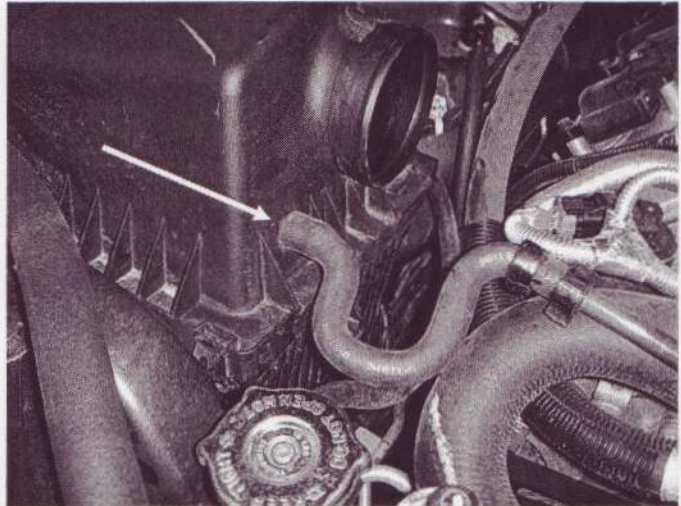

f) Disconnect the breather hose at the air box.



g) Disconnect the other end of the breather hose at the crankcase. This hose will not be reused.

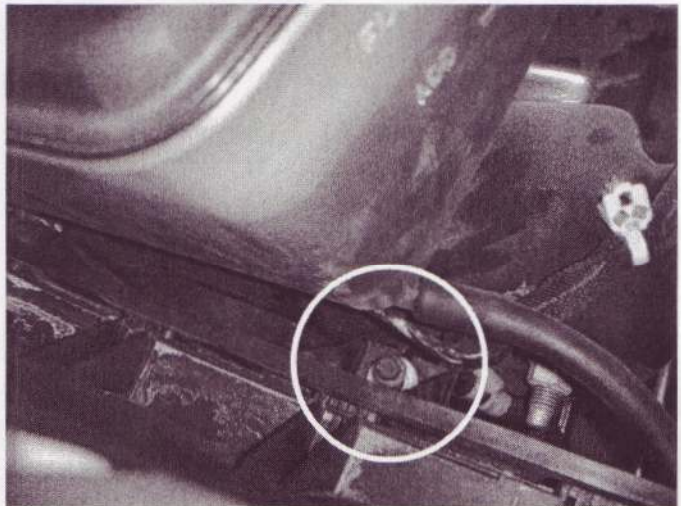

h) There is a bolt located between the coolant reservoir and the air box. Loosen and remove this bolt in order to remove the air box.



INSTALLATION INSTRUCTIONS
COLD AIR INTAKE KIT
2005 JEEP GRAND CHEROKEE 5.7L V8
PART NUMBER P5153374

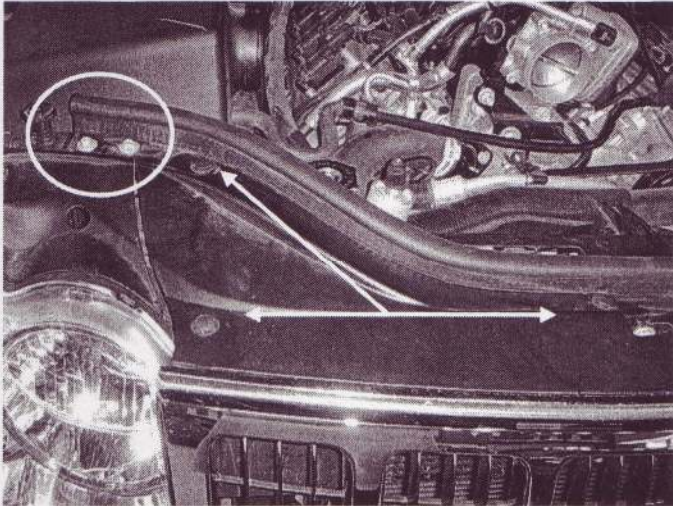

i) Remove tabs front the grill. Loosen and remove the grill mounting bolts.

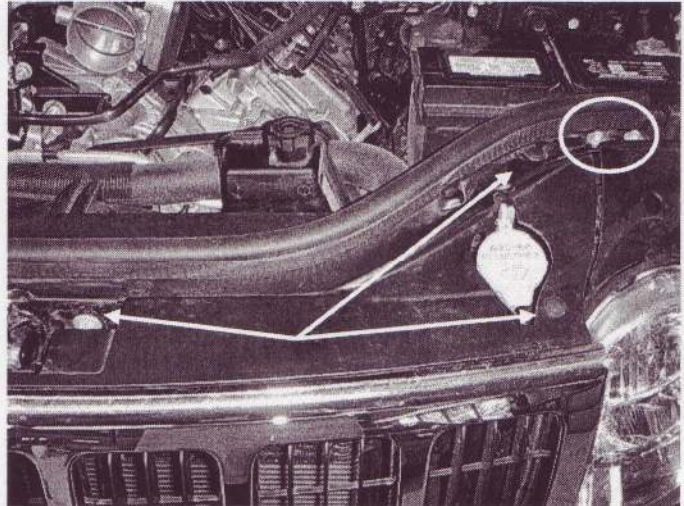

j) Remove tabs on the grill on the opposite side. Loosen and remove the grill mounting bolts.

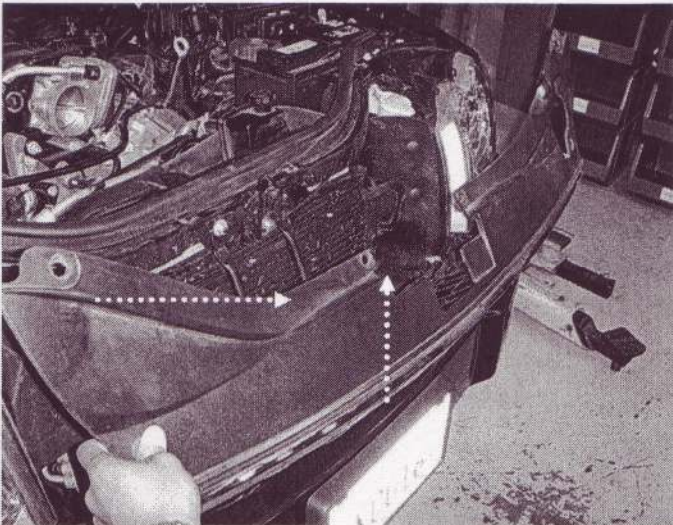

k) With the tabs and remaining mounting hardware removed, pull forward on the grill. Then pull up to remove.

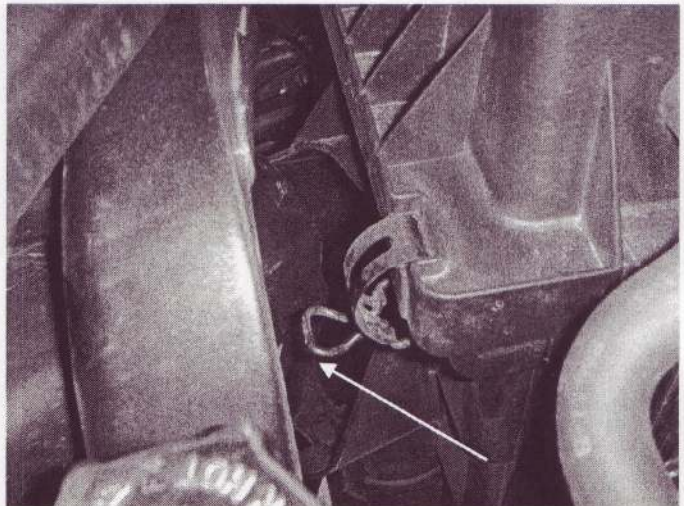

l) Disconnect the air tube on the lower half of the air box by pulling towards the front of the vehicle.



INSTALLATION INSTRUCTIONS
COLD AIR INTAKE KIT
2005 JEEP GRAND CHEROKEE 5.7L V8
PART NUMBER P5153374

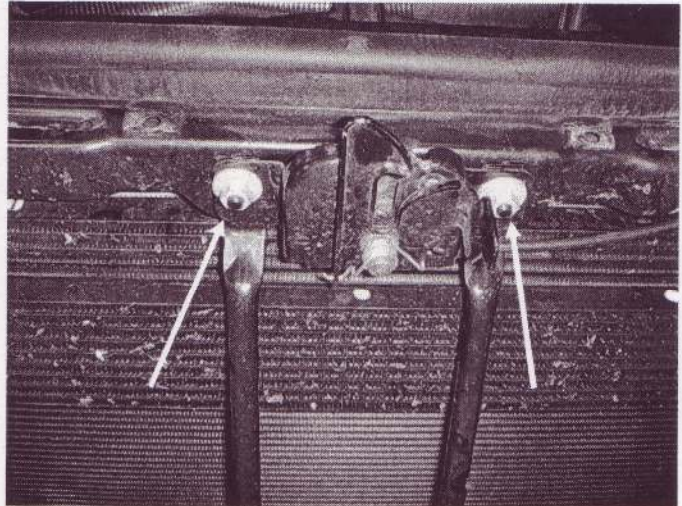
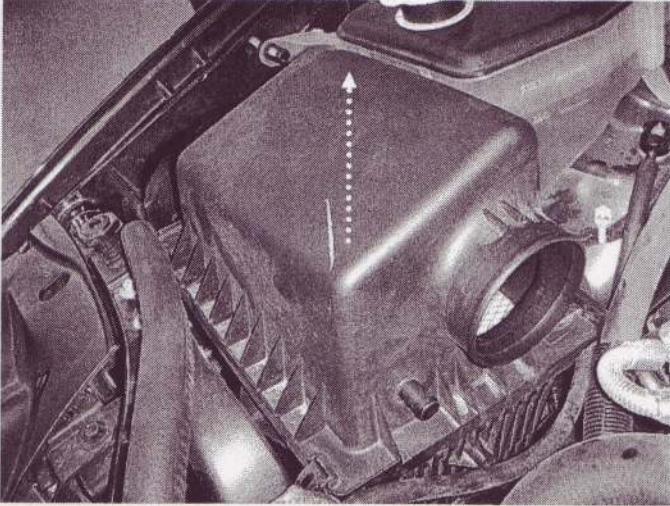

m) Remove air box by pulling straight up.

n) Loosen nuts on the hood latch. Do not remove.

3) Installation of the MOPAR Cold Air Intake System

- a) When installing the MOPAR Cold Air Intake System, DO NOT completely tighten the hose clamps or mounting tab hardware until instructed to do so later in these instructions.

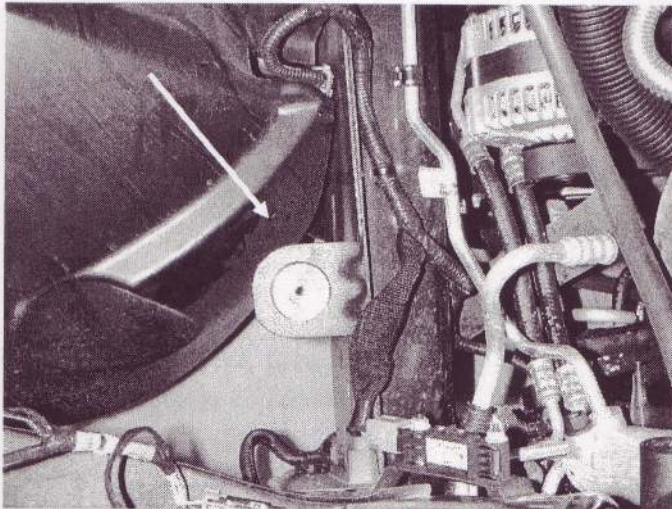

b) Install the supplied spacer. The spacer should seat into the factory air box mounting grommet.

c) Assemble the 1/4" washer and bolt as shown.



INSTALLATION INSTRUCTIONS
COLD AIR INTAKE KIT
2005 JEEP GRAND CHEROKEE 5.7L V8
PART NUMBER P5153374

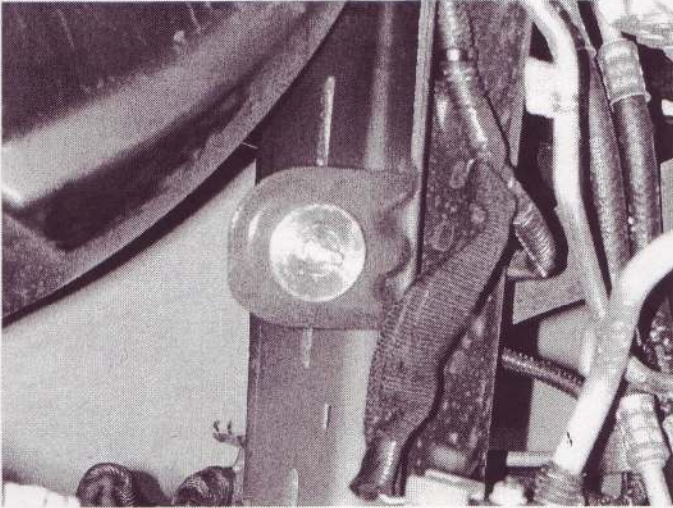

d) Insert the bolt and washer assembly from the previous step. The assembly inserts upward through the spacer. Tighten with supplied nut.

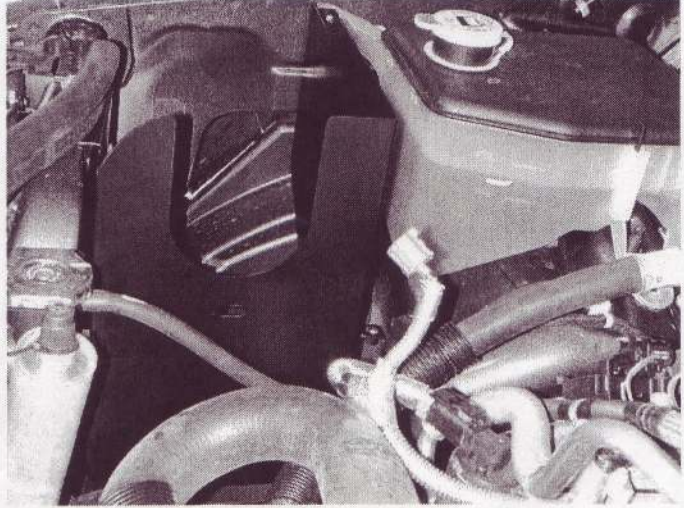

e) Insert heat shield.

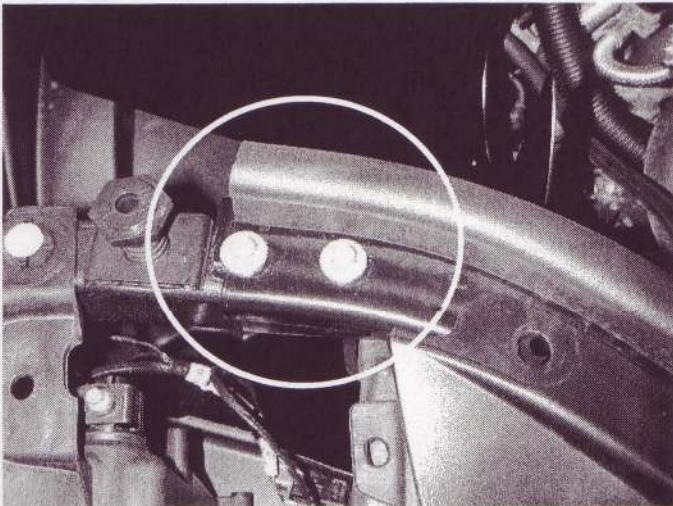

f) The heat shield tab installs under the radiator hood latch support. Secure with factory hardware.

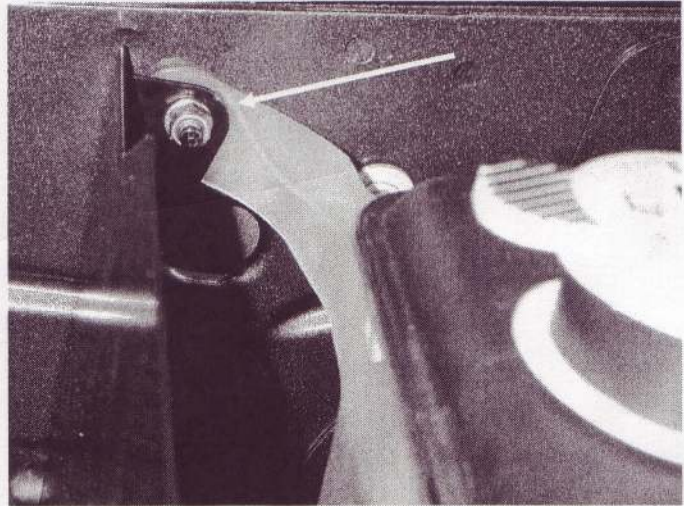

g) Secure tab with supplied M6 washer and M6 Nylok nut.



INSTALLATION INSTRUCTIONS
COLD AIR INTAKE KIT
2005 JEEP GRAND CHEROKEE 5.7L V8
PART NUMBER P5153374

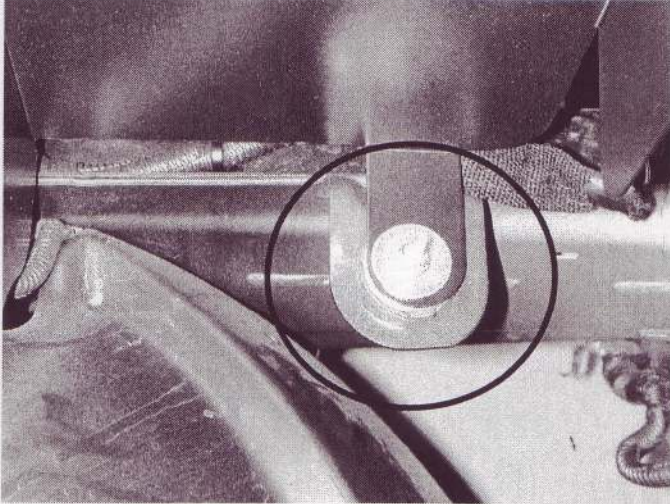

h) Secure the lower tab with supplied washer and 1/4-20 Nylok nut. Check clearance and tighten all heat shield mounting hardware.

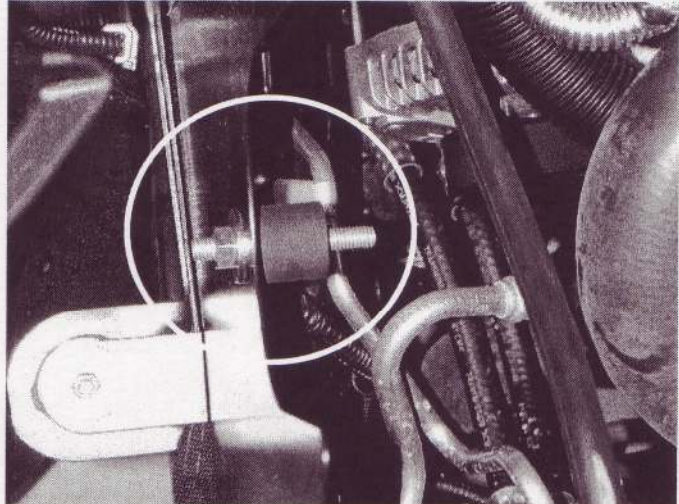

i) Insert the rubber mount and secure in the slot with supplied M8 washer and nut.

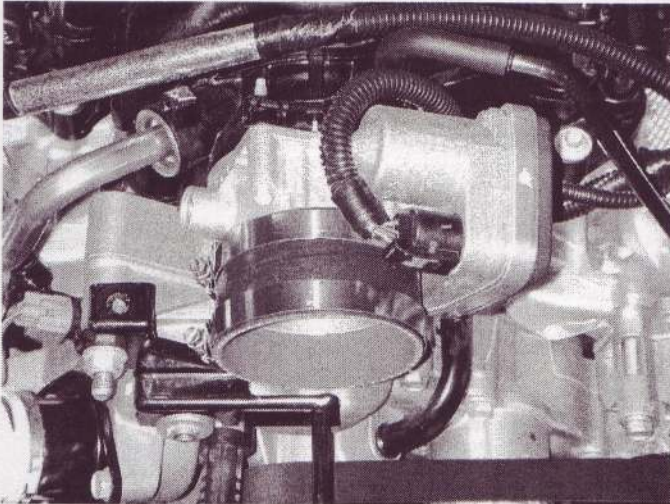

j) Attach coupler to the throttle body. Secure with supplied hose clamps.

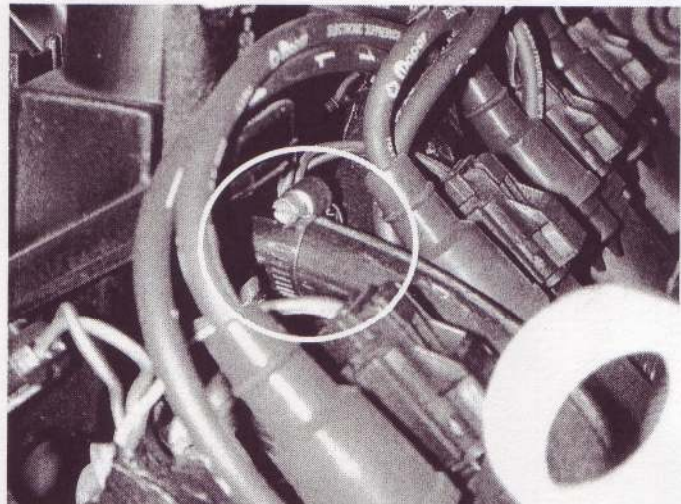

k) Attach breather hose to the factory crankcase vent. Tighten with supplied hose clamp.



INSTALLATION INSTRUCTIONS
COLD AIR INTAKE KIT
2005 JEEP GRAND CHEROKEE 5.7L V8
PART NUMBER P5153374

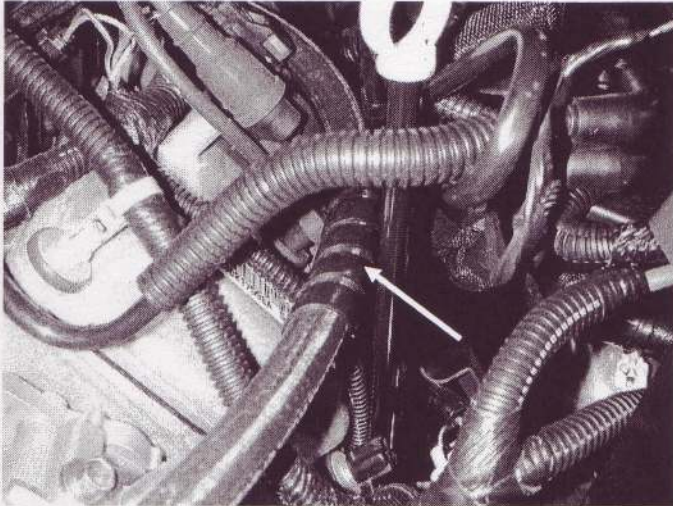

l) Attach the helical bundle wrap to the breather hose where there is contact with the breather hose.

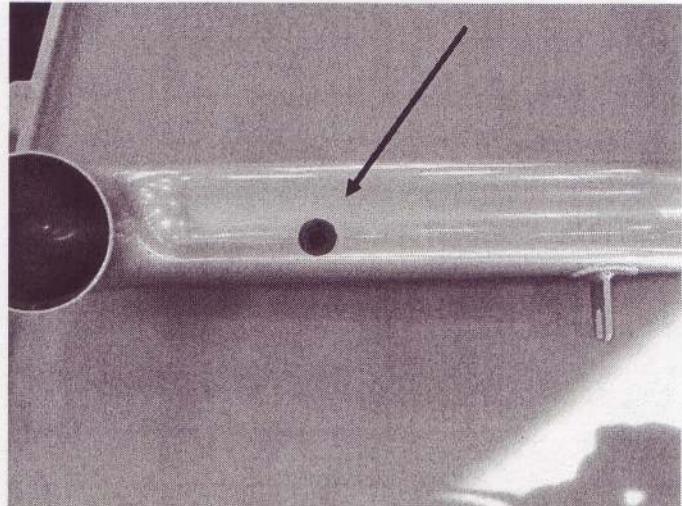

m) Insert rubber grommet into the inlet pipe.



n) Remove O-Ring and reinstall the IAT sensor.



o) Insert inlet pipe as shown.



INSTALLATION INSTRUCTIONS
COLD AIR INTAKE KIT
2005 JEEP GRAND CHEROKEE 5.7L V8
PART NUMBER P5153374

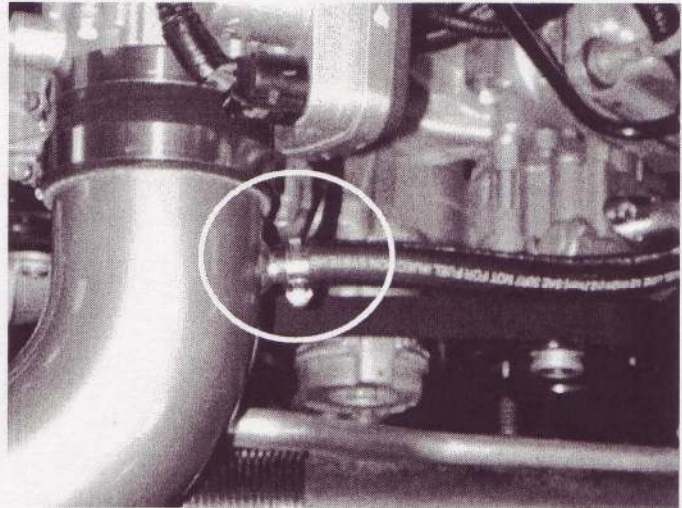

p) Align the inlet pipe mounting bracket to the rubber mount on the heat shield. Check for clearance around the heat shield and secure inlet pipe with supplied M8 washer and nut. See diagram below.

q) Attach breather hose to the inlet pipe. Re-check clearance. Tighten with supplied hose clamp.

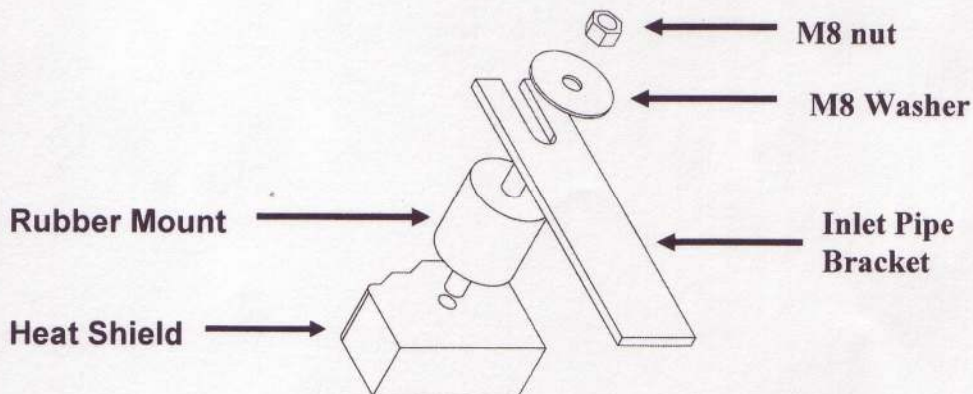



INSTALLATION INSTRUCTIONS
COLD AIR INTAKE KIT
2005 JEEP GRAND CHEROKEE 5.7L V8
PART NUMBER P5153374

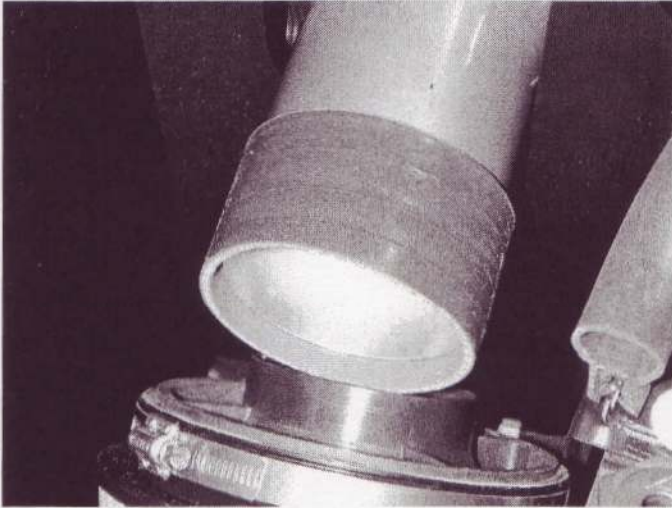

t) Attach coupler to the inlet pipe.

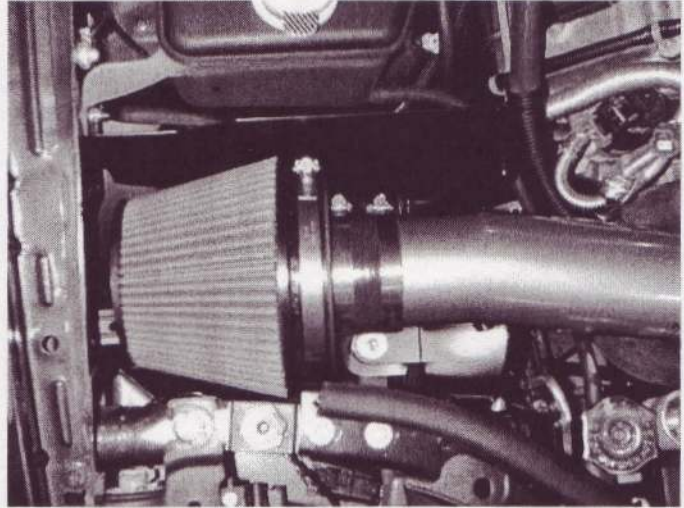

u) Attach filter to the air horn and tighten. Insert air horn into the coupler and secure with supplied hose clamps. Check clearance around the heat shield.

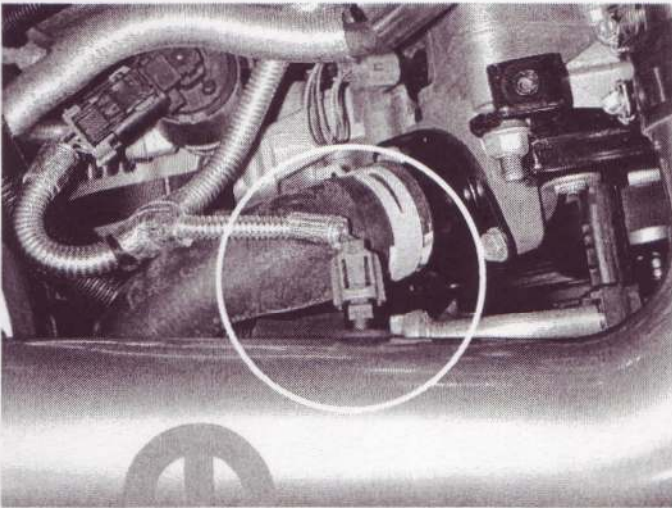

v) Reattach IAT connector.



w) Reinstall engine cover.



INSTALLATION INSTRUCTIONS
COLD AIR INTAKE KIT
2005 JEEP GRAND CHEROKEE 5.7L V8
PART NUMBER P5153374

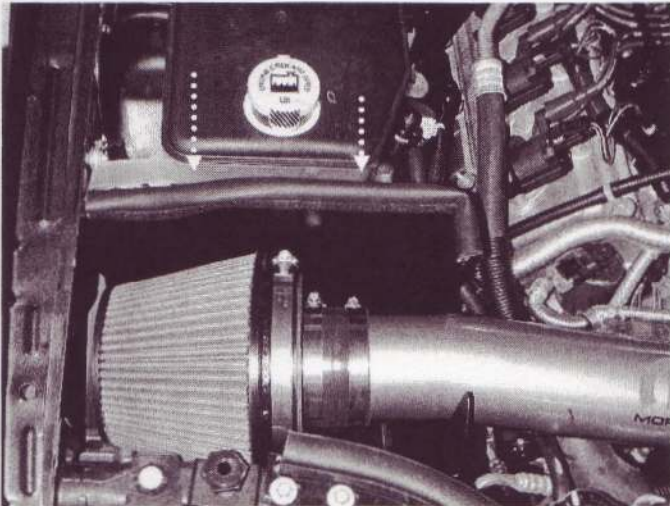

x) Attach foam rubber gasket to the heat shield.

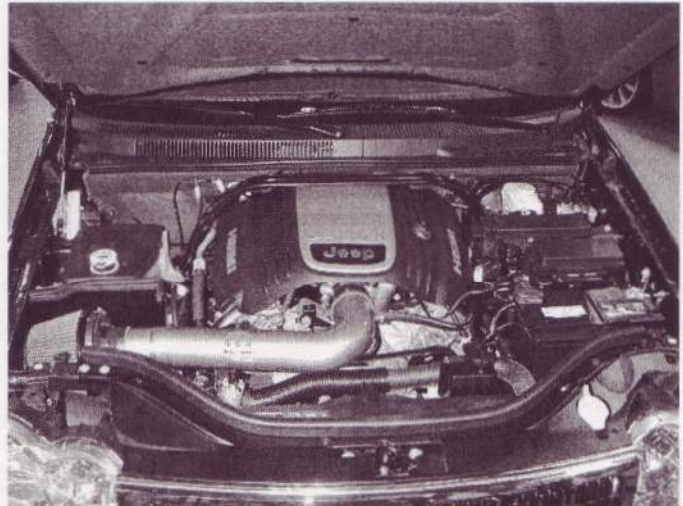

y) Your MOPAR Cold Air System should look like this.

4) Re-assemble the vehicle

- a) Position the filter for best fitment. Be sure that the filter, tube, or any other components do not contact the heat shield or any part of the vehicle.
- b) Tighten all hose clamps.
- c) Tighten the bolts and nuts on the mounting bracket and heat shield.
- d) Inspect the engine bay for any loose tools and check that all fasteners that were moved or removed are tight.
- e) Start engine and perform a final inspection before driving the vehicle.