

JVC

SERVICE MANUAL

CD PORTABLE COMPONENT SYSTEM

PC-X250

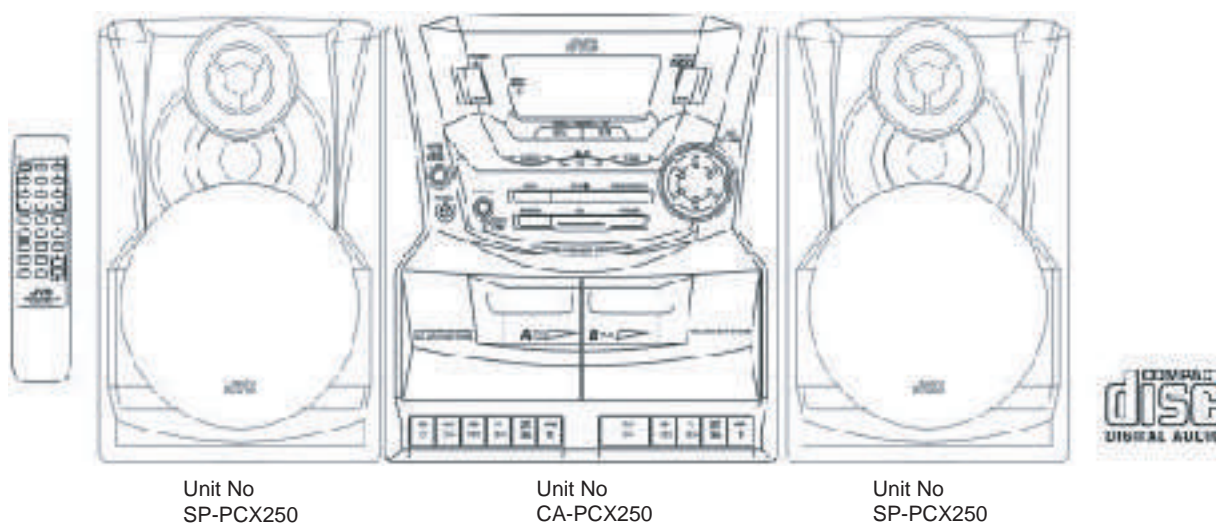

Area Suffix

J --- USA
C --- Canada

Contents

Safety precaution	2	Block/Wiring Diagram	25
Disassembly method	4	Circuit Diagram	27
Adjustment method	6	PCB drawing	29
TOC read	10	Assembly	32
Major IC Description	11	Packing	42

Safety Precautions

1. This design of this product contains special hardware and many circuits and components specially for safety purposes. For continued protection, no changes should be made to the original design unless authorised in writing by the manufacturer. Replacement parts must be identical to those used in the original circuits. Services should be performed by qualified personnel only.
2. Alterations of the design or circuitry of the product should not be made. Any design alterations of the product should not be made. Any design alterations or additions will void the manufacturer's warranty and will further relieve the manufacturer of responsibility for personal injury or property damage resulting therefrom.
3. Many electrical and mechanical parts in the products have special safety-related characteristics. These characteristics are often not evident from visual inspection nor can the protection afforded by them necessarily be obtained by using replacement components rated for higher voltage, the Parts List of Service manual. Electrical components having such features are identified by the shading on the schematics and by (!) on the parts List in the Service Manual. The use of a substitute replacement which does not have the same safety characteristics as the recommended replacement parts shown in the Parts List of Service manual may create shock, fire, or other hazards.
4. The leads in the products are routed and dressed with ties, clamps, tubing's, barriers and the like to be separated from live parts, high temperature parts, moving parts and/or sharp edges for the prevention of electric shock and fire hazard. When service is required, the original lead routing and dress should be observed, and it should be confirmed that they have been returned to normal, after re-assembling.
5. Leakage current check (Electrical Shock hazard testing)
After re-assembling the product, always perform an isolation check on the exposed metal parts of the product (antenna terminals, knobs, metal cabinet, screw heads, headphone jack, control shafts, etc.) to be sure the product is safe to operate without danger of electrical shock.

Do not use a line isolation transformer during this check.

Plug the AC line cord directly into the AC outlet. Using a "Leakage Current Tester", measure the leakage current from each exposed metal part of the cabinet, particularly any exposed metal part having a return path to the chassis, to a known good earth ground. Any leakage current must not exceed 0.5mA AC (r.m.s.)

Alternate check method

Plug the AC line cord directly into the AC outlet. Use an AC voltmeter having 1,000 ohms per volt or more sensitivity in the following manner. Connect a 1,500 ohm 10W resistor paralleled by a 0.15µF AC-type capacitor between an exposed metal part and a known good earth ground.

Measure the AC voltage across the resistor with the AC voltmeter.

Move the resistor connection to each exposed metal part, particularly any exposed metal part having a return path to the chassis and measure the AC voltage across the resistor. Now, reverse the plug in the AC outlet and repeat each measurement. Voltage measured Any must not exceed 0.75 V AC (r.m.s.). This corresponds to 0.5 mA AC (r.m.s.).

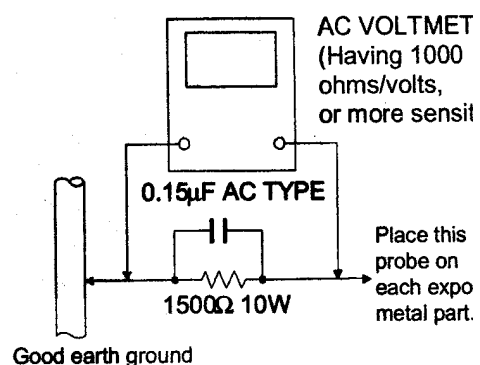

Warning

1. This equipment has been designed and manufactured to meet international safety standards.
2. It is the legal responsibility of the repairer to ensure that these safety standards are maintained.
3. repairs must be made in accordance with the relevant safety standards.
4. It is essential that safety critical components are replaced by approved parts.
5. If mains voltage selector is provided, check setting for local voltage.

CAUTION Burrs formed during moulding may be left over on some parts of the chassis. Therefore, pay attention to such burrs in the case of performing repair of this system.

Preventing static electricity

Electrostatic discharge (ESD), which occurs when static electricity stored in the body, fabric, etc. is discharged, can destroy the laser diode in the traverse unit (optical pickup). Take care to prevent this when performing repairs.

1.1. Grounding to prevent damage by static electricity

Static electricity in the work area can destroy the optical pickup (laser diode) in devices such as DVD players. Be careful to use proper grounding in the area where repairs are being performed.

1.1.1. Ground the workbench

1. Ground the workbench by laying conductive material (such as a conductive sheet) or an iron plate over it before placing the traverse unit (optical pickup) on it.

1.1.2. Ground yourself

1. Use an anti-static wrist strap to release static electricity built up in your body.

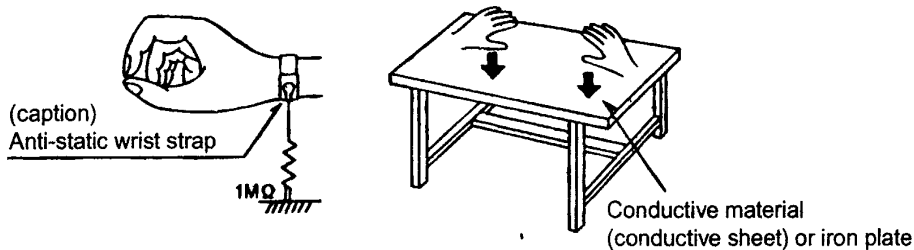

1.1.3. Handling the optical pickup

1. In order to maintain quality during transport and before installation, both sides of the laser diode on the replacement optical pickup are shorted. After replacement, return the shorted parts to their original condition. (Refer to the text.)
2. Do not use a tester to check the condition of the laser diode in the optical pickup. The tester's internal power source can easily destroy the laser diode.

1.2. Handling the traverse unit (optical pickup)

1. Do not subject the traverse unit (optical pickup) to strong shocks, as it is a sensitive, complex unit.
2. Cut off the shorted part of the flexible cable using nippers, etc. after replacing the optical pickup. For specific details, refer to the replacement procedure in the text. Remove the anti-static pin when replacing the traverse unit. Be careful not to take too long a time when attaching it to the connector.
3. Handle the flexible cable carefully as it may break when subjected to strong force.
4. It is not possible to adjust the semi-fixed resistor that adjusts the laser power. Do not return it.

Disassembly method

■ Removing the rear panel

1. From behind the body, remove the Five screws **A** retaining the rear panel.
2. Then remove the Two screws **B** retaining the bottom of rear panel.
3. Take out the rear panel from the body.

Note:

Be careful of the FM antenna white wire, it is connection with the tuner PCB up side.
You can directly take out from the tuner PCB.

When you re-assembly the product, plug the FM antenna white wire into the Tuner PCB's "FM ANT" position.

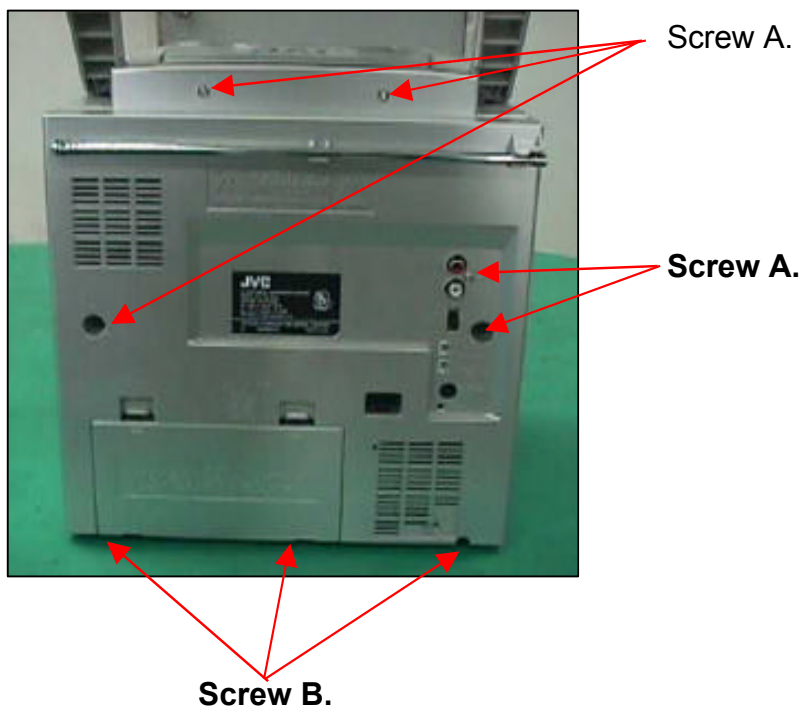

■ Removing the Audio Board

1. Open & remove the rear panel
2. Remove the Connector CN201, CN202, CN203, CN405, CN502, CN801 & CN301 on the Audio Board.
3. Remove the two Screws **C** retaining the Audio Board.

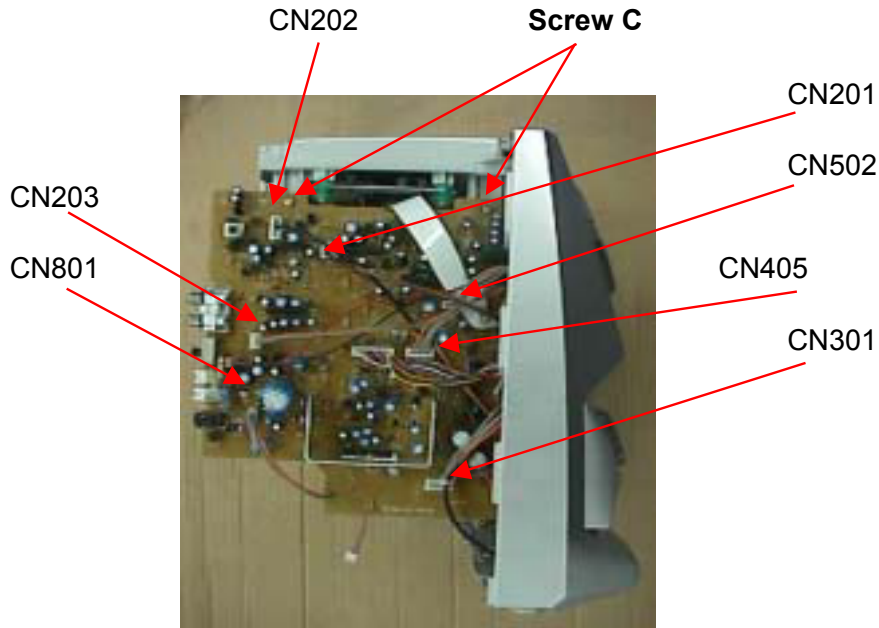

■ Removing the CD Mechanism

- 1 Open & remove the rear panel
- 2 Remove the Audio PCB
- 3 Remove the Two Screws **D** retaining the CD Tray Backet.

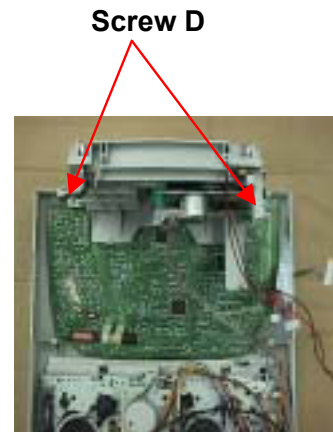

■ Removing the Tuner PCB

- 1 Open & remove the rear panel.
- 2 Remove the Audio PCB.
- 3 Remove CD mechanism.
- 4 Remove the Eight Screws **E** retaining on the Tuner Board.

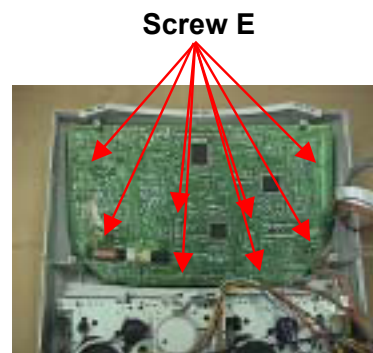

Adjustment method

■ Measurement instruments required for adjustment

- 1 Low frequency oscillator
This oscillator should have a capacity to output 0dBs to 600 at an oscillation frequency of 50Hz-20KHz
- 2 Electronic voltmeter
- 3 Distortion meter
- 4 Frequency counter
- 5 Wow & flutter meter
- 6 Test tape
TCC-112 : Tape speed and running unevenness (3KHz)
TCC-140 : Reference level (1KHz)
TCC-182A : Head angle (8KHz) , playback frequency characteristics (1KHz) and dubbing frequency characteristics (125Hz and 8KHz)
Because of frequency - mixed tape with 63 , 1 , 10 and 14KHz (250nWb/m -24dB) , use this tape together with a filter .
- 7 Black tape
TYPE I : AC - 225
TYPE II : AC - 514
- 8 Torque gauge : For play and back tension
FWD(TW2111A) , REV(TW2121a) and FF/REW(TW2231A)

■ Measurement conditions

Power supply voltage ----- AC 120V (60Hz)
Reference output ----- Speaker : 0.866V/3
Headphone : 0.245V/32
Reference frequency and ----- 1KHz , AUX : 450~500mV input level
Input for confirming recording and ----- AUX : -28dBs playback characteristics
Measurement output terminal ----- Speaker J3002
* Load resistance ----- 3

■ Radio Input signal

AM frequency ----- 400Hz
AM modulation ----- 30%
FM frequency ----- 1 KHz
FM frequency deviation ----- 22.5KHz

● Tuner section

Voltage applied to tuner ----- +B:DC 4.9V
VT:DC 12V
Reference measurement ----- 26.1mV(0.28V)/3 output
Input positions ----- AM : Standard loop antenna
FM : TP1 (hot) and TP2 (GND)

● Standard measurement position of volume

Bass ----- Off
Active hoper bass pro ----- Off
Up and down adjustment of volume ----- Vol : 23

Precautions for measurement

- 1 Apply 30PF and 33 Kohm to the IF sweeper output side and 0.082UF and 100 Kohm in series to the sweeper input side .
- 2 The IF sweeper output level should be made as low as possible within the adjustable range .
- 3 Since the IF sweeper is a fixed device , there is no need to adjust this sweeper .
- 4 Since a ceramic oscillator is used , there is no need to perform any MIX adjustment .
- 5 Since a fixed coil is used , there is no need to adjust the FM tracking .
- 6 The input and output earth systems are separated . In case of simultaneously measuring the voltage in both of the input and output systems with an electronic voltmeter for two channels , therefore , the earth should be connected particularly carefully .
- 7 In the case of BTL connection amp . , the minus terminal of speaker is not for earthing . Therefore , be sure not to connect any other earth terminal to this terminal . This system is of an BTL system .
- 8 For connecting a dummy resistor when measuring the output , use the wire with a greater code size .
- 9 Whenever any mixed tape is used , use the band pass filter (DV-12V)

TAPE DECK ADJUSTMENTS

1 HEAD AZIMUTH ADJUSTMET

- (1) Load the test tape TCC-182A 8KHz for azimuth adjustment.
- (2) Press the PLAY button.
- (3) Use a cross-tip screwdriver to turn the screw for azimuth adjustment so that the left and right output are maximized
- (4) Press the STOP button
- (5) After completion of the adjustment. Use thread lock(TB-1401B) to secure the azimuth-adjustment screw.

2 AC BIAS FREQUENCY ADJUSTMENTS

- (1) Connect frequency counter to CN202(BS);
- (2) R/P swith in recording state;
- (3) Adjusting T801 use a plastic screwdriver, AC bias frequency ;61kHz +/- 1kHz..

3 TAPE SPEED ADJUSTMENT

- (1) Insert the test tape(MTT-111N,3,000 HZ)
- (2) Press the PLAY button.
- (3) Use a flat-tip screwdriver to turn the VR 501.

Adjust VR501 so that the frequency counter become 3,000Hz

TAPE HEAD AND SPEED ADJUSTMENT DIAGRAM

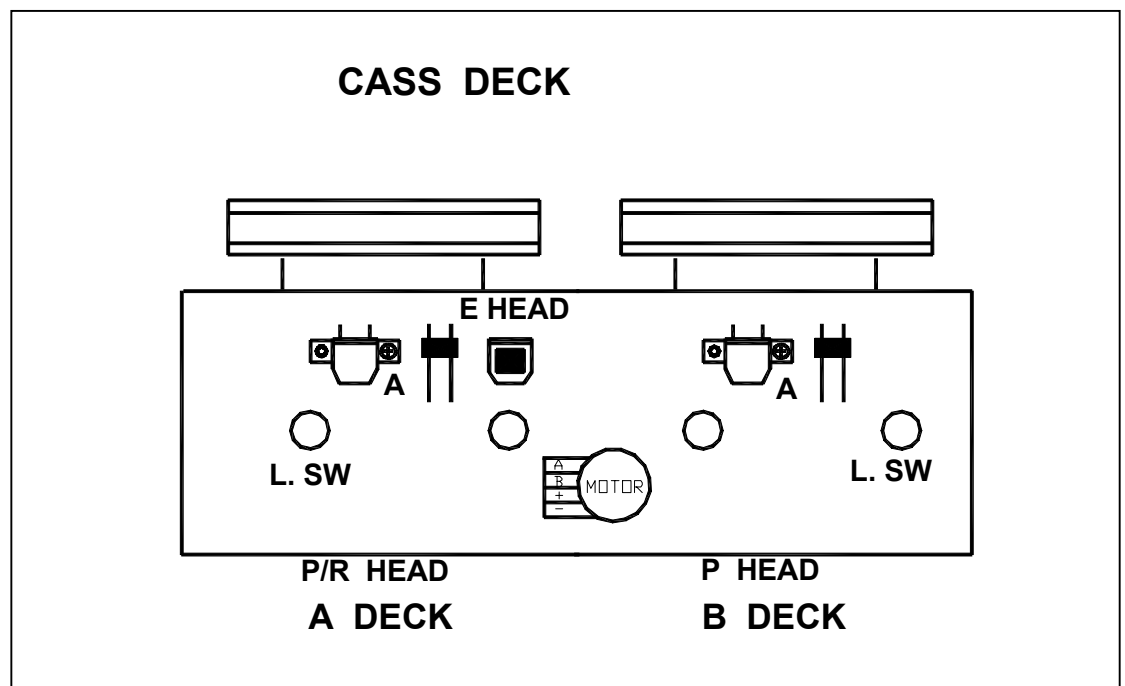

■ Tape recorder section

Items	Measurement conditions	Measurement method	Standard Values	Adjusting] positions
Confirmation of head angle	Test tape :TA-182A(8KHz) Measurement output terminal :Speaker terminal Sperker R (Load resistance:3) :Headphone terminal	1 Playback the test tape TCC-182A (8KHz) 2 With the recording & playback mechanism, adjust the head azimuth screw so that the left and right output levers become maximum, After adjustment, lock the head azimuth at least by half turn.	Maximum output	Adjust the head azimuth screw only when the head has been changed
Confirmation of tape speed	Test tape :TCC-112(3000Hz) Measurement output terminal :Headphone terminal	Adjust VR501 so that the frequency counter reading becomes 3,010Hz +/-15Hz when playing back the test tape TCC-112 (3000Hz) with playback and recording mechanism after ending forward winding if the taoe.	Tape speed of deck :3,010Hz +/-15Hz	VR501

■ Reference Values for Confirmation Items

ITEMS	Measurement conditions	Measurement method	Standard Values	Adjusting] positions
Wow & flutter	Test tape :TCC-112(3000Hz) Measurement outut terminal :Headphone terminal	When the test tape TCC-112 (3000Hz) has been played back with the recording and playback mecganism at the beginning of forward winding, the frequency counter reading of wow & flutter should be 0.25% or less (WRMS).	0.25% or less (WRMS)	

■ Electrical Performance

ITEMS	Measurement conditions	Measrrnment method	Standard Values	Adjusting positions
Adjustment of recording bias current (Reference Value)	Mode:Forward or reverse mode Recording mode Test tape TDK-60 Measurement output terminal :Both recording and headphone terminals	1 With the recording and playback mechanism, load thd test tapes TDK-60 , and set the mechanism to the recording and pausing condition in advance . 2 After connecting 100 in series to the recorder head, measure the bias current with a valve voltmeter at both of the terminals	4.5 A +/-0.5 A	

Adjustment of recording and playback frequency characteristics	Reference frequency :1KHz and 8KHz (REF.: -20dB) Test tape TDK-60 Measurement input terminal :OSC IN	1 with the recording and playback mechanism, load the test tapes (TDK-60) and set the mechanism to the recording and pausing condition in advance 2 While repetitively inputting the reference frequency signal of 1KHz and 10KHz from OSC IN, record and playback the tape.	Output deviation between 1KHz and 8KHz :-1dB +/-2dB	
--	--	---	--	--

■ Reference Values for Electrical Function Confirmation Items

Items	Measurement conditions	Measrrnment method	Standard Values	Adjusting positions
Recording bias frequency	Forward or reverse Test tape TDK-60 Measurement terminal : BIAS TP on P.C. board	1 While changing over to and form BIAS 1 and 2, confirm that the frequency is changed 2 With the recording and playback mechanism, load the test tape. (TDK-60) , and set the mechanism to the recording and pausing condition in advance. 3 Confirm that the BIAS TP frequency on the P.C. board is 61KHz +/-1KHz	61KHz +/-1KHz	

Flow of functional operation until TOC read

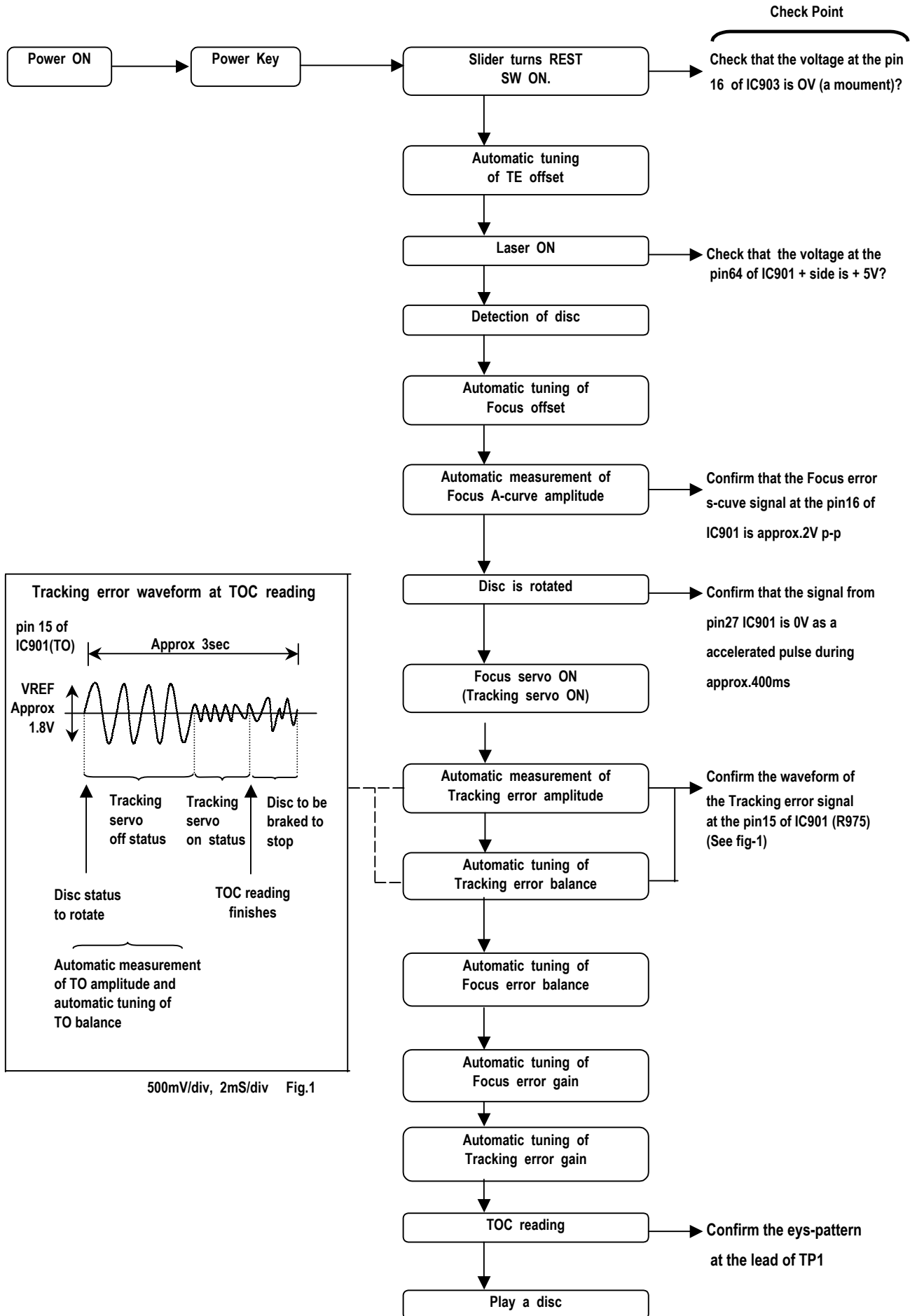

Description of major ICs
LC587008

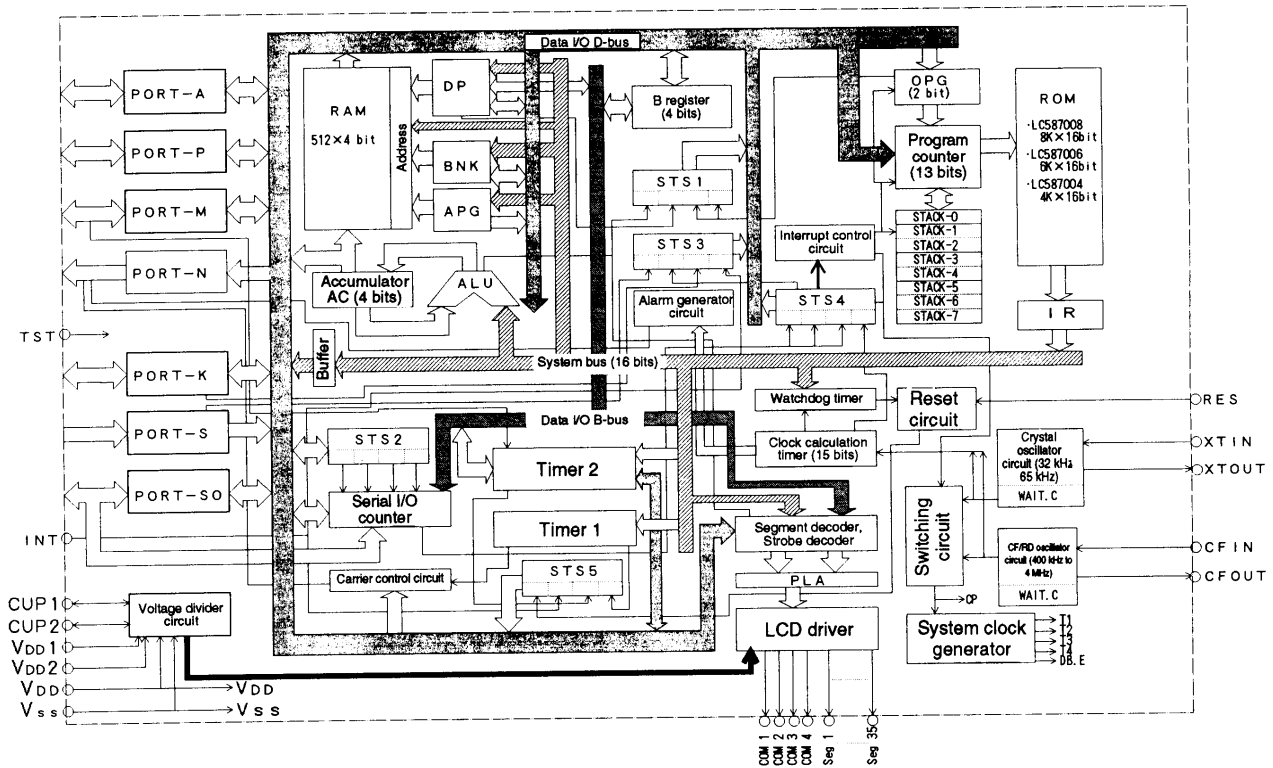

System Block Diagram for the LC587008, LC587006 and LC587004

- | | | | |
|------|---------------------------|---------|--|
| RAM: | Data memory | IR: | Instruction register |
| ROM: | Program memory | STS1: | Status register 1 |
| DP: | Data pointer register | STS2: | Status register 2 |
| BNK: | Bank register | STS3: | Status register 3 |
| APG: | RAM page flags | STS4: | Status register 4 |
| AC: | Accumulator | STS5: | Status register 5 |
| ALU: | Arithmetic and logic unit | PLA: | Segment data and strobe programmable logic array |
| B: | B register | WAIT.C: | Waiting time counter |
| OPG: | ROM page flag | | |
| PC: | Program counter | | |

LC72131 Block Diagram

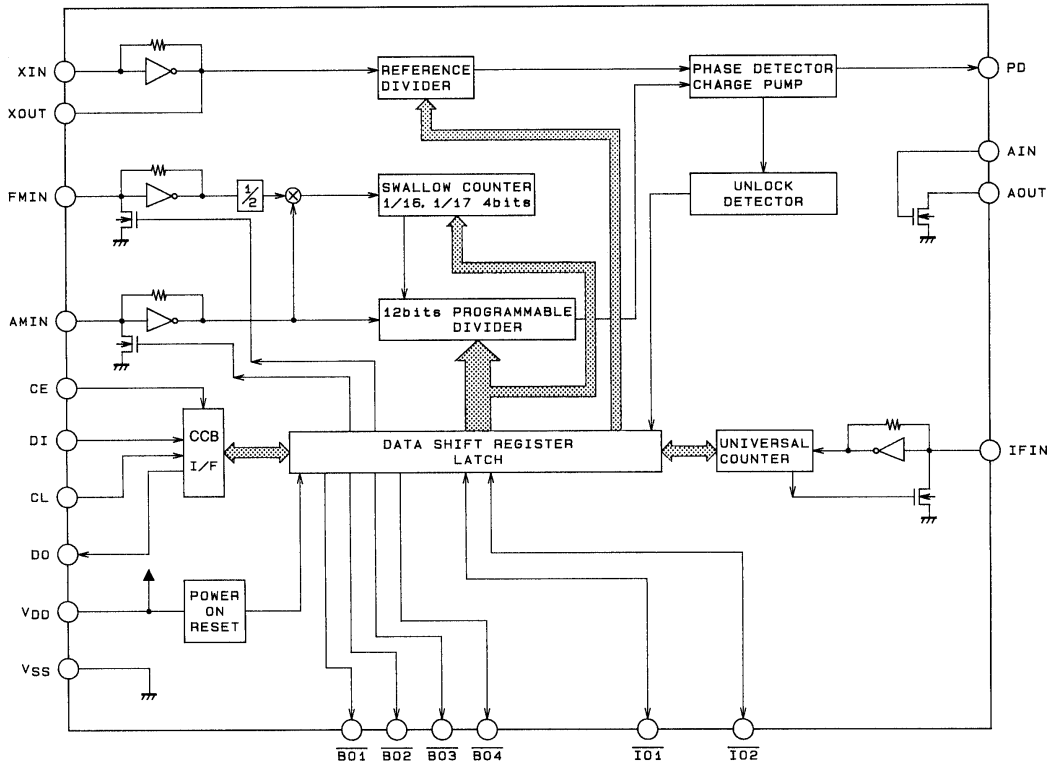

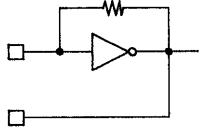
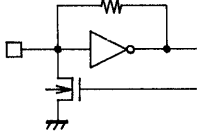
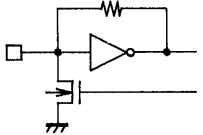

A02597

LC72131 Pin Functions

Symbol	Pin No. (MFP pin Nos. are in parentheses.)	Type	Functions	Circuit configuration
XIN XOUT	1 (1) 22 (20)	Xtal OSC	¥ Crystal resonator connection (4.5/7.2 MHz)	 A02598
FMIN	16 (14)	Local oscillator signal input	¥ FMIN is selected when the serial data input DVS bit is set to 1. ¥ The input frequency range is from 10 to 160 MHz. ¥ The input signal passes through the internal divide-by- two prescaler and is input to the swallow counter. ¥ The divisor can be in the range 272 to 65535. However, since the signal has passed through the divide-by-two prescaler, the actual divisor is twice the set value.	 A02599
AMIN	15 (13)	Local oscillator signal input	¥ AMIN is selected when the serial data input DVS bit is set to 0. ¥ When the serial data input SNS bit is set to 1: Ñ The input frequency range is 2 to 40 MHz. Ñ The signal is directly input to the swallow counter. Ñ The divisor can be in the range 272 to 65535, and the divisor used will be the value set. ¥ When the serial data input SNS bit is set to 0: Ñ The input frequency range is 0.5 to 10 MHz. Ñ The signal is directly input to a 12-bit programmable divider. Ñ The divisor can be in the range 4 to 4095, and the divisor used will be the value set.	 A02599
CE	3 (2)	Chip enable	Set this pin high when inputting (DI) or outputting (DO) serial data.	
CL	5 (4)	Clock	¥ Used as the synchronization clock when inputting (DI) or outputting (DO) serial data.	
DI	4 (3)	Data input	¥ Inputs serial data transferred from the controller to the LC72131.	
DO	6 (5)	Data output	¥ Outputs serial data transferred from the LC72131 to the controller. The content of the output data is determined by the serial data DOC0 to DOC2.	
V _{DD}	17 (15)	Power supply	¥ The LC72131 power supply pin (V _{DD} = 4.5 to 5.5 V) ¥ The power on reset circuit operates when power is first applied.	

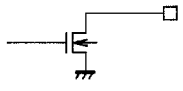
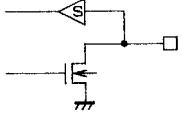
LC72131 Pin Functions

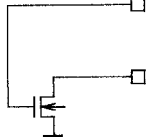
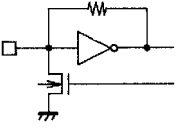
Symbol	Pin No. (MFP pin Nos. are in parentheses.)	Type	Functions	Circuit configuration
V _{SS}	21 (19)	Ground	<p>¥ The LC72131 ground</p>	
$\overline{BO1}$ $\overline{BO2}$ $\overline{BO3}$ $\overline{BO4}$	7 (6) 8 (7) 9 (8) 10 (9)	Output port	<p>¥ Dedicated output pins</p> <p>¥ The output states are determined by $\overline{BO1}$ to $\overline{BO4}$ bits in the serial data. Data: 0 = open, 1 = low</p> <p>¥ A time base signal (8 Hz) can be output from the $\overline{BO1}$ pin. (When the serial data TBC bit is set to 1.)</p> <p>¥ Care is required when using the $\overline{BO1}$ pin, since it has a higher on impedance than the other output ports (pins $\overline{BO2}$ to $\overline{BO4}$).</p> <p>¥ All output ports are set to the open state following a power on reset.</p>	 <p style="text-align: right;">A02601</p>
$\overline{IO1}$ $\overline{IO2}$	11 (10) 13 (12)	I/O port	<p>¥ I/O dual-use pins</p> <p>¥ The direction (input or output) is determined by bits IOC1 and IOC2 in the serial data. Data: 0 = input port, 1 = output port</p> <p>¥ When specified for use as input ports: The state of the input pin is transmitted to the controller over the DO pin. Input state: low = 0 data value high = 1 data value</p> <p>¥ When specified for use as output ports: The output states are determined by the IO1 and IO2 bits in the serial data. Data: 0 = open, 1 = low</p> <p>¥ These pins function as input pins following a power on reset.</p>	 <p style="text-align: right;">A02602</p>
PD	18 (16)	Charge pump output	<p>¥ PLL charge pump output</p> <p>When the frequency generated by dividing the local oscillator frequency by N is higher than the reference frequency, a high level is output from the PD pin. Similarly, when that frequency is lower, a low level is output. The PD pin goes to the high impedance state when the frequencies match.</p>	 <p style="text-align: right;">A02603</p>
AIN AOUT	19 (17) 20 (18)	LPF amplifier transistor	<p>¥ The n-channel MOS transistor used for the PLL active low-pass filter.</p>	 <p style="text-align: right;">A02604</p>
IFIN	12 (11)	IF counter	<p>¥ Accepts an input in the frequency range 0.4 to 12 MHz.</p> <p>¥ The input signal is directly transmitted to the IF counter.</p> <p>¥ The result is output starting the MSB of the IF counter using the DO pin.</p> <p>¥ Four measurement periods are supported: 4, 8, 32, and 64 ms.</p>	 <p style="text-align: right;">A02599</p>

LC75342 Pin Assignment

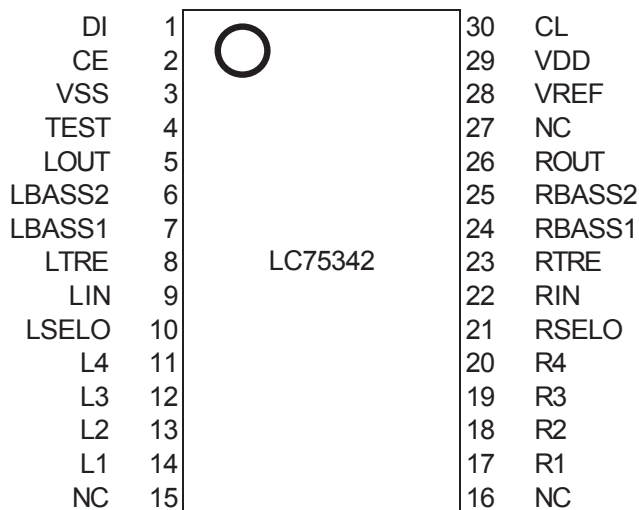

TOP VIEW

LC75342 Pin Functions.

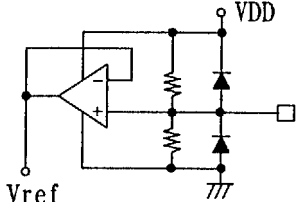
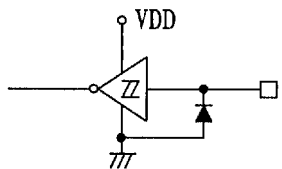
Pin No.	Pin	Description	Notes
28	Vref	<p>¥ Connection to the $0.5 \times V_{DD}$ voltage generator circuit used as the analog signal ground.</p> <p>Applications must connect a capacitor of about $10 \mu\text{F}$ between this pin and V_{SS} to exclude power supply ripple.</p>	
3	V_{SS}	¥ Ground	
29	V_{DD}	¥ Power supply	
2	CE	<p>¥ Chip enable</p> <p>Data is written to the internal latch when this pin goes from high to low. The internal analog switches operate at this point. Data transfer is enabled when this pin is high.</p>	
1 30	DI CL	¥ Serial data and clock inputs used for IC control.	
4	V_{SS}	<p>¥ Electronic volume and tone control testing</p> <p>This pin must be tied to V_{SS} during normal operation.</p>	
15 16 27	NC	<p>¥ Unused.</p> <p>These pins must be left open or connected to V_{SS} during normal operation.</p>	

LC75342 Pin Functions

Pin No.	Pin	Description	Notes
14 13 12 11 17 18 19 20	L1 L2 L3 L4 R1 R2 R3 R4	¥ Input signal connections	
10 21	LSEL0 RSEL0	¥ Input selector outputs	
7 6 24 25	LBASS1 LBASS2 RBASS1 RBASS2	¥ Connections for the resistors and capacitors that form the bass band filters.	
9 22	LIN RIN	¥ Volume control and equalizer input	
5 26	LOUT ROUT	¥ Volume and equalizer outputs	
8 23	LTRE RTRE	¥ Connections for the capacitors that form the treble band filters.	

LC78622 Pin Assignment

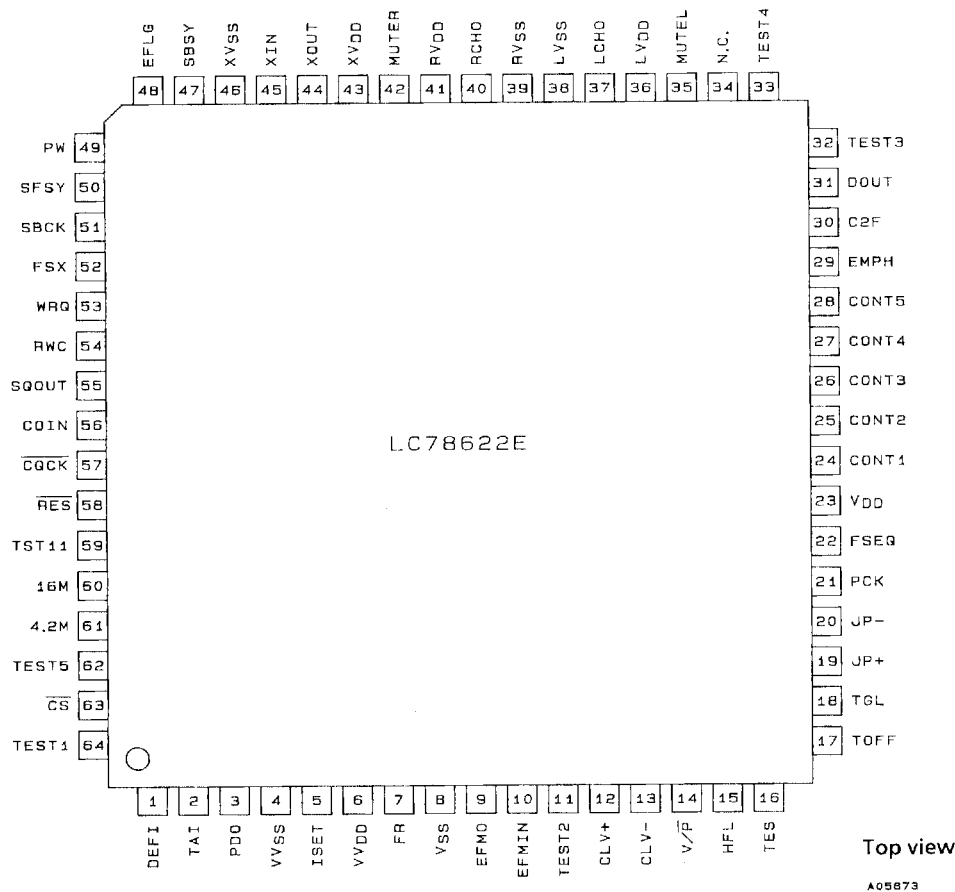

LC78622 Pin Function

Pin No.	Symbol	I/O	Function
51	SBCK	I	Subcode readout clock input. This is a Schmitt input. (Must be connected to 0 V when unused.)
52	FSX	O	Output for the 7.35 kHz synchronization signal divided from the crystal oscillator
53	WRQ	O	Subcode Q output standby output
54	RWC	I	Read/write control input. This is a Schmitt input.
55	SQOUT	O	Subcode Q output
56	COIN	I	Command input from the control microprocessor
57	CQCK	I	Input for both the command input clock and the subcode readout clock. This is a Schmitt input.
58	RES	I	Chip reset input. This pin must be set low briefly after power is first applied.
59	TST11	O	Test output. Leave open. (Normally outputs a low level.)
60	16M	O	16.9344 MHz output.
61	4.2M	O	4.2336 MHz output
62	TEST5	I	Test input. A pull-down resistor is built in. Must be connected to 0 V.
63	CS	I	Chip select input. A pull-down resistor is built in. Must be connected to 0 V if not controlled.
64	TEST1	I	Test input. No pull-down resistor. Must be connected to 0 V.

Note: The same potential must be supplied to all power supply pins, i.e., V_{DD}, VV_{DD}, LV_{DD}, RV_{DD}, and XV_{DD}.

PC-X250

LC78622 Pin Functions

Pin No.	Symbol	I/O	Function	
1	DEFI	I	Defect detection signal (DEF) input. (Must be connected to 0 V when unused.)	
2	TAI	I	PLL pins	Test input. A pull-down resistor is built in. Must be connected to 0 V.
3	PDO	O		External VCO control phase comparator output
4	VV _{SS}	Ⓜ		Internal VCO ground. Must be connected to 0 V.
5	ISET	AI		PDO output current adjustment resistor connection
6	VV _{DD}	Ⓜ		Internal VCO power supply
7	FR	AI		VCO frequency range adjustment
8	V _{SS}	Ⓜ		Digital system ground. Must be connected to 0 V.
9	EFMO	O	Slice level control	EFM signal output
10	EFMIN	I		EFM signal input
11	TEST2	I	Test input. A pull-down resistor is built in. Must be connected to 0 V.	
12	CLV ⁺	O	Disc motor control output.	
13	CLV [Ⓜ]	O	Three-value output is also possible when specified by microprocessor command.	
14	V [Ⓜ] / _P	O	Rough servo/phase control automatic switching monitor output. Outputs a high level during rough servo and a low level during phase control.	
15	HFL	I	Track detection signal input. This is a Schmitt input.	
16	TES	I	Tracking error signal input. This is a Schmitt input.	
17	TOFF	O	Tracking off output	
18	TGL	O	Tracking gain switching output. Increase the gain when low.	
19	JP ⁺	O	Track jump output.	
20	JP [Ⓜ]	O	Three-value output is also possible when specified by microprocessor command.	
21	PCK	O	EFM data playback clock monitor. Outputs 4.3218 MHz when the phase is locked.	
22	FSEQ	O	Synchronization signal detection output. Outputs a high level when the synchronization signal detected from the EFM signal and the internally generated synchronization signal agree.	
23	V _{DD}	Ⓜ	Digital system power supply.	
24	CONT1	I/O	General-purpose I/O pin 1	Controlled by serial data commands from the microprocessor. Any of these that are unused must be either set up as input ports and connected to 0 V, or set up as output ports and left open.
25	CONT2	I/O	General-purpose I/O pin 2	
26	CONT3	I/O	General-purpose I/O pin 3	
27	CONT4	I/O	General-purpose I/O pin 4	
28	CONT5	I/O	General-purpose I/O pin 5	
29	EMPH	O	De-emphasis monitor pin. A high level indicates playback of a de-emphasis disk.	
30	C2F	O	C2 flag output	
31	DOUT	O	Digital output. (EIAJ format)	
32	TEST3	I	Test input. A pull-down resistor is built in. Must be connected to 0 V.	
33	TEST4	I	Test input. A pull-down resistor is built in. Must be connected to 0 V.	
34	N.C.	Ⓜ	Unused. Must be left open.	
35	MUTEL	O	Left channel one-bit D/A converter	Left channel mute output
36	LV _{DD}	Ⓜ		Left channel power supply
37	LCHO	O		Left channel output
38	LV _{SS}	Ⓜ		Left channel ground. Must be connected to 0 V.
39	RV _{SS}	Ⓜ	Right channel one-bit D/A converter	Right channel ground. Must be connected to 0 V.
40	RCHO	O		Right channel output
41	RV _{DD}	Ⓜ		Right channel power supply
42	MUTER	O		Right channel mute output
43	XV _{DD}	Ⓜ	Crystal oscillator power supply.	
44	X _{OUT}	O	Connections for a 16.9344 crystal oscillator element	
45	X _{IN}	I		
46	XV _{SS}	Ⓜ	Crystal oscillator ground. Must be connected to 0 V.	
47	SBSY	O	Subcode block synchronization signal output	
48	EFLG	O	C1, C2, single and double error correction monitor pin	
49	PW	O	Subcode P, Q, R, S, T, U, V and W output	
50	SFSY	O	Subcode frame synchronization signal output. This signal falls when the subcodes are in the standby state.	

LA6541D Pin Assignment

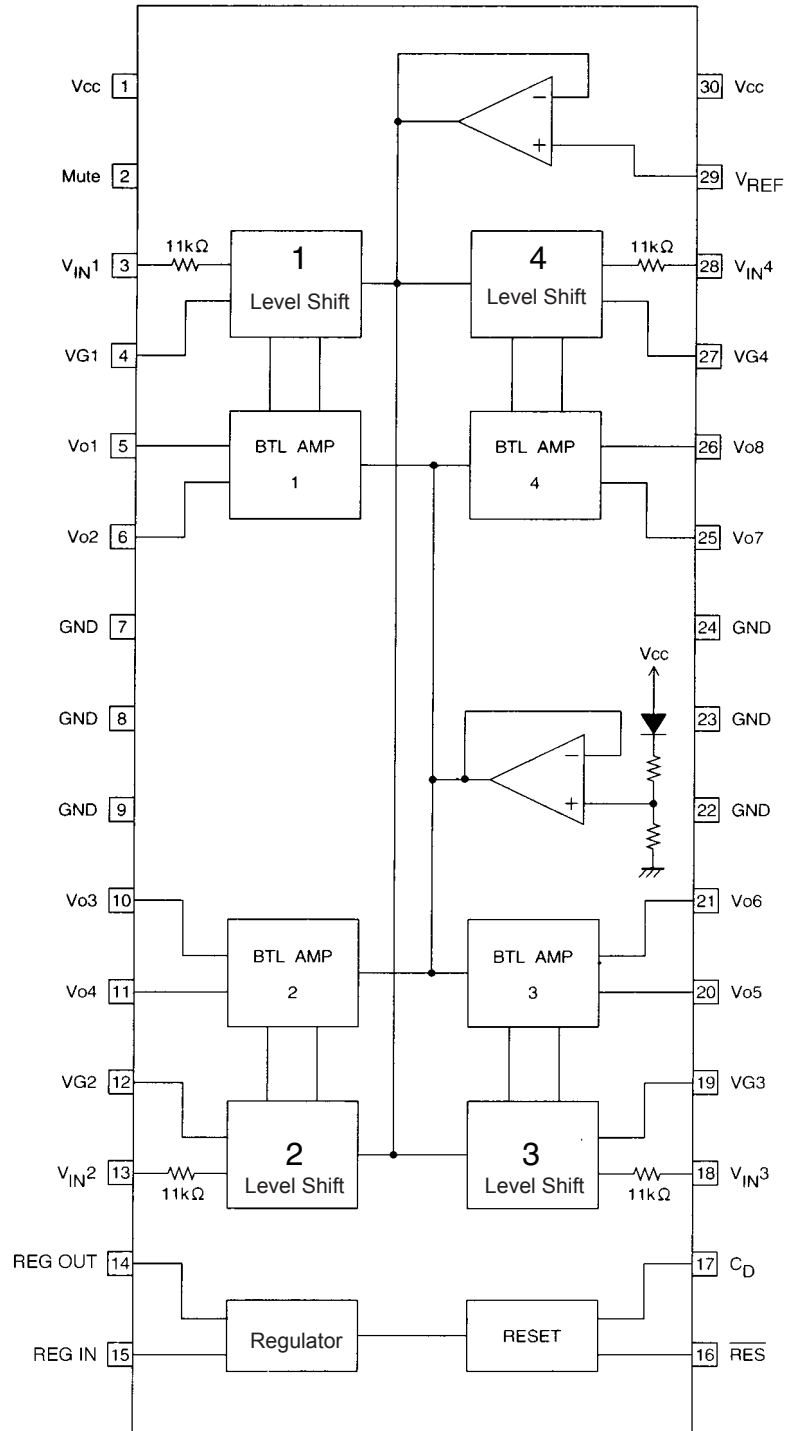

A06422

PC-X250

LA6541D Pin Functions

Pin No.	Pin Name	Description (Function)
1	V _{CC}	Power supply (shorted with pin 30)
2	Mute	ON/OFF control for all BTL AMP outputs
3	V _{IN1}	BTL AMP 1 input
4	VG1	BTL AMP 1 input (for gain control)
5	V _{O1}	BTL AMP 1 output (non-inverting side)
6	V _{O2}	BTL AMP 1 output (inverting side)
7	GND	GND (minimum electric potential)
8	GND	GND (minimum electric potential)
9	GND	GND (minimum electric potential)
10	V _{O3}	BTL AMP 2 output (inverting side)
11	V _{O4}	BTL AMP 2 output (non-inverting side)
12	VG2	BTL AMP 2 input (for gain control)
13	V _{IN2}	BTL AMP 2 input
14	REG OUT	Connection for collector of external transistor (PNP); 5 V supply output
15	REG IN	Connection for base of external transistor (PNP)
16	$\overline{\text{RES}}$	Reset output
17	C _D	Reset output delay time setting (with capacitor)
18	V _{IN3}	BTL AMP 3 input
19	VG3	BTL AMP 3 input (for gain control)
20	V _{O5}	BTL AMP 3 output (non-inverting side)
21	V _{O6}	BTL AMP 3 output (inverting side)
22	GND	GND (minimum electric potential)
23	GND	GND (minimum electric potential)
24	GND	GND (minimum electric potential)
25	V _{O7}	BTL AMP 4 output (inverting side)
26	V _{O8}	BTL AMP 4 output (non-inverting side)
27	VG4	BTL AMP 4 input (for gain control)
28	V _{IN4}	BTL AMP 4 input
29	V _{REF}	Reference voltage input for level shift circuit
30	V _{CC}	Power supply (shorted with pin 1)

LA9241M Equivalent Circuit Block Diagram

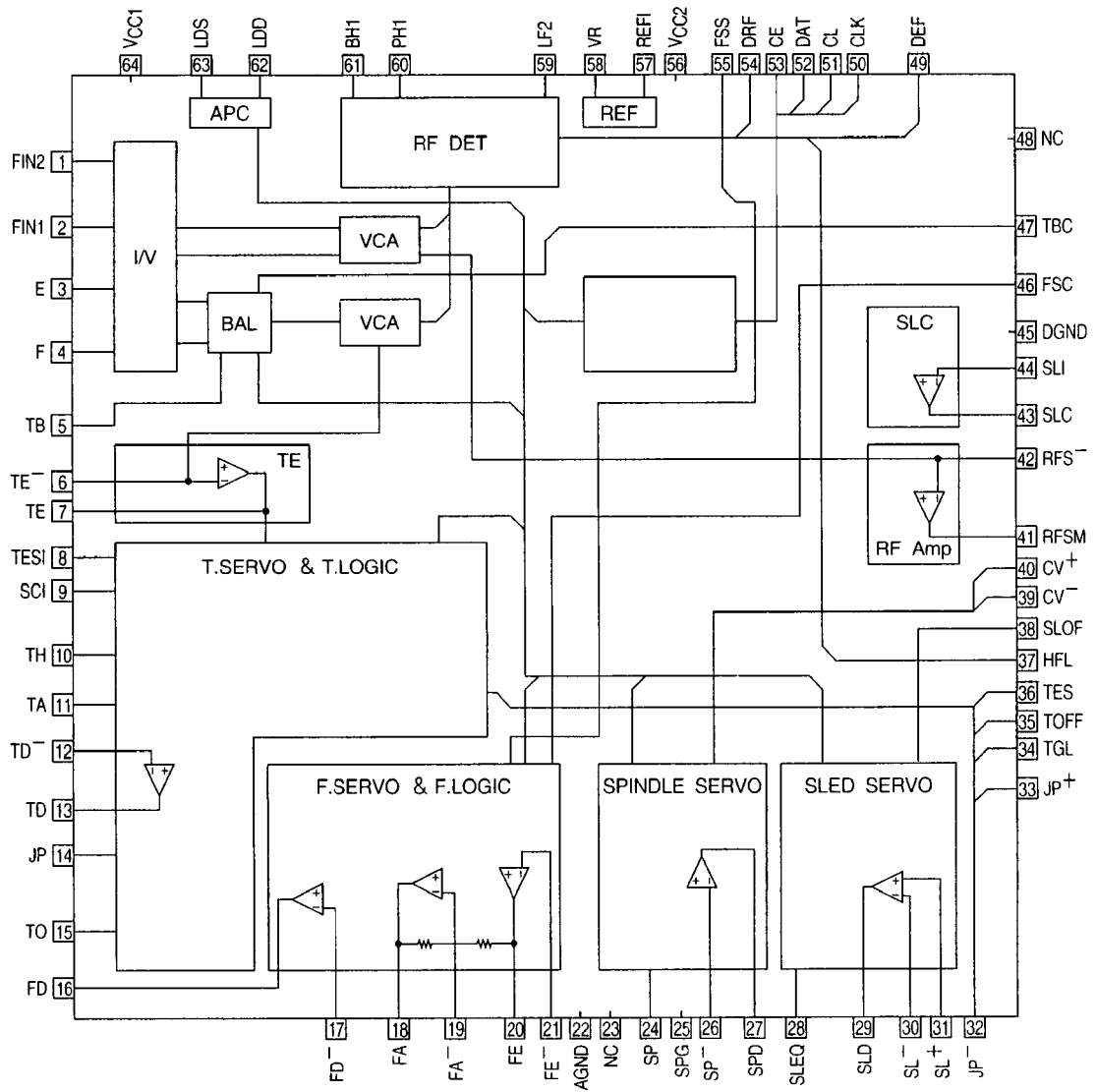

A06435

LA9241 Pin Functions

Pin No.	Symbol	Contents
1	FIN2	Pickup photodiode connection pin. Added to FIN1 pin to generate the RF signal, subtracted from FIN1 pin to generate the FE signal.
2	FIN1	Pickup photodiode connection pin.
3	E	Pickup photodiode connection pin. Subtracted from F pin to generate the TE signal.
4	F	Pickup photodiode connection pin.
5	TB	TE signal DC component input pin.
6	TE [?]	Pin which connects the TE signal gain setting resistor between this pin and TE pin.
7	TE	TE signal output pin.
8	TESI	TES (Track Error Sense) comparator input pin. The TE signal is input through a bandpass filter.
9	SCI	Shock detection input pin.
10	TH	Tracking gain time constant setting pin.
11	TA	TA amplifier output pin.
12	TD [?]	Pin for configuring the tracking phase compensation constant between the TD and VR pins.
13	TD	Tracking phase compensation setting pin.
14	JP	Tracking jump signal (kick pulse) amplitude setting pin.
15	TO	Tracking control signal output pin.
16	FD	Focusing control signal output pin.
17	FD [?]	Pin for configuring the focusing phase compensation constant between the FD and FA pins.
18	FA	Pin for configuring the focusing phase compensation constant between the FD [?] and FA [?] pins.
19	FA [?]	Pin for configuring the focusing phase compensation constant between the FA and FE pins.
20	FE	FE signal output pin.
21	FE [?]	Pin which connects the FE signal gain setting resistor between this pin and FE pin.
22	AGND	Analog signal GND.
23	NC	No connection
24	SP	CV ⁺ and CV [?] pins input signal single-end output.
25	SPG	12-cm spindle mode gain setting resistor connection pin.
26	SP [?]	Spindle phase compensation constant connection pin, along with the SPD pin.
27	SPD	Spindle control signal output pin.
28	SLEQ	Sled phase compensation constant connection pin.
29	SLD	Sled control signal output pin.
30	SL [?]	Input pin for sled movement signal from microprocessor.
31	SL ⁺	Input pin for sled movement signal from microprocessor.
32	JP [?]	Input pin for tracking jump signal from DSP.
33	JP ⁺	Input pin for tracking jump signal from DSP.
34	TGL	Input pin for tracking gain control signal from DSP. Gain is low when TGL is high.
35	TOFF	Input pin for tracking off control signal from DSP. Tracking servo is off when TOFF is high.
36	TES	Output pin for TES signal to DSP.
37	HFL	The High Frequency Level is used to determine whether the main beam is positioned over a bit or over the mirrored surface.
38	SLOF	Sled servo off control input pin
39	CV [?]	Input pin for CLV error signal from DSP.
40	CV ⁺	Input pin for CLV error signal from DSP.
41	RFSM	RF output pin.
42	RFS [?]	RF gain setting and EFM signal 3T compensation constant setting pin, along with the RFSM pin.
43	SLC	Slice Level Control is an output pin that controls the data slice level used by the DSP for the RF waveform.
44	SLI	Input pin used by DSP for controlling the data slice level.
45	DGND	Digital system GND pin.
46	FSC	Focus search smoothing capacitor output pin.
47	TBC	Tracking Balance Control; EF balance adjustment variable range setting pin
48	NC	No connection
49	DEF	Disc defect detection output pin.
50	CLK	Reference clock input pin. 4.23 MHz signal from the DSP is input.
51	CL	Microprocessor command clock input pin.
Pin No.	Symbol	Contents
52	DAT	Microprocessor command data input pin.
53	CE	Microprocessor command chip enable input pin.
54	DRF	RF level detection output (Detect RF).
55	FSS	Focus Search Select; focus search mode (\pm search/+search vs. the reference voltage) switching pin
56	V _{CC2}	Servo system and digital system V _{CC} pin.
57	REFI	By-pass capacitor connection pin for reference voltage.
58	VR	Reference voltage output pin.
59	LF2	Disc defect detection time constant setting pin.
60	PH1	RF signal peak hold capacitor connection pin.
61	BH1	RF signal bottom hold capacitor connection pin.
62	LDD	APC circuit output pin.
63	LDS	APC circuit input pin.
64	V _{CC1}	RF system V _{CC} pin.

BA3126 Block Diagram

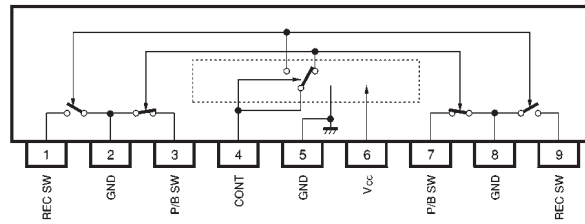

BA3308 Block Diagram

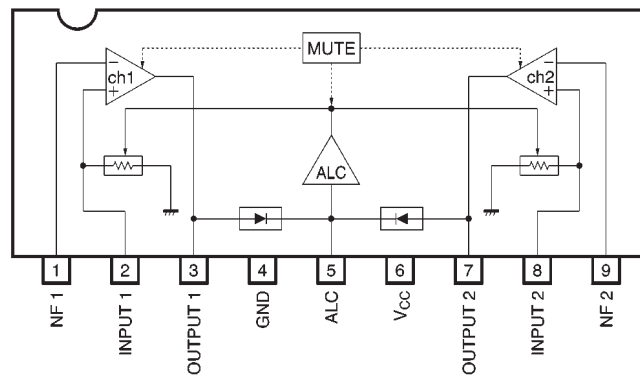

BA3416BL Block Diagram

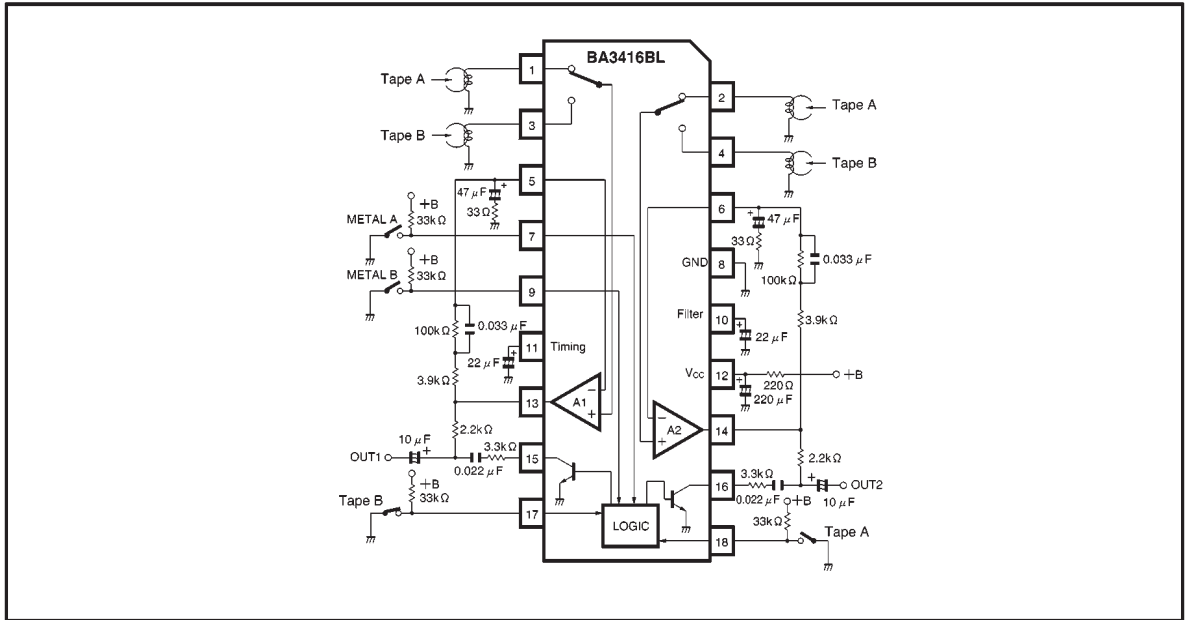

Block Diagram

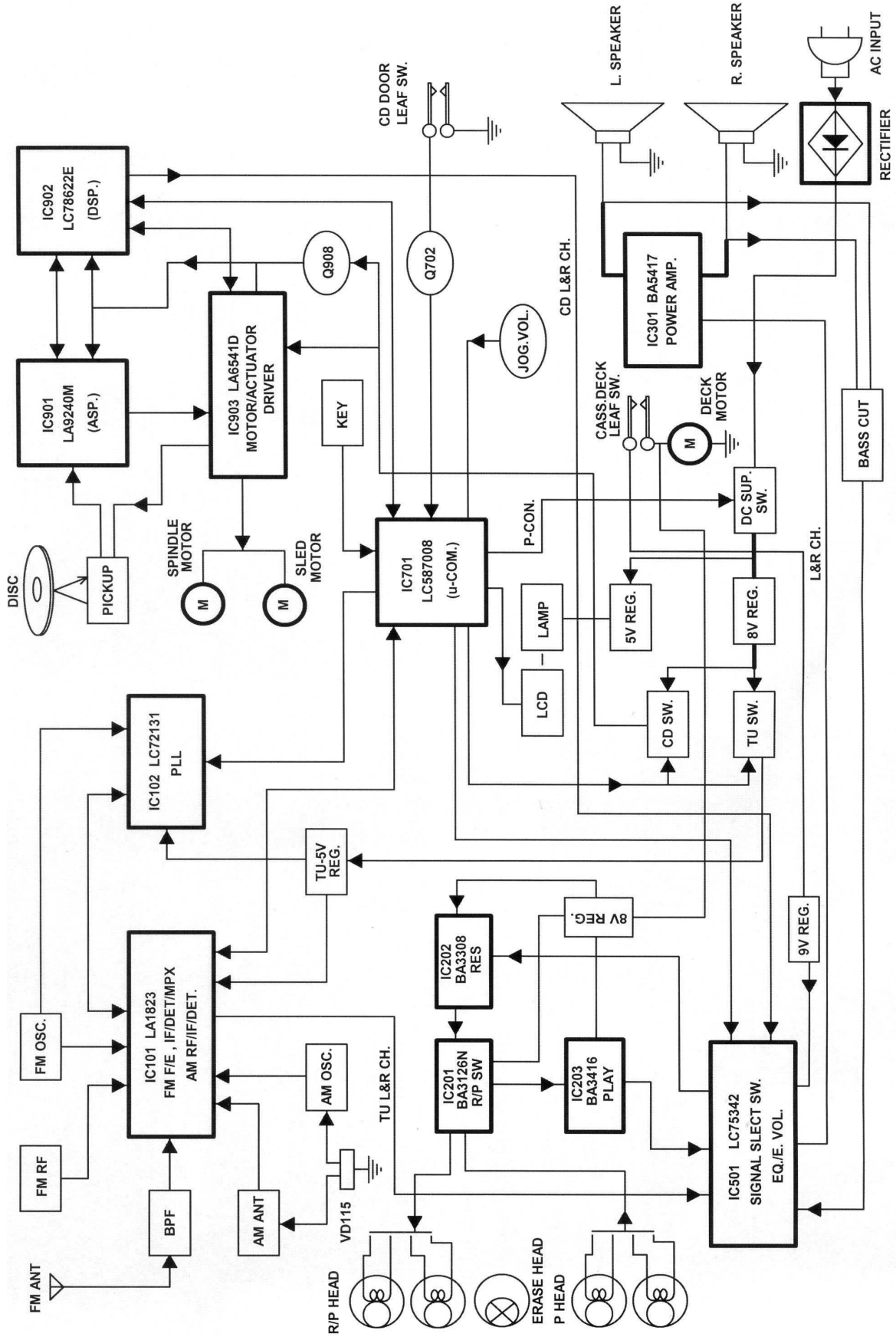

Wiring Diagram

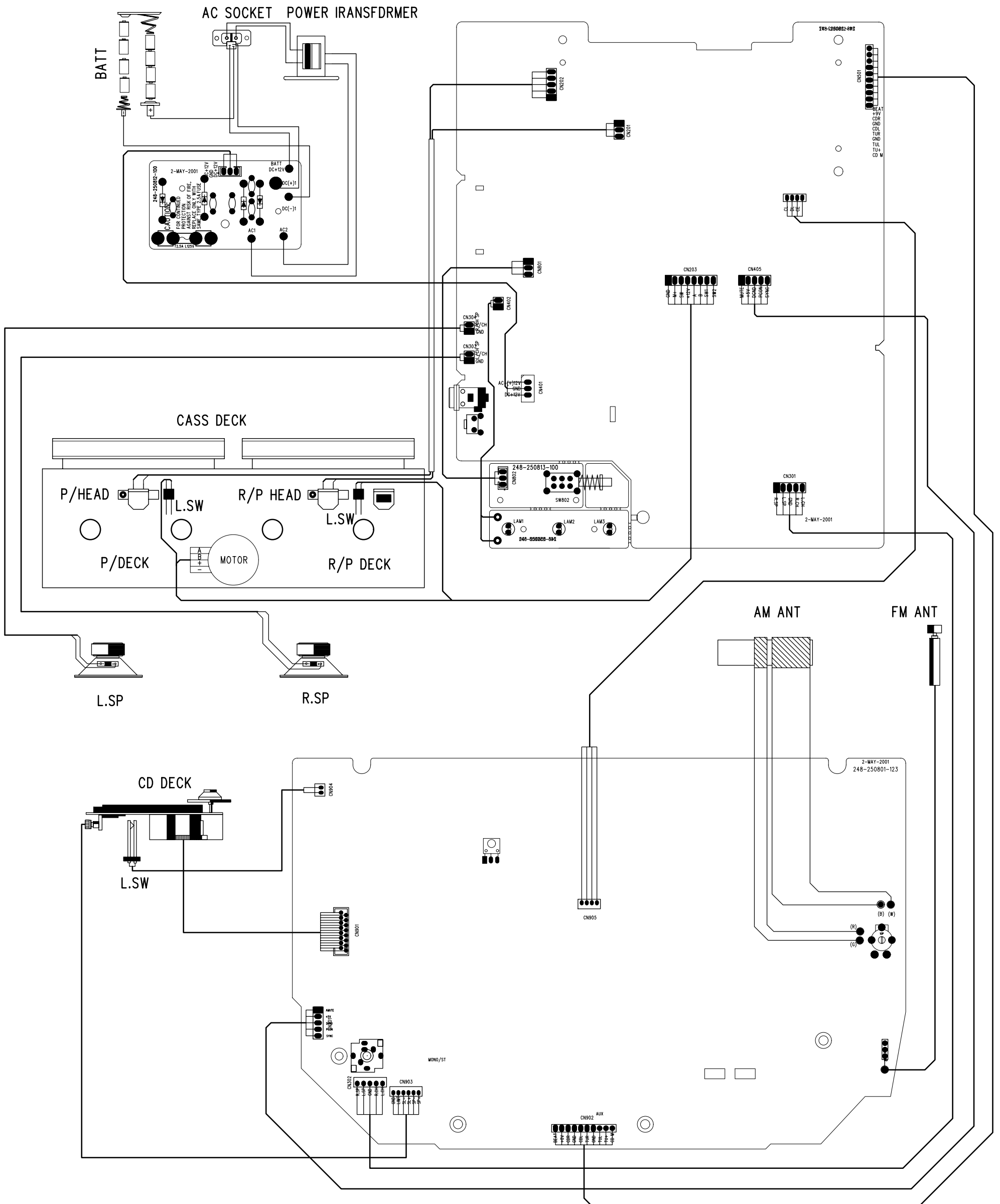

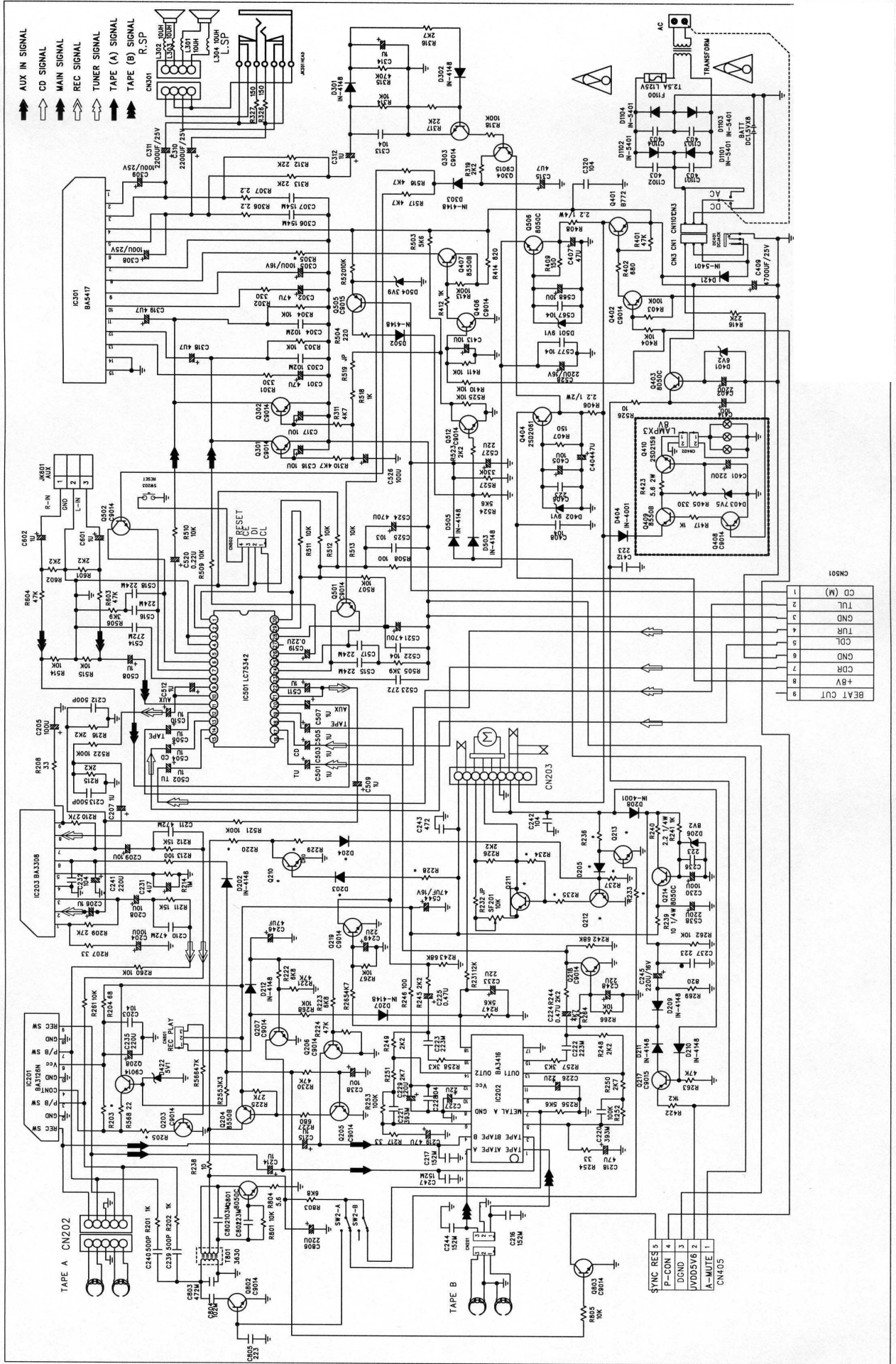

1	CD (M)
2	TUN
3	GND
4	TUR
5	CDL
6	GND
7	CDR
8	+BV
9	BEAT CUT

Circuit Diagram -2

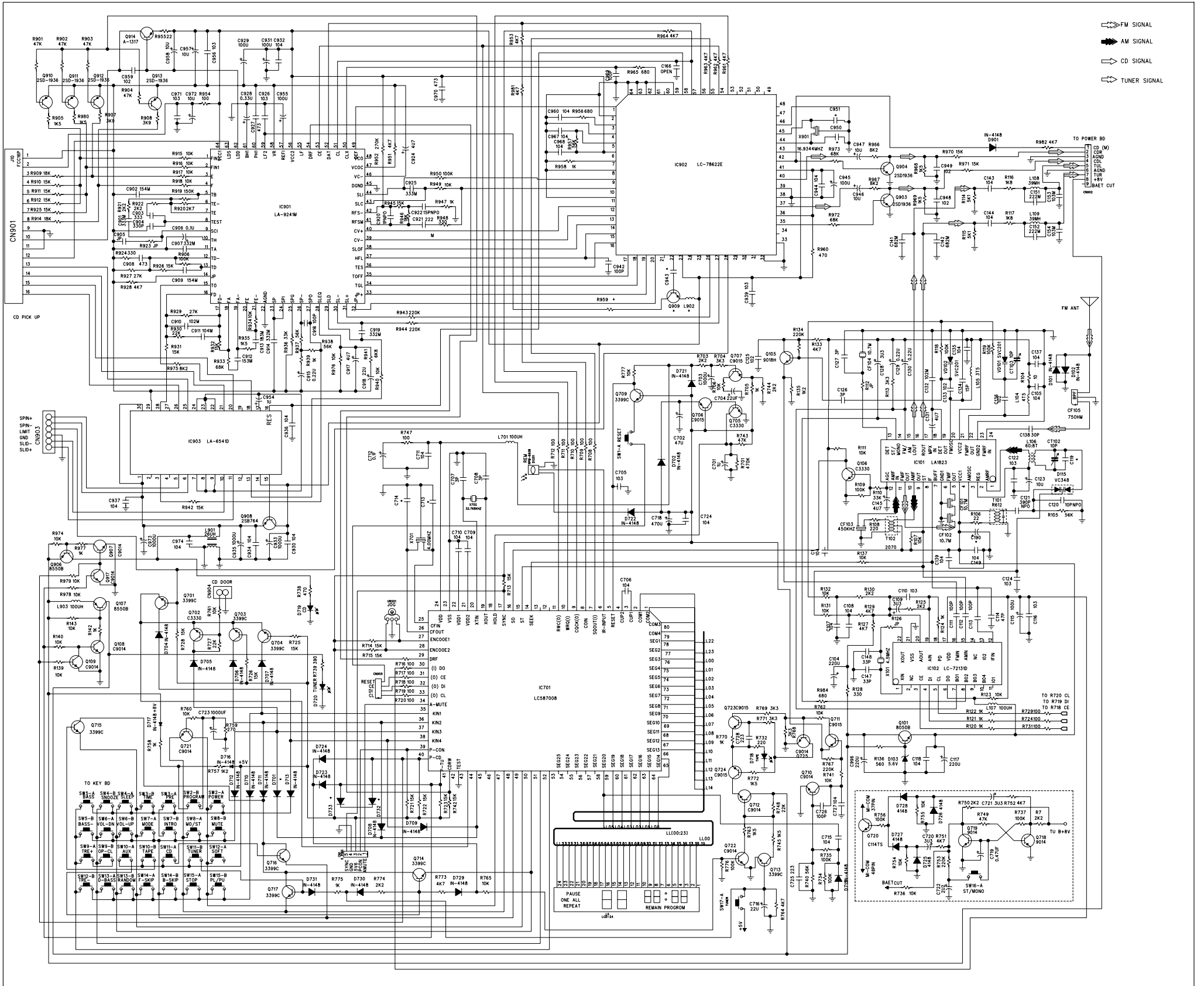

PCB Layout-1

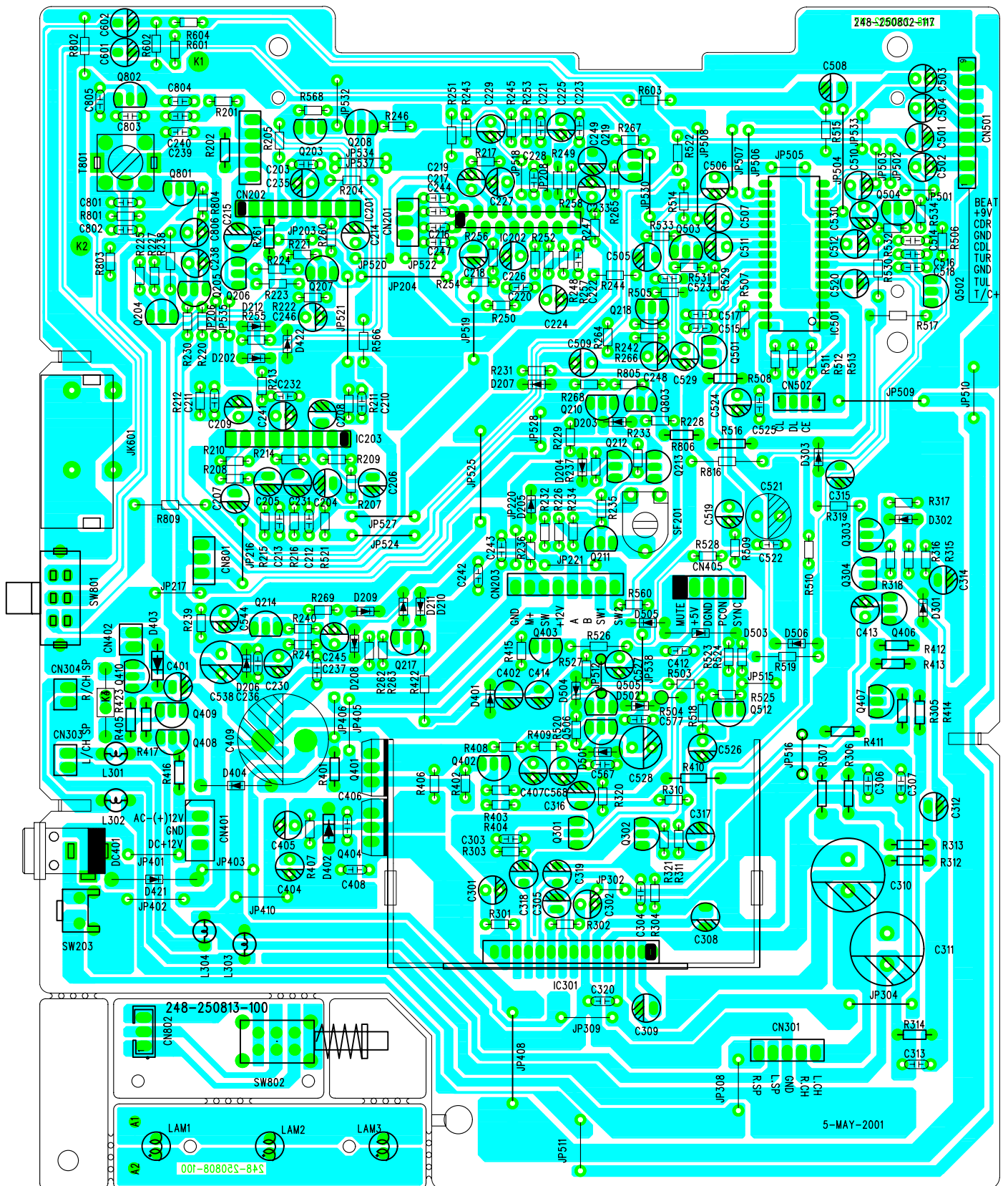

PCB Layout-3

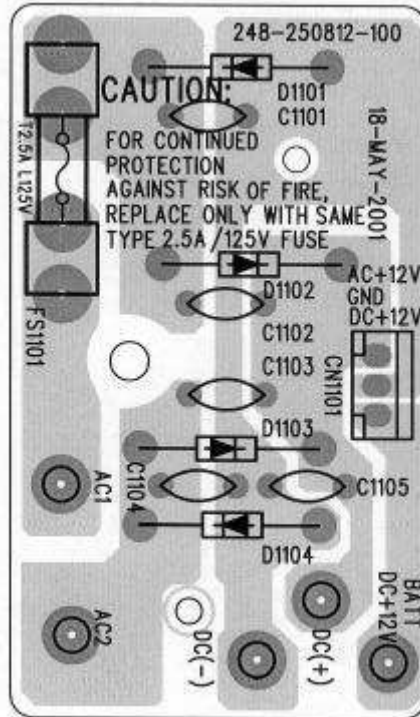

PC-X250

Assembly- 1

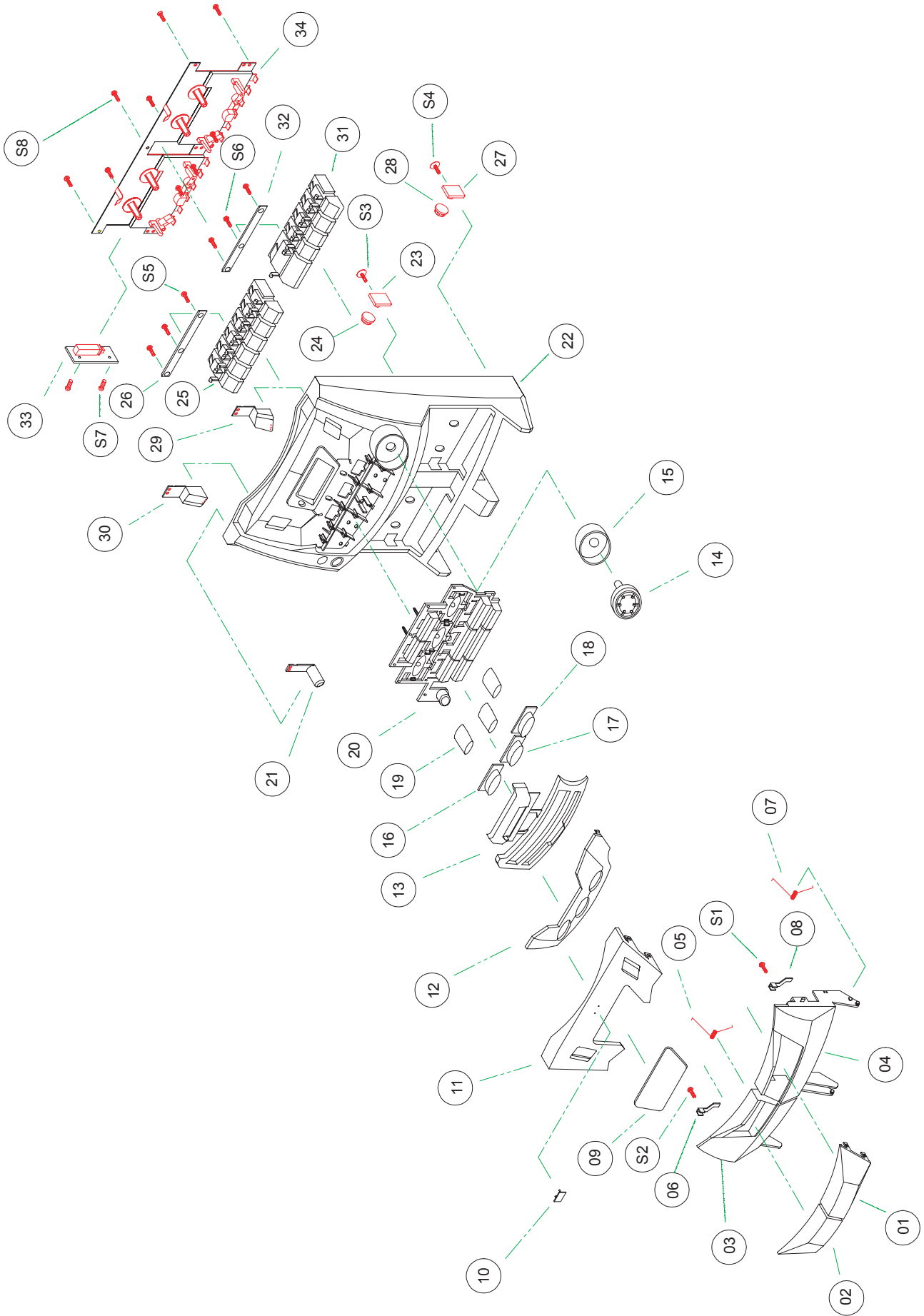

Assembly- 1

!	ITEM	PARTS NUMBER	PARTS NAME	Q'TY	DESCRIPTION/LOCALITY
	01	525-073030-011	RIGHT CASS DOOR LENS	1	
	02	525-072030-011	LEFT CASS DOOR LENS	1	
	03	525-0030S3-012	LEFT CASS DOOR	1	
	04	525-0130S3-012	RIGHT CASS DOOR	1	
	05	766-250000-000	LEFT CASS DOOR SPRING	1	
	06	525-029300-000	LEFT CASS TAPE BRACKET	1	
	07	766-250000-000	RIGHT CASS DOOR SPRING	1	
	08	525-029300-000	RIGHT CASS TAPE BRACKET	1	
	09	525-080400-013	CD DISPLAY LENS	1	
	10	500-810200-011	"JVC" NAME PLATE	1	
	11	525-045430-013	DISPLAY PANEL	1	
	12	525-0453S3-011	CONTROL PLATE	1	
	13	525-045817-011	FUNCTION PLATE	1	
	14	525-0074S3-000	VOLUME KNOB	1	
	15	525-090427-000	VOLUME KNOB RING	1	
	16	525-078827-011	RADIO KNOB LENS	1	
	17	525-078327-011	CD KNOB LENS	1	
	18	525-078027-011	TAPE KNOB LENS	1	
	19	525-080800-000	REFLECTION LENS	3	
	20	525-0500S3-013	CD CONTROL KNOB	12pcs/KIT	
	21	525-0072S3-000	SUPER BASS KNOB	1	
	22	525-0010S3-012	FRONT CABINET	1	
	23	539-121200-000	LEFT CASS DOOR GEAR HOLDER	1	
	24	539-121100-000	LEFT CASS DOOR GEAR	1	
	25	525-0102S3-012	LEFT CASS KNOB	5pcs/KIT	
	26	463-380000-000	LEFT CASS KNOB PLATE	1	
	27	539-121200-000	RIGHT CASS DOOR GEAR HOLDER	1	
	28	539-121100-000	RIGHT CASS DOOR GEAR	1	
	29	525-0085S3-000	EQ KNOB	1	
	30	525-0510S3-000	POWER CONTROL KNOB	1	
	31	525-0108S3-012	RIGHT CASS KNOB	6pcs/KIT	
	32	463-380000-000	RIGHT CASS KNOB PLATE	1	
	33	248-250813-000	RECORDING BOARD	1	
	34	156-255609-254	CASS DECK	1	
	S1	238-120060-602	SCREW 2 X 6 PB	1	FIX RIGHT TAPE BRACKET
	S2	238-120060-602	SCREW 2 X 6 PB	1	FIX LEFT TAPE BRACKET
	S3	238-130080-632	SCREW 3 X 8 PWB	1	FIX LEFT CASS DOOR GEAR
	S4	238-130080-632	SCREW 3 X 8 PWB	1	FIX RIGHT CASS DOOR GEAR
	S5	238-130060-602	SCREW 3 X 6 PB	3	FIX LEFT CASS DOOR PLATE
	S6	238-130060-602	SCREW 3 X 6 PB	3	FIX RIGHT CASS DOOR PLATE
	S7	238-220050-903	SCREW 2 X 5 MC	2	FIX THE RECORDING BOARD
	S8	238-130100-602	SCREW 3 X 10 PB	6	FIX CASS DECK

PC-X250

Assembly- 2

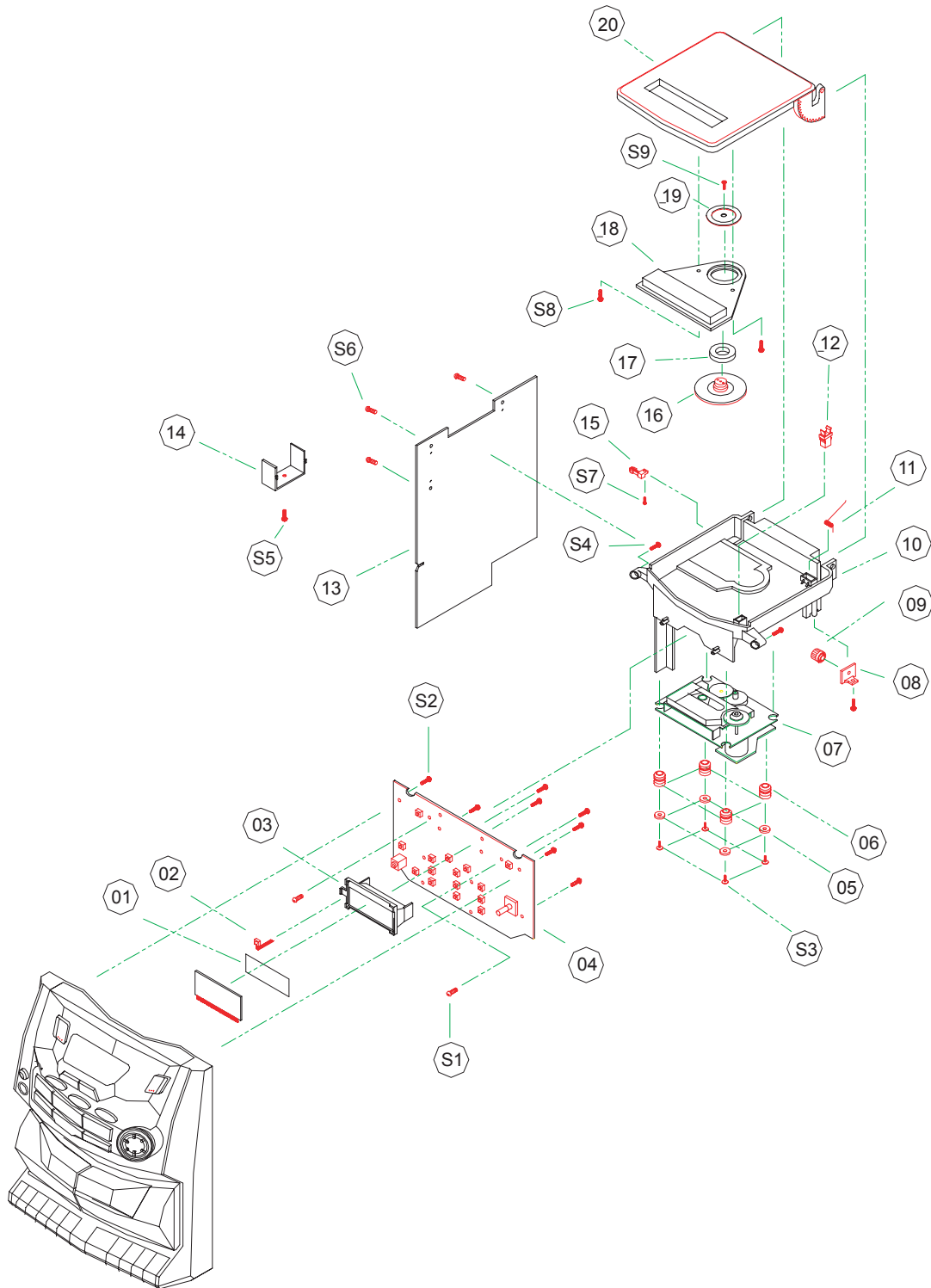

Assembly- 2

!	ITEM	PART NO.	PARTS NAME	Q'TY	DESCRIPTION/LOCALITY
	01	466-756350-050	PVC BACK LIGHT PLATE	1	
	02	206-106938-000	REMOTE RECEIVER	1	
	03	525-031064-000	CD DISPLAY BRACKET	1	
	04	248-250802-117	AUDIO BOARD	1	
	05	453-030100-050	METAL WASHER	4	
	06	458-328840-220	RUBBER SILICON	4	
	07	356-110300-091	CD DECK	1	
	08	539-121200-000	CD DOOR GEAR HOLDER	1	
	09	539-121100-000	CD DOOR GEAR	1	
	10	525-0470S3-000	CD TRAY	1	
	11	479-328800-000	CD DOOR SPRING	1	
	12	846-209000-000	CD DOOR LOCK	1	
	13	248-250801-123	TUNER BOARD	1	
	14	408-146395-150	HEAT SINK	1	
	15	217-200035-050	LEAF SWITCH	1	
	16	500-291942-501	CD CHUCK (M)	1	
	17	473-300160-500	CD MAGNET RING	1	
	18	525-080330-011	CD DOOR LENS	1	
	19	500-100000-000	CD CHUCK (A)	1	
	20	525-0490S3-014	CD DOOR	1	
	S1	238-130150-602	SCREW 3 x 15 PB	2	FROM AUDIO BOARD TO CD TRAY
	S2	238-130080-602	SCREW 3 x 8 PB	8	FIX THE AUDIO BOARD
	S3	238-126080-632	SCREW 2.6 X 8 PWB	4	FIX THE CD DECK
	S4	238-130100-602	SCREW 3 x 10 PB	2	FROM CD TRAY TO FRONT CABINET
	S5	238-230086-202	SCREW 3 X 8 BB (HARD)	1	FIX HEAT SINK
	S6	238-130080-602	SCREW 3 X 8 PB	3	FIX THE MAIN BOARD
	S7	238-120060-602	SCREW 2 X 6 PB (BLACK)	1	FIX CD LEAF SWITCH
	S8	238-130082-102	SCREW 3 X 8 KB (BLACK)	2	FIX CD DOOR LENS
	S9	238-220060-202	SCREW 2 X 6 BB	1	FIX CD CHUCK A

PC-X250

Assembly- 3

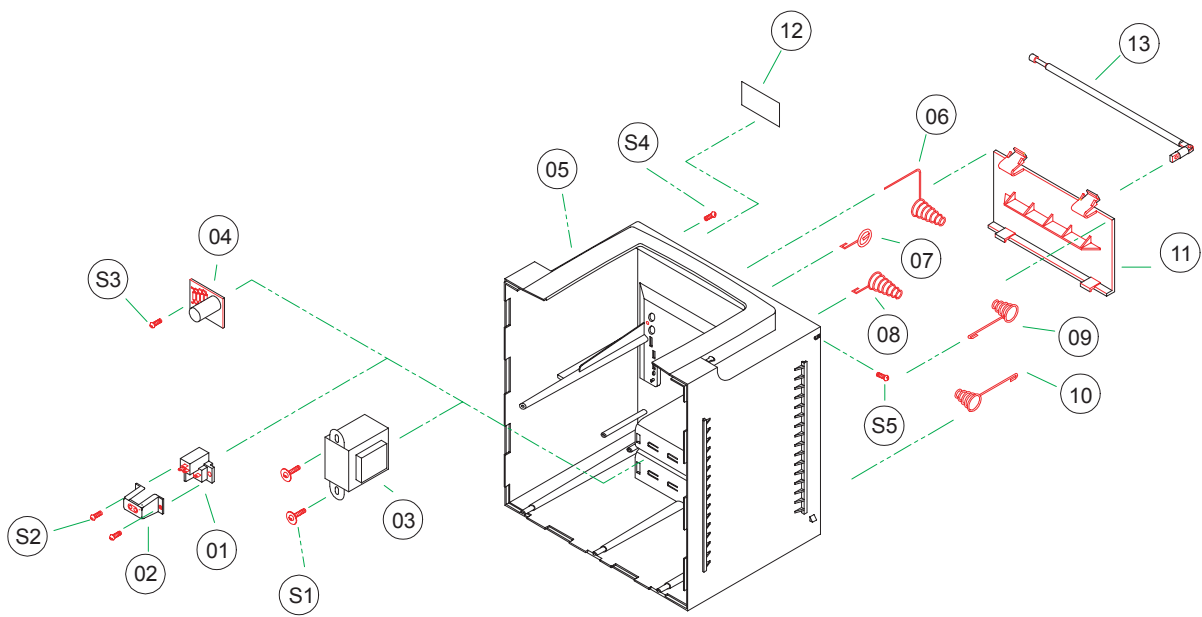

Assembly- 3

!	ITEM	PART NO.	PARTS NAME	Q'TY	DESCRIPTION/LOCALITY
!	01	158-000117-622	AC SOCKET	1	
!	02	500-025100-000	AC SOCKET COVER	1	
!	03	152-112560-225	POWER TRANSFORMER	1	
	04	248-250812-100	RECTIFIER BOARD	1	
	05	525-0020S3-012	BACK CABINET	1	
	06	763-250000-000	BATTERY SPRING (+/--)	1	
	07	764-701300-000	BATTERY SPRING (+)	1	
	08	765-901000-000	BATTERY SPRING (--)	1	
	09	763-455000-000	BATTERY SPRING (+/--)	1	
	10	763-331800-000	BATTERY SPRING (+/--)	1	
	11	525-0040S3-000	BATTERY DOOR	1	
	12	466-756350-050	PVC PLATE FOR VOLTAGE SELECTOR HOLE	1	COVER THE VOLTAGE SELECTOR HOLE
	13	155-420026-238	RADIO ANTENNA	1	
	S1	238-130200-632	SCREW 3 X 20 PWB	2	FIX POWER TRANSFORMER
	S2	238-128120-602	SCREW 2.8 X 12 PB	2	FIX AC SOCKET COVER
	S3	238-130080-602	SCREW 3 X 8 PB	1	FIX RECTIFIER BOARD
	S4	238-128120-602	SCREW 3 X 10 PB	1	FIX AUX JACK
	S5	238-130100-203	SCREW 3 X 10 BM (BLACK)	1	FIX RADIO ANTENNA

PC-X250

Assembly- 4

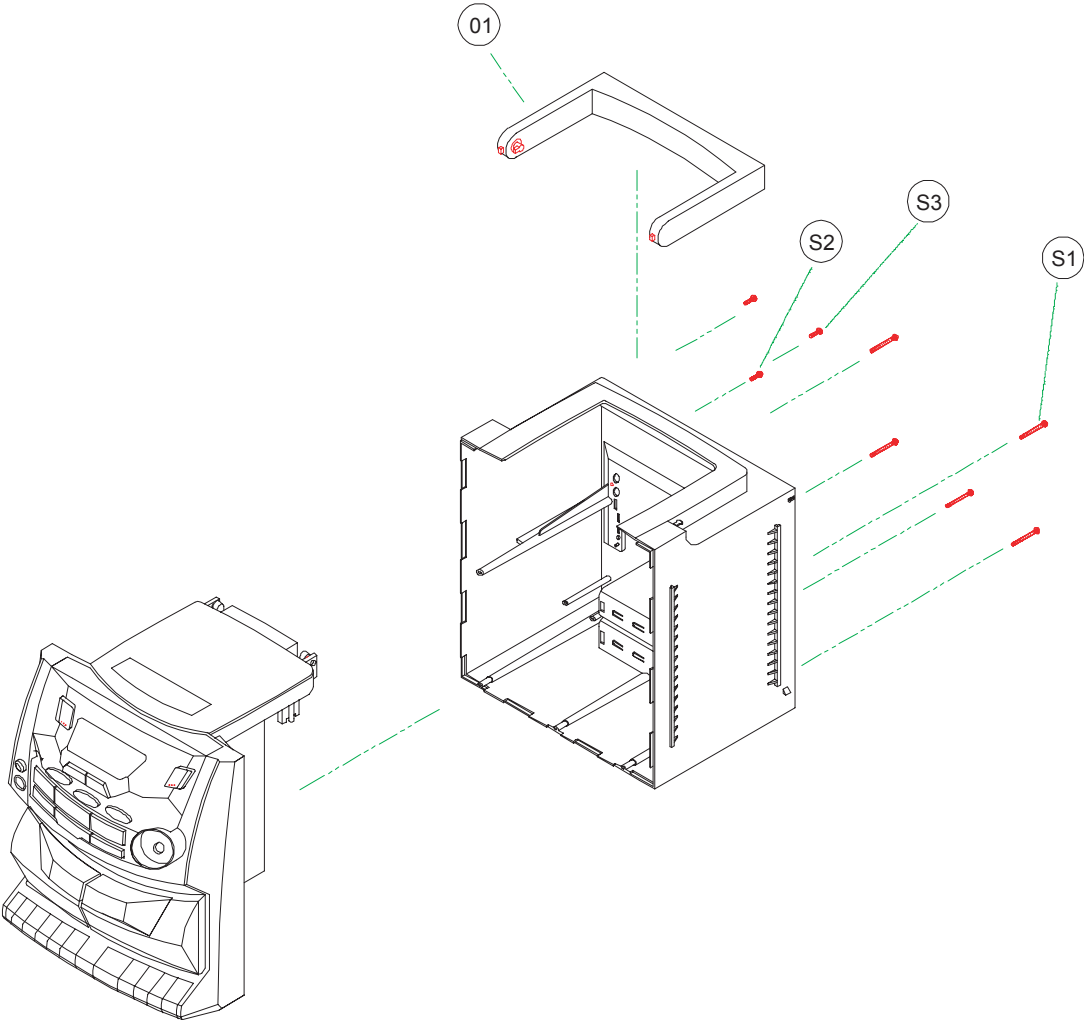

Assembly- 4

!	ITEM	PART NO.	PARTS NAME	Q'TY	DESCRIPTION/LOCALITY
	1	525-0050S3-000	HANDLE	1	
	S1	238-130250-602	SCREW 3 X 25 PB	5	FROM FRONT CASINET TO BACK CABINET
	S2	238-130100-602	SCREW 3 X 10 PB	1	FIX THE AUX JACK
	S3	238-128120-602	SCREW 2 X 5 MC	2	FIX THE RECORDING BOARD

Assembly- 5

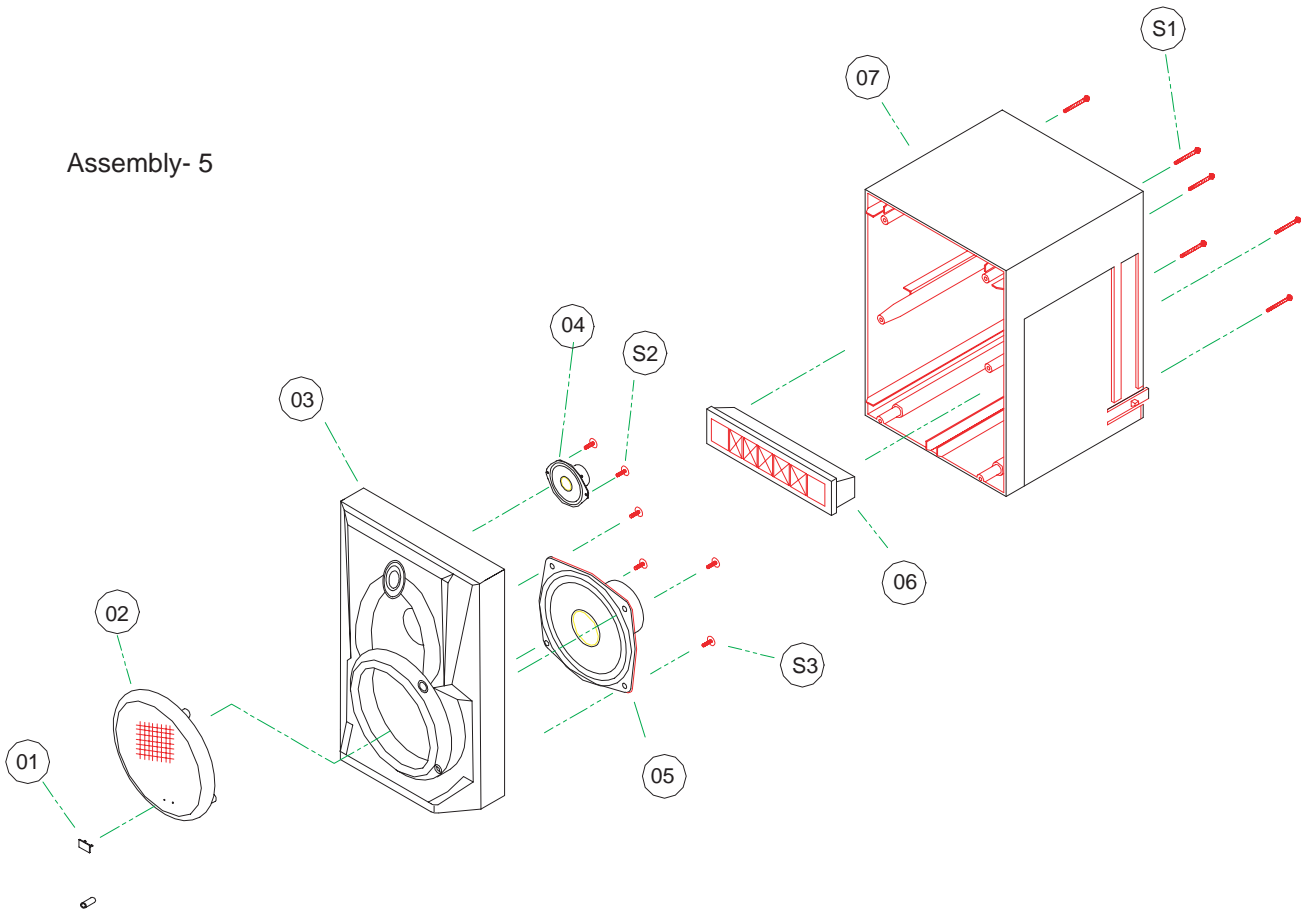

Assembly- 6

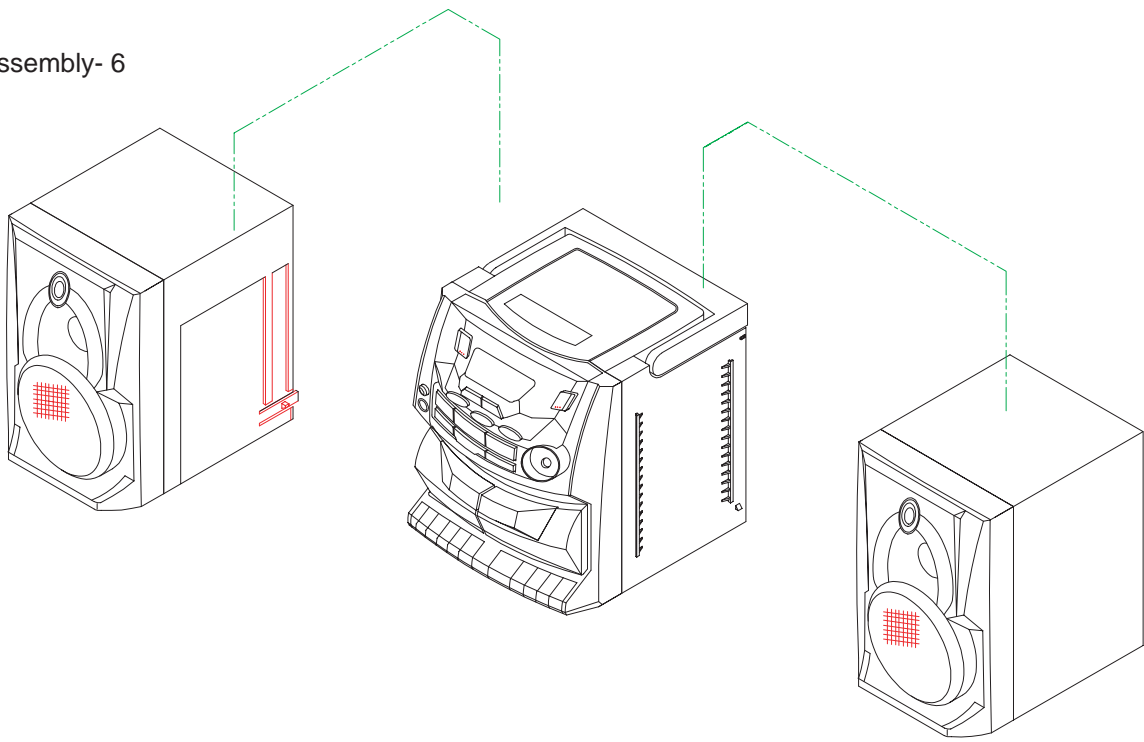

Assembly- 5

FOR RIGHT SPEAKER BOX ASSEMBLY

!	ITEM	PART NO.	PARTS NAME	Q'TY	DESCRIPTION/LOCALITY
	01	500-810200-011	"JVC" NAME PLATE	1	
	02	525-040000-000	SPEAKER NET HOLDER	1	
	03	525-0410S3-010	SPEAKER BOX PANEL	1	
	04	154-178450-329	LOUD SPEAKER	1	
	05	154-508380-609	SPEAKER	1	
	06	525-026900-000	SPEAKER CORD HOLDER	1	
	07	525-0390S3-008	RIGHT SPEAKER BOX BACK	1	
	S1	238-130300-602	SCREW 3 X 30 PB	6	FROM SPEAKER PANEL TO SPEAKER BOX BACK
	S2	238-130080-632	SCREW 3 X 8 PWB	2	FIX THE SPEAKER
	S3	238-130080-632	SCREW 3 X 8 PWB	4	FIX THE LOUD SPEAKER

FOR LEFT SPEAKER BOX ASSEMBLY

	ITEM	PART NO.	PARTS NAME	Q'TY	DESCRIPTION/LOCALITY
	01	500-810200-011	"JVC" NAME PLATE	1	
	02	525-040000-000	SPEAKER NET HOLDER	1	
	03	525-0410S3-010	SPEAKER BOX PANEL	1	
	04	154-508380-609	SPEAKER	1	
	05	154-178450-329	LOUD SPEAKER	1	
	06	525-026900-000	SPEAKER CORD HOLDER	1	
	07	525-0390S3-002	LEFT SPEAKER BOX BACK	1	
	S1	238-130300-602	SCREW 3 X 30 PB	6	FROM SPEAKER PANEL TO SPEAKER BOX BACK
	S2	238-130080-632	SCREW 3 X 8 PWB	4	FIX THE SPEAKER
	S3	238-130080-632	SCREW 3 X 8 PWB	2	FIX THE LOUD SPEAKER

Packing

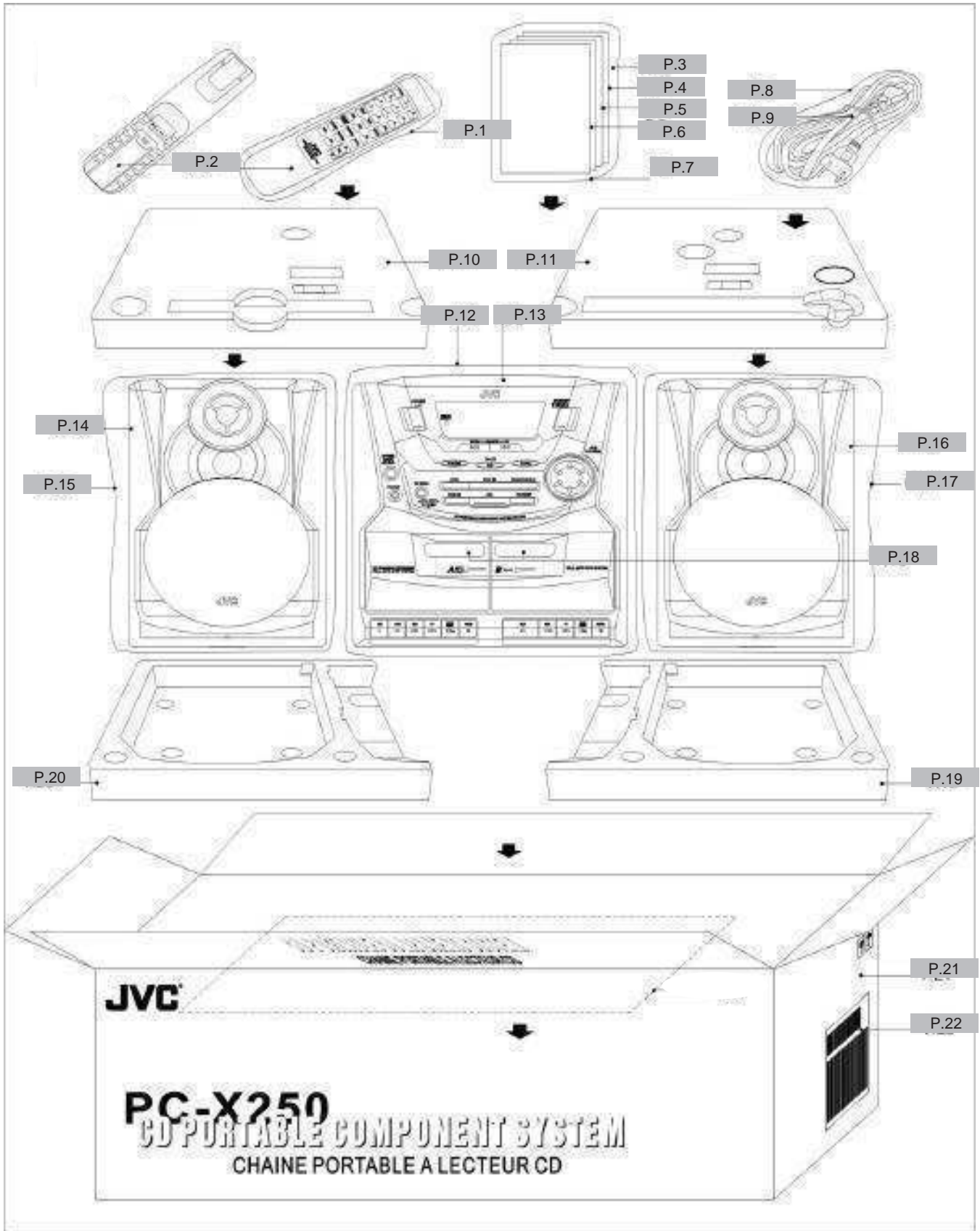

Packing List

Item	Part's Name	Parts No.
P.1	Poly Bag	RC27-100S3-011
P.2	Remote Control Unit	
P.3	Instruction Manual	601-250000-010
P.4	Warranty Card	602-700388-001
P.5	Registration card	602-700337-000
P.6	Safety Instruction Sheet	602-900276-000
P.7	Poly Bag	676-070100-040
P.8	Poly Bag	676-040130-040
P.9	Power Cord Set	151-117117-612
P.10	Poly Form, Top Left	875-351000-000
P.11	Poly Form, Top Right	
P.12	Poly Bag	676-215240-040
P.13	Main Unit	-
P.14	Speaker Unit, Left	AS00-25002
P.15	Poly Bag	676-180240-040
P.16	Speaker Unit, Right	AS00-25008
P.17	Poly Bag	676-180240-040
P.18	POP Label-Left	629-080097-000
	POP Label-Right	629-080096-000
P.19	Poly Form, Bottom Right	875-351000-000
P.20	Poly Form, Bottom Left	
P.21	Gift Box	891-250102-010
P.22	Bar Code Label	612-080131-000

JVC

~~VICTOR COMPANY OF JAPAN, LIMITED~~ (By JCA)

~~AUDIO & COMMUNICATION BUSINESS DIVISION~~ (By JCA)

~~PERSONAL & MOBILE NETWORK BUSINESS UNIT, 10-1, 1 Chome, Ohwatari-machi, Maebashi-city, 371-8543, Japan~~ (By JCA)



PARTS LIST

[PC-X250]

* All printed circuit boards and its assemblies are not available as service parts.

Area suffix	
J	USA
C	Canada

- Contents -

□	
Electrical Parts List (Tuner circuit pcb)	2 - 2
Electrical Parts List (Audio circuit pcb)	2 - 9
Electrical Parts List (Rectifier circuit pcb)	2 - 14
Electrical Parts List (Tape recording circuit pcb)	2 - 15
Electrical Parts List (Display lighting circuit pcb)	2 - 16

Tuner pcb

Part No.	Materials	Qty	Position/ECN
199-741005-000	GOLD CAP DX-5R5H104 0.1 F/5.5V	1 PCS	
201-000330-185	RESISTOR 3.3 OHM +-5% 1/8W	1 PCS	J216
201-001000-185	RESISTOR 10 OHM +-5% 1/8W	2 PCS	R75,R89
201-002200-185	RESISTOR 22 OHM +-5% 1/8W	1 PCS	R902
201-011000-185	RESISTOR 100 OHM +-5% 1/8W	16 PCS	R310,R702,R970,R971,R703,R704,R705,R706,R708,R709,R710,R711, R712,R723,R724,R725
201-013300-185	RESISTOR 330 OHM +-5% 1/8W	4 PCS	R201,R208,R931,R20
201-014700-185	RESISTOR 470 OHM +-5% 1/8W	2 PCS	R950,R716
201-016800-185	RESISTOR 680 OHM +-5% 1/8W	2 PCS	R932,R939
201-021000-185	RESISTOR 1 KOHM +-5% 1/8W	13 PCS	R106,R119,R120,R121,R123,R125,R26,R30,R1,R920,R930,R402,R1043
201-021200-185	RESISTOR 1.2 KOHM +-5% 1/8W	2 PCS	R103,R941
201-021500-185	RESISTOR 1.5 KOHM +-5% 1/8W	3 PCS	R2,R11,R915
201-022200-185	RESISTOR 2.2 KOHM +-5% 1/8W	10 PCS	R57,R520,R521,R19,R719,R720,R741,R905,R910,R11
201-023300-185	RESISTOR 3.3 KOHM +-5% 1/8W	3 PCS	R11,R946,R949
201-023900-185	RESISTOR 3.9 KOHM +-5% 1/8W	2 PCS	R945,R948
201-024700-185	RESISTOR 4.7 KOHM +-5% 1/8W	12 PCS	R147,R148,R21,R933,R934,R938,R2,R5,R9,R945,R956,R730,R741
201-025100-185	RESISTOR 5.1 KOHM +-5% 1/8W	2 PCS	R112,R113
201-025600-185	RESISTOR 5.6 KOHM +-5% 1/8W	2 PCS	R12,R17
201-026800-185	RESISTOR 6.8 KOHM +-5% 1/8W	4 PCS	R951,R904,R923,R926
201-028200-185	RESISTOR 8.2 KOHM +-5% 1/8W	5 PCS	R49,R34,R916,R944,R947
201-031000-185	RESISTOR 10 KOHM +-5% 1/8W	22 PCS	R115,R126,R131,R133,R952,R954,R961,R965,R58,R1,R6,R22,R24,R27,R28, R29,R32,R33,R917,R922,R927,R3
201-031500-185	RESISTOR 15 KOHM +-5% 1/8W	22 PCS	R4,R5,R7,R8,R38,R46,R47,R48,R713,R714,R727,R728,R729,R734,R735, R908,R913,R928,R96,R77,R92,R40
201-032200-185	RESISTOR 22 KOHM +-5% 1/8W	3 PCS	R912,R929,R985
201-032700-185	RESISTOR 27 KOHM +-5% 1/8W	2 PCS	R35,R911
201-033300-185	RESISTOR 33 KOHM +-5% 1/8W	5 PCS	R108,R10,R14,R918,R974
201-034700-185	RESISTOR 47 KOHM +-5% 1/8W	9 PCS	R3,R4,R6,R7,R8,R9,R13,R18,R715
201-035600-185	RESISTOR 56 KOHM +-5% 1/8W	4 PCS	R137,R919,R921,R940
201-036800-185	RESISTOR 68 KOHM +-5% 1/8W	2 PCS	R907,R914
201-041000-185	RESISTOR 100 KOHM +-5% 1/8W	5 PCS	R101,R102,R134,R906,R942
201-041500-185	RESISTOR 150 KOHM +-5% 1/8W	1 PCS	R903
201-042200-185	RESISTOR 220 KOHM +-5% 1/8W	3 PCS	R104,R924,R925
201-042700-185	RESISTOR 270 KOHM +-5% 1/8W	1 PCS	R25
201-051000-185	RESISTOR 1 MOHM +-5% 1/8W	2 PCS	R945,R948
202-100505-505	G CERAMIC CAP 5 PF/50V SL +-5%	1 PCS	C920
202-101805-505	G CERAMIC CAP 18 PF/50V SL	1 PCS	C140
202-103005-505	H CERAMIC CAP 30 PF/50V SL	6 PCS	C105,C106,C138,C139,C713,C714
202-103305-505	H CERAMIC CAP 33 PF/50V SL	2 PCS	C950,C951
202-104705-505	H CERAMIC CAP 47 PF/50V SL	1 PCS	C114

Tuner pcb

202-211005-101	G CERAMIC CAP 100 PF/50V B(X7R)	5 PCS	C111,C112,C113,C916,C952
202-213005-101	G CERAMIC CAP 300 PF/50V B(X7R)	1 PCS	C121
202-213305-101	G CERAMIC CAP 330 PF/50V B(X7R)	2 PCS	C904,C942
202-221005-101	G CERAMIC CAP 0.001 UF/50V B	8 PCS	C125,C133,C136,C910,C943,C948,C949,C983
202-422201-202	G CERAMIC CAP 0.0022 UF/16V X	1 PCS	C921
202-422701-101	G CERAMIC CAP 0.0027 UF/16V X	1 PCS	C132
202-423301-202	G CERAMIC CAP 0.0033 UF/16V X	3 PCS	C907,C914,C919
202-500305-505	G CERAMIC CAP 3 PF/50V NPO	2 PCS	C126,C127
202-500335-505	G CERAMIC CAP 3.3 PF/50V NPO	2 PCS	C707,C708
202-500505-505	G CERAMIC CAP 5 PF/50V NPO	1 PCS	C120
202-501505-101	G CERAMIC CAP 15 PF/50V NPO	1 PCS	C134
202-501505-505	G CERAMIC CAP 15 PF/50V NPO	1 PCS	C922
202-631002-802	G CERAMIC CAP 0.01 UF/25V F	7 PCS	C110,C116,C119,C926,C972,C980,C998
202-631502-802	G CERAMIC CAP 0.015 UF/25V F	1 PCS	C912
202-631802-802	G CERAMIC CAP 0.018 UF/25V F	3 PCS	C141,C142,C913
202-632002-802	G CERAMIC CAP 0.020 UF/25V F	1 PCS	C122
202-632202-802	G CERAMIC CAP 0.022 UF/25V F	2 PCS	C103,C118
202-633302-802	G CERAMIC CAP 0.033 UF/25V F	4 PCS	C902,C903,C905,C923
202-634702-802	G CERAMIC CAP 0.047 UF/25V F	3 PCS	C908,C927,C930
202-641002-802	G CERAMIC CAP 0.1 UF/25V F(Y5V)	18 PCS	C107,C108,C135,C137,C143,C144,C706,C709,C710,C711,C911,C932,C944,C968,C970,C984,C985,C986
202-641502-802	G CERAMIC CAP 0.15 UF/25V F(Y5)	2 PCS	C901,C909
203-041050-202	ELECT CAP 0.1 UF/50V +-20%	1 PCS	C130
203-042250-202	ELECT CAP 0.22 UF/50V +-20%	1 PCS	C931
203-051050-202	ELECT CAP 1 UF/50V +-20%	1 PCS	C712
203-053350-202	ELECT CAP 3.3 UF/50V +-20%	1 PCS	C145
203-054750-202	ELECT CAP 4.7 UF/50V +-20%	3 PCS	C145,C701,C935
203-061025-212	ELECT CAP 10 UF/25V +-20%	7 PCS	C18,C963,C965,C915,C901,C905,C963
203-062210-202	ELECT CAP 22 UF/10V +-20%	1 PCS	C933
203-064710-202	ELECT CAP 47 UF/10V +-20%	2 PCS	C6,C146
203-072210-202	ELECT CAP 220 UF/10V +-20%	3 PCS	C1,C27,C967
203-074710-202	ELECT CAP 470 UF/10V +-20%	1 PCS	C969
203-081010-202	ELECT CAP 1000 UF/10V +-20%	1 PCS	C971
206-100201-000	DIODE VCD/SVC201 NSX1900	2 PCS	VD101,VD102
206-100348-000	G DIODE VCD/SVC348 PC-X250	1 PCS	D115
206-104148-000	DIODE IN-4148 38.39.4630.63.	20 PCS	D1,D2,D3,D5,D7,D101,D102,D701,D702,D703,D709,D711,D713,D715,D716,D717,D718,D719,D901,D902
206-106938-000	DIODE RPM-6938-V4 (ROHM) AM201	1 PCS	
206-200056-102	ZENER 5.6V 1/2W CD82/CD978/CH	1 PCS	D102
207-003330-000	TRANSISTOR 2SC-3330U CD9788/	3 PCS	Q104,Q903,Q904
207-003399-000	E TRANSISTOR C3399 PC-X250	6 PCS	Q6,Q702,Q705,Q706,Q707,Q708
207-008550-020	TRANSISTOR 8550B/C #38/39/4630	2 PCS	Q918,Q919

Tuner pcb

2-4

207-009014-030	TRANSISTOR 9014C #38/39/4630/	10 PCS	Q1,Q2,Q3,Q4,Q8,Q9,Q11,Q12,Q723,Q921
207-009018-080	TRANSISTOR 9018-H 38/39/63/731	1 PCS	Q15
207-190764-040	TRANSISTOR 2SB-764-D CD85.97	1 PCS	Q909
207-191317-913	TRANSISTOR 2SA-1317-S-AC CD84.	1 PCS	Q901
207-191346-130	TRANSISTOR 2SA-1346-AC CD84.85	2 PCS	Q902,Q34
207-191936-913	TRANSISTOR 2SD-1936-S-AC CD84	4 PCS	Q1,Q2,Q3,Q4
208-010720-118	CERAMIC FILTER 10.7 MCI-A 2PIN	1 PCS	CF104
208-010730-018	CERAMIC FILTER 10.7 MHz 3 PINS	2 PCS	CF101,CF102
208-045030-000	CERAMIC FILTER 450 KHz 3 PINS	1 PCS	CF106
209-181612-010	I.F.T. OSC 1A612R RED 10 mm MW	1 PCS	T101
209-252070-010	I.F.T. IF 2070 YELLOW 10 mm	1 PCS	T103
210-001823-000	I.C. SANYO LA-1823-ESIA CD9938	1 PCS	IC101
210-006541-004	I.C. SANYO LA-6541D CD72.76.83	1 PCS	IC903
210-009241-013	I.C. SANYO LA-9241M CD7588/PC-	1 PCS	IC901
210-072131-000	I.C. SANYO LC-72131D AMR211/31	1 PCS	IC1
210-078622-005	I.C. SANYO LC-78622E CD72.82.	1 PCS	IC902
210-587008-000	G I.C. SANYO LC-587008 PC-X250	1 PCS	IC701
212-065025-100	AM COIL 65:25T WIRE 4 x 100mm	1 PCS	L6
213-035035-070	FM COIL 3.5T 3.5 x 0.7 mm	1 PCS	L105
213-035045-070	FM COIL 3.5T 4.5 x 0.7 mm	1 PCS	L104
216-000010-018	TRIMMER 10 PF RED	2 PCS	CT102,CT103
217-060650-450	TACT SWITCH H=5mm W=6x6mm	15 PCS	SW1-SW11,SW13-SW16
217-200035-050	LEAF SWITCH LS-N35 #CD8488/	1 PCS	
220-207634-241	G LCD DISPLAY 76x34 mm 24 PINS	1 PCS	LCD701
222-010070-000	FERRITE BAR 10 x 70 mm	1 PCS	
226-002600-000	CHOKE COIL 26 uH x2 , COMMON	1 PCS	L1
226-010000-000	CHOKE COIL 100 uH #38.7017.801	1 PCS	L2
227-060505-000	LED ROUND TYPE FLAT HEAD	3 PCS	D1,D4,D6
229-016934-000	CRYSTAL 16.9344 MHz #AMR209.	1 PCS	X901
229-040000-000	G CRYSTAL 4 MHz PC-X250	1 PCS	X701
229-045000-000	CRYSTAL 4.5 MHz	1 PCS	X105
229-327680-200	CRYSTAL 32.768KHz 20PPM HOOR,	1 PCS	X702
232-160190-310	FFC HEADER 16 PINS 1.0mm V	1 PCS	CN901
233-020200-020	HEADER 2 PINS "JST" 2.0mm V	1 PCS	CN904
233-030200-020	HEADER 3 PINS "JST" 2.0mm V	1 PCS	CN702
233-040200-025	HEADER 4 PINS "JST" 2.5mm V	1 PCS	CN701
233-050200-025	HEADER 5 PINS "JST" 2.5mm V	1 PCS	CN302
233-060200-020	HEADER 6 PINS "JST" 2.0 mm V	1 PCS	CN903
237-260080-055	JUMPER WIRE #26 80 mm YELLOW	1 PCS	TUNER BD. C TO D
237-260100-058	JUMPER WIRE #26 100 mm ORANG	1 PCS	TUNER BD. E TO F
237-260150-021	JUMPER WIRE #26 150 mm BLUE	1 PCS	TUNER BD. A TO B
238-120060-102	SCREW ST 2 x 6 mm KB BLACK	5 PCS	CD DOOR LENS

PC-X250

Tuner pcb

238-120060-602	SCREW ST 2 x 6 mm PB BLACK	1 PCS	LEAF SW.
238-126080-632	SCREW ST 2.6 x 8 mm PWB	4 PCS	CD DECK
238-130080-602	SCREW ST 3 x 8 mm PB	10 PCS	CONTROL BD.
238-130080-632	SCREW ST 3 x 8 mm PWB	1 PCS	CD DOOR GEAR
248-250801-123	G P.C.B. PC-X250 TUNER BD.	1 PCS	
270-121524-122	ROTARY ENCODER EC12E24204F2	1 PCS	VR501
356-110300-091	E CD DECK MECHANISM (SANYO) I	1 PCS	
401-101032-000	ANTENNA BAR HOLDER (8012) 801:	2 PCS	
453-030100-050	METAL WASHER 3x10x0.5mm	4 PCS	
458-328840-220	RUBBER SILICON(BLACK) HARDNE	4 PCS	
473-300160-500	CD MAGNET RING 30x16X5mm CD8	1 PCS	
479-328800-000	SPRING FOR CD DOOR	1 PCS	
500-100000-000	CD CHUCK A (FOR SONY&SANYO (1 PCS	
500-291942-501	CD CHUCK M (FOR SANYO DA11)	1 PCS	
500-991110-000	CD MEDHANISM COVER (FOR SAN'	1 PCS	
525-031064-000	DISPLAY BRACKET PC-X250	1 PCS	
539-121100-000	GEAR FOR CASS DOOR 3918	1 PCS	
539-121200-000	GEAR HOLER FOR CASS DOOR 39'	1 PCS	
846-209000-000	CD DOOR LOCK AMR-209M/V3/340	1 PCS	
201-000330-185	RESISTOR 3.3 OHM +-5% 1/8W	1 PCS	J216
201-001000-185	RESISTOR 10 OHM +-5% 1/8W	2 PCS	R75,R89
201-002200-185	RESISTOR 22 OHM +-5% 1/8W	1 PCS	R902
201-011000-185	RESISTOR 100 OHM +-5% 1/8W	16 PCS	R310,R702,R970,R971,R703,R704,R705,R706,R708,R709,R710,R711,R712, R723,R724,R725
201-013300-185	RESISTOR 330 OHM +-5% 1/8W	4 PCS	R201,R208,R931,R20
201-014700-185	RESISTOR 470 OHM +-5% 1/8W	2 PCS	R950,R716
201-016800-185	RESISTOR 680 OHM +-5% 1/8W	2 PCS	R932,R939
201-021000-185	RESISTOR 1 KOHM +-5% 1/8W	13 PCS	R106,R119,R120,R121,R123,R125,R26,R30,R1,R920,R930,R402,R1043
201-021200-185	RESISTOR 1.2 KOHM +-5% 1/8W	2 PCS	R103,R941
201-021500-185	RESISTOR 1.5 KOHM +-5% 1/8W	3 PCS	R2,R11,R915
201-022200-185	RESISTOR 2.2 KOHM +-5% 1/8W	10 PCS	R57,R520,R521,R19,R719,R720,R741,R905,R910,R11
201-023300-185	RESISTOR 3.3 KOHM +-5% 1/8W	3 PCS	R11,R946,R949
201-023900-185	RESISTOR 3.9 KOHM +-5% 1/8W	2 PCS	R945,R948
201-024700-185	RESISTOR 4.7 KOHM +-5% 1/8W	12 PCS	R147,R148,R21,R933,R934,R938,R2,R5,R9,R945,R956,R730,R741
201-025100-185	RESISTOR 5.1 KOHM +-5% 1/8W	2 PCS	R112,R113
201-025600-185	RESISTOR 5.6 KOHM +-5% 1/8W	2 PCS	R12,R17
201-026800-185	RESISTOR 6.8 KOHM +-5% 1/8W	4 PCS	R951,R904,R923,R926
201-028200-185	RESISTOR 8.2 KOHM +-5% 1/8W	5 PCS	R49,R34,R916,R944,R947
201-031000-185	RESISTOR 10 KOHM +-5% 1/8W	22 PCS	R115,R126,R131,R133,R952,R954,R961,R965,R58,R1,R6,R22,R24,R27, R28,R29,R32,R33,R917,R922,R927,R3
201-031500-185	RESISTOR 15 KOHM +-5% 1/8W	22 PCS	R4,R5,R7,R8,R38,R46,R47,R48,R713,R714,R727,R728,R729,R734,R735,

Tuner pcb

2-6

201-032200-185	RESISTOR 22 KOHM +-5% 1/8W	3 PCS	R908,R913,R928,R96,R77,R92,R40
201-032700-185	RESISTOR 27 KOHM +-5% 1/8W	2 PCS	R912,R929,R985
201-033300-185	RESISTOR 33 KOHM +-5% 1/8W	5 PCS	R35,R911
201-034700-185	RESISTOR 47 KOHM +-5% 1/8W	9 PCS	R108,R10,R14,R918,R974
201-035600-185	RESISTOR 56 KOHM +-5% 1/8W	4 PCS	R3,R4,R6,R7,R8,R9,R13,R18,R715
201-036800-185	RESISTOR 68 KOHM +-5% 1/8W	2 PCS	R137,R919,R921,R940
201-041000-185	RESISTOR 100 KOHM +-5% 1/8W	5 PCS	R907,R914
201-041500-185	RESISTOR 150 KOHM +-5% 1/8W	1 PCS	R101,R102,R134,R906,R942
201-042200-185	RESISTOR 220 KOHM +-5% 1/8W	3 PCS	R903
201-042700-185	RESISTOR 270 KOHM +-5% 1/8W	1 PCS	R104,R924,R925
201-051000-185	RESISTOR 1 MOHM +-5% 1/8W	2 PCS	R25
202-100505-505	G CERAMIC CAP 5 PF/50V SL +-5%	1 PCS	R945,R948
202-101805-505	G CERAMIC CAP 18 PF/50V SL	1 PCS	C920
202-103005-505	H CERAMIC CAP 30 PF/50V SL	6 PCS	C140
202-103305-505	H CERAMIC CAP 33 PF/50V SL	2 PCS	C105,C106,C138,C139,C713,C714
202-104705-505	H CERAMIC CAP 47 PF/50V SL	1 PCS	C950,C951
202-211005-101	G CERAMIC CAP 100 PF/50V B(X7R	5 PCS	C114
202-213005-101	G CERAMIC CAP 300 PF/50V B(X7R	1 PCS	C111,C112,C113,C916,C952
202-213305-101	G CERAMIC CAP 330 PF/50V B(X7R	2 PCS	C121
202-221005-101	G CERAMIC CAP 0.001 UF/50V B	8 PCS	C904,C942
202-422201-202	G CERAMIC CAP 0.0022 UF/16V X	1 PCS	C125,C133,C136,C910,C943,C948,C949,C983
202-422701-101	G CERAMIC CAP 0.0027 UF/16V X	1 PCS	C921
202-423301-202	G CERAMIC CAP 0.0033 UF/16V X	3 PCS	C132
202-500305-505	G CERAMIC CAP 3 PF/50V NPO	2 PCS	C907,C914,C919
202-500335-505	G CERAMIC CAP 3.3 PF/50V NPO	2 PCS	C126,C127
202-500505-505	G CERAMIC CAP 5 PF/50V NPO	1 PCS	C707,C708
202-501505-505	G CERAMIC CAP 15 PF/50V NPO	2 PCS	C120
202-631002-802	G CERAMIC CAP 0.01 UF/25V F	7 PCS	C922
202-631502-802	G CERAMIC CAP 0.015 UF/25V F	1 PCS	C110,C116,C119,C926,C972,C980,C998
202-631802-802	G CERAMIC CAP 0.018 UF/25V F	3 PCS	C912
202-632002-802	G CERAMIC CAP 0.020 UF/25V F	1 PCS	C141,C142,C913
202-632202-802	G CERAMIC CAP 0.022 UF/25V F	2 PCS	C122
202-633302-802	G CERAMIC CAP 0.033 UF/25V F	4 PCS	C103,C118
202-634702-802	G CERAMIC CAP 0.047 UF/25V F	3 PCS	C902,C903,C905,C923
202-641002-802	G CERAMIC CAP 0.1 UF/25V F(Y5V	18 PCS	C908,C927,C930
202-641502-802	G CERAMIC CAP 0.15 UF/25V F(Y5	2 PCS	C107,C108,C135,C137,C143,C144,C706,C709,C710,C711,C911,C932,C944, C968,C970,C984,C985,C986
203-041050-202	ELECT CAP 0.1 UF/50V +-20%	1 PCS	C901,C909
203-042250-202	ELECT CAP 0.22 UF/50V +-20%	1 PCS	C130
203-051050-202	ELECT CAP 1 UF/50V +-20%	1 PCS	C931
203-053350-202	ELECT CAP 3.3 UF/50V +-20%	1 PCS	C712
			C145

PC-X250

Tuner pcb

203-054750-202	ELECT CAP 4.7 UF/50V +-20%	3 PCS	C145,C701,C935
203-061025-212	ELECT CAP 10 UF/25V +-20%	7 PCS	C18,C963,C965,C915,C901,C905,C963
203-062210-202	ELECT CAP 22 UF/10V +-20%	1 PCS	C933
203-064710-202	ELECT CAP 47 UF/10V +-20%	2 PCS	C6,C146
203-072210-202	ELECT CAP 220 UF/10V +-20%	3 PCS	C1,C27,C967
203-074710-202	ELECT CAP 470 UF/10V +-20%	1 PCS	C969
203-081010-202	ELECT CAP 1000 UF/10V +-20%	1 PCS	C971
206-100201-000	DIODE VCD/SVC201 NSX1900	2 PCS	VD101,VD102
206-100348-000	G DIODE VCD/SVC348 PC-X250	1 PCS	D115
206-104148-000	DIODE IN-4148 38.39.4630.63.	20 PCS	D1,D2,D3,D5,D7,D101,D102,D701,D702,D703,D709,D711,D713,D715, D716,D717,D718,D719,D901,D902
206-106938-000	DIODE RPM-6938-V4 (ROHM) AM201	1 PCS	
206-200056-102	ZENER 5.6V 1/2W CD82/CD978/CH	1 PCS	D102
207-003330-000	TRANSISTOR 2SC-3330U CD9788/	3 PCS	Q104,Q903,Q904
207-003399-000	E TRANSISTOR C3399 PC-X250	6 PCS	Q6,Q702,Q705,Q706,Q707,Q708
207-008550-020	TRANSISTOR 8550B/C #38/39/4630	2 PCS	Q918,Q919
207-009014-030	TRANSISTOR 9014C #38/39/4630/	10 PCS	Q1,Q2,Q3,Q4,Q8,Q9,Q11,Q12,Q723,Q921
207-009018-080	TRANSISTOR 9018-H 38/39/63/731	1 PCS	Q15
207-190764-040	TRANSISTOR 2SB-764-D CD85.97	1 PCS	Q909
207-191317-913	TRANSISTOR 2SA-1317-S-AC CD84.	1 PCS	Q901
207-191346-130	TRANSISTOR 2SA-1346-AC CD84.85	2 PCS	Q902,Q34
207-191936-913	TRANSISTOR 2SD-1936-S-AC CD84	4 PCS	Q1,Q2,Q3,Q4
208-010720-118	CERAMIC FILTER 10.7 MCI-A 2PIN	1 PCS	CF104
208-010730-018	CERAMIC FILTER 10.7 MHz 3 PINS	2 PCS	CF101,CF102
208-045030-000	CERAMIC FILTER 450 KHz 3 PINS	1 PCS	CF106
209-181612-010	I.F.T. OSC 1A612R RED 10 mm MW	1 PCS	T101
209-252070-010	I.F.T. IF 2070 YELLOW 10 mm	1 PCS	T103
210-001823-000	I.C. SANYO LA-1823-ESIA CD9938	1 PCS	IC101
210-006541-004	I.C. SANYO LA-6541D CD72.76.83	1 PCS	IC903
210-009241-013	I.C. SANYO LA-9241M CD7588/PC-	1 PCS	IC901
210-072131-000	I.C. SANYO LC-72131D AMR211/31	1 PCS	IC1
210-078622-005	I.C. SANYO LC-78622E CD72.82.	1 PCS	IC902
210-587008-000	G I.C. SANYO LC-587008 PC-X250	1 PCS	IC701
212-065025-100	AM COIL 65:25T WIRE 4 x 100mm	1 PCS	L6
213-035035-070	FM COIL 3.5T 3.5 x 0.7 mm	1 PCS	L105
213-035045-070	FM COIL 3.5T 4.5 x 0.7 mm	1 PCS	L104
216-000010-018	TRIMMER 10 PF RED	2 PCS	CT102,CT103
217-060650-450	TACT SWITCH H=5mm W=6x6mm	15 PCS	SW1-SW11,SW13-SW16
217-200035-050	LEAF SWITCH LS-N35 #CD8488/	1 PCS	
220-207634-241	G LCD DISPLAY 76x34 mm 24 PINS	1 PCS	LCD701
222-010070-000	FERRITE BAR 10 x 70 mm	1 PCS	
226-002600-000	CHOKE COIL 26 uH x2 , COMMON	1 PCS	L1

Tuner pcb

2-8

226-010000-000	CHOKE COIL 100 uH #38.7017.801	1 PCS	L2
227-060505-000	LED ROUND TYPE FLAT HEAD	3 PCS	D1,D4,D6
229-016934-000	CRYSTAL 16.9344 MHz #AMR209.	1 PCS	X901
229-040000-000	G CRYSTAL 4 MHz PC-X250	1 PCS	X701
229-045000-000	CRYSTAL 4.5 MHz	1 PCS	X105
229-327680-200	CRYSTAL 32.768KHz 20PPM HOOR,	1 PCS	X702
232-160190-310	FFC HEADER 16 PINS 1.0mm V	1 PCS	CN901
233-020200-020	HEADER 2 PINS "JST" 2.0mm V	1 PCS	CN904
233-030200-020	HEADER 3 PINS "JST" 2.0mm V	1 PCS	CN702
233-040200-025	HEADER 4 PINS "JST" 2.5mm V	1 PCS	CN701
233-050200-025	HEADER 5 PINS "JST" 2.5mm V	1 PCS	CN302
233-060200-020	HEADER 6 PINS "JST" 2.0 mm V	1 PCS	CN903
237-260080-055	JUMPER WIRE #26 80 mm YELLOW	1 PCS	TUNER BD. C TO D
237-260100-058	JUMPER WIRE #26 100 mm ORANG	1 PCS	TUNER BD. E TO F
237-260150-021	JUMPER WIRE #26 150 mm BLUE	1 PCS	TUNER BD. A TO B
238-120060-102	SCREW ST 2 x 6 mm KB BLACK	5 PCS	CD DOOR LENS
238-120060-602	SCREW ST 2 x 6 mm PB BLACK	1 PCS	LEAF SW.
238-126080-632	SCREW ST 2.6 x 8 mm PWB	4 PCS	CD DECK
238-130080-602	SCREW ST 3 x 8 mm PB	10 PCS	CONTROL BD.
238-130080-632	SCREW ST 3 x 8 mm PWB	1 PCS	CD DOOR GEAR
248-250801-123	G P.C.B. PC-X250 TUNER BD.	1 PCS	
270-121524-122	ROTARY ENCODER EC12E24204F2	1 PCS	VR501
356-110300-091	E CD DECK MECHANISM (SANYO) I	1 PCS	
401-101032-000	ANTENNA BAR HOLDER (8012) 801:	2 PCS	
453-030100-050	METAL WASHER 3x10x0.5mm	4 PCS	
458-328840-220	RUBBER SILICON(BLACK) HARDNE	4 PCS	
473-300160-500	CD MAGNET RING 30x16X5mm CD8	1 PCS	
479-328800-000	SPRING FOR CD DOOR	1 PCS	
500-100000-000	CD CHUCK A (FOR SONY&SANYO C	1 PCS	
500-291942-501	CD CHUCK M (FOR SANYO DA11)	1 PCS	
500-991110-000	CD MEDHANISM COVER (FOR SAN'	1 PCS	
525-031064-000	DISPLAY BRACKET PC-X250	1 PCS	
539-121100-000	GEAR FOR CASS DOOR 3918	1 PCS	
539-121200-000	GEAR HOLER FOR CASS DOOR 39'	1 PCS	
846-209000-000	CD DOOR LOCK AMR-209M/V3/340	1 PCS	

Audio pcb

Part No.	Materials	Qty	Position
201-000220-125	RESISTOR 2.2 OHM +-5% 1/2W	2 PCS	R240,R406
201-000220-145	RESISTOR 2.2 OHM +-5% 1/4W	1 PCS	R408
201-000220-185	RESISTOR 2.2 OHM +-5% 1/8W	2 PCS	R306,R307
201-000560-185	RESISTOR 5.6 OHM +-5% 1/8W	1 PCS	R804
201-001000-145	RESISTOR 10 OHM +-5% 1/4W	1 PCS	R239
201-002200-185	RESISTOR 22 OHM +-5% 1/8W	1 PCS	R568
201-003300-185	RESISTOR 33 OHM +-5% 1/8W	5 PCS	R207,R208,R217,R238,R254
201-008200-185	RESISTOR 82 OHM +-5% 1/8W	1 PCS	R414
201-011000-185	RESISTOR 100 OHM +-5% 1/8W	4 PCS	R204,R221,R246,R508
201-011500-185	RESISTOR 150 OHM +-5% 1/8W	3 PCS	R407,R409,R412
201-012200-145	RESISTOR 220 OHM +-5% 1/4W	2 PCS	R301,R302
201-012200-185	RESISTOR 220 OHM +-5% 1/8W	1 PCS	R213
201-013300-185	RESISTOR 330 OHM +-5% 1/8W	1 PCS	R405
201-015600-185	RESISTOR 560 OHM +-5% 1/8W	1 PCS	R402
201-016800-185	RESISTOR 680 OHM +-5% 1/8W	1 PCS	ZD201
201-021000-185	RESISTOR 1 KOHM +-5% 1/8W	5 PCS	R201,R202,R221,R223,R241
201-022200-185	RESISTOR 2.2 KOHM +-5% 1/8W	11 PCS	R215,R235,R244,R245,R248,R249,R250,R251,R253,R316,R319
201-022700-185	RESISTOR 2.7 KOHM +-5% 1/8W	1 PCS	R316
201-023300-185	RESISTOR 3.3 KOHM +-5% 1/8W	3 PCS	R247,R257,R258
201-023900-185	RESISTOR 3.9 KOHM +-5% 1/8W	2 PCS	R505,R506
201-024700-185	RESISTOR 4.7 KOHM +-5% 1/8W	6 PCS	R220,R311,R516,R569,R570,R571
201-025600-185	RESISTOR 5.6 KOHM +-5% 1/8W	3 PCS	R247,R256,R803
201-031000-185	RESISTOR 10 KOHM +-5% 1/8W	16 PCS	R303,R304,R320,R321,R404,R410,R507,R509,R510,R571,R511,R512, R513,R801,R802,R805
201-031200-185	RESISTOR 12 KOHM +-5% 1/8W	5 PCS	R11,R227,R312,R313,R2105
201-031500-185	RESISTOR 15 KOHM +-5% 1/8W	2 PCS	R211,R212
201-032200-185	RESISTOR 22 KOHM +-5% 1/8W	3 PCS	R259,R317,R569
201-032700-185	RESISTOR 27 KOHM +-5% 1/8W	1 PCS	R225
201-034700-185	RESISTOR 47 KOHM +-5% 1/8W	10 PCS	R234,R235,R209,R210,R565,R566,R562,R228,R401,R230
201-036800-185	RESISTOR 68 KOHM +-5% 1/8W	2 PCS	R242,R243
201-038200-185	RESISTOR 82 KOHM +-5% 1/8W	2 PCS	R501,R521
201-041000-185	RESISTOR 100 KOHM +-5% 1/8W	8 PCS	R221,R236,R252,R253,R403,R413,R561,R564
201-041500-185	RESISTOR 150 KOHM +-5% 1/8W	1 PCS	R237
201-044700-185	RESISTOR 470 KOHM +-5% 1/8W	1 PCS	R315
201-051000-185	RESISTOR 1 MOHM +-5% 1/8W	1 PCS	R214
202-215005-101	H CERAMIC CAP 500 PF/50V B(X	4 PCS	C212,C213,C239,C240
202-221005-101	G CERAMIC CAP 0.001 UF/50V B	3 PCS	C303,C304,C804
202-421501-202	G CERAMIC CAP 0.0015 UF/16V)	4 PCS	C216,C217,C244,C247
202-422701-202	G CERAMIC CAP 0.0027 UF/16V)	2 PCS	C514,C523
202-424701-202	G CERAMIC CAP 0.0047 UF/16V)	3 PCS	C210,C211,C803

Audio pcb

202-631002-802	G CERAMIC CAP 0.01 UF/25V F	1 PCS	C802
202-632202-802	G CERAMIC CAP 0.022 UF/25V F	6 PCS	C203,C222,C223,C234,C406,C805
202-633902-802	G CERAMIC CAP 0.039 UF/25V F	2 PCS	C220,C221
202-641002-802	G CERAMIC CAP 0.1 UF/25V F(Y5)	10 PCS	C228,C232,C315,C408,C515,C516,C517,C518,C522,C1
202-641502-802	G CERAMIC CAP 0.15 UF/25V F(Y5)	2 PCS	C306,C307
203-044750-202	ELECT CAP 0.47 UF/50V +-20%	2 PCS	C224,C225
203-051050-202	ELECT CAP 1 UF/50V +-20%	18 PCS	C204,C206,C207,C208,C209,C236,C312,C314,C314,C501,C502, C503,C505,C506,C509,C510,C511,C512
203-052250-202	ELECT CAP 2.2 UF/50V +-20%	1 PCS	C231
203-054725-202	ELECT CAP 4.7 UF/25V +-20%	4 PCS	C316,C317,C502,C519
203-061016-202	ELECT CAP 10 UF/16V +-20%	7 PCS	C238,C576,C412,C14,C568,C214,C215
203-062216-202	ELECT CAP 22 UF/16V +-20%	4 PCS	C226,C227,C233,C523
203-064725-202	ELECT CAP 47 UF/25V +-20%	11 PCS	C301,C302,C305,C402,C407,C315,C544,C404,C243,C237,C242
203-071010-202	ELECT CAP 100 UF/10V +-20%	6 PCS	C218,C219,C230,C226,C227,C241
203-071016-202	ELECT CAP 100 UF/16V +-20%	4 PCS	C308,C309,C229,C538
203-072216-202	ELECT CAP 220 UF/16V +-20%	3 PCS	C2,C401,C806
203-074710-202	ELECT CAP 470 UF/10V +-20%	2 PCS	C521,C524
203-081016-202	ELECT CAP 1000 UF/16V +-20%	2 PCS	C310,C311
203-083325-202	ELECT CAP 3300 UF/25V +-20%	1 PCS	C409
204-021099-101	MYLAR CAP 0.001 UF/100V +-10%	3 PCS	C303,C304,C804
204-021599-101	MYLAR CAP 0.0015 UF/100V +-10%	4 PCS	C216,C217
204-024799-101	MYLAR CAP 0.0047 UF/100V +-10%	3 PCS	C210,C803
204-031099-101	MYLAR CAP 0.01 UF/100V +-10%	1 PCS	C802
204-032299-101	MYLAR CAP 0.022 UF/100V +-10%	3 PCS	C222,C223,C801
204-033950-101	MYLAR CAP 0.039 UF/50V +-10%	2 PCS	C220,C221
204-041599-101	MYLAR CAP 0.15 UF/100V +-10%	2 PCS	C306,C307
206-104148-000	DIODE IN-4148 38.39.4630.63.	5 PCS	D203,D205,D301,D302,D303
206-200043-102	ZENER 4.3V 1/2W CH818RC	1 PCS	D423
206-200056-102	ZENER 5.6V 1/2W CD82/CD978/C	2 PCS	D401,D422
206-200082-102	ZENER 8.2V 1/2W #CD32.42.72.71	1 PCS	D206
206-200091-102	ZENER 9.1V 1/2W CD3508	2 PCS	D1,D402
206-304001-000	RECTIFIER IN-4001 38.39.63.70.	1 PCS	D421
207-000772-250	TRANSISTOR B772-Y SKC-V3	1 PCS	Q401
207-008050-030	TRANSISTOR 8050C/D #38/39/63/	4 PCS	Q214,Q403,Q506,Q801
207-008550-020	TRANSISTOR 8550B/C #38/39/46/	4 PCS	Q204,Q211,Q407,Q409
207-009014-030	TRANSISTOR 9014C #38/39/4630.	20 PCS	Q303,Q406,Q203,Q402,Q208,Q408,Q301,Q302,Q205,Q802,Q206,Q207, Q208,Q511,Q510,Q501,Q502,Q212,Q512,Q803
207-009015-030	TRANSISTOR 9015C #38/39/4630.	1 PCS	Q304
207-182061-500	TRANSISTOR 2SD-2061E #AMR2	1 PCS	Q404
207-182159-050	TRANSISTOR 2SD-2159E 8017/CI	1 PCS	Q410
209-223630-010	I.F.T. AC BIAS 3630 BLACK 10mr	1 PCS	T801
210-003126-014	G I.C. ROHM BA3126N PC-X250	1 PCS	IC201

Audio pcb

210-003308-000	I.C. ROHM BA-3308 #39/63/73/79	1 PCS	IC203
210-003416-022	I.C. ROHM BA-3416BL 63/73/8025	1 PCS	IC202
210-005417-000	I.C. ROHM BA-5417 AMR209/M90	1 PCS	IC301
210-075342-000	G I.C. SANYO LC75342 PC-X250	1 PCS	IC501
215-800500-000	SEMI-FIXED FRB-085-500 OHM /	1 PCS	SF201
218-622400-900	PUSH SWITCH PS-22E03 2P2T W	1 PCS	SW201
233-030200-025	HEADER 3 PINS "JST" 2.5mm V	1 PCS	CN201
233-040200-020	HEADER 4 PINS "JST" 2.0mm V	1 PCS	CN502
233-050200-025	HEADER 5 PINS "JST" 2.5mm V	2 PCS	CN202,CN405
233-080200-025	HEADER 8 PINS "JST" 2.5mm V	2 PCS	CN203,CN501
240-004000-000	DC JACK DC-400	1 PCS	DC401
241-000252-638	G RCA JACK MSP-252V-04 NI PC	1 PCS	JK301
248-250802-117	G P.C.B. PC-X250 AUDIO BD.	1 PCS	
201-000220-125	RESISTOR 2.2 OHM +-5% 1/2W	2 PCS	R240,R406
201-000220-145	RESISTOR 2.2 OHM +-5% 1/4W	1 PCS	R408
201-000220-185	RESISTOR 2.2 OHM +-5% 1/8W	2 PCS	R306,R307
201-000560-185	RESISTOR 5.6 OHM +-5% 1/8W	1 PCS	R804
201-001000-145	RESISTOR 10 OHM +-5% 1/4W	1 PCS	R239
201-002200-185	RESISTOR 22 OHM +-5% 1/8W	1 PCS	R568
201-003300-185	RESISTOR 33 OHM +-5% 1/8W	5 PCS	R207,R208,R217,R238,R254
201-008200-185	RESISTOR 82 OHM +-5% 1/8W	1 PCS	R414
201-011000-185	RESISTOR 100 OHM +-5% 1/8W	4 PCS	R204,R221,R246,R508
201-011500-185	RESISTOR 150 OHM +-5% 1/8W	3 PCS	R407,R409,R412
201-012200-145	RESISTOR 220 OHM +-5% 1/4W	2 PCS	R301,R302
201-012200-185	RESISTOR 220 OHM +-5% 1/8W	1 PCS	R213
201-013300-185	RESISTOR 330 OHM +-5% 1/8W	1 PCS	R405
201-015600-185	RESISTOR 560 OHM +-5% 1/8W	1 PCS	R402
201-016800-185	RESISTOR 680 OHM +-5% 1/8W	1 PCS	ZD201
201-021000-185	RESISTOR 1 KOHM +-5% 1/8W	5 PCS	R201,R202,R221,R223,R241
201-022200-185	RESISTOR 2.2 KOHM +-5% 1/8W	11 PCS	R215,R235,R244,R245,R248,R249,R250,R251,R253,R316,R319
201-022700-185	RESISTOR 2.7 KOHM +-5% 1/8W	1 PCS	R316
201-023300-185	RESISTOR 3.3 KOHM +-5% 1/8W	3 PCS	R247,R257,R258
201-023900-185	RESISTOR 3.9 KOHM +-5% 1/8W	2 PCS	R505,R506
201-024700-185	RESISTOR 4.7 KOHM +-5% 1/8W	6 PCS	R220,R311,R516,R569,R570,R571
201-025600-185	RESISTOR 5.6 KOHM +-5% 1/8W	3 PCS	R247,R256,R803
201-031000-185	RESISTOR 10 KOHM +-5% 1/8W	16 PCS	R303,R304,R320,R321,R404,R410,R507,R509,R510,R571,R511,R512, R513,R801,R802,R805
201-031200-185	RESISTOR 12 KOHM +-5% 1/8W	5 PCS	R11,R227,R312,R313,R2105
201-031500-185	RESISTOR 15 KOHM +-5% 1/8W	2 PCS	R211,R212
201-032200-185	RESISTOR 22 KOHM +-5% 1/8W	3 PCS	R259,R317,R569
201-032700-185	RESISTOR 27 KOHM +-5% 1/8W	1 PCS	R225
201-034700-185	RESISTOR 47 KOHM +-5% 1/8W	10 PCS	R234,R235,R209,R210,R565,R566,R562,R228,R401,R230

Audio pcb

201-036800-185	RESISTOR 68 KOHM +-5% 1/8W	2 PCS	R242,R243
201-038200-185	RESISTOR 82 KOHM +-5% 1/8W	2 PCS	R501,R521
201-041000-185	RESISTOR 100 KOHM +-5% 1/8W	8 PCS	R221,R236,R252,R253,R403,R413,R561,R564
201-041500-185	RESISTOR 150 KOHM +-5% 1/8W	1 PCS	R237
201-044700-185	RESISTOR 470 KOHM +-5% 1/8W	1 PCS	R315
201-051000-185	RESISTOR 1 MOHM +-5% 1/8W	1 PCS	R214
202-215005-101	H CERAMIC CAP 500 PF/50V B(X	4 PCS	C212,C213,C239,C240
202-221005-101	G CERAMIC CAP 0.001 UF/50V B	3 PCS	C303,C304,C804
202-421501-202	G CERAMIC CAP 0.0015 UF/16V)	4 PCS	C216,C217,C244,C247
202-422701-202	G CERAMIC CAP 0.0027 UF/16V)	2 PCS	C514,C523
202-424701-202	G CERAMIC CAP 0.0047 UF/16V)	3 PCS	C210,C211,C803
202-631002-802	G CERAMIC CAP 0.01 UF/25V F	1 PCS	C802
202-632202-802	G CERAMIC CAP 0.022 UF/25V F	6 PCS	C203,C222,C223,C234,C406,C805
202-633902-802	G CERAMIC CAP 0.039 UF/25V F	2 PCS	C220,C221
202-641002-802	G CERAMIC CAP 0.1 UF/25V F(Y	10 PCS	C228,C232,C315,C408,C515,C516,C517,C518,C522,C1
202-641502-802	G CERAMIC CAP 0.15 UF/25V F(Y	2 PCS	C306,C307
203-044750-202	ELECT CAP 0.47 UF/50V +-20%	2 PCS	C224,C225
203-051050-202	ELECT CAP 1 UF/50V +-20%	18 PCS	C204,C206,C207,C208,C209,C236,C312,C314,C314,C501,C502,C503, C505,C506,C509,C510,C511,C512
203-052250-202	ELECT CAP 2.2 UF/50V +-20%	1 PCS	C231
203-054725-202	ELECT CAP 4.7 UF/25V +-20%	4 PCS	C316,C317,C502,C519
203-061016-202	ELECT CAP 10 UF/16V +-20%	7 PCS	C238,C576,C412,C14,C568,C214,C215
203-062216-202	ELECT CAP 22 UF/16V +-20%	4 PCS	C226,C227,C233,C523
203-064725-202	ELECT CAP 47 UF/25V +-20%	11 PCS	C301,C302,C305,C402,C407,C315,C544,C404,C243,C237,C242
203-071010-202	ELECT CAP 100 UF/10V +-20%	6 PCS	C218,C219,C230,C226,C227,C241
203-071016-202	ELECT CAP 100 UF/16V +-20%	4 PCS	C308,C309,C229,C538
203-072216-202	ELECT CAP 220 UF/16V +-20%	3 PCS	C2,C401,C806
203-074710-202	ELECT CAP 470 UF/10V +-20%	2 PCS	C521,C524
203-081016-202	ELECT CAP 1000 UF/16V +-20%	2 PCS	C310,C311
203-083325-202	ELECT CAP 3300 UF/25V +-20%	1 PCS	C409
204-021099-101	MYLAR CAP 0.001 UF/100V +-10%	3 PCS	C303,C304,C804
204-021599-101	MYLAR CAP 0.0015 UF/100V +-10%	4 PCS	C216,C217
204-024799-101	MYLAR CAP 0.0047 UF/100V +-10%	3 PCS	C210,C803
204-031099-101	MYLAR CAP 0.01 UF/100V +-10%	1 PCS	C802
204-032299-101	MYLAR CAP 0.022 UF/100V +-10%	3 PCS	C222,C223,C801
204-033950-101	MYLAR CAP 0.039 UF/50V +-10%	2 PCS	C220,C221
204-041599-101	MYLAR CAP 0.15 UF/100V +-10%	2 PCS	C306,C307
206-104148-000	DIODE IN-4148 38.39.4630.63.	5 PCS	D203,D205,D301,D302,D303
206-200043-102	ZENER 4.3V 1/2W CH818RC	1 PCS	D423
206-200056-102	ZENER 5.6V 1/2W CD82/CD978/C	2 PCS	D401,D422
206-200082-102	ZENER 8.2V 1/2W #CD32.42.72.71	1 PCS	D206
206-200091-102	ZENER 9.1V 1/2W CD3508	2 PCS	D1,D402

Audio pcb

206-304001-000	RECTIFIER IN-4001 38.39.63.70.	1 PCS	D421
207-000772-250	TRANSISTOR B772-Y SKC-V3	1 PCS	Q401
207-008050-030	TRANSISTOR 8050C/D #38/39/63/	4 PCS	Q214,Q403,Q506,Q801
207-008550-020	TRANSISTOR 8550B/C #38/39/46:	4 PCS	Q204,Q211,Q407,Q409
207-009014-030	TRANSISTOR 9014C #38/39/4630.	20 PCS	Q303,Q406,Q203,Q402,Q208,Q408,Q301,Q302,Q205,Q802,Q206,Q207, Q208,Q511,Q510,Q501,Q502,Q212,Q512,Q803
207-009015-030	TRANSISTOR 9015C #38/39/4630.	1 PCS	Q304
207-182061-500	TRANSISTOR 2SD-2061E #AMR2	1 PCS	Q404
207-182159-050	TRANSISTOR 2SD-2159E 8017/CI	1 PCS	Q410
209-223630-010	I.F.T. AC BIAS 3630 BLACK 10mr	1 PCS	T801
210-003126-014	G I.C. ROHM BA3126N PC-X250	1 PCS	IC201
210-003308-000	I.C. ROHM BA-3308 #39/63/73/79	1 PCS	IC203
210-003416-022	I.C. ROHM BA-3416BL 63/73/8025	1 PCS	IC202
210-005417-000	I.C. ROHM BA-5417 AMR209/M90	1 PCS	IC301
210-075342-000	G I.C. SANYO LC75342 PC-X250	1 PCS	IC501
215-800500-000	SEMI-FIXED FRB-085-500 OHM /	1 PCS	SF201
218-622400-900	PUSH SWITCH PS-22E03 2P2T V	1 PCS	SW201
233-030200-025	HEADER 3 PINS "JST" 2.5mm V	1 PCS	CN201
233-040200-020	HEADER 4 PINS "JST" 2.0mm V	1 PCS	CN502
233-050200-025	HEADER 5 PINS "JST" 2.5mm V	2 PCS	CN202,CN405
233-080200-025	HEADER 8 PINS "JST" 2.5mm V	2 PCS	CN203,CN501
240-004000-000	DC JACK DC-400	1 PCS	DC401
241-000252-638	G RCA JACK MSP-252V-04 NI PC	1 PCS	JK301
248-250802-117	G P.C.B. PC-X250 AUDIO BD.	1 PCS	

Rectifier pcb

Part No.	Materials	Qty	Position
202-634002-802	A CERAMIC CAP 0.040 UF/25V F	4 PCS	C1101-C1104
206-305401-000	RECTIFIER IN-5401 #AMR209.309L	4 PCS	D1101-D1104
231-220005-125	GLASS TUBE FUSE 2A 125V TSP	1 PCS	
233-020200-025	HEADER 2 PINS "JST" 2.5mm V	1 PCS	CN1101
248-250812-100	G P.C.B. PC-X250 RECTIFIER BD.	1 PCS	
406-050090-000	FUSE HOLDER 5 x 9 mm MW1010K	2 PCS	
202-634002-802	A CERAMIC CAP 0.040 UF/25V F	4 PCS	C1101-C1104
206-305401-000	RECTIFIER IN-5401 #AMR209.309L	4 PCS	D1101-D1104
231-220005-125	GLASS TUBE FUSE 2A 125V TSP	1 PCS	
233-020200-025	HEADER 2 PINS "JST" 2.5mm V	1 PCS	CN1101
248-250812-100	G P.C.B. PC-X250 RECTIFIER BD.	1 PCS	
406-050090-000	FUSE HOLDER 5 x 9 mm MW1010K	2 PCS	

Recording pcb

Part No.	Material	Qty	Position
218-085085-180	PUSH SWITCH PS-8.5x8.5-180G	1 PCS	SW802
233-030200-025	HEADER 3 PINS "JST" 2.5mm V	2 PCS	CN801,CN802
248-250813-100	G P.C.B. PC-X250 RECORDING BD.	1 PCS	

Lighting pcb

2-16

Part No.	Assembly/B.O.M.	Qty	Position
227-020302-86	(LIGHT BULB 8V 60 mA DIA=3 mm	3 PCS	LAMP701,LAMP702,LAMP703
248-250808-10	(G P.C.B. PC-X250 LIGHT BD.	1 PCS	
402-030070-02	1 LIGHT BULB COVER 3 mm (BLUE	3 PCS	LAMP701,LAMP702,LAMP703

PC-X250