

Computer Networks: A Systems Approach
Fifth Edition
Solutions Manual

Larry Peterson and Bruce Davie

2011

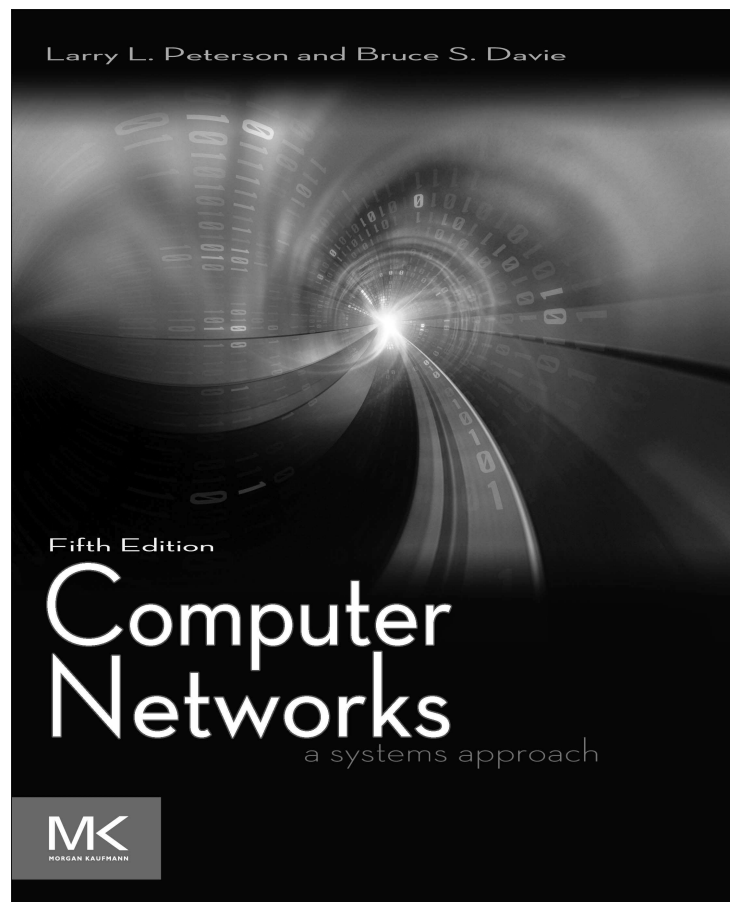

Dear Instructor:

This *Instructors' Manual* contains solutions to most of the exercises in the fifth edition of Peterson and Davie's *Computer Networks: A Systems Approach*.

Exercises are sorted (roughly) by section, not difficulty. While some exercises are more difficult than others, none are intended to be fiendishly tricky. A few exercises (notably, though not exclusively, the ones that involve calculating simple probabilities) require a modest amount of mathematical background; most do not. There is a sidebar summarizing much of the applicable basic probability theory in Chapter 2.

An occasional exercise is awkwardly or ambiguously worded in the text. This manual sometimes suggests better versions; also see the errata at the web site.

Where appropriate, relevant supplemental files for these solutions (*e.g.* programs) have been placed on the textbook web site, <http://mkp.com/computer-networks>. Useful other material can also be found there, such as errata, sample programming assignments, PowerPoint lecture slides, and EPS figures.

If you have any questions about these support materials, please contact your Morgan Kaufmann sales representative. If you would like to contribute your own teaching materials to this site, please contact our Associate Editor David Bevans, D.Bevans@elsevier.com.

We welcome bug reports and suggestions as to improvements for both the exercises and the solutions; these may be sent to netbugsPD5e@elsevier.com.

Larry Peterson
Bruce Davie
March, 2011

Solutions for Chapter 1

3. We will count the transfer as completed when the last data bit arrives at its destination. An alternative interpretation would be to count until the last ACK arrives back at the sender, in which case the time would be half an RTT (25 ms) longer.
 - (a) 2 initial RTT's (100ms) + 1000KB/1.5Mbps (transmit) + RTT/2 (propagation = 25ms)

$$\approx 0.125 + 8\text{Mbit}/1.5\text{Mbps} = 0.125 + 5.333 \text{ sec} = 5.458 \text{ sec.}$$
 If we pay more careful attention to when a mega is 10^6 versus 2^{20} , we get $8,192,000\text{bits}/1,500,000\text{bps} = 5.461 \text{ sec}$, for a total delay of 5.586 sec.
 - (b) To the above we add the time for 999 RTTs (the number of RTTs between when packet 1 arrives and packet 1000 arrives), for a total of $5.586 + 49.95 = 55.536$.
 - (c) This is 49.5 RTTs, plus the initial 2, for 2.575 seconds.
 - (d) Right after the handshaking is done we send one packet. One RTT after the handshaking we send two packets. At n RTTs past the initial handshaking we have sent $1 + 2 + 4 + \dots + 2^n = 2^{n+1} - 1$ packets. At $n = 9$ we have thus been able to send all 1,000 packets; the last batch arrives 0.5 RTT later. Total time is $2+9.5$ RTTs, or .575 sec.
4. The answer is in the book.
5. Propagation delay is $4 \times 10^3 \text{ m} / (2 \times 10^8 \text{ m/s}) = 2 \times 10^{-5} \text{ sec} = 20 \mu\text{s}$. 100 bytes/ $20 \mu\text{s}$ is 5 bytes/ μs , or 5 MBps, or 40 Mbps. For 512-byte packets, this rises to 204.8 Mbps.
6. The answer is in the book.
7. Postal addresses are strongly hierarchical (with a geographical hierarchy, which network addressing may or may not use). Addresses also provide embedded "routing information". Unlike typical network addresses, postal addresses are long and of variable length and contain a certain amount of redundant information. This last attribute makes them more tolerant of minor errors and inconsistencies. Telephone numbers, at least those assigned to landlines, are more similar to network addresses: they are (geographically) hierarchical, fixed-length, administratively assigned, and in more-or-less one-to-one correspondence with nodes.
8. One might want addresses to serve as *locators*, providing hints as to how data should be routed. One approach for this is to make addresses *hierarchical*. Another property might be *administratively assigned*, versus, say, the *factory-assigned* addresses used by Ethernet. Other address attributes that might be relevant are *fixed-length* v. *variable-length*, and *absolute* v. *relative* (like file names).

If you phone a toll-free number for a large retailer, any of dozens of phones may answer. Arguably, then, all these phones have the same non-unique “address”. A more traditional application for non-unique addresses might be for reaching any of several equivalent servers (or routers). Non-unique addresses are also useful when global reachability is not required, such as to address the computers within a single corporation when those computers cannot be reached from outside the corporation.

9. Video or audio teleconference transmissions among a reasonably large number of widely spread sites would be an excellent candidate: unicast would require a separate connection between each pair of sites, while broadcast would send far too much traffic to sites not interested in receiving it. Delivery of video and audio streams for a television channel only to those households currently interested in watching that channel is another application.

Trying to reach any of several equivalent servers, each of which can provide the answer to some query, would be another possible use, although the receiver of many responses to the query would need to deal with the possibly large volume of responses.

10. STDM and FDM both work best for channels with constant and uniform bandwidth requirements. For both mechanisms bandwidth that goes unused by one channel is simply wasted, not available to other channels. Computer communications are bursty and have long idle periods; such usage patterns would magnify this waste.

FDM and STDM also require that channels be allocated (and, for FDM, be assigned bandwidth) well in advance. Again, the connection requirements for computing tend to be too dynamic for this; at the very least, this would pretty much preclude using one channel per connection.

FDM was preferred historically for TV/radio because it is very simple to build receivers; it also supports different channel sizes. STDM was preferred for voice because it makes somewhat more efficient use of the underlying bandwidth of the medium, and because channels with different capacities was not originally an issue.

11. $10 \text{ Gbps} = 10^{10} \text{ bps}$, meaning each bit is 10^{-10} sec (0.1 ns) wide. The length in the wire of such a bit is $.1 \text{ ns} \times 2.3 \times 10^8 \text{ m/sec} = 0.023 \text{ m}$ or 23mm
12. $x \text{ KB}$ is $8 \times 1024 \times x \text{ bits}$. $y \text{ Mbps}$ is $y \times 10^6 \text{ bps}$; the transmission time would be $8 \times 1024 \times x/y \times 10^6 \text{ sec} = 8.192x/y \text{ ms}$.
13. (a) The minimum RTT is $2 \times 385,000,000 \text{ m} / 3 \times 10^8 \text{ m/s} = 2.57 \text{ seconds}$.
 (b) The delay \times bandwidth product is $2.57 \text{ s} \times 1 \text{ Gbps} = 2.57 \text{ Gb} = 321 \text{ MB}$.
 (c) This represents the amount of data the sender can send before it would be possible to receive a response.

- (d) We require at least one RTT from sending the request before the first bit of the picture could begin arriving at the ground (TCP would take longer). 25 MB is 200Mb. Assuming bandwidth delay only, it would then take $200\text{Mb}/1000\text{Mbps} = 0.2$ seconds to finish sending, for a total time of $0.2 + 2.57 = 2.77$ sec until the last picture bit arrives on earth.
14. The answer is in the book.
15. (a) Delay-sensitive; the messages exchanged are short.
 (b) Bandwidth-sensitive, particularly for large files. (Technically this does presume that the underlying protocol uses a large message size or window size; stop-and-wait transmission (as in Section 2.5 of the text) with a small message size would be delay-sensitive.)
 (c) Delay-sensitive; directories are typically of modest size.
 (d) Delay-sensitive; a file's attributes are typically much smaller than the file itself.
16. (a) On a 100 Mbps network, each bit takes $1/10^8 = 10$ ns to transmit. One packet consists of 12000 bits, and so is delayed due to bandwidth (serialization) by $120\ \mu\text{s}$ along each link. The packet is also delayed $10\ \mu\text{s}$ on each of the two links due to propagation delay, for a total of $260\ \mu\text{s}$.
 (b) With three switches and four links, the delay is
- $$4 \times 120\ \mu\text{s} + 4 \times 10\ \mu\text{s} = 520\ \mu\text{s}$$
- (c) With cut-through, the switch delays the packet by 200 bits = $2\ \mu\text{s}$. There is still one $120\ \mu\text{s}$ delay waiting for the last bit, and $20\ \mu\text{s}$ of propagation delay, so the total is $142\ \mu\text{s}$. To put it another way, the last bit still arrives $120\ \mu\text{s}$ after the first bit; the first bit now faces two link delays and one switch delay but never has to wait for the last bit along the way.
17. The answer is in the book.
18. (a) The effective bandwidth is 100 Mbps; the sender can send data steadily at this rate and the switches simply stream it along the pipeline. We are assuming here that no ACKs are sent, and that the switches can keep up and can buffer at least one packet.
 (b) The data packet takes $520\ \mu\text{s}$ as in 16(b) above to be delivered; the 400 bit ACKs take $4\ \mu\text{s}/\text{link}$ to be sent back, plus propagation, for a total of $4 \times 4\ \mu\text{s} + 4 \times 10\ \mu\text{s} = 56\ \mu\text{s}$; thus the total RTT is $576\ \mu\text{s}$. 12000 bits in $576\ \mu\text{s}$ is about 20.8 Mbps.
 (c) $100 \times 4.7 \times 10^9 \text{ bytes} / 12 \text{ hours} = 4.7 \times 10^{11} \text{ bytes} / (12 \times 3600 \text{ s}) \approx 10.9 \text{ MBps} = 87 \text{ Mbps}$.
19. (a) $100 \times 10^6 \text{ bps} \times 10 \times 10^{-6} \text{ sec} = 1000 \text{ bits} = 125 \text{ bytes}$.

- (b) The first-bit delay is $520 \mu\text{s}$ through the store-and-forward switch, as in 16(a). $100 \times 10^6 \text{bps} \times 520 \times 10^{-6} \text{sec} = 52000 \text{ bits} = 650 \text{ bytes}$.
- (c) $1.5 \times 10^6 \text{ bps} \times 50 \times 10^{-3} \text{ sec} = 75,000 \text{ bits} = 9375 \text{ bytes}$.
- (d) The path is *through* a satellite, *i.e.* between two ground stations, not *to* a satellite; this ground-to-satellite-to-ground path makes the total one-way travel distance $2 \times 35,900,000$ meters. With a propagation speed of $c = 3 \times 10^8$ meters/sec, the one-way propagation delay is thus $2 \times 35,900,000 / c = 0.24 \text{ sec}$. Bandwidth \times delay is thus $1.5 \times 10^6 \text{ bps} \times 0.24 \text{ sec} = 360,000 \text{ bits} \approx 45 \text{ KBytes}$

20. (a) Per-link transmit delay is $10^4 \text{ bits} / 10^8 \text{ bps} = 100 \mu\text{s}$. Total transmission time including link and switch propagation delays = $2 \times 100 + 2 \times 20 + 35 = 275 \mu\text{s}$.

- (b) When sending as two packets, the time to transmit one packet is cut in half. Here is a table of times for various events:

T=0	start
T=50	A finishes sending packet 1, starts packet 2
T=70	packet 1 finishes arriving at S
T=105	packet 1 departs for B
T=100	A finishes sending packet 2
T=155	packet 2 departs for B
T=175	bit 1 of packet 2 arrives at B
T=225	last bit of packet 2 arrives at B

This is smaller than the answer to part (a) because packet 1 starts to make its way through the switch while packet 2 is still being transmitted on the first link, effectively getting a $50 \mu\text{s}$ head start. Smaller is faster, here.

21. (a) Without compression the total time is $1 \text{ MB} / \text{bandwidth}$. When we compress the file, the total time is

$$\text{compression_time} + \text{compressed_size} / \text{bandwidth}$$

Equating these and rearranging, we get

$$\text{bandwidth} = \text{compression_size_reduction} / \text{compression_time}$$

$$= 0.5 \text{ MB} / 1 \text{ sec} = 0.5 \text{ MB/sec for the first case,}$$

$$= 0.6 \text{ MB} / 2 \text{ sec} = 0.3 \text{ MB/sec for the second case.}$$

- (b) Latency doesn't affect the answer because it would affect the compressed and uncompressed transmission equally.
22. The number of packets needed, N , is $\lceil 10^6 / D \rceil$, where D is the packet data size. Given that overhead = $50 \times N$ and loss = D (we have already counted the lost packet's header in the overhead), we have overhead+loss = $50 \times \lceil 10^6 / D \rceil + D$.

D	overhead+loss
1000	51000
10000	15000
20000	22500

The optimal size is 10,000 bytes which minimizes the above function.

23. Comparison of circuits and packets result as follows :

- (a) Circuits pay an up-front penalty of 1024 bytes being sent on one round trip for a total data count of $2048 + n$, whereas packets pay an ongoing per packet cost of 24 bytes for a total count of $1024 \times n/1000$. So the question really asks how many packet headers does it take to exceed 2048 bytes, which is 86. Thus for files 86,000 bytes or longer, using packets results in more total data sent on the wire.
- (b) The total transfer latency for packets is the sum of the transmit delays, where the per-packet transmit time t is the packet size over the bandwidth b ($8192/b$), introduced by each of s switches ($s \times t$), total propagation delay for the links ($(s + 2) \times 0.002$), the per packet processing delays introduced by each switch ($s \times 0.001$), and the transmit delay for all the packets, where the total packet count c is $n/1000$, at the source ($c \times t$). Resulting in a total latency of $(8192s/b) + 0.003s + 0.004 + (8.192n/b) = (0.02924 + 0.000002048n)$ seconds. The total latency for circuits is the transmit delay for the whole file ($8n/b$), the total propagation delay for the links, and the setup cost for the circuit which is just like sending one packet each way on the path. Solving the resulting inequality $0.02924 + 8.192(n/b) > 0.076576 + 8(n/b)$ for n shows that circuits achieve a lower delay for files larger than or equal to 987,000 B.
- (c) Only the payload to overhead ratio size effects the number of bits sent, and there the relationship is simple. The following table show the latency results of varying the parameters by solving for the n where circuits become faster, as above. This table does not show how rapidly the performance diverges; for varying p it can be significant.

s	b	p	pivotal n
5	4 Mbps	1000	987000
6	4 Mbps	1000	1133000
7	4 Mbps	1000	1280000
8	4 Mbps	1000	1427000
9	4 Mbps	1000	1574000
10	4 Mbps	1000	1721000
5	1 Mbps	1000	471000
5	2 Mbps	1000	643000
5	8 Mbps	1000	1674000
5	16 Mbps	1000	3049000
5	4 Mbps	512	24000
5	4 Mbps	768	72000
5	4 Mbps	1014	2400000

- (d) Many responses are probably reasonable here. The model only considers the network implications, and does not take into account usage of processing or state storage capabilities on the switches. The model also ignores the presence of other traffic or of more complicated topologies.

24. The time to send one 12000-bit packet is $12000 \text{ bits}/100 \text{ Mbps} = 120 \mu\text{s}$. The length of cable needed to exactly contain such a packet is $120 \mu\text{s} \times 2 \times 10^8 \text{ m/sec} = 24,000 \text{ meters}$.

12000 bits in 24000 meters is 50 bits per 100 m. With an extra 10 bits of delay in each 100 m, we have a total of 60 bits/100 m or 0.6 bits/m. A 12000-bit packet now fills $12000/(.6 \text{ bits/m}) = 20,000 \text{ meters}$.

25. For music we would need considerably more bandwidth, but we could tolerate high (but bounded) delays. We could *not* necessarily tolerate higher jitter, though; see Section 6.5.1.

We might accept an audible error in voice traffic every few seconds; we might reasonably want the error rate during music transmission to be a hundredfold smaller. Audible errors would come either from outright packet loss, or from jitter (a packet's not arriving on time).

Latency requirements for music, however, might be much lower; a several-second delay would be inconsequential. Voice traffic has at least a tenfold faster requirement here.

26. (a) $640 \times 480 \times 3 \times 30 \text{ bytes/sec} = 26.4 \text{ MB/sec}$
 (b) $160 \times 120 \times 1 \times 5 = 96,000 \text{ bytes/sec} = 94 \text{ KB/sec}$
 (c) $650 \text{ MB}/75 \text{ min} = 8.7 \text{ MB/min} = 148 \text{ KB/sec}$
 (d) $8 \times 10 \times 72 \times 72 \text{ pixels} = 414,720 \text{ bits} = 51,840 \text{ bytes}$. At 14,400 bits/sec, this would take 28.8 seconds (ignoring overhead for framing and acknowledgments).
27. The answer is in the book.
28. (a) A file server needs lots of peak bandwidth. Latency is relevant only if it dominates bandwidth; jitter and average bandwidth are inconsequential. No lost data is acceptable, but without real-time requirements we can simply retransmit lost data.
 (b) A print server needs less bandwidth than a file server (unless images are extremely large). We may be willing to accept higher latency than (a), also.
 (c) A file server *is* a digital library of a sort, but in general the world wide web gets along reasonably well with much less peak bandwidth than most file servers provide.
 (d) For instrument monitoring we don't care about latency or jitter. If data were continually generated, rather than bursty, we might be concerned mostly with average bandwidth rather than peak, and if the data really were routine we might just accept a certain fraction of loss.
 (e) For voice we need guaranteed average bandwidth and bounds on latency and jitter. Some lost data might be acceptable; e.g. resulting in minor dropouts many seconds apart.

- (f) For video we are primarily concerned with average bandwidth. For the simple monitoring application here, relatively modest video of Exercise 26(b) might suffice; we could even go to monochrome (1 bit/pixel), at which point $160 \times 120 \times 5$ frames/sec requires 12KB/sec. We could tolerate multi-second latency delays; the primary restriction is that if the monitoring revealed a need for intervention then we still have time to act. Considerable loss, even of entire frames, would be acceptable.
- (g) Full-scale television requires massive bandwidth. Latency, however, could be hours. Jitter would be limited only by our capacity to absorb the arrival-time variations by buffering. Some loss would be acceptable, but large losses would be visually annoying.
29. In STDM the offered timeslices are always the same length, and are wasted if they are unused by the assigned station. The round-robin access mechanism would generally give each station only as much time as it needed to transmit, or none if the station had nothing to send, and so network utilization would be expected to be much higher.
30. (a) In the absence of any packet losses or duplications, when we are expecting the N th packet we *get* the N th packet, and so we can keep track of N locally at the receiver.
- (b) The scheme outlined here is the stop-and-wait algorithm of Section 2.5; as is indicated there, a header with at least one bit of sequence number is needed (to distinguish between receiving a new packet and a duplication of the previous packet).
- (c) With out-of-order delivery allowed, packets up to 1 minute apart must be distinguishable via sequence number. Otherwise a very old packet might arrive and be accepted as current. Sequence numbers would have to count as high as

$$\text{bandwidth} \times 1 \text{ minute} / \text{packet_size}$$

31. In each case we assume the local clock starts at 1000.

- (a) Latency: 100. Bandwidth: high enough to read the clock every 1 unit.

1000		1100	
1001		1101	
1002		1102	
1003		1104	tiny bit of jitter: latency = 101
1004		1104	

- (b) Latency=100; bandwidth: only enough to read the clock every 10 units. Arrival times fluctuate due to jitter.

1000		1100	
1020		1110	latency = 90
1040		1145	
1060		1180	latency = 120
1080		1184	

(c) Latency = 5; zero jitter here:

1000		1005	
1001		1006	
1003		1008	we lost 1002
1004		1009	
1005		1010	

32. Generally, with `MAX_PENDING = 1`, one or two connections will be accepted and queued; that is, the data won't be delivered to the server. The others will be ignored; eventually they will time out.

When the first client exits, any queued connections are processed.

34. Note that UDP accepts a packet of data from any source at any time; TCP requires an advance connection. Thus, two clients can now talk simultaneously; their messages will be interleaved on the server.

Solutions for Chapter 2

1.

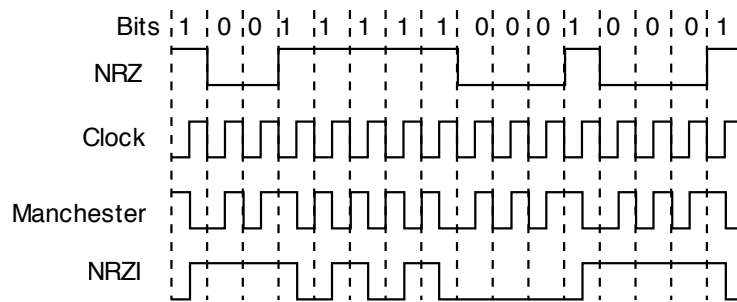

2.

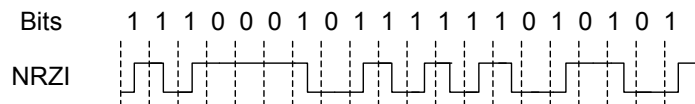

3. The answer is in the book.

4. One can list all 5-bit sequences and count, but here is another approach: there are 2^3 sequences that start with 00, and 2^3 that end with 00. There are two sequences, 00000 and 00100, that do both. Thus, the number that do either is $8+8-2 = 14$, and finally the number that do neither is $32 - 14 = 18$. Thus there would have been enough 5-bit codes meeting the stronger requirement; however, additional codes are needed for control sequences.

5. The stuffed bits (zeros) are in bold:

1101 0111 **1100** 1011 **1110** 1010 1111 **1011** 0

6. The \wedge marks each position where a stuffed 0 bit was removed. There were no stuffing errors detectable by the receiver; the only such error the receiver could identify would be seven 1's in a row.

1101 0111 1 \wedge 10 1111 1 \wedge 010 1111 1 \wedge 110

7. The answer is in the book.

8. ..., DLE, DLE, DLE, ETX, ETX

9. (a) X DLE Y, where X can be anything besides DLE and Y can be anything except DLE or ETX. In other words, each DLE must be followed by either DLE or ETX.

(b) 0111 1111.

10. (a) After $48 \times 8 = 384$ bits we can be off by no more than $\pm 1/2$ bit, which is about 1 part in 800.
- (b) One frame is 810 bytes; at STS-1 51.8 Mbps speed we are sending $51.8 \times 10^6 / (8 \times 810) =$ about 8000 frames/sec, or about 480,000 frames/minute. Thus, if station B's clock ran faster than station A's by one part in 480,000, A would accumulate about one extra frame per minute.
11. Suppose an undetectable three-bit error occurs. The three bad bits must be spread among one, two, or three rows. If these bits occupy two or three rows, then some row must have exactly one bad bit, which would be detected by the parity bit for that row. But if the three bits are all in one row, then that row must again have a parity error (as must each of the three columns containing the bad bits).
12. If we flip the bits corresponding to the corners of a rectangle in the 2-D layout of the data, then all parity bits will still be correct. Furthermore, if four bits change and no error is detected, then the bad bits must form a rectangle: in order for the error to go undetected, each row and column must have no errors or exactly two errors.
13. If we know only one bit is bad, then 2-D parity tells us which row and column it is in, and we can then flip it. If, however, two bits are bad in the same row, then the row parity remains correct, and all we can identify is the columns in which the bad bits occur.
14. We need to show that the 1's-complement sum of two non-0x0000 numbers is non-0x0000. If no unsigned overflow occurs, then the sum is just the 2's-complement sum and can't be 0000 without overflow; in the absence of overflow, addition is monotonic. If overflow occurs, then the result is at least 0x0000 plus the addition of a carry bit, i.e. $\geq 0x0001$.
15. Let's define $\text{swap}([A,B]) = [B,A]$, where A and B are one byte each. We only need to show $[A, B] + [C, D] = \text{swap}([B, A] + [D, C])$. If both (A+C) and (B+D) have no carry, the equation obviously holds.

If A+C has a carry and B+D+1 does not,

$$[A, B] + [C, D] = [(A+C) \& 0xEF, B+D+1]$$

$$\text{swap}([B, A] + [D, C]) = \text{swap}([B+D+1, (A+C) \& 0xEF]) = [(A+C) \& 0xEF, B+D+1]$$

(The case where B+D+1 has also a carry is similar to the last case.)

If B+D has a carry, and A+C+1 does not,

$$[A, B] + [C, D] = [A+C+1, (B+D) \& 0xEF].$$

$$\text{swap}([B, A] + [D, C]) = \text{swap}([(B+D) \& 0xEF, A+C+1]) = [A+C+1, (B+D) \& 0xEF].$$

If both (A+C) and (B+D) have a carry,

$$[A, B] + [C, D] = [((A+C) \& 0xEF) + 1, ((B+D) \& 0xEF) + 1]$$

$$\text{swap}([B, A] + [D, C]) = \text{swap}([((B+D) \& 0xEF) + 1, ((A+C) \& 0xEF) + 1]) = [((A+C) \& 0xEF) + 1, ((B+D) \& 0xEF) + 1]$$

16. Consider only the 1's complement sum of the 16-bit words. If we decrement a low-order byte in the data, we decrement the sum by 1, and can incrementally revise the old checksum by decrementing it by 1 as well. If we decrement a high-order byte, we must decrement the old checksum by 256.
17. Here is a rather combinatorial approach. Let a, b, c, d be 16-bit words. Let $[a, b]$ denote the 32-bit concatenation of a and b , and let $\text{carry}(a, b)$ denote the carry bit (1 or 0) from the 2's-complement sum $a + b$ (denoted here $a +_2 b$). It suffices to show that if we take the 32-bit 1's complement sum of $[a, b]$ and $[c, d]$, and then add upper and lower 16 bits, we get the 16-bit 1's-complement sum of a, b, c , and d . We note $a +_1 b = a +_2 b +_2 \text{carry}(a, b)$.

The basic case is supposed to work something like this. First,

$$[a, b] +_2 [c, d] = [a +_2 c +_2 \text{carry}(b, d), b +_2 d]$$

Adding in the carry bit, we get

$$[a, b] +_1 [c, d] = [a +_2 c +_2 \text{carry}(b, d), b +_2 d +_2 \text{carry}(a, c)] \quad (1)$$

Now we take the 1's complement sum of the halves,

$$a +_2 c +_2 \text{carry}(b, d) +_2 b +_2 d +_2 \text{carry}(a, c) + (\text{carry}(\text{wholething}))$$

and regroup:

$$\begin{aligned} &= a +_2 c +_2 \text{carry}(a, c) +_2 b +_2 d +_2 \text{carry}(b, d) + (\text{carry}(\text{wholething})) \\ &= (a +_1 c) +_2 (b +_1 d) + \text{carry}(a +_1 c, b +_1 d) \\ &= (a +_1 c) +_1 (b +_1 d) \end{aligned}$$

which by associativity and commutativity is what we want.

There are a couple annoying special cases, however, in the preceding, where a sum is 0xFFFF and so adding in a carry bit triggers an additional overflow. Specifically, the $\text{carry}(a, c)$ in (1) is actually $\text{carry}(a, c, \text{carry}(b, d))$, and secondly adding it to $b +_2 d$ may cause the lower half to overflow, and no provision has been made to carry over into the upper half. However, as long as $a +_2 c$ and $b +_2 d$ are not equal to 0xFFFF, adding 1 won't affect the overflow bit and so the above argument works. We handle the 0xFFFF cases separately.

Suppose that $b +_2 d = 0xFFFF =_2 0$. Then $a +_1 b +_1 c +_1 d = a +_1 c$. On the other hand, $[a, b] +_1 [c, d] = [a +_2 b, 0xFFFF] + \text{carry}(a, b)$. If $\text{carry}(a, b) = 0$, then adding upper and lower halves together gives $a +_2 b = a +_1 b$. If

$carry(a, b) = 1$, we get $[a, b] +_1 [c, d] = [a +_2 b +_2 1, 0]$ and adding halves again leads to $a +_1 b$.

Now suppose $a +_2 c = 0xFFFF$. If $carry(b, d) = 1$ then $b +_2 d \neq 0xFFFF$ and we have $[a, b] +_1 [c, d] = [0, b +_2 d +_2 1]$ and folding gives $b +_1 d$. The $carry(b, d) = 0$ case is similar.

Alternatively, we may adopt a more algebraic approach. We may treat a buffer consisting of n -bit blocks as a large number written in base 2^n . The numeric value of this buffer is congruent mod $(2^n - 1)$ to the (exact) sum of the “digits”, that is to the exact sum of the blocks. If this latter sum has more than n bits, we can repeat the process. We end up with the n -bit 1’s-complement sum, which is thus the remainder upon dividing the original number by $2^n - 1$.

Let b be the value of the original buffer. The 32-bit checksum is thus $b \bmod 2^{32} - 1$. If we fold the upper and lower halves, we get $(b \bmod (2^{32} - 1)) \bmod (2^{16} - 1)$, and, because $2^{32} - 1$ is divisible by $2^{16} - 1$, this is $b \bmod (2^{16} - 1)$, the 16-bit checksum.

18. (a) We take the message 11100011, append 000 to it, and divide by 1001 according to the method shown in Section 2.4.3. The remainder is 100; what we transmit is the original message with this remainder appended, or 11100011 100.
- (b) Inverting the first bit of the transmission gives 0110 0011 100; dividing by 1001 ($x^3 + 1$) gives a remainder of 10; the fact that the remainder is non-zero tells us a bit error occurred.
19. The answer is in the book.

20. (b)

p	q	C×q
000	000	000 000
001	001	001 101
010	011	010 111
011	010	011 010
100	111	100 011
101	110	101 110
110	100	110 100
111	101	111 001

- (c) The bold entries 101 (in the dividend), 110 (in the quotient), and 101 110 in the body of the long division here correspond to the bold row of the preceding table.

25. The answer is in the book.
26. If the receiver delays sending an ACK until buffer space is available, it risks delaying so long that the sender times out unnecessarily and retransmits the frame.
27. For Fig 2.17(b) (lost frame), there are no changes from the diagram in the text.

The next two figures correspond to the text's Fig 2.17(c) and (d); (c) shows a lost ACK and (d) shows an early timeout. For (c), the receiver timeout is shown slightly greater than (for definiteness) twice the sender timeout.

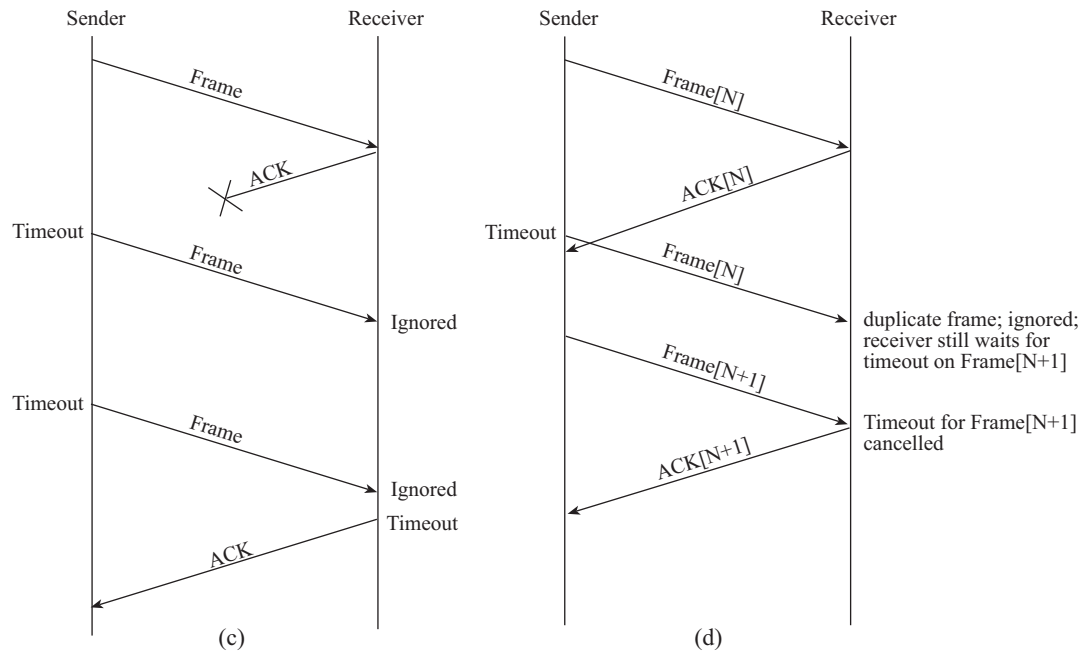

Here is the version of Fig 2.17(c) (lost ACK), showing a receiver timeout of approximately half the sender timeout.

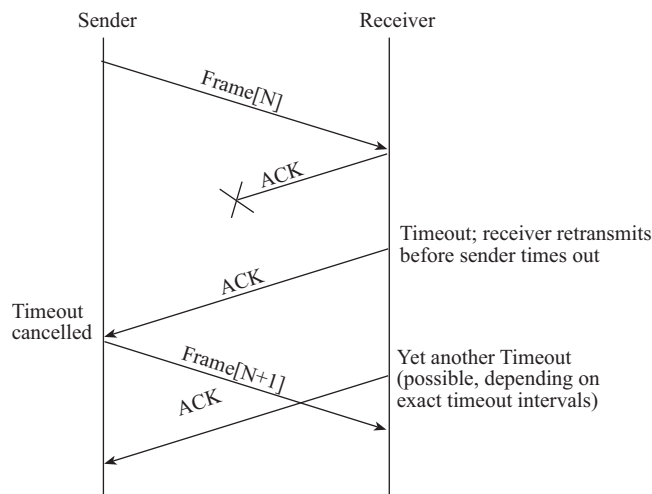

28. (a) The duplications below continue until the end of the transmission.

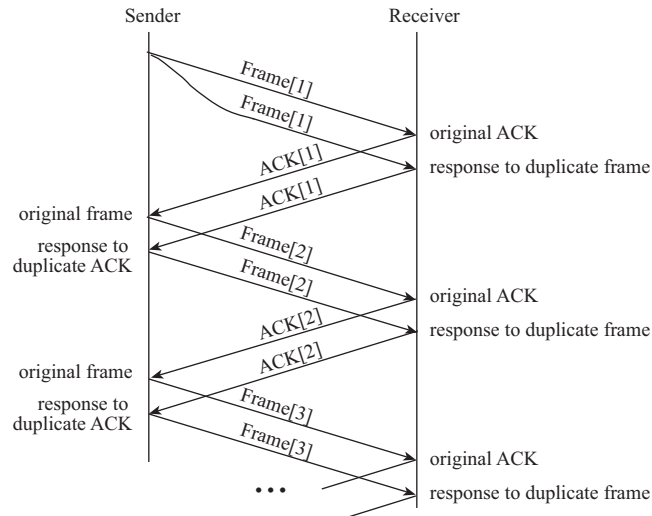

- (b) To trigger the sorcerer's apprentice phenomenon, a duplicate data frame must cross somewhere in the network with the previous ACK for that frame. If both sender and receiver adopt a resend-on-timeout strategy, *with the same timeout interval*, and an ACK is lost, then both sender and receiver will indeed retransmit at about the same time. Whether these retransmissions are synchronized enough that they cross in the network depends on other factors; it helps to have some modest latency delay or else slow hosts. With the right conditions, however, the sorcerer's apprentice phenomenon can be reliably reproduced.

29. The following is based on what TCP actually does: every ACK might (optionally

or not) contain a value the sender is to use as a maximum for SWS. If this value is zero, the sender stops. A later ACK would then be sent with a nonzero SWS, when a receive buffer becomes available. Some mechanism would need to be provided to ensure that this later ACK is not lost, lest the sender wait forever. It is best if each new ACK reduces SWS by no more than 1, so that the sender's LFS never decreases.

Assuming the protocol above, we might have something like this:

- T=0 Sender sends Frame1-Frame4. In short order, ACK1...ACK4 are sent setting SWS to 3, 2, 1, and 0 respectively.
The Sender now waits for $SWS > 0$.
- T=1 Receiver frees first buffer; sends ACK4/SWS=1.
Sender slides window forward and sends Frame5.
Receiver sends ACK5/SWS=0.
- T=2 Receiver frees second buffer; sends ACK5/SWS=1.
Sender sends Frame6; receiver sends ACK6/SWS=0.
- T=3 Receiver frees third buffer; sends ACK6/SWS=1.
Sender sends Frame7; receiver sends ACK7/SWS=0.
- T=4 Receiver frees fourth buffer; sends ACK7/SWS=1.
Sender sends Frame8; receiver sends ACK8/SWS=0.

30. Here is one approach; variations are possible.

If frame[N] arrives, the receiver sends ACK[N] if $NFE=N$; otherwise if N was in the receive window the receiver sends SACK[N].

The sender keeps a bucket of values of $N > LAR$ for which SACK[N] was received; note that whenever LAR slides forward this bucket will have to be purged of all $N \leq LAR$.

If the bucket contains one or two values, these could be attributed to out-of-order delivery. However, the sender might reasonably assume that whenever there was an $N > LAR$ with frame[N] unacknowledged but with three, say, later SACKs in the bucket, then frame[N] was lost. (The number three here is taken from TCP with fast retransmit, which uses duplicate ACKs instead of SACKs.) Retransmission of such frames might then be in order. (TCP's fast-retransmit strategy would only retransmit frame[LAR+1].)

31. The right diagram, for part (b), shows each of frames 4-6 timing out after a $2 \times RTT$ timeout interval; a more realistic implementation (*e.g.* TCP) would probably revert to $SWS=1$ after losing packets, to address both congestion control and the lack of ACK clocking.

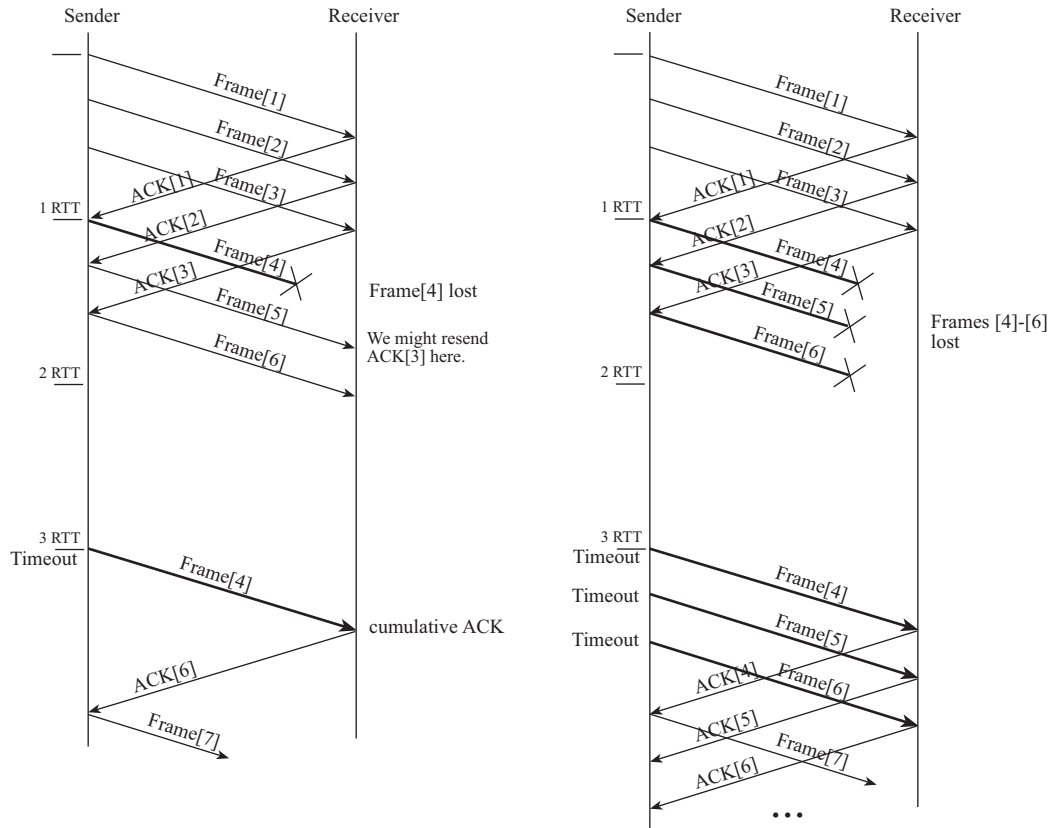

32. The answer is in the book.
33. In the following, ACK[N] means that all packets with sequence number *less* than N have been received.
- The sender sends DATA[0], DATA[1], DATA[2]. All arrive.
 - The receiver sends ACK[3] in response, but this is slow. The receive window is now DATA[3]..DATA[5].
 - The sender times out and resends DATA[0], DATA[1], DATA[2]. For convenience, assume DATA[1] and DATA[2] are lost. The receiver accepts DATA[0] as DATA[5], because they have the same transmitted sequence number.
 - The sender finally receives ACK[3], and now sends DATA[3]-DATA[5]. The receiver, however, believes DATA[5] has already been received, when DATA[0] arrived, above, and throws DATA[5] away as a "duplicate". The protocol now continues to proceed normally, with one bad block in the received stream.
34. We first note that data below the sending window (that is, <LAR) is never sent again, and hence – because out-of-order arrival is disallowed – if DATA[N] arrives at the receiver then nothing at or before DATA[N-3] can arrive later. Similarly, for ACKs, if ACK[N] arrives then (because ACKs are cumulative) no ACK

before ACK[N] can arrive later. As before, we let ACK[N] denote the acknowledgment of all data packets less than N.

- (a) If DATA[6] is in the receive window, then the earliest that window can be is DATA[4]-DATA[6]. This in turn implies ACK[4] was sent, and thus that DATA[1]-DATA[3] were received, and thus that DATA[0], by our initial remark, can no longer arrive.
- (b) If ACK[6] may be sent, then the lowest the sending window can be is DATA[3]..DATA[5]. This means that ACK[3] must have been received. Once an ACK is received, no smaller ACK can ever be received later.
35. (a) The smallest working value for MaxSeqNum is 8. It suffices to show that if DATA[8] is in the receive window, then DATA[0] can no longer arrive at the receiver. We have that DATA[8] in receive window
 \Rightarrow the earliest possible receive window is DATA[6]..DATA[8]
 \Rightarrow ACK[6] has been received
 \Rightarrow DATA[5] was delivered.
 But because SWS=5, all DATA[0]'s sent were sent before DATA[5]
 \Rightarrow by the no-out-of-order arrival hypothesis, DATA[0] can no longer arrive.
- (b) We show that if MaxSeqNum=7, then the receiver can be expecting DATA[7] and an old DATA[0] can still arrive. Because 7 and 0 are indistinguishable mod MaxSeqNum, the receiver cannot tell which actually arrived. We follow the strategy of Exercise 27.
1. Sender sends DATA[0]...DATA[4]. All arrive.
 2. Receiver sends ACK[5] in response, but it is slow. The receive window is now DATA[5]..DATA[7].
 3. Sender times out and retransmits DATA[0]. The receiver accepts it as DATA[7].
- (c) $\text{MaxSeqNum} \geq \text{SWS} + \text{RWS}$.
36. (a) Note that this is the canonical $\text{SWS} = \text{bandwidth} \times \text{delay}$ case, with $\text{RTT} = 4$ sec. In the following we list the progress of one particular packet. At any given instant, there are four packets outstanding in various states.
- T=N Data[N] leaves A
 T=N+1 Data[N] arrives at R
 T=N+2 Data[N] arrives at B; ACK[N] leaves
 T=N+3 ACK[N] arrives at R
 T=N+4 ACK[N] arrives at A; DATA[N+4] leaves.
- Here is a specific timeline showing all packets in progress:

- T=0 Data[0]...Data[3] ready; Data[0] sent
 T=1 Data[0] arrives at R; Data[1] sent
 T=2 Data[1] arrives at R; Data[0] arrives at B; ACK[0] starts back; Data[2] sent
 T=3 ACK[0] arrives at R; Data[2] arrives at R; Data[1] arrives at B;
 ACK[1] starts back; Data[3] sent
 T=4 ACK[0] arrives at A; ACK[1] arrives at R; Data[3] arrives at R;
 Data[2] arrives at B; ACK[2] starts back; Data[4] sent
 T=5 ACK[1] arrives at A; ACK[2] arrives at R; Data[4] arrives at R;
 Data[3] arrives at B; ACK[3] starts back; Data[5] sent
- (b) T=0 Data[0]...Data[3] sent
 T=1 Data[0]...Data[3] arrive at R
 T=2 Data arrive at B; ACK[0]...ACK[3] start back
 T=3 ACKs arrive at R
 T=4 ACKs arrive at A; Data[4]...Data[7] sent
 T=5 Data arrive at R
37. T=0 A sends frames 1-4. Frame[1] starts across the R-B link.
 Frames 2,3,4 are in R's queue.
 T=1 Frame[1] arrives at B; ACK[1] starts back; Frame[2] leaves R.
 Frames 3,4 are in R's queue.
 T=2 ACK[1] arrives at R and then A; A sends Frame[5] to R;
 Frame[2] arrives at B; B sends ACK[2] to R.
 R begins sending Frame[3]; frames 4,5 are in R's queue.
 T=3 ACK[2] arrives at R and then A; A sends Frame[6] to R;
 Frame[3] arrives at B; B sends ACK[3] to R;
 R begins sending Frame[4]; frames 5,6 are in R's queue.
 T=4 ACK[3] arrives at R and then A; A sends Frame[7] to R;
 Frame[4] arrives at B; B sends ACK[4] to R.
 R begins sending Frame[5]; frames 6,7 are in R's queue.
 The steady-state queue size at R is two frames.
38. T=0 A sends frames 1-4. Frame[1] starts across the R-B link.
 Frame[2] is in R's queue; *frames 3 & 4 are lost*.
 T=1 Frame[1] arrives at B; ACK[1] starts back; Frame[2] leaves R.
 T=2 ACK[1] arrives at R and then A; A sends Frame[5] to R.
 R immediately begins forwarding it to B.
 Frame[2] arrives at B; B sends ACK[2] to R.
 T=3 ACK[2] arrives at R and then A; A sends Frame[6] to R.
 R immediately begins forwarding it to B.
 Frame[5] (not 3) arrives at B; B sends no ACK.
 T=4 Frame[6] arrives at B; again, B sends no ACK.
 T=5 A TIMES OUT, and retransmits frames 3 and 4.
 R begins forwarding Frame[3] immediately, and enqueues 4.

- T=6 Frame[3] arrives at B and ACK[3] begins its way back.
R begins forwarding Frame[4].
- T=7 Frame[4] arrives at B and ACK[6] begins its way back.
ACK[3] reaches A and A then sends Frame[7].
R begins forwarding Frame[7].

39. Hosts sharing the same address will be considered to be the same host by all other hosts. Unless the conflicting hosts coordinate the activities of their higher level protocols, it is likely that higher level protocol messages with otherwise identical demux information from both hosts will be interleaved and result in communication breakdown.

40. One-way delays:

Coax:	1500m	6.49 μ s
link:	1000m	5.13 μ s
repeaters	two	1.20 μ s
transceivers	six	1.20 μ s
	(two for each repeater, one for each station)	
drop cable	6 \times 50m	1.54 μ s
Total:		15.56 μ s

The roundtrip delay is thus about 31.1 μ s, or 311 bits. The “official” total is 464 bits, which when extended by 48 bits of jam signal exactly accounts for the 512-bit minimum packet size.

The 1982 Digital-Intel-Xerox specification presents a delay budget (page 62 of that document) that totals 463.8 bit-times, leaving 20 nanoseconds for unforeseen contingencies.

41. A station must not only detect a remote signal, but for collision detection it must detect a remote signal *while it itself is transmitting*. This requires much higher remote-signal intensity.
42. (a) Assuming 48 bits of jam signal was still used, the minimum packet size would be 4640+48 bits = 586 bytes.
- (b) This packet size is considerably larger than many higher-level packet sizes, resulting in considerable wasted bandwidth.
- (c) The minimum packet size could be smaller if maximum collision domain diameter were reduced, and if sundry other tolerances were tightened up.
43. (a) A can choose $k_A=0$ or 1; B can choose $k_B=0,1,2,3$. A wins outright if (k_A, k_B) is among (0,1), (0,2), (0,3), (1,2), (1,3); there is a 5/8 chance of this.
- (b) Now we have k_B among 0...7. If $k_A=0$, there are 7 choices for k_B that have A win; if $k_A=1$ then there are 6 choices. All told the probability of A's winning outright is 13/16.

- (c) $P(\text{winning race 1}) = 5/8 > 1/2$ and $P(\text{winning race 2}) = 13/16 > 3/4$; generalizing, we assume the odds of A winning the i th race exceed $(1 - 1/2^{i-1})$. We now have that

$$\begin{aligned} & P(\text{A wins every race given that it wins races 1-3}) \\ & \geq (1 - 1/8)(1 - 1/16)(1 - 1/32)(1 - 1/64)\dots \\ & \approx 3/4. \end{aligned}$$

- (d) B gives up on it, and starts over with B_2 .

44. (a) If A succeeds in sending a packet, B will get the next chance. If A and B are the only hosts contending for the channel, then even a wait of a fraction of a slot time would be enough to ensure alternation.
- (b) Let A and B and C be contending for a chance to transmit. We suppose the following: A wins the first race, and so for the second race it defers to B and C for two slot times. B and C collide initially; we suppose B wins the channel from C one slot time later (when A is still deferring). When B now finishes its transmission we have the third race for the channel. B defers for this race; let us suppose A wins. Similarly, A defers for the fourth race, but B wins.
- At this point, the backoff range for C is quite high; A and B however are each quickly successful – typically on their second attempt – and so their backoff ranges remain bounded by one or two slot times. As each defers to the other for this amount of time after a successful transmission, there is a strong probability that if we get to this point they will continue to alternate until C finally gives up.
- (c) We might increase the backoff range given a decaying average of A's recent success rate.
45. If the hosts are not perfectly synchronized the preamble of the colliding packet will interrupt clock recovery.
46. Here is one possible solution; many, of course, are possible. The probability of four collisions appears to be quite low. Events are listed in order of occurrence.

A attempts to transmit; discovers line is busy and waits.

B attempts to transmit; discovers line is busy and waits.

C attempts to transmit; discovers line is busy and waits.

D finishes; A, B, and C all detect this, and attempt to transmit, and collide.

A chooses $k_A=1$, B chooses $k_B=1$, and C chooses $k_C=1$.

One slot time later A, B, and C all attempt to retransmit, and again collide.

A chooses $k_A=2$, B chooses $k_B=3$, and C chooses $k_C=1$.

One slot time later C attempts to transmit, and succeeds. While it transmits, A and B both attempt to retransmit but discover the line is busy and wait.

C finishes; A and B attempt to retransmit and a third collision occurs. A and B back off and (since we require a fourth collision) once again happen to choose the same $k < 8$.

A and B collide for the fourth time; this time A chooses $k_A=15$ and B chooses $k_B=14$.

14 slot times later, B transmits. While B is transmitting, A attempts to transmit but sees the line is busy, and waits for B to finish.

47. Many variations are, of course, possible. The scenario below attempts to demonstrate several plausible combinations.

D finishes transmitting.

First slot afterwards: all three defer ($P=8/27$).

Second slot afterwards: A,B attempt to transmit (and collide); C defers.

Third slot: C transmits (A and B are presumably backing off, although no relationship between p -persistence and backoff strategy was described).

C finishes.

First slot afterwards: B attempts to transmit and A defers, so B succeeds.

B finishes.

First slot afterwards: A defers.

Second slot afterwards: A defers.

Third slot afterwards: A defers.

Fourth slot afterwards: A defers a fourth time ($P=16/81 \approx 20\%$).

Fifth slot afterwards: A transmits.

A finishes.

48. (a) The second address must be distinct from the first, the third from the first two, and so on; the probability that none of the address choices from the second to the one thousand and twenty-fourth collides with an earlier choice is

$$(1 - 1/2^{48})(1 - 2/2^{48}) \cdots (1 - 1023/2^{48}) \\ \approx 1 - (1 + 2 + \dots + 1023)/2^{48} = 1 - 1,047,552/(2 \times 2^{48}).$$

Probability of a collision is thus $1,047,552/(2 \times 2^{48}) \approx 1.86 \times 10^{-9}$. The denominator should probably be 2^{46} rather than 2^{48} , since two bits in an Ethernet address are fixed.

- (b) Probability of the above on $2^{20} \approx 1$ million tries is 1.77×10^{-3} .
- (c) Using the method of (a) yields $(2^{30})^2/(2 \times 2^{48}) = 2^{11}$; we are clearly beyond the valid range of the approximation. A better approximation, using logs, is presented in Exercise 8.18. Suffice it to say that a collision is essentially certain.
49. (a) Here is a sample run. The bold backoff-time binary digits were chosen by coin toss, with heads=1 and tails=0. Backoff times are then converted to decimal.

T=0: hosts A,B,C,D,E all transmit and collide. Backoff times are chosen by a single coin flip; we happened to get $k_A=1$, $k_B=0$, $k_C=0$, $k_D=1$, $k_E=1$. At the end of this first collision, T is now 1. B and C retransmit at T=1; the others wait until T=2.

T=1: hosts B and C transmit, immediately after the end of the first collision, and collide again. This time two coin flips are needed for each backoff; we happened to get $k_B = 00 = 0$, $k_C = 11 = 3$. At this point T is now 2; B will thus attempt again at T=2+0=2; C will attempt again at T=2+3=5.

T=2: hosts A,B,D,E attempt. B chooses a three-bit backoff time as it is on its third collision, while the others choose two-bit times. We got $k_A = 10 = 2$, $k_B = 010 = 2$, $k_D = 01 = 1$, $k_E = 11 = 3$. We add each k to T=3 to get the respective retransmission-attempt times: T=5,5,4,6.

T=3: Nothing happens.

T=4: Station D is the only one to attempt transmission; it successfully seizes the channel.

T=5: Stations A, B, and C sense the channel before transmission, but find it busy. E joins them at T=6.

- (b) Perhaps the most significant difference on a real Ethernet is that stations close to each other will detect collisions almost immediately; only stations at extreme opposite points will need a full slot time to detect a collision. Suppose stations A and B are close, and C is far away. All transmit at the same time T=0. Then A and B will effectively start their backoff at $T \approx 0$; C will on the other hand wait for T=1. If A, B, and C choose the same backoff time, A and B will be nearly a full slot ahead.

Interframe spacing is only one-fifth of a slot time and applies to all participants equally; it is not likely to matter here.

50. Here is a simple program:

```
#define USAGE "ether N"
// Simulates N ethernet stations all trying to transmit at once;
// returns average # of slot times until one station succeeds.

#include <iostream.h>
#include <stdlib.h>
#include <assert.h>

#define MAX 1000 /* max # of stations */

class station {
public:
    void reset() { _NextAttempt = _CollisionCount = 0;}
    bool transmits(int T) {return _NextAttempt==T;}
    void collide() { // updates station after a collision
        _CollisionCount ++;
        _NextAttempt += 1 + backoff(_CollisionCount);
    }
};
```

```

        //the 1 above is for the current slot
    }
private:
    int _NextAttempt;
    int _CollisionCount;
    static int backoff(int k) {
        //choose random number 0..2^k-1; ie choose k random bits
        unsigned short r = rand();
        unsigned short mask = 0xFFFF >> (16-k); // mask = 2^k-1
        return int (r & mask);
    }
};

station S[MAX];

// run does a single simulation
// it returns the time at which some entrant transmits
int run (int N) {
    int time = 0;
    int i;
    for (i=0;i<N;i++) { S[i].reset(); }
    while(1) {
        int count = 0;    // # of attempts at this time
        int j= -1; // count the # of attempts; save j as index of one of them
        for (i=0; i<N; i++) {
            if (S[i].transmits(time)) {j=i; ++count;}
        }
        if (count==1) // we are done
            return time;
        else if (count>1) { // collisions occurred
            for (i=0;i<N;i++) {
                if (S[i].transmits(time)) S[i].collide();
            }
        }
        ++time;
    }
}

int RUNCOUNT = 10000;

void main(int argc, char * argv[]) {
    int N, i, runsum=0;
    assert(argc == 2);
    N=atoi(argv[1]);
    assert(N<MAX);
    for (i=0;i<RUNCOUNT;i++) runsum += run(N);
}

```

```

    cout << "runsum = " << runsum
         << " RUNCOUNT= " << RUNCOUNT
         << " average: " << ((double)runsum)/RUNCOUNT << endl;
    return;
}

```

Here is some data obtained from it:

# stations	slot times
5	3.9
10	6.6
20	11.2
40	18.8
100	37.7
200	68.6

51. We alternate $N/2$ slots of wasted bandwidth with 5 slots of useful bandwidth. The useful fraction is: $5/(N/2 + 5) = 10/(N+10)$

52. (a) The program is below. It produced the following output:

λ	# slot times	λ	# slot times
1	6.39577	2	4.41884
1.1	5.78198	2.1	4.46704
1.2	5.36019	2.2	4.4593
1.3	5.05141	2.3	4.47471
1.4	4.84586	2.4	4.49953
1.5	4.69534	2.5	4.57311
1.6	4.58546	2.6	4.6123
1.7	4.50339	2.7	4.64568
1.8	4.45381	2.8	4.71836
1.9	4.43297	2.9	4.75893
2	4.41884	3	4.83325

The minimum occurs at about $\lambda=2$; the theoretical value of the minimum is $2e - 1 = 4.43656$.

(b) If the contention period has length C , then the useful fraction is $8/(C + 8)$, which is about 64% for $C = 2e - 1$.

```

#include <iostream.h>
#include <stdlib.h>
#include <math.h>

const int RUNCOUNT = 100000;

// X = X(lambda) is our random variable
double X(double lambda) {
    double u;
    do {

```

```

        u= double(rand())/RAND_MAX;
    } while (u== 0);
    double val = - log(u)*lambda;
    return val;
}

double run(double lambda) {
    int i = 0;
    double time = 0;
    double prevtime = -1;
    double nexttime = 0;
    time = X(lambda);
    nexttime = time + X(lambda);
    // while collision: adjacent times within +/- 1 slot
    while (time - prevtime < 1 || nexttime - time < 1) {
        prevtime = time;
        time = nexttime;
        nexttime += X(lambda);
    }
    return time;
}

void main(int argc, char * argv[]) {
    int i;
    double sum, lambda;
    for (lambda = 1.0; lambda <= 3.01; lambda += 0.1) {
        sum = 0;
        for (i=0; i<RUNCOUNT; i++) sum += run(lambda);
        cout << lambda << " " << sum/RUNCOUNT << endl;
    }
}

```

53. This is the case in the hidden node problem, illustrated in Figure 2.30, in which A interferes with C's communication to B, and C interferes with A's communication to B.
54. Whereas in wired networks, the sender can detect collisions as they occur, this is not true in wireless. The hidden node problem (see previous question) is one reason for this, and the half-duplex nature of wireless links is another.
55. 802.11 uses the RTS-CTS mechanism to try to address hidden terminals. A node that has data to send begins by sending a short RTS packet indicating that it would like to send data, and the receiver responds with a CTS, which is also likely to be received by nodes that are in reach of the receiver but hidden from the sender. While this doesn't prevent collisions, the fact that RTS and CTS are short packets makes collisions less likely.

56. A base station topology would require an infrastructure of base stations in place. Existing base stations (and their hardline connections) may be wiped out by the disaster, and installing new ones may be difficult and time-consuming. With a mesh topology, each additional node would piggyback on existing nodes.
57. GPS is considered too expensive and consumes too much power for the majority of nodes. A typical solution requires a few nodes called *beacons* to determine their own absolute locations based on GPS or manual configuration. The majority of nodes can then derive their absolute location by combining an estimate of their position relative to the beacons with the absolute location information provided by the beacons.

Solutions for Chapter 3

1. The following table is cumulative; at each part the VCI tables consist of the entries at that part and also all previous entries. Note that at the last stage when a connection comes in to A, we assume the VCI used at stage (a) cannot be re-used in the opposite direction, as would be the case for bi-directional circuits (the most common sort).

Exercise part	Switch	Input		Output	
		Port	VCI	Port	VCI
(a)	1	2	0	3	0
(b)	1	0	0	1	0
	2	3	0	0	0
	3	0	0	3	0
(c)	1	0	1	1	1
	2	3	1	0	1
	3	0	1	2	0
(d)	1	2	1	1	2
	2	3	2	0	2
	3	0	2	3	1
(e)	2	1	0	0	3
	3	0	3	1	0
	4	2	0	3	0
(f)	1	1	3	2	2
	2	1	1	3	3
	4	0	0	3	1

2. The answer is in the book.

3. Node A:

Destination	Next hop
B	C
C	C
D	C
E	C
F	C

Node B:

Destination	Next hop
A	E
C	E
D	E
E	E
F	E

Node C:

Destination	Next hop
A	A
B	E
D	E
E	E
F	F

Node D:

Destination	Next hop
A	E
B	E
C	E
E	E
F	E

Node E:	Destination	Next hop
	A	C
	B	B
	C	C
	D	D
	F	C

Node F:	Destination	Next hop
	A	C
	B	C
	C	C
	D	C
	E	C

4. S1:

destination	port
A	1
B	2
default	3

S2:

destination	port
A	1
B	1
C	3
D	3
default	2

S3:

destination	port
C	2
D	3
default	1

S4:

destination	port
D	2
default	1

5. In the following, $S_i[j]$ represents the j th entry (counting from 1 at the top) for switch S_i .

A connects to D via $S_1[1]$ — $S_2[1]$ — $S_3[1]$

A connects to B via $S_1[2]$

B connects to D via $S_1[3]$ — $S_2[2]$ — $S_3[2]$

6. We provide space in the packet header for a second address list, in which we build the return address. Each time the packet traverses a switch, the switch must add the *inbound* port number to this return-address list, in addition to forwarding the packet out the outbound port listed in the “forward” address. For example, as the packet traverses Switch 1 in Figure 3.7, towards forward address “port 1”, the switch writes “port 2” into the return address. Similarly, Switch 2 must write “port 3” in the next position of the return address. The return address is complete once the packet arrives at its destination.

Another possible solution is to assign each switch a locally unique name; that is, a name not shared by any of its directly connected neighbors. Forwarding switches (or the originating host) would then fill in the sequence of these names. When a packet was sent in reverse, switches would use these names to look up the previous hop. We might reject locally unique names, however, on the grounds

that if interconnections can be added later it is hard to see how to permanently allocate such names without requiring global uniqueness.

Note that switches cannot figure out the reverse route from the far end, given just the original forward address. The problem is that multiple senders might use the same forward address to reach a given destination; no reversal mechanism could determine to which sender the response was to be delivered. As an example, suppose Host A connects to port 0 of Switch 1, Host B connects to port 0 of Switch 2, and Host C connects to port 0 of Switch 3. Furthermore, suppose port 1 of Switch 1 connects to port 2 of Switch 3, and port 1 of Switch 2 connects to port 3 of Switch 3. The source-routing path from A to C *and* from B to C is (0,1); the reverse path from C to A is (0,2) and from C to B is (0,3).

7. Here is a proposal that entails separate actions for (a) the switch that lost state, (b) its immediate neighbors, and (c) everyone else. We will assume connections are bidirectional in that if a packet comes in on $\langle \text{port}_1, \text{VCI}_1 \rangle$ bound for $\langle \text{port}_2, \text{VCI}_2 \rangle$, then a packet coming in on the latter is forwarded to the former. Otherwise a reverse-lookup mechanism would need to be introduced.
 - (a). A switch that has lost its state might send an *I am lost* message on its outbound links.
 - (b). Immediate neighbors who receive this would identify the port through which the lost switch is reached, and then search their tables for any connection entries that use this port. A *connection broken* message would be sent out the *other* port of the connection entry, containing that port's corresponding VCI.
 - (c). The remaining switches would then forward these *connection broken* messages back to the sender, forwarding them the usual way and updating the VCI on each link.

A switch might not be aware that it has lost some or all of its state; one clue is that it receives a packet for which it was clearly expected to have state, but doesn't. Such a situation could, of course, also result from a neighbor's error.
8. If a switch loses its tables, it could notify its neighbors, but we have no means of identifying what hosts down the line might use that switch.

So, the best we can do is notify senders by sending them an *unable to forward* message whenever a packet comes in to the affected switch.
9. We now need to keep a network address along with each outbound port (or with every port, if connections are bidirectional).
10. (a) The packet would be sent $S1 \rightarrow S2 \rightarrow S3$, the known route towards B. S3 would then send the packet back to S1 along the new connection, thinking it had forwarded it to B. The packet would continue to circulate.
 - (b) This time it is the setup message itself that circulates forever.
11. As one possible answer, we use a modified version of Figure 3.44, in which hosts H and J are removed, and port 0 of Switch 4 is connected to port 1 of Switch 3.

Here are the $\langle \text{port}, \text{VCI} \rangle$ entries for a path from Host E to host F that traverses the Switch2—Switch4 link twice; the VCI is 0 wherever possible.

Switch 2: $\langle 2,0 \rangle$ to $\langle 1,0 \rangle$

Switch 4: $\langle 3,0 \rangle$ to $\langle 0,0 \rangle$ (recall Switch 4 port 0 now connects to Switch 3)

Switch 3: $\langle 1,0 \rangle$ to $\langle 0,0 \rangle$

Switch 2: $\langle 0,0 \rangle$ to $\langle 1,1 \rangle$

Switch 4: $\langle 3,1 \rangle$ to $\langle 2,0 \rangle$

12. There is no guarantee that data sent along the circuit won't catch up to and pass the process establishing the connections, so, yes, data should not be sent until the path is complete.

13.

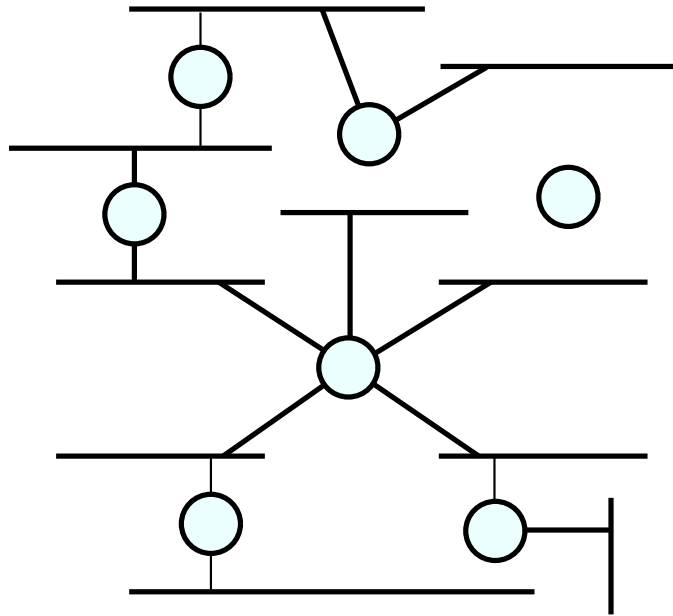

14. The answer is in the book.

15. When A sends to C, all bridges see the packet and learn where A is. However, when C then sends to A, the packet is routed directly to A and B4 does not learn where C is. Similarly, when D sends to C, the packet is routed by B2 towards B3 only, and B1 does not learn where D is.

B1:	A-interface:	A	B2-interface:	C (not D)	
B2:	B1-interface:	A	B3-interface:	C	B4-interface: D
B3:	B2-interface:	A,D	C-interface:	C	
B4:	B2-interface:	A (not C)	D-interface:	D	

16. The answer is in the book.

17. (a) When X sends to W the packet is forwarded on all links; all bridges learn where X is. Y's network interface would see this packet.
- (b) When Z sends to X, all bridges already know where X is, so each bridge forwards the packet only on the link towards X, that is, $B3 \rightarrow B2 \rightarrow B1 \rightarrow X$. Since the packet traverses all bridges, all bridges learn where Z is. Y's network interface would not see the packet as B2 would only forward it on the B1 link.
- (c) When Y sends to X, B2 would forward the packet to B1, which in turn forwards it to X. Bridges B2 and B1 thus learn where Y is. B3 and Z never see the packet.
- (d) When W sends to Y, B3 does not know where Y is, and so retransmits on all links; Z's network interface would thus see the packet. When the packet arrives at B2, though, it is retransmitted only to Y (and not to B1) as B2 does know where Y is from step (c). B3 and B2 now know where W is, but B1 does not learn where W is.
18. B1 will be the root; B2 and B3 each have two equal length paths (along their upward link and along their downward link) to B1. They will each, independently, select one of these vertical links to use (perhaps preferring the interface by which they first heard from B1), and disable the other. There are thus four possible solutions.
19. (a) The packet will circle endlessly, in both the $M \rightarrow B2 \rightarrow L \rightarrow B1$ and $M \rightarrow B1 \rightarrow L \rightarrow B2$ directions.
- (b) Initially we (potentially) have four packets: one from M clockwise, one from M counterclockwise, and a similar pair from L.
- Suppose a packet from L arrives at an interface to a bridge B_i , followed immediately via the same interface by a packet from M. As the first packet arrives, the bridge adds $\langle L, \text{arrival-interface} \rangle$ to the table (or, more likely, updates an existing entry for L). When the second packet arrives, addressed to L, the bridge then decides not to forward it, because it arrived from the interface recorded in the table as pointing towards the destination, and so it dies.
- Because of this, we expect that in the long run only one of the pair of packets traveling in the same direction will survive. We may end up with two from M, two from L, or one from M and one from L. A specific scenario for the latter is as follows, where the bridges' interfaces are denoted "top" and "bottom":
1. L sends to B1 and B2; both place $\langle L, \text{top} \rangle$ in their table. B1 already has the packet from M in the queue for the top interface; B2 this packet in the queue for the bottom.
 2. B1 sends the packet from M to B2 via the top interface. Since the destination is L and $\langle L, \text{top} \rangle$ is in B2's table, it is dropped.
 3. B2 sends the packet from M to B1 via the bottom interface, so B1 updates its table entry for M to $\langle M, \text{bottom} \rangle$

4. B2 sends the packet from L to B1 via the bottom interface, causing it to be dropped.
The packet from M now circulates counterclockwise, while the packet from L circulates clockwise.
20. (a) In this case the packet would never be forwarded; as it arrived from a given interface the bridge would first record $\langle M, \text{interface} \rangle$ in its table and then conclude the packet destined for M did not have to be forwarded out the other interface.
- (b) Initially we would have a copy of the packet circling clockwise (CW) and a copy circling counterclockwise (CCW). This would continue as long as they traveled in perfect symmetry, with each bridge seeing alternating arrivals of the packet through the top and bottom interfaces. Eventually, however, something like the following is likely to happen:
0. Initially, B1 and B2 are ready to send to each other via the top interface; both believe M is in the direction of the bottom interface.
 1. B1 starts to send to B2 via the top interface (CW); the packet is somehow delayed in the outbound queue.
 2. B2 does send to B1 via the top interface (CCW).
 3. B1 receives the CCW packet from step 2, and immediately forwards it over the bottom interface back to B2. The CW packet has not yet been delivered to B2.
 4. B2 receives the packet from step 3, via the bottom interface. Because B2 currently believes that the destination, M, lies on the bottom interface, B2 drops the packet.
- The clockwise packet would then be dropped on its next circuit, leaving the loop idle.
21. (a) If the bridge forwards all spanning-tree messages, then the remaining bridges would see networks D,E,F,G,H as a single network. The tree produced would have B2 as root, and would disable the following links:
- from B5 to A (the D side of B5 has a direct connection to B2)
 - from B7 to B
 - from B6 to either side
- (b) If B1 simply drops the messages, then as far as the spanning-tree algorithm is concerned the five networks D-H have no direct connection, and in fact the entire extended LAN is partitioned into two disjoint pieces A-F and G-H. Neither piece has any redundancy alone, so the separate spanning trees that would be created would leave all links active. Since bridge B1 still presumably *is* forwarding other messages, all the original loops would still exist.
22. (a) Whenever any host transmits, the packet collides with itself.
- (b) It is difficult or impossible to send status packets, since they too would self-collide as in (a). Repeaters do not look at a packet before forwarding, so they wouldn't be in a position to recognize status packets as such.

- (c) A hub might notice a loop because collisions *always* occur, whenever any host transmits. Having noticed this, the hub might send a specific signal out one interface, during the rare idle moment, and see if that signal arrives back via another. The hub might, for example, attempt to verify that whenever a signal went out port 1, then a signal always appeared immediately at, say, port 3.

We now wait some random time, to avoid the situation where a neighboring hub has also noticed the loop and is also disabling ports, and if the situation still persists we disable one of the looping ports.

Another approach altogether might be to introduce some distinctive signal that does not correspond to the start of any packet, and use this for hub-to-hub communication.

23. Once we determine that two ports *are* on the same LAN, we can choose the smaller-numbered port and shut off the other.

A bridge will know it has two interfaces on the same LAN when it sends out its initial “I am root” configuration messages and receives its own messages back, without their being marked as having passed through another bridge.

24. A 53-byte ATM cell has 5 bytes of headers, for an overhead of about 9.4% for ATM headers alone. ATM adaptation layers add varying amounts of additional overhead.

25. The drawbacks to datagram routing for small cells are the larger addresses, which would now take up a considerable fraction of each cell, and the considerably higher per-cell processing costs in each router that are not proportional to cell size.

26. Since the I/O bus speed is less than the memory bandwidth, it is the bottleneck. Effective bandwidth that the I/O bus can provide is $800/2$ Mbps because each packet crosses the I/O bus twice. Therefore, the number of interfaces is $\lfloor 400/100 \rfloor = 4$.

27. The answer is in the book.

28. The workstation can handle $1000/2 = 500$ Mbps, limited by the I/O bus. Let the packet size be x bits; to support 500,000 packets/second we need a total capacity of $500000 \times x$ bps; equating $5 \times 10^5 \times x = 500 \times 10^6$ bps, we get $x = 1000$ bits = 125 bytes. For packet sizes below this, packet forward rate is the limiter, above this the limit is the I/O bus bandwidth.

29. Switch with input FIFO buffering :

(a) An input FIFO may become full if the packet at the head is destined for a full output FIFO. Packets that arrive on ports whose input FIFOs are full are lost regardless of their destination.

(b) This is called *head-of-line blocking*.

- (c) By redistributing the buffers exclusively to the output FIFOs, incoming packets will only be lost if the destination FIFO is full.
30. Each stage has $n/2$ switching elements. Since after each stage we eliminate half the network, *i.e.* half the rows in the $n \times n$ network, we need $\log_2 n$ stages. Therefore the number of switching elements needed is $(n/2) \log_2 n$. For $n = 8$, this is 12.
31. A Batcher network sorts elements into ascending (or descending) order. As long as no two elements have the same index, the ordered list can then be routed to the correct output by a Banyan network. However, some additional mechanism is needed to ensure that there are no duplicates. The paper by Giacomelli et al. [GHMS91] gives one approach.
32. (a) After the upgrade the server—switch link is the only congested link. For a busy Ethernet the contention interval is roughly proportional to the number of stations contending, and this has now been reduced to two. So performance should increase, but only slightly.
- (b) A switch makes it impossible for a station to eavesdrop on traffic not addressed to it. On the other hand, switches tend to cost more than hubs, per port.
33. IP addresses include the network/subnet, so that interfaces on different networks must have different network portions of the address. Alternatively, addresses include location information and different interfaces are at different locations, topologically.
- Point-to-point interfaces can be assigned a duplicate address (or no address) because the other endpoint of the link doesn't use the address to reach the interface; it just sends. Such interfaces, however, cannot be addressed by any other host in the network. See also RFC1812, section 2.2.7, page 25, on “unnumbered point-to-point links”.
34. The IPv4 header allocates only 13 bits to the *Offset* field, but a packet's length can be up to $2^{16} - 1$. In order to support fragmentation of a maximum-sized packet, we must count offsets in multiples of $2^{16-13} = 2^3$ bytes.
- The only concerns with counting fragmentation offsets in 8-byte units are that we would waste space on a network with $MTU = 8n + 7$ bytes, or that alignment on 8-byte boundaries would prove inconvenient. 8-byte chunks are small enough that neither of these is a significant concern.
35. All 0's or 1's over the entire packet will change the *Version* and *HLen* fields, resulting in non-IPv4 packets. The checksum algorithm would also catch this error — a header consisting of all zeroes should have a checksum of all ones, and vice versa. In reality, the checksum calculation would probably not even be attempted after the version was found to be wrong.

36. Consider the first network. An MTU of 1024 means that is the largest IP datagram that can be carried, so a datagram has room for $1024 - 20 = 1004$ bytes of IP-level data; because 1004 is not a multiple of 8, each fragment can contain at most $8 \times \lfloor 1004/8 \rfloor = 1000$ bytes. We need to transfer $1024 + 20 = 1044$ bytes of data when the TCP header is included. This would be fragmented into fragments of size 1000, and 44.

Over the second network the 44-byte packet would be unfragmented but the 1000-data-byte packet would be fragmented as follows. The 576-byte MTU allows for up to $576 - 20 = 556$ bytes of payload, so rounding down to a multiple of 8 again allows for 552 bytes in the first fragment with the remaining 448 in the second fragment.

37. The answer is in the book.
38. (a) The probability of losing both transmissions of the packet would be $0.1 \times 0.1 = 0.01$.
- (b) The probability of loss is now the probability that for some pair of identical fragments, both are lost. For any particular fragment the probability of losing both instances is $0.01 \times 0.01 = 10^{-4}$, and the probability that this happens at least once for the 10 different fragments is thus about 10 times this, or 0.001.
- (c) An implementation *might* (though generally most do not) use the same value for `Ident` when a packet had to be retransmitted. If the retransmission timeout was less than the reassembly timeout, this might mean that case (b) applied and that a received packet might contain fragments from each transmission.

39. M	offset	bytes data	source
1	0	360	1st original fragment
1	360	152	1st original fragment
1	512	360	2nd original fragment
1	872	152	2nd original fragment
1	1024	360	3rd original fragment
0	1384	16	3rd original fragment

If fragmentation had been done originally for this MTU, there would be four fragments. The first three would have 360 bytes each; the last would have 320 bytes.

40. The `Ident` field is 16 bits, so we can send 576×2^{16} bytes per 60 seconds, or about 5Mbps. If we send more than this, then fragments of one packet could conceivably have the same `Ident` value as fragments of another packet.
41. IPv4 effectively requires that, if reassembly is to be done at the downstream router, then it be done at the link layer, and will be transparent to IPv4. IP-layer fragmentation is only done when such link-layer fragmentation isn't practical, in which case IP-layer reassembly might be expected to be even less practical, given how busy routers tend to be. See RFC791, page 23.

IPv6 uses link-layer fragmentation exclusively; experience had by then established reasonable MTU values, and also illuminated the performance problems of IPv4-style fragmentation. (Path-MTU discovery is also mandatory, which means the sender always knows just how large the data passed to IP can be to avoid fragmentation.)

Whether or not link-layer fragmentation is feasible appears to depend on the nature of the link; neither version of IP therefore requires it.

42. If the timeout value is too small, we clutter the network with unnecessary re-requests, and halt transmission until the re-request is answered.

When a host's Ethernet address changes, *e.g.* because of a card replacement, then that host is unreachable to others that still have the old Ethernet address in their ARP cache. 10-15 minutes is a plausible minimal amount of time required to shut down a host, swap its Ethernet card, and reboot.

While self-ARP (described in the following exercise) is arguably a better solution to the problem of a too-long ARP timeout, coupled with having other hosts update their caches whenever they see an ARP query from a host already in the cache, these features were not always universally implemented. A reasonable upper bound on the ARP cache timeout is thus necessary as a backup.

43. The answer is maybe, in theory, but the practical consequences rule it out. A MAC address is statically assigned to each hardware interface. ARP mapping enables indirection from IP addresses to the hardware MAC addresses. This allows IP addresses to be dynamically reallocated when the hardware moves to the different network, *e.g.* when a mobile wireless devices moves to a new access network. So using MAC addresses as IP addresses would mean that we would have to use static IP addresses.

Since the Internet routing takes advantage of address space hierarchy (use higher bits for network addresses and lower bits for host addresses), if we would have to use static IP addresses, the routing would be much less efficient. Therefore this design is practically not feasible.

44. After B broadcasts any ARP query, all stations that had been sending to A's physical address will switch to sending to B's. A will see a sudden halt to all arriving traffic. (To guard against this, A might monitor for ARP broadcasts purportedly coming from itself; A might even immediately follow such broadcasts with its own ARP broadcast in order to return its traffic to itself. It is not clear, however, how often this is done.)

If B uses self-ARP on startup, it will receive a reply indicating that its IP address is already in use, which is a clear indication that B should not continue on the network until the issue is resolved.

45. (a) If multiple packets after the first arrive at the IP layer for outbound delivery, but before the first ARP response comes back, then we send out multiple unnecessary ARP packets. Not only do these consume bandwidth, but,

because they are broadcast, they interrupt every host and propagate across bridges.

- (b) We should maintain a list of currently outstanding ARP queries. Before sending a query, we first check this list. We also might now retransmit queries on the list after a suitable timeout.
- (c) This might, among other things, lead to frequent and excessive packet loss at the beginning of new connections.

46. (a)

Information Stored at Node	Distance to Reach Node					
	A	B	C	D	E	F
A	0	∞	3	8	∞	∞
B	∞	0	∞	∞	2	∞
C	3	∞	0	∞	1	6
D	8	∞	∞	0	2	∞
E	∞	2	1	2	0	∞
F	∞	∞	6	∞	∞	0

(b)

Information Stored at Node	Distance to Reach Node					
	A	B	C	D	E	F
A	0	∞	3	8	4	9
B	∞	0	3	4	2	∞
C	3	3	0	3	1	6
D	8	4	3	0	2	∞
E	4	2	1	2	0	7
F	9	∞	6	∞	7	0

(c)

Information Stored at Node	Distance to Reach Node					
	A	B	C	D	E	F
A	0	6	3	6	4	9
B	6	0	3	4	2	9
C	3	3	0	3	1	6
D	6	4	3	0	2	9
E	4	2	1	2	0	7
F	9	9	6	9	7	0

47. The answer is in the book.

48.	D	Confirmed	Tentative
	1.	(D,0,-)	
	2.	(D,0,-)	(A,8,A) (E,2,E)
	3.	(D,0,-) (E,2,E)	(A,8,A) (B,4,E) (C,3,E)
	4.	(D,0,-) (E,2,E) (C,3,E)	(A,6,E) (B,4,E) (F,9,E)
	5.	(D,0,-) (E,2,E) (C,3,E) (B,4,E)	(A,6,E) (F,9,E)
	6.	previous + (A,6,E)	
	7.	previous + (F,9,E)	

50. Traceroute sends packets with limited TTL values. If we send to an unassigned network, then as long as the packets follow default routes, traceroute will get normal answers. When the packet reaches a default-free (backbone) router, however (or more precisely a router which recognizes that the destination doesn't exist), the process will abruptly stop. Packets will not be forwarded further.

The router that finally realizes the error will send back "ICMP host unreachable" or "ICMP net unreachable", but this ICMP result may not in fact be listened for by traceroute (*is not*, in implementations with which I am familiar), in which case the traceroute session will end with timeouts either way.

51. A can reach B and D but not C. Because A hasn't been configured with subnet information, it treats C and B as being on the same network (it shares a network number with them, being in the same site). To reach B, A sends ARP requests directly to B; these are passed by RB as are the actual Ethernet packets. To reach D, which A recognizes as being on another network, A uses ARP to send to R2. However, if A tries to ARP to C, the request will not pass R1.
52. The cost=1 links show A connects to B and D; F connects to C and E. F reaches B through C at cost 2, so B and C must connect. F reaches D through E at cost 2, so D and E must connect. A reaches E at cost 2 through B, so B and E must connect.

These give:

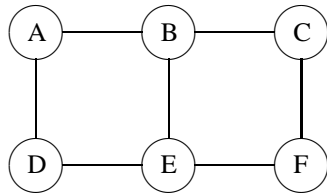

As this network is consistent with the tables, it is the unique minimal solution.

53. The answer is in the book.

54. (a)

A:	dest	cost	nexthop
	B	∞	-
	C	3	C
	D	∞	-
	E	∞	-
	F	9	C

B:	dest	cost	nexthop
	A	∞	-
	C	∞	-
	D	4	E
	E	2	E
	F	∞	-

D:	dest	cost	nexthop
	A	∞	-
	B	4	E
	C	∞	-
	E	2	E
	F	∞	-

F:	dest	cost	nexthop
	A	9	C
	B	∞	-
	C	6	C
	D	∞	-
	E	∞	-

(b)

A:	dest	cost	nexthop
	B	12	D
	C	3	C
	D	8	D
	E	10	D
	F	9	C

D:	dest	cost	nexthop
	A	8	A
	B	4	E
	C	11	A
	E	2	E
	F	17	A

(c)

C:	dest	cost	nexthop
	A	3	A
	B	15	A
	D	11	A
	E	13	A
	F	6	F

55. Apply each subnet mask and if the corresponding subnet number matches the SubnetNumber column, then use the entry in Next-Hop. (In these tables there is always a unique match.)

- (a) Applying the subnet mask 255.255.255.128, we get 128.96.39.0. Use interface0 as the next hop.
- (b) Applying subnet mask 255.255.255.128, we get 128.96.40.0. Use R2 as the next hop.
- (c) All subnet masks give 128.96.40.128 as the subnet number. Since there is no match, use the default entry. Next hop is R4.
- (d) Next hop is R3.
- (e) None of the subnet number entries match, hence use default router R4.

56. The answer is in the book.

57. (a) A necessary and sufficient condition for the routing loop to form is that B reports to A the networks B believes it can currently reach, after A discovers the problem with the A—E link, but before A has communicated to B that A no longer can reach E.

- (b) At the instant that A discovers the A—E failure, there is a 50% chance that the next report will be B's and a 50% chance that the next report will be A's. If it is A's, the loop will not form; if it is B's, it will.
- (c) At the instant A discovers the A—E failure, let t be the time until B's next broadcast. t is equally likely to occur anywhere in the interval $0 \leq t \leq 60$. The event of a loop forming is the same as the event that B broadcasts first, which is the event that $t < 1.0$ sec; the probability of this is $1/60$.
58. Denote the act of A's sending an update to B about E by $A \Rightarrow B$. Any initial number of $B \Rightarrow C$ or $C \Rightarrow B$ updates don't change E entries. By split horizon, $B \Rightarrow A$ and $C \Rightarrow A$ are disallowed. Since we have assumed A reports to B before C, the first relevant report must be $A \Rightarrow B$. This makes C the sole believer in reachability of E; C's table entry for E remains (E,2,A).

At this point legal and relevant updates are $A \Rightarrow C$, $C \Rightarrow B$, and $B \Rightarrow C$; $A \Leftrightarrow B$ exchanges don't change E entries and $C \Rightarrow A$ is disallowed by split horizon. If $A \Rightarrow C$ or $B \Rightarrow C$ the loop formation is halted, so we require $C \Rightarrow B$. Now C's table has (E,2,A) and B's has (E,3,C); we have two believers.

The relevant possibilities now are $B \Rightarrow A$, or $A \Rightarrow C$. If $B \Rightarrow A$, then A's table has (E,4,C) and the loop is complete. If $A \Rightarrow C$, then B becomes the sole believer. The only relevant update at that point not putting an end to belief in E is $B \Rightarrow A$, which then makes A a believer as well.

At this point, exchange $A \Rightarrow C$ would then form the loop. On the other hand, $C \Rightarrow B$ would leave A the sole believer. As things progress, we could either

- (a) form a loop at some point,
 - (b) eliminate all belief in E at some point, or
 - (c) have sole-believer status migrate around the loop, $C \rightarrow B \rightarrow A \rightarrow C \rightarrow \dots$, alternating with the dual-believer situation.
59. (a) The book already explains how poison reverse is not needed when F-G fails. When the A-E link fails, the following sequence (or something similarly bad) may happen depending on the timing, whether or not poison reverse is used.
- i. A sends (E, inf) to B.
 - ii. C sends (E, 2) to B. This route is via A.
 - iii. A sends (E, inf) to C.
 - iv. B sends (E, 3) to A. This route is via C.
 - v. C sends (E, inf) to B.
 - vi. A sends (E, 4) to C. This route is via B.
 - vii. B sends (E, inf) to A.
 - viii. C sends (E, 5) to B. This route is via A.
 - ix. A sends (E, inf) to C.
 - x. B sends (E, 6) to A. The oscillation goes on and on like this.

- (b) Without poison reverse, A and B would send each other updates that simply didn't mention X; presumably (this does depend somewhat on implementation) this would mean that the false routes to X would sit there until they eventually aged out. With poison reverse, such a loop would go away on the first table update exchange.
- (c)
 1. B and A each send out announcements of their route to X via C to each other.
 2. C announces to A and B that it can no longer reach X; the announcements of step 1 have not yet arrived.
 3. B and A receive each others announcements from step 1, and adopt them.

60. We will implement hold-down as follows: when an update record arrives that indicates a destination is unreachable, all subsequent updates within some given time interval are ignored and discarded.

Given this, then in the EAB network A ignores B's reachability news for one time interval, during which time A presumably reaches B with the correct unreachability information.

Unfortunately, in the EABD case, this also means A ignores the valid B–D–E path. Suppose, in fact, that A reports its failure to B, D reports its valid path to B, and then B reports to A, all in rapid succession. This new route will be ignored.

One way to avoid delaying discovery of the B–D–E path is to keep the hold-down time interval as short as possible, relying on triggered updates to spread the unreachability news quickly.

Another approach to minimizing delay for new valid paths is to retain route information received during the hold-down period, but not to use it. At the expiration of the hold-down period, the sources of such information might be interrogated to determine whether it remains valid. Otherwise we might have to wait not only the hold-down interval but also wait until the next regular update in order to receive the new route news.

61. We will also assume that each node increments its sequence number only when there is some change in the state of its local links, not for timer expirations (“no packets time out”).

The central *point* of this exercise is intended to be an illustration of the “bringing-up-adjacencies” process: in restoring the connection between the left- and right-hand networks, it is not sufficient simply to flood the information about the restored link. The two halves have evolved separately, and full information must be exchanged.

Given that each node increments its sequence number whenever it detects a change in its links to its neighbors, at the instant before the B—F link is restored the LSP data for each node is as follows:

node	seq#	connects to
A	2	B,C,D
B	2	A,C
C	2	A,B,D
D	2	A,C
F	2	G
G	2	F,H
H	1	G

When the B–F link is restored, OSPF has B and F exchange their full databases of all the LSPs they have seen with each other. Each then floods the other side’s LSPs throughout its side of the now-rejoined network. These LSPs are as in the rows of the table above, except that B and F now each have sequence numbers of 3.

The initial sequence number of an OSPF node is actually $-2^{31} + 1$.

62. Step	confirmed	tentative
1	(A,0,-)	
2	(A,0,-)	(D,2,D) (B,5,B)
3	(A,0,-) (D,2,D)	(B,4,D) (E,7,D)
4	(A,0,-) (D,2,D) (B,4,D)	(E,6,D) (C,8,D)
5	(A,0,-) (D,2,D) (B,4,D) (E,6,D)	(C,7,D)
6	(A,0,-) (D,2,D) (B,4,D) (E,6,D) (C,7,D)	

63. The answer is in the book.

64. (a) This could happen if the link changed state recently, and one of the two LSP’s was old.
- (b) If flooding is working properly, and if A and B do in fact agree on the state of the link, then eventually (rather quickly) whichever of the two LSP’s was old would be updated by the same sender’s newer version, and reports from the two sides of C would again agree.

65. This exercise does not, alas, quite live up to its potential.

The central idea behind Ethernet bridges is that they learn new host locations by examining ordinary data packets, and do *not* receive new-host notices from other bridges. Thus the first part of the final sentence of the exercise effectively removes from consideration a genuine bridge-style approach for routers. While there are good reasons for this, outlined in the final paragraph below, a better way to phrase this might be to ask why IP routers do not work like learning bridges, or, even more basically, why bridges do not use vector-distance routing.

Furthermore, a consequence of the second half of the final sentence is that there is no real difference in the cases (a) and (b) with bridge-style learning. Proper configuration would prevent address-assignment inconsistencies in each, which apparently had been the original concern.

So we are left with a model of “bridge-style learning” in which routers learn about each other through messages each sends periodically to other routers. This is not terribly bridge-like. Moreover, it is not clear what it means for routers to learn of each other by this method; if they are sending each other messages then either they already know about each other or else some form of broadcast is used. And broadcast runs into serious problems if there is a possibility of loops. If routers are sending out messages that are just broadcast on directly connected subnets, listing all the subnets they know about, and these messages include distance information, then they are more-or-less doing vector-distance routing. One routing approach that might qualify under the terms of the exercise is if routers send out link-state-style periodic messages identifying their directly connected networks, and that these are propagated by flooding.

The main reason that IP routers cannot easily learn new subnet locations by examination of *data* packets is that they would then have to fall back on network-wide broadcast for delivery to unknown subnets. IP does indeed support a notion of broadcast, but broadcast in the presence of loop topology (which IP must support) fails rather badly unless specific (shortest-path) routes to each individual subnet are already known by the routers. And even if some alternative mechanism were provided to get routing started, path-length information would not be present in data packets, so future broadcasting would remain loop-unsafe. We note too that subnet routing requires that the routers learn the subnet masks, which are also not present in data packets. Finally, bridges may prefer passive learning simply because it avoids bridge-to-bridge compatibility issues.

66. If an IP packet addressed to a specific host A were inadvertently broadcast, and all hosts on the subnet did forwarding, then A would be inundated with multiple copies of the packet.

Other reasons for hosts’ not doing routing include the risk that misconfigured hosts could interfere with routing, or might not have up-to-date tables, or might not even participate in the same routing protocol that the real routers were using.

68. (a) Giving each department a single subnet, the nominal subnet sizes are 2^7 , 2^6 , 2^5 , 2^5 respectively; we obtain these by rounding up to the nearest power of 2. For example, a subnet with 128 addresses is large enough to contain 75 hosts. A possible arrangement of subnet numbers is as follows. Subnet numbers are in binary and represent an initial segment of the bits of the last byte of the IP address; anything to the right of the / represents host bits. The / thus represents the subnet mask. Any individual bit can, by symmetry, be flipped throughout; there are thus several possible bit assignments.

A	0/	one subnet bit, with value 0; seven host bits
B	10/	
C	110/	
D	111/	

The essential requirement is that any two distinct subnet numbers remain distinct when the longer one is truncated to the length of the shorter.

- (b) We have two choices: either assign multiple subnets to single departments, or abandon subnets and buy a bridge. Here is a solution giving A two subnets, of sizes 64 and 32; every other department gets a single subnet of size the next highest power of 2:

```
A   01/
    001/
B   10/
C   000/
D   11/
```

69. To solve this with routing, C has to be given its own subnet. Even if this is small, this reduces the available size of the original Ethernet to at most seven bits of subnet address. Here is a possible routing table for B; subnet numbers and masks are in binary. Note that many addresses match neither subnet.

net	subnet	mask	interface
200.0.0	0/000 0000	1000 0000	Ethernet
200.0.0	1000 00/00	1111 1100	direct link

Here C's subnet has been made as small as possible; only two host bits are available (a single host bit can't be used because all-zero-bits and all-ones-bits are reserved in the host portion of an address). C's address might now be 200.0.0.10000001, with the last octet again in binary.

70. (a) A would broadcast an ARP request "where is C?"
 B would answer it; it would supply its own Ethernet address.
 A would send C's packet to B's Ethernet address.
 B would forward the packet to C.
- (b) For the above to work, B must know to forward the packet *without* using subnet addressing; this is typically accomplished by having B's routing table contain a "host-specific route":

net/host	interface
C	direct link
200.0.0	Ethernet

Host-specific routes must be checked first for this to work.

71. (a) DHCP will have considerable difficulty sorting out to which subnet various hosts belonged; subnet assignments would depend on which server answered first. The full DHCP deals with this by allowing servers to be manually configured to ignore address-assignment requests from certain physical addresses on the other subnet. Note that subnet assignment in this situation may matter for consistent naming, performance reasons, certain security access rules, and for broadcast protocols.

(b) ARP will not be affected. Hosts will only broadcast ARP queries for other hosts on the same subnet; hosts on the other subnet will hear these but won't answer. A host on one subnet *would* answer an ARP query from the other subnet, if it were ever issued, but it wouldn't be.

72. (a): B (b): A (c): E (d): F (e): C (f): D
(For the last one, note that the first 14 bits of C4.6B and C4.68 match.)

73. The answer is in the book.

74. (a) each department expects the growth in the number of machines as follows

- Engineering expects machine number increase by one per week, thus by 52 per year. Note that we need 5 machines initially.
- Sales expects client number increase by $(-1) \cdot 0.20 + (+1) \cdot 0.60 + 0 \cdot 0.20 = 0.40$, thus machine number increase by $0.40 \cdot 1/2 = 0.20$ per week, so by $0.20 \cdot 52 = 10.4$ per year. Note that we do not need any machines in the first year, but at the beginning of the second year, we need 3 machines since we have 6 clients then.
- Marketing expects no increase.

To guarantee addresses for at least seven years, we need $(5 + 52 \cdot 7) + (3 + 10.4 \cdot 6) + 16 = 450.4$ addresses. Therefore, the new company needs a slash 23 address range to accommodate 512 addresses.

(b) To determine how long the 512 addresses allocation would last: suppose it would last n years, $(5 + 52 \cdot n) + (3 + 10.4 \cdot (n - 1)) + 16 = 13.6 + 62.4 \cdot n = 512$. Thus, $n = 7.99$. The address assignment would be, for engineering, $5 + 52 \cdot n = 420.32 \sim 420$, for sales, $(3 + 10.4 \cdot (n - 1)) = 75.67 \sim 76$, for marketing, 16.

(c) Since class B supports 65534 host addresses and class C supports 254 addresses (note that two addresses are always reserved in each network class), the company could get one class B range or two class C ranges.

75. There are many possible answers to this problem. One approach might be to use a tree of all netmasks. We decide on the left versus right subtree at level i based on the i th bit of the address. A network with an n -bit mask is marked in the tree at level n . Given an address, we use the bits to proceed down the tree until we reach a dead end. At that point we use the last-encountered network; this ensures the longest match was found. Such a tree is sometimes called a trie.

This strategy is linear in the address size. Performance might be enhanced by handling 4 or even 8 address bits at each level of the tree, although this would lead to some increased space used.

Another approach might be to maintain a separate dictionary for each n , $1 \leq n \leq 24$, of all masks of length n . We start with the longest mask length and work backwards, at stage n searching for the first n bits of the address in the length- n dictionary. If dictionary lookup were sufficiently fast this might also be roughly linear in address length.

Solutions for Chapter 4

1. (a) Q will receive three routes to P, along links 1, 2, and 3.
 - (b) $A \rightarrow B$ traffic will take link 1. $B \rightarrow A$ traffic will take link 2. Note that this strategy minimizes cost to the source of the traffic.
 - (c) To have $B \rightarrow A$ traffic take link 1, Q could simply be configured to prefer link 1 in all cases. The only general solution, though, is for Q to accept into its routing tables some of the internal structure of P, so that Q for example knows where A is relative to links 1 and 2.
 - (d) If Q were configured to prefer AS paths through R, or to avoid AS paths involving links 1 and 2, then Q might route to P via R.
2. In the diagram below, the shortest path between A and B (measured by number of router hops) passes through AS P, AS Q, and AS P.

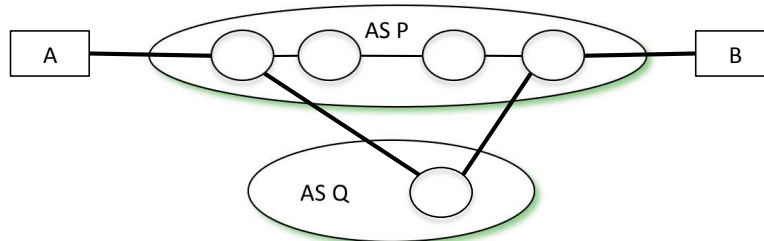

While such a path might be desirable (the path via Q could be much faster or offer lower latency, for example), BGP would see the same AS number (for AS P) twice in the AS_PATH. To BGP, such an AS_PATH would appear as a loop, and be disallowed.

3. (a) The diameter D of a network organized as a binary tree, with root node as “backbone”, would be of order $\log_2 A$. The diameter of a planar rectangular grid of connections would be of order \sqrt{A} .
 - (b) For each AS S , the BGP node needs to maintain a record of the AS_PATH to S , requiring $2 \times \text{actual_path_length}$ bytes. It also needs a list of all the networks within S , requiring $4 \times \text{number_of_networks}$ bytes. Summing these up for all autonomous systems, we get $2AD + 4N$, or $2AC \log A + 4N$ and $2AC\sqrt{A} + 4N$ for the models from part (a), where C is a constant.
4. Many arrangements are possible, although perhaps not likely. Here is an allocation scheme that mixes two levels of geography with providers; it works with 48-bit InterfaceIDs. The subdivisions become much more plausible with 64-bit InterfaceIDs.

- Bytes 0-1: 3-bit prefix + country where site is located
(5 bits is not enough to specify the country)
- Bytes 2-3: provider
- Bytes 4-5: Geographical region within provider
- Bytes 6-8: Subscriber (large providers may have >64K subscribers)
- Bytes 8-9: (Byte 8 is oversubscribed) Subnet
- Bytes 10-15: InterfaceID

5. (a) P's table:

address	nexthop
C2.0.0.0/8	Q
C3.0.0.0/8	R
C1.A3.0.0/16	PA
C1.B0.0.0/12	PB

Q's table:

address	nexthop
C1.0.0.0/8	P
C3.0.0.0/8	R
C2.0A.10.0/20	QA
C2.0B.0.0/16	QB

R's table:

address	nexthop
C1.0.0.0/8	P
C2.0.0.0/8	Q

(b) The same, except for the following changes of one entry each to P's and R's tables:

- P: C3.0.0.0/8 Q // was R
- R: C1.0.0.0/8 Q // was P

(c) Note the use of the longest-match rule to distinguish the entries for Q & QA in P's table, and for P & PA in Q's table.

P's table:

address	nexthop
C2.0.0.0/8	Q
C2.0A.10.0/20	QA // for QA
C1.A3.0.0/16	PA
C1.B0.0.0/12	PB

Q's table:

address	nexthop
C1.0.0.0/8	P
C1.A3.0.0/16	PA // for PA
C2.0A.10.0/20	QA
C2.0B.0.0/16	QB

6. The longest-match rule is intended for this. Note that *all* providers now have to include entries for PA and QB, though.

P's table:

address	nexthop	
C2.0.0.0/8	Q	
C3.0.0.0/8	R	
C1.A3.0.0/16	Q	// entry for PA
C1.B0.0.0/12	PB	
C2.0B.0.0/16	R	// entry for QB

Q's table:

address	nexthop	
C1.0.0.0/8	P	
C3.0.0.0/8	R	
C1.A3.0.0/16	PA	// now Q's customer
C2.0A.10.0/20	QA	
C2.0B.0.0/16	R	// entry for QB

R's table:

address	nexthop	
C1.0.0.0/8	P	
C2.0.0.0/8	Q	
C1.A3.0.0/16	Q	// R also needs an entry for PA
C2.0B.0.0/16	QB	// QB is now R's customer

7. (a) Inbound traffic takes a single path to the organization's address block, which corresponds to the organization's "official" location. This means all traffic enters the organization at a single point even if much shorter alternative routes exist.
(b) For outbound traffic, the organization could enter into its own tables all the highest-level geographical blocks for the outside world, allowing the organization to route traffic to the exit geographically closest to the destination.
(c) For an approach such as the preceding to work for inbound traffic as well, the organization would have to be divided internally into geographically based subnets, and the outside world would then have to accept routing entries for each of these subnets. Consolidation of these subnets into a single external entry would be lost.
(d) We now need each internal router to have entries for internal routes to all the other internal IP networks; this suffices to ensure internal traffic never leaves.
8. Perhaps the primary problem with geographical addressing is what to do with geographically dispersed sites that have their own internal connections. Routing all traffic to a single point of entry seems inefficient.

At the time when routing-table size became a critical issue, most providers were regional and thus provider-based addressing *was* more or less geographical.

9. As described, ISP X is a customer of both ISP A and ISP B. If he advertises a path learned from A to ISP B, then B may send him traffic that he will then

have to forward on to A. At the least, this consumes resources for ISP X without producing any income, and it may even increase his costs if he pays either A or B based on volume. Hence, it would not typically be a good idea for ISP X to advertise such a path.

10.
 - (a) If Q does not advertise A to the world, then only traffic originating within Q will take the Q—A link. Other traffic will be routed first to P. If Q does advertise A, then traffic originating at an external site B will travel in via Q whenever the B—Q—A path is shorter than the B—P—A path.
 - (b) Q must advertise A’s reachability to the world, but it may put a very low “preference value” on this link.
 - (c) The problem is that most outbound traffic will take the DEFAULT path, and nominally this is a single entry. Some mechanism for load-sharing must be put into place. Alternatively, A could enter into its internal routing tables some of its most common external IP destinations, and route to these via Q.
11.
 - (a) R1 should be configured to forward traffic destined for outside of A to the new ISP. R2 should route traffic for A to A as before. Note that if a host on N sends its outbound traffic to R2 by mistake, R2 will send it via the old link. R2 should continue to advertise N to the rest of A. N’s outbound traffic would then take the new link, but inbound traffic would still travel via A. Subnets are not announced into the backbone routing tables, so R1 would not announce N to the world.
 - (b) If N has its own IP network number, then R1 does announce its route to N to the world. R1 would not necessarily announce its route to A, however. R2 would not change: it would still announce N into A. Assuming A does not announce its route to N into its provider, all external traffic to and from N now goes through the new link, and N-A traffic goes through R2.
 - (c) If A wants to use N’s R1 link as a backup, then R1 needs to announce to the backbone that it has a route to A, but give this route a cost higher than that of A’s original link (techniques for doing this via BGP include route preference indications and “padding” the report with extra ASs.)
12. IP has a subrange of its address space reserved for multicast addresses. In IPv4, these addresses are assigned in the class D address space, and IPv6 also has a portion of its address space (see Table 4.11) reserved for multicast group addresses.
13. Yes. Some subranges of the multicast ranges are reserved for intradomain multicast, so they can be reused independently by different domains.
14. The host must have joined at least one of the other 31 IP multicast groups whose addresses share the same high-order 5 bits and hence the same Ethernet multicast address.
15. The answer is in the book.

16. See figure on following page. Note that we have assumed that all hosts *except* the sources are members of G. (This was unclear in the first printing.)
17. (a) One multicast transmission involves all $k + k^2 + \dots + k^{N-1} = (k^N - k)/(k - 1)$ links.
 (b) One unicast retransmission involves N links; sending to everyone would require $N \times k^N$ links.
 (c) Unicast transmission to x fraction of the recipients uses $x \times N \times k^N$ links. Equating this to the answer in (a), we get $x = (k^N - k)/((k - 1) \times N \times k^N) \approx 1/(k - 1) \times N$
18. (a) In the PIM-SM scheme, each router in a multicast group independently decides when to create a source-specific tree for a particular source. The router does so by sending a source-specific Join message toward the source. Hosts connected to the router benefit from this in the form of decreased latency of the multicasts they receive. The intention is that the router would do so only in response to a high data rate being observed from that source, since it imposes a cost, in additional routing state, on other routers. An unscrupulously configured router, however, could indiscriminately trigger source-specific trees, without the justification of high data rates.
 (b) In the PIM-SSM scheme, any host can join a source-specific group, thereby triggering creation of a source-specific tree with the attendant source-specific routing state. This is presumably not a problem since whoever assigned the SSM address to the group (a subrange of the IP multicast addresses is reserved for SSM) did so because SSM was appropriate for the particular group.
19. A simple example where the routes are different has a connected triangle of routers: the source router, the group member router, and a router on the RP address's link. A simple example where the routes are the same has the source and group member routers each connected only to a router on the RP address's link.
20. (a) correct
 (b) incorrect (::: is not defined as abbreviating notation)
 (c) incorrect (shorthand can only be used for one set of contiguous 0's)
 (d) correct
 (e) incorrect (an IPv4 address mapped to IPv6 should be preceded by FFFF hex).
21. First, MPLS labels are of link-local scope—this means that the same label can be used on different links to mean different things. This in turn means that the number of labels needed on a link is just the number of forwarding equivalence classes (FECs) that are meaningful on that link. Thus, if each label is used to represent a prefix in the routing table, as described in Section 4.5.1, then up to a million prefixes could be handled with 20 bits.

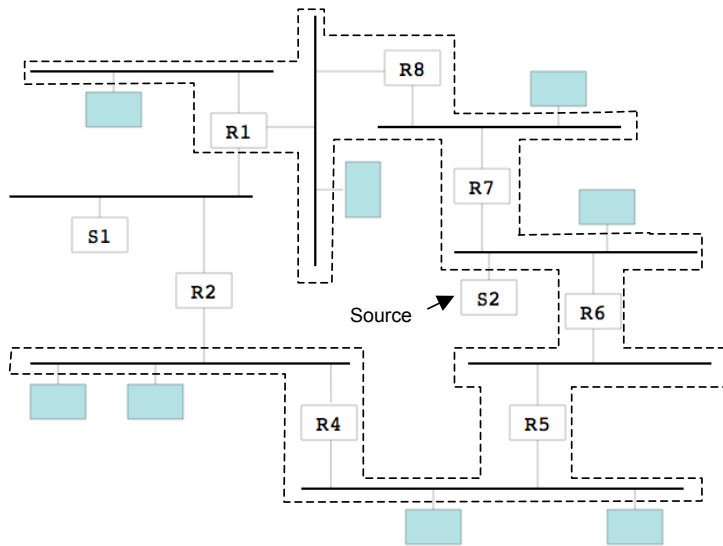
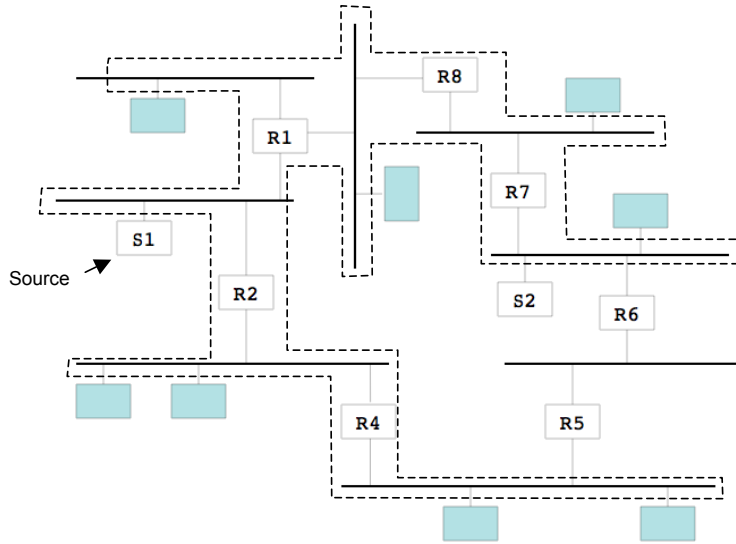

Figure 1: Answers to question 4.16
53

22. MPLS has been thought to improve router performance because each label is a direct index in the routing table, and thus an MPLS-only router could avoid running the more complex longest IP prefix match algorithm. But packet forwarding has many other aspects that influence performance, such as enqueueing packets and switching them across a backplane. These aspects are independent of the forwarding algorithm and have turned out to be the dominant performance-influencing factors.
23.
 - (a) 8 bytes are needed to attach two MPLS labels.
 - (b) 20 bytes are needed for an additional IP header.
 - (c) Bandwidth efficiency for MPLS is $300/308 = 0.97$, and for IP is $300/320 = 0.94$. For 64-byte packets, MPLS has $64/72 = 0.89$ and IP has $64/84 = 0.76$. MPLS is relatively more efficient when the payload size is smaller.
24. Source routing cannot specify a long path because of the option size limit. Second, IP option processing is considerably more complex than normal IP forwarding, and can cause significant performance penalties. Finally, source routing cannot readily aggregate the traffic with the same route into one class; by contrast, MPLS can aggregate such traffic as one FEC, represented by a single label at each hop, thus improving scalability.
25. A correspondent node has no way of knowing that the IP address of a mobile node has changed, and hence no way to send it a packet. A TCP connection will break if the IP address of one endpoint changes.
26. The home agent and the mobile node may be very far apart, leading to suboptimal routing.
27. Without some sort of authentication of updates, an attacker could tell the correspondent node to send all the traffic destined for a mobile node to a node that the attacker controls, thus stealing the traffic. Or, an attacker can tell any number of correspondent nodes to send traffic to some other node that the attacker wishes to flood with traffic.

Solutions for Chapter 5

1.
 - (a) An application such as TFTP, when sending initial connection requests, might want to know the server isn't accepting connections.
 - (b) On typical Unix systems, one needs to open a socket with attribute `IP_RAW` (traditionally requiring special privileges) and receive all ICMP traffic.
 - (c) A receiving application would have no way to identify ICMP messages as such, or to distinguish between these messages and protocol-specific data.
2.
 - (a) In the following, the client receives file "foo" when it thinks it has requested "bar".
 1. The client sends a request for file "foo", and immediately aborts locally. The request, however, arrives at the server.
 2. The client sends a new request, for file "bar". It is lost.
 3. The server responds with first data packet of "foo", answering the only request it has actually seen.
 - (b) Requiring the client to use a new port number for each separate request would solve the problem. To do this, however, the client would have to trust the underlying operating system to assign a new port number each time a new socket was opened. Having the client attach a timestamp or random number to the file request, to be echoed back in each data packet from the server, would be another approach fully under the application's control.
3. The TFTP protocol is a reasonable model although with some idiosyncrasies that address other issues; see RFC 1350. TFTP's first packet, called Read Request, RRQ, simply names a file. Upon receipt, the server creates a new ephemeral port from which to answer, and begins sending data from that new port. The client assumes that the first well-formed packet it receives is this server data, and records the data's source port. Any subsequent packets from a different port are discarded and an error response is sent.

The basic stop-and-wait transfer is standard, although one must decide if sequence numbers are allowed to wrap around or not. Here are approaches, TFTP's and otherwise, for (a)-(c):

- (a) The most basic approach here is to require the server to keep track of connections, as long as they are active. The problem with this is that the client is likely to be simply an application, and can exit at any time. It may exit and retransmit a request for a different file, or a new request for the same file, before the server knows there was a problem or status change.
A more robust mechanism for this situation might be a `CONNECT_NUM` field, either chosen randomly or clock-driven or incremented via some central file for each client connection attempt. Such a field would correspond roughly with TCP's initial sequence number (ISN).

In TFTP, if the RRQ is duplicated then the server might well create two processes and two ports from which to answer. (A server that attempted to do otherwise would have to maintain considerable state about past RRQ's.) Whichever process contacted the client first would win out, though, while the other would receive an error response from the client. In one sense, then, duplicate TFTP RRQ's do duplicate the connection, but only one of the duplicates survives.

- (b) The TFTP approach here is to have the client enter a “dallying” period after the final data was received, so that the process is still around (perhaps moved to the background) to receive and re-acknowledge any retransmissions of the final data. This period roughly corresponds to TIME_WAIT.
 - (c) The dallying approach of (b) also ties up the client socket for that period, preventing another incarnation of the connection. (However, TFTP has no requirement that dallying persist for a time interval approaching the MSL.) TFTP also specifies that *both* sides are to choose “random” port numbers for each connection (although “random” is generally interpreted as “assigned by the operating system”). If either side chooses a new port number, then late-arriving packets don't interfere even if the other side reuses its previous port number. A CONNECT_NUM field would also be effective here.
4. Host A has sent a FIN segment to host B, and has moved from ESTABLISHED to FIN_WAIT_1. Host A then receives a segment from B that contains both the ACK of this FIN, and also B's own FIN segment. This could happen if the application on host B closed its end of the connection immediately when the host A's FIN segment arrived, and was thus able to send its own FIN along with the ACK.

Normally, because the host B application must be scheduled to run before it can close the connection and thus have the FIN sent, the ACK is sent before the FIN. While “delayed ACKs” are a standard part of TCP, traditionally only ACKs of DATA, not FIN, are delayed. See RFC 813 for further details.

5. The two-segment-lifetime timeout results from the need to purge old late duplicates, and uncertainty of the sender of the last ACK as to whether it was received. For the first issue we only need one connection endpoint in TIME_WAIT; for the second issue, a host in the LAST_ACK state expects to receive the last ACK, rather than send it.
6. The receiver includes the advertised window in the ACKs to the sender. The sender probes the receiver to know when the advertised window becomes greater than 0; if the receiver's ACK advertising a larger window is lost, then a later sender probe will elicit a duplicate of that ACK.

If responsibility for the lost window-size-change ACK is shifted from the sender to the receiver, then the receiver would need a timer for managing retransmission of this ACK until the receiver were able to verify it had been received.

A more serious problem is that the receiver only gets confirmation that the sender has received the ACK when new data arrives, so if the connection happens to fall idle the receiver may be wasting its time.

8. The sequence number doesn't always begin at 0 for a transfer, but is randomly or clock generated.
9. (a) The advertised window should be large enough to keep the pipe full; delay (RTT) \times bandwidth here is $100 \text{ ms} \times 1 \text{ Gbps} = 100 \text{ Mb} = 12.5 \text{ MB}$ of data. This requires 24 bits if we assume the window is measured in bytes ($2^{24} \approx 16$ million) for the `AdvertisedWindow` field. The sequence number field must not wrap around in the maximum segment lifetime. In 30 seconds, $30 \text{ Gb} = 3.75 \text{ GB}$ can be transmitted. 32 bits allows a sequence space of about 4GB, and so will not wrap in 30 seconds. (If the maximum segment lifetime were not an issue, the sequence number field would still need to be large enough to support twice the maximum window size; see "Finite Sequence Numbers and Sliding Window" in Section 2.5.)
 - (b) The bandwidth is straightforward from the hardware; the RTT is also a precise measurement but will be affected by any future change in the size of the network. The MSL is perhaps the least certain value, depending as it does on such things as the size and complexity of the network, and on how long it takes routing loops to be resolved.
10. The answer is in the book.
11. The problem is that there is no way to determine whether a packet arrived on the first attempt or whether it was lost and retransmitted.

Having the receiver echo back immediately and measuring the elapsed times would help; many Berkeley-derived implementations measure timeouts with a 0.5 sec granularity and round-trip times for a single link without loss would generally be one to two orders of magnitude smaller. But verifying that one had such an implementation is itself rather difficult.
12. (a) This is 125MB/sec; the sequence numbers wrap around when we send $2^{32} \text{ B} = 4 \text{ GB}$. This would take $4\text{GB}/(125\text{MB}/\text{sec}) = 32$ seconds.
 - (b) Incrementing every 32 ms, it would take about $32 \times 4 \times 10^9$ ms, or about four years, for the timestamp field to wrap.
13. The answer is in the book.
14. (a) If a SYN packet is simply a duplicate, its ISN value will be the same as the initial ISN. If the SYN is not a duplicate, and ISN values are clock-generated, then the second SYN's ISN will be different.
 - (b) We will assume the receiver is single-homed; that is, has a unique IP address. Let $\langle raddr, rport \rangle$ be the remote sender, and $lport$ be the local port. We suppose the existence of a table T indexed by $\langle lport, raddr, rport \rangle$

and containing (among other things) data fields IISN and rISN for the local and remote ISNs.

```

if (connections to lport are not being accepted)
    send RST
else if (there is no entry in T for  $\langle lport, raddr, rport \rangle$ ) // new SYN
    Put  $\langle lport, raddr, rport \rangle$  into a table,
    Set rISN to be the received packet's ISN,
    Set IISN to be our own ISN,
    Send the reply SYN+ACK
    Record the connection as being in state SYN_REC'D
else if (T[ $\langle lport, raddr, rport \rangle$ ] already exists)
    if (ISN in incoming packet matches rISN from the table)
        // SYN is a duplicate; ignore it
    else
        send RST to  $\langle raddr, rport \rangle$ 

```

15. $x =< y$ if and only if $(y - x) \geq 0$, where the expression $y - x$ is taken to be signed even though x and y are not.

16. (a) A would send an ACK to B for the new data. When this arrived at B, however, it would lie outside the range of “acceptable ACKs” and so B would respond with its own current ACK. B’s ACK would be acceptable to A, and so the exchanges would stop.

If B later sent less than 100 bytes of data, then this exchange would be repeated.

(b) Each end would send an ACK for the new, forged data. However, when received both these ACKs would lie outside the range of “acceptable ACKs” at the other end, and so each of A and B would in turn generate their current ACK in response. These would again be the ACKs for the forged data, and these ACKs would again be out of range, and again the receivers would generate the current ACKs in response. These exchanges would continue indefinitely, until one of the ACKs was lost.

If A later sent 200 bytes of data to B, B would discard the first 100 bytes as duplicate, and deliver to the application the second 100 bytes. It would acknowledge the entire 200 bytes. This would be a valid ACK for A.

For more examples of this type of scenario, see Joncheray, L; A Simple Active Attack Against TCP; *Proceedings of the Fifth USENIX UNIX Security Symposium*, June, 1995.

17. Let H be the host to which A had been connected; we assumed B is able to guess H. As we are also assuming telnet connections, B can restrict probes to H’s telnet port (port 23).

First, B needs to find a port A had been using. For various likely ephemeral port numbers N, B sends an ACK packet from port N to $\langle H, \text{telnet} \rangle$. For many implementations, ephemeral ports start at some fixed value (e.g. N=1024) and increase sequentially; for an unshared machine it is unlikely that very many ports

had been used. If A had had no connection from port N, H will reply to B with a RST packet. But if H *had* had an outstanding connection to $\langle A, N \rangle$, then H will reply with either nothing (if B's forged ACK happened to be Acceptable, *i.e.* in the current window at the point when A was cut off), or the most recent Acceptable ACK (otherwise). Zero-byte data packets can with most implementations also be used as probes here.

Once B finds a successful port number, B then needs to find the sequence number H is expecting; once B has this it can begin sending data on the connection as if it were still A. To find the sequence number, B again takes advantage of the TCP requirement that H reply with the current ACK if B sends an ACK or DATA inconsistent with H's current receive window [that is, an "unacceptable ACK"]. In the worst case B's first probe lies in H's window, in which case B needs to send a second probe.

18. We keep a table T, indexed by $\langle \text{address, port} \rangle$ pairs, and containing an integer field for the ISN and a string field for the connection's DATA.

We will use $=<$ for sequence number comparison as in Exercise 15.

if (SYN flag is set in P.TCPHEAD.Flags)

 Create the entry $T[\langle P.IPHEAD.SourceAddr, P.TCPHEAD.SrcPort \rangle]$

$T[...].ISN = P.TCPHEAD.SequenceNum$

$T[...].DATA = \langle \text{empty string} \rangle$

else

 See if DATA bit in P.TCPHEAD.Flags is set; if not, ignore

 Look up $T[\langle P.IPHEAD.SourceAddr, P.TCPHEAD.SrcPort \rangle]$

 (if not found, ignore the packet)

 See if $P.TCPHEAD.SequenceNum =< T[...].ISN+100$.

 If so, append the appropriate portion of the packet's data to $T[...].DATA$

19. (a) 1. C connects to A, and gets A's current clock-based ISN_{A1} .
 2. C sends a SYN packet to A, purportedly from B. A sends SYN+ACK, with ISN_{A2} to B, which we are assuming is ignored.
 3. C makes a guess at ISN_{A2} , e.g. ISN_{A1} plus some suitable increment, and sends the appropriate ACK to A, along with some data that has some possibly malign effect on A. As in Step 2, this packet too has a forged source address of B.
 4. C does nothing further, and the connection either remains half-open indefinitely or else is reset, but the damage is done.
- (b) In one 40 ms period there are $40 \text{ ms} / 4 \mu\text{sec} = 10,000$ possible ISN_{AS} ; we would expect to need about 10,000 tries.

Further details can be found in Morris, RT; A Weakness in the 4.2BSD UNIX TCP/IP Software; *Computing Science Technical Report No. 117*, AT&T Bell Laboratories, Murray Hill, NJ, 1985.

20. (a) T=0.0 'a' sent
 T=1.0 'b' collected in buffer
 T=2.0 'c' collected in buffer
 T=3.0 'd' collected in buffer
 T=4.0 'e' collected in buffer
 T=4.1 ACK of 'a' arrives, "bcde" sent
 T=5.0 'f' collected in buffer
 T=6.0 'g' collected in buffer
 T=7.0 'h' collected in buffer
 T=8.0 'i' collected in buffer
 T=8.2 ACK arrives; "fghi" sent
- (b) The user would type ahead blindly at times. Characters would be echoed between 4 and 8 seconds late, and echoing would come in chunks of four or so. Such behavior is quite common over telnet connections, even those with much more modest RTTs, but the extent to which this is due to the Nagle algorithm is unclear.
- (c) With the Nagle algorithm, the mouse would appear to skip from one spot to another. Without the Nagle algorithm the mouse cursor would move smoothly, but it would display some inertia: it would keep moving for one RTT after the physical mouse were stopped. (We've assumed in this case that the mouse and the display are at the same end of the connection.)
21. (a) We have 4096 ports; we eventually run out if the connection rate averages more than $4096/60 = 70$ per sec. (The range used here for ephemeral ports, while small, is typical of older TCP implementations.)
- (b) In the following we let A be the host that initiated the close (and that is in TIME_WAIT); the other host is B. A is nominally the client; B the server. If B fails to receive an ACK of its final FIN, it will eventually retransmit that FIN. So long as A remains in TIME_WAIT it is supposed to reply again with the corresponding ACK. If the sequence number of the FIN were incorrect, A would send RST.
- If we allow reopening before TIME_WAIT expires, then a given very-late-arriving FIN might have been part of any one of a number of previous connections. For strict compliance, host A would have to maintain a list of prior connections, and if an old FIN arrived (as is theoretically possible, given that we are still within the TIME_WAIT period for the old connection), host A would consult this list to determine whether the FIN had an appropriate sequence number and hence whether an ACK or RST should be sent.
- Simply responding with an ACK to all FINs with sequence numbers before the ISN of the current connection would seem reasonable, though. The old connection, after all, no longer exists at B's end to be reset, and A knows this. A knows, in fact, that a prior final ACK or RST that it sent in response to B's FIN *was* received by B, since B allowed the connection to be reopened, and so it might justifiably not send anything.

22. Whichever endpoint remains in `TIME_WAIT` must retain a record of the connection for the duration of `TIME_WAIT`; as the server typically is involved in many more connections than clients, the server's record-keeping requirements would be much more onerous.

Note also that some implementations of `TIME_WAIT` simply disallow *all* new connections to the port in question for the duration, not only those from the particular remote connection that initiated the `TIME_WAIT`. Since a server cannot choose a new port, this might mean it could process at most one connection per `TIME_WAIT` interval.

In situations where the client requests some variable-length stream (*eg* a file), the server might plausibly initiate the active close to indicate the end of the data.

23. `Timeouts` indicates that the network is congested and that one should send fewer packets rather than more. Exponential backoff immediately gives the network twice as long to deliver packets (though a single linear backoff would give the same); it also rapidly adjusts to even longer delays, thus it in theory readily accommodating sharp increases in RTT without further loading the already overtaxed routers. If the RTT suddenly jumps to 15 times the old `Timeout`, exponential increase retransmits at $T=1, 3, 7, \text{ and } 15$; linear increase would retransmit at $T=1, 3, 6, 10, \text{ and } 15$. The difference here is not large. Exponential backoff makes the most difference when the RTT has increased by a very large amount, either due to congestion or network reconfiguration, or when "polling" the network to find the initial RTT.
24. The probability that a Normally distributed random variable is more than π standard deviations above the mean is about 0.0816%.
25. If every other packet is lost, we transmit each packet twice.
- Let $E \geq 1$ be the value for `EstimatedRTT`, and $T = 2 \times E$ be the value for `Timeout`. We lose the first packet and back off `Timeout` to $2 \times T$. Then, when the packet arrives, we resume with `EstimatedRTT` = E , `Timeout` = T . In other words, `Timeout` doesn't change.
 - Let T be the value for `Timeout`. When when we transmit the packet the first time, it will be lost and we will wait time T . At this point we back off and retransmit using `Timeout` = $2 \times T$. The retransmission succeeds with an RTT of 1 sec, but we use the backed-off value of $2 \times T$ for the next `Timeout`. In other words, `Timeout` doubles with each received packet. This is Not Good.
26. Using initial `Deviation` = 1.0 it took 21 iterations for `Timeout` to fall below 4.0. With an initial `Deviation` of 0.1, it took 20 iterations; with an initial `Deviation` of 2 it took 22.

Iteration	SampleRTT	EstRTT	Dev	diff	TimeOut
0	1.00	4.00	1.00		
1	1.00	3.63	1.25	-3.00	8.63
2	1.00	3.31	1.42	-2.63	8.99
3	1.00	3.03	1.53	-2.31	9.15
4	1.00	2.78	1.59	-2.03	9.14
5	1.00	2.56	1.61	-1.78	9.00
6	1.00	2.37	1.61	-1.56	8.81
7	1.00	2.20	1.58	-1.37	8.52
8	1.00	2.05	1.54	-1.20	8.21
9	1.00	1.92	1.48	-1.05	7.84
10	1.00	1.81	1.41	-.92	7.45
11	1.00	1.71	1.34	-.81	7.07
12	1.00	1.63	1.27	-.71	6.71
13	1.00	1.56	1.19	-.63	6.32
14	1.00	1.49	1.12	-.56	5.97
15	1.00	1.43	1.05	-.49	5.63
16	1.00	1.38	.98	-.43	5.30
17	1.00	1.34	.91	-.38	4.98
18	1.00	1.30	.84	-.34	4.66
19	1.00	1.27	.78	-.30	4.39
20	1.00	1.24	.72	-.27	4.12
21	1.00	1.21	.66	-.24	3.85

27. The answer is in the book.
28. One approach to this, shown below, is to continue the table above, except that whenever `TimeOut` would fall below 4.0 we replace the `SampleRTT` of that row with 4.0.

We could also create a table starting from scratch, using an initial `Estimate-dRTT` of 1.0 and seeding the first few rows with a couple instances of `SampleRTT = 4.0` to get `TimeOut ≥ 4.0` in the first place.

Either way, `N` is between 6 and 7 here.

row #	SampleRTT	EstRTT	Dev	diff	TimeOut
19	1.00	1.24	0.72	-0.27	4.13
20	4.00	1.58	0.98	2.76	5.50
21	1.00	1.51	0.93	-0.58	5.22
22	1.00	1.45	0.88	-0.51	4.95
23	1.00	1.39	0.82	-0.45	4.68
24	1.00	1.34	0.77	-0.39	4.42
25	1.00	1.30	0.72	-0.34	4.16
26	4.00	1.64	0.96	2.70	5.49
27	1.00	1.56	0.92	-0.64	5.25
28	1.00	1.49	0.88	-0.56	4.99
29	1.00	1.43	0.83	-0.49	4.74
30	1.00	1.37	0.78	-0.43	4.48
31	1.00	1.33	0.73	-0.37	4.24
32	4.00	1.66	0.97	2.67	5.54

29. Here is the table of the updates to the EstRTT, etc statistics. Packet loss is ignored; the SampleRTTs given may be assumed to be from successive singly transmitted segments. Note that the first column, therefore, is simply a row number, *not* a packet number, as packets are sent without updating the statistics when the measurements are ambiguous. Note also that both algorithms calculate the same values for EstimatedRTT; only the TimeOut calculations vary.

	SampleRTT	EstRTT	Dev	diff	new TimeOut EstRTT+4×Dev	old TimeOut 2×EstRTT
		1.00	0.10		1.40	2.00
1	5.00	1.50	0.59	4.00	3.85	3.00
2	5.00	1.94	0.95	3.50	5.74	3.88
3	5.00	2.32	1.22	3.06	7.18	4.64
4	5.00	2.66	1.40	2.68	8.25	5.32

New algorithm (TimeOut = EstimatedRTT + 4 × Deviation):

There are a total of three retransmissions, two for packet 1 and one for packet 3.

The first packet after the change times out at $T=1.40$, the value of TimeOut at that moment. It is retransmitted, with TimeOut backed off to 2.8. It times out again 4.2 sec after the first transmission, and TimeOut is backed off to 5.6.

At $T=5.0$ the first ACK arrives and the second packet is sent, using the backed-off TimeOut value of 5.6. This second packet does not time out, so this constitutes an unambiguous RTT measurement, and so timing statistics are updated to those of row 1 above.

When the third packet is sent, with TimeOut=3.85, it times out and is retransmitted. When its ACK arrives the fourth packet is sent, with the backed-off TimeOut value, $2 \times 3.85 = 7.70$; the resulting RTT measurement is unambiguous so timing statistics are updated to row 2. When the fifth packet is sent, TimeOut=5.74 and no further timeouts occur.

If we continue the above table to row 9, we get the maximum value for `TimeOut`, of 10.1, at which point `TimeOut` decreases toward 5.0.

Original algorithm ($\text{TimeOut} = 2 \times \text{EstimatedRTT}$):

There are five retransmissions: for packets 1, 2, 4, 6, 8.

The first packet times out at $T=2.0$, and is retransmitted. The ACK arrives before the second timeout, which would have been at $T=6.0$.

When the second packet is sent, the backed-off `TimeOut` of 4.0 is used and we time out again. `TimeOut` is now backed off to 8.0. When the third packet is sent, it thus does not time out; statistics are updated to those of row 1.

The fourth packet is sent with $\text{TimeOut}=3.0$. We time out once, and then transmit the fifth packet without timeout. Statistics are then updated to row 2.

This pattern continues. The sixth packet is sent with $\text{TimeOut} = 3.88$; we again time out once, send the seventh packet without loss, and update to row 3. The eighth packet is sent with $\text{TimeOut}=4.64$; we time out, back off, send packet 9, and update to row 4. Finally the tenth packet does not time out, as $\text{TimeOut}=2 \times 2.66=5.32$ is larger than 5.0.

`TimeOut` continues to increase monotonically towards 10.0, as `EstimatedRTT` converges on 5.0.

30. Let the real RTT (for successful transmissions) be 1.0 units. By hypothesis, every packet times out once and then the retransmission is acknowledged after 1.0 units; this means that each `SampleRTT` measurement is $\text{TimeOut}+1 = \text{EstimatedRTT}+1$. We then have

$$\begin{aligned} \text{EstimatedRTT} &= \alpha \times \text{EstimatedRTT} + \beta \times \text{SampleRTT} \\ &= \text{EstimatedRTT} + \beta \times (\text{SampleRTT} - \text{EstimatedRTT}). \\ &\geq \text{EstimatedRTT} + \beta \end{aligned}$$

Thus it follows that the N th `EstimatedRTT` is greater than or equal to $N\beta$.

Without the assumption $\text{TimeOut} = \text{EstimatedRTT}$ we still have $\text{SampleRTT} - \text{EstimatedRTT} \geq 1$ and so the above argument still applies.

31. For the steady state, assume the true RTT is 3 and `EstimatedRTT` is 1. At $T=0$ we send a data packet. Since `TimeOut` is twice `EstimatedRTT`=1, at $T=2$ the packet is retransmitted. At $T=3$ the ACK of the original packet returns (because the true RTT is 3); measured `SampleRTT` is thus $3-2 = 1$; this equals `EstimatedRTT` and so there is no change. This is illustrated by the following diagram:

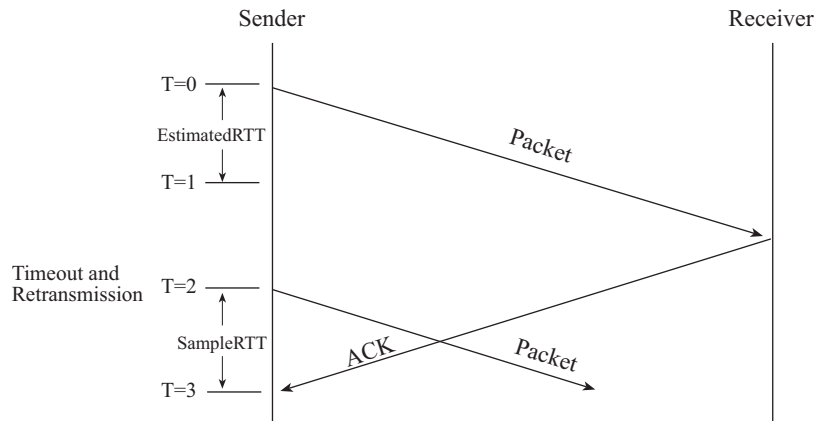

To get to such a steady state, assume that originally $RTT = EstimatedRTT = 1.45$, say, and RTT then jumps to 3.0 as above. The first packet sent under the new rules will time out and be retransmitted at $T=2.9$; when the ACK arrives at $T=3.0$ we record $SampleRTT = 0.1$. This causes $EstimatedRTT$ to decrease. It will continue to grow smaller, monotonically (at least if β is not too large), converging on the value 1.0 as above.

32. A FIN or RST must lie in the current receive window. A RST outside this window is ignored; TCP responds to an out-of-window FIN with the current ACK:

If an incoming segment is not acceptable, an acknowledgment should be sent in reply (unless the RST bit is set, if so drop the segment and return) [RFC793]

Note that a RST can lie anywhere within the current window; its sequence number need not be the next one in sequence.

If a FIN lies in the current window, then TCP waits for any remaining data and closes the connection. If a RST lies in the current window then the connection is immediately closed:

If the RST bit is set then, any outstanding RECEIVES and SEND should receive “reset” responses. All segment queues should be flushed. Users should also receive an unsolicited general “connection reset” signal. Enter the CLOSED state, delete the TCB, and return.

33. (a) The first incarnation of the connection must have closed successfully and the second must have opened; this implies the exchange of FIN and SYN packets and associated ACKs. The delayed data must also have been successfully retransmitted.
- (b) One plausible hypothesis is that two routes were available from one host to the other. Traffic flowed on one link, which suddenly developed severe congestion or routing-loop delays at which point subsequent traffic was switched to the other, now-faster, link. It doesn't matter whether the two

routes were both used initially on an alternating basis, or if the second route was used only after the first route failed.

34. We suppose A is connected to B and wishes to hand off the connection to C. There is more than one approach; in the following we assume that A and C do most of the work, and that A decides on a point in the sequence number stream after which B is to send to C. It could be argued that B is better positioned to make that determination. C also continues here with the sequence numbers started by A.

New function call event: `handoff()`; allowed in ESTABLISHED state only.

New packet types:

```
HANDOFF_REQ      // request from A to C
HANDOFF_DO       // request from A to B
```

New states:

```
HANDOFF_CALLED   // for A
H_REQ_SENT       // for A, HANDOFF_REQ sent to C
H_REQ_ACK        // for A; C has acknowledged HANDOFF_REQ
H_REQ_REC'D      // for C
H_START_WAIT     // for C
H_TIME_WAIT      // for A
```

Here is a chronology of events.

1. `handoff()` called. A moves to state `HANDOFF_CALLED`, and identifies a sequence number `H_SEQ` (for B) after which data is to be sent to C. A waits for B to send up to this sequence number, blocking further transmissions by shrinking the upper edge of the receive window to `H_SEQ`. Whether or not A buffers data following `H_SEQ`, and forwards it to C, is optional.
2. A sends `HANDOFF_REQ` to C, with sequence number `H_SEQ-1` (from B) and A's own current sequence number. C moves to state `H_REQ_REC'D`. A moves to state `H_REQ_SENT`. If A has been buffering data past `H_SEQ`, it might send it to C at this point.
3. C sends an `ACK` to A to accept the handoff (or `RST` to reject it). If the former, A moves to state `H_REQ_ACK`. C moves to `H_START_WAIT`, and waits to hear from B.
4. A sends `HANDOFF_DO` to B, with `H_SEQ`. B remains `ESTABLISHED`, and sends an `ACK` to A, which moves to `H_TIME_WAIT`. B also sends an `ACK` to C, which moves to `ESTABLISHED`.

Any data with sequence number before `H_SEQ` that arrives at A during the `H_TIME_WAIT` period is now forwarded by A to C.

35. (a) In order to disallow simultaneous open, an endpoint in state `SYN_SENT` should not accept `SYN` packets from the other end. This means that the

edge in the state diagram from SYN_SENT to SYN_RECV should be removed. Instead, the response to SYN in SYN_SENT would be something like RST.

- (b) As long as either side is allowed to close, no. The timings of the `close()` calls are an application-level issue. If both sides happen to request at approximately the same instant that a connection be closed, it hardly seems appropriate to hold the connection open while the requests are serialized.

Looked at another way, disallowing simultaneous opens in effect simply requires that both sides adhere to the established roles of “client” and “server”. At the point of closing, however, there simply is no established role for whether client or server is to close the connection. It would indeed be possible to require that the client, for example, had to initiate the close, but that would leave the server somewhat at the mercy of the client.

- (c) The minimum additional header information for this new interpretation is a bit indicating whether the sender of the packet was the client for that connection or the server. This would allow the receiving host to figure out to which connection the arriving packet belongs.

With this bit in place, we can label the nodes and edges at or above the ESTABLISHED state with “client” or “server” roles. The edge from LISTEN to SYN_SENT is the exception, traversed only if a server (LISTEN state) takes on a client role (SYN_SENT). We replace this edge with a notion of creating the second connection; the original endpoint remains in the server-role LISTEN state and a new endpoint (with same port number), on in effect a new diagram, is created in the client-role SYN_SENT state.

The edge from SYN_SENT to SYN_RECV would be eliminated; during a simultaneous open the arriving SYN would be delivered to the server-role endpoint, still in the LISTEN state, rather than to the client-role endpoint in state SYN_SENT.

36. (a) One would now need some sort of connection number assigned by the client side to play the role of the port number in demultiplexing traffic; with this in place, headers might not change much at all. Client and server sockets will now be fundamentally different objects. Server sockets would be required to `bind()` themselves to a port number (perhaps at creation time); clients would be forbidden to do this.

- (b) We still need to make sure that a client connection number is not reused within the $2 \times \text{MSL}$ period, at least not with the same server port. However, this is now a TCP-layer responsibility, not an application concern. Assuming the client connection number were assigned at the time of connection, clients would not need to be aware of `TIME_WAIT` at all: they would be freed of the requirement they close one socket and reopen a new one to get a fresh port number.

Since client connection numbers are now not visible to the client, simply placing a connection number out of service entirely during the `TIME_WAIT` interval, for connections to any server, would be a tolerable approach.

- (c) The rlogin/rsh protocol authenticates clients by seeing that they are using a “reserved” port on the sending host (normally, a port only available to system-level processes). This would no longer be possible.

However, the following variation would still be possible: when an rsh server host *S* receives a client request from host *C*, with connection number *N*, then *S* could authenticate the request with *C* by initiating a second connection to a reserved port on *C*, whereupon some sort of authentication application on *C* would verify that connection number *N* was indeed being used by an authorized rsh client on *C*. Note that this scheme implies that connection numbers are at least visible to the applications involved.

37. (a) A program that `connect()`s, and then sends whatever is necessary to get the server to close its end of the connection (eg the string “QUIT”), and then sits there, idle but not disconnecting, will suffice. Note that the server has to be willing to initiate the active close based on some client action.
- (b) Alas, most telnet clients do *not* work here. Although many can connect to an arbitrary port, and issue a command such as QUIT to make the server initiate the close, they generally do close immediately in response to receiving the server’s FIN.

However, the `sock` program, written by W. Richard Stevens, can be used instead. In the (default) client mode, it behaves like a command-line telnet. The option `-Q 100` makes `sock` wait 100 seconds after receiving the server FIN before it closes its end of the connection. Thus the command

```
sock -Q 100 hostname 25
```

can be used to demonstrate `FIN_WAIT_2` with an SMTP (email) server (port 25) on *hostname*, using the QUIT command.

`sock` is available from <http://www.icir.org/christian/sock.html>

38. Let *A* be the closing host and *B* the other endpoint. *A* sends message1, pauses, sends message2, and then closes its end of the connection for reading. *B* gets message1 and sends a reply, which arrives after *A* has performed the half-close. *B* doesn’t read message2 immediately; it remains in the TCP layer’s buffers. *B*’s reply arrives at *A* after the latter has half-closed, and so *A* responds with RST as per the quoted passage from RFC 1122. This RST then arrives at *B*, which aborts the connection and the remaining buffer contents (i.e. message2) are lost.

Note that if *A* had performed a full-duplex close, the same scenario can occur. However, it now depends on *B*’s reply crossing *A*’s FIN in the network. The half-close-for-reading referred to in this exercise is actually purely a local state change; a connection that performs a half-close closing its end for *writing* may however send a FIN segment to indicate this state to the other endpoint.

39. Incrementing the Ack number for a FIN is essential, so that the sender of the FIN can determine that the FIN was received and not just the preceding data.

For a SYN, any ACK of subsequent data would increment the acknowledgment number, and any such ACK would implicitly acknowledge the SYN as well (data

cannot be ACKed until the connection is established). Thus, the incrementing of the sequence number here is a matter of convention and consistency rather than design necessity.

40. (a) One method would be to invent an option to specify that the first n bytes of the TCP data should be interpreted as options.
- (b) A TCP endpoint receiving an unknown option might
- *close/abort the connection*. This makes sense if the connection cannot meaningfully continue when the option isn't understood.
 - *ignore the option but keep the TCP data*. This is the current RFC 1122 requirement.
 - *send back "I don't understand"*. This is simply an explicit form of the previous response. A refinement might be to send back some kind of list of options the host *does* understand.
 - *discard the accompanying the TCP data*. One possible use might be if the data segment were encrypted, or in a format specified by the option. Some understanding would be necessary regarding sequence numbers for this to make sense; if the entire TCP data segment was an extended option block then the sequence numbers shouldn't increase at all.
 - *discard the first n bytes of the TCP data*. This is an extension of the previous strategy to handle the case where the first n bytes of the TCP data was to be interpreted as an expanded options block; it is not clear though when the receiver might understand n but not the option itself.
41. TCP faces two separate crash-and-reboot scenarios: a crash can occur in the middle of a connection, or between two consecutive incarnations of a connection. The first leads to a "half-open" connection where one endpoint has lost all state regarding the connection; if either the stateless side sends a new SYN or the stateful side sends new data, the other side will respond with RST and the half-open connection will be dissolved bilaterally.
- If one host crashes and reboots between two consecutive connection incarnations, the only way the first incarnation could affect the second is if a late-arriving segment from the first happens to fit into the receive window of the second. TCP establishes a quasi-random initial sequence number during its three-way handshake at connection open time. A 64KB window, the maximum allowed by the original TCP, spans less than 0.0015% of the sequence number space. Therefore, there is very little chance that data from a previous incarnation of the connection will happen to fall in the current window; any data outside the window is discarded. (TCP also is supposed to implement "quiet time on startup", an initial $1 \times \text{MSL}$ delay for all connections after bootup.)
42. (a) Non-exclusive open, reading block N, writing block N, and seeking to block N all are idempotent, *i.e.* have the same effect whether executed once or twice.

- (b) `create()` is idempotent if it means “create if nonexistent, or open if it exists already”. `mkdir()` is idempotent if the semantics are “create the given directory if it does not exist; otherwise do nothing”. `delete()` (for either file or directory) works this way if its meaning is “delete if the object is there; otherwise, ignore.”

Operations fundamentally incompatible with at-least-once semantics include exclusive open (and any other form of file locking), and exclusive create.

- (c) The directory-removing program would first check if the directory exists. If it does not, it would report its absence. If it does exist, it invokes the system call `rmdir()`.
43. (a) The problem is that reads aren’t serviced in FIFO order; disk controllers typically use the “elevator” or SCAN algorithm to schedule writes, in which the pool of currently outstanding writes is sorted by disk track number and the writes are then executed in order of increasing track number. Using a single channel would force writes to be executed serially even when such a sequence required lots of otherwise-unnecessary disk head motion.
- If a pool of N sequential channels were used, the disk controller would at any time have about N writes to schedule in the order it saw fit.
- (b) Suppose a client process writes some data to the server, and then the client system shuts down “gracefully”, flushing its buffers (or avails itself of some other mechanism to flush the buffer cache). At this point data on a local disk would be safe; however, a *server* crash would now cause the loss of client data remaining in the server’s buffers. The client might *never* be able to verify that the data was safely written out.
- (c) One approach would be to modify a protocol that uses sequential channels to support multiple independent outstanding requests on a single logical channel, and to support replies in an arbitrary order, not necessarily that in which the corresponding requests were received. Such a mechanism would allow the server to respond to multiple I/O requests in whatever order was most convenient.
- A subsequent request could now no longer serve as an ACK of a previous reply; ACKs would have to be explicit and non-cumulative. There would be changes in retransmission management as well: the client would have to maintain a list of the requests that hadn’t yet been answered and the server would have to maintain a list of replies that had been sent but not acknowledged. Some bound on the size of these lists (corresponding to window size) would be necessary.
44. (a) The client sends the request. The server executes it (and successfully commits any resulting changes to disk), but then crashes just before sending its reply. The client times out and resends the request, which is executed a second time by the server as it restarts.

(b) The tipoff to the client that this *might* have happened is that the server's boot ID field incremented over that from the previous request (which would always cause the RPC call to fail). While a server reboot would always be indicated by an incremented boot ID, it would not necessarily be the case that any particular request was actually executed twice.

45. We will use the log blocks to maintain a “transaction log”, a simplified version of the strategy used by database applications. In this particular example the actual update is atomic; if two data blocks had to be updated together we would have additional complications.

Upon receipt of the request, the RPC server does the following:

- reads in block N from the disk.
- records in the log block the CID and MID values, the values of X and N, and an indication that the transaction is in progress.
- performs the actual update write.
- replaces the log entry with one that contains CID and MID and an indication that the operation was successful, and sends the reply stating this.

This last logfile record is retained until the client ACKs the reply.

On restart the server looks in the log block. If this indicates nothing about the transaction, then either the transaction was never started or else the final ACK was received; either way, the RPC server has no further immediate responsibilities. If the log block indicates that the transaction completed successfully, we reload its status as completed but unacknowledged. The server doesn't know if the reply has been sent, but this doesn't matter as it will be retransmitted if necessary when the appropriate timeout occurs. If such a retransmission was unnecessary, then the client will infer this from the expired MID.

Finally, if the restarting server finds the in-progress indication in the log, then it reads data block N and determines, by comparing X there with the X in the log, whether the write operation completed. If so, the log is updated as in the fourth step above; if not, the server resumes the sequence above at the third step, the point of performing the actual write.

46. (a) If a client has only sent the request once, and has received a reply, and if the underlying network never duplicates packets, then the client can be sure its request was only executed once.
- (b) To ensure at-most-once semantics a server would have to buffer a reply with a given transaction XID until it had received an acknowledgment from the client that the reply had been received properly. This would entail adding such ACKs to the protocol, and also adding the appropriate buffering mechanism to the implementation.
47. One TCP connection can manage multiple outstanding requests, and so is capable of supporting multiple logical channels; we will assume that this is the case. The alternative, of one TCP connection per channel, is similar.

- (a) The overlying RPC protocol would need to provide a demultiplexing field corresponding to the channel ID. (In the one-TCP-connection-per-channel setting, the TCP socketpair defining the connection represents the channel ID.)
- (b) The message ID would correspond to the sequence number; the primary purpose of the message ID is to keep track of acknowledgments.
- (c) Boot ID is dealt with by the stateful nature of TCP; if either end rebooted and the other end eventually sent a message, the RST response would be an indication of that reboot.
- (d)(e) The RPC request and reply messages would now become RPC headers that divide the TCP byte stream into discrete messages. There would be no guarantee, of course, that these headers were transmitted in the same segment as the associated data.
- (f) The RPC ACK would be replaced by the TCP ACK.
- (g) Some sort of *are-you-alive?* messages would still have to be generated by the client, if they were desired; although TCP does support KeepAlive messages they are for a vastly different (~2-hour) time scale and they do not address the issue of whether the server process is alive.

If the TCP layer delayed sending ACKs for, say, 100ms (such “Delayed ACKs” are standard practice), then in many instances the reply might be available in time for it to be sent with the TCP ACK. This would achieve the effect of implicit ACKs in having only one packet handle both ACK and reply.

- 49.
 - An application that encodes audio or video might produce a group of packets at a certain time that needed to be spread out in time for appropriate playback. The application would typically do better sending those packets when they are ready rather than trying to pace them smoothly into the network (which could increase total delay).
 - An application might send video and audio data at slightly different times that needed to be synchronized, or a single video frame might be sent in multiple pieces over time.

It follows from the above that only the application (not the RTP stack or the network) has the appropriate knowledge of when a particular item should be played back, and thus the application should provide the timestamps.

- 50. This allows the server to make accurate measurements of jitter. This in turn allows an early warning of transient congestion; see the solution to Exercise 53 below. Jitter data might also allow finer control over the size of the playback buffer, although it seems unlikely that great accuracy is needed here.
- 51. Each receiver gets 1/1000 of 5% of 320 kbps, or 16bps, which means one 84-byte RTCP packet every 42 sec. At 10K recipients, it’s one packet per 420 sec, or 7 minutes.

52. (a) The answer here depends on how closely frame transmission is synchronized with frame display. Assuming playback buffers on the order of a full frame or larger, it seems likely that receiver frame-display finish times would not be synchronized with frame transmission times, and thus would not be particularly synchronized from receiver to receiver. In this case, receiver synchronization of RTCP reports with the end of frame display would not result in much overall synchronization of RTCP traffic.

In order to achieve such synchronization, it would be necessary to have both a very uniform latency for all receivers and a rather low level of jitter, so that receivers were comfortable maintaining a negligible playback buffer. It would also be necessary, of course, to disable the RTCP randomization factor. The number of receivers, however, should not matter.

- (b) The probability that any one receiver sends in the designated 5% subinterval is 0.05, assuming uniform distribution; the probability that all 10 send in the subinterval is 0.05^{10} , which is negligible.
- (c) The probability that one designated set of five receivers sends in the designated interval, and the other five do not, is $(.05)^5 \times (.95)^5$. There are $(10 \text{ choose } 5) = 10!/5!5!$ ways of selecting five designated receivers, and so the probability that *some* set of five receivers all transmit in the designated interval is $(10 \text{ choose } 5) \times (.05)^5 \times (.95)^5 = 252 \times 0.0000002418 = 0.006\%$. Multiplying by 20 gives a rough estimate of about 0.12% for the probability of an upstream traffic burst rivaling the downstream burst, in any given reply interval.

53. If most receivers are reporting high loss rates, a server might consider throttling back. If only a few receivers report such losses, the server might offer referrals to lower-bandwidth/lower-resolution servers. A regional group of receivers reporting high losses might point to some local congestion; as RTP traffic is often tunneled, it might be feasible to address this by re-routing traffic.

As for jitter measurements, we quote RFC 1889:

The interarrival jitter field provides a second short-term measure of network congestion. Packet loss tracks persistent congestion while the jitter measure tracks transient congestion. The jitter measure may indicate congestion before it leads to packet loss.

54. Many answers are possible here. RTT estimation, and hence calculation of suitable timeout values, is more difficult than TCP because of the lack of a closed feedback loop between sender and receiver. The solution could include looking for gaps in the RTP sequence number space. Running another protocol on top of RTP (see DCCP, RFC 4340, for example) to detect losses via an acknowledgment mechanism is another option.

Solutions for Chapter 6

1. (a) From the application's perspective, it is better to define flows as process-to-process. If a flow is host-to-host, then an application running on a multi-user machine may be penalized (by having its packets dropped) if another application is heavily using the same flow. However, it is much easier to keep track of host-to-host flows; routers need only look at the IP addresses to identify the flow. If flows are process-to-process (i.e. end-to-end), routers must also extract the TCP or UDP ports that identify the endpoints. In effect, routers have to do the same demultiplexing that is done on the receiver to match messages with their flows.

(b) If flows are defined on a host-to-host basis, then `FlowLabel` would be a hash of the host-specific information; that is, the IP addresses. If flows are process-to-process, then the port numbers should be included in the hash input.
2. (a) In a rate-based TCP the receiver would advertise a rate at which it could receive data; the sender would then limit itself to this rate, perhaps making use of a token bucket filter with small bucket depth. Congestion-control mechanisms would also be converted to terms of throttling back the rate rather than the window size. Note that a window-based model sending one window-full per RTT automatically adjusts its rate inversely proportional to the RTT; a rate-based model might not. Note also that if an ACK arrives for a large amount of data, a window-based mechanism may immediately send a burst of a corresponding large amount of new data; a rate-based mechanism would likely smooth this out.

(b) A router-centric TCP would send as before, but would receive (presumably a steady stream of) feedback packets from the routers. All routers would have to participate, perhaps through a connection-oriented packet-delivery model. TCP's mechanisms for inferring congestion from changes in RTT would all go away.

TCP might still receive some feedback from the receiver about its rate, but the receiver would only do so as a "router" of data to an application; this is where flow control would take place.
3. For Ethernet, throughput with N stations is $5/(N/2 + 5) = 10/(N + 10)$; to send one useful packet we require $N/2$ slots to acquire the channel and 5 slots to transmit. On average, a waiting station has to wait for about half the others to transmit first, so with N stations the delay is the time it takes for $N/2$ to transmit; combining this with a transmission time of $N/2 + 5$ this gives a total delay of $N/2 \times (N/2 + 5) = N(N + 10)/4$. Finally, power is throughput/delay = $40/N(N + 10)^2$. Graphs are below.

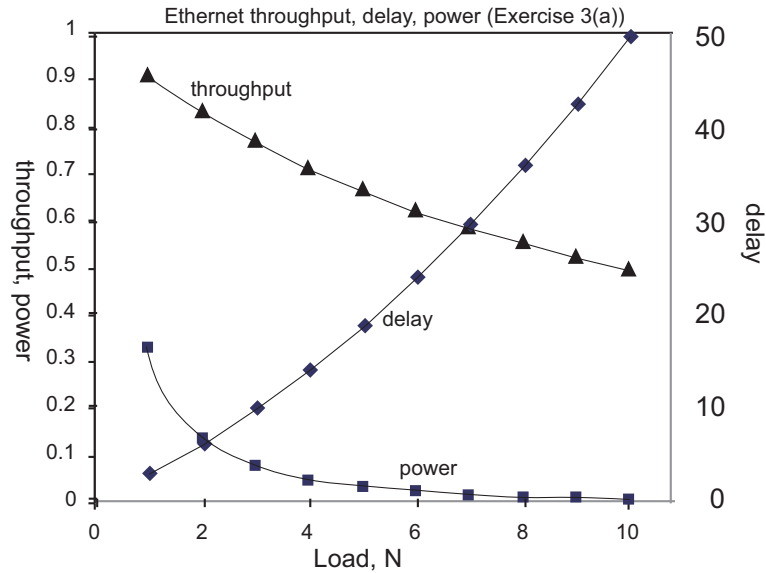

The power curves has its maximum at $N = 1$, the minimum N , which is somewhat artificial and is an artifact of the unnatural way we are measuring load.

4. Throughput here is $\min(x, 1)$, where x is the load. For $x \leq 1$ the delay is 1 second, constantly. We cannot sustain $x > 1$ at all; the delay approaches infinity. The power curve thus looks like $y = x$ for $x \leq 1$ and is undefined beyond that.

Another way to measure load might be in terms of the percentage of time the peak rate exceeds 1, assuming that the average rate remains less than 1.

5. Yes, particularly if the immediate first link is high-bandwidth, the first router has a large buffer capacity, and the delay in the connection is downstream. **CongestionWindow** can grow arbitrarily; the excess packets will simply pile up at the first router.
6. R1 cannot become congested because traffic arriving at one side is all sent out the other, and the bandwidths on each side are the same.

We now show how to congest only the router R2 that is R1's immediate left child; other R's are similar.

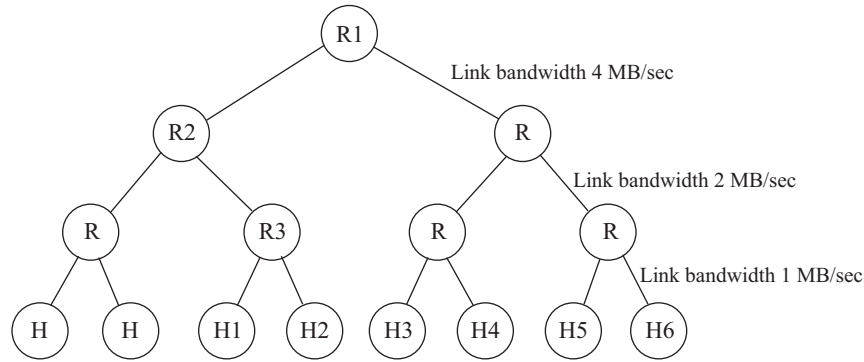

We arrange for H3 and H4 to send 1MB/sec to H1, and H5 and H6 to send 1MB/sec to H2. Each of the links to the right of R1 reaches its maximum capacity, as does the R1—R2 link, but none of these routers becomes congested. However, R2 now wants to send 4MB/sec to R3, which it cannot.

R3 is not congested as it receives at 2MB/sec from R2 and this traffic is evenly divided between H1 and H2.

7. (a) The fairness index is 0.9360; $x_1 + \dots + x_5 = 715$ and $x_1^2 + \dots + x_5^2 = 109225$.
 (b) The index falls to 0.4419.
8. F_i still represents a timestamp, but now when computing F_i as a packet arrives we run the clock slow by the sum of the weights w of the active flows, rather than by the number of active flows.

Consider two flows with weights 1 and 2. If the the packet size of the packet in the queue for flow 2 is twice that of the packet in flow 1, then both packets should look equally attractive to transmit. Hence, the effective packet size of the second packet should be $P_i/2$. In general, if the flow has a weight w then the effective packet size is P_i/w . Hence the final time-stamps are calculated as

$$F_i = \max(F_{i-1}, A_i) + P_i/w$$

9. If we are in the process of transmitting a large sized packet and a small packet arrives just after the start of the transmission, then due to non-preemption the small packet gets transmitted after the large. However, in perfect bit-by-bit round robin the small packet would have finished being transmitted before the large packet gets completely transmitted.
10. (a) First we calculate the finishing times F_i . We don't need to worry about clock speed here since we may take $A_i = 0$ for all the packets. F_i thus becomes just the cumulative per-flow size, *i.e.* $F_i = F_{i-1} + P_i$.

Packet	size	flow	F_i
1	100	1	100
2	100	1	200
3	100	1	300
4	100	1	400
5	190	2	190
6	200	2	390
7	110	3	110
8	50	3	170

We now send in increasing order of F_i :

Packet 1, Packet 7, Packet 8, Packet 5, Packet 2, Packet 3, Packet 6, Packet 4.

- (b) To give flow 2 a weight of 4 we divide each of its F_i by 4, *i.e.* $F_i = F_{i-1} + P_i/4$; again we are using the fact that there is no waiting.

Packet	size	flow	weighted F_i
1	100	1	100
2	100	1	200
3	100	1	300
4	100	1	400
5	190	2	47.5
6	200	2	97.5
7	110	3	110
8	50	3	170

Transmitting in increasing order of the weighted F_i we send as follows:

Packet 5, Packet 6, Packet 1, Packet 7, Packet 8, Packet 2, Packet 3, Packet 4.

11. The answer is in the book.
12. (a) The advantage would be that the dropped packets are the resource hogs, in terms of buffer space consumed over time. One drawback is the need to recompute *cost* whenever the queue advances.
- (b) Suppose the queue contains three packets. The first has size 5, the second has size 15, and the third has size 5. Using the sum of the sizes of the earlier packets as the measure of time remaining, the cost of the third packet is $5 \times 20 = 100$, and the cost of the (larger) second is $15 \times 5 = 75$. (We have avoided the issue here of whether the first packet should always have cost 0, which might be mathematically correct but is arguably a misleading interpretation.)
- (c) We again measure cost in terms of size; *i.e.* we assume it takes 1 time unit to transmit 1 size unit. A packet of size 3 arrives at $T=0$, with the queue such that the packet will be sent at $T=5$. A packet of size 1 arrives right after.
- At $T=0$ the costs are $3 \times 5 = 15$ and $1 \times 8 = 8$.
- At $T=3$ the costs are $3 \times 2 = 6$ and $1 \times 5 = 5$.

At $T=4$ the costs are $3 \times 1 = 3$ and $1 \times 4 = 4$; *cost* ranks have now reversed. At $T=5$ the costs are 0 and 3.

13. (a) With round-robin service, we will alternate one telnet packet with each ftp packet, causing telnet to have dismal throughput.
- (b) With FQ, we send roughly equal volumes of data for each flow. There are about $552/41 \approx 13.5$ telnet packets per ftp packet, so we now send 13.5 telnet packets per ftp packet. This is better.
- (c) We now send 512 telnet packets per ftp packet. This excessively penalizes ftp.

Note that with the standard Nagle algorithm a backed-up telnet would not in fact send each character in its own packet.

14. In light of the complexity of the solution here, instructors may wish to consider limiting the exercise to those packets arriving before, say, $T=6$.

- (a) For the i th arriving packet on a given flow we calculate its estimated finishing time F_i by the formula $F_i = \max\{A_i, F_{i-1}\} + 1$, where the clock used to measure the arrival times A_i runs slow by a factor equal to the number of active queues. The A_i clock is global; the sequence of F_i 's calculated as above is local to each flow. A helpful observation here is that packets arrive and are sent at integral wallclock times.

The following table lists all events by wallclock time. We identify packets by their flow and arrival time; thus, packet A4 is the packet that arrives on flow A at wallclock time 4, *i.e.* the third packet. The last three columns are the queues for each flow for the subsequent time interval, *including* the packet currently being transmitted. The number of such active queues determines the amount by which A_i is incremented on the subsequent line. Multiple packets appear on the same line if their F_i values are all the same; the F_i values are in *italic* when $F_i = F_{i-1} + 1$ (versus $F_i = A_i + 1$).

We decide ties in the order flow A, flow B, flow C. In fact, the only ties are between flows A and C; furthermore, *every* time we transmit an A packet we have a C packet tied with the same F_i .

Wallclock	A_i	arrivals	F_i	sent	A's queue	B's queue	C's queue
1	1.0	A1,C1	2.0	A1	A1		C1
2	1.5	B2 A2,C2	2.5 3.0	C1	A2	B2	C1,C2
3	1.833	C3	4.0	B2	A2	B2	C2,C3
4	2.166	A4	4.0	A2	A2,A4		C2,C3
5	2.666	C5	5.0	C2	A4		C2,C3,C5
6	3.166	A6 B6 C6	5.0 4.166 6.0	A4	A4,A6	B6	C3,C5,C6
7	3.5	A7 C7	6.0 7.0	C3	A6,A7	B6	C3,C5,C6,C7
8	3.833	B8 C8	5.166 8.0	B6	A6,A7	B6,B8	C5,C6,C7,C8
9	4.166	A9	7.0	A6	A6,A7,A9	B8	C5,C6,C7,C8
10	4.5	A10	8.0	C5	A7,A9,A10	B8	C5,C6,C7,C8
11	4.833	B11	6.166	B8	A7,A9,A10	B8,B11	C6,C7,C8
12	5.166	B12	7.166	A7	A7,A9,A10	B11,B12	C6,C7,C8
13	5.5			C6	A9,A10	B11,B12	C6,C7,C8
14	5.833			B11	A9,A10	B11,B12	C7,C8
15	6.166	B15	8.166	A9	A9,A10	B12,B15	C7,C8
16				C7	A10	B12,B15	C7,C8
17				B12	A10	B12,B15	C8
18				A10	A10	B15	C8
19				C8		B15	C8
20				B15		B15	

(b) For weighted fair queuing we have, for flow C,

$$F_i = \max\{A_i, F_{i-1}\} + 0.5$$

For flows A and B, F_i is as before. Here is the table corresponding to the one above.

Wallclock	A_i	arrivals	F_i	sent	A's queue	B's queue	C's queue
1	1.0	A1	2.0	C1	A1		C1
		C1	1.5				
2	1.5	A2	3.0	A1	A1,A2	B2	C2
		B2	2.5				
		C2	2.0				
3	1.833	A3	2.5	C2	A2	B2	C2,C3
4	2.166	A4	4.0	B2	A2,A4	B2	C3
5	2.5	C3	3.0	C3	A2,A4		C3,C5
6	3.0	A6	5.0	A2	A2,A4,A6	B6	C5,C6
		B6	4.0				
		C6	3.5				
7	3.333	A7	6.0	C5	A4,A6,A7	B6	C5,C6,C7
		C7	4.0				
8	3.666	B8	5.0	C6	A4,A6,A7	B6,B8	C6,C7,C8
		C8	4.5				
9	4.0	A9	7.0	A4	A4,A6,A7,A9	B6,B8	C7,C8
10	4.333	A10	8.0	B6	A6,A7,A9,A10	B6,B8	C7,C8
11	4.666	B11	6.0	C7	A6,A7,A9,A10	B8,B11	C7,C8
12	5.0	B12	7.0	C8	A6,A7,A9,A10	B8,B11,B12	C8
13	5.333			A6	A6,A7,A9,A10	B8,B11,B12	
14	5.833			B8	A7,A9,A10	B8,B11,B12	
15	6.333	B15	8.0	A7	A7,A9,A10	B11,B12,B15	
16				B11	A9,A10	B11,B12,B15	
17				A9	A9,A10	B12,B15	
18				B12	A10	B12,B15	
19				A10	A10	B15	
20				B15		B15	

15. The answer is in the book.

16. (a) In slow start, the size of the window doubles every RTT. At the end of the i th RTT, the window size is 2^i KB. It will take 10 RTTs before the send window has reached 2^{10} KB = 1 MB.
- (b) After 10 RTTs, 1023 KB = 1 MB - 1 KB has been transferred, and the window size is now 1 MB. Since we have not yet reached the maximum capacity of the network, slow start continues to double the window each RTT, so it takes 4 more RTTs to transfer the remaining 9MB (the amounts transferred during each of these last 4 RTTs are 1 MB, 2 MB, 4 MB, 1 MB; these are all well below the maximum capacity of the link in one RTT of 12.5 MB). Therefore, the file is transferred in 14 RTTs.
- (c) It takes 0.7 seconds (14 RTTs) to send the file. The effective throughput is $(10\text{MB} / 0.7\text{s}) = 14.3\text{MBps} = 114.3\text{Mbps}$. This is only 11.4% of the available link bandwidth.

17. Let the sender window size be 1 packet initially. The sender sends an entire window-full in one batch; for every ACK of such a window-full that the sender receives, it increases its effective window (which is counted in packets) by one. When there is a timeout, the effective window is cut into half the number of packets.

Now consider the situation when the indicated packets are lost. The window size is initially 1; when we get the first ACK it increases to 2. At the beginning of the second RTT we send packets 2 and 3. When we get their ACKs we increase the window size to 3 and send packets 4, 5 and 6. When these ACKs arrive the window size becomes 4.

Now, at the beginning of the fourth RTT, we send packets 7, 8, 9, and 10; by hypothesis packet 9 is lost. So, at the end of the fourth RTT we have a timeout and the window size is reduced to $4/2 = 2$.

Continuing, we have

RTT	5	6	7	8	9
Sent	9-10	11-13	14-17	18-22	23-28

Again the congestion window increases up until packet 25 is lost, when it is halved, to 3, at the end of the ninth RTT. The plot below shows the window size vs. RTT.

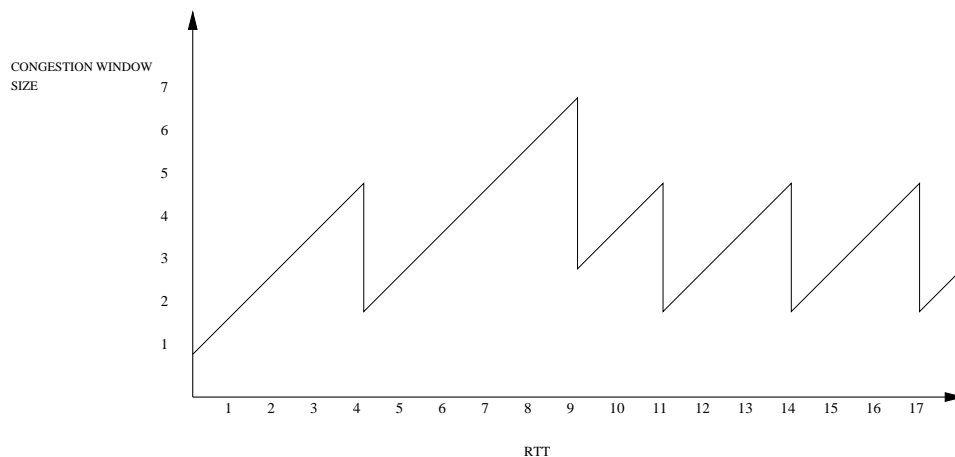

18. From the figure for the preceding exercise we see that it takes about 17 RTTs for 50 packets, including the necessary retransmissions. Hence the effective throughput is $50/17 \times 100 \times 10^{-3} \text{ KB/s} = 29.4 \text{ KB/s}$.
19. The formula is accurate if each new ACK acknowledges one new MSS-sized segment. However, an ACK can acknowledge either small size packets (smaller than MSS) or cumulatively acknowledge many MSS's worth of data.

Let $N = \text{CongestionWindow}/\text{MSS}$, the window size measured in segments. The goal of the original formula was so that after N segments arrived the net increment would be MSS, making the increment for one MSS-sized segment MSS/N . If instead we receive an ACK acknowledging an arbitrary AmountACKed, we should thus expand the window by

$$\begin{aligned} \text{Increment} &= \text{AmountACKed}/N \\ &= (\text{AmountACKed} \times \text{MSS})/\text{CongestionWindow} \end{aligned}$$

20. We may still lose a batch of packets, or else the window size is small enough that three subsequent packets aren't sent before the timeout. Fast retransmit needs to receive three duplicate ACKs before it will retransmit a packet. If so many packets are lost (or the window size is so small) that not even three duplicate ACKs make it back to the sender, then the mechanism cannot be activated, and a timeout will occur.
21. We will assume in this exercise and the following two that when TCP encounters a timeout it reverts to stop-and-wait as the outstanding lost packets in the existing window get retransmitted one at a time, and that the slow start phase begins only when the existing window is fully acknowledged. In particular, once one timeout and retransmission is pending, subsequent timeouts of later packets are suppressed or ignored until the earlier acknowledgment is received. Such timeouts are still shown in the tables below, but no action is taken.

We will let Data N denote the N th packet; Ack N here denotes the acknowledgment for data up through and *including* data N .

- (a) Here is the table of events with $\text{TimeOut} = 2$ sec. There is no idle time on the R-B link.

Time	A recvs	A sends	R sends	cwnd size
0		Data0	Data0	1
1	Ack0	Data1,2	Data1	2
2	Ack1	Data3,4 (4 dropped)	Data2	3
3	Ack2	Data5,6 (6 dropped)	Data3	4
4	Ack3/timeout4	Data 4	Data5	1
5	Ack3/timeout5&6		Data4	1
6	Ack5	Data 6	Data6	1
7	Ack 6	Data7,8 (slow start)	Data7	2

- (b) With $\text{TimeOut} = 3$ sec, we have the following. Again nothing is transmitted at $T=6$ because ack 4 has not yet been received.

Time	A recvs	A sends	R sends	cwnd size
0		Data0	Data0	1
1	Ack0	Data1,2	Data1	2
2	Ack1	Data3,4 (4 dropped)	Data2	3
3	Ack2	Data5,6 (6 dropped)	Data3	4
4	Ack3	Data7,8 (8 dropped)	Data5	5
5	Ack3/timeout4	Data4	Data7	1
6	Ack3/timeout5&6		Data4	1
7	Ack5/timeout7&8	Data6	Data6	1
8	Ack7	Data8	Data8	1
9	Ack8	Data9,10 (slow start)	Data9	2

22. We follow the conventions and notation of the preceding exercise. Although the first packet is lost at T=4, it wouldn't have been transmitted until T=8 and its loss isn't detected until T=10. During the final few seconds the outstanding losses in the existing window are made up, at which point slow start would be invoked.

	A recvs Ack #	cwnd size	A sends Data	R sending/R's queue	
T=0		1	1	1/	
T=1	1	2	2,3	2/3	
T=2	2	3	4,5	3/4,5	
T=3	3	4	6,7	4/5,6,7	
T=4	4	5	8,9	5/6,7,8	9 lost
T=5	5	6	10,11	6/7,8,10	11 lost
T=6	6	7	12,13	7/8,10,12	13 lost
T=7	7	8	14,15	8/10,12,14	15 lost
T=8	8	9	16,17	10/12,14,16	17 lost
T=9	8	9		12/14,16	
T=10	8	9	9	14/16,9	2nd duplicate Ack8
T=11	8			16/9	
T=12	8			9/	
T=13	10		11	11/	B gets 9
T=14	12		13	13/	
T=15	14		15	15/	
T=16	16		17	17/	
T=17	17	2	18,19	18/19	slow start

23. R's queue size is irrelevant because the R-B link changed from having a bandwidth delay to having a propagation delay only. That implies that packets leave R as soon as they arrive and hence no queue can develop. The problem now becomes rather trivial compared to the two previous questions. Because no queue can develop at the router, packets will not be dropped, so the window continues to grow each RTT. In reality this scenario could happen but would ultimately be limited by the advertised window of the connection.

Note that the question is somewhat confusingly worded—it says that 2 packets

take one second to send, but since this is propagation delay rather than bandwidth delay, *any* number of packets can be sent in one second.

Notation and conventions are again as in #21 above.

	A recvs	cwnd	A sends data #
T=0		1	1
T=1	Ack1	2	2,3
T=2	Ack3	4	4,5,6,7
T=3	Ack7	8	8–15
T=4	Ack15	16	16–31
T=5	Ack31	32	32–63
T=6	Ack63	64	64–127
T=7	Ack127	128	127–255
T=8	Ack255	256	255–511

24. With a full queue of size N , it takes an idle period on the sender's part of $N+1$ seconds for $R1$'s queue to empty and link idling to occur. If the connection is maintained for any length of time with $\text{CongestionWindow}=N$, no losses occur but EstimatedRTT converges to N . At this point, if a packet is lost the timeout of $2 \times N$ means an idle stretch of length $2N - (N+1) = N-1$.

With fast retransmit, this idling would not occur.

25. The router is able in principle to determine the actual number of bytes outstanding in the connection at any time, by examining sequence and acknowledgment numbers. This we can take to be the congestion window except for immediately after when the latter decreases.

The host is complying with slow start at startup if only one more packet is outstanding than the number of ACKs received. This is straightforward to measure.

Slow start after a coarse-grained timeout is trickier. The main problem is that the router has no way to know when such a timeout occurs; the TCP might have inferred a lost packet by some other means. We may, however, on occasion be able to rule out three duplicate ACKs, or even two, which means that a retransmission might be inferred to represent a timeout.

After any packet is retransmitted, however, we should see the congestion window fall at least in half. This amounts to verifying multiplicative decrease, though, not slow start.

26. Using ACKs in this manner allow very rapid increase and control over CongestionWindow . Stefan Savage suggests requiring ACKS to include a *nonce* as a solution. That is, ACKs must include information from that data which is being ACKed to be valid.

27. Slow start is active up to about 0.5 sec on startup. At that time a packet is sent that is lost; this loss results in a coarse-grained timeout at $T=1.9$.

At that point slow start is again invoked, but this time TCP changes to the linear-increase phase of congestion avoidance before the congestion window gets large

enough to trigger losses. The exact transition time is difficult to see in the diagram; it occurs sometime around $T=2.4$.

At $T=5.3$ another packet is sent that is lost. This time the loss is detected at $T=5.5$ by fast retransmit; this TCP feature is the one not present in Figure 6.11 of the text, as all lost packets there result in timeouts. Because the congestion window size then drops to 1, we can infer that fast recovery was not in effect; instead, slow start opens the congestion window to half its previous value and then linear increase takes over. The transition between these two phases is shown more sharply here, at $T=5.7$.

28. We assume here that the phone link delay is due to bandwidth, not latency, and that the rest of the network path offers a bandwidth at least as high as the phone link's. During the first RTT we send one packet, due to slow start, and by the final assumption we thus transmit over the link for a third of the RTT, and thus use only a third of the total bandwidth, or 1 KB/sec. During the second RTT we send two packets; in the third and subsequent RTTs send three packets, saturating the phone link. The sequence of averages, however, climbs more slowly: at the end of the second RTT the fraction of bandwidth used is $3/6$; at the end of the third RTT it is $6/9$, then $9/12$, at the end of the N th RTT we have used $1-1/N$ of the bandwidth.

Packet losses cause these averages to drop now and then, although since the averages are cumulative the drops are smaller and smaller as time goes on.

29. (a) Here is how a connection startup might progress:

Send packet 1

Get ack 1

Send packets 2 & 3

Get ack 2

Send packet 4, which is lost due to link errors, so `CongestionWindow=1`.

One way or another, we get lots of coarse-grained timeouts when the window is still too small for fast retransmit. We will never be able to get past the early stages of slow start.

- (b) Over the short term such link losses cannot be distinguished from congestion losses, unless some router feedback mechanism (e.g. ICMP Source Quench) were expanded and made more robust. (Over the long term, congestion might be expected to exhibit greater temporal variability, and careful statistical analysis might indicate when congestion was present.)
- (c) In the presence of explicit congestion indications, TCP might now be tuned to respond to ordinary timeout losses by simply retransmitting, without reducing the window size. Large windows could now behave normally.

We would, however, need some way for keeping the ACK clocking running; coarse-grained timeouts would still necessitate a return to `CongestionWindow= 1` because ACKs would have drained. Either TCP's existing fast retransmit/fast recovery, or else some form of selective ACKs,

might be appropriate. Either might need considerable tuning to handle a 25% loss rate.

30. Suppose the first two connections keep the queue full 95% of the time, alternating transmissions in lockstep and timed so that their packets always arrive just as a queue vacancy opens. Suppose also that the third connection's packets happen always to arrive when the queue is full. The third connection's packets will thus be lost, whether we use slow start or not. The first two connections will not be affected.

Congestion avoidance by the first two connections means that they will eventually try a window size of 4, and fall back to 2, and give the third connection a real foot in the door. Slow start for the third connection would mean that if a packet got through, then the window would expand to 2 and the third sender would have about twice the probability of getting at least one packet through. However, since a loss is likely, the window size would soon revert to 1.

31. (a) We lose 1100 ms: we wait 300 ms initially to detect the third duplicate ACK, and then one full 800 ms RTT as the sender waits for the ACK of the retransmitted segment. If the lost packet is sent at $T=-800$, the lost ACK would have arrived at $T=0$. The duplicates arrive at $T=100, 200$, and 300 . We retransmit at $T=300$, and the ACK finally arrives at $T=1100$.
- (b) We lose $1100 - 400 = 700$ ms. As shown in the diagram, the elapsed time before we resume is again 1100 ms but we have had four extra chances to transmit during that interval, for a savings of 400 ms.

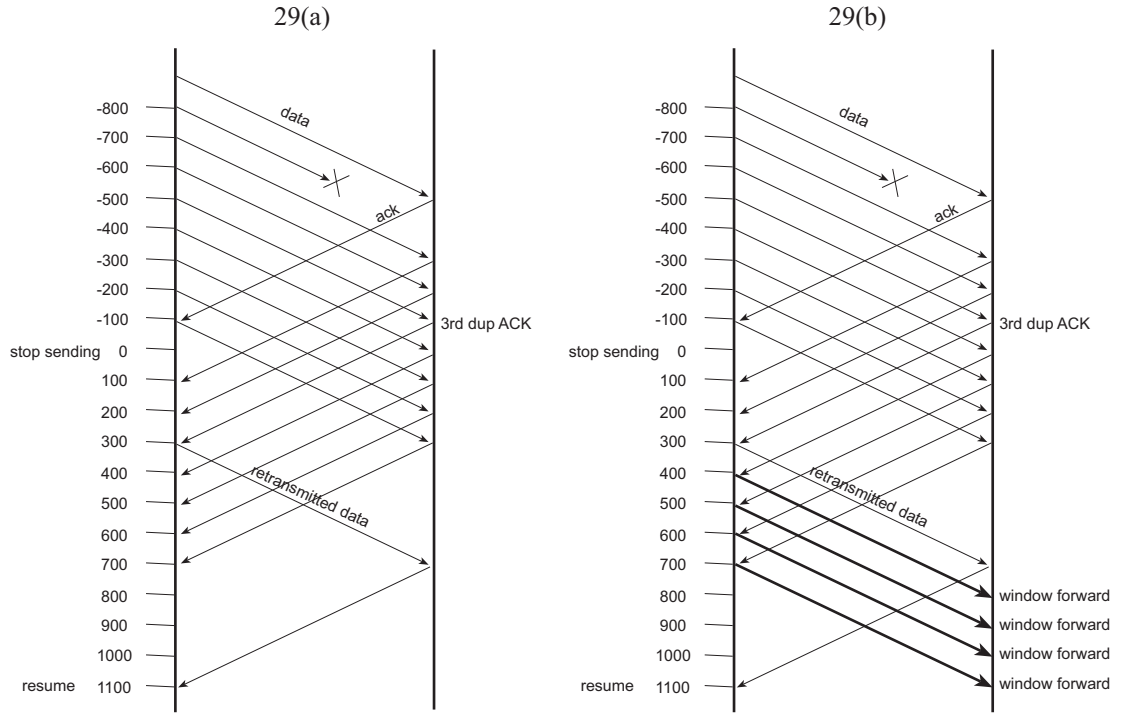

32. We might alternate between congestion-free backoff and heavy congestion, moving from the former to the latter in as little as 1 RTT. Moving from congestion back to no congestion unfortunately tends not to be so rapid.

TCP Reno also oscillates between congestion and non-congestion, but the periods of non-congestion are considerably longer.

33. Marking a packet allows the endpoints to adjust to congestion more efficiently—they may be able to avoid losses (and timeouts) altogether by slowing their sending rates. However, transport protocols must be modified to understand and account for the congestion bit. Dropping packets leads to timeouts, and therefore may be less efficient, but current protocols (such as TCP) need not be modified to use RED. Also, dropping is a way to rein in an ill-behaved sender.

34. (a) We have

$$\text{TempP} = \text{MaxP} \times \frac{\text{AvgLen} - \text{MinThreshold}}{\text{MaxThreshold} - \text{MinThreshold}}$$

AvgLen is halfway between MinThreshold and MaxThreshold, which implies that the fraction here is 1/2 and so $\text{TempP} = \text{MaxP}/2 = 0.005$.

We now have $P_{\text{count}} = \text{TempP}/(1 - \text{count} \times \text{TempP}) = 1/(200 - \text{count})$. For count=1 this is 1/199; for count=100 it is 1/100.

(b) Evaluating the product $(1 - P_1) \times \cdots \times (1 - P_{50})$ gives

$$\frac{198}{199} \times \frac{197}{198} \times \frac{196}{197} \times \cdots \times \frac{150}{151} \times \frac{149}{150}$$

which all telescopes down to $149/199$, or 0.7487 .

35. The answer is in the book.
36. The difference between `MaxThreshold` and `MinThreshold` should be large enough to accommodate the average increase in the queue length in one RTT; with TCP we expect the queue length to double in one RTT, at least during slow start, and hence want `MaxThreshold` to be at least twice `MinThreshold`. `MinThreshold` should also be set at a high enough value so that we extract maximum link utilization. If `MaxThreshold` is too large, however, we lose the advantages of maintaining a small queue size; excess packets will simply spend time waiting.
37. Only when the *average* queue length exceeds `MaxThreshold` are packets automatically dropped. If the average queue length is less than `MaxThreshold`, incoming packets may be queued even if the real queue length becomes larger than `MaxThreshold`. The router must be able to handle this possibility.
38. It is easier to allocate resources for an application that can precisely state its needs, than for an application whose needs vary over some range. Bursts consume resources, and are hard to plan for.
39. Between `MinThreshold` and `MaxThreshold` we are using the drop probability as a signaling mechanism; a small value here is sufficient for the purpose and a larger value simply leads to multiple packets dropped per TCP window, which tends to lead to unnecessarily small window sizes.
Above `MaxThreshold` we are no longer signaling the sender. There is no logical continuity intended between these phases.
40. The bit allows for incremental deployment, in which some endpoints respond to congestion marks and some do not. Without this bit, ECN-enabled routers would mark packets during congestion rather than dropping them, but some (presumably older, not updated) endpoints would not recognize the mark, and hence would not back off during congestion, crowding out the ECN-compliant endpoints, which would then have the incentive to ignore ECN marks as well. The result could actually be congestion collapse as in the pre-congestion-controlled Internet.
41. (a) Assume the TCP connection has run long enough for a full window to be outstanding (which may never happen if the first link is the slowest). We first note that each data packet triggers the sending of exactly one ACK, and each ACK (because the window size is constant) triggers the sending of exactly one data packet.

We will show that two consecutive RTT-sized intervals contain the same number of transmissions. Consider one designated packet, `P1`, and let the

first RTT interval be from just before P1 is sent to just before P1's ACK, A1, arrives. Let P2 be the data packet triggered by the arrival of A1, let A2 be the ACK for P2, and let the second interval be from just before the sending of P2 to just before the receipt of A2. Let N be the number of segments sent within the first interval, *i.e.*, counting P1 but not P2. Then, because packets don't cross, this is the number of ACKs received during the second RTT interval, and these ACKs trigger the sending of exactly N segments during the second interval as well.

- (b) The following shows a window size of four, but only two packets sent per RTT once the steady state is reached. It is based on an underlying topology A—R—B, where the A—R link has infinite bandwidth and the R—B link sends one packet per second each way. We thus have $RTT=2$ sec; in any 2-second interval beginning on or after $T=2$ we send only two packets.

T=0 send data[1] through data[4]

T=1 data[1] arrives at destination; ACK[1] starts back

T=2 receive ACK[1], send data[5]

T=3 receive ACK[2], send data[6]

T=4 receive ACK[3], send data[7]

The extra packets are, of course, piling up at the intermediate router.

42. The first time a timed packet takes the doubled RTT, TCP Vegas still sends one windowful and so measures an $ActualRate = CongestionWindow/RTT_{new}$ of half of what it had been, and thus about half (or less) of $ExpectedRate$. We then have $Diff = ExpectedRate - ActualRate \approx (1/2) \times ExpectedRate$, which is relatively large (and, in particular, larger than β), so TCP Vegas starts reducing $CongestionWindow$ linearly. This process stops when $Diff$ is much closer to 0; that is, when $CongestionWindow$ has shrunk by a factor close to two.

The ultimate effect is that we underestimate the usable congestion window by almost a factor of two.

43. (a) If we send 1 packet, then in either case we see a 1 sec RTT. If we send a burst of 10 packets, though, then in the first case ACKs are sent back at 1 sec intervals; the last packet has a measured RTT of 10 sec. The second case gives a 1 sec RTT for the first packet and a 2 sec RTT for the last.

The technique of packet-pairs, sending multiple instances of two consecutive packets right after one another and analyzing the minimum time difference between their ACKs, achieves the same effect; indeed, packet-pair is sometimes thought of as a technique to find the minimum path bandwidth. In the first case, the two ACKs of a pair will always be 1 second apart; in the second case, the two ACKs will sometimes be only 100 ms apart.

- (b) In the first case, TCP Vegas will measure $RTT = 3$ as soon as there is a full window outstanding. This means $ActualRate$ is down to 1 packet/sec. However, $BaseRTT$ is 1 sec, and so $ExpectedRate = CongestionWindow/BaseRTT$ is 3 packets/sec. Hence, $Diff$ is 2 packets/sec, and $CongestionWindow$ will be decreased.

In the second case, when a burst of three packets is sent the measured RTTs are 1.0, 1.1, 1.2. Further measurements are similar. This likely does not result in enough change in the measured RTT to decrease `ActualRate` sufficiently to trigger a decrease in `CongestionWindow`, and depending on the value of α may even trigger an increase. At any rate, `ActualRate` decreases much more slowly than in the first case.

44. If an application running over UDP has no congestion control, and it shares a bottleneck link with an application that runs over congestion-controlled TCP, then only the TCP traffic will reduce its sending rate in response to congestion. In the extreme, the throughput of TCP traffic could drop to zero if there is enough UDP traffic to congest the link on its own.

An application that receives RTCP receiver reports, however, can detect loss, and attempt to emulate the congestion control behavior of TCP. For example, a video application might respond to an RTCP report of packet loss by dropping its transmission rate, perhaps by changing the video resolution or the strength of its compression algorithm.

A detailed specification of a protocol that can run over UDP and yet respond to congestion in a TCP-like way is in RFC 4340.

45. An ATM network may be only one network, or one type of network, in an internet. Making service guarantees across such an ATM link does not in this setting guarantee anything on an end-to-end basis. In other words, congestion management is an end-to-end issue.

If IP operates exclusively over ATM, then congestion management at the ATM level may indeed address total congestion (although if partial packet discard is not implemented then dropped cells do not correspond very well to dropped packets). In this setting, congestion control at the TCP level has the drawback that it doesn't address other protocols, and doesn't take into account the switches' knowledge of virtual circuits.

46. (a) Robot control is naturally realtime-intolerant: the robot can not wait indefinitely for steering control if it is about to crash, and it can not afford to lose messages such as "halt", "set phasers on stun", or even "switch to blue paint". Such an application could be adaptive in a setting where we have the freedom to slow the robot down.
- (b) If an application tolerates a loss rate of x , $0 < x < 1$, then it is only receiving fraction $1 - x$ of the original bandwidth and can tolerate a reduction to that bandwidth over a lossless link.
- (c) Suppose the data being transmitted are positioning coordinates for some kind of robotic device. The device must follow the positions plotted, though some deviation is permitted. We can tolerate *occasional* lost data, by interpolating the correct path (there is a continuity assumption here); this would qualify the application as loss-tolerant.

We also want to be able to claim that the application is non-adaptive. So we will suppose that too much transmission delay means the robot cannot

follow the path closely enough (or at least not with the required speed), making the application non-delay-adaptive. A significant rate reduction, similarly, might mean the device can't keep to within the required tolerance – perhaps it requires at least 80% of the coordinates – and so it would qualify as non-rate-adaptive.

47. (a) One way to solve this is to imagine that we start with an empty bucket but allow the bucket volume to become negative (while still providing packets); we then get the following table of bucket “indebtedness”: At $T=0$, for example, we withdraw 8 tokens from the bucket (the number of packets sent) and deposit 2 (the token rate).

Time, secs	0	1	2	3	4	5
Bucket volume	-6	-8	-7	-5	-9	-8

We thus need an initial bucket depth of 9, so as not to run out at $T=4$. Because all the volumes above are negative, the bucket with depth 9 never overflows.

- (b) If we do the same thing as above we get

Time, secs	0	1	2	3	4	5
Bucket volume	-4	-4	-1	3	1	4

A bucket depth of 4 will thus accommodate $T=0$ and $T=1$. In this case because the volume is sometimes positive we also need to check that the bucket doesn't overflow. If we start with an initially full bucket of depth 4, we get

Time, secs	0	1	2	3	4	5
Bucket volume	0	0	2	4	2	4

Note that the bucket does become full of tokens at $T=3$ and $T=5$ but that we are able to handle the 6 packets at $T=4$ because we had 4 tokens in the bucket plus the 4 more tokens that arrive each interval. So 4 is the size of the minimal token bucket.

48. The answer is in the book.
49. (a) If the router queue is empty and all three flows dump their buckets at the same time, the burst amounts to 15 packets for a maximum delay of 1.5 sec. Since the router can keep up with packets due to steady-state traffic alone, and can drain any earlier bucket dumps faster than the buckets get refilled, such a burst is in fact the maximum queue.
- (b) In 2.0 seconds the router can forward 20 packets. If flow1 sends an initial burst of 10 at $T=0$ and another single packet at $T=1$, and flow2 sends 4 at $T=0$ and 2 at $T=1$, that amounts to 17 packets in all. This leaves a minimum capacity of 3 packets for flow3. Over the long term, of course, flow3 is guaranteed an average of 8 packets per 2.0 seconds.
50. (a) If the router was initially combining both reserved and nonreserved traffic into a single FIFO queue, then reserved flows before the loss were not getting genuine service guarantees. After the loss the router is still handling all

traffic via a single FIFO queue; the only difference is that all traffic is now considered nonreserved. The state loss should thus make no difference.

- (b) If the router used weighted fair queuing to segregate reserved traffic, then a state loss may lead to considerable degradation in service, because the reserved traffic now is forced to compete on an equal footing with *hoi polloi* traffic.
- (c) Suppose new reservations from some third parties reach the router before the periodic refresh requests are received to renew the original reservations; if these new reservations use up all the reservable capacity the router may be forced to turn down the renewals.

Solutions for Chapter 7

- Each string is preceded by a count of its length; the array of salaries is preceded by a count of the number of elements. That leads to the following sequence of integers and ASCII characters being sent:

```
7 R I C H A R D 4376 8 D E C E M B E R 2 1998 3 80000 85000 90000
2
```

- The answer is in the book.
- Limited measurements suggest that, at least in one particular setting, use of `htonl` slows the array-converting loop down by about a factor of two.
- The following measurements were made on a 300MHz Intel system, compiling with Microsoft's Visual C++ 6.0 and optimizations turned off. We normalize to the case of a loop that repeatedly assigns the same integer variable to another:

```
for (i=0;i<N;i++) {j=k}
```

Replacing the loop body above with `j=htonl(k)` made the loop take about 2.9 times longer. The following homemade byte-swapping code took about 3.7 times longer:

```
char * p = (char *) & k;
char * q = (char *) & j;
q[0]=p[3];
q[1]=p[2];
q[2]=p[1];
q[3]=p[0];
```

For comparison, replacing the loop body with an array copy `A[i]=B[i]` took about 2.8 times longer.

- ASN.1 encodings are as follows:

INT	4	101
INT	4	10120
INT	4	16909060

- The answer is in the book.
- Here are the encodings.

```
101 be 00000000 00000000 00000000 01100101
101 le 01100101 00000000 00000000 00000000

10120 be 00000000 00000000 00100111 10001000
10120 le 10001000 00100111 00000000 00000000

16909060 be 00000001 00000010 00000011 00000100
16909060 le 00000100 00000011 00000010 00000001
```

For more on big-endian versus little-endian we quote Jonathan Swift, writing in *Gulliver's Travels*:

...Which two mighty powers have, as I was going to tell you, been engaged in a most obstinate war for six and thirty moons past. It began upon the following occasion. It is allowed on all hands, that the primitive way of breaking eggs before we eat them, was upon the larger end: but his present Majesty's grandfather, while he was a boy, going to eat an egg, and breaking it according to the ancient practice, happened to cut one of his fingers. Whereupon the Emperor his father published an edict, commanding all his subjects, upon great penalties, to break the smaller end of their eggs. The people so highly resented this law, that our histories tell us there have been six rebellions raised on that account.... Many hundred large volumes have been published upon this controversy: but the books of the Big-Endians have been long forbidden, and the whole party rendered incapable by law of holding employments.

10. The answer is in the book.
11. The problem is that we don't know whether the `RPCVersion` field is in big-endian or little-endian format until after we extract it, but we need this information to decide on which extraction to do.

It would be possible to work around this problem provided that among all the version IDs assigned, the big-endian representation of one ID never happened to be identical to the little-endian representation of another. This would be the case if, for example, future versions of XDR continued to use big-endian format for the `RPCVersion` field, but not necessarily elsewhere.
12. It is often possible to do a better job of compressing the data if one knows something about the type of the data. This applies even to lossless compression; it is particularly true if lossy compression can be contemplated. Once encoded in a message and handed to the encoding layer, all the data looks alike, and only a generic, lossless compression algorithm can be applied.
13. [The DEC-20 was perhaps the best-known example of 36-bit architecture.]

Incoming 32-bit integers are no problem; neither are outbound character strings. Outbound integers could either be sent as 64-bit integers, or else could lose the high-order bits (with or without notification to the sender). For inbound strings, one approach might be to strip them to 7 bits by default, make a flag available to indicate whether any of the eighth bits had been set, and, if so, make available a lossless mechanism (perhaps one byte per word) of re-reading the data.
14. Here is a C++ solution, in which we make `netint`⇒`int` an automatic conversion. To avoid potential ambiguity, we make use of the `explicit` keyword in the constructor converting `int` to `netint`, so that this does not also become an automatic conversion. (Note that the ambiguity would require additional code to realize.)

To support assignment `netint = int`, we introduce an assignment operator.

```
class netint {  
    public:
```

```

operator int() {return ntohl(_netint);}
netint() : _netint(0) // default constructor
explicit netint (int n) : _netint(ntohl(n)) {}
netint & operator=(int n) {
    _netint = htonl(n);
    return *this;
}
int raw() {return _netint;} // for testing
private:
    int _netint;
};

```

The above strategy doesn't help at all with pointers, and not much with structures and arrays. It doesn't address alignment problems, for example.

15. Transmission bit order is the province of the network adapter, which addresses this as it transmits or receives each byte. Generally all numeric formats on the same machine (different sizes of ints, floats, etc) use the same bit order; only if they didn't would the programmer have to make distinctions.
16. For big-endian network byte order the average number of conversions is $0 \times p^2 + 1 \times 2p(1 - p) + 2 \times (1 - p)^2$. For receiver-makes-right this is $0 \times p^2 + 1 \times 2p(1 - p) + 0 \times (1 - p)^2$; that is, if both sender and receiver are little-endian then no conversion is done. These are evaluated below:

	$p = 0.1$	$p = 0.5$	$p = 0.9$
big-endian network	1.80	1.00	0.20
receiver-makes-right	0.18	0.50	0.18

17. (a) Replace the markup tag text with corresponding codes. One or two bytes would suffice for most XML languages.
 (b) Represent numerical data using a numerical representation instead of text.
18. Try data files with lots of byte-string-level redundancy.

19. (a)

letter	encoding
a	1
b	01
c	001
d	000

- (b) $1 \times 0.5 + 2 \times 0.3 + 3 \times 0.1 + 3 \times 0.1 = 1.7$ So the compressed data uses $1.7/2 \times 100 = 85\%$ as many bits, or a 15% compression gain.
- (c) The table is the same, although we could now give either **a** or **b** the 1-bit encoding. The average compression is now $1 \times 0.4 + 2 \times 0.4 + 3 \times 0.15 + 3 \times 0.05 = 1.8$, i.e., we use 90% as many bits or a 10% compression gain.

20. (a) This is a counting argument: there are 2^N strings of length N and only $2^0 + 2^1 + \dots + 2^{N-1} = 2^N - 1$ strings of length $< N$. Some string, therefore, cannot get shorter.

(c) We let

$$c'(s) = \begin{cases} 0 \frown c(s) & \text{if } \text{length}(c(s)) < \text{length}(s) \\ 1 \frown s & \text{otherwise} \end{cases}$$

(where $0 \frown c(s)$ is $c(s)$ with a zero-bit prepended). The initial bit is a flag to indicate whether the remainder was compressed or not.

21. Bytes that occur with a run length of 1 we represent with themselves. If a byte occurs in a run of more than 1, we represent it with the three bytes

[ESC] [count] [byte]

The byte [ESC] can be any agreed-upon escape character; if it occurs alone it might be represented as [ESC][ESC].

22. A sample program appears on the web page; it generated the following data. The uncompressed size of RFC 791 is 94892 bytes. There are 11,243 words in all; the number of distinct words is 2255 and the dictionary size is 18226 bytes. The encoded size of the non-dictionary part with 12 bits per word is thus $(12 \times 11243)/8 = 16865$ bytes; together with the dictionary we get a compressed size of 35091 bytes, 37% of the original size. There are 132 words appearing at least 13 times, with a total frequency count of 6689. This means the 128 most common words appear a total of 6637 times; this gives a compressed size of $(8 \times 6637 + 13 \times (11243 - 6637))/8 = 14122$ bytes, plus the dictionary; the total is now 34% of the original size. Note that exact numbers are sensitive to the precise definition of a “word” used.

23. (a) For “symmetric” data such as this, coefficients $DCT(i)$ for $i = 1, 3, 5, 7$ (starting the indexing at $i = 0$) should be zero or near-zero.

(b) If we keep six coefficients, the maximum error in $pixel(i)$ after applying the DCT and its inverse is about 0.7%, for $i = 1$ and $i = 2$. If we keep only four or five coefficients (note that both choices lead to the same values for the inverse DCT), then the maximum error is 6%, at $i = 0$; the error at $i = 1$ is 5.6%.

(c) The input vectors for this problem look like $\langle 1, 0, 0, 0, 0, 0, 0, 0 \rangle$ with the 1 moving one position to the right as i increases. Here is a table listing, for each s_i , the percentage error in the i th place of the final result. The smallest error is for $i = 0$ and 7; the largest is for $i = 1$ and 6.

i	0	1	2	3	4	5	6	7
% error	12.3	53.1	39.6	45.0	45.0	39.6	53.1	12.3

24. The all-white image generates all zeros in the DCT phase. The quantization phase leaves the 8×8 grid of 0’s unchanged; the encoding phase then compresses it to almost nothing.

25. Here is the first row of an 8×8 pixmap consisting of a black line (value 0) in the first column, and the rest all white:

```
00 FF FF FF FF FF FF FF
```

Here is the image after default-quality (cjpeg -quality 75) JPEG compression and decompression; there is some faint vertical fringing (the columns with FC, FD, and FE would appear as progressively fainter grey lines). All rows are identical; here is the first:

```
01 FC FF FD FF FF FE FF
```

With -quality 100, or even -quality 90, the fringing is gone; the image after compression and decompression is identical to the original.

26. We start with an example specifically generated for the 8×8 grid; note that the letters change gradually in both directions. Here is the original data:

```
a b c d e f g h
b c d e f g h i
c d e f g h i j
d e f g h i j k
e f g h i j k l
f g h i j k l m
g h i j k l m n
h i j k l m n o
```

We get the following after default-quality (quality=75) jpeg compression and decompression; no letter is off by more than 1 ASCII value.

```
b b c d e g h h
b c d e f g h h
c d d f g h i i
d e f g h i j j
f f g h i j k l
g g h i j l l m
h h i j k l m n
h h i k l m n n
```

At quality=100 the text is preserved exactly. However, this is the best case.

Here is the first line of Lincoln's Gettysburg Address,

Fourscore and seven years ago our fathers brought forth on this continent....,

compressed and decompressed. With spaces between words eliminated and everything made lowercase, at quality=75 we get:

```
hnruugdtdihjpkirmqicjlfgowpekoifappiosqrbnnjonkppqjioidjulafnrhq
```

At quality=100 we get:

```
fourscoreandsevenyeassagooyrfathersbroughtfnrthonthiscontinentan
```

The three errors are underlined. Leaving in the spaces, then at quality=100 we get:

```
fourscre and seven years ago our fathers bsought eosth_on this
```

where the “_” character is the character with decimal value 31, versus 32 for a space character.

Lowercase letters are all within the ASCII range 97-122 numerically. Space characters are numerically 32; these thus appear to the DCT as striking discontinuities.

27. Jpeg includes an encoding phase, but as this is lossless it doesn't affect the image. JPEG's quantization phase, however, potentially rounds off all coefficients, to a greater or lesser degree; the strategy here however leaves un-zeroed coefficients alone.
28. Recalling that $C(0) = 1/\sqrt{2}$, we have

$$\begin{aligned}
 DCT(0,0) &= \frac{1}{2\sqrt{2}N} \sum_{x=0}^{N-1} \sum_{y=0}^{N-1} pixel(x,y) \\
 &= \frac{N\sqrt{N}}{2\sqrt{2}} \times \frac{1}{N^2} \sum_{x=0}^{N-1} \sum_{y=0}^{N-1} pixel(x,y) \\
 &= \frac{N\sqrt{N}}{2\sqrt{2}} \times (\text{average of the } pixel(x,y)\text{'s})
 \end{aligned}
 \tag{2}$$

30. If you display I frames only, then the fast-forward speed is limited to the rate at which I-frames are included; note that this may be variable.

The worst case for decoding an arbitrary frame is when the frame you want is a B frame. It depends on a previous P frame P and a future P or I frame Q . To decode the B frame you want, you will first need P and its I frame, and also Q . If Q is a P frame, then its I frame is the same as that of P . The total number of frames processed, including the one wanted, is four.

33. (a) For a while, the intervening B frames would show each macroblock containing a point as an appropriately translated macroblock from the original I frame. The δ for the frame is zero. Once the two points were close enough that they were in the same macroblock, however, we would need a nonzero δ to represent the frame, perhaps translating a macroblock from the original I frame so as to show one point, and using a δ with one nonzero entry to show the second point.
- (b) If the points were of a fixed color, the only difference from the above is that color macroblocks come at a different resolution. With points that are *changing* in color, modest deltas are needed from the beginning to indicate this.

Solutions for Chapter 8

2.

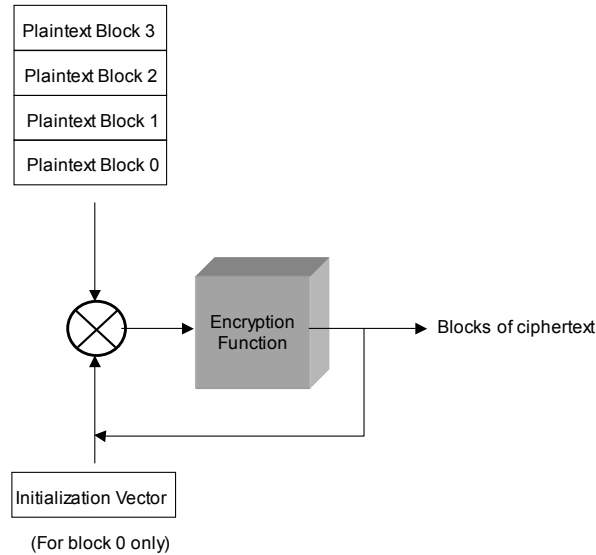

4. If the outputs are not truly random, then the algorithm becomes more vulnerable to a brute force attack. For example, if some outputs are twice as likely to be produced as others, an attacker can test fewer input strings to produce one of those more likely outputs. A factor of two probably doesn't matter too much, but large non-randomness would weaken the hash significantly.
5. The adversary would replay, to Bob, the third message of the Needham-Schroeder authentication protocol. Consistent with the protocol, Bob would extract the apparently new, but actually old, session key, and use it to encrypt a nonce in a reply. The adversary, having discovered the session key, would be able to decrypt the received nonce and reply as Alice would have.
6. We have $password[N] = g(password[N - 1])$; the essential property of g is that it be believed that knowing $g(x)$ does not provide any information that can be used to find x .
7. (a) let q be the first $N - 1$ characters of the password p , of length N . The eavesdropper is in possession of q at the point indicated in the hint; we now assume that "sufficiently slowly" means that the eavesdropper can try all passwords $q \frown ch$, for all characters ch , before the original user has typed

the N th character. If we assume passwords are restricted to 7-bit printable ASCII, that's only 96 tries.

- (b) Other attacks include a compromised utility to calculate the one-time password $f(mp, N)$ from the master password mp , discovery of a way to invert the function g at least partially, eavesdropping on the initial selection of mp , and “hijacking” a connection after authentication has been completed. There are doubtless others, as well.

8. The FAQ at www.rsasecurity.com explains:

The Diffie-Hellman key exchange is vulnerable to a man-in-the-middle attack. In this attack, an opponent Carol intercepts Alice's public value and sends her own public value to Bob. When Bob transmits his public value, Carol substitutes it with her own and sends it to Alice. Carol and Alice thus agree on one shared key and Carol and Bob agree on another shared key. After this exchange, Carol simply decrypts any messages sent out by Alice or Bob, and then reads and possibly modifies them before re-encrypting with the appropriate key and transmitting them to the other party. This vulnerability is present because Diffie-Hellman key exchange does not authenticate the participants. Possible solutions include the use of digital signatures and other protocol variants.

9. Because s is short, an exhaustive search conducted by generating all possible s and comparing the MD5 checksums with m would be straightforward. Sending $\text{MD5}(s \frown r)$, for some random or time-dependent r , would suffice to defeat this search strategy, but note that now we would have to remember r and be able to present it later to show we knew s . Using RSA to encrypt $s \frown r$ would be better in that sense, because we could decrypt it at any time and verify s without remembering r .
10. Each side chooses x_i privately. They exchange signatures of their respective choices as in the previous exercise, perhaps $\text{MD5}(x_i \frown r_i)$ for random r_i . Then they exchange the actual x_i 's (and r_i 's); because of the signatures, whoever reveals their x_i last is not able to change their choice based on knowing the other x_i . Then let $x = x_1 \oplus x_2$; as long as either party chooses their x_i randomly then x is random.
11. Let P_N be the probability that of N messages each checksum value is different from all the preceding. As in Chapter 2 Exercise 41 we have

$$P_N = \left(1 - \frac{1}{2^{128}}\right) \left(1 - \frac{2}{2^{128}}\right) \cdots \left(1 - \frac{N-1}{2^{128}}\right)$$

Taking logs and approximating we get

$$\begin{aligned} \log P_N &= -(1/2^{128} + 2/2^{128} + \cdots + (N-1)/2^{128}) \\ &= -(1 + 2 + \cdots + (N-1))/2^{128} \\ &\approx -N^2/2^{129} \end{aligned}$$

So $P_N \approx e^{-N^2/2^{129}}$. For $N = 2^{63}$ the exponent here is $-2^{126}/2^{129} = -1/8$; for $N = 2^{64}$ and $N = 2^{65}$ it is $-1/2$ and -2 respectively. Thus, the probabilities are

$$\begin{aligned} P_{63} &= e^{-1/8} = 0.8825, \\ P_{64} &= e^{-1/2} = 0.6065, \\ P_{65} &= e^{-2} = 0.1353. \end{aligned}$$

The probability two messages have the same checksum is $1 - P_N$.

12. The problem with padding each 1-byte message with seven zero bytes before encrypting is that we now are transmitting only 256 possible different encrypted blocks and a codebreaking attack is quite straightforward.

Here are some better options. Each involves encrypting a full block for each plaintext byte transmitted; the first two also require that we transmit a full block.

1. We could pad each plaintext byte with 7 random bytes before encrypting. This is quite effective, if the random bytes are truly random.
 2. We could make use of cipher block chaining, padding each plaintext byte p_i with seven zero-bytes before XORing with the previous Cipher $_{i-1}$ block. A roughly equivalent alternative, perhaps more like the previous option, is to pad p_i with seven bytes from Cipher $_{i-1}$, and omit the XOR.
 3. So-called cipher-feedback (CFB) mode is sometimes used. Let c_i denote the i th encrypted byte. Given p_i , we first use 3DES to encrypt the block $\langle c_{i-8} \cdots c_{i-1} \rangle$, and then let c_i be the XOR of p_i and the first byte of this encryption result. CFB makes assumptions about the pseudo-randomness of 3DES output that may not be initially apparent.
13. (a) Here is one possible approach. We add the following fields to the packets (which presumably contain a Packet Type field and a Block Number field already):

Sender's time when the connection was initiated
Receiver's time when the connection was initiated
Keyed MD5 checksum field

The latter consists of the MD5 checksum of everything else in the packet concatenated with the sender's own key. The packet sent does not include the sender's key. The recipient is able to recompute this checksum, because we have assumed both keys are known to both parties.

The checksum field provides both message integrity and authentication; at least it confirms that whoever created the packet knew the sender's key.

The timestamps guard against replay attacks. Both sides must exchange timestamps through a three-way handshake before any data is sent, much like ISNs in TCP. If we include only the client's timestamp, then the server could only detect replay attacks by keeping track of the previous client timestamp used. With both timestamps, each party is assured of a new connection as long as it has chosen a new timestamp.

- (b) The timestamps guard against late packets from a prior incarnation; older incarnations would have at least one timestamp wrong. However, they do nothing to protect against sequence number wraparound within a connection.
16. This is the chain-of-trust problem. Even though the root CA may have done a fine job of checking the identity of the second-tier CA, it is hard for Bob to know that the second-tier CA did the same for Alice. That is, Bob might doubt whether the root CA checks the operations of the second-tier CA before signing their certificate.
 17.
 - (a) The user gets a message the first time he or she attempts to connect to the given server. At that point, the user can cancel, go ahead with the connection this one time, or go ahead with the connection and save the server's public key for future authentications.
 - (b) Client authentication is up to the server. Password-based schemes are probably the most common. Public-key authentication is another possibility, and PuTTY provides support for that.
 - (c) The user ranks the ciphers in order of preference, and PuTTY negotiates with the server to use the user's most preferred cipher among those supported by the server.
 - (d) Some servers may support only a weak cipher. PuTTY gives the user the option of accepting the risk of using a weak cipher. The user sets a threshold in the user's ranking of the ciphers, and PuTTY warns the user if the negotiated cipher falls below that threshold, giving the user the opportunity to cancel the connection.
 - (e) The security derived from a session key decreases over time since more time is available to perform cryptanalysis. It also decreases as more encrypted data becomes available for cryptanalysis. So a session key should only be used short-term with a limited amount of data.
 18.
 - (a) An internal telnet client can presumably use any port ≥ 1024 . In order for such clients to be able to connect to the outside world, the firewall must pass their return, inbound traffic. If the firewall bases its filtering solely on port numbers, it must thus allow inbound TCP connections to any port ≥ 1024 .
 - (b) If the firewall is allowed access to the TCP header **Flags** bits, then to block all inbound TCP connections it suffices to disallow inbound packets with **SYN** set but not **ACK**. This prevents an outside host initiating a connection with an inside host, but allows any outbound connection. No port filtering is needed.
 19.
 - (a) The FTP client uses the **PORT** command to tell the server what port to use for the data connection. If this port can be taken from a limited range, in which we are sure there are no other servers to which an outsider might

- attempt to connect, then a firewall can be configured to allow outside access to this range (by examining both port numbers and the TCP Flags) without unduly compromising security. This range cannot be limited to a single port, though, because otherwise that port would frequently be in TIME_WAIT and unavailable.
- (b) Instead of using the `PORT` command to tell the FTP server to what client port it should connect for data transfer, an FTP client can send the server the `PASV` (“passive”) command. The server response, assuming it supports `PASV`, is to send an acknowledgment containing a server port number. The client then initiates the data-transfer connection to this server port. As this is typically an outbound connection through the firewall it can be safely permitted.
20. The routers are configured as follows:
- R1 blocks inbound traffic to the telnet port, unless the destination subnet is net2.
 - R2 blocks all telnet traffic from net 2 to net 1.
21. The ISP might want to prohibit attacks (such as the IP spoofing attack described in Exercise 5.17 or, for that matter, email spamming) launched by its own customers.
22. RFC 2402 and RFC 2406 are handy for this exercise.
- (a) IPsec ESP transport mode is incompatible with NAT. In the case of TCP/UDP packets, NAT would need to update the checksum in TCP/UDP headers, when an address in IP header is changed. However, as the TCP/UDP header is encrypted by the ESP, NAT would not be able to make this checksum update. As a result, TCP/UDP packets encrypted in transport mode ESP, traversing a NAT device will fail the TCP/UDP checksum validation on the receiving end and will simply not reach the target application.
 - (b) IPsec ESP tunnel mode may work with NAT. Since IPsec ESP tunnel mode attach a new IP header and encapsulate the original IP packet in it. Since the way ESP encryption works is that it only encrypts and authenticate the IP payload, when the tunnel IP header gets stripped off, TCP/UDP checksum is preserved and still correct for the original IP packet. Therefore the original IP packet can reach the target application.
 - (c) It is obvious that (a) will not work with PAT due to the same reasons above. Now, as for the case (b), clearly IPsec ESP tunnel mode will not work with PAT. PAT needs to look at the port numbers to do the translation, but those are encrypted by ESP. The case (b) only works in true NAT case. There is an effort called “NAT traversal” to work around this problem using UDP encapsulation. With NAT traversal, the case (b) may work with PAT.

Solutions for Chapter 9

1. Both SMTP and HTTP are already largely organized as a series of requests sent by the client, and attendant server reply messages. Some attention would have to be paid in the request/reply protocol, though, to the fact that SMTP and HTTP data messages can be quite large (though not so large that we can't determine the size before beginning transmission).

We might also need a MessageID field with each message, to identify which request/reply pairs are part of the same transaction. This would be particularly an issue for SMTP.

It would be quite straightforward for the request/reply transport protocol to support persistent connections: once one message was exchanged with another host, the connection might persist until it was idle for some given interval of time.

Such a request/reply protocol might also include support for variable-sized messages, without using flag characters (CRLF) or application-specific size headers or chunking into blocks. HTTP in particular currently includes the latter as an application-layer issue.

3. Existing SMTP headers that help resist forgeries include mainly the **Received:** header, which gives a list of the hosts through which the message has actually passed, by IP address.

A mechanism to identify the specific user of the machine (as is provided by the `identd` service), would also be beneficial.

4. If an SMTP host cannot understand a command, it responds with
500 Syntax error, command unrecognized

This has (or is supposed to have) no other untoward consequences for the connection. A similar message is sent if a command parameter is not understood.

This allows communicating SMTPs to query each other as to whether certain commands are understood, in a manner similar to the WILL/WONT protocol of, say, telnet.

RFC 1869 documents a further mechanism: the client sends EHLO (Extended HELO), and an EHLO-aware server responds with a list of SMTP extensions it supports. One advantage of this is that it better supports command pipelining; it avoids multiple exchanges for polling the other side about what it supports.

5. Further information on command pipelining can be found in RFC 2197.
 - (a) We could send the HELO, FROM, and TO all together, as these messages are all small and the cost of unnecessary transmission is low, but it would seem appropriate to examine the response for error indications before both-ering to send the DATA.
 - (b) The idea here is that a server reading with `gets()` in this manner would be unable to tell if two lines arrived together or separately. However, a TCP

buffer flush immediately after the first line was processed could wipe out the second; one way this might occur is if the connection were handed off at that point to a child process. Another possibility is that the server busyreads after reading the first line but before sending back its response; a server that willfully refused to accept pipelining might demand that this busyread return 0 bytes. This is arguably beyond the scope of `gets()`, however.

- (c) When the client sends its initial EHLO command (itself an extension of HELO), a pipeline-safe server is supposed to respond with 250 PIPELINING, included in its list of supported SMTP extensions.
6. Implementers are free to add new subtypes to MIME, but certain default interpretations may apply. For example, unrecognized subtypes of the `application` type are to be treated as being equivalent to `application/octet-stream`. New experimental types and subtypes can be introduced; names of such types are to begin with X- to mark them as such. New image and text subtypes may be formally registered with the IANA; senders of such subtypes may also be encouraged to send the data in one of the “standard” formats as well, using `multipart/alternative`.
 7. We quote from RFC 1521:

NOTE: From an implementor’s perspective, it might seem more sensible to reverse this ordering, and have the plainest alternative last. However, placing the plainest alternative first is the friendliest possible option when `multipart/alternative` entities are viewed using a non-MIME-conformant mail reader. While this approach does impose some burden on conformant mail readers, interoperability with older mail readers was deemed to be more important in this case.

It seems likely that anyone who has received MIME messages through text-based non-MIME-aware mail readers would agree.

8. The `base64` encoding actually defines 65 transmission characters; the 65th, “=”, is used as a pad character. The data file is processed in input blocks of three bytes at a time; each input block translates to an output block of four 6-bit pieces in the `base64` encoding process. If the final input block of the file contains one or two bytes, then zero-bits are first added to bring the data to a 6-bit boundary (if the final block is one byte, we add four zero bits; if the final block is two bytes, we add two zero bits). The two or three resulting 6-bit pieces are then encoded in the usual way, and two or one “=” characters are appended to bring the output block to the required four pieces. In other words, if the encoded file ends with a single =, then the original file size was $\equiv 2 \pmod{3}$; if the encoded file ends with two =s then the original file size was $\equiv 1 \pmod{3}$.
9. (a) Enabling arbitrary SMTP relaying allows “spammers” to send unsolicited email via someone else’s machine.
(b) One simple solution to this problem would be the addition of a password option as part of the opening SMTP negotiation.

- (c) One approach is to use a VPN, to make one's external client IP address appear to be internal. Relatively recently (relative to the length of time SMTP has been around) RFC4954 specified "SMTP Service Extension for Authentication", which is in wide deployment today.
10. When the server initiates the `close`, then it is the server that must enter the `TIME-WAIT` state. This requires the server to keep extra records; a server that averaged 100 connections per second would need to maintain about 6000 `TIMEWAIT` records at any one moment. HTTP 1.1 has a variable-sized message transfer mechanism; the size and endpoint of a message can be inferred from the headers. The server can thus transfer a file and wait for the client to detect the end and close the connection. Any request-reply protocol that could be adapted to support arbitrarily large messages would also suffice here.
 11. For supplying an alternative error page, consult www.apache.org or the documentation for almost any other web server; `apache` provides a setting for `ErrorDocument` in `httpd.conf`.
RFC 2068 (on HTTP) states:
10.4.5 404 Not Found

The server has not found anything matching the Request-URI [Uniform Resource Identifier, a more general form of URL].

However, nothing in RFC 2068 requires that the part of a URL following the host name be interpreted as a *file* name. In other words, HTTP servers are allowed to interpret "matching", as used above, in whatever manner they wish; in particular, a string representing the name of a nonexistent file may be said to "match" a designated `ErrorDocument`. Another example of a URL that does not represent a filename is a dynamic query.
 12. One server may support multiple web sites with multiple hostnames, a technique known as *virtual hosting*. HTTP GET requests are referred by the server to the appropriate directory based on the hostname contained in the request.
 13. A TCP endpoint can *abort* the connection, which entails the sending of a RST packet rather than a FIN. The endpoint then moves directly to `TIMEWAIT`.
To abort a connection using the Berkeley socket library, one first sets the `SO_LINGER` socket option, with a linger time of 0. At this point an application `close()` triggers an abort as above, rather than the sending of a FIN.
 14. (a) A mechanism within HTTP would of course require that the client browser be aware of the mechanism. The client could ask the primary server if there were alternate servers, and then choose one of them. Or the primary server might *tell* the client what alternate to use. The parties involved might measure "closeness" in terms of RTT, in terms of measured throughput, or (less conveniently) in terms of preconfigured geographical information.

- (b) Within DNS, one might add a WEB record that returned multiple server addresses. The client resolver library call (*e.g.* `gethostbyname()`) would choose the “closest”, determined as above, and return the single closest entry to the client application as if it were an A record. Also, some CDNs today use DNS resolution to try to direct a client to a nearby CDN node. This is usually done without the client’s knowledge.

See the answer to question 37 for more on this topic.

15. The number of B2B and EAI network applications is potentially huge. A Web Services protocol framework simplifies the task of specifying, developing, and maintaining their protocols, and managing their operation. (Imagine creating and running, say, one million custom FTP- and SMTP-like protocols!)
16. Amazon’s S3 (Simple Storage Service) Web Service is a fee-based, high-availability, high-speed Internet storage service. Its storage model has “buckets” that are like directories; they contain “objects.”

The SOAP operations are:

- ListAllMyBuckets
- CreateBucket
- DeleteBucket
- ListBucket
- GetBucketAccessControlPolicy
- SetBucketAccessControlPolicy
- PutObjectInline
- PutObject
- GetObject
- GetObjectExtended
- DeleteObject
- GetObjectAccessControlPolicy
- SetObjectAccessControlPolicy

The REST operations are HTTP operations. Their interpretation depends on what strings are appended to the base URI of the web service. For example, the URI `http://s3.amazonaws.com/foo` refers to the bucket “foo,” while the URI `http://s3.amazonaws.com/foo/bar` refers to the object “bar” in the bucket “foo.” The base URI `http://s3.amazonaws.com` may be considered to refer to the user’s overall S3 account (both SOAP and REST S3 APIs authenticate the sender of a request).

Using this convention, the REST operations (and their equivalents in parentheses) are:

- GET Service (ListAllMyBuckets)

- PUT Bucket (CreateBucket)
- GET Bucket (ListBucket)
- DELETE Bucket (DeleteBucket)
- PUT Object (PutObject, PutObjectInline). The SOAP interface gives you a choice between transmitting the Object in the body of the SOAP message, or as a DIME attachment.
- GET Object (GetObject, GetObjectExtended). GetObjectExtended supports some conditionals similar to those provided by HTTP GET headers, e.g. return the object only if it has been modified since a specified time.
- HEAD Object. Retrieves metadata about the object.
- DELETE Object (DeleteObject)

The REST interface does not have distinct operations for access control policies. “There are two ways to set the access control policy with REST. You can set the access control list (ACL) for an existing bucket or object by requesting a PUT to /bucket?acl or /bucket/key?acl. Or, at the time you are writing a bucket or object you can include an x-amz-acl header with your PUT request that stores a canned ACL with the written resource.”

Note that the resource/service in this example, with its buckets and objects, maps nicely onto URIs. Other resources/services might have to embed comparable information in the data instead of the URI, which would probably be more in line with the REST philosophy.

17. Consider the GetObject operation of Amazon’s S3 (Simple Storage Service) Web Service.

GetObject’s input message is a GetObjectRequest, and its output message is a GetObjectResponse:

```
<wsdl:operation name="GetObject">
  <wsdlsoap:operation soapAction="" />
  <wsdl:input name="GetObjectRequest">
    <wsdlsoap:body use="literal" />
  </wsdl:input>
  <wsdl:output name="GetObjectResponse">
    <wsdlsoap:body use="literal" />
  </wsdl:output>
</wsdl:operation>
```

A GetObjectRequest message consists of a GetObject element

```
<wsdl:message name="GetObjectRequest">
  <wsdl:part element="tns:GetObject" name="parameters" />
</wsdl:message>
```

which has the following fields:

```
<xsd:element name="GetObject">
  <xsd:complexType>
    <xsd:sequence>
      <xsd:element name="Bucket" type="xsd:string"/>
      <xsd:element name="Key" type="xsd:string"/>
      <xsd:element name="GetMetadata" type="xsd:boolean"/>
      <xsd:element name="GetData" type="xsd:boolean"/>
      <xsd:element name="InlineData" type="xsd:boolean"/>
      <xsd:element name="AWSAccessKeyId" type="xsd:string" minOccurs="0"/>
      <xsd:element name="Timestamp" type="xsd:dateTime" minOccurs="0"/>
      <xsd:element name="Signature" type="xsd:string" minOccurs="0"/>
      <xsd:element name="Credential" type="xsd:string" minOccurs="0"/>
    </xsd:sequence>
  </xsd:complexType>
</xsd:element>
```

A GetObjectResponse message consists of a GetObjectResponse element

```
<wsdl:message name="GetObjectResponse">
  <wsdl:part element="tns:GetObjectResponse" name="parameters"/>
</wsdl:message>
```

of type GetObjectResult

```
<xsd:element name="GetObjectResponse">
  <xsd:complexType>
    <xsd:sequence>
      <xsd:element name="GetObjectResponse" type="tns:GetObjectResult"/>
    </xsd:sequence>
  </xsd:complexType>
</xsd:element>
```

which has the following fields:

```
<xsd:complexType name="GetObjectResult">
  <xsd:complexContent>
    <xsd:extension base="tns:Result">
      <xsd:sequence>
        <xsd:element name="Metadata"
          type="tns:MetadataEntry" minOccurs="0" maxOccurs="unbounded"/>
      </xsd:sequence>
    </xsd:extension>
  </xsd:complexContent>
</xsd:complexType>
```

```

        <xsd:element name="Data"
            type="xsd:base64Binary" nillable="true"/>
        <xsd:element name="LastModified" type="xsd:dateTime"/>
        <xsd:element name="ETag" type="xsd:string"/>
    </xsd:sequence>
</xsd:extension>
</xsd:complexContent>
</xsd:complexType>

```

18. One option would be to allow some receivers to join only the audio portion of the conference while others join both audio and video; these could be advertised as separate sessions. Or there could be high bandwidth and low bandwidth sessions, with the speaker sending to all sessions but receivers joining the session that suits their bandwidth. SAP would be used to notify the receivers of what types of session are available.

A second approach would be to send all the media to a central “mixer” which could then transmit a single audio stream representing the audio mix of all current speakers and a single video stream, perhaps showing the face of the current speaker or speakers.

19. For audio data we might send sample[n] for odd n in the first packet, and for even n in the second. For video, the first packet might contain sample[i,j] for i+j odd and the second for i+j even; dithering would be used to reconstruct the missing sample[i,j] if only one packet arrived.

JPEG-type encoding (for either audio or video) could still be used on each of the odd/even sets of data; however, each set of data would separately contain the least-compressible low-frequency information. Because of this redundancy, we would expect that the total compressed size of the two odd/even sets would be significantly larger than what would be obtained by conventional JPEG compression of the data.

20. URI includes URL and URN. URN (Uniform Resource Name) is a persistent and location-independent name in a namespace, while URL specifies how to “locate” the resource. So, a URL can be moved or disappear, but a URN cannot. An example of URN is urn:ISBN:0-201-62433-8, which refers to a book using the ISBN namespace.

21. MX records supply a list of hosts able to receive email; each listed host has an associated numeric “mail preference” value. This is documented further in RFC 974. Delivery to the host with the lowest-numbered mail preference value is to be attempted first.

For HTTP, the same idea of supporting multiple equivalent servers with a single DNS name might be quite useful for load-sharing among a cluster of servers; however, one would have to ensure that the servers were in fact truly stateless. Another possibility would be for a WEB query to return a list of HTTP servers each with some associated “cost” information (perhaps related to geographical distance); a client would prefer the server with the lowest cost.

22. ARP traffic is always local, so ARP retransmissions are confined to a small area. Subnet broadcasts every few minutes are not a major issue either in terms of bandwidth or CPU, so a small cache lifetime does not create an undue burden.

Much of DNS traffic is nonlocal; limiting such traffic becomes more important for congestion reasons alone. There is also a sizable total CPU-time burden on the root nameservers. And an active web session can easily generate many more DNS queries than ARP queries. Finally, DNS provides a method of including the cache lifetime in the DNS zone files. This allows a short cache lifetime to be used when necessary, and a longer lifetime to be used more commonly.

If the DNS cache-entry lifetime is too long, however, then when a host's IP address changes the host is effectively unavailable for a prolonged interval.

23. DNS servers will now take on ARP's role, by in effect supplying both subnet number and physical address of hosts in its domain. DNS servers must therefore now monitor hosts for possibly changed physical addresses.

A fairly common method in IPv4 of finding ones DNS server is via static configuration, *e.g.* the Unix `/etc/resolv.conf` files. If this mechanism were still used in IPv6, changing the Ethernet address of a local DNS server would now involve considerable updating, both of the local clients and also the DNS parent. IPv6 clients, however, are likely to find their DNS server dynamically, *e.g.* via DHCP, instead.

24. The lookup method here requires trusting of the remote site's DNS PTR data, which may not be trustworthy. Suppose, for example, that it is known that `cicada.cs.princeton.edu` trusts `gnat.cs.princeton.edu`. A request for authentication might arrive at `cicada` from, say, IP address `147.126.1.15`, which is *not* part of the `princeton.edu` domain. If `cicada` followed the strategy of the exercise here, it would look up the string `15.1.126.147.in-addr.arpa` in the DNS PTR data. This query would eventually reach the DNS server for PTR zone `1.126.147.in-addr.arpa`, which if suborned or malicious might well return the string `gnat.cs.princeton.edu` regardless of the fact that it had no connection with `princeton.edu`. Hostname strings returned by DNS servers for PTR searches are arbitrary, and need not be related to the server's assigned domain name.

A forward DNS lookup to confirm the result of the reverse DNS lookup would, however, be reasonably safe.

25. There is little if any relationship, formally, between a domain and an IP network, although it is nonetheless fairly common for an organization (or department) to have its DNS server resolve names for all the hosts in its network (or subnet), and no others. The DNS server for `cs.princeton.edu` could, however, be on a different network entirely (or even on a different continent) from the hosts whose names it resolves. Alternatively, each `x.cs.princeton.edu` host could be on a different network, and each host that *is* on the same network as the `cs.princeton.edu` nameserver could be in a different DNS domain.

If the reverse-mapping PTR records are used, however, then the same nameserver can handle both forward and reverse lookups only when DNS zones do correspond to groups of subnets.

26. If a host uses a nonlocal nameserver, then the host's queries don't go into the local nameserver's cache (although this is only relevant if there is some reason to believe some other local host might make use of the cached entries). Queries have farther to travel, too. Otherwise there is no penalty for having the "wrong" DNS server.

The DNS traffic volume will be the same for the nonlocal nameserver as for a local nameserver, if the nonlocal nameserver is "on the way" to the nameserver that ultimately holds the address requested. Use of a nonlocal nameserver could result in *less* DNS traffic if the nonlocal nameserver has the entries in its cache, and isn't too far away, but local nameserver does not. This might be the case if, for example, a large group of people with similar interests all used the same nonlocal nameserver.

27. Figure 9.17 is "really" a picture of the domain hierarchy again. Nameservers have been abstracted, effectively, into one per zone (duplicates are consolidated, and a nameserver serving multiple zones would appear in multiple entries).

Without this abstraction, a graph of all nameservers would simply be all DNS servers joined by edges corresponding to NS records, from zone parent to child. It would not necessarily be acyclic, even as a directed graph.

28. Here is an example based on `princeton.edu`. `whois princeton.edu` returns:

Domain Name: PRINCETON.EDU

Registrant:

Princeton University
Office of Information Technology
701 Carnegie Center, Suite 302
Princeton, NJ 08540
UNITED STATES

...

29. One would first look up the IP address of the web server, using, say, `host` or `dig`. One would then use `whois` to look up who is assigned that IP address, and compare the resulting identification to that obtained by using `whois` to look up the web server domain name.
30. (a) One could organize DNS names geographically (this hierarchy exists already; `chi.il.us` is the zone for many sites in the Chicago area), or else organize by topic or service or product type. The problems with these alternatives are that they tend to be harder to remember, and there *is* no natural

classification for corporations. Geography doesn't work as large corporations are not localized geographically. Classifying by service or product has also never been successful; this changes too quickly as corporations merge or enter new areas or leave old ones.

- (b) With multiple levels there are lots more individual nameserver queries, and the levels are typically harder to remember.
31. If we just move the .COM entries to the root nameserver, things wouldn't be much different than they are now, in practice. In theory, the root nameservers now could refer all queries about the .COM zone to a set of .COM-specific servers; in practice the root nameservers (*x.root-servers.net* for *x* from **a** to **m**) all do answer .COM queries directly. (They do not, however, answer .int queries directly.) The proposal here simply makes this current practice mandatory, and shouldn't thus affect current traffic at all, although it might leave other zones such as .org and .net and .edu with poorer service someday in the future.

The main problem with moving the host-level entries, such as for **www.cisco**, to a single root nameserver entry such as **cisco**, is that this either limits organizations to a single externally visible host, or else (if the change is interpreted slightly differently) significantly increases root nameserver traffic as it returns some kind of block of multiple host addresses. In effect this takes DNS back to a single central server. Perhaps just as importantly, the updating of the IP addresses corresponding to host names is now out of the hands of the organizations owning the host names, leading to a considerable administrative bottleneck.

However, if we're just browsing the web and need only one address for each organization, the traffic would be roughly equivalent to the way DNS works now. (We are assuming that local resolvers still exist and still maintain request caches; the loss of local caches would put an intolerable burden on the root nameservers.)

32. DNS records contain a TTL value, specified by the DNS server, representing how long a DNS record may be kept in the client cache. RFC 1034 puts it this way:

If a change can be anticipated, the TTL can be reduced prior to the change to minimize inconsistency during the change, and then increased back to its former value following the change.

33. Here is a series of **dig** queries and edited responses. First we try to find top level servers for the **edu**. domain:

```
% dig +norecurse edu.

;; AUTHORITY SECTION:
edu.          143993 IN NS C3.NSTLD.COM.
edu.          143993 IN NS D3.NSTLD.COM.
```

```

edu.          143993 IN NS E3.NSTLD.COM.
edu.          143993 IN NS G3.NSTLD.COM.
...

```

Next, picking one of the top level servers:

```

% dig @c3.nstld.com princeton.edu.

;; AUTHORITY SECTION:
princeton.edu.      172800 IN NS NS1.UCSC.edu.
princeton.edu.      172800 IN NS NS2.FAST.NET.
princeton.edu.      172800 IN NS NS3.NIC.FR.
princeton.edu.      172800 IN NS DNS.princeton.edu.

;; ADDITIONAL SECTION:
DNS.princeton.edu.  172800 IN A 128.112.129.15
NS1.UCSC.edu.       172800 IN A 128.114.142.6

```

Now we can query the name server for Princeton:

```

% dig @128.112.129.15 cs.princeton.edu

;; AUTHORITY SECTION:
cs.princeton.edu.   172800 IN NS ns2.fast.net.
cs.princeton.edu.   172800 IN NS ns3.fast.net.
cs.princeton.edu.   172800 IN NS dns1.cs.princeton.edu.

;; ADDITIONAL SECTION:
ns1.fast.net.       62914 IN A 209.92.1.12
ns1.ucsc.edu.        43200 IN A 128.114.142.6
ns2.fast.net.        62914 IN A 206.245.170.12
dns1.cs.princeton.edu. 172800 IN A 128.112.136.10
dns2.cs.princeton.edu. 172800 IN A 128.112.136.12

```

And then on to one of the CS department's servers:

```

% dig @128.112.136.12 www.cs.princeton.edu

;; ANSWER SECTION:
www.cs.princeton.edu. 21600 IN CNAME coreweb.cs.princeton.edu.
coreweb.cs.princeton.edu.21600 IN A 128.112.136.35

```

34. (b) Use the name of each object returned as the `snmpgetnext` argument in the subsequent call.

35. For example, you can alternate SNMP queries with telnet connections to an otherwise idle machine, and watch `tcp.tcpPassiveOpens` and `tcp.tcpInSegs` tick up appropriately. One can also watch `tcp.tcpOutSegs`.

36. By polling the host's SNMP server, one could find out what `rsh` connections had been initiated. A host that receives many such connections might be a good candidate for attack, although finding out the hosts doing the connecting would still require some guesswork.

Someone able to use SNMP to *set* a host's routing tables or ARP tables, etc, would have many more opportunities.

37. A CDN using only HTTP 302 redirects could operate as follows: the user points his browser at the origin, say `http://www.example.com/page.html`, and the origin redirects using the HTTP 302 response to tell the browser to talk to another node that is part of the CDN, say `http://www.cdn.com/www.example.com/page.html`, and that node, using whatever algorithms the CDN implements to choose a suitable surrogate, issues another HTTP 302 redirect to the appropriate node with the content.

The main limitations of this approach are that, as described, there is still some load on the origin to issue the redirect, and there is added latency to process each redirect.

A CDN using only DNS can (with the permission of the content owner) establish a DNS CNAME for `www.example.com`, so that DNS queries to `www.example.com` would be translated to queries to some other domain under the control of the CDN operator, say `a123.cdn.com`. The CDN operator can then resolve queries to the DNS for `a123.cdn.com` to a suitable surrogate for the content at `www.example.com`.

The main limitation of this approach is that it limits the granularity of information that is available to the CDN for making its choice of surrogates; as described, all the content from `www.example.com` would have to be served by the same surrogates. You could use multiple domains (e.g. `images.example.com`, `videos.example.com`) to address this issue.

Another limitation of using DNS is that the CDN doesn't know as much about the client (e.g. its IP address) because the DNS resolver operated by the CDN operator gets DNS queries from other resolvers, not the clients. This can limit the CDN's ability to pick a surrogate that is close to the client, for example.

A combination is possible. For example, you could use DNS to get `www.example.com` to redirect to `a123.cdn.com`, and then use HTTP 302 redirects to pick a suitable surrogate based on the content requested. Note that this overcomes most of the prior limitations.

38. One problem would be the caching of DNS responses; hosts would tend to keep going to the overloaded server which their local DNS cache considers to be the

right choice, unless every DNS server in the hierarchy implements the redirection scheme.

To circumvent that problem, TTL should be set to a small number, and this causes more queries to the DNS servers higher up the hierarchy, creating potentially high loads on those servers.

39. The following describes one possible approach; many others are possible.

We build on the answer to question 37. Assume that a content origin such as `www.example.com` is directed by means of a DNS CNAME to a node operated by CDN A, which in turn uses HTTP 302 redirects to direct a browser to a surrogate. We can imagine that both CDNs have some designated machines that are responsible for communicating with other CDNs. One such machine in CDN A tells an equivalent machine in CDN B (using some protocol on which they agree) about

- the set of content that CDN A knows how to obtain (such as the content from `www.example.com`), and
- the set of IP address prefixes that CDN A considers to correspond to its end users.

CDN B also provides the corresponding information about its content and end-user prefixes to CDN A. Having exchanged this information, the two CDNs make use of it in their routing of requests to surrogates.

Consider a request from a client that is among the prefixes served by CDN B for a piece of content from `www.example.com`. Thanks to the DNS CNAME, that request will be handled by a node operated by CDN A. But since CDN B provided its list of end user prefixes to CDN A, CDN A can use an HTTP 302 redirect to send the request over to CDN B. CDN B can use its normal methods to redirect the request to a suitable surrogate in CDN B. In addition, CDN B needs to be able to actually obtain the content from `www.example.com` at some point in order to cache it in a surrogate. This might be done by retrieving the content from a node in CDN A, or by going back to `www.example.com`. The former might be preferred since it allows `example.com` to have a relationship with only a single CDN.

40. If a cache node has high cache miss rates, then adding more storage to that node should help to improve that aspect of performance. In particular, one would look for cache misses that arise because a lack of capacity has forced the eviction of content that was later requested.

High CPU load or contention for disk access at the root or intermediate layers of the hierarchy would be a sign that the cost of servicing requests from the lower layers is getting too high, which might imply that adding another level of hierarchy would help.

41. Suppose many people want to watch a popular TV show at the same time. A multicast overlay could be used to stream the video packets from a single origin

to all the viewers. The nodes in the overlay form a tree and the viewers are the leaves.

Now suppose those viewers all want to watch the show, but at different times. They could each subscribe to the multicast feed of video packets, and write the packets to a local disk for later viewing, rather like a digital video recorder such as TiVo. Alternatively, a copy of the show could be placed in a CDN. Assume the CDN is arranged as a hierarchy, as in question 40. Rather than storing the TV show at home to watch later, each viewer can request the show from the CDN when he wants to watch it. A leaf node in the CDN that doesn't already have the show will fetch it from a node higher up in the hierarchy; these requests flow up to the root of the hierarchy. So in both cases, a tree of overlay nodes distributes a single copy from the root to the leaves, the only difference being whether the content is pulled by the leaves or pushed from the root and stored at the leaves.

42. (a) All peers could have the file after n time units. During each time unit, each peer with the piece can transmit it to one peer without the piece, so the number of peers with the piece doubles with each time unit: 1 ($= 2^0$) at time 0, 2 ($= 2^1$) at time 1, 4 ($= 2^2$) at time 2, up to 2^n peers at time n .
- (b) All peers could have the file after less than $2n$ time units. If all pieces were downloaded to just the right peers in just the right order, it is possible for all peers to obtain the file after as few as $n + 2$ time units.

Let's label the two pieces A and B. Let's label as PA the peer that initially has the file. During the first time unit, PA transmits B to another peer, call that other peer PB. Split the peers into two equal groups of $2^{(n-1)}$, one containing PA and the other containing PB. Now, from the result of the first question, we know that all the peers grouped with PA can obtain A within an additional $n - 1$ time units. Because the two sets of peers are disjoint, with no interference or contention between them, all the peers grouped with PB can obtain B during the same $n - 1$ time units.

Together with the initial step, we have used n time units so far. Another time unit will suffice for the peers grouped with PA to transmit A to all the peers grouped with PB. One more time unit will suffice for the peers grouped with PB to transmit B to all the peers grouped with PA (except PA itself, which has had B from the beginning). The 2 time units required for each half to transmit its piece to the other half increases the total to $n + 2$ time units.

It can also be shown that $n + 2$ is the minimum (assuming n is at least 3). We know that it must take exactly $(2^n) - 1$ individual upload/download transactions to propagate A from PA (directly or indirectly) to all of PA's $(2^n) - 1$ peers. Another $(2^n) - 1$ transactions is required for B, making a total of $2^{(n+1)} - 2$ transactions.

On the other hand, not enough peers have pieces to all participate in transactions during the first $n - 1$ time units. During that period, an upper bound on the number of transactions that can occur during the interval $t - 1$ to t

to $2^{(t-1)}$. Some arithmetic gives an upper bound of $2^{(n-1)} - 1$ transactions total during the first $n - 1$ time units.

For an upper bound on the transactions during each subsequent time unit, let's assume every peer is able to participate in a transaction. Then the number of transactions would be $2^{(n-1)}$ per time unit. So the two time units from $n - 1$ to $n + 1$ add 2^n transactions to the previous upper bound. Hence an upper bound on the number of transactions that could occur during the first $n + 1$ time units is $2^n + 2^{(n-1)} - 1$. Some arithmetic shows that, for n at least 3, this is less than the $2^{(n+1)} - 2$ transactions required. Thus $n + 2$ is the minimum time required.