

Predator Wi-Fi

Wi-Fi / 3G Video Intercom

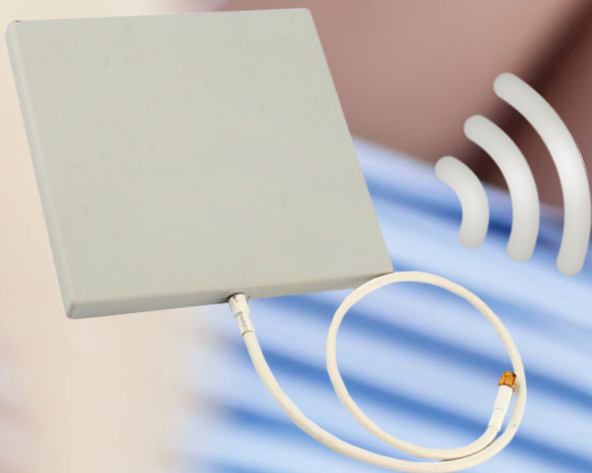
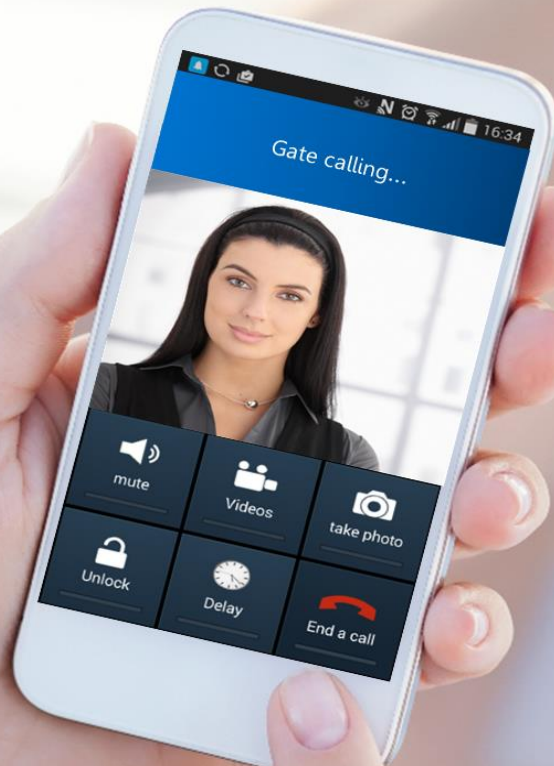

- Speak to and see your visitor from your smart-phone.
- Easy wireless connection to existing home Wi-Fi.
- Up to 60 metre range with included directional antenna (dependant on location of router in house).
- Range can be extended to several hundred metres with additional devices such as wifi repeaters.
- Can call up to 4 devices at the same time.
- Get a video call from your gate / door even when away from home!
- No data use when phone on Wi-Fi connection.
- 2 year manufacturers warranty.

Predator Wi-Fi

Wi-Fi / 3G Video Intercom



Long range antenna
(up to 60m working range
depending on router type and
location)!



Search Predator-Wi-Fi

Predator WiFi

- Simple setup by mobile phone. Connect to the intercom directly through your phone's Wi-Fi, enter the pass code for the home hub Wi-Fi and the device is connected.
- View the gate/door and open any time with monitoring mode.
- Stores images of the last 32 missed callers on your phone.
- Still works locally on Wi-Fi network even if broadband goes down.
- Can work with most market standard outdoor Wi-Fi repeaters for extended range.
- **New features coming soon include...**

-Full duplex speech, 2 relay outputs, latching outputs for hold open, CAT5 terminal port for easy hard wire option, enhanced true colour camera.

Predator Wi-Fi

Wi-Fi / 3G Video Intercom



High gain Wi-Fi antenna
-60 degree transmission to concentrate and extend range.
-Weatherproof for outdoor use.

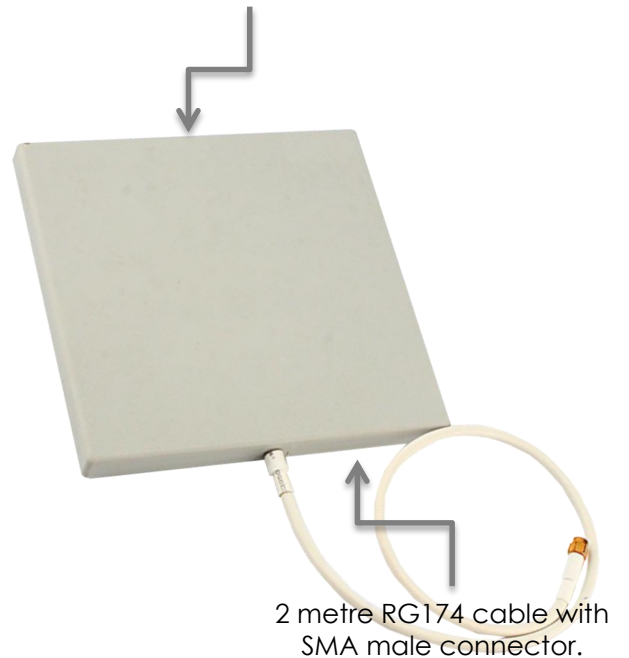

Technical Details

Power supply	24v dc (adaptor included)	App name	Predator Wi-Fi PRO
Current consumption	80mA standby, 300mA calling.	Audio	Half duplex loud speaker mode (Press mic icon to speak)
Relay outputs	1	Keypad option	Yes
Relay type	N/O & N/C contacts	Keypad relays	3
Relay time	Adjustable 1-10 secs	Keypad codes	1200
Relay load	2A 24v AC max	Wi-Fi standard	802.11b/g/n
IP rating	IP55	Security	6 digit passcode protected
Camera	Colour, 110 degree, 640x480 pixel	Uplink bandwidth	110K bits/sec
Night vision	Yes, by infrared illumination		

Predator Wi-Fi

Kits & Part numbers

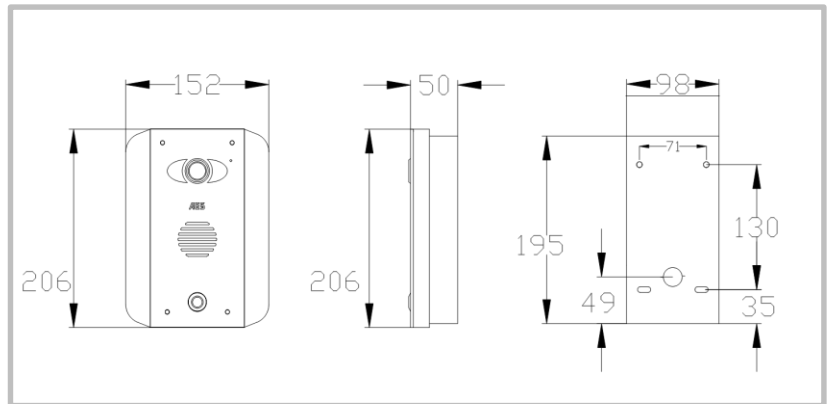

WiFi-AB (Standard Architectural Model)

- Stylish curved architectural model.
- Modern blue back lighting effect.
- Marine grade, brushed stainless steel construction with gloss acrylic trim.
- Kit includes speech panel, antenna, power supply and install manual.

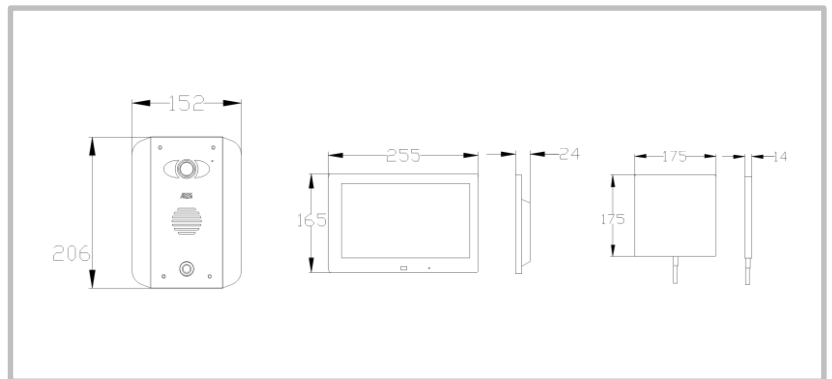

WiFi-AB-Monitor1

- Kit includes WIFI Panel, antenna and 1xPredator Touch Monitor.

For additional monitors please see **Page: 42** for part numbers.

Predator Wi-Fi

Kits & Part numbers

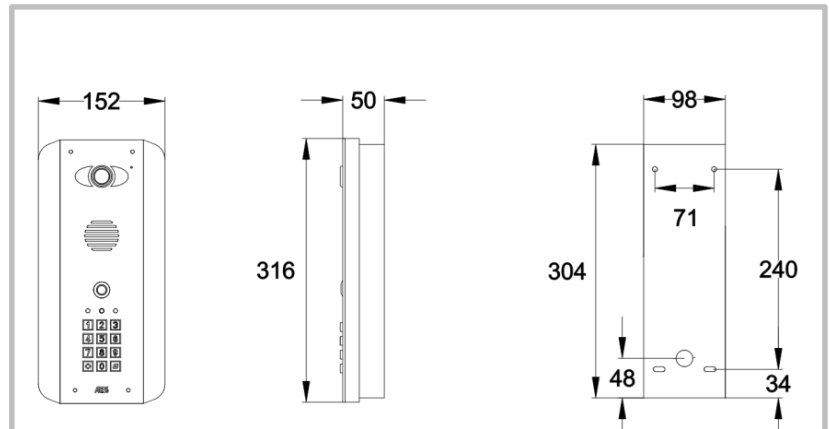

WiFi-ABK (Standard Architectural Model with Keypad)

- Stylish curved architectural model.
- Keypad includes 3 relays, 1200 codes, with latching and momentary operation and more.
- Modern blue back lighting effect.
- Marine grade, brushed stainless steel construction with gloss acrylic trim.
- Kit includes speech panel, antenna, power supply and install manual.

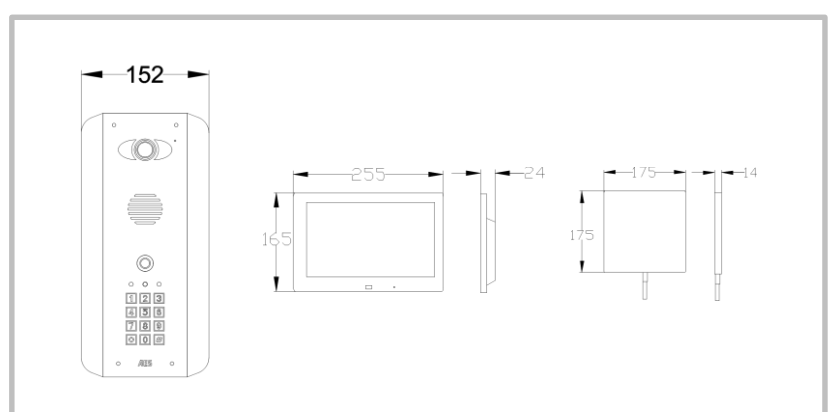

WiFi-ABK- Monitor1 -Kit includes WIFI Panel, antenna and 1xPredator Touch Monitor.

For additional monitors please see **Page: 42** for part numbers.

Predator Wi-Fi

Kits & Part numbers

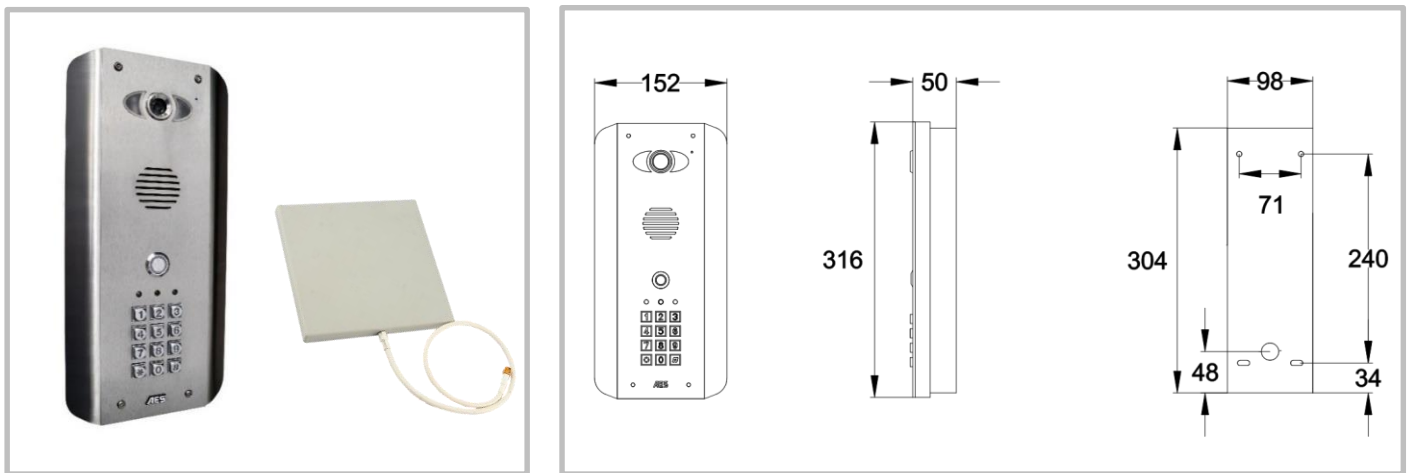

WiFi-ASK (Standard Architectural Model with Keypad)

- Stylish curved architectural model.
- Keypad includes 3 relays, 1200 codes, with latching and momentary operation and more.
- Modern cool white back lighting effect.
- 100% marine grade, brushed stainless steel construction.
- Kit includes speech panel, antenna, power supply and install manual.

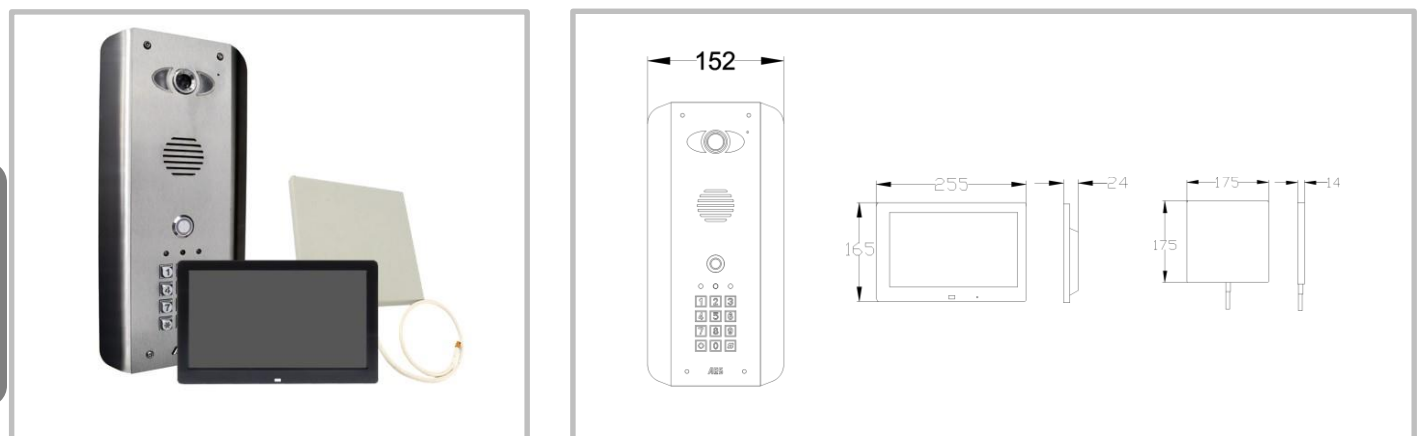

Predator WiFi

WiFi-ASK-Monitor1-Kit includes WiFi Panel, antenna and 1xPredator Touch Monitor.

For additional monitors please see **Page: 42** for part numbers.

Predator Wi-Fi

Kits & Part numbers

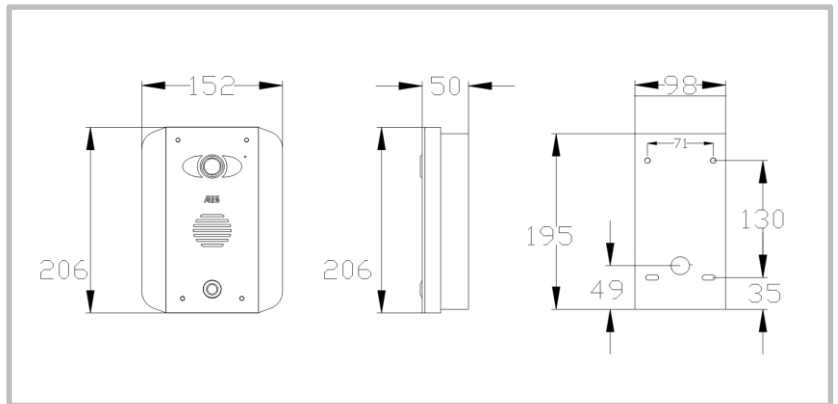

WiFi-AS (Standard Architectural Model)

- Stylish curved architectural model.
- Modern cool white back lighting effect.
- 100% Marine grade, brushed stainless steel construction.
- Kit includes speech panel, antenna, power supply and install manual.

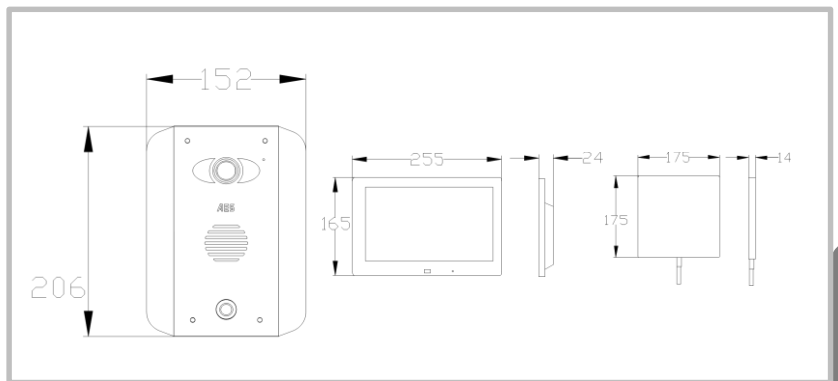

WiFi-AS-Monitor1-Kit includes WIFI Panel, antenna and 1xPredator Touch Monitor.

For additional monitors see **Page: 42** for part numbers.

Predator Wi-Fi

Kits & Part numbers

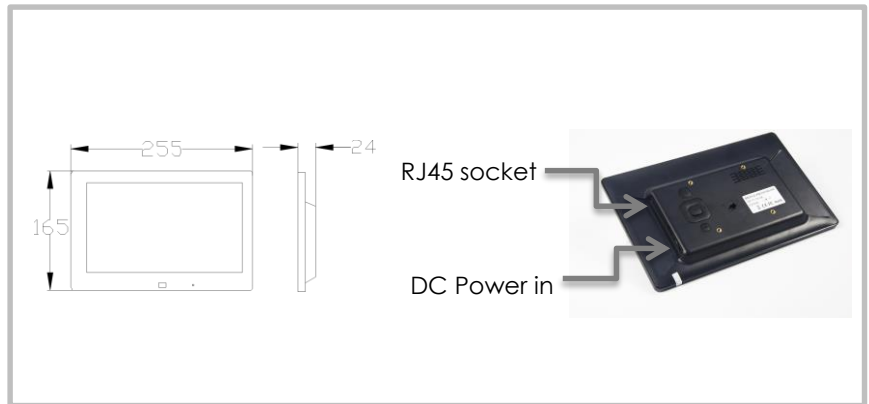

WiFi-touch

- Wall mount touch screen monitor, compatible with the Predator system.
- 10.1 Inch screen.
- 5v dc power supply included with screw terminals for wall mounted installs.
- Complete with both wall mount bracket and desk stand.
- RJ45 LAN socket and wifi connectable.
- Android OS with Predator PRO app pre-loaded.

Predator Wi-Fi

Range Extending Tips

Up to 60 metres
(Depending on home router type, router location and building materials)

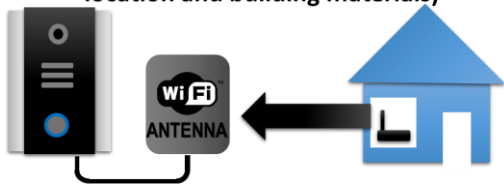

Up to 100 metres

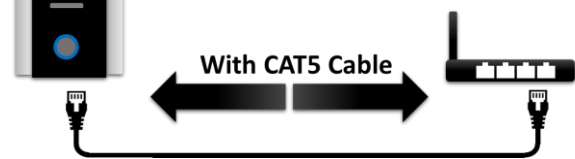

Up to 200 metres
With Homeplugs (depending on electrical circuits)

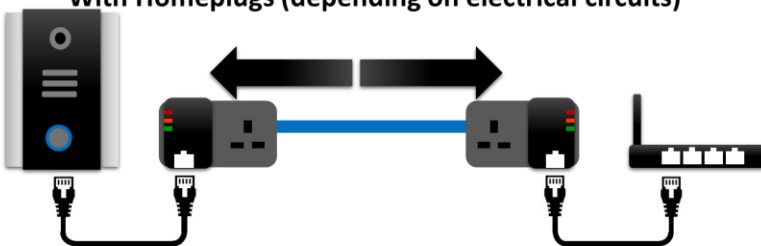

Up to 500 metres
With Point to Point WiFi Link

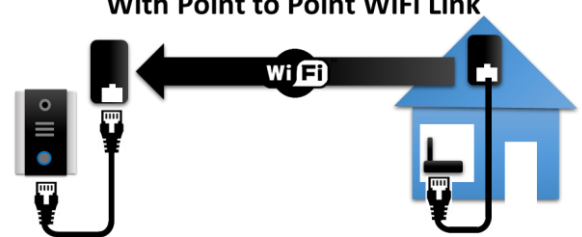

- Range can be extended up to 500 metres by using various open market devices, such as Homeplug Technology, WiFi repeaters and point to point links. Always conduct a site survey before quoting this system.