



Electronic Pressure Switch EDS 3400 with Flush Membrane

Description:

The electronic pressure switch EDS 3400 with a flush membrane was designed specifically for applications in which a standard pressure connection could become blocked, clogged or frozen by the particular medium used. Further applications include processes where the medium changes frequently and any residues could cause mixing or contamination of the media.

Like the standard model, the EDS 3400 with flush membrane has a stainless steel measurement cell with a thin film strain gauge for relative pressure measurement in the high pressure range.

The pressure connection is achieved with a fully-sealed stainless steel front membrane filled internally with a pressure transfer fluid. The process pressure is transmitted hydrostatically to the measurement cell via the pressure transfer fluid.

Depending on the type, the instrument can have up to 2 switching outputs and a switchable analogue output (4 .. 20 mA or 0 .. 10 V).

Special features:

- Pressure connection has a flush membrane
- 1 or 2 PNP transistor switching outputs, up to 1.2 A load per output
- Accuracy $\leq 1\%$ FS
- Optional analogue output selectable (4 .. 20 mA / 0 .. 10 V)
- 4-digit digital display
- Rotation in two planes (axes) for optimum alignment
- Measured value can be displayed in bar, psi or MPa
- Simple operation with key programming
- Switching points and switch-back hystereses can be adjusted independently
- Many useful additional functions
- Option of Desina[®]-compliant pin configuration with diagnostic function

Technical data:

Input data		
Measuring ranges	40; 100; 250; 400; 600 bar	
Overload pressures	80; 200; 500; 800; 900 bar	
Burst pressures ¹⁾	200; 500; 1000; 2000; 2000 bar	
Mechanical connection	G1/2 A DIN 3852 G1/2 with additional front O-ring seal G1/4 with additional front O-ring seal G1/4 A DIN 3852 G1/2 with add. front O-ring seal and cooling section	
Pressure transfer fluid	Silicone-free oil	
Torque value	45 Nm for G1/2, G1/2 A 20 Nm for G1/4	
Parts in contact with medium ²⁾	Mech. conn.:	Stainless steel
	Seal:	FPM
	O-ring:	FPM
Output data		
Accuracy to DIN 16086, Max. setting (display, analogue output)	$\leq \pm 0.5\%$ FS typ. $\leq \pm 1\%$ FS max.	
Repeatability	$\leq \pm 0.25\%$ FS max.	
Temperature drift	$\leq \pm 0.025\%$ FS / °C max. zero point $\leq \pm 0.025\%$ FS / °C max. range	
Analogue output (optional)		
Output signal (selectable)	4 .. 20 mA	load resistance max. 500 Ω
	0 .. 10 V	load resistance min. 1 k Ω
Switch outputs		
Type	PNP transistor output	
Switching current	max. 1.2 A per output	
Switching cycles	> 100 million	
Reaction time	< 10 ms	
Long-term drift	$\leq \pm 0.3\%$ FS typ. / year	
DESINA [®] diagnostic signal (Pin 2)		
Function	OK: HIGH level / not OK: LOW level	
Level	HIGH: approx. +U _B / LOW: < +0.3 V	
Environmental conditions		
Compensated temperature range	-10 .. +70 °C, -10 .. +60 °C for UL spec.	
Operating temperature range	-25 .. +80 °C, -25 .. +60 °C for UL spec.	
Storage temperature range	-40 .. +80 °C	
Fluid temperature range ³⁾	-40 .. +80 °C / -25 .. +80 °C -40 .. +150 °C / -25 .. +150 °C for G1/2 with cooling section	
CE mark	EN 61000-6-1 / 2 / 3 / 4	
UL mark ⁴⁾	Certificate No. E318391	
Vibration resistance to DIN EN 60068-2-6 at 10 .. 500 Hz	≤ 10 g	
Shock resistance to DIN EN 60068-2-29 (11 ms)	≤ 50 g	
Protection class to IEC 60529	IP 67	
Other data		
Supply voltage	9 .. 35 V DC without analogue output 18 .. 35 V DC with analogue output - limited energy - according to 9.3 UL 61010; Class 2; UL 1310/1585; LPS UL 60950	
for use acc. to UL spec.		
Current consumption	max. 2.455 A total max. 35 mA with inactive switching output max. 55 mA with inactive switching output and analogue output	
Display	4-digit, LED, 7 segment, red, height of digits 7 mm	
Weight	~ 120 g	

Note: Reverse polarity protection of the supply voltage, excess voltage, override and short circuit protection are provided.

FS (Full Scale) = relative to the full measuring range

¹⁾ G1/2 with additional front O-ring seal max. 1500 bar

²⁾ Other seal materials on request

³⁾ -25 °C with FPM seal, -40 °C on request

⁴⁾ Environmental conditions according to 1.4.2 UL 61010-1; C22.2 No. 61010-1

Setting options:

All settings offered by the EDS 3400 are grouped in 2 easy-to-navigate menus.

In order to prevent unauthorised adjustment of the device, a programming lock can be set.

Setting ranges for the switch outputs:

Switching point function

Meas. range in bar	Switch point in bar	Hysteresis in bar	Increment* in bar
0 .. 40	0.6 .. 40	0.2 .. 39.6	0.1
0 .. 100	1.6 .. 100	0.6 .. 99.0	0.2
0 .. 250	4.0 .. 250	1.5 .. 247.5	0.5
0 .. 400	6.0 .. 400	2.0 .. 396	1
0 .. 600	9.0 .. 600	3.0 .. 594	1

Window function

Meas. range in bar	Lower switch value in bar	Upper switch value in bar	Increment* in bar
0 .. 40	0.6 .. 39.2	0.9 .. 39.6	0.1
0 .. 100	1.6 .. 98.2	2.4 .. 99	0.2
0 .. 250	4.0 .. 245.5	6.0 .. 247.5	0.5
0 .. 400	6.0 .. 392	9.0 .. 396	1
0 .. 600	9.0 .. 589	14 .. 594	1

* All ranges given in the table are adjustable by the increments shown.

Additional functions:

- Switching mode of the switching outputs adjustable (switching point function or window function)
- Switching direction of the switching outputs adjustable (N/C or N/O function)
- Switch-on and switch-off delay adjustable from 0.00 .. 99.99 seconds
- Choice of display (current pressure, peak value, switch point 1, switch point 2, display off)
- Display filter for smoothing the display value during pressure pulsations
- Analogue output signal selectable 4 .. 20 mA or 0 .. 10 V
- Pressure can be displayed in the measurement units bar, psi, MPa. The scaling can also be adapted to indicate force, weight, etc.

EDS 3400 for self diagnostics:



The DESINA®-compliant pressure switch has been specially developed for customers in the machine tool and mechanical engineering sectors and complies with the DESINA® specification. A diagnostic signal enables errors to be detected and an "ERROR" message also appears in the display. The electrical connection is a round 5-pole M12x1 to IP 67 in accordance with DESINA® requirements.

Model code:

EDS 3 4 Z X - X - XXXX - XXX - 000

Mechanical process connection

Z = Flush membrane

Electrical connection

6 = Male M12x1, 4 pole
only possible on output models "1", "2" and "3"

8 = Male M12x1, 5 pole
only possible on output model "5"

Output

- 1 = 1 switching output
only in conjunction with electrical connection type "6"
- 2 = 2 switching outputs
only in conjunction with electrical connection type "6"
- 3 = 1 switching output and 1 analogue output
only in conjunction with electrical connection type "6"
- 5 = 2 switching outputs and 1 analogue output
only in conjunction with electrical connection type "8"

Pressure ranges in bar

0040; 0100; 0250; 0400; 0600

Mechanical connection

- G01 = G1/2 A DIN 3852
- G02 = G1/2 with additional front O-ring seal
- G04 = G1/4 with additional front O-ring seal
- G05 = G1/4 A DIN 3852
- G12 = G1/2 with add. front O-ring seal and cooling section

Modification number

000 = Standard

Model code:

DESINA®-compliant or
can be connected to DESINA®:



EDS 3 4 Z 8 - X - XXXX - XXX - D00

Mechanical process connection

Z = flush membrane

Electrical connection

8 = M12x1, 5 pole, male

Output

- 1 = 1 switching output
- 3 = 1 switching output and 1 analogue output

Pressure ranges in bar

0040; 0100; 0250; 0400; 0600

Mechanical connection

- G01 = G1/2 A DIN 3852
- G02 = G1/2 with additional front O-ring seal
- G04 = G1/4 with additional front O-ring seal
- G05 = G1/4 A DIN 3852
- G12 = G1/2 with additional front O-ring seal and cooling section

Modification number

D00 = DESINA®-compliant pin configuration for self-diagnostics

Note:

Special models on request.
For instruments with a different modification number, please read the label or the technical amendment details supplied with the instrument.

Accessories:

Appropriate accessories, such as electrical connectors, mechanical adapters, splash guards, clamps for wall-mounting etc can be found in the Accessories brochure.

Dimensions:

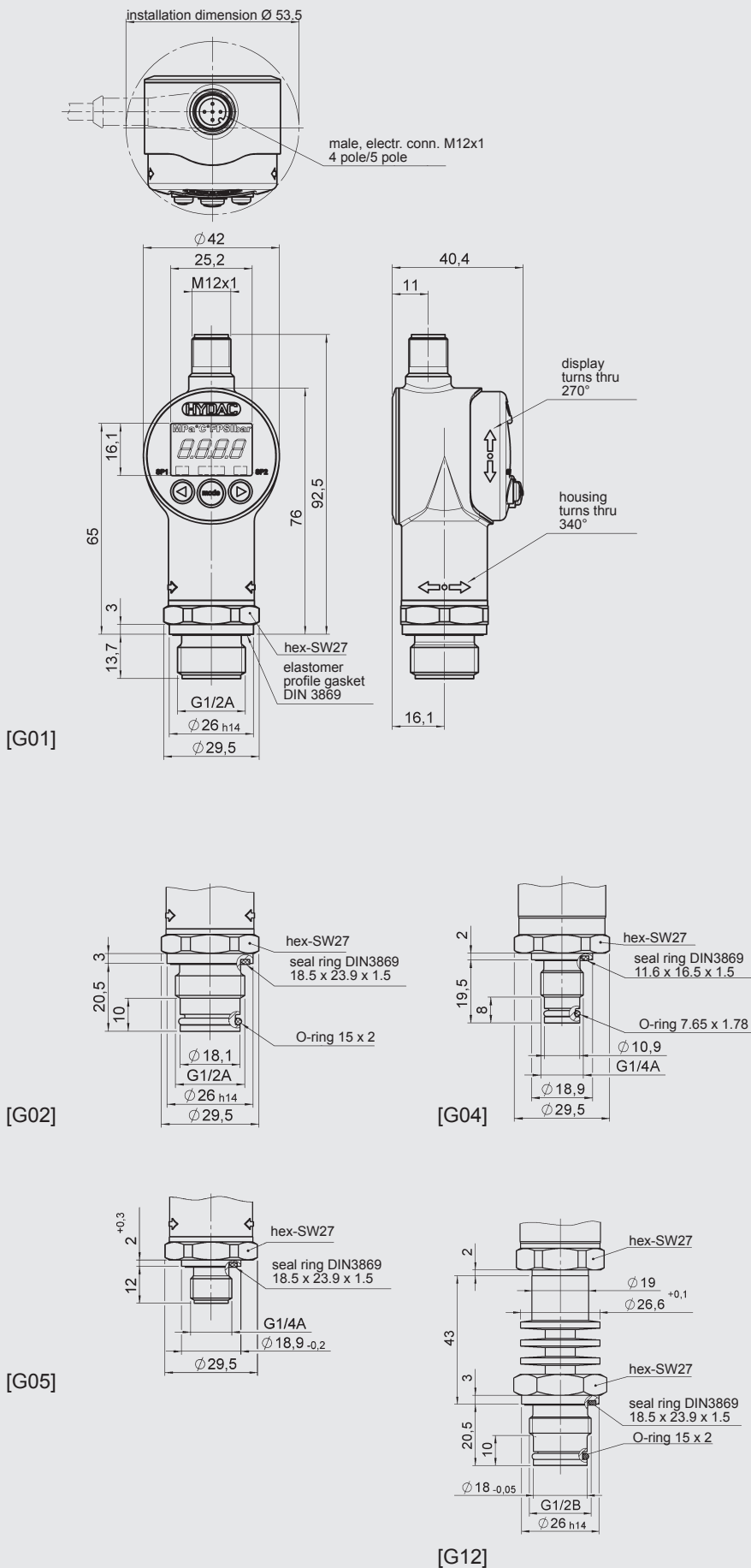

Pin connections:

M12x1, 4 pole

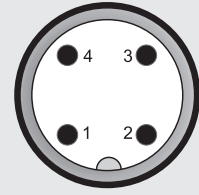

Pin	EDS 34Z6-1	EDS 34Z6-2	EDS 34Z6-3
1	+U _B	+U _B	+U _B
2	n.c.	SP 2	Analogue
3	0 V	0 V	0 V
4	SP 1	SP 1	SP 1

M12x1, 5 pole

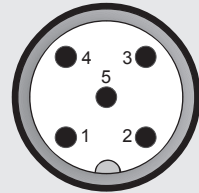

Pin	EDS 34Z8-5
1	+U _B
2	Analogue
3	0 V
4	SP 1
5	SP 2

M12x1, 5 pole

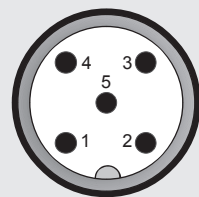

Pin	EDS 34Z8-1	EDS 34Z8-3
1	+U _B	+U _B
2	Diagnostics	Diagnostics
3	0 V	0 V
4	SP 1	SP 1
5	n.c.	Analogue

Note:

The information in this brochure relates to the operating conditions and applications described. For applications and operating conditions not described, please contact the relevant technical department. Subject to technical modifications.

HYDAC ELECTRONIC GMBH
Hauptstraße 27, D-66128 Saarbrücken
Telephone +49 (0)6897 509-01
Fax +49 (0)6897 509-1726
E-mail: electronic@hydac.com
Internet: www.hydac.com

