

Owner's Manual

Superdrive Pump Model PT150-540S

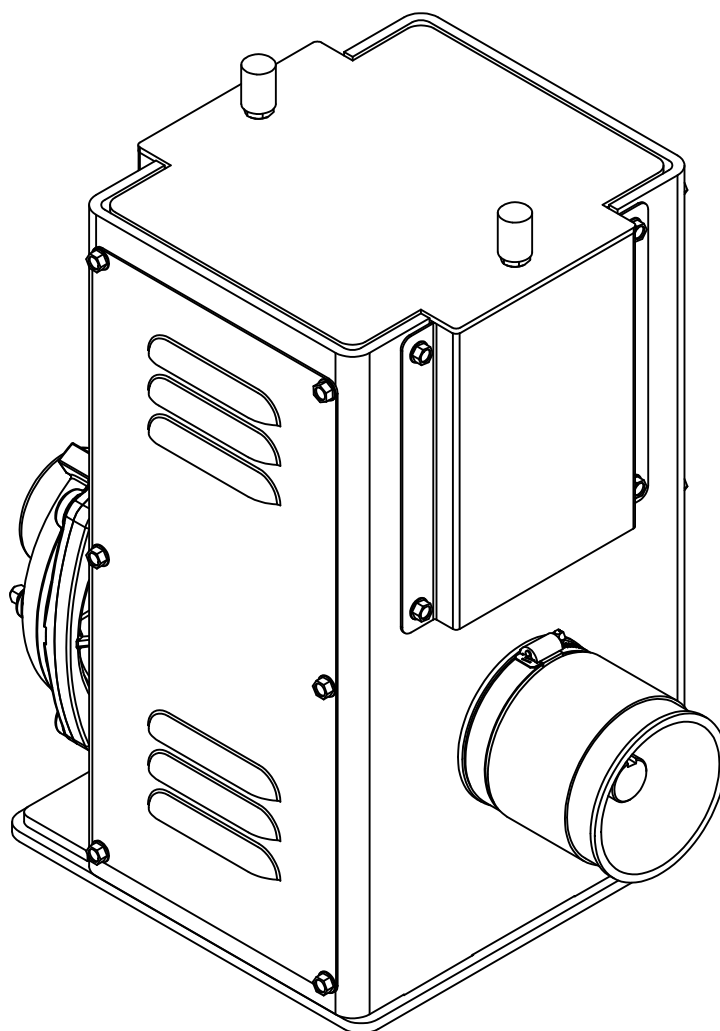

PBZ LLC | 50 Wood Corner Rd | Lititz PA 17543
www.CropCareEquipment.com | (717) 738-7365
A Paul B Zimmerman Inc. Company

CropCare® would like to thank you for choosing to purchase one of our Superdrive pumps. We appreciate your business and want to fill all of your sprayer and equipment needs. We also desire to provide you with the technical support and needed parts that will allow you to continue operating without disruption. For parts and service please contact your local CropCare® dealer.

Table Of Contents

| | | | |
|---------------------------------------|---|--|----|
| Specifications | 3 | Pump Maintenance | 6 |
| Before You Begin | 4 | Winterizing your Pump..... | 7 |
| Safety Precautions | 4 | Troubleshooting | 7 |
| General Guidelines..... | 4 | Pump Repair Instructions | 8 |
| Before Operation | 4 | Breakdowns & Parts Lists | 9 |
| Pump Safety Precautions..... | 4 | Hypro 9203C Pump Breakdown & Parts List..... | 9 |
| Operating Instructions | 5 | PT150-540S Breakdown..... | 10 |
| Mounting Procedure | 5 | PT150-540S Parts List..... | 11 |
| Before/During Operation | 5 | CropCare® Limited Warranty | 12 |
| Maintenance Instructions | 6 | Contact Us | 13 |
| Pump Drive Maintenance..... | 6 | Ordering Parts..... | 13 |

Specifications

Superdrive Pump
Model #: PT150-540S

- Dry weight.....99 lbs
- Max input speed.....600 RPM
- Max pressure.....125 PSI
- Input shaft.....1" diameter
- Seal.....Viton / Silicon Carbide

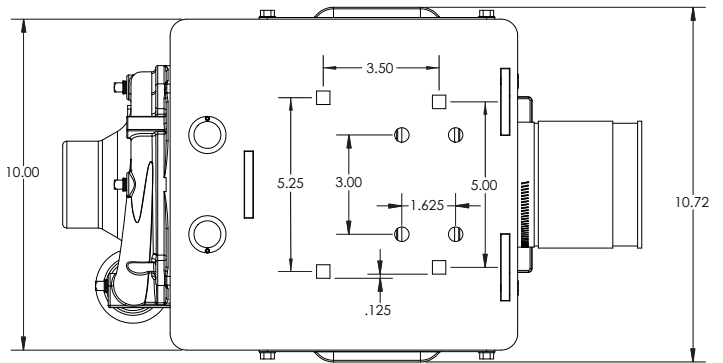
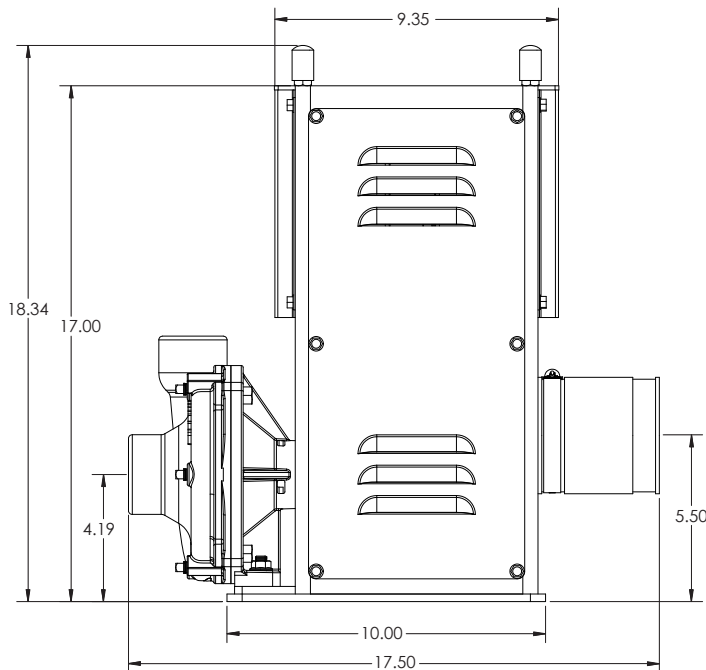

Before You Begin



Please read and understand this manual and its instructions and warnings completely before operating the picking assistant.

- Be aware of all safety guidelines, warnings, and cautions.
- Familiarize yourself and other operators with the picking assistant's components and how all parts are operated.

Safety Precautions



General Guidelines

Every year many unnecessary accidents occur due to improper equipment handling and a disregard for safety precautions. You, the operator, can avoid accidents by observing the precautions in this section.

- The operator should be a responsible adult. Do not allow persons to operate this pump until they have displayed a thorough understanding of the safety precautions and operational use!
- Never attempt to operate this pump while under the influence of alcohol or drugs.
- The best defense against accidents is a careful and responsible operator.
- If there is any portion of this manual that you do not fully understand, please contact an authorized CropCare® dealer.



Before Operation

- Carefully study and understand this owner's manual.
- Give the Superdrive pump a visual inspection for any worn parts, loose bolts, or other visible problems, and make any needed repairs. See the maintenance section (page 6).
- Be sure all exposed moving parts, such as the PTO shafts and adapters, are properly shielded or guarded and that all coupling devices are securely attached before applying power.



Pump Safety Precautions

- Never pump flammable or explosive fluids such as gasoline, fuel oil, kerosene, etc.
- Use only pipe, hose, and fittings rated for the maximum psi rating of the pump.
- Never pump faster than, or above, the maximum recommended speed and pressure.
- Never pump liquids at temperatures higher than the recommended maximum temperature (140° F / 60° C) Do not exceed this temperature.
- Before servicing your pump, disconnect the power, release all pressure, and drain all liquids.
- Do not run pump dry for any amount of time.

Operating Instructions

Mounting Procedure

1. Mount the Superdrive pump on the sprayer using 3/8" bolts and lock washers through either the four square holes, or the four round holes on the bottom of the pump drive housing (Figure 1).
2. Attach the PTO shaft (a) to the pump drive shaft (b) as shown (Figure 2).
3. Connect the inlet and outlet plumbing as shown (Figure 3).

Before/During Operation

1. If the sprayer was completely empty before use, there will be air trapped in the lines when the tank is filled. The pump will need to be primed to release this trapped air.
2. If your pump is not equipped with a bleeder valve, remove the topmost plug (a) (Figure 4) from the face of the pump with the tractor off.
3. With the plug removed, open the inlet suction valve until there is a steady flow of liquid out of the bleeder plug hole, indicating that there is no more air in the system.
4. Replace the bleeder plug before engaging pump.
5. If your pump is equipped with a bleeder valve (a), open the valve with the tractor off until there is a steady flow of liquid out of the hose, indicating that there is no more air in the system (Figure 5).
6. If liquid does not come out with the tractor off, start the tractor, open all valves, and engage the PTO. This will force the rest of the air out.
7. Important: Engage the PTO clutch slowly and smoothly. Avoid sudden starts and fast clutching that can damage the drive section of the pump.

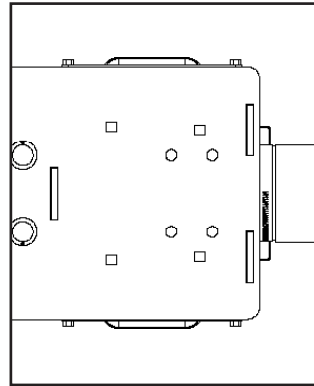

Figure 1: Mounting holes

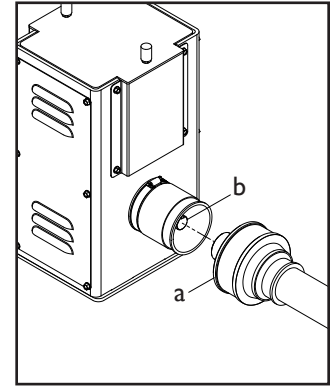

Figure 2: Attaching the PTO

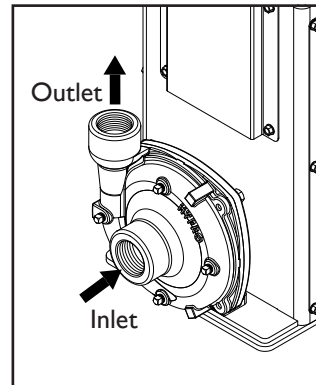

Figure 3: Pump plumbing

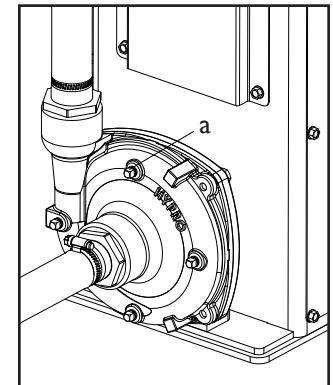

Figure 4: Pump priming with plug

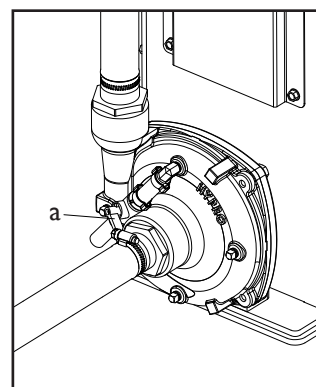

Figure 5: Pump priming with bleeder valve

Maintenance Instructions

Pump Drive Maintenance

1. Follow all pump safety precautions and warnings (page 4). Following these guidelines will help to ensure many years of smooth and trouble-free service.
2. Be sure that the belts (a) are properly tensioned before use. Remove the side cover (b) by loosening the six 1/4" x 3/4" screws (c) that attach it to the main frame, and check the belt tension (Figure 6).
3. The proper tension should be: .120" of deflection with 13.6 lbs of applied force (4 groove belt), and .120" of deflection with 10.2 lbs of applied force (3 groove belt).
4. To adjust the tension, remove the nylon bolt caps (d) that cover the adjustment bolts (e). Loosen the top nut (f) first, then adjust the tension by turning the bottom nut (g). Re-tighten the top nut when the belts are properly tensioned and replace the nylon bolt caps. Replace the side cover when finished (Figure 7).
5. Note: It is extremely important to keep the top shaft parallel with the pump input shaft. Misalignment will greatly reduce belt life.
6. There are 2 take-up bearings (a) on the Superdrive pump that must be greased. To grease the bearings, first remove the take-up bearing cover (b) by removing the four 1/4" x 3/4" screws (c) that attach it to the main frame. Grease the bearings using the grease fitting (d) on the bottom of the bearing. Replace the bearing cover when finished (Figure 8).
7. The recommended greasing interval for the take up bearings is every 50 hours of operation, or once a year.

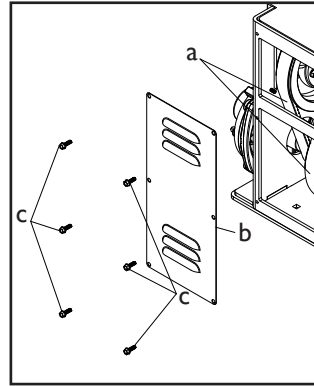

Figure 6: Checking belt tension

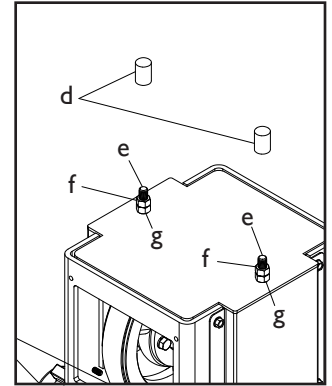

Figure 7: Tensioning the belts

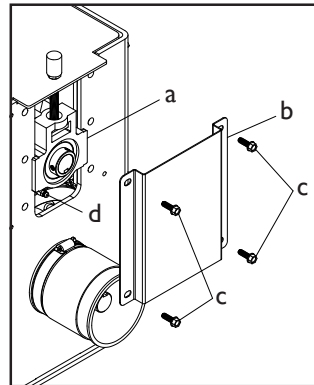

Figure 8: Greasing the Bearings

Pump Maintenance

1. Flush the pump out with fresh water after every use. It is also very important to winterize your pump to prevent freezing and corrosion. Please see the Winterizing your Pump section for winterizing instructions.
2. Refer to the Pump Repair section (page 8) for service recommendations, or contact your local CropCare® dealer.

Maintenance Instructions

Winterizing your Pump

It is essential that you winterize your Superdrive Pump to avoid damage and to allow for optimal performance. The winterization process should be undertaken before freezing conditions and/or after each season of use. **Failure to winterize your pump will void the manufacturer's warranty.**

1. Verify that the sprayer tank is empty and rinsed out. Pour some RV nontoxic antifreeze into the tank. It is not recommended to use engine antifreeze. Engine antifreeze can be harmful to humans, animals, crops, and the environment.
2. Engage the pump and make sure that the antifreeze has been pumped through the entire system.
3. Store the sprayer and pump in a safe, dry location away from the elements and human and animal activity.
4. Before use in the spring, it is recommended to flush the pump with fresh water to cleanse it of the antifreeze and any other buildup. Also do a thorough inspection of the pump before use.

Troubleshooting

If you are having problems with you Superdrive Pump, please attempt to use this troubleshooting section to solve the problem. If you are unable to fix the problem please contact an authorized CropCare® dealer for service.

| Problems/Symptoms | Possible Causes | Solutions |
|--|--|--|
| Low Pressure or Low discharge | Pump not primed | Remove topmost vent plug from face of pump and run pump to expel trapped air. Recommend vent line or bleeder valve be used |
| | Air leaks in suction line | Check and reseal the suction hoses and fittings |
| | Blocked or clogged line strainer or impeller | Inspect strainer and impeller to clear any debris or obstruction |
| | Undersized suction line or collapsed hose | Suction line must be the same or larger diameter as pump inlet port |
| | Broken Impeller | Inspect for cracks and replace if damaged or broken |
| | Pump not operating at 540 RPM | Run tractor at PTO speed (540 RPM) |
| | Belts not properly tensioned | Tension belts (see page 6) |
| Liquid leaking out weep port | Worn seal | Replace seal |
| Rubber smell / Hot belts | Belts not properly tensioned | Tension belts (see page 6) |

Pump Repair Instructions

Pump Housing Disassembly

In most cases, seal replacement requires disassembly of only the pump half of the unit.

1. Remove the four casing cap screws with 9/16" box end wrench. Tap pump casing on discharge port with rubber hammer, if necessary, to break loose from mounting flange. Check inside of pump casing including suction port. If badly eroded (or damaged), pump casing should be replaced. Remove o-ring and discard. O-ring should always be replaced.
2. To remove the impeller nut, clamp the flange in a vise and insert a large screwdriver or file (at least 10" long) into impeller vanes to prevent impeller from turning when loosening nut. Use a 5/8" socket wrench to remove the impeller nut by turning it counterclockwise.
3. Once the nut is removed, place a screwdriver on each side behind the impeller and pry away from the mounting flange. Remove o-ring from the mounting flange.

Pump Seal Removal

1. Lightly lubricate shaft for easier removal of seal. Using two screwdrivers positioned opposite each other, pry the rotary portion of the seal from the shaft.
2. Remove stationary seat and boot by prying out with two small screwdrivers in manner similar to impeller removal. (Caution: The seal will be damaged by removal in this manner. A new seal and rubber gasket MUST be used when pump is reassembled.)

Cleanup Of Pump Housing

1. Using the circular bottle-type wire brush with air or hand drill, clean the discharge port, suction port and the sealing areas of the O-ring on the pump casing and mounting flange.
2. After wire brush cleaning, it is recommended that the pump casing and mounting flange be further cleaned in a solvent tank to remove rust and corrosion particles.

Pump Shaft and Bearing Assembly Removal and Replacement

1. While the pump is disassembled (see the Pump Housing Disassembly section), the driven pulley on the pump shaft must be removed. Remove the large retainer ring in pump bearing bore on the pulley side of housing. Press out the shaft and bearing assembly from the pump side using an arbor press.
2. Bearings must be pressed off each end of shaft and replaced in the same manner. NOTE: Shaft diameter between bearings is larger.
3. For reassembly, reverse the order of instructions.

Seal Replacement & Pump Housing Reassembly

NOTE: Reassemble if drive end is not to be repaired.

Be extremely careful with the new seal. Take special care not to scratch the lapped sealing faces of the rotary washer and stationary seat.

1. Lubricate seal cavity in mounting flange with WD-40, LPS or equivalent.
2. Install the stationary portion of the mechanical seal by sliding over the shaft with the ceramic side out.

IMPORTANT: Make sure the seal cavity is clean and lubricated. Never run the sealing faces dry.

3. To seat the seal in the seal cavity, use a piece of 3/4" PVC pipe 4" to 6" in length. Press it in firmly and squarely.
4. To install the rotary portion of the mechanical seal, place it over the shaft with the carbon side facing in, and press until it bottoms out against the stationary portion.
5. Insert key into shaft key slot. Place impeller on shaft. Put [washer, jam nut and gasket] impeller nut on shaft end, and using a large screwdriver or file in the impeller vanes for support, tighten impeller nut securely.
6. Install o-ring on mounting flange. Replace o-ring if worn or damaged.
7. Place pump casing on mounting flange, insert and tighten bolts evenly.

Breakdowns & Parts Lists

Hypro 9203C Pump Breakdown & Parts List

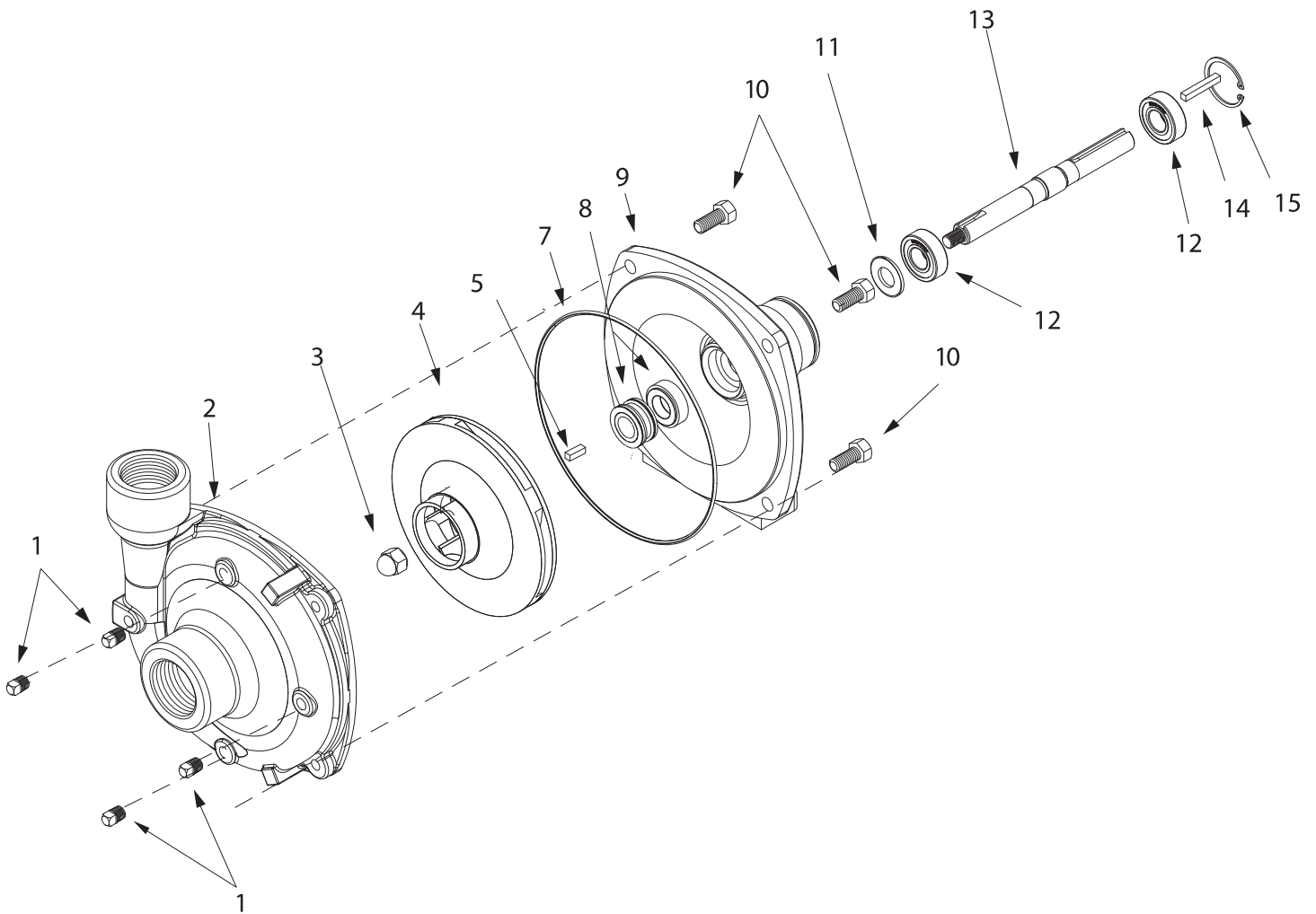

| Ref # | Qty. | Part Number | Description |
|-------|------|-------------|---------------------------------------|
| 1 | 4 | 2406-0007 | Drain plug (cast series) |
| 2 | 1 | 0150-9000C | Pump casing (cast series) |
| 3 | 1 | 2253-0002 | Impeller nut (cast series) |
| 4 | 1 | 0401-9100P | Impeller (model 9203C) (nylon) |
| 5 | 1 | 1610-0015 | Key (cast series) |
| 7 | 1 | 1720-0083 | O-ring |
| 8 | 1 | 3430-0589 | Mechanical seal kit (silicon carbide) |
| 9 | 1 | 0750-9200C3 | Mounting flange (cast series) |
| 10 | 4 | 2210-0020 | Bolt (cast series) |
| 11 | 1 | 1410-0056 | Slinger ring |
| 12 | 2 | 2000-0010 | Ball bearing |
| 13 | 1 | 0505-9200 | Pump shaft |
| 14 | 1 | 1610-0004 | Key |
| 15 | 1 | 1820-0013 | Bearing retainer |

Seal repair kit: 3430-0589 - consists of: (1) ref # 7 O-ring, (1) ref # 8 Mechanical seal

Breakdowns & Parts Lists

PT150-540S Breakdown

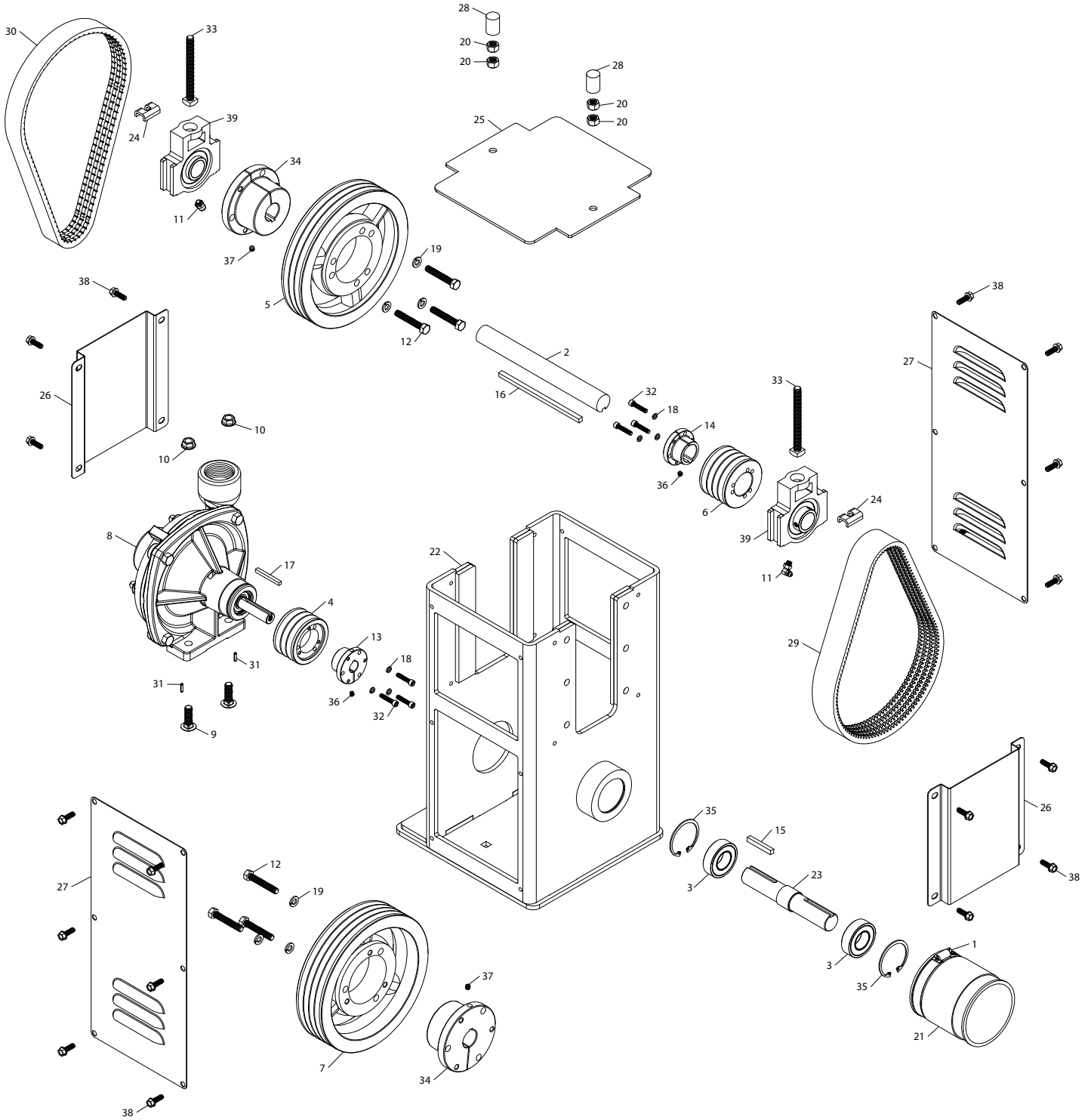

Breakdowns & Parts Lists

PT150-540S Parts List

| Ref # | Qty. | Part Number | Description |
|-------|------|-------------|--|
| 1 | 1 | 6864 | Stainless hose clamp, 2 1/2" - 4 1/2" |
| 2 | 1 | 1441600 | 1" shaft, keyed 1/4", 9" lg. |
| 3 | 2 | 16412RS | Bearing, 1" ID, 2" OD, 9/16" wide |
| 4 | 1 | 3-3V265JA | 2.65" 3 groove sheave - JA bushing |
| 5 | 1 | 3-3V800SK | 8" 3 groove sheave - SK bushing |
| 6 | 1 | 4-3V280JA | 2.8" 4 groove sheave - JA bushing |
| 7 | 1 | 4-3V800SK | 8" 4 groove sheave - SK bushing |
| 8 | 1 | 9203C | Hypro pump (See page 9 for pump breakdown) |
| 9 | 2 | CB38*114G5 | Carriage bolt, 3/8-16 x 1 1/4" grade 5 |
| 10 | 2 | FN38 | Flange nut, 3/8-16 |
| 11 | 2 | GF103 | Grease fitting, 1/4-28 90 degree |
| 12 | 6 | H5C516*2 | Hex head bolt, 5/16-18 x 2" grade 5 |
| 13 | 1 | JA10 | JA bushing 5/8" |
| 14 | 1 | JA16 | JA bushing 1" |
| 15 | 1 | KEY14X134 | 1/4" key stock 1 3/4" lg. |
| 16 | 1 | KEY14X6 | 1/4" key stock 6" lg. |
| 17 | 1 | KEY316X134 | 3/16" key stock 1 3/4" lg. |
| 18 | 6 | LW10 | Lock washer, #10 |
| 19 | 6 | LW516 | Lock washer, 5/16" |
| 20 | 4 | NC38 | Hex nut, 3/8-16 |
| 21 | 1 | PI05633 | Flex coupling 3" |
| 22 | 1 | PT1500 | Main Frame |
| 23 | 1 | PT1501 | Input shaft |
| 24 | 2 | PT1503 | Bolt clip |
| 25 | 1 | PT1504 | Top cover |
| 26 | 2 | PT1505 | Take-up bearing cover |
| 27 | 2 | PT1506 | Side cover |
| 28 | 2 | PT1507 | Vinyl bolt cap |
| 29 | 1 | R3VX315-4 | Belt 31.5" 4 groove |
| 30 | 1 | R3VX335-3 | Belt 33.5" 3 groove |
| 31 | 2 | RP18*12 | Roll pin, 1/8" x 1/2" |
| 32 | 6 | SCC1024*1 | Socket head cap screw, 10-24 x 1" |
| 33 | 2 | SHB38*4 | Square head bolt, 3/8-16 x 4" |
| 34 | 2 | SK16 | SK bushing 1" |
| 35 | 2 | SRI2 | Internal snap ring, 2" |
| 36 | 2 | SSC1024*14 | Allen set screw, 10-24 x 1/4" |
| 37 | 2 | SSC14*14 | Allen set screw, 1/4-20 x 1/4" |
| 38 | 20 | TF14*34 | Hex head self tapping screw, 1/4-20 x 3/4" |
| 39 | 2 | UCT205-16 | Take-up bearing 1" |

CropCare[®] Limited Warranty

Superdrive Pump: Model PT150-540S

Warranty Coverage

CropCare[®] hereby provides a Limited One (1) Year Warranty on Superdrive Pumps, manufactured by CropCare[®]. Superdrive pumps manufactured by CropCare[®] are warranted against any manufacturer's defects in any of the pump's components in the 12 months following the original date of purchase.

Defective components will be repaired or replaced at the discretion of the manufacturer. It is the responsibility of the purchaser to return warranted components to the manufacturer. This warranty is limited to the repair or replacement of pump components only. CropCare[®] is not to be held liable for incidental or consequential damages of any kind. This warranty covers the purchaser of this pump and any other owners who own it during the one year warranty period.

To retain the warranty, the pump must be operated and maintained as ascribed by its owner's manual. For warranty service, please have a copy of the purchase invoice available.

Warranty Is Void if:

1. The pump has been subjected to, in the opinion of CropCare[®], negligent handling, misuse, an accident or if the instructions in the owner's manual were not completely followed.
2. The pump's components have been altered in any manner or repairs have taken place with unapproved parts.
3. The pump and its components were subject to freezing or freezing conditions. The pump must have been winterized as per the maintenance instructions to retain the warranty.
4. A non-compatible chemical was used and/or if the pump operator failed to rinse all chemical residue out of the pump after use.
5. A petroleum-based, oil-based, or flammable product was used and caused damage to the pump.

Getting Service

All Superdrive Pump warranty claims must be made through an authorized CropCare[®] dealer. All warranty claims must be submitted with an invoice or a proof of purchase that denotes the purchase date and place of purchase. If you have any questions or comments concerning this warranty, please contact an authorized CropCare[®] dealer.

Contact Us

We desire to give you continuing service in the best manner possible. This includes listening to your comments, suggestions, and problems. We will do our best to answer all questions thoroughly and in a timely manner. Please feel free to contact our customer service department.

Ordering Parts

Please contact your authorized CropCare® dealer to order replacement parts for your product.

CROPCARE

A brand of **PBZ LLC**
A Brand of Paul B Zimmerman Inc. Company

50 Woodcorner Road
Lititz PA 17543
(717) 738-7365
Fax (717) 738-7369
www.CropCareEquipment.com