



Congratulations on the purchase of your new Prince Table Tennis table. Our products are designed and manufactured to give you years of game playing enjoyment.

*KEEP BOX AND PACKING MATERIAL UNTIL TABLE HAS BEEN COMPLETELY ASSEMBLED.*

*ALL DAMAGE MUST BE REPORTED TO DMI WITHIN TEN DAYS OF RECEIPT.*

*If you have any problems with your new product,*  
**PLEASE DO NOT RETURN IT TO THE STORE.**

Please contact us:

**1.800.399.4402**

**FAX: 215.283.9573**

Please have your model number when inquiring about parts.

Or write to:

DMI Sports

Customer Service

1300 Virginia Drive, Suite 401

Fort Washington PA, 19034

Please visit our web site at:

**[www.dmisports.com](http://www.dmisports.com)**

When contacting DMI Sports, please provide your model number and item number (if applicable) if requesting a replacement part. Item numbers can be found inside this owners manual.

Your Model Number PT200-00

**Your model number is also located on the original carton. These instructions are also available online at: [www.dmisports.com](http://www.dmisports.com).**

## **IMPORTANT!**

**Please Keep Your Instructions!** (You will need your Model number should you need to contact us.) Before attempting assembly, please read through this instruction book to familiarize yourself with all the parts and assembly steps. We recommend that two adults assemble this game. Please refer to the Parts Identifier on the following page and be sure that all parts have been included. This product is manufactured according to the ITTF standards (International Table Tennis Federation), and includes national and international patents.

DMI Sports Inc. warrants this product for one year from the purchase date for any manufacturing or material defect. High-density chipboard is warranted for one year from date of purchase. Although we at DMI Sports are dedicated to giving our customers the highest quality products, occasionally a part may be missing. If you are missing a part, or if you have any questions, please call our customer service department at 1.800.399.4402 Mon-Fri between the hours of 9:00am and 5:00pm E.S.T; or you can reach us at: [www.dmisports.com](http://www.dmisports.com).

**Do not return the game to the store. Please contact us first at: 1.800.399.4402 or on our website at: [www.dmisports.com](http://www.dmisports.com).**

## **TWO ADULTS ARE REQUIRED TO ASSEMBLE THIS TENNIS TABLE**









**TOOLS REQUIRED FOR ASSEMBLY:**

- Phillips Head and Regular Screwdriver (or Electric Screwdriver) **Not Included**
- Wrench Set or Pliers- **Not Included**
- Hammer- **Not Included**

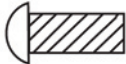
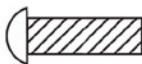

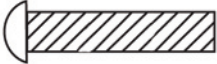









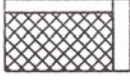
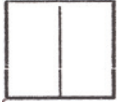
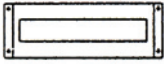

**PARTS IDENTIFIER**

**HARDWARE PARTS**

| H1   | Qty. 4 | H2   | Qty. 4  | H3  | Qty. 2  | H4   | Qty. 4  |
|--|--------|--|---------|---|---------|--|---------|
|   |        |   |         |   |         |   |         |
| TTPH115<br>TTPHKIT2  |        | TTPH117<br>TTPHKIT2  |         | TTPH126<br>TTPHKIT2   |         | TTPH129<br>TTPHKIT2  |         |
| H5   | Qty. 6 | H6   | Qty. 12 | H7  | Qty. 12 | H8   | Qty. 16 |
|  |        |  |         |  |         |  |         |
| TTPH113<br>TTPHKIT2  |        | TTPH125<br>TTPHKIT2  |         | TTPH107<br>TTPHKIT2   |         | TTPH114<br>TTPHKIT2  |         |

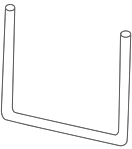
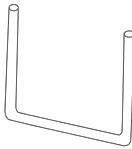
## PARTS IDENTIFIER

### ASSEMBLY PARTS

|   |        |   |        |  |        |   |        |
|---|--------|---|--------|--|--------|---|--------|
| P1  | Qty. 8 | P2  | Qty. 2 | P3   | Qty. 2 | P4  | Qty. 4 |
|    |        |    |        |    |        |    |        |
| Plastic Wheel<br>TTPP101  |        | Wheel Swivel<br>TTPP102   |        | Insert for Wheel Swivel<br>TTPP103   |        | Support Brace<br>TTPM119  |        |
| P5  | Qty. 2 | P6  | Qty. 2 | P7   | Qty. 1 | P8  | Qty. 2 |
|    |        |    |        |    |        |    |        |
| Net Post Support<br>TTPM126   |        | Net Post<br>TTPM127   |        | Nylon Net<br>TTPP119   |        | Table Half<br>TTPW200-00  |        |
| P9  | Qty. 4 | P10   | Qty. 4 | P11  | Qty. 4 | P12   | Qty. 6 |
|   |        |   |        |    |        |   |        |
| Plastic Tray<br>TTPP121   |        | Safety Catch<br>TTPP109   |        | 1" Plastic Leg Cap<br>TTPP114  |        | 1" Half Round Bracket<br>TTPM114  |        |
| P13   | Qty. 4 | P14   | Qty. 4 | P15  | Qty. 2 | P16   | Qty. 2 |
|  |        |  |        |  |        |    |        |
| 1.5" Half Round Bracket<br>TTPM115  |        | 1" Inner Leg<br>TTPM201   |        | 1.5" Outer Leg<br>TTPM202  |        | End Apron<br>TTPM124  |        |
| P17   | Qty. 2 | P18   | Qty. 2 | P19  | Qty. 8 | NOTE: Parts P13 and P15 come pre-assembled to P8. They are only listed here as replacement parts should there be a problem with them. |        |
|  |        |  |        |   |        |   |        |
| Side Apron<br>TTPM125   |        | Plastic Corner<br>TTPP122   |        | 1.5" Plastic Leg Cap<br>TTPP112  |        |   |        |

# Prince Competitor FSA - Code: PT200-00 - Assembly Instructions

Open the box and position the two play surfaces face down on the cardboard.

**Note:** Make sure that the two play surfaces are positioned, with the ends of the table possessing the pre-assembled net support brackets represented in Fig 1.1, facing each other.

**STEP 1.** (Fig. 1.1) Attach Inner Legs (P14) using Half Round Bracket (P12) and Screw (H7).

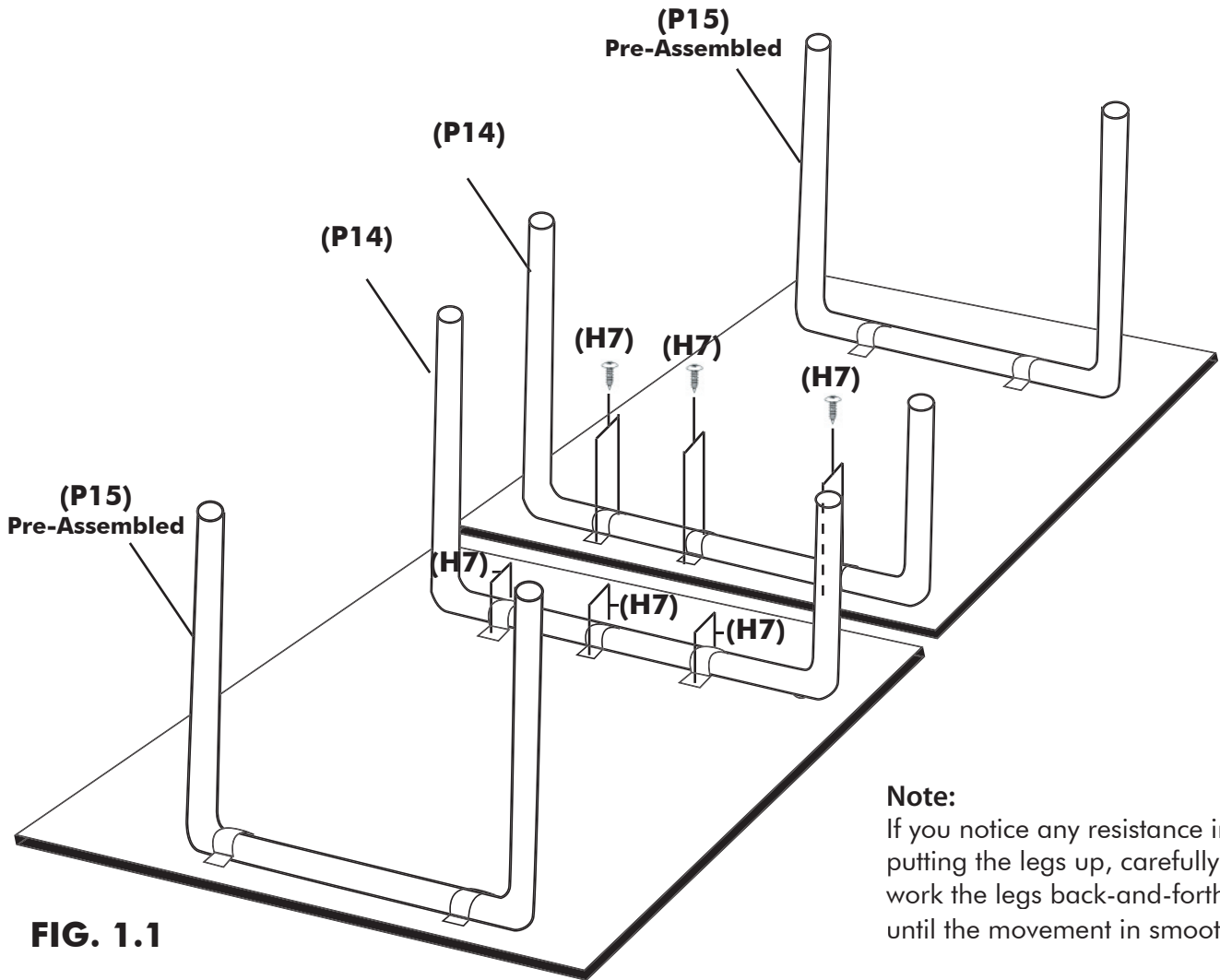

**Note:**

If you notice any resistance in putting the legs up, carefully work the legs back-and-forth until the movement is smooth.

# Prince Competitor FSA - Code: PT200-00 - Assembly Instructions

**STEP 2.** (Fig. 2.1) Attach two Plastic Wheels (P1) using (H1) and (H2) to both Long Inner legs (P16) as pictured below. Fig. 2.1 represents both inner legs.

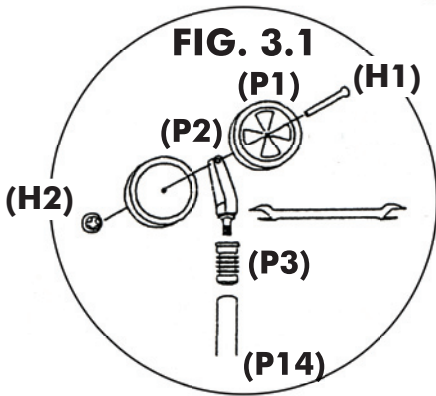
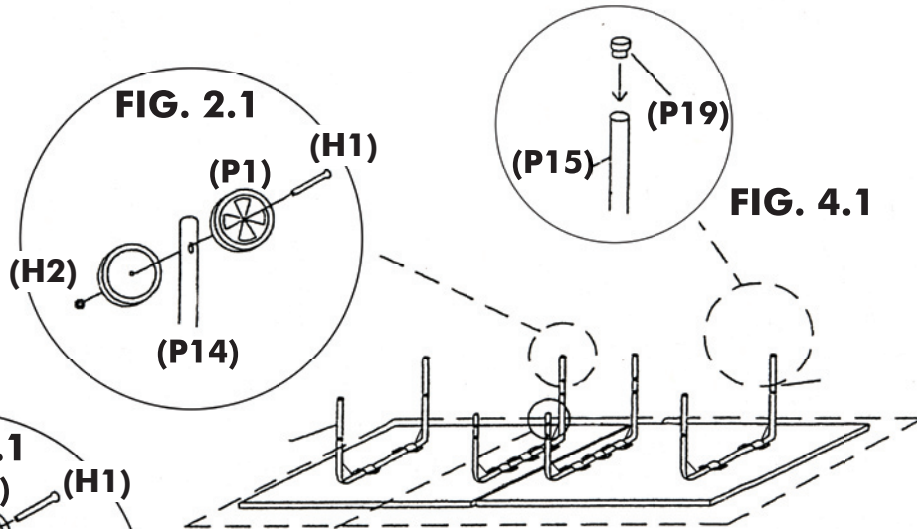

**STEP 3.** (Fig. 3.1) Attach two Plastic Wheels (P1) using (H1) and (H2) to the Wheel Brackets (P2) as shown to the left. Once the wheels are attached, attach the wheels and bracket to the Insert for wheel swivel (P3). The entire unit will then be inserted into the two Inner legs (P14).

**STEP 4.** (Fig. 4.1) Insert the Plastic Leg covers (P19) in the Outer Legs (P15). Gently hammer into place if needed. Fig. 4.1 represents all outer legs.

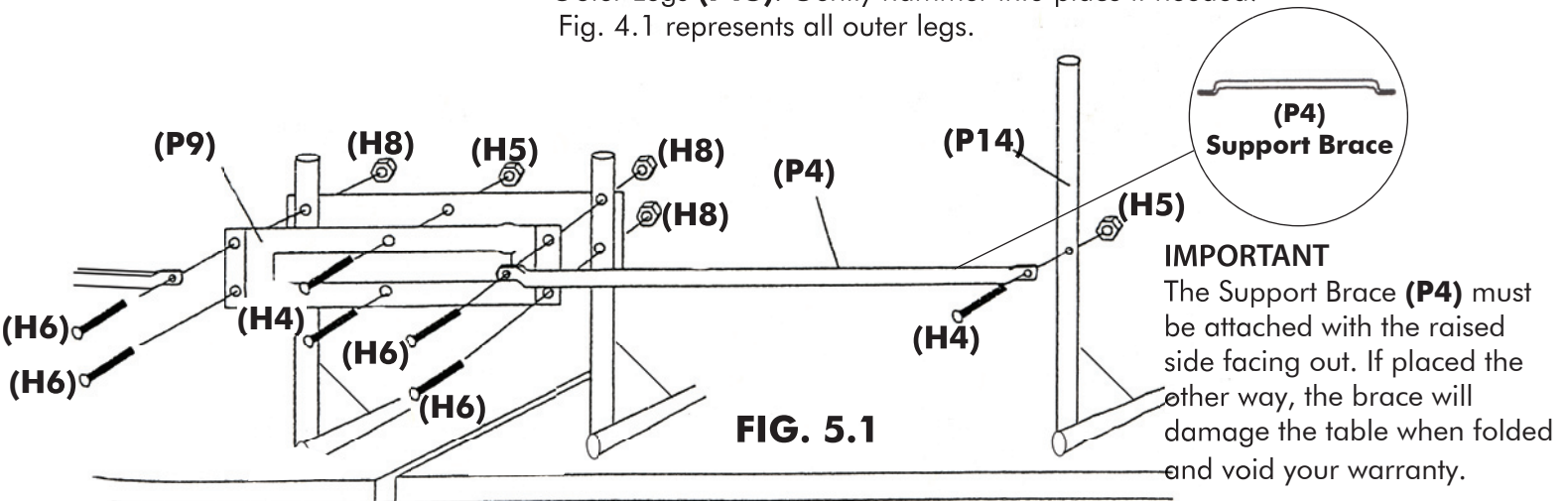

**STEP 5.** (Fig. 5.1) Attach the two Plastic Trays (P9) through the lower holes using (H6) and (H8) to the two Interior legs as shown above. (Repeat on the other side) Secure the top two holes by placing one end of the Support Brace (P4) over the top holes of the Plastic Tray and attaching them to the Interior Leg using (H6) and (H8) as shown in FIG. 5.1. Attach the other end of the Support Brace to the Exterior Leg using (H4) and (H5). Now secure the Plastic Tray by adding two (H4) and (H5) hardware parts.

**Note:** Keep in mind that the table is still up-side-down. So the "lower holes" referred to in Step 5. are closer to the ground in this position.

# Prince Competitor FSA - Code: PT200-00 - Assembly Instructions

**STEP 6.** Before you turn the table over, attach the two Net Post Supports (P5) to the holes in the Side Aprons at this time.

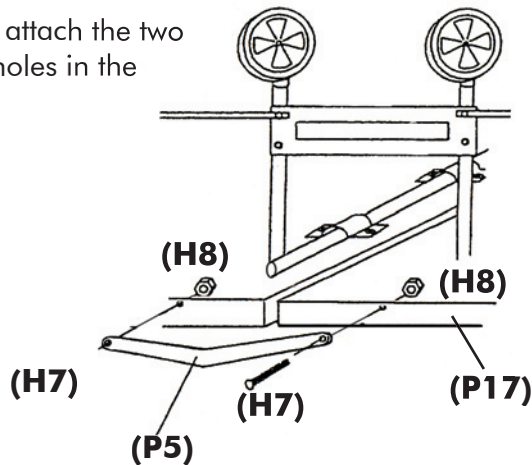

**FIG. 6.1**

**STEP 7.** (Fig. 7.1) Make sure that all hardware is tight. (DO NOT OVER TIGHTEN) With two adults, turn the table over. Don't try to pick it up. Roll it over until upright being careful not to let table fold in half.

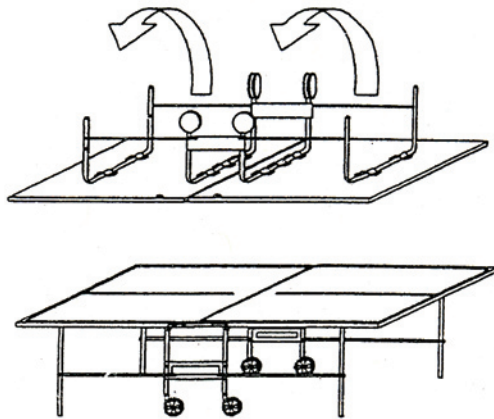

**FIG. 7.1**

**STEP 8.** (Fig. 8.1) Attach the Safety Catches (P10) to the Interior legs (P14) using holes just above trays (P9). Screw nut to Safety Catch (P10) but do not tighten to legs. These must be loose enough to swivel.

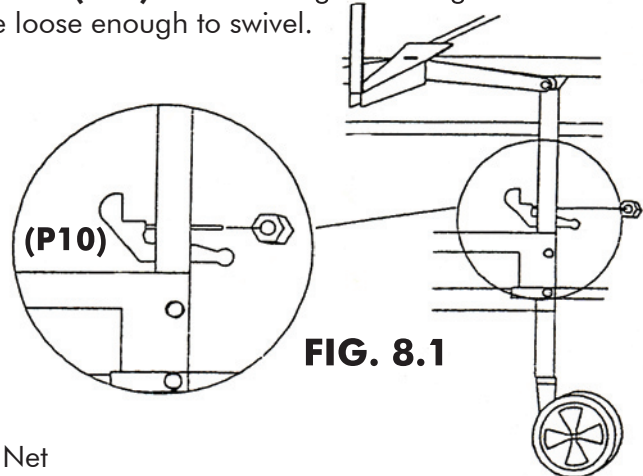

**FIG. 8.1**

**STEP 9.** (Fig. 9.1) Attach the Net Post (P6) to the Net Post Support (P5) using (H3) and (H5) as shown in FIG. 9.1. Once the Net Post is secured, you can attach the Nylon Net (P7). **NOTE:** the Nylon net may appear too small to reach the posts. Simply stretch the net until it slides on the posts.

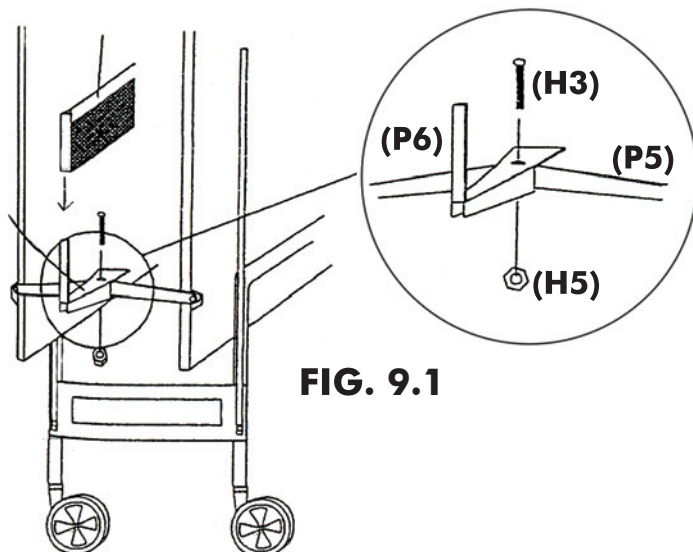

**FIG. 9.1**

**STEP 10.** (Fig. 10) Using Screws (H9) attach the Plastic Corners (P22) to the pre-assembled end and side aprons.

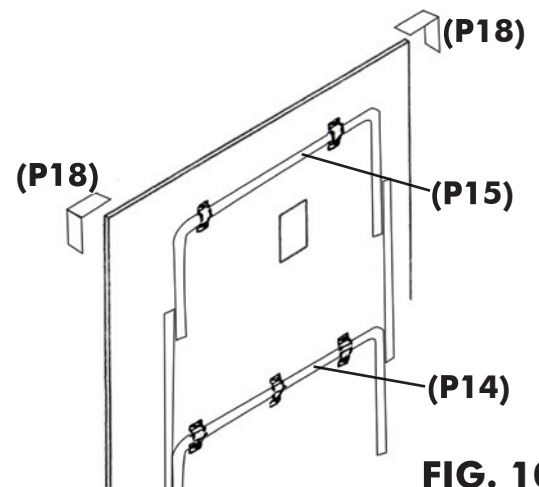

**FIG. 10**



## RECOMMENDATION OF USE AND PRECAUTIONS

**Anyone using or handling this table tennis table must always follow the illustrated instructions attached to the back of the board and be fully aware of the operation instructions.**

1. Handling the table, (Assembly, open, close or to store) should always be done by two adults to prevent accident or injury.
2. Be sure that no persons or objects are in the way of the boards when opening the table.
3. Do not put heavy objects on the table.
4. Do not sit on the table.
5. Do not clean the table with solvents or any other aggressive product because it could damage the paint finish.
6. Do not use sharp objects on the board or painter surface.
7. If the table is used for purposes other than playing table tennis, cover the surface to prevent any damage.
8. Request proof of purchase and keep it during the warranty period.
9. Under no circumstances is the manufacturer responsible for direct or indirect damages including loses of benefits or any other commercial damage occurred by the use of the purchased product.
10. The functioning and storage of this product should always be supervised by an adult.
11. Do not store or handle the table on an unstable floor surface.
12. If safety device malfunction occurs, secure table tops until the problem is solved.
13. To extend the life of this product, (outdoor table or indoor table) protect it from moisture or severe climate changes.
14. Use only the net system supplied. For replacements please contact customer service at: 800.399.4402 and ask for Net Post TTPM126, Net Support TTPM127 and Nylon Net TTPP119.

## Care and Maintenance

### Cleaning your table

Use a soft damp (not wet) cloth only. DO NOT USE ANY CHEMICALS, ABRASIVE OR CLEANING PRODUCTS on the playing surface.

### Maintenance of your table

All moving parts must be oiled including the pivot points. This will insure ease of use and safety of your table.

This table must be stored indoors to avoid damage to the surface. The dampness and temperature changes can cause wood to warp, swell or blister.



## APPLYING LABELS

The very last step in completing the assembly of your new Prince Table Tennis table involves applying the labels to the proper locations on the table. There are two types of labels to be applied.

#1 is the Style label. There are four style labels. Each of the four labels are applied to the four corners of the table's side aprons as shown below.

#2 is the Plastic Tray label. There are two tray labels. One of each of these labels will be applied to each plastic tray on your table.

The labels represented here are not of actual size or color.

**Note:** It is recommended that you write the model number on the under-side of this table for future reference.

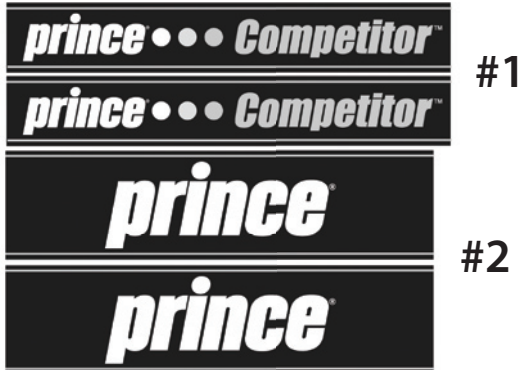

**PARTS RE-ORDER FORM**

**PT200-00 Table Tennis Table**

Send this form along with your check or money order payable to:

**DMI SPORTS**

1300 Virginia Drive, Suite 401  
Fort Washington, PA 19034  
[www.dmisports.com](http://www.dmisports.com)

DATE: \_\_\_\_\_

NAME: \_\_\_\_\_

ADDRESS: \_\_\_\_\_ PHONE: \_\_\_\_\_

CITY: \_\_\_\_\_ STATE: \_\_\_\_\_ ZIP CODE: \_\_\_\_\_

| REF | QTY | PART#       | DESCRIPTION                           | UNIT PRICE | TOTAL AMOUNT |
|-----|-----|-------------|---------------------------------------|------------|--------------|
| H1  |     | TTPHKIT2    | TTPH115 (ea.)                         | 1.00       |              |
| H2  |     | TTPHKIT2    | TTPH117 (ea.)                         | 1.00       |              |
| H3  |     | TTPHKIT2    | TTPH126 (ea.)                         | .50        |              |
| H4  |     | TTPHKIT2    | TTPH129 (ea.)                         | .50        |              |
| H5  |     | TTPHKIT2    | TTPH113 (ea.)                         | .50        |              |
| H6  |     | TTPHKIT2    | TTPH125 (ea.)                         | .50        |              |
| H7  |     | TTPHKIT2    | TTPH107 (ea.)                         | .50        |              |
| H8  |     | TTPHKIT2    | TTPH114 (ea.)                         | .50        |              |
| P1  |     | TTPP101     | Plastic Wheel (ea.)                   | 2.50       |              |
| P2  |     | TTPP102     | Wheel Swivel (ea.)                    | 2.50       |              |
| P3  |     | TTPP103     | Insert for Wheel Swivel (ea.)         | .50        |              |
| P4  |     | TTPM119     | Support Brace (ea.)                   | 10.00      |              |
| P5  |     | TTPM126     | Net Post Support (ea.)                | 5.00       |              |
| P6  |     | TTPM127     | Net Support (ea.)                     | 10.00      |              |
| P7  |     | TTPP119     | Nylon Net (ea.)                       | 9.50       |              |
|     |     |             |                                       |            |              |
| P9  |     | TTPP121     | Plastic Tray (ea.)                    | 7.50       |              |
| P10 |     | TTPP109     | Safety Catch (ea.)                    | 5.00       |              |
| P11 |     | TTPP114     | Plastic Leg Cap (ea.)                 | 1.00       |              |
| P12 |     | TTPM114     | 1" Half Round Bracket (ea.)           | 3.00       |              |
| P13 |     | TTPM115     | 1.5" Half Round Bracket (ea.)         | 3.00       |              |
| P14 |     | TTPM201     | 1" Inner Leg (ea.)                    | 15.00      |              |
| P15 |     | TTPM202     | 1.5" Outer Leg (ea.)                  | 15.00      |              |
| P16 |     | TTPM124     | End Apron (ea.)                       | 12.00      |              |
| P17 |     | TTPM125     | Side Apron (ea.)                      | 12.00      |              |
| P18 |     | TTPP122     | Plastic Corner (ea.)                  | 3.00       |              |
| P19 |     | TTPP112     | 1.5" Plastic Leg Cap (ea.)            | 1.00       |              |
|     |     | TTPH128     | #10-24 x 2" Screw (ea.)               | 1.00       |              |
|     |     | TTPH124     | #10-24 Hex Nut (ea.)                  | 1.00       |              |
|     |     | TTPH123     | #10-24 x 1.5 Screw (ea.)              | 1.00       |              |
|     |     | TT200LABELS | Competitor Label Sheet (1 of 2) (ea.) | 4.50       |              |
|     |     |             |                                       |            |              |
|     |     |             |                                       |            |              |
|     |     |             |                                       |            |              |
|     |     |             |                                       |            |              |

|                                  |  |  |  |   |  |
|----------------------------------|--|--|--|---|--|
| <b>SHIPPING AND HANDLING:</b>    |  |  |  | <b>Subtotal:</b>                                    |  |
| Up to \$15.00 add \$2.00 for S&H |  |  |  | <b>Shipping and Handling Charges:</b>               |  |
| Over \$15.00 CALL                |  |  |  | <b>(PA Residents Add 6% State Sales Tax) TOTAL:</b> |  |