

PaceMaster ***ProPlus^{II}***

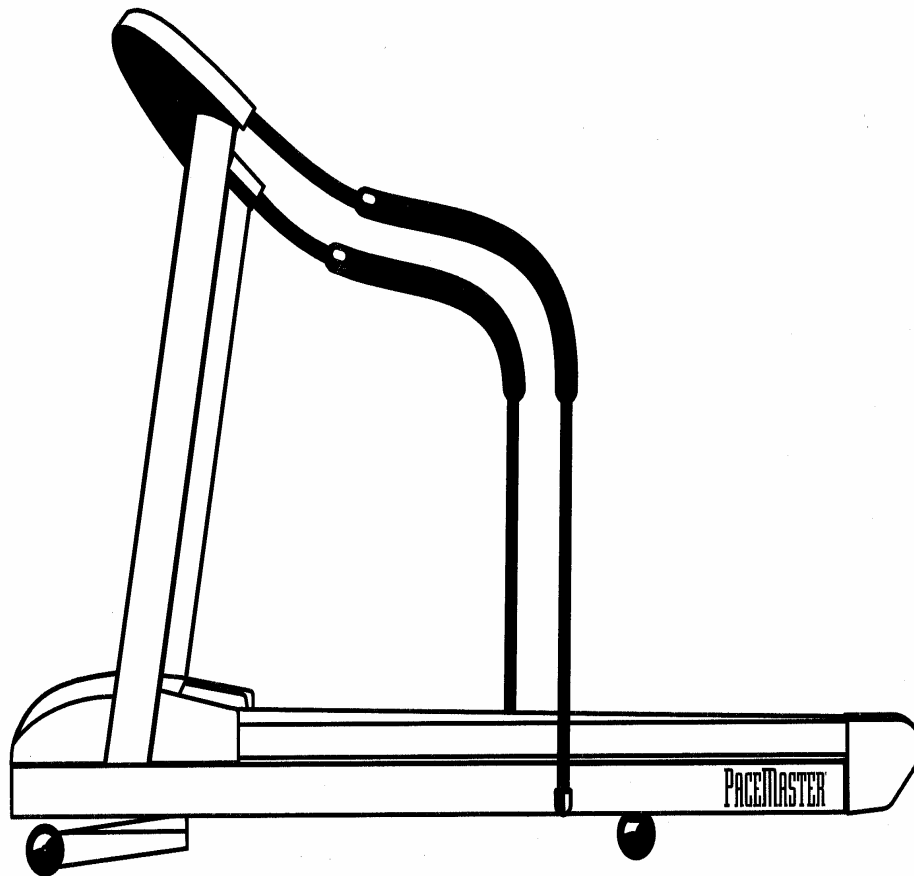

OWNER'S MANUAL

Manufactured by: Aerobics Inc., 34 Fairfield Place West Caldwell, NJ 07006 (973) 276-9700

PPII.DOC

12/02

TABLE OF CONTENTS

INTRODUCTION	2
IMPORTANT SAFETY INSTRUCTIONS	3
ASSEMBLY INSTRUCTIONS	4-6
Installation Requirements	4
Unpacking Your Treadmill	4
Tool Required for Assembly	4
Grounding Instructions	5
Assembly	5-6
Testing Your Treadmill	7
THE CONTROL PANEL	8-9
OPERATING INSTRUCTIONS	10-14
Setting Your Weight	10
Metric Units	10
Warm Up and Cool Down	10
Quick Start	11
Manual Operation	11-12
Preset Workouts	12
Preset Workout Course Specifications	13
Custom Workouts	14
EXCLUSIVE ProPlus^{II} FEATURES	15
Exercise Preview	
Aerobic Points	
Personal Electronic Trainer	
CARE AND MAINTENANCE	16
Deck and Tread Belt Cleaning	
Lubrication	
Centering the Tread Belt	
TROUBLE SHOOTING	17-18
Electronic Error Codes	17
Hesitation of the Belt	17
Drive Belt Tension Adjustment	17-18
Tread Belt Tension Adjustment	18
FREQUENTLY ASKED QUESTIONS	19
ProPlus^{II} TECHNICAL SPECIFICATIONS	20

INTRODUCTION

Congratulations on your commitment toward better health and fitness!

The staff at Aerobics Inc. would like to thank you for purchasing a PaceMaster treadmill. Not only did you buy one of the highest quality treadmills on the market; you also received excellent value for your dollar. PaceMaster treadmills have been rated "*BEST BUY*" by more nationally recognized publications than any other treadmill.

Aerobics Inc. has been designing and manufacturing home treadmills since 1968. We are a family-owned and operated business, comprised of fitness enthusiasts who are committed to providing consumers with outstanding quality treadmills at affordable prices. All PaceMaster treadmills are made in the USA.

Your new PaceMaster treadmill has a wide variety of features to assist you in reaching your fitness goals. Please read this manual in its entirety so you will be thoroughly acquainted with assembly, operation and maintenance information.

About This Manual

It is highly recommended that you read this manual in its entirety before attempting to use your PaceMaster treadmill. It contains information to familiarize you with assembly, basic operations, preset workouts and custom programming.

For your safety, and the protection of your treadmill, we have included warnings and other valuable information throughout this manual. The information will be in bold type and marked by the following symbols. Be absolutely sure to thoroughly read and understand this information.

CAUTION, WARNING or **DANGER** indicates important safety warnings. Failure to read and understand these warnings may result in personal injury or damage to your treadmill. **TIP** indicates useful suggestions to keep in mind while using your PaceMaster treadmill.

This treadmill is in compliance with EN 957-2 class H.

The PROPLUS [®] treadmill is designed for home use only

IMPORTANT SAFETY INSTRUCTIONS

Read these instructions before using your treadmill

CAUTION: Before starting any exercise program, contact your personal physician and have a complete physical. This is highly recommended if you have not been on a regular exercise program within the last year or are over 35 years of age or are overweight.

CAUTION: If at any time during your exercise program you find the exercise abnormally difficult or you encounter dizziness, feel faint, experience chest pains, feel as if your heart may be skipping beats, you experience forced, heavy breathing after minimal exercise or severe pain in your legs, ankles, knees, etc., STOP EXERCISING and consult your physician.

WARNING: To reduce the risk of burns, fire, electrical shock or injury:

- Never operate your PaceMaster treadmill without clipping the magnetic safety key to your clothing at waist level.
- Your PaceMaster treadmill is not designed for use by children under the age of 18 without strict parental supervision.
- Close supervision is necessary when the treadmill is used by or near children or disabled persons.
- Use your PaceMaster treadmill only for its intended use as described in this manual. Do not use accessories or attachments not recommended by Aerobics, Inc.
- Never operate your PaceMaster treadmill if it has a damaged cord or plug, if it is not operating properly, if it has been dropped or damaged or if it has been immersed in water. Should any of these occur, contact your authorized PaceMaster retailer or service center for examination or repair.
- Keep the cord away from heated surfaces.
- Never drop or insert any object into any opening on the treadmill.
- Do not use outdoors.
- Always unplug your PaceMaster treadmill during an electrical storm or during extended periods of non-use.
- Do not operate where aerosol (spray) products are being used or where oxygen is being administered.
- Position the treadmill with a minimum of 4 feet (1219mm) of clearance between the rear of the treadmill and any wall or obstruction.
- Do not allow anyone to reach under or be too near your PaceMaster while it is in use.
- Do not attempt to mount or dismount the tread belt while it is running.
- Never allow more than one person on your PaceMaster treadmill at any time.
- Never move the treadmill while it is plugged into the electrical outlet.
- When you are finished exercising, leave your PaceMaster treadmill in a non-elevated position to avoid toys and other objects from becoming trapped beneath.
- Wear appropriate running or walking shoes and attire while exercising.
- The treadmill should be turned off after each use by removing the safety magnetic key.
- Never apply lubricant to the belt and deck. **It is permanently lubricated at the factory and is maintenance free.**

ASSEMBLY INSTRUCTIONS

Installation Requirements

Your PROPLUS^{II} should be installed indoors on a flat, level surface near a 120Volt/ 15Amp outlet. PaceMaster requires a dedicated, non-switched outlet that is not part of a GFI (Ground Fault Interrupter) circuit, preferably no more than 5 feet from the outlet to eliminate the need for an extension cord. You must have a minimum of 4 feet of clearance between the rear of the treadmill and any wall or obstruction.

TIP: If you are installing your ProPlus^{II} on a carpeted surface, use a treadmill mat or a scrap piece of carpet underneath the treadmill to avoid soiling of the carpet. Deep pile carpet is not recommended.

Unpacking Your Treadmill

The PaceMaster treadmill is packed in five pieces:

- Frame assembly
- Front handlebar assembly with Control Panel
- Two side rails
- Motor cover
- Hardware package

Before assembling your treadmill, open the hardware package and verify that you have the following items:

Two black side rail brackets	Two #8 x 1/2" black sheet metal screws
Two 1" fender washers	3/16" Allen wrench
Four 1/4-20 x 3.5" black carriage bolt	Magnetic safety key with garment clip
Two 1/4-20 x 4" black carriage bolt	Owner's Manual
Six 1/4-20 kep nuts	Warranty registration card

If any parts are missing, contact the authorized PaceMaster retailer where you purchased your PaceMaster treadmill.

Tools Required for Assembly

- 3/16" Allen wrench (supplied)
- 7/16" combination wrench
- Phillips head screwdriver

Grounding Instructions

DANGER: This product must be properly grounded. If it should malfunction or become inoperable, grounding provides a path of least resistance for electric current to reduce the risk of electric shock. This product is equipped with a cord having an equipment-grounding conductor and a grounding plug. The plug must be plugged into an appropriate outlet that is properly installed and grounded in accordance with all local codes and ordinances.

WARNING: Improper connection of the equipment grounding-conductor can result in a risk of electrical shock. Check with a qualified electrician or serviceman if you are in doubt as to whether the product is properly grounded. Do not modify the plug provided with the product. If it will not fit the outlet, have a proper outlet installed by a qualified electrician. This product is rated for more than 15 amperes and is for use on a circuit having a nominal rating of 120 volts. It is factory equipped with a specific electric cord and plug to permit connection to a proper electric circuit. Make sure that the product is connected to an outlet having the same configuration as the plug. **No adapter should be used with this product.** Attempting to bypass it with an adapter or in any way defeating its purpose can result in a serious shock hazard. As a safety precaution you should unplug the treadmill during electrical storms or if the treadmill will not be in use for periods greater than one week.

CAUTION: If you need to use an extension cord it must be a 14 gauge, three wire cord, no longer than 12 feet.

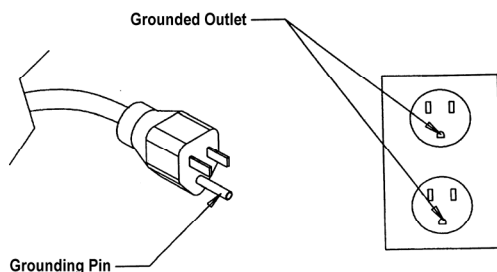

Assembly

Figure 1:

Carefully place the bottom of the handlebar (1) on the frame (2) so the two holes in the plate at the bottom of the handlebar line up with the holes in the frame. **Be extremely careful not to damage the speed sensor while installing the handlebar.**

Insert the 3.5" carriage bolts (3) through the handlebar and the frame. Install a 1/4-20 kep nut (4) to each carriage bolt to keep the handlebar in place. Follow the same procedure for the other handlebar. Do not tighten any nuts until both sides are bolted in place.

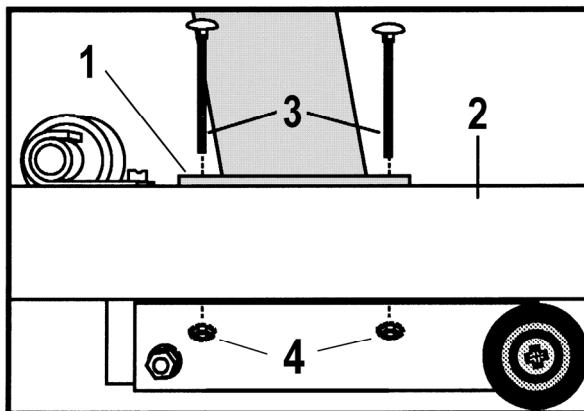

Figure 1

Figure 2:

With the handlebar in place, plug the wire harness (5) into the socket (6) on the power supply board (7).

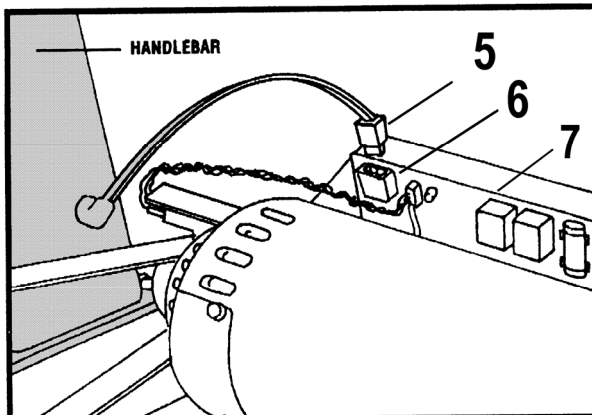

Figure 2

Figure 3:

Take one of the side rails (8) and slide the end with the grip over the end of the steel tube protruding from the control panel (9). Make sure the side rail grip touches the control panel.

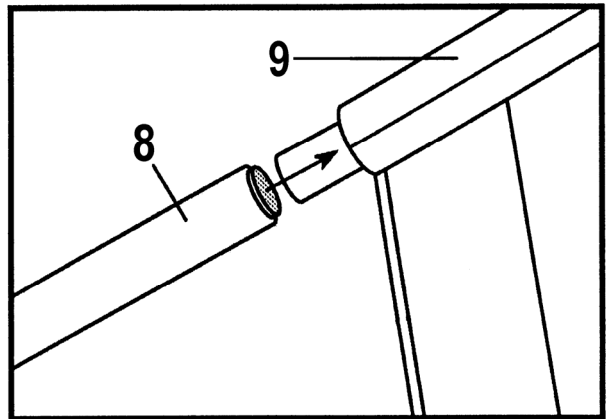

Figure 3

Figure 4:

Insert one of the 4" carriage bolts (10) through the side rail (11), the side rail bracket (12) (the foam on the bracket should be at the top, facing the frame) and finally through the frame (13). Install a 1" fender washer (14) and a 1/4-20 kep nut (15) to the bolt and hand tighten. Install the other side rail following the same procedure. Tighten both side rails with a wrench.

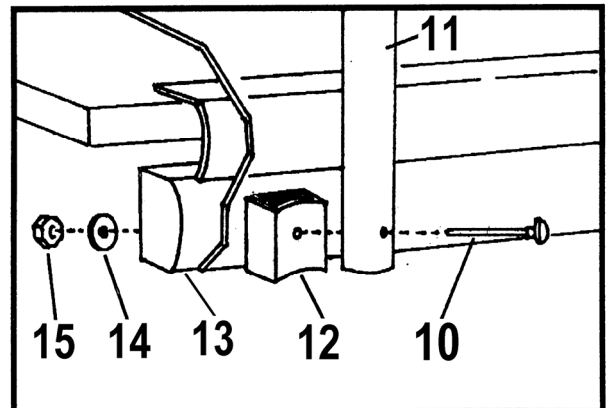

Figure 4

Figure 5:

To install the motor cover, stand in front of the treadmill. Pick up the motor cover (16) so it is level and the word **PaceMaster** is upside down. Holding the motor cover level and waist high, tilt it 45 degrees by lowering your left hand. Then slide it between the handlebars and lower the motor cover until it is level. Lower the cover all the way, keeping it level. Screw the two #8x1/2" black sheet metal screws (17) into the front of the motor cover. Press down on each side of the motor cover where it meets the black plastic shrouds to lock the Velcro pads (18) into place.

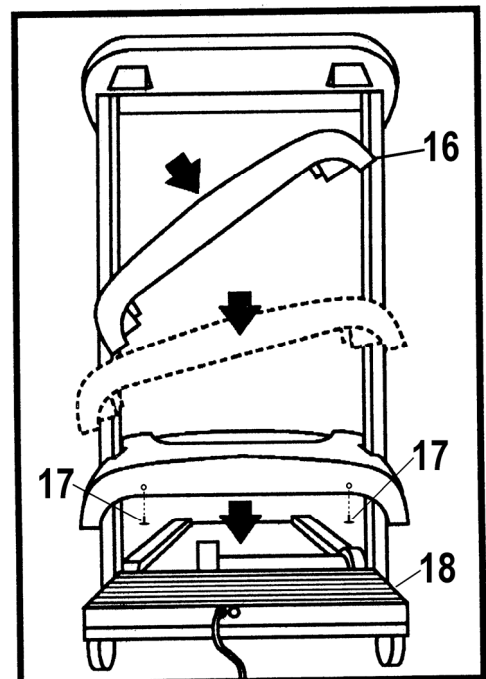

Figure 5

CAUTION: Do not raise or lower motor cover without it being level.

Testing Your Treadmill

Your ProPlus^{II} has been adjusted and tested at the factory. However, due to changes that can occur during shipment, it should be tested prior to use. Once you have assembled your treadmill and it is located where it will be used, proceed as follows. (Do not make any adjustments unless necessary.) **For the purpose of this test, DO NOT stand on the tread belt. Once tested, always start and finish on the tread belt.**

Step One:

After your treadmill is in place and plugged in to the wall outlet, insert the magnetic safety key into the recess on the control panel.

Step Two:

You will see the number **150** in the INCLINE display window and the SET WEIGHT indicator light will be blinking. This is where the user's weight is adjusted. The default weight set at the factory is 150 lbs. For the purpose of this test, it is not necessary to enter your actual weight at this time. Press the **ENTER** (PAUSE) button so the treadmill's computer will accept the information.

Step Three

Set the workout time for 3 minutes by pressing the + button in the TIME display window 3 times until the time displayed is 3:00 minutes.

Step Four:

Set the workout speed by pressing the SPEED + button until the SPEED display window shows 2.5 mph.

Step Five:

Press the **START/STOP** button. Within a few seconds, the tread belt will begin to move. If the tread belt does not move, or the treadmill stops after a few seconds and displays an error code, make a note of the error code and contact the authorized PaceMaster retailer where you purchased your treadmill.

Step Six:

After the treadmill has reached 2.5 mph, observe the tread belt to make sure it is reasonably centered. If the tread belt is not centered, immediately press the STOP button and refer to the CARE and MAINTENANCE section of this manual, under Centering The Tread Belt. Once the tread belt is centered, run the treadmill at 2.5 mph for 2 minutes to be sure it remains centered.

Step Seven:

To test the elevation, the tread belt must be moving. Press the arrow up button to raise the elevation to 3% incline. The elevation will be displayed in the INCLINE display window. Once it reaches 3%, press the down arrow button to reduce the incline to 0%. If the treadmill does not elevate, or stops after a few seconds and displays an error code, make a note of the error code and contact the authorized PaceMaster retailer where you purchased your treadmill.

THE CONTROL PANEL

ProPlus^{II}

Although the ProPlus^{II} has many advanced features to provide versatility in meeting exercise needs, basic operation is extremely easy. Basic operation involves setting your TIME and SPEED goals, then pressing the START button. Your ProPlus^{II} will gradually accelerate to the set speed, maintain that speed until the timer counts to zero, and then gradually come to a complete stop. During your exercise, your time remaining, current speed, distance traveled, calories burned, and Aerobic Points earned are displayed.

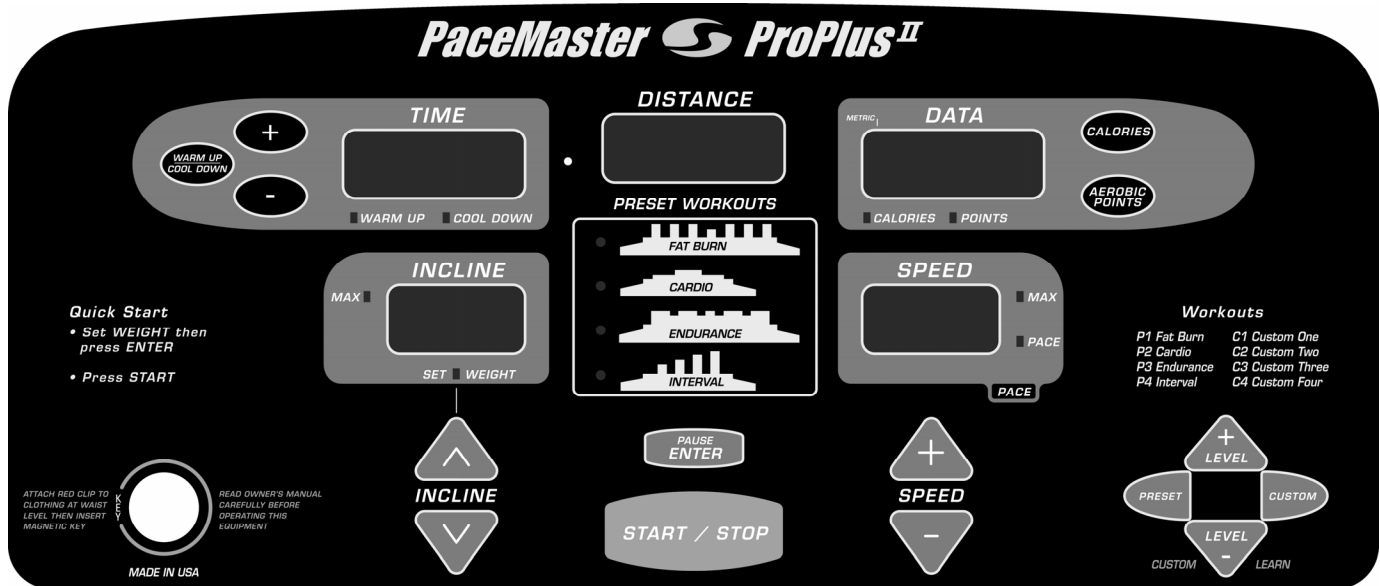

MAGNETIC SAFETY KEY - The MAGNETIC SAFETY KEY, with its red cord and garment clip, is a safety feature. Before you begin your workout, clip the safety cord to your clothing at waist level. This safety key provides a means of powering down the treadmill in an emergency situation. It is also the ON/OFF switch. The ProPlus^{II} will not operate unless the MAGNETIC SAFETY KEY is engaged. To turn your ProPlus^{II} on, insert the MAGNETIC SAFETY KEY into the recess on the control panel. During exercise, an emergency stop can be made at any time by pulling on the cord to release the key from its slot.

Using the key to stop your ProPlus^{II} is an emergency procedure only! To end your exercise routine, press the STOP button or allow the timer to count down to zero. Once your ProPlus^{II} has come to a complete stop, remove the MAGNETIC SAFETY KEY. When not in use, store the MAGNETIC SAFETY KEY in a safe place to prevent unauthorized use.

WARM UP / COOL DOWN - To achieve the maximum benefit from your workout, fitness experts advise that you warm up for a minimum of 5 minutes before and cool down for a minimum of 5 minutes after your main aerobic routine. This is a built-in feature on all PaceMaster treadmills. While in the warm up phase, the WARM UP indicator light will blink. While in the cool down phase, the COOL DOWN indicator light will blink. For details, refer to the WARM UP AND COOL DOWN section in this manual.

TIME + AND - BUTTONS - Prior to beginning your workout, these buttons are used to set your desired exercise time. Each press of the TIME + button adds 1 minute to the clock. While in a manual program, you can increase or decrease the remaining time in one-minute increments by pressing the TIME + or -- button. Time is displayed in minutes and seconds until it reaches 59 minutes and 59 seconds. Then time is displayed in hours and minutes. -1.15 represents 1 hour and 15 minutes.

TIME DISPLAY WINDOW - If you have chosen a warm up and/or cool down mode, time will be displayed as a 5-minute countdown for the warm up phase, a countdown for the main exercise phase and then a 5-minute countdown for the cool down phase. In Quick Start, the TIME DISPLAY WINDOW shows elapsed time.

DISTANCE DISPLAY WINDOW - Before beginning your program, this window displays the total distance you will exercise based on the time and speed entered. During your program, the DISTANCE DISPLAY WINDOW shows the distance thus far.

DATA DISPLAY WINDOW - When selecting a preset workout, the program and level numbers will appear in the DATA DISPLAY WINDOW. Once the program and level have been selected, the ProPlus^{II} calculates your calorie expenditure based on the weight entered and the intensity of your workout. When calories are displayed, the CALORIES indicator light will be illuminated.

Aerobic Points is a system of measuring the aerobic benefit of the workout. You can see how many Aerobic Points you have earned at any time by pressing the AEROBIC POINTS button. The POINTS indicator light will be illuminated. You can toggle between Calories and Aerobic Points by pressing the corresponding button.

When in Metric units operation (kilogram, kilometers and KPH) instead of English units (pounds, miles and MPH), the METRIC indicator light in the upper left corner of the DATA DISPLAY WINDOW will be illuminated. For details, refer to the METRIC UNITS section in this manual.

INCLINE DISPLAY WINDOW - When the magnetic safety key is inserted, the last entered weight will be displayed in the INCLINE DISPLAY WINDOW and the WEIGHT indicator light will blink. To adjust the weight, press the INCLINE arrow up or down buttons until the desired weight is displayed. Then press ENTER. Prior to beginning a preset workout, the maximum incline will be displayed and the MAX indicator light will be illuminated. Once your workout has begun, the current incline will be constantly displayed in the INCLINE DISPLAY WINDOW.

INCLINE UP AND DOWN ARROWS - Incline is adjustable from 0% to 15% in 0.5% increments. You can increase or decrease the incline by pressing the INCLINE UP OR DOWN ARROW buttons at any time during your workout. At the end of your workout, it is recommended that the elevation setting be returned to 0%.

PRESET WORKOUTS – The profiles for the preset workouts are listed here. For details, refer to the PRESET WORKOUTS section in this manual.

ENTER/PAUSE – You can put your exercise "on hold" at any time by pressing the ENTER/PAUSE button. Your ProPlus^{II} will stop, retaining the distance, calories, and Aerobic Points accumulated thus far, as well as the speed and remaining time. The SPEED display window displays -P- to indicate the PAUSE feature has been activated. To resume your workout, press START.

This button is also used to ENTER pertinent information into the treadmill's computer.

START/STOP - Press this button to start or stop your program. To begin using the Quick Start feature, press ENTER then the START button and the ProPlus^{II} will gradually accelerate. For details, refer to the QUICK START section in this manual.

SPEED DISPLAY WINDOW – Prior to beginning a preset workout, the maximum speed will be displayed here. The MAX indicator light will be illuminated. Once your workout has begun, the current speed is constantly displayed in the SPEED DISPLAY WINDOW.

By pressing the PACE button, the current pace will be displayed. The PACE indicator light will be illuminated.

When in Metric units operation (kilogram, kilometers and KPH) instead of English units (pounds, miles and MPH), the METRIC indicator light in the upper left corner of the DATA DISPLAY WINDOW will be illuminated. For details, refer to the METRIC UNITS section in this manual.

SPEED + AND – BUTTONS - Speed is adjustable from 0.7 to 11 mph in 0.1 mph increments. You can adjust your speed by pressing these buttons to increase or decrease at any time during exercise in any program.

PRESET BUTTON – Press the PRESET button until the desired program is displayed in the DATA display window. For details, refer to the PRESET WORKOUTS section in this manual.

LEVEL + / LEVEL – BUTTONS – Once the desired Preset Workout is chosen, press these buttons for the desired level of intensity. The level will be displayed in the DATA display window next to the program number. For details, refer to the PRESET WORKOUTS COURSE SPECIFICATIONS section in this manual.

CUSTOM – Press this key to choose one of four locations to create and store a new CUSTOM program or to select a previously designed program. The CUSTOM program number will be displayed in the DATA display window. For details, refer to the CUSTOM PROGRAMS section in this manual.

CUSTOM LEARN (LEVEL -) – This button must be pressed prior to creating a custom program in order for the program to be stored. When the CUSTOM LEARN feature is activated, LRN . will be displayed in the DATA display window. During your workout, LRN . will reappear in the DATA display window whenever a speed and/or elevation change has been made to signify it is "learning", or recording, the change. LRN . will disappear as soon as the treadmill's computer has accepted the change. Calories burned will then reappear. For details, refer to the CUSTOM PROGRAMS section in this manual.

OPERATING INSTRUCTIONS

Initially, you may want to keep both hands on the side rails until you feel comfortable walking on your ProPlus^{II}. Once comfortable, try removing your hands to let them swing naturally, as you would walking outdoors. Always hold on to the side rail or front handle bar with one hand when operating the buttons of the control panel.

THE FIRST STEP

Stand on the center of the treadmill belt. Attach the garment clip on the end of the magnetic safety key to your clothing at waist level. Insert the safety key into the recess on the control panel keyboard.

SETTING YOUR WEIGHT

Your PROPLUS^{II} calculates caloric expenditure based on the formula developed by the American College of Sports Medicine. To ensure accuracy, your weight is required. The default weight of 150 lbs. has been set at the factory. It is displayed in the INCLINE display window and the SET WEIGHT indicator light will be blinking. By pressing the INCLINE up or down arrow buttons, you will increase or decrease the weight. Adjust to the correct weight, then press the ENTER/PAUSE button. Once you have entered your weight, this is the number that will appear each time the treadmill is powered up until it is changed again.

METRIC UNITS

To select operation in Metric units (kilograms, kilometers and KPH) instead of English units (pounds, miles and MPH) insert the magnetic safety key. While the SET WEIGHT indicator light is blinking, press and hold the PACE button in the SPEED display window until the METRIC indicator light in the left corner of the DATA display window is illuminated.

WARM UP AND COOL DOWN

By warming up prior to beginning the aerobic phase of your workout, you accomplish 2 goals; you stretch and warm up the muscles of the back and extremities and create a slight acceleration of the heart rate so that the body can move gradually into the higher heart rate of the aerobic phase. The aerobic phase should be followed by a minimum 5-minute cool down in which you keep moving at a slower pace. This allows your heart rate to gradually decline and your body to gently adjust to the end of a workout instead of abruptly stopping. The cool down phase also allows blood to be pumped from the lower extremities back to the central circulatory system. Simply put, the function of warming up and cooling down is to ease you from a resting state into an active state and back to a resting state.

The treadmill's computer, based on your main exercise starting and finishing speeds respectively, automatically calculates warm up and cool down speeds. The program's starting and ending incline grade will be added to the warm up and cool down phases.

When in the warm up mode, the TIME display window counts down from 5 minutes, the Warm Up indicator light will blink. When in the Cool Down mode, the TIME display window counts down from 5 minutes, the Cool Down indicator light will blink.

To add warm up and/or cool down to a Manual or Custom program, press the WARM UP / COOL DOWN button. The indicator light will blink, indicating that the desired mode has been added to your workout. You will also notice that the workout time increases by 5 minutes for each addition.

To shorten the warm up mode, press the WARM UP/COOL DOWN button once. Warm up will be ended and you will advance into the main exercise. To shorten the main exercise, press the WARM UP/ COOL DOWN button and you will automatically begin the cool down phase. To end the cool down, press STOP and your session will come to a close.

A cool down phase can be added to any program (even if it wasn't chosen prior to beginning the workout) by pressing the WARM UP/COOL DOWN button before the clock counter reaches 0. When in Quick Start, press the WARM UP/COOL DOWN button when you are ready to end your workout and a 5-minute cool down phase will begin.

Now you are ready to choose your workout mode whether it is Quick Start, Manual, one of the four Preset Workouts or one of the four Custom programs. The following pages give you step-by-step instructions on how to use each program.

QUICK START

Once you have entered your weight, Quick Start allows you to begin your workout by pressing one button. You control the speed, incline and time.

To begin using QUICK START:

Step One:

Stand on the running belt and attach the garment clip on the end of the magnetic safety key to your clothing. Insert the safety key into its recess on the control panel.

TIP: If the magnetic safety key was not removed since the treadmill was last used, skip to Step Three

Step Two:

Enter your weight as described in the OPERATING INSTRUCTIONS, SETTING YOUR WEIGHT.

Step Three:

Press START and your ProPlus^{II} will gradually accelerate until it reaches 1 mph. Or you can enter a specific starting speed prior to pressing START and the treadmill will gradually accelerate until it reaches your desired speed.

- Adjust the speed at any time during your workout by pressing the SPEED + and – buttons. Speed will adjust in 0.1 mph increments
- Add incline at any time during your workout by pressing the incline up and down arrow buttons. Elevation will adjust in 0.5% increments.

TIP: You can pause your program at any time by pressing the PAUSE button. To resume, press the START button.

To end your workout, press the STOP button. The treadmill will display the total time, calories expended, Aerobic Points earned and distance.

If a problem should occur, your ProPlus^{II} can be stopped quickly by pulling on the magnetic safety cord to dislodge the key from the control panel. The treadmill will stop a bit more abruptly, but still gently enough to prevent you from being injured. **This is an emergency procedure only and should not be used as the normal stopping procedure.**

MANUAL OPERATION

Manual operation allows you to choose the length of time and the degree of intensity for your workout. You can make speed and incline adjustments at any time during the program.

To begin using MANUAL OPERATION:

Step One:

Stand on the running belt and attach the garment clip attached to the end of the magnetic safety key to your clothing. Insert the safety key into its recess on the control panel.

TIP: If the magnetic safety key was not removed since the treadmill was last used, skip to Step Three

Step Two:

Enter your weight as described in the OPERATING INSTRUCTIONS, SETTING YOUR WEIGHT.

Step Three:

Enter the starting speed by press the SPEED + button until the desired speed appears in the SPEED display window. Speed can be adjusted at any time during your workout.

Step Four:

Enter the workout time by pressing the TIME + button in the TIME display window until the desired workout time appears.

- If you wish to include warm up and/or cool down to your program, press the WARM UP/COOL DOWN button until the indicator light next to the desired mode is illuminated. You will notice that your workout time will automatically increase by 5 minutes for each addition. For details, refer to the WARM UP AND COOL DOWN section in this manual.
- Adjust incline by pressing the INCLINE up or down arrow buttons. Elevation will be adjusted in 0.5% increments.

Step Five:

Press START and your ProPlus^{II} will gradually accelerate until it reaches the entered speed. To end your workout, either allow the timer to count down to zero or press the STOP button. The treadmill will display total time, calories expended, Aerobic Points earned and distance.

Tip: You can pause your workout at any time by pressing the PAUSE button. To resume, press the START button.

If a problem should occur, your ProPlus^{II} can be stopped quickly by pulling on the magnetic safety cord to dislodge the key from the control panel. The treadmill will stop a bit more abruptly, but still gently enough to prevent you from being injured. **This is an emergency procedure only and should not be used as the normal stopping procedure.**

PRESET WORKOUTS

To assist you in reaching your fitness goals, your ProPlus^{II} comes with 4 Preset workouts- Fat Burn, Cardio, Endurance and Interval. These specifically designed courses each offer 9 different levels of intensity, giving you 36 different workout possibilities. During your workout, you will be alerted to any speed and/or elevation changes in the program with 3 beeps and a flashing speed and/or incline display, then the new speed and/or incline will be displayed

To begin using a PRESET WORKOUT:**Step One:**

Stand on the running belt and attach the garment clip on the end of the magnetic safety key to your clothing. Insert the safety key into its recess on the control panel.

TIP: If the magnetic safety key was not removed since the treadmill was last used, skip to Step Three

Step Two:

Enter your weight as described in the OPERATING INSTRUCTIONS, SETTING YOUR WEIGHT.

Step Three:

Press the PRESET button until the indicator light next to the desired program is illuminated. The program number will be displayed in the DATA display window. Press the + LEVEL button to adjust the level of intensity. The level will be displayed in the DATA display window next to the program number. The maximum speed for that level will be displayed in the SPEED display window and the maximum incline for that level will be displayed in the INCLINE display window. The MAX indicator lights will also be illuminated. You can adjust the level of intensity at any time during your workout by pressing the + LEVEL or LEVEL - buttons.

TIP: The ProPlus^{II} provides you with a “preview” of all of your accomplishments prior to beginning your workout. Total distance is displayed after you select the program and the intensity level. Press the **CALORIES** button for the total caloric expenditure and the **AEROBIC POINTS** button for the total points you will earn. If your goals are different that the program provides, you know that you will need to adjust the intensity level.

Step Four:

Warm up and cool down periods are automatically added to all the preset workouts. If you wish to delete the warm up and/or cool down phases, press the WARM UP / COOL DOWN button until the corresponding indicator light is no longer illuminated.

Step Five:

Press START and your ProPlus^{II} will gradually accelerate. Your workout will end when the timer has counted down to zero or the STOP button is pressed. Total time, calories expended, Aerobic Points earned and total distance will be displayed.

TIP: You can pause your workout at any time by pressing the PAUSE button. To resume, press the START button.

If a problem should occur, your ProPlus^{II} can be stopped quickly by pulling on the magnetic safety cord to dislodge the key from the Control Panel. The treadmill will stop a bit more abruptly, but still gently enough to prevent you from being injured. **This is an emergency procedure only and should not be used as the normal stopping procedure.**

Preset workout course specifications

CUSTOM WORKOUTS

Your ProPlus^{II} offers an easy way for you to create your own programs, customized to your specific fitness level and goals.

To create a CUSTOM PROGRAM:

Step One:

Stand on the running belt and attach the garment clip on the end of the magnetic safety key to your clothing. Insert the safety key into its recess on the control panel.

TIP: If the magnetic safety key was not removed since the treadmill was last used, skip to Step Three.

Step Two:

Enter your weight as described in the OPERATING INSTRUCTIONS, SETTING YOUR WEIGHT.

Step Three:

Press the CUSTOM button to choose an open location, 1 through 4, to store your program. C1, C2, C3 or C4 will be displayed in the DATA display window.

Step Four:

Press the CUSTOM LEARN (LEVEL -) button. C1 L will appear in the DATA display window. (This will erase any program previously stored in this position.) If L is not displayed, your program will not be stored for future use.

Step Five:

Enter the desired starting speed by pressing the SPEED + button. Incline can be added by pressing the INCLINE up arrow button.

Step Six:

Enter your workout time using TIME + button in the TIME display window. If a warm up and/or cool down phase is desired, press the WARM UP/COOL DOWN button until the indicator lights are illuminated.

TIP: It is not necessary to enter a workout time. If no time is entered, the TIME clock will count up to a maximum of 8 hours.

Step Seven:

Press START. LRN . will then disappear from the DATA display window and calorie expenditure will appear. As you are exercising, you can make speed and/or incline adjustments as desired. Each time a change is made, LRN . will appear in the DATA display window, indicating the treadmill's computer is recording the change. As soon as the change is recorded, LRN . will disappear and additional changes can be made. Speed and incline changes can be made simultaneously.

Your workout will end when the timer has counted down to zero or the STOP button has been pressed. **Do not end your workout by removing the safety magnetic or your program will not be recorded.** The treadmill will display total time, calories expended, Aerobic Points earned and total distance.

If a problem should occur, your ProPlus^{II} can be stopped quickly by pulling on the magnetic safety cord to dislodge the key from the control panel. The treadmill will stop a bit more abruptly, but still gently enough to prevent you from being injured. **This is an emergency procedure only and should not be used as the normal stopping procedure.**

EXCLUSIVE PROPLUS^{II} FEATURES

Exercise Preview

You can see exactly what you will accomplish prior to beginning a Manual, Preset Workout or previously recorded Custom program. An EXERCISE PREVIEW predicts the total distance, caloric expenditure and Aerobic Points to be earned based on the time, incline and speed you choose. After you have selected a Preset Workout, a previously-recorded Custom program or have set the speed, time and incline parameters for a Manual program, press the CALORIES button to see the total calories you will burn or the AEROBIC POINTS button for the number of points you will earn. Note that any adjustments to speed, time and incline will change those figures. To get calorie or Aerobic Point information while exercising, press the corresponding button.

Aerobic Points

One of the main reasons people stop exercising is because they don't see the physical changes they expected. Results, however, can only be realized when you are training properly. For this reason, the Aerobic Point System has been incorporated into the design of PaceMaster treadmills since 1968.

The Aerobic Point System was developed by Dr. Kenneth Cooper, the Father of Aerobics and renowned founder of The Cooper Aerobics Center in Dallas, TX, to measure the aerobic benefit of the workout. Dr. Cooper's formula compares the energy costs of aerobic activity from the mathematical relationships between the oxygen expenditures assigned to each exercise at a given intensity and duration. This formula is built into the ProPlus^{II} computer to automatically calculate the number of AEROBIC POINTS you earn for each workout

Dr. Cooper states in his book, *The Aerobics Program For Total Well Being*; "The main idea of this system is that, in order to stay in good shape and move toward a goal of total well-being, a person must earn a certain number of points each week by doing a certain amount of aerobic exercise." His research has determined that a man should **work up to** a minimum of 32 points per week and a woman should **work up to** a minimum of 27 points per week. The number of weekly points you earn correlates with your level of fitness. The fitness categories are:

Classification	Average Points Per Week	
	Men	Women
Very Poor	Less than 10	Less than 8
Poor	10-20	8-15
Fair	21-31	16-26
Good	32-50	27-40
Excellent	51-74	41-64
Superior	75+	65+

If you have not been on a regular exercise program, it is highly recommended that you gradually work up to your desired fitness category and then develop a maintenance program.

You can see the number of AEROBIC POINTS you will earn prior to beginning your program by pressing the AEROBIC POINTS button. To design a program based on the number of AEROBIC POINTS you want to earn, follow the instructions below for PERSONAL ELECTRONIC TRAINER.

Personal Electronic Trainer

Another feature exclusive to PaceMaster treadmills is the PERSONAL ELECTRONIC TRAINER. You can create a workout based on the number of Aerobic Points you want to earn or the number of calories you want to burn.

To create a workout based on Aerobic Points:

Step One:

Determine how many times a week you will be exercising and how many weekly points you want to earn. For example, if you plan on exercising 4 times a week and your goal is to earn 32 points that week, you will need to earn 8 points per workout.

Step Two:

Press the **AEROBIC POINTS** button.

Step Three:

Enter your workout time and warm up and/or cool down, if desired.

Step Four:

Enter speed. You will begin to see the number of Aerobic points you will earn in the DATA display window as you increase the speed.

To create a workout based on calorie expenditure, determine how many calories you want to burn. Press the **CALORIES** button and follow steps 3 and 4 above.

Care and Maintenance

The following section describes necessary maintenance for your ProPlus^{II} treadmill. This maintenance is the responsibility of the purchaser and is not covered under our warranty. Failure to perform this necessary maintenance could result in damage to your treadmill.

CAUTION: Be sure to unplug your treadmill before attempting any cleaning or maintenance.

Deck and Tread Belt Cleaning

The running belt on your ProPlus^{II} rides on a low friction, **maintenance-free** deck. Proper operation will be jeopardized if any water, dirt, solvents, fluids or abrasive materials come between the tread belt and the deck. For this reason, extra care must be used in keeping the belt clean. Use a soft, damp cloth to remove dust, dirt and other substances from the area between the belt and the side of the machine. Do not clean the tread belt by turning on the treadmill.

Lubrication

The motor and roller bearings are sealed for maintenance free operation and require no lubrication. The deck and tread belt are lubricated at the factory and are also maintenance free. Any attempt to lubricate underneath the running belt will result in damage, especially if silicone or any other lubricant is used.

The side rails are made of steel. By occasionally applying a coat of automotive wax to them will help prevent rusting.

Centering the Tread Belt

To improve belt life, the belt should be reasonably centered. To center the belt, walk on the treadmill at 2.5 mph for a few minutes. Determine whether the belt drifts too far to the left or right side. If adjustments are required, stop the treadmill and follow the steps listed below. Never make adjustments while the tread belt is moving.

WARNING: Never make any unnecessary adjustments.

CAUTION: The power must be turned off before making adjustments.

Step One:

If the belt is drifting to the left, using a 3/16" Allen wrench, turn the left-hand adjustment bolt (1) a quarter turn clockwise and the right-hand adjustment bolt (2) a quarter turn counter-clockwise.

If the belt is drifting to the right, using a 3/16" Allen wrench, turn the right-hand adjustment bolt (2) a quarter turn clockwise and the left-hand adjustment bolt (1) a quarter turn counter-clockwise.

Step Two:

Walk on the belt for 1 minute, observing belt tracking. If the belt moves to one side, repeat step 1.

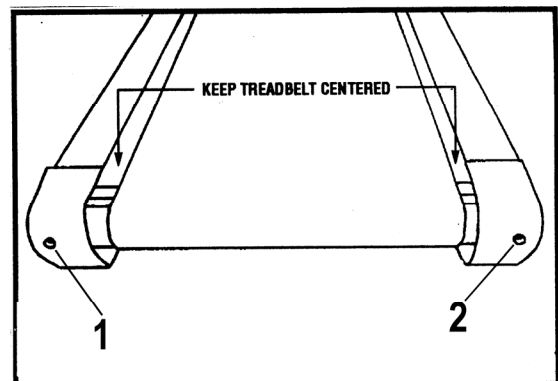

Figure 6

TROUBLESHOOTING

Electronic Error Codes

Your self-diagnostic ProPlus^{II} treadmill has built in sensors that will determine the precise reason for a problem. If the onboard computer detects a problem, an error code will be displayed. If an error code appears during operation of your treadmill, do the following:

- Make a note of the error code number.
- Obtain your serial number, located on the front of the treadmill approximately 10-12 inches to the left of the power cord.
- Write down which mode of operation you were using, the speed and incline that were set and if you were pressing any buttons at the time.
- Contact the PaceMaster dealer where you purchased your treadmill. If you have moved or need the name of the local dealer, visit our website at www.pacemaster.com <<http://www.pacemaster.com>> and choose the dealer locator to find this information.

Hesitation of the Tread belt

Hesitation of the tread belt usually indicates slippage of either the tread belt (the belt you walk on) or the drive belt (the belt connecting the drive roller to the motor). To determine which of these belts is slipping, first adjust the drive belt tension and test to see if the slippage stops. If the hesitation is not corrected than the tread belt tension needs adjustment.

CAUTION: The power must be turned off before making adjustments.

Drive Belt Tension Adjustment

Step One:

Use a Phillips head screwdriver to remove the 2 screws that hold the front of the motor cover in place and remove the motor cover.

Step Two:

Locate the four motor mount screws (1) as shown in the diagram and loosen them each two turns each using the 3/16" allen wrench.

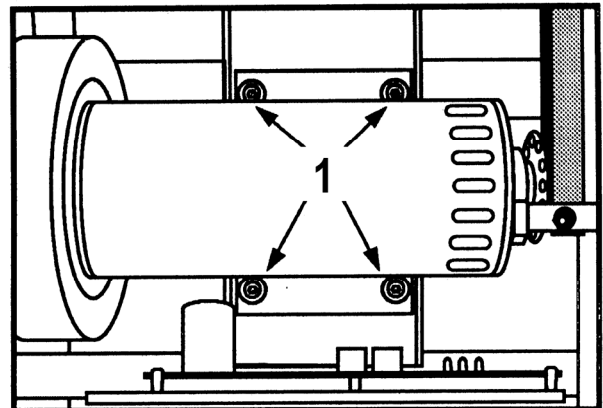

Figure 7

Step Three:

Locate the drive belt adjustment screw (2) in the lower front end of the treadmill. Insert the allen wrench into the drive belt adjustment screw. Turn the screw 1/2 turn clockwise.

Step Four:

Complete the adjustment by tightening the four motor mount screws (1).

Step Five:

Walk on the treadmill to determine if the slippage is decreased or eliminated.

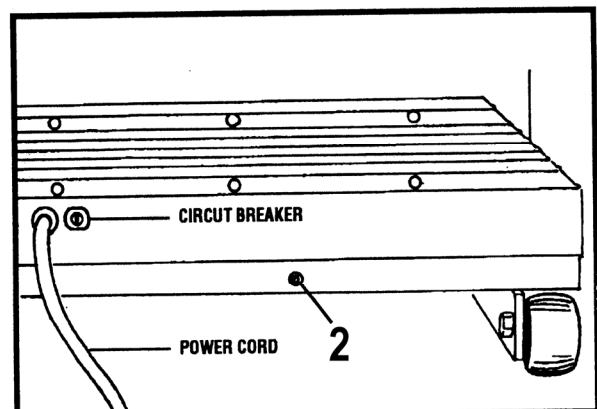

Figure 8

Step Six:

If no improvement is observed, the hesitation may be caused by a loose tread belt - see "Tread belt tension adjustment" below. If improvement is noticed but slippage is still present, repeat the procedure and test again. If you tighten the drive belt adjustment screw 1 1/2 turns and there is still hesitation (slippage) contact your authorized PaceMaster dealer. Tightening the drive belt adjustment screw more than 1 1/2 turns can result in bearing damage to the motor and/or drive roller.

Tread Belt Tension Adjustment

Step One:

Locate the two tread belt adjustment screws (3) and (4) as shown.

Step Two:

Turn both the left and right tread belt adjustment screws 1/2 turn clockwise.

Step Three:

Walk on the treadmill to see if the adjustment you made decreased the slippage.

Step Four:

If a significant decrease in slippage was observed, go to step 2. If you tighten the tread belt 1 1/2 turns per side and slippage is still present, do not continue to adjust the tread belt tension. Contact your authorized PaceMaster dealer.

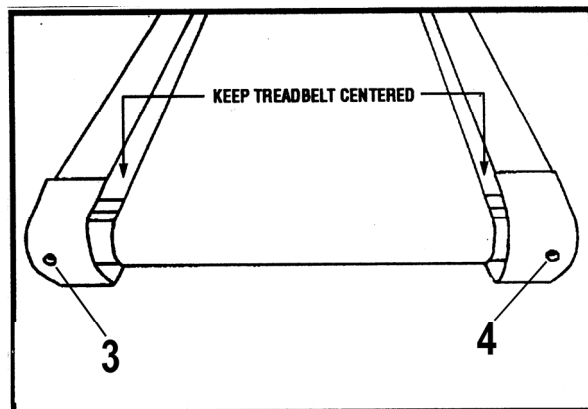

Figure 9

FREQUENTLY ASKED QUESTIONS

- Q.** Why is time displayed as a negative number (- 1:15) ?
- A.** The treadmill's computer displays time in minutes and seconds until it reaches 59 minutes and 59 seconds. At that point, the clock will display in hours and minutes. - 1:15 represents one hour and 15 minutes.
- Q.** Why can't I change the speed in warm up or cool down?
- A.** Warm up and cool down speeds are based on parameters recommended by the American College of Sports Medicine and cannot be overridden. To avoid undue cardiovascular stress, warm up begins at a lower percentage of the programs starting speed and gradually takes you to the programs starting speed. Conversely, cool down gradually reduces speed based on a percentage of the programs ending speed.
- Q.** How do I find out the total miles and time on my treadmill?
- A.** Insert the magnetic safety key and, prior to pressing the ENTER button, press the CUSTOM button. The total mileage and time will appear in their respective windows.
- Q.** Why can't I pause my workout when I'm in a heart rate control program?
- A.** The PAUSE feature is disabled in any heart rate control program to avoid undue cardiovascular stress.
- Q.** Can I add time to a preset workout?
- A.** The user is NOT able to add time to any preset workout.
- Q.** I changed one of the factory set *Body For Life* custom programs. Can I get it back?
- A.** Yes. Press the CUSTOM button until the desired custom location is displayed in the DATA display window. Press the CUSTOM LEARN (LEVEL -) button as if to record a program, then press enter. After a few seconds, pull the safety magnetic key. This will cause the treadmill's computer to revert back to the *Body for Life* workout that was preprogrammed at the factory.
- Q.** Can I eliminate warm up and cool down from a Preset Workout?
- A.** Yes. While in the warm up mode, press the WARM UP/COOL DOWN button and you will advance into the main phase of your workout. While in the cool down mode, press the WARM UP/COOL DOWN button to end your workout.
- Q.** Why is white and/or black dust accumulating underneath my treadmill?
- A.** This is normal. The white dust is excess paraffin wax that acts as the lubricant between the bed and belt. The black dust is a combination of the PVC belt material and the phenolic deck surface as it wears.

ProPlus^{II} Technical Specifications

Overall Dimensions	68"L x 30.5" W x 54"H
Treadmill Weight	180 lbs.
Frame	Welded aircraft grade extruded aluminum alloy
Running Surface	54"L x 20"W
Drive Motor	2.75 HP continuous duty DC with angled brushes
Motor Manufacturer	Pacific Scientific
Motor Control	PWM (Pulse Width Modulation)
Elevation Motor	1000 lb. thrust
Belt	Multi-ply, no stretch polyester with static dispersing fibers
Deck	Maintenance Free custom designed medium density fiberboard with phenolic surface
Rollers	2.5" OD precision machined steel with permanently lubricated, sealed bearings
Shock Absorption System	Tri-Flex™ Low Impact Cushioning System
Speed Range	0.7 to 11mph adjustable in 0.1 mph increments
Elevation Range	0 to 15% grade adjustable in 0.5% increments
Workout Programs	Quick Start, Manual, 4 Preset Workouts (each with 9 levels) and 4 Custom
Weight Limit	350 lbs. (159 kilos)
Warranty	Lifetime Frame, 5 Years Motor, 3 Years Parts, 1 Year Labor
Operating Temperature Range	50° F to 100° F

© Aerobics, Inc. 2000
PaceMaster is a registered trademark of Aerobics Inc.