

# Panasonic®

## Installation Manual Pure IP-PBX



Model No. **KX-NCP500**  
**KX-NCP1000**



Thank you for purchasing a Panasonic Pure IP-PBX.  
Please read this manual carefully before using this product and save this manual for future use.

**KX-NCP500/KX-NCP1000: PBMPR Software File Version 5.0000 or later**



SD Logo is  
a trademark of  
SD-3C, LLC.

Document Version: 2011-10

# System Components

System Components Table

Category	Model No.	Description
<b>Main Unit</b>	KX-NCP500	Main Unit
	KX-NCP1000	Main Unit
<b>Main Processing Card</b>		IP Convergence Main Processing Card (IPCMPR)
<b>IPCMPR Option Cards</b>	KX-NCP1104	4-Channel VoIP DSP Card (DSP4)
	KX-TDE0110	16-Channel VoIP DSP Card (DSP16)
	KX-TDE0111	64-Channel VoIP DSP Card (DSP64)
	KX-TDA0196	Remote Card (RMT)
<b>Activation Key Codes<sup>1</sup></b>	KX-NCS3102	2-Channel IP Trunk Activation Key (2 IP Trunk)
	KX-NCS3104	4-Channel IP Trunk Activation Key (4 IP Trunk)
	KX-NCS3201	1-Channel IP Softphone/IP Proprietary Telephone Activation Key (1 IP Softphone/IP PT)
	KX-NCS3204	4-Channel IP Softphone/IP Proprietary Telephone Activation Key (4 IP Softphone/IP PT)
	KX-NCS3208	8-Channel IP Softphone/IP Proprietary Telephone Activation Key (8 IP Softphone/IP PT)
	KX-NCS3216	16-Channel IP Softphone/IP Proprietary Telephone Activation Key (16 IP Softphone/IP PT)
	KX-NCS3501	1-Channel IP Proprietary Telephone Activation Key (1 IP PT)
	KX-NCS3504	4-Channel IP Proprietary Telephone Activation Key (4 IP PT)
	KX-NCS3508	8-Channel IP Proprietary Telephone Activation Key (8 IP PT)
	KX-NCS3516	16-Channel IP Proprietary Telephone Activation Key (16 IP PT)
	KX-NCS3701	1-Channel SIP Extension Activation Key (1 SIP Extension)
	KX-NCS3704	4-Channel SIP Extension Activation Key (4 SIP Extension)
	KX-NCS3708	8-Channel SIP Extension Activation Key (8 SIP Extension)
	KX-NCS3716	16-Channel SIP Extension Activation Key (16 SIP Extension)
	KX-NCS3910	Activation Key for Software Upgrade to Enhanced Version (Software Upgrade 01)
	KX-NCS2201	Activation Key for CA PRO for 1 User (CA Pro 1user)

Category	Model No.	Description
	KX-NCS2205	Activation Key for CA PRO for 5 Users (CA Pro 5users)
	KX-NCS2210	Activation Key for CA PRO for 10 Users (CA Pro 10users)
	KX-NCS2240	Activation Key for CA PRO for 40 Users (CA Pro 40users)
	KX-NCS2249	Activation Key for CA PRO for 128 Users (CA Pro 128users)
	KX-NCS2301	Activation Key for CA ACD Monitor for 1 ICD Supervisor (CA Supervisor 1user)
<b>Virtual CO Line Cards</b>	-	Virtual 16-Channel VoIP Gateway Card (V-IPGW16) Virtual 16-Channel SIP CO Line Card (V-SIPGW16)
<b>Virtual Extension Cards</b>	- - -	Virtual 32-Channel VoIP Extension Card (V-IPEXT32) Virtual 32-Channel SIP Extension Card (V-SIPEXT32) Virtual 4 IP Cell Station Interface Card (V-IPCS4)
<b>Small Free Slot</b>		
<b>Physical CO Line Cards</b>	KX-NCP1180	4-Port Analog Trunk Card (LCOT4)
	KX-NCP1290	PRI Card (PRI23)
<b>Physical Extension Card</b>	KX-NCP1170	4-Port Digital Hybrid Extension Card (DHLC4)
<b>Regular Free Slot</b>		
<b>Physical CO Line Card</b>	KX-NCP1187	T-1 Trunk Card (T1)
<b>Physical Extension Cards</b>	KX-NCP1171	8-Port Digital Extension Card (DLC8)
	KX-NCP1172	16-Port Digital Extension Card (DLC16)
	KX-NCP1173	8-Port Single Line Telephone Extension Card (SLC8)
	KX-NCP1174	16-Port Single Line Telephone Extension Card (SLC16)
<b>Other Physical Card</b>	KX-NCP1190	Optional 3-Slot Base Card (OPB3)
<b>OPB3</b>		

Category		Model No.	Description
Other Physical Cards		KX-TDA0161	4-Port Doorphone Card (DPH4)
		KX-TDA0164	4-Port External Input/Output Card (EIO4)
		KX-TDA0166	16-Channel Echo Canceller Card (ECHO16)
		KX-TDA0191	4-Channel Message Card (MSG4)
		KX-TDA0194	4-Channel Simplified Voice Message Card (ESVM4)
Cell Stations (CSs)	2.4 GHz	KX-T0141	2-Channel Cell Station Unit Using a DHLC/DLC Card (PT-interface CS) for 2.4 GHz Portable Station
		KX-T0151	2-Channel Cell Station Unit Using a DHLC/DLC Card (PT-interface CS) for 2.4 GHz Portable Station
	DECT 6.0	KX-T0155	DECT 6.0 2-Channel Cell Station Unit Using a DHLC/DLC Card (PT-interface CS) for DECT 6.0 Portable Station
		KX-T0158	DECT 6.0 8-Channel Cell Station Unit Using a DHLC/DLC Card (PT-interface CS) for DECT 6.0 Portable Station
		KX-NCP0158	DECT 6.0 8-Channel IP Cell Station Unit Using a V-IPCS4 Card for DECT 6.0 Portable Station
	Proprietary Equipment		KX-T30865 KX-T7765 KX-T7775

\*1 Note that the types of activation keys are subject to change without notice. For CA activation keys, refer to the documentation for CA.

## Equipment Compatibility

### Compatible Panasonic Proprietary Telephones

The PBX supports the following telephones:

- IP proprietary telephones (e.g., KX-NT300 series)
- IP softphones (e.g., KX-TDA0350)
- Digital proprietary telephones (e.g., KX-DT300 series)
- Analog proprietary telephones (e.g., KX-T7700 series)
- Portable stations (e.g., KX-WT125, KX-TD7690)
- DSS consoles (e.g., KX-DT390)
- Single line telephones

### Incompatible Panasonic Proprietary Telephones

The PBX does not support the following telephones:

- KX-T30800 series proprietary telephones and DSS consoles
- KX-T61600 series proprietary telephones and DSS consoles
- KX-T123200 series proprietary telephones and DSS consoles
- KX-NT136 IP proprietary telephone
- KX-NT265 IP proprietary telephone (apart from software version 2.00 or later)

**Note**

- For the equipment (e.g., Add-on Key Module, USB Module, Headset<sup>\*1</sup>) that can be connected to a particular telephone, refer to the telephone's manual.
  - For other equipment that can be connected to the PBX, refer to "1.1.2 System Connection Diagram".
- <sup>\*1</sup> The KX-T7090 headset can be connected to the KX-T7000, KX-T7200, KX-T7300, and KX-T7400 series telephones.

**Notice**

- This PBX supports SIP Extensions. However, some PBX features may not be available for SIP Extensions, depending on your telephone type.
- Under power failure conditions, the connected telephones may not operate. Please ensure that a separate telephone, not dependent on local power, is available for emergency use.
- Prior to connection of this product, please verify that the intended operating environment is supported. Satisfactory performance cannot be guaranteed for the following:
  - interoperability and compatibility with all devices and systems connected to this product
  - proper operation and compatibility with services provided by telecommunications companies over connected networks

**List of Abbreviations**

- APT → Analog Proprietary Telephone
- CA → Communication Assistant
- DPT → Digital Proprietary Telephone
- IP-PT → IP Proprietary Telephone
- PS → Portable Station
- PT → Proprietary Telephone
- SIP Extension → Session Initiation Protocol Extension (SIP hardphones/SIP softphones)
- SLT → Single Line Telephone

# Safety Notices

Please observe the safety notices in this manual in order to avoid danger to users or other people, and prevent damage to property.

The notices are classified as follows, according to the severity of injury or damage:



## **WARNING**

This notice means that misuse could result in death or serious injury.



## **CAUTION**

This notice means that misuse could result in injury or damage to property.

# Important Information

## SAVE THESE INSTRUCTIONS



### WARNING

#### SAFETY REQUIREMENTS

##### For All Telephone Equipment

- Do not install the product in any other way than described in relevant manuals.
- The product must only be installed and serviced by qualified service personnel. The product should be used as-is from the time of purchase; it should not be disassembled or modified. Disassembly or modification can cause a fire, electric shock, or damage to the product.
- Do not install the product in a place exposed to rain or moisture, or a place where water, oil, or other liquids can drip or splash onto the product. Such conditions can lead to fire or electric shock, and may impair the performance of the product.
- Follow all warnings and instructions marked on the product.
- Do not place the product on an unstable or uneven surface. If the product were to fall over, it may cause injury or damage to the product.
- Products that require a power source should only be connected to the type of electrical power supply specified on the product label. If you are not sure of the type of power supply to your home, consult your dealer or local power company.
- For safety purposes some products are equipped with a grounded plug. If you do not have a grounded outlet, please have one installed. Do not bypass this safety feature by tampering with the plug.
- Do not supply power to a combination of devices that exceeds the total rated capacity of the wall outlets or extension cables used. If outlets, power strips, extension cords, etc. are used in a manner that exceeds their rated capacity, they emit large amounts of heat, which could cause a fire.
- Unplug the product from the wall outlet and have it serviced by qualified service personnel in the following cases:
  - a. When the power supply cord or plug is damaged or frayed.
  - b. If liquid has been spilled into the product.
  - c. If the product has been exposed to rain or water.
  - d. If the product does not operate according to the operating instructions. Adjust only the controls that are explained in the operating instructions. Improper adjustment of other controls may result in damage and may require service by a qualified technician to restore the product to normal operation.
  - e. If the product has been dropped or the cabinet has been damaged.
  - f. If product performance deteriorates.

##### For the PBX

- Only use the 19-inch rack mounting equipment (attachment bracket, screws) included with the PBX.
- If damage to the unit exposes any internal parts, disconnect the power supply cord immediately and return the unit to your dealer.
- To prevent fires, electric shock, injury, or damage to the product, be sure to follow these guidelines when performing any wiring or cabling:
  - a. Before performing any wiring or cabling, unplug the product's power cord from the outlet. After completing all wiring and cabling, plug the power cord back into the outlet.
  - b. When laying cables, do not bundle the product's power cord with the power cords of other devices.
  - c. Do not place any objects on top of the cables connected to the PBX.
  - d. When running cables along the floor, use protectors to prevent the cables from being stepped on.

- e. Do not run any cables under carpeting.
- Unplug this unit from the AC outlet if it emits smoke, an abnormal smell or makes unusual noise. These conditions can cause fire or electric shock. Confirm that smoke has stopped and contact an authorized Panasonic Factory Service Center.
- Do not insert objects of any kind into this product, as they may touch dangerous voltage points or short out parts that could result in a fire or electric shock.



## CAUTION

### SAFETY REQUIREMENTS

#### For All Telephone Equipment

- The product should be kept free of dust, moisture, high temperature (more than 40 °C [104 °F]) and vibration, and should not be exposed to direct sunlight.
- Unplug the product from the wall outlet before cleaning. Wipe the product with a soft cloth. Do not clean with abrasive powders or with chemical agents such as benzene or thinner. Do not use liquid cleaners or aerosol cleaners.

#### For the PBX

- Before touching the product (PBX, cards, etc.), discharge static electricity by touching ground or wearing a grounding strap. Failure to do so may cause the PBX to malfunction due to static electricity.
- When relocating the equipment, first disconnect the telecom connection before disconnecting the power connection. When the unit is installed in the new location, reconnect the power first, and then reconnect the telecom connection.
- The power supply cord is used as the main disconnect device. Ensure that the AC outlet is located near the equipment and is easily accessible.
- The SD Memory Card poses a choking hazard. Keep the SD Memory Card out of reach of children.
- Slots and openings in the front, back and bottom of the cabinet are provided for ventilation; to protect it from overheating, these openings must not be blocked or covered. The openings should never be blocked by placing the product on a bed, sofa, rug, or other similar surface while in use. The product should never be placed near or over a radiator or other heat source. This product should not be placed in a sealed environment unless proper ventilation is provided.
- When this product is no longer in use, make sure to detach it from the rack.

### SECURITY REQUIREMENTS

In order to use the PBX safely and correctly, the Security Requirements below must be observed. Failure to do so may result in:

- Loss, leakage, falsification or theft of user information.
- Illegal use of the PBX by a third party.
- Interference or suspension of service caused by a third party.

#### What is User Information?

User Information is defined as:

1. Information stored on the SD Memory Card  
Phonebook data, user IDs, system settings data, passwords (User/Administrator/Installer), Personal Identification Numbers (PINs), etc.
2. Information sent from the PBX to a PC or other external device:  
Phone call data (including telephone numbers of outside parties), call charge data, etc.

### **Requirements**

1. The SD Memory Card contains software for all the processes of the PBX and all customer data. It can be easily removed and taken away from the PBX by a third party. Therefore, do not allow unauthorized access to prevent data leakage.
2. Always make backups of data stored on the SD Memory Card. For details, refer to "2.6.2 Utility—File Transfer PC to PBX (SD Card)" and "2.6.3 Utility—File Transfer PBX (SD Card) to PC" in the PC Programming Manual.
3. To prevent illegal access from the Internet, activate a Firewall.
4. To avoid unauthorized access and possible abuse of the PBX, we strongly recommend:
  - a. Keeping the password secret.
  - b. Selecting a complex, random password that cannot be easily guessed.
  - c. Changing your password regularly.
5. Perform the following when sending the PBX for repair or handing it over to a third party.
  - a. Make a backup of data stored on the SD Memory Card.
  - b. Using an SD formatter, format the SD Memory Card so that information cannot be retrieved from it.
6. To prevent data leakage, render the SD Memory Card physically unusable before disposal.
7. When user information is sent from the PBX to a PC or other external device, the confidentiality of that information becomes the responsibility of the customer. Before disposing of the PC or other external device, ensure that data cannot be retrieved from it by formatting the hard disk and/or rendering it physically unusable.

### **Notice**

#### **SAFETY REQUIREMENTS**

##### **For All Telephone Equipment**

- Read and understand all instructions.

##### **For the PBX**

- Keep the unit away from heating appliances and devices that generate electrical noise such as fluorescent lamps, motors and televisions. These noise sources can interfere with the performance of the PBX.
- If you are having problems making calls to outside destinations, follow this procedure to test the CO lines:
  - a. Disconnect the PBX from all CO lines.
  - b. Connect known working SLTs to those CO lines.
  - c. Make a call to an external destination using those SLTs.

If a call cannot be carried out correctly, there may be a problem with the CO line that the SLT is connected to. Contact your telephone company.

If all SLTs operate properly, there may be a problem with your PBX. Do not reconnect the PBX to the CO lines until it has been serviced by an authorized Panasonic Factory Service Center

## ***Important Safety Instructions***

When using your telephone equipment, basic safety precautions should always be followed to reduce the risk of fire, electric shock and injury to persons, including the following:

- Do not use the product near water, for example, near a bathtub, wash bowl, kitchen sink, or laundry tub, in a wet basement, or near a swimming pool.
- Avoid using wired telephones during an electrical storm. There is a remote risk of electric shock from lightning.
- Do not use a telephone in the vicinity of a gas leak to report the leak.
- Rack Mount Instructions—The following or similar rack-mount instructions are included with the installation instructions:
  - a. Elevated Operating Ambient—If installed in a closed or multi-unit rack assembly, the operating ambient temperature of the rack environment may be greater than room ambient. Therefore, consideration should be given to installing the equipment in an environment compatible with the maximum ambient temperature (T<sub>ma</sub>) specified by the manufacturer.
  - b. Reliable Earthing—Reliable earthing of rack-mounted equipment should be maintained. Particular attention should be given to supply connections other than direct connections to the branch circuit (e.g., use of power strips).

**SAVE THESE INSTRUCTIONS**

## ***Precaution***

### **WARNING**

**DO NOT REMOVE  
SD MEMORY CARD  
WHILE POWER IS  
SUPPLIED TO THE PBX**

**Doing so may cause the PBX to fail to  
start when you try to restart the system.**

## Password Security

### **CAUTION**

#### ***To the Administrator or Installer regarding the system password***

1. Please provide all system passwords to the customer.
2. To avoid unauthorized access and possible abuse of the PBX, keep the passwords secret, and inform the customer of the importance of the passwords, and the possible dangers if they become known to others.
3. The PBX has default passwords preset. For security, change these passwords the first time that you program the PBX.
4. Change the passwords periodically.
5. It is strongly recommended that passwords of 10 numbers or characters be used for maximum protection against unauthorized access. For a list of numbers and characters that can be used in system passwords, refer to "1.1.2 Entering Characters" in the PC Programming Manual.
6. If a system password is forgotten, it can be found by loading a backup of the system data into a PC, and checking the password using the Maintenance Console software. If you do not have a backup of the system data, you must reset the PBX to its factory defaults and reprogram it. Therefore, we strongly recommend maintaining a backup of the system data. For more information on how to back up the system data, refer to "2.5.1 Tool—SD memory backup" in the PC Programming Manual. However, as system passwords can be extracted from backup copies of the system data file, do not allow unauthorized access to these files.

### **Notice for users in California**

**This product contains a CR coin cell lithium battery that contains perchlorate material—special handling may apply.**

**See [www.dtsc.ca.gov/hazardouswaste/perchlorate](http://www.dtsc.ca.gov/hazardouswaste/perchlorate)**

# Introduction

This Installation Manual is designed to serve as an overall technical reference for the Panasonic Pure IP-PBX, KX-NCP500/KX-NCP1000. It provides instructions for installing the hardware, and programming the PBX using the Maintenance Console.

## The Structure of this Manual

This manual contains the following sections:

### Section 1 System Outline

Provides general information on the PBX, including the system capacity and specifications.

### Section 2 Activation Key Installation

Describes information on activation keys, including how to obtain an activation key and install it in the SD Memory Card.

### Section 3 Installation

Describes the procedures to install the PBX. Detailed instructions for planning the installation site, installing the shelves and optional service cards, and cabling of peripheral equipment are provided. Further information on system expansion and peripheral equipment installation is included.

### Section 4 Guide for the Maintenance Console

Explains the installation procedure, structure, and basic information of the Maintenance Console.

### Section 5 Troubleshooting

Provides information on the PBX and telephone troubleshooting.

## About the Other Manuals

Along with this Installation Manual, the following manuals are available:

### Feature Manual

Describes all basic, optional and programmable features of the PBX.

### PC Programming Manual

Provides step-by-step instructions for performing system programming using a PC.

### PT Programming Manual

Provides step-by-step instructions for performing system programming using a PT.

### Operating Manual

Provides operating instructions for end users using a PT, SLT, PS, or DSS Console.

## About the software version of your PBX

The contents of this manual apply to PBXs with a certain software version, as indicated on the cover of this manual. To confirm the software version of your PBX, see "How do I confirm the software version of the PBX or installed cards?" in 2.7.1 Frequently Asked Questions (FAQ) of the PC Programming Manual, or "[190] Main Processing (MPR) Software Version Reference" in the PT Programming Manual.

## Trademarks

- The Bluetooth® word mark and logos are owned by the Bluetooth SIG, Inc. and any use of such marks by Panasonic Corporation is under license.
- Microsoft, Windows and Windows Vista are either registered trademarks or trademarks of Microsoft Corporation in the United States and/or other countries.
- All other trademarks identified herein are the property of their respective owners.
- Microsoft product screen shot(s) reprinted with permission from Microsoft Corporation.

# F.C.C. REQUIREMENTS AND RELEVANT INFORMATION

## 1. Notification to the Telephone Company

This equipment complies with Part 68 of the FCC rules and the requirements adopted by the ACTA. On the side of this equipment is a label that contains, among other information, a product identifier in the format US: ACJMF04BKX-NCP500. If requested, this number must be provided to the telephone company. Installation must be performed by a qualified professional installer. If required, provide the telephone company with the following technical information:

- Telephone numbers to which the system will be connected
- Make: Panasonic
- Model: KX-NCP500 and KX-NCP1000
- Certification No.: found on the side of the unit
- Ringer Equivalence No.: 0.4B
- Facility Interface Code: 02LS2, 04DU9.BN/DN/1KN/1SN
- Service Order Code: 9.0F, 6.0P
- Required Network Interface Jack: RJ45S, RJ48C

## 2. Ringer Equivalence Number (REN)

The REN is used to determine the number of devices that may be connected to a telephone line. Excessive RENs on a telephone line may result in the devices not ringing in response to an incoming call. In most but not all areas, the sum of RENs should not exceed five (5.0). To be certain of the number of devices that may be connected to a line, as determined by the total RENs, contact the local telephone company. The REN for this product is part of the product identifier that has the format US: ACJMF04BKX-NCP500. The digits represented by 04 are the REN without a decimal point (e.g., 04 is a REN of 0.4). For earlier products, the REN is separately shown on the label.

## 3. Incidence of Harm to the Telephone Lines

If this equipment causes harm to the telephone network, the telephone company will notify you in advance that temporary discontinuance of service may be required. But if advance notice isn't practical, the telephone company will notify the customer as soon as possible. Also, you will be advised of your right to file a complaint with the FCC if you believe it is necessary.

## 4. Changes in Telephone Company Communications Facilities, Equipment, Operations and Procedures

The telephone company may make changes in its facilities, equipment, operations or procedures that could affect the operation of the equipment. If this happens the telephone company will provide advance notice in order for you to make necessary modifications to maintain uninterrupted service.

## 5. Trouble with this equipment

If trouble is experienced with this equipment, for repair or warranty information, please see the attached warranty, which includes the Service Center Directory. If the equipment is causing harm to the telephone network, the telephone company may request that you disconnect the equipment until the problem is resolved.

## 6. Connection to Party Line

Connection to party line service is subject to state tariffs. Contact the state public utility commission, public service commission or corporation commission for information.

## 7. Combined Use with Alarm Equipment

If your home has specially wired alarm equipment connected to the telephone line, ensure the installation of this equipment does not disable your alarm equipment. If you have questions about what will disable alarm equipment, consult your telephone company or a qualified installer.

### Note

This equipment has been tested and found to comply with the limits for a Class B digital device, pursuant to Part 15 of the FCC Rules. These limits are designed to provide reasonable protection against harmful

interference in a residential installation. This equipment generates, uses, and can radiate radio frequency energy and, if not installed and used in accordance with the instructions, may cause harmful interference to radio communications. However, there is no guarantee that interference will not occur in a particular installation. If this equipment does cause harmful interference to radio or television reception, which can be determined by turning the equipment off and on, the user is encouraged to try to correct the interference by one or more of the following measures:

- Reorient or relocate the receiving antenna.
- Increase the separation between the equipment and receiver.
- Connect the equipment into an outlet on a circuit different from that to which the receiver is connected.
- Consult the dealer or an experienced radio/TV technician for help.

**CAUTION**

- Any changes or modifications not expressly approved by the party responsible for compliance could void the user's authority to operate this device.
- When programming emergency numbers and/or making test calls to emergency numbers:
  1. Remain on the line and briefly explain to the dispatcher the reason for the call before hanging up.
  2. Perform such activities in the off-peak hours, such as early morning hours or late evenings.
- The software contained in the ARS and TRS features to allow user access to the network must be upgraded to recognize newly established network area codes and exchange codes as they are placed into service. Failure to upgrade the premises PBXs or peripheral equipment to recognize the new codes as they are established will restrict the customer and the customer's employees from gaining access to the network and to these codes.

KEEP THE SOFTWARE UP-TO-DATE WITH THE LATEST DATA.

# Table of Contents

<b>1</b>	<b>System Outline</b>	<b>19</b>
1.1	<b>Basic System Construction</b>	<b>20</b>
1.1.1	Main Unit	20
1.1.2	System Connection Diagram	21
1.2	<b>Optional Equipment</b>	<b>23</b>
1.2.1	Optional Equipment	23
1.3	<b>Specifications</b>	<b>25</b>
1.3.1	General Description	25
1.3.2	Characteristics	27
1.3.3	System Capacity	28
<b>2</b>	<b>Activation Key Installation</b>	<b>37</b>
2.1	<b>Information about the Activation Keys</b>	<b>38</b>
2.1.1	Activation Keys	38
2.1.2	Activation Key Code and Key Management System	43
2.1.3	Activation Key File	44
<b>3</b>	<b>Installation</b>	<b>45</b>
3.1	<b>Before Installation</b>	<b>46</b>
3.1.1	Before Installation	46
3.2	<b>Installation of the PBX</b>	<b>48</b>
3.2.1	Unpacking	48
3.2.2	Names and Locations	49
3.2.3	Frame Ground Connection	50
3.2.4	Installing/Removing the Optional Service Cards	51
3.2.5	Types of Connectors	53
3.2.6	Attaching a Ferrite Core	54
3.2.7	19-inch Rack Mounting	55
3.2.8	Floor Standing	56
3.2.9	Surge Protector Installation	57
3.3	<b>Information about the Main Processing Card</b>	<b>60</b>
3.3.1	IPCMPR Card	60
3.3.2	DSP4 Card (KX-NCP1104), DSP16 Card (KX-TDE0110), and DSP64 Card (KX-TDE0111)	63
3.3.3	RMT Card (KX-TDA0196)	65
3.4	<b>Information about the Virtual Cards</b>	<b>66</b>
3.4.1	Virtual Cards	66
3.5	<b>Information about the Physical CO Line Cards</b>	<b>67</b>
3.5.1	LCOT4 Card (KX-NCP1180)	67
3.5.2	T1 Card (KX-NCP1187)	69
3.5.3	PRI23 Card (KX-NCP1290)	71
3.6	<b>Information about the Physical Extension Cards</b>	<b>73</b>
3.6.1	DHLC4 Card (KX-NCP1170)	73
3.6.2	DLC8 Card (KX-NCP1171)	75
3.6.3	DLC16 Card (KX-NCP1172)	76
3.6.4	SLC8 Card (KX-NCP1173)	77
3.6.5	SLC16 Card (KX-NCP1174)	78
3.7	<b>Information about the Other Physical Cards</b>	<b>79</b>
3.7.1	OPB3 Card (KX-NCP1190)	79
3.7.2	DPH4 Card (KX-TDA0161)	80
3.7.3	EIO4 Card (KX-TDA0164)	82
3.7.4	ECHO16 Card (KX-TDA0166)	85

3.7.5	MSG4 Card (KX-TDA0191)	86
3.7.6	ESVM4 Card (KX-TDA0194)	87
<b>3.8</b>	<b>Connection of Extensions</b>	<b>88</b>
3.8.1	Maximum Cabling Distances of the Extension Wiring (Twisted Cable)	88
3.8.2	Parallel Connection of the Extensions	90
3.8.3	Digital EXtra Device Port (Digital XDP) Connection	93
3.8.4	First Party Call Control CTI Connection	97
<b>3.9</b>	<b>Connection of Doorphones, Door Openers, External Sensors, and External Relays</b>	<b>98</b>
3.9.1	Connection of Doorphones, Door Openers, External Sensors, and External Relays	98
<b>3.10</b>	<b>Connection of Peripherals</b>	<b>101</b>
3.10.1	Connection of Peripherals	101
<b>3.11</b>	<b>LAN Connection</b>	<b>105</b>
3.11.1	LAN Connection	105
<b>3.12</b>	<b>Power Failure Connections</b>	<b>106</b>
3.12.1	Power Failure Connections	106
<b>3.13</b>	<b>Starting the PBX</b>	<b>108</b>
3.13.1	Starting the PBX	108
<b>4</b>	<b>Guide for the Maintenance Console</b>	<b>111</b>
<b>4.1</b>	<b>Overview</b>	<b>112</b>
4.1.1	Overview	112
<b>4.2</b>	<b>PC Connection</b>	<b>113</b>
4.2.1	PC Connection	113
<b>4.3</b>	<b>Installation of the Maintenance Console</b>	<b>115</b>
4.3.1	Installing and Starting the Maintenance Console	115
<b>5</b>	<b>Troubleshooting</b>	<b>119</b>
<b>5.1</b>	<b>Troubleshooting</b>	<b>120</b>
5.1.1	Installation	120
5.1.2	Connection	123
5.1.3	Operation	125
5.1.4	Using the Reset Button	127
5.1.5	Troubleshooting by Error Log	128
<b>6</b>	<b>Appendix</b>	<b>131</b>
<b>6.1</b>	<b>Revision History</b>	<b>132</b>
6.1.1	PBMPR Software File Version 1.01xx	132
6.1.2	PBMPR Software File Version 2.02xx	133
6.1.3	PBMPR Software File Version 4.1xxx	134
6.1.4	PBMPR Software File Version 5.0xxx	135
	<b>Index</b>	<b>137</b>



---

# **Section 1**

## **System Outline**

*This section provides general information on the PBX, including the system capacity and specifications.*

# 1.1 Basic System Construction

## 1.1.1 Main Unit

The main unit contains a power supply unit (PSU) and an IPCMPR card for starting and controlling the PBX.

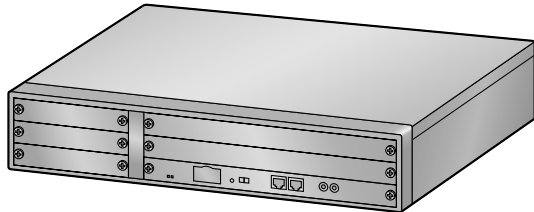

KX-NCP500

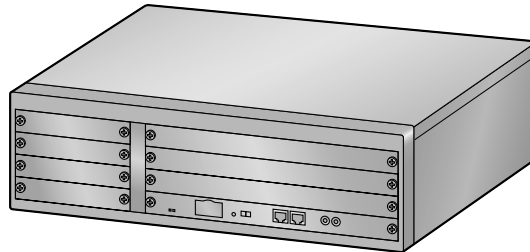

KX-NCP1000

## Construction of the Main Unit

### A. IPCMPR Card

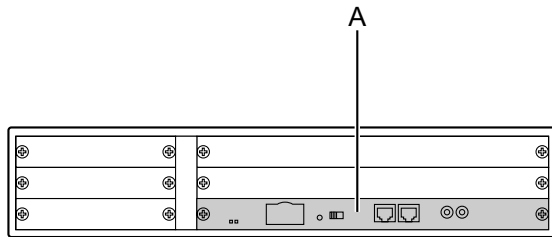

KX-NCP500

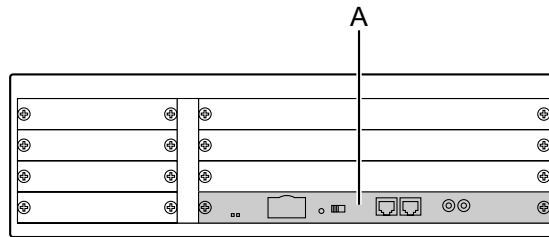

KX-NCP1000

# 1.1.2 System Connection Diagram

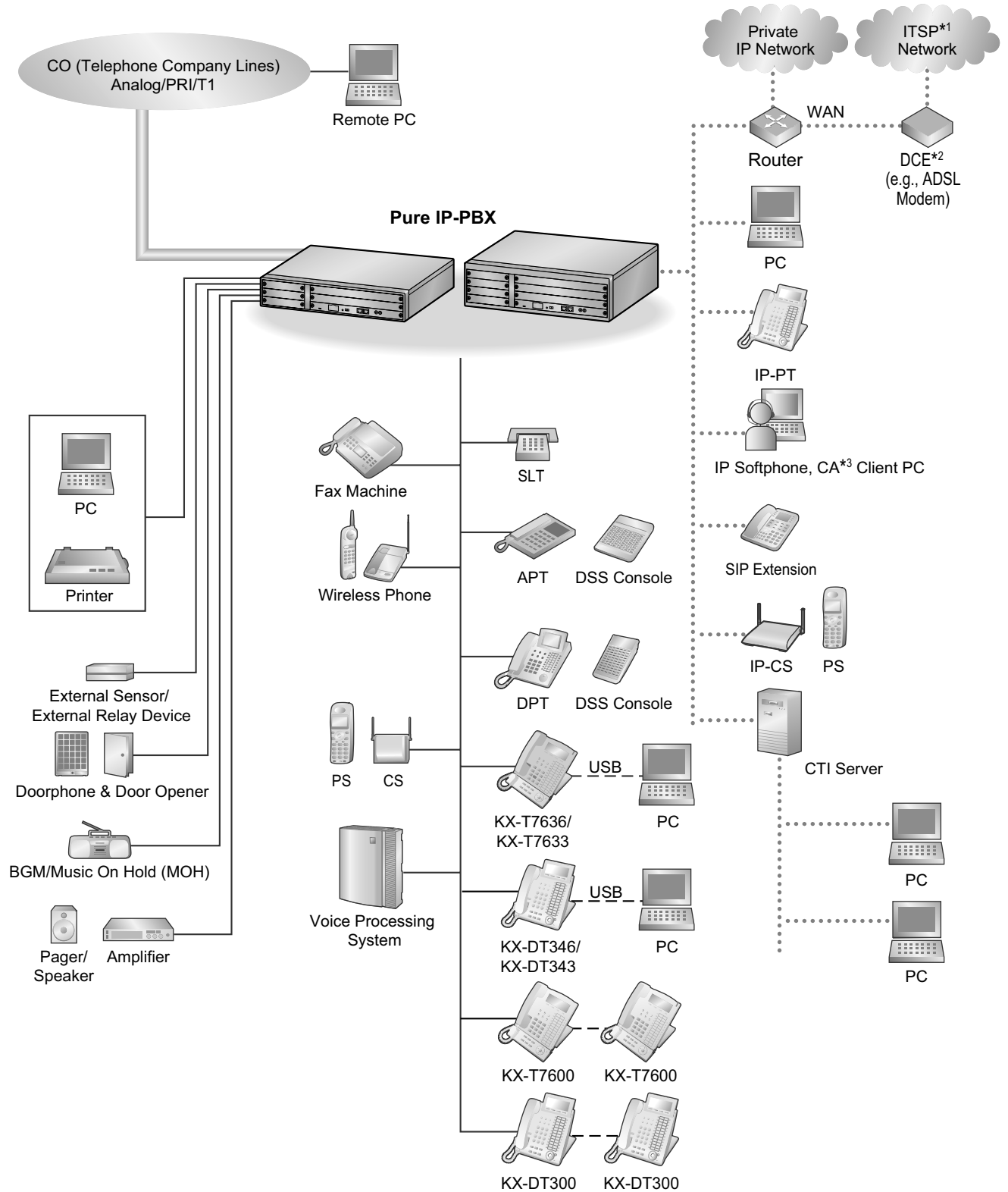

\*1 ITSP: Internet Telephony Service Provider  
 \*2 DCE: Data Circuit Terminating Equipment  
 \*3 CA: Communication Assistant

## 1.1.2 System Connection Diagram

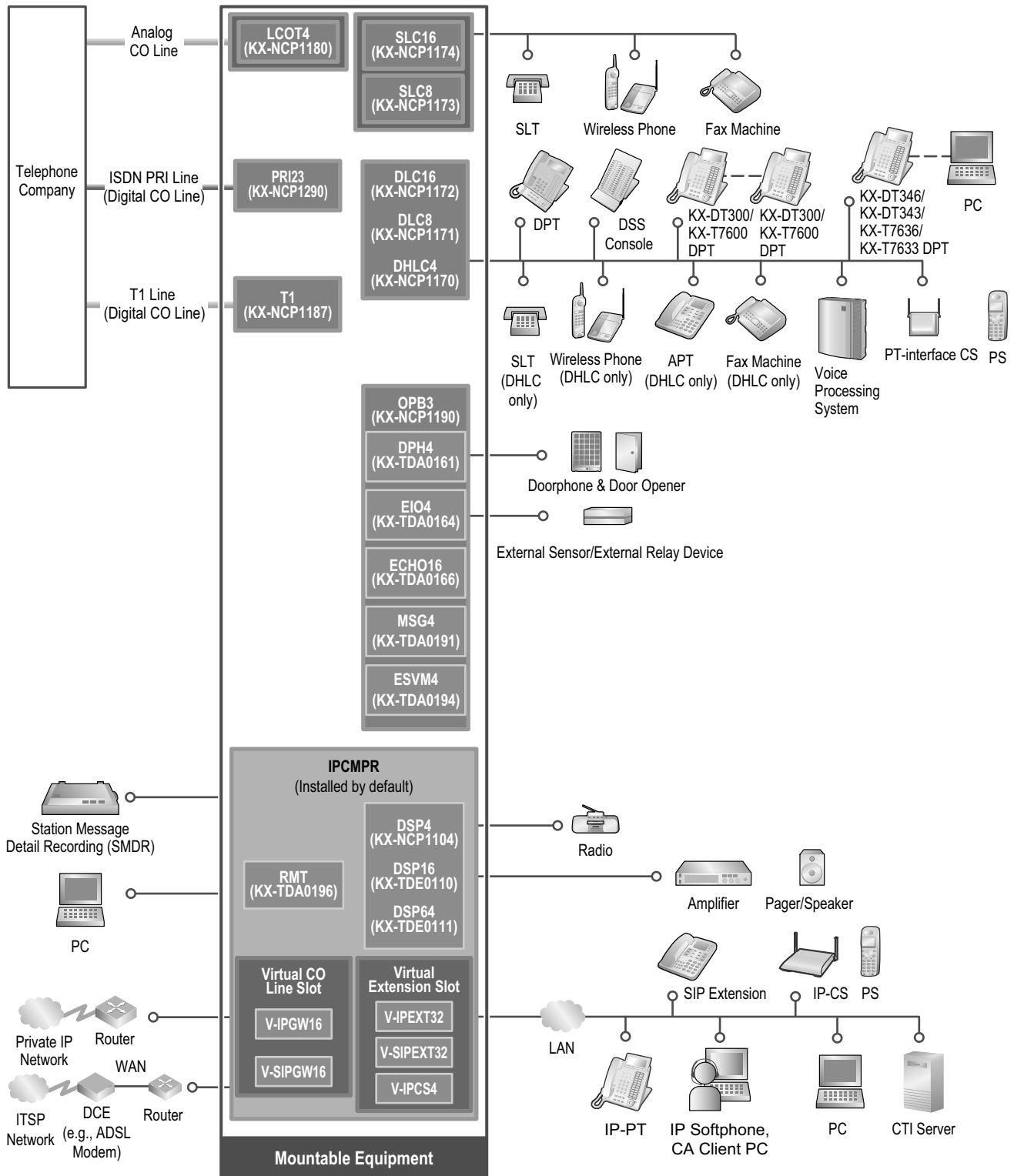

## 1.2 Optional Equipment

### 1.2.1 Optional Equipment

Model No.	Model Name	Description
KX-NCP1104	4-Channel VoIP DSP Card (DSP4)	4-channel digital signal processor card with a 4-Channel IP Trunk activation key and an 8-Channel IP Proprietary Telephone activation key preinstalled. Compliant with ITU-T G.729A and G.711 codec methods. To be mounted on the IPCMPR card.
KX-NCP1170	4-Port Digital Hybrid Extension Card (DHLC4)	4-port digital hybrid extension card for DPTs, APTs, SLTs, DSS consoles, and PT-interface CSs, with 1 power failure transfer (PFT) port.
KX-NCP1171	8-Port Digital Extension Card (DLC8)	8-port digital extension card for DPTs, DSS consoles, and PT-interface CSs.
KX-NCP1172	16-Port Digital Extension Card (DLC16)	16-port digital extension card for DPTs, DSS consoles, and PT-interface CSs.
KX-NCP1173	8-Port Single Line Telephone Extension Card (SLC8)	8-Port Single Line Telephone Extension Card (SLC8)
KX-NCP1174	16-Port Single Line Telephone Extension Card (SLC16)	16-Port Single Line Telephone Extension Card (SLC16)
KX-NCP1180	4-Port Analog Trunk Card (LCOT4)	4-port analog CO line card with 1 power failure transfer (PFT) port.
KX-NCP1187	T-1 Trunk Card (T1)	1-port T1 CO line card. EIA/TIA standard compliant.
KX-NCP1190	Optional 3-Slot Base Card (OPB3)	Optional 3-slot base card for mounting a maximum of 3 option cards.
KX-NCP1290	PRI Card (PRI23)	1-port ISDN Primary Rate Interface card (23B channels). NI (North American standard ISDN protocol) compliant.
KX-TDA0161	4-Port Doorphone Card (DPH4)	4-port doorphone card for 4 doorphones and 4 door openers. To be mounted on the OPB3 card.
KX-TDA0164	4-Port External Input/Output Card (EIO4)	4-port external input/output card. To be mounted on the OPB3 card.
KX-TDA0166	16-Channel Echo Cancellation Card (ECHO16)	16-channel card for echo cancellation during conferences. To be mounted on the OPB3 card.
KX-TDA0191	4-Channel Message Card (MSG4)	4-channel message card. To be mounted on the OPB3 card.
KX-TDA0194	4-Channel Simplified Voice Message Card (ESVM4)	4-channel simplified voice message card for Simplified Voice Message feature. Also supports MSG card features. To be mounted on the OPB3 card.

## 1.2.1 Optional Equipment

---

Model No.	Model Name	Description
KX-TDA0196	Remote Card (RMT)	Analog modem card for remote communication with the PBX. ITU-T V.90 support. To be mounted on the IPCMPR card.
KX-TDE0110	16-Channel VoIP DSP Card (DSP16)	16-channel digital signal processor card with a 4-Channel IP Trunk activation key and an 8-Channel IP Proprietary Telephone activation key preinstalled. Compliant with ITU-T G.729A and G.711 codec methods. To be mounted on the IPCMPR card.
KX-TDE0111	64-Channel VoIP DSP Card (DSP64)	64-channel digital signal processor card with four 4-Channel IP Trunk activation keys and four 8-Channel IP Proprietary Telephone activation keys preinstalled. Compliant with ITU-T G.729A and G.711 codec methods. To be mounted on the IPCMPR card.

### **Note**

For the maximum number of optional service cards that can be installed in the PBX, refer to "1.3.3 System Capacity".

## 1.3 Specifications

### 1.3.1 General Description

<b>Control Bus</b>		Original bus (16-bit, 8 MHz, 10 megabytes per second)
<b>Communication Bus</b>		H.100 bus conformity (1024 time slots)
<b>Switching</b>		Non-blocking
<b>Power Input</b>	<b>KX-NCP500</b>	100 V AC to 130 V AC; 1.0 A/200 V AC to 240 V AC; 0.6 A; 50 Hz/60 Hz
	<b>KX-NCP1000</b>	100 V AC to 130 V AC; 1.3 A/200 V AC to 240 V AC; 0.8 A; 50 Hz/60 Hz
<b>Power Consumption (when fully mounted)</b>	<b>KX-NCP500</b>	51 W (240 V: 122 VA, 200 V: 113 VA, 130 V: 100 VA, 100 V: 92 VA)
	<b>KX-NCP1000</b>	65 W (240 V: 142 VA, 200 V: 134 VA, 130 V: 119 VA, 100 V: 113 VA)
<b>Maximum Power Failure Tolerance<sup>*1</sup></b>		300 ms
<b>Memory Backup Duration</b>		7 years
<b>Dialing</b>	<b>CO Line</b>	Dial Pulse (DP) 10 pps, 20 pps Tone (DTMF) Dialing
	<b>Extension</b>	Dial Pulse (DP) 10 pps, 20 pps Tone (DTMF) Dialing
<b>Mode Conversion</b>		DP-DTMF, DTMF-DP
<b>Ring Frequency</b>		20 Hz/25 Hz (selectable)
<b>Central Office Loop Limit</b>		1600 $\Omega$ maximum
<b>Operating Environment</b>	<b>Temperature</b>	0 °C to 40 °C (32 °F to 104 °F)
	<b>Humidity</b>	10 % to 90 % (non-condensing)
<b>Conference Call CO Line</b>		From 10 $\times$ 3-party conference call to 4 $\times$ 8-party conference call
<b>Music on Hold (MOH)</b>		1 port (Level Control: -6 dB to +6 dB per 3 dB) MOH1: Selectable Internal/External Music Source port
<b>Paging</b>	<b>Internal</b>	Level Control: -6 dB to +3 dB per 3 dB
	<b>External</b>	1 port (Volume Control: -15 dB to +6 dB per 3 dB)
<b>Serial Interface Port</b>	<b>RS-232C</b>	1 (maximum 115.2 kbps)
<b>RJ45 Port</b>	<b>MNT Port</b>	1 (for PC connection)
	<b>LAN Port</b>	1 (for LAN connection)

### 1.3.1 General Description

<b>Extension Connection Cable</b>		SLT	1-pair wire (T, R)
		DPT	1-pair wire (D1, D2) or 2-pair wire (T, R, D1, D2)
		APT	2-pair wire (T, R, D1, D2)
		PT-interface CS (2-channel)	1-pair wire (D1, D2)
		PT-interface CS (8-channel)	4-pair wire (D1, D2)
		DSS Console and Add-on Key Module	1-pair wire (D1, D2)
<b>Dimension</b>	<b>KX-NCP500</b>	430 mm (W) × 88 mm (H) × 340 mm (D) (17 in × 3-1/2 in × 13-3/8 in)	
	<b>KX-NCP1000</b>	430 mm (W) × 130 mm (H) × 340 mm (D) (17 in × 5-1/8 in × 13-3/8 in)	
<b>Weight (when fully mounted)</b>	<b>KX-NCP500</b>	Under 7 kg (15.4 lb)	
	<b>KX-NCP1000</b>	Under 8 kg (17.6 lb)	

\*1 If tolerance may be exceeded, an Uninterruptible Power Supply (UPS) is recommended.

## 1.3.2 Characteristics

<b>Terminal Equipment Loop Limit</b>	<ul style="list-style-type: none"> <li>• PT: KX-DT300/KX-T7600 series DPT: 90 <math>\Omega</math>; all other DPTs/APTs: 40 <math>\Omega</math></li> <li>• SLT: 600 <math>\Omega</math> including set</li> <li>• Doorphone: 20 <math>\Omega</math></li> <li>• CS: 65 <math>\Omega</math></li> </ul>
<b>Minimum Leakage Resistance</b>	15 000 $\Omega$ minimum
<b>Maximum Number of Extension Instruments per Line</b>	<ol style="list-style-type: none"> <li>1. for PT or SLT</li> <li>2. by Parallel or eXtra Device Port connection of an APT/DPT and an SLT</li> <li>3. by Digital eXtra Device Port connection of 2 DPTs and an SLT</li> </ol>
<b>Ring Voltage</b>	75 Vrms at 20 Hz/25 Hz depending on the Ringing Load
<b>Central Office Loop Limit</b>	1600 $\Omega$ maximum
<b>Hookswitch Flash Timing Range</b>	24 ms to 2032 ms
<b>Door Opener Current Limit</b>	24 V DC/30 V AC, 1 A maximum
<b>External Relay Current Limit</b>	24 V DC/30 V AC, 1 A maximum
<b>External Sensor Current Limit</b>	Power to the external sensor is provided from the EIO4 card and must be grounded through the EIO4 card. For the connection diagram, refer to "3.7.3 EIO4 Card (KX-TDA0164)". The PBX detects input from the sensor when the signal is under 100 $\Omega$ .
<b>Paging Terminal Impedance</b>	600 $\Omega$
<b>MOH (Music on Hold) Terminal Impedance</b>	10 000 $\Omega$

## 1.3.3 System Capacity

### Type and Maximum Number of Slots

The PBX supports the following type and number of slots.

Slot Type		Maximum Number	
		KX-NCP500	KX-NCP1000
IPCMPR Card Slot		1	1
Regular Free Slot		2	3
Small Free Slot		3	4
Virtual Slot	Virtual CO Line Slot	4	4
	Virtual Extension Slot	4	4

#### IPCMPR Card Slot and Free Slots

**KX-NCP500**

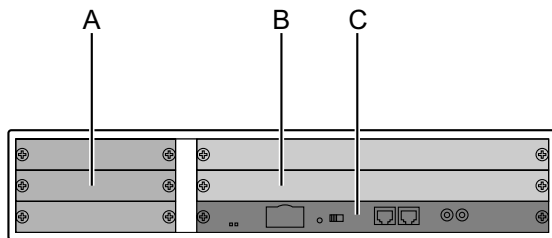

**KX-NCP1000**

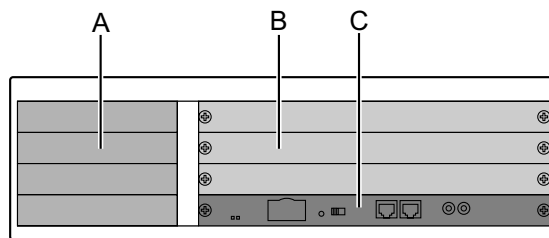

- A.** Small Free Slots
- B.** Regular Free Slots
- C.** IPCMPR Card Slot

### Virtual Slots of the IPCMPR Card

Example: Virtual Slots of the KX-NCP1000

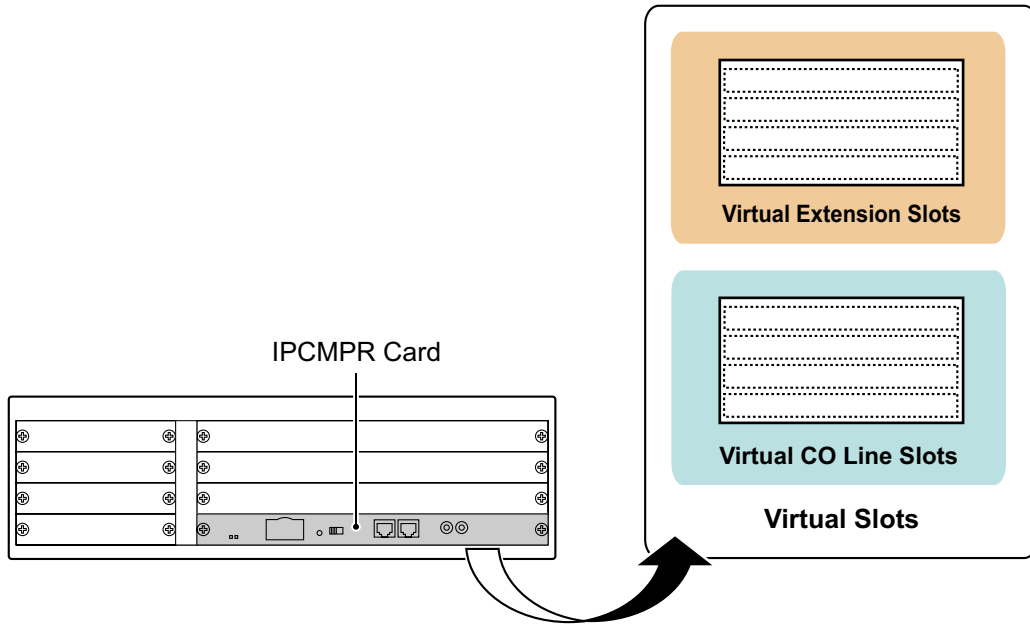

## Maximum Optional Service Cards

The following number of cards can be installed in the Free Slots or Virtual Slots of the PBX.

### Note

- Any card that exceeds the capacity of the PBX will be ignored.
- When the PBX starts up with an invalid configuration, some cards will be ignored.

### Cards Installed in Free Slots or Virtual Slots

◆ : For Small Free Slots

★ : For Regular Free Slots

Card Type	Maximum Number	
	KX-NCP500	KX-NCP1000
IPCMRP	1	1
CO Line Card	9 <sup>*1</sup>	9 <sup>*1</sup>
Virtual CO Line Card	4	4
V-IPGW16	2	2
V-SIPGW16	4	4
Physical CO Line Card	Total 5 <sup>*2</sup>	Total 5 <sup>*2</sup>
◆ LCOT4	3	4
◆ PRI23	2	2
★ T1		
Extension Card	7	7
Virtual Extension Card	4	4
V-IPEXT32	4	4
V-SIPEXT32	4	4
V-IPCS4	4	4
Physical Extension Card	3	3
◆ DHLC4	1	1
★ DLC8	2	2
★ DLC16		
★ SLC8		
★ SLC16		
★ OPB3	2	3
Total	13	15

\*1 When installing T1, PRI23 cards, make sure that the number of these cards × 2 + the number of the other cards does not exceed 9.

\*2 One T1 or PRI23 card counts as 2 cards.

### Cards Mounted on Other Optional Service Cards

Card Type	Maximum Number		Mounted on
	KX-NCP500	KX-NCP1000	
DSP4	1	1	IPCMPR Card
DSP16			
DSP64			
RMT	1	1	
DPH4	4	4	OPB3 Card
ECHO16	2 <sup>*1</sup>	2 <sup>*1</sup>	
MSG4	4	4	
ESVM4			
EIO4	4	4	

\*1 Only 1 ECHO16 card can be mounted on each OPB3 card.

### Maximum CO Lines and Extensions

The PBX supports the following number of CO lines and extensions.

Type	Maximum Number
Total Number of CO lines	128
CO line (Physical CO line Card)	64
CO line (Virtual CO line Card)	64
H.323 CO lines	32
SIP CO lines	64
Total Number of Extensions	172
Extension (Physical Extension Card)	44
Extension (Virtual Extension Card)	128
IP-PT and IP Softphone	128
SIP Extension	

### DSP Card Resources

The maximum number of simultaneous calls using IP protocols is determined by the type of call, codec(s) used, and digital signal processor (DSP) card installed in the PBX.

Below are some example configurations and the maximum number of simultaneous calls for each.

#### For Calls between Virtual CO Lines and Virtual Extensions

Codec(s) Used	Maximum Number of Simultaneous Calls		
	DSP4 Card	DSP16 Card	DSP64 Card
G.711	8	32	64
G.711+G.729A <sup>*1</sup>	2	12	42
G.729A	2	8	32

<sup>\*1</sup> For example, when a virtual extension uses G.711 and a virtual CO line uses G.729A for the same call.

#### For Calls between Virtual CO Lines and Physical Card Extensions (e.g., DPTs, etc.)

Codec Used	Maximum Number of Simultaneous Calls		
	DSP4 Card	DSP16 Card	DSP64 Card
G.711	5	32	64
G.729A	2	12	50

#### For Calls between Virtual Extensions and Physical Card Extensions/CO Lines (e.g., PRI, etc.)

Codec Used	Maximum Number of Simultaneous Calls		
	DSP4 Card	DSP16 Card	DSP64 Card
G.711	16	64	113
G.729A	4	16	64

#### Note

For non-peer-to-peer calls via the DSP card, calls cannot be made or received when all of the card's resources are being used.

## Maximum Terminal Equipment

The following shows the number of each terminal equipment type supported by the PBX.

Terminal Equipment Type	Maximum Number
Telephone	172
SLT	36
KX-DT300/KX-T7600 series DPT	40
Other DPT	10
APT	4
IP-PT <sup>*1</sup>	128 <sup>*2</sup>
SIP Extension	128
DSS console	8
CS	21 <sup>*3</sup>
PT-interface CS (2-channel)	11
PT-interface CS (8-channel)	5
IP-CS (8-channel)	16
PS	64
Voice Processing System (VPS)	2
Doorphone	16
Door Opener	16
External Sensor	16
External Relay	16

<sup>\*1</sup> KX-NT400, KX-NT300 series and KX-NT265 (software version 2.00 or later only)

<sup>\*2</sup> For the KX-NT400, the maximum number of extensions that can be connected to the PBX is 64.

<sup>\*3</sup> One 8-channel PT-interface CS or IP-CS counts as 2 CSs, up to a maximum of 32 CSs. Therefore, the maximum number of CSs is 21 (eleven 2-channel CSs + ten 8-channel CSs).

**Note for KX-NT265 IP-PT users**

The supported card varies depending on the software version of your KX-NT265 IP-PT. To confirm the version, follow the procedure below:

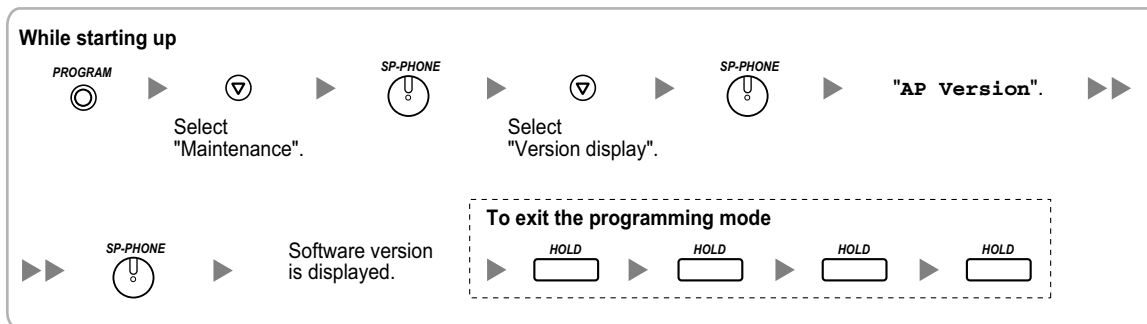

**Digital EXtra Device Port (Digital XDP) Connection Capacity**

The number of Digital XDP ports that can be assigned depends on the following:

- the number of connected DPTs
- the maximum number of DPTs the PBX can support

The table below shows examples of how many Digital XDP ports can be assigned with different configurations. For details about the Digital XDP connection, refer to "3.8.3 Digital EXtra Device Port (Digital XDP) Connection".

	Config.1	Config.2	Config.3	Config.4	Config.5
Small Free Slot	–	DHLC4	–	–	DHLC4
Regular Free Slot	DLC16	DLC16	DLC8	DLC16	DLC16
	–	–	DLC16	DLC16	DLC16
No. of DPT ports	16	20	24	32	36
<b>No. of Digital XDP ports</b>	<b>16</b>	<b>20</b>	<b>16</b>	<b>8</b>	<b>4</b>
Total No. of DPTs (max. 40)	32	40	40	40	40

**Note**

With Config.3, Config.4, and Config.5, the combination of 20 DPT ports and 20 Digital XDP ports is also possible.

**Power Supply Unit Capacity**

The pre-installed power supply unit (PSU) in each PBX supports a different load figure.

PBX Model	Maximum Load Figure
KX-NCP500/KX-NCP1000	44

## Load Figure Calculation

Equipment Type		Load Figure
PT	KX-DT300 series DPT/KX-DT300 series DSS console/KX-T7600 series DPT/KX-T7600 series DSS console	1
	Other DPT/Other DSS console	4
	APT	4
	IP-PT	0
	SIP Extension	0
Extension Card <sup>*1</sup>	DHLC4	4
	SLC8	8
	SLC16	16
PT-interface CS (2-channel) (1 unit)		4
PT-interface CS (8-channel) (1 unit)		8
IP-CS (8-channel) (1 unit)		0
VPS (1 port)		1

\*1 Only the extension cards that can support SLTs count for the load figures.

### Notice

If the total load figure exceeds the maximum load figure of the PBX by 3, the corresponding extension card cannot be supported by the PBX.

### Calculation Example

	Lines and Equipment		Load Figure	Required Card		
				Small Free Slot	Regular Free Slot	Virtual Slot
CO Line	PRI	1 line (23ch)	–	PRI23	–	–
	Analog CO line	4 lines	–	LCOT4	–	–
	SIP CO line	4 lines	–	–	–	V-SIPGW16
	H.323 CO line	4 lines	–	–	–	V-IPGW16

### 1.3.3 System Capacity

	Lines and Equipment		Load Figure	Required Card		
				Small Free Slot	Regular Free Slot	Virtual Slot
Extension	KX-DT300 series DPT	24 units	28	DHLC4 <sup>*1</sup>	DLC16 <sup>*1</sup>	–
	SLT	16 units	16		SLC16	–
	KX-NT300 series IP-PT	40 units	0	–	–	V-IPEXT32 × 2
	SIP Extension	0	0	–	–	–
	VPS	0	0	–	–	–
	CS	0	0	–	–	–

\*1 At least 4 of the 20 DPT ports of DHLC4 and DLC16 cards must be assigned as Digital XDP ports.

The total load figure in the example is 44, and is calculated as follows:  
 $(24 \text{ units} \times 1) + (1 \text{ DHLC4 card} \times 4) + (1 \text{ SLC16 card} \times 16) = 44$

---

## **Section 2**

# ***Activation Key Installation***

*This section describes information on activation keys, including how to obtain an activation key and install it in the SD Memory Card.*

## 2.1 Information about the Activation Keys

### 2.1.1 Activation Keys

To use IP CO lines and IP telephones on a private IP network using the IPCMPR card or to upgrade the software for enhanced features, you need the appropriate activation keys.

Activation keys are provided via the DSP cards and optional activation key files.

### Type and Maximum Number of Activation Keys

The PBX supports the following type and number of activation keys:

Activation Key Type	Description	Maximum Number	Supported IP CO Lines/IP Telephones/CA Users
<b>2 IP Trunk<sup>*1</sup></b>	Allows the use of 2 IP CO lines (H.323/SIP).	32	64 IP CO lines (H.323/SIP)
<b>4 IP Trunk<sup>*1</sup></b>	Allows the use of 4 IP CO lines (H.323/SIP).	16	
<b>1 IP Softphone/IP PT<sup>*2</sup></b>	Allows the use of 1 IP-PT/IP softphone.	128	128 IP-PTs/IP softphones
<b>4 IP Softphone/IP PT<sup>*2</sup></b>	Allows the use of 4 IP-PTs/IP softphones.	32	
<b>8 IP Softphone/IP PT<sup>*2</sup></b>	Allows the use of 8 IP-PTs/IP softphones.	16	
<b>16 IP Softphone/IP PT<sup>*2</sup></b>	Allows the use of 16 IP-PTs/IP softphones.	8	
<b>1 IP PT</b>	Allows the use of 1 IP-PT.	128	128 IP-PTs
<b>4 IP PT</b>	Allows the use of 4 IP-PTs.	32	
<b>8 IP PT</b>	Allows the use of 8 IP-PTs.	16	
<b>16 IP PT</b>	Allows the use of 16 IP-PTs.	8	
<b>1 SIP Extension</b>	Allows the use of 1 SIP Extension.	128	128 SIP Extensions
<b>4 SIP Extension</b>	Allows the use of 4 SIP Extensions.	32	
<b>8 SIP Extension</b>	Allows the use of 8 SIP Extensions.	16	
<b>16 SIP Extension</b>	Allows the use of 16 SIP Extensions.	8	
<b>CA Pro 1user</b>	Allows the use of CA Pro for 1 user.	128	128 users
<b>CA Pro 5users</b>	Allows the use of CA Pro for 5 users.	25	125 users
<b>CA Pro 10users</b>	Allows the use of CA Pro for 10 users.	12	120 users
<b>CA Pro 40users</b>	Allows the use of CA Pro for 40 users.	3	120 users
<b>CA Pro 128users</b>	Allows the use of CA Pro for 128 users.	1	128 users

Activation Key Type	Description	Maximum Number	Supported IP CO Lines/IP Telephones/CA Users
<b>CA Supervisor 1user</b>	Allows the use of CA ACD Monitor for 1 ICD Supervisor.	4	4 users
<b>Software Upgrade 01</b>	Upgrades software to use enhanced features.	1	-

<sup>\*1</sup> You need to set the number of the installed activation key to be used for H.323 CO lines through system programming. By default, all the installed activation keys will be used for SIP CO lines.

<sup>\*2</sup> You can set how many IP softphones can be used with the installed activation keys through system programming. By default, only IP softphones can be used with the installed activation keys.

## Preinstalled Activation Keys in the DSP Cards

The following type and number of activation keys are preinstalled on the DSP card:

Card Type	Activation Key		Supported IP CO Lines/IP-PTs
DSP4	<b>4-Channel IP Trunk</b>	1	4 IP CO lines (H.323/SIP)
	<b>8-Channel IP Proprietary Telephone</b>	1	8 IP-PTs
DSP16	<b>4-Channel IP Trunk</b>	1	4 IP CO lines (H.323/SIP)
	<b>8-Channel IP Proprietary Telephone</b>	1	8 IP-PTs
DSP64	<b>4-Channel IP Trunk</b>	4	16 IP CO lines (H.323/SIP)
	<b>8-Channel IP Proprietary Telephone</b>	4	32 IP-PTs

Depending on the number of IP CO lines and IP-PTs to be used, you need to select the DSP card from the above.

## Additional Activation Keys in the SD Memory Card (Activation Key Files)

When the number of preinstalled activation keys on the DSP card is not enough for the desired configuration or when you wish to use enhanced features, additional activation keys in the form of activation key files can be installed on the SD Memory Card.

The following type and number of additional activation keys can be installed on the SD Memory Card:

### Activation Keys for IP CO Lines

Model No.	Activation Key Type	Maximum Number/Supported IP CO Lines			
		with DSP4/DSP16		with DSP64	
KX-NCS3102	<b>2 IP Trunk</b>	30	60 IP CO lines (H.323/SIP)	24	48 IP CO lines (H.323/SIP)
KX-NCS3104	<b>4 IP Trunk</b>	15		12	

## Activation Keys for IP Telephones

Model No.	Activation Key Type	Maximum Number/Supported IP Telephones			
		with DSP4/DSP16		with DSP64	
KX-NCS3201	1 IP Softphone/IP PT	120	120 IP-PTs/IP softphones	96	96 IP-PTs/IP softphones
KX-NCS3204	4 IP Softphone/IP PT	30	120 IP-PTs/IP softphones	24	96 IP-PTs/IP softphones
KX-NCS3208	8 IP Softphone/IP PT	15	120 IP-PTs/IP softphones	12	96 IP-PTs/IP softphones
KX-NCS3216	16 IP Softphone/IP PT	7	112 IP-PTs/IP softphones	6	96 IP-PTs/IP softphones
KX-NCS3501	1 IP PT	120	120 IP-PTs	96	96 IP-PTs
KX-NCS3504	4 IP PT	30	120 IP-PTs	24	96 IP-PTs
KX-NCS3508	8 IP PT	15	120 IP-PTs	12	96 IP-PTs
KX-NCS3516	16 IP PT	7	112 IP-PTs	6	96 IP-PTs
KX-NCS3701	1 SIP Extension	128	128 SIP Extensions	128	128 SIP Extensions
KX-NCS3704	4 SIP Extension	32		32	
KX-NCS3708	8 SIP Extension	16		16	
KX-NCS3716	16 SIP Extension	8		8	

## Activation Keys for CA Users

Model No.	Activation Key Type	Maximum Number	Supported CA Users
KX-NCS2201	CA Pro 1user	128	128 users
KX-NCS2205	CA Pro 5users	25	125 users
KX-NCS2210	CA Pro 10users	12	120 users
KX-NCS2240	CA Pro 40users	3	120 users
KX-NCS2249	CA Pro 128users	1	128 users
KX-NCS2301	CA Supervisor 1user	4	4 users

## Activation Keys for Software Upgrading

Model No.	Activation Key Type	Maximum Number
KX-NCS3910	Software Upgrade 01	1

### **Note**

- For information about how to obtain the additional activation keys, refer to "2.1.2 Activation Key Code and Key Management System".
- For information about how to install the activation key files on the SD Memory Card, refer to "2.1.3 Activation Key File".

## Activation Key Installation Example

The following shows an example of when using 16 H.323 CO lines, 16 SIP CO lines, 32 IP-PTs, 16 IP softphones, and 16 SIP Extensions on a private IP network using the IPCMPR card.

**Example: KX-NCP1000**

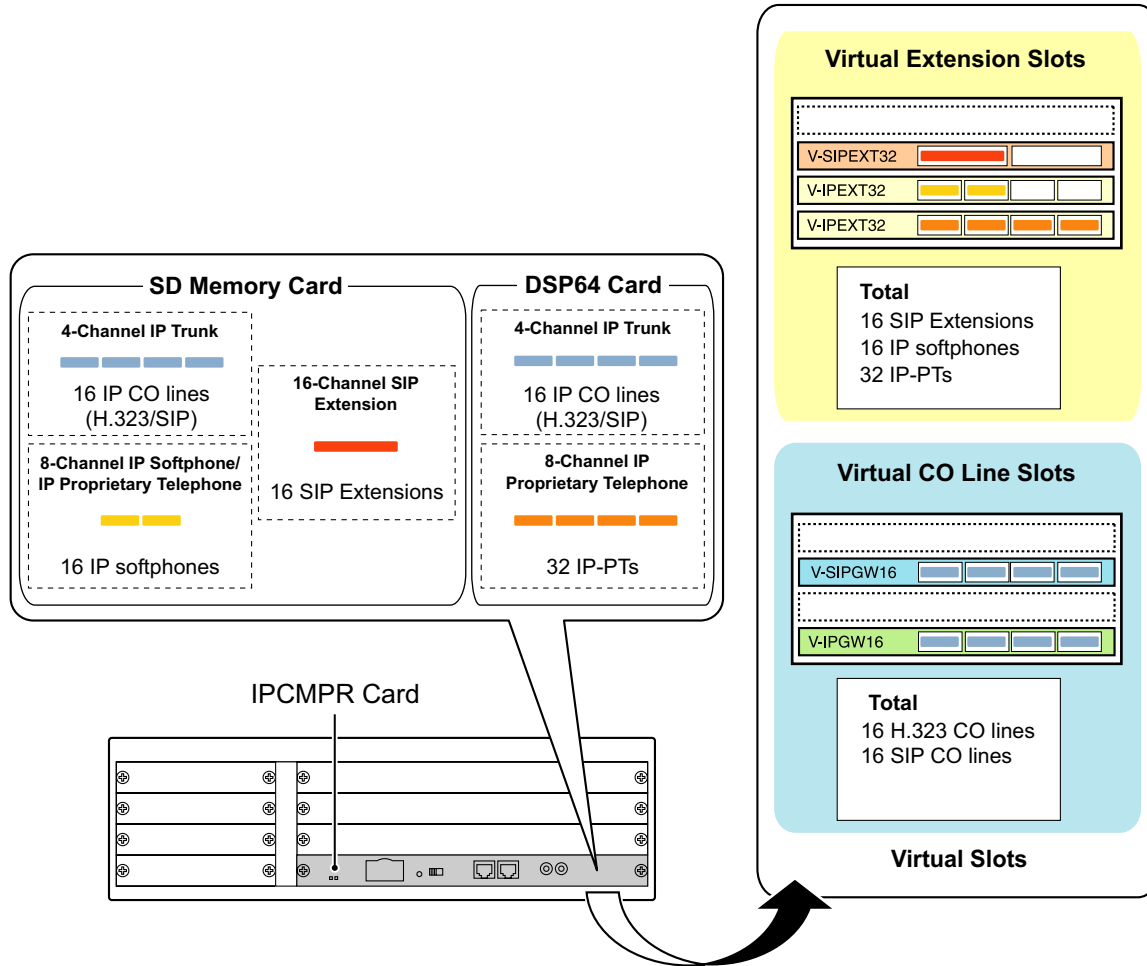

## 2.1.2 Activation Key Code and Key Management System

To obtain additional activation keys, you need to purchase the appropriate activation key codes and access the Key Management System. You can download the activation keys as an activation key file from the Key Management System.

To download the activation keys, enter the MPR ID number shown on the IPCMPR card in the PBX, and activation key number and registration ID provided on each activation key code.

For information about the type of activation key codes available, refer to "Additional Activation Keys in the SD Memory Card (Activation Key Files)".

### **Note**

- You can only download the activation key file once using the activation key number and registration ID provided on the activation key code.
- Up to 8 activation keys can be downloaded as one activation key file.
- Up to 100 activation key files can be installed in the SD Memory Card.
- It is possible to send the activation key file to a specified e-mail address at the same time as downloading it to a PC.
- Make sure to backup the downloaded activation key files on your PC.
- In the event of a system malfunction, you need a temporary activation key for maintenance purposes. The temporary activation key can only be used for a limited time period, and can be downloaded from the Key Management System in the same way as downloading activation key files.

### 2.1.3 Activation Key File

The corresponding number of IP CO lines and IP telephones or enhanced features can be activated by installing the downloaded activation key file(s) in the SD Memory Card of the IPCMPR card using the Maintenance Console.

#### Installing the Activation Key File in the SD Memory Card

Make sure to install the Maintenance Console on the PC in advance, and connect the PC to the PBX. For details about the Maintenance Console, refer to "Section 4 Guide for the Maintenance Console".

1. Start the Maintenance Console from the Start menu on the PC.
2. From the **Utility** menu, select **File Transfer PC to PBX (SD Card)**.  
A dialog box will be displayed.
3. Select the file to upload.  
A window showing the upload progress will be displayed.  
While transferring files to the SD memory card, the PBX automatically renames them according to the header information.  
A message will be displayed when the transfer is complete.
4. Click **OK**.
5. Under **Configuration**, click **Slot**.
6. Click **Activation Key**.
7. For IP Trunk activation key file(s), click **Execute**.  
A confirmation message will be displayed. Click **Yes**.

#### **Notice**

The activation key file can only be installed in the PBX with the MPR ID number entered when the activation key file was downloaded. The activation key file cannot be reissued unless the IPCMPR card crashes.

#### **Note**

- It is necessary to restart the PBX to activate the Software Upgrade 01 activation key after performing the procedure above. To restart the PBX, refer to "5.1.4 Using the Reset Button".
- For information about programming activation keys using the Maintenance Console, refer to "3.3 [1-1] Slot—Activation Key" in the PC Programming Manual.

---

## **Section 3**

# **Installation**

*This section describes the procedures to install the PBX. Detailed instructions for planning the installation site, installing the main unit and optional service cards, and cabling of peripheral equipment are provided. Further information on peripheral equipment installation is included.*

## 3.1 Before Installation

### 3.1.1 Before Installation

Please read the following notes concerning installation and connection before installing the PBX and terminal equipment.

Be sure to comply with all applicable laws, regulations, and guidelines.

### Safety Installation Instructions

#### **WARNING**

When installing telephone wiring, basic safety precautions should always be followed to reduce the risk of fire, electric shock and injury to persons, including the following:

- Never install telephone wiring during a lightning storm.
- Never install telephone jacks in wet locations unless the jack is specifically designed for wet locations.
- Never touch uninsulated telephone wires or terminals unless the telephone line has been disconnected at the network interface.
- Use caution when installing or modifying telephone lines.
- Anti-static precautions should be taken during installation.

### Installation Precautions

The PBX is made for 19-inch rack mounting or floor standing, and should be installed in a location where it is accessible for inspections and maintenance.

To prevent malfunction, noise, or discoloration, follow the instructions below:

#### **WARNING**

Do not install the system in the following locations:

- Areas where shocks or vibrations are frequent or strong. Such activity may lead to the product falling over and causing injury, or may impair the product's performance.
- Areas with high amounts of dust. High amounts of dust can lead to fire or electric shock, and impair the performance of the product.

#### **CAUTION**

Do not install the system in the following locations:

- In direct sunlight and hot, cold, or humid places. Temperature range: 0 °C to 40 °C (32 °F to 104 °F)
- Areas where sulfuric gases may be present, such as near thermal springs.
- Near devices that generate high frequencies, such as sewing machines or electric welders.
- Locations where other objects will obstruct the area around the PBX. Be especially careful to leave at least 5 cm (2 in) to the sides of the PBX for ventilation.

#### **Notice**

Do not install the system in the following locations:

- On or near computers, telexes, or other office equipment, as well as microwave ovens or air conditioners. (It is preferable not to install the system in the same room as the above equipment.)
- Within 1.8 m (6 ft) of radios and televisions. (Both the PBX and PTs should be at least 1.8 m (6 ft) away from such devices.)

Do not perform the following:

- Do not block the openings of the PBX.

- Do not stack up the optional service cards.

## Wiring Precautions

Be sure to follow these instructions when wiring the unit:

### **CAUTION**

- Avoid using the same AC outlet for computers, telexes, and other office equipment, as noise generated by such equipment may hamper system performance or interrupt the system.
- Unplug the system from its power source when wiring, and plug the system back in only after all wiring is completed.
- CO lines should be installed with surge protectors. For details, refer to "3.2.9 Surge Protector Installation".

### **Notice**

- Use 2-pair telephone cables when connecting PTs.  
Use 1-pair telephone cables when connecting SLTs, data terminals, answering machines, computers, Voice Processing Systems, etc.
- Mis-wiring may cause the PBX to operate improperly. Refer to Section 3 "Section 3 Installation" when wiring the system.
- If an extension does not operate properly, disconnect the telephone from the extension line and connect it again, or turn off the PBX using the power switch, then turn it on again.
- Use twisted pair cable for CO line connection.
- To prevent signal noise from interfering with the performance of the product, do not run unshielded telephone cables near AC power cables, computer cables, AC power sources, etc. When running cables near other noise-generating devices or cables, use shielded telephone cables or shield the telephone cables with metal tubing.
- To assure good quality telephone connection, it is recommended new and modifications to existing installation of customer premise wiring shall use solid twisted pair copper conductors with minimum 24 gauge that comply with the electrical specifications for Category 3 wiring as detailed in ANSI/EIA/TIA-570A Building Wiring Standards.

## 3.2 Installation of the PBX

### 3.2.1 Unpacking

Unpack the box and check the items below:

		<b>KX-NCP500</b>	<b>KX-NCP1000</b>
Main Unit		1	1
Ferrite Core (for the IPCMPR card)		2	2
AC Cord		1	1
19-inch Rack Attachment Bracket		2	2
SD Memory Card		1	1
Screw		6	6

## 3.2.2 Names and Locations

### KX-NCP500

Front

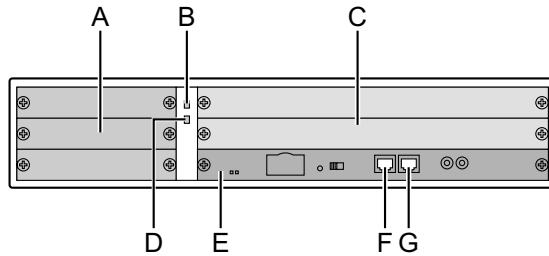

Back

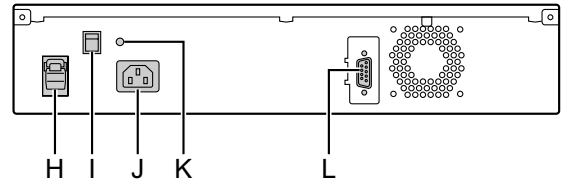

### KX-NCP1000

Front

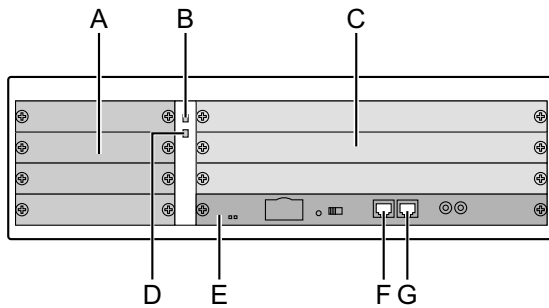

Back

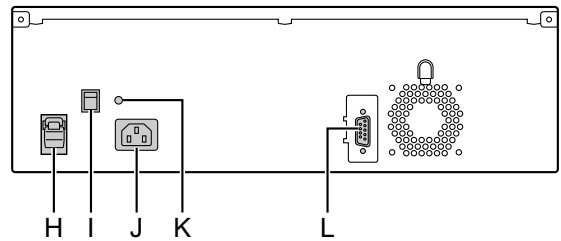

- A.** Small Free Slots
- B.** RUN Indicator
- C.** Regular Free Slots
- D.** ALARM Indicator
- E.** IPCMPR Card Slot
- F.** MNT Port
- G.** LAN Port
- H.** Hook Clip
- I.** Power Switch
- J.** AC Inlet
- K.** Ground Terminal
- L.** RS-232C Port

#### **Note**

A Power Supply Unit (PSU) is pre-installed.

## 3.2.3 Frame Ground Connection

1. Loosen the screw.
2. Insert a grounding wire (user-supplied).
3. Tighten the screw.
4. Connect the grounding wire to ground.

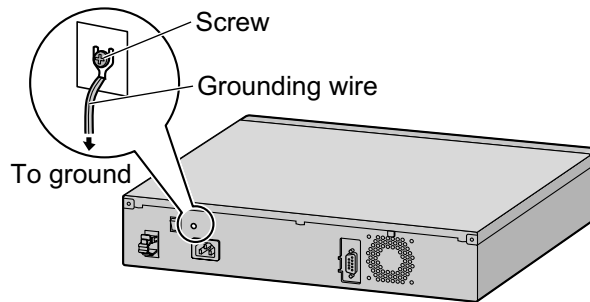

### **WARNING**

- **Proper grounding (connection to ground) is very important to reduce the risk to the user of electrocution or to protect the PBX from the bad effects of external noise in the case of a lightning strike.**
- **The grounding wire of the AC cable has an effect against external noise and lightning strikes, but it may not be enough to protect the PBX. A permanent connection between ground and the ground terminal of the PBX must be made.**

### **CAUTION**

For grounding wire, green-and-yellow insulation is required, and the cross-sectional area of the conductor must be more than 0.75 mm<sup>2</sup> or 18 AWG.

### **Notice**

Be sure to comply with applicable local regulations (e.g., laws, guidelines).

In most of the continental United States, the ground provided by the "Third wire ground" at the commercial power outlet will be satisfactory. However, in a small percentage of cases this ground may be installed incorrectly. Therefore, the following test procedure should be performed.

## Test Procedure

1. Obtain a suitable voltmeter and set it for a possible reading of up to 250 V AC.
2. Connect the meter probes between the 2 main AC voltage points on the wall outlet. The reading obtained should be 108 V AC to 132 V AC.
3. Move one of the meter probes to the 3rd prong terminal (GND).  
Either the same reading or a reading of 0 volt should be obtained.
4. If a reading of 0 volt at one terminal and a reading of 108 V AC to 132 V AC at the other terminal is not obtained, the outlet is not properly grounded.  
This condition should be corrected by a qualified electrician (per article 250 of the National Electrical Code).
5. If a reading of 0 volt at one terminal and a reading of 108 V AC to 132 V AC at the other terminal is obtained, then set the meter to the "OHMS/RX1" scale, place one probe at the GND Terminal and the other probe at the terminal which gave a reading of 0 volt.  
A reading of less than 1 ohm should be obtained. If the reading is not obtained, the outlet is not adequately grounded. See qualified electrician.

## 3.2.4 Installing/Removing the Optional Service Cards

### CAUTION

- To protect the back board from static electricity, do not touch parts on the back board in the main unit and on the optional service cards. To discharge static electricity, touch ground or wear a grounding strap.
- When the  label is attached to an optional service card (for small free slots), be sure to turn the power switch off before installing or removing the card.
- When installing or removing the IPCMPR card, the DC power supply must be turned off.

### Installing/Removing Optional Service Cards

1. Turn the 2 screws anticlockwise to remove the appropriate slot panel.

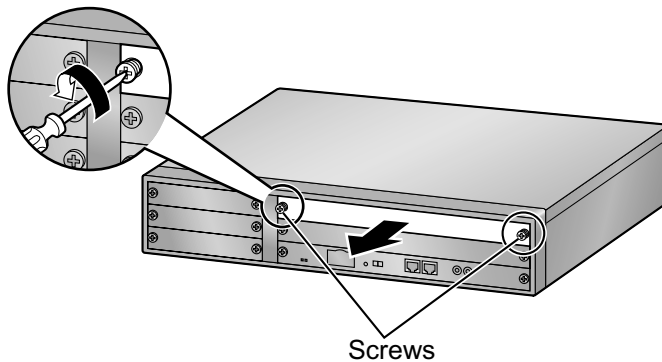

2. Insert the card along the guide rails.

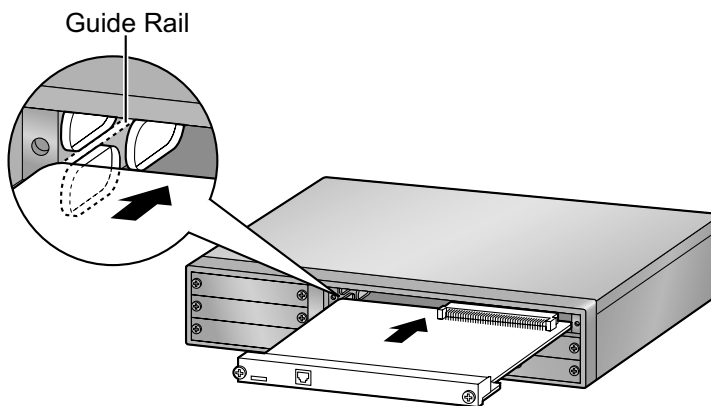

### 3.2.4 Installing/Removing the Optional Service Cards

---

3. Turn the 2 screws clockwise to fix the card in place.

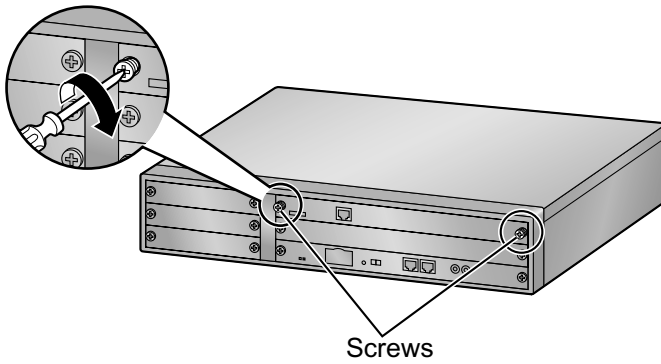



4. To remove the card, reverse the procedure above.

**Note**

Make sure the screws are tightened to ground the card securely.

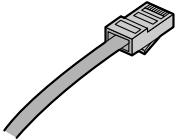
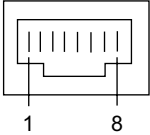
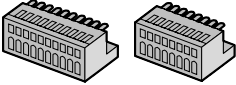
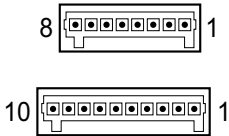
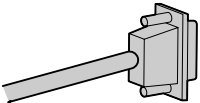
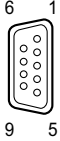
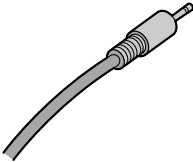
### 3.2.5 Types of Connectors

Connector Type	Pin Number	Used for
<p>RJ45</p>  <p>(Twisted pair cable)</p>		<ul style="list-style-type: none"> <li>• IPCMPR</li> <li>• DHLC4 (KX-NCP1170)</li> <li>• DLC8 (KX-NCP1171)</li> <li>• DLC16 (KX-NCP1172)</li> <li>• SLC8 (KX-NCP1173)</li> <li>• SLC16 (KX-NCP1174)</li> <li>• LCOT4 (KX-NCP1180)</li> <li>• T1 (KX-NCP1187)</li> <li>• PRI23 (KX-NCP1290)</li> </ul>
<p>10-pin Terminal Block    8-pin Terminal Block</p> 		<ul style="list-style-type: none"> <li>• DPH4 (KX-TDA0161)</li> <li>• EIO4 (KX-TDA0164)</li> </ul>
<p>RS-232C</p>  <p>(Shielded cable)</p>		<ul style="list-style-type: none"> <li>• Main Unit</li> </ul>
<p>Mini Plug</p> 		<ul style="list-style-type: none"> <li>• IPCMPR</li> </ul>

## 3.2.6 Attaching a Ferrite Core

A ferrite core must be attached when an RJ45 connector is connected to an IPCMPR card. Wrap the cable once around the ferrite core, then close the case of the ferrite core. Attach the ferrite core 3 cm (1-3/16 in) away from the connector. The ferrite core is included with the PBX.

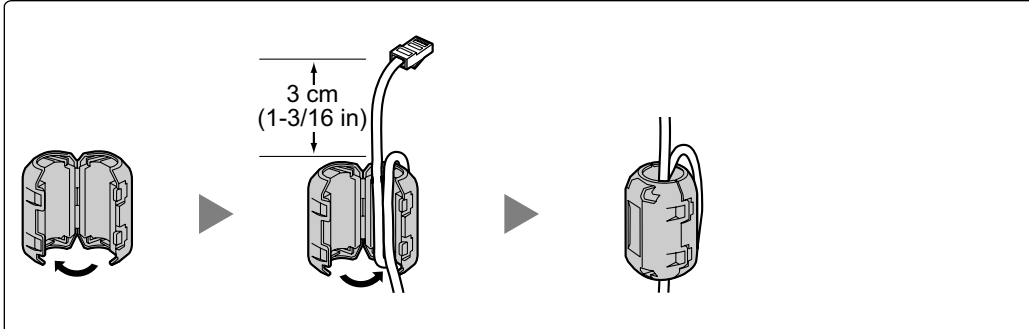

## 3.2.7 19-inch Rack Mounting

### WARNING

- Be careful not to drop any components. Dropping components may damage them or cause an injury.
- Only use the 19-inch rack mounting equipment (attachment bracket, screws) included with the PBX.

### CAUTION

- When the PBX is mounted on a 19-inch rack, make sure that the installation of the unit does not cause the temperature of the rack to exceed its limit.
  - If the PBX is not installed properly using the securing correct methods, the PBX may fall causing serious damage.
  - When this product is no longer in use, make sure to detach it from the rack.
1. Fix the attachment brackets to the left and right sides of the PBX with 3 screws. → ❶
  2. Place the PBX in the 19-inch rack and fix both attachment brackets to the rack with the rack's proprietary mounting equipment. → ❷

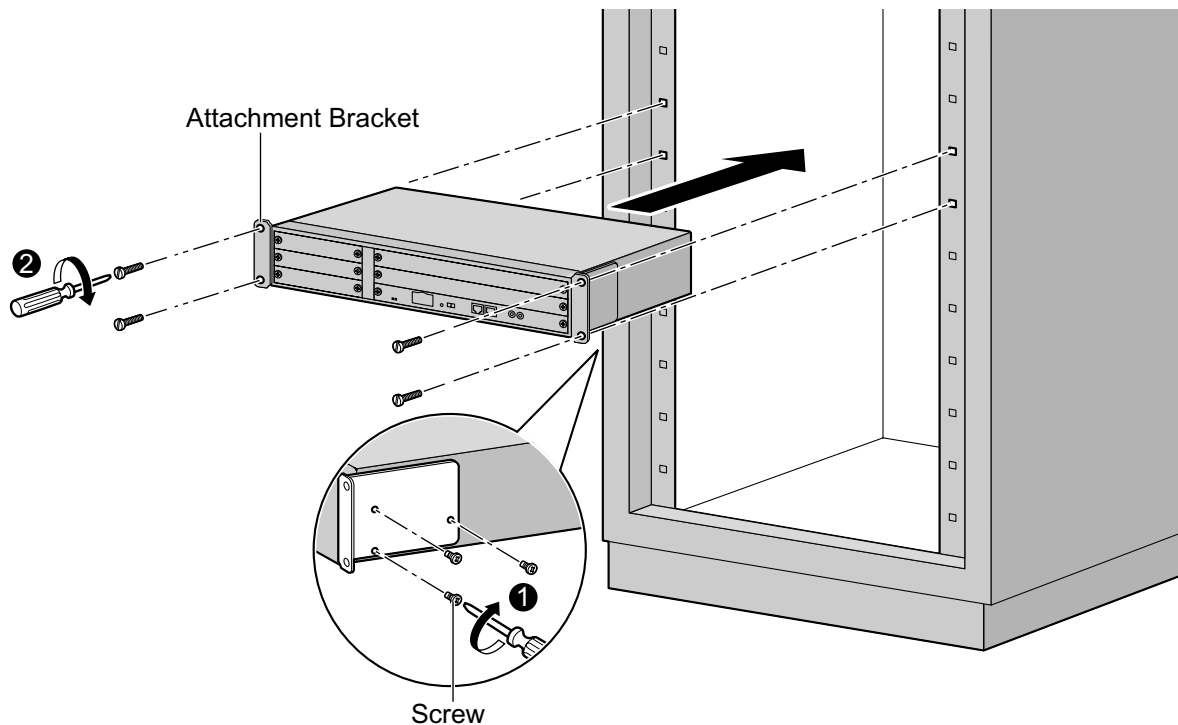

### 3.2.8 Floor Standing

When installing the PBX on the floor, make sure to follow these instructions.

#### **WARNING**

**Be careful not to drop any components. Dropping components may damage them or cause an injury.**

#### **CAUTION**

- Make sure that the PBX is placed as indicated in the diagram below. Do not place it on its side or upside down.
- Do not block the openings of the PBX. Allow space of at least 20 cm (8 in) above and 10 cm (4 in) at the sides of the PBX.
- Make sure that the surface behind the PBX is flat and free of obstacles, so that the openings on the back of the PBX will not be blocked.
- Make sure that the surface behind the PBX is not made of wood.

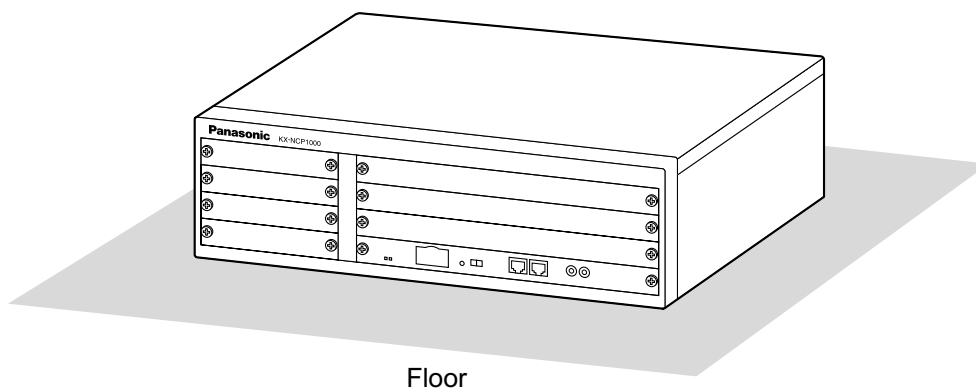

## 3.2.9 Surge Protector Installation

### CAUTION

Performing surge protection is essential. Make sure to follow the instructions in this section.

### Overview

A massive electrical surge can be caused if lightning strikes a telephone cable 10 m (33 ft) above ground, or if a telephone line comes into contact with a power line. A surge protector is a device that is connected to a CO line to prevent potentially dangerous electrical surges from entering the building via the CO line and damaging the PBX and connected equipment.

To protect the system from electrical surges, we strongly recommend connecting the system to a surge protector that meets the following specifications:

- Surge arrester type: 3-electrode arrester
- DC spark-over voltage: 230 V
- Maximum peak current: at least 10 kA

Additionally, proper grounding is very important for the protection of the system (refer to "3.2.3 Frame Ground Connection").

Many countries/areas have regulations requiring surge protection. Be sure to comply with all applicable laws, regulations, and guidelines.

### Installation

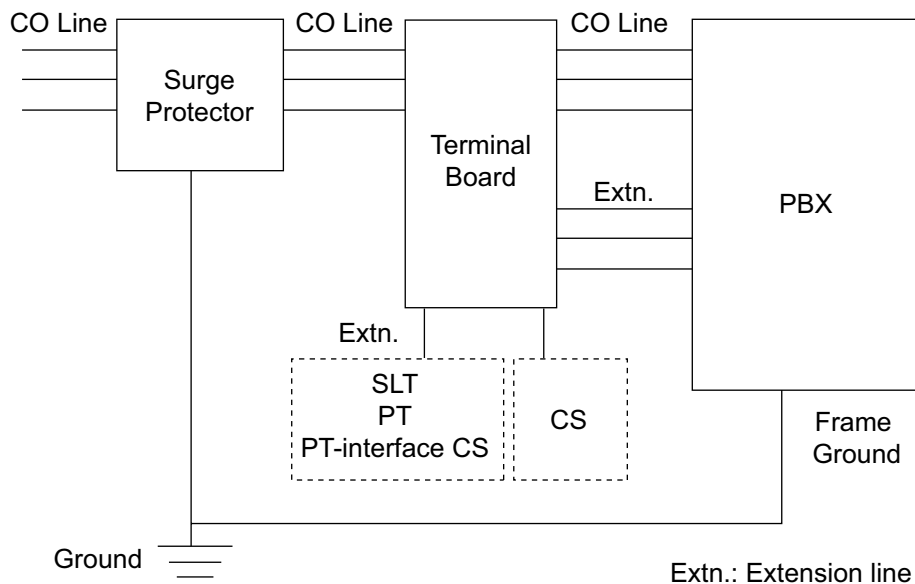

## Outside Installation

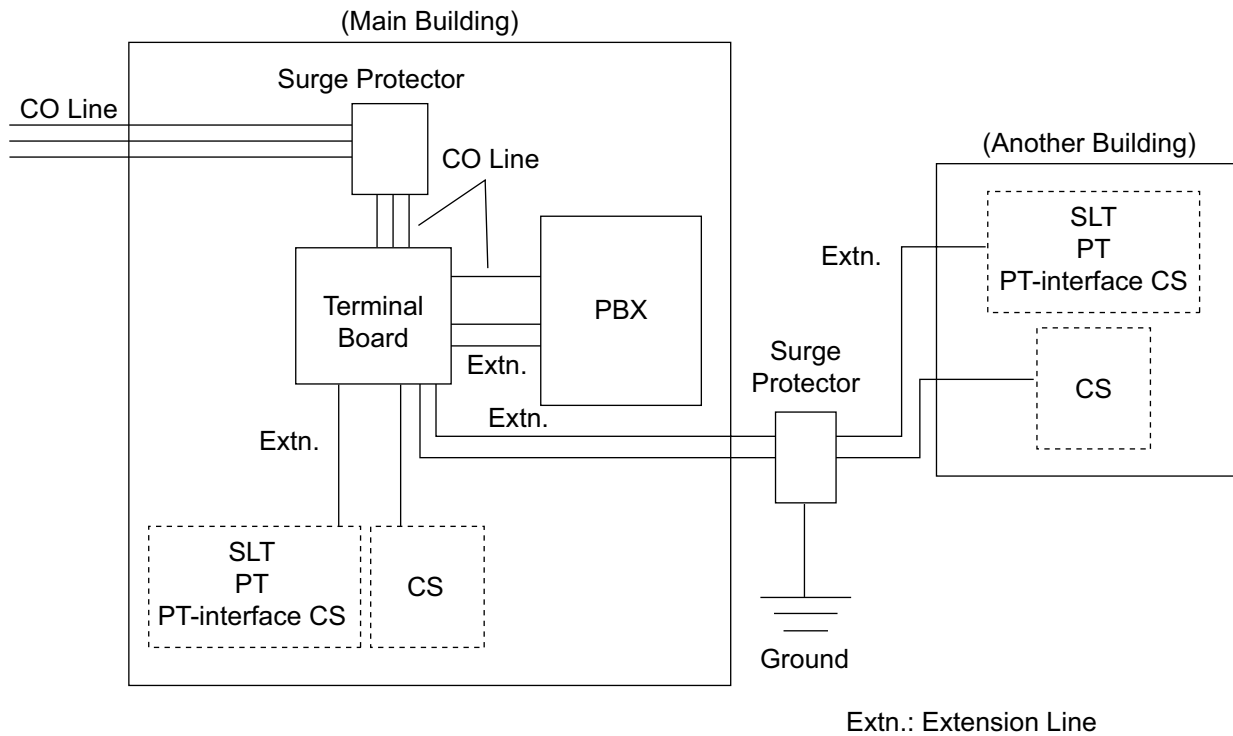

If you install an extension outside of the building, the following precautions are recommended:

- a. Install the extension wire underground.
- b. Use a conduit to protect the wire.

### Note

The surge protector for an extension and CS is different from that for CO lines.

## Installation of a Ground Rod

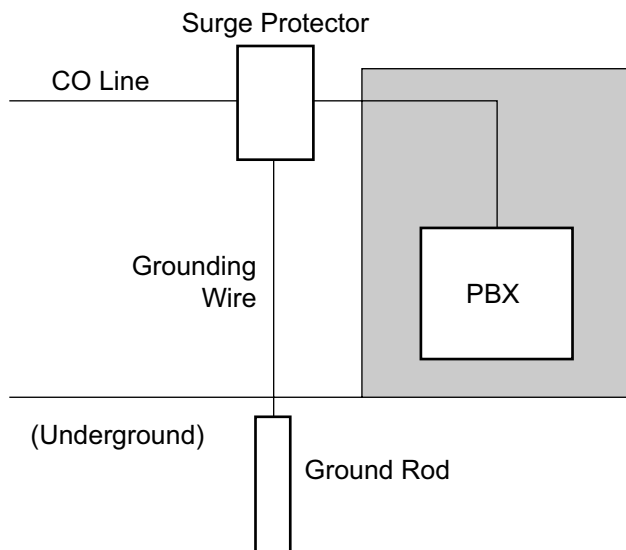

1. Connect the ground rod to the surge protector using a grounding wire with a cross-sectional area of at least 1.3 mm<sup>2</sup>.
2. Bury the ground rod near the protector. The grounding wire should be as short as possible.
3. The grounding wire should run straight to the ground rod. Do not run the wire around other objects.
4. Bury the ground rod at least 50 cm (20 in) underground.

**Note**

- The above figures are recommendations only.
- The length of ground rod and the required depth depend on the composition of the soil.

## 3.3 Information about the Main Processing Card

### 3.3.1 IPCMPR Card

#### Function

The IPCMPR card is the preinstalled main processing card with built-in ESVM card feature (2-channel). The Virtual Cards (CO line/extension) can be installed in Virtual Slots of the IPCMPR card and can be activated with the activation keys. Also, the IPCMPR supports LAN connection so that IP telephones (IP-PTs, IP softphones, SIP Extensions) and PCs can be connected on a private IP network.

#### Mountable Cards

- One of the DSP4, DSP16, or DSP64 cards (refer to "3.3.2 DSP4 Card (KX-NCP1104), DSP16 Card (KX-TDE0110), and DSP64 Card (KX-TDE0111)")
- RMT card (refer to "3.3.3 RMT Card (KX-TDA0196)")

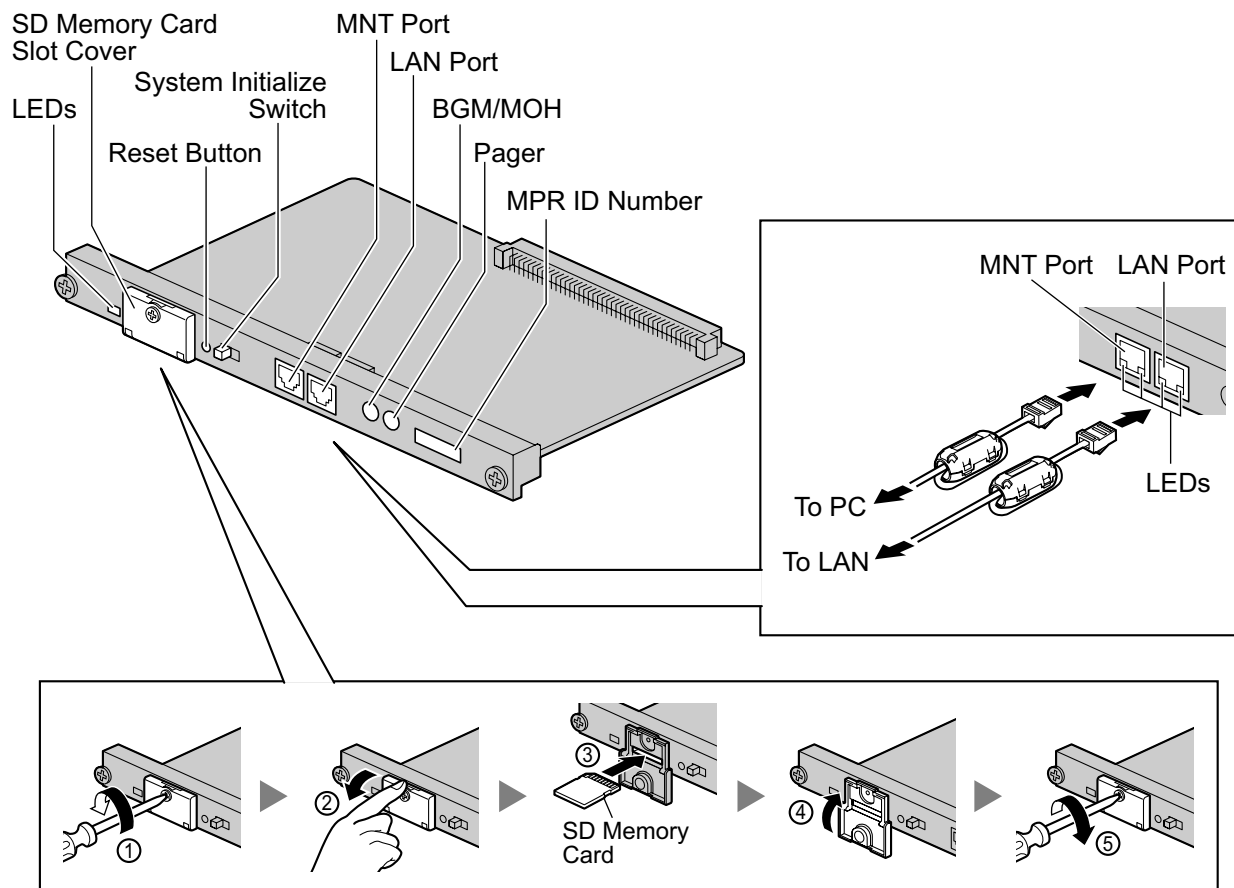

#### Note

- Make sure to use the MNT port for PC connection, and the LAN port for LAN connection.
- The maximum length of the cable to be connected to the IPCMPR card is 100 m (328 ft).
- When connecting the RJ45 connector, attach the ferrite core included with the PBX. Refer to "3.2.6 Attaching a Ferrite Core".
- For details about Virtual Slots, refer to "1.3.3 System Capacity".
- For details about the activation keys, refer to "2.1 Information about the Activation Keys".

- For details about connecting to a LAN, refer to "3.11 LAN Connection"
- For details about connecting peripherals, refer to "3.10.1 Connection of Peripherals"
- For details about System Initialize Switch, refer to "3.13.1 Starting the PBX".
- For details about Reset Button, refer to "5.1.4 Using the Reset Button".
- Portions of this product contains software of Datalight, Inc. Copyright 1993–2000 Datalight, Inc., All Rights Reserved.

### **WARNING**

**A lithium battery is used in the IPCMPR card. There is a risk of explosion if the battery is replaced with the incorrect type. Dispose of used batteries according to the manufacturer's instructions.**

### **CAUTION**

- The SD Memory Card contains software for all the processes of the PBX and all the customer data. It can be easily removed and taken away from the PBX by a third party. Therefore, do not allow unauthorized access to prevent data leakage.
- Do not remove the SD Memory Card while power is supplied to the PBX. Doing so may cause the PBX to fail to start when you try to restart the system.
- To prevent data leakage, render the SD Memory Card physically unusable before disposal.

### **Notice**

- Use only the SD Memory Card included with the PBX.
- The SD Memory Card must be inserted in the SD Memory Card slot of the IPCMPR card before startup.

## Pin Assignments

### MNT Port/LAN Port (10BASE-T/100BASE-TX)

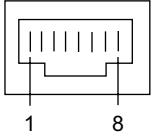
	No.	Signal Name	Input (I)/Output (O)	Function
	1	TPO+	O	Transmit data+
	2	TPO-	O	Transmit data-
	3	TPI+	I	Receive data+
	4-5	Reserved	–	–
	6	TPI-	I	Receive data-
	7-8	Reserved	–	–

## LED Indications

Indication	Color	Description
BATT ALARM	Red	Battery alarm indication <ul style="list-style-type: none"> <li>• OFF: Normal</li> <li>• ON: Alarm</li> </ul>
SD ACCESS	Green	SD memory card status <ul style="list-style-type: none"> <li>• ON: Accessing</li> </ul>

### 3.3.1 IPCMPR Card

Indication				Color	Description
10BASE-T/ 100BASE-TX	MNT	2	LINK	Green	Link status indication <ul style="list-style-type: none"> <li>• OFF: Off-line</li> <li>• ON: Linked normally</li> <li>• Flashing: In communication</li> </ul>
			100	Yellow	Data transmission speed indication <ul style="list-style-type: none"> <li>• OFF: 10 Mbps</li> <li>• ON: 100 Mbps</li> </ul>
	LAN	1	LINK	Green	Link status indication <ul style="list-style-type: none"> <li>• OFF: Off-line</li> <li>• ON: Linked normally</li> <li>• Flashing: In communication</li> </ul>
			100	Yellow	Data transmission speed indication <ul style="list-style-type: none"> <li>• OFF: 10 Mbps</li> <li>• ON: 100 Mbps</li> </ul>

## 3.3.2 DSP4 Card (KX-NCP1104), DSP16 Card (KX-TDE0110), and DSP64 Card (KX-TDE0111)

### Function

- DSP4:** 4-channel digital signal processor card with a 4-Channel IP Trunk activation key and a 8-Channel IP Proprietary Telephone activation key preinstalled. Compliant with ITU-T G.729A and G.711 codec methods. To be mounted on the IPCMPR card.
- DSP16:** 16-channel digital signal processor card with a 4-Channel IP Trunk activation key and an 8-Channel IP Proprietary Telephone activation key preinstalled. Compliant with ITU-T G.729A and G.711 codec methods. To be mounted on the IPCMPR card.
- DSP64:** 64-channel digital signal processor card with four 4-Channel IP Trunk activation keys and four 8-Channel IP Proprietary Telephone activation keys preinstalled. Compliant with ITU-T G.729A and G.711 codec methods. To be mounted on the IPCMPR card.

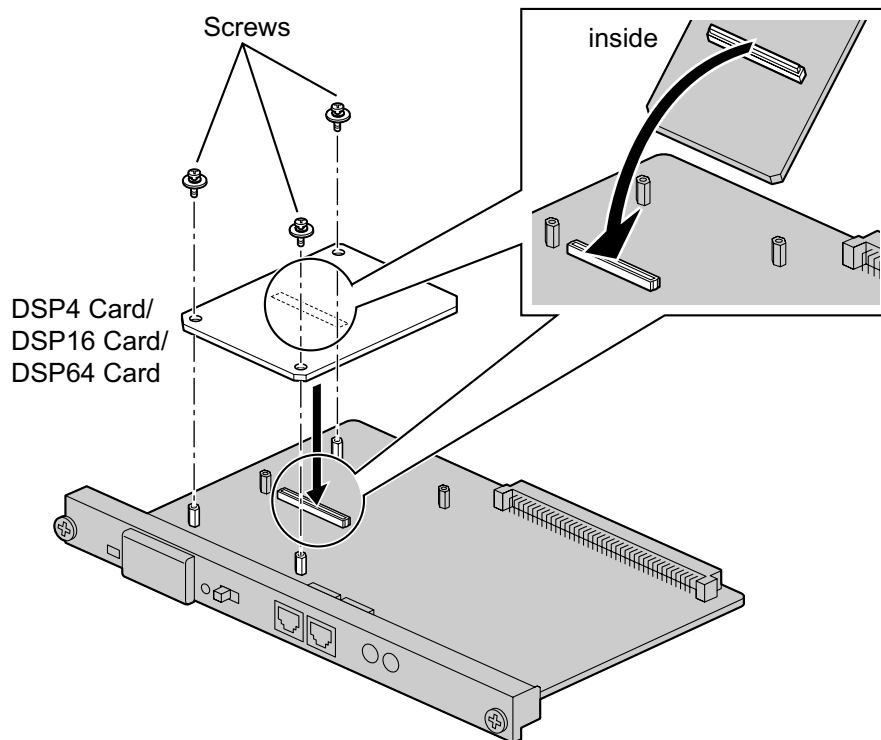

### Accessories and User-supplied Items

**Accessories (included):** Screws × 3

**User-supplied (not included):** none

### Note

- Depending on the number and the type of IP CO lines and IP telephones you wish to use, required activation keys are determined, and the DSP4, DSP16, or DSP64 card is selected to be installed.
- If the preinstalled activation keys on the DSP cards are not enough for the desired configuration, you need to purchase activation key codes. For details about the activation keys, refer to "2.1 Information about the Activation Keys".

### 3.3.2 DSP4 Card (KX-NCP1104), DSP16 Card (KX-TDE0110), and DSP64 Card (KX-TDE0111)

---

- When installing the DSP card, hold down the shaded areas of the card to connect it firmly.

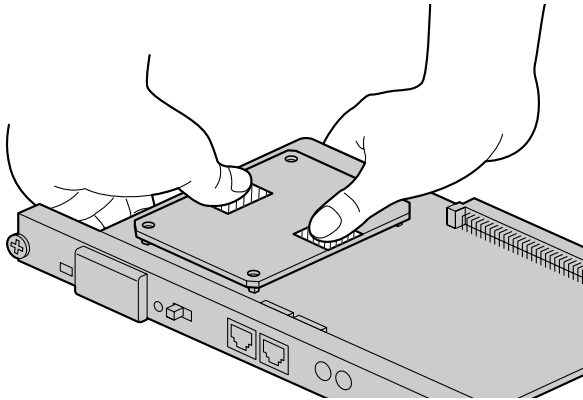

### 3.3.3 RMT Card (KX-TDA0196)

#### Function

Analog modem card for remote communication with the PBX. ITU-T V.90 support. To be mounted on the IPCMPR card.

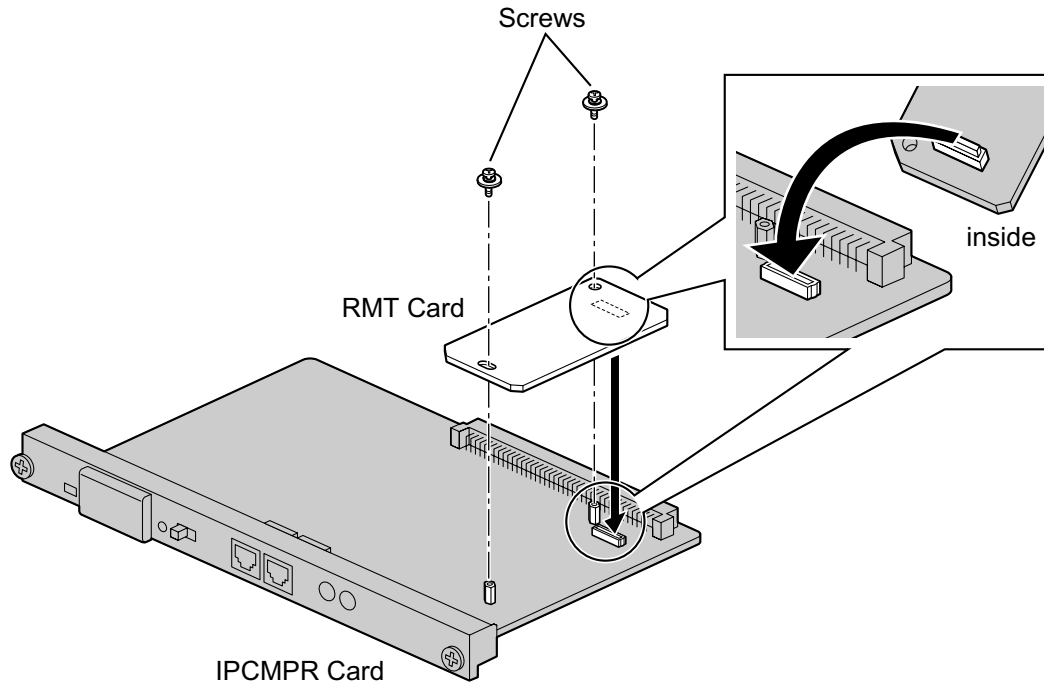

#### Accessories and User-supplied Items

**Accessories (included):** Screws × 2

**User-supplied (not included):** none

## 3.4 Information about the Virtual Cards

### 3.4.1 Virtual Cards

#### Function

Virtual Cards are included with the IPCMPR card and can be activated with the appropriate activation key (Only V-IPCS4 cards can be activated without activation keys). By installing Virtual Cards in the Virtual Slots of the IPCMPR card using the Maintenance Console, IP CO lines, IP extensions, and IP-CSs can be used via the IPCMPR card.

Virtual Card	Description
Virtual 16-Channel VoIP Gateway Card (V-IPGW16)	Virtual Card for 16-channel H.323 CO line. Compliant with VoIP H.323 V.5 protocol. Also supports T.38 protocol.
Virtual 16-Channel SIP CO Line Card (V-SIPGW16)	Virtual Card for 16-channel SIP CO line. Compliant with RFC 3261, 3262, 3264, 3311, 3581, 3960 and 4028 protocols. Also supports T.38 protocol.
Virtual 32-Channel VoIP Extension Card (V-IPEXT32)	Virtual Card for 32 VoIP extensions. Compliant with Panasonic proprietary protocol.
Virtual 32-Channel SIP Extension Card (V-SIPEXT32)	Virtual Card for 32 SIP Extensions. Compliant with RFC 3261, 3264, 3310, 2327 and 4028 protocols.
Virtual 4 IP Cell Station Interface Card (V-IPCS4)	Virtual Card for 4 IP-CSs. Compliant with ITU-T G.729A and G.711 codec methods.

#### Example: Virtual Cards in the Virtual Slots of the KX-NCP1000

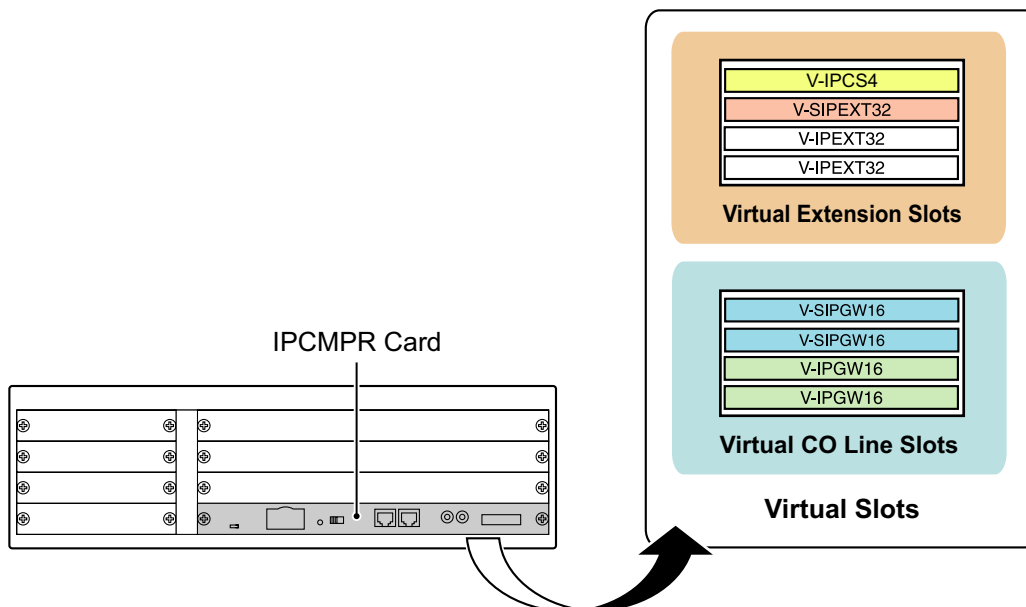

## 3.5 Information about the Physical CO Line Cards

### 3.5.1 LCOT4 Card (KX-NCP1180)

#### Function

4-port analog CO line card with Caller ID (FSK/DTMF) and 1 power failure transfer (PFT) port.

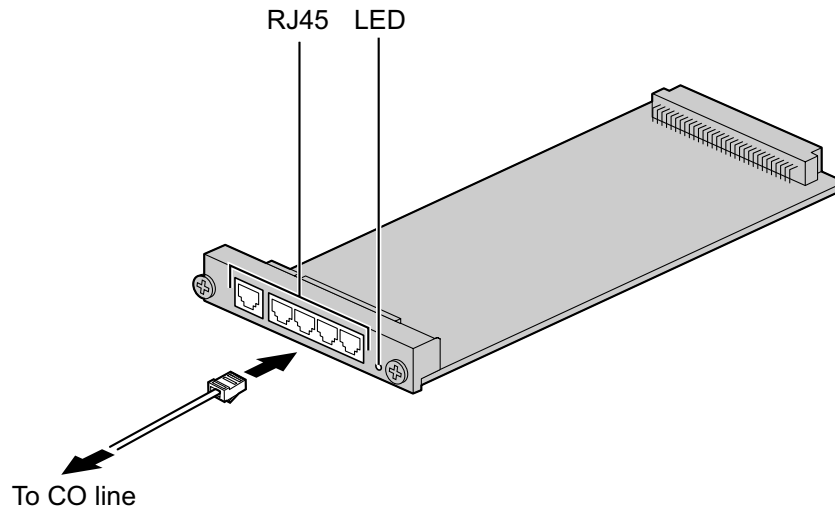

#### Accessories and User-supplied Items

**Accessories (included):** none

**User-supplied (not included):** RJ45 connector

#### CAUTION

To reduce the risk of fire, use only No.26 AWG or larger (e.g., 24 AWG) UL Listed or CSA Certified Telecommunication Line Cord.

#### Note

- For details about power failure transfer, refer to "3.12.1 Power Failure Connections".
- To confirm the CO line connection, refer to "Confirming the CO Line Connection" in "3.13.1 Starting the PBX".

## Pin Assignments

### RJ45 Connector

	No.	Signal Name	Function
	1-3	Reserved	–
	4	R	Ring
	5	T	Tip
	6-8	Reserved	–

## LED Indications

Indication	Color	Description
CARD STATUS	Green/Red	Card status indication <ul style="list-style-type: none"><li>• OFF: Power Off</li><li>• Green ON: Normal (all ports are idle)</li><li>• Green Flashing (60 times per minute): Normal (a port is in use)</li><li>• Red ON: Fault (includes reset)</li><li>• Red Flashing (60 times per minute): Out of Service</li></ul>

## 3.5.2 T1 Card (KX-NCP1187)

### Function

1-port T1 CO line card. EIA/TIA standard compliant.

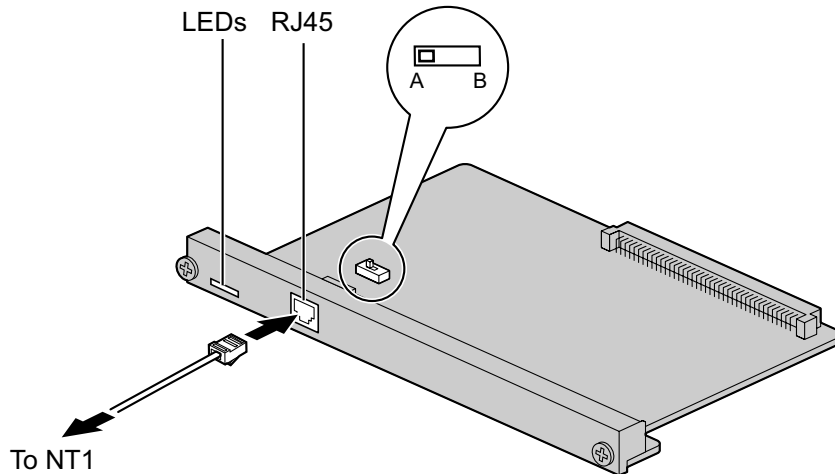

### Accessories and User-supplied Items

**Accessories (included):** none

**User-supplied (not included):** RJ45 connector

### CAUTION

- Connect this optional service card to the CO line through NT1; do not connect to the CO line directly.
- T1 ports are SELV ports and should only be connected to SELV services.

### Note

- T1 Card must be installed behind an FCC registered and UL or CSA-NRTL listed CSU.
- To confirm the CO line connection, refer to "Confirming the CO Line Connection" in "3.13.1 Starting the PBX".

### Switch Settings

Switch	Type	Usage and Status Definition
A/B	Slide	Keep the switch at default A position. Do not change the position of this switch.

## Pin Assignments

### RJ45 Connector

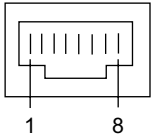
	No.	Signal Name	Level [V]	Function
	1	RX+	(+)	Receive data (+)
	2	RX-	(-)	Receive data (-)
	3	Reserved	–	–
	4	TX-	(-)	Transmit data (-)
	5	TX+	(+)	Transmit data (+)
	6-8	Reserved	–	–

## LED Indications

Indication	Color	Description
CARD STATUS	Green/Red	Card status indication <ul style="list-style-type: none"> <li>• OFF: Power Off</li> <li>• Green ON: Normal (all ports are idle)</li> <li>• Green Flashing (60 times per minute): Normal (a port is in use)</li> <li>• Red ON: Fault (includes reset)</li> <li>• Red Flashing (60 times per minute): Out of Service</li> </ul>
SYNC-ERR	Red	Non-synchronization status indication <ul style="list-style-type: none"> <li>• OFF: Normal</li> <li>• ON: Out of synchronization</li> </ul>
RAI	Red	RAI signal status indication <ul style="list-style-type: none"> <li>• OFF: Normal</li> <li>• ON: Alarm (Clock Slave)</li> <li>• Flashing (60 times per minute): Alarm (Clock Master)</li> </ul>
AIS	Red	AIS status indication <ul style="list-style-type: none"> <li>• OFF: Normal</li> <li>• ON: Alarm</li> </ul>
SYNC	Green	Synchronization status indication <ul style="list-style-type: none"> <li>• OFF: Not synchronized</li> <li>• ON: Synchronized</li> <li>• Flashing (60 times per minute): Synchronized (Clock Master)</li> </ul>

## 3.5.3 PRI23 Card (KX-NCP1290)

### Function

1-port ISDN Primary Rate Interface card (23B channels). NI (North American standard ISDN protocol) compliant.

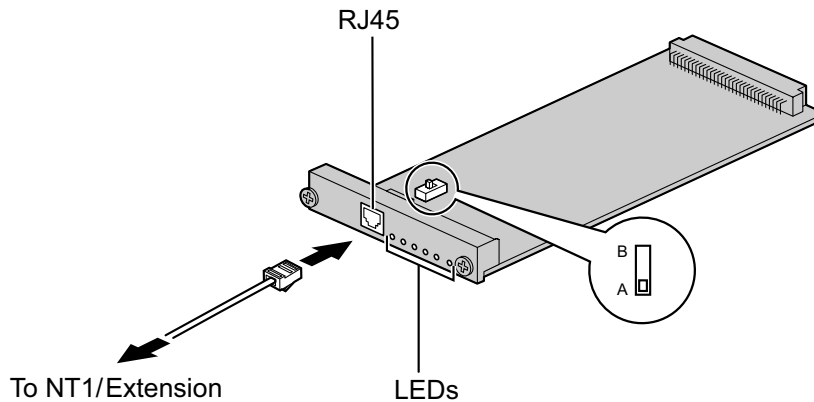

### Accessories and User-supplied Items

**Accessories (included):** none

**User-supplied (not included):** RJ45 connector

### CAUTION

- Connecting this optional service card to the CO line through an NT1; do not connect to the U interface of the CO line directly.
- PRI ports are SELV ports and should only be connected to SELV services.

### Note

To confirm the CO line connection, refer to "Confirming the CO Line Connection" in "3.13.1 Starting the PBX".

### Switch Settings

Switch	Type	Usage and Status Definition
A/B	Slide	Keep the switch at default A position. Do not change the position of this switch.

## Pin Assignments

### RJ45 Connector

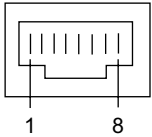
	No.	Signal Name	Level [V]	Function
	1	RX+	(+)	Receive data (+)
	2	RX-	(-)	Receive data (-)
	3	Reserved	–	–
	4	TX-	(-)	Transmit data (-)
	5	TX+	(+)	Transmit data (+)
	6-8	Reserved	–	–

## LED Indications

Indication	Color	Description
CARD STATUS	Green/Red	Card status indication <ul style="list-style-type: none"> <li>• OFF: Power Off</li> <li>• Green ON: Normal (all ports are idle)</li> <li>• Green Flashing (60 times per minute): Normal (a port is in use)</li> <li>• Red ON: Fault (includes reset)</li> <li>• Red Flashing (60 times per minute): Out of Service</li> </ul>
SYNC-ERR	Red	Non-synchronization status indication <ul style="list-style-type: none"> <li>• OFF: Normal</li> <li>• ON: Out of synchronization</li> </ul>
RAI	Red	RAI signal status indication <ul style="list-style-type: none"> <li>• OFF: Normal</li> <li>• ON: Alarm (Clock Slave)</li> <li>• Flashing (60 times per minute): Alarm (Clock Master)</li> </ul>
AIS	Red	AIS status indication <ul style="list-style-type: none"> <li>• OFF: Normal</li> <li>• ON: Alarm</li> </ul>
SYNC	Green	Synchronization status indication <ul style="list-style-type: none"> <li>• OFF: Not synchronized</li> <li>• ON: Synchronized</li> <li>• Flashing (60 times per minute): Synchronized (Clock Master)</li> </ul>
D-LINK	Green	Data link status indication <ul style="list-style-type: none"> <li>• OFF: Not established</li> <li>• ON: Established</li> </ul>

## 3.6 Information about the Physical Extension Cards

### 3.6.1 DHLC4 Card (KX-NCP1170)

#### Function

4-port digital hybrid extension card for DPTs, APTs, SLTs, DSS consoles, and PT-interface CSs, with Caller ID (FSK) and 1 power failure transfer (PFT) port.

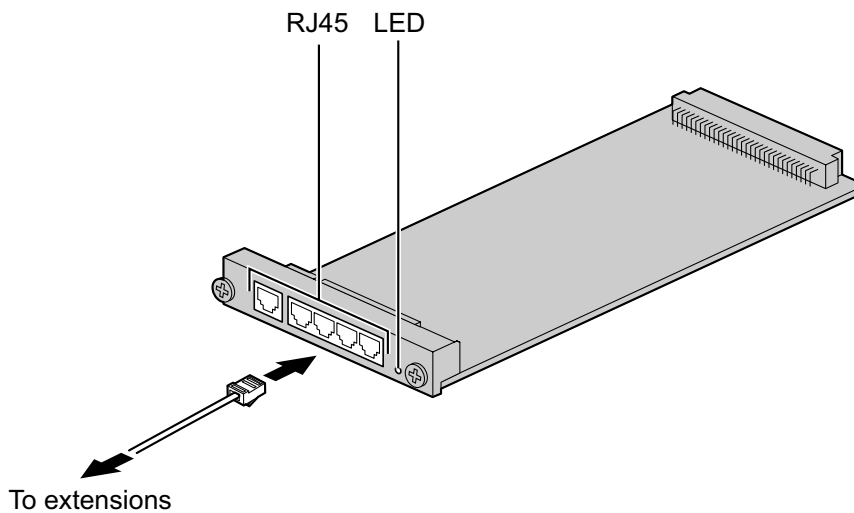

#### Accessories and User-supplied Items

**Accessories (included):** none

**User-supplied (not included):** RJ45 connector

#### Note

For details about power failure transfer, refer to "3.12.1 Power Failure Connections".

## Pin Assignments

### RJ45 Connector

	No.	Signal Name	Function
	1-2	Reserved	–
	3	D1	Data port (High)
	4	T	Tip
	5	R	Ring
	6	D2	Data port (Low)
	7-8	Reserved	–

## LED Indications

Indication	Color	Description
CARD STATUS	Green/ Orange/Red	Card status indication <ul style="list-style-type: none"><li>• OFF: Power Off</li><li>• Green ON: Normal (all ports are idle)</li><li>• Green Flashing (60 times per minute): Normal (a port is in use)</li><li>• Orange Flashing: Detection of PT-interface CS connection (when starting up the PT-interface CS)</li><li>• Red ON: Fault (includes reset)</li><li>• Red Flashing (60 times per minute): Out of Service</li></ul>

## 3.6.2 DLC8 Card (KX-NCP1171)

### Function

8-port digital extension card for DPTs, DSS consoles, and PT-interface CSs.

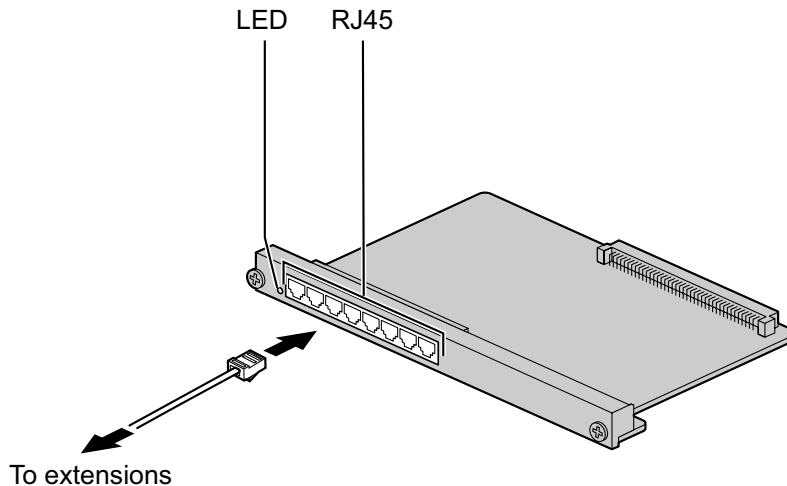

### Accessories and User-supplied Items

**Accessories (included):** none

**User-supplied (not included):** RJ45 connector

### Pin Assignments

#### RJ45 Connector

	No.	Signal Name	Function
	1-2	Reserved	–
	3	D1	Data port (High)
	4-5	Reserved	–
	6	D2	Data port (Low)
	7-8	Reserved	–

### LED Indications

Indication	Color	Description
CARD STATUS	Green/ Orange/Red	Card status indication <ul style="list-style-type: none"> <li>• OFF: Power Off</li> <li>• Green ON: Normal (all ports are idle)</li> <li>• Green Flashing (60 times per minute): Normal (a port is in use)</li> <li>• Orange Flashing: Detection of PT-interface CS connection (when starting up the PT-interface CS)</li> <li>• Red ON: Fault (includes reset)</li> <li>• Red Flashing (60 times per minute): Out of Service</li> </ul>

## 3.6.3 DLC16 Card (KX-NCP1172)

### Function

16-port digital extension card for DPTs, DSS consoles, and PT-interface CSs.

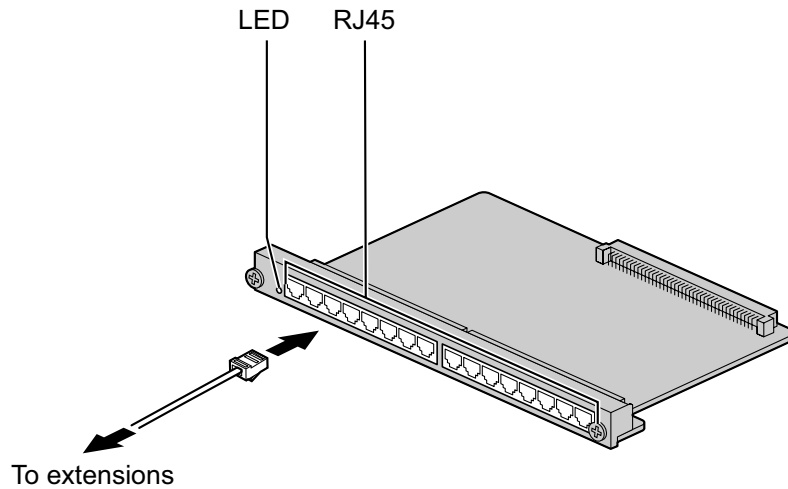

### Accessories and User-supplied Items

**Accessories (included):** none

**User-supplied (not included):** RJ45 connector

### Pin Assignments

#### RJ45 Connector

	No.	Signal Name	Function
	1-2	Reserved	–
	3	D1	Data port (High)
	4-5	Reserved	–
	6	D2	Data port (Low)
	7-8	Reserved	–

### LED Indications

Indication	Color	Description
CARD STATUS	Green/ Orange/Red	Card status indication <ul style="list-style-type: none"> <li>• OFF: Power Off</li> <li>• Green ON: Normal (all ports are idle)</li> <li>• Green Flashing (60 times per minute): Normal (a port is in use)</li> <li>• Orange Flashing: Detection of PT-interface CS connection (when starting up the PT-interface CS)</li> <li>• Red ON: Fault (includes reset)</li> <li>• Red Flashing (60 times per minute): Out of Service</li> </ul>

## 3.6.4 SLC8 Card (KX-NCP1173)

### Function

8-port extension card for SLTs with Caller ID (FSK).

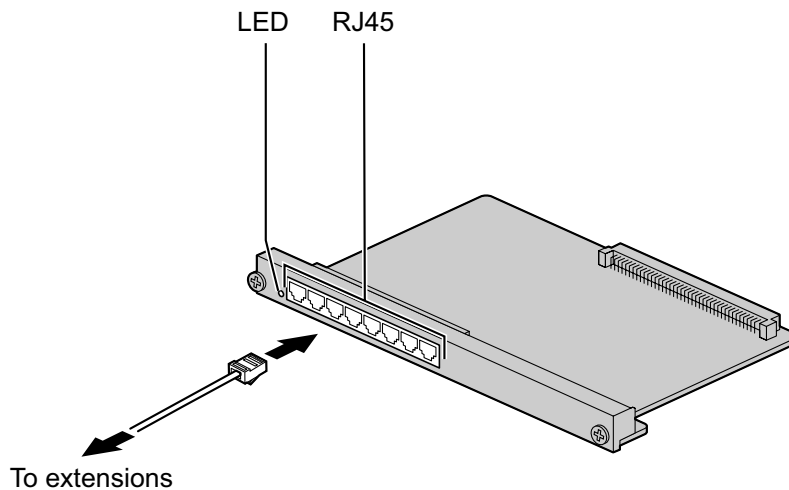

### Accessories and User-supplied Items

**Accessories (included):** none

**User-supplied (not included):** RJ45 connector

### Pin Assignments

#### RJ45 Connector

	No.	Signal Name	Function
	1-3	Reserved	–
	4	T	Tip
	5	R	Ring
	6-8	Reserved	–

### LED Indications

Indication	Color	Description
CARD STATUS	Green/Red	Card status indication <ul style="list-style-type: none"> <li>• OFF: Power Off</li> <li>• Green ON: Normal (all ports are idle)</li> <li>• Green Flashing (60 times per minute): Normal (a port is in use)</li> <li>• Red ON: Fault (includes reset)</li> <li>• Red Flashing (60 times per minute): Out of Service</li> </ul>

## 3.6.5 SLC16 Card (KX-NCP1174)

### Function

16-port extension card for SLTs with Caller ID (FSK).

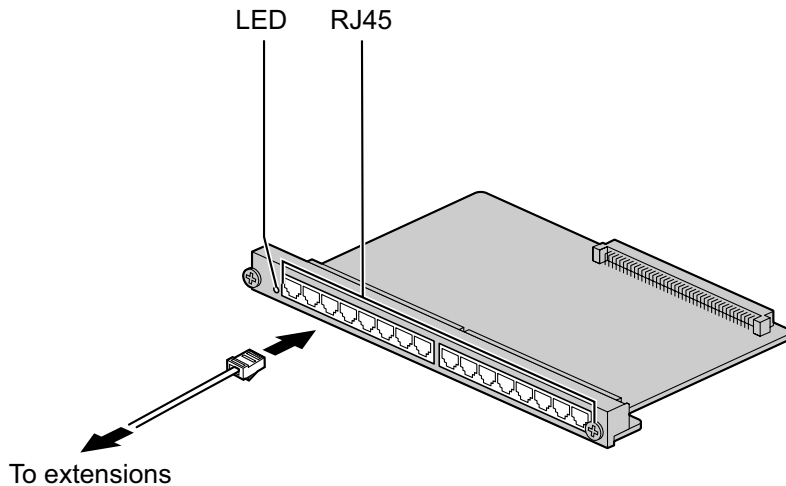

### Accessories and User-supplied Items

**Accessories (included):** none

**User-supplied (not included):** RJ45 connector

### Pin Assignments

#### RJ45 Connector

	No.	Signal Name	Function
	1-3	Reserved	–
	4	T	Tip
	5	R	Ring
	6-8	Reserved	–

### LED Indications

Indication	Color	Description
CARD STATUS	Green/Red	Card status indication <ul style="list-style-type: none"> <li>• OFF: Power Off</li> <li>• Green ON: Normal (all ports are idle)</li> <li>• Green Flashing (60 times per minute): Normal (a port is in use)</li> <li>• Red ON: Fault (includes reset)</li> <li>• Red Flashing (60 times per minute): Out of Service</li> </ul>

## 3.7 Information about the Other Physical Cards

### 3.7.1 OPB3 Card (KX-NCP1190)

#### Function

Optional 3-slot base card for mounting a maximum of 3 option cards from the following:

- DPH4 card
- EIO4 card
- ECHO16 card
- MSG4 card
- ESVM4 card

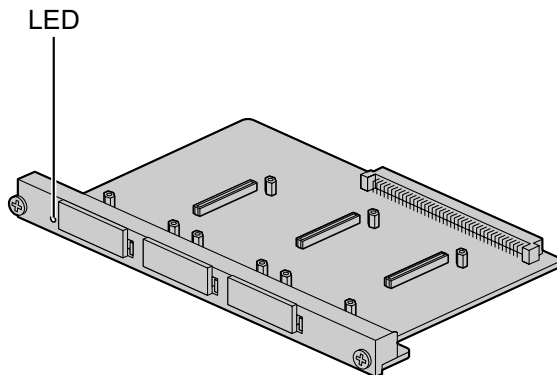

#### Accessories and User-supplied Items

**Accessories (included):** none

**User-supplied (not included):** none

#### **WARNING**

A lithium battery is used in the OPB3 card. There is a risk of explosion if the battery is replaced with the incorrect type. Dispose of used batteries according to the manufacturer's instructions.

#### LED Indications

Indication	Color	Description
CARD STATUS	Green/Red	Card status indication <ul style="list-style-type: none"> <li>• OFF: Power Off</li> <li>• Green ON: Normal (all ports are idle)</li> <li>• Green Flashing (60 times per minute): Normal (a port is in use)</li> <li>• Red ON: Fault (includes reset)</li> <li>• Red Flashing (60 times per minute): Out of Service</li> </ul>

## 3.7.2 DPH4 Card (KX-TDA0161)

### Function

4-port doorphone card for 4 doorphones and 4 door openers. To be mounted on the OPB3 card.

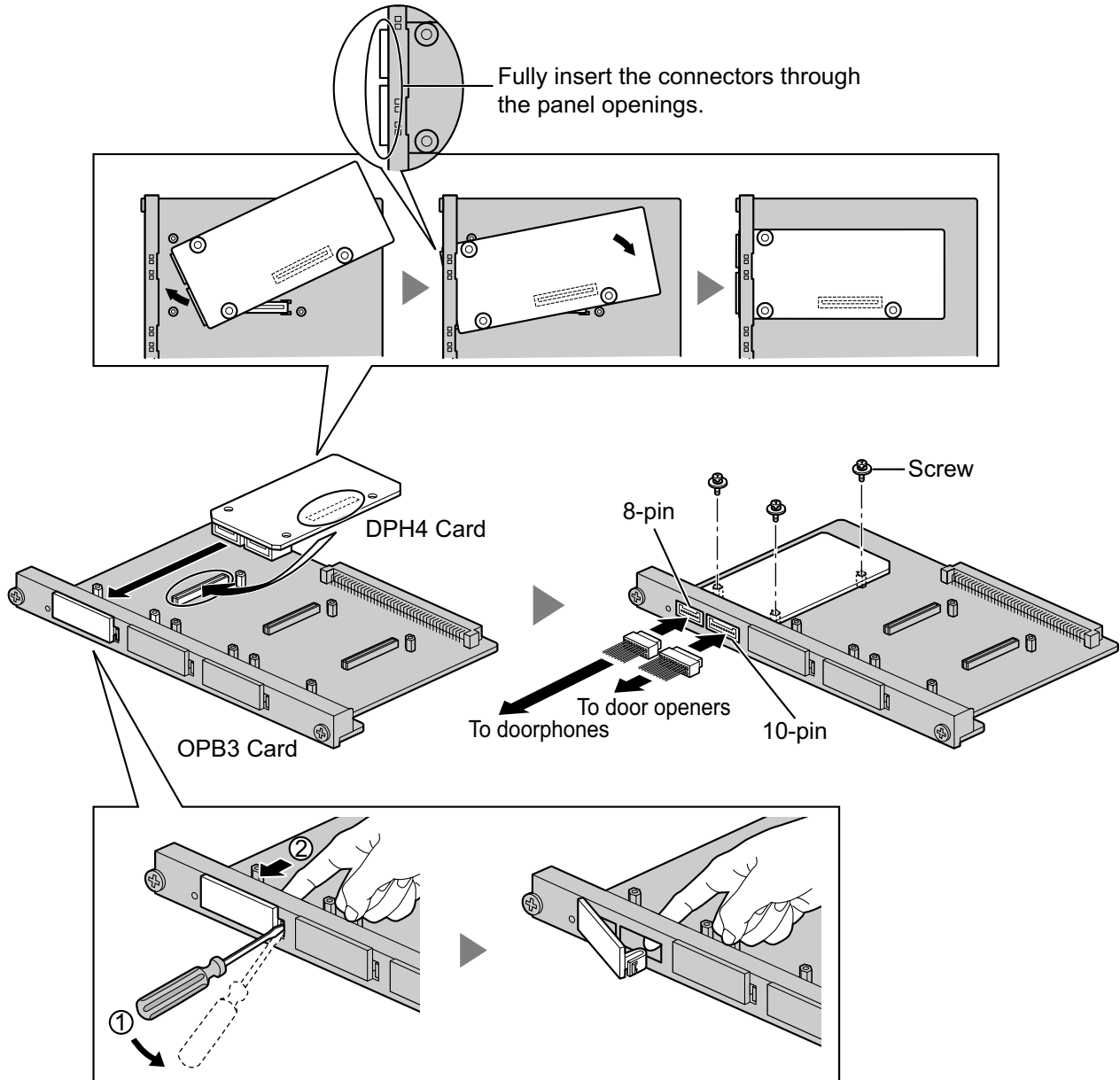

### Accessories and User-supplied Items

**Accessories (included):** Screws × 3, 10-pin terminal block × 1, 8-pin terminal block × 1

**User-supplied (not included):** Copper wire

### Note

For details about connection to doorphones and door openers, refer to "3.9.1 Connection of Doorphones, Door Openers, External Sensors, and External Relays".

## Pin Assignments

### 8-pin Terminal Block

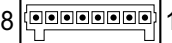
	No.	Signal Name	Function
	1	DP4	Doorphone 4 transmit
	2	com4	Doorphone 4 receive
	3	DP3	Doorphone 3 transmit
	4	com3	Doorphone 3 receive
	5	DP2	Doorphone 2 transmit
	6	com2	Doorphone 2 receive
	7	DP1	Doorphone 1 transmit
	8	com1	Doorphone 1 receive

### 10-pin Terminal Block

	No.	Signal Name	Function
	1-2	Reserved	–
	3	OP4b	Door opener 4
	4	OP4a	Door opener 4 com
	5	OP3b	Door opener 3
	6	OP3a	Door opener 3 com
	7	OP2b	Door opener 2
	8	OP2a	Door opener 2 com
	9	OP1b	Door opener 1
	10	OP1a	Door opener 1 com

## 3.7.3 EIO4 Card (KX-TDA0164)

### Function

4-port external input/output card. To be mounted on the OPB3 card.

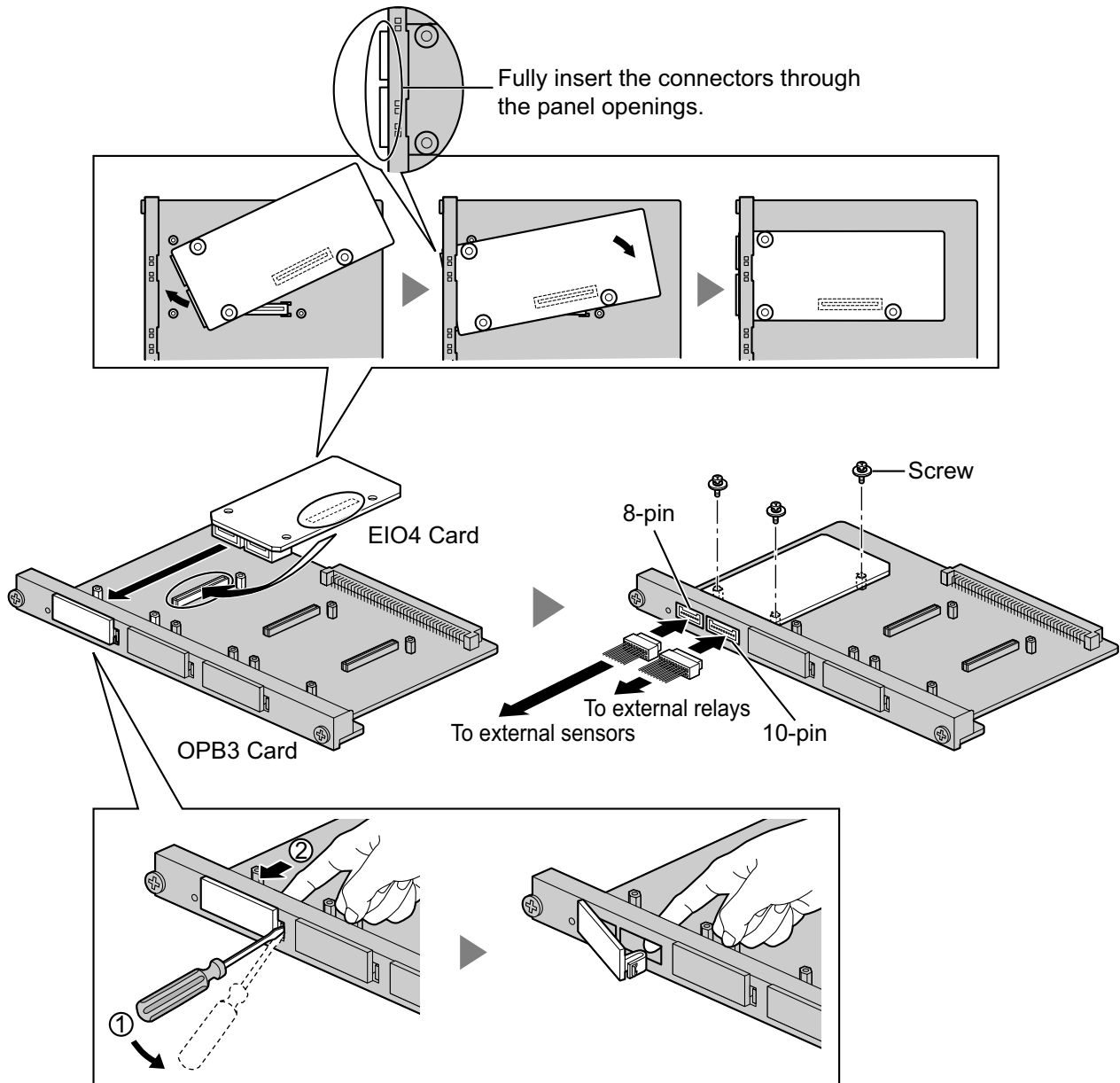

### Accessories and User-supplied Items

**Accessories (included):** Screws × 3, 10-pin terminal block × 1, 8-pin terminal block × 1

**User-supplied (not included):** Copper wire

### Note

For details about connection to external sensors and external relays, refer to "3.9.1 Connection of Doorphones, Door Openers, External Sensors, and External Relays".

## Pin Assignments

### 8-pin Terminal Block

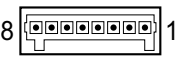
	No.	Signal Name	Function
	1	C4b	Control 4
	2	C4a	Control 4 com
	3	C3b	Control 3
	4	C3a	Control 3 com
	5	C2b	Control 2
	6	C2a	Control 2 com
	7	C1b	Control 1
	8	C1a	Control 1 com

### 10-pin Terminal Block

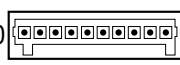
	No.	Signal Name	Function
	1-2	Reserved	–
	3	OP4b	Opener 4
	4	OP4a	Opener 4 com
	5	OP3b	Opener 3
	6	OP3a	Opener 3 com
	7	OP2b	Opener 2
	8	OP2a	Opener 2 com
	9	OP1b	Opener 1
	10	OP1a	Opener 1 com

### External Sensor

Power to the external sensor is provided from the EIO4 card and must be grounded through the EIO4 card as indicated in the diagram below. A pair of "sensor" and "common" lines are connected to the EIO4 card for each external sensor. The PBX detects input from the sensor when the signal is under 100 Ω.

#### Connection Diagram

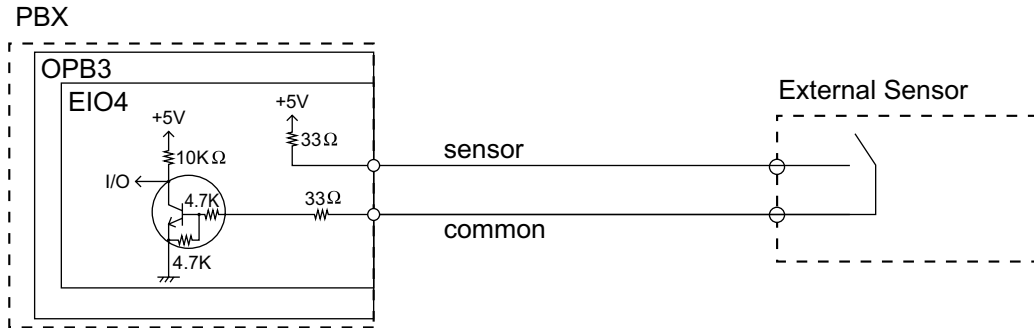

### External Relay

Current Limit: 24 V DC/30 V AC, 1 A maximum

## 3.7.4 ECHO16 Card (KX-TDA0166)

### Function

16-channel card for echo cancellation during conferences. To be mounted on the OPB3 card.

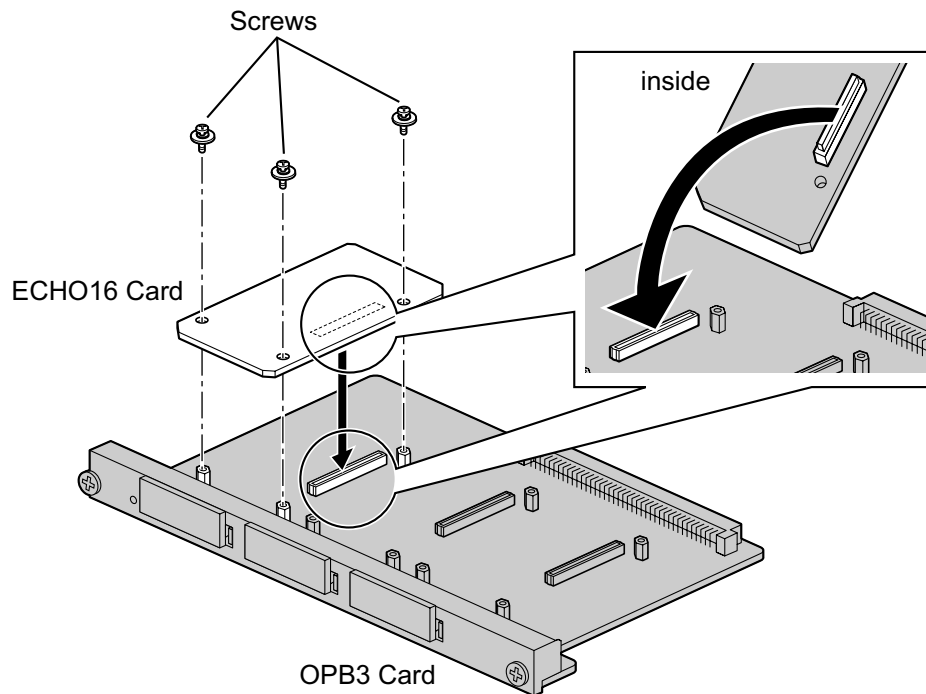

### Accessories and User-supplied Items

**Accessories (included):** Screws × 3

**User-supplied (not included):** none

### Note

To establish a conference call involving 6 to 8 parties, install an ECHO16 card and enable echo cancellation for conferences using the Maintenance Console. For details, refer to "◆ Echo Cancel—Conference" in "4.18 [2-9] System Options" of the PC Programming Manual.

## 3.7.5 MSG4 Card (KX-TDA0191)

### Function

4-channel message card. To be mounted on the OPB3 card.

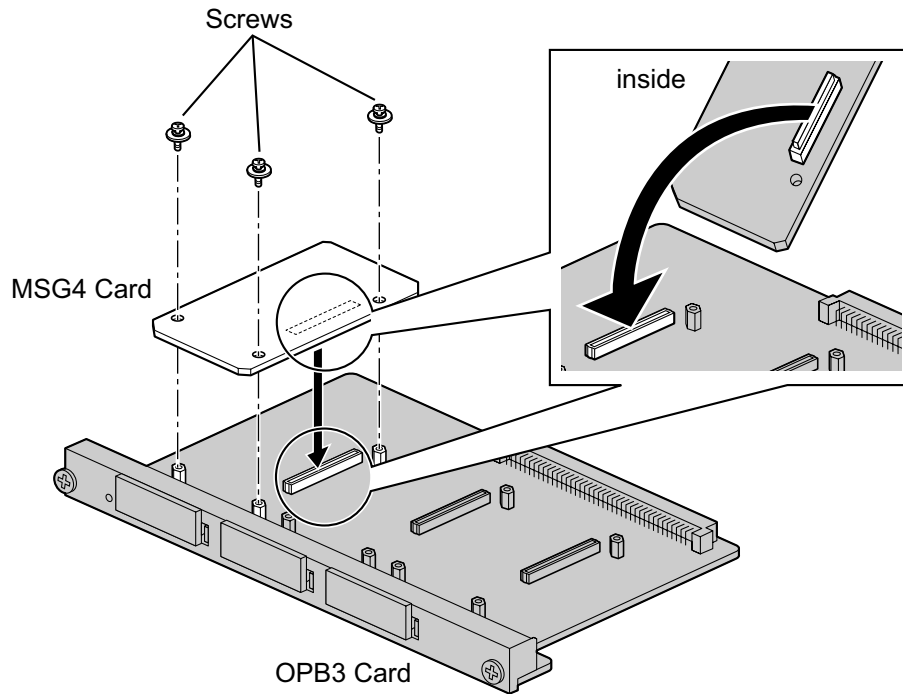

### Accessories and User-supplied Items

**Accessories (included):** Screws × 3

**User-supplied (not included):** none

## 3.7.6 ESVM4 Card (KX-TDA0194)

### Function

4-channel simplified voice message card for Simplified Voice Message feature. Also supports MSG card features. To be mounted on the OPB3 card.

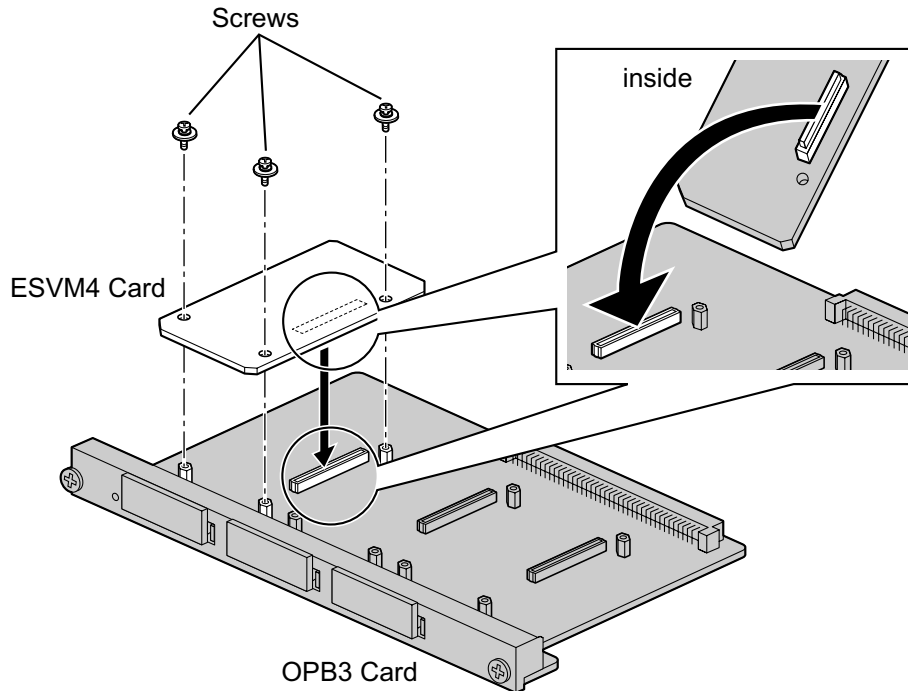

### Accessories and User-supplied Items

**Accessories (included):** Screws × 3

**User-supplied (not included):** none

### CAUTION

When installing/uninstalling an ESVM card, be careful not to damage the chips around the connection parts. Doing so may cause severe damage to the ESVM card.

### Notice

- When replacing an ESVM card, ensure that the status of the OPB3 card is In Service (INS), and then initialize the ESVM card. For details about the initialization procedure, refer to "2.5.4 Tool—Simplified Voice Message—Delete All Recording" in the PC Programming Manual.
- When installing an ESVM card for the first time on an OPB3 card that is already installed in the PBX, do not remove the OPB3 card from the PBX until the card status becomes INS.
- After installing the OPB3 card, with an ESVM card mounted, for the first time, do not remove the OPB3 card from the PBX until the card status becomes INS.

### Note

When using an ESVM card for the SVM feature, it must be mounted on sub-slot 3 (leftmost slot) of the OPB3 card.

## 3.8 Connection of Extensions

### 3.8.1 Maximum Cabling Distances of the Extension Wiring (Twisted Cable)

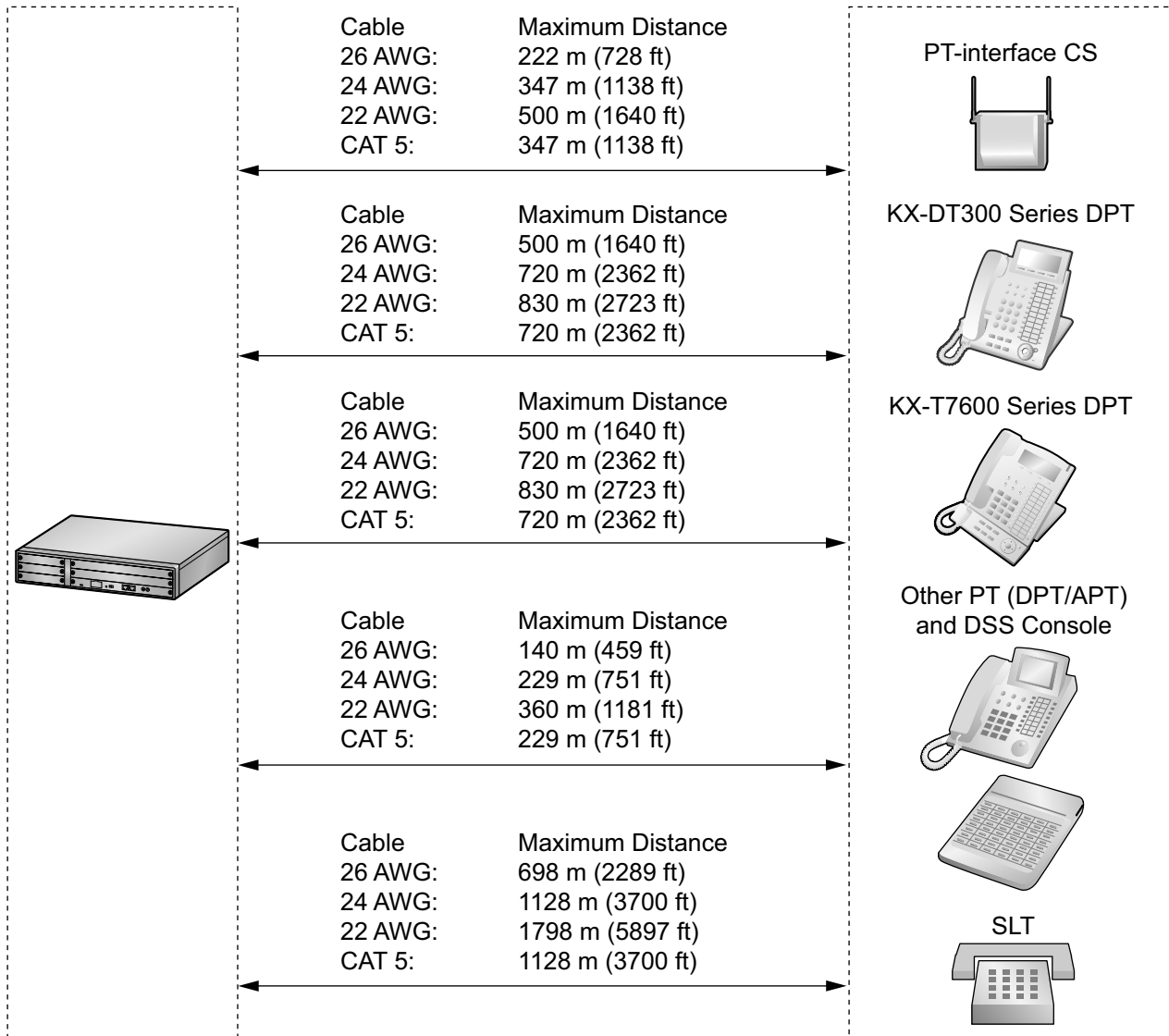

\* The maximum cabling distance from the PBX is the same even when the KX-DT300/KX-T7600 series DPT is the master DPT on the Digital XDP connection.

**Notice**

The maximum cabling distance may vary depending on the conditions.

	PT-interface CS	DPT	APT	DSS Console	SLT
DHLC4 Card	✓	✓	✓	✓	✓
SLC16, SLC8 Cards					✓

### 3.8.1 Maximum Cabling Distances of the Extension Wiring (Twisted Cable)

---

	<b>PT-interface CS</b>	<b>DPT</b>	<b>APT</b>	<b>DSS Console</b>	<b>SLT</b>
DLC16, DLC8 Cards	✓	✓		✓	

"✓" indicates that the extension card supports the terminal.

## 3.8.2 Parallel Connection of the Extensions

Any SLT can be connected in parallel with an APT or a DPT as follows.

### Note

In addition to an SLT, an answering machine, a fax machine or a modem (PC) can be connected in parallel with an APT or a DPT.

### With APT

For parallel connection, eXtra Device Port (XDP) mode must be disabled for that port through system programming. Refer to "13.1.2 Paralleled Telephone" and "5.1.7 Extension Port Configuration" in the Feature Manual for further information.

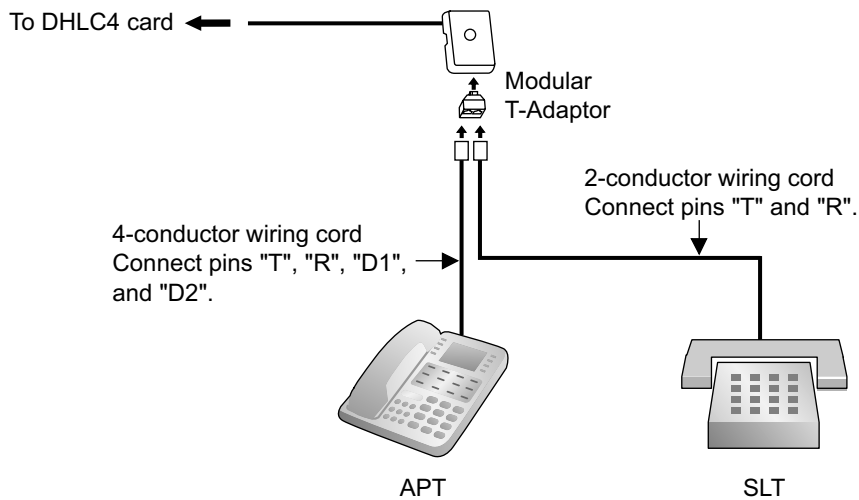

## With DPT

Parallel mode or eXtra Device Port (XDP) mode can be selected through system programming. If XDP mode is enabled through system programming, parallel connection is not possible. Refer to "13.1.2 Paralleled Telephone" and "5.1.7 Extension Port Configuration" in the Feature Manual for further information.

### Using a Modular T-Adaptor

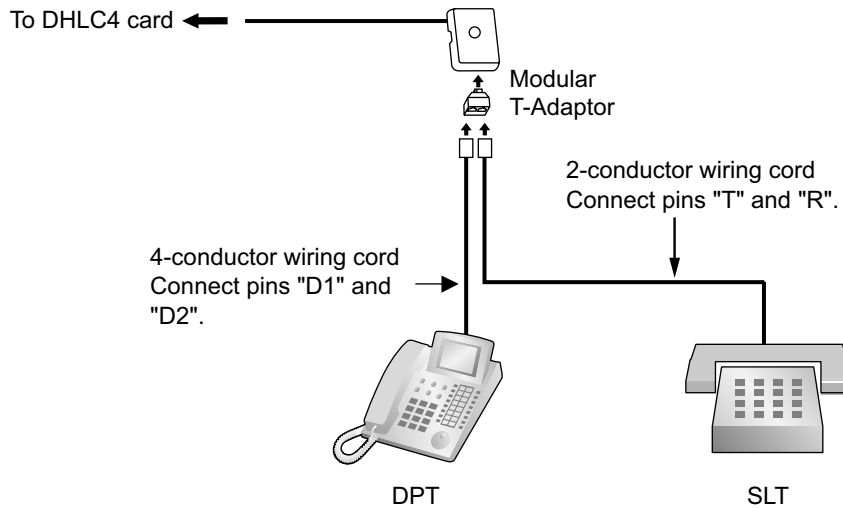

### Using an EXtra Device Port

#### With KX-DT300 Series DPT (except KX-DT321)

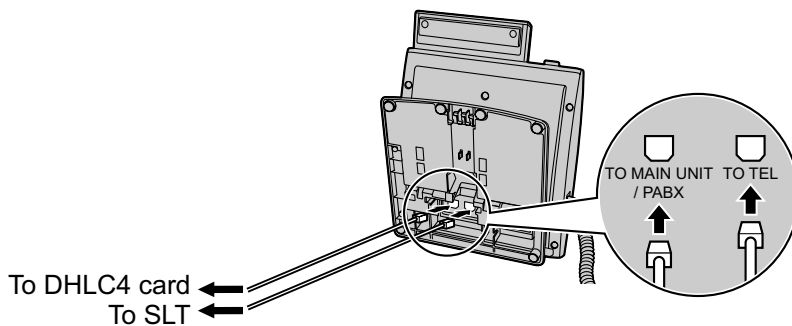
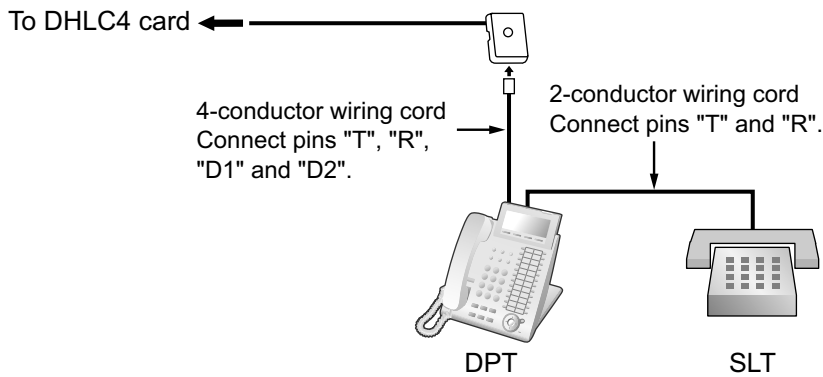

**With KX-T7600 Series DPT (except KX-T7665)**

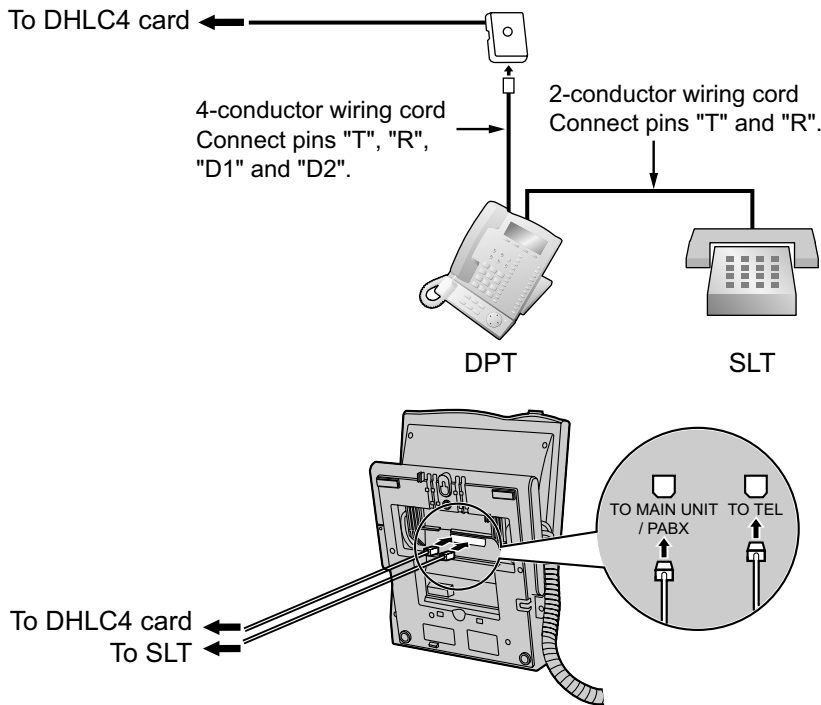

**With Other DPT**

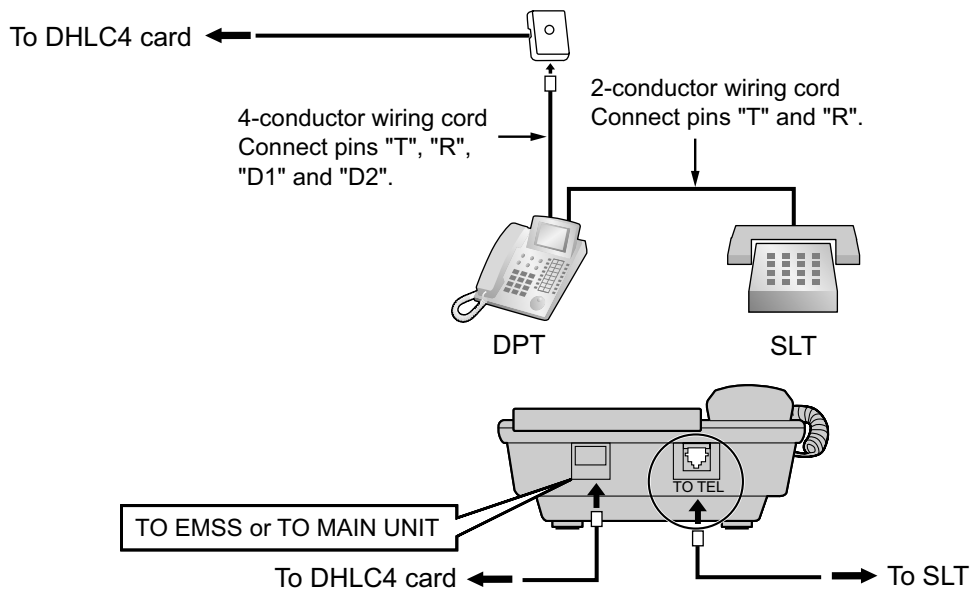

### 3.8.3 Digital EXtra Device Port (Digital XDP) Connection

A DPT can be connected to another DPT on the Digital XDP connection. In addition, if the DPT is connected to a DHLC4 card, it can also have an SLT connected in Parallel mode or XDP mode.

#### Note

- Both DPTs must be KX-DT300/KX-T7600 series DPTs (except KX-T7640). Note that the KX-T7667 can only be connected as a slave DPT.
- Bluetooth® Modules or USB Modules must not be connected to DPTs in the Digital XDP connection.
- Parallel mode or XDP mode can be selected through system programming.
- If XDP mode is enabled through system programming, parallel connection is not possible. Refer to "13.1.2 Paralleled Telephone" and "5.1.7 Extension Port Configuration" in the Feature Manual for further information.

#### With KX-DT300 Series DPT

##### Using a Modular T-Adaptor

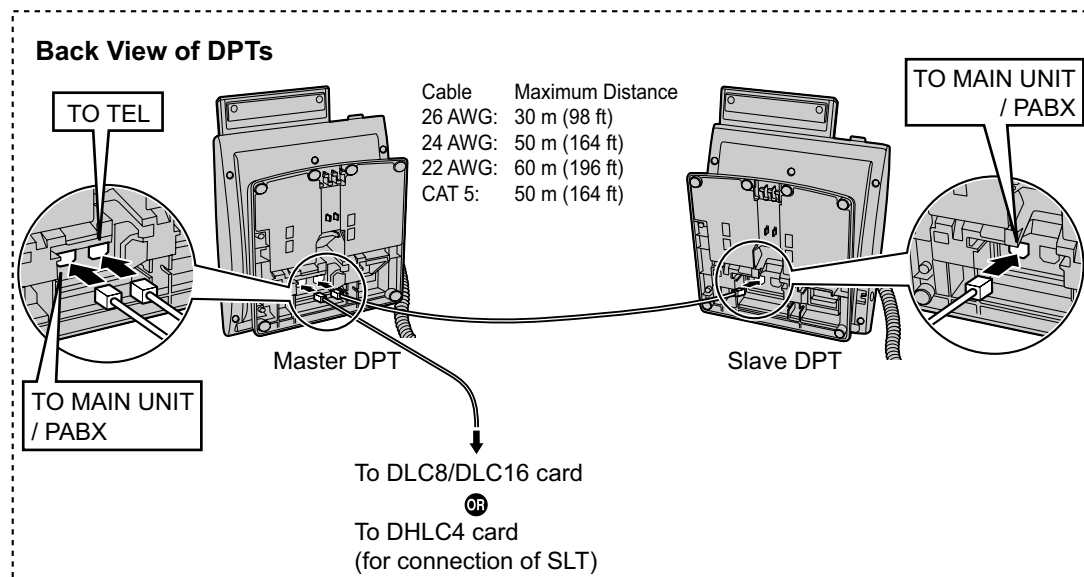
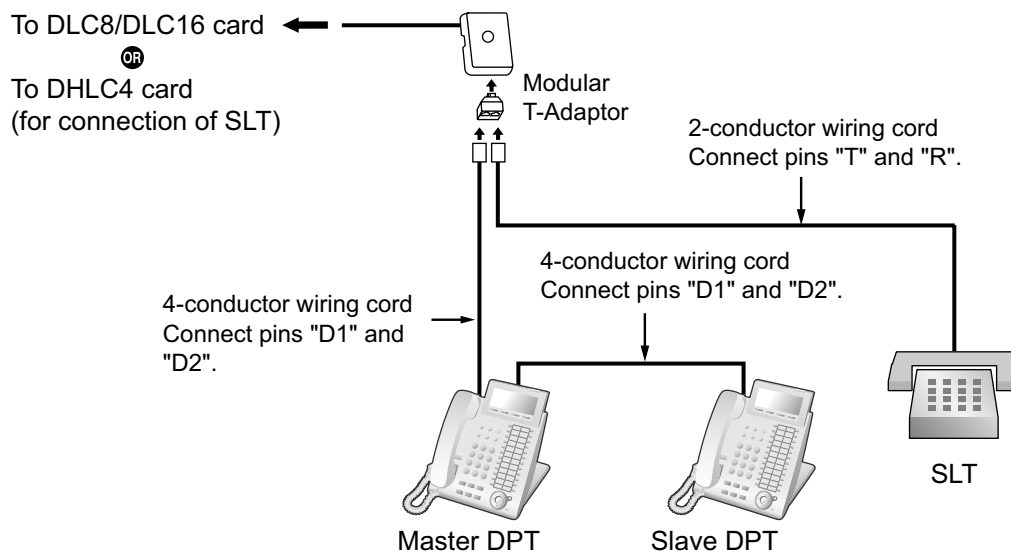

Using an EXtra Device Port

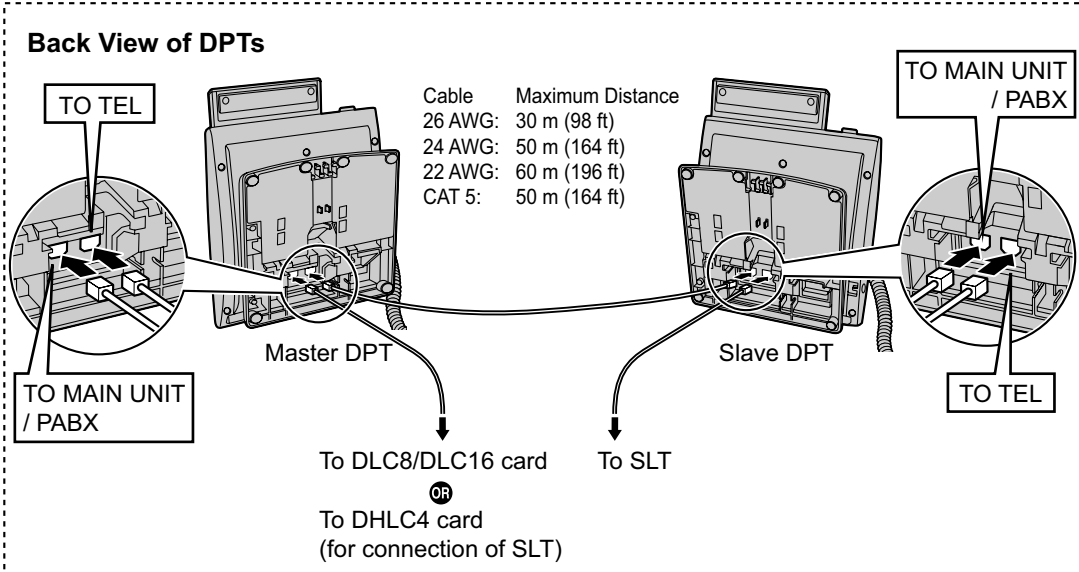
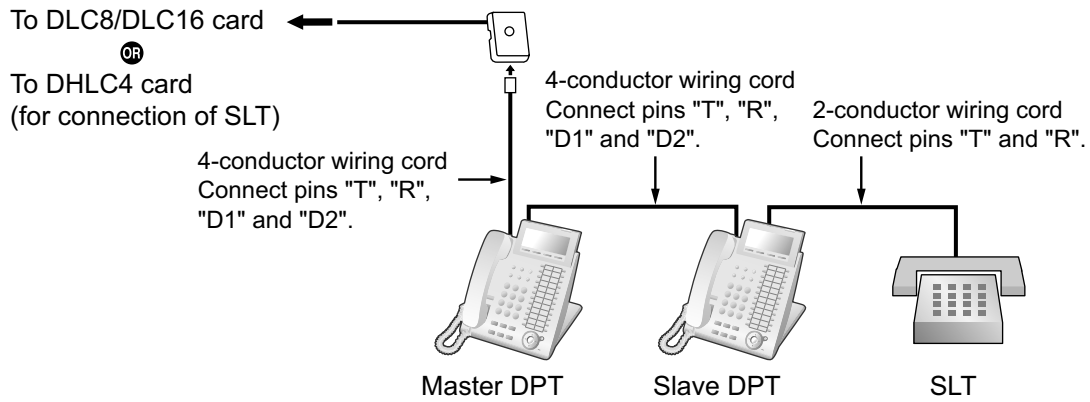

## With KX-T7600 Series DPT

### Using a Modular T-Adaptor

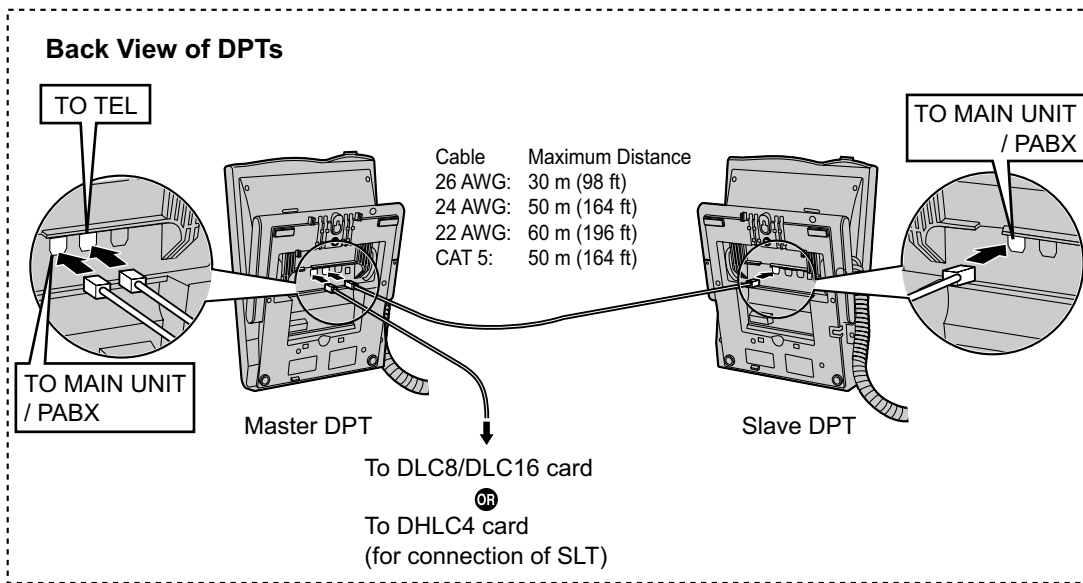
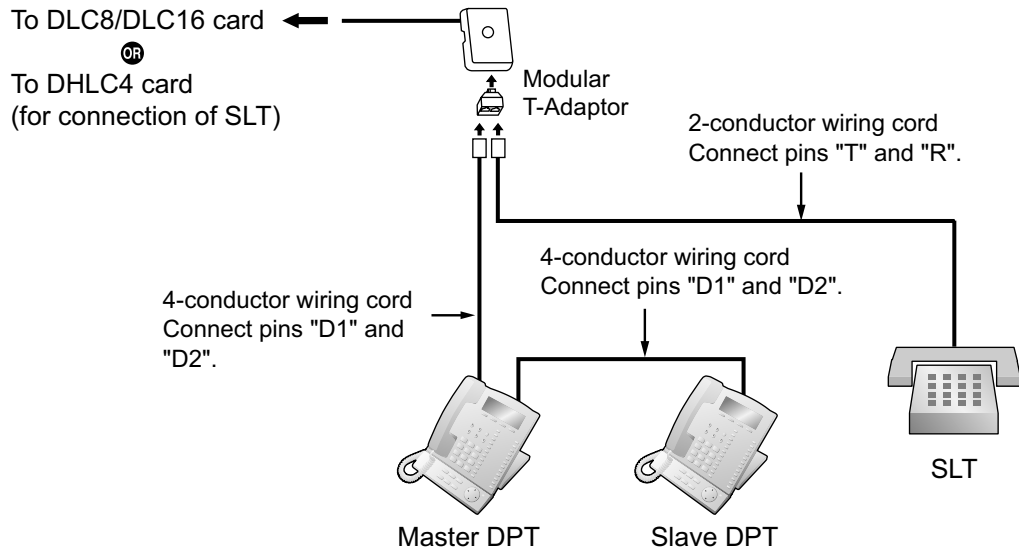

### Using an EXtra Device Port

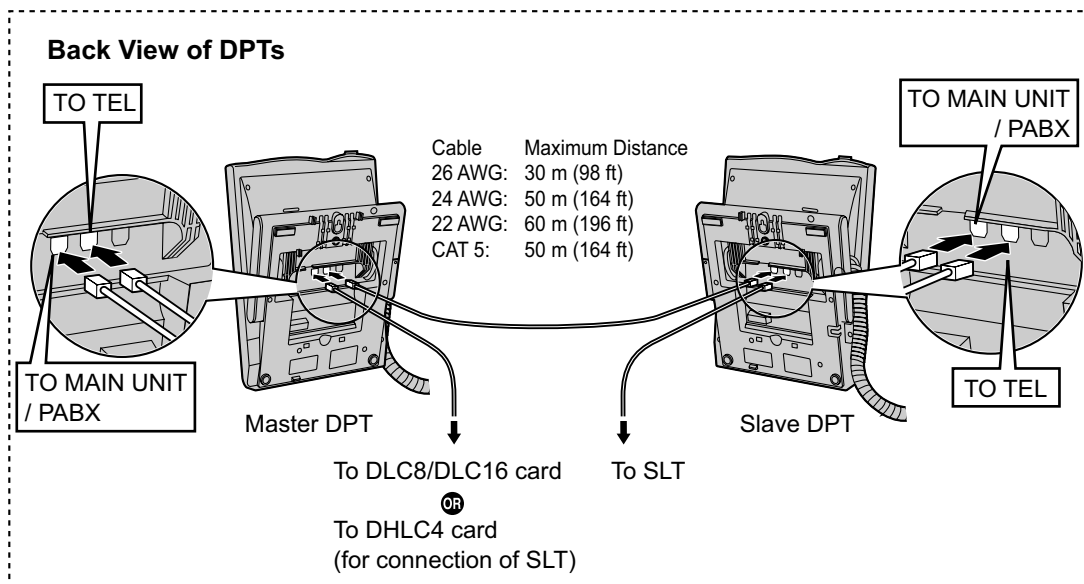
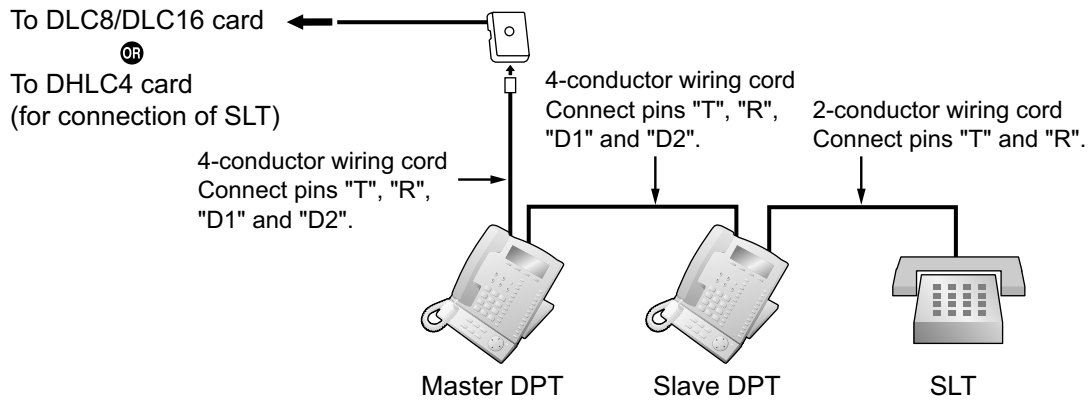

## 3.8.4 First Party Call Control CTI Connection

CTI connection between a PC and a KX-DT343/KX-DT346/KX-T7633/KX-T7636 DPT provides first party call control. The CTI connection is made via a USB interface (version 2.0), and uses the TAPI 2.1 protocol. A USB Module must be connected to the DPTs.

### **Note**

The operating system of the PC required for first party call control depends on your CTI application software. For details, refer to the manual for your CTI application software.

### **KX-DT343/KX-DT346**

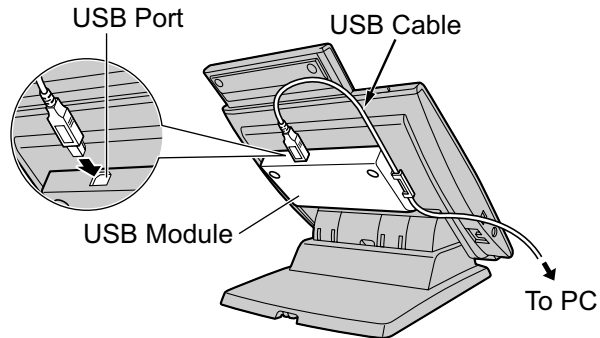

### **KX-T7633/KX-T7636**

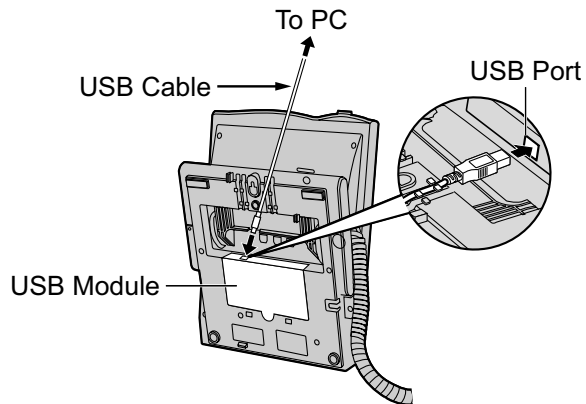

### **Note**

The maximum length of the USB cable is 3 m (9 ft 10 in).

## 3.9 Connection of Doorphones, Door Openers, External Sensors, and External Relays

### 3.9.1 Connection of Doorphones, Door Openers, External Sensors, and External Relays

The PBX supports a maximum of 16 doorphones, 16 door openers, 16 external sensors, and 16 external relays.

**Note**

Doorphones, door openers, external sensors, and external relays are user-supplied.

#### Maximum Cabling Distance

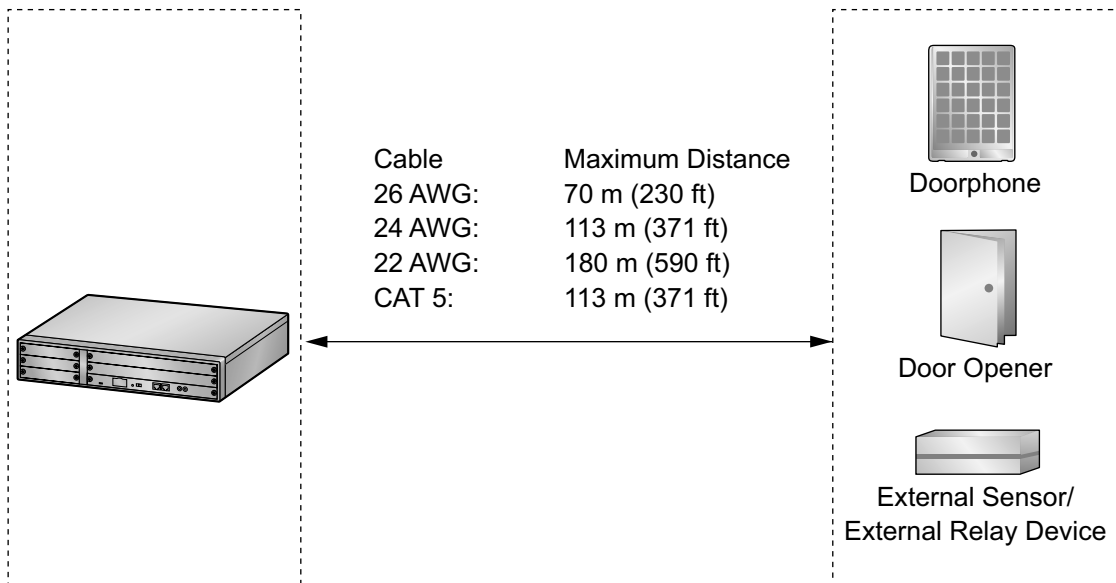

#### Installing the Doorphone (KX-T30865/KX-T7765/KX-T7775)

**Note**

- The illustrations shown in the installation procedure are based on the KX-T30865.
- For details about the installation of the KX-T7775, refer to the Operating Instructions of the KX-T7775.

1. Loosen the screw to separate the doorphone into 2 halves.

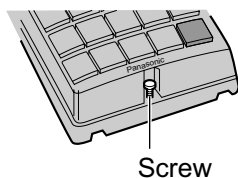

**Note for KX-T7765 Users**

When loosening/tightening the screw, do not scratch the cabinet wall with the driver shaft.

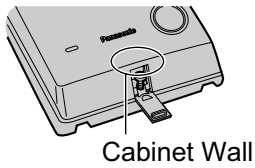

2. Pass the wires through the hole in the base cover, and attach the base cover to a wall using 2 screws.

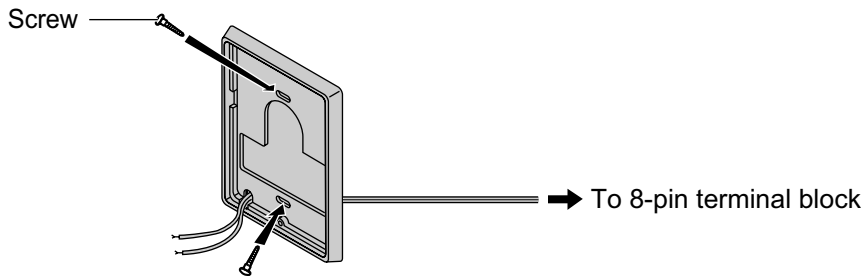

**Note**

Two kinds of screws are included with the doorphone. Please choose the appropriate kind for your wall type.

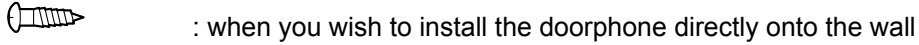
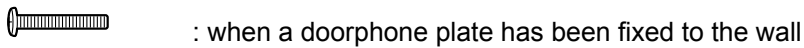

3. Connect the wires to the screws located in the back cover.

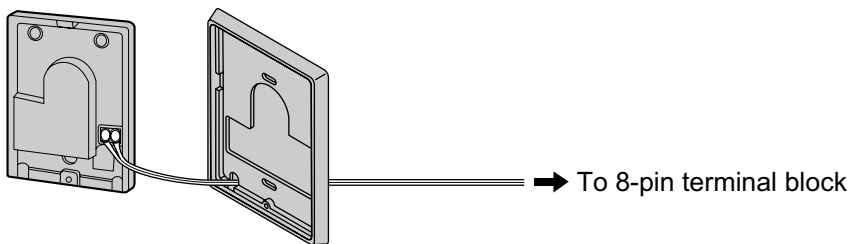

4. Re-attach the 2 halves and re-insert the screw.

## Connection

Use 8-pin and 10-pin terminal blocks (included with the card) for connection.

1. While pressing down on the hole at the top of the terminal block using a screwdriver, insert the wire into the side hole as shown below. Repeat this procedure for other doorphones, door openers, external sensors, and external relays.  
Refer to "3.7.2 DPH4 Card (KX-TDA0161)" and "3.7.3 EIO4 Card (KX-TDA0164)" for pin assignments.

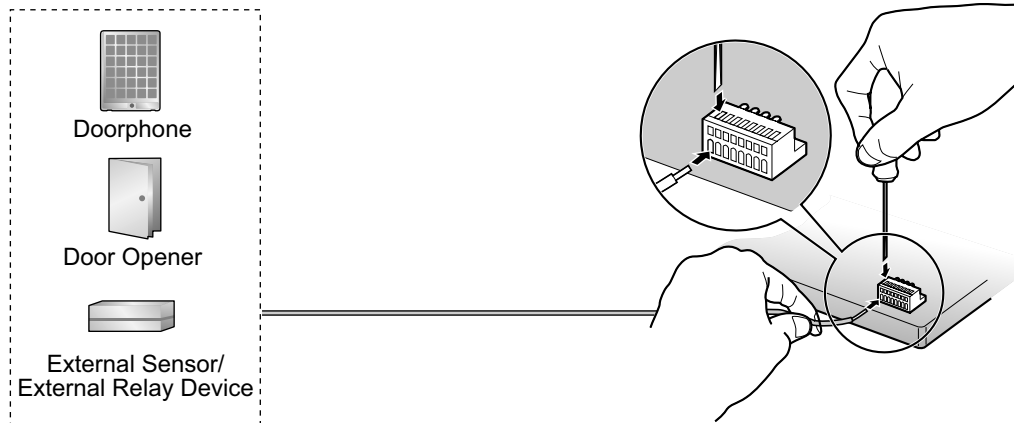

2. Attach the terminal blocks to the connectors of the DPH4/EIO4 card on the PBX.

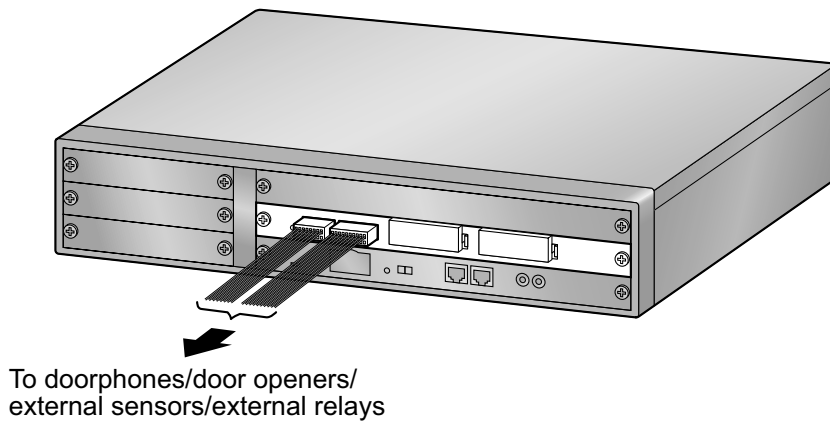

## 3.10 Connection of Peripherals

### 3.10.1 Connection of Peripherals

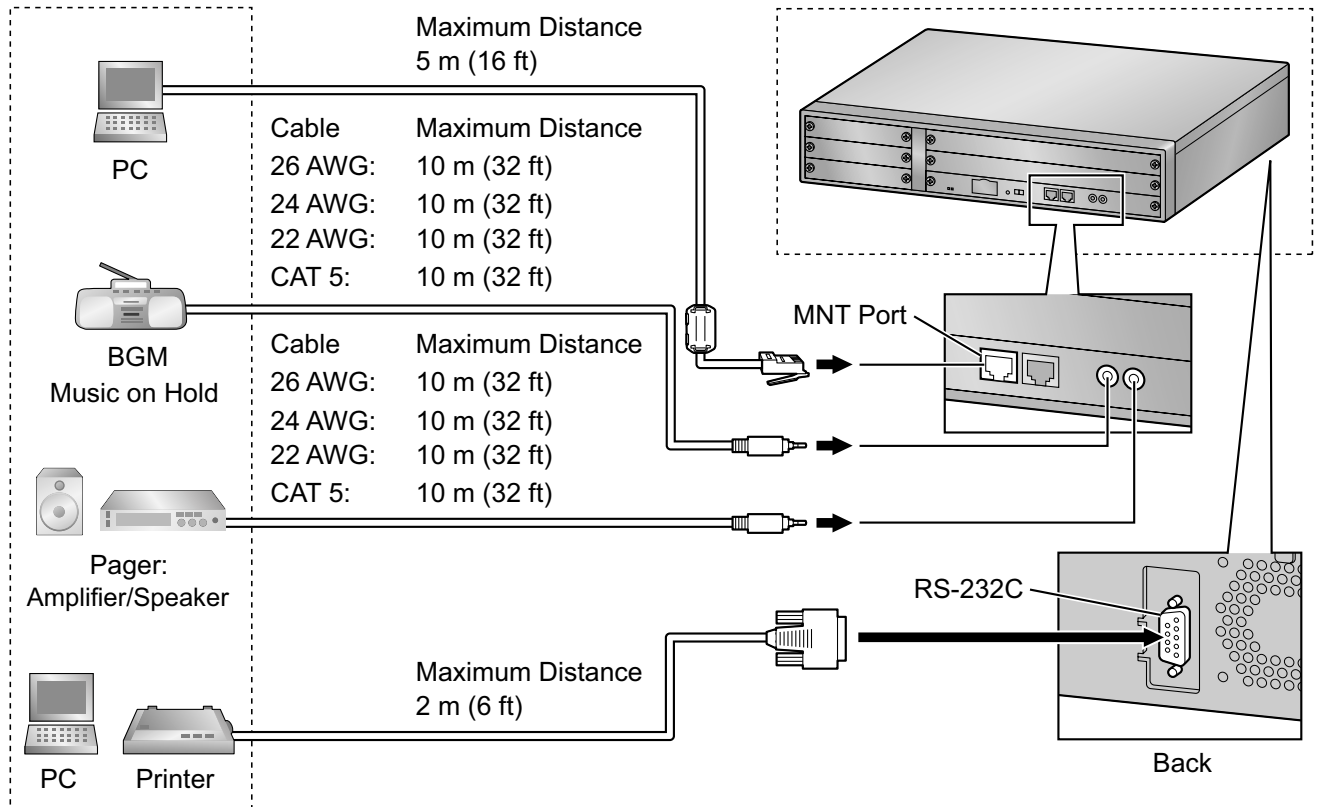

#### PC (via MNT Port)

A PC can be connected to the PBX via the MNT port of the IPCMPR card. It is used for system programming, diagnostics and external system database storage (save/load) functions.

#### Pin Assignments

	No.	Signal Name	Input (I)/Output (O)	Function
	1	TPO+	O	Transmit data+
	2	TPO-	O	Transmit data-
	3	TPI+	I	Receive data+
	4-5	Reserved	–	–
	6	TPI-	I	Receive data-
	7-8	Reserved	–	–

## BGM/MOH

The PBX provides Background Music and Music on Hold. An external music source (e.g., user-supplied radio) can be connected to the PBX.

### CAUTION

The External Music Jack is an SELV port and should only be connected to an approved SELV device.

### Notice

- Wiring should be done carefully to prevent undue force being exerted on the plug. Otherwise, sound may only be heard intermittently.
- When the PBX and external music source are not connected to the same ground, hum noise may be induced into Background Music and Music on Hold.

## Pager

A paging device (user-supplied) can be connected to the PBX.

### CAUTION

The External Paging Jack is an SELV port and should only be connected to an approved SELV device.

## PC/Printer (via RS-232C)

The PBX is equipped with an RS-232C interface. This interface provides communication between the PBX and the user-supplied devices such as PC or line printers. The RS-232C port is used for system programming, SMDR, diagnostics and external system database storage (save/load) functions.

When using special accessories such as cable, the user should use those specified in this installation manual to comply with the limits for a Class B digital device pursuant to the FCC Rules.

### CAUTION

To protect the system, keep the following in mind:

1. Make sure that both connector cases (frame ground) of the RS-232C cross cable (shielded cable) are conductive. If they are not conductive, make sure that both connector cases of the cable are firmly connected.
2. If this is not possible, connect the frame of the PBX to the frame of the PC/Printer using a grounding wire in order to prevent difference in the electrical potentials.

### Pin Assignments

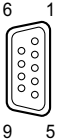
	No.	Signal Name	Function	Circuit Type	
				EIA	CCITT
	2	RD (RXD)	Receive Data	BB	104
	3	SD (TXD)	Transmit Data	BA	103
	4	ER (DTR)	Data Terminal Ready	CD	108.2
	5	SG	Signal Ground	AB	102
	6	DR (DSR)	Data Set Ready	CC	107
	7	RS (RTS)	Request To Send	CA	105
	8	CS (CTS)	Clear To Send	CB	106

## Connection Charts

### For connecting a printer/PC with a 9-pin RS-232C connector

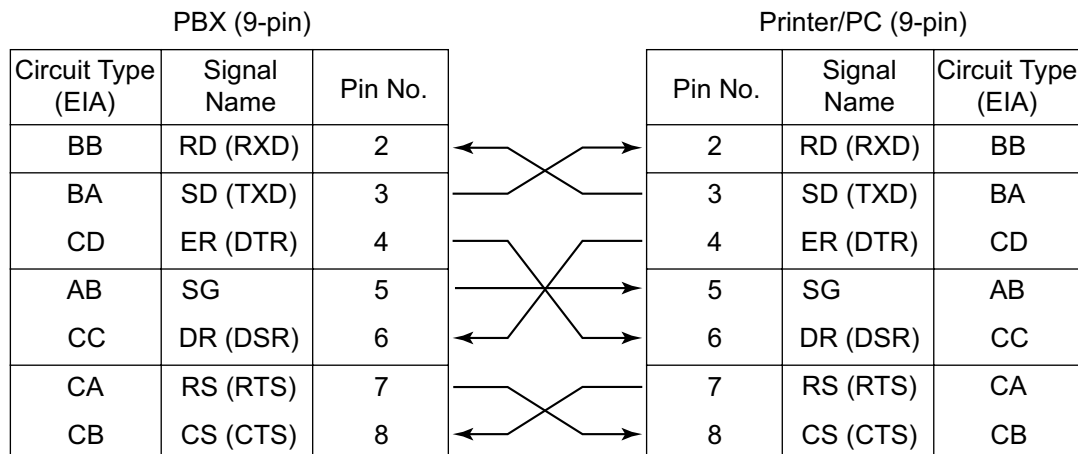

### For connecting a printer/PC with a 25-pin RS-232C connector

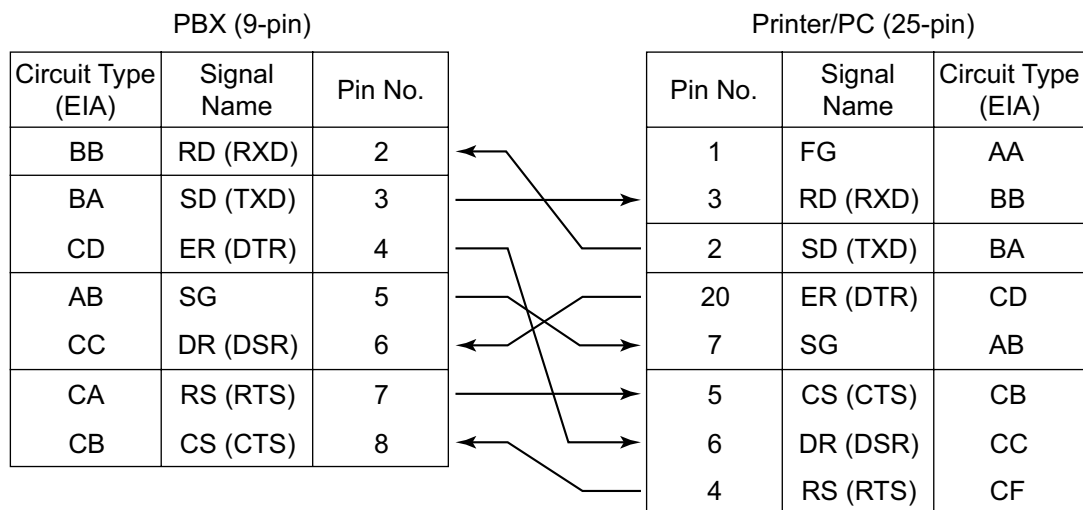

## RS-232C Signals

- **Receive Data (RXD):...**(input)  
Conveys signals from the printer or the PC.
- **Transmit Data (TXD):...**(output)  
Conveys signals from the unit to the printer or the PC. A "Mark" condition is held unless data or BREAK signals are being transmitted.
- **Data Terminal Ready (DTR):...**(output)  
This signal line is turned ON by the unit to indicate that it is ON LINE. Circuit ER (DTR) ON does not indicate that communication has been established with the printer or the PC. It is switched OFF when the unit is OFF LINE.
- **Signal Ground (SG)**  
Connects to the DC ground of the unit for all interface signals.
- **Data Set Ready (DSR):...**(input)  
An ON condition of circuit DR (DSR) indicates the printer or the PC is ready. Circuit DR (DSR) ON does not indicate that communication has been established with the printer or the PC.
- **Request To Send (RTS):...**(output)  
This lead is held ON whenever DR (DSR) is ON.

### 3.10.1 Connection of Peripherals

---

- **Clear To Send (CTS):...**(input)  
An ON condition of circuit CS (CTS) indicates that the printer or the PC is ready to receive data from the unit. The unit does not attempt to transfer data or receive data when circuit CS (CTS) is OFF.
- **Frame Ground (FG)**  
Connects to the unit frame and the ground conductor of the AC power cord.

## 3.11 LAN Connection

### 3.11.1 LAN Connection

#### Connection Chart for LAN Connection

The PBX is equipped with a LAN port for connecting to a LAN so that IP telephones (IP-PTs, IP softphones, SIP Extensions), IP-CSs, PCs and a CTI Server can be connected on a private IP network.

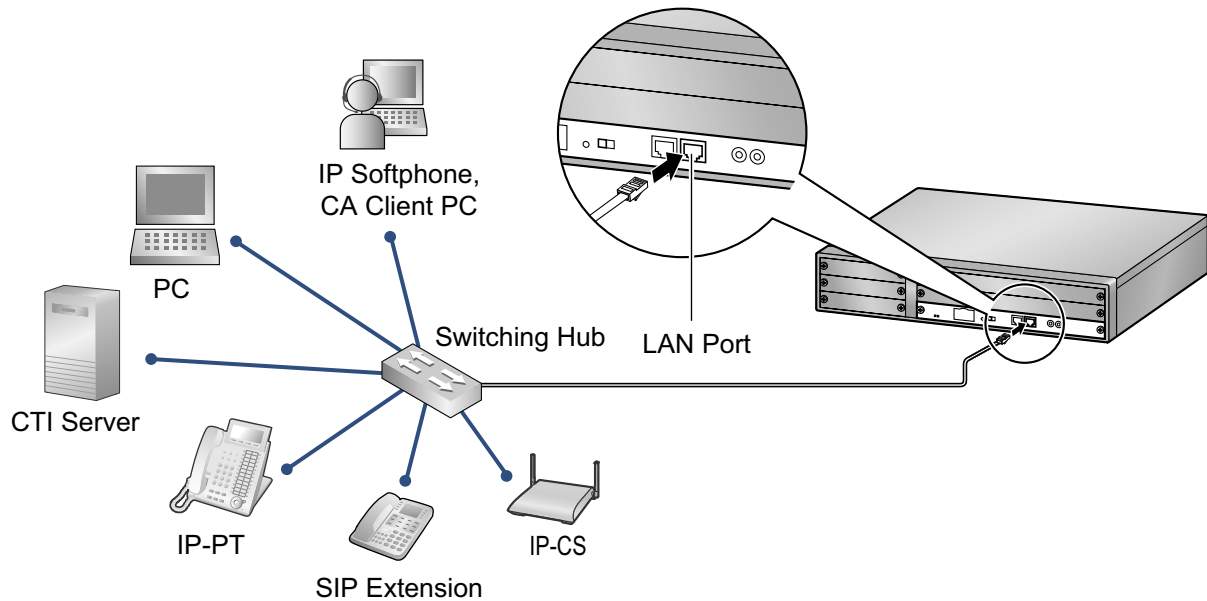

Switching Hub		PBX (LAN Port)	
Signal Name	Pin No.	Pin No.	Signal Name
TX+	1	1	RX+
TX-	2	2	RX-
RX+	3	3	TX+
RX-	6	6	TX-

#### Note

- Use an Ethernet straight cable with an RJ45 connector for connection to a switching hub. The cable should be a 10BASE-T/100BASE-TX CAT 5 or higher cable.
- Make sure that all the CAT 5 cables in use are not over 100 m (328 ft) in length.
- Make sure to create a spanning tree for LAN connection in order to prevent loops from occurring in a multi-bridged environment. Otherwise, some packets may circulate for long periods of time and eventually PBX performance system may degrade.
- The CTI server can be used for connecting PCs on a LAN to provide third party call control CTI. CTI connection uses the CSTA Phase 3 or TAPI 2.1 protocol. The operating system of the PC or CTI server required for third party call control depends on your CTI application software. For details, refer to the manual for your CTI application software.

## 3.12 Power Failure Connections

### 3.12.1 Power Failure Connections

When the power supply to the PBX fails, power failure transfer (PFT) will switch from the current connection to the Power Failure Connection. Refer to "13.1.11 Power Failure Transfer" in the Feature Manual for further information.

#### Using Analog CO Line Card and Extension Card

Power Failure Connection connects a specific SLT and a CO line in the event of power failure. The following analog CO line and extension card can be used for Power Failure Connections:

- **Analog CO line card:** LCOT4 (1 PFT port)
- **Extension card:** DHLC4 (1 PFT port)

To 1 analog CO line card, connect only 1 extension card.

#### Note

By programming the PBX, a CO line conversation established during power failure can be maintained even when the power returns and the connection is switched back to the normal configuration from the Power Failure Connection. However, if no special programming is performed, the connection will be dropped when power returns.

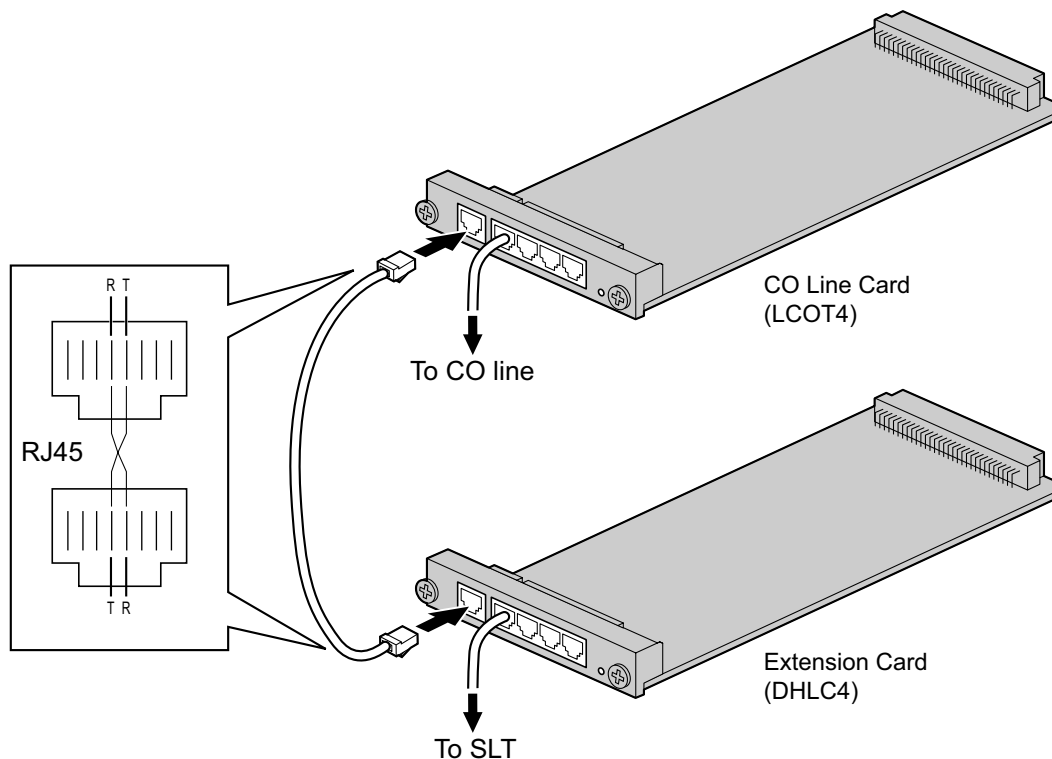

#### Accessories and User-supplied Items

**Accessories (included):** none

**User-supplied (not included):** RJ45 connectors

**RJ45 Connector Pin Assignments for Analog CO line Card****PFT Port**

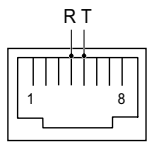
	No.	Signal Name	Function
	1-3	Reserved	–
	4	R	Ring
	5	T	Tip
	6-8	Reserved	–

**RJ45 Connector Pin Assignments for Extension Card****PFT Port**

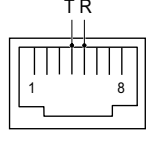
	No.	Signal Name	Function
	1-3	Reserved	–
	4	T	Tip
	5	R	Ring
	6-8	Reserved	–

## 3.13 Starting the PBX

### 3.13.1 Starting the PBX

#### **WARNING**

Make sure that the AC outlet is properly grounded, then securely connect the 3-pin AC plug including the grounded pin.

#### **CAUTION**

- Use only the AC power cord included with the PBX.
- Before touching the System Initialize Switch, discharge static electricity by touching ground or wearing a grounding strap.
- Once you have started the PBX and if you unplug the PBX, do not perform the following procedures to start the PBX again. Otherwise, your programmed data is cleared. To restart the PBX, refer to "5.1.4 Using the Reset Button".
- The power supply cord is used as the main disconnect device. Ensure that the AC outlet is located near the equipment and is easily accessible.

#### **Notice**

The SD Memory Card must be inserted in the SD Memory Card slot of the IPCMPR card before startup.

#### **Note**

The PBX will continue to be powered even if the power switch is turned "OFF".

### System Initialization Procedure

1. Slide the System Initialize Switch to the "SYSTEM INITIALIZE" position.

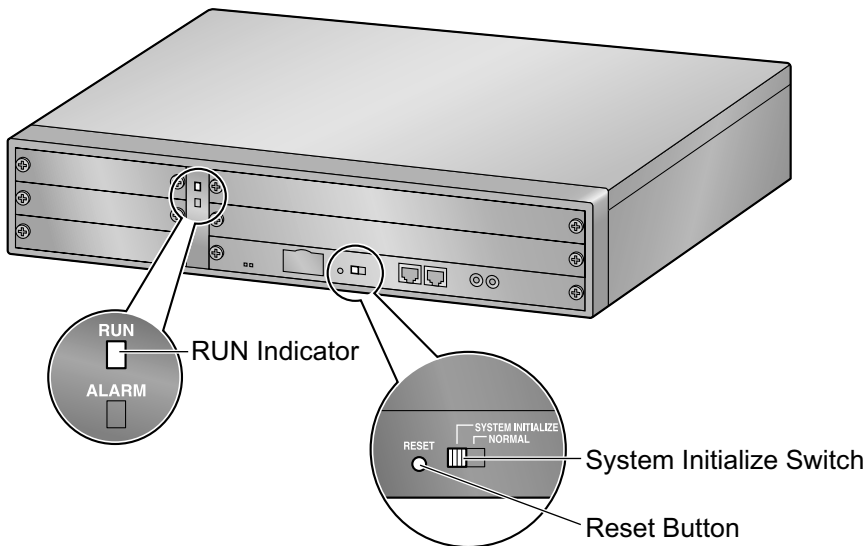

2. Plug the AC power cord into the PBX and pass the cord through the hook clip as indicated. Push the hook clip in the direction of the arrow until it clicks.

**Note**

For safety reasons, do not stretch or pinch the AC power cord.

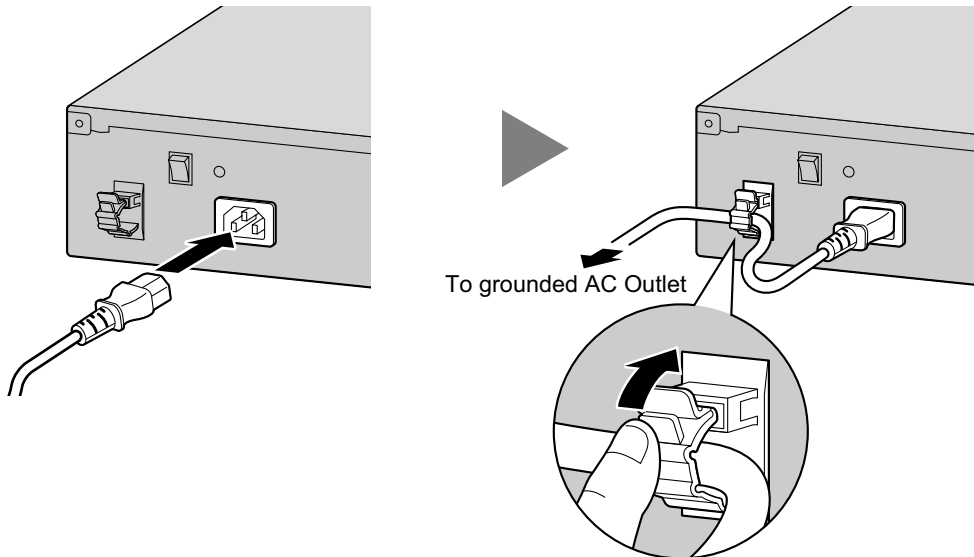

3. Plug the other end of the cord into an AC outlet and turn on the PBX. The RUN indicator will flash.
4. While the RUN indicator is flashing, slide the System Initialize Switch back to the "NORMAL" position. Depending on the configuration, initialization takes about 1 min to 3 min. If successfully executed, the RUN indicator will stop flashing and stay lit. All data will be cleared, and the PBX as well as all optional service cards will be initialized to the default values. The DPTs should show the time as 01:00.

**Note**

When initializing the PBX, the built-in ESVM card will also be initialized. Therefore, the built-in ESVM card feature may not be used for up to 2 minutes after the PBX starts.

## LED Indications

Indication	Color	Description
RUN	Green	PBX status indication <ul style="list-style-type: none"> <li>• OFF: Power Off (includes normal reset)</li> <li>• ON: Power On and running (on-line)</li> <li>• Flashing (60 times per minute): Starting up</li> <li>• Flashing (120 times per minute): Starting up or resetting with:               <ul style="list-style-type: none"> <li>• the System Initialize Switch in "SYSTEM INITIALIZE" position</li> <li>• the SD Memory Card not inserted</li> </ul> </li> </ul>
ALARM	Red	Alarm indication <ul style="list-style-type: none"> <li>• OFF: Normal</li> <li>• ON: Alarm (CPU stop, alarm for each optional service card)</li> <li>• Flashing: Alarm (IPCMPR file error in restarting)</li> </ul>

## Confirming the CO Line Connection

After initialization, program the PBX and connect CO lines to the PBX.

To confirm that the CO lines are successfully connected, dial [\*] [3] [7] + CO line number (3 digits) on a PT, or press the PT's S-CO button. You will hear a dial tone if the CO line is available and connected.

---

## **Section 4**

# **Guide for the Maintenance Console**

*Explains the installation procedure, structure, and basic information of the Maintenance Console.*

# 4.1 Overview

## 4.1.1 Overview

The Maintenance Console is designed to serve as an overall system programming reference for the PBX. To program and administer the PBX by PC, you need to install the Maintenance Console onto the PC. This section describes overview and installation of the Maintenance Console only.

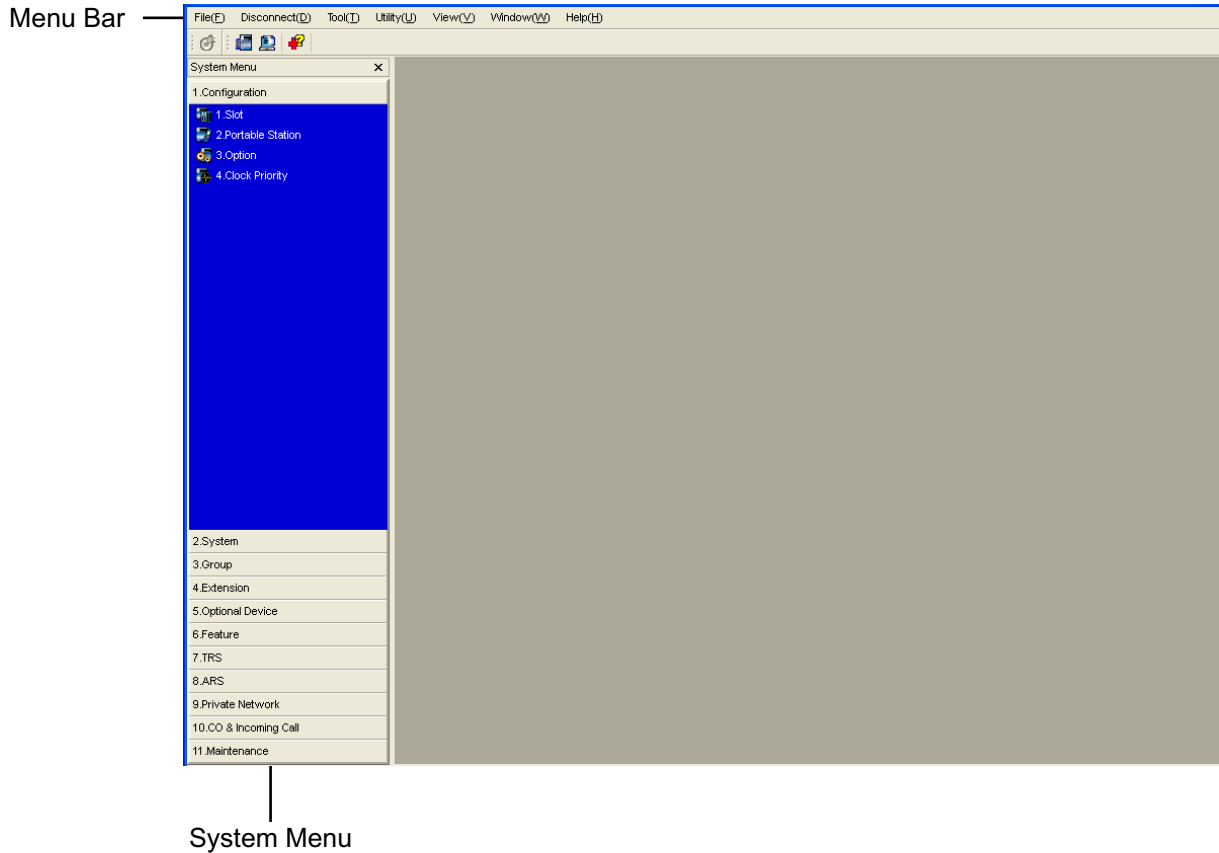

**Note**

The contents and design of the software are subject to change without notice.

## 4.2 PC Connection

### 4.2.1 PC Connection

#### Connection via MNT Port of IPCMPR Card

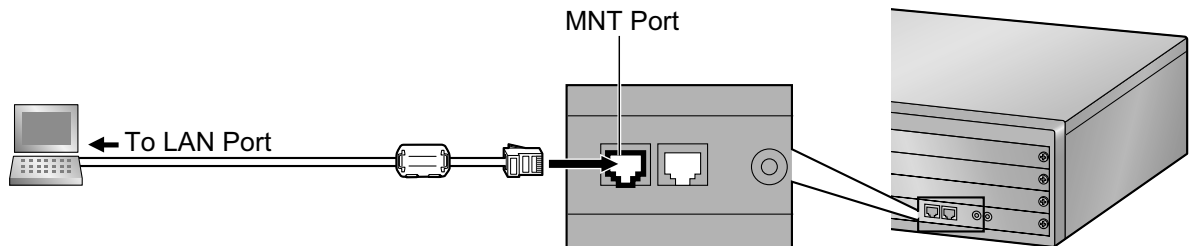

#### **Notice**

When connecting a PC to the PBX, a fixed IP address must be assigned to the PC. For information about fixed IP addresses, ask your network administrator.

#### **Note**

For pin assignments and maximum cabling distance, refer to "3.10.1 Connection of Peripherals".

#### Serial Interface Connection

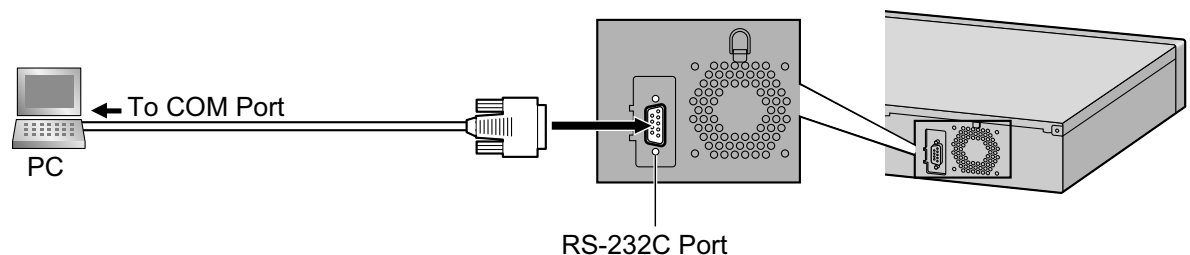

#### **CAUTION**

To protect the system, keep the following in mind:

1. Make sure that both connector cases (frame ground) of the RS-232C cross cable (shielded cable) are conductive. If they are not conductive, make sure that both connector cases of the cable are firmly connected.
2. If this is not possible, connect the frame of the PBX to the frame of the PC using a grounding wire in order to prevent difference in the electrical potentials.

#### **Note**

For pin assignments and maximum cabling distance, refer to "3.10 Connection of Peripherals".

## External Modem Connection

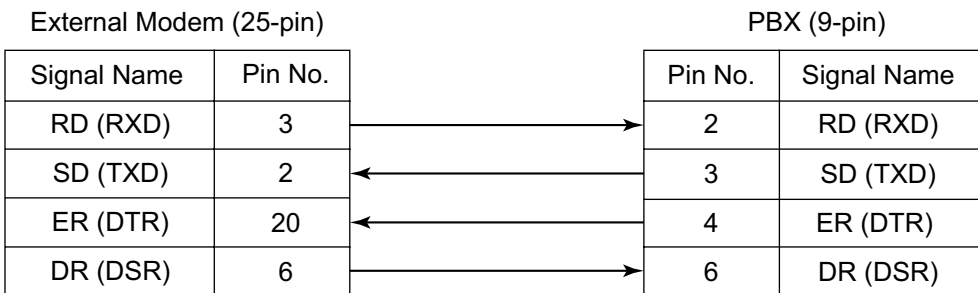
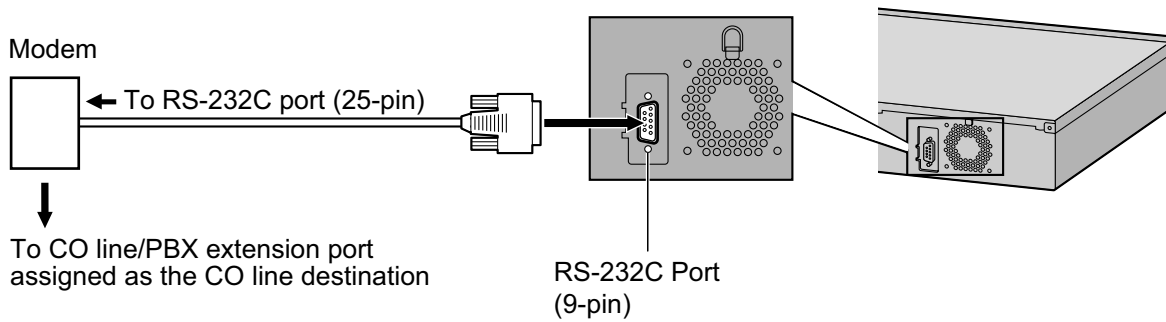

### CAUTION

To protect the system, keep the following in mind:

1. Make sure that both connector cases (frame ground) of the RS-232C straight cable (shielded cable) are conductive. If they are not conductive, make sure that both connector cases of the cable are firmly connected.
2. If this is not possible, connect the frame of the PBX to the frame of the external modem using a grounding wire in order to prevent difference in the electrical potentials.

After connecting the PBX and the external modem, set the power switch of the external modem to "ON", then the external modem will be initialized with the default values.

The following AT command settings may be required for the modem:

- The Data Terminal Ready (DTR) signal should be ignored.
- The Data Terminal Equipment (DTE)/Modem flow control should be turned off.
- Data compression should be disabled.
- Error Correction is not necessary.

### Note

- An AT command (for initialization, enabling automatic answer, etc.) can only be programmed by Maintenance Console. "AT&F" is stored as the default value.
- For more information about the AT command, refer to the external modem's instructions.

## 4.3 Installation of the Maintenance Console

### 4.3.1 Installing and Starting the Maintenance Console

#### System Requirements

##### Required Operating System

- Microsoft® Windows® XP, Windows Vista® Business, or Windows 7 Professional operating system

##### Minimum Hardware Requirements

- HDD: 100 MB of available hard disk space
- The PC must fulfill the hardware requirements of the installed Microsoft Windows operating system.

##### Recommended Display Settings

- Screen resolution: XGA (1024 × 768)
- DPI setting: Normal size (96 DPI)

#### Installing the Maintenance Console

##### Note

- Make sure to install and use the latest version of the Maintenance Console.
  - To install or uninstall the software on a PC running Windows XP Professional, you must be logged in as a user in either the "Administrators" or "Power Users" group.
  - To install or uninstall the software on a PC running Windows Vista Business or Windows 7 Professional, you must be logged in as a user in the "Administrators" group.
1. Copy the setup file of the Maintenance Console to your PC.
  2. Double-click the setup file to run the installer.
  3. Follow the on-screen instructions provided by the installation wizard.

#### Starting the Maintenance Console and Assigning the Basic Items (Quick Setup)

When you start the Maintenance Console with the Installer Level Programmer Code and connect to the PBX for the first time after initialization (with the factory default setting), Quick Setup will launch automatically. During Quick Setup, you will set up the basic items. For details about the basic items, refer to "14.1.2 Quick Setup" in the Feature Manual.

1. Connect the PC to the PBX with an Ethernet straight cable or RS-232C cross cable.
2. Start the Maintenance Console from the Start menu.
3. "Information before programming" appears.
  - a. Carefully read this important additional information, which includes updates to this and other manuals.
  - b. Click **OK** to close this window.
4.
  - a. Enter the Installer Level Programmer Code (default: **INSTALLER**).

##### Note

There are 2 other Programmer Codes with limited authorization: Administrator Level (default: **ADMIN**), and User Level (default: **USER**).

- b. Click **OK**.

5. Click **Connect**.
6.
  - a. Select **KX-NCP500/1000** from **PBX Model**.
  - b. Select the **LAN** or **RS-232C** tab, depending on the type of PC connection with the PBX.
  - c. Specify the settings as required.

**Note**

When connecting to the PBX for the first time selecting **LAN**, the **IP Address** and **Port Number** must be set to **192.168.0.101** and **35300** respectively.

- d. Enter the system password for installer (default: **1234**).
  - e. Click **Connect**.
7. Follow the instructions of the Quick Setup wizard and assign the basic items (Quick Setup). After Quick Setup is completed, if the IP addressing information was not changed and a V-IPEXT card was installed during setup, the IP-PT registration screen is displayed. For information on registering IP-PTs to the PBX, refer to "3.15 [1-1] Slot—Port Property - Virtual IP Extension" in the PC Programming Manual. You may now begin programming the PBX.

**CAUTION**

Do not remove the SD Memory Card while power is supplied to the PBX. Doing so may cause the PBX to fail to start when you try to restart the system.

**Notice**

- During a long programming session, it is highly recommended that you periodically save the system data to the SD Memory Card. If the PBX undergoes a sudden power failure or if the system is reset for some reason, all the system data in RAM will be lost. However, if system data has been saved to the SD Memory Card, it can be easily restored.  
To save the system data to the SD Memory Card, (1) click the "**SD Memory Backup**" icon before resetting the PBX or turning off the power, or (2) exit the Maintenance Console so that the PBX automatically saves the system data.
- When programming PBX data which can be displayed on a proprietary telephone (PT) (extension names, group names, System Speed Dialing names, etc.), it is possible to enter characters which cannot be displayed on a KX-DT300/KX-T7600 series PT.

Characters which can be displayed on a KX-DT300/KX-T7600 series PT are shown below in the white cells.

	00	01	02	03	04	05	06	07	08	09	0a	0b	0c	0d	0e	0f
00																
10																
20		!	"	#	\$	%	&	'	(	)	*	+	,	-	.	/
30	0	1	2	3	4	5	6	7	8	9	:	;	<	=	>	?
40	@	A	B	C	D	E	F	G	H	I	J	K	L	M	N	O
50	P	Q	R	S	T	U	V	W	X	Y	Z	[	\	]	^	_
60	`	a	b	c	d	e	f	g	h	i	j	k	l	m	n	o
70	p	q	r	s	t	u	v	w	x	y	z	{		}	~	
80	€		,	f	„	...	†	‡	^	‰	Š	<	Œ		Ž	
90		‘	’	“	”	•	—	—	~	™	š	>	œ		ž	ÿ
a0		ı	¢	£	¤	¥	¦	§	¨	©	ª	«	¬		®	¯
b0	°	±	²	³	´	µ	¶	·	¸	¹	º	»	¼	½	¾	¿
c0	À	Á	Â	Ã	Ä	Å	Æ	Ç	È	É	Ê	Ë	Ì	Í	Î	Ï
d0	Ð	Ñ	Ò	Ó	Ô	Õ	Ö	×	Ø	Ù	Ú	Û	Ü	Ý	Þ	ß
e0	à	á	â	ã	ä	å	æ	ç	è	é	ê	ë	ì	í	î	ï
f0	ð	ñ	ò	ó	ô	õ	ö	÷	ø	ù	ú	û	ü	ý	þ	ÿ

- The PC will not perform any shutdown operation, or enter the power-saving system standby mode while the Maintenance Console is connected to the PBX. To perform either of the operations above, first close the connection to the PBX.



---

# **Section 5**

## **Troubleshooting**

*This section provides information on the PBX and telephone troubleshooting.*

## 5.1 Troubleshooting

### 5.1.1 Installation

PROBLEM	PROBABLE CAUSE	SOLUTION
You cannot make/receive calls via an IP network.	<ul style="list-style-type: none"> <li>DSP card malfunction</li> </ul>	<ul style="list-style-type: none"> <li>Replace the corresponding card.</li> </ul>
	<ul style="list-style-type: none"> <li>IPCMPR card malfunction</li> </ul>	<ul style="list-style-type: none"> <li>Replace the IPCMPR card (be sure to turn off the PBX when replacing).</li> </ul>
	<ul style="list-style-type: none"> <li>Not enough activation keys</li> </ul>	<ul style="list-style-type: none"> <li>Purchase additional activation key codes. Please consult a certified dealer for details.</li> </ul>
	<ul style="list-style-type: none"> <li>Poor connection</li> </ul>	<ul style="list-style-type: none"> <li>Make sure that an 8-pin twisted pair cable is used for connection.</li> <li>Make sure that none of the CAT 5 cables in use are over 100 m (328 ft) in length.</li> <li>Make sure that a straight cable is used for connection to a switching hub.</li> </ul>
	<ul style="list-style-type: none"> <li>Network malfunction</li> </ul>	<ul style="list-style-type: none"> <li>Make sure that all network devices in use are switched on.</li> <li>Make sure that there is no unwanted firewall in the IP network.</li> </ul>
IP-PTs/SIP Extensions do not operate.	<ul style="list-style-type: none"> <li>DSP card malfunction</li> </ul>	<ul style="list-style-type: none"> <li>Replace the corresponding card.</li> </ul>
	<ul style="list-style-type: none"> <li>IPCMPR card malfunction</li> </ul>	<ul style="list-style-type: none"> <li>Replace the IPCMPR card (be sure to turn off the PBX when replacing).</li> </ul>
	<ul style="list-style-type: none"> <li>Not enough activation keys</li> </ul>	<ul style="list-style-type: none"> <li>Purchase additional activation key codes. Please consult a certified dealer for details.</li> </ul>
	<ul style="list-style-type: none"> <li>IP-PT/SIP Extension not registered</li> </ul>	<ul style="list-style-type: none"> <li>Register the corresponding IP-PT/SIP Extension.</li> </ul>
	<ul style="list-style-type: none"> <li>IP-PT/SIP Extension malfunction</li> </ul>	<ul style="list-style-type: none"> <li>Replace the IP-PT/SIP Extension.</li> </ul>
	<ul style="list-style-type: none"> <li>Poor connection</li> </ul>	<ul style="list-style-type: none"> <li>Make sure that an 8-pin twisted pair cable is used for connection.</li> <li>Make sure that none of the CAT 5 cables in use are over 100 m (328 ft) in length.</li> <li>Make sure that a straight cable is used for connection to a switching hub.</li> </ul>
	<ul style="list-style-type: none"> <li>Network malfunction</li> </ul>	<ul style="list-style-type: none"> <li>Make sure that all network devices in use are switched on.</li> <li>Make sure that the IP-PT/SIP Extension is not blocked by the firewall or other network devices.</li> </ul>

PROBLEM	PROBABLE CAUSE	SOLUTION
Extensions (except IP-PT/SIP Extension) do not operate.	<ul style="list-style-type: none"> <li>Extension card malfunction</li> </ul>	<ul style="list-style-type: none"> <li>Replace the corresponding card.</li> </ul>
	<ul style="list-style-type: none"> <li>Poor connection between the PBX and the extension</li> </ul>	<ul style="list-style-type: none"> <li>Take the extension and plug it into the same extension port using a short telephone cord. If the extension works, then the connection between the PBX and the extension must be repaired.</li> </ul>
	<ul style="list-style-type: none"> <li>A telephone with an A-A1 relay is connected.</li> </ul>	<ul style="list-style-type: none"> <li>Make sure that a 2-wire cord is used.</li> <li>Make sure that the A-A1 relay switch of the telephone is in "OUT" or "OFF" position.</li> </ul>
	<ul style="list-style-type: none"> <li>Extension malfunction</li> </ul>	<ul style="list-style-type: none"> <li>Take the extension and plug it into another extension port that is working. If the extension does not work, replace the extension.</li> </ul>
The PBX does not operate properly.		<ul style="list-style-type: none"> <li>Press the Reset Button (refer to "5.1.4 Using the Reset Button").</li> <li>Turn off the power switch, and then turn it back on.</li> <li>Turn off the power switch, and then unplug the PBX. After 5 minutes, plug the PBX back in, and turn the power switch back on.</li> </ul>
Noise on external paging.	<ul style="list-style-type: none"> <li>Induced noise on the wire between the PBX and the amplifier.</li> </ul>	<ul style="list-style-type: none"> <li>Use a shielded cable as the connection wire between the PBX and amplifier. A short shielded cable is recommended.</li> </ul>
Distorted external music.	<ul style="list-style-type: none"> <li>Excessive input level from external music source.</li> </ul>	<ul style="list-style-type: none"> <li>Decrease the output level of the external music source by using the volume control on the music source.</li> </ul>
Alternate Calling—Ring/Voice and Live Call Screening (LCS) do not function as set when using a Wireless Phone (KX-T7880/KX-T7885/KX-TD7894/KX-TD7895).	<ul style="list-style-type: none"> <li>Voice-calling mode and Hands-free mode with LCS are not available with Wireless Phones.</li> </ul>	<ul style="list-style-type: none"> <li>Switch the calling mode to ring-calling.</li> <li>Set the LCS mode to "Private".</li> </ul>
The ALARM indicator on the front of the cabinet turns on red.	<ul style="list-style-type: none"> <li>A major system error occurs in the PBX.</li> </ul>	<ul style="list-style-type: none"> <li>See the error log using the Maintenance Console (refer to "5.1.5 Troubleshooting by Error Log").</li> </ul>

PROBLEM	PROBABLE CAUSE	SOLUTION
The LINK indicator of the IPCMPR does not turn on.	<ul style="list-style-type: none"> <li>• IPCMPR card malfunction</li> </ul>	<ul style="list-style-type: none"> <li>• Replace the IPCMPR card (be sure to turn off the PBX when replacing).</li> </ul>
	<ul style="list-style-type: none"> <li>• Poor connection.</li> </ul>	<ul style="list-style-type: none"> <li>• Make sure that an 8-pin twisted pair cable is used for connection.</li> <li>• Make sure that none of the CAT 5 cables in use are over 100 m (328 ft) in length.</li> <li>• Make sure that a straight cable is used for connection to a switching hub.</li> </ul>
	<ul style="list-style-type: none"> <li>• Network malfunction</li> </ul>	<ul style="list-style-type: none"> <li>• Make sure that all network devices in use are switched on.</li> </ul>

## 5.1.2 Connection

Connection between the PBX and a PT:

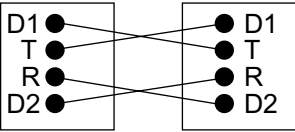
<p>Can you dial an extension?</p>	<p>No</p>	<p><b>CAUSE</b></p> <p>The T/R is connected to the D1/D2.</p>	<p><b>SOLUTION</b></p> <p>Use the correct cord (the inner 2 wires are for T/R and the outer 2 wires are for D1/D2)</p>
		 <p>PBX                      Extension</p>	

Connection between the PBX and an SLT:

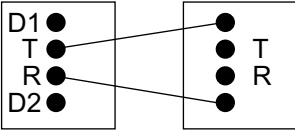
<p>Can you dial an extension?</p>	<p>No</p>	<p><b>CAUSE</b></p> <p>The T/R is connected to the D1/D2.</p>	<p><b>SOLUTION</b></p> <p>Use the correct cord (the inner 2 wires are for T/R).</p> <ul style="list-style-type: none"> <li>• If a telephone equipped with an A-A1 relay is connected to the PBX, set the A-A1 relay switch of the telephone to "OFF".</li> </ul>
		 <p>PBX                      Extension</p>	

Connection between the PBX and an SLT that is polarity-sensitive:

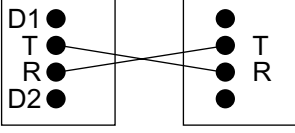
<p>Can you dial an extension?</p>	<p>No</p>	<p><b>CAUSE</b></p> <p>The "T" is connected to the "R".</p>	<p><b>SOLUTION</b></p> <p>Reverse the connections of the T/R.</p>
		 <p>PBX                      Extension</p>	

Yes

(Continued on the next page.)

Connection between the central office and the PBX:

(Continued from the previous page.)

Can you dial out on a CO line?

No

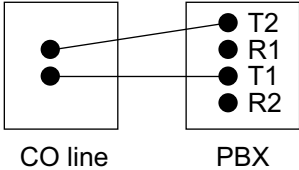
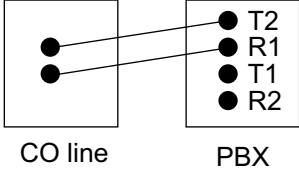
CAUSE	SOLUTION
<p>CO line is connected to the T2/T1.</p>  <p>CO line PBX</p>	<p>Reconnect the CO line to the T1/R1 or T2/R2 of the telephone jack using 2-conductor wiring.</p>
<p>CO line is connected to the T2/R1.</p>  <p>CO line PBX</p>	

## 5.1.3 Operation

PROBLEM	PROBABLE CAUSE	SOLUTION
<ul style="list-style-type: none"> <li>Cannot set the IP address, subnet mask address, and PBX IP address to the IP-PT.</li> </ul>	<ul style="list-style-type: none"> <li>An unusable value is being set.</li> </ul>	<ul style="list-style-type: none"> <li>Set an IP address within the valid range. IP address of the IP-PT/PBX: "1.0.0.0" to "223.255.255.255" Subnet mask address: "0–255.0–255.0–255.0–255" (except 0.0.0.0 and 255.255.255.255)</li> </ul>
<ul style="list-style-type: none"> <li>Cannot register the IP-PT.</li> </ul>	<ul style="list-style-type: none"> <li>The necessary network parameters are not set to the IP-PT.</li> </ul>	<ul style="list-style-type: none"> <li>When not using a DHCP server, set the IP address, subnet mask address, and enter the PBX IP address. If necessary, also enter the IP address of the default gateway.</li> <li>When using a DHCP server, enter the PBX IP address.</li> </ul>
<ul style="list-style-type: none"> <li>The IP-PT cannot connect to the PBX.</li> </ul>	<ul style="list-style-type: none"> <li>The wrong IP address, subnet mask address, PBX IP address, or default gateway address was entered.</li> </ul>	<ul style="list-style-type: none"> <li>Check each parameter and enter the correct value.</li> </ul>
	<ul style="list-style-type: none"> <li>The Ethernet cable is not connected correctly.</li> </ul>	<ul style="list-style-type: none"> <li>Check the Ethernet cable connections.</li> </ul>
	<ul style="list-style-type: none"> <li>The DHCP server is not active.</li> </ul>	<ul style="list-style-type: none"> <li>Restart the DHCP server.</li> <li>Disable DHCP and re-enter settings as appropriate.</li> </ul>
<ul style="list-style-type: none"> <li>Whenever you try to make calls using a SIP Extension, a busy tone is heard.</li> </ul>	<ul style="list-style-type: none"> <li>The status of the port that the SIP Extension is connected to is Out of Service.</li> </ul>	<ul style="list-style-type: none"> <li>Change the port status from Out of Service to In Service using the Maintenance Console.</li> </ul>
<ul style="list-style-type: none"> <li>When using the speakerphone on an APT, nothing is audible.</li> </ul>	<ul style="list-style-type: none"> <li>The HANDSET/ HEADSET selector is set to the "HEADSET" position.</li> </ul>	<ul style="list-style-type: none"> <li>When the headset is not used, set the HANDSET/HEADSET selector to the "HANDSET" position.</li> </ul>
<ul style="list-style-type: none"> <li>When using the speakerphone/monitor mode with a DPT, nothing is audible.</li> </ul>	<ul style="list-style-type: none"> <li>The "HEADSET" mode is selected by Personal Programming, "Handset/Headset Selection".</li> </ul>	<ul style="list-style-type: none"> <li>When the headset is not used, select the "HANDSET" mode by Personal Programming.</li> </ul>
<ul style="list-style-type: none"> <li>The PT does not ring.</li> </ul>	<ul style="list-style-type: none"> <li>The ringer volume is off.</li> </ul>	<ul style="list-style-type: none"> <li>Turn on the ringer volume.</li> </ul>
<ul style="list-style-type: none"> <li>During a power failure, extensions connected to port 1 of DHLC4 card do not operate.</li> </ul>	<ul style="list-style-type: none"> <li>A DPT or APT is connected to the extension port.</li> <li>The dialing mode (tone or pulse) is incorrect.</li> </ul>	<ul style="list-style-type: none"> <li>Disconnect the DPT or APT and connect an SLT.</li> <li>Set the Tone/Pulse switch to the other position.</li> </ul>

PROBLEM	PROBABLE CAUSE	SOLUTION
<ul style="list-style-type: none"> <li>Originating an outside call, call transfer, or conference cannot be performed.</li> </ul>	<ul style="list-style-type: none"> <li>The corresponding flexible button does not exist on the PT.</li> </ul>	<ul style="list-style-type: none"> <li>Program the flexible button. Refer to "6.1.3 Flexible Buttons" in the Feature Manual.</li> </ul>
<ul style="list-style-type: none"> <li>The KX-HGT100 does not work properly, or some features cannot be performed using KX-HGT100.</li> </ul>	<ul style="list-style-type: none"> <li>The firmware of the KX-HGT100 and the MPR software file version of the PBX are not upgraded to their latest versions.</li> </ul>	<ul style="list-style-type: none"> <li>Upgrade the firmware of the KX-HGT100 and the MPR software file version of the PBX to their latest versions.</li> </ul>

## 5.1.4 Using the Reset Button

If the PBX does not operate properly, use the Reset Button. Before using the Reset Button, try the system feature again to confirm whether there definitely is a problem or not.

### CAUTION

In order to avoid possible corruption of data on the SD Memory Card, please ensure that the "SD ACCESS" LED is off before pressing the Reset Button.

### Note

- When the System Initialize Switch is set to "NORMAL", pressing the Reset Button causes the following:
  - Camp-on is cleared.
  - Calls on hold are terminated.
  - Calls on exclusive hold are terminated.
  - Calls in progress are terminated.
  - Call park is cleared.
 Other data stored in memory, except the above, are not cleared.
- Be aware that pressing the Reset Button with the System Initialize Switch in the "SYSTEM INITIALIZE" position clears all data stored in the PBX. Do not perform this operation unless you intend to delete all data from the PBX.

## Operation

If the PBX does not operate properly:

1. Slide the System Initialize Switch to the "NORMAL" position.
2. Press the Reset Button for about 1 second.

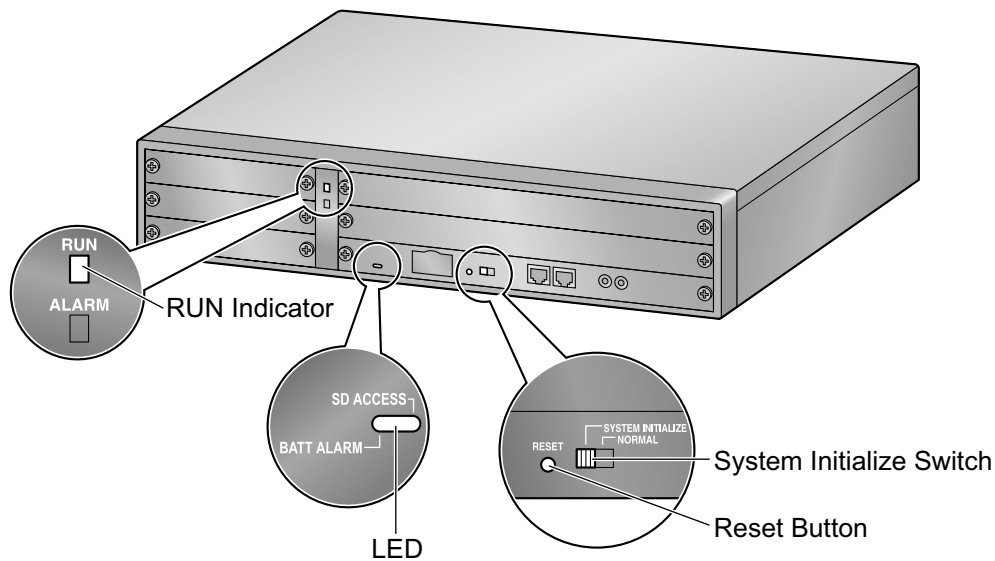

## 5.1.5 Troubleshooting by Error Log

When a major system error occurs in the PBX, the ALARM indicator on the front of the cabinet turns on red, and the system logs the error information.

### Error Log Display Format

Below is the display format of the error log. For information about how to view the error log using the Maintenance Console, refer to "2.6.8 Utility—Error Log" in the PC Programming Manual.

#### Example: Maintenance Console

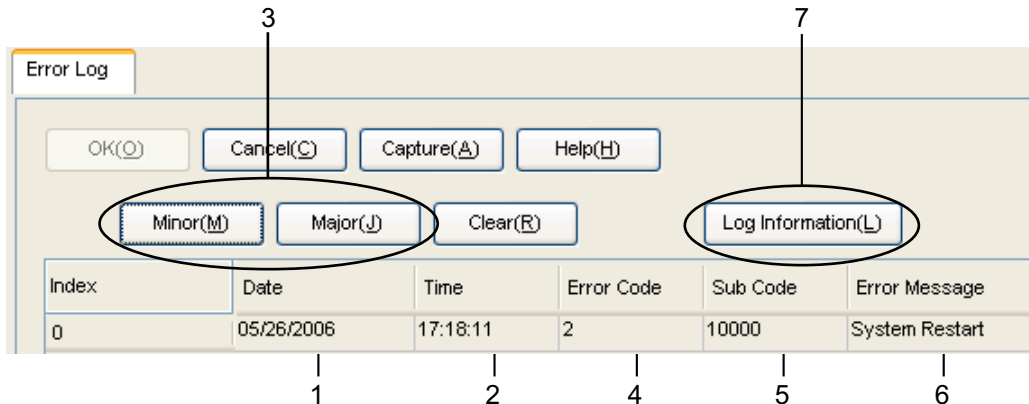

#### Example: Station Message Detail Recording (SMDR)

```
07/01/01 10:37AM MJ ALM #000 10000 MPR WDT overflow
07/01/01 11:07AM MN ALM #010 10000 AC power down
07/01/01 03:55PM MN ALM #301 10501 Digital trunk RAI reception
```

Numbered callouts 1 through 6 are placed below the SMDR lines to indicate field positions: 1 under the date, 2 under the time, 3 under the level, 4 under the alarm number, 5 under the error code, and 6 under the error message.

#### Description

	Item		Description
1	Date		The date of the error detection.
2	Time		The time of the error detection.
3	Level	Minor (MN ALM)	Displays minor errors, which affect only a certain part of system operation.
		Major (MJ ALM)	Displays major errors, which affect operation of the whole system, or result in system failure.
4	Error Code		The 3-digit error code assigned by the PBX.

	Item	Description
5	Sub Code	<p>The 6-digit sub code of the relevant hardware (X1YYZZ).</p> <ul style="list-style-type: none"> <li>• X: Slot type <ul style="list-style-type: none"> <li>– Physical slot: " " (blank)</li> <li>– Virtual slot: "*" (asterisk)</li> </ul> </li> <li>• 1: Cabinet number</li> <li>• YY: Slot number <ul style="list-style-type: none"> <li>– KX-NCP500 (Physical slot): 00 to 05 (00: IPCMPR Card Slot/Built-in ESVM card; 01 to 05: Free Slots)</li> <li>– KX-NCP1000 (Physical slot): 00 to 07 (00: IPCMPR Card Slot/Built-in ESVM card; 01 to 07: Free Slots)</li> <li>– KX-NCP500/KX-NCP1000 (Virtual slot): 01 to 08 (01 to 04: Virtual CO Line Slots; 05 to 08: Virtual Extension Slots)</li> </ul> </li> <li>• ZZ: Port number <ul style="list-style-type: none"> <li>– For optional service cards except OPB3 card: Port number (01 to 16) will be displayed.</li> <li>– For OPB3 card: Sub slot number (1 to 3) + port number (1 to 4) will be displayed as follows: <ul style="list-style-type: none"> <li>• Sub slot 1 of OPB3: 11 to 14</li> <li>• Sub slot 2 of OPB3: 21 to 24</li> <li>• Sub slot 3 of OPB3: 31 to 34</li> </ul> </li> </ul> </li> </ul> <p><b>Note</b></p> <p>When there is no parameter for slot and port number, YY and ZZ will be displayed as "00". Example: Sub code for IPCMPR card = " 10000"</p>
6	Error Message	A description of the error.
7	Log Information	Displays probable causes of the errors and their solutions.



---

# ***Section 6***

## ***Appendix***

## 6.1 Revision History

### 6.1.1 PBMPR Software File Version 1.01xx

#### Changed Contents

- 4.3.1 Installing and Starting the Maintenance Console

## 6.1.2 PBMPR Software File Version 2.02xx

### New Options

- System Components Table
  - KX-NCS2240      Activation Key for CA PRO for 40 Users (CA Pro 40users)
  - KX-NCS2249      Activation Key for CA PRO for 128 Users (CA Pro 128users)
  - KX-NCP0158      DECT 6.0 8-Channel IP Cell Station Unit Using a V-IPCS4 Card for DECT 6.0 Portable Station
  - -                      Virtual 4 IP Cell Station Interface Card (V-IPCS4)

### Changed Contents

- 1.1.2 System Connection Diagram
- 1.3.3 System Capacity
- 2.1.1 Activation Keys
- 2.1.2 Activation Key Code and Key Management System
- 3.4.1 Virtual Cards
- 3.11.1 LAN Connection
- 4.3.1 Installing and Starting the Maintenance Console
- 5.1.3 Operation

## 6.1.3 PBMPR Software File Version 4.1xxx

### Changed Contents

- 1.3.3 System Capacity
- 2.1.1 Activation Keys
- 2.1.2 Activation Key Code and Key Management System

## 6.1.4 PBMPR Software File Version 5.0xxx

### Changed Contents

- 1.3.3 System Capacity
  - Maximum Optional Service Cards
  - Maximum CO Lines and Extensions
  - Maximum Terminal Equipment
  - Digital EXtra Device Port (Digital XDP) Connection Capacity
  - Power Supply Unit Capacity
- 2.1.1 Activation Keys
- 3.3.1 IPCMPR Card



---

# ***Index***

## Numerics

16-Channel Echo Cancellor Card (KX-TDA0166) 23, 85  
 16-Channel IP Proprietary Telephone Activation Key (KX-NCS3516) 40  
 16-Channel IP Softphone/IP Proprietary Telephone Activation Key (KX-NCS3216) 40  
 16-Channel SIP Extension Activation Key (KX-NCS3716) 40  
 16-Channel VoIP DSP Card (KX-TDE0110) 24, 63  
 16-Port Digital Extension Card (KX-NCP1172) 23, 76  
 16-Port Single Line Telephone Extension Card (KX-NCP1174) 23, 78  
 19-inch Rack Mounting 55  
 1-Channel IP Proprietary Telephone Activation Key (KX-NCS3501) 40  
 1-Channel IP Softphone/IP Proprietary Telephone Activation Key (KX-NCS3201) 40  
 1-Channel SIP Extension Activation Key (KX-NCS3701) 40  
 2-Channel IP Trunk Activation Key (KX-NCS3102) 39  
 4-Channel IP Proprietary Telephone Activation Key (KX-NCS3504) 40  
 4-Channel IP Softphone/IP Proprietary Telephone Activation Key (KX-NCS3204) 40  
 4-Channel IP Trunk Activation Key (KX-NCS3104) 39  
 4-Channel Message Card (KX-TDA0191) 23, 86  
 4-Channel Simplified Voice Message Card (KX-TDA0194) 23, 87  
 4-Channel SIP Extension Activation Key (KX-NCS3704) 40  
 4-Channel VoIP DSP Card (KX-NCP1104) 23, 63  
 4-Port Analog Trunk Card (KX-NCP1180) 23, 67  
 4-Port Digital Hybrid Extension Card (KX-NCP1170) 23, 73  
 4-Port Doorphone Card (KX-TDA0161) 23, 80  
 4-Port External Input/Output Card (KX-TDA0164) 23, 82  
 64-Channel VoIP DSP Card (KX-TDE0111) 24, 63  
 8-Channel IP Proprietary Telephone Activation Key (KX-NCS3508) 40  
 8-Channel IP Softphone/IP Proprietary Telephone Activation Key (KX-NCS3208) 40  
 8-Channel SIP Extension Activation Key (KX-NCS3708) 40  
 8-Port Digital Extension Card (KX-NCP1171) 23, 75  
 8-Port Single Line Telephone Extension Card (KX-NCP1173) 23, 77

## A

Activation Key 38  
 Activation Key Code 43  
 Activation Key File 39, 44  
 Activation Key for CA ACD Monitor for 1 ICD Supervisor (KX-NCS2301) 40  
 Activation Key for CA PRO for 1 User (KX-NCS2201) 40  
 Activation Key for CA PRO for 10 Users (KX-NCS2210) 40  
 Activation Key for CA PRO for 128 Users (KX-NCS2249) 40  
 Activation Key for CA PRO for 40 Users (KX-NCS2240) 40  
 Activation Key for CA PRO for 5 Users (KX-NCS2205) 40  
 Activation Key for Software Upgrade to Enhanced Version (KX-NCS3910) 40  
 Activation Key, in the DSP4/DSP16/DSP64 Card 39  
 Activation Key, in the SD Memory Card 39

Activation Key, Maximum Number 38

## B

BGM 102

## C

Cable Distance 88  
 Characteristics 27  
 CO line Connection 110  
 Connection Chart for LAN Connection 105  
 Connection Diagram, System 21  
 Connector Types 53  
 CTI Server Connection (via USB version 2.0) 105  
 CTI—First Party Call Control 97  
 CTI—Third Party Call Control 105

## D

DHLC4 Card (KX-NCP1170) 73  
 Digital EXtra Device Port (Digital XDP) Connection 93  
 Digital XDP 93  
 Digital XDP Connection, Using a Modular T-Adaptor 93, 95  
 Digital XDP Connection, Using an EXtra Device Port 94, 96  
 DLC16 Card (KX-NCP1172) 76  
 DLC8 Card (KX-NCP1171) 75  
 Door Opener 80, 98  
 Doorphone 80, 98  
 DPH4 Card (KX-TDA0161) 80  
 DSP16 Card (KX-TDE0110) 63  
 DSP4 Card (KX-NCP1104) 63  
 DSP64 Card (KX-TDE0111) 63

## E

ECHO16 Card (KX-TDA0166) 85  
 EIO4 Card (KX-TDA0164) 82  
 Error Log 128  
 External Relay 82, 84, 98  
 External Sensor 82, 84, 98  
 EXtra Device Port (XDP) Mode 91, 93

## F

Ferrite Core 54  
 First Party Call Control CTI Connection 97  
 Floor Standing 56  
 Frame Ground Connection 50

## I

Information about the Virtual Cards 66  
 Installation Precautions 46  
 IP Convergence Main Processing Card (IPCMPR Card) 80  
 IPCMPR Card 60  
 IPCMPR Card Slot 28

## K

Key Management System 43  
 KX-NCP1104 (4-Channel VoIP DSP Card) 23, 63  
 KX-NCP1170 (4-Port Digital Hybrid Extension Card) 23, 73

KX-NCP1171 (8-Port Digital Extension Card) 23, 75  
 KX-NCP1172 (16-Port Digital Extension Card) 23, 76  
 KX-NCP1173 (8-Port Single Line Telephone Extension Card) 23, 77  
 KX-NCP1174 (16-Port Single Line Telephone Extension Card) 23, 78  
 KX-NCP1180 (4-Port Analog Trunk Card) 23, 67  
 KX-NCP1187 (T-1 Trunk Card) 23, 69  
 KX-NCP1190 (Optional 3-Slot Base Card) 23, 79  
 KX-NCP1290 (PRI Card [PRI23]) 23, 71  
 KX-NCS2201 (Activation Key for CA PRO for 1 User) 40  
 KX-NCS2205 (Activation Key for CA PRO for 5 Users) 40  
 KX-NCS2210 (Activation Key for CA PRO for 10 Users) 40  
 KX-NCS2240 (Activation Key for CA PRO for 40 Users) 40  
 KX-NCS2249 (Activation Key for CA PRO for 128 Users) 40  
 KX-NCS2301 (Activation Key for CA ACD Monitor for 1 ICD Supervisor) 40  
 KX-NCS3102 (2-Channel IP Trunk Activation Key) 39  
 KX-NCS3104 (4-Channel IP Trunk Activation Key) 39  
 KX-NCS3201 (1-Channel IP Softphone/IP Proprietary Telephone Activation Key) 40  
 KX-NCS3204 (4-Channel IP Softphone/IP Proprietary Telephone Activation Key) 40  
 KX-NCS3208 (8-Channel IP Softphone/IP Proprietary Telephone Activation Key) 40  
 KX-NCS3216 (16-Channel IP Softphone/IP Proprietary Telephone Activation Key) 40  
 KX-NCS3501 (1-Channel IP Proprietary Telephone Activation Key) 40  
 KX-NCS3504 (4-Channel IP Proprietary Telephone Activation Key) 40  
 KX-NCS3508 (8-Channel IP Proprietary Telephone Activation Key) 40  
 KX-NCS3516 (16-Channel IP Proprietary Telephone Activation Key) 40  
 KX-NCS3701 (1-Channel SIP Extension Activation Key) 40  
 KX-NCS3704 (4-Channel SIP Extension Activation Key) 40  
 KX-NCS3708 (8-Channel SIP Extension Activation Key) 40  
 KX-NCS3716 (16-Channel SIP Extension Activation Key) 40  
 KX-NCS3910 (Activation Key for Software Upgrade to Enhanced Version) 40  
 KX-TDA0161 (4-Port Doorphone Card) 23, 80  
 KX-TDA0164 (4-Port External Input/Output Card) 23, 82  
 KX-TDA0166 (16-Channel Echo Canceller Card) 23, 85  
 KX-TDA0191 (4-Channel Message Card) 23, 86  
 KX-TDA0194 (4-Channel Simplified Voice Message Card) 23, 87  
 KX-TDA0196 (Remote Card) 24, 65  
 KX-TDE0110 (16-Channel VoIP DSP Card) 24, 63  
 KX-TDE0111 (64-Channel VoIP DSP Card) 24, 63

**L**

LCOT4 Card (KX-NCP1180) 67  
 LED Indications, PBX 109

**M**

Main Unit 20  
 Main Unit, Construction 20  
 Maintenance Console, Installation 115  
 Maintenance Console, Overview 112  
 Maintenance Console, PC Connection 113  
 Maintenance Console, Quick Setup 115  
 Maintenance Console, System Requirements 115  
 Master DPT, Digital XDP 93  
 MOH 102  
 MSG4 Card (KX-TDA0191) 86

**N**

Names and Locations 49

**O**

OPB3 Card (KX-NCP1190) 79  
 Optional 3-Slot Base Card (KX-NCP1190) 23, 79  
 Optional Equipment 23  
 Optional Service Card, Installation 51  
 Optional Service Card, Maximum Number 28  
 Optional Service Card, Removal 51

**P**

Pager 102  
 Parallel Connection of the Extensions 90  
 Parallel Connection, Using a Modular T-Adaptor 91  
 Parallel Connection, Using an EXtra Device Port 91  
 Parallel Mode 91, 93  
 Password Security 12  
 PBMPR Software File Version 1.01xx 132  
 PBMPR Software File Version 2.02xx 133  
 PBMPR Software File Version 4.1xxx 134  
 PBMPR Software File Version 5.0xxx 135  
 PC Connection (via RS-232C) 102  
 PC Connection (via USB version 2.0) 101  
 Power Failure Connections 106  
 PRI Card (PRI23) (KX-NCP1290) 23, 71  
 PRI23 Card (KX-NCP1290) 71  
 Printer Connection (via RS-232C) 102

**Q**

Quick Setup 115

**R**

Remote Card (KX-TDA0196) 24, 65  
 Reset Button 127  
 RMT Card (KX-TDA0196) 65  
 RUN Indicator 108

**S**

Safety Installation Instructions 46  
 SD Memory Card 60  
 Slave DPT, Digital XDP 93  
 SLC16 Card (KX-NCP1174) 78  
 SLC8 Card (KX-NCP1173) 77  
 Slot for the IPCMPR Card 28  
 Slots for Physical Cards (Free Slots) 28

- Slots for Virtual CO Line Cards 28
- Slots for Virtual Extension Cards 28
- Specifications 25
- Specifications, Characteristics 27
- Specifications, General Description 25
- Specifications, System Capacity 28
- Starting the PBX 108
- Surge Protector Installation 57
- System Capacity 28
- System Connection Diagram 21
- System Initialization Procedure 108
- System Initialize Switch 108, 127
- System Requirements 115

## T

- T1 Card (KX-NCP1187) 69
- T-1 Trunk Card (KX-NCP1187) 23, 69
- Terminal Equipment, Maximum Number 33
- Troubleshooting, by Error Log 128
- Troubleshooting, Connection 123
- Troubleshooting, Installation 120
- Troubleshooting, Operation 125
- Troubleshooting, Using the Reset Button 127

## U

- Unpacking 48

## V

- V-IPCS4 (Virtual 4 IP Cell Station Interface Card) 66
- V-IPEXT32 (Virtual 32-Channel VoIP Extension Card) 66
- V-IPGW16 (Virtual 16-Channel VoIP Gateway Card) 66
- Virtual 16-Channel VoIP Gateway Card (V-IPGW16) 66
- Virtual 32-Channel SIP Extension Card (V-SIPEXT32) 66
- Virtual 32-Channel VoIP Extension Card (V-IPEXT32) 66
- Virtual 4 IP Cell Station Interface Card (V-IPCS4) 66
- Virtual Cards 66
- Virtual CO Line Slot 28
- Virtual Extension Slot 28
- V-SIPEXT32 (Virtual 32-Channel SIP Extension Card) 66

## W

- Wiring Precautions 47



**When you ship the product**

Carefully pack and send it prepaid, adequately insured and preferably in the original carton. Attach a postagepaid letter, detailing the symptom, to the outside of the carton. DO NOT send the product to the Executive or Regional Sales offices. They are NOT equipped to make repairs.

**Product Service**

Panasonic Factory Service Centers for this product are listed in the service center directory. Consult your certified Panasonic dealer for detailed instructions.

**For Future Reference**

Please print, record, and retain the following information for future reference.

**Note**

The serial number of this product can be found on the label affixed to the unit. You should record the model number and the serial number of this unit as a permanent record of your purchase to aid in identification in the event of theft.

MODEL NO.	_____
SERIAL NO.	_____
DATE OF PURCHASE	_____
NAME OF DEALER	_____
DEALER'S ADDRESS	_____ _____ _____
DEALER'S TEL. NO.	_____

**Panasonic Corporation of North America**

One Panasonic Way, Secaucus, New Jersey 07094

<http://www.panasonic.com/bts>

**Copyright:**

This material is copyrighted by Panasonic System Networks Co., Ltd., and may be reproduced for internal use only. All other reproduction, in whole or in part, is prohibited without the written consent of Panasonic System Networks Co., Ltd.

© Panasonic System Networks Co., Ltd. 2010