



PicoZed™ SDR 2x2 System-on-Module

User Guide

Version 1.7

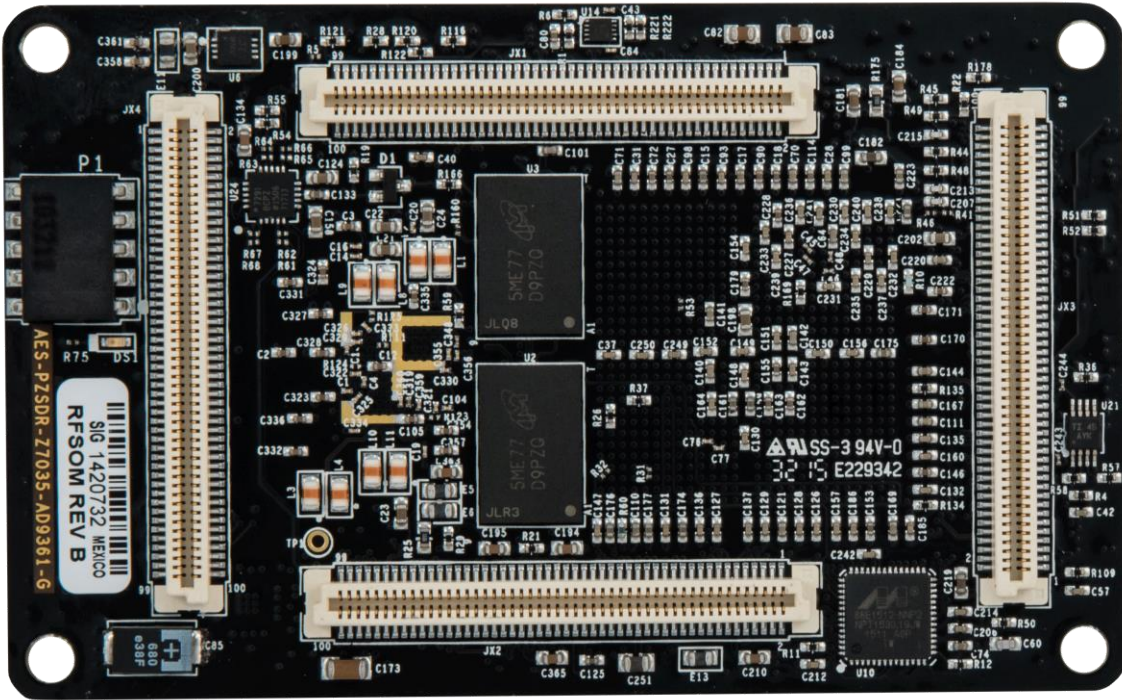
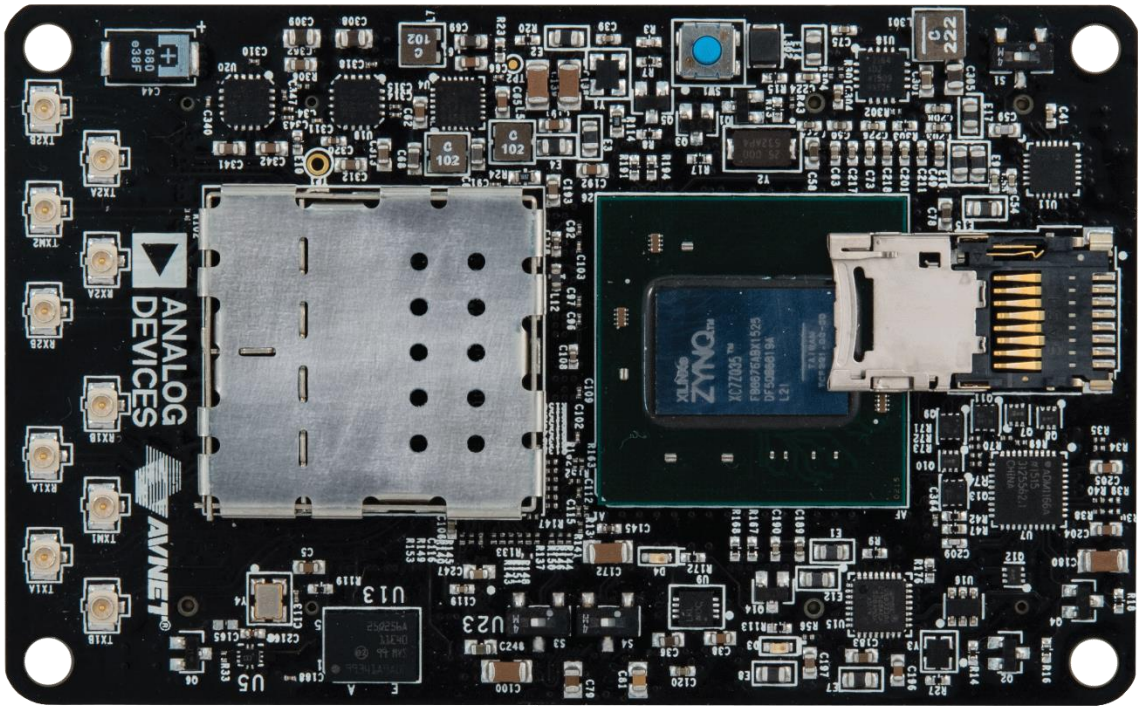

Table of Contents

1	INTRODUCTION.....	7
1.1	KEY FEATURES.....	7
1.2	MODULE SPECS	8
2	SOFTWARE	10
2.1	GETTING STARTED	10
2.2	OPERATING SYSTEMS.....	11
2.3	PROTOTYPE AND DEVELOPMENT TOOLS	11
2.3.1	<i>Xilinx Vivado® Design Suite</i>	11
2.3.2	<i>MathWorks Native Support</i>	11
2.3.3	<i>MathWorks Support by Analog Devices</i>	12
2.4	DRIVERS, SOURCE CODE, AND REFERENCE DESIGNS	12
2.4.1	<i>Analog Devices AD9361 RF Agile Transceiver</i>	12
2.4.2	<i>Xilinx Zynq-7000 AP SoC</i>	12
2.4.3	<i>MATLAB and Simulink Examples</i>	12
3	ELECTRICAL SPECIFICATIONS	14
3.1	XILINX ZYNQ-7000 ALL PROGRAMMABLE SoC.....	15
3.2	ANALOG DEVICES AD9361 RF AGILE TRANSCEIVER	16
3.3	AD9361/ZYNQ SoC CONNECTION	17
3.4	MEMORY	19
3.4.1	<i>DDR3</i>	19
3.4.2	<i>Quad SPI Flash</i>	20
3.4.3	<i>Micro SD Card Interface</i>	21
3.5	USB 2.0 OTG.....	23
3.6	10/100/1000 ETHERNET PHY	24
3.7	USER I/O	26
3.7.1	<i>AD9361 User Pins</i>	26
3.7.2	<i>Zynq PS MIO User Pins</i>	26
3.7.3	<i>Zynq PL SelectIO User Pins</i>	27
3.8	USER AUXILIARY ADC AND DAC INTERFACES	28
3.8.1	<i>AD9361 Auxiliary ADC</i>	28
3.8.2	<i>AD9361 Auxiliary DACs</i>	28
3.8.3	<i>Zynq SoC ADC</i>	28
3.9	ZYNQ MULTI-GIGABIT TRANSCEIVERS (MGTS)	29
3.10	CLOCK SOURCES.....	29
3.10.1	<i>Zynq clocks</i>	29
3.10.2	<i>AD9361 clocks</i>	29
3.10.3	<i>Ethernet Clock</i>	31
3.10.4	<i>USB Clock</i>	32
3.10.5	<i>SDIO Clock</i>	32
3.11	RESET SOURCES	32
3.11.1	<i>AD9361 Reset</i>	32
3.11.2	<i>Zynq Power-on Reset (PS_POR_B)</i>	32
3.11.3	<i>Zynq PROGRAM_B, DONE, PUDC_B, INIT_B Pins</i>	32
3.11.4	<i>Zynq Processor Subsystem Reset</i>	34
3.12	CONFIGURATION MODES.....	35
3.12.1	<i>JTAG Connections</i>	36
3.13	RF CONNECTIONS	36
3.14	MULTI-SOM SYNCHRONIZATION.....	38
3.15	EXPANSION HEADERS	38
3.15.1	<i>Micro Header Pin Summary</i>	38
3.15.2	<i>Micro Header Pin Detail</i>	41
3.16	POWER	46

3.16.1	<i>Input Voltages</i>	46
3.16.2	<i>Module Power Architecture</i>	48
3.16.3	<i>Monitor and Sequencing</i>	49
3.16.4	<i>Power Estimation</i>	51
3.16.5	<i>Battery Backup for Device Secure Boot Encryption Key</i>	52
4	PERFORMANCE.....	53
4.1	ERROR VECTOR MAGNITUDE (EVM).....	53
4.1.1	<i>Tests Parameters</i>	53
4.1.2	<i>Results</i>	53
4.2	TEMPERATURE	55
4.2.1	<i>Zynq Heat Sink</i>	55
4.3	SHOCK, VIBRATION, AND THERMAL TESTS	56
5	MECHANICAL	57
6	REFERENCES	59
7	ADDITIONAL INFORMATION	60
7.1	ADDITIONAL POWER SPECS.....	60
7.1.1	<i>SOM Voltage Regulators and Rails</i>	60
7.2	UPDATING THE ADM1166 SEQUENCER FIRMWARE	61
7.2.1	<i>Automated Update Procedure</i>	61
7.2.2	<i>Manual Update Procedure</i>	62
7.2.3	<i>Standalone Programming with USB Adapter</i>	62
7.3	USB POWER.....	63
7.4	XADC POWER CONFIGURATION	63
7.5	RESTORING THE ANALOG DEVICES SD CARD IMAGE.....	64
7.6	BOARD REVISIONS	65
7.6.1	<i>Rev A</i>	65
7.6.2	<i>Rev B</i>	65
7.6.3	<i>Rev C</i>	65
7.6.4	<i>Rev D</i>	66
7.7	DDR3L TRACE LENGTH.....	66
8	REVISION HISTORY	67

Table of Figures

FIGURE 1 - SIMPLIFIED SYSTEM DIAGRAM	9
FIGURE 2 - PICOZED SDR SOM DEVICE CALLOUT.....	9
FIGURE 3 – ADI GITHUB HDL REPOSITORY	10
FIGURE 4 - DETAILED SYSTEM DIAGRAM.....	14
FIGURE 5 - ZYNQ-7000 AP SOC BLOCK DIAGRAM	15
FIGURE 6 - AD9361 BLOCK DIAGRAM.....	16
FIGURE 7 - AD9361 RECEIVE DATA PATH, LVDS	17
FIGURE 8 - AD9361/ZYNQ Z-7035 INTERFACE	18
FIGURE 9 - SD CARD MULTIPLEXED ARCHITECTURE	21
FIGURE 10 – MICRO SD CAGE AND SELECT SWITCH.....	22
FIGURE 11 - 10/100/1000 ETHERNET INTERFACE	25
FIGURE 12 - AD9361 CLOCK INPUT OPTIONS	30
FIGURE 13 - SYSTEM READY LEDS.....	34
FIGURE 14 - ZYNQ BOOT SWITCHES	35
FIGURE 15 - U.FL PLUG TOOLS (HIROSE)	37
FIGURE 16 - RF TX CONNECTION	37
FIGURE 17 - RF RX CONNECTION	37
FIGURE 18 - POWER SCHEME	48
FIGURE 19 – SOM VOLTAGE REGULATION	49
FIGURE 20 - POWER SEQUENCING (REV D FIRMWARE)	51
FIGURE 21 - IIO SYSTEM OBJECT.....	53
FIGURE 22 - EVM RESULTS.....	54
FIGURE 23 - ZYNQ FAN/HEAT SINKS	55
FIGURE 24 - FCI BERGSTAK RECEPTACLE LOCATOR PEG	57
FIGURE 25 - MECHANICAL DIMENSIONS	58
FIGURE 26 - USB-SDP-CABLEZ.....	62
FIGURE 27 - ADM1166 PROGRAMMING PORT (P1)	62
FIGURE 28 - XADC POWER CONFIGURATION	63
FIGURE 29 - REV B SOM LABEL	65
FIGURE 30 - DDR3L TRACE LENGTHS	66

Table of Tables

TABLE 1 - DDR3 CONNECTIONS	20
TABLE 2 - QSPI FLASH PIN ASSIGNMENT AND DEFINITIONS	21
TABLE 3 - SETTING SD CARD SELECT (S1).....	22
TABLE 4 - ZYNQ PS SDIO CONNECTIONS.....	22
TABLE 5 - USB 2.0 JX3 PIN ASSIGNMENTS	23
TABLE 6 - USB HOST PIN ASSIGNMENT AND DEFINITIONS.....	24
TABLE 7 - ZYNQ PS ETHERNET PHY PIN ASSIGNMENT AND DEFINITIONS	25
TABLE 8 - ZYNQ PS MIO BANK SUMMARY	26
TABLE 9 - ZYNQ PL USER I/O BANK SUMMARY	27
TABLE 10 - ZYNQ GTX CONNECTOR ASSIGNMENTS	29
TABLE 11 - ZYNQ POWER UP / RESET SIGNALS.....	33
TABLE 12 - ZYNQ CONFIGURATION MODES	35
TABLE 13 - JTAG PIN CONNECTIONS.....	36
TABLE 14 - MICRO HEADER JX1 PIN SUMMARY	39
TABLE 15 - MICRO HEADER JX2 PIN SUMMARY	39
TABLE 16 - MICRO HEADER JX3 PIN SUMMARY	40
TABLE 17 - MICRO HEADER JX4 PIN SUMMARY	40
TABLE 18 - JX1 CONNECTIONS	42
TABLE 19 - JX2 CONNECTIONS	43
TABLE 20 - JX 3 CONNECTIONS	44
TABLE 21 - JX4 CONNECTIONS	45
TABLE 22 – SUPPLY VOLTAGE REQUIREMENTS	47
TABLE 23 - POWER GOOD LED STATUS	50
TABLE 24 - OPERATING TEMPERATURE	55
TABLE 25 - REGULATED VOLTAGE RAILS.....	60

1 Introduction

Avnet's PicoZed™ SDR 2x2 is a Software Defined Radio (SDR) that combines the Analog Devices AD9361 integrated RF Agile Transceiver™ with the Xilinx Z7035 Zynq®-7000 All Programmable SoC in a small system-on-module (SOM) footprint suitable for end-product integration.

PicoZed SDR carrier cards are available for fast prototype and are supported by robust simulation and code generation tools that integrate seamlessly with Xilinx Vivado® Design Suite. The final step for most applications includes designing a custom carrier card to mate with the PicoZed SDR SOM for end product deployment.

1.1 Key Features

- **Low-power** Designed with a -2LI version of the Zynq SoC (low power, mid speed, industrial temp), DDR3L, and high-efficiency voltage regulators with margining capability to scale power with performance. Built-in sequencing and monitoring make it easy to power to the module.
- **High bandwidth data connectivity** Move data quickly with dual Gigabit Ethernet, USB2.0, four 6.6 Gb/s serial links (PCIe x4, SFP+, others), and high-speed LVDS I/O for custom interfaces.
- **Wideband, frequency agile RF** Uses the AD9361 to provide a highly integrated radio that enables wideband 2x2 MIMO receive and transmit paths from 70 MHz to 6.0 GHz with tunable channel bandwidth <200kHz to 56MHz.
- **Programmable SoC** Embedded processing with the Zynq Z-7035 SoC provides a Dual ARM® Cortex™-A9 MPCore™ running at 800MHz, with built in peripherals like USB, Gigabit Ethernet, and memory interfaces.
- **Small form factor** 100mm x 62mm footprint, compliant with DP10062 “Sick of Beige v1.0” enclosures from dangerousprototypes.com.
- **Production-ready module** System-on-Module designed for immediate prototype and quick integration in your end application. Industrial temperature rated and tested against MIL-STD 202G methods for Thermal, Vibration, and Shock.
- **Operating systems** Comes with Analog Devices Linux reference design for Zynq, bootable from an SD card. Also supports Linux, Android, FreeRTOS, eCos, VxWorks, and others listed [here](#).
- **Development tools** A broad range of SDR prototype and development environments are supported, including [Analog Devices Linux Applications](#), and [MATLAB® and Simulink® for data streaming and Zynq targeting](#).
- **Open-source code** Analog Devices provides precompiled reference designs on their [PicoZed SDR wiki](#) page and a source code support package hosted on [Github](#), including the HDL and software code (except non-ADI).

1.2 Module Specs

The module specifications are summarized below. The rest of the document provides details.

Radio	Analog Devices AD9361 integrated RF Agile Transceiver™
RF Band	70MHz to 6.0GHz
Tunable Channel BW	<200kHz to 56MHz
RF Connections	4 TX, 4RX, 2 TX monitor
Max output power	6.5 – 8.0 dBm (typical) – see AD9361 datasheet for details
Max input power (RX)	2.5 dBm (peak)
Max input power (TX mon.)	9 dBm (peak)
Processing	Xilinx Zynq XC7Z035-L2 FBG676I AP SoC
Processor	Dual ARM® Cortex™-A9 MPCore™ running at 800MHz
Programmable Logic	275K Kintex-7 logic cells with 900 DSP48 slices
Interface	Four 100-pin Micro Headers
Peripherals	ARM: Gigabit Ethernet, USB2.0, UART, SDIO
User I/O	209 single-ended or 93 LVDS (up to 1250 or 1400 Mb/s DDR)
Serial transceivers	4 Zynq GTX channels @ 6.6Gb/s
Memory	
DDR3L	1GB DDR3L (low power) @ 1,066 Mb/s
Flash	256 Mb QSPI Flash (bootable) @ 400Mb/s
SD card	Lockable Micro SD Card cage (bootable) @ 25MB/s
Power Consumption	< 5Watts (typical)
Main Module Supply	4.5V – 5.5V (5.0V nominal)
Module I/O Supplies	1.0V – 3.3V
Operating system support	Linux, Android, FreeRTOS, eCos, VxWorks, and others
Debug	JTAG
Dimensions	100mm x 62mm
Operating Temp	Industrial -40°C to +85°C ⁽¹⁾

(1) uSD cage rated to -25°C to +85°C operating temperature

Important! PicoZed SDR is not pin compatible with standard PicoZed (non-SDR) carrier cards. New pinouts were required mainly for the Zynq Z-7035 and AD9361 digital I/O.

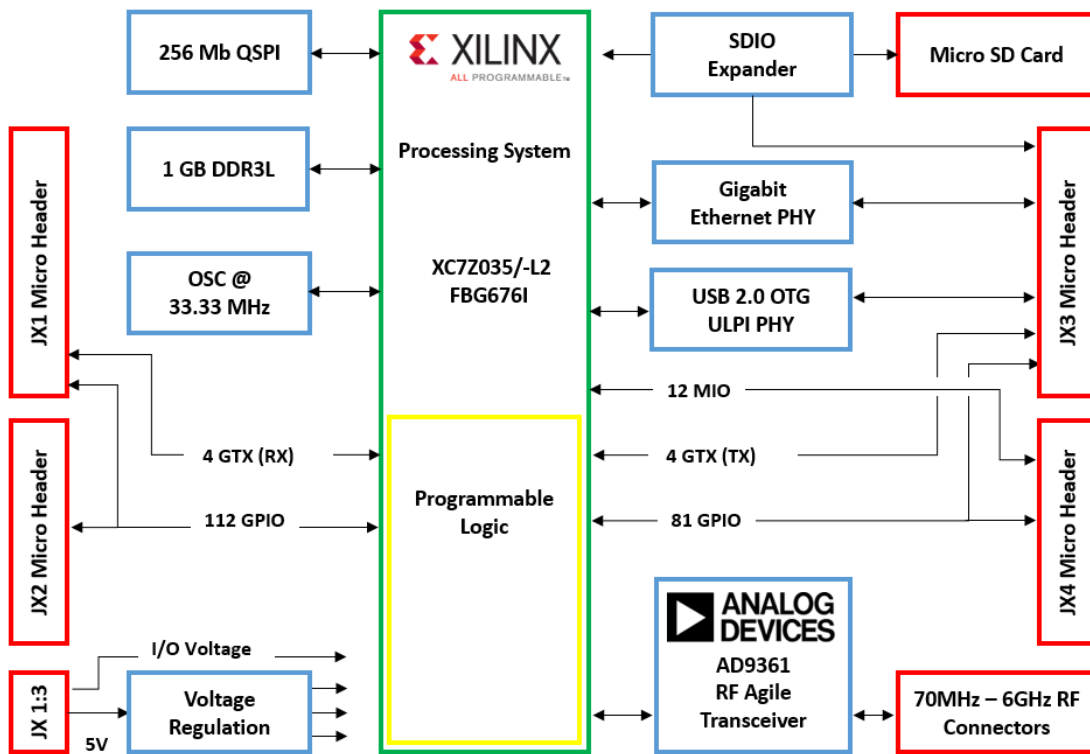

Figure 1 - Simplified System Diagram

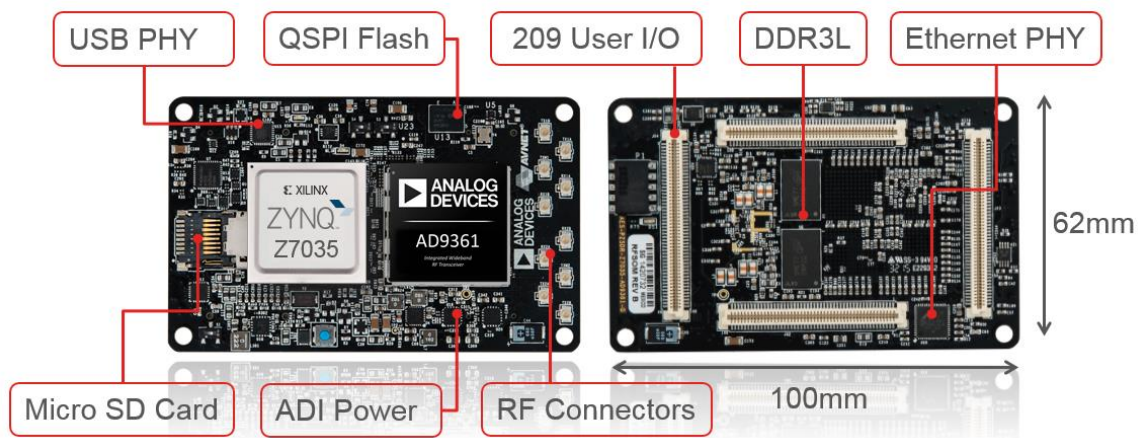

Figure 2 - PicoZed SDR SOM Device Callout

2 Software

The Zynq SoC onboard PicoZed SDR 2X2 contains Dual ARM® Cortex™-A9 MPCore™ processors capable of running a variety of operating systems and is supported by an ecosystem of development tools.

2.1 Getting Started

Avnet offers several carrier cards for PicoZed SDR SOMs to help you start development immediately. We recommend using the Getting Started Guide for those carriers in order to learn how to setup the hardware and run the base reference design. Find carriers and Getting Started Guides at www.picozed.org.

To quickly explore the reference design, here are some resources:

- The [SD card image](#) used to boot the reference design
- The [Analog Devices PicoZed SDR Wiki](#) provides details about reference designs
- The [HDL](#), [no-OS](#) and [Linux](#) sources are hosted on GitHub
 - For HDL, we highly recommend cloning from the latest official tag (released twice per year), not the development branch.
<https://github.com/analogdevicesinc/hdl/releases>

For example, choose branch **hdl_2015_r2** to get the second release of 2015. Notice the support Xilinx Vivado tool version.

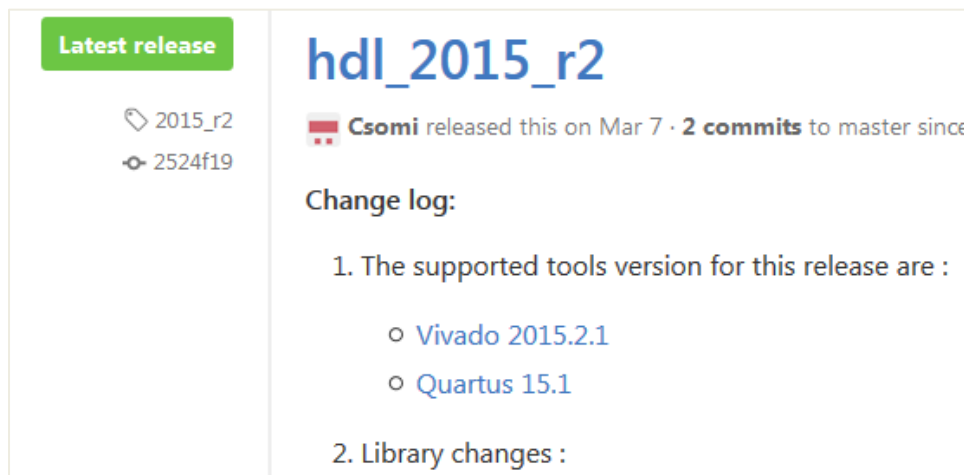

Figure 3 – ADI GitHub HDL repository

- The TCL scripts to build the Vivado project for this carrier are located in **/projects/pzsdr/ccfmc**
- The [ADI Reference Designs HDL User Guide](#) explains how to rebuild the FPGA project.

NOTE: The reference design is based on the HDL code maintained by Analog Devices. To manage dependencies in the build process for Vivado projects, Analog Devices provides Linux-based makefiles. We recommend that Windows users build Vivado projects using 'make' under CYGWIN. Instructions to install a minimal version of CYGWIN that will provide a Linux-like environment under Windows are available [here](#).

2.2 Operating Systems

The following operating Systems are supported on the Zynq ARM processors. The most up-to-date and comprehensive list can be found [here](#) on the Xilinx web site, however the following section will give you an idea of the popular options.

Most software developers will start with the Linux reference design and drivers provided by Analog Devices at the GitHub page listed below. Analog Devices also have a wiki page that provides details of their Linux reference design for PicoZed SDR [here](#).

Non-Commercial OS

- Linux, uBoot, and more on [Xilinx GIT](#) and [Analog Devices GIT](#)
- PetaLinux tools [here](#)
- Android

Commercial OS

- [Wind River Linux](#)

RTOS

- [eCos](#)
- [FreeRTOS](#)
- [Micrium uC/OS-II/III](#)
- [QNX](#)
- [Wind River VxWorks](#)

2.3 Prototype and Development Tools

2.3.1 Xilinx Vivado® Design Suite

- Download a free evaluation from www.xilinx.com/support/download.html.
- Purchase a license at [Avnet Express](#).

2.3.2 MathWorks Native Support

Communications System Toolbox™ Support Package for Xilinx® Zynq®-Based Radios enables you to use [MATLAB®](#) and [Simulink®](#) to prototype and verify practical wireless systems. Using this support package with PicoZed SDR, you can transmit and receive RF signals right out-of-the-box. This enables you to quickly test your design under real world conditions.

Some useful links for more information are provided as follows:

- Zynq SDR Support from Communications System Toolbox
www.mathworks.com/hardware-support/zynq-sdr.html
- Free Trial Software for Software-Defined Radio Design Using PicoZed SDR
www.mathworks.com/picozedsdr-trial
- MATLAB Filter Design Wizard for AD9361
wiki.analog.com/resources/eval/user-guides/ad-fmcomms2-ebz/software/filters
- SimRF Models of the AD9361 Agile RF Transceiver
www.mathworks.com/hardware-support/analog-devices-rf-transceivers.html

2.3.3 MathWorks Support by Analog Devices

Analog Devices works closely with MathWorks to develop custom capabilities for the PicoZed SDR. For example, MathWorks HDL Workflow Advisor support plus MATLAB and Simulink data exchange over Ethernet with IIO System Object.

Some useful links for more information are provided as follows:

- Analog Devices BSP for MathWorks HDL Workflow Advisor
wiki.analog.com/resources/eval/user-guides/ad-fmcomms2-ebz/software/matlab_bsp
- MATLAB and Simulink data exchange over Ethernet with IIO System Object
[https://wiki.analog.com/resources/tools-software/linux-software/libiio/clients/matlab_simulink?s\[\]=system&s\[\]=object](https://wiki.analog.com/resources/tools-software/linux-software/libiio/clients/matlab_simulink?s[]=system&s[]=object)

2.4 Drivers, Source Code, and Reference Designs

Analog Devices provides a comprehensive set of drivers, source code, reference designs, and other technical resources for PicoZed SDR. More information may be found on their [PicoZed SDR wiki](#) page. A source code support package is hosted on [GitHub](#), including the HDL and software code (except non-ADI).

2.4.1 Analog Devices AD9361 RF Agile Transceiver

Analog Devices provides complete drivers for the AD9361 for both bare metal/No-OS and operating systems (Linux). The AD9361 and AD9364 share the same API. The AD9361 and AD9364 drivers can be found at:

- [Linux](#) wiki page
- [No-OS](#) wiki page

Support for these drivers can be found at:

- [Linux](#) engineer zone page
- [No-OS](#) engineer zone page

In addition, Analog Devices provides FPGA [HDL source code](#) for the Xilinx Zynq SoC.

2.4.2 Xilinx Zynq-7000 AP SoC

Analog Devices provides complete drivers for the Zynq SoC ARM peripherals, including those implemented on the PicoZed SDR 2X2 module.

- Ethernet Linux MDIO driver
- USB Linux driver
- SDIO Linux driver

These are included in the Linux kernel images provided at the [Zynq Images](#) wiki page.

2.4.3 MATLAB and Simulink Examples

These designs, provided by Analog Devices, demonstrate high bandwidth data transfer between PicoZed SDR and MATLAB or Simulink running on a host PC. They also provide examples of designing custom baseband functions in the Zynq SoC.

- [Stream data into/out of MATLAB](#)
- [Beacon Frame Receiver Example](#)

- [QPSK Transmit and Receive Example](#)
- [LTE Transmit and Receive Example](#)
- [ADS-B Airplane Tracking Example](#)

3 Electrical Specifications

Designing with the PicoZed SDR 2X2 SOM requires an understanding of the system I/O that are available, how they are powered, and where the signals connect on the SOM. Those details are covered in the remaining sections. This diagram shows a summary of all system peripherals and user I/O available.

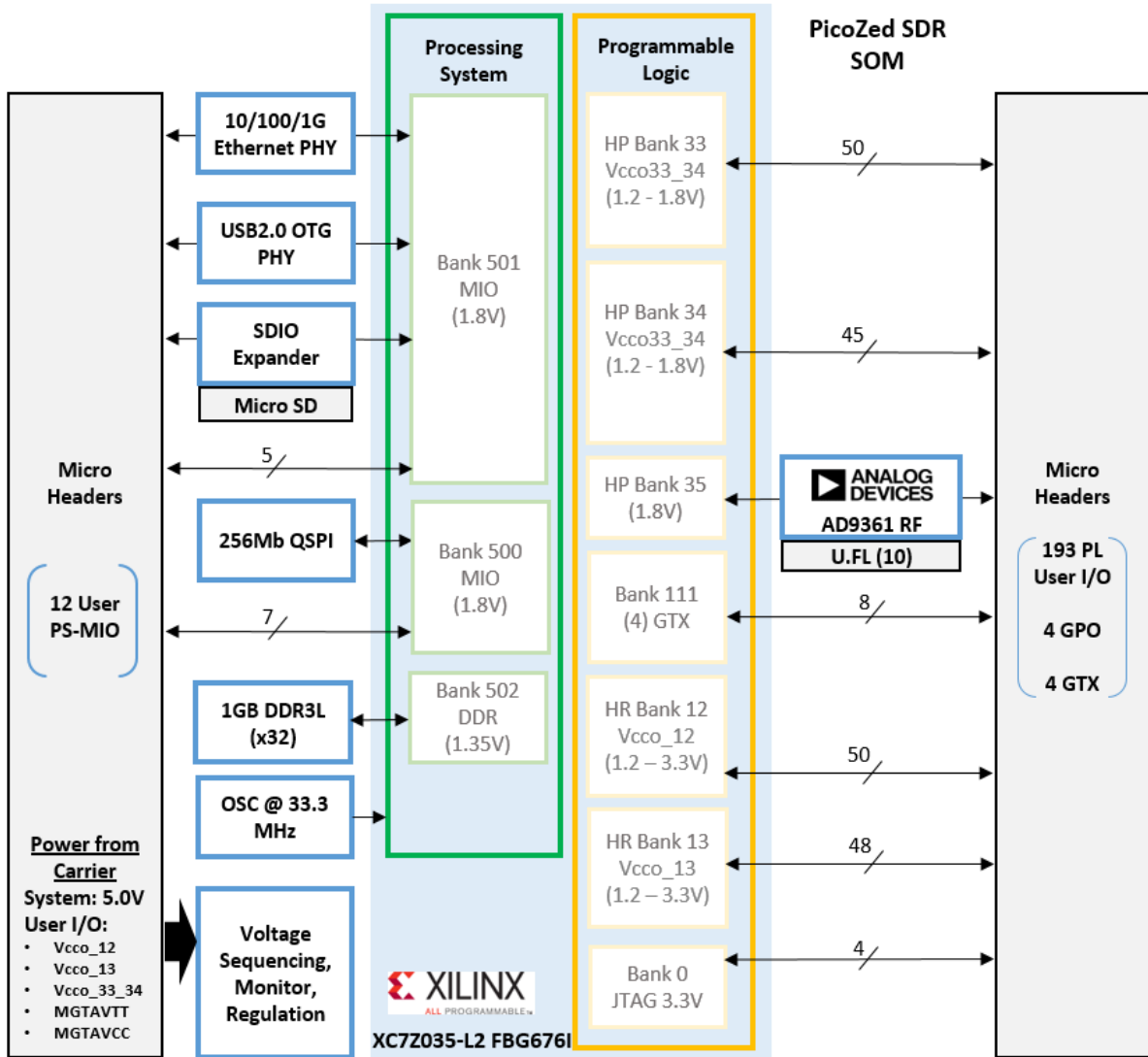

Figure 4 - Detailed System Diagram

3.1 Xilinx Zynq-7000 All Programmable SoC

PicoZed SDR 2X2 includes a Xilinx Zynq XC7Z035-L2 FBG6761 AP SoC. Tight integration between the ARM-based processing system and the on-chip programmable logic creates unlimited possibilities for designers to add virtually any peripheral or create custom accelerators that extend system performance and suit unique application requirements.

This is a -2 speed grade and low power (-L) binned device. All SOM memory and digital interfaces connect to Zynq through the Processing System (PS) or Programmable Logic (PL). The Analog Devices AD9361 connects through Zynq PL.

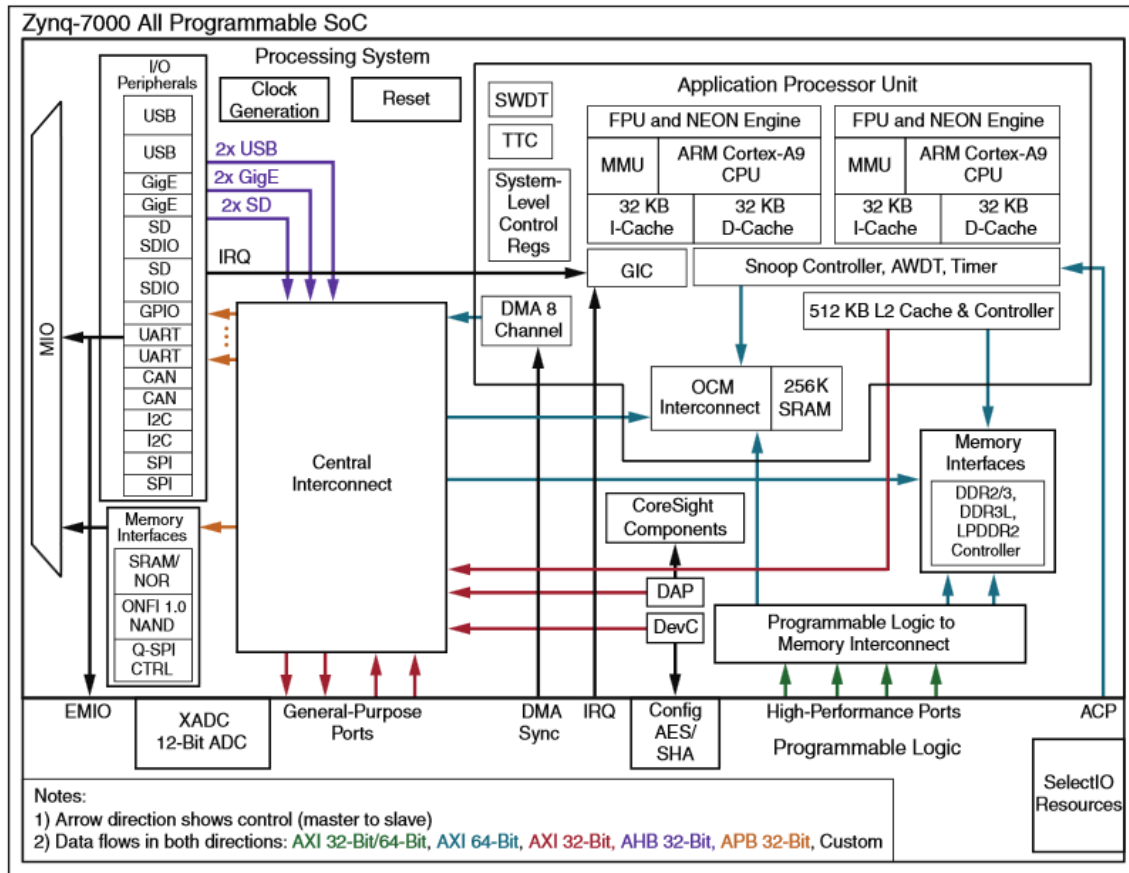

Figure 5 - Zynq-7000 AP SoC Block Diagram

Consult the Xilinx Zynq-7000 AP SoC Technical Reference Manual ([UG585](#)) for more information.

3.2 Analog Devices AD9361 RF Agile Transceiver

PicoZed SDR 2X2 includes an Analog Devices AD9361 RF Agile Transceiver™. The AD9361 is a high performance, highly integrated RF Agile Transceiver™. Its programmability and wideband capability make it ideal for a broad range of transceiver applications. The device combines an RF front-end with a flexible mixed-signal baseband section and integrated frequency synthesizers. The AD9361 operates in the 70 MHz to 6.0 GHz range, covering most licensed and unlicensed bands. Channel bandwidths from less than 200 kHz to 56 MHz are supported.

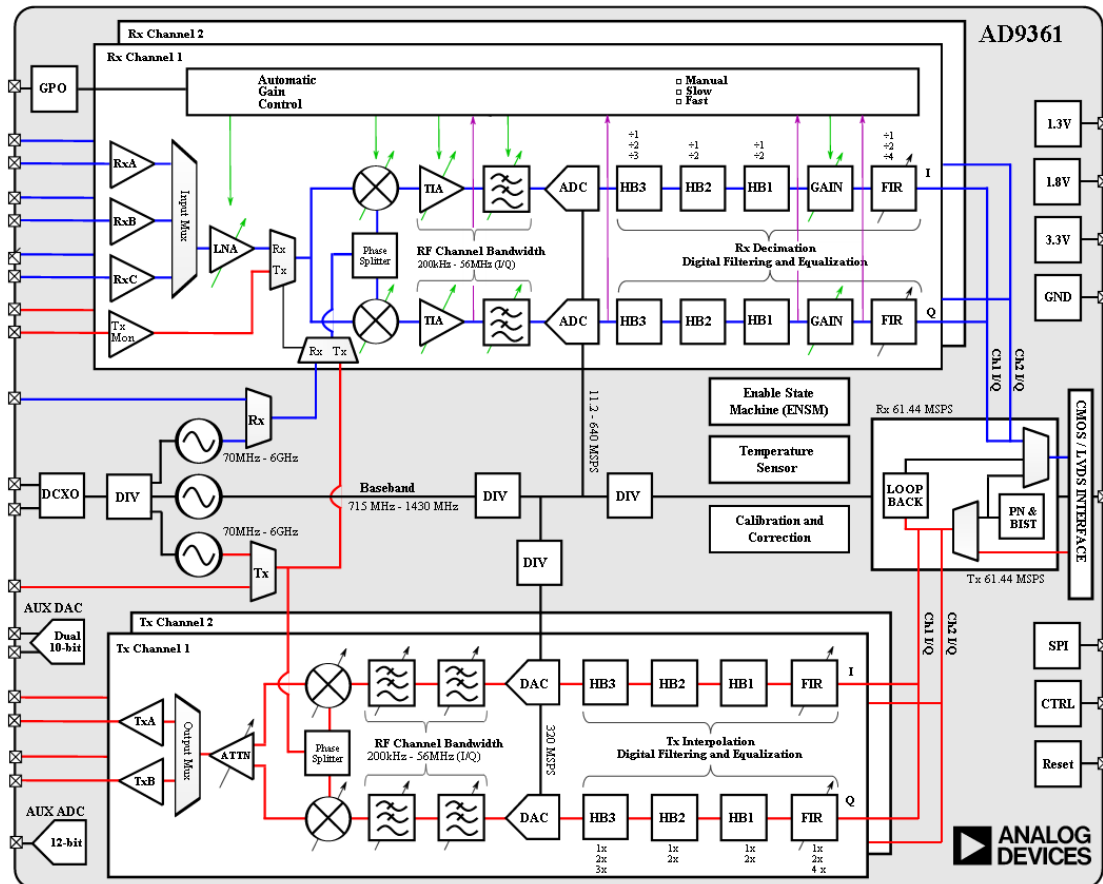

Figure 6 - AD9361 Block Diagram

Consult the AD9361 Reference Manual ([UG-570](#)) for more details.

3.3 AD9361/Zynq SoC Connection

PicoZed SDR 2X2 connects the Xilinx Zynq Z-7035 SoC directly to the AD9361 RF Agile Transceiver with dedicated high bandwidth data ports and clocks, an SPI control interface, and other control and framing signals as shown in Figure 7.

The AD9361 digital interface is comprised of two parallel data ports (P0 and P1) and several clock, synchronization, and control signals to transfer samples between the AD9361 and the Zynq SoC. These signals can be configured as single-ended CMOS signals or as Low Voltage Differential Signal (LVDS, ANSI-644 compatible) signals for systems that require high speed, low noise data transfer. The system level reference designs that exist for the PicoZed SDR all use LVDS, to achieve the maximum data throughput, but can be configured in CMOS mode to better prototype a different hardware subsystem.

In LVDS mode, the interface is operated in double-data rate (DDR) mode. Therefore, 12-bit samples to/from the AD9361 are sent across two 6-bit lanes on differential pairs.

Maximum rate across the Zynq-AD9361 data interface is limited by AD9361 max data rate (122.88MSPS).

The timing diagram below is included for illustration of the data interface. Consult the AD9361 Reference Manual ([UG-570](#)) for more details.

Analog Devices provides Zynq HDL source code and Linux drivers for the AD9361. Designers are encouraged to reuse them. More information can be found at their PicoZed SDR wiki page https://wiki.analog.com/resources/eval/user-guides/picozed_sdr.

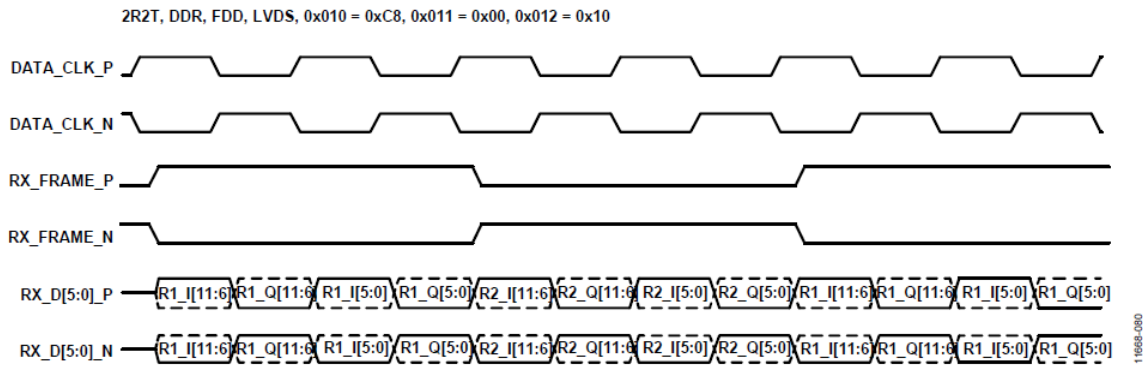

Figure 79. Receive Data Path, LVDS

Figure 7 - AD9361 Receive Data Path, LVDS

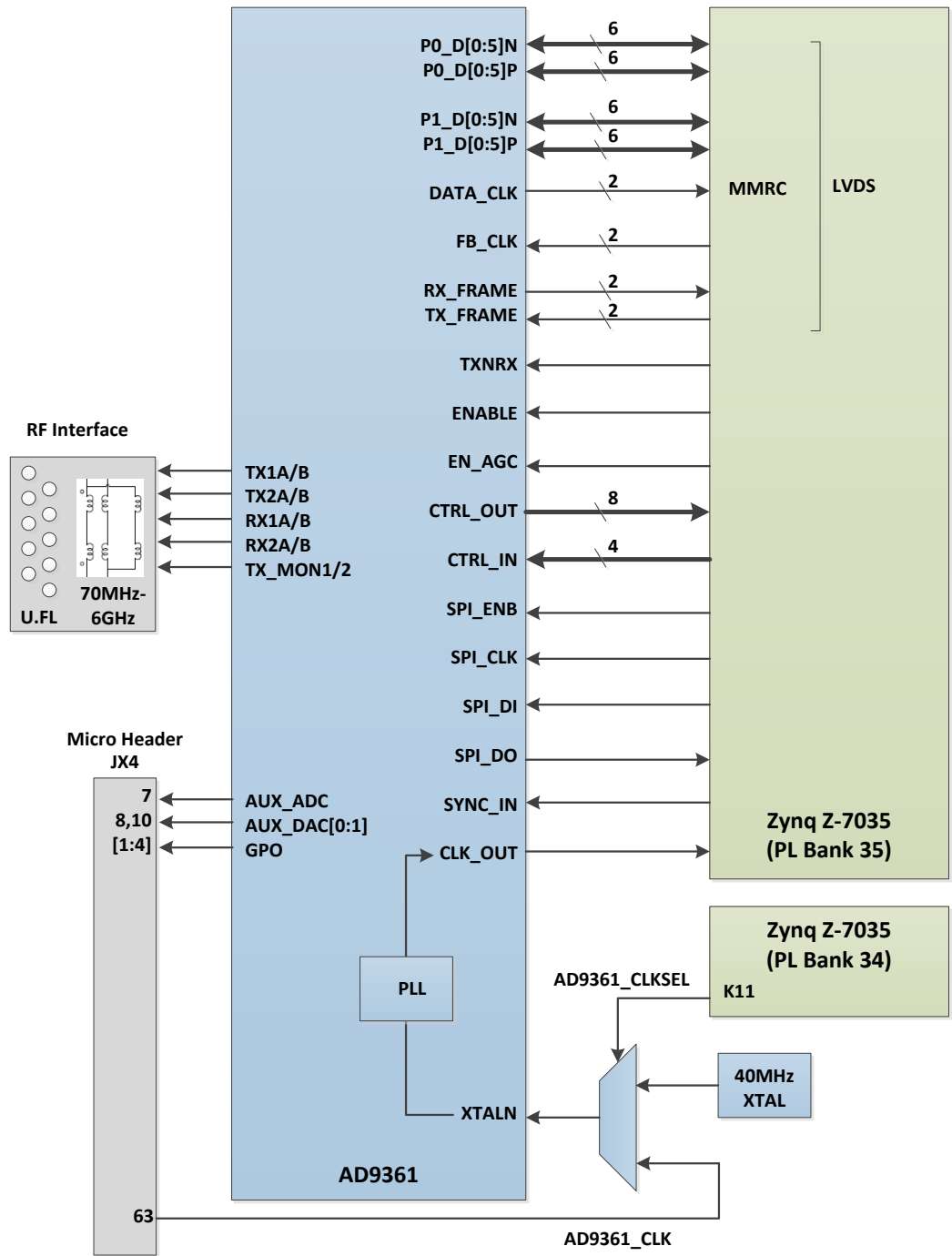

Figure 8 - AD9361/Zynq Z-7035 Interface

3.4 Memory

Zynq contains a hardened PS memory interface unit. The memory interface unit includes a dynamic memory controller and static memory interface modules. PicoZed SDR takes advantage of these interfaces to provide system RAM as well as non-volatile memory.

3.4.1 DDR3

PicoZed SDR includes two Micron MT41K256M16HA-125 DDR3L low power memory components creating a 256M x 32-bit interface, totaling 1 GB of random access memory. The DDR3L memory is connected to the hard memory controller in the PS of the Zynq AP SoC. The PS incorporates both the DDR controller and the associated PHY, including its own set of dedicated I/Os.

Speed of up to 1,066 Mb/s for DDR3L is supported.

The DDR3L interface uses 1.35V SSTL-compatible inputs by default.

DDR3L termination is utilized on PicoZed SDR and configured for fly-by routing topology, as recommended in Xilinx [UG933](#). Additionally the board trace lengths are matched, compensating for the XC7Z035- FBG676 internal package flight times, to meet the requirements listed in the Zynq-7000 AP SoC PCB Design and Pin Planning Guide ([UG933](#)).

The Zynq digitally controlled impedance (DCI) reference resistors (VRP/VRN) are 240Ω. The differential clock DDR3_CK pair is terminated with 80Ω. The DDR3-CKE0 is terminated through 120 ohms to VTT_0P75. The DDR3-ODT has the same 120 ohm to VTT_0P75 termination. This implementation departs from the Xilinx recommendations in UG933. **Termination values for PicoZed SDR are based on data from Micron and chosen to significantly reduce power consumption.** Each DDR3 chip has its own 240-ohm pull-down on ZQ.

Note: DDR-VREF is not the same as DDR-VTT.

Table 1 - DDR3 Connections

Signal Name	Description	Zynq AP SOC pin	DDR3 pin
DDR_CK_P	Differential clock output	R21	J7
DDR_CK_N	Differential clock output	P21	K7
DDR_CKE	Clock enable	U21	K9
DDR_CS_B	Chip select	Y21	L2
DDR_RAS_B	RAS row address select	V23	J3
DDR_CAS_B	RAS column address select	Y23	K3
DDR_WE_B	Write enable	V22	L3
DDR_BA[2:0]	Bank address	PS_DDR_BA[2:0]	BA[2:0]
DDR_A[14:0]	Address	PS_DDR_A[14:0]	A[14:0]
DDR_ODT	Output dynamic termination	Y22	K1
DDR_RESET_B	Reset	H22	T2
DDR_DQ[31:0]	I/O Data	PS_DDR_DQ[31:0]	DDR3_DQ pins [15:0] x2
DDR_DM[3:0]	Data mask	PS_DDR_DM[3:0]	LDM/UDM x2
DDR_DQS_P[3:0]	I/O Differential data strobe	PS_DDR_DQS_P[3:0]	UDQS/LDQS x2
DDR_DQS_N[3:0]	I/O Differential data strobe	PS_DDR_DQS_N[3:0]	UDQS#/LDQS# x2
DDR_VRP	I/O Used to calibrate input termination	W21	N/A
DDR_VRN	I/O Used to calibrate input termination	V21	N/A
DDR_VREF[1:0]	I/O Reference voltage	M21, K21	VTTREF

3.4.2 Quad SPI Flash

PicoZed SDR features a 4-bit SPI (quad-SPI) serial NOR flash. The Micron N25Q256A11E1240 is used on this board. Flash memory is used to provide non-volatile boot, application code, and data storage. It can be used to initialize the Zynq PS subsystem as well as configure the PL subsystem (bitstream). The relevant device attributes are as follows:

- 256Mbit
- x1, x2, and x4 support
- Speeds up to 108 MHz, supporting Zynq configuration rates @ 100 MHz
 - In Quad-SPI mode, this translates to 400Mb/s
- Powered from 1.8V

The SPI Flash connects to the Zynq PS QSPI interface. Booting from SPI Flash requires connection to specific pins in MIO Bank 0/500, specifically MIO[1:6,8] as outlined in the Zynq TRM. Quad-SPI feedback mode is used, thus qspi_sclk_fb_out/MIO[8] is connected to a 20K pull-up resistor to 1.8V. This allows a QSPI clock frequency greater than FQSPICLK2. The 20K pull-ups on MIO[7:8] strap VMODE[0:1], setting Bank 0 and Bank 1 voltage to 1.8V.

Table 2 - QSPI Flash Pin Assignment and Definitions

Signal Name	Description	Zynq Pin	MIO	Quad-SPI Pin
CS	Chip Select	D26 (MIO Bank 0/500)	1	C2
DQ0	Data0	E25 (Bank MIO0/500)	2	D3
DQ1	Data1	D25 (MIO Bank 0/500)	3	D2
DQ2	Data2	F24 (MIO Bank 0/500)	4	C4
DQ3	Data3	C26 (MIO Bank 0/500)	5	D4
SCK	Serial Data Clock	F23 (MIO Bank 0/500)	6	B2
FB Clock	QSPI Feedback	A24 (MIO Bank 0/500)	8	N/A
PS-SRST#	Zynq PS Reset	A22 (Bank 501)	N/A	A4

Note: The QSPI data and clock pins are shared with the VMODE and BOOT_MODE jumpers S3 and S4.

3.4.3 Micro SD Card Interface

The Micro SD card can be used for non-volatile external memory storage as well as booting the Zynq-7000 AP SoC. The Zynq PS SD/SDIO peripheral is connected to a TI TXS02612 SDIO Port Expander With Voltage-Level Translation and ESD protection (U11), providing connectivity to the micro SD interface on the PicoZed SDR SOM or a carrier card through the bottom-side micro header receptacles (JX3).

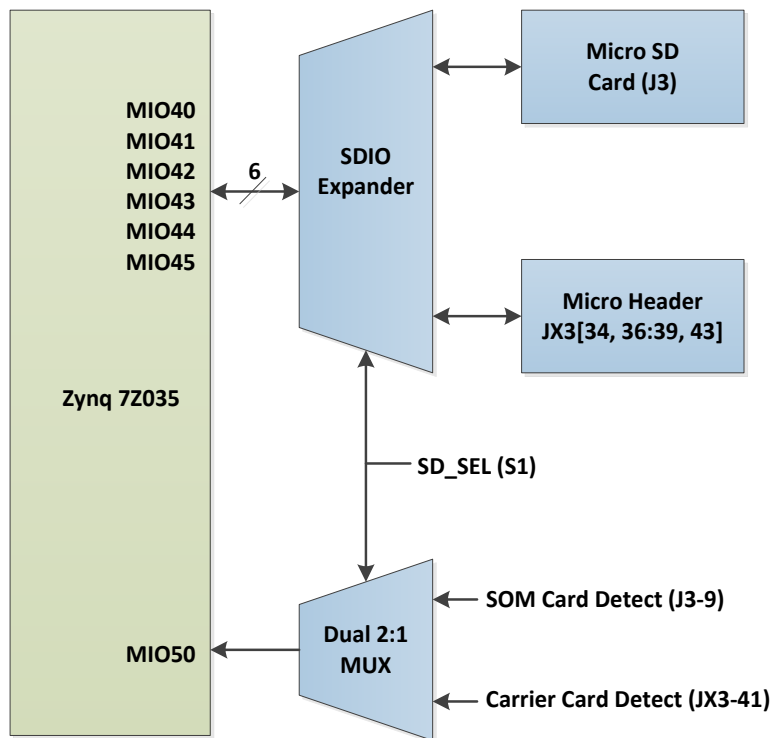

Figure 9 - SD Card Multiplexed Architecture

For example, the PicoZed SDR FMC Carrier implements a standard SD card interface as an alternative to using the micro SD card on the SOM. Switch S1 on the SOM selects the SD source connected to Zynq, as explained below.

Table 3 - Setting SD Card Select (S1)

Signal	Description	Settings
SD_SEL	SOM switch S1 (SD Card Select)	0 = SOM micro SD; 1 = Carrier SD; (white dot on switch is logic 0)

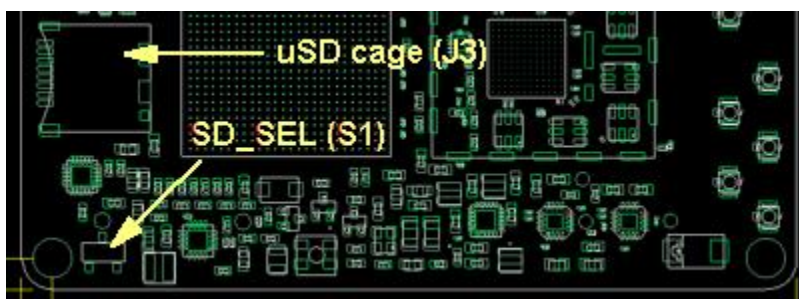

Figure 10 – Micro SD Cage and Select Switch

The Zynq PS peripheral sd0 is connected through Bank 1/501 MIO[40-45]. The Card Detect signals from the SOM (J3-9) and carrier (JX3_SD1_CDN) are multiplexed on the SOM with the ADG772 dual 2:1 MUX (U5), onto one signal connected to Zynq PS MIO50.

Table 4 - Zynq PS SDIO Connections

Signal Name	Description	Zynq Pin	MIO	2 nd SD channel on JX3
SD0_CLK	Clock	C22 (MIO Bank 1/501)	40	JX3-43
SD0_CMD	Command	C19 (MIO Bank 1/501)	41	JX3-34
SD0_DATA0	Data[0]	F17 (MIO Bank 1/501)	42	JX3-37
SD0_DATA1	Data[1]	D18 (MIO Bank 1/501)	43	JX3-36
SD0_DATA2	Data[2]	E18 (MIO Bank 1/501)	44	JX3-39
SD0_DATA3	Data[3]	C18 (MIO Bank 1/501)	45	JX3-38
PS_MIO50_501_SD0_CD	Shared Card Detect signal	B22 (MIO Bank 1/501)	50	JX3-41

The micro SD Card is a 3.3V interface but is connected through MIO Bank 1/501 which is set to 1.8V. Therefore, the SDIO expander device performs voltage translation. As stated in the Zynq Technical Reference Manual (TRM), host mode is the only mode supported configuration.

The micro SD Card connector is located at J3 on the SOM (see Figure 10). If you are using the SD Card for a file system a Class 10 card or better is recommended. We use SanDisk and Delkin. Other vendor cards may work as well, however we've experience issues with a few brands.

3.5 USB 2.0 OTG

The Zynq Z-7035 PS contains two hardened USB 2.0 high speed controllers with on-the-go (OTG) dual role USB host controller or USB device controller operation using the same hardware. PicoZed SDR uses one of these Zynq PS peripherals, in combination with a USB2.0 UTMI+ low pin interface (ULPI) PHY device, to provide USB 2.0 OTG signaling to the JX3 connector.

The external Microchip USB3320 PHY presents an 8-bit ULPI interface to the Zynq PS MIO[28:39] pins in Bank 1/501, corresponding to the Zynq PS USB0 peripheral. The USB PHY Reset signal is connected to Zynq PS MIO[7] Bank 0/500. Signal PS_MIO7 is a 1.8V signal with a pull-up resistor which instructs VMODE[0] to set MIO[0:15] to LVCMOS18 signal standard up boot time.

The USB3320 PHY features a complete HS-USB Physical Front-End supporting speeds of up to 480Mbps. VDDIO for this device can be 1.8V or 3.3V, and on the PicoZed SDR it is powered at 1.8V. The PHY is connected to MIO Bank 1/501, which is also powered at 1.8V. This is critical since a level translator cannot be used as it would impact the tight ULPI timing required between the PHY and the Zynq device.

Additionally, the USB PHY must clock the ULPI interface which requires a 24 MHz crystal or oscillator (configured as ULPI Output Clock Mode). On the PicoZed SDR module, the 24 MHz oscillator is an Abracon ASDMB CMOS oscillator. The oscillator may be powered down using the STANDBY pin, which is controlled by the Zynq PS MIO[9] pin in Bank1/500.

The PicoZed SDR module does not include the USB connector. The SOM is designed to have the USB connector reside on the mating carrier card. The four USB connector signals (USB_OTG_P, USB_OTG_N, USB_ID, and USB_OTG_CPEN) are connected to the JX3 micro header receptacle. The table below shows the connections of these four signals at JX3.

Table 5 - USB 2.0 JX3 Pin Assignments

Signal Name	JX3 Pin
USB_OTG_N	69
USB_OTG_P	67
USB_ID	63
USB_OTG_CPEN	70

If using the Avnet PicoZed SDR FMC Carrier Card as the mating carrier card, the USB signals are routed to a Micro-AB connector.

The PicoZed SDR module is configured such that either Host Mode (OTG) or Device Mode can be used depending on the circuitry of the carrier card. With a standard connection to a baseboard (no power supply used to provide USB power to the connector), the device will operate in Device Mode. Using the USB_OTG_CPEN signal on JX3 allows you to control an external power source for USB VBUS on the carrier board. Other considerations need to be made to accommodate Host Mode. Refer to the Avnet PicoZed SDR FMC Carrier Card design for an example design for configuring the carrier card for either Host Mode or Device Mode.

Table 6 - USB Host Pin Assignment and Definitions

Signal Name	Description	Zynq Bank	MIO	SMSC 3320 Pin	SOM JX3 pins
Data[7:0]	USB Data lines	MIO Bank 1/501	28:39	Data[7:0]	N/A
REFCLOCK	USB Clock	MIO Bank 1/501		26	N/A
DIR	ULPI DIR output signal	MIO Bank 1/501		31	N/A
STP	ULPI STP input signal	MIO Bank 1/501		29	N/A
NXT	ULPI NXT output signal	MIO Bank 1/501		2	N/A
REFSEL[2:0]	USB Chip Select	N/C	N/C	8,11,14	N/A
DP	DP pin of USB Connector			18	67
DM	DM pin of USB Connector			19	69
ID	Identification pin of the USB connector			23	63
CPEN	5V external Vbus power switch	N/C	N/C	17	70
RESET_B	Reset	MIO Bank 0/500	7	27	N/A

3.6 10/100/1000 Ethernet PHY

The Zynq PS includes two 10/100/1000 hardened Ethernet MAC ports. PicoZed SDR implements one Zynq PS 10/100/1000 Ethernet port (Eth0) for network connection using a Marvell 88E1512 PHY. A unique MACID for this port is provided with each SOM as a printed label on the module. It must be manually entered in Linux or included in the boot files for Zynq. A second Ethernet interface can be implemented by using the spare user I/O available on PicoZed SDR.

The Marvell PHY operates at 1.8V. The PHY connects to Zynq PS MIO Bank 1/501 (1.8V) with an RGMII interface. The PHY reset connects to Zynq PS MIO[8] Bank 0/500.

The PicoZed SDR module does not include the RJ-45 interface. The signals are connected to the JX3 micro header receptacle. The intent is that the magnetics and RJ-45 jack are located on the carrier card. An example design enabling two Ethernet ports with RJ-45 connectors can be found in the Avnet PicoZed SDR FMC Carrier Card.

A high-level block diagram the 10/100/1000 Ethernet interface is shown in Figure 11.

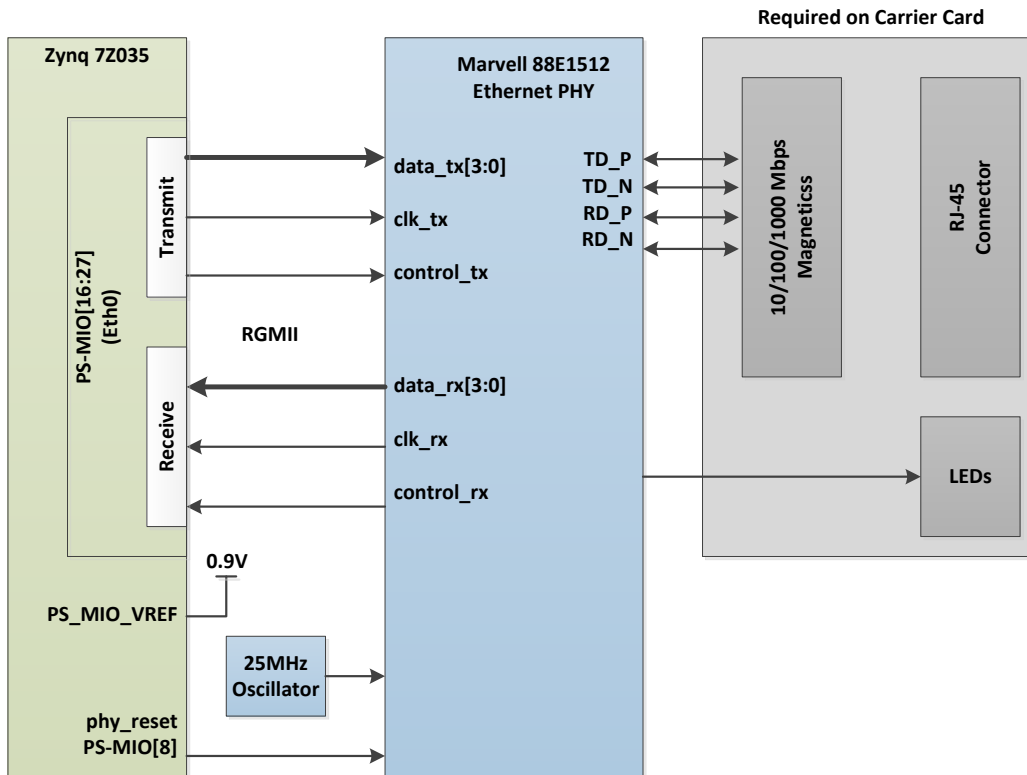

Figure 11 - 10/100/1000 Ethernet Interface

Zynq requires a voltage reference for RGMII interfaces. Thus PS_MIO_VREF, Zynq pin H18, is tied to 0.9V, half the bank voltage of MIO Bank 1/501. The 0.9V reference is generated through a resistor divide circuit. The 88E1512 also requires a 25 MHz input clock. A FOX ABM8G-25.000MHZ-18-D2Y-T crystal is used as this reference.

Table 7 - Zynq PS Ethernet PHY Pin Assignment and Definitions

Signal Name	Description	Zynq pin	MIO	Zynq Bank	88E1512 pin
RX_CLK	Receive Clock	G22	16:27	1 / 501	46
RX_CTRL	Receive Control	F18		1 / 501	43
RXD[3:0]	Receive Data	RXD0: F20		1 / 501	44
		RXD1: J19			45
		RXD2: F19			47
		RXD3: H17			48
TX_CLK	Transmit Clock	G21		1 / 501	53
TX_CTRL	Transmit Control	F22	1 / 501	56	
TXD[3:0]	Transmit Data	TXD0: G17	1 / 501	50	
		TXD1: G20		51	
		TXD2: G19		54	
		TXD3: H19		55	
MDIO	Management Data	A19	53	1 / 501	8
MDC	Management Clock	A20	52	1 / 501	7
ETH_RST_N	PHY Reset	A24	47	0 / 500	16

Note: The datasheet for the Marvell 88E1512 is not available publicly. An NDA is required for this information. Contact your local Avnet or Marvell representative for assistance.

3.7 User I/O

This section describes the various I/O available for use on the PicoZed SDR 2X2 SOM. Pin out details of the available I/O are included in Section 3.15 Expansion Headers.

PicoZed SDR 2X2 SOM features four 100-pin micro header receptacles (FCI, 61082-103400LF) for compact connection to carrier cards. The connector makes available 193 Zynq PL user SelectIO pins, 12 Zynq PS MIO pins, and 4 AD9361 GPO pins – a total of 209 available user I/O. In addition, four Zynq GTX gigabit serial transceiver ports are brought to the micro headers, each comprised of one TX and one RX lane and capable of speeds up to 6.6Gbps. Inputs for two GTX reference clocks are also available at the micro header. Finally, auxiliary data converters provide analog signal interface outside of the AD9361 primary RF path, as described in Section 3.8 User Auxiliary ADC and DAC Interfaces.

3.7.1 AD9361 User Pins

PicoZed SDR 2X2 provides access to four general purpose output pins GPO[3:0] from the AD9361. These pins are normally controlled by the AD9361 state machine, and can be linked to the TDD block (for controlling external Tx/Rx switches), or the AD9361 automatic gain control (ACG) block (for external LNA control), or optionally by registers, accessed through an SPI interface between the Zynq SoC and the AD9361.

The four AD9361 GPO signals are output only. The PicoZed SDR SOM sets the VDDA_GPO voltage level for these pins at 2.5V, but this can be overridden (voltage can be increased up to 3.3V) by placing a higher voltage on the VDDA_GPO_PWR pin on JX4.9

3.7.2 Zynq PS MIO User Pins

The Zynq Z-7035 SoC has 54 PS-MIO pins that connect to the Zynq Processor Sub-System (PS). PicoZed SDR makes 12 of these pins available as general purpose I/O while the remaining 42 are dedicated to peripheral and memory interfaces. Table 8 summarizes these signals.

The 12 available MIO pins can be used to implement of a variety of digital peripherals such as SPI, SDIO, CAN, UART, and I2C. These I/O pins can also be used as general purpose IO to connect push buttons, LEDs, and/or switches to the Zynq from the carrier card.

Note: The PS MIO banks are powered at 1.8V.

Table 8 - Zynq PS MIO Bank Summary

Interface	MIO Signals	Bank	Bank Voltage	Available Pins
Available User MIO	0,10-15	500	1.8V	7
	46-49, 51	501	1.8V	5
			Total	12
Interface	MIO Signals	Bank	Bank Voltage	Dedicated Pins
QSPI_0 FLASH	1-6, 8	500	1.8V	7
USB_0	7, 28-39	500/501	1.8V	13
ETHERNET_0	16-27, 47, 52-53	500/501	1.8V	15
SDIO_0	40-45, 50	501	1.8V	7
			Total	42

3.7.3 Zynq PL SelectIO User Pins

PicoZed SDR 2X2 provides 193 user SelectIO pins which connect to the Zynq Programmable Logic (PL). The voltage for these PL user I/O are set by the carrier card; supplied to the SOM through the JX micro header receptacles. This creates a highly flexible architecture for custom user functions and interfaces implemented in the Zynq Programmable Logic.

All Zynq SelectIO pins can be configured as either Input or Output with voltage signaling standards compliant with their bank voltage. The bank voltages must be delivered by the mating carrier card and within the ranges specified in

Table 9. Consult the Xilinx *7 Series FPGAs SelectIO Resources User Guide* ([UG471](#)) for information about supported I/O signaling standards.

The PL I/O pins are routed with matched lengths to each of the JX connectors. The matched pairs, denoted by an N/P suffix (e.g. IO_L01_13_JX2_P, IO_L01_13_JX2_N) may be used as either single ended I/O or differential pairs depending on the end user's design requirements.

Differential LVDS pairs on a -2L speed grade device are capable of DDR data rates up to 1250Mbps for High Range (HR) banks and 1400 Mbps for High Performance (HP) banks. Additionally, eight of these I/O can be connected as clock inputs (i.e., four MRCC and four SRCC inputs). Each Zynq PL bank can also be configured to be a memory interface with up to four dedicated DQS data strobes and data byte groups. One of the differential pairs (IO_L03_34_JX4_P) in Zynq Bank 34 (Zynq pin H9) is shared with the Zynq "PUDC_B" signal.

See Section [3.11.3 Zynq PROGRAM_B, DONE, PUDC_B, INIT_B Pins](#) for more information.

Table 9 - Zynq PL User I/O Bank Summary

Bank	Bank Voltage	Type	Available Pins	Available as LVDS pairs	Max DDR LVDS rate
12	Set by carrier (1.2 – 3.3V)	HR	50	24	1250 Mbps
13			48	23	
33	Set by carrier (1.2 – 1.8V)	HP	50	24	1400 Mbps
34			45	22	
	Total		193	94	

A detailed mapping of user I/O to the SOM micro header receptacle pins can be found in Section [3.15 Expansion Headers](#)

When using the PL I/O pins care must be taken to ensure that any external signal interface adheres to the respective Zynq PL bank voltages. The carrier card provides the I/O VCCO voltages for the banks shown in

Table 9. Therefore a custom carrier card can support mixed I/O voltage interfaces to the Zynq PL.

Note: The following are restrictions of the PicoZed SDR Zynq Z-7035 SelectIO banks:

- Banks 33 and 34 are high performance (HP) I/O with support for I/O voltage from 1.2 to 1.8V.
- Banks 12 and 13 are high range (HR) I/O with support for I/O voltage from 1.2V to 3.3V and Digitally Controlled Impedance (DCI).
- All 4 banks support LVDS.
- Consult the *Xilinx 7 Series FPGAs SelectIO Resources User Guide* ([UG471](#)) for more information.

It is recommended any custom interface is run through the Xilinx Vivado™ tool suite for a design rule check on place and route and timing closure in advance of end user carrier card manufacturing.

3.8 User Auxiliary ADC and DAC Interfaces

In addition to the data converters included inside of the AD9361 primary signal chain, PicoZed SDR provides access to auxiliary data converters in the AD9361 and Zynq SoC.

3.8.1 AD9361 Auxiliary ADC

The AD9361 contains an auxiliary ADC that can be used to monitor system functions such as temperature or power output. The converter is 12 bits wide and has an input range of 0.05 V to 1.25 V. When enabled, the ADC is free running. SPI reads provide the last value latched at the ADC output. A multiplexer in front of the ADC allows you to select between the AUXADC input pin and a built-in temperature sensor. Both the Linux IIO device driver for the AD9361 and the no-OS driver for the AD9361 expose the built-in temperature sensor and external ADC channel with easy to use entries in sysfs or standard APIs.

PicoZed SDR wires the AD9361 single-ended AUXADC pin to the JX micro header receptacle JX4-7.

3.8.2 AD9361 Auxiliary DACs

The AD9361 contains two identical auxiliary DACs that can provide power amplifier (PA) bias or other system functionality. The auxiliary DACs are 10 bits wide, have an output voltage range of 0.5 V to $V_{DD_GPO} - 0.3$ V, a current drive of 10 mA, and can be directly controlled by the internal enable state machine.

PicoZed SDR wires the AD9361 single-ended AUXDAC1 and AUXDAC2 pins to the JX micro header receptacle JX4-8 and JX4-10 respectively.

More information on the AD9361 auxiliary data converters can be found in Analog Devices document [UG570](#).

3.8.3 Zynq SoC ADC

The Zynq SoC includes the Xilinx Analog-to-Digital Converter (XADC) which contains two 12-bit 1MSPS ADCs with separate track and hold amplifiers, an on-chip analog multiplexer (up to 17 external analog input channels supported), and on-chip thermal and supply sensors. The two ADCs can be configured to simultaneously sample two external-input analog channels. The track and hold amplifiers support a range of analog input signal types, including unipolar, bipolar, and differential. The analog inputs can support signal bandwidths of at least 500 KHz at sample rates of 1MSPS. More information on the XADC can be found in Xilinx document [UG480](#).

PicoZed SDR provides access to the primary XADC differential analog input on Zynq pins VP_0/VN_0, sampled by Zynq ADC_A. The differential pins are wired to PicoZed SDR JX micro header receptacle pins JX3-1 (V_0_P) and JX3-3 (V_0_N).

A Zynq internal multiplexer allows sampling of the following:

- External analog signals at VP_0/VN_0 pins
- Internal die temp sensor
- External thermal diode connected to DXP_0/DXN_0 (SOM pin JX1-98, JX1-100)

3.9 Zynq Multi-Gigabit Transceivers (MGTs)

PicoZed SDR 2X2 enables four of the eight gigabit full-duplex GTX transceiver lanes that reside on Bank 111 (SOM Rev A-C) or Bank 112 (SOM Rev D and beyond) of the Zynq XC7Z035-L2 FBG676I device. These high speed transceivers can be used to interface to multiple high speed interface protocols such as PCI Express, Ethernet, Serial ATA, and more.

The Xilinx XC7Z035-L2 FBG676I is enabled with GTX transceivers which are capable of a transceiver data rate up to 6.6 Gb/s.

Two differential MGT reference clock inputs are available for use with the GTX lanes. Either clock input can be used as the clock reference for any one of the GT lanes in the bank. This allows you to implement various protocols requiring different line rates. The SOM implements dc-blocking capacitors in series with these GTX reference clocks, but not on the data signals.

Gigabit transceiver lanes and their associated reference clocks are connected to the carrier board via the JX micro header receptacles. Table 10 shows the connections between the Zynq device and the JX micro header. Pin assignments can be found in Table 18 - JX1 Connections and Table 20 - JX 3 Connections.

Performance of the four GTX lanes implemented on PicoZed SDR was validated to run at the rated maximum rate of 6.6GB/s. Tests were performed by using the Xilinx Vivado™ serial I/O analyzer software with the Xilinx LogiCORE™ IP Integrated Bit Error Ratio Test (IBERT) core for 7 series FPGA GTX transceivers.

Table 10 - Zynq GTX Connector Assignments

GTX	JX connector
MGTREFCLK0_N/P	JX1
MGTXRX [3:1]_N/P	JX1
MGTXTX [3:1]_N/P	JX3
MGTREFCLK1_N/P	JX3

3.10 Clock sources

High performance RF designs require knowledge of the digital clocks in the system because they can impart unwanted spurs into the RF signal chain. This section details the clocks used on the PicoZed SDR 2X2 SOM and indicates which can be disabled in case of undesired spurs or to implement the lowest power design.

3.10.1 Zynq clocks

PicoZed SDR 2X2 connects a dedicated 33.3333 MHz clock source to the Zynq SoC Processor Subsystem (PS). An ABRACON ASDMB-33.333MHZ-LC-T with 40-ohm series termination is used. The Zynq PS infrastructure can generate up to four PLL-based clocks for the Zynq Programmable Logic (PL) system. The Zynq Z-7035 PL has eight clock management tiles (CMTs), each consisting of one mixed-mode clock manager (MMCM) and one phase-locked loop (PLL).

3.10.2 AD9361 clocks

The AD9361 operates using a reference clock that can be provided by two different sources. This reference clock is used to supply the synthesizer blocks that generate all data clocks, sample clocks, and local oscillators inside the device.

PicoZed SDR provides an on-board 40MHz crystal and an external clocking option by using an analog multiplexor (ADG772). The on-board 40MHz crystal is from Rakon (MFR part # 513371). If an external oscillator is used, the frequency can vary between 10 MHz and 80 MHz. The selection between the two clock sources is under control of a Zynq PL pin in Bank 34 (K11).

The ability to use an external clock source for the AD9361 enables multi-SOM synchronization when used in conjunction with the SYNC_IN signal connected to the Zynq SoC. See Section 3.14 Multi-SOM Synchronization.

Figure 12 provides detail of the clock architecture, signal names, and pin connections.

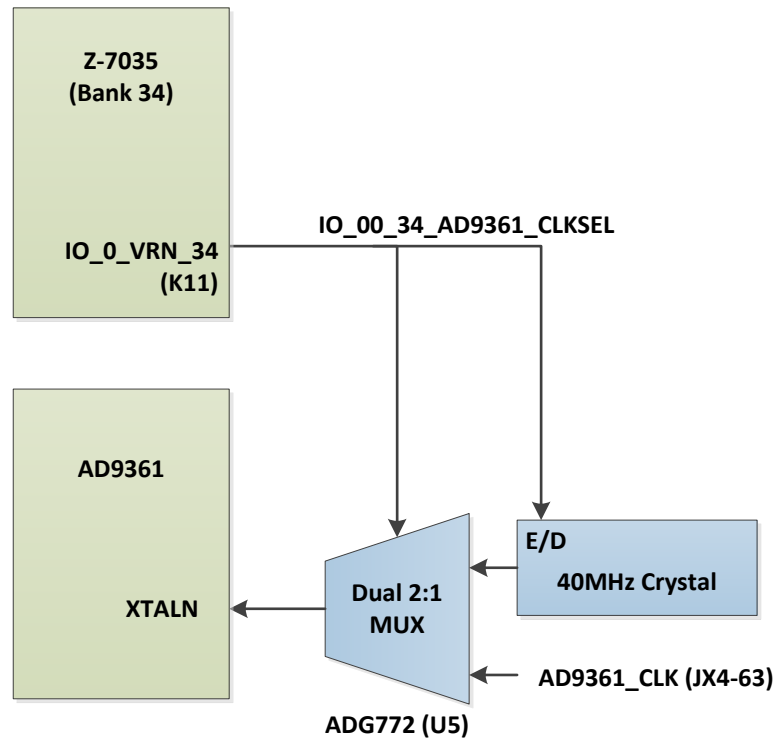

Figure 12 - AD9361 Clock Input Options

In addition to these clocks, the AD9361 creates an output data clock for the Zynq PL. For more information, see Section 0

AD9361/Zynq SoC Connection.

3.10.3 Ethernet Clock

The Marvell 88E1512 Ethernet PHY onboard PicoZed SDR 2X2 receives a 25 MHz input reference clock from a FOX ABM8G-25.000MHZ-18-D2Y-T crystal. This reference cannot be disabled.

The PHY RX_CLK may be disabled through the MDIO management interface. The PHY TX_CLK is supplied by the Zynq PS Ethernet controller and may be disabled in software.

See Section [3.6](#) 10/100/1000 Ethernet PHY for details and a diagram of the interface.

3.10.4 USB Clock

PicoZed SDR 2X2 uses the Microchip USB3320 Transceiver. The device receives a 24.00MHz clock from a CMOS oscillator which may be powered down with the `PS_MIO09_500_USB_CLK_PD` signal, controlled by software on the Zynq PS.

The USB3320 transceiver uses an internal PLL to generate a 60MHz clock for the ULPI interface to Zynq. If the 24MHz reference clock is stopped while 60MHz CLKOUT is running, the PLL will come out of lock and the frequency of the CLKOUT signal will decrease to the minimum allowed by the PLL design. This may cause the USB session to drop. Alternatively, the link controller (Zynq PS) can send a command to enter low power mode thereby disabling the USB3320 60MHz CLKOUT signal.

3.10.5 SDIO Clock

The Zynq SoC provides an SDIO clock for the SD card interface. The SDIO clock frequency and output buffer can be controlled by software using the Zynq PS MIO registers. Consult the Xilinx Zynq-7000 Technical Resource Manual ([UG585](#)) for more information.

3.11 Reset Sources

3.11.1 AD9361 Reset

The AD9361 has a single asynchronous reset pin (RESETB) that is connected directly to the Zynq SoC on Bank 35 – pin H16. Asserting this signal to logic low resets the device and triggers the automatic initialization calibrations. This is managed by the AD9361 device driver, and should **not** be managed by the end user.

3.11.2 Zynq Power-on Reset (PS_POR_B)

The Zynq PS supports an external power-on reset signal. The power-on reset is the master reset of the entire chip. This signal resets every register in the device capable of being reset. On PicoZed SDR, this pin is connected to the power-good output of the final stage of the power regulation circuitry (PWR_GD_1.35V) which holds the Zynq PS_POR_B signal low until the output voltage is valid. In addition, a push button switch (SW1) is connected to PS_POR_B and GND to allow a manual hard reset of the Zynq device.

3.11.3 Zynq PROGRAM_B, DONE, PUDC_B, INIT_B Pins

The Zynq SoC includes several signals related to power up, programming, and reset. This section explains how these signals have been implemented on PicoZed SDR 2X2. Consult Xilinx [UG585](#) for an explanation of these signals.

Table 11 - Zynq Power Up / Reset Signals

Zynq Signal	Description	PicoZed SDR	User Access
INIT_B	Zynq open-drain I/O used to indicate when the PL is initializing or when a configuration error has occurred	Wired to 3.3V with a 4.7kΩ resistor and accessible as a user signal	JX2-9
PROGRAM_B	Zynq input used to reset the PL	Wired to 3.3V with a 4.7kΩ resistor and not accessible as a user signal	N/A
DONE	Zynq drives the DONE signal Low until the PL is successfully configured	Wired to a green LED (D4) turns OFF when the PL is successfully configured. DO NOT LOAD SIGNAL	JX1-8
PUDC_B	Zynq pin controls the state of all Zynq PL SelectIO pins during power up	1kΩ pull-down resistor and the accessible as user I/O. During power up and configuration the Zynq PL SelectIO pins will have internal pull-up resistors enabled until the device comes out of power-on reset (POR)	JX4-25

The Zynq SoC provides a DONE signal to indicate when the PL has been successfully programmed. PicoZed SDR 2X2 uses this signal to control an LED on the SOM. The green LED D4 turns on when the SOM is powered and turns off when the Zynq PL is successfully configured. The signal is routed to the micro header receptacle JX1-8 (FPGA_DONE) for connection to the carrier card if needed for any additional startup logic.

Important! Do not load the FPGA_DONE signal on your carrier. It is sampled internally by the Zynq device. Loading the signal may delay the signal rise/fall times and cause errors during startup.

When mating the SOM to the Avnet PicoZed SDR FMC Carrier Card, a blue LED labeled “CFG DONE” will illuminate when configuration is complete.

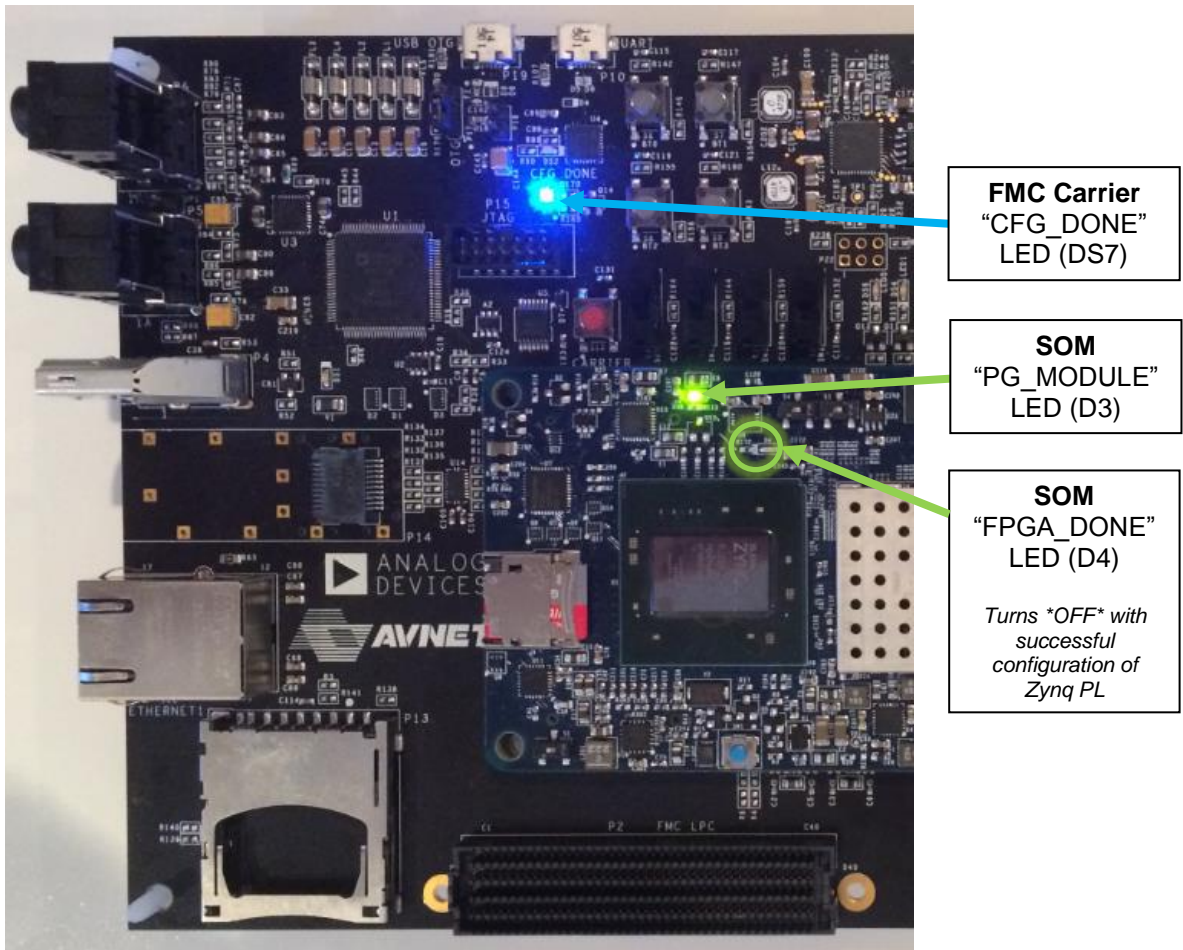

Figure 13 - System Ready LEDs

3.11.4 Zynq Processor Subsystem Reset

System reset, labeled PS_SRST_B, resets the processor as well as erases all debug configurations. This external system reset allows you to reset all the functional logic within the device without disturbing the debug environment. For example, the previous break points you set remain valid after system reset. While PS_SRST_B is held Low, all PS I/Os are held in 3-state.

Due to security concerns, system reset erases all memory content within the PS, including the OCM. The PL is also reset in system reset. System reset does not re-sample the boot mode strapping pins.

This active-low signal can be asserted via the carrier card through the micro header interface at JX1-6. If it is not used on a carrier card, this signal should be tied high.

Note: This signal cannot be asserted while the boot ROM is executing following a POR reset. If PS_SRST_B is asserted while the boot ROM is running through a POR reset sequence it will trigger a lock-down event preventing the boot ROM from completing. To recover from lockdown the device either needs to be power cycled or PS_POR_B needs to be asserted.

3.12 Configuration Modes

The Zynq-7000 AP SoC has seven boot mode strapping pins that are hardware programmed on the SOM using MIO pins [8:2]. They are sampled by the hardware soon after PS_POR_B deasserts and their values are written to software readable registers for use by the Boot ROM and user software.

Zynq-7000 AP SoC devices use a multi-stage boot process that supports both non-secure and secure boot. The Zynq PS is the master of the boot and configuration process. Upon reset, MIO[5:3] pins are read to determine the primary boot device to be used: NOR, NAND, Quad-SPI, SD Card, or JTAG. PicoZed SDR 2X2 enables three of those boot devices: QSPI, SD Card, and JTAG. The SOM contains switches to easily switch settings.

The Zynq PS SD/SDIO peripheral is connected to an SDIO expander chip (U11), providing connectivity to the micro SD interface on the PicoZed SDR SOM or a carrier card through the bottom-side micro header receptacle (JX3). Zynq can boot from either SD interface. The selection is made with switch S1 on the SOM. Table 12 shows the available boot mode configuration setting using switches S1, S3 and S4 on the SOM.

Table 12 - Zynq Configuration Modes

BOOT MODE	S4 (MIO4)	S3 (MIO3)	S1
CASCADE JTAG	0	0	x
NAND (n/a)	0	1	x
QSPI	1	0	x
SD Card (SOM)	1	1	0
SD Card (Carrier)	1	1	1

Note: White dot on switch is logic 0

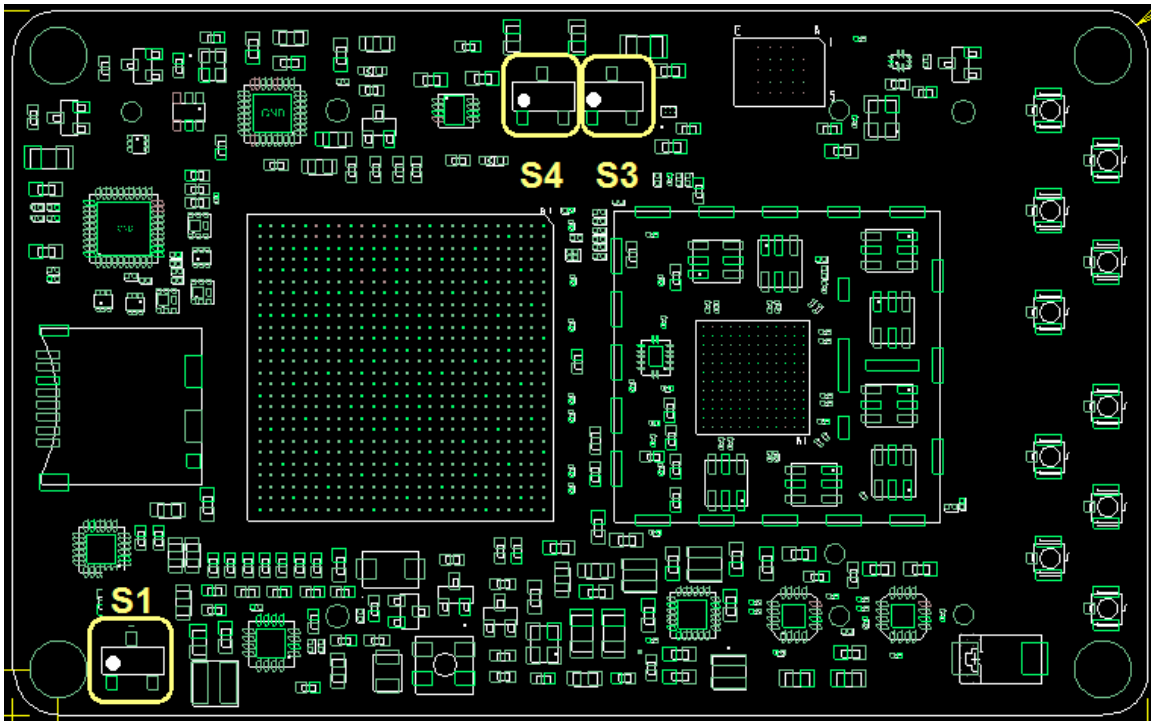

Figure 14 - Zynq Boot Switches

PicoZed SDR powers the Zynq Bank 0 V_{CC0_0} at 3.3V. The configuration voltage select pin (CFGBVS) is pulled high with a 4.7K Ω resistor to set the JTAG I/O in Bank 0 for 3.3V/2.5V.

For information on how configuration signals PROGRAM_B, INIT_B, FPGA_DONE, and PUDC_B are implemented on PicoZed SDR, see Section 3.11.3 Zynq PROGRAM_B, DONE, PUDC_B, INIT_B Pins.

The Zynq PS is responsible for reconfiguring the PL. Zynq will not automatically reconfigure the PL as in standard FPGAs by toggling PROG. Likewise, it is not possible to hold off Zynq boot up with INIT_B as this is now done with POR. If the application needs to reconfigure the PL, the software design must do this, or you can toggle PS_POR_B to restart everything.

3.12.1 JTAG Connections

PicoZed SDR 2X2 requires an external JTAG cable connector populated on the carrier card for JTAG operations. JTAG signals are routed from Bank 0 of the Zynq to the micro header receptacle JX1. Table 13 shows the JTAG signal connections between the Zynq and the micro header receptacle.

The Zynq Bank 0 reference voltage, V_{CC0_0} , is connected to 3.3V. The JTAG Vref on the End User Carrier Card should be connected to 3.3V to ensure compatibility between the interfaces. For reference, see the PicoZed SDR FMC Carrier Card schematics.

Table 13 - JTAG Pin Connections

SoC Pin #	PicoZed SDR Z7035/AD9316 Net	JX1 Pin #
W12	JTAG_TCK	1
W11	JTAG_TMS	2
W10	JTAG_TDO	3
V11	JTAG_TDI	4

3.13 RF Connections

The PicoZed SDR SOM connects four RX and four TX analog RF channels to the AD9361, plus two TX Monitor inputs. The TX/RX analog RF signals have series RF differential-to-single ended transformers from Mini Circuits (TCM1-63AX+). These are 50 Ω transformers featuring a wideband frequency range of 10MHz to 6.0GHz, enabling the full supported bandwidth of the AD9361. The single-ended signals are connected to U.FL miniature coaxial connectors. This creates a compact interface to external modules for amplification and antennae mating on a carrier card.

Important! Take care when plugging and unplugging cables from the U.FL connectors to avoid damaging the surface mount connectors on the SOM. U.FL connectors were designed to connect to cables, not PCBs. It is not recommended to attempt a direct PCB-to-PCB mount with male connectors.

Plug insertion and extraction tools are recommended. An example from Hirose is shown in Figure 15. Details can be found in the Hirose catalog and ordered at [Avnet Express](#).

◆ Plug Extraction Tool

This tool is used for extraction from a mating condition.



Note: Part No. U.FL-LP-N-2 for U.FL-LP-040/066/088.
Part No. U.FL-LP(V)-N-2 for U.FL-LP(V)-040/U.FL-LP-062.

◆ Plug Insertion Tool

This tool is for mating U.FL series plug into receptacle.

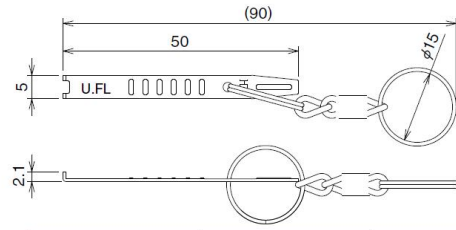

Part No.	HRS No.	RoHS
U.FL-LP-N-2	331-0494-5	○
U.FL-LP(V)-N-2	331-0493-2	

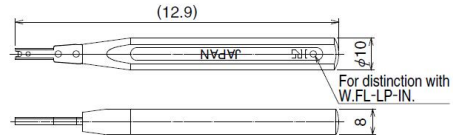

Part No.	HRS No.	RoHS
U.FL-LP-IN	331-0334-9	○

Figure 15 - U.FL Plug Tools (Hirose)

Sample transmit and receive circuits are shown in Figure 16 and Figure 17.

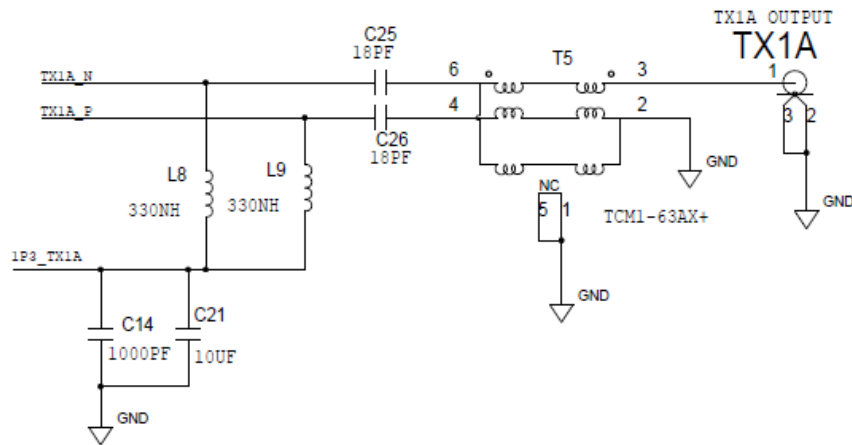

Figure 16 - RF TX Connection

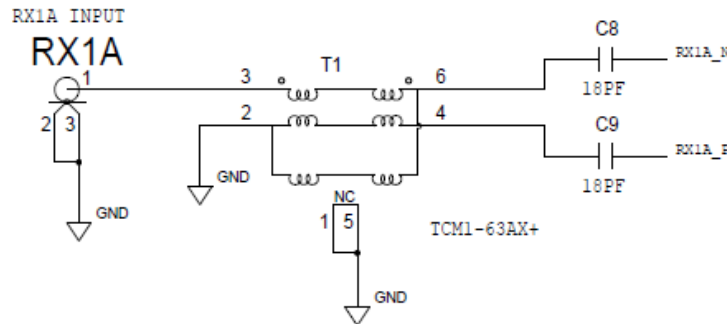

Figure 17 - RF RX Connection

These are designed for wide band (70 MHz to 6 GHz) operation, and it is expected that a small external filter may be required to attenuate undesired signals.

3.14 Multi-SOM Synchronization

For MIMO systems requiring more than two input or two output channels, multiple PicoZed SDR modules and a common reference oscillator are required. The common reference oscillator can be provided from a customer carrier card. In addition, a logic pulse must be delivered to all AD9361 SYNC_IN inputs to align each device's data clock with a common reference. On PicoZed SDR, the SYNC_IN signal is connected directly to the Zynq PL. Again, a customer carrier card could route this signal to additional PicoZed SDR SOMs through any available user I/O.

To learn more about the AD9361 synchronization mechanism, consult the AD9361 Reference Manual ([UG570](#)).

3.15 Expansion Headers

Important! PicoZed SDR is not pin compatible with standard PicoZed (non-SDR) carrier cards.

The following tables summarize bank and signal assignments on the JX connectors. Detailed pin assignments are listed later in this section. Some of the connector pins are used for various power and ground assignments, and some pins are reserved for dedicated peripheral functions such as the Gigabit Ethernet, USB2.0 OTG, and SDIO ports of the PicoZed SDR SOM.

3.15.1 Micro Header Pin Summary

All Zynq PS-MIO and PL SelectIO pins can be configured as either Input or Output with voltage signaling standards compliant with their bank voltage. The bank voltages must be delivered by the mating carrier card and within the ranges specified in the following tables. Consult the Xilinx 7 Series FPGAs SelectIO Resources User Guide ([UG471](#)) for information on supported I/O signaling standards.

The connectors are FCI 0.8mm Bergstak®, 100 Position, Dual Row, BTB Vertical Receptacles (part # 61082-103400LF). These have variable stack heights from 5mm to 16mm, making it easy to connect to a variety of carrier or system boards. Each pin can carry 500mA of current.

Table 14 - Micro Header JX1 Pin Summary

JX1 Pin Summary			
Signals	Source	I/O Voltage	Pins
Bank 33 User I/O	Zynq PL - Bank 33 (HP)	Set by carrier 1.2V to 1.8V	50 (24 LVDS pairs)
MGTREFCLK0_P/N	Zynq Bank 111/112 ²	Set by carrier	10
MGTRX_P/N[3:0]			
JTAG_TMS	Zynq Bank 0	3.3V	4
JTAG_TDI			
JTAG_TCK			
JTAG_TDO			
CARRIER_RESET (PS_SRST_B)	Zynq Bank 501	1.8V	1
FPGA_DONE	Zynq Bank 0	3.3V	1
FPGA_VBATT ⁽¹⁾	Carrier	See Zynq datasheet	1
PWR_ENABLE	Carrier	5.0V max	1
DXP_0	Zynq Bank 0	See Zynq datasheet	2
DXN_0			
JX_VIN	Carrier	5.0V	4
JX_VCCO_12	Carrier	1.2 to 3.3V	3
GND	Carrier	GND	23
Total			100

- (1) FPGA_VBATT (VCCBATT) is required only when using bitstream encryption. If battery is not used, connect VCCBATT to either ground or VCCAUX.
- (2) Rev C SOMs implement Zynq MGTs in Bank 111. Rev D and later SOMs use Bank 112.

Table 15 - Micro Header JX2 Pin Summary

JX2 Pin Summary			
Signals	Source	I/O Voltage	Pins
Bank 12 User I/O	Zynq PL - Bank 12 (HR)	Set by carrier 1.2V to 3.3V	14 (7 LVDS pairs)
Bank 13 User I/O	Zynq PL - Bank 13 (HR)	Set by carrier 1.2V to 3.3V	48 (23 LVDS pairs)
SCL ⁽¹⁾	Zynq PL – Bank 13 (HR)	Set by carrier 1.2V to 3.3V	2
SDA ⁽¹⁾			
INIT_B	Zynq Bank 0	3.3V	1
PG_MODULE	SOM	VIN	1
PG_1P8V	SOM	1.8V	1
JX_VIN	Carrier	5.0V	5
JX_VCCO_13	Carrier	1.2V to 3.3V	1
JX_VCCO_33_34	Carrier	1.2V to 1.8V	3
GND	Carrier	GND	23
Total			99

- (1) See Section 3.16.3 for information on using these I2C signals to program the SOM power sequencing devices.

Table 16 - Micro Header JX3 Pin Summary

JX3 Pin Summary			
Signals	Source	I/O Voltage	Pins
Bank 12 User I/O	Zynq PL – Bank 12 (HR)	Set by carrier 1.2V to 3.3V	32 (16 LVDS pairs)
MGTREFCLK1_P/N	Zynq Bank 111/112 ¹	Set by carrier	10
MGTTX_P/N[3:0]			
V0_N/P	Zynq Bank 0	See Zynq datasheet	2
SDIO_DATA_B1 [3:0]	Zynq PS – Bank 501	3.3V thru SDIO expander / translator	6
SDIO_CLKB1			
SDIO_CMDB1			
JX3_SD1_CDN	Zynq PS – Bank 501	1.8V thru Analog switch	1
ETH_PHY_LED [1:0]	Marvell 88E1512 PHY	Open drain circuit	2
ETHERNET MD [3:0]	Zynq PS – Bank 501 (via Ethernet PHY)	Set by SOM Ethernet PHY	8
USB_OTG_P/N	Zynq PS – Bank 501 (via USB PHY)	Set by SOM USB PHY	2
USB_ID	Carrier	0 to 3.3V	3
USB_VBUS_OTG	Carrier	5.0V	
USB_OTG_CPEN	SOM USB PHY	3.3V	
JX_VCCO_13	Carrier	1.2V to 3.3V	2
JX_MGTAVCC	Carrier	1.05V	4
JX_MGTAVTT	Carrier	1.2V	2
GND	Carrier	GND	26
Total			100

(1) Rev C SOMs implement Zynq MGTs in Bank 111. Rev D and later SOMs use Bank 112.

Table 17 - Micro Header JX4 Pin Summary

JX4 Pin Summary			
Signals	Source	I/O Voltage	Pins
Bank 12 User I/O	Zynq PL – Bank 12 (HR)	Set by carrier 1.2V to 3.3V	4 (1 LVDS pair)
Bank 34 User I/O	Zynq PL – Bank 34 (HP)	Set by carrier 1.2V to 1.8V	44 (22 LVDS pairs)
PUDC_B / User I/O ⁽¹⁾	Zynq PL – Bank 34 (HP)	Set by carrier 1.2V to 1.8V	1
AD9361 GPO [3:0]	AD9361	2.5V	4
AD9361 AUXADC	AD9361	See AD9361 datasheet	3
AD9361 AUXDAC [1:0]			
AD9361_CLK	AD9361	1.3Vp-p	1
PS_MIO [0,10:15]	Zynq PS – Bank 500	1.8V	7
PS_MIO [46:49, 51]	Zynq PS – Bank 501	1.8V	5
VDDA_GPO_PWR	AD9361	2.5V	1
GND	Carrier	GND	28
Total			98

- (1) PUDC_B is a configuration pin for Zynq PL SelectIO during power on. The SOM implements a 1kΩ pulldown on this signal to enable internal pull-up resistors on each SelectIO pin.

3.15.2 Micro Header Pin Detail

The section gives the detailed connection of all signals to the four micro header receptacle (JX) connector pins located on the bottom of the PicoZed SDR SOM. These connectors are used to connect the PicoZed SDR SOM to a carrier card. The carrier card powers the SOM and accesses all user I/O and dedicated peripherals through these micro headers located on the bottom of the SOM.

Important! PicoZed SDR is not pin compatible with standard PicoZed (non-SDR) carrier cards.

The PicoZed SDR product website has the following time saving resources.

- SOM schematic symbol
- Zynq master constraints file for Vivado Design Suite (XDC)

Important! The following tables are for reference. In case of discrepancies, use the software-generated files listed above.

The signals names in the table below use the following nomenclature:

- Zynq PL signals : **IO_L##_<BANK#>_JX#_<N/P>**
 - **IO** : Zynq Programmable Logic SelectIO input/output
 - **L##** : signal number within bank
 - **BANK#** : bank number
 - **JX#** : JX connector (1-4)
 - **N/P** : differential capable signal; otherwise single-ended
- Zynq PS signals: **PS_MIO##_<BANK #>_JX#**
 - **PS** : Zynq Processor Subsystem input/output
 - **MIO** : Zynq PS MIO assignment
 - **JX#** : JX connector (1-4)
- Other signals, such as USB_OTG_P, indicate connection to a dedicated peripheral interface on the SOM. In this case, a USB data signal that originates from the on-board USB2.0 PHY, which is controlled by the Zynq PS USB peripheral.

Table 18 - JX1 Connections

Zynq Bank	Zynq Pin #	PicoZed SDR 2X2 Net	JX1 Pin #	JX1 Pin #	PicoZed SDR 2X2 Net	Zynq Pin #	Zynq Bank
0	W12	JTAG_TCK	1	2	JTAG_TMS	W11	0
0	W10	JTAG_TDO	3	4	JTAG_TDI	V11	0
n/a	n/a	PWR_ENABLE ⁽¹⁾	5	6	CARRIER_RESET ⁽²⁾	A22	501
0	V15	FPGA_VBATT	7	8	FPGA_DONE	W9	0
33	L9	IO_00_33_JX1	9	10	IO_25_33_JX1	N8	33
33	M2	IO_L16_33_JX1_P	11	12	IO_L17_33_JX1_P	N4	33
33	L2	IO_L16_33_JX1_N	13	14	IO_L17_33_JX1_N	M4	33
		GND	15	16	GND		
33	N1	IO_L18_33_JX1_P	17	18	IO_L19_33_JX1_P	M7	33
33	M1	IO_L18_33_JX1_N	19	20	IO_L19_33_JX1_N	L7	33
		GND	21	22	GND		
33	K5	IO_L20_33_JX1_P	23	24	IO_L21_33_JX1_P	M8	33
33	J5	IO_L20_33_JX1_N	25	26	IO_L21_33_JX1_N	L8	33
		GND	27	28	GND		
33	K6	IO_L22_33_JX1_P	29	30	IO_L23_33_JX1_P	N7	33
33	J6	IO_L22_33_JX1_N	31	32	IO_L23_33_JX1_N	N6	33
		GND	33	34	GND		
33	G4	IO_L01_33_JX1_P	35	36	IO_L24_33_JX1_P	K8	33
33	F4	IO_L01_33_JX1_N	37	38	IO_L24_33_JX1_N	K7	33
		GND	39	40	GND		
33	D4	IO_L02_33_JX1_P	41	42	IO_L03_33_JX1_P	G2	33
33	D3	IO_L02_33_JX1_N	43	44	IO_L03_33_JX1_N	F2	33
		GND	45	46	GND		
33	D1	IO_L04_33_JX1_P	47	48	IO_L14_SRCC_33_JX1_P	L5	33
33	C1	IO_L04_33_JX1_N	49	50	IO_L14_SRCC_33_JX1_N	L4	33
		GND	51	52	GND		
33	N3	IO_L15_33_JX1_P	53	54	IO_L05_33_JX1_P	E2	33
33	N2	IO_L15_33_JX1_N	55	56	IO_L05_33_JX1_N	E1	33
n/a		JX_VIN	57	58	JX_VIN		n/a
n/a		JX_VIN	59	60	JX_VIN		n/a
33	F3	IO_L06_33_JX1_P	61	62	IO_L07_33_JX1_P	J1	33
33	E3	IO_L06_33_JX1_N	63	64	IO_L07_33_JX1_N	H1	33
		GND	65	66	GND		
33	H4	IO_L08_33_JX1_P	67	68	IO_L09_33_JX1_P	K2	33
33	H3	IO_L08_33_JX1_N	69	70	IO_L09_33_JX1_N	K1	33
		GND	71	72	GND		
33	H2	IO_L10_33_JX1_P	73	74	IO_L11_SRCC_33_JX1_P	L3	33
33	G1	IO_L10_33_JX1_N	75	76	IO_L11_SRCC_33_JX1_N	K3	33
		GND	77	78	JX_VCCO_12		n/a
n/a		JX_VCCO_12	79	80	JX_VCCO_12		n/a
33	J4	IO_L12_MRCC_33_JX1_P	81	82	IO_L13_MRCC_33_JX1_P	M6	33
	J3	IO_L12_MRCC_33_JX1_N	83	84	IO_L13_MRCC_33_JX1_N	M5	33
		GND	85	86	GND		
111	W6	MGTREFCLK0_111_JX1_P ⁽³⁾	87	88	MGTXRX0_111_JX1_P	AD8	111
111	W5	MGTREFCLK0_111_JX1_N ⁽³⁾	89	90	MGTXRX0_111_JX1_N	AD7	111
111	AE6	MGTXRX1_111_JX1_P	91	92	MGTXRX2_111_JX1_P	AC6	111
111	AE5	MGTXRX1_111_JX1_N	93	94	MGTXRX2_111_JX1_N	AC5	111
		GND	95	96	GND		
111	AD4	MGTXRX3_111_JX1_P	97	98	DX_0_P	R14	0
111	AD3	MGTXRX3_111_JX1_N	99	100	DX_0_N	R13	0

(1) Has 10kΩ pull-up up resistor to VIN.

(2) Connected to Zynq PS-SRST# signal through MOSFET switch enabled by VCCPCOM-1P8V.

(3) Connected to Zynq pin with series dc-blocking capacitor.

Table 19 - JX2 Connections

Zynq Bank	Zynq Pin #	PicoZed SDR 2X2 Net	JX2 Pin #	JX2 Pin #	PicoZed SDR 2X2 Net	Zynq Pin #	Zynq Bank
13	AA25	IO_L01_13_JX2_P	1	2	IO_L02_13_JX2_P	AB26	13
13	AB25	IO_L01_13_JX2_N	3	4	IO_L02_13_JX2_N	AC26	13
13	AE25	IO_L03_13_JX2_P	5	6	IO_L04_13_JX2_P	AD25	13
13	AE26	IO_L03_13_JX2_N	7	8	IO_L04_13_JX2_N	AD26	13
0		INIT_B_0_JX2_09	9	10	PG_1P8V	n/a	n/a
n/a	n/a	PG_MODULE ⁽¹⁾	11	12	JX_VIN		n/a
13	V19	IO_00_13_JX2	13	14	IO_25_13_JX2	V18	13
		GND	15	16	GND		
13	AF24	SCL	17	18	IO_L06_13_JX2_P	AA24	13
13	AF25	SDA	19	20	IO_L06_13_JX2_N	AB24	13
		GND	21	22	GND		
13	AE22	IO_L07_13_JX2_P	23	24	IO_L08_13_JX2_P	AE23	13
13	AF22	IO_L07_13_JX2_N	25	26	IO_L08_13_JX2_N	AF23	13
		GND	27	28	GND		
13	AB21	IO_L09_13_JX2_P	29	30	IO_L10_13_JX2_P	AA22	13
13	AB22	IO_L09_13_JX2_N	31	32	IO_L10_13_JX2_N	AA23	13
		GND	33	34	GND		
13	AD23	IO_L11_SRCC_13_JX2_P	35	36	IO_L12_MRCC_13_JX2_P	AC23	13
13	AD24	IO_L11_SRCC_13_JX2_N	37	38	IO_L12_MRCC_13_JX2_N	AC24	13
		GND	39	40	GND		
13	AD20	IO_L13_MRCC_13_JX2_P	41	42	IO_L14_SRCC_13_JX2_P	AC21	13
13	AD21	IO_L13_MRCC_13_JX2_N	43	44	IO_L14_SRCC_13_JX2_N	AC22	13
		GND	45	46	GND		
13	AF19	IO_L15_13_JX2_P	47	48	IO_L16_13_JX2_P	AE20	13
13	AF20	IO_L15_13_JX2_N	49	50	IO_L16_13_JX2_N	AE21	13
		GND	51	52	GND		
13	AD18	IO_L17_13_JX2_P	53	54	IO_L18_13_JX2_P	AE8	13
13	AD19	IO_L17_13_JX2_N	55	56	IO_L18_13_JX2_N	AF18	13
n/a		JX_VIN	57	58	JX_VIN		n/a
n/a		JX_VIN	59	60	JX_VIN		n/a
13	W20	IO_L19_13_JX2_N	61	62	IO_L20_13_JX2_P	AA20	13
13	Y20	IO_L19_13_JX2_P	63	64	IO_L20_13_JX2_N	AB20	13
		GND	65	66	GND		
13	AC18	IO_L21_13_JX2_P	67	68	IO_L22_13_JX2_P	AA19	13
13	AC19	IO_L21_13_JX2_N	69	70	IO_L22_13_JX2_N	AB19	13
		GND	71	72	GND		
13	W18	IO_L23_13_JX2_P	73	74	IO_L24_13_JX2_P	Y18	13
13	W19	IO_L23_13_JX2_N	75	76	IO_L24_13_JX2_N	AA18	13
		GND	77	78	JX_VCCO_33_34		n/a
n/a		JX_VCCO_33_34	79	80	JX_VCCO_33_34		n/a
12	AE17	IO_L18_12_JX2_P	81	82	IO_L17_12_JX2_P	AE16	12
12	AF17	IO_L18_12_JX2_N	83	84	IO_L17_12_JX2_N	AE15	12
		GND	85	86	GND		
12	AB17	IO_L20_12_JX2_P	87	88	IO_L19_12_JX2_P	Y17	12
12	AB16	IO_L20_12_JX2_N	89	90	IO_L19_12_JX2_N	AA17	12
		GND	91	92	GND		
12	AC17	IO_L21_12_JX2_P	93	94	IO_L22_12_JX2_P	AA15	12
12	AC16	IO_L21_12_JX2_N	95	96	IO_L22_12_JX2_N	AA14	12
12	Y16	IO_L23_12_JX2_P	97	98	JX_VCCO_13		n/a
12	Y15	IO_L23_12_JX2_N	99	100	open		

(1) Has 10kΩ pull-up on resistor to VIN.

Table 20 - JX 3 Connections

Zynq Bank	Zynq Pin #	PicoZed SDR 2X2 Net	JX3 Pin #	JX3 Pin #	PicoZed SDR 2X2 Net	Zynq Pin #	Zynq Bank
0	N14	V_0_P	1	2	MGTREFCLK1_111_JX3_P ⁽¹⁾	AA6	111
0	P13	V_0_N	3	4	MGTREFCLK1_111_JX3_N ⁽¹⁾	AA5	111
n/a		JX_MGTAVCC	5	6	GND		
n/a		JX_MGTAVCC	7	8	MGTXTX0_111_JX3_P	AF8	111
n/a		JX_MGTAVCC	9	10	MGTXTX0_111_JX3_N	AF7	111
n/a		JX_MGTAVCC	11	12	GND		
111	AF4	MGTXTX1_111_JX3_P	13	14	MGTXTX2_111_JX3_P	AE2	111
111	AF3	MGTXTX1_111_JX3_N	15	16	MGTXTX2_111_JX3_N	AE1	111
		GND	17	18	GND		
111	AC2	MGTXTX3_111_JX3_P	19	20	IO_L01_12_JX3_P	Y12	12
111	AC1	MGTXTX3_111_JX3_N	21	22	IO_L01_12_JX3_N	Y11	12
		GND	23	24	GND		
12	AB12	IO_L02_12_JX3_P	25	26	IO_L03_12_JX3_P	Y10	12
12	AC11	IO_L02_12_JX3_N	27	28	IO_L03_12_JX3_N	AA10	12
		GND	29	30	JX_MGTAVTT		n/a
12	AB11	IO_L04_12_JX3_P	31	32	JX_MGTAVTT		n/a
12	AB10	IO_L04_12_JX3_N	33	34	SDIO_CMDB1	n/a	n/a
		GND	35	36	SDIO_DATB1	n/a	n/a
n/a	n/a	SDIO_DATB1	37	38	SDIO_DATB1	n/a	n/a
n/a	n/a	SDIO_DATB1	39	40	GND		
n/a	n/a	JX3_SD1_CDN	41	42	IO_L05_12_JX3_P	W13	12
n/a	n/a	SDIO_CLKB1	43	44	IO_L05_12_JX3_N	Y13	12
n/a		JX_VCCO_13	45	46	JX_VCCO_13		n/a
n/a	n/a	ETH_PHY_LED0	47	48	ETH_PHY_LED1	n/a	n/a
		GND	49	50	GND		
n/a	n/a	ETH_MD1_P	51	52	ETH_MD2_P	n/a	n/a
n/a	n/a	ETH_MD1_N	53	54	ETH_MD2_N	n/a	n/a
		GND	55	56	GND		
n/a	n/a	ETH_MD3_P	57	58	ETH_MD4_P	n/a	n/a
n/a	n/a	ETH_MD3_N	59	60	ETH_MD4_N	n/a	n/a
		GND	61	62	GND		
n/a	n/a	USB_ID	63	64	IO_L06_12_JX3_P	AA13	12
		GND	65	66	IO_L06_12_JX3_N	AA12	12
n/a	n/a	USB_OTG_P	67	68	USB_VBUS_OTG	n/a	n/a
n/a	n/a	USB_OTG_N	69	70	USB_OTG_CPEN	n/a	n/a
		GND	71	72	GND		
12	AE10	IO_L07_12_JX3_P	73	74	IO_L08_12_JX3_P	AE12	12
12	AD10	IO_L07_12_JX3_N	75	76	IO_L08_12_JX3_N	AF12	12
		GND	77	78	GND		
12	AE11	IO_L09_12_JX3_P	79	80	IO_L10_12_JX3_P	AE13	12
12	AF10	IO_L09_12_JX3_N	81	82	IO_L10_12_JX3_N	AF13	12
		GND	83	84	GND		
12	AC12	IO_L11_SRCC_12_JX3_P	85	86	IO_L12_MRCC_12_JX3_P	AC13	12
12	AD12	IO_L11_SRCC_12_JX3_N	87	88	IO_L12_MRCC_12_JX3_N	AD13	12
		GND	89	90	GND		
12	AC14	IO_L13_MRCC_12_JX3_P	91	92	IO_L14_SRCC_12_JX3_P	AB15	12
12	AD14	IO_L13_MRCC_12_JX3_N	93	94	IO_L14_SRCC_12_JX3_N	AB14	12
		GND	95	96	GND		
12	AD16	IO_L15_12_JX3_P	97	98	IO_L16_12_JX3_P	AF15	12
12	AD15	IO_L15_12_JX3_N	99	100	IO_L16_12_JX3_N	AF14	12

(1) Connected to Zynq pin with series dc-blocking capacitor.

Table 21 - JX4 Connections

Zynq Bank	Zynq Pin #	PicoZed SDR 2X2 Net	JX4 Pin #	JX4 Pin #	PicoZed SDR 2X2 Net	Zynq Pin #	Zynq Bank
n/a	n/a	GPO_0	1	2	GPO_1	n/a	n/a
n/a	n/a	GPO_2	3	4	GPO_3	n/a	n/a
		GND	5	6	GND		
n/a	n/a	AUXADC	7	8	AUXDAC1	n/a	n/a
n/a	n/a	VDDA_GPO_PWR	9	10	AUXDAC2	n/a	n/a
		GND	11	12	GND		
12	W16	IO_L24_12_JX4_P	13	14	IO_00_12_JX4	W14	12
12	W15	IO_L24_12_JX4_N	15	16	IO_25_12_JX4	W17	12
		GND	17	18	GND		
34	J11	IO_L01_34_JX4_P	19	20	IO_L02_34_JX4_P	G6	34
34	H11	IO_L01_34_JX4_N	21	22	IO_L02_34_JX4_N	G5	34
		GND	23	24	GND		
34	H9	IO_L03_34_JX4_P(PUDC_B)	25	26	IO_L04_34_JX4_P	H7	34
34	G9	IO_L03_34_JX4_N	27	28	IO_L04_34_JX4_N	H6	34
		GND	29	30	GND		
34	J10	IO_L05_34_JX4_P	31	32	IO_L06_34_JX4_P	J8	34
34	J9	IO_L05_34_JX4_N	33	34	IO_L06_34_JX4_N	H8	34
34	F5	IO_L07_34_JX4_P	35	36	IO_L08_34_JX4_P	D9	34
34	E5	IO_L07_34_JX4_N	37	38	IO_L08_34_JX4_N	D8	34
		GND	39	40	GND		
34	F9	IO_L09_34_JX4_P	41	42	IO_L10_34_JX4_P	E6	34
34	E8	IO_L09_34_JX4_N	43	44	IO_L10_34_JX4_N	D5	34
34	F8	IO_L11_SRCC_34_JX4_P	45	46	IO_L12_MRCC_34_JX4_P	G7	34
34	E7	IO_L11_SRCC_34_JX4_N	47	48	IO_L12_MRCC_34_JX4_N	F7	34
		GND	49	50	GND		
34	C8	IO_L13_MRCC_34_JX4_N	51	52	IO_L14_SRCC_34_JX4_P	D6	34
34	C7	IO_L13_MRCC_34_JX4_P	53	54	IO_L14_SRCC_34_JX4_N	C6	34
		GND	55	56	GND		
34	C9	IO_L15_34_JX4_P	57	58	IO_L16_34_JX4_P	B10	34
34	B9	IO_L15_34_JX4_N	59	60	IO_L16_34_JX4_N	A10	34
		GND	61	62	GND		
n/a	n/a	AD9361_CLK	63	64	IO_25_34_JX4	K10	34
		GND	65	66	GND		
34	A9	IO_L17_34_JX4_P	67	68	IO_L18_34_JX4_P	B7	34
34	A8	IO_L17_34_JX4_N	69	70	IO_L18_34_JX4_N	A7	34
		GND	71	72	GND		
34	C4	IO_L19_34_JX4_P	73	74	IO_L20_34_JX4_P	B5	34
34	C3	IO_L19_34_JX4_N	75	76	IO_L20_34_JX4_N	B4	34
34	B6	IO_L21_34_JX4_P	77	78	IO_L22_34_JX4_P	A4	34
34	A5	IO_L21_34_JX4_N	79	80	IO_L22_34_JX4_N	A3	34
n/a	n/a	3V3_I2C	81	82	<i>open</i>		
		GND	83	84	GND		
500	C24	PS_MIO15_500_JX4	85	86	PS_MIO12_500_JX4	A23	500
500	A25	PS_MIO10_500_JX4	87	88	PS_MIO11_500_JX4	B26	500
		GND	89	90	GND		
500	B25	PS_MIO13_500_JX4	91	92	PS_MIO46_501_JX4	E17	501
500	D23	PS_MIO14_500_JX4	93	94	PS_MIO47_501_JX4	B19	501
		GND	95	96	GND		
500	E26	PS_MIO00_500_JX4	97	98	PS_MIO49_501_JX4	A18	501
501	B21	PS_MIO48_501_JX4	99	100	PS_MIO51_501_JX4	B20	501

(1) On PicoZed SDR, the PUDC_B signal has a 1kΩ pull-down resistor. Therefore, during power-up and configuration the Zynq PL SelectIO pins will have internal pull-up resistors enabled until the device comes out of power-on reset (POR).

3.16 Power

The PicoZed SDR 2X2 SOM was designed to reduce power consumption at every angle. The major features of the power system are as follows:

- The -2LI Xilinx Z-7035 is a low-power, mid-speed grade device that offers 40% lower static power and 10% lower dynamic power than a standard -2I device. ([Reference](#)) See Section [3.16.4](#) for information about power estimation.
- Low power DDR3L Micron SDRAM provides 15% or more power savings over standard DDR3 devices. ([Reference](#))
- High efficiency voltage regulation with built-in sequencing and monitoring. See Sections [0](#) and [7.1.1](#).
- Voltage supplies for unused Zynq I/O banks may be powered down. See section [3.16 Power](#).
- The Zynq SoC and AD9361 subsystems may be powered down to reach maximum power savings for some use cases. See the device datasheets and product websites for guidance and tutorials.
- Peripheral clocks may be disabled to reduce power consumption. See Section [3.10](#).

The following sections provide guidance for powering the SOM.

3.16.1 Input Voltages

The PicoZed SDR 2X2 SOM is powered from the carrier card through micro headers JX1, JX2, and JX3. A user-programmable power sequencing device orchestrates power up and monitor of voltage rails (see section [3.16.3](#)).

The sequencer is programmed such that only a single 5.0V supply (VIN) is required to successfully power up the SOM. In addition, the sequencer monitors all Zynq SoC user bank voltage rails and will power down the SOM if an overvoltage condition is detected.

This scheme allows a carrier to provide voltage only to the banks that are being used, but ground the other unused bank rails. The programmable sequencer also makes it possible to create custom sequencing and monitoring schemes. See section [7.2 Updating the ADM1166 Sequencer Firmware](#).

For example, if you plan to use a Zynq High Range (HR) bank powered at 3.3V, you can modify the firmware to power down the SOM if the bank voltage deviates from a certain margin around the nominal 3.3V potential. This can help you protect your system from driving signals into an I/O bank when the voltage supply on your carrier has failed.

See Table 22 – Supply Voltage Requirements for a summary of acceptable ranges for banks that will be powered.

Table 22 – Supply Voltage Requirements

Voltage Input	Nominal (V)	Range (V)	SOM Pins	Notes
VIN ¹	5.0	4.500 – 5.500	JX1 [57:60] JX2 [12, 57:60]	Main SOM supply.
JX_VCCO_12	1.8 – 3.3	1.140 – 3.465	JX1 [78:80]	Zynq PL HR Bank 12 Optional (GND if unused)
JX_VCCO_13	1.8 – 3.3	1.140 – 3.465	JX2 [98] JX3 [45:46]	Zynq PL HR Bank 13 Optional (GND if unused)
JX_VCCO_33_34 ⁴	1.2 – 1.8	1.140 – 1.890	JX2 [78:80]	Zynq PL HP Banks 33/34 Optional (GND if unused)
JX_MGTAVTT ^{2,3,4}	1.2	1.171 – 1.230	JX3 [30, 32]	Zynq MGT Bank 111/112 Optional (GND if unused)
JX_MGTAVCC ^{2,3,4}	1.0	0.972 – 1.079	JX3 [5,7,9,11]	Zynq MGT Bank 111/112 Optional (GND if unused)
	1.05	0.972 – 1.079		For QPLL > 10.3123 GHz

- (1) VIN is the only required voltage, unused banks should be grounded on your carrier.
- (2) Xilinx recommends less 10mV peak-to-peak voltage from 10 kHz – 80 MHz on MGTAVTT and MGTAVCC supplies (Xilinx UG476). MGTAVCC power consumption can be reduced when the Zynq internal PLL is operated below 10.3123GHz.
- (3) Rev A-C SOMs implement Zynq MGTs in Bank 111. Rev D and later SOMs use Bank 112.
- (4) Deviation from the Zynq datasheet recommended range is a result of the ADM1166 ADC precision.

In addition, you can supply a higher voltage for the AD9361 GPO signals. By default the SOM regulates a 2.5V rail (VDDA_GPO) for these signals indirectly from the system 5.0V rail. However this can be overridden (voltage can be increased up to 3.3V) by placing a higher voltage on the VDDA_GPO_PWR pin (JX4.9). This is an optional input to the SOM from your carrier.

The SOM itself gates the input voltage rails in Table 22, placing them under control of its on-board sequencer. This makes it easy to design your carrier power supplies because the voltages may be applied to the SOM in any order.

3.16.2 Module Power Architecture

Eight regulators reside on the PicoZed SDR SOM that provide a variety of voltage rails required for the Zynq SoC, the AD9361, and their supporting circuitry. These regulators are powered from the end user carrier card through the VIN pins on the SOM Micro Headers – either by direct connection to VIN or derived by cascaded regulators on the SOM.

Figure 18 shows a simplified view of the overall power scheme, while Figure 19 summarizes the voltage regulation and connections.

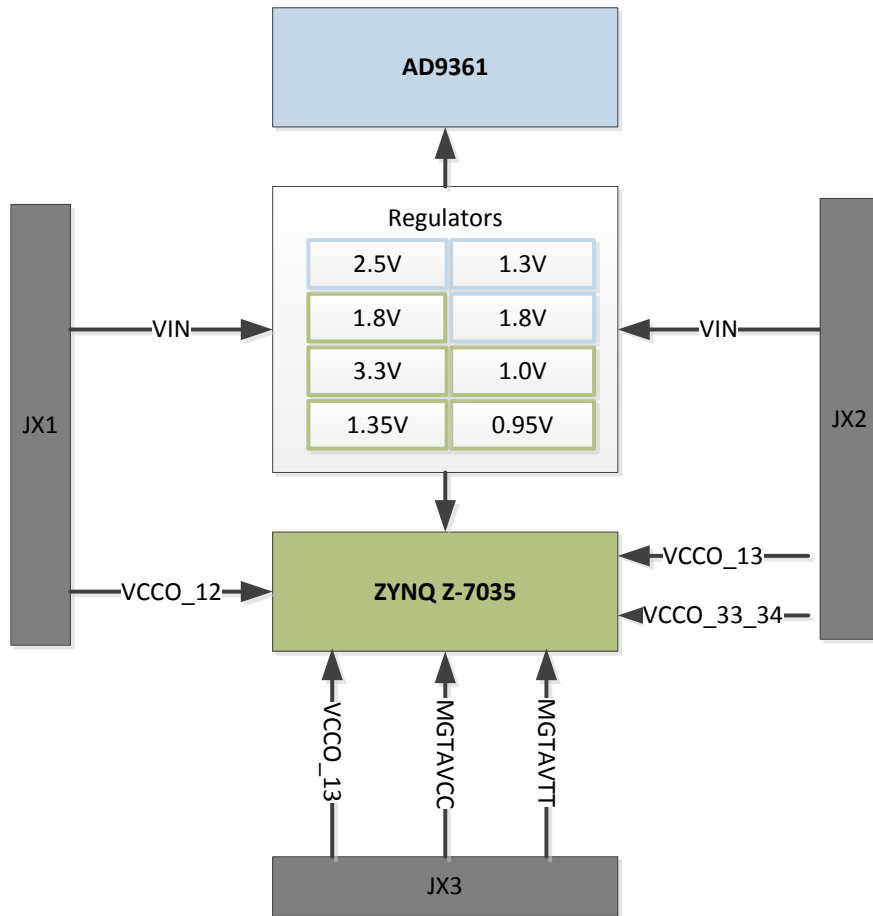

Figure 18 - Power Scheme

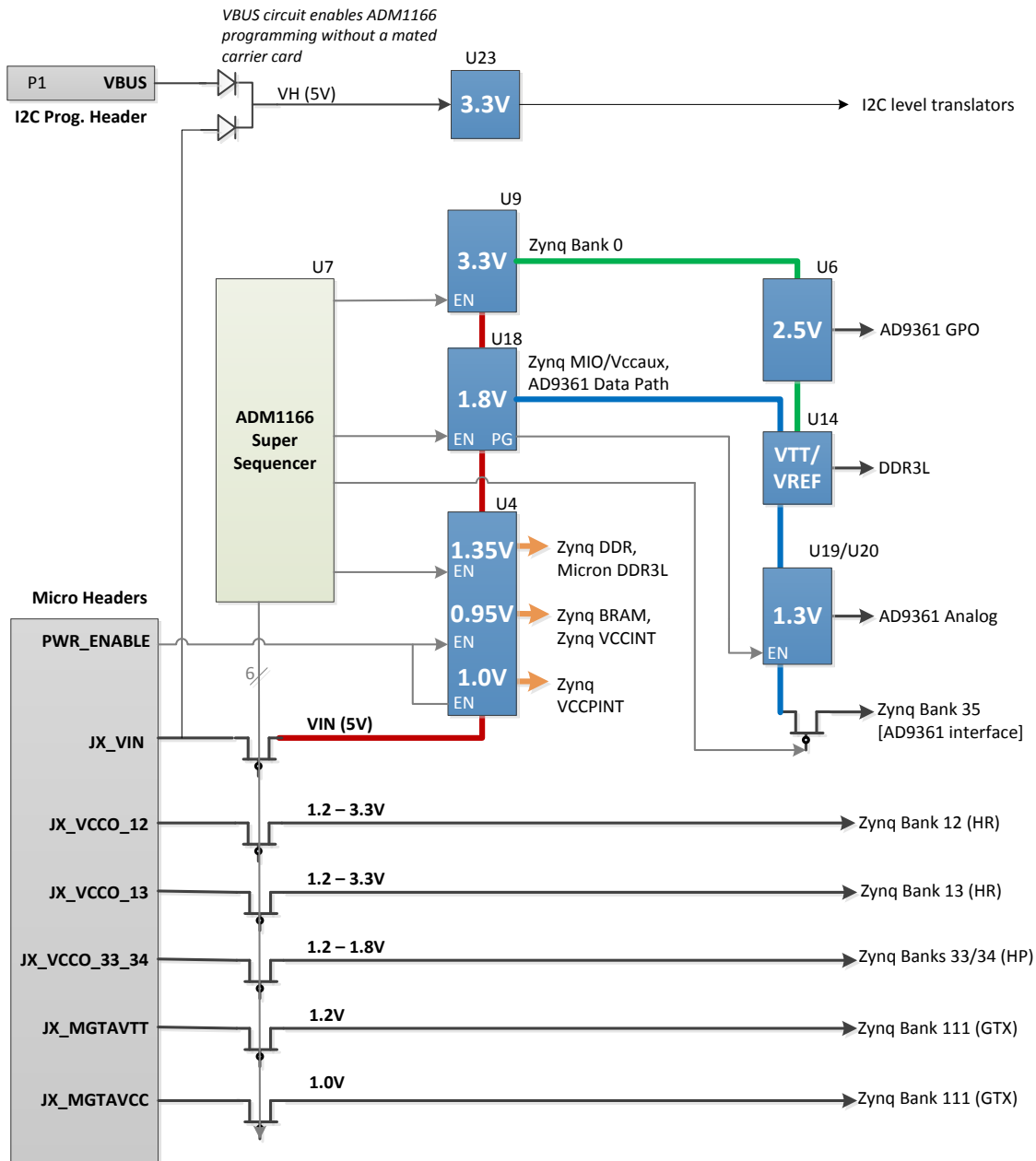

Figure 19 – SOM Voltage Regulation

3.16.3 Monitor and Sequencing

PicoZed SDR 2X2 uses the ADM1166 Super Sequencer (U7) to implement a complete supervisory and sequencing system to ensure all power rails are energized in the required order and maintain regulation. If the SOM detects any of its voltage rails are outside of normal regulation, it will disable all regulators to protect the module from damage.

This functionality is also valuable for designers needing built-in self-test (BIST) capabilities for the SOM once deployed in an end product. The system also makes available supply margining capabilities using the Analog Devices ADM1166. Margining can be useful for testing system regulation and for reducing voltage to certain components during low activity to reduce system power.

While the ADM1166 continuously monitors the critical SOM voltage rails, those not monitored directly by the ADM1166 are measured by an AD7291 ADC (U24). Both devices are connected via I2C to Zynq PL Bank 13 for monitor of all voltage rails with an embedded application. The I2C signals are also brought to the SOM JX micro headers for connection to a carrier card.

The ADM1166 non-volatile memory can be re-programmed. See Section 7.2 Updating the ADM1166 Sequencer Firmware for details.

Figure 20 provides a detailed timing diagram of the system voltage sequencing, but rest assured that the carrier may supply voltages to the SOM in any order.

Zynq Power Supply Sensors: The Zynq SoC on-chip XADC includes a temperature sensor and power supply sensors that capture the voltage level of VCCINT, VCCAUX, VCCBRAM, VCCPINT, VCCPAUX, and VCCO_DDR. These values are captured in registers that may be read by the Zynq ARM processors. Please see Xilinx UG480 for details.

Power Good Signal: The SOM provides a PG_MODULE signal to the JX micro headers for use on the carrier card to indicate when all of the SOM power supplies are on line. For example, this may be used to enable other power supply circuits on the carrier. The PG_MODULE signal has a 10kΩ pull-up to VIN on the SOM. When PG_MODULE is released by the ADM1166 (U7), a power good LED (D3) will illuminate on the SOM. See Figure 13 - System Ready LEDs.

Power Good LED: The SOM uses the PG_MODULE signal to illuminate a green LED (D3) to provide visual status information about the ADM1166 sequencer state machine. See Figure 13 - System Ready LEDs for help locating the Power Good LED. Table 23 provides descriptions of the various states.

Table 23 - Power Good LED Status

LED pattern	Description	Suggested Action
OFF	SOM is not powered	Supply system power to JX_VIN pins
ON Solid	SOM is powered and all voltage rails are within range	n/a
Blinking Slowly ⁽¹⁾	SOM system input voltage (JX_VIN) is out of range	Verify that system input voltage on JX_VIN is within range
Blinking Fast ⁽¹⁾	SOM powered successfully and later observed a voltage rail out of range	Power cycle the board to reset the ADM1166 state machine

(1) Feature included on Rev D and later

Note: The toggling feature for PG_MODULE was introduced with REV D modules. If the toggling behavior of PG_MODULE is undesirable in your system, the ADM1166 firmware may be modified to remove it. See Section 7.2 Updating the ADM1166 Sequencer Firmware.

Power Enable Signal: The carrier card can provide a PWR_ENABLE signal to the module (a so-called “C2M” signal). When the SOM observes that this signal is pulled low, the ADM1166 state machine will not enable any power supplies. Only VIN will be energized on the module, but no downstream regulators will be enabled until PWR_ENABLE is released. This signal has a 10kΩ pull-up to VIN on the SOM.

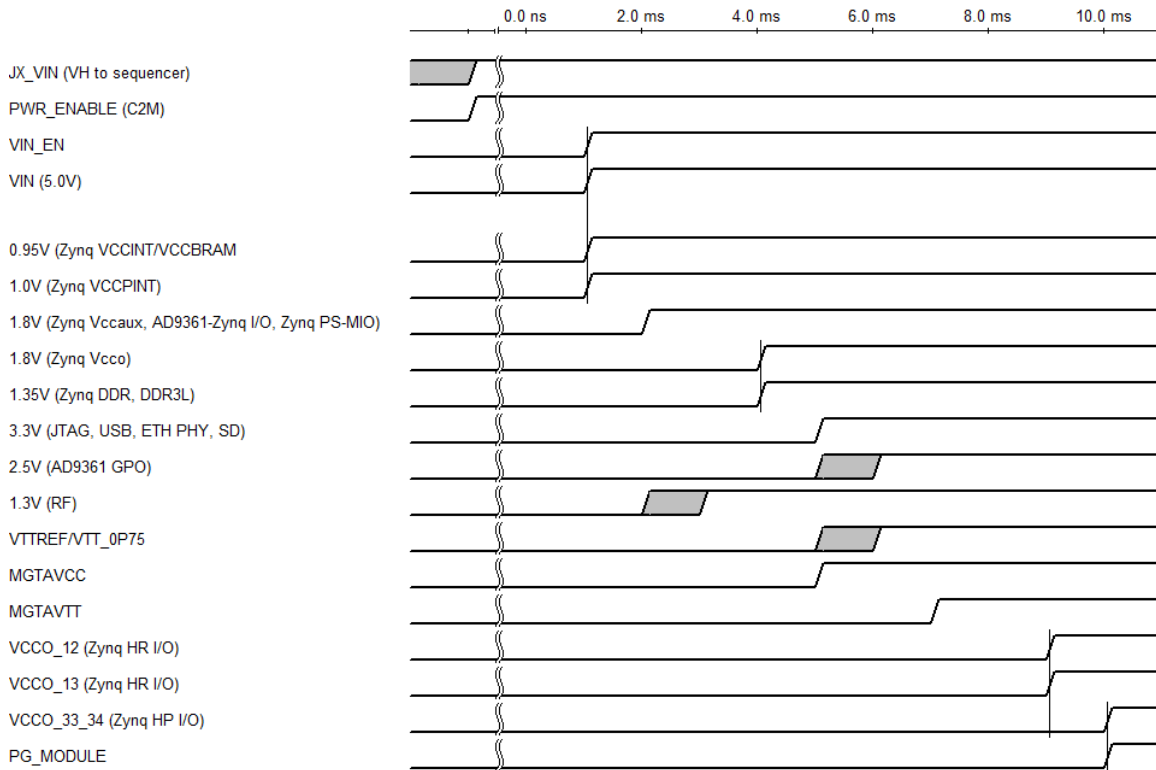

Figure 20 - Power Sequencing (Rev D firmware)

For a more detailed timing diagram, visit the [Analog Devices wiki site](#).

3.16.4 Power Estimation

The total power consumption of the PicoZed SDR 2X2 SOM depends on many factors, but not surprisingly the dependencies are mostly related to the way the Zynq SoC and AD9361 are programmed. The most difficult to predict is the Zynq SoC power consumption, which can vary widely depending upon the configuration of the Zynq PS and its peripherals, and the Zynq PL logic utilization and frequency of operation. Xilinx provides a suite of software tools and documentation to help you evaluate the thermal and power supply requirements of the entire Zynq SoC.

The **Xilinx Power Estimator (XPE)** is a spreadsheet-based tool that estimates the power consumption of your design. It accepts design information through simple design wizards, analyzes them, and provides a detailed power and thermal information. See Xilinx [UG440](#) for details and download the [XPE tool here](#).

The **Xilinx Vivado Design Suite power analysis** feature performs power estimation automatically based on your implemented design. In addition, it can use simulation results to more accurately estimate power based on your expected toggle rates. See Xilinx [UG907](#) and [UG997](#).

The SOM power system was designed to supply sufficient power to the Zynq Z-7035 SoC, the AD9361, and all on-board peripherals using demanding radio use case scenarios, including implementation of a full LTE Media Access Controller (MAC) in the Zynq PL. Of course, the carrier must supply VIN (5.0V) to power the SOM regulators, and therefore must be sized according to the demand of your design. The Zynq user bank I/O voltages are powered from the carrier, but only as needed by your design.

3.16.5 Battery Backup for Device Secure Boot Encryption Key

Zynq power rail V_{CCBATT} is a 1.0V to 1.89V voltage typically supplied by a battery. This supply is used to maintain an encryption key in battery-backed RAM for device secure boot. The encryption key can alternatively be stored in eFuse which does not require a battery.

As specified in the Zynq TRM, if the battery is not used, connect V_{CCBATT} to either ground or V_{CCAUX} . On PicoZed SDR 2X2 V_{CCBATT} is connected through a 0 Ω resistor (R9) to the PicoZed SDR V_{CCAUX} supply (VCCPCOM-1P8V), which is 1.8V. In parallel, the net FPGA_VBATT connects to the V_{CCBATT} pin and is extended to the JX1 micro header for connection on a carrier card.

Important! To apply an external V_{CCBATT} battery to Zynq from the end user carrier card, remove R9 from the PicoZed SDR System-On-Module.

4 Performance

4.1 Error Vector Magnitude (EVM)

This section reports the EVM results for PicoZed SDR 2X2 SOM. The general test setup is shown below. In this test, the block labeled “ADI Hardware System” represents the AD9361 on the SOM; the FPGA/SoC is the Zynq Z-7035 SoC on the SOM.

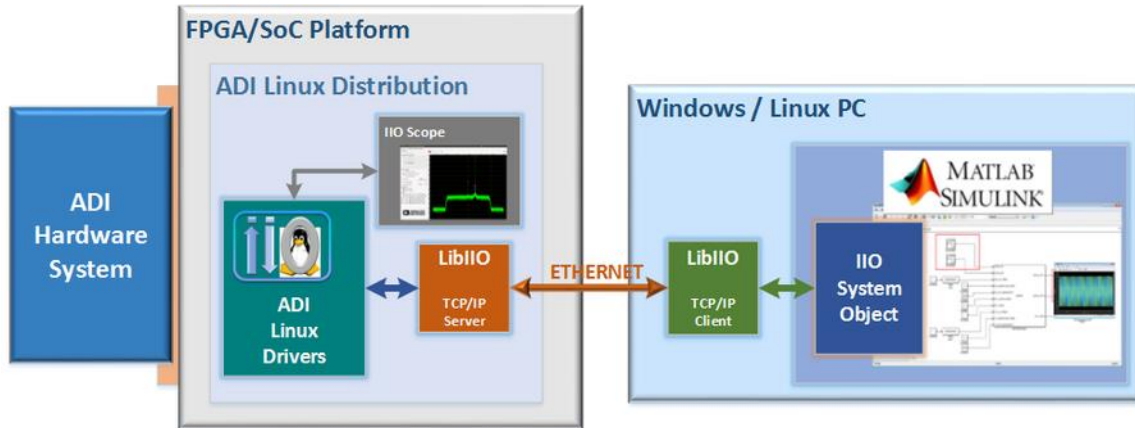

Figure 21 - IIO System Object

4.1.1 Tests Parameters

- LTE10 (64-QAM) waveform (I&Q) generated from the MathWorks LTE System Toolbox.
- This dataset is sent to the AD9361 via the Analog Devices IIO System Object in MATLAB and transmitted through the AD9361 TX signal chain, at various RF frequencies.
- The AD9361 TX is connected to the AD9361 RX with U.FL-to-U.FL loopback cables on the SOM.
- The AD9361 RX signal chain captures the AD9361 LTE 10 transmitted signal, and sends samples back to the IIO system object.
- The IIO System object sends the received I&Q waveforms to the LTE toolbox, where analysis is done.
- This analysis (EVM) is captured and stored, and the RF is changed, and the test continues.
- The tests were performed from 70MHz – 6 GHz in 100MHz steps.
- This test is nominal – test done at room temperature, in lab settings.

4.1.2 Results

All EVM measurements were under ~2.5%. This works out to about -32dB for the accumulation of RX and TX.

The AD9361 datasheet specs are ~ -37.782 dB for TX and -37.462 dB for RX (or about 1.4% each). It is an RMS sum, so we would expect about 1.86% (-34.6dB) based on the datasheet.

The datasheet uses narrowband baluns, and derives some gain from this. Since this test is using the wideband baluns on PicoZed SDR 2X2, that gain is not seen. Therefore we consider the SOM to perform close enough to the AD9361 datasheet, with a difference of 0.6%.

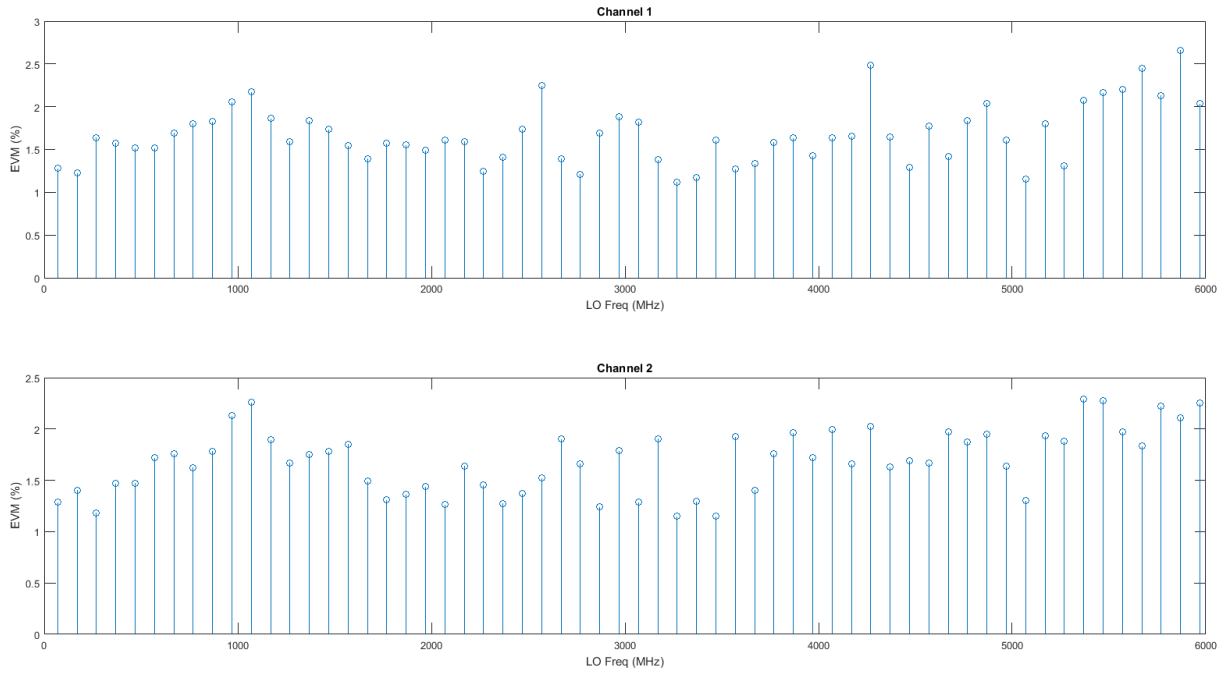

Figure 22 - EVM Results

4.2 Temperature

The PicoZed SDR 2X2 is rated for operation in the industrial temperature range. Please take care to respect the individual device maximum die temperatures over your operating range with your specific design running on the SOM.

Table 24 - Operating Temperature

Specification	Min	Max	Units
Industrial Temp ⁽¹⁾	-40	85	°C

(1) All devices on the SOM are rated for this temperature range, with the exception of the Micro SD card cage, which is rated for operation from -25°C to +85°C; with storage over the full range listed in the table. The SOM has been validated to work reliably over the full industrial temp range as reported in Section 0.

Both the Zynq SoC and the AD9361 have the ability to measure and report their internal die temperature using their built-in data converters. These can be used to monitor the real-time temperature of these devices and, when necessary, start a fan wired to the carrier. In addition, for further heat dissipation, a heat sink may be attached directly to the package of the Zynq SoC on the SOM itself.

4.2.1 Zynq Heat Sink

Selecting heat sinks for Xilinx All-Programmable FPGAs, 3G ICs, and SoCs depends upon many variables including chip size, device utilization, the ambient environment, and other criteria. Avnet and CTS® have created technical aids to ease this process of heat sink identification. For more information, visit Avnet's website [here](#).

PicoZed SDR 2X2 uses the Zynq XC7Z035-2LI device in the FBG676 package. The package outline measures 27 x 27 mm. See [Xilinx UG865](#) for information on package size, thermal resistance, and recommendations for safely attaching heat sinks.



Figure 23 - Zynq Fan/Heat Sinks

4.3 Shock, Vibration, and Thermal Tests

MIL-STD-202G Method 201A - Sinusoidal Vibration

Note: Sine Sweep: 10-55-10Hz Traversed in 1 minute; Amplitude: 0.03in (0.06in max total excursion); this motion shall be applied for a period of 2 hours in each of 3 mutually perpendicular directions.

Note: The test was performed with the unit electrically operating.

MIL-STD-202G Method 214A - Random Vibration

Note: Frequency Range: 50-2000Hz; Amplitude: 5.35g rms

Duration: 1.5 hours/Axis; 3 mutually perpendicular directions.

Note: The test was performed with the unit electrically operating.

MIL-STD-202G Method 213B - Shock

Note: Pulse Shape: Half-Sine; Amplitude: 20g half-sine, 11 msec

Note: 3 shocks positive, 3 shocks negative in 3 mutually perpendicular directions. (Total of 18 shocks)

5 Mechanical

PicoZed SDR 2X2 SOM uses a 20 layer PCB that measures 2.440" x 3.937" (62 mm x 100 mm). The 62mm x 100mm form factor is compatible with the DP10062 "Sick of Beige v1.0" specification from dangerousprototypes.com.

The MicroHeaders used on PicoZed SDR are FCI 0.8mm BergStak®100-position Dual Row, BTB Vertical Receptacles (61082-101400LF). These receptacles mate with any of the FCI 0.8mm BergStak® 100-position Dual Row BTB Vertical Plugs (61083-10x400LF) to provide variable stack heights of 5mm, 6mm, 7mm or 8mm. The SOM uses the FCI "receptacle" while carrier cards use the "plug". Both receptacle and plug include a PCB locator peg that can be used to design precisely mated SOM and carrier layouts.

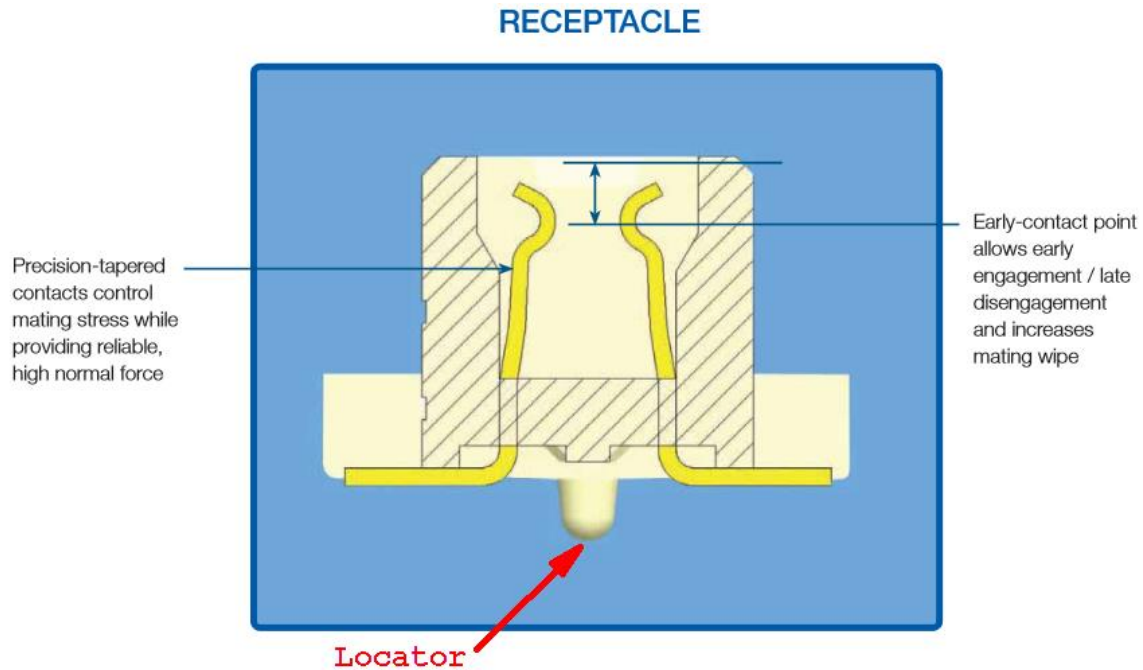

Figure 24 - FCI BergStak receptacle locator peg

More information about these connectors can be found [here](#).
Figure 25 can be downloaded from the PicoZed SDR documentation page in PDF and Cadence Allegro (.brd) formats (<http://picozed.org/support/documentation>).

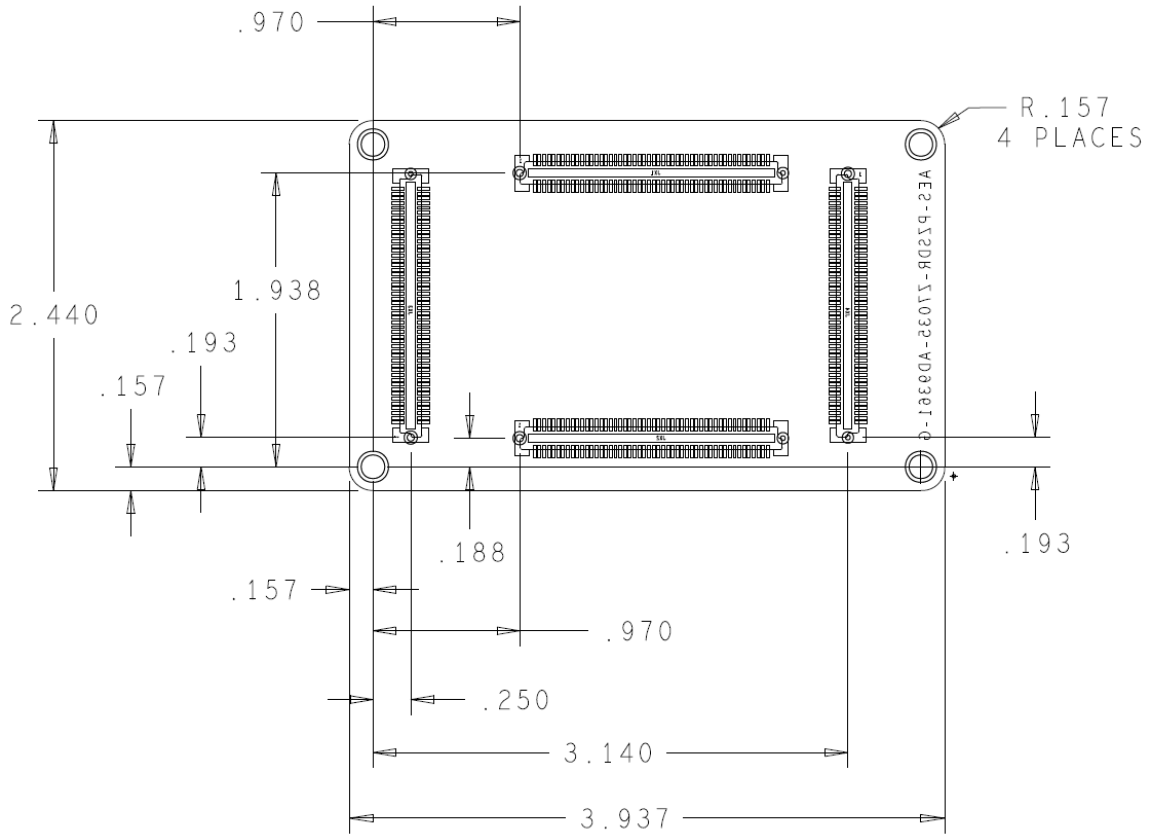

Figure 25 - Mechanical Dimensions

6 References

The following resources may be useful when designing with the PicoZed SDR module:

Analog Devices AD9361 RF Agile Transceiver™ Data Sheet

<http://www.analog.com/media/en/technical-documentation/data-sheets/AD9361.pdf>

Analog Devices AD9361 and AD9364 Integrated RF Agile Transceiver Design Resources (including AD9361 Reference Manual UG570)

<http://www.analog.com/en/design-center/landing-pages/001/ad9361-ad9364-integ-rf-agile-transceiver-design-res.html>

Xilinx Zynq-7000 All Programmable SoC Overview (DS190)

http://www.xilinx.com/support/documentation/data_sheets/ds190-Zynq-7000-Overview.pdf

Xilinx Zynq-7000 All Programmable SoC Technical Reference Manual (UG585)

http://www.xilinx.com/support/documentation/user_guides/ug585-Zynq-7000-TRM.pdf

Zynq-7000 All Programmable SoC (Z-7030, Z-7035, Z-7045, and Z-7100) : DC and AC Switching Characteristics

http://www.xilinx.com/support/documentation/data_sheets/ds191-XC7Z030-XC7Z045-data-sheet.pdf

Xilinx 7 Series FPGAs and Zynq-7000 All Programmable SoC XADC Dual 12-Bit 1 MSPS Analog-to-Digital Converter User Guide (UG480)

http://www.xilinx.com/support/documentation/user_guides/ug480_7Series_XADC.pdf

7 Additional Information

7.1 Additional Power Specs

Designers may find the following additional information valuable when considering a power scheme for the PicoZed SDR 2X2.

7.1.1 SOM Voltage Regulators and Rails

In addition to the voltages supplied to the SOM on the micro headers, the module uses the 5.0V VIN input to regulate a variety of other voltages required by the system, summarized in the following table.

Table 25 - Regulated Voltage Rails

Schematic Voltage Name	Voltage (V)	Schematic Symbol	Device	Max Output Current (A)	Notes
VCCINT-0P95V	0.95	U4	ADP5135	1.8	VCCINT
VCC-BRAM					VCCBRAM
VCCPINT	1.0			VCCPINT	
VCC-1P35	1.35			1.8	DDR3L
VCCO-DDR					Zynq DDR Bank 502
VTT_0P75					
VTTVREF	½ VCC-1P35	U14	TPS51206	2.0	DDR termination/reference
VCCPCOM-1P8V	1.8	U18	ADP2164	4.0	Zynq PL Bank 35, Vccaux
VCCO_1P8V					Zynq PS Bank 500/501,
VDD_INTERFACE					AD9361 Data Interface to Zynq
VDDA_GPO	2.5	U6	ADP7102	0.3	AD9361 General Purpose Outputs
VDDA_GPO_PWR					
VCC-3P3V	3.3	U9	ADP7104	0.5	Zynq Bank 0,
VCC-3P3V-IO					USB, SDIO
PHY1_VDD_3V3					Ethernet PHYs
PHY2_VDD_3V3					
1P3_SUPPLY_A	1.3	U19	ADP1754	1.2	AD9361 Analog Supplies
VDDA_TX_LO					
VDDA_RX_LO					
VDDA_TX_SYNTH					
VDDA_RX_SYNTH					
1P3_SUPPLY_B	1.3	U20	ADP1754	1.2	AD9361 Analog Supplies
VDDA_BB					
VDDA_DIG					
VDDA_RX_TX					
1P3_TX1A					
1P3_TX2A					
1P3_TX1B					
1P3_TX2B					

7.2 Updating the ADM1166 Sequencer Firmware

Your system requirements may call for alternate timing, sequencing, and/or monitoring of the SOM power supplies. The ADM1166 Super Sequencer firmware may be updated to accommodate these changes. Be advised that a number of factors must be considered, including:

- Resistor dividers (and their tolerances) at ADM1166 inputs
- ADM1166 programmable input ranges
- ADM1166 input impedance (voltage dependent)

Analog Devices provide an in depth analysis for calculating ADM1166 thresholds for PicoZed SDR on their wiki page – <https://wiki.analog.com/resources/eval/user-guides/pzsd/power-and-sequencing>

Designers are strongly encouraged to start with the latest ADM166.txt file ([on GitHub](#)) and make changes using the Analog Devices [Super Sequencer Configuration Tool](#). Consult the [Xilinx Zynq datasheet](#) before making any changes.

Important! Consult the Zynq AP SoC and AD9361 datasheets before updating threshold windows for SOM voltage rails. Sequencing changes are strongly discouraged.

Download the latest ADM1166 firmware repository from the GitHub link below. It's important to either clone or download the zip archive.

Clone or download ▾

<https://github.com/analogdevicesinc/PicoZed-SDR>.

Once you have made updates to the ADM1166 firmware file using the configuration tool, there are two methods for programming the device.

- Program the ADM1166 using the Zynq SoC to execute a Linux command line script (See the automated and manual update descriptions starting in section 7.2.1)
- Purchase a [USB-SDP-CABLEZ Serial I/O Interface](#) cable to program the SOM directly (See section 7.2.3 Standalone Programming with USB Adapter Standalone Programming with USB Adapter)

Also note that Avnet can provide SOM programming services for your custom ADM1166 firmware. Send an email to Avnet Engineering Services at customize@avnet.com for a quote.

7.2.1 Automated Update Procedure

Analog Devices provides a simple Linux script executed on Zynq to download the latest ADM1166 firmware and program the SOM. See Section 3.16.3 Monitor and Sequencing for more information about the ADM1166.

You will need a networked router with DHCP capability. Follow the instructions at the wiki site listed below. Look for the section “*Programming the ADM1166 Power Sequencer – Using Linux or HyperTerminal Program*”.

<https://wiki.analog.com/resources/eval/user-guides/pzsd/power-and-sequencing>

This method clones the Analog Devices GIT repository to obtain the latest version of the HEX file for the ADM1166. Note that you need to login as root or use the 'sudo' command to execute the update. The GitHub repository for these files is at the following URL.

<https://github.com/analogdevicesinc/PicoZed-SDR>

Alternatively, you may use the Manual Update Procedure.

7.2.2 Manual Update Procedure

This is an optional "manual" method to update the ADM1166 firmware, provided if you are unable to connect your development kit to a DHCP networked router.

This method can also be used to program your own custom ADM1166 firmware, however *consider whether your custom thresholds will be compatible with the carrier you are using during this process. Upon completion the board may shutdown.* The only way to recover from this situation is to use the USB adapter to program the SOM standalone. If this occurs, see section [7.2.3 Standalone Programming with USB Adapter](#).

7.2.3 Standalone Programming with USB Adapter

The ADM1166 Super Sequencer non-volatile memory can be programmed by connecting an Analog Devices [USB-SDP-CABLEZ](#) I2C/SMBus programmer to the SOM 5-pin P1 connector. Supplying 5.0V to VBUS pin P1-1 allows the device to be powered and programmed without mating the SOM to a carrier (see U23 in Figure 19). Software support for the programmer can be found on the [ADM1166 product page](#).



Figure 26 - USB-SDP-CABLEZ

Important! Damage may occur to the SOM if the ADM1166 sequencing state machine is reprogrammed without regard for the required sequencing of the system. Consult the Zynq-7000 SoC and Analog Devices AD9361 datasheets before modifying the sequencing scheme.

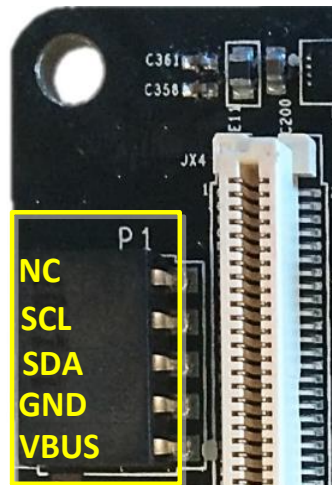

Figure 27 - ADM1166 Programming Port (P1)

Instructions for programming are on the Analog Devices wiki:
<https://wiki.analog.com/resources/eval/user-guides/pzsdr/power-and-sequencing>

Look for the section titled “Using the USB-SDP-CABLEZ Serial I/O Interface”.

7.3 USB Power

The PicoZed SDR 2X2 SOM cannot supply USB power. The USB PHY (U15) on the SOM includes a CPEN signal which is brought to a micro header pin for use as an enable for a USB 5V power supply on the carrier card.

7.4 XADC Power Configuration

The Zynq SoC's XADC component is powered from the filtered 1.8V VCCAUX supply (VCCPCOM-1P8V) utilizing the on-chip reference as shown below:

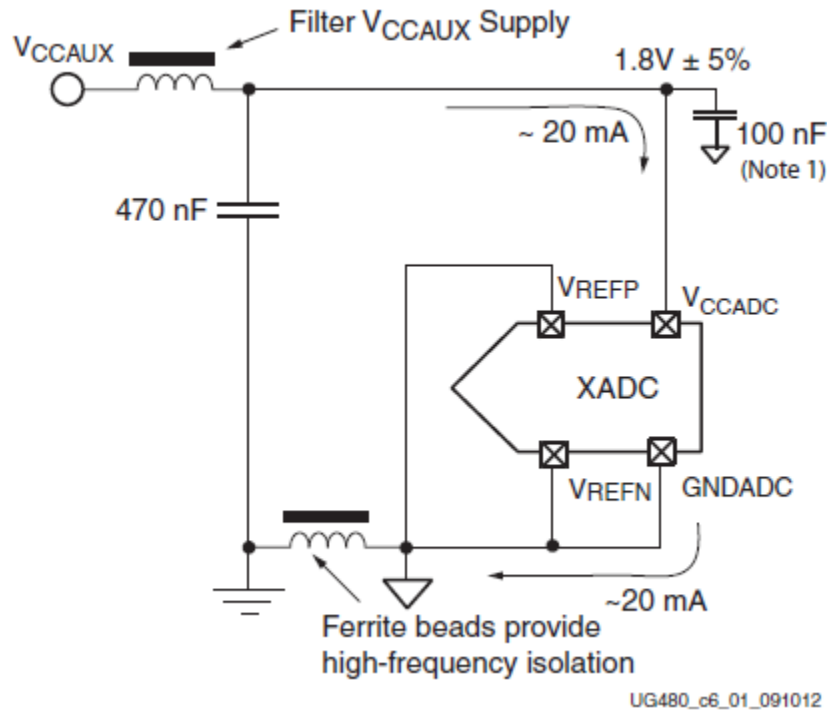

Figure 28 - XADC Power Configuration

7.5 Restoring the Analog Devices SD Card Image

During the course of development with the Analog Devices Linux reference design, should your 8 GB SD card become corrupted or otherwise need to be updated, the directions below will restore the system to the latest version. Instructions are provided for both Linux and Windows hosts.

- If you wish to completely overwrite the SD card, you may download the latest image https://wiki.analog.com/resources/tools-software/linux-software/zynq_images

Important! These steps will overwrite the contents of the SD card, so be certain there is no existing data that needs to be retrieved from the SD card prior to following these steps.

Requirements

- You need a Host PC (Windows or Linux).
- You need a SD card writer connected to above PC (Supported USB SD readers/writers are OK).
- USB keyboard/mouse for the Zynq Device
- HDMI Display (monitor or TV)

Download

The **BOLD** is what you should type. It's not too much more than w [Special Agent Oso's](#) three special steps, and it also allows you to go for that specialty coffee you have been craving.

For different platforms you'll need different images. Currently we provide a single pre-build images, that can work on all the platforms we support.



- **22 December 2015 release (2015_R1)**
- **Actual file**
- Checksum 2015_R1-2015_12_22.img.xz **a8f3ed68625043e180c95677123794bd**
- Checksum 2015_R1-2015_12_22.img **fd1e4154e59e7dc62e508a4cdc522db5**

Otherwise, you may simply run the update scripts at the command line of PicoZed SDR:
https://wiki.analog.com/resources/tools-software/linux-software/zynq_images#staying_up_to_date

As a final step, make sure to copy the contents of the 'zynq-picozed-sdr2' folder to the BOOT partition of the SD card. PicoZed SDR is now fully updated and ready to re-boot.

7.6 Board Revisions

7.6.1 Rev A

Description – Internal only. None released.

Identification – REV A printed in copper.

7.6.2 Rev B

Description – First hardware shipped to customers.

Identification – Sticker printed with **RFSOM REV B** located on the bottom side just above the copper etch AES-PZSDR-Z7035-AD9361-G.

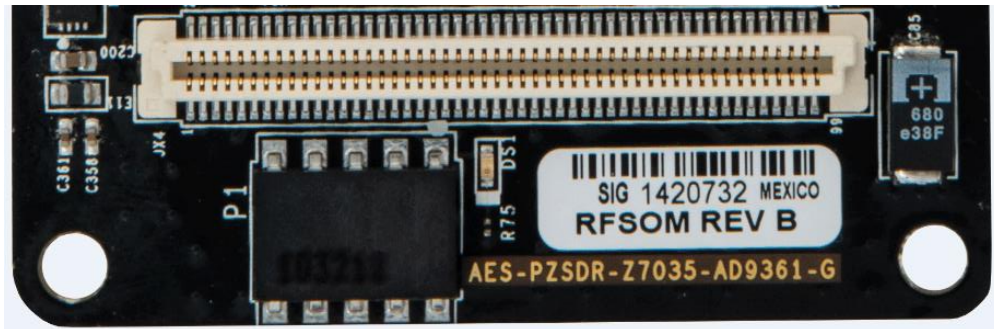

Figure 29 - Rev B SOM Label

7.6.3 Rev C

Description – Small updates. Functionally is equivalent to Rev B (see list of changes below).

Identification – Initial builds used a sticker printed with an **Sxx-xxxx** designator and an enumerated **SN:xxxxxxx** serial number, but no revision printed. Subsequent builds add a **REVC** revision text to the label.

Changes from Rev B to Rev C

1. Replaced on the schematic the Y1 crystal with equivalent part and added a pull-up and pull-down.
2. Replaced the 2 pin Ethernet Phy crystal (Y2) with a 4 pin.
3. Improved PCB layout of address lines between the FPGA and two DDR3 memory chips.
4. Replaced the six pin BGA (U23) ADP7112-3.3 with ADP7118 sot-23.
5. Pull up/down resistors (R26, R37) are now DNP.
6. 50 ohm series (R60) is now 0ohm.

7.6.4 Rev D

Description – Moved GTX ports from Bank 111 to Bank 112 on the Zynq SoC, and modified the control for PG_MODULE. Otherwise, functionally is equivalent to Rev B and Rev C (see list of changes below).

Identification – Sticker printed with an **Sxx-xxxx** designator, an enumerated **SN:xxxxxxx** serial number, board part number, and revision **REVD**.

Changes from Rev C to Rev D

1. Moved all (4) GTX ports from Bank 111 to Bank 112 on the Zynq SoC in order to be in compliance with Xilinx recommended PCIe design rules. The GTX signal assignments at the JX micro headers were unchanged in order to maintain compatibility with existing carrier boards.
2. Added revision and part number to the silkscreen and copper.
3. The LED (D3), used to illuminate when PG_MODULE is asserted, now has its anode connected to the 3V3_I2C supply (formerly connected to 3.3V supply). This was done to allow the LED to be used as a visual state indicator during SOM power up, reflecting different states of the ADM1166 sequencer. In addition, the ADM1166 firmware was updated to include LED toggling (slow/fast), corresponding to specific power up states. See “Power Good LED” in Section 3.16.3 Monitor and Sequencing.

7.7 DDR3L Trace Length

The Xilinx Vivado tools allow entry of the DDR3L trace lengths in order to optimize timing and performance of the PS-based memory controller. The trace lengths for PicoZed SDR 2X2 are listed below. These are also found in the reference design TCL build scripts available on the [Analog Devices GitHub](#) repository.

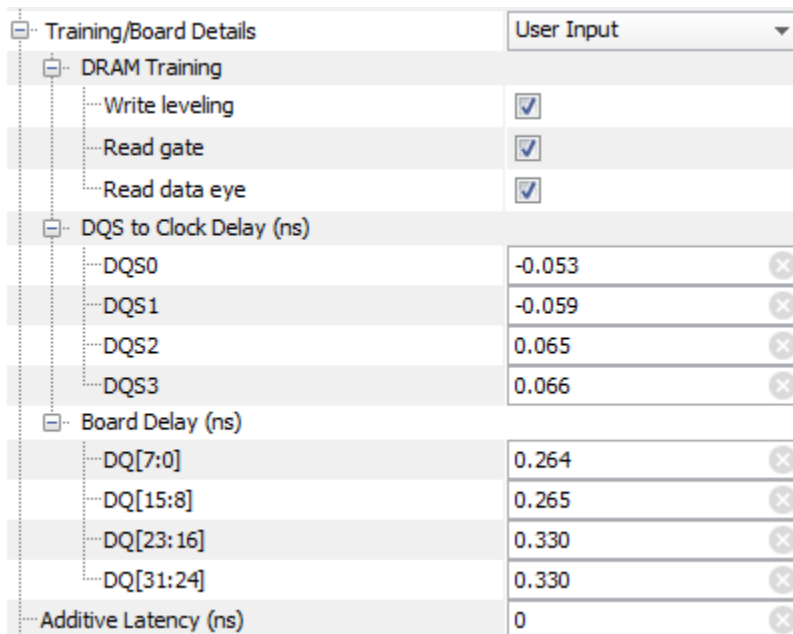

Training/Board Details		User Input
DRAM Training		
Write leveling		<input checked="" type="checkbox"/>
Read gate		<input checked="" type="checkbox"/>
Read data eye		<input checked="" type="checkbox"/>
DQS to Clock Delay (ns)		
DQS0	-0.053	<input type="text"/>
DQS1	-0.059	<input type="text"/>
DQS2	0.065	<input type="text"/>
DQS3	0.066	<input type="text"/>
Board Delay (ns)		
DQ[7:0]	0.264	<input type="text"/>
DQ[15:8]	0.265	<input type="text"/>
DQ[23:16]	0.330	<input type="text"/>
DQ[31:24]	0.330	<input type="text"/>
Additive Latency (ns)	0	<input type="text"/>

Figure 30 - DDR3L Trace Lengths

8 Revision History

Rev date	Rev #	Reason for change
12/08/2015	1.0	Initial release
01/18/2016	1.1	Added section 4.2.1 Zynq Heat Sink. Added warning in section 3.11.3 about loading FPGA_DONE. Added note about Ethernet MACID in 3.6; corrected signal names in Table 20; added better descriptions to section 2.3; added reference to IIO System Object in section 2.3; updated Figure 20 - Power Sequencing; added section 0 Restoring the Analog Devices SD Card Image; removed "ADM1166 Power Sequencer State Machine" section; updated 0 Shock, Vibration, and Thermal Tests;
02/17/2016	1.2	Add connector info and updated diagrams in Mechanical section.
03/10/2016	1.3	Updated Figure 20 - Power Sequencing; Added 0 Board Revisions; Added "Power Good LED" details to section 3.16.3 Monitor and Sequencing; Updated VIN range in 3.16 and 1.2 Module Specs; Added major section 7.2 Updating the ADM1166 Sequencer Firmware; Added sub-section 7.2.1 Automated Update Procedure
3/17/2016	1.4	Updated 1.2 Module Specs; Added Figure 6 - AD9361 Block Diagram; Added Figure 5 - Zynq-7000 AP SoC Block Diagram
5/11/2016	1.5	Edited by technical writer; standardizations; Added max power numbers to 1.2 Module Specs; Added 7.7 DDR3L Trace Length
09/08/2016	1.6	Corrected Zynq part # to XC7Z035-L2 FBG676I; Updated references for GTX to include banks 111 (Rev C) and bank 112 (Rev D); major updates to Power section.
09/23/2016	1.7	Updates to Table 22 – Supply Voltage Requirements; Replaced "PicoZed SDR Z7035/AD9361" with "PicoZed SDR 2x2"