



# PUMPS & MOTORS



Prince Manufacturing Corporation  
North Sioux City, South Dakota

# INDEX

P.T.O. Hydraulic Pump.....	P3-P7
Hydraulic Pump Accessories .....	P8
SP Series Hydraulic Gear Pump Features.....	P9
SP-20B SAE "A" Flange Pump.....	P10
SP-25A SAE "B" Flange Pump .....	P12
SP Pumps with Integral Valving Features .....	P14
SP20P .....	P15
SP25P .....	P16
SPHL1 Hi-Lo Pump Series.....	P17
Double Pumps .....	P18
SP-Accessories (Repair Kits Etc.).....	See Price Book
CMM Series Hydraulic Motor .....	P23
CMM Performance Data .....	P25

The Hand Pumps, PM-HP-30B, PM-HP-20B, PM-HP-15B, PM-HP-10B and PM-HP-5B, Are In The Cylinder Section On Page C20.

PLEASE NOTE: Parts Manuals For All Standard Prince Pumps Are Available On The Prince Web Site At [www.princehyd.com](http://www.princehyd.com)

# PRINCE PTO HYDRAULIC PUMPS

## Up to 40 gallons per minute and up to 2250 psi

### UNIQUE FEATURES:

- Self-adjusting wear plates on both sides of the gears.
- Proper size hose adapters are provided for inlet ports.
- Two outlet ports are provided with a NPT adapter for one port and a plug to seal unused port.
- Center section available in high strength aluminum alloy for std. duty cycle or in high strength cast iron for high duty cycle use.

### IDEAL FOR USE WITH.....

- Tractor front end loaders
- Pull-type cotton pickers
- Cotton balers (module builders)

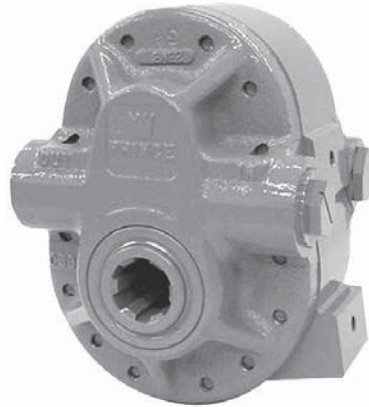

- Tractors imported without integral hydraulics
- Landscape equipment

### PLUS

### STANDARD FEATURES:

- Reliable
- Efficient
- Roller Bearings
- Run fitted body
- Internally splined drive shaft.
- High-tensile cast iron end plates.
- Slips onto tractor PTO shaft (no gear box required).
- Two-bolt installation on farm tractors of all sizes.
- Rotary mowers
- Street Sweepers
- Back hoes

## MODEL FEATURES

### ALUMINUM CENTER HOUSING

- Standard duty cycle
- Reduced weight
- Smaller housing

### CAST IRON CENTER HOUSING

- High duty cycle
- Use in circuits with motors
- Better at higher temperatures
- Increased wear resistance

### REAR PORTED

- Higher flows
- Simplified hose connections
- Higher flows at reduced engine rpm as compared to other PTO pumps

Prince PTO pumps are specifically designed for PTO drive operation on all sizes of farm tractors. No additional gear box is required. Pumps are mounted by sliding the internally splined pump onto the PTO splined shaft and restraining rotation with a torque arm. See page P6 for the PTO pump torque arm kit.

### • SELF ADJUSTING WEAR PLATES

Prince PTO pumps have self-adjusting wear plates that seal around the two unequal size gears. These plates, activated by internal fluid pressure, offset wear or expansion.

### • FILTRATION

The pump must be used in a clean system with clean oil. The fluid cleanliness should meet the ISO 4406 17/14 level. As a minimum, 10 micron filtration is recommended.

### • HYDRAULIC FLUID

A good quality mineral base hydraulic fluid with a viscosity in the 70-250 SUS range at operating temperature is recommended.

### • OPERATING TEMPERATURE

Oil operating temperature should not exceed 180°F. If it does, the reservoir may be too small or a heat exchanger may be needed.

### • SHAFT SPEEDS

Prince PTO pumps are designed to operate at up to 110% of standard PTO shaft speeds. Standard speeds are 540 rpm for the 6 tooth shaft and 1000 rpm for the 21 tooth shaft.

### • CLOSE RUNNING CLEARANCE FOR HIGH FLOW RATE

Another feature that contributes to the excellent and long-lived efficiency of the PTO-Series pump is the minimum clearance between the gears and the center housing. Each pump is assembled with zero clearance between the housing and the tips of the gear teeth, then test run until the teeth establish a proper wear path in the housing. The result is a much tighter clearance than found in traditional pumps.

### • PRESSURE RATING

Pumps are designed for 2250 PSI max. relief valve setting. A relief valve, external to the pump, must be provided in the system.

### • PORTS

All pumps are provided with an inlet port adapter (SAE O-ring boss to hose barb) and outlet port adapter (SAE O-ring boss to female pipe thread) sized appropriately for the ports and required line sizes. A steel plug is provided for the second outlet port.

### • RESERVOIR

As a guideline, a reservoir size in gallons should equal the pump output in gallons per minute. A larger reservoir and/or an oil cooler may be needed for high duty cycle applications.

# ALUMINUM CENTER HOUSING PTO PUMPS

## DIMENSIONAL DATA

PUMP MODEL	ACTUAL DISPLACEMENT	A	B	C	D	E	INLET PORTS	OUTLET PORTS <sup>3</sup>	RECOMMENDED HOSE SIZES	DRIVE SHAFT REQUIRED	SHIP WT. (LB)
HC-PTO-1A	9.9 CI/REV	2.37	2.09	2.19	3.35	6.35	#16 SAE <sup>1</sup>	#12 SAE	1 1/4" IN, 3/4" OUT	1 3/8 DIA. 6 TOOTH	40
HC-PTO-9A	7.8 CI/REV	2.00	1.91	2.00	3.16	5.97	#16 SAE <sup>1</sup>	#12 SAE	1 1/4" IN, 3/4" OUT	1 3/8 DIA. 6 TOOTH	38
HC-PTO-2A	5.7 CI/REV	1.62	1.72	1.81	2.97	5.60	#16 SAE <sup>2</sup>	#12 SAE	1" IN, 1/2" OUT	1 3/8 DIA. 6 TOOTH	36
HC-PTO-3A	5.7 CI/REV	1.62	1.72	1.81	2.97	5.60	#16 SAE <sup>1</sup>	#12 SAE	1 1/4" IN, 3/4" OUT	1 3/8 DIA. 21 TOOTH	36
HC-PTO-7A	3.6 CI/REV	1.26	1.54	1.63	2.78	5.23	#16 SAE <sup>2</sup>	#12 SAE	1" IN, 1/2" OUT	1 3/8 DIA. 6 TOOTH	33
HC-PTO-8A	3.6 CI/REV	1.26	1.54	1.63	2.78	5.23	#16 SAE	#12 SAE	1 1/4" IN, 3/4" OUT	1 3/8 DIA. 21 TOOTH	33

1. Barbed adapter for 1 1/4" hose included. 270011013      2. Barbed adapter for 1" hose included. 270011017      3. Female pipe adaptor for 3/4" NPT included. 500204011

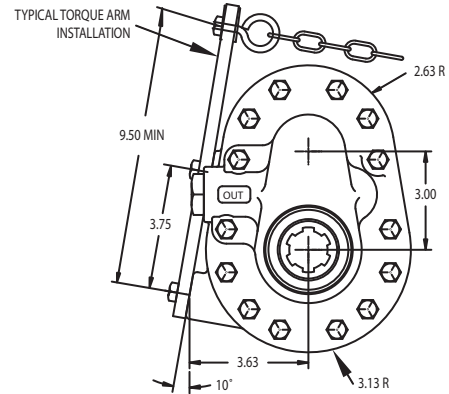
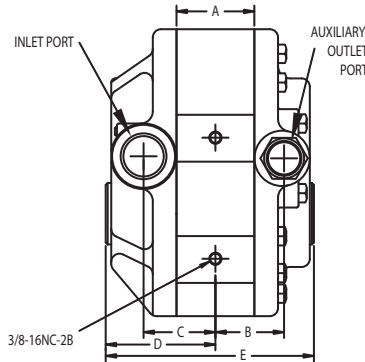
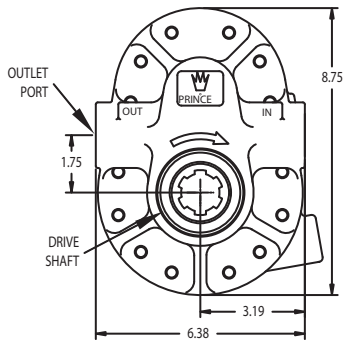

Seal kit No. for all models: PMCK-PTO-1A

# CAST IRON CENTER HOUSING PTO PUMPS

## DIMENSIONAL DATA

PUMP MODEL	ACTUAL DISPLACEMENT	A	B	C	D	E	INLET PORTS	OUTLET PORTS <sup>3</sup>	RECOMMENDED HOSE SIZES	DRIVE SHAFT REQUIRED	SHIP WT. (LB)
HC-PTO-1AC	9.9 CI/REV	2.37	2.09	2.19	3.35	6.35	#16 SAE <sup>1</sup>	#12 SAE	1 1/4" IN, 3/4" OUT	1 3/8 DIA. 6 TOOTH	54
HC-PTO-2AC	5.7 CI/REV	1.62	1.72	1.81	2.97	5.60	#16 SAE <sup>2</sup>	#12 SAE	1" IN, 1/2" OUT	1 3/8 DIA. 6 TOOTH	44
HC-PTO-3AC	5.7 CI/REV	1.62	1.72	1.81	2.97	5.60	#16 SAE <sup>1</sup>	#12 SAE	1 1/4" IN, 3/4" OUT	1 3/8 DIA. 21 TOOTH	44
HC-PTO-8AC	3.6 CI/REV	1.26	1.54	1.63	2.78	5.23	#16 SAE	#12 SAE	1 1/4" IN, 3/4" OUT	1 3/8 DIA. 21 TOOTH	42

1. Barbed adapter for 1 1/4" hose included. 270011013      2. Barbed adapter for 1" hose included. 270011017      3. Female pipe adaptor for 3/4" NPT included. 500204011

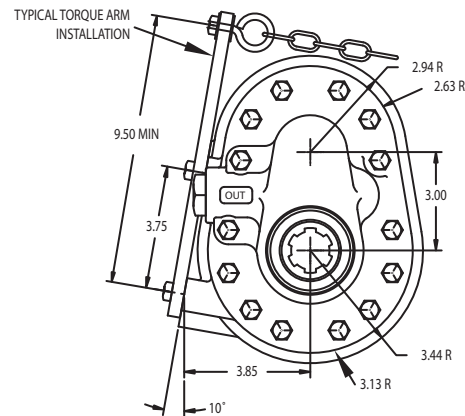
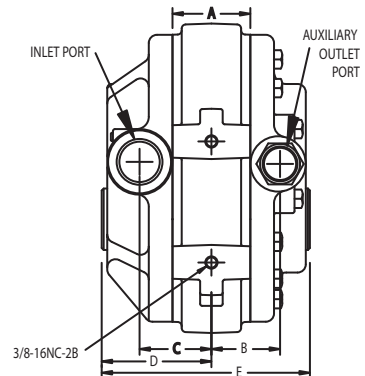
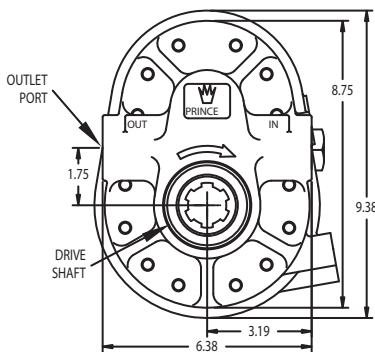

Seal kit No. for all models: PMCK-PTO-1A

## PERFORMANCE DATA

PUMP MODEL	RPM	500 PSI		1000 PSI		1500 PSI		2000 PSI	
		INPUT HP	GPM OUTPUT	INPUT HP	GPM OUTPUT	INPUT HP	GPM OUTPUT	INPUT HP	GPM OUTPUT
HC-PTO-1A & HC-PTO-1AC	540	8.4	21.4	16.1	21.0	23.8	21.0	32.1	21.0
HC-PTO-9A	540	7.1	17.2	13.6	17.0	20.4	16.9	27.4	17.1
HC-PTO-2A & HC-PTO-2AC	540	4.9	12.2	9.3	11.9	13.8	11.6	18.1	11.4
HC-PTO-3A & HC-PTO-3AC	1000	9.3	23.4	17.4	23.0	25.9	22.6	34.3	22.4
HC-PTO-7A	540	2.9	7.6	5.9	7.2	8.8	7.2	11.9	7.1
HC-PTO-8A & HC-PTO-8AC	1000	5.5	14.4	11.0	13.8	16.5	13.5	22.6	13.5

NOTE: Performance values are average values. Individual pump performance may vary. Performance based on 140 SUS oil at 120° F.

# ALUMINUM CENTER HOUSING REAR PORT PTO PUMP

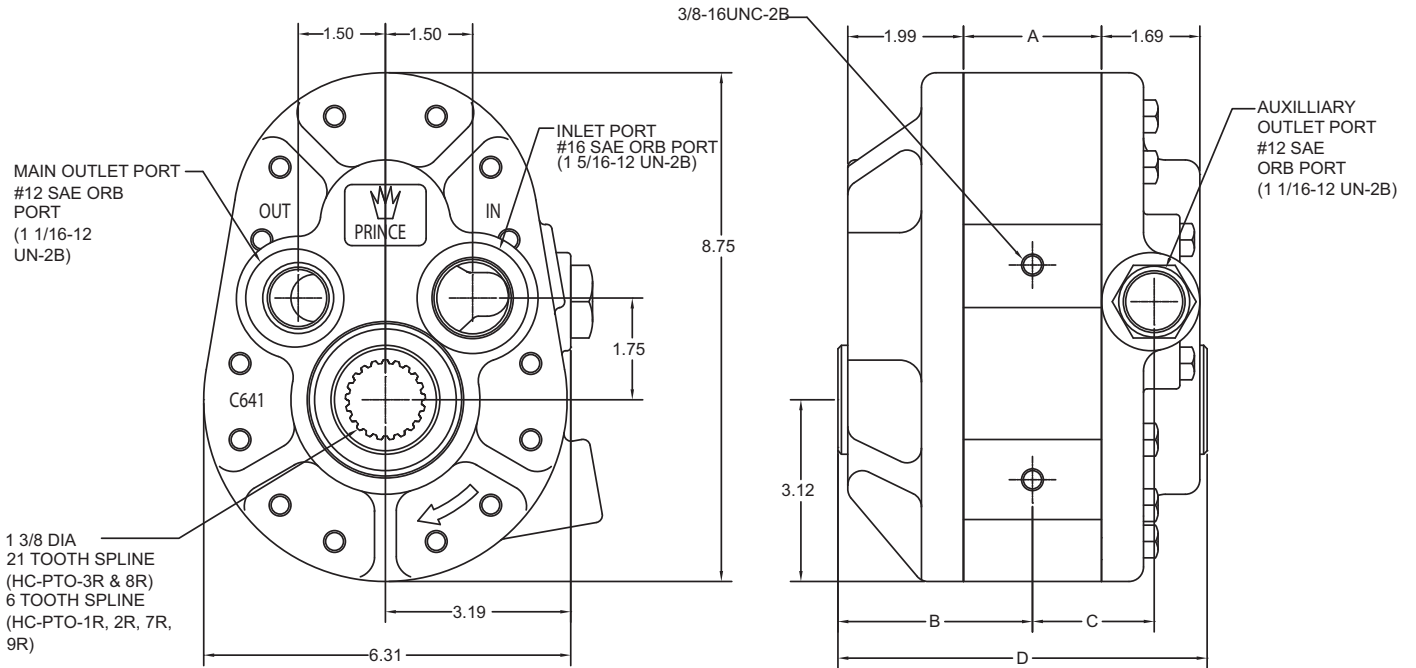

MODEL NUMBER	A	B	C	D
HC-PTO-1R	2.37	3.35	2.09	6.35
HC-PTO-9R	2.00	3.16	1.91	5.97
HC-PTO-2R	1.62	2.97	1.72	5.60
HC-PTO-3R	1.62	2.97	1.72	5.60
HC-PTO-7R	1.26	2.78	1.54	5.23
HC-PTO-8R	1.26	2.78	1.54	5.23

TYPICAL TORQUE ARM INSTALLATION

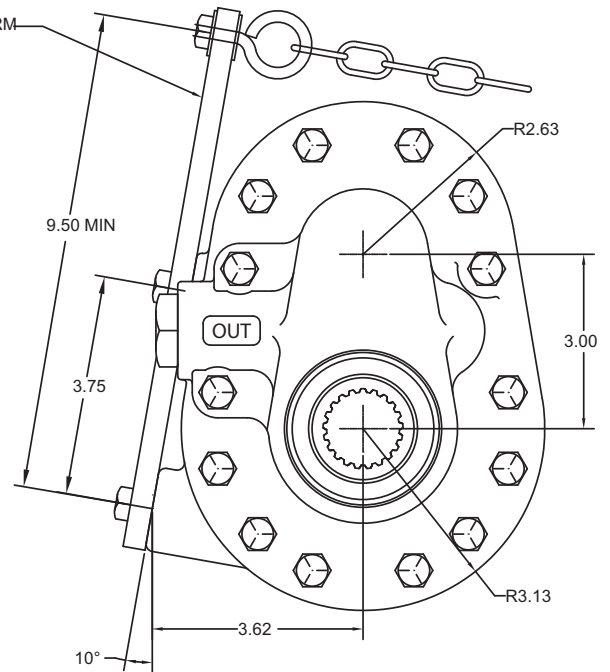

# CAST IRON CENTER HOUSING REAR PORT PTO PUMP

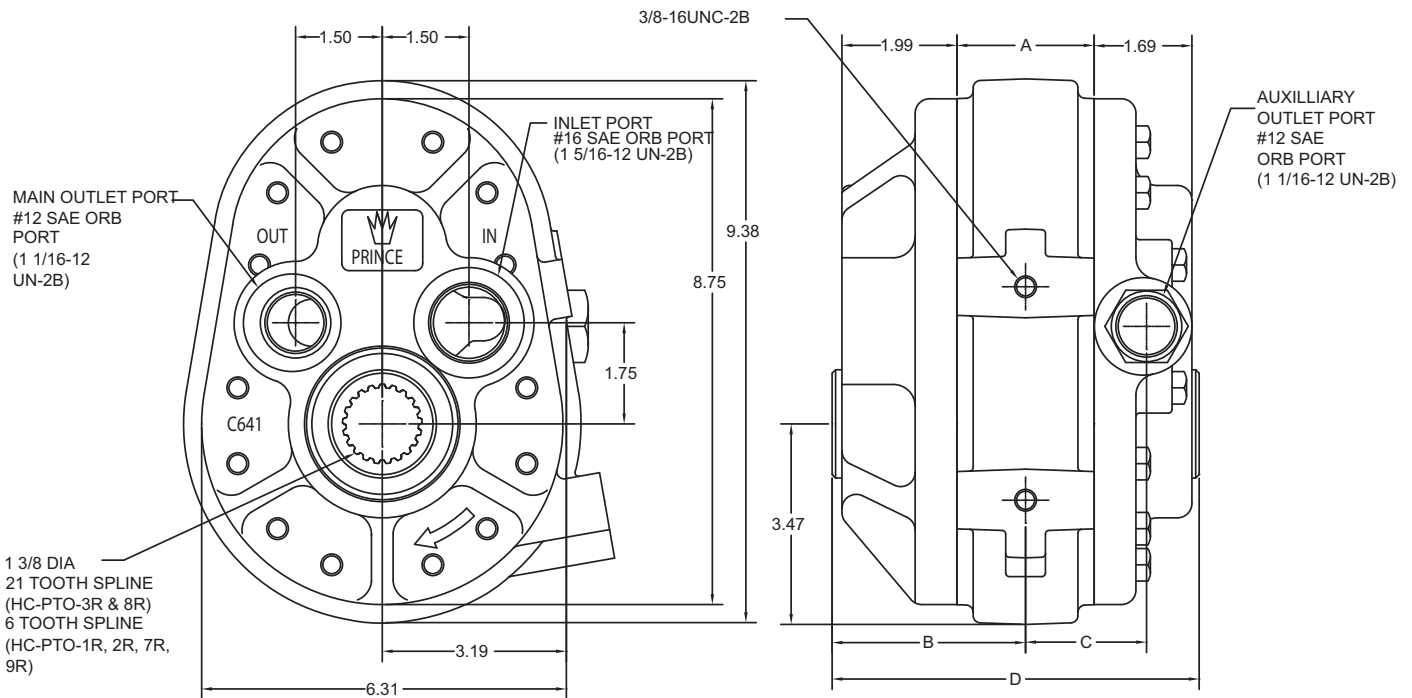

TYPICAL TORQUE ARM  
INSTALLATION

MODEL NUMBER	A	B	C	D
HC-PTO-1RC	2.37	3.35	2.09	6.35
HC-PTO-9RC	2.00	3.16	1.91	5.97
HC-PTO-2RC	1.62	2.97	1.72	5.60
HC-PTO-3RC	1.62	2.97	1.72	5.60
HC-PTO-7RC	1.26	2.78	1.54	5.23
HC-PTO-8RC	1.26	2.78	1.54	5.23

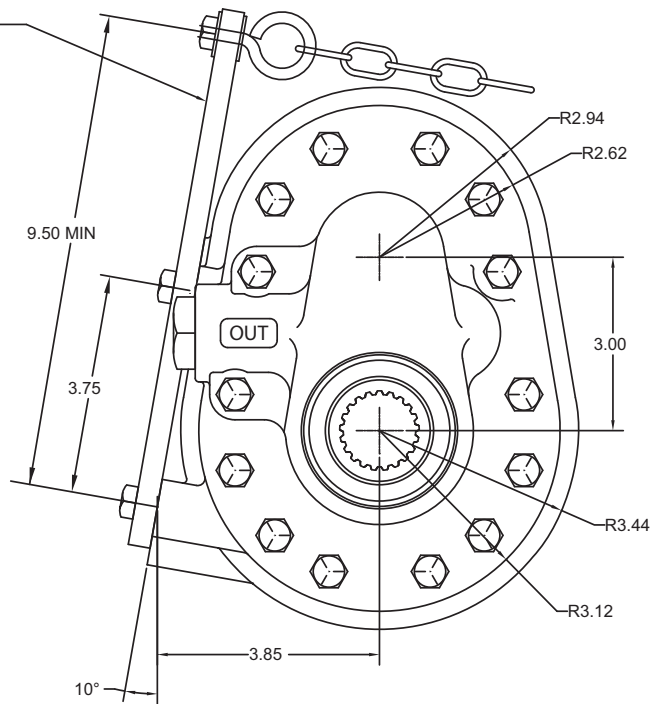

# REAR PORTED PTO PUMPS

## PERFORMANCE DATA

PUMP MODEL	RPM	500 PSI		1000 PSI		1500 PSI		2000 PSI	
		HP INPUT	GPM OUTPUT	HP INPUT	GPM OUTPUT	HP INPUT	GPM OUTPUT	HP INPUT	GPM OUTPUT
HC-P-K11 OR HC-P-K11C	1000	15.5	40.7	29.4	40.1	43.4	40.0	58.8	40.0
	540	8.4	21.4	16.1	21.0	23.8	21.0	32.1	21.0

NOTE: Performance values are average values. Individual pump performance may vary. Performance based on 140 SUS oil at 120° F.

## SPECIFICATIONS

PUMP MODEL	ACTUAL DISP.	INLET PORT	MAIN OUTLET PORT	AUXILIARY OUTLET PORT	INLET ADAPTER	OUTLET ADAPTER	SHIP WT. (LB)
HC-P-K11 OR HC-P-K11C	9.9 CI/REV	#20 SAE O-RING (1 5/8-12UN-2B)	#16 SAE O-RING (1 5/16-12UN-2B)	#12 SAE O-RING (1 1/16-12UN-2B)	#20 SAE TO 2" HOSE BARB	#16 SAE TO 1" FEMALE PIPE	40 OR 54

**SPECIAL NOTE:** Recommended hose sizes for the HC-P-K11 and HC-P-K11C are 2" for the inlet line and 1" for the outlet line.

Seal kit No. for the HC-P-K11 and HC-P-K11C is: PMCK-PTO-1A.  
HC-P-K11 and HC-P-K11C pumps available with 1 3/8 diameter 21 tooth spline drive only.

HC-P-K26 same as HC-P-K11 except 1 3/8"- dia. 6 tooth spline. HC-P-K26C same as HCP-K11C except 1 3/8" dia. 6 tooth spline.  
For use at 540 RPM.

## ALUMINUM CENTER HOUSING (HC-P-K11)

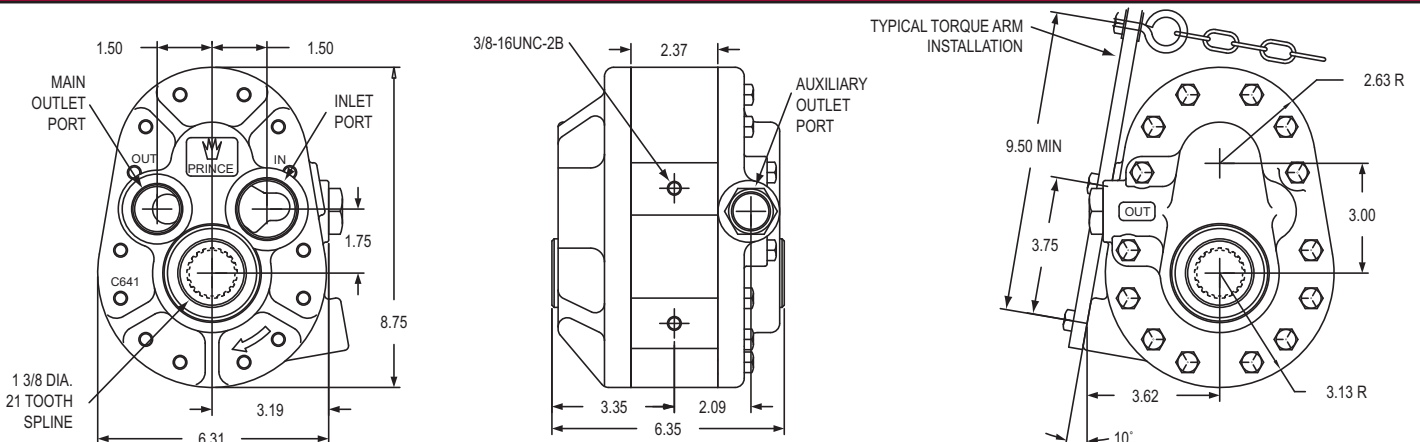

## CAST IRON CENTER HOUSING (HC-P-K11C)

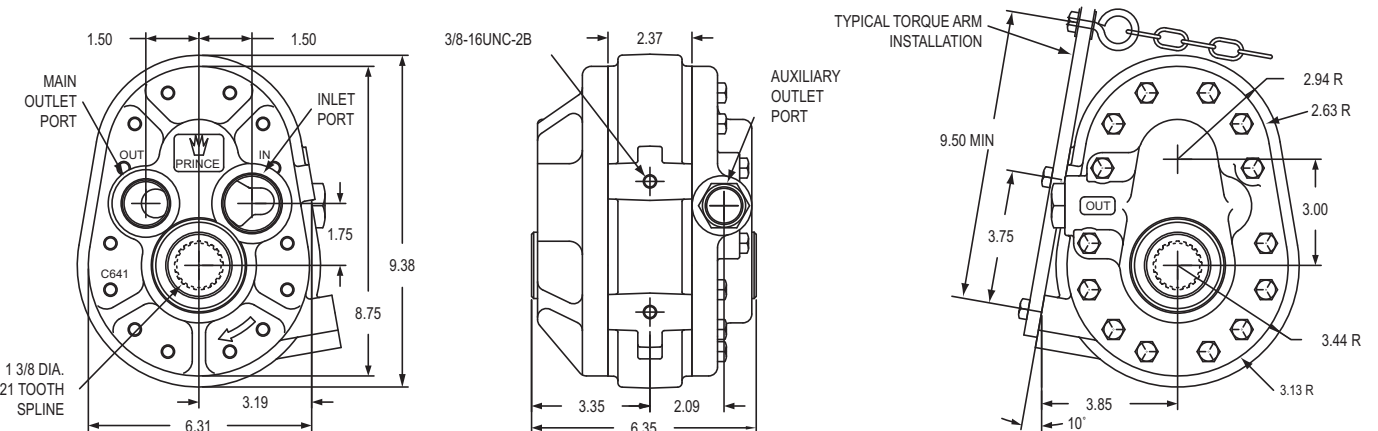

## PUMP ACCESSORIES

### PUMP TORQUE ARM KIT

The 180900877 torque arm kit was designed to simplify Prince PTO pump installation by eliminating the need to fabricate a custom torque arm. Items included in the kit are:

- 1-Torque arm
- 2-3/8-16 mounting bolts
- 1-Eye bolt/chain assembly

**NOTE THAT TORQUE ARM KIT NO. 180900877 FITS ALL MODEL PTO PUMPS**

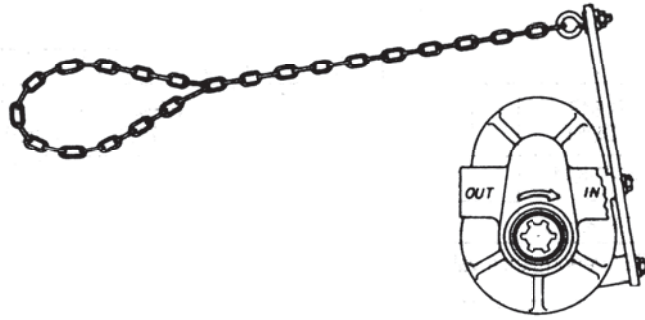

### RESERVOIR BREATHER ADAPTER

The 200400039 breather adapter enables a standard Prince 10 micron spin-on filter element\* to be used as a reservoir breather.

\*Part Number FA10

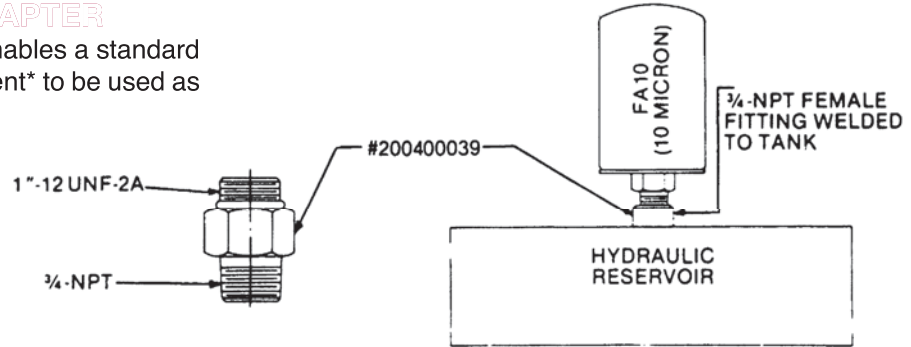

### FITTINGS AND ADAPTERS

MODEL NUMBER	DESCRIPTION	CONFIGURATION
500204013	#16 SAE (1 5/16-12) Male, 1 1/4-NPTF Female	Fig. 1
500204011	#12 SAE (1 1/16-12) Male, 3/4-NPTF Female	Fig. 1
270011014	1 1/4-NPTF Male, 1 1/4 Hose Barb	Fig. 2
270011015	1" NPTF Male, 1" Hose Barb	Fig. 2
270011013	#16 SAE (1 5/16-12) Male, 1 1/4 Hose Barb	Fig. 3
270011017	#16 SAE (1 5/16-12) Male, 1 Hose Barb	Fig. 3
270011046	#20 SAE (1 5/8-12) Male, 2 Hose Barb	Fig. 3
500204012	#16 SAE (1 5/16-12) Male, 1-NPTF Female	Fig. 1

FIG. 1

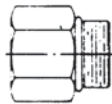

FIG. 2

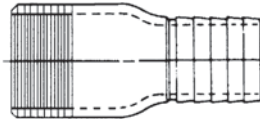
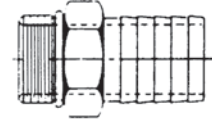

FIG. 3





# SP SERIES HYDRAULIC GEAR PUMP

## OUTSTANDING FEATURES

• **Patented Non-Symmetrical Gears** The adoption of non-symmetrical gears insures greater power per unit volume compared with pumps of conventional design. The compact gear compartment has enabled high-pressure operation. The increased number of gear teeth has reduced the flow pulsation and minimized the noise.

U.S.A.	Patent No.	3817117	
U.K.	Patent No.	1400577	
French	Patent No.	7230448	
German	Patent No.	7231801	Others: Pending

• **Bearings** PTFE composite bearings are used due to the ability to handle heavy loads, low shaft speeds, and high levels of contamination. Engineering tests on the PTFE bearings indicate they will withstand bearing loads over twice as high as conventional steel backed aluminum bearings used in many pumps. The PTFE resin layer will absorb a high degree of contamination with out damage to the pump. Also since the PTFE layer is self lubricating, contamination from bearing wear in high load situations (when no oil film is present) is reduced. The side benefit from reduced friction under all conditions is a reduced consumption of power.

- **Gears and drive shaft** are hardened alloy steel of one piece construction.
- **Special gear design:** Non-symmetrical gear insures low noise and compactness.
- **Highest Quality Workmanship.**
- **Pressures Up To 3000 P.S.I.**
- **Dependable service:** Balanced pressure loading insures small dispersion, good durability and maintains high performance.
- **Extremely Efficient.**
- **Perfect alignment:** "Through bore" design provides perfect alignment of pump element and assures even bearing load.
- **With the aluminum alloy casing,** the SP Series features light weight and easy handling.

- **Double pumps:** Available in SP20, SP25 and SP25/SP20 Combinations.
- **Maximum speed** from 3000 to 4000 RPM using SAE 10W oil.
- **Displacement covers** .400 in<sup>3</sup>/rev. to 3.869 in<sup>3</sup>/rev.
- **Inlet pressure:** Pump inlet should not exceed 5 in. of mercury vacuum or 14 P.S.I. positive pressure.
- **Ports:** SAE straight thread O-ring boss for SP20 & SP25. Other Ports available - consult factory. (Taper pipe threads not available).
- **Working oil:** A mineral based oil with additives to resist corrosion, oxidation, and foaming is recommended. Viscosity at any running condition should be 60 SUS minimum and 250 SUS maximum. 180° F is the maximum recommended system operating temperature.
- **Filtration:** Per ISO cleanliness code level 17/14. As a minimum, 10 micron filtration is recommended.

## INTERNAL COMPONENTS BREAKDOWN

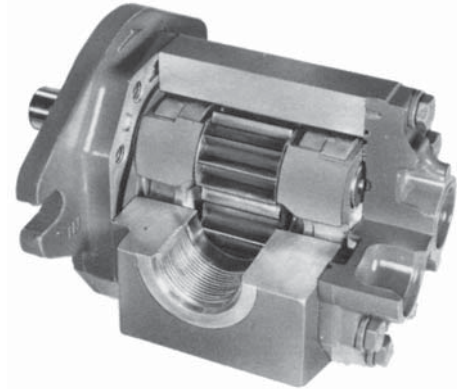

## SP20 SERIES HYDRAULIC PUMPS AND NOISE GENERATION

The accompanying graphs show the typical Pump Sound Pressure Ratings (PSPR, A-weighted Sound Pressure Levels) for the SP20 Series Hydraulic Pumps. The Pump Sound Pressure Ratings (PSPR) shown below in the graphs were computed and determined using Sound Intensity Analysis Methods. Sound Intensity Analysis provides the most accurate and reliable data for predicting and comparing a Pump Sound Pressure Rating (A-weighted Sound Pressure Level), for a pump exposed to various operating and environmental conditions.

Pumps tested below in the graphs were tested as defined by **ANSI/B93.71M**, (Hydraulic fluid power-Pumps-Test code for the determination of airborne noise levels) in a semi-anechoic room. For free-field conditions (i.e. such as a noise source located above the ground in an open area), pump sound pressure ratings (A-weight Sound Pressure Levels) may be estimated by subtracting 3dB(A) from the values shown on the graphs.

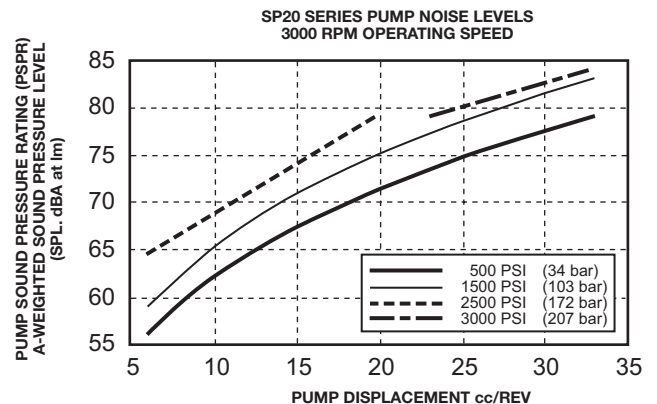
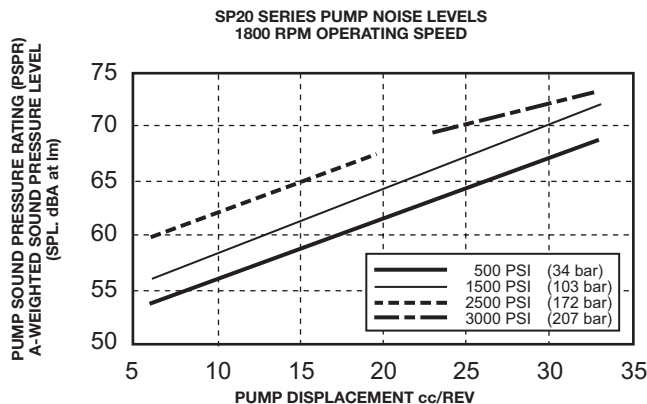

Pump acoustical data was determined in accordance with ANSI/B93.71M. Hydraulic fluid power-Pumps-Test code for the determination of airborne noise levels

# SP20 SERIES SAE "A" FLANGE PUMP



## New Updated Design

- More Port Options
- More Shaft Options
- Lower Price
- Contact your sales representative for more information

The SP20B pump now utilizes self-lubricating thrust blocks that eliminate the need for separate wear plates. They are made from a high strength aluminum alloy with exceptional anti-galling properties. This new thrust block design also incorporates advanced bearings designed specifically for high pressure hydraulic pumps. This new bearing features a robust fluoropolymer PTFE wear surface that yields unsurpassed load carrying capabilities and cavitation resistance even at low speeds and moderate levels of contamination. Also, since the PTFE resin layer is self-lubricating, contamination from bearing wear in high load situations (when no oil film is present) is reduced. This new thrust block design combined with these advanced bearing results in lower friction and less internal oil loss resulting in higher pump efficiencies.

## MODEL CODE

**SP20B 14 A 9 H 2-R**

**SERIES NO** \_\_\_\_\_

**DISPLACEMENT CODE (CC/REV)** \_\_\_\_\_

**PORT LOCATION** \_\_\_\_\_

- A-SIDE INLET AND OUTLET
- C-BOTH SIDE AND REAR W/STEEL PLUGS
- D-REAR INLET AND OUTLET
- E-BOTH SIDE AND REAR W/PLASTIC PLUGS

**PORT TYPE** \_\_\_\_\_

- 9-STANDARD PORTS SAE PER CHART BELOW
- OPTIONAL PORTS CONSULT FACTORY SIDE PORT ONLY
- 8-METRIC O-RING
- 7-BSPP
- 6-SAE SPLIT FLANGE 16-33 CC ONLY
- 5-METRIC SPLIT FLANGE 16-33 CC ONLY

**ROTATION (FACING END OF SHAFT)**

- L-COUNTER CLOCKWISE
- R-CLOCKWISE DRIVE SHAFT

**DRIVE SHAFT**

- 9-SAE 9 TOOTH 16/32 SPLINE
- 2-SAE 5/8" STRAIGHT KEYED
- 3-11 TOOTH 16/32 SPLINE\*
- 4-3/4" STRAIGHT KEYED\*
- 5-SAE 10 TOOTH 16/32 SPLINE

**MOUNTING**

- H-SAE "A" 2 BOLT

\*REQUIRED FOR DISPLACEMENT CODES 30 AND 33

## SPECIFICATIONS

MODEL NUMBER	DISP. IN <sup>3</sup> /REV	RATED PRESSURE (PSI)	MAX <sup>o</sup> RPM	A	B	INLET PORT			OUTLET PORT		FULL THREAD DEPTH	WT. (LB.)
						SAE SIZE		FULL THREAD DEPTH	SAE SIZE			
						SIDE	REAR		SIDE	REAR		
SP20B06	.400	3000	4000	1.79	4.22	7/8-14 UN-2B	1 5/16-12 UN-2B	5/8"	3/4-16 UN-2B	1/16-12 UN-2B	9/16"	5.0
SP20B08	.499	3000	4000	1.83	4.30	1 1/16-12 UN-2B	1 5/16-12	3/4"	7/8-14	1 1/16-12 UN-2B	5/8"	5.1
SP20B09	.589	3000	4000	1.87	4.38				5.3			
SP20B11	.677	3000	4000	1.91	4.46				5.5			
SP20B14	.860	3000	4000	1.99	4.62				5.7			
SP20B16	.976	3000	4000	2.04	4.71				6.0			
SP20B20	1.220	3000	3500	2.15	4.93	1 5/16-12	UN-2B	3/4"	1 1/16-12	UN-2B	3/4"	6.2
SP20B23	1.403	2500	3500	2.23	5.09	UN-2B	UN-2B		1 1/16-12			UN-2B
SP20B27	1.654	2500	3500	2.34	5.31			6.6				
SP20B30	1.881	2500	3500	2.41	5.46			7.1				
SP20B33	2.014	2500	3500	2.49	5.62			7.6				

<sup>o</sup>Max. RPM for side ported models. Rear ported models should be restricted to 21 gpm. Standard Seal Kit for all SP20 Models is Prince Part No. PMCK-SP20.

PUMPS AND MOTORS

## SP20 SERIES DIMENSIONAL DATA

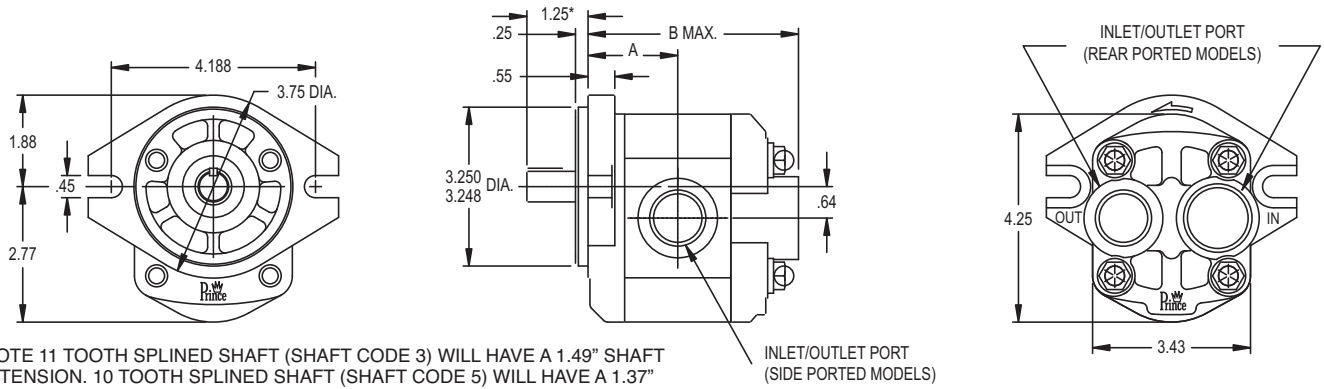

\*NOTE 11 TOOTH SPLINED SHAFT (SHAFT CODE 3) WILL HAVE A 1.49" SHAFT EXTENSION. 10 TOOTH SPLINED SHAFT (SHAFT CODE 5) WILL HAVE A 1.37" SHAFT EXTENSION.

INLET/OUTLET PORT (SIDE PORTED MODELS)

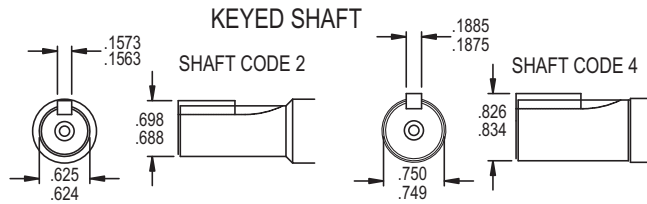

### SPLINED SHAFT

SHAFT CODE 9	SHAFT CODE 5	SHAFT CODE 3
9 TOOTH	10 TOOTH	11 TOOTH
16/32 DP	16/32 DP	16/32 DP
30° PA	30° PA	30° PA
FLAT ROOT SIDE FIT	FLAT ROOT SIDE FIT	FLAT ROOT SIDE FIT

## TYPICAL PERFORMANCE DATA

MODEL		RPM								PRESSURE
		500	1000	1500	2000	2500	3000	3500	4000	(PSI)
SP20B06	FLOW (GPM)	.78	1.62	2.48	3.35	4.24	5.10	5.98	6.92	3000
	INPUT HORSE POWER	1.85	3.77	5.66	7.57	9.45	11.13	13.06	14.80	
SP20B08	FLOW (GPM)	.88	1.91	2.97	4.04	5.10	6.16	7.27	8.33	
	INPUT HORSE POWER	2.23	4.38	6.53	8.83	11.13	13.57	16.17	18.69	
SP20B09	FLOW (GPM)	1.03	2.30	3.52	4.75	5.97	7.19	8.46	9.74	
	INPUT HORSE POWER	2.61	5.03	7.54	10.14	12.84	15.54	18.43	21.31	
SP20B11	FLOW (GPM)	1.27	2.74	4.16	5.63	7.05	8.51	9.98	11.40	
	INPUT HORSE POWER	2.98	5.77	8.75	11.63	14.80	17.87	21.12	24.38	
SP20B14	FLOW (GPM)	1.61	3.36	5.19	7.01	8.91	10.74	12.56	14.39	
	INPUT HORSE POWER	3.68	7.09	10.51	14.19	18.00	21.68	25.49	29.43	
SP20B16	FLOW (GPM)	1.80	3.82	5.87	7.93	9.98	12.11	14.24	16.22	
	INPUT HORSE POWER	4.01	7.86	11.87	15.87	20.17	24.33	28.78	34.12	
SP20B20	FLOW (GPM)	2.35	4.92	7.49	10.05	12.70	15.26	17.76		
	INPUT HORSE POWER	5.21	9.98	14.89	20.10	25.16	30.52	35.73		
SP20B23	FLOW (GPM)	2.80	5.72	8.73	11.60	14.68	17.61	20.55		
	INPUT HORSE POWER	5.06	9.68	14.44	19.21	24.27	29.48	34.54		
SP20B27	FLOW (GPM)	3.30	6.90	10.47	13.90	17.52	20.94	24.46		
	INPUT HORSE POWER	5.98	11.59	17.20	23.00	28.98	34.78	41.13		
SP20B30	FLOW (GPM)	3.85	7.78	11.47	15.36	19.22	23.03	26.86		
	INPUT HORSE POWER	6.40	12.56	18.38	24.64	30.93	37.59	43.80		
SP20B33	FLOW (GPM)	4.13	8.47	12.60	16.86	21.11	25.26	29.52		
	INPUT HORSE POWER	7.14	13.40	19.98	27.04	33.90	41.05	47.89		

Typical Performance Data Based on 140 SUS Oil at 120° F

# SP25 SERIES SAE "B" FLANGE PUMP

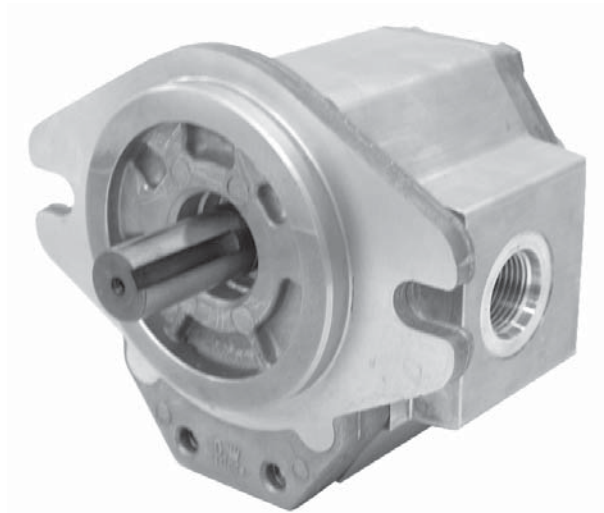

## MODEL CODE

SP25A 38 A 9 H 1-R X

**SERIES NO** \_\_\_\_\_

**DISPLACEMENT CODE (CC/REV)** \_\_\_\_\_

**PORT LOCATION** \_\_\_\_\_

A-SIDE INLET AND OUTLET

D-REAR INLET AND OUTLET

C-BOTH SIDE AND REAR INLET AND OUTLET, STEEL PLUGS

E-BOTH SIDE AND REAR INLET AND OUTLET, PLASTIC PLUGS

**PORT TYPE** \_\_\_\_\_

9-STANDARD PER CHART

**SHAFT SEAL TYPE**

OMIT FOR STANDARD BUNA-N

H-MEDIUM PRESSURE BUNA-N

**ROTATION (FACING END OF SHAFT)**

L-COUNTER CLOCKWISE

R-CLOCKWISE

**DRIVE SHAFT**

1-SAE 13 TOOTH 16/32 SPLINE

2-SAE 7/8" STRAIGHT KEYED

**MOUNTING**

H-SAE "B" 2 BOLT

## SPECIFICATIONS

MODEL NUMBER	DISP. IN <sup>3</sup> /REV (PSI)	RATED PRESSURE	MAX <sup>o</sup> RPM	A	B	INLET PORT			OUTLET PORT			WT. (LB.)
						SAE SIZE		FULL THREAD DEPTH	SAE SIZE		FULL THREAD DEPTH	
						SIDE	REAR		SIDE	REAR		
SP25A19	1.141	3000	3000	2.49	5.50	1 5/16-12	UN-2B	3/4"	1 1/16-12	UN-2B	3/4"	10.4
SP25A22	1.349	3000	3000	2.55	5.62	UN-2B			10.6			
SP25A27	1.660	3000	3000	2.64	5.79	1 5/8-12			12.4			
SP25A32	2.008	3000	3000	2.74	5.99	UN-2B			13.5			
SP25A38	2.318	3000	3000	2.83	6.17	UN-2B			13.9			
SP25A44	2.697	3000	3000	2.94	6.38	UN-2B			14.4			
SP25A52	3.179	2500	3000	3.07	6.66	UN-2B			14.4			
SP25A63	3.869	2500	3000	3.27	7.05	1 7/8-12			15.4			

°Max. RPM for side ported models. Rear ported models should be restricted to 25 GPM due to limitation on the inlet port size. Standard Seal Kit for all SP25 Models is Prince Part No. PMCK-SP25.

PUMPS AND MOTORS

# SP25 SERIES DIMENSIONAL DATA

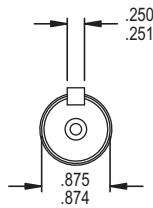
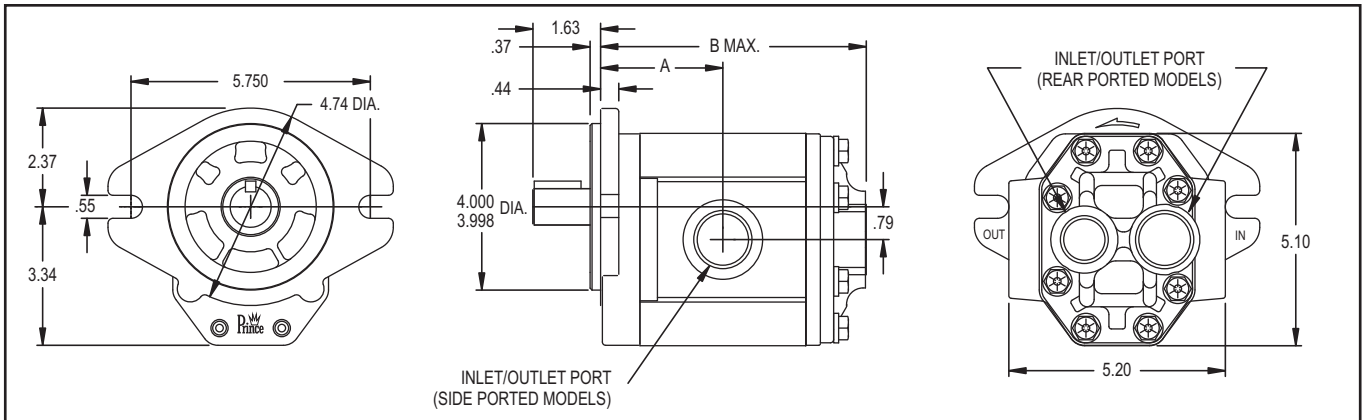

### KEYED SHAFT SHAFT CODE 2

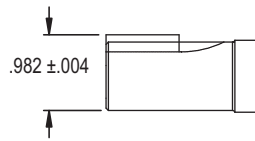

### SPLINED SHAFT

SHAFT CODE 1  
13 TOOTH  
16/32 DP  
30° PA  
FLAT ROOT SIDE FIT

## TYPICAL PERFORMANCE DATA

MODEL		RPM						PRESSURE (PSI)
		500	1000	1500	2000	2500	3000	
SP25A19	FLOW (GPM)	2.09	4.55	6.90	9.39	11.89	14.24	3000
	INPUT HORSE POWER	4.65	9.31	13.96	18.70	23.45	28.29	
SP25A22	FLOW (GPM)	2.64	5.28	8.22	11.08	13.94	16.81	
	INPUT HORSE POWER	5.58	10.98	16.38	21.96	27.36	33.31	
SP25A27	FLOW (GPM)	3.33	6.75	10.27	13.70	17.22	20.74	
	INPUT HORSE POWER	6.99	13.48	20.22	26.97	33.96	40.95	
SP25A32	FLOW (GPM)	3.91	8.22	12.43	16.73	21.14	25.44	
	INPUT HORSE POWER	8.24	15.98	24.22	32.46	40.95	49.94	
SP25A38	FLOW (GPM)	4.26	9.10	14.09	19.08	24.07	28.77	
	INPUT HORSE POWER	8.56	18.24	27.54	36.85	46.90	56.57	
SP25A44	FLOW (GPM)	4.99	10.86	16.44	22.16	27.89	33.61	
	INPUT HORSE POWER	10.42	21.22	32.01	43.18	54.71	66.25	
SP25A52	FLOW (GPM)	6.16	12.92	19.67	26.42	33.17	39.63	2500
	INPUT HORSE POWER	11.17	21.96	32.38	43.55	55.09	67.00	
SP25A63	FLOW (GPM)	7.52	15.60	23.86	31.93	40.00	48.08	
	INPUT HORSE POWER	14.14	26.43	39.45	52.85	66.62	80.77	

Typical Performance Data Based on 140 SUS Oil at 120° F.

## SP PUMP INTEGRAL VALVING OPTIONS

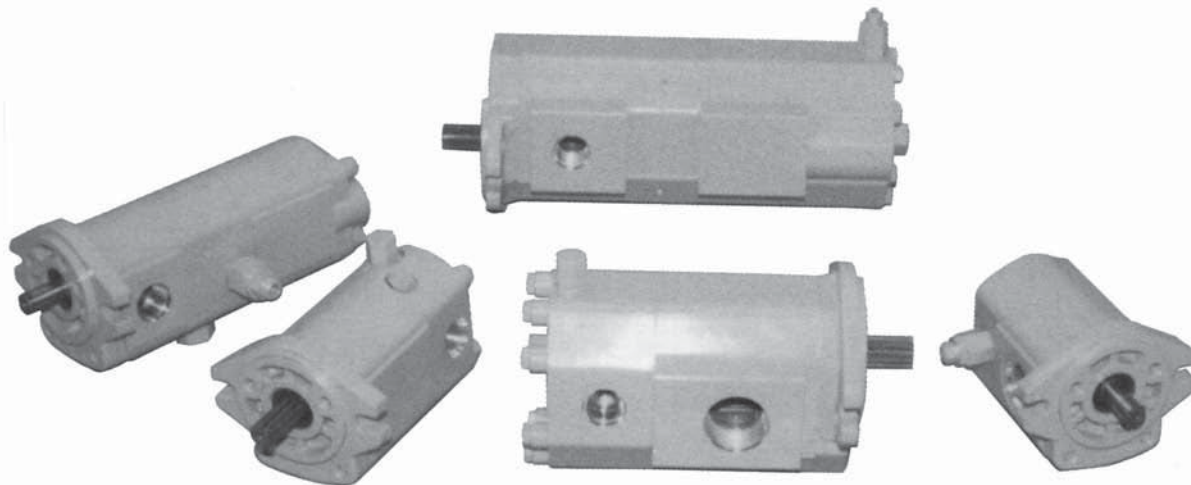

**PRINCE SP PUMPS WITH INTEGRAL VALVING FEATURE EXTRUDED ALUMINUM REAR COVERS. THE EXTRUDED REAR COVERS ALLOW EXCEPTIONAL FLEXIBILITY FOR INCORPORATING DIFFERENT VALVING AND PORTING OPTIONS. PRINCE'S USE OF COMPUTER CONTROLLED MACHINING CENTERS IN THE MANUFACTURING PROCESS ALLOW EITHER STANDARD OR CUSTOM DESIGNS TO BE MADE IN BOTH SMALL AND LARGE QUANTITIES.**

- **PRIORITY FLOW DIVIDER PUMPS**

Priority flow divider pumps split the flow between a priority port and an excess flow port. The flow is initially directed to the priority port until the priority setting is satisfied. At that time any additional flow is directed to the excess flow port. Priority divider pumps are typically used in steering circuits, brake circuits or any circuit where a primary flow needs to be satisfied first.

- **RELIEF VALVES**

Various styles and configurations of relief valves can be provided in the rear cover. The relief return flow can be either ported external to the pump or internally ported back to the inlet. Caution must be used so that the duration of the internally ported flow does not cause excessive heat build up.

- **CUSTOM DESIGN VALVE PACKAGES**

Prince Manufacturing offers custom designed integral valve packages. Configurations are developed based on customer specifications.

- **SOLENOID VALVES**

Various configurations of controlling pump flow by using solenoid cartridge valves are available.

- **SPECIAL REAR PORTING**

A wide variety of port types as well as port locations can be accommodated with the extruded rear cover.

- **DOUBLE PUMP CONFIGURATIONS**

Integral valve configurations can easily be integrated into double pump configurations. Valves in the rear cover typically control flow from the rear pump section, however valves can also be incorporated into the center section of the double pump for additional control options.

- **HIGH-LO PUMPS (Horse power limiting pumps)**

A high-lo configuration is available based on the SP20 series pump. The typical configuration provides 28 gpm low pressure flow and 7 gpm high pressure flow (at 3500 rpm). Typical horsepower requirements are 19 hp at 3000 psi and 3500 rpm.



**PRINCE MANUFACTURING CORPORATION**

P.O. BOX 7000  
NORTH SIOUX CITY, SD 57049-7000  
TELEPHONE: 605-235-1220  
FAX: 605-235-1082

# SP20P SERIES - PRIORITY FLOW DIVIDER PUMPS MODEL CODE

**SP20PB 23 K 185 H 2 R**

**SERIES NO.** \_\_\_\_\_

**DISPLACEMENT CODE (CC/REV)** \_\_\_\_\_

**PRIORITY FLOW +** \_\_\_\_\_

G - 1.5 GPM PRIORITY FLOW  
 H - 2.0 GPM PRIORITY FLOW  
 J - 2.5 GPM PRIORITY FLOW  
 K - 3.0 GPM PRIORITY FLOW  
 L - 3.5 GPM PRIORITY FLOW  
 M - 4.0 GPM PRIORITY FLOW  
 N - 4.5 GPM PRIORITY FLOW  
 P - 5.0 GPM PRIORITY FLOW

**PRIORITY FLOW RELIEF SETTING** \_\_\_\_\_

THE THREE DIGIT CODE REPRESENTS RELIEF VALVE SETTING DIVIDED BY 10. FOR INSTANCE A CODE NUMBER OF 185 REPRESENTS A RELIEF SETTING OF 1850 PSI. (RELIEF SETTING MUST BE BETWEEN 1000 AND 2250 PSI.)

**ROTATION (FACING END OF SHAFT)**  
 L-COUNTER CLOCKWISE  
 R-CLOCKWISE

**DRIVE SHAFT**  
 9-SAE 9 TOOTH 16/32 SPLINE  
 2-SAE 5/8" STRAIGHT KEYED  
 3-11 TOOTH 16/32 SPLINE  
 4-3/4" STRAIGHT KEYED  
 5-SAE 10 TOOTH 16/32 SPLINE

**MOUNTING**  
 H-SAE "A" 2 BOLT

+ FOR PRIORITY FLOWS AND RELIEF SETTINGS NOT INDICATED, CONTACT FACTORY.  
 ° FOR DISPLACEMENT CODES 08 THROUGH 27, SHAFT CODES 2 AND 9 ARE STANDARD. FOR DISPLACEMENT CODES 30 AND 33, SHAFT CODES 3 AND 4 ARE STANDARD. PUMPS WITH NONSTANDARD SHAFT CODES ARE AVAILABLE IN MINIMUM QUANTITIES.

## SP20P SERIES DIMENSIONAL DATA

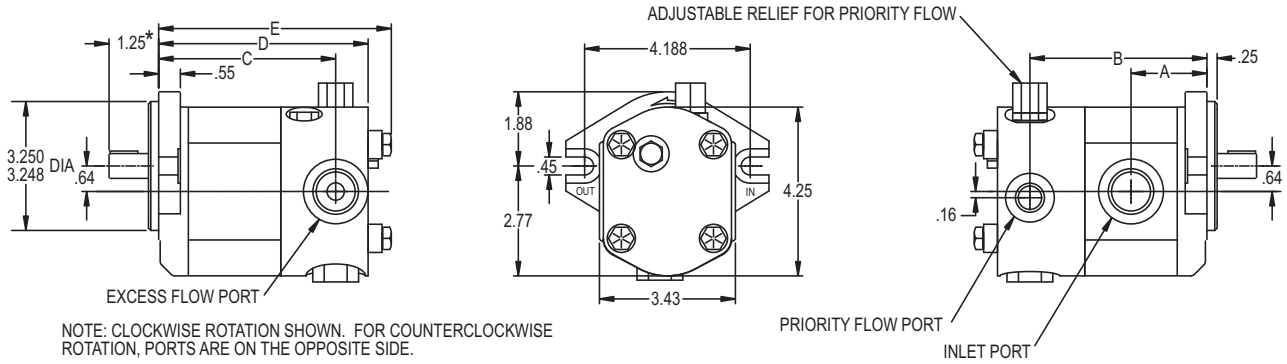

## SPECIFICATIONS

MODEL NUMBER	DISP. IN <sup>3</sup> /REV	RATED PRESSURE PSI	MAX RPM	A	B	C	D	E	INLET PORT SIZE	EXCESS FLOW PORT SIZE	PRIORITY FLOW PORT SIZE	WT. (LB.)
SP20PB06	.400	3000	4000	1.79	4.22	4.22	5.04	5.36	7/8-14 UN-2B 5/8" FULL THREAD DEPTH	1 1/16-12 UN-2B	9/16-18 UNF-2B	6.7
SP20PB08	.499	3000	4000	1.83	4.30	4.30	5.12	5.82	6.8			
SP20PB09	.589	3000	4000	1.87	4.38	4.38	5.20	5.80	3/4" FULL THREAD DEPTH	3/4" FULL THREAD DEPTH	7.0	
SP20PB11	.677	3000	4000	1.91	4.46	4.46	5.28	5.88			7.2	
SP20PB14	.860	3000	4000	1.99	4.62	4.62	5.44	5.81	1 5/16-12 UN-2B	3/4" FULL THREAD DEPTH	3/4" FULL THREAD DEPTH	7.4
SP20PB16	.976	3000	4000	2.04	4.72	4.72	5.53	5.84				7.7
SP20PB20	1.220	3000	3500	2.15	4.93	4.93	5.75	6.35	3/4" FULL THREAD DEPTH	3/4" FULL THREAD DEPTH	3/4" FULL THREAD DEPTH	7.9
SP20PB23	1.403	2500	3500	2.23	5.09	5.09	5.91	6.28				8.1
SP20PB27	1.654	2500	3500	2.34	5.31	5.31	6.12	6.82				8.3
SP20PB30	1.881	2500	3000	2.41	5.46	5.46	6.28	6.88				8.8
SP20PB33	2.014	2500	3000	2.49	5.62	5.62	6.44	6.81				9.3

FOR PUMP PERFORMANCE DATA AND DIMENSIONAL DATA, REFER TO THE SP20B PUMP SECTION Standard Seal Kit for all SP20B Models is Prince Part No. PMCK-SP20.

# SP25P SERIES - PRIORITY FLOW DIVIDER PUMPS MODEL CODE

**SP25P 52 J 185 H 2 R**

**SERIES NO.** \_\_\_\_\_

**DISPLACEMENT CODE (CC/REV)** \_\_\_\_\_

**PRIORITY FLOW** + \_\_\_\_\_

G - 1.5 GPM PRIORITY FLOW  
H - 2.0 GPM PRIORITY FLOW  
J - 2.5 GPM PRIORITY FLOW  
K - 3.0 GPM PRIORITY FLOW  
L - 3.5 GPM PRIORITY FLOW  
M - 4.0 GPM PRIORITY FLOW  
N - 4.5 GPM PRIORITY FLOW  
P - 5.0 GPM PRIORITY FLOW

**PRIORITY FLOW RELIEF SETTING** + \_\_\_\_\_

THE THREE DIGIT CODE REPRESENTS RELIEF VALVE SETTING DIVIDED BY 10. FOR INSTANCE A CODE NUMBER OF 185 REPRESENTS A FULL FLOW RELIEF SETTING OF 1850 PSI. (RELIEF SETTING MUST BE BETWEEN 1000 AND 2250 PSI.)

**ROTATION (FACING END OF SHAFT)**  
L-COUNTERCLOCKWISE  
R-CLOCKWISE

**DRIVE SHAFT**  
1-SAE 13 TOOTH 16/32 SPLINE  
2-SAE 7/8" STRAIGHT KEYED

**MOUNTING**  
H-SAE "B" 2 BOLT

+ FOR PRIORITY FLOWS AND RELIEF SETTINGS NOT INDICATED, CONTACT FACTORY.

## SP25P SERIES DIMENSIONAL DATA

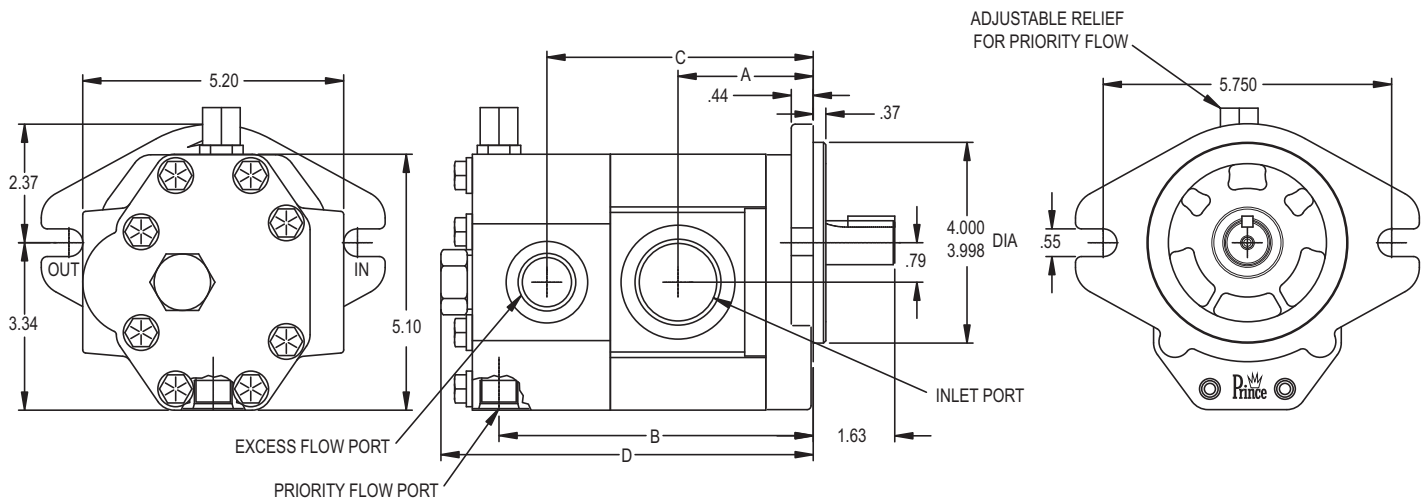

RIGHT HAND ROTATION SHOWN. FOR LEFT HAND ROTATION, INLET AND EXCESS FLOW PORTS GO TO THE OPPOSITE SIDE OF THE PUMP, PRIORITY FLOW PORT GOES FROM THE BOTTOM TO THE TOP OF THE PUMP.

## SPECIFICATIONS

MODEL NUMBER	DISP. IN <sup>3</sup> /REV	RATED PRESSURE	MAX. RPM	A	B	C	D	INLET PORT SIZE		EXCESS FLOW PORT SIZE	PRIORITY FLOW PORT SIZE	WT. (LB.)
SP25P19	1.141	3000	3000	2.49	6.26	5.32	7.42	1 5/16-12 UN-2B	3/4" FULL THREAD DEPTH	1 1/16-12 UN-2B	3/4-16 UN-2B	14.7
SP25P22	1.349	3000	3000	2.55	6.38	5.44	7.54					14.9
SP25P27	1.660	3000	3000	2.64	6.56	5.62	7.71	1 5/8-12 UN-2B	3/4" FULL THREAD DEPTH	3/4" FULL THREAD DEPTH	9/16" FULL THREAD DEPTH	15.3
SP25P32	2.008	3000	3000	2.74	6.75	5.82	7.91					16.7
SP25P38	2.318	3000	3000	2.83	6.93	5.99	8.09					17.8
SP25P44	2.697	3000	3000	2.94	7.15	6.21	8.30					18.2
SP25P52	3.179	2500	2500	3.07	7.42	6.49	8.58	1 7/8-12				18.7
SP25P63	3.869	2500	2100	3.27	7.82	6.88	8.97	1 7/8-12				19.7

FOR PUMP PERFORMANCE DATA AND SHAFT DIMENSIONAL DATA, REFER TO THE SP25A PUMP SECTION.  
Standard Seal Kit for all SP25 Models is Prince Part No. PMCK-SP25.



# SPHL1 HI-LO PUMP SERIES MODEL CODE

**SPHL1B 0616 H 2 R**

**SERIES NO.** \_\_\_\_\_

**DISPLACEMENT CODE (CC/REV)** \_\_\_\_\_

06 16 (CC/REV)  
08 23 (CC/REV)

**MOUNTING** \_\_\_\_\_

H-SAE "A" 2 BOLT  
TIME FACTORY SETTING FOR THE SHIFTING SEQUENCE CARTRIDGE IS SET FOR 500 PS. SHIFTING SEQUENCE CARTRIDGE IS ADJUSTABLE.

**ROTATION (FACING END OF SHAFT)**  
L-COUNTERCLOCKWISE  
R-CLOCKWISE

**DRIVE SHAFT**  
9-SAE 9 TOOTH 16/32 SPLINE  
2-SAE 5/8" STRAIGHT KEYED

## SPHL1 DIMENSIONAL DATA

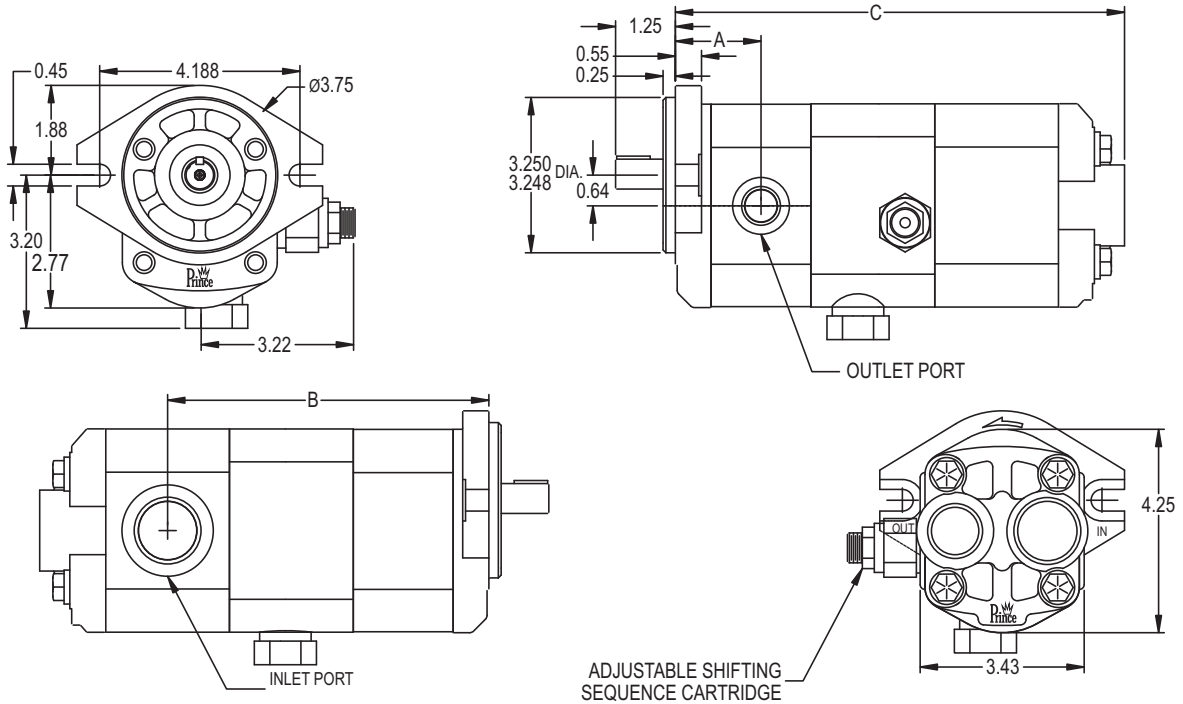

NOTE: CLOCKWISE ROTATION SHOWN. FOR COUNTERCLOCKWISE ROTATION, PORTS ARE ON THE OPPOSITE SIDES.

## SPECIFICATIONS

MODEL NUMBER	FRONT DISP. IN <sup>3</sup> /REV.	REAR DISP. IN <sup>3</sup> /REV.	RATED PRESSURE	MAX RPM	A	B	C	INLET PORT SIZE	OUTLET PORT SIZE	FULL THREAD DEPTH	WT. (LB.)
SPHL1B0616	.400	.976	3000	3600	1.79	6.72	9.39	1 5/16-12 UN-2B	3/4-16 UN-2B	3/4"	14.4
SPHL1B0823	.499	1.403	3000	3600	1.83	6.99	9.85		1 1/16-12 UN-2B		14.7

## PERFORMANCE

PUMP	RPM	HIGH FLOW (GPM)	LOW FLOW (GPM)	RECOMMENDED INPUT HORSEPOWER FOR 3000 PSI MAXIMUM WORKING PRESSURE	*NOTE: PLEASE CONSULT FACTORY FOR HORSEPOWER REQUIREMENTS OF DIFFERENT WORKING AND SHIFT PRESSURES.
SPHL1B0616	1800	10.51	2.98	7.8	
	3600	21.01	6.00	16.0	
SPHL1B0823	1800	14.40	3.70	10.0	
	3600	28.52	7.51	22.0	

Seal Kit for SPHL1 is Prince Part No. PMCK-SPHL1

## SPD2 DOUBLE PUMPS



SPD2 as shown from rear

The SPD2 series of pumps are special SP-25A series pumps with through shafts. The through shafts have 9 tooth internal splines at the rear and the pump's rear cover has an integral SAE A-2 bolt mount pad. For double pump operation, a standard SAE A-2 bolt-splined shaft pump can be directly mounted on the rear on the SPD2. Typical performance of the pump is the same as indicated for the SP-25A series pump.

### MODEL NO. CODING

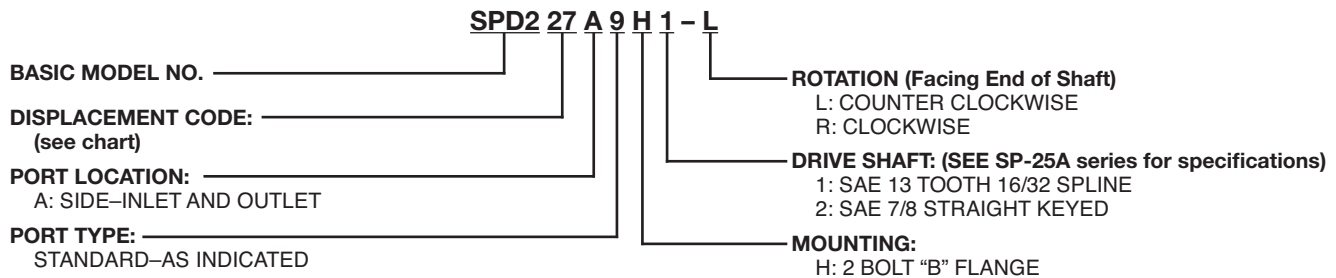

### SPECIFICATIONS

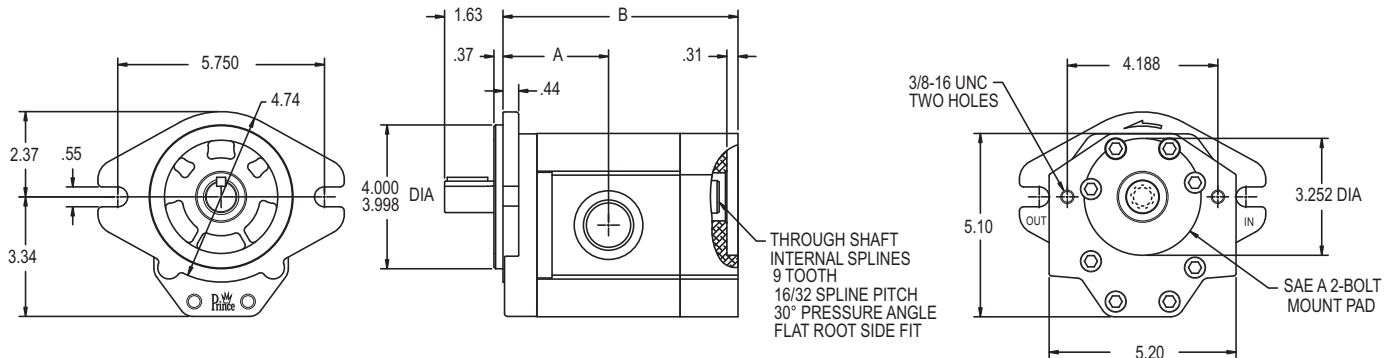

#### SPD2 THROUGH SHAFT PUMPS (PLUG-IN STYLE DOUBLE PUMPS)

MODEL NUMBER & DISPLACEMENT CODE	DISP. IN <sup>3</sup> /REV	RATED* PRESSURE (PSI)	MAX RPM	A (IN)	B (IN)	INLET PORT SIZE°	OUTLET PORT SIZE°	WT. (LB.)
SPD219	1.141	3000	3000	2.49	5.65	1 5/16-12	1 1/16-12	12.9
SPD222	1.349	3000	3000	2.55	5.77	1 5/16-12	1 1/16-12	13.1
SPD227	1.660	3000	3000	2.64	5.95	1 5/16-12	1 1/16-12	13.5
SPD232	2.008	3000	3000	2.74	6.15	1 5/8-12	1 5/16-12	13.9
SPD238	2.318	3000	3000	2.83	6.32	1 5/8-12	1 5/16-12	14.4
SPD244	2.697	3000	3000	2.94	6.54	1 5/8-12	1 5/16-12	14.9
SPD252	3.179	2500	3000	3.07	6.81	1 5/8-12	1 5/16-12	15.7
SPD263	3.869	2500	3000	3.27	7.21	1 7/8-12	1 5/16-12	16.4

° Standard ports as indicated are UN-2B straight thread O-Ring boss ports. Optional sizes and configurations are available. Consult factory. \*Maximum operating pressure may be decreased depending on the displacement and operating pressure of the rear pump. The combination must conform to the following equation  $PF \times DF + PR \times DR < 13200$  where PF and PR are the operation pressures (psi) and DF and DR are the displacements (in<sup>3</sup>/rev) for the front and rear pumps respectively.

## SPD1 DOUBLE PUMPS

The SPD1 series of double pumps consists of two SP20B pump sections. The typical performance of each section and the features of the pump are the same as indicated for the SP20B series of pumps.

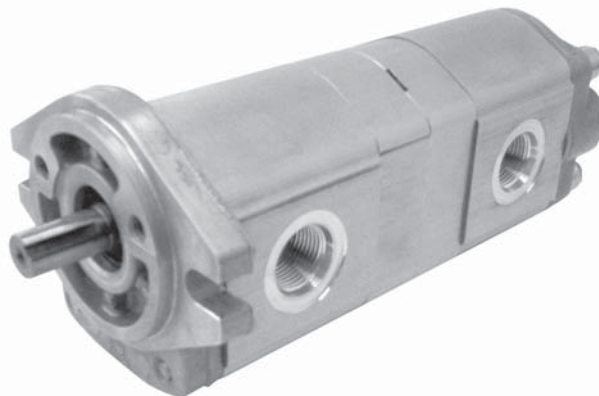

## SPD1 DOUBLE PUMPS

**SPD1B 16 09 - 1 H 9 L**

<p><b>BASIC MODEL NO.</b> _____</p> <p><b>FRONT PUMP (SHAFT END)</b> _____</p> <p>Displacement Code (see chart)</p> <p><b>REAR PUMP</b> _____</p> <p>DISPLACEMENT CODE (SEE CHART)</p>	<p><b>ROTATION: (FACING END OF SHAFT)</b></p> <p>L: COUNTER CLOCKWISE</p> <p>R: CLOCKWISE</p> <p><b>Drive Shaft Code:*</b></p> <p>9: SAE 9 TOOTH 16/32 SPLINE</p> <p>2: SAE 5/8" STRAIGHT KEYED</p> <p>3 - 11 TOOTH 16/32 SPLINE</p> <p>4 - 3/4 STRAIGHT KEYED</p> <p><b>MOUNTING:</b></p> <p>H: 2 BOLT "A" FLANGE</p> <p><b>INLET CODE:</b></p> <p>1: COMMON INLET (NO REAR INLET)</p> <p>2: SEPARATE INLET (INLETS-BOTH SECTIONS)</p>
--	---

\*Pumps with nonstandard shafts available in minimum quantities.

## SPD1 DOUBLE PUMPS

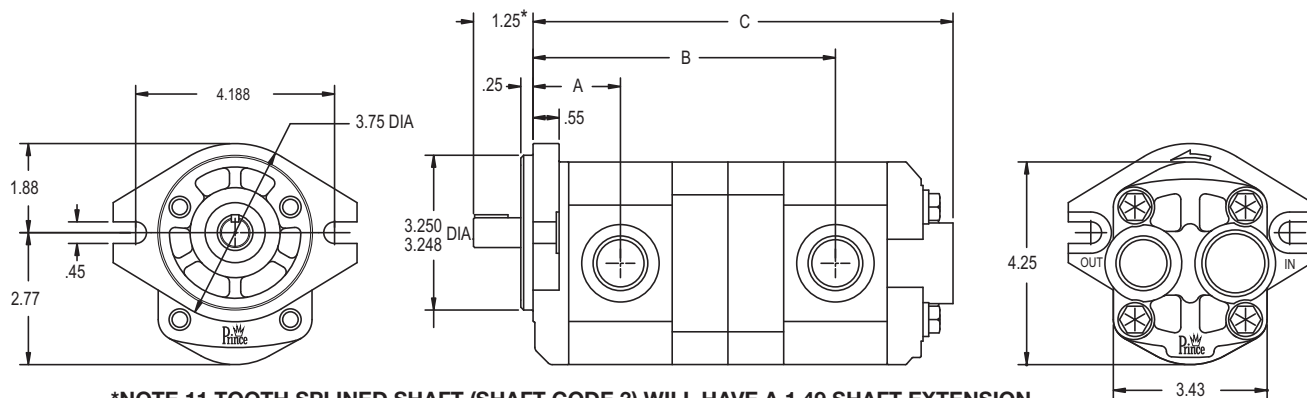

### SPLINED SHAFT SPECIFICATIONS

**SHAFT CODE 9**  
 9 Tooth  
 16/32 DP  
 30° PA  
 Flat Root Side Fit

**SHAFT CODE 3**  
 11 Tooth  
 16/32 DP  
 30° PA  
 Flat Root Side Fit

### KEYED SHAFT SPECIFICATIONS

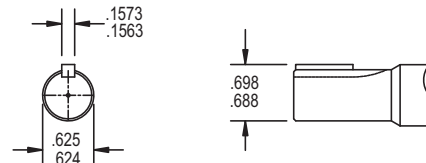

**SPD1 SERIES DOUBLE PUMPS**

BASIC MODEL NUMBER & DISPLACEMENT CODES	DISPLACEMENT		MAXIMUM PRESSURE For 9 tooth & 5/8" shaft (for 11 tooth and 3/4" see formula below)		MAXIMUM SPEED RPM	OUTLET PORT <sup>o</sup> SAE SIZE		INLET PORT SAE SIZE <sup>o</sup> SEPARATE INLET PUMP		INLET PORT SAE SIZE COMMON INLET PUMP		PUMP DIMENSIONS			WT. (L.B.)
	FRONT CU IN/REV	REAR CU IN/REV	FRONT PSI	REAR PSI		FRONT PUMP	REAR PUMP	FRONT PUMP	REAR PUMP	FRONT PUMP	REAR PUMP	A IN.	B IN.	C IN.	
SPD1B 08 08	0.499	0.499	3000	3000	3500	7/8-14	7/8-14	1/1/16-12	1/1/16-12	1/1/16-12	1/1/16-12	1.83	6.35	8.81	11.6
SPD1B 09 08	0.589	0.499	3000	3000	3500	7/8-14	7/8-14	1/1/16-12	1/1/16-12	1/1/16-12	1/1/16-12	1.87	6.43	8.89	11.8
SPD1B 09 09	0.589	0.589	3000	3000	3500	7/8-14	7/8-14	1/1/16-12	1/1/16-12	1/1/16-12	1/1/16-12	1.87	6.46	8.97	12.0
SPD1B 11 08	0.677	0.499	3000	3000	3500+	7/8-14	7/8-14	1/1/16-12	1/1/16-12	1/1/16-12	1/1/16-12	1.91	6.50	8.97	12.0
SPD1B 11 09	0.677	0.589	3000	3000	3500+	7/8-14	7/8-14	1/1/16-12	1/1/16-12	1/1/16-12	1/1/16-12	1.91	6.54	9.05	12.2
SPD1B 11 11	0.677	0.677	3000	3000	3500+	7/8-14	7/8-14	1/1/16-12	1/1/16-12	1/1/16-12	1/1/16-12	1.91	6.58	9.13	12.4
SPD1B 14 08	0.860	0.499	3000	3000	3500	7/8-14	7/8-14	1/1/16-12	1/1/16-12	1/1/16-12	1/1/16-12	1.99	6.66	9.13	12.2
SPD1B 14 09	0.860	0.589	2800*	2800*	3500	7/8-14	7/8-14	1/1/16-12	1/1/16-12	1/1/16-12	1/1/16-12	1.99	6.70	9.21	12.4
SPD1B 14 11	0.860	0.677	2600*	2800*	3500	7/8-14	7/8-14	1/1/16-12	1/1/16-12	1/1/16-12	1/1/16-12	1.99	6.74	9.29	12.6
SPD1B 14 14	0.860	0.860	2400*	2400*	3500	7/8-14	7/8-14	1/1/16-12	1/1/16-12	1/1/16-12	1/1/16-12	1.99	6.82	9.44	12.8
SPD1B 16 08	0.976	0.499	2800*	2800*	3500	7/8-14	7/8-14	1/1/16-12	1/1/16-12	1/1/16-12	1/1/16-12	2.04	6.76	9.23	12.5
SPD1B 16 09	0.976	0.589	2600*	2600*	3500	7/8-14	7/8-14	1/1/16-12	1/1/16-12	1/1/16-12	1/1/16-12	2.04	6.80	9.30	12.7
SPD1B 16 11	0.976	0.677	2400*	2600*	3500	7/8-14	7/8-14	1/1/16-12	1/1/16-12	1/1/16-12	1/1/16-12	2.04	6.84	9.38	12.9
SPD1B 16 14	0.976	0.860	2200*	2400*	3500	7/8-14	7/8-14	1/1/16-12	1/1/16-12	1/1/16-12	1/1/16-12	2.04	6.92	9.54	13.1
SPD1B 16 16	0.976	0.976	2000*	2200*	3500+	7/8-14	7/8-14	1/1/16-12	1/1/16-12	1/1/16-12	1/1/16-12	2.04	6.97	9.64	13.4
SPD1B 20 08	1.220	0.499	2400*	2400*	3500	1/1/16-12	7/8-14	1/5/16-12	1/1/16-12	1/5/16-12	1/5/16-12	2.15	6.98	9.44	12.7
SPD1B 20 09	1.220	0.589	2200*	2400*	3500	1/1/16-12	7/8-14	1/5/16-12	1/1/16-12	1/5/16-12	1/5/16-12	2.15	7.02	9.52	12.9
SPD1B 20 11	1.220	0.677	2200*	2200*	3500	1/1/16-12	7/8-14	1/5/16-12	1/1/16-12	1/5/16-12	1/5/16-12	2.15	7.06	9.60	13.1
SPD1B 20 14	1.220	0.860	2000*	2000*	3500	1/1/16-12	7/8-14	1/5/16-12	1/1/16-12	1/5/16-12	1/5/16-12	2.15	7.13	9.76	13.3
SPD1B 20 16	1.220	0.976	1800*	2000*	3500+	1/1/16-12	7/8-14	1/5/16-12	1/1/16-12	1/5/16-12	1/5/16-12	2.15	7.18	9.86	13.6
SPD1B 20 20	1.220	1.220	1600*	1800*	3500+	1/1/16-12	1/1/16-12	1/5/16-12	1/5/16-12	1/5/16-12	1/5/16-12	2.15	7.29	10.07	13.8
SPD1B 23 08	1.403	0.499	2200*	2200*	3500	1/1/16-12	7/8-14	1/5/16-12	1/1/16-12	1/5/16-12	1/5/16-12	2.23	7.13	9.60	12.9
SPD1B 23 09	1.403	0.589	2000*	2200*	3500	1/1/16-12	7/8-14	1/5/16-12	1/1/16-12	1/5/16-12	1/5/16-12	2.23	7.17	9.68	13.1
SPD1B 23 11	1.403	0.677	2000*	2000*	3500	1/1/16-12	7/8-14	1/5/16-12	1/1/16-12	1/5/16-12	1/5/16-12	2.23	7.21	9.76	13.3
SPD1B 23 14	1.403	0.860	1800*	2000*	3500	1/1/16-12	7/8-14	1/5/16-12	1/1/16-12	1/5/16-12	1/5/16-12	2.23	7.29	9.92	13.5
SPD1B 23 16	1.403	0.976	1800*	1800*	3500	1/1/16-12	7/8-14	1/5/16-12	1/1/16-12	1/5/16-12	1/5/16-12	2.23	7.34	10.01	13.8
SPD1B 23 20	1.403	1.220	1600*	1600*	3500+	1/1/16-12	1/1/16-12	1/5/16-12	1/5/16-12	1/5/16-12	1/5/16-12	2.23	7.45	10.23	14.0
SPD1B 23 23	1.403	1.403	1400*	1600*	3500+	1/1/16-12	1/1/16-12	1/5/16-12	1/5/16-12	1/5/16-12	1/5/16-12	2.23	7.53	10.39	14.2
SPD1B 27 08	1.654	0.499	1800*	2000*	3500	1/1/16-12	7/8-14	1/5/16-12	1/1/16-12	1/5/16-12	1/5/16-12	2.34	7.35	9.82	13.1
SPD1B 27 09	1.654	0.589	1800*	2000*	3500	1/1/16-12	7/8-14	1/5/16-12	1/1/16-12	1/5/16-12	1/5/16-12	2.34	7.39	9.90	13.3
SPD1B 27 11	1.654	0.677	1800*	1800*	3500	1/1/16-12	7/8-14	1/5/16-12	1/1/16-12	1/5/16-12	1/5/16-12	2.34	7.43	9.97	13.5
SPD1B 27 14	1.654	0.860	1600*	1800*	3500	1/1/16-12	7/8-14	1/5/16-12	1/1/16-12	1/5/16-12	1/5/16-12	2.34	7.51	10.13	13.7
SPD1B 27 16	1.654	0.976	1600*	1600*	3500	1/1/16-12	7/8-14	1/5/16-12	1/1/16-12	1/5/16-12	1/5/16-12	2.34	7.56	10.23	14.0
SPD1B 27 20	1.654	1.220	1400*	1600*	3500+	1/1/16-12	1/1/16-12	1/5/16-12	1/5/16-12	1/5/16-12	1/5/16-12	2.34	7.67	10.45	14.2
SPD1B 27 23	1.654	1.403	1400*	1400*	3500+	1/1/16-12	1/1/16-12	1/5/16-12	1/5/16-12	1/5/16-12	1/5/16-12	2.34	7.74	10.60	14.4
SPD1B 27 27	1.654	1.654	1200*	1400*	3500+	1/1/16-12	1/1/16-12	1/5/16-12	1/5/16-12	1/5/16-12	1/5/16-12	2.34	7.85	10.82	14.6

<sup>o</sup> Standard ports as indicated are UN-2B straight thread 0-Ring boss ports. Optional sizes and configurations are available. Consult factory.

\* Different pressure and shaft combinations may be used if required provided they conform to the following equations PF x DF + PR x DR < 4150 for 9 tooth & 5/8" shafts (6250 for 11 tooth & 3/4" shafts) where PF and PR are the operating pressures (psi) and DF and DR are the displacements (cu in/rev) for the front and rear pumps respectively (maximum pressures are 3000 psi for displacement codes 8 - 20 and 2500 psi for displacement codes 23 - 27).

+ Common inlet pumps require a reduction in maximum rpm. Consult factory.

## SPD3 DOUBLE PUMPS

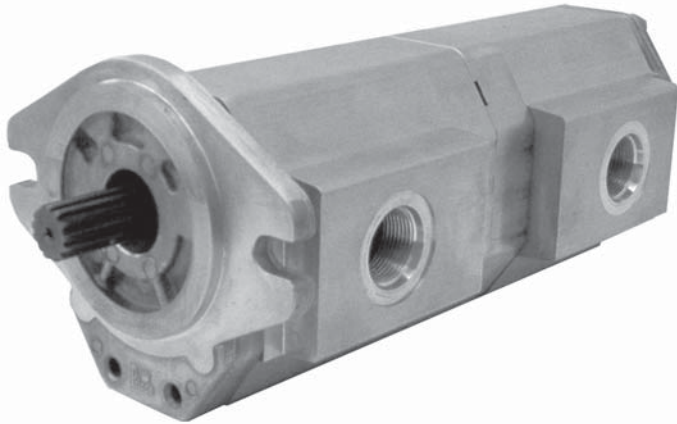

The SPD3 series of double pumps consists of two SP-25A pump sections. The typical performance of each section and the features of the pump are the same as indicated for the SP-25A series of pumps.

### MODEL NO. CODING

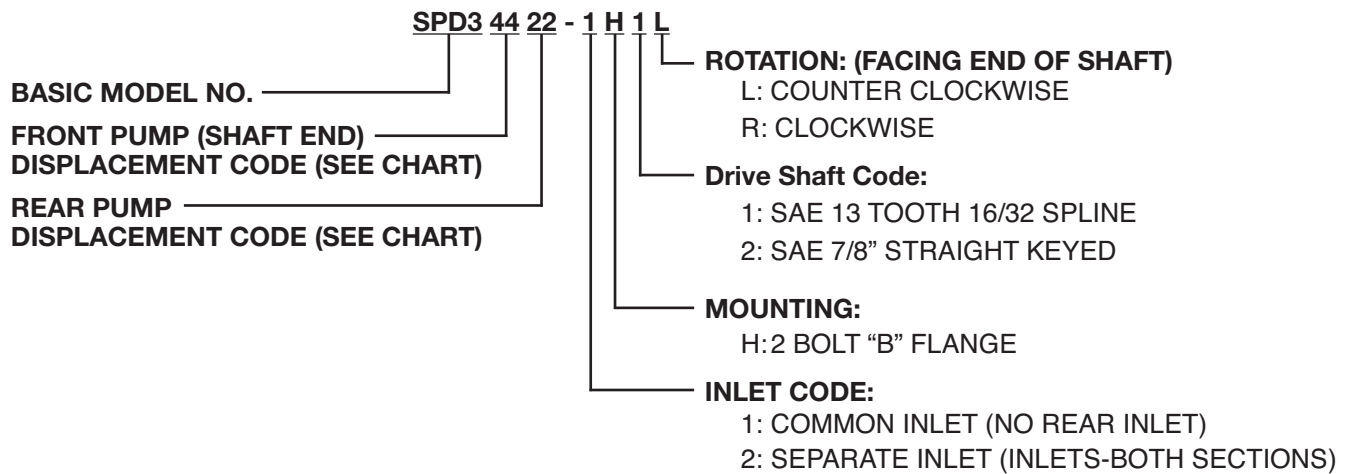

### DIMENSIONS

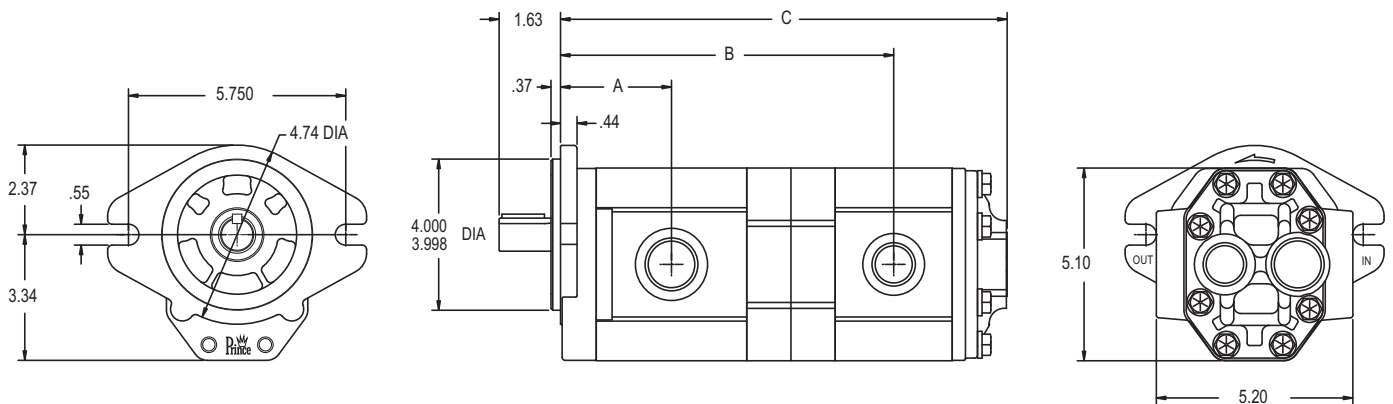

#### SPLINED SHAFT SPECIFICATIONS

Per SAE Specifications

13 Tooth

16/32 Spline Pitch

30 Degree Pressure Angle

Flat Root Side Fit

#### KEYED SHAFT SPECIFICATIONS

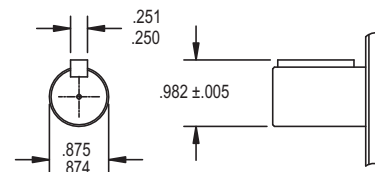

**SPD3 SERIES DOUBLE PUMPS**

BASIC MODEL NUMBER & DISPLACEMENT CODES	DISPLACEMENT		MAXIMUM PRESSURE		MAXIMUM SPEED RPM	OUTLET PORT <sup>o</sup> SAE SIZE		INLET PORT SAE SIZE <sup>o</sup> SEPARATE INLET PUMP		INLET PORT SAE SIZE <sup>o</sup> COMMON INLET PUMP		PUMP DIMENSIONS			WT. (L.B.)
	FRONT CU IN/REV	REAR CU IN/REV	FRONT PSI	REAR PSI		FRONT PUMP	REAR PUMP	FRONT PUMP	REAR PUMP	FRONT PUMP	REAR PUMP	A IN.	B IN.	C IN.	
SPD3 19 19	1.141	1.141	3000	3000	3000	1 1/16-12	1 1/16-12	1 5/16-12	1 5/16-12	1 5/8-12	NONE	2.49	7.93	10.93	23.3
SPD3 22 19	1.349	1.141	3000	3000	3000	1 1/16-12	1 1/16-12	1 5/16-12	1 5/16-12	1 5/8-12	NONE	2.55	8.05	11.05	23.5
SPD3 22 22	1.349	1.349	3000	3000	3000	1 1/16-12	1 1/16-12	1 5/16-12	1 5/16-12	1 5/8-12	NONE	2.55	8.11	11.17	23.7
SPD3 27 19	1.660	1.141	3000	3000	3000	1 1/16-12	1 1/16-12	1 5/16-12	1 5/16-12	1 5/8-12	NONE	2.64	8.23	11.23	23.9
SPD3 27 22	1.660	1.349	3000	3000	3000	1 1/16-12	1 1/16-12	1 5/16-12	1 5/16-12	1 5/8-12	NONE	2.64	8.29	11.35	24.1
SPD3 27 27	1.660	1.660	3000	3000	3000	1 1/16-12	1 1/16-12	1 5/16-12	1 5/16-12	1 5/8-12	NONE	2.64	8.37	11.52	24.5
SPD3 32 19	2.008	1.141	3000	3000	3000	1 5/16-12	1 1/16-12	1 5/8-12	1 5/16-12	1 7/8-12	NONE	2.74	8.42	11.42	24.3
SPD3 32 22	2.008	1.349	3000	3000	3000	1 5/16-12	1 1/16-12	1 5/8-12	1 5/16-12	1 7/8-12	NONE	2.74	8.48	11.54	24.5
SPD3 32 27	2.008	1.660	3000	3000	3000	1 5/16-12	1 1/16-12	1 5/8-12	1 5/16-12	1 7/8-12	NONE	2.74	8.57	11.72	24.9
SPD3 32 32	2.008	2.008	3000	3000	3000	1 5/16-12	1 5/16-12	1 5/8-12	1 5/8-12	1 7/8-12	NONE	2.74	8.67	11.92	25.3
SPD3 38 19	2.318	1.141	3000	3000	3000	1 5/16-12	1 1/16-12	1 5/8-12	1 5/16-12	1 7/8-12	NONE	2.83	8.60	11.60	24.8
SPD3 38 22	2.318	1.349	3000	3000	3000	1 5/16-12	1 1/16-12	1 5/8-12	1 5/16-12	1 7/8-12	NONE	2.83	8.66	11.72	25.0
SPD3 38 27	2.318	1.660	3000	3000	3000	1 5/16-12	1 1/16-12	1 5/8-12	1 5/16-12	1 7/8-12	NONE	2.83	8.75	11.90	25.4
SPD3 38 32	2.318	2.008	3000	3000	3000	1 5/16-12	1 5/16-12	1 5/8-12	1 5/8-12	1 7/8-12	NONE	2.83	8.85	12.09	25.8
SPD3 38 38	2.318	2.318	3000	3000	3000	1 5/16-12	1 5/16-12	1 5/8-12	1 5/8-12	1 7/8-12	NONE	2.83	8.94	12.27	26.3
SPD3 44 19	2.697	1.141	3000	3000	3000	1 5/16-12	1 1/16-12	1 5/8-12	1 5/16-12	1 7/8-12	NONE	2.94	8.82	11.82	25.3
SPD3 44 22	2.697	1.349	3000	3000	3000	1 5/16-12	1 1/16-12	1 5/8-12	1 5/16-12	1 7/8-12	NONE	2.94	8.88	11.94	25.5
SPD3 44 27	2.697	1.660	3000	3000	3000	1 5/16-12	1 1/16-12	1 5/8-12	1 5/16-12	1 7/8-12	NONE	2.94	8.96	12.11	25.9
SPD3 44 32	2.697	2.008	2900*	2700*	3000	1 5/16-12	1 5/16-12	1 5/8-12	1 5/8-12	1 7/8-12	NONE	2.94	9.06	12.31	26.3
SPD3 44 38	2.697	2.318	2800*	2500*	3000+	1 5/16-12	1 5/16-12	1 5/8-12	1 5/8-12	1 7/8-12	NONE	2.94	9.15	12.49	26.8
SPD3 44 44	2.697	2.697	2600*	2300*	3000+	1 5/16-12	1 5/16-12	1 5/8-12	1 5/8-12	1 7/8-12	NONE	2.94	9.26	12.70	27.3
SPD3 52 19	3.179	1.141	2500	3000	3000	1 5/16-12	1 1/16-12	1 5/8-12	1 5/16-12	1 7/8-12	NONE	3.07	9.09	12.09	26.1
SPD3 52 22	3.179	1.349	2500	3000	3000	1 5/16-12	1 1/16-12	1 5/8-12	1 5/16-12	1 7/8-12	NONE	3.07	9.15	12.21	26.3
SPD 52 27	3.179	1.660	2500	3000	3000	1 5/16-12	1 1/16-12	1 5/8-12	1 5/16-12	1 7/8-12	NONE	3.07	9.24	12.39	26.7
SPD3 52 32	3.179	2.008	2500*	2500*	3000	1 5/16-12	1 5/16-12	1 5/8-12	1 5/8-12	1 7/8-12	NONE	3.07	9.34	12.59	27.1
SPD3 52 38	3.179	2.318	2300*	2500*	3000+	1 5/16-12	1 5/16-12	1 5/8-12	1 5/8-12	1 7/8-12	NONE	3.07	9.43	12.76	27.6
SPD3 52 44	3.179	2.697	2100*	2400*	3000+	1 5/16-12	1 5/16-12	1 5/8-12	1 5/8-12	1 7/8-12	NONE	3.07	9.54	12.98	28.1
SPD3 52 52	3.179	3.179	2000*	2100*	3000+	1 5/16-12	1 5/16-12	1 5/8-12	1 5/8-12	1 7/8-12	NONE	3.07	9.67	13.26	28.9
SPD3 63 19	3.869	1.141	2500*	2900*	3000	1 5/16-12	1 1/16-12	1 7/8-12	1 5/16-12	1 7/8-12	NONE	3.27	9.49	12.49	26.8
SPD3 63 22	3.869	1.349	2500*	2500*	3000	1 5/16-12	1 1/16-12	1 7/8-12	1 5/16-12	1 7/8-12	NONE	3.27	9.55	12.61	27.0
SPD3 63 27	3.869	1.660	2300*	2500*	3000	1 5/16-12	1 1/16-12	1 7/8-12	1 5/16-12	1 7/8-12	NONE	3.27	9.63	12.78	27.4
SPD3 63 32	3.869	2.008	2100*	2500*	3000+	1 5/16-12	1 5/16-12	1 7/8-12	1 5/8-12	1 7/8-12	NONE	3.27	9.73	12.98	27.8
SPD3 63 38	3.869	2.318	2000*	2300*	3000+	1 5/16-12	1 5/16-12	1 7/8-12	1 5/8-12	1 7/8-12	NONE	3.27	9.82	13.16	28.3
SPD3 63 44	3.869	2.697	1900*	2100*	3000+	1 5/16-12	1 5/16-12	1 7/8-12	1 5/8-12	1 7/8-12	NONE	3.27	9.93	13.37	28.8
SPD3 63 52	3.869	3.179	1700*	2000*	3000+	1 5/16-12	1 5/16-12	1 7/8-12	1 5/8-12	1 7/8-12	NONE	3.27	10.07	13.65	29.6
SPD3 63 63	3.869	3.869	1500*	1800*	3000+	1 5/16-12	1 5/16-12	1 7/8-12	1 7/8-12	1 7/8-12	NONE	3.27	10.26	14.04	30.3

o Standard ports as indicated are UN-2B straight thread 0-Ring boss ports. Optional sizes and configurations are available. Consult factory.

\* Different pressure combinations may be used if required provided they conform to the following equation PF x DF + PR x DR < 13200 where PF and PR are the operating pressures (psi) and DF and DR are the displacements (cu in/rev) for the front and rear pumps respectively (maximum pressures are 3000 psi for displacement codes 19 - 44 and 2500 psi for displacement codes 52 - 63).

Consult factory.

+ Common inlet pumps require a reduction in maximum rpm. Consult factory.

# CMM SERIES GEROTOR MOTOR – LOW SPEED – HIGH TORQUE

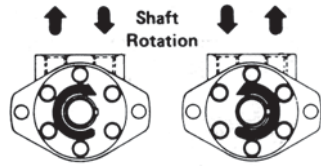

The Prince CMM Series of high-torque, low speed motors incorporates the orbiting gerotor principle for dependable operation over a wide range of applications. Although dimensionally small, this motor is capable of providing considerable power over a wide speed range and is instantly reversible by simply reversing the direction of the hydraulic fluid flow. The needs of many applications requiring high starting, stall and running torque combined with slow speed are met by this motor.

### Feature

- Fully reversible simply by reversing the direction of hydraulic fluid flow.
- Alternative port positioning for versatility of installation. (see next page).
- Optional shaft configurations. (see next page).
- Modular construction for economical servicing and repair, also permits special adaptations.

### Filtration

10 micron or finer. (Per ISO cleanliness code level 17/14.

### APPLICATIONS

Use the CMM Series for light to medium duty applications such as grain augers and elevators, salt and sand spreaders, car wash and sweeper brushes, conveyors, winches, scissor lifts, and many other. To assure optimum motor life, run motor for approximately one hour at 30% of rated pressure before application of full load.

### CROSS REFERENCE

CHARLYNN "H" Series  
DANFOSS "DH" Series

It is not recommended to operate at a condition requiring both maximum torque and speed. Splined shafts are recommended in application operating at above 2500 in-lbs. continuous torque or under conditions of frequent reversal.

ADM	DISPLACEMENT		MAXIMUM PRESSURE				MAXIMUM SPEED		WT.*
	CC/REV	CU.IN/REV	PSI		Kgf/CM <sup>2</sup>		RPM		
			CONT	INT <sup>o</sup>	CONT	INT <sup>o</sup>	CONT	INT <sup>o</sup>	
50	49.1	3.0	1400	2200	98	153	800	1000	12.8
100	99.6	6.1	1300	2000	91	139	600	750	13.4
200	199.2	12.2	1200	1800	84	125	300	400	14.5
300	293.2	17.9	1000	1600	70	111	200	250	15.5
400	398.4	24.4	900	1300	63	90	125	160	16.7

### Ordering Code

**MOTOR TYPE:**  
CMM

**MOTOR SIZE:**  
50  
100  
200  
300  
400

**MOUNTING:**  
2 Hole Flange – 2  
4 Hole Flange – 4

**SHAFT TYPE:**  
Standard 1\* Key R



### PORTS:

P – 1/2 NPTF  
(Standard)

Maximum Axial Thrust Load on Shaft 1000 lbs.

<sup>o</sup>Intermittent operation = 10% Operation of every minute

TEMP: NORMAL OPERATING 80° F TO 140° F, MAX 185° F

Maximum inlet pressure 2,500 psi for motors in series

Maximum back pressure 1,000 psi

OIL: Mineral based hydraulic fluid 100-200 SUS @ operating temperature.

## CMM SERIES

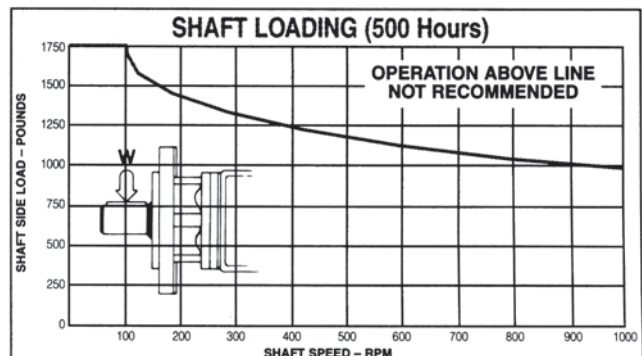
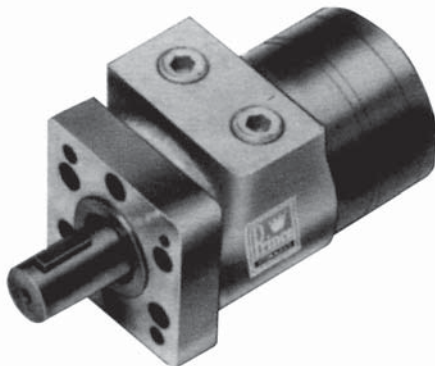

# MOUNTING DIMENSIONS CMM

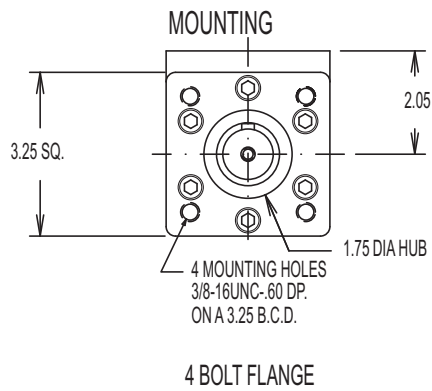

\* NOTE: MOUNTING DIMENSIONS ARE THE SAME FOR THE CMM.

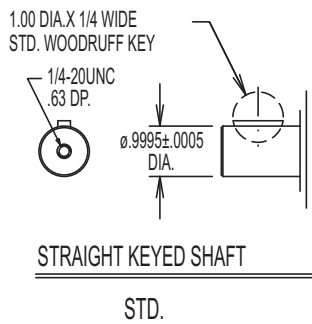

## PORT POSITIONS

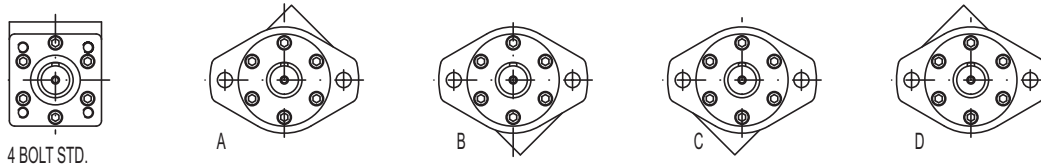

## CMM SERIES

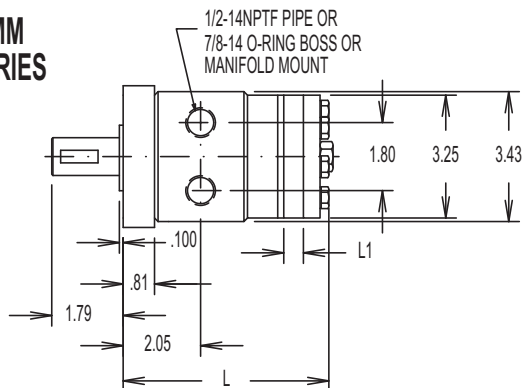

CMM	50	100	200	300	400
L	5.14	5.40	5.89	6.39	6.89
L1	.250	.520	1.00	1.50	2.00



# CMM SERIES MOTORS

346  
280

Colored number on top = TORQUE (in-lbs)  
Black number on bottom = SPEED (RPM)

■ GREATEST EFFICIENCY  
■ HIGH EFFICIENCY

## Performance Data

### CMM 50

		3.0 Cu. In. REV						Δ PSI	Peak
		200	400	600	800	1000	1200	1400	2250
G P M	2	69	139	209	279	349	419	489	787
		149	143	137	131	125	119	113	63
	4	66	136	206	276	346	416	486	784
		304	298	292	286	280	274	268	218
	6	62	132	202	272	342	412	482	780
		459	453	447	441	435	429	423	373
	8	55	125	195	265	335	405	475	775
		614	608	602	596	590	584	578	529
	10	47	117	187	257	327	397	467	768
		769	763	757	751	745	739	733	684
12	37	107	177	247	317	387	457	758	
	924	918	912	906	900	894	888	839	

### CMM 100

		6.07 Cu. In. REV						Δ PSI	Peak
		200	400	600	800	1000	1200	1950	
G P M	2	144	292	440	588	736	884	1437	
		72	68	64	60	56	52	30	
	4	138	286	434	582	730	878	1431	
		147	143	139	135	131	127	105	
	6	130	278	426	574	722	870	1423	
		222	219	216	213	210	207	185	
	8	119	267	415	563	711	859	1412	
		300	297	294	291	288	285	263	
	10	104	252	400	548	696	844	1397	
		375	372	369	366	363	360	368	
12	85	233	381	529	677	825	1378		
	452	449	446	443	440	437	415		
14	64	212	360	508	656	804	1357		
	528	525	522	519	516	513	491		

### CMM 200

		12.15 Cu. In. REV					Δ PSI	Peak
		200	400	600	800	1000	1650	
G P M	2	283	563	843	1123	1403		
		35	32	29	26	23		
	4	273	553	833	1113	1393	2305	
		74	71	68	65	62	45	
	6	258	538	818	1098	1378	2290	
		112	109	106	103	100	83	
	8	237	517	797	1077	1357	2269	
		149	146	143	140	137	120	
	10	209	489	769	1049	1329	2241	
		187	184	181	178	175	158	
12	180	460	740	1020	1300	2112		
	225	223	220	217	214	197		
14	136	416	696	976	1256	2168		
	264	261	258	255	252	235		

### CMM 300

		17.9 Cu. In. REV				Δ PSI	Peak
		200	400	600	800	1350	
G P M	2	426	856	1286	1716		
		23	21	18	16		
	4	413	843	1273	1703	2890	
		49	46	44	41	27	
	6	392	822	1252	1682	2865	
		75	72	70	67	53	
	8	362	791	1222	1652	2830	
		101	98	95	93	79	
	10	324	754	1184	1614	2785	
		126	124	121	119	105	
12	277	707	1137	1567	2735		
	152	150	147	144	131		
14	222	652	1082	1512	2680		
	178	175	173	170	157		

### CMM 400

		24.4 Cu. In. REV				Δ PSI	Peak
		200	400	600	800	1200	
G P M	2	565	1136	1707	2279		
		16	14	12	10		
	4	549	1120	1691	2262	3392	
		36	33	31	29	20	
	6	520	1091	1663	2229	3371	
		55	53	51	48	39	
	8	481	1053	1624	2195	3335	
		74	73	70	68	59	
	10	430	1002	1573	2144	3274	
		94	91	89	86	77	
12	368	939	1511	2082	3213		
	113	11	108	106	97		
14	296	867	1438	2009	3147		
	132	130	127	125	116		

Δ PSI – is the actual pressure difference between the inlet and outlet ports.

A SITUATION OF SIMULTANEOUS PEAK TORQUE AND MAXIMUM RPM SHOULD NOT BE ALLOWED TO OCCUR.

Spined shafts are recommended in applications that operate at torques higher than 2500 in-lbs. Operating motors at both low rpm (10-20 depending on disp) and low torque may result in rpm fluctuations during operation.

To calculate horsepower from chart data use formula:

$$HP (out) = \frac{RPM \times TORQUE (in-lbs)}{63025}$$

## ADM SERIES HYDRAULIC MOTOR CROSS REFERENCE

		DISPLACEMENT CU. IN./REV.							
		SHAFT	PORTS	MOTOR BRAND	2.9	6.1	11.7	17.5	23.4
4 BOLT FLANGE MOUNTING	WOODRUFF KEYED	1/2" NPT	PRINCE CHARLYN H DANFOSS DH	CMM50-4RP 101-1001 151-2121	CMM100-4RP 101-1003 151-2123	CMM200-4RP 101-1005 151-2126	CMM300-4RP 101-1007 151-2128	CMM400-4RP 101-1008 151-2129	

NOTE: THE CROSS REFERENCE INFORMATION IN THIS CHART IS TO BE USED ONLY AS A REFERENCE FOR GUIDELINE PURPOSES ONLY. AFTER SELECTING A MODEL FROM ABOVE, REVIEW THE MOTOR SPECIFICATIONS TO DETERMINE COMPATIBILITY WITH SPECIFIC APPLICATION.