

JVC

SERVICE MANUAL

MODEL

QL-F61

QUARTZ LOCKED
FULLY-AUTOMATIC
TURNTABLE



No. 2560
March 1981

Contents

	Page		Page
1. Specification	1	7-(5) Lead-in Adjustment	10
2. Names of Controls and Their Function	2	7-(6) Tracking Force Adjustment	11
3. Operation of Automatic Mechanism	3	7-(7) Motor RPM Adjustment	11
3-(1) Mechanism	3	7-(8) Quartz Lock Adjustment	11
3-(2) Start/stop Mechanism	3	7-(9) Pitch Control Mechanism Adjustment	11
3-(3) Lead-in Mechanism	4	8. Block Diagrams	12
3-(4) Change Cycle Start Mechanism	5	9. Connection	12
3-(5) Repeat Operation	5	10. Printed Circuit Board Ass'y and Parts List	13
4. Exploded Views and Parts List	6	10-(1) TXX-343A LED P.C. Board Ass'y	13
4-(1) Mechanism Assembly	6	10-(2) TPS-309□Power Supply P.C. Board Ass'y	13
4-(2) Tonearm Assembly	8	10-(3) MC-944SG Motor Driver P.C. Board Ass'y	14
4-(3) Mechanism Base Assembly	8	11. Packing Materials and Part Numbers	15
5. Disassembly	9	12. Power Cord Connections in Different Areas	16
5-(1) Removal of Mechanism Base Assembly	9	12-(1) How to Handle the Solderless Connector	16
5-(2) Removal of Tonearm Assembly	9	13. Parts List with Specified Numbers for Designated Area	17
6. Cartridge Replacement	9	14. Trouble Shooting	18
7. Adjustment Procedures	10	14-(1) When Turntable Operation is Abnormal	18
7-(1) Overhang Adjustment	10	15. QL-F61 Schematic Diagrams	20
7-(2) Anti-skating Adjustment	10	16. Accessories List	22
7-(3) Tonearm Lifter Height Adjustment	10		
7-(4) Lead-out Adjustment	10		

Warning: When replacing the parts marked with \triangle , be sure to use the designated parts to ensure safety.

CHECKING YOUR LINE VOLTAGE (For U.S. Military Market and Other Countries)

Before inserting the power plug, please check this setting to see that it corresponds with the line voltage in your area. If it doesn't, be sure to adjust the voltage selector switch to the proper setting before operating this equipment. The voltage selector switch is located either underneath the platter on the cabinet.

CAUTION Before selecting the "Voltage selector switch" to proper voltage disconnect the power plug.

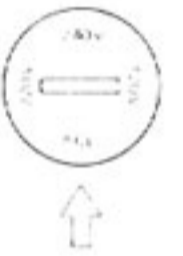

1. Specifications

MOTOR AND TURNTABLE

Type	Quartz Locked Fully-Automatic Turntable
Drive Motor	Coreless DC servomotor
Speeds:	33-1/3 and 45 rpm
Wow and flutter:	Less than 0.025% (WRMS), 0.015% (WRMS)* 0.04% (DIN)
Signal to Noise Ratio:	More than 75 dB (DIN-B)
Speed Adjustment	
Range:	More than $\pm 6\%$
Platter:	295 mm (11-5/8") Diameter Die-cast aluminum alloy

TONARM

Type:	Statically balanced straight tubular arm with JVC developed T.H. (Tracing-Hold) balancing system and tracking force dial in 0.1 gram steps.
Effective Arm Length:	220 mm
Tracking error:	$+3^{\circ}35' - 0^{\circ}43'$
Overhang:	15 mm
Tracking force range:	0 - 3 g
Weight range:	8.5 ~ 12 g
(including headshell)	

CARTRIDGE (not provided on units for U.S.A., Canada and the U.K.)

MODEL:	Z-1S
Type:	Moving Magnet (MD-1025)

Stylus tip:	0.6 mil. diamond (DT-Z1S)
Optimum tracking force:	1.75 ± 0.25 grams
Output:	3 mV (1kHz)
Frequency response:	10 to 25,000 Hz
Separation:	More than 25 dB (1 kHz) (with test record TRS-1)
Load Impedance:	47 k ohms - 100 k ohms
Compliance:	10×10^{-6} cm/dyne (Dynamic) 30×10^{-6} cm/dyne (Static)

GENERAL

Power Source:	See page 22
Power Consumption:	See page 22
Dimensions:	(H)4-1/2" x (W)16-9/16" x (D)14" (H)115 x (W)420 x (D)355mm (with cover closed) (Since the dimensions show only the design measurements, consideration is required when installing the unit in a limited space such as a rack).
Weight (NET):	12.1 lbs. (5.5 kg) (without corrugated cardboard case)

*Measured at attached encoder's output by K & K measuring method.

Design and specifications subject to change without notice.

2. Names of Controls and Their Functions

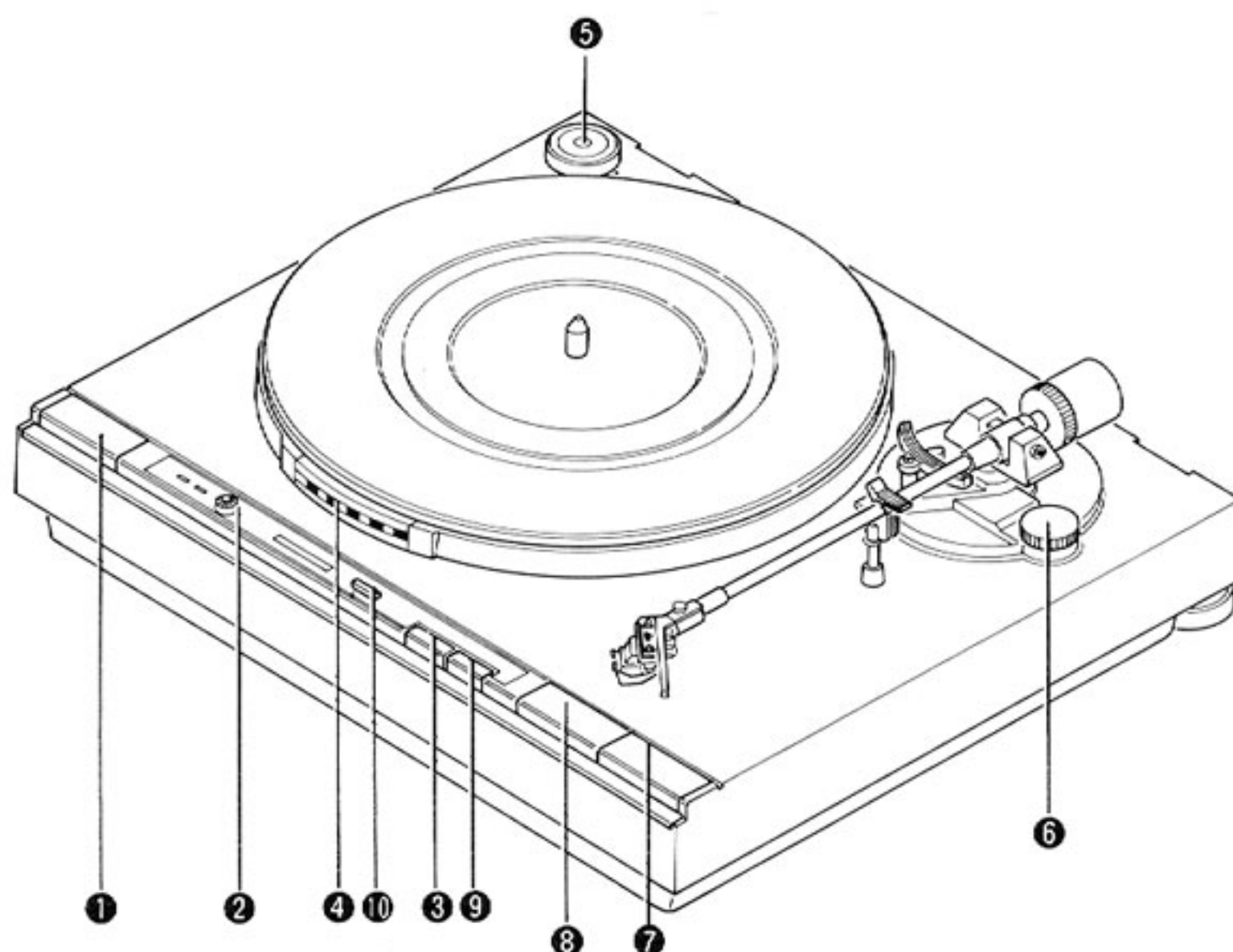

Fig. 1

1. SPEED select button

Depress the button according to the rpm of the record:

45 rpm: Depress it to (—) position.

33-1/3 rpm: Redepress it to (■) position.

2. PITCH CONTROL knob

Turning this knob, with the QUARTZ LOCK/PITCH CONTROL select button in the PITCH CONTROL position (■), adjusts turntable speed within the range of $\pm 6\%$. The SPEED INDICATOR helps check the variation of the speed.

3. Record SIZE select button

Depress the button in an automatic play depending on the size of the record.

17 cm diameter record: depress it to (—) position.

30 cm diameter record: redepress it to (■) position

4. Strobe patterns

The patterns around the periphery of the platter show if the platter rotates at a right speed. When a strobo pattern appears stationary, the platter is rotating at the right speed. If not, adjust the speed by turning the PITCH CONTROL knob to the right or left so as the strobo pattern to appear stationary.

5. EP adaptor

Place the adaptor on the center spindle when playing a record having a larger diameter center hole such as a doughnut record.

6. ANTI-SKATING knob

This device cancels out the centripetal force that pulls the tonearm to the center of the platter. This prevents the stylus tip from skating toward the center of the platter and at the same time eliminates any excessive stylus tip force on the inner wall of the record groove.

Use the ● marked dial when employing a conical stylus.

Use the ● marked dial when employing an elliptical stylus or a SHIBATA stylus.

Turn the dial to the same number on the tracking force dial.

7. Tonearm cueing button (Arm lifter button)

This is used when you want the tonearm gently lifted up or lowered down. When you PUSH it to "UP" position (—), the tonearm will be lifted up, and when you push it to "DOWN" position (■), it will be lowered down gently onto the record surface.

8. START/STOP button

To start to play a disc, depress the START button and the tonearm automatically moves and lowers itself on the record. The button need not be held depressed. To stop play before the record is finished, depress the STOP button. If the repeat button is held depressed, the record play will be automatically repeated.

9. REPEAT button

To enjoy repeated play of a record, depress this button in (—). Redepress it to OFF (■) to release the repeated play.

10. QUARTZ LOCK/PITCH CONTROL select button

QUARTZ LOCK: For playing records at an accurate speed of 33-1/3 or 45 rpm. When this button is pressed in ("—ON"), the turntable operates in the quartz-locked mode.

PITCH CONTROL: When this button is its "■OFF" position, the PITCH CONTROL knob becomes operable. Employ this position for playing records at a speed slightly different from the standard.

3. Operation of Automatic Mechanism

3-(1) Mechanism

The mechanism is illustrated below.

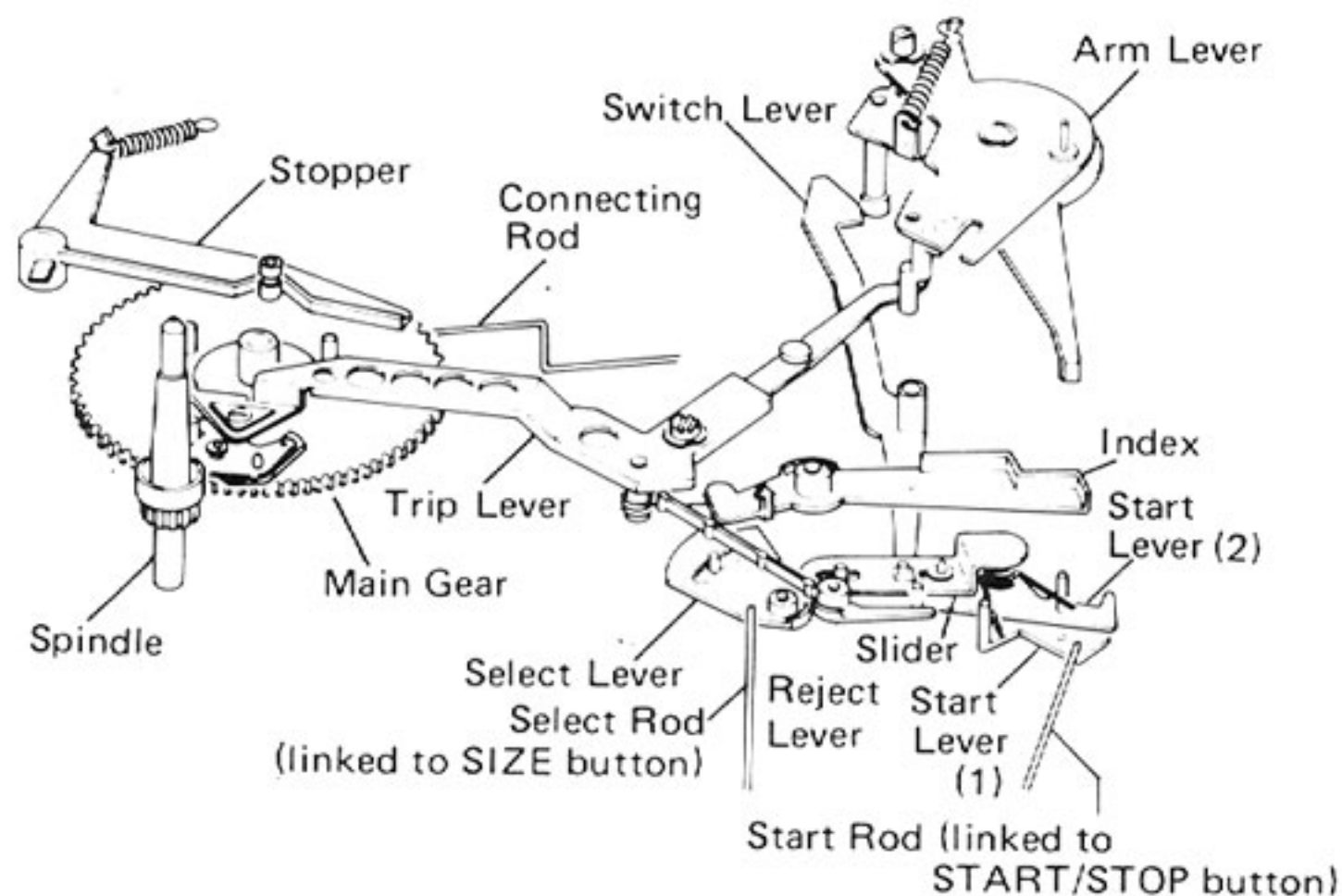

Fig. 2

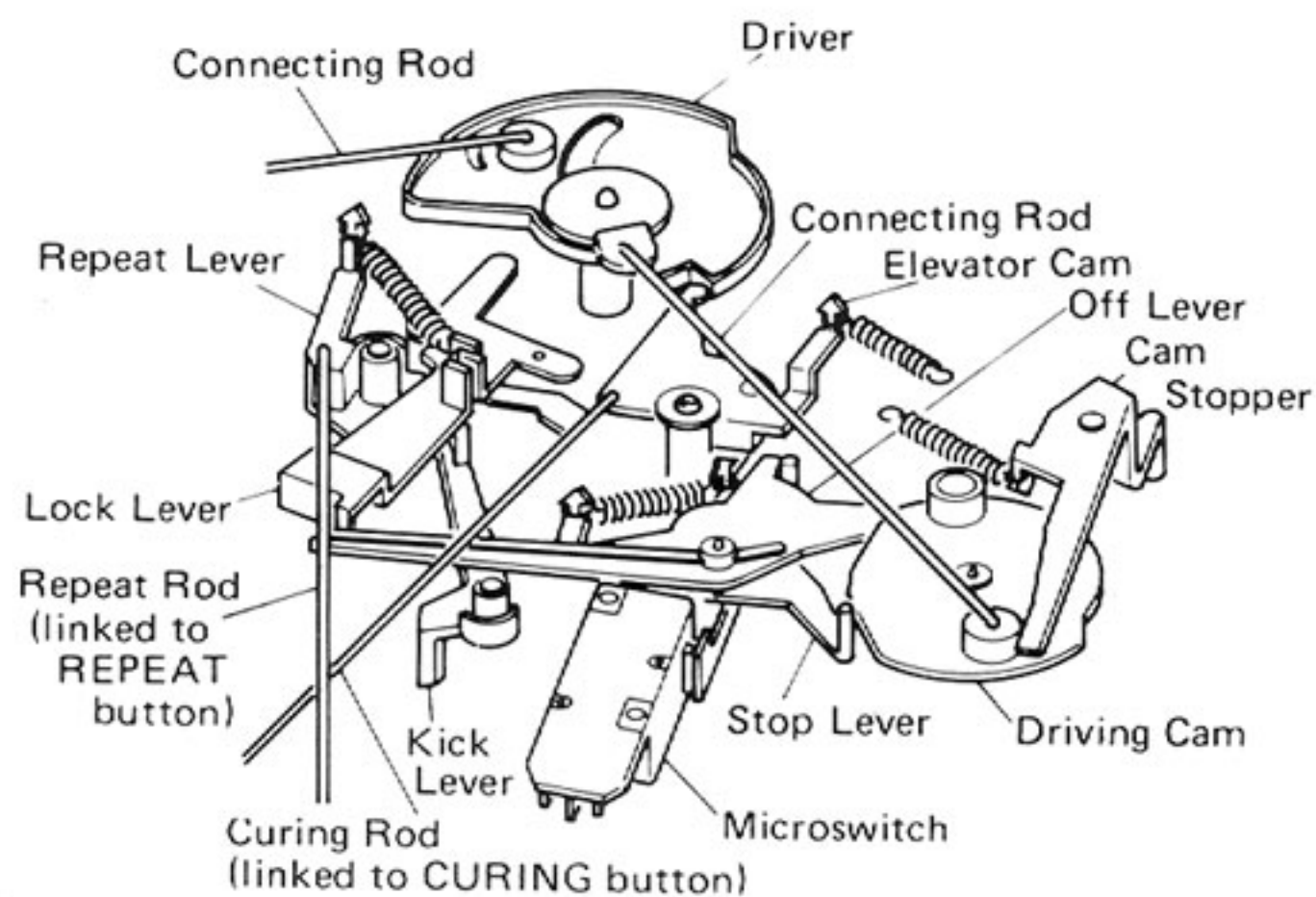

Fig. 3

3-(2) Start/stop Mechanism

1. Start

If you press the START/STOP button when the tone arm is on the rest, the mechanism operates as described below to turn on the player's power and prepare for moving the tonearm to the required position on the record.

Operation (See Figure 4.)

When the start rod is pushed in direction "a", start levers (1) and (2) linked to the start rod rotate in direction "b". During this time, part (A) of the kick lever is pressed which, in turn, presses stud (B) of the lock lever, locking the off and lock levers. As the off lever is locked, the slider moves in direction "c", turning on the micro-

switch. Now power is supplied to the player and the turntable starts to rotate.

On the other hand, as start levers (1) and (2) rotate in direction "b", boss (C) of start lever (2) causes the reject lever to move in direction "d" which, in turn, drives the trip lever in direction "e". The trip lever drives the engagement in direction "f". As a result, the turntable gear engages with the main gear and "change cycle" starts.

Figure 5 shows the state at the end of the above operation.

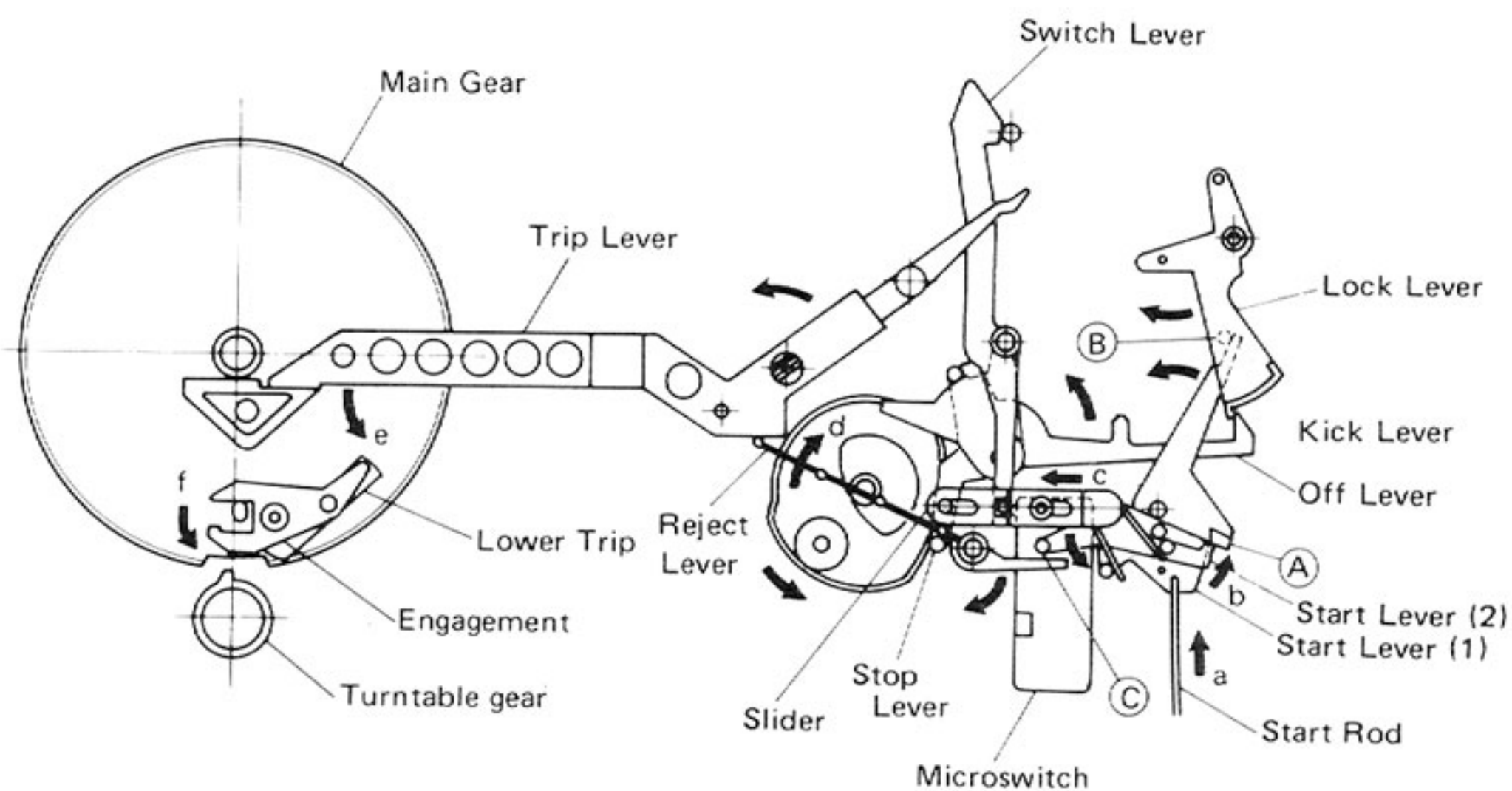

Fig. 4

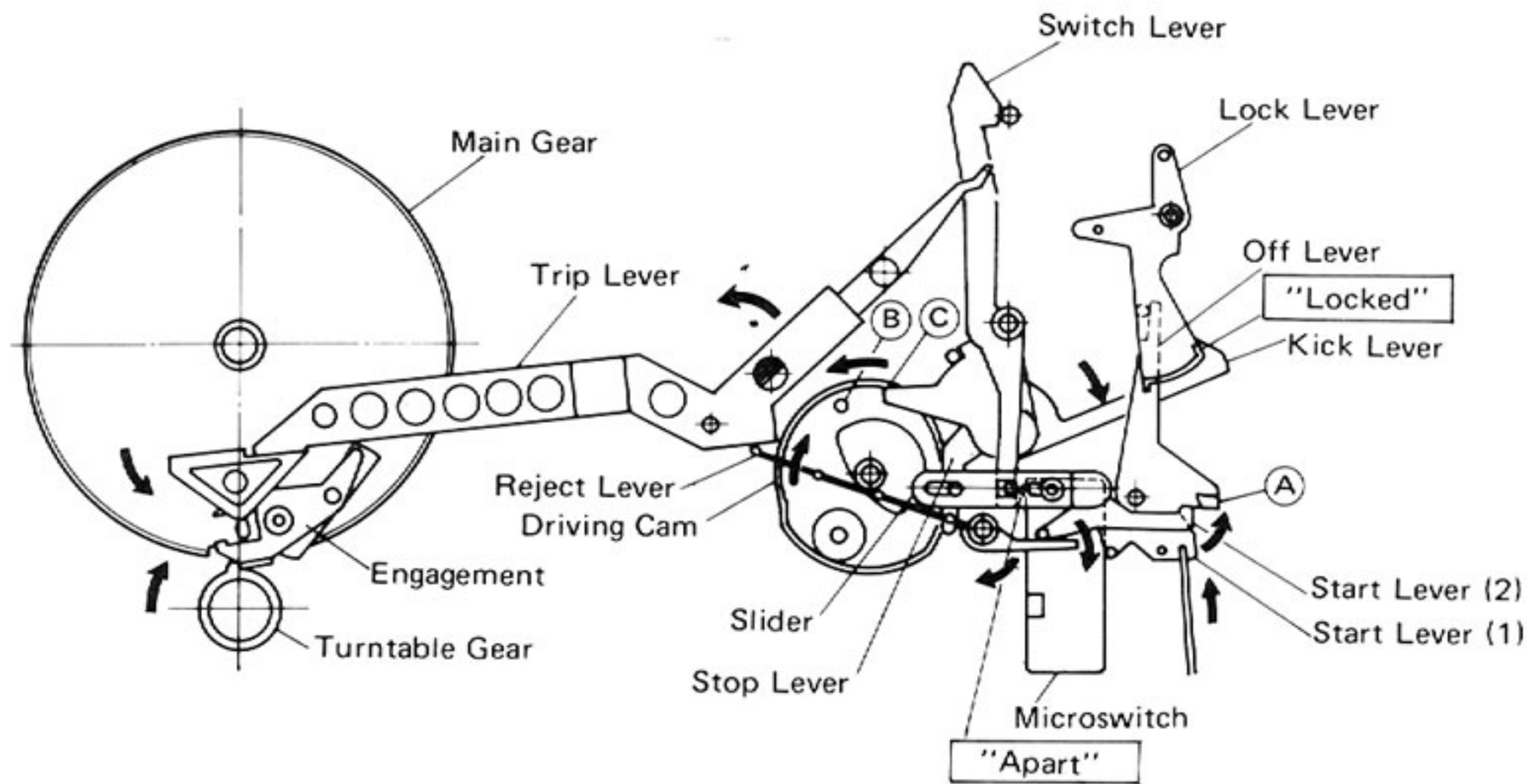

Fig. 5

2. Stop

Stop operation starts if the START/STOP button is pressed when the tonearm is in the "play" position (not on the rest).

Operation (See Figure 5.)

When start levers (1) and (2) rotate in direction "a", the reject lever alone is pushed in direction "b" (A of the kick lever is not pushed). The trip lever is driven by the reject lever and the "change cycle" starts.

In the change cycle, boss B of the driving cam pushes C of the off lever to return the off and lock levers to their initial positions and turn off the microswitch. Now a cycle of operation has ended.

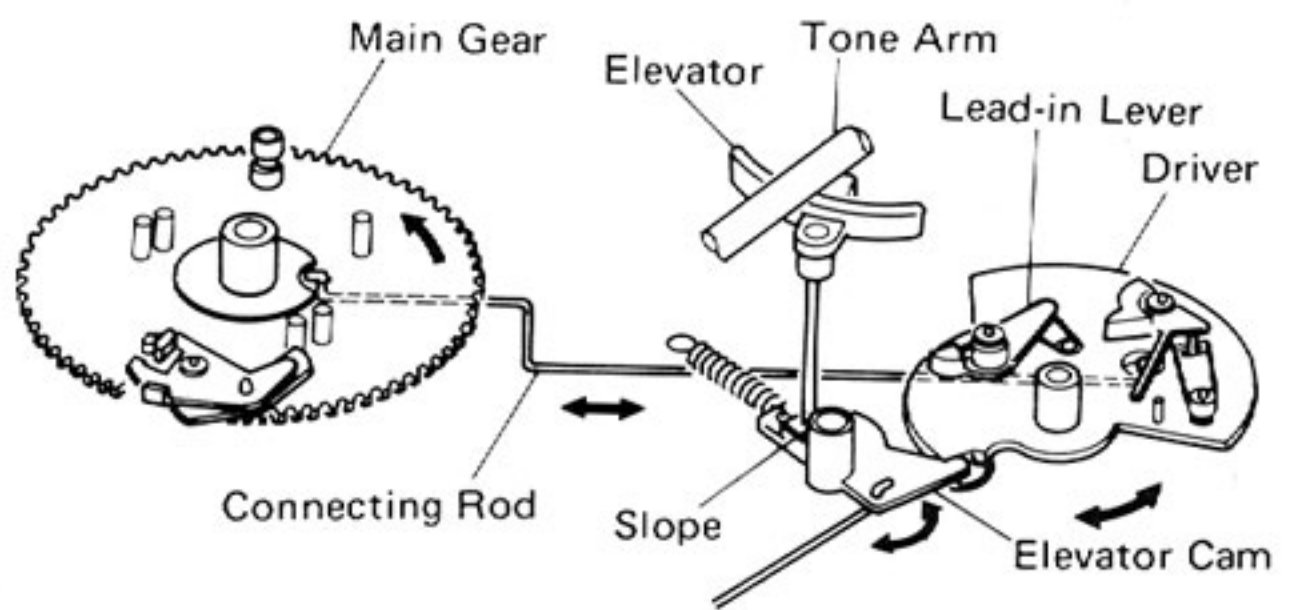

Fig. 6

3-(3) Lead-in Mechanism

When the change cycle starts and main gear rotates, the connecting rod moves the driver which rotates the elevator cam as shown the Figure 6.

As the elevator cam moves with the rotation of the driver toward A, the slope of the elevator cam causes the elevator to rise which, in turn, lifts the tonearm.

The lead-in lever keeps away from arm lever stud (A) see Figure 7.

At the end of rotation of the driver towards A, the lead-in lever contacts A of the lock lever (see Figure 8) and rotates in direction "a" (as if enclosing arm lever (A)). Then the driver rotates in direction B.

Arm lever stud (A) rotates with the driver to move the tonearm onto the record.

Note: When the driver rotates in direction A, the lead-in lever must be directed toward "a" as shown in Figure 7. Take note of this during adjustment.

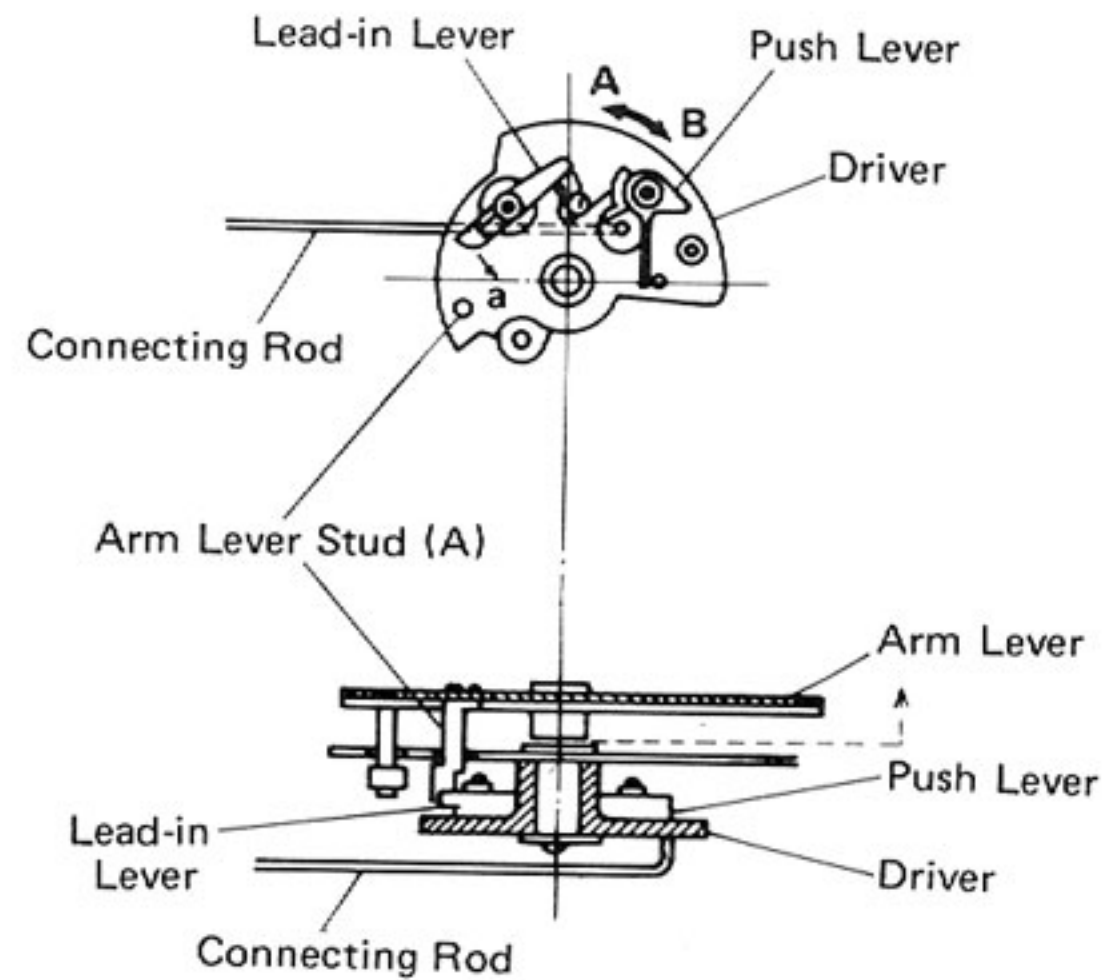

Fig. 7

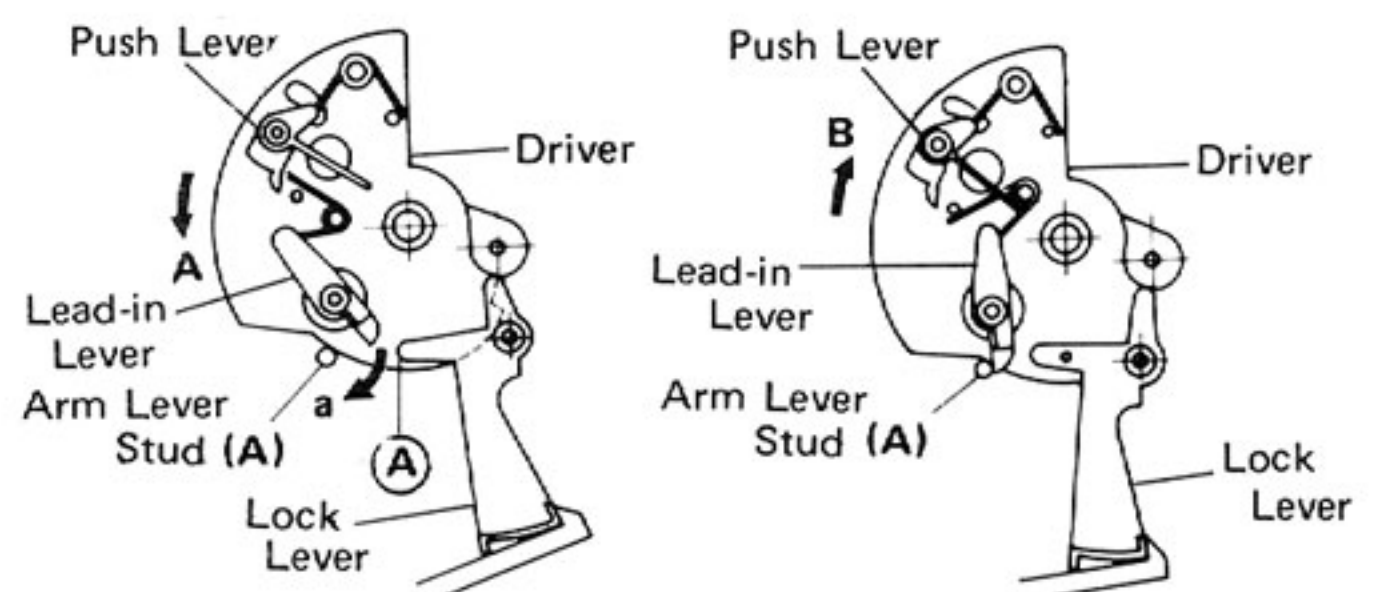

Fig. 8

Fig. 9

According to the SIZE button setting (17 or 30 cm), the tone arm will be moved to the required position on the record. Part (A) of the arm lever (see Figure 10) contacts the index stop (17 or 30 cm) and this determines the lead-in position then the lead-in lever returns toward "a" (see Figure 7).

To adjust the arm lever position (i.e. lead-in position), screw the eccentric adjuster.

3-(4) Change Cycle Start Mechanism

When playing, relationship between the main gear notch and the turntable gear is as shown in Figure 11. Since the projection is apart from the engagement, the main gear is stationary even when the platter is rotating.

As playing proceeds, the arm lever pushes the trip lever and this moves the lower trip, which, in turn, gradually drives out the engagement mounted on the lower trip.

The relationship between the engagement and the turntable projection at this time is as shown in Figure 12. When the pitch of record grooves is small, the pitch of engagement advance is also small and the engagement will be pushed back by the projection. The main gear, therefore, remains stationary.

At the end of playing when the tonearm comes to the lead-out grooves having a larger pitch, the engagement advances more than the projection pushes it back and their relationship is now as shown in Figure 13. The projection pushes the engagement, the main gear starts to turn, the main gear notch moves, and the turntable gear engages the main gear. Thus the change cycle starts as the main gear starts to turn.

When the main gear stops turning, relationship shown in Figure 11 is restored and the main gear remains stationary even when the turntable gear turns.

On the other hand, the driven out engagement and lower trip are pushed back to the initial positions by the edge of the turntable gear just before the main gear stops turning. A boss of the main gear pushes the trip lever back to the initial position earlier than the engagement and lower trip. The return position can be fine-adjusted for earlier or later start by screwing the adjuster.

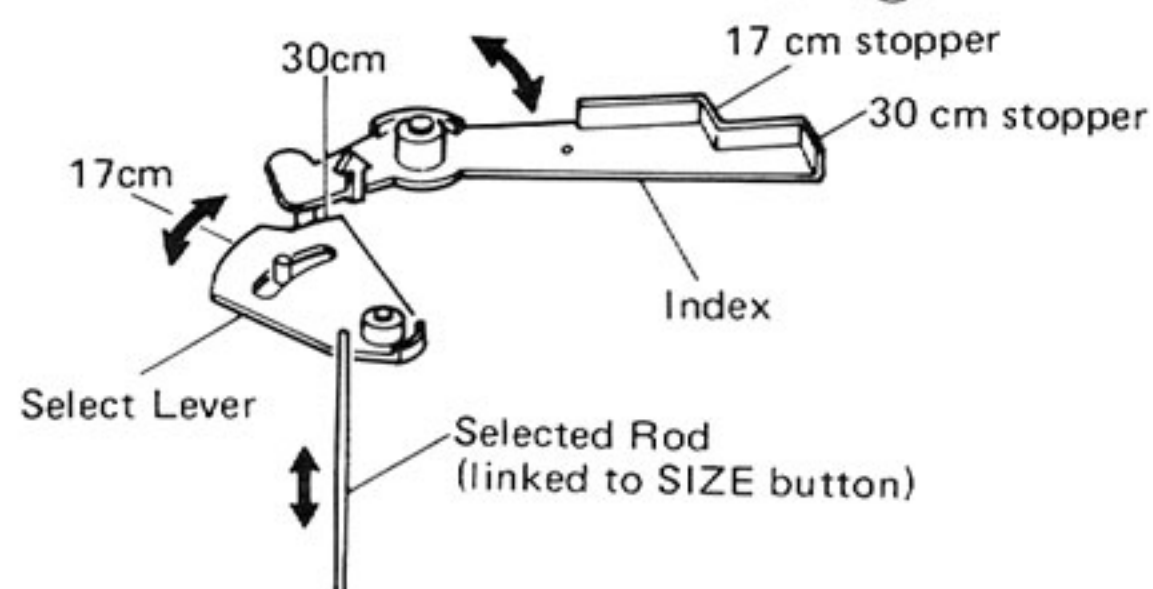
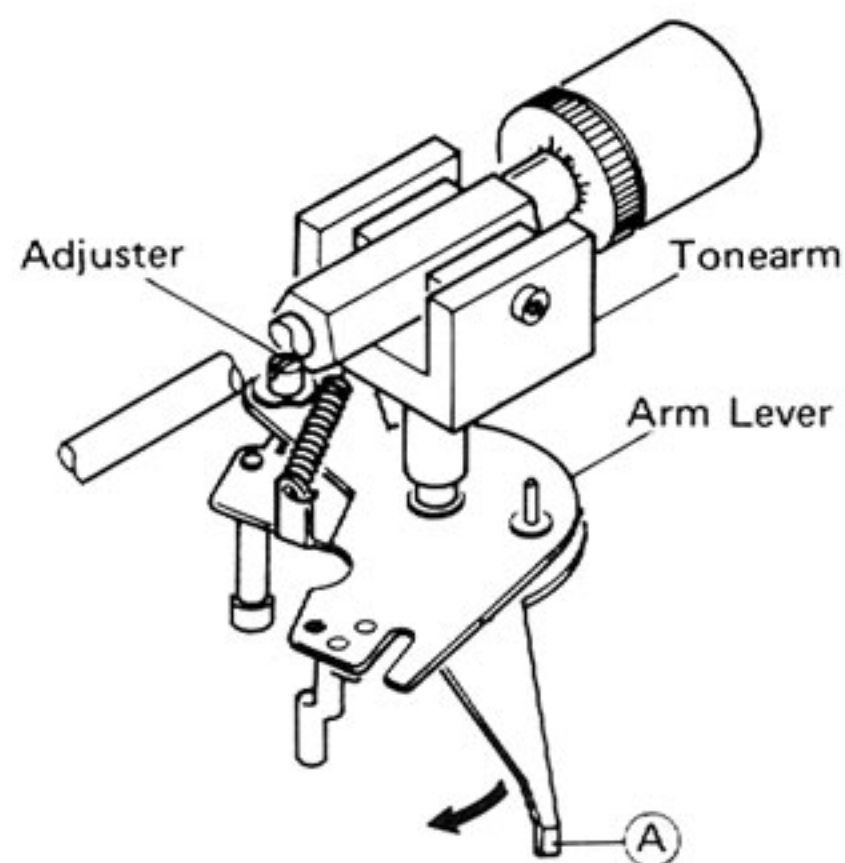

Fig. 10

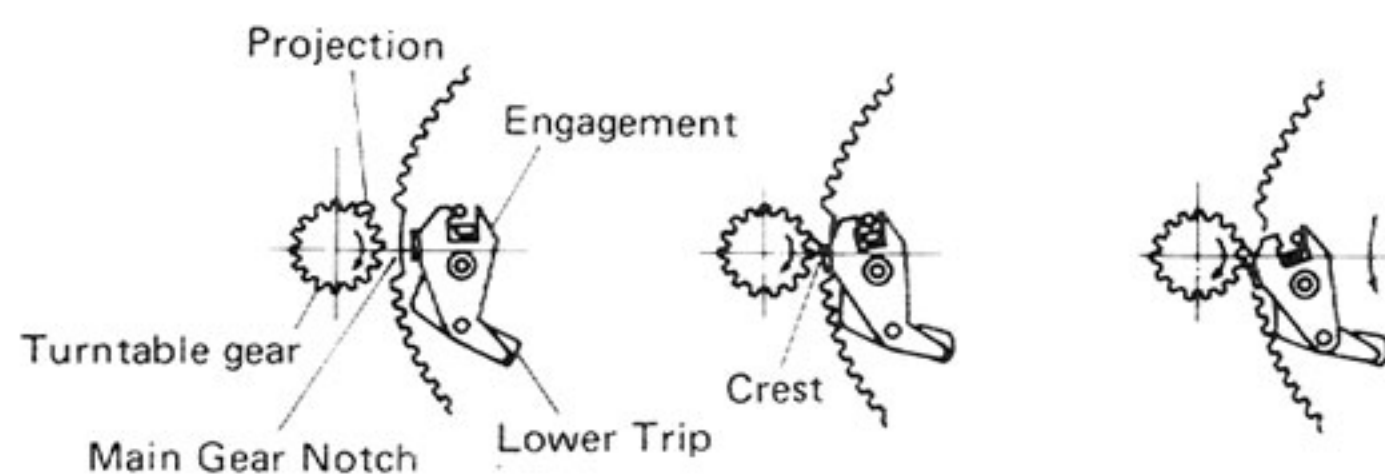

Fig. 11

Fig. 12

Fig. 13

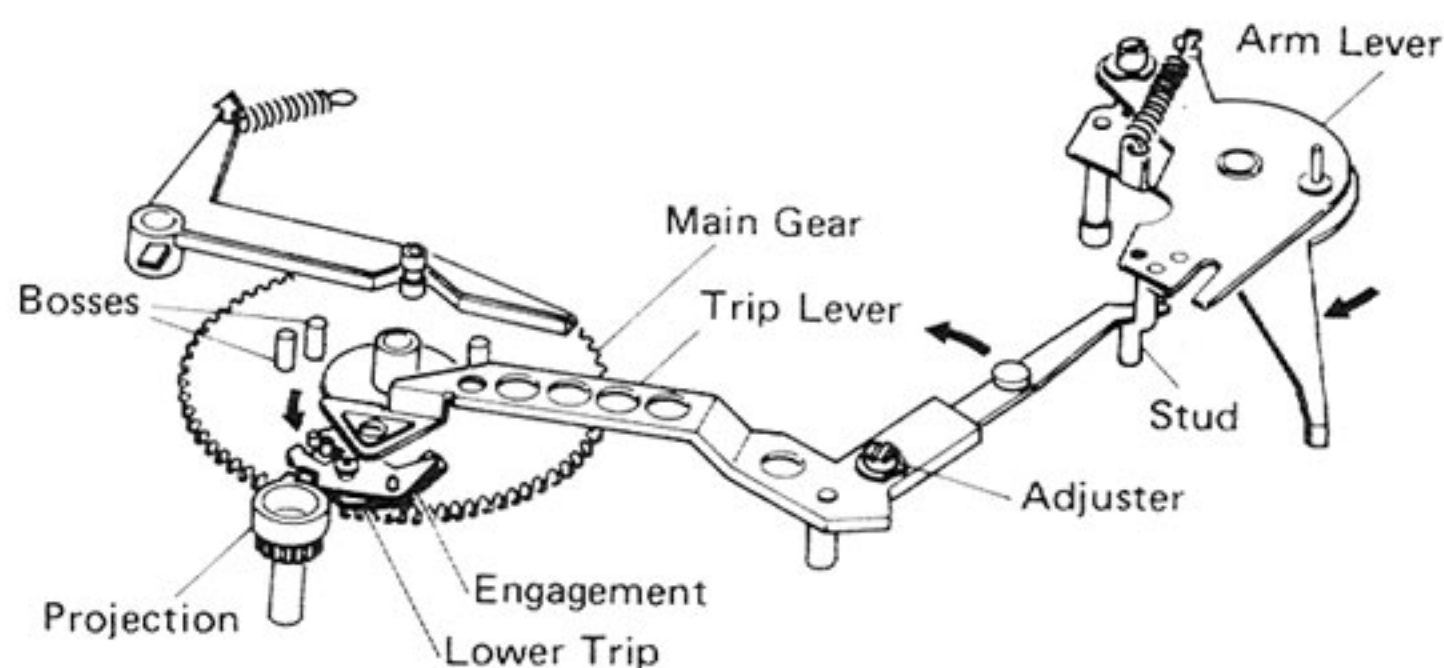

Fig. 14

3-(5) Repeat Operation

When the REPEAT button is pressed, the repeat lever gets the position shown in Figure 15 and the mechanism operates to lead in the tonearm repeatedly to the same position. As the repeat rod moves in direction "a", the repeat lever turns in direction "b" and stays there. If the change cycle starts at this time, the lead-in lever turns in direction "c" and moves with arm lever stud (A). As the driver moves, the tonearm will be driven in direction "d" to perform lead-in operation.

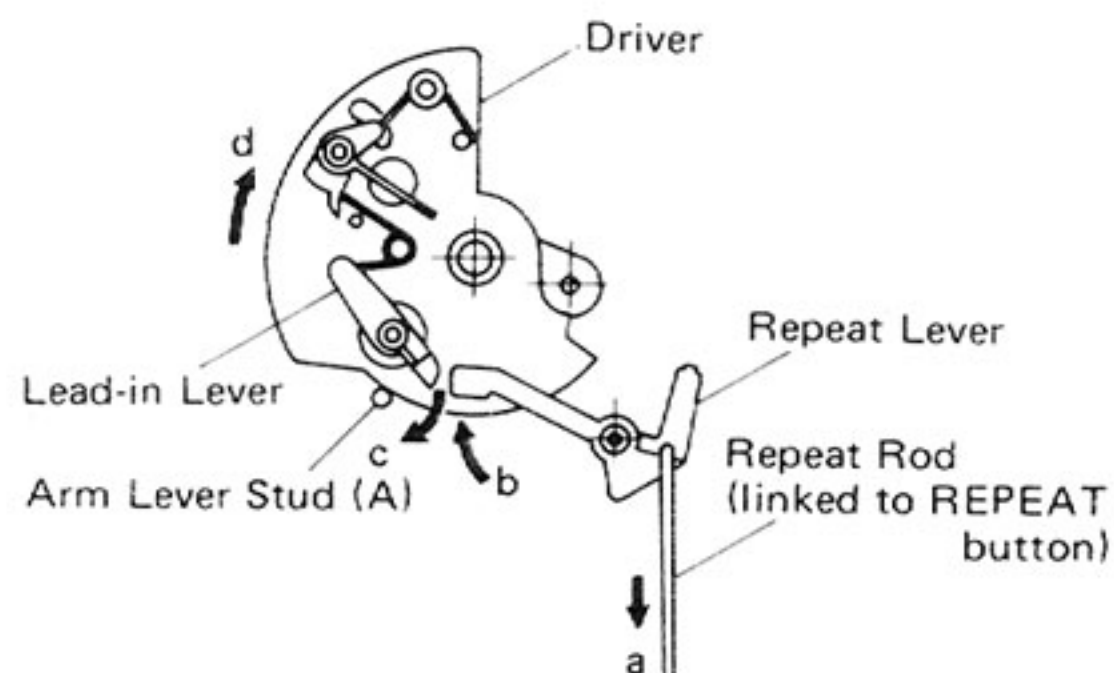

Fig. 15

4. Exploded Views and Parts List

4-(1) Mechanism Assembly

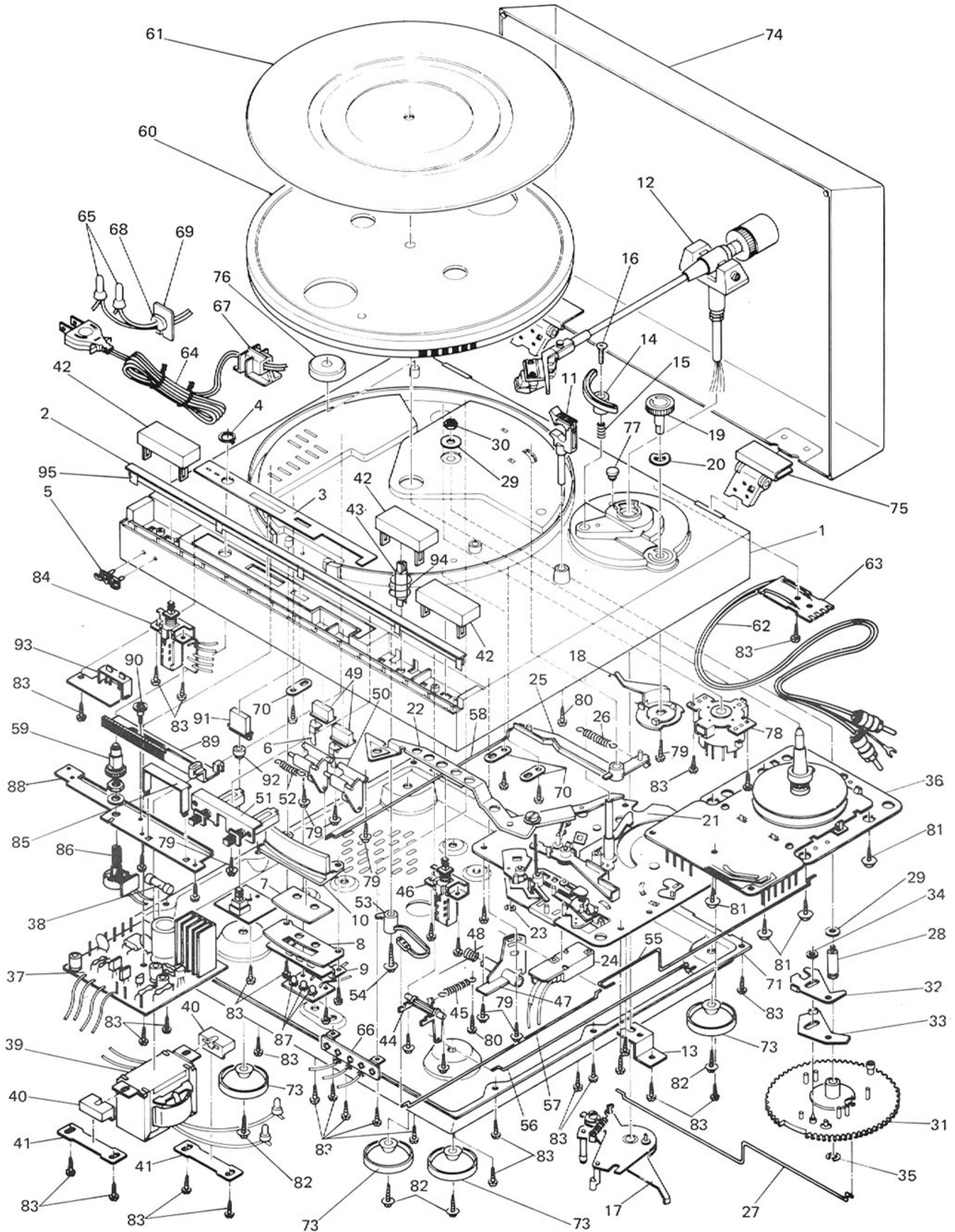











Fig. 16

Parts List

Item No.	Part Number	Description	Q'ty
1	See page 17	Cabinet	1
2	E23733-004	Front Escutcheon	1
3	E301569-002	Ornament	1
4	E68401-001	Knob Collar	1
5	E68120-002	Mark	1
6	E68407-001	Knob Spring	2
7	E68144-001	Sheet (A)	1
8	E68145-001	Sheet (B)	1
9	E68413-001	LED Holder	1
10	E68000-001	Lamp Guard	1
11	E65824-003	Rest Ass'y	1
12	See page 17	Tonearm Ass'y	1
13	E67691-002	Stopper	1
14	E65829-003	Elevator. Ass'y	1
15	E49649-001	Spring	1
16	SSSP3016MS	Screw	1
17	E67688-003	Arm Lever Ass'y	1
18	E67690-001	Anti-skating Ass'y	1
19	E301238-002	Anti-skating knob	1
20	E49602-004	Wave Washer	1
21	F7000	Mechanism Base Ass'y	1
22	E67699-002	Trip Lever Ass'y	1
23	REE3000X	"E" Ring	1
24	QSM1V12-106	Micro Switch 	1
25	E67647-001	Stopper	1
26	E65718-001	Spring	1
27	E67687-001	Connect Rod	1
28	E67684-001	Shaft	1
29	Q03091-109	Washer	2
30	NTB4000S	Nut	1
31	E23642-002	Main Gear	1
32	E49627-002	Engagement Pawl	1
33	E60380-002	Lower Trip Pawl	1
34	E60912-001	Speed Nut	1
35	REE5000X	"E" Ring	1
36	MC944SG	Motor Ass'y	1
37	See page 17	P.C. Board Ass'y	1
38	See page 17	Fuse 	1
39	See page 17	Power Transformer 	1
40	E61824-002	Cushion	2
41	E65751-001	Transformer Plate	2
42	E301556-001	Knob	3
43	E66350-001	Slider	1
44	E68228-001	Lever	1
45	E65251-001	Spring	1
46	E03820-005	Push Switch	1
47	E301242-001	Lever	1

Item No.	Part Number	Description	Q'ty
48	E67692-003	Spring	1
49	E68226-001	Knob	2
50	E67673-002	Lever	2
51	E03819-002	Push Switch	1
52	E67694-001	Spring	1
53	E67678-001	Repeat Lever	1
54	E65923-002	Screw	1
55	E67698-002	Cueing Rod	1
56	E67695-002	Start Rod	1
57	E67696-003	Repeat Rod	1
58	E67697-002	Slide Select Rod	1
59	E301555-001	Knob	1
60	E23732-001	Turntable	1
61	See page 17	Turntable Covering	1
62	E03724-004	Signal Cord	1
63	E68441-001	Signal Circuit Board	1
64	See page 17	Power Cord 	1
65	See page 17	Connector 	2
66	See page 17	Lug Strip 	1
67	See page 17	Cord Clamp 	1
68	See page 17	Cord Stopper 	1
69	See page 17	Cord Stopper Plate	1
70	E67731-002	Stopper	3
71	E10584-001	Bottom Board	1
72	E65119-001	Screw	1
73	See page 17	Foot Ass'y	4
74	E23680-001	Dust Cover Ass'y	1
75	E68188-001	Hinge Ass'y	2
76	E66329-001	EP Adaptor	1
77	See page 17	Mask Cap	1
78	See page 17	Voltage Selector 	1
79	E65922-002	Screw	8
80	E65922-004	Screw	13
81	E65922-005	Screw	4
82	E65923-002	Screw	4
83	E65921-002	Screw	26
84	QSP0219-025	Push Switch	1
85	E68272-001	Bracket	1
86	QVG4A2B-014V	Variable Resistor	1
87	SR603C	L.E.D	3
88	E301553-001	Bracket	1
89	E301554-001	Slide Indicator	1
90	E67242-001	Screw	1
91	E68001-001	Quartz Button	1
92	E68306-001	Spacer	1
93	E68271-001	LED Holder	1
94	E66351-001	Spring	1
95	E68450-001	Holder	5

4-(2) Tonearm Assembly

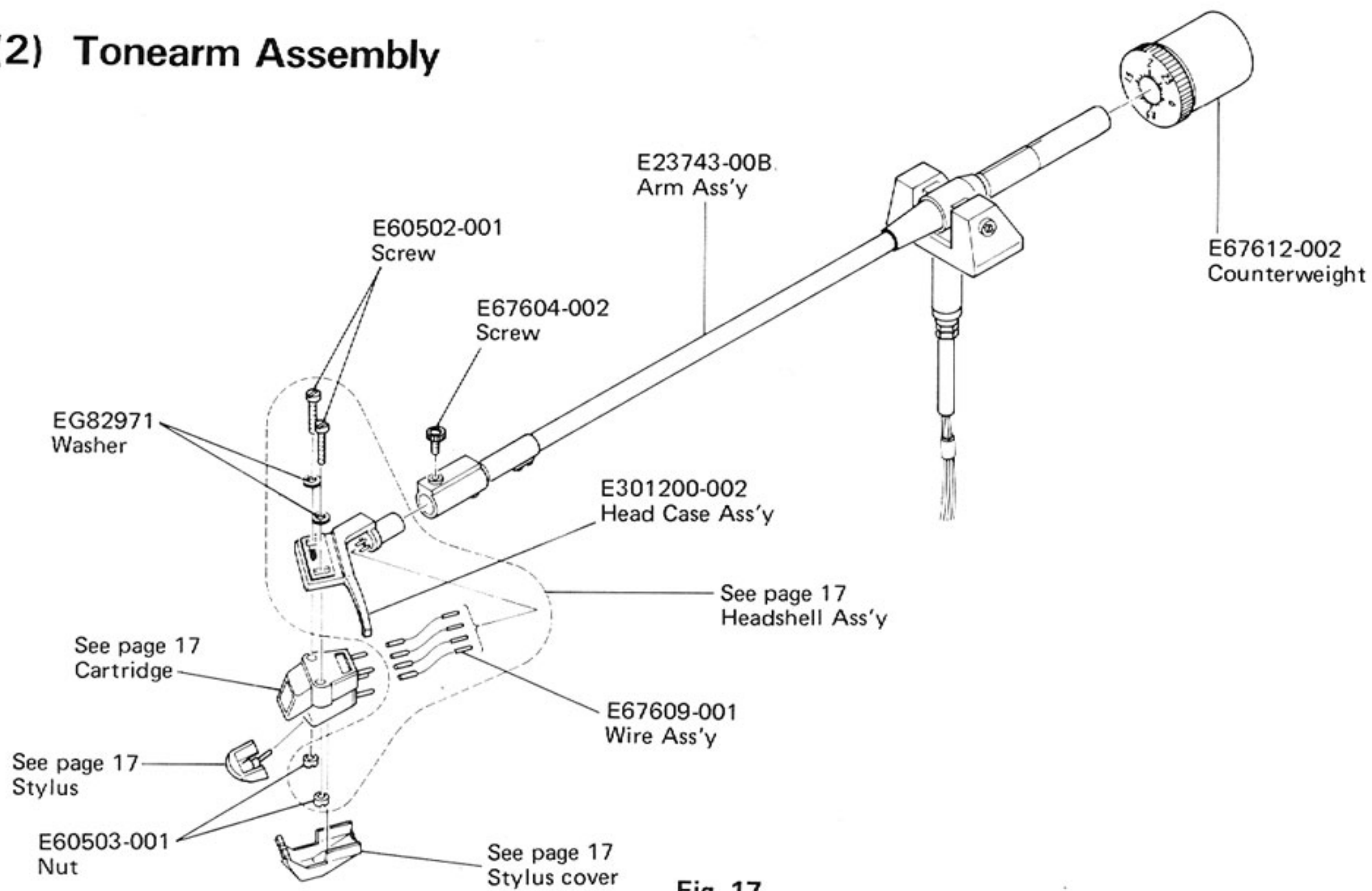

Fig. 17

4-(3) Mechanism Base Assembly

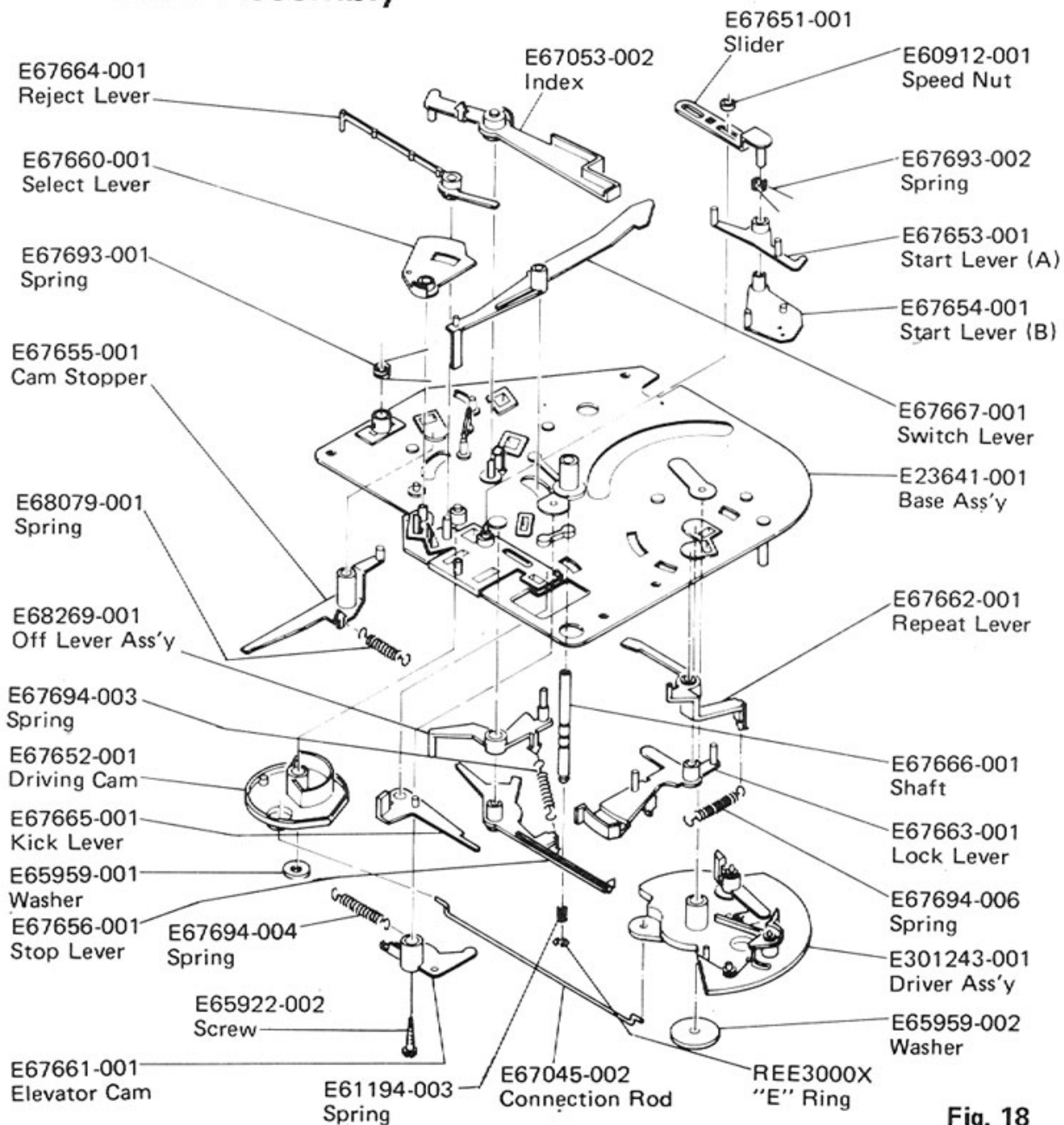

Fig. 18

5. Disassembly

5-(1) Removal of Mechanism Base Assembly

1. Remove the elevator.
Holding the tonearm up and away from the rest, turn the elevator height adjusting screw fully counterclockwise and remove the elevator.
Note: Do not lose the elevator arm spring.
2. Remove five screws ① – ⑤ and remove the motor and main gear.
3. Remove operating levers then the rods.
4. Remove three screws ⑥ – ⑧ and lift up the mechanism.
Note:
 - Be careful not to deform the trip lever and rods.
 - During reassembly, do not mistake connection of rods and levers.
 - Be sure to adjust the elevator height after replacement.

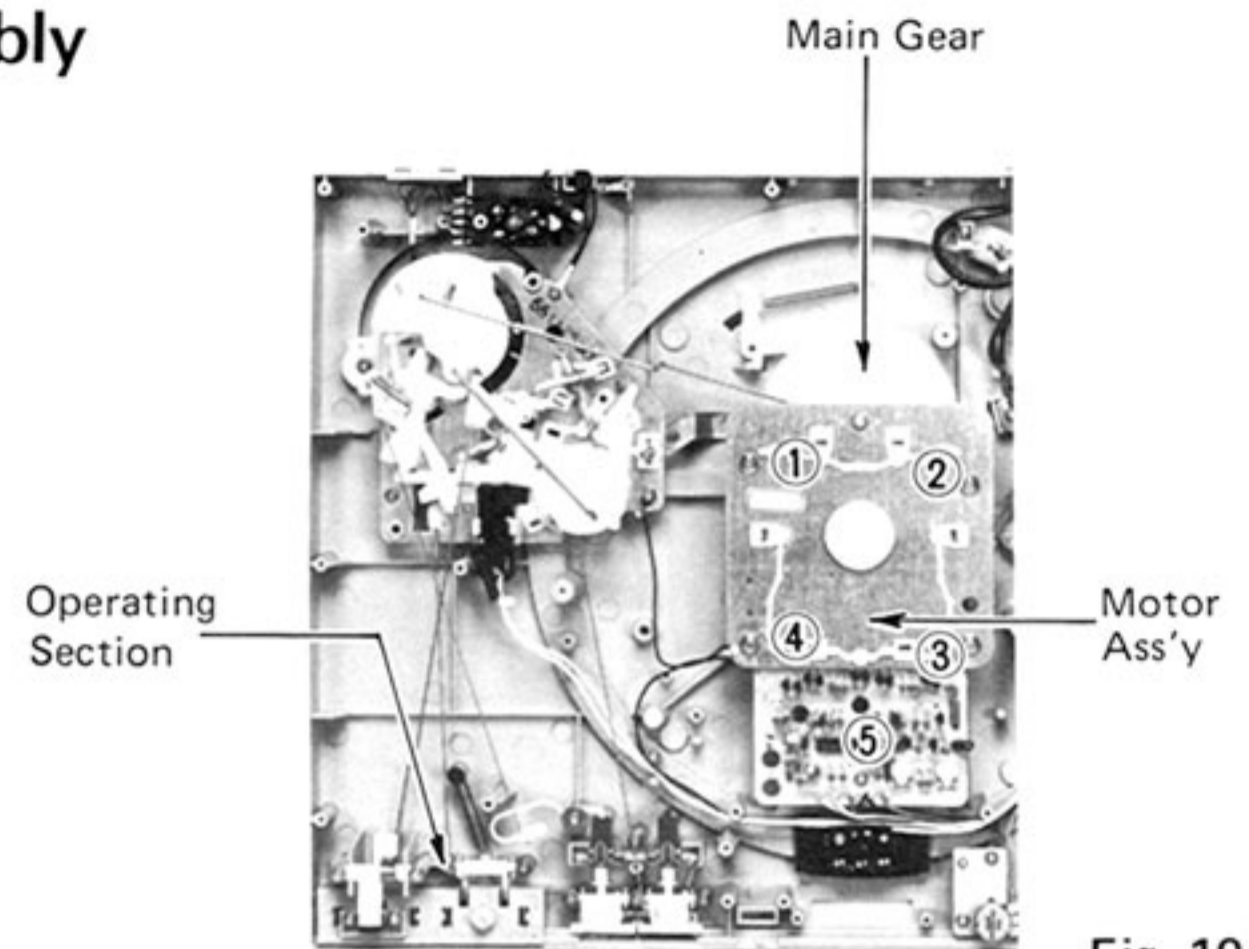

Fig. 19

5-(2) Removal of Tonearm Assembly

1. Remove the mechanism base assembly.
2. Remove the arm lever.
 - (1) Loosen two screws ① – ② with a 2 mm hexagonal wrench.
 - (2) Unsolder the signal leads on the circuit board.
3. Holding the tonearm, remove screw ③ and the stopper.
Note:
 - During reassembly, position the arm lever assembly by aligning the depressed part of the lever with the positioning hole (see Figure 21).

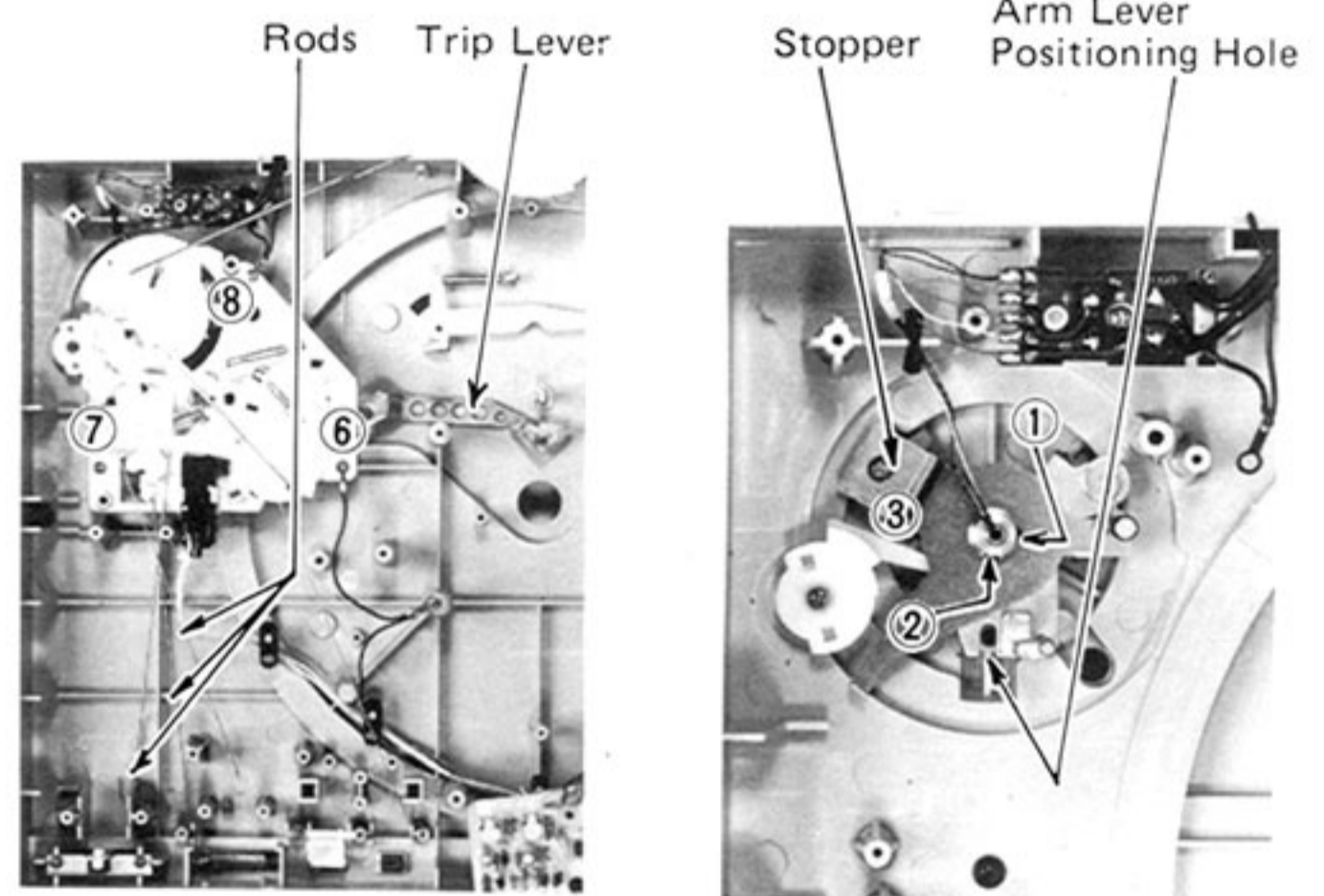

Fig. 20

Fig. 21

6. Cartridge Replacement

1. Unscrew the connector screw to remove the headshell.
2. Remove the two long screws on the headshell which hold the cartridge. (Fig. 00)
3. Connect the lead wires of the headshell to the new cartridge, being careful to match the polarities correctly. Polarity and wire colors are as follows:

White (+) L	Red (+) R
Blue (-) LE	Green (-) RE
4. Attach the cartridge to the headshell squarely, and gently tighten the screws.
5. Set the cueing button to "DOWN", and then bring the stylus tip to the optimum position by sliding the cartridge back and forth. See 6-(1) Overhang Adjustment.
6. After attaching the cartridge, slide the headshell into the tonearm. Tighten the connector screw.
7. Be sure to adjust the tracking force and lead-in position after replacing the cartridge.

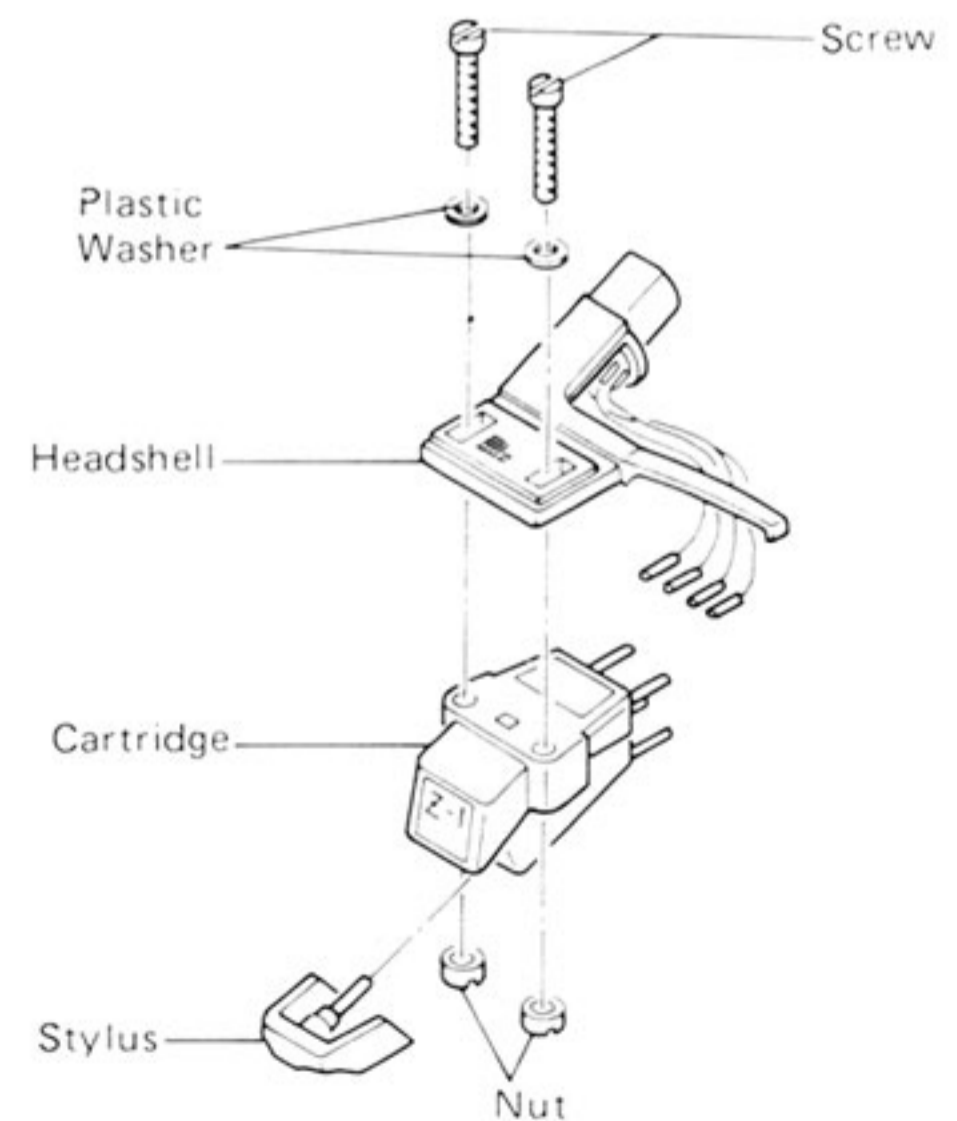

Fig. 22

7. Adjustment Procedures

The following adjustments should be performed only when replacing a cartridge or a headshell. Otherwise, no adjustment is required.

If necessary to replace a cartridge, usage of that headshell exclusive to this unit is recommended.

7-(1) Overhang Adjustment

To obtain optimum overhang, when mounting the cartridge, first align the cartridge's longitudinal axis with that of the headshell and position the cartridge so that the distance between the headshell's end face and the stylus tip equals 32mm as shown in Fig. 23.

Be sure to tighten the set screw after the adjustment. Error within 1mm are negligible from a practical point of view.

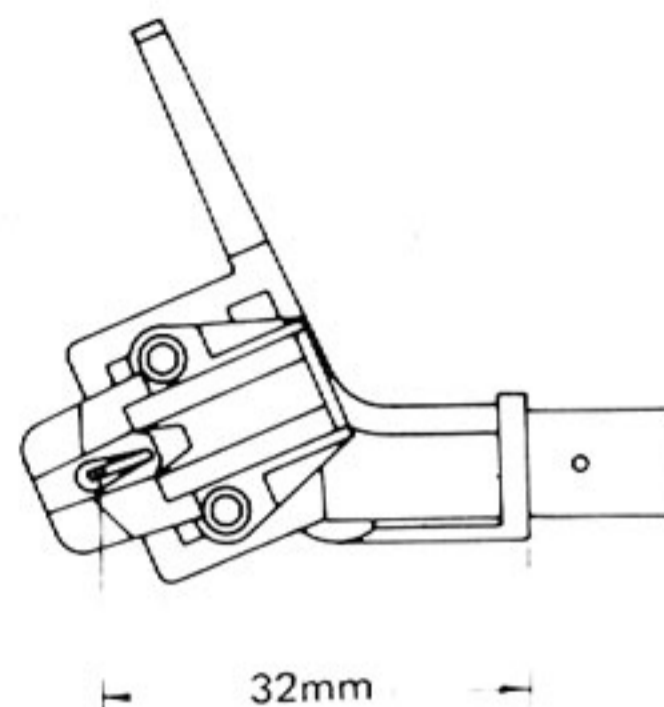

Fig. 23

7-(2) Anti-skating Adjustment

Adjust the anti-skating force according to the cartridge used. Turn the anti-skating knob dial to the same number on the tracking force dial.

Use the ● marked dial when employing conical stylus. Use the ● marked dial for an elliptical or a Shibata stylus. Set the "1.75" to the ● marked dial to the index line since the QL-F61 is provided with a spherical stylus and the tracking force has been adjusted to 1.75 g. (Fig. 24)

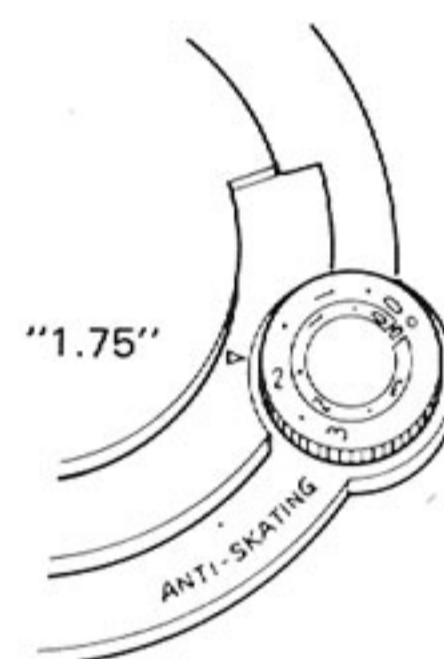

Fig. 24

7-(3) Tonearm Lifter Height Adjustment

Adjust the height of tonearm lifter with the adjustment screw so that the distance between the stylus tip and the surface of record is about 6mm when the stylus is elevated. Turn the height adjustment screw clockwise to lower, and counterclockwise to raise the tonearm lifter level. (See Fig. 25)

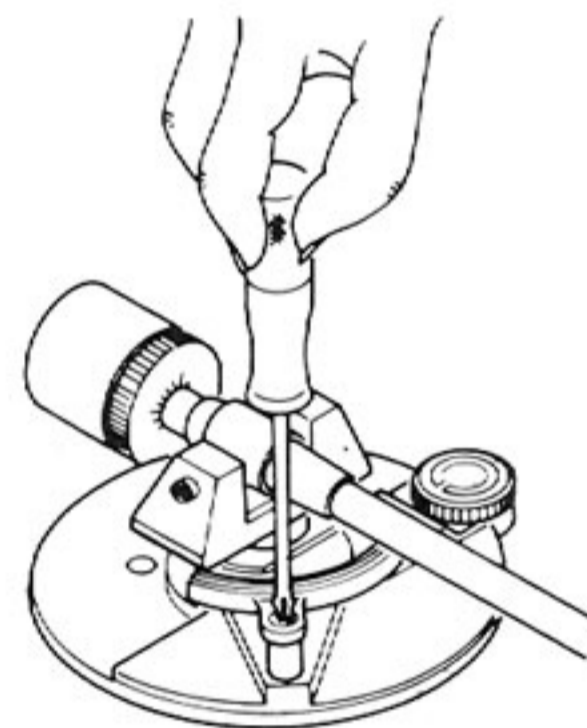

Fig. 25

7-(4) Lead-out Adjustment

When the pulley has been replaced for a different record or if auto-return functions early, adjust as shown in Fig. 26.

- When change cycle starts too late, turn the screw counterclockwise with a screwdriver.
- When change cycle starts too early, turn the screw clockwise.

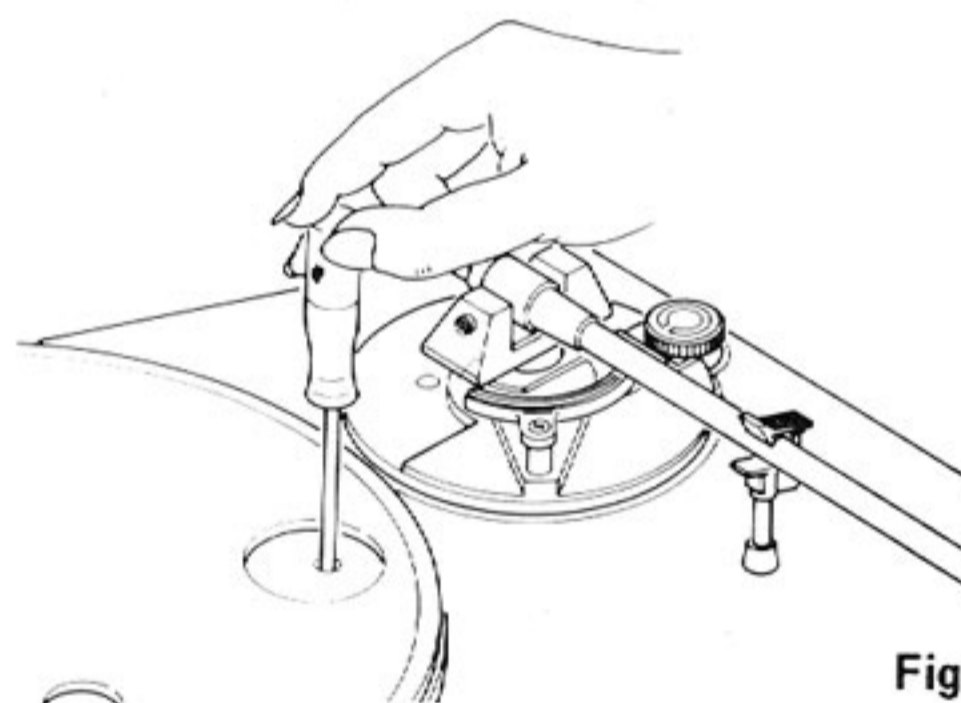

Fig. 26

7-(5) Lead-in Adjustment

Set the SIZE button at "30" and operate for automatic playback. Adjust the mechanism with a screwdriver so that the stylus lands on the record 3-4 mm inside from the outside edge.

Turn the screw clockwise (counterclockwise) to let the stylus land further inside (outside).

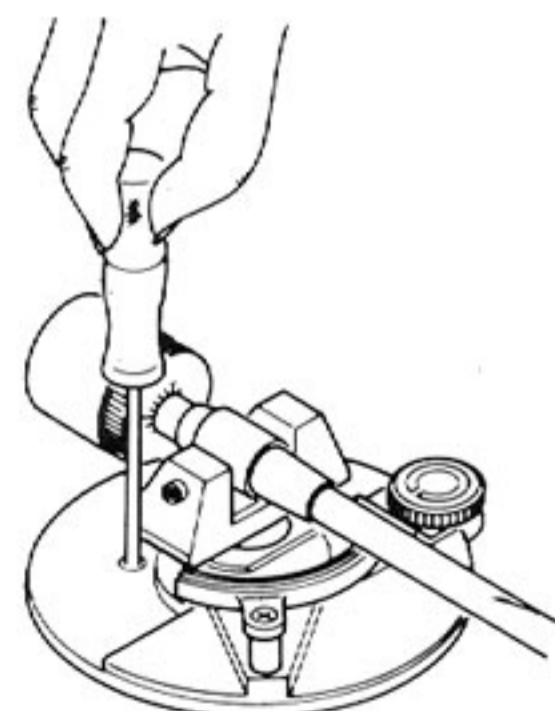

Fig. 27

7-(6) Tracking Force Adjustment

1. Turn the anti-skating knob to make its "0" mark aligned with the index mark.
2. Place an unwarped disc onto the platter.
3. Remove the stylus cover from the stylus.
4. Release the tonearm clamp.
5. Turn the counterweight until the tonearm is balanced.
6. Stop turning the counterweight when the stylus tip is almost touching the disc surface.
7. Return the tonearm to the rest and clamp it.
8. Hold the counterweight at the adjusted position and turn the tracking force dial until the "0" mark is aligned with the index line on the tonearm weight shaft. Turn the counterweight in the A direction until the "1.75" mark on the dial is aligned with the index line for the model preparing cartridge Z-1S except U.S.A. and Canada.

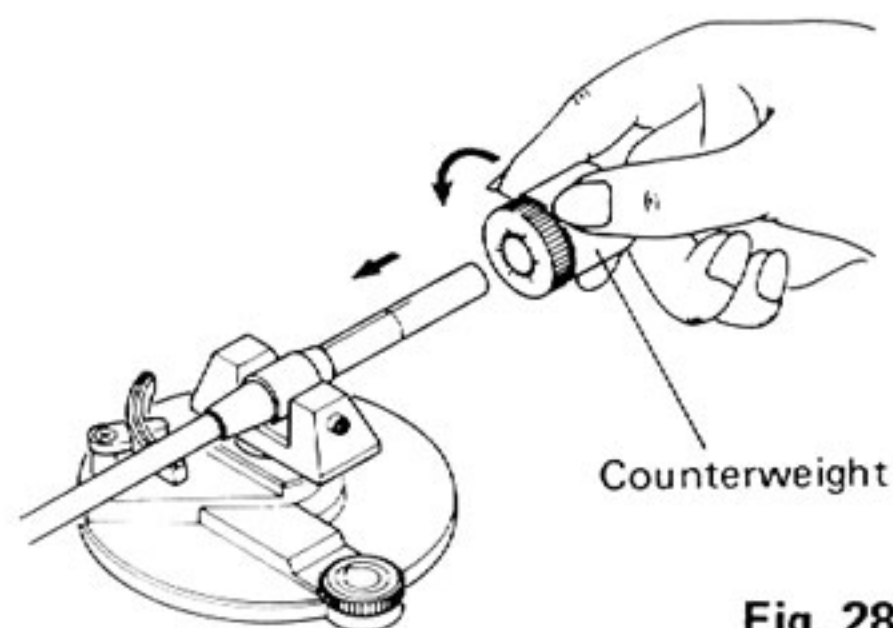

Fig. 28

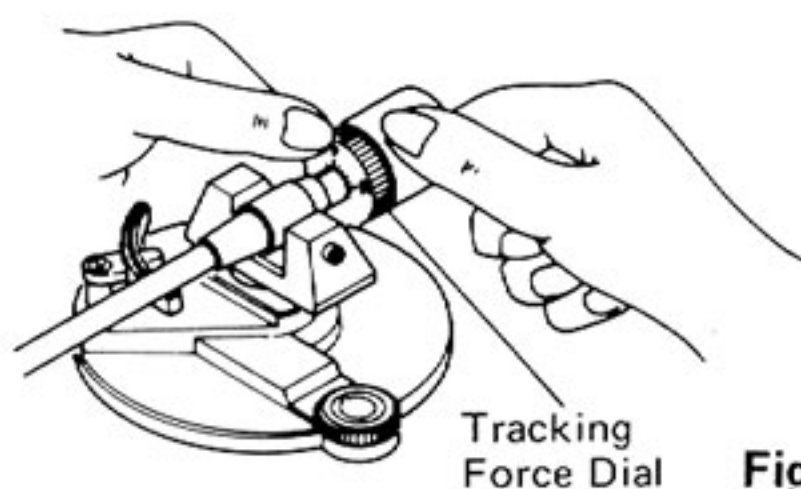

Fig. 29

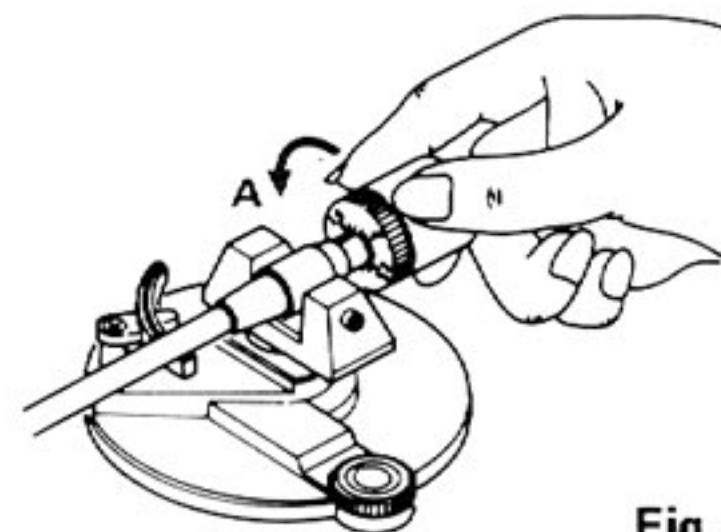

Fig. 30

7-(7) Motor RPM Adjustment

1. Center adjustment of pitch control VR (VR801)
 - 1) Set the quartz-lock switch to OFF, then set the speed select switch to "33-1/3" RPM.
 - 2) Connect a frequency counter between test point (TP-1) on the motor board (MC-944SG) and ground.
 - 3) Set the slide indicator to "0" by turning the pitch control VR.
 - 4) Adjust the rough adjustment VR (VR2) on the motor board so that the indication of the frequency counter is 172.8 ± 0.2 kHz.

NOTE: With the pitch control VR turned fully clockwise, the indication of the frequency counter must be more than 183.2 kHz. With the pitch control VR turned fully counterclockwise, it must be less than 162.4 kHz.

If correct adjustment is not obtained by the above method, perform readjustment after completion of "Pitch control mechanism adjustment" described below.

7-(8) Quartz Lock Adjustment

This adjustment is necessary only after replacing or repairing VC4046 (IC2) or replacing VR1. Prepare a voltmeter or tester having an impedance of more than $20k\Omega/V$. Connect it between TP-5 and the ground terminal and turn VR1 until a reading of 3.0 V is obtained.

Slight adjustment errors are negligible thanks to the automatic lock-in type IC. The adjustment can be correctly performed with a tester having an impedance $1k - 5k\Omega$ if an impedance conversion is performed in some manner, such as using an emitter-follower circuit.

7-(9) Pitch Control Mechanism Adjustment

- 1) Turn the pitch control VR (VR801) fully counterclockwise, then remove the pitch control knob.
- 2) As shown in the diagram, fit the end of the slide indicator to section A of the bracket, then mount the knob.

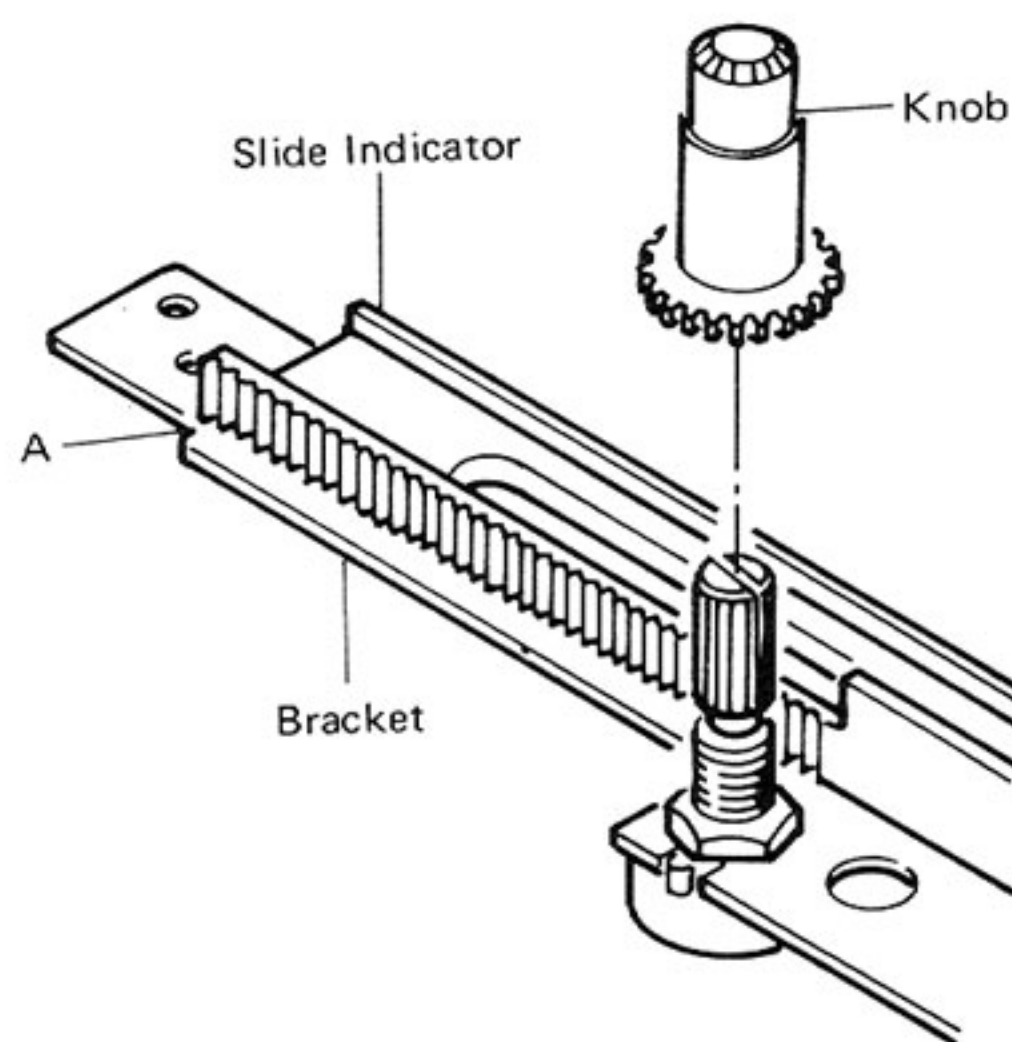

Fig. 31

8. Block Diagrams

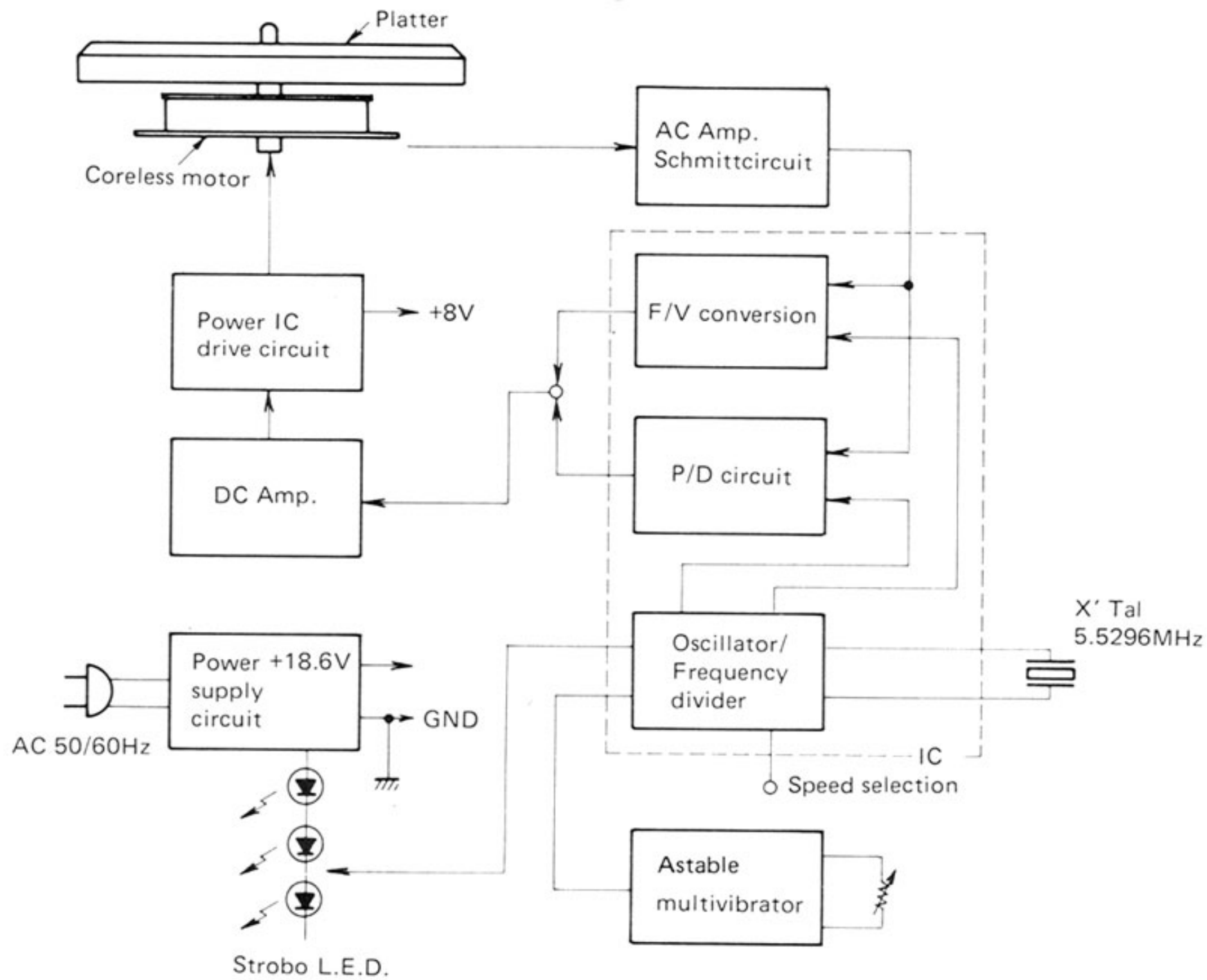

Fig. 32

9. Connection

Connection to a Stereo Amplifier

Firmly connect the white plug of the QL-F61 output cord to the PHONO L (left) terminal of the stereo amplifier, the red plug to the R (right) terminal and Earth wire (black) to the GROUND terminal.

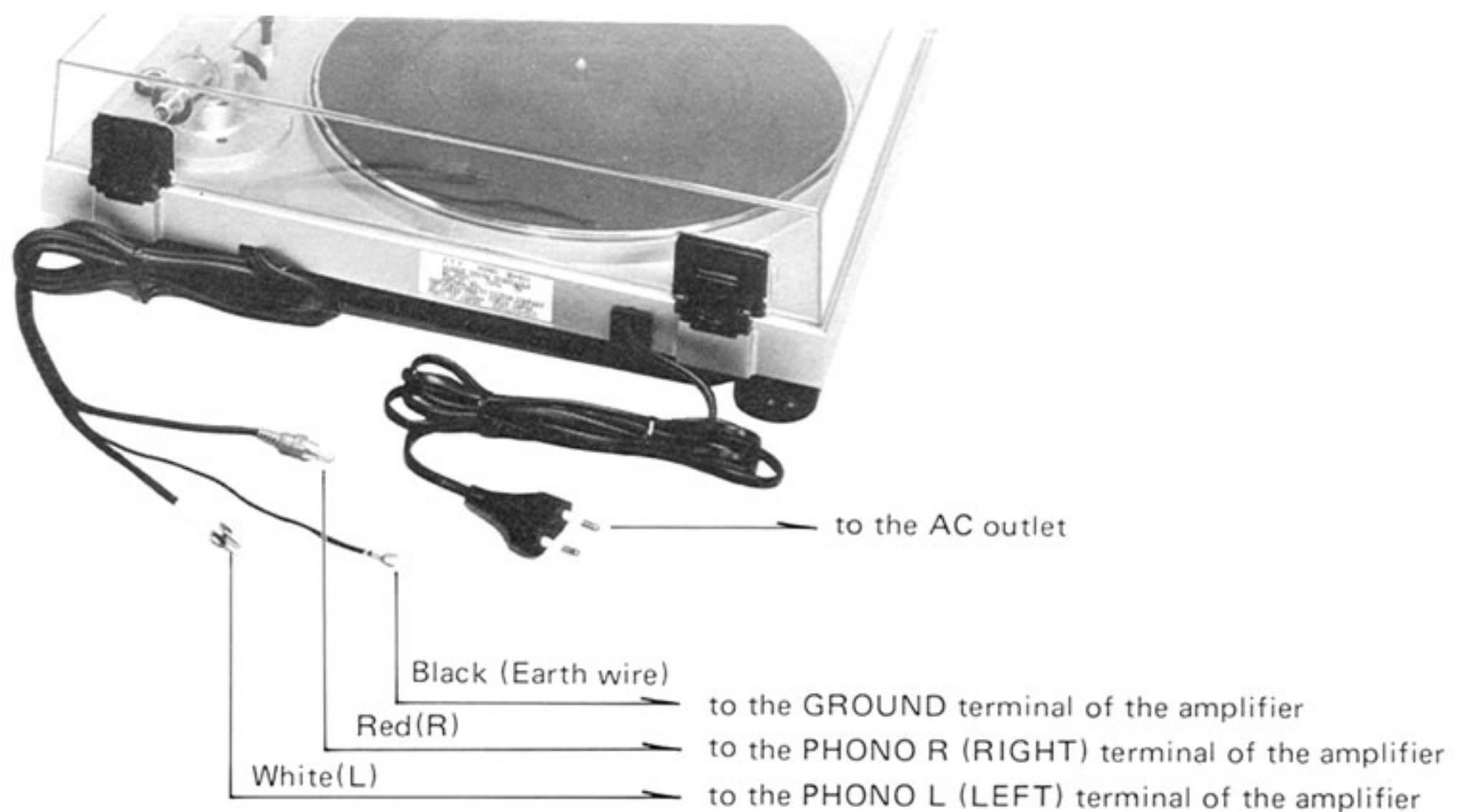

Fig. 33

10. Printed Circuit Board Ass'y and Parts List

10-(1) TXX-343A LED P.C. Board Ass'v

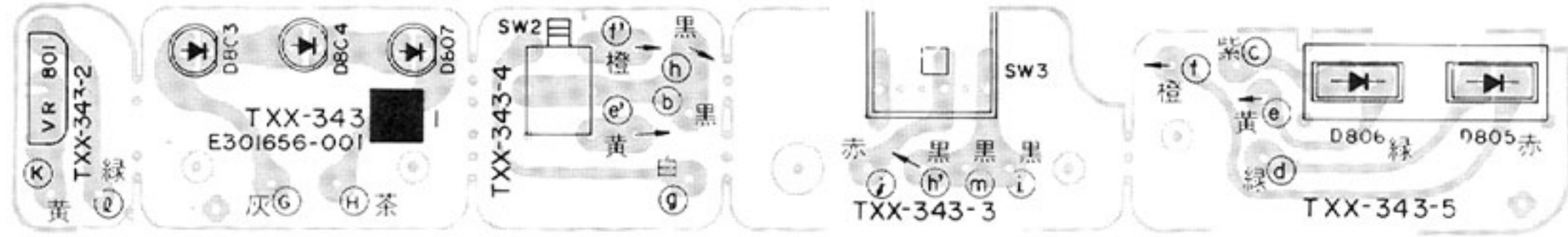
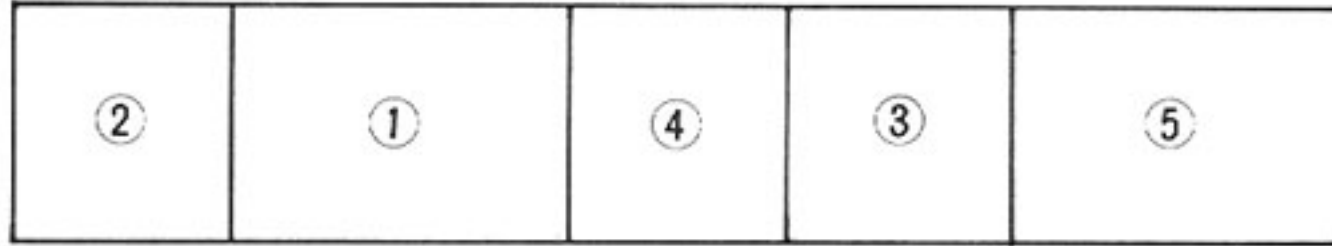

Fig. 34

Each Individual P.C. Board Location



- ① TXX-343-1 : LED P.C. Board Ass'y
- ② TXX-343-2 : Volume P.C. Board Ass'y
- ③ TXX-343-3 : Switch P.C. Board Ass'y
- ④ TXX-343-4 : Switch P.C. Board Ass'y
- ⑤ TXX-343-5 : LED P.C. Board Ass'y

Diodes

Item No.	Part Number	Rating	Description	
				Maker
D803	SR603C		L.E.D.	"
D804	SR603C		"	"
D805	LN217RP		"	Matsushita
D806	LN317GP		"	"
D807	SR603C		"	NEC

Note: The specific symbols (赤 , 黒 , 白 , ... etc.) on a surface of P.C. Board are actually unrelated to the repair service and are significant denotement in order to process the proper assembly of P.C. Board at the factory.

Others

Item No.	Part Number	Rating	Description
SW.2	QSP0219-025		Push Switch
SW.3	QSP0410-001		"
VR801	E68271-001		LED Holder
	QVG4A2B-014V		Variable Resistor
	E301656-001		Circuit Board

10-(2) TPS-309 Power Supply P.C. Board Ass'y

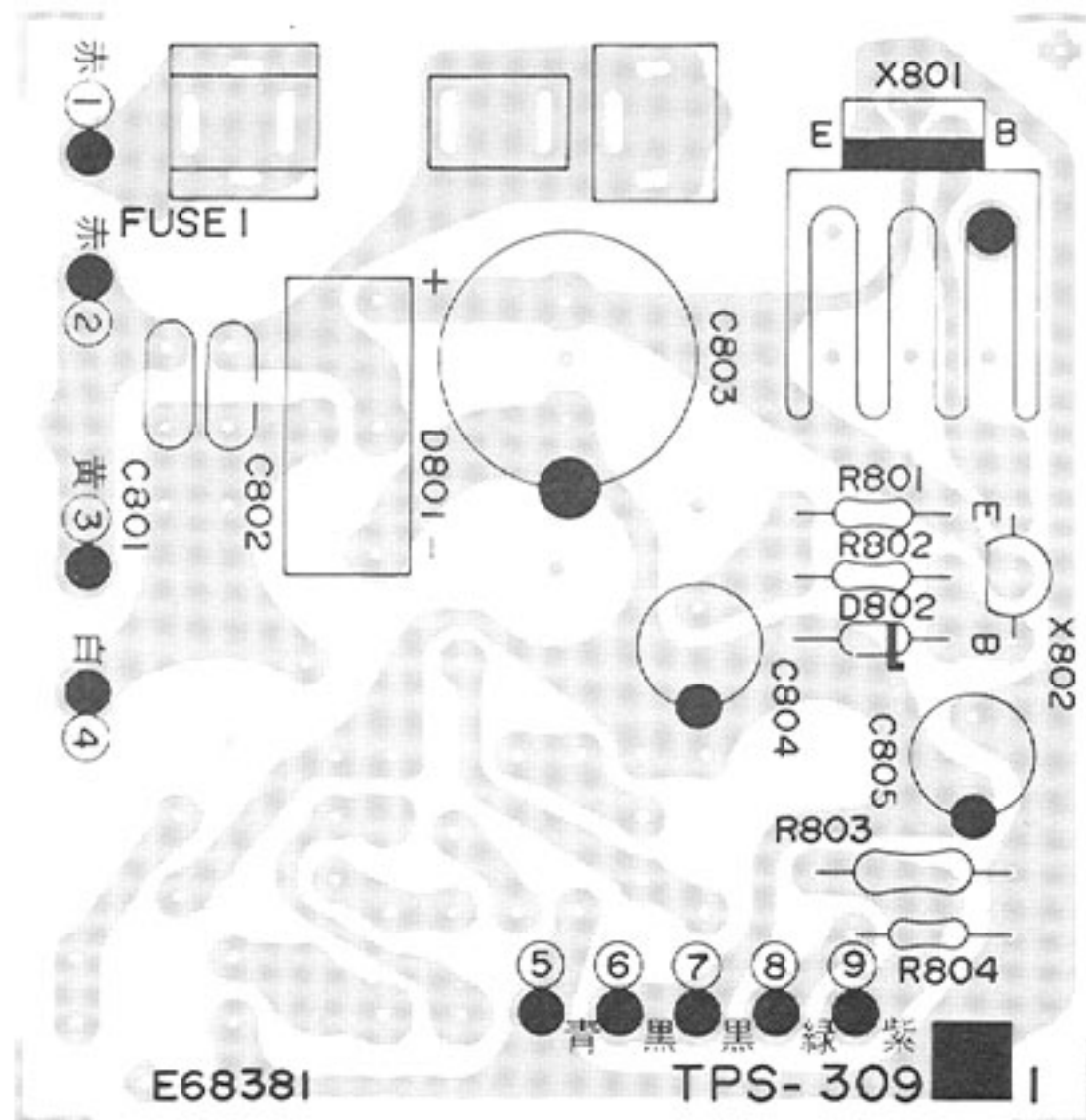

Fig. 35

Note: In □ should be indicated an area code according to the table shown on page 17 section when preparing an order from.

Transistors

Item No.	Part Number	Rating		Description	
		Pc	fT		Maker
X801	2SD313V (D,E)	30W	8MHz	Silicon	NEC
X802	2SC945A (P,Q)	0.25W	250MHz	"	"

Diodes

Item No.	Part Number	Rating	Description	
				Maker
D801	S1RBA20F1		Diode	Sindengen
D802	RD20EB3		"	NEC

Resistors

Item No.	Part Number	Rating	Description
R801	QRD148J-103S	10kΩ	Carbon
R802	QRZ0052-220	22Ω	Fusible ⚠
R803	QRD129J-152	1.5kΩ	Nonflammable ⚠
R804	QRD149J-222S	2.2kΩ	" ⚠

Capacitors

Item No.	Part Number	Rating		Description
C801	QFM82AK-473	0.047μF	DC100V	Mylar ⚠
C802	QCE22HP-103A	0.01μF	DC500V	Ceramic ⚠
C803	QET51HR-477H	470μF	DC50V	Electrolytic
C804	QET51HR-106H	10μF	"	"
C805	QET51HR-476H	47μF	4 "	"

Others

Item No.	Part Number	Rating	Description
	E61537-003		Heat Sink
	E67764-005		Rapping Terminal
	LPSP3008ZS		Screw
	SPSP3006ZS		"
	See page 17		Fuse Crip ⚠
	See page 17		Circuit Board

10-(3) MC-944SG Motor Driver P.C. Board Ass'y

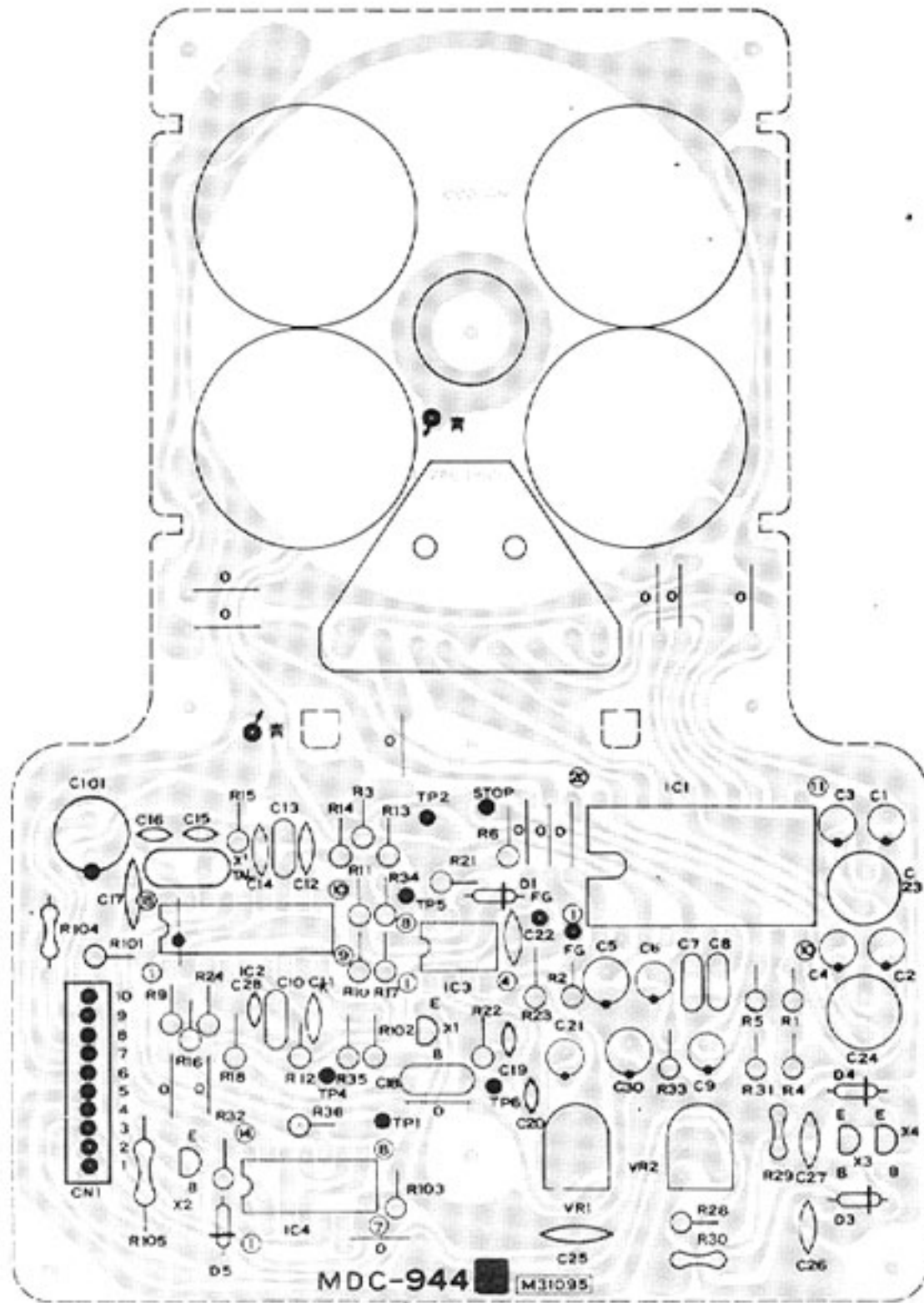

Fig. 36

Transistors

Item No.	Part Number	Rating		Description	
		Pc	fT	Material	Maker
X1	2SC945A(P,K,Q)	0.25W	250MHz	Silicon	NEC
X2	2SC2001(L,K,M)	0.6W	170MHz	"	"
X3	2SC641(KB,KC)	0.1W	400MHz	"	Hitachi
X4	2SC641(KB,KC)	"	"	"	"

Integrated Circuits

Item No.	Part Number	Rating	Description	Maker
				Maker
IC1	VC5021	(Power)	IC	Toshiba
IC2	VC4046	(PLL)	IC	Okidenki
IC3	NJM4558D-D	(OP Amp)	IC	JRC
IC4	MSM4001 or HD14001BP	(Nor-Gate)	IC	Okidenki
			IC	Hitachi

Diodes

Item No.	Part Number	Rating	Description	Maker
				Maker
D1	1S953B		Silicon	NEC
D3	1S953B		"	"
D4	1S953B		"	"
D5	1S953B		"	"

Capacitors

Item No.	Part Number	Rating		Description
		Value	Voltage	
C1	QET41VR-106	10 μ F	DC35V	Electrolytic
C2	QET41VR-106	"	"	"
C3	QET41VR-106	"	"	"
C4	QET41VR-106	"	"	"
C5	QET41VR-226	22 μ F	"	"

Item No.	Part Number	Rating		Description
		Value	Voltage	
C6	QET41VR-106	10 μ F	DC35V	Electrolytic
C7	QFM41HK-473	0.047 μ F	DC50V	Mylar
C8	QFM41HK-473	"	"	"
C9	QET41ER-475	4.7 μ F	DC25V	Electrolytic
C10	QFM41HK-473	0.047 μ F	DC50V	Mylar
C11	QFC11HP-103	0.01 μ F	"	Ceramic
C12	QCF11HP-103	"	"	"
C13	QFM41HK-473	0.047 μ F	DC50V	Mylar
C14	QCF11HP-223	0.022 μ F	"	Ceramic
C15	QCT05UJ-330	33p	"	"
C16	QCT05UJ-330	"	"	"
C17	QCF11HP-473	0.047 μ F	"	"
C18	QFM41HK-104	0.1 μ F	"	"
C19	QCY41HK-102	0.001 μ F	"	"
C20	QCT05UJ-330	33p	"	"
C21	QET41VR-226	22 μ F	DC35V	Electrolytic
C22	QCF11HP-223	0.022 μ F	DC50V	Ceramic
C23	QEN41EA-336	33 μ F	DC25V	Nonpolarized
C24	QEN41EA-336	"	"	"
C25	QCF11HP-473	0.047 μ F	DC50V	Ceramic
C26	QCT05CH-151	150pF	"	"
C27	QCT05CH-151	"	"	"
C28	QCT05UJ-330	33pF	"	"
C30	QET41ER-336	33 μ F	DC25V	Electrolytic
C101	QET41VR-107	100 μ F	DC35V	"

Resistors

Item No.	Part Number	Rating		Description
		Value	Power	
R1	QRZ0041-4R7	4.7 Ω	1/2W	Fusible Δ
R2	QRZ0041-4R7	"	"	Fusible Δ
R3	QRZ141J-222S	2.2k Ω	1/4W	Carbon
R4	QRD141J-391S	390 Ω	"	"
R5	QRD141J-222S	2.2k Ω	"	"
R6	QRD141J-223S	22k Ω	"	"
R9	QRD141J-123S	12k Ω	1/4W	Carbon
R10	QRD141J-224S	220k Ω	"	"
R11	QRD141J-224S	"	"	"
R12	QRD141J-153S	15k Ω	"	"
R13	QRD141J-102S	1k Ω	"	"
R14	QRD141J-394S	390k Ω	"	"
R15	QRD141J-101S	100 Ω	"	"
R16	QRD141J-153S	15k Ω	"	"
R17	QRD141J-224S	220k Ω	"	"
R18	QRD141J-223S	22k Ω	"	"
R21	QRD141J-824S	820k Ω	"	"
R22	QRD141J-150S	1M Ω	"	"
R23	QRD141J-471S	470 Ω	"	"
R24	QRD141J-105S	1M Ω	"	"
R28	QRD141J-182S	1.8k Ω	"	"
R29	QRV146F-2702	27k Ω	"	Film
R30	QRV146F-2202	22k Ω	"	"
R31	QRD141J-182S	1.8k Ω	"	Carbon
R32	QRD141J-223S	22k Ω	"	"
R33	QRD141J-560S	56 Ω	"	"
R34	QRD141J-102S	1k Ω	"	"
R35	QRD141J-102S	"	"	"
R36	QRD141J-102S	"	"	"
R101	QRD141J-332S	3.3k Ω	"	"
R102	QRD141J-473S	47k Ω	"	"
R103	QRD141J-392S	3.9k Ω	"	"
R104	QRD149J-470S	47 Ω	"	"
R105	QRG019J-560S	56 Ω	1W	O.M.F
VR1	RVAV310-223	22k Ω	1/5W	Variable
VR2	RVGV811-103	10k Ω	1/2W	"

Others

Item No.	Part Number	Rating	Description
HG1,HG2	VHE-711 M31095 M40474 LA0303	5.5296MHz	Hall Generator P.W. Board H.G. Board X'tal

11. Packing Materials and Part Numbers

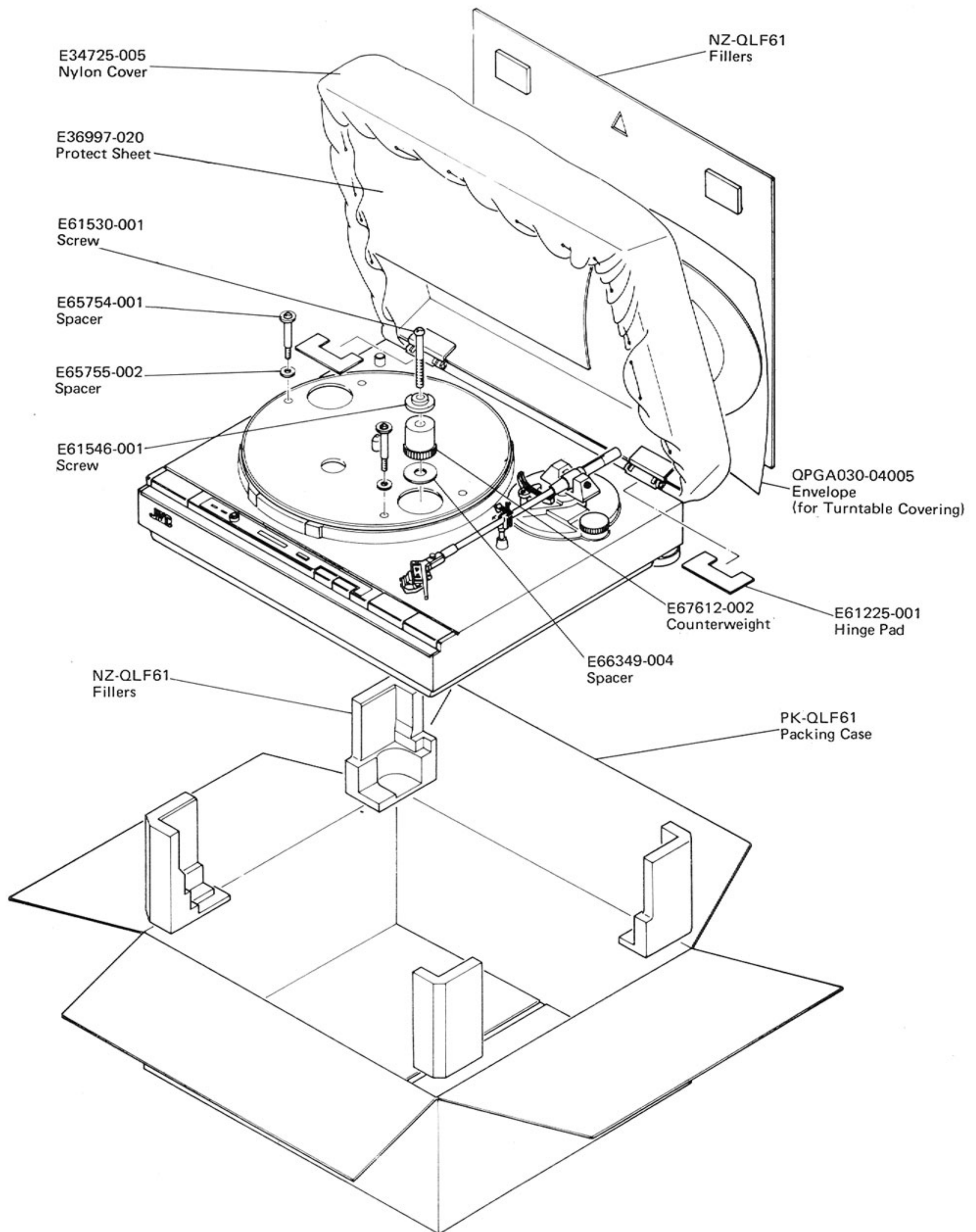

Fig. 37

12. Power Cord Connections in Different Areas

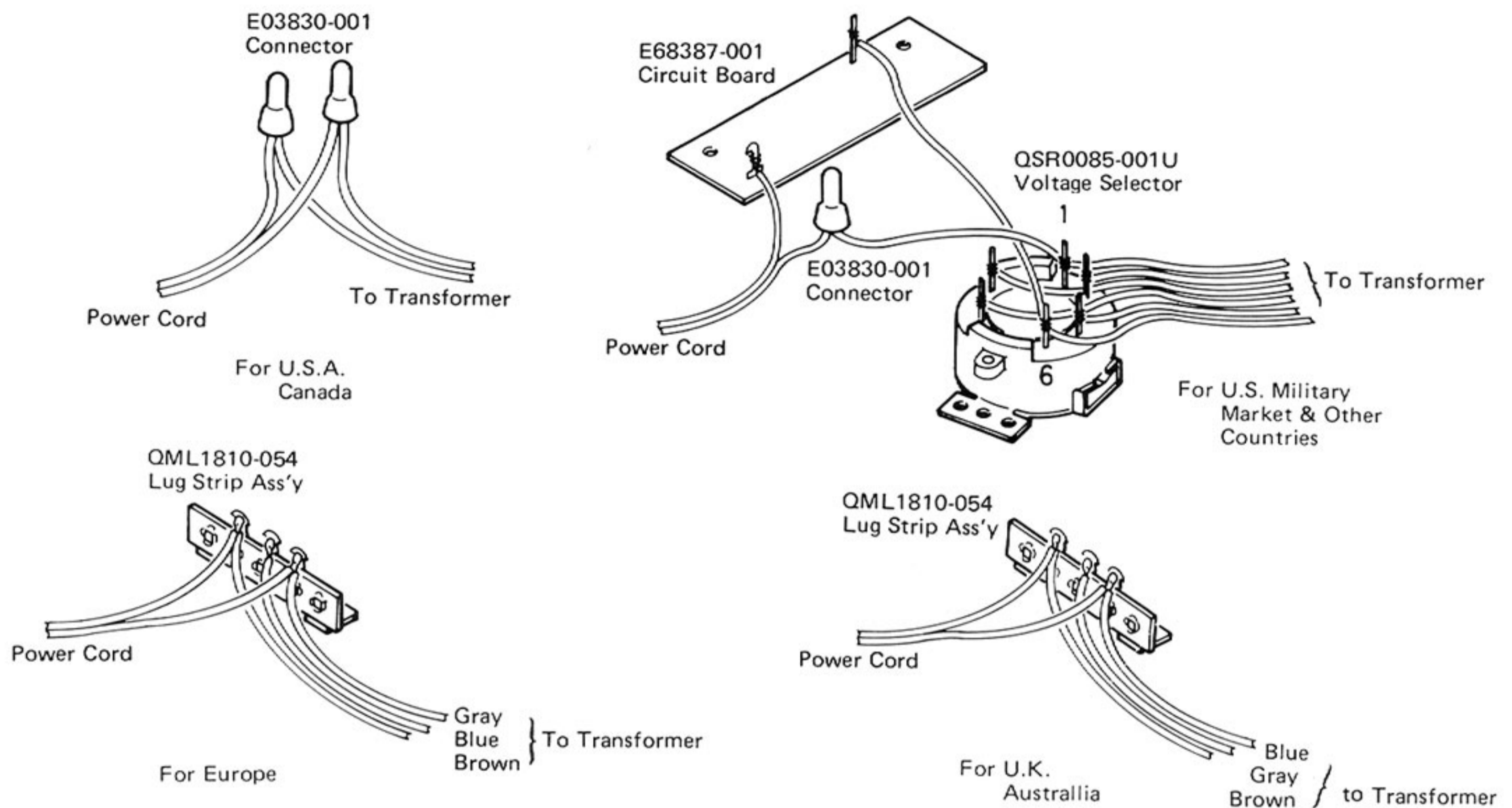

Fig. 38

12-(1) How to Handle the Solderless Connector

In this turntable, a solderless connector is used to connect the power cord with the primary lead wire of the power transformer.

When it is unavoidable to replace this connector for replacement of the power transformer, or the like, positively perform the replacement in accordance with the following procedure to avoid dangers.

- **Connector part number**
E03830-001

- **Tools**
Tool for installing solderless connectors.
Do not use those (small cutting pliers, etc.) other than regular tools.

Example: VACO No. 1963 (Courtesy Vaco Products Co.)

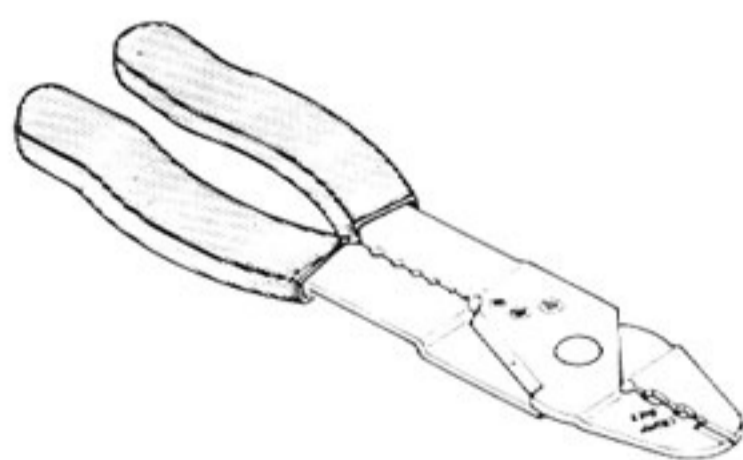

Fig. 39



Fig. 40

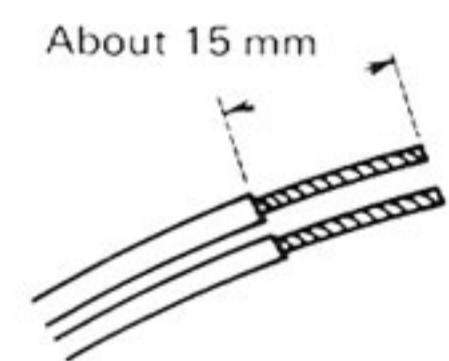

Fig. 41

2. Peel off the coverings so that the respective conductor tops appear by about 15 mm as shown in the Fig. 41.
Note: In the case of stranded wires, twist each wire.
3. Adjust the tips of the power cord and the primary lead wire with each other, then securely insert them into the connector as shown in the Fig. 42.

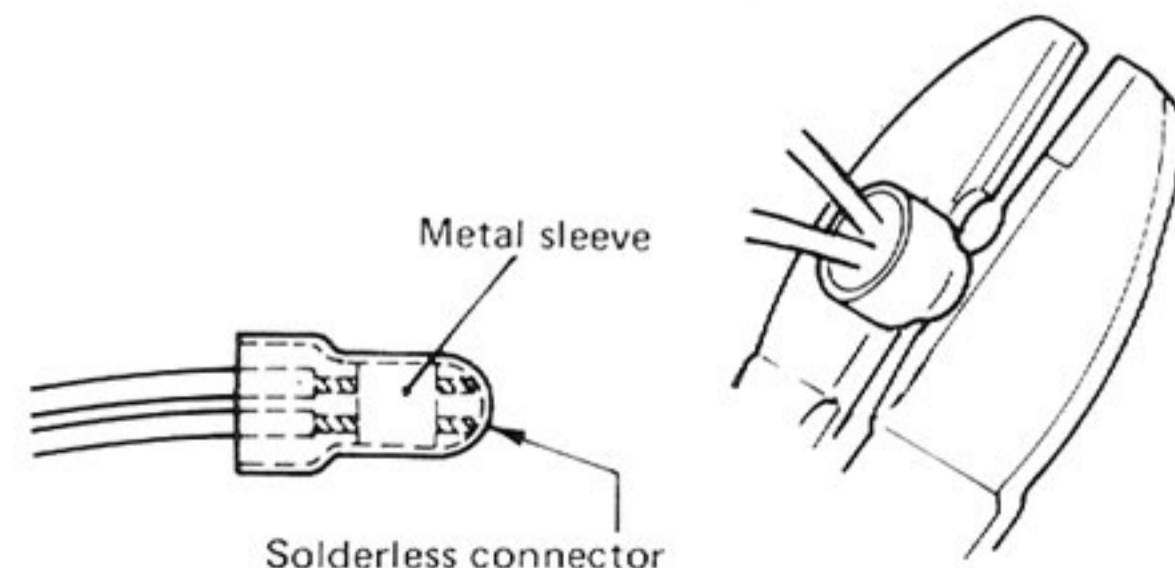

Fig. 42

Fig. 43

- **Replacement**

1. Cut both the power cord and the primary lead wire at near the edge of the connector to be replaced.

Note: Do not re-use the used connector.

4. Secure the nearly equal central part of the metal sleeve with the second concave of the tool for solderless securing as shown in the Fig. 43.

Note: Perform a complete securing.

5. After solderless securing, check the following as shown in the Fig. 44.

Note: Protod connector with isolation tape or vinyl tube for safety. Furthermore, clamp it for out of touch with metal part.

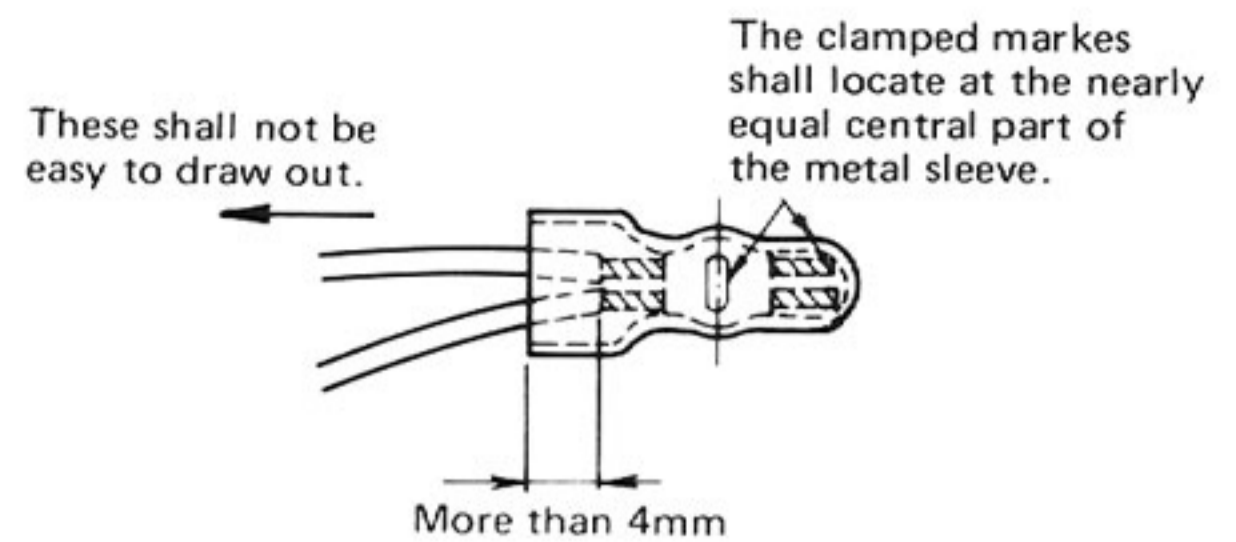

Fig. 44

13. Parts List with Specified Numbers for Designated Area

Item No.	Description	U.S.A. & Canada	U.S. Military Market & Other Countries	Europe	Australia	U.K.
1	Cabinet	E10599-001	E10599-002	E10599-002	E10599-002	E10599-002
12	Tonearm Ass'y	ARM540	MP-322S	MP-322S	MP-322S	ARM540
37	P.C. Board \triangle Ass'y	TPS-309A	TPS-309A	TPS-309B	TPS-309B	TPS-309B
	Circuit Board	E68381-003	E68381-003	E68381-004	E68381-004	E68381-004
	Fuse Clip \triangle	E45524-002	E45524-002	E48965-002	E48965-002	E48965-002
38	Fuse \triangle	QMF61U1-R63	QMF61U1-R63	QMF61U1-R63	QMF51A2-R63L	QMF51A2-R63LBS
39	Power Transformer \triangle	E03032-46B	E03032-46C	E03032-46E	E03032-46E	E03032-46EBS
61	Turntable Covering	E23644-002	E23644-001	E23644-001	E23644-001	E23644-001
64	Power Cord \triangle	QMP1200-200	QMP7600-250	QMP3900-200	QMP2560-244	QMP9017-008BS
65	Connector \triangle	E03830-001	E03830-001	—	—	—
66	Lug Strip \triangle Ass'y	—	—	QML1810-054	QML1810-054	QML1810-054BS
67	Cord Clamp \triangle	—	A37897	A37897	A37897	A37897BS
68	Cord Stopper \triangle	QHS3876-162	—	—	—	—
69	Cord Stopper Plate	E68029-001	—	—	—	—
73	Foot Ass'y (Front) (Rear)	E35857-003 E35857-001	E35857-002 E35857-005	E35857-002 E35857-005	E35857-002 E35857-005	E35857-002 E35857-005
77	Mask Cap	E65395-002	—	—	—	—
78	Voltage Selector \triangle	—	QSR0085-001U	—	—	—
	Cartridge Body Ass'y	—	MD 1025Z	MD 1025Z	MD 1025Z	—
	Stylus Ass'y	—	DT-Z1S	DT-Z1S	DT-Z1S	—
	Stylus Cover	—	E34268-001	E34268-001	E34268-001	—
	Headshell Ass'y	—	E301201-002	E301201-002	E301201-002	—

\triangle Safety Parts

14. Trouble Shooting

14-(1) When Turntable Operation is Abnormal

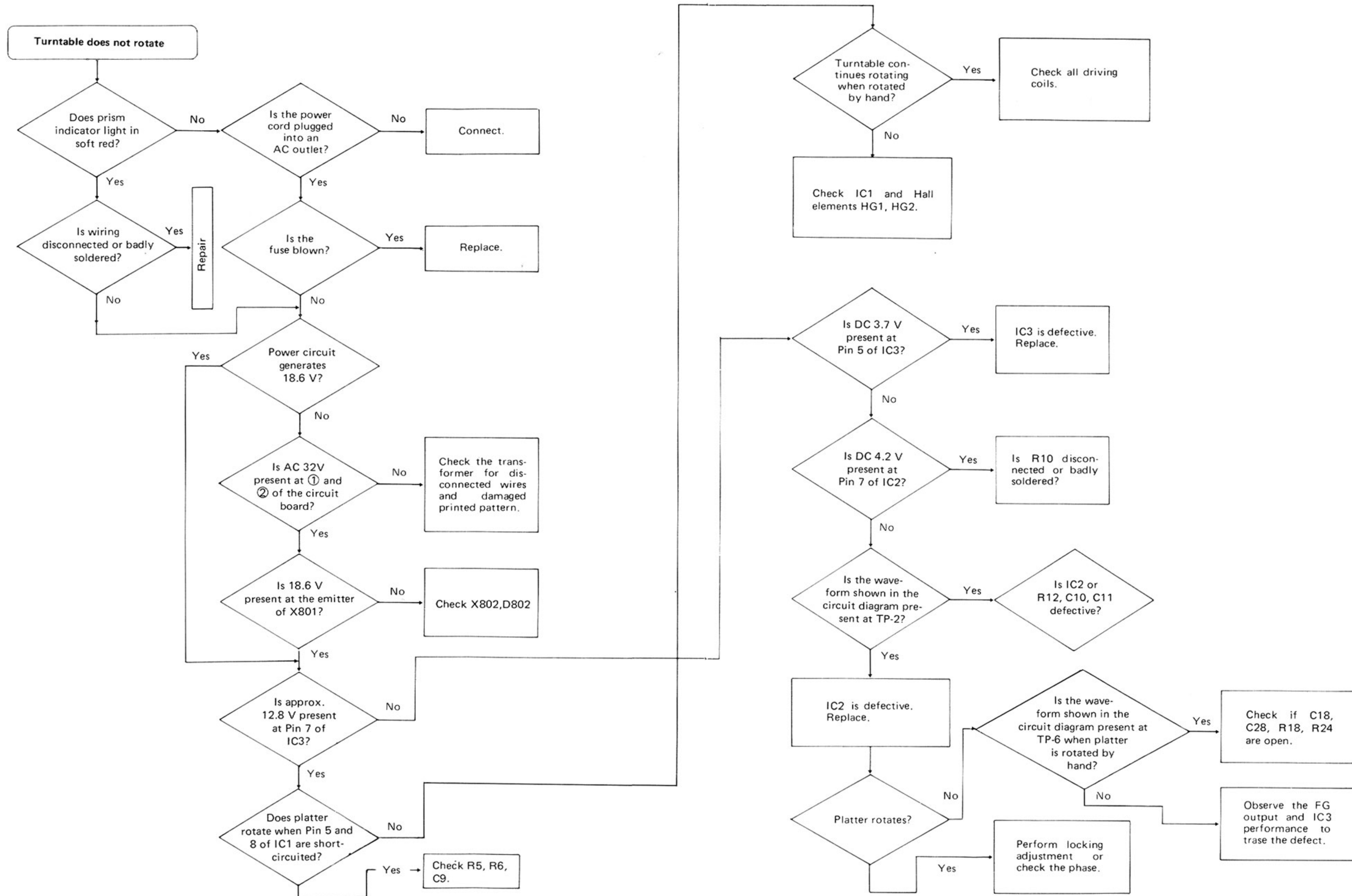

16. Accessories List

Item No.	Description	U.S.A. (& Canada)	U.S. Military Market (& Other Countries)	Europe	Australia	U.K.
1	Instruction Book	E30580-905A (")	E30580-905A (")	E30580-905A	E30580-905A	E30580-905ABS
2	Warranty Card	BT20047 (BT20025D)	BT20047 (-)	-	BT20029C	BT20013C
3	Does it Better	BT20046 (-)	BT20046 (-)	-	-	-
4	E.P. Adaptor	E66329-001 (")	E66329-001 (")	E66329-001	E66329-00	E66329-001
5	Siemen Plug	- (-)	- (E04056)	-	-	-
6	Envelope	E41202-2 (")	E41202-2 (")	E41202-2	E41202-2	E41202-2
7	Safety Inst.	BT20044B (-)	- (-)	-	-	-
8	Envelope	E66416-003 (-)	- (-)	-	-	-

POWER SPECIFICATIONS

Countries	Line Voltage & Frequency	Power Consumption
U.S.A., CANADA	AC 120V~, 60Hz	9.0 watts
EUROPEAN CONTINENT	AC 220V~, 50Hz	9.0 watts
U.K., AUSTRALIA	AC240V~, 50Hz	9.0 watts
U.S. MILITARY MARKET	AC 110/120/220/240~ Selectable, 50/60Hz	9.0 watts
OTHER AREAS	AC 110/120/220/240~ Selectable, 50/60Hz	9.0 watts

15. QL-F61 Schematic Diagrams

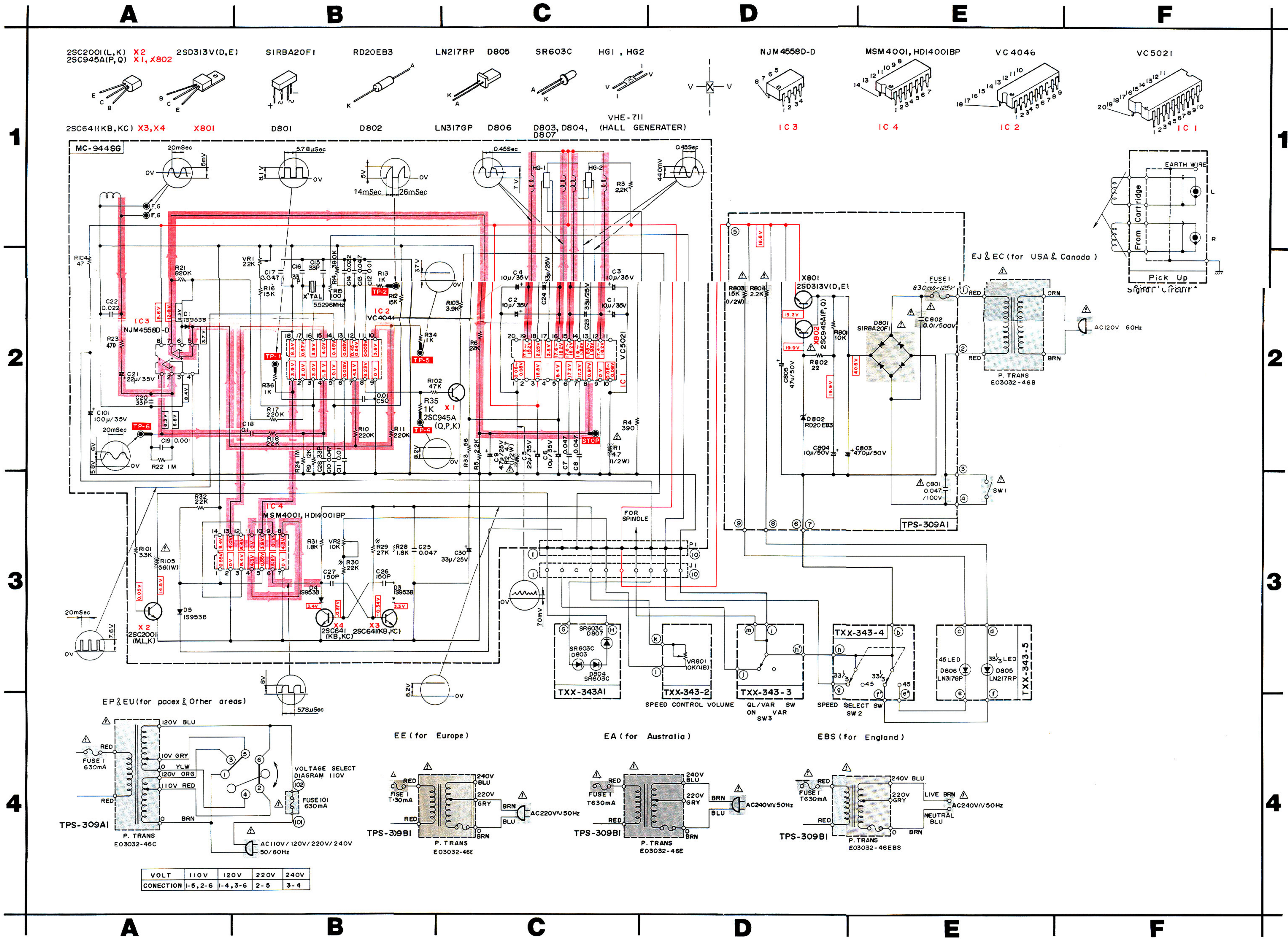

Printed Circuit Board Ass'y Locations

P.C. Board Ass'y	Description	Page
TXX-343A	LED P.C. Board Ass'y	14
TPS-309	Power Supply P.C. Board Ass'y	14
MC-944SG	Motor Driving P.C. Board Ass'y	15

Notes:

1. — indicates positive B (+) power supply.
2. — indicates signal path.
3. Voltage values measure with a tester (impedance 20 kΩ/V) in mode of "33-1/3 r.p.m." are indicated as below.
Example: 13.6 (unit: V)
4. When replacing the parts in the darkened area () and those marked with Δ, be sure to use the designated parts to ensure safety.
5. The components marked with * have been specially selected to maintain the high performance. Therefore, the replacements which are exactly the same specification or listed in the parts list must be use.
6. The following transistors are occasionally used for the substitution.
X1: 2SC1815 (O, Y, GR or BL)
7. This is the standard circuit diagram. The design and contents are subject to change without notice.

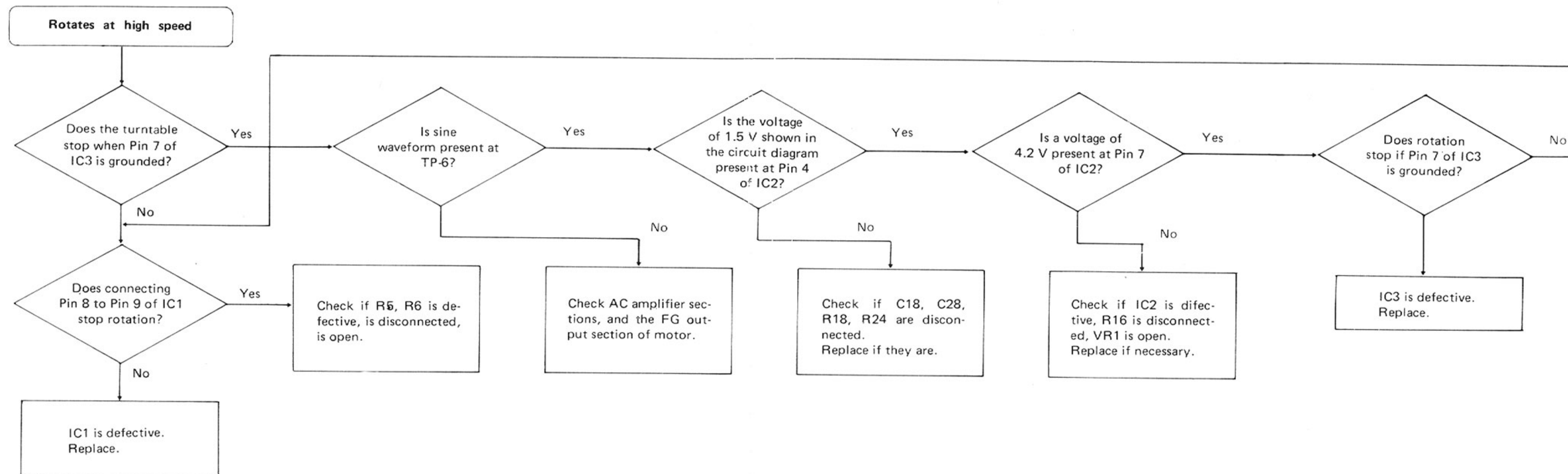

JVC

VICTOR COMPANY OF JAPAN, LIMITED, TOKYO, JAPAN



Printed in Japan
- 5603 - O -