



*Qwest*

2016

HAPPY HOURS







## QWEST EXPERIENCE

Experiencing life on the water can change your state of mind and make you feel like every hour is HAPPY HOUR. Whatever you enjoy on the water – adventure, excitement, fun, relaxing, spending time with family and friends, or enjoying time alone – we at Qwest Pontoons understand that state-of-mind passion and have created a line of unique pontoon boats to meet the needs and budgets of every boating experience.

From sunrise to sunset, it's always happy hour on a Qwest Pontoon. We'll help you enjoy life on the water with special options, added comfort, and exceptional quality for the exact, unique experience you're looking for – the Qwest Experience!



## QWEST ADVANTAGE

PAGES 4-5

## ELECTRIC & SOLAR BOATS

PAGES 22-23

## OPTIONS & ACCESSORIES

PAGES 24-26

## WARRANTY

PAGE 27

## STANDARDS & OPTIONS CHART

PAGE 27

## COLOR OPTIONS

PAGES 28-29

## LAYOUTS

PAGES 30-33

### QWEST LS

Our Luxury Series exhibits elegant styling and attention to every detail. With high end amenities and innovative features, the Qwest LS is a pontoon boat like no other.

PAGES 6-9

### Q3 TRIPLE TUBE

Take your Qwest pontoon boat to the next level. Our optional Q3 Triple Tube package will surprise you with an incredibly smooth, lightweight and exhilarating ride.

PAGES 10-11

### QWEST ADVENTURE

With the perfect blend of deluxe features and plush upholstery, this series is easily adaptable and ready for any adventure.

PAGES 12-13

### QWEST EDGE

Make the most of your time on the water with our new Edge series. Efficient and streamlined designs with robust construction offer an incredible value.

PAGES 14-15

### ANGLER QWEST

This is a serious fishing boat! A Qwest pontoon built and designed by fisherman, for fisherman.

PAGES 16-17

### GILLGETTER

A legacy of efficient and dependable pontoon boats, this series is our original Compact Pontoon. Design with quality standard features and affordable amenities.

PAGES 18-19

### PADDLE QWEST

The first and only compact pontoon boat with pedal power. Fun, easy to operate, and available in manual, electric or electric/solar power.

PAGES 20-21









## QWEST ADVANTAGE



REAL WORLD DESIGNS & FEATURES FOR TODAY'S PONTOON BOATER







Components manufactured in-house.



Dura-Lite seat bases are stronger, lighter weight and provide unmatched storage space.



Ultra-Flow seat design provides optimum ventilation for stored items.

Apex Lightweight Design with 23" Tubes VS Heavier Boats with 25" Tubes

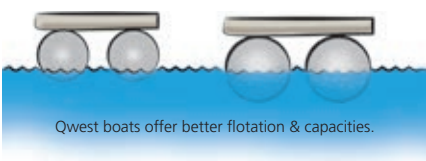

Qwest boats offer better flotation & capacities.

## THE QWEST ADVANTAGE

### PROGRESSIVE IDEAS

We're committed to understanding what our customers expect. With vision and advanced innovation, we are leading the industry with progressive, real world designs and features you can only find with a Qwest Pontoon. Qwest offers an unrivaled array of modern multi-functional layouts, aggressive performance packages, and endless design choices for cruising, fishing, bar boats and water sports.

### LEADING EDGE UPHOLSTERY

- o **Hand crafted** quality to provide the ultimate in comfort and durability.
- o **Ultra Flow** seat ventilation promotes optimum air flow inside the seat bases to aid in drying stored items and to prevent mold/mildew growth.
- o Innovative seat bases constructed with proprietary **Dura-Lite** composite material are stronger, lighter weight and provide unmatched storage space.

### LIGHTWEIGHT DESIGN

With every detail, Qwest Pontoon boats are designed to be lightweight and easy to maneuver both on and off the water. Compared to the competition, Qwest boats offer ample flotation and capacities with smaller diameter pontoons for the maximum boating experience and performance, without sacrificing safety and stability in the water.

### EXCEPTIONAL QUALITY

Unrivaled quality is the hallmark of every Qwest Pontoon boat. We design and build components in-house to assure the highest quality standards are met throughout the entire manufacturing process. We invite you to take a closer look, noticing the fine details and fit and finish.

## MODERN TECHNOLOGY + INNOVATIVE DESIGN = THE ULTIMATE PONTOON EXPERIENCE



INDUSTRY'S FINEST UPHOLSTERY





---

QWEST LS

---





# DETAILS ARE EVERYTHING

A high-end luxury pontoon boat, the Qwest LS offers elegant styling and fine detailing with exclusive amenities and promises to be the ultimate in comfort to make every hour an exceptional Happy Hour.



- Exquisite, luxury appointed upholstery with "linen" soft touch vinyls
- Ultra flow ventilated seat bases
- Deluxe fiberglass helm stand with tilt steering and LS dash package
- Humminbird Helix 5 color, combination GPS/fish finder
- Premium Infinity stereo system with Bluetooth audio and universal media holder
- Stainless steel trim package
- Contoured rub rail with polished corners and custom riser trim

	7514	7516	7518	820	822	824
<b>Pontoon Length</b>	13' 11"	15' 11"	18' 5"	19' 10"	21' 10"	23' 10"
<b>Deck Size</b>	7' 6" x 13' 2"	7' 6" x 15' 2"	7' 6" x 17' 2"	8' x 18' 8"	8' x 20' 8"	8' x 22' 8"
<b>Overall Length</b>	14' 10"	16' 10"	19' 4"	21' 2"	23' 2"	25' 2"
<b>Pontoon Diameter</b>	23"	23"	23"	23"	23"	23"
<b>Maximum Horsepower</b>	30 HP	40 HP	70 HP	90 HP	115 HP	125 HP
<b>Maximum Weight Capacity</b>	1,335 lbs.	1,575 lbs.	1,810 lbs.	2,025 lbs.	2,245 lbs.	2,445 lbs.
<b>Maximum Person Capacity</b>	6 People/ 910 lbs.	8 People/ 1,145 lbs.	9 People/ 1,290 lbs.	10 People/ 1,450 lbs.	11 People/ 1,574 lbs.	12 People/ 1,730 lbs.
<b>Approx. Dry Weight</b>	1,050 lbs.	1,175 lbs.	1,325 lbs.	1,450 lbs.	1,600 lbs.	1,850 lbs.



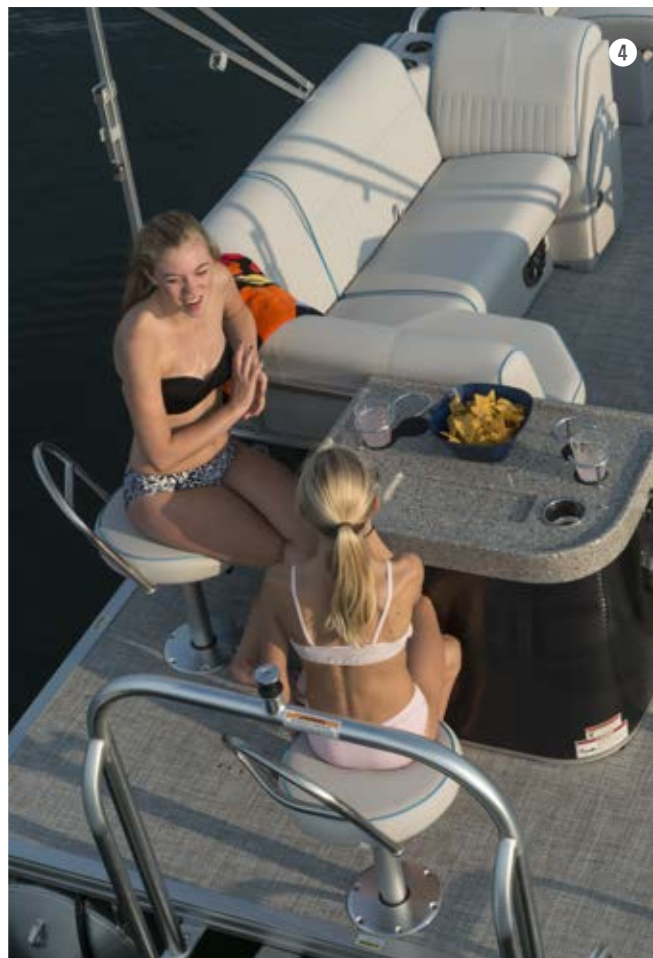





## QWEST LS

### MAKE IT YOUR OWN

Every Qwest is built to enhance the experience of your boating lifestyle. Whether you choose a bar entertainment package, a rear deck extension or prefer sleeper seats, we can create a pontoon boat that is uniquely yours.

1

Lanai Rear Lounge Pad

2

DS Bar Package

3

Splash Pad Rear Deck

4

Splash Pad Rear Bar

5 6

Rear Fishtail

7

Lanai Rear Lounge Pad and Rear Bar Package

8

Lanai Rear Lounge Pad and Deck

9

Front Sleeper Seats







---

Q3 TRIPLE TUBE

---







# THE ULTIMATE IN PERFORMANCE

If you have a need for speed, this is the high performance package for you. The Q3 Triple Tube design is created to use smaller class outboards to achieve maximum speeds, higher performance, and a smoother ride to get your happy hour started faster.



- Three 23" diam. pontoons for increased stability, buoyancy and strength
- Gen II package with integrated 25 gallon fuel tank and gauge in dash
- Lifting strakes on all three tubes offer rapid plane and better control
- Tunnel hull aluminum underskin reduces drag and creates a smoother ride with higher top end speeds
- .090" Thickness pontoons with reinforced heavy duty nose cones
- Sea-star hydraulic steering
- Aluminum ski tow bar (*Gen II only*)
- Standard 8' wide deck
- Trim gauge (*Gen II only*)

	816 TT	818 TT	820 TT	822 TT	824 TT
<b>Pontoon Length</b>	15' 11"	18' 5"	19' 10"	21' 10"	23' 10"
<b>Deck Size</b>	8' x 15' 2"	8' x 17' 2"	8' x 18' 8"	8' x 20' 8"	8' x 22' 8"
<b>Overall Length</b>	17' 7"	20' 1"	21' 6"	23' 6"	25' 6"
<b>Pontoon Diameter</b>	23"	23"	23"	23"	23"
<b>Maximum Horsepower</b>	90 HP	115 HP	150 HP	175 HP	175 HP
<b>Maximum Weight Capacity</b>	1,845 lbs.	2,115 lbs.	2,385 lbs.	2,660 lbs.	2,900 lbs.
<b>Maximum Person Capacity</b>	9 People/ 1,240 lbs.	10 People/ 1,400 lbs.	12 People/ 1,680 lbs.	13 People/ 1,900 lbs.	15 People/ 2,150 lbs.
<b>Approx. Dry Weight</b>	1,600 lbs.	1,750 lbs.	1,900 lbs.	2,050 lbs.	2,200 lbs.





---

## QWEST ADVENTURE

---





# MORE ADVENTURE

The Qwest Adventure Series boasts obvious style and good looks, and makes it the perfect pontoon for hours of adventuring. You will find it delivers an ideal blend of comfort, quality and versatility that makes it easy to adapt to whatever comes your way.



- Premium quality upholstery with exceptional durability, comfort and style
- Ultra-flow ventilated seat bases
- Humminbird Piranhamax 197c color fish finder
- Deluxe fiberglass helm stand with Adventure dash package
- Contoured rub rail with polished corners
- Fishing models with aerated live well and rod holders

	7514	7516	7518	820
<b>Pontoon Length</b>	13' 11"	15' 11"	18' 5"	19' 10"
<b>Deck Size</b>	7' 6" x 13' 2"	7' 6" x 15' 2"	7' 6" x 17' 2"	8' x 18' 8"
<b>Overall Length</b>	14' 10"	16' 10"	19' 4"	21' 2"
<b>Pontoon Diameter</b>	23"	23"	23"	23"
<b>Maximum Horsepower</b>	30 HP	40 HP	70 HP	90 HP
<b>Maximum Weight Capacity</b>	1,335 lbs.	1,575 lbs.	1,810 lbs.	2,025 lbs.
<b>Maximum Person Capacity</b>	6 People/910 lbs.	8 People/1,145 lbs.	9 People/1,290 lbs.	10 People/1,450 lbs.
<b>Approx. Dry Weight</b>	1,050 lbs.	1,175 lbs.	1,325 lbs.	1,450 lbs.





---

QWEST EDGE

---





# LIFE ON THE EDGE

Taking comfort, style and affordability to the edge is what this series is all about. The Edge models are perfect for those who want to buy upstream but don't need all the amenities. Make the most of your time on the water with Qwest Edge.



- Premium quality upholstery with exceptional durability, comfort and style
- Ultra-flow ventilated seat base system
- Deluxe fiberglass helm stand
- Fishing models with aerated live well and rod holders

	7514	7516	7518
<b>Pontoon Length</b>	13' 11"	15' 11"	18' 5"
<b>Deck Size</b>	7' 6" x 13' 2"	7' 6" x 15' 2"	7' 6" x 17' 2"
<b>Overall Length</b>	14' 10"	16' 10"	19' 4"
<b>Pontoon Diameter</b>	23"	23"	23"
<b>Maximum Horsepower</b>	30 HP	40 HP	70 HP
<b>Maximum Weight Capacity</b>	1,335 lbs.	1,575 lbs.	1,810 lbs.
<b>Maximum Person Capacity</b>	6 People/910 lbs.	8 People/1,145 lbs.	9 People/1,290 lbs.
<b>Approx. Dry Weight</b>	1,050 lbs.	1,175 lbs.	1,325 lbs.





---

## ANGLER QWEST

---





# SERIOUS FISHING

If fishing is your main priority, the Angler Qwest is exactly what you're looking for. This series offers a distinctly designed pontoon boat with true fishing amenities and a charter boat feel. Angler Qwest is all about turning time on the water into fish in the cooler.



### Fish & Pro Fish

- Fiberglass center console with front livewell
- Aluminum T-top with matched canvas
- Deluxe buddy style captains seat
- Rear fishing station with livewell
- Walk around design, 4-corner Fish or Fish N Cruise models

### Troll & Pro Troll

- Fiberglass center console with front cooler
- Proprietary diamond-plate rear double wall system
- Pro Models included heavy duty aluminum radar arch with rod holders
- Front Bimini top with rear extension
- Deluxe buddy style captains seat plus rear facing seat

*Variety of floorplans and options for the serious fisherman  
See web or spec sheets for complete details*

	818	820	822	824
<b>Pontoon Length</b>	18' 5"	19' 10"	21' 10"	23' 10"
<b>Deck Size</b>	8' x 17' 2"	8' x 18' 8"	8' x 20' 8"	8' x 22' 8"
<b>Overall Length</b>	19' 9"	21' 2"	23' 2"	25' 2"
<b>Pontoon Diameter</b>	23"	23"	23"	23"
<b>Maximum Horsepower</b>	70 HP	90 HP	115 HP	125 HP
<b>Maximum Weight Capacity</b>	1,810 lbs.	2,025 lbs.	2,245 lbs.	2,445 lbs.
<b>Maximum Person Capacity</b>	9 People/ 1,290 lbs.	10 People/ 1,450 lbs.	11 People/ 1,574 lbs.	12 People/ 1,730 lbs.
<b>Approx. Dry Weight</b>	1,325 lbs.	1,450 lbs.	1,600 lbs.	1,850 lbs.





---

GILLGETTER

---





# EXPERIENCE AFFORDABILITY

The Gillgetter series has been around for over 2 decades and has earned a reputation for being a reliable compact design that offers quality and comfort anyone can appreciate. Experience boating without breaking the bank and spend more time where it matters most.



- Premium quality upholstery with exceptional durability, comfort and style
- Ultra-flow ventilated seat base system
- Deluxe fiberglass helm stand
- Fishing models with aerated live well and rod holders
- Wide selection of models and options

	613	615	7513	7515
<b>Pontoon Length</b>	13' 1"	15' 1"	13' 4"	15' 4"
<b>Deck Size</b>	6' x 10' 8"	6' x 12' 8"	7' 6" x 10' 8"	7' 6" x 12' 8"
<b>Overall Length</b>	13' 5"	15' 5"	13' 8"	15' 8"
<b>Pontoon Diameter</b>	19"	19"	23"	23"
<b>Maximum Horsepower</b>	15 HP	25 HP	30 HP	30 HP
<b>Maximum Weight Capacity</b>	1,085 lbs.	1,225 lbs.	1,300 lbs.	1,500 lbs.
<b>Maximum Person Capacity</b>	4 People/760 lbs.	6 People/900 lbs.	6 People/875 lbs.	7 People/1,050 lbs.
<b>Approx. Dry Weight</b>	595 lbs.	825 lbs.	1,000 lbs.	1,200 lbs.





---

## PADDLE QWEST

---





# NOTHING BUT TIME

Fun and easy to use, a Paddle Qwest can be enjoyed by anyone. Propelled by a rear mounted paddle wheel, they can be powered with electric/manual or strictly manual for those interested in getting a bit of exercise during their journey.

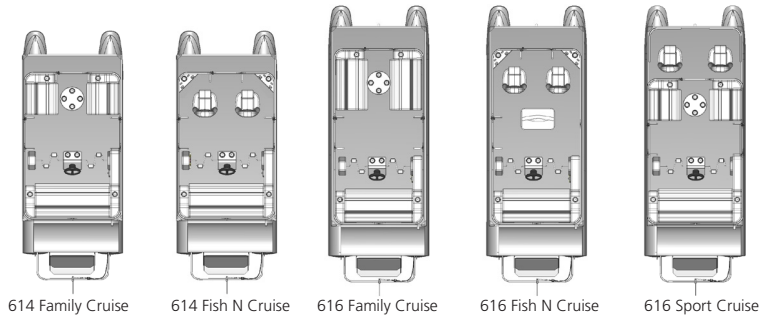

614 Family Cruise    614 Fish N Cruise    616 Family Cruise    616 Fish N Cruise    616 Sport Cruise

- Unique all aluminum riverboat paddle wheel with strategically located "windows" to reduce resistance and accommodate heavier loads
- Health-focused alternative to enjoying time on the water
- Lightweight, compact design with a heavy duty pedal drive system and a central helm make steering and maneuvering a breeze
- Environmentally friendly way to be on the water without on-going fuel costs
- The perfect choice for smaller lakes or lakes that ban internal combustion engines; but also a viable option for use on most waterways and lakes

### OPTIONAL ELECTRIC PACKAGE

24 volt electric drive package and selector clutch allows you to use foot pedals or electric power. Package includes navigation lights, charger and horn.

### OPTIONAL SOLAR PACKAGE

This clean and free renewable energy provides 1-3 hours of electric operation per day from the sun. No cords to plug in and no need to have electricity at the dock.

WITH OPTIONAL 24V ELECTRIC POWER ASSIST PACKAGE		
Battery Runtime		2-4 hrs
Optional Solar System Daily Runtime	Average Sun	Adds 1-2 hrs run time
	Full Sun	Adds 2-3 hrs run time

	614	616
<b>Pontoon Length</b>	14' 1"	16' 1"
<b>Deck Size</b>	6' x 10' 8"	6' x 12' 8"
<b>Overall Length</b>	16' 4"	18' 4"
<b>Length Inside Rails</b>	9' 3"	10' 9"
<b>Overall Width</b>	72"	72"
<b>Pontoon Diameter</b>	19"	19"
<b>Maximum Weight Capacity</b>	1,000 lbs.	1,200 lbs.
<b>Maximum Person Capacity</b>	6 People/1,000 lbs.	8 People/1,200 lbs.
<b>Approx. Dry Weight</b>	750 lbs.	875 lbs.





## ELECTRIC POWER

We are the leaders in Electric Powered Pontoon boats. Environmentally conscious boaters are delighted to discover that electric power is not just for your car, but is now available for your Qwest pontoon boat. Now you can enjoy all the lakes have to offer, even restricted lakes that ban internal combustion outboards, with optimum performance and fuel costs.

- Light Weight, Compact Design Promotes Optimum Performance from Limited Horsepower Electric Outboards
- Environmentally Friendly Way to be on the Water Without On-Going Fuel Costs
- The Perfect Choice for Smaller Lakes or Lakes that Ban Internal Combustion Engines; but Also a Viable Option for Use on Most Waterways and Lakes
- Quiet and Simple to Operate and Maintain
- Remote Steering and Throttle Control Just Like that of a Gas Outboard
- On-board Chargers Ensure Your Pontoon is Ready When You Are

With several drives to choose from, there's an electric package that's perfect for your next Apex Pontoon Boat.

- 1 Torqeedo Cruise 2.OR (24V, Top Speed: 4-5MPH\*)** has the thrust of a 6 HP combustion engine. This highly efficient 24 Volt motor is lightweight and powerful. Includes variable speed throttle control with an integrated display.
- 2 Torqeedo Cruise 4.OR (48V, Top Speed: 6-7MPH\*)** has the thrust of a 9.9 HP combustion engine and unparalleled efficiency in a 48 Volt system. It features an integrated GPS receiver and information center so you always know how much battery power and remaining range you have.
- 3 Minn Kota E-Drive (48V, Top Speed: 4-5MPH\*)** is a 2HP motor operating on a 48 Volt system. This unit is very quiet and user friendly. The E-Drive has power tilt with a dash-mounted gauge. The electronic throttle control features a back-lit display showing battery level and remaining runtime.
- 4 Ray Drive 400 (48V, Top Speed: 5-6MPH\*)** is a 4HP motor operating on a 48 Volt system. This drive has been around since the 1970's and is extremely reliable and efficient. The variable speed throttle has a key switch and battery fuel gauge.

\*Top speed will vary with boat length, loading and weather.



Optional LED Battery Gauge



Optional Panther 35 Tilt







## SOLAR

Solar charging is a great way to extend your time on the water or use as a primary charging source when there is no plug at the dock. The solar panel pulls renewable energy from the sun, continuously charging your batteries. Charging with solar is an excellent way to keep batteries maintained and healthy so they provide a long life. Solar charging is available with any of the electric outboard motors, or charge your trolling motor batteries for limitless fishing.

- Free renewable energy from the sun
- High efficiency crystalline solar panel
- Can charge flooded and AGM lead acid batteries as well as the Apex Lithium Packs
- Compatible with 24, 36 and 48 volt systems
- Use to charge your trolling motor batteries for endless fishing
- 25-year panel performance warranty



## LITHIUM BATTERIES

- Light weight –1/3 the weight of lead acid
- Long life –will last over 3000 charge cycles which is 10-20 times longer than lead acid
- Fast charging –super efficient and high powered chargers will charge the lithium pack in just a few hours from any standard 110 volt outlet
- Packaged into one 24V or 48V battery pack
- Available in multiple capacities
- Can be charged using the new Apex solar systems
- Can be used with any electric motor package and even the Electric Paddle Qwest
- On/off button on battery
- Zero maintenance
- Reserve capacity feature



### BATTERY COMPARISON

	Flooded Lead Acid 48V	Lithium 48V
<b>Weight</b>	244 lbs.	80 lbs.
<b>Volume</b>	3510 in <sup>3</sup>	2500 in <sup>3</sup>
<b>Nominal Voltage</b>	48V	51.2V
<b>Rated Capacity</b>	105 Ah	65 Ah
<b>Usable Capacity</b>	60 Ah	62 Ah
<b>Usable Energy</b>	2880 Wh	3170 Wh
<b>Self Discharge</b>	20% / Month	<1% / Month
<b>Charge Time</b>	10 Hours	2 1/2 Hours
<b>Life</b>	200 Cycles or 2 Years	3000 Cycles

	24V Lithium		48V Lithium	
<b>Capacity</b>	65 AH	110 AH	65 AH	110 AH
<b>Weight</b>	45 lbs.	69 lbs.	80 lbs.	130 lbs.
<b>Charge Rate</b>	40 Amp	40 Amp	25 Amp	25 Amp
<b>Charge Time</b>	1 1/2 Hrs.	3 Hrs.	2 1/2 Hrs.	4 1/2 Hrs.



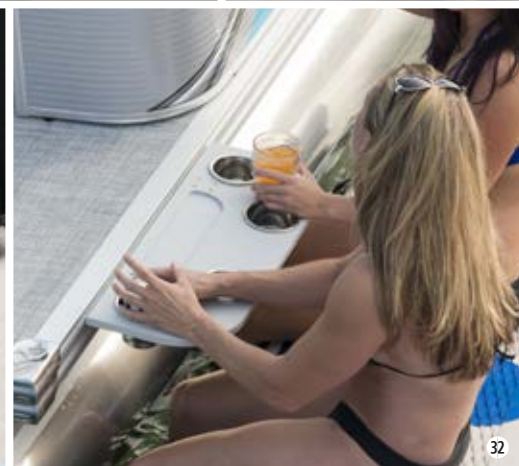
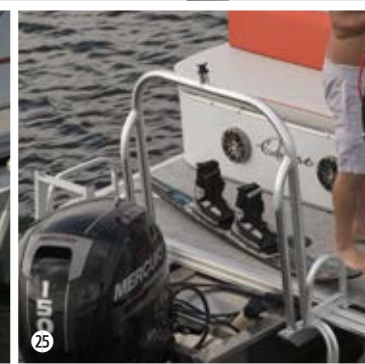
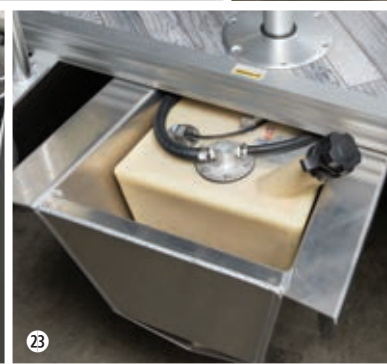
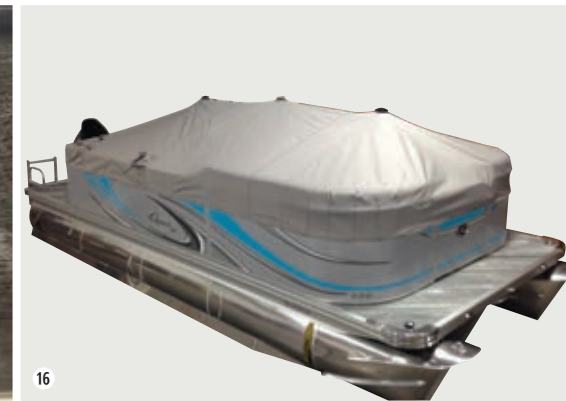



# OPTIONS & ACCESSORIES

## LIGHTING

- 1 Blue Ice Lighting Package. Includes: riser trim lights, underwater lights, speaker lights, lighted cup holders
- 2 Riser trim lights
- 3 Underwater lights
- 4 Speaker lights
- 5 Lighted cup holders
- 6 Courtesy lights
- 7 Docking lights

## ELECTRONICS

- 8 Infinity stereo system, Bluetooth ready with universal cell phone mount
- 9 Extra set of Infinity speakers
- 10 (6) Speaker stereo system with (4) extra Infinity speakers and amplifier
- 11 Prospec mini stereo with auxiliary input
- 12 Extra set of Prospec speakers
- 13 Humminbird PiranhaMax 197c color fish finder (Standard in Adventure models)
- 14 Helix 5 Sonar GPS Fish Finder (Standard in LS models)
- 15 Trim Gauge (Standard with Gen II Triple Tube Package)

## OTHER

- 22 2' Deck/Tube Extension (Bow or Stern)
- 23 17 Gallon built-in motor mount fuel tank with gauge
- 24 Bright .090 Pontoon Tubes with Sharkhide Protectant
- 25 Ski tow bar
- 26 Riser trim (Standard on LS Series)
- 27 1/2 Gate with trolling motor plug
- 28 Starboard side gate (Not available on all models)
- 29 Wheelchair gate
- 30 Port side rear entry ladder
- 31 Minn Kota deckhand power anchor
- 32 Swim Up Wet Bar
- 33 High pressure raw water washdown system
- 34 Rear storage pod (Behind captains seat)
- 35 Raised helm platform
- 36 Ski/storage locker (Triple Tube models only)
- 37 Lilli Pad Diving Board
- 38 Saltwater Package

## CANVAS

- 16 Playpen cover
- 17 Individual seat covers
- 18 Full and partial enclosures
- 19 Front bimini top
- 20 Rear bimini extension
- 21 Blue water top, power top with side curtains & sunroof. See website for more photos & info: [QwestPontoons.com](http://QwestPontoons.com)





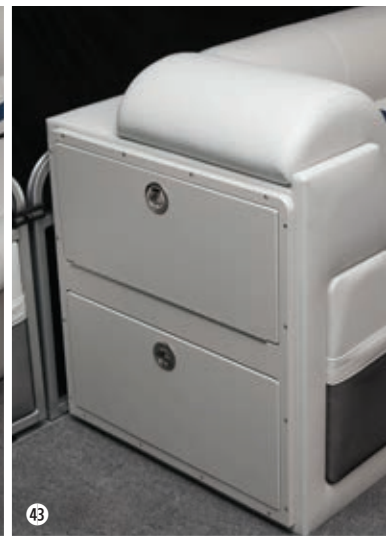

## OPTIONS & ACCESSORIES

### SEATING

- 39** RLS rear sleeper seats  
*(Only available on Luxury Series RLS Models)*
- 40** Front sleeper seats *(Available on select 20'-24' Luxury Series Models) See page 31*
- 41 42 43** Refreshment Center in Layback with Removable Cooler
- 44** Layback with privacy enclosure
- 45** High back reclining captains seat
- 46** Slide out cooler drawer with removable cooler
- 47** Movable foot stool with storage
- 48** Extended front starboard bench with layback *(Available on select Edge Models)*
- 49 50** XRE rear bar package

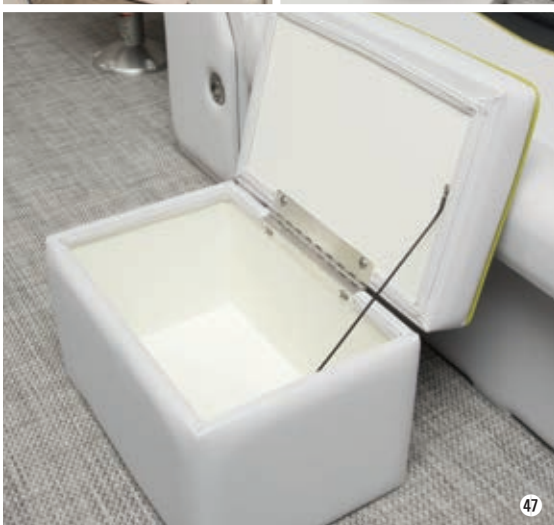



# 2016 STANDARDS & OPTIONS CHART

Angler Qwest Series Standards and Options are listed in the Angler Qwest Section of the website.

## KEY

STD = Standard  
O = Optional  
N/A = Not Available

## NOTES

A: Must be equipped with optional electric drive OR optional switch panel with harness  
B: Bimini Top and Boot is standard on all models EXCEPT Tiller Models

*This chart is provided for your convenience. Further information on standard items, options and floor plans is available from your Apex dealer. Options may not be available on all sizes for each model, even if listed here. Check with your Apex Dealer for specific details. Information is current at time of printing; all specifications and options are subject to change without notice.*

## WARRANTY

Apex Marine warrants all new Apex pontoon boats to be free from defects in material and workmanship. We provide a limited lifetime warranty on the pontoon hulls, cross channels, walls and risers for lifetime of the original owner to be free from weld breaks and cracks. Components not manufactured by Apex are covered by their respective manufacturer. The following is an overview of the warranty coverage.

## OVERVIEW

- Pontoon Tubes: Pontoon Hulls carry a limited lifetime warranty
- Structure: Framing cross channels and risers carry a limited lifetime warranty
- Decking: Our decks consist of treated multi-ply plywood panels that carry a limited lifetime warranty
- Seat Frames: Wood and plastic components in upholstery seat frames carry a limited lifetime warranty
- Seat Vinyl: Upholstery vinyl is warranted for 5 years
- Deluxe Vinyl Flooring: 5 Year limited warranty
- Canvas: High Performance Marine Fabrics are warranted for 5 years
- Components: All components not manufactured by Apex including, but not limited to, Gas and Electric Outboards, radios, fish finders, speakers, and gauges are covered by their respective manufacturer.

Under a program of continued improvement, Apex Marine, Inc., reserves the right to alter details and specifications without prior notice and will assume no obligations as a result of such changes. All warranties are subject to proper use and care. All warranties, expressed or implied, are void in cases of damage sustained in trailering, misuse, accidents, improper storage, improper maintenance or commercial use.

	QWEST LS (Luxury Series)	QWEST ADVENTURE	QWEST EDGE	GILLGETTER	PADDLE QWEST	
HELM	Luxury Series Fiberglass Helm Stand	STD	STD	N/A	N/A	N/A
	Deluxe Fiberglass Helm Stand	N/A	N/A	STD	STD	N/A
	Blackwood Dash Panels with Switches, Tach and Volt Meter	STD	STD	N/A	N/A	N/A
	Upholstered Helm Stand	N/A	N/A	N/A	N/A	STD
	Switch Panels with Accessory Harness	N/A	N/A	STD	STD	O
	Tilt Steering Wheel	STD	O	O	O	N/A
	Courtesy Light in Helm	STD	O	O	O	O (SEE NOTE A)
	Windshield with Quick Release Hardware	STD	STD	STD	STD	N/A
	12 Volt Outlet	STD	O	O	O	O (SEE NOTE A)
Universal Cell Phone Holder	STD	O	O	O	O	
ELECTRONICS	Infinity Stereo System with (2) Infinity Speakers and Bluetooth Audio	STD	O	O	O	O (SEE NOTE A)
	Prospec Mini Stereo with (2) JBL Speakers and Bluetooth Audio	N/A	O	O	O	O (SEE NOTE A)
	Humminbird Helix 5 Sonar Color GPS Fish Finder	STD	O	O	O	N/A
	Humminbird Piranhamax 197c Color Fish Finder	N/A	STD	O	O	O
	Upgrade to 6 Speaker Stereo System with Amp	O	O	N/A	N/A	N/A
	Extra Set of (2) Speakers	O	O	O	O	O (SEE NOTE A)
INTERIOR	Luxury Series Upholstery with LINEN Comfort Touch Vinyls	STD	N/A	N/A	N/A	N/A
	Deluxe Series Upholstery	N/A	STD	STD	STD	STD
	Upgrade to LINEN Comfort Touch Vinyl	STD	O	O	O	O
	Plastic Seat Bases with ULTRA-FLOW Ventilation	STD	STD	STD	STD	STD
	Soft Touch X-Padded Back Vinyls	STD	STD	STD	STD	STD
	Stainless Steel Cupholders	STD	O	O	O	O
	Incamat Seat Liners	STD	STD	STD	STD	STD
	Portable Cup Holder	STD	O	O	O	O
Round Table with Hardware	Tables Are Standard On All Lanai, Splash Pad, Cruise, RLS, Cruise Deluxe, Sport Cruise, and Family Cruise Models					
Aerated Livewell	Livewells Standard On Fish, XRE, Fishtail, Sport Cruise, Sport Deluxe, VX, SP, SC and Fish N Cruise Models					O
FLOORING	Premium Vinyl Flooring (Full Deck)	STD	STD	STD	STD	STD
	Marine Carpet - Available as Partial or Full Deck	O	O	O	O	O
	Diamond Sea Grass or Weave Flooring - Available as Partial or Full Deck	O	O	O	O	O
	TEAK Vinyl Flooring - Available as Partial (Front OR Rear) or Full Deck	O	O	O	O	O
EXTERIOR	Rigid Dent Resistant Aluminum Panels	STD	STD	STD	STD	STD
	Pontoons with Integrated Splash Guard and Full Length Keel	STD	STD	STD	STD	STD
	Dual Saddle Brackets with Extruded C-Channel Stringers	STD	STD	STD	STD	STD
	Stainless Steel "FOLD DOWN" Mooring Cleats	STD	STD	N/A	N/A	N/A
	Composite Mooring Cleats	N/A	N/A	STD	STD	STD
	Riser Trim	STD	O	O	O	O
	Polished Aluminum Corner Caps	STD	STD	N/A	N/A	N/A
	Composite Corner Caps	N/A	N/A	STD	STD	STD
	Contoured Rub Rail with Hidden Fasteners	STD	STD	N/A	N/A	N/A
	Raised Chrome Qwest and LS Logos	STD	N/A	N/A	N/A	N/A
	Robust Aluminum Rear Entry Ladder	STD	STD	STD	N/A	N/A
	Deutsch Style Waterproof Wiring Connectors	STD	STD	STD	STD	STD
COVERS/ BIMINI	Bimini Top with Boot	STD	STD	STD	STD (SEE NOTE B)	STD
	Quick Release Bimini Hardware	STD	STD	STD	STD	STD
	Playpen Cover	O	O	O	O	O
	Individual Seat Covers	O	O	O	O	O
LIGHTING	Navigation Lights	STD	STD	STD	STD	O (SEE NOTE A)
	Docking Lights ( LED )	O	O	O	O	O (SEE NOTE A)
	Riser Trim Lights (May Require Optional Riser Trim )	O	O	O	O	O (SEE NOTE A)
	Underwater Lights	O	O	O	O	O (SEE NOTE A)
	Lighted Cupholders	O	O	O	O	O (SEE NOTE A)
	Courtesy Light Package ( 3 Lights )	O	O	O	O	O (SEE NOTE A)



# WALLS COLOR OPTIONS



Platinum Blueberry shown.

## PLATINUM



### BLUEBERRY

1 Beige Upholstery with Beige Flooring Options



### RUBY

2 Beige Upholstery with Beige Flooring Options



### BLACK

3 Beige Upholstery with Beige Flooring Options



### MOJITO

4 Beige Upholstery with Beige Flooring Options



### CARIBBEAN BLUE

5 Beige Upholstery with Beige Flooring Options



### FIRECRACKER

6 Beige Upholstery with Beige Flooring Options

## CARBON

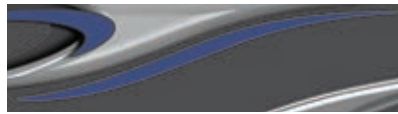

### BLUEBERRY OR BLUEBERRY & GRAY

1 Beige Upholstery with Beige Flooring Options **OR**  
8 Gray Upholstery with Gray Flooring Options



### RUBY OR RUBY & GRAY

2 Beige Upholstery with Beige Flooring Options **OR**  
9 Gray Upholstery with Gray Flooring Options



### BLACK OR BLACK & GRAY

3 Beige Upholstery with Beige Flooring Options **OR**  
10 Gray Upholstery with Gray Flooring Options



### MOJITO OR MOJITO & GRAY

4 Beige Upholstery with Beige Flooring Options **OR**  
11 Gray Upholstery with Gray Flooring Options



### CARIBBEAN BLUE OR CARIBBEAN BLUE & GRAY

5 Beige Upholstery with Beige Flooring Options **OR**  
12 Gray Upholstery with Gray Flooring Options



### FIRECRACKER OR FIRECRACKER & GRAY

6 Beige Upholstery with Beige Flooring Options **OR**  
13 Gray Upholstery with Gray Flooring Options

## FROST WHITE



### BLUEBERRY & GRAY

8 Gray Upholstery with Gray Flooring Options



### RUBY & GRAY

9 Gray Upholstery with Gray Flooring Options



### BLACK & GRAY

10 Gray Upholstery with Gray Flooring Options



### MOJITO & GRAY

11 Gray Upholstery with Gray Flooring Options



### CARIBBEAN BLUE & GRAY

12 Gray Upholstery with Gray Flooring Options



### FIRECRACKER & GRAY

13 Gray Upholstery with Gray Flooring Options

## SILVER ICE



### BLUEBERRY & GRAY

8 Gray Upholstery with Gray Flooring Options



### RUBY & GRAY

9 Gray Upholstery with Gray Flooring Options



### BLACK & GRAY

10 Gray Upholstery with Gray Flooring Options



### MOJITO & GRAY

11 Gray Upholstery with Gray Flooring Options

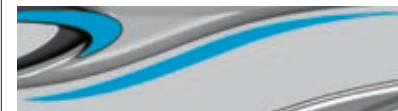

### CARIBBEAN BLUE & GRAY

12 Gray Upholstery with Gray Flooring Options

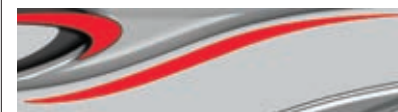

### FIRECRACKER & GRAY

13 Gray Upholstery with Gray Flooring Options

## BLACK



### BLACK PEARL

3 Beige Upholstery with Beige Flooring Options



### BLACK & GRAY

10 Gray Upholstery with Gray Flooring Options

## STEEL BLUE



### STEEL BLUE

7 Beige Upholstery with Beige Flooring Options



### STEEL BLUE & GRAY

14 Gray Upholstery with Gray Flooring Options



# UPHOLSTERY COLOR OPTIONS

## LS MODELS



Shown with Gray Base and Caribbean Blue Accent Color

### BEIGE BASE COLOR OPTIONS



1 Blueberry 2 Ruby 3 Black 4 Mojito



5 Caribbean Blue 6 Firecracker 7 Steel Blue

### GRAY BASE COLOR OPTIONS



8 Blueberry 9 Ruby 10 Black 11 Mojito



12 Caribbean Blue 13 Firecracker 14 Steel Blue

## ALL OTHER MODELS



Main Accent Color  
Secondary Accent Color  
Base Color

Shown with Gray Base (Charcoal Secondary Accent Color) and Ruby Main Accent Color

### BEIGE BASE WITH MAIN ACCENT AND TITANIUM SECONDARY

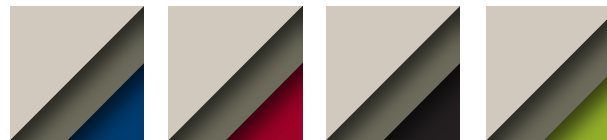

1 Blueberry 2 Ruby 3 Black 4 Mojito

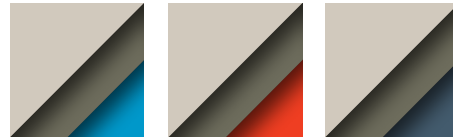

5 Caribbean Blue 6 Firecracker 7 Steel Blue

### GRAY BASE WITH MAIN ACCENT AND CHARCOAL SECONDARY



8 Blueberry 9 Ruby 10 Black 11 Mojito



12 Caribbean Blue 13 Firecracker 14 Steel Blue

# FLOORING COLOR OPTIONS

## BEIGE OPTIONS

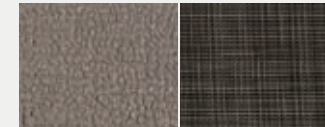

Beige Vinyl  
Standard on all models.

Beige Weave

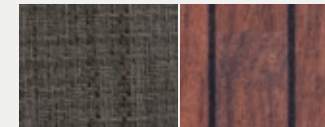

Diamond Sea Grass

Teak Vinyl



Nutmeg

## GRAY OPTIONS

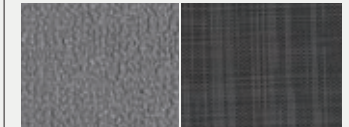

Gray Vinyl  
Standard on all models.

Gray Weave



Gray Diamond  
Sea Grass

Gray Teak Vinyl

Gray and beige carpet available upon request.



Optional  
FLOOR MATS  
& THROW PILLOWS





# QWEST LS

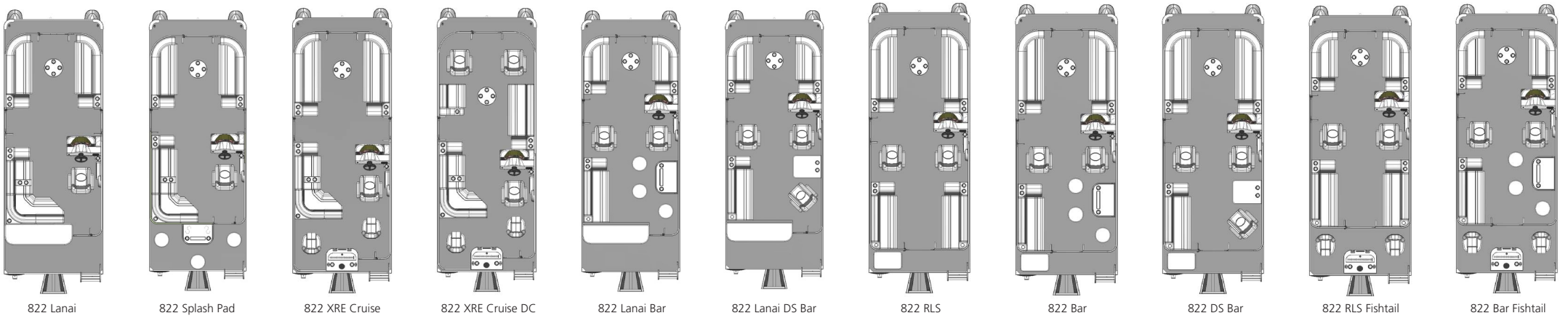
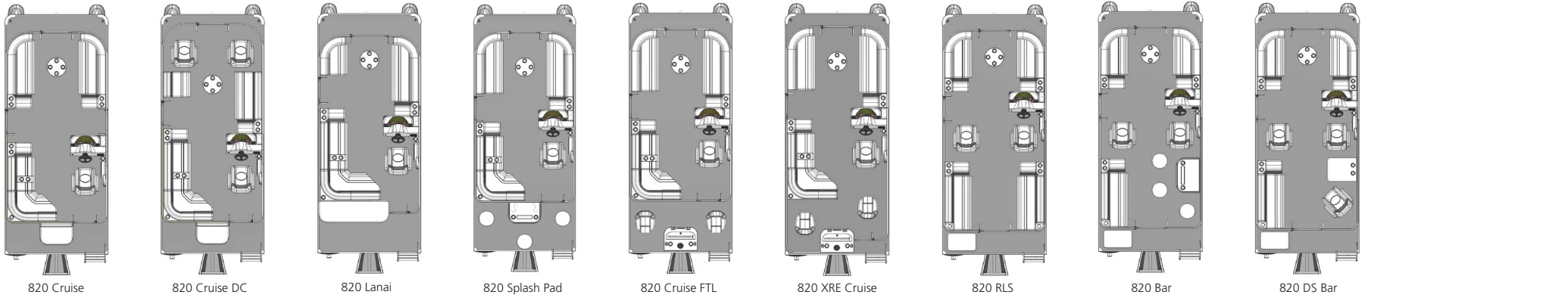
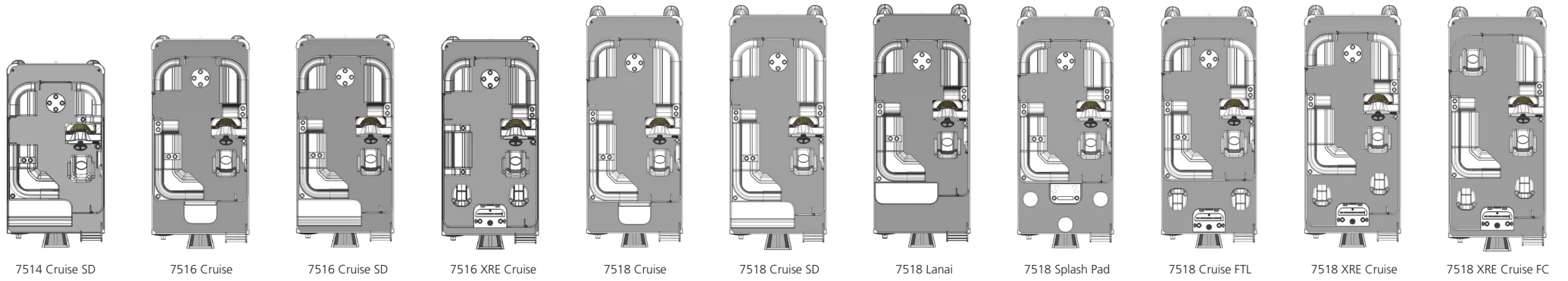



## SLEEPER SEATS



### 60" FRONT SLEEPERS

Available on:  
 822 XRE Cruise  
 822 RLS  
 822 Bar  
 822 DS Bar  
 824 Lanai Bar  
 824 Lanai DS Bar  
 824 RLS Fishtail  
 824 Bar Fishtail  
 824 DS Bar Fishtail

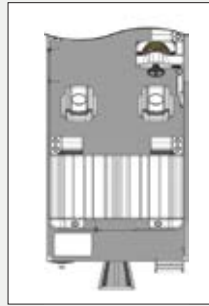

### 44" RLS REAR SLEEPERS

Available on:  
 820 RLS  
 822 RLS  
 822 RLS Fishtail  
 824 RLS Fishtail



### 51"/54" FRONT SLEEPERS

Available on:  
 820 Splash Pad  
 820 Cruise FTL  
 820 XRE Cruise



### 51" FRONT SLEEPERS

Available on:  
 820 Cruise  
 822 Lanai  
 822 Splash Pad

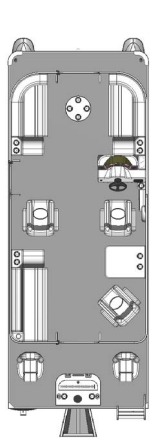

822 DS Bar Fishtail

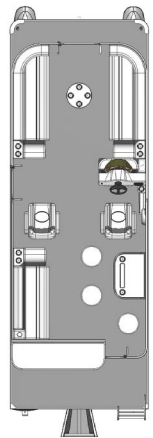

824 Lanai Bar

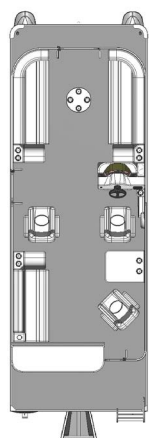

824 Lanai DS Bar

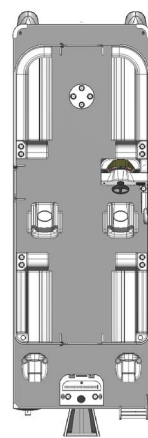

824 RLS Fishtail

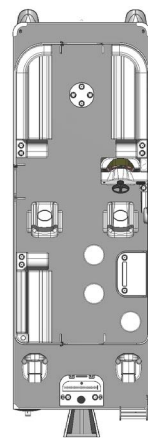

824 Bar Fishtail

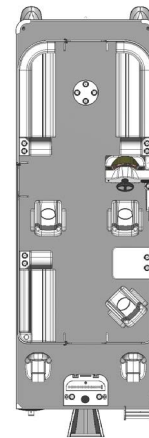

824 DS Bar Fishtail





## QWEST ADVENTURE

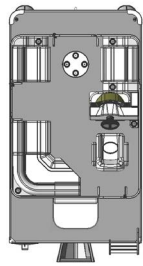

7514 Cruise Deluxe

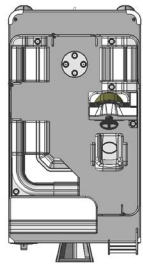

7514 Cruise Deluxe SD

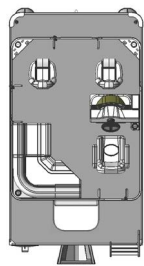

7514 Sport Deluxe

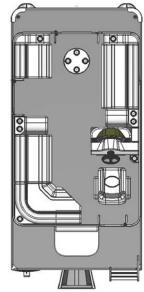

7516 Cruise Deluxe

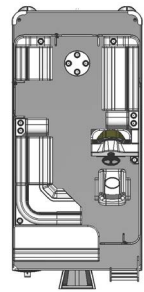

7516 Cruise Deluxe SD

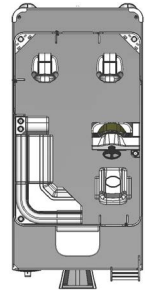

7516 Sport Deluxe

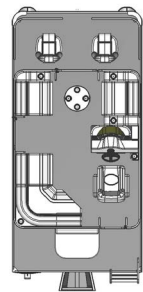

7516 Sport Cruise

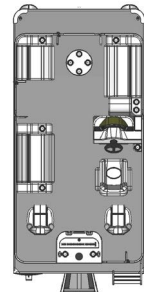

7516 VX Cruise

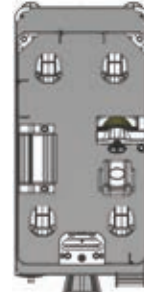

7516 VX Fish

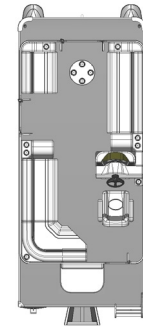

7518 Cruise Deluxe

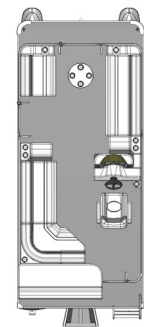

7518 Cruise Deluxe SD

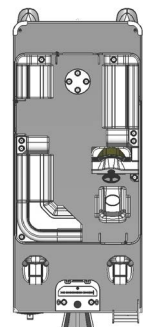

7518 Cruise Deluxe FTL

## ANGLER QWEST

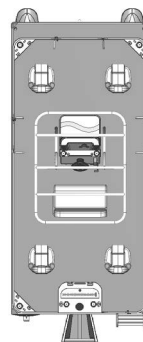

818 Fish

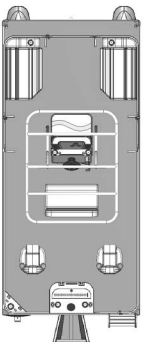

818 Fish N Cruise

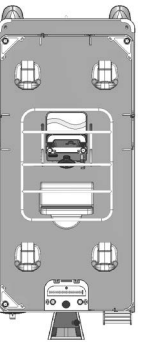

818 Pro Fish

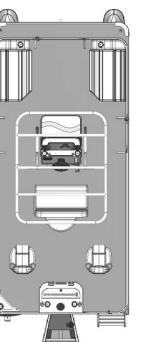

818 Pro Fish N Cruise

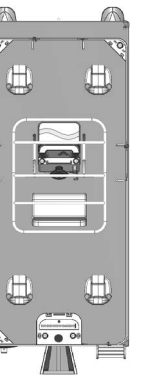

820 Fish

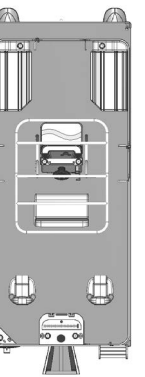

820 Fish N Cruise

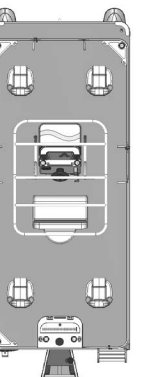

820 Pro Fish

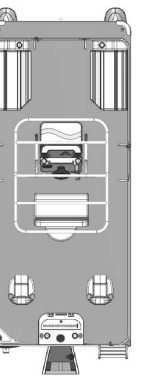

820 Pro Fish N Cruise

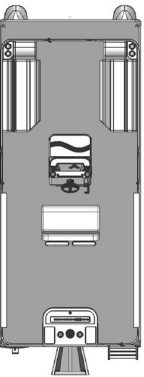

820 Troll

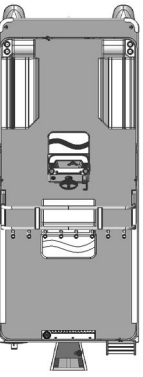

820 Pro Troll



822 Troll

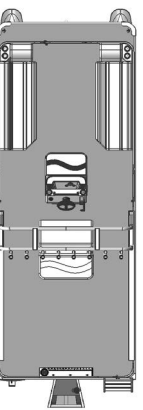

822 Pro Troll

## GILLGETTER

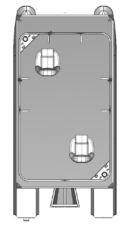

613 Tiller

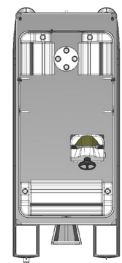

615 Family Cruise

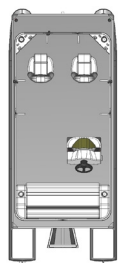

615 Fish N Cruise

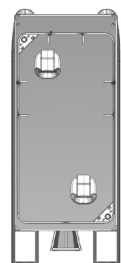

615 Tiller

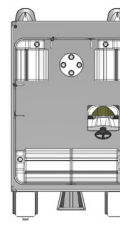

7513 Family Cruise

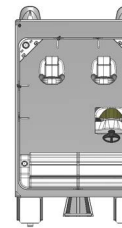

7513 Fish N Cruise

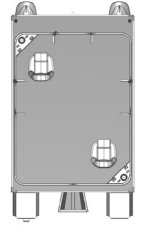

7513 Tiller

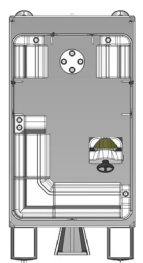

7515 Cruise Deluxe

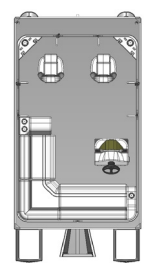

7515 Sport Deluxe

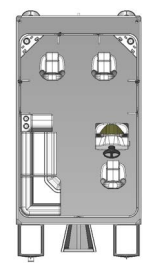

7515 Fishmaster

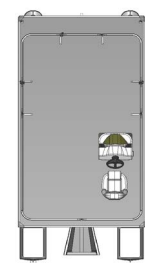

7515 Outfitter

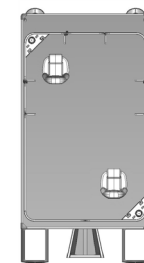

7515 Tiller



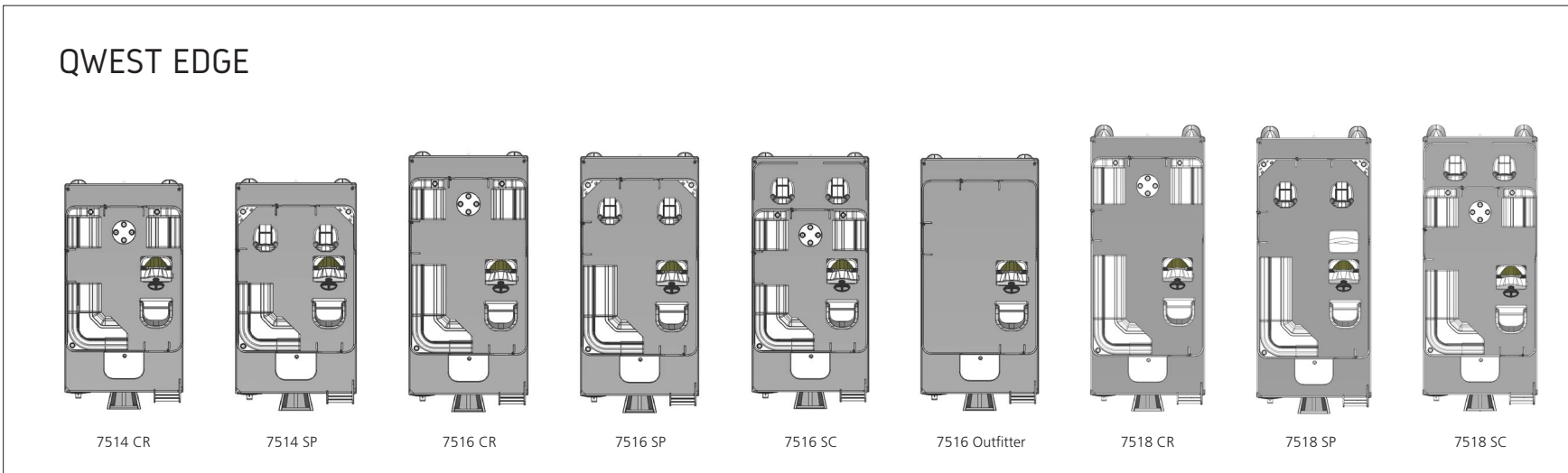
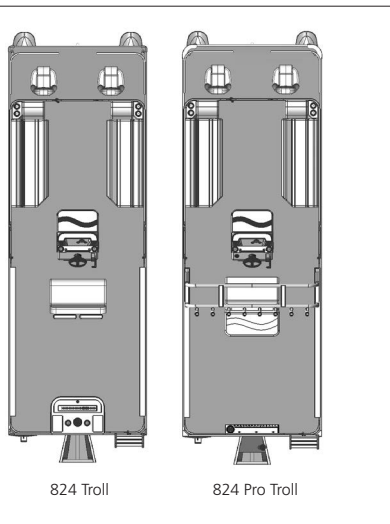
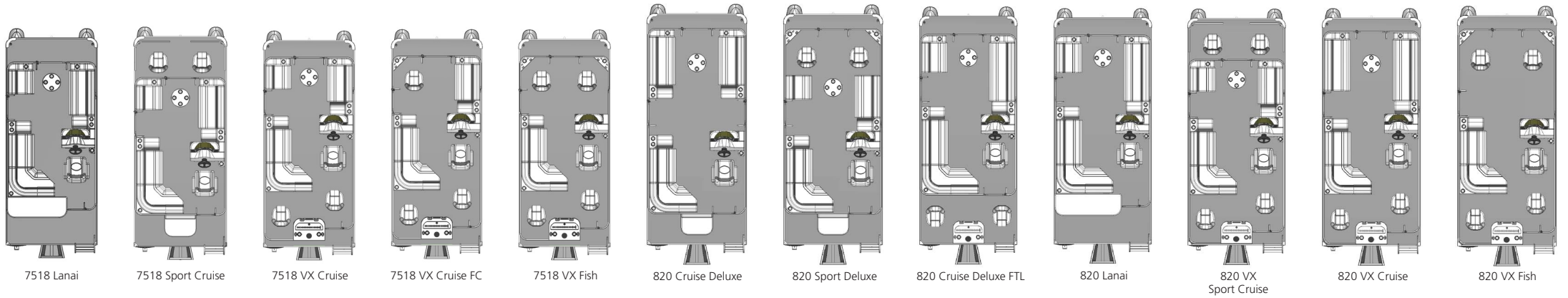





**Apex**  
Marine

300 Woodside Drive • Saint Louis, Michigan 48880  
Phone: 989-681-4300 • Fax: 989-681-4333 • [www.QwestPontoons.com](http://www.QwestPontoons.com)

All specifications, features, colors, and technical information in this brochure are based on the latest information available at the time of publication. Apex Marine reserves the right to make changes at any time without notice. Some images may be shown with optional equipment that is available at additional costs. For more information, call 989-681-4300 or contact your Apex Marine dealer.