

Rational Application Developer V7.5 Programming Guide

Develop application using Java EE 5

Test, debug, and profile with
local and remote servers

Deploy applications to
WebSphere servers

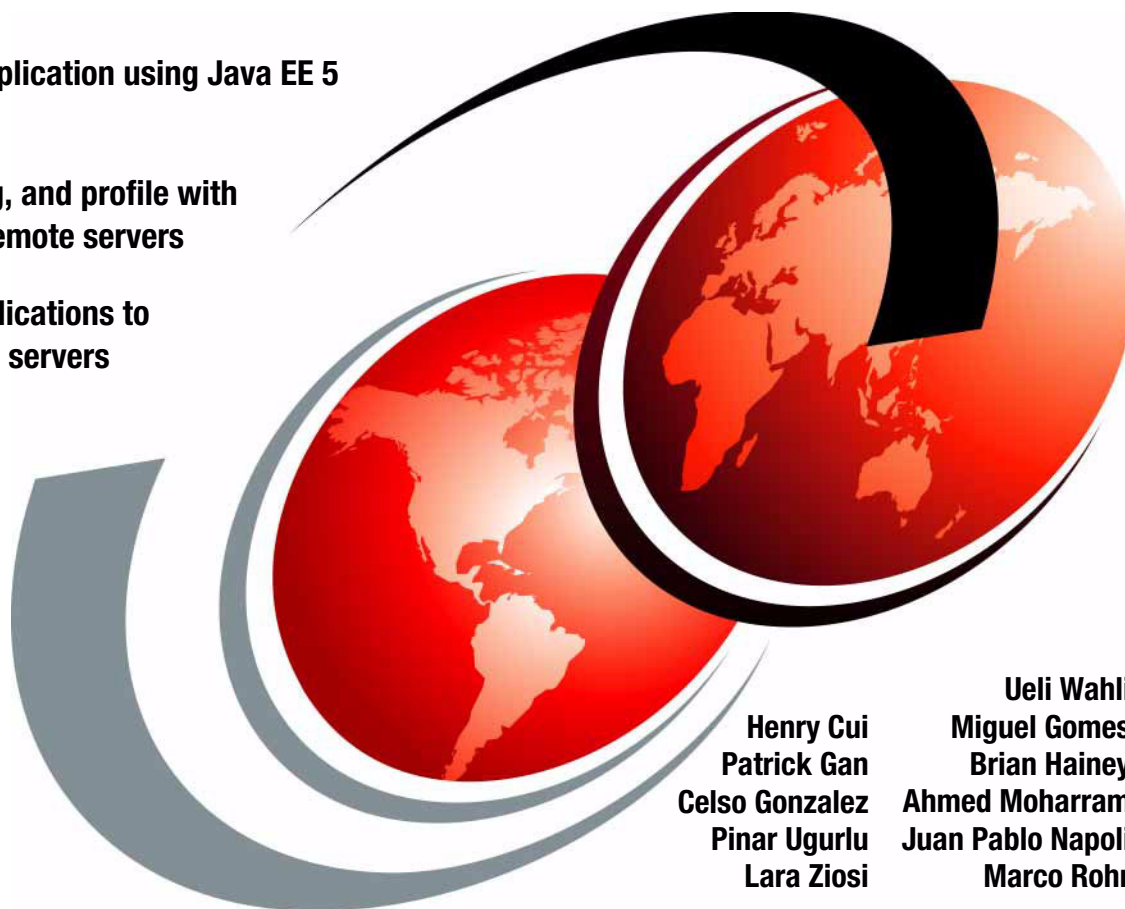

Henry Cui
Patrick Gan
Celso Gonzalez
Pinar Ugurlu
Lara Ziosi

Ueli Wahli
Miguel Gomes
Brian Hainey
Ahmed Moharram
Juan Pablo Napoli
Marco Rohr

This is the second draft

ibm.com/redbooks

Redbooks



International Technical Support Organization

**Rational Application Developer V7.5 Programming
Guide**

December 2008

Note: Before using this information and the product it supports, read the information in “Notices” on page liii.

First Edition (December 2008)

This edition applies to IBM Rational Application Developer for WebSphere Software Version 7.5 and to IBM WebSphere Application Server Version 7.0.

This document created or updated on December 9, 2008.

© Copyright International Business Machines Corporation 2008. All rights reserved.

Note to U.S. Government Users Restricted Rights -- Use, duplication or disclosure restricted by GSA ADP Schedule Contract with IBM Corp.

Contents

Figuresxxvii
Tables	xlvii
Examples	xlix
Notices	liii
Trademarks	liv
Preface	lv
The team that wrote this book	lvi
Become a published author	lix
Comments welcome	lx
Summary of changes	lxi
December 2008, First Edition	lxi
Part 1. Introduction to Rational Application Developer	1
Chapter 1. Introduction	3
Concepts	4
IBM Rational Software Delivery Platform	4
Eclipse and IBM Rational Software Delivery Platform	7
Eclipse Project	7
Eclipse Software Developer Kit (SDK)	9
Application development challenges	9
Product packaging	10
Rational Developer supported platforms and databases	10
Application Developer v7.5 eAssembly	12
Product tools and features	13
Tools	13
Summary of new features in Application Developer v7.5	14
Specification versions	18
Installation and licensing	20
Installation	20
Licensing	21
Updates	21
Uninstall	22
Migration and coexistence	22

Migration	22
Compatibility with previous versions	23
Sample code	24
Summary	24
Chapter 2. Programming technologies	25
Desktop applications	26
Simple desktop applications	26
Database access	29
Graphical user interfaces	30
Extensible Markup Language (XML)	33
Static Web sites	35
Hypertext Transfer Protocol (HTTP)	35
HyperText Markup Language (HTML)	37
Dynamic Web applications	38
Simple Web applications	39
Struts	46
JavaServer Faces (JSF) and persistence using SDO or JPA	48
Web 2.0 Development	51
Portal applications	54
Enterprise JavaBeans and Java Persistence API (JPA)	56
EJB 3.0 specification - What is new?	57
Different types of EJBs	58
Java Persistence API (JPA)	59
Other EJB and JPA features	60
Java EE Application Clients	62
Web services	65
Web services in Java EE 5	66
Messaging systems	70
Java Message Service (JMS)	71
Message-driven EJBs (MDBs)	71
Requirements for the development environment	72
Summary	73
Chapter 3. Workbench setup and preferences	75
Workbench basics	76
Workspace basics	79
Application Developer logging	84
Preferences	86
Automatic builds	87
Manual builds	88
Capabilities	88
File associations	92

Local history	93
Perspectives preferences	95
Web Browser preferences.	96
Internet preferences	97
Java development preferences	98
Java classpath variables	98
Appearance of Java elements.	100
Code style and formatting	102
Java editor settings	109
Compiler options	114
Installed JREs	115
Summary	117
Chapter 4. Perspectives, views, and editors.	119
Integrated development environment (IDE)	120
Perspectives	120
Views.	121
Editors.	121
Perspective layout.	122
Switching perspectives	123
Specifying the default perspective	124
Organizing and customizing perspectives.	124
Application Developer Help	127
Available perspectives	129
Crystal Reports perspective	130
CVS Repository Exploring perspective	130
Data perspective	132
Database Debug perspective	134
Database Development perspective	135
Debug perspective	136
Java perspective	138
Java Browsing perspective	139
Java EE perspective	140
Java Type Hierarchy perspective	142
JavaScript perspective	143
Jazz Administration perspective	144
JPA perspective	146
Plug-in Development perspective	147
Profiling and Logging perspective	149
Report Design perspective	150
Requirement perspective	151
Resource perspective	152
Team Synchronizing perspective	153

Test perspective	154
Web perspective	155
Work items perspective	158
Progress view	159
Summary	160
Chapter 5. Projects	161
The Java Enterprise Edition 5 platform	162
Enterprise application modules	164
Web modules	165
EJB modules	165
Application client modules	165
Resource adapter modules	166
Java Utility Libraries	166
Project basics	166
Creating a new project	166
Project properties	171
Deleting projects	172
Project interchange files	173
Closing projects	173
Java EE 5 project types	174
Project wizards	176
Sample projects	179
Help system samples	179
Example Projects wizard	182
Summary	183
Part 2. Architecture and modeling	1
Chapter 6. RUP, patterns, and SOA	3
Rational Unified Process	4
RUP installation in Application Developer	7
Process Browser	7
Process Advisor	9
Process Search	9
Process preferences	10
Patterns	12
GoF patterns	12
Architectural patterns	14
Enterprise patterns	15
SOA	16
Services	17
Web services interoperability	17
Web Service Business Process Execution Language (WS-BPEL)	18

Additional information	18
Chapter 7. Unified Modeling Language (UML)	21
Overview	22
Constructing and visualizing applications using UML	22
Unified Modeling Language	25
Working with UML class diagrams	28
Creating class diagrams	28
Creating, editing, and viewing Java elements in UML class diagrams	29
Creating, editing, and viewing EJBs in UML class diagrams	34
Creating, editing, and viewing WSDL elements in UML class diagrams	38
Class diagram preferences	48
Exploring relationships in applications	49
Browse diagrams	49
Topic diagrams	51
Describing interactions with UML sequence diagrams	54
Creating sequence diagrams	56
Creating lifelines	56
Creating messages	58
Creating combined fragments	60
Creating references to external diagrams	62
Exploring Java methods by using static method sequence diagrams	63
Sequence diagram preferences	64
More information on UML	66
Part 3. Basic Java and XML development	67
Chapter 8. Develop Java applications	69
Java perspectives, views, and editor overview	70
Java perspective	71
Package Explorer view	71
Hierarchy view	72
Outline view	73
Problems view	73
Declaration view	75
Console view	75
Call Hierarchy view	76
Java Browsing perspective	76
Java Type Hierarchy perspective	77
Developing the ITSO Bank application	78
ITSO Bank application overview	78
Packaging structure	78
Interfaces and classes overview	79
Interfaces and classes structure	79

Interfaces and classes fields and getter & setters	80
Interfaces and classes methods	82
Class constructors and methods	82
Class diagram	85
ITSO Bank application step-by-step development guide	86
Creating a Java project	87
Creating a UML class diagram	90
Creating Java packages	91
Creating Java interfaces	92
Creating Java classes	94
Creating Java attributes (fields) and getter and setter methods	97
Adding method declarations to an interface	101
Adding constructors and Java methods to a class	104
Creating relationships between Java types.	105
Implementing the classes and methods	108
Running the ITSO Bank application	109
Creating a run configuration	110
Understanding the sample code	112
Additional features used for Java applications	116
Using scripting inside the JRE	116
Analyzing source code	118
Debugging a Java application	122
Using the Java scrapbook	122
Pluggable Java Runtime Environment (JRE)	124
Exporting Java applications to a JAR file	125
Running Java applications external to Application Developer	126
Importing Java resources from a JAR file into a project	127
Javadoc tooling	128
Generating Javadoc	128
Generate Javadoc	129
Generate Javadoc from an Ant script	130
Generate Javadoc with diagrams from existing tags	131
Generate Javadoc with diagrams automatically	132
Java editor and rapid application development	133
Navigating through the code	134
Using the Outline view to navigate the code	134
Using the Package Explorer to navigate the code	135
Using bookmarks to navigate the code	135
Source folding	136
Type hierarchy	137
Smart insert.	137
Marking occurrences.	137
Smart compilation	138

Java and file search	138
Working sets	141
Quick fix	142
Quick assist.	144
Content assist	144
Import generation	145
Adding constructors	146
Delegate method generator	148
Refactoring	151
More information	155
Chapter 9. Accelerate development using patterns.	157
Introduction to pattern implementation	158
Pattern specification and pattern implementation	158
Pattern implementation and Application Developer	158
Prepare for the sample	160
Creating a pattern implementation	161
Create a new JET Transform project	161
Populating the transformation model	164
Adding and deriving attributes.	166
Generate and edit templates.	170
Applying the pattern	179
Facade pattern	183
Importing the facade example	183
Facade transformation	183
Running the transformation examples	184
More information	184
Chapter 10. Develop XML applications	185
XML overview and associated technologies	186
XML processors	186
DTDs and XML schemas	187
XSL	188
XML namespaces	188
XPath	189
Rational Application Developer XML tools	189
Creating an XML schema	190
Generating HTML documentation from an XML schema file	199
Generating an XML file from an XML schema	200
Editing an XML file	200
Working with XSL transformation files	202
Transforming an XML file into an HTML file	207
XML mapping	208

Generating JavaBeans from an XML schema	216
Service Data Objects and XML	220
More information	224
Part 4. Persistence application development	225
Chapter 11. Develop database applications	227
Introduction	228
Connecting to the ITSOBANK database	228
Connecting to databases	229
Creating a connection to the ITSOBANK database	229
Browsing a database with the Data Source Explorer	233
Creating SQL statements	235
Creating a data development project	235
Populating the transactions table	236
Creating a select statement	237
Running the SQL query	243
Developing a Java stored procedure	244
Creating a Java stored procedure	244
Deploying a Java stored procedure	248
Running the stored procedure	249
Developing SQLJ applications	249
Creating SQLJ files	250
Examining the generated SQLJ file	253
Testing the SQLJ program	254
Data modeling	255
Creating a data design project	256
Creating a physical data model	257
Modeling with diagrams	260
Generating DDL from physical data model and deploy	263
Analyzing the data model	265
More information	266
Chapter 12. Persistence using the Java Persistence API (JPA)	267
Introducing the Java Persistence API	268
Entities	268
Mapping the table and columns	270
Relationships	271
Entity inheritance	275
Persistence units	275
Object-relational mapping through orm.xml	276
Persistence provider	276
Entity manager	277
JPA query language	278

Developing JPA entities	281
Setting up the ITSOBANK database	282
Creating a JPA project	282
Generating JPA entities from database tables	285
Generated JPA entities	286
Adding business logic	290
Adding named queries	291
Visualizing the JPA entities	293
Testing JPA entities	295
Creating the Java project for entity testing	295
Creating a Java class for entity testing	295
Setting up the build path for OpenJPA	296
Setting up the persistence.xml file	298
Creating the test	299
Running the JPA entity test	303
Displaying the SQL statements	306
Adding inheritance	307
Preparing the entities for deployment in the server	312
Summary	313
More information	313
Part 5. Enterprise application development	315
Chapter 13. Develop Web applications using JSPs and servlets	317
Introduction to Java EE Web applications	318
Java EE applications	319
Model-view-controller (MVC) pattern	323
Web development tooling	324
Web perspective and views	325
Web Site Navigation Designer	327
Web Diagram	328
Page Designer	329
Page templates	330
CSS Designer	331
Security Editor	331
File creation wizards	332
Summary of new features in v7.5	334
RedBank application design	335
Model	335
View layer	336
Controller layer	337
Implementing the RedBank application	339
Creating the Web project	340

Importing the Java RedBank model	345
Defining the Web site navigation and appearance	346
Create frameset pages	351
Customize frameset Web page areas.	353
Customize a style sheet	355
Verify the site navigation and page templates	357
Developing the static Web resources	358
Developing the dynamic Web resources.	361
Working with JSPs	369
Testing the Web application.	381
Prerequisites to run the sample Web application	381
Running the sample Web application	381
Verifying the RedBank Web application	381
RedBank Web application conclusion	385
More information	385
Chapter 14. Develop EJB applications	387
Introduction to Enterprise JavaBeans	388
EJB 3.0 specification.	388
EJB 3.0 simplified model.	388
EJB types and their definition	390
Best practices for developing EJBs.	395
Message-driven bean	396
Web services.	397
Life cycle events	397
Interceptors	399
Dependency injection	400
Using deployment descriptors.	405
EJB 3.0 application packaging	405
EJB features in Application Developer	405
Sample application overview	406
Preparing for the sample	408
Required software	408
Enabling the EJB development capability.	409
Creating and configuring the EJB projects	409
Creating an EJB project	409
Make the JPA entities available to the EJB project.	412
Setting up the ITSOBANK database.	413
Configuring the data source for the ITSOBANK	413
Developing an EJB application.	415
Implementing the session facade.	415
Preparing an exception.	415
Creating the EJBBank session bean.	416

Defining the business interface	418
Completing the session bean	419
Testing the session EJB and the entities	425
Testing with the Universal Test Client	426
Creating a test Web application	428
Visualizing the test application	433
Writing an EJB 3.0 Web application	433
Implementing the RAD75EJBWeb application	434
Running the Web application	436
Cleanup	441
Adding a remote interface	441
Complete EJB application interchange file	442
More information	443
Chapter 15. Develop Web applications using Struts	445
Introduction to Struts	446
Model-view-controller (MVC) pattern with Struts	447
Application Developer support for Struts	450
Preparing for the sample application	451
Setting up the sample database	451
Configuring the data source in the WebSphere Server 7.0	451
Activating Struts development capabilities	451
ITSO Bank Struts Web application overview	452
Creating a dynamic Web project with Struts support	454
Developing a Web application using Struts	457
Creating the Struts components	457
Realizing the Struts components	464
Modify application resources	464
Using the Struts validation framework	465
Page Designer and the Struts tag library	467
Completing the logon action	471
Using the Struts Configuration Editor	473
Completing the application	477
Complete the Web Diagram	477
Completing the application resources	478
Complete the form beans	478
Complete the actions	478
Complete the JSPs	479
Complete the Web Diagram and Struts configuration file	480
Study the sample code	480
Running the Struts Bank Web application	482
Developing a Struts Web application using Tiles	485
Enable the Struts Tiles support	486

Building the Tiles application extension	487
Running the Tiles application	490
Importing the final sample application	491
More information	492
Chapter 16. Develop Web applications using JSF	493
Introduction to JSF	494
JavaServer Faces (JSF) overview	494
Preparing for the sample	498
Setting up the sample database	499
Configuring the data source	499
Developing a Web application using JSF and JPA	500
Project setup	500
Structure of the JSF Web application	503
Editing the Faces JSP pages	509
Editing the login page	509
Creating a JPA manager bean	514
Editing the customer details page	520
Editing the account details page	525
Adding navigation between the pages	528
Implementing deposit and withdraw	530
Running the JSF application	532
Web Diagram	534
Drop-down menu for customer login	535
Adding a deluxe pager	536
Using the data source in the server	538
Cleanup	541
Final code	541
More information on JSF and AJAX	541
Chapter 17. Develop Java EE application clients	543
Introduction to Java EE application clients	544
Overview of the sample application	546
Preparing for the sample application	547
Importing the base EJB enterprise application sample	547
Setting up the sample database	548
Configuring the data source	548
Testing the imported code	548
Developing the Java EE application client	549
Creating the Java EE application client projects	549
Configuring the Java EE application client projects	551
Importing the graphical user interface and control classes	551
Creating the BankDesktopController class	553

Completing the BankDesktopController class	554
Creating an EJB reference and binding	555
Registering the BankDesktopController class as the main class	557
Testing the Java EE application client	558
Packaging the Java EE application client.	561
Running the deployed application client	562
Chapter 18. Develop Web services applications	563
Introduction to Web services	564
Service-oriented architecture (SOA)	564
Web services as an SOA implementation.	565
Related Web services standards	567
JAX-WS programming model.	569
Better platform independence for Java applications	569
Annotations	570
Invoking Web services asynchronously	570
Data binding with JAXB 2.0 and 2.1	572
Dynamic and static clients.	572
MTOM support	572
Multiple payload structures	573
SOAP 1.2 support	573
Web services development approaches	573
Web services tools in Application Developer	574
Creating a Web service from existing resources.	574
Creating a skeleton Web service	574
Client development	575
Testing tools for Web services	575
Preparing for the samples	576
Import the sample	576
Test the application	577
Creating bottom-up Web services from a JavaBean	577
Creating a Web service using annotations	578
Creating Web services using the Web Service wizard	586
Resources generated by the Web Service wizard	591
Creating a synchronous Web service JSP client	592
Resources generated by the Web Service client wizard.	596
Creating a Web service JSF client	598
Creating a Web service thin client	603
Creating asynchronous Web service clients	606
Polling client	606
Callback client	608
Asynchronous message exchange client	610
Creating Web services from an EJB	612

Creating a top-down Web service from a WSDL	614
Designing the WSDL using the WSDL editor	615
Generating the skeleton JavaBean Web service	620
Test the generated Web service	621
Creating Web services with Ant tasks	622
Running the Web service Ant task	623
Sending binary data using MTOM	623
Create a Web service project and import the WSDL	624
Generate the Web service and client	625
Implement the JavaBean skeleton	627
Test and monitor the MTOM enabled Web service.	629
Enabling MTOM on the client	631
Web services security	633
Authentication	633
Message integrity	634
Message confidentiality.	634
Policy set.	635
Apply WS-Security to Web service and client.	635
WS-I Reliable Secure Profile.	640
WS-Policy.	641
Configuring a service provider to share its policy configuration	642
Configuring the client policy using a service provider policy.	643
WS-MetadataExchange (WS-MEX)	645
More information	647
Chapter 19. Develop Web applications using Web 2.0	649
Introduction to Web 2.0	650
Web 2.0 definition	650
Web 2.0 application architecture.	650
Supporting technologies	653
Web 2.0 features in Application Developer v7.5	656
Preparing for the sample	657
Setting up the sample database	657
Create a database connection	657
Configuring the data source	658
Developing a Web 2.0 using JSF, Ajax Proxy, and JPA	658
Project setup	658
Structure of the Web 2.0 application.	660
Adding type-ahead control to the login page.	661
Adding Ajax refresh submit behavior	667
Cleanup.	673
Developing a Web 2.0 application using Dojo and RPC	673
Project setup	673

Architecture of the Web 2.0 application	674
Exposing an RPC Adapter service	675
RPC Adapter Configuration Editor	678
Creating an RPC Converter	679
Creating a service using a servlet	679
Testing the services	681
Creating the Web page	682
Examining the Dojo components	688
Application flow	688
Logging	692
Running the application.	693
Cleanup.	695
Final code	695
More information on Web 2.0 and JSF.	696
Chapter 20. Develop applications to connect to enterprise information systems	697
Introduction to Java EE Connector Architecture	698
System contracts.	698
Resource adapter	700
Common Client Interface	701
WebSphere Adapters	701
Application development for EIS	702
Importers.	702
J2C wizards.	702
What is new in Application Developer v7.5	704
Tooling for WebSphere Adapters	704
Deployment of Websphere Adapters to WebSphere Application Server	705
J2C Java bean deployment: EJB 2.1 and 3.0 support	706
J2C Java bean deployment: Web services support	706
CICS container link support	707
MFS support for IMS.	707
Sample application overview	707
CICS outbound scenario	708
Prerequisites	708
Creating the Java data binding class	709
Creating the J2C bean	710
Deploying the J2C bean as an EJB 3.0 session bean	713
Generating a JSF client.	714
Running the JSF client	717
CICS Channel outbound scenario	718
Creating the Java data binding for the channel and containers	718
Creating the J2C bean that accesses the channel	722

Develop a Web service to invoke the COBOL program	724
Testing the Web service with CICS access	727
SAP outbound scenario	729
Required software and configuration	729
Creating a Connector Project and J2C bean	729
Generating the sample Web application	736
Testing the Web application	737
More information	738
Chapter 21. Develop portal applications	739
Introduction to portal technology	740
Portal concepts and definitions	740
IBM WebSphere Portal	743
Portal and portlet development features in Application Developer	744
Setting up Application Developer with the Portal test environment.	745
Developing applications for WebSphere Portal	745
Portal samples and tutorials	746
Development strategy	746
Portal tools for developing portals	749
New Websphere portal and portlet development tools in Rational Application Developer v7.5	755
Developing portal solutions using portal tools	762
Developing eventing portlets	762
Deploying and running the event handling portlets	767
Creating Ajax and Web 2.0 portlets	770
Deploying and running the application	773
More information	774
Part 6. Test and debug applications	775
Chapter 22. Servers and server configuration	777
Introduction to server configurations	778
Application servers supported by Rational Application Developer 7.5	778
Local and remote test environments	780
Understanding WebSphere Application Server v7.0 profiles	781
Types of profiles	782
WebSphere Application Server v7.0 installation	783
Using WebSphere Application Server v7.0 profiles	784
Creating a new profile using the WebSphere Profile wizard	784
Verifying the new WebSphere profile	787
Deleting a WebSphere profile	789
Defining the new server in Application Developer.	789
Customizing a server	792
Sharing a WebSphere profile between developers	795

Defining a server for each workspace	797
Adding and removing applications to and from a server	797
Adding an application to the server.	797
Removing an application from a server.	798
Configuring application and server resources	799
Creating a data source in the enhanced EAR.	802
Setting substitution variable	806
Configuring server resources	806
Configuring security	807
Configuring security in the server	807
Configuring security in the Workbench	809
Developing automation scripts	810
Creating a Jython project	810
Creating Jython script files	810
Editing Jython script files.	811
Running administrative script files on WebSphere Application Server	811
Generating WebSphere admin commands for Jython scripts.	813
Debugging Jython scripts	816
Jython script for application deployment.	816
More information	817
Chapter 23. Test using JUnit	819
Introduction to application testing.	820
Test concepts	820
Test phases.	820
Test environments.	822
Calibration	823
Test case execution and recording results	823
Benefits of unit and component testing	823
Benefits of testing frameworks	824
Test & Performance Tools Platform (TPTP).	825
JUnit testing [without using TPTP]	825
JUnit fundamentals	826
What is new in JUnit 4.x?	826
Prepare the JUnit sample.	830
Creating a JUnit test case.	831
Creating a JUnit test suite.	835
Running the JUnit test case or JUnit test suite	837
JUnit testing of JPA entities	838
Prepare the JPA unit testing sample.	838
Setting up the ITSOBANK database.	839
Configure the RAD75JUnit project	839
Creating a JUnit test case for a JPA entity	840

Setting up the persistence.xml file	841
Running the JPA unit test	842
JUnit testing using TPTP	844
Creating the TPTP JUnit sample.	844
Running the TPTP JUnit test.	848
Analyzing the test results	848
Web application testing	851
Preparing for the sample.	851
Recording a test	852
Editing the test	854
Generating an executable test	856
Running the test	856
Analyzing the test results	856
Generating test reports	858
Cleaning the workspace	860
Chapter 24. Debug local and remote applications	861
Summary of new features in v7.5.	862
Overview of Application Developer debugging tools	862
Supported languages and environments	862
Basic Java debugging features	863
XSLT debugging	867
Remote debugging	869
Stored procedure debugging for DB2 V9	870
Collaborative debugging using Rational Team Concert Client	870
Debugging a Web application on a local server	871
Importing the sample application	871
Running the sample application in debug mode	872
Setting breakpoints in a Java class.	873
Debug perspective	875
Watching variables	876
Evaluating and watching expressions	877
Using the Display view	878
Working with breakpoints	878
Set breakpoints in a JSP.	879
Debugging a JSP	880
Debugging a Web application on a remote server	882
Exporting the RedBank as an EAR file	883
Deploying the RedBank application	883
Configuring debug on a remote WebSphere Application Server	884
Attaching to the remote server in Application Developer	885
Debugging a remote application	887
Uninstalling the remote application	887

Jython debugger	888
Debugging a sample Jython script	888
Debug extension for Rational Team Concert Client (Team Debug)	890
Introduction	891
Supported environments	892
Prerequisites	892
Sharing a Java debug session by transferring it to another user	893
Sharing a WebSphere Application Server Debug session by parking it on the server	897
More information	899
Part 7. Deploy and profile applications	901
Chapter 25. Build applications with Ant	903
Introduction to Ant	904
Ant build files	904
Ant tasks	905
Ant features in Application Developer	905
Preparing for the sample	906
Creating a build file	907
Project definition	908
Global properties	909
Build targets	909
Content assist	911
Code snippets	911
Formatting an Ant script	914
Defining the format of an Ant script	914
Problems view	916
Building a simple Java application	917
Running Ant	917
Ant console	920
Rerun Ant	920
Forced build	920
Classpath problem	921
Running the sample application to verify the Ant build	921
Building a Java EE application	921
Java EE application deployment packaging	922
Preparing for the sample	922
Creating the build script	923
Running the Ant Java EE application build	925
Running Ant outside of Application Developer	927
Preparing for the headless build	927
Running the headless Ant build script	928

Using the Rational Application Developer Build Utility	929
Example of using the build utility	929
More information on Ant	932
Chapter 26. Deploy enterprise applications	933
Introduction to application deployment	934
Common deployment considerations	934
Java EE application components and deployment modules	935
Deployment descriptors	935
WebSphere deployment architecture	939
Java and WebSphere class loader	946
Preparing for the deployment of the EJB application	950
Reviewing the deployment scenarios	950
Installing the prerequisite software	951
Importing the sample application project interchange files	952
Sample database	952
Packaging the application for deployment	953
Removing the enhanced EAR data source	953
Generating the deploy code	954
Exporting the EAR files	954
Manual deployment of enterprise applications	955
Configuring the data source in the application server	956
Installing the enterprise applications	962
Starting the enterprise applications	965
Verifying the application after manual installation	966
Uninstalling the application	967
Automated deployment using Jython based wsadmin scripting	968
Overview of wsadmin	968
Overview of Jython	969
Developing a Jython script to deploy the ITSO Bank	970
Executing the Jython script	978
Verifying the application after automatic installation	980
Generation Jython source code for wsadmin commands	981
More information	981
Chapter 27. Profile applications	983
Introduction to profiling	984
Profiling features	984
Profiling architecture	987
Profiling and Logging perspective	989
Preparing for the profiling sample	990
Prerequisite software installation	990
Enabling the Profiling and Logging capability	990

Profiling a Java application	992
Importing the sample project interchange file	992
Creating a profiling configuration	993
Running the EntityTester application	995
Analyzing profiling data	995
Execution statistics	996
Execution flow	1000
UML sequence diagrams	1001
Memory statistics	1002
Thread analysis	1004
Reports	1005
Clean up	1005
Profiling a Web application running on the server	1005
Importing the sample project interchange file	1005
Publishing and running sample application	1006
Starting the server in profiling mode	1007
Profile on server: Execution Time Analysis	1008
Run the sample application to collect profiling data	1009
Statistic views	1010
Execution statistics	1010
Execution flow	1012
UML sequence diagrams	1014
Refreshing the views and resetting data	1014
Ending the profiling session	1015
Profile on server: Memory and thread analysis	1015
More information	1015
Part 8. Management and team development	1017
Chapter 28. CVS integration	1019
Introduction to CVS	1020
CVS features	1020
CVS support within Application Developer	1021
CVSNT Server installation and implementation	1022
Installing the CVS server	1023
Configuring the CVS server repository	1024
Creating the Windows users and groups used by CVS	1026
Verifying the CVSNT installation	1027
Creating CVS users	1028
CVS client configuration for Application Developer	1029
Configuring the CVS team capability	1029
Accessing the CVS repository	1030
Configuring CVS in Application Developer	1031

Label decorations	1032
File content	1032
Ignored resources	1034
CVS-specific settings	1036
CVS keyword substitution	1037
Development scenario	1040
Create and share the project (step 1 - cvsuser1)	1041
Adding a shared project to the workspace (step 2a - cvsuser2)	1044
Modifying the servlet (step 2b - cvsuser1)	1048
Synchronizing with the repository (step 3a - cvsuser1)	1048
Synchronizing with the repository (step 3b - cvsuser2)	1050
Parallel development (step 4 - cvsuser1 and cvsuser2)	1050
Creating a version (step 5 - cvsuser1)	1056
CVS resource history	1056
Comparisons in CVS	1058
Comparing a workspace file with the repository	1058
Comparing two revisions in repository	1059
Annotations in CVS	1061
Branches in CVS	1062
Branching	1062
Merging	1067
Working with patches	1070
Disconnecting a project	1070
Team Synchronizing perspective	1072
Custom configuration of resource synchronization	1072
Schedule synchronization	1075
More information	1076
Chapter 29. Rational Team Concert	1077
Introduction to IBM Rational Team Concert	1078
Editions	1078
Architecture	1080
Getting started: Setup a project area	1085
Creating a repository connection and project area	1086
Predefined work items: Define team members	1088
Predefined work items: Define iterations and iteration plans	1091
Process configuration: Define preconditions	1093
New work item: Create components	1095
Creating a repository workspace	1096
Setting up team areas	1097
Source control scenarios	1099
Sharing existing projects	1099
Connecting to the repository and loading projects	1103

Managing conflicts	1105
Building with Team Concert and the Application Developer Build Utility . . .	1110
Creating a build user	1110
Creating a repository workspace owned by the build user	1111
Starting the Jazz build engine	1111
Preparing the Ant build file	1112
Creating a build engine and a build definition	1113
Requesting a build	1115
Running reports (Standard edition only)	1117
Collaborative debugging	1118
More information	1118
Part 9. Appendices	1119
Appendix A. Product installation	1121
Launchpad	1122
IBM Installation Manager	1123
Installing IBM Rational Application Developer	1124
Installing the license for Rational Application Developer	1128
Updating Rational Application Developer	1129
Uninstalling Rational Application Developer	1129
Installing the WebSphere Portal v6.1 test environment	1131
Installing WebSphere Portal v6.1	1131
Adding WebSphere Portal v6.1 to Application Developer	1133
Optimizing the Portal Server for development	1137
Verify development mode	1137
Enable debugging service	1138
Stop the server	1138
Installing IBM Rational Team Concert	1139
Installing Rational Team Concert Express-c server	1139
Installing Rational Team Concert Build Engine and Build Toolkit	1146
Installing the client and the debug extensions	1146
Installing Rational Application Developer Build Utility	1148
Appendix B. Additional material	1149
Locating the Web material	1150
System requirements for downloading the Web material	1150
Using the sample code	1150
Unpacking the sample code	1150
Description of the sample code	1151
Interchange files with final code	1152
Importing sample code from a project interchange file	1152
Setting up the ITSOBANK database	1154
Derby	1154

DB2	1155
Configuring the data source in WebSphere Application Server	1155
Starting the WebSphere Application Server	1155
Configuring the environment variables	1156
Configuring J2C authentication data	1156
Configuring the JDBC provider	1157
Creating the data source	1158
Abbreviations and acronyms	1159
Related publications	1163
IBM Redbooks	1163
Online resources	1163
How to get Redbooks	1164
Help from IBM	1165
Index	1167

Figures

1-1 IBM Rational Software Delivery Platform life cycle categories and products	4
1-2 Eclipse Project overview	8
1-3 Backward compatibility feature	23
2-1 Simple Web application.	46
2-2 JSF and SDO	50
2-3 Ajax overview	52
2-4 Portal applications.	56
2-5 EJBs as part of an enterprise application	61
2-6 Java EE Application Client	65
2-7 Web services foundation technologies	67
2-8 Web services.	70
2-9 Messaging systems.	72
3-1 Application Developer Workbench Welcome page	76
3-2 Welcome page preferences	78
3-3 J2EE perspective in Rational Application Developer	79
3-4 Setting the default workspace on startup	81
3-5 Setting the prompt dialog box for workspace selection on startup	83
3-6 Logging preferences: General tab.	84
3-7 Logging preferences: Loggers tab	85
3-8 Workbench Preferences	86
3-9 Workbench Preferences: Automatic builds	87
3-10 Enable Team capability or role in the Welcome page.	89
3-11 Setting the Team capability using Windows preferences: Part 1	90
3-12 Setting the Team capability using Windows preferences: Part 2	91
3-13 Enable capability by opening a perspective	92
3-14 File associations preferences	93
3-15 Local history preferences	94
3-16 Perspectives preferences	96
3-17 Web Browser preferences.	97
3-18 Internet proxy settings preferences.	98
3-19 Classpath variables preferences.	99
3-20 New Variable Entry dialog.	100
3-21 Java appearance settings	101
3-22 Code style preferences	103
3-23 Formatter preferences.	105
3-24 Formatter preferences: Eclipse profile	106
3-25 Formatter: Braces	107
3-26 Formatter: White Space	108

3-27	Formatter: Control Statements	109
3-28	Java editor preferences.	110
3-29	Java Editor: Content Assist preferences.	111
3-30	Java Editor: Folding preferences	112
3-31	Java Editor: Mark Occurrences preferences.	112
3-32	Using templates for content assist	113
3-33	Java Editor: Templates preferences	113
3-34	Creating a new template	114
3-35	Java: Compiler preferences	115
3-36	Java: Installed JRE preferences	116
4-1	Perspective layout.	122
4-2	Open perspective dialog	123
4-3	Buttons to switch between perspectives	124
4-4	Customize Perspective dialog.	125
4-5	Help window	127
4-6	Context sensitive help when Java editing	128
4-7	Select Search Scope dialog for help	129
4-8	CVS Repository Exploring perspective	131
4-9	Data perspective	133
4-10	Database Debug perspective	134
4-11	Database Development perspective	135
4-12	Debug perspective	136
4-13	Java perspective	138
4-14	Java Browsing perspective	140
4-15	Java EE perspective	141
4-16	Java Type Hierarchy perspective with Hierarchy view	143
4-17	JavaScript perspective	144
4-18	JPA perspective	146
4-19	JPA Details view	147
4-20	Plug-in Development perspective	148
4-21	Profiling perspective	149
4-22	Report Design perspective	150
4-23	Resource perspective	152
4-24	Synchronizing resources using the Team Synchronizing perspective	153
4-25	Test perspective	155
4-26	Web perspective	156
4-27	Web Diagram editorr.	157
4-28	Progress view	159
4-29	Process information in status bar	160
4-30	Progress view	160
5-1	Java EE Architecture Containers	163
5-2	Java EE 5 module structure	164
5-3	New Project dialog with Enterprise Application Project selected	167

5-4	New EAR Application Project: Create a EAR Application	168
5-5	New EAR Application Project: Project Facets	169
5-6	New EAR Application Project: Configure enterprise application settings	170
5-7	Create default Java EE module	171
5-8	Prompt to open relevant perspective	171
5-9	Project properties for an Enterprise Application Project	172
5-10	Project Delete Resources dialog	173
5-11	Java EE projects in Application Developer	174
5-12	Help System samples	180
5-13	JPA JSF Employee List Sample	181
5-14	Import Employee List sample	182
5-15	Example projects in the New Project dialog	183
6-1	Overview of the Rational Unified Process.	5
6-2	Process Browser	8
6-3	Process Advisor displaying RUP content for a selected context.	9
6-4	Process Search.	10
6-5	Process preferences	11
6-6	Classes before refactoring to apply the Singleton pattern	13
6-7	Classes after refactoring to apply the Singleton pattern	14
6-8	Selecting the Struts facet for a the Web project	15
6-9	Applying the Session Facade pattern for an entity bean.	16
7-1	Example workspace when using the UML visualization capabilities.	25
7-2	A new class diagram	29
7-3	A Java class with action bar and modeling assistant arrows visible	30
7-4	Using the Modeling Assistant to create a relationship	31
7-5	Viewing related Java elements using the modeling assistant.	31
7-6	Show Related elements dialog	33
7-7	Class diagram showing different UML elements.	33
7-8	Visualization of an EJB 3.0 Enterprise JavaBeans	34
7-9	Class diagram showing an EJB 3.0 session bean and a JPA entity	35
7-10	Class diagram showing three EJB 3.0 session beans with relationships.	36
7-11	Show Related Elements dialog for EJB 3.0 session beans	36
7-12	Declare the roles dialog and diagram stereotype	37
7-13	EJB 3.0 bean with method permissions on getCustomersAll method	38
7-14	Graphical representation of a Web Service	39
7-15	New WSDL Service wizard	40
7-16	Visualization of a WSDL service component	41
7-17	Port wizard	41
7-18	Port properties shown in the Properties view	42
7-19	New WSDL Port Type wizard	43
7-20	Class diagram representation of a port type	43
7-21	New WSDL Message wizard.	44
7-22	Representation of a WSDL message in a class diagram	44

7-23	Properties view showing the properties of a part	45
7-24	Complex types with attributes	45
7-25	Using XSD complex types as the type for WSDL messages parts	46
7-26	WSDL Input Message wizard	46
7-27	Class diagram showing a port type with messages	47
7-28	Class diagram showing a binding between a port and its port type	47
7-29	Properties view showing binding properties	48
7-30	Browse diagram example	50
7-31	Topic Diagram wizard (1)	52
7-32	Topic Diagram wizard (2)	52
7-33	Topic Diagram wizard (3)	53
7-34	Overview of a sequence diagram	55
7-35	Different representations of lifelines on a sequence diagram	57
7-36	Sending a create message to create a new lifeline during an interaction	58
7-37	Destroying a lifeline during an interaction	59
7-38	Synchronous message invocation	59
7-39	Sequence diagram with an alternative combined fragment	60
7-40	Empty combined fragment with two interaction operands.	62
7-41	Creating a reference to another diagram	63
7-42	static method sequence diagram example	64
7-43	Sequence diagram preferences	65
8-1	Views in the Java perspective [customized]	70
8-2	Package Explorer view	71
8-3	Hierarchy view for a selected class.	72
8-4	Outline view.	73
8-5	Problems view with warnings notification	74
8-6	Configure Contents of Problems view.	74
8-7	Declaration view	75
8-8	Console view with standard outputs and an exception	75
8-9	Call Hierarchy view [Callee Hierarchy]	76
8-10	Views in the Java Browsing perspective.	77
8-11	UML class diagram: ITSO Bank application	86
8-12	New Project dialog	87
8-13	New Java Project: Create a Java project and Java Settings	88
8-14	Visualizer Class Diagram editor with Java Drawer in the Palette	91
8-15	Create a Java package	92
8-16	Action box - add Java class and interface.	93
8-17	Create a Java interface.	93
8-18	Superclass Selection dialog	95
8-19	Implemented Interfaces Selection dialog	95
8-20	New Java Class dialog	96
8-21	Create Java Field dialog	98
8-22	Encapsulate Field dialog.	100

8-23	Generate Getters and Setters dialog	101
8-24	Create Java Method dialog	103
8-25	Create Association dialog	107
8-26	Importing the classes	109
8-27	Console view with output of the ITSO Bank application	110
8-28	Run configuration dialog	111
8-29	Executing the BankClient with scripting	117
8-30	Software Analyzer Results for a Java project	119
8-31	Analysis: Create, manage, and run configurations	120
8-32	Analysis: Domains and rules	120
8-33	Software Analyzer Results view	121
8-34	Run JRE configuration tab	124
8-35	JAR Export	125
8-36	Output from running ITSOBankApplication.jar in Command Prompt	127
8-37	Javadoc view: Context sensitive (BigDecimal)	128
8-38	Javadoc Generation dialog	129
8-39	Javadoc output generated from the Javadoc wizard	130
8-40	Generate Javadoc with Diagrams Automatically dialog	133
8-41	Java editor - Outline view for navigation	134
8-42	Java Editor with a bookmark	135
8-43	Bookmarks view	135
8-44	Java Editor with source folding	136
8-45	Java Editor with quick type hierarchy view	137
8-46	Java Editor with mark occurrences (methods exits)	138
8-47	Search dialog [customized]	139
8-48	Java Search dialog	140
8-49	File Search dialog	141
8-50	New Java Working Set dialog	142
8-51	Java Editor with quick fix	143
8-52	Java Editor with quick assist	144
8-53	Java Editor with content assist	145
8-54	Java Editor with import generation	146
8-55	Generate Constructors from Superclass dialog	147
8-56	Generate Constructor using Fields dialog	147
8-57	Simple car example class diagram (before method delegation)	148
8-58	Generate Delegate Method dialog	150
8-59	Simple car example class diagram (after method delegation)	150
8-60	Refactor - Rename Compilation Unit wizard	154
9-1	Create a JET Transform project with exemplar authoring	162
9-2	JET Transformation Project	162
9-3	Transformation Scope	163
9-4	Exemplar Authoring Editor	164
9-5	Artifacts added to the transformation model under the client type	165

9-6	Create Project Properties	166
9-7	Insert Model Reference	167
9-8	Final definition of the projectName derived attribute	167
9-9	Final project name variable	168
9-10	Adding a reference to the .project path variable	168
9-11	Attribute deriving the directory path from the package attribute	169
9-12	Final version of the BankClient.java path parameter	169
9-13	Final model for the JET transformation	170
9-14	New generated templates	170
9-15	Launching Find/Replace with JET Model Reference	171
9-16	Replacing the project name with the attribute	171
9-17	Creating the varName derived attribute	173
9-18	Replace all occurrences of customer	174
9-19	Client generated by transformation	180
9-20	Creating the run configuration	182
10-1	XML schema Editor: Design view, Detailed	191
10-2	Account complex type	192
10-3	Regular Expression Wizard	193
10-4	Properties view with constraint	194
10-5	new Type dialog	195
10-6	Account type complete	195
10-7	XML schema Validator preferences	198
10-8	Design view, Source view, and Outline view	201
10-9	Snippets view, XSL drawer	203
10-10	XSL Table Wizard, Select XML files	204
10-11	XSL Table wizard, Add A Table To XSL file	205
10-12	XSL stylesheet transformation result	207
10-13	Selecting an input root for the mapping	210
10-14	XML sample input	211
10-15	Workbench layout for the XML Mapping editor	212
10-16	Inline map	212
10-17	Account mapping	213
10-18	Concatenation mapping	214
10-19	Substring mapping	215
10-20	Custom mapping	215
10-21	Custom mapping using XPath	216
10-22	XSD to Java Dialog	217
10-23	Accounts data graph	222
11-1	New Connection: Connection Parameters	230
11-2	New Connection: Filter	231
11-3	Connection with schema and tables in Data Source Explorer	232
11-4	Customer table with columns	233
11-5	Sample contents of Customer table	234

11-6 Data Development Project: Select Connection	236
11-7 New SQL and Editor page	237
11-8 SQL Builder	237
11-9 Add table	239
11-10 Create select statement: Tables	239
11-11 Create select statement: Columns and table joins	240
11-12 Create select statement: Expression Builder (1)	241
11-13 Create select statement: Expression Builder (2)	241
11-14 Create select statement: Columns	242
11-15 Create select statement: Conditions	242
11-16 Create select statement: Groups	243
11-17 Query results	244
11-18 Create stored procedure: Name and Language	245
11-19 Create stored procedure: Joins	246
11-20 Create stored procedure: Conditions	246
11-21 Deploy Routines	248
11-22 Stored procedure results	249
11-23 New SQLJ File	251
11-24 Select the output columns	252
11-25 Specify Runtime Database Connection Information	253
11-26 Data Project Explorer: Data Design project layout	257
11-27 New Physical Data Model: Create from reverse engineering	258
11-28 New Physical Data Model: Options	258
11-29 Data Design Project with physical model and diagram	259
11-30 Overview diagram	259
11-31 Add key, column, index, and trigger	261
11-32 Edit the key	261
11-33 Data diagram with two tables	262
11-34 Add relationship between tables	262
11-35 Key migration	262
11-36 Relationship Details page	263
11-37 Relationship with verbs	263
11-38 Generate DDL	264
11-39 Save and Run DDL	264
11-40 Analyze Model	265
12-1 New JPA Project	283
12-2 JPA Facet	284
12-3 Generate Entities: Database Connection	285
12-4 Generate Entities: Tables	286
12-5 Class diagram with JPA Palette	293
12-6 Customer class visualized	294
12-7 JPA class diagram	294
12-8 Java Build Path of Java project: Source	296

12-9	Java Build Path of Java project: Libraries	296
12-10	Extending a variable	297
12-11	Selecting a runtime JAR file	297
12-12	Library tab with five extra JAR files	298
12-13	Run configuration arguments	304
12-14	Creating the Credit class	308
12-15	Complete class diagram of JPA entities	312
13-1	Java EE related technologies	319
13-2	Structure of EAR and WAR files	321
13-3	Java EE Web component classes	322
13-4	Web perspective	325
13-5	Web Diagram	328
13-6	Page Designer Split Tab	330
13-7	Security Editor example	332
13-8	Class diagram for RedBank model	336
13-9	ListAccounts sequence diagram	338
13-10	PerformTransaction sequence diagram	339
13-11	New Dynamic Web Project	341
13-12	Dynamic Web Project Facets	342
13-13	New Dynamic Web Project, Web Module settings	343
13-14	New Dynamic Web Project, Page Templates	344
13-15	Web project directory structure	345
13-16	Web Site Designer: Navigation view	347
13-17	Web Site Navigation after adding pages	351
13-18	Creating a frameset page	352
13-19	Properties of a frame	354
13-20	Frame design	355
13-21	CSS Designer: gray.css	356
13-22	ITSO RedBank Web site	357
13-23	Preview of welcome.html	359
13-24	Preview the rates.html page	360
13-25	Preview of Insurance.html	360
13-26	Preview of redbank.html	361
13-27	Java EE Module Dependencies dialog	363
13-28	New Servlet wizard (1)	364
13-29	New Servlet wizard (2)	364
13-30	New Servlet wizard page (3)	365
13-31	Inserting the Customer JavaBean	371
13-32	Inserting the accounts JavaBean	372
13-33	Configuring the AccountDetails URL	373
13-34	Adding parameters to c:url tags	374
13-35	Inserting a custom tag	376
13-36	listAccounts.jsp finished	377

13-37	Completed accountDetails.jsp in preview view	379
13-38	Completed listTransactions.jsp in preview view	380
13-39	Completed showException.jsp in the preview view.	380
13-40	ITSO RedBank Login page	382
13-41	Display of customer accounts	382
13-42	Details for a selected account	383
13-43	List of transactions for an account	384
13-44	Withdraw over the limit error	384
14-1	EJB 3.0 architecture	389
14-2	EJB 2.x component interfaces	391
14-3	EJB 2.x home interfaces	391
14-4	EJB is a POJO exposing a POJI.	392
14-5	How to organize the EJB component interface	394
14-6	EJB module class diagram for the sample application	406
14-7	Application component model and workflow	407
14-8	Create an EJB project wizard (1)	410
14-9	Create an EJB project wizard (3)	411
14-10	EAR deployment editor	412
14-11	EAR module dependencies.	413
14-12	EAR enhanced deployment descriptor	415
14-13	Creating a session bean (1)	417
14-14	Creating a session bean (2)	417
14-15	Universal Test Client home	426
14-16	UTC JNDI Explorer	427
14-17	UTC Retrieve a customer	427
14-18	Class diagram of the test Web application	433
14-19	Web site navigation.	434
14-20	RedBank: Login.	437
14-21	RedBank: Customer with accounts.	438
14-22	RedBank: Account details.	438
14-23	RedBank: Transactions.	439
14-24	RedBank: Transactions added	440
14-25	RedBank: New customer and new account	441
15-1	Struts components in the MVC architecture	447
15-2	Struts request sequence	449
15-3	Struts Web Diagram: ITSO Bank sample	453
15-4	Create a Struts-based dynamic Web project: Facets	455
15-5	Web project with Struts support	456
15-6	Web Diagram with the Struts drawer (Web Parts) open in the Palette	458
15-7	Struts Components - Create Struts action	459
15-8	Struts components: Adding a Struts form bean	461
15-9	Struts components: Create Web pages	462
15-10	Struts components: Creating connections	463

15-11	Struts tag library support: Page Designer Struts tag drawers	468
15-12	Struts tags: Struts errors tag rendered by Page Designer	469
15-13	Page Data view with form bean	469
15-14	Creating the logon JSP with a form.	470
15-15	Struts Configuration Editor	473
15-16	Struts Configuration Editor: Creating new forward	474
15-17	Web Diagram action with and without the action form	480
15-18	Running the sample: Logon.jsp.	482
15-19	Running the sample: Account listing.	483
15-20	Running the sample: Account details	483
15-21	Running the sample: Performing transactions	484
15-22	Running the sample: Transaction listing	484
15-23	Running the sample: More transactions	485
15-24	Actions for Tiles.	487
15-25	Editing the Forward Config for local forwards	487
15-26	Customer with accounts and new links.	490
15-27	Tiles page: Contact Us	490
15-28	Tiles page: About Us.	490
15-29	Complete Web Diagram with Tiles actions	491
16-1	JSF application architecture	495
16-2	JSF application structure within Application Developer	496
16-3	Web project for JSF	501
16-4	Web project facets for JSF	502
16-5	JSF Web Diagram completed	534
16-6	Navigation rules in faces-config.xml	535
16-7	Adding a deluxe pager	537
16-8	Display of customer accounts	537
16-9	Details for a selected account with transactions	538
16-10	Deployment of JDBC connection	539
16-11	Runtime connection details	539
16-12	Deployment of the runtime connection	540
17-1	Java applications using Java EE server resources.	544
17-2	Interface for the sample application client.	546
17-3	Class diagram for the Bank Java EE application client.	547
17-4	New Application Client Project	550
17-5	Application Client module	550
17-6	Java EE Module Dependencies	551
17-7	Import existing GUI class	552
17-8	Create class BankDesktopController	553
17-9	Create an EJB reference.	556
17-10	Create an EJB binding	557
17-11	Create a new run configuration for the application client	559
17-12	Login to the secure server.	559

17-13 Bank Desktop opens	560
17-14 Bank Desktop results	560
17-15 Application client export	562
18-1 Service-oriented architecture	564
18-2 Content assist for Web service annotation	578
18-3 Annotate method	579
18-4 Test JAX-WS Web service using Web Services Explorer	582
18-5 JAX-WS Web service test result with Web Services Explorer\	583
18-6 Web Service wizard: Web Services page	586
18-7 Web Service wizard: Service Deployment Configuration	588
18-8 Web Service wizard: Service Endpoint Interface Selection	589
18-9 WebSphere JAX-WS WSDL Configuration page	590
18-10 Web Service wizard: Test Web Service	590
18-11 Generate Web service client	592
18-12 Generate Web service client	593
18-13 JAX-WS Web Service Client Configuration	593
18-14 Web Service Client Test	594
18-15 Sample JSP results	595
18-16 TCP/IP Monitor	596
18-17 Web service client artifacts	597
18-18 New Faces Project	599
18-19 Drag and drop Web Service to JSF design view	600
18-20 Add Web service	600
18-21 Web Services Discovery Dialog: Web Services from your workspace	601
18-22 Web Services Discovery Dialog: Add to Project	601
18-23 Select Web service method	602
18-24 Web service input form	602
18-25 JSF page with Web service invocation	603
18-26 JSF client run	603
18-27 Generating a thin client	604
18-28 Web service thin client build path	604
18-29 Enable asynchronous invocation for generated client	607
18-30 Create Router Module	613
18-31 Create Router Project	614
18-32 New WSDL File wizard	615
18-33 WSDL editor	616
18-34 Schema editor: Start	616
18-35 Schema editor: Index view	617
18-36 Schema editor: Account	617
18-37 Schema editor: Customer	618
18-38 Schema editor: Global elements	618
18-39 Schema editor: Output message	618
18-40 Specify Binding Details wizard	619

18-41	BankWS.wsdl	619
18-42	Create Ant files	622
18-43	Enable MTOM support	626
18-44	WS-I warning against MTOM	627
18-45	Invoking the MTOM Web service sendImage method	629
18-46	SOAP traffic when MTOM is only enabled for the Web service	630
18-47	SOAP message with MTOM enabled for both client and server	633
18-48	Manage Policy Set Attachment	637
18-49	Configure Policy Set and Binding	637
18-50	Client Side Policy Set Attachment	638
18-51	Apply WS-I RSP profile	640
18-52	Configure Policy Sharing	642
18-53	Use Provider Policy	644
18-54	TCP/IP Monitor shows retrieve of WSDL	644
18-55	Share policy set using WS-MetadataExchange	645
19-1	Web 1.0 application architecture	651
19-2	Web 2.0 application architecture	651
19-3	Sample using Web 2.0 technologies	657
19-4	Project Facets for Web 2.0	659
19-5	Ajax Proxy related files	660
19-6	Testing the Ajax type-ahead feature	666
19-7	Web 2.0 RPC dojo application structure	674
19-8	Exposing an RPC Adapter Service	675
19-9	Exposing a service	676
19-10	Configure Methods	676
19-11	RPC Adapter with an exposed service	677
19-12	RPC Adapter Configuration Editor	678
19-13	RPC Adapter - Converter Details	679
19-14	Dojo drawers in the Palette	682
19-15	Dojo application flow	688
19-16	Input validation and type-ahead	689
19-17	Web 2.0 dojo application run	693
19-18	Selecting a customer using type-ahead or drop-down	694
19-19	Welcome message	694
19-20	Customer with list of accounts	694
19-21	Account transactions	695
20-1	Java EE component connecting to EIS through JCA resource adapter	698
20-2	System contract, application server, resource adapter integration	699
20-3	J2C wizards	703
20-4	CICS Terminal showing the installed COBOL program taderc99.cbl	708
20-5	Selection of the resource adapter	710
20-6	Connection Properties	711
20-7	Adding a new Java Method to a J2C Java Bean	712

20-8	InteractionSpec properties	712
20-9	Generate an EJB from a J2C bean (1)	713
20-10	Generate an EJB from a J2C bean (2)	713
20-11	Generate an EJB from a J2C bean (3)	714
20-12	New data component dialog	715
20-13	Creation of an EJB reference in the Web project	716
20-14	Add Session Bean.	716
20-15	Page data view with Service bean to expose EJB 3.	717
20-16	JSF Output from calling a CICS system	718
20-17	Selection of Mapping COBOL CICS Channel to Java	719
20-18	Discovery of the containers defined in the COBOL file.	719
20-19	Definition of the CICS Channel name and related class name.	720
20-20	Definition of the DATECONTAINER	721
20-21	J2C Java Bean Output Properties for CICSChannel	722
20-22	Adding a Java method with channel record as input and output.	723
20-23	Specify the function name in the InteractionSpec (COBOL program).	723
20-24	Link to online help in the Web Service wizard.	724
20-25	Web Service wizard	726
20-26	Enterprise Explorer after generation of bottom-up Web service	727
20-27	Web Services Explorer	728
20-28	New J2C Bean - Resource Adapter Selection	730
20-29	New J2C Bean - Connector Import	730
20-30	New J2C Bean - Connector Setting	731
20-31	New J2C Bean - Adapter Style	731
20-32	New J2C Bean - Discovery Configuration.	732
20-33	New J2C Bean - Object Discovery and Selection	732
20-34	New J2C Bean - Object Discovery and Selection	733
20-35	New J2C Bean - Configure Composite Properties	734
20-36	New J2C Bean - Configure Composite Properties	734
20-37	J2C Bean Creation and Deployment Configuration dialog	735
20-38	J2C Java bean selection	736
20-39	Deployment Information	736
20-40	Simple JSP Creation	737
21-1	Portlets laid out on the Portal Welcome Page.	741
21-2	Portal and portlet development technology samples	746
21-3	New Portal Project wizard	751
21-4	Portal Designer Workbench	753
21-5	New Skin wizard	754
21-6	New Theme wizard	755
21-7	create a portal page with static layout.	756
21-8	Friendly URL feature.	757
21-9	Enabling Client Side Capabilities in New Portlet Project.	758
21-10	Enabling client side support in new Web Pages	759

21-11	Click-to-Action properties	759
21-12	Insert Person menu.	760
21-13	New tabs in the Portlet Deployment Descriptor	761
21-14	Ajax Proxy support	762
21-15	Portlet Deployment Descriptor: Events	764
21-16	Enabling a portlet to publish evens	764
21-17	Browser with CityPortlet	767
21-18	Edit Page Properties	768
21-19	Edit Page Layout.	768
21-20	Portlet Wiring Tool (compressed)	769
21-21	Application with event handling between portlets	769
21-22	Portlet with Ajax support	770
21-23	Resource serving portlet to add city hotels	770
21-24	Portlet application with Ajax	773
22-1	Downloading additional server adapters.	780
22-2	System management topology: Standalone server (Base and Express)	781
22-3	Server Preferences page	785
22-4	Profile Management Tool window	785
22-5	Profile options	786
22-6	Application servers list in the admin console	788
22-7	Define New Server dialog	790
22-8	New Server dialog, WebSphere Server Settings page	791
22-9	Server overview window	793
22-10	Server Configuration Backup dialog	796
22-11	Server Configuration Restore dialog.	796
22-12	Add and Remove Projects	798
22-13	Enhanced EAR	800
22-14	Enterprise application deployment descriptor: Enhanced EAR.	801
22-15	JAAS Authentication Entry	802
22-16	Creating a JDBC provider (page 1).	803
22-17	Creating a JDBC provider (page 2).	804
22-18	Create a data source (1)	804
22-19	Create a data source (2)	805
22-20	Create a data source (3)	806
22-21	Configuring security	808
22-22	Security setting in server editor.	809
22-23	Secured Administrative Console	809
22-24	Running an administrative script.	812
22-25	Administrative Scripting Commands	814
22-26	WebSphere Administration Command View	815
23-1	JUnit Test Case Wizard	832
23-2	Select test methods.	833
23-3	JUnit view: Both test methods passed the assert verifications	837

23-4	JUnit view with failure	838
23-5	JUnit Test Case Wizard	840
23-6	Run configuration arguments	843
23-7	JUnit JPA test case was successful	843
23-8	New JUnit Test source code dialog.	845
23-9	TPTP JUnit Test editor [Behavior tab].	846
23-10	Package Explorer view containing test execution results	848
23-11	TPTP JUnit test execution result.	849
23-12	Test Pass report	850
23-13	Recorder Control view.	854
23-14	TPTP URL Test dialog: Overview tab	855
23-15	TPTP URL Test dialog: Behavior tab	855
23-16	Test Log Overview tab	857
23-17	Test Log Events tab	858
23-18	HTTP Page Response Time report.	859
23-19	HTTP Page Hit Rate report	860
24-1	Typical application running in the Debug perspective.	864
24-2	Drop to Frame Button in the Debug view.	867
24-3	Debugging XSLT.	868
24-4	Setting Debug UI Daemon options	870
24-5	Customer details for the RedBank application	872
24-6	Setting a breakpoint in Java	873
24-7	Breakpoint properties	874
24-8	Displaying variables	876
24-9	Inspect Pop-up window.	877
24-10	Inspecting a variable in Expressions view.	877
24-11	Expression and evaluated result in display view.	878
24-12	Enabling/Disabling Breakpoints	879
24-13	Adding a breakpoint to a JSP page.	880
24-14	Debugging a JSP	881
24-15	JSP Implicit variables in Variable view	882
24-16	Debug config for Remote debugging	886
24-17	Debugging perspective while remote debugging	886
24-18	Jython debugging configuration	889
24-19	Debug perspective when debugging a Jython script.	890
24-20	Workflow for transferring Java Debug session	891
24-21	Debug configuration for a Java Application to be added to team repository	894
24-22	Team Debugging.	895
24-23	Invitation to accept an incoming debug session from another user	896
24-24	Appearance of a debug session added to a Team Repository	898
24-25	Search for parked debug sessions	898
24-26	Team Debug view showing a parked debug session	899

25-1	Import a Java class	907
25-2	Create the build.xml file.	908
25-3	Content assist in Ant editor	911
25-4	Customizing snippets	912
25-5	New Customize Palette dialog	913
25-6	Insert Template dialog.	914
25-7	Ant preferences.	915
25-8	Problems in the Ant editor.	916
25-9	Problems view displaying Ant problems	916
25-10	Ant example dependencies.	917
25-11	Selecting Ant targets to run.	918
25-12	Ant output in the Console	919
25-13	Launching Ant to generate complete build	920
25-14	Launch Ant to build and export a J2EE project (EAR)	926
26-1	J2EE EAR file structure.	936
26-2	Deployment Descriptor editor for an EJB project	938
26-3	Deployment Descriptor editor for Bindings	938
26-4	Deployment architecture	940
26-5	Enhanced EAR Deployment Descriptor Editor	942
26-6	Enhanced EAR: resources.xml	943
26-7	WebSphere Rapid Deployment modes.	945
26-8	Java class loaders hierarchy.	947
26-9	WebSphere class loaders hierarchy	948
26-10	Choices for exporting an EAR file	955
26-11	Welcome page of the administrative console	958
26-12	WebSphere Variable: DERBY_JDBC_DRIVER_PATH \	958
26-13	Create a JDBC provider	959
26-14	Basic configuration for the data source.	960
26-15	Enter the database path or name	961
26-16	Test connection of the data source	961
26-17	Enterprise application installation: Specify the path to the EAR file	962
26-18	Enterprise application installation: Installation options	963
26-19	Enterprise application installation: Map modules to servers	963
26-20	Summary page for the Install Application wizard	964
26-21	Start the newly deployed Enterprise application	965
26-22	ITSO RedBank: Home page	966
26-23	ITSO RedBank: Login page	966
26-24	ITSO RedBank: Accounts page	967
26-25	Structure of a Jython script	970
26-26	Enabling a data source to be used in CMP.	976
26-27	Select the runtime and the WebSphere profile	979
27-1	Profiling architecture of IBM Rational Application Developer V7.0	988
27-2	Profiling and Logging views	990

27-3 Enable Profiling and Logging capability (1)	991
27-4 Enable Profiling and Logging capability (2)	992
27-5 Profile Configuration: Arguments	993
27-6 Profile Configuration: Monitor	994
27-7 Profiling options for execution time analysis	994
27-8 EntityTester run in profiling mode	995
27-9 Profiling statistics icons	996
27-10 Execution time Statistics: Summary	996
27-11 Execution Time Statistics: Expanded	997
27-12 Execution Time Analysis: Call Tree	998
27-13 Execution Time Analysis: Method Invocation Details	999
27-14 Execution Time Analysis: Method invocation	999
27-15 Execution Flow	1000
27-16 UML2 Interaction	1001
27-17 Object Allocations	1002
27-18 Object Allocation Details	1003
27-19 Memory Statistics	1003
27-20 Object References	1003
27-21 profiling Monitor with three runs	1004
27-22 Thread Analysis: Thread Statistics	1004
27-23 Thread Analysis: Visualizer	1005
27-24 Profile on server	1008
27-25 Profiling Monitor	1009
27-26 Execution Statistics	1010
27-27 Execution Statistics by methods of a class	1011
27-28 Method Invocation Details	1012
27-29 Execution Flow	1013
27-30 Execution Flow zoomed in	1013
27-31 UML2 Class Interactions	1014
28-1 Stop the CVSNT services	1024
28-2 Add repository	1025
28-3 Compatibility options	1025
28-4 CVSNT Server Settings	1027
28-5 Verify Team capability CVS Support is enabled	1030
28-6 Add the CVS repository to the workspace	1031
28-7 CVS Repositories view	1031
28-8 CVS Label Decoration preferences	1032
28-9 Team File Content preferences	1033
28-10 Resources that will be ignored when saving to the repository	1035
28-11 CVS Keyword expansion setting	1037
28-12 Setup of a common code template for Java files	1039
28-13 CVS Repositories view	1041
28-14 Create Servlet wizard	1042

28-15	Verification of resources add under CVS revision control	1043
28-16	Adding new file types on check-in	1043
28-17	Creating the View1 view bean	1045
28-18	Creating setters and getters for class View1	1046
28-19	Synchronizing RAD75CVSGuide after creating the viewbean View1	1047
28-20	Verifying committing of resources into repository	1047
28-21	User cvsuser1 merging with CVS repository	1049
28-22	Adding comment for changes to ServletA	1050
28-23	Parallel concurrent development of same resource by multiple developers	1051
28-24	Synchronize view with conflicting changes	1053
28-25	The changes between the local and remote repository	1054
28-26	Merging changes from right to left	1055
28-27	Tagging the project as a version	1056
28-28	Repository view showing new project revision	1056
28-29	CVS History view for ServletA.java	1057
28-30	Comparison between current ServletA.java and revision 1.1	1059
28-31	Highlight the two versions to compare	1060
28-32	Comparisons of two revisions from the repository	1060
28-33	CVS Annotation view	1061
28-34	Branching with two streams	1062
28-35	Creating a new CVS Branch	1063
28-36	Branch information for a project in the local workspace	1064
28-37	List of branches	1064
28-38	Refreshed Branch list	1065
28-39	Code checked into the branch	1066
28-40	Selection of the merge start point	1068
28-41	Files required to be merged	1069
28-42	CVS updates to HEAD from the merge	1069
28-43	Disconnect confirmation	1071
28-44	Reconnect to repository with original CVS meta information	1071
28-45	Selecting ServletA.java for synchronization	1074
28-46	List of synchronizations created	1074
28-47	Drop-down selection for scheduling synchronization	1075
28-48	Setting synchronization schedule	1075
29-1	Kernel and Optional components	1080
29-2	Local and Workspace Repository and their relationship to a Stream	1084
29-3	Work Items perspective	1086
29-4	Create a Jazz repository connection	1086
29-5	Create RedBank project area	1087
29-6	Select the OpenUp process for the project area	1088
29-7	View of work items initially created	1088
29-8	Work Item view	1089

29-9	Assign members to the project and process roles to the members . . .	1090
29-10	Send Team Invitation to new members of a project area	1090
29-11	Define development lines, iterations, dates for the phases of the project. 1092	
29-12	My Work View after completing a few work items	1093
29-13	Available preconditions	1094
29-14	Preconditions on Operation Behavior in the project area	1094
29-15	Team Artifacts view showing stream, component and work item history . 1095	
29-16	Creation of additional components	1096
29-17	Create a repository workspace for the current user	1097
29-18	Creation of new Team Area for the Java Team	1098
29-19	Team Organization view with team areas and team members	1098
29-20	Share an existing project with Jazz Source Control	1099
29-21	Select a component from a repository workspace to share a project	1100
29-22	Package Explorer after sharing a project	1100
29-23	Associate a work item to a change set	1101
29-24	Pending changes view after sharing a project	1101
29-25	History view shows the baselines of the component.	1102
29-26	Methods to load existing projects from a repository workspace	1103
29-27	Loading specific projects into the local Eclipse workspace.	1103
29-28	Check-in operation from Pending Changes view	1104
29-29	Pending Changes view after check-in and change set creation	1104
29-30	Team Advisor with reasons why a deliver operation is not completed	1105
29-31	Conflicts in the pending Changes view	1106
29-32	Auto-Resolve Conflicts dialog	1107
29-33	Unresolved conflict in Pending Changes view	1107
29-34	Possible options for resolving conflicts	1108
29-35	Compare Editor	1109
29-36	Assign a Build System license to the build user	1111
29-37	New build definition of type Command Line - Jazz Build Engine	1114
29-38	Builds view after completion of some builds	1116
29-39	Build Details editor	1116
29-40	Report based on the open vs closed work items template	1117
A-1	Launchpad	1122
A-2	Installation Manager	1123
A-3	Install Packages	1124
A-4	Shared Resource Directory	1125
A-5	Installation location for package group	1125
A-6	Select the features you want to install	1126
A-7	Configuration options	1127
A-8	Import Activation Kit	1128
A-9	Update Packages	1129

A-10	Uninstall Application Developer	1130
A-11	Location of the install image of WebSphere Portal Setup Disk 1	1131
A-12	Installing the WebSphere Portal v6.1 test environment	1132
A-13	WebSphere Portal v6.1 summary	1133
A-14	Define a Portal Server	1134
A-15	List of Installed Server Runtime Environments	1134
A-16	WebSphere Settings	1135
A-17	WebSphere Portal Settings	1136
A-18	Publishing Settings	1136
A-19	Portal Server added to Application Developer	1137
A-20	Running the setup after starting Tomcat	1140
A-21	Selecting Fast Path Setup	1141
A-22	Setting up the user Registry	1142
A-23	Creating the first user account	1143
A-24	Assigning developer licenses	1144
A-25	Summary	1145
A-26	Verify that the debug extension is active on the Team Concert Server	1147
B-1	Import a project interchange file	1153
B-2	Import projects from an interchange file	1153

Tables

1-1	Application development challenges	9
1-2	Technology versions comparison	19
2-1	Some basic HTML tags	37
2-2	Examples of JSP scripting elements	42
3-1	Welcome page assistance capabilities	77
3-2	Startup parameters	82
3-3	Local history settings	94
3-4	Description of appearance settings for Java views	100
3-5	Description of code style settings	104
3-6	Description of Java editor settings	110
8-1	ITSO Bank application packages	78
8-2	ITSO Bank application interfaces	79
8-3	ITSO Bank application classes	80
8-4	Fields of the interfaces	80
8-5	Fields and getter and setter methods of the classes	81
8-6	Method declarations of the Bank interface	82
8-7	Constructors and methods of the classes of the ITSO Bank application	83
8-8	New Java Project - Create a Java Project options	88
8-9	New Java Project - Java Settings options	89
8-10	Refactor actions	152
9-1	Files specific to a JET transform project	161
10-1	Available mapping transformations	208
12-1	Relationship concept in two different worlds	271
12-2	How to create a Query instance	279
13-1	Web pages of the RedBank application	348
13-2	Request scope variables for each JSP	378
15-1	Struts components realization resultstt	464
15-2	Web Diagram connections	477
18-1	Mapping between MIME type and Java type	625
23-1	JUnit 4.x annotation overview	826
23-2	JUnit Assert class: Static methods overview	829
26-1	Enhanced EAR resources supported and their scope	942
26-2	Product mapping for deployment	951
27-1	Basic memory analysis views	985
27-2	Execution time analysis views	985
27-3	Method code coverage view	986
27-4	Types of probes available with Probekit	987
28-1	Category of CVS settings available	1036

28-2 CVS keywords	1038
28-3 Sample development scenario	1040
28-4 CVS resource history terminology	1057
29-1 Feature Comparison of the three editions of Rational Team Concert .	1079
29-2 Main features of Team Concert process templates	1081
B-1 Sample code description	1151

Examples

3-1	Example snippet of code generation output for getters.	103
8-1	BankClient class (abbreviated)	112
8-2	ITSOBank class	113
8-3	Customer class	114
8-4	Account class	114
8-5	Transaction class	115
8-6	Credit class	115
8-7	Java scrapbook examples.	122
8-8	BankClient class with a @viz.diagram tag	131
8-9	Generated constructor code	148
8-10	Car, Engine, and PoorDriver classes (compressed)	148
8-11	Car and HappyDriver class	150
9-1	Template code containing the account and transaction parametrization	176
9-2	Final version of BankClient.java.jet	177
9-3	Sample.xml to run the transformation	180
9-4	Sample2.xml transformation	181
10-1	Accounts.xsd file	196
10-2	Generated Accounts.xsl file	203
10-3	Accounts.xsl file	206
10-4	Final output showing the balanceSum attribute	216
10-5	AccountTest program	218
10-6	Generated accounts.xml file	219
10-7	Code to load an XML document	221
10-8	Java code for navigating the SDO data graph	222
10-9	Updating an SDO data graph	223
11-1	CustomerTransactions.sql	243
11-2	AddCredit.java.	247
11-3	Snippet to give \$100 credit to each account	247
11-4	Embedded SQLJ.	253
11-5	TestSQLJ.java.	254
12-1	Simple entity class with annotations	269
12-2	Entity with mapping to a database table	270
12-3	Extract of a persistence.xml file	276
12-4	Extract of an orm.xml file to define an entity mapping	276
12-5	Account entity	286
12-6	Customer entity	287
12-7	Transaction entity	288
12-8	Processing credit and debit transactions	291

12-9 Persistence.xml file for OpenJPA	298
12-10 Testing JPA entities using a Java program	300
12-11 Sample output of entity tester	304
12-12 Credit class	308
12-13 Debit class.	309
12-14 Processing credit or debit transactions	310
12-15 Persistence.xml file with data source specification	313
13-1 JSP code with JSTL tags to display accounts (formatted)	374
14-1 Applying an interceptor	399
14-2 Injecting an EJB reference inside a servlet	402
14-3 Field injection technique for a data source	403
14-4 Setter injection technique for a data source	404
14-5 Business interface of the session bean.	418
14-6 Session bean getCustomer method	420
14-7 Session bean getCustomers method	420
14-8 Session bean updateCustomer method	421
14-9 Session bean getAccounts method.	421
14-10 Session bean getTransactions method.	422
14-11 Session bean deposit method.	422
14-12 Session bean transfer method	423
14-13 Session bean openAccount method	423
14-14 Session bean closeAccount method.	424
14-15 Session bean addCustomer method.	424
14-16 Session bean deleteCustomer method.	424
14-17 Servlet to test the EJB 3.0 module (abbreviated)	429
14-18 Servlet output	431
14-19 Remote interface of the session bean.	442
15-1 ApplicationResources.properties snippet	465
15-2 validation.xml snippet - LogonForm	466
15-3 validator-rules.xml snippet - Rule configuration for the required rule	467
15-4 Struts tags:- Logon.jsp snippet of the tag in the source view	470
15-5 Skeleton action class (compressed)	471
15-6 Completed execute method of the logon action class.	471
15-7 Struts configuration file: struts-config.xml	475
15-8 Plug-in configuration for Tiles in struts-config.xml file	486
15-9 Controller configuration for Tiles	486
16-1 Logout class	507
16-2 Logon action code.	519
16-3 Row action logic	529
16-4 Logout action.	530
16-5 Deposit and withdraw action logic.	531
17-1 Complete actionPerformed method	555
18-1 JAX-WS annotation.	570

18-2	Asynchronous Methods in the Web service interface	571
18-3	Asynchronous callback handler	571
18-4	Asynchronous polling	571
18-5	Web service annotation template	579
18-6	Annotate JavaBean Web service	579
18-7	WebMethod template	579
18-8	WebMethod annotation	580
18-9	Annotate the method input and output	580
18-10	Validate Web services annotations	581
18-11	JAX-WS annotation processor validation results	581
18-12	Dynamically generated WSDL snippet	584
18-13	WSThinClientTest	605
18-14	BankPortProxy asynchronous methods	607
18-15	BankPollingClient	607
18-16	RetrieveCustomerCallbackHandler	609
18-17	BankCallbackClient	610
18-18	BankCallbackMEPClient	611
18-19	SOAP request for asynchronous message exchange	612
18-20	Annotate a stateless session EJB	613
18-21	Implementation of the Generated JavaBean skeleton	620
18-22	Extract of ProcessDocument.wsdl	624
18-23	ProcessDocumentPortBindingImpl.java	627
18-24	SOAP response message and HTTP header with MTOM enabled	630
18-25	Enable MTOM on the client	632
18-26	WS-Policy in WSDL	643
18-27	WS-MEX request	646
19-1	Ajax Proxy servlet	661
19-2	Suggestions for customer keys	663
19-3	Ajax getWelcome method	668
19-4	RpcAdapterConfig.xml file (formatted)	677
19-5	Servlet doGet method	680
19-6	Retrieving all customers and return a JSON object	680
19-7	CustomerServlet execution result	681
19-8	JSON result of getCustomer request	682
19-9	HTML source with dojo imports	683
19-10	Edit the FilteringSelect source	684
19-11	Complete index.html file with dojo tags highlighted	685
19-12	JavaScript getCustomerInformation function in redBank.js	689
19-13	JavaScript function dojo.js for logging	692
19-14	JavaScript code for logging (in fillAccountGrid function)	692
20-1	DFHCOMMAREA of COBOL program	709
20-2	Definition of Containers in the COBOL file ec03.cpp	720
20-3	Channel name is expected in input in ec03.ccp	721

20-4	Ec03Wrapper.java	725
20-5	Web service response (formatted for readability)	728
21-1	CityPortlet class processAction method	765
21-2	CityInfoPortlet processEvent method	765
21-3	CityPortlet class processAction method (updated)	766
21-4	CityInfoPortlet class processEvent method (updated)	766
21-5	CityInfoPortlet class doView method	766
21-6	Implementing ResourceServingPortlet	771
21-7	CityInfoPortlet serveResource method	772
21-8	CityInfoPortlet doView method	772
21-9	Hotels button and div tag	772
22-1	List JDBC providers using a Jython script (listJDBCProviders.py)	811
23-1	Simple JUnit 4.x test case class	827
23-2	Simple JUnit 4.x test suite class	830
23-3	ITSOBankTest class: testTransfer method	834
23-4	ITSOBankTest class: testInvalidTransfer	835
23-5	AllTests class: A JUnit 4.x test suite class	836
23-6	JUnit test case for JPA	840
23-7	JPA persistence.xml configured for Derby using OpenJPA	842
23-8	ITSOBankTest class	846
25-1	J2EE Ant build.xml script	923
25-2	Snippet of the itsoRunAnt.bat (modified runAnt.bat)	928
25-3	BUbuild.xml for the build utility	930
25-4	Contents of ITSOBUBuild.bat	932
26-1	Jython snippet	969
26-2	Create a JDBC provider using the template for Derby JDBC Provider (XA)	973
26-3	Create a data source	974
26-4	Add resource property set to the data source	975
26-5	Enable the data source for container-managed persistence	976
26-6	Install or update an enterprise application	977
26-7	Start an enterprise application	978
26-8	Output of the Jython script	979
28-1	Example of CVS keywords used in Java	1038
28-2	Contents of Java file after check in and check out from CVS	1039
28-3	Add two private attributes to the View1 class	1045
28-4	ServletA gets a static attribute	1048
28-5	cvsuser2 completes the ServletA as well	1052
29-1	E-mail generated by Team Concert to invite new team member	1090
29-2	Sample batch file to start the Team Concert Build Engine	1112

Notices

This information was developed for products and services offered in the U.S.A.

IBM may not offer the products, services, or features discussed in this document in other countries. Consult your local IBM representative for information on the products and services currently available in your area. Any reference to an IBM product, program, or service is not intended to state or imply that only that IBM product, program, or service may be used. Any functionally equivalent product, program, or service that does not infringe any IBM intellectual property right may be used instead. However, it is the user's responsibility to evaluate and verify the operation of any non-IBM product, program, or service.

IBM may have patents or pending patent applications covering subject matter described in this document. The furnishing of this document does not give you any license to these patents. You can send license inquiries, in writing, to:
IBM Director of Licensing, IBM Corporation, North Castle Drive, Armonk, NY 10504-1785 U.S.A.

The following paragraph does not apply to the United Kingdom or any other country where such provisions are inconsistent with local law: INTERNATIONAL BUSINESS MACHINES CORPORATION PROVIDES THIS PUBLICATION "AS IS" WITHOUT WARRANTY OF ANY KIND, EITHER EXPRESS OR IMPLIED, INCLUDING, BUT NOT LIMITED TO, THE IMPLIED WARRANTIES OF NON-INFRINGEMENT, MERCHANTABILITY OR FITNESS FOR A PARTICULAR PURPOSE. Some states do not allow disclaimer of express or implied warranties in certain transactions, therefore, this statement may not apply to you.

This information could include technical inaccuracies or typographical errors. Changes are periodically made to the information herein; these changes will be incorporated in new editions of the publication. IBM may make improvements and/or changes in the product(s) and/or the program(s) described in this publication at any time without notice.

Any references in this information to non-IBM Web sites are provided for convenience only and do not in any manner serve as an endorsement of those Web sites. The materials at those Web sites are not part of the materials for this IBM product and use of those Web sites is at your own risk.

IBM may use or distribute any of the information you supply in any way it believes appropriate without incurring any obligation to you.

Information concerning non-IBM products was obtained from the suppliers of those products, their published announcements or other publicly available sources. IBM has not tested those products and cannot confirm the accuracy of performance, compatibility or any other claims related to non-IBM products. Questions on the capabilities of non-IBM products should be addressed to the suppliers of those products.

This information contains examples of data and reports used in daily business operations. To illustrate them as completely as possible, the examples include the names of individuals, companies, brands, and products. All of these names are fictitious and any similarity to the names and addresses used by an actual business enterprise is entirely coincidental.

COPYRIGHT LICENSE:

This information contains sample application programs in source language, which illustrate programming techniques on various operating platforms. You may copy, modify, and distribute these sample programs in any form without payment to IBM, for the purposes of developing, using, marketing or distributing application programs conforming to the application programming interface for the operating platform for which the sample programs are written. These examples have not been thoroughly tested under all conditions. IBM, therefore, cannot guarantee or imply reliability, serviceability, or function of these programs.

Trademarks

IBM, the IBM logo, and [ibm.com](http://www.ibm.com) are trademarks or registered trademarks of International Business Machines Corporation in the United States, other countries, or both. These and other IBM trademarked terms are marked on their first occurrence in this information with the appropriate symbol (® or ™), indicating US registered or common law trademarks owned by IBM at the time this information was published. Such trademarks may also be registered or common law trademarks in other countries. A current list of IBM trademarks is available on the Web at <http://www.ibm.com/legal/copytrade.shtml>

The following terms are trademarks of the International Business Machines Corporation in the United States, other countries, or both:

CICS®	IBM®	Redbooks®
ClearCase®	IMS™	Redbooks (logo)  ®
ClearQuest®	Informix®	RequisitePro®
Cloudscape®	Jazz™	RUP®
DB2 Universal Database™	Lotus®	Sametime®
DB2®	Rational Rose®	WebSphere®
developerWorks®	Rational Unified Process®	z/OS®
i5/OS®	Rational®	

The following terms are trademarks of other companies:

Adobe, and Portable Document Format (PDF) are either registered trademarks or trademarks of Adobe Systems Incorporated in the United States, other countries, or both.

SUSE, the Novell logo, and the N logo are registered trademarks of Novell, Inc. in the United States and other countries.

Oracle, JD Edwards, PeopleSoft, Siebel, and TopLink are registered trademarks of Oracle Corporation and/or its affiliates.

BAPI, SAP, and SAP logos are trademarks or registered trademarks of SAP AG in Germany and in several other countries.

EJB, Enterprise JavaBeans, J2EE, J2SE, Java, JavaBeans, Javadoc, JavaMail, JavaScript, JavaServer, JDBC, JDK, JMX, JNI, JRE, JSP, JVM, MySQL, Sun, Sun Java, and all Java-based trademarks are trademarks of Sun Microsystems, Inc. in the United States, other countries, or both.

Excel, Expression, Internet Explorer, Microsoft, PowerPoint, SQL Server, Windows NT, Windows Server, Windows Vista, Windows, and the Windows logo are trademarks of Microsoft Corporation in the United States, other countries, or both.

Intel Pentium, Intel, Pentium, Intel logo, Intel Inside logo, and Intel Centrino logo are trademarks or registered trademarks of Intel Corporation or its subsidiaries in the United States, other countries, or both.

UNIX is a registered trademark of The Open Group in the United States and other countries.

Linux is a trademark of Linus Torvalds in the United States, other countries, or both.

Other company, product, or service names may be trademarks or service marks of others.

Preface

IBM® Rational® Application Developer for WebSphere® Software v7.5 (for short, Rational Application Developer) is the full function Eclipse 3.4 based development platform for developing Java™ Standard Edition Version 6 (Java SE 6) and Java Enterprise Edition Version 5 (Java EE 5) applications with a focus on applications to be deployed to IBM WebSphere Application Server and IBM WebSphere Portal. Rational Application Developer provides integrated development tools for all development roles, including Web developers, Java developers, business analysts, architects, and enterprise programmers.

Rational Application Developer is part of the IBM Rational Software Delivery Platform (SDP), which contains products in four life cycle categories:

- ▶ Architecture management, which includes integrated development environments (Application Developer is here)
- ▶ Change and release management
- ▶ Process and portfolio management
- ▶ Quality management

This IBM Redbooks® publication is a programming guide that highlights the features and tooling included with Rational Application Developer v7.5. Many of the chapters provide working examples that demonstrate how to use the tooling to develop applications, as well as achieve the benefits of visual and rapid application development. This publication is an update of *Rational Application Developer V7 Programming Guide*, SG24-7501.

This book consists of nine parts:

- ▶ Introduction to Rational Application Developer
- ▶ Architecture and modeling
- ▶ Basic Java and XML development
- ▶ Persistence application development
- ▶ Enterprise application development
- ▶ Test and debug applications
- ▶ Deploy and profile applications
- ▶ Management and team development
- ▶ Appendixes

The team that wrote this book

This book was produced by a team of specialists from around the world working at the International Technical Support Organization, San Jose Center, and remotely from Canada, Netherlands, Turkey, and the USA.



Local team

Ueli Wahli is a Consultant IT Specialist at the IBM International Technical Support Organization in San Jose, California. Before joining the ITSO over 20 years ago, Ueli worked in technical support at IBM Switzerland. He writes extensively and teaches IBM classes worldwide about WebSphere Application Server, and WebSphere and Rational application development products. In his ITSO career, Ueli has produced more than 40 IBM Redbooks. Ueli holds a degree in Mathematics from the Swiss Federal Institute of Technology.

Miguel Vieira Ferreira Lopes Gomes is an IT Architect working for IBM Global Business Services, Brazil, and an active member of the Systems Integration / Engineering Group. He has 10 years of experience in the enterprise application development field mainly in the public sector. He holds IBM products, Java, and SOA certifications. He holds a degree in Computer Science from Sao Judas University, Sao Paulo. His areas of expertise include software architecture, Java EE, Web 2.0, Web services, digital signature, Rational Application Developer, Rational Software Architect, WebSphere Application Server, and WebSphere Portal Server.

Brian Hainey is a Senior Lecturer at Glasgow Caledonian University in Scotland, United Kingdom (UK). He currently teaches on the undergraduate and postgraduate programs offered in the School of Engineering and Computing. In addition, he teaches training courses in enterprise software development and Java. He holds a Master of Science degree in electronic engineering from Heriot-Watt University, Edinburgh. He has more than 20 years experience in the field of software development and has worked at companies such as National Westminster Bank, Hewlett-Packard, QA Training, and IBM. He holds industry certifications in Java and enterprise software development. His areas of expertise include Java enterprise systems, Web services, XML, UML modelling, Rational Unified Process®, Rational Rose®, Rational Application Developer, Rational Software Architect, and WebSphere Application Server.

Ahmed Moharram is a Software Engineer at the Cairo Technology Development Center (C-TDC) in IBM Egypt. He holds a degree, and completed post graduate studies, in Computer Science from Cairo University. He has been working in IBM since 2005. He provides bidirectional scripts (Bidi) and globalization support for different IBM products and platforms. Currently, he is a technical lead in Rational multicultural support team with expertise in different areas including Java technologies, Web services, XML, UML modeling, Web 2.0, WebSphere Application Server, WebSphere Portal Server, and Microsoft® .Net. Recently, he has been chosen as a committer in Business Intelligence Reporting Tools (BIRT), one of the Eclipse Open Source projects.

Juan Pablo Napoli is a WebSphere Consultant IT Specialist at IBM Software Group Organization in Sofia, Bulgaria. Juan delivers consulting services since 4 years in IBM regions of Latin America, Eastern Europe, and Middle East, specially focused in banking and governmental sectors. Juan leads the IBM Academic Initiative before entering IBM, and he has senior skills throughout all the roles in the software development life cycle, from J2EE™ development to current middleware architecture leadership in visible projects in the European Union. He teaches SSME post-graduate curricula at Sofia University and holds a degree of Computer Science from the University of Cordoba, Argentina.

Marco Rohr is an Advisory IT Specialist working for IBM Global Business Services in Zurich, Switzerland. He is also an Education Specialist for the application development and WebSphere segment of the IBM training department. He has six years of experience in the enterprise application development field mainly in the public sector. He studied Computer Science at the Engineering School of Rapperswil, Switzerland and he holds a Swiss Federal Certificate in Didactic and Methodology. His areas of expertise include object-oriented analysis and design with UML, implementation of OO concepts in Java SE, and development of the presentation layer of Java EE applications.

Remote team

Henry Cui is a Software Developer working at the IBM Toronto lab. Henry has been in the IBM Rational Application Developer service and support team for six years. He has helped many customers resolve design, development, and migration issues with Java EE development. His areas of expertise include developing Java EE applications using Rational tools, configuring WebSphere Application Servers, EJBs, application security, Web services and SOA. Henry is a frequent contributor of developerWorks® articles. He also co-authored two IBM Redbooks, *Rational Application Developer v7 Programming Guide*, SG24-7501, and *Web Services Feature Pack for WebSphere Application Server V6.1*, SG24-7618. Henry holds a degree in Computer Science from York University.

Patrick Gan is a Senior IT Specialist who works for IBM Global Services, Application Innovation Services Center of Excellence, US. He has eight years of experience and expertise in OOAD/Java Design best practices, J2EE development, SOA, software development methods, and tools. In his current capacity, Patrick's primary responsibility in customer facing engagements is solution design and delivery of custom enterprise solutions. In addition, he has also been involved in the design and development of IBM assets and has authored articles on developerWorks. Patrick has a Computer Science degree from California Polytechnic State University, Pomona.

Celso Gonzalez has been working on software engineering for the last 13 years. He is one of the Rational World Wide Architecture Management leaders. His role is to provide his expertise in domains ranging from business modeling to J2EE development, including requirements management, architecture, and design, to IBM customers and internal resources. Lately Celso has been focusing on SOA and on accelerating development using patterns-based engineering. Before joining the Worldwide Community of Practice team, Celso was part of the Rational Unified Process development team where he contributed to areas like business modeling, requirements, analysis & design, and legacy evolution. Celso holds degrees in Computer Science, Mathematics, and Philosophy.

Pinar Ugurlu is an Advisory IT Specialist in the IBM Software Group, Turkey. She has six years of experience in application design, development, and consulting. She holds a degree in Computer Engineering from Bilkent University. Her areas of expertise include service-oriented architecture, J2EE programming, portals, and e-business integration. She has written extensively on Java EE clients, Ant, profiling, and Java Connector Architecture.

Lara Ziosi is an Advisory Software Engineer in IBM Netherlands. She holds a Doctorate in computational methods of Physics from the University of Bologna, Italy. She has nine years of experience in Rational client support. Her areas of expertise include Java Enterprise, object-oriented analysis and design with UML, the extensibility of the modeling features of Rational Software Architect and the

integration of Rational Software Architect with configuration management tools, such as Rational ClearCase® and Rational Team Concert. Lara is a frequent contributor of Rational Application Developer, Rational Software Architect, and Rational Software Modeler technotes.

Thanks to the following people for their contributions to this project:

- ▶ Kevin Sutter, Randy Schnier, and Jody Grassel, IBM Rochester
- ▶ Matthew Perrins, IBM UK
- ▶ Samantha Chan, Ellen Chen, Ivy Ho, Mike Melick, and Elson Yuen, IBM Toronto
- ▶ Eric Jodet and Philippe J. Krief, IBM France
- ▶ Bruno Tavares, IBM Brazil

Thanks to the authors of the previous editions of this book.

- ▶ Authors of the previous edition, Rational Application Developer V7 Programming Guide, published in September 2007, were: Henry Cui, Craig Fleming, Maan Mehta, Marco Rohr, Pinar Ugurlu, Patrick Gan, Celso Gonzalez, Daniel M Farrell, and Andreas Heerdegen.

Become a published author

Join us for a two- to six-week residency program! Help write a book dealing with specific products or solutions, while getting hands-on experience with leading-edge technologies. You will have the opportunity to team with IBM technical professionals, Business Partners, and Clients.

Your efforts will help increase product acceptance and customer satisfaction. As a bonus, you will develop a network of contacts in IBM development labs, and increase your productivity and marketability.

Find out more about the residency program, browse the residency index, and apply online at:

ibm.com/redbooks/residencies.html

Comments welcome

Your comments are important to us!

We want our books to be as helpful as possible. Send us your comments about this book or other IBM Redbooks in one of the following ways:

- ▶ Use the online **Contact us** review Redbooks form found at:

ibm.com/redbooks

- ▶ Send your comments in an e-mail to:

redbooks@us.ibm.com

- ▶ Mail your comments to:

IBM Corporation, International Technical Support Organization
Dept. HYTD Mail Station P099
2455 South Road
Poughkeepsie, NY 12601-5400

Summary of changes

This section describes the technical changes made in this edition of the book and in previous editions. This edition may also include minor corrections and editorial changes that are not identified.

Summary of changes for ***Rational Application Developer V7.5 Programming Guide, SG24-7672-00***, as created or updated on December 30, 2008.

This book is an update of the IBM Redbooks publication, ***Rational Application Developer V7 Programming Guide, SG24-7501***.

December 2008, First Edition

This revision reflects the addition, deletion, or modification of new and changed information described below.

- ▶ RUP®, Patterns, and SOA: New chapter on architecture
- ▶ Persistence Using the Java Persistence API (JPA): New chapter
- ▶ Develop EJB™ applications: Use of the EJB 3.0 specification and JPA for database access
- ▶ Develop Web applications using JSF: Use of JPA for database access
- ▶ Develop Web services applications: Use of JAX-WS exclusively, and added WS-Policy and WS-MetadataExchange
- ▶ Develop rich Web 2.0 applications: New chapter using Ajax and Dojo
- ▶ Develop applications to connect to enterprise information systems: New chapter with JCA access to CICS® and SAP®
- ▶ Develop Portal applications: ??
- ▶ Debug local and remote applications: New section on debug extension for Rational Team Concert Client
- ▶ Rational Team Concert: New chapter for team development
- ▶ Product installation: New sections for Rational Team Concert and Rational Build Utility
- ▶ Removed chapters on GUI development, EGL development, and Rational Clear Case



Part 1

Introduction to Rational Application Developer

In this part of the book, we introduce IBM Rational Application Developer for WebSphere Software.

The introduction includes packaging, product features, the Eclipse base, installation, licensing, migration, and an overview of the tools.

We then discuss setting up the Workbench, the perspectives, views, and editors, and the different type of projects.



Introduction

IBM Rational Application Developer for WebSphere Software v7.5 is an integrated development environment and platform for building Java Platform Standard Edition (Java SE) and Java Platform Enterprise Edition (Java EE) applications with a focus on applications to be deployed to IBM WebSphere Application Server and IBM WebSphere Portal.

This chapter contains an introduction to the concepts, packaging, and features of the IBM Rational Application Developer V7.5 product.

The chapter is organized into the following sections:

- ▶ Concepts
- ▶ Product packaging
- ▶ Product tools and features
- ▶ Installation and licensing
- ▶ Migration and coexistence
- ▶ Sample code

Concepts

This section provides an introduction to the IBM Rational Software Delivery Platform, Eclipse, and Application Developer.

The Rational product suite helps businesses and organizations manage the entire software development process. Software modelers, architects, developers, and testers can use the same team-unifying Rational Software Delivery Platform tooling to be more efficient in exchanging assets, following common processes, managing change and requirements, maintaining status, and improving quality.

IBM Rational Software Delivery Platform

The IBM Rational Software Delivery Platform offers an array of products, services, and best practices. It is an open, modular, and proven solution that spans the entire software and systems delivery life cycle. Its products are comprised in five life cycle categories. Figure 1-1 shows each of the five life cycle categories with a selection of the embedded Rational tooling.

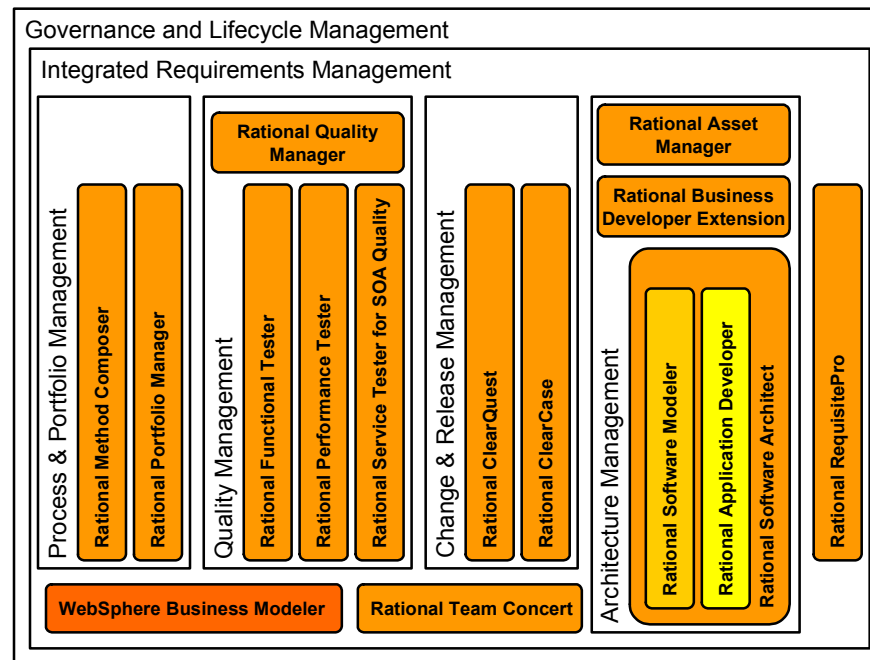

Figure 1-1 IBM Rational Software Delivery Platform life cycle categories and products

The following is a brief description of the products included in the IBM Rational Software Delivery Platform:

▶ **Rational Software Modeler v7.5**

The Software Modeler is a UML 2.0-based visual modeling and design tool for system analysts, software architects, and designers who need to clearly define and communicate their architectural specifications to stakeholders.

New in version 7.5 you can create and leverage your own domain specific modeling languages (DSMLs) to represent your unique business problem and solution domains.

▶ **Rational Software Architect v7.5**

The Software Architect is a design and construction tool that leverages model-driven development with UML 2.0 to create well-architected applications, including those based on service-oriented architecture (SOA). It unifies modeling, Java structural review, Web services, Java SE, Java EE, database, XML, Web development, and process guidance for architects and senior developers creating applications in Java.

New in version 7.5 it comes with a comprehensive support for simpler, new and emerging programming models including Web 2.0, Java EE 5.0, EJB 3.0 and Java Persistence API (JPA).

▶ **Rational Application Developer**

The Application Developer is a full suite of development, analysis and test, and deployment tools for rapidly implementing Java SE and EE, Portal, Web and Web 2.0, Web services and SOA applications.

New in version 7.5 it supports Java EE 5.0, EJB 3.0, JPA, and Web 2.0 with Ajax and Dojo development.

▶ **Rational Business Developer Extension v7.5**

The Business Developer Extension is an Eclipse 3.4 based workbench featuring Enterprise Generation Language (EGL) for delivering multi-platform applications.

▶ **Rational Asset Manager v7.1**

The Asset Manager helps create, modify, govern, find and reuse any type of development assets, including SOA and system development assets.

▶ **Rational Team Concert**

The Team Concert is a Jazz™-based collaborative software delivery environment that empowers project teams to simplify, automate and govern software delivery. Automated data collection and reporting reduces administrative overhead and provides the real-time insight required to effectively govern software projects. It extends the capabilities of the team

with integrated work item, build, software configuration management (SCM) and the collaborative infrastructure of the Jazz Team Server.

Note: Jazz is IBM Rational's new technology platform for collaborative software delivery. It is an extensible framework that dynamically integrates and synchronizes people, processes and assets associated with software development projects. More information about Jazz technology platform can be found here:

<http://www.ibm.com/software/rational/jazz/>

▶ **Rational Functional Tester v8.0**

The Functional Tester is a tooling for automated functional, regression, GUI and data-driven testing. It provides the capability to record robust scripts that can be played back to validate new builds of an application.

▶ **Rational Performance Tester v8.0**

The Performance Tester is a multi-user system performance test product designed to test Web applications, and focuses on scalability.

▶ **Rational Service Tester for SOA Quality**

The Service Tester for SOA Quality tooling provides tester with script-free testing capabilities for functional, regression, and performance testing of GUI-less Web services.

▶ **Rational Quality Manager**

The Quality Manager is a web-based centralized test management environment for business, system and IT decision makers and quality professionals who seek a collaborative and customizable solution for test planning, workflow control, tracking and metrics reporting capable of quantifying how project decisions and deliverables impact and align with business objectives.

▶ **Rational Method Composer**

The Method Composer is a flexible process management platform. It includes a rich process library to help companies implement effective processes for successful software and IT projects.

▶ **Rational Portfolio Manager**

The Portfolio Manager helps businesses to align their IT and system investments with business priorities. It provides optimization of investment funding decisions, cost containment, and maximizing value across the entire portfolio.

▶ **Rational RequisitePro®**

RequisitePro is a requirements management tool for project teams who want to manage their requirements, write good use cases, improve traceability, strengthen collaboration, reduce project risks, and increase quality.

▶ **Rational ClearQuest®**

ClearQuest is a software change management tooling. It provides defect, task and change request tracking, process automation, reporting and lifecycle traceability for better visibility and control of the software development lifecycle.

▶ **Rational ClearCase**

ClearCase is a complete software configuration management tooling. It provides a sophisticated version control, workspace management, parallel development support and build auditing to improve productivity.

▶ **WebSphere Business Modeler**

The WebSphere Business Modeler belongs to the WebSphere brand, but is an important product of the Rational Software Delivery Platform. WebSphere Business Modeler targets the business analyst who models business processes. WebSphere Business Modeler can be used to generate Business Process Execution Language (BPEL) definitions to be imported into WebSphere Integration Developer to create applications for WebSphere Process Server. BPEL from WebSphere Business Modeler provides a more seamless move to implementation and eliminates the need to create paper diagrams for the developer.

Eclipse and IBM Rational Software Delivery Platform

This section provides an overview of the Eclipse Project, as well as how Eclipse relates to the IBM Rational Software Delivery Platform and Application Developer v7.5.

Eclipse Project

The Eclipse Project is an open source software development project devoted to creating a development platform and integrated tooling. Figure 1-2 shows the high-level Eclipse Project architecture and shows the relationship of the following sub projects:

- ▶ Eclipse Platform
- ▶ Eclipse Java Development Tools (JDT)
- ▶ Eclipse Plug-in Development Environment (PDE)

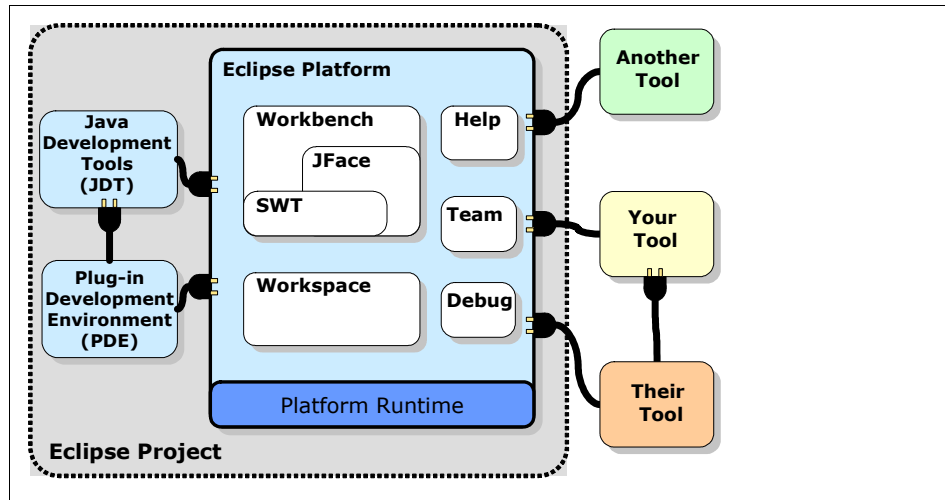

Figure 1-2 Eclipse Project overview

With a common public license that provides royalty free source code and world-wide redistribution rights, the Eclipse Platform provides tool developers with great flexibility and control over their software technology.

Industry leaders like IBM, Borland, Merant, QNX Software Systems, RedHat, SuSE, TogetherSoft, and WebGain formed the initial eclipse.org board of directors of the Eclipse open source project.

Note: IBM Rational Application Developer v7.5 is based on Eclipse v3.4.

More detailed information on Eclipse can be found at:

<http://www.eclipse.org>

Eclipse Platform

The Eclipse Platform provides a framework and services that serve as a foundation for tools developers to integrate and extend the functionality of the platform. The platform includes a workbench, concept of projects, user interface libraries (JFace, SWT), built-in help engine, and support for team development and debug. The platform can be leveraged by a variety of software development purposes including modeling and architecture, integrated development environment (Java, C/C++, Cobol), testing, and so forth.

Eclipse Java Development Tools (JDT)

The JDT provides the plug-ins for the platform specifically for a Java-based integrated development environment, as well as the development of plug-ins for Eclipse. The JDT adds the concepts of Java projects, s, views, editors, wizards, and refactoring tools to extend the platform.

Eclipse Plug-in Development Environment (PDE)

The PDE provides the tools to facilitate the development of Eclipse plug-ins.

Eclipse Software Developer Kit (SDK)

The Eclipse SDK consists of the software created by the Eclipse Project (Platform, JDT, PDE), which can be licensed under the Eclipse Common Public License agreement, as well as other open source third-party licensed software.

Note: The Eclipse SDK does not include a Java Runtime Environment (JRE™) and must be obtained separately and installed for Eclipse to run. IBM Java Runtime Environment 6.0 is used in Application Developer v7.5.

Application development challenges

To better grasp the business value that Application Developer v7.5 provides, it is important to understand the challenges businesses face in application development.

Table 1-1 highlights the key application development challenges as well as desired development tooling solutions.

Table 1-1 Application development challenges

Challenges	Solution tooling
Application development is complex, time consuming, and error prone.	Raise productivity by automating time consuming and error prone tasks.
Highly skilled developers are required and in short supply.	Assist less knowledgeable developers where possible by providing wizards, on-line context sensitive help, an integrated environment and visual tooling.
Learning curves are long.	Shorten learning curves by providing Rapid Application Development (RAD) tooling (visual layout and design, re-usable components, code generators) and ensure development tools have consistent way of working.

Product packaging

This section highlights the product packaging for Application Developer V7.5.

Rational Developer supported platforms and databases

This section describes the platforms and databases supported by the Rational Developer products.

Supported operating system platforms

Application Developer v7.5 supports the following operating systems:

- Microsoft Windows® XP Professional (x32 / x64)
- Microsoft Windows Server® 2003 Standard / Enterprise Edition (x32 / x64)
- Microsoft Windows Vista® Business / Enterprise Ultimate (x32 / x64)
- Microsoft Windows Server 2008 Standard / Enterprise Edition (x32 / x64)
- Red Hat Enterprise Linux® Version 4.0/5.0 AS / ES (x32 / x64)
- Red Hat Enterprise Linux Desktop Version 4.0/5.0 (x32)
- SUSE® Linux Enterprise Server (SLES) Version 9/10 (x32 / x64)
- SUSE Linux Enterprise Desktop (SLED) Version 9/10 (x32 / x64)
- Citrix Presentation Server Version 4.x
- VMWare environment

Test server environments

Application Developer v7.5 supports a wide range of server environments for running, testing, and debugging application code.

The following lists the application servers that are compatible with Application Developer v7.5:

- ▶ IBM WebSphere Application Server, Version 6.0 (included)
(optionally with Feature Pack for Web 2.0)
- ▶ IBM WebSphere Application Server, Version 6.1 (included)
(optionally with Feature Pack for Web 2.0 / EJB 3.0 / Web Services)
- ▶ IBM WebSphere Application Server, Version 7.0 (included)
(optionally with Feature Pack for Web 2.0)
- ▶ IBM WebSphere Portal, Version 6.0
- ▶ IBM WebSphere Portal, Version 6.1 (included)
- ▶ IBM HTTP Servers

The following list of server adapters from the Web Tools Platform 3.0 based on Eclipse technology are included in Application Developer V7.5:

- ▶ HTTP Preview
- ▶ Java EE Preview
- ▶ Apache Tomcat, Versions 3.2, 4.0, 4.1, 5.0, 5.5, and 6.0
- ▶ JBoss, Versions 3.2.3, 4.0, 4.2, and 5.0
- ▶ ObjectWeb Java Open Application Server (JOnAS), Version 4
- ▶ Oracle® Containers for J2EE (OC4J) Standalone Server, V10.1.3 and 10.1.3.n

Note: IBM Rational Deployment Toolkit for WebLogic Server provides a seamless integration of BEA WebLogic Server, Versions 6.1, 7.0, and 8.1 within Application Developer. More information can be found here:

http://www.ibm.com/developerworks/rational/downloads/08/toolkit_weblogicv7

Supported databases

The following databases are compatible with the Application Developer v7.5 workbench:

- ▶ IBM Cloudscape®, Version 5.1
- ▶ Derby, Versions 10.0, 10.1, and 10.2
- ▶ IBM DB2® Database for Linux, UNIX® and Windows, Versions 7.2, 8.1, 8.2, 9.1, and 9.5
- ▶ IBM DB2 for i5/OS®, Versions 5R2, 5R3, and 5R4
- ▶ IBM DB2 for z/OS® Versions 7, 8, 9 (compatibility mode) and 8, 9 (new function mode)

Note: Additional to the compatibility mode, the new function mode includes the generated data model that has all the new catalog features of DB2 for z/OS v8 and v9. Use the new function mode if you plan to work with the generated data models available in IBM Rational Software Delivery Platform products.

- ▶ IBM Informix® Dynamic Server, Versions 9.2, 9.3, 9.4, 10.0, and 11.0
- ▶ HSQLDB, Version 1.8
- ▶ Microsoft SQL Server® Enterprise, Versions 7, 2000, and 2005
- ▶ MySQL™, Versions 4.0, 4.1, 5.0, and 5.1
- ▶ Oracle, Versions 8, 9, 10, and 11
- ▶ SAP MaxDB, Versions 7.6 and 7.7
- ▶ Sybase Adaptive Server Enterprise, Versions 12.x, and 15.0
- ▶ Generic JDBC™ Version 1.0

Application Developer v7.5 eAssembly

IBM Rational Application Developer for WebSphere Software V7.5 is comprised of the following two eAssemblies:

- ▶ IBM Rational Application Developer for WebSphere V7.5 Multilingual Multiplatform eAssembly (Core)
 - Quick Start Guide
 - License Activation Kit
 - Application Developer V7.5 Core (6 parts)
 - WebSphere Application Server Test Environment V6.0 (2 parts)
 - WebSphere Application Server Test Environment V6.1 (4 parts)
 - WebSphere Application Server Test Environment V7.0 (4 parts)
 - Java Runtime Environment V1.6 SR2

Note: At minimum, the six *core* parts and the license activation kit are required.

- ▶ IBM Rational Application Developer for WebSphere V7.5 Multilingual Multiplatform eAssembly (Optional)
 - Application Developer Build Utility V7.5 (5 parts)
 - Rational Enterprise Deployment V7.5 for Windows / Linux (each 1 part) (includes License Server, Installation Manager and Packaging Utility)
 - IBM WebSphere Portal V6.1 for Windows / Linux (each 9 parts)
 - Crystal Reports Server XI Release 2 Windows / Linux (each 2 parts)
 - IBM WebSphere Application Server for Developers V7.0 for Windows / Linux (each 1 part)
 - IBM CICS Transaction Gateway V7.1.0.2 Windows / Linux (each 1 part)
 - Rational Debug Extension for IBM Rational Team Concert Server
 - Rational Agent Controller V8.0

Note: Rational Agent Controller 8.0 is for IBM WebSphere Application Server 7.0. However, for IBM WebSphere Application Server V6.0 and V6.1, Rational Agent Controller V7.0.3.1 is needed.

Product tools and features

This section gives you a summary of the tools and new features of Application Developer v7.5. We provide more detailed information on the tooling and features throughout the chapters of this book.

Tools

Application Developer v7.5 includes a wide array of tooling to simplify or eliminate tedious and error-prone tasks, and provide the ability for Rapid Web Development. We have listed the key areas of tooling included with Application Developer:

- ▶ Java development tools (JDT)
- ▶ Relational database tools
- ▶ XML tools
- ▶ Web development tools
- ▶ Web 2.0 development tools
- ▶ Struts tools
- ▶ JSF development tools
- ▶ SDO development tools
- ▶ Enterprise Generation Language tools
- ▶ EJB tools
- ▶ JPA tools
- ▶ Portal tools
- ▶ Web services tools
- ▶ Team collaboration tools
- ▶ Debugging tools
- ▶ Performance profiling and analysis tools
- ▶ Server configuration tools
- ▶ Testing tools
- ▶ Crystal Report tools
- ▶ Deployment tools
- ▶ Plug-in development tools

Note: Each of the chapters of this book provides a description of the tools related to the given topic and demonstrates how to use the Application Developer tooling.

Summary of new features in Application Developer v7.5

There are lots of new features in Version 7.5, many of which we highlight in detail in the remaining chapters of this book. The objective of this section is to summarize the new features in Application Developer v7.5:

- ▶ Eclipse 3.4 integration: Includes all Eclipse 3.4 features and extends this functionality with visual development tools and IBM WebSphere support
 - ▶ Web based help system with option to run locally
 - ▶ Productivity enhancement features:
 - Flexible installation provides access to only the features you need
 - Cheat sheets for common development patterns
 - ▶ Specification versions: Full support for Java EE 5.0, Java SE 6.0, and IBM WebSphere Application Server v7.0.
 - ▶ **Web tooling:**
 - JavaServer™ Pages (JSP™) 2.1 and servlet 2.5 wizards
 - Ability to split the page designer into a designer and source view
 - Ability to position the widget to an absolute position on the page
 - Struts 1.3 support: Wildcards in action mappings and ability to extend Struts artifacts
 - Web Diagram Editor enhancements: Use the new References framework for refactoring, provide a preview before actually committing changes, and show incoming and outgoing links on a node.
 - Support for links from data grids: Row action added to a data table in a Faces JSP is now displayed in Web Diagram.
 - Enhanced link indexing, validation and refactoring support
- For more detailed information, refer to
- Chapter 13, “Develop Web applications using JSPs and servlets” on page 317,
 - Chapter 15, “Develop Web applications using Struts” on page 445
- ▶ **JavaServer Faces (JSF) tooling:**
 - JavaServer Faces (JSF) 1.2 components and visual tools
 - JSF-based report viewing component for embedding reports into Web applications
 - Integration of third party JSF libraries: Allow users to generate a project containing a definition of how to integrate tooling for the library into Application Developer

- Custom Component Library Builder: Allow users to build a JSF component library from existing components and integrate that library into the tools
- JSF Widget Library: Built-in Ajax-like capabilities and Dojo support
- OpenAjax compliance and co-existence with other Ajax libraries

For more detailed information, refer to Chapter 16, “Develop Web applications using JSF” on page 493.

► **Web 2.0 tooling:**

- Support for developing Ajax and Dojo based applications
- Visual tools for Ajax proxy
- Java Script Editor with Outline view, content assist, validation, and refactoring
- Java Script Debugger: Firebug integration
- Dojo widget content assist, validation, palette items, property views
- Drag and drop of Dojo widgets from the palette to Page Designer Source view
- WebSphere Web 2.0 Feature Pack support: RPC Adapter configuration
- Expose Java beans as REST-style services
- Supports JSON and XML data interchange
- Integrate ATOM and RSS feeds

For more detailed information, refer to Chapter 19, “Develop Web applications using Web 2.0” on page 649.

► **Enterprise JavaBeans™ (EJB) and Java Persistence API (JPA) tooling:**

- As-you-type syntactic validation and code assist for annotations
- EJB 3.0 semantic validation on save
- EJB 3.0 and JPA deployment descriptor editor enhancements
- WAS binding files and deployment descriptors are XML based
- EJB Visualizer updated to view and edit EJB 3.0
- Beans can be annotation or XML deployment descriptor based
- Tool to map JPA beans to database tables
- Enhanced JSF client support for EJB 3.0 and JPA beans
- Support for adding EJB 3.0 modules to existing applications that have J2EE 1.4 deployment descriptors

For more detailed information, refer to Chapter 12, “Persistence using the Java Persistence API (JPA)” on page 267 and Chapter 14, “Develop EJB applications” on page 387.

► **Java Annotation support:**

- Java Editor
 - Content assist for annotations, injected for simple java projects and component defining annotations, for example @Stateless or @WebService
 - Template based to provide prefilled attribute values based on the annotation's java context
 - Indicates where annotation attribute values may be overridden
 - Hovering on indicator provides the value from the deployment descriptor file
- Annotation View
 - Editing for annotations without definitions
 - Annotation attributes of type annotations and array of annotations supported
 - Integrated JPA editing
 - EJB deployment descriptor override indicators
 - Integrated with EJB Visualizer
- Tracing and Logging
 - Java Annotation Index

► **Portal application development:**

- Support of IBM WebSphere Portal 6.1
- Creation of JSR 286 Portlet projects and support for portlet events: JSR 286 allows the portlets to declare events it wants to publish (send), and events it wants to process (receive)
- Portlet Deployment Descriptor editor has new tabs to accommodate for JSR 286 specification.
- Support for client-side programming model: Enables Web 2.0 functionality, reduces repeated round trips to server, user actions in the browser cause JavaScript™ to execute, script communicates directly with the server (XMLHttpRequest or hidden IFRAME)
- Ajax support: WYSIWYG editor for Ajax proxy configurations
- Web 2.0 theme support
- Allows creation of portal pages using static HTML templates
- Friendly URL names: developers can assign simple easy to remember URLs for particular page

For more detailed information, refer to Chapter 21, “Develop portal applications” on page 739.

► **Web services:**

- Full support for Java API for XML Web Services (JAX-WS 2.0), Java Architecture for XML Binding (JAXB 2.0), SOAP 1.2, SOAP with Attachments API for Java (SAAJ 1.3), UDDI 3.0, Web Services Reliable Messaging (WS RM), Web Services Addressing (WS Addressing) and SOAP Message Transmission Optimization Mechanism (MTOM)
- WS-I Basic Profile 1.2 and 2.0
- EJB 3.0 Web services
- Enhanced annotation support: Trigger annotations, templated auto completions, implicit attributes, implied annotations (@WebService implies @BindingType for implementation beans)
- Quick fixes for unresolved annotations, for example useful after import of a module with source using JAX-WS 2.0 annotations, where Web Services Feature Pack Facet was not selected
- Extended WSDL validation: detect and warn about issues that frequently occur

For more detailed information, refer to Chapter 18, “Develop Web services applications” on page 563.

► **Data tooling:**

- Two views replaced (Database Explorer is now Data Source Explorer, Output View is now SQL Results)
- New connection wizard: need to be associated with the right driver and DB2 is version less
- SQL Result view: allow for nested display, timestamp support, and history persisted with the workspace
- New SQL and XQuery Editor: Error reporting, syntax and reference parsers, content assist, and include a DML formatter

For more detailed information, refer to Chapter 11, “Develop database applications” on page 227.

► **Build utility:**

- A scriptable, automated, headless application build tool
- Used for automation of production builds
- Builds and exports are consistent to those from Application Developer
- Based on ANT with specialized Application Developer ANT tasks
- Input is Application Developer projects, and the output is compiled and packaged code in the form of JARs, WARs, and EARs

- ▶ **Line level coverage:**
 - Commonly used for measuring and comparing test coverage
 - Java classes are statically instrumented after compilation (reversible and portable)
 - Code coverage statistics are stored locally for each application launch
 - Indicators and enhanced reports to display levels of covered, uncovered, or partially covered lines
- ▶ **Team debugging:**
 - Rational Team Concert capabilities allow to transfer a live debug session to another user, so he can continue analysis from where you have left off
- ▶ **Server tooling:**
 - Stable server connection for server status update
 - Auto detect connection type
 - Test connection to diagnose server connection problem
 - Improved usability of pop-up menu in the Servers View
 - Improved developer experience for server start and stop
 - Support for WebSphere Feature Packs and class paths
 - EJB 3.0 and JPA universal test clients (UTC) available for WebSphere Application Server (WAS) v7.0
 - Adopt new WAS runtime bundle structure
 - WAS v7.0 Jython Library Support
 - Exploiting the new WAS v7.0 Jython libraries in the Jython editor
 - Two new Java Management Extensions (JMX™) connection types: IPC connection type and JSR 160 RMI

Specification versions

This section highlights the specification versions found in Application Developer v7.5.

Table 1-2 is a comparison of the technology versions supported by Application Developer v7.5 and v7.0. Most of the listed technologies are part of the Java EE 5.0 specification.

Table 1-2 Technology versions comparison

Specification	Application Developer v7.5	Application Developer v7.0
IBM Java Runtime Environment (JRE)	1.6	1.5
JavaServer Pages (JSP)	2.1	2.0
Java Servlet	2.5	2.4
Enterprise JavaBeans (EJB)	3.0	2.1
Java Message Service (JMS)	1.1	1.1
Java Transaction API (JTA)	1.1	1.0
JavaMail™	1.4.1	1.3
Java Activation Framework (JAF)	1.1.1	1.1
Java API for XML Processing (JAXP)	1.4 incl. Java SE 6	1.2 incl. Java SE 1.4
Java EE Connector	1.5	1.5
Java API for XML-based RPC (JAX-RPC)	1.1	1.1
SOAP with Attachments API for Java (SAAJ)	1.3	1.2
Java API for XML Web Services (JAX-WS)	2.0	optional feature
Java Architecture for XML Binding (JAXB)	2.0	optional feature
Java Authentication and Authorization Service (JAAS)	incl. Java SE 6	incl. Java SE 1.4
Java Database Connectivity API (JDBC)	4.0 incl. Java SE 6	3.0 incl. Java SE 1.4
Java API for XML Registries (JAXR)	1.0	1.0
Java EE Management	1.1	1.0
Java Management Extensions (JMX)	1.2 incl. Java SE 6	1.2 incl. Java SE 1.4
Java EE Deployment	1.2	1.1
Java Authorization Service Provider Contract for Containers (JACC)	1.1	1.0
JavaServer Pages Debugging	1.0	n/a
JavaServer Pages Standard Tag Library (JSTL)	1.2	1.2

Specification	Application Developer v7.5	Application Developer v7.0
Web Services Metadata	2.0	n/a
JavaServer Faces	1.2	1.1
Common Annotations	1.0	n/a
Streaming API for XML (StAX)	1.0	n/a
Java Persistence API (JPA)	1.0	n/a
Service Data Objects (SDO)	2.0	1.0
Struts	1.3	1.1

Installation and licensing

This section provides a summary for licensing, installation, product updates, and uninstallation for Application Developer v7.5. Licensing, installation, product updates, and uninstallation are achieved through the IBM Installation Manager (which is installed along with Application Developer v7.5). It is important to note that whenever using IBM Installation Manager on a previously installed product, that particular product must not be in use when making updates.

Installation

The system hardware requirements are as follows:

- ▶ Intel® Pentium® III 800 MHz or higher
- ▶ 1 GB RAM minimum, 2 GB RAM works well
- ▶ 1024 x 768 video resolution or higher
- ▶ 3.5 GB free hard disk space
- ▶ 2 GB temp space during install

What is new in Application Developer v7.5

- ▶ Support non-admin install
- ▶ Help configuration
- ▶ WebSphere Application Server Test Environment are extensions, not features
- ▶ Option on profile creation for WAS Test Environment install

Installation: The detailed steps to install Application Developer v7.5 are described in “Installing IBM Rational Application Developer” on page 1124.

Licensing

Types of licenses

IBM Rational offers three types of product licenses: an *Authorized User License*, an *Authorized User Fixed Term License (FTL)* and a *Floating License*. The best choice for your organization depends upon how many people use the product, how often they require access, and how you prefer to purchase your software.

Authorized User License

An IBM Rational Authorized User License permits a single, specific individual to use a Rational software product. Purchasers must obtain an Authorized User License for each individual user who accesses the product in any manner. An Authorized User License can not be reassigned unless the purchaser replaces the original assignee on a long-term or permanent basis.

Authorized User Fixed Term License

An IBM Rational Authorized User Fixed Term License (FTL) permits a single, specific individual to use a Rational software product for a specific length of time (the term). Purchasers must obtain an Authorized User FTL for each individual user who accesses the product in any manner. An Authorized User FTL can not be reassigned unless the purchaser replaces the original assignee on a long-term or permanent basis.

Floating license

An IBM Rational Floating License is a license for a single software product that can be shared among multiple team members; however, the total number of concurrent users can not exceed the number of floating licenses you purchase.

To use floating licenses, you must obtain floating license keys and install them on a Rational License Server. The server responds to end-user requests for access to the license keys; it will grant access to the number of concurrent users that matches the number of licenses the organization purchased.

License installation: Once you have obtained a license, invoke the IBM Installation Manager. The detailed steps to import a license are described in “Installing the license for Rational Application Developer” on page 1128.

Updates

Once Application Developer V7.5 has been installed, the Installation Manager provides an interface to update the product.

Important: Much of this book was researched and written using Application Developer v7.5.0 **iFix001**.

For more information, refer to the following link, which contains information on the latest fixes available for Application Developer:

<http://www.ibm.com/software/awdtools/developer/application/support/>

Refer to “Updating Rational Application Developer” on page 1129 for detailed instructions.

Uninstall

Application Developer v7.5 can be uninstalled interactively through the IBM Installation Manager.

Refer to “Uninstalling Rational Application Developer” on page 1129 for detailed instructions.

Migration and coexistence

This section highlights the Application Developer v7.5 migration features, and the coexistence and compatibility with Application Developer v6.0.x and v7.0.x.

Migration

Migration includes the migration of Application Developer v6.0.x and v7.0.x as well as Java EE projects and code assets.

What is new in Application Developer V7.5

- ▶ No more stealth auto-migration
 - A plug-in can determine if migration is required for a project
- ▶ New migration wizard
 - Displays projects and resources
 - Ensures resources are read-write
 - User has the option to not migrate all projects
 - Closes any projects which are not migrated

- Allows you to remove the server resources that are no longer required from the workspace
- Provides choices for migration of undefined server runtimes
- Displays messages for the user before migration begins
- ▶ New migration results verification tool
 - Runs automatically at completion of migration
 - Provides a view of the results

Forward migration from version 6.0.x or version 7.0.x:

- ▶ Open an old workspace in v7.5
- ▶ Import projects into vv7.5
- ▶ Check-out projects from a source code management system

Compatibility with previous versions

Application Developer v7.5 includes a compatibility option to facilitate sharing projects with Application Developer v7.0.x.

Projects can be shared with Application Developer v7.0.x developers through a SCM (such as Rational Team Concert or CVS) or using project interchange zip files.

Metadata and project structure are not updated to the new Application Developer format. A `.compatibility` file is added to projects and is used to track the timestamps of resources.

Compatibility support can be removed when finished developing in a mixed environment.

The compatibility feature can be accessed by selecting **Windows** → **Preferences** → **Backward Compatibility** (Figure 1-3).

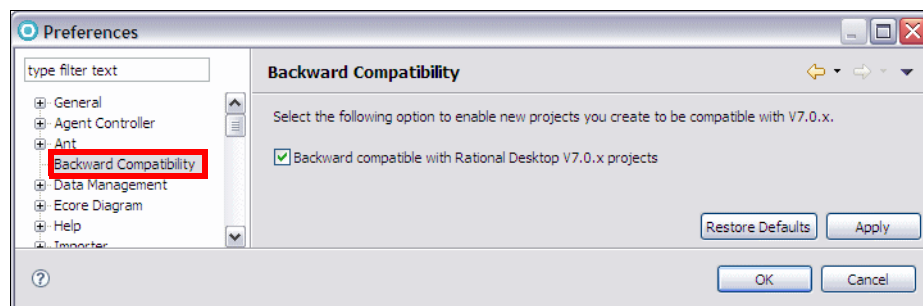

Figure 1-3 Backward compatibility feature

Sample code

The chapters are written so that you can follow along and create the code from scratch. In places where there is lots of typing involved, we have provided snippets of code to cut and paste.

Alternatively, you can import the completed sample code from a project interchange file. For details on the sample code (download, unpack, description, import interchange file, create databases), refer to Appendix B, “Additional material” on page 1149.

Summary

This chapter introduced the concepts behind Application Developer and gave an overview of the features of the various members of the Rational product suite, and where Application Developer fits with regard to the other products. A summary of the version numbers of the various features was given and the Installation Manager was introduced.



Programming technologies

This chapter describes a number of example application development scenarios, based on a simple banking application. Throughout these examples, we will review the Java and supporting technologies, as well as highlight the tooling provided by Application Developer V7.5, which can be used to facilitate implementing the programming technologies.

This chapter is organized into the following sections:

- ▶ Desktop applications
- ▶ Static Web sites
- ▶ Dynamic Web applications
- ▶ Enterprise JavaBeans and Java Persistence API (JPA)
- ▶ Java EE Application Clients
- ▶ Web services
- ▶ Messaging systems

Desktop applications

By *desktop applications* we mean applications in which the application runs on a single machine and the user interacts directly with the application using a user interface on the same machine.

When this idea is extended to include database access, some work might be performed by another process, possibly on another machine. Although this begins to move us into the client-server environment, the application is often only using the database as a service—the user interface, business logic, and control of flow are still contained within the desktop application. This contrasts with full client-server applications in which these elements are clearly separated and might be provided by different technologies running on different machines.

This type of application is the simplest type we will consider. Many of the technologies and tools involved in developing desktop applications, such as the Java editor and the XML tooling, are used widely throughout all aspects of Application Developer.

The first scenario deals with a situation in which a bank requires an application to allow workers in a bank call center to be able to view and update customer account information. We will call this the *Call Center Desktop*.

Simple desktop applications

A starting point for the Call Center Desktop might be a simple stand-alone application designed to run on desktop computers.

Java Platform, Standard Edition (Java SE) provides all the elements necessary to develop such applications. It includes, among other elements, a complete object-oriented programming language specification, a wide range of useful classes to speed development, and a runtime environment in which programs can be executed.

The complete Java SE specification can be found at:

<http://java.sun.com/javase/>

Java language

Java is a general purpose, object-oriented language. The basic language syntax is similar to C and C++, although there are significant differences. Java is a higher-level language than C or C++, in that the developer is presented with a more abstracted view of the underlying computer hardware and is not expected to take direct control of issues such as memory management. The compilation

process for Java does not produce directly executable binaries, but rather an intermediate byte code, which can be executed directly by a virtual machine or further processed by a just-in-time compiler at runtime to produce platform-specific binary output.

What is new in Java Platform, Standard Edition, Version 6.0

Version 6 of the Java Platform, Standard Edition, includes a bunch of useful new features. Here are the top 10 things you need to know about the release:

- ▶ **Web Services:** New support for writing XML Web service client applications. APIs can be exposed as .NET interoperable web services using annotation. Moreover, parsing and XML to Java object-mappings APIs, previously only available in the Java Web Services Pack and Java EE platform implementations, is now added to Java SE.
 - JSR 173 Streaming API for XML (StAX): Java based API for pull-parsing XML (<http://jcp.org/en/jsr/detail?id=173>).
 - JSR 181 Web Services Metadata: An annotated Java format to enable easy definition of Java Web Services in a Java EE container (<http://jcp.org/en/jsr/detail?id=181>).
 - JSR 222 Java Architecture for XML Binding (JAXB) 2.0: Next generation of the API that makes it easier to access XML documents from Java applications (<http://jcp.org/en/jsr/detail?id=222>).
 - JSR 224 Java API for XML-based Web Services (JAX-WS) 2.0: Next generation web services API replacing JAX-RPC 1.0 (<http://jcp.org/en/jsr/detail?id=224>).
- ▶ **Scripting:** JavaScript technology source code can now be mixed with normal Java source code. That may be useful for prototyping purpose.
 - JSR 223 Scripting for the Java Platform: Scripting language programs can access information developed in Java and allows to use scripting language pages in Java server-side applications (<http://jcp.org/en/jsr/detail?id=223>).
- ▶ **More Desktop APIs:** SwingWorker utility helps GUI developers with threading GUI applications, JTable got sorting, filtering and highlighting possibilities, and a new facility for quick splash screens to users.
- ▶ **Database:** JDK™ co-bundles the Java DB, a pure Java JDBC database, based on Apache Derby. JDBC 4.0 API was updated: It supports now XML as an SQL data type and integrates better Binary Large Objects (BLOBs) and Character Large Objects (CLOBs).
 - JSR 221 JDBC 4.0: Java application access to SQL stores (<http://jcp.org/en/jsr/detail?id=221>).

- ▶ **Monitoring and Management:** More diagnostic information are added and the memory-heap analysis tool *jhat* for forensic explorations of core dumps is included (<http://java.sun.com/javase/6/docs/technotes/tools/share/jhat.html>).
- ▶ **Compiler Access:** Java development tool and framework creators get a programmatic access to **javac** for in-process compilation of dynamically generated Java code.
 - JSR 199 Java Compiler API: Service provider that allows a Java program to select and invoke a Java Language Compiler programmatically (<http://jcp.org/en/jsr/detail?id=199>).
- ▶ **Pluggable Annotations:** It allows you to define your own annotations and gives you core support for plug-in and executing the processors.
 - JSR 269 Pluggable Annotation Processing API: Creating and processing of custom annotations (<http://jcp.org/en/jsr/detail?id=269>).
- ▶ **Desktop Deployment:** Better platform look-and-feel in Swing, LCD text rendering, higher GUI performance, better integration of native platforms, new access to the platform's system tray and start menu, and unification of Java Plug-in technology and Java WebStart engines.
- ▶ **Security:** XML Digital Signature API is added to create and manipulate digital signatures. Simplified access to native security services, such as native Public Key Infrastructure (PKI), cryptographic services on Microsoft Windows for secure authentication and communication, Java Generic Security Services (Java GSS), and Kerberos services for authentication, and access to LDAP servers.
 - JSR 105 XML Digital Signature APIs (XML-DSIG): Implementation of the W3C specification (<http://jcp.org/en/jsr/detail?id=105>).
- ▶ **Libraries (Quality, Compatibility, Stability):** Array relocation, new collection type Deque (double ended queue - a linear collection that supports element insertion and removal at both ends), sorted sets and maps with bidirectional navigation, new core IEEE754 (floating point) functions, new password prompting feature, and update of Java Class File specification.
 - JSR 202 Java Class File Specification Update: Increases class file size limits and adds split verification support (<http://jcp.org/en/jsr/detail?id=202>).

Java Virtual Machine

The Java Virtual Machine (JVM™) is a runtime environment designed for executing compiled Java byte code, contained in the `.class` files, which result from the compilation of Java source code. Several different types of JVM exist, ranging from simple interpreters to just-in-time compilers that dynamically translate byte code instructions to platform-specific instructions as required.

Requirements for the development environment

The developer of the Call Center Desktop should have access to a development tool, providing a range of features to enhance developer productivity:

- ▶ A specialized code editor, providing syntax highlighting.
- ▶ Assistance with completing code and correcting syntactical errors.
- ▶ Facilities for visualizing the relationships between the classes in the application.
- ▶ Assistance with documenting code.
- ▶ Automatic code review functionality to ensure that code is being developed according to recognized best practices.
- ▶ A simple way of testing applications.

Application Developer v7.5 provides developers with an integrated development environment with these features.

Database access

It is very likely that the Call Center Desktop will have to access data residing in a relational database, such as IBM DB2 Universal Database™.

Java SE 6.0 includes several integration technologies:

- ▶ JDBC is the Java standard technology for accessing data stores.
- ▶ Java Remote Method Invocation (RMI) is the standard way of enabling remote access to objects within Java.
- ▶ Java Naming and Directory Interface (JNDI) is the standard Java interface for naming and directory services.
- ▶ Java IDL is the Java implementation of the Interface Definition Language (IDL) for the Common Object Request Broker Architecture (CORBA), allowing Java programs to access objects hosted on CORBA servers.

We focus on the Java DataBase Connectivity (JDBC) technology in this section.

JDBC

Java SE 6.0 includes JDBC 4.0. The specification can be downloaded here:

<http://jcp.org/aboutJava/communityprocess/final/jsr221/index.html>

Although JDBC supports a wide range of data store types, it is most commonly used for accessing relational databases using SQL. Classes and interfaces are provided to simplify database programming, such as:

- ▶ `java.sql.DriverManager` and `javax.sql.DataSource` can be used to obtain a connection to a database system.
- ▶ `java.sql.Connection` represents the connection that an application has to a database system.
- ▶ `java.sql.Statement`, `PreparedStatement`, and `CallableStatement` represent executable statements that can be used to update or query the database.
- ▶ `java.sql.ResultSet` represents the values returned from a statement that has queried the database.
- ▶ Various types such as `java.sql.Date` and `java.sql.Blob` are Java representations of SQL data types that do not have a directly equivalent primitive type in Java.

Requirements for the development environment

The development environment should provide access to all the facilities of JDBC 4.0. However, because JDBC 4.0 is an integral part of Java SE 6.0, this requirement has already been covered in “Simple desktop applications” on page 26. In addition, the development environment should provide:

- ▶ A way of viewing information about the structure of an external database.
- ▶ A mechanism for viewing sample contents of tables.
- ▶ Facilities for importing structural information from a database server so that it can be used as part of the development process.
- ▶ Wizards and editors allowing databases, tables, columns, relationships, and constraints to be created or modified.
- ▶ A feature to allow databases created or modified in this way to be exported to an external database server.
- ▶ A wizard to help create and test SQL statements.

These features allow developers to develop test databases and work with production databases as part of the overall development process. They can also be used by database administrators to manage database systems, although they might prefer to use dedicated tools provided by the vendor of their database systems.

IBM Rational Application Developer v7.5 includes these features.

Graphical user interfaces

A further enhancement of the Call Center Desktop is to make the application easier to use by providing a graphical user interface (GUI).

Abstract Window Toolkit (AWT)

The Abstract Window Toolkit (AWT) is the original GUI toolkit for Java. It has been enhanced since it was originally introduced, but the basic structure remains the same. The AWT includes the following items:

- ▶ A wide range of user interface components, represented by Java classes such as [java.awt.] Frame, Button, Label, Menu, and TextArea.
- ▶ An event-handling model to deal with events such as button clicks, menu choices, and mouse operations.
- ▶ Classes to deal with graphics and image processing.
- ▶ Layout manager classes to help with positioning components in a GUI.
- ▶ Support for drag-and-drop functionality in GUI applications.

The AWT is implemented natively for each platform's JVM. AWT interfaces typically perform relatively quickly and have the same look-and-feel as the operating system, but the range of GUI components that can be used is limited to the lowest common denominator of operating system components, and the look-and-feel cannot be changed.

More information on the AWT can be found at:

<http://java.sun.com/javase/6/docs/technotes/guides/awt/>

Swing

Swing is a newer GUI component framework for Java. It provides Java implementations of the components in the AWT and adds a number of more sophisticated GUI components, such as tree views and list boxes. For the basic components, Swing implementations have the same name as the AWT component with a J prefix and a different package structure, for example, java.awt.Button becomes javax.swing.JButton in Swing.

Swing GUIs do not normally perform as quickly as AWT GUIs, but have a richer set of controls and have a pluggable look-and-feel.

More information on Swing can be found at:

<http://java.sun.com/javase/6/docs/technotes/guides/swing/>

Standard Widget Toolkit

The Standard Widget¹ Toolkit (SWT) is the GUI toolkit provided as part of the Eclipse Project and used to build the Eclipse GUI itself. The SWT is written entirely in Java and uses the Java Native Interface (JNI™) to pass the calls

¹ In the context of windowing systems, a widget is a reusable interface component, such as a menu, scroll bar, button, text box, or label.

through to the operating system where possible. This is done to avoid the *lowest common denominator* problem. The SWT uses native calls where they are available and builds the component in Java where they are not.

In many respects, the SWT provides the best of both worlds (AWT and Swing):

- ▶ It has a rich, portable component model, like Swing.
- ▶ It has the same look-and-feel as the native operating system, like the AWT.
- ▶ GUIs built using the SWT perform well, like the AWT, since most of the components simply pass through to operative system components.

A disadvantage of the SWT is that, unlike the AWT and Swing, it is not a standard part of Java SE V6.0. Consequently, any application that uses the SWT has to be installed along with the SWT class libraries. However, the SWT, like the rest of the components that make up Eclipse, is open source and freely distributable under the terms of the Common Public License.

More information on the SWT can be found at:

<http://www.eclipse.org/swt/>

Another popular technology based on SWT and Eclipse is the Eclipse Rich Client Platform. The architecture of Eclipse allows that its components can be used to create any kind of client applications.

More information about Eclipse RCP can be found here:

http://wiki.eclipse.org/index.php/Rich_Client_Platform

Java components providing a GUI

There are two types of Java components that might provide a GUI:

- ▶ Stand-alone Java applications: Launched in their own process (JVM). This category would include Java EE Application Clients, which we will come to later.
- ▶ Java applets: Normally run in a JVM provided by a Web browser or a Web browser plug-in.

An applet normally runs in a JVM with a very strict security model, by default. The applet is not allowed to access the file system of the machine on which it is running and can only make network connections back to the machine from which it was originally loaded. Consequently, applets are not normally suitable for applications that require access to databases, since this would require the database to reside on the same machine as the Web server. If the security restrictions are relaxed, as might be possible if the applet was being used only on a company intranet, this problem is not encountered.

An applet is downloaded on demand from the Web site that is hosting it. This gives an advantage in that the latest version is automatically downloaded each time it is requested, so distributing new versions is trivial. On the other hand, it also introduces disadvantages in that the applet will often be downloaded several times even if it has not changed, pointlessly using bandwidth, and the developer has little control over the environment in which the applet will run.

Requirements for the development environment

The development environment should provide a specialized editor that allows a developer to design GUIs using a variety of component frameworks (such as the AWT, Swing, or the SWT). The developer should be able to focus mainly on the visual aspects of the layout of the GUI, rather than the coding that lies behind it. Where necessary, the developer should be able to edit the generated code to add event-handling code and business logic calls. The editor should be dynamic, reflecting changes in the visual layout immediately in the generated code and changes in the code immediately in the visual display. The development environment should also provide facilities for testing visual components that make up a GUI, as well the entire GUI.

Note: Application Developer **v7.0.x** has a visual editor with this functionality included, however in Application Developer **v7.5** the tooling is **not** yet available.

Extensible Markup Language (XML)

Communication between computer systems is often difficult because different systems use different data formats for storing data. XML has become a common way of resolving this problem.

It can be desirable for the Call Center Desktop application to be able to exchange data with other applications. For example, we might want to be able to export tabular data so that it can be read into a spreadsheet application to produce a chart, or we might want to be able to read information about a group of transactions that can then be carried out as part of an overnight batch operation.

A convenient technology for exchanging information between applications is XML, which is a standard, simple, flexible way of exchanging data. The structure of the data is described in the XML document itself, and there are mechanisms for ensuring that the structure conforms to an agreed format—these are known as Document Type Definitions (DTDs) and XML schemas (XSDs).

XML is increasingly also being used to store configuration information for applications. For example, many aspects of Java EE 5 use XML for configuration files called *deployment descriptors*, and WebSphere Application Server V7.0 uses XML files for storing its configuration settings.

For more information on XML, see the home of XML—the World Wide Web Consortium (W3C) at:

<http://www.w3.org/XML/>

Using XML in Java code

Java SE 6.0 includes the Java API for XML Processing (JAXP). JAXP contains several elements:

- ▶ A parser interface based on the Document Object Model (DOM) from the W3C, which builds a complete internal representation of the XML document
- ▶ The Simple API for XML Parsing (SAX), which allows the document to be parsed dynamically using an event-driven approach
- ▶ XSL Transformations (XSLT), which uses Extensible Stylesheet Language (XSL) to describe how to transform XML documents from one form into another

Since JAXP is a standard part of Java SE V6.0, all these features are available in any Java code running in a JVM.

Requirements for the development environment

In addition to allowing developers to write code to create and parse XML documents, the development environment should provide features that allow developers to create and edit XML documents and related resources. In particular:

- ▶ An XML editor that checks the XML document for well-formedness (conformance with the structural requirements of XML) and for consistency with a DTD or XML Schema.
- ▶ Wizards for:
 - Creating XML documents from DTDs and XML schemas.
 - Creating DTDs and XML schemas from XML documents.
 - Converting between DTDs and XML schemas.
 - Generating JavaBeans to represent data stored in XML documents.
 - Creating XSL.
- ▶ An environment to test and debug XSL transformations.

Application Developer v7.5 includes all these features.

Static Web sites

A static Web site is one in which the content viewed by users accessing the site using a Web browser is determined only by the contents of the file system on the Web server machine. Because the user's experience is determined only by the content of these files and not by any action of the user or any business logic running on the server machine, the site is described as static.

In most cases, the communication protocol used for interacting with static Web sites is the Hypertext Transfer Protocol (HTTP).

In the context of our sample scenario, the bank might want to publish a static Web site in order to inform customers of bank services, such as branch locations and opening hours, and to inform potential customers of services provided by the bank, such as account interest rates. This kind of information can safely be provided statically, since it is the same for all visitors to the site and it changes infrequently.

Hypertext Transfer Protocol (HTTP)

HTTP follows a request/response model. A client sends an HTTP request to the server providing information about the request method being used, the requested Uniform Resource Identifier (URI), the protocol version being used, various other header information and often other details, such as details from a form completed on the Web browser. The server responds by returning an HTTP response consisting of a status line, including a success or error code, and other header information followed by the HyperText Markup Language (HTML) code for the static page requested by the client.

Full details of HTTP can be found at:

<http://www.w3.org/Protocols/>

Information on HTML can be found at:

<http://www.w3.org/html/>

Methods

HTTP 1.1 defines several request methods: GET, HEAD, POST, PUT, DELETE, OPTIONS, and TRACE. Of these, only GET and POST are commonly used in Web applications:

- ▶ GET requests are normally used in situations where the user has entered an address into the address or location field of a Web browser, used a bookmark or favorite stored by the browser, or followed a hyperlink within an HTML document.

- ▶ POST requests are normally used when the user has completed an HTML form displayed by the browser and has submitted the form for processing. This request type is most often used with dynamic Web applications, which include business logic for processing the values entered into the form.

Status codes

The status code returned by the server as the first line of the HTTP response indicates the outcome of the request. In the event of an error, this information can be used by the client to inform the user of the problem. In some situations, such as redirection to another URI, the browser will act on the response without any interaction from the user. The classes of status code are:

- ▶ 1xx: Information—The request has been received and processing is continuing.
- ▶ 2xx: Success—The request has been correctly received and processed; an HTML page accompanies a 2xx status code as the body of the response.
- ▶ 3xx: Redirection—The request did not contain all the information required or the browser needs to take the user to another URI.
- ▶ 4xx: Client error—The request was incorrectly formed or could not be fulfilled.
- ▶ 5xx: Server error—Although the request was valid, the server failed to fulfill it.

The most common status code is 200 (OK), although 404 (Not Found) is very commonly encountered. A complete list of status codes can be found at the W3C site mentioned above.

Cookies

Cookies are a general mechanism that server-side connections can use to both store and retrieve information on the client side of the connection. Cookies can contain any piece of textual information, within an overall size limit per cookie of 4 kilobytes. Cookies have the following attributes:

- ▶ Name: The name of the cookie.
- ▶ Value: The data that the server wants passed back to it when a browser requests another page.
- ▶ Domain: The address of the server that sent the cookie and that receives a copy of this cookie when the browser requests a file from that server. The domain can be set to equal the subdomain that contains the server so that multiple servers in the same subdomain receive the cookie from the browser.
- ▶ Path: Used to specify the subset of URLs in a domain for which the cookie is valid.
- ▶ Expires: Specifies a date string that defines the valid lifetime of that cookie.

- ▶ Secure: Specifies that the cookie is only sent if HTTP communication is taking place over a secure channel (known as HTTPS).

A cookie's life cycle proceeds as follows:

- ▶ The user gets connected to a server that wants to record a cookie.
- ▶ The server sends the name and the value of the cookie in the HTTP response.
- ▶ The browser receives the cookie and stores it.
- ▶ Every time the user sends a request for a URL at the designated domain, the browser sends any cookies for that domain that have not expired with the HTTP request.
- ▶ Once the expiration date has been passed, the cookie crumbles.

Non-persistent cookies are created without an expiry date—they will only last for the duration of the user's browser session. Persistent cookies are set once and remain on the user's hard drive until the expiration date of the cookie. Cookies are widely used in dynamic Web applications, which we address later in this chapter, for associating a user with server-side state information.

More information on cookies can be found at:

<http://www.cookiecentral.com/faq>

HyperText Markup Language (HTML)

HTML is a language for publishing hypertext on the Web. HTML uses tags to structure text into headings, paragraphs, lists, hypertext links, and so forth. Table 2-1 lists some of the basic HTML tags.

Table 2-1 Some basic HTML tags

Tag	Description
<html>	Tells the browser that the following text is marked up in HTML. The closing tag </html> is required and is the last tag in your document.
<head>	Defines information for the browser that might or might not be displayed to the user. Tags that belong in the <head> section are <title>, <meta>, <script>, and <style>. The closing tag </head> is required.
<title>	Displays the title of your Web page, and is usually displayed by the browser at the top of the browser pane. The closing tag </title> is required.
<body>	Defines the primary portion of the Web page. Attributes of the <body> tag enables setting of the background color, the text color, the link color, and the active and visited link colors. The closing tag </body> is required.

Cascading style sheets (CSS)

Although Web developers can use HTML tags to specify styling attributes, the best practice is to use a cascading style sheet (CSS). A CSS file defines a hierarchical set of style rules that the creator of an HTML (or XML) file uses in order to control how that page is rendered in a browser or viewer, or how it is printed.

CSS allows for separation of presentation content of documents from the content of documents. A CSS file can be referenced by an entire Web site to provide continuity to titles, fonts, and colors.

Below is a rule for setting the H2 elements to the color red. Rules are made up of two parts: *Selector* and *declaration*. The selector (H2) is the link between the HTML document and the style sheet, and all HTML element types are possible selectors. The declaration has two parts: Property (color) and value (red):

```
H2 { color: red }
```

More information on CSS can be found at:

<http://www.w3.org/Style/CSS/>

Requirements for the development environment

The development environment should provide:

- ▶ An editor for HTML pages, providing WYSIWYG (*what you see is what you get*), HTML code, and preview (browser) views to assist HTML page designers.
- ▶ A CSS editor.
- ▶ A view showing the overall structure of a site as it is being designed.
- ▶ A built-in Web server and browser to allow Web sites to be tested.

IBM Rational Application Developer v7.5 provides all of these features.

Dynamic Web applications

By *Web applications* we mean applications that are accessed using HTTP (Hypertext Transfer Protocol), usually using a Web browser as the client-side user interface to the application. The flow of control logic, business logic, and generation of the Web pages for the Web browser are all handled by software running on a server machine. Many different technologies exist for developing this type of application, but we will focus on the Java technologies that are relevant in this area.

Because the technologies are based on Java, most of the features discussed in , “Desktop applications” on page 26, are relevant here as well (the GUI features are less significant). In this section we focus on the additional features required for developing Web applications.

In the context of our example banking application, thus far we have provided workers in the bank’s call center with a desktop application to allow them to view and update account information and members of the Web browsing public with information about the bank and its services. We will now move into the Internet banking Web application, called *RedBank* in this document. We want to extend the system to allow bank customers to access their account information online, such as balances and statements, and to perform some transactions, such as transferring money between accounts and paying bills.

Simple Web applications

The simplest way of providing Web-accessible applications using Java is to use Java servlets and JavaServer Pages (JSPs). These technologies form part of the Java Enterprise Edition (Java EE), although they can also be implemented in systems that do not conform to the Java EE specification, such as Apache Jakarta Tomcat:

<http://jakarta.apache.org/tomcat/>

Information on these technologies (including specifications) can be found at the following locations:

- ▶ Servlets:

<http://java.sun.com/products/servlet/>

- ▶ JSPs:

<http://java.sun.com/products/jsp/>

In this book we discuss Java EE 5, because this is the version supported by Application Developer v7.5 and IBM WebSphere Application Server v7.0. Java EE 5 supports Servlet 2.5 and JSP 2.1 specifications. Full details of Java EE 5 can be found at:

<http://java.sun.com/javaee/>

Servlets

A *servlet* is a Java class that is managed by server software known as a *Web container* (sometimes referred to as a *servlets container* or *servlets engine*). The purpose of a servlet is to read information from an HTTP request, perform some processing, and generate some dynamic content to be returned to the client in an HTTP response.

The Servlet Application Programming Interface includes a class, `javax.servlet.http.HttpServlet`, which can be subclassed by a developer. The developer needs to override methods such as the following to handle different types of HTTP requests (in these cases, POST and GET requests; other methods are also supported):

```
public void doPost (HttpServletRequest request, HttpServletResponse response)
public void doGet (HttpServletRequest request, HttpServletResponse response)
```

When a HTTP request is received by the Web container, it consults a configuration file, known as a *deployment descriptor*, to establish which servlets class corresponds to the URL provided. If the class is already loaded in the Web container and an instance has been created and initialized, the Web container invokes a standard method on the servlets class:

```
public void service (HttpServletRequest request, HttpServletResponse response)
```

The `service` method, which is inherited from `HttpServlet`, examines the HTTP request type and delegates processing to the `doPost` or `doGet` method as appropriate. One of the responsibilities of the Web container is to package the HTTP request received from the client as an `HttpServletRequest` object and to create an `HttpServletResponse` object to represent the HTTP response that will ultimately be returned to the client.

Within the `doPost` or `doGet` method, the servlet developer can use the wide range of features available within Java, such as database access, messaging systems, connectors to other systems, or Enterprise JavaBeans.

If the servlet has not already been loaded, instantiated, and initialized, the Web container is responsible for carrying out these tasks. The initialization step is performed by executing the method:

```
public void init ()
```

And there is a corresponding method:

```
public void destroy ()
```

This is called when the servlet is being unloaded from the Web container.

Within the code for the `doPost` and `doGet` methods, the usual processing pattern is:

- ▶ Read information from the request. This often includes reading cookie information and getting parameters that correspond to fields in an HTML form.
- ▶ Check that the user is in the appropriate state to perform the requested action.
- ▶ Delegate processing of the request to the appropriate type of business object.

- ▶ Update the user's state information.
- ▶ Dynamically generate the content to be returned to the client.

The last step could be carried out directly in the servlet code by writing HTML to a `PrintWriter` object obtained from the `HttpServletResponse` object:

```
PrintWriter out = response.getWriter();
out.println("<html><head><title>Page title</title></head>");
out.println("<body>The page content:");
// .....
```

This approach is not recommended, because the embedding of HTML within the Java code means that HTML page design tools, such as those provided by Rational Application Developer, cannot be used. It also means that development roles cannot easily be separated—Java developers must maintain HTML code. The best practice is to use a dedicated display technology, such as JSP, covered next.

The Servlet 2.5 specification introduces the following changes:

- ▶ Dependency on Java SE 5.0—Java SE 5.0 is the minimum platform requirement (because of annotations).
- ▶ Support for annotations—Annotations can be used as an alternative to XML entries which would otherwise go in the `web.xml` deployment descriptor or they can act as requests for the container to perform tasks that otherwise the servlet would have to perform itself.
- ▶ `web.xml` conveniences—Several changes in the file format of `web.xml` deployment descriptor to make its use more convenient, like servlet name wild carding or multiple patterns in mappings.
- ▶ Removed restrictions—Few restrictions around error handling and session tracking have been removed. Error pages are now allowed to call `setStatus()` to alter the error code that triggered them. Included servlets can now call `request.getSession()`, which might implicitly create a session-tracking cookie header. This change is important for the Portlet specification.
- ▶ Clarifications—Several edge cases were clarified to make servlets more portable and guaranteed to work as desired.

JavaServer Pages (JSPs)

JSPs provide a server-side scripting technology that enables Java code to be embedded within Web pages, so JSPs have the appearance of HTML or XML pages with embedded Java code. When the page is executed, the Java code can generate dynamic content to appear in the resulting Web page. JSPs are compiled at runtime into servlets that execute to generate the resulting HTML or XML. Subsequent calls to the same JSP simply execute the compiled servlet.

JSP scripting elements (some of which are shown in Table 2-2) are used to control the page compilation process, create and access objects, define methods, and manage the flow of control.

Table 2-2 Examples of JSP scripting elements

Element	Meaning
Directive	Instructions that are processed by the JSP engine when the page is compiled to a servlet <code><%@ ... %></code> or <code><jsp:directive.page ... /></code>
Declaration	Allows variables and methods to be declared <code><%! ... %></code> or <code><jsp:declaration> ... </jsp:declaration></code>
Expression®	Java expressions, which are evaluated, converted to a String and entered into the HTML <code><%= ... %></code> or <code><jsp:expression ... /></code>
Scriptlet	Blocks of Java code embedded within a JSP <code><% ... %></code> or <code><jsp:scriptlet> ... </jsp:scriptlet></code>
Use bean	Retrieves an object from a particular scope or creates an object and puts it into a specified scope <code><jsp:useBean ... /></code>
Get property	Calls a getter method on a bean, converts the result to a String, and places it in the output <code><jsp:getProperty ... /></code>
Set property	Calls a setter method on a bean <code><jsp:setProperty ... /></code>
Include	Includes content from another page or resource <code><jsp:include ... /></code>
Forward	Forwards the request processing to another URL <code><jsp:forward ... /></code>

The JSP scripting elements can be extended, using a technology known as *tag extensions* (or *custom tags*), to allow the developer to make up new tags and associate them with code that can carry out a wide range of tasks in Java. Tag extensions are grouped in *tag libraries*, which we will discuss shortly.

Some of the standard JSP tags are only provided in an XML-compliant version, such as `<jsp:useBean ... />`. Others are available in both traditional form (for example, `<%= ... %>` for JSP expressions) or XML-compliant form (for example, `<jsp:expression ... />`). These XML-compliant versions have been introduced in order to allow JSPs to be validated using XML validators.

JSPs generate HTML output by default—the Multipurpose Internet Mail Extensions (MIME) type is `text/html`. It might be desirable to produce XML (`text/xml`) instead in some situations. For example, a developer might want to produce XML output, which can then be converted to HTML for Web browsers, Wireless Markup Language (WML) for wireless devices, or VoiceXML for systems with a voice interface. Servlets can also produce XML output in this way—the content type being returned is set using a method on the `HttpServletResponse` object.

The JSP 2.1 specification defines new annotations for dependency injection on JSP tag handlers and context listeners. Moreover, the Unified Expression Language (EL) got some key additions:

- ▶ A pluggable API for resolving variable references into Java objects and for resolving the properties applied to these Java objects.
- ▶ Support for deferred expressions, which may be evaluated by a tag handler when needed.
- ▶ Support for `lvalue` expression. An EL expression used as an `lvalue` represents a reference to a data structure.

Tag libraries

Tag libraries are a standard way of packaging tag extensions for applications using JSPs.

Tag extensions address the problem that arises when a developer wishes to use non-trivial processing logic within a JSP. Java code can be embedded directly in the JSP using the standard tags described above. This mixture of HTML and Java makes it difficult to separate development responsibilities (the HTML/JSP designer has to maintain the Java code) and makes it hard to use appropriate tools for the tasks in hand (a page design tool will not provide the same level of support for Java development as a Java development tool). This is essentially the reverse of the problem described when discussing servlets above. To address this problem, developers have documented the *View Helper* design pattern, as described in *Core J2EE Patterns: Best Practices and Design Strategies* by Crupi, et al. The pattern catalog contained in this book is also available at:

<http://java.sun.com/blueprints/corej2eepatterns>

Tag extensions are the standard way of implementing View Helpers for JSPs. Using tag extensions, a Java developer can create a class that implements some view-related logic. This class can be associated with a particular JSP tag using a tag library descriptor (TLD). The TLD can be included in a Web application, and the tag extensions defined within it can then be used in JSPs. The JSP designer can use these tags in exactly the same way as other (standard) JSP tags. The JSP specification includes classes that can be used as a basis for tag extensions

and a simplified mechanism for defining tag extensions that does not require detailed knowledge of Java.

Many convenient tags are provided in the JSP Standard Tag Library (JSTL), which actually includes several tag libraries:

- ▶ Core tags: Flow control (such as loops and conditional statements) and various general purpose actions.
- ▶ XML tags: Allow basic XML processing within a JSP.
- ▶ Formatting tags: Internationalized data formatting.
- ▶ SQL tags: Database access for querying and updating.
- ▶ Function tags: Various string handling functions.

Tag libraries are also available from other sources, such as those from the Jakarta Taglibs Project (<http://jakarta.apache.org/taglibs/>), and it is also possible to develop tag libraries yourself.

Expression Language

Expression Language (EL) was originally developed as part of the JSTL, but it is now a standard part of JSP (from V2.0). EL provides a standard way of writing expressions within a JSP using implicit variables, objects available in the various scopes within a JSP and standard operators. EL is defined within the JSP V2.0 specification.

Filters

Filters are objects that can transform a request or modify a response. They can process the request before it reaches a servlet, and/or process the response leaving a servlet before it is finally returned to the client. A filter can examine a request before a servlet is called and can modify the request and response headers and data by providing a customized version of the request or response object that wraps the real request or response. The deployment descriptor for a Web application is used to configure specific filters for particular servlets or JSPs. Filters can also be linked together in chains.

Life cycle listeners

Life cycle events enable listener objects to be notified when servlet contexts and sessions are initialized and destroyed, as well as when attributes are added or removed from a context or session.

Any listener interested in observing the `ServletContext` life cycle can implement the `ServletContextListener` interface, which has two methods, `contextInitialized` (called when an application is first ready to serve requests) and `contextDestroyed` (called when an application is about to shut down).

A listener interested in observing the `ServletContext` attribute life cycle can implement the `ServletContextAttributesListener` interface, which has three methods, `attributeAdded` (called when an attribute is added to the `ServletContext`), `attributeRemoved` (called when an attribute is removed from the `ServletContext`), and `attributeReplaced` (called when an attribute is replaced by another attribute in the `ServletContext`).

Similar listener interfaces exist for `HttpSession` and `ServletRequest` objects:

- ▶ `javax.servlet.http.HttpSessionListener`: `HttpSession` life cycle events.
- ▶ `javax.servlet.HttpSessionAttributeListener`: Attributes events on an `HttpSession`.
- ▶ `javax.servlet.HttpSessionActivationListener`: Activation or passivation of an `HttpSession`.
- ▶ `javax.servlet.HttpSessionBindingListener`: Object binding on an `HttpSession`.
- ▶ `javax.servlet.ServletRequestListener`: Processing of a `ServletRequest` has begun.
- ▶ `javax.servlet.ServletRequestAttributeListener`: Attribute events on a `ServletRequest`.

Requirements for the development environment

The development environment should provide:

- ▶ Wizards for creating servlets, JSPs, listeners, filters, and tag extensions.
- ▶ An editor for JSPs that enables the developer to use all the features of JSP in an intuitive way, focussing mainly on page design.
- ▶ An editor for Web deployment descriptors allowing these components to be configured.
- ▶ Validators to ensure that all the technologies are being used correctly.
- ▶ A test environment that allows dynamic Web applications to be tested and debugged.

Application Developer v7.5 includes all these features.

Figure 2-1 shows the interaction between the Web components and a relational database, as well as the desktop application discussed in “Desktop applications” on page 26.

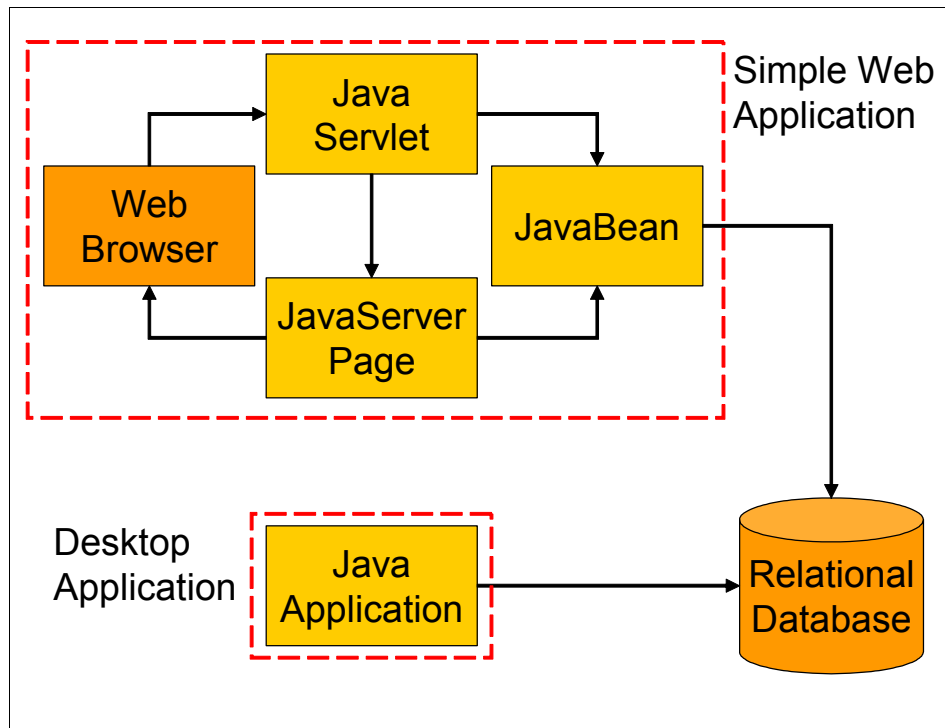

Figure 2-1 Simple Web application

Struts

The model-view-controller (MVC) architecture pattern is used widely in object-oriented systems as a way of dividing applications into sections with well-defined responsibilities:

- ▶ **Model:** Manages the application domain's concepts, both behavior and state. It responds to requests for information about its state and responds to instructions to change its state.
- ▶ **View:** Implements the rendering of the model, displaying the results of processing for the use, and manages user input.
- ▶ **Controller:** Receives user input events, determines which action is necessary, and delegates processing to the appropriate model objects.

In dynamic Web applications, the servlet normally fills the role of *controller*, the JSP fills the role of *view* and various components, and JavaBeans or Enterprise JavaBeans fill the role of *model*. The MVC pattern and Struts are described in Chapter 15, "Develop Web applications using Struts" on page 445.

In the context of our banking scenario, this technology does not relate to any change in functionality from the user's point of view. The problem being addressed here is that, although many developers might want to use the MVC pattern, Java EE 5 does not provide a standard way of implementing it. The developers of the RedBank Web application want to design their application according to the MVC pattern, but do not want to have to build everything from the ground up.

Struts was introduced as a way of providing developers with an MVC framework for applications using the Java Web technologies—servlets and JSPs. Complete information on Struts is available at:

<http://struts.apache.org/>

Struts provides a controller servlets, called `ActionServlet`, which acts as the entry point for any Struts application. When the `ActionServlet` receives a request, it uses the URL to determine the requested action and uses an `ActionMapping` object, created when the application starts up, based on information in an XML file called `struts-config.xml`. From this `ActionMapping` object, the Struts `ActionServlet` determines the action-derived class that is expected to handle the request.

The `Action` object is then invoked to perform the required processing. This `Action` object is provided by the developer using Struts to create a Web application and can use any convenient technology for processing the request. The `Action` object is the route into the model for the application. Once processing has been completed, the `Action` object can indicate what should happen next—the `ActionServlet` uses this information to select the appropriate response agent (normally a JSP) to generate the dynamic content to be sent back to the user. The JSP represents the view for the application.

Struts provides other features, such as form beans, to represent data entered into HTML forms and JSP tag extensions to facilitate Struts JSP development.

Requirements for the development environment

Because Struts applications are also Web applications, all the functionality described in “Simple Web applications” on page 39, is relevant in this context as well. In addition, the development environment should provide:

- ▶ Wizards to create:
 - A Struts and Tiles enabled dynamic Web application
 - A new Struts `Action` class and corresponding `ActionMapping`
 - A new `ActionForm` bean
 - A new Struts exception type
 - A new Struts module

- ▶ An editor to modify the `struts-config.xml` file.
- ▶ A graphical editor to display and modify the relationship between Struts elements, such as actions, action forms, and view components.

In addition, the basic Web application tools should be Struts-aware. The wizard for creating Web applications should include a simple mechanism for adding Struts support, and the wizard for creating JSPs should offer to add the necessary Struts tag libraries.

IBM Rational Application Developer v7.5 provides all of these features.

Figure 2-1 on page 46 still represents the structure of a Web application using Struts. Although Struts provides us with a framework on which we can build our own applications, the technology is still the same as for basic Web applications.

JavaServer Faces (JSF) and persistence using SDO or JPA

When we build a GUI using stand-alone Java applications, we can include event-handling code, so that when UI events take place they can be used immediately to perform business logic processing or update the UI. Users are familiar with this type of behavior in desktop applications, but the nature of Web applications has made this difficult to achieve using a browser-based interface; the user interface provided through HTML is limited, and the request-response style of HTTP does not naturally lead to flexible, event-driven user interfaces.

Many applications require access to data, and there is often a requirement to be able to represent this data in an object-oriented way within applications. Many tools and frameworks exist for mapping between data and objects, but often these are proprietary or excessively heavy weight systems.

In the RedBank Web application we want to make the user interface richer, while still allowing us to use the MVC architecture described in “Struts” on page 46. In addition, our developers want a simple, lightweight, object-oriented database access system, which will remove the need for direct JDBC coding.

JavaServer Faces (JSF)

JavaServer Faces 1.2 is a framework for developing Java Web applications. The JSF framework aims to unify techniques for solving a number of common problems in Web application design and development, such as:

- ▶ **User interface development:** JSF allows direct binding of user interface (UI) components to model data. It abstracts request processing into an event-driven model. Developers can use extensive libraries of prebuilt UI components that provide both basic and advanced Web functionality.

- ▶ **Navigation:** JSF introduces a layer of separation between business logic and the resulting UI pages; stand-alone flexible rules drive the flow of pages.
- ▶ **Session and object management:** JSF manages designated model data objects by handling their initialization, persistence over the request cycle, and cleanup.
- ▶ **Validation and error feedback:** JSF allows direct binding of reusable validators to UI components. The framework also provides a queue mechanism to simplify error and message feedback to the application user. These messages can be associated with specific UI components.
- ▶ **Internationalization:** JSF provides tools for internationalizing Web applications, supporting number, currency, time, and date formatting, and externalizing of UI strings. JSF is easily extended in a variety of ways to suit the requirements of your particular application. You can develop custom components, renderers, validators, and other JSF objects and register them with the JSF runtime.

More information about JSF framework can be found here:

<http://java.sun.com/javaee/javaxserverfaces/>

Service Data Objects (SDO)

SDO is a data programming architecture and API for the Java platform that unifies data programming across data source types; provides robust support for common application patterns; and enables applications, tools, and frameworks to more easily query, view, bind, update, and introspect data.

SDO was originally developed by IBM and BEA Systems and is now the subject of a Java specification request (JSR 235), but has not yet been standardized under this process.

SDOs are designed to simplify and unify the way in which applications handle data. Using SDO, application programmers can uniformly access and manipulate data from heterogeneous data sources, including relational databases, XML data sources, Web services, and enterprise information systems.

The SDO architecture consists of three major components:

- ▶ **Data object:** The data object is designed to be an easy way for a Java programmer to access, traverse, and update structured data. Data objects have a rich variety of strongly and loosely typed interfaces for querying and updating properties. This enables a simple programming model without sacrificing the dynamic model required by tools and frameworks. A data object can also be a composite of other data objects.
- ▶ **Data graph:** SDO is based on the concept of disconnected data graphs. A data graph is a collection of tree-structured or graph-structured data objects.

Under the disconnected data graphs architecture, a client retrieves a data graph from a data source, mutates the data graph, and can then apply the data graph changes to the data source. The data graph also contains some meta data about the data object, including change summary and meta data information. The meta data API allows applications, tools, and frameworks to introspect the data model for a data graph, enabling applications to handle data from heterogeneous data sources in a uniform way.

- ▶ **Data mediator:** The task of connecting applications to data sources is performed by a data mediator. Client applications query a data mediator and get a data graph in response. Client applications send an updated data graph to a data mediator to have the updates applied to the original data source. This architecture allows applications to deal principally with data graphs and data objects, providing a layer of abstraction between the business data and the data source.

More information about SDO can be found here:

<http://www.osoa.org/display/Main/Service+Data+Objects+Home>

Requirements for the development environment

The development environment should provide tooling to create and edit pages based on JSF, to modify the configuration files for JSF applications, and to test them. For SDO, the development environment should provide wizards to create SDOs from an existing database (bottom-up mapping) and should make it easy to use the resulting objects in JSF and other applications.

IBM Rational Application Developer v7.5 includes these features.

Figure 2-2 shows how JSF and SDO can be used to create a flexible, powerful MVC-based Web application with simple database access.

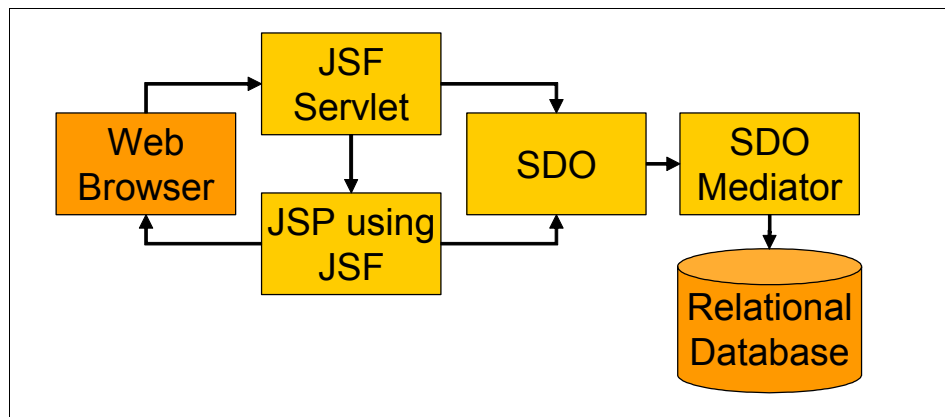

Figure 2-2 JSF and SDO

JSF and Java Persistence API (JPA)

Application Developer v7.5 provides comprehensive tooling to develop JSF applications that use JPA for persistence in relational databases.

Refer to Chapter 12, “Persistence using the Java Persistence API (JPA)” on page 267 for information about JPA, and Chapter 16, “Develop Web applications using JSF” on page 493 for an example of a JSF application with JPA.

Web 2.0 Development

IBM Rational Application Developer v7.5 comes with features to aid the development of responsive Rich Internet Applications.

More information about Web 2.0 development can be found in the redbook *Building Dynamic Ajax Applications Using WebSphere Feature Pack for Web 2.0*, SG24-7635.

Ajax

Ajax is an acronym that stands for Asynchronous JavaScript and XML. Ajax is a Web 2.0 development technique used for creating interactive Web applications. The intent is to make Web pages feel more responsive by exchanging small amounts of data with the server behind the scenes. Technically, in order to send and process a request to the server-side, the Web page will not require a reload. JavaScript is utilized to gather DOM values on the page and data is transmitted from the browser to the server through the XMLHttpRequest object.

Figure 2-3 illustrates the overall Ajax interaction between the client browser and the server-side application. The generic sequence of steps that get executed on a typically Ajax submission are:

- ▶ **JavaScript functional invocation**—Typically, when a Ajax call takes place, the first step is to emulate what typically happens in a synchronous GET or POST. That is, collect the information from the page that is necessary for processing the server-side request. In the case of Ajax, the collection of these values occurs through a JavaScript function (and retrieves DOM values).
- ▶ **XMLHttpRequest.send**—Once we have collected all the necessary information from the DOM, a JavaScript object is created and eventually stores all the collected DOM values. In Mozilla-based browsers, this JavaScript object is a XMLHttpRequest object. Once fully configured, the XMLHttpRequest object is sent to the server-side via HTTP Request.

- ▶ **Server-side processing**—Assuming that the application is based on Java EE, from a Web tier, the Ajax request can either be handled by one of the following Web technologies: Servlet, JSF or Portlet. Once received, the Ajax request from the server-side will continue to execute as usual (accessing a data store, executing business logic, and so forth).
- ▶ **XML response**—Once the server completes processing, the resulting data is returned in a response, typically in XML format.
- ▶ **XMLHttpRequest.callback**—The callback function processes the response. As part of the response, JavaScript function would have to take the response values and update the page (by changing/updating DOM values).

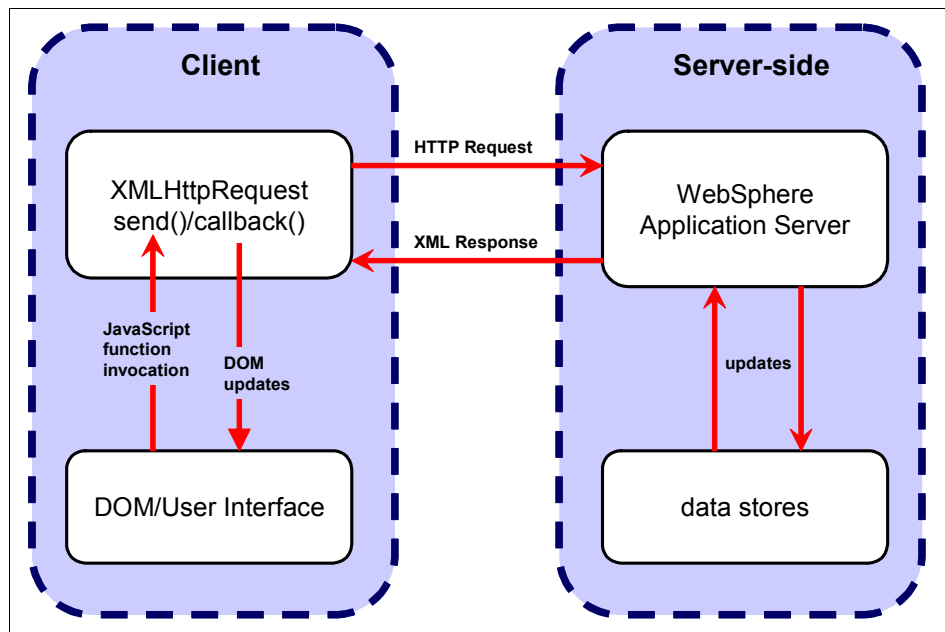

Figure 2-3 Ajax overview

More information about Ajax can be found here:

<http://www.ibm.com/developerworks/ajax>

Application Developer v7.5 supports Ajax development with DOJO Toolkit and IBM extensions.

Information about the DOJO Toolkit are here:

<http://www.dojotoolkit.org>

REST (Representational State Transfer)

Roy Thomas Fielding describes REST in a dissertation as a collection of architecture principles and a software architecture style to build network-enabled systems which define and access resources. It is often used like a framework to transmit data over a protocol such as HTTP without adding additional semantic layers or session management.

REST defines a strict separation of concerns between components that participate in a client-server system that simplifies the implementation of actors involved. REST also strives to simplify communication semantics in a network system to increase scalability and improve performance. REST relies on autonomous requests, between participants in a message exchange which implies that requests must include all information that a client or server requires to understand the context of the request. In a REST-based system, you use minimal sets of possible requests to exchange standard media types.

The REST principle uses uniform resource identifiers (URIs) to locate and access a given representation of a resource. The resource representation, known as representational state, can be created, retrieved, modified, or deleted.

One of the defining principles of REST is that it can exploit existing technologies, standards, and protocols pertaining to the Web, such as HTTP. This reliance on existing technologies and protocols makes REST easier to learn and simpler to use than most other Web-based messaging standards, because little additional overhead is required to enable effective information exchange.

A REST-based conversation operates within stateless conversations, thereby making it a prime facilitator for subscription-based technologies, such as RSS, RDF, OWL, and Atom, in which content is delivered to pre-subscribed clients.

Roy Thomas Fielding's dissertation *Architectural Styles and the Design of Network-based Software Architectures* can be found here:

http://www.ics.uci.edu/~fielding/pubs/dissertation/fielding_dissertation.pdf

Application Developer v7.5 includes the tooling to create REST services to access server-side artifacts through Web remote interfaces and to integrate Atom and RSS feeds.

JSON (JavaScript Object Notation)

JSON is a lightweight data-interchange format. It is easy for humans to read and write and for machines to parse and generate. It is based on a subset of the JavaScript Programming Language and is built on two structures: A collection of name/value pairs and an ordered list of values.

Further information is available at: <http://www.json.org>

Portal applications

Portal applications run on a Portal Server and consist of portal pages that are composed of portlets. Portlets can share and exchange resources and information to provide a seamless Web interface.

Portal applications have several important features:

- ▶ They can collect content from a variety of sources and present them to the user in a single unified format.
- ▶ The presentation can be personalized so that each user sees a view based on their own characteristics or role.
- ▶ The presentation can be customized by the user to fulfill their specific needs.
- ▶ They can provide collaboration tools, which allow teams to work in a virtual office.
- ▶ They can provide content to a range of devices, formatting and selecting the content appropriately according to the capabilities of the device.

In the context of our sample scenario, we can use a portal application to enhance the user experience. The RedBank Web application can be integrated with the static Web content providing information about branches and bank services. If the customer has credit cards, mortgages, personal loans, savings accounts, shares, insurance, or other products provided by the bank or business partners, these could also be seamlessly integrated into the same user interface, providing the customer with a convenient single point of entry to all these services.

The content of these applications can be provided from a variety of sources, with the portal server application collecting the content and presenting it to the user. The user can customize the interface to display only the required components, and the content can be varied to allow the customer to connect using a Web browser, a personal digital assistant (PDA), or mobile phone.

Within the bank, the portal can also be used to provide convenient intranet facilities for employees. Sales staff can use a portal to receive information on the latest products and special offers, information from human resources, leads from colleagues, and so on.

IBM WebSphere Portal

WebSphere Portal runs on top of WebSphere Application Server, using the Java EE standard services and management capabilities of the server as the basis for portal services. WebSphere Portal provides its own deployment, configuration, administration, and communication features.

Java Portlet specification

Based on its history there are different Portlet specifications in use:

- ▶ **IBM Portlet API**—The IBM Portlet API is being deprecated for WebSphere Portal v6.0, but still supported. No new functionality will be added and its recommended you use the Standard Portlet API.
(<http://publib.boulder.ibm.com/infocenter/wpdoc/v6r0>)
- ▶ **JSR 168 Portlet Specification**—Defines a set of APIs for Portal computing addressing the areas of aggregation, personalization, presentation and security. (<http://www.jcp.org/en/jsr/detail?id=168>)
- ▶ **JSR 286 Portlet Specification 2.0**—Since its release in 2003, JSR 168 has gone through many real-life tests in portal development and deployment. Gaps identified by the community take time to evolve and become available to the public as a standard. Meanwhile, many portal vendors have been filling those gaps with their own custom solutions, which unfortunately cause portlets to be not portable. That is the main reason for a new standard.
(<http://www.jcp.org/en/jsr/detail?id=286>)

Requirements for the development environment

The development environment should provide wizards for creating portal applications and the associated components and configuration files, as well as editors for all these files. A test environment should be provided to allow portal applications to be executed and debugged.

Application Developer v7.5 includes the required tooling and is compatible with WebSphere Portal v6.0 and v6.1 unit test environments.

Figure 2-4 shows how portal applications fit in with other technologies mentioned in this chapter.

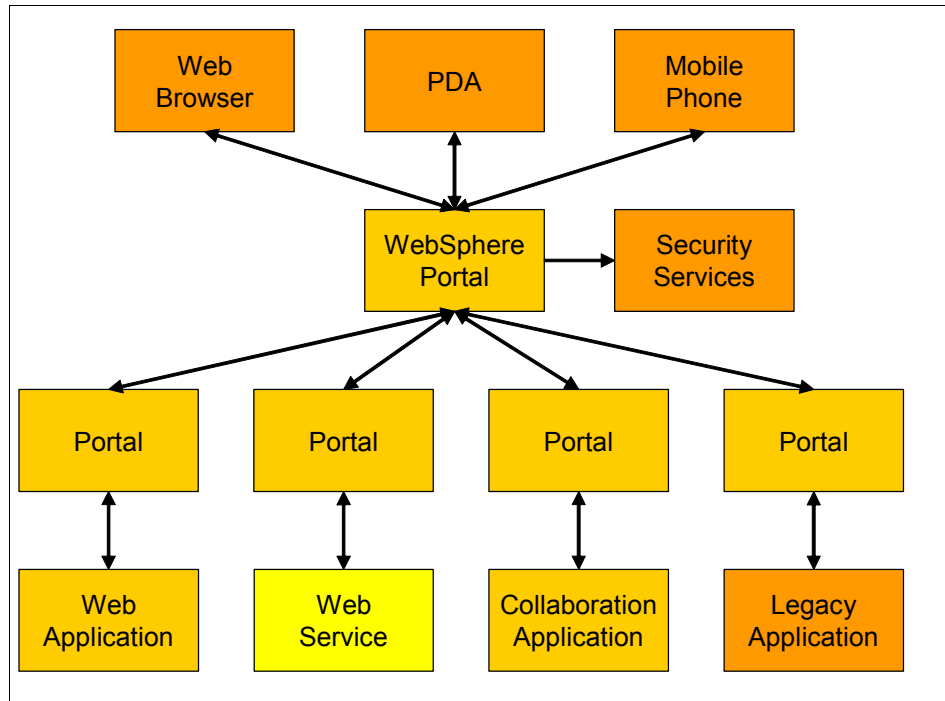

Figure 2-4 Portal applications

Enterprise JavaBeans and Java Persistence API (JPA)

Now that the RedBank Web application is up and running, more issues arise. Some of these relate to the services provided to customers and bank workers and some relate to the design, configuration, and functionality of the systems that perform the back-end processing for the application.

First, we want to provide the same business logic in a new application that will be used by administration staff working in the bank's offices. We would like to be able to reuse the code that has already been generated for the RedBank Web application without introducing the overhead of having to maintain several copies of the same code. Integration of these business objects into a new application should be made as simple as possible.

Next, we want to reduce development time by using an object-relational mapping system that will keep an in-memory, object-oriented view of data with the relational database view automatically, and provide convenient mapping tools to set up the relationships between objects and data. This system should be

capable of dealing with distributed transactions, since the data might be located on several different databases around the bank's network.

Since we are planning to make business logic available to multiple applications simultaneously, we want a system that will manage such issues as multithreading, resource allocation, and security so that developers can focus on writing business logic code without having to worry about infrastructure matters such as these.

Finally, the bank has legacy systems, not written in Java, that we would like to be able to update to use the new functionality provided by these business objects. We would like to use a technology that will allow this type of interoperability between different platforms and languages.

We can get all this functionality by using Enterprise JavaBeans (EJBs) and Java Persistence API (JPA) to provide our back-end business logic and access to data. Later, we will see how EJBs can also allow us to integrate messaging systems and Web services clients with our application logic.

EJB 3.0 specification - What is new?

Enterprise JavaBeans 3.0 is a major enhancement to EJB specification, introducing a new plain old Java object (POJO)-based programming model that greatly simplifies development of Java EE applications. The main features are as follows:

- ▶ EJBs are now POJOs that expose regular business interfaces (plain old Java interfaces - POJI), and there is no requirement for home interfaces.
- ▶ Deployment descriptor information are replaced by annotations.
- ▶ A complete new persistence model is provided (JPA) which supersedes EJB 2.x entity beans.
- ▶ Interceptor facility invokes user methods at the invocation of business services or at life cycle events.
- ▶ Adopts a annotation-based dependency injection pattern to obtain Java EE resources (JDBC data sources, JMS factories and queues, and EJB references).
- ▶ Default values are provided whenever possible ("configuration by exception" approach).
- ▶ Usage of checked exceptions are reduced.
- ▶ All life cycle methods are optional now.

More information about EJB 3.0 and JPA can be found in the IBM Redbooks publication *WebSphere Application Server V6.1 Feature Pack for EJB 3.0*, SG24-7611, in Chapter 12, “Persistence using the Java Persistence API (JPA)” on page 267, in Chapter 14, “Develop EJB applications” on page 387, and here:

<http://java.sun.com/products/ejb>

Different types of EJBs

This section describes the two types of EJB 3.0: Session beans (stateless and stateful) and Message-driven beans.

Note: Entity beans as specified in Enterprise JavaBeans specification 2.x have been replaced by Java Persistence API entities.

Session EJBs

Session EJBs are task-oriented objects, which are invoked by a client code. They are non-persistent and will not survive an EJB container shutdown or crash.

Session beans often act as the external face of the business logic provided by EJBs. The session facade pattern, described in many pattern catalogs including *Core J2EE Patterns: Best Practices and Design Strategies* by Crupi, et al., describes this idea. The client application that needs to access the business logic provided by some EJBs sees only the session beans. The low-level details of the persistence mechanism are hidden behind these session beans (the session bean layer is known as the session facade). As a result of this, the session beans that make up this layer are often closely associated with a particular application and might not be reusable between applications.

It is also possible to design reusable session beans, which might represent a common service that can be used by many applications.

Stateless session EJBs

Stateless session EJBs are the preferred type of session EJB, because they generally scale better than stateful session EJBs. Stateless beans are pooled by the EJB container to handle multiple requests from multiple clients. In order to permit this pooling, stateless beans cannot contain any state information that is specific to a particular client. Because of this restriction, all instances of a stateless bean are equivalent, allowing the EJB container to assign an instance to any client. Stateless session EJBs are marked with the `@Stateless` annotation and its business interface is annotated with the `@Local` (default) or `@Remote` annotation.

Stateful session EJBs

Stateful session EJBs are useful when an EJB client needs to call several methods and store state information in the session bean between calls. Each stateful bean instance must be associated with exactly one client, so the container is unable to pool stateful bean instances. Stateful session EJBs are annotated with the `@Stateful` annotation.

Message-driven EJBs (MDBs)

MDBs are designed to receive and process messages. They can be accessed only by sending a message to the messaging server that the bean is configured to listen to. MDBs are stateless and can be used to allow asynchronous communication between a client EJB logic via some type of messaging system. MDBs are normally configured to listen to Java Message Service (JMS) resources, although from EJB 2.1, other messaging systems can also be supported. MDBs are normally used as adapters to allow logic provided by session beans to be invoked via a messaging system; as such, they can be thought of as an asynchronous extension of the session facade concept described above, known as the message facade pattern. Message-driven beans can only be invoked in this way and therefore have no specific client interface. Message-driven EJBs are annotated with the `@MessageDriven` annotation.

Java Persistence API (JPA)

The Java Persistence API (JPA) provides an object-relational mapping facility for managing relational data in Java applications. Entity beans as specified in the EJB 2.x specification have been replaced by JPA entity classes. These classes are annotated with the `@Entity` annotation. Entities may either use persistent fields (mapping annotation is applied to entity's instance variable) or persistent properties (mapping annotation is applied to getter methods for JavaBeans-style properties). All fields of a entity not annotated with the `@Transient` annotation or not marked with the `transient` Java keyword will be persisted to the data store. The object-relational mapping annotation must be applied to the instance variables. The primary key field is simply annotated with the `@Id` annotation.

There are four types of multiplicities in entity relationships:

- ▶ One-to-one (`@OneToOne`): Each entity instance is related to a single instance of another entity.
- ▶ One-to-many (`@OneToMany`): An entity instance can be related to multiple instances of the other entities.
- ▶ Many-to-one (`@ManyToOne`): Multiple instances of entity can be related to a single instance of another entity.

- ▶ Many-to-many (@ManyToMany): The entity instances can be related to multiple instances of each other.

Entities are managed by the *entity manager*. The entity manager is an instance of `javax.persistence.EntityManager` and is associated with persistence context. A persistence context defines the scope under which particular entity instances are created, persisted, and removed. The `EntityManager` API creates and removes persistent entity instances, finds entities by its primary key, and allows queries to be run on entities. There are two kind of entity managers available:

- ▶ **Container-managed entity manager:** The persistence context is automatically propagated by the container to all application components that use the `EntityManager` instance within a single Java Transaction Architecture (JTA) transaction. To obtain an `EntityManager` instance, inject the entity manager into the application component:

```
@PersistenceContext
EntityManager em;
```

- ▶ **Application-managed entity manager:** Used when applications need to access a persistence context that is not propagated with the JTA transaction across `EntityManager` instances in a particular persistence unit. In this case, each `EntityManager` creates a new, isolated persistence context. To obtain an `EntityManager` instance, inject an `EntityManagerFactory` into the application component by means of the `@PersistenceUnit` annotation:

```
@PersistenceUnit
EntityManagerFactory emf;
```

Then, obtain an `EntityManager` from the `EntityManagerFactory` instance:

```
EntityManager em = emf.createEntityManager();
```

Other EJB and JPA features

This section describes other EJB features not discussed previously.

JPA query language (JPQL)

Java Persistence API specifies a query language that allows to define queries over entities and their persistent state. The Java persistence query language (JPQL) gives a way to specify the semantics of queries in a portable way, independent of the particular database used in the enterprise environment.

JPQL is an extension of the Enterprise JavaBeans query language (EJB QL) and is designed to combine the syntax and simple query semantics of SQL with the expressiveness of an object-oriented expression language.

Further information about JPQL can be found in the Java EE 5 Tutorial:

<http://java.sun.com/javaee/5/docs/tutorial/doc/bnbtg.html>

EJB timer service

The EJB timer service was introduced with EJB 2.1. A bean provider can choose to implement the `javax.ejb.TimedObject` interface, which requires the implementation of a single method, `ejbTimeout`. The bean creates a `Timer` object by using the `TimerService` object obtained from the bean's `EJBContext`. Once the `Timer` object has been created and configured, the bean will receive messages from the container according to the specified schedule; the container calls the `ejbTimeout` method at the appropriate interval.

New in EJB 3.0 instead of implementing the `javax.ejb.TimedObject` interface, the method that gets called by the timer service can be just annotated with the `@Timeout` annotation.

Requirements for the development environment

The development environment should provide wizards for creating the various types of EJB, tools for mapping JPA entities to relational database systems and test facilities.

IBM Rational Application Developer v7.5 provides all these features.

Figure 2-5 shows how EJBs work with other technologies already discussed.

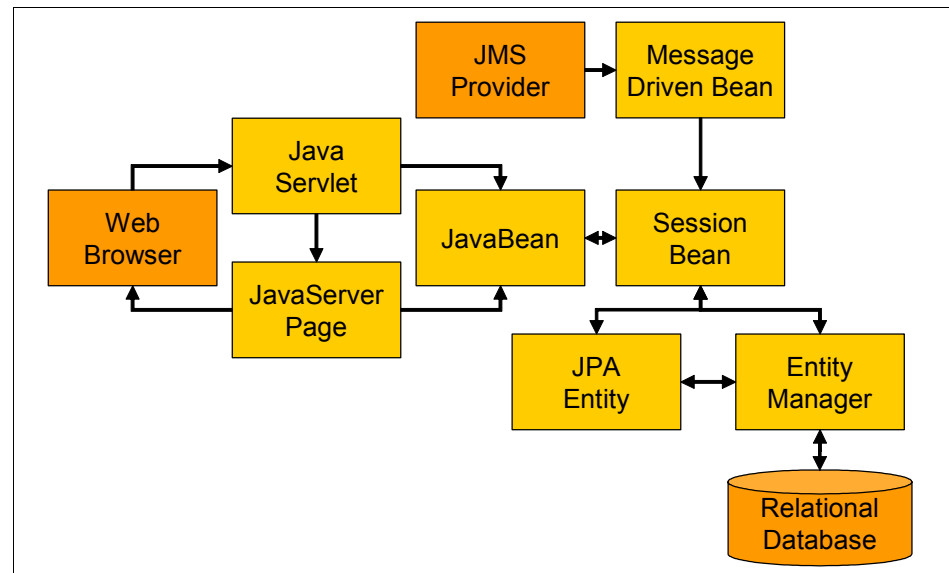

Figure 2-5 EJBs as part of an enterprise application

Java EE Application Clients

Java EE Application Clients are one of the four types of components defined in the Java EE specification—the others being EJBs, Web components (servlets and JSPs), and Java applets. They are stand-alone Java applications that use resources provided by a Java EE application server, such as EJBs, data sources and JMS resources.

In the context of our banking sample application, we want to provide an application for bank workers who are responsible for creating accounts and reporting on the accounts held at the bank. Since a lot of the business logic for accessing the bank's database has now been developed using EJBs, we want to avoid duplicating this logic in our new application. Using a Java EE Application Client for this purpose will allow us to develop a convenient interface, possibly a GUI, while still allowing access to this EJB-based business logic. Even if we do not want to use EJBs for business logic, a Java EE Application Client will allow us to access data sources or JMS resources provided by the application server and will allow us to integrate with the security architecture of the server.

Required Java EE Client Container APIs

The Java EE specification (available from <http://java.sun.com/javaee/>) requires the following APIs to be provided to Java EE Application Clients:

In Java Platform, Standard Edition 5.0:

- ▶ Java Interface Definition Language (IDL)
- ▶ Java Data Base Connectivity (JDBC) 3.0
- ▶ Java Remote Method Invocation over Internet Inter-Orb Protocol (RMI-IIOP)
- ▶ Java Naming and Directory Interface (JNDI)
- ▶ Java API for XML Processing (JAXP) 1.3
- ▶ Java Authentication and Authorization Service (JAAS)
- ▶ Java Management Extension (JMX)

Additional packages:

- ▶ Enterprise JavaBeans (EJB) 3.0 Client API
- ▶ Java Message Service (JMS) 1.1
- ▶ JavaMail 1.4
- ▶ Java Activation Framework (JAF) 1.1
- ▶ Web Services 1.2
- ▶ Java API for XML-Based RPC (JAX-RPC) 1.1
- ▶ Java API for XML Web Services (JAX-WS) 2.0
- ▶ Java Architecture for XML Binding (JAXB) 2.0
- ▶ SOAP with Attachments API for Java (SAAJ) 1.3
- ▶ Java API for XML Registries (JAXR) 1.0
- ▶ Java EE Management 1.1

- ▶ Java EE Deployment 1.2
- ▶ Web Services Metadata 2.0
- ▶ Common Annotations 1.0
- ▶ Streaming API for XML (StAX) 1.0
- ▶ Java Persistence API (JPA) 1.0

Security

The Java EE specification requires that the same authentication mechanisms should be made available for Java EE Application Clients as for other types of Java EE components. The authentication features are provided by the Java EE Application Client container, as they are in other containers within Java EE. A Java EE platform can allow the Java EE Application Client container to communicate with an application server to use its authentication services; WebSphere Application Server allows this.

Naming

The Java EE specification requires that Java EE Application Clients should have exactly the same naming features available as are provided for Web components and EJBs. Java EE Application Clients should be able to use the Java Naming and Directory Interface (JNDI) to look up objects using object references as well as real JNDI names. The reference concept allows a deployer to configure references that can be used as JNDI names in lookup code. The references are bound to real JNDI names at deployment time, so that if the real JNDI name is subsequently changed, the code does not have to be modified or recompiled—only the binding needs to be updated.

References can be defined for:

- ▶ EJBs (for Java EE Application Clients, only remote references, because the client cannot use local interfaces)
- ▶ Resource manager connection factories
- ▶ Resource environment values
- ▶ Message destinations
- ▶ User transactions
- ▶ ORBs

Code to look up an EJB might look like this (this is somewhat simplified):

```
accountHome = (AccountHome)initialContext
                .lookup("java:comp/env/ejb/account");
```

`java:comp/env/` is a standard prefix used to identify references, and `ejb/account` would be bound at deployment time to the real JNDI name used for the Account bean.

Deployment

The Java EE specification only specified the packaging format for Java EE Application Clients, not how these should be deployed—this is left to the Platform provider. The packaging format is specified, based on the standard Java JAR format, and it allows the developer to specify which class contains the *main* method to be executed at run time.

Java EE application clients for the WebSphere Application Server platform run inside the *Application Client for WebSphere Application Server*. This is a product that is available for download from developerWorks, as well the WebSphere Application Server installation CD.

Refer to the WebSphere Application Server Information Center for more information about installing and using the Application Client for WebSphere Application Server.

The Application Client for WebSphere Application Server provides a **launchClient** command, which sets up the correct environment for Java EE Application Clients and runs the main class.

Requirements for the development environment

In addition to the standard Java tooling, the development environment should provide a wizard for creating Java EE Application Clients, editors for the deployment descriptor for a Java EE Application Client module, and a mechanism for testing the Java EE Application Client.

Application Developer v7.5 provides these features.

Figure 2-6 shows how Java EE Application Clients fit into the picture. Because these applications can access other Java EE resources, we can now use the business logic contained in our session EJBs from a stand-alone client application. Java EE Application Clients run in their own JVM, normally on a different machine from the EJBs, so they can only communicate using remote interfaces.

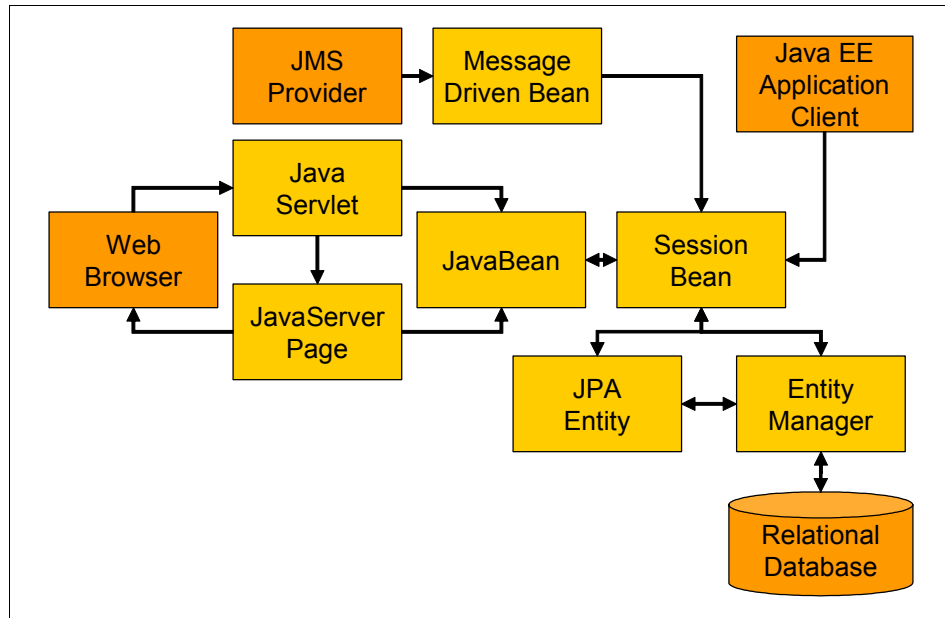

Figure 2-6 Java EE Application Client

Web services

The bank's computer system is now quite sophisticated, comprising:

- ▶ A database for storing the bank's data.
- ▶ A Java application allowing bank employees to access the database.
- ▶ A static Web site, providing information on the bank's branches, products, and services.
- ▶ A Web application, providing Internet banking facilities for customers, with various technology options available.
- ▶ An EJB back-end, providing:
 - Centralized access to the bank's business logic through session beans.
 - Transactional, object-oriented access to data in the bank's database through JPA entities.
- ▶ A Java EE Application Client that can use the business logic in session beans.

So far, everything is quite self-contained. Although clients can connect from the Web to use the Internet banking facilities, the business logic is all contained within the bank's systems, and even the Java application and Java EE Application Client are expected to be within the bank's private network.

The next step in developing our service is to enable mortgage agents, who search many mortgage providers to find the best deal for their customers, to access business logic provided by the bank to get the latest mortgage rates and repayment information. While we want to enable this, we do not want to compromise security, and we need to take into account that fact that the mortgage brokers might not be using systems based on Java at all.

The League of Agents for Mortgage Enquiries has published a description of services that its members might use to get this type of information. We want to conform to this description in order to allow the maximum number of agents to use our bank's systems.

We might also want to be able to share information with other banks; for example, we might want to exchange information on funds transfers between banks. Standard mechanisms to perform these tasks have been provided by the relevant government body.

These issues are all related to interoperability, which is the domain addressed by Web services. Web services will allow us to enable all these different types of communication between systems. We will be able to use our existing business logic where applicable and develop new Web services easily where necessary.

Web services in Java EE 5

Web services provide a standard means of communication among different software applications. Because of the simple foundation technologies used in enabling Web services, it is very simple to provide a Web service regardless of the platform, operating system, language, or technology used to implement it.

A *service provider* creates a Web service and publishes its interface and access information to a *service registry* (or *service broker*). A *service requestor* locates entries in the *service registry*, then binds to the *service provider* in order to invoke its Web service.

Web services use the following standards:

- ▶ **Simple Object Access Protocol (SOAP):** A protocol for exchanging XML-based messages over computer networks, normally using HTTP or HTTPS.

- ▶ **Web Services Description Language (WSDL):** Describes Web service interfaces and access information.
- ▶ **Universal Description, Discovery, and Integration (UDDI):** A standard interface for service registries, which allows an application to find organizations and services.

The specifications for these technologies are available at:

<http://www.w3.org/TR/soap/>
<http://www.w3.org/TR/wsd1/>
<http://uddi.xml.org>

Figure 2-7 shows how these technologies fit together.

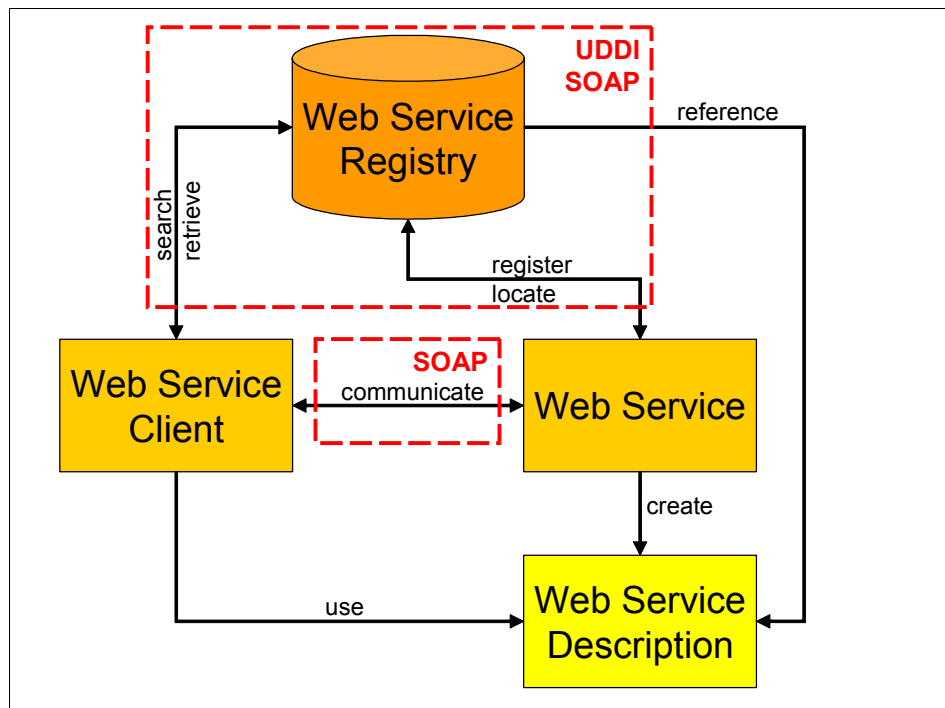

Figure 2-7 Web services foundation technologies

Since Java EE 1.4, Web services are included in the specification, so all Java EE application servers that support Java EE 1.4 or higher have exactly the same basic level of support for Web services; some will also provide enhancements as well.

Java EE 5 provides full support for both clients of Web services as well as web services providers. The following Java technologies work together to provide support for Web services:

- ▶ **Java API for XML Web Services (JAX-WS) 2.0:** It is the primary API for Web services and it is a follow-on to Java API for XML-based Remote Procedure Call (JAX-RPC). JAX-WS offers extensive Web services functionality, with support for multiple bindings/protocols and RESTful Web services. JAX-WS and JAX-RPC are fully interoperable when using SOAP 1.1 over HTTP protocol as constrained by the WS-I basic profile specification (<http://www.jcp.org/en/jsr/detail?id=224>).
- ▶ **Java Architecture for XML Binding (JAXB) 2.0:** It provides a convenient way to bind an XML schema to a representation in Java code as used in SOAP calls. This makes it easy to incorporate XML data and processing functions in Java applications without having to know much about XML itself (<http://www.jcp.org/en/jsr/detail?id=222>).
- ▶ **SOAP with Attachments API for Java (SAAJ) 1.3:** Describes the standard way to send XML documents as SOAP documents over the Internet from the Java platform. It supports SOAP 1.2 (<http://www.jcp.org/en/jsr/detail?id=67>).
- ▶ **Streaming API for XML (StAX) 1.0:** It is a streaming Java-based, event-driven, pull-parsing API for reading and writing XML documents. StAX enables to create bidirectional XML parsers that are fast, relatively easy to program, and have a light memory footprint (<http://www.jcp.org/en/jsr/detail?id=173>).
- ▶ **Web Services Metadata for the Java Platform:** The Web Service Metadata specification defines Java annotations that make it easier to develop Web services (<http://www.jcp.org/en/jsr/detail?id=186>).
- ▶ **Java API for XML Registries (JAXR) 1.0:** It provides client access to XML registry and repository servers (<http://www.jcp.org/en/jsr/detail?id=93>).
- ▶ **Java API for XML Web Services Addressing (JAX-WSA) 1.0:** It is an API and framework for supporting transport-neutral addressing of Web services (<http://www.jcp.org/en/jsr/detail?id=261>).
- ▶ **SOAP Message Transmission Optimization Mechanism (MTOM):** It enables SOAP bindings to optimize the transmission and/or wire format of a SOAP message by selectively encoding portions of the message, whilst still presenting an XML infoset to the SOAP application (<http://www.w3.org/TR/soap12-mtom/>).
- ▶ **Web Services Reliable Messaging (WS-RM):** It is a protocol that allows messages to be delivered reliably between distributed applications in the presence of software component, system, or network failures (<http://www.ibm.com/developerworks/library/specification/ws-rm/>).

- ▶ **Web Services for Java EE** defines the programming and deployment model for Web services in Java EE. It includes details of the client and server programming models, handlers (a similar concept to servlets filters), deployment descriptors, container requirements, and security (<http://www.jcp.org/en/jsr/detail?id=109>) and (<http://www.jcp.org/en/jsr/detail?id=921>).

Since interoperability is a key goal in Web services, an open, industry organization known as the Web Services Interoperability Organization (WS-I, <http://ws-i.org/>) has been created to allow interested parties to work together to maximize the interoperability between Web services implementations. WS-I has produced the following set of interoperability profiles:

- ▶ WS-I Basic Profile 1.1
<http://ws-i.org/Profiles/BasicProfile-1.1.html>
- ▶ WS-I Simple SOAP Binding Profile 1.0
<http://ws-i.org/Profiles/SimpleSoapBindingProfile-1.0.html>
- ▶ WS-I Basic Security Profile 1.0
<http://ws-i.org/Profiles/BasicSecurityProfile-1.0.html>
- ▶ WS-I Attachments Profile 1.0
<http://ws-i.org/Profiles/AttachmentsProfile-1.0.html>

Requirements for the development environment

The development environment should provide facilities for creating Web services from existing Java resources—both JAX-WS or JAX-RPC service endpoint implementations and stateless session EJBs. As part of the creation process, the tools should also produce the required deployment descriptors and WSDL files. Editors should be provided for WSDL files and deployment descriptors.

The tooling should also allow skeleton Web services to be created from WSDL files and should provide assistance in developing Web services clients, based on information obtained from WSDL files.

A range of test facilities should be provided, allowing a developer to test Web services and clients as well as UDDI integration.

Application Developer v7.5 provides all this functionality.

Figure 2-8 shows how the Web services technologies fit into the overall programming model we have been discussing.

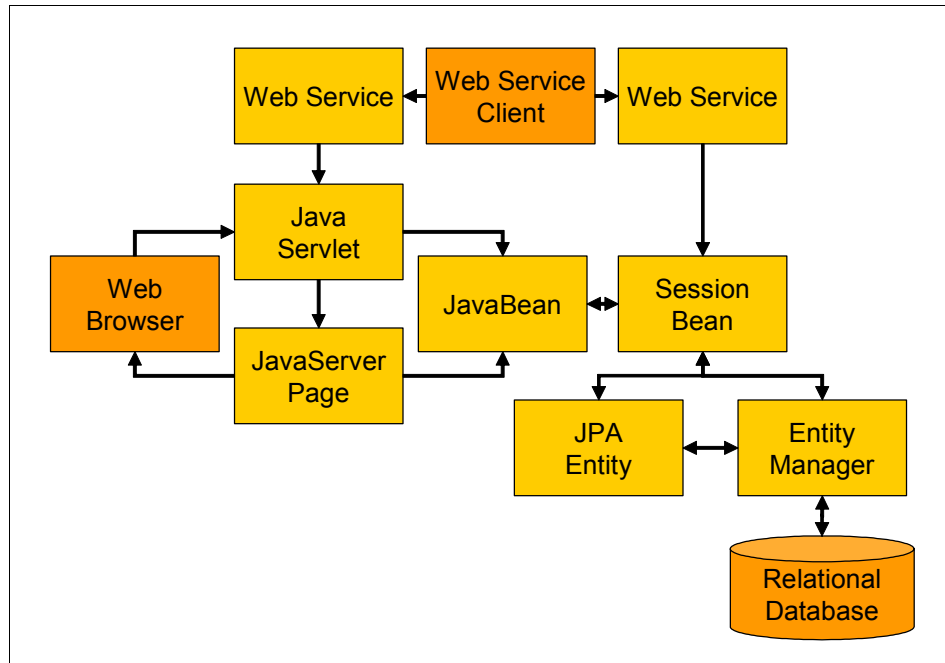

Figure 2-8 Web services

Messaging systems

The bank has several automatic teller machines (ATMs) with an user interface and communication support. The ATMs are designed to communicate with the bank's central computer systems using a secure, reliable, highly scalable messaging system. We would like to integrate the ATMs with our system so that transactions carried out at an ATM can be processed using the business logic we have already implemented. Ideally, we would also like to have the option of using EJBs to handle the messaging for us.

Many messaging systems exist that provide features like these. IBM's solution in this area is IBM WebSphere MQ, which is available on many platforms and provides application programming interfaces in several languages. From the point of view of our sample scenario, WebSphere MQ provides Java interfaces that we can use in our applications—in particular, we will consider the interface that conforms to the Java Message Service (JMS) specification. The idea of JMS is similar to that of JDBC—a standard interface providing a layer of abstraction for developers wishing to use messaging systems without being tied to a specific implementation.

Java Message Service (JMS)

JMS defines (among other things):

- ▶ A messaging model: The structure of a JMS message and an API for accessing the information contained within a message. The JMS interface is `javax.jms.Message`, implemented by several concrete classes, such as `javax.jms.TextMessage`.
- ▶ Point-to-point (PTP) messaging: A queue-based messaging architecture, similar to a mailbox system. The JMS interface is `javax.jms.Queue`.
- ▶ Publish/subscribe (Pub/Sub) messaging: A topic-based messaging architecture, similar to a mailing list. Clients subscribe to a topic and then receive any messages that are sent to the topic. The JMS interface is `javax.jms.Topic`.

More information on JMS can be found at:

<http://java.sun.com/products/jms/>

Message-driven EJBs (MDBs)

MDBs were introduced into EJB 2.0 and have been extended in EJB 2.1. MDBs are designed to consume incoming messages sent from a destination or endpoint system the MDB is configured to listen to. From the point of view of the message-producing client, it is impossible to tell how the message is being processed—whether by a stand-alone Java application, a MDB, or a message-consuming application implemented in some other language. This is one of the advantages of using messaging systems; the message-producing client is very well decoupled from the message consumer (similar to Web services in this respect).

From a development point of view, MDBs are the simplest type of EJB, since they do not have clients in the same sense as session and entity beans. The only way of invoking an MDB is to send a message to the endpoint or destination that the MDB is listening to. In EJB 2.0, MDBs only dealt with JMS messages, but in EJB 2.1 this is extended to other messaging systems. The development of an MDB is different depending on the messaging system being targeted, but most MDBs are still designed to consume messages through JMS, which requires the bean class to implement the `javax.jms.MessageListener` interface, as well as `javax.ejb.MessageDrivenBean`.

A common pattern in this area is the message facade pattern, as described in *EJB Design Patterns: Advanced Patterns, Processes and Idioms* by Marinescu. This book is available for download from:

<http://theserverside.com/articles/>

According to this pattern, the MDB simply acts as an adapter, receiving and parsing the message, then invoking the business logic to process the message using the session bean layer.

Requirements for the development environment

The development environment should provide a wizard to create MDBs and facilities for configuring the MDBs in a suitable test environment. The test environment should also include a JMS-compliant server.

Testing MDBs is challenging, since they can only be invoked by sending a message to the messaging resource that the bean is configured to listen to. However, WebSphere Application Server v7.0, which is provided as a test environment within Rational Application Developer, includes an embedded JMS messaging system that can be used for testing purposes. A JMS client must be developed to create the test messages.

Figure 2-9 shows how messaging systems and MDBs fit into the application architecture.

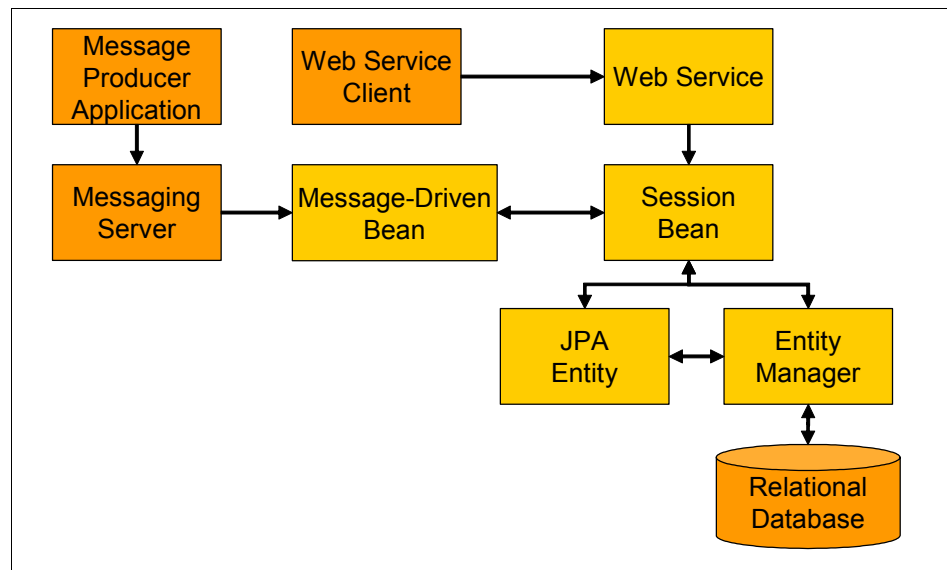

Figure 2-9 Messaging systems

Summary

In this chapter we reviewed the basic technologies supported by Application Developer: Desktop applications, static Web sites, dynamic Web applications, Enterprise JavaBeans, Web services, and messaging.



Workbench setup and preferences

After installing IBM Rational Application Developer V7.0, the Workbench is configured with a default configuration to make it easier to navigate for new users. Developers are made aware of enabling the capabilities of Application Developer, if needed. Alternatively, developers can configure the Workbench preferences for their needs manually at any time. This chapter describes the most commonly used Application Developer preferences.

The chapter is organized into the following sections:

- ▶ Workbench basics
- ▶ Preferences
- ▶ Java development preferences

Workbench basics







After starting Application Developer, after the installation, you see a single window with the Welcome page (Figure 3-1). The Welcome page can be accessed subsequently by selecting **Help** → **Welcome** from the Workbench menu bar. The Welcome page is provided to guide a new user of Application Developer to the various aspects of the tool.



Figure 3-1 Application Developer Workbench Welcome page

The Welcome page presents six icons, each including a description that is visible through hover help (moving the mouse over an icon to display a description). Table 3-1 provides a summary of each icon.

Table 3-1 Welcome page assistance capabilities

Icon Image	Name	Description
	Overview	Provides an overview of the key functions in Application Developer.
	What's New	A description of the major new features and highlights of the product.
	Tutorials	Tutorial screens to learn how to use key features Application Developer. Provides a link to Tutorials Gallery.
	Samples	Sample code for the user to begin working with "live" examples with minimal assistance. Provides a link to Samples Gallery
	First Steps	Step-by-step guidance to help first-time users to perform some key tasks.
	Web Resources	URL links to Web pages where you can find relevant and timely tips, articles, updates, and references to industry standards.

The Welcome page appearance can also be customized through the preferences page. You can click the  **Customize Page** icon on the top right corner of the Welcome page to open the Preferences dialog (Figure 3-2). You can use this preference page to select one of the pre-defined themes, which affects the overall look of the welcome. You can also select which pages will be displayed, and the visibility, layout, and priority of the items within each page.

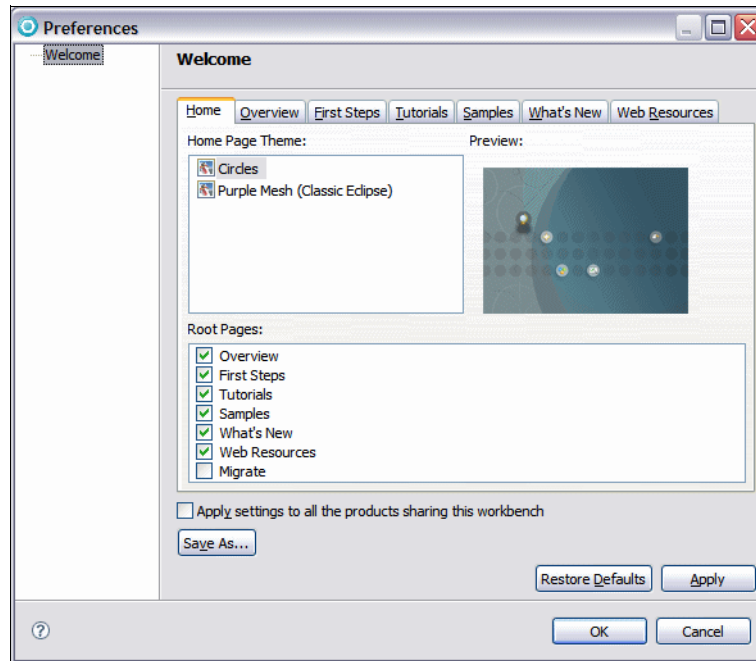

Figure 3-2 Welcome page preferences

Users experienced with Application Developer or the concepts that the product provides can close the Welcome page by clicking the **X** for the view to close it down, or clicking the icon in the top right corner arrow. They will then be presented with the default perspective, the J2EE perspective. Each perspective in Application Developer contains multiple views, such as the Enterprise Explorer view, Outline view, and others. More information regarding perspectives and views are provided in Chapter 4, “Perspectives, views, and editors” on page 119.

The top right of the window has a shortcut icon (Figure 3-3), which allows you to open available perspectives, and places them in the shortcut bar next to it. Once the icons are on the shortcut bar, you are able to navigate between perspectives that are already open. The name of the active perspective is shown in the title of the window, and its icon is in the shortcut bar on the right side as a pushed button.

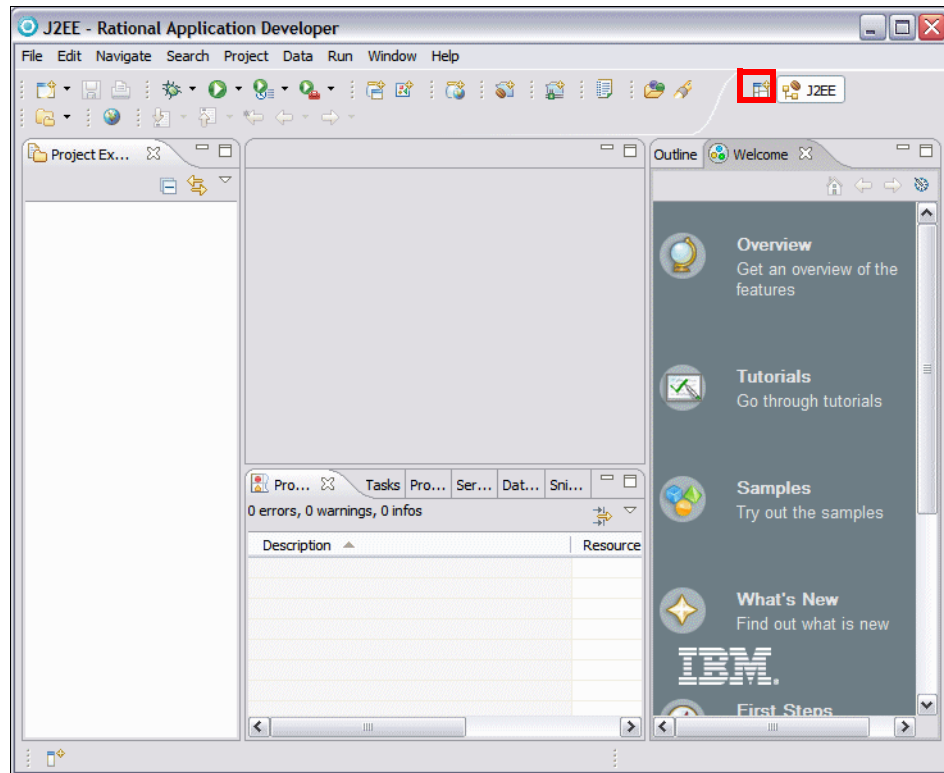

Figure 3-3 J2EE perspective in Rational Application Developer

The term *Workbench* refers to the desktop development environment. Each Workbench window of Application Developer contains one or more perspectives. Perspectives contain views and editors and control what appears in certain menus and toolbars.

Workspace basics

When you start up Application Developer, you are prompted to provide a workspace to start up. On the first startup, the path looks something like the following sample, depending on the installation path:

```
c:\Documents and Settings\\IBM\rational\sd7.0\workspace
```

Where *<user>* is the Windows user ID you used to login.

The Application Developer workspace is a private work area created for the individual developer, and it holds the following information:

- ▶ Application Developer environment meta data, such as configuration information and temporary files
- ▶ Projects that they have created, which includes source code, project definition, or configuration files, and generate files, such as class files

Resources that are modified and saved are reflected on the local file system. Users can have many workspaces on their local file system to contain different projects that they are working on, or different versions. Each of these workspaces can be configured differently, because they have their own copy of meta data with configuration data for that workspace.

Important: Although workspace meta data stores configuration information, this does not mean that the meta data can be transferred between workspaces. In general, we do not recommend copying or using the meta data in one workspace, with another workspace. The recommended approach is to create a new workspace and then configure it appropriately.

Application Developer allows you to open more than one Workbench at a time. It opens another window into the same workspace, allowing you to work in two differing perspectives. Changes that are made in one window are reflected to the other windows. You are not permitted to work in more than one window at a time, that is, you cannot switch between windows while in the process of using a wizard in one window.

Opening a new Workbench in another window is done by selecting **Window** → **New Window**, and a new Workbench with the same perspective will open in a new window. As well as opening a perspective inside the current Workbench window, new perspectives can also be opened in their own window. By default, new perspectives are opened in the current window. This default behavior can be configured using **Window** → **Preferences** → **General** → **Perspectives** (see “Perspectives preferences” on page 95).

The default workspace can be started on first startup of Application Developer by specifying the workspace location on the local machine and selecting the check box **Use this as the default and do not ask again**, as shown in Figure 3-4.

This ensures that on the next startup of Application Developer that the workspace automatically uses the directory specified initially, and it will not prompt for the workspace in the future.

Note: See “Setting the workspace with a prompt dialog” on page 83 describing how to reconfigure Application Developer prompting for the workspace at startup.

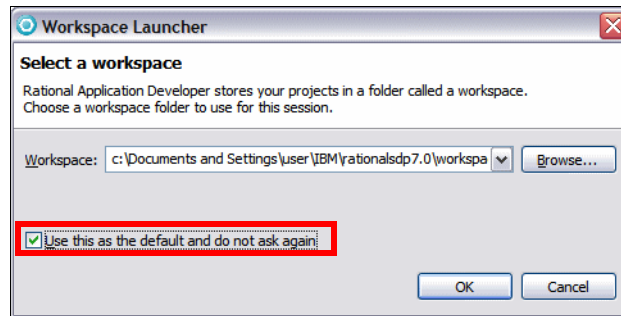

Figure 3-4 Setting the default workspace on startup

The other way to enforce the use of a particular workspace is by using the **-data <workspace>** command-line argument on Application Developer, where <workspace> is a path name on the local machine where the workspace is located, and should be a full path name to remove any ambiguity of location of the workspace.

Tip: On a machine where there are multiple workspaces used by the developer, a shortcut would be the recommended approach in setting up the starting workspace location. The target would be:

```
"<RAD Install Dir>\eclipse.exe" -product com.ibm.rational.rad.product.ide
-data <workspace>
```

By using the **-data** argument, you can start a second instance of Application Developer that uses a different workspace. For example, if your second instance should use the MyWorkspace folder, you can launch Application Developer with this command (assuming that the product has been installed in the default installation directory):

```
c:\Program Files\IBM\SDP70\eclipse.exe -data c:\MyWorkspace
```

There are a number of arguments that you can add when launching Application Developer; some useful arguments are explained in Table 3-2. More advanced arguments can be found by searching for Running Eclipse in **Help → Help Contents**.

Table 3-2 Startup parameters

Command	Description
-configuration <i>configurationFileURL</i>	The location for the Platform configuration file, expressed as a URL. The configuration file determines the location of the Platform, the set of available plug-ins, and the primary feature. Note that relative URLs are not allowed. The configuration file is written to this location when Application Developer is installed or updated.
-consolelog	Mirrors the Eclipse platform's error log to the console used to run Eclipse. Handy when combined with -debug .
-data <workspace directory>	Starts Application Developer with a specific workspace located in <workspace directory>.
-debug [optionsFile]	Puts the platform in debug mode and loads the debug options from the file at the given location, if specified. This file indicates which debug points are available for a plug-in and whether or not they are enabled. If a file location is not given, the platform looks in the directory that eclipse was started from for a file called .options. Both URLs and file system paths are allowed as file locations.
-refresh	Option for performing a global fresh of the workspace on startup to reconcile any changes made on the file system since the platform was last run.
-showlocation [workspaceName]	Option for displaying the location of the workspace in the window title bar. In 3.2, an optional workspace name argument was added that displays the provided name in the window title bar instead of the location of the workspace.
-vm vmPath	This optional option allows you to set the location of Java Runtime Environment (JRE) to run Application Developer. Relative paths are interpreted relative to the directory that Eclipse was started from.
-vmargs -Xmx512M	For large-scale development, you should modify your VM arguments to make more heap available. This example allows the Java heap to grow to 256 MB. This might not be enough for large projects.

Memory considerations

Use the **-vmargs** argument to set limits to the memory that is used by Application Developer. For example, with 1 GB RAM, you might be able to get better performance by limiting the memory:

```
-vmargs -Xmx512M
```

You can also modify VMArgs initialization parameters in the `eclipse.ini` file (under the installation directory):

```
VMArgs=-Xms256M -Xmx512M
```

These arguments significantly limit the memory utilization. Setting the `-Xmx` argument below 512M does begin to degrade performance.

Setting the workspace with a prompt dialog

The default behavior on installation is that Application Developer prompts for the workspace on startup. If you selected the check box on the startup screen to not ask again (Figure 3-4 on page 81), there is a procedure to turn on this option, described as follows:

- ▶ Select **Window** → **Preferences**.
- ▶ In the Preferences dialog select **General** → **Startup and Shutdown**.
- ▶ Select **Prompt for workspace on startup** and click **OK** (Figure 3-5).

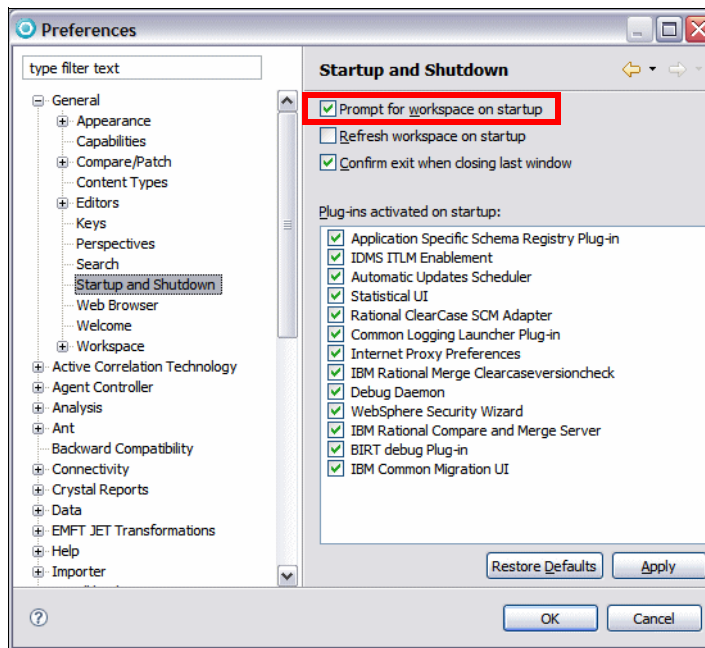

Figure 3-5 Setting the prompt dialog box for workspace selection on startup

On the next startup of Application Developer, the workspace prompt dialog appears, asking the user which workspace to use.

Application Developer logging

Application Developer provides logging functionality for plug-in developers to log and trace important events, primarily expected or unexpected errors. Log files are a crucial part of the Application Developer problem determination process.

The primary reason to use log files is if you encounter unexpected program behavior. In some cases, an error message tells you explicitly to look at the error log.

The logging functionality provided by Application Developer Log and Trace Analyzer implements *common logging*, which enables plug-ins to log events in a common logging log file and logging agent. The Log and Trace Analyzer provides a preferences window to configure the logging level for each of the plug-ins that are configured to log events to the common log file and logging agent. To set the level of records reported to the common log file and logging agent, do these steps:

- ▶ Select **Window** → **Preferences**, and select **Logging**.
- ▶ Select a default logging level for the workbench from the Default logging level list (Figure 3-6). You can also set the number of days after which archived log files will be deleted. The default is 7 days. If you specify 0 for the number of days, the archived files is never deleted.

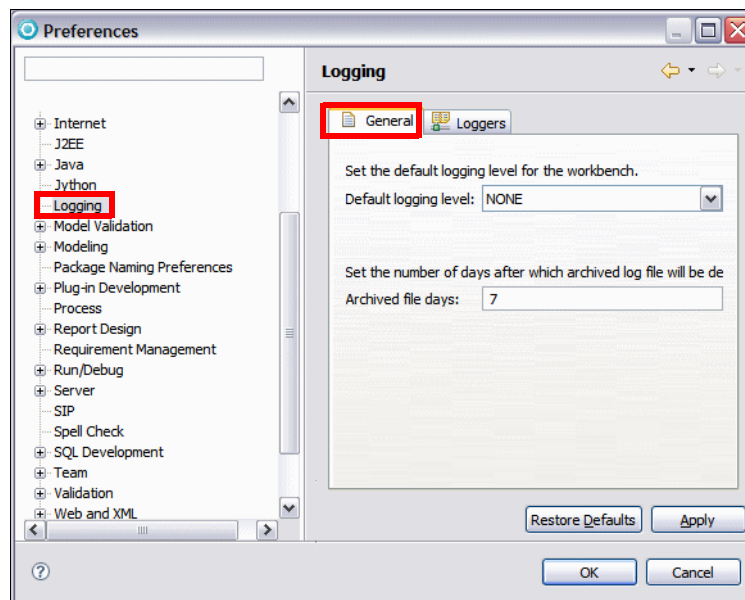

Figure 3-6 Logging preferences: General tab

Note: Logging is turned off by default unless plug-ins explicitly define a logging level in their `plugin.xml` file. Changing the message level from NONE to any other level will enable logging.

- ▶ Select the **Loggers** tab.
- ▶ For each plug-in, you can select the logging level. Only messages with the same or higher logging level than the logging level selected will be logged (Figure 3-7).

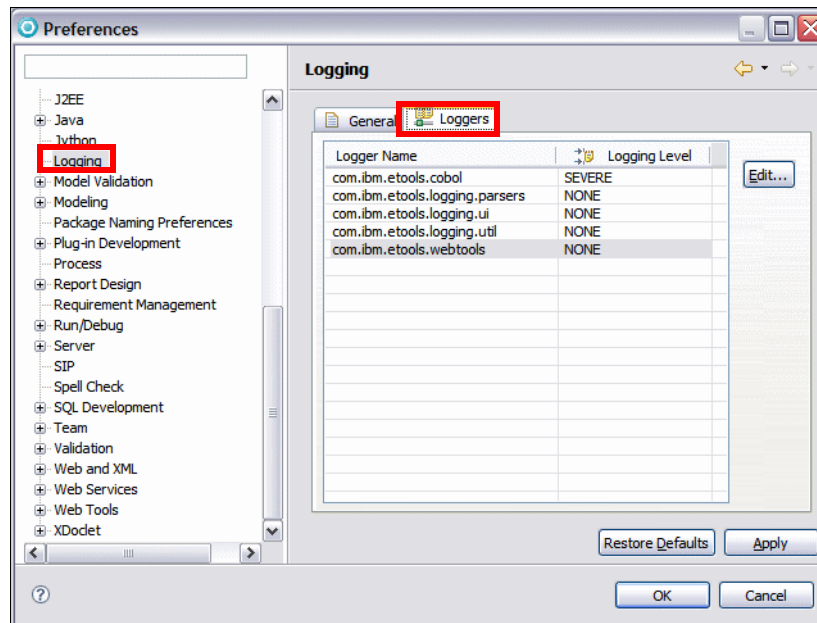

Figure 3-7 Logging preferences: Loggers tab

Log files

There are two main log files in the `.metadata` directory of the workspace folder:

- ▶ **CommonBaseEvents.xml:** This log file is usually of interest to plug-in developers. A new `CommonBaseEvents.xml` file is created every time you start the workbench and the previous `CommonBaseEvents.xml` file is archived. Archived file names have the form `CommonBaseEvents $_{timestamp}$.xml` where `timestamp` is the standard Java timestamp.

This log file can be imported into Log and Trace Analyzer for viewing, analysis, sorting, filtering, and correlation.

- ▶ **.log:** The .log file is used by the Application Developer to capture errors and any uncaught exceptions from plug-ins. The .log file is cumulative, as each new session of Application Developer appends its messages to the end of the .log file without deleting any previous messages. This enables you to see a history of past messages over multiple Application Developer sessions, each one starting with the !SESSION string. This file is an ASCII file and can be viewed with a text editor.

Preferences

The Application Developer Workbench preferences can be modified by selecting **Window** → **Preferences** (Figure 3-8).

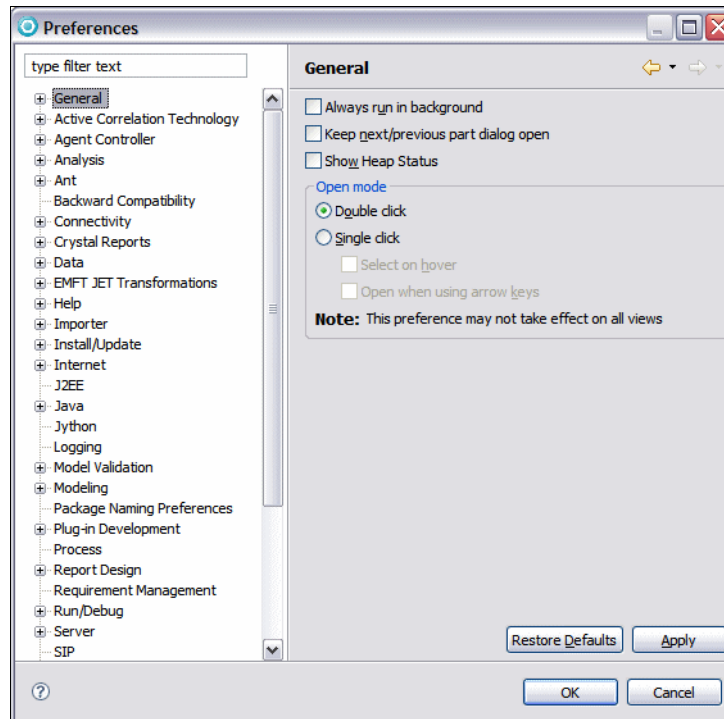

Figure 3-8 Workbench Preferences

In the left pane you can navigate through category of preferences. Each preference has its own page, where you can change the initial options. The Preferences dialog pages can be searched using the filter function.

This section describes the most important workbench preferences. Application Developer contains a complete description of all the options available in the preferences dialogs and Application Developer's help.

Tip: Each page of Application Developer's preferences dialog contains a **Restore Defaults** button (see Figure 3-8 on page 86). If the button is clicked, Application Developer restores the settings of the current dialog to their initial values.

Automatic builds

Builds, or a compilation of Java code in Application Developer, are done automatically whenever a resource has been modified and saved. If you require more control regarding builds, you can disable the automatic build feature, then to perform a build you have to explicitly start it. This might be desirable in cases where you know that building is of no value until you finish a large set of changes.

If you want to turn off the automatic build feature, select **Windows** → **Preferences** → **General** → **Workspace** and clear **Build automatically** (Figure 3-9).

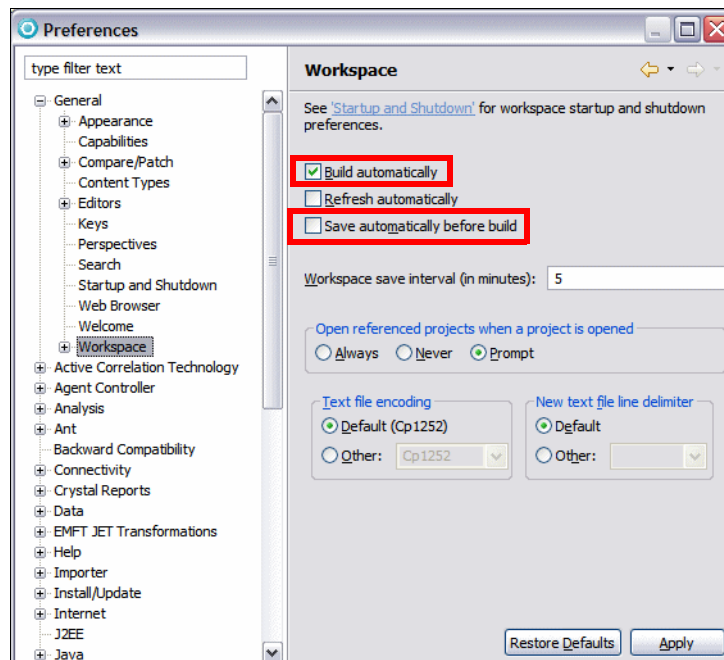

Figure 3-9 Workbench Preferences: Automatic builds

In this same dialog you can specify whether you want unsaved resources to be saved before performing a manual build. Select **Save automatically before build** to enable this feature.

Manual builds

Although the automatic build feature might be adequate for many developers, there are a couple of scenarios in which a developer might want to perform a build manually. First, some developers do not want to build automatically because it can slow down development. In this case the developer needs a method of building at the time of their choosing. Second, there are cases when you want to force a build of a project or all projects to resolve build errors and dependency issues. To address these types of issues, Application Developer provides the ability to perform a manual build, known as a *clean* build.

To perform a manual build, do these steps:

- ▶ Select the desired project in the Enterprise Explorer.
- ▶ Select **Project** → **Build Automatically** to clear the check associated with that selection. Manual build option is only available when the automatic build is disabled.
- ▶ Select **Project** → **Build Project**. Alternatively, select **Project** → **Build All** to build all projects in the workspace. Both of these commands search through the projects and only build the resources that have changed since the last build.

To build all resources, even those that have not changed since the last build, do these steps:

- ▶ Select the desired project in the Enterprise Explorer.
- ▶ Select **Project** → **Clean**.
- ▶ In the Clean dialog select one of the following options and click **OK**:
 - Clean all projects: This performs a build of all projects.
 - Clean selected projects: <project> (The project selected in the previous step is selected by default or you can select it from the projects list.)

Capabilities

Application Developer has the ability to enable and disable capabilities in the tooling. The default setup does not enable some of the capabilities, such as team support for Rational ClearCase, Web services development, or profiling and logging.

Capabilities can be enabled in a number of ways in Application Developer. We describe how to enable capabilities through the following mechanisms:

- ▶ Welcome page
- ▶ Windows preferences
- ▶ Opening a perspective

Enable capability through the Welcome page

Tip: You can display the Welcome page by selecting **Help** → **Welcome**.

The Welcome page provides an icon in the shape of a human figure in the bottom right-hand corner used to enable roles (Figure 3-10). These assist in setting up available capabilities for the user of the tool through the following process.

The scenario that we will attempt is enable the team capability or role so that the developer can save their resources in a repository.



- ▶ In the Welcome page move the mouse to the bottom right corner over the human figure. Click the  icon.
- ▶ Move the mouse until it is over the desired capability or role, and click the icon. For example, move the mouse over the **Team** capability or role  so that it is highlighted and a matching text is shown at the top (Figure 3-10), and click the icon; this enables the Team capability.



Figure 3-10 Enable Team capability or role in the Welcome page

Enable capability through Windows Preferences

To enable the Team capability using the preferences dialog, do these steps:

- ▶ Select **Window** → **Preferences** → **General** → **Capabilities** and click **Advanced** (Figure 3-11).

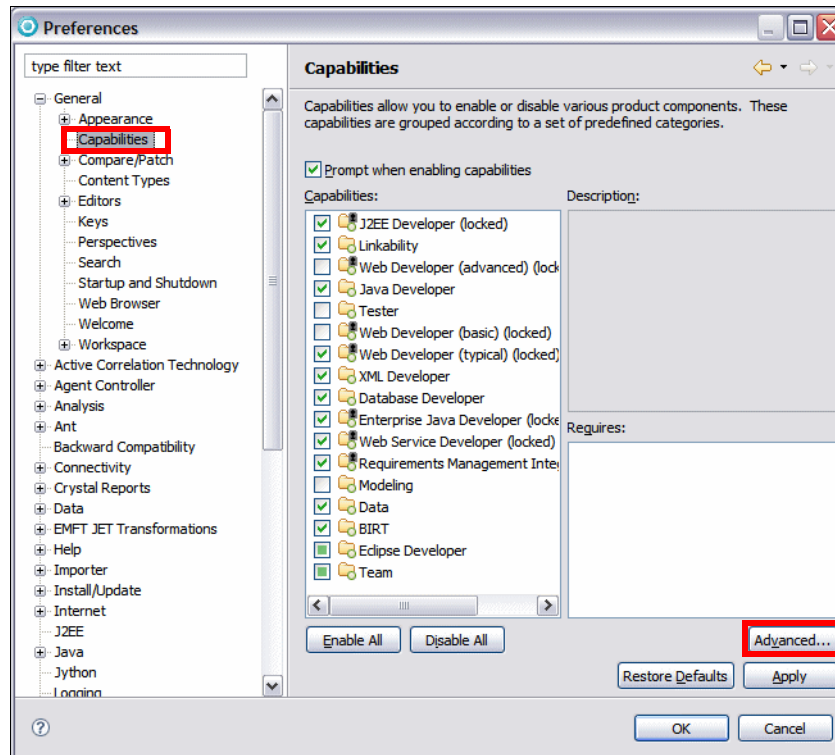

Figure 3-11 Setting the Team capability using Windows preferences: Part 1

- ▶ In the Advanced dialog expand **Team**.
- ▶ Select the **Team** check box, and this selects the check boxes for all components under this tree (Figure 3-12).
- ▶ Click **Apply** and then click **OK**. Now all Team capability is enabled.

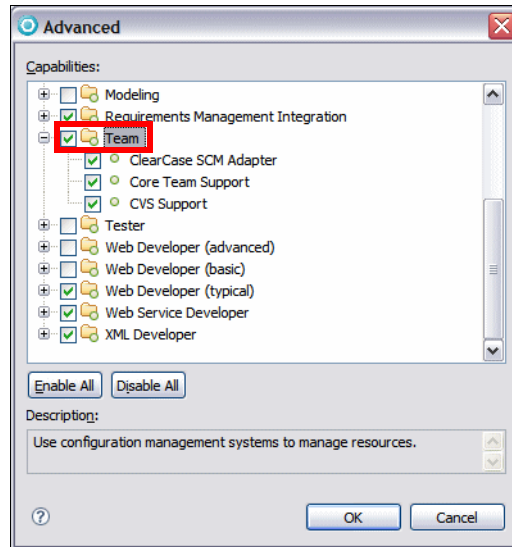

Figure 3-12 Setting the Team capability using Windows preferences: Part 2

Enable a capability by opening a perspective

A capability can be enabled by opening the particular perspective required by the capability. To enable the Profiling and Logging capability by opening a perspective, do these steps:

- ▶ Select **Window** → **Open Perspective** → **Other**.
- ▶ Select **Show all** and select **Profiling and Logging** (Figure 3-13).
- ▶ Click **OK**.
- ▶ In the Confirm Enablement dialog click **OK**, and optionally select **Always enable capabilities and don't ask me again**.

This enables the Profiling and Logging capability and open the Profiling and Logging perspective.

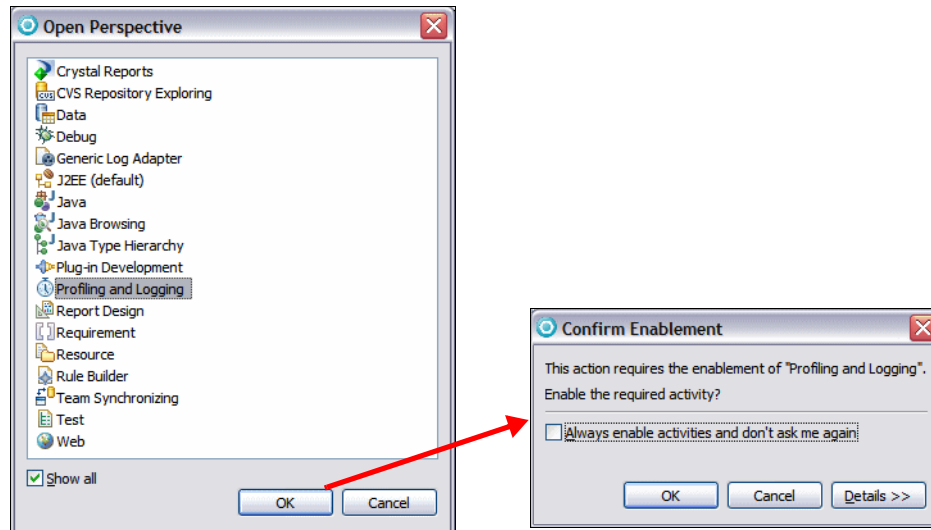

Figure 3-13 Enable capability by opening a perspective

File associations

The File Associations preferences page enables you to add or remove file types recognized by the Workbench. You can also associate editors or external programs with file types in the file types list. To open the preferences page, do these steps:

- ▶ Select **Window** → **Preferences** → **General** → **Editors** → **File Associations** (Figure 3-14).

The top right pane allows you to add and remove the file types. The bottom right pane allows you to add or remove the associated editors.

To add a file association, do these steps:

- ▶ We add the Internet Explorer® as an additional program to open .ddl (database definition language) files. Select *.ddl from the file types list and click **Add** next to the associated editors pane.
- ▶ In the Editor Selection dialog select **External Programs** and click **Browse**.
- ▶ Locate **ieexplore.exe** in the folder where Internet Explorer is installed (for example, C:\Program Files\Internet Explorer), and click **Open**.
- ▶ Click **OK** in the Editor Selection dialog and the program is added to the editors list.

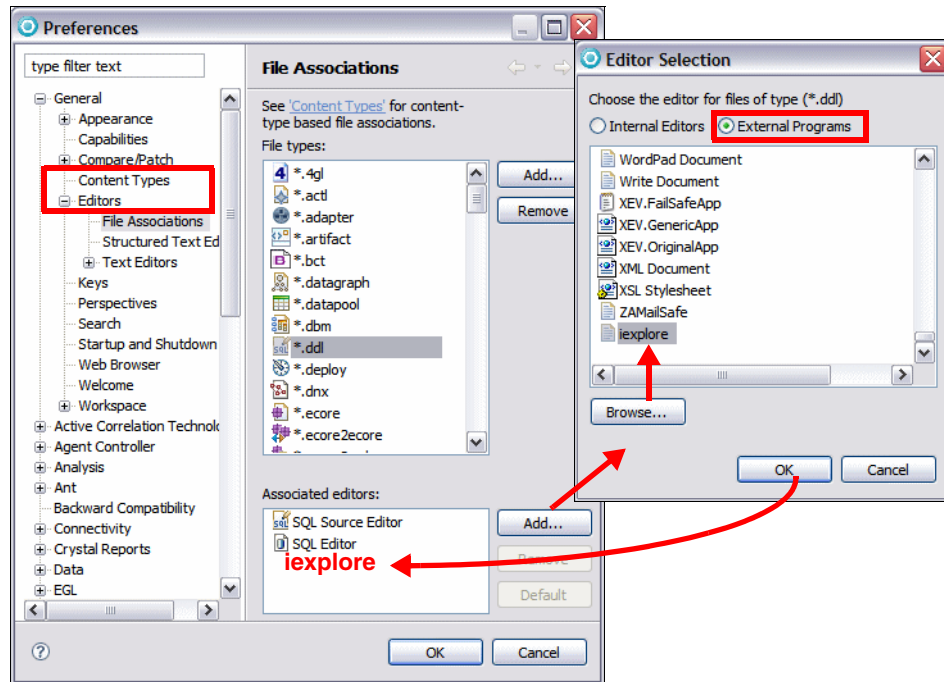

Figure 3-14 File associations preferences

Note: Optionally, you can set this program as the default program for this file type by clicking **Default**.

Now you can open a .ddl file by using the context menu on the file and selecting **Open With**, and selecting the appropriate program.

Local history

A local history of a file is maintained when you create or modify a file. A copy is saved each time you edit and save the file. This allows you to replace the current file with a previous edition or even restore a deleted file. You can also compare the content of all the local editions. Each edition in the local history is uniquely represented by the data and time the file has been saved.

Note: Only files have local history. Projects and folders do not have a local history.

To configure local history settings, select **Window** → **Preferences** → **General** → **Workspace** → **Local History** to open its preferences page (Figure 3-15).

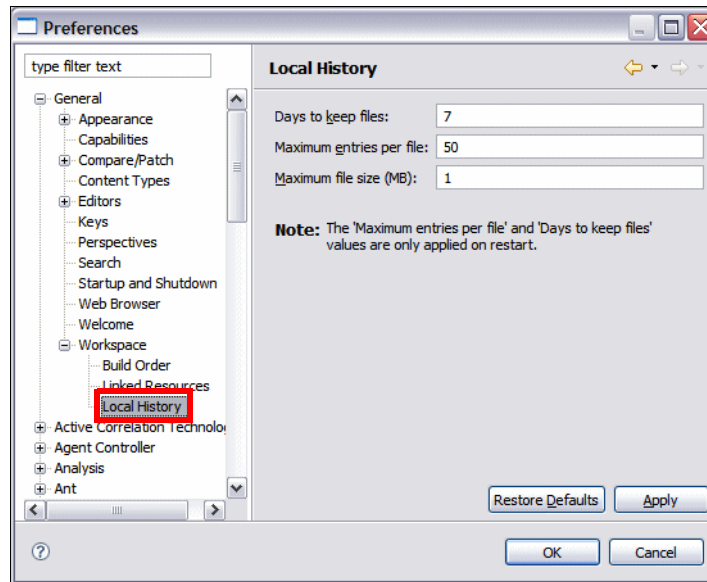

Figure 3-15 Local history preferences

Table 3-3 explains the options for the local history preferences.

Table 3-3 Local history settings

Option	Description
Days to keep files	Indicates for how many days you want to maintain changes in the local history. History states older than this value are lost.
Maximum entries per file	Indicates how many history states per resource you want to maintain in the local history. If you exceed this value, you will lose older history to make room for new history.
Maximum file size (MB)	Indicates the maximum size of individual states in the history store. If a resource is over this size, no local history is kept for that resource.

Compare, replace, and restore local history

To compare a file with the local history, do these steps:

- ▶ This procedure assumes that you have a Java file in your workspace. If you do not, you should add or create a file.

- ▶ Select the Java file, right-click, and select **Compare With** → **Local History**.
- ▶ In the upper pane of the Compare with Local History dialog, all available editions of the file in the local history are displayed.
Select an edition in the upper pane to view the differences between the selected edition and the edition in the workbench.
- ▶ If you are done with the comparison, click **OK**.

To replace a file with an edition from the local history, do these steps:

- ▶ This assumes you have a Java file in your workspace. If you do not, add or create a file.
- ▶ Select the file, right-click, and select **Replace With** → **Local History**.
- ▶ Select the desired file time stamp and then click **Replace**.

To restore a deleted file from the local history, do these steps:

- ▶ Select the folder or project into which you want to restore the deleted file.
- ▶ Right-click and select **Restore from Local History**.
- ▶ Select the files that you want to restore and click **Restore**.

Perspectives preferences

The Perspectives preferences page enables you to manage the various perspectives defined in the Workbench. To open the page, select **Window** → **Preferences** → **General** → **Perspectives** (Figure 3-16).

You can change the following options in the Perspective preferences:

- ▶ Open a new perspective in the same or in a new window.
- ▶ Open a new view within the perspective or as a fast view (docked to the side of the current perspective).
- ▶ The option to always switch, never switch, or prompt when a particular project is created to the appropriate perspective.

There is also a list with all available perspectives where you can select the default perspective. If you have added one or more customized perspectives, you can delete them from here.

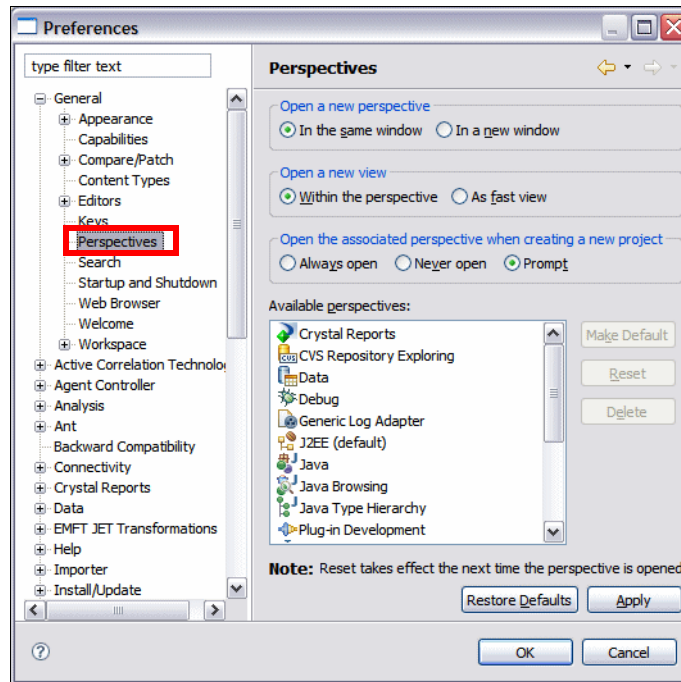

Figure 3-16 Perspectives preferences

Web Browser preferences

The Web browser settings allow the user to select which Web browser is the default browser used by Application Developer for displaying Web information.

To change the Web browser settings,, do these steps:

- ▶ Select **Window** → **Preferences** → **General** → **Web Browser** (Figure 3-17).

The default option is to use the internal Web browser. To change, select **Use external Web browser** and select a browser from the available list; otherwise you can click **New** to add a new Web browser.

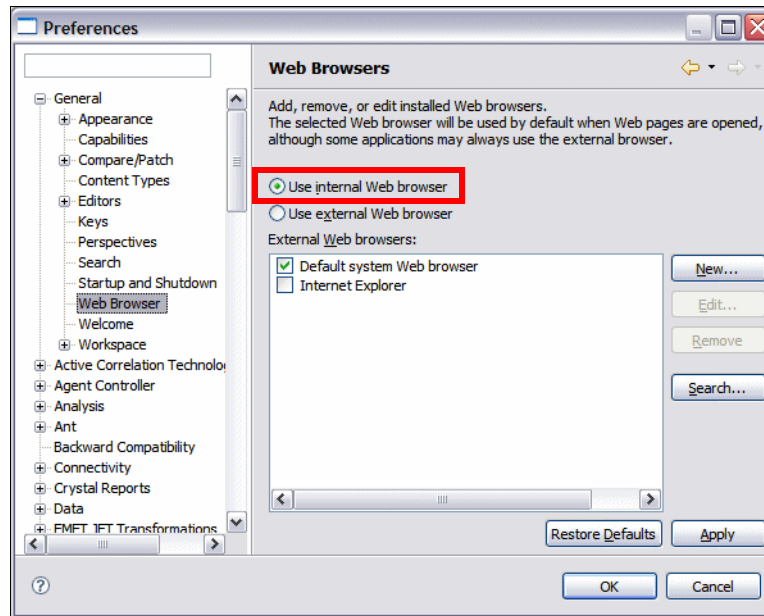

Figure 3-17 Web Browser preferences

Internet preferences

The Internet preferences in Application Developer have three types of settings available to be configured:

- ▶ Cache
- ▶ FTP
- ▶ Proxy settings

Only proxy settings is covered in this section, with the other two settings you can refer to Application Developer's help.

Proxy settings

When using Application Developer and working within an intranet, you might want to use a proxy server to get across a company firewall to access the Internet.

To set the preferences for the HTTP proxy server within the Workbench to allow Internet access from Application Developer, do these steps:

- ▶ Select **Window** → **Preferences** → **Internet** → **Proxy Settings** (Figure 3-18).
- ▶ Select **Enable Proxy** and enter the proxy host and port. There are additional optional settings for the use of SOCKS and enabling proxy authentication.

- ▶ Click **Apply** and then **OK**.

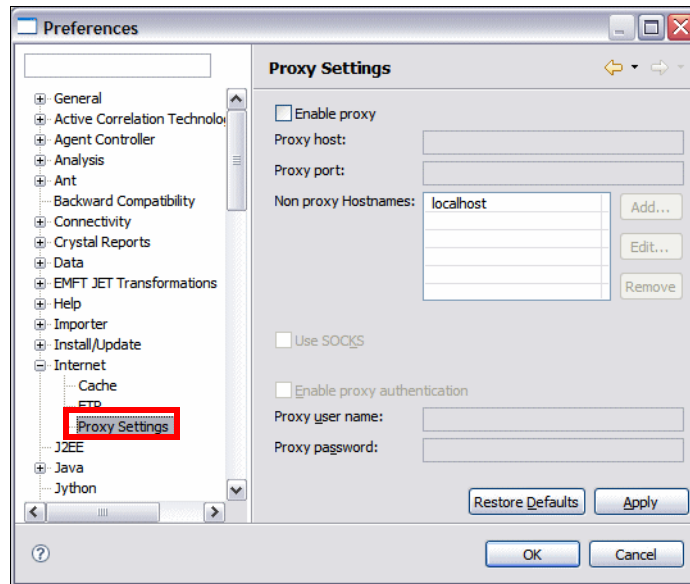

Figure 3-18 Internet proxy settings preferences

Java development preferences

Application Developer provides a number of preferences in different categories such as Java, Web tools, XML, SQL development, and plug-in development. This section only covers the most commonly used Java development preferences. More information about the other preferences are provided in relevant chapters of this book.

Java classpath variables

Application Developer provides a number of default classpath variables that can be used in a Java build path to avoid a direct reference to the local file system in a project. This method ensures that the project only references classpaths using the variable names and not specific local file system directories or paths. This is a good programming methodology when developing within a team and using multiple projects using the same variables. This means that all team members have to set the variables required for a project, and this data is maintained in the workspace.

Tip: We recommend that you standardize the Application Developer installation path for your development team. Many files within the projects have absolute paths based on the Application Developer installation path, thus when you import projects from a team repository such as CVS or ClearCase, you will get errors even when using classpath variables.

Depending on the type of Java coding you plan to do, you might have to add variables pointing to other code libraries. For example, this can be driver classes to access relational databases or locally developed code that you want to reuse in other projects. Once you have created a Java project, you can add any of these variables to the project's classpath.

To configure the default classpath variables, do these steps:

- ▶ Select **Window** → **Preferences** → **Java** → **Build Path** → **Classpath Variables**.

A list of the existing classpath variables is displayed (Figure 3-19).

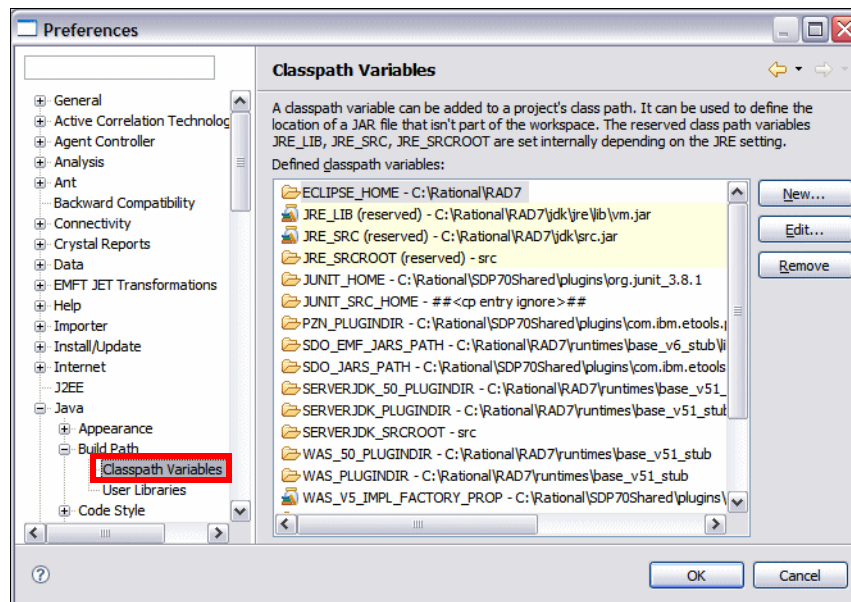

Figure 3-19 Classpath variables preferences

- ▶ Creation, editing, or removing of variables can be performed in this screen. Click **New** to add a new variable.
- ▶ In the New Variable Entry dialog, enter the name of the variable and browse for the path and click **OK** (Figure 3-20).



Figure 3-20 New Variable Entry dialog

Certain class path variables are set internally and cannot be changed in the Classpath variables preferences:

- ▶ JRE_LIB: The archive with the runtime JAR file for the currently used JRE.
- ▶ JRE_SRC: The source archive for the currently used JRE.
- ▶ JRE_SRCROOT: The root path in the source archive for the currently used JRE.

Appearance of Java elements

The appearance and the settings of associated Java elements in views, such as methods, members, and their access types, can be configured:

- ▶ Select **Window** → **Preferences** → **Java** → **Appearance**.

The Appearance preferences page is displayed (Figure 3-21) with appearance check boxes as described in Table 3-4.

Table 3-4 Description of appearance settings for Java views

Appearance setting	Description
Show method return types	If selected, methods displayed in views show the return type.
Show method type parameters	If selected, methods displayed in views show their type parameters.
Show categories	If selected, method, field, and type labels contain the categories specified in their Javadoc™ comment.
Show members in Package Explorer	If selected, displays the members of the class and their scope such as private, private or protected, including others.
Fold empty packages in hierarchical layout	If selected, folds the empty packages that do not contain resources or other child elements.
Compress package name segments	If selected, compresses the name of the package based on a pattern supplied in the dialog below the check box.

Appearance setting	Description
Stack views vertically in the Java Browsing perspective	If selected, displays the views in the Java Browsing perspective vertically rather than horizontally.

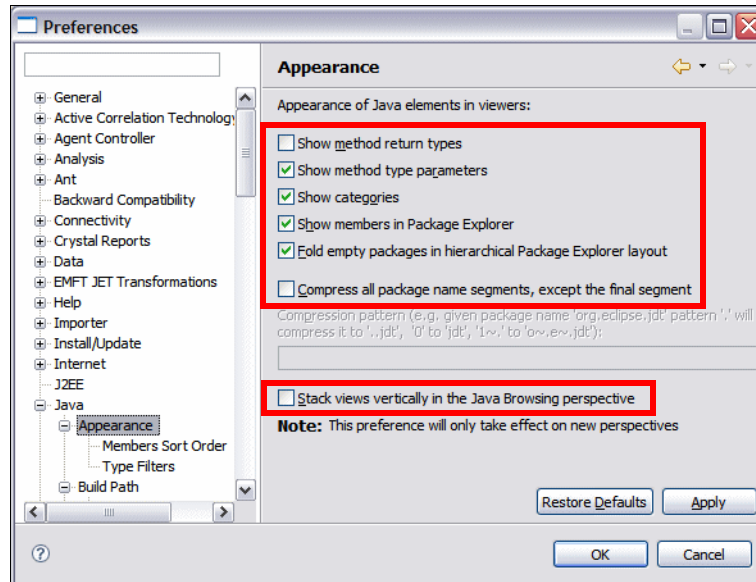

Figure 3-21 Java appearance settings

To change the appearance of the order of the members to be displayed in the Java viewers, do these steps:

- ▶ In the Preferences dialog select **Java** → **Appearance** → **Members Sort Order**. This preference allows you to display the members in the order you prefer, as well as the order of scoping within that type of member.
- ▶ Select the order in which members will be displayed using the **Up** and **Down** buttons. You can also sort in same category by visibility.
- ▶ Click **Apply** and then **OK**.

To specify types and packages to hide in the Open Type dialog and content assist or quick fix proposals, do these steps:

- ▶ In the Preferences dialog select **Java** → **Appearance** → **Type Filters**.
- ▶ You can either create a new filter or add packages to the type filter list. The default is to hide nothing.

Code style and formatting

The Java editor in the Workbench can be configured to format code and coding style in conformance to personal preferences or team-defined standards. When setting up the Workbench, you can decide what formatting style should be applied to the Java files created using the wizards, as well as how the Java editors operate to assist what has been defined.

Important: Working in a team environment requires a common understanding between all the members of the team regarding the style of coding and conventions such as class, member, and method name definitions. The coding standards have to be documented and agreed upon to ensure a consistent and standardized method of operation.

Code style

The Java code style preferences allow you to configure naming conventions, style rules and comment settings.

To demonstrate setting up a style, we define a sample style in which the following conventions are defined:

- ▶ Member attributes or fields will be prefixed by an `m`.
- ▶ Static attributes or fields will be prefixed by an `s`.
- ▶ Parameters of methods will be prefixed by a `p`.
- ▶ Local variables can have any name.
- ▶ Boolean getter methods will have a prefix of `is`.

To configure the customized style, do these steps:

- ▶ Select **Windows** → **Preferences** → **Java** → **Code Style** (Figure 3-22).
- ▶ Select the **Fields** row and click **Edit**.
- ▶ In the Field Name Conventions dialog enter `m` in the **Prefix list** field and click **OK**.
- ▶ Repeat the same steps for all the conventions defined above.

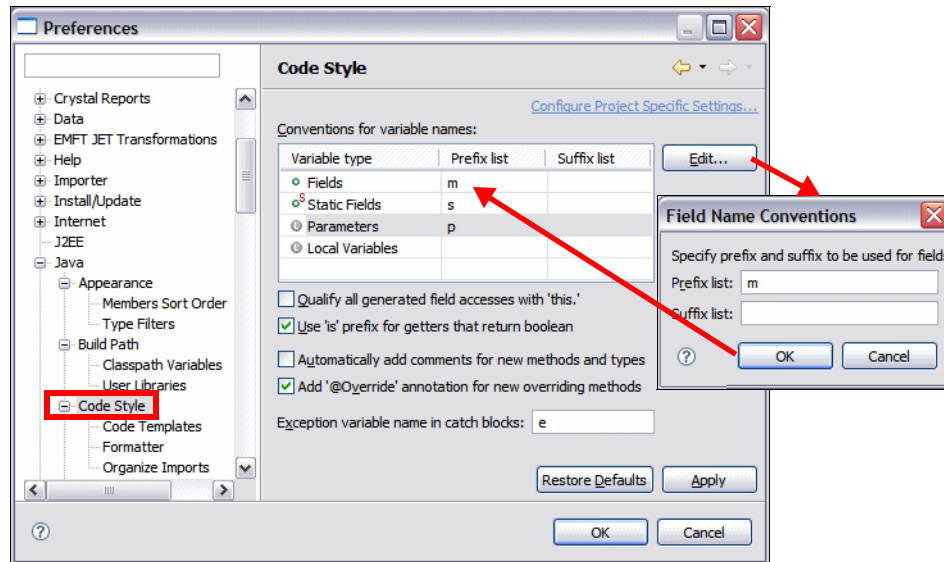

Figure 3-22 Code style preferences

These coding conventions are used in the generation of setters and getters for Java classes:

- ▶ Whenever a prefix of `m` followed by a capital letter is found on an attribute, this would ignore the prefix and generate a getter and setter without the prefix.
- ▶ If the prefix is not found followed by a capitalized letter, then the setter and getter would be generated with the first letter capitalized followed by the rest of the name of the attribute.

An example of the outcome of performing code generation of a getter is shown in Example 3-1 for some common examples of attributes.

Note: The capitalization of getters in Application Developer is based on the way the attributes are named.

Example 3-1 Example snippet of code generation output for getters

```
private long mCounter;
private String maddress;
private float m_salary;
private int zipcode;
/**
 * @return the m_salary
 */
public float getM_salary() {
```

```

        return m_salary;
    }
    /**
     * @return the maddress
     */
    public String getAddress() {
        return maddress;
    }
    /**
     * @return the counter
     */
    public long getCounter() {
        return mCounter;
    }
    /**
     * @return the zipcode
     */
    public int getZipcode() {
        return zipcode;
    }
}

```

The settings described in Table 3-5 specify how newly generated code should look like. These settings are configured in the Code Style preferences page (Figure 3-22 on page 103).

Table 3-5 Description of code style settings

Action	Description
Qualify all generated field accesses with 'this.'	If selected, field accesses are always prefixed with this. , regardless whether the name of the field is unique in the scope of the field access or not.
Use 'is' prefix for getters that return boolean	If selected, the names of getter methods of boolean type are prefixed with is rather than get .
Automatically add comments for new methods and types	If selected, newly generated methods and types are automatically generated with comments where appropriate.
Add '@Override' annotation for overriding methods	If selected, methods which override an already implemented method are annotated with an @Override annotation.
Exception variable name in catch blocks	Specify the name of the exception variable declared in catch blocks.

Formatter

The formatter preferences in Application Developer are used to ensure that the format of the Java code meets the standard defined for a team of developers working on code. There are three profiles built-in with Application Developer with the option of creating new profiles specific for your project:

- ▶ Eclipse (default profile on startup for Application Developer)
- ▶ Eclipse 2.1 (similar to WebSphere Studio V5)
- ▶ Java Conventions

To configure the formatter, do these steps:

- ▶ Select **Window** → **Preferences** → **Java** → **Code Style** → **Formatter** (Figure 3-23).
- ▶ To display the information about a profile, click **Show**, or to create a new profile click **New**.
- ▶ An existing profile can also be loaded by clicking **Import**.

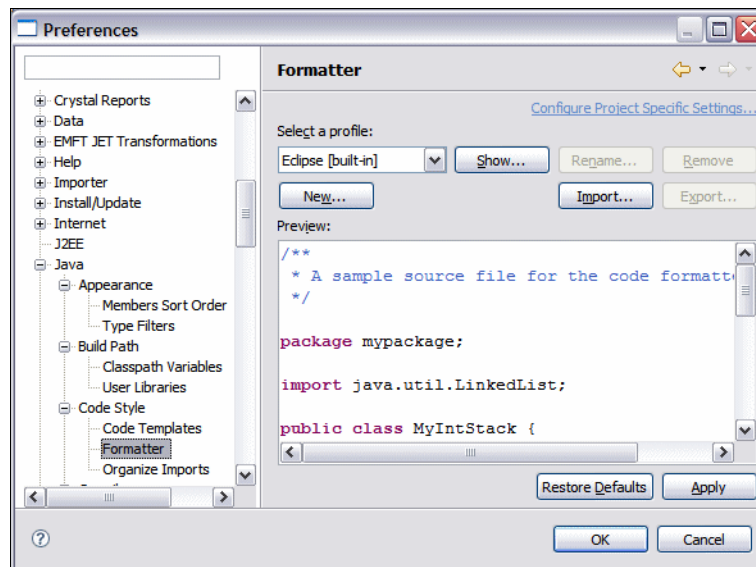

Figure 3-23 Formatter preferences

Enforcing coding standards

The code formatting rules are enforced on code when a developer has entered code using their own style, and which does not conform to the team-defined standard. When this is the case, after the code has been written and tested and preferably before adding the code to the team repository, we recommend that the code is formatted.

The procedure to perform this operation is described here:

- ▶ In the Java editor, right-click, and select **Source** → **Format**. This formatting uses the rules that have been defined in the formatter preferences.

Creating a user-defined profile

User-defined profiles are established from one of the existing built-in profiles, which can be exported to the file system to share with team members. If the existing profile is modified then you are prompted to create a new profile. Any profile that is created can be exported as an XML file that contains the standardized definitions required for your project. This can then be stored in a team repository and imported by each member of the team.

A profile consists of a number of sections that are provided as tab sections to standardize on the format and style that the Java code is written (Figure 3-24). Each of these tab sections are self-explanatory and provide a preview of the code after selection of the required format.

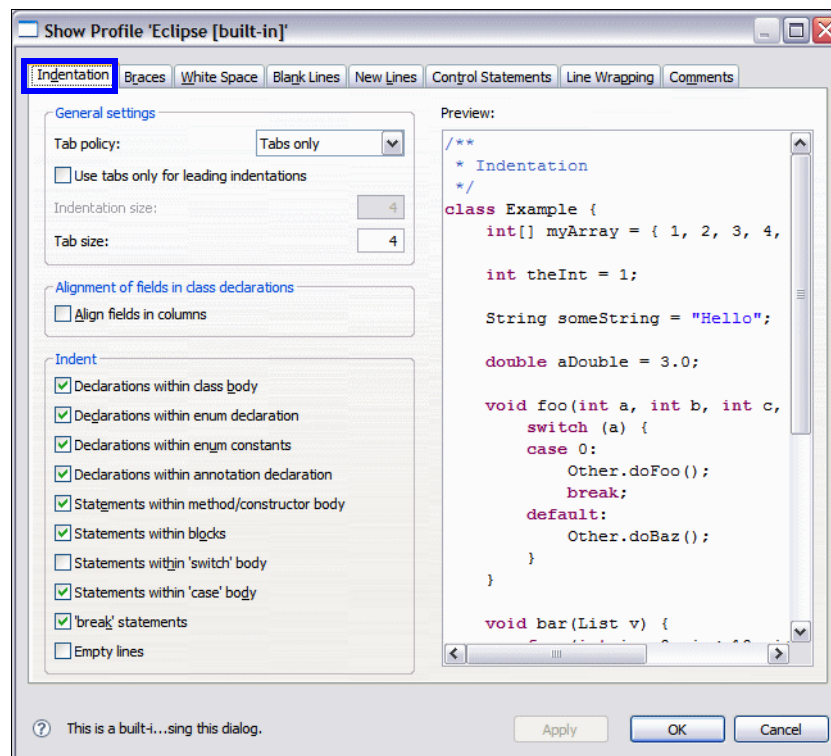

Figure 3-24 Formatter preferences: Eclipse profile

The definition of these tabs are described as follows:

- ▶ **Indentation:** Specifies the indentations that you wish on your Java code in the Workbench (Figure 3-24). The area it covers includes:
 - Tab spacing
 - Alignment of fields
 - Indentation of code
- ▶ **Braces:** Formats the Java style of where braces are placed for a number of Java language concepts. A preview is provided as you select the check boxes to ensure that it fits in with the guidelines established in your team (Figure 3-25).

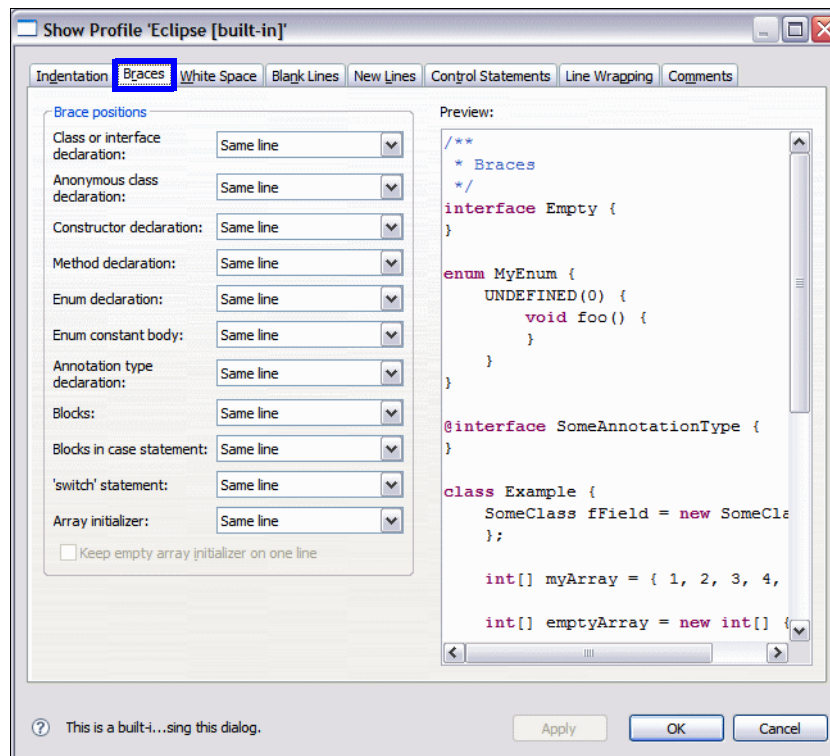

Figure 3-25 Formatter: Braces

- ▶ **White Space:** Format where the spaces are placed in the code based on a number of Java constructs (Figure 3-26).

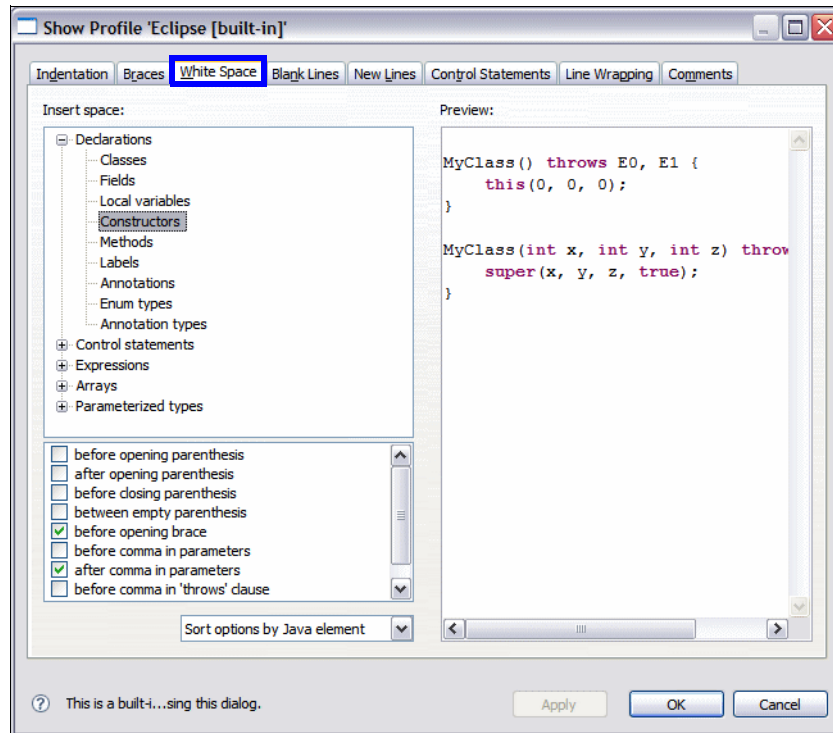

Figure 3-26 Formatter: White Space

- ▶ **Blank Lines:** Specify where you want to place blank lines in the code for readability or style guidelines, for example:
 - Before and after package declaration
 - Before and after import declaration
 - Within a class:
 - Before first declaration
 - Before field declarations
 - Before method declarations
 - At the beginning of a method body
- ▶ **New Lines:** Specifies the option of where you want to insert a new line, for example:
 - In empty class body
 - In empty method body
 - In empty annotation body
 - At end of file

- ▶ **Control Statements:** Control the insertion of lines in control statements, as well as the appearance of *if else* statements of the Java code (Figure 3-27).

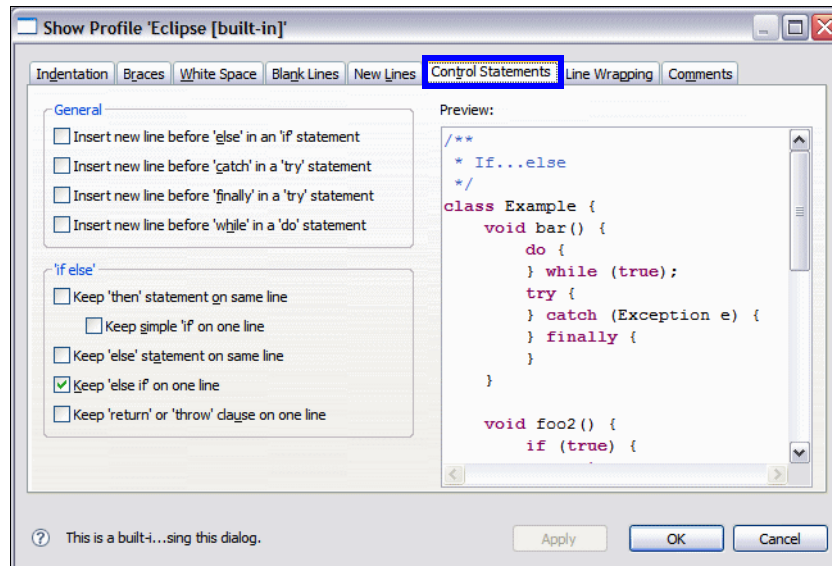

Figure 3-27 Formatter: Control Statements

- ▶ **Line Wrapping:** Provides the style rule on what should be performed with the wrapping of code, for example:
 - Maximum line width (default is 80)
 - Default indentation (2)
 - How declarations, constructors, function calls, and expressions are wrapped
- ▶ **Comments:** Determine the rules of the look of general comments and of Javadoc that are in the Java code.

Java editor settings

The Java editor has a number of settings that assist in the productivity of the user in Application Developer. Most of these options relate to the look and feel of the Java editor in the Workbench. To configure Java editor preferences, do these steps:

- ▶ Select **Windows** → **Preferences** → **Java** → **Editor** (Figure 3-28).

Note: Some options that are generally applicable to text editors can be configured on the text editor preference page under **General** → **Editors** → **Text Editors**.

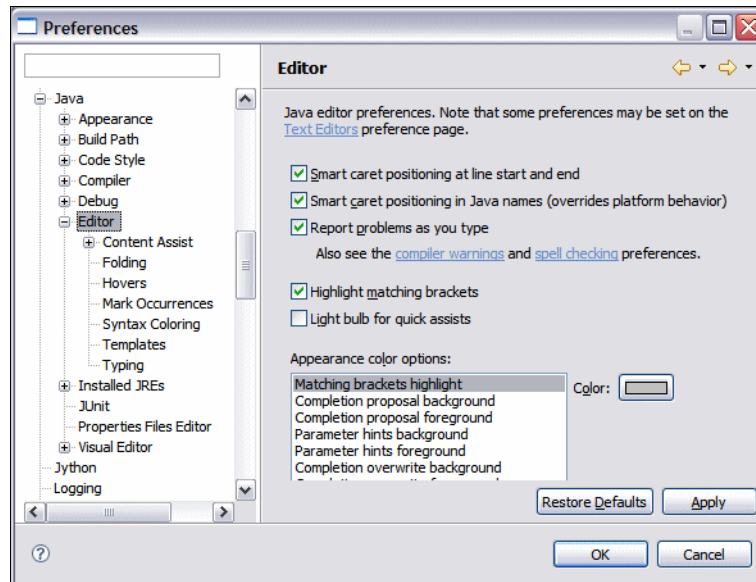

Figure 3-28 Java editor preferences

The main Java editor settings are described in Table 3-6.

Table 3-6 Description of Java editor settings

Option	Description
Smart caret positioning at line start and end	If selected, the Home and End commands jump to the first and last non white space character on a line.
Smart caret positioning in Java names (overrides platform behavior)	If selected, there are additional word boundaries inside Came1 Case Java names.
Report problems as you type	If selected, the editor marks errors and warnings as you type, even if you do not save the editor contents. The problems are updated after a short delay.
Highlight matching brackets	If selected, whenever the cursor is next to a parenthesis, bracket or curly braces, its opening or closing counter part is highlighted. The color of the bracket highlight is specified with Appearance color options.

Option	Description
Light bulb for quick assists	If selected, a light bulb shows up in the vertical ruler whenever a quick assist is available.
Appearance color options	The colors of various Java editor appearance features are specified here.

Some of Java editor preferences sub-pages are described as follows. A detailed description of each sub-page can be found in the Application Developer help.

Content assist

The content assist feature in Application Developer is used in assisting a developer in writing their code rapidly and reducing the errors in what they are writing. It is a feature that is triggered by pressing **Ctrl+Spacebar**, and assists the developer in completion of a variable or method name when coding.

To configure content assist, select **Windows** → **Preferences** → **Java** → **Editor** → **Content Assist** (Figure 3-29).

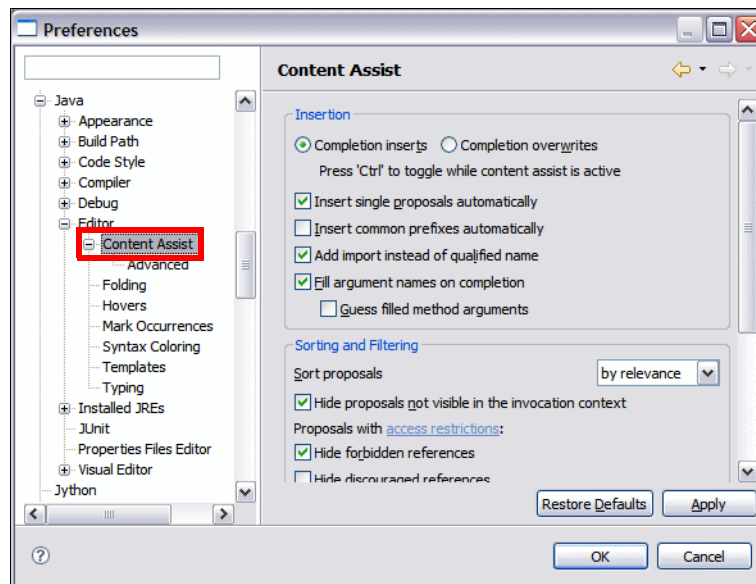

Figure 3-29 Java Editor: Content Assist preferences

Folding

When enabled, a user of the Workbench can collapse a method, comments, or class into a concise single line view.

To configure folding preferences, select **Windows** → **Preferences** → **Java** → **Editor** → **Folding** (Figure 3-30).

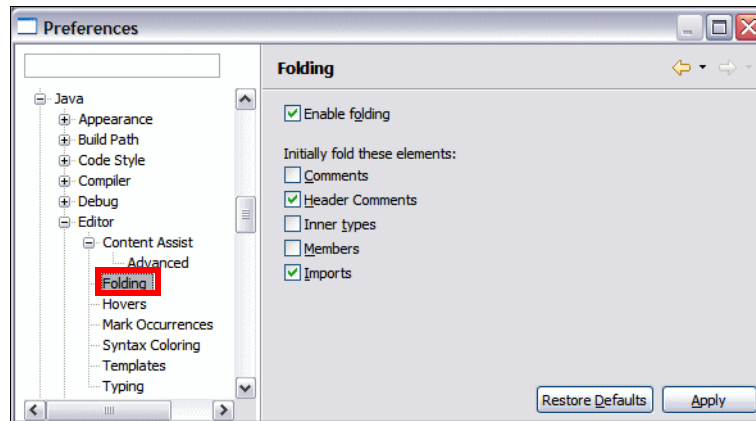

Figure 3-30 Java Editor: Folding preferences

Mark occurrences

When enabled, this highlights all occurrences of the types of entities described in the screen (Figure 3-31). In the Java editor, by selecting an attribute (for example), the editor displays in the far right-hand context bar all occurrences in the resource of that attribute. This can be navigated to by selecting the highlight bar in that context bar.

To configure mark occurrences preferences, select **Windows** → **Preferences** → **Java** → **Editor** → **Mark Occurrences** (Figure 3-31).

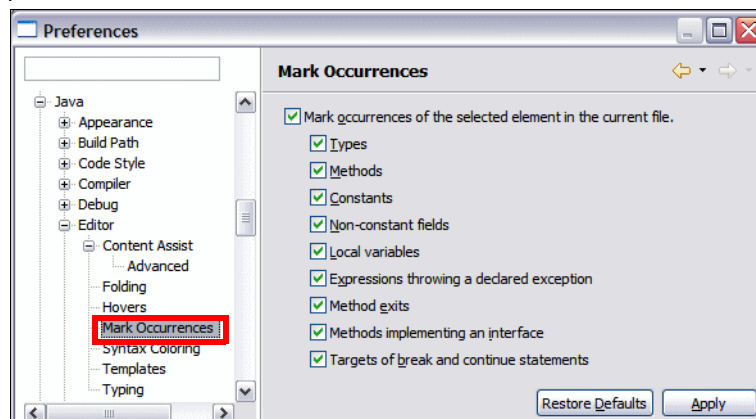

Figure 3-31 Java Editor: Mark Occurrences preferences

Templates

A template is a convenience that allows the programmer to quickly insert often reoccurring source code patterns. Application Developer has pre-defined templates and allows you to create new and edit existing templates.

The templates can be used by typing a part of the statement you want to add; and then by pressing Ctrl+Spacebar in the Java editor, a list of templates matching the key will appear in the presented list. Note that the list is filtered as you type, so typing the few first characters of a template name will reveal it.

The symbol in front of each template (Figure 3-32), in the code assist list is colored yellow, so you can distinguish between a template and a Java statement entry.

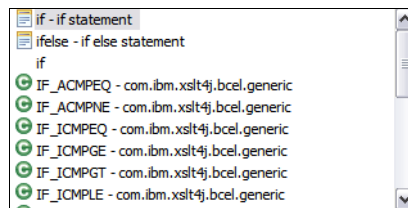

Figure 3-32 Using templates for content assist

To configure templates, select **Windows** → **Preferences** → **Java** → **Editor** → **Templates** (Figure 3-33).

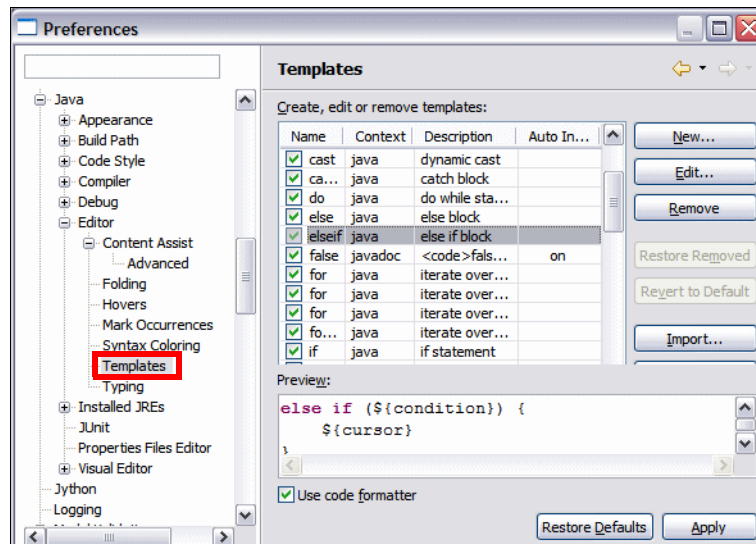

Figure 3-33 Java Editor: Templates preferences

- ▶ Click **New** to add a new template and, for example, enter the information to create a new template for a multi-line if-then-else statement, and click **OK** (Figure 3-34).

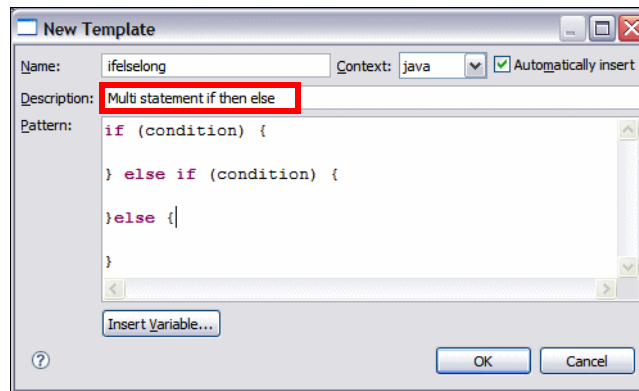

Figure 3-34 Creating a new template

The template is now available for use in the Java editor.

There are also some predefined variables available that can be added in the template. These variables can be inserted by clicking **Insert Variable**. This brings up a list and a brief description of the variable.

Templates that have been defined can be exported and later imported into Application Developer to ensure that a common environment can be set up among a team of developers.

Compiler options

Problems detected by the compiler are classified as either warnings or errors. The existence of a warning does not affect the execution of the program. The code executes as if it had been written correctly. Compile-time errors (as specified by the Java Language Specification) are always reported as errors by the Java compiler.

For some other types of problems you can, however, specify if you want the Java compiler to report them as warnings, errors, or to ignore them.

To configure the compiler options, select **Window** → **Preferences** → **Java** → **Compiler** (Figure 3-35).

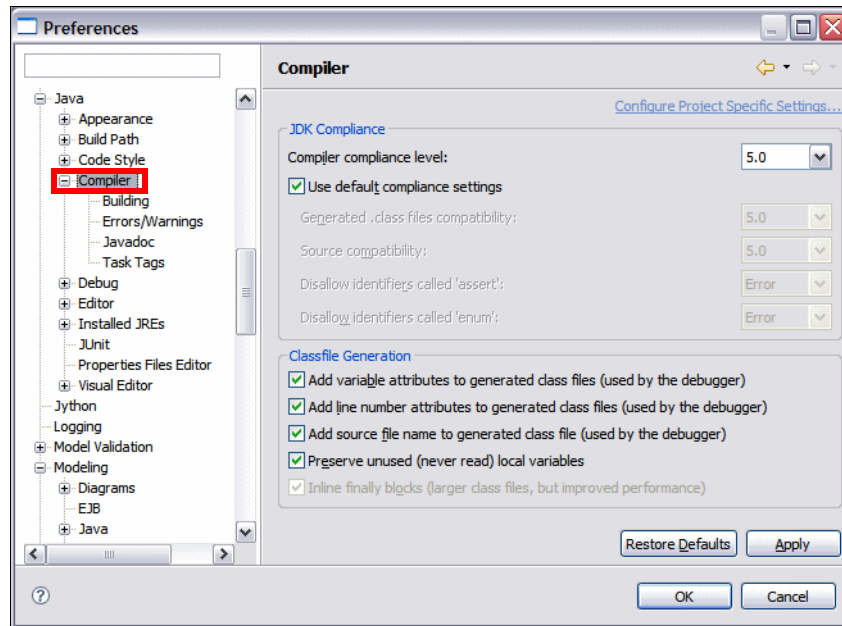

Figure 3-35 Java: Compiler preferences

The compiler preferences page includes four sub-pages that allow you to set the appropriate behavior required to ensure that you obtain the required information from the compiler:

- ▶ **Building:** Indicates your preferences for the Building settings, such as build path problems, output folder, and so on.
- ▶ **Errors/Warnings:** Defines the level the errors and warnings in several categories such as code style, potential programming problems, unnecessary code, annotations, and so on.
- ▶ **Javadoc:** Provides configuration settings on how to deal with Javadoc problems that might arise and what to display as errors.
- ▶ **Task Tags:** Enables you to create, edit and remove Java task tags.

Installed JREs

Application Developer allows you to specify which Java Runtime Environment (JRE) should be used by the Java builder. By default, the standard Java VM that comes with the product is used; however, to ensure that your application is targeted for the correct platform, the same JRE or at least the same version of the JRE should be used to compile the code. If the application is targeted for a

WebSphere Application Server V6.1, then the JRE should be set to use the JRE associated with this environment in Application Developer.

To configure the installed JREs, select **Windows** → **Preferences** → **Java** → **Installed JREs** (Figure 3-36).

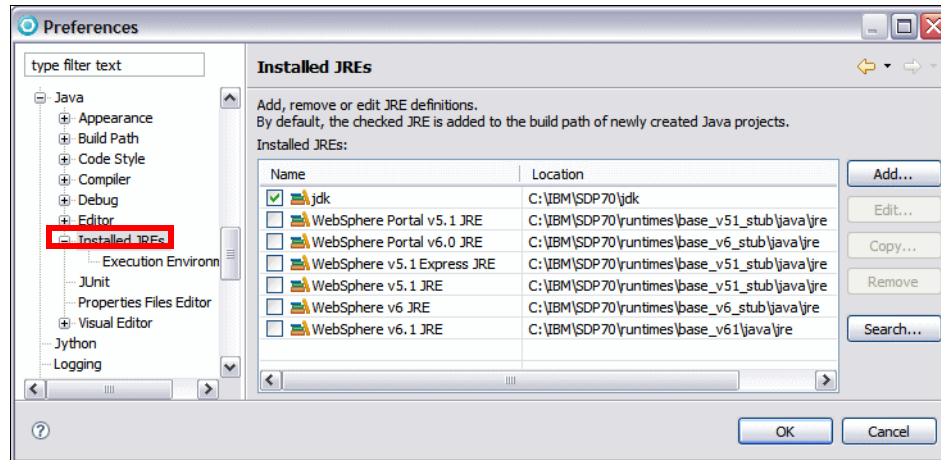

Figure 3-36 Java: Installed JRE preferences

Note: Changing the JRE used for running does not affect the way Java source is compiled. You can adjust the build path to compile against custom libraries.

By default, the JRE used to run the Workbench will be used to build and run Java programs. It appears selected in the list of installed JREs. If the target JRE that the application will run under is not in the list of JREs, then this can be installed on the machine and added onto the list. You can add, edit, or remove a JRE.

Let us assume that the application you are writing requires the latest JRE 1.6 located in the directory C:\Program Files\Java\jre1.6\. The procedure to add a new JRE is as follows:

- ▶ Click **Add**.
- ▶ In the Add JRE dialog, enter the following items:
 - JRE type: A drop-down box indicating whether a Standard VM or Standard 1.1.x VM. In most circumstances this will be set to **Standard VM**.
 - JRE name: Any name for the JRE to identify it.
 - JRE home directory: The location of the root directory of the install for the JRE: C:\Program Files\Java\jre1.6\

- Default VM arguments: Arguments that are required to be passed to the JRE.
 - JRE system libraries: List of Jar files required for the JRE. Add Jar files under the C:\Program Files\Java\jre1.6\lib and C:\Program Files\Java\jre1.6\lib\ext directories.
- ▶ Click **OK** to add.
 - ▶ Select the JRE in the list of installed JREs to set it as the default JRE, click **OK**, and rebuild all the projects in the workspace.

Summary

In this chapter we described how to configure the Workbench preferences in regard to logging, automatic builds, development capabilities, and Java development.



Perspectives, views, and editors

Rational Application Developer supports a role-based development model, which means that the development environment provides different tools, depending on the role of the user. It does this by providing several different perspectives that contain different editors and views necessary to work on tasks associated with each role.

This chapter starts with an introduction to the common structures and features applicable to all perspectives in Application Developer and then describes its help facility. Following this we provide a brief overview of the main features of each perspective available in IBM Rational Application Developer V7.5. Most of these perspectives are described in detail in the chapters within this book.

The chapter is organized into the following sections:

- ▶ Integrated development environment (IDE)
- ▶ Application Developer Help
- ▶ Available perspectives
- ▶ Summary

Integrated development environment (IDE)

An integrated development environment is a set of software development tools such as source editors, compilers and debuggers, that are accessible from a single user interface.

In Rational Application Developer, the IDE is called the **Workbench**. Rational Application Developer's Workbench provides customizable perspectives that support role-based development. It provides a common way for all members of a project team to create, manage, and navigate resources easily.

Views provide different ways of looking at the resources you are working on and editors allow you to create and modify the resources. Perspectives are a combination of views and editors that show various aspects of the project resource, and are organized by developer role or task. For example, a Java developer would work most often in the Java perspective, while a Web designer would work in the Web perspective.

Several default perspectives are provided in Rational Application Developer and team members also can customize them according to their current role and personal preference. More than one perspective can be opened at a time and users can switch perspectives while working with Application Developer. If you find that a particular perspective does not contain the views or editors you require, you can add them to the perspective and position them to suit your requirements.

Perspectives

Perspectives provide a convenient grouping of views and editors that match a particular way of using Rational Application Developer. A different perspective can be used to work on a given workspace depending on the role of the developer or the task that has to be done.

For each perspective, Application Developer defines an initial set and layout of views and editors for performing a particular set of development activities. For example, the Java EE perspective contains views and editors applicable for EJB development. The layout and the preferences in each perspective can be changed and saved as a customized perspective and used again later. This is described in "Organizing and customizing perspectives" on page 124.

Views

Views provide different presentations of resources or ways of navigating through the information in your workspace. For example, The Enterprise Explorer view provides a hierarchical view of the resources in the Workbench. From here, you can open files for editing or select resources for operations such as exporting, while the Outline view displays an outline of a structured file that is currently open in the editor area, and lists structural elements. Rational Application Developer provides synchronization between views and editors, so that changing the focus or a value in an editor or view can automatically update another. In addition, some views display information obtained from other software products, such as database systems or software configuration management (SCM) systems.

A view can appear by itself or stacked with other views in a tabbed notebook arrangement. To quickly move between views in a given perspective, you can select **Ctrl-F7** (and hold down Ctrl), which will show all the open views and let the user move quickly to the desired view. Press **F7** until the required view is selected, then release to move to that view.



Editors

When you open a file, Rational Application Developer automatically opens the editor that is associated with that file type. For example, the Page Designer is opened for .html, .htm, and .jsp files, while the Java editor is opened for .java and .jpage files.

Editors that have been associated with specific file types will open in the editor area of the Workbench. By default, editors are stacked in a notebook arrangement inside the editor area. If there is no associated editor for a resource, Rational Application Developer will open the file in the default editor, which is a text editor. It is also possible to open a resource in another editor by using the **Open With** option from the context menu.

To quickly move between editors open on the workspace, you can select **Ctrl-F6** (and hold down Ctrl) which will show all the open editors and let the user move quickly to the desired one. Press **F6** until the required editor is selected, then release.

The following icons appear in the Toolbar of a perspective to speed up navigation between editors:

- ▶ **Next and Previous cursor location** ( and )—Moves the focus around recent cursor positions.
- ▶ **Last Edit Location** ()— Reveals the location where the last edit occurred.

- ▶ **Next and Previous Annotation** (↕ and ↕)—Depending on the options selected in the associated drop-down menu, this moves the cursor to the next and previous annotation in the associated list. For example, if errors are chosen, these buttons will move the cursor to the next or previous source code error in the resource being edited.

Perspective layout

Many of Rational Application Developer's perspectives use a similar layout. Figure 4-1 shows the general layout that is used for most default perspectives.

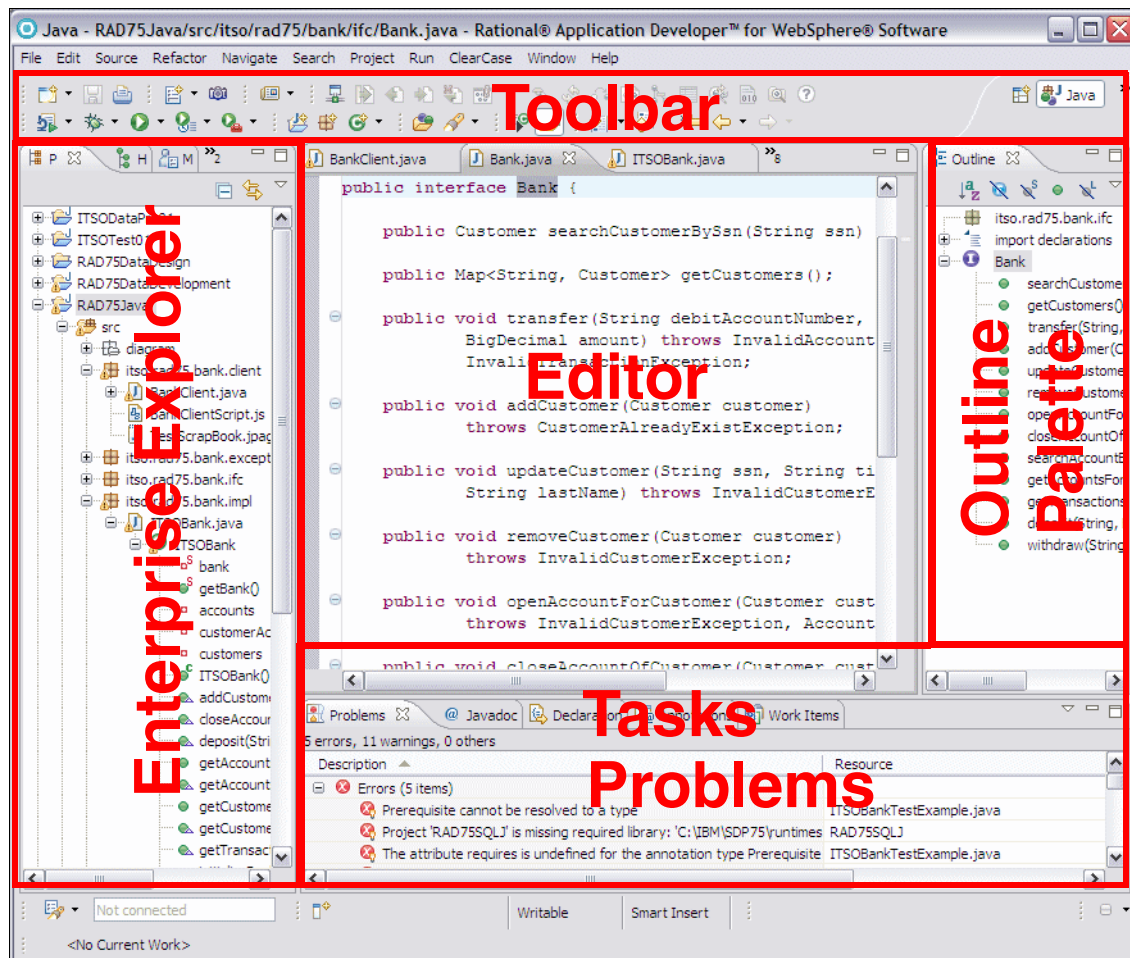



Figure 4-1 Perspective layout

On the left side are views for navigating through the workspace. In the middle of the Workbench is larger pane, where the main editors are shown. The right pane usually contains Outline or Palette views of the file in the main editor. In some perspectives the editor pane is larger and the outline view is located at the bottom left corner of the perspective. At the bottom right is a tabbed series of views including the Tasks view, the Problems view, and the Properties view. This is where smaller miscellaneous views not associated with navigation, editing, or outline information are shown.

Switching perspectives

There are two ways to open another:

- ▶ Click the **Open a perspective** icon () in the top right corner of the Workbench working area and select the appropriate perspective from the list.
- ▶ Select **Window** → **Open Perspective** and select one from the drop-down list shown.

In both cases there is also an **Other** option, which when selected displays the **Open Perspective** dialog that shows list of s (see Figure 4-2). To show the complete list of perspectives, check the **Show all** check box, if exists. Here the user can select the required perspective and click **OK**.

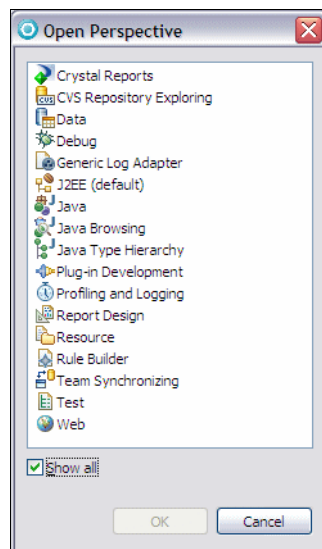

Figure 4-2 Open perspective dialog

In all perspectives, a group of buttons appears in the top right corner of the Workbench (an area known as the shortcut bar). Each button corresponds to an open perspective and the >> icon will show a list if there are too many (see Figure 4-2). Clicking on one of these will move to the associated perspective.

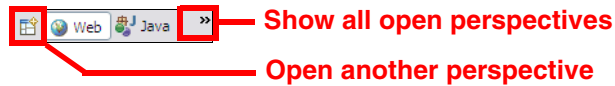

Figure 4-3 Buttons to switch between perspectives

Tips:

- ▶ The name of the perspective is shown in the window title area along with the name of the file open in the editor, which is currently at the front.
- ▶ To close a perspective, right-click the perspective's button on the shortcut bar (top right) and select **Close**.
- ▶ To display only the icons for the perspectives, right-click somewhere in the shortcut bar and clear the **Show Text** option.
- ▶ Each perspective requires memory, so it is good practice to close s that are perspective not used to improve performance.

Specifying the default perspective

The Java EE perspective is Rational Application Developer's default perspective, but this can be changed using the Preferences dialog:

- ▶ From the Workbench, select **Window** → **Preferences**.
- ▶ Expand **General** and select **Perspectives**. Note that the Java EE perspective has **default** after it.
- ▶ Select the perspective that you want to define as the default, and click **Make Default**.
- ▶ Click **OK**.

Organizing and customizing perspectives

Rational Application Developer allows you to open, customize, reset, save, and close perspectives. These actions can be found in the **Window** menu.

To customize the commands and shortcuts available within a perspective, select **Window** → **Customize Perspective**. The Customize Perspective dialog opens (Figure 4-4).

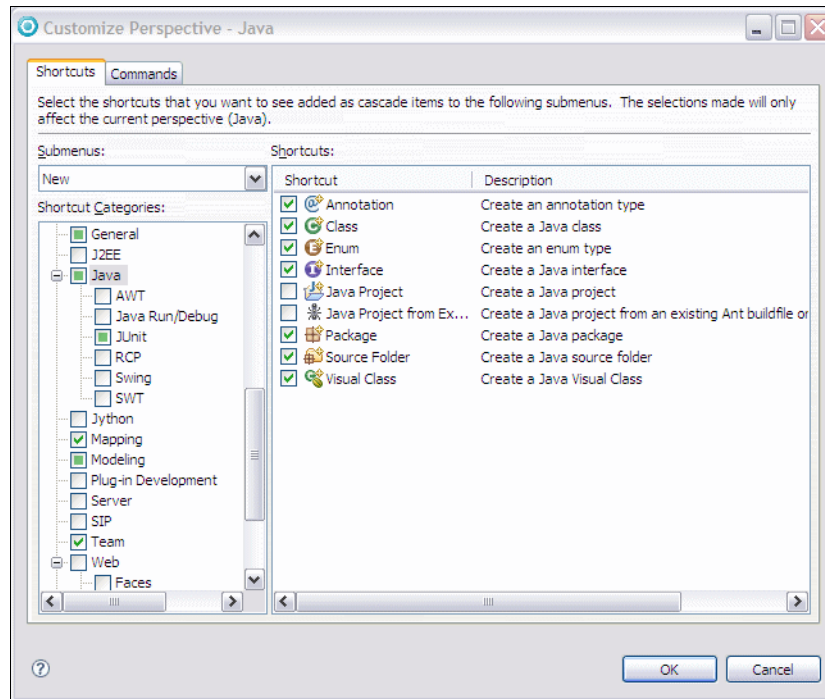

Figure 4-4 Customize Perspective dialog

The **Shortcuts** tab provides the facility to specify which options are shown on the **New**, **Open Perspective**, and **Show View** menu options within the current. Select the menu you want to customize from the **Submenus** drop-down window and check the boxes for whichever options you want to appear. Note that items you do not select are still accessible by clicking the **Other** menu option, which is always present for these options.









The **Commands** tab of the dialog allows you to select command groups that will be added to the menu bar or tool bar for Rational Application Developer in this perspective.

In addition to customizing the Command and options available as shortcuts, it is also possible to reposition any of the views and editors and to add or remove other editors as desired. The following features are available to do this:

- ▶ **Adding and Removing Views**—To add a view to the perspective, select **Window** → **Show View** and select the view you would like to add to the currently open perspective. To remove a view, simply close it from its title bar.
- ▶ **Move**—You can move a view to another pane by using drag and drop. To do this, select its title bar and drag the view to another place on the workspace.

While you drag the view, the mouse cursor changes into a drop cursor, which indicates where the view will appear when it is released. In each case, the area that is filled with the dragged view is highlighted with a rectangular outline.

The drop cursor will look like one of the following:

-  The view will dock below the view under the cursor.
 -  The view will dock to the left of the view under the cursor.
 -  The view will dock to the right of the view under the cursor.
 -  The view will dock above the view under the cursor.
 -  The view will appear as a tab in the same pane as the view under the cursor.
 -  The view will dock in the status bar (at the bottom of the Rational Application Developer window) and become a **Fast View** (see below). This icon will appear when a view is dragged to the bottom left corner of a work-space.
 -  The view becomes a separate child window of the main Rational Application Developer window. This icon will appear when you drag a view to an area outside the work-space. To return the view back into the work-space, right click its title bar and clear the **Detached** menu item.
- ▶ **Fast View**—A Fast View appears as a button in the status bar of Rational Application Developer in the bottom left corner of the workspace. Clicking the button will toggle whether or not the view is displayed on top of the other views in the perspective.
 - ▶ **Maximize and minimize a view**—To maximize a view to fill the whole working area of the Workbench, you can double-click the title bar of the view, press Ctrl+M, or click the Maximize icon () in the view's toolbar. To restore the view double-click the title bar, select the restore button () or press Ctrl+M again. The Minimize button in the toolbar of a view minimizes the tab group so that only the tabs are visible; click the **Restore** button or one of the view tabs to restore the tab group.
 - ▶ **Save**—Once you have configured the perspective to your preferences, you can save it as your own perspective by selecting **Window** → **Save Perspective As** and type a new name. The new perspective now appears as an option on the **Open Perspective** window.
 - ▶ **Restore**—To restore the currently open perspective to its original layout, select **Window** → **Reset Perspective**.

Application Developer Help

The Rational Application Developer Help system lets you browse, search, bookmark, and print help documentation. The documentation is organized into sets of information that are analogous to books. The help system also supplies a text search capability for finding the information you need by search phrase or keyword, and context-sensitive help for finding information to describe the particular function you are working with.

The Help contents can be displayed in a separate window, by selecting **Help** → **Help Contents** from the menu bar (Figure 4-5).

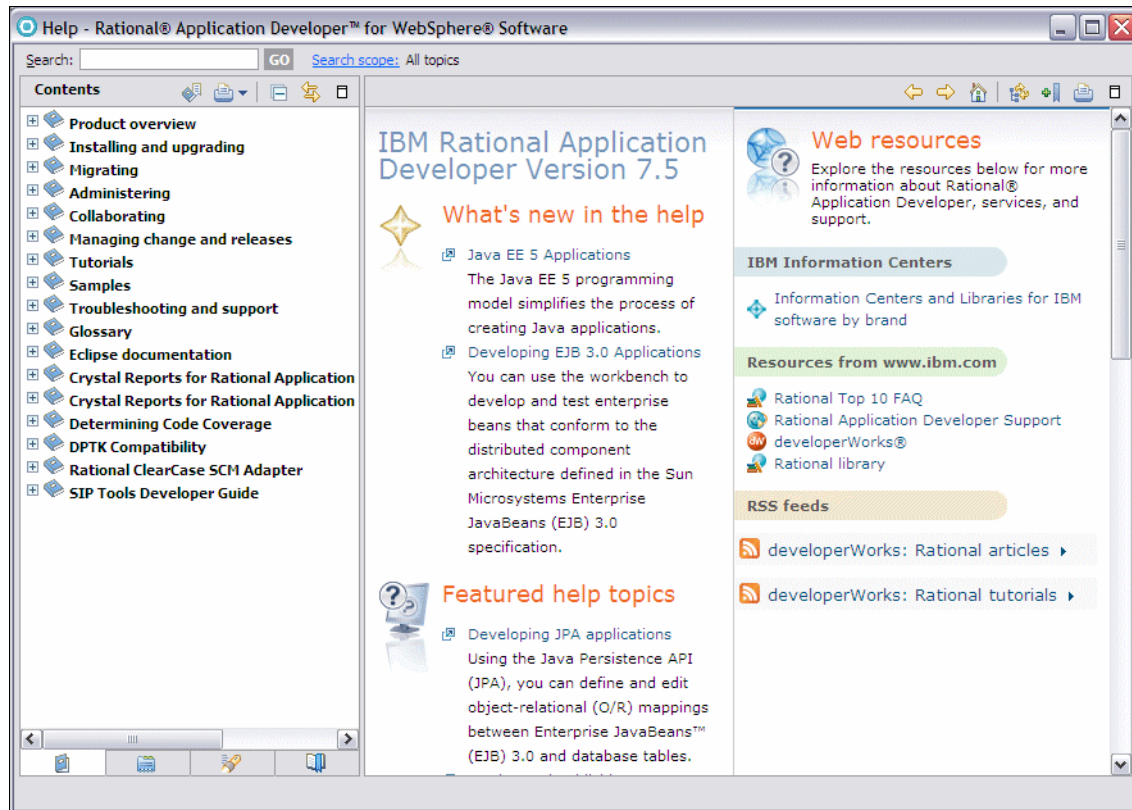

Figure 4-5 Help window

In the Help window you see the available books in the left pane and the content in the right pane. When you select a book (📖) in the left pane, the appropriate table of contents opens up and you can select a topic (📄) within the book. When a page (📄) is selected, the page content is displayed in the right pane.

You can navigate through the help documents by clicking **Go Back** (←) and **Go Forward** (→) in the toolbar of the right pane.

The following buttons are also available in the toolbar:

- ▶ **Show in Table of Contents** (📖)—Synchronizes the navigation frame with the current topic, which is helpful when the user follows several links to related topics in several files, and wants to see where the current topic fits into the navigation path.
- ▶ **Bookmark Document** (📌)—Adds a bookmark to the Bookmarks view, which is one of the tabs on the left pane.
- ▶ **Print Page** (🖨)—Provides the option to print the page current displayed in the right-hand window.
- ▶ **Maximize** (📐)—Maximizes the right hand pane to fill the whole help window. Note that when this pane is maximized, the icon changes to **Restore** (📏) which allows the user to return the page back to normal.

Also, the left hand pane of the help window can be tabbed between the **Contents**, **Index**, **Search Results**, and **Bookmarks** views, which provide different methods of accessing information the help contents.

Rational Application Developer's help system contains a lot of useful information about the tools and technologies available from the workbench, and is loosely arranged around different types of development possible (for example Java, Web, XML and many others). While performing any task within Application Developer, you can press **F1** at any time and the **Help** view displays the context help showing a list of relevant topics for the current view or editor. For example, Figure 4-6 shows the context help when editing normal Java code.

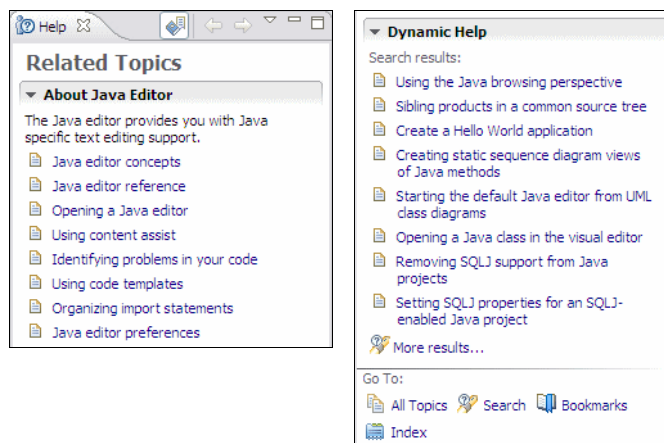

Figure 4-6 Context sensitive help when Java editing

Also, at any time it is possible to display the Help contents as a view within the workspace, by selecting **Window** → **Show View** → **Other** → **Help** → **Help**.

The Search field allows you to do a search which will be through all the Help contents by default. Clicking the **Search Scope** link opens a dialog box where you can select a scope for your search (Figure 4-7). This will show any previously defined search scopes and give the user the opportunity to create a new one.

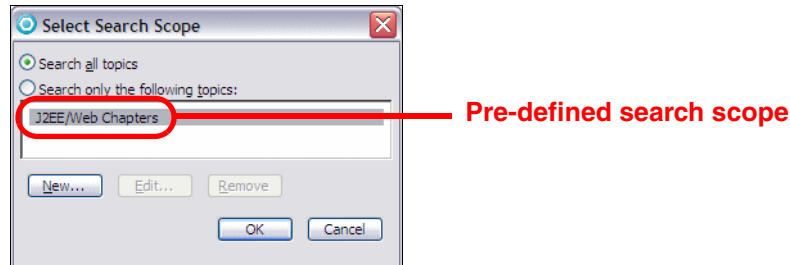

Figure 4-7 Select Search Scope dialog for help

Once the search list has been saved, it can be selected as a search scope from the main search page.

Clicking **Go** performs the search across the selected scope and display the results in the **Search Results** view, and from there the user can open the pages within the Help facility.

Available perspectives

In this section all the perspectives that are available in Rational Application Developer are briefly described. The perspectives are covered in alphabetical order which is how they appear in the **Open Perspective** dialog.

Rational Application Developer allows a developer to disable or enable capabilities to simplify the interface or make it more capable for specific types of development work respectively. This is described in “Capabilities” on page 88. For this section, all capabilities have been enabled in the product. If this is not done, certain perspectives, associated with specific capabilities, may not available.

IBM Rational Application Developer v7.5 includes the following perspectives:

- ▶ Crystal Reports perspective
- ▶ CVS Repository Exploring perspective
- ▶ Data perspective

- ▶ Database Debug perspective
- ▶ Database Development perspective
- ▶ Debug perspective
- ▶ Java perspective
- ▶ Java Browsing perspective
- ▶ Java EE perspective
- ▶ Java Type Hierarchy perspective
- ▶ JavaScript perspective
- ▶ Jazz Administration perspective
- ▶ JPA perspective
- ▶ Plug-in Development perspective
- ▶ Profiling and Logging perspective
- ▶ Report Design perspective
- ▶ Requirement perspective
- ▶ Resource perspective
- ▶ Team Synchronizing perspective
- ▶ Test perspective
- ▶ Web perspective
- ▶ Work items perspective

Crystal Reports perspective

The Crystal Reports features are an optional extra that can be selected when installing Application Developer. If this is installed, then the Crystal Reports perspective provides the tools to work with a database and produce simple or complex reports (using Crystal reports) which can be published to the Web or incorporated into an application. The main editor uses a Layout page where report elements can be placed on report templates from the Palette view and a Preview page to show what a report will look like. These work with the Data Source Explorer View and the Field Explorer View to position various fields from results of queries and database tables onto the report.

The Rational Application Developer Help has a large section on the details of using this perspective.

CVS Repository Exploring perspective

The CVS Repository Exploring perspective (Figure 4-8) lets you connect to Concurrent Versions System (CVS) repositories and to inspect the revision history of resources in those repositories.

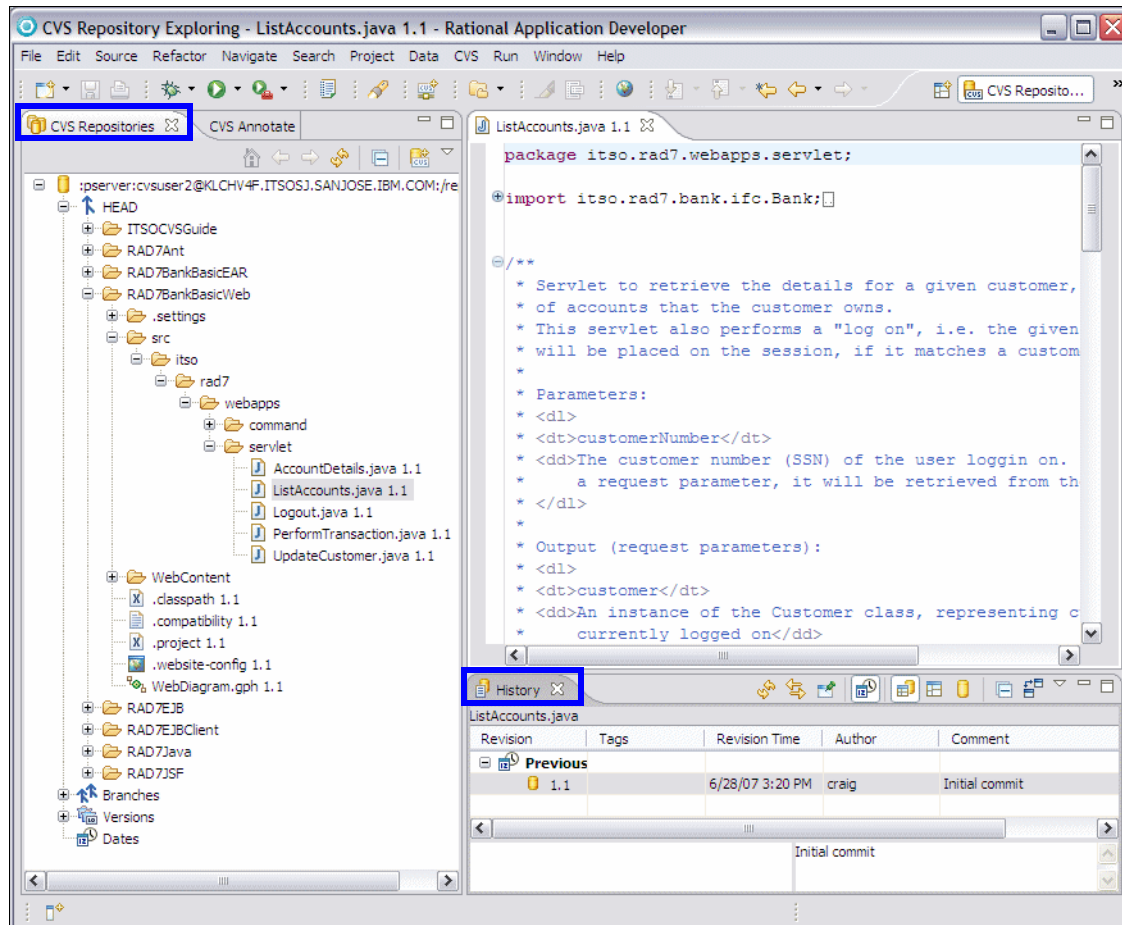

Figure 4-8 CVS Repository Exploring perspective

- ▶ **CVS Repositories view**—Shows the CVS repository locations that have been added to the Workbench. Expanding a location reveals the main trunk (HEAD), project versions, and branches in that repository. You can further expand the project versions and branches to reveal the folders and files contained within them.
The context menu for this view also allows you to specify new repository locations. The CVS Repositories view can be used to check out resources from the repository to the Workbench, configure the branches and versions shown by the view, view a resource's history and compare resource versions.
- ▶ **Editor**—Files that exist in the repositories can be viewed by double-clicking them in a branch or version. This opens the version of the file specified in the editor pane. Note that the contents of the editor are read-only.

- ▶ **CVS Resource History view**—Displays a detailed history of each file providing a list of all the revisions of it in the repository. From this view you can also compare two revisions or open an editor on a revision.
- ▶ **CVS Annotation view**—To show this view, select a resource in the CVS Repositories view, right-click and select **Show Annotation**. The CVS Annotate view will come to the front and will display a summary of all the changes made to the resource since it came under the control of the CVS server. The CVS Annotate view will link with the main editor, showing which CVS revisions apply to which source code lines.

More details about using the CVS Repository Exploring perspective, and other aspects of CVS functionality in Rational Application Developer, can be found in Chapter 28, “CVS integration” on page 1019.

Data perspective

The Data perspective (Figure 4-9) lets you access a set of relational database tools, where you can create and manipulate the database definitions for your projects.

The important views are as follows:

- ▶ **Data Project Explorer**—The main navigator view in the Data perspective showing only the data projects in the workspace. This view lets you work directly with data definitions and define relational data objects. It can hold local copies of existing data definitions imported from the DB Servers view, designs created by running DDL scripts, or new designs that you have created directly in the Workbench.
- ▶ **Data Source Explorer view**—This view provides a list of configured connection profiles. If the Show Category button  is selected, you can see the list grouped into categories, for example, Databases and ODA Data Sources. Use the Data Source Explorer to connect to, navigate, and interact with resources associated with the selected connection profile. It also provides import and export capabilities to share connection profile definitions with other Workbenches.
- ▶ **Tasks view**—The Tasks view displays system-generated errors, warnings, or information associated with a resource, typically produced by builders. Tasks can also be added manually and optionally associated with a resource in the Workbench.
- ▶ **Navigator view**—The optional Navigator view provides a hierarchical view of all the resources in the Workbench. By using this view you can open files for editing or select resources for operations such as exporting. The Navigator view is essentially a file system view, showing the contents of the workspace

and the directory structures used by any projects that have been created outside the workspace.

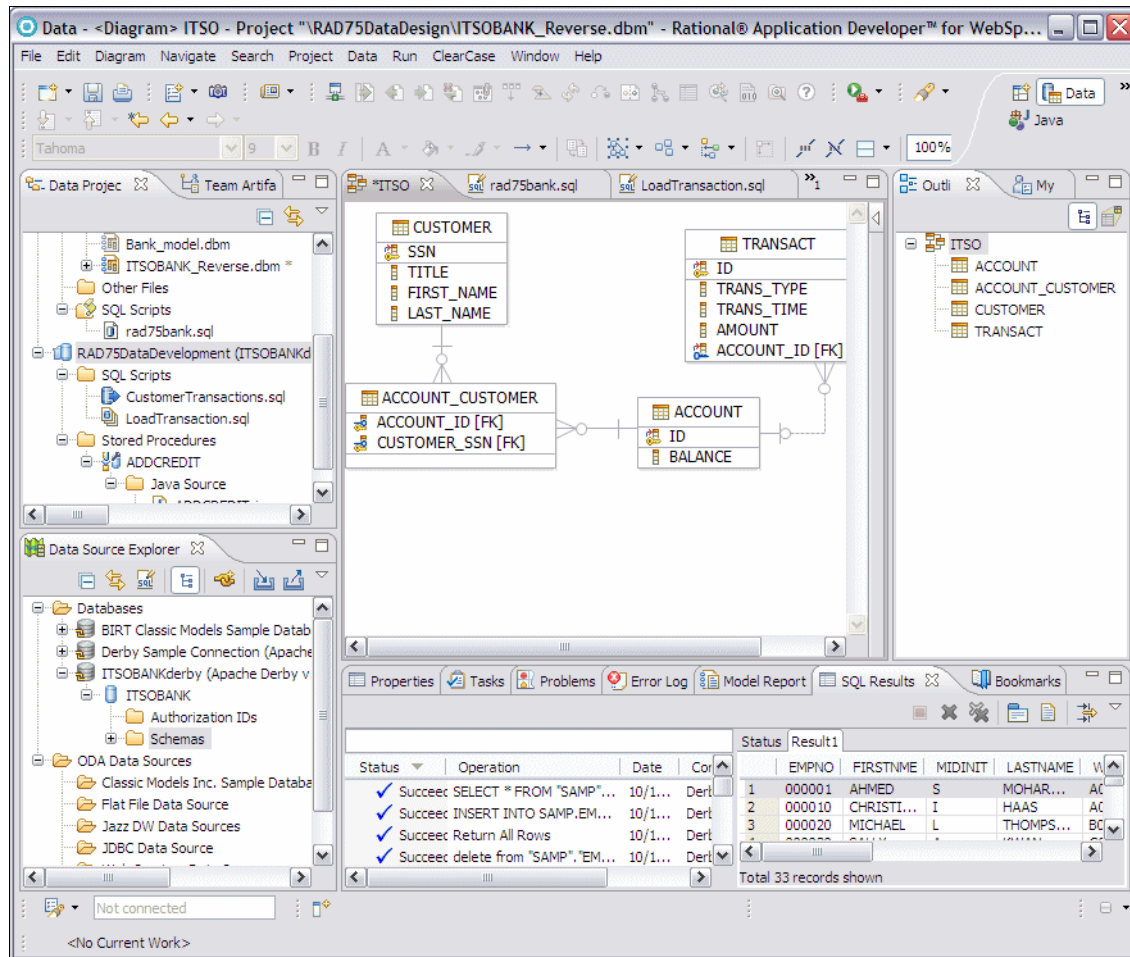

Figure 4-9 Data perspective

- ▶ **Console view**—The Console view shows the output of a process and allows you to provide keyboard input to a process. The console shows three different kinds of text, each in a different color: Standard output, standard error, and standard input.
- ▶ **SQL Results view**—The SQL Results view displays information about actions that are related to running SQL statements, stored procedures, and user-defined functions (UDFs), or creating database objects. For example, when you run a stored procedure on the database server, the SQL Results view displays messages, parameters, and the results of any SQL statements

that are run by the stored procedure. The SQL Results view also displays results when you sample the contents of a selected table. The SQL Results view consists of a history pane and a details pane. The history pane displays the history for past queries. The details pane displays the status and results of the last run. Use the view pull-down menu to filter history results and set preferences.

- ▶ **SQL Builder/Editor**—This view shows specialized wizards for creating and editing of SQL statements.
- ▶ **Data Diagram Editor**—This view shows an Entity Relationship diagram of the selected database.

More details about using the Data perspective can be found in Chapter 11, “Develop database applications” on page 227.

Database Debug perspective

The Database Debug perspective (Figure 4-10) lets you debug your database stored procedures where you can watch the values of the variables and monitor the breakpoints.

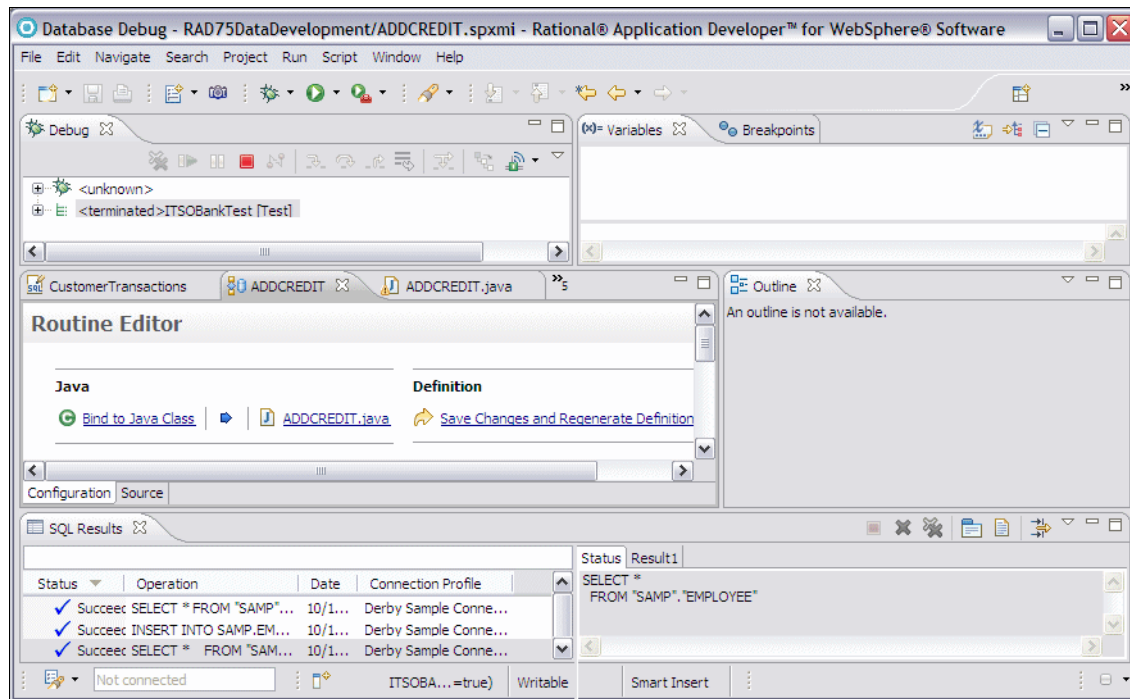

Figure 4-10 Database Debug perspective

This perspective includes the views: Debug, Variables, Breakpoints, Outline, and SQL Results which have been already discussed earlier in this chapter.

Database Development perspective

The Database Development perspective (Figure 4-11) is a simpler version of the Data perspective with only one view added which is the Execution Plan view. This view displays your current SQL execution plans which helps you optimize the execution of your queries, displays execution plans history, and can read SQL execution plans from files. More details about this perspective are in Chapter 11, “Develop database applications” on page 227.

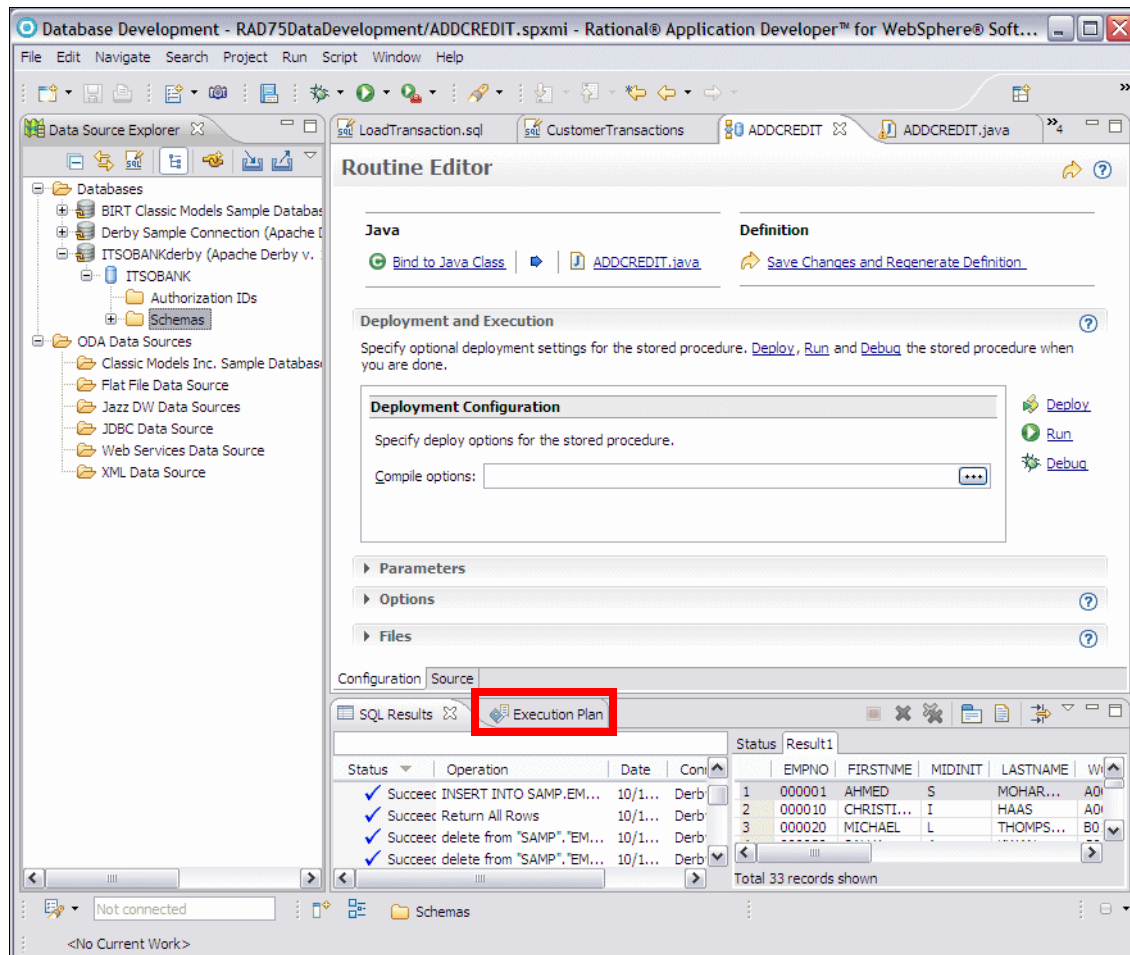

Figure 4-11 Database Development perspective

Debug perspective

By default, the Debug perspective (Figure 4-12) contains five panes with the following views:

- ▶ **Top left**—Shows Debug and Servers views
- ▶ **Top right**—Shows Breakpoints and Variables views.
- ▶ **Middle left**—Shows the editor for the resource being debugged.
- ▶ **Middle right**—Shows the Outline view of the resource being debugged.
- ▶ **Bottom**—Shows the Console and the Tasks view

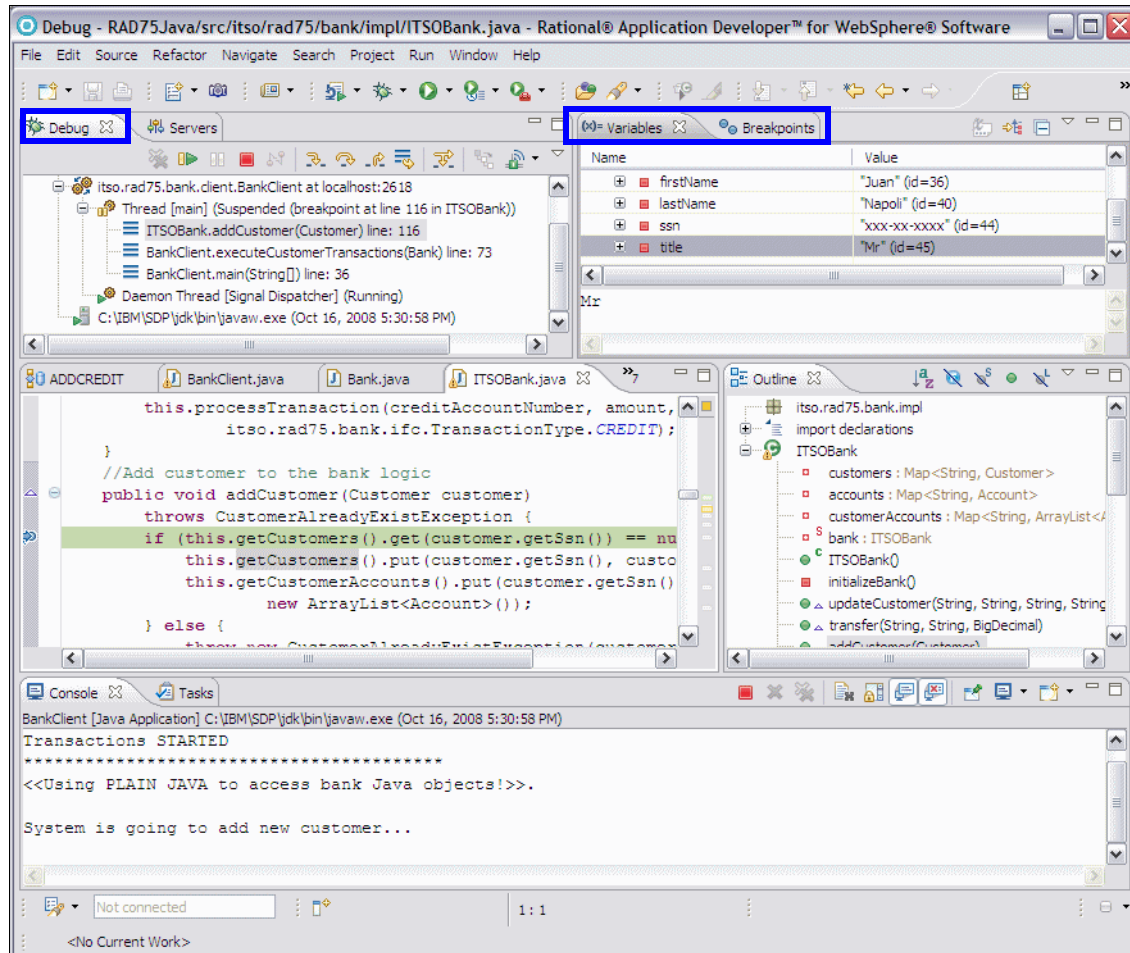

Figure 4-12 Debug perspective

The important views while debugging are as follows:

- ▶ **Debug view**—The Debug view displays the stack frame for the suspended threads for each target you are debugging. Each thread in your program appears as a node in the tree. If the thread is suspended, its stack frames are shown as child elements.

If the resource containing a selected thread is not open and/or active, the file opens in the editor and becomes active, focusing on the point in the source where the thread is currently positioned.

The Debug view contains a number of command buttons which enable users to perform actions such as start, terminate, and step-by-step debug actions.

- ▶ **Variables view**—The Variables view displays information about the variables in the currently selected stack frame.
- ▶ **Breakpoints view**—The Breakpoints view lists all the breakpoints you have set in the Workbench projects. You can double-click a breakpoint to display its location in the editor. In this view, you can also enable or disable breakpoints, remove them, change their properties, or add new ones. This view also lists Java exception breakpoints, which suspend execution at the point where the exception is thrown.
- ▶ **Servers view**—The Servers view lists all the defined servers and their status. Right-clicking a server displays the server context menu, which allows the server to be started, stopped, and to republish the current applications.
- ▶ **Outline view**—The Outline view shows the elements (imports, class, fields, and methods) that exist in the source file in the front editor. Clicking an item in the outline will position you in the editor view at the line where that structure element is defined.
- ▶ **Problems view**—This view shows all errors, warnings, and information messages related to resources in the workspace. The items listed in this view can be used to navigate to the line of code containing error, warning, or information point.

The Console and Tasks views have already been discussed in earlier sections of this chapter.

More information about the Debug perspective can be found in Chapter 24, “Debug local and remote applications” on page 861.

Java perspective

The Java perspective (Figure 4-13) supports developers with the tasks of creating, editing, and compiling Java code.

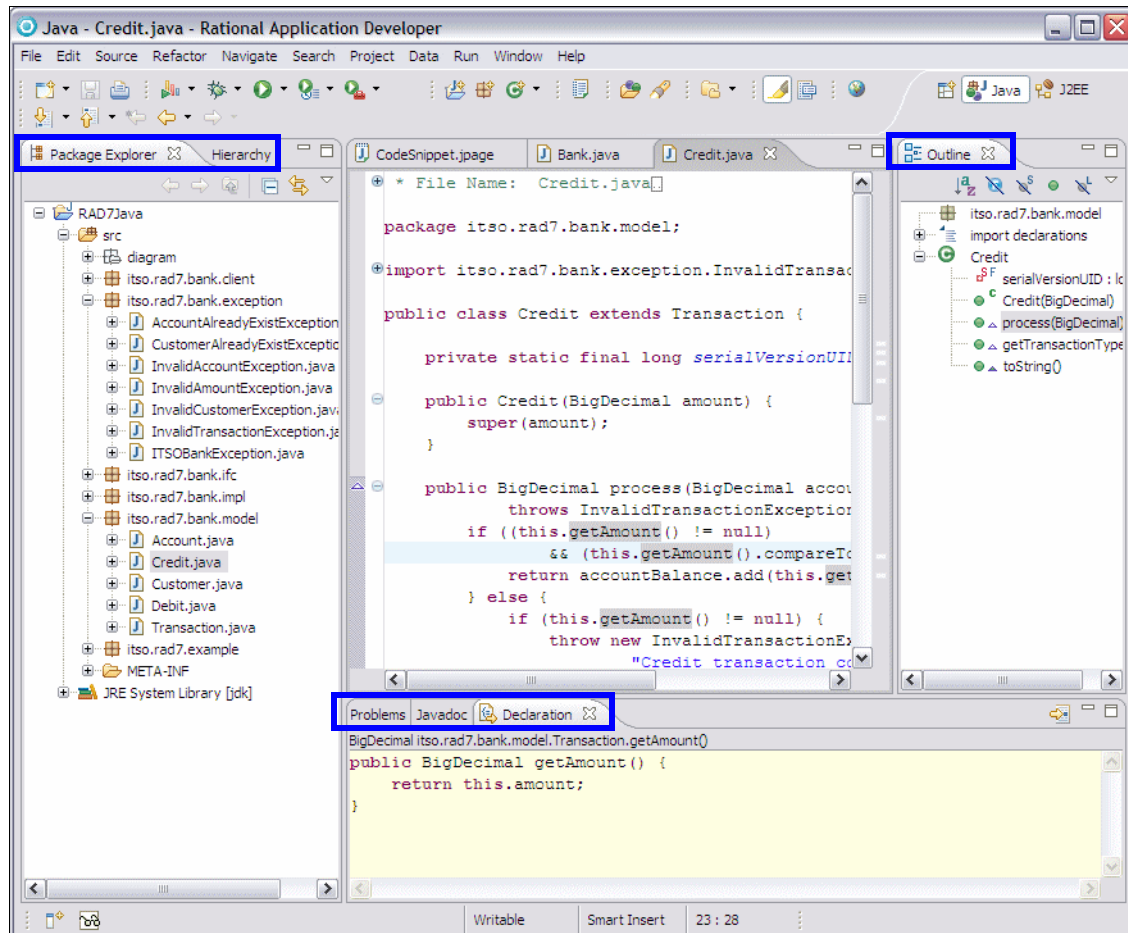





Figure 4-13 Java perspective

It consists of a main editor area and displays by default, the following views:

- ▶ **Package Explorer view**—Shows the Java element hierarchy of all the Java projects in your Workbench. This is a Java-specific view of the resources shown in the Navigator view (which is not shown by default in the Java perspective). For each project, its source folders and referenced libraries are shown in the tree view and from here it is possible to open and browse the contents of both internal and external JAR files.

- ▶ **Hierarchy view**—Can be opened for a selected type to show its super-classes and subclasses. It offers three different ways to look at a class hierarchy, by selecting the icons buttons at the top of the view:
 - The **Type Hierarchy icon** () displays the type hierarchy of the selected type. This includes its position in the hierarchy along with all its superclass and subclasses.
 - The **Supertype Hierarchy icon** () displays the supertype hierarchy of the selected type and any interfaces the type implements.
 - The **Subtype Hierarchy icon** () displays the subtype hierarchy of the selected type or, for interfaces, displays classes that implement the type.

More information about the Hierarchy view is provided in , “Java Type Hierarchy perspective” on page 142.

- ▶ **Javadoc view**—This view shows the Javadoc comments associated with the element selected in the editor or outline view.
- ▶ **Declarations view**—Shows the source code declaration of the element selected in the editor, in the hierarchy view or in outline view.

The Outline and Problems views are also applicable to the Java perspective and have already been discussed in earlier sections of this chapter.

Refer to Chapter 8, “Develop Java applications” on page 69 for more information about how to work with the Java, Java Browsing, and Java Type Hierarchy perspectives.

Java Browsing perspective

The Java Browsing perspective is also for Java development (Figure 4-14), but it provides different views from the Java perspective.

The Java Browsing perspective has a larger editor area and several views to select the programming element you want to edit:

- ▶ **Projects view**—Lists all Java projects
- ▶ **Packages view**—Shows the Java packages within the selected project
- ▶ **Types view**—Shows the types defined within the selected package
- ▶ **Members view**—Shows the members of the selected type

The Toggle Mark occurrences button () when toggled on highlights all occurrences of the previously search text within the current editor.

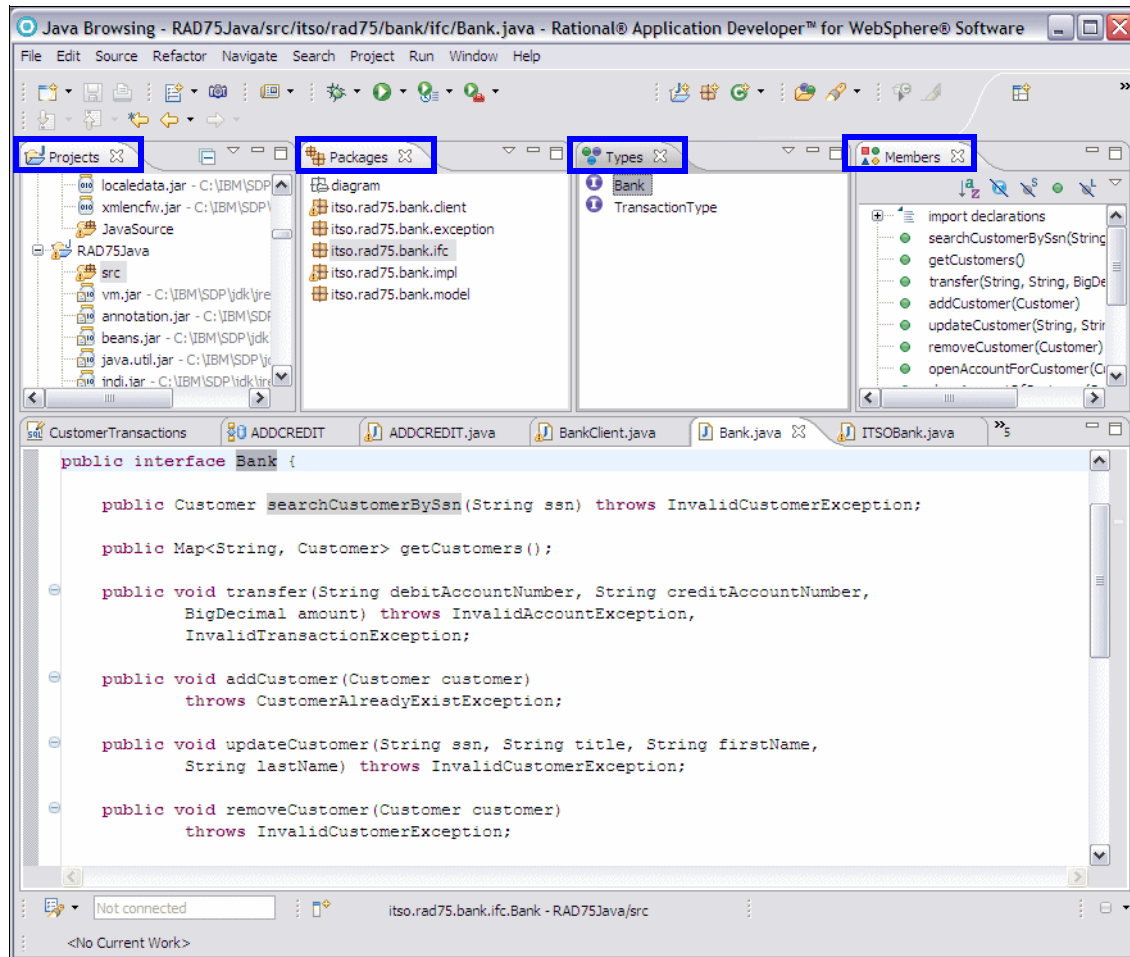

Figure 4-14 Java Browsing perspective

Java EE perspective

The Java EE perspective (Figure 4-15) includes workbench views that you can use when developing resources for enterprise applications, EJB modules, Web modules, application client modules, and connector projects or modules.

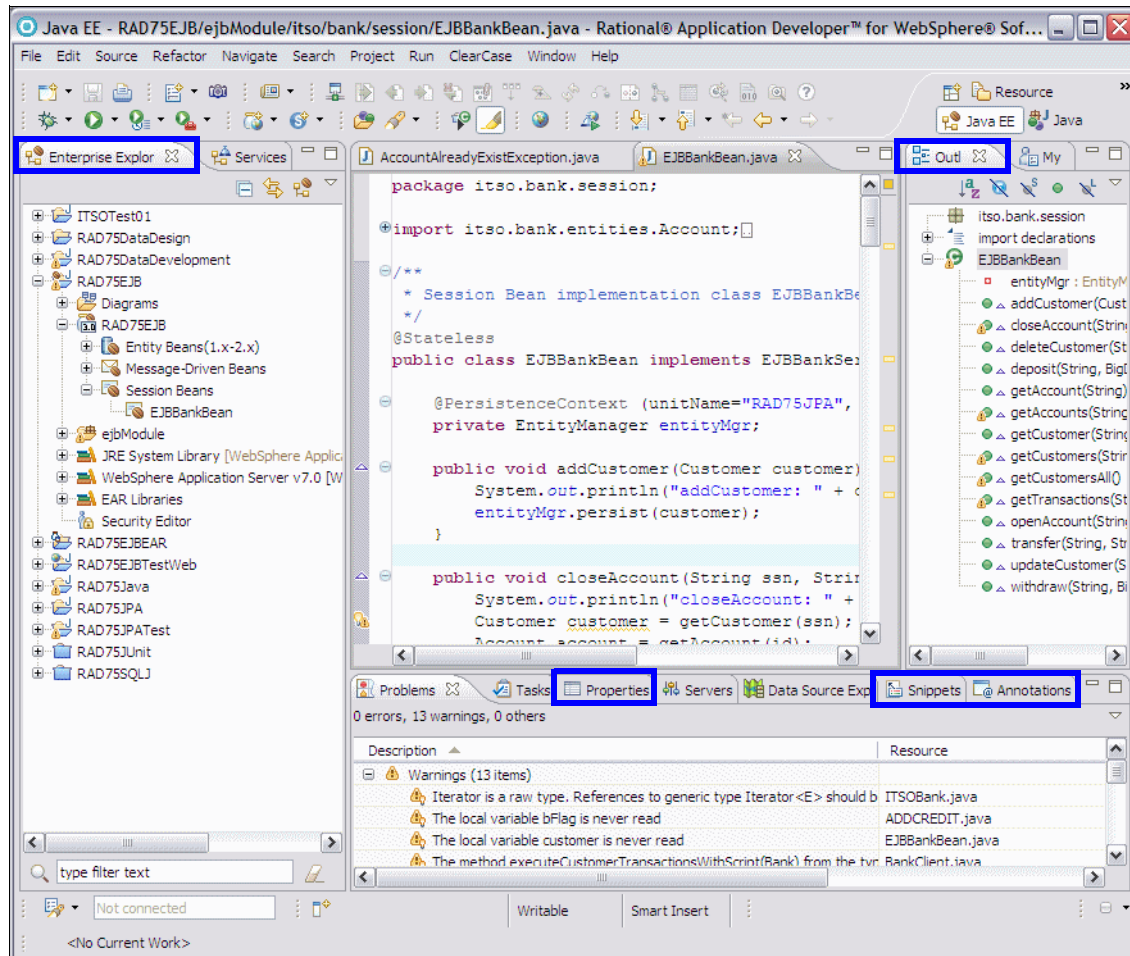

Figure 4-15 Java EE perspective

The Java EE perspective contains the following views typically used when developing Java EE applications:

- ▶ **Enterprise Explorer view**—This view provides an integrated view of your projects and their artifacts related to Java EE development. You can show or hide your projects based on working sets. This view displays navigable models of Java EE deployment descriptors, Java artifacts (source folders, packages, and classes), navigable models of the available Web services, and specialized views of Web modules to simplify the development of dynamic Web applications. In addition, EJB database mapping and the configuration of projects for a Java EE application server are made readily available.

- ▶ **Annotations view**—The Annotations view, new in this release, provides a way for you to create, edit, browse, and generally keep track of the annotations that you use in your applications.
- ▶ **Snippets view**—The Snippets view lets you catalog and organize reusable programming objects, such as Web services, EJB, and JSP code snippets. The view can be extended based on additional objects that you define and include. The available snippets are arranged in *drawers*, and the drawers can be customized by right-clicking a drawer and selecting **Customize**.
- ▶ **Properties view**—This view provides a tabular view of the properties and associated values of objects in files you have open in an editor. The format of this view differs depending on what is selected in the editor, and by default it shows the file properties (last modification date, file path and so on).

The Outline, Servers, Problems, Tasks, and Data Source Explorer views are also relevant to the Java EE perspective and have already been discussed in earlier sections of this chapter.

More details about using the Java EE perspective can be found in Chapter 14, “Develop EJB applications” on page 387.

Java Type Hierarchy perspective

This perspective is also for Java developers and allows users to explore the type hierarchy. It can be opened on types, compilation units, packages, projects, or source folders and consists of the **Hierarchy** view and an editor.

The Hierarchy view shows only an information message until you select a type:

To display the type hierarchy, select a type (for example, in the outline view or in the editor), and select the 'Open Type Hierarchy' menu option. Alternatively, you can drag and drop an element (for example, project, package, type) onto this view.

To open a type in the Hierarchy view, open the context menu for a Java class in any view or editor (for example, the main source code editor) and select **Open Type Hierarchy**. The type hierarchy is displayed in the Hierarchy view. Figure 4-16 shows the Hierarchy view of the `DebitBean` class from Chapter 14, “Develop EJB applications” on page 387.

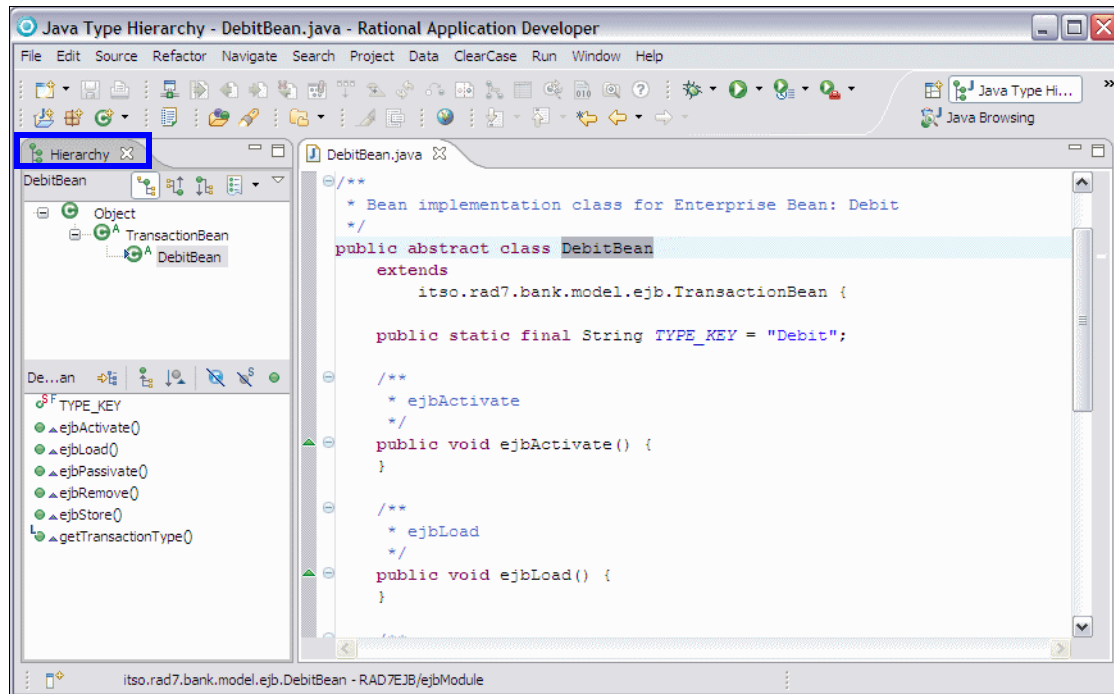

Figure 4-16 Java Type Hierarchy perspective with Hierarchy view

Although the Hierarchy view is also present in the Java perspective and the Java Type perspective only contains two views, it is useful as it provides a way for developers to explore and understand complex object hierarchies without the clutter of other information.

JavaScript perspective

The JavaScript perspective (Figure 4-17) is mainly used in coding, exploring, and documenting JavaScript.

The important view of this perspective are as follows:

- ▶ **Script Explorer view**—Shows the resources in a folder view and explores object orient JavaScript code in a tree view.
- ▶ **Jsdoc view**—Shows the JavaScript documentation for the selected JavaScript element in the Editor view or in the Outline view.

The Outline and the Declaration views appear in this perspective and they have been already discussed earlier in this chapter

More details about working with JavaScript is provided in Chapter 19, “Develop Web applications using Web 2.0” on page 649.

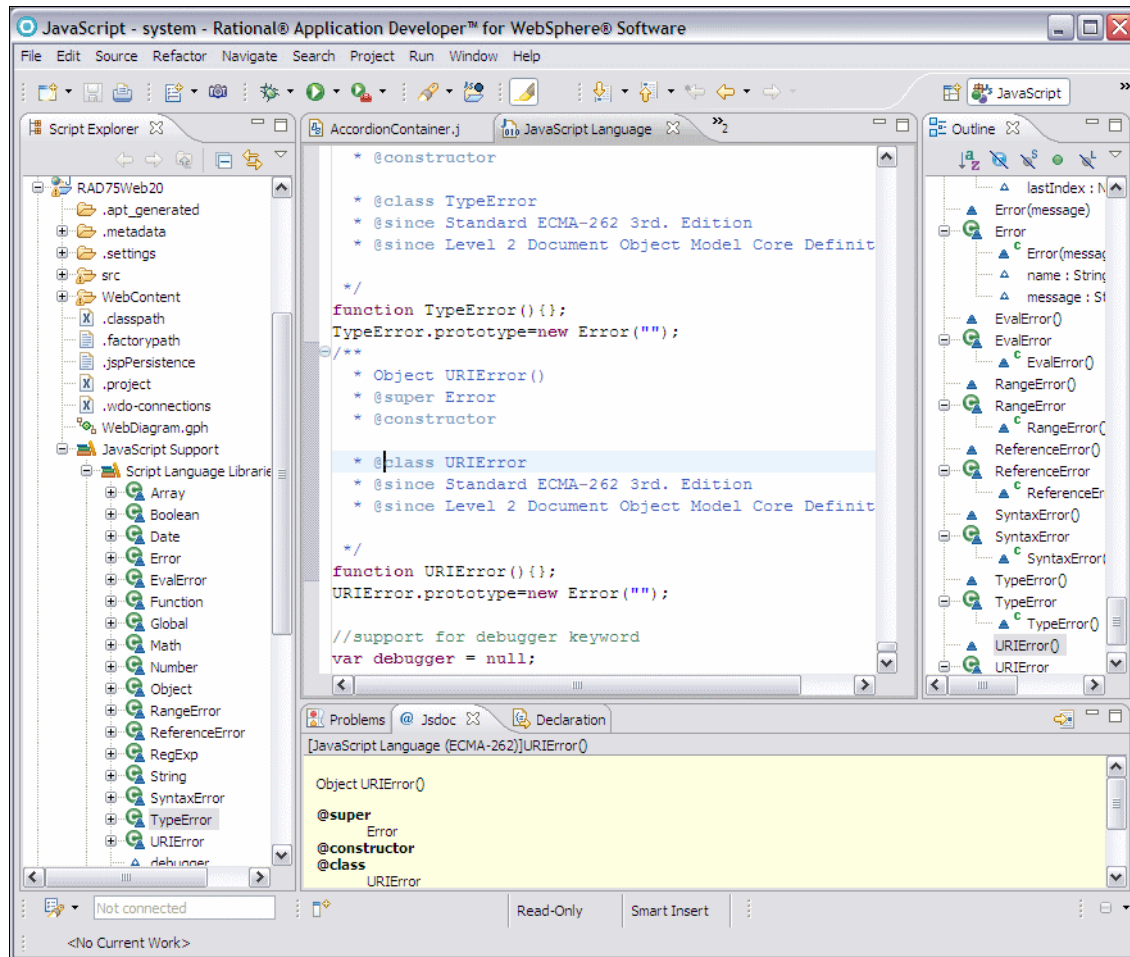

Figure 4-17 JavaScript perspective

Jazz Administration perspective

The Jazz is IBM Rational's new technology platform for collaborative software delivery. Uniquely attuned to global and distributed teams, the Jazz platform is designed to transform how people work together to build software-making software delivery more collaborative, productive and transparent. You can think of Jazz technology as an extensible framework that dynamically integrates and

synchronizes people that have a role to play in the successful delivery of software - not just software professionals, processes and assets associated with software development projects.

Jazz is a technology platform, not a product. IBM's Product offerings that are built on the Jazz platform to leverage a rich set of capabilities for team-based software development and delivery is The Rational Team Concert.

The important views of this perspective are as follows:

- ▶ **Team Organization view**—Manages Connections to project areas and create new ones, and helps you organize larger team members with multiple development lines and subteams.
- ▶ **Process Templates view**—Manages your process templates. There are several predefined processes to choose from: Agile, Eclipse Way, Scrum, OpenUp, and Simple. But you can also define your own processes or modify an existing one.
- ▶ **Team Artifacts view**—Manages your connections to a repository and a project area. When you are connected to a project area you can access its artifacts. The artifacts are grouped into different nodes.
- ▶ **Team Advisor view**—Opens when you execute an operation that violates a process configuration. This view tells you what went wrong and often provides a quick fix for the problem.
- ▶ **ClearCase Synchronized Streams view**—Creates, manages and monitors ClearCase Synchronization streams and also lets the user switch between different team areas.
- ▶ **Work Items view**—Shows you the work items returned from a work item query.

More details about using this perspective in Chapter 29, “Rational Team Concert” on page 1077.

Also for more information about Jazz, see the IBM Rational Team Concert link in Rational Application Developer Welcome page and the Jazz Community Site:

<http://jazz.net>

Author Comment: A screenshot to be added after the finish of the team concert chapter

JPA perspective

The JPA perspective (Figure 4-18) provides you with the ability to manage relational data in Java applications using Java Persistence API by introducing new capabilities such as defining and editing object-relational mappings for EJB 3.0 JPA entities and adding JPA Support to a plain Java project.

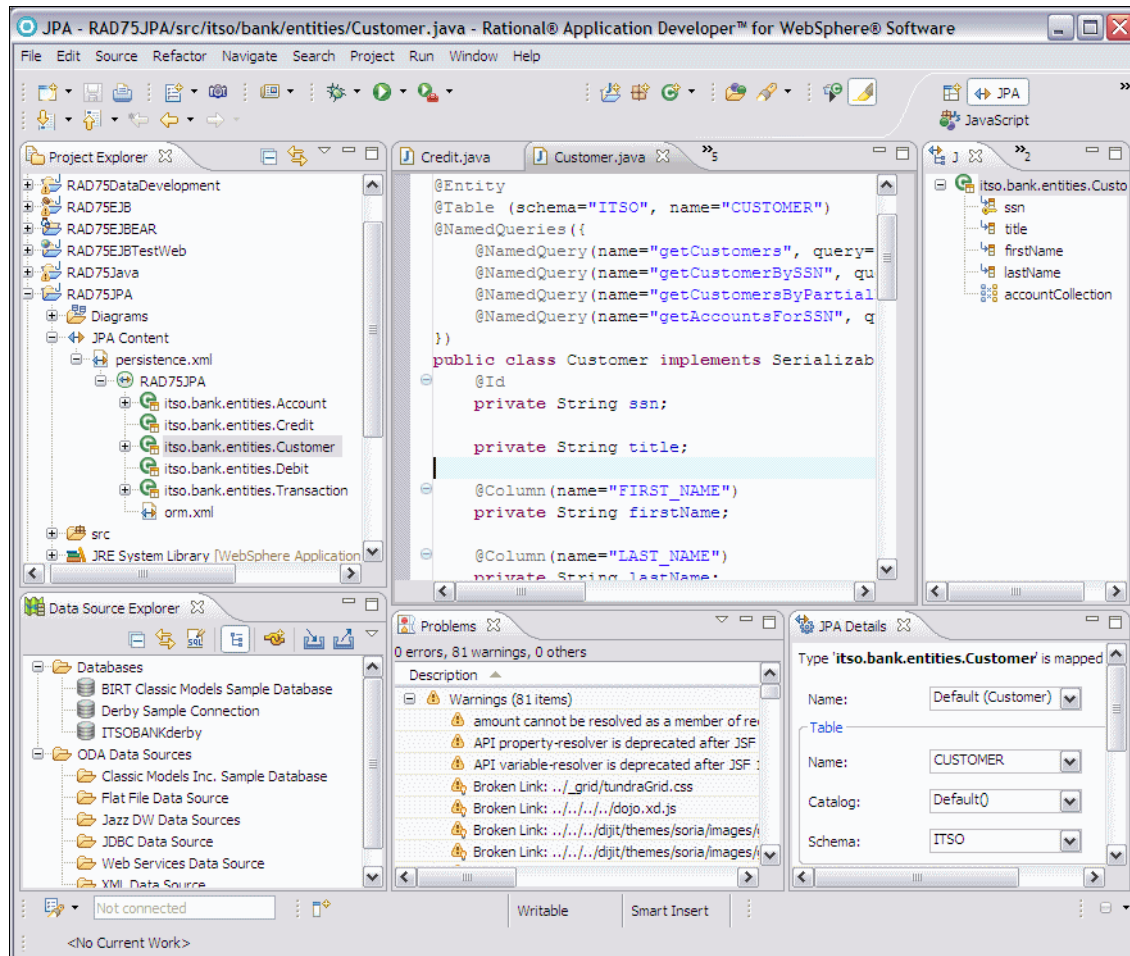

Figure 4-18 JPA perspective

The important view of this perspective are as follows:

- ▶ **JPA Structure view**—Displays an outline of the structure (its attributes and mappings) of the entity that is currently selected or opened in the editor.
- ▶ **JPA Details view**— the JPA Details view (Figure 4-19) displays the persistence information for the currently selected entity and show different tabs depending on whether the selection is on entity, attribute, or `orm.xml`.

You can work with JPA properties in either the JPA Details view or the Annotations view, so that you don't need to keep both views open at once. For clarity, the Annotations view distinguishes between implied and specified annotation attributes.

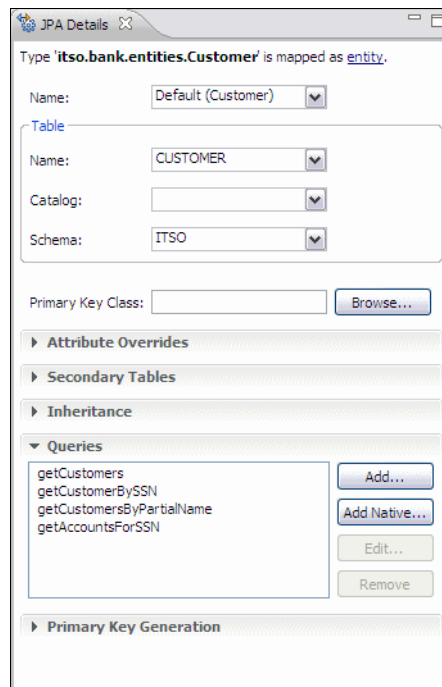

Figure 4-19 JPA Details view

More details about working with JPA in Chapter 12, “Persistence using the Java Persistence API (JPA)” on page 267.

Plug-in Development perspective

The ability to write extra features and plug-ins is an important part of the philosophy of the Eclipse framework. Using this perspective, you can develop your own Application Developer or Eclipse tools.

The Plug-in Development perspective (Figure 4-20) includes:

- ▶ **Plug-ins view**—Shows the combined list of workspace and external plug-ins.
- ▶ **Error Log view**—Shows the error log for the software development platform, allowing a plug-in developer to diagnose problems with plug-in code.

The perspective also includes Package Explorer, Outline, Tasks, and Problems views, which have already been described earlier in this chapter.

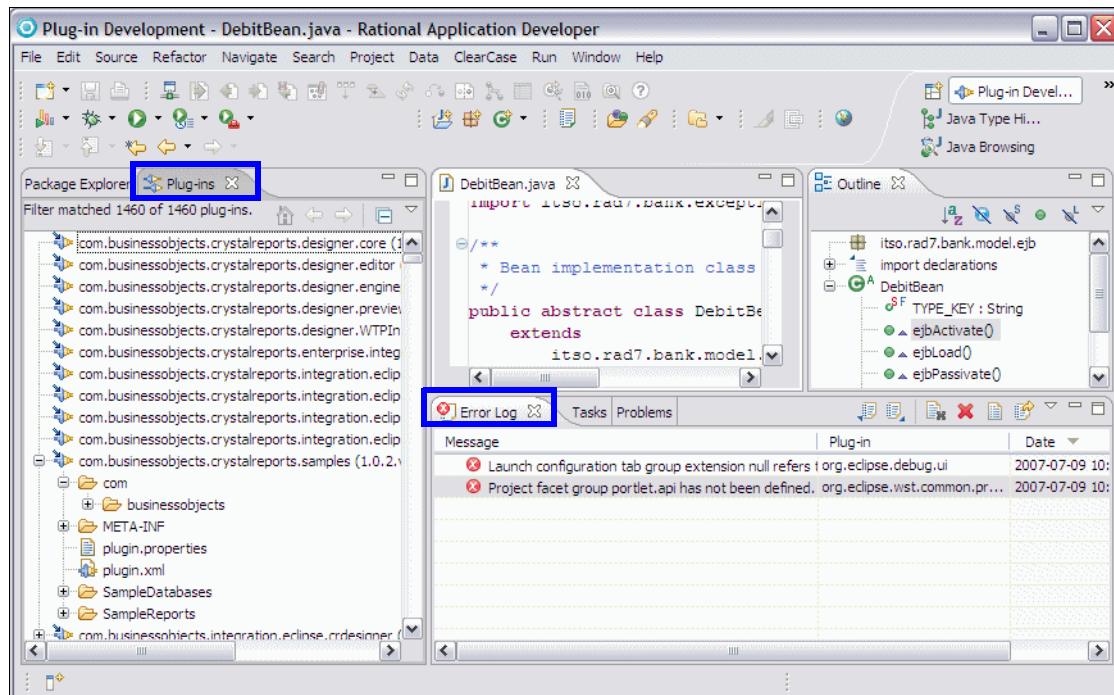

Figure 4-20 Plug-in Development perspective

This book does not cover how to develop plug-ins for Rational Application Developer or Eclipse. To learn more about plug-in development, refer to the IBM Redbooks publication, *Eclipse Development using the Graphical Editing Framework and the Eclipse Modeling Framework*, SG24-6302, or *The Java Developer's Guide to Eclipse-Second Edition*, by D'Anjou et al (refer to <http://jdg2e.com>).

Profiling and Logging perspective

The Profiling and Logging perspective (Figure 4-21) provides a number of views for working with logs and for profiling applications:

- ▶ **Profiling Monitor view**—This view shows the process that can be controlled by the profiling features of Rational Application Developer. Performance and statistical data can be collected from processes using this feature and displayed in various specialized views and editors.

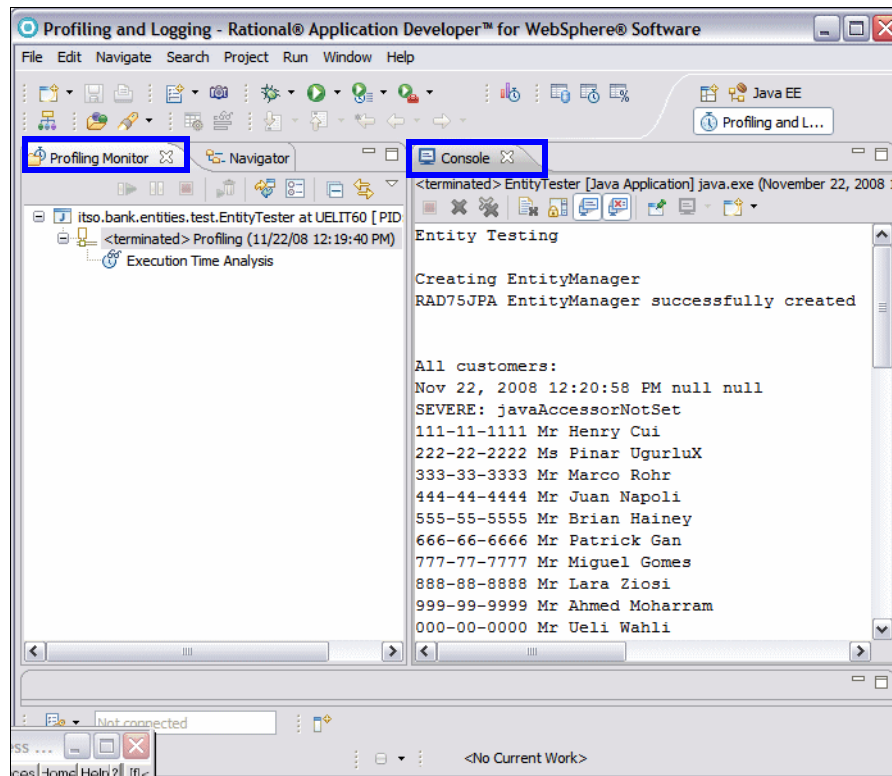

Figure 4-21 Profiling perspective

In addition to this, there are several editors for viewing the results of profiling, for example the **Memory Statistics** view and the **Object References** view. More details about these views and the techniques required to use them can be found in Chapter 27, "Profile applications" on page 983.

Report Design perspective

The Report Design perspective (Figure 4-22) allows developers to design and develop report templates using the Business Intelligence and Reporting Tools (BIRT) framework, which is an Eclipse-based open source reporting system for Web applications, especially those based on Java and Java EE.

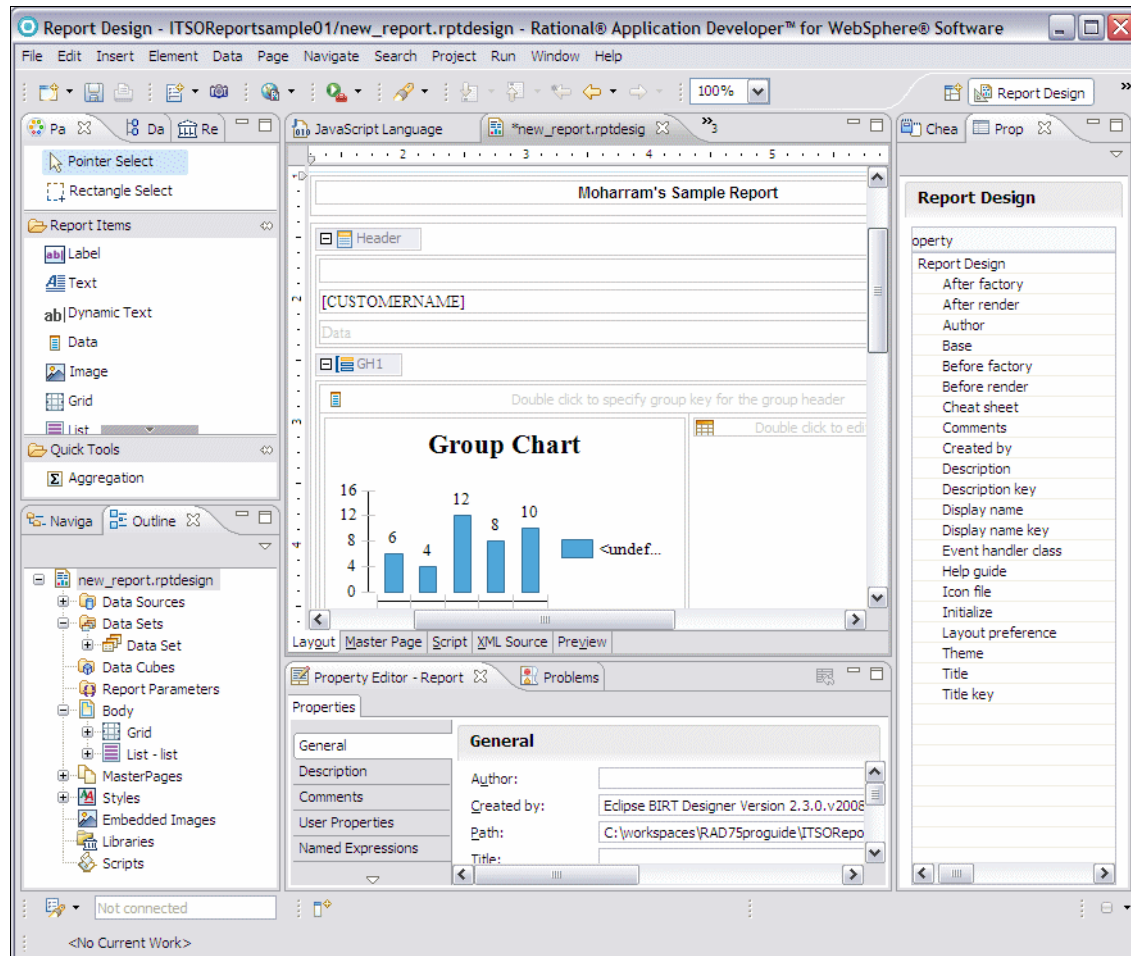

Figure 4-22 Report Design perspective

The BIRT system also includes a runtime component to process these reports which can be added to an Application Server. The Reports Designer editor provides the facility to layout the fields on the report template and to map these fields with data from XML schemas, Web Services, flat files, or database definitions and to test them within Application Developer.

For more information about using Rational Application Developer for generating reports with BIRT, see the Help or visit the following link which is a reference to the Eclipse project for providing the functionality of this perspective:

<http://eclipse.org/birt/phoenix/project>

Requirement perspective

This perspective defines an initial set and layout of views in the Workbench window. The Requirement perspective includes a set of views that supports access to Rational RequisitePro requirements, documents, query results, properties, and traceability.

The Requirement perspective includes the following views:

- ▶ **Requirement Explorer view**—Manages the set of requirement available in the Rational RequisitePro server.
- ▶ **Requirement Link Problems view**—This view can be used to review and resolve link problems between requirements and domain elements. Association (or link) problems occur when associated artifacts are moved, deleted, or are otherwise unavailable.
- ▶ **Requirement Query Results view**—Using this view you can create a view of query results for a particular requirement type. You can filter the view by searching, sorting, or displaying specific requirement attributes or properties.
- ▶ **Link Clipboard view**—Using this view, system architects or development managers can create association with the requirements in linkable domains such as Java EE.
- ▶ **Requirement Trace view**—In this view and modify traceability relationships in the Requirement Trace view.
Requirement traceability is a relationship between two requirements that implies the source, derivation, or dependencies between the artifacts
- ▶ **Requirement Text view**—Displays the name and description of the selected requirement.
- ▶ **Requirement Editor view**—In this view you can edit the name, description, and attributes for requirements.

Important: Rational RequisitePro has to be installed on your machine in order to have the requirement management capability enabled in Rational Application Developer v7.5 on the same machine. This is clear in the message box which appears when you switch to the Requirement perspective and Rational RequisitePro is not installed on your machine.

Resource perspective

The Resource perspective is a very simple perspective (Figure 4-23). By default it contains only **Navigator**, **Outline**, and **Tasks** views and an editor area. It can be useful when it is necessary to view the underlying files and folders present for a project without any extra information added. All the views in this perspective are available in other perspectives and have been described previously.

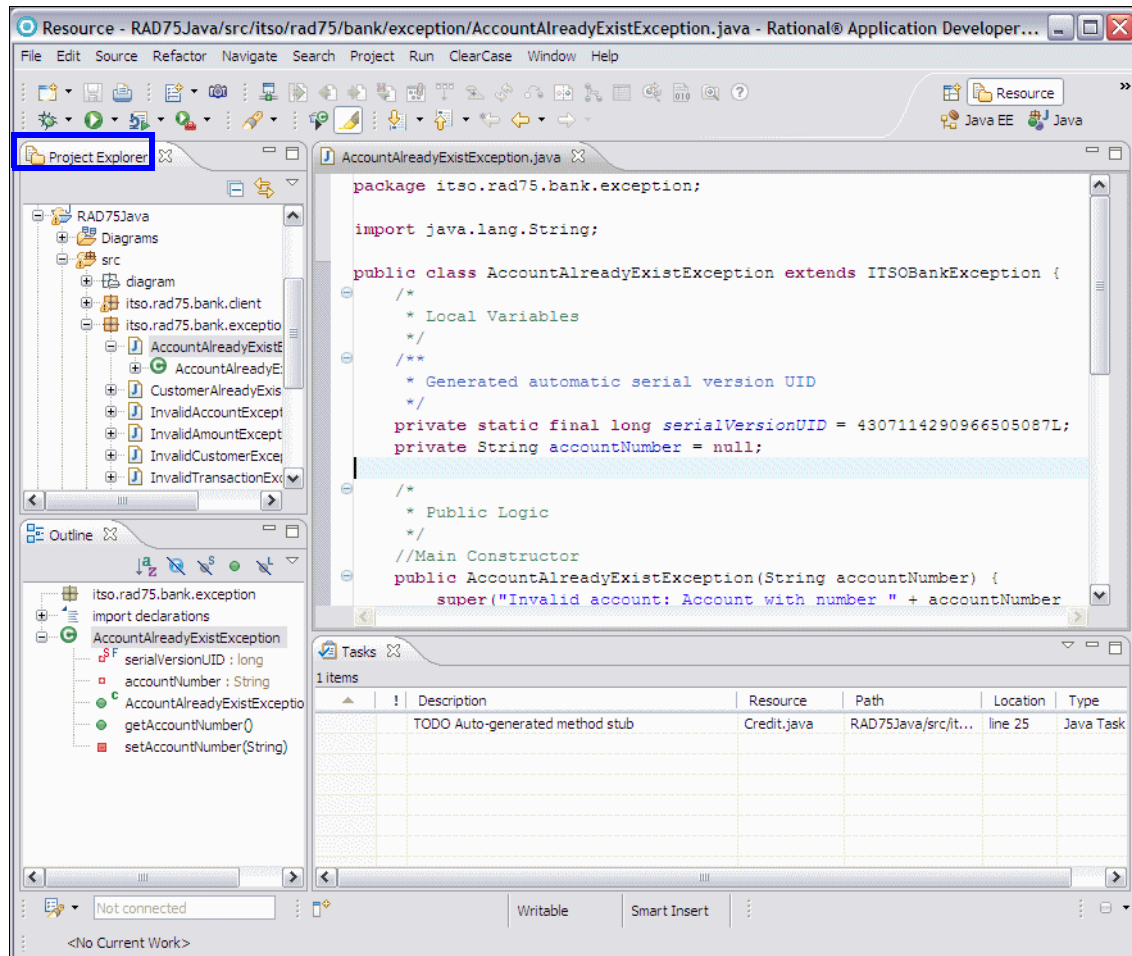

Figure 4-23 Resource perspective

Team Synchronizing perspective

The Team Synchronizing perspective provides the features necessary to synchronize the resources in the workspace with resources held on an SCM repository system. This perspective is used with CVS and ClearCase repositories, plus any other source code repository which might run as an additional plug-in to Application Developer.

Figure 4-23 shows a typical layout while working in the Team Synchronizing perspective.

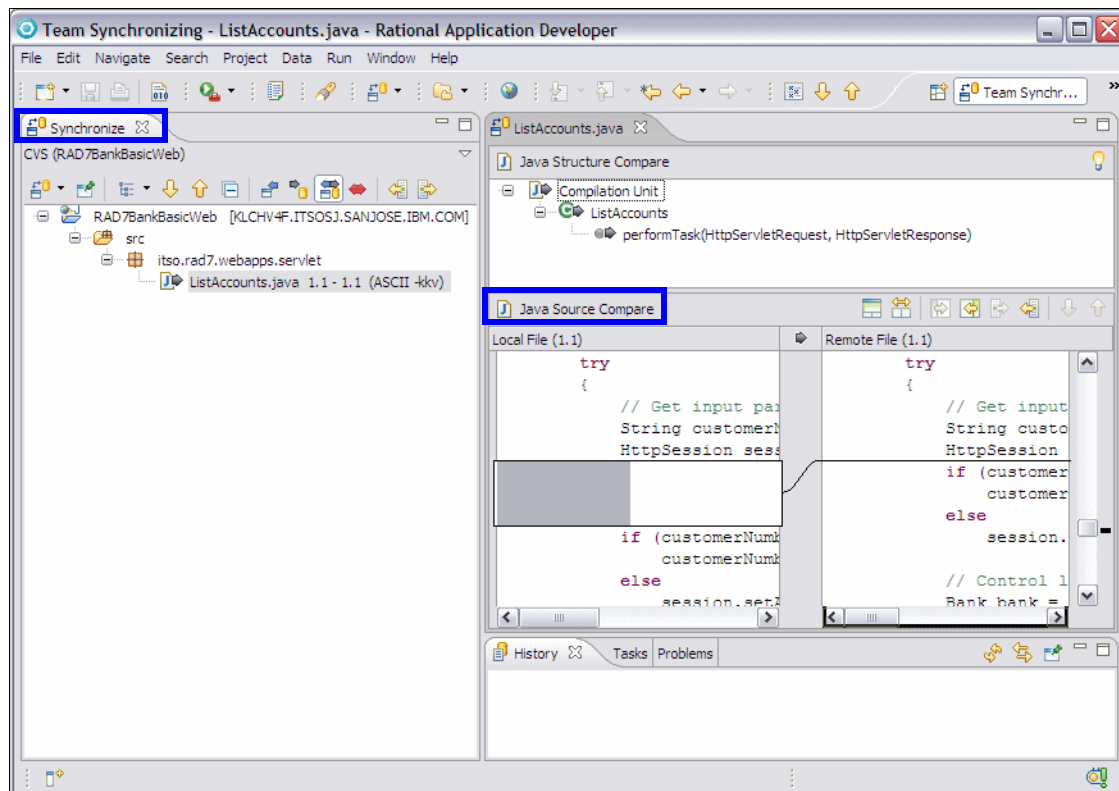

Figure 4-24 Synchronizing resources using the Team Synchronizing perspective

The following views are important when working in this perspective:

- ▶ **Synchronize view**—For any resource with is under source control, the user can select **Team** → **Synchronize**, which prompts the user to move to the Team Synchronizing and show the Synchronize view. It displays the list of synchronization items that result from the analysis of the differences between

the local and repository versions of your projects. Double-clicking an item will open the comparison view to help you in completing the synchronization.



- ▶ **Source Code Comparison editor**—This editor appears in the main editor area and shows a line by line comparison of two revisions of the same source code.

Also present in the Team Synchronizing perspective is the **History** view to show the revision history of a given resource file and the Tasks and Problems view. More details about these views on this perspective and how to use them can be found in Chapter 28, “CVS integration” on page 1019.

Test perspective

The Test perspective (Figure 4-25) provides a framework for defining and executing test cases and test suites. Note that the focus here is on running the tests and examining the results rather than building the code contained in JUnit tests. Building JUnit tests involves writing sometimes complex Java code and is best done in the Java perspective.

The following views are important when working in this perspective:

- ▶ **Test Navigator**—The main navigator view for browsing and editing test suites and reviewing test results. It has two main options to structure the display of these resources. The **Show the Resource test navigator** () option shows the resources based around the file system but with the test suites displayed at the bottom containing their associated test cases. The **Show the Logical test navigator** () option shows the resources arranged by Test suites, source code and test results.
- ▶ **Test Log view**—If the user clicks on a test result, this view is shown in the main editor area showing the date/time and result of the test.
- ▶ **Test editor**—Shows a summary of a test suite and its contained tests.

The Tasks, Properties, and Outline views are also present and useful when working in the Test perspective. These have already been covered in this chapter.

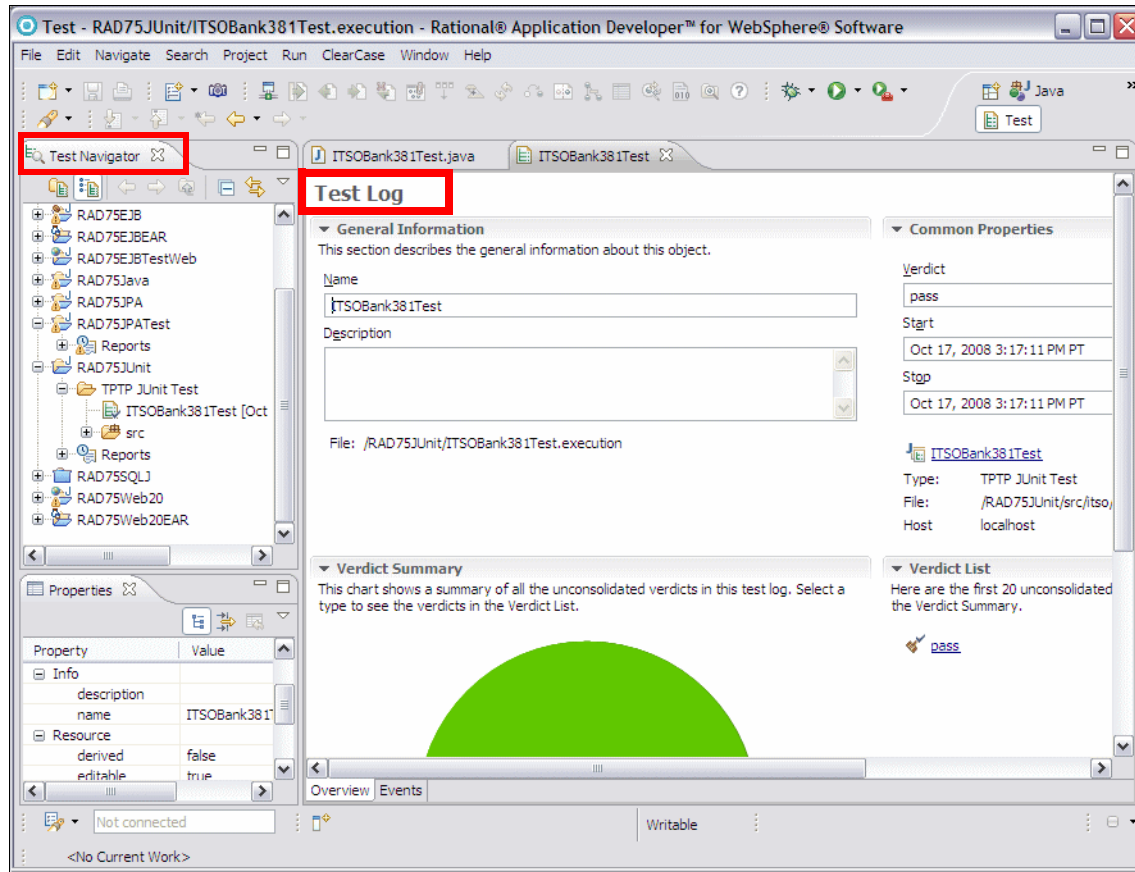

Figure 4-25 Test perspective

More information about Component Testing is located in Chapter 23, “Test using JUnit” on page 819.

Web perspective

Web developers can use the Web to build and edit Web resources, such as servlets, JSPs, HTML pages, style sheets and images as well as the deployment descriptor web.xml. Figure 4-26 shows a typical layout while developing in this perspective.

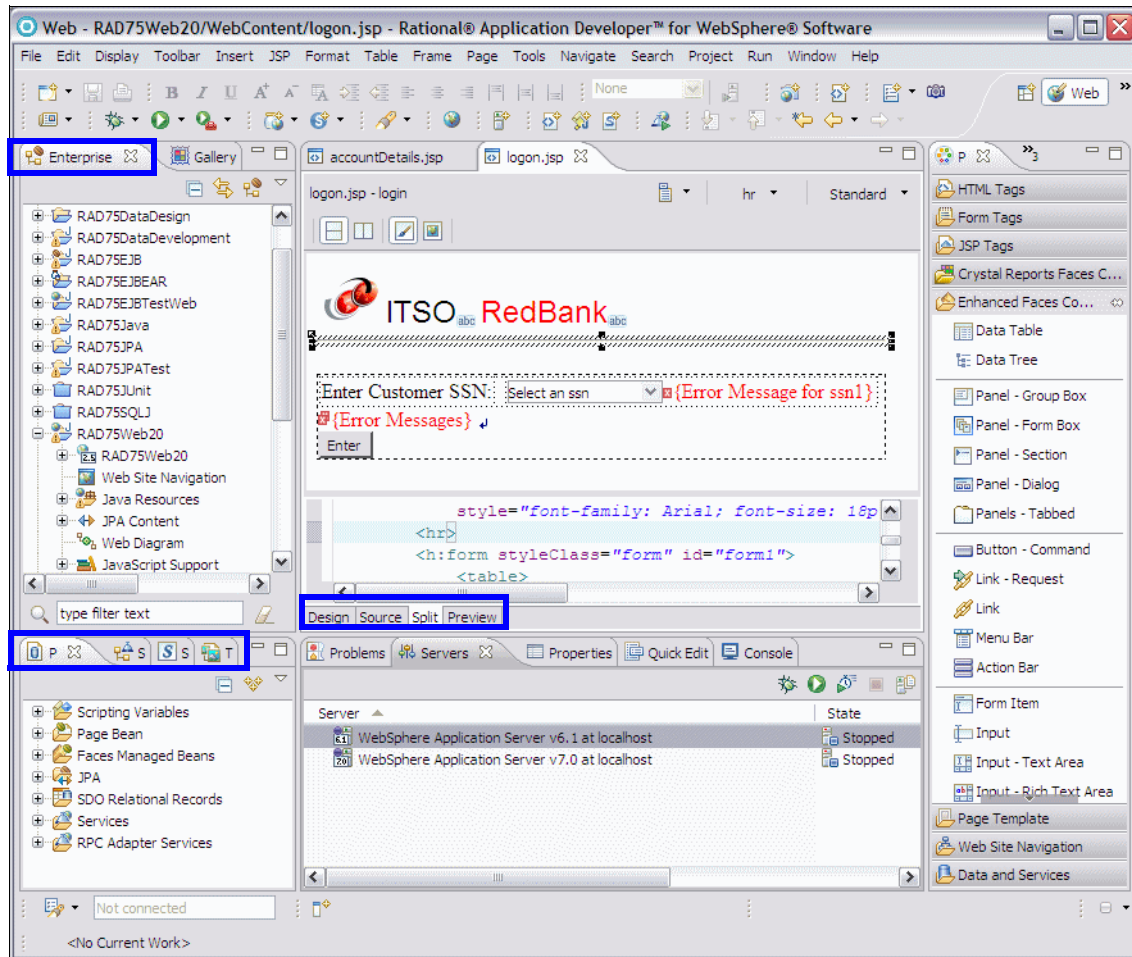

Figure 4-26 Web perspective

The Web perspective contains the following views and editors:

- ▶ **Page Designer**—Page Designer allows you to work with HTML files, JSP files, and embedded JavaScript. Within the Page Designer, you can move among three tabs that provide different ways for you to work with the file that you are editing. This editor is synchronized with the Outline and Properties views, so that the selected HTML or JSP element always appears in these views. The main tabs provided by Page Designer are as follows:
 - **Design**—The Design page of Page Designer is the WYSIWYG mode for editing HTML and JSP files. As you edit in the Design page, your work reflects the layout and style of the Web pages you build without the added complexity of source tagging syntax, navigation, and debugging. Although

all tasks can also be done in the Source page, the Design view should allow most operations to be done more efficiently and without requiring a detailed knowledge of HTML syntax.

- **Source**—The Source page enables you to view and work with a file's source code directly.
- **Split**—Combines the Source page and either the Design page or the Preview page in a split screen view. Changes that you make in one part of the split screen can immediately be seen in the other part of the split screen. You can split the screen horizontally or vertically.
- **Preview**—Shows how the current page is likely to look when viewed in a Web browser. JSPs shown in this view will contain only static HTML output.
- ▶ **Web Diagram editor** —Use the Web diagram editor (Figure 4-27) to design and construct the logic of a Web application. From within the Web diagram editor you can configure your Web application by creating a navigation structure, adding data to pages, and creating actions and connections. The palette allows you to add visual representations called nodes for Web pages, Web projects, connections, and JSF and Struts resources (if you have these facets added to your Web project).

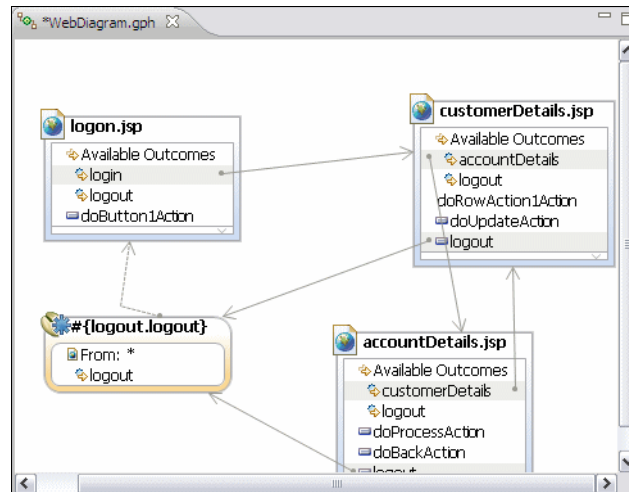

Figure 4-27 Web Diagram editor

- ▶ **Gallery view**—Contains a variety of catalogs of reusable files that can be applied to Web pages. The file types available include images, wallpaper, Web art, sound files and style sheet files.
- ▶ **Page Data view**—Allows you manage data from a variety of sources such as Enterprise JavaBeans, JavaBeans, Service Data Objects, Java Persistence

API, and Web Services, which can be configured and dropped onto a JSP page.

- ▶ **Services view**—Lists all of the services available to all of your projects including Web services and RPC Adapter services. This view does not require you to open a Web page in the editor in order to view the services specific to that particular page.
- ▶ **Styles view**—Provides guided editing for cascading style sheets and individual style definitions for HTML elements.
- ▶ **Thumbnails view**—Shows thumbnails of the images in the selected project, folder, or file. This view is especially valuable when used with the Gallery view to add images from the artwork libraries supplied by Application Developer to your page designs. When used with the Gallery view, thumbnail also displays the contents of a selected folder. You can drag and drop from this view into the Enterprise Explorer view or to the Design or Source page of Page Designer.
- ▶ **Quick Edit view**—Allows you to edit small bits of code, including adding and editing actions assigned to tags. This view is synchronized with what element is selected in the Page Designer. You can drag and drop items from the Snippets view into the Quick Edit view.
- ▶ **Palette view**—Contains expandable drawers of drag and drop objects. Allows you to drag objects, such as tables or form buttons, onto the Design or Source page of the Page Designer.

The Enterprises Explorer, Outline, Properties, Servers, Console, Problems, and Snippets views are also present in the Web perspective and have already been discussed in this chapter.

More information about developing JSPs and other Web application components in the Web perspective can be found in Chapter 13, “Develop Web applications using JSPs and servlets” on page 317.

Work items perspective

The Work Items perspective enables team members to easily see and track work assigned to them and submitted against the categories for which they are responsible. Project managers can use this perspective to plan development work for iterations and obtain metrics that indicate the progress the team is making towards its development and quality goals. This perspective is similar to the Jazz Administration perspective with more focus on team members' work items.

The views of this perspective are as follows:

- ▶ **My Work view**—Use this view to triage new work items assigned to you; manage work items in progress; and manage work items that you plan to resolve in a future iteration.
- ▶ **Team Central view**—This view is organized into multiple News, Events, and Queries sections that are updated continually with the latest developments, such as build operations, change set deliveries, and work item modifications that affect your project.
- ▶ **Tag Cloud view**—Use this view to create a tag cloud. For a given query, a tag cloud displays the number of work items by tag attribute.

Team Artifact and Work Items views are also present in this perspective and have been already discussed earlier in this chapter.

Progress view

The Progress view is not part of any perspective by default, but is a very useful tool when using Rational Application Developer. When Rational Application Developer is carrying out a task that takes a substantial amount of time, a prompt might appear with two options available (Figure 4-28).

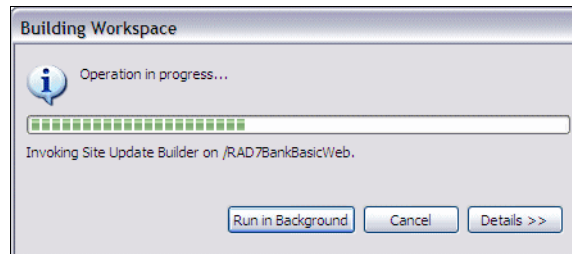



Figure 4-28 Progress view

The user can either watch the dialog until the operation completes, or the user can click **Run in Background** and the task continues in the background. If the second option is selected, Rational Application Developer runs more slowly, but the developer can carry out other tasks while waiting. Examples of tasks that might be worth running in the background would be publishing and running an enterprise application, checking a large project into CVS, or rebuilding a complex set of projects.

If **Run in Background** is clicked, then the **Progress** view can be shown again to review the status of the running task by clicking the  icon in the bottom right of the workspace. Note that this icon only shows if there are processes running in the background.

Some processes do not prompt the user with a dialog and run in the background when they are initiated. In these cases, the Progress view can be accessed in the same way.

For example, when a Web application is published to the test server and the server has to be started, this process might take some time. By default this condition shows as a flashing status bar in the bottom left of the workspace and the icon to show the Progress view appears (Figure 4-29).

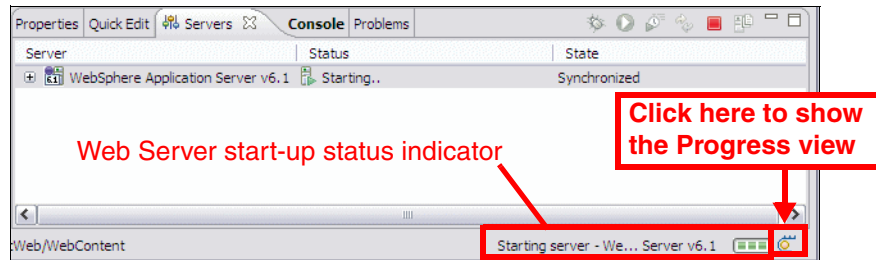

Figure 4-29 Process information in status bar

If the user becomes concerned about the time the deployment process is taking, then the Progress view can be opened, the current process reviewed, and if necessary, stopped (Figure 4-30).

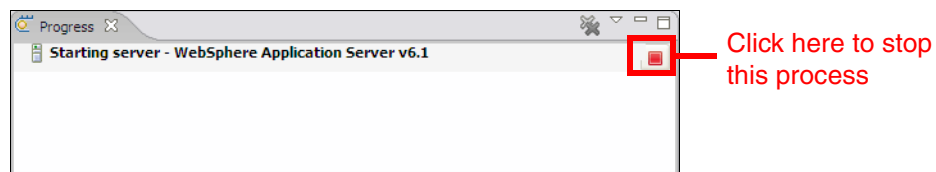

Figure 4-30 Progress view

Summary

In this chapter, the perspectives available within Application Developer and the main views associated were described. Parts 2, 3, 4, and 5 of this book demonstrate in detail the use of most of these perspectives for various development scenarios.



Projects

This chapter provides an overview of the types of projects that can be created with Rational Application Developer and the main features of each project type.

Since many of the available project types are used when constructing Java Enterprise Edition 5 (Java EE 5) applications the chapter starts with a review of the main features of the Java EE 5 platform, including the packaging of project code for deployment to an application server.

Basic techniques for the manipulation of projects including project creation and deletion are covered next, followed by a section listing all the project wizards provided by Application Developer for the creation of new projects. Finally, there is a discussion of the sample projects provided.

The chapter is organized into the following sections:

- ▶ The Java Enterprise Edition 5 platform
- ▶ Java EE 5 project types
- ▶ Project basics
- ▶ Project wizards
- ▶ Sample projects
- ▶ Summary

The Java Enterprise Edition 5 platform

Java EE is platform used to host enterprise applications ensuring that they highly available, reliable, scalable, and secure. Java EE 5 is the latest version of the Java Enterprise Edition platform and is fully supported by Rational Application Developer V7.5.

The Java EE 5 specification, along with many other resources relating to Java EE 5, are available at

<http://java.sun.com/javaee/index.jsp>

The Java EE architecture is composed of a set of containers each of which is a runtime environment that hosts specific Java EE components and provides services to those components. The details of the services provided by each container are documented in the Java EE specification document available at:

<http://jcp.org/aboutJava/communityprocess/final/jsr244/index.html>

The four containers which comprise the Java EE architecture are:

- ▶ The Enterprise JavaBeans (EJB) container. This container hosts EJB components which are typically used to provide business logic functionality with full transactional support. This container runs on the application server.
- ▶ The Web container. This container hosts Web components such as servlets and JavaServer Pages which are executed in response to HTTP requests from a Web client application such as a Web browser. This container runs on the application server.
- ▶ The Application Client container. This container hosts standard Java applications, with or without a GUI and provides the services required for those applications to access enterprise components in an EJB container. This container runs on a client machine.
- ▶ The Applet container. This container hosts Java applets. Applets are GUI applications that are typically presented by a Web browser. The applet container runs on a client machine under the control of a Web browser.

The Java EE architecture containers are shown in Figure 5-1. The diagram also includes a database which is typically used for the persistence of enterprise application data. It is not necessary to employ all of the containers in a specific enterprise application. In some enterprise applications only the Web container is employed. All business logic and persistence functionality executes in the Web container along with the code which presents the user interface. In other enterprise applications only the Web container and EJB container are employed. The user interface is presented by components in the Web container with all

business logic and persistence functionality delegated to the EJB container and the EJB components it contains.

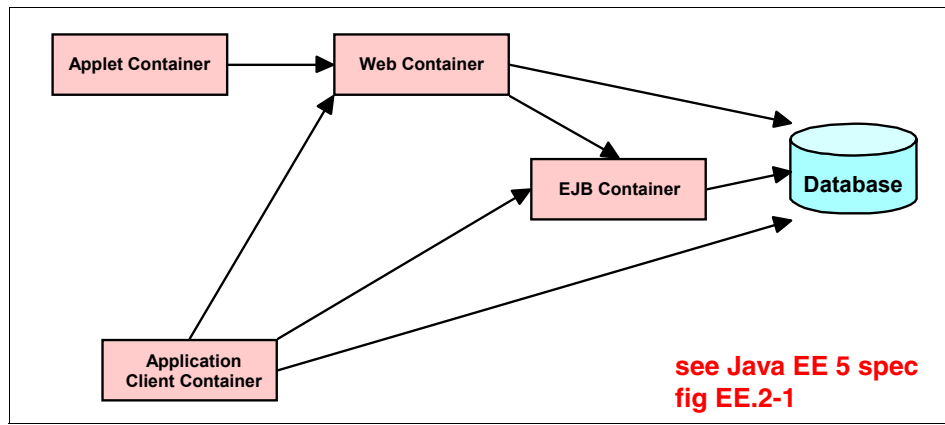

Figure 5-1 Java EE Architecture Containers

A Java EE enterprise application is assembled from one or more Java EE modules. Java EE modules contain one or more enterprise application components. An optional deployment descriptor, which describes the module and the components it contains may also be included in the module. The following sections provide a summary of the purpose served by each of the modules and the types of component typically contained in the module. Subsequent sections describe the types of projects within Application Developer that are used to create each module.

A high level view of the module structure of a Java EE enterprise application is shown in Figure 5-2.

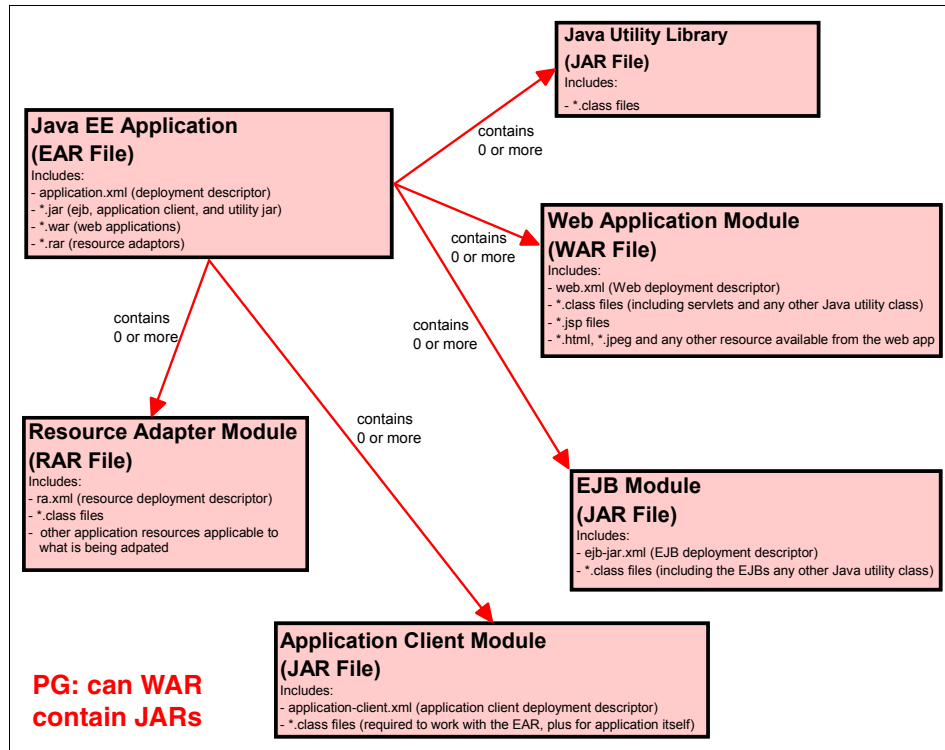

Figure 5-2 Java EE 5 module structure

Enterprise application modules

Enterprise application modules contain one or more of the other types of Java EE modules. They act as the highest level enterprise application packaging unit in that they do not themselves contain any components, just modules. Modules contained in an enterprise application are deployed as a unit to the WebSphere Application Server. Enterprise application modules are packaged as EAR files with the extension .ear. EAR files are standard Java archive files which have a defined directory structure. An optional deployment descriptor called application.xml may be included.

An enterprise application module can include zero or more of the following modules:

- ▶ Web modules—WAR files with the extension .war
- ▶ EJB modules—EJB JAR files with the extension .jar
- ▶ Application client modules—Application client JAR files with the extension .jar

- ▶ Resource adapter modules—Resource adapter archive files with the extension `.rar`
- ▶ Utility Libraries—JAR files with the extension `.jar` which are shared by all the other modules packaged in the EAR.

Web modules

Web modules contain all the components that are part of a specific Web application. These components often include:

- ▶ HyperText Markup Language (HTML) files
- ▶ Cascading style sheets (CSS) files
- ▶ JavaServer Pages (JSP) files
- ▶ Compiled Java servlet classes
- ▶ Other compiled Java classes
- ▶ Image files
- ▶ Portlets (portal applications)

Web modules are packaged as WAR files with the extension `.war`. WAR files have a defined directory structure and include a deployment descriptor called `web.xml`, which contains the configuration information for the Web module. The `web.xml` is optional if the module only contains JSP files. Each Web module has a defined context root which determines the URL required to access the components present in the Web module.

EJB modules

An EJB module contains EJB components. EJB modules are packaged as JAR files with the extension `.jar`. EJB JAR files have a defined directory structure and include an optional deployment descriptor called `ejb-jar.xml`, which contains configuration information for the EJB module. Alternatively, the configuration can be defined using annotations in the Java classes.

Application client modules

An Application Client module contains enterprise application client code. Application client modules are packaged as JAR files with the extension `.jar`. An application client module typically includes the classes and interfaces to allow a client application to access EJB components in an EJB module. Code in an application client module can also access components in a Web module. The file has a defined directory structure and includes an optional deployment descriptor called `application-client.xml`.

Resource adapter modules

A Resource Adapter (RA) module contains resource adapters. Resource adapter modules are packaged as .rar files. Resource adapters provide access to back-end resources using services provided by the application server. Resource adapters are often provided by vendors of Enterprise Information Systems such as SAP and PeopleSoft® to facilitate access from Java EE 5 applications.

Resource adapter modules can be installed as a stand-alone modules within the application server, allowing them to be shared by several enterprise applications. They may also be included in a specific EAR in which case they are only available to the modules contained within that EAR. A .rar file has a defined directory structure and contains a deployment descriptor is called ra.xml.

Java Utility Libraries

Java utility libraries can be included in a Java EE enterprise application so that all the modules included in the application can share the code they contain. Java utility libraries are packaged as standard Java JAR files with the extension .jar.

Project basics

Within Rational Application Developer projects are contained in a workspace. A project must be present in a workspace before it can be accessed and used. Many different types of projects can be created as required for a specific application. Projects are typically created or imported using one of the wizards available in Rational Application Developer. The full set of available project wizards is listed in “Project wizards” on page 176.

Unless otherwise specified, projects are stored in the Application Developer workspace directory. A workspace is chosen when Rational Application Developer is started although it is also possible to switch workspaces at a later time by selecting **File** → **Switch Workspace**.

Creating a new project

Development on a new application is usually started by creating one or more projects. The projects required should be planned beforehand, and then relevant project wizards should be used to create a skeleton set of projects for the application under construction. It is also possible to open existing projects if they are to be used as part of the current application.

As an example of the new project creation process, the following instructions demonstrate the *New Enterprise Application* wizard:

- ▶ To launch this wizard, select **File** → **New** → **Project**.
- ▶ Select **Java EE** → **Enterprise Application Project** and click **Next**. The New Project dialog with Enterprise Application Project selected is shown in (Figure 5-3).

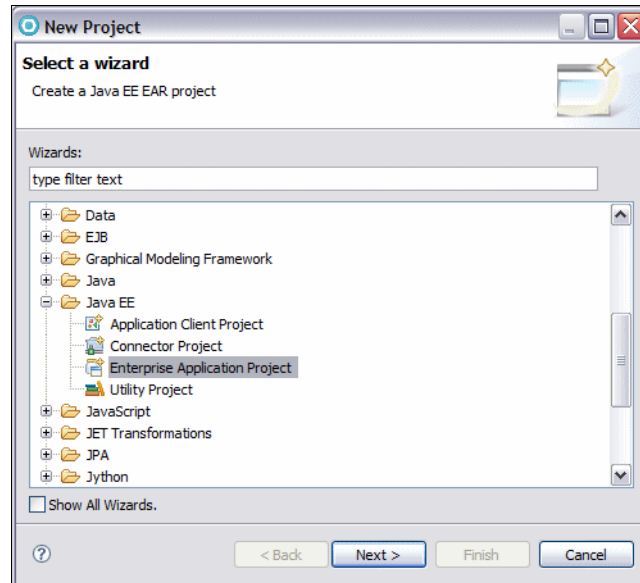

Figure 5-3 New Project dialog with Enterprise Application Project selected

- ▶ The first dialog of the Enterprise Application Project wizard is shown in Figure 5-4.

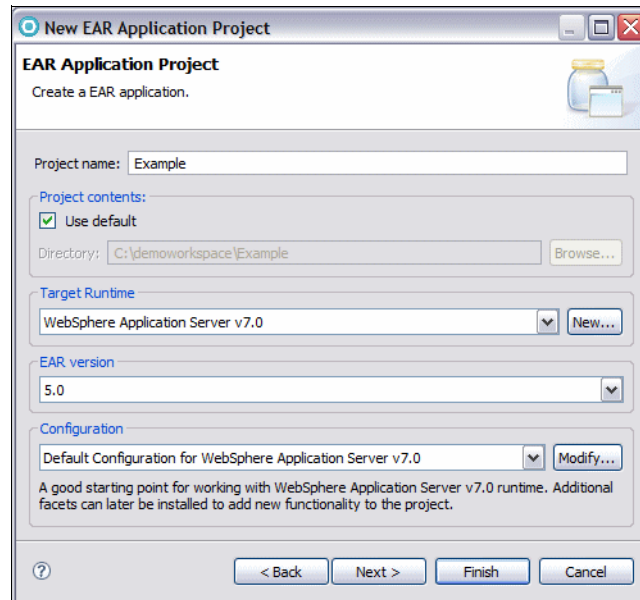

Figure 5-4 New EAR Application Project: Create a EAR Application

On this dialog you can specify:

- **Project Name**—The project name, Example in this case.
- **Project contents**—By default, projects are stored in a subdirectory that is created for the project in the workspace directory. Using this option, another location can be specified.
- **Target Runtime**—An enterprise application project is targeted to run on an Application Server. This option allows the user to configure the target runtime environment.
- **EAR Version**—An enterprise application can be created for a specific version of Java EE such as 1.4 or 5. In this case version 5 is selected from the drop down list.
- **Configuration**—This drop-down provides a list of saved configurations which have been created for previous enterprise application projects. A configuration can include a specific set of features and available versions and it is often a good idea to make sure all similar projects use the same configuration. An existing configuration can be chosen or <custom> can be selected. When <custom> is selected the user has the opportunity to specify their own configuration. Clicking the **Modify** button allows a configuration to be modified.

- ▶ If the **Modify** button is clicked the **Project Facets** dialog is presented (Figure 5-5).

This dialog allows the user to customize which features and versions of a feature will be available in the new project. It is also possible to save the configuration so that it can be used for subsequent projects. This project facets page is also used when creating a new Web, EJB, and connector project but the facet options available are applicable to the type of project being created.

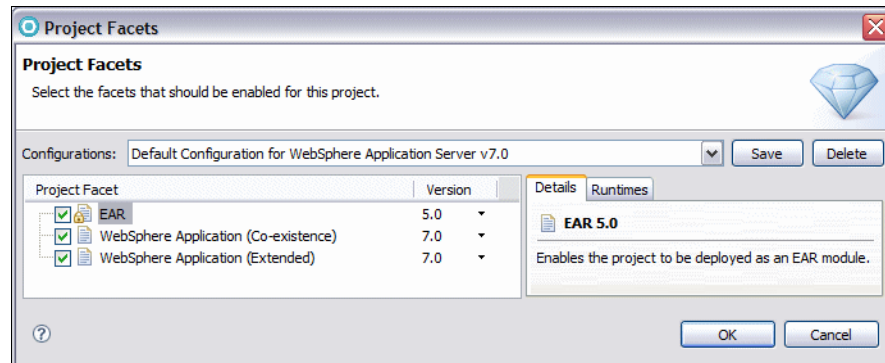

Figure 5-5 New EAR Application Project: Project Facets

- ▶ The final dialog (Figure 5-6) gives the user the opportunity to select any other projects that are to be part of this new enterprise application. This dialog includes select boxes for all the Java, EJB, Web and Application Client projects in the current workspace, which, if selected, will be included in the project references for the new project.

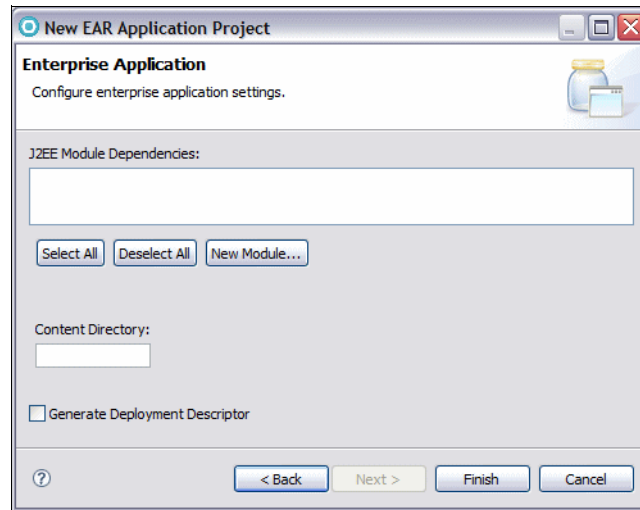

Figure 5-6 New EAR Application Project: Configure enterprise application settings

On this dialog you can specify:

- **Content Directory**—This specifies the folder within the Enterprise Application project under which the contents will be stored. This can be left empty meaning that all contents will be stored under the root directory.
- **New Module**—This button provides the ability to automatically create empty projects referenced by the new Enterprise Application project. Clicking **New Module** displays the dialog shown in Figure 5-7. Since the current workspace in this example does not contain any other projects the existing modules list is empty. If other projects are available they are listed and can be selected or deselected as required.
- **Generate Deployment Descriptor**—Because the deployment descriptor file, `application.xml`, is optional, you can choose whether you want one included or not.

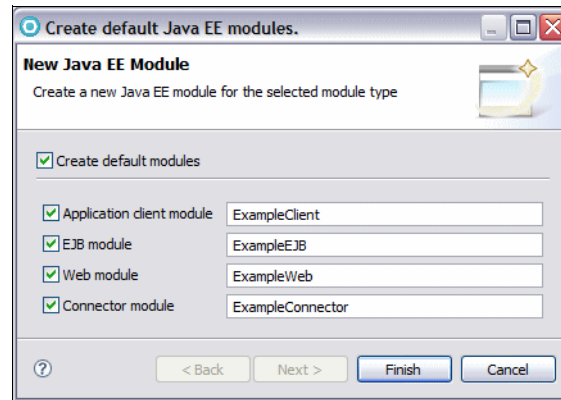

Figure 5-7 Create default Java EE module

- Click **Cancel** if you decide not to create any default Java EE modules.
- Select the boxes for the projects you want to create, change the names if desired, and click **Finish**.
- ▶ Click **Finish** in the New EAR Application Project wizard, Configure enterprise application settings dialog, and the new project (and associated projects) are created.

If the project you have created is associated with a particular perspective, in this case with the Java EE perspective, but you currently have a different perspective selected, Rational Application Developer prompts to ask if you wish to switch over to the relevant perspective (Figure 5-8).

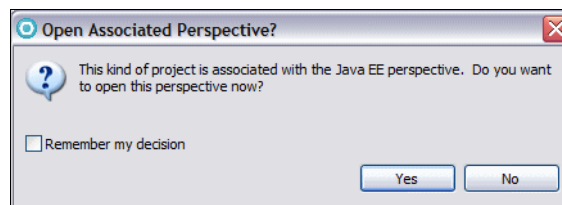

Figure 5-8 Prompt to open relevant perspective

Project properties

To make changes to the properties of a project, right-click the project and select **Properties** from the context menu. Figure 5-9 shows the Properties dialog for an Enterprise Application project.

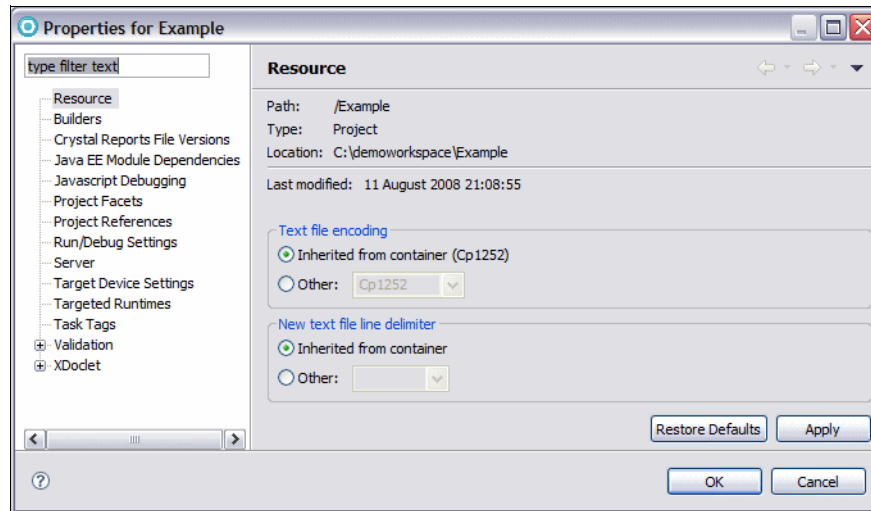

Figure 5-9 Project properties for an Enterprise Application Project

In the Properties dialog you can edit most project attributes. Each type of project has different available options.

The options available for an Enterprise Application project include:

- ▶ **Java EE Module Dependencies**—Other projects (Web, Java, or Resource) which this project is dependent upon.
- ▶ **Project Facets**—Shows the facets available for this project and provides the opportunity to add or remove facets.
- ▶ **Project References**—Used to configure project dependencies and classpath entries.
- ▶ **Server**—Specifies the default application server to use when running this application.
- ▶ **Validation**—Indicates whether to run any non-default validation tools, and if so, which ones to run after making changes.
- ▶ **Java Build Path** (not for an enterprise application)—Specifies the build path used to compile the Java code of the project.

Deleting projects

To delete a project from the workspace, right-click the project and select **Delete** from the context menu. When deleting projects from a workspace, Rational Application Developer offers the option to delete the project contents on disk. Figure 5-10 shows the Delete Resources dialog presented when deleting a

project. The default only removes the project from the workspace and leaves the project files on disk intact. Select the option box if you wish to remove the project completely. Its important to realize that deleting a project from disk is permanent and the project cannot be opened again. If a project is only removed from the workspace then it can later be imported by selecting **File** → **Import** → **General** → **Existing Projects Into Workspace**. A project that has been deleted from the workspace takes up no memory and is not examined during the build process. Deleting projects from the workspace can improve the performance of Rational Application Developer.

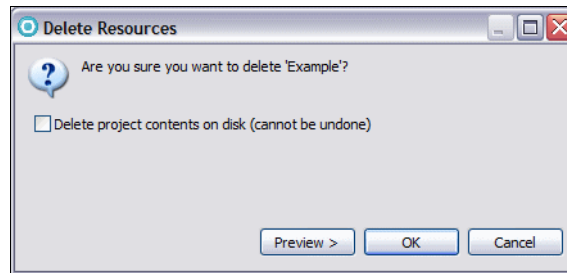

Figure 5-10 Project Delete Resources dialog

Project interchange files

Projects can be transferred between workspaces as project interchange files. A project interchange file is a ZIP format file used to encapsulate a project. To create a project interchange file for any project simply select **File** → **Export** → **Other** → **Project Interchange** and specify which projects to export and to which location. To import projects, stored as a project interchange file, into another workspace select **File** → **Import** → **Other** → **Project Interchange**. Note that when exporting and importing a project, the project interrelationships are also transferred but not the referenced projects. It might therefore also be necessary to export all the related projects.

Closing projects

It is also possible to close projects present in a workspace. Closing a project locks it so that it cannot be edited or referenced from another project. This can be done selecting either **Close Project** or **Close Unrelated Projects** from the Enterprise Explorer context menu. Closed projects are still visible in the workspace but they cannot be expanded.

Closing non-important projects can speed up compilation times as the underlying application builders only have to check for resources in open projects. Closed projects can be re-opened by selecting **Open Project** from the context menu.

Java EE 5 project types

Rational Application Developer complies with the Java EE 5 specifications for the development of enterprise applications.

Module packaging into files as described in “The Java Enterprise Edition 5 platform” on page 162, is only applied by Rational Application Developer when a Java EE project is exported or deployed.

While working within Rational Application Developer only the projects present in the workspace are edited. The relationships between the enterprise application projects, and the modules they contain, are managed by Rational Application Developer, and are applied on export or deployment to produce a properly packaged EAR file.

The arrangement between projects and their associated outputs is shown in Figure 5-11. Note that this diagram relates to Figure 5-2 on page 164, where the relationships between various Java EE modules are reflected in the Application Developer project references.

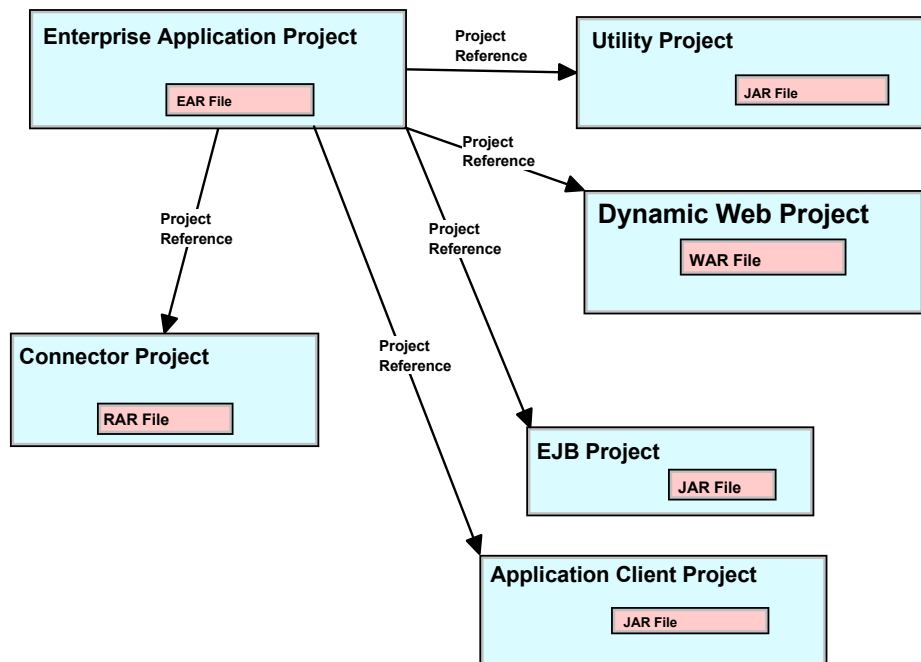

Figure 5-11 Java EE projects in Application Developer

Enterprise application project

Enterprise Application projects contain the resources needed for enterprise applications and can contain references to a combination of Web projects, EJB projects, application client projects, resource adapter projects and utility library projects.

The relationships can be specified when creating a new Enterprise Application project through the wizard as previously shown or through the project properties.

For more information on developing Java EE enterprise applications, see Chapter 14, “Develop EJB applications” on page 387.

Application client project

Application Client projects contain the resources needed for application client modules. An application client module is used to contain a fully-functioning client Java application (non-Web-based) that connects to and uses the resources in an enterprise application and an application server. By holding a reference to the associated enterprise application, it shares information such as the Java Naming and Directory Interface (JNDI) references to EJBs and to data sources.

The wizard allows the Java EE version, the target server, and the associated enterprise application to be specified. For more information on developing application clients, refer to Chapter 17, “Develop Java EE application clients” on page 543.

Dynamic Web project

A dynamic Web project contains the resources needed for Web applications, such as JSPs, Java Servlets, HTML and other files. The dynamic Web project wizard provides the capability to configure the version of the Java servlet specification, target server, EAR file name, and context root. The wizard also allows various other features to be added to the dynamic Web project, including:

- ▶ A CSS file
- ▶ Struts support
- ▶ A Web diagram
- ▶ JSP tag libraries
- ▶ Web page templates
- ▶ Struts support
- ▶ JSP support

When building a dynamic Web project, the user is prompted for the facets which are to be used by the new project, and then the wizard automatically adds the supporting libraries and configuration files to the new project. By selecting the appropriate facets, it is possible to create a project which uses Struts or JavaServer Faces as the framework for building a Web application.

For more information on developing Web applications, see Chapter 13, “Develop Web applications using JSPs and servlets” on page 317.

EJB project

EJB projects contain the resources for EJB applications. This includes the classes and interfaces for the EJB components, the deployment descriptor for the EJB module, IBM extensions, and bindings files, and files describing the mapping between entity beans in the project and relational database resources.

The wizard allows the EJB version, target server, and EAR file to be specified as well as a selection of facet features applicable for EJBs. An EJB Client JAR can also be created, which includes all the resources needed by client code to access the EJB module (the interfaces and stubs).

For more information on developing EJBs, see Chapter 14, “Develop EJB applications” on page 387.

Connector project

A connector project contains the resources required for a Java EE resource adapter. The wizard allows a set of facets (including the J2EE Connector Architecture (JCA) version) and associated EAR file to be specified.

Utility project

A Utility project is Java project containing Java packages and Java code as .java files and .class files. They have an associated Java builder that incrementally compiles Java source files as they are changed and can be exported as JAR files or into a directory structure.

Project wizards

The following list describes many of the wizards that can be used to create projects within Application Developer. To invoke a wizard, simply use **File** → **New** → **Project** and select the appropriate project wizard. A wizard prompts the user for the required information as appropriate for the type of project.

- ▶ **Project (General)**—This is the simplest project which just contains a collection of files and folders. It contains no builders and is useful for creating a project which has no application code, for example, a project to store XML or XSD files or to store application configuration information.
- ▶ **Faceted Project (General)**—Allows a project to be created using a specific pre-existing configuration or using a selection of facets selected when the wizard is executed.

- ▶ **Report Project (Business Intelligence and Reporting tools, BIRT)**—The BIRT system (refer to <http://eclipse.org/birt/phoenix/project>) is an initiative to build an open source reporting system in Java. This wizard creates a report project which has facilities to combine database information or content from XML into report templates.
- ▶ **Crystal Reports Web project (Crystal Reports)**—This creates a Web project with Crystal reports features activated. The new project includes the libraries for the Java Reporting Component and support for Crystal Reports Viewer pages, which is built on JSP technology. Note that support for Crystal reports must be selected on installation of Application Developer for this to be available.
- ▶ **User Function Library (Crystal Reports)**—This type of project allows Java code to be called from a Crystal reports formula. The wizard creates a project very similar to a Java project but with links to the Crystal Reports Java libraries.
- ▶ **Projects from CVS (CVS)**—This wizard guides the user through the creation of a new project by checking out an existing project within CVS. It is possible to check-out a complete project from CVS, or to create a new project as part of the check-out process.
- ▶ **Data Design Project (Data)**—This wizard creates a project to store data design artifacts, including data design models and SQL statements.
- ▶ **Data Development Project (Data)**—This wizard creates a project which stores a connection to a given database. From within such a project it is possible to create resources to interrogate and manipulate the associated database. Initially the wizard creates folders to store SQL scripts and stored procedures.
- ▶ **Existing RAD6.x Data Definition Project (Data)**—The tooling which supports database definitions has changed since Application Developer V6.0.X and V5.1.2. Therefore, any data project which contain database definitions or other database objects created in the Data definition view from previous versions of Application Developer must be migrated to work with V7.5. This wizard takes a project folder in the old format and migrates it for V7.5.
- ▶ **EJB Project (EJB)**—Guides the user through the process of creating a project suitable for containing EJB components. This procedure also creates an empty EJB deployment descriptor and associates the project with an enterprise application project.
- ▶ **Application Client Project (Java EE)**—Guides the user through the creation of an empty Application Client project. The wizard prompts for the associated EAR project and presents a list of facets applicable for Java EE Application Client projects.

- ▶ **Connector Project (Java EE)**—Guides the user through the creation of a Java EE connector project, which includes specifying the associated enterprise application project and a set of facets applicable to this type of project.
- ▶ **Enterprise Application Project (Java EE)**—Creates a new EAR project. Includes options for creating associated Web, EJB, and Application Client projects.
- ▶ **Utility Project (Java EE)**—Assists in the construction of a Java utility library project which is associated with an Enterprise Application project. Code present in a Java utility library that is present in a Java EE application is shared between the modules present in the application.
- ▶ **Java Project (Java)**—A simple wizard use to create a Java application project. The wizard allows the class path including project dependencies to be specified.
- ▶ **Java Project from Existing Ant Buildfile (Java)**—It is possible to export the build settings of a project as an Ant file (use **File** → **Export** → **General** → **Ant Buildfiles**). Given such an Ant build file, this wizard can be used to create a new project based on the instructions contained within it.
- ▶ **Jython Project (Jython)**—Creates an empty project for developing Jython resources.
- ▶ **JPA Project (JPA)**—Creates a Java Persistence API (JPA) project. JPA is a Java EE 5 standardized object-relational mapping framework taht works together with the EJB 3.0 standard.
- ▶ **Feature Patch, Feature Project, Fragment Project, Plug-in from Existing JAR Archives, Plug-in Project and Update Site Project (Plug-in Development)**—These wizards assist in the creation of Eclipse plug-ins, features, and fragments, which can enhance existing Eclipse (or Application Developer) perspectives or create entirely new ones. The Rational Application developer help system has a section on how to use these wizards, and the Eclipse plugin central home page (<http://www.eclipseplugincentral.com>) has information on many plug-ins already built and tutorials on building new ones.
- ▶ **SIP 1.0 Project (SIP)**—The Session Initiation Protocol (SIP) is an extension to the Java EE servlets API intended for telecommunications applications using technologies such as Voice Over IP (VOIP). This wizard creates a Web project with the appropriate facets selected to allow the construction of SIP applications.
- ▶ **Dynamic Web Project (Web)**—Create a project for a Web application, which can include JSPs, servlets, and other dynamic content.

- ▶ **Static Web Project (Web)**—Creates a project for a Web application containing only images, HTML files, and other static Web resources. A static Web project contains no dynamic content.

Each wizard will create an empty project of the specified type with the structures, files, folders, supporting libraries, and references to support such a project. Once created, it is still possible to change aspects of the project through the project properties.

Sample projects

Rational Application Developer provides a wide range of sample applications that can help you to explore the features provided by the software development platform and the different types of projects that can be created.

The samples can be accessed in two ways:

- ▶ The **Help** → **Samples** option from the main menu. This displays the application developer help system samples page.
- ▶ The welcome screen, presented when a new workspace is started. On the welcome screen you can click the **Samples** icon (a grey circle containing a yellow ball, blue cube, and green pyramid) . This presents a samples page which links to samples present in the application developer help system.

Help system samples

The help system samples can be selected from a hierarchical list in the left-hand pane (Figure 5-12).

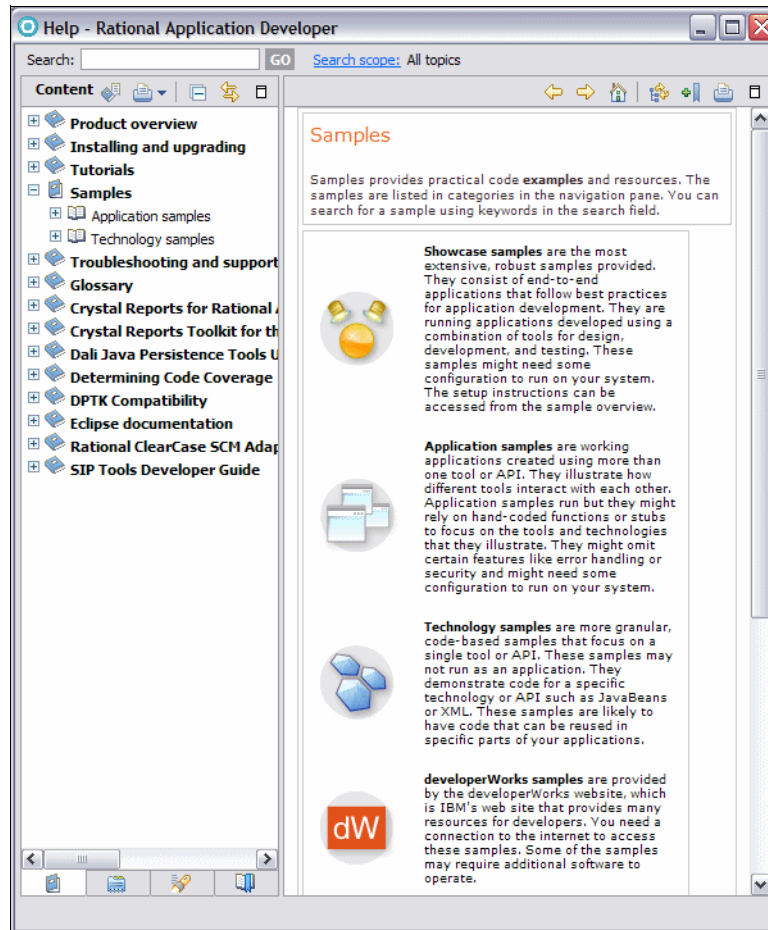

Figure 5-12 Help System samples

The samples are arranged in four main categories:

- ▶ **Showcase samples**—The most extensive samples provided. These contain complete multi-tier, end-to-end applications that follow best practices for application development.
- ▶ **Application samples**—Applications created using more than one tool or API, showing how different tools within Rational Application Developer interact with each other.
- ▶ **Technology samples**—Smaller, code-based samples that focus on a single tool or API.

- ▶ **developerWorks samples**—These samples are linked to the IBM developerWorks Web site and contain the latest samples published on this site. An internet connection is required to access these samples.

For example, the JPA JSF Employee List application is one of the Faces Application samples. The starting page for this sample provides an introduction and links to setting up the sample, getting the sample code, running the sample, and references for further information. Figure 5-13 shows the starting page for the JPA JSF Employee List sample application.

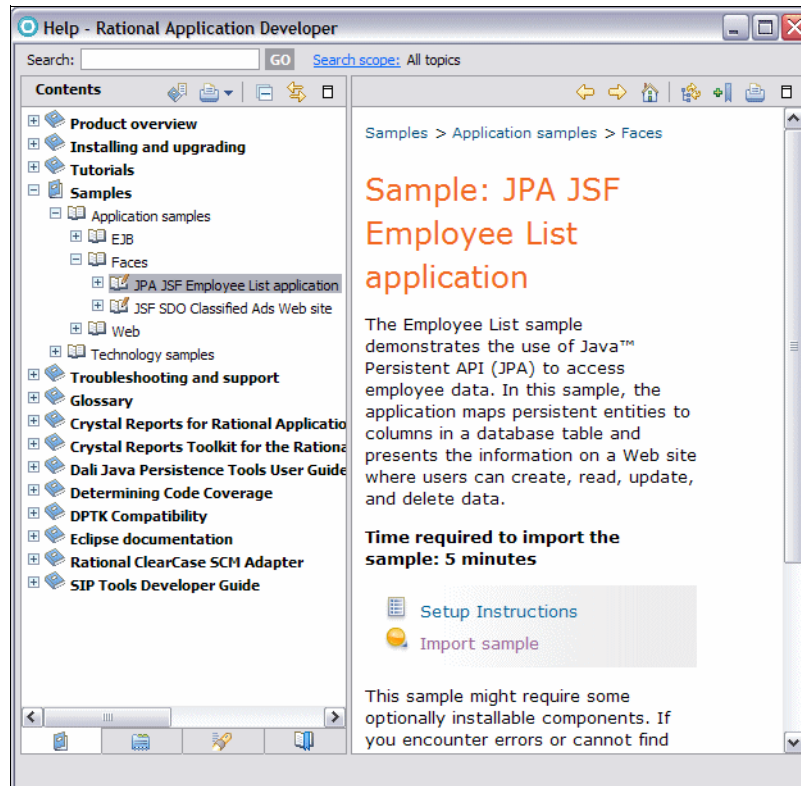

Figure 5-13 JPA JSF Employee List Sample

The **Import sample** link shows the user the sample projects that can be imported to the current workspace (Figure 5-14).

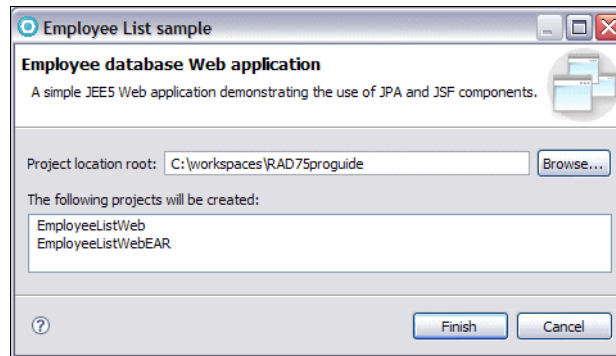

Figure 5-14 Import Employee List sample

Click **Finish** to import the sample projects (in this case two projects) and build them. The user is now free to run, modify, and experiment with the imported code as required.

Example Projects wizard

An additional way to access sample projects is through the New Project dialog. Application Developer provides a number of example projects wizards that can be used to add sample projects to a workspace. Select **New** → **Project** → **Examples**, and choose one of the sample projects from the list (Figure 5-15).

For example, the sample projects provide model solutions for application logging and XML processing. Running the wizard adds the example project to the workspace and also displays an entry from Application Developer help describing the sample.

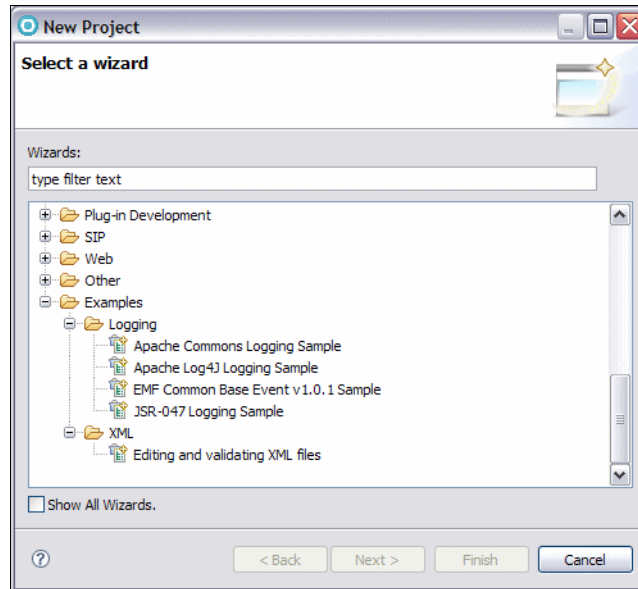

Figure 5-15 Example projects in the New Project dialog

Summary

In this chapter we discussed the main types of project that can be created with Application Developer, in particular, those used in the development of Java EE applications.

We also presented the basic techniques for handling projects within an Application Developer workspace, looked at the range of wizards available for the creation of projects and provided an introduction to the samples that are supplied with Application Developer.

In the remaining chapters of this book we discuss in more detail the use of the each different type of projects in Application Developer and the specific features available in each project type when building different types of applications.



Part 2

Architecture and modeling

In this part of the book we introduce the Rational Unified process (RUP), patterns, service-oriented architecture, and the Unified Modeling Language (UML).



RUP, patterns, and SOA

This chapter provides an overview of topics which underpin all modern software development. To begin with the chapter illustrates how a software development project can ensure that quality software is delivered on time and on budget by using the Rational Unified Process (RUP). Support for RUP is built into Rational Application Developer so its very easy to access and use.

In addition, the chapter looks at patterns. Patterns are so widely used nowadays, on practically every software development project, that its important to have at least some familiarity with them. Support is provided in Rational Application for the refactoring of software to apply specific patterns.

Finally, the chapter looks briefly at the software-oriented architecture (SOA) approach to architecting software systems. This approach is being used by enterprises both internally to coordinate their own business processes and externally to allow inter-enterprise software functionality.

The chapter is organized into the following sections:

- ▶ Rational Unified Process
- ▶ Patterns
- ▶ SOA
- ▶ Additional information

Rational Unified Process

A software development process provides a structured approach to the building, deploying and maintenance of software. A process provides an answer to the question: *Who* is doing *what* and *when*. Many different processes are currently in use and many share similar characteristics. A popular software development process, that is supported by Rational Application Developer 7.5, is the **Rational Unified Process** (RUP).

RUP is a software development process that provides best practice and guidance for successful software development. It describes a set of tasks, work products (artifacts), roles and responsibilities that can be applied to a software development project to ensure the production of high quality software that meets the client's requirements within a predictable schedule and budget.

The Rational Unified Process combines the following commonly accepted six best practices into a cohesive and well documented process description:

- ▶ **Adapt the process.** The RUP can be used for projects large and small. Its important to use the parts of RUP that are appropriate to the project being undertaken.
- ▶ **Balance competing stakeholder priorities.** When undertaking software development the needs of stakeholders must always be considered. It is however important to balance the needs of stakeholders, because often their needs are in conflict and must be resolved.
- ▶ **Collaborate across teams.** Since most software systems are complex, software development is undertaken by teams of developers rather than a single developer working alone. Its important that a proper collaborative environment is in place to support adequate communication between team members.
- ▶ **Demonstrate value iteratively.** RUP is an iterative software development process. An iterative development process can deal with the inevitable requirements changes that occur while development is taking place and allows the changes to be accommodated. Risk reduction is one of the main benefits of working iteratively.
- ▶ **Elevate level of abstraction.** Modern software systems are inherently complex. Working at a high level of abstraction can help to minimize complexity. Software reuse, modeling, and development of a stable architecture as soon as possible can all help with this.
- ▶ **Focus continuously on quality.** The production of high quality software is one of the main reasons that a software development process is followed. Dealing with issues of quality at some specific point during the process perhaps at the end of development does not work. Quality is something that

must be considered throughout development. The fact that one of the key principles of RUP is that software be developed iteratively helps this to be achieved.

Note: The six tried and tested best practices that underpin RUP have evolved over the years. The set presented here are the culmination of that evolution.

The diagram shown in Figure 6-1 is the RUP lifecycle diagram. The diagram shows the RUP **Disciplines** and the RUP **Phases**.

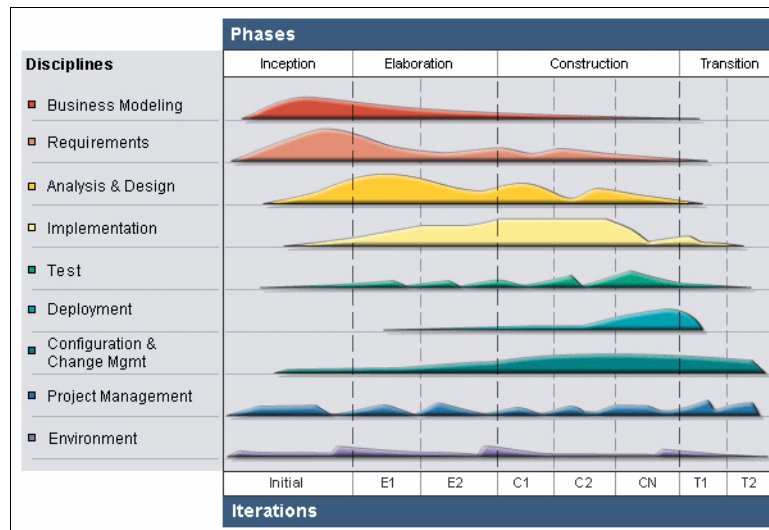

Figure 6-1 Overview of the Rational Unified Process

Disciplines

The RUP disciplines are shown on the vertical axis. They represent the groupings of the tasks that must be undertaken to provide the artifacts that are produced while following the process. Consider for example the **Implementation** discipline. Many tasks are undertaken in this discipline such as Implement Design Elements (coding) where the artifact programming language source code is produced and Implement Developer Test where test scripts are created and perhaps implemented as actual test code using a framework such as JUnit. Often developers specialize in a specific RUP discipline but some have expertise in more than one discipline.

Phases

The RUP phases are shown on the horizontal axis. RUP is an incremental process where the time spent on working on a project is broken down into phases and iterations.

- ▶ A *phase* marks a major stage in the process where specific disciplines are emphasized and specific artifacts are produced. Each phase is broken down into *iterations* which are time boxed and may vary in duration from one week to many weeks depending on the project.
- ▶ The number of iterations in each phase also varies depending on the specific project. Typically there are more iterations in the Elaboration and Construction phases than in the Inception and Transition phases. Inception is typical one iteration, but in very large projects may be more than one.
- ▶ The graphs give an indication of the effort expended in each discipline at each phases and iteration. Effort may be expended in each discipline in any iteration and in any phase but as can be seen from the graphs disciplines have peaks and troughs depending on the specific phase. Tasks undertaken as part of the requirements discipline typically peak during inception but can still be undertaken even towards the end of construction. The implementation discipline tasks peak in the construction phase because they are concerned mainly with the creation and testing of source code.

Each RUP phase has a specific purpose;

- ▶ **Inception.** This is the first phase of RUP. The main purpose of this phase is to achieve concurrence among all stakeholders on the life cycle objectives for the project.
- ▶ **Elaboration.** This is the second phase of RUP. The main purpose of this phase is to baseline the architecture of the system and provide a stable basis for the bulk of the design and implementation effort in the next phase.
- ▶ **Construction.** This is the third phase of RUP. The main purpose of this phase is to complete the development of the system based upon the baselined architecture.
- ▶ **Transition.** This is the fourth and final phase of RUP. The main purpose of this phase is to ensure that software is ready for delivery to its users.

One of the ways in which RUP guarantees the development of quality software is that it requires that at the end of each iteration a build of the application is available (working software) with certain known functionality.

RUP describes in detail the individual artifacts to be produced by the tasks which are undertaken in each discipline as well as the specific roles involved with each task. One task mentioned previously was Implement Design Elements. The role involved with this task is *Implementor*, and one of the artifacts produced is

Implementation Element. Implementation element artifacts, as stated in the RUP documentation, are the physical parts that make up an implementation, including both files and directories. They include software code files (source, binary or executable), data files, and documentation files, such as online help files.

RUP is not only a process framework that can be used to organize and structure a software development project. RUP is also a complete description of the process itself and provides:

- ▶ **Guidelines for all team members.** Guidance is provided for both the high-level thought process, as well as for more tedious day to day activities. The guidance is published in HTML form for easy platform independent access on your desktop.
- ▶ **Tool mentors.** Tool mentors provide additional guidance when working with any of the software development tools offered by IBM Rational, such as Rational Application Developer for software development and Rational ClearCase for configuration management.
- ▶ **Templates and examples.** These are provided for all major process artifacts.

RUP installation in Application Developer

Rational Application Developer facilitates the use of the Rational Unified Process through its Process Browser, Process Advisor, and Process Search features.

Important: To have RUP available in Application Developer, you must select the RUP feature at installation time: Select **Team integrations** → **Rational Unified Process (RUP) Process Advisor and Process Browser**.

You can add the feature later by using the Installation Manager.

Process Browser

The Process Browser window displays the full set of RUP process content from the installed process configuration and provides the ability to navigate to topics with the use of the two tabs: *Developer* and *Team* as shown in Figure 6-2.

To launch the Process Browser, select **Help** → **Process Browser**.

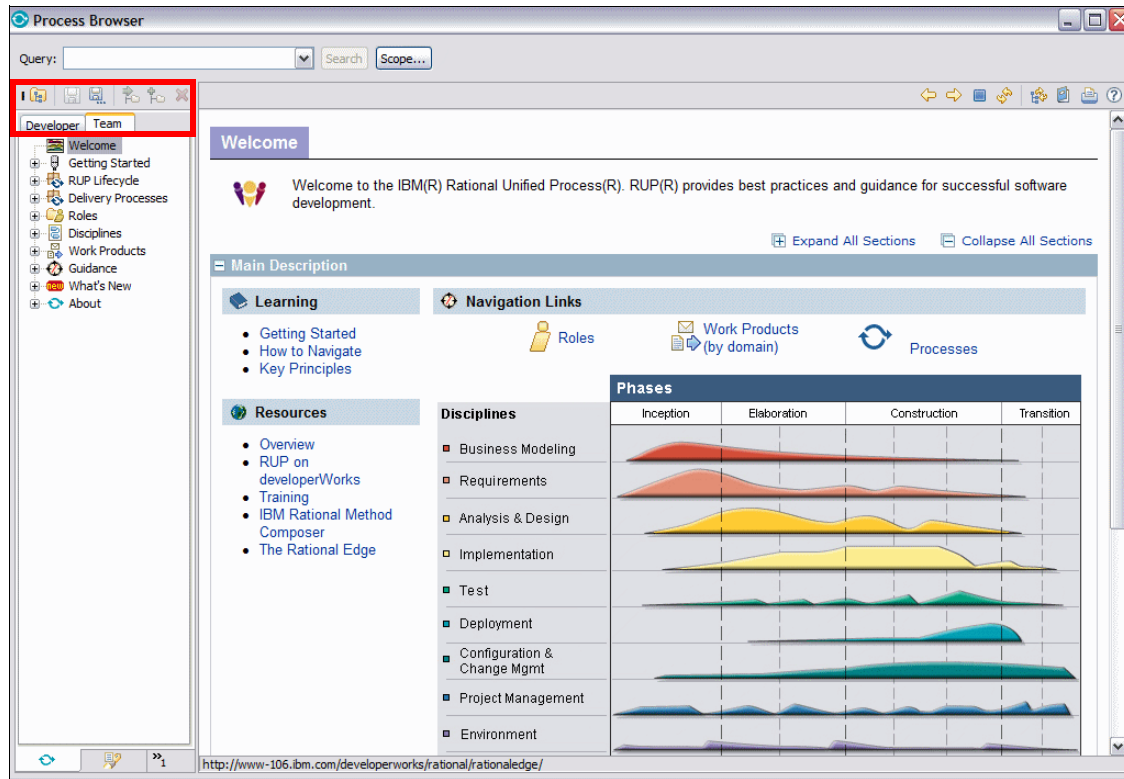



Figure 6-2 Process Browser

The **Process Views** tab  shows two individual process views. A process view is the hierarchical set of process elements associated with a particular role or major category. Process views are used to group and customize the various elements of the installed process configuration including templates, guidelines and examples.

The default process configuration provides two predefined tabs: Team and Developer. While the **Team** tab contains the full method content, the **Developer** tab provides the subset of elements suitable for developers.

If you want to adapt this configuration to your own requirements, you can create one or more new process views and customize them by using the toolbar buttons at the top of the window. Select a view you want to start with and select **Save View As** to create your own copy. This view can then be modified by adding nodes or selecting the desired information for display.

Process Advisor

This feature provides seamless integration of the development process into the Rational Application Developer development environment. It provides context sensitive information based on the elements being worked with within the environment. The Process Advisor is accessed by selecting **Help** → **Process Advisor**.

Figure 6-3 shows a UML class diagram and a class selected in that diagram. The figure also shows the Process Advisor window. Because the element selected in this case is a class, the information provided in the Process Advisor is RUP specific information that is relevant to a class. You can see that artifacts such as **Design Class** and **Design Model** are listed. Clicking on one of these opens the Process Browser at the relevant page in the RUP documentation. It is therefore possible for a developer to jump quickly to the RUP guidance documentation for any specific element they are working with.

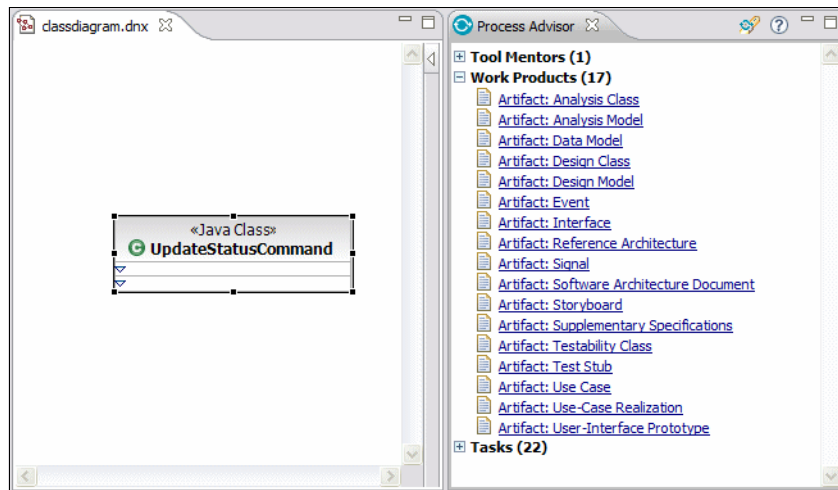

Figure 6-3 Process Advisor displaying RUP content for a selected context

Process Search

An important feature for quickly finding information is Process Search. This feature provides search capabilities with advanced filtering and is tightly integrated with the standard Rational Application Developer search capabilities. You can access this tool either by clicking **Process Search** in the Process Advisor toolbar or directly from the menu by selecting **Search** → **Search** and then selecting the **Process Search** tab. The Process Search dialog is shown in Figure 6-4.

Process Search allows you to customize the search results. By selecting the appropriate check boxes you can specify the relevant topics you want to include in your search results.

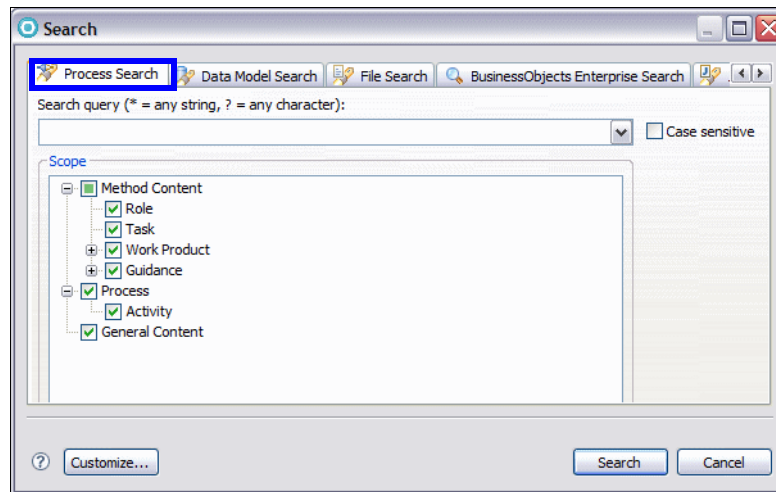

Figure 6-4 Process Search

Process preferences

Process Advisor allows you to select different process configurations or to set content filtering options for dynamic searches displayed in Process Advisor. This is achieved through the **Process** page of the Preferences dialog (Figure 6-5). The Process preferences page is accessible from within Rational Application Developer by selecting **Window** → **Preferences**.

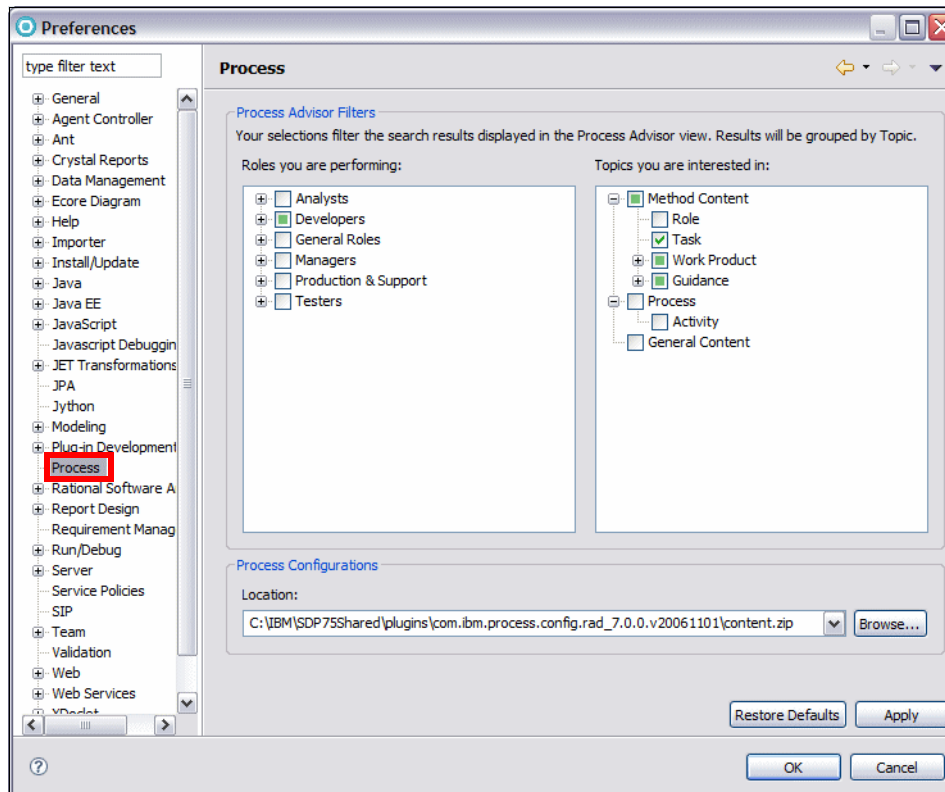

Figure 6-5 Process preferences

Rational Application Developer provides a default process configuration that focuses on the needs of application developers. This process configuration is a subset of the full process information available in the standard configuration of the RUP.

In addition to this default process configuration, you can use specific process configurations that you create and publish with IBM Rational Method Composer. You can then point to these process configurations with the process advisor. You can do this in the preferences page shown in Figure 6-5. To do this you click on the **Browse** button to point the Process Advisor to the published process configuration.

Another essential part of the Process Advisor feature is the ability to select filters to determine what context based content will appear in the Process Advisor view. On the process preferences page you can select the roles and topics you are interested in by selecting the appropriate check boxes.

Patterns

Designing a software system from scratch is not easy. Over the years software developers became aware of the fact that each time a new system was developed similar design solutions to the problems encountered during development were found. These tried and proven design solutions to recurring problems in a specific software development context came to be known as *Design Patterns*. Catalogs of design patterns have been developed over the years which in effect act as handbooks of best practice when designing software. One of the most widely known and applied patterns catalogs is the Gang of Four (GoF) patterns catalog. This catalog was first publicized in the book *Design Patterns: Elements of Reusable Object-Oriented Software* by Erich Gamma, Richard Helm, Ralph Johnson, and John Vlissides. The name GoF came about because the book had four authors and is still widely used today to describe the patterns set and specific patterns from this set.

Design patterns deal with small sections of the overall architecture of a software application typically involving only a few classes. They are different from architectural patterns which deal with the architecture of a complete application or software system. We discuss architectural patterns later as well as other patterns applicable to enterprise systems development.

GoF patterns

The GoF design patterns catalog organizes the design patterns into three groups:

- ▶ **Creational Patterns.** The patterns in this group deal with the instantiation of objects within a system. Examples of patterns in this group are Factory Method and Singleton.
- ▶ **Structural Patterns.** The patterns in this group deal with the organization of a classes within a system. Examples of patterns in this group are Facade and Adapter.
- ▶ **Behavioral Patterns.** The patterns in this group deal with the assignment of responsibility to the classes present in an application, how information is passed around the system and the flow of control within the system. Examples of patterns in this group are Command and Observer.

It is beyond the scope of this chapter to look in detail at each of the GoF patterns, but it is important to look at how patterns might be applied when using Rational Application Developer. Patterns can be applied from the outset when designing a system but often a design is arrived at and must be refactored so that the design is improved by the application of a specific GoF pattern. The comprehensive

support built into Rational Application Developer for the refactoring of code can be put to good use when applying patterns. In addition the ability to visualize classes in UML class diagrams is invaluable when applying patterns and looking for classes within an application that require a pattern to be applied. Additional support for patterns, through the Pattern Explorer view, is available in Rational Software Architect and Rational Software Modeler.

To demonstrate the kind of refactoring that would be undertaken using Rational Application Developer when applying a specific pattern, we consider an existing design example where the application of the Singleton pattern improves the design. Refactoring is the process of changing software so that it performs the same function as before but where the software structure has been. Refactoring includes changing the names of methods in a class, changing the name of a class or adding and removing classes.

Figure 6-6 shows a class diagram which includes two classes present in an application.

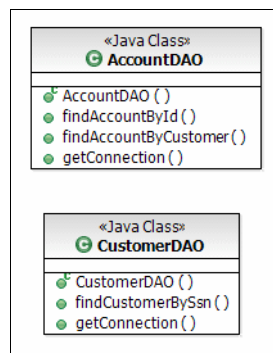

Figure 6-6 Classes before refactoring to apply the Singleton pattern

In this case both classes take responsibility for creating their own connection to a database. A better design is to delegate the creation the database connections to an object which is guaranteed to be present only once within the system. It is decided by the developer, in this case, that the Singleton pattern should be applied in the form of a database manager class that manages the creation of database connections. Figure 6-7 shows the class diagram after refactoring to apply the Singleton pattern.

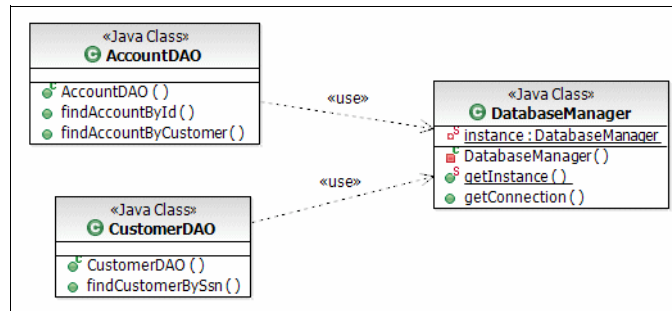

Figure 6-7 Classes after refactoring to apply the Singleton pattern

Note: Additional support for patterns, specifically the automatic application of patterns, is available in Rational Application Developer through Exemplar Authoring and Java Emitter Templates (JET). This is covered in detail in Chapter 9, “Accelerate development using patterns” on page 157.

Architectural patterns

Architectural patterns are similar to design patterns except that they are applied at the architectural level and typically involve many classes or a complete application. Some widely applied architectural patterns are layers, multi-tier, model-view-controller, and service-oriented architecture. Rational Application Developer provides support for many architectural patterns though the types of projects it supports and the frameworks that may be used within projects.

The multi-tier architectural pattern is a feature of Java Enterprise Edition (Java EE). When the multi-tier architecture is applied, applications are partitioned so that the components present in a particular partition are hosted in a specific tier. Example tiers in Java EE are the Web or presentation tier and the business or EJB tier. Rational Application Developer supports the multi-tier architectural pattern by allowing developers to create EJB projects for the development of EJB business tier components and Dynamic Web projects for the development of Web components such as servlets and JSP pages.

Another example of architectural pattern support in Rational Application Developer concerns Dynamic Web applications. Dynamic Web applications can be configured using facets. One facet which is available is the *Struts* facet. Struts is a Web application framework that uses the model-view-controller architectural pattern. Figure 6-8 shows the project properties dialog with the Struts facet selected.

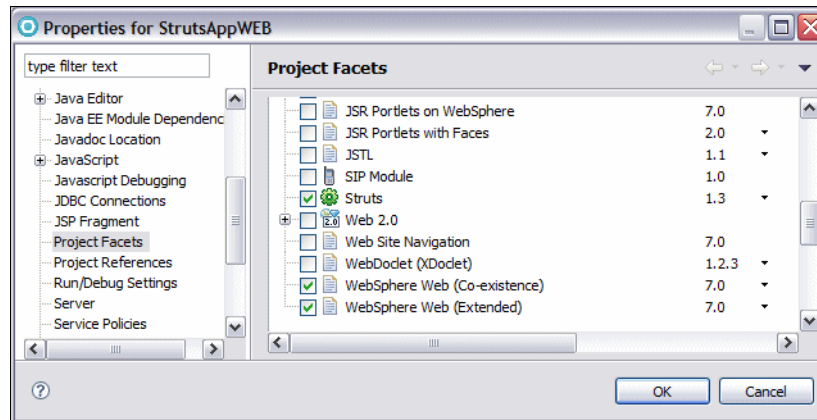

Figure 6-8 Selecting the Struts facet for a the Web project

Enterprise patterns

Enterprise design patterns build on the GoF design patterns discussed previously and catalog design patterns that are applicable for distributed enterprise systems. In a similar way to the GoF patterns, they have come about from the fact that developers found tried and proven design solutions to recurring problems in the contexts found in distributed enterprise systems. They are widely applied when creating Java EE systems.

The original enterprise pattern catalog was produced when Java 2 Enterprise Edition (J2EE) was widely used. Although J2EE has evolved to become Java EE 5 many of the patterns are still relevant.

The enterprise patterns catalog organizes the patterns into three groups based on the fact that enterprise applications use the multi-tier architectural pattern and most enterprise patterns are specific to a particular tier:

- ▶ **Presentation (Web) Tier Patterns.** The patterns in this group are concerned with the management of views and the presentation of information to clients. Example patterns in this group are Front Controller and View Helper.
- ▶ **Business (EJB) Tier Patterns.** The patterns in this group are concerned with persistence and the processing of business information (business logic). Example patterns in this group are Session Facade, Service Locator and Business Delegate.
- ▶ **Integration Tier Patterns.** The patterns in this group are concerned with the integration of one enterprise system with another and the integration of enterprise systems with other systems such as database servers. Example patterns in this group are: Data Access Object and Service Activator.

Some support is available within Rational Application Developer for enterprise design patterns. This is in addition to the refactoring facilities and the use of class diagrams as discussed previously for the GoF patterns. One example concerns EJB 2.1 entity beans. It is possible to select an EJB 2.1 entity bean in the Enterprise Explorer, and through the context menu apply the Session Facade pattern to automatically generate a session bean facade for the entity bean. Figure 6-9 shows the context menu and the **Create Session Bean Facade** entry in the menu.

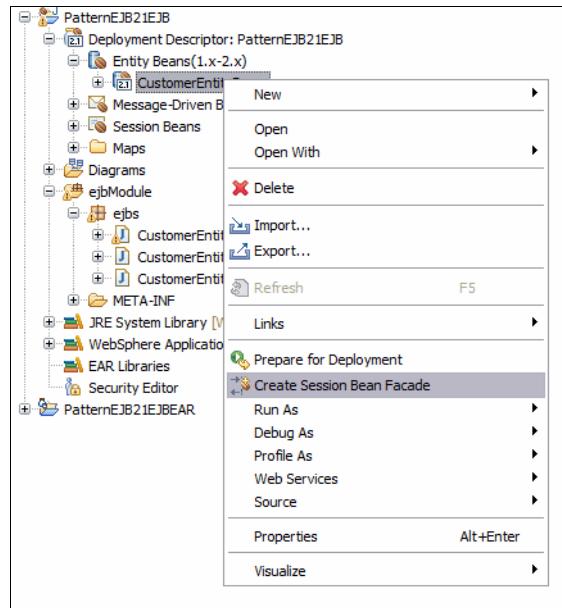

Figure 6-9 Applying the Session Facade pattern for an entity bean

SOA

Service-oriented architecture (SOA) is an architectural pattern used for the construction of systems that support business processes with software services as the fundamental architectural component. A service is a specific unit of business functionality which is reused again and again during normal business operations. Example units of business functionality that qualify as services are opening a bank account and verifying a credit card. When using SOA, business processes are therefore a collection of services connected as required to provide required business functionality.

SOA uses open standards for the representation of the services that are combined to form the business processes. The service interfaces and the

assembly of services into usable business processes is the main focus rather than how the functionality present in the service behind the interface is actually provided. Typically services are implemented using object oriented Java or .NET components but equally they may be provide using the functionality implemented by legacy system. The fact that the emphasis is on service interfaces and service assembly means that SOA is agnostic to the implementation technology. This approach has many advantages. In the past inter operability between systems, implemented using different technologies, was fraught with problems. SOA completely removes this barrier.

Traditional software engineering principles such as cohesion, modularity, loose coupling and encapsulation also accrue form the SOA approach.

Services

Services are units of functionality that are accessible over a network through interfaces defined in a standardized way. The underlying transport used to invoke services is not fixed and a whole range of transports may be used as required such as synchronous HTTP or asynchronous messaging. A service is supplied by a *service provider* and is used by a *service consumer*. Mediation between services, for instance to allow a consumer to find a required service, is also part of SOA. Currently services are typically provided over the Web using technologies associated with the Web and standards controlled by the World Wide Web Consortium (W3C). Services implemented in this way are called *Web services*. Web services are the preferred way to implement SOA at present. The technologies used for the implementation of Web Services are:

- ▶ **Extensible Markup Language (XML)**. XML is used by most of the other Web service technologies to create the documents involved.
- ▶ **Web Service Description Language (WSDL)**. WSDL is used to fully specify Web service interfaces using XML.
- ▶ **Simple Object Access Protocol (SOAP)**. SOAP is the protocol used when interacting with a Web service
- ▶ **Universal Description, Discovery, and Integration (UDDI)**. UDDI is a specification for the publishing and discovery of Web services. UDDI is XML based.

Web services interoperability

The Web Services Interoperability Organization (WS-I) exists to promote good practice in the development of Web services as well as tests for inter operability between different Web service providers. WS-I provide test tools and interpretability profiles. WS-I profiles define a specific set of Web service

standards specified to the standards revision number and guidelines on interpretability and implementation specific to that profile. If a provider of a Web service guarantees that it has been developed to a specific WSI-I profile, then a consumer is in no doubt about how to use the Web service. The *WS-I Basic Profile* (BP) is the core profile provided by WS-I and concerns the Web service standards SOAP, WSDL, and UDDI.

Note: Rational Application Developer provides support for the generation of Web services from both session EJB and JavaBeans. The development of Web Services is covered in detail in Chapter 18, “Develop Web services applications” on page 563.

Web Service Business Process Execution Language (WS-BPEL)

SOA is concerned with business processes which are typically constructed using Web services. The Web Service Business Process Execution Language (WS-BPEL) is a standard of the Organization for the Advancement of Structured Information Standards (OASIS). WS-BPEL is a language for specifying business processes and business process protocols.

Additional information

For more information on RUP, refer to:

<http://www.ibm.com/developerworks/rational/>
<http://www.ibm.com/developerworks/rational/products/rup/>

For more information on Design Patterns, refer to:

<http://www.hillside.net/patterns/>
<http://www.hillside.net/patterns/DPBook/GOF.html>
<http://www.ibm.com/developerworks/edu/ar-dw-ar-designpat1.html>

For more information on Architectural Patterns, refer to:

<http://www.ibm.com/developerworks/edu/ar-dw-ar-designpat2.html>
<http://www.opengroup.org/architecture/togaf7-doc/arch/p4/patterns/patterns.htm>

For more information on Enterprise Patterns, refer to:

http://www.ibm.com/developerworks/websphere/techjournal/0701_botzum/0701_botzum.html
<http://www.corej2eepatterns.com/>

For more information on SOA, refer to:

<http://www-01.ibm.com/software/solutions/soa/>
<http://www.ibm.com/developerworks/webservices>
<http://www.w3.org/>
<http://www.ibm.com/developerworks/webservices/newto/>
<http://www.ws-i.org/>
<http://bpel.xml.org/>



Unified Modeling Language (UML)

The Unified Modeling Language (UML), an Object Management Group (OMG) standard, is now used by the vast majority of those involved in modern software development. UML defines a graphical notation for the visual representation of a wide range of the artifacts that are created during the software development process. The visual modeling capabilities of UML range from the functionality expected of a system to the classes and components from which a system is constructed to the servers and systems on which the components are deployed. Rational Application Developer 7.5 provides visual UML tooling which, although it does not support the full capabilities of UML, is appropriate for those involved in the design and coding of software applications and components. If full UML support is required it is provided by the products Rational Software Architect and Rational Software Modeler.

The chapter is organized into the following sections:

- ▶ Overview
- ▶ Constructing and visualizing applications using UML
- ▶ Working with UML class diagrams
- ▶ Describing interactions with UML sequence diagrams
- ▶ More information on UML

Overview

Rational Application Developer 7.5 provides features to allow developers to leverage UML to visually develop and represent software development artifacts such as Java classes, interfaces, Enterprise JavaBeans and Web services. Rational Application Developer provides a customizable UML 2.1 based modeling tool that integrates tightly with the development environment. The discussion of UML in this chapter focuses on this tool.

Constructing and visualizing applications using UML

Rational Application Developer provides UML visual editing support to simplify the development of complex Java applications. Developers can create and modify Java classes and interfaces visually using class diagrams. Review of the structure of an application, by viewing the relationships between the various elements that comprise the application, is facilitated using Rational Application Developer **Browse** and **Topic** diagrams. Model elements such as classes and packages are synchronized automatically with their corresponding source code allowing developers the freedom to choose to edit the model or the source code as required.

The code visualization capabilities provide several diagrams which enable developers to view existing code from different perspectives. Unlike the diagrams offered in Rational Software Modeler or Rational Software Architect, these are visualizations of actual code only. This means that full UML 2.1 modelling is not possible using Rational Application Developer. The UML support is present only to provide a way to visualize and understand the code or to allow the editing of code from its visual representation in a model. This is in fact a very common way in which UML is typically employed.

Visual editing offers developers the ability to produce code without explicitly typing the code into a text editor. A palette is used to drag and drop different modelling elements, such as classes and interfaces, onto a diagram. In the case of classes it is possible to edit them visually, for example, to add operations and attributes or to define their relationships with other classes.

Rational Application Developer supports the following types of UML diagram:

- ▶ **Class diagrams**—This type of UML diagram presents the static structure of an application. A class diagram shows visually the classes and interfaces from which the application is composed, their internal structure and the relationships which exist between them. A specific class diagram is created to help with understanding the application and to allow development of the

application to take place. When visually representing the static view of an application as many class diagrams are created by the developer as required and a single class diagram typically presents a subset of all the classes and interfaces present in an application. Class diagrams are created within a project and exist permanently in that project until deleted.

- ▶ **Sequence diagrams**—This type of UML diagram presents the dynamic structure of an application. It shows the interactions between objects present in an executing application. Objects present in a executing application interact through the exchange of messages and the sequencing of this message exchange is an important aspect of any application. In the case of Java applications the most basic type of messaging between objects is the method call. Sequence diagrams visually represent objects and their lifelines and the messages they exchange. They also provide information on the sequencing of messages in time. Sequence diagrams are created within a project and exist permanently in that project until deleted.
- ▶ **Browse diagrams**—Browse diagrams are specific to Rational Application Developer. They are not a new type of diagram as such just a facility provided within Rational Application Developer for the creation of diagrams. A browse diagram exists temporarily, is not editable and allows a developer to explore the details of an application through its underlying elements and relationships. Browse diagrams are not a permanent part of a model, they are created as needed to allow exploration of a model. A browse diagram provides a view of a chosen context element. Context element exploration takes place in a similar way to the way Web pages are viewed in a Web browser when navigating a Web site. You cannot add or modify individual diagram elements or save a browse diagram in an project. However, you can convert a browse diagram to a UML class diagram or save it as an image file for use elsewhere.
- ▶ **Topic diagrams**—Topic diagrams share many of the features of browse diagrams except that they are generated through the execution of a query on the application model and remain permanently in a project when created. You can customize the underlying query, open multiple topic diagrams at the same time and save them away for further use. Each time a topic diagram is opened the query is executed and the diagram is populated. They are invaluable when discovering the architecture of an existing application.
- ▶ **Static method sequence diagrams**—This is a type of topic diagram that is used for viewing sequence diagrams. They are non-editable diagrams that visually represent and explore the chronological sequence of messages between instances of Java elements in an interaction. You can create a static sequence diagram view of a method (operation), including signatures, in Java classes and interfaces to illustrate the logic inside that operation.

All of these diagrams help developers to understand and document code. To provide further documentation you can also generate Javadoc HTML documentation that contains UML diagram images. Refer to “Generate Javadoc with diagrams automatically” on page 132.

The UML visualization tools are applicable not only to Java classes but also to other types of artifacts, such as Web services and Enterprise JavaBeans. Rational Application Developer also supports data visualization using UML or Information Engineering notation.

Figure 7-1 provides an overview of the workspace you might see when using the UML visualization capabilities:

- ▶ The center area is the UML editor. This editor is used to display and modify the different elements present in the model.
- ▶ Built into the editor is a palette that is used to drag and drop elements onto the editor work area. The items that appear in the palette are specific to the type of project that is being visualized. The palette is only available when the diagram is editable. The palette is not displayed for topic and browse diagrams
- ▶ The Outline view enables you to see, in miniature, the whole diagram currently being viewed with the area of the diagram you have zoomed in on highlighted. This can be very useful for finding your way around a complex diagram, since you can left click the area of the outline view that is highlighted and drag it around to see a different zoomed area. You can also change the outline view to show a tree of all the different elements that are present in the current diagram.
- ▶ The Properties view enables you to review or change any property that is related to a selected diagram or a diagram element.
- ▶ Finally, you can drag and drop project elements from the Enterprise Explorer or Package Explorer view directly into the editor work area to add these items to the diagram. You can, for example, drag a Java class from the Enterprise Explorer to the editor work area where it will be rendered as a UML class in the diagram. If relationships exist between the Java class you have dragged, such as an association with another class, then this will be rendered as well.

In Figure 7-1 the diagram shown was created by dragging the `DepositCommand` class, `TransferCommand` class, and `Command` interface to the editor work area. In this case the `TransferCommand` and `DepositCommand` implement the `Command` interface, and as you can see UML implements relationships have also been rendered in the diagram.

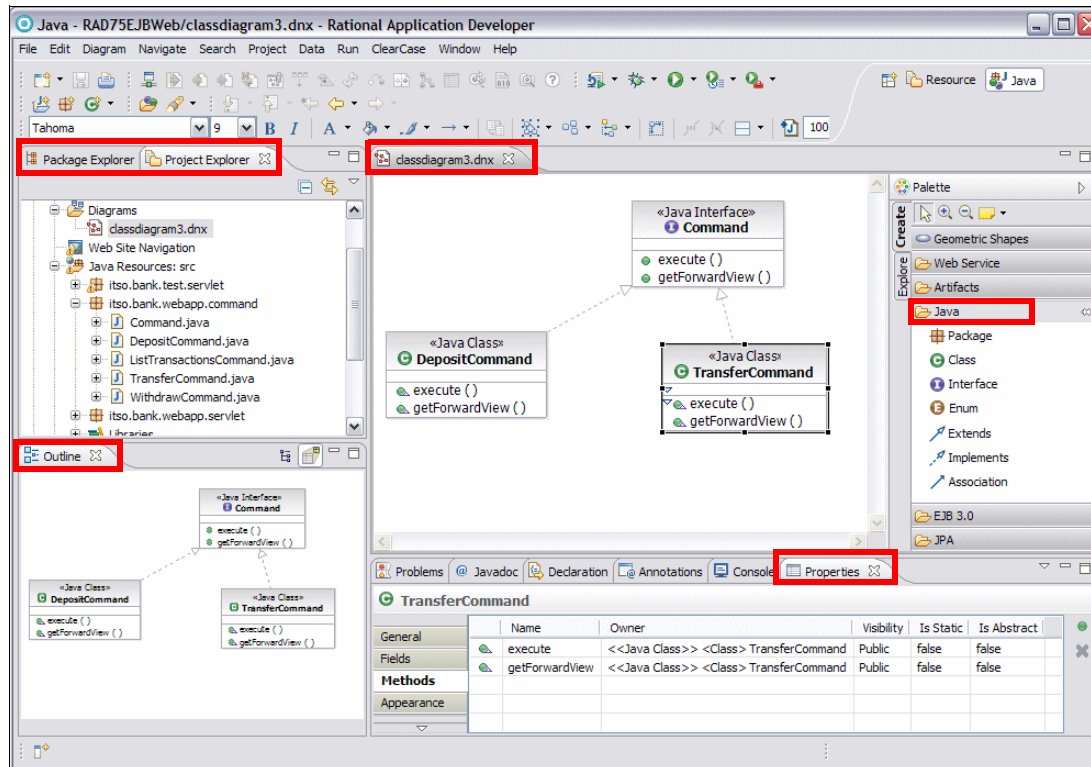

Figure 7-1 Example workspace when using the UML visualization capabilities

Unified Modeling Language

A model is a description of a system from a particular perspective, omitting irrelevant details so that the characteristics of interest are seen more clearly. In other words a model is a simplification of reality. The more complex a system is the more important that it is modeled. Models are useful for problem solving and understanding, communicating with team members and stakeholders, preparing documentation, and designing applications. Modeling promotes a better understanding of requirements, cleaner designs and more maintainable applications.

The Unified Modeling Language (UML) is a standardized language for modelling the different aspects of an application. You can use this language to visualize, specify, construct and document the different artifacts of an application. UML models are constructed using three kinds of building blocks: Elements, relationships, and diagrams.

Elements

Elements are an abstraction of the structural or behavioral features of the system being modeled. Each element type has specific semantics and gives meaning to any diagram in which it is included. UML defines four kinds of elements:

- ▶ **Structural elements**—This type of element is used to model the static parts of a system. Examples of this type of element are interfaces, classes, components, and actors.
- ▶ **Behavioral elements**—This type of element models the dynamic parts of a system. They are typically found in UML interaction diagrams as well as in other diagram types. Examples of this type of element are objects, messages, activities, and decisions.
- ▶ **Grouping or organizational elements**—This type of element is used to group together other elements into a meaningful set. An example of a grouping element is the package.
- ▶ **Annotational elements**—This type of element is used to comment and describe a model. Examples of this type of element are notes and constraints.

Relationships

Relationships are used to document the semantic ties that exist between model elements. Four commonly used categories of UML relationships are listed here:

- ▶ **Dependency relationships**—This type of relationship is used to indicate that changes to a specific model element can affect another model element. For example consider a Bank class which depends on an Account class. An operation that can be called on an object of the Bank class might take as a parameter a reference to an object of the Account class. The Account object has been created elsewhere but the Bank object uses it and therefore depends on it. After the Account object has been used, the Bank object does not retain its reference to it. A dependency relationship therefore exists between the Account class and the Bank class.
- ▶ **Association relationships**—This type of relationship indicates that instances of a specific model element are connected to instances of another model element. For example a Customer class may have an association with an Account class. When an object of the Customer class obtains a reference to an object of the Account class, it retains it and can interact with the Account object whenever required. If the classes were to be implemented in Java, then typically the Customer class would include an instance variable to hold the reference to an Account object. There are several different types of association relationship that can be used depending on how tightly connected the modelling elements are. Consider for example a relationship between a Car and Engine class. In this case the association is stronger than in the previous Customer and Account example. One of the stronger types of association such as aggregation or even composition might therefore be used

in the model. In the case of composition the connection between the classes is so strong that the lifetimes of the objects are bound together. The object of one class never exists without an object of the other, and when one is deleted so is the other.

- ▶ **Generalization relationships**—This type of relationship is used to indicate that a specific model element is a generalization or specialization of another model element. Generalization relationships are used to show inheritance between model element. If Java is used to implement a UML class element and that element has a generalization relationship with another class in a model, the Java extends keyword would be used in the source code to establish this relationship. For example, an Account class might be a generalization of a SavingsAccount class. Another way to say this is that the SavingsAccount is a specialization of the Account class, or that the SavingsAccount class inherits from the Account class.
- ▶ **Realization relationships**—This type of relationship is used to indicate that a specific model element provides a specification that another model element implements. Realization relationships are typically used between an interface and the class which implements it. The interface defines operations and the class implements the operations by providing the method behind each operation. In Java this maps to the implements keyword. For example, consider a Command interface and a DepositCommand class. A realization relationship would exist in the model between the DepositCommand class and the Command interface. In other words the DepositCommand class implements the Command interface.

Diagrams

A UML diagram provides a visual representation of an aspect of a system. A UML diagram illustrates the aspects of a system that can be described visually such as relationships, behavior, structure and functionality. Depending on the content of a diagram it can provide information on the design and architecture of a system from the lowest level to the highest level. UML provides thirteen types of diagrams that let the user capture, communicate, and document all aspects of an application.

The individual diagrams can be categorized into three main types: Static, dynamic and functional. Each type represents a different view of an application.

- ▶ **Static**—Diagrams of this type show the static aspects of a system. This includes the things from which the application is constructed for example the classes and how the things are related to each other. This type of diagram does not show changes which occur in the system over time. Examples of this type of diagram are the component diagram, the class diagram, and the deployment diagram.

- ▶ **Dynamic**—Diagrams of this type show the dynamic aspects of a system. They document how an application responds to requests or otherwise evolves over time by showing the collaborations that take place between objects and the changes to the internal states of objects. Objects in a system achieve nothing unless they interact or collaborate. Examples of this type of diagram are the sequence diagram and the communication diagram.
- ▶ **Functional**—Diagrams of this type of show the functional requirements of a system. Examples of this type of diagram are the use case diagram.

Additional information on UML can be found at:

<http://www-01.ibm.com/software/rational/uml>

Working with UML class diagrams

A UML class diagram is a diagram that provides a static view of an application. It shows some or all of the components or elements in an application and the relationships between them such as inheritance and association. You can use class diagrams to visually represent and develop Java applications and Java EE Enterprise JavaBeans applications. Rational Application Developer also allows Web Service Description Language (WSDL) elements, such as WSDL services, port types, and messages to be shown on class diagrams. In Rational Application Developer 7.5, enhanced support is provided for UML visualization of EJB 3.0 applications.

The content of a class diagram is stored in a file with a .dinx extension. The UML class diagram editor consists of an editor window which displays the current class diagram and a palette that contains individual drawers containing the elements that can be added to a class diagram.

Creating class diagrams

A new class diagram is created using the **New Class Diagram** wizard. You can launch this wizard directly from the menu in Rational Application Developer. To create a class diagram from the menu select **File** → **New** → **Other** → **Modeling** → **Class Diagram**. Alternatively, from the Enterprise Explorer, right-click on any resource, such as a project or a package, to bring up the context menu and select **New** → **Class Diagram**.

Once the wizard has started you can enter the name for your class diagram and specify the folder where the class diagram file should be stored. When you click on **Finish** the new class diagram is created and opened for editing with the associated palette on the right hand side as shown in Figure 7-2.

Alternatively, you can create a UML class diagram from existing source elements within a project, including packages, classes, interfaces and EJBs. In the Enterprise Explorer, right-click the desired source element or elements and select **Visualize** → **Add to New Diagram File** → **Class Diagram**. In a similar way it is also possible to add elements to an existing class diagram.

You can create as many class diagrams as you want to depict different aspects of your application.

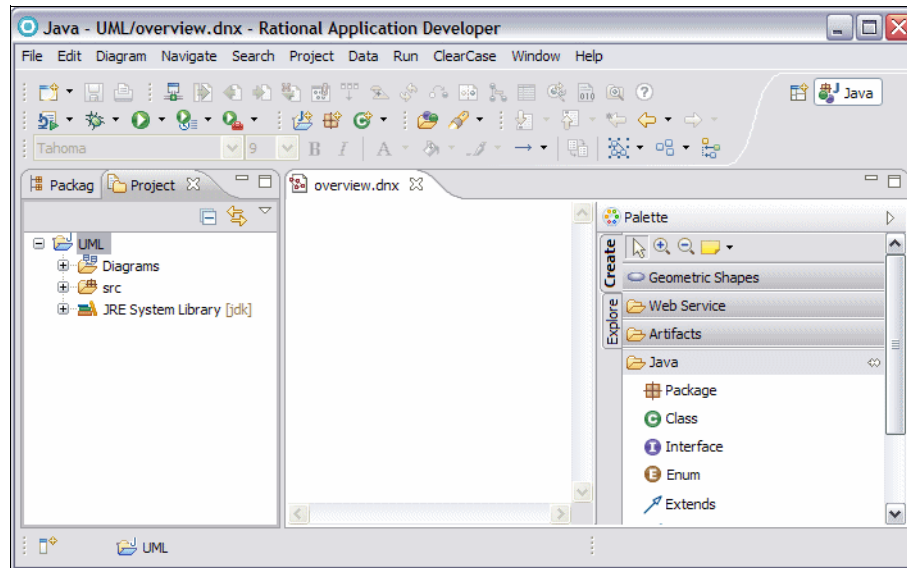

Figure 7-2 A new class diagram

Creating, editing, and viewing Java elements in UML class diagrams

When working with class diagrams developers can create, edit and delete Java elements such as packages, classes, interfaces, and enum types to allow the visual development of Java application code.

To draw a class diagram you simply select the desired elements from the palette and drag them to the class diagram editor window. This launches the appropriate wizard, such as the **New Java Class** wizard if you drag a Java class from the palette, that guides you in the creation of the new element. Alternatively, elements can be created directly in the Enterprise Explorer and placed on the diagram later.

Figure 7-3, shows a class as it is seen when added to a class diagram. The class is rendered as specified in the UML standard.

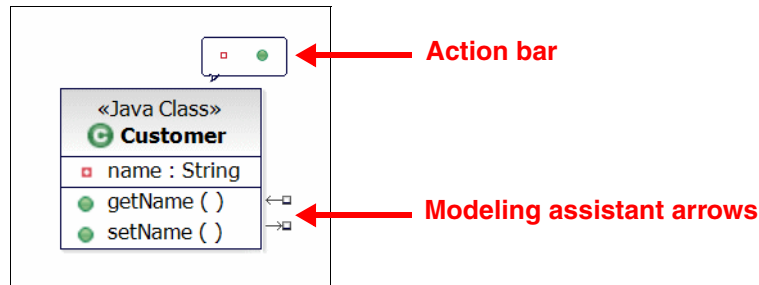

Figure 7-3 A Java class with action bar and modeling assistant arrows visible

In this case three compartments are visible:

- ▶ The upper compartment or name compartment contains the class name and if required a stereotype. A stereotype is a string, surrounded by guillemets (angled brackets) that indicates the kind of element more precisely. In this case we have a class, but more precisely its a Java class.
- ▶ The middle compartment is the attribute compartment and contains the attributes present in the class.
- ▶ The lower compartment is the operation compartment and contains the operations present in the class.

You can show or hide individual compartments so that only the compartments you are interested in appear. To do this right-click on the class and select **Filters** → **Show/Hide Compartment**. A submenu offers you the available options.

Also, when you hover the mouse cursor over a class, the action bar and the modeling assistant arrows are displayed:

- ▶ The **action bar** is an icon-based context menu that provides quick access to commands that allow you to edit a diagram element. In the case of a Java class you can add fields and methods to the class. The actions, available on the action bar, are also available through **Add Java** in the context menu presented if you right-click on the class in the diagram.
- ▶ The **modeling assistant** allow you to create and view relationships between the selected element and other elements such as packages, classes or interfaces. One modeling assistant arrow points towards the element and the other points away. The arrow pointing towards the element is for incoming relationships. Thus, when creating a relationship where the selected element is the target, you would use the incoming arrow. Similarly, the arrow pointing away from the element is for outgoing relationships and is used in a similar way.

To create a relationship from one Java element to another element execute the following steps:

- ▶ Move the mouse cursor over the source element so that the modeling assistant is available and click on the small box at the end of the outgoing arrow.
- ▶ Drag the connector that appears and drop it on the desired element or on an empty space inside the diagram if you want to create a new element.
- ▶ Select the required relationship type from the context menu that appears when the connector is dropped (Figure 7-4).

You can create incoming relationships in the same way by using the incoming arrow. Alternatively, you can select the desired relationship in the tool palette and place it on the individual elements.

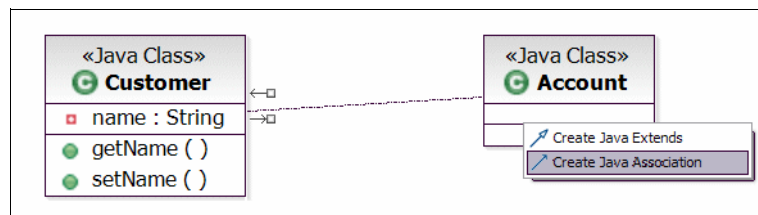

Figure 7-4 Using the Modeling Assistant to create a relationship

The modeling assistant also allows you to view related elements that are based on a specific relationship. These are elements which exist in the model but that are not currently shown on the class diagram. To do this double-click the small box at the end of the outgoing or incoming arrow and select the desired relationship from the resulting context menu as shown in Figure 7-5. This is equivalent to selecting **Filter** → **Show Related Elements** from the element's context menu.

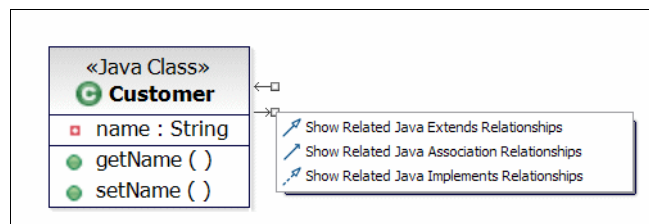

Figure 7-5 Viewing related Java elements using the modeling assistant

The context menu for a class includes several additional editing options that have not yet been discussed. Some of the additional options are as follows:

- ▶ **Delete from Diagram**—This option removes the visual representation of the selected element(s) from the diagram. It does not delete the element from the project. Note that when you delete Java elements from a class diagram, the underlying associations remain intact.
- ▶ **Format**—This option changes the properties of the selected element that govern its appearance and location in a diagram. Modifying these properties only changes the appearance of this specific rendition of the element, it does not affect how the element is rendered elsewhere on the diagram or in another diagram. Some of the properties can be configured globally using the modeling preferences dialog.
- ▶ **Filters**—This option allows you to manage the visual representation of elements in UML class diagrams but is concerned with what is visible on a diagram when the element is rendered irrespective of what the element contains. For example, UML allows a class to have operations but allows the operations to be hidden, if required, when the class is drawn on a class diagram. With the filters option you can show or hide attributes and operations, determine if operation signatures are displayed or specify if the fully qualified names of individual classes are shown.
- ▶ **Filters** → **Show Related Elements**—This is a particular function of the **Filters** option and requires its own explanation because it is so useful. **Show Related Elements** helps developers to query for related elements in a diagram. As shown in Figure 7-6, the Show Related Elements dialog allows you to select from a set of predefined queries. By clicking on **Details** you can view and change the actual relationships, along with other settings related to the selected query.
- ▶ **Refactor** and **Source** provide the same functionality to change and edit the underlying Java code as they do when invoked on the class directly in the Enterprise Explorer.

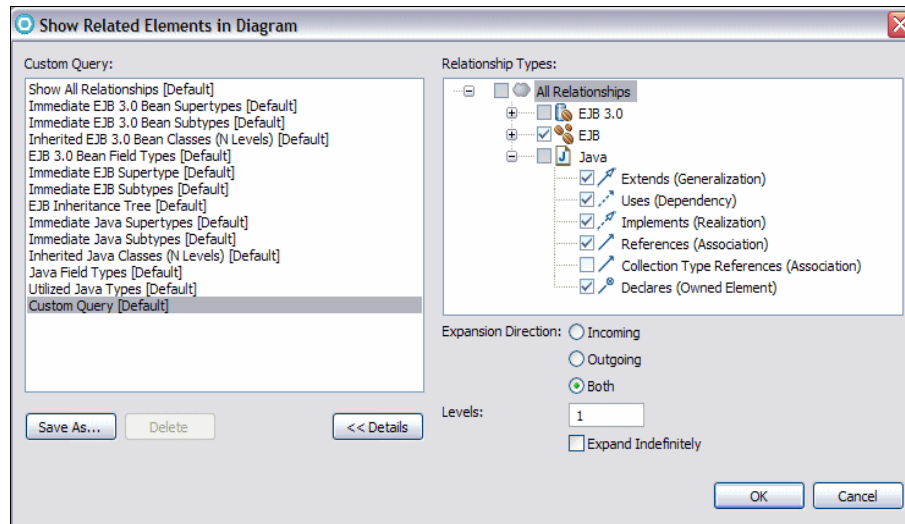

Figure 7-6 Show Related elements dialog

Figure 7-7 provides an example of a class diagram showing some elements and the relationships between them.

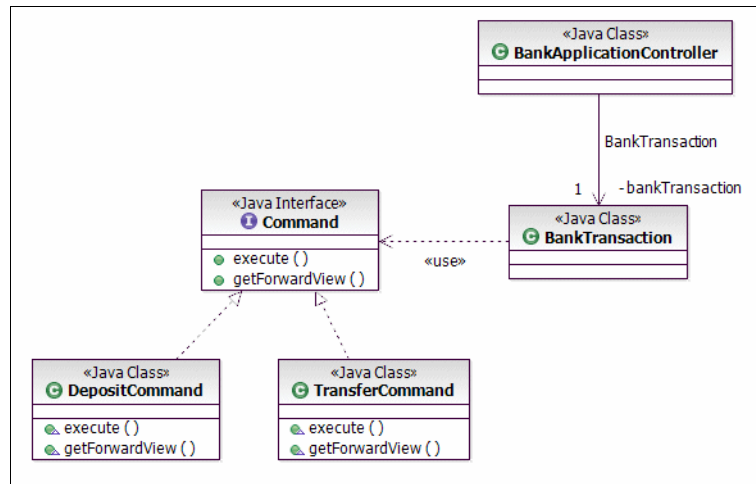

Figure 7-7 Class diagram showing different UML elements

Creating, editing, and viewing EJBs in UML class diagrams

Class diagrams also allow developers to visually represent and develop Enterprise JavaBeans (EJBs) in EJB applications. Developers can create class diagrams and populate them with existing EJBs to allow the business tier architecture to be documented and understood. Class diagrams can also be used to develop new EJBs including EJB relationships such as inheritance and association and to configure the security aspects of bean access such as security roles and method permissions.

Rational Application Developer 7.5 now supports EJB 3.0, and class diagrams can be drawn showing EJB 3.0 beans. The support for drawing class diagrams showing EJB 2.1 and earlier beans is still supported, but will not be discussed here.

To use the EJB class diagram capabilities a class diagram must be created within the context of an EJB project. The palette can then be used to create and edit as before but now with the addition of EJBs. Alternatively, you can create the EJBs in the Enterprise Explorer and place them on a diagram later.

Figure 7-8 shows the graphical representation of an EJB 3.0 session bean.

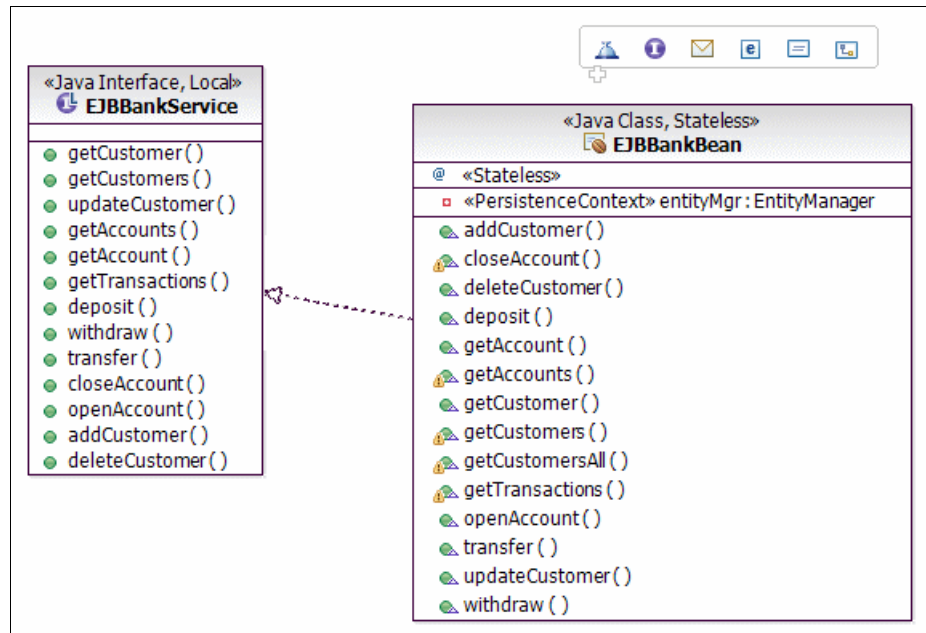

Figure 7-8 Visualization of an EJB 3.0 Enterprise JavaBeans

To visualize an EJB simply drag it from the Enterprise Explorer to the class diagram editor. EJBs are rendered as a class which is stereotyped as <<Java Class>> with appropriate stereotype for the type of bean. In this case the other stereotype is <<Stateless>> because we have an EJB 3.0 stateless session bean. An EJB exposes its functionality to clients through either a remote interface, a local interface or less commonly both. The session bean shown in Figure 7-8 provides only a local interface. The interface is shown on the class diagram as a class stereotyped as <<Java Interface>> and <<Local>>.

EJBs in an EJB 3.0 project usually employ Java Persistence API (JPA) entities to provide data persistence rather than EJB 2.1 entity beans. Figure 7-9 shows an EJB 3.0 session bean and a JPA entity. Note that the JPA entity is shown in the diagram as a class with appropriate stereotypes.

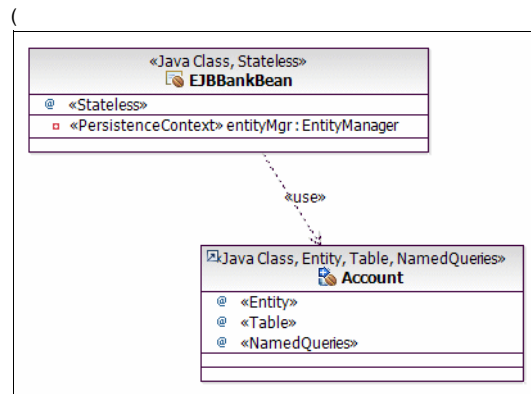

Figure 7-9 Class diagram showing an EJB 3.0 session bean and a JPA entity

Relationships between EJBs

You can use a class diagram to create relationships between EJBs. The palette supports two kinds of relationship between beans:

- ▶ EJB inheritance
- ▶ EJB reference

EJB inheritance is a standard Java generalization relationship between two EJB classes. An EJB reference relationship is shown on the class diagram as an association and is implemented in the source code as an EJB 3.0 reference.

Figure 7-10 shows three EJB 3.0 session beans with relationships. An inheritance relationship exists between TestSessionBean and BaseTestSessionBean, this is drawn on the class diagram as a UML generalization arrow. EJBBankBean holds an EJB 3.0 reference to TestSessionBean and this is shown in the diagram as a directed UML association between the two beans.

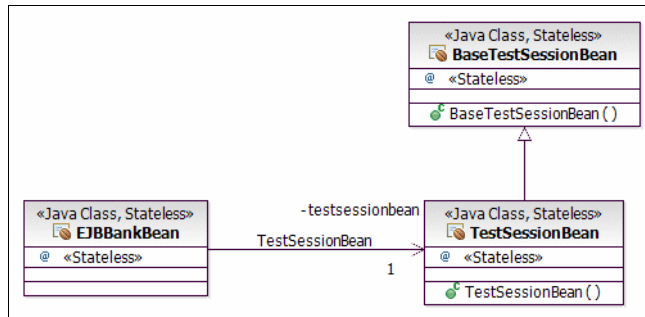

Figure 7-10 Class diagram showing three EJB 3.0 session beans with relationships.

Previously we looked at the Filters option, available when we right-click on a class in a class diagram. This feature works for EJB 3.0 beans but an appropriate set of predefined custom queries is shown for this type of element. Figure 7-11 shows the dialog for an EJB 3.0 session bean.

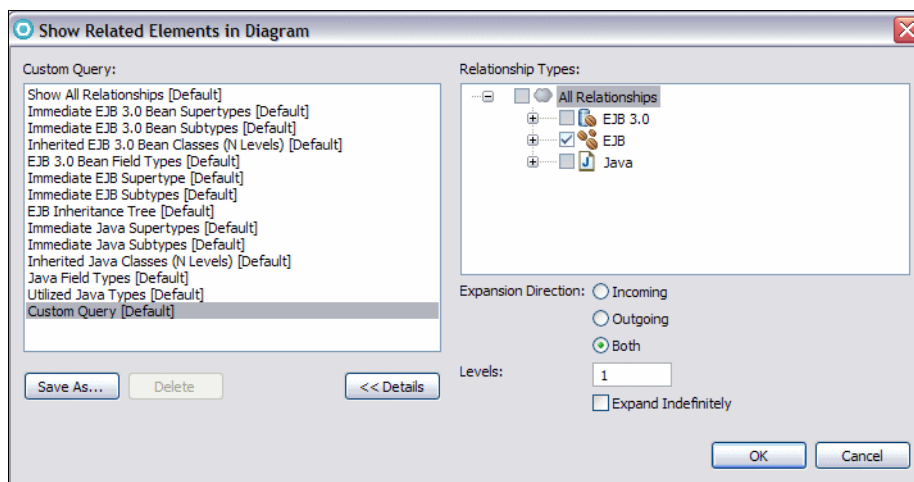

Figure 7-11 Show Related Elements dialog for EJB 3.0 session beans

By default, the details are collapsed and only the left pane in the dialog is visible. By clicking **Details** the actual relationships along with other settings related to the selected query can be viewed. You can select the different types of relationship that should be included in the query along with the expansion direction. If you select **Incoming**, all elements are shown that are related to the selected element. On the other hand, if you want to see all elements that have a relationship to the selected element, select **Outgoing**. Any changes made to the queries can be saved for future use.

From the context menu there are several other options available to edit a selected EJB or to change its appearance. Most of these features have been described previously so the following discussion focuses only on topics that are specific to EJBs. Some of these features are exposed as wizards.

Security roles and method permissions

You can use UML class diagrams to visually manage EJB security. This includes creating security roles and configuring method permissions. Only the support for for configuring security for EJB 3.0 beans using security annotations is discussed here.

An EJB 3.0 security configuration involves the creation of required security roles and the definition of the EJB method security permissions. Linking of security to roles to roles defined in the container is not discussed here. This is typically done using annotations. The following steps document how this is achieved:

- ▶ To create a security role for a specific EJB right-click on the bean and select **Add EJB 3.0** → **Security** → **Declare Roles**. In the Declare the Roles dialog (Figure 7-12, left), click the **Add** button and provide the name of a security role, for example, Customer. Click **Finish** on the add dialog and then **Finish** again in the Declare the Roles dialog to complete the process.
- ▶ This adds the annotation `@DeclareRoles (value="Customer")` to the source code for the EJB, and the EJB shown in the class diagram is updated with `<<DeclaredRoles>>` to indicate that a security role is now present (Figure 7-12, right).

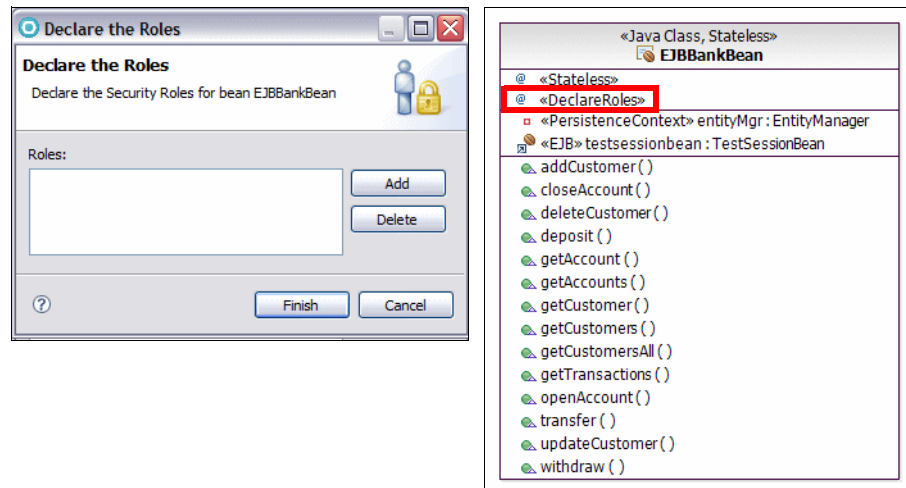

Figure 7-12 Declare the roles dialog and diagram stereotype

- ▶ To define method permissions for an EJB 3.0 bean, select a bean method in the class diagram, for example, `getCustomersAll`. To define method permissions right-click on the selected method and select **Add EJB 3.0** → **Security** → **Set Allowed Roles**. The roles permitted to execute the method can then be selected from the **Set Allowed Roles** dialog. This adds the annotation `@RolesAllowed(value="Customer")` to the `getCustomersAll` method in the source file for the bean and updates the method in the class diagram with `<<RolesAllowed>>`. Figure 7-13 shows an EJB with method permissions set for its `getCustomerAll` method.

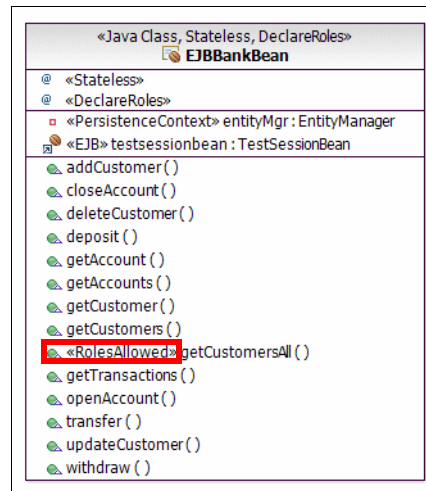

Figure 7-13 EJB 3.0 bean with method permissions on `getCustomersAll` method

Creating, editing, and viewing WSDL elements in UML class diagrams

Rational Application Developer 7.5 enables developers to represent and create Web Service Description Language (WSDL) Version 1.1 and XML Schema (XSD) definition elements using UML class diagrams.

To use this feature, the Web Service Modeling capability must be enabled beforehand. In the preferences dialog, accessed by selecting **Window** → **Preferences**, expand the **General** node to access the **Capabilities** page. In the **Capabilities** page click **Advanced**. In the dialog expand the **Web Service Developer** node and select **Web Service Development**.

Figure 7-14 shows the graphical representation of a WSDL service. To visualize a service, select its WSDL file from the Enterprise Explorer and drag it to a class diagram. Alternatively, right-click a WSDL file and select **Visualize** → **Add to New Diagram File** → **Class Diagram**.

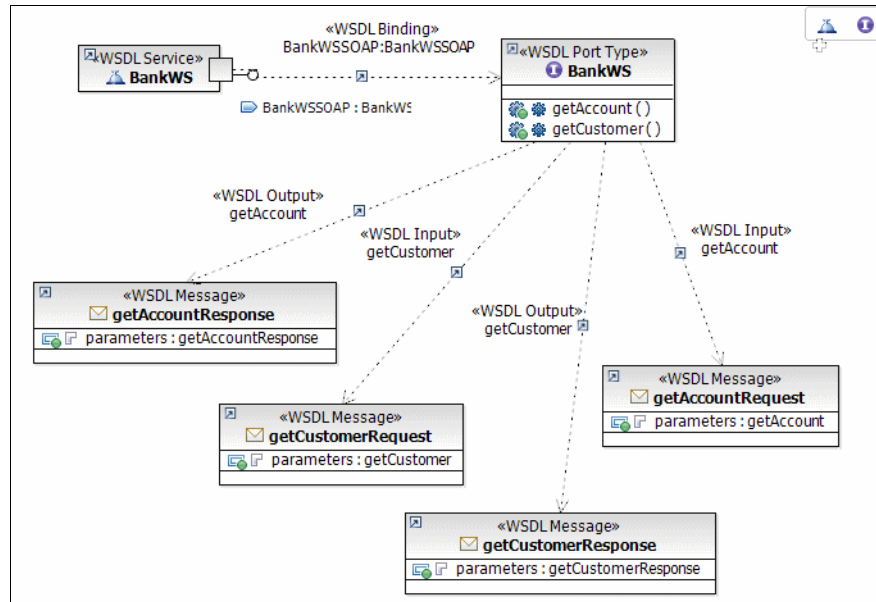

Figure 7-14 Graphical representation of a Web Service

Note that by default the external view of a service is shown. If you want to switch to the compressed view, right-click the service and select the **Filter** submenu and clear then **Show External View**.

Like Enterprise JavaBeans, WSDL services are displayed as UML classes on a class diagram with appropriate stereotypes:

- ▶ The individual ports of a service are depicted as small squares on the side of the class. The class is stereotyped as `«WSDL Service»`. The functionality provided by a port is exposed by a port type.
- ▶ A port type is displayed as a UML interface that is modeled using the *lollipop* notation. In Figure 7-14 you can see the port type explicitly displayed as an interface being linked to its port. This link is realized as a dependency with stereotype `«WSDL Binding»`. It describes the binding being used for this port type. A port type references messages that describe that type of data being communicated with clients.
- ▶ A message itself consists of one or more parts that are linked to types. Types are defined by XSD elements. Figure 7-14 shows that messages are displayed as UML classes with the `«WSDL Message»` stereotype. XSD elements are also displayed as UML classes although none are shown in Figure 7-14.

Creating a WSDL service

This section provides a sample scenario that describes how the UML class diagram editor can be used to create a new Web service from scratch. We use different tools provided by the tool palette to create the various elements of a Web service, such as services, ports, port types, operations and messages.

Creation of the service involves the following steps:

- ▶ Creating a WSDL service
- ▶ Adding ports to a WSDL service
- ▶ Creating WSDL port types and operations
- ▶ Creating WSDL messages and parts
- ▶ Editing parts and creating XSD types
- ▶ Creating bindings between WSDL ports and port types

Each step is documented in detail in the following sections.

Creating a WSDL service

If you select the WSDL Service element in the tool palette and drop it on an empty space inside a class diagram the New WSDL Service wizard starts to create a new WSDL service along with a port as shown in Figure 7-15.

To begin with you must specify the WSDL file that will contain the service. You can either click **Browse** to select an existing file or you can click **Create New** to launch the New WSDL File wizard. If you create a new WSDL file, then on the Options page clear **Create WSDL Skeleton**, because you will create these elements later in the next tasks. Finally, provide a name for the service and port and click **Finish**.

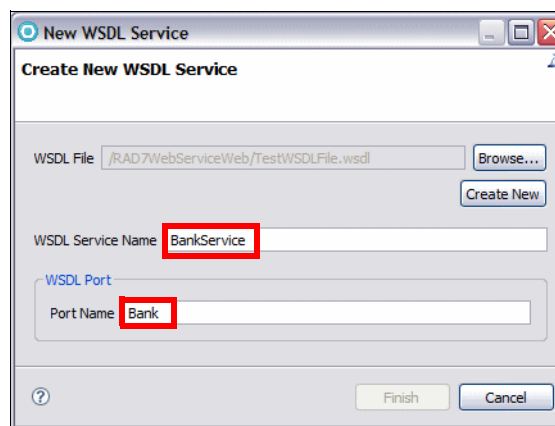

Figure 7-15 New WSDL Service wizard

The result of this task is shown in Figure 7-16. Like an EJB, a WSDL service is displayed as a UML class but with the stereotype `«WSDL Service»`. The port is depicted as a small square on the side of the class. Note that the external view of the component is shown. To switch to the compressed view, open the context menu and clear **Show External View** from the Filter submenu. In this case the port will not be visible.

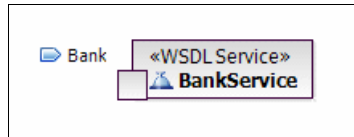

Figure 7-16 Visualization of a WSDL service component

Adding ports to a WSDL service

A WSDL service consists of one or more individual ports. A port describes an endpoint of a WSDL service that can be accessed by clients. It contains the properties name, binding, and address. The name property provides a unique name across all the ports defined within the enclosing WSDL file, the binding property references a specific binding and the address property contains the network address of the port.

To add a port to a WSDL service, right-click the service and select **Add WSDL** → **Port**. This launches the Port wizard (Figure 7-17). Enter the name of the port then click **Finish**. Optionally you can specify a binding and a protocol.

Note that this task is not required for our scenario because a port has already been created and added to the service in the previous task.

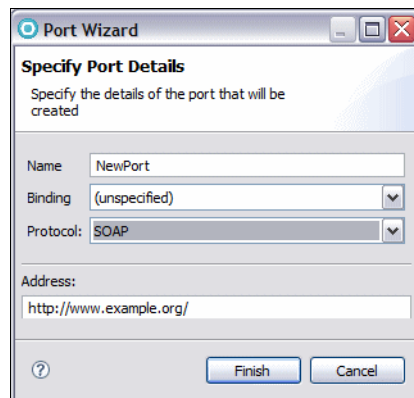

Figure 7-17 Port wizard

After you have created a port, you can use the Properties view to review or change any property of the port. Right-click the square representing the desired port and select **Show Properties View**. Then select **General** on the left side of the Properties view. On this page, you can enter a new name and address and you can select a binding and protocol (Figure 7-18).

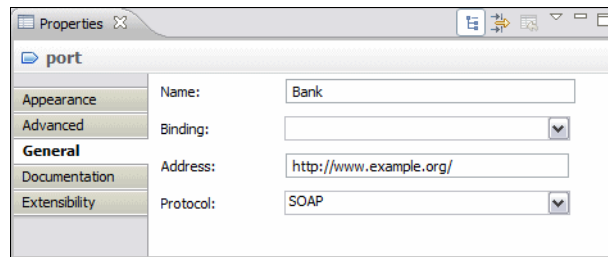

Figure 7-18 Port properties shown in the Properties view

Creating WSDL port types and operations

A port type describes the behavior of a port. It defines individual operations that can be performed and the messages that are involved. An operation is an abstract description of an action supported by a service. It provides a unique name and the expected inputs and outputs. It might also contain a fault element that describes any error data the operation might return.

You can create a new port type together with an operation with the help of the **New WSDL Port Type** wizard (Figure 7-19). You can launch this wizard either by dragging a WSDL Port Type from the palette to the class diagram or by right-clicking in the diagram and selecting **Add WSDL** → **Port Type**.

First you must specify the WSDL file that should contain the port type. A port type is not restricted to be in the same WSDL file as the enclosing WSDL service. As described previously you can click **Browse** to select an existing WSDL file or click **Create New** to create a new file. Next you must provide the port type name and operation name and then finally click **Finish**.

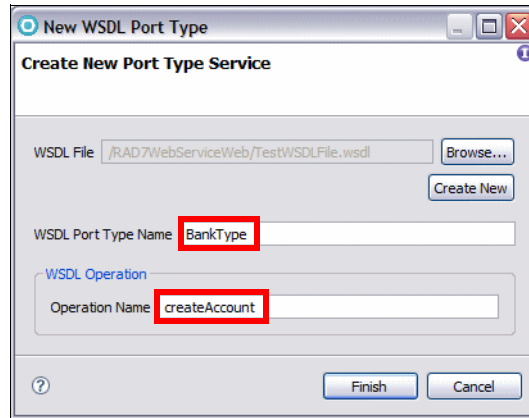

Figure 7-19 New WSDL Port Type wizard

The result is shown in Figure 7-20. A port type is visualized in the diagram using an interface with the stereotype `<<WSDL Port Type>>`. You can add further operations by selecting **Add WSDL** → **Operation** from the context menu.

Note that we have not created a connection between this port type and the port. We will do this in the last task.

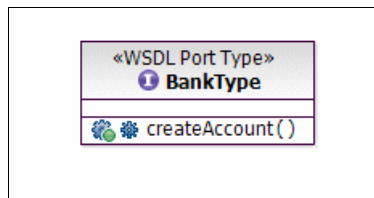

Figure 7-20 Class diagram representation of a port type

Creating WSDL messages and parts

Messages are used by operations to describe the kind of data being communicated with clients. An operation can have an input, output and a fault message. A message is composed of one or several parts and each part is linked to a type. The individual parts of a message can be compared to the parameters of a method call in the Java language.

To create a new message along with a part, select the WSDL Message tool in the tool palette and drag it to the diagram. This opens the dialog shown in Figure 7-21.

First, you must specify the WSDL file that should contain the message. WSDL services or port types and messages are top-level objects that can be defined in

a separate WSDL file. As described previously you can either browse to select an existing file or create a new one. Finally, enter the message name and part name and click **Finish**.

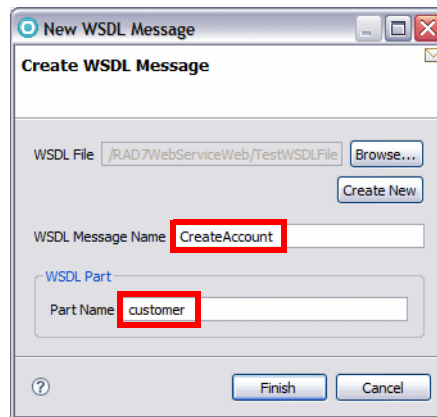

Figure 7-21 New WSDL Message wizard

The result is shown in Figure 7-22. The newly created message is displayed using UML class notation with stereotype `WSDL Message`. If you want to add any further part to this message, right-click the class and select **Add WSDL** → **Add Part**.

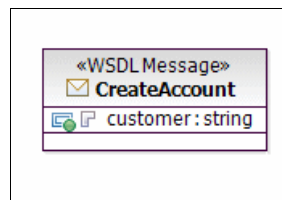

Figure 7-22 Representation of a WSDL message in a class diagram

The CreateAccount message is associated with the input-element of the createAccount operation in the next task. Before you proceed, create a second message CreateAccountResponse along with a part named account. This message will be associated with the output-element of this operation.

Editing parts and creating XSD types

WSDL recommends the use of XML Schema Definition (XSD) to define the type of a part. You can use the class diagram to create and edit the required XSD objects such as XSD elements, simple types, or complex types. If you right-click in the class diagram and select **Add WSDL** you can select the required item from the submenu. Alternatively, you can drag the item from the palette to the class

diagram. The wizards involved are similar to the ones described previously in that you specify the WSDL file and enter a name for the XSD object to be created.

If the XSD element added is a complex type you can add new elements to it. To do this, right-click the complex type and select **Add XSD** → **Add New Element**. This creates a new element within the selected complex type with type string. You can further set or change the type of an existing XSD element. In the diagram editor, right-click an XSD element or an element within a complex type and select **Add XSD** → **Set XSD Type**. The dialog that opens provides a list of available types that you can select.

Note that once you have created an XSD element, you can just as easily delete it from the diagram. If you want to delete it permanently from the underlying WSDL file, you must edit the file directly.

To review or change a type of a part of a WSDL message select the part to bring up its properties in the Properties view, then select the **General** tab. As shown in Figure 7-23, you can select the desired type in the drop-down combo box.

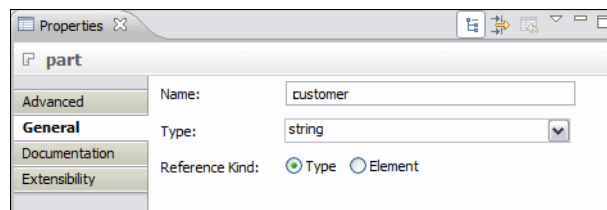

Figure 7-23 Properties view showing the properties of a part.

To proceed with this exercise, create two complex types, Account and Customer, and add the attributes amount, name, and firstName as shown in Figure 7-24.

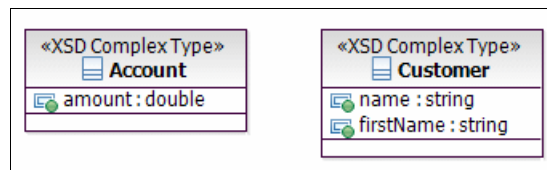

Figure 7-24 Complex types with attributes

Finally, link these types to the parts of the messages you have created as shown in Figure 7-25.

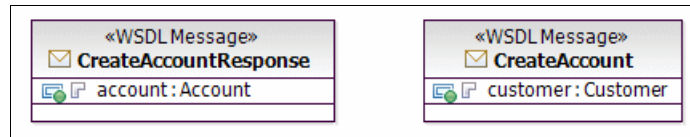

Figure 7-25 Using XSD complex types as the type for WSDL messages parts

Adding messages to WSDL operations

An operation can reference three different types of messages to describe the data communicated with clients. These are input message, output message, and fault message.

To add a message to an operation select either WSDL Input Message, WSDL Output Message or WSDL Fault Message in the palette. Click the port type you wish to add the message to and drag the cursor from the port type to the message you want to add. In the dialog select the desired operation and click **Finish** (Figure 7-26). Alternatively, you can use the modeling assistant to do this.

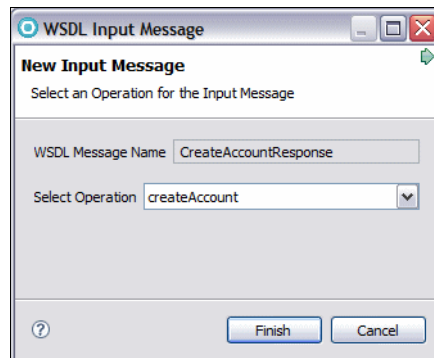

Figure 7-26 WSDL Input Message wizard

To proceed with the exercise, create a WSDL input message from the createAccount operation to the CreateAccount message. Then create a WSDL output message from the same operation to the CreateAccountResponse message (Figure 7-27).

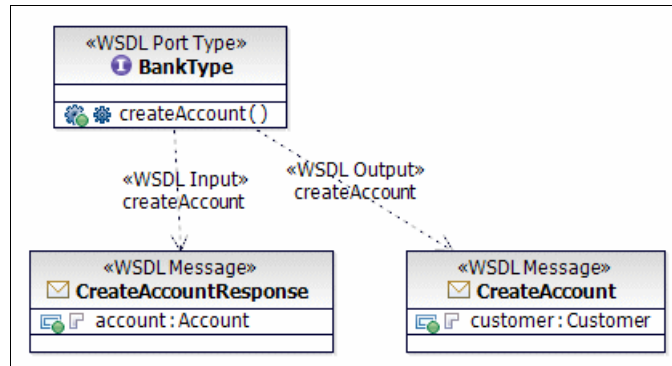

Figure 7-27 Class diagram showing a port type with messages

Create bindings between WSDL ports and port types

A binding is used to link a port type to a port. The class diagram editor offers you several ways to do this. For example, you can use the **WSDL Binding Creation** tool in the palette. To do this choose the tool in the palette and click on the port (remember that a port is shown as a small square on the side of a service). Then drag the cursor to the port type. A new binding is created between the port and the port type. As shown in Figure 7-28, this binding is modeled as a dependency with stereotype <<WSDL Binding>> between the two elements. The lollipop notation is used to represent the interface provided by the port.

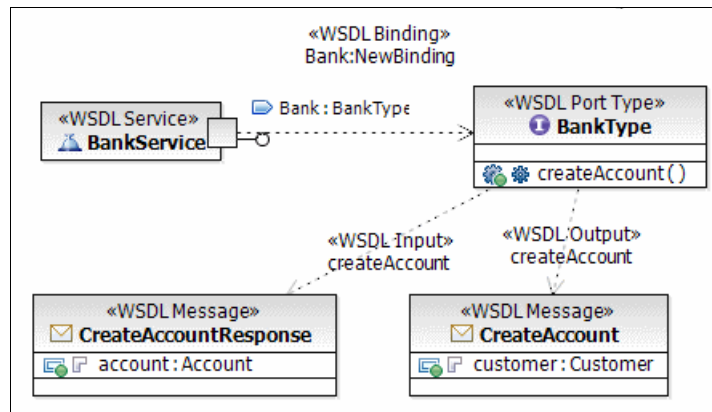

Figure 7-28 Class diagram showing a binding between a port and its port type

The last step is to generate the content for this binding. Select the dependency representing the binding and open the Properties view. On the General page click **Generate Binding Content** and complete the wizard (Figure 7-29).

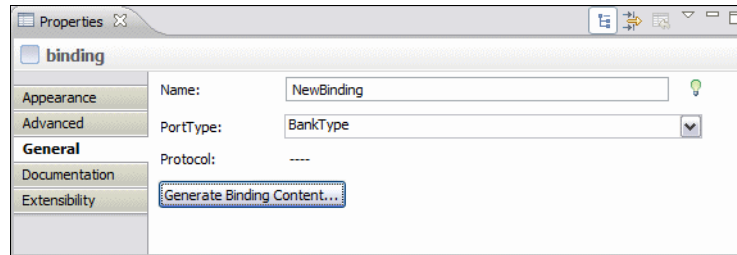

Figure 7-29 Properties view showing binding properties

After you have created the entire Web service, you can directly create an implementation of the Web Service within the diagram editor. Right-click a WSDL service component and select **Implement Web Service**. This will start the Web Service wizard that guides you through the process. You can also use the diagram editor to create a Web Service client for a given Web Service. To do this right-click a WSDL service component and select **Consume Web Service**.

Class diagram preferences

Rational Application Developer allows users to review and edit default settings or preferences that affect the appearance and the behavior of UML class diagrams and their content. These preferences are organized under the Modeling node within the Preferences dialog (select **Window** → **Preferences**).

Before you create a new UML class diagram, you can set the default global preferences for attributes and operations, such as visibility styles, showing or hiding attributes and operations, showing or hiding operation signatures, and showing or hiding parent names of classifiers. Most configuration settings are present under the following Preferences dialog nodes:

- ▶ **UML diagrams**—This node and the nodes beneath it such as `Class` and `Component` allow users can specify several preferences regarding the style, fonts and colors that are displayed in UML diagrams when they are created. Users can change the default settings for showing or hiding attributes, operations, operation signatures, or parent names of classifiers. They can also specify which compartments are shown by default when a new UML element is created.
- ▶ **Java**—This node and the nodes beneath it allow users to specify settings that deal with Java code when it is used in a UML model. One example is the configuration of corresponding wizards that should be used when new fields or methods are created within a class diagram.

- The settings for this are under **Field and Method Creation**. Its even possible to specify the default values that should be applied to these wizards.
- **Show Related Elements Filters** provides the option to filter out binary Java types when the Show Related Elements action is executed. Binary Java types are types that are not defined in the workspace, but instead are available to the workspace through referenced JAR libraries.
- ▶ **EJB**—The EJB preferences node allows users to specify if newly generated or created EJBs are visualized in a selected class diagram. If this option is selected and a diagram is not selected while creating or generating a new bean, this bean is opened in a *default* class diagram.
- ▶ **Web Service**—This node allows users to change the default settings for visually representing existing WSDL elements. You can specify if the external or compressed view of an existing WSDL element is shown. Furthermore you can specify which WSDL components are visually represented in class diagrams. To show or hide WSDL components, select or clear the corresponding check boxes on this page.

Exploring relationships in applications

Rational Application Developer provides browse and topic diagrams that can be used to explore and navigate through an application and to view the details of its elements and relationships. They are designed to assist developers in understanding and documenting existing code by quickly creating UML representations of an existing application.

Browse diagrams

A browse diagram is a structural diagram which provides a view of a context element such as a class, a package, or an EJB. It is a temporary and non editable diagram that provides the capability to explore the given context element. You can view the element details, including attributes, methods, and relationships to other elements, and you are able to navigate to those elements. Browse diagrams can be applied to various elements including Java classes and Enterprise JavaBeans, but excluded are all elements related to Web services.

You can create a browse diagram from any source element or its representation within a class diagram. To create a browse diagram, right-click the desired element and select **Visualize** → **Explore in Browse Diagram**. A browse diagram is created and shown in the corresponding diagram editor. The diagram editor consists of a panel displaying the selected element along with its

relationships and a tool bar. Because a browse diagram is not editable, the palette and the modeling assistant are not available. Depending on the elements shown, the diagram is displayed either using the radial or generalization tree layout type. The radial layout type shows the selected element in the center of the diagram, whereas the generalization tree layout type organizes the general classes at the top of the diagram and the subclasses at the bottom.

The browse diagram acts like a Web browser for your code. It provides a history and navigation, and you can customize the UML relationships you want to see. The tool bar located at the top of the browse diagram displays the context element you are currently browsing. At any one time, there is only one browse diagram open. When you browse another element, it is displayed in the same diagram replacing the previous element.

Figure 7-30 shows an example browse diagram with the Java class `DatabaseManager` as the context element. You can see all the attributes and methods declared by this class. In this case the dependency filter button is the only one highlighted and so elements involved in a dependency relationship with `DatabaseManager` are shown as well. You can see that `AccountDAO` and `CustomerDAO` both depend on `DatabaseManager`.

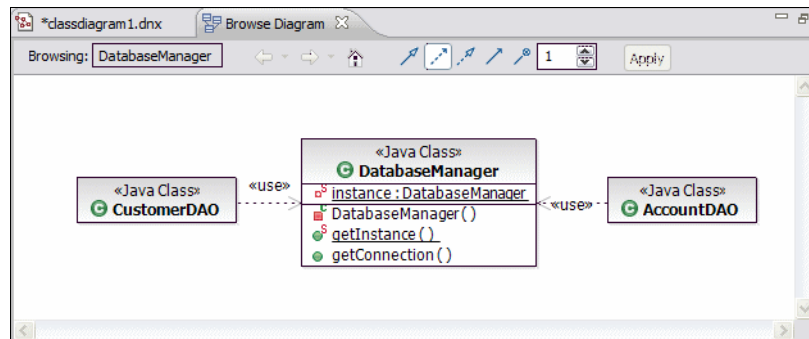

Figure 7-30 Browse diagram example

The browse diagram retains the history of elements you have viewed so far. You can use the two arrow buttons provided in the tool bar to navigate backward or forward to browse previously viewed elements.

When you click the **Home** icon, the first element in the history is displayed. Furthermore, the tool bar contains a list of filter icons that can be used to filter the types of relationships that are shown along with the context element. Note that there are different filters available depending on the type of element you are currently browsing for example Java class or EJB. To enable or disable a filter, click the appropriate icon and then click **Apply**. You can also change the number

of levels of relationships that are shown for the context element. The default value is one. To change this value, specify a number and click **Apply**.

In Figure 7-30 the **Home** icon and the two arrow icons are disabled, so the current element is the first element in the browse diagram history.

If you want to explore the details of a diagram element, double-click it. This element becomes the new context element. When you right-click a diagram element, the **Navigate** submenu provides several options such as opening the Java source of a diagram element.

A browse diagram cannot be changed or saved, but Rational Application Developer lets you save any browse diagram view as a diagram file that is fully editable. Right-click an empty space inside a browse diagram and select **File** → **Save as Diagram File**. If you want to use a browse diagram as part of permanent documentation, you can save a browse diagram view as an image file using **File** → **Save as Image File**.

Topic diagrams

Topic diagrams provide another way to create structural diagrams from the code in your application. They are used to quickly create a query based view of relationships between existing elements in your application. These queries are called *topics* and represent commonly required views of your code, such as showing the super type or sub types of a given class. Topic diagrams are applicable to various elements, such as Java classes, EJBs or WSDL files. Like browse diagrams these diagrams are not editable, but they can be saved as editable UML diagrams and shared with other team members.

A new topic diagram of an application element is created by the Topic Diagram wizard. To launch this wizard, right-click the desired element in the Enterprise Explorer and select **Visualize** → **Add to New Diagram File** → **Topic Diagram**. Once the wizard has started, on the Topic Diagram Location page, enter or select the parent folder and provide a name for the file as shown in Figure 7-31. Then click **Next**.

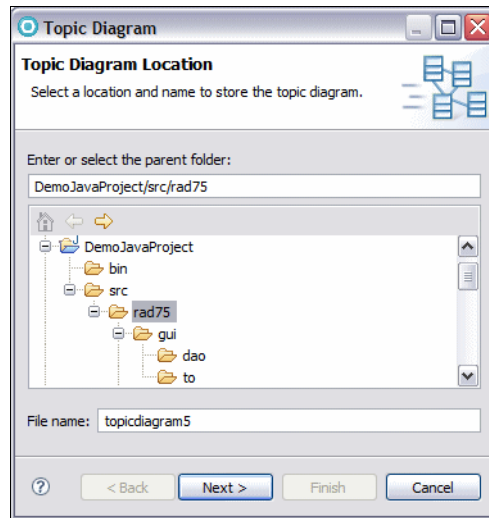

Figure 7-31 Topic Diagram wizard (1)

The Topics page shown in Figure 7-32 provides a list of standard topics Rational Application Developer can create. Select a predefined query and click **Finish**. This creates a new topic diagram based on default values associated with the selected topic.

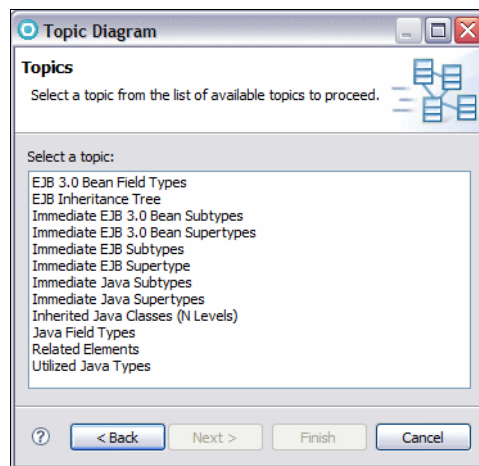

Figure 7-32 Topic Diagram wizard (2)

If you want to review or change these values click **Next** instead. The Related Elements page shown in Figure 7-33 appears.

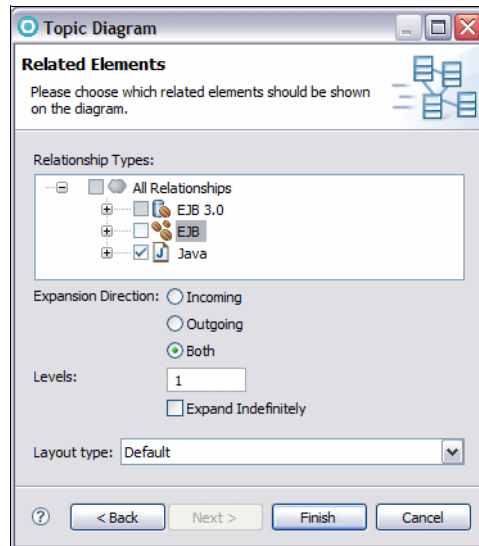

Figure 7-33 Topic Diagram wizard (3)

This page shows the details of the previous selected topic and allows you to change these values. You can select different types of relationship that should be included in the query along with the expansion direction:

- ▶ If you select **Incoming**, all elements are shown that are related to the context element.
- ▶ On the other hand, if you want to see all elements that have a relationship to the context element, select **Outgoing**.
- ▶ You can further specify the number of levels of relationships to query and the layout type for the diagram. The possible values are **Default** and **Radial**. These values map to the generalization and radial tree layout type described previously.

Once a topic diagram is created, you can review or change the underlying query. To do this right-click on empty space inside the topic diagram and select **Customize Query**.

Like browse diagrams, topic diagrams are not editable, so the tool palette and the modeling assistant are not available. You can add more elements to the diagram by right-clicking them in the Enterprise Explorer and selecting **Visualize** → **Add to Current Diagram**.

It is also possible to save a topic diagram as an editable diagram or as an image as we did previously with browse diagrams. To do this right-click on empty space in a topic diagram and select either **File** → **Save as Diagram File** or **File** → **Save as Image File**.

The query and the context element that you have specified are persisted in the topic diagram. Every time you open a topic diagram the underlying elements are queried and the diagram is automatically populated with the most current results. If you make changes to the underlying elements when a topic diagram is already open, the diagram might not represent the current status of the elements until you refresh the diagram manually. To do this right-click on empty space in the topic diagram and select **Refresh**.

Describing interactions with UML sequence diagrams

Rational Application Developer provides the capability to develop and manage sequence diagrams. A sequence diagram is an interaction diagram that can be used to describe the dynamic behavior of a system. It depicts the sequence of messages which are sent between objects in a certain interaction or scenario.

Sequence diagrams can be used at different stages during the development process:

- ▶ Within the analysis phase, a sequence diagram can be used to describe the realization of a use case that is a use case scenario.
- ▶ Within the design phase, sequence diagrams can be more refined to show how a system accomplishes an interaction and in this case shows objects of actual design classes interacting.

A sequence diagram consists of a group of objects their associated lifelines and the messages that these objects exchange over time during the interaction. In this context, the term object does not necessarily refer to software objects instantiated from a class. An object represents any structural thing defined by UML.

Figure 7-34 provides an overview of a sample sequence diagram. It describes the scenario where a customer wants to withdraw cash from an ATM. A sequence diagram has a two-dimensional nature. The horizontal axis shows each of the objects that are involved in an interaction, while the vertical axis shows the lifelines, the messages exchanged and the sequence of creation and destruction of the objects. Most objects that appear in a sequence diagram are in existence for the duration of the entire interaction, so their lifelines are placed at the top of the diagram. Objects can be created or destroyed during an

interaction. In this case their lifelines start or end respectively with the receipt of a corresponding message to create or destroy them.

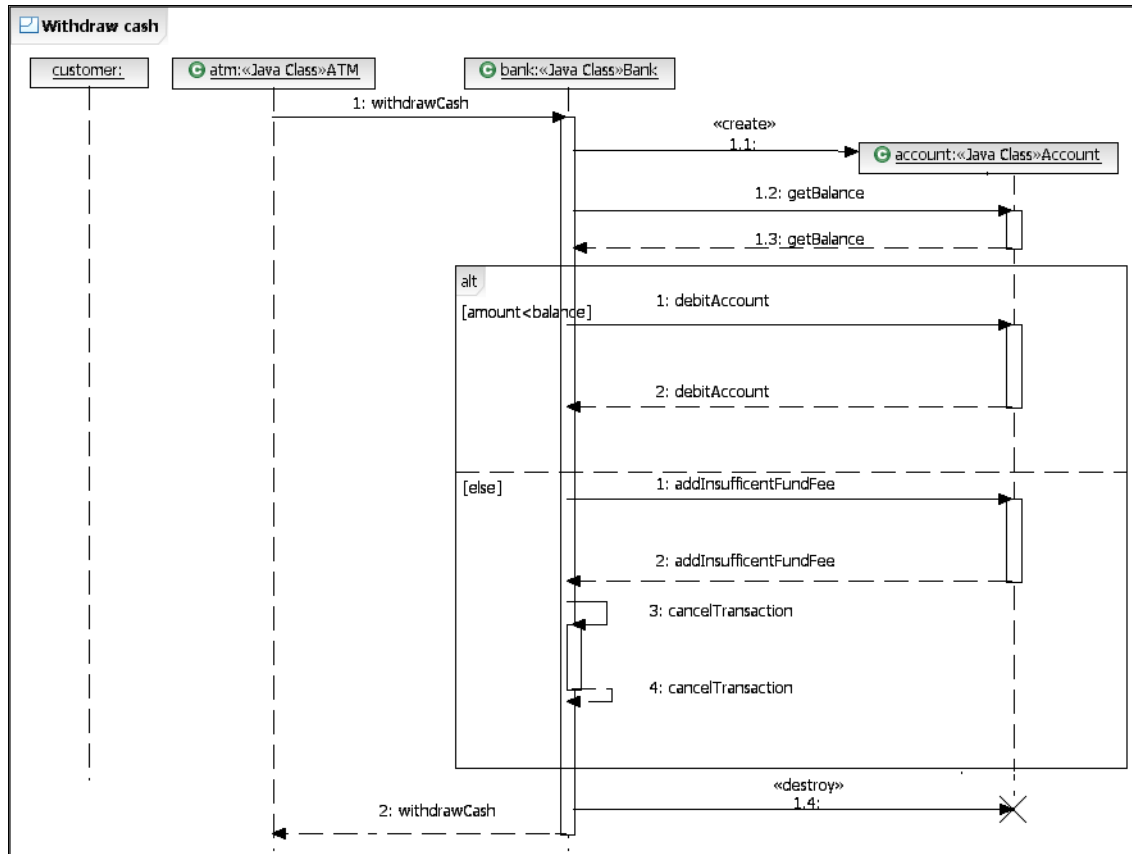

Figure 7-34 Overview of a sequence diagram

The main focus of Rational Application Developer when using sequence diagrams is to document and visualize the dynamic behavior of a system rather than to develop source code. The tool enables developers to create, edit, and delete the various elements of a sequence diagram such as lifelines, messages and combined fragments in a visual manner. In contrast to a class diagram, the elements of a sequence diagram are not related to existing elements, such as classes or interfaces. So changes made in a sequence diagram do not affect any code.

Rational Application Developer has two different concepts of what a sequence diagram is. The first kind of sequence diagram is created by a developer, within a project, to document development work. In this case the developer adds lifelines,

messages and elements to the diagram to show specific object interactions. The second kind of sequence diagram is referred to as Static Method Sequence Diagram. This non-editable diagram is used to visualize the flow of messages between existing Java objects in an executing application.

Creating sequence diagrams

To create a new sequence diagram, you must use the New Sequence Diagram wizard that can be launched either directly from the top menu of Rational Application Developer by selecting **File** → **New** → **Other** → **Modeling** → **Sequence Diagram** or from within the Enterprise Explorer from the context menu of any resource, such as projects or packages.

You can also create a new sequence diagram of an existing class or interface. To do this in the Enterprise Explorer, right-click the desired source element and select **Visualize** → **Add to New Diagram File** → **Sequence Diagram**. Once the wizard has started you provide a name for the file that will be created to contain the content of the diagram, and specify the parent folder where this file should be stored. Clicking **Finish** completes the process and creates a new sequence diagram. A sequence diagram has a corresponding diagram editor and palette on the right side offers different tools which can be used to add new elements to the diagram such as lifelines, messages or combined fragments. Also, there are two items in the tool palette where a solid triangle is shown right next to the item. When you click this triangle, a context menu is displayed that allows you to select another tool from this category.

A sequence diagram is enclosed in a frame. A diagram frame provides a visual border and enables the diagram to be easily reused in a different context. The frame is depicted as a rectangle with a notched descriptor box in the top left corner that provides a place for the diagram name. If you want to change the name, select this box and enter the new name.

Creating lifelines

A lifeline represents the existence of an object involved in an interaction over a period of time. A lifeline is depicted as a rectangle representing the object involved in the interaction which contains the object's name, type and stereotype with a vertical dashed line beneath indicating the progress of time. Figure 7-35 shows several examples of possible lifelines for objects of a class called Customer. It is important to note that the terminology used with sequence diagrams is different in UML 2.0 and later when compared with earlier versions of UML. Also, text in a lifeline object box does not have to be underlined although it can be rendered that way if required.

- ▶ The first lifeline represents an instance of the Customer Java class and the instance is named customer.
- ▶ The second lifeline represents an anonymous instance of the Customer Java class.
- ▶ The last lifeline represents an object named customer whose type is not shown.



Figure 7-35 Different representations of lifelines on a sequence diagram

To add a lifeline from an existing Java class or interface to a sequence diagram, select the desired element in the Enterprise Explorer view and drag it on an empty place in the diagram. This creates a new lifeline and places it at the top of the diagram aligned horizontally with the other lifelines. If you drag a different class over the top of an existing lifeline on the sequence diagram then the class of the lifeline is changed to the new class.

You can also use the tool palette to create a new lifeline. Select the **Lifeline** in the palette and drop it on an empty space inside the diagram. Note, that this creates a lifeline representing an object whose type is not specified but with a default name. Once a lifeline is created, you can change the name and type of the object it represents.

If you want to change the name, select the lifeline's shape and enter the new name. If you want to change the type and a class or interface is available in the Enterprise Explorer, select the desired class or interface in the Enterprise Explorer and drag it on the lifeline's shape. You can also use the Properties view to review or change any property of a given lifeline.

By default, a lifeline is shown as a rectangle containing the lifeline name, type, and stereotype. If you right-click a lifeline, the **Filters** submenu provides several options to change the lifeline's appearance.

Creating messages

A message describes the kind of communication that occurs between two lifelines. A message is sent from a source lifeline to a target lifeline to initiate some kind of action or behavior such as invoking an operation on the target or creation/destruction of a lifeline. The target lifeline often responds with a further message to indicate that it has finished processing.

A message is visualized as a labeled arrow that originates from the source lifeline and ends at the target lifeline. The message is sent by the source and received by target and the arrow points from source to target. The label is used to identify the message. It contains either a name or an operation signature if the message is used to call an operation. The label also contains a sequence number that indicates the ordering of the message within the sequence of messages.

- ▶ To create a message between two lifelines, hover the mouse pointer over the source lifeline so that the modeling assistant is available. Then click on the small box at the end of the outgoing arrow and drag the resulting connector on the desired target lifeline. In the context menu that appears when you drop the connector on the target, click the desired message type such as synchronous or asynchronous and enter either a name or select an operation from the drop-down combo box. Only if the target already has available operations will you be able to select one.
- ▶ You can also use the tool palette to create a message. Select the desired message type by clicking the solid triangle right next to the Message category, then click the source lifeline and drag the cursor to the target lifeline.
- ▶ Selecting **Create Message** from the Palette allows the source lifeline to create a new lifeline. The new lifeline starts when it receives this message. The symbol at the head of this lifeline is shown at the same level as the message that caused the creation (Figure 7-36). The message itself is visualized as a dashed line with an open arrowhead. This type of message is used to highlight that a new object is created during an interaction.

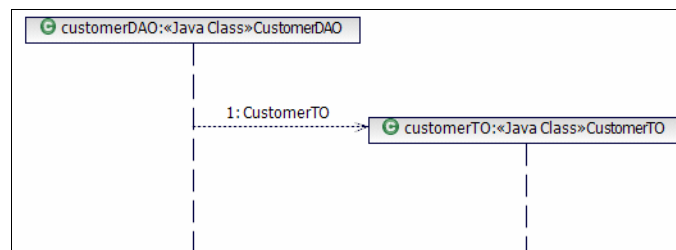

Figure 7-36 Sending a create message to create a new lifeline during an interaction

- ▶ In contrast, a **Destroy Message** enables a lifeline to delete an existing lifeline. The target lifeline is terminated at that point when it receives the message. The end of the lifeline is denoted using the stop notation, a large X (Figure 7-37). A destroy message is drawn in a similar way to a Create Message. You can use this type of message to describe that an object is destroyed during an interaction. Once a lifeline has been destroyed it is not possible for it to be the target of any messages.

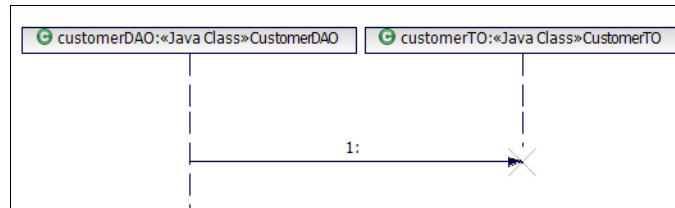

Figure 7-37 Destroying a lifeline during an interaction

- ▶ A **Synchronous Message** enables the source lifeline to invoke an operation provided by the target lifeline. The source lifeline continues and can send more messages only after it receives a response from the target lifeline. When you create a Synchronous Message, Application Developer places three elements in the diagram (Figure 7-38):
 - A line with a solid arrowhead representing a synchronous operation invocation.
 - A dashed line with a solid arrowhead representing the return message.
 - A thin rectangle called an activation bar or execution occurrence representing the behavior performed.

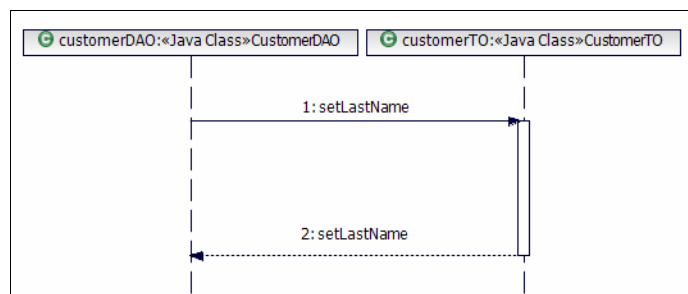

Figure 7-38 Synchronous message invocation

By default, only the operation's name is shown. If you want to see the full operation signature, right-click the message arrow and select **Filters** → **Show Signature**.

- ▶ An **Asynchronous Message** allows the source lifeline to invoke an operation provided by the target lifeline. The source lifeline can then continue and send more messages without waiting. When an asynchronous message is sent the source does not have to wait until the target processes it. An Asynchronous Message is drawn similar as a synchronous message, but the line is drawn with an open arrowhead, and the response is omitted. You can send another kind of asynchronous message, the **Asynchronous Signal Message**. This is a special form of a message that is not associated with a particular operation.

Creating combined fragments

UML 2.0 introduced the concept of combined fragments to support conditional and looping constructs such as if-then-else statements or to enable parts of an interaction to be reused.

Combined fragments are frames that encompass portions of a sequence diagram or provide reference to other diagrams.

A combined fragment is represented by a rectangle that comprises one or more lifelines. Its behavior is defined by an interaction operator that is drawn as a notched descriptor box in the upper left corner of the combined fragment. For example, the alternative interaction operator (**alt**) acts like an if-then-else statement and is shown in Figure 7-39.

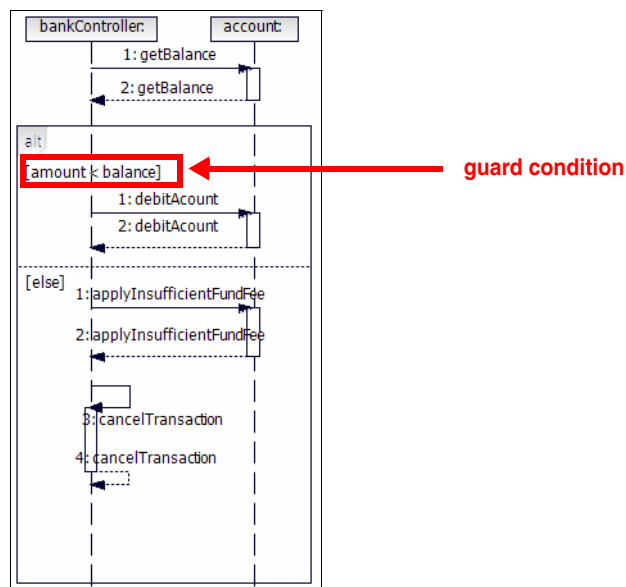

Figure 7-39 Sequence diagram with an alternative combined fragment

UML 2.0 provides many other interaction operators for use with combined fragments. Depending on its type, a combined fragment can have one or more interaction operands. Each interaction operand represents a fragment of the interaction with an optional *guard condition*. The interaction operand is executed only if the guard condition is true at runtime. The absence of a guard condition means that the combined fragment is always executed. The guard condition is displayed as plain text enclosed within two square brackets. A combined fragment separates the contained interaction operands with a dashed horizontal line between each operand within the frame of the combined fragment. When the combined fragment contains only one operand, the dashed line is unnecessary.

Figure 7-39 shows a fragment being used in a withdraw cash interaction. The combined fragment is used to model an alternative flow in the interaction. Because of the guard condition [**amount<balance**], if the account balance is greater than the amount of money the customer wants to withdraw, the first interaction operand is executed. This means the interaction debits the account. Otherwise the [**e1se**] guard forces the second interaction operand to be executed. An insufficient fund fee is added to the account and the transaction is canceled.

To create a combined fragment, you must first select the desired fragment in the palette. Click the solid triangle right next to the **Combined Fragment** category and select the desired fragment from the available fragments. Then click the left mouse button within an empty place in the diagram and drag the combined fragment across the lifelines that you want to include in it. When you release the mouse button, the Add Covered Lifelines dialog opens and this allows you to select the individual lifelines to be covered by the combined fragment. Each lifeline is represented by a check box, and each of them is selected by default. When you click **OK** a new combined fragment along with one or two interaction operands is created.

Figure 7-40 shows a newly created alternative combined fragment with two empty interaction operands. If you want to specify a guard condition for an interaction operand, select the corresponding brackets and enter the text. You can create messages between the individual lifelines covered by the combined fragment in the same way as described previously. Note how the sequence numbers of the individual messages change within an interaction operand. You can also nest other combined fragments within an existing combined fragment.

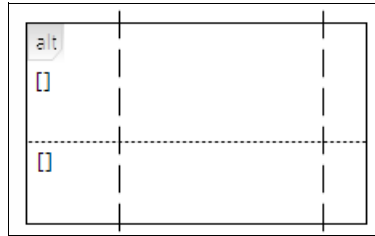

Figure 7-40 Empty combined fragment with two interaction operands

Once created, it is not possible to change the type of a combined fragment, or more importantly its interaction operator. But if you right-click a combined fragment the context menu allows you to add new interaction operands if you select **Add Interaction Operand** or to add and remove lifelines from the selected element if you select **Covered Lifelines**.

When you create an interaction operand, it appears in an expanded state. By clicking the small triangle at the top of the interaction operand you can collapse it to hide the entire operand and its associated messages. From the context menu of an operand there are several options available to remove or reposition the selected operand. Further, you are able to add a guard condition to the operand or to add a new interaction operand if the enclosing combined fragment allows multiple operands

Creating references to external diagrams

UML 2.1 provides the capability to reuse interactions that are defined in another context. This provides you the ability to create complex sequence diagrams from smaller and simpler interactions. A reference to another diagram is modeled using the **Interaction Use** element. Like a combined fragment, an Interaction Use element is represented by a frame. The operator `ref` is placed inside the descriptor box in the upper left corner, and the name of the sequence diagram being referenced is placed inside the frame's content area along with any parameters for the sequence diagram.

An interaction use can encompass a single activation bar or several lifelines. To create a reference to another sequence diagram:

- ▶ Select **Interaction Use** in the palette and place the cursor on an empty space inside the source sequence diagram.
- ▶ When you drop the cursor, you are prompted to choose the current lifelines that will be covered.
- ▶ In the Add Covered Lifelines dialog that opens, select the lifelines that should be encompassed by the interaction use element and click **OK**.

In Figure 7-41 the interaction use element references an interaction called `sequencediagram2`, which provides further information on how the `withdrawCash` operation is realized.

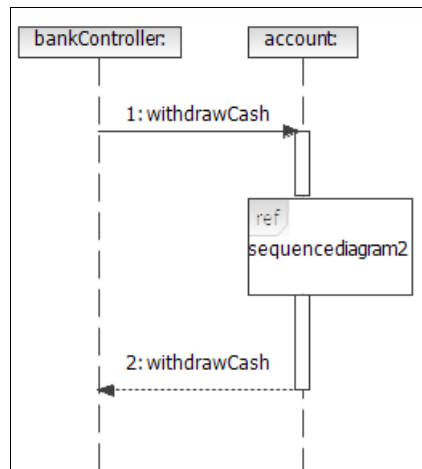

Note: At the time of writing it was not possible to truly reference another diagram. Instead it was only possible to provide a simple name.

Figure 7-41 Creating a reference to another diagram

Exploring Java methods by using static method sequence diagrams

The static method sequence diagram feature provided by Rational Application Developer enables developers to visualize a Java method. Existing Java code can quickly be rendered in a sequence diagram in order to visually examine the behavior of an application. A static sequence diagram from a Java method provides the full view of the entire method call sequence.

To create a static method sequence diagram for a Java method:

- ▶ Right-click the desired method in the Enterprise Explorer or Package Explorer view and select **Visualize** → **Add to New Diagram File** → **Static Method Sequence Diagram**.
- ▶ The diagram is created and shown in the corresponding diagram editor.

A static method sequence diagram is a topic diagram, so the diagram content is stored in a file with a `.tpx` extension. Like other topic diagrams, it is read only; the tool palette, the tool bar, and the modeling assistant are not available.

When you right-click an empty space inside the diagram, the **File** submenu provides you the options to either save the diagram as an image using **Save as Image File** to convert this diagram to an editable UML sequence diagram using **Save as Diagram File**, or to print the entire diagram using **Print**.

Figure 7-42 shows a basic example of a static sequence diagram. It describes the flow of control when the `withdrawCash` method provided by the `ATM` class is called from the `main` method of this class. The synchronous message from the diagram frame that invokes the method, in this case `main`, is called a found message. The corresponding return message is referred to as a lost message.

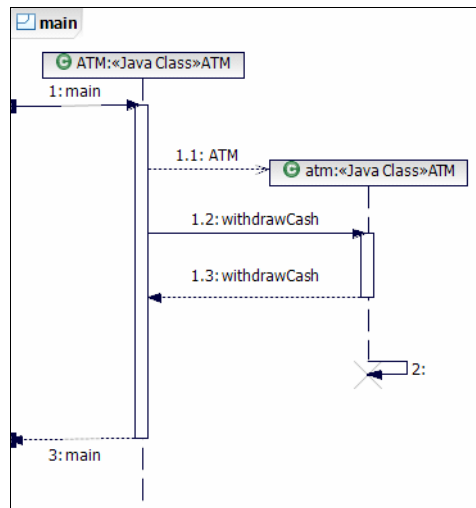

Figure 7-42 static method sequence diagram example

A static sequence diagram for a Java method has to be created only once. Like other topic diagrams, the query and context that have been specified when creating the diagram are stored in the diagram itself. So each time a sequence diagram is opened, Rational Application Developer queries the underlying elements and populates the diagram with the latest updates. If you want to refresh the contents of a static sequence diagram to reflect the latest changes in the source code, right-click an empty space inside the diagram and select **Refresh**.

Note: At the time of writing, Application Developer failed to update the contents of a static sequence diagram when the source code was changed. A workaround is to restart Rational Application Developer with the **-clean** option.

Sequence diagram preferences

Using the Sequence and Communication node in the Preferences dialog, you can change default values that affect the appearance of sequence diagrams (Figure 7-43).

For example, you can specify if return messages should be created automatically or that message numbering is shown.

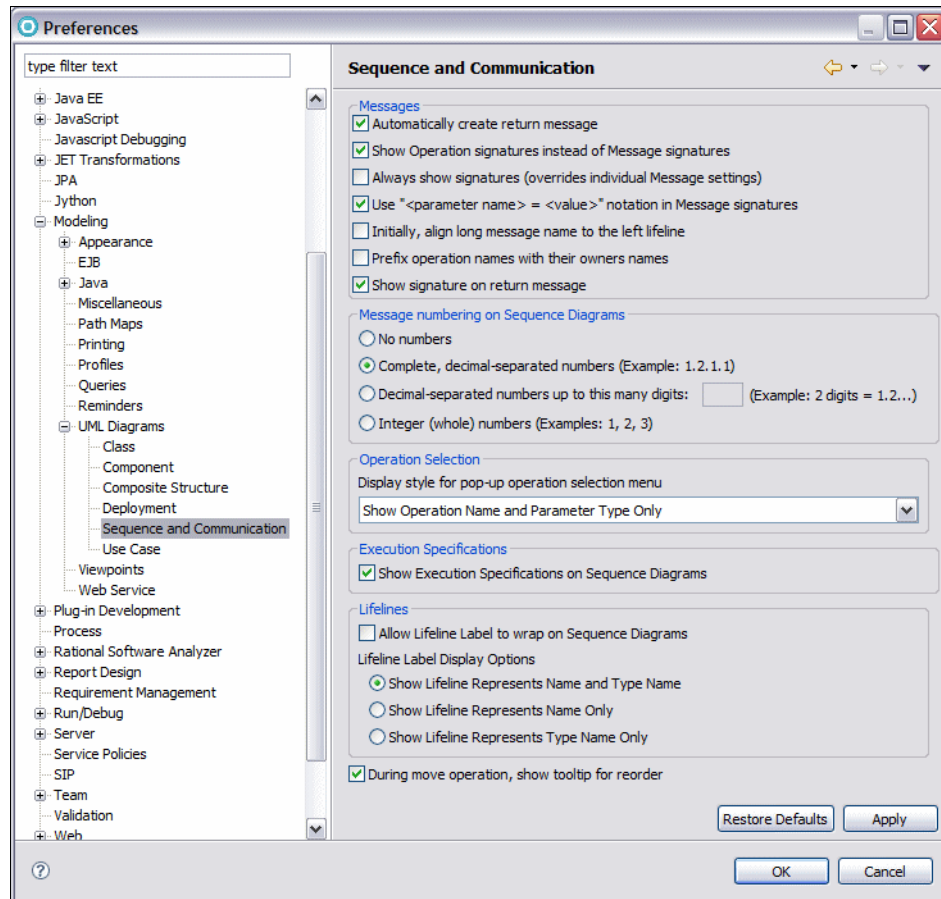

Figure 7-43 Sequence diagram preferences

More information on UML

For more information about UML, we recommend the following resources. These Web sites provide information on modeling techniques, best practices, and UML standards:

- ▶ IBM developerWorks Rational: Provides guidance and information that can help you implement and deepen your knowledge of Rational tools and best practices. This network includes access to white papers, artifacts, source code, discussions, training, and other documentation:

<http://www.ibm.com/developerworks/rational/>

In particular, we would like to highlight the following series of high quality Rational Edge articles focusing on UML topics:

<http://www.ibm.com/developerworks/rational/library/content/RationalEdge/archives/uml.html>

- ▶ The IBM Rational Software UML Resource Center: This is a library of UML information and resources that IBM continues to build upon and update. In addition to current news and updates about the UML, you can find UML documentation, white papers, and learning resources:

<http://www.ibm.com/software/rational/uml/index.html>

- ▶ Object Management Group (OMG): These OMG Web sites provide formal specifications on UML that have been adopted by the OMG and are available in either published or downloadable form, and technical submissions on UML that have not yet been adopted:

<http://www.omg.org>

<http://www.uml.org>

- ▶ Craig Larmann's home page: Provides articles and related links on topics regarding to UML:

<http://www.craiglarman.com/>



Part 3

Basic Java and XML development

In this part of the book, we describe the tooling and technologies provided by Application Developer to develop applications using Java, aptterns, and XML.

Note: The sample code for all the applications developed in this part is available for download at:

<ftp://www.redbooks.ibm.com/redbooks/SG247672>

Refer to Appendix B, “Additional material” on page 1149 for instructions.



8

Develop Java applications

This chapter introduces the Java development capabilities and tooling features of Application Developer by developing the ITSO Bank application.

The chapter is organized into the following sections:

- ▶ Java perspectives, views, and editor overview
- ▶ Developing the ITSO Bank application
- ▶ Understanding the sample code
- ▶ Java editor and rapid application development

Note: Application Developer V7.5 fully supports the Java SE 6.0 compliance. However newer JRE versions can be downloaded, installed, and used in the Application Developer by the customer themselves, as described in “Pluggable Java Runtime Environment (JRE)” on page 124.

The sample code for this chapter is in `7672code\java`.

Author Comment: Red text represent functionalities not found in the current version

Java perspectives, views, and editor overview

Within Application Developer, there are three predefined perspectives containing the views and editor that are most commonly used while developing Java SE applications:

- ▶ Java perspective
- ▶ Java Browsing perspective
- ▶ Java Type Hierarchy perspective

Those perspectives and their main views were briefly introduced in Chapter 4, “Perspectives, views, and editors” on page 119. In this section we go deeper into the details and describe some more useful views. The highlighted areas in Figure 8-1 indicate all perspectives and views we discuss.

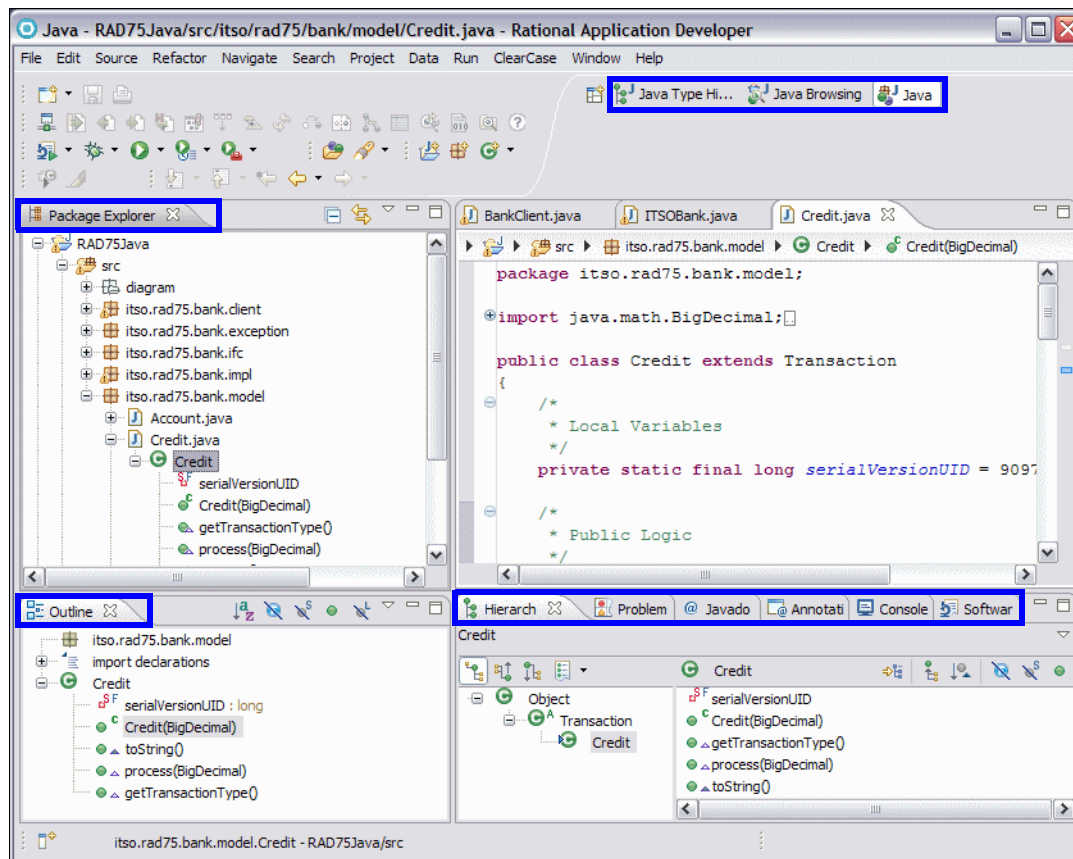

Figure 8-1 Views in the Java perspective [customized]

Note: Figure 8-1 shows a customized Java perspective. It is the predefined Java perspective with some more useful views added. We recommend that you also customize the perspectives so that they fit your requirements. A customized perspective can be saved: **Window** → **Save Perspective As**. A modified perspective can be set back to a predefined or saved perspective: **Window** → **Reset Perspective**.

Java perspective

We use the Java perspective to develop Java SE applications or utility Java projects (utility JAR files) containing code that is shared across multiple modules within an enterprise application. Views can be added by selecting **Window** → **Show View**.

Package Explorer view

The Package Explorer view displays all projects, packages, interfaces, classes, member variables, and member methods contained in the workspace, as shown in Figure 8-2. It allows us to easily navigate through the workspace.

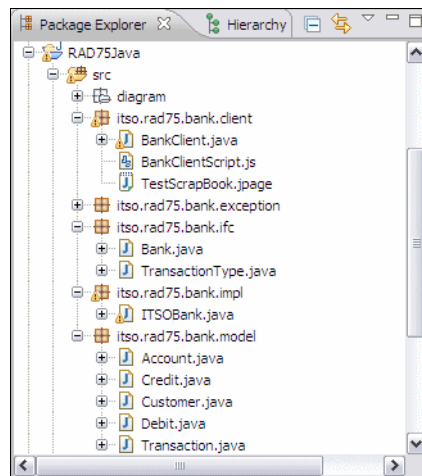

Figure 8-2 Package Explorer view

Note: In this view, you cannot see the generated `.class` files. If you want to see the folders and files as they are in the file system, open the Navigator view by selecting **Window** → **Show View** → **Navigator**. Now you can see the source code in the `src` directory and the byte code files in the `bin` directory.

Hierarchy view

We use the Hierarchy view to display the type hierarchy of a selected type.

To view the hierarchy of a class type, select the class in the Package Explorer, and press **F4** or right-click the class and select **Open Type Hierarchy**. The hierarchy of the selected class is displayed, as shown in Figure 8-3.

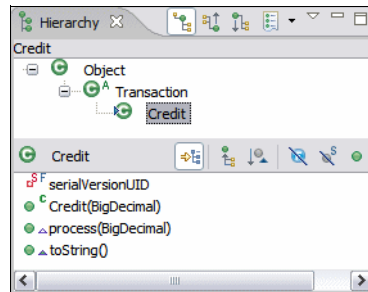









Figure 8-3 Hierarchy view for a selected class

The Hierarchy view provides three kinds of hierarchy layouts:

- ▶  Type Hierarchy: All supertypes and subtypes of the selected type are shown.
- ▶  Supertype Hierarchy: Only all supertypes of the selected type are shown.
- ▶  Subtype Hierarchy: Only all subtypes of the selected type are shown.

Other options in the Hierarchy view:

- ▶  Locks the view and shows members in hierarchy. For example, use this option if you are interested in all types implementing the `toString()` method.
- ▶  Shows all inherited members.
- ▶  Sorts members by their defining types. Defining type is displayed before the member name.
- ▶  Filters the displayed members.

Outline view

The Outline view is very useful and is the recommended way to navigate through a type that is currently opened in the Java editor. It lists all elements including package, import declarations, type, fields, and methods. The developer can sort and filter the elements that are displayed by using the icons highlighted in Figure 8-4.

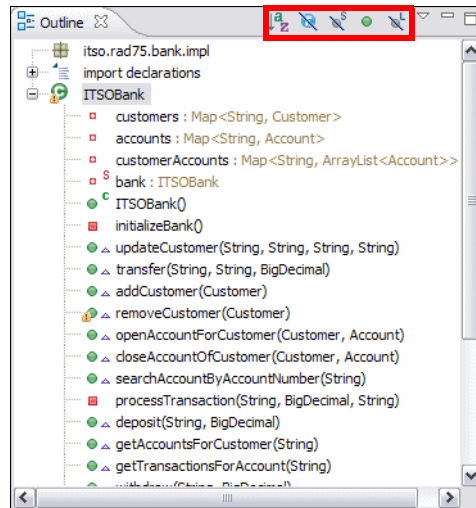





Figure 8-4 Outline view

Problems view

While editing resource files, various builders can automatically log problems, errors, or warnings in the Problems view. For example, when you save a Java source file that contains syntax errors, those will be logged as errors, as shown in Figure 8-5. When you double-click the icon for a problem , error , or warning , the editor for the associated resource automatically opens to the relevant line of code.

Application Developer provides a quick fix for some problems. How to process a quick fix is described in “Quick fix” on page 142.

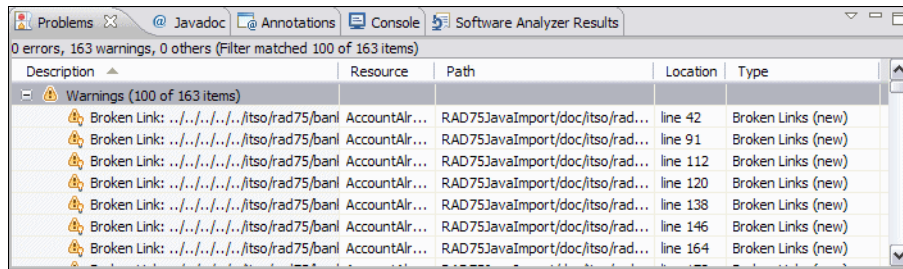



Figure 8-5 Problems view with warnings notification

Note: The Java builder is responsible for all Java resource files. However, in an enterprise application project, other builders can be used. Builders can be enabled and disabled for each project. Right-click the project in the Package Explorer and select **Properties** and then **Builders**.

The Problems view allows you to filter the problems to show only specific types of problems by clicking the View Menu icon , which opens a menu from which you can sort the content or select the Configure Contents dialog (Figure 8-6).

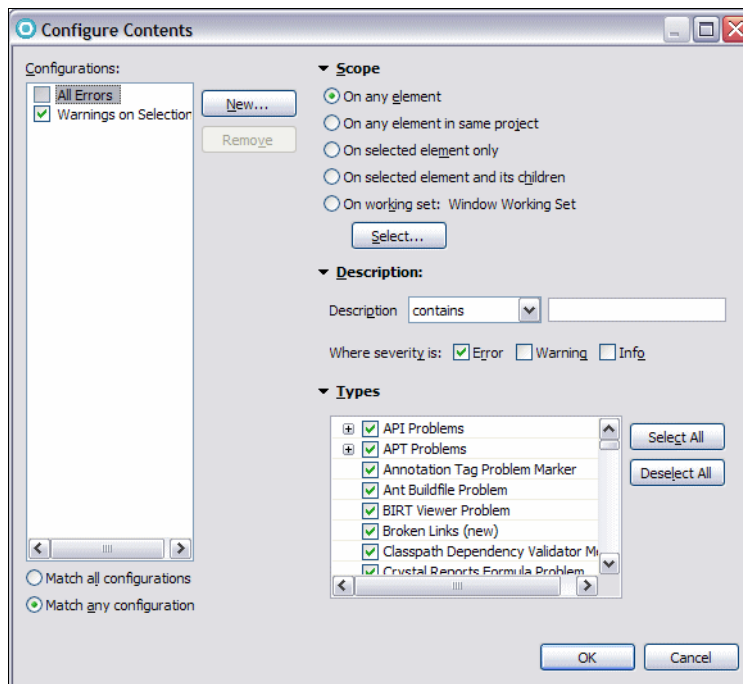



Figure 8-6 Configure Contents of Problems view

Declaration view

This view displays the declaration and definition of the currently selected type or element, as shown in Figure 8-7. It is most useful to see the source code of a referenced type within your code. For example, if you reference a customer within your code and you want to see the implementation of the Customer class, just select the referenced type Customer, and the source code of the Customer class is displayed in this view. Clicking  directly opens the source file of the selected type in the Java editor.

```

itso.rad75.bank.model.Customer.Customer(String ssn, String title, String firstName, String lastName)
public Customer(String ssn, String title, String firstName, String lastName)
{
    this.setSsn(ssn);
    this.setTitle(title);
    this.setFirstName(firstName);
    this.setLastName(lastName);
    this.setAccounts(new ArrayList<Account>());
}

```

Figure 8-7 Declaration view

Console view

The console is the view in which the Application Developer writes all outputs of a process and allows you to provide keyboard inputs to the Java application while running it. Uncaught exceptions are also displayed in the console.

The highlighted link in Figure 8-8 directs you to the line in the source code where the exception has been thrown.







```

<terminated> BankClient [Java Application] C:\IBM\SDP75Beta\
ITSO Bank is listing all account information of xxx-xx-xxxx Mr Napoli Juan...
[Account 1: --> Current balance: $12500.00
  Transactions:
  1. itso.rad75.bank.model.Credit@660a660a
, Account 2: --> Current balance: $15000.00
  Transactions:
  1. Debit: --> Amount $1234.23 on 2008-08-26 17:41:20.921
  2. itso.rad75.bank.model.Credit@3ec53ec5
]
at itso.rad75.bank.client.BankClient.executeCustomerTransactions(BankClient.java:159)
at itso.rad75.bank.client.BankClient.main(BankClient.java:39)

```

Figure 8-8 Console view with standard outputs and an exception

Other options in the Console view:

- ▶  Terminates the currently running process. It is a useful button to terminate a process running in an endless loop.
- ▶  and  Removes terminated launches from the console.
- ▶  Clears the console.
- ▶  Enables scroll lock in the console.
- ▶  Pins the current console to remain on the top.
- ▶  Shows the console when JVM logs are updated.

Call Hierarchy view

The Call Hierarchy view displays all callers and callees of a selected method, as shown in Figure 8-9. To view the call hierarchy of a method, select it in the Package Explorer or in the source code, and press **Ctrl+Alt+H** or right-click, and select **Open Call Hierarchy**.

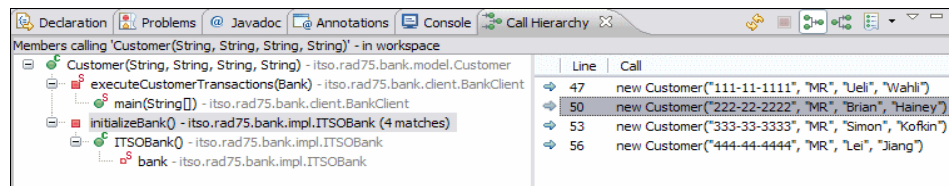



Figure 8-9 Call Hierarchy view [Callee Hierarchy]

Call Hierarchy view provides two kind of hierarchy layouts:

- ▶  Caller Hierarchy: All the members calling the selected method are shown.
- ▶  Callee Hierarchy: All members called by the selected method are shown.

Java Browsing perspective

The Java Browsing perspective is used to browse and manipulate your code. In contrast to the Package Explorer view, which organizes all Java elements in a tree, this perspective uses distinct views highlighted in Figure 8-10 to present the same information.

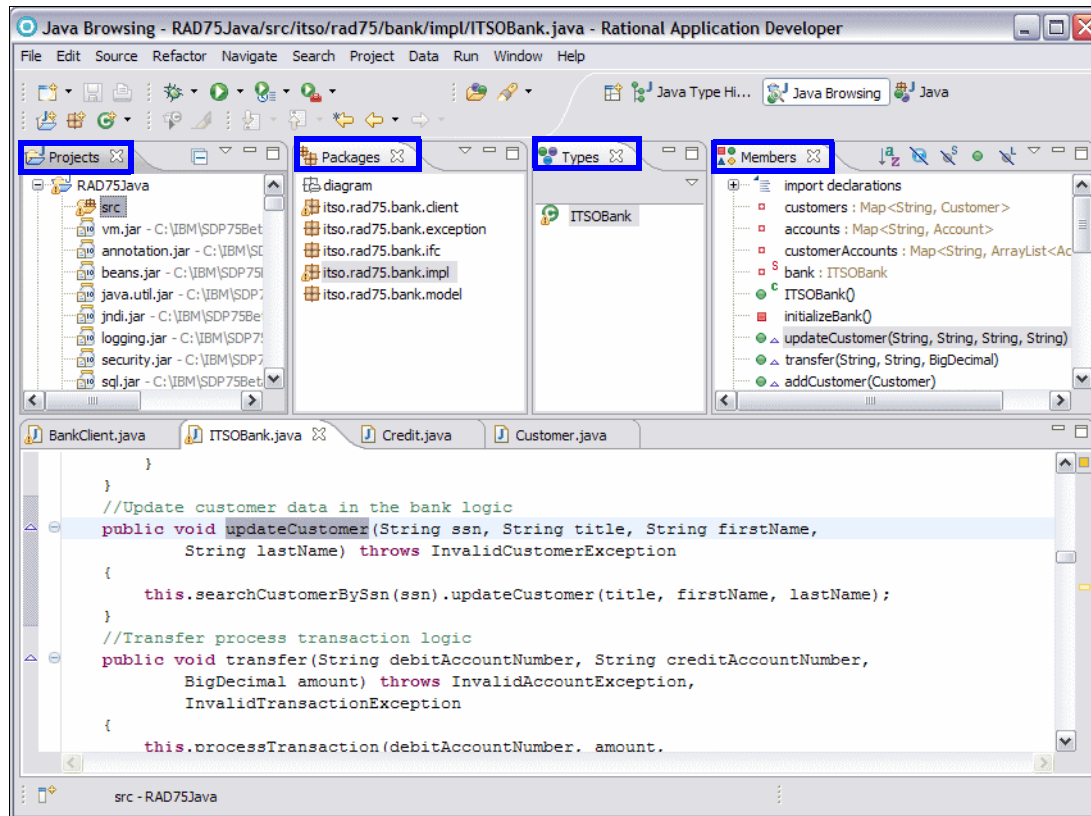

Figure 8-10 Views in the Java Browsing perspective

Java Type Hierarchy perspective

The Java Type Hierarchy perspective contains only the Hierarchy view, which was described in “Hierarchy view” on page 72.

Developing the ITSO Bank application

In this section we demonstrate how Application Developer can be used to develop a Java SE application. We create a Java project including several packages, interfaces, classes, fields, and methods.

Note: The sample code described in this chapter can be completed by following along in the procedures documented. Alternatively, you can import the sample Java code provided in:

```
c:\7672code\zInterchange\java\RAD75Java.zip
```

Refer to Appendix B, “Additional material” on page 1149 for instructions on how to download the sample code.

ITSO Bank application overview

The example application to work through in this section is called ITSO Bank. The banking example is deliberately over-simplified, and the exception handling is ignored to keep the example concise and relevant to our discussion.

Packaging structure

The ITSO Bank application contains several packages. Table 8-1 lists the packages and describes their purpose.

Table 8-1 ITSO Bank application packages

Package	Description
itso.rad75.bank.ifc	Contains the interfaces of the application
itso.rad75.bank.impl	Contains the bank implementation class
itso.rad75.bank.model	Contains all business model classes of the application
itso.rad75.bank.exception	Contains the exception classes of the application
itso.rad75.bank.client	Contains the application client which we use to run the application

Interfaces and classes overview

The application contains the following classes and interfaces:

- ▶ **Bank** interface—This defines common operations a bank would perform, and typically includes customer, account, and transaction related services.
- ▶ **TransactionType** interface—This defines the kind of transactions the bank allows.
- ▶ **ITSOBank** class—This is an implementation of the Bank interface.
- ▶ **Account** class—This is the representation of a bank account. It logs all transactions performed on it for logging and querying purposes.
- ▶ **Customer** class—This is the representation of a client of bank, an account holder. A customer can have one or more accounts.
- ▶ **Transaction** class—This is an abstract supertype of all transactions. A transaction is a single operation that will be performed on an account. In the example only two transaction types exist: Debit and Credit.
- ▶ **Debit** class—This is one of the two existing concrete subtypes of the Transaction class. This transaction results in an account being debited by the amount indicated.
- ▶ **Credit** class—This is the other concrete subtype of Transaction class. It results in an account being credited by the amount indicated.
- ▶ **BankClient** class—This is the executable class of the ITSO Bank application. It creates instances of ITSOBank, Customer, Account classes, and performs some transactions on the accounts.
- ▶ All exception classes in the package `itso.rad75.bank.exception`—These are the implemented exceptions that can occur in the ITSO Bank application. **ITSOBankException** is the supertype of all ITSO Bank application exceptions.

Interfaces and classes structure

The ITSO Bank interfaces and classes structure are described in Table 8-2 (interfaces) and Table 8-3 (classes).

Table 8-2 ITSO Bank application interfaces

Interface name	Package	Modifiers
TransactionType	<code>itso.rad75.bank.ifc</code>	<code>public</code>
Bank	<code>itso.rad75.bank.ifc</code>	<code>public</code>

Table 8-3 ITSO Bank application classes

Class name	Package	Superclass	Modifiers	Interfaces
ITSOBank	itso.rad75.bank.impl	java.lang.Object	public	itso.rad75.bank.ifc. Bank
Account	itso.rad75.bank.model	java.lang.Object	public	java.io.Serializable
Customer	itso.rad75.bank.model	java.lang.Object	public	java.io.Serializable
Transaction	itso.rad75.bank.model	java.lang.Object	public abstract	java.io.Serializable
Credit	itso.rad75.bank.model	Transaction	public	
Debit	itso.rad75.bank.model	Transaction	public	
BankClient	itso.rad75.bank.client	java.lang.Object	public	
ITSOBankException	itso.rad75.bank.exception	java.lang.Exception	public	
AccountAlready ExistException	itso.rad75.bank.exception	ITSOBankException	public	
CustomerAlready ExistException	itso.rad75.bank.exception	ITSOBankException	public	
InvalidAccount Exception	itso.rad75.bank.exception	ITSOBankException	public	
InvalidAmount Exception	itso.rad75.bank.exception	ITSOBankException	public	
InvalidCustomer Exception	itso.rad75.bank.exception	ITSOBankException	public	
InvalidTransaction Exception	itso.rad75.bank.exception	ITSOBankException	public	

Interfaces and classes fields and getter & setters

The fields of the interfaces are described in Table 8-4 and the fields of the classes are described in Table 8-5. The fields marked with *) are the implementations of UML associations.

Table 8-4 Fields of the interfaces

Interface	Field	Type	Initial value	Visibility, Modifiers
TransactionType	CREDIT	String	"CREDIT"	public static final
	DEBIT	String	"DEBIT"	public static final

Table 8-5 Fields and getter and setter methods of the classes

Class	Field name	Type	Initial value	Visibility, Modifiers	Methods
ITSOBank	accounts *) customers *)	Map<String,Account> Map<String, Customer>	null	private	getter: public, setter: private
	customer Accounts	Map<String, ArrayList<Account>>			
	bank	ITSOBank	new	private static	
Account	accountNumber	java.lang.String	null	private	getter: public, setter: private
	balance	java.math.BigDecimal			
	transactions *)	ArrayList<Transaction>			
Customer	ssn title firstName lastName	java.lang.String	null	private	getter: public, setter: private
	accounts *)	ArrayList<Account>			
Transaction	timeStamp	Timestamp	null	private	
	amount	java.math.BigDecimal			
	transactionId	int			
AccountAlready ExistException	accountNumber	java.lang.String	null	private	
CustomerAlready ExistException	ssn	java.lang.String	null	private	
InvalidAccount Exception	accountNumber	java.lang.String	null	private	
InvalidAmount Exception	amount	java.lang.String	null	private	
InvalidCustomer Exception	ssn	java.lang.String	null	private	
Invalid Transaction Exception	transactionType	java.lang.String	null	private	
	amount	java.math.BigDecimal			
	account	Account			

Interfaces and classes methods

The methods of the Bank interface are described in Table 8-6.

Table 8-6 Method declarations of the Bank interface

Method name	Return type	Parameters	Exceptions
addCustomer	void	Customer customer	CustomerAlreadyExistException
closeAccountOfCustomer	void	Customer customer, Account account	InvalidAccountException, InvalidCustomerException
deposit	void	String accountNumber, BigDecimal amount	InvalidAccountException, InvalidTransactionException
getAccountsForCustomer	ArrayList <Account>	String customerSsn	InvalidCustomerException
getCustomers	Map<String, Customer>		
getTransactionsForAccount	ArrayList <Transaction>	String accountNumber	InvalidAccountException
openAccountForCustomer	void	Customer customer, Account account	InvalidCustomerException, AccountAlreadyExistException
removeCustomer	void	Customer customer	InvalidCustomerException
searchAccountByAccountNumber	Account	String accountNumber	InvalidAccountException
searchCustomerBySsn	Customer	String ssn	InvalidCustomerException
transfer	void	String debitAccountNumber, String creditAccountNumber, BigDecimal amount	InvalidAccountException, InvalidTransactionException
updateCustomer	void	String ssn, String title, String firstName, String lastName	InvalidCustomerException
withdraw	void	String accountNumber, BigDecimal amount	InvalidAccountException, InvalidTransactionException

Class constructors and methods

The constructors and methods of the classes of the application are described in Table 8-7.

Table 8-7 Constructors and methods of the classes of the ITSO Bank application

	Method name	Modi- fiers	Type	Parameters	Exceptions
ITSOBank					
	ITSOBank	private	constructor		
	addCustomer	public	void	Customer customer	CustomerAlreadyExistException
	removeCustomer		void	Customer customer	InvalidCustomerException
	openAccountFor Customer		void	Customer customer, Account account	InvalidCustomerException, AccountAlreadyExistException
	closeAccountOf Customer		void	Customer customer, Account account	InvalidAccountException, InvalidCustomerException
	searchAccountBy AccountNumber		Account	String accountNumber	InvalidAccountException
	searchCustomerBySsn		Customer	String ssn	InvalidCustomerException
	processTransaction	private	void	String accountNumber, BigDecimal amount, String transactionType	InvalidAccountException, InvalidTransactionException
	getAccountsFor Customer	public	ArrayList<A ccount>	String customerSsn	InvalidCustomerException
	getTransactionsFor Account		ArrayList<T ransaction>	String accountNumber	InvalidAccountException
	updateCustomer		void	String ssn, String title, String firstName, String lastName	InvalidCustomerException
	deposit		void	String accountNumber, BigDecimal amount	InvalidAccountException, InvalidTransactionException
	withdraw		void	String accountNumber, BigDecimal amount	InvalidAccountException, InvalidTransactionException
	transfer		void	String debitAccountNumber, String creditAccountNumber, BigDecimal amount	InvalidAccountException, InvalidTransactionException
	initializeBank	private	void		
Account					

	Method name	Modi-fiers	Type	Parameters	Exceptions
	Account	public	constructor	String accountNumber, BigDecimal balance	
	processTransaction	public	void	BigDecimal amount, String transactionType	InvalidTransactionException
	toString		String		
Customer					
	Customer	public	constructor	String ssn, String title, String firstName, String lastName	
	updateCustomer	public	void	String title, String firstName, String lastName	
	addAccount		void	Account account	AccountAlreadyExistException
	removeAccount		void	Account account	InvalidAccountException
	toString		String		
Transaction					
	Transaction	public	constructor	BigDecimal amount	
	getTransactionType	public abstract	String		
	process		BigDecimal	BigDecimal accountBalance	InvalidTransactionException
Credit					
	Credit	public	constructor	BigDecimal amount	
	getTransactionType	public	String		
	process		BigDecimal	BigDecimal accountBalance	InvalidTransactionException
	toString		String		
Debit					
	Debit	public	constructor	BigDecimal amount	

	Method name	Modi-fiers	Type	Parameters	Exceptions
	getTransactionType	public	String		
	process		BigDecimal	BigDecimal accountBalance	InvalidTransactionException
	toString		String		
BankClient					
	main	public static	void	String[] args	

Class diagram

A UML class diagram helps to overview the interfaces and classes and their relationships. In the class diagram in Figure 8-11, we added the packages as well to get a complete picture of the ITSO Bank application.

We create this diagram by using Application Developer's UML modeling tool in "Creating a UML class diagram" on page 90.

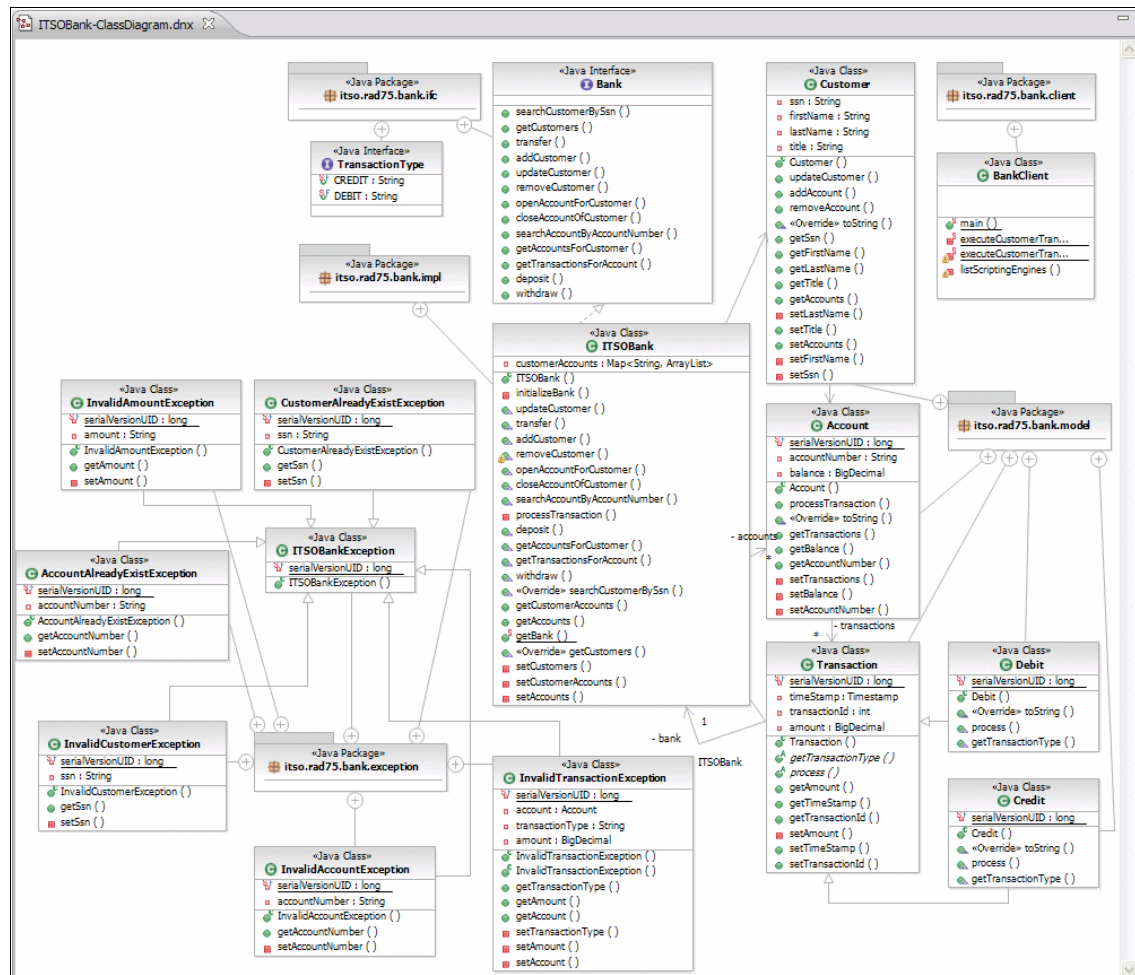

Figure 8-11 UML class diagram: ITSO Bank application

ITSO Bank application step-by-step development guide

The next sections provide a step by step guide to develop the ITSO Bank application in Application Developer.

Creating a Java project

Java projects are not defined in the Java SE specification, they are used as the lowest unit to organize the workspace and contains all resources needed for a Java application as images, source, class and properties files.

With Application Developer started we recommend to switch to the Java perspective as described in “Switching perspectives” on page 123.

We create a new Java project from the New Java Project wizard. Launch the New Java Project wizard using the New Project dialog (Figure 8-12) selecting **File** → **New** → **Project** in the workbench and then select **Java Project** or **Java** → **Java Project** and click **Next**.

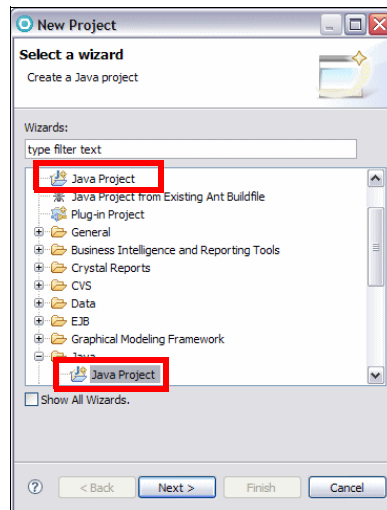



Figure 8-12 New Project dialog

Another way to launch the New Java Project wizard is directly from the workbench by selecting **File** → **New** → **Java Project** or clicking the **New Java Project** icon  in the toolbar.

- ▶ In the New Java Project - Create a Java Project dialog, enter the project name and accept the default settings for each of the other fields (Figure 8-13, left):
 - Project name: (type) **RAD75Java**
 - Contents: **Create new project in workspace.** (Selected)
 - JRE: **Use default JRE (Currently 'jdk').** (Selected)
 - Project layout: **Create separate source and output folders.** (Selected)
 - Click **Next**.

- ▶ In the New Java Project - Java Settings dialog accept the default settings for each of the tabs by just clicking **Finish** (Figure 8-13, right). This dialog allows you to change the build path settings for a Java project. The build class path is a list of paths visible to the compiler when building the project.

Click **Finish**.

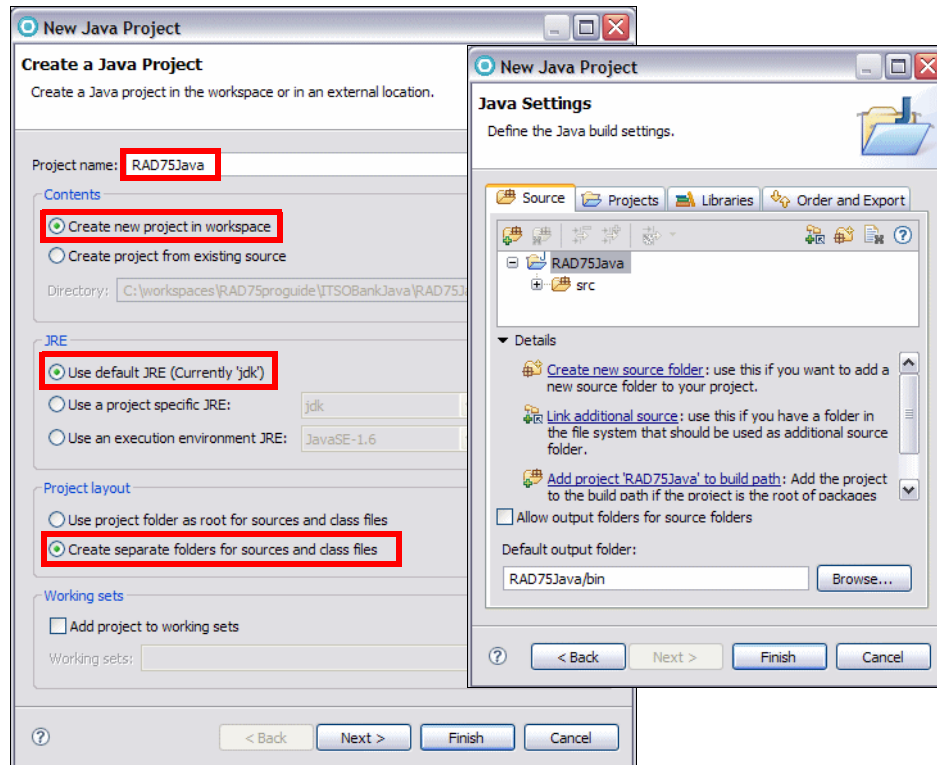

Figure 8-13 New Java Project: Create a Java project and Java Settings

The New Java Project wizard dialogs options are described in Table 8-8 and Table 8-9, explaining the dialogs capabilities.

Table 8-8 New Java Project - Create a Java Project options

Option	Description
Project name	Type a name for the new project

Option	Description
Contents	<p>Create new project in workspace: Create a new project with the specified name in the workspace.</p> <p>Create project from existing source: Retrieves an existing Java project, setting up the build path automatically. Click Browse for a location of an existing Java project.</p>
JRE	<p>Use default JRE: Uses the workspace default JRE and compiler compliance. Click Configure default to configure JREs.</p> <p>Use project specific JRE: Specify the JRE to be used for the new Java project and also set the matching JRE compiler compliance.</p> <p>Use an execution environment JRE: Specify the execution environment and compiler to be used for the new Java project.</p>
Project layout	<p>Use project folder as root for sources and class files: The project folder is used both as source folder and as output folder for class files.</p> <p>Create separate folders for sources and class files: Creates a source folder for Java source files and an output folder which holds the class files of the project.</p>
Working sets	<p>Add project to working sets: The new project will be added to the working sets shown in Working Sets drop down field. The drop down field shows a list of previous selected working sets. Click Select to select working sets to which to add the new project.</p>

Table 8-9 New Java Project - Java Settings options

Tab	Description
Source	Allows to add and remove source folders from the Java project. The compiler translates all .java files found in the source folders to .class files and stores them to the output folder. The output folder is defined per project except if a source folder specifies an own output folder. Each source folder can define an exclusion filter to specify which resources inside the folder are not visible to the compiler.
Projects	Allows to add another project within the workspace to the build path for this new project (project dependencies).

Tab	Description
Libraries	<p>Allows to add libraries to the build path. There are five options:</p> <p>Add JARs—Allows you to navigate the workspace hierarchy and select JAR files to add to the build path.</p> <p>Add External JARs—Allows you to navigate the file system (outside the workspace) and select JAR files to add to the build path.</p> <p>Add Variable—Allows you to add classpath variables to the build path. Classpath variables are an indirection to JARs with the benefit of avoiding local file system paths in a classpath. This is needed when projects are shared in a team. Variables can be created and edited in the Classpath Variable preference page. Select Window → Preferences → Java → Build Path → Classpath Variables.</p> <p>Add Library—Allows you to add predefined libraries like JUnit or Standard Widget Toolkit (SWT).</p> <p>Add Class Folder—Allows you to navigate the workspace hierarchy and select a class folder for the build path.</p> <p>Add External Class Folder—Allows you to navigate the file system (outside the workspace) and select a class folder for the build path.</p> <p>Migrate Jar—Migrate a jar on the build path to a newer version. If the newer version contains refactoring scripts the refactoring stored in the script will be executed.</p>
Order and Export	<p>This tab allows you to change the build path order. You specify the search order of the items in the build path.</p> <p>Select an entry in the list if you want to export it. Exported entries are visible to other projects that require the new Java project being created.</p>

Creating a UML class diagram

Application Developer supports UML class diagrams. It allows the developer to create a static visual representation of the packages, interfaces, classes, and their relationships. Application Developer calls automatically the related wizard to create the Java code while adding elements to the diagram.

Create a UML class diagram using the Class Diagram wizard

For our example we create an UML class diagram with the following steps:

- ▶ Create a new folder for diagrams:
 - Right-click the **src** folder in the RAD75Java project in the Package Explorer and select **New** → **Folder** or **New** → **Other** → **General** → **Folder**.
 - For Folder name, type **diagram** and click **Finish** to create the folder.

- ▶ Create an empty class diagram:
 - Right-click the **diagram** folder in the Enterprise Explorer and select **New** → **Class Diagram** or **New** → **Other** → **Modeling** → **Class Diagram**.
 - Type **ITSOBank-ClassDiagram** as the field name and click **Finish**.
 - Click **OK** to confirm enabling of Java Modeling.
- ▶ The file `ITSOBank-ClassDiagram.dnx` appears in the `diagram` folder and opens in the Visualizer Class Diagram editor.
- ▶ Notice that the Java Drawer is open in the Palette (Figure 8-14). Application Developer automatically opens the Java Drawer by default for a Java project.

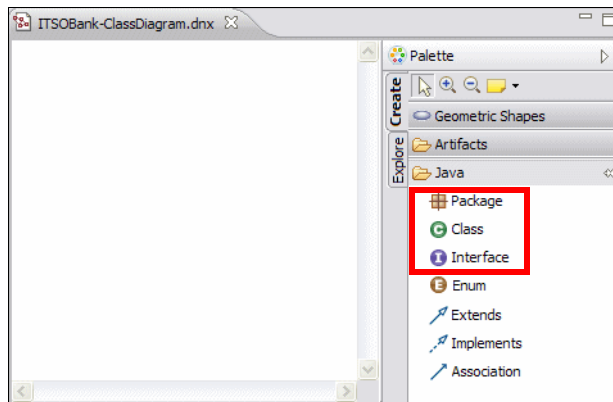
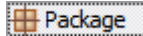



Figure 8-14 Visualizer Class Diagram editor with Java Drawer in the Palette

Note: You can also add already existing elements to a class diagram. Drag the element in the Package Explorer with the left mouse button and drop it in the class diagram by releasing the button.

Creating Java packages

Once the Java project has been created, Java packages can be added to the project using the New Java Package wizard. Here are the options to launch the New Java package wizard from the Visualizer Class Diagram editor.

- ▶ Select  **Package** in the Java Drawer, as shown in the Figure 8-14, and click anywhere in class diagram editor.
- ▶ Right-click the **src** folder in the Java project and select **New** → **Package** or **New** → **Other** → **Java** → **Package**.
- ▶ Or click  in the toolbar.

Note: To add a package to the class diagram just drag and drop the package to the class diagram editor, or right-click the package in the Package Explorer and select **Visualize** → **Add to Current Diagram**.

Create a Java package using the New Java Package wizard

For our example we create a Java package with the following steps:

- ▶ Select the **src** folder in the RAD75Java project and click  in the toolbar.
- ▶ Type the package name (**itso.rad75.bank.model**) and click **Finish** to create the package (Figure 8-15).

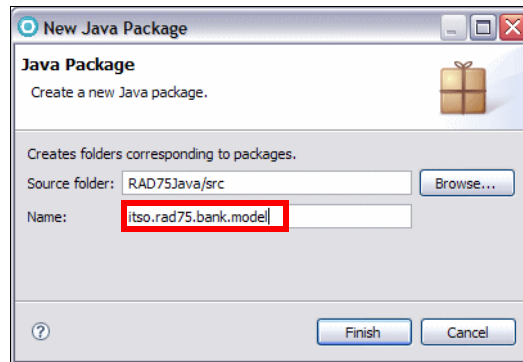



Figure 8-15 Create a Java package

ITSOBank example—Packages

- ▶ Repeat the above mentioned steps to create the following Java packages, as are described in “Packaging structure” on page 78:
 - itso.rad75.bank.model
 - itso.rad75.bank.ifc
 - itso.rad75.bank.impl
 - itso.rad75.bank.exception
 - itso.rad75.bank.client

Creating Java interfaces

Once the Java packages has been created, Java interfaces can be added to the packages using the New Java Interface wizard. You can launch the New Java interface wizard from the Visualizer Class Diagram editor choosing one of the following options.

- ▶ Select  **Interface** in the Java Drawer and click anywhere in class diagram editor field. The New Java Interface wizard opens.

- ▶ Right-click the desired package and select **Add Java** → **Interface**.
- ▶ Or just mouse over a package and a action box will pop-up (Figure 8-16), then click on the icon **Add Java Interface**.

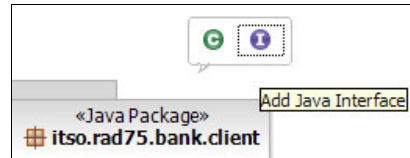

Figure 8-16 Action box - add Java class and interface

Create a Java interface using the New Java Interface wizard

For our example we create java interfaces with the following steps:

- ▶ Select or mouse over on the package `itso.rad75.bank.ifc` and click on the icon **Add Java Interface**. The New Java Interface wizard opens.
- ▶ In the New Java Interface dialog, enter the following data (Figure 8-17):
 - Source folder: `RAD75Java/src` (default)
 - Package: `itso.rad75.bank.ifc` (click **Browse** to select the package)
 - Name: **Bank**
 - Keep the default for all other settings.
 - Click **Finish** to create the Java interface.

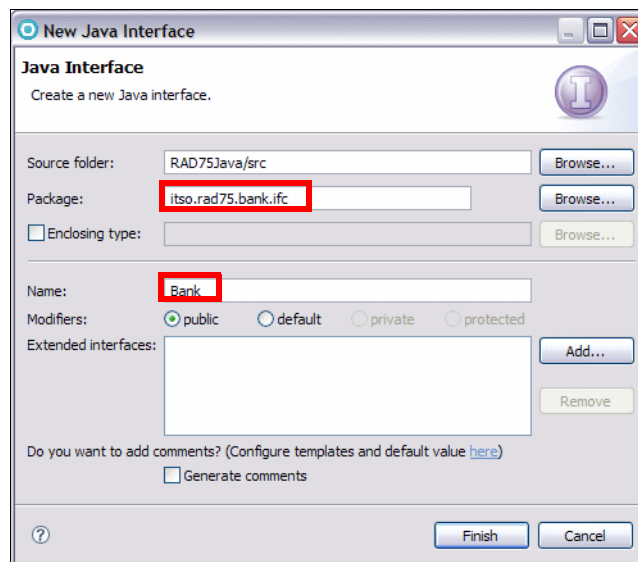

Figure 8-17 Create a Java interface

- ▶ Notice that a line appears between the package and the Bank interface.

Note: To add an interface to the class diagram, you can just drag and drop the interface to the class diagram editor, or select the interface in the Package Explorer and **Visualize** → **Add to Current Diagram**.



ITSOBank example—Interfaces

Repeat the above mentioned steps to create the following Java interfaces, as are described in “Interfaces and classes overview” on page 79.

- Interface: Bank—Package: `itso.rad75.bank.ifc`
- Interface: TransactionType—Package: `itso.rad75.bank.ifc`

Creating Java classes

With Java packages and Java interfaces created now we add the Java classes to the packages using the New Java class wizard. You can launch the New Java class wizard from the Visualizer Class Diagram editor choosing one of the following options.

- ▶ Select  **Class** in the Java Drawer and click anywhere in class diagram editor. The New Java Class wizard opens.
- ▶ Right-click on the appropriate package and select **Add Java** → **Class**
- ▶ Mouse over on the package an action box appears (Figure 8-16), and then click on the icon  **Add Java Class**.

Create a Java class using the New Java Class wizard

To create a Java class using the New Java Class wizard:

- ▶ Select the `itso.rad75.bank.model` package and click on the **Add Java Class** on the mentioned action box.
- ▶ In the New Java Class dialog enter the following data and click **Finish**.
 - Package: `itso.rad75.bank.model` (click **Browse** to select the package)
 - Name: **Transaction**
 - Modifiers: Select **public** (default) and **abstract**
 - Superclass: `java.lang.Object` (default). You can change the superclass by clicking **Browse** in the Superclass Selection dialog (Figure 8-18), in the **Choose a type** field type the name of the superclass and click **OK**. All matching types are listed while writing.

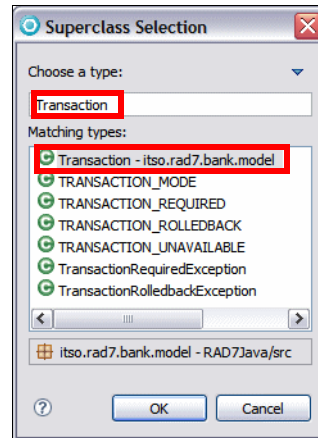

Note: The Superclass Selection dialog is just illustrative and not part of our example.

Figure 8-18 Superclass Selection dialog

- Interfaces: `java.io.Serializable`, click **Add** and type the interface name in the Choose interfaces field. All matching types are listed. Select the required interface and click **Add**. If you have added all required interfaces, click **OK** to leave the dialog (Figure 8-19).

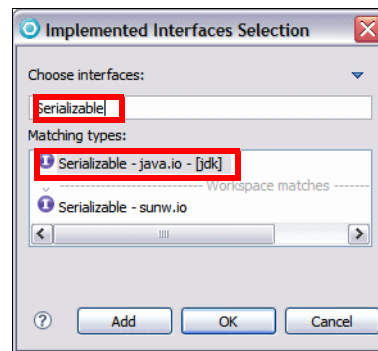

Figure 8-19 Implemented Interfaces Selection dialog

- Which method stubs would you like to create:
 - `public static void main(String[] args): clear (default)`—Adds an empty main method to the class and makes the class an executable one. In the example, only the class `BankClient` must be executable.
 - Constructors from superclass: `clear (default)`—Copies the constructors from the superclass to the new class.
 - Inherited abstract methods: `clear`—Adds to the new class stubs of any abstract methods from superclasses or methods of interfaces that need

to be implemented. In the example, it is useful for the classes ITSOBank, Credit, and Debit.

- Generate comments: clear (default)
- Click **Finish** to create the Java class (Figure 8-20).

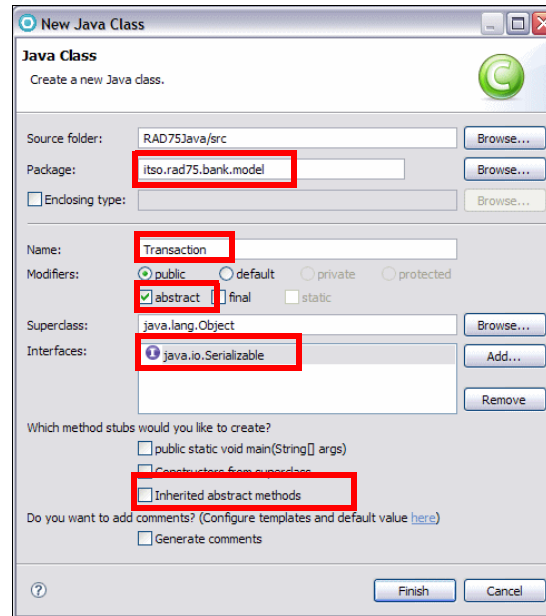

Figure 8-20 New Java Class dialog

- ▶ Notice that a line appears between the package and the Bank interface.

Note: You can add a class to the class diagram using drag and drop, or select **Visualize** → **Add to Current Diagram**.

ITSOBank example—Classes

- ▶ Repeat the above mentioned steps to create the following Java classes, that are described in “Interfaces and classes structure” on page 79
 - Transaction class into package itso.rad75.bank.model
 - Customer class into package itso.rad75.bank.model
 - Account class into package itso.rad75.bank.model
 - ITSOBank into package itso.rad75.bank.impl
 - ITSOBankException into package itso.rad75.bank.exception
 - InvalidCustomerException into package itso.rad75.bank.exception
 - InvalidAccountException into package itso.rad75.bank.exception

- InvalidTransactionException into package itso.rad75.bank.exception

Creating Java attributes (fields) and getter and setter methods

Once we have the needed Java classes and interfaces, we add Java attributes (fields) to them using the Create Java Field wizard or writing directly the field declaration into the interface or class body in the Java editor. The Create Java Field wizard gets only called through the Visualizer Class Diagram editor, choosing one of the following options.

- ▶ Move the mouse pointer anywhere over the interface or class in the diagram editor, and click **Add Java Field** in the pop-up action box that appears.

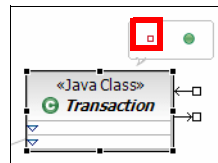

- ▶ Or right-click the interface or class in the diagram editor and select **Add Java** → **Field**. The Create Java Field wizard opens

Create a Java field using the Create Java field wizard

For our example we create java fields with the following steps:

- ▶ Select the **Transaction** class and click the **Add Java Field** icon from the action box.
- ▶ In the Create Java Field dialog, enter the following data (Figure 8-21).
 - Name: **timeStamp**
 - Type: **java.sql.Timestamp**. To select this type click **Browse**, type in the Pick a class or interface field, and click **OK**. Required import statements are added to the source code automatically.
 - Dimensions: 0 (default)—Changing the value of this field is for creating an array of the selected type with the selected dimension.
 - Contained by Java Collection: clear (default)

Note: Select this field if the required attribute has a multiplicity higher than 1. If selected, the wizard allows you to select the required Java collection class. If you select any kind of Map class, you can select the type of the key in the Java collection key type field. Finally, you can create parameterized types by selecting the use generic collection checkbox. More information about generic types can be found here:

<http://java.sun.com/developer/technicalArticles/J2SE/generics/>

- Initial value: null
- Visibility: private (default)
- Modifiers: clear all (default)
- Click **Finish** to create the Java field.

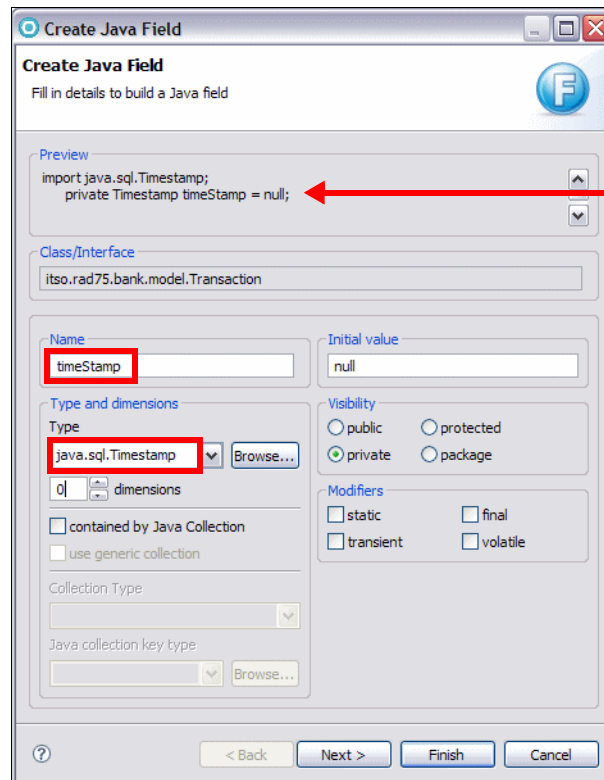

The Preview field shows the source code that is created

Figure 8-21 Create Java Field dialog

Note: There are two reasons why you might not see the attributes in the class diagram:

- ▶ Class diagram attribute compartment is collapsed—Select the interface or class and click the little blue arrow in the compartment in the middle. That expands the attribute compartment.
- ▶ Class diagram attribute compartment is filtered out—Right-click the interface or class and select **Filters** → **Show/Hide Compartment** → **Attribute Compartment**.

Create getter and setter methods using refactor feature

This section describes how to generate getter and setter methods for Java attributes by using the refactor feature of Application Developer.

To generate getter and setter methods for a Java attribute using the refactor feature, do these steps:

- ▶ Select in the class `Transaction` in the Package Explorer view, right-click the **timestamp** attribute, and select **Refactor** → **Encapsulate Field**.
- ▶ In the Encapsulate Field dialog, enter the following data (Figure 8-22):
 - Getter name: `getTimeStamp` (default)
 - Setter name: `setTimeStamp` (default)
 - Insert new methods after: As first method (default)
 - Access modifier: select **public**. You can later change the access modifier of the setter method to `private` in the source code.
 - Field access in declaring type: use getter and setter (default). It is good programming style when you use the getter and setter method also internally in the class to access member variables.
 - Generate method comments: clear (default)
 - Click **OK** to generate the getter and setter methods.

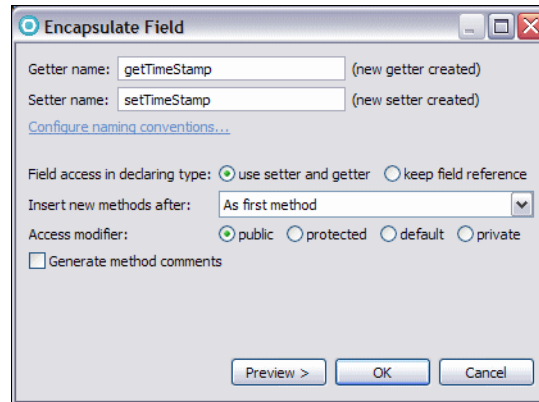

Figure 8-22 Encapsulate Field dialog

Create getters and setters methods using source feature

This section describes how to generate getter and setter methods for Java attributes by using the source feature of Application Developer.

To generate getter and setter methods for a Java attribute using the source feature, do these steps:

- ▶ Create a field in the Transaction class:
 - Name: transactionId
 - Type: int
 - Initial value: 0
- ▶ Right-click the attribute in the diagram editor or in the Outline view and select **Source** → **Generate Getters and Setters**.

Note: If the source code is open in the Java editor, you can just right-click somewhere in the Java editor and select **Source** → **Generate Getters and Setters**, or you can select **Source** → **Generate Getters and Setters** in the menu bar.

- ▶ In the Generate Getters and Setters dialog, enter the following data (Figure 8-23):
 - Select getters and setters to create:
 - getTransactionId and setTransactionId(int) (default)
 - Insertion point: Last method (default)
 - Sort by: First getters, then setters (default)
 - Access modifier: public (default)

You can later change the access modifier of the setter method to private in the source code.

- Generate method comments: clear (default)
- Click **OK** to generate the getter and setter methods.

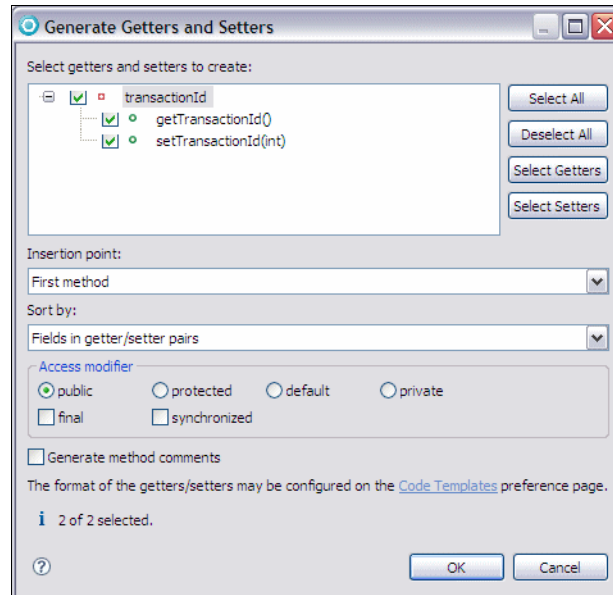



Figure 8-23 Generate Getters and Setters dialog

ITSOBank example—Fields and getters & setters

- ▶ Repeat the above mentioned steps to create the following fields to interfaces and generate getters and setters for the ITSO Bank application classes. Table 8-4 lists the fields of the interfaces, and Table 8-5 lists the fields and getter/setter methods for the classes.
 - Interface `TransactionType`—fields: `CREDIT` and `DEBIT`—`java.lang.String`
 - Class `Customer`—fields: `ssn`, `firstName` and `lastName`—`java.lang.String`
 - Generate getters (`public`) and setters (`private`) for the `Customer` class,

Adding method declarations to an interface

There are two ways to add a methods to a class or interface: We add a Java method by using the Create Java Method wizard, or by writing directly the method declaration into the interface or class body in the Java editor. The Create Java Method wizard gets only called through the Visualizer Class Diagram editor:

- ▶ Right-click the `Bank` interface in the diagram editor and select **Add Java** → **Method**, or just move the mouse pointer anywhere over the interface in the diagram editor, and click  in the action bar above the class.
- ▶ In the Create Java Method dialog, enter the following data (Figure 8-24).
 - Name: **searchCustomerBySsn**
 - Visibility: public (default)
 - Modifiers: clear all (default)

Restriction: All methods of a Java interface are `public abstract`. Modifier `abstract` can be omitted, as it is per default `abstract`. Therefore, there is no choice by Visibility and Modifiers when you are adding a method declaration to an interface. An interface has never a constructor, so the constructor check box is never active.

- Type: void (default)
- Dimensions: 0 (default)
- Throws: `itso.rad75.bank.exception.InvalidCustomerException`. Add an exception, by clicking **Add** and typing the exception class name in the **Pick one or more exception types to throw** field. All matching types are listed in the Matching types field. Select the required exceptions and click **OK**. The class `InvalidCustomerException` must be created first under the package `itso.rad75.bank.exception` in order to be selected from the Browse Types list. Follow the instructions
- Parameters: `java.lang.String ssn`

Note: To add a parameter, click **Add**. Enter the name, select the type and dimensions in the Create Parameter dialog, and click **OK** to add the parameter. In the example, we do not pass any array parameters, and dimensions are always 0 (default).

- Click **Finish** to create the Java method.

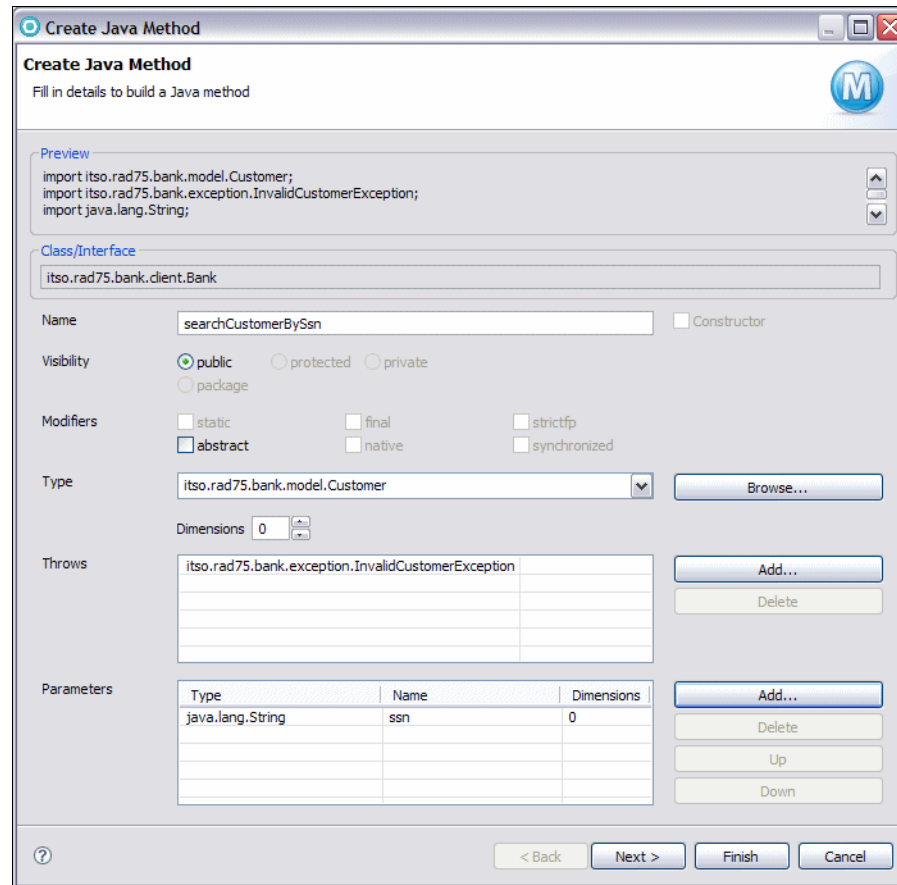

Figure 8-24 Create Java Method dialog

Note: There are two reasons why you might not see the methods in the class diagram:

- ▶ Class diagram method compartment is collapsed—Select the interface or class and click the little blue arrow in the compartment in the bottom. That expands the method compartment.
- ▶ Class diagram method compartment is filtered out—Right-click the interface or class and select **Filters** → **Show/Hide Compartment** → **Method Compartment**.

ITSOBank example—Interface methods

- ▶ Repeat the above mentioned steps to create the following method declarations to the Bank interface of the ITSO Bank application. Table 8-6 lists all method declarations that can be created:
 - searchCustomerBySsn()—Type: itso.rad75.bank.model.Customer
 - getCustomers()—Type: java.util.Map
 - transfer()—Type: void

Notes:

- ▶ Do not forget to set the right parameters and exceptions to the methods that you create.
- ▶ You can also import the final code later on “Implementing the classes and methods” on page 108

Adding constructors and Java methods to a class

The way to add constructors and methods to a class is the same as when you add a method declaration to an interface, you can check the steps as explained in “Adding method declarations to an interface” on page 101, except that there are no restrictions as described for the interfaces.

ITSOBank example—Class methods

- ▶ Repeat the above mentioned steps to create the following class methods for the ITSO Bank application. Be aware that you have to select **Constructor** when adding a constructor to a class. Table 8-7 lists all method declarations that can be created:
 - Class: ITSOBank —Method: updateCustomer() and transfer()
 - Class: Customer —Method: Constructor
 - Class: Transaction—Method: getTransactionType()

Note: You can also import the final code later on “Implementing the classes and methods” on page 108

Tip: If you want to add a method to a class that implements or overrides an existing method in an interface or a superclass, there is a much faster way to add it than by using the Create Java Method wizard. Use the source feature **Override/Implement Methods**:

- ▶ Right-click the class in the diagram editor or in the Package Explorer and select **Source** → **Override/Implement Methods**. In the Override/Implement Methods dialog, all methods that can be implemented or overridden by this class are listed. Select the methods you want to override or implement and click **OK** to add the method stubs to the selected class.
- ▶ For example, you can implement the `toString` method in the `Transaction` class.

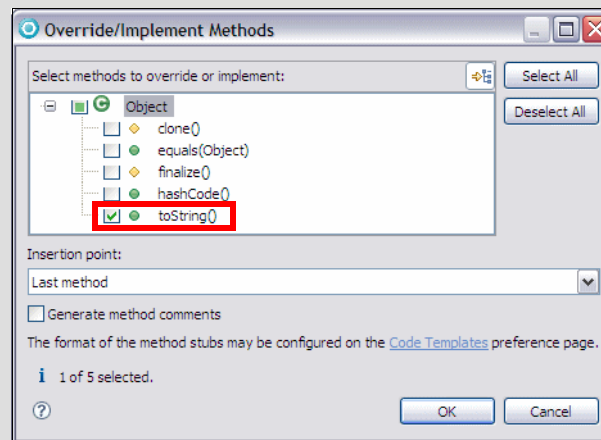

Creating relationships between Java types

The classes in the ITSO Bank application have the following relationships:

- ▶ ITSOBank remembers the customers and accounts.
- ▶ A customer knows his or her accounts.
- ▶ An account logs all the transactions for logging and querying purposes.

In Application Developer it is possible to model the relationships between Java types in the Visualizer Class Diagram editor. This section includes the following topics:

- ▶ Extends relationship
- ▶ Implements relationship
- ▶ Association relationship

Extends relationship

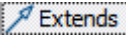
Extend relationships are used inside the Class diagram to represent inheritance between Java classes. To create an *extends* relationship between existing classes, select  in the Java Drawer and drag the mouse with the left mouse button down from any point on the child class to the parent class.

ITSOBank example—extends relationship

The only case of inheritance in our application is between the `Transaction` class as a superclass of the `Credit` and `Debit` classes. Following the next steps you will create those relationships:

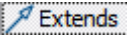
- ▶ Create the `Credit` class as mentioned in “Creating Java classes” on page 94. Remember to select `itso.rad75.bank.model.Transaction` as superclass.
- ▶ Create the `Debit` class as with the `Credit` class but this time leave the default `java.lang.Object` as superclass.
- ▶ Then select  in the Java Drawer and drag the mouse with the left mouse button down from any point on the `Debit` class to the `Transaction` class.
- ▶ A solid line with a triangular arrow is displayed from the `Credit` class and the `Debit` class to the `tso.rad75.bank.model.Transaction` class indicating that the extends relationships were created successfully.

Implements relationship

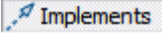
Implements relationships are used inside the Class diagram to represent usage of one or many Java interfaces by a Java class. To create an *implements* relationship between an existing class and an interface select  in the Java Drawer and drag the mouse with the left mouse button down from any point in the implementation class to the interface. The implements relationship is displayed using a dashed line with a triangular arrow pointing to the interface.

ITSOBank example—implements relationship

There is already an implements relationship in the class diagram: The `ITSOBank` class implements the `Bank` interface.

Association relationship

Association relationships are used inside the Class diagram to represent the object level dependencies between Java classes. To create an association relationship between two classes, do these steps:

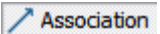
- ▶ Select  in the Java drawer.
- ▶ Drag the mouse with the left mouse button down from any point on the `Customer` class to the `Account` class.

- ▶ In the Create Association dialog, enter the following data (Figure 8-25).
 - Name: **accounts**
 - Type: - (not active)
 - Dimensions: 0 (default)
 - Contained by Java Collection: select
 - Collection type: java.util.ArrayList
 - Java Collection key type: - (not active)
 - Use generic collection: select
 - Initial value: null
 - Visibility: private (default)
 - Modifiers: clear all (default)
 - Click **Finish** to create the association.

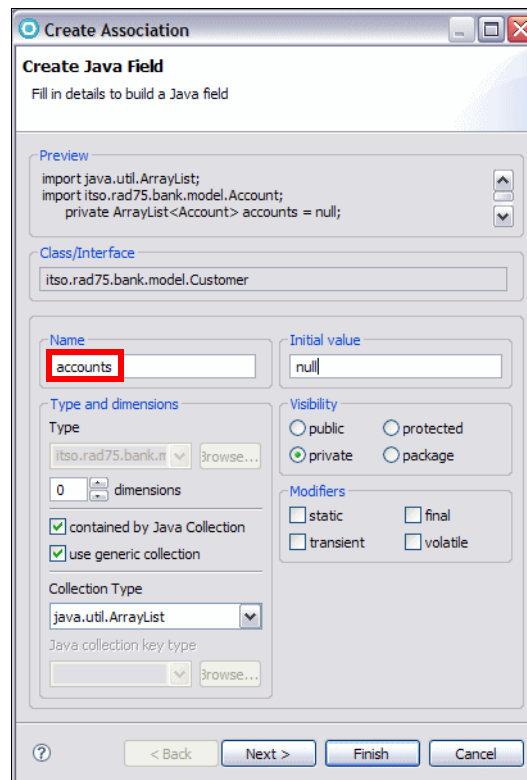

Figure 8-25 Create Association dialog

Note: An association can be displayed as an arrow or an attribute:

- ▶ Show as **attribute**—To display the association as an attribute, right-click the association arrow and select **Filters** → **Show As Attribute**.
- ▶ Show as **association arrow**—To display the attribute as an association, right-click the attribute and select **Filters** → **Show As Association**.

ITSOBank example—association relationship

- ▶ Repeat the above mentioned steps to create the following association relationships of the ITSO Bank application. The associations are listed in Table 8-5 on page 81.
 - Class: ITSOBank—field: accounts (Map <String, Account>)
 - Class: ITSOBank—field: customers (Map <String, Customer>)
 - Class: Account—field: transactions (ArrayList<Transaction>)

Implementing the classes and methods

In the previous sections of the ITSO Bank application example, we have included step-by-step approaches with the objective of demonstrating the Application Developer tooling and the logical process of developing a Java application. In this section we import all the classes with the method code.

Import the classes

- ▶ Right-click the **src** folder and select **Import**.
- ▶ Select **General File System**, then click **Browse** and navigate to the folder C:\76721code\java\import.
- ▶ Select the **import** folder and click **Finish** (Figure 8-26).

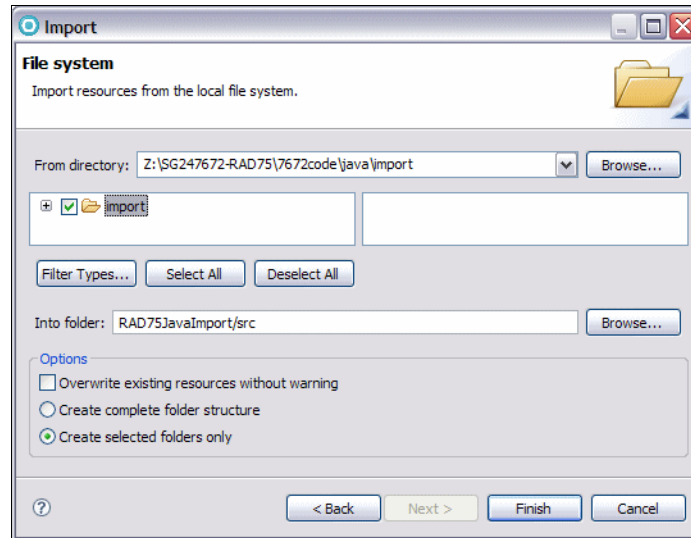



Figure 8-26 Importing the classes

- ▶ You can add all the classes to the diagram manually, or import the diagram into the diagram folder from:

```
C:\7672code\java\diagram\ITSOBank-Diagram.dnx
```
- ▶ To change the appearance of the diagram, right-click in the diagram and select **Filters** → **Show/Hide Connector Labels** → **All** or **No connector Labels**, or **Filters** → **Show/Hide Relationships** and select the relationships to be displayed or hidden. For example, you can hide the many <<use>> relationships.

Running the ITSO Bank application

Once you have completed the ITSO Bank application and resolved any outstanding errors, you are ready to test the application. To launch the application, we use a generic Java Application launch configuration that derives most of the launch parameters from the Java project and the workbench preferences. To run the ITSO Bank application, do these steps:

- ▶ Right-click the **BankClient** class in the Package Explorer and select **Run As** → **Java Application** or click the arrow of  in the toolbar and select **Run As** → **Java Application**.

Note: The selected class must be executable—containing a public static void main(String[] args) method—otherwise, the application cannot run.

- ▶ You can see the output in the Console view (Figure 8-27 shows part).

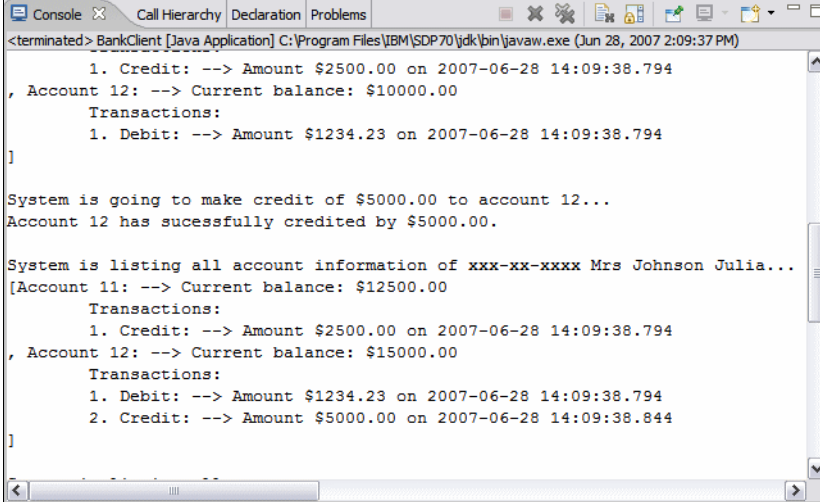

```
<terminated> BankClient [Java Application] C:\Program Files\IBM\SDP70\jdk\bin\javaw.exe (Jun 28, 2007 2:09:37 PM)
1. Credit: --> Amount $2500.00 on 2007-06-28 14:09:38.794
, Account 12: --> Current balance: $10000.00
Transactions:
1. Debit: --> Amount $1234.23 on 2007-06-28 14:09:38.794
]



System is going to make credit of $5000.00 to account 12...
Account 12 has sucessfully credited by $5000.00.

System is listing all account information of xxx-xx-xxxx Mrs Johnson Julia...
[Account 11: --> Current balance: $12500.00
Transactions:
1. Credit: --> Amount $2500.00 on 2007-06-28 14:09:38.794
, Account 12: --> Current balance: $15000.00
Transactions:
1. Debit: --> Amount $1234.23 on 2007-06-28 14:09:38.794
2. Credit: --> Amount $5000.00 on 2007-06-28 14:09:38.844
]
```

Figure 8-27 Console view with output of the ITSO Bank application

Creating a run configuration

In some cases, you might want to override the derived parameters or specify additional arguments. To create a run configuration, do these steps:

- ▶ Select **Run** → **Run Configurations**, or click the arrow of  in the toolbar and select **Run Configurations**.
- ▶ In the Run dialog, select  **Java Application** and then click  to create a new configuration (Figure 8-28). Notice that we already have a configuration from running the BankClient application.

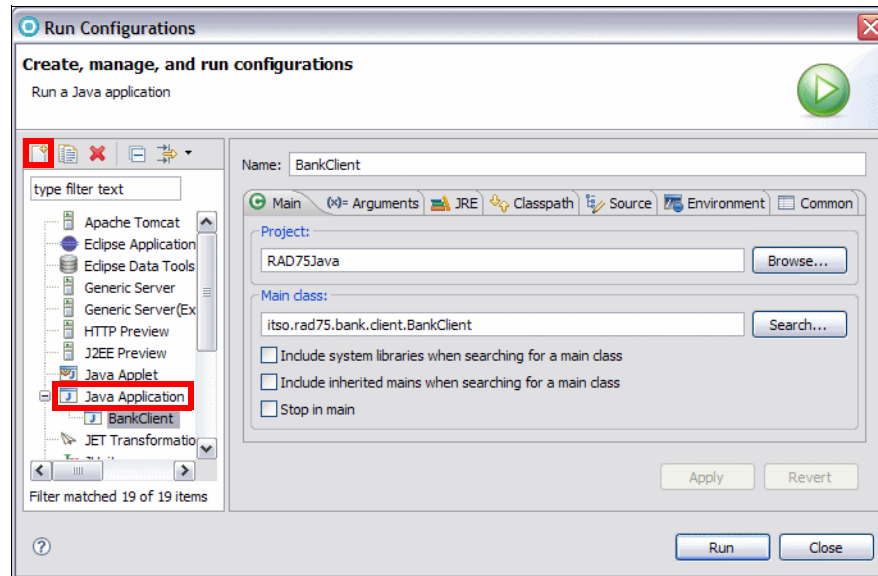

Figure 8-28 Run configuration dialog

- ▶ The Main tab defines the class to be launched:
 - Project: Select the project containing the class to launch.
 - Main class: Click **Search** to get a list of all executable main classes in the project. Select the main class to be launched.
 - With the check boxes **Include system libraries when searching for a main class** and **Include inherited mains when searching for main class**, you can expand the area where Application Developer is searching for an executable class.
 - **Stop in main**: The program stops in the main method whenever it is launched in debug mode. You do not have to specify a project, but doing so allows a default classpath, source lookup path, and JRE to be chosen.
- ▶ The Arguments tab defines the arguments to be passed to the application and to the virtual machine. To add a program argument, do these steps:
 - You can type a value directly into the field, or you can use a variable:
 - Click **Variables** below the Program arguments field.
 - Select one of the predefined variables or create your own variable by clicking **Edit Variables** and then **New**.
 - Enter the name and the value for the variable and click **OK** to add it.

- Click **OK** again to return to the Select a variable dialog. The new variable is now available in the list. Select it and click **OK** to return to the Arguments tab.
 - In the same way, you can also add VM arguments.
 - You can also specify the working directory to be used by the launched application.
- ▶ The JRE tab defines the JRE used to run or debug the application. You can select a JRE from the already defined JREs, or define a new JRE.
- ▶ The Classpath tab defines the location of class files used when running or debugging an application. By default, the user and bootstrap class locations are derived from the associated project's build path. You can override these settings here.
- ▶ The Source tab defines the location of source files used to display source when debugging a Java application. By default, these settings are derived from the associated project's build path. You can override these settings here.
- ▶ The Environment tab defines the environment variable values to use when running or debugging a Java application. By default, the environment is inherited from the Eclipse runtime. You can override or append to the inherited environment.
- ▶ The Common tab defines general information about the launch configuration. You can select to store the launch configuration in a specific file and specify which perspectives become active when the launch configuration is launched.
- ▶ Click **Run** to launch the class.

Understanding the sample code

In this section we explain the content of the sample code for the ITSO Bank solution. You can later study all the sample code imported it into the project.

BankClient class

Is the starting class for the sample application, it basically creates an instance of the ITSOBank class and uses the different Customer, Account and Transaction methods to operate with the bank information. Example 8-1 shows some of the relevant Java source code in simplified format of the BankClient class.

Example 8-1 BankClient class (abbreviated)

```
package itso.rad75.bank.client;
public class BankClient {
    public static void main(String[] args) {
        Bank iTSOBank = ITSOBank.getBank();
    }
}
```



```

        executeCustomerTransactions(itSOBank);
    }

    private static void executeCustomerTransactions(Bank bank)
        throws ITSOBankException {
        .....
        customer1 = new Customer("xxx-xx-xxxx", "Mr", "Juan", "Napoli");
        bank.addCustomer(oCustomer);
        (...)
    }
}

```

ITSOBank class

This class implements the logic for the interface Bank and contains all the business logic related to the manipulation of customers, accounts and transactions in the ITSOBank application. Example 8-2 shows some of the relevant Java source code in simplified format of the ITSOBank class.

Example 8-2 ITSOBank class

```

public class ITSOBank implements Bank {
    public ITSOBank() {
        this.setCustomers(new HashMap<String, Customer>());
        this.setAccounts(new HashMap<String, Account>());
        this.setCustomerAccounts(new HashMap<String, ArrayList<Account>>());
        this.initializeBank();
    }

    private void initializeBank() {
        Customer customer1 = new Customer("111-11-1111", "MR", "Ueli",
            "Wahli");
        this.addCustomer(customer1);
        (...)
    }

    public void updateCustomer(String ssn, String title, String firstName,
        String lastName) throws InvalidCustomerException {
        this.searchCustomerBySsn(ssn).updateCustomer(title, firstName,
            lastName);
    }

    public void withdraw(String accountNumber, BigDecimal amount)
        throws InvalidAccountException, InvalidTransactionException {
        this.processTransaction(accountNumber, amount,
            itso.rad75.bank.ifc.TransactionType.DEBIT);
    }

    .....
}

```

Customer class

This class handles the data and process the logic of the customer entity in the ITSO Bank application, a customer can have many accounts therefore handles the relationship with the Account class. Example 8-3 shows some of the relevant Java source code in simplified format of the Customer class.

Example 8-3 Customer class

```
package itso.rad75.bank.model;
public class Customer {
    public Customer(String ssn, String title, String firstName,
        String lastName) {
        this.setSsn(ssn);
        this.setTitle(title);
        this.setFirstName(firstName);
        this.setLastName(lastName);
        this.setAccounts(new ArrayList<Account>());
    }
    public void addAccount(Account account) throws AccountAlreadyExistException
    {
        if (!this.getAccounts().contains(account)) {
            this.getAccounts().add(account);
            .....
        }
        .....
    }
}
```

Account class

This class handles the data and process the logic of the account entity in the ITSO Bank application, on an account many transactions can be held therefore handles the relationship with the Transaction class. Example 8-4 shows some of the relevant Java source code in simplified format of the Account class.

Example 8-4 Account class

```
package itso.rad75.bank.model;
public class Account implements Serializable {
    public Account(String accountNumber, BigDecimal balance) {
        this.setAccountNumber(accountNumber);
        this.setBalance(balance);
        this.setTransactions(new ArrayList<Transaction>());
    }
    public void processTransaction(BigDecimal amount, String transactionType)
        throws InvalidTransactionException {
        .....
        if (TransactionType.CREDIT.equals(transactionType)) {
            transaction = new Credit(amount);
        }
    }
}
```

```

        else if (TransactionType.DEBIT.equals(transactionType)) {
            transaction = new Debit(amount);
            .....
        }
        .....
    }
}

```

Transaction class

This class handles the data and process the logic of a transaction in the ITSO Bank application, a transaction can be either credit or debit type that is why both inherits the transaction class structure. Example 8-5 shows some of the relevant Java source code in simplified format of the Transaction class.

Example 8-5 Transaction class

```

package itso.rad75.bank.model;
public abstract class Transaction implements Serializable {
    static int transactionCtr = 1; // to increment transactionId
    public Transaction(BigDecimal amount) {
        this.setTimeStamp(new Timestamp(System.currentTimeMillis()));
        this.setAmount(amount);
        this.setTransactionId(transactionCtr++);
    }
    public abstract String getTransactionType();
    public abstract BigDecimal process(BigDecimal accountBalance)
        throws InvalidTransactionException;
    .....
}

```

Credit class

This class handles the implementation code of a transaction class for credit operations. Example 8-6 shows some of the relevant Java source code in simplified format of the Credit class.

Example 8-6 Credit class

```

package itso.rad75.bank.model;
public class Credit extends Transaction {
    public BigDecimal process(BigDecimal accountBalance)
        throws InvalidTransactionException {
        .....
        return accountBalance.add(this.getAmount());
        .....
    }
    (...)
}

```

Debit class

The `Debit` class is similar to the `Credit` class, but subtracts the amount from the balance.

Additional features used for Java applications

The Java editor of the Application Developer provides a set of useful features to develop the code. In this section we are highlighting some key features of Application Developer when working on a Java project:

- ▶ Using scripting inside the JRE
- ▶ Analyzing source code
- ▶ Debugging a Java application
- ▶ Using the Java scrapbook
- ▶ Plugable Java Runtime Environment (JRE)
- ▶ Exporting Java applications to a JAR file
- ▶ Running Java applications external to Application Developer
- ▶ Importing Java resources from a JAR file into a project

Using scripting inside the JRE

Since Java Runtime environment JRE version 1.6, scripting code can be executed inside the virtual machine environment with the usage of the classes in the `javax.script.*` native Java package. The classes included in the JRE release contains Java implementation logic for Mozilla open source Rhino and ECMAScript Javascript language engines, but many others like Ruby or Python can be included, as well as making your own scripting interpreter.

ITSOBank example—scripting invocation

In our application example, we created a scripting implementation, that you already imported in “Import the classes” on page 108. The scripting module has two components:

- ▶ `BankClientScript.js` scripting file in the package `itso.rad75.bank.client`, which contains a similar logic as implemented by the method `executeCustomerTransactions(Bank oBank)` in the `BankClient` class.
- ▶ `executeCustomerTransactionsWithScript(Bank oBank)` method in the class `BankClient`, that invokes the script file and evaluates its logic.

To test the scripting functionality we have to modify two lines of code in the method `main(String[] args)` of the class `BankClient`.

- ▶ Look for the following code:

```
//Here you can switch the logic to be implemented in Java or Scripting
executeCustomerTransactions(oITSOBank);
//executeCustomerTransactionsWithScript(oITSOBank);
```
- ▶ Comment the second line by selecting the line, then right-click, and select **Source** → **Toggle Comment**.
- ▶ Uncomment the third line, with the same steps.
- ▶ Save the changes (Ctrl+S).
- ▶ Run the ITSOBank Application as described in “Running the ITSO Bank application” on page 109.
- ▶ Verify that the output console has no errors and shows the message <<Using JAVASCRIPT to access bank Java objects!>> (Figure 8-29).

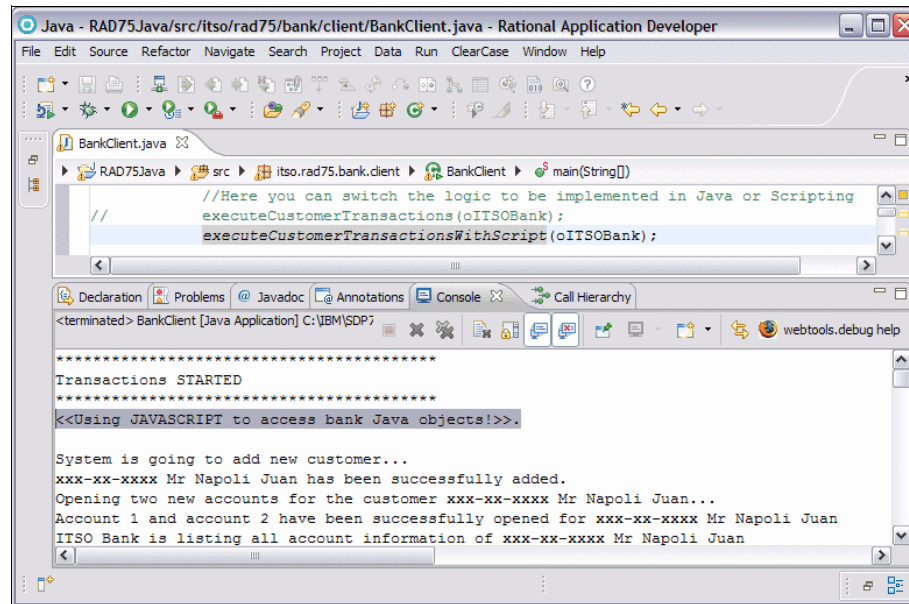

Figure 8-29 Executing the BankClient with scripting

How does the scripting example work?

Study the code of the executeCustomerTransactionsWithScript method:

```
private static void executeCustomerTransactionsWithScript(Bank oBank)
    throws ScriptException {
    //Lookup for the scripting engine
    ScriptEngineManager engineMgr = new ScriptEngineManager();
    ScriptEngine engine = engineMgr.getEngineByName("ECMAScript");
    //Insert the bank object in the Bindings scope
```

```
engine.put("bank", oBank);
//Execute the script
try {
    InputStream inputStream = Thread.currentThread()
        .getContextClassLoader()
        .getResourceAsStream("itso/rad75/bank/client/BankClientScript.js");
    Reader reader = new InputStreamReader(inputStream);
    engine.eval(reader);
} catch (ScriptException e) {
    throw e;
}
```

- ▶ The example uses the ECMAScript scripting engine.
- ▶ The bank object from the main method is inserted into the binding scope.
- ▶ The script, `BankClientScript.js`, is loaded and then evaluated by the engine.
- ▶ The script itself is very similar to the `executeCustomerTransactions` method.

Analyzing source code

The **Rational Software Analyzer** is a part of the Test and Performance Tools Platform (TPTP) analysis framework. It lets you run a static analysis of the resources that you are working with to detect violations of rules and rule categories.

This section describes how to work with the Rational Software Analyzer:

- ▶ Creating and editing a static analysis configuration
- ▶ Running a static analysis

Creating and editing a static analysis configuration

For each resource, you can create an analysis configuration that specifies the rules and rule categories that are used when analyzing the resource. A static analysis code review, for example, detects violations of specific programming rules and rule categories and generates a report in the Software Analyzer Results view (Figure 8-30).

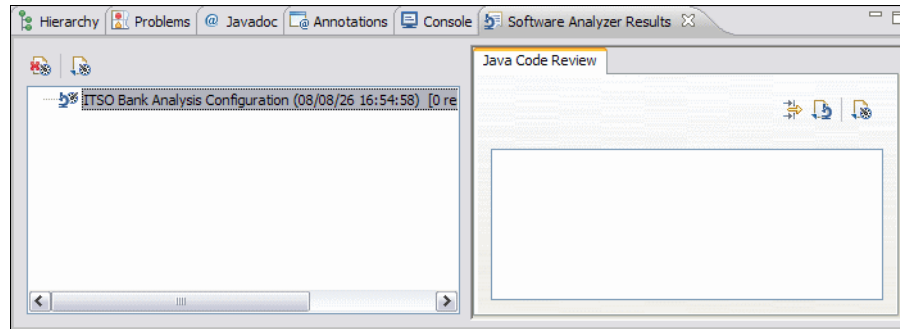





Figure 8-30 Software Analyzer Results for a Java project

To create an analysis configuration, you must be working in a perspective that supports analysis capabilities. The Java and the Debug perspectives support analysis capabilities by default. In all other perspectives, you can add it. Select **Window** → **Customize Perspective**, select the **Commands** tab and **Software Analyzer**.

To create an analysis configuration, do these steps:

- ▶ Click **Run** → **Analysis**, or right-click a project in the Package Explorer and select **Software Analyzer** → **Software Analyzer Configurations**, or click the arrow of  in the toolbar and select **Software Analyzer Configurations**.
- ▶ In the Software Analyzer Configurations dialog, select  **Software Analyzer** and click the **New** icon  to create a configuration (Figure 8-31):
 - Type **ITSO Bank Analysis Configuration** as a name for the analysis configuration
 - Set the scope of the analysis:
 - Analyze entire workspace: The rules that you select on the Rules tab are applied to all the resources in your workspace.
 - Analyze a resource working set: The rules that you select on the Rules tab are applied to a specific set of projects, folders, or files in your workspace.
 - Analyze selected projects: The rules that you select on the Rules tab are applied to the resources in the project you select.
 - Select **Analyze selected projects** and select the **RAD75Java** project.
 - Click **Apply**.

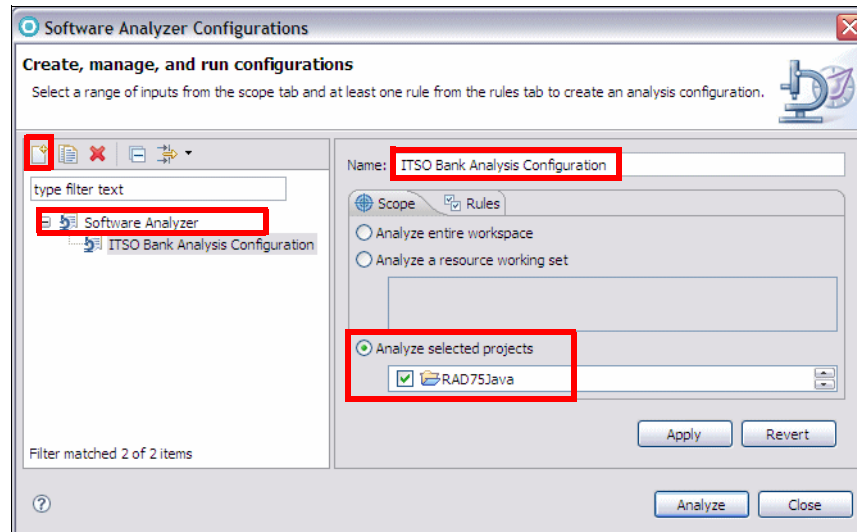

Figure 8-31 Analysis: Create, manage, and run configurations

- ▶ Select the **Rules** tab to specify the rule categories, rules, or rule sets to apply during the analysis:
 - Rule Sets: Select a defined rule set, for example, **Java Quick Code Review**, and click **Set** to configure the domains and rules.
 - Analysis Domains and Rules: Expand the tree and select domains and rules. For example, select **Java Code review** → **Design Principles**.

Note that setting a rule set selects a subset of domains and rules. In our case, several **J2SE Best Practices** rules are preselected. Expand that domain to see the selected rules (Figure 8-32).

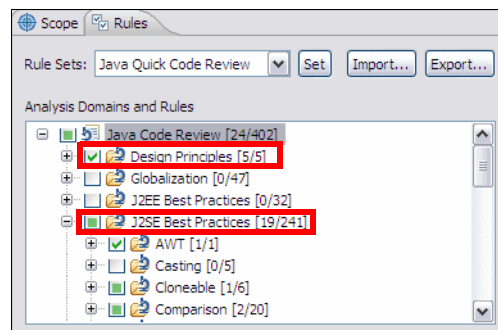

Figure 8-32 Analysis: Domains and rules

- Click **Apply**.

Running a static analysis

You can analyze your source code using the analysis configurations that you created. To run a static analysis, select an existing configuration or create a new configuration, and click **Analyze**.

While the analysis runs, the Software Analyzer Results view opens and, if your source code does not conform to the rules in the analysis configuration, the view populates with results. The results are listed in chronological order and are grouped into the same categories that you specified in the analysis configuration.

If you run the analysis for the RAD75Java project, no problems are reported.

If you run the analysis for the RAD75EJB project (from Chapter 14, “Develop EJB applications” on page 387), one problem is reported (Figure 8-33).

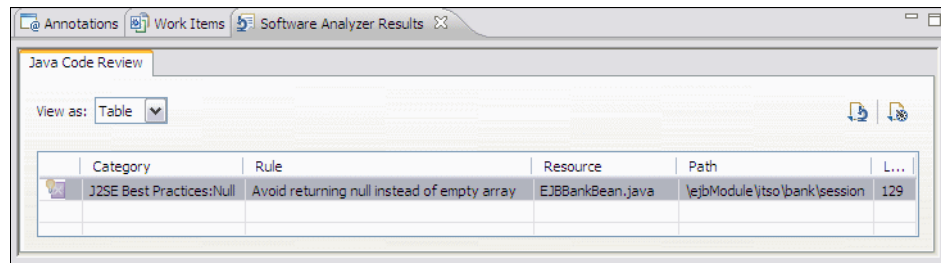

Figure 8-33 Software Analyzer Results view

Static analysis results

A static analysis result is a concise explanation of a rule violation. The result is a line item in the Software Analyzer Results view that shows that the resource does not comply with the rules that you applied.

A result is not necessarily a problem, mistake, or bug, but you have to evaluate each result in the list to determine what action, if any, you have to take. If the result is a problem that has a trivial solution, the author of the rule might have provided a quick fix that automatically corrects the resource.

To locate a problem, right-click an entry in the Software Analyzer Results view and select **View Result**. This action opens the Java source file with the problem code highlighted.

If a Quick Fix is provided, right-click an entry and select **Quick Fix**. The source code is changed and the entry disappears from the list.

Debugging a Java application

For details debugging an application, refer to Chapter 24, “Debug local and remote applications” on page 861.

Using the Java scrapbook

The scrapbook feature can be used to quickly run and test Java code without having to create an executable testing class. Snippets of Java code can be entered in a scrapbook page and evaluated by simply selecting the code and running it.

A scrapbook page can be added to any project and package. The extension of a scrapbook page is `.jpage`, to distinguish it from normal Java source file.

To create and run a scrapbook page, do these steps:

- ▶ Right-click a package (`itso.rad75.bank.client`) in the Package Explorer and select **New** → **Other** → **Java** → **Java Run/Debug** → **Scrapbook Page**.
- ▶ Enter a file name (`TestScrapBook`) and click **Finish**. Note that we already imported such a scrapbook.
- ▶ The scrapbook page is opened in the Java editor and you can enter the snippet Java code.

Example 8-7 contains two little snippets. The first one is related to the ITSO Bank application and based on the `BankClient` class `main` method, and the second one is a simple code snippet to produce a multiplication table.

Example 8-7 Java scrapbook examples

```
// ITSO Bank Snippet
itso.rad75.bank.ifc.Bank oITSOBank =
    itso.rad75.bank.impl.ITSOBank.getBank();
System.out.println("\nITSO Bank is listing all customers status");
System.out.println(oITSOBank.getCustomers() + "\n");
for (itso.rad75.bank.model.Customer
    customer:oITSOBank.getCustomers().values())
{
    System.out.println("Customer: "+ customer);
    System.out.println(oITSOBank.getAccountsForCustomer(customer.getSsn()));
}

// Multiplication Table Snippet
String line;
int result;
```

```

for (int i = 1; i <= 10; i++) {
    line = "row " + i + ": ";

    // begin inner for-loop
    for (int j = 1; j <= 10; j++) {
        result = i*j;
        line += result + " ";
    } // end inner for-loop
    System.out.println(line);
}

```



Important: All classes that are not from the `java.lang` package must be fully qualified, or you have to set import statements:

- ▶ Right-click anywhere in the scrapbook page editor and select **Set Imports**.
- ▶ For the example, add the following types and packages:

```

itso.rad75.bank.model.*
itso.rad75.bank.ifc.Bank
itso.rad75.bank.impl.ITS0Bank

```

- ▶ You can execute, display, or inspect a snippet:
 - Select the code of the Multiplication Table Snippet, right-click, and select **Execute**, or press **Ctrl+U**, or click  in the toolbar. All output is displayed in the Console view.
 - Select the ITS0 Bank Snippet, right-click, and select **Display**, or click  in the toolbar. Again, all output is displayed in the Console view.
 - Select the ITS0 Bank Snippet, right-click, and select **Inspect**, or press **Ctrl+Shift+I**, or click  in the toolbar. Again, all output is displayed in the Console view. But in addition, an expression box opens, which allows you to inspect the current variables. Pressing **Ctrl+Shift+I** again opens the Expression view, which you can find in the Debug perspective, as described in Chapter 24, “Debug local and remote applications” on page 861.

Note: You cannot execute, display, or inspect a snippet in the scrapbook page, unless you have selected the code.

- ▶ Click  in the Console view to end the scrapbook evaluation.

Pluggable Java Runtime Environment (JRE)

Application Developer supports Java projects to run under different versions of the Java Runtime Environment. New JREs can be added to the workspace, and projects can be configured to use any of the JREs available. By default, the Application Developer v7.5 uses and provides projects with support for IBM Java Runtime Environment v6.0.

To add another JRE to the workspace, do these steps:

- ▶ Select **Window** → **Preferences** and in the Preferences dialog, select **Java** → **Installed JREs**.
- ▶ Click **Add** to add a new JRE to the workspace.
- ▶ Click **Browse** and select the home directory of the JRE you want to use.
- ▶ Click **OK**. The new added JRE is now available in the list. By default, the selected JRE is added to the build path of newly created Java projects.

The JRE that is used to run a program can also be chosen in the Run Configurations dialog (Figure 8-34).

To change the JRE in a run configuration, do these steps:

- ▶ Select **Run** → **Run Configurations**.
- ▶ Select an existing Java application run configuration.
- ▶ Select the JRE tab, select **Alternate JRE**, and change the JRE.

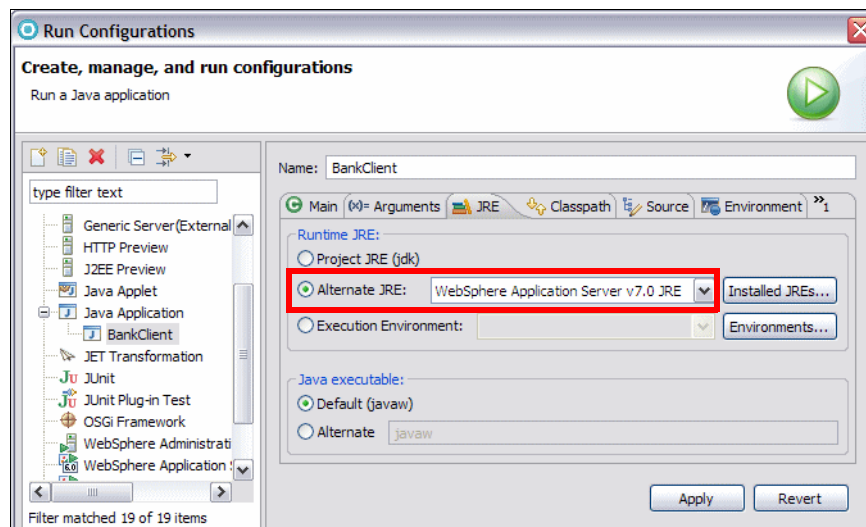

Figure 8-34 Run JRE configuration tab

Exporting Java applications to a JAR file

This section describes how to export a Java application to a JAR file that can be run outside Application Developer using a JRE in a Windows Command Prompt. We demonstrate how to export and run the ITSO Bank application.

To export the ITSO Bank application code to a JAR file, do these steps:

- ▶ Right-click the **RAD75Java** project and select **Export**.
- ▶ In the Export dialog, select **Java** → **JAR file** and click **Next**.
- ▶ In the JAR Export dialog, enter the following data (Figure 8-35).

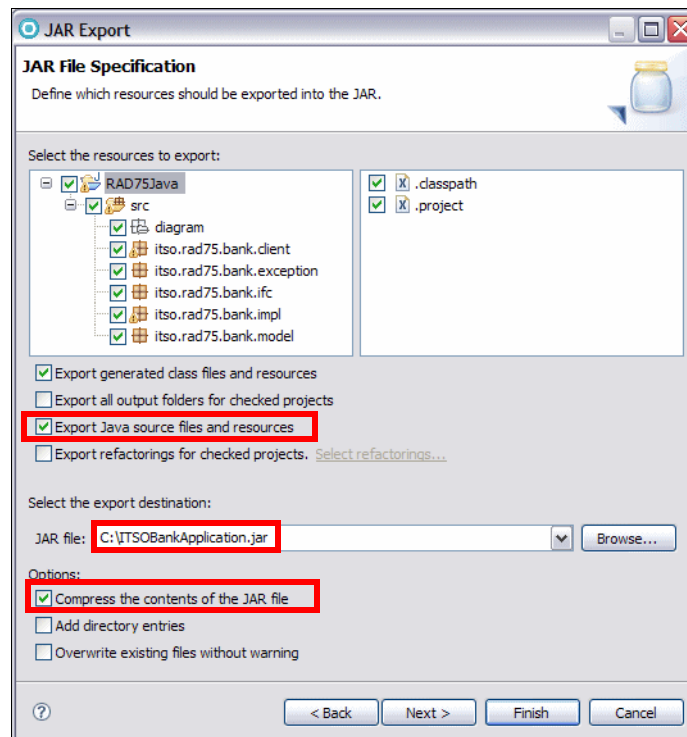

Figure 8-35 JAR Export

- Select the **RAD75Java** project.
- Select **Export generated class files and resources** (default).
- Select **Export Java source files and resources**.

Note: We select to include the source to demonstrate later how to import a JAR file into a project. It is not necessary or desirable to include Java sources in a JAR file for execution.

- JAR file: **C:\ITSOBankApplication.jar**
- Select **Compress the contents of the JAR file** (default).
- Clear other check boxes.
- ▶ In the JAR Packaging Options dialog accept the defaults and click **Next**.
- ▶ In the JAR Manifest Specification dialog, click **Browse** for the Main class, and select the **BankClient** class.
- ▶ Click **Finish** to export the entire Java project as a JAR file.
- ▶ click **OK** if the warning window appear.

Running Java applications external to Application Developer

Once you have exported the Java application as a JAR file you can run the Java application on any installed JRE on your system (at least as long as there are no version conflicts).

Note: Ensure that the JRE is set in the Windows environment variable called PATH. You can add the JRE to the path with the following command in the Windows Command Prompt:

```
set path=%path%;{JREInstallDirectory}\bin
set path=%path%;C:\IBM\SDP75Beta\jdk\bin
```

To run a Java application external to Application Developer on a Windows system, do these steps:

- ▶ Open a Command Prompt and navigate to the directory to which you have exported the JAR file, for example C:\.
- ▶ Enter the following command to run the ITSO Bank application:

```
java -jar ITSOBankApplication.jar
```

This results in the `main` method of `BankClient` being executed, and the results are shown in Figure 8-36.

```

C:\>java -jar ITS0BankApplication.jar
*****
Transactions STARTED
*****
<<Using PLAIN JAVA to access bank Java objects!>>.

System is going to add new customer...
xxx-xx-xxxx Mr Napoli Juan has been successfully added.

ITS0 Bank is opening two new accounts for customerxxx-xx-xxxx Mr Napoli Juan...
Account 1 and account 2 have been successfully opened for xxx-xx-xxxx Mr Napoli
Juan.

ITS0 Bank - listing all account information of xxx-xx-xxxx Mr Napoli Juan...
[Account 1: --> Current balance: $10000.00, Account 2: --> Current balance: $112
34.23]

ITS0 Bank is going to make credit of $2500.00 to account 1...
Account 1 has successfully credited by $2500.00.

ITS0 Bank is going to make debit of $1234.23 to account 2...
Account 2 has successfully debited by $1234.23.

ITS0 Bank is listing all account information of xxx-xx-xxxx Mr Napoli Juan...
[Account 1: --> Current balance: $12500.00
Transactions:
1. itso.rad75.bank.model.Credit@70727072
Account 2: --> Current balance: $10000.00
Transactions:
1. Debit: --> Amount $1234.23 on 2008-08-22 17:56:32.001

```

Figure 8-36 Output from running ITS0BankApplication.jar in Command Prompt

Importing Java resources from a JAR file into a project

This section describes how to import Java resources from a JAR file into an existing Java project in the workspace.

We use the ITS0BankApplication.jar file which we have created in “Exporting Java applications to a JAR file” on page 125. Alternatively, you can use the ITS0BankApplication.jar provided in the c:\7672code\java\jar directory included with the Redbooks publication sample code.

- ▶ Create a Java project called **RAD75JavaImport** with the default options.
- ▶ Right-click the **RAD75JavaImport** project in the Package Explorer and select **Import**.
- ▶ In the Import dialog, select **General** → **Archive File** and click **Next**.
- ▶ In the Import - Archive File dialog click **Browse** and locate the JAR file (for example, c:\ITS0BankApplication.jar).
- ▶ Clear the files .classpath and .project and the folder META-INF. These file are created when required.
- ▶ Select **RAD75JavaImport/src** as Into folder, and click **Finish**.
- ▶ Test the imported Java project, select and run the BankClient class from the Package Explorer.

Javadoc tooling

Javadoc is a very useful tool in the Java Development Kit used to document Java code. It generates a Web-based (HTML files) documentation of the packages, interfaces, classes, methods, and fields.

Application Developer has a Javadoc view, which is implemented using a SWT browser widget to display HTML. In the Java perspective, the Javadoc view is context sensitive. It only displays the Javadoc associated with the Java element where the cursor is currently located within the Java editor.

To demonstrate the use of Javadoc, we use the RAD75JavaImport project that we imported.

- ▶ Open the Javadoc view in the Java perspective if it is not already open.
- ▶ Open the `BankClient` class in the Java editor.
- ▶ You will notice that when the cursor selects a type, its Javadoc is shown in the Javadoc view. Select the `BigDecimal` type, and the Javadoc view changes to the documentation associated with `BigDecimal` (Figure 8-37).

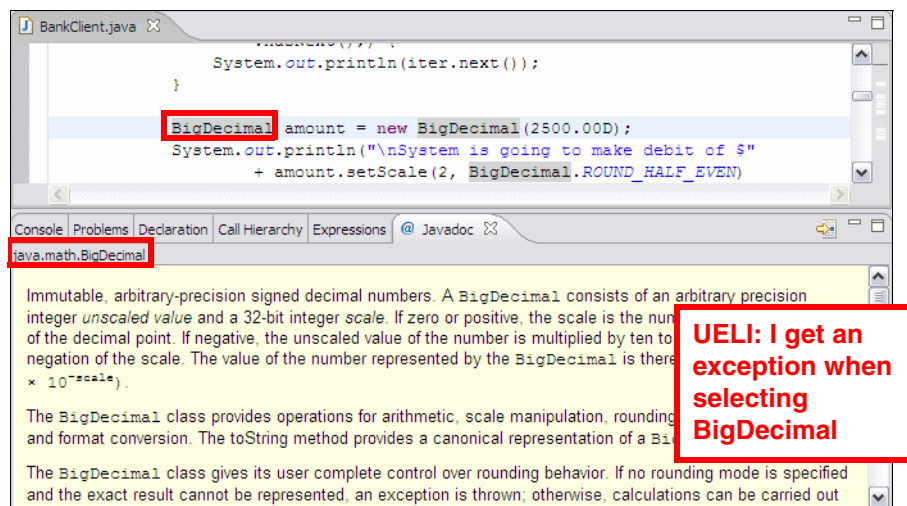

Figure 8-37 Javadoc view: Context sensitive (`BigDecimal`)

Generating Javadoc

This section explains how to generate Javadoc from an existing Java project. Application Developer supports the following types of Javadoc generation:

- ▶ Generate Javadoc

- ▶ Generate Javadoc with diagrams from existing tags
- ▶ Generate Javadoc with diagrams automatically
- ▶ Generate Javadoc from an Ant script

Generate Javadoc

To generate Javadoc from an existing Java project, do these steps:

- ▶ Right-click the **RAD75JavaImport** project in the Package Explorer and select **Export** → **Java** → **Javadoc**, or select **Project** → **Generate Javadoc**.
- ▶ In the Javadoc Generation dialog, enter the following data (Figure 8-38):
 - The Javadoc command is predefined.
 - Select **Public** for Create Javadoc for members with visibility (default).
 - Select **Use Standard Doclet**. Alternatively, you can specify a custom doclet with the name of the doclet and the classpath to the doclet implementation.
 - Destination: {workspaceDirectory}\RAD75Java\doc (default)
Generates Javadoc in the doc directory of current project.

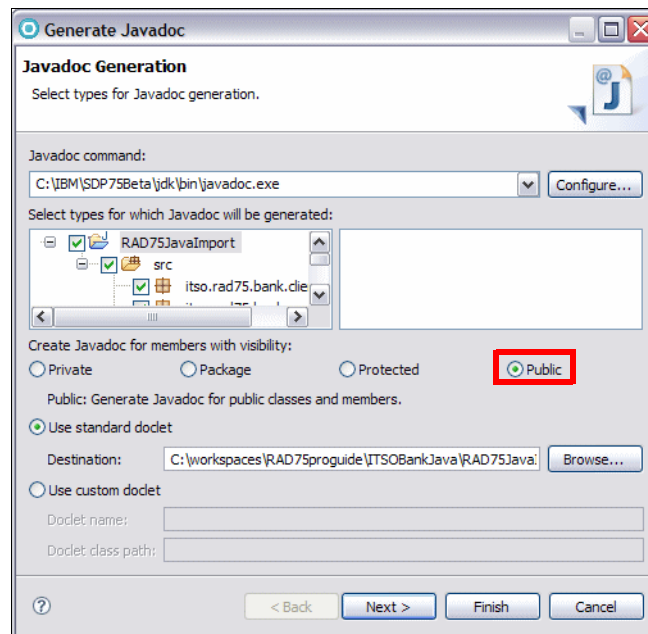

Figure 8-38 Javadoc Generation dialog

- ▶ In the Configure Javadoc arguments for standard doclets dialog accept the default settings and click **Next**.
- ▶ In the Configure Javadoc arguments dialog, enter the following data:
 - Select **1.6** for JRE source compatibility because we use generic types in the project, which are only supported from JDK version 1.5 (5.0) or higher.
 - Select **Save the settings for this Javadoc export as an Ant script** and accept the destination: {workspace}\RAD75JavaImport\javadoc.xml
- ▶ Click **Finish** to generate the Javadoc.
- ▶ When prompted to update the Javadoc location, click **Yes to all**.
- ▶ When prompted that the Ant file will be created, click **OK**.
- ▶ Open the Javadoc in a browser by right-clicking **index.html** (in RAD75JavaImport/doc) and selecting **Open With** → **Web Browser** (Figure 8-39).

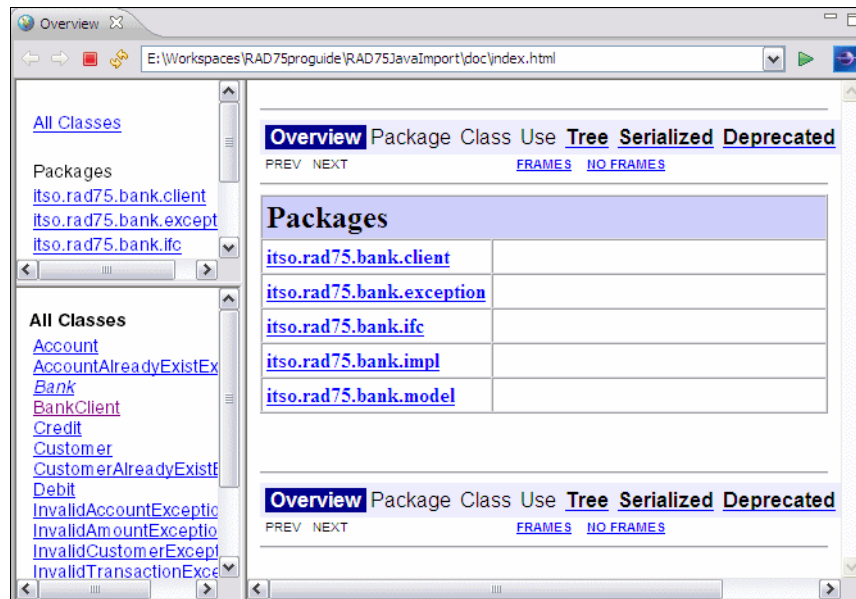

Figure 8-39 Javadoc output generated from the Javadoc wizard

Generate Javadoc from an Ant script

In “Generate Javadoc” on page 129, we selected **Save Settings for this Javadoc export as an Ant script**. This generated the `javadoc.xml` ant script, which can be used to invoke the Javadoc command.

To generate Javadoc from an Ant script, do these steps:

- ▶ Right-click `javadoc.xml` in the Package Explorer and select **Run As** → **Ant Build**.
- ▶ The Javadoc generation process starts. If you cannot see the new generated doc folder in the project, select the project and press **F5** to refresh the view.

Generate Javadoc with diagrams from existing tags

Application Developer enables you to embed a `@viz.diagram` tag into Javadoc on the class, interface, or package level. The `@viz.diagram` tag assumed that the diagram being referenced is placed in the same folder as the Java file containing the `@viz.diagram` tag, and the wizard then exports that diagram into a GIF, JPG, or BMP, and embed it to the generated Javadoc.

Example 8-8 shows the use of the `@viz.diagram` tag in the `BankClient` class.

Example 8-8 BankClient class with a @viz.diagram tag

```
package itso.rad75.bank.client;
...
/**
 * @viz.diagram ITS0Bank-ClassDiagram.dnx
 */
public class BankClient {
    public static void main(String[] args) {
        try {
            ...
        }
    }
}
```

To generate Javadoc with diagrams from existing tags, do these steps:

- ▶ Add the `@viz.diagram` tag to the source code, as shown in Example 8-8, and copy the `ITS0Bank-Diagram.dnx` file from the `diagram` folder to the `itso.rad75.bank.client` package.

Restriction: For Web applications, this has the side effect of the class diagrams being packaged into the WAR file with the compiled Java code. We found two possible work-arounds:

- ▶ Manually remove these diagrams from the WAR file after exporting.
- ▶ Configure an exclusion filter for the EAR export feature. Refer to “Filtering the content of an EAR” on page 955 for information on techniques for filtering files (include and exclude) when exporting the EAR.

- ▶ Right-click the project in the Package Explorer and select **Project** → **Generate Javadoc with Diagrams** → **From Existing tags**.
- ▶ In the Javadoc Generation dialog, use the same options as in Figure 8-38 on page 129.
- ▶ Click **Next** in the next dialog panel.
- ▶ In the Configure Javadoc arguments dialog, select **1.6** for JRE source compatibility.
- ▶ In the Choose diagram image generation options dialog, accept the default settings and click **Finish**.
- ▶ When prompted to update the Javadoc location, click **Yes to all**.
- ▶ Open the Javadoc (`RAD75JavaImport/doc/index.html`) in a browser. Verify that a diagram has been added to the generated Javadoc for the `BankClient` class by selecting the `BankClient` class in the All Classes pane.

Generate Javadoc with diagrams automatically

If you do not have diagrams that you want to embed to the generated Javadoc, you can let Application Developer to generate diagrams for you and embed them to the Javadoc.

To generate Javadoc with diagrams automatically, do these steps:

- ▶ Select the project in the Package Explorer, and select **Project** → **Generate Javadoc with Diagrams** → **Automatically**.
- ▶ In the Generate Javadoc with diagrams automatically dialog, enter the following data (Figure 8-40):
 - Javadoc command: path to `javadoc.exe`
`{JDKInstallDirectory}\bin\javadoc.exe`
 - Keep the defaults for Diagrams.
 - Optionally select **Contribute diagrams and diagrams tags to source** if you want the `@viz.diagram` tags to be stored in the Java sources and the generated diagrams to be stored in the packages of the Java sources.
 - Click **Finish** to generate the Javadoc, then open the Javadoc and browse the classes with the generated diagrams.

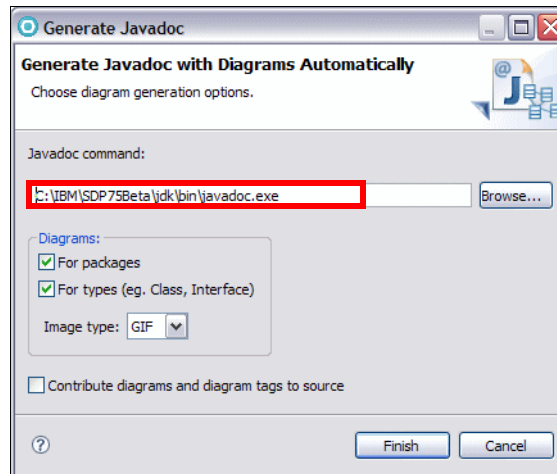

Figure 8-40 Generate Javadoc with Diagrams Automatically dialog

Java editor and rapid application development

Application Developer contains a number of features that ease and expedite the code development process. These features are designed to make life easier for both experienced and novice Java programmers by simplifying or automating many common tasks.

This section is organized into the following topics:

- ▶ Navigating through the code
- ▶ Source folding
- ▶ Type hierarchy
- ▶ Smart insert
- ▶ Marking occurrences
- ▶ Smart compilation
- ▶ Java and file search
- ▶ Working sets
- ▶ Quick fix
- ▶ Quick assist
- ▶ Content assist
- ▶ Import generation
- ▶ Adding constructors
- ▶ Delegate method generator
- ▶ Refactoring

Navigating through the code

This section highlights the use of the Outline view, Package Explorer, and bookmarks to navigate through the code.

Using the Outline view to navigate the code

The Outline view displays an outline of a structured file that is currently open in the editor area, and lists structural elements. The contents of the Outline view are editor-specific.

For example, in a Java source file, the structural elements are package name, import declarations, class, fields, and methods. We use the RAD75Java project to demonstrate the use of the Outline view to navigate through the code:

- ▶ Select and expand the **RAD75Java** → **src** → **itso.rad75.bank.model** from the Package Explorer.
- ▶ Double-click **Account.java** to open the file in the Java editor.
- ▶ By selecting elements in the Outline view, you can navigate to the corresponding point in your code. This allows you to easily find method and field definitions without scrolling through the Java editor, as shown in Figure 8-41.

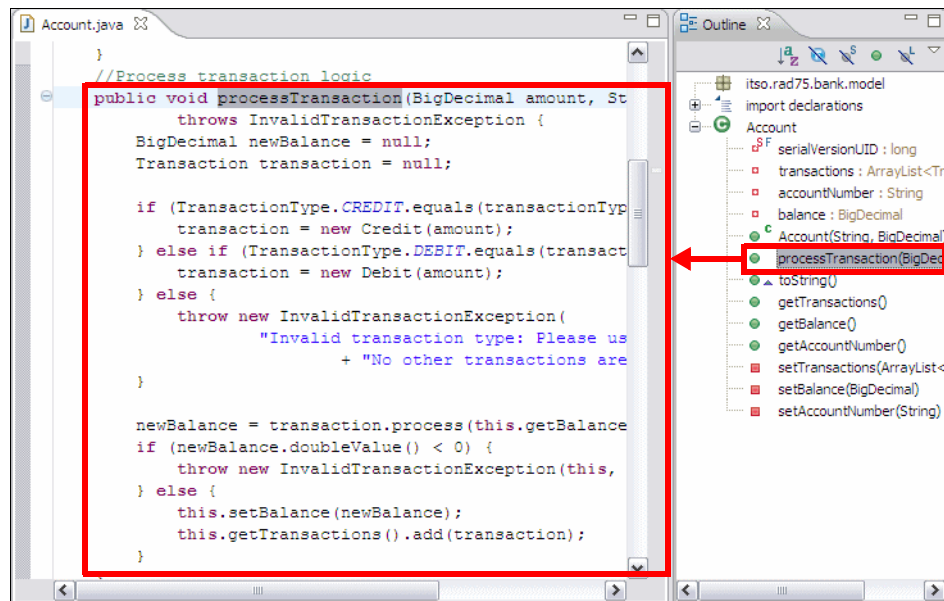

Figure 8-41 Java editor - Outline view for navigation

Using the Package Explorer to navigate the code

The Package Explorer, which is available by default in the Java perspective, can also be used for navigation. The Package Explorer provides you with a Java-specific view of the resources shown in the Enterprise Explorer view. The element hierarchy is derived from the project's build paths.

Using bookmarks to navigate the code

Bookmarks are another simple way to navigate to resources that you frequently use. The Bookmarks view displays all bookmarks in the workspace.

Set bookmark

To set a bookmark in the code, right-click in the gray sidebar to the left of the code in the Java editor and select **Add Bookmar**, or select **Edit** → **Add Bookmark**. In the Add Bookmark dialog, enter the name of the bookmark and click **OK**.

View bookmark

Bookmarks are indicated by the symbol  in the gray sidebar (Figure 8-42), and are listed in the Bookmarks view (Figure 8-43). Double-clicking the bookmark entry in the Bookmarks view opens the file and navigates to the line where the bookmark has been set.

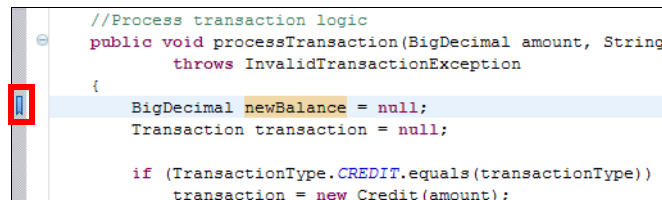

Figure 8-42 Java Editor with a bookmark

Show the Bookmarks view

To show the Bookmarks view, select **Window** → **Show View** → **Other** → **General** → **Bookmarks**.

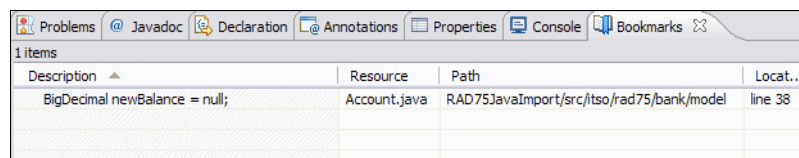

Figure 8-43 Bookmarks view

Delete bookmarks



A bookmark can be removed by right-clicking the bookmark symbol  in the gray sidebar and selecting **Remove Bookmark**, or right-click the bookmark in the Bookmarks view and select **Delete**.

Note: Bookmarks can also be given for a file they are not specific to Java code. Select the file in the Enterprise Explorer and select **Edit** → **Add Bookmark**. They can be used in any file to provide a quick way of navigating to a specific location.

Source folding

Application Developer folds the source of import statements, comments, types, and methods. Source folding can be configured through the Java editor preferences.

To configure the folding feature, select **Window** → **Preferences**. In the Preferences dialog, select **Java** → **Editor** → **Folding**.

Folded source is marked by a  symbol, expanded source by a  symbol on the left side of the source code, as shown in Figure 8-44. Click the symbol to fold or expand the source code.

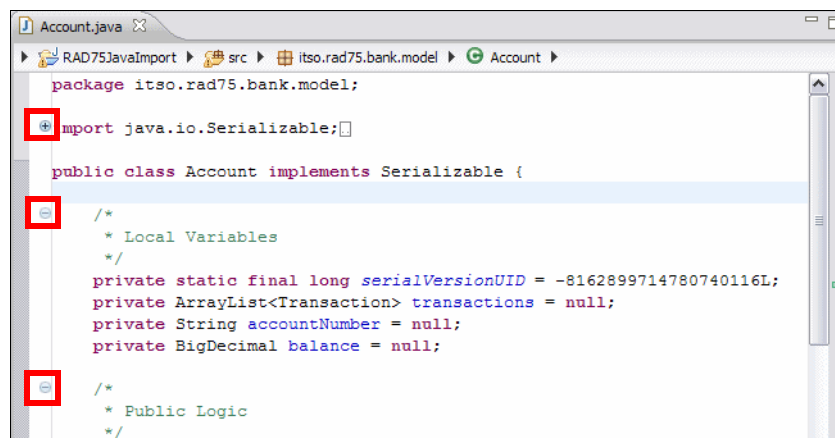

Figure 8-44 Java Editor with source folding

Type hierarchy

The Java editor allows the quick viewing of type hierarchy of a selected type. Select a type with the cursor and press **Ctrl+T** to displays the hierarchy (Figure 8-45).

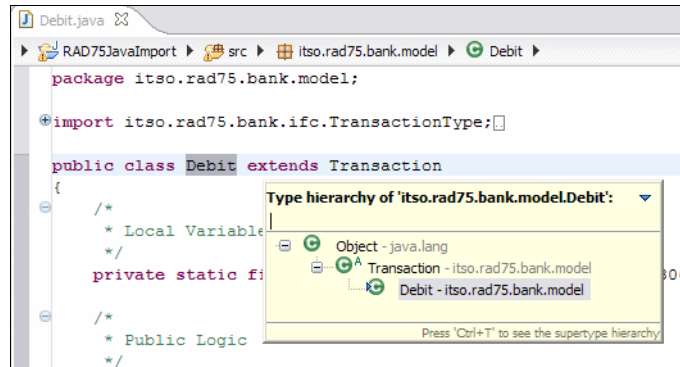

Figure 8-45 Java Editor with quick type hierarchy view

Smart insert

To toggle the editor between smart insert and insert modes, press **Ctrl+Shift+Insert**. When the editor is in smart insert mode, the editor provides extra features specific to Java. For example, in smart insert mode when you cut and paste code from a Java source to another Java source, all the needed imports are automatically added to the target Java file.

To configure the smart insert mode, select **Window** → **Preferences**. In the Preferences dialog, select **Java** → **Editor** → **Typing**, and study the different options.

Note the small text at the bottom of the window as it changes from Smart Insert to Insert when you press Ctrl+Shift+Insert.

Marking occurrences

When enabled, the editor highlights all occurrences of types, methods, constants, non-constant fields, local variables, expressions throwing a declared exception, method exits, methods implementing an interface, and targets of break and continue statements, depending on the current cursor position in the source code (Figure 8-46). For better orientation in large files, all occurrences are marked with a white line on the right side of the code.

The feature can be enabled and disabled by pressing **Alt+Shift+O**, or by clicking  in the toolbar. To configure mark occurrences, select **Window** → **Preferences**. In the Preferences dialog, select **Java** → **Editor** → **Mark Occurrences**.

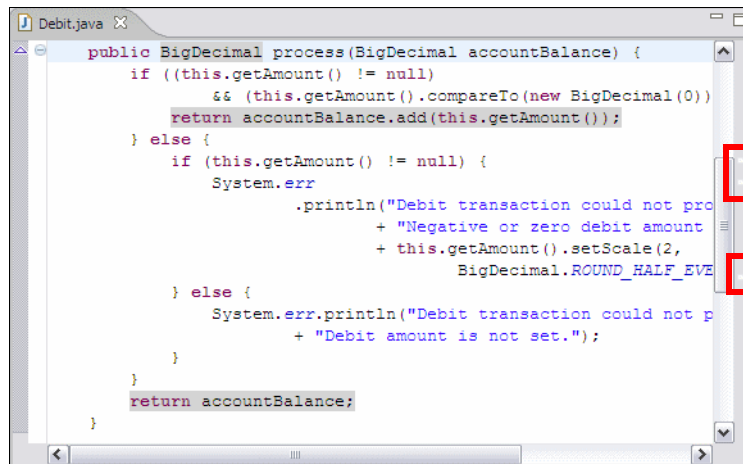



Figure 8-46 Java Editor with mark occurrences (methods exits)

Smart compilation

The Java builder in the Application Developer workbench incrementally compiles the Java code in the background as it is changed and displays any compilation errors automatically, unless you disable the automatic build feature. Refer to Chapter 4, “Perspectives, views, and editors” on page 119 for information on enabling and disabling automatic builds and running workbench tasks in the background.

Java and file search

Application Developer provides support for various searches. To display the Search dialog click  in the toolbar, or press **Ctrl+H**. The Search dialog can be configured to display different searches by clicking **Customize**. In Figure 8-47 the search dialog has been customized to display only the Java and File Search tabs.

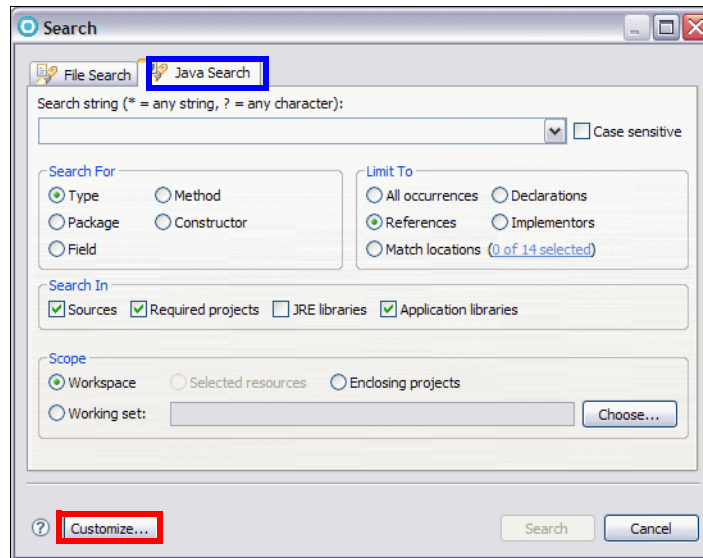

Figure 8-47 Search dialog [customized]

In the Search dialog, you can perform the following searches:

- ▶ Java searches operate on the structure of the code.
- ▶ File searches operate on the files by name and/or text content.
- ▶ Text searches allow you to find matches inside comments and strings.

Java searches are faster, because there is an underlying indexing structure for the code.

Performing a Java search from the workbench (example)

To perform a Java search from the workbench, do these steps:





- ▶ In the Java perspective click  in the toolbar, or select **Search** → **Java**, or press **Ctrl+H**.
 - Select the Java Search tab and enter the following data (Figure 8-48).
 - Search string: processTransaction
 - Select **Method**.
 - Select **References**.
 - Select **Workspace**.



Figure 8-48 Java Search dialog

- ▶ Click **Search**. While searching, you can click **Cancel** at any time to stop the search. Partial results will be shown. The Search view shows the search results.
- ▶ Click  or  in the toolbar of the Search view to navigate to the next or previous match. If the file in which the match was found is not currently open, it is opened in the Java editor at the position of the match. Search matches are tagged with a  symbol on the left side of the source code line.

Searching from a Java view or editor

Java searches can also be performed from specific views, including the Outline view, Hierarchy view, Package Explorer, or even the Search view, or from the Java editor.

Right-click the resource you are looking for in the view or editor and select **References** → **Workspace**, or press **Ctrl+Shift+G**.

Performing a file search (example)

- ▶ In the Java perspective click  in the toolbar, or select **Search** → **File**, or press **Ctrl+H**.
 - Select the File Search tab and enter the following data (Figure 8-49).
 - Containing text: ROUND_HALF_EVEN
 - File name patterns: *.java (default)
 - Select **Workspace**.

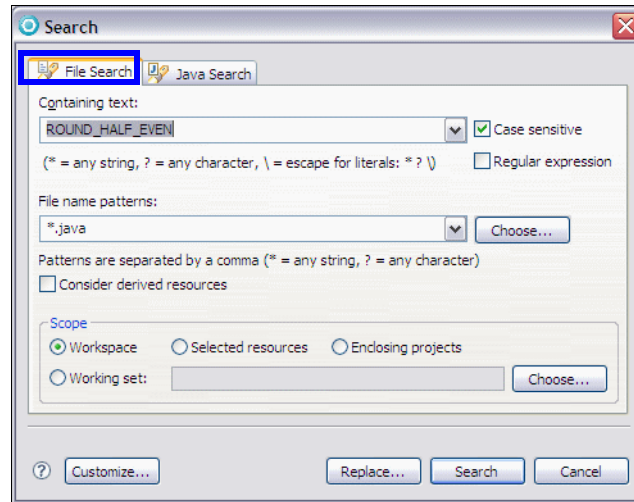



Figure 8-49 File Search dialog

- ▶ Click **Search**. While searching, you can click **Cancel** at any time to stop the search. Partial results will be shown. The Search view shows the search results.

Note: To find all files of a given file name pattern, leave the Containing text field empty.

Viewing previous search results

Click first  on the right side of  in the Search view toolbar, and select one of the previous searches. The list can be cleared by selecting **Clear History**.

Working sets

Working sets are used to filter resources by only including the specified resources. They are selected and defined using the view's filter selection dialog. We use an example to demonstrate the creation and use of a working set as follows:

- ▶ Click  in the toolbar, or select **Search** → **Java**, or press **Ctrl+H** to open the Java Search Dialog.
- ▶ Enter `itso.rad75.bank.model.Credit` in the Search string field, select **Working set** under Scope, and then click **Choose**.
- ▶ In the Select Working Set dialog click **New** to create a new working set.

- ▶ In the New Working Set dialog, select **Java** to indicate that the working set includes only Java resources and then click **Next**.
- ▶ In the Java Working Set dialog, select only **RAD75JavaImport** → **src** → **itso.rad75.bank.model** and click **Add**, then type `EntityPackage` in the Working set name field, and click **Finish** (Figure 8-50).

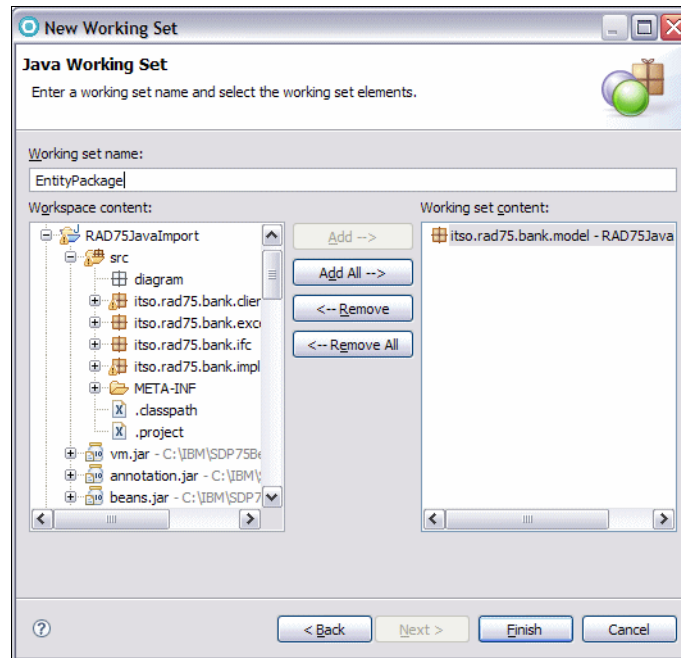







Figure 8-50 New Java Working Set dialog

- ▶ Select the new **EntityPackage** working set in the Select Working Sets dialog, and click **OK**.
- ▶ We have now created a working set named `EntityPackage` containing Java resources comprised of all the Java files in the `itso.rad75.bank.model` package.
- ▶ Click **Search** to start the search process.

Quick fix

Application Developer offers a quick fix for some kind of problems, which were detected during the code compilation or static code analysis. The developer can process the quick fix to correct his code.

The following symbols show the developer that a quick fix is available:

- ▶ Static code analysis:
 -  Quick fix for a result with a severity level of recommendation
 -  Quick fix for a result with a severity level of warning
 -  Quick fix for a result with a severity level of severe
- ▶ Code compilation:
 -  Quick fix for a warning
 -  Quick fix for an error

To process the quick fix, click on the symbol. All suggestions to correct the problem are displayed in an overlaid window. As soon a suggestion is selected, a code preview is shown, so that the developer can see, what will be changed (Figure 8-51). Double-click one of the suggestion to process the quick fix.

Note: The problem symbol is grayed out but still visible. Save the source and the problem symbol disappears.

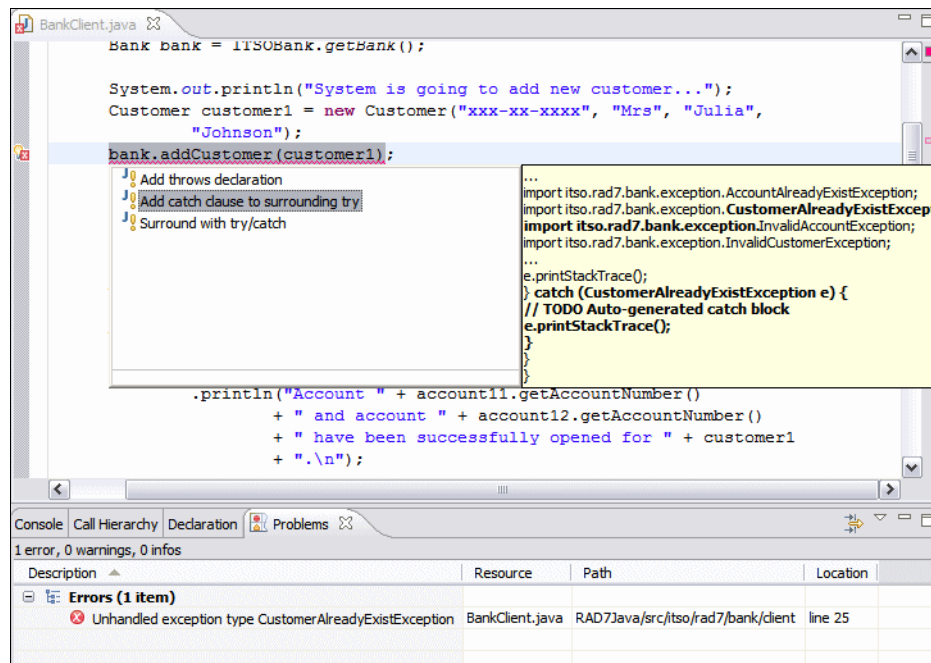



Figure 8-51 Java Editor with quick fix

Quick assist

Application Developer supports quick assists in the Java editor to provide suggestions to complete tasks quickly. Quick assist depends on the current cursor position. When there is a suggestion and quick assist highlighting is enabled, a green light bulb  is displayed on the left side of the code line.

Enable quick assist highlighting

By default, the display of the quick assist light bulb is disabled. To enable it, do these steps:

- ▶ Select **Window** → **Preferences**.
- ▶ In the Preferences dialog, select **Java** → **Editor**.
- ▶ Select **Light bulb for quick assists**.

Invoking quick assist

To use the quick assist feature, double-click  or press **Ctrl+1** to provide a list of intelligent suggestions. Select one to complete the task (Figure 8-52).

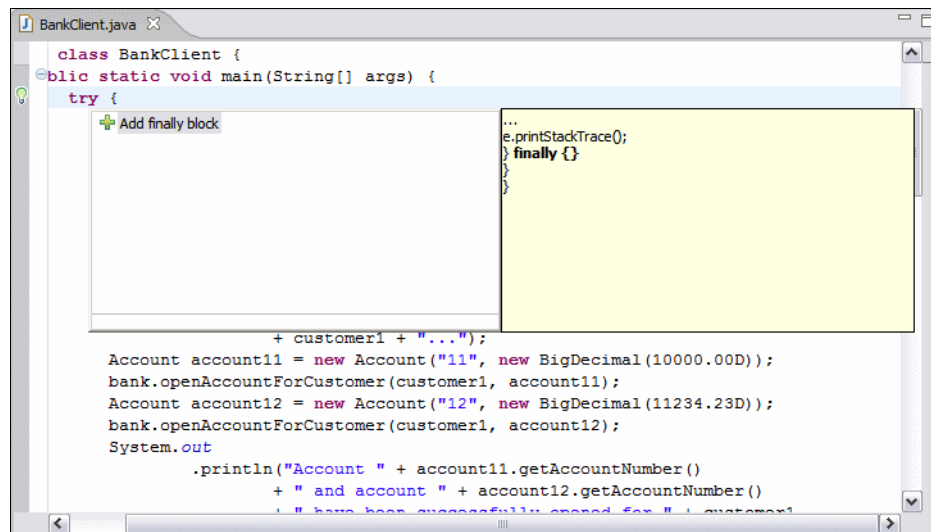

Figure 8-52 Java Editor with quick assist

Content assist

This feature displays possible code completions that are valid with the current context.

Content assist preferences

To configure the Content Assist preferences, do these steps:

- ▶ Select **Window** → **Preferences**.
- ▶ In the Preferences dialog, select **Java** → **Editor** → **Content Assist**.
- ▶ Modify the settings as desired and click **Apply** and **OK**.

Invoke content assist

Press **Ctrl+Spacebar** at any point in the Java editor, to invoke the content assist.

The content assist provides the all possible code completions that are valid for the current context in a overlaid window (Figure 8-53). Double-click the desired completion, or use the arrow keys to select it, and press **Enter**.

Tip: If there are still too many possible completions, just continue to write the code yourself and the amount of suggestions becomes smaller.

Content assist can also be invoked to insert or to complete Javadoc tags.

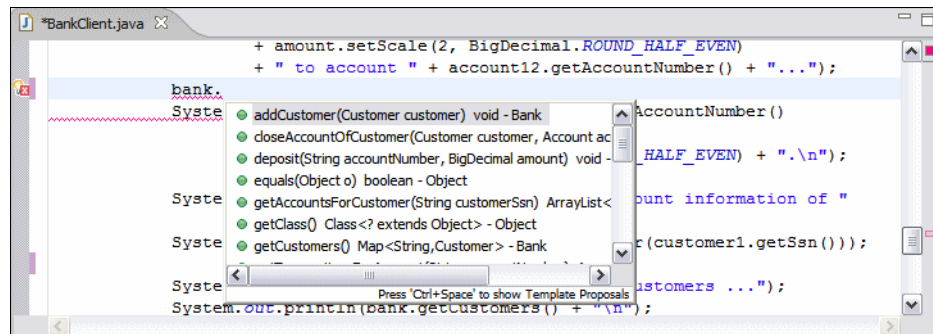

Figure 8-53 Java Editor with content assist

Import generation

The Java editor simplifies the task of finding the correct import statements to use in the Java code.

Simply right-click the unknown type in the code and select **Source** → **Add Import**, or select the type and press **Ctrl+Shift+M**. If the type is unambiguous, the import statement is directly added. If the type exists in more than one package, a window with all the types is displayed and you can select the correct type for the import statement.

Figure 8-54 shows an example where the selected type (`BigDecimal`) exists in several packages. Once you have determined that the `java.math` package is what you want, double-click the entry in the list, or select it and click **OK**, and the import statement is generated in the code.

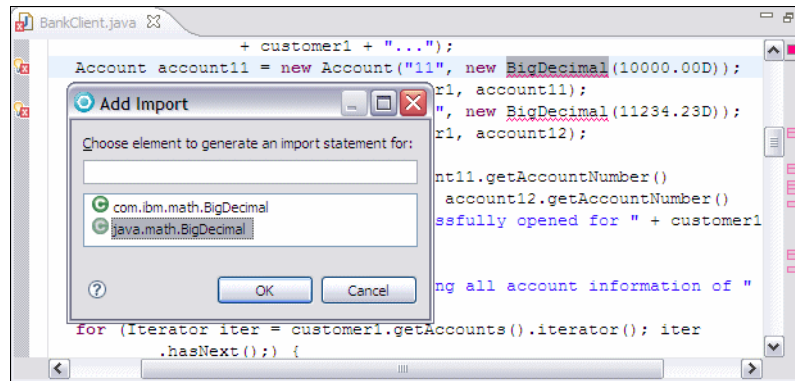

Figure 8-54 Java Editor with import generation

You can also add the required import statements for the whole compilation unit. Right-click a project, package, or Java type in the Package Explorer, and select **Source** → **Organize Imports**, or select the project, package, or Java type and press **Ctrl+Shift+O**. The code in the compilation unit is analyzed and the appropriate import statements are added.

Adding constructors

This feature allows you to automatically add constructors to the open type. The following constructors can be added:

- ▶ Constructors from superclass
- ▶ Constructor using fields

Constructors from superclass

Add any or all of the constructors defined in the superclass for the currently opened type. Right-click anywhere in the Java editor and select **Source** → **Add Constructors from Superclass**. Select the constructors which you want to add to the current opened type, and click **OK** (Figure 8-55).

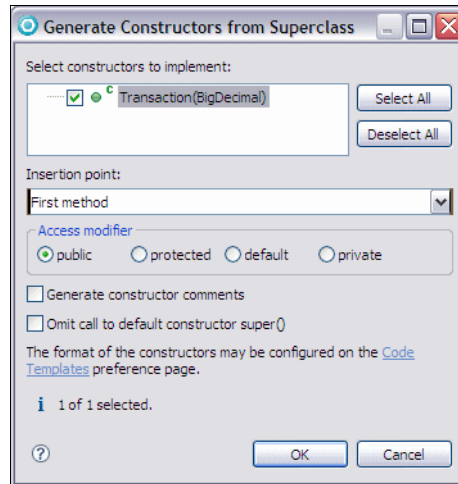

Figure 8-55 Generate Constructors from Superclass dialog

Constructor using fields

This option adds a constructor which initialized any or all of the defined fields of the currently opened type. Right-click anywhere in the Java editor and select **Source** → **Add Constructors using Fields**. Select the fields which you want to initialize with the constructor and click **OK** (Figure 8-56).

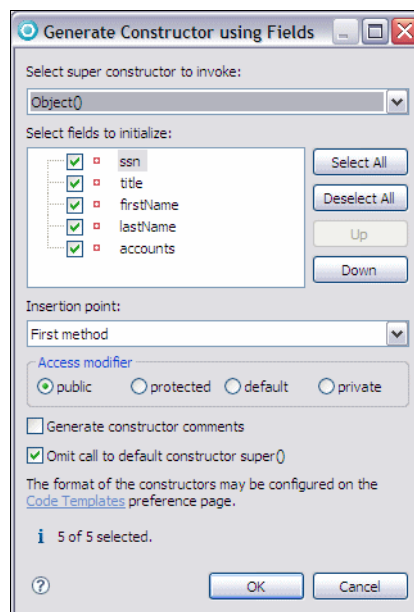

Figure 8-56 Generate Constructor using Fields dialog

Example 8-9 shows the constructor code which would be generated with the settings shown in Figure 8-56.

Example 8-9 Generated constructor code

```
public Customer(String ssn, String title, String firstName, String lastName,
               ArrayList<Account> accounts) {
    this.ssn = ssn;
    this.title = title;
    this.firstName = firstName;
    this.lastName = lastName;
    this.accounts = accounts;
}
```

Delegate method generator

The delegate method generator feature allows you to delegate methods from one class to another for better encapsulation. We use a simple example to explain this feature. A car has an engine, and a driver wants to start his car. Figure 8-57 shows that the engine is not encapsulated, the PoorDriver has to use the Car and the Engine class to start his car.

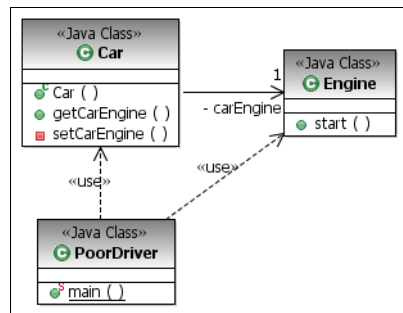

Figure 8-57 Simple car example class diagram (before method delegation)

Example 8-10 shows how the poor driver has to start his car.

Example 8-10 Car, Engine, and PoorDriver classes (compressed)

```
// Car class
package itso.rad75.example;
import itso.rad75.example.Engine;
public class Car {
    private Engine carEngine = null;
    public Car(Engine carEngine) {
        this.setCarEngine(carEngine);
    }
}
```

```
    public Engine getCarEngine() {
        return carEngine;
    }
    private void setCarEngine(Engine carEngine) {
        if (carEngine != null) {
            this.carEngine = carEngine;
        } else {
            this.carEngine = new Engine();
        }
    }
}

// Engine class
package itso.rad75.example;
public class Engine {
    public void start() {
        // code to start the engine
    }
}

// PoorDriver class
package itso.rad75.example;
import itso.rad75.example.Car;
public class PoorDriver {
    public static void main(String[] args) {
        Car myCar = new Car(null);
        /* How can I start my car?
         * Do I really have to touch the engine?
         * - Yes, there is no other way at the moment.
         */
        myCar.getCarEngine().start();
    }
}
```

To make the driver happy, we delegate the start method from the Engine class to the Car class. To delegate a method, do these steps:

- ▶ Right-click the carEngine field in the Car class and select **Source** → **Generate Delegate Methods**.
- ▶ In the Generate Delegate Methods dialog, select only the start method and click **OK** (Figure 8-58).

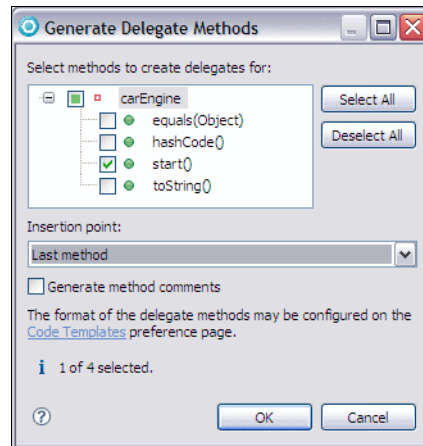

Figure 8-58 Generate Delegate Method dialog

- ▶ This action adds the start method to the Car class, and code is added in the body of the method to delegate the method call to the Engine class through the carEngine attribute.
- ▶ Figure 8-59 and Example 8-11 shows how the HappyDriver can start the car.

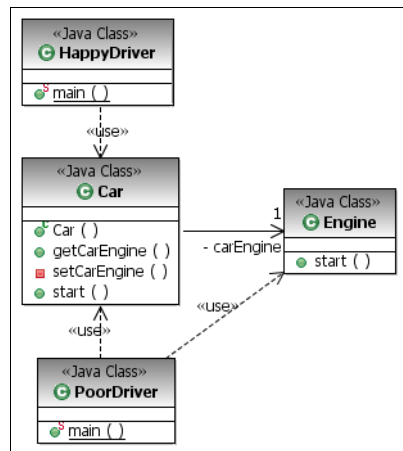

Figure 8-59 Simple car example class diagram (after method delegation)

Example 8-11 Car and HappyDriver class

```

// Car class
package itso.rad75.example;
import itso.rad75.example.Engine;
public class Car {

```

```
private Engine carEngine = null;
public Car(Engine carEngine) {
    this.setCarEngine(carEngine);
}
public Engine getCarEngine() {
    return carEngine;
}
private void setCarEngine(Engine carEngine) {
    if (carEngine != null) {
        this.carEngine = carEngine;
    } else {
        this.carEngine = new Engine();
    }
}
public void start() {
    carEngine.start();
}
}

// HappyDriver class
package itso.rad75.example;
public class HappyDriver {
    public static void main(String[] args) {
        Car myAdvancedCar = new Car(null);
        // Start the car - I don't care about technical details
        myAdvancedCar.start();
    }
}
```

Refactoring

During the development of a Java application, it might be necessary to perform tasks, such as renaming classes, moving classes between packages, and breaking out code into separate methods. Such tasks are both time consuming and error prone, because it is up to the programmer to find and update each and every reference throughout the project code. Application Developer provides a list of refactor actions to automate the this process.

The Java development tools (JDT) of Application Developer provide assistance for managing refactor. In the each refactor wizard you can select:

- ▶ **Refactor with preview:** Click **Next** in the dialog to bring up a second dialog panel where you are notified of potential problems and are given a detailed preview of what the refactor action will do.

- **Refactor without preview:** Click **Finish** in the dialog and have the refactor performed. If a stop problem is detected, refactor cancels and a list of problems is displayed.

Table 8-10 provides a summary of common refactor actions.

Table 8-10 *Refactor actions*

Name	Function
Rename	<p>Starts the Rename Compilation Unit wizard. Renames the selected element and (if enabled) corrects all references to the elements (also in other files). It is available on methods, fields, local variables, method parameters, types, compilation units, packages, source folders, projects, and on a text selection resolving to one of these element types.</p> <p>Right-click the element and select Refactor → Rename, or select the element and press Alt+Shift+R, or select Refactor → Rename from the menu bar.</p>
Move	<p>Starts the Move wizard. Moves the selected elements and (if enabled) corrects all references to the elements (also in other files). Can be applied on one or more static methods, static fields, types, compilation units, packages, source folders and projects, and on a text selection resolving to one of these element types.</p> <p>Right-click the method signature and select Refactor → Move, or select the method signature and press Alt+Shift+V, or select Refactor → Move from the menu bar.</p>
Change Method Signature	<p>Starts the Change Method Signature wizard. You can change the visibility of the method, change parameter names, parameter order, parameter types, add parameters, and change return types. The wizard updates all references to the changed method.</p> <p>Right-click the element and select Refactor → Change Method Signature, or select the element and press Alt+Shift+C, or select Refactor → Change Method Signature from the menu bar.</p>
Extract Interface	<p>Starts the Extract Interface wizard. You can create an interface from a set of methods and make the selected class implements the newly created interface.</p> <p>Right-click the class and select Refactor → Extract Interface, or select the element and select Refactor → Extract Interface from the menu bar.</p>

Name	Function
Push Down	<p>Starts the Push Down wizard. Moves a field or method to its subclasses. Can be applied to one or more methods from the same type or on a text selection resolving to a field or method.</p> <p>Right-click the type and select Refactor → Push Down, or select the element and select Refactor → Push Down from the menu bar.</p>
Pull Up	<p>Starts the Pull Up wizard. Moves a field or method to its superclass. Can be applied on one or more methods and fields from the same type or on a text selection resolving to a field or method.</p> <p>Right-click the type and select Refactor → Push Up, or select the element and select Refactor → Push Up from the menu bar.</p>
Extract Method	<p>Starts the Extract Method wizard. Creates a new method containing the statements or expressions currently selected, and replaces the selection with a reference to the new method.</p> <p>Right-click the statement or expression and select Refactor → Extract Method, or select it and press Alt+Shift+M, or select Refactor → Extract Method from the menu bar.</p>
Extract Local Variable	<p>Starts the Extract Local Variable wizard. Creates a new variable assigned to the expression currently selected and replaces the selection with a reference to the new variable.</p> <p>Right-click the expression and select Refactor → Extract Local Variable, or select it and press Alt+Shift+L, or select Refactor → Extract Local Variable from the menu bar.</p>
Extract Constant	<p>Starts the Extract Constant wizard. Creates a static final field from the selected expression and substitutes a field reference, and optionally replaces all other places where the same expression occurs.</p> <p>Right-click the expression and select Refactor → Extract Constant, or select Refactor → Extract Constant from the menu bar.</p>
Inline	<p>Starts the Inline Method wizard. Inlines local variables, non abstract methods, or static final fields.</p> <p>Right-click the element and select Refactor → Inline, or select the element and press Alt+Shift+I, or select Refactor → Inline from the menu bar.</p>

Name	Function
Encapsulate Field	<p>Starts the Encapsulate Field wizard. Replaces all references to a field with getter and setter methods. Is applicable to a selected field or a text selection resolving to a field.</p> <p>Right-click the field, and select Refactor → Encapsulate Field..., or select the element and select Refactor → Encapsulate Field... from the menu bar.</p>

Refactor example (rename a class)

The following example of a refactor operation assumes that you want to rename the class Transaction to BankTransaction in the RAD7Java project.

To rename the Transaction class to BankTransaction, do these steps:

- ▶ Right-click the Transaction class in the Package Explorer and select **Refactor** → **Rename**.
- ▶ In the Rename Compilation Unit wizard, enter the following data (Figure 8-60):
 - New name: BankTransition
 - Select **Update references** (default).
 - Clear other check boxes.

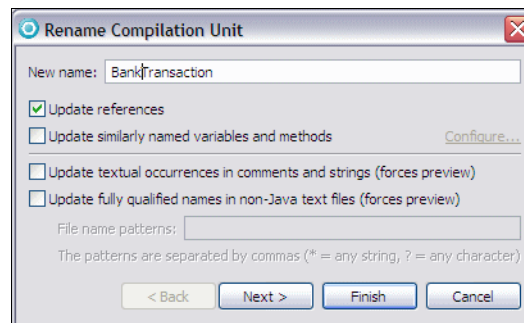

Figure 8-60 Refactor - Rename Compilation Unit wizard

- ▶ Click **Next** to see the preview and potential problems.
- ▶ Click **Finish** to process the rename task.

Note: If there are any files with unsaved changes in the workspace and you have not indicated in the preferences that the save has to be done automatically, you are prompted to save these files before continuing the refactor operation.

If there are problems or warnings, the wizard displays the **Found Problems** window. If the problems are severe, the **Continue** button is disabled and the refactor must be aborted until the problems have been corrected.

More information

We highly recommend the help feature provided by Application Developer. Click **Help** → **Help Contents** → **Developing Java applications**. There is also a Watch and Learn tutorial available, called Create a Hello World Java Application. To start the tutorial click **Help** → **Welcome** → **Tutorials** → **Create a Hello World Java application**.

The following URLs provide further information about Eclipse and Java technology:

- ▶ **Sun™ Java™ SE Technology Home page**—Contains links to specifications, API Javadoc, and articles about Java SE:
<http://java.sun.com/javase/index.jsp>
- ▶ **IBM Developerworks Java Technology**—Java news, downloads and CDs, and learning resources:
<http://www.ibm.com/developerworks/java/>
- ▶ **Eclipse Open Source Community**—Official home page of the eclipse open source community:
<http://www.eclipse.org/>



Accelerate development using patterns

This chapter introduces the concept of pattern implementation, how it relates to pattern specification, and the benefits that pattern implementation can bring to software application development.

The focus of the chapter is to demonstrate by example how to use the Rational Application Developer patterns tooling to develop and use patterns.

The chapter is organized into the following sections:

- ▶ Introduction to pattern implementation
- ▶ Creating a pattern implementation
- ▶ Applying the pattern

Introduction to pattern implementation

As a developer, you are probably familiar with the concept of pattern as it relates to software development, where a pattern is a proven solution to a common problem within a given context. However, you might be less familiar with the concept of pattern implementation and how it would help you accelerate your development.

Pattern specification and pattern implementation

As do many developers, you probably read patterns-related books, where a pattern is described along with its benefits, the problem it solves, and the context it should be applied. This description is what is commonly referred as the *pattern specification*, and its intent is to help you understand how and when to use the pattern.

The idea of *pattern implementation* came from the desire to go further than just using the pattern specification as a blueprint—to try to automate as much as possible the application of the pattern. The result is to codify the pattern specification into a pattern implementation, allowing you to automatically apply it into a given environment.

The core idea behind pattern implementation is that as we have codified and automated best practices, applying them is now faster than doing it manually, and more consistent, because it involves less manual modifications.

Pattern implementation and Application Developer

In the context of Application Developer, the pattern implementation—rather than being derived by a community design patterns—comes from your best practices and existing successful implementations you would like to apply to other projects. This approach is called *exemplar authoring* in Application Developer.

Exemplar authoring consists of using an *exemplar* to build the pattern implementation. An exemplar is a representative output of the pattern and contains an instance of each artifact you expect the pattern implementation to generate. A good exemplar should be built following the applicable best practices and must allow you to define the points of variability of the pattern and the input model. All the purpose of the exemplar authoring is to leverage your best practices and existing assets to increase the development efficiency and productivity. To do so, you codify the best practices to make their application automatic.

The exemplar authoring tool leverages the Eclipse's Java Emitter Templates (JET), which is part of the Eclipse Modeling Framework (EMF). JET is similar to JavaServer Pages syntax and is powerful to generate Java, SQL, and any other text based files.

JET allows you to customize the output artifacts into an XML input file and a set of templates. The structure of this input file, as well as how it impacts the different artifacts, is based on what you are doing when creating your transformation using the Application Developer exemplar authoring tools. Because the tools produce JET, exemplar authoring transformations are also sometimes referred to as JET transformations.

Exemplar authoring is not only a set of tools, but more importantly, it is a process to create pattern based into exemplars.

Exemplar authoring process

A key aspect to succeeding with creating patterns is that there is a proven repeatable set of steps that you can follow in building your own patterns. This approach to building patterns is known as *exemplar analysis*. In this process we take steps to identify what artifacts have to be generated by the pattern and determine which elements of the pattern are dynamic versus static. We use those elements that are dynamic as the basis for the input model for the pattern. Within the input model we have to identify the roles, their cardinality, and their attributes.

At a high level, these are the steps we follow as part of exemplar analysis:

1. **Identify artifact roles.** When examining the exemplar, we often find that there are multiple elements that are based on the same abstraction. For instance, in the case of JavaBeans we often see that there is a pair of elements: An interface and a class that adheres to the interface. Our exemplar might contain multiple JavaBeans, but if the intent of our pattern is to generate JavaBeans, we just have to pick out the most representative pair and can ignore the other repeating cases. In this case, although the exemplar contains multiple beans, we have just a single role for the class and one for the interface. An important aspect of this identification is that a JET template is associated with each role.
2. **Create role groups.** Using the exemplar authoring tooling, we then have to group the roles based on their cardinality. One time roles appear at the highest level, and then we create subgroups for roles that repeat. Many subgroups can exist with all elements within a subgroup sharing the same cardinality. For instance, an Eclipse project can contain a number of artifacts such as a `.project` file and a `.classpath` file, which occur only once per project. However, we might have multiple JavaBeans within a project. As such

we would place the `.project` and `.classpath` roles into a group at the top level, and then place the `JavaBeans` role into subgroup.

At this point we have to keep in mind that each role will have a JET template associated with it. When we run the pattern, the JET template is used to generate instance of artifacts based on the role. Also, the input model, which by default is an XML file, contains a set of elements based on the groups defined. However, at this point, our elements do not provide any useful information. Therefore, we now have to focus on the information that is assigned to the element.

3. **Identify attributes.** At this point we know the type of dynamic information that we have to pass into the pattern. However, we have to be more specific in terms of the information required. For example, in the case of a `JavaBean` we likely have to know what name to provide, a package name, and a directory location. As such, we create a set of attributes that we assign to the role groups, which in turn become attributes on the XML elements. As part of this effort we have to perform a normalization step, whereby we review the attributes to determine which attributes are atomic and which can be derived. A derived attribute is one that can be calculated using information known about the pattern and details provided by atomic attributes.
4. **Customize templates.** Once we have completed the previous steps, we have to go through each of the JET templates and replace the static text with tags that allow us to access and process the dynamic information provided by the input model.

Prepare for the sample

We use the ITSO Bank sample application created in Chapter 8, “Develop Java applications” on page 69, with some small changes as the exemplar for our pattern implementation.

Import the `c:\7672code\patterns\RAD75Patterns.zip` project interchange file into Application Developer. Refer to “Importing sample code from a project interchange file” on page 1152. Select both projects (`RAD75Patterns` and `RAD75PatternsClient`).

After importing the projects, verify that the `BankClient` runs properly. For more information refer to “Running the ITSO Bank application” on page 109.

Note: The `BankClient` is now in the `RAD75PatternsClient` project because we split the initial `RAD75Java` project into 2 different projects:

- ▶ **RAD75Patterns:** Model and implementation
- ▶ **RAD75PatternsClient:** Client application and solution files (**assets**)

Creating a pattern implementation

In this section we demonstrate how Application Developer exemplar authoring tools can be used to develop a pattern implementation. The pattern we decide to implement allows us to easily create different test clients for our bank application. We decide to use the BankClient application as our exemplar because it is our best implementation of a test client for this bank application.

Note: The example we will be walking you through in the rest of the chapter is probably not the best representation of a pattern implementation as its scope of application is small (we will generate bank test clients). We selected this example because it is providing enough variability to allow you to understand how the exemplar authoring works, but not too much to not overwhelm you by language and command details.

A more interesting example is described in “Facade pattern” on page 183.

Here are the tasks we perform to develop our pattern implementation:

- ▶ Create a new JET Transform project
- ▶ Populating the transformation model
- ▶ Adding and deriving attributes
- ▶ Generate and edit templates

Create a new JET Transform project

A JET Transform project contains all the elements required for JET transformations, including the transformation model. Table 9-1 provides an overview of the specific files contained into this kind of projects.

Table 9-1 Files specific to a JET transform project

File(s)	Description
*.tma	The transformation model
*.jet	JET templates files, initially generated from the transformation model.
input.ecore	EMF input model generated from the transformation model
schema.xsd	XML schema corresponding to the input model
sample.xml	Sample of input file that would be used by the transformation

To create a new JET Transform project, do these steps:

- ▶ In the Java perspective, select **File** → **New** → **Project**.
- ▶ In the New Project dialog, select **JET Transformations** → **JET Project with Exemplar Authoring** (Figure 9-1), and click **Next**.

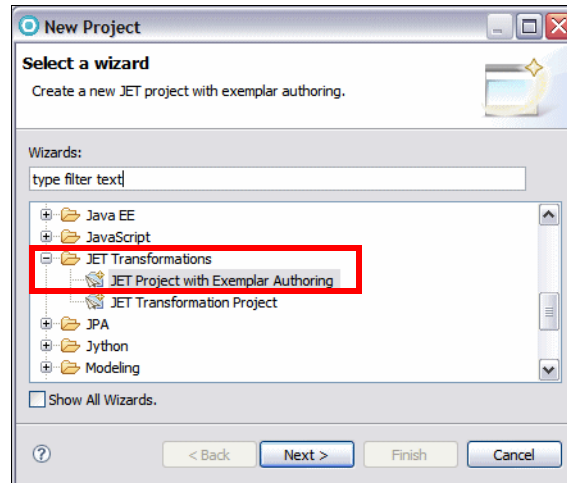

Figure 9-1 Create a JET Transform project with exemplar authoring

- ▶ In the New Jet Transformation Project dialog (Figure 9-2):

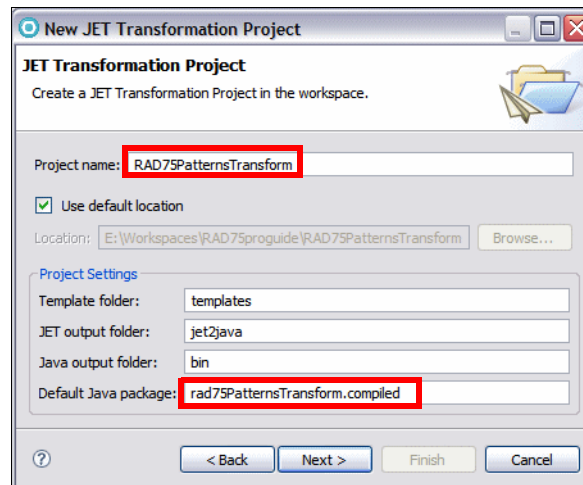

Figure 9-2 JET Transformation Project

- Type **RAD75PatternsTransform** as the project name.

- Change the Default Java package text to make it start with a lowercase letter (**rad75PatternsTransform.compiled**).
- Click **Next**.

Note: At the time of writing this book, the **Default Java package** field is filled automatically with the same letters entered in the Project Name field, and the dialog displays an error message because the first character of the package name is an uppercase letter. To activate the **Next** button, clear **Use default location** and select it again.

- ▶ Leave the default values as is in the JET Transformation Properties Dialog and click **Next**.
- ▶ In the Transformation Scope dialog, select the **RAD75PatternsClient** project, leave the **Import existing input schema model from ecore file** cleared (Figure 9-3).

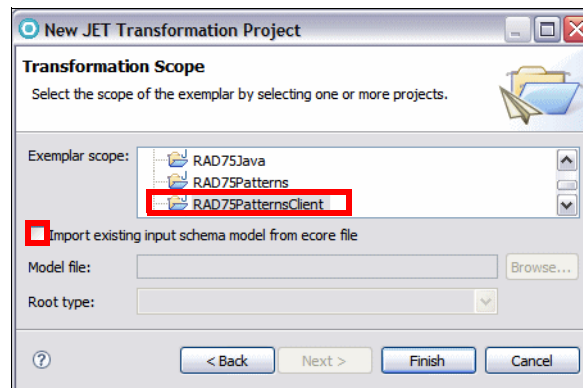

Figure 9-3 Transformation Scope

Note: The **Import existing input schema model from ecore file** option allows you to seed the transformation model from an existing ecore file, allowing you to extend an existing transformation without reentering all the information provided in the base transformation.

- ▶ Click **Finish** and the JET Transformation project is created. The Exemplar Authoring editor now displays the **RAD75JavaClient** exemplar and an empty model (Figure 9-4). The underlying file of this transformation is called `transform.tma` (in case you have to reopen the transformation).

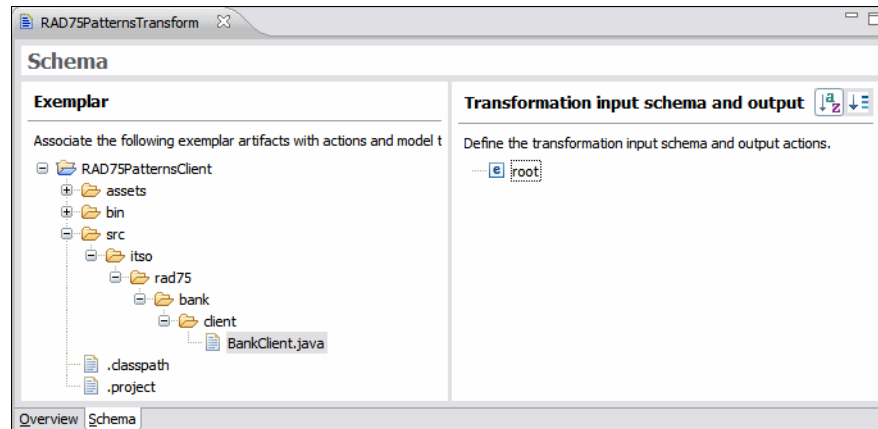

Figure 9-4 Exemplar Authoring Editor

Populating the transformation model

Now that the project is created, we can start populate the model with the different elements we want the transformation to create.

- ▶ The first thing to do is to create a new type to contain our transformation. To do so, right-click on the **root** element and select **New** → **Type**. Type **client** for the new type.
- ▶ The analysis of the exemplar lets us identify the files as the artifacts we want the transform to generate:
 - The Java project **RAD75PatternsClient**
 - The project metadata files **.classpath** and **.project**
 - The main class **itso.rad75.bank.client.BankClient.java**
- ▶ We add these artifacts to the transformation model by dragging them from the left pane (exemplar) to the right pane (model) onto the **client** type we just created (Figure 9-5).

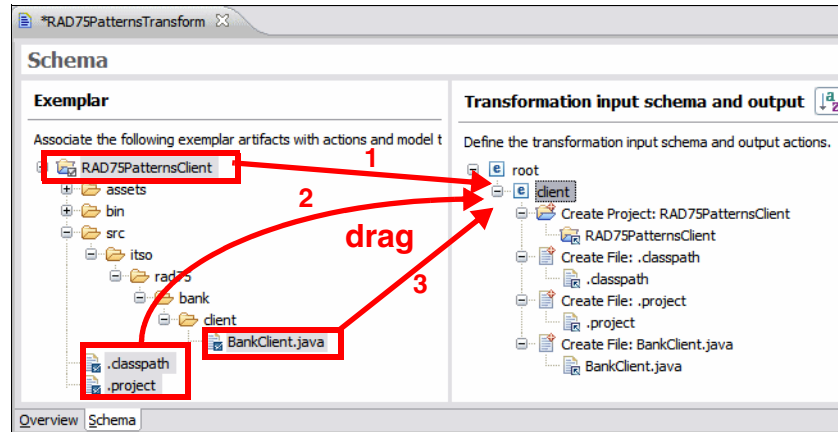

Figure 9-5 Artifacts added to the transformation model under the *client* type

Note: As you can see in Figure 9-5, each time you drag an artifact from the exemplar to the model:

- ▶ A create action (create project or create file) is created into the model.
- ▶ The corresponding artifact into the exemplar is marked by a blue check mark.

- ▶ Each of the create actions will create the corresponding Eclipse resource. Below are the names and paths of the associated exemplar artifacts:
 - RAD75PatternsClient
 - RAD75PatternsClient/.classpath
 - RAD75PatternsClient/.project
 - RAD75PatternsClient/src/itso/rad75/bank/client/BankClient.java

Some of the components of the names and paths that are likely to vary from one test client to another:

- RAD75PatternsClient (project name)
- itso/rad75/bank/client (client directory corresponding to the client package)

According to JET transformation best practices, these variable names have to be stored in attributes and derived attributes.

Adding and deriving attributes

In JET transformations, variable information is stored into attributes. The exemplar authoring tool identifies two different types of attributes:

- ▶ **Attribute:** Input attribute that has to be provided by the input model
- ▶ **Derived attribute:** Attribute derived from an input attribute, usually used to satisfy a naming convention (such as artifacts, Java variables)

Let us now add the necessary attributes and derived attributes:

- ▶ Right-click the **client** type, and select **New** → **Attribute**. Call this new attribute **name**.
- ▶ Repeat the previous operation to add the **package** attribute.
- ▶ Select the **Create Project: RAD75PatternsClient** action and view its properties into the Properties view (Figure 9-6). The **name** action parameter is used by the transformation to name the test client project when it is first created. As we said above, this name must be variable and related to the **name** attribute we just created. This is what we do in the next steps.

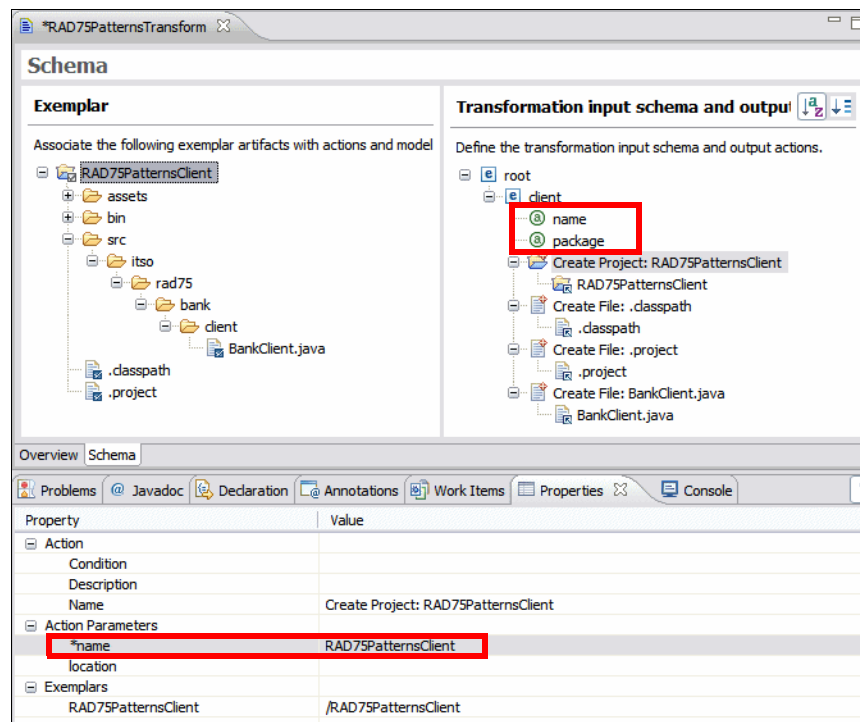

Figure 9-6 Create Project Properties

- ▶ Select the entire text of the action parameters name, right-click, and select **Replace with Model Reference**.
- ▶ In the Replace with Model References dialog, select the **client** type and click **New**, because we want to add the **Client** string to the name attribute.
- ▶ In the Create New Derived Attribute dialog, enter **projectName** as Attribute Name. Point the cursor to the start of the Calculation field and click **Insert Model Reference** (Figure 9-7).

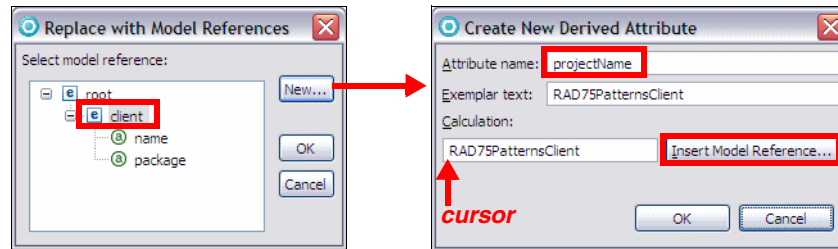

Figure 9-7 Insert Model Reference

- ▶ In the Select Model Reference dialog, select the **name** attribute of the client type and click **OK**.
- ▶ Note that a query expression for the name attribute as been inserted as `{ $client/@name }RAD75PatternsClient`. Change the expression to `{ $client/@name }Client` to define the calculation correctly (Figure 9-8). Click **OK** to get back to **Replace with Model References** dialog.

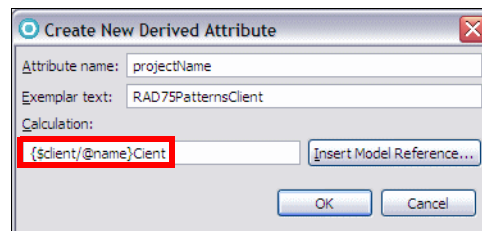

Figure 9-8 Final definition of the projectName derived attribute

Note: The syntax used for the calculation is related to the fact that access to the variable content is done by navigating an XML Domain Object Model (DOM) using XPath.

- ▶ In the Replace with Model References dialog, select the **projectName** attribute and click **OK** (Figure 9-9).

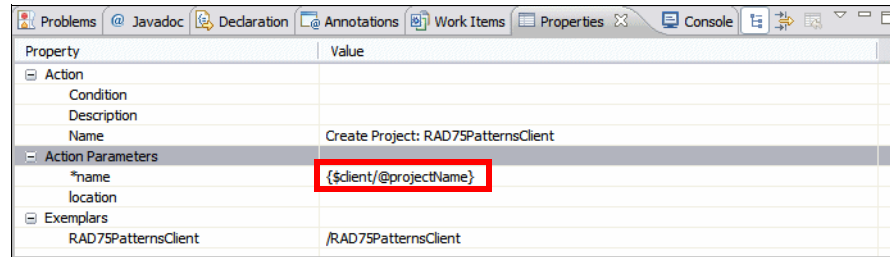

Figure 9-9 Final project name variable

- ▶ Using the same approach to replace the **path** parameter of the **.classpath** and **.project** elements. Select **RAD75PatternsClient** and replace the text with a model reference to the **projectName** attribute (Figure 9-10):

```
{$client/$projectName}/.classpath
{$client/$projectName}/.project
```

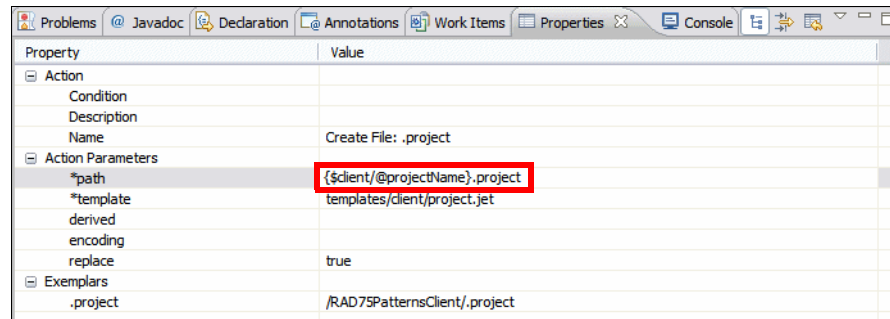

Figure 9-10 Adding a reference to the .project path variable

- ▶ Select the **Create File: BankClient.java** action, and in the Properties view replace **RAD75PatternsClient** in the value of the path action parameter with a model reference to the **projectName** attribute:

```
{$client/$projectName}/src/itso/rad75/bank/client/BankClient.java
```

- ▶ We defined package as a variable, therefore we want to replace **itso/rad75/bank/client** by a new derived attribute. Right-click **client** and select **New** → **Derived Attribute**. Name the derived attribute **clientDirectory** (Figure 9-11).

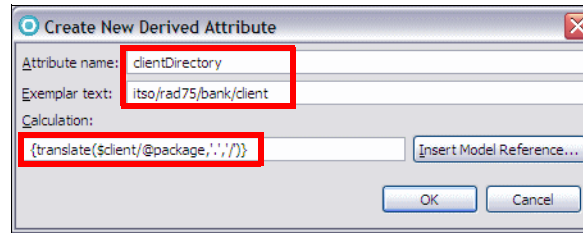

Figure 9-11 Attribute deriving the directory path from the package attribute

Note: Consider the expression on the Calculation box:

```
{translate($client/@package, '.', '/')}
```

This translates the package attribute (in the form `itso.rad75.bank.client`) into a directory path (in the form `itso/rad75/bank/client`).

The `translate` function is a standard XPath function. To learn more about the standard XPath function go to <http://www.w3.org/TR/xpath>. To learn more about the Rational Application Developer additional XPath functions look into the help at **Developing** → **Developing XML applications** → **Creating XPath expressions**.

- Select the **Create File: BankClient.java** action and in the Properties view replace the package directory with a reference to the **clientDirectory** attribute (Figure 9-12):

old: `{$client/@projectName}/src/itso/rad75/bank/client/BankClient.java`

new: `{$client/$projectName}/src/{$client/$clientDirectory}/BankClient.java`

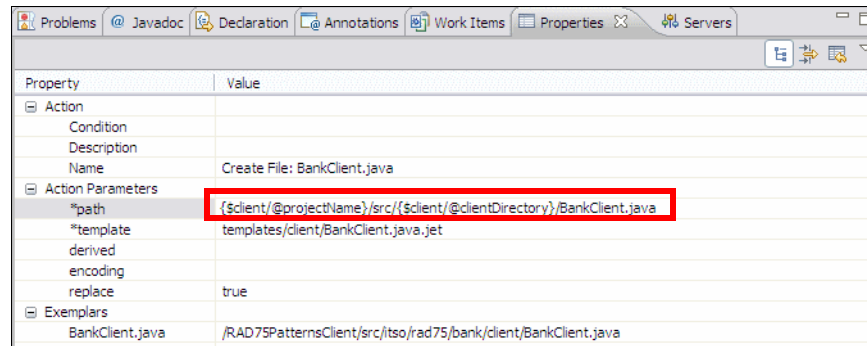

Figure 9-12 Final version of the BankClient.java path parameter

- Save the transformation. The completed model is shown in Figure 9-13.

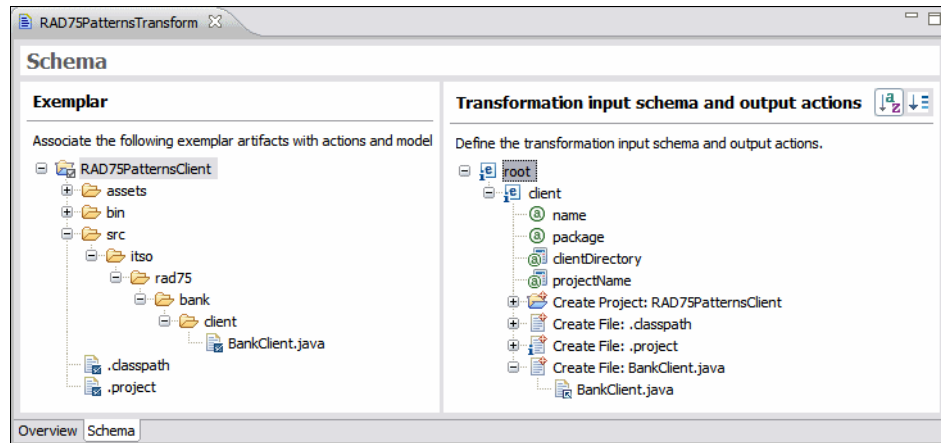

Figure 9-13 Final model for the JET transformation

Generate and edit templates

So far we have only made file names and paths variable; with templates we can make the file content variable. Templates are the means used by JET to allow us to modify the content of the files generated based on attributes (and derived attributes) provided by the input model.

Let us generate the templates and insert variables into the content of these templates. Right-click in the model transformation pane and select **Update Project**. New Templates are generated into the project (Figure 9-14).

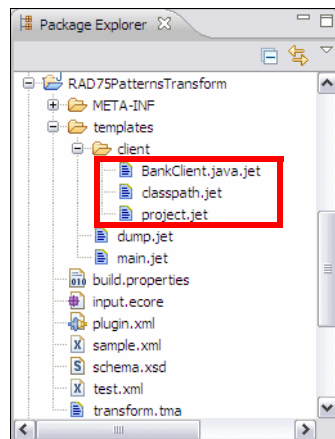

Figure 9-14 New generated templates

Updating the project.jet file

Double-click **project.jet** to edit the template.

Note: There is a blue underscore under the name element, indicating that the underscored string matches the exemplar strings of one of the attributes. This indicates that the string should probably be replaced by a variable expression referencing this attribute.

- ▶ Select the underscored text, right-click, and select **Find/Replace with JET Model Reference** (Figure 9-15).

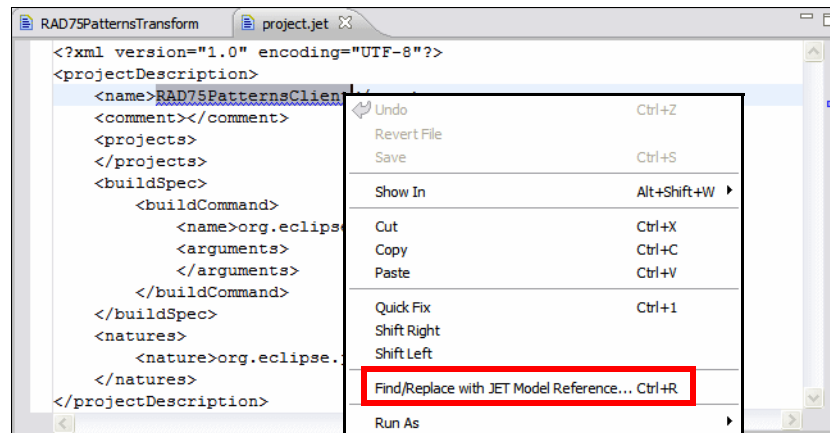

Figure 9-15 Launching Find/Replace with JET Model Reference

- ▶ In the **Find/Replace with JET Model Reference** dialog, select **projectName**, click **Replace**, and then click **Close** (Figure 9-16).

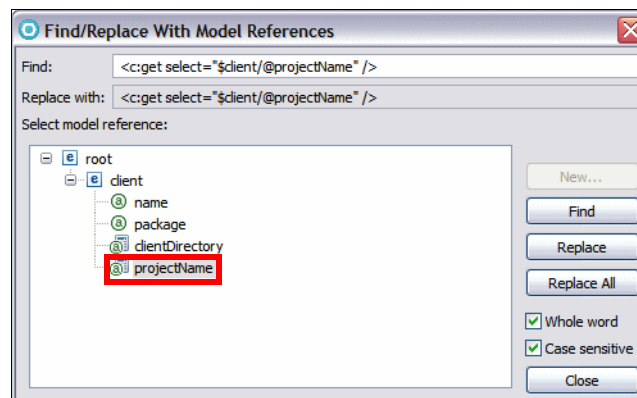

Figure 9-16 Replacing the project name with the attribute

- ▶ The name in the template has been replaced by the `<c:get>` tag:

```
<name><c:get select="$client/@projectName" /></name>
```

- ▶ Save and close `project.jet`.

Updating the `classpath.jet` file

Open `classpath.jet`. The classpath contain a reference to the **RAD75Patterns** project, that implements the bank application:

```
<?xml version="1.0" encoding="UTF-8"?>
<classpath>
  <classpathentry kind="src" path="src"/>
  <classpathentry kind="con"
    path="org.eclipse.jdt.launching.JRE_CONTAINER"/>
  <classpathentry combineaccessrules="false" kind="src"
    path="/RAD75Patterns"/>
  <classpathentry kind="output" path="bin"/>
</classpath>
```

- ▶ It would be good to make the project name a variable in case we decide to rename the project or decide to use a new project. However, we do not yet have an attribute to store this value. We have to add it to the model.
- ▶ Switch back to the **RAD75PatternsTransform** model and add a new attribute called **reference** under **client**.
- ▶ Switch back to `classpath.jet` and replace `/RAD75Patterns` (with the `/` at the beginning) by the new created attribute called **reference**.

```
<classpathentry combineaccessrules="false" kind="src"
  path="<c:get select="$client/@reference" />"/>
```

Note: You have to clear **Whole word** in the Find/Replace dialog to replace the string with the slash.

- ▶ Save and close `classpath.jet`.

Updating the `BankClient.java.jet` file

We update the client program with many templates:

- ▶ Open `BankClient.java.jet` and replace the package name with the package attribute in the same manner:

```
package <c:get select="$client/@package" />;

import itso.rad75.bank.exception.ITS0BankException;
.....
```

Using a customer template

- ▶ Analyzing the code of the **BankClient**, we can see that it creates one customer (**customer1**), two accounts for this customer (**account11** and **account12**), and executes a deposit transaction on the first account and a debit transaction on the second account. We make this variable, allowing us to create as many customers and accounts as we like and perform all the transactions we want.
- ▶ A customer is defined by four parameters (SSN, title, first name, and last name). We create it as a type and add the parameters as attributes. We also have to add an **id** attribute to allow us to create multiple customers.

Switch back to the transformation model, select the **client** type, and select **New** → **Type**. Name the new type **customer**. Add to the customer type four attributes called **ssn**, **title**, **firstName**, **lastName**, and an extra attribute **id**.

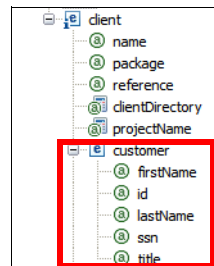

The ssn cannot be used as an ID for customer variables. Therefore an extra id attribute, which is not part of the customer data, is created.

- ▶ When done, save all changes, right-click in the white space next to the model, and select **Update Project**, to make the model modifications available for use in the JET templates.
- ▶ Switch back to `BankClient.java.jet`. Select **customer1** in the Java code:

```
Customer customer1 = null;
```

Right-click, and select **Find/Replace with JET Model Reference**.

- ▶ In the Find/Replace with JET Model Reference dialog, select **customer** and click **New** to create a new derived attribute. Call the new derived attribute **varname** and type **customer{\$customer/@id}** into the Calculation box (Figure 9-17). Click **OK** to go back to the previous dialog.

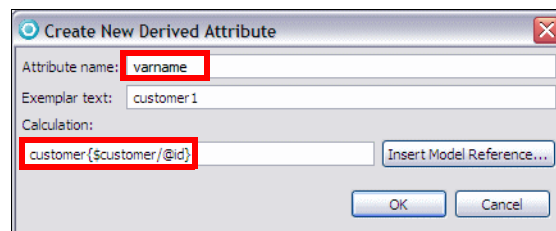

Figure 9-17 Creating the varName derived attribute

- ▶ In the **Find/Replace with JET Model Reference** dialog, select **varname**, click **Replace All** to replace all the instances of **customer1**, and then click **Close** (Figure 9-18). All references to customer1 are replaced by the variable:

```
Customer <c:get select="$customer/@varname" /> = null;
```

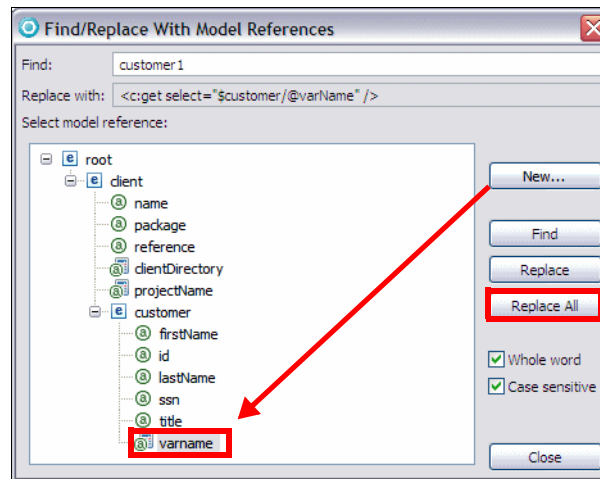

Figure 9-18 Replace all occurrences of customer

- ▶ When the customer is created (new Customer(. . . .)), replace the parameters by their corresponding model attribute (**xxx-xx-xxxx** by **\$customer/@ssn**, **Mr** by **\$customer/@title**, **Juan** by **\$customer/@firstName**, and **Napoli** by **\$customer/@lastName**). Add the Customer class name.

```
Customer <c:get select="$customer/@varname" /> = new Customer(
    "<c:get select=\"$customer/@ssn\" />",
    "<c:get select=\"$customer/@title\" />",
    "<c:get select=\"$customer/@firstname\" />",
    "<c:get select=\"$customer/@lastname\" />");
```

Using an account template

- ▶ As we did for customer, we have to create a new type for account. Because an account belongs to a given customer, we create this new type under **customer** and we call it **account**. It contains two attributes, **id** and **amount**.

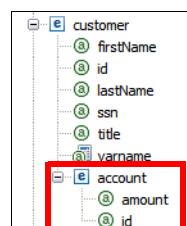

- ▶ Replace all occurrences of **account11** by a new **account** derived attribute called **varname**, with the calculation **account{\$account/@id}**.

Note: Do not forget to select **account** before clicking **New** in the **Find/Replace With Model Reference** dialog.

- ▶ When the account is created (new Account (.)), replace the parameters by their corresponding attributes (**11** by **\$account/@id**, **10000.00D** by **\$account/@amount**). Add the Account class name.

```
Account <c:get select="$account/@varname" /> = new Account(
    "<c:get select="$account/@id" />",
    new BigDecimal(<c:get select="$account/@amount" />));
```

- ▶ The **account12** lines of code are similar to the **account11** lines we just replaced; they just create a second account. To reproduce that (and allow us to create more than two accounts), we delete the **account12** creation lines and embed the account lines by a **<c:iterate>** tag, creating as many blocks of lines as there are account elements declared in the input file:

```
<c:iterate select="$customer/account" var="account">
    Account <c:get select="$account/@varname" /> = new Account
        ("<c:get select="$account/@id" />",
         new BigDecimal(<c:get select="$account/@amount" />));
    bank.openAccountForCustomer(<c:get select="$customer/@varname" />,
                               <c:get select="$account/@varname" />);
//Create and Add second account to the customer
    System.out.println("Account "
        + <c:get select="$account/@varname" />.getAccountNumber()
        + " and account " + account12.getAccountNumber()
        + " has been successfully opened for "
        + <c:get select="$customer/@varname" /> + ".\n");
</c:iterate>
```

Note: We also updated the output line before **</c:iterate>** to replace it with only one account reference.

Using a transaction template

- ▶ A transaction is always linked to only one account, so we create a new type called **transaction**, under the **account** type. Because there can be debit and credit transactions, we add a **type** attribute to the **transaction** type. We also add an **amount** attribute to contain the amount the transaction applies to.

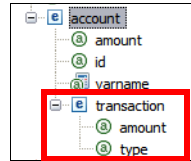

- ▶ Replace the transaction amounts by the **\$transaction/@amount** attribute. Because we want to perform more than one transaction, we also have to add a **<c:iterate>** tag on the **transaction** type. As there could be debit or credit transactions, we need to perform a test on the **type** attribute to insert the correct line of code. To do so, we use the **<c:choose>**, **<c:when>**, and **<c:otherwise>** tags. Example 9-1 shows the resulting template.

Example 9-1 Template code containing the account and transaction parametrization

```

<c:iterate select="$customer/account" var="account">
  Account <c:get select="$account/@varname" /> = new Account(
    "<c:get select="$account/@id" />",
    new BigDecimal(<c:get select="$account/@amount" />));
  bank.openAccountForCustomer(<c:get select="$customer/@varname" />,
    <c:get select="$account/@varname" />);
  System.out.println("Account "
    + <c:get select="$account/@varname" />.getAccountNumber()
    + " has been successfully opened for "
    + <c:get select="$customer/@varname" /> + ".\n");
  System.out.println("System is listing all account information of "
    + <c:get select="$customer/@varname" /> + "...");
  System.out.println(bank.getAccountsForCustomer
    (<c:get select="$customer/@varname" />.getSsn()));

  <c:iterate select="$account/transaction" var="transaction">
    amount = new BigDecimal(<c:get select="$transaction/@amount" />);
    <c:choose select="$transaction/@type">
      <c:when test="'Credit'">
        System.out.println("\nSystem is going to make credit of $"
          + amount.setScale(2, BigDecimal.ROUND_HALF_EVEN)
          + " to account " + <c:get select="$account/@varname" />
            .getAccountNumber() + "...");
        bank.deposit(<c:get select="$account/@varname" />
          .getAccountNumber(), amount);
        System.out.println("Account "
          + <c:get select="$account/@varName" />.getAccountNumber()
          + " has successfully credited by $"
          + amount.setScale(2, BigDecimal.ROUND_HALF_EVEN) + ".\n");
      </c:when>
      <c:when test="'Debit'">
        System.out.println("System is going to make debit of $"
          + amount.setScale(2, BigDecimal.ROUND_HALF_EVEN)

```



```

        + " to account " + <c:get select="$account/@varname" /
            .getAccountNumber() + "...");
    bank.withdraw(<c:get select="$account/@varname" />
        .getAccountNumber(), amount);
    System.out.println("Account "
        + <c:get select="$account/@varName" />.getAccountNumber()
        + " has sucessfully debited by $"
        + amount.setScale(2, BigDecimal.ROUND_HALF_EVEN) + ".\n");
    </c:when>
</c:choose>
</c:iterate> // transaction
</c:iterate> // account

```

Notes:

- ▶ Because we iterate to create different amounts, the declaration of the amount variable (`BigDecimal amount;`) must be before the first `<c:iterate>` tag.
 - ▶ As the debit code is applied to **account12**, the easiest way to reuse the lines of code is to replace **account12** by `$account/@varName`, so it could be applied to any account we create.
 - ▶ The account iteration closing tag (`</c:iterate>`) has been moved after the transaction iteration closing tag because a transaction is a subtype of the **account** type.
 - ▶ We also remove the remaining transactions and the account close command, as we do not expect our clients program to close any accounts.
-
- ▶ We said previously that eventually we would like to create more than one customer. To do so, we create a `<c:iterate>` tag before creating the customer.
 - ▶ Remove the declarations of the local variables, except `BigDecimal amount`.
 - ▶ Example 9-2 shows the final **BankClient.java.jet** with all the tags.

Example 9-2 Final version of BankClient.java.jet

```

/*
 * File Name: BankClient.java
 */
package <c:get select="$client/@package" />;

import itso.rad75.bank.exception.ITS0BankException;
import itso.rad75.bank.ifc.Bank;
import itso.rad75.bank.impl.ITS0Bank;
import itso.rad75.bank.model.Account;
import itso.rad75.bank.model.Customer;

```

```

import java.math.BigDecimal;

public class BankClient {
    public static void main(String[] args) {
        // code unchanged
    }

    // Method to test the Bank application
    private static void executeCustomerTransactions(Bank bank)
        throws ITSOBankException {
        try {
            //Declare local variables
            BigDecimal amount = null;
            <c:iterate select="$client/customer" var="customer">
            System.out.println("System is going to add new customer...");
            Customer <c:get select="$customer/@varName" /> =
                new Customer("<c:get select=\"$customer/@ssn\" />",
                    "<c:get select=\"$customer/@title\" />",
                    "<c:get select=\"$customer/@firstName\" />",
                    "<c:get select=\"$customer/@lastName\" />");
            bank.addCustomer(<c:get select="$customer/@varname" />);
            System.out.println(<c:get select="$customer/@varname" />
                + " has been successfully added.\n");
            System.out.println
                ("System is going to open new accounts for the customer "
                    + <c:get select="$customer/@varName" /> + "...");
            <c:iterate select="$customer/account" var="account">
            Account <c:get select="$account/@varName" /> =
                new Account("<c:get select=\"$account/@id\" />",
                    new BigDecimal(<c:get select="$account/@amount" />));
            bank.openAccountForCustomer(<c:get select="$customer/@varname" />,
                <c:get select="$account/@varname" />);
            System.out.println("Account "
                + <c:get select="$account/@varname" />.getAccountNumber()
                + " has been successfully opened for "
                + <c:get select="$customer/@varname" /> + ".\n");
            System.out.println("System is listing all account information of "
                + <c:get select="$customer/@varname" /> + "...");
            System.out.println(bank.getAccountsForCustomer
                (<c:get select="$customer/@varname" />.getSsn()));
            <c:iterate select="$account/transaction" var="transaction">
            amount = new BigDecimal(<c:get select="$transaction/@amount" />);
            <c:choose select="$transaction/@type">
            <c:when test="'Credit'">
            System.out.println("\nSystem is going to make credit of $"
                + amount.setScale(2, BigDecimal.ROUND_HALF_EVEN)
                + " to account " + <c:get select="$account/@varname" />
                    .getAccountNumber() + "...");
            bank.deposit(<c:get select="$account/@varname" />

```

```

        .getAccountNumber(), amount);
    System.out.println("Account "
    + <c:get select="$account/@varname" />.getAccountNumber()
    + " has successfully credited by $"
    + amount.setScale(2, BigDecimal.ROUND_HALF_EVEN) + ".\n");
</c:when>
<c:when test="'Debit'">
    System.out.println("System is going to make debit of $"
    + amount.setScale(2, BigDecimal.ROUND_HALF_EVEN)
    + " to account " + <c:get select="$account/@varname" />
    .getAccountNumber() + "...");
    bank.withdraw(<c:get select="$account/@varname" />
    .getAccountNumber(), amount);
    System.out.println("Account "
    + <c:get select="$account/@varname" />.getAccountNumber()
    + " has successfully debited by $"
    + amount.setScale(2, BigDecimal.ROUND_HALF_EVEN) + ".\n");
</c:when>
</c:choose>
</c:iterate> // transaction
</c:iterate> // account
    System.out.println("System is listing all account information of "
    + <c:get select="$customer/@varname" /> + "...");
    System.out.println(bank.getAccountsForCustomer
    (<c:get select="$customer/@varname" />.getSsn()));
</c:iterate> // customer

    } //Catch exceptions and printout stack trace in console
    catch (ITSOBankException e){throw e;}
}
}

```

Note: The final **BankClient.java.jet** is available in the **RAD75PatternsClient** project in the **assets** directory.

Save all the files. Run **Update Project** before running the sample to make the model modifications available for use in the JET templates.

Applying the pattern

To apply the pattern, we create an XML input file for the JET transformation:

- ▶ Let us start by creating a **sample.xml** that creates the same test client we used as exemplar. Open the **sample.xml** file that is contained in the

RAD75PatternsTransform project. Modify it to match what is in (Example 9-3).

Example 9-3 Sample.xml to run the transformation

```

<root>
  <client name="RAD75Patterns2" package="itso.rad75.bank.client"
    reference="/RAD75Patterns">
    <customer id="1" ssn="xxx-xx-xxxx" title="Mr" firstName="Ahmed"
      lastName="Moharram">
      <account id="11" amount="10000.00D">
        <transaction type="Credit" amount="2500.00D"></transaction>
      </account>
      <account id="12" amount="11234.23D">
        <transaction type="Debit" amount="1234.23D"></transaction>
        <transaction type="Credit" amount="5000.00D"></transaction>
      </account>
    </customer>
  </client>
</root>

```

Note: A version of **sample.xml** is available in the **RAD75PatternsClient** project in the **assets** directory.

- ▶ Right-click **sample.xml** and select **Run As** → **Input for Jet Transformation**.
- ▶ Explore the newly created **RAD75Patterns2Client** project (Figure 9-19):
 - A package `itso.rad75.bank.client` is created.
 - The client program `BankClient.java` is created.
 - The classpath has been set so that there are no errors.

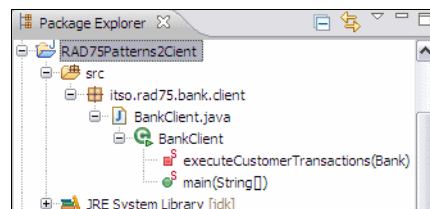

Figure 9-19 Client generated by transformation

Running the generated client

Open the generated client and study the source code.

Right-click **BankClient.java** → **Run As** → **Java Application** to verify that it produces a similar output as the exemplar.

Note: You can verify that both accounts have been created, that all transactions were performed, and that the balance is the same between the generated project and the exemplar project.

Running another transformation

This time we are running a different XML file, **sample2.xml**, that is in the **RAD75PatternsClient** project in the **assets** directory.

- ▶ Open **sample2.xml** and explore the content. As you can see in Example 9-4, we have two customers (Jane Doe and John Doe). Jane Doe has two accounts and we perform a debit and a credit transactions on her first account. John Doe has only one account and we do not perform any transactions. We generate the client into the same **RAD75Patterns2Client** project, but a new package (`itso.rad75.bank2.client`).

Example 9-4 Sample2.xml transformation

```
<root>
  <client name="RAD75Patterns2" package="itso.rad75.bank2.client"
    reference="/RAD75Patterns">
    <customer id="1" ssn="999-99-9999" title="Mrs" firstName="Jane"
      lastName="Doe">
      <account id="11" amount="10000.00">
        <transaction type="Debit" amount="2399.99"></transaction>
        <transaction type="Credit" amount="2399.99"></transaction>
      </account>
      <account id="12" amount="11234.23">
      </account>
    </customer>
    <customer id="2" ssn="888-88-8888" title="Mr" firstName="John"
      lastName="Doe">
      <account id="21" amount="10000.00"></account>
    </customer>
  </client>
</root>
```

- ▶ To run the transform, right-click **sample2.xml** and select **Run As** → **Input for Jet Transformation**. Because the containing project is not a JET transformation project, the **Edit launch configuration properties** dialog is displayed. In this dialog, select **RAD75PatternsTransform** as transformation id from the drop-down list (Figure 9-20).

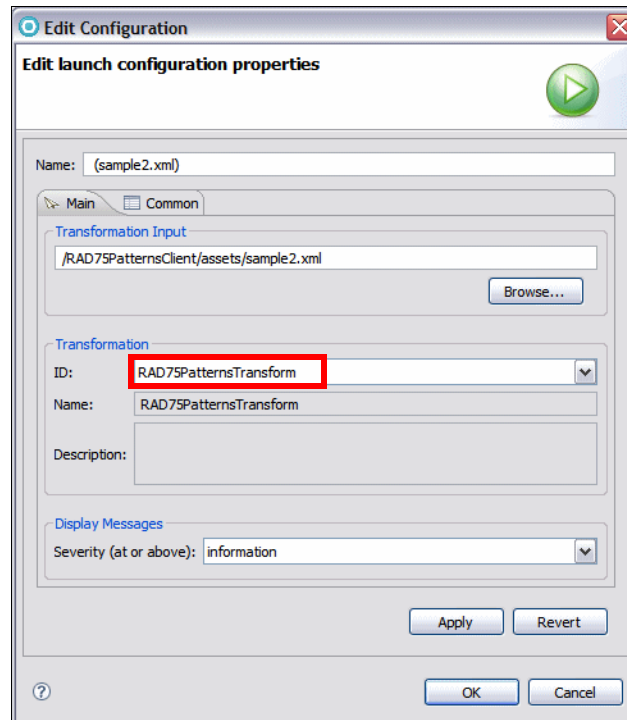

Figure 9-20 Creating the run configuration

Note: After doing this initial configuration, the JET transformation can be rerun just by right-clicking **sample2.xml** and selecting **Run As** → **Input for Jet Transformation**.

- ▶ Explore the newly created **itso.rad75.bank2.client.BankClient.java** and study the generated source code. You can run the client to verify that it runs.

Facade pattern

In this section we introduce a second transformation example, which generates the facade (interface and implementation) for the sample banking application.

Importing the facade example

Import the project interchange file for the facade example, by selecting **File** → **Import** → **Other** → **Project Interchange**. Click **Next**. Locate the example in:

```
c:\7672code\patterns\RAD75PatternsFacade.zip
```

Select the RAD75PatternsFacade and RAD75PatternsFacadeTransform projects, and click **Finish**. Note that RAD75PatternsFacade refers to RAD75Patterns as the model. Study the two projects:

- ▶ RAD75PatternsFacade is the exemplar project. We will generate the interface, `itso.rad75.bank.ifc.Bank`, and the implementation class, `itso.rad75.bank.impl.ITS0Bank`.
- ▶ RAD75PatternsFacadeTransform is the JET Transformation project.

Facade transformation

Open the **transform.tma** file in RAD75PatternsFacadeTransform. The transformation defines:

- ▶ Attributes: `name` (of the interface), `package` (base package), `systemProjName` (underlying project with the model)
- ▶ Derived attributes: `facadeDirectory` (folders from package), `facadeVarname` (variable for the interface), `ifcPackage` (package of interface), `implClass` (implementation class name), `implPackage` (package of implementation), and `projectName` (generated project)
- ▶ Elements: `entity` (to define model objects), and `operation` (to define the methods of the interface)
- ▶ Creates: `Project`, `.classpath`, `.project`, `Bank.java` (interface), `ITS0Bank.java` (implementation)

The template files (`templates\facade`) include:

- ▶ `classpath.jet`: `.classpath` template
- ▶ `project.jet`: `.project` template
- ▶ `Bank.java.jet`: interface template
- ▶ `ITS0Bank.java.jet`: implementation template

Running the transformation examples

We provide two XML files to run the transformation and generate an interface and an implementation class:

- ▶ **BankSample.xml**: This example generates a **BankFacadeGenerated** project, with the Bank interface and the ITS0Bank implementation class, matching the original classes in the RAD75Patterns project.
- ▶ **LibrarySample.xml**: This example generates a **LibraryFacadeGenerated** project, with a Library interface and an ITS0Library implementation class. This example demonstrates that the transformation can generate any interface and a matching implementation class. The library example is based on Book and Borrower model classes. Note that we do not provide the underlying RAD75LibraryJava project with the model classes, and errors are reported for the LibraryFacadeGenerated project..

More information

The following URLs provide further information for the topics covered in this chapter:

- ▶ You can find several articles on pattern transformations on the IBM developerWorks Web site (search for JET pattern transformation):
<http://www.ibm.com/developerworks>
- ▶ More information on using Exemplar Authoring and JET transformations can be found at IBM developerWorks in the article *Create powerful custom tools quickly with Rational Software Architect Version 7.0*:
http://www.ibm.com/developerworks/rational/library/07/0109_peterson/
- ▶ For more information on patterns based development, visit the Patterns Solution area at IBM developerWorks:
http://www.ibm.com/developerworks/rational/products/patternsolutions/index.html?S_TACT=105AGX15&S_CMP=LP
- ▶ More information on the XPath functions can be found at:
<http://www.w3.org/TR/xpath>



Develop XML applications

This chapter provides an overview of current XML technologies and covers the XML capabilities provided by Rational Application Developer 7.5.

The chapter is organized into the following sections:

- ▶ XML overview and associated technologies
- ▶ Rational Application Developer XML tools
- ▶ Creating an XML schema
- ▶ Generating HTML documentation from an XML schema file
- ▶ Generating an XML file from an XML schema
- ▶ Editing an XML file
- ▶ Working with XSL transformation files
- ▶ Transforming an XML file into an HTML file
- ▶ XML mapping
- ▶ Generating JavaBeans from an XML schema
- ▶ Service Data Objects and XML

The sample code for this chapter is in `7672code\xml`.

XML overview and associated technologies

Extensible Markup Language (XML) is a subset of Standard Generalized Markup Language (SGML). Both XML and SGML are meta languages, because they allow the definition of a chosen set of elements and attributes to meet the requirements of a specific application area. Markup languages are used to annotate information so that it is easier to manipulate and understand. Markup is also used to define how information should be presented for display. One example of this is HTML. HTML is used to mark up document information so that it can be displayed by a Web browser. The elements within an XML document are organized hierarchically with a single root element at the top of the hierarchy.

XML is a key part of the software infrastructure. It provides a simple and flexible means of defining, creating, and storing data. XML is used for a variety of purposes such as systems configuration, messaging and data storage.

The set of rules which define what can be present in any specific XML document are held in either a Document Type Definition (DTD) or an XML schema Definition (XSD). If a DTD or XSD is available it is possible to check that an XML document is valid. If an XML documents is to usable it must first be well-formed. This means that it must adhere to all the XML syntax rules as defined in the XML specification document. Only a well-formed XML document can be checked using a DTD or XSD to see if it is valid. A valid XML document is guaranteed to contain only what it should.

Detailed information on XML can be found at:

<http://www.w3.org/XML/>

XML processors

XML is tag-based; however there are no predefined XML tags. Tags are the markup inserted in an XML document to define the elements from which it is composed.

XML documents follow strict syntax rules. To create, read, and update XML documents, you require an XML processor or parser. At the heart of an XML application is an XML processor that parses an XML document allowing the document elements to be retrieved and used as required. Parsers are also responsibility for checking the syntax and structure of XML documents. The two main XML parsers are the Simple API for XML (SAX) parser and the Document Object Model (DOM) parser.

Detailed information on SAX and DOM can be found at:

<http://www.saxproject.org/>
<http://www.w3.org/DOM/>

DTDs and XML schemas

DTDs and XML schemas are both used to describe XML document structure; however, in recent years the acceptance of XML schemas has gained momentum. Both DTDs and XML schemas define the building blocks for XML documents, the elements, attributes and entities.

XML schemas are more powerful than DTDs. Here are some of the advantages of XML schemas over DTDs:

- ▶ They can define data types for elements and attributes, and their default and fixed values. The data types can be of string, decimal, integer, boolean, date, time, or duration.
- ▶ They can apply restrictions to elements, by stating minimum and maximum values, for example, an age element might be restricted to hold values from 1 to 90 or a string value may be restricted to only hold one value from a specific list of values a defined allowed list such as *Fixed*, *Savings* or *Loan*. Restrictions can also be applied to characters and patterns of characters, for example, characters may be restricted to those from 'a' to 'z' and the length of the character string may be restricted to only three letters. Another restriction may be that the string may have a range of lengths, for example, a password must be between 4 and 8 characters.
- ▶ They can define complex element types. Complex types can contain simple types or other complex types. Restrictions can be applied to the sequence and frequency of the occurrence of each type. Complex types can be used in the definition of other complex types.
- ▶ XML schema documents, unlike DTDs, are actually XML documents. This implies that XML schema documents can be automatically checked for validity and authoring XML schema documents is simpler for those already familiar with XML. Also, XML parsers do not have to be enhanced to provide support for DTDs. Transformation of XML schema documents can be carried out using Extensible Stylesheets Language Transformation (XSLT) documents and they can be manipulated using the XML Document Object Model (DOM).

Detailed information on DTD and XML schema can be found at:

<http://www.w3.org/TR/2006/REC-xml-20060816/>
<http://www.w3.org/XML/Schema>

XSL

Extensible Stylesheet Language (XSL) is a set of recommendations defined by the W3C.

XSL is composed of the following three W3C recommendations:

- ▶ XSL transformations (XSLT): This is an XML markup language which is used for the transformation of XML documents
- ▶ XML Path language (XPath): This is a language used to access or refer to parts of an XML document
- ▶ XSL-FO: This is a XML markup language which is used to format information for the purpose of presentation in similar way to the way that HTML marks up information for presentation by a Web browser.

XML document transformations defined using XSLT are XML documents. The elements present in the XSLT document are defined in the XSLT namespace. Namespaces are discussed later in this chapter.

An XSLT transformation processor is required when transforming a document using XSLT. The processor takes as input a source XML document and an XSLT transformation document. The transformations defined in XSLT document are used to transform the source file into the output file. XSLT uses pattern matching and templates to define the required transformation. When a pattern defined in the XSLT transformation document is found in the source document the associated template, also defined in the XSLT transformation document, is placed in the output file.

The output file produced is typically another XML document.

Detailed information on XSLT can be found at:

<http://www.w3.org/TR/xslt.html>

XML namespaces

Namespaces are used when there is a requirement for elements and attributes of the same name to take on a different meaning depending on the context in which they are used. For instance, an element called TITLE would have a different meaning, depending on whether it was present within a PERSON element or within a BOOK element. In the case of the PERSON element it would be something that is placed in front of a persons name, such as Mr or Dr. In the case of BOOK element it would be the title of the book, such as Programming Guide.

If both elements, PERSON and BOOK, have to be defined in the same document, for example, in a library entry that associates a book with its author, a mechanism is required to distinguish between the two so that the correct semantics apply when the TITLE element is used in the document.

Namespaces provide this mechanism by allowing a namespace and an associated prefix to be defined. Elements that use a specific namespace prefix are said to be present in that namespace and have the meaning defined for them in the namespace. The prefix is separated from the element name by a colon character. In our example TITLE would be defined in two different namespace. One namespace would be concerned with elements relevant to holding information on books and the other namespace would be concerned with elements storing information on people. Example start tags for the elements might be <book:TITLE> and <people:TITLE>.

Detailed information on XML namespaces can be found at:

<http://www.w3.org/TR/REC-xml-names/>

XPath

The XML path language (XPath) is used to address parts of an XML document. The XML document is considered to be a tree of nodes and an XPath expression selects a specific node or set of nodes within the tree. This is achieved by defining the path to the node or nodes. An XPath expression in addition can include instructions to manipulate values held at a specific node or set of nodes. XPath is used with XSLT, discussed previously, as well as other XML technologies.

Detailed information on XPath can be found at:

<http://www.w3.org/TR/xpath>

Rational Application Developer XML tools

Rational Application Developer provides a comprehensive visual XML development environment. The tool set includes components for building DTDs, XML schemas, XML Documents, and XSL files.

Rational Application Developer includes the following XML development tools:

- ▶ DTD editor
- ▶ XML editor
- ▶ XML schema editor
- ▶ XSL editor
- ▶ XPath Expression wizard

- ▶ XML to XML Mapping editor
- ▶ XSL debugger and XML transformer
- ▶ XML schema to JavaBean generator
- ▶ XML schema to HTML documentation generator
- ▶ XML, DTD, and relational tables to XML schema generator

Creating an XML schema

In this section, we create an XML schema for use in storing bank account information. The XML document structure defined in the schema is a collection of accounts. Each account has an account ID, account type, account balance, interest rate, and related customer information. The account ID is allowed to be from 6 to 8 digits long and each digit must be in the range 0 to 9. The value of the interest rate is allowed to be between 0 and 100. The phone number is in the format (xxx) xxx-xxxx. The following steps create a project to hold our schema document and create an empty schema document:

- ▶ Open the **Resource** perspective and create a project named RAD75XMLBank:
 - Select **File** → **New** → **Project** → **General** → **Project**, then click **Next**.
 - In the Project name field type **RAD75XMLBank**.
 - Click **Finish** and the project is displayed in the Enterprise Explorer.
 - Right-click the **RAD75XMLBank** project and select **New** → **Folder**. Enter `xml` as folder name, and click **Finish**.
- ▶ Create an XML schema:
 - Right-click the **xml** folder and select **New** → **Other** → **XML** → **XML schema**. Click **Next**.
 - The parent folder is set to `RAD75XMLBank/xml`. In the File name field type `Accounts.xsd`. Click **Finish**.
 - Make sure that the Properties view is visible. If you cannot see the Properties view, select **Window** → **Show view** → **Properties**.

Working with the Design view

The XML editor allows the XML source for the schema to be edited directly but also features a Design view. The Design view presents the XML document in such a way that it makes editing and navigation through the document easier. The Design view can be used with any type of XML document but because we are working with an XML schema, a format understood by the editor, the editor can help with the creation of the schema document. We will create the schema in the Design view.

- ▶ Select the **Design** view. Notice that the top-right corner displays View: Simplified.
 - **Simplified**—The Simplified view hides many of the complicated XML schema capabilities so that you can only create XML schemas that conform to best practice authoring patterns.
 - **Detailed**—The Detailed view exposes the full set of XML schema capabilities so you can create XML data structures using any authoring pattern. XML schema elements such as `xsd:choice`, `xsd:sequence`, `xsd:group`, and element references are not displayed in the Simplified view and actions in the editor that enable the creation of these elements are not available.

We use the Detailed view for this exercise.

- ▶ Select **Detailed** from the View: drop down list (Figure 10-1). Dismiss the pop-up about switching view modes.

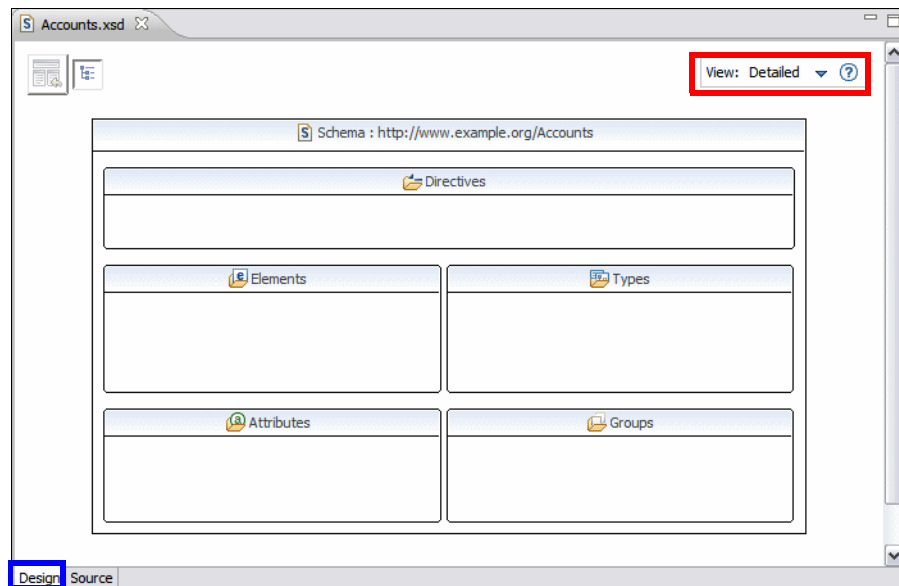



Figure 10-1 XML schema Editor: Design view, Detailed

Note: In the detailed view the top level view is called the **schema index view**. We can navigate to this at any time while editing the schema by clicking on the **Show schema index view** button in the top left of the design view. The button has the icon . In Figure 10-1 this is currently greyed out because we are already viewing the schema index.

- ▶ Change the namespace prefix and target namespace:
 - In the Properties view, select the **General** tab. You can see the current namespace prefix and target namespace. The values are tns and `http://www.example.org/Accounts`.
 - Change the Prefix to `itso`.
 - Change the Target namespace to `http://itso.rad75.xml.com`.
- ▶ The `Accounts.xsd` file must contain a complex type element where we will define the account information, including account id, account type, balance, interest, and customer information:
 - In the Design view, right-click the **Types** category and select **Add ComplexType**. Overtyp the name provided with the value **Account**.

Tip: Alternatively, you can change the element name in the **Properties** view, **General** tab, Name field. The Properties view provides many options for modifying the properties of an XML schema.

- ▶ Right-click the **Account** complex type, and select **Add Sequence**. The design view switches from showing the schema index to only showing the **Account** complex type:
 - Clicking the **Show schema index view** icon returns to the schema index.
 - Double-clicking on the **Account** complex type shows only this type in the detailed view.

Note: In simplified view you are not able to see the Add Sequence option in the context menu, because the Simplified view hides many of the more complicated XML elements.

- ▶ Right-click the **Account** complex type, and select **Add Element**.
- ▶ Change the element name to **accountID** (Figure 10-2).

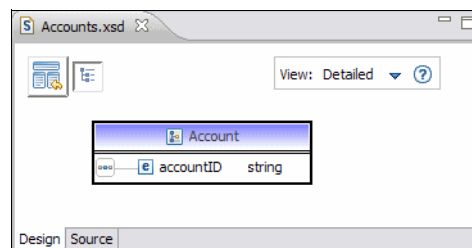

Figure 10-2 Account complex type

- ▶ In our bank, the account ID is 6 to 8 digits long and takes numerical values in the range 0-9:
 - Click the element **accountID**, and in the Properties view select the **Constraints** tab.
 - In the Specific constraint values section, select **Patterns** and Click **Add**. The **Regular Expression Wizard** opens.
 - In the Regular Expression Wizard (Figure 10-3):
 - Type **[0-9]{6,8}** in the current regular expression field, and click **Next**.
 - In the Sample text area, type **123456**. Note that the warning at the top of the dialog box disappears.
 - Click **Finish**.

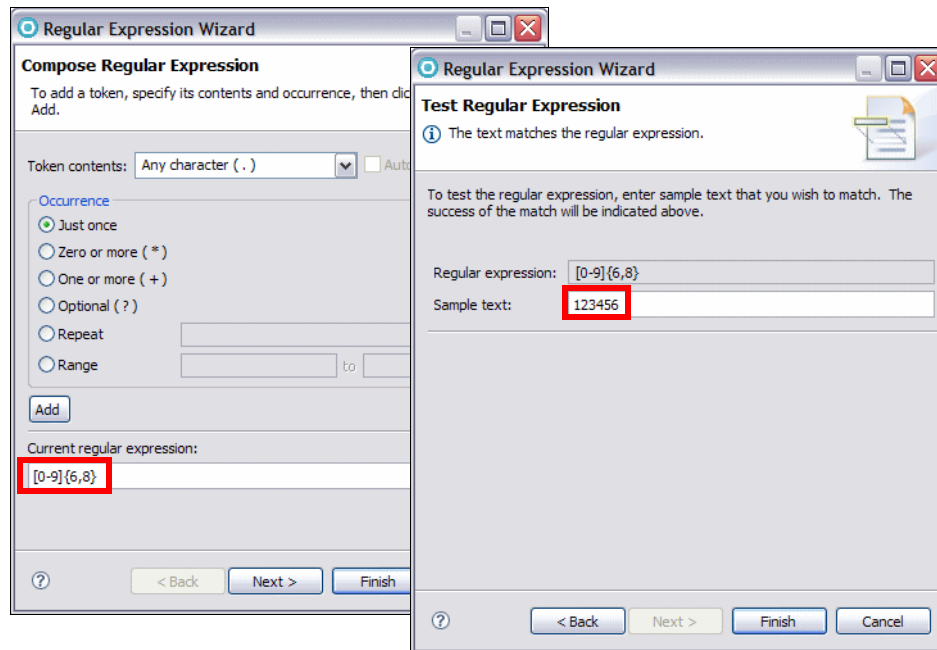

Figure 10-3 Regular Expression Wizard

- Note that the type for **accountID** changes from `string` to `AccountIDType`, because we have constrained the string to create a new type.
- The Properties view with the constraint value is shown in Figure 10-4.

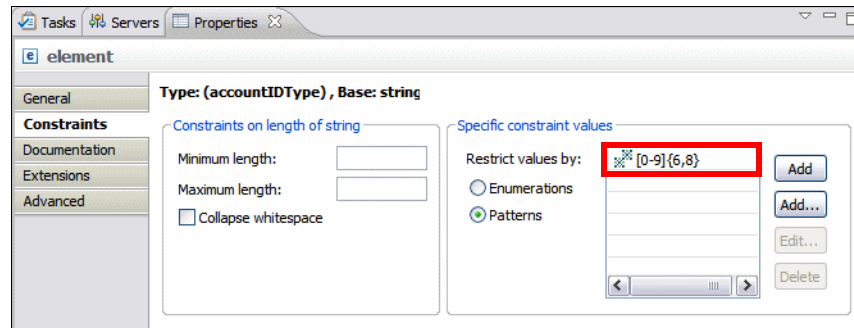



Figure 10-4 Properties view with constraint

- ▶ In the Design view, right-click the sequence icon  and select **Add Element**. Change its name to **accountType**. A bank account has three account types: Savings, Loan, and Fixed:
 - In the Properties view, select the **Constraints** tab. Under Specific constraint values, select **Enumerations**.
 - Click **Add** and enter Savings.
 - Click **Add** and enter Loan.
 - Click **Add** and enter Fixed.
- ▶ Add the **balance** element:
 - In the Design view, right-click the sequence icon  and select **Add Element**. Change its name to **balance**.
 - In the **Properties** view, **General** tab, select the drop-down menu for **Type**.
 - Select **Browse** from the drop-down menu, then select **decimal**.
- ▶ Add the **interest** element:
 - Add an element named **interest** and set the type to **decimal** as before.
 - In the Properties view **Constraints** tab set the Minimum value to **0** and Maximum value to **100**.
- ▶ Add the **customerInfo** element:
 - Add an element named **customerInfo**.
 - In the Properties view, **General** tab, select the drop-down menu for the **Type** and select **New**.
 - In the New Type dialog, select **Complex Type** and **Create as local anonymous type**, then click **OK** (Figure 10-5).

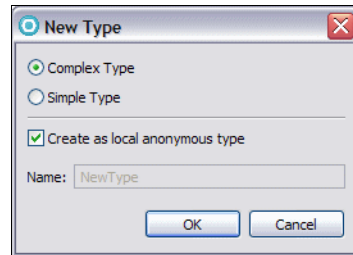

Figure 10-5 new Type dialog

- ▶ Click the plus sign to the right of `customerInfo`, and a `(CustomerInfoType)` box appears to the right of the `Account` box.
- ▶ Right-click **(CustomerInfoType)** and select **Add Element**. Change the name to **firstName**.
- ▶ Add another element named **lastName**.
- ▶ Add another element named **phoneNumber**, which holds values with a format such as (408) 456-7890:
 - In the Properties view, **Constraints** tab, select **Patterns**.
 - Click **Add...** In the **Current regular expression** area, type `\{[0-9]{3}\} [0-9]{3}-[0-9]{4}`, and click **Next**. Note that there is a space between the area code and the local phone number.
 - Enter **(408) 456-7890** as Sample text and click **Finish**.

The Design view is shown in Figure 10-6.

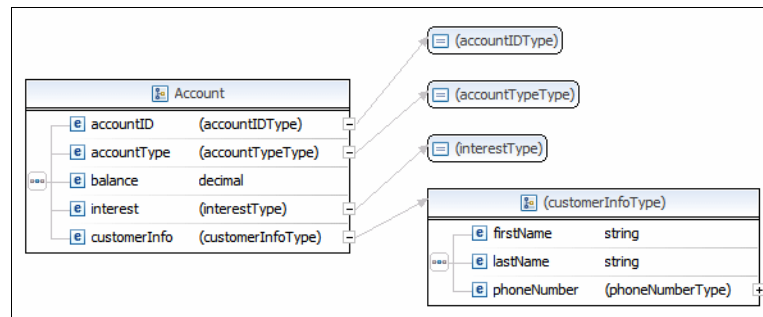



Figure 10-6 Account type complete

Tip: The Design view can be exported as an image for use elsewhere by selecting **XSD** → **Export Diagram as Image** from the menu.

- ▶ If this XML schema is to define the structure of an XML document that can actually be created, the XML schema must have a global element. All we have at present is a complex type definition. We have to define at least one element of this type. We can add a global element named **accounts** as follows:
 - Click the show schema index view icon  at the top left corner.
 - In the Design view of the schema, right-click the **Elements** category and select **Add Element**.
 - Change the name to **accounts**.
 - In the Properties view, **General** tab, select the drop-down menu for **Type** and select **New**. In the New Type dialog, select **Complex Type** and **Create as local anonymous type**, and click **OK**.
 - Double-click **accounts** and you are switched to the detailed view for the **accounts** element. Right-click **accountsType** and select **Add Element**.
 - Change the name to **account**.
 - Right-click **account** and select **Set Type** → **Browse** → **Account**.
 - In the Design view, make sure **account** is selected. In the Properties view, General tab, set the Minimum Occurrence to **1** and Maximum Occurrence to **unbounded**.

Source view

Finally we tidy up the XML source code that has been created. Select the Source tab, right-click anywhere in the source code, and select **Source** → **Format** to format the XSD file so that it has a tidy layout.

Save and close the file. The generated Accounts.xsd file is listed in Example 10-1.

Example 10-1 Accounts.xsd file

```
<?xml version="1.0" encoding="UTF-8"?>
<schema targetNamespace="http://itso.rad75.xml.com"
  elementFormDefault="qualified" xmlns="http://www.w3.org/2001/XMLSchema"
  xmlns:itso="http://itso.rad75.xml.com">
  <complexType name="Account">
    <sequence>
      <element name="accountID">
        <simpleType>
          <restriction base="string">
            <pattern value="[0-9]{6,8}"></pattern>
          </restriction>
        </simpleType>
      </element>
```

```

<element name="accountType">
  <simpleType>
    <restriction base="string">
      <enumeration value="Savings"></enumeration>
      <enumeration value="Loan"></enumeration>
      <enumeration value="Fixed"></enumeration>
    </restriction>
  </simpleType>
</element>
<element name="balance" type="decimal"></element>
<element name="interest">
  <simpleType>
    <restriction base="decimal">
      <minExclusive value="0"></minExclusive>
      <maxExclusive value="100"></maxExclusive>
    </restriction>
  </simpleType>
</element>
<element name="customerInfo">
  <complexType>
    <sequence>
      <element name="firstName" type="string"></element>
      <element name="lastName" type="string"></element>
      <element name="phoneNumber">
        <simpleType>
          <restriction base="string">
            <pattern value="\{3\} \{3\}-\{4\}">
              </pattern>
            </restriction>
          </simpleType>
        </element>
      </sequence>
    </complexType>
  </element>
</sequence>
</complexType>
<element name="accounts">
  <complexType>
    <sequence>
      <element name="account" type="itso:Account" minOccurs="1"
        maxOccurs="unbounded"></element>
    </sequence>
  </complexType>
</element>
</schema>

```

Validating an XML schema

In Application Developer v7.5, two validators are available, the Eclipse XSD-based XML schema validator and the Xerces-based XML schema validator. The Eclipse XSD-based XML validator is faster when validating large schemas and is set as the default. You can verify the setting in **Window** → **Preferences** → **Validation** → **XML schema Validator** (Figure 10-7):

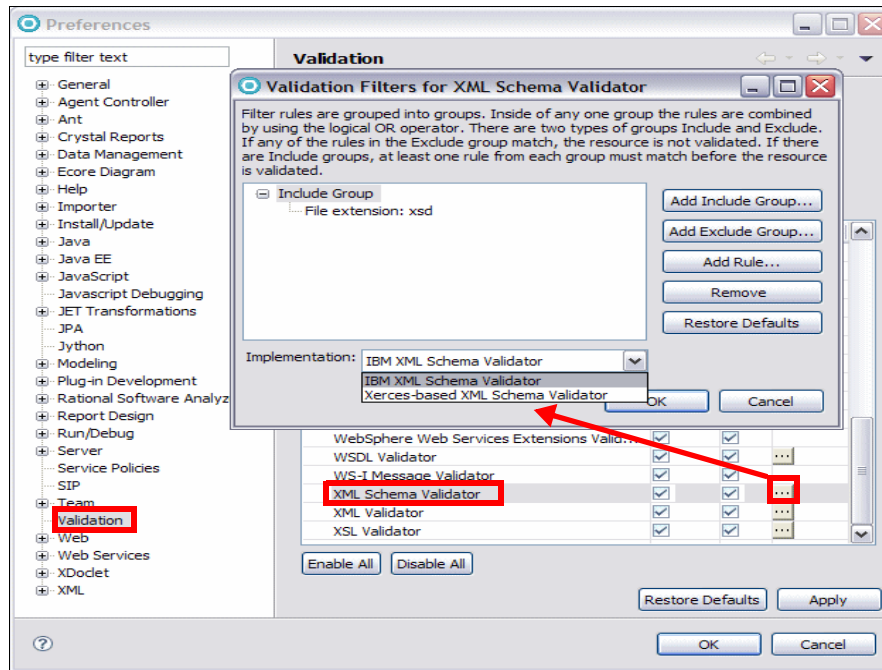

Figure 10-7 XML schema Validator preferences

In some cases, when you build a large Java Enterprise Edition (Java EE) project, the XSD validation process can take some time. You can disable the validator either at the project level, or, at the global level:

- ▶ To disable the validator at the project level, right-click the project and select **Properties** → **Validation**, select **Enable project specific settings**, and clear the **XML Schema Validator** check box in the Build column.
- ▶ To disable the validator at the global level, use the **Window** → **Preferences** dialog (Figure 10-7) and clear the **XML Schema Validator** check box in the Build column.

Run schema validation manually

The validation builder is not added to the simple projects, such as our project. To validate your XML schema, complete the following steps:

- ▶ Right-click `Account.xsd` in the Enterprise Explorer and select **Validate**.
- ▶ If validation is successful, a Validation Results pop-up informs you of the success. There are no errors in the Problems view.
- ▶ If validation is not successful, validation errors are displayed in the Problems view (you may have to open the view using **Window** → **Show View**). In addition, a red X appears next to the file and in the Source view.

You should not receive any XML schema validation errors for `Accounts.xsd`, because we created it in Design view and did not enter the XML manually.

If you want to make the document invalid so that you can see an error report, change the type of one of the elements from **decimal** to **deximal**, and execute validation again. After doing this and reading the error message, correct the error and run validation again to remove the error message.

Generating HTML documentation from an XML schema file

HTML documentation generated from an XML schema contains information about the schema such as its name, location, and namespace, as well as details about the elements and types contained in the schema. This can be useful because it provides a summary of the content of a schema in a form that is easily readable.

The following steps generate HTML documentation based on an XML schema file:

- ▶ In the Enterprise Explorer, right-click **Accounts.xsd** and select **Generate** → **HTML**. The **XSD Documentation Generation Options** dialog opens.
- ▶ Select **Generate XSD Documentation with frames**. Selecting this option generates schema documentation that uses HTML frames. If frame are not required then select **Generate XSD Documentation without frames**
- ▶ Click **Next**. Type **docs** as the folder name, and click **Finish**.

The HTML files are created in the location specified and the generated `index.html` file is opened inside Application Developer. Explore the generated documentation by selecting the **Account** type. You can see the diagram and expand the underlying source code.

Generating an XML file from an XML schema

Rational Application Developer is capable of generating an XML document from an XML schema. This is useful since it allows a developer to gain familiarity with XML documents that are valid against a specific schema. In practice a schema is used to validate XML documents created elsewhere. Also, an XML document generated from a schema is often called an XML instance document or simple an instance document. To generate an XML file from our XML schema file, follow these steps:

- ▶ In the Enterprise Explorer, right-click **Accounts.xsd** and select **Generate** → **XML File**.
- ▶ Accept the default name `Accounts.xml`. Click **Next**.
- ▶ The XML schema you created earlier does not have optional attributes or elements. Accept the default values in the Select Root Element page (**Create first choice of required choice, Fill elements and attributes with data**). Click **Finish**.
- ▶ The XML file opens in the editor.
- ▶ Right-click the generated XML file **Account.xml** and select **Validate**. Notice the validation errors against `AccountID`, `interest`, and `phoneNumber`. The default values inserted by Rational Application Developer are not valid against the schema.
 - The XML schema specifies that the account id is 6 to 8 digits long. Change the account id to 123456.
 - Change the interest value to one which is valid (5.5).
 - Change the phone number to a valid (xxx) xxx-xxxx format, for example, (123) 456-7890.
 - Optionally change the `firstName` and `lastName` to your name.
- ▶ Right-click **Account.xml** and select **Validate**. You should have no validation errors.

Editing an XML file

The XML editor enables you to directly edit XML files. There are several different views you can use to edit an XML file (Figure 10-8):

- ▶ **Source view**—You can manually insert, edit, and delete elements and attributes in the Source view of the XML editor. To facilitate this effort, you can use content assist (Ctrl-Space).
- ▶ **Design view**—You can insert, delete, and edit elements, attributes, comments, and processing instructions in this view. We used this view

previously when we created our XML schema. When editing an XML file which is not a schema the Design view presents the document as a tree of elements with attributes rather than the format we saw previously.

- ▶ **Outline view**—You can insert and delete elements attributes, comments, and processing instructions in this view.

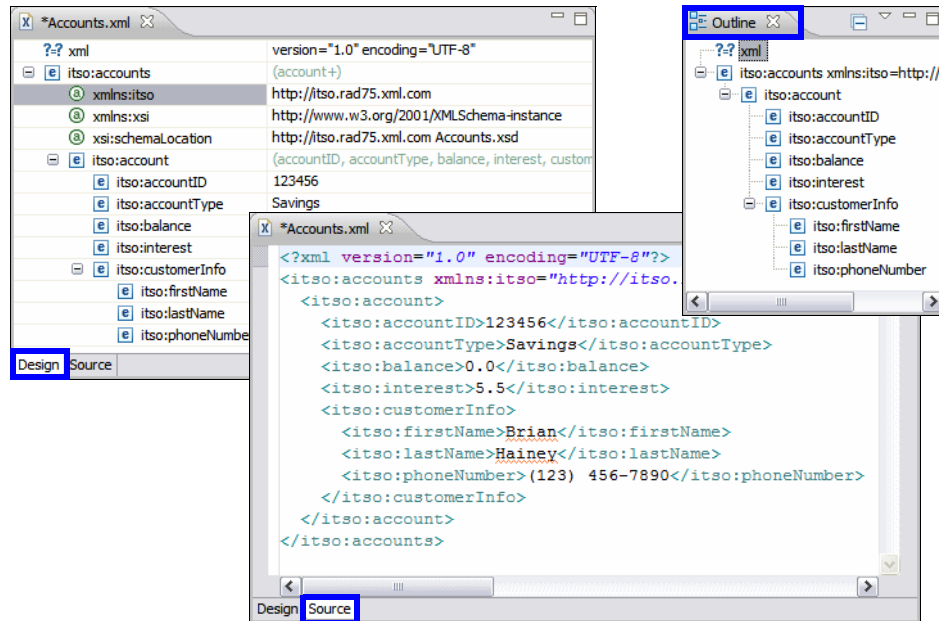

Figure 10-8 Design view, Source view, and Outline view

Editing in the Source view

We continue to work on the XML file we generated in the last section:

- ▶ In the Source view, place your cursor after the closing tag `</itso:account>`.
- ▶ Press **Ctrl+Space** to activate code assist. A pop-up list of available choices, which is based on the context, is displayed. Double-click `<itso:account>`.

Note: Content assist works because the document is associated with the schema we created, and the editor can use the schema to determine what is valid content for specific locations in the document. The start tag shows how this association is specified:

```
<itso:accounts xmlns:itso="http://itso.rad75.xml.com"
  xmlns:xsi="http://www.w3.org/2001/XMLSchema-instance"
  xsi:schemaLocation="http://itso.rad75.xml.com Accounts.xsd ">
```

- ▶ While the cursor is still between `<itso:account>` tags, press **Ctrl+Space** and double-click `<itso:accountID>`.
- ▶ Type a number for accountID between the start and end tags.
- ▶ Repeat the same procedure to use the code assist feature to input the rest of the information, such as accountType, balance, and so forth. Note that all child tags are required.
- ▶ After you finish typing, you can **right-click** in the XML source area and select **Format** → **Document**.

Editing in the Design view

- ▶ In the Design view, right-click **itso:accounts** and select **Add Child** → **account**.
- ▶ Expand the Account element you just created. All the child elements are created with default values. You can now edit the values of the child elements. In the Source view you have to add each child tag individually.

Editing in the Outline view

- ▶ In the Outline view, right-click **itso:accounts**. You see a similar context menu as in the Design view.
- ▶ Save and close the file.

Working with XSL transformation files

An XSL transformation file is a style sheet that can be used to transform XML documents into other document types and to format the output. In this section, we create a simple XSL style sheet to format the XML file data into a table in an HTML file.

Create a new XSL transformation file

To create a sample XSL transformation file, follow these steps:

- ▶ Right-click the **xml** folder and select **New** → **Other** → **XML** → **XSL**, then click **Next**.
- ▶ In the File name field type **Accounts.xsl** and click **Next**.
- ▶ In the Select XML file dialog, select the **Accounts.xml** file (expand RAD75XMLBank/xml). This associates the Accounts.xml file with the Accounts.xsl file.
- ▶ Click **Finish**.

The generated XSL file is listed in Example 10-2.

Example 10-2 Generated Accounts.xml file

```
<?xml version="1.0" encoding="UTF-8"?>
<xsl:stylesheet xmlns:xsl="http://www.w3.org/1999/XSL/Transform"
  version="1.0"
  xmlns:xalan="http://xml.apache.org/xslt">
</xsl:stylesheet>
```

Creating the XSL transformation file

The XSL editor provides help with creating content in the style sheet through the **Snippets** view. We use the Snippets view here to add an HTML header and an table.

Note: If you cannot see the Snippets view, select **Window** → **Show View** → **Other** → **General** → **Snippets**.

To add code snippets to the XSL file, do the following:

- ▶ In the XSL editor position the **cursor** between the `<xsl:stylesheet>` tags, right after `xmlns:xalan="http://xml.apache.org/xslt">`.
- ▶ Select the **Snippets** view and select the **XSL drawer** (Figure 10-9).

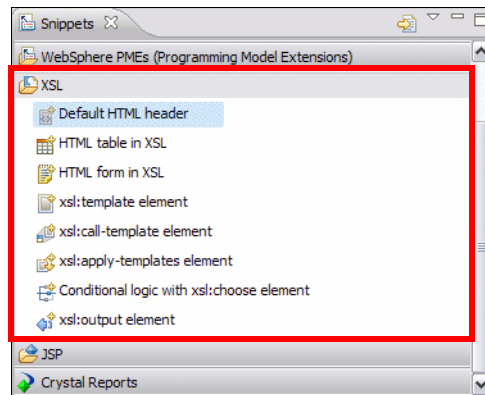
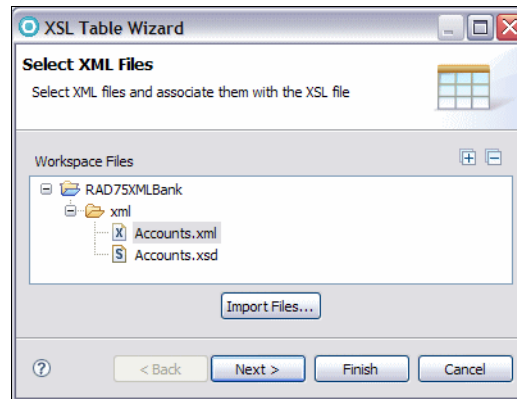

Figure 10-9 Snippets view, XSL drawer

- ▶ Double-click **Default HTML header**. This adds default HTML header information to the XSL file.
- ▶ Position the **cursor** after the end tag `</xsl:template>`.
- ▶ In the XSL drawer double-click **HTML table in XSL**. The XSL Table Wizard opens.

- ▶ If we did not associate the XSL file with an XML file, the first page of the wizard allows us to do the association (Figure 10-10)



In our case this page is skipped because we already did the association.

Figure 10-10 XSL Table Wizard, Select XML files

Tip: It is possible to view or change XML file associations at any time by right-clicking the xsl file in Enterprise Explorer and selecting **Properties**. Select **Associations** to view and edit the associations for the XSL file.

- ▶ The next page of the wizard is where we add the table to the XSL file (Figure 10-11):
 - Select **Wrap table in a template**.
 - Select **Include header** to indicate that you want to include a header row in the table.
 - Select one of the nodes on the left (for example, `itso:account`), and you can see the generated code at the bottom.
 - Click **Next**.

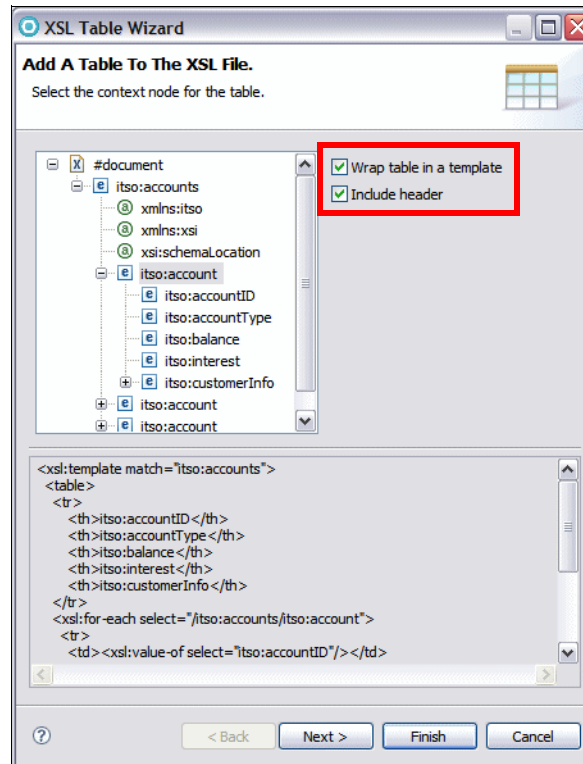

Figure 10-11 XSL Table wizard, Add A Table To XSL file

- ▶ The final wizard page allows properties for the table to be specified. Type **5** for the Border field and **10** for the Cell spacing field. Select a background color (**light cyan**), and a row color (**white**).
- ▶ Click **Finish**, and the `Accounts.xsl` file is completed.
- ▶ In the Source, make a few changes:
 - Right-click and select **Source** → **Format**.
 - Change the `<title>` to **Accounts**.
 - Remove the `itso:` prefix from the values in the table header fields, for example, `<th>itso:AccountID</th>`.
 - Save and close the file.
- ▶ Right-click **Accounts.xsl** and select **Validate**. You should not receive any validation errors or warnings.
- ▶ The generated `Accounts.xsl` file is listed in Example 10-3.

Example 10-3 Accounts.xsl file

```

<?xml version="1.0" encoding="UTF-8"?>
<xsl:stylesheet xmlns:xsl="http://www.w3.org/1999/XSL/Transform"
  version="1.0" xmlns:xalan="http://xml.apache.org/xslt"
  xmlns:itso="http://itso.rad75.xml.com">
  <xsl:output method="html" encoding="UTF-8" />
  <xsl:template match="/">
    <html>
      <head>
        <title>Accounts</title>
      </head>
      <body>
        <xsl:apply-templates />
      </body>
    </html>
  </xsl:template>
  <xsl:template match="itso:accounts">
    <table bgcolor="#80ffff" border="5" cellspacing="10">
      <tr bgcolor="#ffffff">
        <th bgcolor="#ffffff">
          <th>accountID</th>
          <th>accountType</th>
          <th>balance</th>
          <th>interest</th>
          <th>customerInfo</th>
        </tr>
        <xsl:for-each select="/itso:accounts/itso:account">
          <tr bgcolor="#ffffff">
            <td>
              <xsl:value-of select="itso:accountID" />
            </td>
            <td>
              <xsl:value-of select="itso:accountType" />
            </td>
            <td>
              <xsl:value-of select="itso:balance" />
            </td>
            <td>
              <xsl:value-of select="itso:interest" />
            </td>
            <td>
              <xsl:value-of select="itso:customerInfo" />
            </td>
          </tr>
        </xsl:for-each>
      </table>
    </xsl:template>
  </xsl:stylesheet>

```

Transforming an XML file into an HTML file

We can now use the XSL stylesheet file to generate an HTML file from the sample XML file:

- ▶ In the Enterprise Explorer, hold down the **Ctrl** key and select both the **Accounts.xml** and **Accounts.xsl** files.
- ▶ Right-click and select **Run As** → **XSL Transformation**.
- ▶ The resulting file name is **_Accounts_transform.html**. The file is automatically opened in the Page Designer.
- ▶ Select the **Split** view (Figure 10-12).

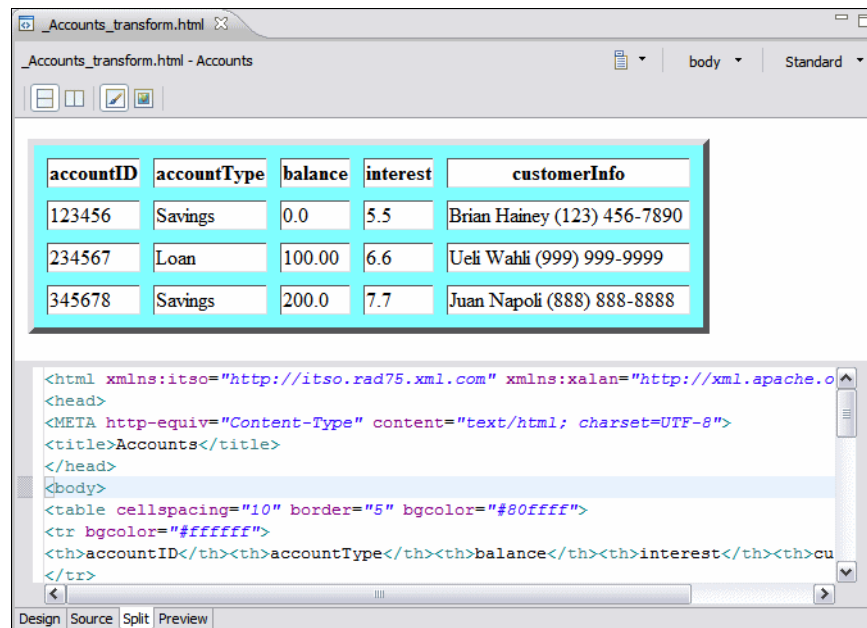



Figure 10-12 XSL stylesheet transformation result

- ▶ Notice the transformation messages in the Console view:

```

Processing:
XSL file name:
file:///E:/Workspaces/RAD75proguide/RAD75XMLBank/xml/Accounts.xsl.
XML input file name:
file:///E:/Workspaces/RAD75proguide/RAD75XMLBank/xml/Accounts.xml.
Result file name:
E:/Workspaces/RAD75proguide/RAD75XMLBank/xml/_Accounts_transform.html.

```

Note: The **Split** view in the **Page Designer** is new to Rational Application Developer 7.5. It is a combination of the **Design** view and the **Source** view where both the Design and the Source can be viewed simultaneously. The split between the two views can be either vertical or horizontal by clicking one of the icons in the tool bar . Note that changing the source code automatically changes the design.

XML mapping

The XML Mapping editor is a visual data mapping tool that is designed to transform any combination of XML schema, DTD, or XML documents, and produce a deployable transformation document. You can map XML-based documents graphically by connecting elements from a source document to elements from a target document. You can extend built-in transformation functions using custom XPath expressions and XSLT templates. The mapping tool automates XSL code generation and produces a transformation document based on the mapping information you provide.

When mapping between a source XML file and target XML file many different types of mapping transformation can be applied. The simplest is **Move** where the values are simply transferred between source and target. Other mapping transformations such as **Concat** perform more complex processing on the values. The different types of mapping transformation that are available are shown in Table 10-1.

Table 10-1 Available mapping transformations

Option	Description
Move	This type copies data from a source to a target.
Concat	This type creates a string concatenation that allows you to retrieve data from two or more entities to link them into a single result.
Inline map	This type enables the map to call out to other maps, but other maps cannot call it. It can only be used within the current map. If the inputs and outputs are arrays, the inline map is implicitly iterated over the inputs.
Submap	This type references another map. It calls or invokes a map from this or another map file. Choosing this transform type is most effective for reuse purposes.

Option	Description
Substring	This type extracts information as required. For example, the substring lastname, firstname with a "," delimiter and a substring index of 0 returns the value lastname. If the substring index was changed to 1 the output would now be firstname.
Group	This type takes an array or collection of data and groups them into a collection of a collection. Essentially, it is an array containing an array. Grouping is done at the field level, meaning that it is done by selecting a field of the input collection such as "department."
Normalize	This type normalizes the input string. For example, it can be used to remove multiple occurrences of white space (such as space, tab, or return).
Custom	This type allows you to enter custom code or call reference code to be used in the transform. You can extend built-in transformation functions using custom XPath expressions and XSLT templates.
Assign	Assign a constant value to an output element (right-click the output element and select Create transform). Set the value in the Properties view (use single quotes for strings).

In this section, we show an example involving the mapping of two XML schemas. We use the mapping transformations **Move**, **Concat**, **Inline map**, **Substring**, and **Custom**.

Preparation and import

To prepare for the XML mapping import the provided XSD files and XML file:

- ▶ Accounts.xsd—This is the same file that we created previously and is the source schema for the mapping.
- ▶ AccountsList.xsd—This is an alternate representation of accounts and is our target schema for the mapping.
- ▶ Accounts.xml—This XML file contains sample data and is similar to the file we created previously.

To import the files, do the following:

- ▶ Create a new folder in the RAD75XMLBank project by right-clicking **RAD77XMLBank** and selecting **New** → **Folder**. Type **mapping** as the folder name and click **Finish**.
- ▶ Right-click the **mapping** folder and select **Import** → **General** → **File System** and click **Next**. Click **Browse** to navigate to the **c:\7672code\xml** folder. Click **OK**. Select **AccountList.xsd** and click **Finish**.

- ▶ Copy the `Accounts.xml` and `Accounts.xsd` files from the `xml` folder to the mapping folder.

Launching the XML Mapping editor

The XML Mapping editor is used to create a mapping between the two XML schemas:

- ▶ To launch the XML Mapping editor, right-click the **mapping** folder and select **New** → **Other** → **XML** → **XML Mapping** and click **Next**.
- ▶ The parent folder is set to `RAD75XMLBank/mapping`.
- ▶ In the File name field type **Accounts.map**, and click **Next**.
- ▶ For Root inputs, click **Add**:
 - Select **XML schema** from the Files of type drop-down list, and click **Browse**. Expand `RAD75XMLBank` and select **mapping** → **Accounts.xsd** and click **OK**.
 - Select the `accounts` element from the Global elements and types list. Click **OK** (Figure 10-13).

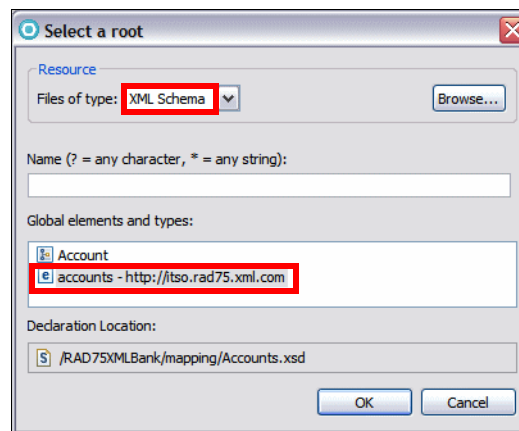

Figure 10-13 Selecting an input root for the mapping

- ▶ For Root outputs, click **Add**, select the **AccountsList.xsd** file and the **accounts** element (same as for the Root input).
- ▶ Click **Next**.
- ▶ To select a sample XML input file, click **Add**. Select **Accounts.xml** and click **OK** (Figure 10-14).

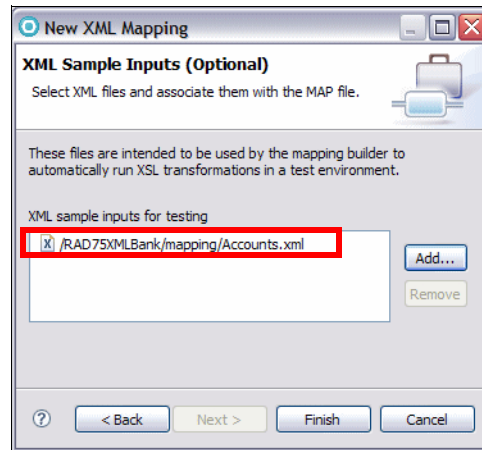

Figure 10-14 XML sample input

- ▶ Click **Finish** and the XML Mapping editor opens.

In the Enterprise Explorer, three new files are generated:

- `Accounts.xsl`: An XSL transformation file
- `Accounts-out.xml`: The transformation output XML file
- `Accounts.map`: The mapping file

Organizing the XML Mapping editor

Part of the beauty of this tool is that you can see the changes you making to the resulting output xml file when you work on a mapping.

Before we start editing the mapping, we do the following:

- ▶ Open **Accounts-out.xml**, then drag the editor panel down to the bottom part of the mapping file (until a down arrow appears), so that it sits under `Accounts.map`.
- ▶ In the Workbench layout, the mapping file is at the top. The resulting xml file is in the middle, and the Properties view is at the bottom (Figure 10-15).

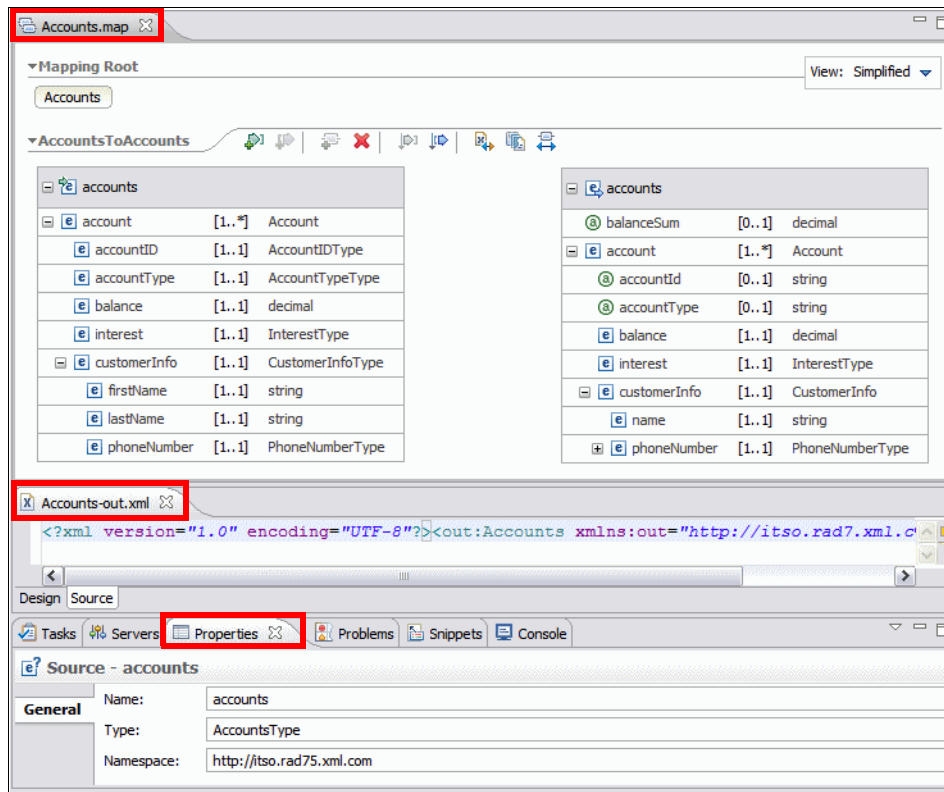

Figure 10-15 Workbench layout for the XML Mapping editor

Editing the XML mapping

We now create the mapping between the two XML schemas:

- ▶ In the XML Mapping editor, select the **account** element from `Accounts.xsd` on the left hand side, and drag it to the **account** element from `AccountList.xsd` on the right hand side (Figure 10-16).

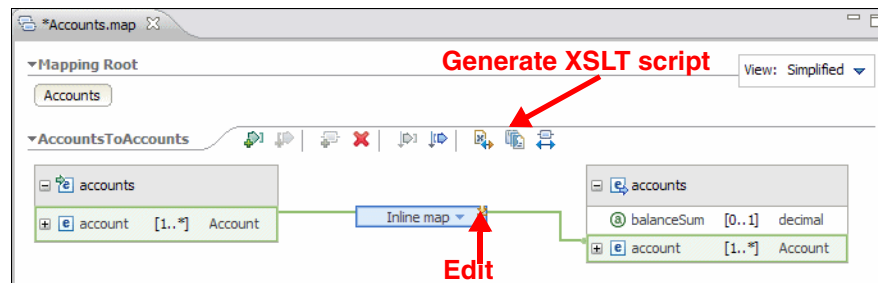

Figure 10-16 Inline map

- ▶ Click **Generate XSLT script**. See Figure 10-16 for help in finding this icon. Check the **Accounts-out.xml** file and you will see that it has changed.

Note: Alternatively, you can simply save the mapping file and the changes are automatically reflected in the resulting xml file.

Inline mapping

- ▶ Click **Edit** at the top right corner of the **Inline map**. See Figure 10-16 to find the **Edit** icon.
- ▶ In the Inline map details view, perform the following mapping transforms:
 - Map the `accountID`, `accountType`, `balance`, and `interest` by dragging the elements from the left to the corresponding elements on the right. Note that we map the element `accountID` to the attribute `accountId`.
 - Click **Generate XSLT script** and verify how the account information is generated in the XML output.
 - Map the `customerInfo` element from left to right. This creates an inline map (Figure 10-17).

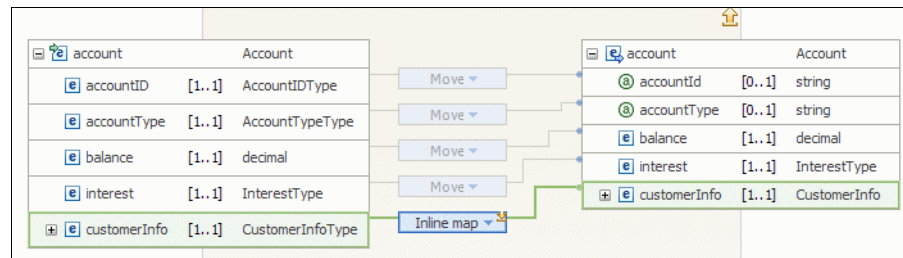

Figure 10-17 Account mapping

- ▶ Click **Generate XSLT script** to see the change in the output XML file.

Concatenation mapping

The mapper allows us to define mappings where a set of input values are concatenated to a single output value. Here we will concatenate `firstName` and `lastName` in the source into one `Name` element in the target:

- ▶ Click **Edit** at the top right corner of the `customerInfo` Inline map and add these transformations:
 - Select the `firstName` element and drag it to the `name` element on the right.
 - Select the `lastName` element and drag it to the **Move** transform box between the `firstName` and `name`. When you drag a second element to the

transform type box, the transform type automatically changes to **Concat** (Figure 10-18).

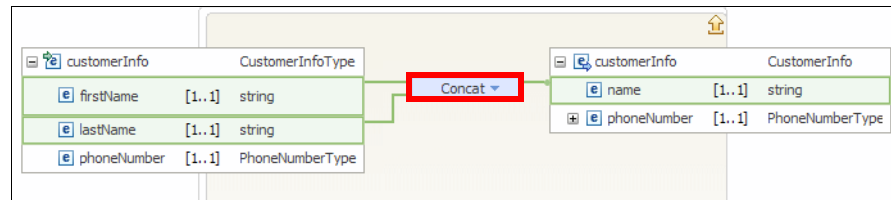



Figure 10-18 Concatenation mapping

- ▶ We want to concatenate the name in the format `lastName, firstName`:
 - Select the **Concat** transformation, and in the Properties view, select the **Order** tab.
 - Select **lastName** and click the **Reorder Up** icon .
 - Select the **General** tab, select **lastName**, and put `,` in the Delimiter column (with a space after the comma).
 - Click **Generate XSLT script icon**. The changes are visible in **Accounts-out.xml** file.

Substring mapping

The phone number is stored as a single data type in the source document and we want to separate it into the sub-elements of area code and local number in the target document.

- ▶ The following steps perform the Substring mapping transformation :
 - Select the `phoneNumber` element on the left and drag it to the `areaCode` element on the right. You have to expand the `phoneNumber` element in the target to see the `areaCode` element.
 - Click the **drop-down arrow** in the transformation and select **Substring** from the list.
 - Right-click the transformation and select **Show in Properties**.
 - In the Properties view, select the **General** tab. In the Delimiter field put a space. Because the phone number format is `(xxx) xxx-xxxx`, the space should be the delimiter between area code and local number.
 - In the Substring index field, type **0**.
 - Select the `phoneNumber` element and drag it to the `localNumber` element.
 - Change the transform type to **Substring**.
 - In the Properties view, Delimiter field, type a space.

- In the Substring index field, type **1**. The current mapping is shown in (Figure 10-19).

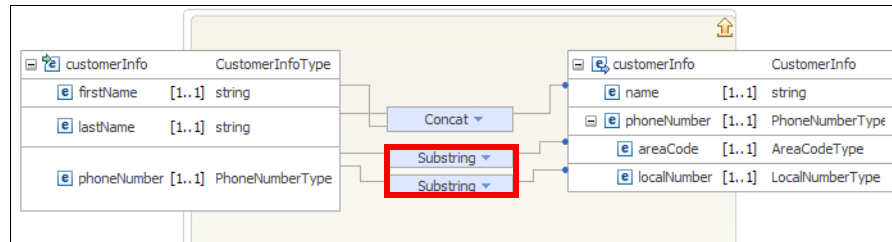



Figure 10-19 Substring mapping

- ▶ To return to the main map, click the **Up a level** icon  at the top right of the inline map details page. Do it twice to return to the main map.

Calculation

We want to calculate the sum of the balance from all accounts and put it in the `balanceSum` attribute of the output document. An XPath expression is used to calculate this total.

- ▶ Select the **accounts** element on the left and drag it to the **balanceSum** attribute on the right.
- ▶ Click the **transform type box**, and select **Custom** (Figure 10-20).

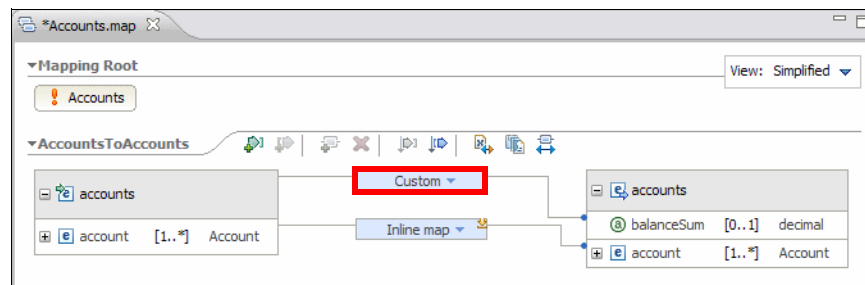

Figure 10-20 Custom mapping

- ▶ Select the **Custom** mapping transformation. In the Properties view select the **General** tab. Select **XPath** option for Code and type **sum(./in:balance)** as the XPath expression (Figure 10-21).

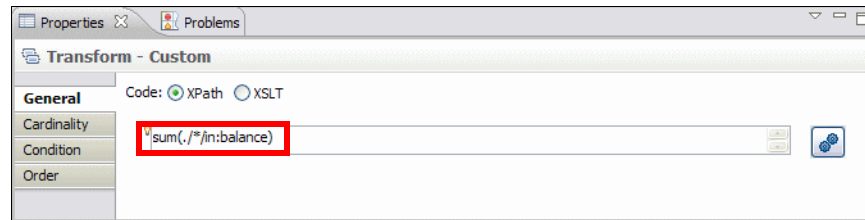

Figure 10-21 Custom mapping using XPath

- ▶ Save the mapping file and click **Generate XSLT script** to see the final output XML file. Notice the `balanceSum` attribute of the `accounts` element, the concatenated name, and the area code and local number (Example 10-4).

Example 10-4 Final output showing the `balanceSum` attribute

```

<?xml version="1.0" encoding="UTF-8"?>
<out:accounts xmlns:out="http://itso.rad75.xml.com"
  xmlns:xsi="http://www.w3.org/2001/XMLSchema-instance" balanceSum="300">
  <out:account accountId="123456" accountType="Savings">
    <out:balance>0.0</out:balance>
    <out:interest>5.5</out:interest>
    <out:customerInfo>
      <out:name>Hailey, Brian</out:name>
      <out:phoneNumber>
        <out:areaCode>(123)</out:areaCode>
        <out:localNumber>456-7890</out:localNumber>
      </out:phoneNumber>
    </out:customerInfo>
  </out:account>
  .....
</out:accounts>

```

Generating JavaBeans from an XML schema

To allow developers to quickly build an XML application, the XML schema editor supports the generation of beans from an XML schema. Using these beans, you can quickly create an instance document or load an instance document that conforms to the XML schema.

To generate beans from an XML schema, do the following:

- ▶ Create a Java project to contain the beans:
 - Select **File** → **New** → **Project** → **Java** → **Java Project** and Click **Next**.
 - Type **RAD75XMLBankJava** in the Project name field and click **Finish**.

- If you are prompted to switch to the Java perspective, click **Yes**.
- ▶ Generate the JavaBeans:
 - In the Enterprise Explorer, expand project RAD75XMLBank, right-click on **Accounts.xsd** and select **Generate** → **Java**.
 - When the Generate Java dialog is displayed (Figure 10-22), select the **SDO Generator** and click **Next**.

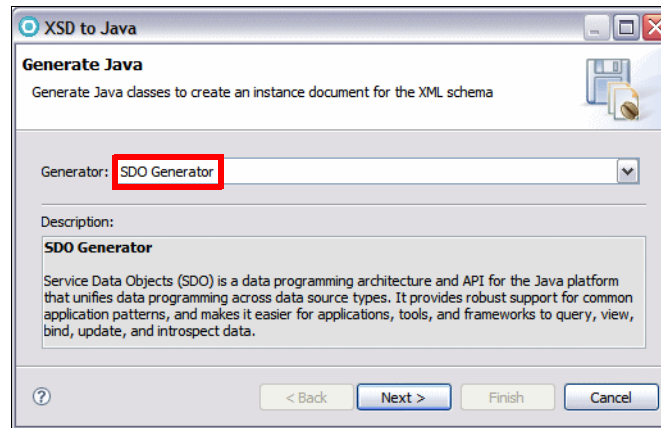

Figure 10-22 XSD to Java Dialog

- ▶ For the Container field, click **Browse**, select **/RAD75XMLBankJava/src**, and click **Finish**.
- ▶ Expand the RAD75XMLBankJava project and study the generated packages:
 - `com.xml.rad75.itso`—interfaces
 - `com.xml.rad75.itso.impl`—implementation classes
 - `com.xml.rad75.itso.util`—utility classes

Use the generated JavaBeans

To test the generated beans, we create a test class named `AccountsTest`. This class creates an instance of the `Accounts` object and serialize the instance into XML format:

- ▶ In the Enterprise Explorer, right-click **RAD75XMLBankJava** and select **New** → **Class**.
- ▶ Type `com.xml.rad75.itso.sdo` for the package name and **AccountsTest** for the class name, and click **Finish**.
- ▶ Complete the class with the sample code shown in Example 10-5. You can find the `AccountsTest.java` file in the `c:\7672code\xml` folder.

Study the main method first, then study the helper methods that are called from the main method, marked in bold. The call to the save method on the class `ItsoResourceUtil` serializes the SDO object tree and outputs the string to the supplied file name or output stream class instance.

Example 10-5 AccountTest program

```
package com.xml.rad75.itso.sdo;

import java.math.BigDecimal;
import com.xml.rad75.itso.*;
import com.xml.rad75.itso.util.ItsoResourceUtil;

public class AccountsTest {
    private DocumentRoot createDocumentRoot() {
        DocumentRoot documentRoot = ItsoFactory.eINSTANCE.createDocumentRoot();
        return documentRoot;
    }

    private AccountType createAccountType() {
        AccountType accountType = ItsoFactory.eINSTANCE.createAccountType();
        return accountType;
    }

    private Account createAccount(AccountType accountType,
        String accountId, BigDecimal balance, BigDecimal interest,
        CustomerInfoType customerInfo) {
        Account account = ItsoFactory.eINSTANCE.createAccount();
        account.setAccountType(accountType);
        account.setAccountID(accountId);
        account.setBalance(balance);
        account.setInterest(interest);
        account.setCustomerInfo(customerInfo);
        return account;
    }

    private CustomerInfoType createCustomerInfo(String firstName,
        String lastName, String phoneNumber) {
        CustomerInfoType customerInfo =
            ItsoFactory.eINSTANCE.createCustomerInfoType();
        customerInfo.setFirstName(firstName);
        customerInfo.setLastName(lastName);
        customerInfo.setPhoneNumber(phoneNumber);
        return customerInfo;
    }

    public static void main(String args[]) throws Exception {
        AccountsTest sample = new AccountsTest();
        DocumentRoot documentRoot = sample.createDocumentRoot();
    }
}
```

```

AccountsType accountsType = sample.createAccountsType();
CustomerInfoType customerInfo;

customerInfo = sample.createCustomerInfo("Brian", "Hainey",
                                         "(123) 456-7891");
Account account = sample.createAccount(AccountTypeType.SAVINGS_LITERAL,
                                       "123456", new BigDecimal(20000.00),
                                       new BigDecimal(3.5), customerInfo);
accountsType.getAccount().add(account);

customerInfo = sample.createCustomerInfo("Ueli", "Wahli",
                                         "(408) 345-6780");
account = sample.createAccount(AccountTypeType.FIXED_LITERAL, "123457",
                               new BigDecimal(50000.00), new BigDecimal(6.0), customerInfo);
accountsType.getAccount().add(account);

customerInfo = sample.createCustomerInfo("Juan", "Napoli",
                                         "(408) 345-6789");
account = sample.createAccount(AccountTypeType.LOAN_LITERAL, "123458",
                               new BigDecimal(60000.00), new BigDecimal(8.0), customerInfo);
accountsType.getAccount().add(account);

documentRoot.setAccounts(accountsType);

ItsoResourceUtil.getInstance().save(documentRoot, System.out);
ItsoResourceUtil.getInstance().save(documentRoot, "accounts.xml");
}
}
}

```

Run the sample

To execute the Java application, do the following:

- ▶ Right-click on **AccountTest.java** and select **Run As** → **Java Application**. The XML result is displayed in the Console view and stored in a file called `accounts.xml`.
- ▶ In the Package Explorer, right-click the **RAD75XMLBankJava** project and select **Refresh**. The generated `accounts.xml` file is shown in Example 10-6.

Example 10-6 Generated `accounts.xml` file

```

<?xml version="1.0" encoding="UTF-8"?>
<itso:accounts xmlns:itso="http://itso.rad75.xml.com">
  <itso:account>
    <itso:accountID>123456</itso:accountID>
    <itso:accountType>Savings</itso:accountType>
    <itso:balance>20000</itso:balance>
    <itso:interest>3.5</itso:interest>
  </itso:account>

```

```
<itso:customerInfo>
  <itso:firstName>Brian</itso:firstName>
  <itso:lastName>Hainey</itso:lastName>
  <itso:phoneNumber>(123) 456-7891</itso:phoneNumber>
</itso:customerInfo>
</itso:account>
<itso:account>
  .....
</itso:accounts>
```

Service Data Objects and XML

Service Data Objects (SDO) is a framework for data application development, which includes an architecture and API. SDO simplifies the Java EE programming model and abstracts data in a Service Oriented Architecture (SOA). SDO unifies data application development and supports data held in XML documents, incorporates Java EE patterns and best practices and provides uniform access to a variety of data sources.

The core concepts in the SDO architecture are the data object and the data graph:

- ▶ A data object holds a set of named properties, each of which is either of primitive Java type such as `int` or `char` or a reference to another data object. The data object API provides functionality for the manipulation of these properties.
- ▶ A data graph provides an envelope for data objects, and is the normal unit of transport of objects between components. Data graphs are also responsible for tracking the changes made to the graph of data objects, including inserts, deletes, and the modification of data object properties.

Data graphs are typically constructed from data sources, such as XML files, EJBs, XML databases, relational databases, or from services, such as Web services, JCA Resource Adapters and JMS messages. Components that populate data graphs from data sources and commit changes to data graphs back to the data source are called *Data Mediator Services* (DMS). The DMS architecture and associated APIs are outside the scope of the SDO specification.

In this section, we describe how to use SDO to access XML documents.

Loading an SDO data graph from XML

In this example we load the `accounts.xml` file into a data graph and display the content of the data graph on the console. To do this complete the following steps:

- ▶ Create a new Java class:

- In the Enterprise Explorer, right-click the **com.xml.rad75.itso.sdo** package in and select **New** → **Class**.
- Type **SDOSample** as the class name., and select **public static void main(String[] args)** so that a main method is generated.
- Click **Finish**.
- ▶ In the Enterprise Explorer, right-click **RAD75XMLBankJava** and select **Properties**. In the Properties dialog:
 - Select **Java Build Path** → **Libraries**.
 - Click **Add External JARs**, and add the **org.eclipse.emf.ecore.change_2.4.0.v200806091234.jar**, which is located in the installation folder <SDP7xShared>/plugins.
 - Click **OK** to add the new Jar to the project.
- ▶ Add the sample code to the main method including throws IOException (Example 10-7).

Example 10-7 Code to load an XML document

```
public static void main(String[] args) throws IOException {
    System.out.println("\n--- Printing XML document to System.out ---");
    DocumentRoot documentRoot =
        ItsoResourceUtil.getInstance().load("Accounts.xml");
    ItsoResourceUtil.getInstance().save(documentRoot, System.out);
    System.out.println("\n\n--- Done ---");
}
```

- ▶ Select **Source** → **Organize Imports** to add import statements.
- ▶ Right-click **SDOSample** and select **Run As** → **Java Application**. The `accounts.xml` file is displayed in the Console.

Navigating the SDO data graph

XPath expressions are used to obtain data from the data objects present in the data graph after the XML file is loaded.

Figure 10-23 shows the data graph for the `accounts.xml` file.

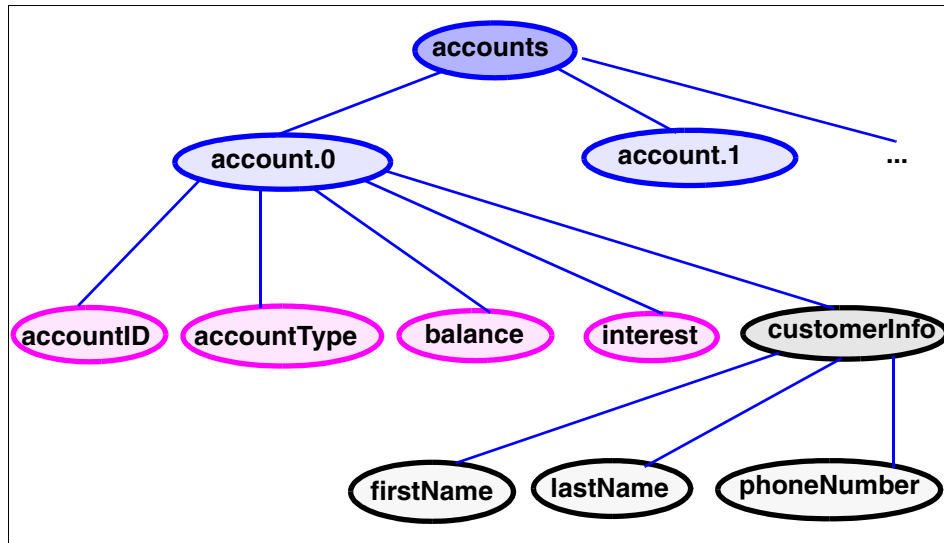

Figure 10-23 Accounts data graph

- Add the code shown in Example 10-8 to the main method.

Example 10-8 Java code for navigating the SDO data graph

```

// navigating the SDO data graph
AccountsType accountsType = documentRoot.getAccounts();
DataObject accountsTypeImpl = (AccountsTypeImpl) accountsType;
DataObject account1 = accountsTypeImpl.getDataObject("account.0");
System.out.println("\n\nThe first account is: " + account1 + "\n");
DataObject account2 = accountsTypeImpl.getDataObject
    ("account[accountID = '123457']");
System.out.println("The second account is: " + account2 + "\n");
DataObject account2CustomerInfo = accountsTypeImpl.getDataObject
    ("account[accountID = '123457']/customerInfo");
System.out.println("The second account customer information is: " +
    account2CustomerInfo + "\n");
String account1CustomerName = account1.getString("customerInfo/firstName");
System.out.println("The first account customer first name is " +
    account1CustomerName + "\n");

```

- The XPath dot notation is used to index data objects. The first object has index 0, therefore `account.0` returns the first account data object.
- The XPath expression `account[accountID = '123457']` returns the account data object whose account ID equals 123457.
- `account[accountID = '123457']/customerInfo` is an XPath expression that returns a data object multiple levels below the root data object.

- ▶ Right-click **SDOSample** and select **Run As** → **Java Application**. You can also select **Run** → **Run History** → **SDOSample**.

The Console output from the SDO graph navigation code is shown here:

```
The first account is: com.xml.rad75.itso.impl.AccountImpl@d8d0d8d
(accountID: 123456, accountType: Savings, balance: 20000, interest: 3.5)
```

```
The second account is: com.xml.rad75.itso.impl.AccountImpl@64d764d7
(accountID: 123457, accountType: Fixed, balance: 50000, interest: 6)
```

```
The second account customer information is:
com.xml.rad75.itso.impl.CustomerInfoTypeImpl@65506550 (firstName: Ueli,
lastName: Wahli, phoneNumber: (408) 345-6780)
```

```
The first account customer first name is Brian
```

Updating the SDO data graph

An SDO data graph can be modified and the modifications reflected in the source XML file which was loaded. In this example we update the interest rate of one account, add an account, and finally delete an existing account (Example 10-9).

Example 10-9 Updating an SDO data graph

```
// updating the SDO data graph
account1.setString("interest", "10");
DataObject account3 = accountsTypeImpl.createDataObject("account");
account3.setString("accountID", "333333");
account3.set("accountType", AccountTypeType.LOAN_LITERAL);
account3.setString("balance", "999999");
account3.setString("interest", "2.5");
DataObject newCustomerInfo = account3.createDataObject("customerInfo");
newCustomerInfo.setString("firstName", "Mike");
newCustomerInfo.setString("lastName", "Smith");
newCustomerInfo.setString("phoneNumber", "(201) 654-8754");
account2.delete();
System.out.println("\n--- Printing updated XML document ---");
ItsoResourceUtil.getInstance().save(documentRoot, System.out);
```

- ▶ The complete code listing of `SDOSample.java` can be found in the `c:\7672code\xml` folder.
- ▶ Select **Run** → **Run History** → **SDOSample**.

You can see that the interest rate for the first account (accountID = '123456') has been updated, the second account (accountID = '123457') has been removed, and a new account (accountID = '333333') has been added.

Note that the `accounts.xml` file is not updated because we only saved to the Console.

More information

For more information on XML schemas, refer to:

<http://www.w3.org/XML/Schema>

For more information on XML, refer to:

<http://www.w3.org/XML/>

For more information on XML parsers, refer to:

▶ Xerces (XML parser - Apache):

<http://xml.apache.org/xerces2-j>

▶ Xalan (XSLT processor - Apache):

<http://xml.apache.org/xalan-j>

▶ JAXP (XML parser - Sun):

<http://java.sun.com/xml/jaxp>

▶ SAX2 (XML API):

<http://sax.sourceforge.net>

For more information on SDO, refer to:

<http://www-128.ibm.com/developerworks/java/library/j-sdo/>

<http://www.osoa.org/display/Main/SDO+Resources>



Part 4

Persistence application development

In this part of the book, we describe the tooling and technologies provided by Application Developer to develop applications using databases and the Java Persistence API (JPA).

Note: The sample code for all the applications developed in this part is available for download at:

<ftp://www.redbooks.ibm.com/redbooks/SG247672>

Refer to Appendix B, “Additional material” on page 1149 for instructions.



Develop database applications

In an enterprise environment, applications that use databases are very common. In this chapter we explore technologies that are used in developing Java database applications. Our focus is on highlighting the database tooling provided with IBM Rational Application Developer v7.5.

This chapter is organized into the following sections:

- ▶ Introduction
- ▶ Connecting to the ITSOBANK database
- ▶ Connecting to databases
- ▶ Creating SQL statements
- ▶ Developing a Java stored procedure
- ▶ Developing SQLJ applications
- ▶ Data modeling

Introduction

Rational Application Developer provides rich features to make it easier to work with tables, views, and filters; create and work with SQL statements; create and work with database routines (such as stored procedures and user-defined functions), and create and work with SQLJ files. You can also create, modify, and generate data models. Depending on your goals, you might have to take certain steps to set up your work environment.

Depending on your goals, this chapter is written for three types of users:

- ▶ If you want to **access** databases and discover information about them, you can use the database explorer to create a connection to those databases. After you have set up connection information for a database, you can connect, refresh a connection, and browse the objects that are contained in the database.
- ▶ If you want to **develop** database related activities such as SQL queries and stored procedures, you have to create a data development project. The data development project stores your routines and other data development objects. Application developer also provides tooling to assist you to develop SQLJ applications, and offers a DB beans package to access database information without directly using the JDBC interface.
- ▶ If you want to **design** your database model, you have to create a data design project to store your objects. The modeling tool assists you to build a data model, analyze the model, perform the impact analysis, and so forth.

All examples in this chapter are demonstrated against the open source embedded Derby database server. The embedded version of Derby is bundled inside Rational Application Developer, so its availability is guaranteed. These examples can be easily applied to DB2 databases.

Connecting to the ITSOBANK database

We provide two implementations of the ITSOBANK database, Derby and DB2. Follow the instructions in “Setting up the ITSOBANK database” on page 1154 to set up the database.

The ITSOBANK database has four tables: CUSTOMER, ACCOUNT, ACCOUNT_CUSTOMER, and TRANSACT. Note that the name TRANSACTION is reserved in the Derby database, therefore we used TRANSACT.

An account can have multiple transactions and the ACCOUNT_ID becomes the foreign key in the TRANSACT table and is related to the primary key of the ACCOUNT table.

There is a many-to-many association between customers and accounts. ACCOUNT_CUSTOMER is the junction table to turn this many-to-many relationship into a one-to-many relationship between CUSTOMER and ACCOUNT_CUSTOMER and a one-to-many relationship between ACCOUNT and ACCOUNT_CUSTOMER.

Connecting to databases

Application Developer enables you to create a connection to the following databases:

- ▶ Cloudscape
- ▶ DB2 for Linux, UNIX, and Windows
- ▶ DB2 i5/OS
- ▶ DB2 for z/OS
- ▶ Derby
- ▶ HSQLDB
- ▶ Informix
- ▶ MaxDB
- ▶ MySQL
- ▶ Oracle
- ▶ SQL Server
- ▶ Sybase
- ▶ Generic JDBC

Creating a connection to the ITSOBANK database

To connect to the Derby **ITSOBANK** database using the New Database Connection wizard, do these steps:

- ▶ Stop the WebSphere Application Server v7 if it is running and has accessed the ITSOBANK database for other chapters, as Derby only allows one connection.
- ▶ Open the Data perspective by selecting **Window** → **Open Perspective** → **Other**. In the Open Perspective dialog, select **Data** and click **OK**. The Data perspective opens.
- ▶ Locate the Data Source Explorer view, typically at the bottom left in the Data perspective.
- ▶ In the Data Source Explorer, right-click **Databases** and select **New**.

- ▶ In the New Connection wizard, do these steps (Figure 11-1):
 - Clear **Use default naming convention** and type **ITSOBANKderby** as Connection Name.
 - For Select a database manager select **Derby**.
 - For JDBC driver select **Derby 10.2 - Embedded JDBC Driver Default**.
 - For Database location click **Browse** and locate **C:\7672code\database\derby\ITSOBANK**.
 - Leave the User name and Password fields empty, as derby database does not require authentication.
 - Select **Create database (if required)**.
 - Click **Test Connection**, and a pop-up displays Connection succeeded. Click **OK** to close the pop-up.
 - Click **Next**.

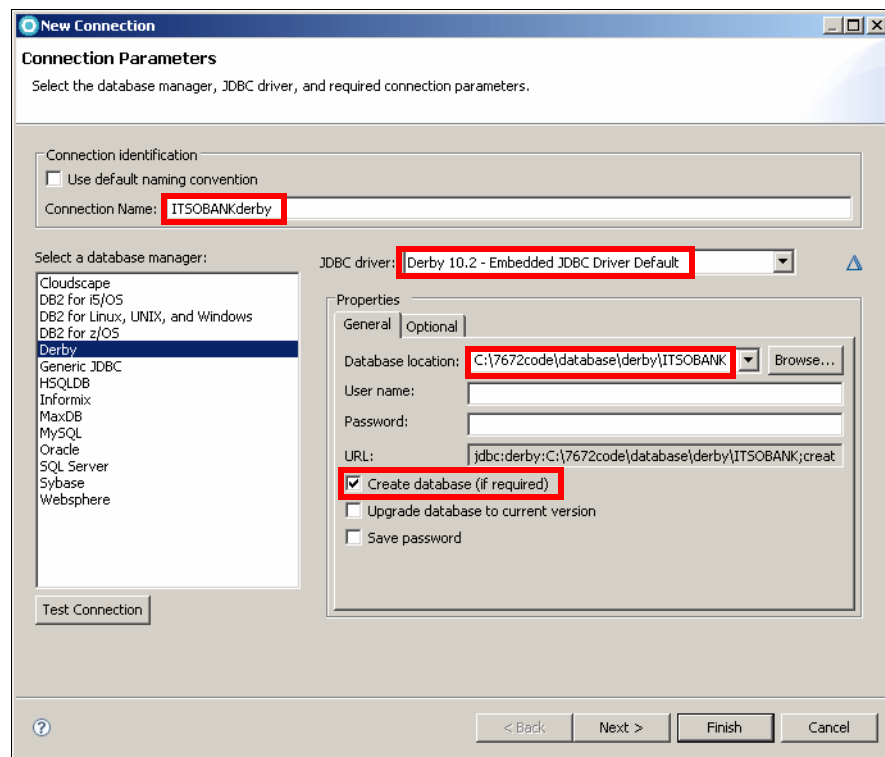

Figure 11-1 New Connection: Connection Parameters

- ▶ You can use filters to exclude data objects (such as tables, schemas, stored procedures, and user-defined functions) from the view. Only the data objects that match the filter condition are shown. We only want to see the objects in schema **ITSO** (Figure 11-2):
 - Clear **Disable filter**.
 - Select **Selection**.
 - Select **Include selected items**.
 - From the schema list, select **ITSO**.
 - Click **Finish**.

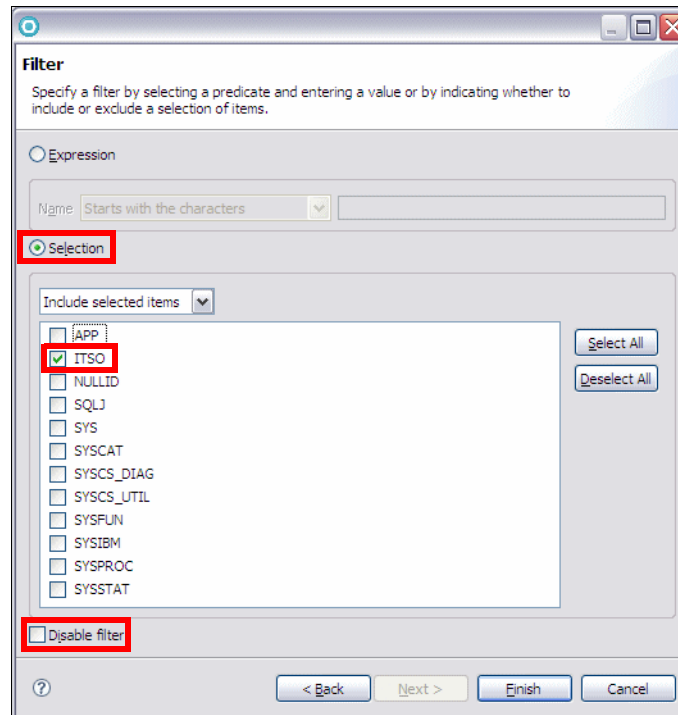

Figure 11-2 New Connection: Filter

- ▶ The connection is displayed in the Data Source Explorer. Expand **ITSOBANKderby [Derby 10.3.1.4 ...]** → **ITSOBANK**. The Schemas folder is marked as **[Filtered]**. There is only one schema (**ITSO**) listed, the others are filtered (Figure 11-3).

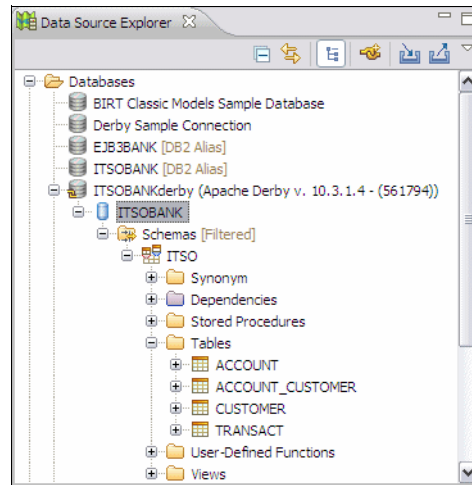

Figure 11-3 Connection with schema and tables in Data Source Explorer

- ▶ The filter framework allows you to filter out the tables at a more granular level. Suppose we only want to see tables that start with the letter A. Expand the schema **ITSO**, right-click **Tables** and select **Filter**. In the Filter dialog, do these steps:
 - Clear **Disable filter**.
 - Select **Expression**.
 - In the Name section, select **Starts with the characters** and enter **A**.
 - Click **OK**.
- ▶ Now you can only see two tables in the Database Explorer: **ACCOUNT** and **ACCOUNT_CUSTOMER**.
- ▶ We have to use the four tables in later sections. To disable the filter, right-click **Tables [Filtered]** and select **Filters**, select **Disable filter** and click **OK**.

Note: You may see the following error in the Problems view:

Problem with driver "Cloudscape - Cloudscape Embedded JDBC Driver Default." (Error: Unable to locate JAR/zip in file system as specified by the driver definition: db2j.jar.)

This file is not shipped with Application Developer. You can remove the driver in the Preferences dialog:

- ▶ Select **Window** → **Preferences**.
- ▶ Select **Data Management** → **Connectivity** → **Driver Definitions** on the left.
- ▶ Select **Cloudscape - Cloudscape Embedded JDBC Driver Default** and click **Remove**.
- ▶ Click **OK**.

Browsing a database with the Data Source Explorer

The Data Source Explorer view operates much like any similar, graphical directory browsing program. It provides a list of configured connection profiles. Here you can create and manage database connections, browse data objects in a connection, modify data objects and more.

Exploring the Derby database ITS0BANK:

- ▶ Expand **ITS0BANKderby (...)** → **ITS0BANK** → **Schemas** → **ITSO** → **Tables** → **CUSTOMER** (Figure 11-4).
 - Expand **Columns**. All the columns in table CUSTOMER are listed. SSN is marked as primary key.
 - Expand **Constraints**. PK_CUSTOMER is listed as the primary key constraint.

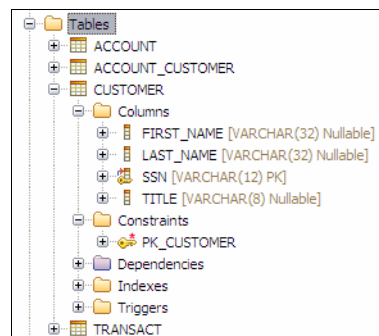

Figure 11-4 Customer table with columns

- ▶ In the Data Source Explorer view, right-click the **Customer** table and select **Data** → **Sample Contents**. The action opens the SQL Results view, and the running result is Succeeded. Highlight the **Succeeded** run and then select the **Results1** tab to see the list of customers (Figure 11-5).

Status	Operation	Date	Connection Profile	SSN	TITLE	FIRST_NAME	LAST_NAME
✓ Succeeded		10/12/08 10:14 AM	ITSOBANKderby	111-11-1111	Mr	Henry	Cui
				222-22-2222	Ms	Pinar	Ugurlu
				333-33-3333	Mr	Marco	Rohr
				444-44-4444	Mr	Juan	Napoli
				555-55-5555	Mr	Brian	Hainey
				666-66-6666	Mr	Patrick	Gan
				777-77-7777	Mr	Miguel	Gomes
				888-88-8888	Mr	Lara	Ziosi
				999-99-9999	Mr	Ahmed	Moharram
				000-00-0000	Mr	Ueli	Wahli

Figure 11-5 Sample contents of Customer table

Edit, extract, and load

The context menu produced by a **right-click** on the **Customer** table has many more options, such as:

- ▶ **Data** → **Edit** allows you to directly affect the contents of the target table in a spreadsheet like interface.
- ▶ **Data** → **Extract** allows you to extract data into a file using a delimiter (comma, semicolon, space, tab, vertical bar):

```
"111-11-1111", "Mr", "Henry", "Cui"
"222-22-2222", "Ms", "Pinar", "Ugurlu"
.....
```

- ▶ **Data** → **Load** allows you to load data from a file, such as produced by extract.
- ▶ **Data** → **Extract as XML** allows you to generate an XML file from the database table:

```
<?xml version="1.0" encoding="UTF-8"?>
<SQLResult>
  <CUSTOMER>
    <SSN>111-11-1111</SSN>
    <TITLE>Mr</TITLE>
    <FIRSTNAME>Henry</FIRSTNAME>
    <LASTNAME>Cui</LASTNAME>
  </CUSTOMER>
  .....
</SQLResult>
```

- ▶ **Data** → **Load from XML** allows you to update a database table from an XML file, such as produced by Extract as XML.

Creating SQL statements

You can create an SQL statement by using the SQL builder or the SQL editor in the Data perspective.

The SQL editor supports any statements that can be run by the database to which you are connected. You can create single or multiple SQL statements, single or multiple XQuery statements, XQuery statements that are nested in SQL statements, and SQL statements that are nested in XQuery statements. The SQL editor provides features such as multiple statement support, syntax highlighting, content assist, query parsing and validation etc.

The SQL builder provides a graphical interface for creating and running SQL statements. Statements that are generated by the SQL builder are saved in a file with the extension `.sql`. The SQL builder supports creating SELECT, INSERT, UPDATE, DELETE, FULLSELECT, and WITH (DB2 only) statements.

In this section, we create and run an SQL query to retrieve a customer name based on the social security number, and the total amount of money involved in each transaction type (credit, debit). The SQL select statement includes table aliases, table joins, a query condition, a column alias, a sort type, a database function expression and a grouping clause.

Creating a data development project

Before you create routines or other database development objects, you must create a data development project to store your objects. A data development project is linked to one database connection in the Database Explorer.

A data development project is used to store routines and queries. You can store and develop the following types of objects in a database development project:

- ▶ SQL scripts
- ▶ DB2 and Derby stored procedures
- ▶ DB2 user-defined functions

You can also test, debug, export, and deploy these objects from a data development project. The wizards that are available in a data development project use the connection information that is specified for the project to help you develop objects that are targeted for that specific database.

To create a data development project:

- ▶ In the Data perspective, Data Project Explorer, select **File** → **New** → **Data Development Project** (alternatively right-click in the Data Project Explorer and select **New** → **Data Development Project**). Click **Next**.

- ▶ In the New Data Development Project page of the wizard, type **RAD75DataDevelopment** for the project name. Clear **Omit current schema in generated SQL Statements**. Click **Next**.
- ▶ In the Select Connection page, select **ITSOBANKderby** from the connections list (Figure 11-6).

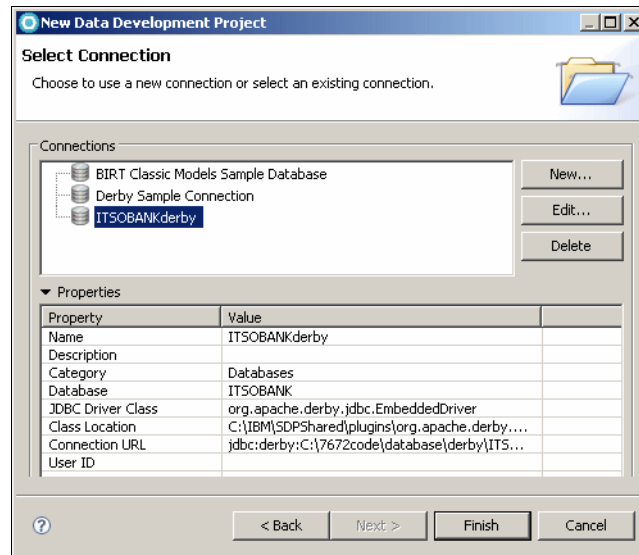

Figure 11-6 Data Development Project: Select Connection

- ▶ Click **Finish**. The data development project is displayed in the Data Project Explorer view.

Populating the transactions table

Before we build the SQL query, we want to populate the TRANSACT table with more data (only one customer has transactions already). To load the records into this table, do these steps:

- ▶ In the Data Project Explorer right-click the project **RAD7DataDevelopment** and select **Import** → **General** → **File System**, and click **Next**.
- ▶ Click **Browse** and locate the C:\7672code\database\samples directory. Select **LoadTransaction.sql** and click **Finish**.
- ▶ The **LoadTransaction.sql** appears in the **SQL Scripts** folder. Right-click **LoadTransaction.sql** and select **Run SQL** from the context menu.
- ▶ The results are displayed in the SQL Results view. For the INSERT SQL statements, the status should be Succeeded.

Creating a select statement

We want to retrieve a customer name and the total amount of money involved in each transaction type (credit, debit).

To create the select statement:

- ▶ In the Data Project Explorer view right-click the **SQL Scripts** folder in the **RAD75DataDevelopment** project and select **New** → **SQL or XQuery Script**.
- ▶ In the Script Name and Editor page, enter **CustomerTransactions** as the name. Select **SQL Builder** as the editing tool and **SELECT** as the statement type (Figure 11-7).

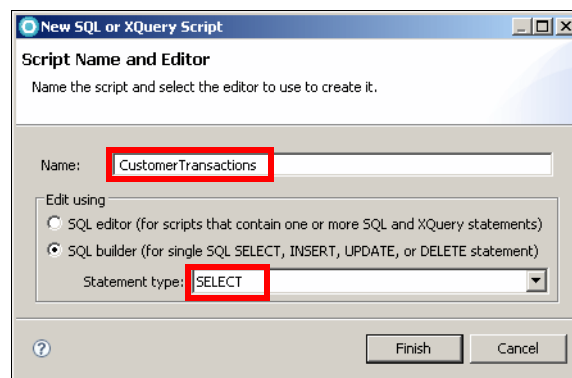

Figure 11-7 New SQL and Editor page

- ▶ Click **Finish** and the SELECT statement template is created and opens in the SQL builder (Figure 11-8).

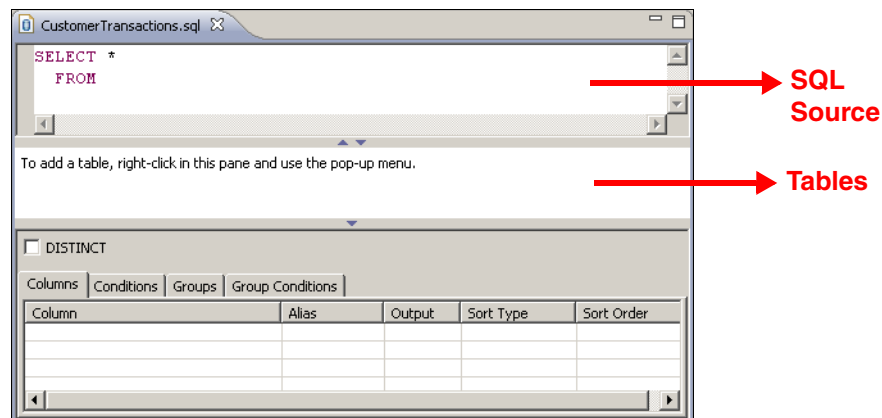

Figure 11-8 SQL Builder

Using the SQL Builder

The SQL Builder has three main sections:

- ▶ **SQL source pane**—The SQL Source pane contains the source code of the SQL statement. You can type the SQL statement in this pane, or use the features that are provided by the SQL builder to build the statement. Content assist is available as you type and through the pop-up menu in the SQL Source pane. This pane also provides content tips through the pop-up menu. A content tip shows a simple example for the type of statement that you are creating.
- ▶ **Tables pane**—The Tables pane provides a graphical representation of the table references that are used in the statement. In this pane, you can add or remove a table, give a table an alias, and select or exclude columns from the table. When you build a SELECT statement, you can also define joins between tables in this pane.
- ▶ **Design pane**—The options in the Design pane vary, depending on the type of statement that you are creating. When more than one set of options is available, the options appear as notebook pages. For example, for a SELECT statement, some of the options include selecting columns, creating conditions, creating groups, and creating group conditions.

Adding tables to the statement

We add four tables to the SELECT statement for the CustomerTransactions query, because this query traverses from CUSTOMER through to ACCOUNT and TRANSACT. We also create an alias for each of the tables in the SELECT statement. An alias is an indirect method of referencing a table so that an SQL statement can be independent of the qualified name of that table. If the table name changes, only the alias definition must be changed.

The aliases for the ACCOUNT, CUSTOMER, TRANSACT, and ACCOUNT_CUSTOMER will be A, C, T, and AC, respectively.

To add tables to the statement:

- ▶ In the Data Source Explorer expand **ITSOBANKderby** → **ITSOBANK** → **Schemas** → **ITSO** → **Tables**. You can see the four tables.
- ▶ Right-click in the Tables pane, and then click **Add Table** on the pop-up menu.
- ▶ In the Table name list, expand the **ITSO** schema and select **CUSTOMER**. Enter **C** as the table alias, and then click **OK** (Figure 11-9). The CUSTOMER table is shown in the Tables pane, and the source code in the SQL Source pane shows the addition of the CUSTOMER table in the SELECT statement.

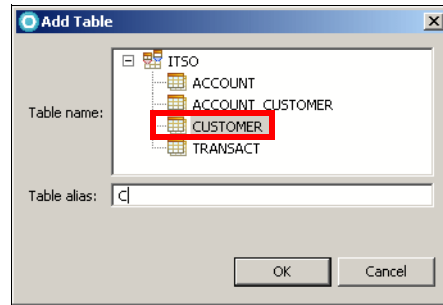

Figure 11-9 Add table

- ▶ Follow the same procedure to add the ACCOUNT_CUSTOMER (alias AC), ACCOUNT (alias A), and TRANSACT (alias T) tables to the Tables pane in the SQL builder.
- ▶ Select a table and drag the sides to adjust the size of the displayed rectangle (Figure 11-10).

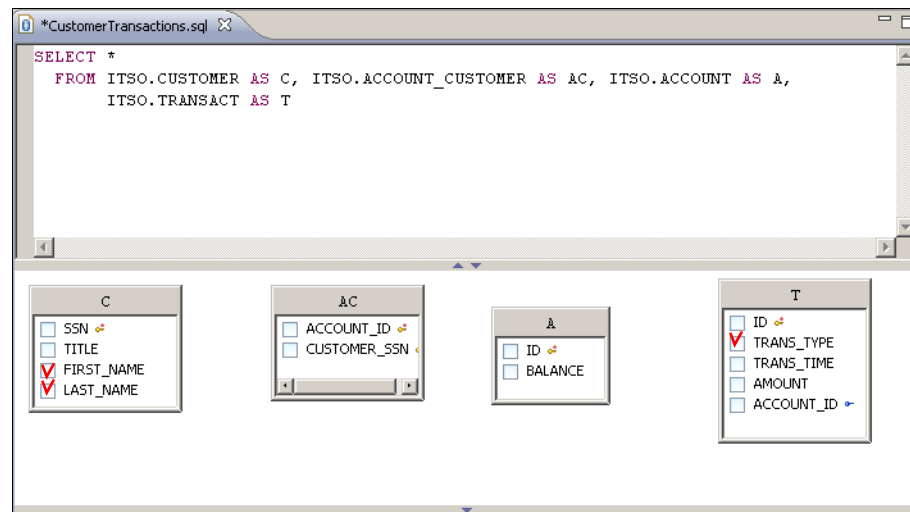

Figure 11-10 Create select statement: Tables

Selecting columns for the result set

We add the following columns to the result set by selecting the columns in the tables pane:

- ▶ Select FIRSTNAME and LASTNAME columns in the C (CUSTOMER) table.
- ▶ Select TRANS_TYPE column in the T (TRANSACT) table.

Joining tables

A join operation lets you retrieve data from two or more tables based on matching column values. Three joins are needed for this query:

- ▶ Drag the cursor from column **SSN** column in the **C** (CUSTOMER) table to column **CUSTOMERS_SSN** in **AC** (ACCOUNT_CUSTOMER) table.
- ▶ Drag the cursor from **ACCOUNT_ID** in the **AC** (ACCOUNT_CUSTOMER) table to **ID** in the **A** (ACCOUNT) table.
- ▶ Drag the cursor from **ID** in the **A** (ACCOUNT) table to **ACCOUNT_ID** in the **T** (TRANSACTION) table.
- ▶ Relationship lines are drawn between the selected columns (Figure 11-11).

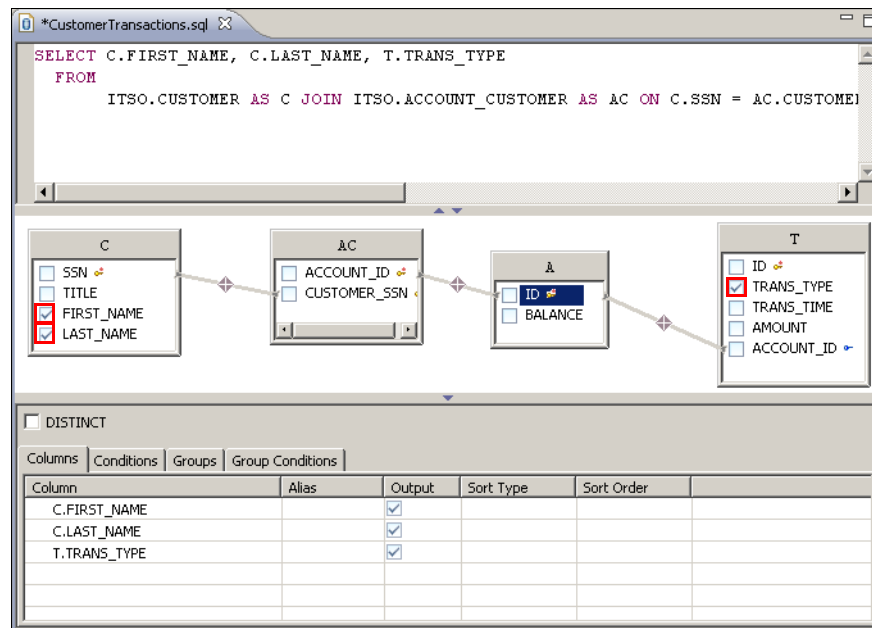

Figure 11-11 Create select statement: Columns and table joins

Add a function expression to the result set

The fourth column for the query result set will be the result of a column expression. We add together the total amount of each transaction type. This can be calculated using the expression builder wizard:

- ▶ In the Columns tab of the Design pane, click into the fourth cell in the Column column (the first empty cell), select **Build Expression** from the drop-down list, and press **Enter**.
- ▶ The Expression Builder wizard opens (Figure 11-12).

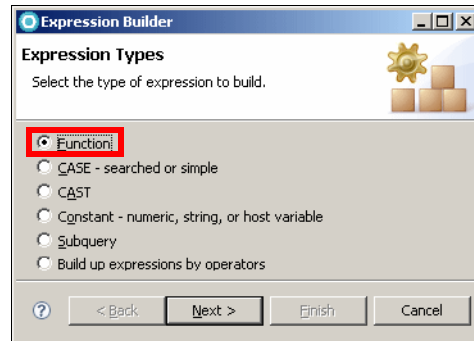

Figure 11-12 Create select statement: Expression Builder (1)

- ▶ Select **Function** and click **Next**.
- ▶ In the Function Builder page, select the following options (Figure 11-13):
 - For Select a function category, select **Aggregate**.
 - For Select a function, select **SUM**.
 - For Select a function signature, select **SUM(expression) → expression**.
 - In the Value column of the argument table, click the cell, and select **T.AMOUNT** in the drop-down list.
 - The preview of the function expression shows as **SUM(AMOUNT)**.
 - Click **Finish**.

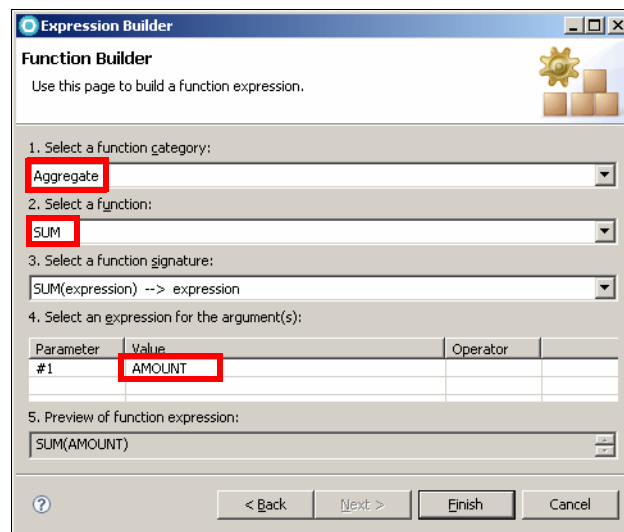

Figure 11-13 Create select statement: Expression Builder (2)

Adding a column alias and sort type

We add a column alias for the function column expression and sort the results:

- ▶ Click the **Columns** tab in the Design pane.
- ▶ Click the cell in the Alias column next to the SUM(T.AMOUNT) column expression, type **TotalAmount**, and press **Enter**.
- ▶ Click the cell in the Sort Type column next to the TotalAmount alias, select **Ascending**, and press **Enter**.
- ▶ The Columns page is seen in Figure 11-14.

Column	Alias	Output	Sort Type	Sort Order
C.FIRST_NAME		<input checked="" type="checkbox"/>		
C.LAST_NAME		<input checked="" type="checkbox"/>		
T.TRANS_TYPE		<input checked="" type="checkbox"/>		
SUM(T.AMOUNT)	TotalAmount	<input checked="" type="checkbox"/>	Ascending	1

Figure 11-14 Create select statement: Columns

Creating a query condition

The query needs a query condition so that the query extracts only result rows with a given customer social security number. We add conditions to the query by using the Conditions page in the Design pane.

To create a query condition:

- ▶ In the Design pane, select the **Conditions** tab.
- ▶ In the first row, click the cell in the **Column** column and select **C.LAST_NAME** in the list.
- ▶ In the same row, click the cell in the **Operator** column, and select the **LIKE** operator.
- ▶ In that row, click the cell in the **Value** column, and enter **%u%**.

A colon followed by a variable name is the SQL syntax for a host variable that will be substituted with a value when you run the query.

- ▶ The Conditions page is shown in Figure 11-15.

Column	Operator	Value	AND/OR
C.LAST_NAME	LIKE	'%u%'	

Figure 11-15 Create select statement: Conditions

Adding a GROUP BY clause

We group the query by the transaction type so that we have one sum of the amount for each type of transaction (credit, debit):

- ▶ In the Design pane, select the **Groups** tab.
- ▶ In the Column table, click the first row, select **T.TRANS_TYPE** in the list, and then press **Enter**.
- ▶ Repeat this for **C.FIRST_NAME** and **C.LAST_NAME**.
- ▶ The Groups page is shown in Figure 11-16.

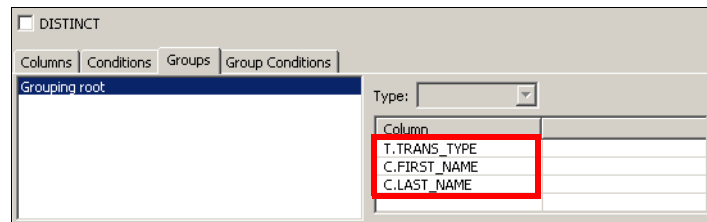

Figure 11-16 Create select statement: Groups

The query is now complete. **Save** the select statement. The SQL statement is listed in Example 11-1.

Example 11-1 CustomerTransactions.sql

```

SELECT C.FIRST_NAME, C.LAST_NAME, T.TRANS_TYPE, SUM(T.AMOUNT) AS "TotalAmount"
FROM
    ITSO.CUSTOMER AS C JOIN ITSO.ACCOUNT_CUSTOMER AS AC ON C.SSN =
        AC.CUSTOMER_SSN JOIN ITSO.ACCOUNT AS A ON AC.ACCOUNT_ID = A.ID JOIN
        ITSO.TRANSACT AS T ON A.ID = T.ACCOUNT_ID
WHERE C.LAST_NAME LIKE '%u%'
GROUP BY T.TRANS_TYPE, C.FIRST_NAME, C.LAST_NAME
ORDER BY "TotalAmount" ASC

```

Running the SQL query

To run the select statement:

- ▶ In the Data Project Explorer, right-click **CustomerTransactions.sql** and select **Run SQL**.
- ▶ Click **Finish**. The result is seen in Figure 11-17. You can see the total amount of money for each transaction type is calculated and the results are ordered by TotalAmount in ascending order.

Status	Operation	Date	Connection Pr	FIRST_NAME	LAST_NAME	TRANS_TYPE	TOTALAMOUNT
✓ Succeeded	SELECT C.FI...	10/15/08...	ITSOBANKderb	Pinar	Ugurlu	Debit	2680.78
				Pinar	Ugurlu	Credit	9611.15
				Henry	Cui	Debit	368212.77
				Henry	Cui	Credit	2161069.89

Figure 11-17 Query results

Developing a Java stored procedure

A stored procedure is a block of procedural constructs and embedded SQL statements that are stored in a database and can be called by name. Stored procedures can help improve application performance and reduce database access traffic. All database access must go across the network, which, in some cases, can result in poor performance. For each SQL statement, a database manager application must initiate a separate communication with database.

To improve application performance, you can create stored procedures that run on a database server. A client application can then simply call the stored procedures to obtain results of the SQL statements that are contained in the procedure. Because the stored procedure runs the SQL statements on the server for you, database performance is improved.

Stored procedures can be written as SQL procedures, or as C, COBOL, PL/I, or Java programs. In this section, we develop a Java stored procedure against the ITSOBANK Derby database to obtain the account information based on a partial customer last name. While doing so, we will give also give \$100 credit to every account retrieved (this would be nice!).

Creating a Java stored procedure

To create a stored procedure using the Stored Procedure wizard, do these steps:

- ▶ In the Data Project Explorer view, expand the **RAD7DataDevelopment** project, right-click the **Stored Procedures** folder, and select **New** → **Stored Procedure**. The New Stored Procedure wizard opens.
- ▶ In the Name and Language page:
 - RAD75DataDevelopment is preselected.
 - Type **AddCredit** for the Name.

- Select **Java** as the language.

Because we are developing a stored procedure against Derby database, **Java** is the only option for the **Language**. If you develop stored procedures against a DB2 database, you will see two options: **Java** and **SQL**.

- Type **itso.bank.data** as the package name.
- Select **Dynamic SQL using JDBC** (Figure 11-18).
- Click **Next**.

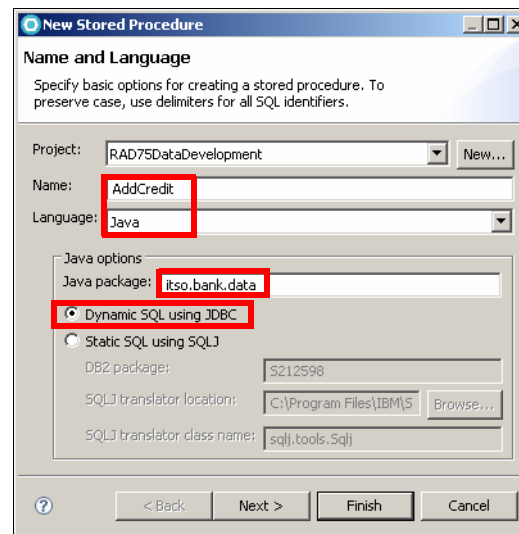

Figure 11-18 Create stored procedure: Name and Language

- ▶ In the SQL Statements page, click **Create SQL**. This action launches the New SQL Statement wizard that guides you through the creation of an SQL statement.
- ▶ In the first page of the New SQL Statement wizard, keep the defaults to create a **SELECT** statement using the wizard, and click **Next**.
- ▶ We go through several tabs to create the SQL statement:
 - In the **Tables** tab, in the Available Tables list, expand the ITS0 schema, select **ITSO.ACCOUNT**, **ITSO.ACCOUNT_CUSTOMER**, and **ITSO.CUSTOMER**, and click > to move the three tables to the Selected Tables list.
 - Select the **Columns** tab, expand the CUSTOMER table and select **FIRST_NAME** and **LAST_NAME**. Expand the ACCOUNT table and select **ID** and **BALANCE**. Click > to move the columns to the Selected Columns list.

- Select the **Joins** tab, drag the cursor from **SSN (CUSTOMER)** to **CUSTOMER_SSN (ACCOUNT_CUSTOMER)**, and from **ID (ACCOUNT)** to **ACCOUNT_ID (ACCOUNT_CUSTOMER)** to create two joins (Figure 11-19).

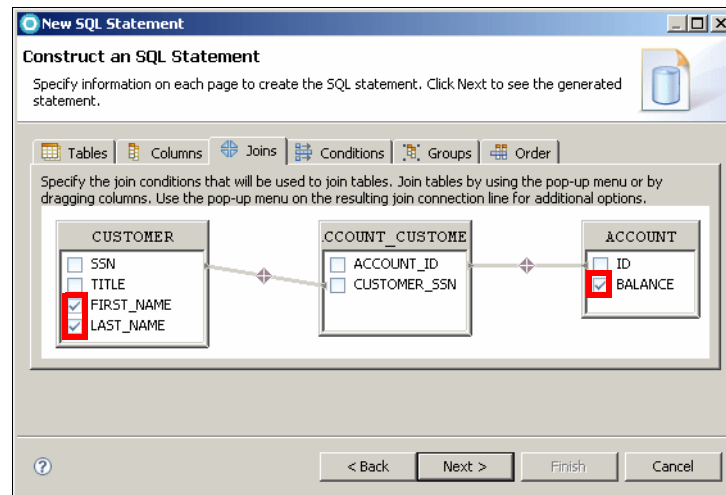

Figure 11-19 Create stored procedure: Joins

- Select the **Conditions** tab. In the first row click the cell under Column and select **CUSTOMER.LASTNAME**. In the same row select **LIKE** as the Operator and type **:PARTIALNAME** as the Value (Figure 11-20). Click **Next**.

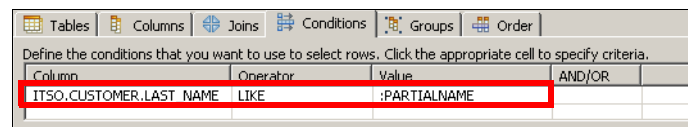

Figure 11-20 Create stored procedure: Conditions

- ▶ In the Change the SQL Statement page, review the generated SQL statement and click **Finish** to close the New SQL Statement wizard.
- ▶ Back in the New Stored Procedure wizard, select **One** for the Result set and click **Next**.
- ▶ In the Parameters page, leave the settings as default and click **Next**.
- ▶ In the Deploy Options page of the wizard, clear **Deploy on Finish**. We will deploy the stored procedure in later steps. Click **Next**.
- ▶ In the Code Fragments page of the wizard, click **Next**.
- ▶ Review the selections on the Summary page of the wizard and click **Finish**.

- ▶ The stored procedure opens in the routine editor. Select the **Configuration** tab in the routine editor. In the Java section, click **ADDCREDIT.java**. The generated file opens and is shown in Example 11-2.

Example 11-2 AddCredit.java

```
package itso.bank.data;

import java.sql.*; // JDBC classes

public class ADDCREDIT {
    public static void addCREDIT(java.lang.String PARTIALNAME, ResultSet[] rs1)
        throws SQLException, Exception {
        // Get connection to the database
        Connection con = DriverManager.getConnection("jdbc:default:connection");
        PreparedStatement stmt = null;
        boolean bFlag;
        String sql;

        sql = "SELECT ITSO.CUSTOMER.FIRST_NAME, ITSO.CUSTOMER.LAST_NAME,
                ITSO.ACCOUNT.BALANCE"
            + " FROM"
            + "     ITSO.ACCOUNT JOIN ITSO.CUSTOMER JOIN
                ITSO.ACCOUNT_CUSTOMER ON ITSO.CUSTOMER.SSN =
                ITSO.ACCOUNT_CUSTOMER.CUSTOMER_SSN ON ITSO.ACCOUNT.ID
                = ITSO.ACCOUNT_CUSTOMER.ACCOUNT_ID"
            + " WHERE ITSO.CUSTOMER.LAST_NAME LIKE ?";
        stmt = con.prepareStatement(sql);
        stmt.setString(1, PARTIALNAME);
        bFlag = stmt.execute();
        rs1[0] = stmt.getResultSet();
    }
}
```

- ▶ We will give \$100 credit to the selected accounts. Add the following code **under the rs1[0] = stmt.getResultSet()** statement (Example 11-3):

Example 11-3 Snippet to give \$100 credit to each account

```
String sql2 = "UPDATE ITSO.ACCOUNT SET BALANCE = (BALANCE + 100)"
    + " WHERE ID IN " +
    "(SELECT ITSO.ACCOUNT.ID FROM ITSO.ACCOUNT"
    + " JOIN ITSO.ACCOUNT_CUSTOMER"
    + " ON ITSO.ACCOUNT.ID = ITSO.ACCOUNT_CUSTOMER.ACCOUNT_ID"
    + " JOIN ITSO.CUSTOMER ON ITSO.ACCOUNT_CUSTOMER.CUSTOMER_SSN ="
    + " ITSO.CUSTOMER.SSN"
    + " WHERE ITSO.CUSTOMER.LAST_NAME LIKE ?)";
stmt = con.prepareStatement(sql2);
stmt.setString( 1, PARTIALNAME );
```

```
stmt.executeUpdate();
```

- ▶ The modified `AddCredit.java` can also be found in:
C:\7672code\database\samples

Deploying a Java stored procedure

A stored procedure must be deployed to the database where it is stored in the catalog, ready for execution.

To deploy a Java stored procedure to a database:

- ▶ In the Data Project Explorer, expand **RAD75DataDevelopment** → **Stored Procedures**, right-click **ADDCREDIT**, and select **Deploy**.
- ▶ The Deploy Routines wizard opens. Enter **ITSO** as the Schema name and click **Finish** (Figure 11-21).

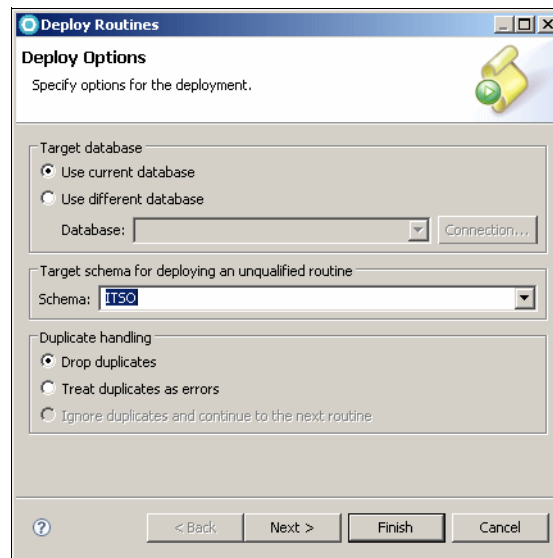

Figure 11-21 Deploy Routines

- ▶ You can see a succeeded build status in the SQL Results view.
- ▶ In the Data Source Explorer, expand **ITSOBANK** → **Schemas** → **ITSO** → right-click **Stored Procedures**, and select **Refresh**. You can see that **ADDCREDIT** has been added to the Stored Procedures folder.

Running the stored procedure

Application Developer provides a test facility for testing the Java stored procedures.

To run the stored procedure:

- ▶ In the Data Project Explorer, right-click the stored procedure **ADDCREDIT**, and select **Run**.
- ▶ The Specify Parameter Values window opens. In the Value field type **C%** in the cell and press **Enter** (PARTIALNAME LIKE 'C%' retrieves only the customer with last name starts with C).
- ▶ Click **OK**.
- ▶ The result is shown in Figure 11-22. You can see \$100 has been added to the related accounts and the balances are updated.

Status	Operation	Date	FIRST_NAME	LAST_NAME	BALANCE
✓ Succeeded	Deploy ITSO.ADDCREDIT(IN PARTIALNAME VARCH...	10/12/08	1 Henry	Cui	12445.67
✓ Succeeded	Run ITSO.ADDCREDIT(IN PARTIALNAME VARCHAR(...	10/12/08	2 Henry	Cui	6643.21
			3 Henry	Cui	198.76
			4 Henry	Cui	232.12

Total 4 records shown

Figure 11-22 Stored procedure results

Developing SQLJ applications

SQLJ enables you to embed SQL statements into Java programs. SQLJ is an ANSI standard developed by a consortium of leading providers of database and application server software.

The SQLJ translator translates an SQLJ source file into a standard Java source file plus an SQLJ serialized profile that encapsulates information about static SQL in the SQLJ source. The translator converts SQLJ clauses to standard Java statements by replacing the embedded SQL statements with calls to the SQLJ runtime library. An SQLJ customization script binds the SQLJ profile to the database, producing one or more database packages. The Java file is compiled and run (with the packages) on the database. The SQLJ runtime environment consists of an SQLJ runtime library that is implemented in pure Java. The SQLJ runtime library calls the JDBC driver for the target database.

SQLJ provides better performance by using static SQL. SQLJ generally requires fewer lines of code than JDBC to perform the same tasks. The SQLJ translator checks the syntax of SQL statements during translation. SQLJ uses database connections to type-check static SQL code. With SQLJ, you can embed Java variables in SQL statements. SQLJ provides strong typing of query output and return parameters and allows type-checking on calls. SQLJ provides static package-level security with compile-time encapsulation of database authorization.

Using the SQLJ wizard shipped with Application Developer, you can do the following actions:

- ▶ Name an SQLJ file and specify its package and source folder.
- ▶ Specify advanced project properties, such as additional JAR files, to add to the project classpath, translation options, and whether to use long package names.
- ▶ Select an existing SQL SELECT statement, or construct and test a new one.
- ▶ Specify information for connecting to the database at run time.

In this section, we will create an SQLJ application to retrieve the customer and the associated account information.

Creating SQLJ files

You can create SQLJ files by using the New SQLJ File wizard. The SQLJ support is automatically added to the project when you use this wizard.

Work around: Right-click the **ITSOBANKderby** connection and select **Disconnect**. The SQLJ wizard does not show the tables when the connection is active.

We create a Java project named **RAD75SQLJ** and then create the SQLJ file in this project:

- ▶ Open the Java perspective, select **File** → **New** → **Java Project**. Enter **RAD75SQLJ** as the Project name and click **Finish**.
- ▶ Select **File** → **New** → **Other** → **Data** → **SQLJ Applications** → **SQLJ File** and click **Next**.
- ▶ In the SQLJ File page, enter **itso.bank.data.sqlj** as the package name and **CustomerAccountInfo** as the file name and click **Next** (Figure 11-23).

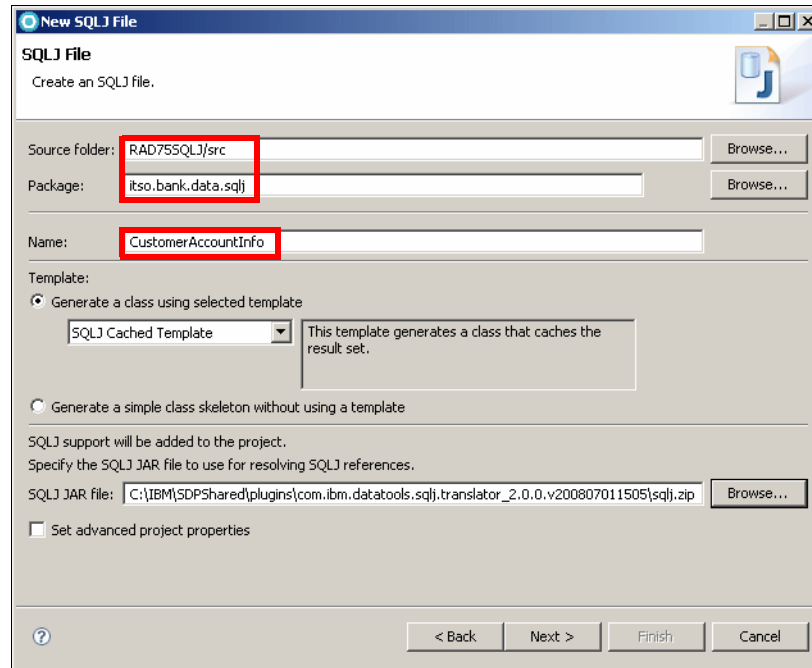

Figure 11-23 New SQLJ File

- ▶ In the Select an Existing Statement Saved in Your Workspace page, click **Next**. We create a new SQL statement.
- ▶ In the Specify SQL Statement Information page, select **Be guided through creating an SQL statement**, click **Next**.
- ▶ In the Select Connection page, select the **ITSOBANKderby** connection that you created in the previous section. Click **Reconnect** to reconnect to the database if it is disconnected. Click **Next**.
- ▶ In the Construct an SQL Statement page, we go through several pages:
 - In the Tables tab, for Available Tables, expand the **ITSO** schema, select the **CUSTOMER**, **ACCOUNT**, and **ACCOUNT_CUSTOMER** tables, and click > to move these three tables to the Selected Tables list.
 - Select the **Columns** tab. In the Available columns list, select **TITLE**, **FIRST_NAME** and **LAST_NAME** under the CUSTOMER table, and **ID** and **BALANCE** under the ACCOUNT table, and then click > to move these columns to the selected Columns list (Figure 11-24).

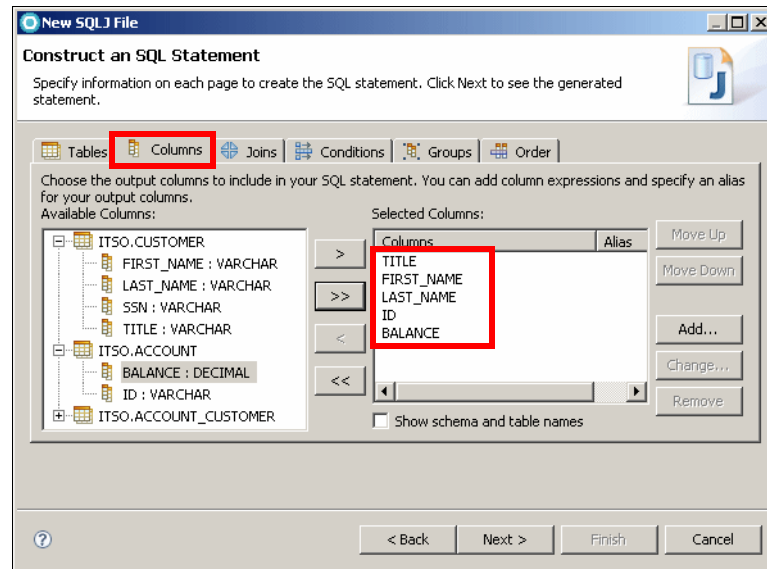

Figure 11-24 Select the output columns

- Select the **Joins** tab. Drag the cursor from CUSTOMER.SSN to CUSTOMER_SSN and from ACCOUNT.ID to ACCOUNT_ID (refer to Figure 11-19 on page 246).
- Select the **Conditions** tab. In the first row click the cell in the Column and select **ACCOUNT.BALANCE**. In the same row select **>=** as the Operator and type **:BALANCE** as the Value.
- Select the **Order** tab. Select **BALANCE** under ACCOUNT table and click **>**. For Sort order select **DESC**. The results will be listed with the highest balance first.
- Click **Next**.
- ▶ In the Change the SQL Statement page, review the generated SQL statement and click **Next**.

```
SELECT ITSO.CUSTOMER.TITLE, ITSO.CUSTOMER.FIRST_NAME,
ITSO.CUSTOMER.LAST_NAME, ITSO.ACCOUNT.ID, ITSO.ACCOUNT.BALANCE
FROM ITSO.CUSTOMER JOIN ITSO.ACCOUNT_CUSTOMER ON ITSO.CUSTOMER.SSN =
ITSO.ACCOUNT_CUSTOMER.CUSTOMER_SSN JOIN ITSO.ACCOUNT ON
ITSO.ACCOUNT_CUSTOMER.ACCOUNT_ID = ITSO.ACCOUNT.ID
WHERE ITSO.ACCOUNT.BALANCE >= :BALANCE
ORDER BY BALANCE DESC
```
- ▶ In the Specify Runtime Database Connection Information page, select **Use DriverManager Connection** (Figure 11-25). Derby does not use authentication. Select **Variables inside of method** and leave the user ID as **its0** and the password empty.

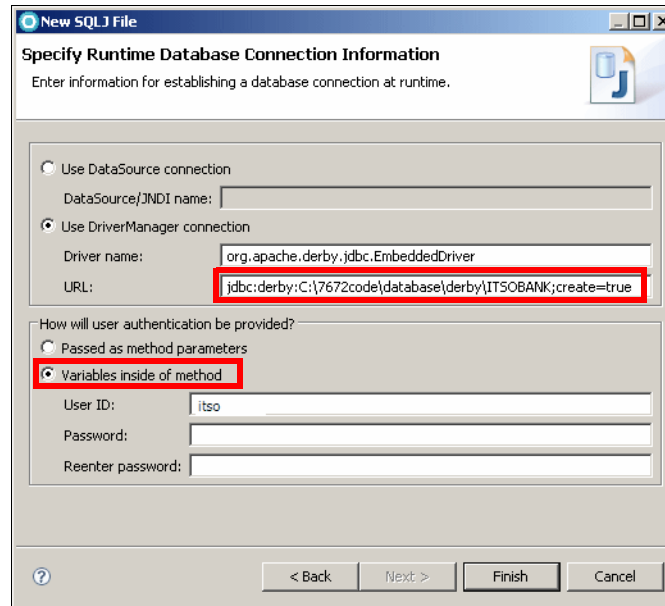

Figure 11-25 Specify Runtime Database Connection Information

- ▶ Click **Finish**. The SQLJ file is generated.

Examining the generated SQLJ file

Before testing the SQLJ program, let us examine the generated SQLJ file:

- ▶ The **establishConnection** method creates the database connection.
- ▶ The **execute** method executes the SQL query and stores the result set in a cache. The SQLJ statement is embedded in this method (Example 11-4):

Example 11-4 Embedded SQLJ

```
#sql [ctx] cursor1 = {SELECT ITSO.CUSTOMER.TITLE,
    ITSO.CUSTOMER.FIRST_NAME, ITSO.CUSTOMER.LAST_NAME, ITSO.ACCOUNT.ID,
    ITSO.ACCOUNT.BALANCE FROM ITSO.CUSTOMER JOIN ITSO.ACCOUNT_CUSTOMER
    ON ITSO.CUSTOMER.SSN = ITSO.ACCOUNT_CUSTOMER.CUSTOMER_SSN JOIN
    ITSO.ACCOUNT ON ITSO.ACCOUNT_CUSTOMER.ACCOUNT_ID = ITSO.ACCOUNT.ID
    WHERE ITSO.ACCOUNT.BALANCE >= :BALANCE ORDER BY BALANCE DESC};
```

- ▶ The **next** method moves to the next row of the result set if one exists.
- ▶ The **close** method commits changes and closes the connection.

- ▶ The corresponding setter and getter methods for the table fields in the database are also generated. You can use the getter methods to retrieve the columns in a row.

Testing the SQLJ program

To create a test program to invoke the SQLJ program, do these steps:

- ▶ In the Package Explorer right-click the package **itso.bank.data.sqlj** and select **New** → **Java Class**.
- ▶ Enter **TestSQLJ** as the class name. Select **public static void main(String[] args)** and click **Finish**.

Copy/paste the following code to TestSQLJ (Example 11-5). The TestSQLJ.java code can be found in C:\7672code\database\samples.

Example 11-5 TestSQLJ.java

```
package itso.bank.data.sqlj;

import java.math.BigDecimal;

public class TestSQLJ {

    public static void main(String[] args) {
        try {
            CustomerAccountInfo info = new CustomerAccountInfo();
            info.execute(new BigDecimal(10000)); // minimum balance displayed
            while (info.next()) {
                System.out.println("Customer name: " + info.getCUSTOMER_TITLE()
                    + " " + info.getCUSTOMER_FIRST_NAME() + " "
                    + info.getCUSTOMER_LAST_NAME());
                System.out.println("Account ID: " + info.getACCOUNT_ID() +
                    " Balance: " + info.getACCOUNT_BALANCE());
                System.out.println("-----");
            }
            info.close();
        } catch (Exception e) {
            e.printStackTrace();
        }
    }
}
```

- ▶ We have to add the Derby JDBC driver library to the project build path:
 - Right-click project **RAD75SQLJ** and select **Properties**.

- In the **Java Build Path, Libraries** tab, click **Add External JARs** and select **derby.jar**, which is in <RAD_HOME>\runtimes\base_v7\derby\lib. Click **OK**.
- ▶ Derby accepts only one database connection at a time. Switch to the Data perspective. In the Database Explorer right-click the **ITSOBANK** connection and select **Disconnect**.
- ▶ In the Java perspective, right-click **TestSQLJ.java** → **Run As** → **Java Application**.
- ▶ The result is displayed in the console:

```
Retrieve some data from the database.
Customer name: Mr Brian Hainey
Account ID: 005-555002 Balance: 72213.41
-----
Customer name: Mr Ueli Wahli
Account ID: 000-000001 Balance: 66666.66
-----
Customer name: Ms Pinar Ugurlu
Account ID: 002-222001 Balance: 65484.23
-----
Customer name: Mr Juan Napoli
Account ID: 004-444003 Balance: 23156.46
-----
Customer name: Mr Henry Cui
Account ID: 001-111001 Balance: 12545.67
-----
.....
```

Note: If you get the following exception:

```
Failed to start database 'C:/7672code/database/derby/ITSOBANK'
```

This means that the Derby database is locked by another connection. Check the Database Explorer if the ITSOBANK connection is still active. Disconnect the connection, or restart the workbench.

Data modeling

Application Developer provides tools to create, modify, and generate DDL for data models. At any time when you are building a data model, you can analyze the model to verify that it is compliant with the defined constraints. If you make changes to the data model, Application Developer provides tooling to compare the changed data model with the original data model. You can also perform an impact analysis to determine how the changes might affect other objects.

A physical data model is a database-specific model that represents relational data objects (for example, tables, columns, primary keys, and foreign keys) and their relationships. A physical data model can be used to generate DDL statements which can then be deployed to a database server.

In the Workbench, you can create and modify data models by using the Data Project Explorer, the Properties view, or a diagram of the model. You can also analyze models and generate DDL.

In this section, we will create the physical model from template, create tables using the data diagram and deploy the physical model to the database. This section includes the following tasks:

- ▶ Creating a data design project
- ▶ Creating a physical data model
- ▶ Modeling with diagrams
- ▶ Generating DDL from physical data model and deploy

Creating a data design project

Before you create data models or other data design objects, you must create a data design project to store your objects.

A data design project is primarily used to store modeling objects. You can store the following types of objects in a data design project:

- ▶ Logical data models
- ▶ Physical data models
- ▶ Domain models
- ▶ Glossary models
- ▶ SQL scripts, including DDL scripts

To create a data design project:

- ▶ In the Data perspective, select **File** → **New** → **Data Design Project**.
- ▶ The New Data Design Project wizard opens.
- ▶ In the Project Name field type **RAD75DataDesign**, then click **Finish**.
- ▶ The data design project is displayed in the Data Project Explorer view (Figure 11-26).

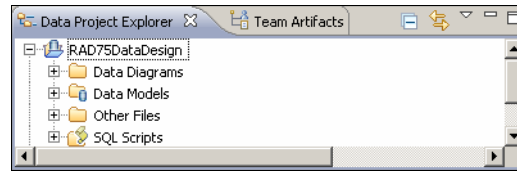

Figure 11-26 Data Project Explorer: Data Design project layout

Creating a physical data model

A physical data model is a database-specific model that represents relational data objects (for example, tables, columns, primary and foreign keys) and their relationships. A physical data model can be used to generate DDL statements which can then be deployed to a database server.

Using the data tooling, you can create a physical data model in several ways:

- ▶ Create a blank physical model by using a wizard.
- ▶ Create a physical model from a template by using a wizard.
- ▶ Reverse engineer a physical model from a database or a DDL file by using a wizard or by dragging data objects from the Database Explorer.
- ▶ Import a physical data model file from the file system.

In this section, we show you two ways to create the physical data model. First we create a physical data model by reversing the model from an existing database ITSOBANK. Then we create a new physical data model from a template and deploy this new model to the database.

Creating a physical data model using reverse engineering

To create a physical data model by reverse engineering an existing database schema, do these steps:

- ▶ In the Data Source Explorer, right-click **ITSOBANKDerby** and select **Connect**.
- ▶ In the Data Project Explorer, right-click **RAD75DataDesign** and select **New** → **Physical Data Model**. The New Physical Data Model wizard opens (Figure 11-27). Enter the following:
 - File name: **ITSOBANK_Reverse**
 - Database and Version: **Derby**, and **10.2**
 - Select **Create from reverse engineering**.

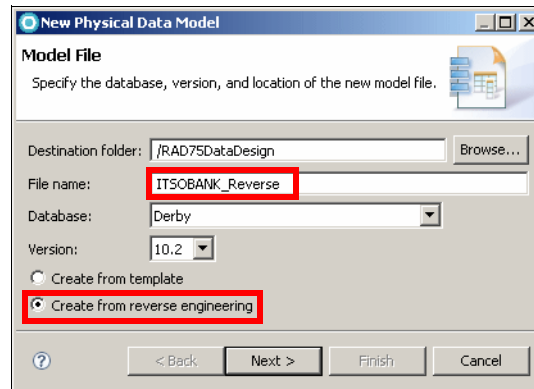

Figure 11-27 New Physical Data Model: Create from reverse engineering

- ▶ In the Select connection page, select **ITSOBANKderby** from the existing connections list. Click **Next**.
- ▶ In the Schema page, select **ITSO** and click **Next**.
- ▶ In the Database Elements page, select **Tables** and click **Next**.
- ▶ In the Options page, select **Overview** in the Generate diagrams section (Figure 11-28).
- ▶ Click **Finish**.

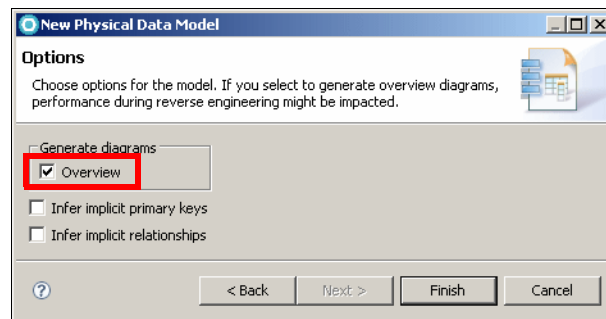

Figure 11-28 New Physical Data Model: Options

- ▶ The physical model is created and added to the Data Models folder. The overview diagram is added to the Data Diagrams folder (Figure 11-29).

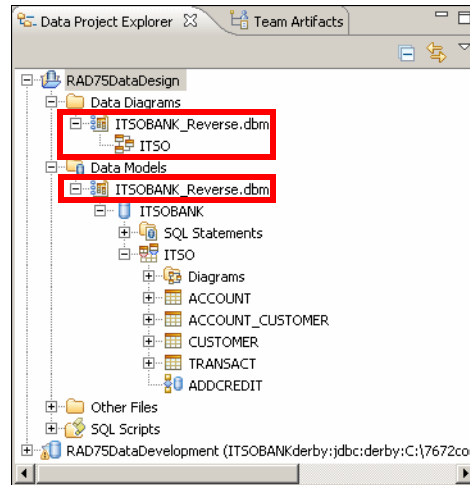

Figure 11-29 Data Design Project with physical model and diagram

- ▶ The Physical Data Model editor is open on the ITSOBANK_Reverse model. Descriptive information can be added. Do not close the physical model. It must be open to open the diagram.
- ▶ Open the **ITSO** overview diagram in the Data Diagrams folder. It contains all the tables that are in the schema. You can move the tables to get a better diagram (Figure 11-30).

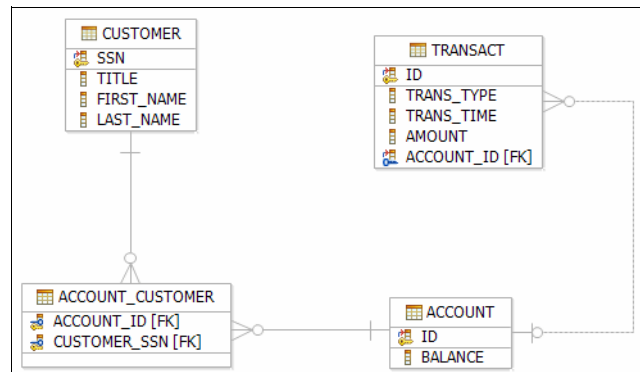

Figure 11-30 Overview diagram

- ▶ Select a table in the diagram, then look at the Properties view to see the columns and relationships.

- ▶ Select a relationship (line) in the diagram and look at the Properties view to see the cardinality (Details tab). The cardinality is also displayed visually in the diagram.
- ▶ Save and close the ITS0 diagram and the ITS0BANK_Reverse.dbm model.

Creating a physical data model from a template

To create a physical data model from a template, do these steps:

- ▶ Right-click **RAD75DataDesign** and select **New** → **Physical Data Model**. In the New Physical Data Model wizard (refer to Figure 11-27 on page 258), enter the following information:
- ▶ File name: **Bank_model**
- ▶ Database and Version: **Derby**, and **10.2**
- ▶ Select **Create from template**.
- ▶ Click **Finish**.

The physical model is created and displayed in the Data Models folder. The data diagram for the schema opens in the diagram editor.

Modeling with diagrams

You can use data diagrams to visualize and edit objects that are contained in data projects. Data diagrams are a view representation of an underlying data model. You can create diagrams that contain only a subset of model objects that are of interest.

In this section, we create a schema named RAD75Bank in the physical data model. Under this schema, we create two tables: ACCOUNT and TRANSACT. we add a foreign key relationship between the ACCOUNT and TRANSACT tables.

- ▶ In the Data Project Explorer select **RAD75DataDesign** → **Data Models** → **Bank_model.dbm** → **Database** → **Schema**, and in the Properties view change the schema name from Schema to **RAD75Bank**.
- ▶ To add a table, do these steps:
 - In the diagram editor, select the **Data** drawer in the palette and select **Table** in the Data drawer.
 - Click the empty area in the data diagram. A new table is added to the diagram.
 - Overtyping the table name with **ACCOUNT**.
- ▶ Hover the mouse over the **ACCOUNT** table in the diagram and you see four icons appearing outside of the table (Figure 11-31). Click the **Add Key** icon.

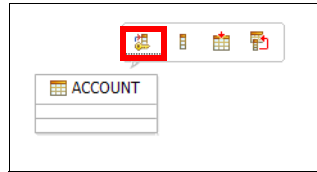

Figure 11-31 Add key, column, index, and trigger

- ▶ Overtyping the name with **ID** (or change the name in the Properties view, General tab).
- ▶ Select the ID column, and in the Properties view, Type tab, change the Data type to **VARCHAR**. Set the Length to **16** (Figure 11-32).

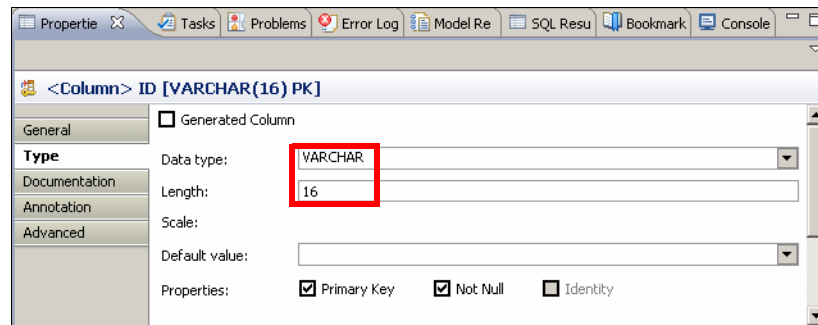

Figure 11-32 Edit the key

Note: The key **ID** must be uppercase. If you use lowercase, you might get the following error message when you run DDL on server in later section:

SQL Exception: 'ID' is not a column in table or VTI 'ACCOUNT'..

- ▶ Hover the mouse over the **ACCOUNT** table and click the **Add Column** icon.
- ▶ In the Properties view change the Name to **BALANCE**, the data type to **DECIMAL**, enter **8** as the precision and **2** as the scale, and select **Not Null**.
- ▶ Follow the same procedure to create the **TRANSACTION** table:
 - Key: ID VARCHAR(250) NOT NULL
 - Columns:

TRANS_TYPE	VARCHAR(32) NOT NULL
TRANS_TIME	TIMESTAMP NOT NULL
AMOUNT	DECIMAL(8,2) NOT NULL
ACCOUNT_ID	VARCHAR(16)

- ▶ The data diagram is shown in Figure 11-33.

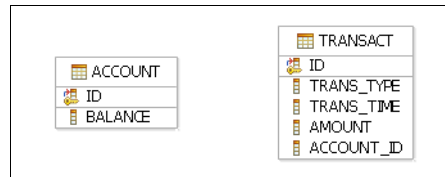

Figure 11-33 Data diagram with two tables

- ▶ Hover the mouse over the **ACCOUNT** table object in the diagram and you should see two arrows appearing outside of the table, pointing in opposite directions. Use the arrow that points away from the **ACCOUNT** table (representing a relationship from parent to child) to create a relationship between the **ACCOUNT** table and the **TRANSACT** table.
- ▶ Drag the arrow that points away from the **ACCOUNT** table, and drop it on the **TRANSACT** table. In the menu that opens select **Create Non-Identifying Optional FK Relationship** (Figure 11-34)

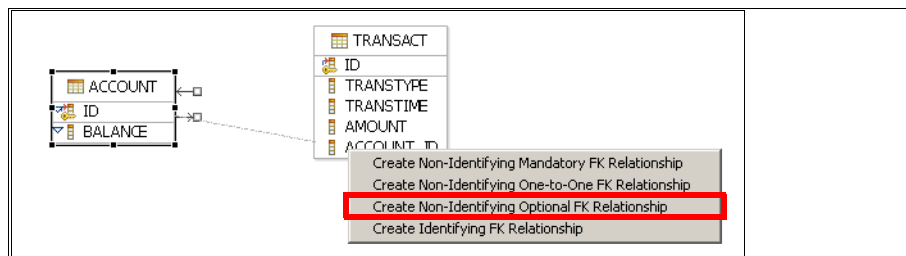
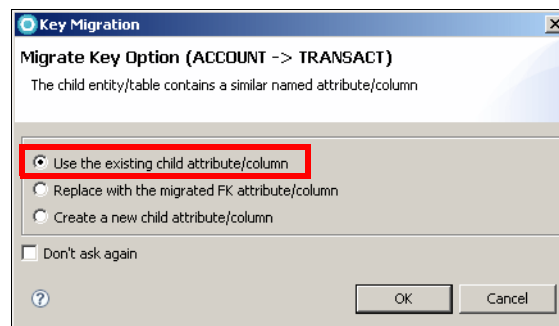



Figure 11-34 Add relationship between tables

- ▶ In the Migrate Key Option dialog, select **Use the existing child attribute/column**, and click **OK** (Figure 11-35).



We use an existing column (ACCOUNT_ID) as foreign key

Figure 11-35 Key migration

- ▶ Select the foreign key relationship you just created. In the Properties view, select the **Details** page.
- ▶ Click the ellipsis button  next to the Key Columns field. In the dialog, that opens, select **ACCOUNT_ID** and clear **ID** (use the check boxes). Click **OK**.
- ▶ Add information to the relationship properties to identify the roles of each table in the relationship (Figure 11-36):
 - In the Inverse Verb Phrase field, type **transaction**.
 - In the Verb Phrase field, type **account**.
 - Leave the cardinality as * and 0..1.

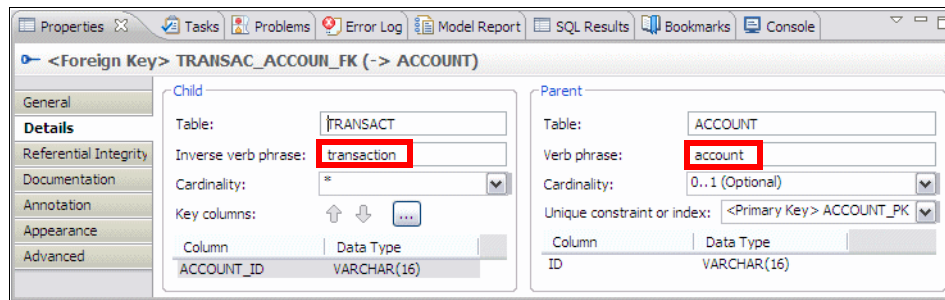

Figure 11-36 Relationship Details page

- ▶ Save but do not close the diagram. Notice the relationship verbs in the diagram (Figure 11-37).

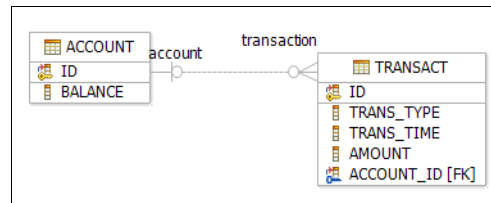
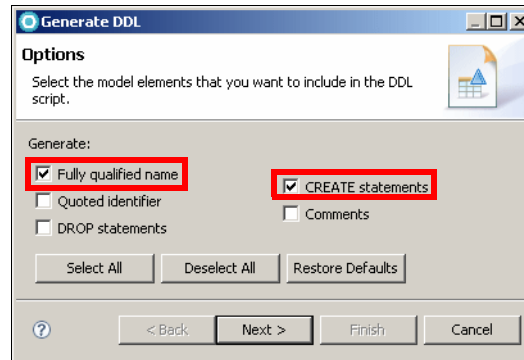

Figure 11-37 Relationship with verbs

Generating DDL from physical data model and deploy

In this section, we generate the DDL and run the generated DDL into the Derby database:

- ▶ In the Data Project Explorer, right-click the schema (Data Models → Bank_model.dbm → Database) **RAD75Bank** → **Generate DDL**.
- ▶ In the Generate DDL dialog, select **Fully qualified name** and **CREATE statements** (Figure 11-38), and click **Next**.



Quoted identifiers are required if the names contains blanks.

Figure 11-38 Generate DDL

- ▶ In the Objects page, leave everything selected and click **Next**.
- ▶ In the Save and Run DDL page, change the file name to **rad75bank.sql**, review the DDL, select **Run DDL on server**, and click **Next** (Figure 11-39).

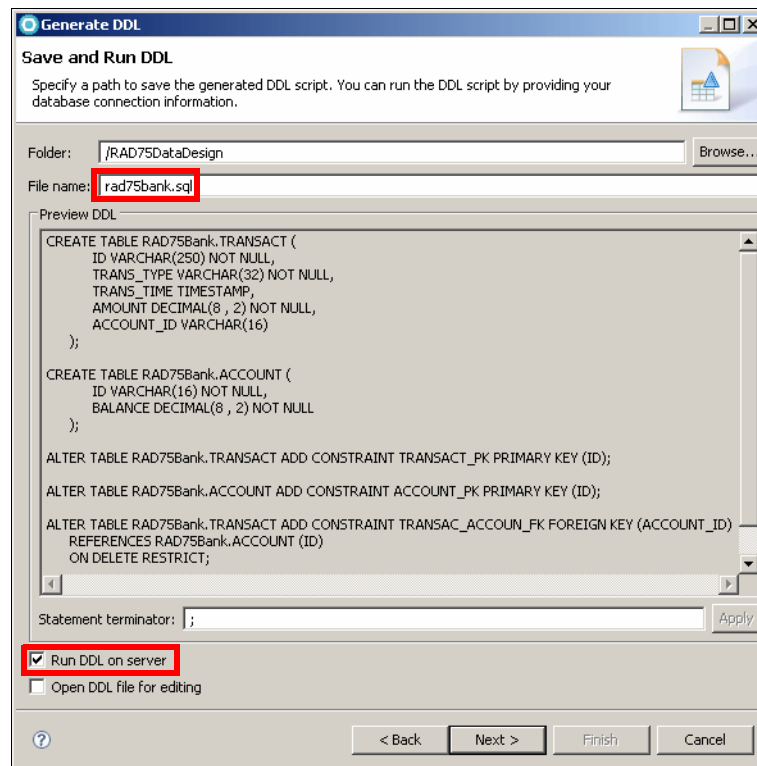

Figure 11-39 Save and Run DDL

- ▶ In the Select connection page, select **ITSOBANKDerby**, and click **Next**.
- ▶ In the Summary page, click **Finish**.
- ▶ The SQL script is created and stored in the **SQL Scripts** folder. Open `rad75bank.sql` to review the DDL.
- ▶ In the Database Explorer right-click the **ITSOBank** connection and select **Refresh**. You can see RAD75BANK schema is displayed.

Tip: If you cannot see the RAD75BANK schema, you can right-click **Schemas** → **Properties** and make sure both ITSO and RAD75BANK are selected. The RAD75BANK schema with two tables is now visible.

Analyzing the data model

The Analyze Model wizard analyzes a data model to ensure that it meets certain specifications. Model analysis helps to ensure model integrity and helps to improve model quality by providing design suggestions and best practices.

To analyze the RAD75Bank schema in the physical data model:

- ▶ In the Data Project Explorer, right-click the schema **RAD75Bank** (in Data Models → Bank_model.dbm → Database) and select **Analyze Model**.
- ▶ The Analyze Model dialog opens (Figure 11-40). Select the different items in the list to see the rules that are checked.
- ▶ Click **Apply** if you made any changes, then click **Finish**.

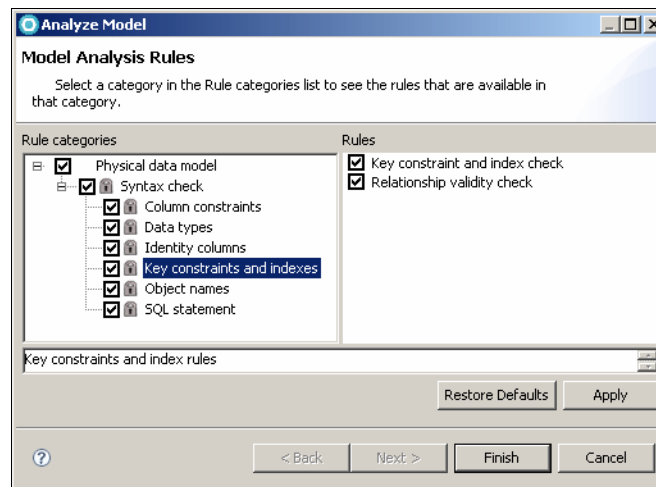

Figure 11-40 Analyze Model

- ▶ The result is displayed in the console:
Validation - 0 error(s), 0 warning(s), 0 informational message(s).
- ▶ Close all the open files.

More information

More information on JDBC can be found at:

<http://java.sun.com/j2se/1.4.2/docs/guide/jdbc/>
<http://java.sun.com/javase/technologies/database/>
<http://developers.sun.com/product/jdbc/drivers>

More information on SQLJ can be found at:

<http://www.javaworld.com/javaworld/jw-05-1999/jw-05-sqlj.html>
<http://www.onjava.com/pub/st/27>



Persistence using the Java Persistence API (JPA)

In this chapter, we create the JPA entities that coordinate and mediate access with the ITSOBANK database. We can use either the Derby or the DB2 database to create the matching JPA entities (Customer, Account, and Transaction) in a *bottom-up* scenario. Once we have the entities, we can connect the entity model to any of the two databases by using a JNDI data source in the server.

To illustrate the JPA tooling we use the Derby database to create the entities.

Finally, we add inheritance to the entity model by introducing Credit and Debit subclasses of the Transaction entity.

The sample code for this chapter is in `7672code\jpa`.

Introducing the Java Persistence API

This section is an extract from the IBM Redbooks publication *WebSphere Application Server Version 6.1 Feature Pack for EJB 3.0*, SG24-7611, Chapter 2, *Introduction to JPA*.

The persistence layer in a typical J2EE application that interacts with a relational database has been implemented over the last years in several ways:

- ▶ EJB 2.x entity beans
- ▶ Data access object (DAO) pattern
- ▶ Data mapper frameworks (such as iBatis)
- ▶ Object-relational mapping (ORM) frameworks both commercial (such as Oracle Toplink) or from the open-source world (such as Hibernate)

Data mapper and ORM frameworks gained a great approval among developers communities, because they give a concrete answer to the demand of simplification of the design of the persistence layer, and let developers concentrate on the business related aspects of their solutions.

However, even if these frameworks overcome the limitations of EJB 2.x CMP entity beans, one of the common concerns related to the adoption of such frameworks was that they were not standardized.

One of the main innovative concepts introduced by EJB 3.0 is the provisioning of a single persistence standard for the Java platform that can be used in both the Java EE and Java SE environments, and that can be used to build the persistence layer of a Java EE application. Furthermore, it defines a pluggable service interface model, so that you can plug in different provider implementations, without a significant changes to your application.

The Java Persistence API provides an object relational mapping facility to Java developers for managing relational data in Java applications. Java persistence consists of three areas:

- ▶ Java Persistence API
- ▶ Object-relational mapping metadata
- ▶ Query language

Entities

In the EJB 3.0 specification entity beans have been substituted by the concept of entities, which are sometimes called entity objects to clarify the distinction between EJB 2.1 entity beans and JPA entities (entity objects).

A JPA entity is a Java object that must match the following rules:

- ▶ It is a plain old Java object (POJO) that does not have to implement any particular interface or extend a special class.
- ▶ The class must not be declared final, and no methods or persistent instance variables must be declared final.
- ▶ The entity class must have a no-argument constructor that is public or protected. The entity class may have other constructors as well.
- ▶ The class must either be annotated with the `@Entity` annotation or specified in the `orm.xml` JPA mapping file. We will use annotations in our examples.
- ▶ The class must define an attribute that is used to identify in an unambiguous way an instance of that class (it corresponds to the primary key in the mapped relational table).
- ▶ Both abstract and concrete classes can be entities, and entities may extend non-entity classes (this is a significant limitation with EJB 2.x).

Note: Entities have overcome the traditional limitation that is present in EJB 2.x entity beans: They can be transferred *on the wire* (for example, they can be serialized over RMI-IIOP). Of course, you must remember to implement the `java.io.Serializable` interface in the entity.

A simple entity example

Example 12-1 shows a simple Customer entity with a few fields.

Example 12-1 Simple entity class with annotations

```
package itso.bank.entities;

@Entity
public class Customer implements java.io.Serializable {

    @Id
    private String ssn;

    private String title;
    private String firstName;
    private String lastName;

    public String getSsn() { return this.ssn; }
    public void setSsn(String ssn) { this.ssn = ssn; }

    // more getter and setter methods
}
```

- ▶ The **@Entity** annotation identifies a Java class as an entity.
- ▶ The **@Id** annotation is used to identify the property that corresponds to the primary key in the mapped table.
- ▶ The class is conforming to the JavaBean specification.

Mapping the table and columns

To specify the mapping of the entity to a database table we use **@Table** and **@Column** annotations (Example 12-2).

Example 12-2 Entity with mapping to a database table

```
@Entity
@Table (schema="ITS0", name="CUSTOMER")
public class Customer implements java.io.Serializable {

    @Id
    @Column (name="SSN")
    private String ssn;
    @Column (name="LAST_NAME")
    private String lastName;
    private String title;
    private String firstName;
    .....
}
```

- ▶ The **@Table** annotation provides information related to which table and schema the entity corresponds to.
- ▶ The **@Column** annotation provides information related to which column is mapped by an entity property. By default, properties are mapped to columns with the same name, and the **@Column** annotation is used when the property and column names differ.

Note: Entities support two types of persistence mechanisms:

- ▶ Field-based persistence—The entity properties must be declared as public or protected and instruct the JPA provider to ignore getter/setters.
- ▶ Property-based persistence—You must provide getter/setter methods.

We recommend to use the property-based approach (as in Example 12-2), because it is more adherent to the Java programming guidelines.

Relationships

Before starting our discussion of entity relationships, it is useful to refresh how the concept of relationships is defined in object-oriented and in relational database worlds (Table 12-1).

Table 12-1 Relationship concept in two different worlds

Java/JPA	RDBMS
A relationship is a reference from one object to another. Relationships are defined through object references (pointers) from a source object to the target object.	Relationships are defined through foreign keys.
If a relationship involves a collection of other objects, a collection or array type is used to hold the contents of the relationship.	Collections are either defined by the target objects have a foreign key back to the source object's primary key, or by having an intermediate join table to store the relationships.
Relationships are always unidirectional, in that if a source object references a target object, it is not guaranteed that the target object also has a relationship to the source object.	Relationships are defined through foreign keys and queries, such that the inverse query always exists.

JPA defines the following relationships: one-to-one, many-to-one, one-to-many, and many-to-many.

One-to-one relationship

In this type of relationship each entity instance is related to a single instance of another entity. The `@OneToOne` annotation is used to define this single value association, for example, a `Customer` is related to a `CustomerRecord`:

```
@Entity
public class Customer {

    @OneToOne
    @JoinColumn(
        name="CUSTREC_ID", unique=true, nullable=false, updatable=false)
    public CustomerRecord getCustomerRecord() {
        return customerRecord;
    }
    ....
}
```

In many situations the target entity of the one-to-one has a relationship back to the source entity, but this is not required. In our example, `CustomerRecord` could have a reference back to the `Customer`. When this is the case, we call it a bidirectional one-to-one relationship.

There are two rules for bi-directional one-to-one associations:

- ▶ The `@JoinColumn` annotation must be specified in the entity that is mapped to the table containing the join column, or the owner of the relationship.
- ▶ The `mappedBy` element should be specified in the `@OneToOne` annotation in the entity that does not define a join column, that is, the inverse side of the relationship.

Many-to-one and one-to-many relationships

Many-to-one mapping is used to represent simple pointer references between two Java objects. In Java, a single pointer stored in an attribute represents the mapping between the source and target objects. Relational database tables implement these mappings using foreign keys.

On the other side, One-to-many mapping is used to represent the relationship between a single source object and a collection of target objects. This relationship is usually represented in Java with a collection of target objects, but is more difficult to implement using relational databases (where you retrieve related rows through a query).

For example, an `Account` entity object can be associated with many `Transact` entity objects:

```

@Entity
@Table (schema="ITSO", name="ACCOUNT")
public class Account implements Serializable {
    @Id
    private String id;
    private BigDecimal balance;

    @OneToMany (mappedBy="account")
    private Set<Transaciont> transactionCollection;

    ....
}
=====
@Entity
@Table (schema="ITSO", name="TRANSACTION")
public class Transaction implements Serializable {
    @Id
    private String id;
    .....
}

```



```

    @ManyToOne
    @JoinColumn(name="ACCOUNT_ID")
    private Account account;
    ....
}

```

Using the @JoinColumn annotation

In the database, a relationship mapping means that one table has a reference to another table. The database term for a column that refers to a key (usually the primary key) in another table is a foreign key column.

In the Java Persistence API we call them join columns, and the @JoinColumn annotation is used to configure these types of columns.

Note: If you do not specify @JoinColumn, then a default column name is assumed. The algorithm used to build the name is based on a combination of both the source and target entities. It is the name of the relationship attribute in the Transaction source entity (the **account** attribute), plus an underscore character (_), plus the name of the primary key column of the target Account entity (the **id** attribute).

Therefore a foreign key named **ACCOUNT_ID** is expected inside the TRANSACTION table. If this is not applicable, you must use @JoinColumn to override this automatic behavior.

The @JoinColumn annotation also applies to one-to-one relationships.

Many-to-many relationship

When an entity A references multiple B entities, and other As might reference some of the same Bs, we say there is a many-to-many relation between A and B. To implement a many to many relationship there must be a distinct join table that maps the many-to-many relationship. This is called an association table.

For example, a Customer entity object can be associated with many Account entity objects, and an Account entity object can be associated with many Customer entity objects:

```

@Entity
public class Customer implements Serializable {
    .....

    @ManyToMany(mappedBy="customerCollection")
    private Set<Account> accountCollection;
    .....
}

```

```

=====
@Entity
public class Account implements Serializable {
    .....

    @ManyToMany
    @JoinTable(name="ACCOUNT_CUSTOMER", schema="ITS0",
        joinColumns=@JoinColumn(name="ACCOUNT_ID"),
        inverseJoinColumns=@JoinColumn(name="CUSTOMER_SSN"))
    private Set<Customer> customerCollection;
    ....
}

```

The `@JoinTable` annotation is used to specify the table and columns in the database that associate customers with accounts. The entity that specifies the `@JoinTable` is the owner of the relationship, so in this case the `Account` entity is the owner of the relationship with the `Customer` entity.

The join column pointing to the owning side is described in the `joinColumns` element, while the join column pointing to the inverse side is specified by the `inverseJoinColumns` element.

Note: Neither the `CUSTOMER` nor the `ACCOUNT` table contains a foreign key. The foreign keys are in the association table. Therefore, the `Customer` or the `Account` entity can be defined as the owning entity.

Fetch modes

When an entity manager retrieves an entity from the underlying database, it can use two types of strategies:

- ▶ **Eager mode:** When you retrieve an entity from the entity manager or by using a query, you are guaranteed that all of its fields (with relationships too) are populated with data store data.
- ▶ **Lazy mode:** This is a hint to the JPA runtime that you want to defer loading of the field until you access it. Lazy loading is completely transparent, when you attempt to read the field for the first time, the JPA runtime will load the value from the data store and populate the field automatically.

```

@OneToMany(mappedBy="accounts", fetch=FetchType.LAZY)
private Set<Transaction> transactionCollection;

```

Lazy mode is the default for 1:m and m:m relationships, so the specification is optional in those cases.

Note: The use of eager mode can greatly impact the performance of your application, especially if your entities have many and recursive relationships, because all the entity will be loaded at once.

On the other hand, if the entity after that has been read by the entity manager, is detached and sent over the network to another layer, you usually should assure that all the entity attributes have been read from the underlying data store, or that the receiver does not require related entities.

Entity inheritance

For several years we hear the term *impedance mismatch*, which describes the difficulties in bridging the object and relational worlds. In regard to inheritance, unfortunately, there is no natural and efficient way to represent an inheritance relationship in a relational database.

JPA introduces three strategies to support inheritance:

- ▶ **Single table**—This strategy maps all classes in the hierarchy to the base class table. This means that the table contains the superset of all the data contained in the class hierarchy. For an example of single table inheritance, refer to “Adding inheritance” on page 307.
- ▶ **Joined tables**—With this strategy, the top level entry in the entity hierarchy is mapped to a table that contains columns common to all the entities, while each of the other entities down the hierarchy are mapped to a table that contain only columns specific to that entity.
- ▶ **Table per class**—With this strategy both the superclass and subclasses are stored in their own table and no relationship exists between any of the tables. Therefore, all the entity data are stored in their own tables.

Persistence units

A persistence unit defines a set of entity classes that are managed by one entity manager (described hereafter) instance in an application. This set of entity classes represents the data contained within a single data store.

Persistence units are defined by the `persistence.xml` configuration file. The JAR file or directory whose `META-INF` directory contains `persistence.xml` is called the root of the persistence unit. The scope of the persistence unit is determined by the persistence unit's root.

Example 12-3 shows an extract of the `persistence.xml` file.

Example 12-3 Extract of a persistence.xml file

```
<persistence version="1.0" .....>
  <persistence-unit name="ITSOBank" transaction-type="JTA">
    <jta-data-source>jdbc/itsobank</jta-data-source>
    <class>itso.bank.entities.Account</class>
    <class>itso.bank.entities.Customer</class>
    <class>itso.bank.entities.Transaction</class>
  </persistence-unit>
</persistence>
```

Object-relational mapping through orm.xml

As we have seen in this chapter, the object relational (o/r) mapping of an entity can be done through the use of annotations. As an alternative you can specify the same information in an external file (called **orm.xml**) that must be packaged in the META-INF directory of the persistence module, or in a separate file packaged as a resource and defined in persistence.xml with the mapping-file element.

Example 12-4 shows an extract of an orm.xml file that defines the Account entity.

Example 12-4 Extract of an orm.xml file to define an entity mapping

```
<entity-mappings .....>
  <entity class="itso.bank.entity.Account" metadata-complete="true"
    name="Account">
    <description>Account of ITSO Bank</description>
    <table name="ACCOUNT" schema="ITSO"></table>
    <attributes>
      <id name="accountNumber">
        <column name="id"/>
      </id>
      <basic name="balance"></basic>
      <one-to-many name="transactionCollection"></one-to-many>
    </attributes>
  </entity>
  .....
</entity-mappings>
```

Persistence provider

Persistence providers are implementations of the Java Persistence API (JPA) specification and can be deployed in the Java EE compliant application server that supports JPA persistence.

There are two built-in JPA persistence providers for WebSphere Application Server:

- ▶ IBM WebSphere JPA persistence provider
- ▶ Apache OpenJPA persistence provider

If an explicit provider element is not specified in the persistence unit definitions, the application server will use the default persistence provider, which is the WebSphere JPA persistence provider.

IBM WebSphere JPA persistence provider

While built from the Apache OpenJPA persistence provider, the WebSphere Application Server JPA persistence provider contains enhancements, including the following:

- ▶ Statement batching support
- ▶ Version ID generation
- ▶ ObjectGrid cache plug-in support
- ▶ WebSphere product-specific commands and scripts
- ▶ Translated message files

Apache OpenJPA persistence provider

WebSphere Application Server provides the Apache OpenJPA persistence provider to support the open source implementation of JPA, and allow for easy migration of existing OpenJPA applications to the application server's solution for JPA.

Entity manager

Entities cannot persist themselves on the relational database; annotations are used only to declare a POJO as an entity or to define its mapping and relationships with the corresponding tables on the relational database.

JPA has defined the `EntityManager` interface for this purpose to let applications manage and search for entities in the relational database.

The `EntityManager` primary definition is:

- ▶ An API that manages the life cycle of entity instances (extract):
 - `persist`—Insert a new entity instance
 - `find`—Find an instance by key
 - `remove`—Delete an instance
 - `merge`—Merge changes of an entity
 - `flush`—Synchronize with database
 - `refresh`—Reload from database

- createNamedQuery—Create an instance of a predefined query
- ▶ Each EntityManager instance is associated with a *persistence context*.
- ▶ A persistence context defines the scope under which particular entity instances are created, persisted, and removed through the APIs made available by an EntityManager.
- ▶ An object that manages a set of entities defined by a persistence unit.

The entity manager tracks all entity objects within a persistence context for changes and updates made, and flushes these changes to the database. Once a persistence context is closed, all managed entity object instances become detached from the persistence context and its associated entity manager, and are no longer managed.

Managed and unmanaged entities: An entity object instance is either *managed* (attached) by an entity manager or *unmanaged* (detached):

- ▶ When an entity is attached to an entity manager, the manager monitors any changes to the entity and synchronizes them with the database whenever the entity manager decides to flush its state.
- ▶ When an entity is detached, and therefore is no more associated with a persistence context, it is unmanaged, and its state changes are not tracked by the entity manager and synchronized with the database.

JPA query language

The Java persistence query language (JPQL) is used to define searches against persistent entities independent of the mechanism used to store those entities. As such, JPQL is *portable*, and not constrained to any particular data store.

The Java persistence query language is an extension of the Enterprise JavaBeans query language, EJB QL, and is designed to combine the syntax and simple query semantics of SQL with the expressiveness of an object-oriented expression language.

- ▶ The application creates an instance of the `javax.persistence.EntityManager` interface.
- ▶ The EntityManager creates an instance of the `javax.persistence.Query` interface, through its public methods, for example `createNamedQuery`.
- ▶ The Query instance executes a query (to read or update entities).

Query types

Query instances are created using the methods exposed by the `EntityManager` interface (Table 12-2).

Table 12-2 How to create a Query instance

Method name	Description
<code>createQuery(String qlString)</code>	Create an instance of Query for executing a Java Persistence query language statement.
<code>createNamedQuery(String name)</code>	Create an instance of Query for executing a named query (in the Java Persistence query language or in native SQL).
<code>createNativeQuery(String qlString)</code>	Create an instance of Query for executing a native SQL statement, for example, for update or delete.
<code>createNativeQuery(String qlString, Class resultClass)</code>	Create an instance of Query for executing a native SQL query that retrieves a single entity type.
<code>createNativeQuery(String qlString, String resultSetMapping)</code>	Create an instance of Query for executing a native SQL query statement that retrieves a result set with multiple entity instances.

Query basic

A simple query that retrieves all the Customer entities from the database is shown here:

```
EntityManager em = ...
Query q = em.createQuery("SELECT c FROM Customer c");
List<Customer> results = (List<Customer>)q.getResultList();
```

A JPQL query has an internal name space declared in the `from` clause of the query. Arbitrary identifiers are assigned to entities so that they can be referenced elsewhere in the query. In the query example above, the identifier `c` is assigned to the Customer entity.

The `where` condition is used to express a logical condition:

```
EntityManager em = ...
Query q = em.createQuery("SELECT c FROM Customer c
                        where c.ssn='111-11-1111'");
List<Customer> results = (List<Customer>)q.getResultList();
```

Operators

JPQL several operators; the most important and used are:

- ▶ Logical operators: NOT, AND, OR
- ▶ Relational operators: =, >, >=, <, <=, <>, [NOT] BETWEEN, [NOT] LIKE, [NOT] IN, IS [NOT] NULL, IS [NOT] EMPTY, [NOT] MEMBER [OF]
- ▶ Arithmetic operators: +, -, /, *

Named queries

JPQL defines two types of queries:

- ▶ **Dynamic queries:** They are created on the fly.
- ▶ **Named queries:** They are intended to be used in contexts where the same query is invoked several times. Their main benefits include the improved reusability of the code, a minor maintenance effort, and finally better performance, because they are evaluated once.

Note: From this point of view, there is a strong similarity between Dynamic/Named queries and JDBC Statement/PreparedStatement. However, named queries are stored in a global scope, which enable them to be accessed by different EJB 3.0 components.

Defining a named query

Named queries are defined using the `@NamedQuery` annotation:

```
@Entity
@Table (schema="ITSO", name="CUSTOMER")
@NamedQuery (name="getCustomerBySSN",
             query="select c from Customer c where c.ssn = ?1")
public class Customer implements Serializable {
    ...
}
```

The name attribute is used to uniquely identify the named query, while the query attribute defines the query. We can see how this syntax resembles the syntax used in JDBC code with `jdbc.sql.PreparedStatement` statements.

Instead of a positional parameter (`?1`), the same named query can be expressed using a named parameter:

```
@NamedQuery (name="getCustomerBySSN",
             query="select c from Customer c where c.ssn = :ssn")
```

Completing a named query

Named queries must have all their parameters specified before being executed. The `javax.persistence.Query` interface exposes two methods:

```
public void setParameter(int position, Object value)
```



```
public void setParameter(String paramName, Object value)
```

A complete example that uses a named query is shown here:

```
EntityManager em = ...
Query q = em.createNamedQuery ("getCustomerBySSN");
q.setParameter(1, "111-11-1111");
//q.setParameter("ssn", "111-11-1111"); // for named parameter
List<Customer> results = (List<Customer>)q.getResultList();
```

Defining multiple named queries

If there are more than one named query for an entity, they are placed inside an **@NamedQueries** annotation, which accepts an array of one or more **@NamedQuery** annotations:

```
@NamedQueries({
    @NamedQuery(name="getCustomers",
        query="select c from Customer c"),
    @NamedQuery(name="getCustomerBySSN",
        query="select c from Customer c where c.ssn =?1"),
    @NamedQuery(name="getAccountsBySSN",
        query="select a from Customer c, in(c.accountCollection) a
            where c.ssn =?1 order by a.accountNumber")
})
```

Relationship navigation

Relations between objects can be traversed using Java-like syntax:

```
SELECT t FROM Transaction t WHERE t.account.id = '001-111001'
```

There are other ways to use queries to traverse relationships. For example, if the Account entity has a property called `transactionCollection` that is annotated as a **@OneToMany** relationship, then this query retrieves all the Transaction instances of one Account:

```
@NamedQuery(name="getTransactionsByID",
    query="select t from Account a, in(a.transactionCollection) t
        where a.id =?1 order by t.transTime")
```

Developing JPA entities

In this section we develop the JPA entities from an existing database.

Setting up the ITSOBANK database

The JPA entities are based on the ITSOBank database. Therefore, we have to define a database connection within Application Developer that the mapping tools use to extract schema information from the database.

Refer to “Setting up the ITSOBANK database” on page 1154 for instructions on how to create the ITSOBANK database. For the JPA entities we can either use the DB2 or Derby database. For simplicity we use the built-in Derby database in this chapter.

Setting up the database connection

For this section we assume that the **ITSOBANKderby** connection has been defined as described in “Creating a connection to the ITSOBANK database” on page 229.

Creating a JPA project

We generate the JPA entities from the ITSOBANK database into a JPA project. JPA projects are basically utility projects that hold the Java classes, which represent the JPA entities.

To create the JPA project, perform these steps:

- ▶ In the Java EE perspective, Enterprise Explorer view, right-click and select **New → Project**.
- ▶ In the New Project wizard, select **JPA → JPA Project**, and click **Next**.
- ▶ In the New JPA Project wizard, JPA Project page (Figure 12-1):
 - Type **RAD75JPA** as Project name.
 - For Target Runtime, select **WebSphere Application Server v7.0**.
 - For Configuration, select **Utility JPA project with Java 5.0**.
 - Clear **Add project to an EAR**.
 - Click **Next**.

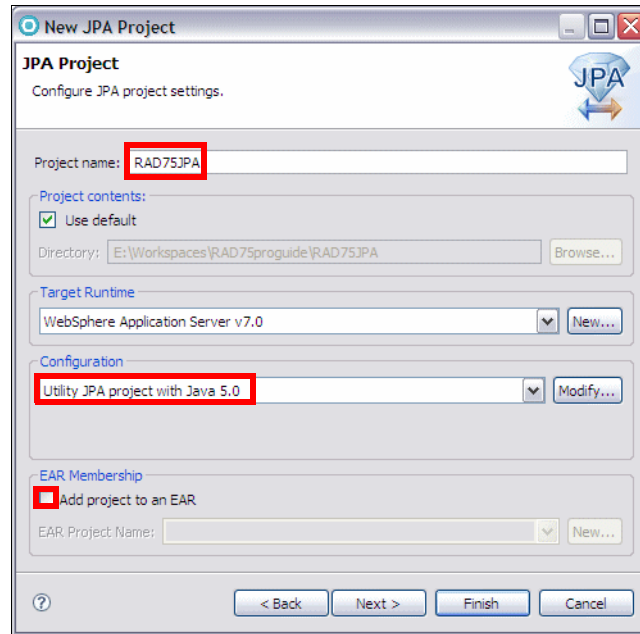

Figure 12-1 New JPA Project

- ▶ In the New JPA Project wizard, JPA Facet page (Figure 12-2):
 - For Platform select **RAD JPA Platform**.
 - For Connection select **ITSOBANKderby**. If the connection is not active, click **Connect**.
 - Clear **Override default schema from connection** (ITSO is the schema).
 - For JPA implementation, select **Use implementation provided by the server runtime**.
 - For persistent class management select **Discover annotated classes automatically**.
 - Select **Create orm.xml**.
 - Click **Finish**.



Figure 12-2 JPA Facet

- ▶ When prompted to switch to the JPA perspective, click **Yes**.
- ▶ The RAD75JPA project is created. Two files are created in the src/META-INF folder:
 - An empty orm.xml file that can be used for explicit mapping of entities to database tables.

- A persistence.xml file that defines a persistence unit (RAD75JPA):

```
<?xml version="1.0" encoding="UTF-8"?>
<persistence version="1.0"
  xmlns="http://java.sun.com/xml/ns/persistence"
  xmlns:xsi="http://www.w3.org/2001/XMLSchema-instance"
  xsi:schemaLocation="http://java.sun.com/xml/ns/persistence
    http://java.sun.com/xml/ns/persistence/persistence_1_0.xsd">
  <persistence-unit name="RAD75JPA">
  </persistence-unit>
</persistence>
```

This file holds the persistent entity classes.

Generating JPA entities from database tables

Now we can generate the JPA entities from the ITSOBANK database into the JPA project. Perform these steps.

- ▶ In the Project Explorer, right-click the **RAD75JPA** project and select **JPA Tools** → **Generate Entities**.
- ▶ In the Generate Entities wizard, Database Connection page, the connection (ITSOBANKderby) and schema (ITSO) are preselected. Click **Next** (Figure 12-3).

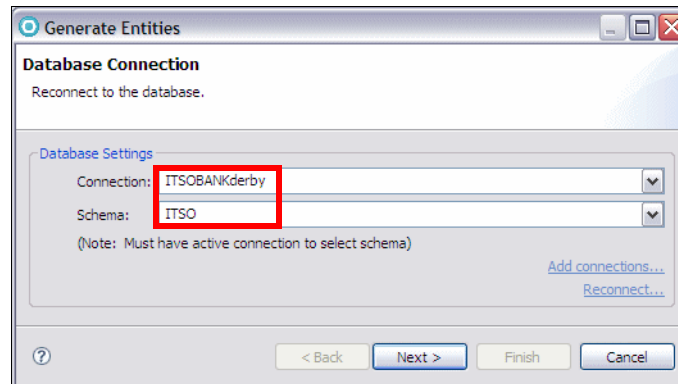

Figure 12-3 Generate Entities: Database Connection

- ▶ In the Generate Entities from Tables page (Figure 12-4):
 - For Package type **itso.bank.entities**.
 - Select **Synchronize Classes in persistence.xml** so that the generated classes are added to the file.
 - Click **Select All** to select the four tables.
 - Overwrite the entity name for the TRANSACT table as **Transaction**.
 - Click **Finish**.

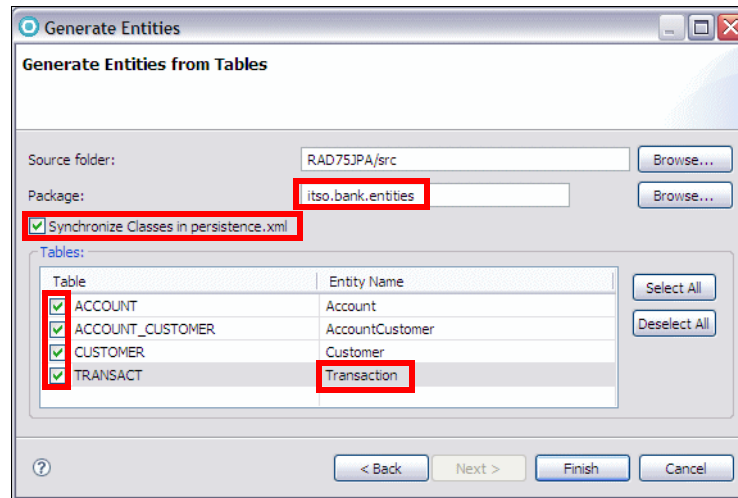

Figure 12-4 Generate Entities: Tables

- ▶ The `itso.bank.entities` package with three classes is generated, and the three classes are added to the `persistence.xml` file.

Generated JPA entities

Let us study the generated entities.

Account entity

Example 12-5 shows an extract of the `Account` class.

Example 12-5 Account entity

```
package itso.bank.entities;

import java.io.Serializable;
import java.math.BigDecimal;
import java.util.Set;
import javax.persistence.Entity;
import javax.persistence.Id;
import javax.persistence.JoinColumn;
import javax.persistence.JoinTable;
import javax.persistence.ManyToMany;
import javax.persistence.OneToOne;
```

@Entity

```
public class Account implements Serializable {
    @Id
```

```

private String id;

private BigDecimal balance;

@OneToMany(mappedBy="account")
private Set<Transaction> transactCollection;

@ManyToMany
@JoinTable(
    joinColumns=@JoinColumn(name="ACCOUNT_ID"),
    inverseJoinColumns=@JoinColumn(name="CUSTOMER_SSN"))
private Set<Customer> customerCollection;

.....
// constructor, getter, setter methods

```

- ▶ The **@Entity** annotation defined the class as an entity.
- ▶ The **@Id** annotation defines `id` as the primary key.
- ▶ The **@OneToMany** annotation defines the 1:m relationship with `Transaction`. The mapping is defined in the `Transaction` entity. A `Set<Tranasaction>` field holds the related instances.
- ▶ The **@ManyToMany** and **@JoinTables** annotations define the m:m relationship with `Customer`, including the two join columns. A `Set<Customer>` field holds the related instances. We have to add the name of the relationship table (`ITS0.ACCOUNT_CUSTOMER`).

Customer entity

Example 12-6 shows an extract of the `Customer` class.

Example 12-6 Customer entity

```

import .....;

@Entity
public class Customer implements Serializable {
    @Id
    private String ssn;

    private String title;

    @Column(name="FIRST_NAME")
    private String firstName;

    @Column(name="LAST_NAME")
    private String lastName;

```

```

@ManyToMany(mappedBy="customerCollection")
private Set<Account> accountCollection;

.....
// constructor, getter, setter methods

```

- ▶ The **@Entity** annotation defined the class as an entity.
- ▶ The **@Id** annotation defines `ssn` as the primary key.
- ▶ The **@Column** annotation maps the fields to a table column if the names do not match. Note that by convention, columns names with underscores (`FIRST_NAME`) create nice Java field names (`firstName`).
- ▶ The **@ManyToMany** annotation defines the m:m relationship with `Account`. The mapping is defined in the `Account` entity.

Transaction entity

Example 12-7 shows an extract of the `Transaction` class.

Example 12-7 Transaction entity

```

@Entity
@Table(name="TRANSACT")
public class Transaction implements Serializable {
    @Id
    private String id;

    @Column(name="TRANS_TYPE")
    private String transType;

    @Column(name="TRANS_TIME")
    private Timestamp transTime;

    private BigDecimal amount;

    @ManyToOne
    private Account account;

    .....
    // constructor, getter, setter methods

```

- ▶ The **@Entity** annotation defined the class as an entity.
- ▶ The **@Table** annotation defines the mapping to the `TRANSACT` table. Note that the schema name (`ITS0`) is missing. The other two classes have no `@Table` annotation because the entity name is identical to the table name.
- ▶ The **@Id** annotation defines `id` as the primary key.

- ▶ The **@Column** annotation maps the fields to a table column if the names do not match.
- ▶ The **@ManyToOne** annotation defines the m:1 relationship with Account. The mapping defaults to `account_id` as the column name.

Completing the entity classes

The generated entities are missing the table mapping, such as `ITS0.CUSTOMER`. Without explicit mapping, default table names are assumed, and such default names have the current user ID as schema name.

- ▶ For the Account entity we add the **@Table** annotation to the entity and the relationship:

```
@Entity
@Table (schema="ITS0", name="ACCOUNT")
public class Account implements Serializable {
    .....

    @ManyToOne
    @JoinTable(name="ACCOUNT_CUSTOMER", schema="ITS0",
        joinColumns=@JoinColumn(name="ACCOUNT_ID"),
        inverseJoinColumns=@JoinColumn(name="CUSTOMER_SSN"))
    private Set<Customer> customerCollection;
```

- ▶ For the Customer entity we add the **@Table** annotation:

```
@Entity
@Table (schema="ITS0", name="CUSTOMER")
public class Customer implements Serializable {
```

- ▶ For the Transaction entity we add the schema to the **@Table** annotation, and the **@ForeignKey** annotation to the relationship with Account:

```
@Entity
@Table(schema="ITS0", name="TRANSACTION")
public class Transaction implements Serializable {
    .....
    @ManyToOne
    @ForeignKey
    private Account account;
```

- ▶ Resolve the missing import statement by selecting **Source** → **Organize Imports** or press **Ctrl+Shift+O**.

Verifying the persistence.xml file

Open the `persistence.xml` file and verify that the three class have been added:

```
<persistence version="1.0" .....>
  <persistence-unit name="RAD75JPA">
    <class>
```

```
        itso.bank.entities.Account</class>
    <class>
        itso.bank.entities.Customer</class>
    <class>
        itso.bank.entities.Transaction</class>
</persistence-unit>
</persistence>
```

Adding business logic

We want to add business logic, so that an account balance can only be changed through a deposit or withdraw of funds. In addition, a deposit or withdraw must create a transaction record.

Transaction class

To create transaction records, we define the possible values for transaction type (credit and debit), and add a constructor with parameters,

- ▶ Define two constants in the Transaction class:

```
public static final String DEBIT = "Debit";
public static final String CREDIT = "Credit";
```

- ▶ Add a constructor that sets the `id` to a universally unique identifier (UUID), and the `transTime` to the current time stamp.

```
public Transaction(String transType, BigDecimal amount) {
    super();
    setId(java.util.UUID.randomUUID().toString());
    setTransType(transType);
    setAmount(amount);
    setTransTime( new Timestamp(System.currentTimeMillis()) );
}
```

Note: Transaction objects must have a unique key, and the time stamp (`transTime` field) is not unique on fast machines. Therefore, we create a UUID using a Java utility class.

Account class

First, we change the constructor to initialize the balance. Open the Account class and change the code of the constructor:

```
public Account() {
    super();
    setBalance(new BigDecimal(0.00));
}
```

Next, we make the `setBalance` method private, so that it cannot be used by clients:

```
private void setBalance(BigDecimal balance) {
    this.balance = balance;
}
```

Finally, we add a `processTransaction` method that performs the credit or debit of funds, and creates a transaction instance (Example 12-8).

Example 12-8 Processing credit and debit transactions

```
public Transaction processTransaction
    (BigDecimal amount, String transactionType) throws Exception {
    if (Transaction.CREDIT.equals(transactionType)) {
        balance = balance.add(amount);
    } else if (Transaction.DEBIT.equals(transactionType)) {
        if (balance.compareTo(amount) < 0)
            throw new Exception("Not enough funds for DEBIT of " + amount);
        balance = balance.subtract(amount);
    } else
        throw new Exception("Invalid transaction type");
    Transaction transaction = new Transaction(transactionType, amount);
    transaction.setAccount(this);
    return transaction;
}
```

Notice that the method verifies that enough funds are available for withdraw (debit). After adjusting the balance, a transaction instance is created, and the account is set into the new transaction.

Resolve the missing imports by selecting **Source** → **Organize Imports**, or press Ctrl-Shift-O.

Adding named queries

Named queries can provide additional functionality, such as retrieving all the instances of a class, or retrieving related instances by following a relationship and sorting the results. When following the relationships through the generated collection (`Set`), the related instances can be in any order.

Note that named queries are based on the entity attributes, and not on the column names in the mapped table.

Customer class

For the Customer class we want to be able to retrieve all customers, retrieve a customer by partial last name, and we want to retrieve the list of accounts sorted by the account ID.

- ▶ Open the Customer class.
- ▶ Add a **@NamedQueries** annotation that defines four named queries:

```
@Entity
@Table (schema="ITS0", name="CUSTOMER")
@NamedQueries({
    @NamedQuery(name="getCustomers", query="select c from Customer c"),
    @NamedQuery(name="getCustomerBySSN", query="select c from Customer c
        where c.ssn =?1"),
    @NamedQuery(name="getCustomersByPartialName", query="select c from
        Customer c where c.lastName like ?1"),
    @NamedQuery(name="getAccountsForSSN", query="select a from Customer
        c, in(c.accountCollection) a where c.ssn =?1 order by a.id")
})
public class Customer implements Serializable {
```

- ▶ The four queries enable these functions:

getCustomers	Retrieve all customers
getCustomerBySSN	Retrieve the customer for a given ssn, as an alternative to the entity manager find method
getCustomerByPartialName	Retrieve a list of customer by partial last name
getAccountsForSSN	Retrieve the accounts of one customer

- ▶ The last query illustrates how to follow a relationship (`accountCollection`) from a customer to the related accounts, and sort them by their ID.
- ▶ Always organize imports (select **Source** → **Organize Imports** or press **Ctrl+Shift+O**).

Account class

In the Account class we add two named queries to retrieve the accounts for a customer, and to retrieve the transactions for an account. Both queries follow the relationships defined in the Account class.

- ▶ Open the Account class.
- ▶ Add two named queries:

```
@Entity
@Table (schema="ITS0", name="ACCOUNT")
@NamedQueries({
    @NamedQuery(name="getAccountsBySSN", query="select a from Account a,
        in(a.customerCollection) c where c.ssn =?1 order by a.id"),
```

```

    @NamedQuery(name="getTransactionsByID", query="select t from
        Account a, in(a.transactCollection) t where a.id =?1
        order by t.transTime")
})
public class Account implements Serializable {

```

- ▶ Note that we use either the `getAccountsForSSN` query defined in the `Customer` class, or the `getAccountsBySSN` query defined in the `Account` class, to retrieve the accounts of a customer.

Visualizing the JPA entities

A UML diagram can visualize JPA entities and their relationships. Entities can be created from the diagram, or the UML diagram can be used to visualize existing entities.

We create a UML class diagram from the generated JPA entities.

- ▶ Right-click the **RAD75JPA** project and select **New** → **Class Diagram**.
- ▶ Accept the default name (`classdiagram`), and click **Finish**.
- ▶ When prompted to enable modeling capabilities, click **OK**.
- ▶ The class diagram opens. Expand the Palette, JPA drawer (Figure 12-5).

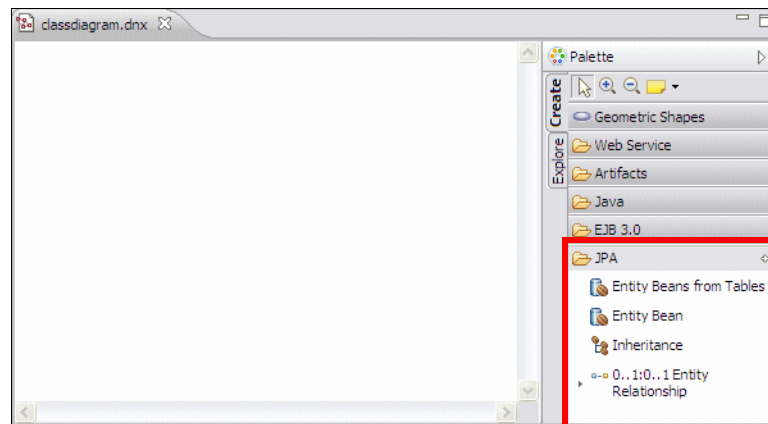

Figure 12-5 Class diagram with JPA Palette

- ▶ Drag the **Customer** class into the diagram (Figure 12-6).

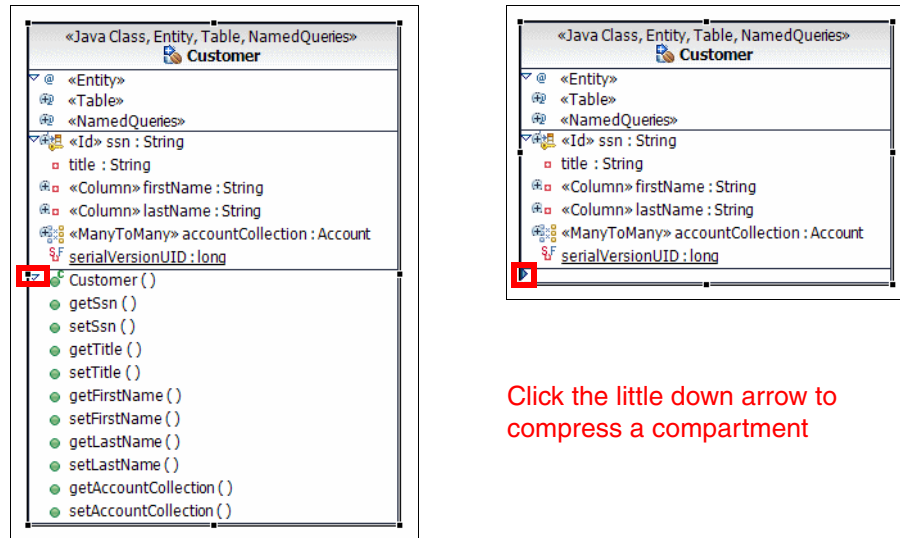

Figure 12-6 Customer class visualized

- Drag the **Account** and **Transaction** classes into the diagram. Close the method compartments. Select and drag the <<use>> arrows to separate them (Figure 12-7). Save and close the diagram.

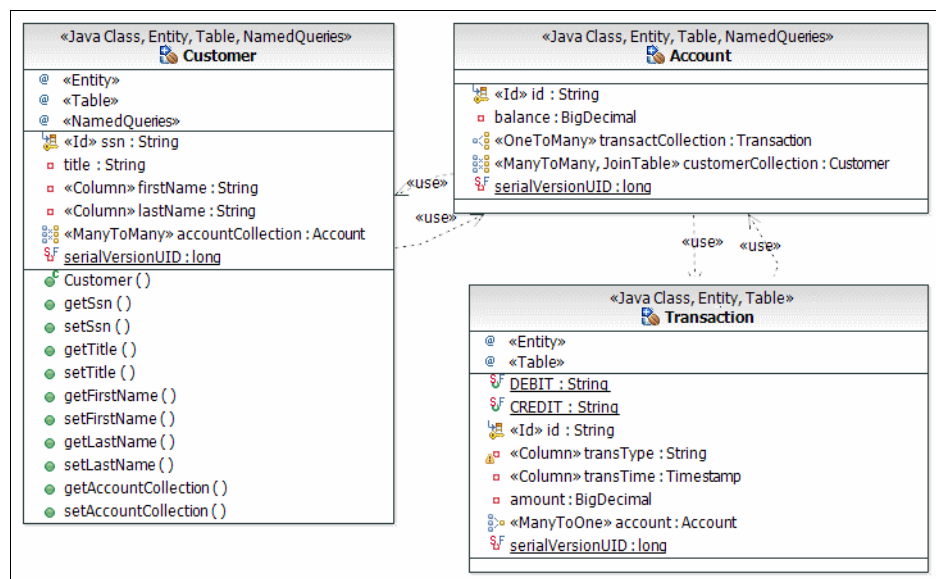

Figure 12-7 JPA class diagram

Testing JPA entities

One of the benefits of JPA entities over CMP beans is that they can be tested outside of a WebSphere application server using a Java class with a `main` method. JPA entities can also be tested using the JUnit framework. JUnit will be covered in Chapter 23, “Test using JUnit” on page 819.

To test the entities we create an independent project (RAD75JPATest) that links to the JPA project (RAD75JPA). To run JPA outside of the server, we have to use the OpenJPA implementation, and not the JPA implementation of the server. This requires modifications to the `persistence.xml` file.

Creating the Java project for entity testing

To test the JPA entities, we use a simple Java project.

- ▶ In the Java perspective, right-click in the Package Explorer and select **New** → **Java Project**.
- ▶ In the Create a Java Project dialog, type **RAD75JPATest** as Project name, accept all the defaults, and click **Next**.
- ▶ In the Java Settings dialog, select the **Projects** tab, and click **Add**. Select the **RAD75JPA** project—which we will be testing—and click **OK**.
- ▶ Click **Finish**.
- ▶ When prompted to switch to the Java perspective, click **Yes**.

Creating a Java class for entity testing

Let us create an `EntityTester` class with a `main` method.

- ▶ Right-click the **RAD75JPATest** project and select **New** → **Class**.
- ▶ In the Java Class dialog:
 - Type **itso.bank.entities.test** as Package.
 - Type **EntityTester** as Name.
 - For Which method stubs would you like to create, select **public static void main(String[] args)**.
 - Click **Finish**, and the `EntityTester` class opens in the editor.

Setting up the build path for OpenJPA

Because this class runs outside of the server, we have to add the required JPA and server libraries to the build path.

- ▶ Right-click the **RAD75JPATest** project and select **Properties**.
- ▶ In the Properties dialog, select **Java Build Path** (on the left) and the **Source** tab. Change the output folder from `RAD75JPATest/bin` to `RAD75JPATest/src` (Figure 12-8). Without this change, the `persistence.xml` file that we create will not be found.

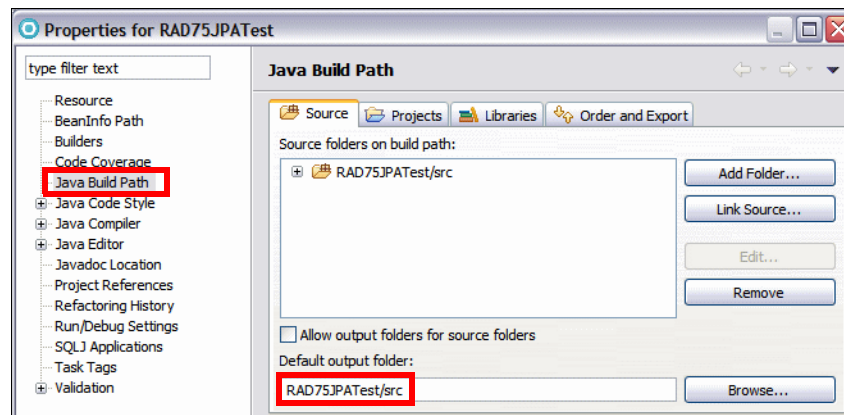

Figure 12-8 Java Build Path of Java project: Source

- ▶ Select the **Libraries** page (Figure 12-9):

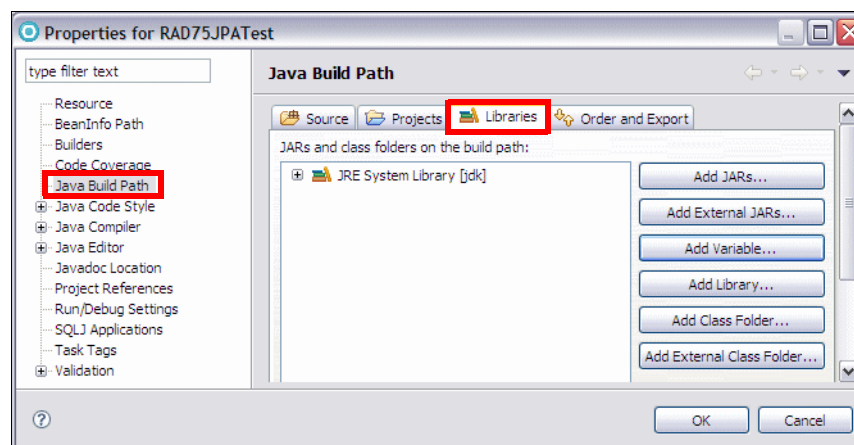
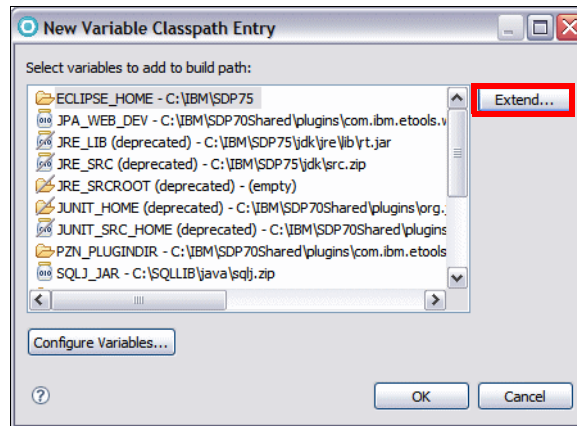

Figure 12-9 Java Build Path of Java project: Libraries

- Click **Add Variable**.
- In the New variable Classpath Entry dialog, select **ECLIPSE_HOME**, and click **Extend** (Figure 12-10).



Note that relative references through variables are more flexible than references to external JAR files.

Figure 12-10 Extending a variable

- In the Variable Extension dialog, expand **runtimes** → **base_v7** → **lib**, select the **j2ee.jar**, and click **OK** (Figure 12-11).

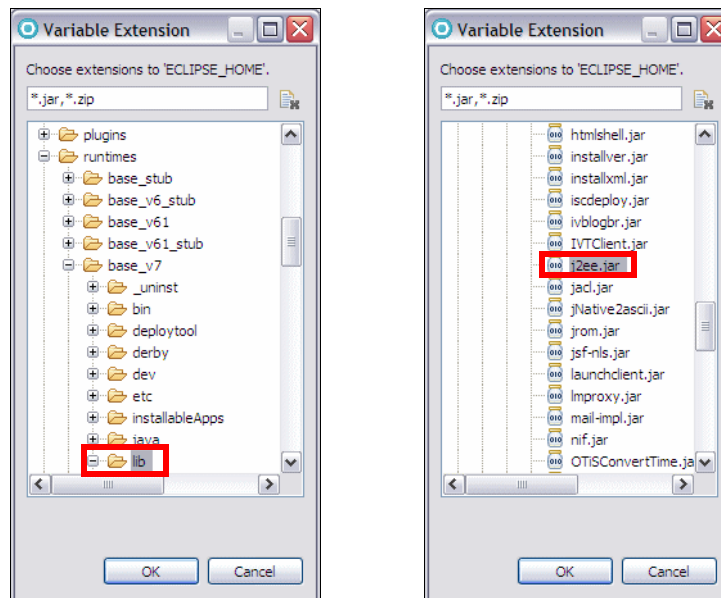

Figure 12-11 Selecting a runtime JAR file

- Repeat this sequence by extending the ECLIPSE_HOME variable, and select these JAR files:

```

runtimes/base_v7/derby/lib/derby.jar
runtimes/base_v7/plugins/com.ibm.ffdc.jar
runtimes/base_v7/plugins/com.ibm.ws.jpa.jar
runtimes/base_v7/plugins/com.ibm.ws.prereq.common-collections.jar

```

- The Libraries tab shows now the extra JAR files (Figure 12-12).

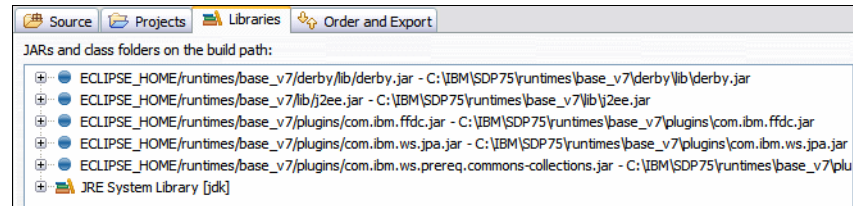

Figure 12-12 Library tab with five extra JAR files

- Click **OK** to close the Properties dialog.

Setting up the persistence.xml file

The persistence.xml file is used to configure the OpenJPA implementation. Because we want to use the RAD75JPA project later in the WebSphere server, we do not want to change that file. We can create a similar file in the RAD75JPATest project, so that it overwrites the file in the RAD75JPA project.

- ▶ Right-click the **src** folder in the RAD75JPATest project and select **New** → **Folder**. Enter **META-INF** as Folder name and click **Finish**.
- ▶ Copy the persistence.xml file from the RAD75JPA project into the META-INF folder of the RAD75JPATest project.
- ▶ Open the persistence.xml file. In the editor (Example 12-9).
 - Add transaction-type to the <persistence-unit> tag.
 - Remove the <jta-data-source> tag.
 - Add a <provider> tag.
 - Add four properties to setup connection to the ITS0BANK database and for logging.

Example 12-9 Persistence.xml file for OpenJPA

```

<?xml version="1.0" encoding="UTF-8"?>
<persistence .....

```

```

</provider>
<class>
itso.bank.entities.Account</class>
<class>
itso.bank.entities.Customer</class>
<class>
itso.bank.entities.Transaction</class>
<properties>
  <property name="openjpa.ConnectionURL"
    value="jdbc:derby:C:\7672code\database\derby\ITSOBANK" />
  <property name="openjpa.ConnectionDriverName"
    value="org.apache.derby.jdbc.EmbeddedDriver" />
  <property name="openjpa.ConnectionUserName" value="itso" />
  <property name="openjpa.Log" value="none" />
</properties>
</persistence-unit>
</persistence>

```

- ▶ You can copy and paste the code from 7672code\jpa\test\persistence.xml.

Note: If you want to use DB2 for the JPA entities, add these JAR files to the Libraries page:

```

<SQLLIB-HOME>/java/db2jcc.jar
<SQLLIB-HOME>/java/db2jcc_license_cu.jar

```

Change the JPA properties in the persistence.xml file to:

```

<property name="openjpa.ConnectionURL"
  value="jdbc:db2://localhost:50000/ITSOBANK" />
<property name="openjpa.ConnectionDriverName"
  value="com.ibm.db2.jcc.DB2Driver" />
<property name="openjpa.ConnectionUserName" value="db2admin" />
<property name="openjpa.ConnectionPassword" value="<password>" />
<property name="openjpa.Log" value="none" />

```

Creating the test

To test the JPA entities we complete the main method in the EntityTester class (Example 12-10).

- ▶ Copy and paste the code from 7639code\jpa\test\EntityTester.java.
- ▶ Select **Source** → **Organize Imports**, be sure to resolve:

```

java.math.BigDecimal
javax.persistence.Query
itso.bank.entities.Transaction
java.util.List

```

Example 12-10 Testing JPA entities using a Java program

```

public class EntityTester {

    static EntityManager em;

    public static void main(String[] args) {
        String customerId = "111-11-1111";
        if (args.length > 0) customerId = args[0];
        System.out.println("Entity Testing");

        System.out.println("\nCreating EntityManager");
        em = Persistence.createEntityManagerFactory("RAD75JPA")
            .createEntityManager();
        System.out.println("RAD75JPA EntityManager successfully created\n");
        em.getTransaction().begin();

        System.out.println("\nAll customers: ");
        Query query1 = em.createNamedQuery("getCustomers");
        List<Customer> custList1 = query1.getResultList();
        for (Customer cust : custList1) {
            System.out.println(cust.getSsn() + " " + cust.getTitle() + " "
                + cust.getFirstName() + " " + cust.getLastName());
        }

        System.out.println("\nCustomers by partial name: a");
        Query query2 = em.createNamedQuery("getCustomersByPartialName");
        query2.setParameter(1, "%a%");
        List<Customer> custList2 = query2.getResultList();
        for (Customer cust : custList2) {
            System.out.println(cust.getSsn() + " " + cust.getTitle() + " "
                + cust.getFirstName() + " " + cust.getLastName());
        }

        System.out.println("\nRetrieve one customer: " + customerId);
        Customer cust = em.find(Customer.class, customerId);
        System.out.println(cust.getSsn() + " " + cust.getTitle() + " "
            + cust.getFirstName() + " " + cust.getLastName());

        Set<Account> acctSet = cust.getAccountCollection();
        System.out.println("Customer has " + acctSet.size() + " accounts");
        for (Account account : acctSet) {
            System.out.println("Account: " + account.getId() + " balance "
                + account.getBalance());
        }
        System.out.println
            ("\nRetrieve customer accounts sorted using named query:");
        Query query3 = em.createNamedQuery("getAccountsBySSN");
        query3.setParameter(1, cust.getSsn());
    }
}

```

```

List<Account> acctList = query3.getResultList();
for (Account account : acctList) {
    System.out.println("Account: " + account.getId() + " balance "
        + account.getBalance());
}

System.out.println("\nPerform transactions on one account: ");
Account account = acctList.get(0);
System.out.println("Account: " + account.getId() + " balance "
    + account.getBalance());

Transaction tx = null;
try {
    BigDecimal balance = account.getBalance();
    tx = account.processTransaction(new BigDecimal(100.00), "Credit");
    em.persist(tx); // make insert persistent
    System.out.println("Tx created: " + tx.getAccount().getId() + " "
        + tx.getTransType() + " " + tx.getAmount() + " "
        + tx.getTransTime() + " id " + tx.getId());
    tx = account.processTransaction(new BigDecimal(50.00), "Debit");
    em.persist(tx);
    System.out.println("Tx created: " + tx.getAccount().getId() + " "
        + tx.getTransType() + " " + tx.getAmount() + " "
        + tx.getTransTime() + " id " + tx.getId());
    tx = account.processTransaction( balance.add(new BigDecimal(200.00)),
        "Debit");

    em.persist(tx);
} catch (Exception e) {
    System.out.println("Transaction failed: " + e.getMessage());
}

em.flush(); // make inserts persistent in the DB
em.refresh(account); // retrieve account again to access transactions

System.out.println("\nAccount: " + account.getId() + " balance "
    + account.getBalance());
//List<Transaction> transList = (List<Transaction>)account
    .getTransactCollection();

Query query4 = em.createNamedQuery("getTransactionsByID");
query4.setParameter(1, account.getId());
List<Transaction> transList = query4.getResultList();
System.out.println("Account has " + transList.size() + " transactions");
for (Transaction tran : transList) {
    System.out.println("Transaction: " + tran.getTransType() + " "
    + tran.getAmount() + " " + tran.getTransTime() + " id " + tran.getId());
}
em.getTransaction().commit ();
}
}

```

Understanding the entity testing code

Let us understand how to work with entities:

- ▶ We require an entity manager for the RAD75JPA persistence unit.

```
static EntityManager em;
.....
em = Persistence.createEntityManagerFactory("RAD75JPA")
                .createEntityManager();
```

- ▶ We start a transaction (this is not required for read-only access).

```
em.getTransaction().begin();
```

- ▶ We retrieve all the customers with the `getCustomers` named query. A named query with multiple results returns a list.

```
Query query1 = em.createNamedQuery("getCustomers");
List<Customer> custList1 = query1.getResultList();
```

- ▶ We use the new Java 5 support for iterating through a list.

```
for (Customer cust : custList1) { .... }
```

- ▶ We use the `getCustomersByPartialName` named query to retrieve customer with the letter a in the last name. This query illustrates how to set a parameter in the query.

```
Query query2 = em.createNamedQuery("getCustomersByPartialName");
query2.setParameter(1, "%a%");
```

- ▶ We use the `accountCollection` relationship in the `Customer` class to list the related accounts. When we list the accounts they are in any order.

```
Set<Account> acctSet = cust.getAccountCollection();
```

- ▶ We use the `getAccountsBySSN` named query to retrieve the related accounts in sorted order.

```
Query query3 = em.createNamedQuery("getAccountsBySSN");
query3.setParameter(1, cust.getSsn());
List<Account> acctList = query3.getResultList();
```

- ▶ We process transactions on one account. The last transaction fails because the amount is larger than the balance.

```
tx = account.processTransaction(new BigDecimal(100.00), "Credit");
tx = account.processTransaction(new BigDecimal(50.00), "Debit");
tx = account.processTransaction( balance.add(new BigDecimal(200.00)),
                                "Debit");
```

- ▶ We have to persist each new transaction.

```
em.persist(tx);
```

- ▶ We want to retrieve the account and see all the transactions. The flush method writes the updates to the database, and the refresh method refreshes the account in memory.

```
em.flush();           // make inserts persistent in the DB
em.refresh(account); // retrieve account again to access transactions
```

- ▶ We list the transactions of the account in time stamp sequence using the getTransactionsByID named query. The transactCollection would return the transactions in any sequence.

```
//List<Transaction> transList = (List<Transaction>)account
//                               .getTransactCollection();
Query query4 = em.createNamedQuery("getTransactionsByID");
query4.setParameter(1, account.getId());
List<Transaction> transList = query4.getResultList();
```

- ▶ We commit all the changes.

```
em.getTransaction().commit();
```

Running the JPA entity test

Now we can run the test.

- ▶ Make sure that the ITS0BANKderby connection is disconnected (with Embedded Derby you can only have one active connection to a database). You can verify this in the JPA perspective, Data Source Explorer. If the connection is active, right-click the connection and select **Disconnect**.
- ▶ Right-click the **EntityTester** class and select **Run As** → **Java Application**.
- ▶ You receive error messages in the Console that the Customer class cannot be found.
- ▶ Select **Run** → **Run Configurations**. You can find the **EntityTester** configuration under Java Application.
- ▶ Select the **Arguments** tab.
- ▶ For Program arguments, type **333-33-3333** (we want to work with that employee).
- ▶ For VM arguments, type (use the installation directory):

```
-javaagent:c:/IBM/SDP75/runtimes/base_v7/plugins/com.ibm.ws.jpa.jar
```

Note: OpenJPA includes a Java agent for automatically enhancing persistent classes as they are loaded into the JVM. Java agents are classes that are invoked prior to your application's main method. OpenJPA's agent uses JVM hooks to intercept all class loading to enhance classes that have persistence metadata before the JVM loads them.

- ▶ Figure 12-13 shows the run configuration arguments.

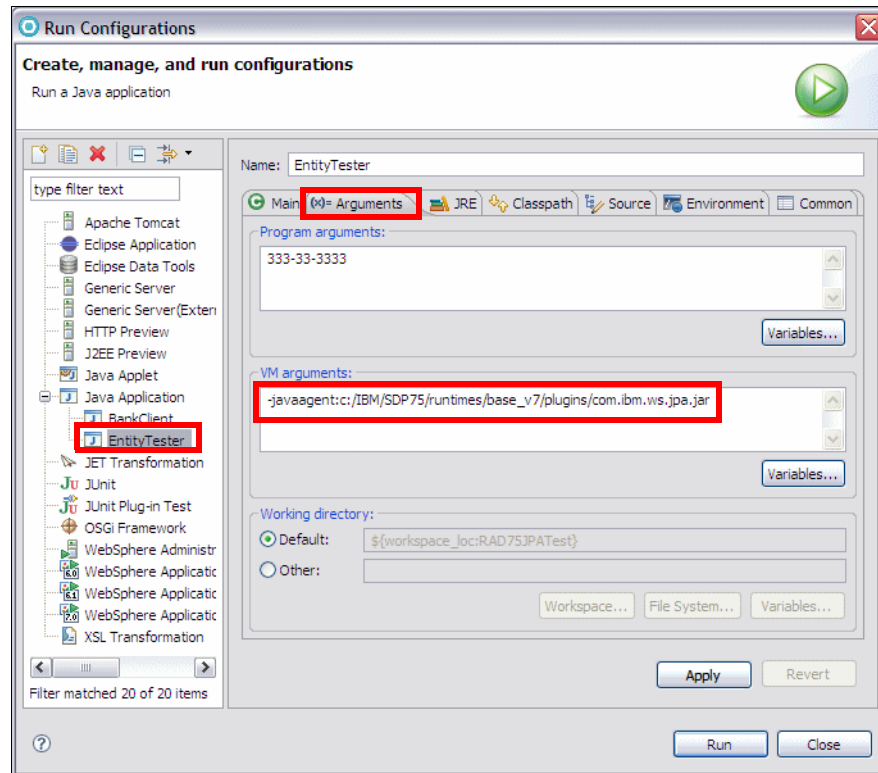

Figure 12-13 Run configuration arguments

- ▶ Click **Apply**, then click **Run**. The Console displays the output (Example 12-11).

Example 12-11 Sample output of entity tester

Entity Testing

```
Creating EntityManager
RAD75JPA EntityManager successfully created
```

All customers:

```
Aug 11, 2008 3:54:30 PM null null
SEVERE: javaAccessorNotSet
111-11-1111 Mr Henry Cui
222-22-2222 Ms Pinar Ugurlu
333-33-3333 Mr Marco Rohr
444-44-4444 Mr Xxxxx Yyyyyyy
555-55-5555 Mr Aaaa Bbbbb
```

666-66-6666 Mr Patrick Gan
777-77-7777 Mr Celso Gonzales
888-88-8888 Mr Cccccc Dddddd
999-99-9999 Mr Eeeeeee Ffffffff
000-00-0000 Mr Ueli Wahli

Customers by partial name: a

666-66-6666 Mr Patrick Gan
777-77-7777 Mr Celso Gonzales
000-00-0000 Mr Ueli Wahli

Retrieve one customer: 333-33-3333

333-33-3333 Mr Marco Rohr
Customer has 3 accounts
Account: 003-999000777 balance 9926.52
Account: 003-999000999 balance 21.56
Account: 003-999000888 balance 568.79

Retrieve customer accounts sorted using named query:

Account: 003-999000777 balance 9876.52
Account: 003-999000888 balance 568.79
Account: 003-999000999 balance 21.56

Perform transactions on one account:

Account: 003-999000777 balance 9876.52
Tx created: 003-999000777 Credit 100 2008-08-11 16:01:46.14 id
5c6e691c-f107-4902-8be8-93e4230fcb6
Tx created: 003-999000777 Debit 50 2008-08-11 16:01:46.14 id
25a93a1a-7ef5-4a23-a925-6f7c638cddd3

Transaction failed: Not enough funds for DEBIT of 10076.52

Account: 003-999000777 balance 9926.52

Account has 2 transactions

Transaction: Credit 100 2008-08-11 16:01:46.14 id
5c6e691c-f107-4902-8be8-93e4230fcb6
Transaction: Debit 50 2008-08-11 16:01:46.14 id
25a93a1a-7ef5-4a23-a925-6f7c638cddd3

- ▶ Repeat the test by selecting **Run** → **Run History** → **Entity Tester**. This time four transactions are listed for the account.

Displaying the SQL statements

We can configure the OpenJPA properties so that the SQL statements issued against the database are displayed.

- ▶ Open the **persistence.xml** file (in RAD75JPATest).

- ▶ Change the **openjpa.Log** property to the value **SQL=TRACE**.

```
<property name="openjpa.Log" value="SQL=TRACE" />
```

- ▶ Rerun the test (**Run** → **Run History** → **Entity Tester**) and you can see the SQL statements.

- All customers:

```
SELECT t0.ssn, t0.FIRST_NAME, t0.LAST_NAME, t0.title FROM ITSO.CUSTOMER
t0
```

- Customers by partial last name:

```
SELECT t0.ssn, t0.FIRST_NAME, t0.LAST_NAME, t0.title FROM ITSO.CUSTOMER
t0 WHERE (t0.LAST_NAME LIKE ? ESCAPE '\') [params=(String) %a%]
```

- Accounts of a customer:

```
SELECT t1.id, t1.balance FROM ITSO.ACCOUNT_CUSTOMER t0 INNER JOIN
ITSO.ACCOUNT t1 ON t0.ACCOUNT_ID = t1.id WHERE t0.CUSTOMER_SSN = ?
[params=(String) 333-33-3333]
```

- Accounts of a customer sorted:

```
SELECT t0.id, t0.balance FROM ITSO.ACCOUNT t0 INNER JOIN
ITSO.ACCOUNT_CUSTOMER t1 ON t0.id = t1.ACCOUNT_ID INNER JOIN
ITSO.CUSTOMER t2 ON t1.CUSTOMER_SSN = t2.ssn WHERE (t1.CUSTOMER_SSN = ?)
ORDER BY t0.id ASC [params=(String) 333-33-3333]
```

- Perform a transaction:

```
INSERT INTO ITSO.TRANSACT (id, amount, TRANS_TIME, TRANS_TYPE,
ACCOUNT_ID) VALUES (?, ?, ?, ?, ?) [params=(String)
c77b2cb3-a4a6-4db3-bb27-22dec71b8bb2, (BigDecimal) 50, (Timestamp)
2008-08-11 16:12:49.406, (String) Debit, (String) 003-999000777]
```

- Update the account balance after the transactions:

```
UPDATE ITSO.ACCOUNT SET balance = ? WHERE id = ? [params=(BigDecimal)
10026.52, (String) 003-999000777]
```

- Transactions of an account:

```
SELECT t1.id, t1.ACCOUNT_ID, t1.amount, t1.TRANS_TIME, t1.TRANS_TYPE
FROM ITSO.ACCOUNT t0 INNER JOIN ITSO.TRANSACT t1 ON t0.id =
t1.ACCOUNT_ID WHERE (t0.id = ?) ORDER BY t1.TRANS_TIME ASC
[params=(String) 003-999000777]
```

- ▶ Replace value "SQL=TRACE" by the value "none" to deactivate the trace.

Adding inheritance

We have two types of transactions, Credit and Debit. The two types are distinguished in the database table by the `TRANS_TYPE` column, which became the `transType` field in the `Transaction` class.

In this section we define two subclasses of `Transaction`, `Credit` and `Debit`. We use single table inheritance, that is, we map all three classes to one table. The `TRANS_TYPE` column becomes the discriminator column, and the `transType` field goes away from the `Transaction` class.

Changing the `Transaction` class for inheritance

Inheritance is defined through three annotations:

- ▶ `@Inheritance`—Defines that inheritance is present
- ▶ `@DiscriminatorColumn`—Defines the discriminator column
- ▶ `@DiscriminatorValue`—Defines the value for each class

To define inheritance in the `Transaction` class, perform these steps:

- ▶ Open the `Transaction` class.
- ▶ Add the annotations and make the class **abstract** (there are no `Transaction` instances, only `Credit` and `Debit`):

```
@Entity
@Table(schema="ITSO", name="TRANSACT")
@Inheritance
@DiscriminatorColumn(name="TRANS_TYPE",
                    discriminatorType=DiscriminatorType.STRING, length=32)
public abstract class Transaction implements Serializable {
```

- ▶ The `transType` field is not part of the instances, once the matching column is used as the discriminator column. Remove or comment the `transType` field:

```
//@Column(name="TRANS_TYPE")
//private String transType;
```

- ▶ Change the `getTransType` method to abstract (we still want to provide the `transType` value to clients), and remove the setter:

```
public abstract String getTransType();
public void setTransType(String transType) { ..... }
```

- ▶ Remove `transType` from the constructor:

```
public Transaction(String transType, BigDecimal amount) {
    super();
    setId(java.util.UUID.randomUUID().toString());
setTransType(transType);
    setAmount(amount);
    setTransTime( new Timestamp(System.currentTimeMillis()) );
}
```

}

Adding the Credit subclass

The Credit class is a subclass of the Transaction class, and is mapped to the same ITSO.TRANSACT table.

- ▶ Create a **Credit** class in the **itso.bank.entities** package as a subclass of Transaction (Figure 12-14):
 - Set the superclass to **itso.bank.entities.Transaction**.
 - Select **Constructor from superclass**, and **Inherited abstract methods**.
 - Click **Finish**.

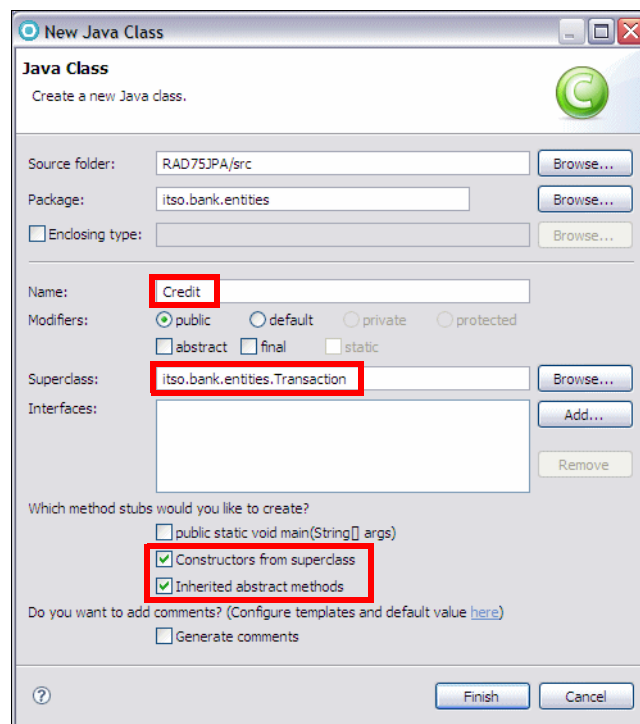

Figure 12-14 Creating the Credit class

- ▶ Complete the code with annotations and implement the getTransType method (Example 12-12).

Example 12-12 Credit class

```
@Entity
@Table (schema="ITSO", name="TRANSACT")
```

```

@Inheritance
@DiscriminatorValue("Credit")
public class Credit extends Transaction {

    public Credit() {
        super(new BigDecimal(0.00));
    }

    public Credit(BigDecimal amount) {
        super(amount);
    }

    @Override
    public String getTransType() {
        return Transaction.CREDIT;
    }
}

```

- To resolve the warning that the class does not implement a `serialVersionUID`, click the warning marker, and select **Add default serial version ID**.

Adding the Debit subclass

Repeat the sequence and define the Debit subclass (Example 12-13).

Example 12-13 Debit class

```

@Entity
@Table (schema="ITS0", name="TRANSACT")
@Inheritance
@DiscriminatorValue("Debit")
public class Debit extends Transaction {

    private static final long serialVersionUID = 1L; //generated

    public Debit() {
        super(new BigDecimal(0.00));
    }

    public Debit(BigDecimal amount) {
        super(amount);
    }

    @Override
    public String getTransType() {
        return Transaction.DEBIT;
    }
}

```

Changing the Account class to process transactions

The processTransaction method in the Account class shows an error, because we create a Transaction instance. We have to change the method to create either a Credit or a Debit instance.

- ▶ Open the Account class.
- ▶ Change the processTransaction method (Example 12-14).

Example 12-14 Processing credit or debit transactions

```
public Transaction processTransaction(BigDecimal amount,
                                       String transactionType) throws Exception {
    Transaction transaction = null;
    if (Transaction.CREDIT.equals(transactionType)) {
        balance = balance.add(amount);
        transaction = new Credit(amount);
    } else if (Transaction.DEBIT.equals(transactionType)) {
        if (balance.compareTo(amount) < 0)
            throw new Exception("Not enough funds for DEBIT of " + amount);
        balance = balance.subtract(amount);
        transaction = new Debit(amount);
    } else throw new Exception("Invalid transaction type");
    Transaction transaction = new Transaction(transactionType, amount);
    transaction.setAccount(this);
    return transaction;
}
```

Adding toString methods for printing

To facilitate nice output when testing, especially with the Universal Test Client, we add toString methods to the classes.

- ▶ Open the Account class and add the toString method:

```
public String toString() {
    return "Account: " + getId() + " balance " + getBalance();
}
```

- ▶ Open the Customer class and add the toString method:

```
public String toString() {
    return "Customer: " + getSsn() + " " + getTitle() + " "
        + getFirstName() + " " + getLastName();
}
```

- ▶ Open the Transaction class and add the toString method:

```
public String toString() {
    return getTransType() + ": " + getAmount() + " at "
        + getTransTime() + " (" + getAccount().getId() + ")";
}
```

Testing inheritance

The `EntityTester` class shows no errors, and we can run the test unchanged (select **Run** → **Run History** → **EntityTester**). However, if you run the test, you get an error message:

```
Transaction failed: No metadata was found for type "class
itso.bank.entities.Credit". The class does not appear in the list of
persistent types: [itso.bank.entities.Customer, itso.bank.entities.Account,
itso.bank.entities.Transaction].
```

We have to add the new types to the `persistence.xml` file:

```
<class>
itso.bank.entities.Account</class>
<class>
itso.bank.entities.Customer</class>
<class>
itso.bank.entities.Transaction</class>
<class>
itso.bank.entities.Credit</class>
<class>
itso.bank.entities.Debit</class>
```

Note: You have to update the `persistence.xml` files in both projects (RAD75JPA and RAD75JPATest). For now, changing it in RAD75JPATest is enough, but for later we need it in RAD75JPA as well.

Now you can rerun the test and it works.

Adding inheritance to the class diagram

We can add the two subclasses to the class diagram by dragging them into the diagram. Then rearrange the diagram for better visibility (Figure 12-15).

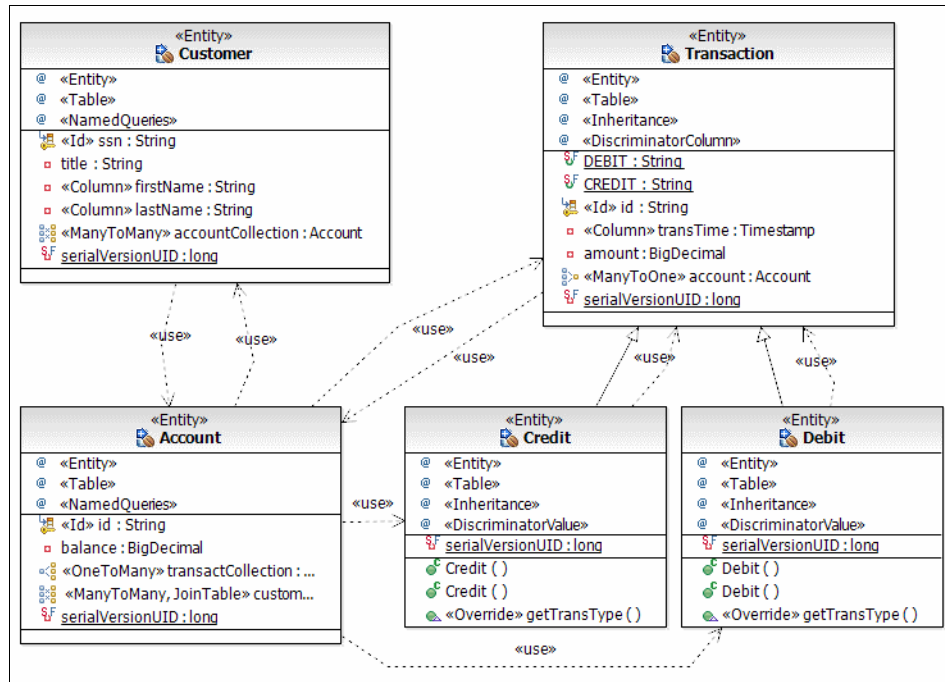

Figure 12-15 Complete class diagram of JPA entities

Preparing the entities for deployment in the server

In later chapters we access the JPA entities from EJB 3.0 session beans. For that we have to configure the server with a data source for the ITSOBANK database, and we have to configure the `persistance.xml` file to specify the JNDI name of the data source.

- ▶ The data source of the ITSOBANK database is defined in “Configuring the data source in WebSphere Application Server” on page 1155:
 - For user with DB2, we define data sources for both Derby and DB2. The JNDI names are **jdbc/itsobank** and **jdbc/itsobankdb2**.
 - We use **jdbc/itsobank** for the JPA entities. By changing the JNDI names in the server, we can run with either database without changing the application code.
- ▶ To let JPA know what database to use at runtime, we have to add the JNDI name of the data source to the `persistance.xml` file. This is only required in the RAD75JPA project, and not in the RAD75JPATest project (Example 12-15).

Example 12-15 Persistence.xml file with data source specification

```
<persistence .....>
  <persistence-unit name="RAD75JPA">
    <jta-data-source>jdbc/itsobank</jta-data-source>
    <class>
      .....
  </persistence-unit>
</persistence>
```

Alternative: For testing purposes, the data source can also be configured in the WebSphere Enhanced EAR of an enterprise application. This technique is described in “Creating a data source in the enhanced EAR” on page 802.

Summary

The EJB 3.0 specification and the Java Persistence API (JPA) make development of EJB applications much easier. There is no need for looking up EJB homes, Web applications can access session EJBs through their business interface by simple EJB injection. There is almost no need to develop data transfer objects (DTO), the JPA entities can be used as DTOs.

More information

The Java Persistence API (JPA) is documented as part of the EJB 3.0 specification, and is available at:

<http://jcp.org/aboutJava/communityprocess/final/jsr220/index.html>

IBM developerWorks has many articles on JPA. Just type JPA into the search field at the developerWorks Web site:

<http://www.ibm.com/developerworks/>



Part 5

Enterprise application development

In this part of the book, we describe the tooling and technologies provided by Application Developer to develop enterprise applications using JSPs, servlets, Enterprise JavaBeans (EJB), Struts, JavaServer Faces, Web services, Web 2.0 tools, Java Connector Architecture (JCA), and Portal Server.

Note: The sample code for all the applications developed in this part is available for download at:

<ftp://www.redbooks.ibm.com/redbooks/SG247672>

Refer to Appendix B, “Additional material” on page 1149 for instructions.



Develop Web applications using JSPs and servlets

This chapter focuses on developing Web applications using JavaServer Pages (JSPs), Java EE servlet technology, and static HTML pages, which are fundamental technologies for building Java EE Web applications. Through the RedBank example, the chapter guides you through the features available in Rational Application Developer V7.5 to work with these technologies.

In the first section, we describe the main tools available in Application Developer to Web developers and introduce the new features provided with v7.5. Next we present the design of the ITSO RedBank application, then we build and test the application using the various tools available within Application Developer. In the final section, we list sources of further information on Java EE Web components and the Web tools within Application Developer.

The chapter is organized into the following sections:

- ▶ Introduction to Java EE Web applications
- ▶ Web development tooling
- ▶ Summary of new features in v7.5
- ▶ RedBank application design
- ▶ Implementing the RedBank application
- ▶ Testing the Web application
- ▶ More information

Introduction to Java EE Web applications

Java EE (Java Enterprise Edition) is an application development framework that is the most popular standard for building and deploying Web applications in Java. Two of the key underlying technologies for building the Web components of Java EE applications are servlets and JSPs. Servlets are Java classes that provide the entry point to logic for handling a Web request and return a Java representation of the Web response. JSPs are a mechanism to combine HTML with logic written in Java. Once compiled and deployed, JSPs run as a servlet, where they also take a Web request and return a Java object representing the response page.

Typically, in a large project, the JSPs and servlets are part of the presentation layer of the application and include logic to invoke the higher level business methods. The core business functions are usually separated out into a clearly defined set of interfaces, so that these components can be used and changed independently of the presentation layer (or layers, when there is more than one interface).

Enterprise JavaBeans (EJBs) are also a key feature included in the Java EE framework and are one popular option to implement the business logic of an application. These are described in detail in Chapter 14, “Develop EJB applications” on page 387. The separation of the presentation logic, business logic, and the logic to combine them is referred to as the model-view-controller pattern and is described later.

Technologies such as Struts, JavaServer Faces (JSF), various JSP tag libraries and numerous others have been developed to extend the JSP and servlets framework in different ways to improve aspects of Java EE Web development (for example, JSF facilitates the construction of reusable UI components which can be added to JSP pages). Some of these are described in detail in other chapters of this book, however, it is important to note that the underlying technologies of these tools are extensions to Java servlets and JSPs.

When planning a new project, the choice of technology depends on several criteria (size of project, previous implementation patterns, maturity of technology, skills of the team, and so on) and using JSPs with servlets and HTML is a comparatively simple option for building Java EE Web applications. Figure 13-1 show the relationship between Java EE, Enterprise Application, Web applications, EJBs, servlets, JSPs and additions such as Struts and JSF.

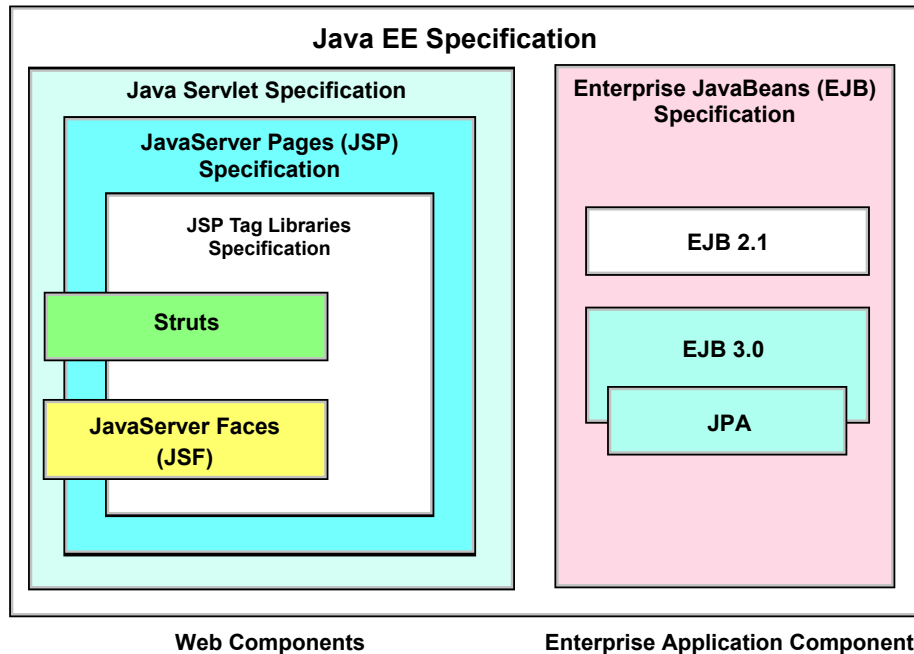

Figure 13-1 Java EE related technologies

Our focus in this chapter is on developing Web applications using JSPs, servlets, and static pages using HTML with the tools included with Application Developer. Once these concepts are mastered, it should be easier to understand the other technologies available.

Java EE applications

At the highest level, the Java EE specification describes the construction of two application types that can be deployed on any Java EE compliant application server. These are Web applications represented by a Web Application Archive (WAR) file or an enterprise application represented by an Enterprise Application Archive (EAR) file. Both files are constructed in zip file format, with a defined directory and file structure. Web applications generally contain the Web components required to build the information presented to the end user and some lower level logic, while the enterprise application contains an entire application including the presentation logic and logic implementing its interactions with an underlying database or other back-end system.

Also note that an EAR file can include one or more WAR files where the logic within the Web applications (WARs) usually invokes the application logic in the EAR.

Enterprise applications

An enterprise application project contains the hierarchy of resources that are required to deploy an enterprise (Java EE) application to WebSphere Application Server. It can contain a combination of Web applications (WAR files), EJB modules, Java libraries, and application client modules (all stored in JAR format). They also must include a deployment descriptor (`application.xml` within the `META-INF` directory), which contains meta information to guide the installation and execution of the application.

The JAR files within an enterprise application can be used by the other contained modules. This allows sharing of code at the application level by multiple Web or EJB modules.

On deployment, the EAR file is unwrapped by the application server and the individual components (EJB modules, WAR files, and associated JAR files) are deployed individually, however, some aspects are configured across the enterprise application as a whole including, for example, shared JAR files.

The use of EJBs is not compulsory within an enterprise application. When developing an enterprise application (or even a Web application) the developer can write whatever Java is most appropriate for the situation. EJBs are the defined standard within Java EE for implementing application logic, but many factors can determine the decision for implementing this part of a solution. In the RedBank sample application presented later in this chapter, the business logic is implemented using standard Java classes that use HashMaps to store data.

Web applications

A Web application server publishes the contents of a WAR file under a defined URL root (called a context root) and then directs Web requests to the right resources and returns the appropriate Web response to the requestor. Some requests can be simply mapped to a simple static resource (such as HTML files and images) while others are mapped to a specific JSP or servlet class, which are referred to as dynamic resources. It is through these requests that the Java logic for a Web application is initiated and calls to the main business logic are processed.

When a Web request is received, the application server looks at the context root of the URL to identify which WAR the request is intended for, then the server looks at the contents after the root to identify which resource to send the request to. This might be a static resource (html file), the contents of which are simply returned, or a dynamic resource (servlet or JSP), where the processing of the request is handed over to JSP or servlet code.

In every WAR file there is descriptive meta information that describes this information and guides the application server in its deployment and execution of the servlets and JSPs within the Web application.

The structure of these elements within the WAR file is standardized and compatible between different Web application servers. The Java EE specification defines the hierarchical structure for the contents of a Web application that can be used for deployment and packaging purposes. All Java EE compliant servlet containers, including the test Web environment provided by Rational Application Developer, support this structure.

The structure of a WAR file (and an EAR file) is shown in Figure 13-2.

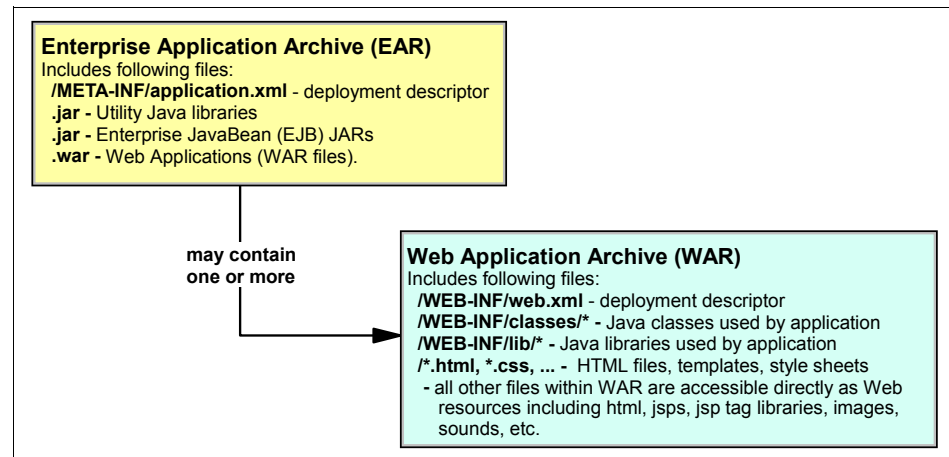

Figure 13-2 Structure of EAR and WAR files

The `web.xml` file (also referred to as the deployment descriptor) is read on deployment by the Web application server and guides the setting up and running of the application. In particular, it has configuration information for starting up the servlets and then ensuring that Web requests are mapped to the right servlet or JSP. It also contains information on security (which user groups can access a particular set of URLs), filters (a mechanism to call some Java code before a request is processed), listeners (a mechanism to call some Java code on certain events), and configuration parameters to be passed to servlets or the application as a whole.

There are no requirements for the directory structure of a Web application outside of the `WEB-INF` directory. All these resources are accessible to clients (generally but not always Web browsers) directly from a URL given the context root. Naturally, we recommend that you structure the Web resources in a logical way for easy management (for example, an `images` folder to store graphics).

Java EE Web APIs

The main classes used within the Java EE framework and the interactions between them are shown in Figure 13-3. The class `ApplicationServlet` is the only class outside of the Java EE framework, and would contain the application logic.

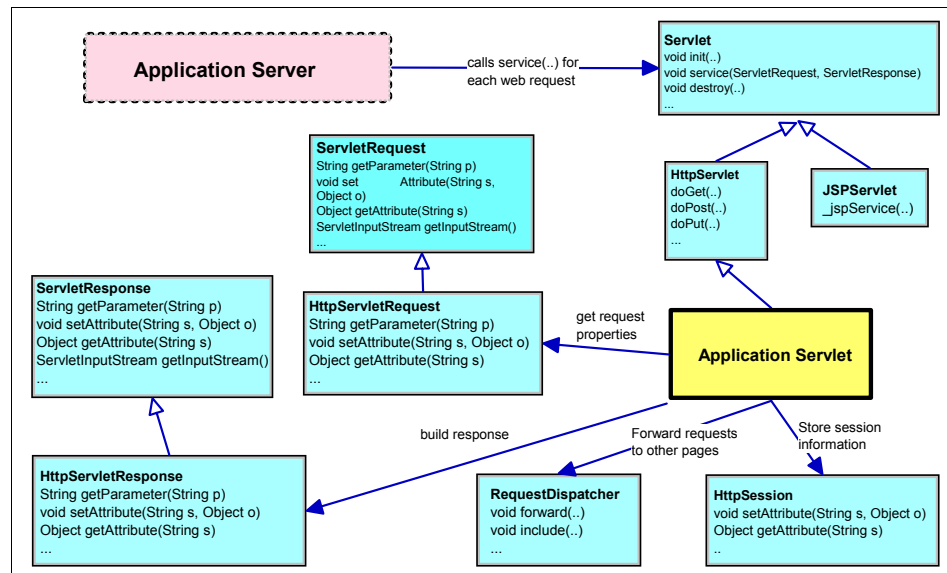

Figure 13-3 Java EE Web component classes

The main classes are as follows:

- ▶ **HttpServlet (extends Servlet)**—The main entry point for handling a Web request. The `doGet`, `doPost` (and others) methods invoke the logic for building the response given the request and the underlying business data and logic.
- ▶ **HttpJspServlet (extends Servlet)**—The Application Server will automatically compile a JSP into a class that extends this type. It runs like a normal servlet and its only entry point is the `_jspService` method.
- ▶ **HttpRequest (extends Request)**—Provides an API for accessing all pertinent information in a request.
- ▶ **HttpResponse (extends Response)**—Provides an API for creating whatever response is required given the request and the application state.
- ▶ **HttpSession**—Stores any information required to be stored across a user session with the application (as opposed to a single request).
- ▶ **RequestDispatcher**—Within a Web application, it is often required to redirect the processing of a request to another servlet. This class provides methods to do this.

Note that there are other classes in the Java EE Web components framework, and for a full description of the classes available refer, to “More information” on page 385, which provides a link to the Java EE servlet specifications.

JSPs

It is possible to include any valid fragment of Java code in a JSP and mix it with HTML. In the JSP code, the Java tags are marked by `<%` and `%>` and on deployment (or sometimes the first page request, depending on configuration) the JSP is compiled into a servlet class. This process combines the HTML and the scriptlets in the JSP file in the `_jspService` method that populates the `HttpResponse` variable. Combining a lot of complex Java code with HTML can result in a very complicated JSP file, and except for very simple examples, this practice should be avoided.

One way around this is to use custom JSP tag libraries, which are tags defined by developers that initiate calls to a Java class. These classes implement the `Tag`, `BodyTag` or `IterationTag` interfaces from the `javax.servlet.jsp.tagext` package which is part of the Java EE framework. Each tag library is defined by a `.tld` file which includes the location and content of the `taglib` class file. A reference to this file has to be included in the deployment descriptor.

Note: JSP 2.0 introduces XML based tag files. Tag files no more requires `.tld` file. Tags now can be developed using JSP or XML syntax.

The most widely available tag library is the JavaServer Pages Standard Template Library (JSTL), which provides some simple tags to handle simple operations required in most JSP programming tasks, including looping, internationalization, XML manipulation, and even processing of SQL result sets.

The RedBank application presented later uses JSTL tags to display tables and add URLs to a page, and the final section of this chapter contains references on what is possible with JSPs and tag libraries.

Model-view-controller (MVC) pattern

The model-view-controller (MVC) concept is a pattern used many times when describing and building applications with a user interface component, including Java EE applications.

Following the MVC concept, a software application or module should separate its business logic (model) from its presentation logic (view). This is desirable because it is likely that the view will change over time and it should not be necessary to change the business logic each time. Also, many applications might have different views of the same business model, and if the view is not

separated, then adding an additional view causes considerable disruptions and increase the component's complexity.

This separation can be achieved through the layering of the component into a *model* layer (responsible for implementing the business logic) and a *view* layer (responsible for rendering the user interface to a specific client type). In addition the *controller* layer sits between the two, intercepting the a requests from the view (or presentation) layer and mapping them to calls on the business model and then returning the response based on a response page selected by the controller layer. The key advantage provided by the controller layer is that the presentation can focus just on the presentation aspects of the application and leave the flow control and mapping to controller layer.

There are several ways to achieve this separation in Java EE applications and various technologies, such as JavaServer Faces (JSF) and Struts, focus on different ways of applying the MVC pattern. The focus of this chapter is on JSPs and servlets that fit into the view and controller layers of the MVC pattern. If only servlets and JSPs are used in an application, then the details of how to implement the controller layer is left to whatever mechanism the development team decides is appropriate, and which they can create using Java classes.

In one example presented later in this chapter, a *Command* pattern (see *Design Patterns, Elements of Reusable Object-Oriented Software* in the bibliography) is applied to encompass the request to the business logic and interactions made with the business logic through a facade class, while in the other interactions the request is sent directly to a servlet that makes method calls through the facade.

Web development tooling

Application Developer includes many Web development tools for building static and dynamic Web applications. Some of these are focused on technologies such as struts, portals and JavaServer Faces which are described in other chapters. In this section, we highlight the following tools and features, which focus on the more fundamental aspects of Web development.

The tools described in this section include:

- ▶ Web perspective and views
- ▶ Web Site Navigation Designer
- ▶ Web Diagram
- ▶ Page Designer
- ▶ Page templates
- ▶ CSS Designer
- ▶ Security Editor
- ▶ File creation wizards

Some of these tools are illustrated further in the RedBank Web application example built later in this chapter.

Web perspective and views

The Web perspective and its supporting views is designed to help Web developers build and edit Web resources, such as servlets, JSPs, HTML pages, style sheets, and images, as well as the deployment descriptor files.

The Web perspective can be opened by selecting **Window** → **Open Perspective** → **Web** from the Workbench. Figure 13-4 displays the default layout of the Web perspective with a simple `index.html` open in the editor.

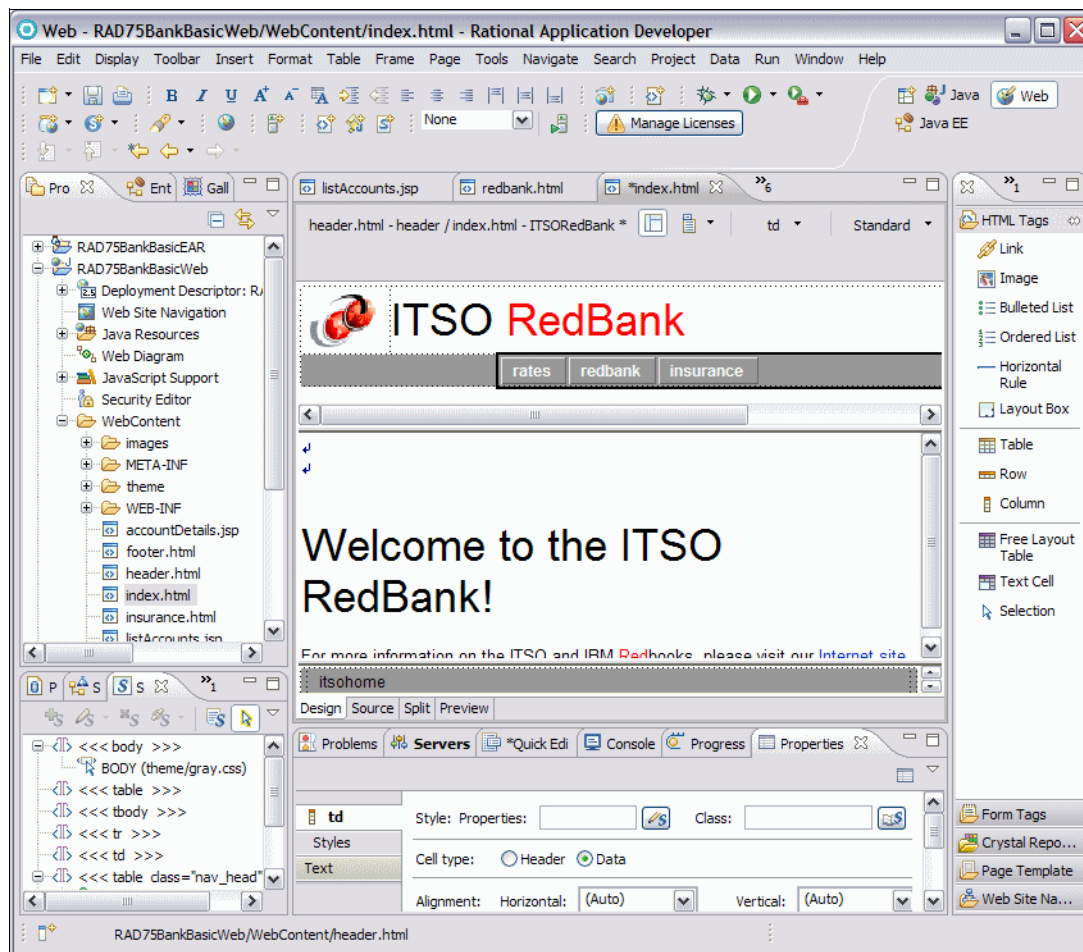

Figure 13-4 Web perspective

In the Web perspective, there are many views accessible (by selecting **Window** → **Show View**), several of which are already open in the Web perspective default setting.

By default, the views available in the Web perspective are as follows:

- ▶ **Colors view**—When working with an HTML or JSP page in the Page Designer view, the colors view gives the user the facility to manipulate colors of cells, text, tables, and other HTML tags.
- ▶ **Console view**—Shows output to SystemOut from any running processes.
- ▶ **Gallery view**—Provides a large set of folders of predefined images, sounds, and style sheets users can apply to their Web pages.
- ▶ **Links view**—Given what is shown in the Page Designer view, the Links view shows the links out from this file and elements in the Web project that link to it.
- ▶ **Navigator view**—Provides a project and folder view of the workspace (similar to Enterprise Explorer) but shows the files exactly as they exist in the file system.
- ▶ **Outline view**—Shows an outline of the file being viewed. For HTML and JSP this shows a hierarchy of tags around the current cursor position. Selecting a tag in this view will move the cursor in the main view to the selected element. This is particularly useful for moving quickly around a large HTML file.
- ▶ **Page Data view**—When editing JSP files, this gives a list of any page or scripting variables available.
- ▶ **Page Designer**—WYSIWYG editor for JSP and HTML. This consists of three tabs, Design (where the user can drag and drop components onto the page), Source (showing the HTML), and Preview (giving an indication of what the final page looks like).
- ▶ **Palette view**—When editing JSP or HTML files, this provides a list of HTML items (arranged in drawers) which can be dragged and dropped onto pages.
- ▶ **Problems view**—Shows any outstanding errors, warnings, or informational messages for the current workspace.
- ▶ **Enterprise Explorer view**—Shows a hierarchy view of all projects, folders and files in the workspace. Note that in the Web perspective it structures the information within Web projects in a way that makes navigation easier.
- ▶ **Properties view**—Shows the properties for the item currently selected in the main editor.
- ▶ **Quick Edit view**—When editing HTML or JSP files, the Quick Edit view provides a mechanism to quickly add Java Script to a given screen component on certain events, for example `onClick`.

- ▶ **Servers view**—Useful if the user wants to start or stop test servers while debugging.
- ▶ **Snippets view**—Allows editing of small bits of code, including adding and editing actions assigned to tags. Items from the Snippets view can be drag and dropped into the Quick Edit view.
- ▶ **Styles view**—Allows the user to edit and apply both pre-built and user-defined styles sheets to HTML elements and files.
- ▶ **Tasks view**—Allows the user to maintain a list of things to be done within the workspace. Note for Java code comment text tags can be configured which will automatically add items to the Tasks list (see **Window** → **Preferences** then **Java** → **Compiler** → **Task Tags** to edit these tags)
- ▶ **Thumbnails view**—Given the selection of a particular folder in the Gallery view, this view shows the contents of the folder.

Note: For more information on the Web perspective and views, refer to “Web perspective” on page 155.

Web Site Navigation Designer

The Web Site Navigation Designer is provided to simplify and speed up the creation of the entire Web site navigation and can launch wizards to facilitate the creation of HTML pages and JSPs. The tool provides features to view the Web site in the Navigation tab, to add new pages, delete pages, and move pages within in the site. This tool is especially useful for building pages in a Web application that uses a page template.

The flow of an application can be visually laid out and then the elements (JSPs, HTML pages) rearranged until it fits the requirements. Once the flow is arranged, a developer can begin creating pages based on this design.

As a Web site design is built, the information is stored in the `website-config.xml` file so that navigation links can be generated automatically. This can include a page trail (showing the hierarchy of Web pages to get to the currently shown page) or a set of page tabs to quickly navigate to other aspects of the application.

When the structure of a site changes, (for example when a new page is added) the navigation links are automatically regenerated to reflect the new Web site structure.

To launch the Web Site Designer, double-click **Web Site Navigation** found in the root of the Web project folder.

Note: For a detailed example of using the Web Site Designer, refer to “Launching the Web Site Designer” on page 346.

Web Diagram

The Web Diagram (Figure 13-5) is another view of the Web application, which shows the pages, the links between pages, and the page variables available on each page. In addition, if Struts or JavaServer Faces technologies are being used in the application, this view can include extra information to link the pages and data together as appropriate for the selected technology.

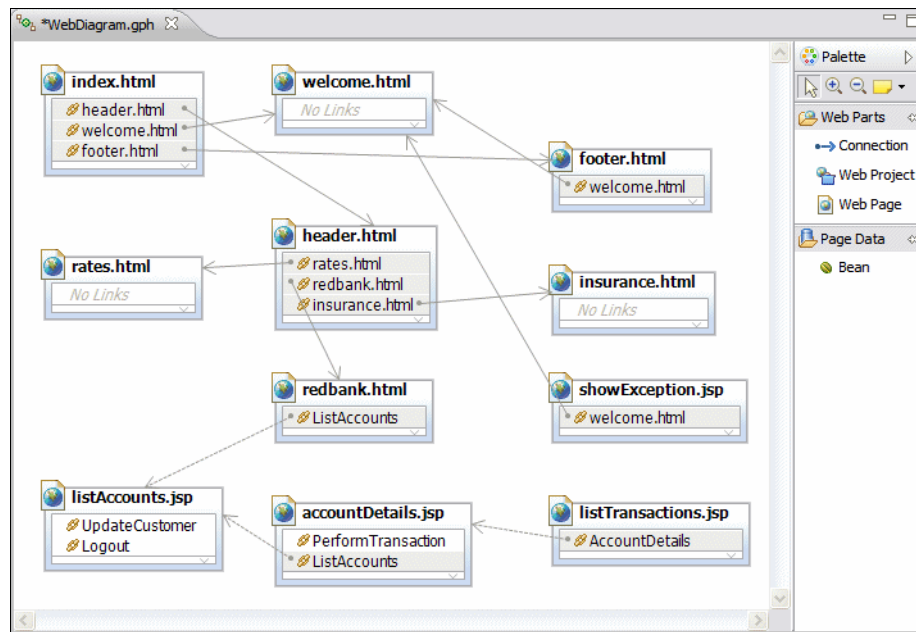

Figure 13-5 Web Diagram

In the RedBank example, the Web Diagram is not used to build the application. Instead, the Web Site Navigation Designer is the tool with which pages are built and relationships between pages are shown. Chapter 16, “Develop Web applications using JSF” on page 493 and Chapter 15, “Develop Web applications using Struts” on page 445 both provide examples of how to apply the Web Diagram.

Page Designer

Page Designer is the primary editor within Application Developer for building HTML, XHTML, JSPs, and JSF source code. It provides four representations of a page: Design, Source, Split and Preview:

- ▶ The Design tab provides a WYSIWYG environment to visually design the contents of the page.
- ▶ The Source tab provides access to the page source code showing the raw HTML or JSP contents.
- ▶ The Split tab (Figure 13-6) combines the Source tab and either the Design tab or the Preview tab in a split screen view.
- ▶ The Preview tab shows what the page would like if displayed in a Web browser.

A good development technique is to work within the Design tab of Page Designer and build up the HTML contents by clicking and dragging items from the Palette view onto the page and arranging them with the mouse or editing properties directly from the Properties view. Tags can be positioned absolutely instead of relative. The Outline view is also very helpful to navigate quickly to another tag that is related (for example, an ancestor) to the tag being edited. The Source tab can be used to change details not immediately obvious in the Design tab, the Split tab is very helpful to see design and source tab in one view, changes are immediately reflected. The Preview tab can be used throughout the process to verify the look of the final result.

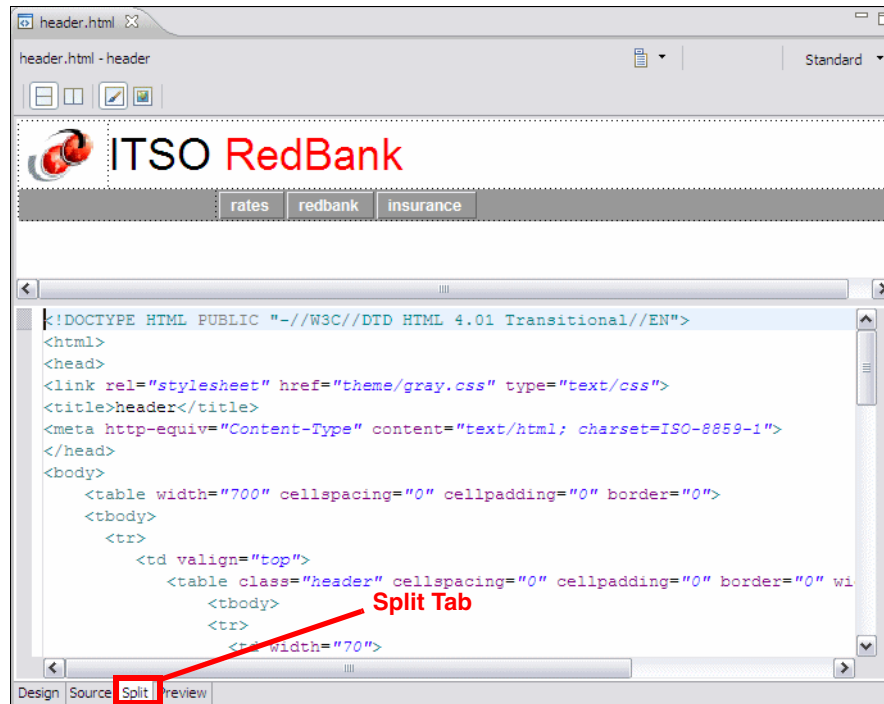

Figure 13-6 Page Designer Split Tab

Often it is the case that HTML content is provided to a development team and created from tools other than Application Developer. These files can be imported simply using the context menu on the target directory and selecting **File** → **Import** → **General** → **File System** and browsing to the new file and clicking **Import**. When an imported file is opened in Page Designer, all the standard editing features are available.

Note: For a detailed example of using the Page Designer, refer to “Developing the static Web resources” on page 358 and “Working with JSPs” on page 369.

Page templates

A page template contains common areas that you want to appear on all pages, and content areas which are intended to be unique on each page. They are used to provide a common look and feel for a Web project.

The Page Template File creation wizard is used to create these files. Once created the file can be modified in Page Designer. The page templates are stored as *.html files for HTML pages and *.jsp files for JSP pages. Changes to the

page template are reflected in pages that use that template. Templates can be applied to individual pages, groups of pages, or applied to an entire Web project. Areas can be marked as read-only meaning that Page Designer will not allow the user to modify those areas.

When creating a new page template, the user is prompted if the template is to be a **dynamic page template** or a **design time template**:

- ▶ Dynamic page template use Struts-Tiles technology to generate pages on the Web server.
- ▶ Design time templates allow changes to be made and applied to the template at design or build time, but once an application is deployed and running, the page template cannot be changed. Design time templates do not rely on any technologies other than the standard Java EE servlet libraries.

CSS Designer

Cascading style sheets (CSS) are a tool used with HTML pages to ensure that an application has consistent colors, fonts, and sizes across all pages. It is possible to create a default style sheet when creating a new project and there are several samples included with Application Developer.

Usually, a good idea is to decide on the overall theme (color, fonts) for your Web application in the beginning and create the style sheet at the start of the development effort. Then, as you create the HTML and JSP files, you can select that style sheet to ensure that the look of the Web pages are consistent. Style sheets are commonly kept in the `WebContent/theme` folder.

The CSS Designer is used to modify cascading style sheet `*.css` files. It provides two panels, the right hand side showing all the text types and their respective fonts, sizes, and colors which are all editable. On the left hand side, a sample of how the various settings will look. Any changes made are immediately applied to the design in Page Designer if the HTML file is linked to the CSS file.

Note: An example of customizing style sheets used by a page template can be found in “Customize a style sheet” on page 355.

Security Editor

The Security Editor is a new enhancement with Application Developer V7.5. It provides a wizard to specify security groups within a Web application and the URLs that group has access to. The Java EE specification allows for security groups and levels of access to defined sets of URLs to be defined in the

deployment descriptor and the Security Editor provides a nice interface for this information (Figure 13-7).

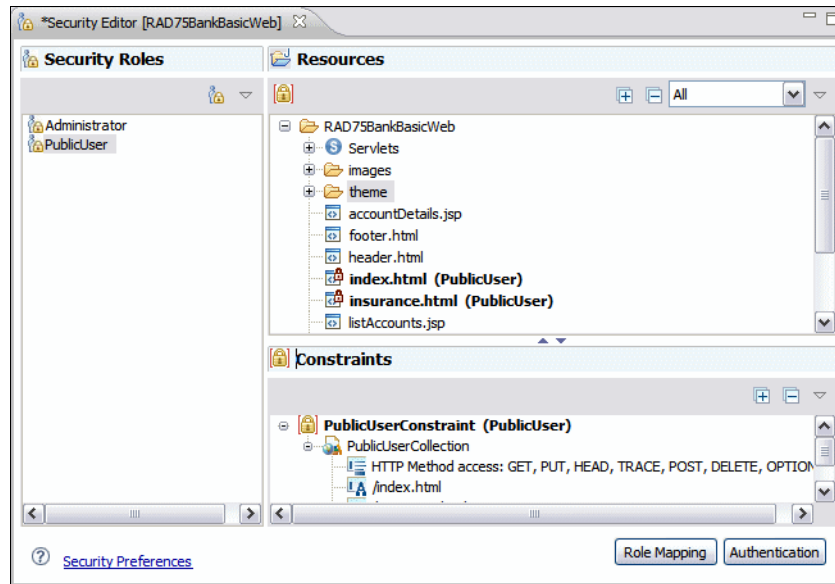

Figure 13-7 Security Editor example

Selecting an entry in the Security Roles pane shows the resources members of that role in the Resources pane, and the Constraint rules that are applicable for the role and resource (if one is selected). Each entry in the Constraints window has a list of resource collections, which specify the resources available to it and which HTTP methods can be used to access these resources. Using context menus it is possible to create new roles, security constraints, and add resource collections to these restraints.

Note that Java EE security specification defines the mechanism for declaring groups and the URL sets that each group can access, but it is up to the Web Container to map this information to an external security system. WebSphere's administrative console provides the mechanism to configure an external LDAP directory. Refer to the IBM Redbooks publication, *Experience J2EE! Using WebSphere Application Server V6.1*, SG24-7297.

File creation wizards

Application Developer provides many Web development file creation wizards by selecting **File** → **New** → **Other** and then from Select a wizard expand the Web folder and select the type of file required. These wizards prompt the user for the key features of the new artifact and can help a user to quickly get a skeleton of

the component they require. The artifact created by the wizard can always be manipulated directly if required.

The wizards available in the Web perspective are as follows:

- ▶ **CSS**—The CSS file wizard is used to create a new cascading style sheet (CSS) in a specified folder.
- ▶ **Dynamic Web Project**—Steps the user through the creation of a new Web project, including which features the project use and any page templates present.
- ▶ **Filter**—Constructs a skeleton Java class for a Java EE filter, which provides a mechanism for performing processing on a Web request before it reaches a servlet. The wizard also updates the *web.xml* file with the filter details.
- ▶ **Filter Mapping**—Steps the user through the creation of a set of URLs to map a Java EE filter with, The result of this wizard is stored in the deployment descriptor.
- ▶ **HTML**—Steps the user through the creation an HTML file in a specified folder, with the option to use HTML Templates
- ▶ **JSP**—Steps the user through the creation an JSP file in a specified folder, with the option to use JSP Templates
- ▶ **Life-cycle Listener**—The Java EE specification allows for classes to be configured to receive pertinent events from the Web container. For example the classes that implement the `HttpSessionListener` interface and are declared in the deployment descriptor, receive notification every time a `HttpSession` is created or destroyed. This wizard guides the user through the creation of such a listener and adds a reference to the deployment descriptor.
- ▶ **Listener**—A listener can be used to monitor and react to events in a servlet's life-cycle by defining methods that get invoked when life-cycle events occur. This wizard guides the user through the creation of such a listener and to select the application lifecycle events to listen to.
- ▶ **Security Constraint**—Used to populate the `<security-constraint>` in the deployment descriptor that contains a set of URLs and a set of http methods, which members of a particular security role are entitled to access.
- ▶ **Security Role**—Adds a `<security-role>` element to the deployment descriptor.
- ▶ **Servlet**—Used to create a skeleton servlet class and add the servlet to the deployment descriptor.
- ▶ **Servlet Mapping**—Steps the user through the creation of new URL to servlet mapping and adds it to the deployment descriptor.

- ▶ **Static Web Project**—Steps the user through building a new Web project containing only static pages.
- ▶ **Tag**—Steps the user through create a new Tag library file
- ▶ **Web Diagram**—It is possible to create a Web Diagram for a Web project which already has a large number of pages. This wizard creates an empty Web Diagram onto which the user can place existing pages and show existing page relationships.
- ▶ **Web Page**—The Web Page wizard allows you to create an HTML or JSP file in a specified folder, with the option to create from a large number of page templates.
- ▶ **Web Page Template**—The Page Template File wizard is used to create new page template files in a specified folder, with the option to create from a page template or create as a JSP fragment, and define the markup language (HTML, HTML Frameset, Compact HTML, XHTML, XHTML Frameset, and WML 1.3). You can select from one of the following models: Template contains Faces Components, Template containing only HTML, Template containing JSP.

Note: There are also a number of wizards specifically for Struts and JSF, which are discussed in other chapters

Summary of new features in v7.5

Rational Application Developer V7.5 has a comprehensive supports for the Java EE 5 specification, servlet 2.5, and JSP 2.1.

There have been significant changes in the tools available for creating artifacts within a Web application.

The main changes are as follows:

- ▶ **Page Designer**—The following enhancements are available:
 - Split tab: Working in split view with design helps looking at the source and also at the design page simultaneously
 - New Layout Mode: Absolute Positioning provides a way to position tags anywhere int the design page
- ▶ **JPA Web tooling**—The Java Persistence API (JPA) Web tooling enables you to create Web applications that access JPA entities, which map to relational tables. You can use exiting entities or create them while building the Web

application. The functionality of the entity manager is encapsulated into JPA manager beans that provide methods to work with the JPA entities.

RedBank application design

In this section we describe the design for the ITSO RedBank Web application, also known as RedBank. The intent is to outline the design of the RedBank application and how it fits into the Java EE Web framework, particularly with regard to JSPs and servlets.

Model

The model for the RedBank project is implemented using a simple Java project, exposed to other components through a facade interface (called `ITSOBank`). The main `ITSOBank` object is a singleton object, accessible by a single static public method called `getBank`.

The `ITSOBank` object is composed of the other business objects which make up the application, including `Customer`, `Account`, and `Transaction`. The facade into the bank object includes methods such as `getCustomer`, `getAccounts`, and `withdraw`, `deport`, and `transfer`. Figure 13-8 shows a simplified UML class diagram of the model. The model is described in detail in Chapter 8, “Develop Java applications” on page 69.

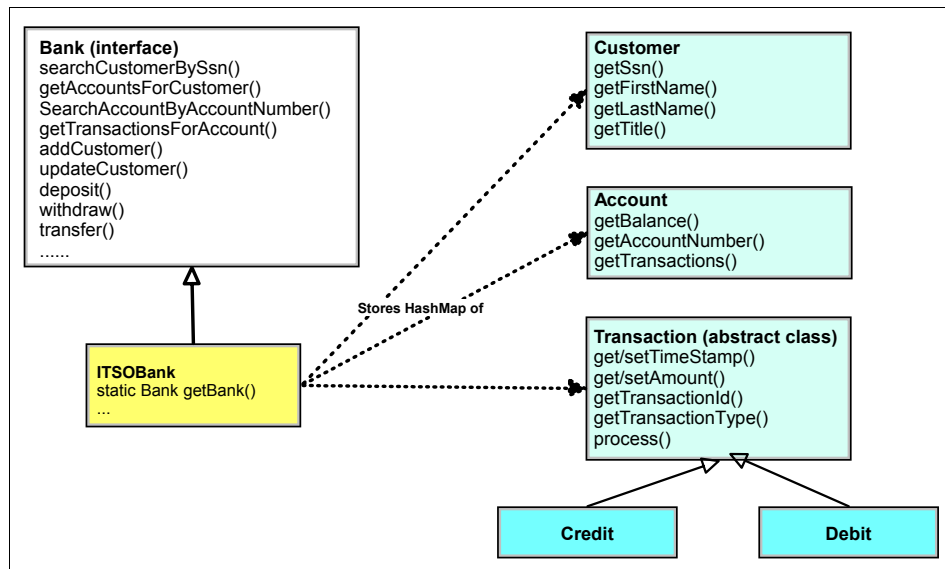

Figure 13-8 Class diagram for RedBank model

The underlying technology to store data used by the ITS0Bank application are Java HashMaps. These are populated at startup in the constructor and obviously the data is lost every time the application is restarted. In a real world example this would be stored in a database, but for the purposes of this example HashMaps are fine. In Chapter 14, “Develop EJB applications” on page 387 the ITS0Bank model is modified to run as EJBs and the application data is stored in a database.

View layer

The view layer of the RedBank application is composed of four HTML files and four JSP files. The application home page is the `index.html` containing a link to four HTML pages (`welcome.html`, `rates.html`, `insurance.html`, and `redbank.html`).

- ▶ `welcome.html`, `rates.html` and `insurance.html` are simple static HTML pages showing information, without forms or entry fields.
- ▶ `redbank.html` contains a single form which allows a user to type in the customer ID to access the customer services such as accessing balance, and performing transactions. Note that although the account number is verified, security issues (logon and password) are not covered in this example.
- ▶ From `redbank.html` the user is shown the `listAccounts.jsp` page, which shows the customer's details, a list of accounts, and a button to logout.

- ▶ Selecting an account brings up the `accountDetails.jsp`, which also shows the balance for the selected account and a form through which a transaction can be performed. This screen also shows the current account number and balance, both dynamic values. A simple JavaScript code controls whether the amount and destination account fields are available, depending on the option selected. One of the transaction options on the `accountDetails.jsp` is List Transactions, which invokes the `listTransactions.jsp`.
- ▶ If anything goes wrong in the regular flow of events, the exception page (`showException.jsp`) is shown to inform the user of the error.
- ▶ These four JSP pages (`listAccounts.jsp`, `accountDetails.jsp`, `listTransactions.jsp`, and `showException.jsp`) make up the dynamic pages of the RedBank application.

Refer to Figure 13-17 on page 351 for a diagram showing the planned structure of pages within the RedBank application. The diagram was created using the Web Site Designer tool.

Controller layer

The controller layer was implemented using two different strategies: One straightforward; and the other more complex, but more applicable to a real world situation.

The application has a total of five servlets:

- ▶ **ListAccounts**—Gets the list of accounts for one customer.
- ▶ **AccountDetails**—Displays the account balance and the selection of operations: List transactions, deposit, withdraw, and transfer.
- ▶ **Logout**—Invalidates the session data.
- ▶ **PerformTransaction**—Performs the selected operation by calling the appropriate control action: ListTransactions, Deposit, Withdraw, or Transfer.
- ▶ **UpdateCustomer**—Updates the customer information.

The first three servlets use a simple function call from the servlet to the model classes to implement their controller logic and then use the `RequestDispatcher` to forward control onto another JSP or HTML resource. The pattern used is shown in the sequence diagram in Figure 13-9.

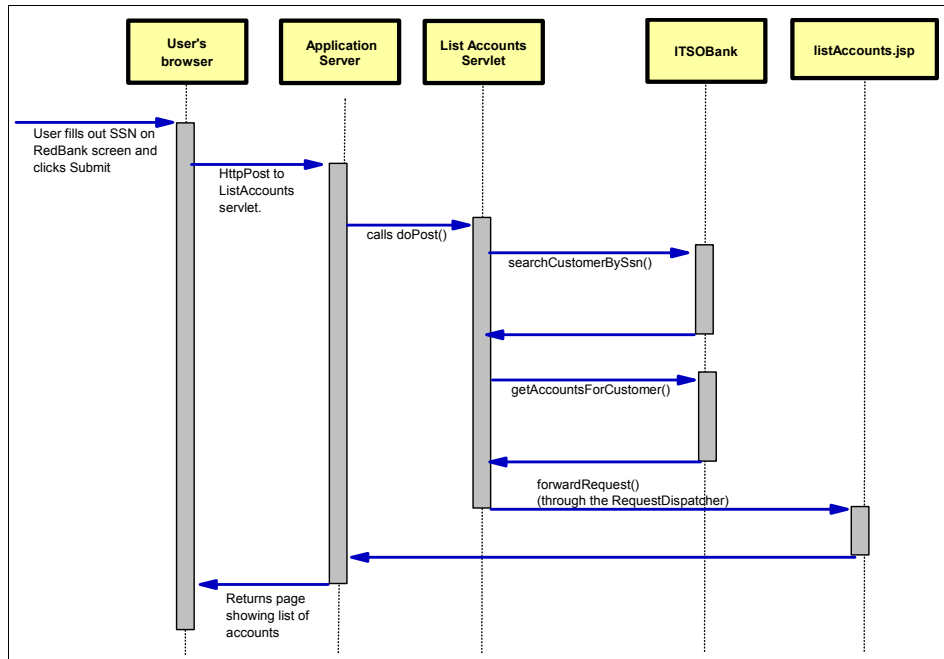

Figure 13-9 ListAccounts sequence diagram

PerformTransaction uses a different implementation pattern. It acts as a front controller, simply receiving the HTTP request and passing it to the appropriate control action object. These objects are responsible for carrying out the control of the application. Figure 13-10 shows a sequence diagram for the list transaction operation from the account details page, including the function calls through PerformTransaction, the ListTransactionsCommand class, onto the model classes, and forwarding to the appropriate JSP.

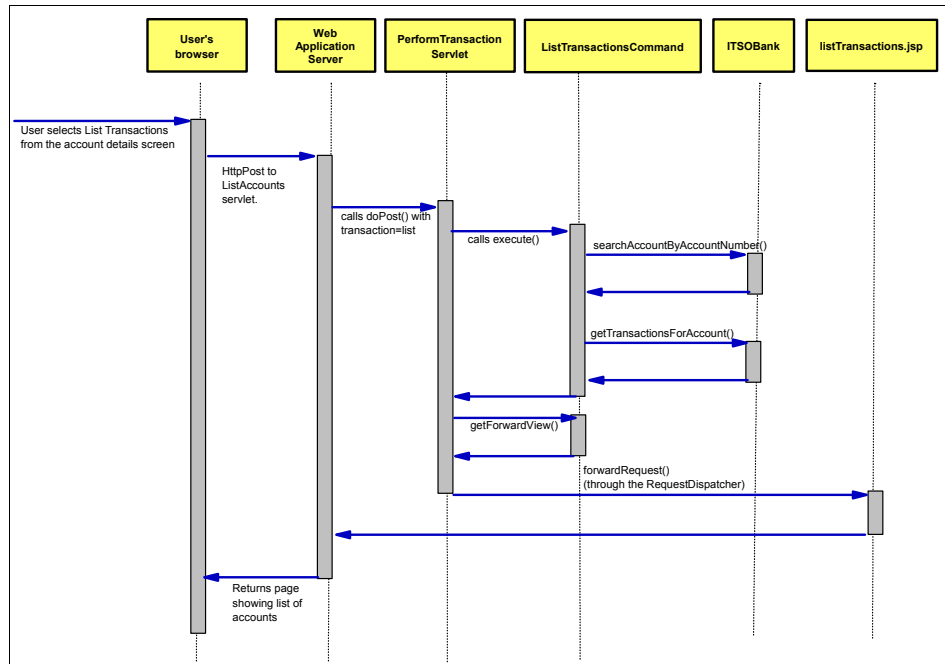

Figure 13-10 PerformTransaction sequence diagram

The Struts framework provides a much more detailed implementation of this strategy and in a standardized way. Refer to Chapter 15, “Develop Web applications using Struts” on page 445 for more details.

Note: Action objects, or commands, are part of the command design pattern. For more information, refer to *Design Patterns: Elements of Reusable Object-Oriented Software*.

Implementing the RedBank application

Using an example, this section introduces you to the tools within Application Developer’s that facilitate the development of Web applications. In the example, we step through the creation of different Web artifacts (including page templates, HTML, JSPs and servlets) and demonstrate how to use the tools available.

Note that the completed application has already been developed and is available to explore if required by importing the project interchange file:

```
c:\7672code\zInterchange\webapp\RAD75BankBasicWeb.zip
```

The section is organized as follows:

- ▶ Creating the Web project
- ▶ Importing the Java RedBank model
- ▶ Defining the Web site navigation and appearance
- ▶ Developing the static Web resources
- ▶ Developing the dynamic Web resources
- ▶ Working with JSPs

At the end of this section, the RedBank application should be ready for testing.

Creating the Web project

The first step is to create a Web project in the workspace.

Note: Before this, it might be a good idea to check that Web capabilities are enabled. Select **Windows** → **Preferences** and expand **General** → **Capabilities** make sure that **Web Developer** options (including basic, typical and advanced) are selected.

There are two types of Web projects available in Application Developer, namely, static and dynamic. Static Web projects contain static HTML resources and no Java code, and thus are comparatively simple. In order to demonstrate as many features of Application Developer as possible, and because the RedBank application contains both static and dynamic content, a Dynamic Web project is used for this example.

In Application Developer, perform the following steps:

- ▶ Open the Web perspective by selecting **Window** → **Open Perspective** → **Web**.
- ▶ To create a new Web Project, select **File** → **New** → **Dynamic Web Project**.
- ▶ In the New Dynamic Web Project dialog, enter the following items (Figure 13-11):
 - Type **RAD75BankBasicWeb** in the name field.
 - For Project contents, select **Use Default** (default). This specifies where the project files should be placed on the file system. The default option of leaving them in the workspace is usually fine.
 - Target Runtime: Select **WebSphere Application Server v7.0** (default). This option will display the supported test environments that have been installed. Use WebSphere Application Server V7.0 Test Environment.
 - Dynamic Web Module version: Select **2.5**.

- Configuration: We define the configuration as the last item.
- EAR Membership: Select **Add module to an EAR** (default). Dynamic Web Projects, such as the one we are creating, run exclusively within an enterprise application. For this reason, you have to either create a new EAR project or select an existing project.
- EAR Project Name: **RAD75BankBasicEAR** (overtypes the default). Because we selected **Add module to an EAR project**, the wizard will create a new EAR project.

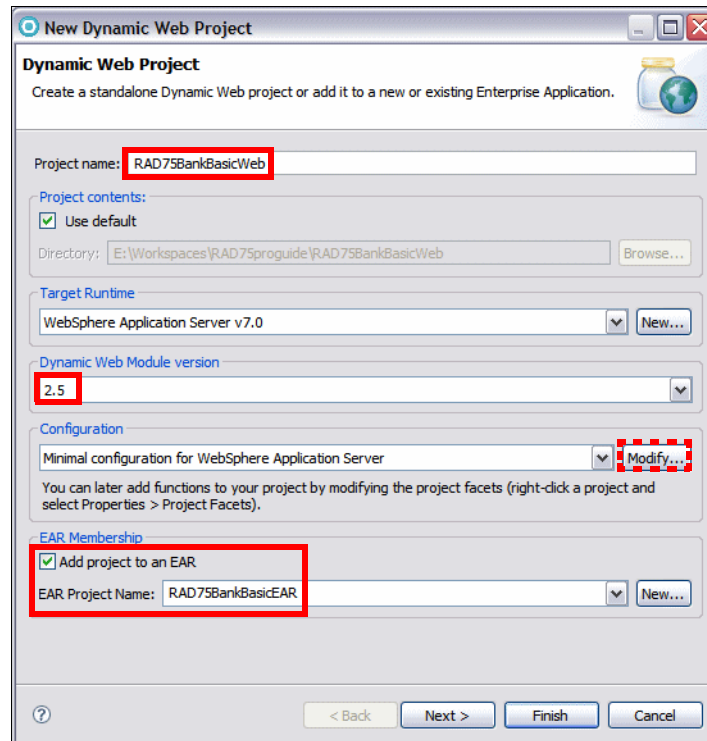

Figure 13-11 New Dynamic Web Project

- ▶ For Configuration, click **Modify** to open the Project Facets dialog: Select the additional features **Default Style Sheet**, **JSTL**, and **Web Site Navigation** (Figure 13-12). Click **OK** and the configuration changes to <custom>.

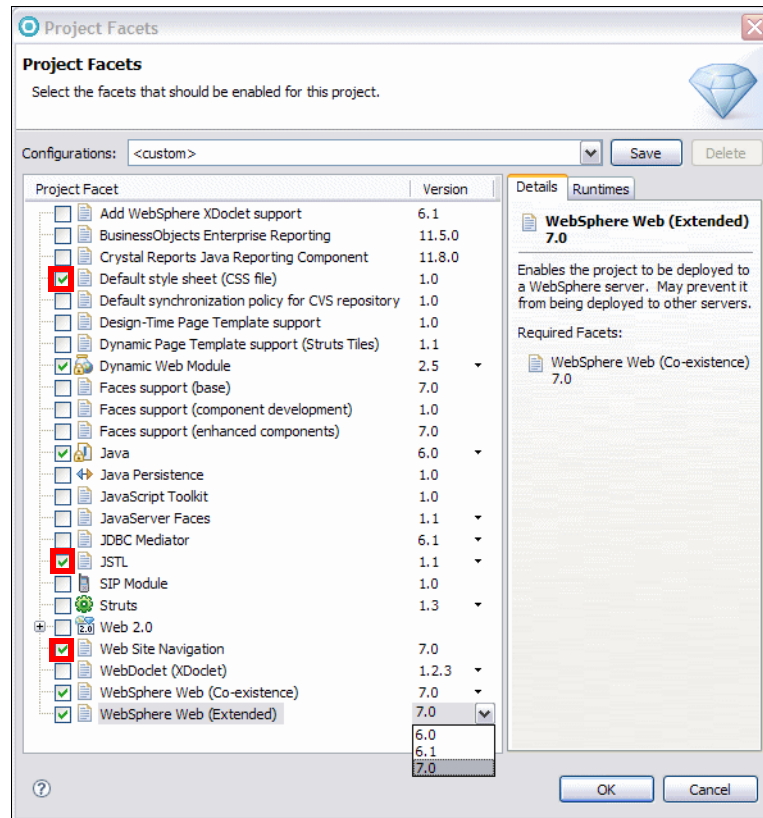

Figure 13-12 Dynamic Web Project Facets

Notes:

- ▶ The options shown with a down arrow allow you to alter the underlying version of this feature being selected. By default, the latest version available is selected.
- ▶ From this dialog, it is also possible to save the configuration for future projects. To do this, click **Save** and enter a configuration name and a description.

- ▶ Click **Next**.
- ▶ In the Web Module page, accept the default options (Figure 13-13).

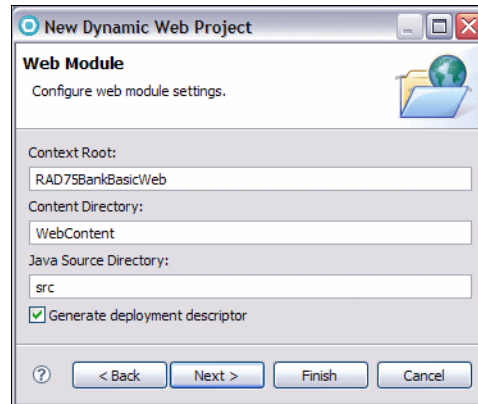

Figure 13-13 New Dynamic Web Project, Web Module settings

The settings here are as follows:

- Context Root: RAD75BankBasicWeb

The context root defines the base of the URL for the Web application. The context root is the root part of the URI under which all the application resources are going to be placed, and by which they will be referenced later. It is also the top level directory for your Web application when it is deployed to an application server.

- Content Directory: WebContent

This specifies the directory where the files intended for the WAR file are created. All the contents of the WEB-INF directory, HTML, JSPs, images and any other files that are deployed with the application are contained under this directory. Usually the folder WebContent is sufficient.

- Java Source Directory: src

This specifies the directory where any Java source code used by the Web application is stored. Again, the default value of src should be sufficient for most cases.

Click **Next** to accept the default values.

- ▶ In the Select a Page template for the Web Site dialog (Figure 13-14), leave **Use a default Page template for the Web Site** cleared. This dialog allows you to select from page templates supplied with Application Developer.

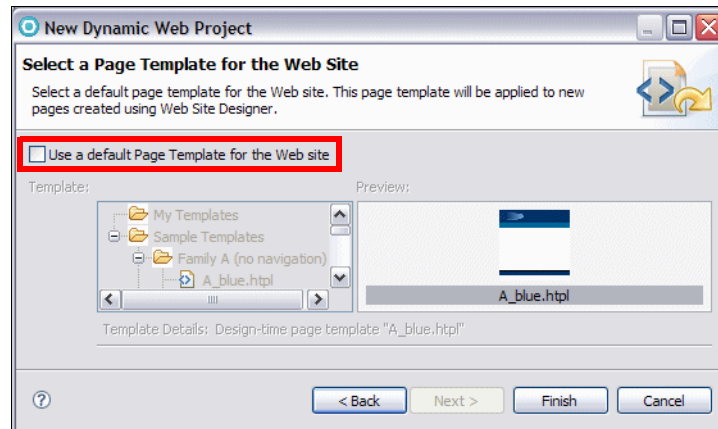

Figure 13-14 New Dynamic Web Project, Page Templates

- ▶ Click **Finish** and the Dynamic Web Project is created.

The Technology Quickstarts opens. You can browse features help topics. When done, close the Technology Quickstart.

The Web project directory structure for the newly created RAD75BankBas i cweb project and its associated RAD75BankBas i cEAR project (enterprise application) is displayed in Figure 13-15.

The main folders shown under the Web project are as follows:

- ▶ **Deployment Descriptor**—This shows an abstracted view of the contents of the projects `web.xml`. It includes sub folders for the main pieces which make up a Web project configuration, including servlets and servlet mappings, filters and filter mappings, listeners, security roles, and references.
- ▶ **Web Site Navigation**—Clicking on this starts up the tool for editing the page navigation structure.
- ▶ **Java Resources: src**—This folder contains the Java source code for regular classes, JavaBeans, and servlets. When resources are added to a Web project, they are automatically compiled, and the generated class files are added to the `WebContent\WEB-INF\classes` folder.
- ▶ **WebContent**—This folder holds the contents of the WAR file that is deployed to the server. It contains all the Web resources, including compiled Java classes and servlets, HTML files, JSPs, and graphics needed for the application.

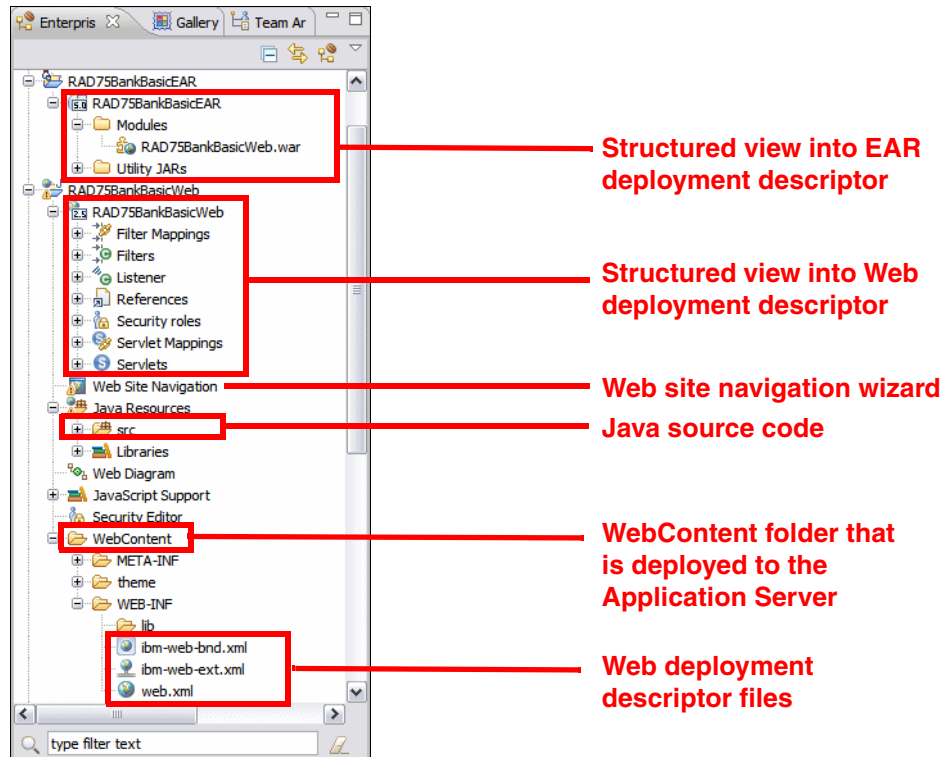

Figure 13-15 Web project directory structure

Important: Files that are not under WebContent are not deployed when the Web project is published. Typically this would include Java source and SQL files. Make sure that you place everything that should be published under the WebContent folder.

Importing the Java RedBank model

The ITSO Bank Web application requires the classes created in Chapter 8, “Develop Java applications” on page 69. This section describes how to import the project interchange file. You can skip this import if you already have the final RAD75Java project in the workspace.

- ▶ Select **File** → **Import**.
- ▶ In the Import dialog, select **Other** → **Project Interchange** and click **Next**.

- ▶ In the **Import Projects** dialog, click **Browse** to locate the interchange file `c:\7672code\zInterchange\java\RAD75Java.zip`. Select the **RAD75Java** project, and click **Finish**.

To verify that the model is running, it is possible to run the main method of the class `itso.rad75.bank.client.BankClient` class. This will invoke the bank facade classes directly, make some simple transactions directly and print out the results to the console.

We will add the RAD75Java project to the RAD75BankBasicEAR enterprise application in “Adding RAD75Java as a Web Library project” on page 362.

Defining the Web site navigation and appearance

This section demonstrates how to define the site pages and navigation using the Web Site Designer. A frameset index page and style sheet are also created to provide a common interface for the RedBank Web site navigation. The frameset index page is used to define a standard user interface layout (header, navigation menu, footer), and the style sheet is used by the Web pages to define standard fonts, colors, table formatting, and other style factors. Then the empty pages are created and the application is run to verify the basic navigation.

This section includes the following tasks:

- ▶ Launching the Web Site Designer
- ▶ Create the Web site navigation and related pages
- ▶ Customize a style sheet.

Launching the Web Site Designer

To launch Web Site Designer from the Enterprise Explorer, double-click **Web Site Navigation** (Figure 13-16).

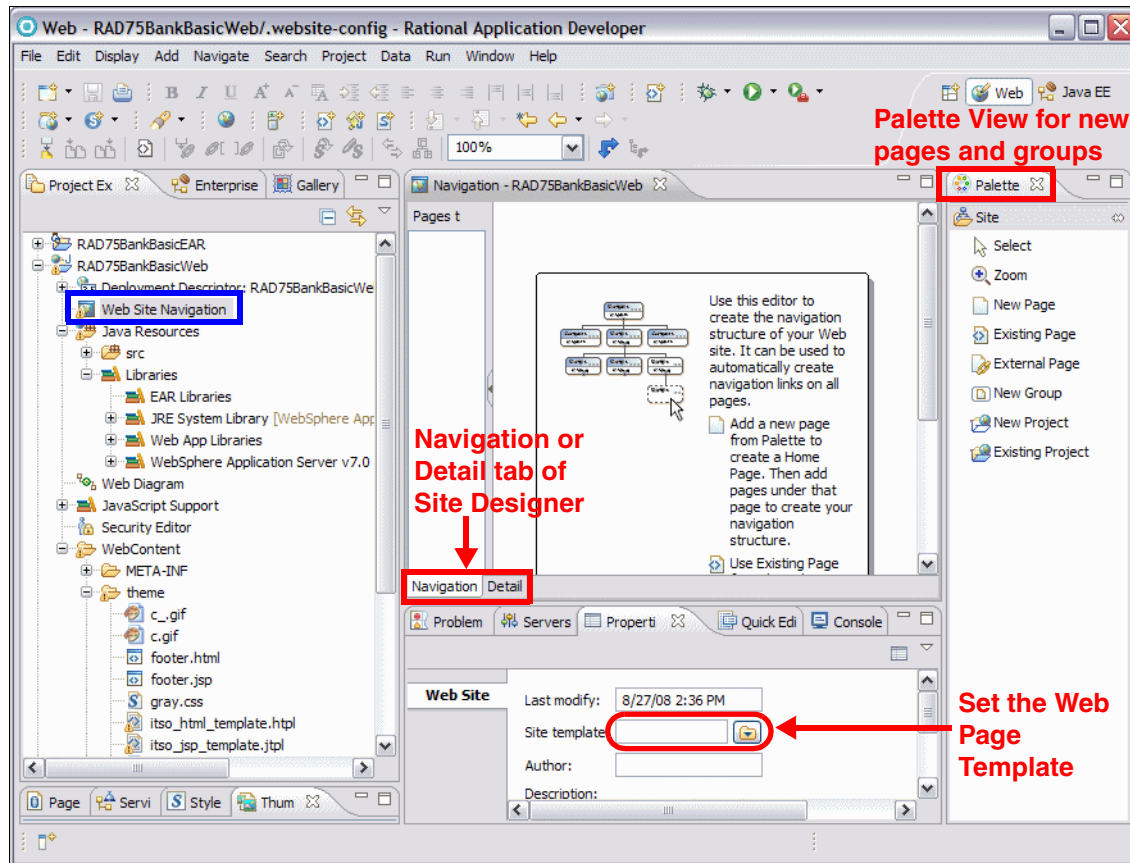

Figure 13-16 Web Site Designer: Navigation view

Notice the following features:

- ▶ **Navigation and Detail tab**—The **Navigation** tab (the default tab) allows a user to visually design the layout of the site and the **Detail** tab is used to define the fine details for each page including the ID, Navigation Label, File Path, File Name /URL, Servlet URL, and Page Title.
- ▶ **Palette view**—Selections from the Palette can be dragged to the Navigation page. For example, the **New Page** icon can be dragged from the Palette to create a new page, or the **New Group** icon can be dragged onto the page to logically organize pages in a hierarchical grouping.
- ▶ **Site template**—In the Properties view you can select a site template to define the appearance of the site. This can be a sample page template included with Application Developer, or a user-defined page template. New pages built from the Web Site Designer will use this template by default.

Create the Web site navigation and related pages

In this section, we use the Web Site Designer to construct the page navigation and page skeletons for the RedBank Web site. At the end we will have a working skeleton of the application, where we can navigate from page to page using the tabs below the page header and the ancestor tabs. The pages will not have any actual content, but this is added later.

We will create the navigation pages and corresponding HTML or JSP page for each of the following pages (Table 13-1).

Table 13-1 Web pages of the RedBank application

Navigation label	HTML or JSP file
itsohome	welcome.html
rates	rates.html
insurance	insurance.html
redbank	redbank.html
listaccounts	listAccounts.jsp
accountdetails	accountDetails.jsp
listtransactions	listTransactions.jsp
showexception	showException.jsp

Import Web resources for the RedBank application

Prior to the creation of the Web pages we have to import resources to provide the correct look and feel for web pages used in our example, such as, images and CSS files. Import those resources following the next steps:

- ▶ Expand **RAD75BankBasicWeb** → **WebContent** and from the context menu select **Import**.
- ▶ Select **General** → **File System** and click **Next**.
- ▶ In the From directory type `c:\7672code\webapp`, select the **images** and **theme** folders, and click **Finish**.
- ▶ The `itso_logo.gif` and `c.gif` images and the `grey.css` file are imported.

Create navigation HTML and JSP pages

To define the site navigation and create the HTML and JSP page skeletons, perform the following steps in the Web Site Designer:

- ▶ Launch the **Web Site Designer** from the Enterprise Explorer (if not open already).

- ▶ Create the root static navigation page (welcome.html):
 - Select **New Page** from the Palette and click on the Navigation page to add the first page.
 - After the new page is added, the navigation label can be entered in the Navigation page or in the Properties view under Navigation label. Type **itsohome**. Save the Navigation page.
 - Double-click the **itsohome** page to create the HTML file associated.
 - In the New Web Page dialog, enter the following values:
 - File name: **welcome.html**
 - Folder: /RAD75BankBasicWeb/WebContent
 - Template: Expand **Basic Templates** and select HTML/XHTML
 - Launch the Document Markup dialog by clicking **Options** and verify the following values, Markup Language=HTML, Document Type=HTML 4.01 Transitional.
 - Select **Style Sheets** and add **gray.css** as style sheet, removing the Master.css.
 - Click **Close** and **Finish** to create the HTML page.
 - The welcome.html page opens in the editor. Close this editor.
- ▶ Define the navigation root.

In our example, itsohome (welcome.html) is the *navigation root*. By default, when a page is created it is set as a *navigation candidate*, which is the desired format for all other pages.

To make this change, select **itsohome** on the Web Site Navigation Diagram, and from the context menu select **Set Navigation** → **Set Navigation Root**.
- ▶ Add three static pages as children of itsohome. From the **itsohome** context menu on Page Designer, select **Add** → **New Page** → **As Child**. Perform this three times and type the navigation labels as **rates**, **redbank**, and **insurance**.
- ▶ Double-click each page and type the file names as **rates.html**, **redbank.html**, and **insurance.html**. Leave the template HTML/XHTML selected (note that the **gray.css** style sheet is selected by default). Close the editor that opens.
- ▶ Create a new group named RedBank.

Page groups are used to logically build or organize pages into a movable block of related pages. In the RedBank example the JSPs under redbank.html are grouped together.

 - Select the **redbank** page, right-click, and select **Add** → **New Group** → **As Child**. A Group box appears below the redbank page.

- Select the group and in the **Properties** view, **Group** tab, type **RedBank** as the group name.
- Save the Navigation page.
- ▶ Create the dynamic pages (JSPs) `listaccounts`, `accountdetails`, `listtransactions`, and `showexception`.
 - From the context menu of the **RedBank** group, select **Add** → **New Page** → **Into Group**.
 - After the New Page is added, notice you can type the navigation label in the Navigation page or in the Properties view as Navigation label. For the first page, type `listaccounts`.
 - Double-click the `listaccounts` box to create the JSP file associated with the navigation label.
 - In the New Web Page dialog, enter the following items and then click **Next**:
 - File name: `listAccounts.jsp`
 - Template: Expand **Basic Templates** and select **JSP**.
 - Click **Options** and verify the `gray.css` cascade style sheet.

Note: You can provide options to automatically generate servlet stubs methods and to add extra fields to the `web.xml` file. For this example, the default options are fine.

- Click **Finish** to create the page. Close the editor that opens.
- ▶ Repeat the steps to add the `accountdetails` (`accountDetails.jsp`), `listtransactions` (`listTransactions.jsp`), and `showexception` (`showException.jsp`) pages.

Important: The spelling and capitalization of the JSP file names must be exact as shown.

- ▶ The `showexception` page only appears when there is a problem and is not part of the standard navigation. Therefore, select the `showexception` page, and clear **Show in Navigation** in the Properties view.
- ▶ Change the Page Title column of each JSP through the Navigation view, **Detail** tab, to: **List Accounts**, **Account Details**, **List Transactions**, and **Show Exception**. This action changes the `<title>` tag in the source code of each JSP.
- ▶ Save and close the Navigation page.

The completed Web Site Navigation is shown in Figure 13-17.

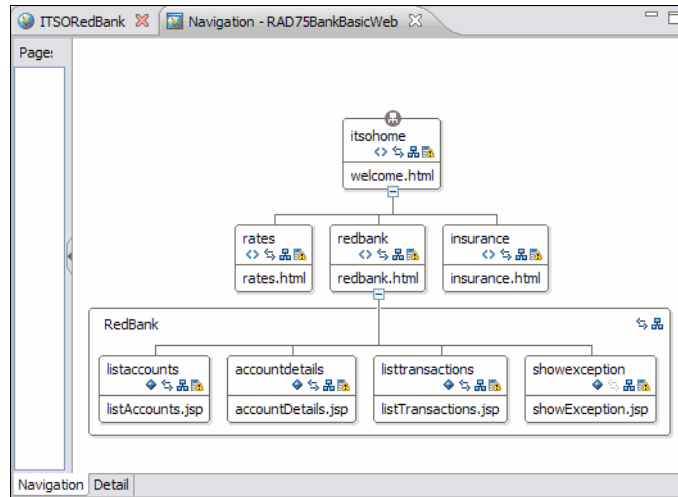

Figure 13-17 Web Site Navigation after adding pages

Create frameset pages

The RedBank user interface (view) is made up of a combination of static HTML pages and dynamic JSPs. In this section we describe how to create an HTML frameset page (`index.html`) that will define the layout of the web pages created in the section “Create navigation HTML and JSP pages” on page 348

Note: By default, a Web server looks for `index.html` (or `index.htm`) when a Web project is run. Although this behavior can be changed, we recommend that you use `index.html` as the top level page name.

Frameset pages provide an efficient method of creating a common layout for the user interface of the Web application, because has the same structure as a table, where the rows are defined in a tag element called `<frameset>` and the columns are individually defined in a tag element called `<frame>`.

In our example we only have three rows or areas and no column separations:

- ▶ **Header area**—With company logo and the navigation bar to other pages.
- ▶ **Workspace area**—Where the rest of the operational pages are displayed.
- ▶ **Footer area**—With the option to return to the main menu.

Create an HTML frameset page

To create a new HTML frameset page (`index.html`) to be used for the RedBank layout, perform the following steps:

- ▶ Right-click **WebContent** and select **New** → **Web Page** from the context menu.
- ▶ In the **New Web Page** dialog, enter the following values as shown in Figure 13-18:
 - File name: **index.html**
 - Template: Select **Basic Templates** → **HTML/XHTML**.
 - Click **Options**, and for Markup Language select **HTML Frameset** and click **Close**.
 - Click **Finish** to create the `index.html` frameset.

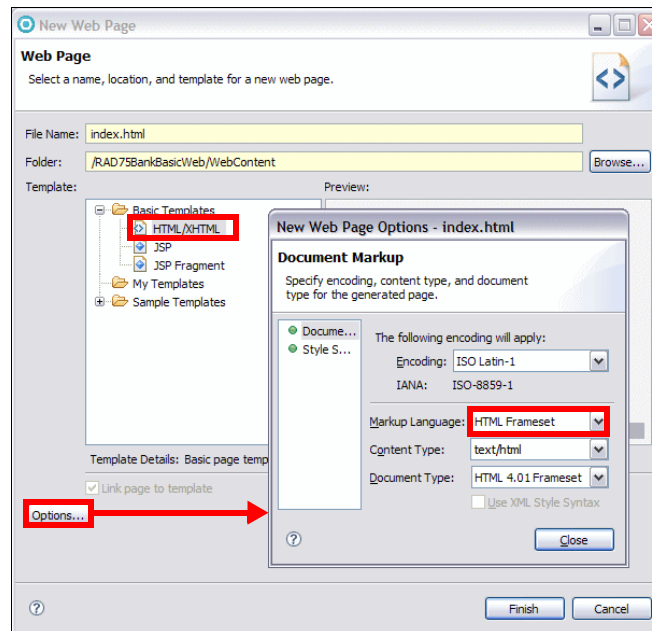

Figure 13-18 Creating a frameset page

Create an HTML header for all Web pages

We create the static HTML web page for the header area that will show the logo and heading information.

Right-click **WebContent** and select **New** → **Web Page** from the context menu.

- ▶ Create a new web page **New** → **Web Page** from the context menu.

- ▶ In the **New Web Page** dialog, enter the following values:
 - File name: **header.html**
 - Template: Select **Basic Templates** → **HTML/XHTML**.
 - Click **Options**, and for Markup Language select **HTML** and click **Close**.
 - Click **Finish** to create the static header.html.
- ▶ Import the code for the logo, title, and action bar into the header.html file as follows:
 - Locate the file c:\7672code\webapp\html\SnippetForHeaderHTML.txt and open it in a simple text editor (for example Notepad).
 - Open header.html in Page Designer and select the **Source** tab.
 - Paste the code from SnippetForHeaderHTML.txt between the <body> and </body> tags.
 - Save the header.html file and verify that the page has the ITSO RedBank text and logo as desired by selecting the **Preview** tab.

Create an HTML footer for all Web pages

We create the Web page that holds the source of the footer area in the same way as for the header page:

- ▶ Create a new Web page named **footer.html** under WebContent.
- ▶ Copy/paste the code from SnippetForFooterHTML.txt between the <body> and </body> tags.
- ▶ Save the footer.html file and switch to the **Preview** tab to see the newly created link.

Customize frameset Web page areas

This section describes how to add frame references to the pages that are part of the user interface frame areas. We describe how to customize the following elements of the HTML page template (index.html, header.html and footer.html) created in “Launching the Web Site Designer” on page 346.

Define the areas in the frameset

To create the mentioned areas/frames in the frameset and link the areas with the previously created header.html and footer.html Web pages, do the following steps:

- ▶ In the Enterprise Explorer, expand **RAD75BankBasicWeb** → **WebContent**, and open the **index.html** Web page.

- ▶ In the Page Designer, select the **Split** tab to work simultaneously with the source code and interface design.
- ▶ To define the frameset areas, add a rows attribute to the frameset tag with the following steps:
 - In the Outline view right click the frameset tag and select **Add Attribute** → **New Attribute**.
 - In the New Attribute dialog type **rows** as name and **20%,70%,10%** as value.
 - Verify in the **Source** tag the value `<frameset rows="20%,70%,10%">`.
- ▶ Link the header area with the header.html Web page, with the following steps:
 - In the Outline view expand **html** → **frameset** and select the **frame** node.
 - In the Properties view (Figure 13-19), select the following attributes in the **frame** tab:
 - URL: Type **header.html**, or click the **Browse** icon  and select **File**, and in the File Selection dialog select **header.html** and click **OK**.
 - Frame name: **headerArea**
 - Leave the rest of the values by default and save the changes.
 - Verify in the Split tab of the Page Designer that the `<frame>` code was replaced by `<frame src="header.html" name="headerArea">`.

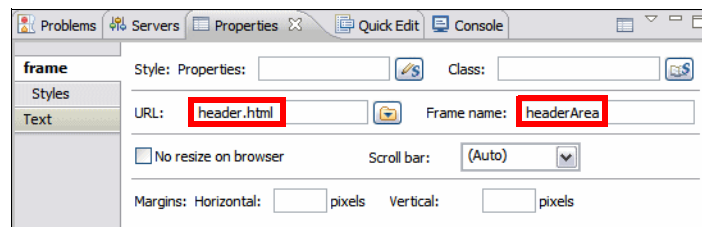



Figure 13-19 Properties of a frame

- ▶ To link the workspace area, create a new frame and link it to the welcome.html Web page with the following steps:
 - In the Outline view right click the **frame** tag and select **Add After** → **frame**.
 - In the Properties view, set the URL to **welcome.html** and the Frame name to **workspaceArea**.
- ▶ To link the footer area, create a new frame and link it to the **footer.html** Web page and frame name **footerArea**.
- ▶ Click the **Show frames** icon  to see the frames disposition (Figure 13-20).

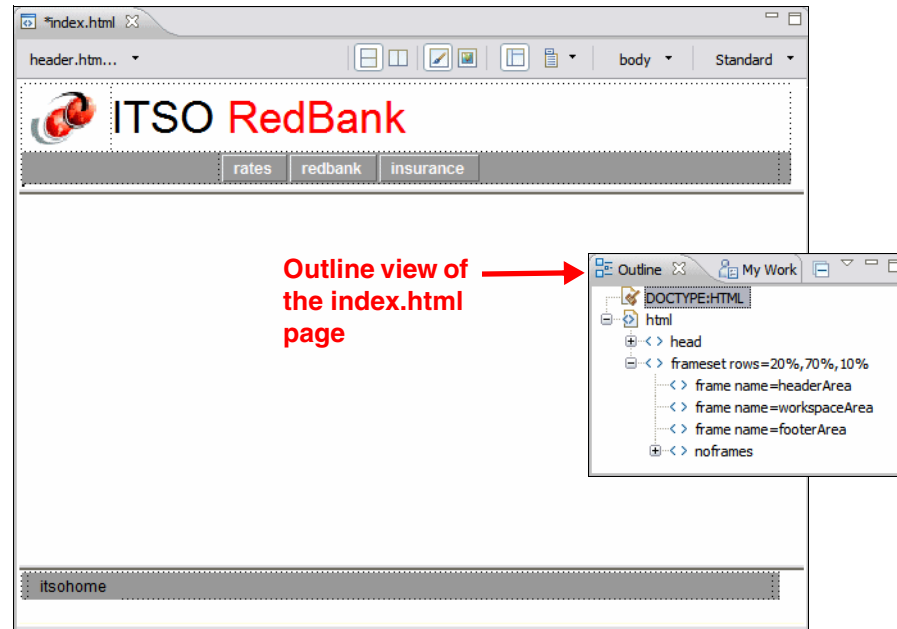

Figure 13-20 Frame design

Note: The workspace area display the pages we created with the Web Site Navigation in “Create the Web site navigation and related pages” on page 348. It Initially displays the welcome.html web page, then the user can navigate to other pages through the header area actions bar.

Customize a style sheet

Style sheets can be created when a Web Project is created (by selecting the **Default style sheet (CSS File)** option from the Project Facets dialog), when a page template is created from a sample, or at any time by launching CSS File creation wizard.

In the RedBank example a style sheet named `gray.css` was imported as part of the process of “Import Web resources for the RedBank application” on page 348. Both the HTML and the JSP Web pages we created reference the `gray.css` style sheet to have a common appearance of fonts and colors.

In the following example, we customize the colors used on the navigation bar links when you hover over a link. By default the link text in the navigation bar is orange (`cc6600`) when hovering. We will customize this to be red (`ff0000`).

To customize the `gray.css` style sheet, do these steps:

- ▶ Open the **theme/gray.css** file in the CSS Designer (Figure 13-21).

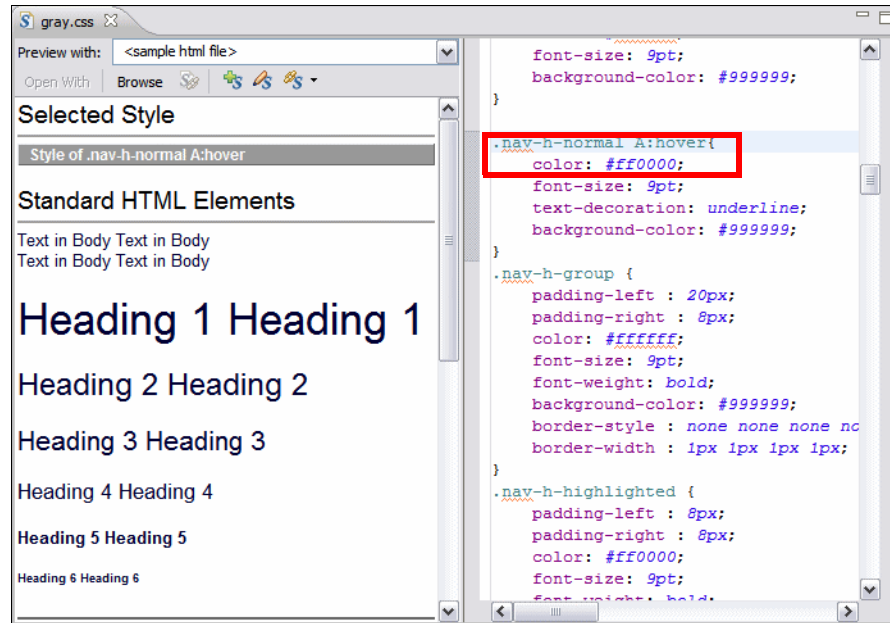

Figure 13-21 CSS Designer: `gray.css`

By selecting the text style `.nav-h-normal A:hover` in the right-hand pane (scroll down to locate the style, or find the style in the Styles view at the bottom left), the text in the left-hand pane is displayed and highlighted. This makes it easy to change the settings and see the change immediately.

- ▶ Change the Hex HTML color code for `.nav-h-normal A:hover` from `color: #cc6600;` (orange) to **`color: #ff0000;`** (red).
- ▶ Customize the footer highlighted link text. Locate the `.nav-f-normal A:hover` style and change the color from `#ff6600` (orange) to **`#ff0000`** (red).
- ▶ Save the file.

Now when you hover over the links in the header and footer, the color changes to red. Obviously any number of changes can be applied to the style sheets to change the look, feel, and color of the application.

Verify the site navigation and page templates

At this stage although the pages have no content, we can verify that the page templates look as expected and that the navigation links in the header and footer navigation bars work as required, in order to do that we follow the next steps:

- ▶ First add some text to identify each of the Web pages created in with the Web Site Navigation.
 - Open **welcome.html** in the Page Designer and go to the **Source** tab.
 - Type **Welcome Page** between the tags `<body></body>`, the final code should look as follows: `<body>Welcome Page</body>`.
 - Repeat same steps indicating their names in the body page for: `rates.html`, `redbank.html` and `insurance.html`.
- ▶ Start the WebSphere Application Server V7.0 Test Environment in the Servers view if it is not running.
- ▶ In the Enterprise Explorer, right-click **RAD75BankBasicWeb**, and select **Run As** → **Run on Server**.
- ▶ In the Run Server dialog, select **Choose an existing server** and **WebSphere Application Server v7.0**. Click **Finish**.
- ▶ A browser pane starts at the index page and the user can click on the tabs for rates, redbank, and insurance to move between these pages (Figure 13-22).



Figure 13-22 ITSO RedBank Web site

- ▶ To remove the project from the test server, in the Servers view right-click **WebSphere Application Server v7.0**, select **Add Remove Projects**, and remove `RAD75BankBasicEAR`.

Alternatively, expand **WebSphere Application Server v7.0**, right-click the **RAD75BankBasicEAR** project and select **Remove**.

Developing the static Web resources

In this section we create the content for the four static pages of our sample with the objective of highlighting some of the features of Page Designer. Page Designer facilitates the building of HTML pages by allowing the user to add HTML elements from the Pallet view using drag and drop. HTML fragments can also be imported directly into the source tab and this options is also demonstrated.

The topics in this section are as follows:

- ▶ Create the welcome.html page content (text, links)
- ▶ Create the rates.html page content (tables)
- ▶ Import the insurance.html page contents
- ▶ Import the redbank.html page contents

Create the welcome.html page content (text, links)

The RedBank home page is `index.html`. The links to the child pages are included as part of the header and footer of the our page template. In the following example, we describe how to add static text to the page, and add a link to the page to the IBM Redbooks Web site.

- ▶ Open the **welcome.html** file in Page Designer.
- ▶ Select the **Design** tab.
- ▶ Insert the welcome message text.
 - Delete the Welcome Page text.
 - Insert two line breaks:
 - In the Context Area right click and select **Insert** → **Line Break**, leave Type: Normal (default).
 - Repeat the steps for the second line break.
 - In the Context Area, right click, and select **Insert** → **Paragraph** → **Heading 1**.
 - Enter the text **Welcome to the ITSO RedBank!** between the `<h1>` tags.
- ▶ Insert a Link to the IBM Redbooks Web site.
 - Add an empty line after the heading.
 - From the menu bar, select **Insert** → **Paragraph** → **Normal**.
 - Enter the text For more information on the ITSO and IBM Redbooks, please visit our Internet site into the new area.

- Highlight the text **Internet site**, right-click and select **Insert Link**.
- In the Insert Link dialog, select **HTTP**, type `http://www.ibm.com/redbooks` in the URL field, and click **OK**.
- ▶ Customize the text font face, size, and color. This is done through the Properties view.
 - Select the word **Red** from Redbooks from the text created in the previous step (use the keyboard Shift and arrow keys).
 - In the **Text** tab in the Properties view select the color **Red** to make this partial word stand out a little.
 - The source changes to `...IBM Redbooks, ...`
- ▶ Save the page.
- ▶ Select the **Preview** tab and the page is displayed (Figure 13-23).

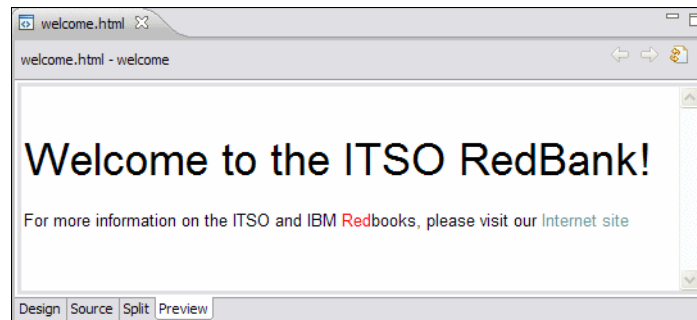



Figure 13-23 Preview of welcome.html

Create the rates.html page content (tables)

In this example we demonstrate how to add a static table containing interest rates using the Page Designer.

- ▶ Open the **rates.html** file in Page Designer and select the **Design** tab.
- ▶ Delete the Rates Page text.
- ▶ Expand **HTML Tags** in the Palette.
- ▶ Select and drag a **Table** from the Palette to the content area.
- ▶ In the Insert Table dialog, enter **5** for Rows and **5** for Columns and also **5** for Padding inside cells, then click **OK**.
- ▶ Resize the table as desired.
- ▶ Enter the descriptions and rates (as seen in Figure 13-24) into the table.
- ▶ Select each heading text, and in the Properties view click the **Bold** icon .

Note: Additional table rows and columns can be added and deleted with the Table menu option.

- ▶ Save the page.
- ▶ Select the **Preview** tab and the page is displayed (Figure 13-24).

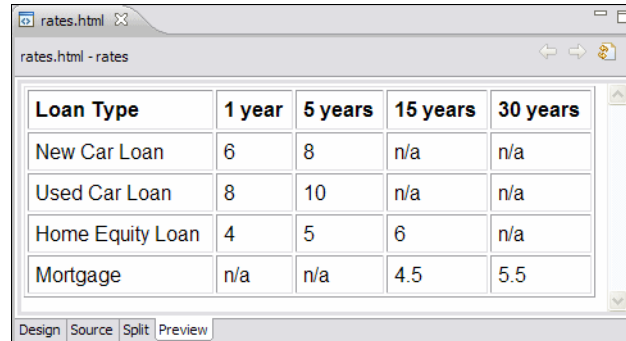

Loan Type	1 year	5 years	15 years	30 years
New Car Loan	6	8	n/a	n/a
Used Car Loan	8	10	n/a	n/a
Home Equity Loan	4	5	6	n/a
Mortgage	n/a	n/a	4.5	5.5

Figure 13-24 Preview the rates.html page

Import the insurance.html page contents

In this section, we import the body of the **insurance.html** file:

- ▶ Locate the file `c:\7672code\webapp\html\SnippetForInsuranceHTML.txt` and open it in a simple text editor (for example Notepad).
- ▶ Open `insurance.html` in Page Designer and select the **Source** tab.
- ▶ Select the text between the tags: `<body></body>`
- ▶ Insert the text from the `SnippetForInsuranceHTML.txt` file.
- ▶ Save the file and switch to the **Preview** tab (Figure 13-25).

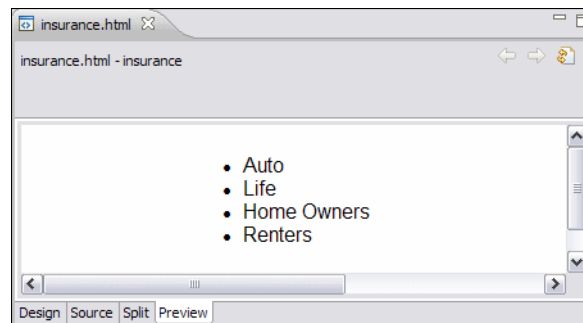

Figure 13-25 Preview of Insurance.html

Import the redbank.html page contents

Repeat the import of the body of the **redbank.html** file:

- ▶ Locate the file `c:\7672code\webapp\html\SnippetForBankHTML.txt`.
- ▶ Replace existing content area text with the text from the snippet.
- ▶ Switch to the **Preview** tab (Figure 13-26).

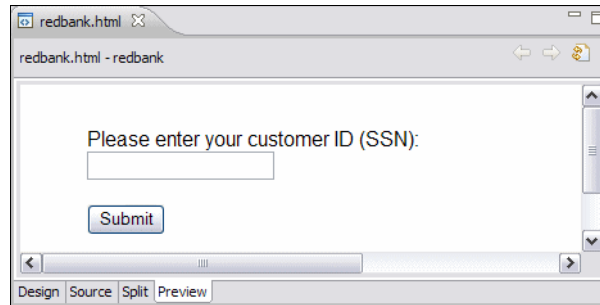

Figure 13-26 Preview of *redbank.html*

The static HTML pages for the RedBank application are now complete. You can navigate the site using the header action bar and the footer itsosome link.

Developing the dynamic Web resources

In addition to the tools created for building HTML content and designing the flow and navigation in a Web application. Application Developer also provides several wizards to help you quickly build JavaServer Pages (JSPs) and Java servlets, even if you are not an expert programmer. The products of these wizards can be used as-is, or modified to fit specific needs.

The wizards not only support the creation of servlets and JSPs, they also compile the Java code and store the class files in the correct folders for publishing to your application servers. Finally, as the wizards generate project resources, the deployment descriptor file (`web.xml`) is updated automatically with the appropriate configuration information for the servlets that are created.

In the previous section we described how to create each of the static Web pages. In this section we demonstrate the process of creating and working with servlets. The example servlets are first built using the wizards, then the code contents are imported from the sample solution. In the next section “Working with JSPs” on page 369, the JSP pages are created which invoke the logic in these servlets.

Working with servlets

As described in the “Introduction to Java EE Web applications” on page 318, servlets are flexible and scalable server-side Java components based on the Sun Microsystems Java Servlet API, as defined in the Sun Microsystems Java Servlet Specification. For Java EE Version 5, the supported API is Servlet 2.5, which is used by Application Developer V7.5.

Servlets generate dynamic content by responding to Web client requests. When an HTTP request is received by the application server, the Web Server determines, based on the request URI, which servlet is responsible for answering that request and forwards the request to that servlet. The servlet then performs its logic and builds the response HTML that is returned back to the Web client, or forwards the control to a JSP.

Application Developer provides the features to make servlets easy to develop and integrate into your Web application. From the Workbench it is possible to develop, debug, and deploy servlets. It is also possible to set breakpoints within servlets, and step through the code in a debugger, and finally any changes made are dynamically folded into the running Web application, without having to restart the server each time.

In the sections that follow, we implement the `ListAccounts`, `UpdateCustomer`, `AccountDetails`, and `Logout` servlets. Then the command or action pattern is applied in Java to implement the `PerformTransaction` servlet.

Adding RAD75Java as a Web Library project

Before the implementation of the servlet classes can proceed, we must add a reference from the **RAD75BankBasicWeb** project to the **RAD75Java** project, because the servlets call the methods from classes in this project.

This uses a facility within Application Developer known as **Web Library** projects, where a Java project can be associated with a Web project so that the Java resources in the Web project can call those in the Java project. Also, when the WAR file is built, a JAR file representing the Java project is automatically added to the `WEB-INF/lib` directory.

To add **RAD75Java** as a Web Library project, perform the following steps:

- ▶ Select the **RAD75BankBasicWeb** project, right-click, select **Properties**, and select **Java EE Module Dependencies**.
- ▶ Select the **Web Libraries** tab.
- ▶ Select **RAD75Java** and click **OK** (Figure 13-27).

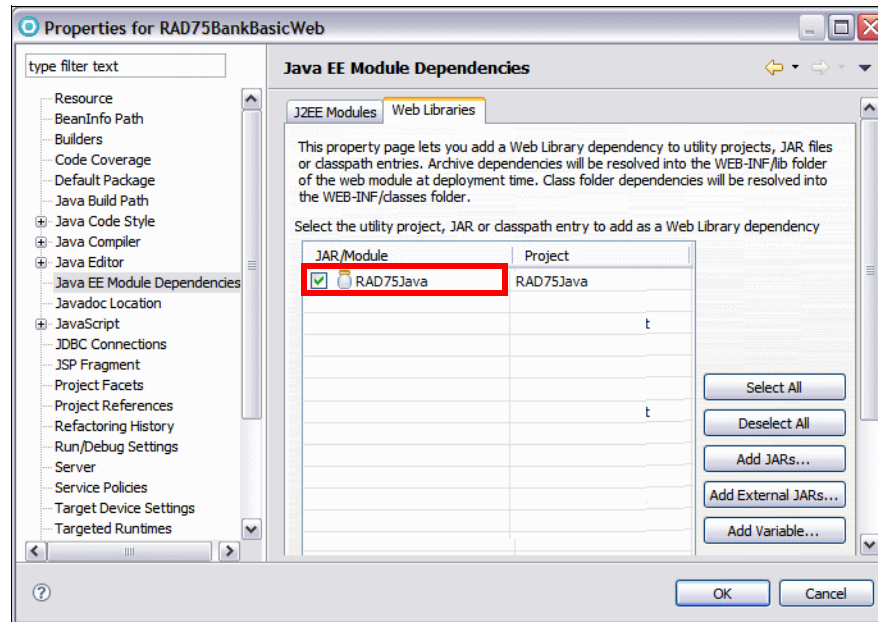

Figure 13-27 Java EE Module Dependencies dialog

The classes within **RAD75Java** can now be accessed by Java code in **RAD75BankBasicWeb**.

Adding the ListAccounts servlet to the Web project

Application Developer provides a servlet wizard to assist you in adding servlets to your Web application. Follow these steps:

- ▶ Select **File** → **New** → **Other** → **Web** → **Servlet** and click **Next**.

Tip: The Create Servlet wizard can also be accessed by right-clicking the project and selecting **New** → **Servlet**.

- ▶ The first page of the Create Servlet wizard opens.

Type **itso.rad75.webapps.servlet** as the package and **ListAccounts** as the class name (Figure 13-28). Click **Next**.

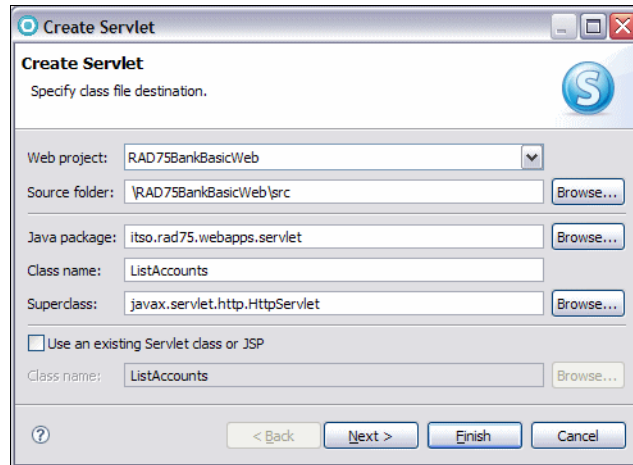

Figure 13-28 New Servlet wizard (1)

- ▶ The second page provides space for the name and description of the new servlet (Figure 13-29).

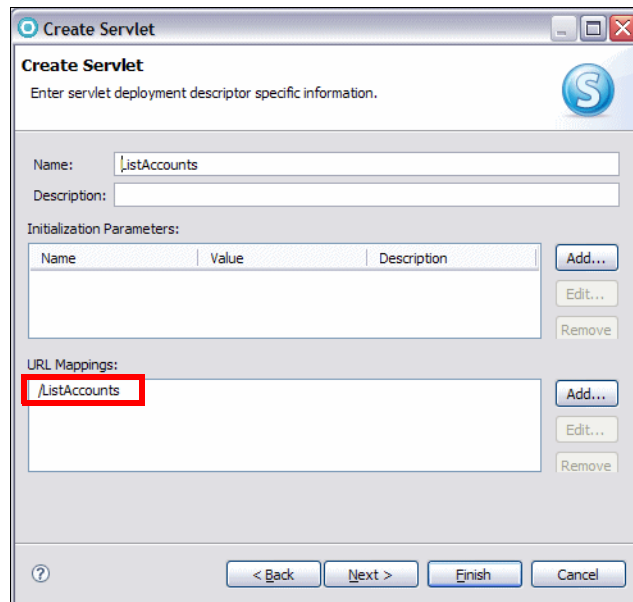

Figure 13-29 New Servlet wizard (2)

The page also allows the addition of servlet initialization parameters, which are used to parameterize a servlet. Servlet initialization parameters can be changed at runtime from within the WebSphere Application Server administrative console.

The wizard will automatically generate the URL mapping `/ListAccounts` for the new servlet. If a different, or additional URL mappings are required, these can be added here.

In our sample, we do not require additional URL mappings or initialization parameters. Click **Next**.

- ▶ The third and final page (Figure 13-30) gives the option to have the wizard create stubs methods for methods available from the `HttpServlet` interface. The `init` method is called at start-up and `destroy` is called at shutdown. The `doPost`, `doGet`, `doPut`, and `doDelete` methods are called when an HTTP request is received for this servlet. All of the `do` methods have two parameters, namely a `HttpServletRequest` and a `HttpServletResponse`. It is the job of these methods is to extract the pertinent details from the request and populate the response object.

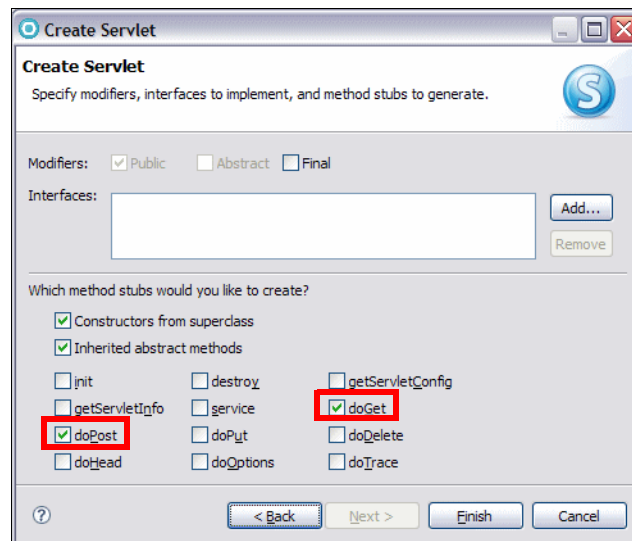

Figure 13-30 New Servlet wizard page (3)

For the `ListAccounts` servlet, only `doGet` and `doPost` should be selected. Usually, HTTP gets are used with direct links, when no information has to be sent to the server. HTTP posts are typically used when information in a form has to be sent to the server.

There is no initialization required for our new servlet and so the `init` method is not selected.

- ▶ Click **Finish**.

The servlet is generated and added to the project. The source code can be found in the Java Resources folder of the project, while the configuration for the servlet is found in Servlets tab of the Web deployment descriptor.

Now expand the deployment descriptor for the `RAD75BankBasicWeb` (immediately under the project in the Enterprise Explorer), and you see that the `ListAccounts` servlet is listed.

Implementing the `ListAccounts` servlet

A skeleton servlet now exists but does not perform any actions when it is invoked. We now have to add code to the servlet in order to implement the required behavior.

- ▶ The `ListAccounts.java` code of the servlet is already opened.
- ▶ Locate the file:

```
c:\7672code\webapp\servlet>ListAccounts.java
```
- ▶ Replace the contents of the `ListAccounts.java` with the sample file. This should compile successfully with no errors.
- ▶ Look at the source code for the `ListAccounts.java` servlet. This class implements the `doPost` and `doGet` methods, both of which call the `performTask` method.

The `performTask` method does the following tasks:

- First the method deals with the HTTP request parameters supplied in the request. This servlet expects to either receive a parameter called `customerNumber` or none at all. If the parameter is passed, we store it in the HTTP session for future use. If it is not passed, we look for it in the HTTP session, because it might have been stored there earlier.
- Next the method implements the control logic. Access to the Bank facade is obtained through the `ITSOBank.getBank` method and it is used to get the customer object and the array of accounts for that customer.
- The third section adds the customer and account variables to the `HttpRequest` object so that the presentation renderer (`ListAccounts.jsp`) gets the parameters it requires to perform its job. The control of processing the request is then passed through to `ListAccounts.jsp` using the `RequestDispatcher.forward` method, which builds the response to be shown on the browser.

- The final part of the method is the error handler. If an exception is thrown in the previous code, the catch block will ensure that control is passed to the `showException.jsp` page.

See Figure 13-9 on page 338 for a sequence diagram of the design of this class.

- ▶ The `ListAccounts` servlet is now complete. The changes should be saved and the source editor closed.

Implementing the UpdateCustomer servlet

The `UpdateCustomer` servlet is used for updating the customer information and is invoked from the `ListAccounts` JSP through a push button.

The servlet requires that the SSN of the customer that is to be updated is already placed on the session (as should be done in the `ListAccounts` servlet). It extracts the **title**, **firstName**, and **lastName** parameters from the `HttpRequest` object, calls the `bank.getCustomer(String customerNumber)` method and then uses the simple setters on the `Customer` class to update the details.

Follow the procedures described in “Adding the `ListAccounts` servlet to the Web project” on page 363 and “Implementing the `ListAccounts` servlet” on page 366 for building the servlet, including the `doGet` and `doPost` methods.

The code to use for this class is in:

```
c:\7672code\webapp\servlet\UpdateCustomer.java
```

Implementing the AccountDetails servlet

The `AccountDetails` servlet retrieves the account details and forwards control to the `accountDetails.jsp` page to show these details. The servlet expects the parameter `accountId` in the request which specifies the account for which data should be shown. The servlet then calls the `bank.getAccount(..)` method which returns an `Account` object and adds it as a variable to the request. It then uses the `RequestDispatcher` to forward the request onto the `accountDetails.jsp`.

Note: A real-life implementation would perform security and authorization, where the current user has the required access rights to the requested account. This can be implemented using the Security Editor tool as described in “Security Editor” on page 331.

Follow the procedures described in “Adding the `ListAccounts` servlet to the Web project” on page 363 and “Implementing the `ListAccounts` servlet” on page 366 for building the servlet.

The code to use for this class is in:

```
c:\7672code\webapp\servlet\AccountDetails.java
```

Implementing the Logout servlet

The Logout servlet is used for logging the customer off from the RedBank application. The servlet requires no parameters, and the only logic performed in the servlet is to remove the SSN from the session, simulating a log off action. This is done by calling the `session.removeAttribute` and `session.invalidate` methods. Finally it uses the `RequestDispatcher` class to forward the browser to the `index.html` page.

Follow the procedures described in “Adding the ListAccounts servlet to the Web project” on page 363 and “Implementing the ListAccounts servlet” on page 366 for building the servlet.

The code to use for this class is in:

```
c:\7672code\webapp\servlet\Logout.java
```

Implementing the PerformTransaction command classes

In the `PerformTransaction` servlet, a command design pattern is used to implement it as a front controller class that forwards control to one of the four command objects namely `Deposit`, `Withdraw`, `Transfer`, and `ListTransactions`.

The design for this was presented in “Controller layer” on page 337, and this implementation is based on the sequence diagram (Figure 13-10 on page 339).

Import the code for the commands package. The source is located in the folder:

```
C:\7672code\webapp\command
```

- ▶ Create the package `itso.rad75.webapps.command`. In the Enterprise Explorer, right-click the **Java Resources: src** folder and select **New** → **Package**.
- ▶ Enter `itso.rad75.webapps.command` as the package name and click **Finish**.
- ▶ From the context menu of the new package, select **Import**, then **General** → **File system**. Click **Next**.
- ▶ Click **Browse** and navigate to the folder `C:\7672code\webapp\command`. Click **OK**.
- ▶ Select the five Java files and click **Finish**:

```
Command.java  
DepositCommand.java  
ListTransactionsCommand.java  
TransferCommand.java  
WithdrawCommand.java
```

The command classes perform the operations on the RedBank model classes (from the RAD75Java project) through the Bank facade. They also return the file-name for the next screen to be shown after the command has been executed.

Implementing the PerformTransaction servlet

Now that all the commands for the PerformTransaction framework have been realized, the PerformTransaction servlet can be created. The servlet uses the value of the transaction request parameter to determine what command to execute.

The Create Servlet wizard can be used to create a servlet named PerformTransaction. The servlet class should be placed in the package `itso.rad75.webapps.servlet`.

Follow the procedures described in “Implementing the ListAccounts servlet” on page 366 for preparing the servlet, including the `doGet` and `doPost` methods.

The code to use for this class is in:

```
c:\7672code\webapp\servlet\PerformTransaction.java
```

PerformTransaction stores a HashMap of the action strings (deposit, withdraw, transfer, and list) to instances of Command classes. Both the `doGet` and `doPost` methods call `performTask`. In the `performTask` method the `execute` method is called on the appropriate Command class that performs the transaction on the Bank classes. After the `execute` is completed, the `getForwardView` method is called on the Command class, which returns the next page to display, and PerformTransaction uses the RequestDispatcher to forward the request to the next page.

Note about refactoring servlets: It is possible to rename an existing servlet by selecting **Refactor** → **Rename** from the context menu. However, the default options given on the renaming dialog do not update references to a servlet in the `web.xml` file. When renaming a servlet, select **Update fully qualified names in non-Java text files** option and enter `*.xml` in the File name patterns field. This will then inform the user that `web.xml` is updated with the renaming and give them the opportunity to cancel the operation.

Working with JSPs

JSP files are edited in Page Designer, the same editor used to edit the HTML page. When working with a JSP page in Page Designer, the Palette view has additional elements (JSP tags) that can be used, such as JavaBean references, Java Standard Template Language (JSTL) tags, and scriptlets containing Java code.

In this section, the implementation of `listAccounts.jsp` is described in detail and the other JSPs (`accountDetails.jsp`, `listTransactions.jsp`, and `showException.jsp`) are imported from the solution.

Implementing the List Accounts JSP

Customizing a JSP file by adding static content is done in the Page Designer tool in the same way that an HTML file can be edited. It is also possible to add the standard JSP declarations, scriptlets, expressions, and tags, or any other custom tag developed or retrieved from the internet.

In this example, the `listAccounts.jsp` file is built up using page data variables for customer and accounts (and array of `Account` classes for that customer). These variables are added to the page by the `ListAccounts` servlet and are accessible to the Java code and tags used in the JSP.

To complete the body of the `listAccounts.jsp` file, perform the following steps:

- ▶ Open the **listAccounts.jsp** in Page Designer and select the **Design** tab.
- ▶ Add the customer and accounts variables to the page data meta information in the Page Data View (by default on the bottom left of the window). These variables are added to the request object in the `ListAccounts` servlet, as discussed in “Implementing the ListAccounts servlet” on page 366. Page Designer needs to be aware of these variables:
 - In the Page Data view expand **Scripting Variables**, right-click **requestScope**, and select **New** → **Request Scope Variable**.
 - In the Add Request Scope Variable dialog, enter the following information and click **OK**:
 - Variable name: **customer**
 - Type: `itso.rad75.bank.model.Customer`

Tip: You can use the browse-button (marked with an ellipsis) to find the class using the class browser.

- Repeat this procedure to add the following request scope variable:
 - Variable name: **accounts**
 - Type: `itso.rad75.bank.model.Account []`

Important: Note the square brackets—the variable `accounts` is an array of accounts.

- ▶ In the Palette view, select **Form Tags** → **Form** and click anywhere on the JSP page in the content table. A dashed box appears on the JSP page, representing the new form.
- ▶ In the Properties view for the new **Form** element, enter the following items:
 - Action: Type **UpdateCustomer**.
 - Method: Select **Post**.

Note: You can use the Outline view to navigate to the form tag quickly.

- ▶ Add a table with customer information:
 - In the Page Data view, expand and select **Scripting Variables** → **requestScope** → **customer** (`itso.rad75.java.model.Customer`).
 - Select and drag the customer object into the form that was previously created.
 - In the Insert JavaBean dialog (Figure 13-31), do these steps:
 - Select **Displaying data (read-only)**.
 - Use the arrow up and down buttons to arrange the fields in the order shown, and overtype the labels.
 - Clear the **accounts** field (we do not display the accounts).

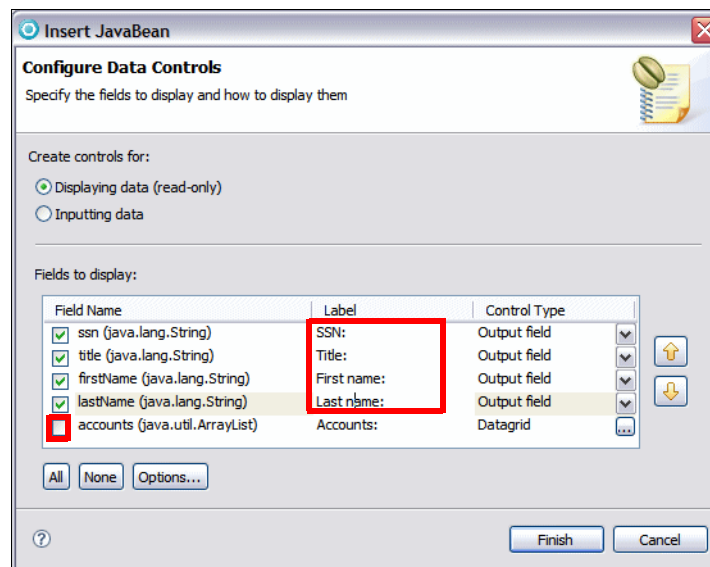

Figure 13-31 Inserting the Customer JavaBean

Note: The newly created table with customer data is changed in a later stage to use input fields for the title, first name, and last name fields. At the time of writing, this was not possible to achieve through the use of the available wizards.

- ▶ Right-click the last row of the newly created table (select the LastName cell) and select **Table** → **Add Row Below**.
- ▶ In the Palette view select **Form Tags** → **Submit Button** and click in the right-hand cell of the new row. Enter **Update** in the Label field and click **OK**. The Name field can be left empty.
- ▶ In the Palette view, select **HTML Tags** → **Horizontal Rule** and click in the area immediately below the form.
- ▶ In the Page Data view, expand and select **Scripting Variables** → **requestScope** → **accounts** (`itso.rad75.java.model.Account []`).
- ▶ Select and drag the accounts object below of the Horizontal Rule created
- ▶ In the Insert JavaBean wizard (Figure 13-32), do these steps:
 - Clear transactions (we do not display the transactions).
 - For both fields, select **Output link** in the Control Type column.
 - In the Label field for the accountNumber field, enter Account Number.
 - Ensure that the order of the fields is accountNumber and balance.
 - Click **Finish**, and the accounts Bean is added to the page and is displayed as a list.

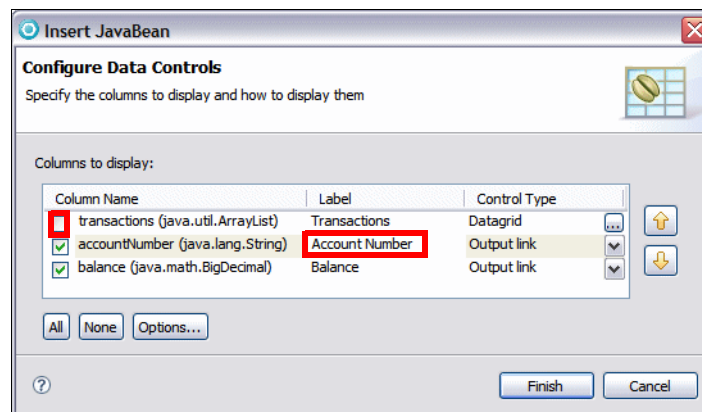

Figure 13-32 Inserting the accounts JavaBean

- ▶ The wizard inserts a JSTL `c:forEach` tag and an HTML table with headings, as entered in the Insert JavaBean window. Because we selected **Output link** as the Control Type for each column, corresponding `c:url` tags have been inserted. We now have to edit the URL for these links to make sure they are identical and to pass the `accountId` variable as a URI parameter.
 - Select the first `<c:url>` tag under the heading **Account Number**, which has the text `/${varAccounts.accountNumber}`. In the Properties view, enter `AccountDetails` in the Value field (Figure 13-33).
 - The tag changes to `AccountDetails`.

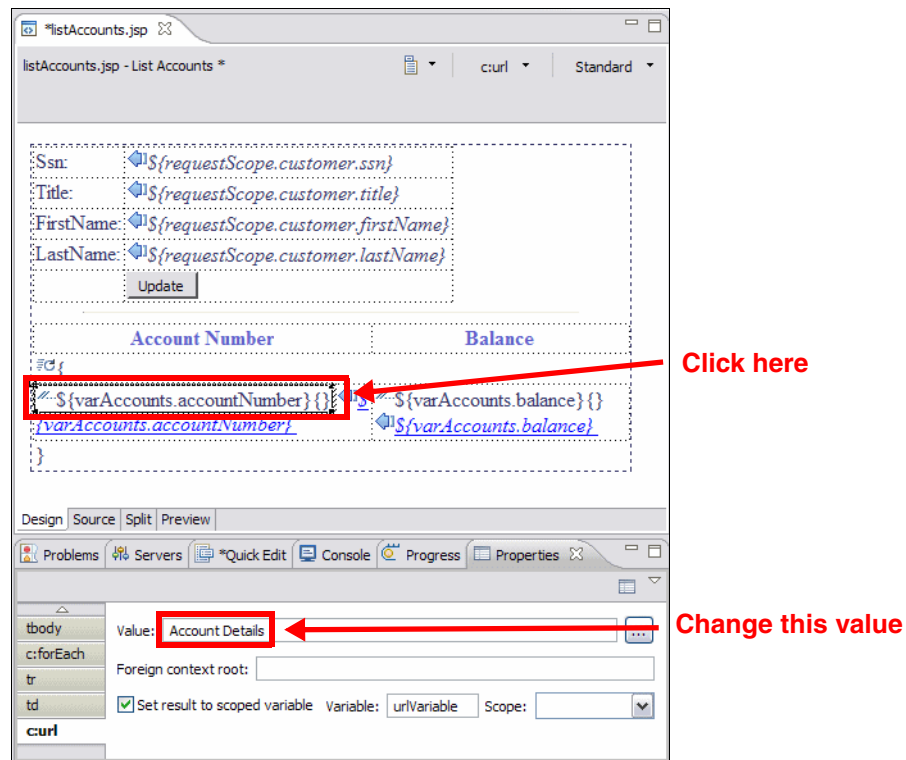

Figure 13-33 Configuring the `AccountDetails` URL

- Select the second `<c:url>` tag under the heading **Balance**, which has the text `/${varAccounts.balance}`. In the Properties view, enter `AccountDetails` into the Value field. This specifies the target URL for the link, which in this case maps to the `AccountDetails` servlet.
- Now we must add a parameter to this URL, so ensure the link goes to the correct account. In the Palette view select **JSP Tags** → **Parameter** and

click on the first `<c:url>` in the Account Number column. This has the text `AccountDetails{}` (Figure 13-34).

- In the Properties view, for the **c:param** tab, enter **accountId** in the Name field and **`${varAccounts.accountNumber}`** in the Value field. This adds a parameter to the account url with a name of `accountId` and the value of the `accountNumber` request variable.

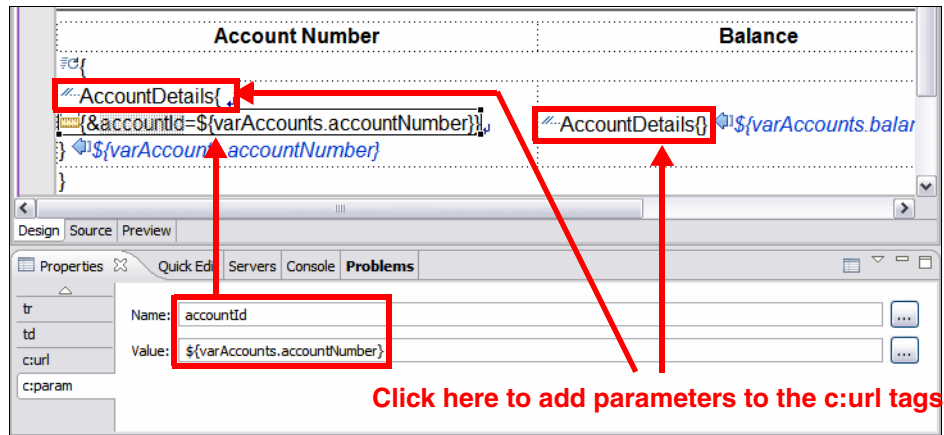

Figure 13-34 Adding parameters to `c:url` tags

- Repeat the two previous steps to add a parameter to the second `<c:url>` tag in the Balance column, showing the text `Account Number{}`. Type **accountId** as Name field and **`${varAccounts.accountNumber}`** in the Value field.
- ▶ Click anywhere in the Balance column, and select the **td** tag in the Properties view. Select **Right** in the Horizontal alignment list box. This makes the contents of the Balance cells right-justified.
- ▶ Select the Source tab and compare the code to display the accounts to Example 13-1. This JSP code displays the accounts as a list, using the `<c:forEach>` tag to loop through each account, and the `<c:out>` tag to reference the current loop variable. The `<c:url>` tag builds a URL to `AccountDetails` and the `<c:param>` tag adds the `accountId` parameter (with account number value) to that URL.

Example 13-1 JSP code with JSTL tags to display accounts (formatted)

```

<c:forEach var="varAccounts" items="${requestScope.accounts}">
  <tr>
    <td>
      <c:url value="AccountDetails" var="urlVariable">
        <c:param name="accountId" value="${varAccounts.accountNumber}" />
      </c:url>
    </td>
    <td>
      <out value="${varAccounts.balance}" />
    </td>
  </tr>
</c:forEach>

```

```

        value="{varAccounts.accountNumber}"></c:param>
    </c:url>
    <a href="{c:out value='{urlVariable}' />">
        <c:out value="{varAccounts.accountNumber}"></c:out>
    </a>
</td>
<td align="right">
    <c:url value="AccountDetails" var="urlVariable">
        <c:param name="accountId"
            value="{varAccounts.accountNumber}"></c:param>
    </c:url>
    <a href="{c:out value='{urlVariable}' />">
        <c:out value="{varAccounts.balance}" />
    </a>
</td>
</tr>
</c:forEach>

```

- ▶ In the Palette view, select **HTMLTags** → **Horizontal Rule** and click in the area below the account details table.
- ▶ Add a logout form:
 - In the Palette view, select **Form Tags** → **Form** and click below the new horizontal rule. A dashed box will appear on the JSP page, representing the new form.
 - In the Properties view for the new form tag, enter the following items:
 - Action: Type **Logout**.
 - Method: Select **Post**.
 - In the Palette view, select **Form Tags** → **Submit Button** and click into the new form. When the Logout button is clicked, the doPost method is called on the Logout servlet.
 - In the Insert Submit Button dialog, enter **Logout** in the Label field and click **OK**.
- ▶ The remaining part is to change the title, first name and last name to be entry fields, so that the user can update the customer details.

Do the following steps to convert the Title, First name, and Last name text fields to allow text entry:

- Select the `{requestScope.customer.title}` field.
- Select the **Source** tab and you can see the code:

```
<td><c:out value="{requestScope.customer.title}" /></td>
```
- Change the code to:

```
<td><input type="text" name="title"
```

```
value="<c:out value='${requestScope.customer.title}' />" /></td>
```

- Repeat this for the first name and last name fields:

```
<td><input type="text" name="firstName"
value="<c:out value='${requestScope.customer.firstName}' />" /></td>
.....
<td><input type="text" name="lastName"
value="<c:out value='${requestScope.customer.lastName}' />" /></td>
```

This changes the customer fields from display only fields to be editable, so that the details can be changed.

You can change the length of the three input fields in the properties view, for example, **6** columns and **3** maximum length for the title, and **32** columns for the names.

- ▶ The width of the content areas can be changed in the source code as well.
- ▶ The account balance is a `BigDecimal` and must be formatted, otherwise it displays with many digits:
 - Click on the balance field `${varAccounts.balance}` in the Balance column.
 - Select **JSP** → **Insert Custom**.
 - In the Insert Custom Tag dialog (Figure 13-35), click **Add** to add another tag library.
 - Locate and select the `http://java.sun.com/jsp/jstl/fmt` URI and click **OK**.
 - Select the new tag library and select `formatNumber` as the custom tag. Click **Insert** and **Close**.

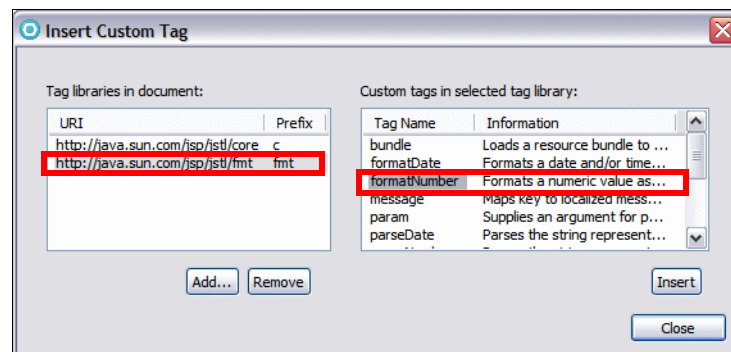

Figure 13-35 Inserting a custom tag

- In the **Source** tab, select the `<fmt:formatNumber>` tag and in the Properties view set `maxFractionDigits` and `minFractionDigits` to **2**. For the value type `${varAccounts.balance}`.

- Remove the `<c:out value=.... >` and `</c:out>` tags:

```
<a href="<c:out value='${urlVariable}' />">
  <c:out value="${varAccounts.balance}" />
  <fmt:formatNumber maxFractionDigits="2" minFractionDigits="2"
    value="${varAccounts.balance}"></fmt:formatNumber>
</c:out>
</a>
```

- ▶ Select any field in the accounts table, and in the Properties view select the **table** tab. Set the width to **100** and select **%**.
- ▶ Select the **Account Number** heading, and in the Properties view set the horizontal alignment to **Left**. For the **Balance** heading set the horizontal alignment to **Right**.
- ▶ Save the file.
- ▶ The JSP is shown in Figure 13-36.

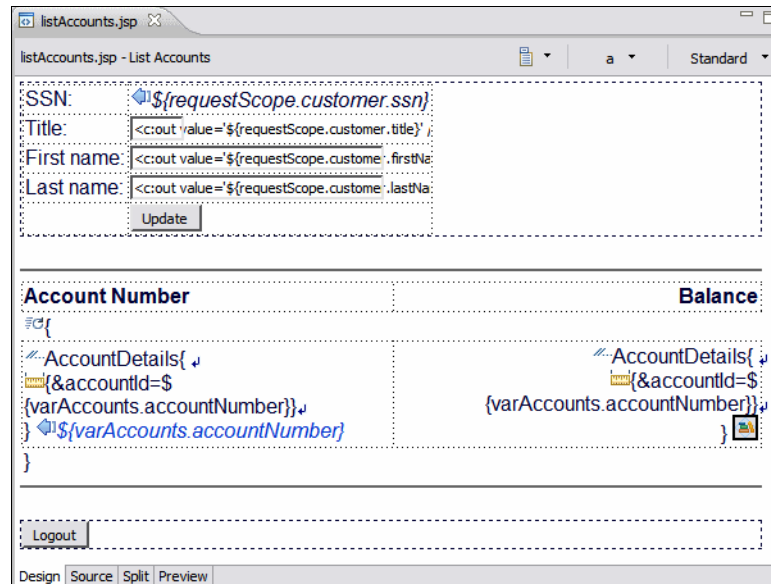

Figure 13-36 *listAccounts.jsp* finished

Note: The jSP source code for the `listAccounts.jsp` is provided in `c:\7672code\webapp\jsp\listAccounts.jsp`. You can import the code into the WebContent folder, or copy/paste directly into Application Developer.

Implementing the other JSPs

The other JSPs have already been created as part of the model solution. These were built by a similar process of adding request beans to the JSPs and building HTML and JSP elements around them.

To import the other JSP files, and to be able to view them in Page Designer, perform the following steps:

- ▶ Select the **WebContent** folder and **Import**, then select **General** → **File System**. Click **Next**.
- ▶ Click **Browse** and navigate to `c:\7672code\webapps\jsp`.
- ▶ Select all the JSP files except **listAccounts.jsp** (which has already been completed). Click **Finish**.
- ▶ When prompted whether to override the existing files, click **Yes to All**.

Note: Imported pages do not have the associated request beans showing in the Page Data view because these are maintained in the **.jspPersistence** file immediately under the Web project directory, you have to specifically add them to the PageData View.

Add the required variables to the appropriate Page Data view, following the next steps for each of the mentioned JSPs in the table (Table 13-2):

- ▶ Open each JSP file and in the Page Designer
- ▶ And in the Page Data view, select **Scripting Variables** → **New** → **Request Scope Variable**.

Table 13-2 Request scope variables for each JSP

JSP File	variable	type
accountDetails.jsp	account	itso.rad75.bank.model.Account
listTransactions.jsp	account	itso.rad75.bank.model.Account
listTransactions.jsp	transactions	itso.rad75.bank.model.Transaction[]
showException.jsp	message	java.lang.String
showException.jsp	forward	java.lang.String

Account Details JSP

The `accountDetails.jsp` shows the details for a particular customer account and gives options to execute a transaction:

- ▶ The JSP uses a single request variable called `account` to populate the top portion of the body of the page, which shows the account number and balance.
- ▶ The middle section is a simple static form, which provides fields for the details of a transaction (transaction type, amount, and destination account) and posts the request to the `PerformTransaction` servlet for processing.
- ▶ The Customer Details button navigates the user to the `listAccounts.jsp` page.
- ▶ The Page Designer view of this page is shown Figure 13-37.

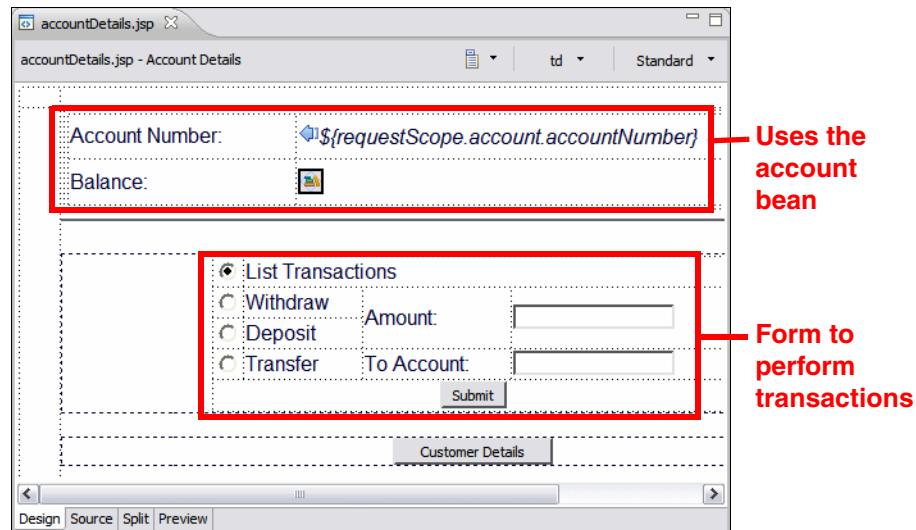

Figure 13-37 Completed `accountDetails.jsp` in preview view

List Transactions JSP

The `listTransactions.jsp` shows a read only view of the account including the account number and balance plus a list of all transactions:

- ▶ The JSP uses two request variables called `account` and `transactions`. The first section of the page uses the `account` request bean to populate a table showing the account number and balance.
- ▶ The middle section uses the `transactions[]` request bean to show a list of transactions. This uses the JSTL tag library to iterate through the transaction list and build up an HTML representation of the transaction history.
- ▶ The Account Details button returns the browser to the `accountDetails.jsp` page.
- ▶ The Page Designer view of this page is shown Figure 13-38.

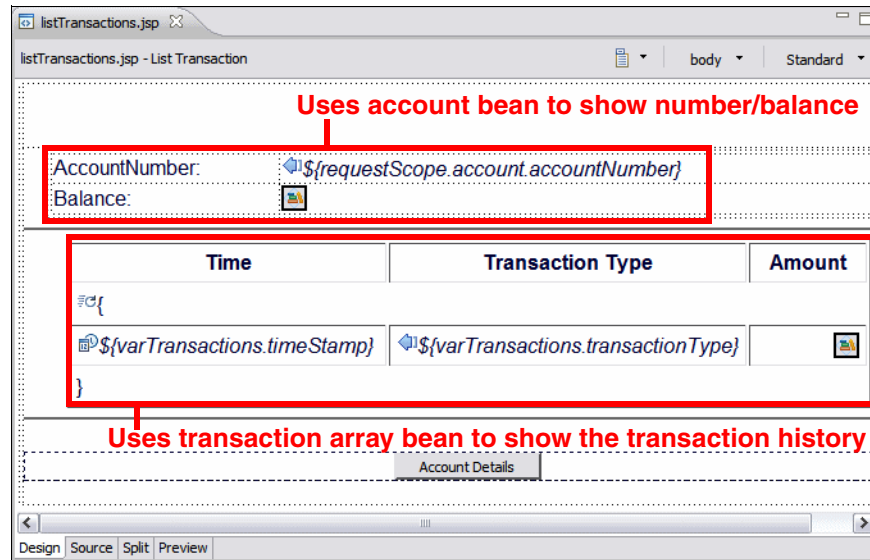

Figure 13-38 Completed `listTransactions.jsp` in preview view

Show Exception JSP

The `showException.jsp` is displayed when an exception occurs in the processing of a request:

- ▶ The JSP shows a simple error message and gives a link to another page within the RedBank application to allow the user to continue.
- ▶ There are two request beans used on this page; `message` stores the text to display to the user, and `forward` stores a URL for the next page to continue. The URL is hidden behind the text Click here to continue.
- ▶ Figure 13-39 shows this page in the design view of Page Designer.

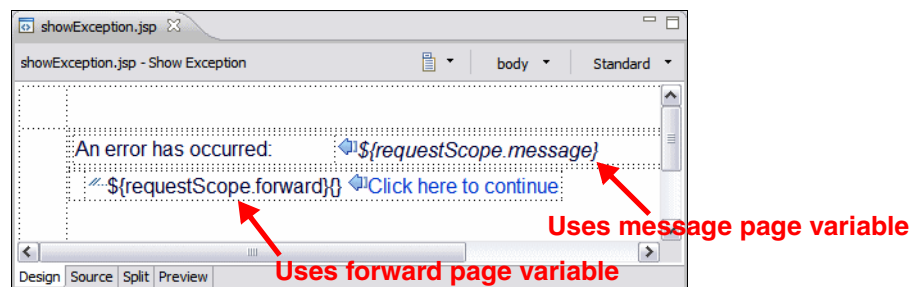

Figure 13-39 Completed `showException.jsp` in the preview view

The RedBank application is finished and ready to be tested.

Testing the Web application

This section demonstrates how to run the sample RedBank application, built in the previous sections.

Prerequisites to run the sample Web application

To run the RedBank application, you must do one of the following actions:

- ▶ Complete the sample following the procedures described in “Implementing the RedBank application” on page 339.

- ▶ Import the completed project interchange file from:

```
c:\7672code\zInterchange\webapps\RAD75BankBasicWeb.zip
```

Refer to “Importing sample code from a project interchange file” on page 1152 for details.

Running the sample Web application

To run the RedBank Web application in the test environment, do these steps:

- ▶ Right-click **RAD75BankBasicWeb** in the Enterprise Explorer and select **Run As** → **Run on Server**.
- ▶ In the Server Selection dialog, select **Choose an existing server**, select **WebSphere Application Server v7.0**, and click **Finish**.

The main page of the Web application should be displayed in a Web browser inside Application Developer.

Verifying the RedBank Web application

Once you have launched the application by running it on the test server, there are some basic steps that can be taken to verify the Web application is working properly.

- ▶ From the main page, select the **redbank** menu option.
- ▶ In the RedBank page type a customer social security number, for example, **444-44-4444** (Figure 13-40).

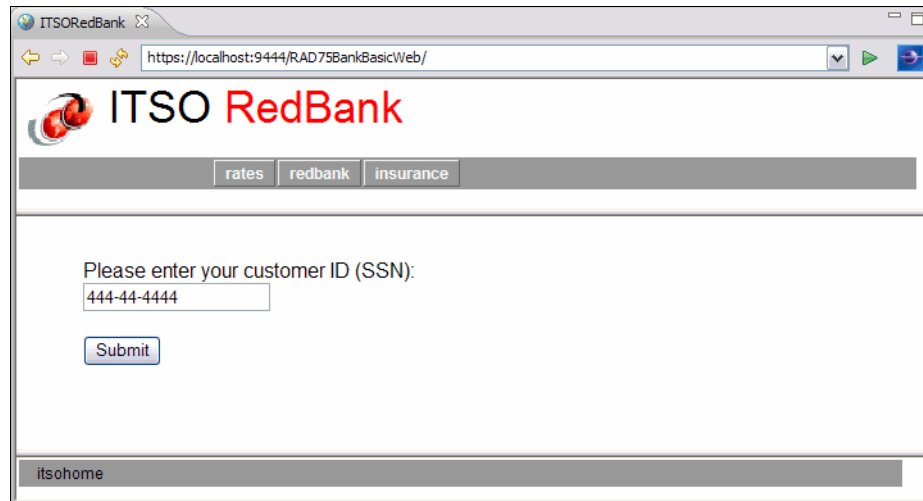

Figure 13-40 ITSO RedBank Login page

- ▶ Click **Submit**, and the customer and the accounts are listed (Figure 13-41).



Figure 13-41 Display of customer accounts

- ▶ These actions are supported:
 - Change the customer title or name fields and click **Update**. This performs the doPost method of the UpdateCustomer servlet. For example, change the title to **Sir** and then click **Update**.
 - Clicking **Logout** performs a logout and returns to the Login page.
 - Clicking on any account displays the account information (Figure 13-42).

ITSO RedBank

rates redbank insurance

Account Number: 004-999000777

Balance: 987.65

List Transactions

Withdraw

Deposit

Transfer

Amount: 123.45

To Account: 004-999000888

Submit

Customer Details

itsohome

Figure 13-42 Details for a selected account

- ▶ These actions are supported:
 - Select **List Transactions** and click **Submit**. There are no transactions yet.
 - Select **Deposit** or **Withdraw**, enter an amount and click **Submit** to execute a banking transaction. The page is redisplayed with the balance updated.
 - Select **Transfer**, enter an amount and a target account, and click **Submit**. The page is redisplayed with the balance updated.
 - Click **Customer Details** to return to the account listing.
- ▶ Run a few transactions (deposit, withdraw, transfer), then select **List Transactions** and click **Submit**. The transaction listing is displayed (Figure 13-43).

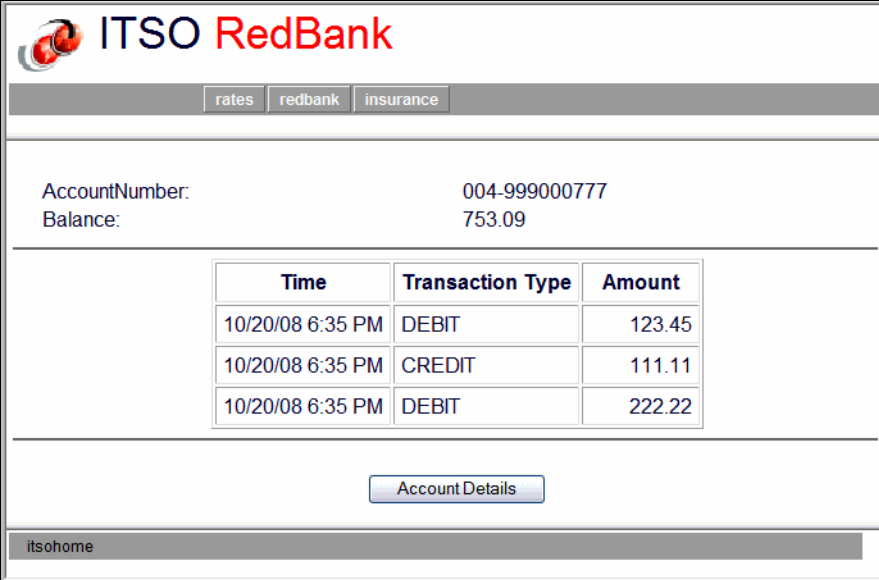

The screenshot shows the ITSO RedBank website interface. At the top left is the logo. Below it is a navigation bar with tabs for 'rates', 'redbank', and 'insurance'. The main content area displays account information: 'AccountNumber: 004-999000777' and 'Balance: 753.09'. Below this is a table of transactions:

Time	Transaction Type	Amount
10/20/08 6:35 PM	DEBIT	123.45
10/20/08 6:35 PM	CREDIT	111.11
10/20/08 6:35 PM	DEBIT	222.22

Below the table is a button labeled 'Account Details'. At the bottom of the page is a footer with the text 'itsohome'.

Figure 13-43 List of transactions for an account

- ▶ Try a withdraw of an amount greater than the balance. The Show Exception JSP is displayed with an error message (Figure 13-44).

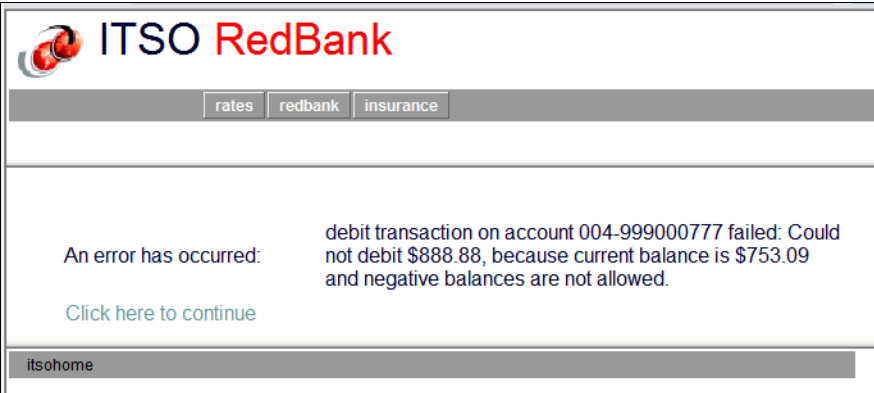

The screenshot shows the ITSO RedBank website interface displaying an error message. The navigation bar and logo are the same as in Figure 13-43. The main content area contains the following text:

An error has occurred: debit transaction on account 004-999000777 failed: Could not debit \$888.88, because current balance is \$753.09 and negative balances are not allowed.

[Click here to continue](#)

At the bottom of the page is a footer with the text 'itsohome'.

Figure 13-44 Withdraw over the limit error

RedBank Web application conclusion

We hope that all of the foregoing demonstrations worked successfully for you. The example has demonstrated the following features, which are just a subset of the tools available within Application Developer for Web development:

- ▶ Basic servlets
- ▶ Basic JSPs
- ▶ Page Designer
- ▶ Page templates
- ▶ Web Site Navigation editor
- ▶ CSS editor
- ▶ JSP tags
- ▶ New Servlet wizard
- ▶ New Web Project wizard
- ▶ Web Library projects
- ▶ Navigation tabs
- ▶ JSTL tag library

More information

There are many ways that the RedBank application can be improved, by adding features or using other technologies. Some of these are covered in subsequent chapters of this book, including these:

- ▶ Using EJBs to store the model—Chapter 14, “Develop EJB applications” on page 387
- ▶ Using a database rather than HashMaps—Chapter 11, “Develop database applications” on page 227
- ▶ Using Struts to handle the requests—Chapter 15, “Develop Web applications using Struts” on page 445
- ▶ Using JSF components rather than JSTL—Chapter 16, “Develop Web applications using JSF” on page 493
- ▶ Debugging the application—Chapter 24, “Debug local and remote applications” on page 861

The Help feature provided with Application Developer has a large section on Developing Web sites and applications. It contains reference information for all the features presented in this chapter and further information on topics only covered briefly here, including JSP tag libraries, Security, and use of the Web Diagram Editor.

Finally, the following URLs provide further information for the topics covered in this chapter:

- ▶ **Sun Java Servlet Technology Home page**—Contains links to the specification, API Javadoc, and articles on servlets.
<http://java.sun.com/products/servlet/index.jsp>
- ▶ **Sun JavaServer Pages Technology Home page**—Home page for technical information on JSPs:
<http://java.sun.com/products/jsp/jstl/>
- ▶ **Sun JavaServer Pages Standard Tag Library (JSTL)**—Home page for technical information on JSTL:
<http://java.sun.com/products/jsp/jstl/>
- ▶ **Online Color Scheme**—Useful for figuring out the hex code for a particular color:
<http://www.colorschemer.com/online.html>
- ▶ **JSP and Servlets best practices**—This is an old article, but it articulates clearly the different ways of applying an MVC pattern to JSPs and servlets:
http://java.sun.com/developer/technicalArticles/javaserverpages/servlets_jsp/
- ▶ **Experience J2EE! Using WebSphere Application Server V6.1, SG24-7297**
This book has an excellent section on implementing J2EE security in WebSphere Application Server:
<http://www.redbooks.ibm.com/abstracts/sg247297.html>



Develop EJB applications

This chapter introduces Enterprise JavaBeans (EJB) and demonstrates by example how to create, maintain, and test such components in the J2EE platform.

We describe how to develop entity beans, and explain the relationships between the entity beans and session beans. Then we integrate the EJBs with a front-end Web application for the sample application. We include examples for creating, developing, and testing the EJBs using Rational Application Developer.

The chapter is organized into the following sections:

- ▶ Introduction to Enterprise JavaBeans
- ▶ Sample application overview
- ▶ Preparing for the sample
- ▶ Developing an EJB application
- ▶ You can play with the UTC to make sure all of the EJB methods work. When you are done, close the UTC pane.
- ▶ More information

Note: Document server-wide property for Was v7:

```
com.ibm.websphere.ejb.UseEJB61FEPScanPolicy=true
```

Introduction to Enterprise JavaBeans

Enterprise JavaBeans (EJB) is an architecture for server-side component-based distributed applications written in Java.

EJB 3.0 specification

In this section we learn about the EJB 3.0 specifications that describes session EJBs and message-driven EJBs. This section is an extract from the IBM Redbooks publication *WebSphere Application Server Version 6.1 Feature Pack for EJB 3.0*, SG24-7611, *Chapter 1, Introduction to EJB 3.0*.

EJB 3.0 simplified model

There are many publications that discuss the complexities and differences between the old EJB programming model and the new. For this reason, this book will focus on diving right into the new programming model. To overcome the limitations of the EJB 2.x, the new specification introduces a really new simplified model, whose main features are:

- ▶ Entity EJBs are now plain old java objects (POJO) that expose regular business interfaces (POJI), and there is no requirement for home interfaces.
- ▶ Removal of the requirement for specific interfaces and deployment descriptors (deployment descriptor information can be replaced by annotations).
- ▶ A complete new persistency model (based on the JPA standard), that supersedes EJB 2.x entity beans (see Chapter 12, “Persistence using the Java Persistence API (JPA)” on page 267).
- ▶ Interceptor facility to invoke user methods at the invocation of business methods or at life cycle events.
- ▶ Default values are used whenever possible (“configuration by exception” approach).
- ▶ Reduction of the requirements for usage of checked exception.

Figure 14-1 shows how the model of J2EE 1.4 has been completely reworked with the introduction of the EJB 3.0 specification.

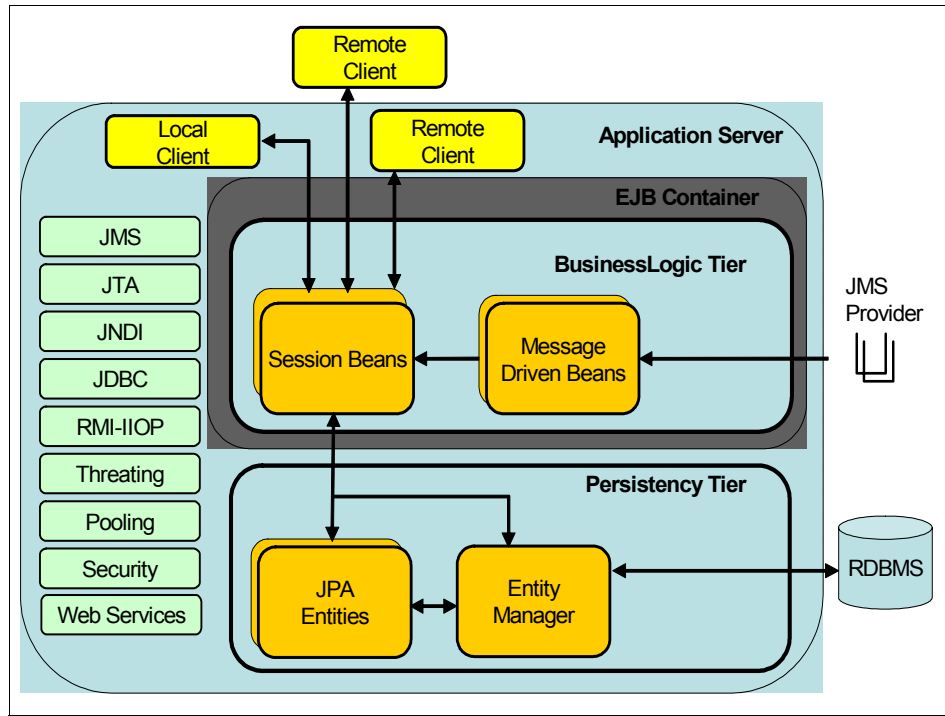

Figure 14-1 EJB 3.0 architecture

In this chapter we introduce these features.

Meta data annotations

EJB 3.0 uses *meta data annotations*, as part of Java SE 5.0.

Annotations are similar to XDoclet, a powerful open-source framework extensible, metadata-driven, attribute-oriented framework that is used to generate Java code or XML deployment descriptors. However unlike XDoclet, that requires pre-compilation, annotations are syntax checked by the Java compiler at compile-time, and sometimes compiled into classes.

By specifying special annotations, developers can create POJO classes that are EJB components.

In the sections that follow we illustrate the most popular use of annotations and EJB 3.0 together.

EJB types and their definition

In EJB 3.0 there are two types of EJB:

- ▶ Session beans (stateless and stateful)
- ▶ Message driven beans

Note: EJB2.x entity beans have been replaced by JPA entities, that are discussed in Chapter 12, “Persistence using the Java Persistence API (JPA)” on page 267.

Let us describe how annotations can be used to declare session beans and MDB beans.

Stateless session EJB

Session stateless EJBs have always been used to model a task being performed for a client code that invokes it. They implement business logic or rules of a system, and provide coordination of those activities between beans, such as a banking service, that allows for a transfer between accounts.

A session stateless bean, is generally used for business logic that spans a single request and therefore cannot retain client-specific state among calls.

Because a stateless EJB does not maintain a conversational state, all the data exchanged between the client and the EJB must be passed either as input parameters, or as return value, declared on the EJB business method interface.

To better appreciate the simplification effort done by the EJB 3.0 specification, let us have a comparison of the steps involved in the definition of an EJB according to 2.x and 3.0.

Steps to define a stateless session bean in EJB 2.x

To define a stateless session EJB for EJB 2.x, you have to define the following components:

- ▶ **EJB component interface:** Used by an EJB client to gain access to the capabilities of the bean. This is where the business methods are defined. The component interface is called the **EJB object**. There are two types of component interfaces (Figure 14-2):
 - Remote component (EJBObject)—Used by a remote client to access the EJB through the RMI-IIOP protocol.
 - Local component (EJBLocalObject)—Used by a local client (that runs inside the same JVM) to access the EJB.

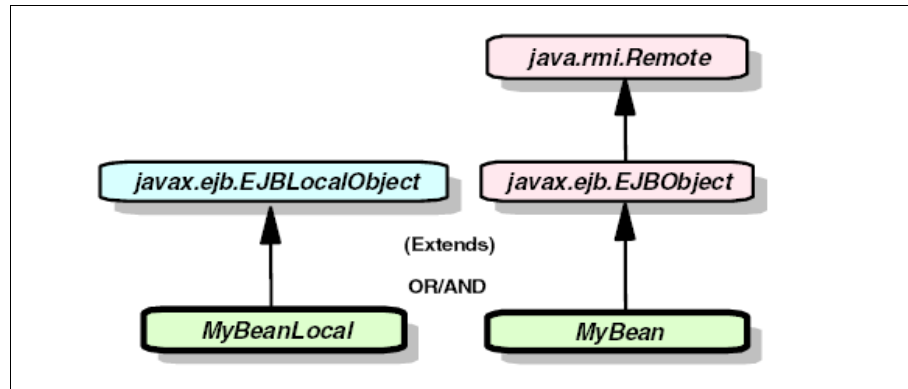

Figure 14-2 EJB 2.x component interfaces

- ▶ **EJB home interface:** Used by an EJB client to gain access to the bean. Contains the bean life cycle methods of create, find, or remove. The home interface is called the **EJB home**. The EJBHome object is an object which implements the home interface, and as in EJBObject, is generated from the container tools during deployment, and includes container specific code. At startup time the EJB container instantiates the EJBHome objects of the deployed enterprise beans and registers the home in the naming service. An EJB client accesses the EJBHome objects using the Java Naming and Directory Interface (JNDI). There are two types of home interfaces (Figure 14-3):
 - Remote interface (EJBHome)—Used by a remote client to access the EJB through the RMI-IIOP protocol.
 - Local interface (EJBLocalHome)—Used by a local client (that runs inside the same JVM) to access the EJB.

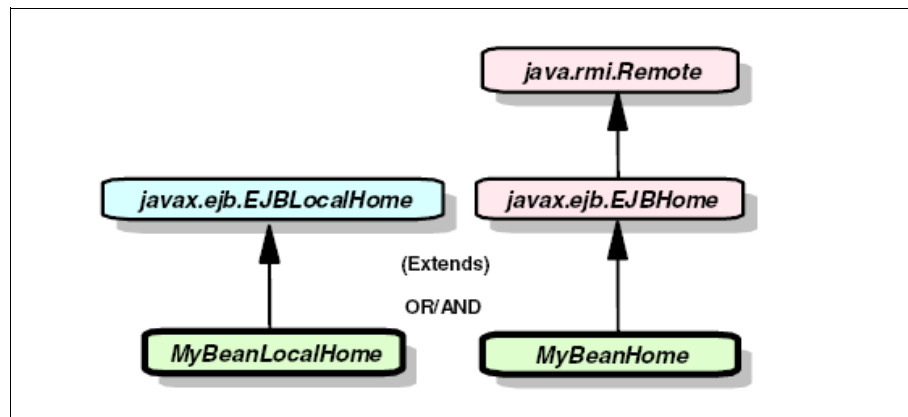

Figure 14-3 EJB 2.x home interfaces

- ▶ **EJB bean class:** Contains all of the actual bean business logic. Is the class that provides the business logic implementation. Methods in this bean class associate to methods in the component and home interfaces.

Steps to define a stateless session bean in EJB 3.0

To declare a session stateless bean, according to EJB 3.0 specification, you can simply define a POJO:

```
@Stateless
public class MyFirstSessionBean implements MyBusinessInterface {

    // business methods according to MyBusinessInterface
    .....
}
```

Let us have a look at the new, revolutionary aspects of this approach:

- ▶ `MyFirstSessionBean` is a POJO that exposes a plain old Java interface (POJI), in this case `MyBusinessInterface`. This interface will be available to clients to invoke the EJB business methods.
- ▶ The **@Stateless** annotation indicates to the container that the given bean is stateless session bean so that the proper life cycle and runtime semantics can be enforced.
- ▶ By default, this session bean is accessed through a local interface.

This is all you need to set up a session EJB! There are no special classes to extend and no interfaces to implement. The very simple model of EJB 3.0 is shown in Figure 14-4.

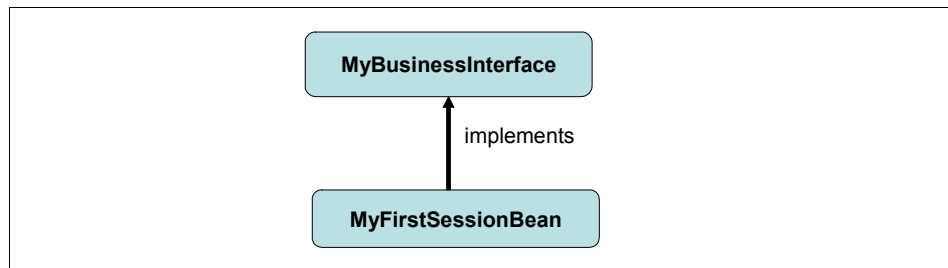

Figure 14-4 EJB is a POJO exposing a POJI

On the other hand, if we want to expose the same bean on the remote interface, we would use the **@Remote** annotation:

```
@Remote(MyRemoteBusinessInterface.class)
@Stateless
public class MyBean implements MyRemoteBusinessInterface {
```



```
    // ejb methods
    .....
}
```

Tip: If the session bean implements only one interface, you can also just code `@Remote` (without a class name).

Stateful session EJB

Stateful session EJBs are usually used to model a task or business process that spans multiple client requests, therefore, a stateful session bean retains state on behalf of an individual client. The client, on the other hand, has to store the handle to the stateful EJB, so that it always accesses the same EJB instance.

Using the same approach we adopted before, to define a stateful session EJB is to declare a POJO with the annotations:

```
@Stateful
public class MySecondSessionBean implements MyBusinessStatefulInterface {

    // ejb methods
    .....
}
```

The **@Stateful** annotation indicates to the container that the given bean is stateful session bean so that the proper life cycle and runtime semantics can be enforced.

Business interfaces

EJBs can expose different business interfaces, according to the fact that the EJB could be accessed either from a local or remote client. We recommend that common behaviors to both local and remote interfaces should be placed in a super-interface, as shown in Figure 14-5.

Please take care of the following aspects:

- ▶ A business interface cannot be both a local and a remote business interface of the bean.
- ▶ If a bean class implements a single interface, that interface is assumed to be the business interface of the bean. This business interface will be a *local* interface, unless the interface is designated as a remote business interface by use of the `@Remote` annotation or by means of the deployment descriptor.

This give you a great flexibility during the design phase, because you can decide which methods are visible to local and remote clients.

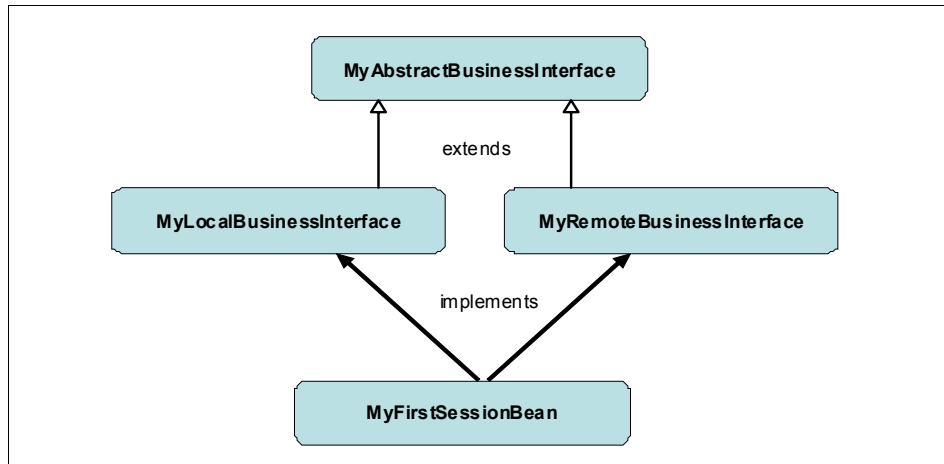

Figure 14-5 How to organize the EJB component interface

Using these guidelines, our first EJB is refactored as shown here:

```

@Stateless
public class MyFirstSessionBean
    implements MyLocalBusinessInterface, MyRemoteBusinessInterface {

    // implementation of methods declared in MyLocalBusinessInterface
    ....
    ....

    // implementation of methods declared in MyRemoteBusinessInterface
    ....
    ....
}
  
```

The MyLocalBusinessInterface is declared as interfaces with a @Local or @Remote annotation:

```

@Local
public interface MyLocalBusinessInterface
    extends MyAbstractBusinessInterface {

    // methods declared in MyLocalBusinessInterface
    .....
}

@Remote
public interface MyRemoteBusinessInterface
    extends MyAbstractBusinessInterface {

    // methods declared in MyRemoteBusinessInterface
  
```

```

    .....
}

```

Another techniques to define the business interfaces exposed either as local or remote is to specify **@Local** or **@Remote** annotations with the full class that implements these interfaces:

```

@Stateless
@Local(MyLocalBusinessInterface.class)
@Remote(MyRemoteBusinessInterface.class)
public class MyFirstSessionBean implements MyLocalBusinessInterface,
                                           MyRemoteBusinessInterface {

    // implementation of methods declared in MyLocalBusinessInterface
    ....
    ....

    // implementation of methods declared in MyRemoteBusinessInterface
    ....
    ....
}

```

You can declare arbitrary exceptions on the business interface, but take into account the following rules:

- ▶ Do not use `RemoteException`.
- ▶ Any runtime exception thrown by the container is wrapped into an `EJBException`.

Best practices for developing EJBs

An EJB 3.0 developer must be adherent to the following basic rules:

- ▶ Each session bean must be a POJO, the class must be concrete (therefore neither abstract or final), and must have a no-argument constructor (if not present, the compiler will insert a default constructor).
- ▶ The POJO must implement *at least* one POJI. We stress at least, because you can have different interfaces for local and remote clients.
- ▶ If the business interface is `@Remote` annotated, all the values passed through the interface must implement `java.io.Serializable`. Typically the declared parameters are defined serializable, but this is not required as long as the actual values passed are serializable.
- ▶ A session EJB can subclass a POJO, but cannot subclass another session EJB.

Message-driven bean

Message-driven beans are used for the processing of asynchronous JMS messages within J2EE based applications. They are invoked by the container on the arrival of a message.

In this way, they can be thought of as another interaction mechanism for invoking EJBs, but unlike session beans, the container is responsible for invoking them when a message is received, not a client (or another bean).

To define a message-driven bean in EJB 3.0 you declare a POJO:

```
@MessageDriven(activationConfig = {
    @ActivationConfigProperty(propertyName="destinationType",
        propertyValue="javax.jms.Queue"),
    @ActivationConfigProperty(propertyName="destination",
        propertyValue="queue/myQueue")
})
public class MyMessageBean implements javax.jms.MessageListener {

    public void onMessage(javax.jms.Message inMsg) {
        // implement the onMessage method
        // to handle the incoming message
        ....
    }
}
```

The main relevant features of this example are:

- ▶ In EJB 3.0, the MDB bean class is annotated with the **@MessageDriven** annotation, which specifies a set of activation configuration parameters. These parameters are unique to the particular kind of JCA 1.5 adapter that is used to drive the MDB. Some adapters have configuration parameters that let you specify the destination queue of the MDB. In the case where the adapter does not support this, the destination name must be specified using a `<message-destination>` entry in the XML binding file.
- ▶ The bean class has to implement the **MessageListener** interface, which defines only one method, `onMessage`. When a message arrives in the queue monitored by this MDB, the container calls the `onMessage` method of the bean class and passes the incoming message in as the parameter.
- ▶ Furthermore, the `activationConfig` property of the **@MessageDriven** annotation provides messaging system-specific configuration information.

Web services

Exposing EJB 3.0 beans as Web services using the `@WebService` annotation is covered in Chapter 18, “Develop Web services applications” on page 563, where we show how to implement a Web service from an EJB 3.0 session bean.

Life cycle events

Another very powerful use of annotations is to *mark* callback methods for session bean life cycle events.

EJB 2.1 and prior releases required implementation of several life cycle methods, such as `ejbPassivate`, `ejbActivate`, `ejbLoad`, and `ejbStore`, for every EJB even if you do not need these methods.

Because we use POJOs in EJB 3.0, the implementation of these life cycle methods have been made optional. Only if you implement any callback method in the EJB, the container will invoke that specific method.

The life cycle of a session bean may be categorized into several phases or events. The most obvious two events of a bean life cycle are creation and destruction for stateless session beans.

After the container creates an instance of a session bean, the container performs any *dependency injection* (described in the section that follows), and then invokes the method annotated with **@PostConstruct** (if there is one).

The client obtains a reference to a session bean, and then invokes a business method.

Note: The actual life cycle of a **stateless** session bean is independent of when a client obtains a reference to it. For example, the container may hand out a reference to the client, but not create the bean instance until some later time, for example, when a method is actually invoked on the reference. Or, the container may create a number of instances at startup time, and match them up with references at a later time.

At the end of the life cycle, the EJB container calls the method annotated with **@PreDestroy**, if there is one. The bean instance is then ready for garbage collection.

A stateless session bean with the two callback methods is shown here:

```
@Stateless  
public class MyStatelessBean implements MyBusinessLogic {
```

```
// .. bean business method

@PostConstruct
public void initialize() {
    // initialize the resources uses by the bean
}

@PreDestroy
public void cleanup() {
    // deallocates the resources uses by the bean
}
}
```

All stateless and stateful EJBs go through these two phases.

In addition, stateful session beans go through the passivation/activation cycle. Because an instance of a stateful bean is bound to a specific client (and therefore it cannot be reused among different requests), and the EJB container must manage the amount of physical available resources, the EJB container may decide to deactivate, or passivate, the bean by moving it from memory to secondary storage.

In correspondence with this more complex life cycle, we have further callback methods, specific to stateful session beans:

- ▶ The EJB container invokes the method annotated with **@PrePassivate**, immediately before passivating it.
- ▶ If a client invokes a business method on the bean while it is in the passive stage, the EJB container activates the bean by calling the method annotated with **@PostActivate**, if any, and then moves it to the ready stage.
- ▶ At the end of the life cycle, the client explicitly invokes a method annotated with **@Remove**, and the EJB container in turns calls the callback method annotated **@PreDestroy**.

Note: Because a stateful bean is bound to a particular client, it is best practice to correctly design session stateful beans to minimize their footprint inside the EJB container, and to correctly un-allocate it at the end of its life cycle, by invoking the method annotated with **@Remove**.

Stateful session beans have a *time-out* value. If the session stateful bean has not been used in the time-out period, it is marked inactive and is eligible for automatic deletion by the EJB container. Of course, it is still best practice for applications to remove the bean when the client is through with it, rather than relying on the time-out mechanism to do this.

Developers can explicitly invoke only the life cycle method annotated with `@Remove`, the other methods are invoked automatically by the EJB container.

Interceptors

The EJB 3.0 specification defines the ability to apply custom made interceptors to the business methods of both session and message driven beans. Interceptors take the form of methods annotated with the `@AroundInvoke` annotation (Example 14-1).

Example 14-1 Applying an interceptor

```
@Stateless
public class MySessionBean implements MyBusinessInterface {

    @Interceptors(LoggerInterceptor.class)
    public Customer getCustomer(String ssn) {
        ...
    }
    .....
}

public class LoggerInterceptor {
    @AroundInvoke
    public Object logMethodEntry(InvocationContext invocationContext)
        throws Exception {
        System.out.println("Entering method: "
            + invocationContext.getMethod().getName());
        Object result = invocationContext.proceed();
        // could have more logic here
        return result;
    }
}
```

We have the following notes for this example:

- ▶ The `@Interceptors` annotation is used to identify the session bean method where the interceptor should be applied;
- ▶ The `LoggerInterceptor` interceptor class defines a method (`logMethodEntry`) annotated with `@AroundInvoke`.
- ▶ The `logMethodEntry` method contains the advisor logic (in this case very simply logs the invoked method name), and invokes the `proceed` method on the `InvocationContext` interface to advice the container to proceed with the execution of the business method.

The implementation of interceptor in EJB 3.0 is a bit different from the analogous implementation of this aspect-oriented programming (AOP) paradigm that you can find in frameworks like Spring or AspectJ, because EJB 3.0 does not support *before* or *after* advisors, but only *around* interceptors. However, around interceptors may act as before or after interceptors, or both. Interceptor code before the `invocationContext.proceed` call is run before the EJB method, and interceptor code after that call is run after the EJB method.

A very common use of interceptors is to provide preliminary checks (validation, security, and so forth) before the invocation of business logic tasks, and therefore they can throw exceptions. Because the interceptor is called together with the session bean code at run-time, these potential exceptions are sent directly to the invoking client.

In this sample we have seen an interceptor applied on a specific method; actually, the `@Interceptors` annotation may be applied at class level. In this case the interceptor will be called for every method.

Furthermore, the `@Interceptors` annotation accepts a list of classes, so that multiple interceptors can be applied to the same object.

Note: To give further flexibility, EJB 3.0 introduces the concept of a default interceptor that can be applied on every session (or MDB) bean contained inside the same EJB module. A default interceptor cannot be specified using an annotation, instead you should define it inside the deployment descriptor of the EJB module.

Note that the execution order in which interceptors are run is the following:

- ▶ Default interceptor
- ▶ Class interceptors
- ▶ Method interceptors

To disable the invocation of a default interceptor or a class interceptor on a specific method, you can use the `@ExcludeDefaultInterceptors` and `@ExcludeClassInterceptors` annotations, respectively.

Dependency injection

The new specification introduces a powerful mechanism for obtaining Java EE resources (JDBC data source, JMS factories and queues, EJB references) and to inject them into EJBs, entities, or EJB clients.

In EJB 2.x the only way to obtain these resources was to use JNDI lookup using resource references, with a piece of code that could become cumbersome and

vendor specific, because very often you had to specify properties related to the specific J2EE container provider.

EJB 3.0 adopts a *dependency injection* (DI) pattern, which is one of best ways to implement loosely coupled applications. It is much easier to use and more elegant than older approaches, such as dependency lookup through JNDI or container callbacks.

The implementation of dependency injection in the EJB 3.0 specification is based on annotations or XML descriptor entries, which allow you to inject dependencies on fields or setter methods.

Instead of complicated XML EJB references or resource references, you can use the `@EJB` and `@Resource` annotations to set the value of a field or to call a setter method within your beans with anything registered within JNDI. With these annotations, you can inject EJB references and resource references such as data sources and JMS factories.

In this section we show the most common usage of dependency injection in EJB 3.0.

@EJB annotation

The `@EJB` annotation is used for injecting session beans into a client. This injection is only possible within managed environments, such as another EJB, or a servlet. We cannot inject an EJB into a JSF managed bean or Struts action, for example.

The parameters for the `@EJB` annotation are optional. The annotation parameters are:

- ▶ `name`—Specifies the JNDI name that is used to bind the injected EJB in the environment naming context (`java:comp/env`).
- ▶ `beanInterface`—Specifies the business interface to be used to access the EJB. By default, the business interface to be used is taken from the Java type of the field into which the EJB is injected. However, if the field is a supertype of the business interface, or if method-based injection is used rather than field-based injection, the `beanInterface` parameter is typically required, because the specific interface type to be used might be ambiguous without the additional information provided by this parameter.
- ▶ `beanName`—Specifies a *hint* to the system of the `ejb-name` of the target EJB that should be injected. It is analogous to the `<ejb-link>` stanza that can be added to an `<ejb-ref>` or `<ejb-local-ref>` stanza in the XML descriptor.

To access a session bean from a Java servlet we use the code shown in Example 14-2.

Example 14-2 Injecting an EJB reference inside a servlet

```
import javax.ejb.EJB;
public class TestServlet extends javax.servlet.http.HttpServlet
    implements javax.servlet.Servlet {

    // inject the remote business interface
    @EJB(beanInterface=MyRemoteBusinessInterface.class)
    MyAbstractBusinessInterface serviceProvider;

    protected void doGet(HttpServletRequest request,
        HttpServletResponse response)
        throws ServletException, IOException {
        // call ejb method
        serviceProvider.myBusinessMethod();
        .....
    }
}
```

Here are some remarks on this example:

- ▶ We have specified the `beanInterface` attribute, because the EJB exposes two business interfaces (`MyRemoteBusinessInterface` and `MyLocalBusinessInterface`).
- ▶ If the EJB exposes only one interface, you are not required to specify this attribute, however, it can be useful to make the client code more readable.

Special notes for stateful EJB injection:

- ▶ Because a servlet is a multi-thread object, you cannot use dependency injection, but you must explicitly lookup the EJB through JNDI.
- ▶ You can safely inject a stateful EJB inside another session EJB (stateless or stateful), because a session EJB instance is guaranteed to be executed by only a single thread at a time.

@Resource annotation

The `@Resource` annotation is the main annotation that can be used to inject resources in a managed component. In the following we show the most common usage scenarios of this annotation.

We show here how to inject a typical resource such as a data source inside a session bean.

Field injection technique

Example 14-3 shows how to inject a data source inside a property that is used in a business method:

```
@Resource (name="jdbc/dataSource")
```

Example 14-3 Field injection technique for a data source

```
@Stateless
public class CustomerSessionBean implements CustomerServiceInterface {

    @Resource (name="jdbc/dataSource")
    private DataSource ds;

    public void businessMethod1() {
        java.sql.Connection c=null;
        try {
            c = ds.getConnection();
            // .. use the connection
        } catch (java.sql.SQLException e) {
            // ... manage the exception
        } finally {
            // close the connection
            if(c!=null) {
                try { c.close(); } catch (SQLException e) { }
            }
        }
    }
}
```

All parameters for the `@Resource` annotation are optional. The annotation parameters are:

- ▶ `name`—Specifies the component-specific internal name—resource reference name—within the `java:comp/env` name space. It does not specify the global JNDI name of the resource being injected. A binding of the reference reference to a JNDI name is necessary to provide that linkage, just as it is in J2EE 1.4.
- ▶ `type`—Specifies the resource manager connection factory type.
- ▶ `authenticationType`—Specifies whether the container or the bean is to perform authentication.
- ▶ `shareable`—Specifies whether resource connections are shareable or not.
- ▶ `mappedName`—Specifies a product specific name that the resource should be mapped to. WebSphere does not make any use of `mappedName`.
- ▶ `description`—Description.

Setter method injection

Another technique is to inject a setter method. The setter injection technique is based on JavaBeans property naming conventions (Example 14-4).

Example 14-4 Setter injection technique for a data source

```
@Stateless
public class CustomerSessionBean implements CustomerServiceInterface {

    private Datasource ds;

    @Resource (name="jdbc/dataSource")
    public void setDatasource(DataSource datasource) {
        this.ds = datasource;
    }
    ...
    public void businessMethod1() {
        ...
    }
}
```

Some remarks on these two examples:

- ▶ In this example, we directly used the data source inside the session bean. This is not good practice, because you should put JDBC code in specific components, such as data access objects.
- ▶ We recommend to use the setter injection technique, which gives more flexibility:
 - You can put initialization code inside the setter method.
 - The session bean is setup to be easily tested as a stand-alone component.

Other interesting usages of @Resource are:

- ▶ To obtain a reference to the EJB session context:

```
@Stateless
public class CustomerSessionBean implements CustomerServiceInterface {
    ...
    @Resource javax.ejb.SessionContext ctx;
}
```

- ▶ To obtain the value of an environment variable, which is configured inside the deployment descriptor with env-entry:

```
@Stateless
public class CustomerSessionBean implements CustomerServiceInterface {
    ...
}
```

```
@Resource String myEnvironmentVariable;  
  
}
```

- ▶ Injection of JMS resources, such as JMS factories or queues.

Using deployment descriptors

Up to now we have seen how to define an EJB, how to inject resources into it, or how to specify its life cycle event with annotations. We can get the same result by specifying a deployment descriptor (`ejb-jar.xml`) with the necessary information in the EJB module.

EJB 3.0 application packaging

Session beans and MDBs can be packaged in Java standard JAR file. This can be achieved by two strategies:

- ▶ Using a Java project or Java Utility project
- ▶ Using an EJB project

If you use the first approach you have to add the Java Project to the EAR project, by editing the deployment descriptor (`application.xml`), and adding the lines:

```
<module>  
  <ejb>MyEJB3Module.jar</ejb>  
</module>
```

When using the second approach, the IDE can automatically update the `application.xml` file, and setup an `ejb-jar.xml` inside the EJB project. However, in EJB 3.0 you are not required to define the EJBs and related resources in an `ejb-jar.xml` file, because they are usually defined through the use of annotations. The main usage of deployment descriptor files is to override or complete behavior specified by annotations.

EJB features in Application Developer

The following features, supported by Application Developer, are for the EJB 3.0 specification and require a Java EE 5 compatible application server, such as WebSphere Application Server v6.1 with the Feature Pack for EJB 3.0, or WebSphere Application Server v7.0:

- ▶ Ability to create session and message-driven enterprise beans
- ▶ Ability to build data persistence using JPA entities.
- ▶ Ability to generate deployment code automatically in the server

- ▶ Stateless session beans can implement a Web service endpoint.
- ▶ Enterprise beans can utilize external Web services.
- ▶ The container-managed timer service is provided.
- ▶ Message-driven beans support more messaging types in addition to JMS.
- ▶ The JPA query language allows to run SQL like statements against the JPA entity model.

Sample application overview

In this chapter, we reuse the design of the application, described in Chapter 8, “Develop Java applications” on page 69 with same small changes. However, the content of this chapter does not depend on that chapter. You can complete the sample in this chapter without knowledge of the sample developed in the Java chapter.

The focus of this chapter is on implementing EJBs for the business model, instead of regular JavaBeans. The rest of the application’s layers (control and view) still apply as designed.

Figure 14-6 shows the sample application model layer design.

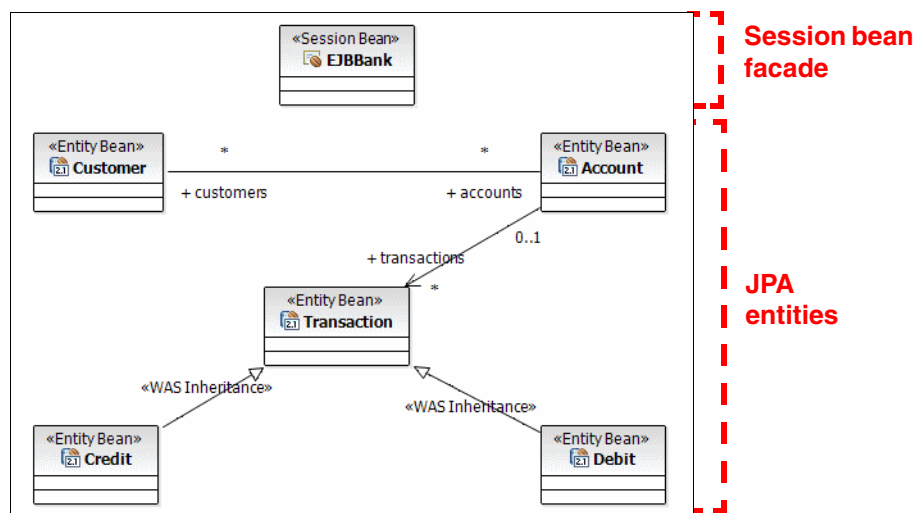

Figure 14-6 EJB module class diagram for the sample application

The **EJBBank** session bean acts as a facade for the EJB model. Our business entities (Customer, Account, Transaction, Credit, and Debit) are implemented as

CMP entity beans with local interfaces, as opposed to regular JavaBeans. By doing so, we automatically gain persistence, security, distribution, and transaction management services. On the other hand, this also implies that the control and view layers are not able to reference these entities directly, because they can be placed in a different JVM. Only the session bean (EJBBank) can access the business entities through their local interfaces.

You might be asking yourself, then, why we do not expose a remote interface for the entity beans as well? The problem with doing that is two-fold. First, in such a design, clients would probably make many remote calls to the model to resolve each client request. This is not a recommended practice because remote calls are more expensive than local ones. Finally, allowing clients to see into the model breaks the layer's encapsulation, promoting unwanted dependencies and coupling.

Because the control layer is not able to reference the model objects directly, we reuse the Customer, Account, Transaction, Credit, and Debit from the Java application in Chapter 8, "Develop Java applications" on page 69 as data transfer objects, carrying data to the servlets and JSPs, but allowing no direct access to the underlying model.

Figure 14-7 shows the application component model and the flow of events.

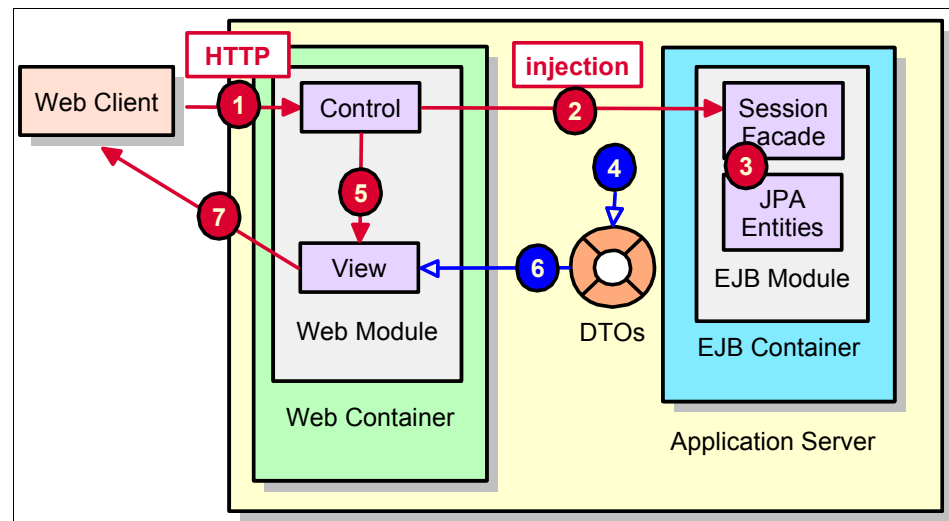

Figure 14-7 Application component model and workflow

The flow of events, as shown in Figure 14-7, is as follows:

1. The first event that occurs is the HTTP request issued by the Web client to the server. This request is answered by a servlet in the control layer, also known

as the front controller, which extracts the parameters from the request. The servlet sends the request to the appropriate control JavaBean. This bean verifies whether the request is valid in the current user and application states.

2. If so, the control layer sends the request through the @EJB injected interface to the session EJB facade. This involves using JNDI to locate the session bean's interface and creating a new instance of the bean.
3. The session EJB executes the appropriate business logic related to the request. This includes having to access JPA entities in the model layer.
4. The facade returns DTOs to the calling controller servlet with the response data. The DTO returned can be a JPA entity, a collection of JPA entities, or any Java object. In general, it is not necessary to create extra DTOs for entity data.
5. The front controller servlet sets the response DTO as a request attribute and forwards the request to the appropriate JSP in the view layer, responsible for rendering the response back to the client.
6. The view JSP accesses the response DTO to build the user response.
7. The result view, possibly in HTML, is returned to the client.

Preparing for the sample

This section describes the steps to prepare for developing the sample EJB application.

Required software

To complete the EJB development sample in this chapter, you must have the following software installed:

- ▶ IBM Rational Application Developer v7.5
- ▶ Database software, either of these products:
 - Derby v10.2 (installed by default with Application Developer)
 - IBM DB2 Universal Database v8.2 or newer

Note: For more information on installing the software, refer to Appendix A, “Product installation” on page 1121.

Enabling the EJB development capability

To develop EJBs, we have to enable the EJB development capability in Rational Application Developer:

- ▶ Select **Window** → **Preferences**.
- ▶ Select **General** → **Capabilities** → **Enterprise Java Developer** and click **OK** (the capability may already be enabled).

Creating and configuring the EJB projects

In Application Developer, we create and maintain Enterprise JavaBeans and associated Java resources in EJB and utility projects. Within an EJB project, these resources can be treated as a portable, cohesive unit.

With the EJB 3.0 specification, the entities are developed and managed by the Java Persistence API (JPA), as described in Chapter 12, “Persistence using the Java Persistence API (JPA)” on page 267. EJBs can be session beans or message-driven beans.

An EJB module, with underlying JPA entities, typically contains components that work together to perform some business logic. This logic can be self-contained, or access external data and functions as needed. It should be comprised of a facade (session bean) and the business entities. (JPA entities). The facade is usually implemented using one or more session beans and message-driven beans.

In this chapter we develop a session EJB as a facade for the JPA entities (Customer, Account, Transaction), as shown in Figure 14-6 on page 406. The RAD75JPA project must be available in the workspace (you can import the project from `c:\7672code\zInterchange\jpa`).

Creating an EJB project

To develop the session EJB, we create an EJB project. It is also typical to create an enterprise application (EAR) project that is the container for deploying the EJB project.

Note: With EJB 3.0, we can also use a utility project to hold the EJB classes, but it is more flexible to use an EJB project.

To create a Java EE EJB project, do these steps:

- ▶ Open the Java EE perspective.

- ▶ In the Workbench, select **File** → **New** → **Project**.
- ▶ In the New Project dialog, select **EJB** → **EJB Project** and click **Next**.
- ▶ In the New EJB Project dialog (Figure 14-8):
 - Enter **RAD75EJB** in the Name field.
 - For Target Runtime, select **WebSphere Application Server v7.0**.
 - For EJB Module version, select **3.0**.
 - Select **Add project to an EAR** (default) and enter **RAD75EJBEAR** for EAR Project Name field. Default behavior is to create a new EAR project, but you can also select an existing project from the drop-down combo box. If you would like to create a new project and also configure its location, click **New**. For our example, we use the given default value.
 - For Configuration, select **Default Configuration for WebSphere Application Server v7.0**. Optionally click **Modify** to see the project facets (EJB Module 3.0, Java 6.0, WebSphere EJB (Extended) 7.0).
 - Click **Next**.

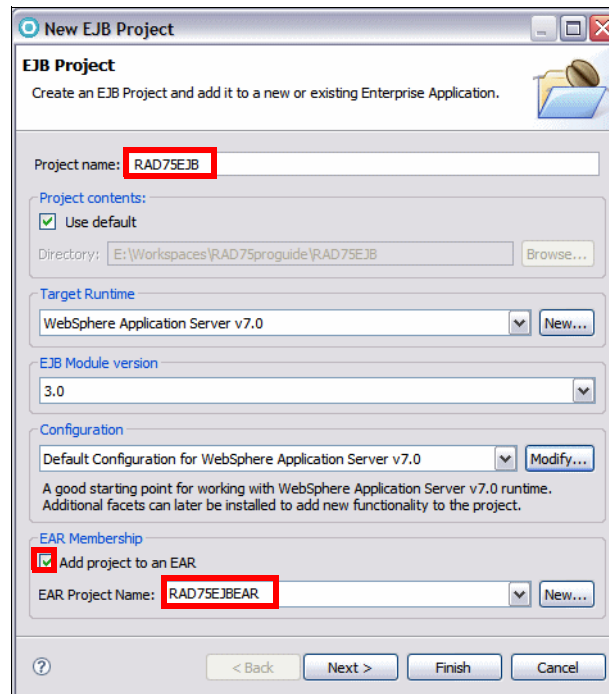

Figure 14-8 Create an EJB project wizard (1)

- ▶ In the EJB Module dialog (Figure 14-9) enter the following items:
 - Source folder: `ejbModule` (default)
 - Clear **Create an EJB Client JAR Project to hold client interfaces and classes** (default).
 - Select **Generate deployment descriptor**.
 - Click **Finish**.

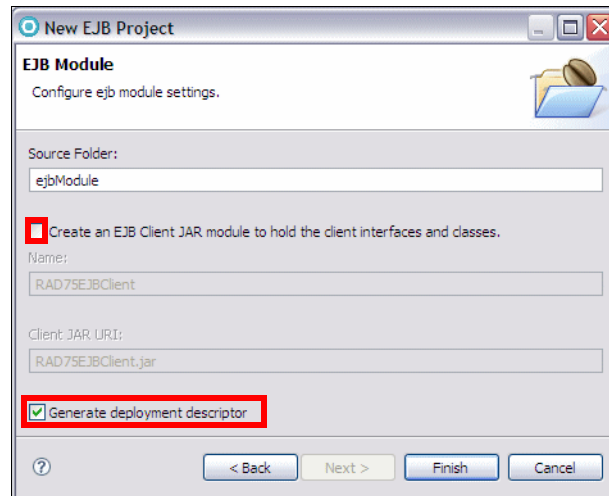

Figure 14-9 Create an EJB project wizard (3)

Note: The EJB client JAR holds the interfaces of the enterprise beans, and other classes that these interfaces depend on, such as their superclasses and implemented interfaces, the classes and interfaces used as method parameters, results, and exceptions.

The EJB client JAR can be deployed together with a client application that accesses the EJBs. This results in a smaller client application as compared to deploying the EJB project with the client application.

However, with EJB 3.0, EJBs are annotated Java classes that are lightweight compared to EJB 2.1 EJBs, so the need for a client JAR is minimal.

- ▶ If the current perspective is not the Java EE perspective when you create the project, Application Developer prompts, asking if you want to switch to the Java EE perspective. Click **Yes**.

- ▶ The Technology Quickstarts view opens. You can click on a link to open the Application Developer Help with a matching tutorial. Close the view.
- ▶ The Enterprise Explorer contains the RAD75EJB project and the RAD75EJBEAR enterprise application.

Make the JPA entities available to the EJB project

To make the JPA entities available to the EJBs, we add the RAD75JPA project to the RAD75EJBEAR enterprise application and create a dependency.

- ▶ Right-click the **RAD75EJBEAR** project and select **Java EE** → **Generate Deployment Descriptor Stub**.
- ▶ A META-INF folder with an application.xml file is created in the project.
- ▶ Open the application.xml file.
- ▶ In the editor, select the **Design** tab, and you can see the EJB module as part of the EAR (Figure 14-10). Close the editor.

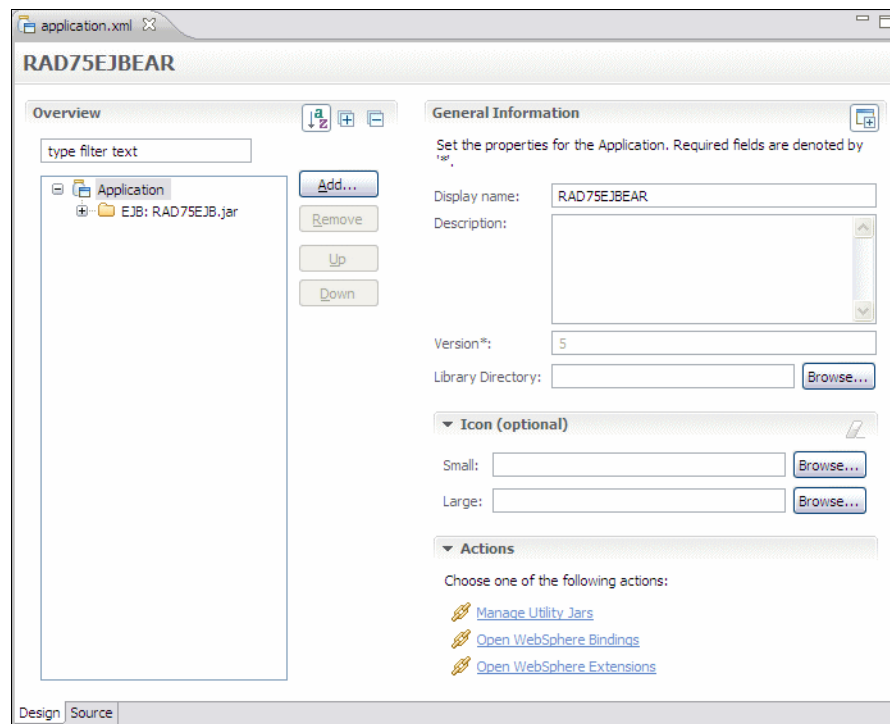

Figure 14-10 EAR deployment editor

- ▶ Right-click the **RAD75EJBEAR** project and select **Properties**.

- ▶ In the Properties dialog, select **Java EE Module Dependencies**, select the **RAD75JPA** module, and click **OK** (Figure 14-11).

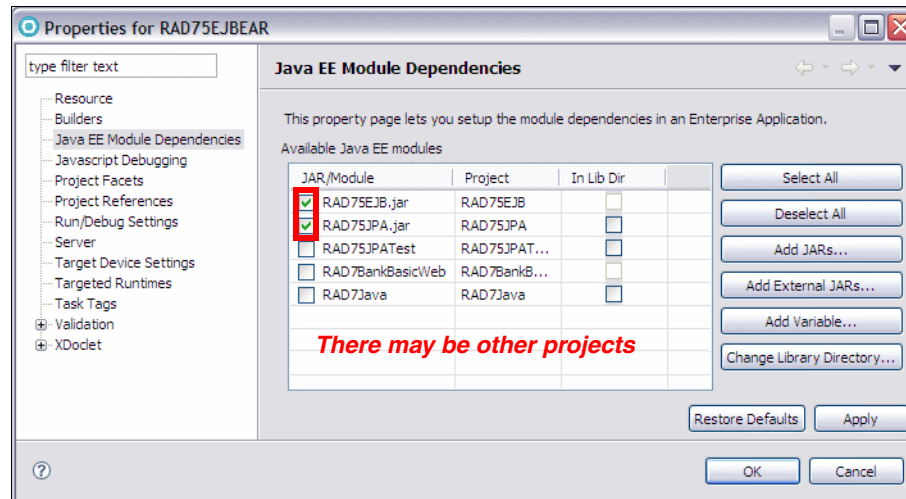

Figure 14-11 EAR module dependencies

- ▶ Right-click the **RAD75EJB** project and select **Properties**. In the Properties dialog, select **Java EE Module Dependencies**, select the **RAD75JPA.jar**, and click **OK** (same as Figure 14-11).

Setting up the ITSOBANK database

The JPA entities are based on the ITSOBANK database. Therefore, we have to define a database connection within Application Developer that the mapping tools use to extract schema information from the database.

Refer to “Setting up the ITSOBANK database” on page 1154 for instructions on how to create the ITSOBANK database. We can either use the DB2 or Derby database. For simplicity we use the built-in Derby database in this chapter.

Configuring the data source for the ITSOBANK

There are a couple of methods that can be used to configure the data source, including using the WebSphere Administrative Console or using the WebSphere enhanced EAR, which stores the configuration in the deployment descriptor and is deployed with the application.

The definition of the data source in the WebSphere Administrative Console is covered in “Configuring the data source in WebSphere Application Server” on page 1155.

This section describes how to configure the data source using the WebSphere enhanced EAR capabilities. The enhanced EAR is configured in the Deployment tab of the EAR Deployment Descriptor editor. If you select to import the complete sample code, you only have to verify that the value of the `databaseName` property in the deployment descriptor matches the location of the database.

Note: For more information on configuring data sources and general deployment issues, refer to Chapter 26, “Deploy enterprise applications” on page 933.

Configure the data source using enhanced EAR

To configure a new data source using the enhanced EAR capability in the deployment descriptor, do these steps:

- ▶ Right-click the **RAD75EJBEAR** project and select **Java EE → Open WebSphere Application Server Deployment**.
- ▶ The WebSphere Deployment editor opens.
- ▶ Select **Derby JDBC Provider (XA)** from the JDBC provider list. This JDBC Provider is configured by default.
- ▶ Click **Add** next to data source.
- ▶ In the Create a Data Source dialog:
 - Select **Derby JDBC Provider (XA)** under the JDBC provider and **Version 5.0 data source**, and click **Next**.
 - Type **ITSOBANKejb** (as Name), **jdbc/itsobank** (as JNDI name), **Data Source for ITSOBANK EJBs** (Description). Clear **Use this data source in container managed persistence (CMP)**. Click **Next**.
- ▶ In the Create Resource Properties dialog, select **databaseName** and enter the value **C:\7672code\database\derby\ITSOBANK**. Clear the description.
- ▶ Click **Finish**.
- ▶ Save and close the deployment descriptor (Figure 14-12).

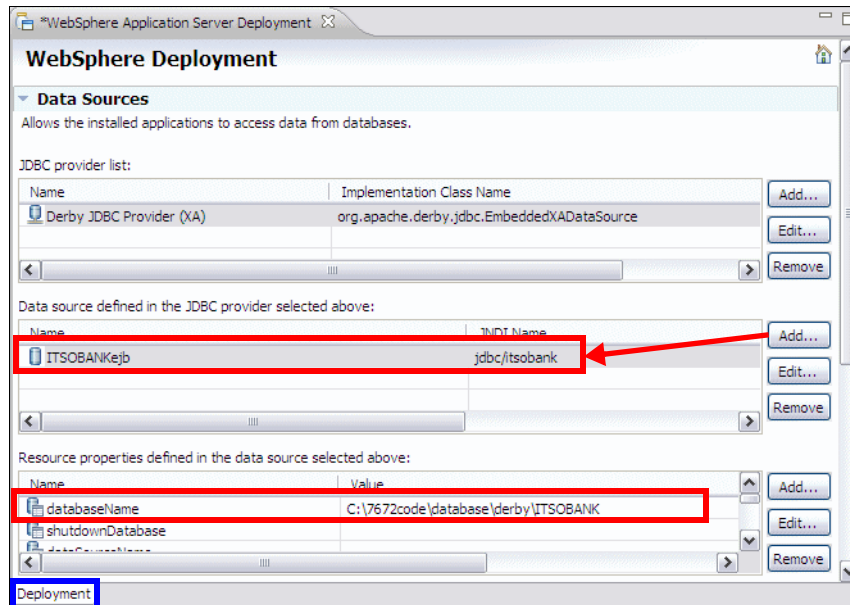

Figure 14-12 EAR enhanced deployment descriptor

Developing an EJB application

The EJB application consists of a Web module with a simple servlet, and an EJB module with an EJB 3.0 session bean that uses the JPA entities to access the database.

Implementing the session facade

The front-end application communicates with the JPA entity model through a session facade. This design patterns makes the entities invisible to the EJB client.

In this section we build the session facade, `EJBBank`, a stateless session bean.

Preparing an exception

The business logic of the session bean throws an exception when errors occur. Let us create an application exception named `ITSOBanException`:

- ▶ Right-click the **RAD75EJB** project and select **New** → **Class**.
- ▶ In the New Java Class dialog, type **itso.bank.exception** as package, and **ITSOBankException** as Name. Set the superclass to **java.lang.Exception**. Click **Finish**.
- ▶ Complete the code in the editor:

```
public class ITSOBankException extends Exception {  
    private static final long serialVersionUID = 1L;  
  
    public ITSOBankException(String message) {  
        super(message);  
    }  
}
```

- ▶ Save and close the class.

Creating the EJBBank session bean

To create the session bean, do these steps:

- ▶ Right-click the **RAD75EJB** project and select **New** → **Session Bean**.
- ▶ In the Create EJB 3.0 Session Bean dialog (Figure 14-13):
 - For Java package type **itso.bank.session**.
 - For Class name type **EJBBankBean**.
 - For State type select **Stateless**.
 - For Create business interface, select **Local**, and set the name to **itso.bank.service.EJBBankService**.
 - Click **Next**.

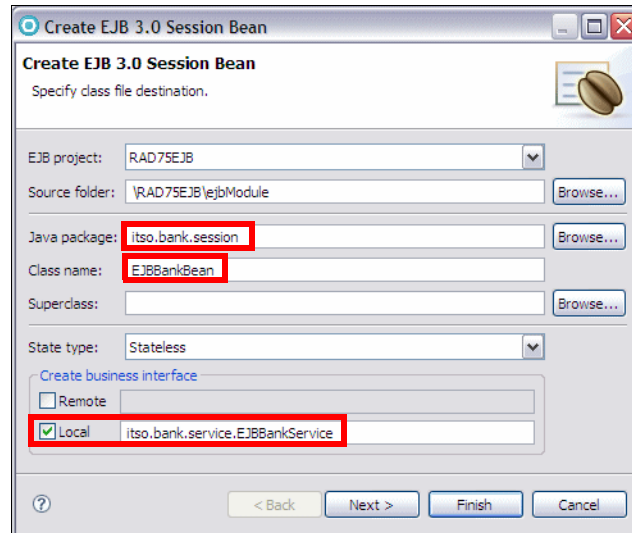

Figure 14-13 Creating a session bean (1)

- ▶ In the next dialog, accept the default of **Container** as transaction type, and click **Next** (Figure 14-14).

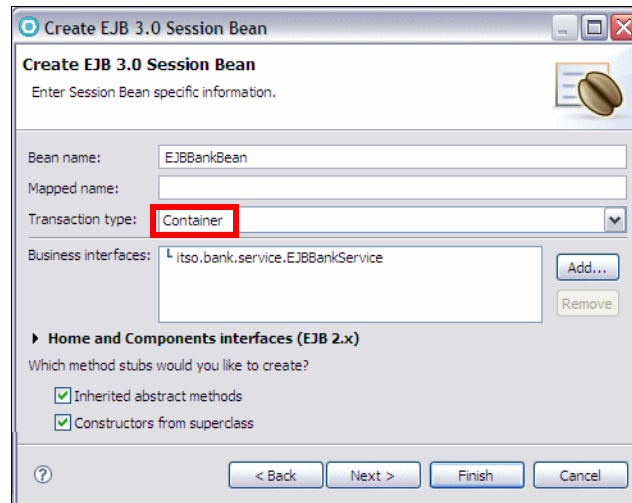

Figure 14-14 Creating a session bean (2)

- ▶ In the Select Class Diagram for Visualization dialog, select **Add bean to Class Diagram**, and accept the default name of `classdiagram.dnx`.
- ▶ Click **Finish**.

- ▶ When prompted for enablement of EJB 3.0 Modeling, click **OK**.
- ▶ Save and close the class diagram.
- ▶ The EJBBean is open in the editor. Notice the `@Stateless` annotation. Before we can write the code, we have to complete the business interface.

Defining the business interface

In EJB 3.0, a session bean implements a business interface, which is the interface clients use to access the session bean. The session bean can implement multiple interfaces, for example a local interface and a remote interface. We keep it simple with one local interface, `EJBBankService`.

The session bean wizard has created the `EJBBankService` interface. To complete the code:

- ▶ Open the `EJBBankService` interface. Notice the `@Local` annotation.
- ▶ In the Java editor, add the methods to the interface (Example 14-5). The code is available in `c:\7672code\ejb\source\EJBBankService.txt`.

Example 14-5 Business interface of the session bean

```
@Local
public interface EJBBankService {

    public Customer getCustomer(String ssn) throws ITS0BankException;
    public Customer[] getCustomersAll();
    public Customer[] getCustomers(String partialName)
        throws ITS0BankException;
    public void updateCustomer(String ssn, String title, String firstName,
        String lastName) throws ITS0BankException;
    public Account[] getAccounts(String ssn) throws ITS0BankException;
    public Account getAccount(String id) throws ITS0BankException;
    public Transaction[] getTransactions(String accountID)
        throws ITS0BankException;
    public void deposit(String id, BigDecimal amount)
        throws ITS0BankException;
    public void withdraw(String id, BigDecimal amount)
        throws ITS0BankException;
    public void transfer(String idDebit, String idCredit, BigDecimal amount)
        throws ITS0BankException;
    public void closeAccount(String ssn, String id)
        throws ITS0BankException;
    public String openAccount(String ssn) throws ITS0BankException;
    public void addCustomer(Customer customer) throws ITS0BankException;
    public void deleteCustomer(String ssn) throws ITS0BankException;
}
```

- ▶ Organize the imports (Ctrl+Shift+O). Select `java.math.BigDecimal` and `itso.bank.entities.Transaction` when prompted. Save and close the interface.

Completing the session bean

We now add the facade methods that are used by clients to perform banking operations.

Generate skeleton methods

We can generate method skeletons for the methods of the business interface that must be implemented:

- ▶ Open the **EJBBankBean** (if you closed it).
- ▶ Select **Source** → **Override/Implement Methods**.
- ▶ In the Override/Implement Methods dialog, select all the methods of the `EJBBankService` interface. For Insertion point select **After 'EJBBankBean()'**. Click **OK**.
- ▶ The method skeletons are generated. Delete the default constructor.

Create an entity manager

The session bean works with the JPA entities to access the `ITSOBANK` database. We require an entity manager bound to the persistent context.

- ▶ Add these definitions to the `EJBBankBean` class:

```
@PersistenceContext (unitName="RAD75JPA",
                    type=PersistenceContextType.TRANSACTION)
private EntityManager entityMgr;
```

The `@PersistenceContext` annotation defines the persistence context unit with transactional behavior. The unit name matches the name in the `persistence.xml` file in the `RAD75JPA` project:

```
<persistence-unit name="RAD75JPA">
```

The `EntityManager` instance is used to execute JPA methods to retrieve, insert, update, delete, and query instances.

- ▶ Organize imports (select the `javax.persistence` package).

Complete the methods

Tip: The Java code for this section can be copied from the file `c:\7672code\ejb\source\EJBBankBean.txt`.

We complete the methods of the session bean in a logical sequence, not in alphabetical sequence of the generated skeletons.

getCustomer method

The `getCustomer` method retrieves one customer by ssn. Note that we use `entityMgr.find` to retrieve one instance. Alternatively we could use the `getCustomerBySSN` query (code in comments). If no instance is found, null is returned (Example 14-6).

Example 14-6 Session bean getCustomer method

```
public Customer getCustomer(String ssn) throws ITSOBankException {
    System.out.println("getCustomer: " + ssn);
    //Query query = null;
    try {
        //query = entityMgr.createNamedQuery("getCustomerBySSN");
        //query.setParameter(1, ssn);
        //return (Customer)query.getSingleResult();
        return entityMgr.find(Customer.class, ssn);
    } catch (Exception e) {
        System.out.println("Exception: " + e.getMessage());
        throw new ITSOBankException(ssn);
    }
}
```

getCustomers method

The `getCustomers` methods use a query to retrieve a collection of customers (Example 14-7). The query is created and executed. The result list is converted into an array and returned. Remember the query from the Customer entity:

```
select c from Customer c where c.lastName like ?1
```

This query looks like SQL but works on entity objects. In our case the entity name and the table name are the same, but they do not have to be identical.

Example 14-7 Session bean getCustomers method

```
public Customer[] getCustomers(String partialName) throws ITSOBankException {
    System.out.println("getCustomer: " + partialName);
    Query query = null;
    try {
        query = entityMgr.createNamedQuery("getCustomersByPartialName");
        query.setParameter(1, partialName);
        List<Customer> beanlist = query.getResultList();
        Customer[] array = new Customer[beanlist.size()];
        return beanlist.toArray(array);
    } catch (Exception e) {
        throw new ITSOBankException(partialName);
    }
}
```

```

    }
}

```

updateCustomer method

The `updateCustomer` method is very simple (Example 14-8). Note that no call to the entity manager is necessary. The table is updated automatically when the method (transaction) ends.

Example 14-8 Session bean updateCustomer method

```

public void updateCustomer(String ssn, String title, String firstName,
                           String lastName) throws ITSOBankException {
    System.out.println("updateCustomer: " + ssn);
    Customer customer = getCustomer(ssn);
    customer.setTitle(title);
    customer.setLastName(lastName);
    customer.setFirstName(firstName);
    System.out.println("updateCustomer: " + customer.getTitle() + " "
                      + customer.getFirstName() + " " + customer.getLastName());
}

```

getAccount method

The `getAccount` method retrieves one account by key, similar to the `getCustomer` method.

getAccounts method

The `getAccounts` method uses a query to retrieve all the accounts of a customer (Example 14-9). The query in the `Account` entity is:

```

select a from Account a, in(a.customerCollection) c where c.ssn =?1
order by a.id

```

This query looks for accounts that belong to a customer with a given ssn. An alternate query in the `Customer` class could also be used:

```

select a from Customer c, in(c.accountCollection) a where c.ssn =?1
order by a.id

```

Example 14-9 Session bean getAccounts method

```

public Account[] getAccounts(String ssn) throws ITSOBankException {
    System.out.println("getAccounts: " + ssn);
    Query query = null;
    try {
        query = entityMgr.createNamedQuery("getAccountsBySSN");
        query.setParameter(1, ssn);
        List<Account>accountList = query.getResultList();
    }
}

```

```

        Account[] array = new Account[accountList.size()];
        return accountList.toArray(array);
    } catch (Exception e) {
        System.out.println("Exception: " + e.getMessage());
        throw new ITSOBankException(ssn);
    }
}

```

getTransactions method

The `getTransactions` method (Example 14-10) retrieves the transactions of an account. It is similar to the `getAccounts` method.

Example 14-10 Session bean getTransactions method

```

public Transaction[] getTransactions(String accountID) throws ITSOBankException
{
    System.out.println("getTransactions: " + accountID);
    Query query = null;
    try {
        query = entityMgr.createNamedQuery("getTransactionsByID");
        query.setParameter(1, accountID);
        List<Transaction> transactionsList = query.getResultList();
        Transaction[] array = new Transaction[transactionsList.size()];
        return transactionsList.toArray(array);
    } catch (Exception e) {
        System.out.println("Exception: " + e.getMessage());
        throw new ITSOBankException(accountID);
    }
}

```

deposit and withdraw methods

The `deposit` method adds money to an account by retrieving the account and calling its `processTransaction` method with the `Transaction.CREDIT` code. The new transaction instance is persisted (Example 14-11). The `withdraw` method is similar.

Example 14-11 Session bean deposit method

```

public void deposit(String id, BigDecimal amount) throws ITSOBankException {
    System.out.println("deposit: " + id + " amount " + amount);
    Account account = getAccount(id);
    try {
        Transaction tx = account.processTransaction(amount, Transaction.CREDIT);
        entityMgr.persist(tx);
    } catch (Exception e) {
        throw new ITSOBankException(e.getMessage());
    }
};

```

 }

transfer method

The transfer method calls withdraw and deposit on two accounts to move funds from one account to the other (Example 14-12).

Example 14-12 Session bean transfer method

```
public void transfer(String idDebit, String idCredit, BigDecimal amount)
    throws ITS0BankException {
    System.out.println("transfer: " + idCredit + " " + idDebit + " amount "
        + amount);
    withdraw(idDebit, amount);
    deposit(idCredit, amount);
}
```

openAccount method

The openAccount method creates a new account instance with a randomly constructed account number. The instance is persisted and the customer is added to the customerCollection (Example 14-13).

Example 14-13 Session bean openAccount method

```
public String openAccount(String ssn) throws ITS0BankException {
    System.out.println("openAccount: " + ssn);
    Customer customer = getCustomer(ssn);
    int acctNumber = (new java.util.Random()).nextInt(899999) + 100000;
    String id = "00" + ssn.substring(0, 1) + "-" + acctNumber;
    Account account = new Account();
    account.setId(id);
    entityMgr.persist(account);
    //customer.getAccountCollection().add(account); // does not work
    java.util.Set<Customer> custSet = new java.util.TreeSet<Customer>();
    custSet.add(customer);
    account.setCustomerCollection(custSet);
    System.out.println("openAccount: " + id);
    return id;
}
```

Note: The m:m relationship must be added from the *owning* side of the relationship, in our case from the Account. The code to add the relationship from the Customer side runs without error, but the relationship is not added.

closeAccount method

The `closeAccount` method retrieves an account and all its transactions, then deletes all instances using the entity manager `remove` method (Example 14-14).

Example 14-14 Session bean closeAccount method

```
public void closeAccount(String ssn, String id) throws ITSOBankException {
    System.out.println("closeAccount: " + id + " of customer " + ssn);
    Customer customer = getCustomer(ssn);
    Account account = getAccount(id);
    Transaction[] trans = getTransactions(id);
    for (Transaction tx : trans) {
        entityMgr.remove(tx);
    }
    entityMgr.remove(account);
    System.out.println("closed account with " + trans.length
        + " transactions");
}
```

addCustomer method

The `addCustomer` method accepts a fully constructed `Customer` instance and makes it persistent (Example 14-15).

Example 14-15 Session bean addCustomer method

```
public void addCustomer(Customer customer) throws ITSOBankException {
    System.out.println("addCustomer: " + customer.getSsn());
    entityMgr.persist(customer);
}
```

deleteCustomer method

The `deleteCustomer` method retrieves a customer and all its accounts, then closes the accounts and deletes the customer (Example 14-16).

Example 14-16 Session bean deleteCustomer method

```
public void deleteCustomer(String ssn) throws ITSOBankException {
    System.out.println("deleteCustomer: " + ssn);
    Customer customer = getCustomer(ssn);
    Account[] accounts = getAccounts(ssn);
    for (Account acct : accounts) {
        closeAccount(ssn, acct.getId());
    }
    entityMgr.remove(customer);
}
```

Organize the imports (select `javax.persistence.Query`, and `java.util.List`).

The EJBBean session bean is now complete. In the following sections we first test the EJBs using a servlet, and then proceed to integrate the EJBs with a sample Web application.

Testing the session EJB and the entities

To test the session EJB we can use the Universal Test Client, and we can develop a simple servlet that executes all the functions.

Deploy the application to the server

To deploy the test application, perform these steps:

- ▶ Start the WebSphere Application Server v7.0 in the Servers view.

Note: Make sure that the data source for the ITSOBANK database is configured with a JNDI name of **jdbc/itsobank**. This can be done either in the WebSphere Deployment editor (“Configuring the data source for the ITSOBANK” on page 413) or in the administrative console of the server (see “Configuring the data source in WebSphere Application Server” on page 1155).

- ▶ Select the server and **Add and Remove Projects**. Add the RAD75EJBEAR enterprise application and click **Finish**. Wait for the publishing to finish.
- ▶ Notice the EJB binding messages in the Console:

```
[...] 00000010 ResourceMgrIm I   WSVR0049I: Binding ITS0BANKejb as  
jdbc/itsobank  
[...] 00000015 EJBContainerI I   CNTR0167I: The server is binding the  
EJBBankService interface of the EJBBean enterprise bean in the  
RAD75EJB.jar module of the RAD75EJBEAR application. The binding  
location is: ejblocal:RAD75EJBEAR/RAD75EJB.jar/EJBBean#itso.bank  
.service.EJBBankService  
[...] 00000015 EJBContainerI I   CNTR0167I: The server is binding the  
EJBBankService interface of the EJBBean enterprise bean in the  
RAD75EJB.jar module of the RAD75EJBEAR application. The binding  
location is: ejblocal:itso.bank.service.EJBBankService
```

EJB 3.0 session beans are automatically bound to a long and a short JNDI name.

Testing with the Universal Test Client

Before we integrate the EJB application with the Web application, we test the session bean with the access to the JPA entities to see that it work as expected. We use the enterprise application Universal Test Client (UTC), which is contained in Application Developer.

In this section we describe some of the operations you can perform with the Universal Test Client. We use the test client to retrieve a customer and its accounts.

To test the session bean, do these steps:

- ▶ In the Servers view, right-click the server and select **Universal test client** → **Run**.
- ▶ Accept the certificate, and login as admin/admin (the user ID setup when installing Application Developer).
- ▶ The Universal Test Client opens (Figure 14-15).

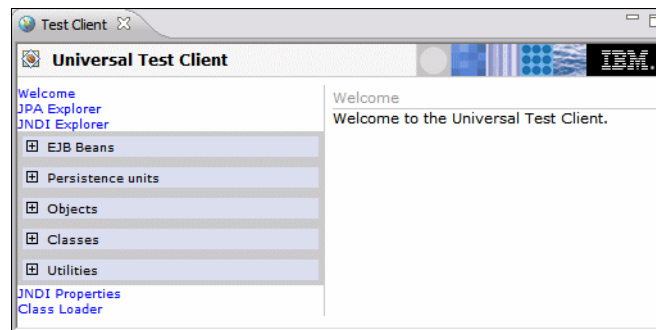

Figure 14-15 Universal Test Client home

- ▶ Select **JNDI Explorer**. On the right side, expand **[Local EJB Beans]**.
- ▶ Select **itso.bank.service.EJBBankService**. The EJBBankService appears under EJB Beans. Expand the interface (Figure 14-16).

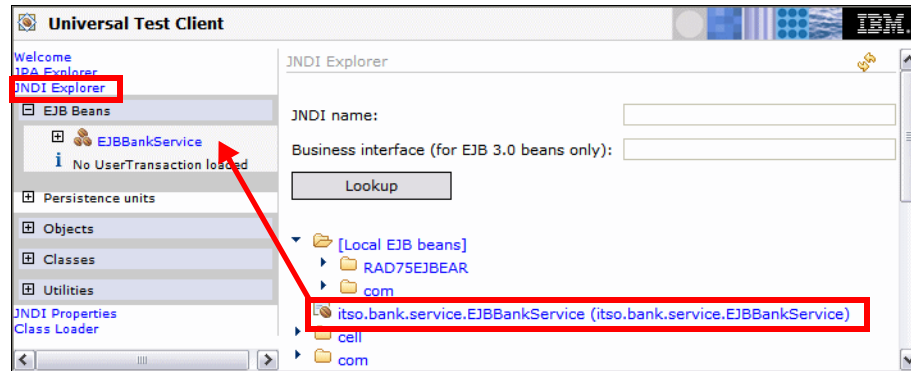

Figure 14-16 UTC JNDI Explorer

- ▶ Expand **EJBBankService** (on the left) and select the **getCustomer** method . The method with its parameter opens on the right.
- ▶ Type **111-11-1111** as value on the right, and click **Invoke**.
- ▶ A Customer instances is displayed as result (Figure 14-17).

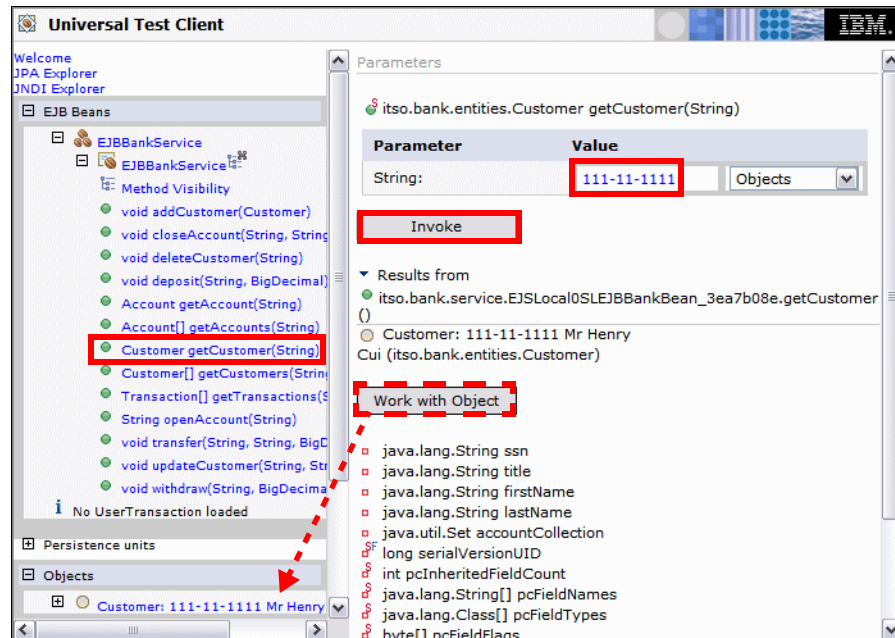

Figure 14-17 UTC Retrieve a customer

- ▶ Click **Work with Object**. The customer instance appears under Objects. You can expand the object, and invoke its methods (for example, `getLastName`) to see the customer name.
- ▶ Select the **getAccounts** method in the `EJBBankService` interface. Type **222-22-2222** as parameter value, and click **Invoke**. Three accounts are displayed as result.
- ▶ Select the **getTransactions** method. Type **002-222002** as parameter value, and click **Invoke**. Several transaction records are displayed.
- ▶ Select the **OpenAccount** method. Type **111-11-1111** as parameter value, and click **Invoke**. A new account with a random ID (for example, 001-169749) is created.
- ▶ Select the **deposit** method. Type the new account number (001-xxxxxx) and **100.00** as parameter values, and click **Invoke**.
- ▶ Select the **getAccount** method. Type the new account number (001-xxxxxx) as parameter value, and click **Invoke**. Click **Work with Object**, expand the account object, and invoke the **getBalance** method to verify the balance.
- ▶ Select the **closeAccount** method. Type **111-11-1111** and the new account number (001-xxxxxx) as parameter values, and click **Invoke**.
- ▶ Verify in the Console that the account is closed:

```
closed account with 1 transactions
```

You can play with the UTC to make sure all of the EJB methods work. When you are done, close the UTC pane.

Creating a test Web application

To test the EJB 3.0 session bean and entity model, we create a small Web application with one servlet:

- ▶ Select **File** → **New Project** → **Web** → **Dynamic Web Project**:
 - Enter **RAD75EJBTestWeb** as name.
 - Select **2.5** for Dynamic Web Module version.
 - Add the project to the RAD75EJBEAR enterprise application.
 - Click **Finish** and close the help that opens.
- ▶ Right-click the **RAD75EJBTestWeb** project and **Properties**. In the Properties dialog, Java EE Module Dependencies page, select the **RAD75EJB.jar** module, and click **OK**.
- ▶ Right-click the **RAD75EJBTestWeb** project and select **New** → **Servlet**.

- ▶ Enter **itso.test.servlet** as package name and **BankTest** as class name. Click **Next** twice, and select to generate doPost and doGet methods. Click **Finish**.
- ▶ After the class definition, add an injector for the business interface:

```
@javax.ejb.EJB EJBBankService bank;
```

The injection of the business interface into the servlet resolves to the automatic binding of the session EJB.
- ▶ In the doGet method, enter the code:

```
doPost(request, response);
```
- ▶ Complete the doPost method with the code of Example 14-17, which is available in 7672code\ejb\source\BankTest.txt. This servlet executes the methods of the session bean, after getting a reference to the business interface.

Example 14-17 Servlet to test the EJB 3.0 module (abbreviated)

```
protected void doPost(HttpServletRequest request,
    HttpServletResponse response) throws ServletException, IOException {
    try {
        PrintWriter out = response.getWriter();
        String partialName = request.getParameter("partialName");
        out.println("<html><body><h2>Customer Listing</h2>");
        if (partialName == null) partialName = "%";
        else partialName = "%" + partialName + "%";

        out.println("<p>Customers by partial Name: " + partialName + "<br>");
        Customer[] customers = bank.getCustomers(partialName);

        for (Customer cust : customers) {
            out.println("<br>" + cust);
        }

        Customer cust1 = bank.getCustomer("222-22-2222");
        out.println("<p>" + cust1);

        Account[] accts = bank.getAccounts(cust1.getSsn());
        out.println("<br>Customer: " + cust1.getSsn() + " has "
            + accts.length + " accounts");
        Account acct = bank.getAccount("002-222002");
        out.println("<p>" + acct);

        out.println("<p>Transactions of account: " + acct.getId());
        Transaction[] trans = bank.getTransactions("002-222002");
        out.println("<p><table border=1><tr><th>Type</th><th>Time</th>...");
        for (Transaction t : trans) {
            out.println("<tr><td>" + t.getTransType() + "</td><td>" + ...);
        }
    }
}
```

```

out.println("</table>");

String newssn = "xxx-xx-xxxx";
bank.deleteCustomer(newssn); // for rerun
out.println("<p>Add a customer: " + newssn);
Customer custnew = new Customer();
custnew.setSsn(newssn);
custnew.setTitle("Mrs");
custnew.setFirstName("Julia");
custnew.setLastName("Roberts");
bank.addCustomer(custnew);
Customer cust2 = bank.getCustomer(newssn);
out.println("<br>" + cust2);

out.println("<p>Open two accounts for customer: " + newssn);
String id1 = bank.openAccount(newssn);
String id2 = bank.openAccount(newssn);
out.println("<br>New accounts: " + id1 + " " + id2);
Account[] acctnew = bank.getAccounts(newssn);
out.println("<br>Customer: " + newssn + " has " + acctnew.length + "...");
Account acct1 = bank.getAccount(id1);
out.println("<br>" + acct1);

out.println("<p>Deposit and withdraw from account: " + id1);
bank.deposit(id1, new java.math.BigDecimal("777.77"));
bank.withdraw(id1, new java.math.BigDecimal("111.11"));
acct1 = bank.getAccount(id1);
out.println("<br>Account: " + id1 + " balance " + acct1.getBalance());

trans = bank.getTransactions(id1);
out.println("<p><table border=1><tr><th>Type</th><th>Time</th>...");
for (Transaction t : trans) {
    out.println("<tr><td>" + t.getTransType() + "...");
}
out.println("</table>");

out.println("<p>Close the account: " + id1);
bank.closeAccount(newssn, id1);

out.println("<p>Update the customer: " + newssn);
bank.updateCustomer(newssn, "Mr", "Julius", "Roberto");
cust2 = bank.getCustomer(newssn);
out.println("<br>" + cust2);
out.println("<p>Delete the customer: " + newssn);
bank.deleteCustomer(newssn);

out.println("<p>Retrieve non existing customer: ");
Customer cust3 = bank.getCustomer("zzz-zz-zzzz");
out.println("<br>customer: " + cust3);

```

```

        out.println("<p>End</body></html>");
    } catch (Exception e) {
        System.out.println("Exception: " + e.getMessage());
        e.printStackTrace();
    }
}

```

Testing the sample Web application

To test the Web application we run the servlet:

- ▶ Expand the test Web project **Deployment Descriptor** → **Servlets**, select the **BankTest** servlet, and **Run As** → **Run on Server**.
- ▶ In the Run On Server dialog, select the **WebSphere Application Server v7.0** server, select **Always use this server when running this project**, and click **Finish**.
- ▶ Accept the security certificate (if security is enabled).
- ▶ A sample output of the servlet is shown in Example 14-18.

Example 14-18 Servlet output

Customer Listing

Customers by partial Name: %

```

Customer: 111-11-1111 Mr Henry Cui
Customer: 222-22-2222 Ms Pinar Ugurlu
Customer: 333-33-3333 Mr Marco Rohr
Customer: 444-44-4444 Mr Juan Napoli
Customer: 555-55-5555 Mr Brian Hainey
Customer: 666-66-6666 Mr Patrick Gan
Customer: 777-77-7777 Mr Miguel Gomes
Customer: 888-88-8888 Mr Lara Ziosi
Customer: 999-99-9999 Mr Ahmed Moharram
Customer: 000-00-0000 Mr Ueli Wahli

```

Customer: 222-22-2222 Ms Pinar Ugurlu

Customer: 222-22-2222 has 3 accounts

Account: 002-222002 balance 87.96

Transactions of account: 002-222002

Type	Time	Amount
Debit	2002-06-06 12:12:12.0	3.33
Credit	2003-07-07 14:14:14.0	6666.66
Credit	2004-01-08 23:03:20.0	700.77

Add a customer: xxx-xx-xxxx

Customer: xxx-xx-xxxx Mrs Julia Roberts

Open two accounts for customer: xxx-xx-xxxx

New accounts: 00x-861080 00x-414074

Customer: xxx-xx-xxxx has 2 accounts

Account: 00x-861080 balance 0.00

Deposit and withdraw from account: 00x-861080

Account: 00x-861080 balance 666.66

Type	Time	Amount
Debit	2008-08-13 16:40:15.203	111.11
Credit	2008-08-13 16:40:15.203	777.77

Close the account: 00x-861080

Update the customer: xxx-xx-xxxx

Customer: xxx-xx-xxxx Mr Julius Roberto

Delete the customer: xxx-xx-xxxx**Retrieve non existing customer:**

customer: null

End

Visualizing the test application

We can improve the generated class diagram by adding the business interface, the entities, and the servlet to the diagram (Figure 14-18).

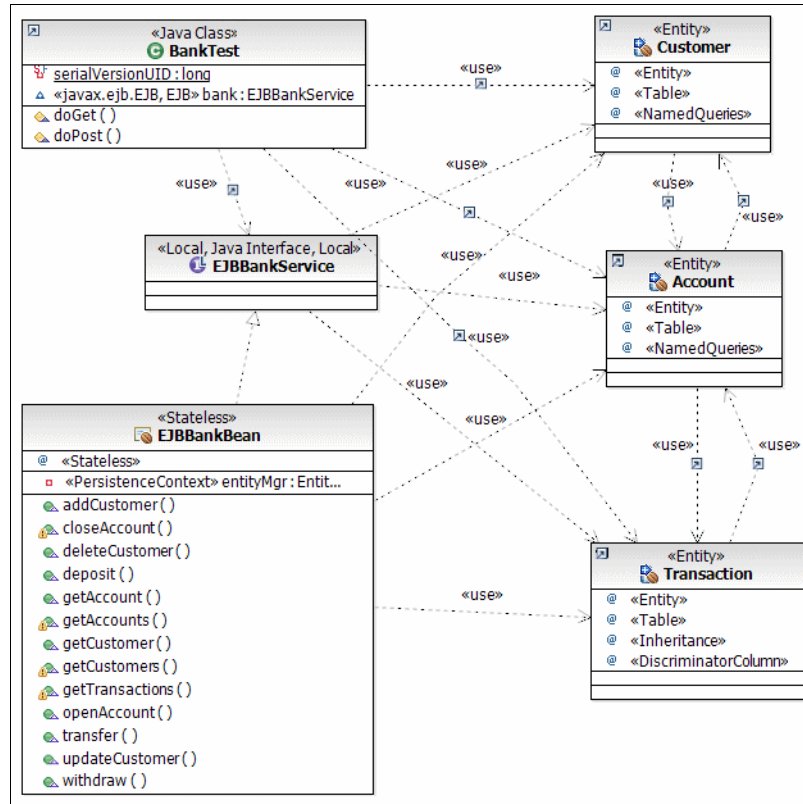

Figure 14-18 Class diagram of the test Web application

Writing an EJB 3.0 Web application

The RAD75EJBWeb application is basically a copy of the RAD7BankBasicWeb application from the previous redbook. However, it uses the JPA entities and accesses the entities through the `EJBBankBean` session bean.

Implementing the RAD75EJBWeb application

We change the original RAD57BankBasicWeb application to use EJB 3.0 APIs to communicate with the EJBBankBean session bean.

You can import the finished application from the interchange file at:

```
c:\7672code\zInterchange\ejb\RAD75EJBWeb.zip
```

Note: If you already have RAD75EJB and RAD75JPA projects in the workspace, only import RAD75EJBWeb and RAD75EJBWebEAR.

Web application navigation

The navigation between the Web pages is shown in Figure 14-19.

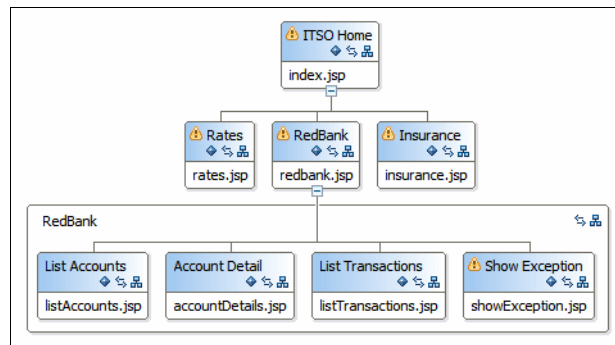

Figure 14-19 Web site navigation

- ▶ From the home page (index.jsp), there are three static pages (rates.jsp, insurance.jsp, and redbank.jsp).
- ▶ The redbank.jsp is the login panel for customers.
- ▶ After login, the customer details and the list of accounts is displayed (listAccounts.jsp).
- ▶ An account is selected in the list of accounts, and the details of the account and a form for transaction list, deposit, withdraw, and transfer operations is displayed (accountDetails.jsp).
- ▶ From the account details form, banking transactions are executed:
 - List transaction displays the list of previous debit and credit transactions (listTransactions.jsp).
 - Deposit, withdraw, and transfer operations are executed, and the updated account information is displayed in the same page.

- ▶ Additional functions are delete of an account, update customer information, adding an account to a customer, and delete of the customer.
- ▶ In case of errors, an error page is displayed (`showException.jsp`).

The JSPs are based on the template that provides navigation bars through headers and footers:

```
/theme/itso_jsp_template.jtpl, nav_head.jsp, footer.jsp
```

Servlets and commands

A number of servlets provide the processing and switching between the Web pages:

- ▶ `ListAccounts`—Perform the customer login, retrieve the customer and the accounts, and forward to the `accountDetails.jsp`.
- ▶ `AccountDetails`—Retrieve one account and forward to the `accountDetails.jsp`.
- ▶ `PerformTransaction`—validate the form values and call one of the commands (`ListTransactionsCommand`, `DepositCommand`, `WithdrawCommand`, or `TransferCommand`). The commands perform the requested banking transaction and forward to the `listTransactions.jsp` or the `accountDetails.jsp`.
- ▶ `UpdateCustomer`—Process updates of customer information, and also delete of a customer.
- ▶ `DeleteAccount`—Delete an account and forward to the `listAccounts.jsp`.
- ▶ `NewAccount`—Create an account and forward to the `listAccounts.jsp`.
- ▶ `Logout`—Logout and display the home page.

Java EE dependencies

The enterprise application (`RAD75EJBWebEAR`) includes the Web module (`RAD75EJBWeb`), the EJB module (`RAD75EJB`), and the JPA utility project (`RAD75JPA`).

The Web module (`RAD75EJBWeb`) has a dependency on the EJB module (`RAD75EJB`), which has a dependency on the JPA project (`RAD75JPA`).

Accessing the session EJB

All database processing is done through the `EJBBankBean` session bean, using the business interface (`EJBBankService`).

The servlets use EJB 3.0 injection to access the session bean:

```
@EJB EJBBankService bank;
```

After this injection, all the methods of the session bean can be invoked, such as:

```
Customer customer = bank.getCustomer(customerNumber);
Account[] accounts = bank.getAccounts(customerNumber);
bank.deposit(accountId, amount);
```

Additional functionality

The original Web application does not execute some of the functions of the EJB 3.0 module. We improved the application and added these functions:

- ▶ On the customer details panel (`ListAccounts.jsp`) we add three buttons:
 - **New Customer**—Enter data into the title, first name, and last name fields, then click **New Customer**. A customer is created with a random social security number.
 - **Add Account**—This action adds an account to the customer, with a random account number and zero balance.
 - **Delete Customer**—Deletes the customer and all related accounts.

The logic for adding and deleting a customer is in the `UpdateCustomer` servlet. The logic for a new account is in a new `NewAccount` servlet.

- ▶ On the account details page (`accountDetails.jsp`) we add one button:
 - Delete Account**—Deletes the account with all its transactions. The customer with its remaining accounts are displayed next.
- ▶ For the Login panel we added logic (in the `ListAccounts` servlet) so that the user can enter a last name instead of the social security number.

If the search by ssn fails, we retrieve all customers with that partial name. If only one result is found, we accept it and display the customer. This allows entry of partial names, such as **Ro%** to find the Rohr customer.

Running the Web application

Before running the Web application we must have the data source for the ITS0BANK database configured. Refer to “Setting up the ITS0BANK database” on page 413 for instructions. You can either configure the enhanced EAR in the RAD75EJBWebEAR application, or define the data source in the server. We suggest to define the data source in the server, as described in “Configuring the data source in WebSphere Application Server” on page 1155.

To run the Web application perform these steps:

- ▶ Select the server in the Servers view and **Add and Remove Projects**. Remove the RAD75EJB EAR application, and add the RAD75EJBWebEAR application, then click **Finish**.
- ▶ Right-click the **RAD75EJBWeb** project and **Run As** → **Run on Server**.
- ▶ Select the WebSphere Application Server v7.0 when prompted.
- ▶ The home page is displayed. Click **redbank** to go to the login page (Figure 14-20).



Figure 14-20 RedBank: Login

- ▶ Enter a customer number (222-22-2222) and click **Submit**. The customer details and the list of accounts are displayed (Figure 14-21).

ITSO RedBank

Rates RedBank Insurance

SSN: 222-22-2222
 Title: Ms
 First name: Pinar
 Last name: Ugurlu

Update New Customer Delete Customer

Account Number	Balance
002-222001	65,484.23
002-222002	87.96
002-222003	654.65

Add Account Logout

Figure 14-21 RedBank: Customer with accounts

- ▶ Click on an account (002-222001) and the details and actions are displayed (Figure 14-22).

ITSO RedBank

Rates RedBank Insurance

Account Number: 002-222001
 Balance: 65,484.23

List Transactions
 Withdraw
 Deposit
 Transfer

Amount:
 To Account:

Submit

Customer Details

ITSO Home RedBank

Figure 14-22 RedBank: Account details

- ▶ Select **List Transactions** and click **Submit**. The transactions are listed (Figure 14-23).

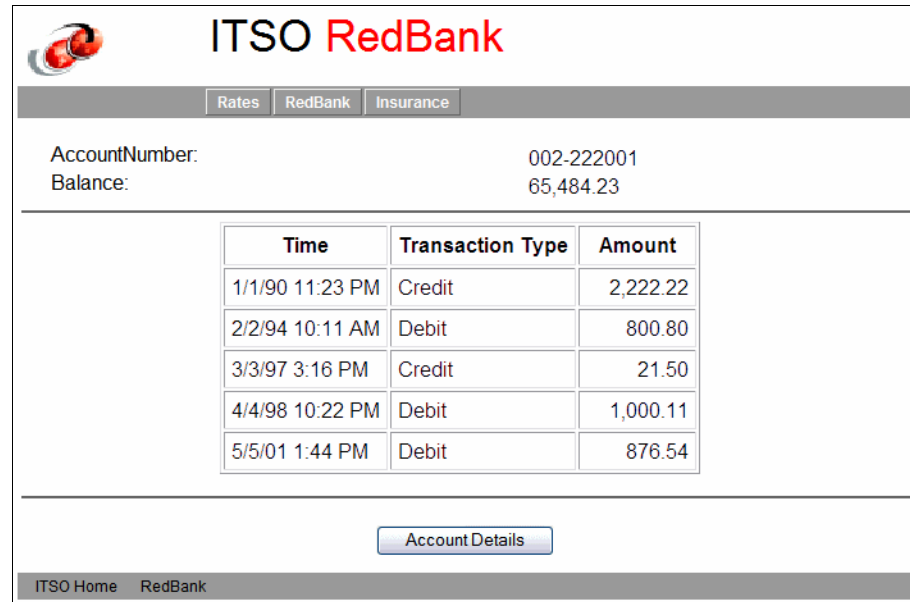

The screenshot displays the ITSO RedBank web interface. At the top left is the RedBank logo. A navigation bar contains links for 'Rates', 'RedBank', and 'Insurance'. Below this, the account information is shown: 'AccountNumber: 002-222001' and 'Balance: 65,484.23'. A table lists the following transactions:

Time	Transaction Type	Amount
1/1/90 11:23 PM	Credit	2,222.22
2/2/94 10:11 AM	Debit	800.80
3/3/97 3:16 PM	Credit	21.50
4/4/98 10:22 PM	Debit	1,000.11
5/5/01 1:44 PM	Debit	876.54

Below the table is a button labeled 'Account Details'. At the bottom of the page, there are links for 'ITSO Home' and 'RedBank'.

Figure 14-23 RedBank: Transactions

- ▶ Click **Account Details** to go back to the account.
- ▶ Select **Deposit**, enter an amount (.33) and click **Submit**. The balance is updated to 65,485.00.
- ▶ Select **Withdraw**, enter an amount (485) and click **Submit**. The balance is updated to 65,000.00.
- ▶ Select **Transfer**, enter an amount (1000) and a target account (002-222002) and click **Submit**. The balance is updated to 64,000.00.
- ▶ Select **List Transactions** and click **Submit**. The transactions are listed and there are three more entries (Figure 14-24).

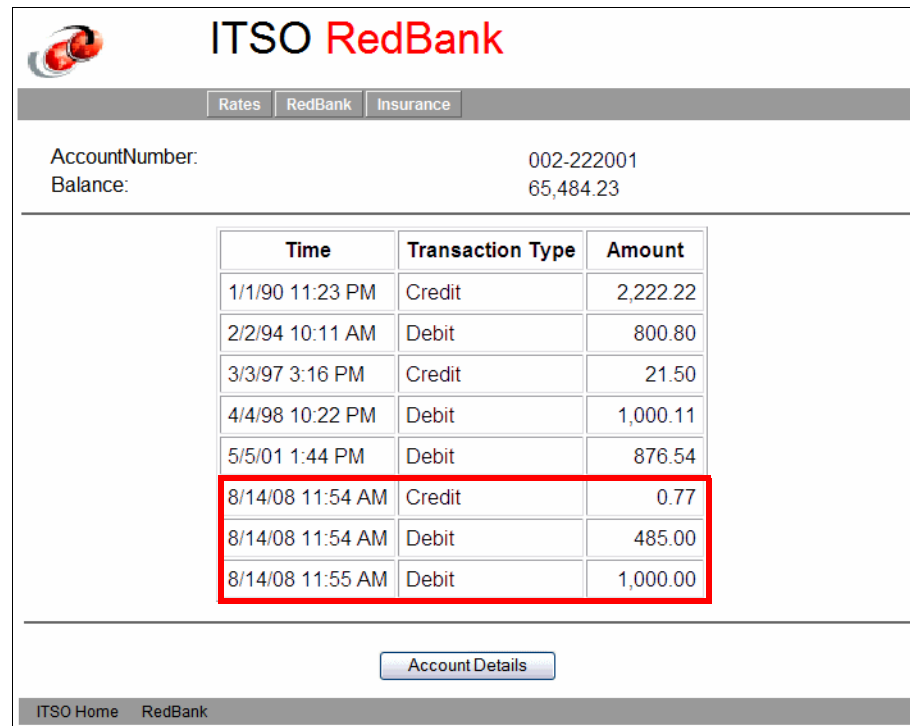

ITSO RedBank

Rates RedBank Insurance

AccountNumber: 002-222001
Balance: 65,484.23

Time	Transaction Type	Amount
1/1/90 11:23 PM	Credit	2,222.22
2/2/94 10:11 AM	Debit	800.80
3/3/97 3:16 PM	Credit	21.50
4/4/98 10:22 PM	Debit	1,000.11
5/5/01 1:44 PM	Debit	876.54
8/14/08 11:54 AM	Credit	0.77
8/14/08 11:54 AM	Debit	485.00
8/14/08 11:55 AM	Debit	1,000.00

AccountDetails

ITSO Home RedBank

Figure 14-24 RedBank: Transactions added

- ▶ Click **AccountDetails** to go back to the account. Click **Customer Details** to go back to the customer.
- ▶ Click on the second account, then click **Submit** and you can see that the second account has a transaction from the transfer operation.
- ▶ Back in the customer details, change the last name and click **Update**. The customer information is updated.
- ▶ Overtyping the names with **Julia Roberts**, and click **New Customer**.
- ▶ Click **Add Account** and an account is added to the customer (Figure 14-25).

ITSO RedBank

Rates RedBank Insurance

SSN: 480-50-1708
 Title: Mrs
 First name: Julia
 Last name: Roberts

Update New Customer Delete Customer

Account Number	Balance
004-245144	0.00

Add Account Logout

ITSO Home RedBank

Figure 14-25 RedBank: New customer and new account

- ▶ Perform some transactions on the new account.
- ▶ Go back to customer details and click **Delete Customer**.
- ▶ In the Login panel, enter **Ro%** and click **Submit**. The customer is found and displayed.
- ▶ In the Login panel, enter a bad value and click **Submit**. The customer details panel is displayed with a NOT FOUND last name.
- ▶ Click **Logout**.

Cleanup

Remove the RAD75EJBWebEAR application from the server.

Adding a remote interface

For testing using JUnit and for some Web applications, we also want to have a remote interface for the EJBBankBean session bean.

- ▶ In the RAD75EJB project, itso.bank.service package, create an interface named **EJBBankRemote**, that extends the business interface, EJBBankService.
- ▶ Add one method to the interface, getCustomersAll, to retrieve all the customers.
- ▶ Add a @Remote annotation.
- ▶ Example 14-19 shows the remote interface.

Example 14-19 Remote interface of the session bean

```
package itso.bank.service;
import itso.bank.entities.Customer;
import javax.ejb.Remote;
@Remote
public interface EJBBankRemote extends EJBBankService {
    public Customer[] getCustomersAll();
}
```

- ▶ Open the EJBBankBean session bean:
 - Add the EJBBankRemote interface to the implements list.
 - Implement the getCustomersAll method similar to the getCustomers method, using the getCustomers named query (without a parameter):

```
public class EJBBankBean implements EJBBankService, EJBBankRemote {
    .....
    public Customer[] getCustomersAll() {
        System.out.println("getCustomers: all");
        Query query = null;
        try {
            query = entityMgr.createNamedQuery("getCustomers");
            List<Customer> beanlist = query.getResultList();
            Customer[] array = new Customer[beanlist.size()];
            return beanlist.toArray(array);
        } catch (Exception e) {
            System.out.println("Exception: " + e.getMessage());
            return null;
        }
    }
}
```

Complete EJB application interchange file

The completed enterprise applications are available in:

C:\7672code\zInterchange\ejb

More information

For more information on EJB, we recommend the following resources:

- ▶ *WebSphere Application Server Version 6.1 Feature pack for EJB 3.0*, SG24-7611, Redbooks publication, found at:
<http://www.redbooks.ibm.com/abstracts/sg247611.html>
- ▶ *EJB 2.0 Development with WebSphere Studio Application Developer*, SG24-6819, Redbooks publication, found at:
<http://www.redbooks.ibm.com/abstracts/sg246819.html>
- ▶ Java EE Enterprise JavaBeans technology at:
<http://java.sun.com/products/ejb/>
- ▶ Mastering Enterprise JavaBeans 3.0
<http://www.theserverside.com/tt/books/wiley/masteringEJB3/index.tss>



Develop Web applications using Struts

Apache Struts is an instance of a servlet/JSP model-view-controller (MVC) framework. The goal of Apache Struts is to provide an open source framework useful in building Web applications with Java servlet and JavaServer Pages (JSP) technology. In addition, Struts encourages application architectures based on the MVC design paradigm.

In this chapter, we explore the tooling support found in Rational Application Developer Version 7.5 for Apache Struts.

The chapter is organized into the following sections:

- ▶ Introduction to Struts
- ▶ Preparing for the sample application
- ▶ Developing a Web application using Struts
- ▶ Running the Struts Bank Web application
- ▶ Developing a Struts Web application using Tiles

Introduction to Struts

The Struts framework control layer uses technologies such as servlets, JavaBeans, and XML. The view layer is implemented using JSPs and tag libraries. The Struts architecture encourages the implementation of the concepts of the model-view-controller (MVC) architecture pattern. By using Struts, you can get a clean separation between the presentation (view) and business logic (model) layers of your application.

Struts also speeds up Web application development by providing an extensive JSP tag library, parsing and validation of user input, error handling, and internationalization support.

The focus of this chapter is on the Application Developer tooling used to develop Struts-based Web applications. Although we do introduce some basic concepts of the Struts framework, we recommend that you refer to the following sites for further in-depth information:

- ▶ Apache Struts home page:
<http://struts.apache.org/>
- ▶ Apache Struts User Guide:
<http://struts.apache.org/userGuide/introduction.html>

Note: Since the prior version of Application Developer (Version 6.x), Struts has forked into three distinct frameworks:

- ▶ Struts Classic (which is the original Struts framework)
- ▶ Struts 2 (which is Struts + Webwork)
- ▶ Struts Shale (which is a JSF version of Struts, now known as *Shale*)

Application Developer v7.5 includes support for only Struts Classic. The versions supported by Application Developer are Struts 1.2 and 1.3. At the time of writing this book, the latest version of the Struts Classic framework was 1.3.8 for general availability and 1.3.9 in beta.

Model-view-controller (MVC) pattern with Struts

In “Model-view-controller (MVC) pattern” on page 323, we described the general concepts and architecture of the MVC pattern. Figure 15-1 shows the Struts components in relation to the MVC pattern:

- ▶ **Model:** Struts does not provide model classes. Specifically, Struts does not provide the separation between the controller and model layers. The separation must be provided by the Web application developer as a facade, service locator, EJB, or Java Bean.
- ▶ **View:** Struts provides action forms (or form beans) in which data is automatically or manually collected from HTTP requests with the purpose to pass data between the view and controller layers. In addition, Struts provides custom JSP tag libraries that assist developers in creating interactive form-based applications using JSPs. Application resource files hold text constants and error message, translated for each language, that are used in JSPs.
- ▶ **Controller:** Struts provides an `ActionServlet` (controller servlet) that populates action forms from JSP input fields and then delegates work to an action class where the application developer implements the logic to interface with the model.

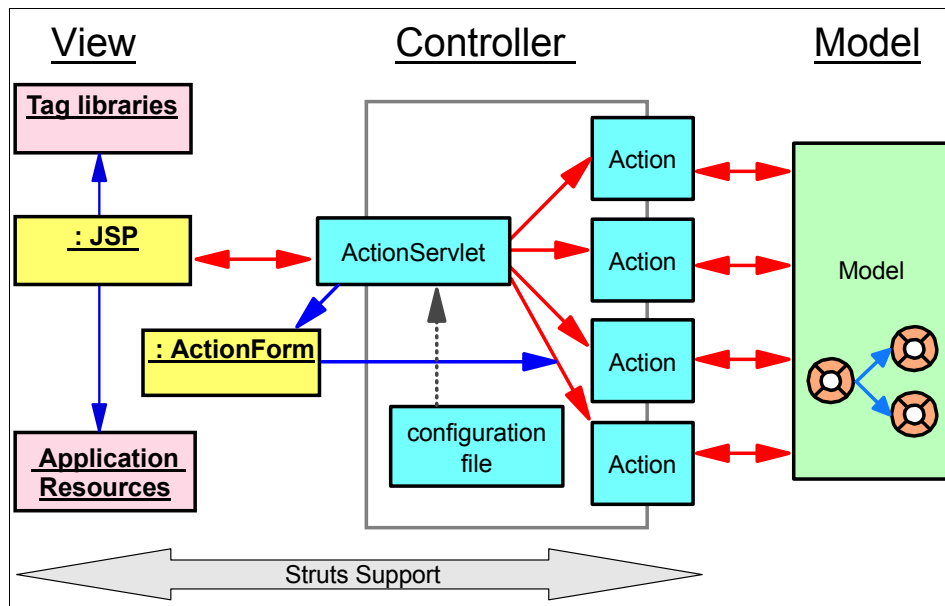

Figure 15-1 Struts components in the MVC architecture

A typical Struts Web application is composed of the following components:

- ▶ **Action servlet**—A single servlet (extending `org.apache.struts.action.ActionServlet`) implements the primary function of mapping a request URI to an action class. Before calling the action class, it populates the action form associated to the action with the fields from the input JSP. If specified, the action servlet also requests the action form to validate the data. It then calls the action class to carry out the requested function. If action form validation fails, control is returned to the input JSP so the user can correct the data. The action servlet is configured in the Web deployment descriptor (`web.xml`). The action servlet controls and manages the relationship between other Struts components which is configured in the Struts configuration file (`struts-config.xml`).
- ▶ **JSPs**—Multiple JSPs that provide the end-user view. Struts includes an extensive tag library to make JSP coding easier. The JSPs display the information prepared by the action classes and requests new information from the user.
- ▶ **Action classes**—Multiple action classes (extending any one of the Struts action classes like `org.apache.struts.action.Action`) that interface with the model. When an action has performed its processing, it returns an action forward object, which determines the view that should be called to display the response (or alternatively forward to another action class). The action class prepares the information required to display the response, usually as an action form (although, it is not recommended), and makes it available to the JSP. Usually the same action form that was used to pass information to the action is used also for the response, but it is also common to have special view beans tailored for displaying the data. An action forward has properties for its name (logical mapping), path (URI), and a flag specifying if a forward or a send redirect call should be made. The address to an action forward is usually externalized in the Struts configuration file, but can also be generated dynamically by the action class.
- ▶ **Action forms**—Multiple action forms (extending one of the Struts action form classes like `org.apache.struts.action.ActionForm`) to help facilitate transfer form data from JSPs. The action forms are generic JavaBeans with getters and setters for the input fields available on the JSPs. Usually there is one form bean per Web page, but you can also use more coarse-grained form beans holding the properties available on multiple Web pages (this fits very well for wizard-style Web pages). If data validation is requested (a configurable option) the form bean is not passed to the action until it has successfully validated the data. Therefore the form beans can act as a sort of firewall between the JSPs and the actions, only letting valid data into the system.
- ▶ **Resource files**—One application resource file per language supported by the application holds text constants and error messages and makes internationalization easy.

Figure 15-2 shows the basic flow of information for an interaction in a Struts Web application.

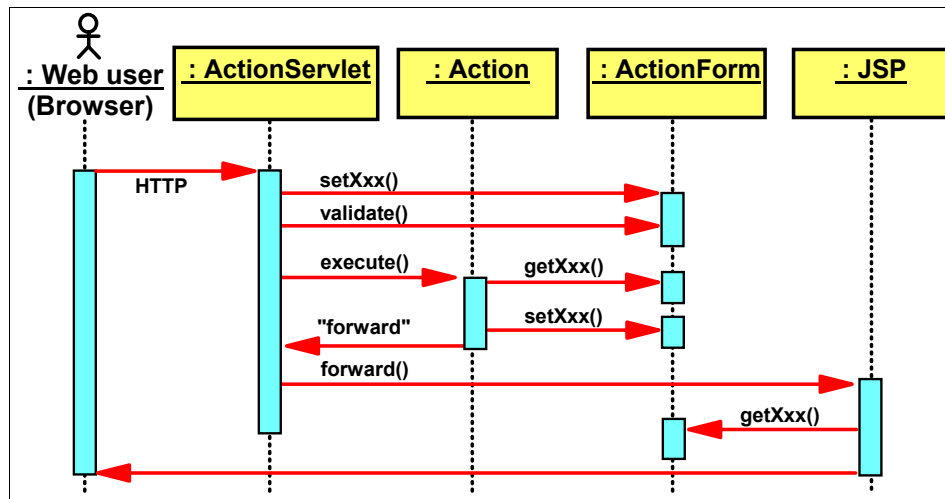

Figure 15-2 Struts request sequence

- ▶ A request from a Web browser is first received by the Struts action servlet.
- ▶ If the action that handles the request has a form bean associated with it, Struts creates the action form and (and if specified, automatically) populates it with the data from the input form.
- ▶ It then calls the validate method of the action form. If validation fails, the user is returned to the input page to correct the input. If validation succeeds, Struts calls the action's execute method.
- ▶ The action retrieves the data from the form bean and performs the appropriate logic. The action often call session EJBs to perform the business logic.
- ▶ When done, the action either creates a new action form (or other appropriate view bean) or reuses the existing one, populates it with new data, and stores it in the request (or session) scope.
- ▶ The action then returns a forward object to the action servlet, which forwards to the appropriate output JSP (or alternatively forwards to another action).
- ▶ The JSP uses the data in the action form to render the result.

Application Developer support for Struts

Application Developer provides the following support for Struts-based Web applications:

- ▶ A Web project can be configured for Struts. This adds the Struts runtime (and dependent JARs), tag libraries, and the action servlet to the project, and creates skeleton Struts configuration and application resources files. Application Developer support for Struts 1.2 or 1.3 can be selected when setting up the project.
- ▶ A set of *Struts Component Wizards* allows you to define action form classes, action classes with action forwarding information, and JSP skeletons with the tag libraries included.
- ▶ The *Struts Configuration Editor* is provided to maintain the control information for the action servlet.
- ▶ The *Web Diagram Editor* provides a graphical design tool to edit a graphical view of the Web application from which components (action forms, actions, JSPs) can be created using the wizards. The Web Diagram Editor provides top-down development (developing a Struts application from scratch), bottom-up development (that is, you can easily diagram an existing Struts application that you may have imported), and meet-in-the-middle development (that is, enhancing or modifying an existing diagrammed Struts application). The Web Diagram Editor is now written on top of the Graphical Modeling Framework (GMF). Improved support allows direct/in-sync manipulation of actual components/artifacts to reflect changes in the Web Diagram Editor.

Note: The Web Diagram in Application Developer, which supports the creation of various Struts components, can also be applied in the creation of Struts components when using the IBM Struts Portlet framework.

Specifically, when working with a Portlet project and the project has been enabled to use the IBM Struts Portlet framework, the same palette options of the Web Diagram are available to the Portlet project.

- ▶ The *Enterprise Explorer* view provides a hierarchical (tree-like) view of the application. This view shows the Struts artifacts (such as actions, action forms, global forwards, global exceptions, and Web pages). You can expand the artifacts to see their attributes. For example, an action can be expanded to see the Action Forms, and forwards and local exceptions associated with the selected Action. This is useful for understanding specific execution paths of your application. The Enterprise Explorer view is available in the Web perspective.

- ▶ The *JSP Page Designer* provides support for rendering the Struts tags, making it possible to properly view Web pages that use the Struts JSP tags. This support is customizable using Application Developer's Preferences settings.
- ▶ *Validators* to validate the Struts XML configuration file and the JSP tags used in the JSP pages.

Preparing for the sample application

This section describes the tasks that have to be completed prior to developing the Web application using Struts.

Note: A completed version of the ITSO RedBank Web application built using Struts can be found in the project interchange file:

```
C:\7672code\zInterchange\struts\RAD75Struts.zip
```

If you do not want to develop the sample yourself, but want to see it run, follow the procedures described in “Importing the final sample application” on page 491.

Setting up the sample database

The ITSOBANK database can be set up using either DB2 or Derby.

The instructions for creating the ITSOBANK database are given in “Setting up the ITSOBANK database” on page 1154.

Configuring the data source in the WebSphere Server 7.0

The instructions for configuring the data source are given in “Configuring the data source in WebSphere Application Server” on page 1155.

Activating Struts development capabilities

To activate the Struts development capabilities, such as the Struts Configuration Editor, we must update the Application Developer preferences:

- ▶ Select **Window** → **Preferences** → **General** → **Capabilities**.
- ▶ Select **Advanced**.

- ▶ In the Advanced dialog, expand **Web Developer (advanced)** and select **Struts Development**.
- ▶ Click **OK** twice to close the dialogs.

ITSO Bank Struts Web application overview

We use the ITSO Bank as the theme of our sample Web application using Struts. Similar samples were developed in the following chapters using other Web application technologies:

- ▶ Chapter 13, “Develop Web applications using JSPs and servlets” on page 317
- ▶ Chapter 16, “Develop Web applications using JSF” on page 493

The ITSO Bank sample application allows a customer to enter a customer ID (social security number), select an account to view detailed transaction information, or perform a deposit or withdrawal on the account. The model layer of the application is implemented within the action classes using Java beans for the sake of simplicity.

In the banking sample, we use the Struts framework for the controller and view components of the Web application. To start, we implement the model using the in-memory implementation provided by the RAD75Java project developed in Chapter 8, “Develop Java applications” on page 69.

Figure 15-3 displays the Struts Web Diagram for the sample banking application. The basic description and flow of the banking sample application are as follows:

- ▶ The `login.jsp` page is displayed as the initial page of the banking sample application. The customer is allowed to enter her or his social security number. In our case we use simple validation of the Struts framework to check for an empty value. If the customer does not enter a valid value, the Struts framework returns to the `login.jsp` page and display the appropriate message to the user.
- ▶ The `login` action logs in the user, and on successful login retrieves the customer and the account information and lists all the accounts associated with the customer using the `customerlisting.jsp` Web page.
- ▶ In the `customerlisting.jsp`, the customer can select to see details of an account using the `accountDetails` action, or perform a transaction on an account using the `transact.jsp`.
- ▶ In the `accountDetails.jsp`, the details of the account are displayed, including the transactions that have been performed on the account. The customer can select to perform another transaction using the `transact.jsp`.

- ▶ The `transact.jsp` invokes the `performTransaction` action. After a successful transaction the `accountDetails` action is invoked to redisplay the `accountDetails.jsp`.
- ▶ The customer can log off using the `logoff` link, which invokes the `logoff` action.
- ▶ In case of errors, an `error.jsp` is displayed.

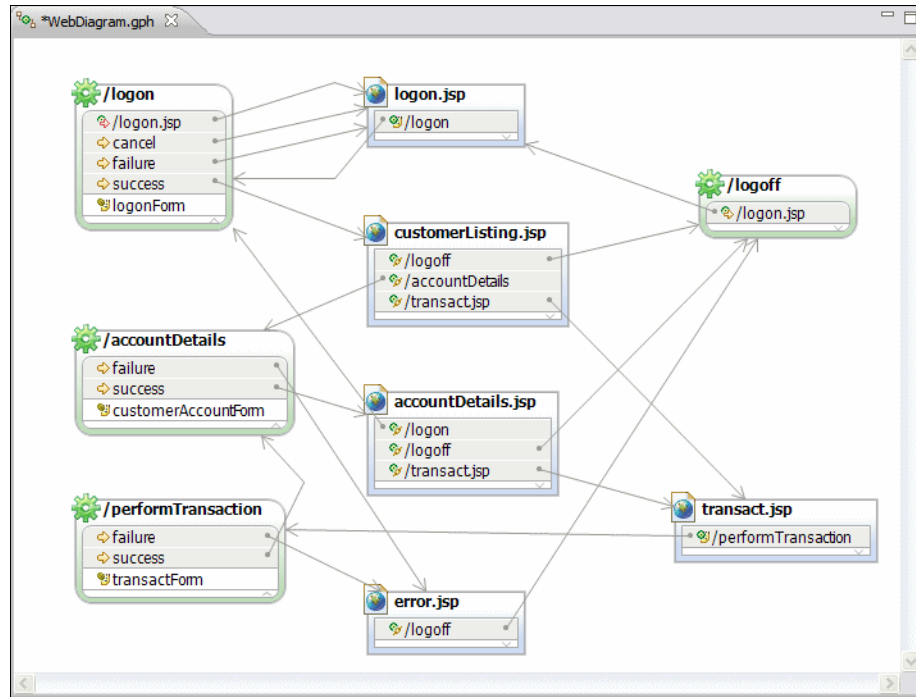

Figure 15-3 Struts Web Diagram: ITSO Bank sample

In this section we focus on creating the various Struts components, including the Struts controller, actions, action forms, and Web pages, and relate these components together. We implement the following steps to demonstrate the capabilities of Application Developer:

- ▶ Create a dynamic Web application with Struts support: In this section the process of creating a dynamic Web application with Struts support and the wizard generated support for Struts is described.
- ▶ Create Struts components: In this section we focus on creating Web pages, actions, action forms, exceptions (local and global), and forwards using the Web Diagram, and modify the properties of Struts components using the Struts Configuration Editor.

- ▶ **Struts Configuration Editor:** In this section we focus on creating Struts components using the Struts Configuration Editor that provides a visual editor to modify the Struts configuration file `struts-config.xml`.
- ▶ **Import the complete sample banking Web application:** In the previous sections we created various Struts components. Here we import the complete banking sample implemented as shown in Figure 15-3 on page 453.
- ▶ **Run the sample banking application:** In this section we verify the data source configurations in the extended application descriptor of the imported sample and then run and test the application in the WebSphere V7.0 Test Environment.

Note: Because this chapter focuses on Application Developer's Struts tools and wizards (more than on the architecture and best practices of a Struts application), we try to use the Struts tools and wizards as much as possible when creating our application.

After having used the wizards to create some components (JSPs, form beans, actions), you might find it faster to create new components by copying and pasting from your existing components than by using all the wizards.

Creating a dynamic Web project with Struts support

Important: Be sure to have installed the struts package during the installation phase of Rational Application Developer, because it is not selected by default, or you will not be able to use the Struts capabilities in your projects.

To verify and enable the Struts tool,s launch the Installation Manager from **Help** → **IBM Installation Manager**, and enable the Struts support in the **Modify Packages** dialog under **IBM Rational Application Developer** → **Web Development Tools** → **Struts Tools**.

To create a dynamic Web project with Struts support, do these steps:

- ▶ Open the Web perspective.
- ▶ Select **File** → **New** → **Dynamic Web Project** and click **Next**.
- ▶ In the **New Dynamic Web Project** dialog, enter the following values:
 - Project Name: Type **RAD75StrutsWeb**.
 - Dynamic Web Module version: Select **2.5**.

- Configuration: Click **Modify** to open the Project Facets dialog. IN the Project Facets dialog, select **Default Style sheet (CSS file)**, and **Struts** (default version 1.3), then click **OK** (Figure 15-4).
- EAR Membership: Select **Add project to an EAR** and type **RAD75StrutsEAR** as name.

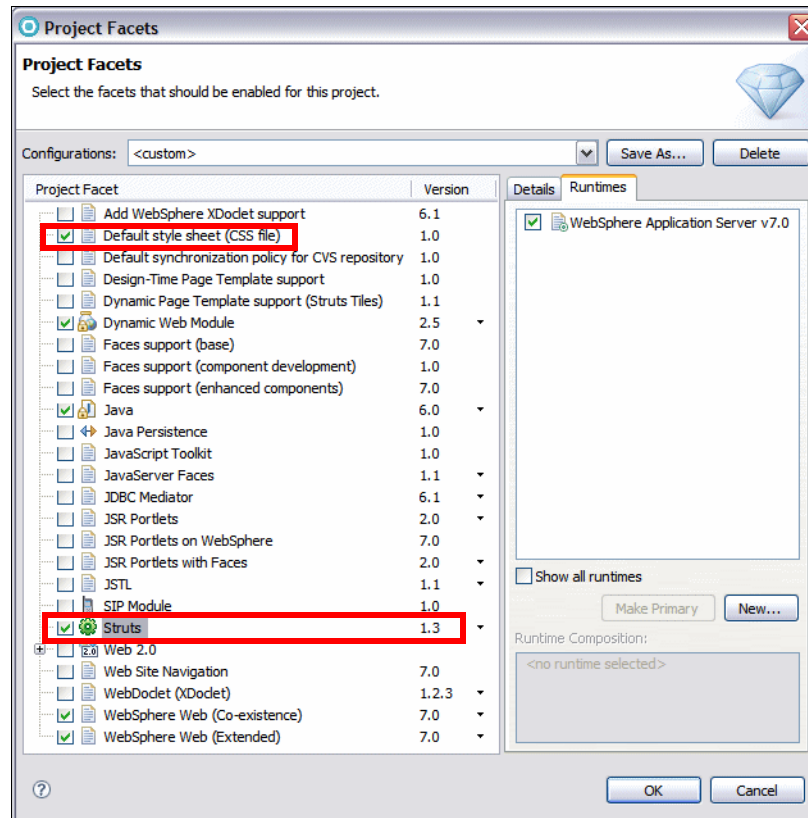

Figure 15-4 Create a Struts-based dynamic Web project: Facets

- ▶ Accept the defaults in the Web Module dialog for Context Root, Content Directory and Java Source Director. Select **Generate deployment descriptor**, and click **Next**.
- ▶ Accept the defaults in the Struts Settings dialog for the resource bundle and click **Finish**.

At this point, a new dynamic Web project with Struts support (RAD75StrutsWeb) and an enterprise application project (RAD75StrutsEAR) have been created. Close the Technology Quickstarts.

Struts artifacts

The following Struts-specific artifacts are created and Web application configurations are modified by the wizard related to Struts when a new dynamic Web application is created with Struts support (Figure 15-5).

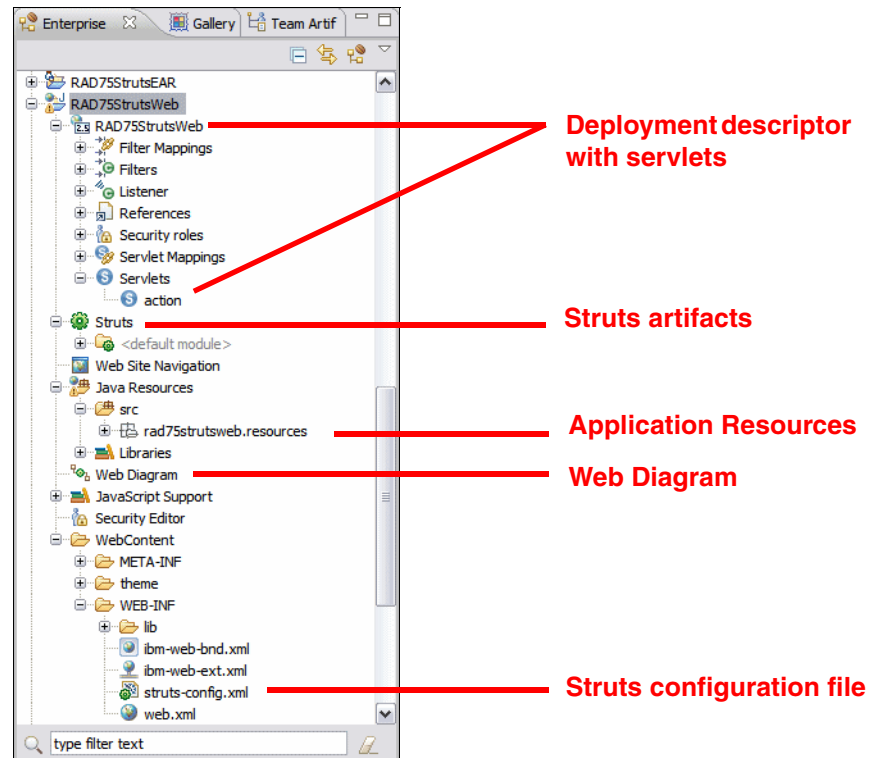

Figure 15-5 Web project with Struts support

- ▶ Struts configuration file `struts-config.xml` in `WebContent/WEB-INF`.
- ▶ Web deployment descriptor (`web.xml`) with an action servlet that maps to the Struts `ActionServlet` class, and has a mapping of `*.do`. (To see the servlet mapping, open the Web deployment descriptor.)

Note: The Struts `ActionServlet` is configured (in `web.xml`) to intercept all requests with a URL ending in `.do`. This is common for Struts applications, but equally common is using a servlet mapping of `/action/*` to intercept all URLs beginning with `/action`.

- ▶ Default Struts module with the name `<default module>` under which all the Struts components are created.

- ▶ `ApplicationResources.properties` in the package specified in the Struts Settings dialog in the creation of a dynamic project. This is a property file used in Struts to externalize messages and form field labels to accommodate for a language and locale independent fashion (or internationalization - i18n).
- ▶ Default Web Diagram (`WebDiagram.gph`) used by the Struts Web Diagram Editor is used to create Struts components in a top-down design approach.

Adding the model classes to the application

We use the banking model developed in Chapter 8, “Develop Java applications” on page 69.

- ▶ If you do not have the `RAD75Java` project in the workspace, import the project from `C:\7672code\zInterchange\java\Rad75Java.zip`. Select **File** → **Import** → **Other** → **Project Interchange**, then locate the zip file, select the **RAD75Java** project, and click **Finish**.
- ▶ Right-click the **RAD75StrutsEAR** project and select **Properties**. Select **Java EE Module Dependencies**, select **RAD75Java**, and click **OK**.
- ▶ Right-click the **RAD75StrutsWeb** project and select **Properties**. Select **Java EE Module Dependencies**, select **RAD75Java.jar**, and click **OK**.

Developing a Web application using Struts

This section describes how to develop a Web application using Struts with the tooling provided by Application Developer.

The section is organized into the following tasks:

- ▶ Creating the Struts components
- ▶ Modify application resources
- ▶ Using the Struts validation framework
- ▶ Page Designer and the Struts tag library
- ▶ Using the Struts Configuration Editor

Important: This section demonstrates how to develop a Web application using Struts with the tooling included with Application Developer. We do not cover the details for all of the sample code. A procedure to import and run the completed Struts Bank Web application sample can be found in “Developing a Struts Web application using Tiles” on page 485.

Creating the Struts components

There are several ways to create Struts components:

- ▶ In the Enterprise Explorer, expand and right-click **RAD75StrutsWeb** → **Struts** and select **New** to create a Struts **Module**, **Action Mapping**, **Form Bean**, **Global Forward**, and **Global Exception**.
- ▶ Using the Struts Configuration Editor: Application Developer provides a Struts Configuration Editor, which is used to create Struts components and to modify the Struts configuration file `struts-config.xml`. We describe how to use the Struts Configuration Editor in detail in “Using the Struts Configuration Editor” on page 473.
- ▶ In the Struts Web Diagram Editor, use the Struts Palette to create Struts components.

In this chapter, we take a top-down approach to design the Web application by laying out all the components in the Web diagram using the Web Diagram Editor.

This section is organized into the following tasks:

- ▶ Start the Web Diagram Editor
- ▶ Create a Struts action
- ▶ Create a Struts form bean
- ▶ Create a Web page
- ▶ Create a Struts Web connection

Start the Web Diagram Editor

Open the Web Diagram under the RAD75StrutsWeb project (Figure 15-6).

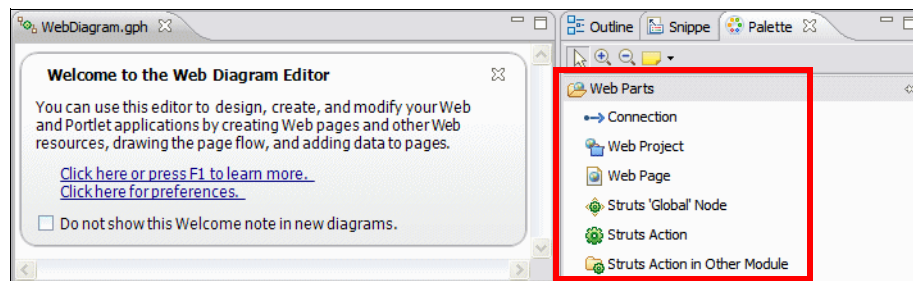



Figure 15-6 Web Diagram with the Struts drawer (Web Parts) open in the Palette

Create a Struts action

To create the Struts Action for logon, do these steps:

- ▶ Close the Welcome
- ▶ Drag and drop the **Struts Action** icon ( **Struts Action**) from the Palette.
- ▶ Overtyping the name of the action with `/logon` and press **Enter** (Figure 15-7).

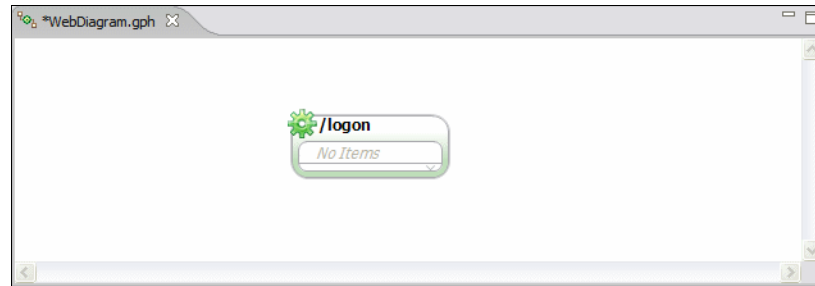

Figure 15-7 Struts Components - Create Struts action

Note: When initially typing in the name, the logon component appears in black and white. This is because the component has not yet been realized. Once you are done with the typing in the name, the Struts action becomes automatically realized and as a result, the action widget is displayed in color.

Notice that the Web Diagram Editor directly manipulates the underlying artifacts (creation of action class and updating of the struts-config.xml) in this case a LogonAction class is created in the rad75strutsweb.actions package, and the Struts configuration file is updated.

Create a Struts form bean

In the previous section we created the logon action. The logon action is invoked when the customer enters a customer ID (social security number). This information is passed to the action as a Struts form bean.

To create and associate the logonForm form bean to the logon action, do these steps:

- ▶ Hover with the mouse over the /logon action, then click the **Add Form Bean** icon () from the selections presented.
- ▶ In the Form Bean Selection dialog, do these steps:
 - Click **New**.
 - In the New Form Bean dialog (Figure 15-8), type **LogonForm** as the Form Bean Name.
 - Click the **Form Bean Type** link to launch the New ActionForm Class dialog.
 - In the New ActionForm Class dialog, accept the defaults for package, modifiers, superclass, and method stubs. Accept the generated name LogonForm for the ActionForm class name. Click **Next**.

- In the Create new fields for your ActionForm class dialog, click **Add** to create a field named **ssn** of type `String`. Click **Finish**.
- At this time the Form Bean Type field contains the value `rad75strutsweb.forms.LogonForm`. Accept the values for the New Form-Bean dialog. Click **Finish**.
- The `logonForm` bean is added to the Form Bean Selection dialog. Click **OK**.
- ▶ A `LogonForm` class is created in the `rad75strutsweb.forms` package and the Struts configuration file is updated.
- ▶ Figure 15-8 shows the creation of the form bean and the result in the Web Diagram.

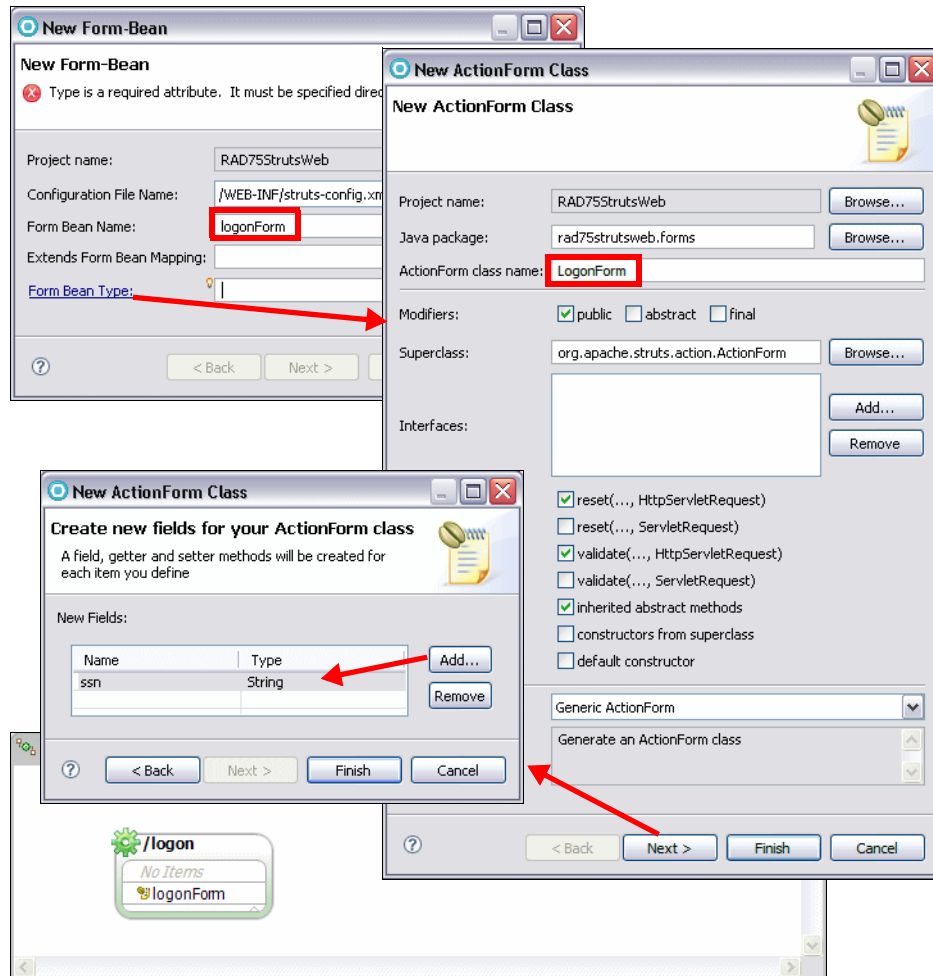



Figure 15-8 Struts components: Adding a Struts form bean

Create a Web page

Now that we have created the `logon` action and the `logonForm` action form, we have to create the input and output pages for the `logon` action. The input page (`logon.jsp`) lets the customer enter a customer ID (SSN) through the input form.

To create the `logon.jsp` and `customerListing.jsp` Web pages, do these steps:

- ▶ From the Web Parts drawer of the Palette, drag and drop the **Web Page** icon () into the Web diagram and type **logon.jsp** as the page name.
- ▶ Repeat this to create the **customerListing.jsp** (Figure 15-9).

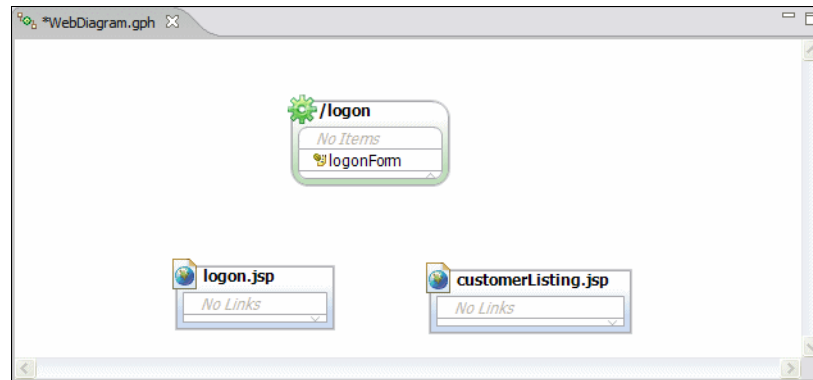

Figure 15-9 Struts components: Create Web pages

- ▶ Two JSP files (with skeleton tags) are created under WebContent.

Create a Struts Web connection

A connection is typically used to connect two nodes in a Web diagram. In a Struts context, when a connection is dragged from a Struts action, a pop-up connection wizard is displayed, enabling the user to create the connection. When any of these connections are realized, the corresponding Struts action mapping entry in the Struts configuration file `struts-config.xml` is modified appropriately. As in prior sections, once the connections are drag and defined on the palette, the realization occurs automatically.

When you select **Connection** from the palette and drag it from a Struts action to any other node, you are able to create the following:

- ▶ **Local Exception:** When Local Exception is selected, the handler class that is created is invoked when the Struts action throws the local exception.
- ▶ **Action Input:** When the Struts validation framework is used, the action has to forward the control back to the page that invoked the action in case of validation failures. This is specified by specifying an action input mapping.
- ▶ **Include Action Mapping:** The action in the action mapping entry is configured as an include.
- ▶ **Forward Action Mapping:** The action in the action mapping entry is configured as a forward.
- ▶ **Global Forward:** When Global Forward is selected, a global forward entry is added in the configuration file.
- ▶ **Local Forward:** When Local Forward is selected, a local forward entry is added in the configuration file.

- ▶ **Global Exception:** When Global Exception is selected, a global exception entry is added in the configuration file.

In our sample, when a user enters an invalid customer ID (SSN), the logon action fails and then forwards the user back to the logon page to enable the user to re-enter this information. Likewise, if the logon action succeeds, the customer has to be forwarded to the `customerListing.jsp` that displays the customer's account information.

To create the local forwards for success and failures for the logon action, do these steps:

- ▶ Select **Connection** in the Palette. Click on the **logon.jsp** and drag the cursor to the **/logon** action. Select **Struts Form** when prompted.
- ▶ Select **Connection** in the Palette. Click on the **/logon** action and drag the cursor to the **logon.jsp**. Select **Action Input** when prompted.
- ▶ Select **Connection** in the Palette. Click on the **/logon** action and drag the cursor to the **customerListing.jsp**. Select **Local Forward** when prompted. Accept the generated forward name of **success**.
- ▶ Select **Connection** in the Palette. Click on the **/logon** action and drag the cursor to the **logon.jsp**. Select **Local Forward** when prompted. Accept the generated forward name of **failure**. Note that you can select the forward name and overwrite it.
- ▶ The resulting Web Diagram is shown in Figure 15-10.

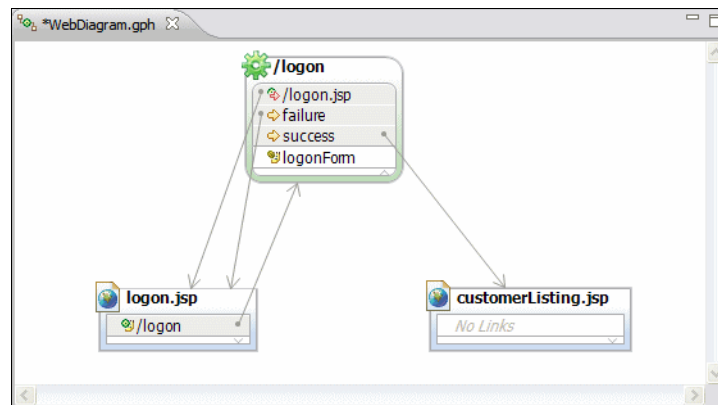

Figure 15-10 Struts components: Creating connections

- ▶ Save the Web Diagram.

Tip: You can select a component in the Web diagram and overtype the name and the forward names.

To improve the layout of the application flow, you can drag components to another spot. You can rearrange connections by dragging their middle point.

Realizing the Struts components

In Application Developer v7.5, the Web Diagram Editor automatically realizes the components drawn onto the palette. In terms of Struts components, this realization has differing consequences for each type of component. Table 15-1 describes the item generated and artifacts updated, given a realization of a specific component.

Table 15-1 *Struts components realization resultst.*

Object	Resulting action when realized
Struts Form Beans	Creating a new form bean from within an action creates a new form bean class. In addition, it also updates the <code>struts-config.xml</code> file with a form bean mapping and form bean to action association.
Struts Actions	Dragging a new action onto the palette creates a new action class. In addition, it also updates the <code>struts-config.xml</code> with an action mapping.
Local/Global Forwards, Exceptions, Action Input Connections	Dragging a connection onto the palette updates the <code>struts-config.xml</code> file with the appropriate configuration.
JSP	Dragging a Web page onto the palette creates a new Web page JSP.

Modify application resources

The wizard created an empty `ApplicationResources.properties` file in the `rad75strutsweb.resources` package for us and we have to update it with the texts and messages for our application.

While developing Struts applications, you usually find yourself having this file open, because you typically add messages to it as you go along writing your code. Again, this properties file is meant to externalize messages and more importantly support i18n (internationalization) for Web site language support. Example 15-1 shows a completed `ApplicationResources.properties` file.

Example 15-1 ApplicationResources.properties snippet

```
# Optional header and footer for <errors/> tag.
#errors.header=<ul>
#errors.footer=</ul>
errors.prefix=<li>
errors.suffix=</li>

form.ssn=SSN
form.accountId=Account Id
form.balance=Balance
form.amount=Amount

form.accountDetails.transactionId=Transaction ID
form.accountDetails.transactionType=Transaction Type
form.accountDetails.transactionTime=Transaction Date-Time
form.accountDetails.transactionAmount=Transaction Amount

form.transaction.amount=Amount

errors.required={0} is a required Field
error.ssn=Verify that the customer ssn entered is correct.
error.amount=Verify that the amount entered is valid.
error.timeout=Your session has timed out. Please login again.
errors.systemError=The system is currently unavailable. Please try again later.
```

Initially this file only contains optional header and footer for errors. At this point you can open the file and add two lines:

```
form.ssn=SSN
errors.required={0} is a required field.
```

We use this message to validate—using the Struts Validation Framework—the logon form in `logon.jsp` to ensure that the user enters a value for the customer (SSN).

Using the Struts validation framework

The Struts validation framework provides automatic validation of forms using configuration files. The `validation.xml` and `validator-rules.xml` are the two configuration files used by the Struts validation framework to validate forms.

Note: More information on the architecture and further documentation of Struts validation framework can be found at:

<http://struts.apache.org>

To validate the `logonForm` using the Struts validation framework, do these steps:

- ▶ We have provided a `validation.xml` and `validation-rules.xml` as part of the sample code in `C:\7672code\struts\validation`. Import the two files into `RAD75StrutsWeb/WebContent/WEB-INF` (you can also drag the files from Windows Explorer into the `WEB-INF` folder in Application Developer).
- ▶ Add the Struts validator plug-in and required property to the plug-in indicating the location of the validation configuration files.
 - Expand **RAD75StrutsWeb** → **WebContent** → **WEB-INF**.
 - Open the `struts-config.xml` file in the Struts Configuration Editor.
 - Select the **Plug-ins** tab in the Struts Configuration Editor.
 - Click **Add** for Plug-ins, type **ValidatorPlugIn**, select the matching class from the `struts-core-1.3.8.jar`, and click **OK**. The Struts validator plug-in has now been added.
 - Add the required parameter by clicking **Add** under the Plug-in Mapping Extensions.
 - Set the Property field to **pathnames** and the Value field to **/WEB-INF/validator-rules.xml,/WEB-INF/validation.xml**.
- ▶ Save and close the Struts configuration file.

The `validation.xml` file contains the following:

- ▶ All the Struts form beans
- ▶ The fields within the form bean that is validated,
- ▶ The rule that is applied to validate the bean.
- ▶ The snippet that validates the `logonForm` and makes the `ssn` field required is shown in Example 15-2.

Example 15-2 validation.xml snippet - LogonForm

```

<form-validation>
  <formset>
    <form name="logonForm">
      <field property="ssn" depends="required">
        <arg0 key="form.ssn" />
      </field>
    </form>
  </formset>
  .....
  .....
</form-validation>

```

The `validator-rules.xml` file contains the configuration for all the rules defined in the `validation.xml` file.

- ▶ The snippet for the *required* rule is shown in Example 15-3.

Example 15-3 validator-rules.xml snippet - Rule configuration for the required rule

```
<form-validation>
  <global>
    <validator name="required"
      classname="org.apache.struts.validator.FieldChecks"
      method="validateRequired"
      methodParams="java.lang.Object,
        org.apache.commons.validator.ValidatorAction,
        org.apache.commons.validator.Field,
        org.apache.struts.action.ActionErrors,
        javax.servlet.http.HttpServletRequest"
      msg="errors.required" />
  </global>
</form-validation>
```

Page Designer and the Struts tag library

The Struts framework provides a tag library to help in the development of Struts-based Web applications. The Page Designer is used to design and develop HTML and dynamic Web pages within Application Developer. The features of the Page Designer are explained in detail in Chapter 13, “Develop Web applications using JSPs and servlets” on page 317.

Struts tag library overview

In this section we explore the support for the Struts tag libraries within the Page Designer. The Page Designer supports the Struts tag libraries by allowing dropping of tags from the Page Designer Palette and into the design view of the Page Designer.

Open the `login.jsp` to see the Palette in Page Designer (Figure 15-11).

Note: You must be editing a JSP in order to see the Struts tag libraries list.

- ▶ **Struts HTML tags:** Struts provides tags to render HTML content. Examples of the Struts HTML tags are button, cancel, check box, form, and errors. These tags can be dragged and dropped into a page in the page designer’s design perspective. We drag and drop the errors tag to the `login.jsp` and display a message to the user if no ssn is entered later in this section.

- ▶ **Struts Bean tags:** The bean tag library provides tags to access bean properties, request parameters, create page attributes, and so forth.
- ▶ **Struts Logic tags:** The Logic tag library provides tags to implement conditional, looping, and control related functionality.
- ▶ **Struts Nested tags:** The Nested tag library provides tags to access complex beans with nested structures.
- ▶ **Struts Template tags:** The Template tag library provides tags for creation of dynamic JSP templates.
- ▶ **Struts Tiles Tags:** The Tiles tag library facilitates development of dynamic Web applications in a tiled fashion where the tile can be reused throughout the application.

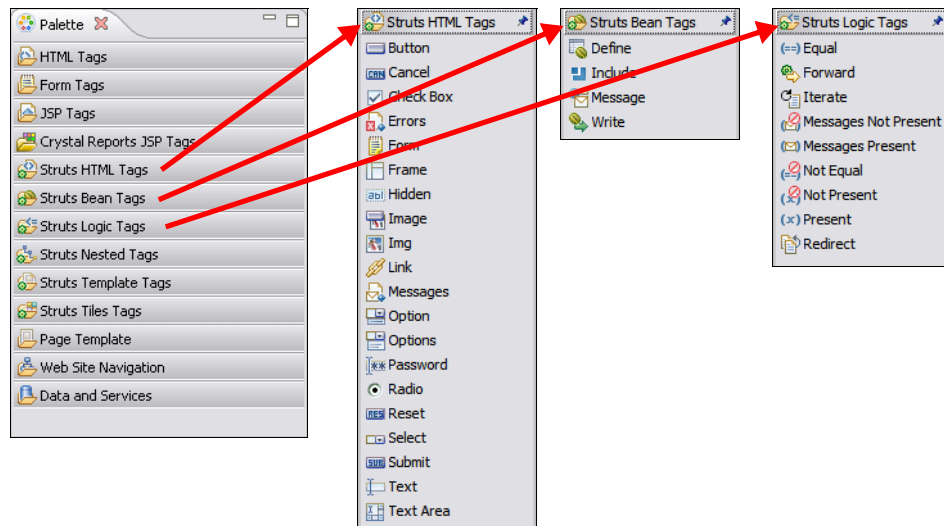

Figure 15-11 Struts tag library support: Page Designer Struts tag drawers

Tip: If you do not see all the Struts tag libraries in the palette, right-click the palette and select **Customize**. From the Customize Palette dialog box, select the drawers that you want to have available in the palette.

Completing the logon JSP

We now add a simple HTML error tag to `logon.jsp`, which displays an HTML error message that occurs due to the validation check by the Struts Validation Framework. To add the HTML error tag to `logon.jsp`, do these steps:

- ▶ Open the `logon.jsp` in Page Designer.

- ▶ Select the **Design** tab. Note that there is some generated code with a Submit Query button.
- ▶ Select the **Source** tab and delete the complete `<div>` section that was generated.
- ▶ Select the **Design** tab or the **Split** tab.
- ▶ Select the **Errors** icon from the Struts HTML Tags drawer and drop it at the top of the page (Figure 15-12).

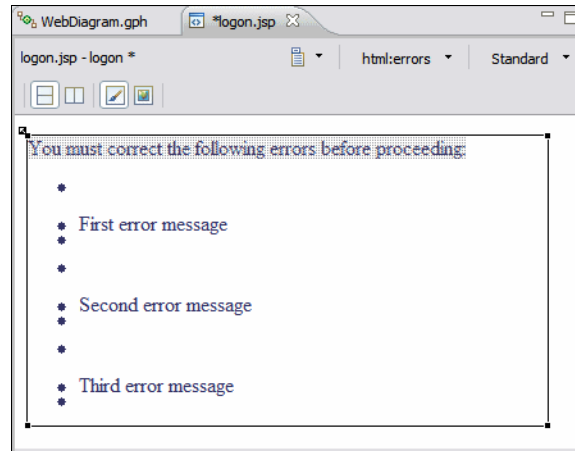

Figure 15-12 Struts tags: Struts errors tag rendered by Page Designer

Creating the input form

The `logon.jsp` page contains an input form with the customer SSN and a submit button, similar to the form with the **Submit Query** button that was generated.

- ▶ In the Page Data view on the left below corner select **Struts Form Beans** → **logonForm** and drag it into the JSP form under the error list (Figure 15-13).

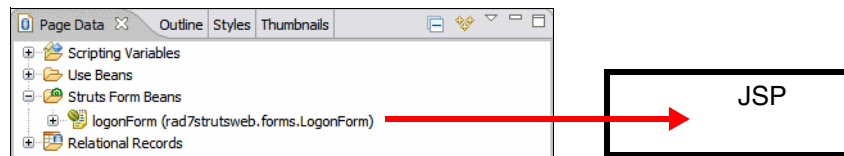

Figure 15-13 Page Data view with form bean

- ▶ In the Configure Data Controls dialog (Figure 15-14):
 - Select **Updating an existing record** and change the label of the `ssn` field to **Customer ID:**. The HTML Form Action is prefilled with `/logon` (based on the Web Diagram connection).

- Click **Options** and select **Submit** and clear **Delete**. Click **OK**.
- Click **Finish** and the form is generated.

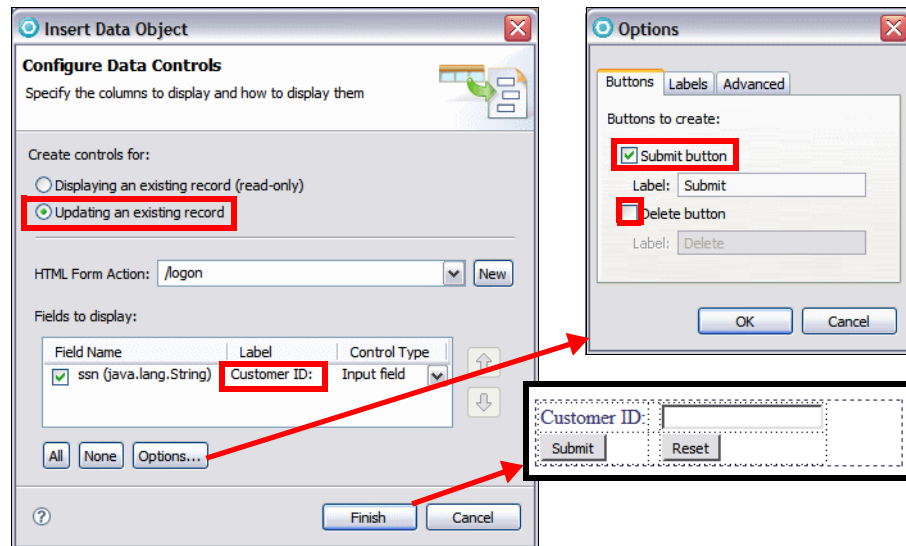

Figure 15-14 Creating the logon JSP with a form

- The source is shown in the Example 15-4. Notice the `<html:errors />` and the form that the wizard has added for rendering the action form.

Example 15-4 Struts tags:- Logon.jsp snippet of the tag in the source view

```

<html:errors />
<html:form action="/logon">
  <TABLE>
    <TBODY>
      <TR>
        <TD align="left">Customer ID:</TD>
        <TD width="5">&nbsp;</TD>
        <TD><html:text property="ssn"></html:text></TD>
      </TR>
      <TR>
        <TD align="left"><html:submit property="Submit"
          value="Submit"></html:submit></TD>
        <TD width="5">&nbsp;</TD>
        <TD><html:reset /></TD>
      </TR>
    </TBODY>
  </TABLE>
</html:form>

```

Completing the logon action

The skeleton code for the LogonAction class was created from the Web Diagram and is shown in Example 15-5.

Example 15-5 Skeleton action class (compressed)

```
package rad75strutsweb.actions;

import javax.servlet.http.HttpServletRequest;
import javax.servlet.http.HttpServletResponse;
import org.apache.struts.action.*;

public class LogonAction extends Action {

    public ActionForward execute(ActionMapping mapping, ActionForm form,
        HttpServletRequest request, HttpServletResponse response)
        throws Exception {
        ActionMessages errors = new ActionMessages();
        ActionForward forward = new ActionForward(); // return value
        try {
            // do something here
        } catch (Exception e) {
            // Report the error using the appropriate name and ID.
            errors.add("name", new ActionMessage("id"));
        }
        // If a message is required, save the specified key(s)
        // into the request for use by the <struts:errors> tag.
        if (!errors.isEmpty()) {
            saveErrors(request, errors);
            // Forward control to the appropriate 'failure' URI (...)
            //forward = mapping.findForward("failure");
        } else {
            // Forward control to the appropriate 'success' URI (...)
            forward = mapping.findForward("success");
        }
        // Finish with
        return (forward);
    }
}
```

We have to complete the execute method with our logic. The final code is shown in Example 15-6. Select **Source** → **Organize Imports** or press **Ctrl+Shift+O** to resolve the imports.

Example 15-6 Completed execute method of the logon action class

```
public class LogonAction extends Action {
```

```

public ActionForward execute(ActionMapping mapping, ActionForm form,
    HttpServletRequest request, HttpServletResponse response)
    throws Exception {

    ActionMessages errors = new ActionMessages();
    ActionForward forward = new ActionForward(); // return value

    LogonForm logonForm = (LogonForm) form;
    String ssn = logonForm.getSsn();

    try {
        // Create a bank object with pre-generated in-memory data
        Bank bank = ITS0Bank.getBank();
        Customer customerBean = bank.searchCustomerBySsn(ssn);
        // Add the customer to the request object for the JSP pages to use it
        request.setAttribute("customer", customerBean);
        // Add the bank and ssn objects to the session for further use
        request.getSession().setAttribute("ssn", logonForm.getSsn());
        request.getSession().setAttribute("ITS0Bank", bank);
    } catch (InvalidCustomerException e){
        errors.add("ssn", new ActionError("error.ssn"));
    } catch (Exception e) {
        errors.add("error", new ActionError("errors.systemError"));
    }
    // If a message is required, save the specified key(s)
    // into the request for use by the <struts:errors> tag.
    if (!errors.isEmpty()) {
        saveErrors(request, errors);
        // Forward control to the appropriate 'failure' URI (.....)
        forward = mapping.findForward("failure");
    } else {
        // Forward control to the appropriate 'success' URI (.....)
        forward = mapping.findForward("success");
    }
    // Finish with
    return (forward);
}
}

```

Let us understand some of the action class coding:

- ▶ The ActionForm parameter is cast to the correct LogonForm class and the ssn value is extracted.
- ▶ The customer and accounts are retrieved from the in-memory data autogenerated on invocation to the ITS0Bank.getBank() method.

- ▶ The `ssn` and `bank` objects are stored as session data and the customer information is stored in the request block. The session data is available to all actions and JSPs.
- ▶ If exceptions are thrown by the data access, an `ActionMessage` is added to the Struts errors list. The error text ("`error.ssn`" or "`errors.systemError`") comes from the `ApplicationResources` file (see Example 15-1 on page 465).
- ▶ An `ActionForward` of either "`failure`" or "`success`" is returned. Struts will find the appropriate resulting action or JSP in the configuration file.

Using the Struts Configuration Editor

Application Developer provides an editor for the Struts `struts-config.xml` configuration file. This editor is yet another way you can add new form beans and actions and customize their attributes. You can also directly edit the XML source file, should you prefer to do this manually instead of by using the wizards. The Struts Configuration Editor is shown in Figure 15-15.

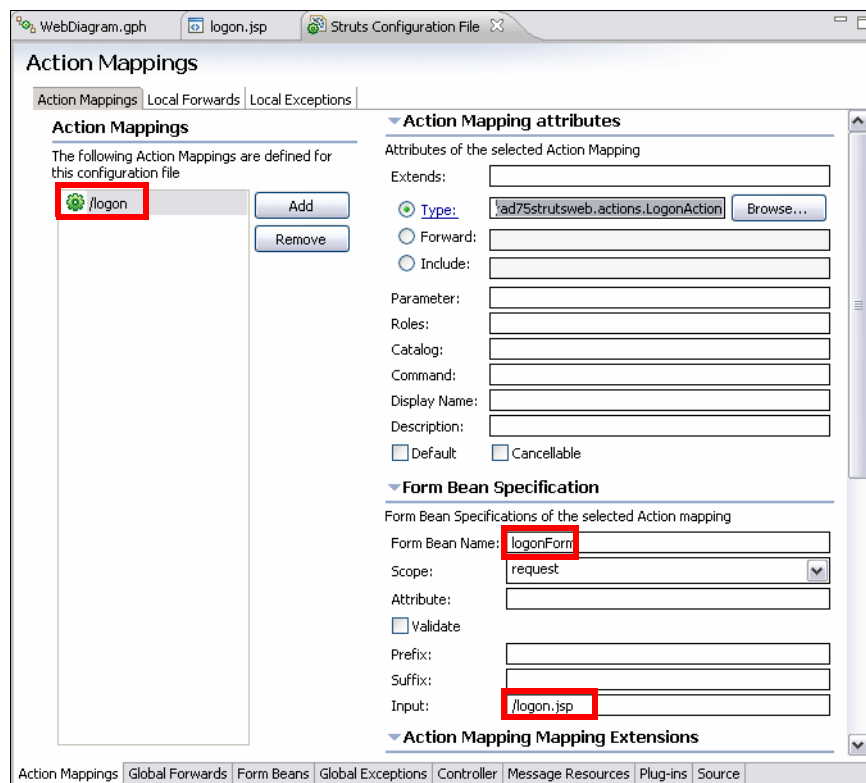

Figure 15-15 Struts Configuration Editor

We use this editor to add a local forward called *cancel* to the logon action. This forward can be used by the logon action's execute method to forward the user to the logon.jsp page, as we map this forward to the logon.jsp page.

We also specify the input attribute for all our actions. This attribute specifies which page should be displayed if the validate method of a form bean or the Struts validation framework fails to validate. Usually you want to display the input page where the user entered the data so they can correct their entry.

- ▶ Open the struts-config.xml file under **RAD75StrutsWeb** → **WebContent** → **WEB-INF**.
- ▶ The editor has tabs at the bottom of the screen to navigate between the different Struts artifacts it supports.
 - In the **Action Mappings** tab select the **/logon** action. You can see the logonForm (Form Bean Name) and the logon.jsp (Input).
 - Notice the Scope value of request; an alternative would be session.
- ▶ Create a forward:
 - Select the **Local Forwards** tab found at the top of the Action Mappings page. Select the **/logon** action. We already have two forwards named failure and success.
 - Click **Add** in the **local forwards** section. A new forward with the name forward1 is created.
 - Overtyping the name with **cancel** and enter **/logon.jsp** in the Path field in the Forward Attributes (Figure 15-16).

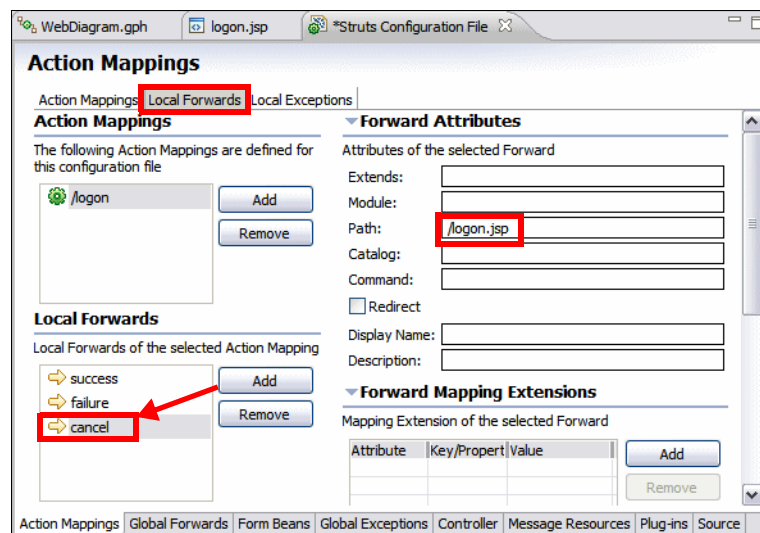

Figure 15-16 Struts Configuration Editor: Creating new forward

Note: The Redirect check box allows you to select if a redirect or forward call should be made. A forward call keeps the same request with all attributes it contains and just passes control over to the path specified. A redirect (or send redirect) call tells the browser to make a new HTTP request, which creates a new request object (and you lose any attributes set in the original request).

A forward call does not change the URL in the browser's address field, as it is unaware that the server has passed control to another component. With a redirect call, however, the browser updates the URL in its address field to reflect the requested address.

You can also redirect or forward to other actions. It does not necessarily have to be a JSP.

- ▶ Save the file.
- ▶ Select the **Source** tab to look at the Struts configuration file. Example 15-7 shows parts of the `struts-config.xml` XML source.

Example 15-7 Struts configuration file: struts-config.xml

```
<?xml version="1.0".....>
<struts-config>
  <!-- Data Sources -->
  .....
  <!-- Form Beans -->
  <form-beans>
    <form-bean name="logonForm" type="rad75strutsweb.forms.LogonForm">
    </form-bean>
  </form-beans>
  <!-- Global Exceptions -->
  .....
  <!-- Global Forwards -->
  .....
  <!-- Action Mappings -->
  <action-mappings>
    <action path="/logon" type="rad75strutsweb.actions.LogonAction"
      name="logonForm" scope="request" input="/logon.jsp">
      <forward name="success" path="/customerListing.jsp">
      </forward>
      <forward name="failure" path="/logon.jsp">
      </forward>
      <forward name="cancel" path="/logon.jsp">
      </forward>
    </action>
  </action-mappings>
```

```
<message-resources
  parameter="rad75strutsweb.resources.ApplicationResources"/>
<plug-in className="org.apache.struts.tiles.TilesPlugin">
  <set-property property="definitions-config"
    value="/WEB-INF/tiles-defs.xml"/>
  <set-property property="definitions-parser-validate" value="true"/>
  <set-property property="moduleAware" value="true"/>
</plug-in>
<plug-in className="org.apache.struts.validator.ValidatorPlugIn">
  <set-property property="pathnames"
    value="/WEB-INF/validator-rules.xml,/WEB-INF/validation.xml"/>
</plug-in>
</struts-config>
```

As you can see, the Struts tools have defined the `logonForm` bean in the `<form-beans>` section and the `logon` action in the `<action-mappings>` section. The JSPs, however, are not specified in the Struts configuration file. They are completely separate from the Struts framework (only the forwarding information is kept in the configuration file). At the end of the file is the name of the application resources file where our texts and error messages are stored.

The Struts Configuration Editor does round-trip editing, so if you edit something in the XML view it is reflected in the other views.

The forwards we use are local to each action, meaning that only the action associated with the forward can look it up. In the `<global-forwards>` section you can also specify global forwards that are available for all actions in the application. Normally you have a common error page to display any severe error messages that may have occurred in your application and that prevents it from continuing. Pages like these are good targets for global forwards, and so are any other commonly used forward. Local forwards override global forwards.

- ▶ Close the configuration file editor.

Notes: We recommend that all requests for JSPs go through an action class so that you have control over the flow and can prepare the view beans (form beans) necessary for the JSP to display properly. Struts provides simple forwarding actions that you can use to accomplish this.

In our example we do not perform any customization on the Struts action servlet (`org.apache.struts.action.ActionServlet`). If you have to do any custom life cycle processing needed to be executed, you would want to create your own action servlet, extending the `ActionServlet` class, and overriding the appropriate `ActionServlet` methods. You would then also modify the `\WEB-INF\web.xml` file and replace the name of the Struts `ActionServlet` with the name of your action servlet class.

Completing the application

Completing the application as shown in Figure 15-3 on page 453 would be quite complex. Here are abbreviated instructions if you want to try this yourself.

Complete the Web Diagram

This is how we complete the Web Diagram:

- ▶ Open the Web Diagram and rearrange the tree existing components to the layout of Figure 15-3 on page 453.
- ▶ Add three actions: `logout`, `accountDetails`, and `performTransaction`.
- ▶ Add three Web pages (JSPs): `accountDetails.jsp`, `transact.jsp`, and `error.jsp`.
- ▶ Create two action forms:
 - In the `accountDetails` action create the `customerAccountForm` with two attributes (`String ssn` and `String accountId`).
 - In the `performTransaction` action create the `transactForm` with two attributes (`String accountId` and `String amount`).
- ▶ Create connections according to Table 15-2.

Table 15-2 Web Diagram connections

From	To	Type of connection
<code>/logout</code>	<code>login.jsp</code>	Static Forward

From	To	Type of connection
customerListing.jsp	/logoff	Struts Link
	/accountDetails	Struts Link
	transact.jsp	Struts Link
/accountDetails	accountDetails.jsp	Local Forward success
	error.jsp	Local Forward failure
accountDetails.jsp	/logon	Struts Link
	/logoff	Struts Link
	transact.jsp	Struts Link
transact.jsp	/performTransaction	Struts Form
/performTransaction	/accountDetails (action)	Local Forward success
	error.jsp	Local Forward failure
error.jsp	/logoff	Struts Link
/logon	logon.jsp	Local Forward cancel

Completing the application resources

Complete the `ApplicationResources.properties` file according to Example 15-1 on page 465, or import the file from `C:\7672code\struts\resource`.

Complete the form beans

You can compare the generated form classes with the code provide in `C:\7672code\struts\form`.

Complete the actions

The completed code is provided in `C:\7672code\struts\action`:

- ▶ The `LogonAction` is already complete.
- ▶ The `LogoffAction` has three lines in the execute method try clause:

```
//Destroy the objects in session.
request.getSession().setAttribute("ssn", null);
request.getSession().setAttribute("ITS0Bank", null);
```

- ▶ Complete the AccountDetailsAction class execute method:

```
CustomerAccountForm customerAccountForm = (CustomerAccountForm) form;
String accountId = customerAccountForm.getAccountId();
try {
    // Retrieve the account from the bank
    Bank bank = (Bank)request.getSession().getAttribute("ITS0Bank");
    Account accountBean = bank.searchAccountByAccountNumber(accountId);

    // Add the account info to request scope
    request.setAttribute("account", accountBean);
} catch (Exception e) {
    // Report the error using the appropriate name and ID.
    errors.add("error", new ActionMessage("errors.systemError"));
}
.....
forward = mapping.findForward("failure");
```

- ▶ Complete the PerformTransactionAction class execute method:

```
TransactForm transactForm = (TransactForm) form;
String accountId = transactForm.getAccountId();
String amountf = transactForm.getAmount();
BigDecimal amount = null;
try {
    // convert the amount and perform withdraw or deposit
    Bank bank = (Bank)request.getSession().getAttribute("ITS0Bank");
    amount = new BigDecimal(amountf);
    if ( amount.compareTo(new BigDecimal(0)) < 0 ){
        bank.withdraw(accountId, amount.negate());
    } else {
        bank.deposit(accountId, amount);
    }
} catch (NumberFormatException e) {
    errors.add("amount", new ActionMessage("error.amount"));
} catch (InvalidTransactionException e) {
    errors.add("amount", new ActionMessage("error.amount"));
}
.....
forward = mapping.findForward("failure");
```

Import java.math.BigDecimal and
itso.rad75.bank.exception.InvalidTransactionException.

Complete the JSPs

The completed code is provided in C:\7672code\struts\jsp:

- ▶ For a uniform look, import the rbhome.gif into WebContent/theme.

- ▶ Complete the `logon.jsp` with a heading:

```
<body>
<IMG border="0" src="theme/rbhome.gif">
<font face="Arial" size="5"><b>ITSO Bank</B></font>
<HR>
<html:errors />
.....
```

- ▶ Replace the remaining generated JSPs with the provided code:
 - `accountDetails.jsp`
 - `customerListing.jsp`
 - `transact.jsp`
 - `error.jsp`

Note: You can drag a source file from Windows Explorer into the appropriate package in Application Developer

Complete the Web Diagram and Struts configuration file

The diagram and Struts configuration file should be complete. However, you can optionally replace the Web Diagram (`WebDiagram.gph`) and Struts configuration file (`struts-config.xml`):

- ▶ Replace the `struts-config.xml` file from the `config` folder into the project folder `WebContent/WEB-INF`.
- ▶ Replace the `WebDiagram.gph` file from the `diagram` folder into the project root directory. When you open the Web Diagram the action forms may not be visible in the actions. Double-click in the small space at the bottom to display the action form (Figure 15-17).

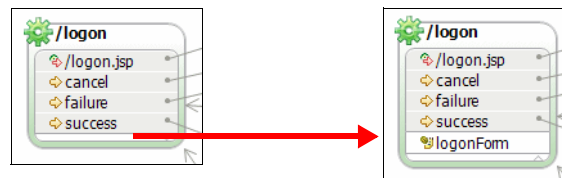

Figure 15-17 Web Diagram action with and without the action form

Study the sample code

Study the sample code, especially the actions and the JSPs:

- ▶ The Java classes with the transfer beans and action forms are easy to understand, they are standard Java beans.

- ▶ The AccountDetailsAction retrieves one customer account and the transactions of that account and stores the data in the data transfer beans.
- ▶ The PerformTransactionAction adds or subtracts the transaction amount from the balance, the logic for this is handled in the imported Java project on the ITSOBank class in the package `itso.rad75.bank.impl`.

Note: For more information about the RAD75Java project logic please refer to the Chapter 8, “Develop Java applications” on page 69.

- ▶ The `customerListing.jsp` displays the customer name and the list of accounts, for that several Struts tags are used:
 - Additional tag library:

```
<%@taglib uri="http://struts.apache.org/tags-logic"
           prefix="logic"%>
```

Note: With Struts 1.3.8 the `uri` attribute in the JSP tags are changed, from: `http://jakarta.apache.org/struts/tags-***` to `http://struts.apache.org/tags-***`.

- `<bean:write>`: display data from a JavaBean:

```
<bean:write name="customer" scope="request" property="firstName" />
```

- `<html:link>`: An HTML link to another Web page or action:

```
<html:link action="/logoff">logoff</html:link>
<html:link page="/transact.jsp" name="queryParams"> Deposit/Withdraw
</html:link>
```

Parameters for the link (`accountId`, `balance`) are stored in a `HashMap`.

- `<logic:present>`: Verify and retrieve session and request data:

```
<logic:notPresent name="ssn" scope="session">
  <logic:redirect page="/logon.jsp" />
</logic:notPresent>
<logic:present name="ssn" scope="session">
  <logic:present name="customer" property="accounts" scope="request">
```

- `<logic:iterate>`: Loop over a property:

```
<logic:iterate name="customer" property="accounts" scope="request"
              id="account">
```

- ▶ The `accountDetails.jsp` displays the account information and the list of transactions of that account:
 - `<bean:message>`: Retrieve a text from the application resource file:

```
<bean:message key="form.accountId" />
```

- <nested> tags: Nested loops

```
<nested:iterate name="account" property="transactions" id="transaction">
  <nested:present name="account" property="transactions">
    <bean:write name="transaction" property="timeStamp"/>
  </nested:present>
</nested:iterate>
```

- ▶ The `transact.jsp` displays the account information and a form to submit a transaction amount for deposit or withdraw.
- ▶ The `error.jsp` displays the Struts errors.

Running the Struts Bank Web application

In this section we run the sample application and explore the functionality built using Application Developer and its support for rapid development of Struts-based Web applications.

To run the sample ITSO Bank application, do these steps:

- ▶ Start the WebSphere Application Server v7.0 if it is not running.
- ▶ Expand **RAD75StrutsWeb** → **WebContent**, right-click the **logon.jsp** and select **Run As** → **Run on Server**.
- ▶ In the Server Selection wizard select **Choose and existing server**, select the **WebSphere Application Server v7.0** server, select **Always use this server when running this project**, and click **Finish**.
- ▶ The home page `logon.jsp` is displayed (Figure 15-18).



Figure 15-18 Running the sample: Logon.jsp

- ▶ If you click **Submit** without entering an ID, the Struts Validation Framework is activated and displays the error message from the resources:
Verify that the customer ssn entered is correct

- ▶ Enter a sample ID of 111-11-1111 and click **Submit**. The customer and a list of accounts is displayed (Figure 15-19). Here the logon action is responsible for retrieving this information. In a real world application, the logon action talks to the business tier to retrieve this information. The business tier architecture is described in detail in Chapter 14, “Develop EJB applications” on page 387.

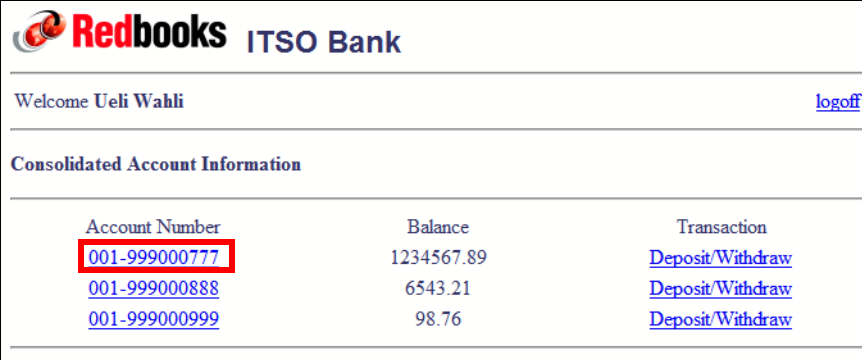

Account Number	Balance	Transaction
001-999000777	1234567.89	Deposit/Withdraw
001-999000888	6543.21	Deposit/Withdraw
001-999000999	98.76	Deposit/Withdraw

Figure 15-19 Running the sample: Account listing

- ▶ To view details of a particular account, click the Account Number (for example, 001-999000777) and the account information is listed. At this point there may be no transactions (Figure 15-20).



Transaction ID	Transaction Type	Transaction Date-Time	Transaction Amount
----------------	------------------	-----------------------	--------------------

Figure 15-20 Running the sample: Account details

- ▶ To perform a transaction on the account, click **Deposit/Withdraw**. The link is also available in the account listing (click **back** to get to the listing again).
- ▶ The transaction page is displayed. Enter a positive number for a deposit and a negative number for a withdrawal. We enter in 55.55 to indicate a deposit and click **Submit** (Figure 15-21).



Redbooks ITSO Bank

Account Details

SSN: 111-11-1111
 Account Id: 001-999000777
 Balance: 1234567.89

Amount: Enter negative amounts for withdrawals

Figure 15-21 Running the sample: Performing transactions

- ▶ The Account Details page is redisplayed with the updated balance and an entry made for the last transaction (Figure 15-22).

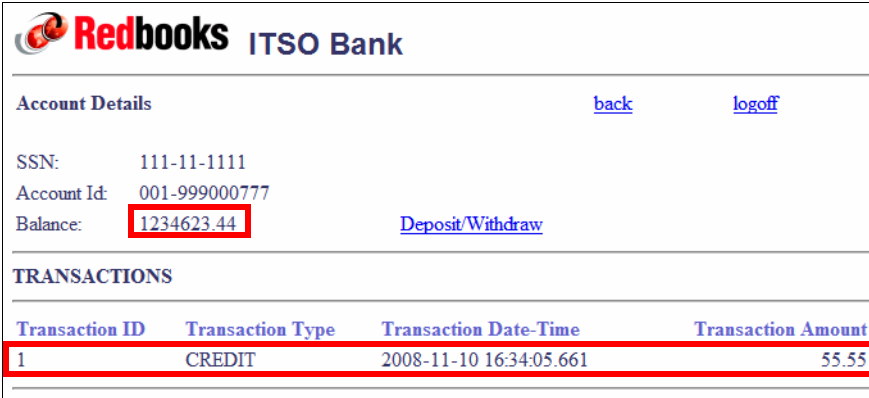

Redbooks ITSO Bank

Account Details [back](#) [logout](#)

SSN: 111-11-1111
 Account Id: 001-999000777
 Balance: **1234623.44** [Deposit/Withdraw](#)

TRANSACTIONS

Transaction ID	Transaction Type	Transaction Date-Time	Transaction Amount
1	CREDIT	2008-11-10 16:34:05.661	55.55

Figure 15-22 Running the sample: Transaction listing

- ▶ Run a few more transactions and the list of transaction grows (Figure 15-23).

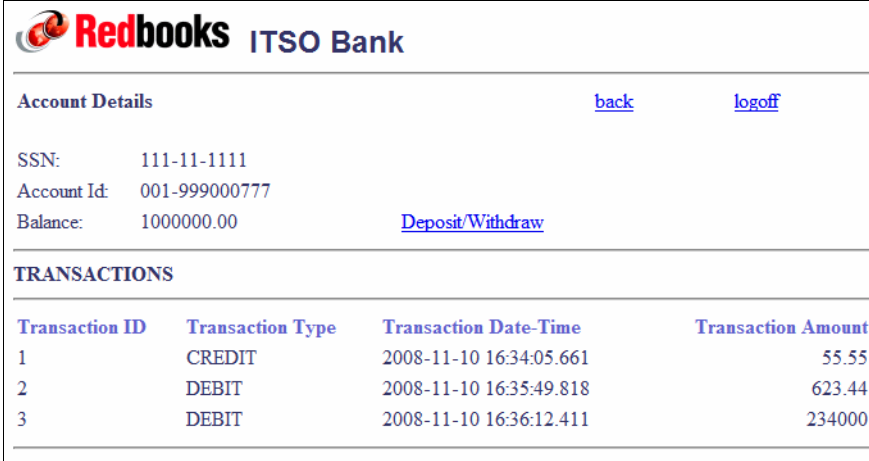

Redbooks ITSO Bank

Account Details [back](#) [logout](#)

SSN: 111-11-1111
 Account Id: 001-999000777
 Balance: 1000000.00 [Deposit/Withdraw](#)

TRANSACTIONS

Transaction ID	Transaction Type	Transaction Date-Time	Transaction Amount
1	CREDIT	2008-11-10 16:34:05.661	55.55
2	DEBIT	2008-11-10 16:35:49.818	623.44
3	DEBIT	2008-11-10 16:36:12.411	234000

Figure 15-23 Running the sample: More transactions

- ▶ Enter an invalid amount (for example, alphabetic) or a withdraw amount greater than the balance, and you get the exception error:
 Verify that the amount entered is valid.
- ▶ Use the **back** and **logout** links to go back to the logon panel.

Developing a Struts Web application using Tiles

Apache Tiles is a templating framework built to simplify the development of Web application user interfaces. Apache Tiles allows application developers and page authors to define page fragments (tiles) which are assembled into a complete page at runtime. These tiles are a step up from `jsp:include` directives and can be used to reduce the duplication of common page elements or embedded within other tiles to develop a series of reusable templates. These templates streamline the development of a consistent look and feel across an entire application.

Note: For more information on Tiles, please visit the following site:

<http://tiles.apache.org/>

Application Developer provides a minimal support for Tiles framework. Nevertheless, we are going to show the extent of Tiles support.

Enable the Struts Tiles support

In our prior example when creating a Dynamic Web project, we did not enable Struts Tiles in the Web project.

To enable the support, right-click the **RAD75StrutsWeb** project and select **Properties**. In the Properties dialog, select Project Facets, select **Dynamic Page Template Support (Struts Tiles)**, and click **OK**. This action creates the Tiles configuration and updates the Struts configuration to use Tiles. In addition a TilesServlet is added to the Web deployment descriptor.

The Tiles configuration file (tiles-def.xml) is created under WebContent/WEB-INF, and it has no definitions yet. In addition, the struts-config.xml file is updated with a plug-in configuration (Example 15-8).

Example 15-8 Plug-in configuration for Tiles in struts-config.xml file

```
<plug-in className="org.apache.struts.tiles.TilesPlugin">
  <set-property property="definitions-config"
    value="/WEB-INF/tiles-defs.xml" />
  <set-property property="definitions-parser-validate" value="true"/>
  <set-property property="moduleAware" value="true"/>
</plug-in>
```

There is also another piece of configuration that you have to put in manually. In the struts-config.xml, after the <action-mappings> section, insert the line shown in Example 15-9.

Example 15-9 Controller configuration for Tiles

```
<controller processorClass="org.apache.struts.tiles.TilesRequestProcessor" />
```

As a reference, these two entries in the struts-config.xml informs Struts that Tiles is used in this Web application. Specifically, we can now use ActionForward to forward control onto a Tiles configuration (among other things).

Note: Ignore the errors that are listed in the Problems view. This is a known defect that will be fixed in an upcoming FixPack. You can disable the Struts validator in the project Properties, **Validation** tab, clear **Struts Configuration File Validator**, and rebuild (clean) the project.

Building the Tiles application extension

In this section we create an example using Tiles. we only update the `customerListing.jsp` with two links to Tiles pages.

Tile actions with local forward

We create two actions to display About Us and Contact Us pages.

- ▶ Open the Web Diagram, as we have done in the prior sections, use the Struts Action button ( **Struts Action**) to create actions with names of `/contactUs` and `/aboutUs`.
- ▶ For each action, create a local forward by selecting the action and **Add Link** → **Local Forward** (or use the arrow icon when hovering over the action). Accept the default local forward name of `success` (Figure 15-24).



Figure 15-24 Actions for Tiles

- ▶ Set the path value for both actions in the Properties view, Forward Config tab, when selecting the `success` local forward (Figure 15-25). For `/contactUs`, have the path of the `success` local forward point to `contactUs.config`, and for `/aboutUs` to `aboutUs.config`.

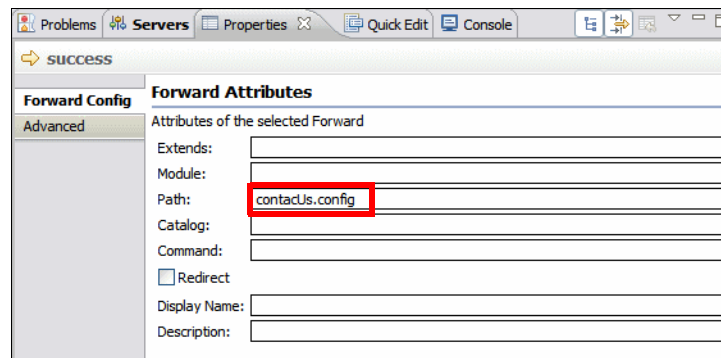

Figure 15-25 Editing the Forward Config for local forwards

- ▶ Add two connections from `customerListing.jsp` to the two actions, and select **Struts Link** when prompted.

Tiles configuration file

We modify the Tiles configuration file to define Tiles areas actions and their relationship with the Web pages. To do that open the Tiles configuration file `tiles-def.xml` and add these definitions, or replace it with the following one `C:\7672code\struts\tiles\tiles-def.xml`:

```

<!--Define each of your definitions here-->
<definition name="contactUs.config" path="/bankTemplate.jsp">
  <put name="header" value="/bankHeaderTile.jsp"/>
  <put name="body" value="/bankContactUsTile.jsp"/>
</definition>
<definition name="aboutUs.config" path="/bankTemplate.jsp"
              extends="contactUs.config">
  <put name="body" value="/bankAboutUsTile.jsp"/>
</definition>

```

Tiles Web pages

The web pages of our Tiles application have the following logic:

- ▶ Tile Contact Us page is built using a template `bankTemplate.jsp`, a header `bankHeaderTile.jsp`, and a body `bankContactUsTile.jsp`.
- ▶ Tile About Us page extends the Contact Us page with another body.

Import the following Tiles Web pages from `C:\7672code\struts\tiles` into `WebContent`:

```

bankAboutUsTile.jsp
bankContactUsTile.jsp
bankHeaderTile.jsp
bankTemplate.jsp

```

- ▶ The template points to the header and body pages.
- ▶ The header includes the image and ITSO Bank title.
- ▶ The body pages contain descriptive text.

Add the links to the Struts Web page

The two Struts links have been added to the `customerListing.jsp`. Copy the two links from the `<div>` section at the top to a place before the `logout` link:

- ▶ Generated code in `<div>`:

```

<html:link action="/contactUs">Struts Link Label</html:link><br>
<html:link action="/aboutUs">Struts Link Label</html:link><br>

```

- ▶ Final code in HTML table:

```

<TD>Welcome <B>
  <bean:write name="customer" scope="request" property="firstName" />
  <bean:write name="customer" scope="request" property="lastName" /> ...

```



```

<TD width="128" align="right"><html:link action="/contactUs">
    Contact Us</html:link></TD>
<TD width="128" align="right"><html:link action="/aboutUs">
    About Us</html:link></TD>
<TD width="128" align="right"><html:link action="/logout">
    logout</html:link></TD>

```

- ▶ Delete the <div> section after copying the links into the HTML table.

Tiles recapitulation

We have created and/or imported the necessary components. In essence, we have created two action classes which each (when executed successfully) forwards to a Tiles configuration. The Tiles configuration contains information on how the eventual page should render. The actual page is constructed at runtime.

The action entries in the `struts-config.xml` file have this format:

```

<action path="/contactUs" type="rad75strutsweb.actions.ContactUsAction">
  <forward name="success" path="contactUs.config">
    </forward>
</action>
<action path="/aboutUs" type="rad75strutsweb.actions.AboutUsAction">
  <forward name="success" path="aboutUs.config">
    </forward>
</action>

```

Note: There is a mapping in the logical name between the path value of the success local forward within the `/contactUs` action mapping entry in the `struts-config.xml` and the `contactUs.config` entry in the `tiles-def.xml`.

The `ContactUsAction` and `AboutUsAction` classes were generated automatically when we added the actions to the Web Diagram. No code change is necessary.

Tiles runtime behavior

When a `/contactUs` request arrives, Struts invokes the `ContactUsAction` class, which forwards a success local forward. Struts forwards control to the `contactUs.config` Tiles configuration. This configuration is based on the `bankTemplate.jsp`, with a header `bankHeaderTile.jsp` and a body `bankContactUsTile.jsp`. The assembly of the page displayed occurs at runtime.

The processing for an `/aboutUs` request is similar, however, the `aboutUs` configuration extends the `contactUs` configuration and inherits the header.

Running the Tiles application

To test the Tiles application, start with the **logon.jsp** → **Run As** → **Run on Server**:

- ▶ Logon as a customer and the accounts are displayed (Figure 15-26).

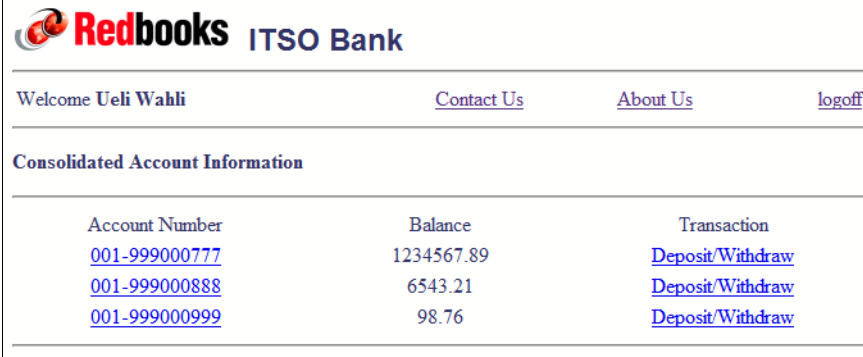

Redbooks ITSO Bank		
Welcome Ueli Wahli		Contact Us
		About Us
logoff		
Consolidated Account Information		
Account Number	Balance	Transaction
001-999000777	1234567.89	Deposit/Withdraw
001-999000888	6543.21	Deposit/Withdraw
001-999000999	98.76	Deposit/Withdraw

Figure 15-26 Customer with accounts and new links

- ▶ Click **Contact Us** and the Tiles page is displayed (Figure 15-27).

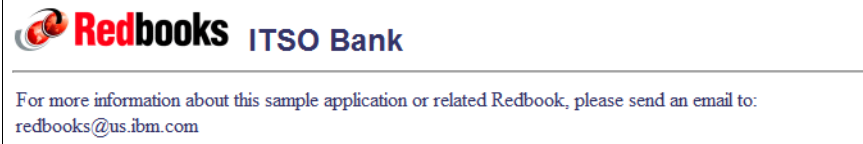

Redbooks ITSO Bank	
For more information about this sample application or related Redbook, please send an email to: redbooks@us.ibm.com	

Figure 15-27 Tiles page: Contact Us

- ▶ Click **About Us** and the Tiles page is displayed (Figure 15-28).



Redbooks ITSO Bank	
IBM International Technical Support Organization	
IBM Redbooks are developed and published by the IBM International Technical Support Organization, ITSO. The ITSO develops and delivers skills, technical know-how, and materials to IBM technical professionals, Business Partners, clients, and the marketplace in general.	
The ITSO works with IBM Divisions and Business Partners in the process of developing IBM Redbooks, Redpapers, Technotes, workshops, and other materials. The ITSO is part of the IBM Global Content Services organization within IBM Sales & Distribution.	

Figure 15-28 Tiles page: About Us

Importing the final sample application

In the previous sections we described how to build and run a Struts Web application. If you did not manage to build the application, you can import the project interchange file from:

```
C:\7672code\zInterchange\struts\RAD75Struts.zip
C:\7672code\zInterchange\struts\RAD75Struts-Tiles.zip
```

- ▶ Select **File** → **Import** → **Project Interchange** and click **Next**.
- ▶ In the Import wizard select **Other** → **Project Interchange** and click **Next**.
- ▶ Click **Browse** to locate the interchange ZIP file and click **Open**.
- ▶ Select both projects and click **Finish**.
- ▶ The RAD75StrutsWeb and RAD75StrutsEAR projects are imported.
- ▶ Open the Web Diagram in the RAD75StrutsWeb project (Figure 15-29). The diagram looks like Figure 15-3 on page 453, with the two Tiles action added and two more links from `customerListing.jsp` to the two Tiles actions.

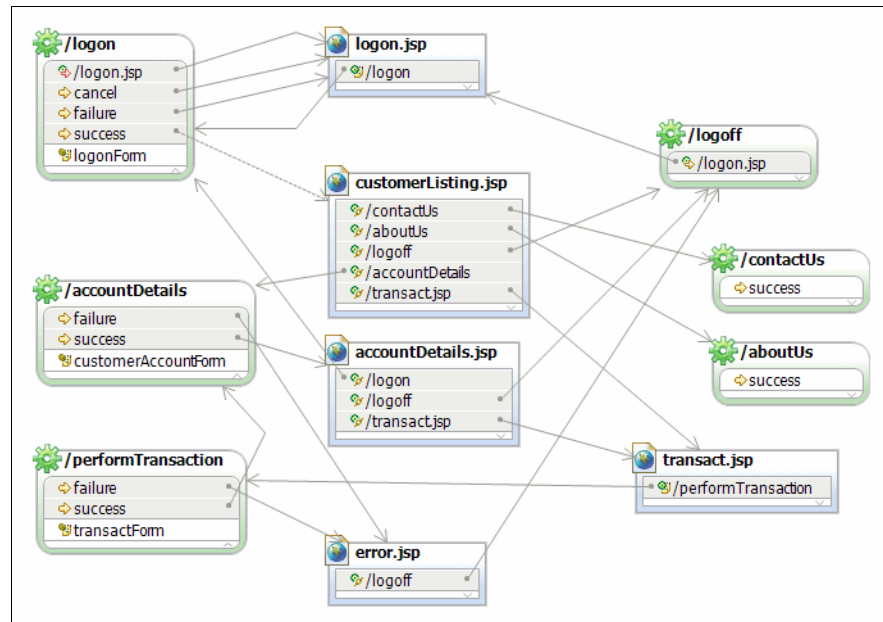

Figure 15-29 Complete Web Diagram with Tiles actions

More information

For more information about Struts and Tiles, consult these Web sites:

- ▶ Apache Struts home page:
<http://struts.apache.org/>
- ▶ Apache Struts User Guide:
<http://struts.apache.org/userGuide/introduction.html>
- ▶ Apache Tiles home page:
<http://tiles.apache.org/>
- ▶ IBM developerWorks (search for Struts and Tiles):
<http://www.ibm.com/developerworks/>



Develop Web applications using JSF

JavaServer Faces (JSF) is a framework that simplifies building user interfaces for Web applications. JPA is the Java Persistence API, described in Chapter 12, “Persistence using the Java Persistence API (JPA)” on page 267.

This chapter introduces the features, benefits, and architecture of JSF. The focus of the chapter is to demonstrate the Rational Application Developer support and tooling for JSF. The chapter includes an example Web application using JSF, with persistence implemented in JPA.

The chapter is organized into the following sections:

- ▶ Introduction to JSF
- ▶ Developing a Web application using JSF and JPA

The sample code for this chapter is in `7672code\jsf`.

Introduction to JSF

This section provides an introduction to JavaServer Faces (JSF).

JavaServer Faces (JSF) overview

JavaServer Faces is a framework that simplifies building user interfaces for Web applications. The combination of the JSF technology and the tooling provided by IBM Rational Application Developer allows developers of differing skill levels the ability to achieve the promises of rapid Web application development.

This section provides an overview of the following aspects of JSF:

- ▶ JSF features and benefits
- ▶ JSF application architecture
- ▶ JSF features in Application Developer 7.0

Note: Detailed information on the JSF specification can be found at:

<http://java.sun.com/j2ee/javaserverfaces/download.html>

JSF features and benefits

The following list describes the key features and benefits of using JSF for Web application design and development:

- ▶ **Standards-based Web application framework:**
 - JSF is a standards-based Web application framework. JavaServer Faces technology is the result of the Java Community process JSR-127 and evolved from Struts. JSF addresses more of the model-view-controller pattern than Struts, in that it more strongly addresses the view or presentation layer through UI components, and addresses the model through managed beans. Although JSF is an emerging technology and is likely to become a dominant standard, Struts is still widely used.
 - JSF is targeted at Web developers with little knowledge of Java and eliminates much of the hand coding involved in integrating Web applications with back-end systems.
- ▶ **Event driven architecture:** JSF provides server-side rich UI components that respond to client events.
- ▶ **User interface development:**
 - UI components are de-coupled from their rendering. This allows for other technologies such as WML to be used (for example, mobile devices).
 - JSF allows direct binding of user interface (UI) components to model data.

- Developers can use extensive libraries of prebuilt UI components that provide both basic and advanced Web functionality.
- ▶ **Session and object management:** JSF manages designated model data objects by handling their initialization, persistence over the request cycle, and cleanup.
- ▶ **Validation and error feedback:** JSF allows direct binding of reusable validators to UI components. The framework also provides a queue mechanism to simplify error and message feedback to the application user. These messages can be associated with specific UI components.
- ▶ **Internationalization:** JSF provides tools for internationalizing Web applications, including supporting number, currency, time, and date formatting, and externalization of UI strings.

JSF application architecture

The JSF application architecture can be easily extended in a variety of ways to suit the requirements of your particular application. You can develop custom components, renderers, validators, and other JSF objects and register them with the JSF runtime.

The focus of this section is to highlight the JSF application architecture depicted in Figure 16-1.

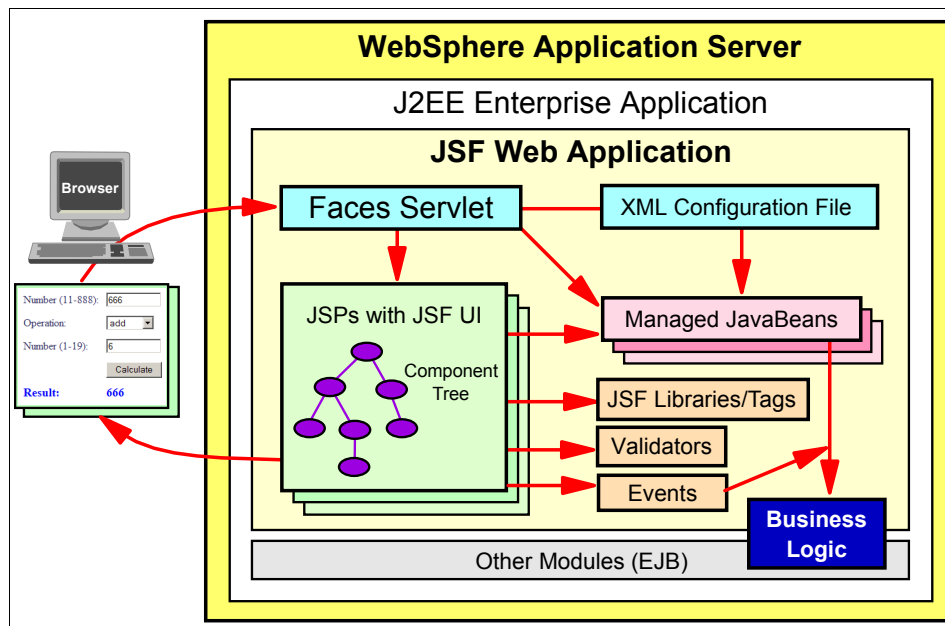

Figure 16-1 JSF application architecture

- ▶ Faces JSP pages are built from JSF components, where each component is represented by a server-side class.
- ▶ Faces servlet: One servlet (FacesServlet) controls the execution flow.
- ▶ Configuration file: An XML file (faces-config.xml) that contains the navigation rules between the JSPs, validators, and managed beans.
- ▶ Tag libraries: The JSF components are implemented in tag libraries.
- ▶ Validators: Java classes to validate the content of JSF components, for example, to validate user input.
- ▶ Managed beans: JavaBeans defined in the configuration file to hold the data from JSF components. Managed beans represent the data model and are passed between business logic and user interface. JSF moves the data between managed beans and user interface components.
- ▶ Events: Java code executed in the server for events (for example, a push button). Event handling is used to pass managed beans to business logic.

Figure 16-2 represents the structure of a simple JSF application created in Application Developer.

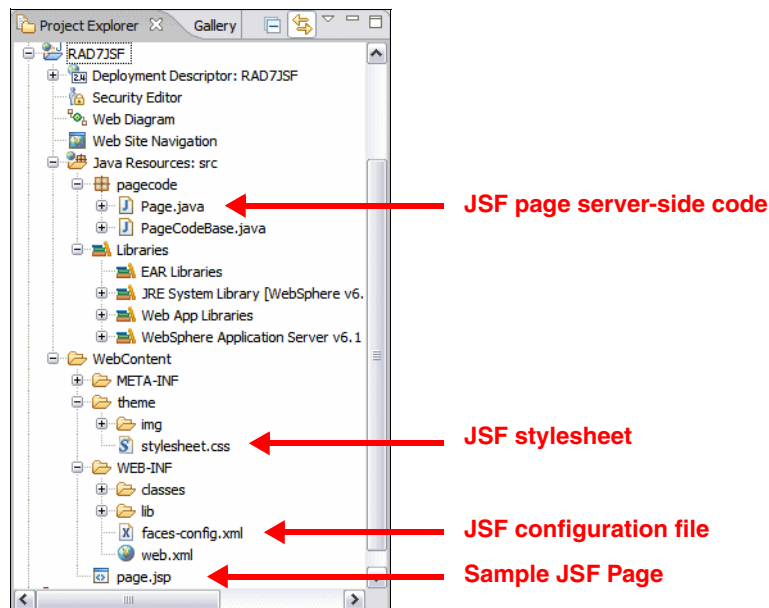

Figure 16-2 JSF application structure within Application Developer

JSF features in Application Developer 7.0

Application Developer includes a wide range of features for building highly functional Web applications. Application Developer includes full support to make drag-and-drop Web application development a reality.

Application Developer includes the following support and tooling for JSF Web application development:

- ▶ Visual page layout of JSF components using Page Designer
- ▶ Web Diagram Editor for defining the flow of a JSF application
- ▶ Built-in Component Property editor
- ▶ Built-in tools to simplify and automate event handling
- ▶ Page navigation defined declaratively
- ▶ Automatic code generation for data validation, formatting, and CRUD functions for data access
- ▶ Multiple faces configuration file support for different purposes, such as navigation and managed beans
- ▶ Relational database support
- ▶ EJB support
- ▶ Web services support
- ▶ Data abstraction objects for easy data connectivity using JPA
- ▶ Data objects can be bound easily to user interface components
- ▶ Support for runtime page templates with Tiles

Application Developer v7.0 has additional rich and powerful components for JSF. These components include Menu Bar (displays a menu bar of buttons and/or hyperlinks), Panel - Dialog (creates a block panel that behaves like a modal or modeless dialog box), Panel - Form Box (creates a block panel that contains a header area and one or more form label/field pairs), Panel - Section (creates a block panel that has a header that can be used to expand/collapse the display of the panel's content), Select - Color (displays a drop-down combo box from which the user chooses a color), Select - Calendar (adds small calendar to the page), Progress Bar (displays an animated progress bar), Link - Request (generates an HTML link with a URL that can pass parameters and navigate to a page by passing a string to JSF navigation rules), Data Iterator (iterates over rows of model data allowing values from each row to be used in child components).

Application Developer v7.0 also provides additional improvements to existing JSF components. Some of these improvements are as follows:

- ▶ Command buttons can now have icons.

- ▶ A Data Table component can now have sortable columns.
- ▶ Data Table component rows can now have single select mode using the radio buttons.
- ▶ A JSF panel content can now be updated using AJAX.

In addition to new and enriched JSF components, Application Developer v7.0 introduces new tools to provide much more development efficiency and minimize development time. These new tools for JSF are:

- ▶ **VBL Expression Builder:** Attributes of JSF components can be specified by expressions created visually using the expression builder.
- ▶ **Pattern Builder:** Some JSF components that have date and number formats can use patterns created visually using the pattern builder.
- ▶ **Resource bundle editor:** JSF applications support localization that requires externalizing all the strings used in Faces JSP files into resource bundles. The resource bundle editor visually works with these resource bundle files so that the user can easily externalize all the strings.
- ▶ **Improved Quick Edit view:** The Quick Edit view lets you add short scripts to your HTML and JSP files. The view now supports a library of pre-defined JavaScript functions on JSF components.

JSF features in Application Developer 7.5

Application Developer 7.5 provides additional features for JSF:

- ▶ Dynamic Web project with JSF support
- ▶ Improved Faces Configuration editor
- ▶ Customizable property templates for data types (such as Date)
- ▶ 3rd party library integration with customizable palette
- ▶ Custom component library building
- ▶ Integration with JPA to easily create Web applicaitons with persistence

Preparing for the sample

This section describes the tasks that must be completed prior to developing the JSF and JPA sample application.

Note: A completed version of the Web application built using JSF and SDO can be found in the `c:\7672code\zInterchange\jsf\RAD75JSF.zip` project interchange file. If you do not want to create the sample yourself, but want to see it run, follow the procedures described in “Running the JSF application” on page 532.

Setting up the sample database

To use JPA components, we require a relational database. This section provides instructions for deploying the ITSOBANK sample database and populating the database with sample data. For simplicity we use the built-in Derby database.

Follow the instructions in “Setting up the ITSOBANK database” on page 1154 to create and load the sample ITSOBANK database.

Create a database connection

Follow the instructions in “Creating a connection to the ITSOBANK database” on page 229 to create the **ITSOBANKderby** connection (if you do not have the connection already defined).

Configuring the data source

There are a couple of methods that can be used to configure the data source, including using the WebSphere Administrative Console or using the WebSphere Enhanced EAR, which stores the configuration in the deployment descriptor and is deployed with the application.

While developing JSF and JPA Web applications with Application Developer v7.5, the data source is created automatically when you add JPA managed data to a Faces JSP file. The data source configuration is added to the EAR deployment descriptor.

However, if you already have defined the **ITSOBANKderby** data source in the server (“Configuring the data source in WebSphere Application Server” on page 1155), then you can run into problems because you can only have one active connection to the database. Removing all applications from the server and restarting the server clears the connection.

Developing a Web application using JSF and JPA

In this section we describe a Web application implemented with JavaServer Faces (JSF).

We could use a similar technique as we used for the Struts application, and implement a helper class to interact with the session bean. In JSF, for each JSP a managed bean class is generated. For each action in the JSPs, a method in the managed bean class is invoked. In those methods we could use the helper class to interact with the session bean and retrieve the necessary data.

Application Developer 7.5 provides tooling to interact directly with the JPA entities without using a session bean. A helper classed is created for each JPA entity, with methods such as find, create, delete, update, and named query invocation. We use this tooling support for our example.

Project setup

We use two projects for this application:

- ▶ RAD75JSFEAR—Enterprise application with one Web module
- ▶ RAD75JSFWeb—JSF Web application with facets for JSF and JPA

Creating the Web project

We create a dynamic Web project named RAD75JSFWeb with JSF and JPA support:

- ▶ Create the project (Figure 16-3):
 - Type the Project name as **RAD75JSFWeb**.
 - For Target Runtime, select **WebSphere Application Server v7.0**.
 - For Dynamic Web Module version, select **2.5**.
 - For EAR Membership, **Add project to an EAR**, and type **RAD75JSFEAR** as EAR Project Name.
 - For Configuration, select **JavaServer Faces v1.2 Project**, then click **Modify**.

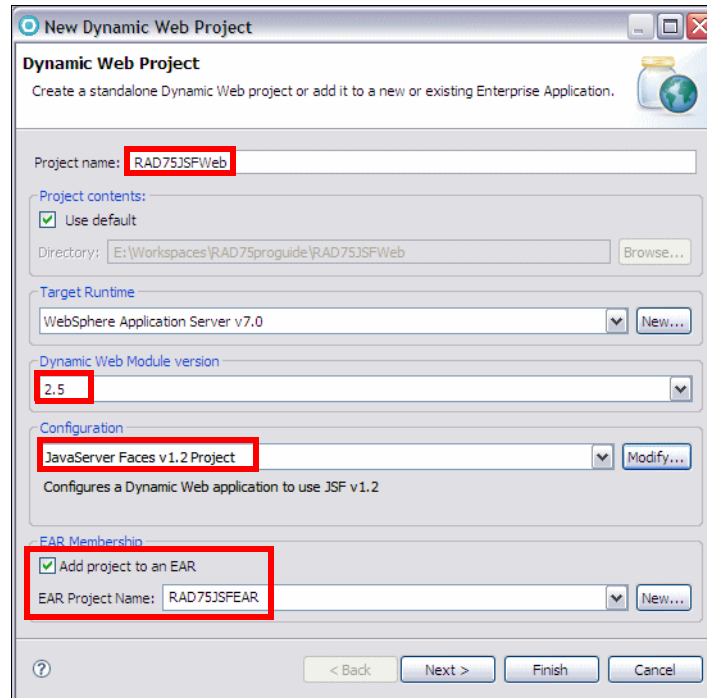

Figure 16-3 Web project for JSF

- ▶ In the Project Facets dialog (Figure 16-4):
 - Select **Faces support (base)**, **Faces support (enhanced components)**, **Java Persistence**, **JavaServer Faces** (preselected), **JSTL**, **WebSphere Web (Co-existence)** and **WebSphere Web (Extended)**.
 - Click **OK**. The configuration changes to <custom>.

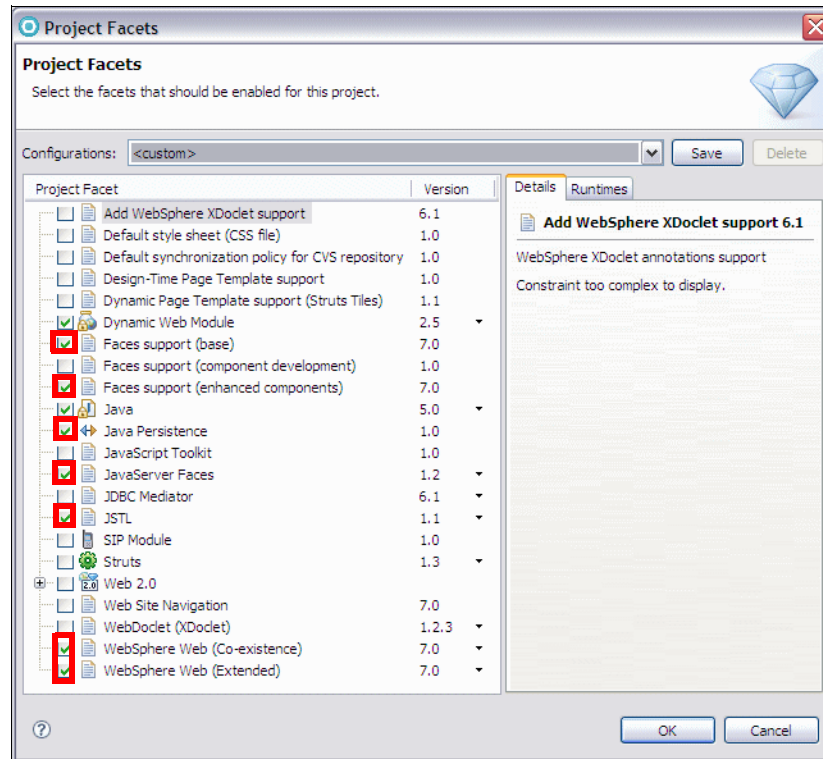

Figure 16-4 Web project facets for JSF

- ▶ Click **Next**, accept the context root, and select **Generate deployment descriptor**.
- ▶ For JPA Facet:
 - Select the **ITSOBANKderby** connection that was defined for the JPA sample application. Click **Connect** if the connection is not active.
 - Select **Use implementation provided by the server runtime, Discover annotated classes automatically**, and **Create orm.xml**.
 - Click **Next**.
- ▶ For JSF Capabilities, select **Server Supplied JSF Implementation**, and accept the other defaults (such as `/WEB-INF/faces-config.xml`).
- ▶ Click **Finish** and the project is created.
- ▶ Switch to the Web perspective when prompted.
- ▶ Close the Technology Quickstarts editor.

Project facets

You can review and change the project facets in the Properties dialog of the project by selecting **Project Facets**.

Structure of the JSF Web application

We can build the basic structure of the Web application using the Web Diagram. The sample application consists of the following three pages:

- ▶ Login page (logon): Validate the social security number (SSN). If it is valid it then display the customer details for the customer.
- ▶ Customer details page (customerDetails): Display the accounts of the customer and allow you to select an account to view the transactions.
- ▶ Account details page (accountDetails): Display the selected account details.

Create a Faces JSP page using the Web Diagram Editor

To create a Faces JSP page using the Web Diagram Editor, do these steps:

- ▶ In the Enterprise Explorer, expand **RAD75JSFWeb**.
- ▶ Open the **Web Diagram**.
- ▶ Select **Web Page** from the Web Parts palette (the Palette view is on the top right in the Web perspective) and drag it onto the page. The page appears as an icon, with the name (page) selected and a **...** button.
- ▶ Click the **...** button immediately to launch the page selection wizard. If you react too late, delete the page.jsp that is created.
- ▶ In the **Web Page Selection** dialog, click **New Web Page** to create a new page.

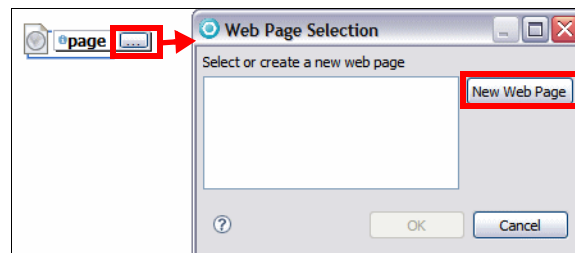

- ▶ In the New Web Page dialog, type **logon.jsp** as File Name. In the Template section, select **Basic Templates** → **JSP** (preselected) and click **Finish**.
- ▶ In the Web Page Selection dialog, select the **logon.jsp** and click **OK**.
- ▶ A *realized node* is shown in the diagram.

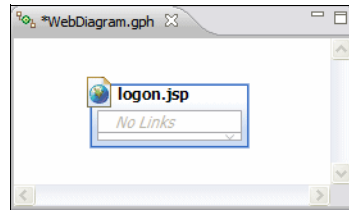

A node in a Web Diagram is *realized* when its underlying resource exists. Otherwise the node is *unrealized*. When you add a node to a Web Diagram, its underlying resource (for example, a Web page) is normally created automatically. In other words, you realize a node by default when you create it. Alternatively, you can add a node to a diagram without creating its underlying resource.

In a Web Diagram, realized and unrealized nodes are shown differently. Realized nodes have color and black title text. Unrealized nodes are gray and have gray title text. In our sample, the logon page is realized.

Tip: If you want to create the associated resource later, press **Shift+Enter** after you drag **Web Page**  onto the page, otherwise the underlying resource is created automatically.

- ▶ Repeat the process to create Web pages for the other two JSF pages:
 - `customerDetails.jsp`—Customer details and account overview
 - `accountDetails.jsp`—Account details with transactions

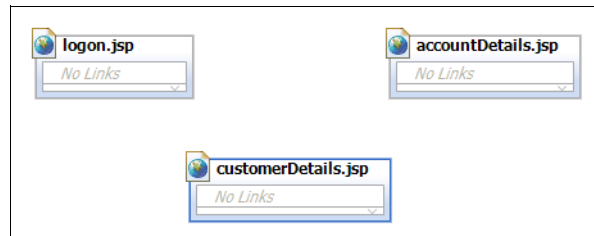

- ▶ Notice that all three pages are realized (black title). Save the Web Diagram.

Create connections between Faces JSP pages

Now that the pages have been created, we can create connections between the pages using the Web Diagram Editor.

To add connections between pages, do these steps:

- ▶ Place the mouse over the **logon.jsp**. A connection handle is displayed near the top right corner of the node. Drag the connection handle to the **customerDetails.jsp**. When prompted, select **Faces Navigation** as connection type.

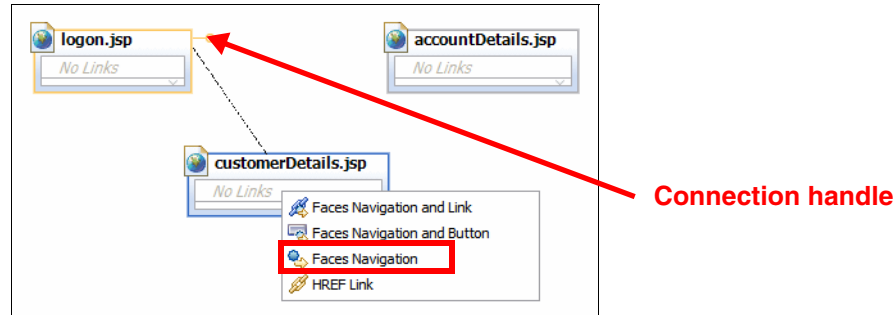

- ▶ Change the name of the success action under Available Outcomes. Select the **success** action to highlight the text. Change the name in the Properties view, Outcome Named field, from success to **login**.

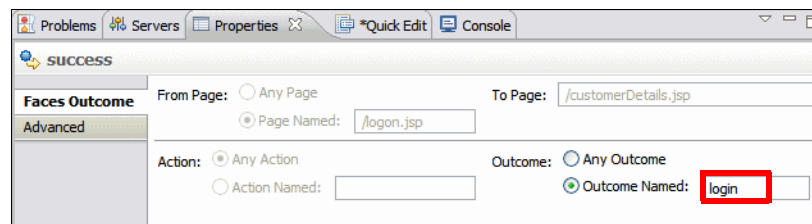
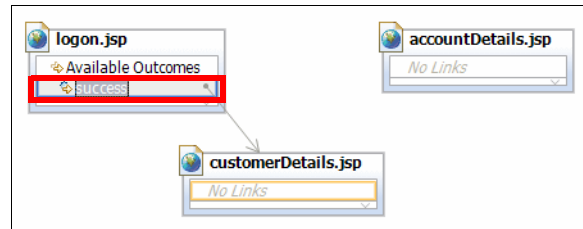

- ▶ Save the Web Diagram.
- ▶ An arrow is drawn from `logon` to `customerDetails`. The line is solid because the connection has been *realized* (added to the `faces-config.xml`).
- ▶ We have a link from the `logon.jsp` to the `customerDetails.jsp`. This link is activated when the outcome of an action on the `logon` page is `login`. To review how this link is realized in the JSF configuration, do these steps:



- Expand **RAD75JSFWeb** → **WebContent** → **WEB-INF** and open the **faces-config.xml** file.
- Verify that the navigation rule was added in the Source tab:

```
<navigation-rule>
  <from-view-id>/logon.jsp</from-view-id>
  <navigation-case>
    <from-outcome>login</from-outcome>
    <to-view-id>/customerDetails.jsp</to-view-id>
  </navigation-case>
</navigation-rule>
```
- The navigation rule is also visible in the Navigation Rule tab.
- Close the **faces-config.xml** file.

Create a Faces action

The Web Diagram Editor provides the means to create faces actions and connect Web pages to these actions.

To create a new Faces action, do these steps:

- ▶ Create an empty class `itso.jsf.action.Logout` (select **New** → **Class**, and type **itso.jsf.action** as package and **Logout** as class name).
- ▶ In the Web Diagram, from the Web Parts palette select **Faces Action (Managed Bean)**  **Faces Action (Managed Bean)** and drag it onto the page. Click the  button immediately to launch the Faces Action selection dialog.
- ▶ Click **New** to create a new Faces action.
- ▶ In the New Faces Action dialog:
 - Type **logout** in the Managed bean name and **logout** in the Action method field.
 - Select **request** for Scope.
 - Click **Browse** and locate an existing managed bean. Select the **Logout** class.

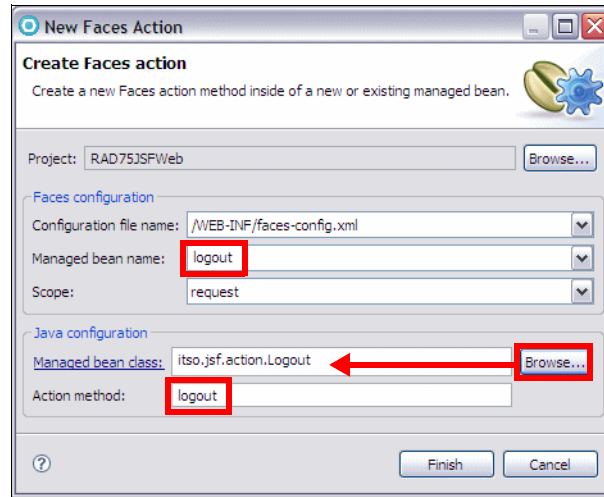

- ▶ Click **Finish**.
- ▶ In the Faces Action Selection dialog, select **logout** → **logout** and click **OK**. (You may have to close the dialog and reopen it with the  button to see the new action.)
- ▶ A logout method is added to the Logout class (Example 16-1). Replace the generated code with `return "logout";`

Example 16-1 Logout class

```

package itso.jsf.action;
public class Logout {
    public String logout() {
        //Put your logic here, returning appropriate outcome strings.
        boolean condition=true;
        if (condition) {
            return "success";
        }
        return "failure";
        return "logout";
    }
}

```

The logout action is added to the Web Diagram.

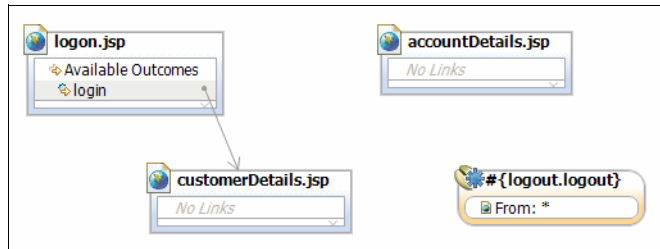

Add a connection for the action

To add a connection from the Action to a page, do these steps:

- ▶ Place the mouse over the **logout** action. A connection handle is displayed near the top right corner of the node. Drag the connection handle to the **logon.jsp**.
- ▶ Change the name of the success action to **logout** (in the Properties view). The new navigation rule is added to the `faces-config.xml` file.

Add remaining navigation rules

We now have an action bean that performs an action to return the user to the logon screen. We have to define the remaining navigation rules in the Web Diagram:

- ▶ Create a connection from `customerDetails` to `accountDetails` (Faces Navigation) and name the action **accountDetails**.
- ▶ Create a connection from `accountDetails` to `customerDetails` and name the action **customerDetails**.
- ▶ After adding the connections and rearranging the pages and action, rearrange and save the Web Diagram.

Tip: To change the shape of a connection, select the connection, point somewhere on the line and drag the mouse away to reshape the line for better visibility.

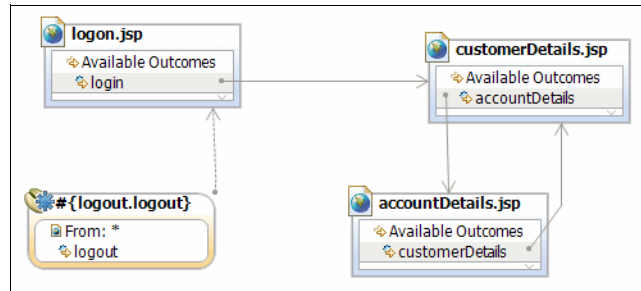

- ▶ Most functions in the Web Diagram Editor are available from the context-menu. To access any of these functions, right-click in the diagram and select an item from the menu.

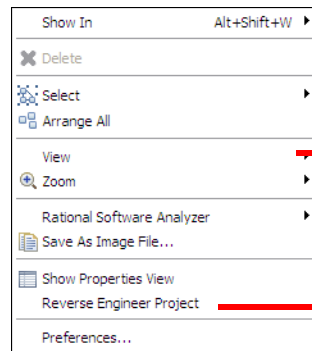

Grid, Rulers

Populate diagram from existing Web pages

Editing the Faces JSP pages

This section demonstrates the JSF editing features in Application Developer by using the JSF pages created through the Web Diagram.

Editing the login page

We complete the login page in a few stages.

Add the UI components

To add the UI components to the `logon.jsp` page, do these steps:

- ▶ Open the **logon.jsp** by double-clicking the file in the Web diagram or in the WebContent folder. Select the **Design** or the **Split** tab.
- ▶ Use the Enhanced Faces Components palette to drag and drop components.

- ▶ Add the `itso_logo.gif` image to WebContent from the sample code (`7672code\jsf\jsp`).
- ▶ Drag an **Image** component from the Enhanced Faces Components into the JSP.
- ▶ Drag the **itso_logo.gif** image onto the component.
- ▶ Add an **Output** component, and in the Properties view set the value to **EJB 3.0 Bank**, change the style to Arial size 18 (click the **Style** icon, select the **Arial** font and click **Add**, set the size to **18**).
- ▶ Add a Horizontal Rule (from the HTML Tags palette).

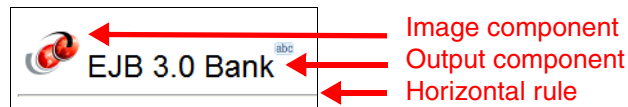

Add a variable for the SSN

When a page has a field where text is entered, the input can be stored. This is accomplished by creating a session scope variable to store the entered value and bind it with an input field.

To create a variable, do these steps:

- ▶ In the Page Data view, expand **Scripting Variables**.
- ▶ Right-click **sessionScope** and select **New** → **Session Scope Variable**.
- ▶ In the Add Session Scope Variable dialog, enter **SSN** for the Variable name, and `java.lang.String` for Type, and click **OK**. The variable is added to the Page Data view.

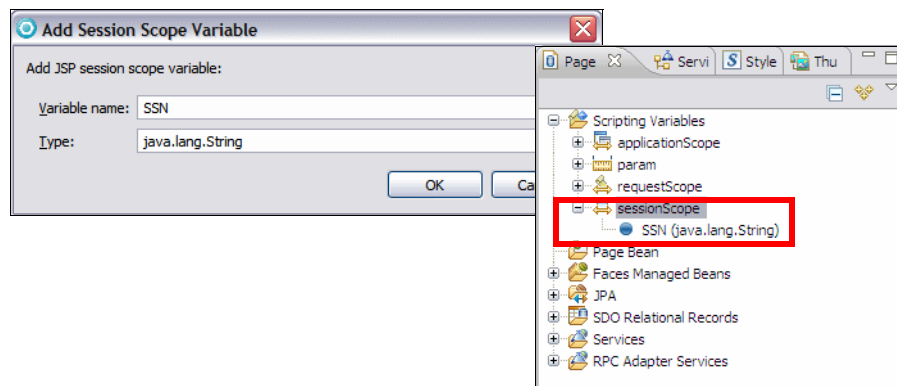

Create a form for the SSN

A variable can be dropped into the page to create a form with an input field and a push button:

- ▶ In the Page Data view, expand and select **Scripting Variables** → **sessionScope** → **SSN**. Drag SSN into the area under the horizontal line. A tooltip pop-up says *Drop here to insert new controls for "SSN"*.
- ▶ In the Insert JavaBean dialog:
 - Select **Inputting data**.
 - Overtyping the generated Label with **Enter Customer SSN:**.
 - Leave the control type as **Input Text**.
 - Click **Options**, select **Submit button**, type **Enter** for the Label, and click **OK**.

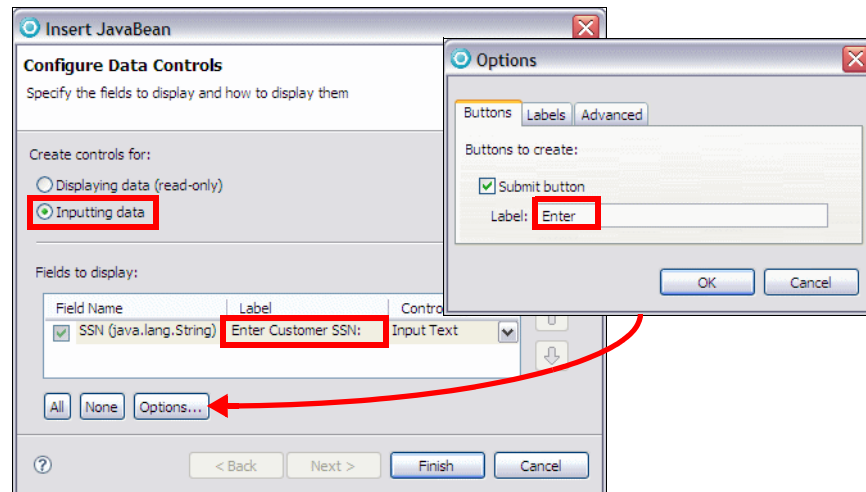

- ▶ Click **Finish**. Select the **{ErrorMessage}** control and change the style color to red in the Properties view. For Style: Props enter **color: red**. (You could also click the Style icon  and select the red color for the Color field.)

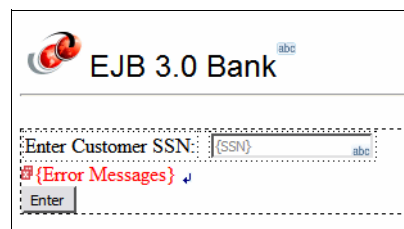

- ▶ Save the `login.jsp`.
- ▶ Select the `{SSN}` input field and verify in the Properties view that the value is set to `#{sessionScope.SSN}`. This value indicates that the input field is bound to the session variable `SSN`. The session variable value will be displayed in the field and any change to the value is stored in the session variable.

Add simple validation

JSF offers a framework for performing validation on input fields such as required values, validation on the length of the input, and input check for all alphabetic or digits. You can also define your custom validations.

To add simple validation to an input field, do these steps:

- ▶ Select the Input component `{SSN}` in the Design tab.
- ▶ In the Properties view for the input component. Enter the following items in the Validation tab:
 - Select **Value is required**.
 - Select **Display validation error message in an error message control**. When you select this check box an error message component is added next to the Input box.
 - Enter **11** in the Minimum and Maximum length fields.

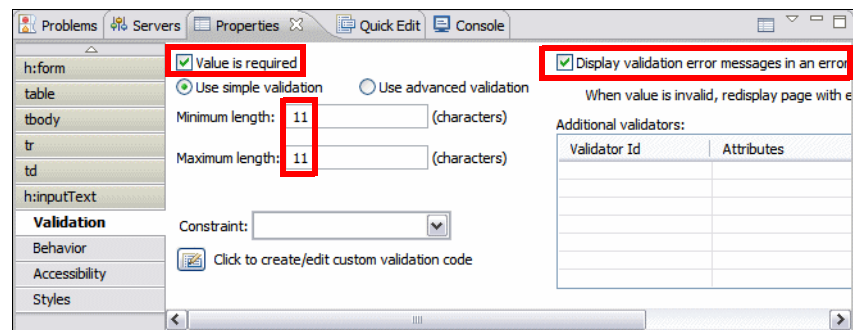

- ▶ Make the `{Error Message for ssn1}` component red.

Note: If we do not add an error message field for an input field, messages are displayed automatically in the `{Error Messages}` field for the whole page.

Add static navigation to a page

Static navigation is called when the page is submitted. The string value returned by the method is matched against the application's navigation rules.

To add static navigation to the page, do these steps:

- ▶ Select the **Enter** component (Command - Button).
- ▶ Next to the Properties view, select the **Quick Edit** view. Click in the code snippet field, and sample code is generated. Complete the return statement as:

```
return "login";
```

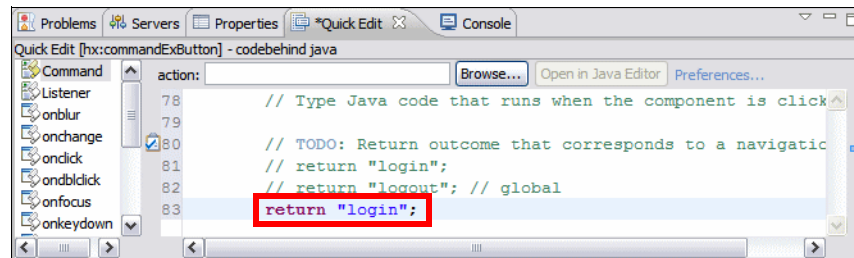

- ▶ Save the login.jsp. The action logic is stored as a doButton1Action method in the pagecode.Logon.java file.
- ▶ In the Source tab you can see the generated source code for the input field and the Enter button:

```
<h:inputText styleClass="inputText" id="ssn1"
  value="#{sessionScope.SSN}" required="true">
  <f:validateLength minimum="11" maximum="11"></f:validateLength>
</h:inputText>
<h:message for="ssn1" style="color: red"></h:message>
.....
<hx:commandExButton id="button1" styleClass="commandExButton"
  type="submit" value="Enter" action="#{pc_Logon.doButton1Action}">
</hx:commandExButton>
```

We have to compare the customer SSN to the values in the database. We do so by using a JPA entity to retrieve the records from the database.

Important: To retrieve records from the relational database, we require a connection. We use the **ITSOBANKderby** connection that was created in "Creating a connection to the ITSOBANK database" on page 229.

Creating a JPA manager bean

In this section we create a JPA manager bean and JPA entities for the EJB3BANK database. With the `logon.jsp` open in the editor, go to the Page Data view:

- ▶ If the server is running and uses the connection to the database, stop the server. Otherwise we cannot connect to the Derby database.
- ▶ Expand **JPA**. Right-click **JPA Manager Beans** and select **New** → **JPA Manager Bean**.
- ▶ In the JPA Manager Bean Wizard click **Create New JPA Entities**.

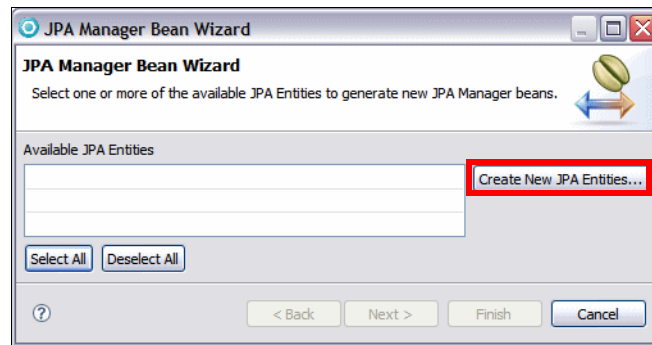

- ▶ For Connection, select the **ITSOBANKderby** connection. Click **Reconnect** if not connected already. Select the **ITSO** schema. Click **Next**.

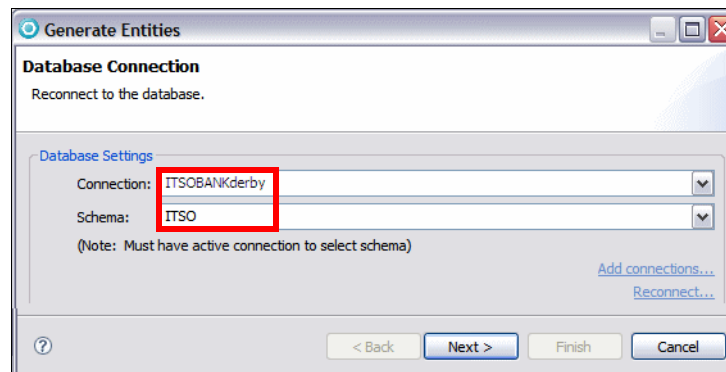

- ▶ Type **itso.bank.entity** as package name. Select **Synchronize Classes in persistence.xml** and select all the tables.
Overtyping the Transact entity name with **Transaction**.
Click **Finish**.

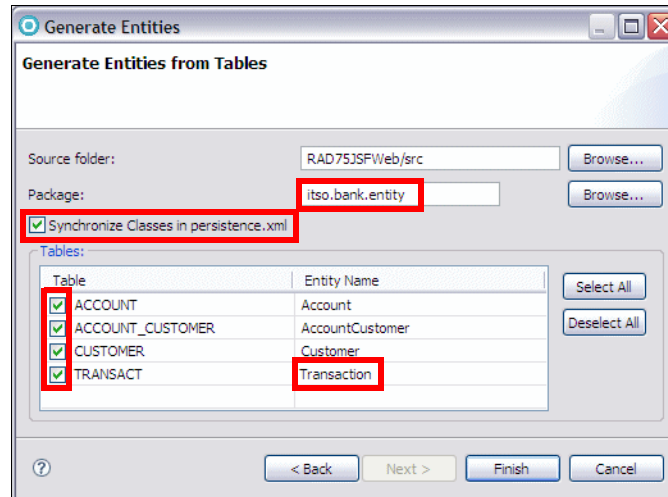

- Select the **Customer** entity and click **Next**.

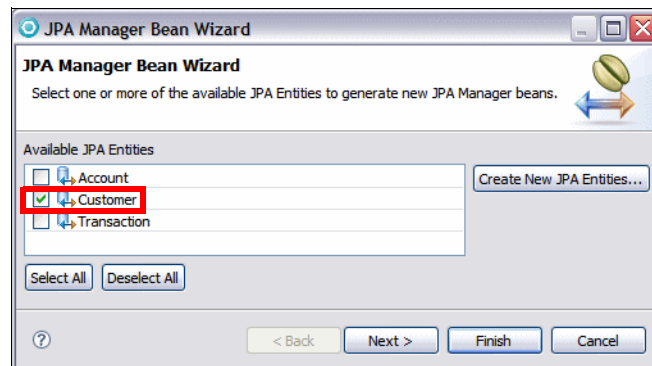

- For the Customer entity go through the pages on the left-hand side:
 - Primary key: Select **ssn** (preselected).
 - Query Methods: Remove `getCustomerByFirstname`, `getCustomerByLastname`, and `getCustomerByTitle`.
 - Relationships: **Account** (preselected)
 - Concurrency Control: **No Concurrency Control** (preselected)
 - Other: Select all, except **Use Resource Injection** and **Generate JSF Converter for target entity**. Click on **What do these options mean?** and you get a description of all the options.

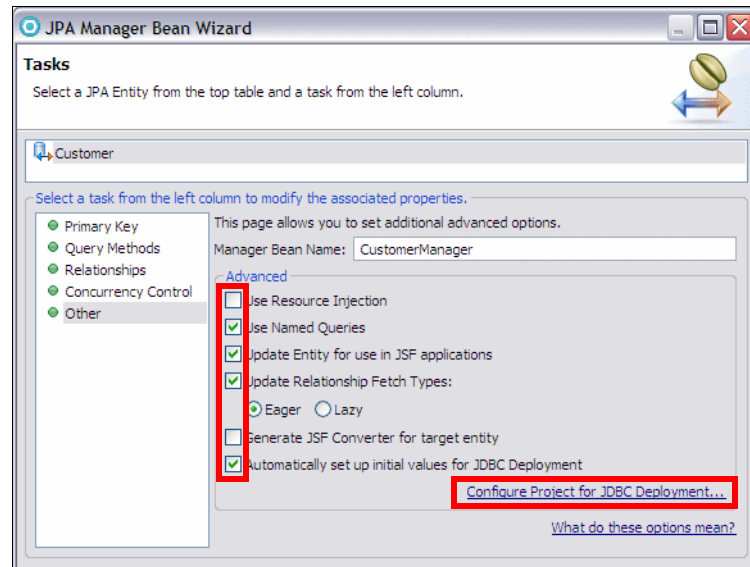

- ▶ Click **Configure Project for JDBC Deployment** to open the Set up connections for deployment dialog. Select the **ITSOBANKderby** connection, **ITSO** schema, clear **Deploy JDBC Connection information to server**, and click **OK**.

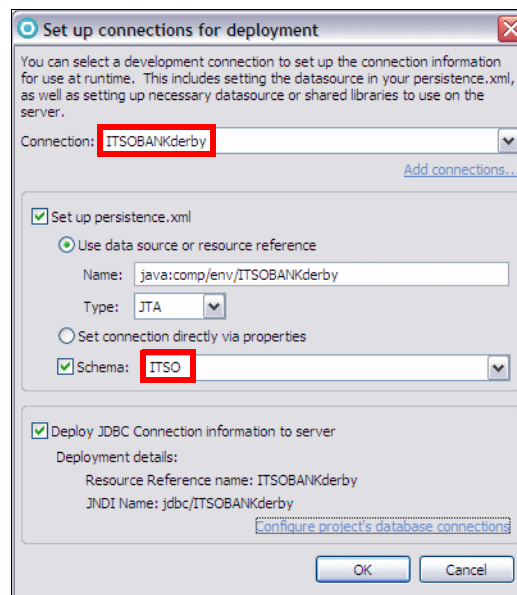

- ▶ Click **Finish**.
- ▶ Notice that the three generated JPA entities (Customer, Account, Transaction) do not contain @Table annotations with the ITSO schema:
 - Open the **Customer** entity (itso.bank.entity.Customer). Add the @Table annotation after the @Entity annotation:

```
import javax.persistence.Table;
@Entity
@NamedQueries(...)
@Table (schema="ITSO", name="CUSTOMER")
```
 - Open the **Account** entity, add the @Table annotation, and also add the table and schema in the @JoinTable annotation:

```
@Entity
@Table (schema="ITSO", name="ACCOUNT")
.....
@ManyToOne
@JoinTable(name="ACCOUNT_CUSTOMER", schema="ITSO",
  joinColumns=@JoinColumn(name="ACCOUNT_ID"),
  inverseJoinColumns=@JoinColumn(name="CUSTOMER_SSN"))
```
 - Open the **Transaction** entity and add the schema to the @Table annotation:

```
@Entity
@Table (schema="ITSO", name="TRANSACTION")
```
 - Select **Source** → **Organize Imports** to resolve the classes
- ▶ Open the generated itso.bank.entity.controller.CustomerManager. Notice the methods that have been generated for usage in JSF action code:
 - createCustomer—Persist a new customer entity
 - deleteCustomer—Delete a customer entity
 - updateCustomer—Update a customer entity
 - findCustomer—Find a customer entity by key
 - getCustomer—Retrieve all customers using a named query
 - getCustomerOrdered—Retrieve all customers sorted by ssn
 - getCustomerSelectList—Retrieve a list of ssn for a combo box
- ▶ The CustomerManager is added to the Page Data view of the logon.jsp.

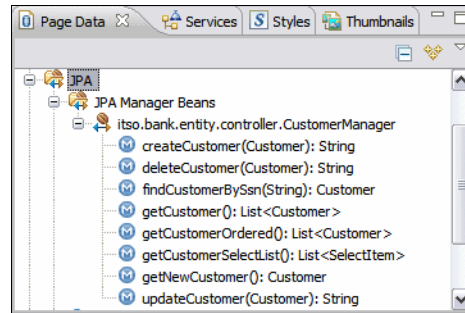

Verify the connection information

The connection information to a data source has been added in several places:

- ▶ The src/META-INF/persistence.xml file contains the <jta-data-source> tag with java:comp/env/ITSOBANKderby.

```
<persistence .....>
  <persistence-unit name="RAD75JSFWeb">
    <jta-data-source>java:comp/env/ITSOBANKderby</jta-data-source>
    <class>
      itso.bank.entity.Account</class>
    .....
  </persistence-unit>
</persistence>
```

- ▶ The WEB-INF/web.xml file contains a resource reference for the data source with the name ITSOBANKderby.
- ▶ The WEB-INF/ibm-web-bnd.xml file contains the JNDI name for the resource reference, binding-name="jdbc/ITSOBANKderby".
- ▶ The RAD75JSFEAR WebSphere deployment descriptor contains the definition of the data source:
 - Right-click **RAD75JSFEAR** and select **Java EE** → **Open WebSphere Application Server Deployment**.
 - Select the **Generated Derby JDBC Provider** and you can see the ITSOBANKderby data source.

This JDBC provider and the data source are deployed to the server together with the enterprise application.

Completing the action code for login

In the login action code we retrieve the customer and return login to pass control to the customerDetails.jsp:

- ▶ Open **Logon.java** in the pagecode package. You can also right-click in the logon.jsp and select **Edit Page Code**.

- ▶ Complete the action code (refer to 7672code\jsf\doButton1Action.txt, Example 16-2). Select **Source** → **Organize Imports** to resolve the classes.

Example 16-2 Logon action code

```
public String doButton1Action() {
    try {
        String ssn = (String)getSessionScope().get("SSN");
        System.out.println("Logon " + ssn);
        CustomerManager customerManager = (CustomerManager)
            getManagedBean("customerManager");
        Customer customer = customerManager.findCustomerBySsn(ssn);
        if (customer == null) throw new Exception("Customer not found");
        return "login";
    } catch (Exception e) {
        System.out.println("Login exception: " + e.getMessage());
        getFacesContext().addMessage("ssn1",
            new FacesMessage("Customer record not found."));
        return "failed";
    }
}
```

- ▶ We take the ssn and retrieve the customer. If no customer is found, we construct a JSF error message and place it into the error field associated with the ssn1 input field.

Testing the logon

At this point we can test if the logon process works:

- ▶ Disconnect the **ITSOBANKderby** connection in the Data Source Explorer view.
- ▶ Start the **WebSphere Application Server v7.0** server.
- ▶ In the Servers view, select the **WebSphere Application Server v7.0** server and **Add and Remove Projects**, and add the RAD75JSFEAR application.
- ▶ When the application is deployed and started, select the **logon.jsp** and **Run As** → **Run on Server**. When prompted select the server and click **Finish**.
- ▶ Type an invalid ssn (less than 11 characters) and you get a validation error message (actually it is displayed twice because we have two error message fields).
- ▶ Type a valid ssn (123-45-6789) that does not exist in the database and you get the tailored error message (Customer Record not found).
- ▶ Type a valid ssn (000-00-0000) and you are forwarded to the customer details JSP, which for now is empty.

Editing the customer details page

We complete the `customerDetails.jsp` in a few steps:

- ▶ Open the `customerDetails.jsp`.
- ▶ Add the header (image, EJB 3.0 Bank, and horizontal line). Note that you can use copy/paste the components from the `login.jsp`.
- ▶ Add an output component with the text `Customer` (Arial font, size 14).

Create a JPA entity object for the customer

We create a JPA customer object to hold the data retrieved:

- ▶ In the Page Data view, right-click **JPA** and select **New** → **JPA Data Consumption**.
- ▶ In the Add JPA data to page dialog, the `CustomerManager` is preselected. Select **Retrieve a single record** and click **Next**.

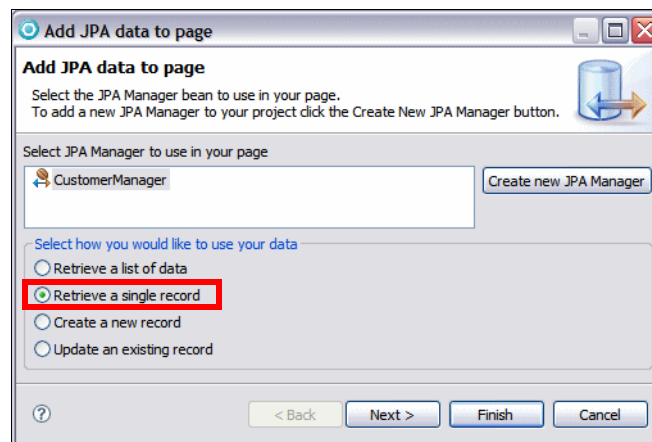

- ▶ On the next panel select **Get record by primary key: findCustomerBySsn** (preselected), and click **Next**.
- ▶ For Set filter values, change the Primary Key Value from `{param.ssn}` to `{sessionScope.SSN}`. Click **Finish**.

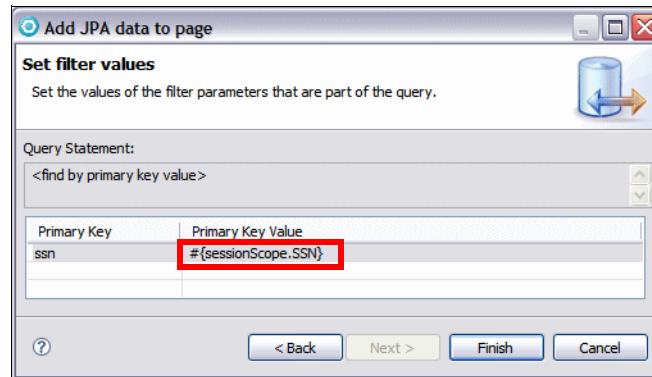

- ▶ An entry customer (JPA Data) appears in the Page Data view under JPA → JPA Page Data.

Add the customer object to the JSP

To display the customer data:

- ▶ Drag the **customer (JPA Data)** into the JSP under the Customer text. A Configure Data Controls dialog opens:
 - Select **Inputting data**. All the fields are Input Text.
 - Leave all fields selected.
 - Verify that the sequence of the fields is `ssn`, `title`, `firstName`, `lastName`, and `accountCollection`
 - Change the labels to `SSN:`, `First name:`, `Last name:`, and `Accounts:`.
 - Change the Control Type of `ssn` to **Display Text**. We cannot modify the `ssn`.
 - Click **Options**. In the Options dialog, select **Submit button**, and set the Label to **Update**. Clear **Delete button**. Click **OK**.
 - Click on the  icon for the account collection.
 - Select only **id** and **balance**, and change the id label to **Number**.
 - Click **Finish**.

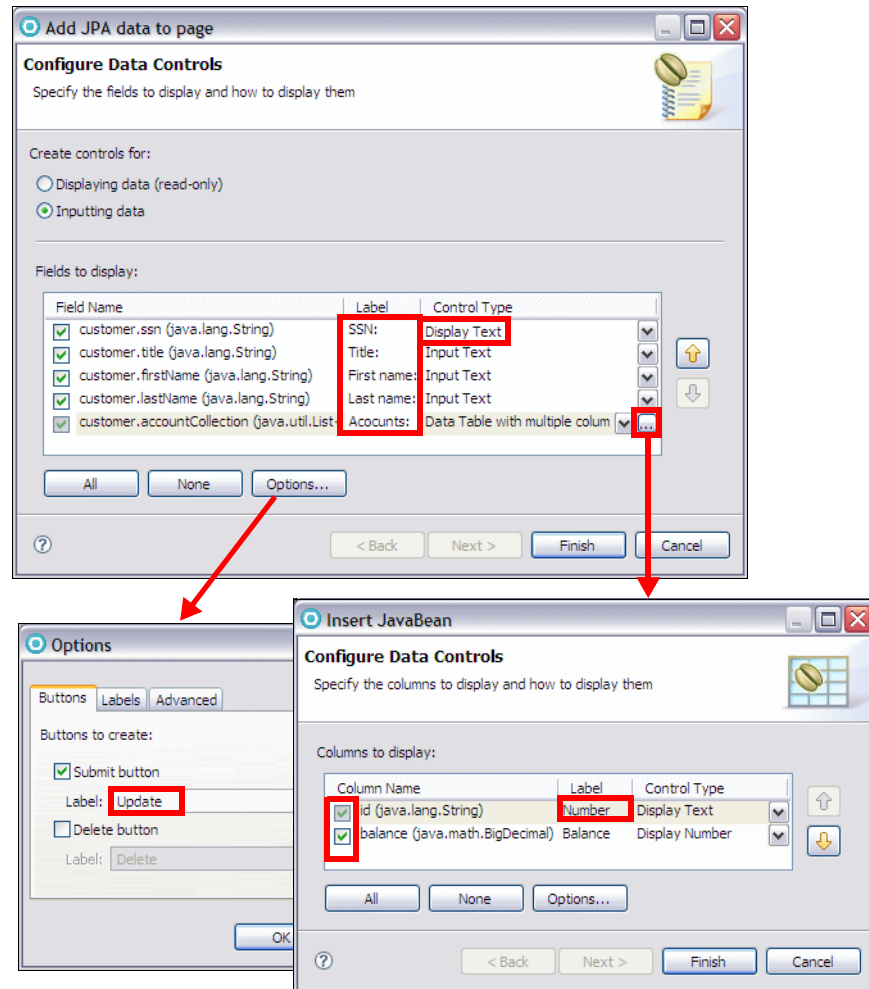

- Click **Finish**. The table with customer information and accounts is added to the JSP.
- ▶ Select the Update button, and in the properties view change the id to **update**.
- ▶ Add a **Button - Command** component at the bottom, next to the Update button. In the Properties view, change the id to **logoff**, and set the label to **Logoff** (under Display options).

The screenshot shows a web form for 'EJB 3.0 Bank'. It has a header with a logo and the text 'EJB 3.0 Bank'. Below the header is a section for 'Customer' with a dropdown arrow. This section contains four input fields: 'SSN:' with value '{ssn}', 'Title:' with value '{title}', 'First name:' with value '{firstName}', and 'Last name:' with value '{lastName}'. Below the customer fields is a section for 'Accounts:' containing a table with two columns: 'Number' and 'Balance'. The 'Number' column has a value '{id}' and the 'Balance' column has a value '{balance}'. At the bottom of the form, there is a red error message icon and the text '{Error Messages}'. A red arrow points from the text 'Make the error message red' to this icon.

- ▶ Save the JSP. Open the page code (CustomerDetails.java, select **Edit Page Code**) and you can see a getCustomer method that retrieves the customer:

```
@JPA(targetEntityManager =
        itso.bank.entity.controller.CustomerManager.class,
        targetAction = JPA.ACTION_TYPE.FIND)
@JPAFilter(name = "ssn", value = "#{sessionScope.SSN}")
public Customer getCustomer() {
    if (customer == null) {
        CustomerManager customerManager = (CustomerManager)
            getManagedBean("customerManager");
        String ssn = (String) resolveParam("customer_ssn",
            "#{sessionScope.SSN}", "java.lang.String");
        customer = customerManager.findCustomerBySsn(ssn);
    }
    return customer;
}
```

- ▶ Republish the application to the server and run it. The customer is displayed with the accounts.
- ▶ To improve the look of the accounts table, select the table. In the Properties view select **hx:dataTableEx** and set the border to **1**. Select the balance column (**hx:columnEx**) and set horizontal alignment to **Right**.

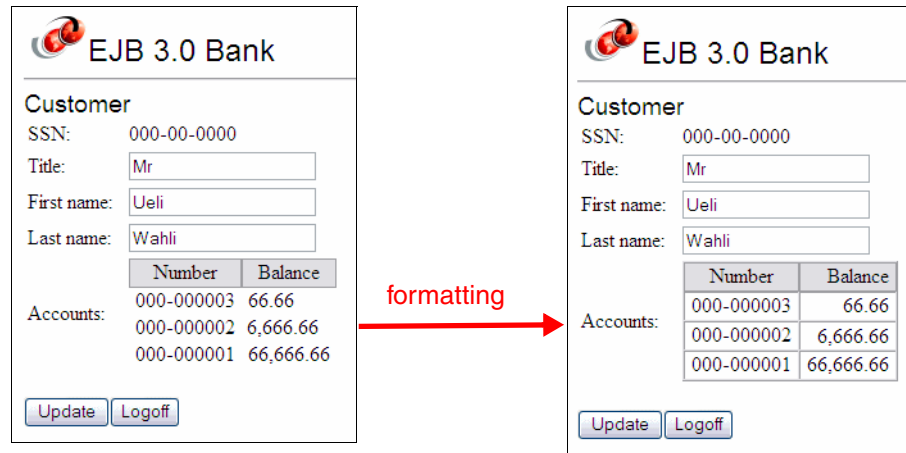

Make the logoff action global

Select the **Logoff** button. In the Properties view, select the **logout** rule and click **Edit Rule**. In the Edit Navigation Rule dialog, select **All Pages, Any action**, and click **OK**.

Implementing customer update

The title, first name, and last name of the customer can be updated through the generated input fields. We have to provide the logic for the Update button. The CustomerManager contains the updateCustomer method that we can invoke.

- ▶ In the customerDetails.jsp, select the **Update** button, and go to the Quick Edit view.
- ▶ Click into the action code and a doUpdateAction method is created.
- ▶ Complete the code of the doUpdateAction method (refer to C:\7672code\jsf\doUpdateAction.txt):

```
try {
    CustomerManager customerManager =
        (CustomerManager) getManagedBean("customerManager");
    customerManager.updateCustomer(customer);
    System.out.println("Customer updated: " + customer.getSsn());
} catch (Exception e) {
    System.out.println("Customer update failed: " + customer.getSsn());
}
return "";
```

- ▶ Publish and test the application. You can now change the title, first name, and last name of a customer, and the update is persistent.

Editing the account details page

We complete the `accountDetails.jsp` in a few steps:

- ▶ Open the `accountDetails.jsp`.
- ▶ Add the header (image, EJB 3.0 Bank, and horizontal line).
- ▶ Add an output component with the text `Account` (Arial font, size 14).
- ▶ Add a new session scope variable named **accountID** (String). We pass the ID of a selected account from the customer page to the account page.

Add a JPA manager bean for the account

To display an account and its transactions, we build a JPA manager bean for the account:

- ▶ In the Page Data view, select **JPA Manager Beans** and **New** → **JPA Manager Bean**.
- ▶ Select **Account** and click **Next**. In the Tasks dialog:
 - Primary Key: `id`
 - Query Methods: Remove all
 - Relationships: Leave both
 - Concurrency Control: No Concurrency Control
 - Other: Select **Update Entity for use in JSF applications**, clear others.
 - Click **Finish** and the `AccountManager` class is generated.

Create a JPA entity object for the account

We create a JPA account object to hold the data retrieved:

- ▶ In the Page Data view, right-click **JPA** and select **New** → **JPA Data Consumption**.
- ▶ In the Add JPA data to page dialog, select **AccountManager** and **Retrieve a single record**. Click **Next**.
- ▶ On the next panel select **Get record by primary key: findAccountById** (preselected), and click **Next**.
 - a. For Set filter values, change the Primary Key Value from `#{param.id}` to **`#{sessionScope.accountID}`**.
- ▶ Click **Finish**.

Add the account to the page

To display the account data:

- ▶ Drag the **account (JPA Data)** into the JSP. In the dialog:

- Select **Displaying data (read-only)**.
- Only select **id** and **balance**. Change the label from Id to Number.
- Click **Finish**.
- ▶ Add a horizontal line under the account data.
- ▶ Add an output component with the text Transactions (Arial font, size 14).

We want to display the transactions separately at the bottom in time sorted order. We have to use a query for this purpose.

Add a JPA manager object for transactions

To display the transaction of an account, we build a JPA manager object for the transaction list:

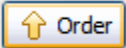
- ▶ In the Page Data view, select **JPA Manager Beans** and **New** → **JPA Manager Bean**.
- ▶ Select **Transaction** and click **Next**. In the Tasks dialog:
 - Primary Key: id
 - Query Methods: remove all except `getTransactionsByAccount`.
 - Select **getTransactionsByAccount** and click **Edit**.
 - In the Order Results tab, select **transTime** and click  .
 - The query becomes:

```
SELECT t FROM Transaction t WHERE t.account.id = :account_id
                                ORDER BY t.transTime
```
 - Click **OK**.
 - Relationships: leave Account
 - Concurrency Control: No Concurrency Control
 - Other: Select **Use Named Queries** and **Update Entity for use in JSF applications**, clear others.
 - Click **Finish** and the `TransactionsManager` class is generated.

Create a JPA entity object for the transactions

We create a JPA transaction object to hold the data retrieved:

- ▶ In the Page Data view, right-click **JPA** and select **New** → **JPA Data Consumption**.
- ▶ In the Add JPA data to page dialog, select **TransactionsManager** and **Retrieve a list of data**. Click **Next**.

- ▶ On the next panel select **get TransactionsByAccount** (preselected), and click **Next**.
- ▶ For Set filter values, change the Filter variable from `#{param.account_id}` to `#{sessionScope.accountID}`.
- ▶ Click **Finish**.

Add the transaction list to the page

To display the transaction list:

- ▶ In the Page Data view, expand the **transactionList (JPA Data)**.
- ▶ Drag the **Contained Type:itso.bank.entity.Transaction** into the JSP. In the dialog:
 - Select **Data Table with multiple columns** (preselected).
 - Clear **account** (the account number is always the same).
 - Arrange the fields: `transtime`, `transtype`, `amount`, `id`
 - Change the labels to **Timestamp**, **Type**, **Amount**, and **ID**.
 - Click **Finish**.
- ▶ Set the table border to **1**. Select the **Amount** column and set horizontal alignment to **Right**. Select the `{transTime}` value and set the format (Date/Time) type to **Date and time**.
- ▶ Add a horizontal line under the transaction list.
- ▶ Add two **Button - Command** components under the line. Set the ids to **back** and **logoff**, and the labels to **Back** and **Logoff**. Add an **Output** component between them for separation (value one blank).

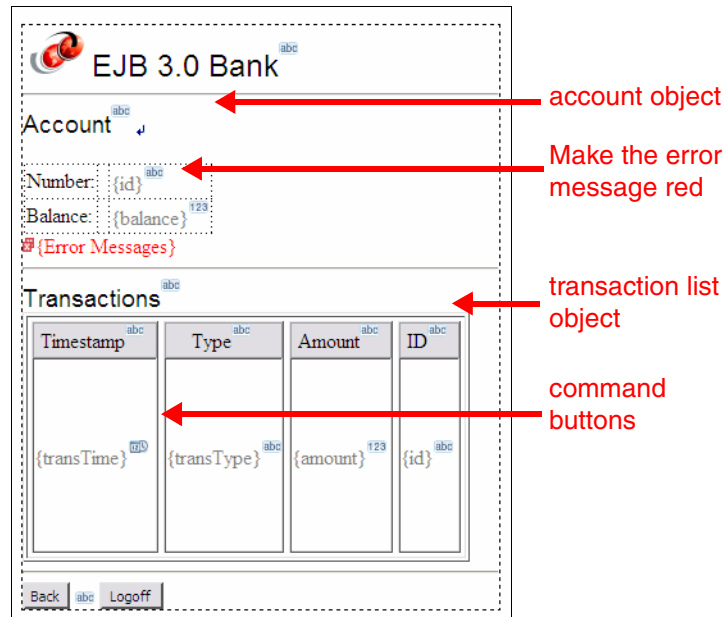

Adding navigation between the pages

We already implemented the navigation from logon to customer details. Now we implement the rest of the navigation:

- ▶ In the `accountDetails.jsp`:
 - In the Page Data view, expand **Faces Managed Beans** → **logout (...)** → **logout**. Drag the **logout** action on top of the **Logoff** button. This creates the binding `#{logout.logout}`.
 - Select the **Back** button, and in the Quick Edit view, click in the empty code, then complete the code as:

```
return "customerDetails";
```
- ▶ In the `customerDetails.jsp`:
 - In the Page Data view, expand **Faces Managed Beans** → **logout (...)** → **logout**. Drag the **logout** action on top of the **Logoff** button. This creates the binding.

Account selection

In the `customerDetails.jsp`, we want to select an account and invoke the account details page:

- ▶ Select the data table of the account list (**hx:dataTableEx** in the Properties view).
- ▶ Select **Row actions** (under `hx:dataTableEx`).
- ▶ Click **Add** for Add an action that's performed when a row is clicked.
- ▶ In the dialog, select **Clicking the row submits the form to the server**. **Parameters have to be set up manually**. Click **OK**. A column with a link is added to the data table.

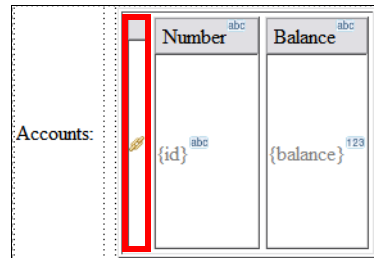

- ▶ Select the link and go to the Quick Edit view. Code is automatically generated. Save the skeleton code.
- ▶ Open the page code (select **Edit Page Code**), and locate the generated `doRowAction1Action` method. Complete the code, which retrieves the parameter (`id`), adds it into session scope (`accountID`), and forwards to the account details page (Example 16-3). Refer to `7672code\jsf\doAction1Action.txt`.

Example 16-3 Row action logic

```
public String doRowAction1Action() {
    //.....
    int row = getRowAction1().getRowIndex();
    String id = customer.getAccountCollection().get(row).getId();
    System.out.println("Row action: " + row + " account " + id);
    getSessionScope().put("accountID", id);
    return "accountDetails";
}
```

Logoff

In the logoff code we have to clean the session scope:

- ▶ Open the `itso.jsf.action.Logout` class and complete the code (refer to `7672code\jsf\Logout.java`, Example 16-4).

Example 16-4 Logout action

```

package itso.jsf.action;

import java.util.Map;
import javax.faces.context.FacesContext;

public class Logout {

    private static final String CUSTOMERSSN_KEY = "SSN";
    private static final String ACCOUNTID_KEY = "accountID";

    public String logout() {
        FacesContext facesContext = FacesContext.getCurrentInstance();
        Map<String, Object> sessionScope =
            facesContext.getExternalContext().getSessionMap();
        if (sessionScope.containsKey(CUSTOMERSSN_KEY))
            sessionScope.remove(CUSTOMERSSN_KEY);
        if (sessionScope.containsKey(ACCOUNTID_KEY))
            sessionScope.remove(ACCOUNTID_KEY);
        return "logout";
    }
}

```

Implementing deposit and withdraw

We want to be able to deposit and withdraw funds into and from an account. We implement these actions in the `accountDetails.jsp`:

- ▶ Click in the account table and select **Table** → **Add Column to Right**. Add three columns.



- ▶ Select the third cell and set the width to **30** pixels in the Properties view.
- ▶ Drag an **Output** component into cell four, with text **Amount (- for withdraw):**.
- ▶ Drag an **Input** component into cell four/row two. Set the id to **amountstring**.
- ▶ Drag a **Button - Command** component into cell five of row two. Set the id to **process**, and the label to **Deposit/Withdraw**.



- ▶ In the Page Data view, create a request scope variable with the name **amount** (String). Then drag the amount variable onto the input field to create a binding of `#{requestScope.amount}`.
- ▶ Select the **Deposit/Withdraw** button and go to the Quick Edit view to generate an action method named `doProcessAction`.
- ▶ Complete the `doProcessAction` method in the page code (refer to 7672code\jsf\doProcessAction.txt, Example 16-5).

Example 16-5 Deposit and withdraw action logic

```
public String doProcessAction() {
    String amountstring = (String)getRequestScope().get("amount");
    System.out.println("deposit/withdraw amount: " + amountstring);
    try {
        BigDecimal amount = new BigDecimal(amountstring);
        if (amount.scale() > 2) throw
            new Exception("Only 2 digits allowed for cents");
        Account account = getAccount();
        BigDecimal balance = account.getBalance();
        if (amount.doubleValue() == 0) {
            throw new Exception("Amount is zero");
        } else if (amount.doubleValue() > 0) {
            balance = balance.add(amount);
        } else {
            if (balance.compareTo(amount.abs()) < 0)
                throw new Exception("Withdraw amount too big");
            balance = balance.add(amount);
        }
        account.setBalance(balance);
        AccountManager accountManager = (AccountManager)
            getManagedBean("accountManager");
        accountManager.updateAccount(account);
        System.out.println("deposit/withdraw balance: " + balance);
        // create transaction
        TransactionManager transactionManager = (TransactionManager)
            getManagedBean("transactionManager");
        Transaction t = new Transaction();
        t.setId( (new com.ibm.ejs.util.Uuid()).toString() );
        t.setAmount(amount.abs());
        t.setTransTime( new Timestamp(System.currentTimeMillis()) );
        if (amount.doubleValue() > 0) t.setTransType("Credit");
        else t.setTransType("Debit");
        t.setAccount(account);
        transactionManager.createTransaction(t);
        transactionList = null;
        getTransactionList();
        getRequestScope().put("amount","");
    } catch (NumberFormatException e) {
```

```
        getFacesContext().addMessage("amount",
            new FacesMessage("Bad amount"));
    } catch (Exception e) {
        getFacesContext().addMessage("amount",
            new FacesMessage("Deposit/withdraw failed: " + e.getMessage()));
    }
    return "";
}
```

Be sure that you import `java.math.BigDecimal` and `java.sql.Timestamp`.

- ▶ This action logic performs the following steps:
 - Retrieve the input amount.
 - Verify that a withdraw amount does not exceed the balance.
 - Change the balance and call the `AccountManager` to update the database.
 - Build a transaction record and call the `TransactionManager` to insert the record into the database.
 - Retrieve the transaction records again to display the new record in the list.
 - Issue JSF error messages for bad data.

Running the JSF application

When we run the finished application we can see the power of the combination of JSF and JPA entities:

- ▶ Logon:

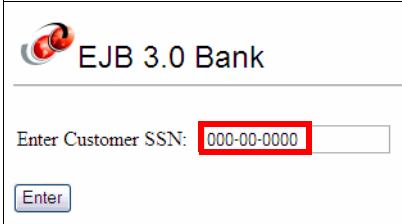

EJB 3.0 Bank

Enter Customer SSN:

Enter

- ▶ The customer and accounts are displayed, click on an account:

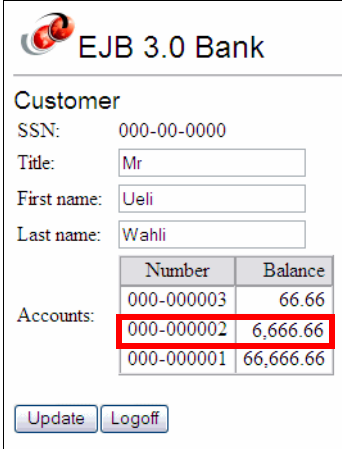

EJB 3.0 Bank

Customer

SSN: 000-00-0000

Title:

First name:

Last name:

Number	Balance
000-000003	66.66
000-000002	6,666.66
000-000001	66,666.66

Accounts:

- ▶ The account is displayed without any transactions. Run a deposit:

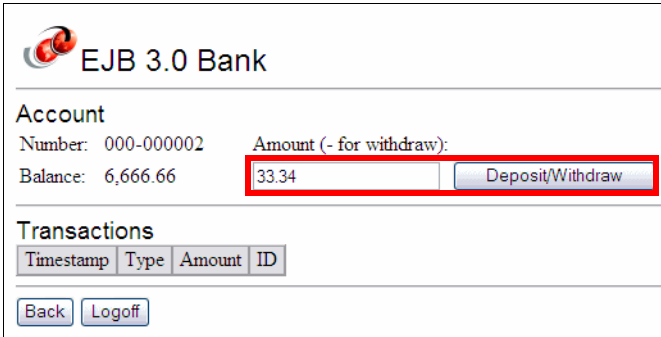

EJB 3.0 Bank

Account

Number: 000-000002 Amount (- for withdraw):

Balance: 6,666.66

Transactions

Timestamp	Type	Amount	ID
-----------	------	--------	----

- ▶ The account balance is updated and the transaction is added. Try a big withdraw and an error is displayed:

EJB 3.0 Bank

Account
 Number: 000-000002 Amount (- for withdraw):
 Balance: 6,700.00

• Deposit/withdraw failed: Withdraw amount too big

Transactions

Timestamp	Type	Amount	ID
Sep 5, 2008 3:07:32 PM	Credit	33.34	348e4a26-011c-f1f2-2008-092b2064aa77

- Click **Back** or **Logoff**.

Web Diagram

Open the Web Diagram. We can complete the diagram by drawing connections for the new actions that we defined (Figure 16-5).

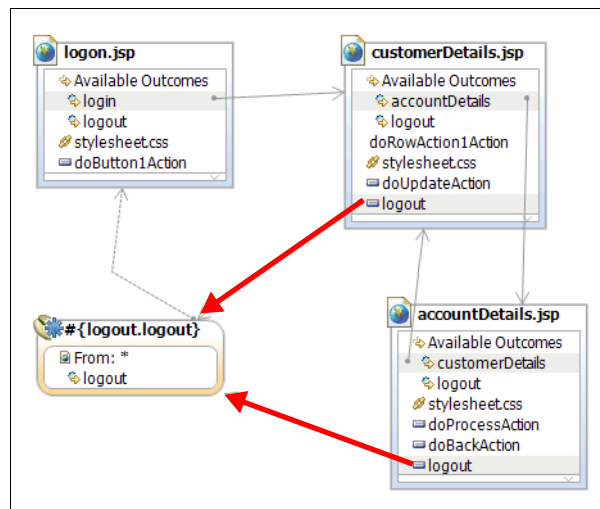

Figure 16-5 JSF Web Diagram completed

The actions are also visible in the `faces-config.xml` file editor, Navigation Rule tab (Figure 16-6).

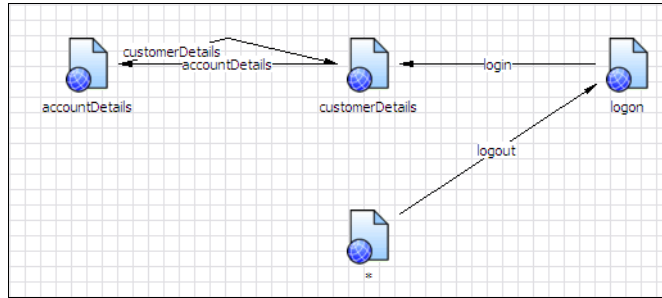

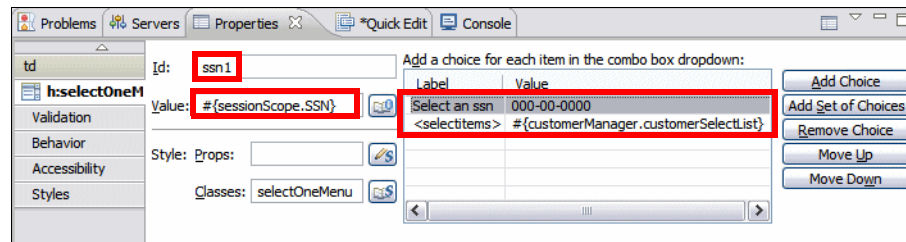

Figure 16-6 Navigation rules in faces-config.xml

Drop-down menu for customer login

The CustomerManager class contains a `getCustomerSelectList` method that retrieves the ssn of all the customers. This list can be used to populate a drop-down menu for customer login:

- ▶ Open the `login.jsp`.
- ▶ Replace the input field with a Combo Box component:
 - Id: `ssn1`
 - Value: `#{sessionScope.SSN}`
- ▶ Add two choices for the list:
 - Click **Add Choice** (Label: Select an ssn, Value: 000-00-0000)
 - Click **Add Set of Choices** (Label: `<selectitems>`, Value: click  and locate `#{customerManager.customerSelectList}`)



- ▶ Validation: Select **Value is required**.

getCustomerSelectList method

This method retrieves customer objects and populates a list with these objects. For our purpose we only need the ssn:

- ▶ Open the CustomerManager at the `getCustomerSelectList` method.

- ▶ Change the code so that the label and the value of the drop-down menu are the same, namely the ssn:

```
public List<SelectItem> getCustomerSelectList() {
    List<Customer> customerList = getCustomerOrdered();
    List<SelectItem> selectList = new ArrayList<SelectItem>();
    // MessageFormat mf = new MessageFormat("{0}");
    for (Customer customer : customerList) {
        // selectList.add(new SelectItem(customer, mf.format(
        //     new Object[] { customer.getSsn() }, new StringBuffer(),
        //     null).toString()));
        selectList.add(new SelectItem(customer.getSsn(),
                                     customer.getSsn()));
    }
    return selectList;
}
```

Redeploy the application, and the drop-down list is populated with the SSNs of all the customers.

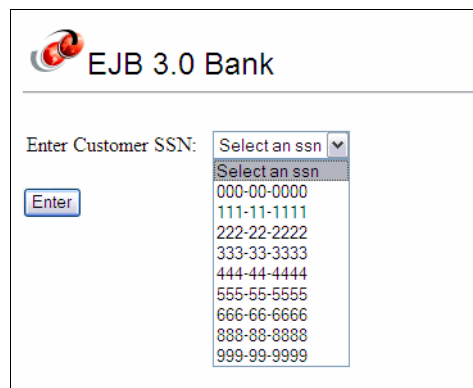

Note: This does not make sense for a real application, but it illustrates the concept of populating a drop-down list with the results of a JPA query.

Adding a deluxe pager

JSP provides the Data Table component with many options, for example, paging. We can add paging to the customer account list:

- ▶ Open the **customerDetails.jsp**.
- ▶ Select the account list table, and in the Properties view, expand **hxDataTableEx** → **Display options**.

- ▶ Click **Add a deluxe pager**. The deluxe pager appears under the data table.
- ▶ For Paging, set the Rows per page to **2** (Figure 16-7).

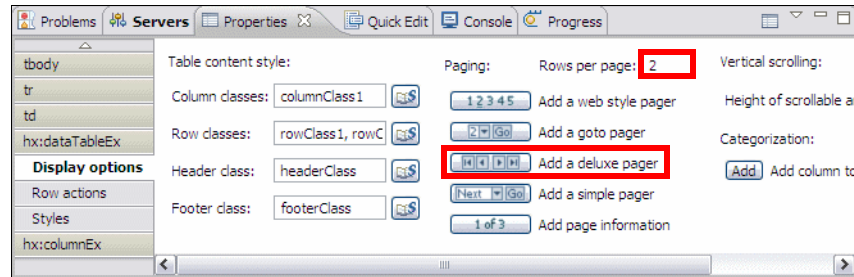

Figure 16-7 Adding a deluxe pager

Test the deluxe pager

With the deluxe pager, only two accounts are displayed for a customer, and the pager has a forward button. You can test the paging by clicking the **>** and the **<** buttons.

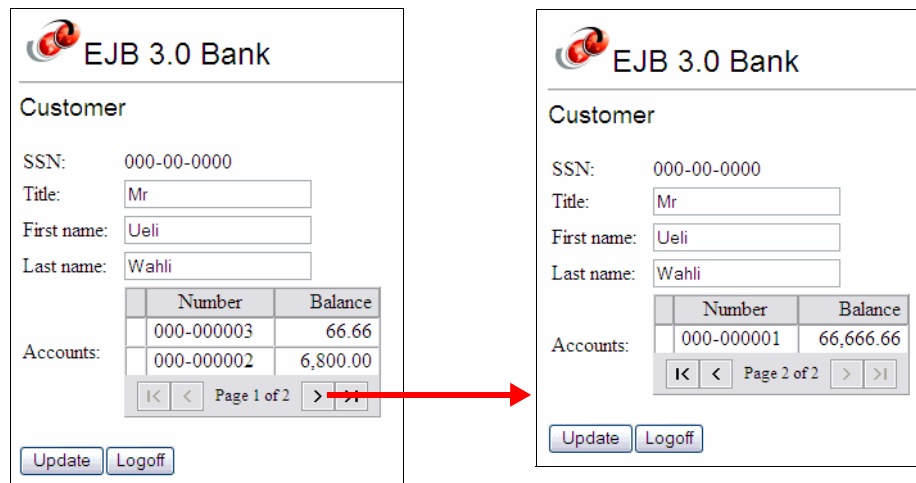

Figure 16-8 Display of customer accounts

- ▶ Change the fields to update customer information. This verifies write access to the database using JPA. For example, change the first name to **Ulrich** and click **Update**.
- ▶ Click one of the accounts (**000-000002**) to display the account information with the transactions.

- ▶ Run some deposit and withdraw transactions and watch the list of transactions grow (Figure 16-9).

The screenshot shows the EJB 3.0 Bank application interface. At the top left is the EJB 3.0 Bank logo. Below it, the 'Account' section displays the account number '000-000002' and the current balance '6,800.00'. There is an input field for the transaction amount and a 'Deposit/Withdraw' button. The 'Transactions' section contains a table with the following data:

Timestamp	Type	Amount	ID
Sep 5, 2008 3:07:32 PM	Credit	33.34	348e4a26-011c-f1f2-2008-092b2064aa77
Sep 7, 2008 3:46:06 AM	Credit	300.00	3c6b227b-011c-e642-0b1a-c0a89f01aa77
Sep 7, 2008 3:46:12 AM	Debit	200.00	3c6b3a1a-011c-f39f-2741-c0a89f01aa77

At the bottom of the interface are 'Back' and 'Logout' buttons.

Figure 16-9 Details for a selected account with transactions

Using the data source in the server

The application is configured to use the data source defined in the enterprise application RAD75JSFEAR. For the final application we want to use the data source configured in the server with the JNDI name `jdbc/itsobank`.

To configure the JSF application for the data source in the server, perform these steps:

- ▶ Open the **ibm-web-bnd.xml** file (in `RAD75JSFWeb/WebContent/WEB-INF`). Change the resource reference to:

```
<resource-ref name="ITSOBANKderby"
  binding-name="jdbc/itsobank">
  <authentication-alias name="ITSOBANKderby" />
</resource-ref>
```

Save and close the file.

- ▶ Right-click **RAD75JSFWeb** and select **JPA Tools** → **Configure Project for JDBC Deployment**:
 - Click **OK** in the Cannot connect to connection profile ITSOBANK warning.
 - Click **Cancel** in the Properties dialog.

- ▶ In the Set up connections for deployment dialog:
 - Select **ITSOBANKderby** for the Connection.
 - Clear **Deploy JDBC Connection information to server** (Figure 16-10).

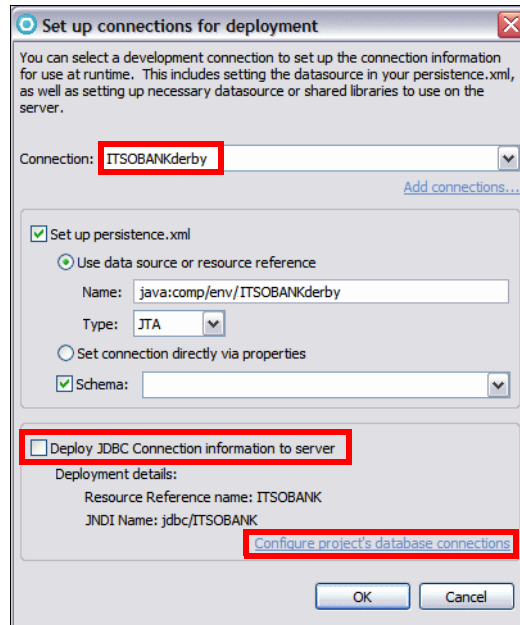

Figure 16-10 Deployment of JDBC connection

- Click **Configure project's database connections**.
- In the Properties for RADJSFWeb dialog, click **Edit** for Runtime connection details (Figure 16-11).

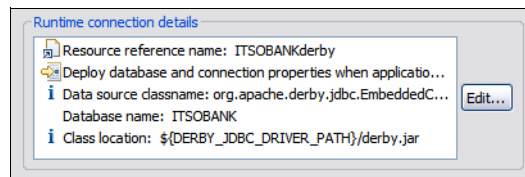

Figure 16-11 Runtime connection details

- In the Runtime Connection dialog, clear **Deploy database and connection properties when application is run on unit test server**, and click **Finish** (Figure 16-12).

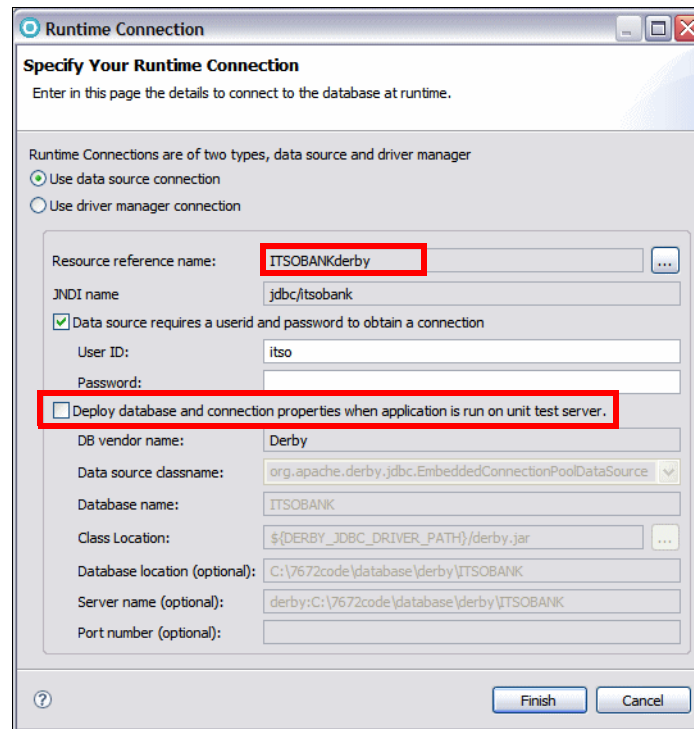

Figure 16-12 Deployment of the runtime connection

- ▶ The runtime connection is removed. Click **OK** in the Properties dialog.
- ▶ Click **OK** in the Set up connections for deployment dialog.
- ▶ Open the **persistence.xml** file (in WebContent/WEB-INF) and change the data source JNDI name to **jdbc/itsobank**.

```
<persistence .....>
  <persistence-unit name="RAD75JSFWeb">
    <jta-data-source>jdbc/itsobank</jta-data-source>
```

- ▶ Right-click **RAD75JSFEAR** and select **Java EE** → **Open WebSphere Application Server Deployment**:
 - Select **Generated Derby JDBC Provider** and verify that there is no data source configured.
 - Close the editor.

Note: Connection information is stored in the **.wdo-connections** file of the RAD75JSFWeb project. You can only see that file by changing the filter in the Enterprise Explorer (**Down Arrow** icon → **Customize View**, then clear **.*resources**).

Cleanup

Remove the RAD75JSFEAR application from the server.

Final code

To run the Web application you must have completed the sample JSF application:

- ▶ Either you completed the JSF pages as described in “Developing a Web application using JSF and JPA” on page 500.
- ▶ Or, you can import the interchange file of the application from:
c:\7672code\zInterchange\jsf\RAD75JSF.zip
Refer to “Importing sample code from a project interchange file” on page 1152 for details.
- ▶ You also must have set up the ITSOBANK database as described in “Setting up the sample database” on page 499.

So far we have a JSF application with JPA access to a relational database. We could certainly enhance the appearance of the pages and the error messages.

More information on JSF and AJAX

For more information on JSF and AJAX, we recommend the following resources.

- ▶ *Improve the usability of Web applications with type-ahead input fields using JSF, AJAX, and Web services in Rational Application Developer V7*, article found at:
http://www.ibm.com/developerworks/rational/library/06/1205_kats_rad1/index.html
- ▶ *Advanced usage of the Typeahead control in Rational Application Developer V7.0*, article found at:
http://www.ibm.com/developerworks/rational/library/07/0206_bermingham/index.html

- ▶ *JSF and Ajax: Web 2.0 application made easy with Rational Application Developer V7*, article found at:
http://www.ibm.com/developerworks/rational/library/06/1205_kats_rad2/index.html
- ▶ *Creating a sorted JavaServer Faces Widget Library dataTable using Rational Application Developer V7.0*, article found at:
http://www.ibm.com/developerworks/rational/library/07/0220_gallagher/index.html
- ▶ *New features of the JavaServer Faces Widget Library dataTable component in IBM Rational Application Developer 7.0*, article found at:
http://www.ibm.com/developerworks/rational/library/07/0213_gallagher/index.html
- ▶ *Using the ProgressBar JSF Component in Rational Application Developer*, article found at:
http://www.ibm.com/developerworks/rational/library/07/0626_kats/
- ▶ *Improve the look and feel of your Web pages by using the Dynamic Page Template*, article found at:
http://www.ibm.com/developerworks/rational/library/07/0508_koinuma/index.html



Develop Java EE application clients

This chapter provides an introduction to Java EE application clients and the facilities supplied by the Java EE application client container. In addition, we highlight the features provided by Application Developer for developing and testing Java EE application clients.

The chapter is organized into the following sections:

- ▶ Introduction to Java EE application clients
- ▶ Overview of the sample application
- ▶ Preparing for the sample application
- ▶ Developing the Java EE application client
- ▶ Testing the Java EE application client
- ▶ Packaging the Java EE application client

Introduction to Java EE application clients

A Java EE application server is capable of making several different types of resources available for remote access, such as:

- ▶ Enterprise JavaBeans (EJBs)
- ▶ JDBC data sources
- ▶ Java Message Service (JMS) resources (queues and topics)
- ▶ Java Naming and Directory Interface (JNDI) services

These resources are most often accessed from a component that is running within the Java EE application server itself, such as an EJB, servlet, or JSP. However, these resources can also be used from a stand-alone Java application (known as a *Java EE application client*) running in its own Java Virtual Machine (JVM), possibly on a different computer from the server. Figure 17-1 shows the resource access scenarios described.

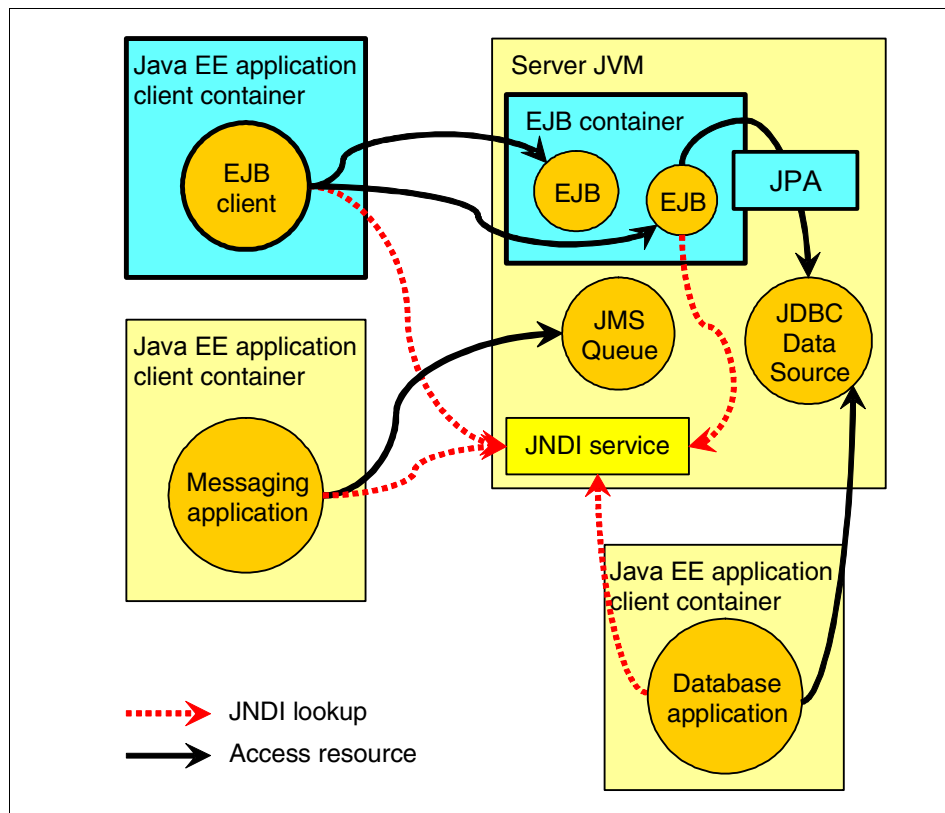

Figure 17-1 Java applications using Java EE server resources

Note: The clients shown in Figure 17-1 might conceptually be running on the same physical node, or even in the same JVM as the application server. However, in this chapter the focus is on clients running in distributed environments. Throughout this chapter, we develop an EJB client, invoking the EJBs from Chapter 14, “Develop EJB applications” on page 387, to provide a simple ITSO Bank client application.

Because a regular JVM does not support accessing such application server resources, additional setup for the runtime environment is required for a Java EE application. There are two methods to achieve this:

- ▶ Add the required packages to the Java Runtime Environment manually.
- ▶ Package the application according to the Java EE application client specification and execute the application in a Java EE application client container.

In this chapter, we focus on the second of these options. In addition to providing the correct runtime resources for Java applications accessing Java EE server resources, the Java EE application client container provides additional features, such as mapping references to JNDI names and integration with server security features.

IBM WebSphere Application Server v7.0 includes a Java EE application client container and a facility for launching Java EE application clients. The Java EE application client container, known as *Application Client for WebSphere Application Server*, can be installed separately from the WebSphere Application Server installation CDs, or downloaded from developerWorks, and runs a completely separate JVM on the client machine.

When the JVM starts, it loads the necessary runtime support classes to make it possible to communicate with WebSphere Application Server and to support Java EE application clients that will use server-side resources. Refer to the WebSphere Application Server Information Center for more information about installing and using the Application Client for WebSphere Application Server.

Note: Although the Java EE specification describes the JAR format as the packaging format for Java EE application clients, the Application Client for WebSphere Application Server expects the application to be packaged as a JAR inside an Enterprise Application Archive (EAR). The Application Client for WebSphere Application Server does not support execution of a standalone Java client JAR.

Application Developer includes tooling to assist with developing and configuring Java EE application clients, and a test facility that allows Java EE application clients to be executed in an appropriate container. The focus of this chapter is on the Application Developer tooling for Java EE application clients, so we will be looking only at this facility.

Overview of the sample application

The sample application that we develop for this chapter is a simple Java EE application client application. It invokes the services of the EJB application that was developed in Chapter 14, “Develop EJB applications” on page 387, to look up the customer information and account overview from a specified customer SSN.

The application uses a graphical user interface, implemented with Swing components, which displays the details for the customer with SSN 222-22-2222 (Figure 17-2).

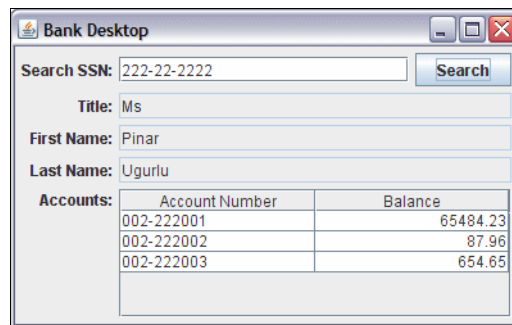

Figure 17-2 Interface for the sample application client

Figure 17-3 shows a class diagram of the finished sample application:

- ▶ The classes on the right-hand side of the class diagram are classes from the EJB enterprise application, while the three left-hand classes are part of the application client.
- ▶ As the class diagram outlines, the application client controller class, `BankDesktopController`, uses the `EJBBankBean` session EJB to retrieve `Customer` and `Account` object instances, representing the customer and associated account(s) that are retrieved from the `ITSOBANK` database.

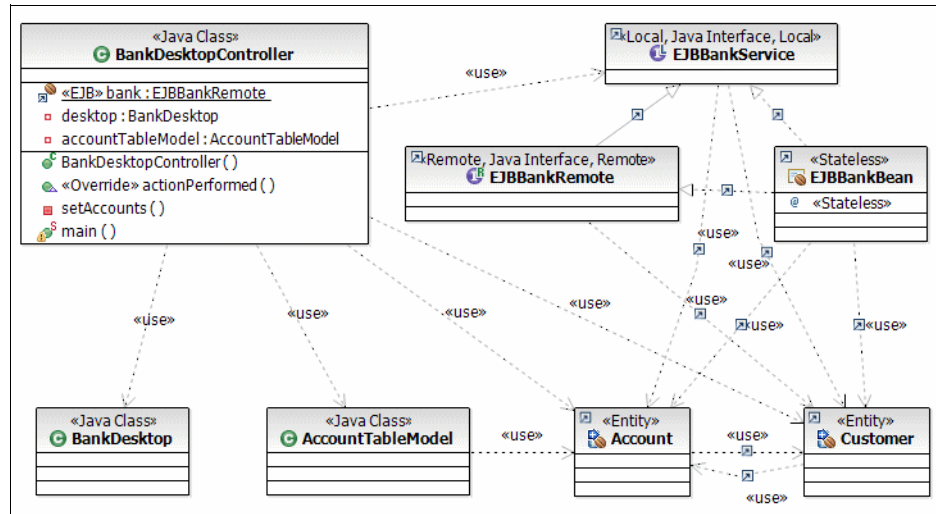

Figure 17-3 Class diagram for the Bank Java EE application client

Preparing for the sample application

Prior to working on the sample for this chapter, we have to set up the database for the sample application, import the EJB projects, and ensure that everything is working.

Importing the base EJB enterprise application sample

To import the base enterprise application sample that we use as a starting point for this chapter, do these steps:

- ▶ From the workbench, select **File** → **Import**.
- ▶ In the Import dialog, select **Project Interchange** and click **Next**.
- ▶ In the Import Project Interchange Contents dialog, locate the file `c:\7672code\zInterchange\ejb\RAD75EJB.zip`.
- ▶ Select all projects (RAD75EJB, RAD75EJBEAR, RAD75EJBTestWeb and RAD75JPA). Click **Finish**.

After the Import wizard has completed the import, four projects have been added to the workspace:

- ▶ **RAD75EJB:** This project contains the EJBs, that makes up the business logic of the ITSO Bank. The EJBBankBean session bean acts as a facade for the EJB application. This project is packaged inside RAD75EJBEAR when exported and deployed on an application server.
- ▶ **RAD75EJBEAR:** This is the deployable enterprise application, which functions as a container for the remaining projects. This enterprise application must be executed on an application server.
- ▶ **RAD75EJBTestWeb:** This is the sample Web application that is developed to test the EJB 3.0 session bean and entity model. This project is packaged inside RAD75EJBEAR when exported and deployed on an application server.
- ▶ **RAD75JPA:** This Java project holds JPA entities that are passed between the session facade and the client applications.

Setting up the sample database

The JPA entities are based on the ITSOBANK database. Therefore, we have to define a database connection within Application Developer that the mapping tools use to extract schema information from the database.

Refer to “Setting up the ITSOBANK database” on page 1154 for instructions on how to create the ITSOBANK database. We can either use the DB2 or Derby database. For simplicity we use the built-in Derby database in this chapter.

Configuring the data source

If the ITSOBANKderby data source has not been already configured for RAD7EJBEAR, follow the instructions in “Configuring the data source for the ITSOBANK” on page 413 or “Configuring the data source in WebSphere Application Server” on page 1155.

Testing the imported code

Before continuing with the sample application, we suggest that you test the imported code. Follow the instructions in “Testing the sample Web application” on page 431.

Developing the Java EE application client

We now use Application Developer to create a project containing a Java EE application client. This application client will be associated with its own enterprise application.

Note: While it is possible to use the new client application with the existing RAD75EJBEAR enterprise application, this is not the recommended approach. The EJB project contains other server resources that should not be distributed to the clients, such as passwords or proprietary business logic.

To develop the Java EE application client sample, we complete the following tasks:

- ▶ Creating the Java EE application client projects
- ▶ Configuring the Java EE application client projects
- ▶ Importing the graphical user interface and control classes
- ▶ Creating the BankDesktopController class
- ▶ Completing the BankDesktopController class
- ▶ Registering the BankDesktopController class as the main class

Creating the Java EE application client projects

To create a Java EE application client project, do these steps:

- ▶ In the Java EE perspective, select **File** → **New** → **Project**. Expand the **Java EE** folder, and select **Application Client Project**. (Alternatively, right-click in the Enterprise Explorer and select **New** → **Application Client Project**.)
- ▶ In the New Application Client Project dialog (Figure 17-4):
 - Type **RAD75AppClient** as the Project name
 - Type **RAD75AppClientEAR** as the EAR Project Name.
 - Accept the defaults of **WebSphere Application Server v7.0** for Target Runtime and **5.0** for Application Client module version.
 - Click **Next**.

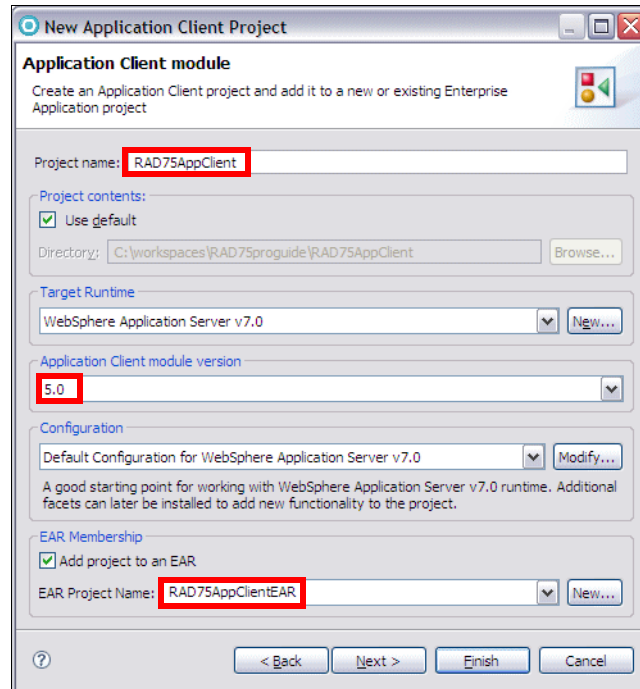

Figure 17-4 New Application Client Project

- ▶ In the Application Client module dialog, clear **Create a default Main class**, select **Generate deployment descriptor**, and click **Finish** (Figure 17-5).

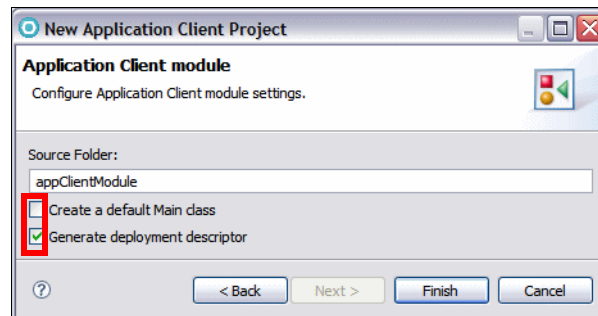

Figure 17-5 Application Client module

When the wizard is complete, the following two projects are created in your workspace:

- ▶ RAD75AppClientEAR: This is an enterprise application project that acts as a container for the code to be deployed on the application client node.

- ▶ **RAD75AppClient**: This project contains the code for the application client. For now, it is empty, except for the META-INF/application-client.xml file, which is the application client deployment descriptor.

Configuring the Java EE application client projects

The application client project has to reference the **RAD75EJB** and **RAD75JPA** projects. In this section, we configure this dependency by adding the **RAD75EJBClient** as a dependency to both projects:

- ▶ In the Enterprise Explorer, right-click **RAD75AppClientEAR** and select **Properties**.
- ▶ Select **Java EE Module Dependencies**, then select **RAD75EJB** and **RAD75JPA**, and click **OK** (Figure 17-6).

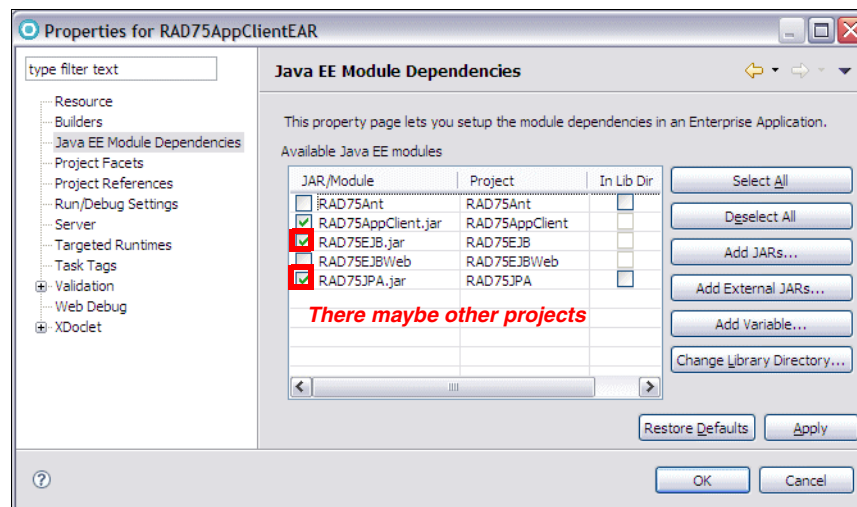

Figure 17-6 Java EE Module Dependencies

- ▶ Right-click **RAD75AppClient**, and select **Properties**. In the Properties dialog, select **Java EE Module Dependencies**, then select **RAD75EJB.jar**, and click **OK**.

Importing the graphical user interface and control classes

In this section, we complete the graphical user interface (GUI) for the Java EE application client.

Because this chapter focuses on the aspects relating to development of Java EE application clients, we import the finished user interface and focus on implementing the code for accessing the EJBs.

To import the framework classes for the Java EE application client, do these steps:

- ▶ In the Enterprise Explorer, right-click **RAD75AppClient** and select **New** → **Package**. Type **itso.rad75.client.ui** as Name and click **Finish**.
- ▶ Right-click **itso.rad75.client.ui**, and select **Import**.
- ▶ In the Import dialog, expand **General** → **File System** and click **Next**.
- ▶ In the Import file dialog, click **Browse** to locate **c:\7672code\appclient**.
- ▶ Select **AccountTableModel** and **BankDesktop**, and click **Finish** (Figure 17-7).

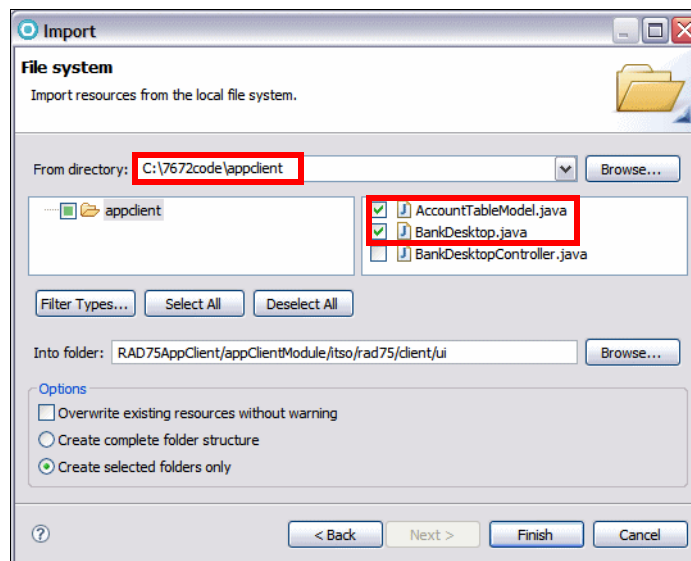

Figure 17-7 Import existing GUI class

Two classes have been imported to the `RAD75AppClient` project:

- ▶ `itso.rad75.client.ui.BankDesktop`—This is a visual class, extending the `Swing JFrame`, that contains the view for the Java EE application client.
- ▶ `itso.rad75.client.ui.AccountTableModel`—This is an implementation of the interface `javax.swing.table.AbstractTableModel`. The class provides the relevant `TableModel` interface for a `JTable`, given an array of `Account` instances.

Creating the BankDesktopController class

In this section, we create the controller class for the Java EE application client. This class is also the main class for the application and contains the EJB lookup code.

To create the `BankDesktopController` class, do these steps:

- ▶ In the Enterprise Explorer, expand **RAD75AppClient**, right-click **appClientModule**, and select **New** → **Class**.
- ▶ In the New Java Class dialog (Figure 17-8), type **itso.rad75.client.control** in the Package field, **BankDesktopController** in the Name field, select **public static void main(String[] args)** and **Constructors from superclass**.
- ▶ Click **Add** next to the Interface section. In the Implemented Interfaces Selection dialog, type **ActionListener** in the Choose interfaces field, select **ActionListener - java.awt.event** in the Matching types list, and click **OK**.

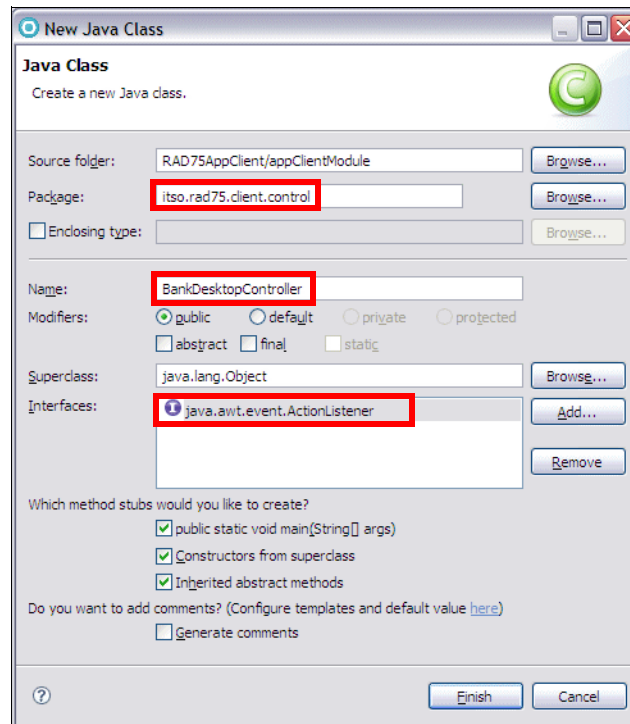

Figure 17-8 Create class `BankDesktopController`

Completing the BankDesktopController class

In this section we add control logic to the BankDesktopController class, as well as the code to look up customer and account information from the EJB application.

Note: The code found in this section can be copied from the complete BankDesktopController class that is supplied in the sample code:

```
c:\7672code\applient\BankDesktopController.java
```

We suggest that you copy the sections as noted in our procedure from the completed BankDesktopController.java (step by step).

To complete the BankDesktopController class, do these steps:

- ▶ The **BankDesktopController.java** is open in the Java editor.
- ▶ The client invokes methods of the EJBBankBean session bean through its remote interface. Inject the remote interface of the session bean:

```
public class BankDesktopController implements ActionListener {

    @EJB(name="ejb/bank",beanInterface=EJBBankRemote.class)
    static EJBBankRemote bank;
```

After every step, select **Source** → **Organize Imports** (or press **Ctrl+Shift+O**) to generate the required import statement.

- ▶ Add two fields to the beginning of the class definition:

```
private BankDesktop desktop = null;
private AccountTableModel accountTableModel = null;
```

- ▶ Locate the constructor and add the code (the new code is in bold):

```
public BankDesktopController() {
    desktop = new BankDesktop();
    accountTableModel = new AccountTableModel();
    desktop.getTblAccounts().setModel(accountTableModel);
    desktop.getBtnSearch().addActionListener(this);
    desktop.setVisible(true);
}
```

- ▶ Locate the **main** method, add the throws clause, and add three lines:

```
public static void main(String[] args) throws Exception {
    BankDesktopController controller = new BankDesktopController();
    // without the next line, app client fails in IDE, works outside
    bank.getAccounts("xxx");
}
```

- ▶ Locate the **actionPerformed** method stub and complete the method as shown in Example 17-1.

Example 17-1 Complete actionPerformed method

```
public void actionPerformed(ActionEvent e) {
    // we know that we are only listening to action events from
    // the search button, so...
    String ssn = desktop.getTfSSN().getText();
    try {
        // look up the customer
        Customer customer = bank.getCustomer(ssn);
        if (customer == null) throw new ITSOBankException
            ("Customer not found: " + ssn);

        // look up the accounts
        Account[] accounts = bank.getAccounts(ssn);
        // update the user interface
        desktop.getTfTitle().setText(customer.getTitle());
        desktop.getTfFirstName().setText(customer.getFirstName());
        desktop.getTfLastName().setText(customer.getLastName());
        // store the accounts in the table model and set the model in the GUI
        accountTableModel.setAccounts(accounts);
    } catch (ITSOBankException x) {
        // unknown customer. Report this using the output fields...
        desktop.getTfTitle().setText("not found");
        desktop.getTfFirstName().setText("not found");
        desktop.getTfLastName().setText("not found");
        accountTableModel.setAccounts(new Account[0]);
    }
}
```

- ▶ Save and close the BankDesktopController.

Creating an EJB reference and binding

An EJB 3.0 session bean has a short binding and a long binding that can be used to inject the EJB reference. For the EJBBankBean session bean, the short and long bindings for the remote interface are:

```
itso.bank.service.EJBBankRemote
ejb/RAD75EJBEAR/RAD75EJB.jar/EJBBankBean#itso.bank.service.EJBBankRemote
```

For this example, we use the long binding to invoke EJBBankRemote interface. We have to define an EJB reference in deployment descriptor. Follow these steps to add this EJB reference with the long binding.

- ▶ Expand **RAD75AppClient** and open (double-click) the  **RAD75AppClient** deployment descriptor. (Alternatively, right-click **application-client.xml** (in `appClientModule/META-INF`) and select **Open With** → **Application Client Deployment Editor**).
- ▶ In the Design tab, click **Add** to add a new EJB reference. Select **EJB Reference** and click **OK**. Type **ejb/bank** as EJB Reference Name, **Session** as EJB Reference Type, and **itso.bank.service.EJBBankRemote** as Remote Interface (Figure 17-9).

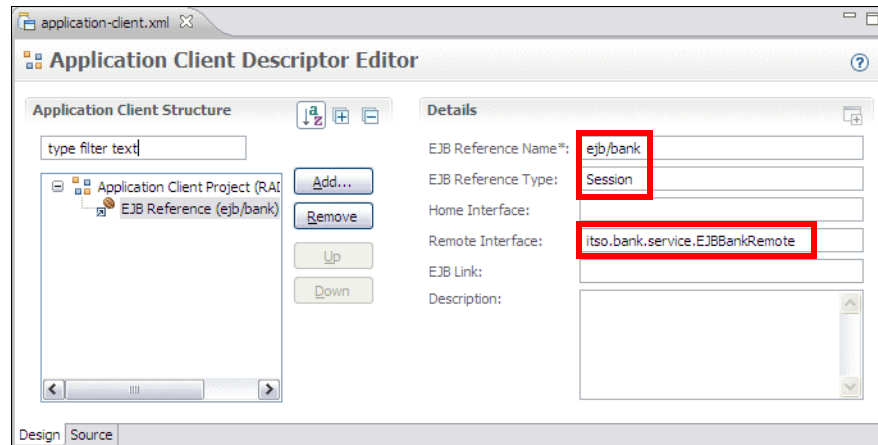

Figure 17-9 Create an EJB reference

- ▶ The Source tab shows the XML source of the EJB reference:

```
<ejb-ref>
  <ejb-ref-name>ejb/bank</ejb-ref-name>
  <ejb-ref-type>Session</ejb-ref-type>
  <remote>itso.bank.service.EJBBankRemote</remote>
</ejb-ref>
```
- ▶ Save and close the `application-client.xml` file.
- ▶ Right-click **RAD75AppClient** and select **Java EE** → **Generate WebSphere Bindings Deployment Descriptor** to create a stub of `ibm-application-client-bnd.xml` file.
- ▶ In the Design tab, click **Add** to add a new EJB reference. Select **EJB Reference** and click **OK**. Type **ejb/bank** as Name and **ejb/RAD75EJBEAR/RAD75EJB.jar/EJBBankBean#itso.bank.service.EJBBankRemote** as Binding Name (Figure 17-10).

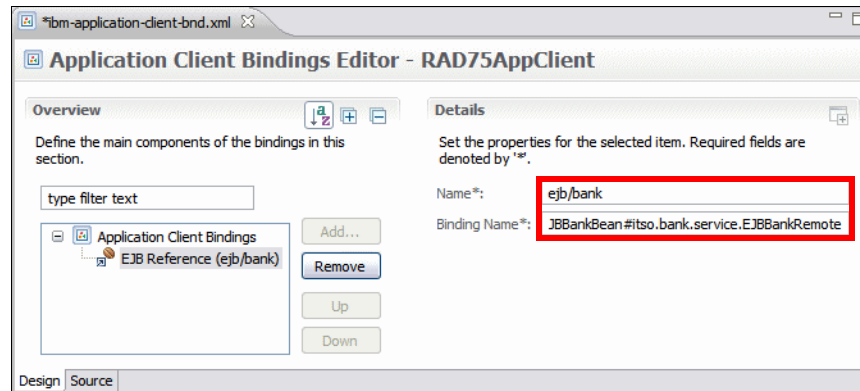

Figure 17-10 Create an EJB binding

- ▶ The Source tab shows the XML source of the EJB binding:

```
<ejb-ref name="ejb/bank" binding-name="ejb/RAD75EJB/EJB.jar
/EJBBankBean#itso.bank.service.EJBBankRemote" />
```

- ▶ Save and close the `ibm-application-client-bnd.xml` file.

The code and configuration for the ITSO Bank Java EE application client is now complete. Now we just need to register the `BankDesktopController` class as the main class for the application client.

Registering the `BankDesktopController` class as the main class

The `BankDesktopController` class contains the logic for the Java EE application client. We have to register that this is the main class for the application client, such that Java EE application client containers know how to launch the application:

- ▶ Right-click **RAD75AppClient** and select **Open With** → **JAR Dependency Editor**.
- ▶ In the JAR Dependency editor, click **Browse** next to the Main-Class entry field (at the bottom).
- ▶ In the Type Selection dialog, start typing **BankDesk...** for the Select a class using field, then select the **BankDesktopController** in the Matching types list, and click **OK**.
- ▶ Save and close the JAR Dependency editor.

Testing the Java EE application client

Now that the code has been updated, we can test the Java EE application client as follows:

- ▶ Make sure that the WebSphere Application Server v7.0 is started.
- ▶ Ensure that the RAD75EJB EAR enterprise application is deployed on the server:
 - In the Servers view, right-click **WebSphere Application Server v7.0** and select **Add and Remove Projects**. Add the **RAD75EJB EAR** project if it is not deployed to the server already.
 - Do not add the **RAD75AppClientEAR** to the server. We run the application client outside of the server.
- ▶ In the Enterprise Explorer, right-click **RAD75AppClient** and select **Run As** → **Run Configurations**.
- ▶ In the Run Configurations dialog, double-click **WebSphere v7.0 Application Client** in the left pane. A **New_configuration** is added and displayed in the right pane (Figure 17-11):
 - Type **RAD75AppClient** in the Name field.
 - Select **RAD75AppClientEAR** as Enterprise application and **RAD75AppClient** as Application Client module.
 - Select **Enable application client to connect to a server** and accept **WebSphere Application Server v7.0** as the specific server.

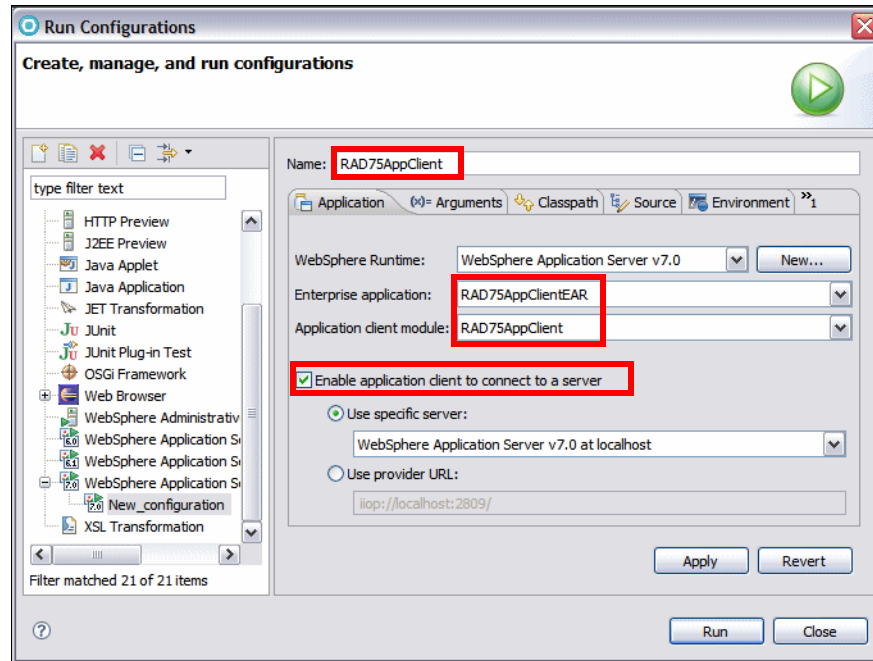

Figure 17-11 Create a new run configuration for the application client

- ▶ Click **Apply**, and then click **Run**.
- ▶ If prompted with SSL Signer Exchange Prompt, click **Yes**.
- ▶ If security is enabled in the Application Server, the Login at the Target Server po-up appears. Enter admin/admin (the user ID configured for the server) and click **OK** (Figure 17-12).

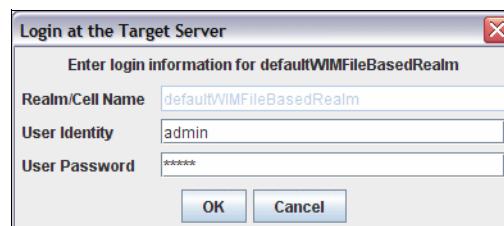

Figure 17-12 Login to the secure server

- ▶ A number of messages are displayed in the Console:

```
IBM WebSphere Application Server, Release 7.0
Java EE Application Client Tool
Copyright IBM Corp., 1997-2008
```

```
WSCL0012I: Processing command line arguments.
.....
WSCL0013I: Initializing the Java EE Application Client Environment.
.....
WSCL0035I: Initialization of the Java EE Application Client Environment
           has completed.
WSCL0014I: Invoking the Application Client class
           itso.rad75.client.control.BankDesktopController
```

- ▶ The Bank Desktop window opens (Figure 17-13).

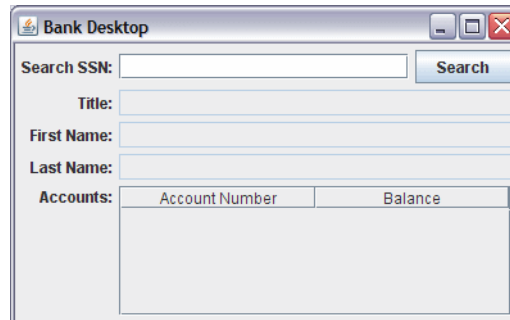

Figure 17-13 Bank Desktop opens

- ▶ Type a customer SSN and click **Search**. The customer and the accounts are displayed (Figure 17-14).

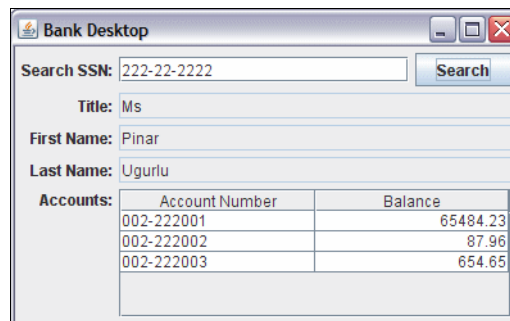

Figure 17-14 Bank Desktop results

- ▶ Type an invalid customer SSN and the name is displayed as (not found).
- ▶ Close the client window.

Note: In the main method of the BankDesktopController we added the line:

```
bank.getAccounts("xxx");
```

Without this initial communication with the server to run the getAccounts query, the application client fails when run inside Application Developer.

```
Exception in thread "AWT-EventQueue-0" java.rmi.MarshalException: CORBA
MARSHAL 0x4942f896 No; nested exception is:
  org.omg.CORBA.MARSHAL: Unable to read value from underlying bridge :
    null vmcid: IBM minor code: 896 completed: No
  at com.ibm.CORBA.iiop.UtilDelegateImpl.mapSystemException
    (UtilDelegateImpl.java:271)
  at javax.rmi.CORBA.Util.mapSystemException(Util.java:84)
  at itso.bank.service._EJBBankRemote_Stub.getAccounts
    (_EJBBankRemote_Stub.java)
  at itso.rad75.client.control.BankDesktopController.actionPerformed
    (BankDesktopController.java:40)
```

Packaging the Java EE application client

To run the application client outside Application Developer, we have to package the application.

Note: Although the Java EE specification names the JAR format as the principle means for distributing Java EE application clients, the WebSphere Application Server application client container expects an Enterprise Application Archive (EAR) file.

To package the application client for deployment, do these steps:

- ▶ In the Enterprise Explorer, right-click **RAD75AppClientEAR** and select **Export** → **EAR file**.
- ▶ In the EAR Export dialog, click **Browse** to select a destination (Figure 17-15), for example, c:\7672code\deployment\RAD75AppClientEAR.ear. Click **Finish** to generate the EAR.

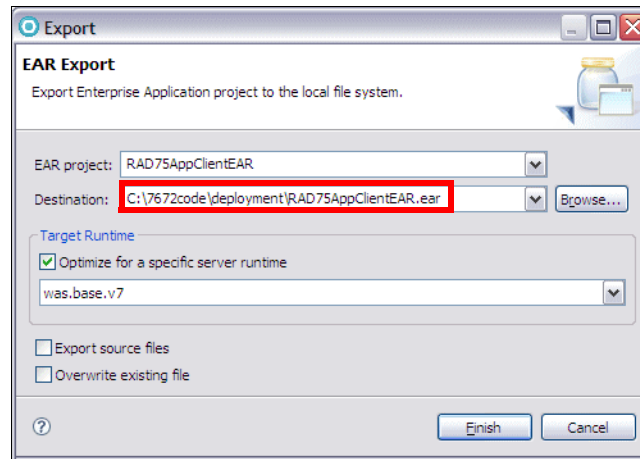

Figure 17-15 Application client export

The exported EAR file can now be deployed to a client node and executed using the Application Client for WebSphere Application Server.

Running the deployed application client

You can use the **launchClient** command to run the application client outside of Application Developer. You can find information on the command at:

http://publib.boulder.ibm.com/infocenter/wasinfo/v7r0/index.jsp?topic=/com.ibm.websphere.base.doc/info/aes/ae/rcli_javacmd.html

To execute the application client follow these steps:

- ▶ Open a command window at <RAD_HOME>\runtimes\base_v7\bin.
- ▶ Execute the **launchClient** command:

```
launchClient c:\7672code\deployment\RAD75AppClientEAR.ear
             -CCBootstrapHost=localhost -CCBootstrapPort=28xx
```

Note: The **-CCBootstrapHost** parameter specifies the host machine where the WebSphere Application Server v7.0 is running (default is `localhost`), and the **-CCBootstrapPort** parameter specifies the RMI port (default 2809).

You can find the RMI port by opening the server configuration (double-click the server in the Servers view) and look at server connection types.

- ▶ The Bank Desktop window opens and you can run the application client (refer to Figure 17-13 and Figure 17-14 on page 560).



Develop Web services applications

This chapter introduces the concepts of a service-oriented architecture (SOA) and explains how such an architecture can be realized using the Java Enterprise Edition (Java EE) Web services implementation.

We explore the features provided by Application Developer for Web services development and look at two Web services development approaches: top-down and bottom-up. We also demonstrate how Application Developer can help with testing Web services and developing Web services client applications.

The chapter is organized into the following sections:

- ▶ Introduction to Web services
- ▶ JAX-WS programming model
- ▶ Creating bottom-up Web services from a JavaBean
- ▶ Creating a synchronous Web service JSP client
- ▶ Creating a Web service JSF client
- ▶ Creating a Web service thin client
- ▶ Creating asynchronous Web service clients
- ▶ Creating Web services from an EJB
- ▶ Creating a top-down Web service from a WSDL and using an Ant task
- ▶ Web services security
- ▶ WS-Policy and WS-MetadataExchange (WS-MEX)

Introduction to Web services

This section introduces architecture and concepts of the service-oriented architecture (SOA) and Web services.

Service-oriented architecture (SOA)

In a service-oriented architecture, applications are made up from loosely coupled software services, which interact to provide all the functionality needed by the application. Each service is generally designed to be very self-contained and stateless to simplify the communication that takes place between them.

There are three main roles involved in a service-oriented architecture:

- ▶ Service provider
- ▶ Service broker
- ▶ Service requester

The interactions between these roles are shown in Figure 18-1.

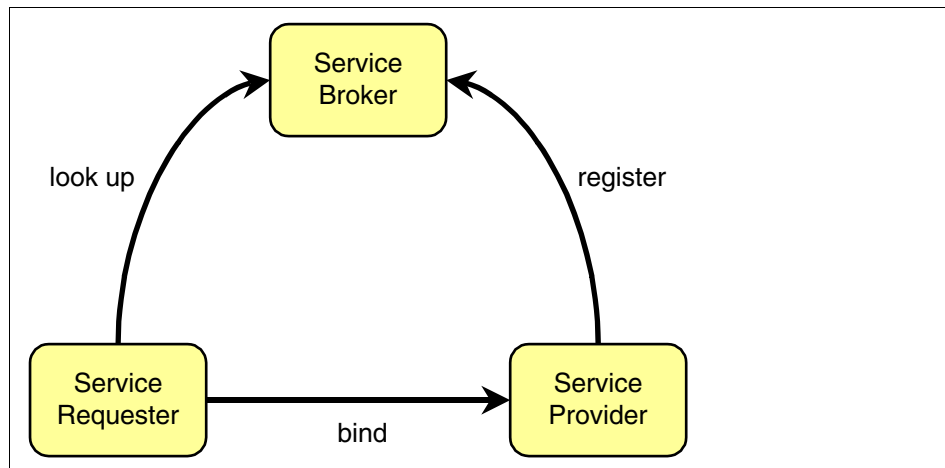

Figure 18-1 Service-oriented architecture

Service provider

The *service provider* creates a service and can publish its interface and access information to a *service broker*.

A service provider must decide which services to expose and how to expose them. There is often a trade-off between security and interoperability; the service provider must make technology decisions based on this trade-off. If the service

provider is using a service broker, decisions must be made on how to categorize the service, and the service must be registered with the service broker using agreed-upon protocols.

Service broker

The *service broker*, also known as the *service registry*, is responsible for making the service interface and implementation access information available to any potential service requester.

The service broker will provide mechanisms for registering and finding services. A particular broker might be public (for example, available on the Internet) or private—only available to a limited audience (for example, on an intranet). The type and format of the information stored by a broker and the access mechanisms used will be implementation-dependent.

Service requester

The *service requester*, also known as a *service client*, discovers services and then uses them as part of its operation.

A service requester uses services provided by service providers. Using an agreed-upon protocol, the requester can find the required information about services using a broker (or this information can be obtained in some other way). Once the service requester has the necessary details of the service, it can bind or connect to the service and invoke operations on it. The binding is usually static, but the possibility of dynamically discovering the service details from a service broker and configuring the client accordingly makes dynamic binding possible.

Web services as an SOA implementation

Web services provides a technology foundation for implementing a service-oriented architecture. A major focus during the development of this technology is to make the functional building blocks accessible over standard Internet protocols which are independent of platforms and programming languages to ensure that very high levels of interoperability are possible.

Web services are self-contained software services that can be accessed using simple protocols over a network. They can also be described using standard mechanisms, and these descriptions can be published and located using standard registries. Web services can perform a wide variety of tasks, ranging from simple request-reply to full business process interactions.

Using tools like Application Developer, existing resources can be exposed as Web services very easily.

The following core technologies are used for Web services:

- ▶ XML
- ▶ SOAP
- ▶ WSDL

XML

Extensible Markup Language (XML) is the markup language that underlies Web services. XML is a generic language that can be used to describe any kind of content in a structured way, separated from its presentation to a specific device. All elements of Web services use XML extensively, including XML namespaces and XML schemas.

The specification for XML is available at:

<http://www.w3.org/XML/>

SOAP

Simple Object Access Protocol (SOAP) is a network, transport, and programming language neutral protocol that allows a client to call a remote service. The message format is XML. SOAP is used for all communication between the service requester and the service provider. The format of the individual SOAP messages depends on the specific details of the service being used.

The specification for SOAP is available at:

<http://www.w3.org/TR/soap/>

WSDL

Web Services Description Language (WSDL) is an XML-based interface and implementation description language. The service provider uses a WSDL document in order to specify:

- ▶ The operations a Web service provides
- ▶ The parameters and data types of these operations
- ▶ The service access information

WSDL is one way to make service interface and implementation information available in a service registry. A server can use a WSDL document to deploy a Web Service. A service requester can use a WSDL document to work out how to access a Web Service (or a tool can be used for this purpose).

The specification for WSDL is available at:

<http://www.w3.org/TR/wsdl/>

Related Web services standards

The basic technologies of XML, SOAP, and WSDL are fundamental to Web services, but many other standards have been developed to help with developing and using them.

An excellent resource for information on standards related to Web services can be found at:

<http://www.ibm.com/developerworks/views/webservices/standards.jsp>

Web services in Java EE 5

Java EE 5 includes several API specifications. The main technologies in Java EE 5 that provide Web services support are as follows:

JAX-WS – JSR 224

Java API for XML Web Services (JAX-WS) is a new programming model that simplifies application development through support of a standard, annotation-based model to develop Web services applications and clients. The JAX-WS 2.1 programming standard aligns itself with the document-centric messaging model and replaces the remote procedure call programming model defined by the Java API for XML-based RPC (JAX-RPC) specification.

JAXB – JSR-222

Java Architecture for XML Binding (JAXB), which is also known as JSR-222, is a Java technology that provides an easy and convenient way to map Java classes and XML schema for simplified development of Web services. JAXB leverages the flexibility of platform-neutral XML data in Java applications to bind XML schema to Java applications without requiring extensive knowledge of XML programming.

JAXB is the default data binding technology that the Java API for XML Web Services (JAX-WS) tooling uses and is the default implementation within this product. You can develop JAXB objects for use within JAX-WS applications.

Implementing Enterprise Web services – JSR 109

Implementing Enterprise Web Services (JSR 109) defines the programming model and run-time architecture to deploy and look up Web services in the Java EE environment; more specifically, in the Web, EJB, and Client Application containers. One of its main goals is to ensure vendors' implementations interoperate.

SAAJ – JSR 67

The SOAP with Attachments API for Java (SAAJ) interface is used for SOAP messaging that provides a standard way to send XML documents over the Internet from a Java programming model. SAAJ is used to manipulate the SOAP message to the appropriate context as it traverses through the runtime environment.

StAX – JSR 173

Streaming API for XML (StAX) is streaming Java-based, event-driven, pull-parsing API for reading and writing XML documents. StAX enables you to create bidirectional XML parsers that are fast, relatively easy to program, and have a light memory footprint.

Web Services Metadata for the Java Platform – JSR 181

Web Services Metadata for the Java Platform defines an annotated Java format that uses Java Language Metadata (JSR 175) to enable easy definition of Java web services in a J2EE container.

The specifications for Web services support in Java EE 5 are available at:

<http://java.sun.com/javaee/technologies/webservices/>

Web services interoperability

In an effort to improve the interoperability of Web services, the Web Services Interoperability Organization (known as WS-I) was formed. WS-I produces a specification known as the *WS-I Basic Profile*, which describes the technology choices that maximize interoperability between Web services and clients running on different platforms, using different runtime systems, and written in different languages.

The WS-I Basic Profile is available at:

<http://ws-i.org/deliverables/workinggroup.aspx?wg=basicprofile>

Web services security

The WS-Security specification describes extensions to SOAP that allow for quality of protection of SOAP messages. This includes, but is not limited to, message authentication, message integrity, and message confidentiality. The specified mechanisms can be used to accommodate a wide variety of security models and encryption technologies. It also provides a general-purpose mechanism for associating security tokens with message content. For additional information, refer to:

http://www.oasis-open.org/committees/tc_home.php?wg_abbrev=wss

JAX-WS programming model

Java API for XML-Based Web Services (JAX-WS), which is also known as JSR-224, is the next generation Web services programming model that extends the foundation provided by the Java API for XML-based RPC (JAX-RPC) programming model. Using JAX-WS, developing Web services and clients is simplified with greater platform independence for Java applications by the use of dynamic proxies and Java annotations. The Web services tools included in Application Developer support JAX-WS 2.0 and 2.1.

JAX-WS is a new programming model that simplifies application development through support of a standard, annotation-based model to develop Web Service applications and clients. The JAX-WS programming standard strategically aligns itself with the current industry trend toward a more document-centric messaging model and replaces the remote procedure call programming model as defined by JAX-RPC. Although Application Developer still supports the JAX-RPC programming model and applications, JAX-RPC has limitations and does not support many current document-centric services. JAX-WS is the strategic programming model for developing Web services and is a required part of the Java EE 5 platform.

Implementing the JAX-WS programming standard provides the following enhancements for developing Web services and clients:

Better platform independence for Java applications

Using JAX-WS APIs, developing Web services and clients is simplified with better platform independence for Java applications. JAX-WS takes advantage of dynamic proxies whereas JAX-RPC uses generated stubs. The dynamic proxy client invokes a Web service based on a service endpoint interface (SEI) which is generated or provided. The dynamic proxy client is similar to the stub client in the JAX-RPC programming model. Although the JAX-WS dynamic proxy client and the JAX-RPC stub client are both based on the SEI that is generated from a WSDL file, there is a major difference. The dynamic proxy client is dynamically generated at run time using the Java 5 dynamic proxy functionality, while the JAX-RPC-based stub client is a non-portable Java file that is generated by tooling. Unlike the JAX-RPC stub clients, the dynamic proxy client does not require you to regenerate a stub prior to running the client on an application server for a different vendor because the generated interface does not require the specific vendor information.

Annotations

JAX-WS introduces support for annotating Java classes with metadata to indicate that the Java class is a Web service. JAX-WS supports the use of annotations based on the Metadata Facility for the Java Programming Language (JSR 175) specification, the Web Services Metadata for the Java Platform (JSR 181) specification and annotations that are defined by the JAX-WS 2.0/2.1 specification. Using annotations in the Java source and in the Java class simplifies development of Web services by defining some of the additional information that is typically obtained from deployment descriptor files, WSDL files, or mapping metadata from XML and WSDL files into the source artifacts.

For example, you can embed a simple `@WebService` tag in the Java source to expose the bean as a Web service (Example 18-1).

Example 18-1 JAX-WS annotation

```
@WebService
public class BankBean {
    public String getCustomerFullName(String ssn) { ... }
}
```

The `@WebService` annotation tells the server runtime environment to expose all public methods on that bean as a Web service. Additional levels of granularity can be controlled by adding additional annotations on individual methods or parameters. Using annotations makes it much easier to expose Java artifacts as Web services. In addition, as artifacts are created from using some of the top-down mapping tools starting from a WSDL file, annotations are included within the source and Java classes as a way of capturing the metadata along with the source files.

Invoking Web services asynchronously

With JAX-WS, Web services can be called both synchronously and asynchronously. JAX-WS adds support for both a polling mechanism and callback mechanism when calling Web services asynchronously. Using a polling model, a client can issue a request, get a response object back, which is polled to determine whether the server has responded. When the server responds, the actual response is retrieved. Using the polling model, the client can continue to process other work without waiting for a response to return. Using the callback model, the client provides a callback handler to accept and process the inbound response object. Both the polling and callback models enable the client to focus on continuing to process work while providing for a more dynamic and efficient model to invoke Web services.

For example, a Web service interface has methods for both synchronous and asynchronous requests (Example 18-2). Asynchronous requests are identified in bold.

Example 18-2 Asynchronous Methods in the Web service interface

```
@WebService
public interface CreditRatingService {
    // sync operation
    Score getCreditScore(Customer customer);
    // async operation with polling
    Response<Score> getCreditScoreAsync(Customer customer);
    // async operation with callback
    Future<?> getCreditScoreAsync(Customer customer,
        AsyncHandler<Score> handler);
}
```

The asynchronous invocation that uses the callback mechanism requires an additional input by the client programmer. The callback handler is an object that contains the application code that is executed when an asynchronous response is received. Example 18-3 shows an asynchronous callback handler.

Example 18-3 Asynchronous callback handler

```
CreditRatingService svc = ...;

Future<?> invocation = svc.getCreditScoreAsync(customerFred,
    new AsyncHandler<Score>() {
        public void handleResponse(Response<Score> response) {
            Score score = response.get();
            // do work here...
        }
    }
);
```

Example 18-4 shows an asynchronous polling client.

Example 18-4 Asynchronous polling

```
CreditRatingService svc = ...;
Response<Score> response = svc.getCreditScoreAsync(customerFred);

while (!response.isDone()) {
    // do something while we wait
}

// no cast needed, thanks to generics
Score score = response.get();
```

Data binding with JAXB 2.0 and 2.1

JAX-WS leverages the JAXB API and tools as the binding technology for mappings between Java objects and XML documents. JAX-WS tooling relies on JAXB tooling for default data binding for two-way mappings between Java objects and XML documents. JAXB data binding replaces the data binding described by the JAX-RPC specification.

WebSphere Application Server Version v7.0 supports the JAXB 2.1 specification. JAX-WS 2.1 requires JAXB 2.1 for data binding. JAXB 2.1 provides enhancements such as improved compilation support and support for the @XML annotation, and full schema 1.0 support.

Dynamic and static clients

The dynamic client programming API for JAX-WS is called the dispatch client (`javax.xml.ws.Dispatch`). The dispatch client is an XML messaging oriented client. The data is sent in either PAYLOAD or MESSAGE mode:

- ▶ **PAYLOAD:** When using the PAYLOAD mode, the dispatch client is only responsible for providing the contents of the `<soap:Body>` element and JAX-WS adds the `<soap:Envelope>` and `<soap:Header>` elements.
- ▶ **MESSAGE:** When using the MESSAGE mode, the dispatch client is responsible for providing the entire SOAP envelope including the `<soap:Envelope>`, `<soap:Header>`, and `<soap:Body>` elements and JAX-WS does not add anything additional to the message. The dispatch client supports asynchronous invocations using a callback or polling mechanism.

The static client programming model for JAX-WS is called the proxy client. The proxy client invokes a Web service based on a service endpoint interface (SEI) which is generated or provided.

MTOM support

Using JAX-WS, you can send binary attachments such as images or files along with Web services requests. JAX-WS adds support for optimized transmission of binary data as specified by Message Transmission Optimization Mechanism (MTOM).

Multiple payload structures

JAX-WS exposes the following binding technologies to the user: XML Source, SOAP Attachments API for Java (SAAJ) 1.3, and Java Architecture for XML Binding (JAXB) 2.0.

XML Source enables a user to pass a `javax.xml.transform.Source` into the runtime which represents the data in a source object to be passed to the runtime. SAAJ 1.3 now has the ability to pass an entire SOAP document across the interface, rather than just the payload itself. This is done by the client passing the SAAJ `SOAPMessage` object across the interface. JAX-WS leverages the JAXB 2.0 support as the data binding technology of choice between Java and XML.

SOAP 1.2 support

Support for SOAP 1.2 was added to JAX-WS 2.0. JAX-WS supports both SOAP 1.1 and SOAP 1.2. SOAP 1.2 provides a more specific definition of the SOAP processing model, which removes many of the ambiguities that sometimes led to interoperability problems in the absence of the Web Services-Interoperability (WS-I) profiles. SOAP 1.2 should reduce the chances of interoperability issues with SOAP 1.2 implementations between different vendors. It is not interoperable with earlier versions.

Web services development approaches

There are two general approaches to Web service development: top-down and bottom-up:

- ▶ In the top-down approach, a Web service is based on the Web service interface and XML types, defined in Web Services Description Language (WSDL) and XML Schema Definition (XSD) files. The developer first designs the implementation of the Web service by creating a WSDL file using the WSDL editor. The developer can then use the Web Service wizard to create the Web service and skeleton Java classes to which the developer can add the required code. The developer then modifies the skeleton implementation to interface with the business logic.

The top-down approach allows for more control over the Web service interface and the XML types used, and is the recommended approach for developing new Web services.

- ▶ In the bottom-up approach, a Web service is created based on the existing business logic in Java beans or EJBs. A WSDL file is generated to describe the resulting Web service interface.

The bottom-up pattern is often used for exposing existing function as a Web service. It might be faster, and no XSD or WSDL design skills are needed. However, if complex objects (for example, Java collection types) are used, then the resulting WSDL might be hard to understand and less interoperable.

Web services tools in Application Developer

Application Developer provides tools to create Web services from existing Java and other resources or from WSDL files, as well as tools for Web services client development and for testing Web services.

Creating a Web service from existing resources

Application Developer provides wizards for exposing a variety of resources as Web services. The following resources can be used to build a Web Service:

- ▶ **JavaBean:** The Web Service wizard assists you in creating a new Web service from a simple Java class, configures it for deployment, and deploys the Web service to a server. The server can be the WebSphere Application Server v6.1 or v7.0 test environment included with Rational Application Developer or another application server.
- ▶ **EJB:** The Web Service wizard assists you in creating a new Web service from a stateless session EJB, configures it for deployment, and deploys the Web service to a server.

Creating a skeleton Web service

Application Developer provides the functionality to create Web services from a description in a WSDL (or WSIL) file:

- ▶ **JavaBean from WSDL:** The Web services tools assist you in creating a skeleton JavaBean from an existing WSDL document. The skeleton bean contains a set of methods that correspond to the operations described in the WSDL document. When the bean is created, each method has a trivial implementation that you replace by editing the bean.
- ▶ **Enterprise JavaBean from WSDL:** The Web services tools support the generation of a skeleton EJB from an existing WSDL file. Apart from the type of component produced, the process is similar to that for Java beans.

Client development

To assist in development of Web service clients, Application Developer provides these features:

- ▶ **Java client proxy from WSDL:** The Web Service client wizard assists you in generating a proxy JavaBean. This proxy can be used within a client application to greatly simplify the client programming required to access a Web service.
- ▶ **Sample Web application from WSDL:** Rational Application Developer can generate a sample Web application, which includes the proxy classes described above, and sample JSPs that use the proxy classes.
- ▶ **Web Service Discovery Dialog:** This dialog allows you to discover a Web service that exists online or in your workspace, create a proxy for the Web service, and then place the methods of the proxy into a Faces JSP file.

Testing tools for Web services

To allow developers to test Web services, Application Developer provides a range of features:

- ▶ **WebSphere Application Server v7.0 and V6.x test environment.** These servers are included with Rational Application Developer as a test server and can be used to host Web services. It provides a range of Web services runtimes, including an implementation of the J2EE specification standards.
- ▶ **Sample JSP application:** The Web application mentioned above can be used to test Web services and the generated proxy it uses.
- ▶ **Web Services Explorer:** This is a simple test environment that can be used to test any Web Service, based only on the WSDL file for the service. The service can be running on a local test server or anywhere else on the network.
- ▶ **Universal Test Client:** The Universal Test Client (UTC) is a very powerful and flexible test application that is normally used for testing EJBs. Its flexibility makes it possible to test ordinary Java classes, so it can be used to test the generated proxy classes created to simplify client development.
- ▶ **TCP/IP Monitor:** The TCP/IP Monitor works like a proxy server, passing TCP/IP requests on to another server and directing the returned responses back to the originating client. The TCP/IP messages that are exchanged are displayed in a special view within Rational Application Developer.

Preparing for the samples

To prepare for this sample, we import some sample code. This is a simple Web application that includes Java classes and an Enterprise JavaBean.

Import the sample

This section describes the steps required for preparing the environment for the Web services application samples:

- ▶ In the Java EE perspective, select **File** → **Import** → **Other** → **Project Interchange**.
- ▶ In the Import Projects dialog, click **Browse** to navigate to and select the **RAD7WebServicesStart.zip** in the `c:\7672code\webservice` folder, and click **Open**.
- ▶ Click **Select All** and click **Finish**.

After the build, there should be no warning or error messages in the workspace.

Sample projects

The sample application that we use for creating Web service consists of the following projects:

- ▶ **RAD75WebServiceUtility** project: Simple banking model with BankMemory, Customer, and Account beans. This is a simplified version of the RAD75Java project used in Chapter 8, “Develop Java applications” on page 69.
- ▶ **RAD75WebServiceWeb** project: Contains the SimpleBankBean, a JavaBean with a few methods that retrieve data from the MemoryBank, a search HTML page, and a result JSP. We will use **annotations** to generate Web services for this project.
- ▶ **RAD75WebServiceWeb2** project: Contains the same code as the RAD75WebServiceWeb project. We will use the **Web Service wizard** to generate Web services for this project.
- ▶ **RAD75WebServiceEJB** project: Contains the SimpleBankFacade session EJB with a few methods that retrieve data from the MemoryBank.
- ▶ **RAD75WebServiceEAR** project: Enterprise application that contains the other four projects.

Test the application

To start and test the basic application, do these steps:

- ▶ In the Servers view, start the WebSphere Application Server v7.0.
- ▶ Right-click the server and select **Add and remove projects**.
- ▶ In the Add and Remove Projects dialog, select **RAD75WebServiceEAR** under, click **Add**, then click **Finish**.
- ▶ Expand **RAD7WebServiceWeb** → **WebContent**, right-click **search.html**, and select **Run As** → **Run on Server**.
- ▶ Select **Choose an existing server** and the V7.0 server to run the application and then click **Finish**.
- ▶ The search page opens in a Web browser. Enter an appropriate value in the Social Security Number field, for example, 111-11-1111, and click **Search**. If everything is working correctly, you can see the customer's full name and first account with the balance, which have been read from the memory data.
- ▶ The stateless session EJB, `SimpleBankFacade`, can be tested using the Universal Test Client (UTC). Refer to "Testing with the Universal Test Client" on page 426 for more information on using the UTC. The methods are:
 - `getCustomerFullName(ssn)`—Retrieves the full name (use 111-11-1111).
 - `getNumAccounts(ssn)`—Retrieves the number of accounts.
 - `getAccountId(ssn, int)`—Retrieves the account ID by index (0,1,2,...).
 - `getAccountBalance(accountId)`—Retrieves the balance.
- ▶ ~~Stop the WebSphere Application Server v7.0.~~

We now have some resources in preparation for the Web services sample, including a JavaBean in the `RAD75WebServiceWeb` project and a session EJB in the `RAD75WebServiceEJB` project. We use these as a base for developing and testing the Web services examples.

Creating bottom-up Web services from a JavaBean

In this section, we create a Web service from an existing Java class using the bottom-up approach. The imported application contains a Java class called `SimpleBankBean`, which has various methods to get customer and account information from the bank. We can either use the Web Service wizard to generate the Web service, or use the annotations directly. The Web Service wizard will inject annotation to the delegate class derived from the JavaBean. So these two approaches are essentially the same.

Creating a Web service using annotations

The Java API for XML-Based Web Services (JAX-WS) programming standard relies on the use of annotations to specify metadata that is associated with Web service implementations. The standard also relies on annotations to simplify the development of Web services. The JAX-WS standard supports the use of annotations that are based on several Java Specification Requests (JSRs):

- ▶ A Metadata Facility for the Java Programming Language (JSR 175)
- ▶ Web Services Metadata for the Java Platform (JSR 181)
- ▶ Java API for XML-Based Web Services (JAX-WS) 2.1 (JSR 224)
- ▶ Common Annotations for the Java Platform (JSR 250)

Using annotations from the JSR 181 standard, we can annotate a service implementation class or a service interface. Then we can generate a Web service with a wizard or by publishing the application to a server. Using annotations within both Java source code and Java classes simplifies Web service development. Using annotations in this way defines additional information that is typically obtained from deployment descriptor files, Web Services Description Language (WSDL) files, or mapping metadata from XML and WSDL into source artifacts.

In this section, we create a bottom-up Web service from a JavaBean using annotations. The Web services are generated by publishing the application to a server. No wizard is required in this example.

Annotate a JavaBean

We can annotate types, methods, fields, and parameters in the JavaBean to specify a Web service. To annotate the JavaBean:

- ▶ In the RAD75WebServiceWeb project, open the **SimpleBankBean** (in `its0.rad75.bank.model.simple`).
- ▶ Before the class declaration, type **@W** and press content assist (**Ctrl+space**), scroll down to the bottom and select **WebService(Web Service Template) - javax.ws** (Figure 18-2).

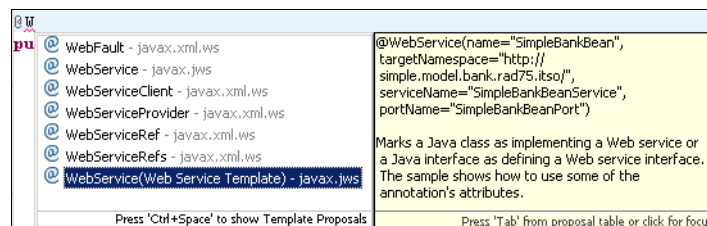

Figure 18-2 Content assist for Web service annotation

- ▶ The annotation template is added to the Java class (Example 18-5).

Example 18-5 Web service annotation template

```
@WebService(name="SimpleBankBean",
    targetNamespace="http://simple.model.bank.rad75.itso/",
    serviceName="SimpleBankBeanService", portName="SimpleBankBeanPort")
```

The **@WebService** tag marks a Java class as implementing a Web service.

- The *name* attribute is used as the name of the `wsdl:portType` when mapped to WSDL 1.1.
 - The *targetNamespace* attribute is the XML namespace used for the WSDL and XML elements generated from this Web service.
 - The *serviceName* attribute specifies the service name of the Web service: `wsdl:service`.
 - The *portName* attribute is the name of the endpoint port.
- ▶ Change the Web service name, service name, and port name as listed in Example 18-6.

Example 18-6 Annotate JavaBean Web service

```
@WebService(name="Bank",
    targetNamespace="http://simple.model.bank.rad75.itso/",
    serviceName="BankService", portName="BankPort")
```

- ▶ Before the **getCustomerFullName** method, type **@W** and press content assist (**Ctrl+space**), scroll down to the bottom and select **WebMethod(Web Service Template) - javax.ws** (Figure 18-3).

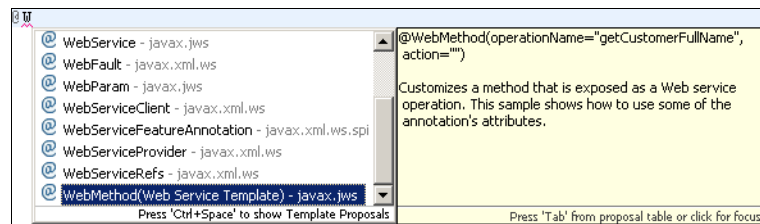

Figure 18-3 Annotate method

- ▶ The annotation template is added to the method (Example 18-7).

Example 18-7 WebMethod template

```
@WebMethod(operationName="getCustomerFullName", action="")
```

The **@WebMethod** tag identifies the individual methods of the Java class that are exposed externally as Web Service operations. In this example, we only expose the `getCustomerFullName` method as a Web service operation.

- *operationName* is the name of the `wsdl:operation` matching this method.
- *action* determines the value of the soap action for this operation.

- ▶ Change the `operationName` and `action` (Example 18-8).

Example 18-8 WebMethod annotation

```
@WebMethod(operationName="RetrieveCustomerName",
           action="urn:getCustomerFullName")
```

- ▶ Annotate the method input and output (Example 18-9).

Example 18-9 Annotate the method input and output

```
@WebMethod(operationName="RetrieveCustomerName",
           action="urn:getCustomerFullName")
@WebResult(name="CustomerFullName")
public String getCustomerFullName(@WebParam(name="ssn")String ssn)
    throws CustomerDoesNotExistException
```

The **@WebParam** and **@WebResult** tags customize the mapping of the method parameters and results to message parts and XML elements.

- ▶ Select **Source** → **Organize Imports** (or `Ctrl+shift+O`) to resolve the imports.

Validating Web services annotations

When developing Web services, you can benefit from two levels of validation. The first level involves validating syntax and Java-based default values. This level of validation is performed by the Eclipse Java Development Tools (JDT). The second level of validation involves implicit default checking, as well as verification of Web Services Description Language (WSDL) contracts. This second level is performed by a JAX-WS annotations processor.

When you enable the annotation processor, warnings and errors for annotations are displayed like Java errors. You can work with these warnings and errors in various workbench locations, such as the Problems view.

Note: The annotation processing is enabled by default. If you want to disable annotation processing, you can right-click the Web service project in the Enterprise Explorer, select **Properties** → **Java Compiler** → **Annotation Processing**, and clear **Enable annotation processing**.

By using the annotations processor to detect problems at build time, you can prevent these problems from occurring at run time. For example, if you make the changes of Example 18-10), you receive validation errors as shown in Example 18-11.

Example 18-10 Validate Web services annotations

```
@WebService(name="!Bank", targetNamespace="simple.model.bank.rad75.itso/",
serviceName="BankService", portName="BankPort")
public class SimpleBankBean implements Serializable {
    private static final long serialVersionUID = -637536840546155853L;
    public SimpleBankBean() {
    }
    @WebMethod(operationName="!RetrieveCustomerName",
action="urn:getCustomerFullName")
    @WebResult(name="CustomerFullName")
    @Oneway
    public String getCustomerFullName(@WebParam(name="ssn")String ssn)
        throws CustomerDoesNotExistException {
```

Example 18-11 JAX-WS annotation processor validation results

```
JSR-181, 4.3.1: Oneway methods cannot return a value
JSR-181, 4.3.1: Oneway methods cannot throw checked exceptions
name must be a valid nmToken
operationName must be a valid nmToken
targetNamespace must be a valid URI
```

Creating a Web service from an annotated JavaBean by publishing to the server

After annotating a Java bean, you can generate a Web service application by publishing the application project of the bean directly to a server. When the Web service is generated, no WSDL file is created in your project.

To create a Web service from an annotated JavaBean:

- ▶ In the Servers view, start **WebSphere Application Server v7.0** (if not running).
- ▶ Publish the Web service project on the server. Depending on the server configuration this happens automatically, or manually (right-click the server and select **Publish**).

Test the JAX-WS Web service using the Web Services Explorer

To test the Web service using the Web services explorer, do these steps:

- ▶ Switch to the **Services** view that is below the Enterprise Explorer.

- ▶ Expand the **JAX-WS** folder, then right-click **RAD75WebServiceWeb: {http://simple.model.bank.rad75bank.itso/}BankService** and select **Test with Web Services Explorer** (Figure 18-4).

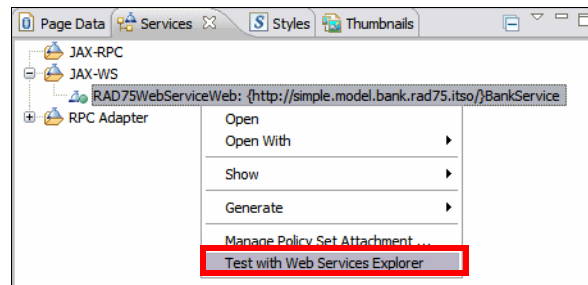

Figure 18-4 Test JAX-WS Web service using Web Services Explorer

Behind the scenes: The Web Services Explorer is a JSP Web application hosted on the Apache Tomcat servlet engine contained within Eclipse. The Web Services Explorer uses the WSDL to render a SOAP request. It does not involve data marshalling and unmarshalling. The return parameter is stripped out and the values are displayed in a pre-defined format.

- ▶ The Web Services Explorer opens in the internal or external browser, depending on the **Window** → **Web Browser** setting.
- ▶ Select the **RetrieveCustomerName** operation.
- ▶ Click **Add** and type 111-11-1111 in the ssn field.
- ▶ Click **Go** and the result (Mr. Henry Cui) is displayed in the status pane (Figure 18-5).

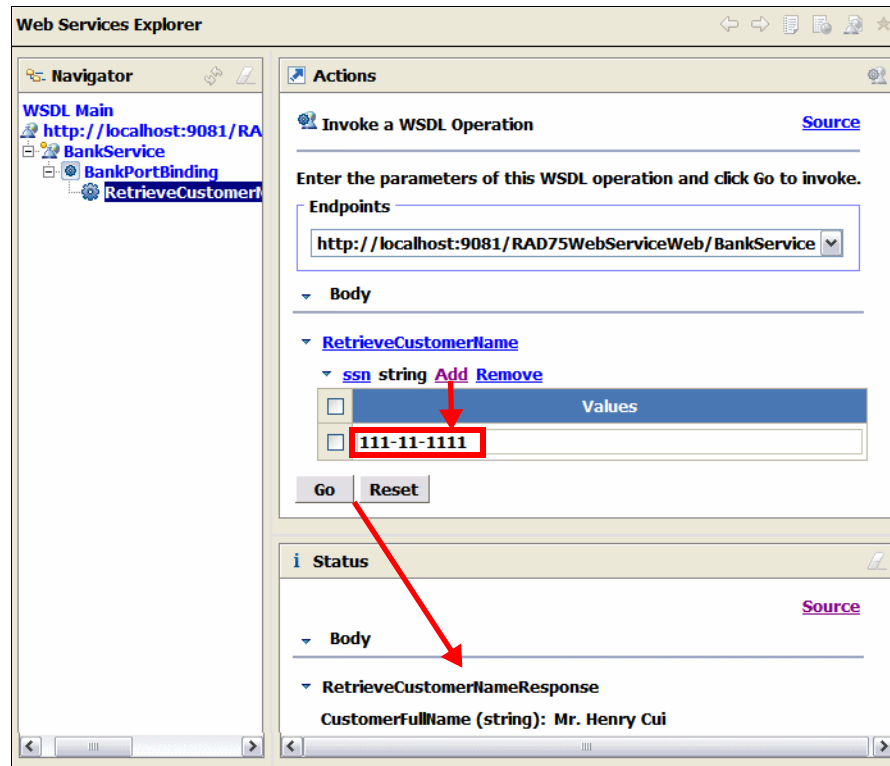

Figure 18-5 JAX-WS Web service test result with Web Services Explorer

- ▶ Double-click the **Status** pane bar to maximize it. Then click **Source** to view the SOAP messages as raw XML:
 - SOAP Request Envelope:
 - <soapenv:Envelope xmlns:soapenv="http://schemas.xmlsoap.org/soap/envelope/" xmlns:q0="http://simple.model.bank.rad75.itso/" xmlns:xsd="http://www.w3.org/2001/XMLSchema" xmlns:xsi="http://www.w3.org/2001/XMLSchema-instance">
 - <soapenv:Body>
 - <q0:RetrieveCustomerName>
 - <ssn>111-11-1111</ssn>
 - </q0:RetrieveCustomerName>
 - </soapenv:Body>
 - </soapenv:Envelope>

- SOAP Response Envelope:
 - <soapenv:Envelope
 - xmlns:soapenv="http://schemas.xmlsoap.org/soap/envelope/">
 - <soapenv:Body>
 - <RetrieveCustomerNameResponse
 - xmlns:ns2="http://simple.model.bank.rad75.itso/">
 - <CustomerFullName>Mr. Henry Cui</CustomerFullName>
 - </RetrieveCustomerNameResponse>
 - </soapenv:Body>
 - </soapenv:Envelope>

View the dynamically generated WSDL

In JAX-WS Web services, the deployment descriptors are optional because it uses annotations. The WSDL file can also be dynamically generated by the runtime based on information it gathers from the annotations added to the Java classes.

The URL for the dynamically generated WSDL is in this format:

```
http://<hostname>:<port>/<Web project context root>/<service name>?wsdl
```

To view the dynamically generated WSDL:

- ▶ Enter the following URL in the browser (**908x** is the port number, most probably 9080 or 9081):

```
http://localhost:908x/RAD75WebServiceWeb/BankService?wsdl
```

Note: You can find the URL using the Web Services Explorer. The URL is shown in the navigator view.

- ▶ The dynamically generated WSDL file is displayed. We also notice that the URL for the WSDL is changed to:

```
http://localhost:908x/RAD75WebServiceWeb/BankService/BankService.wsdl
```

- ▶ Examine the generated WSDL. We can see that the generated WSDL matches the Web services annotations that we added. An extract of the generated WSDL snippet is listed in Example 18-12.

Example 18-12 Dynamically generated WSDL snippet

```
<?xml version="1.0" encoding="UTF-8" ?>
<definitions name="BankService"
  targetNamespace="http://simple.model.bank.rad75.itso/"
  xmlns="http://schemas.xmlsoap.org/wsdl/"
  xmlns:xsd="http://www.w3.org/2001/XMLSchema" xmlns:tns=
    "http://simple.model.bank.rad75.itso/"
  xmlns:soap="http://schemas.xmlsoap.org/wsdl/soap/">
```



```

<types> .....
<message> .....
.....
<portType name="Bank">
  <operation name="RetrieveCustomerName">
    <input message="tns:RetrieveCustomerName" />
    <output message="tns:RetrieveCustomerNameResponse" />
    <fault name="CustomerDoesNotExistException"
      message="tns:CustomerDoesNotExistException" />
  </operation>
</portType>
<binding name="BankPortBinding" type="tns:bank">
  <soap:binding style="document"
    transport="http://schemas.xmlsoap.org/soap/http" />
  <operation name="RetrieveCustomerName">
    <soap:operation soapAction="urn:getCustomerFullName" />
    <input>
      <soap:body use="literal" />
    </input>
    <output>
      <soap:body use="literal" />
    </output>
    <fault name="CustomerDoesNotExistException">
      <soap:fault name="CustomerDoesNotExistException" use="literal"/>
    </fault>
  </operation>
</binding>
<service name="BankService">
  <port name="BankPort" binding="tns:BankPortBinding">
    <soap:address
      location="http://localhost:9080/RAD75WebServiceWeb/BankService" />
  </port>
</service>
</definitions>

```

-
- ▶ To see the dynamically generated XML schema, use this URL:
http://localhost:9080/RAD75WebServiceWeb/BankService/BankService_schema1.xsd
 - ▶ A simple test to verify that the Web service is running in the server can be performed using this URL:
<http://localhost:9080/RAD75WebServiceWeb/BankService>

The result displayed in the browser is:

```
{http://simple.model.bank.rad75.itso/}BankService
Hello! This is an Axis2 Web Service!
```

Creating Web services using the Web Service wizard

The Web Service wizard assists you in creating a new Web service, configuring it for deployment, and deploying the Web service to a server. To create a Web service from a JavaBean, do these steps:

- ▶ In the Java EE perspective, expand **RAD75WebServiceWeb2** → **Java Resources: src** → **itso.rad75.bank.model.simple**.
- ▶ Right-click **SimpleBankBean.java** and select **Web Services** → **Create Web service**. The Web Service wizard starts (Figure 18-6).

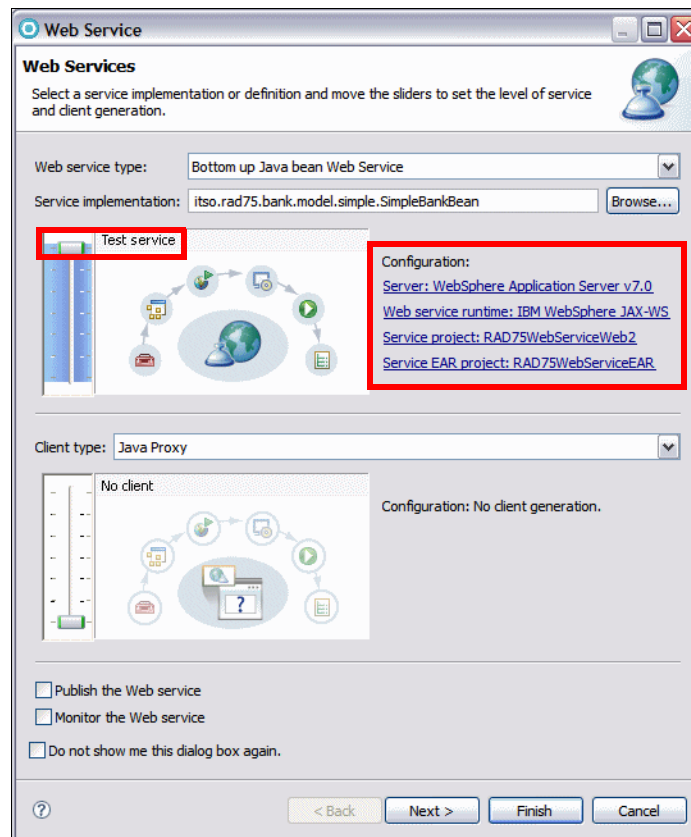

Figure 18-6 Web Service wizard: Web Services page

- ▶ Select the Web Services options in the Web Services page:
 - Select **Bottom up Java bean Web Service** as your Web service type. This should be selected by default.
 - Move the slider for the service to the **Test** position (top). This provides options for testing the service in subsequent pages of the wizard.

Behind the scenes:

The slider allows you to select the stages of Web services development. It allows more granular division of Web services development:

- ▶ **Develop:** Develops the WSDL definition and implementation of the Web service. This includes such tasks as creating the modules which will contain the generated code, WSDL files, deployment descriptors, and Java files when appropriate.
 - ▶ **Assemble:** Ensures that the project which will host the Web service or client will get associated to an EAR when required by the target application server.
 - ▶ **Deploy:** Creates the deployment code for the service.
 - ▶ **Install:** Installs and configures the Web module and EARs on the target server. If any changes to the endpoints of the WSDL file are required, they are made in this stage.
 - ▶ **Start:** Starts the Web service once the service has been installed on the server.
 - ▶ **Test:** Provides various options for testing the service, such as using the Web Service Explorer or sample JSPs.
- Ensure that the following server-side configurations are selected:
 - Server: WebSphere Application Server v7.0
 - Web service runtime: IBM WebSphere JAX-WS
 - Service project: RAD75WebServiceWeb2
 - Service EAR project: RAD75WebServiceEAR
 - If you click the hyperlink **Server: WebSphere Application Server v7.0**, the Service Deployment Configuration dialog is displayed (Figure 18-7).

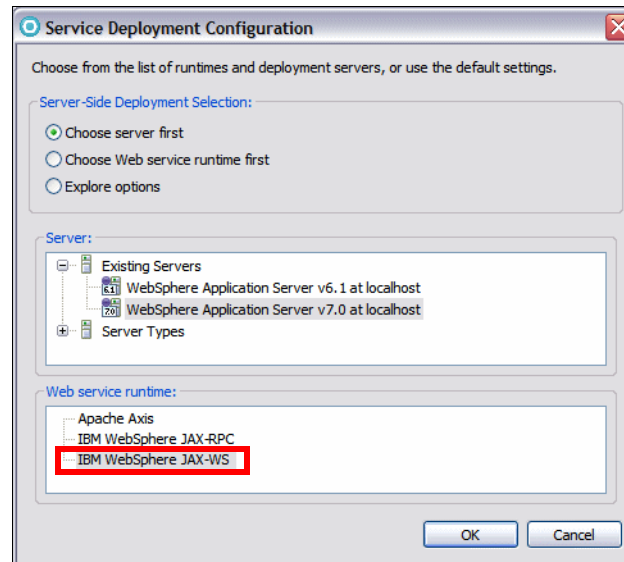

Figure 18-7 Web Service wizard: Service Deployment Configuration

- This page allows you to select the server and runtime. We will leave this page as default and click **Cancel** to exit this page.
- Clear **Publish the Web service** (we do not publish to a UDDI registry) and clear **Monitor the Web service** (we will do that later).
- Click **Next** in the Web Services page.
- ▶ In the WebSphere JAX-WS Bottom Up Web Service Configuration dialog (Figure 18-8):
 - Leave the Delegate class name as default (`SimpleBankBeanDelegate`).
The delegate class is a wrapper that contains all the methods from the Java bean as well as the JAX-WS annotation the runtime recognizes as a Web service.
 - Leave the Java to WSDL mapping style as default.
The style defines encoding style for messages sent to and from the Web service. The recommended WSDL style is **Document Wrapped**.
 - Select **Generate WSDL file into the project**.
Because the annotations in the delegate class are used to tell the runtime that the bean is a Web service, a static WSDL file is no longer generated into your project automatically. The runtime can dynamically generate a WSDL file from the information in the bean. Select this to generate a static

WSDL file for the Web service. This is a convenient option if you plan to create the client at a later time or publish the WSDL for other users.

- Select **Generate Web service deployment descriptor**.

For JAX-WS Web services deployment information is generated dynamically by the runtime; static deployment descriptors are optional. Selecting this check box will generate the deployment descriptors.

- Click **Next**.

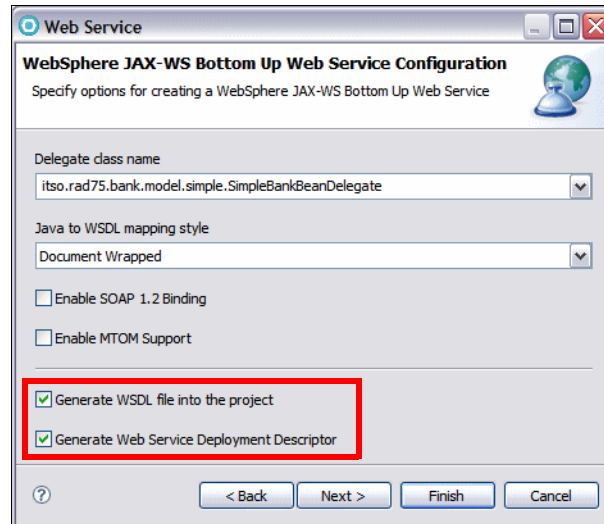

Figure 18-8 Web Service wizard: Service Endpoint Interface Selection

- ▶ In the WebSphere JAX-WS WSDL Configuration page (Figure 18-9):
 - Select **WSDL Target Namespace**, and enter **http://bank.rad75.itso/** as the WSDL Target Namespace.
 - Select **Configure service name**, and enter **BankService** as the WSDL Service Name.
 - Select **Configure WSDL Port Name**, and enter **BankPort** as the WSDL Port Name.
 - Click **Next**.

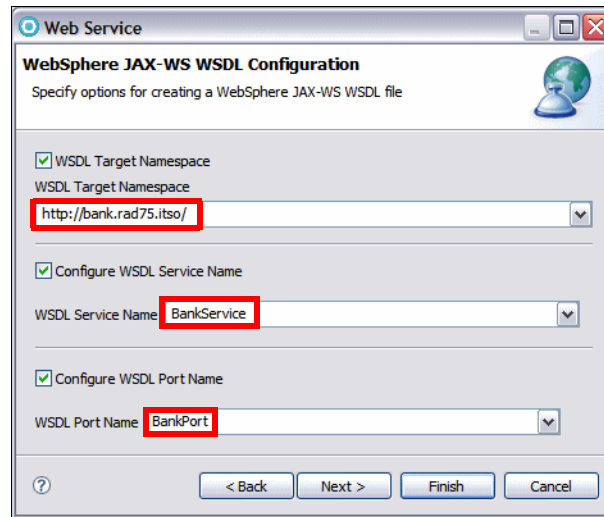

Figure 18-9 WebSphere JAX-WS WSDL Configuration page

- ▶ The Web service is generated and deployed to the server.
- ▶ The Test Web Services dialog (Figure 18-10) shows because we moved the slider for the service to the Test position. Click **Launch** to launch the Web Services Explorer.

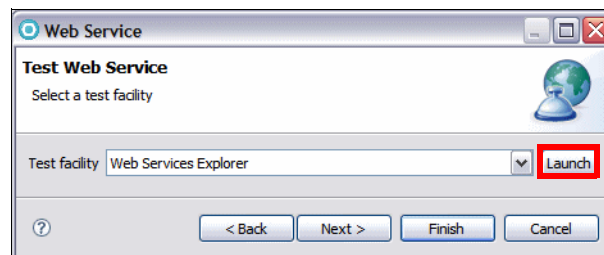

Figure 18-10 Web Service wizard: Test Web Service

- ▶ The Web Services Explorer opens in an external Web browser.
- ▶ The Web services are available at two endpoints: one is the HTTP endpoint and the other is the HTTPS endpoint. If your server is secured, the endpoint of the Web service listed in the Web service explorer should be:

`https://localhost:944x/RAD75WebServiceWeb2/BeanService`

To test the HTTPS protected Web service with the Web Services Explorer, you must configure the workbench JRE to work with a secured server. The signer certificate from the WebSphere Application Server must be imported

into the Eclipse trust store. This involves complicated SSL configuration. To make things easier, you can just send the SOAP request to the HTTP endpoint.

- In the endpoints section, click **Add** and then enter the following endpoint:
`http://localhost:908x/RAD75WebServiceWeb2/BankService`
- Click **Go**.
- Select the **getNumAccounts** operation, then click **Add**.
- Enter a value for the customer ID, such as **111-11-1111**, and click **Go**.
- The result 2 is displayed in the status pane.
- Optionally try other operations.
- ▶ Close the Web Services Explorer.
- ▶ Click **Finish** to exit the Web Service wizard.

You have successfully created Web services from a Java bean.

Resources generated by the Web Service wizard

After code generation, examine the generated code. You can see that the wizard generates the following artifacts:

- ▶ A delegate class named **SimpleBankBeanDelegate**. The delegate class is a wrapper that contains all the methods from the Java bean as well as the JAX-WS annotation the runtime recognizes as a Web service. The annotation **@javax.jws.WebService** in the delegate class tells the server runtime environment to expose all public methods on that bean as a Web service. The `targetNamespace`, the `serviceName`, and the `portName` are what we specified in the Web Service wizard.

```
@javax.jws.WebService (targetNamespace="http://bank.rad75.itso/",  
    serviceName="BankService", portName="BankPort",  
    wsdlLocation="WEB-INF/wsdl/BankService.wsdl")
```

- ▶ A `webservices.xml` file in the `WebContent/WEB-INF` folder. This is the optional Web services deployment descriptor. A deployment descriptor can be used to override or enhance the information provided in the Service. For example, if the `<wsdl-service>` element is provided in the deployment descriptor, then the namespace used in this element overrides the `targetNamespace` member attribute in the annotation.
- ▶ A WSDL file (`BankService.wsdl`) and an XSD file (`BankService_schema1.xsd`) in the `WEB-INF/wsdl` folder. If you plan to create the client at a later time or publish the WSDL for other users, you can use this WSDL file.

Creating a synchronous Web service JSP client

The Web Service Client wizard assists you in generating a Java bean proxy and a sample application. The sample Web application demonstrates how to invoke the Web services proxy. You can invoke the Web services using the JAX-WS synchronous model, or the asynchronous model. In the section, we generate a synchronous Web service client.

To generate a client and test the client proxy, do these steps:

- ▶ Switch to the **Services** view, right-click the **RAD75WebServiceWeb** and select **Generate** → **Client** (Figure 18-11).

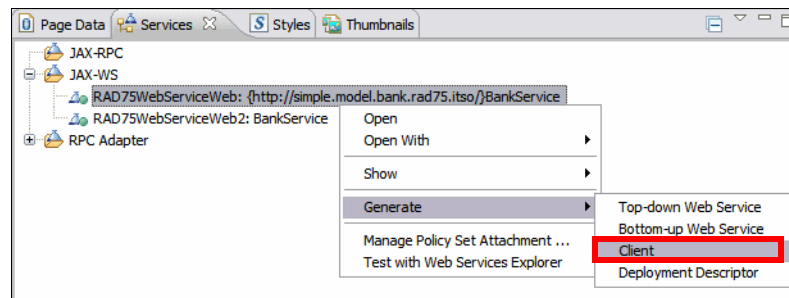

Figure 18-11 Generate Web service client

- ▶ In the Web Services Client dialog (Figure 18-12):
 - Move the slider up to the **Test** position. This provides options for testing the service using a JSP-based sample application.
 - Select **Monitor the Web service**.

We recommend that the Web service and Web service client are in separate Web and EAR projects:

- Click **Client project...**. The Specify Client Project Settings dialog opens.
- Change the client project name to **RAD75WebServiceClient**.
- Accept **Dynamic Web project** as the project type.
- Accept the client EAR project name as **RAD75WebServiceClientEAR**.
- Click **OK**. The wizard creates the Web and EAR projects.
- Click **Next**.

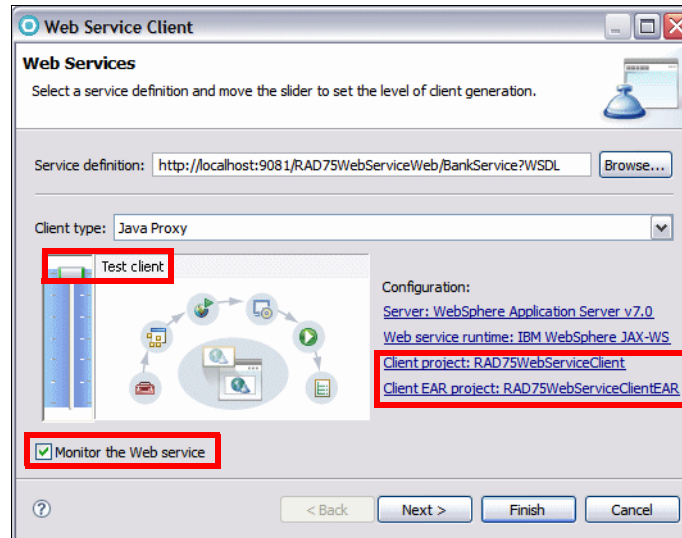

Figure 18-12 Generate Web service client

- ▶ In the WebSphere JAX-WS Web Service Client Configuration dialog, select **Generate Web Service Deployment Descriptor** (Figure 18-13). This will generate the JSR 109 1.2 deployment descriptor. Click **Next**.

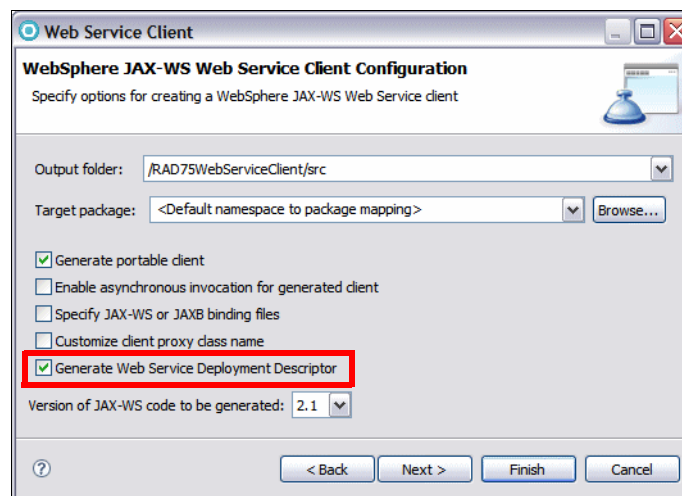

Figure 18-13 JAX-WS Web Service Client Configuration

- ▶ The client code is generated into the new client project.

- ▶ In the Web Service Client Test dialog (Figure 18-14), use these settings:
 - Select **Test the generated proxy**.
 - Test facility: Select **JAX-WS JSPs** (default).
 - Folder: **sampleSimpleBankBeanProxy** (default). You can specify a different folder for the generated application if you want.
 - Methods: Leave all methods selected.
 - Select **Run test on server**.
- ▶ Click **Finish**.

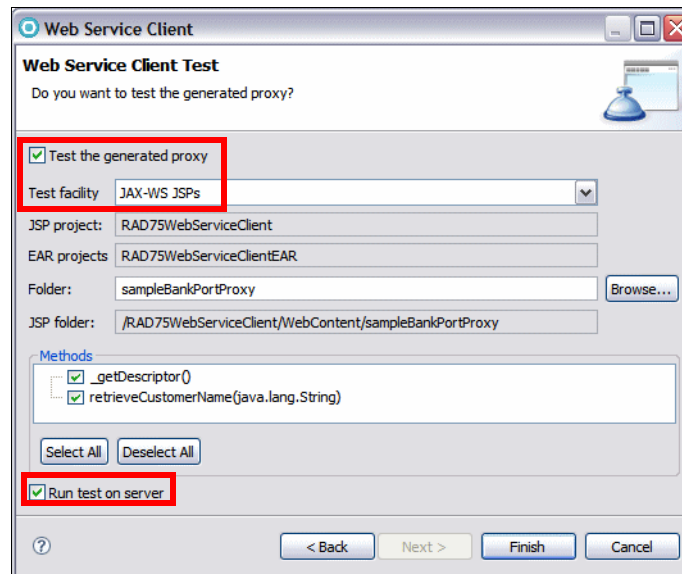

Figure 18-14 Web Service Client Test

- ▶ The sample application is published to the server and the sample JSP is displayed in a Web browser.
- ▶ Select the **retrieveCustomerName** method, enter a valid value in the customer ID field (such as 111-11-1111), and then click **Invoke**. The results are displayed in the result pane (Figure 18-15).

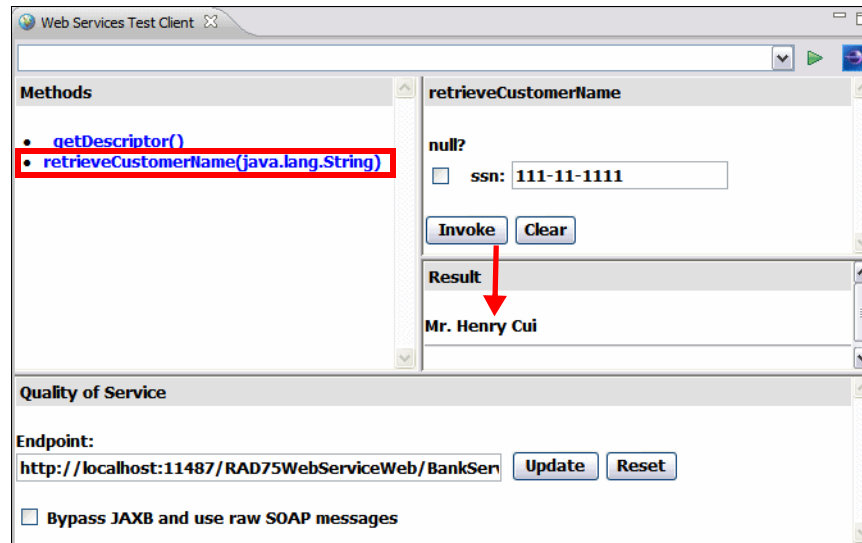

Figure 18-15 Sample JSP results

- ▶ Notice the **Endpoint** in the Quality of Service pane:
 - `http://localhost:11487/RAD75WebServiceWeb/BankService`
 You might see a port number other than above. It depends on what port number the wizard generated for the TCP/IP Monitor.
- ▶ The TCP/IP Monitor is also started. The TCP/IP Monitor lets you intercept and examine the SOAP traffic coming in and out of a Web service.
- ▶ If you select **Window** → **Preferences** → **Run/Debug** → **TCP/IP Monitor**, you can see a new Monitor is there to listen to the same port number (11487). The TCP/IP Monitor is started and ready to listen to the SOAP request and direct it to the Web service provider (at port 908x).

Behind the scenes:

- ▶ When you select **Monitor the Web service** in the Web Service wizard page, the Web Service Client wizard dynamically creates the TCP/IP Monitor for you. It uses certain algorithm to find an available listening port for the Monitor, and the sample JSP client page uses the URL to dynamically set the Web service endpoint to match the Monitor port.
- ▶ Using the wizard to create the TCP/IP Monitor is very handy as the user does not have to spend time to figure out how to redirect the SOAP request to the TCP/IP Monitor, especially in the case of monitoring remote Web services.

- ▶ All requests and responses are routed through the TCP/IP Monitor and appear in the TCP/IP Monitor view.
- ▶ The TCP/IP Monitor view probably appears in the top right pane. Move it to the same pane as the Servers view.

The TCP/IP Monitor view shows all the intercepted requests in the top pane, and when a request is selected, the messages passed in each direction are shown in the bottom panes (request in the left pane, response in the right). This can be a very useful tool in debugging Web services and clients.

Select the **XML** view to display the SOAP request and response in XML format (Figure 18-16).

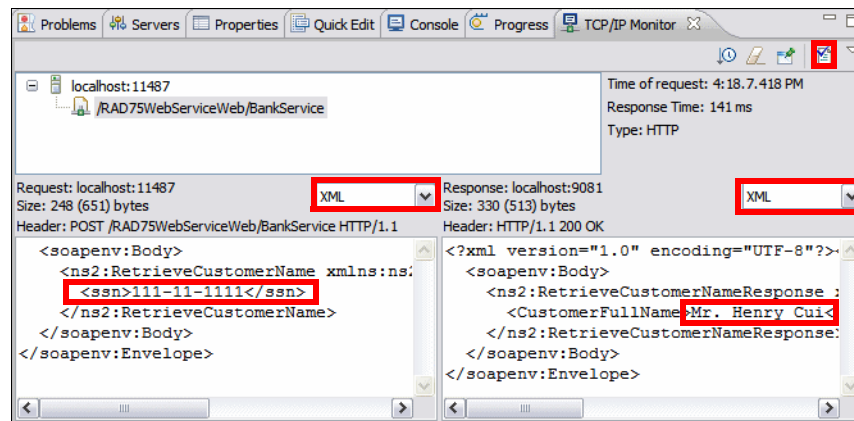



Figure 18-16 TCP/IP Monitor

- ▶ To ensure that the Web service SOAP traffic is WS-I compliant, you can generate a log file by clicking the icon  at the top right corner. In the dialog box that opens, select a name for the log file and specify where you want it to be stored (for example in the client project).
- ▶ The log file is validated for WS-I compliance. You will see a confirmation dialog stating *The WS-I Message Log file is valid*. You can open the log file in an XML editor to examine its contents.
- ▶ Stop the TCP/IP Monitor by selecting **Window** → **Preferences** → **Run/Debug** → **TCP/IP Monitor** and **stop** the TCP/IP Monitor from the list.

Resources generated by the Web Service client wizard

Figure 18-17 on page 597 shows the generated Web services client artifacts.

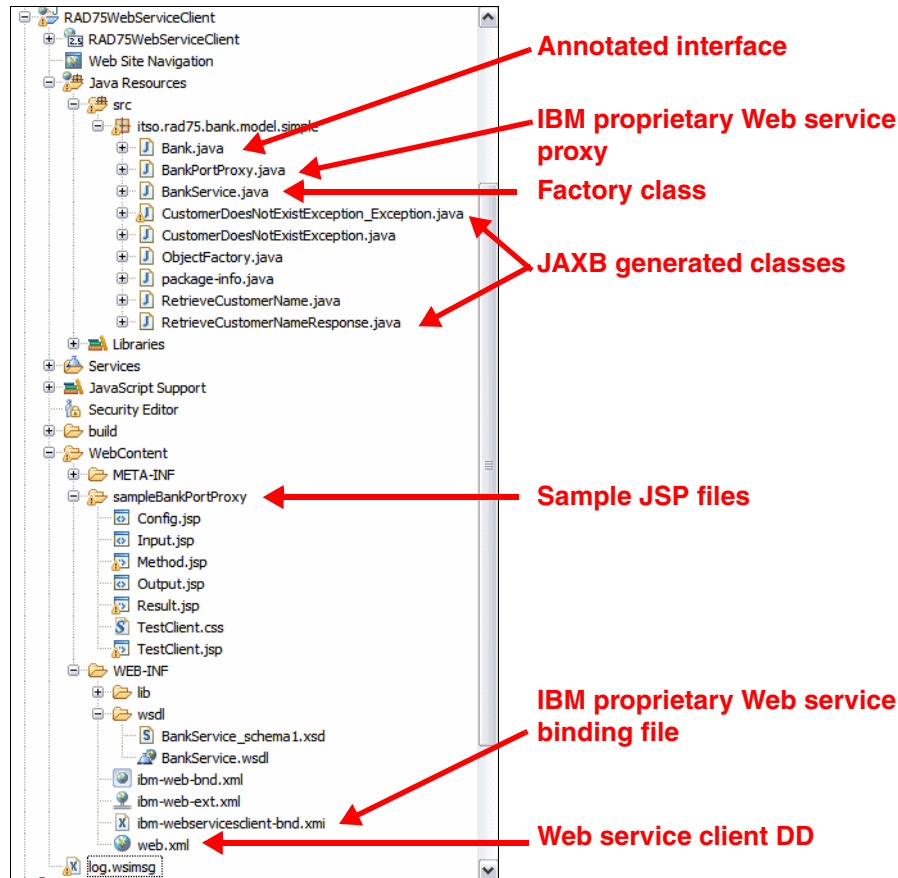

Figure 18-17 Web service client artifacts

- ▶ **Bank.java** is the annotated service interface based on the WSDL to Java mapping.
- ▶ **BankService.java** is generated from the WSDL service. It is a factory class that returns an instance that implements the service's interface. In JAX-RPC, this implementation class is called a stub. In JAX-WS, no stub class exists; the stub is a class dynamically generated from WSDL.
- ▶ **BankPortProxy.java** is an IBM-proprietary proxy class. JAX-WS does not define this class. It is a convenience class which implements the Web service's interface and hides programming details such as the service factory and binding provider calls.
- ▶ The rest Java classes are the JAXB artifacts based on the schema types used by the WSDL.

- ▶ The **sampleBankPortProxy** folder contains the generated sample JSPs, which demonstrates how to invoke Web services proxy.
- ▶ **web.xml** is the standard Web deployment descriptor, and it contains the JSR 109 1.2 Web service deployment information (<service-ref> tag).

Creating a Web service JSF client

The Web Service Discovery Dialog allows you to discover a Web service that exists online or in the workspace, create a proxy to the Web service, and then place the methods of the proxy on a Faces JSP file:

- ▶ Remove the `RAD75WebServiceClientEAR` from the server using **Add and Remove Projects** (we will add a project to the EAR and automatic publishing gets into the way), or expand the server, right-click the project, and select **Remove**.
- ▶ Create a dynamic Web project In the Web perspective select **File** → **New** → **Dynamic Web Project**.
 - Enter **RAD75WebServiceJSFClient** as the project name.
 - In the Configurations section, select **JavaServer Faces v1.2 Project** to add the required JSF facets to the project facets list.
 - Select **RAD75WebServiceClientEAR** as the EAR project name.
 - Click **Finish** (Figure 18-18). If you are prompted to open the Web perspective, click **Yes**.

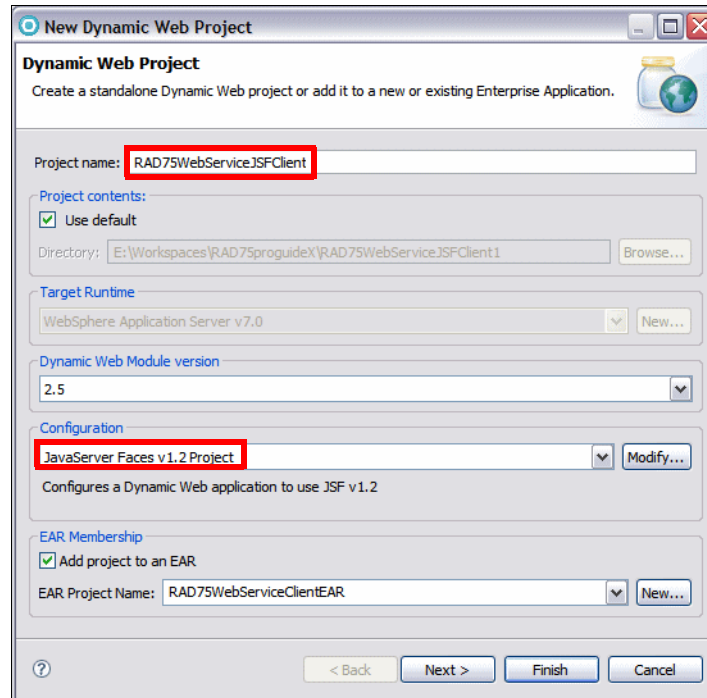

Figure 18-18 New Faces Project

- ▶ In the **RAD75WebServiceJSFClient** project, right-click the **WebContent** and select **New** → **Web Page**.
- ▶ Enter **WSJSFClient** as the file name. Select **JSP** as the basic template and click **Finish**.
- ▶ The `WSJSFClient.jsp` opens in an editor. Select the **Design** or **Split** tab.
- ▶ In the Palette, select the **Data and Services** category. Select **Web Service** and click into the JSF page (Figure 18-19).

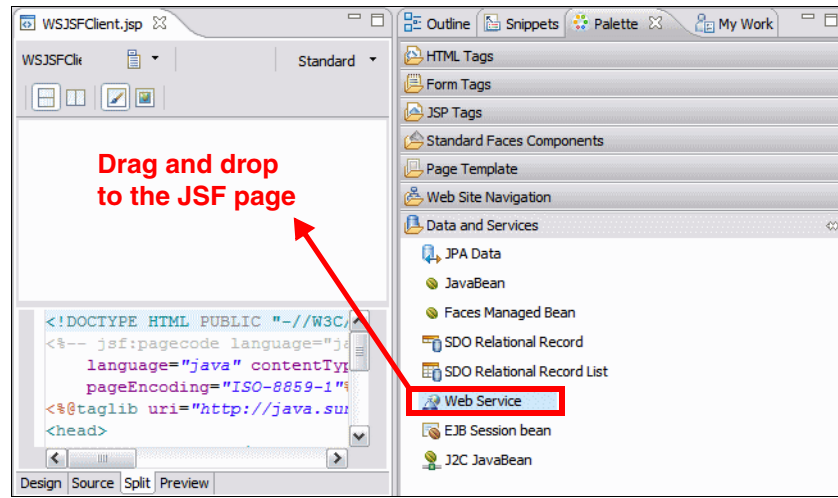

Figure 18-19 Drag and drop Web Service to JSF design view

- ▶ The Add Web Service dialog (Figure 18-20) comes up. Click **Add**. The Web Services Discovery Dialog opens. Select **Web services from your workspace**.

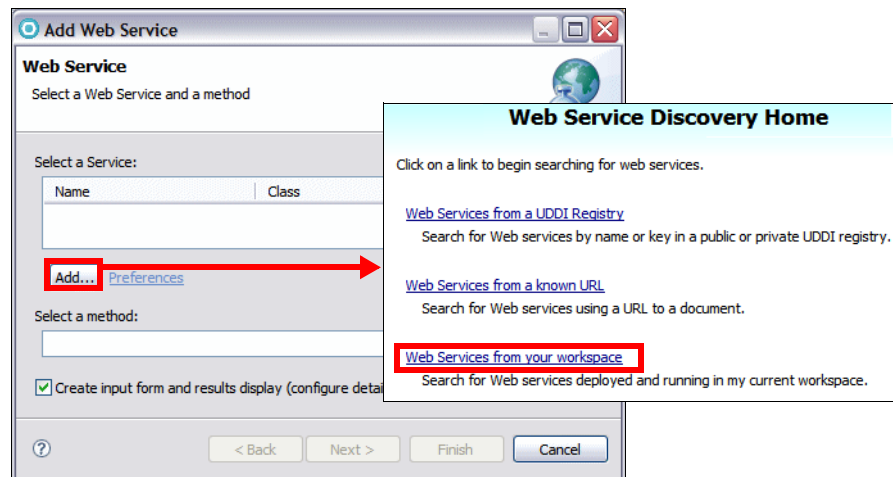

Figure 18-20 Add Web service

- ▶ In the Web Services from your workspace page (Figure 18-21), click **BankService** with the URL of the **RAD75WebServiceWeb** project (not the RAD75WebServiceWeb2 project).

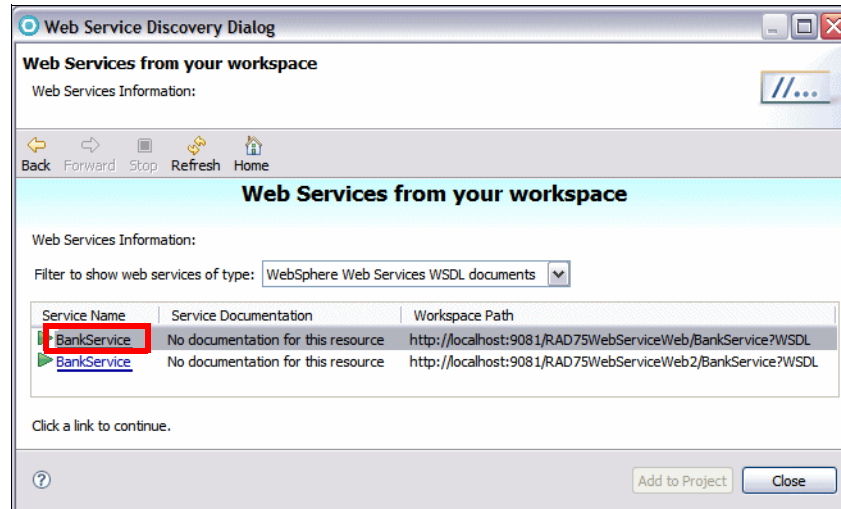

Figure 18-21 Web Services Discovery Dialog: Web Services from your workspace

- ▶ The service is listed with its port. Select **Port: BankPort** and click **Add to Project** (Figure 18-22).

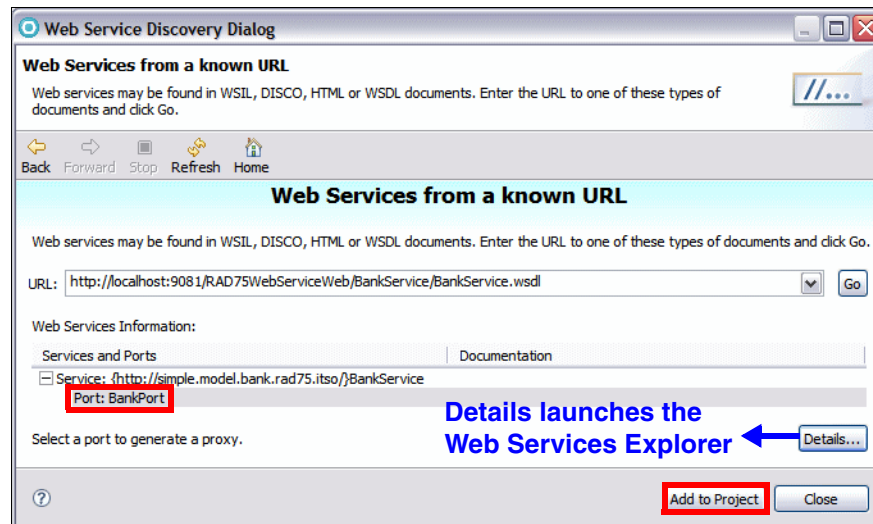

Figure 18-22 Web Services Discovery Dialog: Add to Project

- ▶ The Web service you selected is now listed in the list of Web services. Select **Bank** as the service, **retrieveCustomerName(String)** as method, **Create input form and results display**, and click **Next** (Figure 18-23).

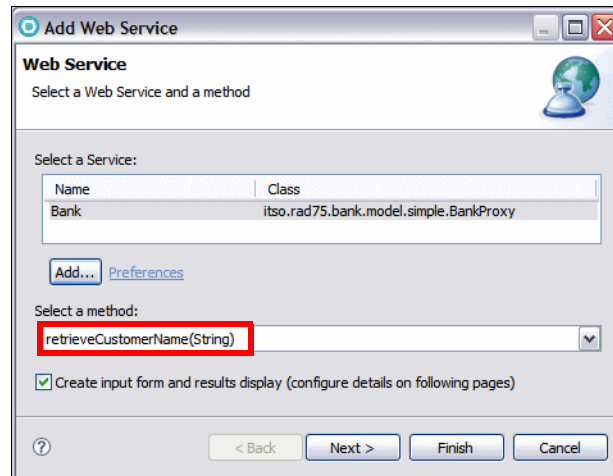

Figure 18-23 Select Web service method

- ▶ In the Input form page (Figure 18-24):
 - Change the label to **Enter Social Security Number:**.
 - Click **Options** and change the label from Submit to **Get Full Name**. Click **OK**.
 - Click **Next**.

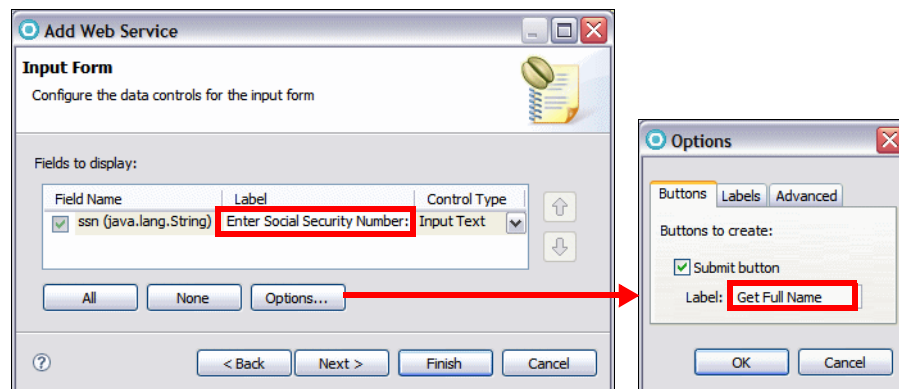

Figure 18-24 Web service input form

- ▶ In the Results form page, change the Label to **Customer's full name is:**.
- ▶ Click **Finish** to generate the input and output parts into the JSF page (Figure 18-25). **Save** the file.

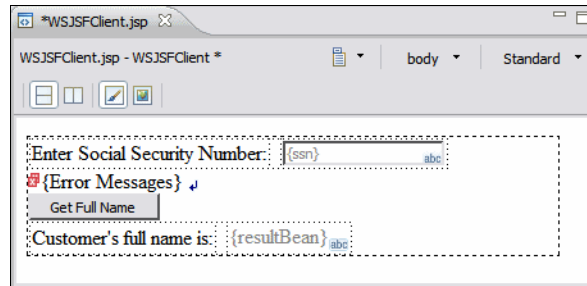

Figure 18-25 JSF page with Web service invocation

- ▶ Right-click **WSJSFClient.jsp** and select **Run As** → **Run on Server**. The client application is deployed to the server for testing. Type **111-11-1111**, click **Get Full Name**, and the result is displayed (Figure 18-26).

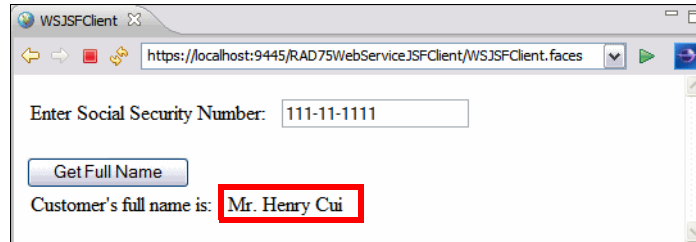

Figure 18-26 JSF client run

Creating a Web service thin client

WebSphere Application Server provides an unmanaged client implementation that is based on the Java API for XML-based Web Services (JAX-WS) 2.1 specification. The *thin client* for JAX-WS with WebSphere Application Server is an unmanaged and stand-alone Java client environment that enables running JAX-WS Web services client applications to invoke Web services that are hosted by WebSphere Application Server. A Web service thin client relies only on a JDK that is compatible with IBM WebSphere Application Server v7 and a thin client jar file that is available at:

```
<RAD_HOME>\runtimes\base_v7\runtimes\com.ibm.jaxws.thinclient_7.0.0.jar
```

Create the thin client project and generate the client code

To create the Web service thin client, do the following:

- ▶ Create a Java project by selecting **File** → **New** → **Project** → **Java Project**.

- ▶ Enter **RAD75WebServiceThinClient** as the project name and click **Finish**.
- ▶ In the Java EE perspective, Services view, expand **JAX-WS**, then right-click **RAD75WebServiceWeb: {http://...}BankService** and select **Generate** → **Client**.
- ▶ Keep the slider at **Deploy client** level. Click the hyperlink **Client project:...**
- ▶ In the Specify Client Project Settings dialog, select **RAD75WebServiceThinClient** as the client project, and click **OK** (Figure 18-27).

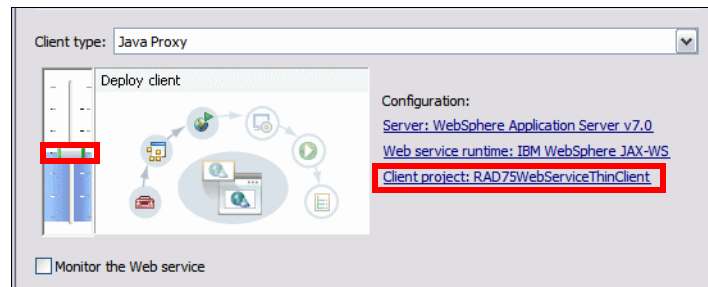

Figure 18-27 Generating a thin client

- ▶ Click **Finish** to generate the helper classes and WSDL file into the client project.
- ▶ After the code generation, switch to the Enterprise Explorer view. Right-click **RAD75WebServiceThinClient** and select **Properties**. Select **Java Build Path** → **Libraries** (Figure 18-28).

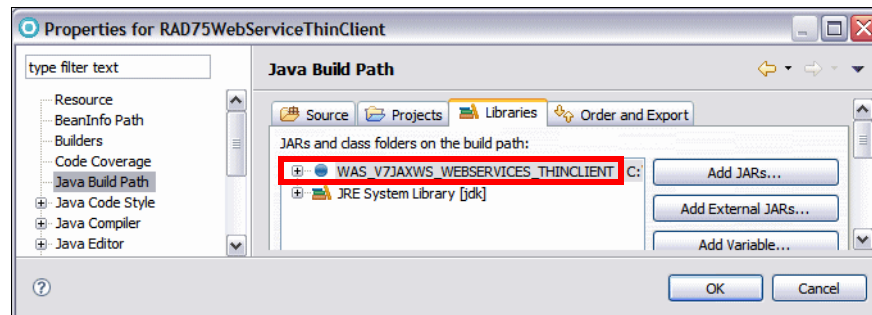

Figure 18-28 Web service thin client build path

Notice that the thin client only requires the JRE and a thin client jar file. The wizard adds a class path variable `WAS_V7JAXWS_WEBSERVICES_THINCLIENT`, which points to the `com.ibm.jaxws.thinclient_7.0.0.jar`.

Create the client class to invoke the Web service

To invoke the Web service we create a simple Java class.

- ▶ Right-click **RAD75WebServiceThinClient** and select **New** → **Class**.
- ▶ Type **itso.rad75.bank.test** as the package name and **WSThinClientTest** as the class name. Select **public static void main(String[] args)** and click **Finish**.
- ▶ Copy/paste the code from C:\7672code\webservice\thinclient (Example 18-13).

Example 18-13 WSThinClientTest

```
package itso.rad75.bank.test;

import itso.rad75.bank.model.simple.BankPortProxy;
import itso.rad75.bank.model.simple
    .CustomerDoesNotExistException_Exception;
import java.util.Scanner;

public class WSThinClientTest {

    public static void main(String[] args) {
        try {
            Scanner scanner = new Scanner(System.in);
            BankPortProxy proxy = new BankPortProxy();
            System.out.println
                ("Please enter customer's social security number: ");
            String ssn = scanner.next();
            System.out.println("Customer's name is " +
                proxy.retrieveCustomerName(ssn);
            } catch (CustomerDoesNotExistException_Exception e) {
                System.out.println("The customer does not exist!");
            }
        }
    }
}
```

Notice how easy it is to invoke the Web service: Instantiate the proxy class (BankPortProxy) and call the method (retrieveCustomerName) in the proxy.

- ▶ Right-click **WSThinClientTest.java** and select **Run As** → **Java Application**.
- ▶ When prompted in the Console, type **000-00-0000** as the customer's social security number, and the customer's names is displayed:

```
Retrieving document at '.../RAD75WebServiceThinClient/bin/META-INF/wsdl/'.
Retrieving schema at 'BankService_schema1.xsd', relative to ....
Please enter customer's social security number:
000-00-0000
Customer's name is Mr. Ueli Wahli
```

Creating asynchronous Web service clients

An asynchronous invocation of a Web service sends a request to the service endpoint and then immediately returns control to the client program without waiting for the response to return from the service. JAX-WS asynchronous Web service clients consume Web services using either the polling approach or the callback approach:

- ▶ Using a **polling** model, a client can issue a request and receive a response object that is polled to determine if the server has responded. When the server responds, the actual response is retrieved.
- ▶ Using the **callback** model, the client provides a callback handler to accept and process the inbound response object. The `handleResponse` method of the handler is called when the result is available.

Both the polling and callback models enable the client to focus on continuing to process work without waiting for a response to return, while providing for a more dynamic and efficient model to invoke Web services.

Polling client

Using the polling model, a client can issue a request and receive a response object that can subsequently be polled to determine if the server has responded. When the server responds, the actual response can then be retrieved. The response object returns the response content when the `get` method is called. The client receives an object of type `javax.xml.ws.Response` from the `invokeAsync` method. That `Response` object is used to monitor the status of the request to the server, determine when the operation has completed, and to retrieve the response results.

To create an asynchronous Web service client using the polling model, do the following:

- ▶ In the Java EE perspective, Services view, expand **JAX-WS**, then right-click **RAD75WebServiceWeb: {http://...}BankService** and select **Generate** → **Client**.
- ▶ Keep the slider at **Deploy client** level. Click the hyperlink **Client project:**. In the Specify Client Project Settings dialog, select **RAD75WebServiceThinClient**, and click **OK**. Click **Next**.
- ▶ Select **Enable asynchronous invocation for generated client** (Figure 18-29) and click **Finish**.

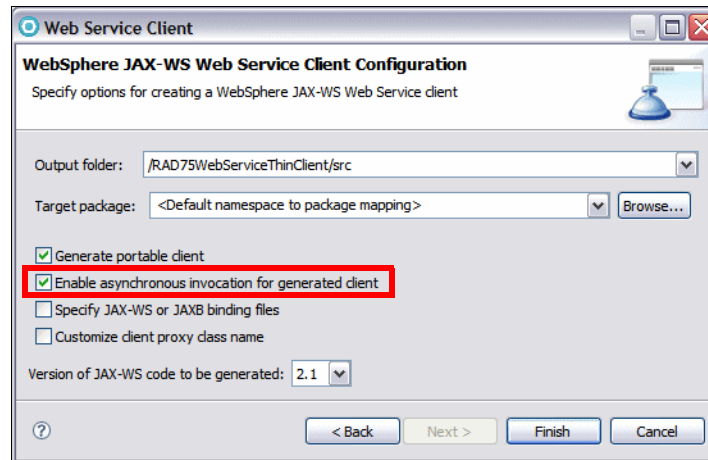

Figure 18-29 Enable asynchronous invocation for generated client

- ▶ After the code generation, open **BankPortProxy.java** (Example 18-14). For each method in the Web service, two additional methods are created. These are polling and callback methods which allow the client to function asynchronously. The `retrieveCustomerNameAsync` method that returns a `Response` is used for polling, while the method that returns a `Future` is used for callback.

Example 18-14 BankPortProxy asynchronous methods

```
public Response<RetrieveCustomerNameResponse>
    retrieveCustomerNameAsync(String ssn) {
    return _getDescriptor().getProxy().retrieveCustomerNameAsync(ssn);
}

public Future<?> retrieveCustomerNameAsync(String ssn,
    AsyncHandler<RetrieveCustomerNameResponse> asyncHandler) {
    return _getDescriptor().getProxy().retrieveCustomerNameAsync
        (ssn, asyncHandler);
}
```

- ▶ Create a new class called **BankPollingClient** in the `itso.rad75.bank.test` package and copy/paste the code (Example 18-15).

Example 18-15 BankPollingClient

```
package itso.rad75.bank.test;

import itso.rad75.bank.model.simple.BankPortProxy;
import itso.rad75.bank.model.simple.RetrieveCustomerNameResponse;
import java.util.concurrent.ExecutionException;
```

```
import javax.xml.ws.Response;

public class BankPollingClient {

    public static void main(String[] args) {
        try {
            BankPortProxy proxy = new BankPortProxy();
            Response<RetrieveCustomerNameResponse> resp =
                proxy.retrieveCustomerNameAsync("111-11-1111");
            // Poll for the response.
            while (!resp.isDone()) {
                // You can do some work that does not depend on the customer
                // name being available
                // For this example, we just check if the result is available
                // every 0.2 seconds.
                System.out.println
                    ("retrieveCustomerName async still not complete.");
                Thread.sleep(200);
            }
            RetrieveCustomerNameResponse rcnr = resp.get();
            System.out.println
                ("retrieveCustomerName async invocation complete.");
            System.out.println("Customer's name is " +
                rcnr.getCustomerFullName());
        } catch (InterruptedException e) {
            System.out.println(e.getCause());
        } catch (ExecutionException e) {
            System.out.println(e.getCause());
        }
    }
}
```

- ▶ Right-click **BankPollingClient.java** and select **Run As** → **Java Application**. The output is written to the console:

```
retrieveCustomerName async still not complete.
retrieveCustomerName async still not complete.
retrieveCustomerName async invocation complete.
Customer's name is Mr. Henry Cui
```

Callback client

To implement an asynchronous invocation that uses the callback model, the client provides an `AsynchHandler` callback handler to accept and process the inbound response object. The client callback handler implements the `javax.xml.ws.AsynchHandler` interface, which contains the application code that is run when an asynchronous response is received from the server.

The `AsyncHandler` interface contains the `handleResponse(Response)` method that is called after the run time has received and processed the asynchronous response from the server. The response is delivered to the callback handler in the form of a `javax.xml.ws.Response` object. The response object returns the response content when the `get` method is called.

Additionally, if an error was received, then an exception is returned to the client during that call. The response method is then invoked according to the threading model used by the `executor` method, `java.util.concurrent.Executor` on the client's `javax.xml.ws.Service` instance that was used to create the dynamic proxy or dispatch client instance. The executor is used to invoke any asynchronous callbacks registered by the application. Use the `setExecutor` and `getExecutor` methods to modify and retrieve the executor configured for the service.

To create an asynchronous Web service client using the callback model, do the following:

- ▶ Create the call back handler class **RetrieveCustomerCallbackHandler** in the `itso.rad75.bank.test` package and copy/paste the code (Example 18-16).

Example 18-16 RetrieveCustomerCallbackHandler

```
package itso.rad75.bank.test;

import itso.rad75.bank.model.simple.RetrieveCustomerNameResponse;
import java.util.concurrent.ExecutionException;
import javax.xml.ws.AsyncHandler;
import javax.xml.ws.Response;

public class RetrieveCustomerCallbackHandler implements
    AsyncHandler<RetrieveCustomerNameResponse> {
    private String customerFullName;

    public void handleResponse(Response<RetrieveCustomerNameResponse> resp){
        try {
            RetrieveCustomerNameResponse rcnr = resp.get();
            customerFullName = rcnr.getCustomerFullName();
        } catch (ExecutionException e) {
            System.out.println(e.getCause());
        } catch (InterruptedException e) {
            System.out.println(e.getCause());
        }
    }

    public String getResponse() {
        return customerFullName;
    }
}
```

- ▶ Create the call back client class **BankCallbackClient** in the **itso.rad75.bank.test** package and copy/paste the code (Example 18-17).

Example 18-17 BankCallbackClient

```
package itso.rad75.bank.test;

import itso.rad75.bank.model.simple.BankPortProxy;
import java.util.concurrent.Future;

public class BankCallbackClient {

    public static void main(String[] args) throws Exception {
        BankPortProxy proxy = new BankPortProxy();
        // Set up the callback handler.
        RetrieveCustomerCallbackHandler callbackHandler =
            new RetrieveCustomerCallbackHandler();
        // Make the Web service call.
        Future<?> response = proxy.retrieveCustomerNameAsync
            ("111-11-1111", callbackHandler);
        System.out.println("Wait 5 seconds.");
        // Give the callback handler a chance to be called.
        Thread.sleep(5000);
        System.out.println("Customer's full name is "
            + callbackHandler.getResponse() + ".");
        System.out.println("RetrieveCustomerName async end.");
    }
}
```

- ▶ Right-click **BankCallbackClient.java** and select **Run As → Java Application**. The output is written to the console:

```
Wait 5 seconds.
Customer's full name is Mr. Henry Cui.
RetrieveCustomerName async end.
```

Asynchronous message exchange client

By default, asynchronous client invocations do not have asynchronous behavior of the message exchange pattern on the wire. The programming model is asynchronous; however, the exchange of request or response messages with the server is not asynchronous. IBM has provided a feature that goes beyond the JAX-WS specification to provide the asynchronous message exchange support.

In the asynchronous message exchange case, the client listens on a separate HTTP channel to receive the response messages from a service-initiated HTTP channel. The client uses WS-Addressing to provide the ReplyTo endpoint reference (EPR) value to the service. The service initiates a connection to the

ReplyTo EPR to send a response. To use an asynchronous message exchange, the `com.ibm.websphere.webservices.use.async.mep` property must be set on the client request context with a boolean value of `true`. When this property is enabled, the messages exchanged between the client and server are different from messages exchanged synchronously.

To create an asynchronous message exchange client, do the following:

- ▶ Create the **BankCallbackMEPClient** class in the `itso.rad75.bank.test` package and copy/paste the code (Example 18-18).

Example 18-18 BankCallbackMEPClient

```
package itso.rad75.bank.test;

import itso.rad75.bank.model.simple.BankPortProxy;
import java.util.concurrent.Future;
import javax.xml.ws.BindingProvider;

public class BankCallbackMEPClient {

    public static void main(String[] args) throws Exception {
        BankPortProxy proxy = new BankPortProxy();
        //proxy._getDescriptor().setEndpoint
        ("http://localhost:11487/RAD75WebServiceWeb/BankService");
        // setup the property for asynchronous message exchange
        BindingProvider bp = (BindingProvider)
            proxy._getDescriptor().getProxy();
        bp.getRequestContext().put
            ("com.ibm.websphere.webservices.use.async.mep", Boolean.TRUE);
        // Set up the callback handler.
        RetrieveCustomerCallbackHandler callbackHandler =
            new RetrieveCustomerCallbackHandler();
        // Make the Web service call.
        Future<?> response = proxy.retrieveCustomerNameAsync
            ("111-11-1111", callbackHandler);
        System.out.println("Wait 5 seconds.");
        // Give the callback handler a chance to be called.
        Thread.sleep(5000);
        System.out.println("Customer's full name is "
            + callbackHandler.getResponse() + ".");
        System.out.println("RetrieveCustomerName async end.");
    }
}
```

- ▶ Right-click **BankCallbackMEPClient.java** and select **Run As** → **Java Application**. The output is written to the console:

```
[WASHttpAsyncResponseListener] listening on port 4070
Wait 5 seconds.
```

Customer's full name is Mr. Henry Cui.
RetrieveCustomerName async end.

- ▶ Note the new line in the WebSphere Application Server Console:

```
[...] 00000090 WSChannelFram A   CHF0019I: The Transport Channel
      Service has started chain HttpOutboundChain:9.48.61.46:4070.
```
- ▶ If you are interested to see the SOAP request message, you can activate the comment line:

```
proxy._getDescriptor().setEndpoint
    ("http://localhost:11487/RAD75WebServiceWeb/BankService");
```

Note that the port **11487** must match the port of the TCP/IP Monitor.

- ▶ Run the application again. The SOAP request is shown in Example 18-19.

Example 18-19 SOAP request for asynchronous message exchange

```
<soapenv:Header xmlns:wsa="http://www.w3.org/2005/08/addressing">
  <wsa:To>http://localhost:11487/RAD75WebServiceWeb/BankService</wsa:To>
  <wsa:ReplyTo>
    <wsa:Address>http://9.48.61.46:4597/axis2/services/BankService.BankPort
    </wsa:Address>
  </wsa:ReplyTo>
  <wsa:MessageID>urn:uuid:57A98210F9B1DA90111228429634645</wsa:MessageID>
  <wsa:Action>urn:getCustomerFullName</wsa:Action>
</soapenv:Header>
<soapenv:Body>
  <ns2:RetrieveCustomerName
    xmlns:ns2="http://simple.model.bank.rad75.itso/">
    <ssn>111-11-1111</ssn>
  </ns2:RetrieveCustomerName>
</soapenv:Body>
</soapenv:Envelope>
```

- ▶ Because the client listens on a separate HTTP channel to receive the response messages from a service-initiated HTTP channel, the TCP/IP Monitor is not able to capture the SOAP response.

Creating Web services from an EJB

You can generate EJB Web services using either the Web Service wizard, or the annotations directly. In this section, we create a JAX-WS Web service from an EJB session bean using the annotations directly:

- ▶ Expand the EJB project **RAD75WebServiceEJB** and open the **SimpleBankFacadeBean** (in `ejbModule/itso.rad75.bank.ejb.facade`).

- ▶ Add the `@WebService` annotation on the line above the `@Stateless` annotation (Example 18-20). Press **Ctrl+Shift+O** to resolve the import.

Example 18-20 Annotate a stateless session EJB

```
@WebService
@Stateless
public class SimpleBankFacadeBean implements SimpleBankFacadeBeanLocal {
    .....
}
```

- ▶ Wait for the RAD75WebServiceEAR application to publish on the server (or force a manual publish). Notice that a new Web service named **RAD75WebServiceEJB** is added in the Services views under JAX-Ws.
- ▶ An HTTP router module is needed to allow transport of SOAP messages over the HTTP protocol. In the Services view, right-click the new **RAD75WebServiceEJB** and select **Create Router Modules (EndpointEnabler)** (Figure 18-30).

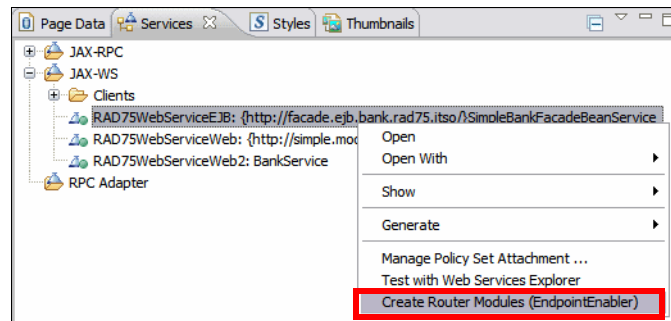

Figure 18-30 Create Router Module

- ▶ In the Create Router Project dialog, two EJB bindings are listed: HTTP and JMS. Note you can select both. This feature is called multiprotocol binding.

Behind the scenes:

- ▶ The multiprotocol binding support for JAX-WS Web service is a new feature of Application Developer v7.5. The multiprotocol support for JAX-WS is an extension of the JAX-WS programming model, and extends the existing JAX-WS capabilities to support binding types like HTTP (SOAP over HTTP) and JMS (SOAP over JMS).
- ▶ SOAP over HTTP is the most commonly used Web services binding type. However, if you are looking for a more reliable, scalable, and guaranteed messaging mechanism, consider using SOAP over JMS.
- ▶ Only SOAP over HTTP is WS-I compliant.

- ▶ For this example, we only use SOAP over HTTP. Accept **HTTP** as the default EJB Web service binding (Figure 18-31) and click **Finish**.

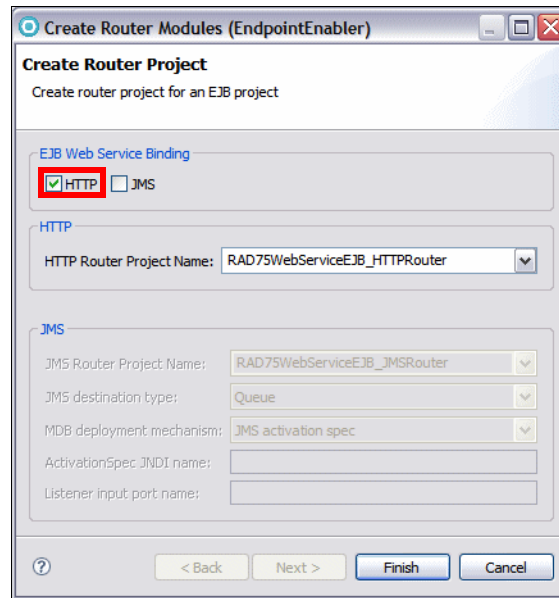

Figure 18-31 Create Router Project

- ▶ Open the deployment descriptor of the RAD75WebServiceEJB_HTTPRouter project and you can see the generated servlet.
- ▶ In the Services view, right-click **RAD75WebServiceEJB** and select **Test with Web Services Explorer**.
- ▶ Select the **getAccountBalance** operation, click **Add** and type **001-999000777** as the account number.
- ▶ Click **Go** and you can see the result of the Web service call:

```
getAccountBalanceResponse  
return (decimal): 12345.67
```

Creating a top-down Web service from a WSDL

When creating a Web service using a top-down approach, first you design the implementation of the Web service by creating a WSDL file. You can do this using the WSDL editor. You can then use the Web Service wizard to create the Web service and skeleton Java classes to which you can add the required code. The top-down approach is the recommended way of creating a Web service.

Designing the WSDL using the WSDL editor

In this section, we create a WSDL with two operations: `getAccount` (using an account ID to retrieve an account) and `getCustomer` (using a customer ID to retrieve a customer).

The WSDL editor allows you to easily and graphically create, modify, view, and validate WSDL files. To create a WSDL, do these steps:

- ▶ Create a Dynamic Web project to host the new Web service:
 - Web project: `RAD75TopDownBankWS`
 - EAR project: `RAD75TopDownBankEAR`
- ▶ Create a WSDL file:
 - Right-click **WebContent** (in `RAD75TopDownBankWS`) and select **New** → **Other** → **Web services** → **WSDL**, and click **Next**.
 - Change the File name to **BankWS.wsdl** and click **Next**.
 - In the Options page, leave the default and click **Finish** (Figure 18-32).

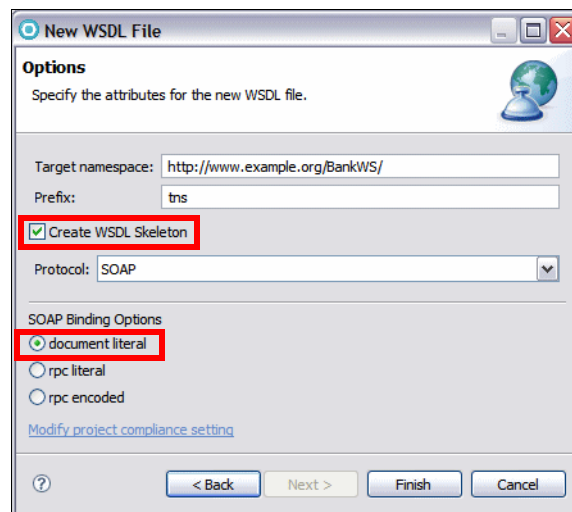

Figure 18-32 New WSDL File wizard

- ▶ The WSDL editor opens with the new WSDL file. Select the **Design** tab.
 - In the WSDL editor, select **Advanced** from the View drop-down menu at the top right corner.
 - Select the **Properties** view. Now you are ready to edit the WSDL file (Figure 18-33).

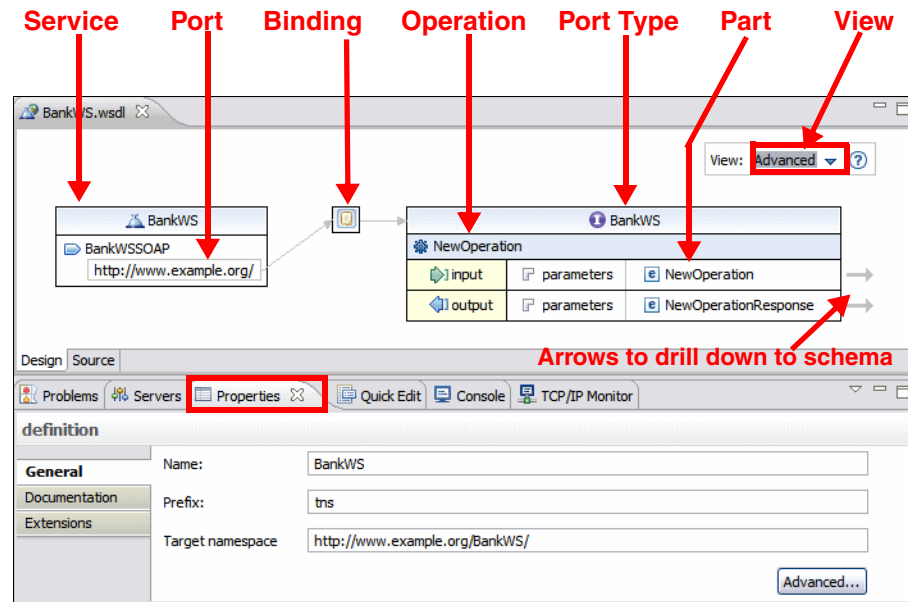

Figure 18-33 WSDL editor

Editing the WSDL file

We define the operations and parameters of the WSDL.

- ▶ Change the operation name by double-clicking **NewOperation** and overtyping the name with **getAccount**. (You can also select the operation and change the name in the Properties view.)
- ▶ Add a new operation. In the Design view, right-click the port type **BankWS**, select **Add Operation**, and name the operation **getCustomer**.
- ▶ To change the input type of the WSDL operation **getAccount**, click the **right arrow** to the right of the input operation to drill into the schema.
- ▶ The Inline Schema Editor opens. Select the **Design** tab and switch to the **Detailed** view (Figure 18-34).

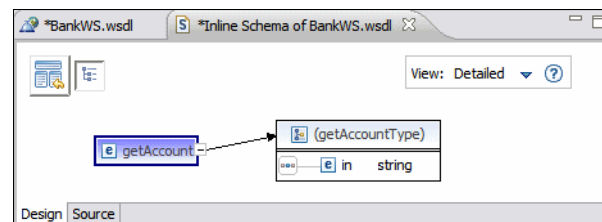



Figure 18-34 Schema editor: Start

- Select the **in** element, and in the Properties view change the name to **accountId** (leave the type as `xsd:string`).
- Click the **Show schema index view** icon  at the top left to show all the directives, elements, types, attributes, and groups in the WSDL (Figure 18-35).

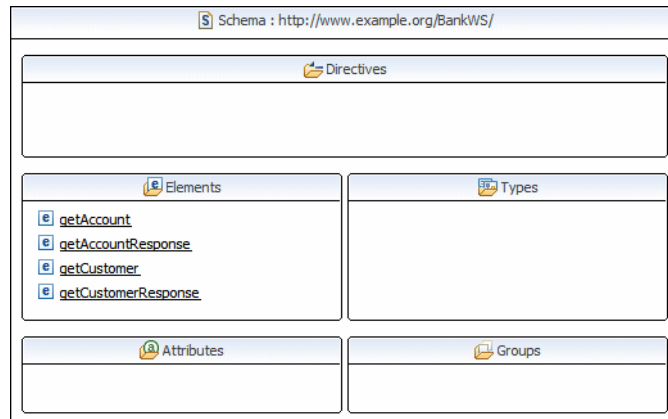



Figure 18-35 Schema editor: Index view

- In the Types category, right-click and select **Add Complex Type**. Change the name to **Account**.
- Right-click **Account** and select **Add Sequence**.
- Right-click **Account** again, and select **Add Element**. Change the name to **id**.
- Right-click the content model object  and select **Add Element**. Change the name to **balance**, and select the type as **decimal** using the **Browse** option (Figure 18-36).

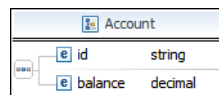



Figure 18-36 Schema editor: Account

- Click the icon  at the top left corner. In the Types section, right-click and select **Add Complex Type**. Change the name to **Customer**.
- Right-click **Customer** and select **Add Sequence**, then add four elements: **ssn**, **firstName**, **lastName**, and **title**, all of type string (Figure 18-37).

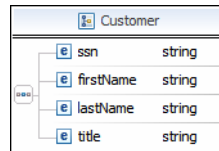



Figure 18-37 Schema editor: Customer

- Click the icon  at the top left corner. We have to add global element for the complex types.
 - Right-click the **Elements** category and click **Add Element**. Change the element name to **Account**. Right-click **Account** and select **Set Type** → **Browse** → select **Account**.
 - Add global element **Customer**, set type to **Customer** (Figure 18-38).

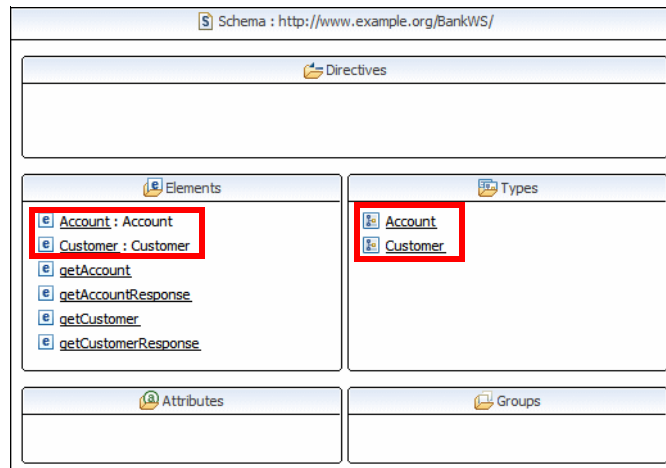

Figure 18-38 Schema editor: Global elements

- ▶ In the WSDL editor, click the **right arrow** to the right of the element **getAccountResponse** to drill down into the schema. Right-click element **out** and select **Set Type** → **Browse** → select **Account** (Figure 18-39).



Figure 18-39 Schema editor: Output message

- ▶ In the WSDL editor, click the **right arrow** to the right of the element **getCustomer** to drill down into the schema. Change the element name from **in** to **customerId**.
- ▶ In the WSDL editor, click the **right arrow** to the right of the element **getCustomerResponse** to drill down into the schema. Right-click element **out** and select **Set Type** → **Browse** → select **Customer**.
- ▶ In the WSDL editor, right-click the **binding** icon (as shown in Figure 18-33 on page 616) and select **Generate Binding Content**.
- ▶ In the Binding wizard, select **Overwrite existing binding information** and click **Finish** (Figure 18-40).

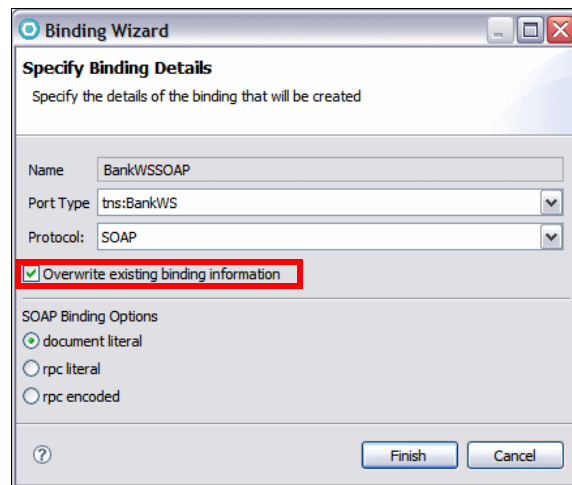

Figure 18-40 Specify Binding Details wizard

- ▶ Save the schema and WSDL file (Figure 18-41).

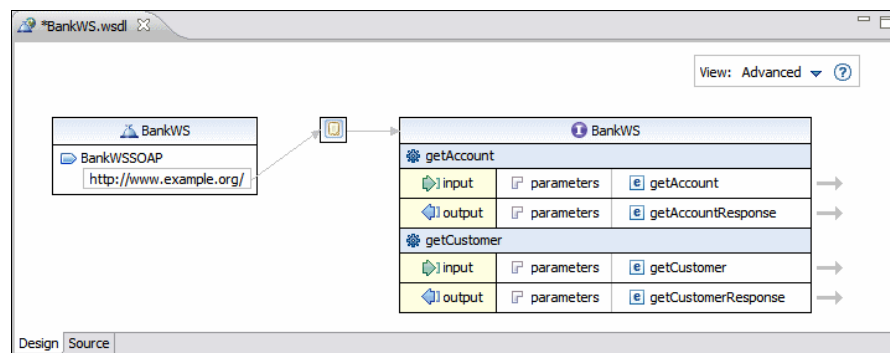

Figure 18-41 BankWS.wsdl

- ▶ In the Enterprise Explorer, right-click **BankWS.wsdl** and select **Validate**. A dialog confirms that there are no errors or warnings. Click **OK**.
- ▶ If you have a problem when creating the WSDL file, you can import the BankWS.wsdl from C:\7672code\webservice\topdown.

Generating the skeleton JavaBean Web service

To generate a skeleton JavaBean Web service from a WSDL, do these steps:

- ▶ Right-click **BankWS.wsdl** and select **Web Services** → **Generate Java bean skeleton**.
- ▶ Keep the slider at **Start service** level. Notice the code is generated into the RAD75TopDownBankWS project.
- ▶ Click **Finish**.
- ▶ After the code generation, the skeleton class **BankWSSOAPImpl.java** opens in the Java editor. Notice the annotation of the class:

```
@javax.jws.WebService (endpointInterface="org.example.bankws.BankWS",
    targetNamespace="http://www.example.org/BankWS/", serviceName="BankWS",
    portName="BankWSSOAP")
```

- ▶ The RAD75TopDownBankEAR is deployed to the server, and the Web service appears in the Services view.

Implement the generated JavaBean skeleton

We have to provide the business logic for the generated JavaBean skeleton. We use the simple implementation shown in Example 18-21.

Example 18-21 Implementation of the Generated JavaBean skeleton

```
package org.example.bankws;

import java.math.BigDecimal;

@javax.jws.WebService (endpointInterface="org.example.bankws.BankWS",
    targetNamespace="http://www.example.org/BankWS/", serviceName="BankWS",
    portName="BankWSSOAP")
public class BankWSSOAPImpl{

    public Account getAccount(String accountId) {
        Account account = new Account();
        account.setId(accountId);
        account.setBalance(new BigDecimal(1000.00));
        return account;
    }
}
```

```
public Customer getCustomer(String customerId) {  
    Customer customer = new Customer();  
    customer.setSsn(customerId);  
    customer.setFirstName("Henry");  
    customer.setLastName("Cui");  
    customer.setTitle("Mr.");  
    return customer;  
}  
}
```

Test the generated Web service

To test the Web service we use the Web Services Explorer.

Note: You cannot use the BankWS.wsdl in the WebContent folder to test the Web service. The Web service endpoint is set to `http://www.example.org/` when we created this WSDL. The dynamic WSDL loading from the Services view will set the endpoint correctly.

- ▶ To test the Web service, expand JAX-WS in the Services view, right-click **RAD75TopDownBankWS** and select **Test with Web Services Explorer**.
- ▶ Test the **getCustomer** and **getAccount** operation. You should see that the correct result is displayed in the Web Services Explorer.

Explore!

Once you have created a Web service, you might want to make changes to it:

- ▶ For example, you might want to add a new WSDL operation `getBalanceByAccountId` to the WSDL. Once the WSDL is changed, you have to regenerate the Web service code and the existing business logic may be wiped out.
- ▶ To retain your changes while updating the Web service, you can use the *skeleton merge* feature. This allows you to regenerate the Web service while keeping your changes intact. Select **Window** → **Preferences** → **Web Services** → **Resource Management** → **Merge generated skeleton file**.

Creating Web services with Ant tasks

If you prefer not to use the Web Service wizard, you can use Ant tasks to create Web service using the IBM WebSphere JAX-WS runtime environment. The Ant tasks support creating Web services using both top-down and bottom-up approaches. Once you have created a Web service, you can then deploy it to a server, test it, and publish it as a business entity or business service.

In this section, we will use Ant tasks to automate the top-down code generation process that we did in the last section.

- ▶ Create a Dynamic Web project to host the Web service generated by Ant tasks: **RAD75WebServiceAnt** in **RAD75WebServiceEAR**.
- ▶ Copy the **BankWS.wsdl** from **RAD75TopDownBankWS/WebContent** folder to the **RAD75WebServiceAnt** folder (not under WebContent).
- ▶ Right-click **RAD75WebServiceAnt** and select **New** → **Other** → **Web Services** → **Ant Files** and click **Next**.
- ▶ In the Create Ant Files dialog, select **IBM WebSphere JAX-WS** as the Web service runtime and **Top down Java bean Web Service** as the Web service type (Figure 18-42), click **Finish**.

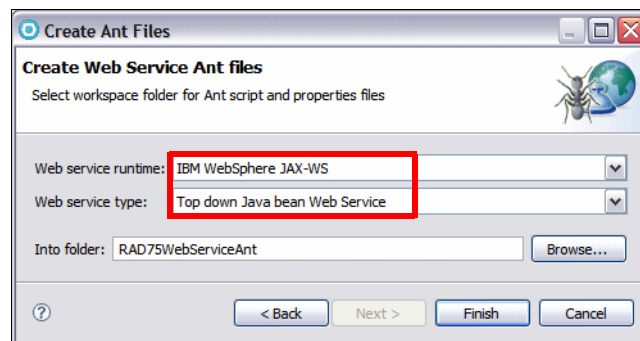

Figure 18-42 Create Ant files

- A **wsgenTemplates** folder is created with two files: **was_jaxws_tdjava.xml** and **was_jaxws_tdjava.properties**.
- ▶ Open **was_jaxws_tdjava.properties**, and change InitialSelection= to:

```
InitialSelection=/RAD75WebServiceAnt/BankWS.wsdl
```

 Change the Service.ServerId line to:

```
Service.ServerId=com.ibm.ws.ast.st.v7.server.base
```

 Save and close the file.

Running the Web service Ant task

To run the Ant task, right-click `was_jaxws_tdjava.xml` and select **Run As** → **2 Ant Build**:

- ▶ In the Edit Configuration dialog, select the **JRE** tab and select **Run in the same JRE as the workspace**.
- ▶ Click **Apply** and then click **Run**.

The Web service is generated:

- ▶ The Web service artifacts are generated into Java Resources folder.
- ▶ You can implement the generated skeleton (`BankWSSOAPImp1`) and test the Web service, as we did in the last section.

Sending binary data using MTOM

SOAP Message Transmission Optimization Mechanism (MTOM) is a standard that is developed by the World Wide Web Consortium (W3C). MTOM describes a mechanism for optimizing the transmission or wire format of a SOAP message by selectively re-encoding portions of the message while still presenting an XML Information Set (Infoset) to the SOAP application.

MTOM uses the XML-binary Optimized Packaging (XOP) in the context of SOAP and MIME over HTTP. XOP defines a serialization mechanism for the XML Infoset with binary content that is not only applicable to SOAP and MIME packaging, but to any XML Infoset and any packaging mechanism. It is an alternate serialization of XML that just happens to look like a MIME multipart or related package, with XML documents as the root part.

That root part is very similar to the XML serialization of the document, except that base64-encoded data is replaced by a reference to one of the MIME parts, which is not base64 encoded. This reference enables you to avoid the bulk and overhead in processing that is associated with encoding. Encoding is the only way binary data can work directly with XML.

In this section we use the top-down approach to create a JAX-WS Web service to send binary attachments along with SOAP request, and receive binary attachments along with SOAP response using MTOM.

The Web service client sends three types of document: Microsoft Word, image, and PDF file. We describe several ways to send the documents:

- ▶ The client uses **byte[]** to send the Word document.
- ▶ The client uses **java.awt.Image** to send the image file.
- ▶ The client uses **javax.activation.DataHandler** to send the PDF file.

Once the Web service receives the binary data from the client, it stores the received document on the local hard disk and then passes the same document back to the client. In a real world scenario, the provider or the consumer can just send an acknowledgement message, once it receives the binary data from the other side. For our example, we want to show how to enable the MTOM on both the client and the server side in a compact example.

Create a Web service project and import the WSDL

To create a Web service project, do these steps:

- ▶ Select **File** → **New** → **Dynamic Web Project**.
 - Project Name: **RAD75WSMTOM**
 - EAR Project Name: **RAD75WSMTOMEAR**
 - Click **Finish**.
- ▶ Import the `c:\7672code\webservice\mtom\ProcessDocumentService.wsdl` file into the **RAD75WSMTOM/WebContent** folder.
- ▶ Open the `ProcessDocumentService.wsdl` and take a look at the source. You will see some interesting attributes, highlighted in Example 18-22.

Example 18-22 Extract of ProcessDocument.wsdl

```
<xs:schema xmlns:xs="http://www.w3.org/2001/XMLSchema"
            xmlns:xmime="http://www.w3.org/2005/05/xmlmime"
            xmlns:tns="http://mtom.rad7.ibm.com/"
            targetNamespace="http://mtom.rad7.ibm.com/" version="1.0">
<xs:complexType name="sendPDFFile">
  <xs:sequence>
    <xs:element minOccurs="0" name="arg0" type="xs:base64Binary"
                  xmime:expectedContentTypes="*/*/"/>
  </xs:sequence>
</xs:complexType>
<xs:complexType name="sendWordFile">
  <xs:sequence>
    <xs:element minOccurs="0" name="arg0" type="xs:base64Binary"/>
  </xs:sequence>
</xs:complexType>
<xs:complexType name="sendImage">
  <xs:sequence>
```



```

    <xs:element minOccurs="0" name="arg0" type="xs:base64Binary"
                xmime:expectedContentTypes="image/jpeg"/>
  </xs:sequence>
</xs:complexType>

```

Default mapping

The default mapping for `xs:base64Binary` is `byte[]` in Java. If you want to use a different mapping, you can add the `xmime:expectedContentTypes` attribute to the element containing the binary data. This attribute is defined in the <http://www.w3.org/2005/05/xmlmime> namespace and specifies the MIME types that the element is expected to contain. The setting of this attribute changes how the code generators create the JAXB class for the data. Depending on the `expectedContentTypes` value contained in the WSDL file, the JAXB artifacts generated are in the Java type as described in Table 18-1.

Table 18-1 Mapping between MIME type and Java type

MIME type	Java type
image/gif	java.awt.Image
image/jpeg	java.awt.Image
text/plain	java.lang.String
text/xml	javax.xml.transform.Source
application/xml	javax.xml.transform.Source
/	javax.activation.DataHandler

Based on this table we can predict that:

- ▶ `sendWordFile` will be mapped to `byte[]` in Java.
- ▶ `sendPDFFile` will be mapped to `javax.activation.DataHandler`.
- ▶ `sendImage` will be mapped to `java.awt.Image`.

Generate the Web service and client

To create the Web service and client using the Web Service wizard, do these steps:

- ▶ Right-click **ProcessDocumentService.wsdl** and select **Web Services** → **Generate Java bean skeleton**. The Web Service wizard starts with the Web Services page.

- ▶ Select the following options for the Web service:
 - Server: **WebSphere Application Server v7.0**
 - Web service runtime: **IBM WebSphere JAX-WS**
 - Service project: **RAD75WSMTOM**
 - Service EAR project: **RAD75WSMTOMEAR**
- ▶ Select the following options for the Web service client:
 - Move the slider to **Test client**.
 - Server: **WebSphere Application Server v7.0**.
 - Web service runtime: **IBM WebSphere JAX-WS**
 - Client project: **RAD75WSMTOMClient**
 - Client EAR project: **RAD75WSMTOMClientEAR**

Because the Web service client project is not yet in the workspace when we run the Web Service wizard, the wizard creates the project for you.

- ▶ Select **Monitor the Web service** and then click **Next**.
- ▶ In the WebSphere JAX-WS Top Down Web Service Configuration page, select **Enable MTOM Support** and click **Next** (Figure 18-43).

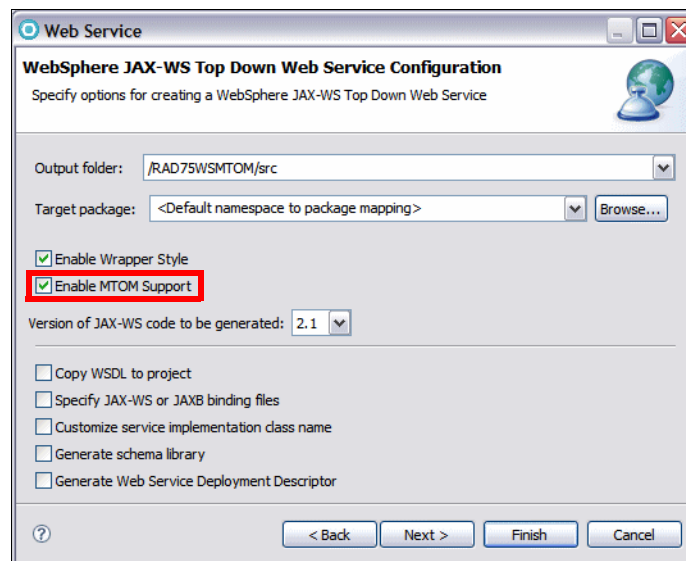

Figure 18-43 Enable MTOM support

- ▶ A warning pops up. Click **Details** to view the complete message (Figure 18-44.) Click **Ignore** to continue the code generation.

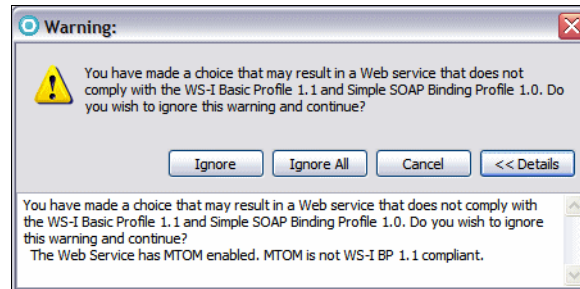

Figure 18-44 WS-I warning against MTOM

- ▶ In the Test Web Service page click **Next**.
- ▶ In the WebSphere JAX-WS Web Service Client Configuration page accept the defaults, and click **Next**.
- ▶ In the Web Service Client Test page, select **JAX-WS JSPs** as the Test Facility, and click **Finish**. The generated JavaBean skeleton is opened, as well as the sample JSP client.

Implement the JavaBean skeleton

Before we test the sample JSP client, we have to implement the generated Java Bean skeleton. The Web services stores the received document on the local hard drive and then passes the same document back to the client. Do these steps:

- ▶ Examine the generated skeleton class `ProcessDocumentPortBindingImpl`. We can see that `sendWordFile` is mapped to `byte[]`, `sendPDFFile` is mapped to `javax.activation.DataHandler`, and `sendImage` is mapped to `java.awt.Image`, as we expected.
- ▶ Copy/paste the code into `ProcessDocumentPortImpl.java` from `C:\7672code\webservice\mtom` (Example 18-23).

Example 18-23 ProcessDocumentPortBindingImpl.java

```
package com.ibm.rad75.mtom;

import java.awt.Graphics2D;
import java.awt.Image;
import java.awt.image.BufferedImage;
import java.io.BufferedInputStream;
import java.io.File;
import java.io.FileOutputStream;
import javax.activation.DataHandler;
import javax.imageio.ImageIO;
```

```
@javax.jws.WebService
(endpointInterface="com.ibm.rad75.mtom.ProcessDocumentDelegate",
targetNamespace="http://mtom.rad75.ibm.com/",
serviceName="ProcessDocumentService", portName="ProcessDocumentPort")
@javax.xml.ws.BindingType
(value=javax.xml.ws.soap.SOAPBinding.SOAP11HTTP_MTOM_BINDING)
public class ProcessDocumentPortBindingImpl{

    public byte[] sendWordFile(byte[] arg0) {
        try {
            FileOutputStream fileOut = new FileOutputStream
                (new File("C:/7672code/webservices/mtomresult/RAD-intro.doc"));
            fileOut.write(arg0);
        } catch (Exception e) {
            e.printStackTrace();
        }
        return arg0;
    }

    public Image sendImage(Image arg0) {
        try {
            File file = new File
                ("C:/7672code/webservices/mntomresult/BlueHills.jpg");
            BufferedImage bi = new BufferedImage(arg0.getWidth(null),
                arg0.getHeight(null), BufferedImage.TYPE_INT_RGB);
            Graphics2D g2d = bi.createGraphics();
            g2d.drawImage(arg0, 0, 0, null);
            ImageIO.write(bi, "jpeg", file);
        } catch (Exception e) {
            e.printStackTrace();
        }
        return arg0;
    }

    public DataHandler sendPDFFile(DataHandler arg0) {
        try {
            FileOutputStream fileOut = new FileOutputStream(new File(
                "C:/7672code/webservices/mtoresult/JAX-WS.pdf"));
            BufferedInputStream fileIn = new BufferedInputStream
                (arg0.getInputStream());

            while (fileIn.available() != 0) {
                fileOut.write(fileIn.read());
            }
        } catch (Exception e) {
            e.printStackTrace();
        }
        return arg0;
    }
}
```

- ▶ Examine the code listed in Example 18-23.
 - The `sendWordFile` method takes a `byte[]` as input and stores the binary data as `C:/7672code/webservices/mtomresult/RAD-intro.doc`.
 - The `sendImage` method takes an image as input and stores the binary data as `C:/7672code/WebServices/mtomresult/BlueHills.jpg`.
 - The `sendPDFFile` method takes a `DataHandler` as input and stores the data in `C:/7672code/WebServices/mtomresult/JAX-WS.pdf`.
 - All the three methods return the received data to the client after storing it on the local drive.

Test and monitor the MTOM enabled Web service

Now it is the time to see if MTOM really optimizes the transmission of the data.

- ▶ The output folder is `C:\7672code\webservice\mtomresult`. We use this folder to store the document received by the Web service JavaBean.
- ▶ In the sample JSP client, select the **sendImage** method.
- ▶ Click **Browse** and navigate to `C:\7672code\webservice\mtom`. Select **BlueHills.jpg** and click **Open**.
- ▶ Click **Invoke** to invoke the `sendImage` method (Figure 18-45).

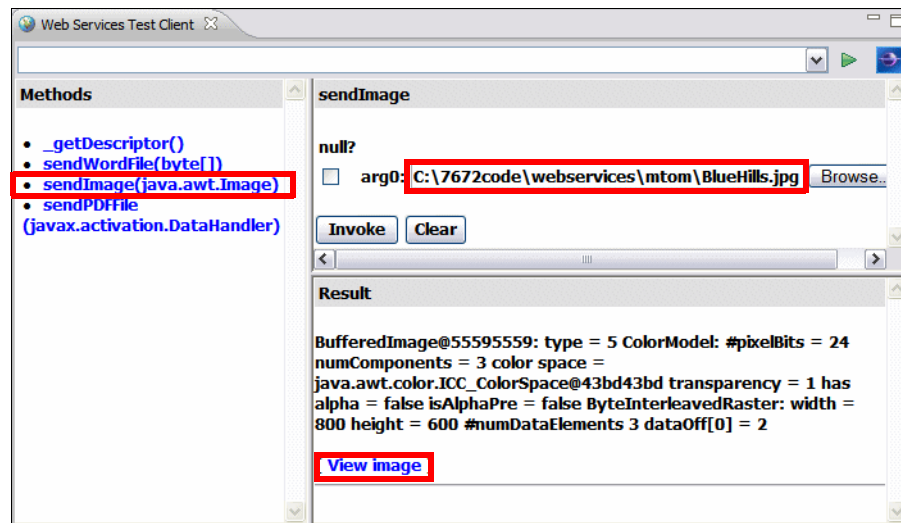



Figure 18-45 Invoking the MTOM Web service `sendImage` method

- ▶ In the Result pane, click **View image**. The image is displayed in the Results pane.

- ▶ Examine the C:\7672code\webservice\mtomresult folder. You can see that BlueHills.jpg is stored in this folder. Note that the size is different from the same file in the mtom folder (probably a different JPEG compression is used).
- ▶ Select the TCP/IP Monitor tab to view the SOAP traffic. Click the  icon and then select **Show Header**. The HTTP header and the SOAP traffic are shown in Figure 18-46.

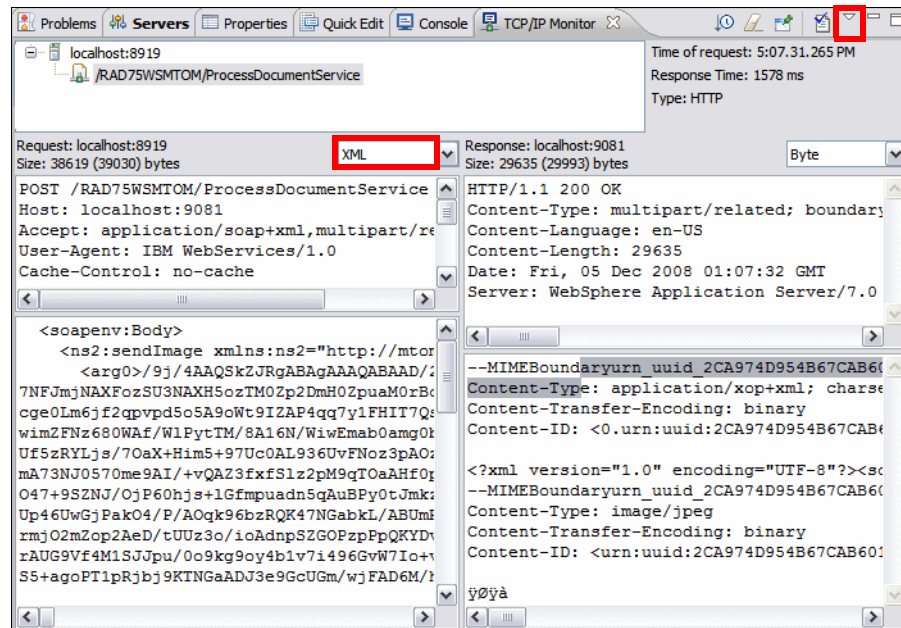

Figure 18-46 SOAP traffic when MTOM is only enabled for the Web service

- ▶ Take a look at the SOAP request and response:
 - The Web service (provider) has MTOM enabled after the code generation. Therefore, the SOAP response has a smaller payload! The Web service sends the binary data as a MIME attachment outside the XML document to realize the optimization.
 - The SOAP request has a much larger payload because MTOM is not enabled. The Web service client sends binary data as base64 encoded data within the XML document.
- ▶ The SOAP response and its HTTP header are shown in Example 18-24 (formatted by hand).

Example 18-24 SOAP response message and HTTP header with MTOM enabled

```
HTTP/1.1 200 OK
Content-Type: multipart/related;
```

```

boundary=MIMEBoundaryurn_uuid_2CA974D954B67CAB601228439267478;
type="application/xop+xml";
start="<0.urn:uuid:2CA974D954B67CAB601228439267479@apache.org>";
start-info="text/xml"
Content-Language: en-US
Content-Length: 29635
Date: Fri, 05 Dec 2008 01:07:32 GMT
Server: WebSphere Application Server/7.0
=====
--MIMEBoundaryurn_uuid_7EF64465327292D3521225396635214
Content-Type: application/xop+xml; charset=UTF-8; type="text/xml"
Content-Transfer-Encoding: binary
Content-ID: <0.urn:uuid:2CA974D954B67CAB601228439267479@apache.org>

<?xml version="1.0" encoding="UTF-8"?>
<soapenv:Envelope
xmlns:soapenv="http://schemas.xmlsoap.org/soap/envelope/">
  <soapenv:Body>
    <ns2:sendImageResponse xmlns:ns2="http://mtom.rad75.ibm.com/">
      <return>
        <xop:Include xmlns:xop="http://www.w3.org/2004/08/xop/include"
href="cid:urn:uuid:2CA974D....@apache.org"/>
      </return>
    </ns2:sendImageResponse>
  </soapenv:Body>
</soapenv:Envelope>
--MIMEBoundaryurn_uuid_2CA974D954B67CAB6012284392674784
Content-Type: image/jpeg
Content-Transfer-Encoding: binary
Content-ID: <urn:uuid:2CA974D954B67CAB601228439267605@apache.org>

ÿÿÿ

```

The type and content-type attributes have the value **application/xop+xml**, which indicates that the message was successfully optimized using XML-binary Optimized packaging (XOP) when MTOM was enabled.

Enabling MTOM on the client

Now let us enable MTOM on the client side as well:

- ▶ In the Enterprise Explorer expand **RAD7MTOMClient** → **Java Resources** → **src** → **com.ibm.rad75.mtom** and open **ProcessDocumentPortProxy.java**.
- ▶ Add one lines of code to each business method to invoke a new **enableMTOMClient** method (Example 18-25). Refer to C:\7672code\webservice\mtom\ProcessDocumentPortProxy.java.

Example 18-25 Enable MTOM on the client

```
import javax.xml.ws.soap.SOAPBinding;

public class ProcessDocumentPortProxy{
    .....
    public byte[] sendWordFile(byte[] arg0) {
        enableMTOMClient();
        return _getDescriptor().getProxy().sendWordFile(arg0);
    }

    public Image sendImage(Image arg0) {
        enableMTOMClient();
        return _getDescriptor().getProxy().sendImage(arg0);
    }

    public DataHandler sendPDFFile(DataHandler arg0) {
        enableMTOMClient();
        return _getDescriptor().getProxy().sendPDFFile(arg0);
    }

    private void enableMTOMClient(){
        SOAPBinding binding = (SOAPBinding)
            ((BindingProvider)_getDescriptor().getProxy()).getBinding();
        binding.setMTOMEnabled(true);
    }
}
```

- ▶ Run the sample JSP again using the **sendImage** method and the ...\\mtom\BlueHills.jpg file. The SOAP request also has a small payload after MTOM is enabled for the Web service client (Figure 18-47).
- ▶ In the sample JSP client, invoke the **sendWordFile** method. Click **Browse** to locate the word document ...\\mtom\RAD-intro.doc, and click **Invoke**. Watch the SOAP traffic in the TCP/IP Monitor.
- ▶ Invoke the **sendPDFFile** method. Click **Browse** to locate the PDF document ...\\mtom\JAX-WS.pdf, and click **Invoke**. Watch the SOAP traffic in the TCP/IP Monitor.
- ▶ Verify the C:\7672code\webservice\mtomresult folder. We can see that the image file, word document, and PDF file are all stored successfully.

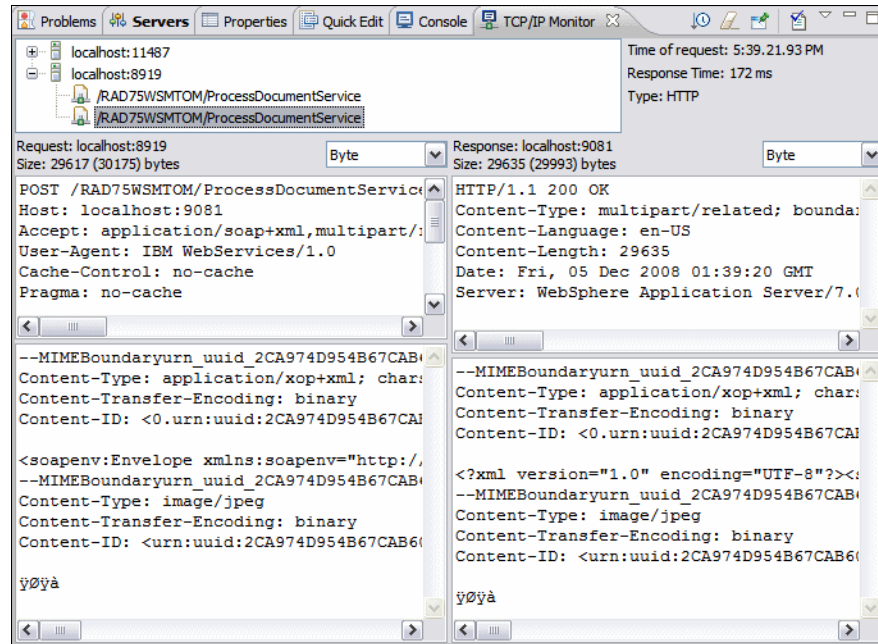

Figure 18-47 SOAP message with MTOM enabled for both client and server

Web services security

Web services security for WebSphere Application Server v7.0 is based on standards included in the Organization for the Advancement of Structured Information Standards (OASIS) Web services security (WSS) Version 1.0/1.1 specification, the Username Token Profile 1.0/1.1, and the X.509 Certificate Token Profile 1.0/1.1.

WS-Security addressed three major issues involved in securing SOAP message exchanges: authentication, message integrity, and message confidentiality.

Authentication

Authentication is used to ensure that parties within a business transaction are really who they claim to be; thus proof of identity is required. This proof can be claimed in various ways:

- ▶ One simple way is by presenting a user identifier and a password. This is referred to as a username token in WS-Security domain.

- ▶ A more complex way is to use an X.509 certificate issued by a trusted certificate authority.

The certificate contains identity credentials and has a pair of private and public keys associated with it. The proof of identity presented by a party includes the certificate itself and a separate piece of information that is digitally signed using the certificate's private key. By validating the signed information using the public key associated with the party's certificate, the receiver can authenticate the sender as being the owner of the certificate, thereby validating their identity.

Two WS-Security specifications, the Username Token Profile 1.0/1.1 and the X.509 Certificate Token Profile 1.0/1.1, describe how to use these authentication mechanisms with WS-Security.

Message integrity

To validate a message has not been tampered with or corrupted during its transmission over the Internet, the message can be digitally signed using security keys. The sender uses the private key of their X.509 certificate to digitally sign the SOAP request. The receiver uses the sender's public key to check the signature and identity of the signer. The receiver signs the response with their private key, and the sender is able to validate the response has not been tampered with or corrupted using the receiver's public key to check the signature and identity of the responder. The WS-Security: SOAP Message Security 1.0/1.1 specification describes enhancements to SOAP messaging to provide message integrity.

Message confidentiality

To keep the message safe from eavesdropping, encryption technology is used to scramble the information in Web services requests and responses. The encryption ensures that no-one accesses the data in transit, in memory, or after it has been persisted, unless they have the private key of the recipient. The WS-Security: SOAP Message Security 1.0/1.1 specification describes enhancements to SOAP messaging to provide message confidentiality.

There are two options to configure WS-Security for JAX-WS Web services:

- ▶ Policy set
- ▶ Programming API for securing SOAP message with Web Service Security (WSS API) and Service Programming Interfaces (SPI) for a service provider

We will use Policy set in our examples.

Policy set

You can use policy sets to simplify configuring the qualities of service for Web services and clients. Policy sets are assertions about how Web services are defined. Using policy sets, you can combine configurations for different policies. You can use policy sets with JAX-WS applications, but not with JAX-RPC applications.

A policy set is identified by a unique name. An instance of a policy set consists of a collection of policy types. An empty policy set has no policy instance defined.

Policies are defined on the basis of a quality of service. Policy definitions are typically based on WS-Policy standards language. For example, the WS-Security policy is based on the current WS-SecurityPolicy language from the Organization for the Advancement of Structured Information Standards (OASIS) standards.

Policy sets omit application or user-specific information, such as keys for signing, key store information, or persistent store information. Instead, application and user-specific information is defined in the bindings. Typically, bindings are specific to the application or the user, and bindings are not normally shared. On the server side, if you do not specify a binding for a policy set, a default binding will be used for that policy set. On the client side, you must specify a binding for each policy set.

A policy set attachment defines which policy set is attached to service resources, and which bindings are used for the attachment. The bindings define how the policy set is attached to the resources. An attachment is defined outside of the policy set, as metadata associated with the application. To enable a policy set to work with an application, a binding is required.

Apply WS-Security to Web service and client

In this section, we apply the Username WSSecurity default policy set to our Web service and client. This policy set provides the following features:

- ▶ Message integrity by digital signature (using RSA public-key cryptography) to sign the body, timestamp, and WS-Addressing headers using the WS-Security specifications.
- ▶ Message confidentiality by encryption (using RSA public-key cryptography) to encrypt the body, signature, and signature confirmation elements using the WS-Security specifications.
- ▶ A username token included in the request message to authenticate the client to the service. The username token is encrypted in the request.

Sample bindings for JAX-WS applications

WebSphere Application Server v7.0 includes provider and client sample bindings for testing purposes. In the bindings, the product provides sample values for supporting tokens for different token types, such as the X.509 token and the username token. The bindings also include sample values for message protection information for token types such as X.509. Both provider and client sample bindings can be applied to the applications attached with a policy set.

In production environment, you must modify the bindings to meet your security needs before using them in a production environment by making a copy of the bindings and then modifying the copy. For example, you must change the key and keystore settings to ensure security, and modify the binding settings to match your environment.

Configure the username token

When using the Username WSSecurity default policy set, you must configure the username and password for username token authentication separately from the security settings defined in the bindings. The sample binding does not include a username or password for token authentication, as it is specific to the target deployed system. You must specify a valid username and password in your environment using the WebSphere administrative console.

- ▶ In the Servers view, right-click **WebSphere Application Server v7.0** and select **Administration** → **Run administrative console**.
- ▶ Log in using user ID and password (admin).
- ▶ Select **Services** → **Policy sets** → **General client policy set bindings**.
- ▶ Click **Client sample** to edit the binding.
- ▶ Click **WS-Security**.
- ▶ Click **Authentication and protection**.
- ▶ In the Authentication tokens list, select **gen_signunametoken** to edit the username token settings.
- ▶ Click **Callback handler** in the Additional Bindings section (bottom).
- ▶ Enter the **admin** as the username and **admin** as the password and confirm password. Click **Apply**.
- ▶ Click **Save** and then **Logout**.

Attach the Username WSSecurity policy set to the Web service

To attach the Username WSSecurity default policy set to the Web service, do these steps:

- ▶ In the Java EE perspective, Services view, expand the JAX-WS node.

- ▶ Right-click **RAD75WebServiceWeb:{...}BankService** and select **Manage Policy Set Attachment** (Figure 18-48).

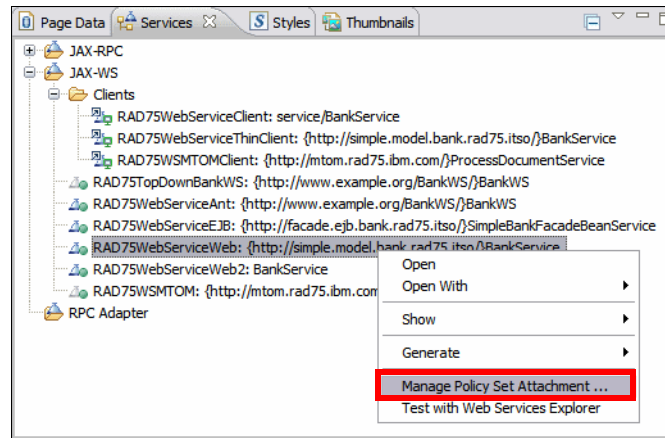

Figure 18-48 Manage Policy Set Attachment

- ▶ Click **Add**.
- ▶ From the Policy Set drop-down list, select **Username WSSecurity default**, and for the Binding ensure **Provider Sample** is selected. This is a service-side general binding packaged with WebSphere Application Server. Click **OK** (Figure 18-49).

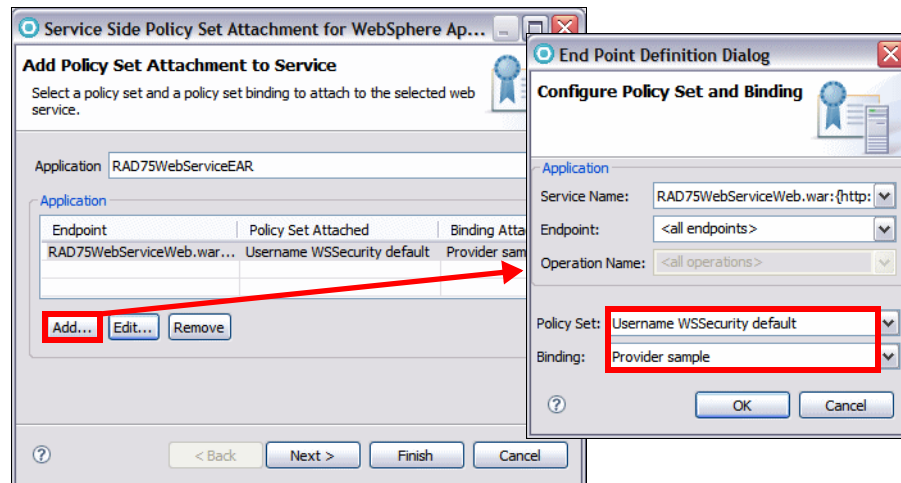

Figure 18-49 Configure Policy Set and Binding

You can apply a policy set at the service, port, or operation level. Different policy sets may be applied to various endpoints and operations within a single Web service. However the service and client must have the same policy set settings. For this example, we apply the policy set to the entire service, so the Endpoint and Operation Name fields are left blank.

- ▶ A warning window is displayed. Click **Ignore**. WS-Security was included in the WS-I Basic Security Profile. The WS-I Basic Security Profile Version 1.0 was in Final Material status.
- ▶ Click **Finish**. Notice the service application is republished to the server.

Attach the policy set to the Web service client

To attach the Username WSSecurity default policy set to the Web service client, do these steps:

- ▶ In the Services view, expand the **JAX-WS** → **Clients**. Right-click **RAD75WebServiceClient: service/BankService** and select **Manage Policy Set Attachment**.
- ▶ Click **Next**.
- ▶ In the Application section, click **Add** to attach a policy set to the endpoint and specify the bindings. Because the service is secured at the service level rather than the endpoint or operation level, the client will be secured at this level as well (Figure 18-50).

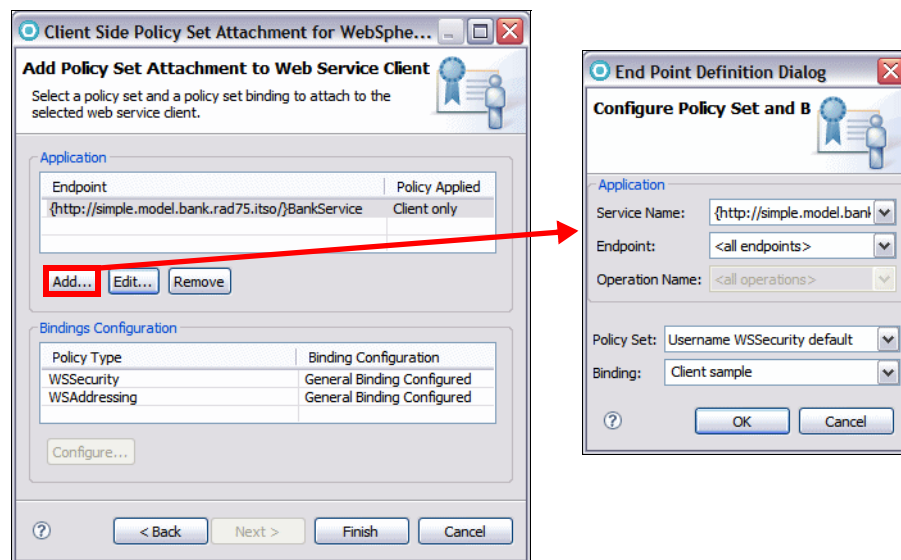

Figure 18-50 Client Side Policy Set Attachment

- ▶ Accept the settings for Service Name (**BankService**), Endpoints (**all**), Policy Set (**Username WSSecurity default**), Binding (**Client sample**). This is a client-side general binding packaged with WebSphere Application Server.
- ▶ Click **OK** and then click **Ignore**.
- ▶ The policy types contained by the policy set you selected are listed in the Bindings Configuration table. The configuration for these policy types are already complete.
- ▶ Click **Finish** to complete the wizard.

Test the secured Web service

To test the secured Web service, do these steps:

- ▶ Select **Window** → **Preferences** → **Run/Debug** → **TCP/IP Monitor**. Make sure the TCP/IP Monitor is started. Note the monitor port (xxxxx).
- ▶ In the Enterprise Explorer, expand the RAD75WebServiceClient project, right-click **TestClient.jsp** → **Run As** → **Run on Server**. Select the v7.0 server and click **Finish**.
- ▶ In the sample JSP client, Quality of Service pane, change the endpoint to the monitor port and click **Update**:

```
http://localhost:xxxxx/RAD75WebServiceWeb/BankService
```

- ▶ Invoke the **retrieveCustomerName** with a customer number of 111-11-1111. In the TCP/IP Monitor view, verify that the message is signed and encrypted, and the Username token in the SOAP header is encrypted:

```
<soapenv:Envelope xmlns:soapenv="http://.../soap/envelope/">
<soapenv:Header xmlns:wsa="http://www.w3.org/2005/08/addressing">
<wsse:Security xmlns:wss="http://docs.oasis-open.org/wss/2004/01
/oasis-200401-wss-wssecurity-secext-1.0.xsd" soapenv:mustUnderstand="1">
<wsu:Timestamp xmlns:wsu="http://docs.oasis-open.org/wss/2004/01
/oasis-200401-wss-wssecurity-utility-1.0.xsd"
wsu:Id="wssecurity_signature_id_24">
<wsu:Created>2008-12-05T17:05:35.953Z</wsu:Created>
</wsu:Timestamp>
<wsse:BinarySecurityToken xmlns:wsu="http://docs.oasis-open.org/wss/2004
/01/oasis-200401-wss-wssecurity-utility-1.0.xsd" wsu:Id="x509bst_26"
EncodingType="http://docs.oasis-open.org/wss/2004/01
/oasis-200401-wss-soap-message-security-1.0#Base64Binary"
ValueType="http://docs.oasis-open.org/wss/2004/01
/oasis-200401-wss-x509-token-profile-1.0#X509v3">
MIICQzCCAaygAwI.....
```

WS-I Reliable Secure Profile

Following on from the Reliable Asynchronous Messaging Profile (RAMP) Version 1.0 specification, the Web Services Interoperability organization (WS-I) Reliable Secure Profile working group has developed Version 1.0 of an interoperability profile dealing with secure, reliable messaging capabilities for Web services.

WS-I Reliable Secure Profile 1.0 provides secure reliable session-oriented Web services interactions. WS-I Reliable Secure Profile 1.0 builds on WS-I Basic Profile 1.2, WS-I Basic Profile 2.0, WS-I Basic Security Profile 1.0, and WS-I Basic Security Profile 1.1, and adds support for WS-Reliable Messaging 1.1, WS-Make Connection 1.0, and WS-Secure Conversation 1.3:

- ▶ WS-Reliable Messaging 1.1 is a session-based protocol that provides message level reliability for Web services interactions.
- ▶ WS-Make Connection 1.0 was developed by the WS-Reliable Messaging workgroup to address scenarios where a Web services endpoint is behind a firewall or the endpoint has no visible endpoint reference. If a Web services endpoint loses connectivity during a reliable session, WS-Make Connection provides an efficient method to re-establish the reliable session.
- ▶ WS-Secure Conversation 1.3 is a session-based security protocol that uses an efficient symmetric key based encryption algorithm for message level security.

The configuration steps to apply WS-I RSP Policy set are basically the same as the steps for Username WSSecurity Policy set. Select WS-I RSP as the policy set when adding a policy set attachment to the service (Figure 18-51). We leave it as an exercise for the reader to explore this functionality.

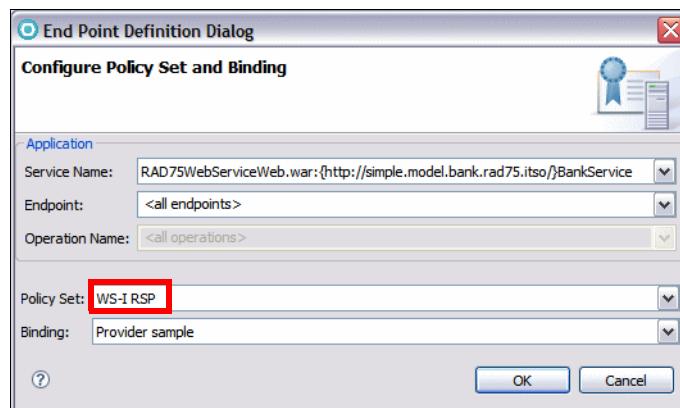

Figure 18-51 Apply WS-I RSP profile

Note: For more detailed information regarding **Reliable Messaging, Secure Conversation, Policy set** and the **RSP profile**, refer to the Redbooks publication, *Web Services Feature Pack for WebSphere Application Server V6.1*, SG24-7618.

WS-Policy

WS-Policy is an interoperability standard that is used to describe and communicate the policies of a Web service so that service providers can export policy requirements in a standard format. Clients can combine the service provider requirements with their own capabilities to establish the policies required for a specific interaction.

WebSphere Application Server conforms to the Web services Policy Framework (WS-Policy) specification. You can use the WS-Policy protocol to exchange policies in standard format. A policy represents the capabilities and requirements of a Web service, for example whether a message is secure and how to secure it, and whether a message is delivered reliably and how this is achieved. You can communicate the policy configuration to any other client, service registry, or service that supports the WS-Policy specification, including non-WebSphere Application Server products in a heterogeneous environment.

For a service provider, the policy configuration can be shared in a published WSDL, that is obtained by a client using an HTTP get request, or by using the Web Services Metadata Exchange (WS-MetadataExchange) protocol. The WSDL is in the standard WS-PolicyAttachments format.

For a client, the client can obtain the policy of the service provider in the standard WS-PolicyAttachments format and use this information to establish a configuration that is acceptable to both the client and the service provider. In other words, the client can be configured dynamically, based on the policies supported by its service provider. The provider policy can be attached at the application or service level.

Relationship to policy set

Policy sets are not inherently concerned with the WS-Policy specification, but deal with the configuration of Web services and should be considered as a front-end to WS-Policy. Policy sets provide a mechanism to specify a policy within a Websphere environment. They do not provide a mechanism to communicate this policy to non-Websphere partners in a heterogeneous environment. In addition, policy set functionality does not provide a mechanism for the client to

calculate effective policy (that is, the policy acceptable to both client and provider) based the intersection of a list of client and provider policies.

Configuring a service provider to share its policy configuration

In this section, we configuring a service provider to share its policy configuration:

- ▶ In the Services view, right-click **RAD75WebServiceWeb:{...}BankService** and select **Manage Policy Set Attachment**.
- ▶ The Username WSSecurity default should be listed as the attached policy set from the last section. Click **Next**.
- ▶ In the Configure Policy Sharing dialog, select the service and click **Configure**. Select **Share Policy Information via WSDL** and click **OK** (Figure 18-52).

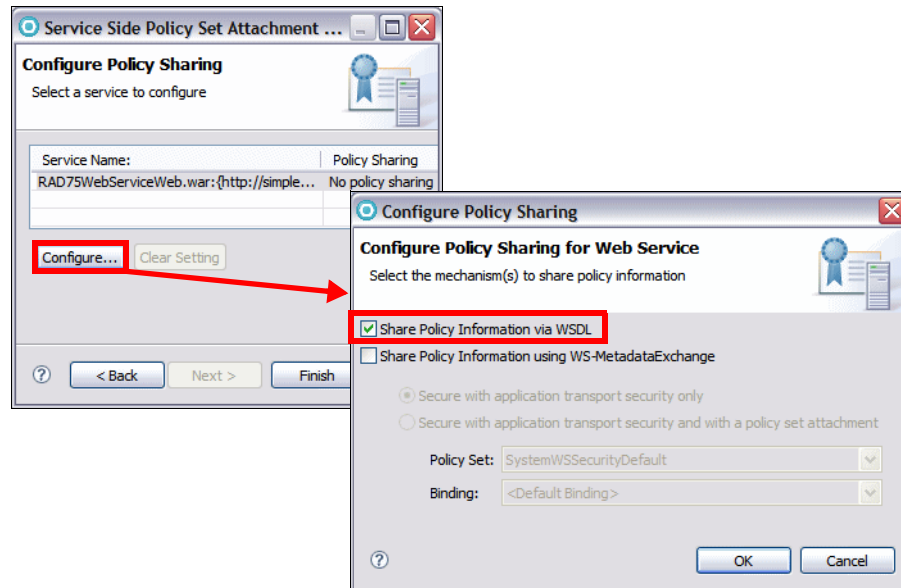

Figure 18-52 Configure Policy Sharing

- ▶ Click **Ignore** for the warning and then click **Finish**.
- ▶ Once the server is published, open a browser and enter the following URL in the browser (**908x** is the port number, most probably 9081):
<http://localhost:908x/RAD75WebServiceWeb/BankService?wsdl>
- ▶ The WS-Policy information is embedded in the WSDL document (Example 18-26).

Example 18-26 WS-Policy in WSDL

```

.....
<service name="BankService">
  <port name="BankPort" binding="tns:BankPortBinding">
    <soap:address
      location="http://localhost:9081/RAD75WebServiceWeb/BankService"/>
    </port>
  </service>
  <wsp:Policy wsu:Id="8a877980db584a2bacf018d1d2dd8c8f">
    <wsp:ExactlyOne>
      <wsp>All>
        <addressing:Addressing>
          <wsp:Policy>
            <wsp:ExactlyOne>
              <wsp>All> </wsp>All>
            </wsp:ExactlyOne>
          </wsp:Policy>
        </addressing:Addressing>
      </wsp>All>
    </wsp:ExactlyOne>
  </wsp:Policy>
</definitions>
.....

```

Configuring the client policy using a service provider policy

To configure the client policy using the service provider policy, do the following:

- ▶ We have to remove the policy we applied in the last section, because we use WS-Policy to request the service provider's policy information.
 - In the Services view, right-click **RAD75WebServiceClient: service/BankService** and select **Manage Policy Set Attachment**.
 - Click **Next**.
 - Click **Remove**, and then click **Finish**.
- ▶ Right-click **RAD75WebServiceClient: service/BankService**, select **Manage Policy Set Attachment**.
- ▶ Click **Use Provider Policy**.
- ▶ In the Configure Policy acquisition for Web Service Client page, select **HTTP Get request targeted at <default WSDL URL>**, and click **OK** (Figure 18-53).
The Policy Acquisition field for the service changes to **Acquire Provider Policy**.

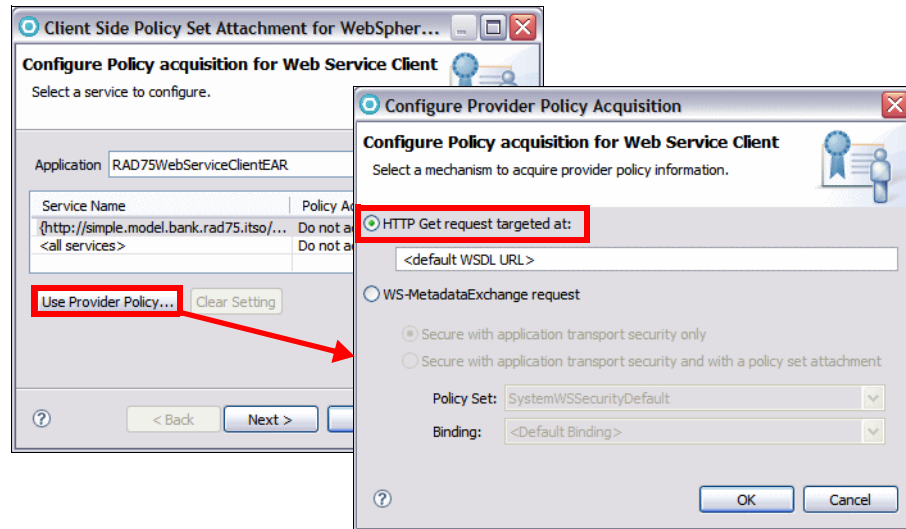

Figure 18-53 Use Provider Policy

- ▶ Click **Ignore** for the warning, and then click **Finish**.
- ▶ Test the Web service again. In the TCP/IP Monitor, you can see the client first acquires the WSDL through the HTTP GET (Figure 18-54). The client policy calculations for a service is performed at the first invocation on that service. Calculated policies are cached in the client for performance.

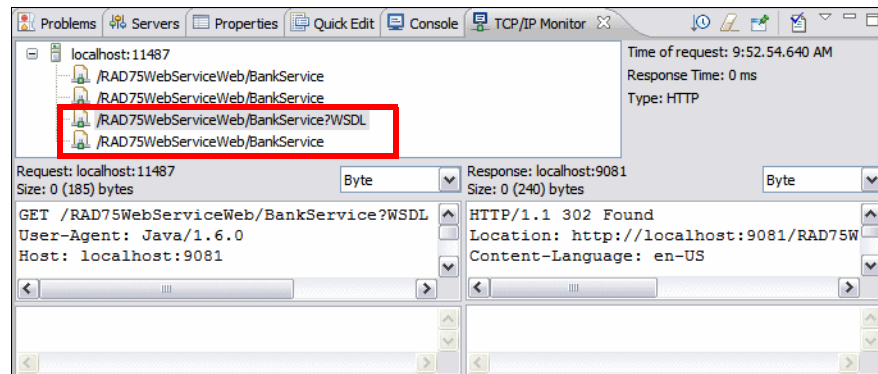

Figure 18-54 TCP/IP Monitor shows retrieve of WSDL

WS-MetadataExchange (WS-MEX)

In WebSphere Application Server Version v7.0, using JAX-WS, you can enable the Web Services Metadata Exchange (WS-MetadataExchange) protocol so that the policy configuration of the service provider is included in the WSDL and is available to a WS-MetadataExchange GetMetadata request. A service provider can use a WS-MetadataExchange request to share its policies, and a service client can use a WS-MetadataExchange request to apply the policies of a provider.

One advantage of using the WS-MetadataExchange protocol is that you can apply transport-level or message-level security to WS-MetadataExchange GetMetadata requests by using a suitable system policy set. Another advantage is that the client does not have to match the provider configuration, or have a policy set attached. The client only needs the binding information, and then the client can operate based on the provider policy, or based on the intersection of the client and provider policies.

To configuring a service provider to share its policy configuration using WS-MEX, do the following:

- ▶ In the Services view, right-click **RAD75WebServiceWeb:{...}BankService** and select **Manage Policy Set Attachment**.
- ▶ The **Username WSSecurity default** should be listed as the attached policy set from the last section. Click **Next**.
- ▶ In the Configure Policy Sharing dialog, select the service and then click **Configure**.
- ▶ Select **Share Policy Information using WS-MetadataExchange** and click **OK** (Figure 18-55).

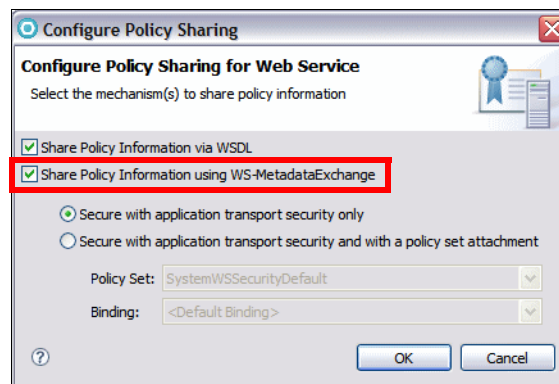

Figure 18-55 Share policy set using WS-MetadataExchange

- ▶ Click **Ignore** for the warning, and then click **Finish**.

To configuring the client policy configuration using WS-MEX, do the following:

- ▶ Right-click **RAD75WebServiceClient: service/BankService**, select **Manage Policy Set Attachment**, and then click **Use Provider Policy**
- ▶ In the Configure Policy acquisition for Web Service Client page, select **WS-MetadataExchange** and then click **OK**.
- ▶ Click **Ignore** for the warning, and then click **Finish**.
- ▶ Test the Web service again. In the TCP/IP Monitor, you can see the client first issues a WS-MEX GetMetadata request to the actual Web service endpoint, and the dialect of the request is WSDL (Example 18-27).

Example 18-27 WS-MEX request

```
<soapenv:Header xmlns:wsa="http://www.w3.org/2005/08/addressing">
  <wsa:To>http://localhost:11487/RAD75WebServiceWeb/BankService</wsa:To>
  <wsa:MessageID>urn:uuid:5F71ABE9421927F47C1228500226211</wsa:MessageID>
  <wsa:Action>
    http://schemas.xmlsoap.org/ws/2004/09/mex/GetMetadata/Request
  </wsa:Action>
</soapenv:Header>
<soapenv:Body>
  <mex:GetMetadata xmlns:mex="http://schemas.xmlsoap.org/ws/2004/09/mex">
    <mex:Dialect>http://schemas.xmlsoap.org/wsdl/</mex:Dialect>
  </mex:GetMetadata>
</soapenv:Body>
```

- ▶ The GetMetadata response returns the WSDL with the policy information.

More information

For more information on Web services, refer to these resources:

- ▶ If you want to learn more about JAX-WS, Reliable Messaging, Secure Conversation, Policy set and RSP profile, see the Redbooks publication, *Web Services Feature Pack for WebSphere Application Server V6.1*, SG24-7618.
- ▶ For JAX-RPC Web services tools shipped with Application Developer v7.0, see the Redbooks publications: *Rational Application Developer V7 Programming Guide*, SG24-7501, and *Web Services Handbook for WebSphere Application Server Version 6.1*, SG24-6957.
- ▶ IBM developerWorks has a whole section on SOA and Web services:
<http://www.ibm.com/developerworks/webservices>
- ▶ An online list of current and emerging Web services standards can be found on developerWorks under **SOA and Web services** → **Standards**:
<http://www.ibm.com/developerworks/webservices/standards/>
- ▶ The JAX-WS specification is available at:
<http://jcp.org/aboutJava/communityprocess/pfd/jsr224/index.html>
- ▶ The JAXB specification is available at:
<http://jcp.org/en/jsr/detail?id=222>
- ▶ The MTOM specification is available at:
<http://www.w3.org/TR/soap12-mtom/>
- ▶ Read about JAX-WS annotations at:
<https://jax-ws.dev.java.net/jax-ws-ea3/docs/annotations.html>
http://publib.boulder.ibm.com/infocenter/wasinfo/v6r1/index.jsp?topic=/com.ibm.websphere.wsfep.multipatform.doc/info/ae/ae/rwbs_jaxwsannotations.html
- ▶ The WS-Policy specification is available at:
<http://www.w3.org/Submission/WS-Policy/>
- ▶ The WS-MetadataExchange specification is available at:
<http://www.ibm.com/developerworks/webservices/library/specification/ws-mex/>



Develop Web applications using Web 2.0

Web 2.0 represents a paradigm shift in designing and developing Web applications. JavaServer Faces (JSF) is a framework that simplifies building user interfaces for Web applications, described in Chapter 16, “Develop Web applications using JSF” on page 493. JPA is the Java Persistence API, described in Chapter 12, “Persistence using the Java Persistence API (JPA)” on page 267.

This chapter introduces the features, benefits, and architecture of Web 2.0. The focus of the chapter is to demonstrate the Rational Application Developer support and tooling for Web 2.0, using Ajax Proxy, DOJO toolkit, and RPC Adapter. The chapter includes an example Web application using Web 2.0, with a front controller implemented with JSF and persistence implemented with JPA.

The chapter is organized into the following sections:

- ▶ Introduction to Web 2.0
- ▶ Developing a Web 2.0 using JSF, Ajax Proxy, and JPA
- ▶ Developing a Web 2.0 application using Dojo and RPC

Note: The code snippets for this chapter are located in C:\7672code\web20. Project Interchanges for this chapter are located in: C:\7672code\zInterchange\web20.

Introduction to Web 2.0

This section provides an introduction to Web 2.0.

Web 2.0 definition

Before we dive into the technical concepts, let us start by defining what exactly is meant by the term Web 2.0. The term *Web* in Web 2.0 refers to the World Wide Web technology which we have all grown to know and love. The *2.0* indicator in Web 2.0 does not specify a new version release of a technical specification which supports World Wide Web technology. Rather, it indicates a paradigm shift (or evolution) in the way which Web applications and its components are designed and developed and ultimately share information and collaborate within the internet and with one another. In many ways, Web 2.0 also enables a paradigm shift of the computing platform from the desktop to the Internet.

Web 2.0 application architecture

To fully understand Web 2.0, we describe Web 2.0 in the following context:

- ▶ Web 2.0 characteristics
- ▶ Evolution from Web 1.0 to Web 2.0 applications
- ▶ Comparing code on client browser and application server
- ▶ Web 2.0 features and benefits
- ▶ Effect on Web users

Web 2.0 characteristics

Web 2.0 applications usually involve the following characteristics.

- ▶ The content of Web applications are delivered through a Web browser. Web 2.0 applications adhere to Web standards.
- ▶ The usage of Web 2.0 applications feels less like classic Web applications, but rather like desktop applications.
- ▶ Web 2.0 applications often have user interface that fall in the Rich Internet Application category. They often use pre-built/re-usable widgets that enables a rich set of user interface features.

Evolution from Web 1.0 to Web 2.0 applications

Let us examine how Web applications have evolved from Web 1.0 to Web 2.0.

In Web 1.0 applications, a request for more server side data retrieval and/or page navigation typically requires an invocation of HTTP request/response pair. The end result is that a Web page refresh is incurred. Web page refreshes are typically viewed by end-users as a cumbersome delay in their workflow.

Figure 19-1 shows browser and server interaction in Web 1.0 applications.

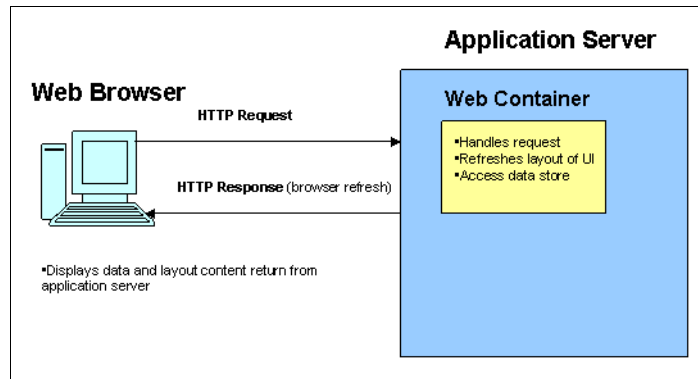

Figure 19-1 Web 1.0 application architecture

In contrast, in Web 2.0, a request for more server side data retrieval and/or page navigation typically still requires an invocation of HTTP request/response pair. However, Web 2.0 applications leverage technologies which makes server-side data retrieval and/or page navigation possible without incurring a Web page refresh. In most cases, only the portions of the user interface is updated with the changed data.

Figure 19-2 shows the different approach taken in Web 2.0 applications.

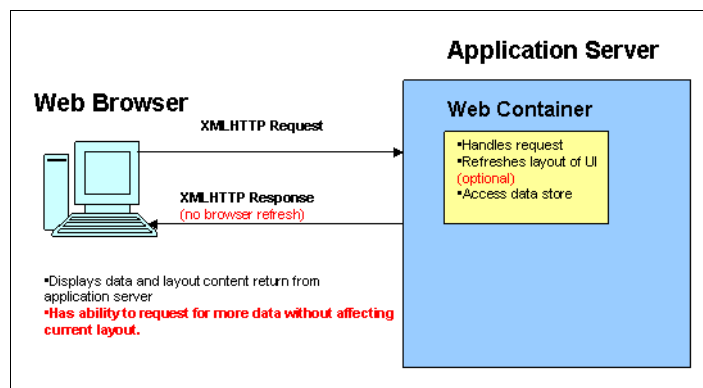

Figure 19-2 Web 2.0 application architecture

Comparing code on client browser and application server

In Web 1.0, for the most part, code on the application server (JSPs, tag libraries and/or servlets) are responsible for delivering the user interface layout and data. In this paradigm, the browser is primarily used as a medium for viewing the data and the layout in which the data is displayed. Both data and layout is tightly-coupled to one another, in that in order to refresh data, the layout must also be refreshed.

In contrast, in Web 2.0 applications, the data is loosely coupled from the layout. Under the Web 2.0 paradigm, it is possible for the application server to deliver the layout content once and using client-side code (for example, JavaScript) subsequent request for data can be initiated and completed independent of the layout content.

Web 2.0 features and benefits

In this section we describe the features and benefits of Web 2.0.

Advantages of Web 2.0 architecture

As mentioned, the main benefits of the Web 2.0 architecture is that developers can build applications that are responsive to the user and their actions. In essence, the application behaves like a desktop program in that it appears that it does not have wait for a server response each time an action is taken on the page. Another benefit is for developers is that the popularity of this approach has seen an increase in the number of tools available for creating Web 2.0 applications. There has an abundance of freely available components and widgets which developers can leverage/re-use.

Disadvantages of Web 2.0 architecture

The Web 2.0 architecture does bring associated concerns. First, Web 2.0 is a new approach using existing technologies. However, it does require to a rethinking in the way to approach Web development. Furthermore, we are pushing more code onto the client (as opposed to mainly server side). Therefore, we must be cognizant of the impact (performance and security wise) that this paradigm has on the client.

Effect on Web users

From the end user's perspective, incorporating Web 2.0 makes a Web-based application often indistinguishable from a desktop program. Similar to a desktop program, a Web 2.0 application would provide immediate feedback to the user and support user-browser interaction without a browser refresh. The end result is a Web 2.0 application is in a position to deliver a rich set of content and functionality to the web user. Often, Web 2.0 enabled application are referred to as Rich Internet Applications (or RIA).

Supporting technologies

There are a handful of technologies which enables the paradigm shift of Web 2.0. Some of the supporting technologies for Web 2.0 are:

Ajax

Asynchronous JavaScript and XML (Ajax) refers to a group of technologies that are used to develop interactive Web applications. By combining these technologies, Web pages appear more responsive since small amounts of data are exchanged with the server and Web pages are not reloaded each time a user makes an input change.

In classic Web applications users have to submit forms (HTTP requests) to exchange data with the server. After some processing phase, the server returns the whole page to the client.

Ajax moves this server-side logic to the client. Instead of loading the whole page, the client can refresh the parts of page. The users' HTTP requests turn simply into JavaScript calls to the Ajax engine that is loaded by the browser.

Ajax is made up of the following technologies:

- ▶ HTML and CSS for presenting information
- ▶ JavaScript for dynamically interacting with the information presented
- ▶ XML, XSLT, and XMLHttpRequest object to manipulate data asynchronously with the Web server

Ajax Proxy

Let us discuss the meaning of an Ajax Proxy and what purpose does it serve in the Web 2.0 paradigm.

Ajax communication methods include XMLHttpRequest (XHR) and IFrame requests. These methods allow the browser to send HTTP requests to a server at any time with or without a user action. One limitation of an IFrame or XHR request is the restriction to make a request to a different server other than the one that served the original HTML page. This limitation is sometimes known as a same domain limitation and exists as a security measure to prevent hacker from injecting a malicious script by redirecting the page to an untrusted server.

However, an Ajax-based Web application may have to make a request to a server that is different than the server that served the main HTML page. Client-side methods exist to work around the same-domain limitation, but these methods have limitations. The recommended solution to the same-domain limitation is to use a proxy server to forward the request to a server on a different domain.

The need for a solution for the same-domain restriction is amplified when using Ajax techniques. Ajax techniques can involve XHR or IFrame requests to server-side services. An Ajax application that collects data from multiple sources or services and combines them into one cohesive view is called a *mashup*. As an Ajax-enabled application, or mashup, accesses more services to gather data and as mashup usage increases, there is an increased chance that Ajax applications must access a cross-domain service. The cross-domain service that needs to be accessed might be a third-party service or an internal service running on a different domain or port.

Choosing to proxy Ajax requests instead of using a client-side, browser-based proxy alternative can be beneficial. A proxy server can be configured to only support access to certain Web sites whereas a browser-based solution does not have the ability to restrict cross-domain access on a per server basis. Another proxy server benefit is content filtering from a third-party site. One form of content filtering would be configuring a proxy server to only return content from a third-party Web site if it matches a permissible content type. A final benefit is using the proxy server to convert response data to a format a Web application expects. A proxy server converting a Web service response from XML to JavaScript Object Notation (JSON) for consumption by a browser is an example of a proxy server converting data.

JSON

JavaScript Object Notation (JSON) is loosely based on a subset of the JavaScript programming language. JSON was built to function as a data interchange format. To make JSON re-usable across programming languages and platforms, JSON is:

- ▶ Language independent
- ▶ Uses well-known/accepted programming concepts

JSON is built on two structures:

- ▶ A collection of name/value pairs. In most programming languages, the construct equivalent is either an object, record, structure, dictionary, hash table, keyed list, or associative array.
- ▶ An ordered list of values. In most programming languages, the construct equivalent is either an array, vector, list, or sequence.

These are universal data structures. Virtually all modern programming languages support them in one form or another. It makes sense that a data format that is interchangeable with programming languages also be based on these structures.

In JSON, data structures have these forms:

- ▶ An object is an unordered set of name/value pairs. An object begins with { (left brace) and ends with } (right brace). Each name is followed by : (colon) and the name/value pairs are separated by , (comma).
- ▶ An array is an ordered collection of values. An array begins with [(left bracket) and ends with] (right bracket). Values are separated by , (comma).

The JSON4J library is an implementation of a set of JavaScript Object Notation (JSON). With this library we can construct and manipulate data to be rendered as the JSON implementation.

DOJO Toolkit

The Dojo Toolkit is an open source JavaScript library. It can be used to create rich user interfaces and it is not tied to specific server-side technologies. It runs natively in most of web browsers and provides an abstract layer for JavaScript development. More details about Dojo Toolkit can be found at:

<http://www.dojotoolkit.org>

Dojo is divided in three modules:

- ▶ **Dojo Core:** All the major functions needed to do Ajax developments and others similar effect functions (fading, sliding, for example).
- ▶ **Dijit:** A high quality set of interactions rich widgets and themes for use when developing Ajax applications.
- ▶ **DojoX (Dojo Extensions):** An area that contains a set of subprojects that extend the Dojo Toolkit.

REST and RPC Adapter

Web-remoting is a pattern that provides support for JavaScript or client-side code to directly invoke server side logic. This pattern provides the ability to invoke Java methods from JavaScript. The invocation is by means of a JSON-RPC call. The most common usage is asynchronous calls with XMLHttpRequest. Data is transferred between the server and client in JSON format. Therefore, this pattern is essentially a form of JSON Web services.

The IBM implementation for Web remoting is referred to as the RPC adapter for IBM. The RPC adapter is designed to help developers create command-based services quickly and easily in a manner that complements programming styles for Ajax applications and other lightweight clients. Implemented as a generic servlet, the RPC adapter provides an HTTP interface to registered JavaBeans.

The RPC adapter provides an HTTP interface to Registered JavaBeans. It will deserialize the input and call the corresponding method in the JavaBean. It will serialize the output from the JavaBean to JSON/XML format.

The RPC adapter currently supports two RPC protocols:

- ▶ HTTP RPC, which encodes RPC invocations as URLs with query parameters, for HTTP GET, or form parameters, for HTTP POST.
- ▶ JSON-RPC, supports the SMD service descriptor employed by the Dojo `dojo.rpc.JsonService` API.

HTTP RPC

In HTTP RPC, invocations are made using URLs with query parameters or form parameters. The RPC adapter intercepts and deserializes the URL to get service name, method name, and input parameters. Using these information RPC adapter invokes the corresponding method of matching JavaBeans.

JSON-RPC

In JSON-RPC, method invocation is made using JSON objects. The response generated is also a JSON object. The registered JavaBeans can be accessed through the Dojo JSON-RPC API.

Web 2.0 features in Application Developer v7.5

Application Developer v7.5 provides the following Web 2.0 features:

- ▶ Support for server-side Web 2.0 technologies
- ▶ Visual Tools for RPC Adapter services
- ▶ Visual Tools for Ajax Proxy
- ▶ Visual Tools for Dojo development
- ▶ Built in sample applications for each of the aforementioned Web 2.0 technologies. These sample applications are accessible through the **Help** menu:

Select **Help** → **Samples**, then navigate to **Samples** → **Application samples** → **Web** (Figure 19-3).

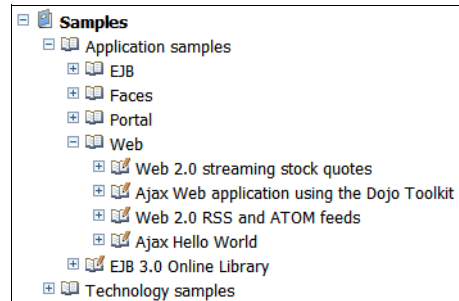

Figure 19-3 Sample using Web 2.0 technologies

Preparing for the sample

This section describes the tasks that must be completed prior to developing the Web 2.0 and JPA sample application. For the most part, steps taken to set up the Ajax Proxy and DOJO/RPC Adapter are identical. We will refer to this project setup section for both examples.

Note: A completed version of the Web applications built using Web 2.0 Ajax Proxy and DOJO/RPC Adapter can be found in the project interchange files:

```
C:\7672code\zInterchange\web20\RAD75Web20AjaxProxy.zip  
C:\7672code\zInterchange\web20\RAD75Web20Dojo.zip
```

Setting up the sample database

For the most part, setting up the sample database for Web 2.0 development is no different from the JSF development.

To use JPA components, we require a relational database. This section provides instructions for deploying the ITSOBANK sample database and populating the database with sample data. For simplicity we use the built-in Derby database.

Follow the instructions in “Setting up the ITSOBANK database” on page 1154 to create and load the sample ITSOBANK database.

Create a database connection

Follow the instructions in “Creating a connection to the ITSOBANK database” on page 229 to create the **ITSOBANKderby** connection (if you do not have the connection already defined).

Configuring the data source

For the most part, configuring the data source for Web 2.0 development is no different from the JSF development.

There are a couple of methods that can be used to configure the data source, including using the WebSphere Administrative Console or using the WebSphere Enhanced EAR, which stores the configuration in the deployment descriptor and is deployed with the application.

While developing Web 2.0 and JPA Web applications with Application Developer v7.5, the data source is created automatically when you add JPA managed data to a Faces JSP file. The data source configuration is added to the EAR deployment descriptor.

You can also use the data source configured in the server, as described in “Configuring the data source in WebSphere Application Server” on page 1155.

Developing a Web 2.0 using JSF, Ajax Proxy, and JPA

In this section we describe a Web application implemented with Web 2.0.

We leverage the work done for the JSF chapter (Chapter 16, “Develop Web applications using JSF” on page 493). The examples in this chapter will continue to use JSF as the MVC framework. Ajax is then added on top of that work to add and exemplify Web 2.0 features and functionality.

Project setup

We use two projects for this application:

- ▶ **RAD75Web20EAR**—Enterprise application with one Web module
- ▶ **RAD75Web20**—JSF based Web application with facets for JSF, Web 2.0 and JPA

Creating the projects

Because we are going to re-use the JSF projects, we will not go through the trouble of recreating the base JSF projects from scratch. Instead, we will walk through the steps taken to ensure that the JSF projects are well-equipped for Web 2.0 development.

We provide an initial project interchange file to setup the Web and EAR projects which are properly configured for development work of this chapter. Import the start-up Web 2.0 project interchange file located in:

C:\7672code\web20\RAD75Web20-Ajax-Initial.zip

Select both projects:

- ▶ **RAD75Web20**—Web project, basically a copy of RAD75JSFWeb that we developed in Chapter 16, “Develop Web applications using JSF” on page 493. We changed the table for the customer SSN input to a **Panel - Group Box** component.
- ▶ **RAD75Web20EAR**—Enterprise application, a copy of RAD85JSFEAR.

First we verify the configuration of the Web project:

- ▶ Right-click on **RAD75Web20** and select **Properties**.
- ▶ In the Properties dialog, select **Project Facets** on the left, and verify that Web 2.0 is selected with **Ajax Proxy**, **Dojo Toolkit**, and **Server-side technologies** under it (Figure 19-4).

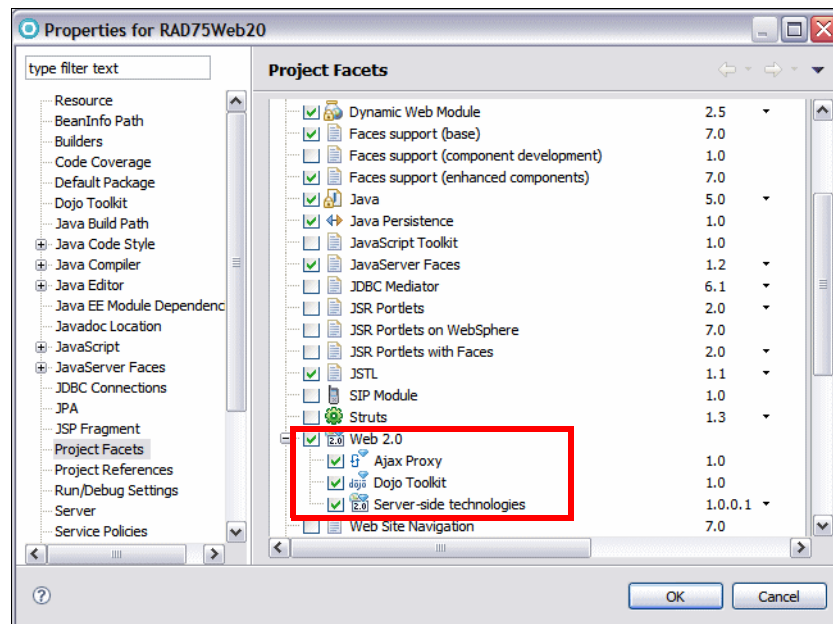

Figure 19-4 Project Facets for Web 2.0

- ▶ Click **Cancel**.

Structure of the Web 2.0 application

We leverage the existing JSF application in the Web 2.0 samples. The application continues to consist of the following three pages:

- ▶ Login page (login): Validate the social security number (SSN). If it is valid it then display the customer details for the customer. In the Web 2.0 exercise, there will be two implementations of the login page which showcases two different Ajax features.
- ▶ Customer details page (customerDetails): Display the accounts of the customer and allow you to select an account to view the transactions.
- ▶ Account details page (accountDetails): Display the selected account details.

Ajax Proxy files

Earlier, we provided instructions on enabling Web 2.0 features within the Web project. Now, let us examine configuration details related to Ajax Proxy.

All of the relevant Ajax Proxy files are located in the **WebContent/WEB-INF** directory (Figure 19-5).

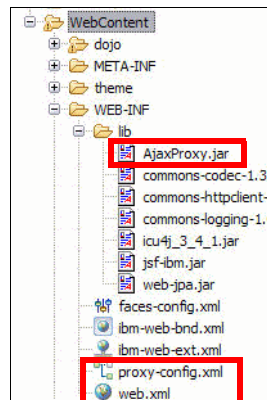

Figure 19-5 Ajax Proxy related files

- ▶ **AjaxProxy.jar**: contains all Ajax Proxy classes necessary for runtime and compile time.
- ▶ **proxy-config.xml**: contains proxy policy mapping information (such as URI to HTTP method mapping, header mapping info, mime types, and cookies).
- ▶ **web.xml**: The Web deployment descriptor is not a file specific to Ajax Proxy. This file is part of the servlet specification. However, there are entries related to Ajax Proxy which are registered into this file. There is a servlet mapping entry for the controller servlet for Ajax Proxy (Example 19-1).

Example 19-1 Ajax Proxy servlet

```

<servlet>
  <servlet-name>ProxyServlet</servlet-name>
  <servlet-class>
    com.ibm.ws.ajaxproxy.servlet.ProxyServlet</servlet-class>
</servlet>

```

Adding type-ahead control to the login page

When a type-ahead control is attached to an input field, as a user types in the field, a list of suggestions is constructed and displayed in a pop-up list box attached to the field. Alternatively, as a user types, the field can be automatically completed with a suggestion (and the user can keyboard to additional suggestions. Type-ahead uses Ajax requests to communicate with the server when building the list of suggestions. As a result, the page remains on display (it is not submitted/redrawn) while the list is being build. The user interface remains active while the list is being built.

In our sample, type-ahead control is used to generate suggestions for customer SSN numbers. To keep the code simple, we generate static SSN numbers, but in real applications, you would probably require complex generators.

Add type-ahead to the login page

To add type-ahead control to the login page, do these steps:

- ▶ In the Web perspective, Enterprise Explorer, open the **logon.jsp** (in RAD75Web20/WebContent).

We replace the drop-down box with a input text element to show the type-ahead feature.

- ▶ In the Design or Split tab, select the **Select an ssn** drop-down box and press **Delete**. Then select the **{Error Message for ssn1}** and press **Delete**.

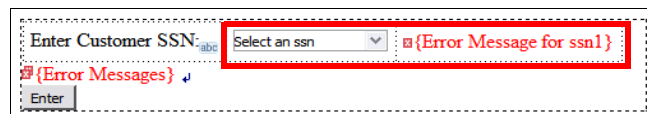

- ▶ Drag an **Input** component from the Enhanced Faces Component palette into the panel box, right after SSN:abc (make sure the generated source tag is inside <hx:panelBox>).

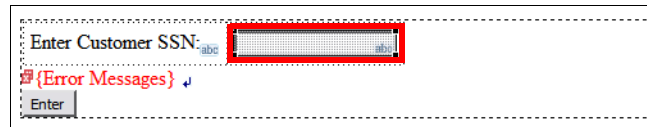

- ▶ In the Page Data view, expand **Scripting Variables** → **sessionScope** and drag the **SSN** on top of the input field to create the binding.
- ▶ Select the **{SSN}** input text component and locate the Properties view. You can see the value binding of `# {sessionScope.SSN}`.
- ▶ In the Properties view, select **Behavior** under **h:inputText**, and select **Enable typeahead option**.

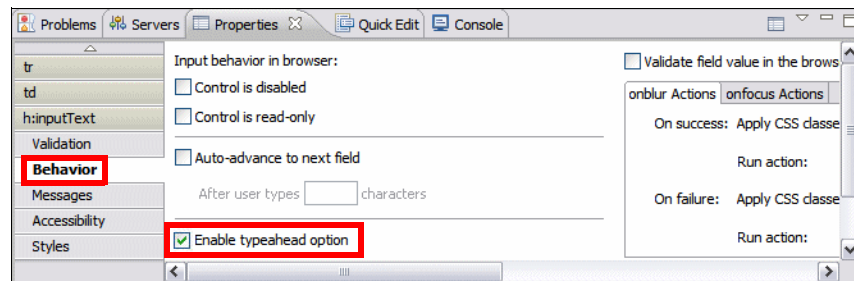

- ▶ An `hx:inputHelperTypeahead` tab is added to the Properties view. Notice that the input field is now enabled for type-ahead support.

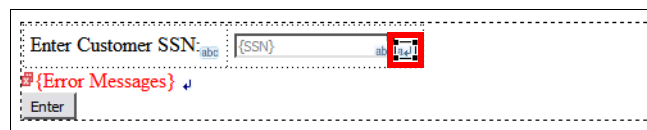

Generate a suggestion list

We have to generate a suggestion list for the type-ahead component. We can do that by simply implementing a Java class that generates suggestions and returns them in an `ArrayList` object. In our sample suggestions for the customer SSN are generated in two ways:

- ▶ A fixed list of SSNs (111-11-1111, 222-22-2222, ...)
- ▶ A variable list of SSNs retrieved from the database using the `CustomerManager` and JPA entities. This technique was used in the JSF application to populate the drop-down list.

To create the suggestions class, do these steps:

- ▶ In the Enterprise Explorer, right-click **RAD75Web20** and select **New** → **Class**.
- ▶ In the New Java Class dialog, enter these values:
 - Package: **itso.rad75.web20.suggestions**
 - Name: **CustomerSsnSuggestions**
 - Superclass: **java.util.AbstractMap**
 - Click **Finish**.

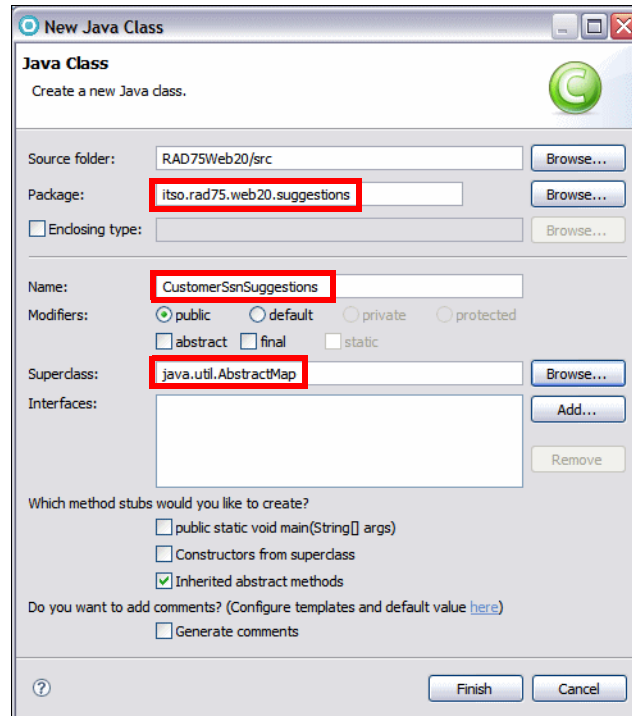

- ▶ The **CustomerSsnSuggestions** class opens in the editor. Replace the code with `c:\7672code\web20\CustomerSsnSuggestions.java` (Example 19-2).

Example 19-2 Suggestions for customer keys

```
package itso.rad75.web20.suggestions;

import itso.bank.entity.controller.CustomerManager;

import java.util.AbstractMap;
import java.util.ArrayList;
import java.util.List;
import java.util.Set;
```

```

import javax.faces.model.SelectItem;

public class CustomerSsnSuggestions extends AbstractMap {

    static ArrayList<String> ssnSuggestions = null;
    int arrayLength = 10;

    @Override
    public Set entrySet() {
        return null;
    }
    // generate fix set of SSNs
    public Object get(Object key) {
        if (ssnSuggestions == null) {
            ssnSuggestions = new ArrayList<String>(arrayLength);
            for (int i = 0; i < arrayLength; i++) {
                String suggestion =
                    new String(i+""+i+""+i+"-"+"i+""+i+"-"+"i+""+i+""+i+""+i);
                ssnSuggestions.add(suggestion);
            }
        }
        return compareSuggestions(key);
    }
    // generate variable set of SSNs from the database
    public Object get2(Object key) {
        if (ssnSuggestions == null) {
            CustomerManager customerManager = new CustomerManager();
            List<SelectItem> list = customerManager.getCustomerSelectList();
            ssnSuggestions = new ArrayList<String>(list.size());
            for (SelectItem item: list) {
                ssnSuggestions.add( (String)item.getValue() );
            }
        }
        return compareSuggestions(key);
    }
    // compare user data with the list of SSNs
    public Object compareSuggestions(Object key) {
        String first = key.toString().substring(0,1);
        System.out.println("SsnSuggestion input: " + key);
        ArrayList<String> result = new ArrayList<String>(arrayLength);
        for ( String entry: ssnSuggestions) {
            if (first.equals( entry.substring(0,1) ))
                result.add(entry);
        }
        // store result in session scope
        FacesContext.getCurrentInstance().getExternalContext()
            .getSessionMap().put("SSN", result.get(0));
        return result;
    }
}

```



```
}
}
```

- ▶ We bind the `CustomerSsnSuggestions` class to type-ahead component.
 - In `logon.jsp`, Select the **typeahead** component (icon).
 - In the Properties view, locate the **hx:inputHelperTypeahead** tab.
 - Examine the other attributes of type-ahead component, such as maximum number of suggestions displayed, delay time before a suggestion is made, and match width of the suggestion area with the input field.
 - click **Browse** for the Value field.

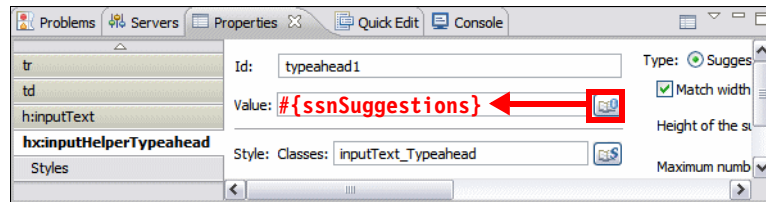

- In the Select Page Data Object dialog, click **New Data Object**.
- In the New Data Component dialog, select **Faces Managed Beans** → **Faces Managed Bean** and click **OK**.
- In the Add JavaBean dialog, enter the following:
 - Name: **ssnSuggestions**
 - Locate and select the **CustomerSsnSuggestions** class.
 - Select **session** scope.
 - Select **Finish**.
- In the Select Page Data Object dialog, select **ssnSuggestions** and click **OK**. If the new bean is not visible, cancel the dialog, and open it again from the Properties view, A value binding of `#{ssnSuggestions}` is generated.

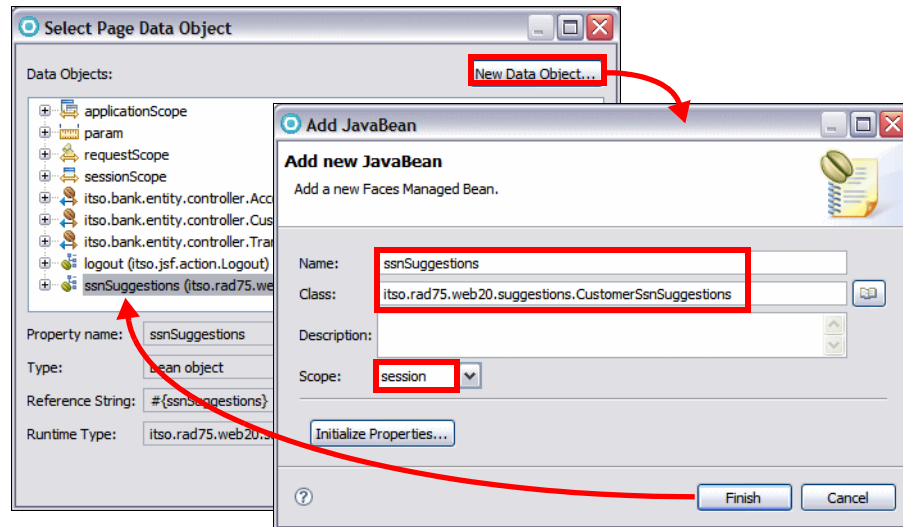

Test the login page with type-ahead suggestions

To test the login page with suggestions, execute the following steps:

- ▶ In the Enterprise Explorer, expand **RAD75Web20** → **WebContent**, right-click **login.jsp**, and select **Run As** → **Run on Server**.
- ▶ Select the WebSphere Application Server v7.0 and click **Finish** to complete publish onto the WebSphere Server.
- ▶ In the login page, start typing **666** into the customer SSN field. As soon as you stop typing, the suggestion list opens with customer SSN returned from the suggestions bean (Figure 19-6).

Select the displayed SSN and click **Submit** to display the customer.

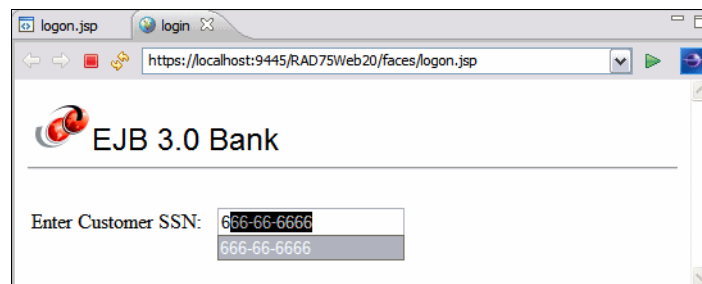

Figure 19-6 Testing the Ajax type-ahead feature

- ▶ Notice that the type-ahead feature only displays SSNs from the list of all SSNs that match the first character of the value entered.

- ▶ You can test the retrieve of SSNs from the database by renaming the methods:
 - get ==> get1 (fixed set of SSNs)
 - get2 ==> get (variable set of SSNs from the database)

Adding Ajax refresh submit behavior

Ajax refresh submit behavior defines alternative content for the panel, which can be asynchronously retrieved after the page has been loaded into the browser without refreshing the whole page.

Whenever an action is triggered (for example, a button click), the client requests the alternative content for the panel and it replaces the existing panel content with new content. The page containing the panel is not replaced by the get, instead, this tag allows part of the page to be replaced. The revised content is retrieved from the same JSP from which the original content came.

Both the server life cycle copy of the page and the client-side page are kept in sync. The new page content is retrieved using a post HTTP request operation. The contents of the form containing the panel are posted as part of the request so that the values in the form are available to the server code calculating the new content to put in the panel.

In our example, we want to display a welcome message with the customer's name when an SSN is entered into the entry field.

Create an alternate logon page

We continue to leverage the resources in the existing JSF projects. In addition to the existing JSP pages, we create an alternate logon JSP page. Refer to “Create a Faces JSP page using the Web Diagram Editor” on page 503, and create a JSP page called **logon-ajax.jsp**, or more simply:

- ▶ In the Enterprise Explorer, right-click **WebContent**, and select **New** → **Web Page**.
- ▶ In the New Web Page dialog, type **logon-ajax.jsp** as name, select **Basic Template** → **JSP**, and click **Finish**:
- ▶ Open both the **logon-ajax.jsp** and the existing **logon.jsp**, and in the **Split** tab copy the content from **logon.jsp** to **logon-ajax.jsp**, starting with the tag:

```
<%@taglib uri="http://java.sun.com/jsf/core" prefix="f"%>
```

Do not copy the `<%-- jsf:pagecode ...>` tag. It must remain as:

```
<%-- jsf:pagecode language="java"
    location="/src/pagecode/LogonAjax.java" --%>
```

- ▶ Select the **Split** tab, and save **logon-ajax.jsp**.

Copy the action code

We have to copy the action code for the Enter button to the new page.

- ▶ Open **Logonajax.java** by right-clicking in the **logon-ajax.jsp** and selecting **Edit Page Code**.
- ▶ Open the **Logon.java** code in the same way.
- ▶ Copy the **doButton1Action** method from `Logon.java` to `Logonajax.java`.
- ▶ Close `logon.jsp` and `Logon.java`.
- ▶ Select the editor of the `logon-ajax.jsp`, and in the Page Data view, expand **Page Bean** and drag **doButton1Action** onto the **Enter** button in the JSP. This creates the binding `#{pc_Logonajax.doButton1Action}`, and this method is invoked when the **Enter** button is clicked,

Add an output field for the welcome message

To display the welcome message we use an output component.

- ▶ Drag an **Output** component from the palette into the panel box, right after the input field.

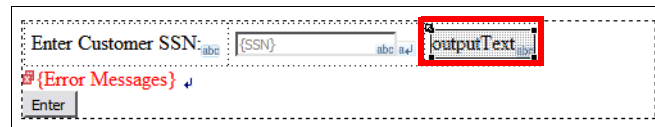

- ▶ Add a **getWelcome** method to `Logonajax.java` (Example 19-3).

Example 19-3 Ajax getWelcome method

```
public String getWelcome() {
    String welcome = "";
    String ssn = (String)getSessionScope().get("SSN");
    System.out.println("Ajax welcome: " + ssn);
    try {
        if (ssn != null) {
            CustomerManager customerManager =
                (CustomerManager)getManagedBean("customerManager");
            Customer customer = customerManager.findCustomerBySsn(ssn);
            welcome = "Welcome " + customer.getFirstName() + " " + customer
                .getLastName() + "! Click Submit to logon ...";
        }
    } catch (Exception e) {
        System.out.println("Ajax failed: " + e.getMessage());
        welcome = "Ajax failed";
    }
}
```

```
}  
    return welcome;  
}
```

- ▶ From the Page Data view, drag the **welcome** property (under Page Bean) onto the **outputText** field to create a binding of `{pc_Logonajax.welcome}`. In the source or Properties view, notice the id of the field, for example, **text3**.



- ▶ This action retrieves the welcome message from the page code.

Add the navigation

When **Enter** is clicked, we want to display the customer details page.

- ▶ In the Split tab, select the **Enter** button.
- ▶ In the Properties view, click **Add Rule** (on the right side).
- ▶ In the Add Navigation Rule dialog:
 - For Page, select **customerDetails.jsp**.
 - Select **The outcome named:** and type **login**.
 - Select **This page only** (preselected).
 - Click **OK**.

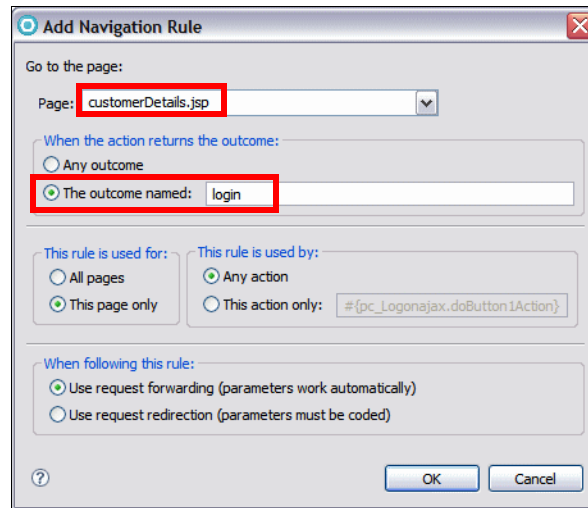

- ▶ The navigation rule is added to the WEB-INF/faces-config.xml file.

Add Ajax refresh behavior

Finally we add the Ajax refresh behavior to the panel box and the input field.

- ▶ In the logon-ajax.jsp select the panel box (<hx:panelBox> in the source).
- ▶ In the Properties view, select **Ajax** under <hx:panelBox>.
- ▶ Select **Allow Ajax updates** and **Submit**.

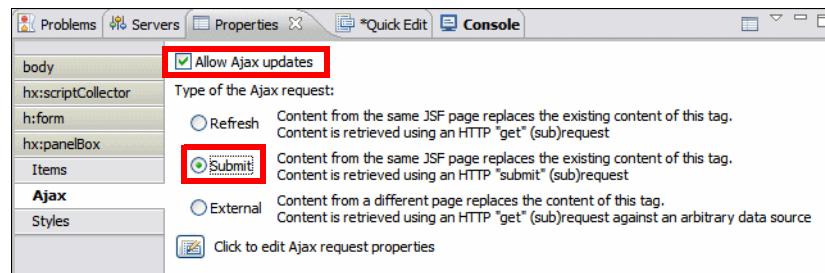

- ▶ This action creates the tag:

```
<hx:ajaxRefreshSubmit target="box1" id="ajaxRefreshSubmit1"> </hx:ajax...>
```
- ▶ Select the **{SSN}** input field.
- ▶ Select the **Quick Edit** view (in the same pane as the Properties view):
 - Select **onChange** on the left.

- Select Use pre-defined behavior.
- For Action, select **Invoke Ajax behavior on the specified tag**.
- For Target, select **box1** (the id of the panel box).

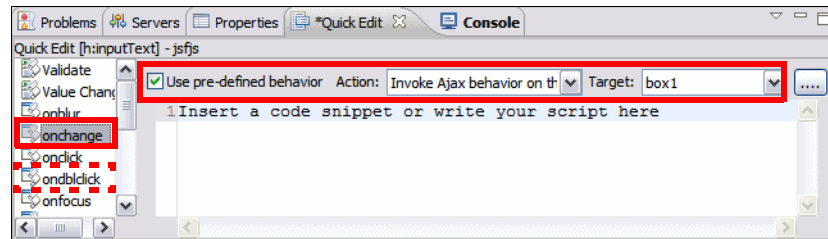

- ▶ Select **ondblclick**, and select the same behavior.
- ▶ Notice the tags that are added under the input field:

```
<hx:behavior event="onchange" id="behavior1" behaviorAction="get"
  targetAction="box1"></hx:behavior>
<hx:behavior event="ondblclick" id="behavior2" behaviorAction="get"
  targetAction="box1"></hx:behavior>
```
- ▶ Save the JSP, which also saves the Java code.

Test the logon page with Ajax refresh behavior

To test the Ajax refresh behavior, publish the application to the server.

- ▶ Run the `logon-ajax.jsp`.
- ▶ Start typing a customer SSN.
- ▶ The type-ahead feature displays the matching SSN.

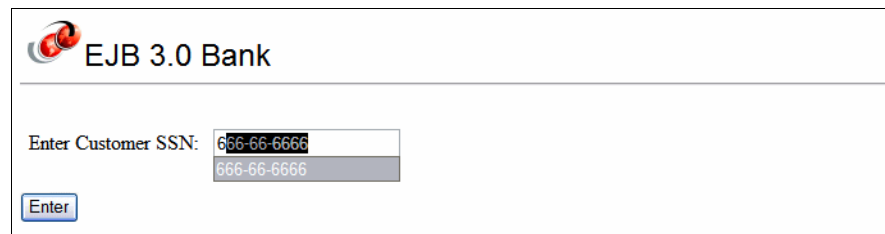

- ▶ Select the SSN.
- ▶ The `onChange` event does not seem to work.
- ▶ Double-click in the input field and the welcome message appears.

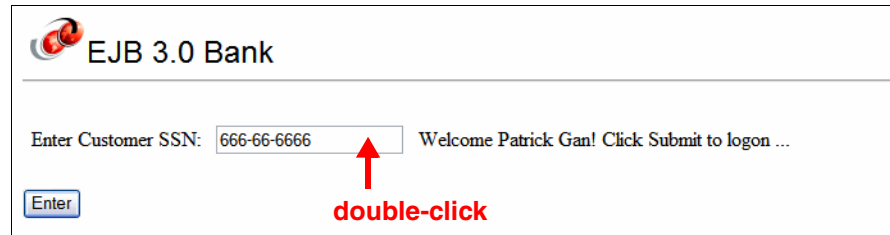

- ▶ Click **Enter** to continue with the application.

Testing onChange behavior with a combo box

To test the refresh behavior without double-clicking we use a combo box.

- ▶ Add a combo box next to the input field.

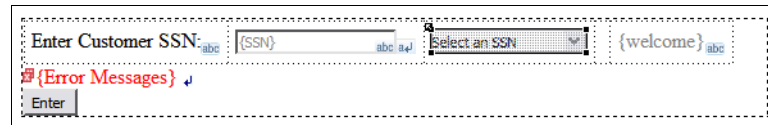

- ▶ In the Properties view, click **Add Choice** and **Add Set of Choices**:
 - For the first choice, set the label to **Select an SSN**, and the value to **000-00-0000**.
 - For the set of choices, accept the label as **<selectitems>**, and set the value to **#{customerManager.customerSelectList}** (you can use the **Bind** button).
- ▶ Drop the session scope variable SSN onto the combo box to create a binding of **#{sessionScope.SSN}**.

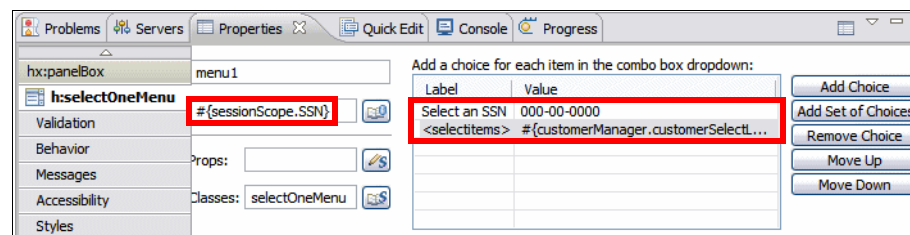

Testing the refresh

To test the Ajax refresh behavior, publish the application to the server.

- ▶ Run the `logon-ajax.jsp`.

- ▶ Select an SSN from the drop-down list that has been populated through the `CustomerManager.customerSelectList` method.
- ▶ The welcome message is displayed.

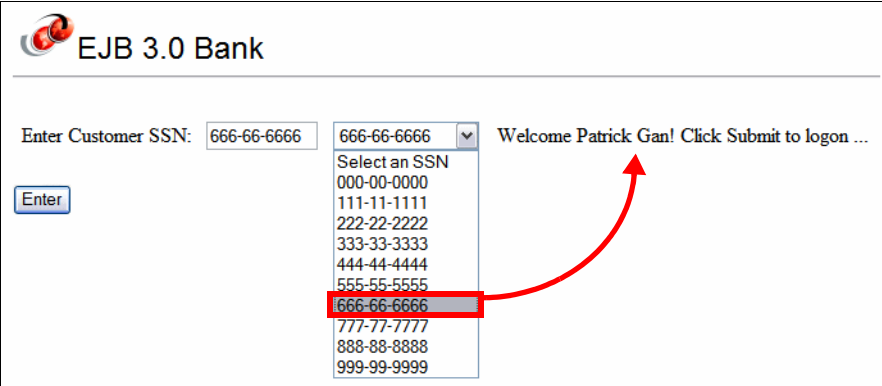

The screenshot shows a web application titled "EJB 3.0 Bank". It features a form with the following elements:

- A text input field labeled "Enter Customer SSN:" containing the value "666-66-6666".
- A dropdown menu with the selected value "666-66-6666". The dropdown list is open, showing a list of SSN options: "000-00-0000", "111-11-1111", "222-22-2222", "333-33-3333", "444-44-4444", "555-55-5555", "666-66-6666" (highlighted with a red box), "777-77-7777", "888-88-8888", and "999-99-9999".
- A "Welcome Patrick Gan! Click Submit to logon ..." message.
- An "Enter" button.

A red arrow points from the highlighted "666-66-6666" option in the dropdown menu to the "Welcome Patrick Gan!" message.

Cleanup

Remove the RAD75Web20EAR application from the server.

Developing a Web 2.0 application using Dojo and RPC

In this section we develop a Web application using the Web 2.0 technologies of Dojo and RPC.

Project setup

We use two projects for this application:

- ▶ **RAD75Web20DojoEAR**—Enterprise application with one Web module
- ▶ **RAD75Web20Dojo**—Web application with facets for Web 2.0 and JPA, and one Web page

Configuring the Web project

The focus of this sample is to show Dojo, RPC Adapter, and JPA working together. For this reason, we will use an existing basic project with JPA properly configured, and we enable it for Web 2.0.

- ▶ Import the project interchange file from:

C:\7672code\web20\RAD75Web20-Dojo-Initial.zip

Select both projects (RAD75Web20Dojo and Rad75Web20DojoEAR). This application is a copy of the JSF application developed in Chapter 16, “Develop Web applications using JSF” on page 493.

- ▶ Configure the Web project for Web 2.0 development:
 - Right-click **RAD75Web20Dojo** and select **Properties**.
 - In the Properties dialog, select **Project Facets**.
 - In the Project Facets pane, select **Web 2.0**, which selects **AJAX Proxy**, **Dojo Toolkit**, and **Serverside technologies**.
 - Click **OK**.

Architecture of the Web 2.0 application

The sample application is based on JSF sample developed in Chapter 16, “Develop Web applications using JSF” on page 493, with reduced functionality. We will use the same JPA entities and rewrite the JSF pages to HTML with Dojo Toolkit.

We will create three services (Figure 19-7):

- ▶ **CustomerServlet:** Returns all SSN for the user selection.
- ▶ **CustomerService:** Returns information and accounts for one SSN.
- ▶ **TransactionService:** Returns information about a selected account.

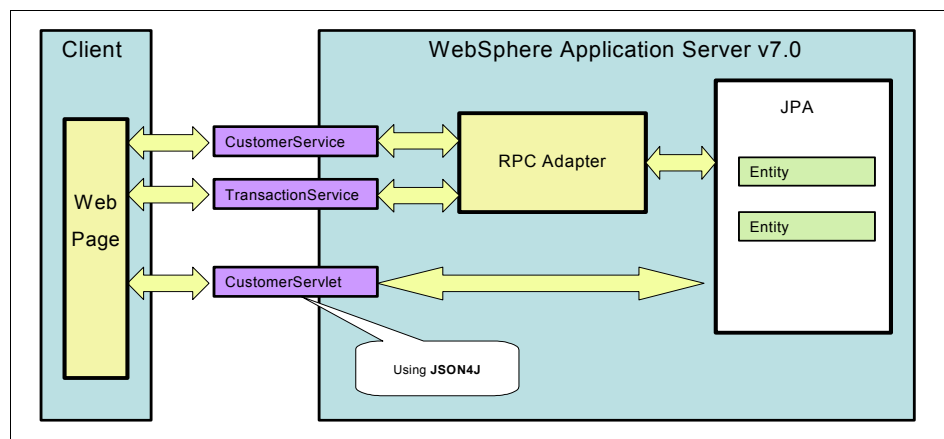

Figure 19-7 Web 2.0 RPC dojo application structure

Exposing an RPC Adapter service

In this step we create the RPC Adapter service that returns a JSON response. We require a service that returns the customer information by SSN.

To expose a service, do these steps:

- ▶ In the Web perspective, select **Window** → **Show View** → **Other** → **General** → **Services**.
- ▶ In the Services view, right-click **RPC Adapter** and select **Expose RPC Adapter Service** (Figure 19-8).

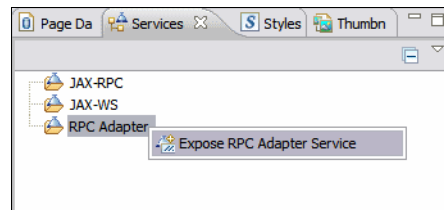

Figure 19-8 Exposing an RPC Adapter Service

- ▶ In the Expose RPC Adapter Service dialog (Figure 19-9), enter the following data:
 - Web Project: **RAD75Web20Dojo**
 - Class: **itso.bank.entity.controller.CustomerManager**
 - Service Name: **CustomerService**
 - Methods: Select **findCustomerBySsn**.
 - Click **Next**.

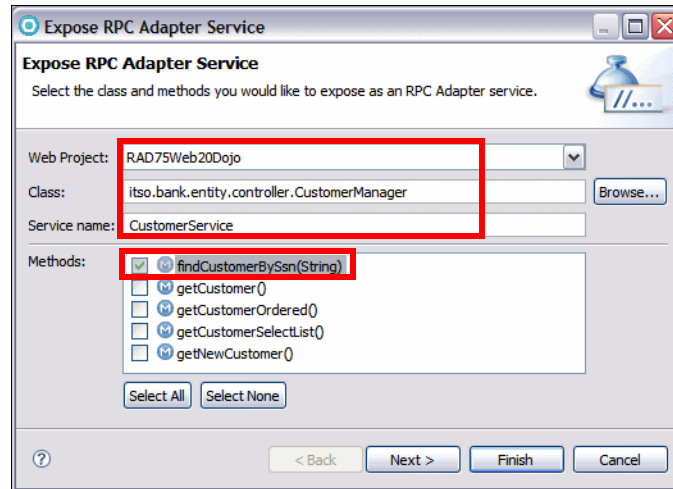

Figure 19-9 Exposing a service

- ▶ In the Configure Methods dialog (Figure 19-10), accept the default options and then click **Finish**.

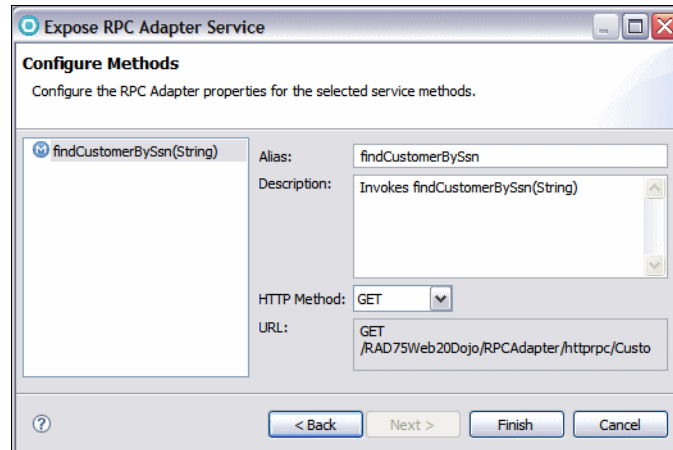

Figure 19-10 Configure Methods

- ▶ The service has been exposed. The RPC adapter is created in the Services view and the `findCustomerBySsn` method is exposed (Figure 19-11).

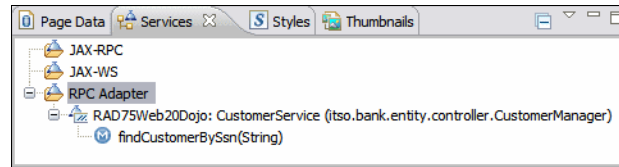

Figure 19-11 RPC Adapter with an exposed service

When we create an RPV Adapter service, we are adding an abstract layer, no matters which technology is used on the server to obtain the information requested. The client side only needs to know the address (URL) and the format of the data returned. Services provides encapsulation, reuse, and loose-coupling.

The service is stored in the WebContent/WEB-INF/RpcAdapterConfig.xml file (Example 19-4).

Example 19-4 *RpcAdapterConfig.xml* file (formatted)

```
<rpcAdapter .....>
  <default-format>json</default-format>
  <converters></converters>
  <validators>
    <validator id="default">
      <validation-regex>([A-Za-z])+</validation-regex>
      <validation-class>com.ibm.websphere.rpcadapter.DefaultValidator
      </validation-class>
    </validator>
  </validators>
  <services>
    <pojo>
      <name>CustomerService</name>
      <implementation>itso.bank.entity.controller.CustomerManager</...>
      <methods filter="whitelisting">
        <method>
          <name>findCustomerBySsn</name>
          <alias>findCustomerBySsn</alias>
          <description>Invokes findCustomerBySsn(String)</description>
          <http-method>GET</http-method>
          <parameters>
            <parameter>
              <name>ssn</name>
              <type>java.lang.String</type>
              <description></description>
            </parameter>
          </parameters>
        </method>
      </methods>
    </pojo>
  </services>
</rpcAdapter>
```

```
</pojo>
</services>
<serialized-params></serialized-params>
</rpcAdapter>
```

Adding the transaction service

Next, we define a service that returns the transactions of one account. Repeat the same steps to expose this service.

In the Expose RPC Adapter Service dialog, enter the following items

- ▶ Web Project: **RAD75Web20Dojo**
- ▶ Class: **itso.bank.entity.controller.TransactionManager**
- ▶ Service Name: **TransactionService**
- ▶ Methods: select **getTransactionByAccount**
- ▶ Click **Finish**.

RPC Adapter Configuration Editor

The configuration of the RPC Adapter in the `RpcAdapterConfig.xml` file can be edited using the RPC Adapter Configuration Editor (Figure 19-12, which is opened by double-clicking a service entry in the Services view, or double-clicking the `RpcAdapterConfig.xml` file).

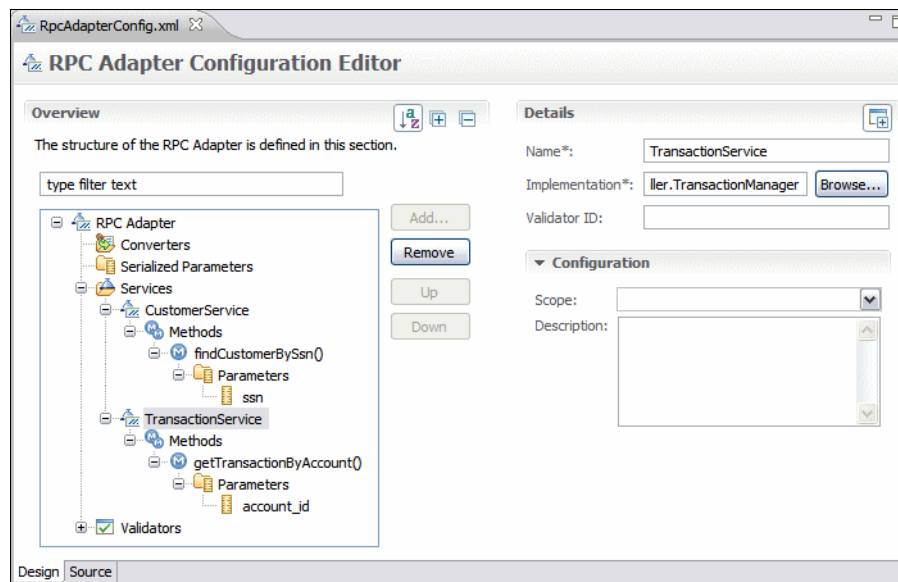

Figure 19-12 RPC Adapter Configuration Editor

The RPC Adapter Configuration Editor makes it easy to configure the services. This editor enables you to create, change, and remove services, add parameters, create validators and other features about RPC adapter. The underlying XML code can be viewed in the Source tab (Example 19-4 on page 677).

Creating an RPC Converter

Some type of classes require special handling by the RPC Adapter. For that purpose we can create a converter.

For example, the `getTransTime` method of the `Transaction` entity class returns a `java.util.Date`, but the JSON result is an OpenJPA subclass named `org.apache.openjpa.util.java$util$Date$proxy`.

To create an RPC Converter, do these steps:

- ▶ Open the RPC Adapter Configuration Editor.
- ▶ Expand **RPC Adapter** → **Converters**, and click **Add**.
- ▶ In the Add Item dialog, select **Converter** (the only choice), and click **OK**.
- ▶ Select the new empty entry, and in the Details pane (Figure 19-13), enter:
 - Bean: **org.apache.openjpa.util.java\$util\$Date\$proxy**
 - Converter: **com.ibm.websphere.rpcadapter.converters.util.Date**

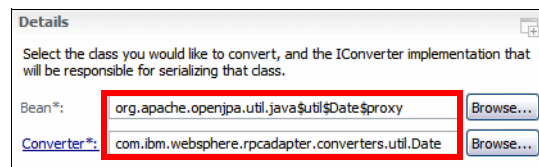

Figure 19-13 RPC Adapter - Converter Details

- ▶ Save and close the editor.

Creating a service using a servlet

We can create a service with a servlet, by writing the code to return a response in JSON format.

Note: For this example, we use a servlet and the JSON4J library to demonstrate a programmatic way to return information in JSON format.

To expose a servlet as a service, do these steps:

- ▶ Right-click **RAD75Web20Dojo** and select **New** → **Servlet**.
- ▶ In the **Create Servlet** dialog, enter the following items, and click **Finish**.
 - Java Package: **itso.bank.servlet**
 - Class Name: **CustomerServlet**
- ▶ The `CustomerServlet` class opens in the editor. Use the code in `C:\7672code\web20\CustomerServlet.java` to complete the code.
 - Remove the constructor and the `doPost` method.
 - Complete the `doGet` method (Example 19-5).

Example 19-5 Servlet doGet method

```
protected void doGet(...) throws ServletException, IOException {
    response.setContentType("text/plain");
    response.getWriter().write(getCustomers());
    response.getWriter().flush();
    response.getWriter().close();
}
```

- Add the `getCustomers` method (Example 19-6).

Example 19-6 Retrieving all customers and return a JSON object

```
private String getCustomers() {
    JSONObject jsonObject = new JSONObject();
    JSONArray jsonArray = new JSONArray();
    try {
        jsonObject.put("items", jsonArray);
        CustomerManager customerManager = new CustomerManager();
        List<Customer> customerList =
            customerManager.getCustomerOrdered();
        for (Customer customer : customerList) {
            JSONObject obj = new JSONObject();
            obj.put("ssn", customer.getSsn());
            jsonArray.add(obj);
        }
        jsonObject.put("identifier", "ssn");
        jsonObject.put("items", jsonArray);
    } catch (Exception ex) {
        ex.printStackTrace();
    }
    return jsonObject.toString();
}
```

- Select **Source** → **Organize Imports** (or press **Ctrl+Shift+O**) to resolve the classes (`com.ibm.json.java.JSONObject`, `java.util.List`).
- ▶ The new `getCustomers` method returns a response in JSON format to populate a combo box with a list of SSN.
- ▶ Save and close the `CustomerServlet`.

Testing the services

Before writing any Web pages we can test the services that we created. Make sure that the WebSphere Application Server v7.0 is started.

To test the services provided by the servlet, execute the following steps:

- ▶ In the Enterprise Explorer, expand **RAD75Web20Dojo**, right-click the **CustomerServlet** (either in the deployment descriptor or the Java class) and select **Run As** → **Run on Server**.
- ▶ The application is deployed to the server and the servlet is invoked. The result of the servlet is displayed in Example 19-7.

Example 19-7 CustomerServlet execution result

```
{ "items": [ { "ssn": "000-00-0000" }, { "ssn": "111-11-1111" }, { "ssn": "222-22-2222" },
  { "ssn": "333-33-3333" }, { "ssn": "444-44-4444" }, { "ssn": "555-55-5555" }, { "ssn": "666-66-6666" },
  { "ssn": "777-77-7777" }, { "ssn": "888-88-8888" }, { "ssn": "999-99-9999" } ], "identifier": "ssn" }
```

To test the services provided by RPC Adapter, execute the following steps:

- ▶ In the Services View, expand **RPCAdapter** → **RAD75Web20Dojo: CustomerService** → **findCustomerBySsn(String)**.
- ▶ Right-click **findCustomerBySsn(String)** and select **Run As** → **Run on Server**.
- ▶ When prompted to save the file, click **Cancel**.
- ▶ An information page is displayed, because the parameter is missing.
- ▶ In the browser URL address, complete the request with a customer SSN:

```
https://localhost:944x/RAD75Web20Dojo/RPCAdapter/httprpc/CustomerService/findCustomerBySsn?ssn=777-77-7777
```

Press **Enter** to send the request.
- ▶ When prompted to save the file, click **Save** and navigate to a folder where you can find the `findCustomerBySsn` file that is created.
- ▶ Open the file in an editor (Example 19-8).

Example 19-8 JSON result of getCustomer request

```
{ "result": { "lastName": "Gomes", "title": "Mr", "firstName": "Miguel", "accountCollection": [ { "transactCollection": null, "id": "007-777001", "customerCollection": null, "balance": 500.00 } ], "ssn": "777-77-7777" } }
```

- ▶ Repeat the test for the `getTransactionByAccount` method of the `TransactionService`. Use this URL:

```
https://localhost:944x/RAD75Web20Dojo/RPCAdapter/httprrpc/TransactionService/getTransactionByAccount?account_id=002-222001
```

- ▶ The result of this call is:

```
{ "result": [ { "transType": "Credit", "transTime": "1990-01-01T23:23:23-0800", "amount": 2222.22, "id": "0000001", "account": { "transactCollection": null, "id": "002-222001", "customerCollection": null, "balance": 65484.23 } }, ..... ] }
```

Creating the Web page

We want to display the results of the RPC calls on a Web page that contains:

- ▶ A combo box populated with a list of SSN
- ▶ A button to logon
- ▶ A table with a list of accounts for the selected SSN
- ▶ A table with a list of transactions for the selected account

To create the Web Page, following these steps:

- ▶ In the Enterprise Explorer, expand **RAD75Web20Dojo**, right-click **WebContent**, and select **New** → **Web Page**.
- ▶ In the New Web Page dialog, enter the following values:
 - File Name: Type **index.html**.
 - Template: Select **HTML/XHTML**.
 - Click **Finish**.
- ▶ The HTML file opens in Page Designer. Because this is a Web 2.0 project, the Palette has four additional drawers for dojo (Figure 19-14)

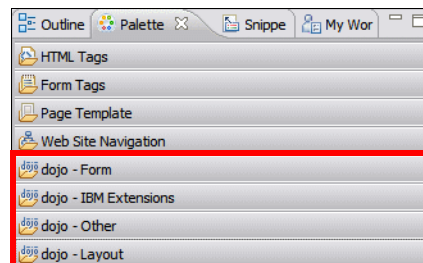

Figure 19-14 Dojo drawers in the Palette

- ▶ The `index.html` file has been added with some JavaScript and CSS code to build Dojo applications (Example 19-9).

Example 19-9 HTML source with dojo imports



```
<script type="text/javascript" src="dojo/dojo/dojo.js"
  djConfig="isDebug: true, parseOnLoad: true"></script>
<style type="text/css">
@import "dojo/dojo/resources/dojo.css";
@import "dojo/dijit/themes/tundra/tundra.css";
@import "dojo/dijit/themes/dijit.css";
```

Adding components to index.html

To design the HTML page, use the **Source** or **Split** tab in Page Designer. The Design tab does not work well with Web 2.0 pages.

- ▶ From the Palette, select **dojo - Layout** → **BorderContainer** and drag it onto the page. This creates one line in the source:

```
<body class="tundra">
  <div dojotype="dijit.layout.BorderContainer"></div>
</body>
```

- ▶ Select the **BorderContainer**.
- ▶ In the Properties view, set the style to **height: 100%; width: 640px;**. You can use the Styles icon  and set the values for Layout, or click the All Attributes icon  and set the style attribute there.
- ▶ From the Palette, select **dojo - Layout** → **ContentPane** and drag it on top of the `BorderContainer`.
- ▶ Select **ContentPane** in the source, and in the Properties view enter the following values:
 - `splitter=true`
 - `region=top`
 - `style=height: 150px; border: 1px solid black;`
 - `id=logonPane`
- ▶ From the Palette, select **HTML Tags** → **Table** and drag it onto the page, before the ending `</div>` tag of the `ContentPane`.
- ▶ In the Table dialog, enter **2** for Rows and **3** for Columns, **0** for Border width, and **10** for Spacing outside cells. Then click **OK**
- ▶ In the first row (`<tr>`) and column (`<td>`) type **Enter Customer SSN: .**
- ▶ In the third column add an **id** attribute with the value **welcome** and color definitions:

```
table border="0" cellspacing="10">
```

```

<tbody>
  <tr>
    <td>Enter Customer SSN:</td>
    <td></td>
    <td id="welcome" style="color: blue;background-color: #eaeaea;"
        align="center"></td>
  </tr>

```

- ▶ Add a heading **<h2>Logon</h2>** between the `<div>` tag and the `<table>`.
- ▶ Create two more **ContentPane** (without a table) after `</table></div>` tags:

```

<div preload="true" dojotype="dijit.layout.ContentPane" href=""></div>
<div preload="true" dojotype="dijit.layout.ContentPane" href=""></div>

```

Tip: Application Developer v7.5 provides content assist for dojo tags. Just press **Ctrl+Space** inside a dojo tag.

- ▶ Select the second ContentPane and in the Properties view enter the following values:
 - splitter=**true**
 - region=**center**
 - style=**height: 100px; border: 1px solid black;**
 - id=**accountPane**
- ▶ Select the third ContentPane and in the Properties view enter the following values:
 - splitter=**true**
 - region=**bottom**
 - style=**height: 250px; border: 1px solid black;**
 - id=**transactionPane**
- ▶ Basically, we divided the page in three regions: top, center, and bottom.
- ▶ In the Palette, select **dojo - Form** → **FilteringSelect** and drag it onto page, into the top region, first row and second column of the table.
- ▶ Select **FilteringSelect** and in the Properties view enter the following values:
 - store=**customStore**
 - searchAttr=**ssn**
 - id=**ssnCb**
 - invalidMessage=**Enter a valid SSN**
- ▶ Edit the source of the FilteringSelect, and delete some of the attributes (Example 19-10).

Example 19-10 Edit the FilteringSelect source

```

<select dojotype="dijit.form.FilteringSelect" name="select2"

```

```

autocomplete="false" value="Val1" store="customStore"
searchattr="ssn" id="ssnCb" invalidmessage="Enter a valid SSN">
<option value="Val1" selected="selected">Value1</option>
<option value="Val2">Value2</option>
</select>

```

- ▶ From the Palette, select **dojo - Form** → **Button** and drag it onto page, into the second row and first column of the table.
- ▶ Select **Button** and in the Properties view enter the following values:
 - id=**logonBt**
 - label=**Logon**
- ▶ In the Palette, select **dojo - Others** → **Grid** and drag it onto page, between the <div> and </div> for the second ContentPane (accountPane). Change the code to:

```

<div id="grid" dojotype="dojox.Grid" model="" structure="layout"
      jsId="accountGrid" autoheight="true"></div>

```

Note: The jsId attribute was not in the Properties view. The jsId creates a global JavaScript variable.

- ▶ Add a **Grid** to the third ContentPane (transactionPanel) and change the code to:

```

<div id="grid0" dojotype="dojox.Grid" model="" structure="layout"
      jsId="transactionGrid" autoheight="true"></div>

```

- ▶ Add headings between the second and third ContentPane and the Grid:

```

<b>Accounts</b><p>
<b>Transactions</b><p>

```

- ▶ Add the following code between <style type="text/css"> and </style> tags, after the other imports:

```

@import "dojo/dojox/grid/_grid/tundraGrid.css";

```

- ▶ In the Palette, select **dojo - Others** → **ItemFileReadStore** and drag it onto page, after the <body class="tundra"> tag. Then change the code to:

```

<div dojotype="dojo.data.ItemFileReadStore" jsId="customStore"
      url="/RAD75Web20Dojo/CustomerServlet"></div>

```

- ▶ The index.html file is now complete (Example 19-11),

Example 19-11 Complete index.html file with dojo tags highlighted

```

<!DOCTYPE HTML PUBLIC "-//W3C//DTD HTML 4.01 Transitional//EN">
<html>
<head>
<script type="text/javascript" src="dojo/dojo/dojo.js"

```

```

    djConfig="isDebug: true, parseOnLoad: true"></script>
<script type="text/javascript">
dojo.require("dojo.parser");
dojo.require("dijit.layout.BorderContainer");
dojo.require("dijit.layout.ContentPane");
dojo.require("dijit.form.FilteringSelect");
dojo.require("dijit.form.Button");
dojo.require("dojox.grid.Grid");
dojo.require("dojo.data.ItemFileReadStore");
</script>
<script type="text/javascript" src="redBank.js" ></script> (added next)
<style type="text/css">
@import "dojo/dojo/resources/dojo.css";
@import "dojo/dijit/themes/tundra/tundra.css";
@import "dojo/dijit/themes/dijit.css";
@import "dojo/dojox/grid/_grid/tundraGrid.css";
</style>
<title>index</title>
<meta http-equiv="Content-Type" content="text/html; charset=ISO-8859-1">
</head>
<body class="tundra">
<div dojotype="dojo.data.ItemFileReadStore" jsId="customStore"
    url="/RAD75Web20Dojo/CustomServlet"></div>
<div dojotype="dijit.layout.BorderContainer"
    style="height: 100%; width: 640px;">
<div preload="true" dojotype="dijit.layout.ContentPane" href=""
    splitter="true" region="top"
    style="height: 150px; border: 1px solid black;" id="logonPane">
    <h2>Logon</h2>
    <table border="0" cellspacing="10">
    <tbody>
    <tr>
        <td>Enter Customer SSN:</td>
        <td><bselect dojotype="dijit.form.FilteringSelect"
            store="customStore" searchattr="ssn" id="ssnCb"
            invalidmessage="Enter a valid SSN">
            </select>
        </td>
        <td id="welcome" style="color: blue;background-color: #eaeaea;"
            align="center"></td>
    </tr>
    <tr>
        <td>
            <bdiv dojotype="dijit.form.Button" id="logonBt"
            label="Logon"></div>
        </td>
        <td></td>
        <td></td>
    </tr>
    </tbody>
    </table>

```

```

        </tbody>
    </table>
</div>
<div preload="true" dojotype="dijit.layout.ContentPane" href=""
    splitter="true" region="center"
    style="height: 100px; border: 1px solid black;" id="accountPane">
    <b>Accounts</b><p>
    <div id="grid" dojotype="dojox.Grid" model="" structure="layout"
        jsId="accountGrid" autoheight="true">
    </div>
</div>
<div preload="true" dojotype="dijit.layout.ContentPane" href=""
    splitter="true" region="bottom"
    style="height: 250px; border: 1px solid black;"
    id="transactionPane">
    <b>Transactions</b><p>
    <div id="grid0" dojotype="dojox.Grid" model="" structure="layout"
        jsId="transactionGrid" autoheight="true">
    </div>
</div>
</div>
</body>
</html>

```

Creating the JavaScript file that drives the application

Most of the actions are driven by a JavaScript file (redBank.js):

- ▶ Create a JavaScript source file:
 - Select **File** → **New** → **Other** → **JavaScript** → **JavaScript Source File**.
 - In the New JavaScript file dialog, enter the following values:
 - Parent Folder: **/RAD75Web20Dojo/WebContent**
 - File Name: **redBank.js**
 - Click **Finish**.
- ▶ Complete the redBank.js with the code from C:\7672code\web20\redBank.js.
- ▶ Add the following code into index.html between the <head> and </head>, after the other <script> tags (before the <style> tag):

```
<script type="text/javascript" src="redBank.js" ></script>
```

Examining the Dojo components

Let us explain some of the Dojo components that we added to the page:

- ▶ **dojo.data.ItemFileReadStore:** Dojo provides a basic mechanism to store information in JSON format. The `url` attribute is where the store looks for the data, in our case by calling the `CustomerServlet` (which returns a list of SSN).

```
<div dojotype="dojo.data.ItemFileReadStore" jsId="customStore"
    url="/RAD75Web20Dojo/CustomerServlet"></div>
```

- ▶ **dijit.form.FilteringSelect:** This is an HTML select tag that can be populated dynamically. The `store` attribute refers to the `ItemFileReadStore`, and `ssn` is the search attribute.

```
<select dojotype="dijit.form.FilteringSelect" store="customStore"
    searchattr="ssn" id="ssnCb" invalidmessage="Enter a valid SSN">
</select>
```

- ▶ **dojox.Grid:** This is a basic grid, with a layout (rows and columns) and a model (the contents).

Application flow

Figure 19-15 shows how the information is retrieved and displayed.

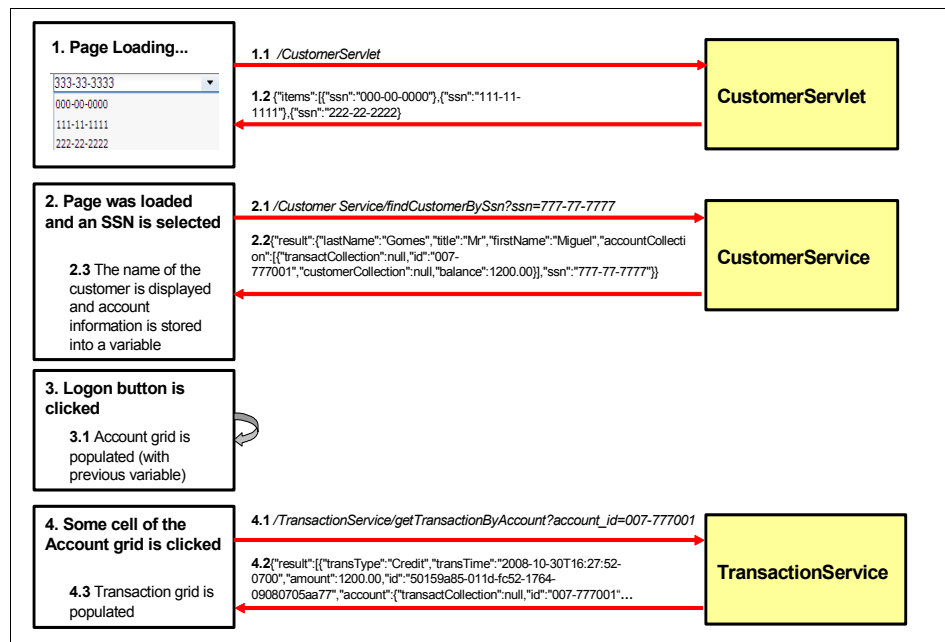

Figure 19-15 Dojo application flow

Page loading

When the page is loading the `dojo.data.ItemFileReadStore` calls the `CustomerServlet` to populate `dijit.form.FilteringSelect`. The `FilteringSelect` provides facilities such as:

- ▶ Input validation: If the user types a value that not exists in the list, a warning message (customized message) is displayed (Figure 19-16).
- ▶ Type-ahead: While the user is typing, the field is automatically completed with a suggestion (Figure 19-16).

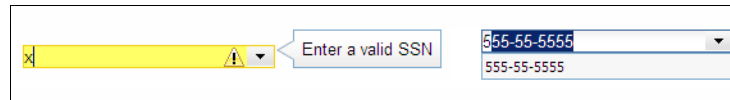

Figure 19-16 Input validation and type-ahead

- ▶ Drop-down box: the user can select an item from the drop-down box that is populated with the customer SSNs.

Initialization

The `init` method (in `redBank.js`) prepares the `getInfo` function for a combo box selection (`onChange`), and the `logon` function for the **Logon** button (`onClick`).

```
function init() {
    button = dijit.byId("logonBt");
    combo = dijit.byId("ssnCb");
    var getInfo = function(){
        getCustomerInformation(combo.getValue());
    };
    dojo.connect(combo, "onChange", getInfo);
    dojo.connect(button, "onClick", logon);
}
```

Calling a service to get the information

The `getInfo` function call the `getCustomerInformation` function. So, when the user selects a valid SSN, the `getCustomerInformation` function calls a service (`CustomerService`) to get information about the SSN selected (Example 19-12).

Example 19-12 JavaScript `getCustomerInformation` function in `redBank.js`

```
var getCustomerInformation=function(ssn){
    var serviceURL = "/RAD75Web20Dojo/RPCAdapter/httprpc/CustomerService
                    /findCustomerBySsn?ssn="+ssn;

    dojo.xhrGet({
        url: serviceURL,
        load: getCustomerFields,
        error: handleError,
```

```

        handleAs: 'json'
    });
};

```

The `dojo.xhrGet` returns the contents of a GET call on a URL. The data that is arriving will be passed to the `load` function, `getCustomerFields`, which displays the welcome message in the field with the `welcome id`. The text appears with a fade-in effect.

```

function getCustomerFields(data,ioArgs){
    customer = data.result;
    var out= dojo.fadeOut({ node: "welcome",duration: 500 });
    dojo.connect(out,"onEnd",function(){
        dojo.byId("welcome").innerHTML="&nbsp;&nbsp;&nbsp;Welcome: " +
            customer.firstName + " " + customer.lastName + " !&nbsp;&nbsp;&nbsp;";
        dojo.fadeIn({ node:"welcome", duration:1000,delay:100 }).play();
    });
    out.play();
    clearTables();
}

```

Application Developer provides a easy way to obtain the URL of a service exposed by the RPC Adapter:

- ▶ In the Services view, expand the **RPCAdapter** → **RAD75Web20Dojo: CustomerService**.
- ▶ Right-click **findCustomerBySsn(String)** and select **Copy Service URL to Clipboard**.
- ▶ Paste the clipboard content into the JavaScript code:

```
/RAD75Web20Dojo/RPCAdapter/httprpc/CustomerService/findCustomerBySsn
```

Logon

When the **Logon** button is clicked, the `logon` function displays the accounts of the customer in the account grid through the `fillAccountGrid` function.

```

var logon=function(){
    fillAccountGrid(customer.accountCollection);
};

```

Displaying the accounts

The `fillAccountGrid` function defines the headers of the account listing and fills the grid with data. Note that the width of the columns can be set, a formatter function is invoked for the balance, and the value is right aligned.

```

function fillAccountGrid(account){
    accountView = {
        cells: [
            [{name:'ID'},
                {name:'Balance',width:'110px',formatter:formatterCurrency,
                    styles:'text-align: right;'}]
            ]
        };
    // a grid layout is an array of views.
    accountLayout = [ accountView ];
    accountData=[];
    // Model for the Data Grid
    accountModel = new dojox.grid.data.Table(null,accountData);
    for(i=0;i<account.length;i++){
        console.log(account[i]);
        accountData.push([account[i].id,account[i].balance]);
    }
    accountModel.setData(accountData);
    accountGrid.setModel(accountModel);
    accountGrid.setStructure(accountLayout);
    dojo.connect(accountGrid, "onCellClick", showDetails);
}

```

When the user clicks on an account (onCellClick), the showDetails function is invoked.

Account selection

When an account is selected (click), the showDetails function calls the getTransactionInformation function to retrieve the transactions of the account:

```

function showDetails(e){
    getTransactionInformation(accountModel.getDatum(e.rowIndex,0));
}

```

The getTransactionInformation function (same as the getCustomerInformation function) calls a service (TransactionService) to retrieve the transactions.

```

var getTransactionInformation=function(id){
    var serviceURL = "/RAD75Web20Dojo/RPCAdapter/httpRPC/TransactionService
                    /getTransactionByAccount?account_id="+id;
    dojo.xhrGet({
        url: serviceURL,
        load: fillTransactionGrid,
        error: handleError,
        handleAs: 'json'
    });
};

```

The `fillTransactionGrid` function displays the transactions in the grid, similar to the `fillAccountGrid` function.

```
transactionView = {
  cells: [
    [{name: 'Timestamp',width: '180px'}, {name: 'Type'},
     {name: 'Amount',width: '75px',formatter:formatterCurrency,
      styles:'text-align: right;'},
     {name: 'ID',width: '280px'}]
  ]
};
```

The `formatterCurrency` function adds the currency sign to the value.

```
function formatterCurrency(value){
  dojo.require("dojo.currency");
  return dojo.currency.format(value, {currency: "USD"});
}
```

Logging

Dojo provides a mechanism for logging in the application. To log certain events:

- ▶ Include the `isDebug` configuration parameter (Example 19-13).

Example 19-13 JavaScript function `dojo.js` for logging

```
<script type="text/javascript" src="dojo/dojo/dojo.js"
  djConfig="isDebug: true, parseOnLoad: true">
</script>
```

- ▶ When the `isDebug` flag is true, we can log the application execution using the `console.log` call (Example 19-14).

Example 19-14 JavaScript code for logging (in `fillAccountGrid` function)

```
for(i=0;i<account.length;i++){
  console.log(account[i]);
  accountData.push([account[i].id,account[i].balance]);
}
```

- ▶ The result of a logging call appears in the browser at the bottom as `{002-222001}`, and when clicked shows the details:

```
transactCollection : {}
id : 002-222001
customerCollection : {}
balance : 65484.23
```

- ▶ To disable the log, just change `isDebug: false`.

Running the application

In the Enterprise Explorer, expand **RAD75Web20Dojo** → **WebContent**, then right-click **index.html**, and select **Run As** → **Run on Server**.

- ▶ On the subsequent dialog box, select **Finish** to complete publishing onto the WebSphere Application Server.
- ▶ When prompted with a security alert, click **Yes**.
- ▶ The home page displays (Figure 19-17):
 - You can drag the borders between the section to adjust their size.
 - If the bottom part of the page does not display, you can maximize the browser pane, or you can use an external browser (select **Window** → **Web Browser** → **Internet Explorer**).

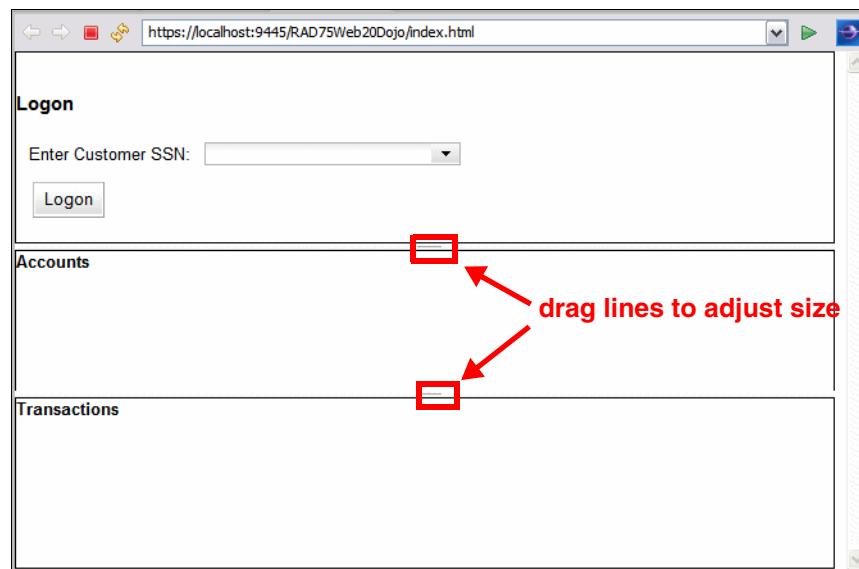

Figure 19-17 Web 20.0 dojo application run

- ▶ You can use the drop-down menu to select an SSN, or you can start typing an SSN and the type-ahead feature displays the matching number (Figure 19-18).

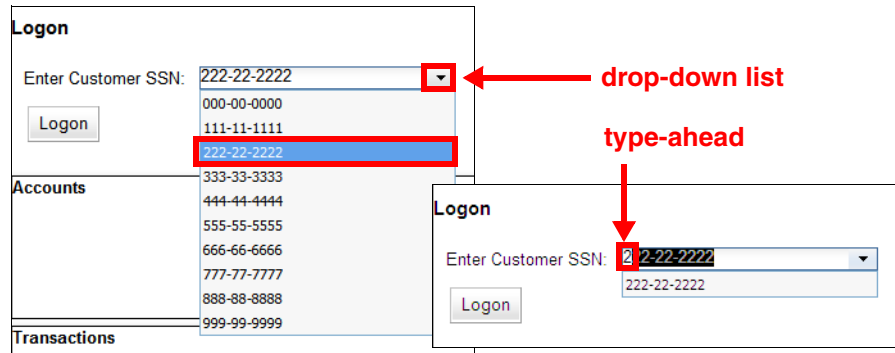

Figure 19-18 Selecting a customer using type-ahead or drop-down

Remember that the drop-down list was populated through the servlet that retrieved the list of customer SSNs.

- ▶ When a customer SSN is selected, the welcome message with the customer name is displayed with a fade-in effect (Figure 19-19).

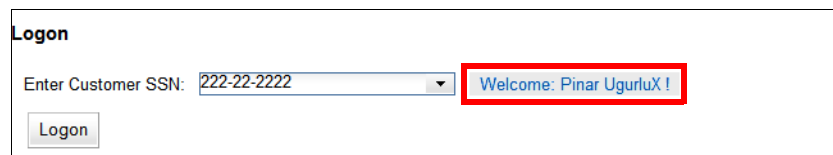

Figure 19-19 Welcome message

Remember that the customer with the accounts is retrieved by the RPC service CustomerService, which invokes the findCustomerBySsn method.

- ▶ Click **Logon** to populate the account list (Figure 19-20).

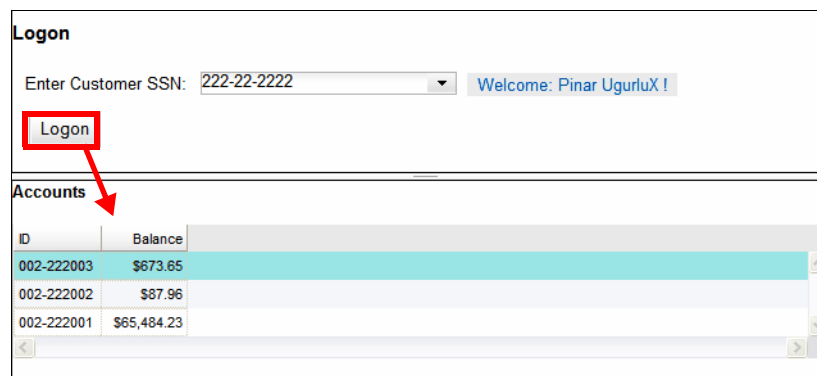

Figure 19-20 Customer with list of accounts

- ▶ Click on one account to display its transactions (Figure 19-21).

Accounts	
ID	Balance
002-222003	\$673.65
002-222002	\$87.96
002-222001	\$65,484.23

Transactions			
Timestamp	Type	Amount	ID
1990-01-01T23:23:23-0800	Credit	\$2,222.22	0000001
1994-02-02T10:11:12-0800	Debit	\$800.80	0000002
1997-03-03T15:16:17-0800	Credit	\$21.50	0000003
1998-04-04T22:22:22-0800	Debit	\$1,000.11	0000004
2001-05-05T13:44:20-0700	Debit	\$876.54	0000005

Figure 19-21 Account transactions

Remember that the transactions of an account are retrieved by the RPC service `TransactionService`, which invokes the `getTransactionByAccount` method.

Cleanup

- Remove the `RAD75Web20DojoEAR` application from the server.

Final code

To run the Web application you must have completed the sample Web 2.0 application:

- ▶ Either you completed the Web 2.0 application as described in “Developing a Web 2.0 using JSF, Ajax Proxy, and JPA” on page 658, and “Developing a Web 2.0 application using Dojo and RPC” on page 673.
- ▶ Or, you can import the interchange file of the applications from:

```
c:\7672code\zInterchange\web20\RAD75Web20-Ajax.zip
c:\7672code\zInterchange\web20\RAD75Web20-Dojo.zip
```

Refer to “Importing sample code from a project interchange file” on page 1152 for details.

- ▶ You also must have set up the `ITS0BANK` database as described in “Setting up the sample database” on page 657.

So far we have a Web 2.0 application with Ajax, Dojo, and JPA access to a relational database. We could certainly enhance the appearance of the pages and the error messages.

More information on Web 2.0 and JSF

For more information on JSF and Ajax, we recommend the following resources.

- ▶ Dojo Toolkit

<http://dojotoolkit.org/>

- ▶ JSON

<http://www.json.org/>

- ▶ REST

http://en.wikipedia.org/wiki/Representational_State_Transfer



Develop applications to connect to enterprise information systems

Java EE Connector Architecture (JCA) plays a key role in the integration of applications and data using open standards. This chapter introduces JCA, and demonstrates by example how to access operations and data on enterprise information systems (EIS) such as CICS, IMS™, SAP, Siebel®, PeopleSoft, JD Edwards®, and Oracle within the Java EE platform.

We describe how to develop Java EE applications using Java EE Connector tools within Application Developer v7.5.

The chapter is organized into the following sections:

- ▶ Introduction to Java EE Connector Architecture
- ▶ Application development for EIS
- ▶ Sample application overview
- ▶ More information

Introduction to Java EE Connector Architecture

Java EE Connector Architecture (JCA) is a standard architecture for connecting enterprise information systems (EIS) such as CICS, IMS, Sap, Siebel, Peoplesoft, JD Edwards, and Oracle. JCA standardizes the way Java EE application components, Java EE compliant application servers and EIS resources interact with each other. Resource adapters and application servers implement the contract defined in the JCA specification. Resource adapters run in the context of the application server and enable J2EE application components to interact with the EIS using a common client interface. JCA compliant application servers can support any JCA compliant resource

Figure 20-1 shows the Java EE component connected to an EIS through the JCA resource adapter.

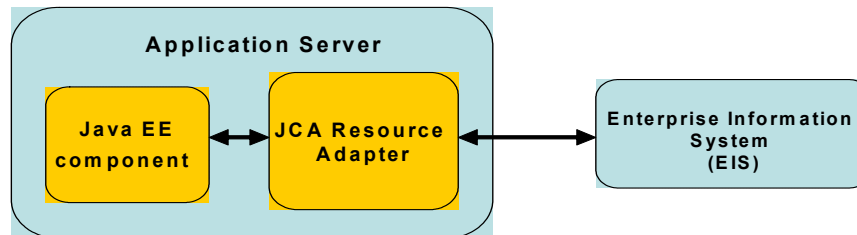

Figure 20-1 Java EE component connecting to EIS through JCA resource adapter

JCA was developed under the Java Community Process as JSR 16 (JCA 1.0) and JSR 112 (JCA 1.5), which is the current version.

System contracts

In this section we learn about the basic components of the JCA architecture. JCA defines a standard set of system-level contracts between the Java EE application server and a resource adapter. The application server and the resource adapter connect and interact with each other using the system contracts.

Seven types of system contracts are defined in the JCA specification:

- ▶ **Connection management contract:** Allows the application server to create a physical connection to the EIS. It also provides a mechanism for the application sever to manage connection pooling.
- ▶ **Transaction management contract:** Provides transactional support allowing the EIS to participate in a transaction. Transactions can be managed by the application server's transaction manager with multiple EISs and other resources as participants.

- ▶ **Security contract:** Allows application components in an application server to access the EIS securely. The security contract is an extension of the connection management contract implemented by adding Java Authentication and Authorization Service (JAAS) into connection management interfaces.
- ▶ **Life cycle management contract:** Allows the application server to manage the life cycle of the resource adapter. It provides a mechanism for the application server to start and shutdown an instance of the resource adapter.
- ▶ **Work management contract:** Allows the resource adapter to submit work to the application server for execution. The application server dispatches a thread to handle the work. This contract is optional.
- ▶ **Transaction inflow contract:** Allows the EIS to propagate a transaction through the resource adapter to the application server.
- ▶ **Message inflow contract:** Allows the resource adapter to pass synchronous or asynchronous inbound messages to message endpoints on the application server.

Figure 20-2 shows the integration between EIS, application server and application component. These components are bound together using JCA contracts.

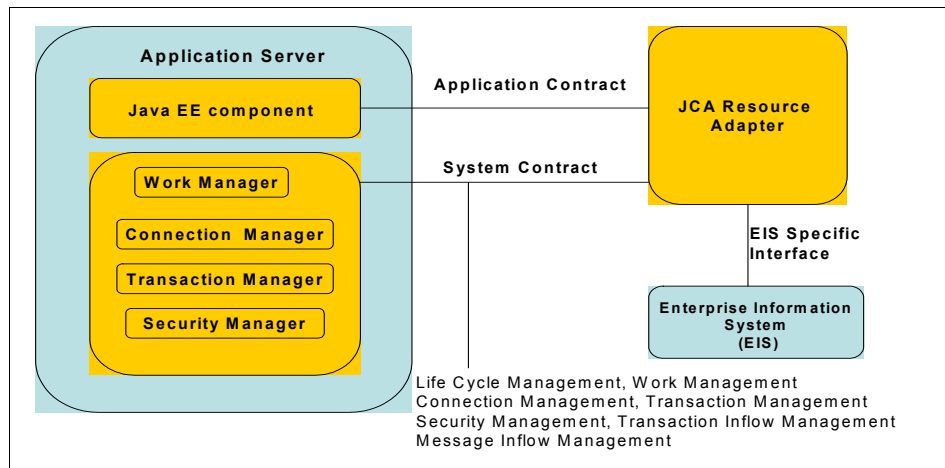

Figure 20-2 System contract, application server, resource adapter integration

To find out more about JCA Specification, visit the JCA specification Web site at:

<http://java.sun.com/j2ee/connector/download.html>

Resource adapter

To achieve a standard system-level pluggability between application servers and EISs, the JCA architecture defines a standard set of system-level contracts between an application server and EIS as discussed in “System contracts” on page 698. The JCA resource adapter implements the EIS-side of these system-level contracts.

A JCA resource adapter is a system-level software driver used by an application server or an application client to connect to an EIS. By plugging into an application server, the resource adapter collaborates with the server to provide the underlying mechanisms, the transactions, security, and connection pooling mechanisms. A JCA resource adapter is used within the address space of the application server.

The list of JCA Resource Adapters available to you in Application Developer v7.5 include:

- ▶ CICS ECI adapter 5.1.0.3
- ▶ CICS ECI adapter 6.0.2.x
- ▶ CICS ECI adapter 7.1.0.x
- ▶ CICS ECI XA adapter 7.1.0.x
- ▶ IMS resource adapter 10.2.0
- ▶ IMS resource adapter 9.1.0.2.5a (Support for English only)
- ▶ IMS resource adapter 9.1.0.1.5b

JCA resource adapters support two-way communication between the Java EE components and an EIS:

- ▶ An **outbound communication** is initiated by a J2EE component, which acts as a client to access an EIS.
- ▶ An **inbound communication** is initiated by the EIS to notify a Java EE component, which subscribed for events from that EIS. Inbound communications are performed asynchronously using the messaging infrastructure provided by the hosting application server as message providers.

Java EE components that use the resource adapter may co-reside with the adapter on the same application server or operate remotely.

Common Client Interface

The Common Client Interface (CCI) is a standard API that allows application components and Enterprise Application Integration (EAI) frameworks to interact with the resource adapter. It provides a standard way for application components to invoke functions on an EIS and get the returned results. The CCI is intended for use by Enterprise Application Integration (EAI) and enterprise tools vendors. So, WebSphere Adapters use CCI for outbound communication with an EIS.

WebSphere Adapters

WebSphere Adapter portfolio is a new generation of adapters based on the Java EE Platform, Enterprise Edition standard. A WebSphere Adapter implements the JCA specification 1.5. Also known as resource adapters or JCA adapters, WebSphere Adapters enable managed, bidirectional connectivity and data exchange between a number of EIS resources including PeopleSoft, SAP, Siebel, JD Edwards, and Oracle.

The list of WebSphere Adapters available in Rational Application Developer v7.5 include:

- ▶ WebSphere Adapter for JDBC
- ▶ WebSphere Adapter for Sap Software
- ▶ WebSphere Adapter for Sap Software with transaction support
- ▶ WebSphere Adapter for Siebel Business Applications
- ▶ WebSphere Adapter for PeopleSoft
- ▶ WebSphere Adapter for JD Edwards EnterpriseOne

When developing a custom JCA compliant resource adapter, you can choose to develop either the WebSphere type of resource adapter or the base JCA type of resource adapter. WebSphere Adapters are fully compliant with the JCA 1.5 specification and contain IBM extensions. If you choose to develop an IBM WebSphere type of resource adapter, you can leverage the services provided by the adapter foundation classes. You can extend the generically implemented system contract classes to fit the needs of your custom adapter. Your custom adapter can also make use of the built-in utility APIs to handle common adapter tasks. Using adapter foundation classes significantly reduces your development time and effort to create a custom adapter.

Note: For more information on custom adapter development, refer to *WebSphere Adapter Development*, SG24-6387, at:

<http://www.redbooks.ibm.com/abstracts/sg246387.html>

Application development for EIS

Rational Application Developer v7.5 simplifies application development for EIS by providing wizard based tools and a list of adapters ready to use. This section introduces these tools and their capabilities.

The Java EE Connector tools enable you to create Java EE applications running on WebSphere Application Server to access operations and data on enterprise information systems (EIS). J2C tools offer a number of qualities of service that can be provided by an application server:

- ▶ Security credential management
- ▶ Connection pooling
- ▶ Transaction management

These qualities of service are provided by means of system-level contracts between a resource adapter provided by the connector (for example, CICS Transaction Gateway or IMS Connect), and the application server.

Importers

IMS or CICS ECI transactions are often written in COBOL, C, or PL/I. For a Java application to access these transactions through J2C resource adapters, the data has to be imported and mapped to Java data structures. The importers are tools that deliver this data mapping. Three importers are available for you to use in your application: C Importer, COBOL Importer, and PL/I Importer. Once you import a COBOL, C, or PL/I file into a project, you can work with this data as you would with any data construct.

J2C wizards

Rational Application Developer v7.5 provides J2C wizards that enable you to create J2C applications, either as standalone programs or as added function to existing applications. The wizards

- ▶ Dynamically import your selected resource adapter
- ▶ Allow you to set the connection properties to connect to the EIS servers
- ▶ Guide you through the file importing and data mapping steps
- ▶ Facilitate the creation of Java classes and methods to access the transformed source data

A typical J2C application consists of a J2C JavaBean with one or more methods that call EIS functions. For CICS and IMS, the input and outputs to these functions are data binding classes that are created by the CICS/IMS Java Data Binding Wizard. When you have created a J2C JavaBean, you then can create Web pages, an EJB, or a Web service for the JavaBean.

To use the J2C wizard within Application Developer v7.5 follow these steps:

- ▶ Switch to the **Java EE** perspective.
- ▶ Select **File** → **New** → **Other** → **J2C** and select the J2C wizard that you want to launch (Figure 20-3).

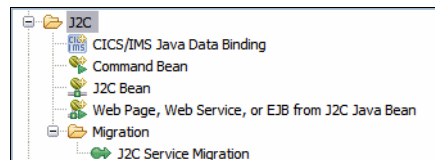

Figure 20-3 J2C wizards

CICS or IMS Java Data Binding: You can create the data binding classes on their own. These classes are used in J2C methods that invoke CICS or IMS functions.

Command Bean: You can use this wizard (optionally) to expose selected methods as a command bean.

J2C Bean: You can use this wizard to create a JavaBean that communicates with an EIS through JCA.

Web page, Web service, or EJB from J2C Java Bean: You can use this wizard to create a Java EE resource that wraps the functionality provided by a J2C JavaBean. For example, you can create a JSP to deploy the J2C bean on WebSphere application server. The Java EE resource types available with this wizard are: Simple JSP, Faces JSP, EJB, and Web service.

J2C Service Migration: You can use this wizard to migrate JCA applications created in WebSphere Studio Application Developer Integration Edition applications into Rational Application Developer projects.

Note: For more information on J2C wizard, refer to the Rational Application Developer InfoCenter at:

<http://publib.boulder.ibm.com/infocenter/radhelp/v7r5/index.jsp>

What is new in Application Developer v7.5

This section describes the principal new features of J2C tools in Application Developer 7.5, as well as changes in the behavior of features present in previous versions. These include:

- ▶ Tooling for WebSphere Adapters
- ▶ Deployment of Websphere Adapters to WebSphere Application Server
- ▶ J2C Java bean deployment: EJB 2.1 and 3.0 support
- ▶ J2C Java bean deployment: Web services support
- ▶ CICS container link support
- ▶ MFS support for IMS

Tooling for WebSphere Adapters

This section describes how you can install the WebSphere Adapters and which tooling support is available to generate and maintain J2C beans.

Distinct installation features

Installation Manager now offers the following individually selectable features:

- ▶ Java EE Connectors (J2C) Tools
- ▶ WebSphere Adapters

When you select to install WebSphere Adapters they are copied into:

```
<RAD_installation>\ResourceAdapters
```

Generation of J2C beans

You can generate a J2C bean for one of the WebSphere Adapters specifying either *outbound* and *inbound* support. You can specify connection information to browse the EIS metadata while stepping through the wizard. The output is based on the selected objects and methods that are discovered, and it consists of Java data binding beans (along with the XSD that they are created from), and a J2C Java bean.

Code regeneration, refactoring, and clean up

The J2C Java data bindings life cycle is based on the generation of the following artifacts from the discovered EIS metadata:

```
XSD → Java data binding → J2C Java bean
```

The following scenarios are supported:

- ▶ Editing of the data type schema and regeneration of J2C Java data binding:
 - Use the XSD editor to modify one of the generated XSD files.
 - Right-click on the XSD file and select: **Source** → **Generate J2C Java data bindings**.

Note: even if you select a leaf schema all the records corresponding to the top most schema will be regenerated.

- ▶ Cleanup of unused J2C Java data bindings: After making multiple changes to the XSD files and regenerating the Java data bindings it is possible that the workspace contains Java data binding classes which are no longer associated with any types in the XDS files. To clean up the workspace do the following:
 - Right-click on the XSD file and select: **Source** → **Remove unused J2C Java data bindings**.
- ▶ Refactoring of XSD type name and regeneration of corresponding J2C Java data bindings:
 - Right-click on a type in the XSD editor and select **Refactor** → **Rename**.
 - The J2C Java beans and other Java types that depend on that J2C Java data binding are refactored as well, to reference the J2C Java data binding by its new name.

Deployment of Websphere Adapters to WebSphere Application Server

By default, WebSphere Adapters are deployed to WebSphere Application Server when you run the **Web page, an EJB, or Web service to deploy your J2C Java bean** wizard. Many WebSphere Adapters require additional files provided by the EIS vendors. For the resource adapter to function properly, these files have to be added to the resource adapters class path. The class path of the installed adapter is automatically updated on the server the next time publishing occurs, based on the connection information provided when generating the J2C bean. The end result of the automated deploy can be viewed from the administrative console, looking at **Resources** → **Resource Adapters** → **Resource adapters**.

If you have to use different versions of the adapter for different projects, you may have to deploy the RAR file in the Enhanced EAR so that it is visible only to one application EAR. To deploy the RAR in the Enhanced EAR, perform the following steps:

- ▶ Add the RAR module to the EAR project.

- ▶ Open the Enhanced EAR editor and add a new shared library.
- ▶ Specify the Shared library parameters (name, description, application dependency files and native system dependency files) and click **OK**.
- ▶ Deploy the EAR to the server.

This process is described in detail in the resource adapter documentation under Developing → Developing Enterprise Applications → Connecting to Enterprise Information Systems → Resource Adapters → WebSphere Adapters for PeopleSoft, SAP, Siebel, JD. Edwards, and Oracle.

J2C Java bean deployment: EJB 2.1 and 3.0 support

The wizard **File** → **New** → **Other** → **J2C Web Page, Web Service, or EJB from J2C Java Bean** allows you to deploy the J2C beans as Enterprise Java Beans implementing the EJB specification 2.1 or 3.0.

Deployment of J2C beans as EJB 2.1

When deploying a J2C bean as an EJB 2.1, XDoclet EJB tags are used to define the EJB. If the J2C Java bean is located in a Java project, the code is copied into the EJB project before the XDoclet tags are added.

Deployment of J2C beans as EJB 3.0

When deploying a J2C bean as an EJB 3.0 to an Application Server v7.0 (or v6.1 with the Feature Pack for EJB 3.0), the `@Stateless` annotation is used to define the stateless EJB. If the J2C bean is located in a Java project, the J2C tools will turn the Java project into EJB 3.0 project by adding appropriate project facets. No code will be copied and the `@Stateless` annotation is injected into the existing J2C bean. Observe that no annotation is added to the J2C bean interface, where you might want to add `@Remote` and/or `@Local`, depending on how you intend to access the EJB from a client application.

J2C Java bean deployment: Web services support

The wizard **File** → **New** → **Other** → **J2C Web Page, Web Service, or EJB from J2C Java Bean** provides you with a link to information about the generation of Web services, but does not actually generate one (the **Finish** button is always disabled). This differs from the behavior of version 7.0, where a Web service was actually generated. The reason for the different behavior is that a top-down or a meet-in-the-middle approach may be required in order to map Java types in the J2C bean that are not supported by the chosen Web service specification (JAX-RPC or JAX-WS).

CICS container link support

Application Developer v7.5 has two new importers called **COBOL CICS Channel to Java** and **PL1 CICS Channel to Java**, which can be used to create J2C Java applications for COBOL/PL1 sources that contain CICS Container or Channel commands. Containers and channels can be described as follows:

- | | |
|------------|---|
| Containers | Named blocks of data designed for passing information between programs. You can think of them as <i>named communication areas</i> (COMMAREA). The size of a container is limited only by the amount of storage that you have available. |
| Channels | Containers are grouped together in sets called channels. A channel is analogous to a parameter list. There is no limit to the number of containers that can be added to a channel. |

The new CICS Channel support enhances how data is transferred between programs, especially since COMMAREAs were limited in size to 32kb.

MFS support for IMS

Message Format Service (MFS) enables application programmers to specify screen formats, application input and output fields, and various device characteristics that define the end-user interface to an IMS transaction. While MFS manages device-specific information, the application program defines the application logic. For more information on this topic see the product help at Developing → Developing Enterprise Applications → Connecting to Enterprise Information Systems → Resource Adapters → IMS TM Resource Adapter → IMS MFS SOA Support Resource Adapter.

Sample application overview

In this section we show three sample applications that connect to different types of EIS (CICS and SAP) and illustrate outbound communication. The following examples are provided:

- ▶ CICS outbound scenario
- ▶ CICS Channel outbound scenario
- ▶ SAP outbound scenario

CICS outbound scenario

In this example we show how you can expose a COBOL program as a EJB 3.0 session bean that is invoked by a JavaServer Faces JSP. The product documentation contains related samples and tutorials that are used as the starting point for this scenario:

- ▶ Tutorials → Watch and learn → Create a J2C application for a CICS transaction with the same input and output
- ▶ Samples → Technology Samples → Java → J2C Samples → CICS adapter samples → Same input and outputs

Prerequisites

You must configure the CICS server and the CICS Transaction Gateway for this example to work. This configuration is beyond the scope of this book. You should obtain from your CICS administrator the parameters required to connect to the CICS Transaction Gateway, which typically include:

- ▶ URL
- ▶ Server name
- ▶ Port
- ▶ User name
- ▶ Password

The sample COBOL program, `taderc9.cb1`, is located in:

```
<RAD_Install-SDPShared>/plugins/com.ibm.j2c.cheatsheet.content_7.0.1.v20080710-1450/Samples/CICS/taderc99
```

This program must be installed on the CICS server and you should be able to query it from a CICS Terminal (Figure 20-4) using the command:

```
CEMT INQ PROG(taderc99)
```

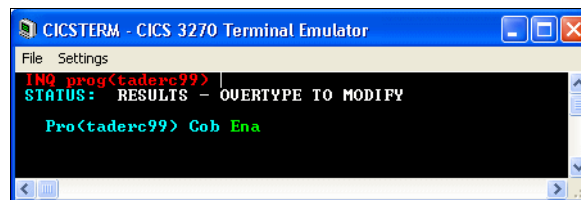

Figure 20-4 CICS Terminal showing the installed COBOL program `taderc99.cb1`

Creating the Java data binding class

The CICS/IMS Java Data Binding wizard enables you to create a class or set of classes that map to COBOL, to C, or to PL/I data structures.

- ▶ Select **File** → **New** → **Other** → **J2C** → **CICS/IMS Java Data Binding**, and click **Next**.
- ▶ In the Data Import dialog, for Choose mapping, select **COBOL to Java**, then click **Browse** and locate the file **taderc99.cb1** in the directory:

```
<RAD_Install_SDPShared>\plugins\com.ibm.j2c.cheatsheet.content_7.0.1.v20080710-1450\Samples\CICS\taderc99
```

The COBOL DFHCOMMAREA structure in taderc99 is shown in Example 20-1.

Example 20-1 DFHCOMMAREA of COBOL program

```
01 DFHCOMMAREA.
   02 CustomerNumber    PIC X(5).
   02 FirstName         PIC A(15).
   02 LastName          PIC A(25).
   02 Street            PIC X(20).
   02 City              PIC A(20).
   02 Country           PIC A(10).
   02 Phone             PIC X(15).
   02 PostalCode        PIC X(7).
```

- ▶ Click **Next**.
- ▶ In the Importer dialog, you can set values for the platform, code page and other properties. For Data Structures the default **DFHCOMMAREA** is preselected. Click **Next**.
- ▶ In the Saving Properties dialog, enter:
 - Project Name: **Taderc99** (click **New** and create a new Java project)
 - Package Name: **sample.cics.data**
 - ClassName: Change the default DFHCOMMAREA to **CustomerInfo**.
- ▶ Click **Finish**.

Review the generated Java file CustomerInfo class. Notice that it implements `javax.resource.cci.Record` and that it exposes getters and setters for all the fields of DFHCOMMAREA (for example, `getFirstName` and `setFirstName`).

Creating the J2C bean

Next we create the J2C bean.

- ▶ Select **File** → **New** → **Other** → **J2C** → **J2C Bean**, and click **Next**.
- ▶ Select the resource adapter **CICS** → **ECIRResourceAdapter (IBM: 7.1.0.2)**, and click **Next** (Figure 20-5).

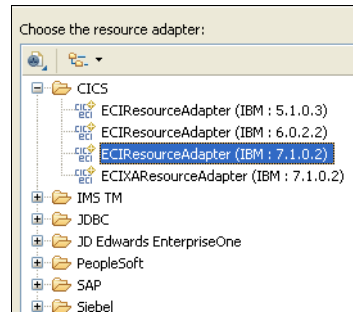

Figure 20-5 Selection of the resource adapter

This action imports the file:

```
<RAD_Install>/ResourceAdapters/cics15/cicseci7102.rar
```

- ▶ In the Connector Import dialog:
 - Connector file: <RAD_HOME>\ResourceAdapters\cics15\cicseci7102.rar
 - Connector project: cicseci7102
 - Target Server: WebSphere Application Server 7.0
 - Click **Next**.
- ▶ In Connection Properties (Figure 20-6):
 - Clear **Managed Connection**.
 - Select **Non-Managed Connection**.
 - Enter the connection details provided by your CICS administrator, typically: Connection URL, Server name, Port number, User name, Password
 - Click **Next**.

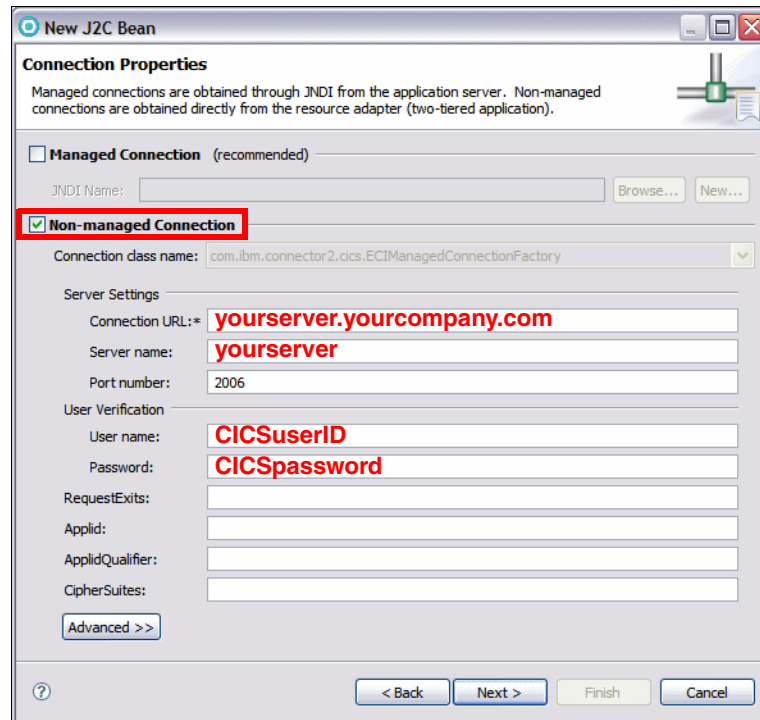

Figure 20-6 Connection Properties

- ▶ In the J2C Java Bean Output Properties dialog, enter:
 - Project Name: **Taderc99**
 - Package name: **sample.cics**
 - Interface name: **Customer**
 - Implementation Name: **CustomerImpl** (automatically filled)
 - Click **Next**.
- ▶ In the Java Methods dialog, click **Add** to open the Java Method dialog.
- ▶ In the Java Method dialog (Figure 20-7):
 - Name: **getCustomer**
 - Input type: Click **Browse** and type **cust** to locate the **CustomerInfo** class in the **sample.cics.data** package. The value becomes:

```
/Taderc99/src/sample/cics/data/CustomerInfo.java
```
 - Select **Use the input type for output**.
 - Click **Finish**.

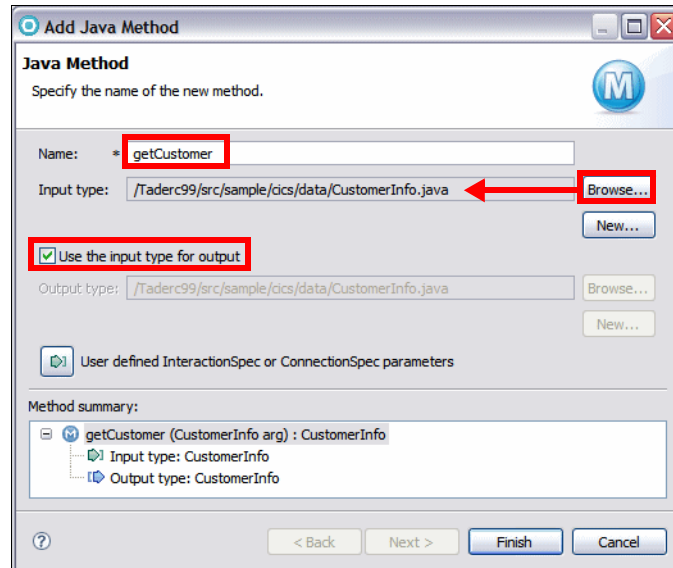

Figure 20-7 Adding a new Java Method to a J2C Java Bean

- Back in the Java Methods dialog (Figure 20-8), you can see that the method `getCustomer` is listed. In the `InteractionSpec` properties, specify the Function name as **taderc99** (this must match the name of the CICS program).

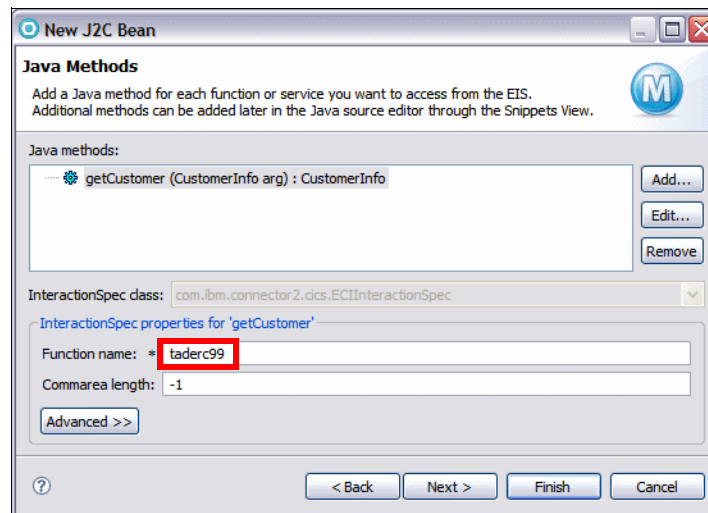

Figure 20-8 `InteractionSpec` properties

- Click **Next** and **Finish**.

This action generates a Customer interface and a CustomerImpl class into the Taderc99 project. In addition the **cicseci7102** project is created, containing a plug-in (j2c_plugin.xml) and a CICS resource adapter XML file (ra.xml).

Deploying the J2C bean as an EJB 3.0 session bean

From the J2C bean we generate a session EJB.

- ▶ Select **File** → **New** → **Other** → **Web page, Web Service or EJB from J2C Java bean**, and click **Next**.
- ▶ Click **Browse**, locate the **CustomerImpl** class, and click **Next** (Figure 20-9).

\Taderc99\src\sample\cics\CustomerImpl.java

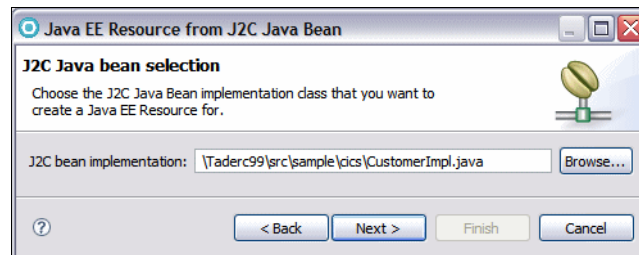

Figure 20-9 Generate an EJB from a J2C bean (1)

- ▶ In the Deployment Information dialog, select **EJB** (Figure 20-10). The target project containing the J2C bean will be transformed into an EJB 3.0 project, and the J2C bean class will be annotated as a session bean. Click **Next**.

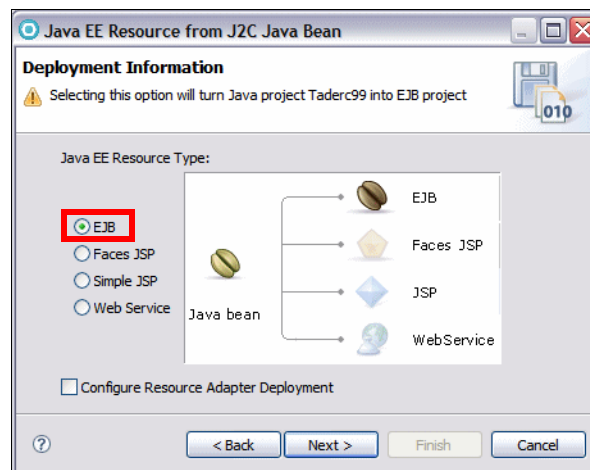

Figure 20-10 Generate an EJB from a J2C bean (2)

- ▶ In the EJB Creation dialog (Figure 20-11), type **j2c/taderc99** as JNDI name, and accept the other values. Click **Finish**.

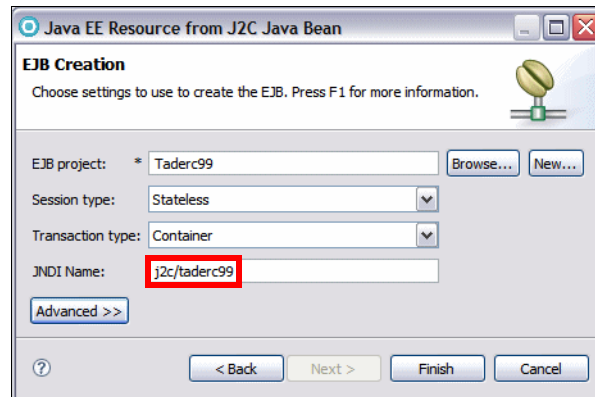

Figure 20-11 Generate an EJB from a J2C bean (3)

- ▶ Open the **CustomerImpl** class and verify that the annotation was added:

```
@Stateless(mappedName="j2c/taderc99")
public class CustomerImpl implements sample.cics.Customer {
```
- ▶ Optimally, open the **Customer** class and add the **@Local** annotation (this is the default):

```
@Local
public interface Customer {
```

Generating a JSF client

We now generate a Java Server Faces client to test the EJB and the access to the CICS system.

Create a Web project and enterprise application

- ▶ Create a new Dynamic Web Project:
 - Project name: **Taderc99Web**
 - Target Runtime: **WebSphere Application Server v7.0**
 - Dynamic Web Module version: **2.5**
 - Configuration: **JavaServer Faces v1.2 Project**
 - EAR membership: **Taderc99EAR**
 - Click **Finish**.

- ▶ Add the projects Taderc99 and cicseci7102 to the Java EE Module dependencies list of the EAR project and of the Web project:
 - Right-click **Taderc99EAR** and select **Properties**. Select **Taderc99** and **cicseci7102** and click **OK**.
 - Right-click **Taderc99Web** and select **Properties**. Select **Taderc99.jar** and **cicseci7102.rar** and click **OK**.

Create a Web page

- ▶ Add a new Web page called **CustomerPage**:
 - Right-click **WebContent** (in Taderc99Web) and select **New** → **Web Page**.
 - Type **CustomerPage**, as name, select **Basic Templates** → **JSP**, and click **Finish**.

Create a data component

- ▶ Look at the Page Data view:

If you do not see a Services folder, click the **Create a new data component icon** , select **Services**, and click **OK** (Figure 20-12).

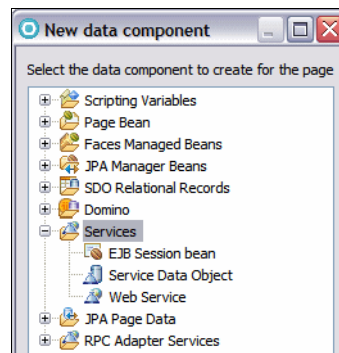

Figure 20-12 New data component dialog

- ▶ In the Page Data view, right-click **Services** and select **New** → **EJB Session bean**.
- ▶ In the Add Session Bean dialog:
 - Click **Add** to open the Add EJB Reference dialog.
 - In the EJB Reference dialog (Figure 20-13), select **Taderc99EAR** → **Taderc99** → **CustomerImpl**.
 - The Name becomes `ejb/CustomerImpl`.
 - For RefType, select **Local**.

- Click **Finish**.

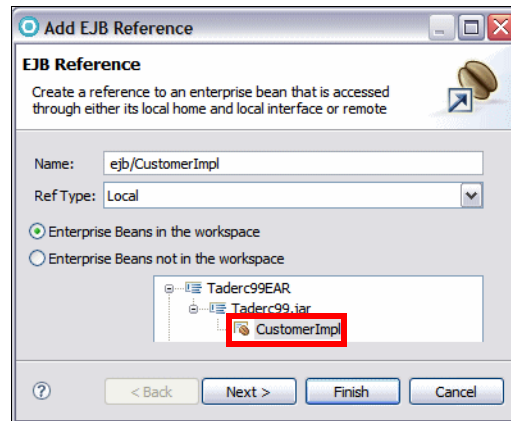

Figure 20-13 Creation of an EJB reference in the Web project

- ▶ The `ejb/CustomerImpl` service is added to the Add Session Bean dialog. The `getCustomer` method is selected (Figure 20-14). Click **Finish**.

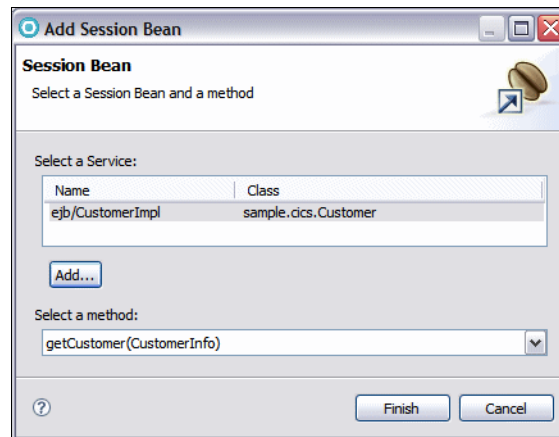

Figure 20-14 Add Session Bean

- ▶ In the Page Data view (Figure 20-15) you can see:
 - A `customer_GetCustomer` method with a input Param Bean and an output Result Bean both of type `sample.cics.data.CustomerInfo`
 - An action `customer_GetCustomer.doAction`

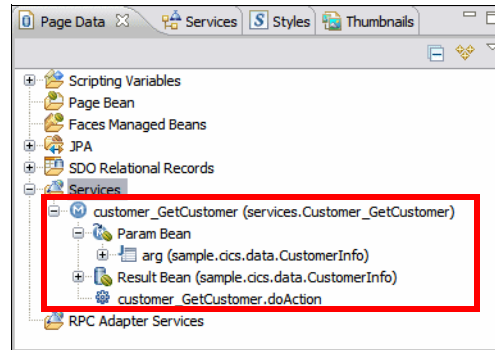

Figure 20-15 Page data view with Service bean to expose EJB 3

Create the Web page content

- ▶ Expand **customer_GetCustomer** → **Param Bean** → **arg**.
- ▶ Select **customerNumber** and drag it into the editor of the Web page.
When prompted for Configuring Data Controls:
 - Select **Inputting data**.
 - Change the label to **Customer number**.
 - Click **Options** and verify that a Submit button is created.
 - Click **Finish**.
 - This adds an Input Control and a Button to the page
- ▶ Drag and drop the action: **customer_GetCustomer.doAction** onto the Submit button
- ▶ Drag and drop the Result Bean below the Submit button.
When prompted for Configuring Data Controls
 - Select the fields that were present in DFHCOMMAREA (starting with **customerNumber**).
 - Optionally tailor the labels and the sequence.
 - Click **Finish**.
- ▶ Save and close the Web page.

Running the JSF client

To run the JSF client, do these steps:

- ▶ Make sure the WebSphere Application Server v7.0 is started.

- ▶ Add the **Taderc99EAR** enterprise application to the server.
- ▶ Right-click **CustomerPage.jsp** and select: **Run As** → **Run on Server**. When prompted select the Websphere Application Server v7.0
 - Enter the customer number **44444** and click **Submit**.
 - The EIS system is invoked and the customer information is returned (Figure 20-16).

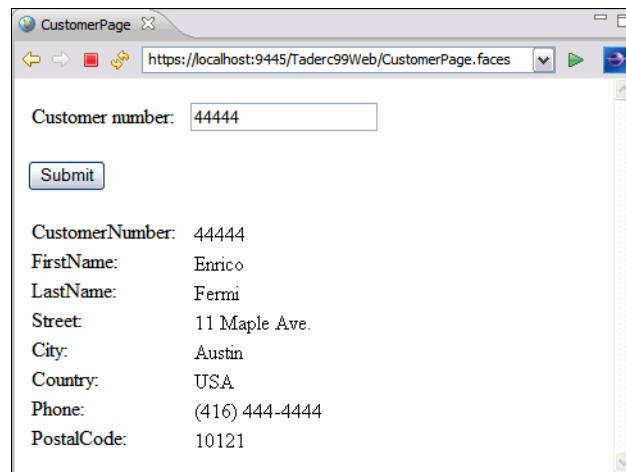

Figure 20-16 JSF Output from calling a CICS system

CICS Channel outbound scenario

In this example we show how you can create and execute the sample contained in the product help under Samples → Technology Samples → Java → J2C Samples → CICS adapter samples → Same input and outputs.

We recreate this sample so that it can be invoked by a JAX-WS Web service.

Creating the Java data binding for the channel and containers

To create the sample, proceed as follows:

- ▶ Select **New** → **Other** → **J2C** → **CICS/IMS Java Data Binding**.
- ▶ In the Data Import dialog (Figure 20-17):
 - For Choose Mapping, select **COBOL CICS Channel to Java**
 - You see a message: 'Containers' cannot be empty.
 - Near the Containers area, click **New**.

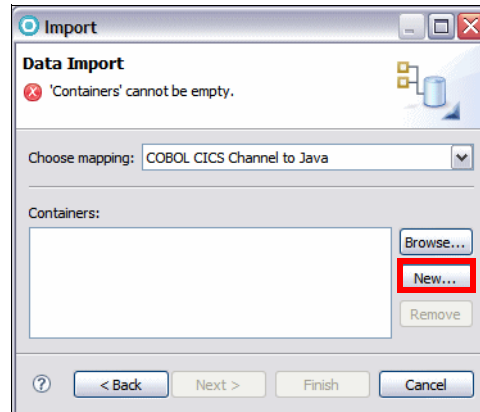

Figure 20-17 Selection of Mapping COBOL CICS Channel to Java

- ▶ In the new Data Import (Specify data import configuration properties) dialog:
 - For Import File, browse to the sample COBOL file, and click **Next**.

```
<SDPShared_dir>\plugins\com.ibm.j2c.cheatsheet.content_7.0.1.v20080710-1450\Samples\CICS32K\ec03.ccp
```
- ▶ In the Importer (Select a communication data structure) dialog, select **DATECONTAINER**, **TIMECONTAINER**, **INPUTCONTAINER**, **OUTPUTCONTAINER**, and **LENGTHCONTAINER**, and click **Finish** (Figure 20-18).

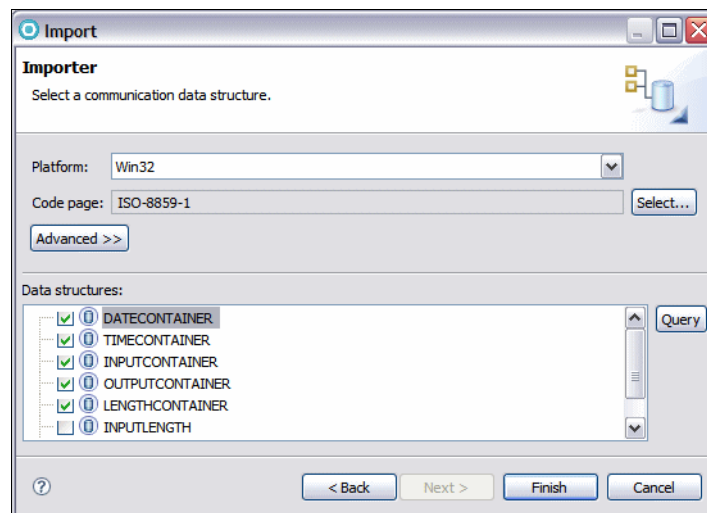

Figure 20-18 Discovery of the containers defined in the COBOL file

Note that there are other data structures listed in the dialog. We made the selection to create Java beans for the five containers that are defined in the COBOL file (Example 20-2):

Example 20-2 Definition of Containers in the COBOL file ec03.ccp

```
* Container names
01 DATECONTAINER      PIC X(16) VALUE 'CurrentDate'.
01 TIMECONTAINER      PIC X(16) VALUE 'CurrentTime'.
01 INPUTCONTAINER     PIC X(16) VALUE 'InputData'.
01 OUTPUTCONTAINER    PIC X(16) VALUE 'OutputMessage'.
01 LENGTHCONTAINER    PIC X(16) VALUE 'InputDataLength'.
```

- ▶ The Data Import dialog appears again, with the five containers listed. Click **Next**.
- ▶ In the Saving Properties dialog (Figure 20-19).
 - For Project Name, click **New**. The New Source Project dialog opens:
 - Select **Java project**, and click **Next**.
 - Type **CICSChannel** as name, and click **Finish**.
 - For Package Name, type **sample.cics.data**.
 - For Class Name, type **EC03ChannelRecord**.
 - For Channel Name, type **InputRecord**.

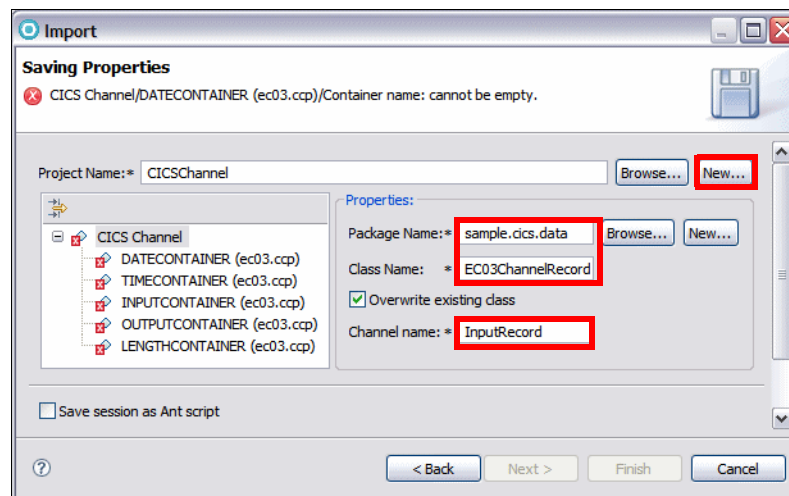

Figure 20-19 Definition of the CICS Channel name and related class name.

We can use an arbitrary channel name because the COBOL file expects to receive the channel name as input (Example 20-3).

Example 20-3 Channel name is expected in input in ec03.ccp

```

* Get name of channel
EXEC CICS ASSIGN CHANNEL(CHANNELNAME)
      END-EXEC.
* If no channel passed in, terminate with abend code NOCH
IF CHANNELNAME = SPACES THEN
      EXEC CICS ABEND ABCODE('NOCH') NODUMP
      END-EXEC
END-IF.

```

- ▶ Select the DATECONTAINER (Figure 20-20) and enter the following values:
 - For Package Name, accept `sample.cics.data`.
 - For Class Name, type **DateContainer**.
 - For Container name, type **CURRENTDATE**.
 - For Container type, select **CHAR**.

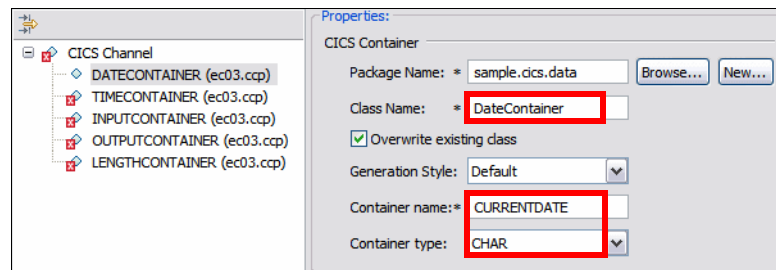

Figure 20-20 Definition of the DATECONTAINER

- ▶ Repeat this step for all other containers using the following data:
 - Class name: TimeContainer, InputContainer, OutputContainer, LengthContainer
 - Container name: CURRENTTIME, INPUTDATA, OUTPUTMESSAGE, INPUTDATALENGTH
 - Container type: CHAR

Note that the class names can be chosen arbitrarily, but the names of the containers must match those defined in the COBOL file (Example 20-2 on page 720).

- ▶ The dialog shows no more errors. Click **Finish**.

At this point the CICSChannel connector project is generated with a EC03ChannelRecord and five container classes in the `sample.cics.data` package. Close the editor of the EC03ChannelRecord class.

Creating the J2C bean that accesses the channel

To create the J2C bean, follow these steps:

- ▶ Select **File** → **New** → **Other** → **J2C** → **J2C Bean**, and click **Next**.
- ▶ Select the resource adapter **CICS** → **ECIResourceAdapter (IBM: 7.1.0.2)** → **cicseci7102**, and click **Next**.
- ▶ In Connection Properties (same as in Figure 20-6 on page 711):
 - Clear **Managed Connection**.
 - Select **Non-Managed Connection**.
 - Enter the connection details provided by your CICS administrator, typically Connection URL, Server name, Port number, User name, and Password.
 - Click **Next**.
- ▶ In the dialog J2C Java Bean Output properties (Figure 20-21):
 - For Project name, accept **CICSChannel**.
 - For Package name, type **sample.cics**.
 - For Interface name, type **Ec03**.
 - This sets the implementation name to **Ec03Impl**.

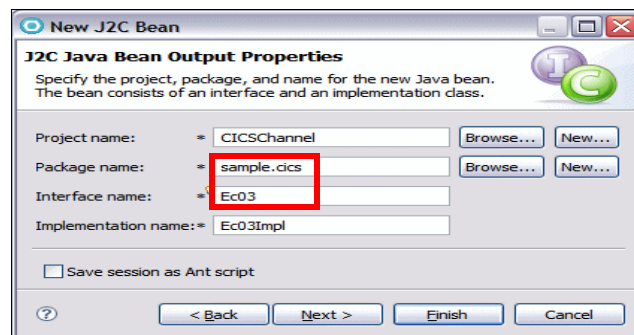

Figure 20-21 J2C Java Bean Output Properties for CICSChannel

- ▶ In the Java Methods dialog, click **Add**.
- ▶ In the Java Method dialog (Figure 20-22):
 - For Name, type **invoke**.
 - For Input type, click **Browse** and select **EC03ChannelRecord**.
 - Click **Finish**.

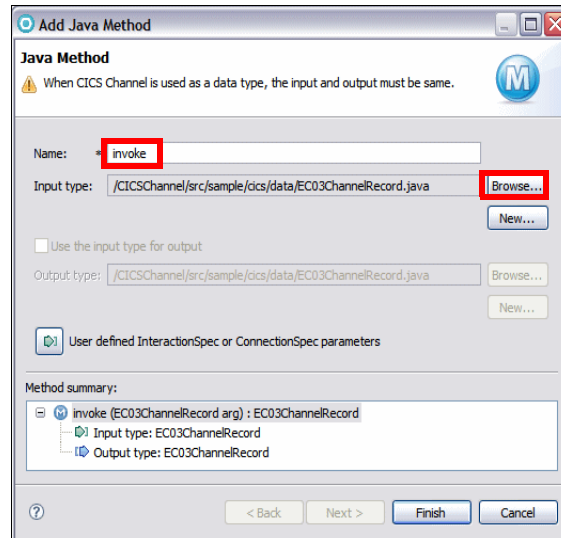

Figure 20-22 Adding a Java method with channel record as input and output

- ▶ In the Java Methods dialog (Figure 20-23), the `invoke` method is now listed. In the InteractionSpec properties, specify the Function name as **EC03** (this must match the name of the CICS program). Click **Next**.

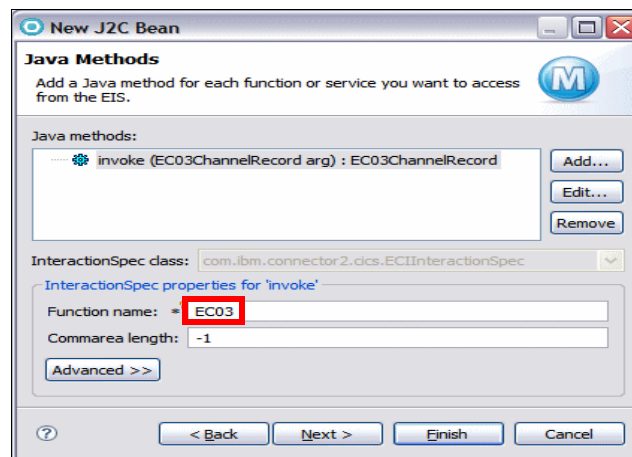

Figure 20-23 Specify the function name in the InteractionSpec (COBOL program)

Develop a Web service to invoke the COBOL program

In the Deployment Information dialog (Figure 20-24):

- ▶ Select **Create a Web page, Web Service, or EJB from the J2C bean**, then select **Web Service**.

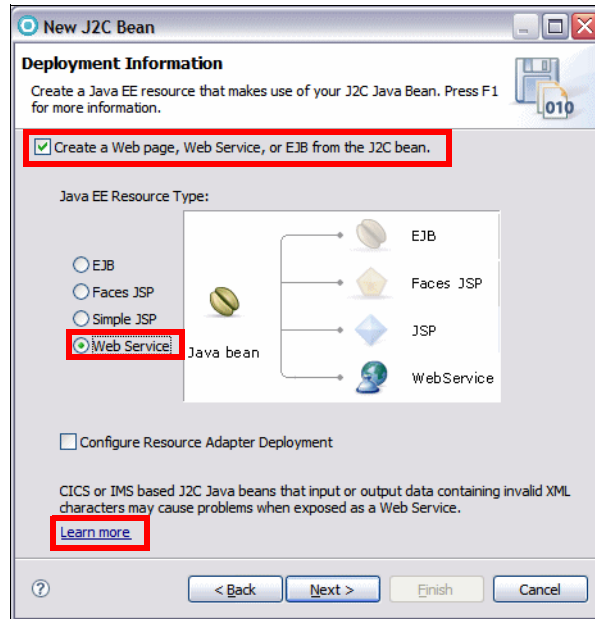

Figure 20-24 Link to online help in the Web Service wizard.

- ▶ Notice the **Learn more** link, which opens a product help page that states that the code generated by the J2C bean tool does not allow for serialization. Therefore, the bottom-up approach for Web Service creation is not readily available.
- ▶ Clear **Create a Web page, Web Service, or EJB from the J2C bean**, and click **Finish**. The Ec03 interface and the Ec03Imp1 class are generated into the CICSChannel project.

Using an alternative approach

In this simple case it is easy to create a Java bean wrapper that encapsulates the more complex types and let you run a bottom-up code generation.

- ▶ In the CICSChannel project, add a **Ec03Wrapper** class with the code of Example 20-4.

Example 20-4 Ec03Wrapper.java

```
package sample.cics;

import javax.resource.ResourceException;

import sample.cics.data.EC03ChannelRecord;
import sample.cics.data.InputContainer;

public class Ec03Wrapper {

    public String invoke(String in) throws ResourceException{
        Ec03Impl test = new Ec03Impl();
        InputContainer inputContainer = new InputContainer();
        inputContainer.setInputContainer_inputcontainer(in);
        EC03ChannelRecord inputRecord = new EC03ChannelRecord();
        inputRecord.setInputContainer(inputContainer);
        EC03ChannelRecord output = test.invoke(inputRecord);
        return output.toString();
    }

}
```

- ▶ Create a new Dynamic Web Project called **CICSChannelWeb** associated to EAR **CICSChannelEAR** (use the default module version 2.5 and the v7.0 target server).
- ▶ In the Enterprise Explorer, Expand **CICSChannelEAR**, right-click on **Modules**, and select **Modify**.
Select **CICSChannel** (it will be listed as an Utility JAR) and **cicseci7102** (it will be listed as Module), and click **OK**.
- ▶ Start the WebSphere Application Server v7.0 (if not running).
- ▶ Right-click **Ec03Wrapper.java** (in CICSChannel) and select **Web Services** → **Create Web service**.
- ▶ The Web Service wizard open (Figure 20-25). Accept all the defaults on the first page, and click **Next**.

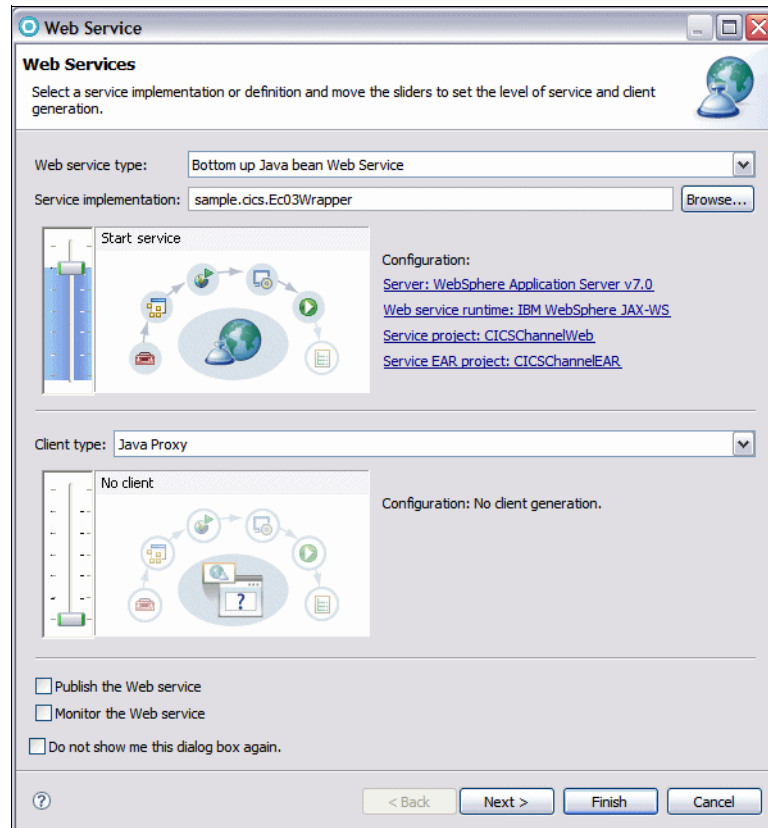

Figure 20-25 Web Service wizard

- ▶ On the second page, select **Generate WSDL file into the project** (to see the generated WSDL), and **Generate Web Service Deployment Descriptor**.
- ▶ Accept all the default settings until the end of the wizard and click **Finish**.
- ▶ In the Enterprise Explorer, CICChannelWeb project (Figure 20-26), you can see:
 - The Services node with the Ec03WrapperService
 - The WSDL file (Ec03WrapperService.wsdl) under WEB-INF/wsdl, with an associated XML Schema (Ec03WrapperService_schema1.xsd)
 - The Web service deployment descriptor (webservices.xml)

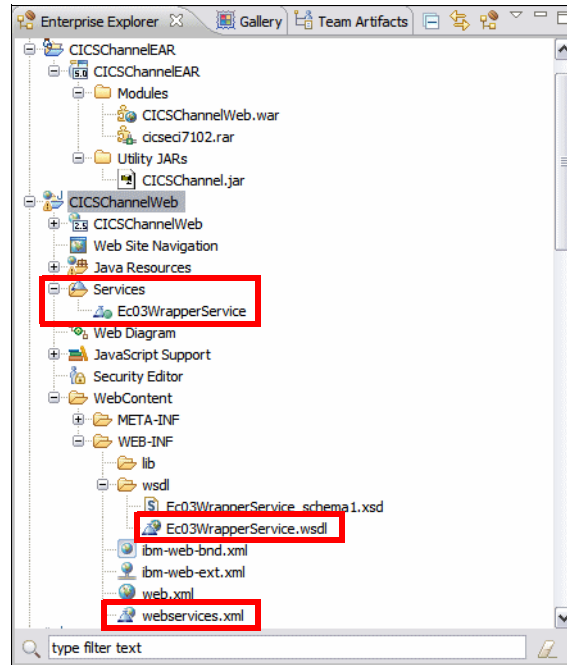

Figure 20-26 Enterprise Explorer after generation of bottom-up Web service

- ▶ The CICSCChannelEAR enterprise application is deployed to the server.

Testing the Web service with CICS access

To test the generated code we use the Web Services Explorer.

- ▶ Right-click **Ec03WrapperService.wsdl** and select **Web Services** → **Test with Web Services Explorer**.
- ▶ The Web Services Explorer opens (Figure 20-27):
 - Click on the **invoke** operation.
 - For the arg0 parameter, click **Add**
 - Type **Hello** as value.
 - Click **Go**.

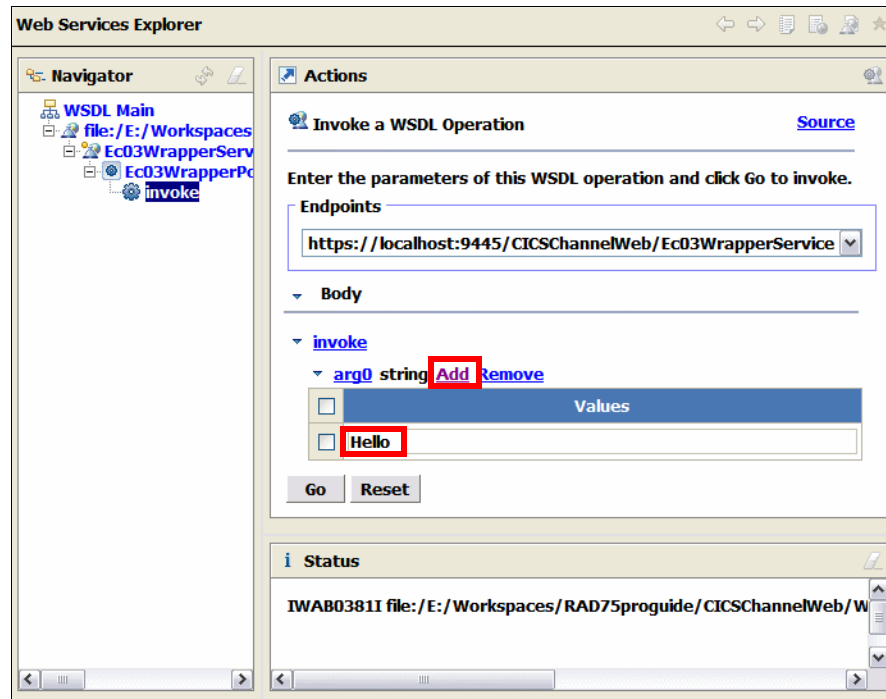

Figure 20-27 Web Services Explorer

- ▶ The Web service is invoked and you should obtain a SOAP message result as shown in Example 20-5. Click **Source** in the Status pane to see the SOAP messages.

Example 20-5 Web service response (formatted for readability)

```

<soapenv:Envelope
    xmlns:soapenv="http://schemas.xmlsoap.org/soap/envelope/">
  <soapenv:Body>
    <invokeResponse xmlns:ns2="http://cics.sample/">
      <return>
        sample.cics.data.EC03ChannelRecord@4f474f47
        sample.cics.data.OutputContainer@5e905e90 Input data was: Hello
        sample.cics.data.InputContainer@5f005f00 Hello
        sample.cics.data.LengthContainer@5f255f25 Buffer Size: 4 bytes
        00000010 00000000 00000000 00000000 |.....|
      </return>
    </invokeResponse>
  </soapenv:Body>
</soapenv:Envelope>

```

SAP outbound scenario

This sample demonstrates the how to use the WebSphere SAP resource adapter to create and retrieve information on an SAP system.

Required software and configuration

To complete the SAP adapter sample in this chapter, you must have the following software installed:

- ▶ IBM Rational Application Developer v7.5
 - ▶ J2EE Connector (J2C) tools. To install J2C tools, follow these steps:
 - Open the Installation Manager. Click **Modify**, and click **Next**.
 - In the Modify Packages page, select **IBM Software Deliver Platform**, and click **Next**.
 - In the Features list, select **IBM Rational Application Developer for WebSphere Software 7.5.0**, and click **Next**.
 - On the Install Packages page, select **Java EE Connector (J2C) Tools** → **Java EE Connector (J2C) Tools** → **WebSphere Adapters**.
 - Click **Install**.
 - ▶ You have to obtain these files from your SAP server administrator and add them to the following directories:
 - sapjco.jar: copy to <WAS_DIR>\lib
 - librfr32.dll: copy to <WAS_DIR>\bin and <WAS_DIR>\java\jre\bin
 - sapjcorfc.dll: copy to <WAS_DIR>\bin and <WAS_DIR>\java\jre\bin
- <WAS_DIR> = <RAD_HOME>\runtimes\base_v7

Creating a Connector Project and J2C bean

To create the SAP connector project and related J2C Beans for creating and retrieving information to and from SAP system follow these steps:

- ▶ Open the Java EE perspective.
- ▶ In the Workbench, select **File** → **New** → **Other** → **J2C** → **J2C Bean**.
- ▶ In the New J2C Bean dialog (Figure 20-28), select **IBM WebSphere Adapter for SAP Software (IBM: 6.1.0.3ifix001w)** and click **Next**.

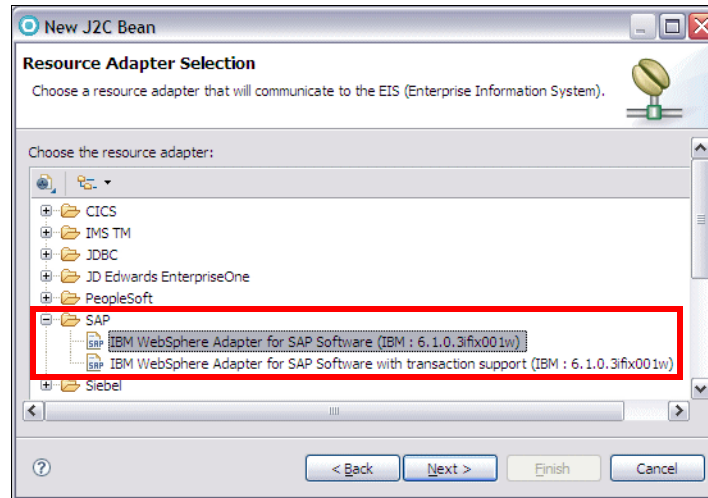

Figure 20-28 New J2C Bean - Resource Adapter Selection

- ▶ In the Connector Import dialog (Figure 20-29):
 - Type **CWYAP_SAPAdapter** in the connector project name field.
 - For Target server, select **WebSphere Application Server 7.0**.
 - Click **Next**.

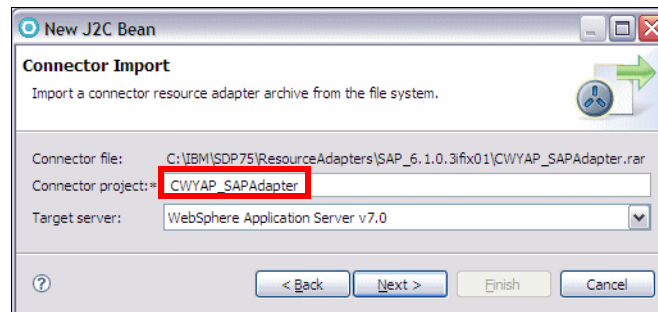

Figure 20-29 New J2C Bean - Connector Import

- ▶ In the Connector Settings dialog (Figure 20-30), click **Browse** for each file required to access to SAP server, navigate to the **sapjco.jar**, **librfc32.dll**, and **sapjcorfc.dll** that we copied to the server folders. Click **Next**.

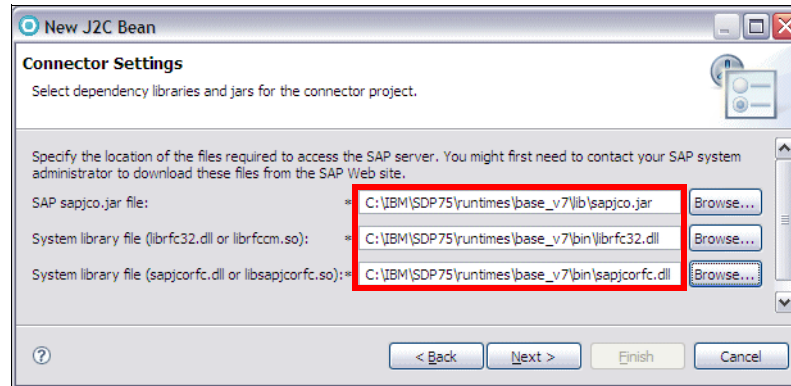

Figure 20-30 New J2C Bean - Connector Setting

- In the Adapter Style dialog (Figure 20-31), select **Outbound** and click **Next**.

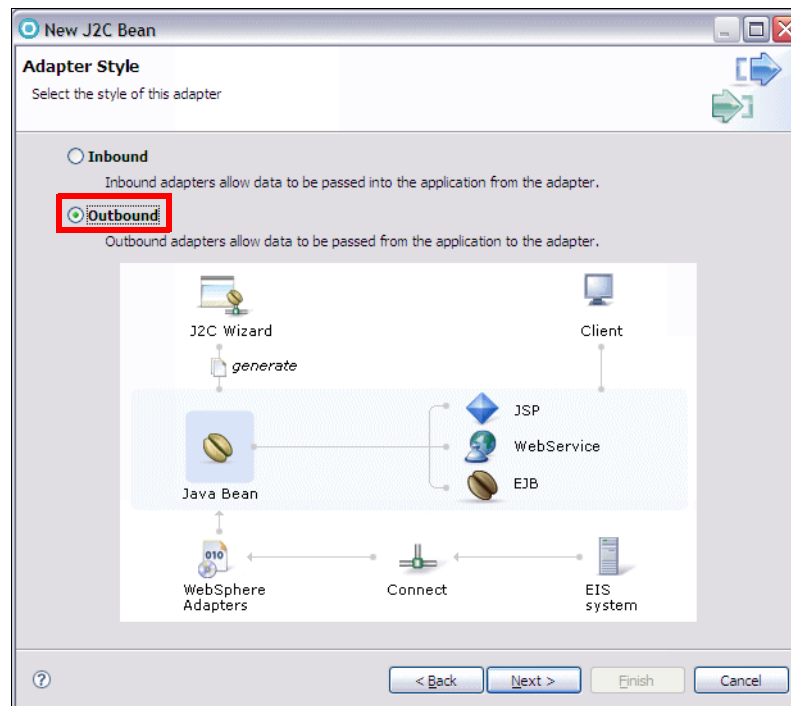

Figure 20-31 New J2C Bean - Adapter Style

- In the Discovery Configuration dialog (Figure 20-32), enter your SAP Server connection information. For this sample, select **BAPI®** as SAP interface name. Click **Next**. The wizard retrieve the objects discovered by the query.

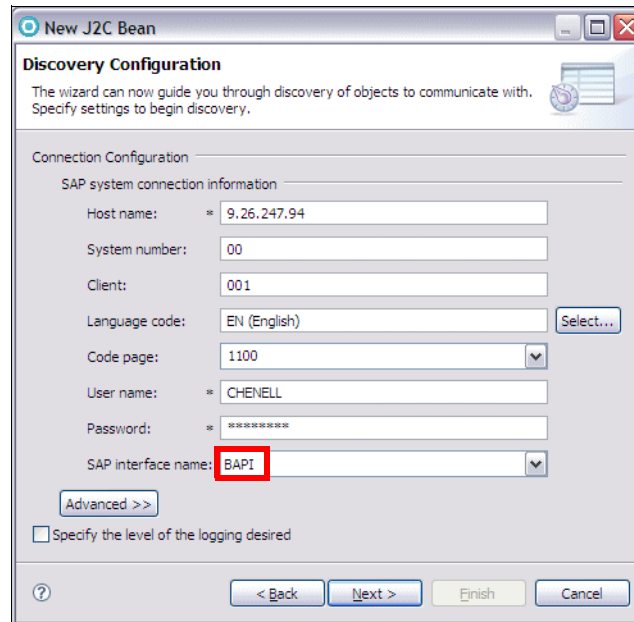



Figure 20-32 New J2C Bean - Discovery Configuration

- ▶ In the Object Discovery and Selection dialog (Figure 20-33), select **RFC** from the from Objects tree, then click **Create or edit filter** .
- ▶ In the Filter Properties for 'RFC' dialog enter **BAPI_CUSTOMER_*** for **Find objects with this pattern** field, and click **OK**.

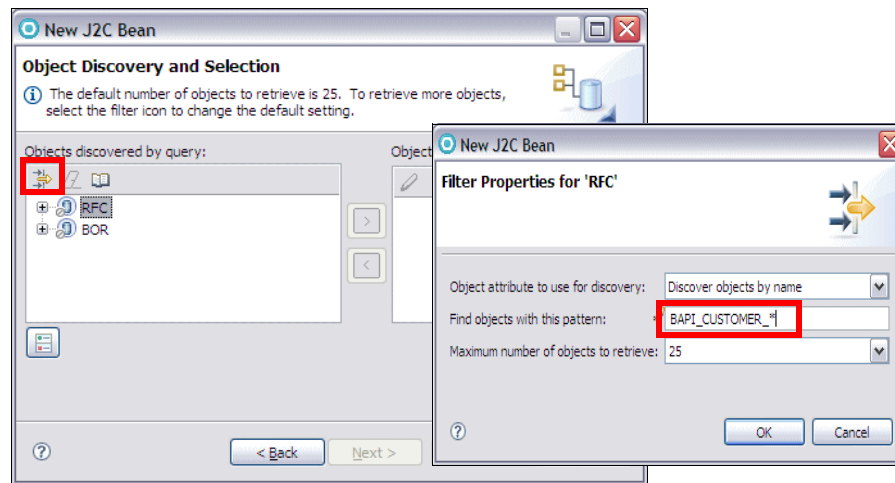



Figure 20-33 New J2C Bean - Object Discovery and Selection

- ▶ In the Object Discovery and Selection dialog (Figure 20-34), expand **RFC (filtered)**, select **BAPI_CUSTOMER_CREATEFROMDATA1** and **BAPI_CUSTOMER_GETDETAIL**, click  to add them to **Objects to be imported**. A **Configuration Parameters** dialog shows up, accept the defaults and click **OK**. Click **Next**.

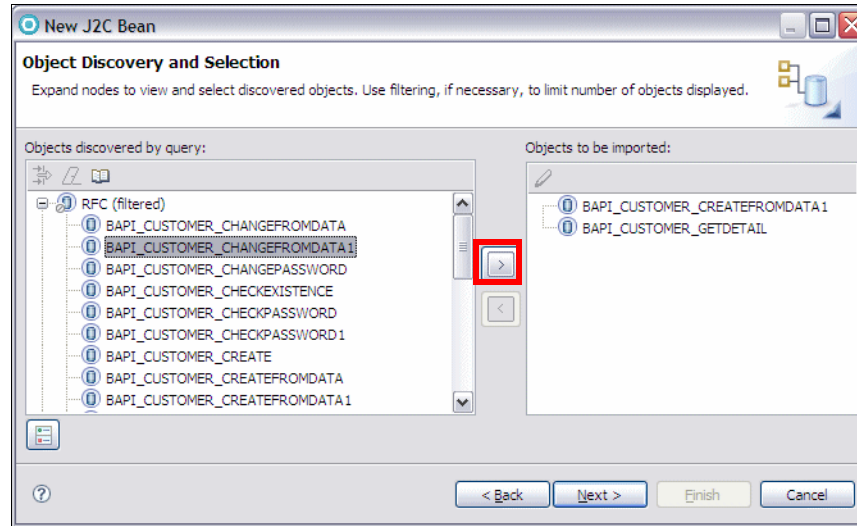

Figure 20-34 New J2C Bean - Object Discovery and Selection

- ▶ In Configure Composite Properties dialog (Figure 20-35), enter **RAD75BAPI** for **Business objects name for service operations** field. Click **Add**, in the Add Value dialog, select **Create** and click **OK**. Select **BAPI_CUSTOMER_CREATEFROMDATA1** from RFC function for selected operation list.

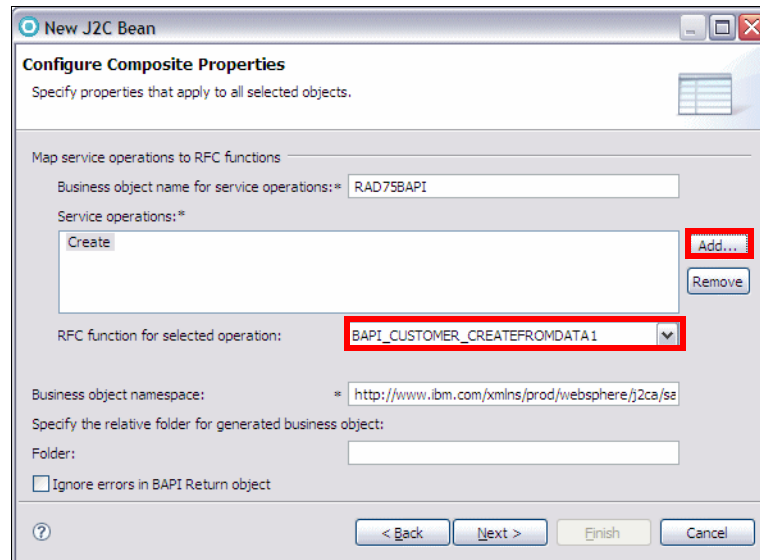

Figure 20-35 New J2C Bean - Configure Composite Properties

- ▶ Repeat the previous step by selecting **Retrieve**, and **BAPI_CUSTOMER_GETDETAIL** for RFC function for selected operation list (Figure 20-36). Click **Next**.

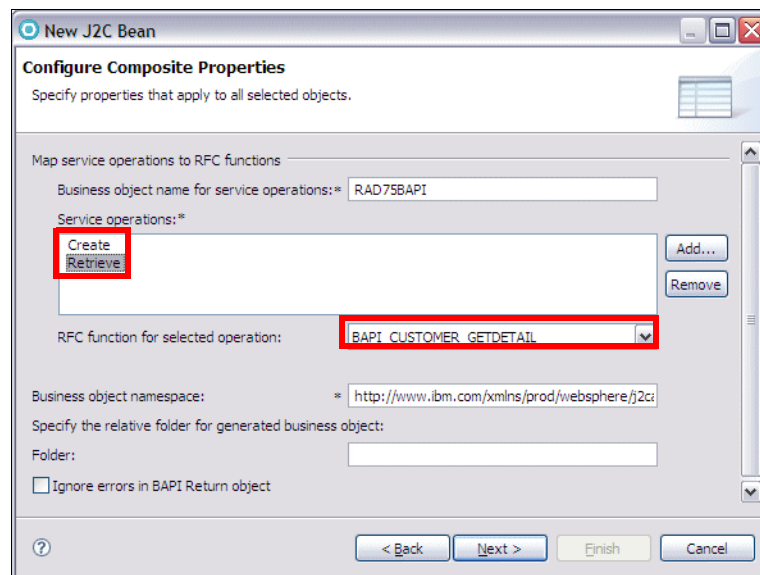

Figure 20-36 New J2C Bean - Configure Composite Properties

- ▶ In J2C Bean Creation and Deployment Configuration dialog, click **New** for Project name field to create a new Java project that contain the generated J2C beans.
- ▶ In New Source Project Creation dialog, select **Java project** and click **Next**.
- ▶ In the Create a Java project dialog, enter **RAD75SAP** for Project name, accept the defaults, and click **Finish**.
- ▶ In J2C Bean Creation and Deployment Configuration dialog (Figure 20-37):
 - Enter **itso.rad75.babi** as Package Name.
 - Enter **Customer** as Interface Name.
 - Enter **CustomerImpl** as Implementation Name.
 - Clear **Managed Connection**, select **Non-managed Connection**.
 - Click **Finish**.

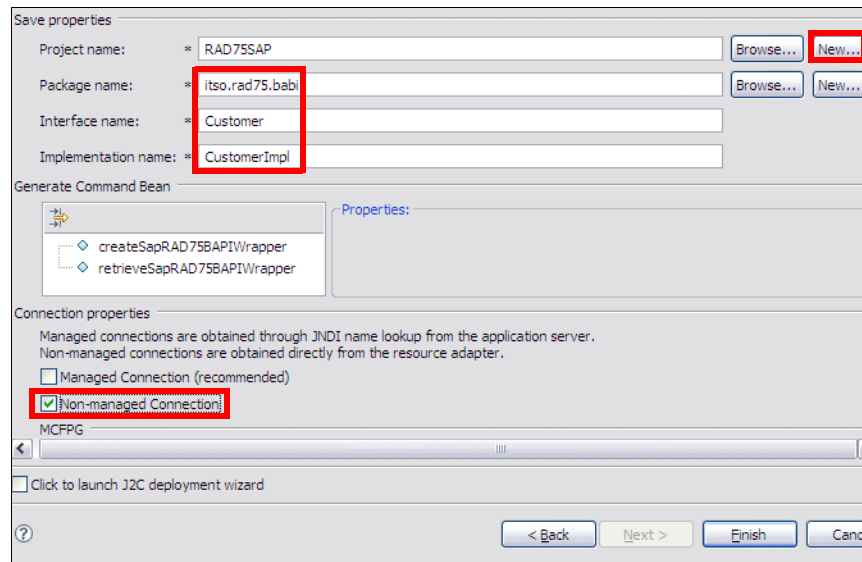

Figure 20-37 J2C Bean Creation and Deployment Configuration dialog

After finishing with the J2C Wizard, you have the following two projects in your workspace:

- CWYAP_SAPAdapter: SAP Adapter Project
- RAD75SAP: Java Project that holds generated J2C Beans

To test this generated J2C Beans, we now generate a simple Web Application using J2C wizards.

Generating the sample Web application

To generate the simple Web Application follow these steps:

- ▶ In the Workbench, select **File** → **New** → **Other** → **J2C** → **Web Page, Web Service, or EJB from J2C Java Bean**.
- ▶ In the Java EE Resource from J2C Bean dialog (Figure 20-38) click **Browse** for the J2C Bean implementation and select **CustomerImpl**. Click **Next**.

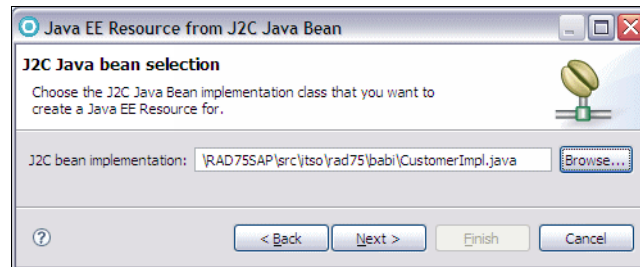

Figure 20-38 J2C Java bean selection

- ▶ In the Deployment Information dialog (Figure 20-39), select **Simple JSP** and click **Next**.

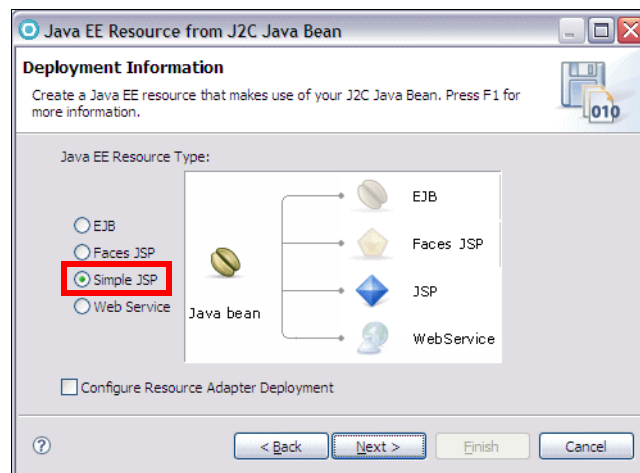

Figure 20-39 Deployment Information

- ▶ In Simple JSP Creation dialog, click **New** for Web project field to create a new Web project.
- ▶ In the Dynamic Web Project dialog, enter **RAD75SAPTestWeb** as Project name and **RAD75SAPTestWebEAR** as EAR Project Name. Ensure that

WebSphere Application Server v7.0 is selected for Target Runtime. Click **Finish**.

- ▶ In Simple JSP Creation dialog (Figure 20-40), enter **SampleJSP** as JSP Folder. Click **Finish**.

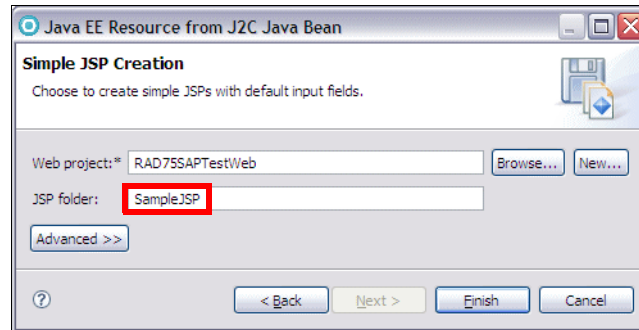

Figure 20-40 Simple JSP Creation

- ▶ After finishing with the Simple JSP Creation Wizard, you have the following two projects created in your workspace:
 - RAD75SAPTestWeb
 - RAD75SAPTestWebEAR
- ▶ The RAD75SAPTestWebEAR project has to reference the CWYAP_SAPAdapter project. We configure this dependency by adding the CWYAP_SAPAdapter as a dependency to the EAR project:
 - In the Enterprise Explorer, right-click **RAD75SAPTestWebEAR** and select **Properties**. Select **Java EE Module Dependencies** and select **CWYAP_SAPAdapter**, then click **OK**.
 - Right-click **RAD75SAPTestWeb** and select **Properties**. Select **Java EE Module Dependencies** and select **CWYAP_SAPAdapter.rar**, then click **OK**.

Testing the Web application

To test the sample Web Application follow these steps:

- ▶ Expand **RAD75SAPTestWeb** → **WebContent** → **SampleJSP**, right-click **TestClient.jsp** and select **Run As** → **Run on Server**. Select the server (WebSphere Application Server v7.0) and click **Finish**.
- ▶ The application opens in a Web browser.

- ▶ From the Methods Pane, click **createSapRAD75BAPWrapper**. Scroll down the page for **Inputs**, enter input values for **sapBapiCustomerCreatefromdata1Input** and click **Invoke**.
- ▶ The response from the SAP system is displayed in the Results pane.
- ▶ From the Methods Pane, click **retrieveSapRAD75BAPWrapper**. Scroll down the page for **sapBapiCustomerGetdetail**, enter an input value for **customerToBeRequired** and click **Invoke**.
- ▶ The response from the SAP system is displayed in the Results pane.

More information

The product help contains the following relevant chapters:

- ▶ Developing → Developing Data Access Applications → Connecting to enterprise information systems
- ▶ Tutorials → Watch and learn → Create a J2C application for a CICS transaction with the same input and output
- ▶ Tutorials → Do and learn → Create a J2C application for a CICS transaction containing multiple possible outputs
- ▶ Samples → Technology Samples → Java → J2C Samples
- ▶ Cheat Sheets → J2C Java Bean

Other sources of information:

- ▶ Generating a J2C bean using the J2C Tools in Rational Application Developer V7.0
http://www.ibm.com/developerworks/rational/library/06/1212_nigul/
- ▶ Create a J2C application for an Information Management System (IMS) phone book transaction using IMS TM Resource Adapter
<http://www.ibm.com/developerworks/rational/library/08/dw-r-j2cimsresource/>
- ▶ Working with J2C Ant Scripts in Rational Application Developer V7
http://www.ibm.com/developerworks/rational/library/06/1205_ho-benedek/
- ▶ *Revealed! The Next Generation of Distributed CICS*, SG24-7185



Develop portal applications

This chapter introduces important support of the portal development tools that is included in IBM Rational Application Developer v7.5 with more focus on the new features added to the current version. We also highlight how the portal tools in Application Developer can be used to develop a portal and associated portlet applications for WebSphere Portal v6.1. Finally, we have included a development scenario to demonstrate how to use the new integrated portal tooling to develop a portal, customize the portal, and develop two portlets.

The chapter is organized into the following sections:

- ▶ Introduction to portal technology
- ▶ Developing applications for WebSphere Portal
- ▶ New Websphere portal and portlet development tools in Rational Application Developer v7.5
- ▶ Developing portal solutions using portal tools

For more detailed information on IBM WebSphere Portal v6.1, refer to “More information” on page 774

Introduction to portal technology

As J2EE technology has evolved, much emphasis has been placed on the challenges of building enterprise applications and bringing those applications to the Web. At the core of the challenges currently being faced by Web developers is the integration of disparate user content into a seamless Web application and well-designed user interface. Portal technology provides a framework to build such applications for the Web.

Because of the increasing popularity of portal technologies, the tooling and frameworks used to support the building of new portals has evolved. The main job of a portal is to aggregate content and functionality. Portal servers provide:

- ▶ A server to aggregate content
- ▶ A scalable infrastructure
- ▶ A framework to build portal components and extensions

Additionally, many portals offer personalization and customization features. Personalization enables the portal to deliver user-specific information targeting a user based on their unique information. Customization allows the user to organize the look and feel of the portal to suit their individual needs and preferences.

Portals deliver e-business applications over the Web to many types of client devices from PCs to PDAs. Portals provide site users with a single point of access to multiple types of information and applications. Regardless of where the information resides or what format it is in, a portal aggregates all of the information in a way that is relevant to the user.

The goal of implementing an enterprise portal is to enable a working environment that integrates people, their work, personal activities, and supporting processes and technology.

Portal concepts and definitions

Before beginning development for portals, you should become familiar with some common definitions and descriptions of portal-related terminology.

Portal page

A portal page is a single Web page that can be used to display content aggregated from multiple sources. The content that appears on a portal page is displayed by an arrangement of one or more portlets. For example, a World Stock Market portal page might contain two portlets that display stock tickers for popular stock exchanges and a third portlet that displays the current exchange rates for world currencies.

Portlet

A portlet is an individual application that displays content on a portal page. To a user, a portlet is a single window or panel on the portal page that provides information or Web application functionality. To a developer, portlets are Java-based pluggable modules that can access content from a source such as another Web site, an XML feed, or a database, and display this content to the user as part of the portal page.

Figure 21-1 shows a portal welcome page and its contained portlets.

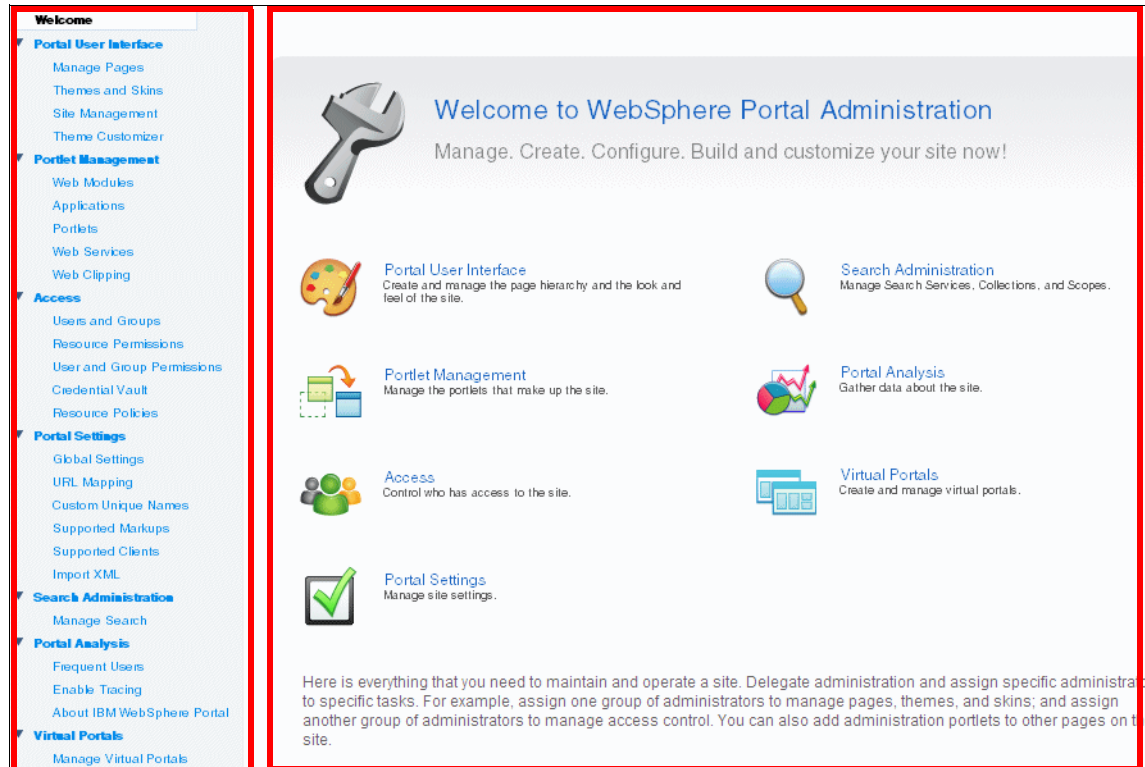

Figure 21-1 Portlets laid out on the Portal Welcome Page

Portlet application

A portlet application is a deployable unit that contains one or more portlets. It encapsulates all the resources required by the portlets; such as Java classes, JSP files, images, deployment descriptors, libraries and other resources.

Portlet states

Portlet states determine how individual portlets look when a user accesses them on the portal page. These states are very similar to minimize, restore, and maximize window states of applications run on any popular operating system just in a Web-based environment.

The state of the portlet is stored in the `PortletWindowState` object and can be queried for changing the way a portlet looks or behaves based on its current state. The IBM portlet API defines three possible states for a portlet:

- ▶ **Normal**—The portlet is displayed in its initial state, as defined when it was installed.
- ▶ **Minimized**—Only the portlet title bar is visible on the portal page.
- ▶ **Maximized**—The portlet fills the entire body of the portal page, hiding all other portlets.

Portlet modes

Portlet modes allow the portlet to display a different *face* depending on how it is being used. This allows different content to be displayed within the same portlet, depending on its mode. Modes are most commonly used to allow users and administrators to configure portlets or to offer help to the users. There are four modes in the IBM Portlet API:

- ▶ **View**—Initial face of the portlet when created. The portlet normally functions in this mode.
- ▶ **Edit**—This mode allows the user to configure the portlet for their personal use (for example, specifying a city for a localized weather forecast).
- ▶ **Help**—If the portlet supports the help mode, this mode displays a help page to the user.
- ▶ **Configure**—If provided, this mode displays a face that allows the portal administrator to configure the portlet for a group of users or a single user.

Portlet events

Some portlets only display static content in independent windows. To allow users to interact with portlets and to allow portlets to interact with each other, portlet events are used. Portlet events contain information to which a portlet might need to respond. For example, when a user clicks a link or button, this generates an *action* event. To receive notification of a given event, the portlet must also have the appropriate *event listener* implemented within the portlet class. There are three commonly used types of portlet events:

- ▶ **Action**—Generated when an HTTP request is received by the portlet that is associated with an action, such as when a user clicks a link.

- ▶ **Message**—Generated when one portlet within a portlet application sends a message to another portlet.
- ▶ **Window**—Generated when the user changes the state of the portlet window.

IBM WebSphere Portal

IBM WebSphere Portal provides an extensible framework that allows the end user to interact with enterprise applications, people, content, and processes. They can personalize and organize their own view of the portal, manage their own profiles, and publish and share documents. WebSphere Portal provides additional services such as single sign-on (SSO), security, credential vault, directory services, document management, Web content management, personalization, search, collaboration, search and taxonomy, support for mobile devices, accessibility support, internationalization, e-learning, integration to applications, and site analytics. Clients can further extend the portal solution to provide host integration and e-commerce.

WebSphere Portal allows you to plug in new features or extensions using portlets. In the same way that a servlet is an application within a Web server, a portlet is an application within WebSphere Portal. Developing portlets is the most important task when providing a portal that functions as the user's interface to information and tasks.

Portlets are an encapsulation of content and functionality. They are reusable components that combine Web-based content, application functionality, and access to resources. Portlets are assembled into portal pages that, in turn, make up a portal implementation.

Portal solutions such as IBM WebSphere Portal are proven to shorten the development time. Pre-built adapters and connectors are available so that customers can leverage on the company's existing investment by integrating with the existing legacy systems without re-inventing the wheel.

What's new in WebSphere Portal v6.1?

WebSphere Portal v6.1 has some new features to help you develop more robust enterprise solutions:

- ▶ Improved installation, configuration, and security.
- ▶ Support for new portlet standards: WebSphere Portal now supports the two new portlet standards Java Portlet Specification 2.0 (JSR 286) and Web Services for Remote Portlets (WSRP) Version 2.0.

- ▶ Enriched search experience: The Search Center in all themes is more responsive because it uses AJAX with a Dojo-based client-side Java Script programming model.
- ▶ New infrastructure supports Web 2.0 theme:
 - More responsive user interfaces provide better context awareness for the user through client-side aggregation of portal pages.
 - Client-side mashups and interactive portal applications can be developed using Ajax with a Dojo-based client-side JavaScript programming model.
 - Portal models like navigation, page layout, and user information are remotely accessible through REST services.
 - Improved scalability results from enhanced caching capabilities. Page fragments can be cached separately rather than caching entire pages.
 - Dynamic behaviors such as context menus, annotations, highlighting, and drag-and-drop interaction can be applied by an extensible set of semantic tags.
 - The new FeedReader portlet is based on Ajax.
- ▶ Site management: The new Resource Manager portlet allows administrators to create a page on a source server and publish it to a target server where only a selected group of users can see and test the new page. After testing is complete, you can promote the new page so that all users on the target server with the appropriate access rights can view the new page.
- ▶ Customization through themes and skins: The new Theme Customizer portlet features a tabbed design and live preview that let you quickly and easily customize key site elements including the banner, navigation, fonts, and colors.

More information about WebSphere Portal v6.1 new features can be found at the product information center at:

<http://publib.boulder.ibm.com/infocenter/wpdoc/v6r1m0/index.jsp>

Portal and portlet development features in Application Developer

Application Developer provides development tools for portal and portlet applications destined to WebSphere Portal. Bundled with IBM Rational Application Developer v7.5 are a number of portal tools that allow you to create, test, debug, and deploy portal and portlet applications. Application Developer supports portlet development using the Standard and IBM portlet APIs.

The following tools are provided to support development of your portlet applications:

- ▶ Portlet application samples
- ▶ New Portlet Project wizard
- ▶ WPAI mediator access
- ▶ Portlet deployment descriptor editor
- ▶ Portal server configuration
- ▶ Portal server test, debug, and deploy
- ▶ Import and export Web archive (WAR) file
- ▶ Visual tooling to insert portlet objects into JSP files, using Page Designer.
- ▶ Cooperative portlet wizards
- ▶ Business process message access
- ▶ Personalization wizard

Portal test environments

Application Developer v7.5 provides the following versions of integrated test environments to run and test your portal and portlet projects from within the Application Developer Workbench:

- ▶ IBM WebSphere Portal Server 6.0.x
- ▶ IBM WebSphere Portal Server 6.1

In this chapter we are using the Version 6.1 of WebSphere Portal.

Setting up Application Developer with the Portal test environment

Setting up of Portal test environment in Application Developer is now a much easier and more streamlined task. We perform the following high-level activities to complete the setup of Portal test environment in Application Developer, documented under “Installing the WebSphere Portal v6.1 test environment” on page 1131:

- ▶ Installing WebSphere Portal v6.1
- ▶ Adding WebSphere Portal v6.1 to Application Developer
- ▶ Optimizing the Portal Server for development

Developing applications for WebSphere Portal

Application Developer includes many tools to help you quickly develop portals and individual portlet applications. In this section, we cover some basic portlet development strategies and provide an overview of the tools included Application Developer to aid with development of WebSphere Portal.

Portal samples and tutorials

Application Developer also comes with several samples and tutorials to aid you with the development of WebSphere Portal. The Samples Gallery provides sample portlet applications to illustrate portlet development.

To access portlet samples, click **Help** → **Samples**. Then expand **Technology samples** and **Portlet** (Figure 21-2). Here you can select a Basic Portlet, Faces Portlet, or Struts Portlet Framework to view sample portlet application projects that you can then modify and build upon for your own purposes.

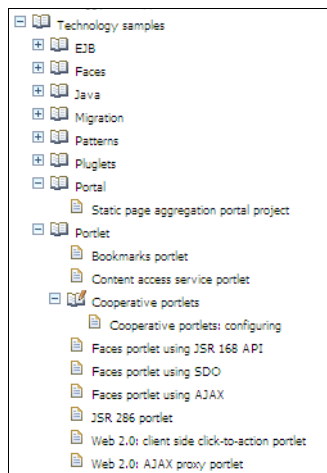

Figure 21-2 Portal and portlet development technology samples

The Tutorials Gallery provides detailed tutorials to illustrate portlet development. These are accessible by selecting **Help** → **Tutorials**. Then expand **Do and Learn**. You can select **Create a portal application**.

Development strategy

A portlet application consists of Java classes, JSP files, and other resources, such as deployment descriptors and image files. Before beginning development, several decisions must be made regarding the development strategy and technologies that is used to develop a portlet application.

Choosing a portlet API: JSR 168, JSR 286, or IBM

Application Developer supports the development of portlets using the JSR 168 portlet API, the JSR 286 portlet API, and the IBM portlet API. All three types of portlets can be deployed to WebSphere Portal.

This section provides you with information that can help you decide which API to use when you develop portlets.

- ▶ **JSR 168 portlet API** is a Java specification from the Java Community Process that addresses the requirements of aggregation, personalization, presentation, and security for portlets running in a portal environment. Portlets that conform to the JSR 168 specification are more portable and reusable, because they can be deployed to any JSR 168-compliant portal. Rational tools supports portlet development based on the JSR 168 specification.

<http://www.jcp.org/en/jsr/detail?id=168>

Note: Click-to-Action cooperative behavior and portlet messaging are not supported in JSR 168 Faces portlets.

- ▶ **JSR 286 portlet API** is a Java specification from the Java Community Process that has improved upon the JSR 186 portlet API by providing additional capabilities, such as filters, events, and public render parameters. These improvements have necessitated changes to the XSD for the Portlet Deployment Descriptor (PDD) that adds new elements to it.

<http://www.jcp.org/en/jsr/detail?id=286>

- ▶ **IBM portlet API** is IBM's portlet API that was initially supported for WebSphere Portal v4.x, and in subsequent versions of WebSphere Portal v5.x and v6.x. Note that the IBM portlet API is deprecated in v6.x,m but is still supported. No new functionality will be added and it is recommended you use the Standard Portlet API.

Deciding which API to use

The IBM portlet API extends the servlet API and many of the main interfaces (request, response, session). JSR 168 API does not extend the servlet API, but shares many of the same characteristics. JSR 168 leverages much of the functionality provided by the servlet specification, such as deployment, class loading, Web applications, Web application life cycle management, session management, and request dispatching.

For new portlets, consider using JSR 286 to take advantage of its additional capabilities. If you cannot use JSR 286 for some reason, consider JSR 168 when the functionality it provides is sufficient for the portlet's needs or when the portlet is expected to be published as a Web Service for Remote Portlets (WSRP) service. WSRP is another portal-based standard used to integrate the presentation of remote portlets provided as Web services into the local portal page. The concepts in JSR 168 and WSRP have been aligned to allow JSR 168 portlets to be published as Web services. Some of these concepts include portlet modes and states, URL and name space encoding, and the handling of transient and persistent information.

Choosing markup languages

WebSphere Portal supports multiple client types by generating pages in multiple markup languages. Three are officially supported: HTML, WML, and cHTML. Using Application Developer tools, you can develop portlet applications that support these markup languages.

- ▶ HTML is a markup language for desktop computers. All portlet applications must support HTML, at a minimum.
- ▶ WML is a markup language for WAP devices, which are typically mobile phones.
- ▶ cHTML is a markup language for mobile devices in the NTT DoCoMo i-mode network.

To edit WML files and cHTML files, you can use Page Designer, as you do when editing other Web content.

To run or debug a portlet application that supports WML or cHTML, you can use a device emulator provided by a device vendor. To add a device emulator:

- ▶ Select **Window** → **Preferences**.
- ▶ In the Preferences dialog, select **General** → **Web browser**.
- ▶ Click **New** to locate and define a Web browser type that is appropriate for the device that you wish to test and debug.

More information about markup languages can be found under the Markup guidelines topic in the WebSphere Portal Information Center.

Choosing other frameworks

JavaServer Faces (JSF) and Struts technology can be easily incorporated into a portlet development strategy. Application Developer provides extensive tooling support to help in the creation and code generation for creating a JSF portlet or Struts portlet.

JavaServer Faces (JSF)

Faces-based application development can be applied to portlets, similar to the way that Faces development is implemented in Web applications. Faces support in Rational Application Developer simplifies the process of writing Faces portlet applications and eliminates the need to manage many of the underlying requirements of portlet applications.

Rational tools provide a set of wizards that help you create Faces portlet-related artifacts. In many cases, these wizards are identical to the wizards used to create standard Faces artifacts

Refer to the Application Developer Faces documentation in the InfoCenter for usage details. Also refer to Chapter 16, “Develop Web applications using JSF” on page 493 for more detailed information on application development using the JSF framework.

Struts

Struts-based application development can also be applied to portlets, similar to the way that Struts development is implemented in Web applications. The Struts Portal Framework (SPF) was developed to merge these two technologies. SPF support in Application Developer simplifies the process of writing Struts portlet applications and eliminates the need to manage many of the underlying requirements of portlet applications.

The Struts portlet tooling supports development of portlet applications based on both the JSR 168 API and the IBM portlet API. There are differences in the runtime code included with projects, tag libraries supported, Java class references, and configuration architecture, but, unless otherwise noted, these differences are managed by the product tooling.

In addition, multiple wizards are present to help you create Struts portlet-related artifacts. These are the same wizards used in Struts development. Refer to the Application Developer Struts documentation for usage details.

More information on Struts can be found at:

<http://struts.apache.org/>

Web development using Struts for non-portal applications is covered in Chapter 15, “Develop Web applications using Struts” on page 445.

Portal tools for developing portals

A portal is essentially a J2EE Web application. It provides an aggregation framework where developers can associate many portlets and portlet applications via one or more portal pages.

Application Developer includes several new portal site creation tools that enable you to visually customize portal page layout, themes, skins, and navigation.

Portal Import wizard

One way to create a new Portal project is to import an existing portal site from a WebSphere Portal server into Application Developer. Importing is also useful for updating the configuration of a project that already exists in Application Developer.

The portal site configuration on WebSphere Portal server contains the following resources: Global settings, resource definitions, portal content tree, and page layout. Importing these resources from WebSphere Portal server to Application Developer overwrites duplicate resources within the existing Portal project. Non-duplicate resources from the server configuration are copied into the existing Portal project. Likewise, resources that are unique to the Portal project are not affected by the import.

Application Developer uses the XML configuration interface to import a server configuration, and optionally retrieves files from `installedApps/node/wps.ear` of the Application Server installation. These files include the JSP, CSS, and image files for themes and skins. When creating a new Portal project, retrieving files is mandatory. To retrieve files, Application Developer must have access to this directory, as specified when you define a new server for this project.

Enabling the Portal development capability

By default, Application Developer portal development capability is not enabled. To enable portal development capability, do these steps:

- ▶ Select **Window** → **Preferences**.
- ▶ In the Preferences dialog, expand **General** → **Capabilities** and click **Advanced**.
- ▶ In the Advanced dialog, expand **Web Developer (advanced)**, select **Portal Development** and click **OK**.
- ▶ Click **OK** in the Preferences dialog and portal development is enabled.

Now you can access the Portal Import wizard by selecting **File** → **Import** and expand Portal then selecting **Portal**. You have to specify the server and options for importing the project into Application Developer.

Follow the instructions in the Help Topics on Developing Portal Applications to ensure that the configuration in the development environment accurately reflects that of the staging or runtime environment. If you do not do this, you might experience compilation errors after the product is imported or encounter unexpected portal behaviors.

Portal project wizard

The New Portal Project wizard guides you through the process of creating a Portal project within Application Developer.

During this process, you are able to:

- ▶ Specify a project name.
- ▶ Select the version of the Portal server.

- ▶ Select a default theme.
- ▶ Select a default skin for the chosen theme.

Important: You should not name your project *wps* or anything that resembles this string, in order to avoid internal naming conflicts.

The project that you create with this wizard does not have any portlet definitions, labels, or pages. The themes and skins that are available in this wizard are the same as if you had imported a portal site from a WebSphere Portal server. To create a new Portal Project, do these steps:

- ▶ Select **File** → **New** → **Project** → **Portal**.
- ▶ Expand **Portal** and select **Portal Project**. Click **Next**.
- ▶ In the New Portal Project dialog, type, for example, **MyPortal** in the Project Name field. Use the default path, select the Portal Server v6.1 as your server, select the WebSphere Portal v6.1 as the target runtime environment, type the name of the EAR project (**MyPortalEAR**), and click **Next** (Figure 21-3).

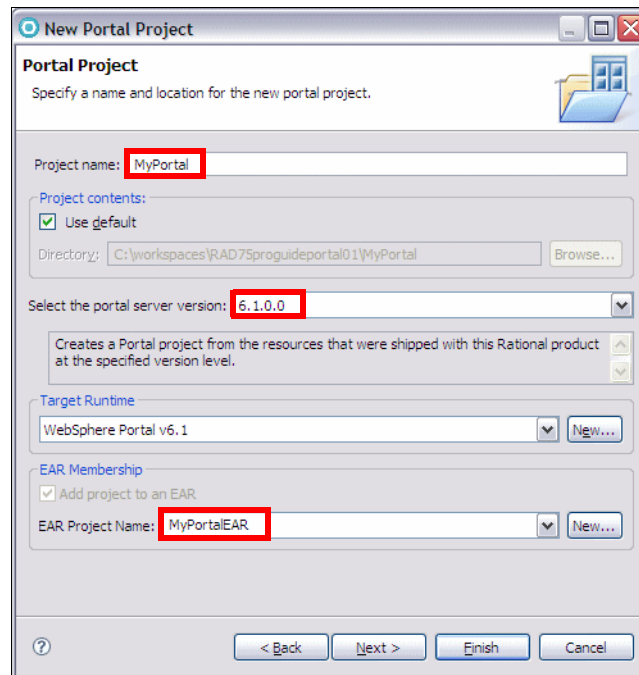

Figure 21-3 New Portal Project wizard

- ▶ In the Select Theme dialog, select the default theme (Portal) and click **Next**.
- ▶ In the Select Skin dialog, select the default skin (IBM) and click **Finish**.

- ▶ The Portal Designer editor is opened with the selected theme and skin.

Portal Designer

For portal site layout and appearance, you can think of Portal Designer as a what-you-see-is-what-you-get (WYSIWYG) editor. It renders the graphic interface of items such as themes, skins, page layouts, and basic portlets.

Portal Designer also displays the initial pages of JSF and Struts portlets within your portal pages. Portal Designer will not display the content for WSRP remote portlets. For more information on how to display basic portlets, refer to the section Viewing portlets in Portal Designer in the Application Developer Help.

Use this editor to customize both the graphic design of your portal and the layout of your portal pages. Use it as you would use any WYSIWYG Web editor. Functions you can perform include:

- ▶ Right-clicking a design element and selecting an Insert menu item
- ▶ Clicking on a design element to edit its properties. Scroll down to read more about working with properties
- ▶ Using Page Designer to alter the graphic design of themes, skins and styles. These editors are available in the Edit menu.

PortalConfiguration is the name of the layout source file that resides in the root of the Portal project folder (Figure 21-4). To open Portal Designer, double-click the `ibm-portal-topology.xml` file under the PortalConfiguration folder in the Enterprise Explorer.

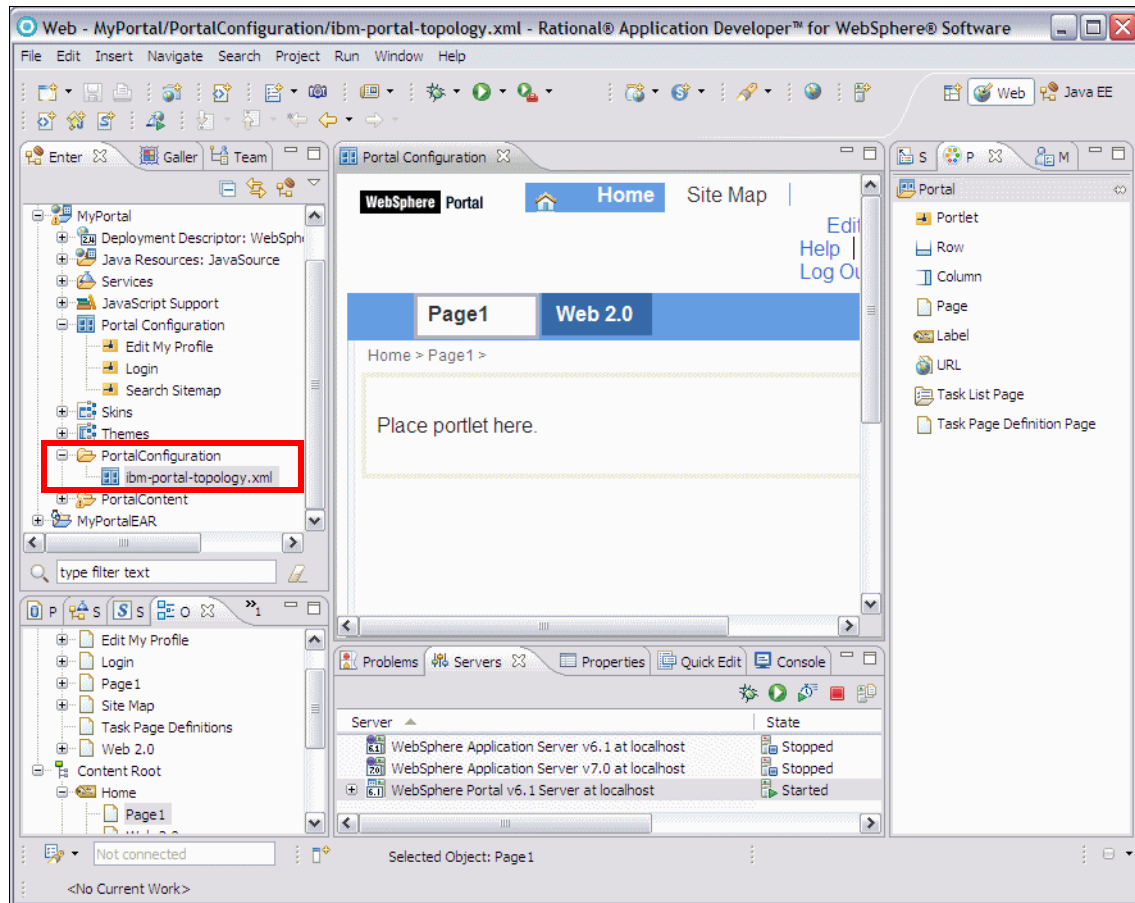

Figure 21-4 Portal Designer Workbench

Skin and theme design and editing

A skin is the border around each portlet within a portal page. Unlike themes, which apply to the overall look and feel of the portal, skins are limited to the look and feel of each portlet that you insert into your portal application.

Application Developer installation includes pre-built themes and skins to use with portal projects. There are also wizards to create new themes and skins. Changing themes and skins was previously done through portal administration. In addition to these wizards for creating new skins and themes, there are tools that can be used to change or edit these.

Once created, skins and themes are displayed in the Enterprise Explorer view. Double-click a skin or theme to manually edit it.

New Skin wizard

In addition to using the pre-made skins that came with the installation, you can use the New Skin wizard to create customized skins for your project.

- ▶ Right-click the Portal project in the Enterprise Explorer view and select **New** → **Skin**. The New Skin page opens (Figure 21-5).

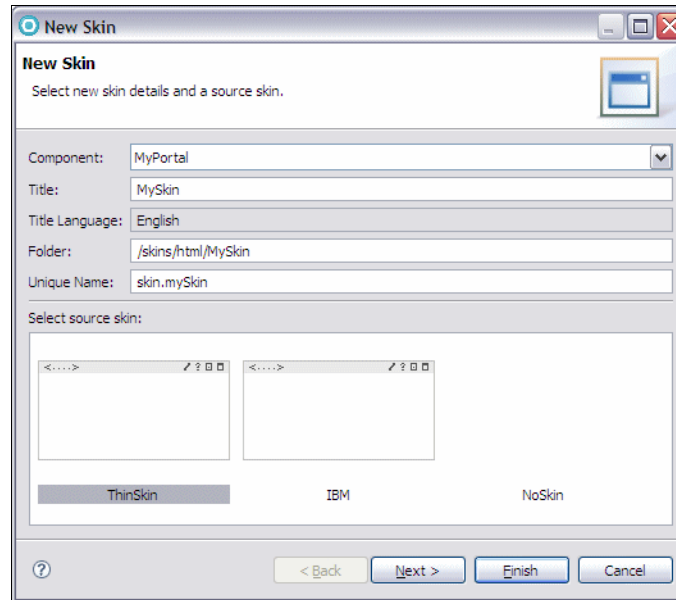

Figure 21-5 New Skin wizard

- ▶ In the Select Themes page, select the themes that allow the skin you created, then click **Finish**.

New Theme wizard

Themes provide the overall look and feel of your portal application. In addition to using the pre-existing themes, you can use the New Theme wizard to create customized themes for your project:

- ▶ Right-click the Portal project in the Enterprise Explorer view and select **New** → **Theme**. The New Them page opens (Figure 21-6).

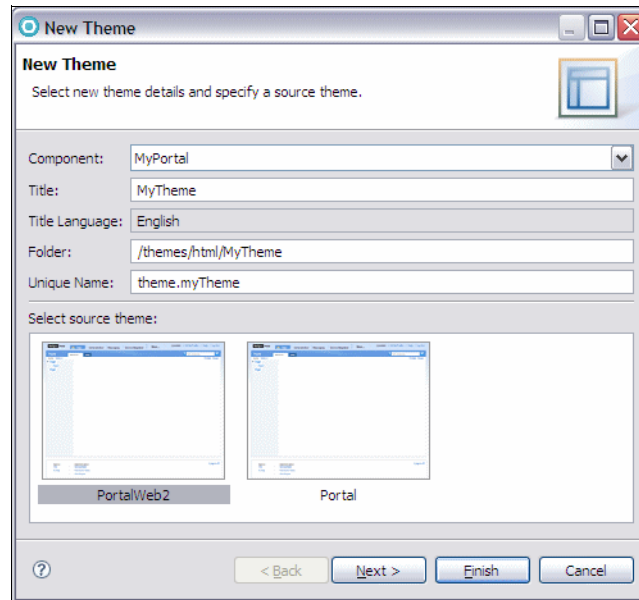

Figure 21-6 New Theme wizard

- ▶ In the Select Skins page, select the allowed skins for the theme, then click **Finish**.

New Websphere portal and portlet development tools in Rational Application Developer v7.5

For those who are already familiar with portal and portlet development tools in the previous version of the Application Developer, we briefly introduce the new portal and portlet tooling in Application Developer v7.5.

Theme editing support

To edit a theme in the Portal Designer, select **Edit Theme** from the menu. The `Default.jsp` file for the active theme opens in Page Designer, and gives you WYSIWIG editor to work with. Also, one of the predefined themes has the Web 2.0 support so that users can make use of the Web 2.0 capabilities.

Creating portal pages using static page aggregation

Portal tools now supports the static page aggregation (SPA) feature in WebSphere Portal Server v6.1. This feature helps you create generic HTML pages as static Portal pages.

To create a portal page with static layout (Figure 21-7):

- ▶ Right-click on a page or a label, and select **Insert Static Page**. or from the main menu, click **Insert** → **Static page**.
- ▶ In the new portal page of the static layout wizard, enter a file name.
- ▶ Create a portal page, depending on your layout:
 - To use a new layout file (index.html), click **Finish**.
 - To use an existing layout, select **Create using ZIP or HTML file**, then use **Browse** to navigate to the.zip or HTML file. Click **Finish**.

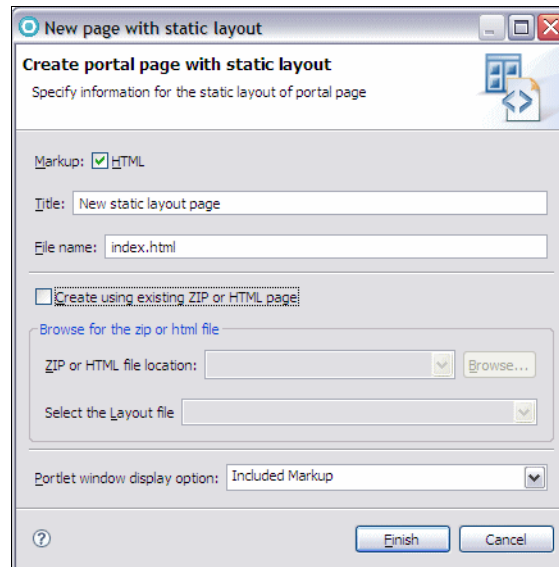

Figure 21-7 create a portal page with static layout

Creating user friendly URLs

Friendly URL is a new feature in WebSphere Portal v6.1 that allows portal administrators to create constant user friendly URLs and map them to portal pages. As administrators create the URLs, they can define human readable names for them. These can be easily remembered and are therefore more user friendly.

This feature enables you to manually:

- ▶ Modify WebSphere Portal URLs (displayed in the browser address bar) to let them navigate to another portal page.
- ▶ Enter a complete portal URL into the browser address bar to navigate to a particular page (omitting any rich navigational state).

To set a friendly URL to a portal label, page, or URL (Figure 21-8):

- ▶ Select a label, page, or URL.
- ▶ In the properties view, select the corresponding, Label, Page, or URL tab.
- ▶ In the Friendly URL name field, specify a name. For example, **support**.
- ▶ Save the settings.

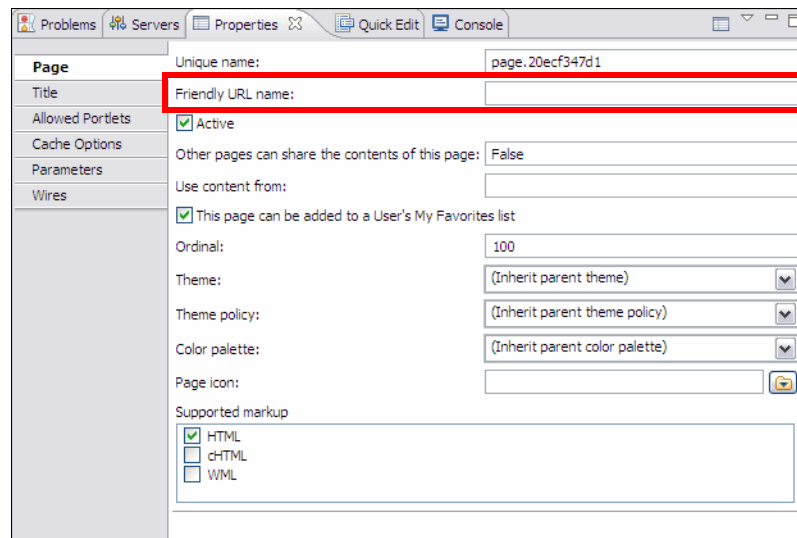

Figure 21-8 Friendly URL feature

Client side click-to-action support

WebSphere Portal v6.1 provides client side programming model to reduce roundtrips to the server and Application Developer v7.5 provides the necessary client-side programming.

Client side click-to-action is one of the mechanism by which portlets can interact and share information among each other. All components that contribute HTML to a page can be a source or a target for exchanging information.

- ▶ To add client side support when creating new Portlet projects, select **Client side Capabilities** in the advanced settings of the New Portlet Project wizard (Figure 21-9).

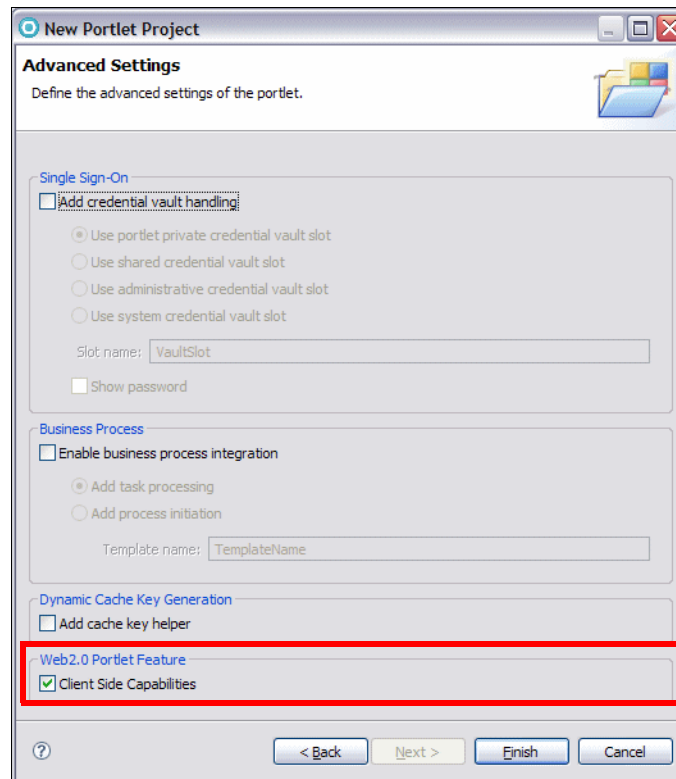

Figure 21-9 Enabling Client Side Capabilities in New Portlet Project

- ▶ To enable the client side support in a new Web page of an existing Portlet project, click **Options** in the New Web Page wizard, then select **Portlet JSP** from the list on the left, and afterwards select the **Client Side Capabilities** check box (Figure 21-10).

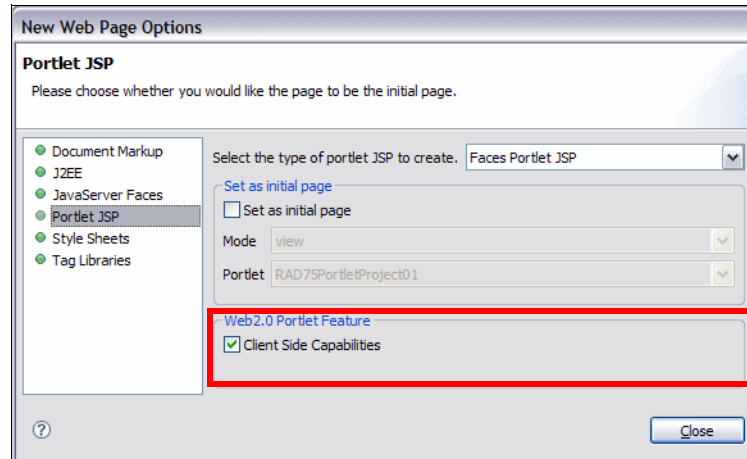

Figure 21-10 Enabling client side support in new Web Pages

- Client-to-Action properties can be added to a Web page by dragging and dropping them from the Palette into Page Designer (Figure 21-11)

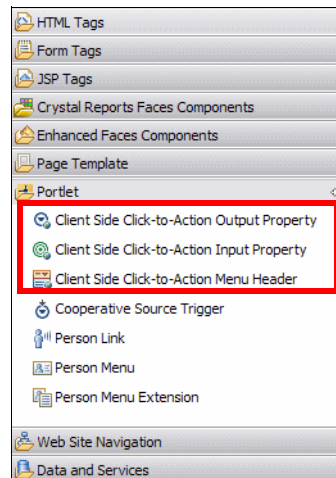
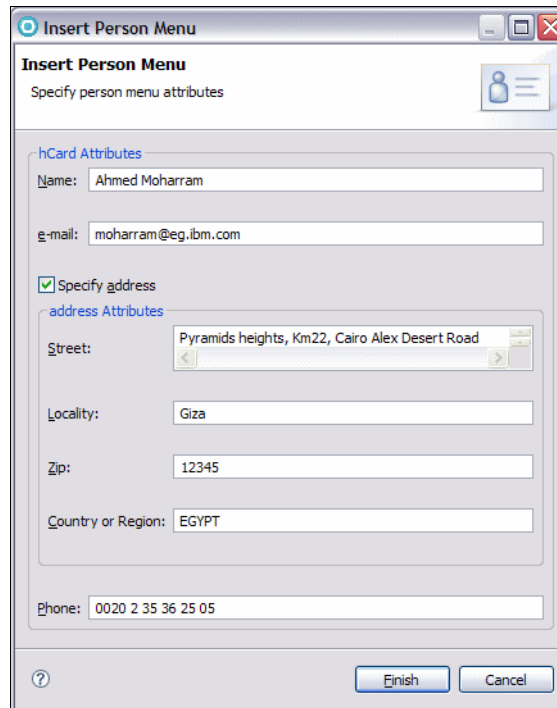

Figure 21-11 Click-to-Action properties

Note: The new Click-to-Action feature is available only if the target server is WebSphere Portal v6.1.

Person tagging support

Application Developer v7.5 provides new features called Person Menu and Person Menu Extension, where Person Menu (Figure 21-12) displays a set of contact information, and Person Menu Extension allows users to extend Person Menu and enable JavaScript actions.



The screenshot shows a dialog box titled "Insert Person Menu" with the subtitle "Specify person menu attributes". It contains the following fields and options:

- hCard Attributes:**
 - Name: Ahmed Moharram
 - e-mail: moharram@eg.ibm.com
- Specify address
- address Attributes:**
 - Street: Pyramids heights, Km22, Cairo Alex Desert Road
 - Locality: Giza
 - Zip: 12345
 - Country or Region: EGYPT
- Phone: 0020 2 35 36 25 05

At the bottom of the dialog, there are "Finish" and "Cancel" buttons, along with a help icon (?) on the left.

Figure 21-12 Insert Person menu

Application Developer 7.5 automatically generates JSP code corresponding to the created Person Menu.

JSR 286 new PDD editor

Application Developer v7.5 has new tabs added to the Portlet Deployment Descriptor to accommodate for the JSR 286 specification. The new tabs are for events, render parameter, and filters (Figure 21-13).

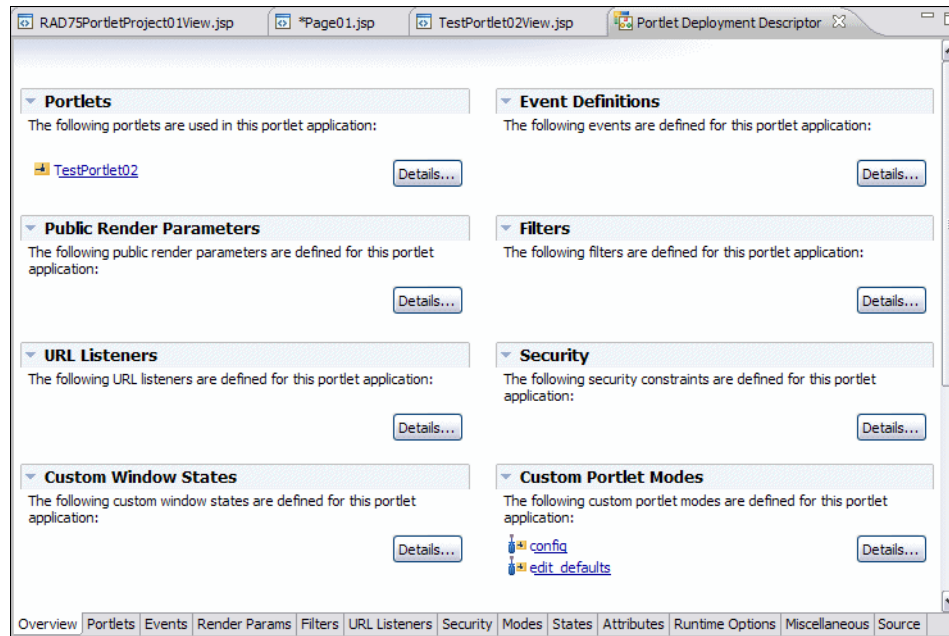

Figure 21-13 New tabs in the Portlet Deployment Descriptor

Ajax Proxy support

Ajax-based Web applications sometimes require sending Ajax requests to servers different from the server that served by the HTML content. This can be done using portlets with an Ajax proxy facet enabled in Application Developer v7.5 (Figure 21-14).

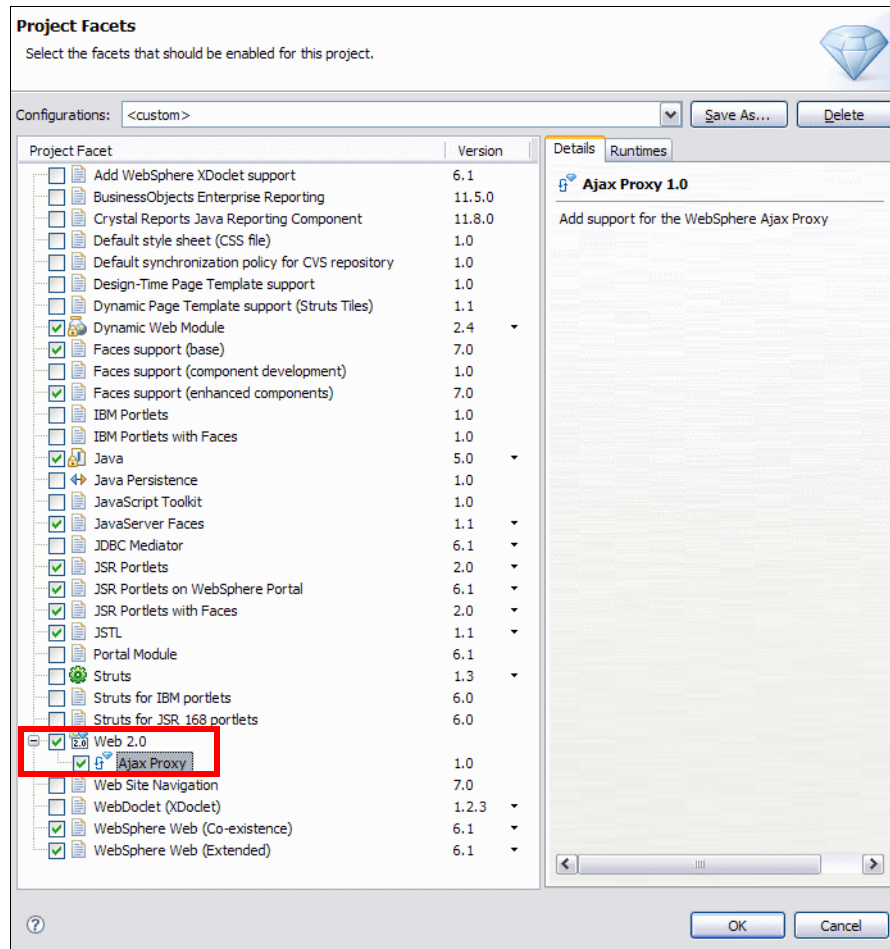

Figure 21-14 Ajax Proxy support

Developing portal solutions using portal tools

In this section, we provide an example to develop eventing portlets.

Developing eventing portlets

Events are a powerful and flexible mechanism for communication between JSR 286 portlets. Events can be used to exchange complex data between portlets and to trigger portlet activity such as updates to back-end systems. In the portal,

they can also work with other communication mechanisms such as cooperative portlets and click-to-action portlets.

Application Developer v7.5 provides wizards and user friendly editors to create and configure events.

Wizards help portlets publish and receive events. You specify a unique name for the event that has to be published or processed, using either the default name space or a custom name space. In addition, the alias address in the name space indicates that these events are compatible with any events of another portlet that has the same alias and can therefore work with input or output values of the provided address type.

Events subscribe to a server-side model or to a client-side model (IBM API and JSR API portlets targeted on WebSphere Portal v6.1) for declaring, publishing, and sharing information. Events can be distributed between local and remote portlets.

Server-side model portlets communicate with each other using the WebSphere Portal property broker. These portlets subscribe to the broker by publishing typed data items, or properties, that they can share, either as a provider or as a recipient.

Project setup

We use two projects for this application:

- ▶ **RAD75PortletEventEAR**—Enterprise application
- ▶ **RAD75PortletEvent**—Application with two portlets (based on JSR 286)

Import these projects from the interchange file located at:

```
C:\7672code\portal\RAD75PortletEventStart.zip
```

Structure of the sample application

The sample application consist of the following two portlets:

- ▶ **CityPortlet**—Contains a list of cities for the user to select
- ▶ **CityInfoPortlet**—Display detailed information about the city selected

Create an event to connect the portlets

We create an event to connect these two portlets:

- ▶ In the Enterprise Explorer, expand **RAD75PortletEvent**.
- ▶ Double-click in **Portlet Deployment Descriptor**

- ▶ In the Portlet Deployment Descriptor editor, select the **Events** tab, where we define the events for the portlet application (Figure 21-15). Click **Add**.

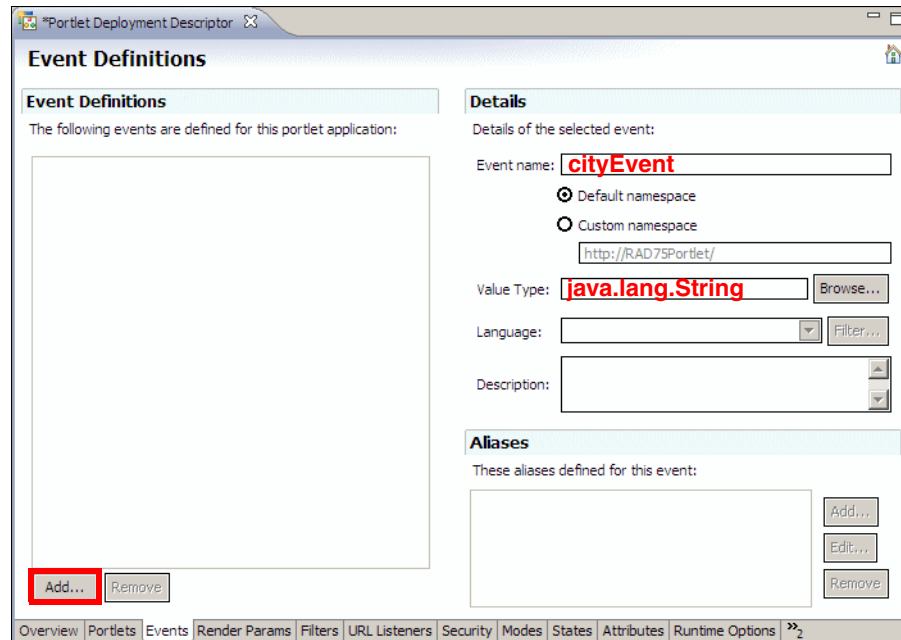

Figure 21-15 Portlet Deployment Descriptor: Events

- ▶ In the Details pane (right side), type **cityEvent** for Event Name, and **java.lang.String** for the Value Type. Save and close the editor.

To enable a portlet to publish an event, do these steps:

- ▶ In the Enterprise Explorer, expand **RAD75PortletEvent** → **Portlet Deployment Descriptor**.
- ▶ Right-click **CityPortlet** and select **Events** → **Enable this portlet to publish events** (Figure 21-16).

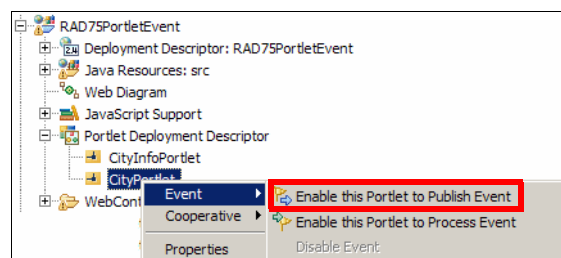

Figure 21-16 Enabling a portlet to publish events

- ▶ In the Event - Enable this Portlet to Publish events dialog, select **cityEvent** for the Event name, and click **Finish**.
- ▶ As a result, a processAction method is added to the CityPortlet class (Example 21-1).

Example 21-1 CityPortlet class processAction method

```
public void processAction(ActionRequest request, ActionResponse response)
    throws PortletException, java.io.IOException {

    //Initialize the fields in the class as per your requirement
    java.lang.String sampleObject = new java.lang.String();
    response.setEvent("cityEvent", sampleObject);
}
```

To enable a portlet to process an event, do these steps:

- ▶ In the Enterprise Explorer, expand **RAD75PortletEvent** → **Portlet Deployment Descriptor**.
- ▶ Right-click **CityInfoPortlet** and select **Events** → **Enable this portlet to process events**.
- ▶ In the Event - Enable this Portlet to Process events dialog, select **cityEvent** for the Event name, and click **Finish**
- ▶ As a result, a processEvent method is added to the CityInfoPortlet class (Example 21-2).

Example 21-2 CityInfoPortlet processEvent method

```
public void processEvent(EventRequest request, EventResponse response)
    throws PortletException, java.io.IOException {

    Event sampleEvent = request.getEvent();
    if(sampleEvent.getName().toString().equals("cityEvent")) {
        Object sampleProcessObject = sampleEvent.getValue();
    }
}
```

Adding the event logic to the two portlets

We have to put logic into the processAction method of the CityPortlet class and the processEvent method of the CityInfoPortlet class.

When the user submits the CityPortlet, the processAction method is called. We have to trigger an event with the value of the selected city to the CityInfoPortlet to process this event.

- ▶ Open the **CityPortlet** class and change the `processAction` method (Example 21-3).

Example 21-3 CityPortlet class processAction method (updated)

```
public void processAction(ActionRequest request, ActionResponse response)
    throws PortletException, java.io.IOException {
    //Initialize the fields in the class as per your requirement
    java.lang.String sampleObject = new java.lang.String();
    response.setEvent("cityEvent", sampleObject);
    String city = request.getParameter("cityCombo");
    response.setEvent("cityEvent", city);
}
```

- ▶ Open the **CityInfoPortlet** class and change the `processEvent` method to get the value of the event received and delegate this value to the `CityDB` helper class, which returns a `CityInfoBean` object with the information about the selected city (Example 21-4).

Example 21-4 CityInfoPortlet class processEvent method (updated)

```
public void processEvent(EventRequest request, EventResponse response)
    throws PortletException, IOException {

    Event sampleEvent = request.getEvent();
    if(sampleEvent.getName().toString().equals("cityEvent")) {
        Object sampleProcessObject = sampleEvent.getValue();
        String city = (String) sampleEvent.getValue();
        cityInfoBean = CityDB.getCityInfo(city);
    }
}
```

- ▶ The `doView` method of the `CityInfoPortlet` class puts the `cityInfoBean` on request scope and forwards processing to a JSP to display the result (Example 21-5).

Example 21-5 CityInfoPortlet class doView method

```
public void doView(RenderRequest request, RenderResponse response)
    throws PortletException, IOException {
    // Set the MIME type for the render response
    response.setContentType(request.getResponseContentType());
    request.setAttribute("info", cityInfoBean);
    // Invoke the JSP to render
    PortletRequestDispatcher rd = getPortletContext().getRequestDispatcher
        (getJspFilePath(request, VIEW_JSP));
    rd.include(request,response);
}
```

- ▶ The `CityInfoPortletView.jsp` in the `CityInfoPortlet` retrieves the `cityInfoBean` and displays the information about the selected city.

Deploying and running the event handling portlets

In the Enterprise Explorer, right click **RAD75PortletEvent** → **Run As** → **Run on Server**.

In the subsequent dialog, select **Finish** to complete publishing to the WebSphere Portal server. After the application has been deployed, Application Developer opens a browser in the Workbench (Figure 21-17).

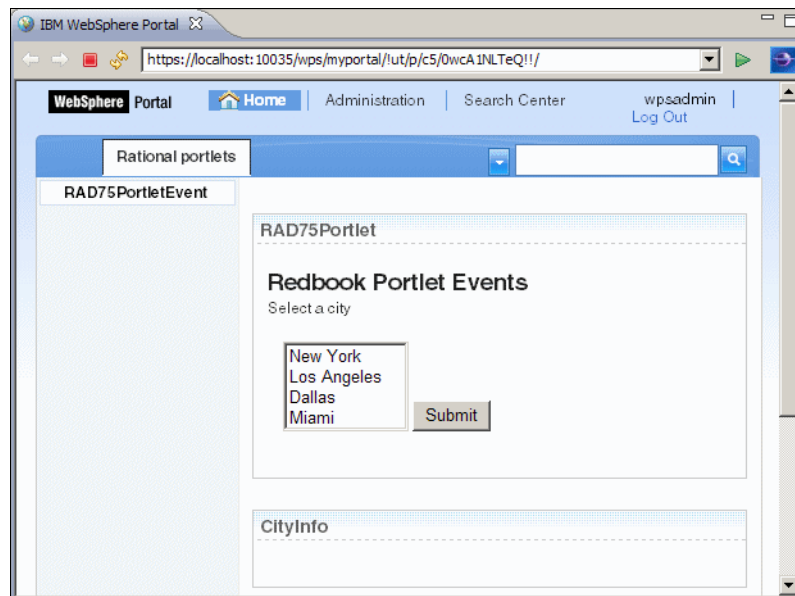

Figure 21-17 Browser with CityPortlet

Connecting the portlets

Now, we have to use wires to exchange information or actions between portlets. To access the wiring tool, following these steps:

- ▶ With the browser opened with the `CityPortlet`, pass the mouse over the **RAD75PortletEvent** label.
- ▶ An arrow appears on the right side, click the arrow to open a menu.
- ▶ In the menu, select **Edit Page Properties** (Figure 21-18).

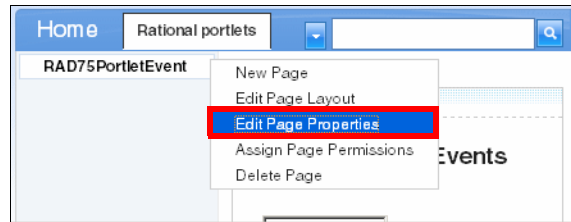

Figure 21-18 Edit Page Properties

- ▶ In the Page Properties dialog, type **rad75.portlet.page** as Unique name, and click **OK**.
- ▶ Again, pass the mouse over the **RAD75PortletEvent** label.
- ▶ In the menu, select **Edit Page Layout**.
- ▶ In the Page Customizer dialog, select in the **Wires** tab (Figure 21-19).

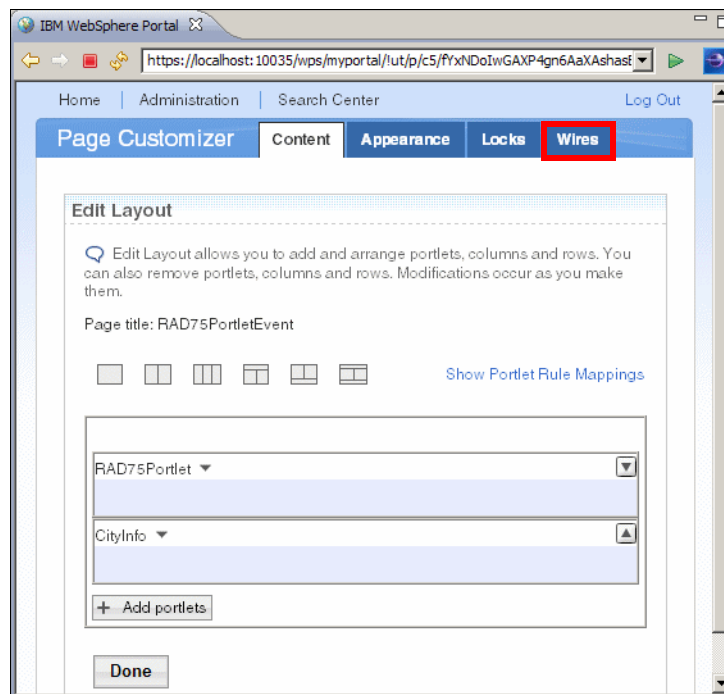

Figure 21-19 Edit Page Layout

- ▶ In the Portlet Wiring Tool, we connect the portlets (Figure 21-20):
 - Source Portlet: Select **RAD75Portlet**.
 - Sending: Select **publish.{http://RAD75Portlet}cityEvent**.

- Target Page: Select **RAD75PortletEvent (rad75.portlet.page)**.
- Target portlet: Select **CityInfo**.
- Receiving: Select **process.{http://RAD75Portlet/}cityEvent**.
- Click in the plus icon **+** to add the wire.
- Click **Done**, then click **Home**.

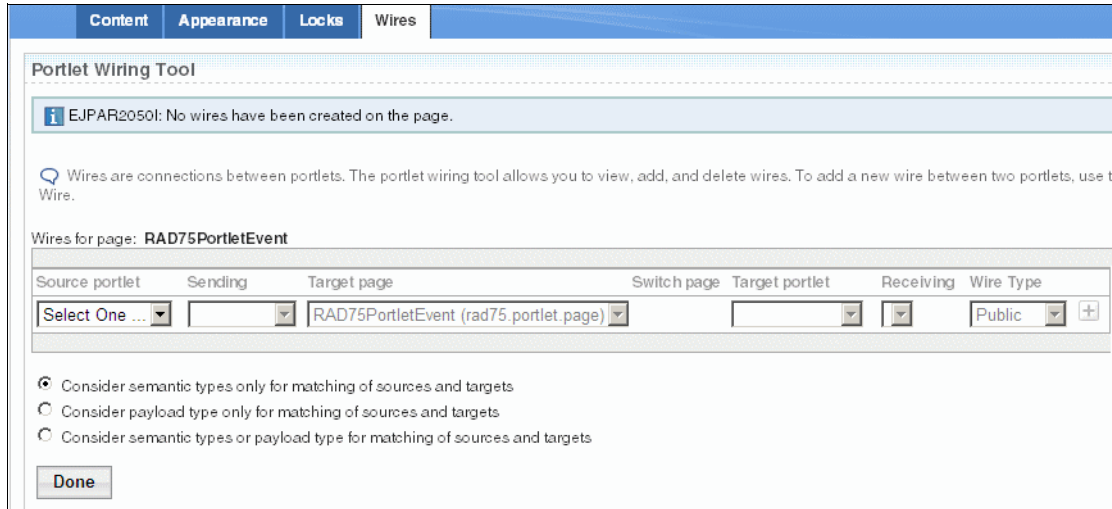

Figure 21-20 Portlet Wiring Tool (compressed)

Testing the application

To test the event link between the two portlets:

- ▶ Select **New York** in the first portlet and click **Submit**.
- ▶ The second portlet shows information about the selected city (Figure 21-21).



Figure 21-21 Application with event handling between portlets

Creating Ajax and Web 2.0 portlets

The new JSR 286 contains improvements to develop AJAX portlets. One of the new features is called *resource serving*.

Ajax using JSR 286 resource serving

Resource serving allows portlets to serve resource requests in resource URLs. With WSRP 2.0, requests for resources such as PDF documents are addressed within the WSRP protocol. Formerly an out-of-band connection was required for such resources, for example HTTP. Resources are now portal context aware, as the context information is passed directly over the WSRP protocol.

Resource serving allows Ajax support inside portlets, and the portlets have a way to return XML, JSON, HTML fragments, or other content. Only the portlet that made the requisition is updated, not the entire page (Figure 21-22).

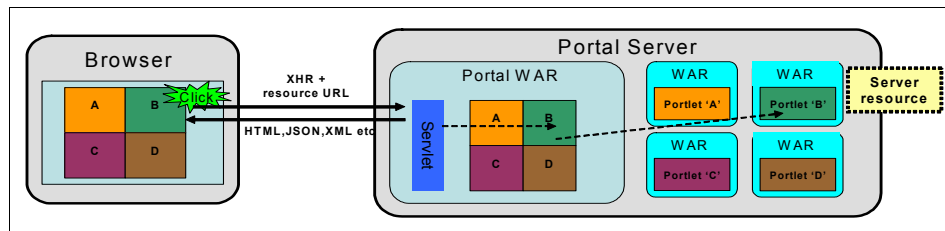

Figure 21-22 Portlet with Ajax support

A resource request is a new callback interface triggered by so-called *resource URLs*. To make a portlet be a resource serving portlet, we have to implement the `ResourceServingPortlet` interface and implement the `serveResource` method. The output for the `serveResource` method must have a separate content page.

Resource serving example

We adapt the previous portlet events example to add Ajax behavior. The `CityInfoPortlet` will have a button to retrieve a list of hotels about the current city (Figure 21-23).

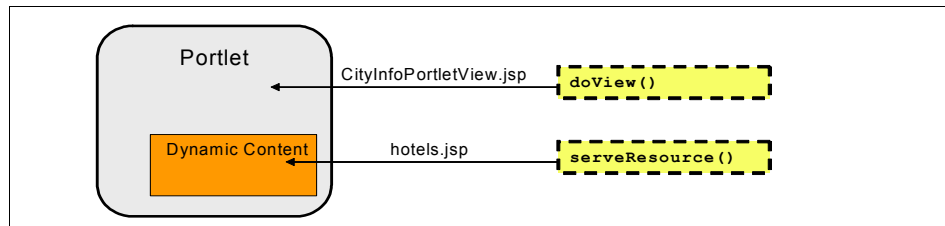

Figure 21-23 Resource serving portlet to add city hotels

Project setup

We have to projects:

- ▶ RAD75PortletEventAjaxEAR—Enterprise application
- ▶ **RAD75PortletEventAjax**—Application with two portlets (based on JSR 286)

Import these projects from the interchange file located at:

C:\7672code\portal\RAD75PortletEventAjaxStart.zip

First, we have to import some files before developing the others artifacts:

- ▶ Select **File** → **Import**.
- ▶ In the Import dialog, select **General** → **File System**. Click **Next**.
- ▶ In the File system dialog:
 - For From directory, click **Browse** to locate **C:\7672code\portal**.
 - Select **hotel.jsp** in the right frame.
 - For Into folder, click **Browse** and locate:

```
RAD75PortletEvent/WebContent/_CityInfo/jsp/html
```
 - Click **Finish**.
- ▶ Repeat the import to place **HotelInfoBean.java** into the **com.ibm.rad75portlet.bean** package.
- ▶ Repeat the import to place **HotelDB.java** into the **com.ibm.rad75portlet.db** package.

Tip: You can also drag and drop a file from a Windows Explorer folder directly into the appropriate folder or package in Application Developer.

Developing the Ajax code

Open the **CityInfoPortlet** class in the editor and perform these steps:

- ▶ Add an implements clause to the class declaration (Example 21-6).

Example 21-6 Implementing ResourceServingPortlet

```
public class CityInfoPortlet extends GenericPortlet
    implements ResourceServingPortlet {
```

Select **Source** → **Organize Imports** (or Ctrl+Shift+O) to resolve the import.

- ▶ Right-click in the editor window and select **Source** → **Override/Implement Methods**. Select the **serveResource** method, **After processEvent(...)** for Insertion point, and click **OK**.

- ▶ When the `serveResource` method is called, we have to find the hotels of the selected city and set a parameter with the hotel list to the JSP file. Add the code below to the `serveResource` method (Example 21-7).

Example 21-7 CityInfoPortlet serveResource method

```
public void serveResource(ResourceRequest request,
    ResourceResponse response) throws PortletException, IOException {
    String cityId = request.getParameter("cityId");
    request.setAttribute("hotels", HotelDB.getHotels(cityId));
    PortletRequestDispatcher rd = getPortletContext()
        .getRequestDispatcher(JSP_FOLDER + "/html/hotel.jsp");
    rd.include(request, response);
}
```

Select **Source** → **Organize Imports** (or Ctrl+Shift+O) to resolve the import.

- ▶ Add the code below (in bold) in the `doView` method to create the resource URL and add it to the request (Example 21-8).

Example 21-8 CityInfoPortlet doView method

```
public void doView(RenderRequest request, RenderResponse response)
    throws PortletException, IOException {
    // Set the MIME type for the render response
    response.setContentType(request.getResponseContentType());
    request.setAttribute("info", cityInfoBean);
    String resourceUrl = response.createResourceURL().toString();
    request.setAttribute("resourceUrl", resourceUrl);
    // Invoke the JSP to render
    PortletRequestDispatcher rd = getPortletContext()
        .getRequestDispatcher(getJspFilePath(request, VIEW_JSP));
    rd.include(request, response);
}
```

- ▶ Locate the JavaScript snippet file and copy its contents:

```
C:\7672code\portal\SnippetJavaScriptAjax.txt
```
- ▶ Paste the code into the `CityInfoPortletView.jsp` after the tags `<portlet-client-model:init>.....</portlet-client-model:init>`. This code has JavaScript functions that call Ajax functions.
- ▶ Next, we create a **Hotels** button with an event click that targets the resource URL, and a `<div>` tag where the list of hotels will appear. Add the code below into `CityInfoPortletView.jsp` after the `</table>` tag (Example 21-9).

Example 21-9 Hotels button and div tag

```
</table>
<br> <===== existing tag
```

```

<form>
  <input type="button"
    onclick="<portlet:namespace/>getHotels('${requestScope.resourceUrl}',
      'hotels','${requestScope.info.cityId}')" value="Hotels" >
</form>

</c:if> <===== existing tag

<div id="hotels"> </div>

```

Deploying and running the application

In the Enterprise Explorer, right-click **RAD75PortletEvent** → **Run As** → **Run on Server**.

In the subsequent dialog, select **Finish** to publish the application to the WebSphere Portal server. After the application has been deployed, Application Developer opens a browser in the Workbench.

Note: After deploying the application, you have to connect the Portlets. Follow the instructions in “Connecting the portlets” on page 767.

Testing the application

To test the Ajax functionality, perform these steps:

- ▶ In the first portlet, select **New York** from the list box and click **Submit**.
- ▶ The second portlet shows the information about New York city.
- ▶ Click **Hotels** to call an Ajax function that retrieves a list of Hotels (Figure 21-24).



Figure 21-24 Portlet application with Ajax

More information

For more information on portal technology, refer to these resources:

- ▶ The following Redbooks publications cover the Portlet Application Development for the older versions of WebSphere Portal:
 - *Building Composite Applications*, SG24-7367
 - *IBM WebSphere Portal V5 A Guide for Portlet Application Development*, SG24-6076
 - *IBM WebSphere Portal V5.1 Portlet Application Development*, SG24-6681
- ▶ WebSphere Portal v6.0 refresh pack 1 and instructions (WP v6.0.1):
<http://www-1.ibm.com/support/docview.wss?rs=688&uid=swg24015257>
http://publib.boulder.ibm.com/infocenter/wpdoc/v6r0/index.jsp?topic=/com.ibm.wp.ent.doc/wpf/pui_intro601.html
- ▶ WebSphere Portal Update Installer:
<http://www-1.ibm.com/support/docview.wss?rs=688&uid=swg24006942>
- ▶ WebSphere Application Server v6.0.2 Fix Pack 17 (WAS v6.0.2.17) for Windows platforms:
<http://www-1.ibm.com/support/docview.wss?rs=180&uid=swg24014309>
- ▶ Update Installer for WebSphere Application Server v6.0 releases:
<http://www-1.ibm.com/support/docview.wss?rs=180&uid=swg24008401>
- ▶ Troubleshooting - Rational Application Developer v7.x cannot sense the proper state of Portal Server v6.x:
http://www-1.ibm.com/support/docview.wss?rs=2042&context=SSRTLW&context=SSJM4G&context=SSCG7C&dc=DB520&uid=swg21258582&loc=en_US&cs=utf-8&lang=en
- ▶ Installing and configuring WebSphere Portal v6.0 Servers for development with Rational Application Developer v7.0 and Rational Software Architect v7.0:
http://www.ibm.com/developerworks/rational/library/07/0327_riordan/index.html



Part 6

Test and debug applications

In this part of the book, we describe the tooling and technologies provided by Application Developer for testing and debugging.



Servers and server configuration

Application Developer provides support for testing, debugging, profiling, and deploying Enterprise applications to local and remote test environments.

To run an enterprise application or Web application in Application Developer, the application must be published (deployed) to the server. This is achieved by deploying the EAR project, for the application, to an application server. With the server started the application can be tested using a Web browser, or by using the Universal Test Client (UTC) if it includes EJBs.

This chapter describes the features and concepts of server configuration, as well as demonstrating how to configure a server to test applications.

The chapter is organized into the following sections:

- ▶ Introduction to server configurations
- ▶ Understanding WebSphere Application Server v7.0 profiles
- ▶ WebSphere Application Server v7.0 installation
- ▶ Using WebSphere Application Server v7.0 profiles
- ▶ Adding and removing applications to and from a server
- ▶ Configuring application and server resources
- ▶ Configuring security
- ▶ Developing automation scripts

Introduction to server configurations

Application Developer includes integrated test environments for WebSphere Application Server v6.1 and v7.0 and WebSphere Portal v5.1 and v6.0, as well as support for many third-party servers obtained separately. The server configuration is the same for WebSphere Application Server v7.0 (base), Express, and Network Deployment Editions. One of the many great features of the server tooling is the ability to simultaneously run multiple server configurations and test environments on the same development node where Application Developer is installed.

When using Application Developer, it is very common for a developer to have multiple test environments or server configurations, which are made up of workspaces, projects, preferences and supporting test environments (local or remote).

Some of the key features of test environment configuration include:

- ▶ Multiple workspaces with different projects, preferences, and other configuration settings defined
- ▶ Multiple Application Developer test environment servers configured
- ▶ When using WebSphere Application Server v7.0 test environments, multiple profiles, each potentially representing a different server configuration

For example, a developer might want to have a separate server configuration for WebSphere Application Server v7.0 with a unique set of projects and preferences in a workspace, and a server configuration pointing to a newly created and customized WebSphere Application Server v7.0 profile. On the same system, the developer might create a separate portal server configuration with unique portal workspace projects and preferences, as well as a WebSphere Portal v6.0 Test Environment. This chapter describes how to create, configure, and run multiple WebSphere Application Server v7.0 instances on the same development system.

Application servers supported by Rational Application Developer 7.5

The most commonly used application server with Application Developer is WebSphere Application Server. WebSphere Application Server is tightly integrated with Application Developer, which offers tooling to test, run, and debug applications from the workbench, for example, by using the run-on-server functionality. You can specify server-specific configurations such as extensions and bindings for a WebSphere Application Server from the Workbench.

You can launch tooling for WebSphere Application Server from within the Workbench, such as the **WebSphere Administrative Console** and the **Profile Management Tool**. In addition, you can develop, run, and debug administrative scripts against a WebSphere Application Server.

In Application Developer, the integration with WebSphere Application Server v7.0 for deployment, testing, and administration is the same as for the WebSphere Application Server v7.0 test environment installed with Rational Application Developer and also for the Network Deployment edition.

The following application servers are compatible with Rational Application Developer v7.5:

- ▶ IBM WebSphere Application Server versions 5.1, 6.0, 6.1 and 7.0
- ▶ IBM WebSphere Application Server Express version 5.1
- ▶ IBM WebSphere Portal version 5.1 and 6.0
- ▶ J2EE Publishing Server (publish EAR to a server)
- ▶ Static Web Publishing Server (HTTP server for static Web projects)

Application Developer server tools are based on the Eclipse Web Tools Platform (WTP) project. WTP provides a facility for publishing an Enterprise Application project and all of its modules to a runtime environment for testing purposes.

Server adapters are tools installed into the Workbench that support a particular server. The server adapters on the following list are included, by default, in the Web Tools Platform installed with Rational Application Developer:

- ▶ Apache Tomcat versions 3.2, 4.0, 4.1, 5.0, 5.5 and 6.0
- ▶ IBM Websphere Portal Server versions 6.0 and 6.1
- ▶ IBM Websphere Application Server versions 6.0, 6.1 and 7.0
- ▶ JBoss versions 3.2, 3, 4.0, 4.2 and 5.0
- ▶ ObjectWeb Java Open Application Server (JOnAS) version 4
- ▶ Oracle Containers for Java EE (OC4J) Standalone Server version 10.1.3 and 10.1.3.n

Additional servers adapters can be obtained by clicking on **Download additional server adapters** in the **New Server** dialog as shown in Figure 22-1. To open the **New Server** dialog right-click on the Servers window and select **New** → **Server**. Some of the additional server adapters that could be obtained at the time of writing were:

- ▶ Apache Geromino Server versions 1.0, 1.1.x, 2.0 and 2.1
- ▶ IBM Websphere Application Server Community Edition versions 1.1.x, 2.0 and 2.1

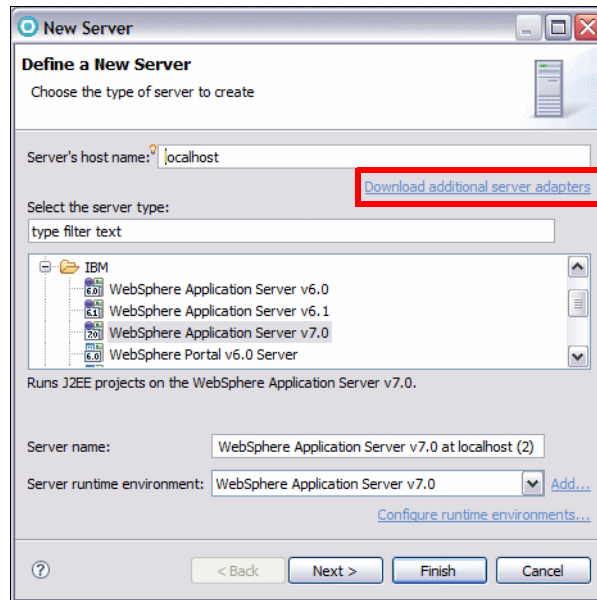

Figure 22-1 Downloading additional server adapters

Local and remote test environments

When configuring a test environment, the server can be either a local integrated server or a remote server. Once the server itself is installed and configured, the server definition within Rational Application Developer is very similar for local and remote servers.

In both the local and remote configurations Remote Method Invocation (RMI) or SOAP connectors can be used by Rational Application Developer to control the server using Java Management Extensions (JMX). The RMI (ORB bootstrap) port is designed to improve performance and communication with the server. The SOAP connector port is designed to be more firewall compatible and uses HTTP as the base protocol. In the case of local configurations the Inter Process Communication (IPC) connector is also available and is in fact the recommended connector.

Understanding WebSphere Application Server v7.0 profiles

The concept of server profiles was introduced starting with WebSphere Application Server v6.0. The WebSphere Application Server installation process simply lays down a set of core product files required by the runtime processes. After installation, you have to create one or more profiles that define the runtime settings for a functional system. The core product files are shared between the runtime components defined by these profiles.

With WebSphere Application Server Base and Express Editions, you can only have standalone application servers (Figure 22-2). Each application server is defined within a single cell and node. The administration console is hosted within the application server and can only connect to that application server. No central management of multiple application servers are possible. An application server profile defines this environment.

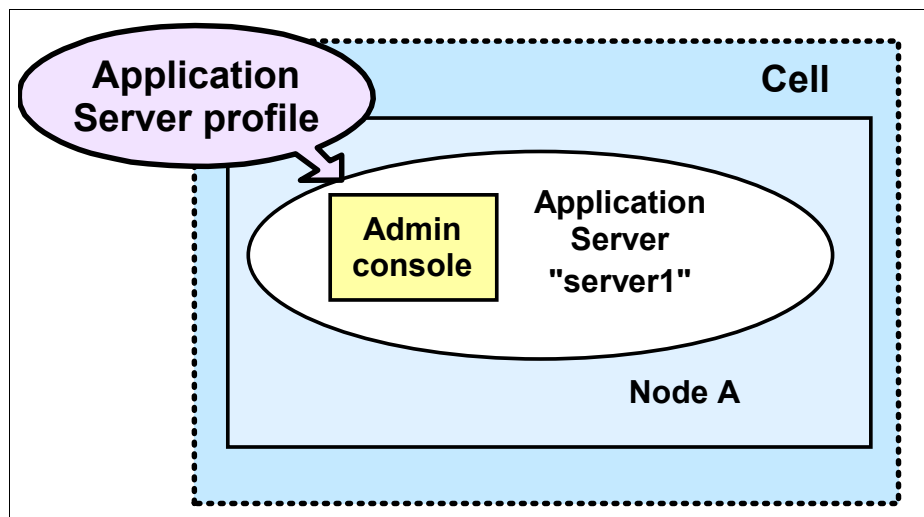

Figure 22-2 System management topology: Standalone server (Base and Express)

You can also create standalone application servers with the Network Deployment package, though you would most likely do so with the intent of federating that server into a cell for central management at some point.

With the Network Deployment package, you have the option of defining multiple application servers with central management capabilities. For more information on profiles for the IBM WebSphere Application Server v7.0 Network Deployment Edition, refer to *WebSphere Application Server V6.1: Systems Management and Configuration*, SG24-7304.

Types of profiles

There are three types of profiles used when defining the runtime of an application server:

- ▶ Application server profile

Note: This is the application server profile used by Rational Application Developer for the WebSphere Application Server v7.0 test environment.

- ▶ Deployment manager profile
- ▶ Custom profile

Application server profile

The application server profile defines a single standalone application server. Using a profile will give you an application server that can run standalone (unmanaged) with the following characteristics:

- ▶ The profile consists of one cell, one node, and one server. The cell and node are not relevant in terms of administration, but you will see them when you administer the server through the administrative console.
- ▶ The name of the application server is **server1**.
- ▶ The WebSphere sample applications are automatically installed on the server.
- ▶ The server has a dedicated administrative console.

The primary use for this type of profile could be any of the following:

- ▶ To build a server in a Base or Express installation, including a test environment within Rational Application Developer.
- ▶ To build a standalone server in a Network Deployment installation that is not managed by the deployment manager, for example, to build a test machine.
- ▶ To build a server in a distributed server environment to be federated and managed by the deployment manager. If you are new to WebSphere Application Server and want a quick way of getting an application server complete with samples, this is a good option. When you federate this node, the default cell becomes obsolete and the node is added to the deployment manager cell. The server name remains as **server1**, and the administrative console is removed from the application server.

Deployment manager profile

The deployment manager profile defines a deployment manager in a Network Deployment installation. Although you could conceivably have the Network Deployment package and run only standalone servers, this would bypass the primary advantages of Network Deployment, which are workload management, failover, and central administration.

In a Network Deployment environment, you should create one deployment manager profile. This will give you:

- ▶ A cell for the administrative domain
- ▶ A node for the deployment manager
- ▶ A deployment manager with an administrative console.
- ▶ No application servers

Once you have the deployment manager, you can:

- ▶ Federate nodes built either from existing application server profiles or custom profiles.
- ▶ Create new application servers and clusters on the nodes from the administrative console.

Custom profile

A custom profile is an empty node, intended for federation to a deployment manager. This type of profile is used when you are building a distributed server environment. You would use this as follows:

- ▶ Create a deployment manager profile.
- ▶ Create one custom profile on each node on which you will run application servers.
- ▶ Federate each custom profile, either during the custom profile creation process or later using the **addNode** command, of the deployment manager.
- ▶ Create new application servers and clusters on the nodes from the administrative console.

WebSphere Application Server v7.0 installation

The IBM WebSphere Application Server v7.0 integrated test environment is an installation option available in **IBM Installation Manager** when Installing Rational Application Developer.

For details on how to install the WebSphere Application Server V7.0 Test Environment, refer to “Installing IBM Rational Application Developer” on page 1124 (Figure A-6 on page 1126).

Prior to the IBM WebSphere Application Server v7.0 test environment installation, the runtimes directory looks as follows:

```
<rad_home>\runtimes\base_v7_stub
```

The stub folder contains minimal sets of compile-time libraries that allow you to build applications for a server when it is not installed locally.

After the WebSphere Application Server v7.0 test environment is installed you will see the directory:

```
<rad_home>\runtimes\base_v7
```

The base_v7 folder is the Application Server installation directory.

Using WebSphere Application Server v7.0 profiles

In “Understanding WebSphere Application Server v7.0 profiles” on page 781, we reviewed WebSphere V7.0 profile concepts. The Profile Management tool is a WebSphere Application Server tool that creates the profile for each runtime environment. It is also a graphical user interface to the WebSphere Application Server command-line tool, `wasprofile`. You can use the tools in Rational Application Developer to start the WebSphere Application Server Profile Management tool.

Creating a new profile using the WebSphere Profile wizard

To create a new WebSphere Application Server v7.0 profile using the WebSphere Profile Management Tool, do the following from within the Rational Application Developer environment:

- ▶ In the workbench, select **Window** → **Preferences**.
- ▶ In the Preferences window, expand **Server** → **WebSphere Application Server**.
- ▶ Under the WebSphere Application Server local server profile management list, select **WebSphere Application Server v7.0** (Figure 22-3).

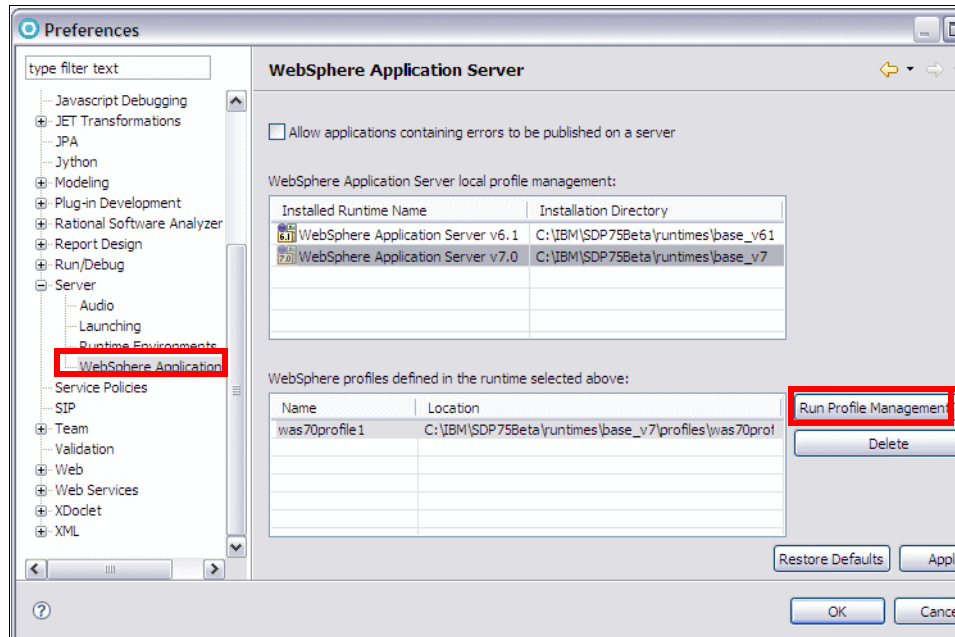

Figure 22-3 Server Preferences page

- ▶ Click **Run Profile Management Tool** next to the WebSphere profiles defined in the runtime selected above list, which lists all the profiles defined for the runtime environment selected in the previous step.
- ▶ In the Profile Management Tool window, click **Profile Management Tool**.
- ▶ The existing profile (was70profile1) is listed. Click **Create** (Figure 22-4).

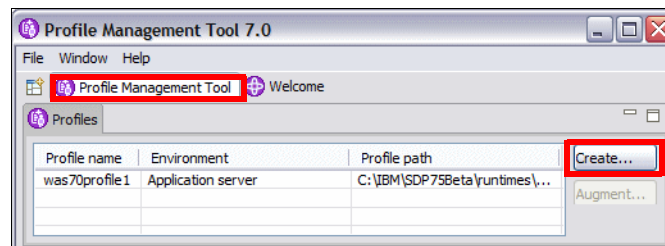

Figure 22-4 Profile Management Tool window

- ▶ In the Environment selection page, WebSphere Application Server is preselected. Click **Next**.
- ▶ In the Profile Creation Options page, select **Typical profile creation** and click **Next** (Figure 22-5).

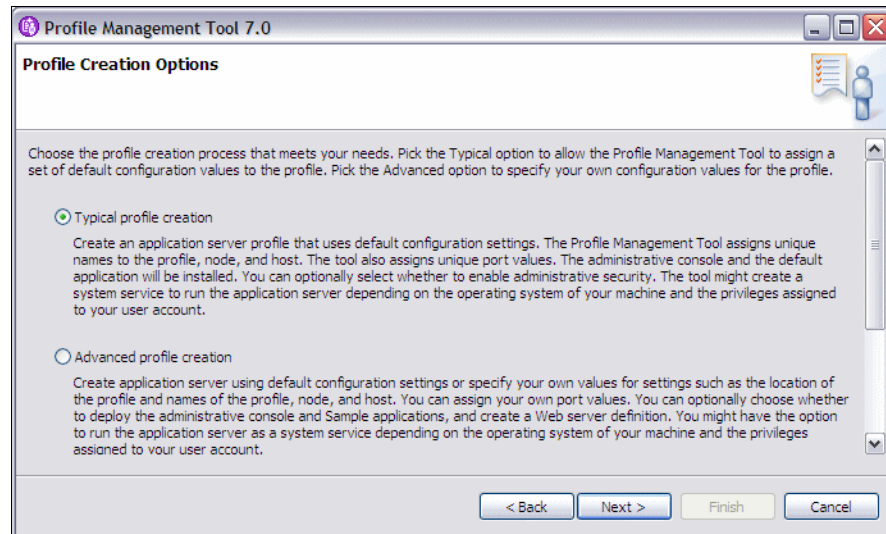

Figure 22-5 Profile options

- ▶ In the Administrative Security page, clear **Enable administrative security** and click **Next**. Alternatively, select **Enable administrative security** and enter a user name and password (for example, admin).
- ▶ In the Profile Creation Summary page, review the profile settings. You can see that the ports are incremented by 1 for the new profile you are creating so that the new profile does not conflict with an existing profile. Click **Create**.
- ▶ In the Profile Creation Complete page, clear **Launch the First steps console**, and click **Finish**.
- ▶ Notice that information that you can start the Profile Management Tool using the `pmt` command in the `<app_server_root>/bin/ProfileManagement` directory (`<rad-home>/runtimes/base_v7/bin/ProfileManagement`).
- ▶ Back in the Profile Management Tool window, you can see the new profile is present in the Profiles list with the name **AppSrv01**.
- ▶ When you close the Profile Management tool window and return to the Preferences window you can also see that the new profile is listed under the WebSphere profiles defined in the runtime selected above list.

Note: The new server is installed as a Windows service that is started automatically. You may want to edit the service in the Windows Services dialog and set the Startup Type to **Manual**.

Verifying the new WebSphere profile

After creating the WebSphere profile, you can verify that it was created properly and familiarize yourself with how to use it by doing the following:

- ▶ View the directory structure and find the new profile:

```
<rad_home>/runtimes/base_v7/profiles/<profile_name>  
<rad_home>/runtimes/base_v7/profiles/AppSrv01
```

This is where you will find, among other things, the config directory containing the application server configuration files, the bin directory, for commands, and the logs directory where log information is recorded.

Note: For simplicity, we will now refer to the entire path for the profile as *<profile_home>*.

- ▶ Start the server by opening a command prompt, and issuing the **startserver** commands:

```
cd <profile_home>\bin  
startserver server1
```

- ▶ Once the server has started the following message is displayed in the command prompt but probably with a different process id:

```
ADMU3000I: Server server1 open for e-business; process id is xxxx
```

The server log files are in the *<profile_home>/logs/server1* folder. Open the following file to see the logging messages:

```
<profile_home>/logs/server1/SystemOut.log
```

- ▶ Open the WebSphere Administrative Console by accessing its URL from a Web browser. The format of the required URL and a specific example are:

```
http://<appserver_host>:<admin_console_port>/ibm/console  
http://localhost:9062/ibm/console/
```

The administrative console port was listed in the Profile Creation Summary page during profile creation. If the port used in your case is different from the example given, you can determine the port from the *SystemOut.log*. Search for the string **bound to admin_host** in the log file. The first number in the square brackets following this string is the admin port being used. In this example the values are [**:9062,*:9045*].

- ▶ Click **Log in** to access the admin console functionality. Security is not active at this time so you do not have to enter a user name. If you choose to enter a name, it can be any name. If you enter a name it will be used to track changes you made to the configuration.

- ▶ In the admin console you can see **Servers** and **Applications** in the list presented on the left hand side of the display. To investigate a portion of the server configuration do the following:
 - Select **Servers** → **Server Types** → **WebSphere application servers**, and the server1 is listed (Figure 22-6). To see the configuration for this server, click its name in the list.

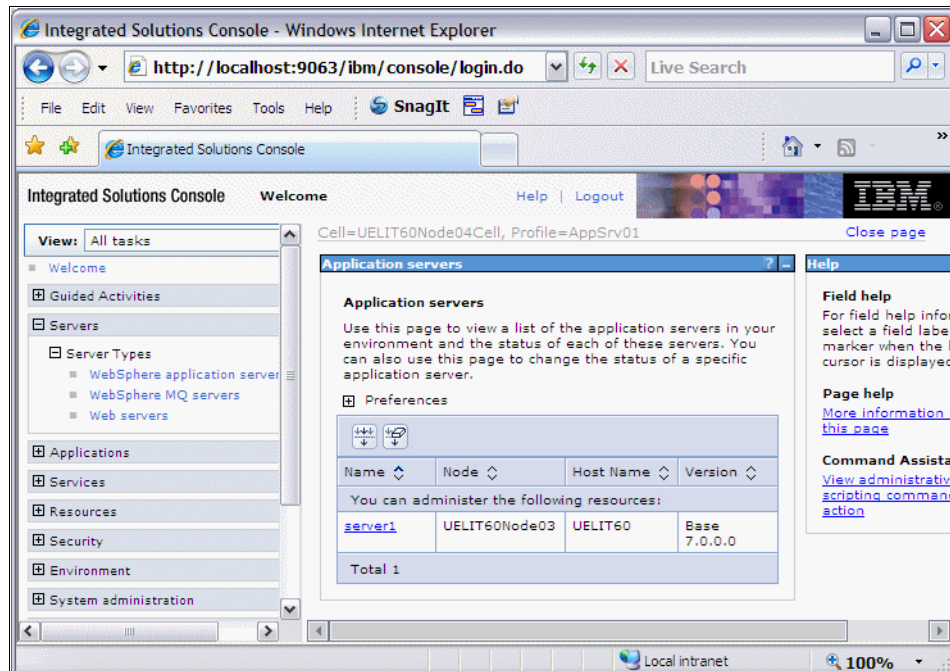

Figure 22-6 Application servers list in the admin console

- Select **Applications** → **Application Types** → **WebSphere enterprise applications**. You can see a list of applications installed on server1.
- Click **Logout** and close the browser.
- ▶ Stop the application server by executing the **stopserver** command in the command window:

```
stopserver server1
```

The following message will be displayed in the console once the server has stopped:

```
ADMU4000I: Server server1 stop completed.
```

Deleting a WebSphere profile

The steps required are provided here for future reference but do **not** perform the steps now, because we want to retain the newly created profile:

- ▶ From the menu bar of the workbench, select **Window** → **Preferences** → **Server** → **WebSphere Application Server**.
- ▶ Under the WebSphere Application Server local server profile management list, select the installed runtime environment containing the profile to be deleted.
- ▶ Under the WebSphere profiles defined in the runtime selected list above, select the profile to be deleted and click **Delete**. The registry and configuration files associated with the profile selected for deletion, are removed from the file system; however, any log files remain on the file system. and can be removed manually.

Defining the new server in Application Developer

Once you have created a WebSphere profile, you can define the new server in Rational Application Developer, to be used for the deployment of applications. A server definition points to a server defined within the specific selected WebSphere profile, such as the default profile created during installation, or a profile created using the Profile Management Tool. There are a few things to consider concerning the definition of a new server in Rational Application Developer:

- ▶ The profile **was70profile1** is created when the **WebSphere Application Server v7.0 Integrated Test Environment** feature is selected during the installation of Rational Application Developer. Also, a WebSphere Application Server v7.0 test environment server is defined and configured to use the **was70profile1** profile.
- ▶ A Rational Application Developer server definition is essentially a pointer to a WebSphere profile.

Create a server definition in Rational Application Developer

To create a server definition in Application Developer execute the following steps:

- ▶ Select the **Servers** view, in the Java EE or Web perspective.
- ▶ Right-click in the Servers view and select **New** → **Server**.
- ▶ In the Define a New Server dialog shown in Figure 22-7, do the following:
 - Leave the **Server's host name** at its default value of `localhost`.

- Select a **Server runtime environment of WebSphere Application Server v7.0.**
- Click **Next.**

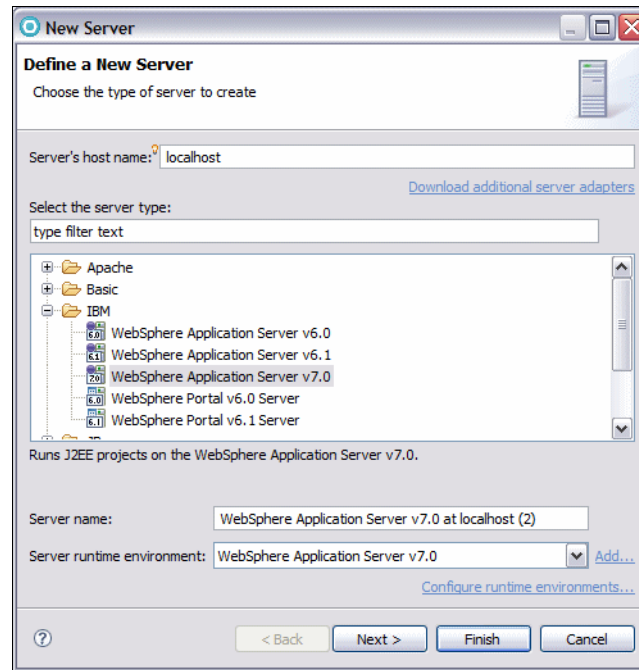

Figure 22-7 Define New Server dialog

- ▶ In the New Server dialog, WebSphere Server Settings page (Figure 22-8), do the following:
 - Select the Websphere profile we created previously as the **WebSphere profile name**. The profile to select is **AppSrv01**.
 - Select **Automatically determine connection settings** under Server connection types and administrative ports.
 - Select **Run server with resources within the workspace**.
 - Enter the value **server1** for the Websphere server name.
 - Click **Next**.

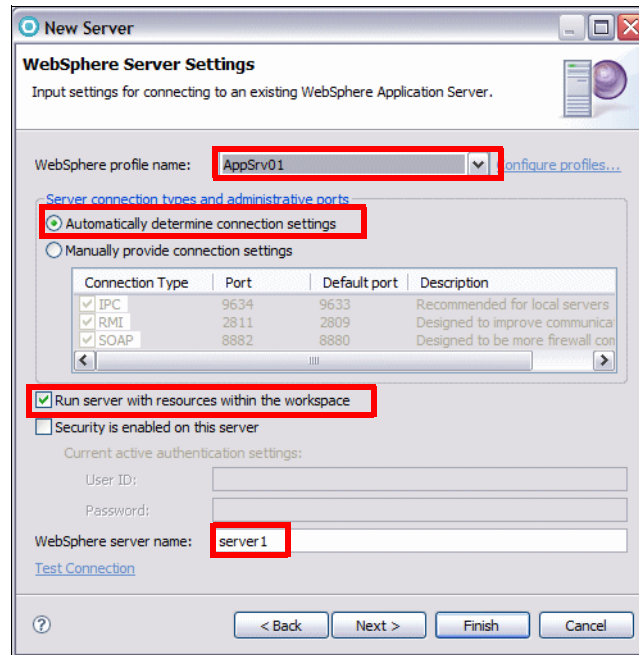

Figure 22-8 New Server dialog, WebSphere Server Settings page

- In the Add and Remove Projects dialog, we do not select a project at this time so click **Finish**.

The server definition is created and displayed in the Servers view. In our example, the server definition **WebSphere Application Server v7.0 at localhost (2)** is created.

Tip: Open the new server configuration by double-clicking on it. This allows you to change the configuration settings, for example, you can change the name of the server, but let us leave the name for now.

Verify the server

After you have completed defining the server within Application Developer, we recommend that you perform some basic verification steps to ensure that the server is configured properly:

- In the Servers view, right-click **WebSphere Application Server v7.0 at localhost (2)**, and select **Start** (or click the Start icon .

- ▶ Review the server startup output in the console. Also view the server logs `startServer.log` and `SystemOut.log` for errors:
 - <profile_home>/logs/server1/startServer.log
 - <profile_home>/logs/server1/SystemOut.log
- ▶ Right-click the server and select **Administration** → **Run administrative console**.
- ▶ After accessing several pages of the WebSphere Administrative Console to verify it is working properly, click **Logout** and close the browser.
- ▶ Verify that the server stops properly using the following steps:
 - In the Servers view, right-click the server, and select **Stop**. The server status should change to Stopped, after a while.
 - Verify that the server has really stopped by entering the following commands to verify the server status:

```
cd <profile_home>/bin
serverStatus -all
```
 - The server status output should show that the server has stopped. If not, stop the server by entering the following command:

```
stopServer server1
```

Customizing a server

Once the server has been defined in Rational Application Developer, it is very easy to customize its settings. To do this, in the Servers view, double-click the server you want to customize. The server overview window is shown in Figure 22-9. This window allows the server configuration to be modified.

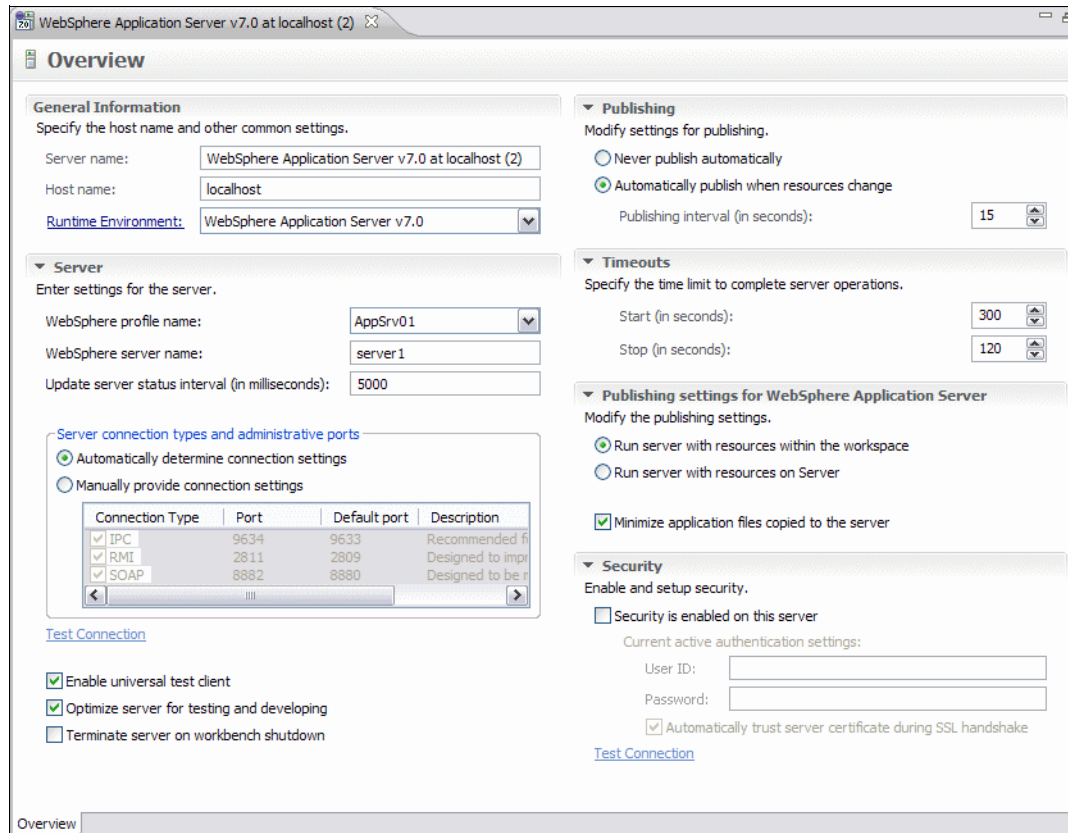

Figure 22-9 Server overview window

There are a several key settings that are worth covering in detail:

► **Server:**

- **WebSphere Profile name.** This is where the desired WebSphere application server profile is selected.
- **Server connection type and administrative ports.** The method used by Rational Application developer to communicate with the server is selected here. The radio buttons allow you to have the connection settings chosen automatically or manually. If manual connection settings are chosen then you can select whether to use **IPC**, **RMI** or **SOAP** as the communication channel between the development environment and the server. By default, the automatic setting radio button is active. When working with a local server **IPC** is the recommended connection setting although all settings will work. If you are working with a remote server, then **SOAP** or **RMI** can be used.

- **Terminate server on workbench shutdown.** If you want the server to be terminated after the workbench is shutdown, you have to select this option. Otherwise, the server continues to run after you shut down the development environment. The next time you start the IDE, the server is found again in its current state.
- ▶ **Publishing:**
 - **Never publish automatically.** Specifies that the workbench should not automatically publish files to the server. A developer can still publish to the server but must do this manually.
 - **Automatically publish when resources change.** Specifies that a change to the files running on the server should automatically be published to the server. **Publishing interval (in seconds)** specifies how often the publishing takes place. If you set the publishing interval to 0 seconds, a change to the files running on the server automatically causes publishing to occur.
- ▶ **Publishing settings for Websphere Application Server:**
 - **Run server with resources on Server.** This option installs and copies the full application and its server-specific configuration from the workbench into the directories of the server. The advantage of selecting the Run server with resources on Server setting is you are running your application from the directories of your server and you can edit advanced application-specific settings for your application using the WebSphere Administrative Console. However, when you choose to add your application to the server using the Add and Remove Projects wizard, this option takes a longer time to complete than the Run server with resources within the workspace option, as it involves more files being copied to the server.
 - **Run server with resources within the workspace.** This option requests the server to run your application from the workspace. The Run server with resources within the workspace setting is useful when developing and testing your application. It is designed to operate faster than the Run server with resources on Server option, as fewer files are involved when copying over to the server.
 - **Minimize application files copied to the server.** This option is designed to optimize the publishing-time on the server by reducing the files copied to the server. In addition to the application files not getting copied into the `installedApps` directory of the server, the application also does not get copied into your server configuration directory. As a result, when configuring your application, you cannot use the WebSphere Administrative Console to edit deployment descriptor information. You are limited to editing the Java EE deployment descriptor files for your

application within the workbench. Clear this option if you have to use the WebSphere Administrative Console to edit the deployment descriptor.

The **Security** settings are discussed in “Configuring security” on page 807.

Sharing a WebSphere profile between developers

The configuration of a server can be time consuming and error-prone. Once you have configured the server resources, you might want to let other members of the team use the same configuration from their local environment, without duplicating the same effort.

To replicate server configurations across multiple profiles, you can use the **Server Configuration Backup** wizard to create a backup of a WebSphere Application Server v7.0 profile in a Configuration Archive (CAR) file. This performs the same functionality as the `wsadmin` command:

```
wsadmin AdminTask exportWasprofile
```

You can also use the **Server Configuration Restore** wizard to restore a WebSphere Application Server v7.0 profile from a configuration archive file. This performs the same functionality as the `wsadmin` command:

```
wsadmin AdminTask importWasprofile
```

Server configuration backup

To backup the server configuration from WebSphere Application Server v7.0 at localhost, do the following:

- ▶ Configure the data source using WebSphere Application Server v7.0, as described in “Configuring the data source in WebSphere Application Server” on page 1155.
- ▶ Create a new project to store the configuration archive file:
 - Select **File** → **New** → **Project** → **General** → **Project** and click **Next**.
 - For the project name, enter **WAS70Car** and Click **Finish**.
- ▶ In the Servers view right-click on WebSphere Application Server v7.0 at localhost and select **Server Configuration** → **Backup**.
- ▶ In the **Server Configuration Backup** dialog, specify **/WAS70Car** as the Parent folder and **WAS70AppSrv1** as the File name and click **OK** (Figure 22-10).

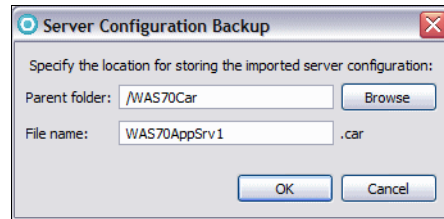

Figure 22-10 Server Configuration Backup dialog

- ▶ After the server configuration backup process completes, you should see the WAS70AppSrv1.car file under the WAS70Car project.

Server configuration restore

To restore the server configuration to a different server, in this case WebSphere Application Server v7.0 at localhost (2) do the following:

- ▶ Make sure that WebSphere Application Server v7.0 at localhost (2) is not running and if it is stop it.
- ▶ In the Servers view, right-click WebSphere Application Server v7.0 at localhost (2) and select **Server Configuration** → **Restore**.
- ▶ In the **Server Configuration Restore** dialog, specify **/WAS70Car** as the Parent folder and **WAS70AppSrv1.car** as the file name and click **OK** (Figure 22-11).

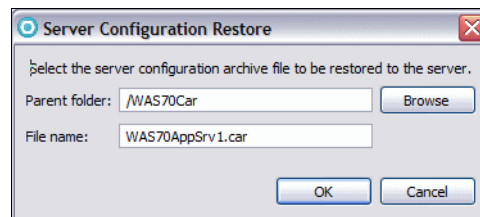

Figure 22-11 Server Configuration Restore dialog

- ▶ After the server configuration restore process completes, start WebSphere Application Server v7.0 at localhost (2).
- ▶ Right-click WebSphere Application Server v7.0 at localhost (2) and select **Administration** → **Run administrative console**. You should see the data source you configured for WebSphere Application Server v7.0 at localhost now also appears in the administrative console for WebSphere Application Server v7.0 at localhost (2).

Defining a server for each workspace

If you want to switch workspaces and keep applications deployed on the server, you can create a new WebSphere profile for each new Application Developer workspace, as described in “Creating a new profile using the WebSphere Profile wizard” on page 784. Then define only that server in the Servers view, as described in “Create a server definition in Rational Application Developer” on page 789.

This approach requires more disk space for each WebSphere profile and server configuration, and requires additional memory if the servers run concurrently.

Adding and removing applications to and from a server

Once the server is configured, it can be further configured with server resources and be used to run applications by adding applications to it.

This section describes how to add an enterprise application to a server. Note that you cannot add Web or EJB projects to a server, only enterprise applications EAR projects.

Adding an application to the server

To add an application to the server, do the following:

- ▶ Verify that the server has started.
- ▶ In the Servers view, right-click a server, and select **Add and Remove Projects**.
- ▶ In the Add and Remove Projects dialog (Figure 22-12), select one of the listed EAR projects and click **Add**. After you click **Add** the project appears in the **Configured projects**.
- ▶ Click **Finish**.

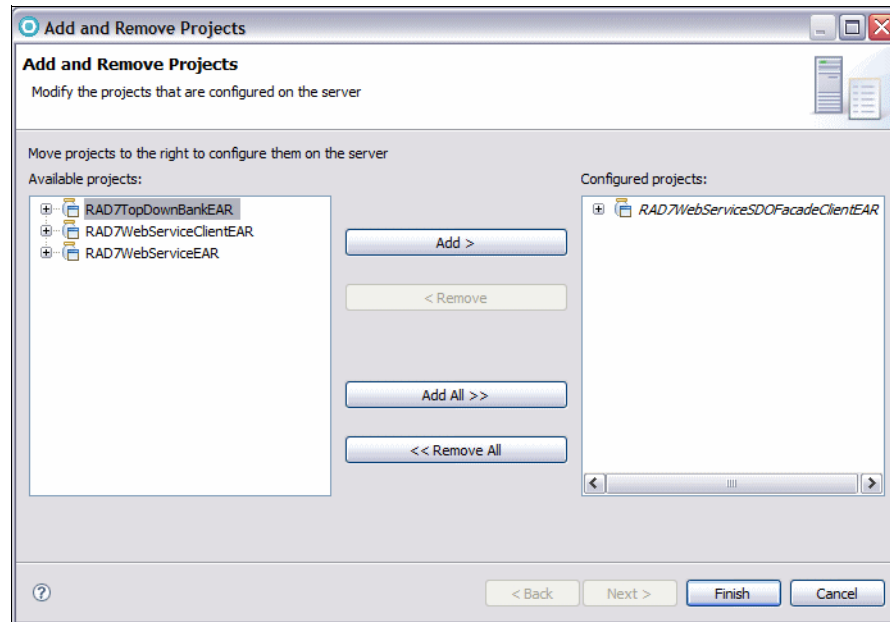

Figure 22-12 Add and Remove Projects

- ▶ Once an application is added to the server you can run any of the HTML pages or JSPs.

Removing an application from a server

An Application Developer server configuration is essentially a pointer to a server defined in a WebSphere profile. In this section we describe two scenarios for removing published projects from the server.

Remove an application using Application Developer

In most cases, you can remove the project from the test server within Rational Application Developer as follows:

- ▶ In the Servers view, right-click the server where the application is published, and select **Add and remove projects**. In the Add and Remove Projects dialog, select the project in the Configured projects list, click **Remove**, and then click **Finish**.
- ▶ Alternatively, expand the server in the servers view, right-click the EAR project to be removed, and select **Remove**.
- ▶ This operation uninstalls the application from the server.

Remove an application using the administrative console

In some cases you may decide to uninstall the application using the WebSphere Administrative Console.

For example, if you have published a project in Rational Application Developer to the test server, it is deployed to the server defined in the WebSphere profile. If you then switch workspaces without first removing the project from the server, you have broken the association between the Rational Application Developer server and the server defined in the WebSphere profile.

To address issues like the scenario described, uninstall the enterprise application from the WebSphere Administrative Console as follows:

- ▶ Make sure the server is started.
- ▶ Start the WebSphere Administrative Console either by right-clicking the server and selecting **Administration** → **Run administrative console** and then if necessary clicking **Log in**.
- ▶ Select **Applications** → **Application Types** → **Websphere Enterprise Applications**.
- ▶ Select the desired application to uninstall, and click **Uninstall**.
- ▶ When prompted, click **OK**.
- ▶ When uninstallation is complete, save the changes.

Note: After you uninstall the application using the WebSphere Administrative Console, you can see that the project still appears in the Configured projects section if you start the Add and Remove Projects wizard. You have to click **Remove** to move the project to the Available projects section.

Configuring application and server resources

In WebSphere Application Server v7.0, application-related properties and data sources can be defined within an Enhanced EAR file to simplify application deployment as shown in Figure 22-13. The properties are used by the application after it is deployed.

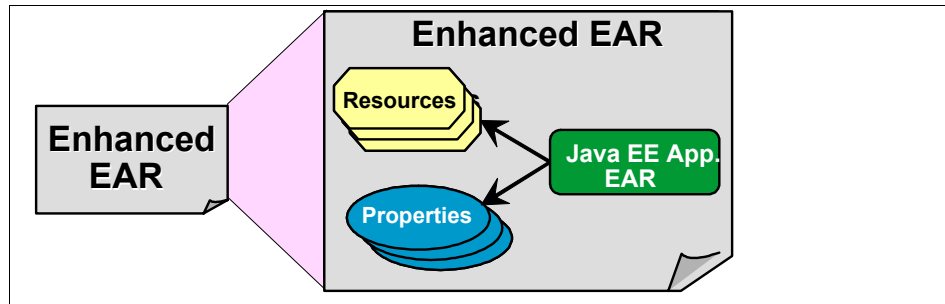

Figure 22-13 Enhanced EAR

The enhanced EAR tooling is available in the WebSphere Application Server Deployment Editor, as shown in Figure 22-14. Deployment information is saved under the application `/META-INF/ibmconfig` directory.

Note: The Enhanced EAR editor is used to edit several WebSphere Application Server v7.0 specific configurations, such as data sources, class loader policies, substitution variables, shared libraries, virtual hosts, and authentication settings. It lets you configure these settings with little effort and allows them to be published every time you publish the application.

The benefit of this is that it makes the testing process simpler and easily repeatable, because the configurations are saved to files that are usually shared in the team repository. Thus, even though it will not let you configure all the runtime settings, it is a good tool for development purposes because it eases the process of configuring the most common settings.

The downside is that the configuration settings are stored in the EAR file, and are not visible from administrative console. The console is only able to edit settings that belong to the cluster, node, and server contexts. When you change a configuration using the Enhanced EAR editor, this change is made at the application context. Furthermore, in most cases these settings are dependent on the node where the application server will be installed in anyway, so it makes little sense to configure them at the application context for deployment purposes.

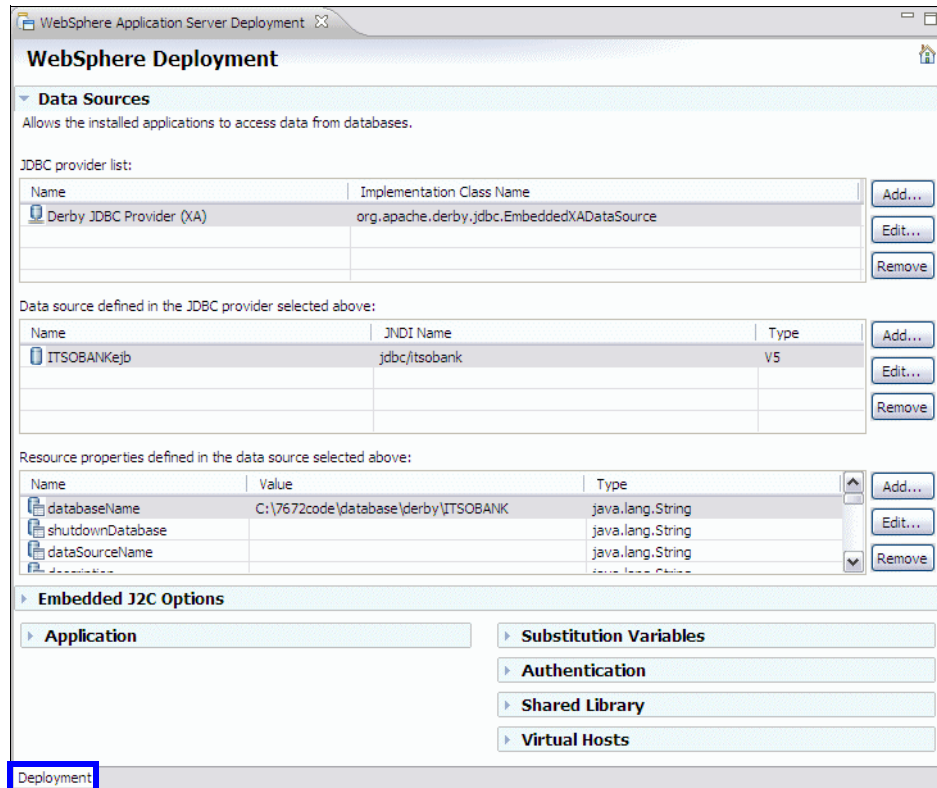

Figure 22-14 Enterprise application deployment descriptor: Enhanced EAR

The server configuration data that you specify in this editor gets embedded within the application itself. This improves the administration process of publishing to WebSphere Application Server v7.0 when installing a new application to an existing local or remote WebSphere Server by preserving the existing server configuration.

The following resource types can be added to the enhanced EAR:

- ▶ JDBC resources (Data Sources section)
- ▶ Resource adapters (Embedded J2C Options section)
- ▶ Application class loader settings (Application section)
- ▶ Substitution variables
- ▶ JAAS Authentication entries
- ▶ Shared Library
- ▶ Virtual Hosts

Creating a data source in the enhanced EAR

The data sources that support EJB entity beans must be specified before the application can be started. There are several ways to do it, but the easiest is to use the Enhanced EAR editor.

For an example of configuring the enhanced EAR against the Derby database, refer to [“Configuring the data source for the ITSOBANK” on page 413](#). In this section, we demonstrate how to create a data source for a DB2 database using enhanced EAR settings:

- ▶ In the Enterprise Explorer, right-click **RAD7EJBEAR** and select **Java EE** → **Open WebSphere Application Server Deployment**.
- ▶ Scroll down the page until you find the **Authentication** section. This allows you to define a login configuration used by JAAS.
- ▶ Click **Add** to create a new configuration (Figure 22-15).

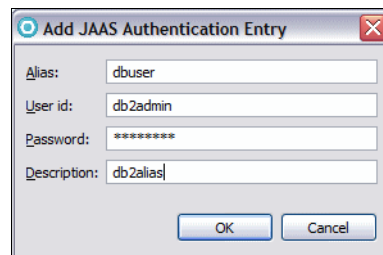

Figure 22-15 JAAS Authentication Entry

- ▶ Type **dbuser** as the Alias, and the appropriate user ID and password for your configuration. Click **OK** to complete the creation of the configuration.
- ▶ In the Enhanced EAR editor scroll back up to the Data Sources, JDBC provider list section. By default, the Derby JDBC Provider (XA) is predefined.
- ▶ Because we are using DB2 for this example, we have to add a DB2 JDBC provider by clicking **Add** next to the provider list.
- ▶ The Create JDBC Provider dialog opens (Figure 22-16):
 - Select **IBM DB2** as the database type.
 - Then select **DB2 Universal JDBC Driver Provider (XA)** as the provider type.
 - Click **Next**.

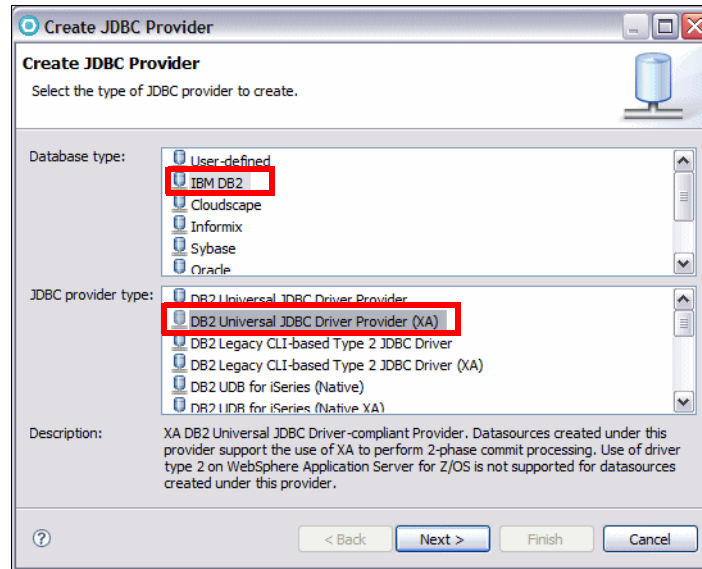

Figure 22-16 Creating a JDBC provider (page 1)

Note: Note that for our development purposes, the DB2 Universal JDBC Driver Provider (non XA) would work fine, because we do not require XA (two-phase commit) capabilities.

- ▶ In the second page of the wizard (Figure 22-17):
 - Type **DB2 XA JDBC Provider** as the name.
 - Notice the variables that are used to locate the JDBC driver:

```

          ${DB2UNIVERSAL_JDBC_DRIVER_PATH}
          ${UNIVERSAL_JDBC_DRIVER_PATH}
          ${DB2UNIVERSAL_JDBC_DRIVER_NATIVEPATH}
          
```

 If these variables are not set globally for the WebSphere Application Server, we can set them under Substitution Variables.
 - Click **Finish**.

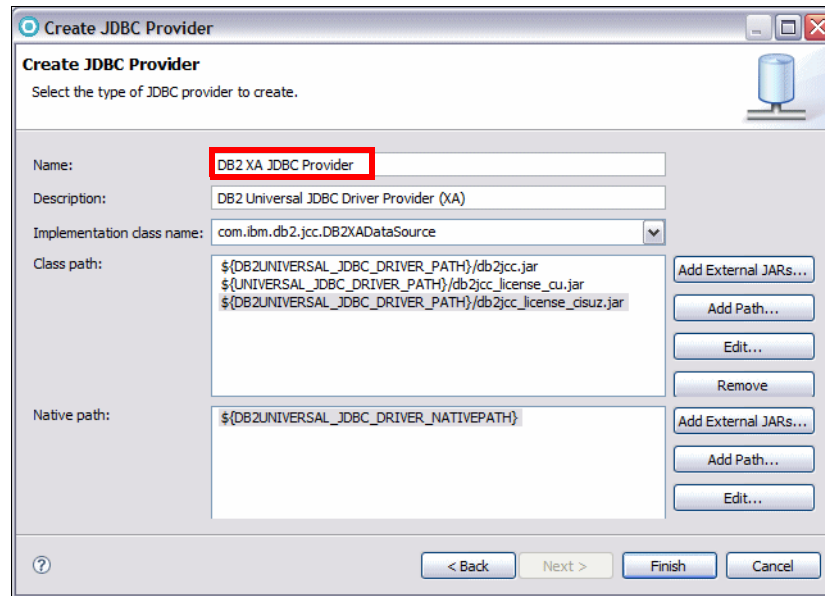

Figure 22-17 Creating a JDBC provider (page 2)

- ▶ With the new DB2 provider selected, click **Add** next to the defined data sources list. In the Create Data Source dialog (Figure 22-18):
 - Select **DB2 Universal JDBC Driver Provider (XA)** from the JDBC provider type list.
 - Select **Version 5.0 data source**.
 - Click **Next**.

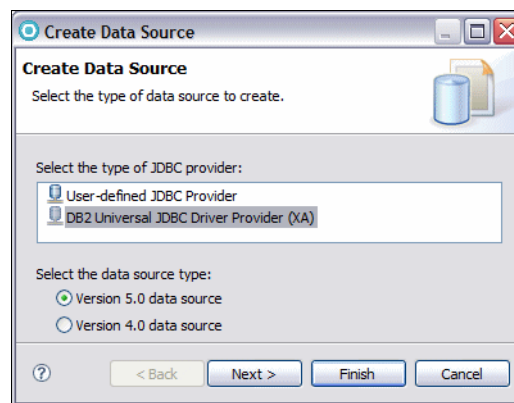

Figure 22-18 Create a data source (1)

- ▶ In the next page (Figure 22-19):
 - Type **RAD75DS** as the data source name and **jdbc/itsobankdb2** as the JNDI name.
 - Select the **dbuser** alias for Component-managed authentication alias.
 - Clear **Use this data source in container manager persistence (CMP)**. We are using JPA entities and not EJB 2.1 entity beans.
 - Click **Next**.

The screenshot shows the 'Create Data Source' wizard dialog box. The title bar reads 'Create Data Source'. Below the title bar, there is a subtitle 'Create Data Source' and a description 'Select the type of data source to create.' The dialog contains several fields and a checkbox:

- Name: RAD75DS
- JNDI name: jdbc/itsobankdb2
- Description: DB2 Universal Driver Datasource
- Category: (empty)
- Statement cache size: 10
- Data source helper class name: com.ibm.websphere.rsadapter.DB2UniversalDataStoreHelper
- Connection timeout: 180
- Maximum connections: 10
- Minimum connections: 1
- Reap time: 180
- Unused timeout: 1800
- Aged timeout: 0
- Purge policy: EntirePool
- Component-managed authentication alias: dbuser
- Container-managed authentication alias: (empty)

At the bottom, there is a checkbox labeled 'Use this data source in container manager persistence (CMP)' which is unchecked. Below the checkbox is the text '* Required field.' At the bottom right, there are four buttons: '< Back', 'Next >', 'Finish', and 'Cancel'. The 'Next >' button is highlighted.

Figure 22-19 Create a data source (2)

- ▶ In the last page of the wizard (Figure 22-20):
 - Set the `databaseName` property value to **ITSOBANK**.
 - Click **Finish** to conclude the wizard.

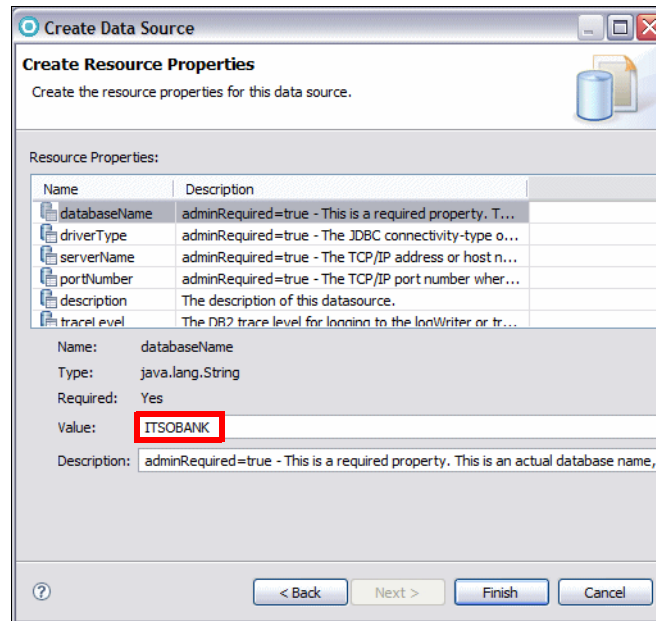

Figure 22-20 Create a data source (3)

- ▶ Save the deployment descriptor.

Setting substitution variable

If the variables to access the DB2 JDBC drivers are not set server wide (using the administrative console), you can expand the Substitution Variable section and define the variables:

- ▶ Click **Add**.
- ▶ In the Add Variable dialog, define the name of the variable (for example, `${DB2UNIVERSAL_JDBC_DRIVER_PATH}`), and set the value to the location where DB2 JDBC drivers are installed, for example, `c:\SQLLIB\java`.

Configuring server resources

Within Application Developer, the WebSphere administrative console is the primary interface for configuring WebSphere Application Server v7.0 test servers, both local and remote. Complicated resource configurations such as messaging resources can only be configured using the WebSphere administrative console.

There are a couple of methods for accessing the WebSphere administrative console. In each case the WebSphere Application Server v7.0 test server must be started.

Once the WebSphere Application Server v7.0 test server has started, you can right-click the server and select **Administration** → **Run administrative console**.

Configuring security

If the WebSphere Application Server v7.0 runtime environment has administrative security enabled, you have to communicate the administrative settings from your development environment to the runtime server. In Rational Application Developer you have to specify that security is enabled in the runtime environment, and provide the user ID and password in the server editor for the secured server. If you are working with a secured WebSphere Application Server Version v7.0 server, you have to establish a trust between the Rational Application Developer development environment and the server.

Note: For more information on configuring WebSphere security, refer to *IBM WebSphere Application Server V6.1 Security Handbook*, SG24-6316.

In this section, we show you how to enable administrative security, using the local operating system registry for authentication, by using the WebSphere Administrative Console. We also show you how to pass the administrative settings from the development environment to the runtime server.

Configuring security in the server

First, we configure the server so that it runs with security enabled:

- ▶ Start the test server called **WebSphere Application Server v7.0 at localhost (2)**.
- ▶ Right-click the server and select **Administration** → **Run administrative console**.
- ▶ Click **Log in**.
- ▶ Expand **Security** → **Global Security** (Figure 22-21):
 - Select **Enable administrative security** and **Enable application security**.
 - Clear **Use Java 2 security to restrict application access to local resources**.

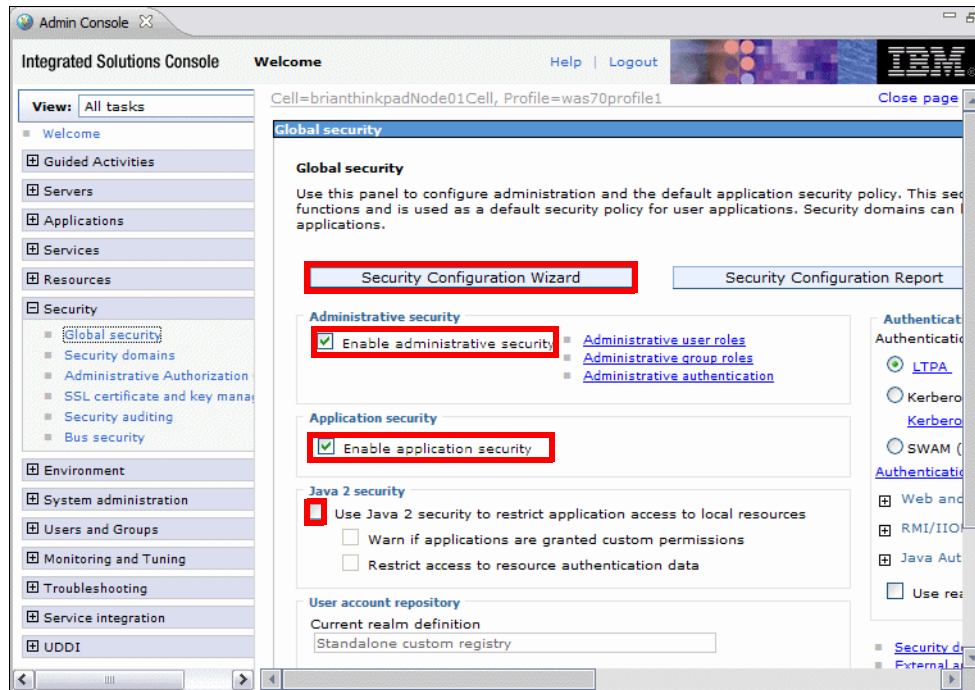

Figure 22-21 Configuring security

- ▶ Click **Security Configuration wizard**.
- ▶ In the **Specify extent of protection** page, click **Next**.
- ▶ In the **Select user repository** page, select **Local operating system**.
- ▶ In the **Configure user repository** page, enter the primary administrative user name, and click **Next**.

Note: The specified user must have the required privileges in Windows, such as the permission to log on as service. For more information see section 2.3 of the *IBM WebSphere Application Server V6.1 Security Handbook*, SG24-6316.

- ▶ Click **Finish**, then click **Save**, then click **Logout** to log off from the administrative console.
- ▶ Stop the server.

Configuring security in the Workbench

We have to edit the server configuration to specify that security is enabled:

- ▶ In the Servers view, double-click **WebSphere Application Server v7.0 at localhost (2)**. The server configuration editor opens (Figure 22-22).
 - Expand the **Security** section.
 - Select **Security is enabled on this server**.
 - The User ID and Password fields specify the administrator user of the WebSphere administrative console. These values must be the same as those entered in the Security Configuration wizard dialog, as described in “Configuring security in the server” on page 807.
 - Select **Automatically trust server certificate during SSL handshake** is selected

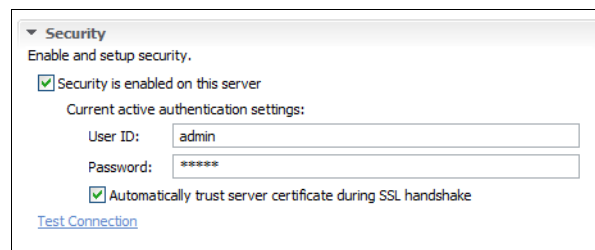

Figure 22-22 Security setting in server editor

- ▶ Save and close the server configuration editor.
- ▶ Start the server and run the administrative console.
- ▶ You should see the secured administrative console (Figure 22-23). Enter the user ID and password and click **Log in**.

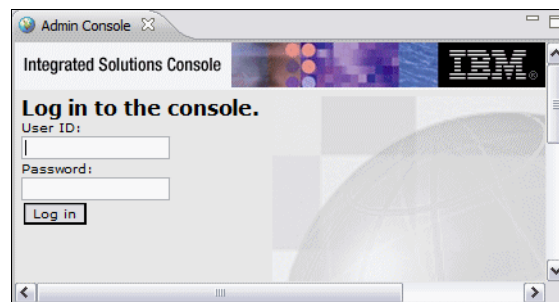

Figure 22-23 Secured Administrative Console

Developing automation scripts

Scripting is a non-graphical alternative that you can use to configure and manage a WebSphere Application Server. The WebSphere administrative scripting tool, `wsadmin`, is a non-graphical command interpreter environment that allows you to run administrative operations on a server in a scripting language.

There are five `wsadmin` objects available when you use scripts:

- ▶ **AdminControl**. This is used to run operational commands.
- ▶ **AdminConfig**. This is used to run configuration commands to create or modify WebSphere Application Server configuration elements.
- ▶ **AdminApp**. This is used to administer applications.
- ▶ **AdminTask**. This is used to run administrative commands.
- ▶ **Help**. This is used to obtain general help.

The WebSphere administrative scripting program, `wsadmin`, supports two scripting languages: Java Tcl (Jacl) and Java Python (Jython).

With the Version 6.1 release of WebSphere Application Server, IBM announced the start of the deprecation process for the Jacl syntax associated with `wsadmin`.

In this chapter, we describe how to create a Jython project and Jython script, how to edit the Jython script, and how to run it.

Creating a Jython project

To create a Jython project, follow these instructions:

- ▶ Select **File** → **New** → **Project** → **Jython** → **Jython Project** and click **Next**.
- ▶ For the Project name, type **RAD75Jython** and click **Finish**.

Creating Jython script files

To create a Jython script file, follow these instructions:

- ▶ Select **File** → **New** → **Other** → **Jython** → **Jython Script File** and click **Next**.
- ▶ Specify **/RAD75Jython** as the Parent folder and **listJDBCProviders.py** as the File name.
- ▶ Click **Finish**.

Editing Jython script files

The Jython editor is the tool for editing Jython scripts. The Jython editor has many text editing features, such as content assist, syntax highlighting, unlimited undo or redo, and automatic tab indentation.

Type the code shown in Example 22-1. It lists all defined JDBC providers in the WebSphere Application Server. During typing, you can use content assist by pressing Ctrl+Space. You can find the code in:

```
c:\7672code\Jython\listJDBCProviders.py
```

Example 22-1 List JDBC providers using a Jython script (listJDBCProviders.py)

```
def showJdbcProviders():
    providerEntries = AdminConfig.list("JDBCProvider")
    # split long line of entries into individual entries in list
    providerEntryList = providerEntries.split(1f)
    # print contents of list
    for provider in providerEntryList:
        print provider

AdminConfig.reset()
cell = AdminControl.getCell()
node = AdminControl.getNode()
lf = java.lang.System.getProperty("line.separator")
slash = java.lang.System.getProperty("file.separator")
print "System information: Cell=" + cell
print "System information: Node=" + node
showJdbcProviders()
```

Running administrative script files on WebSphere Application Server

You can run administrative scripts from within Application Developer, without having to switch to the non-graphical `wsadmin` command. To run a Jython script, follow these instructions:

- ▶ Make sure the server has started.
- ▶ Right-click the server **WebSphere Application Server v7.0 at localhost** and select **Administration** → **Run administrative script**.
- ▶ The Script page is the main page of the WebSphere Administrative Script Launcher (Figure 22-24):
 - In the Administrative Script field click **Workspace**.
 - In the File Selection dialog, expand the **RAD7Jython** project and select **listJDBCProviders.py** and click **OK**.

- For Scripting runtime select **WebSphere Application Server v7.0**.
- For WebSphere profile, select **AppSrv01** (or **was70profile1**), whatever server is running.
- In the Security section, if the administrative security is still enabled with local operating system registry, as you configured in “Configuring security” on page 807, select **Specify** and enter the required User ID and Password.

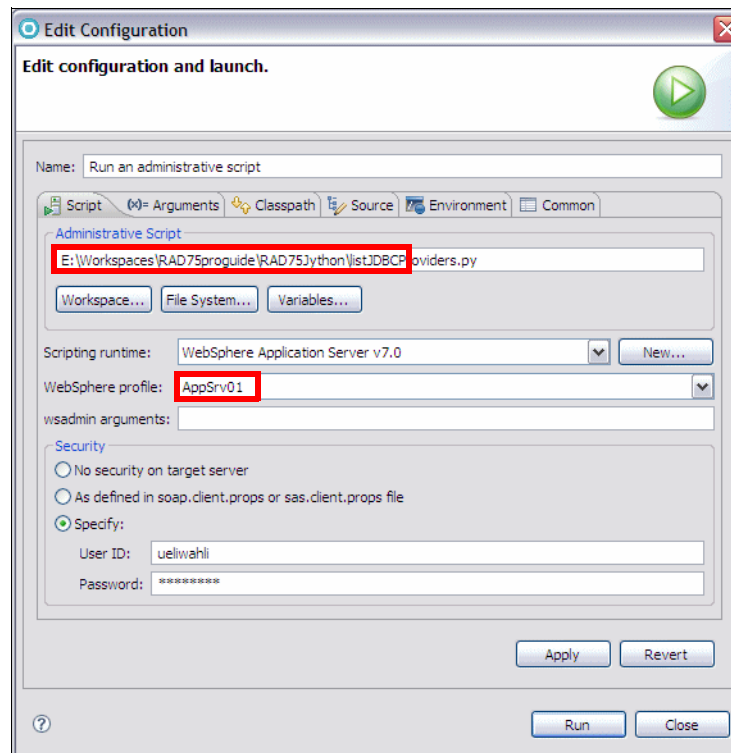

Figure 22-24 Running an administrative script

- ▶ Click **Apply** to save the configuration.
- ▶ Click **Run** to run the Jython script. You should see console output similar to that listed below:

```
WASX7209I: Connected to process "server1" on node KLCHL2YNode01 using
  SOAP connector; The type of process is: UnManagedProcess
System information: Cell=KLCHL2YNode01Cell
System information: Node=KLCHL2YNode01
"Derby JDBC Provider (XA) (cells/KLCHL2YNode01Cell/nodes/KLCHL2YNode01/
servers/server1/resources.xml#builtin_jdbcprovider)"
```

```
"Derby JDBC Provider (XA)(cells/KLCHL2YNode01Cell|resources.xml
#builtin_jdbcprovider)"
"Derby JDBC Provider(cells/KLCHL2YNode01Cell/nodes/KLCHL2YNode01/
servers/server1|resources.xml#JDBCProvider_1182202633563)"
```

Generating WebSphere admin commands for Jython scripts

You can use the WebSphere Administration Command assist tool to generate WebSphere administrative, wsadmin, Jython scripting language commands as you interact with the WebSphere Administrative Console. When you perform server operations in the WebSphere Administrative Console, the WebSphere Administration Command assist tool captures and displays the wsadmin commands issued. You can transfer the output from the WebSphere Administration Command view directly to a Jython editor, enabling you to develop Jython scripts based on actual console actions.

To generate wsadmin commands as you interact with the WebSphere Administrative Console, do the following:

- ▶ Enable the command assistance notification option in the WebSphere Administrative Console:
 - Make sure the server has started.
 - Right-click the server **WebSphere Application Server v7.0 at localhost (2)** and select **Administration** → **Run administrative console**.
 - Specify the User ID and the Password if the server is secured and click **Log in**.
 - On the left-pane, expand **Applications** → **Application Types** → **Websphere enterprise applications**.
 - Scroll to the right of the **Enterprise Applications** page and under the **Command Assistance** section, click **View administrative scripting command for last action**.
 - Expand **Preferences**, select the **Enable command assistance notifications** (Figure 22-25). Click **Apply** and close the window.

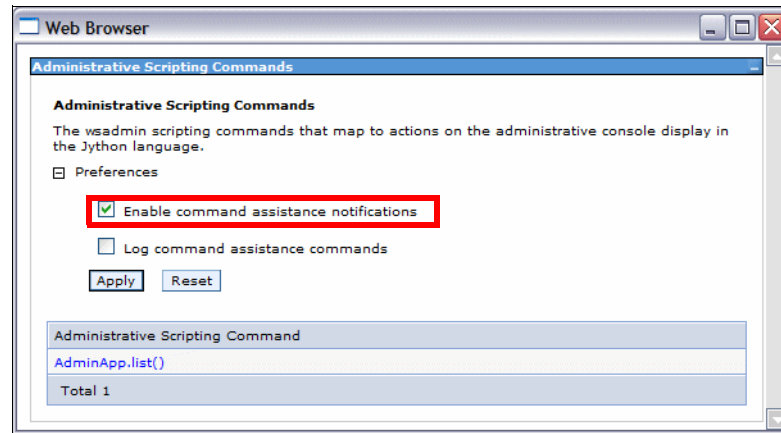



Figure 22-25 Administrative Scripting Commands

- ▶ In the Servers view, right-click the server and select **Administration** → **WebSphere administration command assist**. The WebSphere Administration Command window opens. The view might open on the top-right, but you can move it to a better place, such as where the Servers and Console views are.
- ▶ In the **Select Server to Monitor** pull-down , select **WebSphere Application Server v7.0 at localhost (2)**, to ensure the server is selected.
- ▶ In the WebSphere Administrative Console select **Applications** → **Application Types** → **WebSphere enterprise applications** in the left-pane. You should see that the **WebSphere Administration Command** view is populated with a wsadmin command for Jython.

Note: There might be a few seconds delay before you see the Jython command in the **WebSphere Administration Command** view.

- ▶ In the WebSphere Administrative Console, left-pane, select **Resources** → **JDBC** → **JDBC Providers**. Another command will appear in the WebSphere Administration Command window (Figure 22-26).

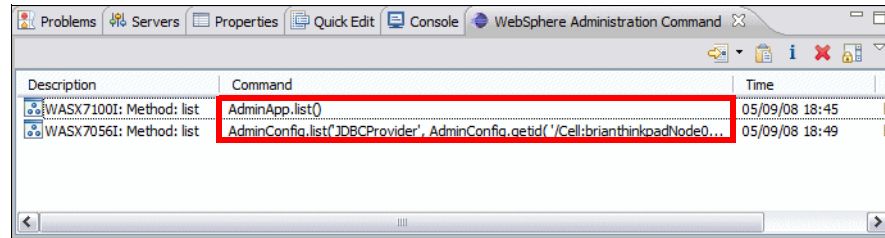

Figure 22-26 WebSphere Administration Command View

- ▶ Create a Jython script file in the **RAD75Jython** project and name it **CommandAssist.py**.
- ▶ To transfer the wsadmin commands generated in the WebSphere Administration Command view to the Jython script:
 - Make sure the Jython editor for **CommandAssist.py** is open.
 - In the Jython editor place the cursor at the bottom of the editor window.
 - In the WebSphere Administration Command view use the **Shift** key and the mouse to select both commands. Right-click the commands and select **Insert**.
- ▶ In the editor, two commands are added:

```
AdminApp.list()
AdminConfig.list(\
    'JDBCProvider', AdminConfig.getid( \
    '/Cell:KLCHL2YNode01Cell/'))
```
- ▶ Add the print method in front of each of the two commands so that we have the following:

```
print AdminApp.list()
print AdminConfig.list(\
    'JDBCProvider', AdminConfig.getid( \
    '/Cell:KLCHL2YNode01Cell/'))
```
- ▶ Save the file.
- ▶ Right-click **CommandAssist.py** and select **Run As** → **Administrative Script**.
- ▶ In the Script page of the WebSphere Administrative Script Launcher, select the following items:
 - For Scripting runtime, select **WebSphere Application Server v7.0**.
 - For WebSphere profile, select **AppSrv01** (or was70profile1).
 - In the Security section, if administrative security is enabled, enter the required User ID and Password.

- ▶ Click **Apply** and then click **Run** to execute the script. You should see console output similar to that listed below:

```
WASX7209I: Connected to process "server1" on node KLCHL2YNode01 using
SOAP connector; The type of process is: UnManagedProcess
DefaultApplication
```

```
IBMUTC
```

```
ivtApp
```

```
query
```

```
"Derby JDBC Provider
(XA)(cells/KLCHL2YNode01Cell/nodes/KLCHL2YNode01/servers/
server1|resources.xml#builtin_jdbcprovider)"
```

```
"Derby JDBC Provider (XA)(cells/KLCHL2YNode01Cell|resources.xml#
builtin_jdbcprovider)"
```

```
"Derby JDBC
Provider(cells/KLCHL2YNode01Cell/nodes/KLCHL2YNode01/servers/
server1|resources.xml#JDBCProvider_1182202633563)"
```

The command assist feature is great when you are learning Jython and allows you to easily create scripts for future use.

Debugging Jython scripts

The Jython debugger enables you to detect and diagnose errors in Jython scripts that are run on a WebSphere Application Server.

For an example of debugging the sample `listJDBCProviders` script (Example 22-1 on page 811), refer to “Jython debugger” on page 888.

Jython script for application deployment

For a complete Jython script that creates a JDBC provider and a data source, and installs and starts an enterprise application, refer to “Automated deployment using Jython based wsadmin scripting” on page 968.

More information

For more information, consult the following IBM Redbooks publications:

- ▶ *WebSphere Application Server V6.1: Systems Management and Configuration*, SG24-7304
- ▶ *IBM WebSphere Application Server V6.1 Security Handbook*, SG24-6316

For more information on Jython please refer to the following documents:

- ▶ Get to know Jython:

<http://www.ibm.com/developerworks/java/library/j-alj07064/>

- ▶ WebSphere InfoCenter scripting:

http://publib.boulder.ibm.com/infocenter/wasinfo/v6r0/index.jsp?topic=/com.ibm.websphere.express.doc/info/exp/ae/cxml_jython.html



Test using JUnit

The Application Developer test framework is built on the Eclipse Test & Performance Tools Platform (TPTP), which extends the Eclipse Hyades Tool Project. It contains monitoring, tracing, profiling, and testing tools. *JUnit* is one of the testing tools and can be used for automated component testing. TPTP also includes profiling capabilities for memory, performance, and other execution time code analysis. We explore profiling in Chapter 27, “Profile applications” on page 983.

In this chapter we introduce application testing concepts, and provide an overview on TPTP and JUnit, as well as the features of Application Developer for testing. In addition, we include working examples to demonstrate how to create, and run component tests using JUnit, as well as demonstrate how to test Web applications.

The chapter is organized into the following sections:

- ▶ Introduction to application testing
- ▶ JUnit testing [without using TPTP]
- ▶ JUnit testing of JPA entities
- ▶ JUnit testing using TPTP
- ▶ Web application testing

The sample code is available in `c:\7672code\junit`.

Introduction to application testing

Although the focus of this chapter is on component testing, we have included an introduction to testing concepts, such as test phases and environments, to put into context where component testing fits within the development cycle. Next, we provide an overview on the TPTP and JUnit testing frameworks. The remainder of the chapter provides a working example of using the features of TPTP and JUnit within Application Developer.

Test concepts

Within a typical development project, there are various types of testing performed during the different phases of the development cycle. Project requirements based on size, complexity, risks, and costs determine the levels of testing to be performed. The focus of this chapter is on component testing and unit testing.

Test phases

In this section we outline the key test phases and categorize them.

Unit test

Unit tests are informal tests that are generally executed by the developers of the application code. They are often quite low-level in nature, and test the behavior of individual software components, such as individual Java classes, servlets, or EJBs.

Because unit tests are usually written and performed by the application developer, they tend to be white-box in nature—that is, they are written using knowledge about the implementation details and test-specific code paths. This is not to say that all unit tests have to be written this way; one common practice is to write the unit tests for a component based on the component specification, before developing the component itself. Both approaches are valid, and you might want to make use of both when defining your own unit testing policy.

Component test

Component tests are used to verify particular components of the code before they are integrated into the production code base. Component tests can be performed on the development environment. Within the context of Application Developer, a developer configures a test environment and supporting testing tools such as JUnit. Using the test environment, you can test customized code

including JavaBeans, Enterprise JavaBeans, and JavaServer Pages without having to deploy this code to a runtime system.

Build verification test (BVT)

Members of the development team check their source code into the source control tool, and mark the components as part of a build level. The build team is responsible for building the application in a controlled environment, based on the source code available in the source control system repository. The build team extracts the source code from the source control system, executes scripts to compile the source code, packages the application, and tests the application build.

The test run on the application of the build produced is called a *build verification test* (BVT). BVT is a predefined and documented test procedure to ensure that basic elements of the application are working properly, before accepting the build and making it available to the test team for function verification test (FVT) and/or system verification test (SVT).

Function verification test (FVT)

These tests are used to verify individual functions of an application. For example, you can verify if the taxes are being calculated properly within a banking application.

Note: Within the Rational product family, the **IBM Rational Function Tester** is an ideal choice for this type of testing.

System verification test (SVT)

System verification tests are used to test a group of functions. A dedicated test environment should be used with the same system and application software as the target production environment. To get the best results from such tests, you have to find the most similar environment and involve as many components as possible, and verify that all functions are working properly in an integrated environment.

Note: Within the Rational product family, the **IBM Rational Manual Tester** is an ideal choice for this type of testing.

Performance test

Performance tests simulate the volume of traffic that you expect to have for the application(s) and ensure that the system will support this stress, and to determine if the system performance is acceptable.

Note: Within the Rational product family, the **IBM Rational Performance Tester** is an ideal choice for this type of testing.

Customer acceptance test

This is a level of testing in which all aspects of an application or system are thoroughly and systematically tested to demonstrate that it meets business and non-functional requirements. The scope of a particular acceptance test is defined in the acceptance test plan.

Test environments

When sizing a project, it is important to consider the system requirements for the test environments. Here is a list of some common test environments that are used.

- ▶ **Component test environment:** This is often the development system and the focus of this chapter. In larger projects, we recommend that development teams have a dedicated test environment to be used as a sandbox to integrate the components of the team members, before putting the code into the application build.
- ▶ **Build verification test environment:** This test environment is used to test the application produced from a controlled build. For example, a controlled build should have source control, build scripts, and packaging scripts for the application. The build verification team runs a subset of tests, often known as regression tests, to verify basic functionality of the system that is representative to a wider scale of testing.
- ▶ **System test environment:** This test environment is used for FVT and SVT to verify the functionality of the application and integrate it with other components. There can be many test environments with teams of people focused on different aspects of the system.
- ▶ **Staging environment:** The staging environment is critical for all sizes of organizations. Prior to deploying the application to production, the staging environment is used to simulate the production environment. This environment can be used to perform customer acceptance tests.
- ▶ **Production environment:** This is the live runtime environment that customers will use to access the e-commerce Web site. In some cases, customer acceptance testing might be performed on the production environment. Ultimately, the customers test the application. You must have a process to track customer problems and to implement fixes to the application within this environment.

Calibration

By definition, *calibration* is a set of gradations that show positions or values. When testing, it is important to establish a base line for such things as performance and functionality for regression testing. For example, when regression testing, you have to provide a set of tests that have been exercised on previous builds of the application, before you test the new build. This is also very important when setting entrance and exit criteria.

Test case execution and recording results

When trying to determine why a piece of functionality of a component within an application has become broken, it is useful to know when the test case last executed successfully. Recording the successes and failures of test cases for a designated application build is essential to having an accountable test organization and a quality application.

Benefits of unit and component testing

It might seem obvious as to why we want to test our code. Unfortunately, many people do not understand the value of testing. Simply put, we test our code and applications to find defects in the code, and to verify that changes we have made to existing code do not break that code. In this section, we highlight the key benefits of unit and component testing.

Perhaps it is more useful to look at the question from the opposite perspective, that is, why developers *do not* perform unit tests. In general, the simple answer is because it is too hard or because nobody forces them to. Writing an effective set of unit tests for a component is not a trivial undertaking. Given the pressure to deliver that many developers find themselves subjected to, the temptation to postpone the creation and execution of unit tests in favor of delivering code fixes or new functionality is often overwhelming.

In practice, this usually turns out to be a false economy, because developers very rarely deliver bug-free code, and the discovery of code defects and the costs associated with fixing them are simply pushed further out into the development cycle, which is inefficient. The best time to fix a code defect is immediately after the code has been written, while it is still fresh in the developer's mind.

Furthermore, a defect discovered during a formal testing cycle must be written up, prioritized, and tracked. All of these activities incur cost, and might mean that a fix is deferred indefinitely, or at least until it becomes critical.

Based on our experience, we believe that encouraging and supporting the development and regular execution of unit test cases ultimately leads to significant improvements in productivity and overall code quality. The creation of unit test cases does not have to be a burden. If done properly, developers can find the intellectual challenge quite stimulating and ultimately satisfying. The thought process involved in creating a test can also highlight shortcomings in a design, which might not otherwise have been identified when the main focus is on implementation.

We recommend that you take the time to define a unit testing strategy for your own development projects. A simple set of guidelines, and a framework that makes it easy to develop and execute tests, pays for itself surprisingly quickly.

Once you have decided to implement a unit testing strategy for your project, the first hurdles to overcome are the factors that dissuade developers from creating and running unit tests in the first place. A testing framework can help by making it easier to:

- ▶ Write tests
- ▶ Run tests
- ▶ Rerun a test after a change

Tests are easier to write, because a lot of the infrastructure code that you require to support every test is already available. A testing framework also provides a facility that makes it easier to run and re-run tests, perhaps via a GUI. The more often a developer runs tests, the sooner the problems can be located and fixed, because the difference between the code that last passed a unit test, and the code that fails the test, is smaller.

Benefits of testing frameworks

Testing frameworks also provide other benefits such as these:

- ▶ **Consistency:** Every developer is using the same framework, all of your unit tests work in the same way, can be managed in the same way, and report results in the same format.
- ▶ **Maintenance:** A framework has already been developed and is already in use in a number of projects, and you spend less time maintaining your testing code.
- ▶ **Ramp-up time:** If you select a popular testing framework, you might find that new developers coming into your team are already familiar with the tools and concepts involved.
- ▶ **Automation:** A framework can offer the ability to run tests unattended, perhaps as part of a daily or nightly build.

Note: A common practice in many development environments is the use of daily builds. These automatic builds are usually initiated in the early hours of the morning by a scheduling tool.

Test & Performance Tools Platform (TPTP)

TPTP provides an open platform supplying powerful frameworks and services that allow software developers to build unique test and performance tools.

TPTP addresses the entire test and performance life cycle, from early testing to production application monitoring, including test editing and execution, monitoring, tracing and profiling, and log analysis capabilities.

Within the scope of Application Developer, it includes the following types of testing:

- ▶ JUnit testing
- ▶ Manual testing
- ▶ Performance testing of Web applications

Although each of these areas of testing has its own unique set of tasks and concepts, two sets of topics are common to all three types:

- ▶ Providing tests with variable data
- ▶ Creating a test deployment

Further information about TPTP can be found here:

<http://www.eclipse.org/tptp>

JUnit testing [without using TPTP]

This section provides JUnit fundamentals as well as a working example of how to create and run a JUnit test within Application Developer.

The JUnit home page is located at:

<http://www.junit.org/>

JUnit fundamentals

A unit test is a collection of tests designed to verify the behavior of a single unit. A unit is always the smallest testable part of an application. In object-oriented programming, the smallest unit is always a class.

JUnit tests your class by scenario, and you have to create a testing scenario that uses the following elements:

- ▶ Instantiate an object
- ▶ Invoke methods
- ▶ Verify assertions

Note: An assertion is a statement that allows you to test the validity of any assumptions made in your code.

What is new in JUnit 4.x?

For the first time in its history, JUnit 4 has significant changes to previous releases. It simplifies testing by using the annotation feature, which was introduced in Java 5 (JDK 1.5). One helpful feature is that tests no longer rely on sub classing, reflection, and naming conventions. JUnit 4 allows you to mark any method in any class as an executable test case, just by adding the `@Test` annotation in front of the method. Table 23-1 lists some important annotations.

Table 23-1 JUnit 4.x annotation overview

Annotation name	Description
<code>@Test</code>	Marks that this method is a test method.
<code>@Test(expected=ExceptionClassName.class)</code>	Tests if the method throws the named exception.
<code>@Test(timeout=100)</code>	Fails if execution of method takes longer than 100 milliseconds.
<code>@Ignore</code>	Ignores the test method.
<code>@BeforeClass</code>	Marks the method that must be executed once before the start of all the tests. For example to connect to the database.
<code>@AfterClass</code>	Marks the method that must be executed once after the execution of all the tests. For example to disconnect from the database.

Annotation name	Description
@Before	Marks the method that must be executed before each test (setUp).
@After	Marks the method that must be executed after each test (tearDown).

There is an Open Source project available called *JUnit 4 Extensions*. It provides the `@prerequisite(requires="methodName")` annotation, which can be very helpful. It allows you to call another method before entering the test. The test will only be executed if this method returns *true*. An example is provided below.

More information about the JUnit 4 Extension project are here:

<http://www.junitext.org/>

Test case class

Example 23-1 shows a test case class using JUnit 4.x. The code is available in `c:\7672code\junit\examples\ITSOBankTestExample.java`.

Example 23-1 Simple JUnit 4.x test case class

```
package itso.rad75.bank.test.junit.example;

import static org.junit.Assert.assertEquals;

// Imports for the annotations (other imports omitted)
import org.junit.After;
import org.junit.AfterClass;
import org.junit.Before;
import org.junit.BeforeClass;
import org.junit.Test;
import org.junitext.Prerequisite;

public class ITSOBankTestExample {

    private Bank bank = null;
    private static final String ACCOUNT_NUMBER = "001-999000777";
    private static final String CUSTOMER_SSN = "111-11-1111";

    @BeforeClass
    public static void runBeforeClass() {}

    @AfterClass
    public static void runAfterClass() {}

    @Before
    public void runBeforeEveryTest() {
```

```
        if (this.bank == null) {
            // Instantiate objects
            this.bank = ITSOBank.getBank();
        }
    }

    @After
    public void runAfterEveryTest() {}

    @Prerequisite(requires="isBankAvailable")
    @Test
    public final void testSearchAccountByAccountNumber() {

        try {
            // Invoke a method

            Account bankAccount = this.bank
                .searchAccountByAccountNumber(ITSOBankTestExample.ACCOUNT_NUMBER);

            // Verify an assertion
            assertEquals(bankAccount.getAccountNumber(),
                ITSOBankTestExample.ACCOUNT_NUMBER);
        } catch (InvalidAccountException e) {
            e.printStackTrace();
        }
    }

    @Test(expected=InvalidAccountException.class)
    public final void testSearchAccountByInvalidAccountNumber()
        throws InvalidAccountException {

        Account bankAccount = this.bank
            .searchAccountByAccountNumber("966-11100999");
    }

    @Test
    public final void testSearchCustomerBySsn() {

        // Invoke a method
        try {
            Customer bankCustomer = this.bank
                .searchCustomerBySsn(ITSOBankTestExample.CUSTOMER_SSN);

            // Verify an assertion
            assertEquals(bankCustomer.getSsn(),
                ITSOBankTestExample.CUSTOMER_SSN);
        } catch (InvalidCustomerException e) {
            e.printStackTrace();
        }
    }
}
```

```

    }

    public boolean isBankAvailable() {
        if (this.bank != null) {
            return true;
        } else {
            return false;
        }
    }
}

```

In JUnit each test is implemented as a Java method that should be declared as `public void` and should take no parameters. This method is then invoked from a test runner. In previous JUnit releases, all the test method names had to begin with `test...`, so the test runner could find them automatically and run them. In JUnit 4.x, this is no longer required, because we mark the test methods with the `@Test` annotation.

Important: The package structure `junit.framework` used in JUnit 3.8.1 has been changed to `org.junit` in JUnit 4.x.

JUnit Assert class

JUnit provides a number of static methods in the `org.junit.Assert` class that can be used to assert conditions and fail a test if the condition is not met. Table 23-2 summarizes the provided static methods.

Table 23-2 JUnit Assert class: Static methods overview

Method name	Description
<code>assertEquals</code>	Asserts that two objects or primitives are equal. Compares objects using <code>equals</code> method, and compares primitives using <code>==</code> operator.
<code>assertFalse</code>	Asserts that a boolean condition is false.
<code>assertNotNull</code>	Asserts that an object is not null.
<code>assertNotSame</code>	Asserts that two objects do not refer the same object. Compares objects using <code>!=</code> operator.
<code>assertNull</code>	Asserts that an object is null.
<code>assertSame</code>	Asserts that two objects refer to the same object. Compares objects using <code>==</code> operator.
<code>assertTrue</code>	Asserts that a boolean condition is true.
<code>fail</code>	Fails the test.

All of these methods include an optional `String` parameter that allows the writer of a test to provide a brief explanation of why the test failed. This message is reported along with the failure when the test is executed. The full JUnit 4 API documentation can be found here:

<http://junit.org/junit/javadoc/4.5/>

Test suite class

Test cases can be organized into test suites. In JUnit 4.x, the way to build test suites has been completely replaced and no longer uses subclassing, reflection, and naming conventions. Example 23-2 shows how to build a test suite class in JUnit 4.x. The code is available in `c:\7672code\junit\examples\AllTests.java`.

Example 23-2 Simple JUnit 4.x test suite class

```
package itso.rad75.bank.test.junit;

import org.junit.runner.RunWith;
import org.junit.runners.Suite;
import org.junit.runners.Suite.SuiteClasses;

@RunWith(Suite.class)
@SuiteClasses({ITSOBankTest.class})
public class AllTests {}
```

The `AllTests` class is a simple placeholder for the `@RunWith` and `@SuiteClasses` annotations, and does not require a static suite method. The `@RunWith` annotation tells the JUnit 4 test runner to use the `org.junit.runners.Suite` class for running the `AllTests` class. The `@SuiteClasses` annotation allows you to define which test classes to include in this suite and in which order. If you add more than one test class, the syntax is:

```
@SuiteClasses({TestClass1.class, TestClass2.class})
```

Prepare the JUnit sample

We use the ITSO Bank application created in “Developing the ITSO Bank application” on page 78 for the JUnit test working example.

Important: Use a new workspace for the JUnit example. If you work in your regular workspace, the Java builder will not function properly any more for projects with non-Java files in `src/META-INF`, such as projects with JPA. Refer to “Cleaning the workspace” on page 860 for a circumvention.

The JUnit sample is based on the RAD75Java project. Import the RAD75Java project into the new workspace from:

```
c:\7672code\zInterchange\java\RAD75Java.zip
```

Make a copy of RAD75Java with the name **RAD75JUnit**:

- ▶ Right-click **RAD75Java** and select **Copy**.
- ▶ Right-click in the Enterprise Explorer and select **Paste**. When prompted type **RAD75JUnit** as the new name.

Verify that the project works by executing the `BankClient` class (right-click the class and select **Run As** → **Java Application**).

The completed code for this section can also be imported from the `c:\7672code\zInterchange\junit\RAD75JUnit.zip` project interchange file.



Creating a JUnit test case

Application Developer provides wizards to help you build JUnit test cases and test suites. The following step-by-step guide leads you through the example, so that you get familiar with the JUnit tooling within Application Developer:

- ▶ Create a new package called `itso.rad75.bank.test.junit` in the RAD75JUnit project (under `src`).
- ▶ Add the JUnit library to the Java project so that the classes from the JUnit framework can be resolved:
 - Right-click the RAD75JUnit project and select **Properties**, or press **Alt+Enter**.
 - Select **Java Build Path** and select the **Libraries** tab. Click **Add Library**.
 - In the Add Library dialog, select **JUnit** and click **Next**.
 - Select **JUnit 4** in the JUnit library version field and click **Finish**.
 - Click **OK** to close the Properties dialog.

Create a JUnit test case

To create a test case for the `transfer` method of the `ITSOBank` class, do these steps:

- ▶ Right-click the `itso.rad75.bank.impl.ITSOBank` class and select **New** → **JUnit Test Case** (only available in the Java perspective), or select **New** → **Other** → **Java** → **JUnit** → **JUnit Test Case**, or click the arrow in the  icon in the toolbar and select  **JUnit Test Case**.
- ▶ In the JUnit Test Case dialog, enter the following data (Figure 23-1).

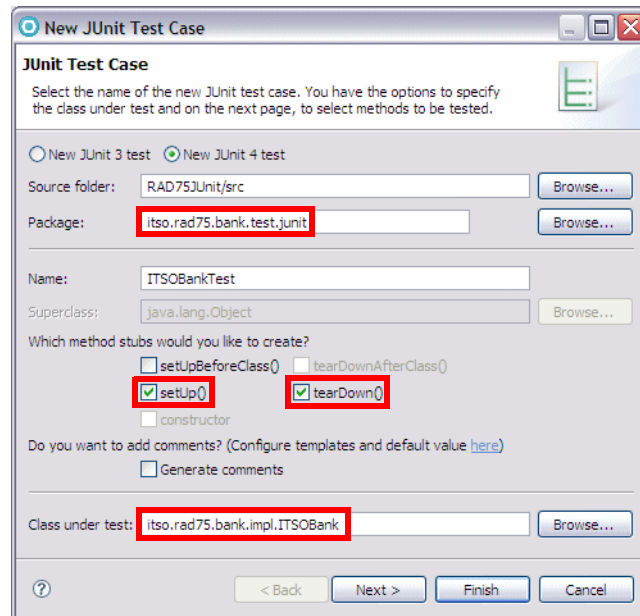

Figure 23-1 JUnit Test Case Wizard

- Select **New JUnit 4 test**.
- For Package, click **Browse** and select **itso.rad75.bank.test.junit**.
- For Name, accept: **ITSOBankTest**
- Select **setUp()** and **tearDown()** methods.
- Clear Generate comments (default).
- Verify that the class under test is set to **ITSOBank**.
- Click **Next**.

Note: A *stub* is a skeleton method so that you can add the body of the method yourself.

- ▶ In the Test Methods dialog, select the **transfer** method and **Create final method stubs** (Figure 23-2) and then click **Finish**.

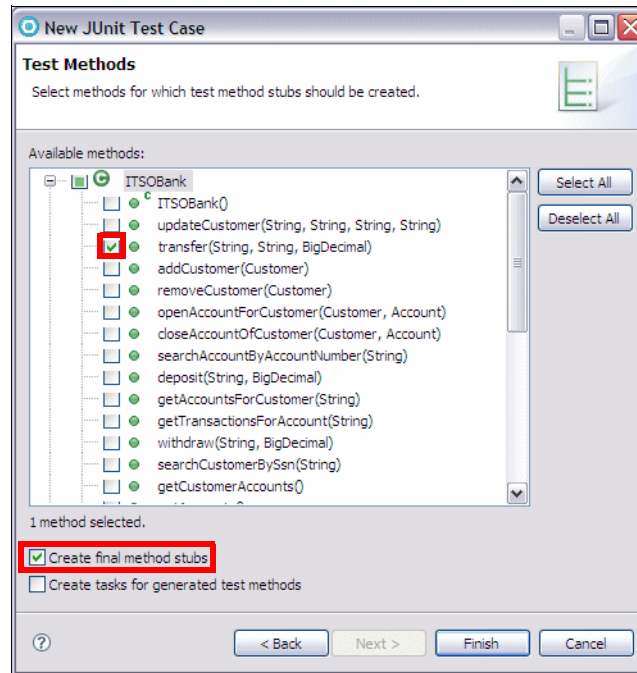

Figure 23-2 Select test methods

- ▶ The wizard generates the `ITSOBankTest` class and opens the file in the editor.

Complete the test class

Typically, you run several tests in one test case. To make sure there are no side effects between test runs, the JUnit framework provides the `setUp` and `tearDown` methods. Every time the test case is run, `setUp` is called at the start and `tearDown` is called at the end of the run.

- ▶ Add three variables to `ITSOBankTest` class:

```
private Bank bank = null;
private static final String ACCOUNT_NUMBER_1 = "001-999000777";
private static final String ACCOUNT_NUMBER_2 = "002-999000777";
```

Remember that you can add missing imports by selecting **Source** → **Organize Imports**, or by pressing **Ctrl+Shift+O**.

The `bank` variable is instantiated in the `setUp` method before starting each test and is available for use in the test methods.

- ▶ Add the code to the `setUp` method:

```
@Before
public void setUp() throws Exception {
```

```

    /* Instantiate objects
    * The getBank method returns the initialized (containing Customers
    * and Accounts) ITS0Bank instance.
    */
    if (this.bank == null) {
        this.bank = ITS0Bank.getBank();
    }
}

```

- Keep the generated code of the `tearDown` method unchanged.

Note: The JUnit framework calls the `setUp` method before each test method. The `ITS0Bank` class is implemented as a *singleton* (only one object of this class exists). Therefore, you get always the same `ITS0Bank` object, when you call the static `getBank` method. When the `setUp` method gets called a second time, you would get the same `ITS0Bank` instance as in the first call.

For example, if you have removed all the customers in the first test method, the `ITS0Bank` object that you get in the second call of the `setUp` method would be empty, because removing a customer from the bank closes automatically all of his accounts. Therefore, it can be useful to call a kind of clean up service in the `tearDown` method to reset the `ITS0Bank` instance. In our example this is not needed.

Complete the test methods

When the `ITS0BankTest` is generated, the stub of the `testTransfer` method is added. This section describes the steps to implement this test method and add a second method.

- Complete the `testTransfer` method (Example 23-3).

Example 23-3 ITS0BankTest class: testTransfer method

```

@Test
public final void testTransfer() {
    try {
        BigDecimal account1AmountBeforeTransfer = this.bank
            .searchAccountByAccountNumber(
                ITS0BankTest.ACCOUNT_NUMBER_1).getBalance();
        BigDecimal account2AmountBeforeTransfer = this.bank
            .searchAccountByAccountNumber(
                ITS0BankTest.ACCOUNT_NUMBER_2).getBalance();
        BigDecimal transferAmount = new BigDecimal(20.00D);

        // Invoke a method
        this.bank.transfer(ITS0BankTest.ACCOUNT_NUMBER_1,
            ITS0BankTest.ACCOUNT_NUMBER_2, transferAmount);
    }
}

```

```

    // Verify assertions
    Assert.assertEquals(this.bank.searchAccountByAccountNumber(
        ITSOBankTest.ACCOUNT_NUMBER_1).getBalance().doubleValue(),
        account1AmountBeforeTransfer.subtract(transferAmount)
            .doubleValue(), 0.00D);
    Assert.assertEquals(this.bank.searchAccountByAccountNumber(
        ITSOBankTest.ACCOUNT_NUMBER_2).getBalance().doubleValue(),
        account2AmountBeforeTransfer.add(transferAmount)
            .doubleValue(), 0.00D);
} catch (ITSOBankException e) {
    e.printStackTrace();
    Assert.fail("Transfer failed: " + e.getMessage());
}
}

```

Note: Make sure you import `java.math.BigDecimal` and `org.junit.Assert`.

This test method transfers an amount from one account to another one. After the credit and debit transactions have completed, the method verifies that the balances of the two involved accounts have changed accordingly.

- ▶ If you really want to test the method completely, you have to write a test method for each possible outcome of that method. In our example we just add another test method called `testInvalidTransfer`, as shown in Example 23-4. This method also calls the `transfer` method, but this time we make a transfer where the debit account does not have enough funds. The method verifies that you receive an `InvalidTransactionException`.

Example 23-4 ITSOBankTest class: testInvalidTransfer

```

@Test(expected = InvalidTransactionException.class)
public final void testInvalidTransfer() throws Exception {
    BigDecimal transferAmount = this.bank.searchAccountByAccountNumber(
        ITSOBankTest.ACCOUNT_NUMBER_1).getBalance().multiply(
        new BigDecimal(2.00D));

    // Invoke a method
    this.bank.transfer(ITSOBankTest.ACCOUNT_NUMBER_1,
        ITSOBankTest.ACCOUNT_NUMBER_2, transferAmount);
}

```

Creating a JUnit test suite

A JUnit test suite is used to run one or more test cases at once. Application Developer contains a simple wizard to create a test suite for JUnit 3.8.1 test cases.

Important: We found that the New JUnit Test Suite wizard does not allow us to select between JUnit 3.8.1 and JUnit 4.x test suites. The wizard can only be used for JUnit 3.8.1 test suites and therefore, it only lets you add JUnit 3.8.1 or lower JUnit version test cases. This is a known Eclipse bug:

http://bugs.eclipse.org/bugs/show_bug.cgi?id=155828

We had to create the JUnit test suite for the example manually. We provide below a step-by-step guide to create a test suite for JUnit 3.8.1 test cases. This guide is just given for completeness and cannot be used for the example.

To create a JUnit 4.x test suite manually, do these steps:

- ▶ Create a new class called **AllTests** in the same package. The class extends the default super class `java.lang.Object`, and does not require any interfaces or method stubs.
- ▶ Add the import statements and annotations to the `AllTests` class, as shown in Example 23-5. The structure of that class is described in “**Test suite class**” on page 830.

Example 23-5 AllTests class: A JUnit 4.x test suite class

```
package itso.rad75.bank.test.junit;

import org.junit.runner.RunWith;
import org.junit.runners.Suite;
import org.junit.runners.Suite.SuiteClasses;

@RunWith(Suite.class)
@SuiteClasses({ITS0BankTest.class})
public class AllTests {}
```

In our example we only have added a single test class, and thus a test suite is not required. However, as you add more and more test cases, a test suite quickly becomes a more practical way to manage your unit testing.

To create a JUnit 3.8.1 test suite using the New JUnit Test Suite wizard, do these steps:

- ▶ Right-click the **junit** package and select **New** → **Other** → **Java** → **JUnit** → **JUnit Test Suite**.
- ▶ In the JUnit Test Suite dialog, enter the following data:
 - Name: `AllTests`
 - Test classes to include in suite: select all test classes which you want to include in this suite.

- Click **Finish**.

Running the JUnit test case or JUnit test suite

To run a JUnit test case or JUnit test suite, do these steps:

- ▶ Select the **ITSOBankTest** or **AllTests** class and click the arrow of  in the toolbar and select **Run As** → **JUnit Test** (or right-click the class and select **Run As** → **JUnit Test**).
- ▶ In our example, Application Developer runs the two test methods defined in `ITSOBankTest` class.
- ▶ The JUnit view opens. You might want to move the JUnit view on top of the Console view.
- ▶ Notice that the two test methods passed the asserts verification (Figure 23-3).

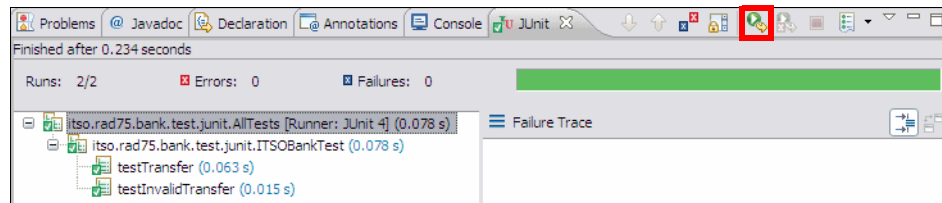



Figure 23-3 JUnit view: Both test methods passed the assert verifications

Tip: To run the same test again, click  in the JUnit view toolbar.

Modify and run the JUnit test case with assert failures

In our example we test only for success (even one method throws an exception, but that was what we had expected). A test is considered to be *successful*, if the test method returns normally. A test *fails*, if one of the methods could not pass all assert verifications. An *error* indicates that an unexpected exception is raised by any test, `setUp`, or `tearDown` method. The JUnit view is more interesting when an error or failure occurs.

- ▶ Modify the process method of the `itso.rad75.bank.model.Credit` class:

```
public BigDecimal process(BigDecimal accountBalance)
    throws InvalidTransactionException {
    if ((this.getAmount() != null)
        && (this.getAmount().compareTo(new BigDecimal(0.00D)) > 0)) {
        return accountBalance.subtract(this.getAmount());
    } else {
        ..... // rest unchanged
    }
}
```

We change **add** to **subtract**, which is obviously an error in the business logic.

- ▶ Run the `ITSOBankTest` class again as a JUnit Test.

This time, a failure and its trace information is displayed for the `testTransfer` method in the JUnit view (Figure 23-4).

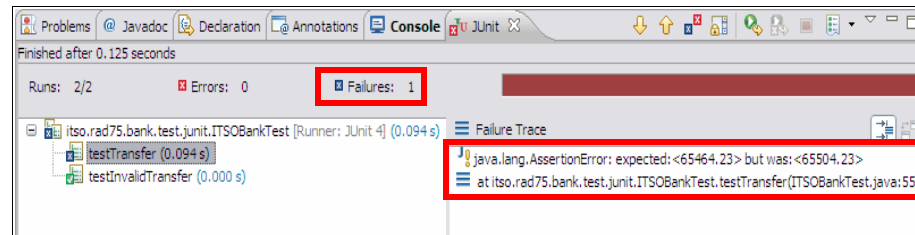

Figure 23-4 JUnit view with failure

Double-clicking the entry in the Failure Trace list takes you to the specified line in the specified Java source file. This is the line where to set a breakpoint and start debugging the application. For details how to debug an application, refer to Chapter 24, “Debug local and remote applications” on page 861.

- ▶ Correct the process method of the `Credit` class, by undoing the change we made before.

JUnit testing of JPA entities

According to the Java Persistence API (JPA) specification, JPA entities are not bound to any Java EE container. They can run in a Java SE environment and therefore unit testing of JPA entities is easier than it was to test EJB 2.x entity beans.

Prepare the JPA unit testing sample

We use the JPA project created in “Creating a JPA project” on page 282 for the JPA unit test working example.

The JPA unit test sample is based on the `RAD75JPA` project. If you do not have that project in the workspace, import the `RAD75JPA` project from:

```
c:\7672code\zInterchange\jpa\RAD75JPA.zip
```

Setting up the ITSOBANK database

The JPA entities are based on the ITSOBank database. Therefore, we have to define a database connection within Application Developer.

Refer to “Setting up the ITSOBANK database” on page 1154 for instructions on how to create the ITSOBANK database. For the JPA entities we can either use the DB2 or Derby database. For simplicity we use the built-in Derby database in this chapter.

Configure the RAD75JUnit project

The RAD75JUnit project must be configured, so it can be used to run JPA entity unit tests. Do the following steps, to configure the RAD75JUnit project properly:

- ▶ In the Package Explorer, right-click the **RAD75JUnit** project and select **Properties**.
- ▶ Select **Java Build Path** in the tree and select the **Libraries** tab.
 - Click **Add Variable**, select **ECLIPSE_HOME** and click **Extend**. Select **runtimes/base_v7/derbylib/derby.jar** and click **OK**.
 - Click **Add Variable**, select **ECLIPSE_HOME** and click **Extend**. Select **runtimes/base_v7/runtimes/com.ibm.ws.jpa.thinclient_7.0.0.jar** and click **OK**.
- ▶ Select the **Projects** tab.
- ▶ Click **Add**, select the **RAD75JPA** project and click **OK**.
- ▶ Select the **Source** tab.
- ▶ In the Default Output Folder field, type **RAD75JUnit/src** (overwriting **RAD75JUnit/bin**).



Note: This change is necessary so that the `persistence.xml` file, which we create later in the `RAD75JUnit/src/META-INF` folder, will be found while executing the test case.

- ▶ Click **OK**. In the Setting Build Path dialog, click **Yes** to delete the `RAD75JUnit\bin` folder.

The RAD75JUnit project is now properly configured for JPA unit testing.

Creating a JUnit test case for a JPA entity

To create a JUnit test case for a JPA entity, do the following steps:

- ▶ Create a new package called **itso.rad75.bank.test.junit.jpa** under RAD75JUnit/src.
- ▶ Right-click the **itso.rad75.bank.test.junit.jpa** package and select **New** → **JUnit Test Case** (only available in the Java perspective), or select **New** → **Other** → **Java** → **JUnit** → **JUnit Test Case**, or click the arrow in the  icon in the toolbar and select  **JUnit Test Case**.
- ▶ In the New JUnit Test Case dialog, select **New JUnit 4 test**, type **AccountJPATest** as Name, select **setUp** and **tearDown** methods, and click **Finish** (Figure 23-5).

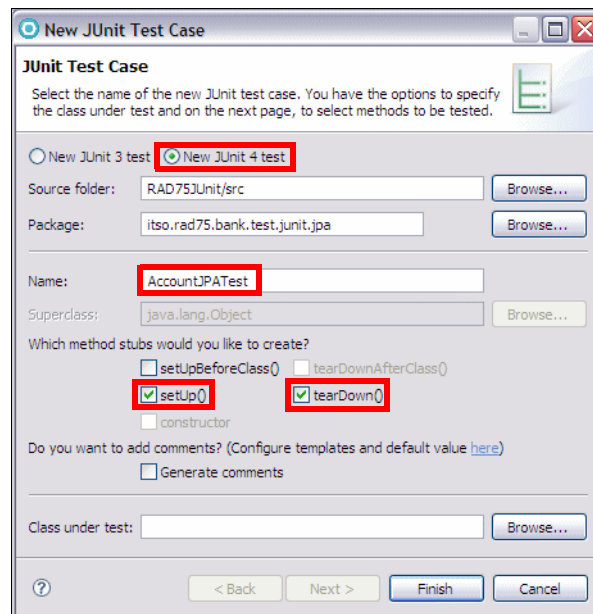

Figure 23-5 JUnit Test Case Wizard

- ▶ Implement the AccountJPATest class as shown in Example 23-6. The code is available in c:\7672code\junit\jpa\AccountJPATest.java.

Example 23-6 JUnit test case for JPA

```
package itso.rad75.bank.test.junit.jpa;

import .....

public class AccountJPATest {
```



```
EntityManager em;

@Before
public void setUp() throws Exception {
    if (em == null) {
        em = Persistence
            .createEntityManagerFactory("RAD75JPA")
            .createEntityManager();
    }
}

@After
public void tearDown() throws Exception {
    if (em != null) {
        em.close();
    }
}

@Test
public void testLoadAccount() {
    try {
        Account ac = em.find(Account.class, "001-111001");
        assertNotNull(ac);
    } catch (Exception e) {
        fail("Error: Account not found!");
        e.printStackTrace();
    }
}
}
```

Setting up the persistence.xml file

We have to modify the persistence.xml file because the JUnit test runs in Java SE, not in the server. Instead of connecting to the database through a data source, we connect directly through a JDBC driver. We could modify the persistence.xml file in the RAD75JPA project, but it is better to leave that file configured for the data source in the server, and place a new file into the RAD75JUnit project, overwriting the file in the RAD75JPA project.

- ▶ In the Package Explorer, right-click the **RAD75JUnit** → **src** folder and select **New** → **Folder**. Type **META-INF** as folder name and click **Finish**.
- ▶ Copy the file RAD75JPA/src/META-INF/persistence.xml to RAD75JUnit/src/META-INF.
- ▶ Open the persistence.xml file (in RAD75JUnit/src/META-INF), and change it as shown in Example 23-7. The updated file is available in c:\7672code\junit\jpa\persistence.xml.

Example 23-7 JPA persistence.xml configured for Derby using OpenJPA

```

<?xml version="1.0" encoding="UTF-8"?>
<persistence .....
  <persistence-unit name="RAD75JPA" transaction-type="RESOURCE_LOCAL">
    <jta-data-source jdbc/itsobank</jta-data-source>
    <provider>
      org.apache.openjpa.persistence.PersistenceProviderImpl
    </provider>
    <class>itso.bank.entities.Account</class>
    <class>itso.bank.entities.Customer</class>
    <class>itso.bank.entities.Transaction</class>
    <class>itso.bank.entities.Debit</class>
    <class>itso.bank.entities.Credit</class>
    <properties>
      <property name="openjpa.ConnectionURL"
        value="jdbc:derby:C:\7672code\database\derby\ITSOBANK" />
      <property name="openjpa.ConnectionDriverName"
        value="org.apache.derby.jdbc.EmbeddedDriver" />
      <property name="openjpa.Log" value="none" />
    </properties>
  </persistence-unit>
</persistence>

```

- ▶ To use the ITSOBANK database in DB2, the properties would be:

openjpa.ConnectionURL:	jdbc:db2://localhost:50000/ITSOBANK
openjpa.ConnectionDriverName:	com.ibm.db2.jcc.DB2Driver
openjpa.ConnectionUserName:	db2admin (or similar)
openjpa.ConnectionPassword:	<xxxxxxx>
- ▶ To see the SQL statements that are issued, set `openjpa.Log` to the value `SQL=TRACE`.

Running the JPA unit test

Finally, the JPA JUnit test can be executed. To run the `AccountJPATest`, do the following steps:

- ▶ Make sure that the ITSOBANKderby connection is disconnected (with Embedded Derby you can only have one active connection to a database). You can verify this in the Data perspective, Data Source Explorer. If the ITSOBANKderby connection is available and active, right-click the connection and select **Disconnect**.
- ▶ In the Package Explorer, right-click the **AccountJPATest** class and select **Run As** → **Run Configurations**.
- ▶ Double-click **JUnit** in the tree. A new JUnit Run Configuration for `AccountJPATest` class is created.

- ▶ Select the **Arguments** tab (Figure 23-6), and in the VM arguments field, type:
`-javaagent:c:/IBM/SDP75/runtimes/base_v7/plugins/com.ibm.ws.jpa.jar`
 Make sure to use the directory where Application Developer is installed.
 Without this agent, the JPA entities are not found.

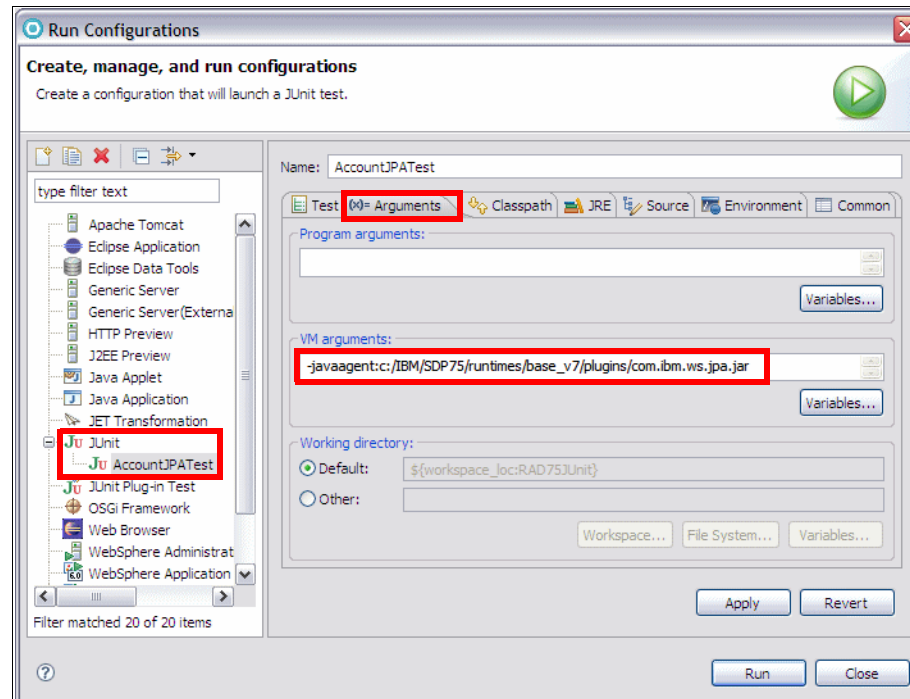

Figure 23-6 Run configuration arguments

- ▶ Click **Apply**, then click **Run**.
- ▶ The JUnit view opens showing that the AccountJPATest test case was successful (Figure 23-7).

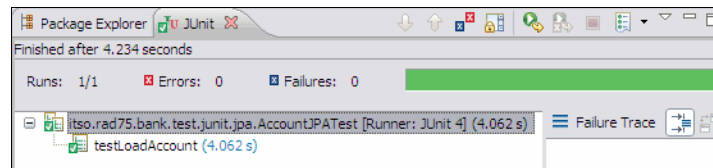

Figure 23-7 JUnit JPA test case was successful

JUnit testing using TPTP

TPTP JUnit test generates an execution history from which a report can be generated. In this section we discuss the following topics:

- ▶ Creating the TPTP JUnit sample
- ▶ Importing an existing JUnit test case
- ▶ Running the TPTP JUnit test
- ▶ Analyzing the test results
- ▶ Generating test reports

Note: TPTP JUnit Tests are based on JUnit version 3.8.1.

Creating the TPTP JUnit sample

In this section we continue with the RAD75JUnit project that we created in “JUnit testing [without using TPTP]” on page 825.

Note: If you imported the final RAD75JUnit project from the sample code and you want to create this example on your own, delete the `itso.rad75.bank.test.tptp` package.

Create new package

Add a new package called `itso.rad75.bank.test.tptp` to the RAD75JUnit project.

Create a TPTP JUnit test manually

To create a TPTP JUnit test manually, do these steps:

- ▶ Right-click the `itso.rad75.bank.test.tptp` package and select **New** → **Other** → **Test** → **TPTP JUnit Test**.
Select **Show All Wizards** (at the bottom) to see the Test category.
- ▶ If the Confirm Enablement dialog appears, click **OK** to enable the Core Testing Support capability of Application Developer.
- ▶ In the New JUnit Test Definition dialog, enter the following data (Figure 23-8):
 - Source folder: Click **Browse** and select **RAD75JUnit/src**. Click **Yes** when prompted to allow Application Developer to add all the required libraries to the classpath.
 - Package: `itso.rad75.bank.test.tptp`
 - Name: **ITSOBankTest**
 - Select **In the test editor** {default}.

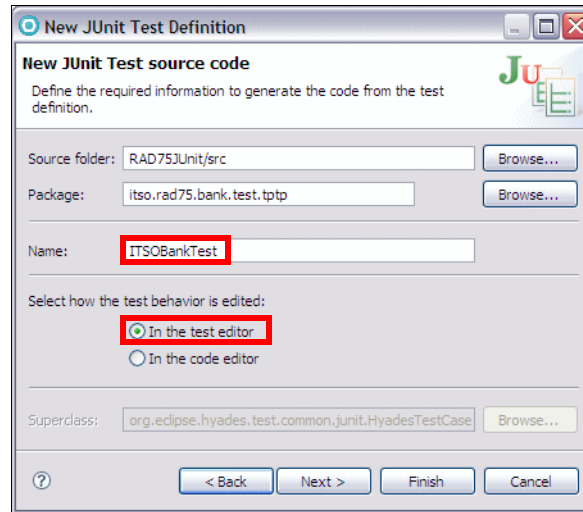

Figure 23-8 New JUnit Test source code dialog

- ▶ In the JUnit Test Definition dialog, accept the parent folder (AD75JUnit/src/itso/rad75/bank/test/tptp) and name (ITS0BankTest) and click **Finish**.

Note: In the previous step we enter the name and location of the source code, while in this step we enter the name and location of the TPTP Test (the model). By default, they are identical.

- ▶ The JUnit Test Suite editor opens and you can create and remove methods on a JUnit test, and control how those methods are invoked. Three tabs are visible: Overview, Test Methods, and Behavior.
- ▶ In the **Test Methods** tab, click **Add** and enter **testSearchCustomerBySsn** in the name field.
- ▶ In the **Behavior** tab, click **Add** and select **Loop**. Select the **Loop 1**, click **Add** again, select **invocation**, select the **testSearchCustomerBySsn** method and click **OK**.

At this point the Behavior tab looks as shown in Figure 23-9.

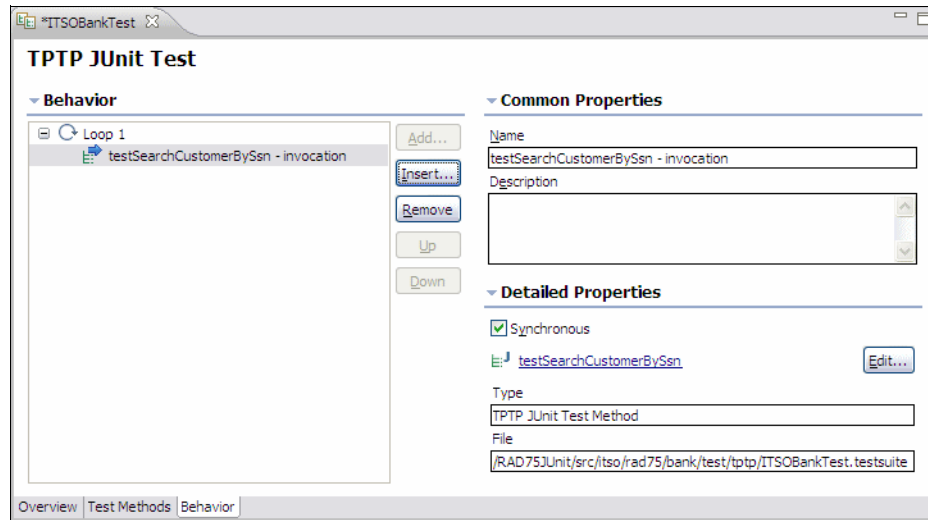

Figure 23-9 TPTP JUnit Test editor [Behavior tab]

Note: In the Overview tab:

- ▶ If **Implement Test Behavior as code** is selected, the behavior is purely code-based, that is, the test methods are executed exactly as presented in the Test Methods view.
- ▶ If **Implement Test Behavior as code** is cleared, then the Behavior tab becomes available. The behavior feature should be used only for TPTP JUnit tests that have been created manually.

- ▶ Save the TPTP JUnit Test editor.
- ▶ In the JUnit Code Update Preview Options dialog, select **Never** and **Always skip to the preview page**. Click **Finish**.
- ▶ Open the generated `itso.rad75.bank.test.tptp.ITSOBankTest` class in the Java editor and add the highlighted code, as shown in Example 23-8.

Example 23-8 ITSOBankTest class

```
package itso.rad75.bank.test.tptp;

import itso.rad75.bank.exception.InvalidCustomerException;
import itso.rad75.bank.ifc.Bank;
import itso.rad75.bank.impl.ITSOBank;
import itso.rad75.bank.model.Customer;

// Keep other imports unchanged
```

```
// All documentation is omitted

public class ITSOBankTest extends HyadesTestCase {

    private Bank bank = null;
    private static final String CUSTOMER_SSN = "111-11-1111";

    public ITSOBankTest(String name) {
        super(name);
    }

    public static Test suite() {
        // Keep method body unchanged
    }

    protected void setUp() throws Exception {
        if (this.bank == null) {
            this.bank = ITSOBank.getBank();
        }
    }

    protected void tearDown() throws Exception {
    }

    public void testSearchCustomerBySsn() throws Exception {
        try {
            Customer bankCustomer = this.bank
                .searchCustomerBySsn(ITSOBankTest.CUSTOMER_SSN);
            assertEquals(bankCustomer.getSsn(), ITSOBankTest.CUSTOMER_SSN);
        } catch (InvalidCustomerException e) {
            e.printStackTrace();
        }
    }
}

```

Importing an existing JUnit test case

To create a TPTP JUnit Test by importing an existing JUnit test case, do these steps:

- ▶ Import the `ITSOBank381Test.java` class into the `itso.rad75.bank.test.tptp` package from `C:\7672code\junit\examples`.
- ▶ Right-click somewhere in the Package Explorer, select **Import** → **Test** → **JUnit tests to TPTP**, and click **Next**.
- ▶ In the Import JUnit tests to TPTP dialog, select **RAD75JUnit** → **itso.rad75.bank.test.tptp** → **ITSOBank381Test.java**, and click **Finish**.

Note: Notice that the *Import JUnit tests to TPTP* dialog does not allow us to select test cases that are JUnit 4.x based because TPTP cannot handle JUnit 4.x.

- ▶ The `ITS0Bank381Test.testsuite` is created in the same package.
- ▶ Open the `ITS0Bank381Test.testsuite` in the TPTP JUnit Test editor. Verify in the **Test Methods** tab that two test methods are invoked.
- ▶ Save and close the editor.

Running the TPTP JUnit test

To run a TPTP JUnit test, do these steps:

- ▶ Right-click `ITS0BankTest.testsuite` or `ITS0Bank381Test.testsuite` and **Run As** → **Test**. This creates the run configuration automatically and runs the test.
- ▶ You can verify the run configurations by selecting **Run** → **Run Configurations**. The configurations show up under the **Test** category.

Analyzing the test results

When the test run is finished, the execution results  are generated in the `RAD75JUnit` project (Figure 23-10).

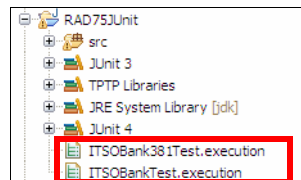

Figure 23-10 Package Explorer view containing test execution results

To analyze the test results, double-click the `ITS0BankTest.execution` result (Figure 23-11).

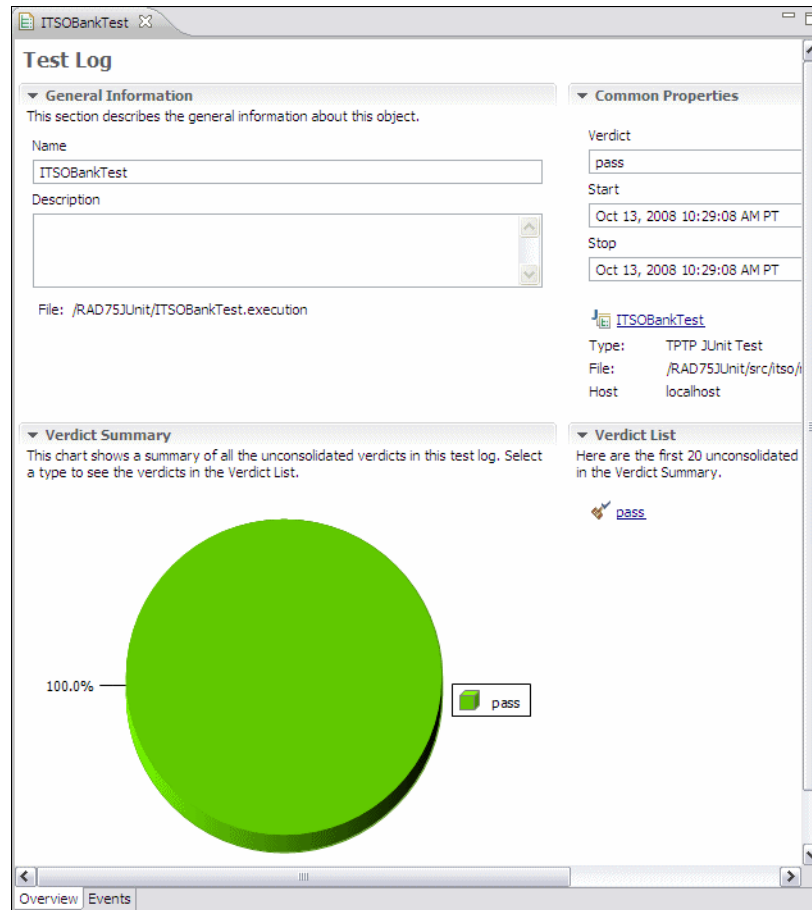

Figure 23-11 TPTP JUnit test execution result

- ▶ In Test Log Overview tab, you can see the test verdict (**pass**) and the starting and stopping time of the test run.
- ▶ The Test Log Events tab lists each single step of the test run with further information about it.

Note: To view the graphic, you have to install the Scalable Vector Graphics (SVG) browser plug-in. You can get this free viewer from the Adobe® Web site:

<http://www.adobe.com/svg/viewer/install/auto/>

Generating test reports

Based on a test execution results file, you can generate analysis reports:

- ▶ **Test Pass report:** Summary of the latest test execution result with graphical presentation of test success.
- ▶ **Time Frame Historic report:** Summary of all test execution result within a time frame with graphical presentation of the test success.

To generate a Test Pass Report, do these steps:

- ▶ Open the Test perspective.
- ▶ Expand **RAD75JUnit** → **src** → **itso** → **rad75** → **bank** → **test** → **tptp**.
- ▶ In the Test Navigator, right-click **ITSOBankTest** and select **Report**.
- ▶ In the New Report dialog, select **Test Pass Report** and click **Next**.
- ▶ In the Test Pass Report dialog, enter **ITSOBankTest_TestPass** as name (the folder is preselected), and click **Next**.
- ▶ In the Select a time frame dialog, enter the start and end date and time:
 - The end time is set as the current time.
 - For the start time, enter a time before you started testing (by default set to the beginning of the day).
 - Click **Finish** and a Test Pass report is generated.
- ▶ Right-click **ITSOBankTest_TestPass** and select **Open With** → **Web Browser**.
- ▶ The Test Pass report opens in the Web Browser (Figure 23-12)

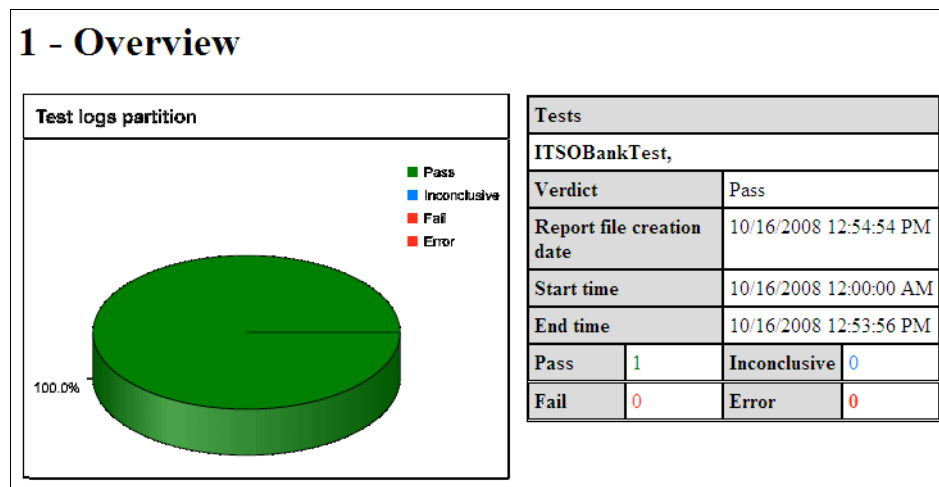

Figure 23-12 Test Pass report

Web application testing

You can also create test cases that run against one of the Web projects, RAD75BankBasicWeb or RAD75StrutsWeb or RAD75EJBWeb. However, when testing anything that runs inside a servlet container, a testing framework like *Cactus* could make the testing much easier.

Note: Cactus is an open source sub-project in the Apache Software Foundation's Jakarta Project. It is a simple framework for unit testing server-side Java code, such as servlets, EJBs, tag libraries, and filters.

The objective of Cactus is to lower the cost of writing tests for server-side code. Cactus supports so-called white box testing of server-side code. It extends and uses JUnit.

More information here: <http://jakarta.apache.org/cactus/>

In addition to providing a common framework for test tools and support for JUnit test generation, TPTP includes features allowing you to test Web applications.

TPTP provides the following Web testing tasks:

- ▶ Recording a test—The test creation wizard starts the Hyades proxy recorder, which records your interactions with a browser-based application. When you stop recording, the wizard starts a test generator, which creates a test from the recorded session.
- ▶ Editing a test—You can inspect and modify a test prior to compiling and running it.
- ▶ Generating an executable test—Follow this procedure to generate an executable test. Before a test can be run, the Java source code of the test must be generated and compiled. This process is called code generation.
- ▶ Running a test—Run the generated test.
- ▶ Analyzing test results—All the conclusion of a test run you see an execution history, including a test verdict, and you can request two graphical reports showing a page response time and a page hit analysis.

Preparing for the sample

As a prerequisite to the Web application testing sample, you must have the WebSphere Application Server V7.0 test environment installed and running. We use the RAD75BankBasicWeb application created in Chapter 13, “Develop Web

applications using JSPs and servlets” on page 317, for the Web application testing sample.

If you do not have the RAD75BankBasicWeb application in the workspace, import the `c:\7672code\zInterchange\webapp\RAD75BankBasicWeb.zip` project interchange file into the workspace (select all three projects).

The completed code for this section can also be imported from the `C:\7672code\zInterchange\junit\RAD75JUnitWebTest.zip` project interchange file.

To verify that the Web application runs, do these steps:

- ▶ Switch to the Web perspective.
- ▶ Right-click the RAD75BankBasicWeb project in the Enterprise Explorer and select **Run As** → **Run on Server**.
- ▶ Verify that the Web browser starts and the welcome page of *ITSO RedBank* is shown. Close the page.

Create a Java project

Create a new Java project called **RAD75JUnitWebTest**.

Recording a test

To create a simple HTTP test, do these steps:

Note: To make sure your recording accurately captures HTTP traffic, clear the browser cache.

- ▶ Open the Test perspective.
- ▶ Right-click **RAD75JUnitWebTest** in the Test Navigator view, select **New** → **Test Element** → **Test From Recording** and click **Next**.
- ▶ Select **Create Test From New Recording** and click **Next**.
- ▶ In the Select Location for Test Suite dialog, select the **RAD75JUnitWebTest** project, accept the test file name of **RAD75JUnitWebTest.testsuite**, and click **Finish**.

A progress dialog box opens while your browser starts. Your browser settings are updated and a local proxy is enabled. If you are using a browser other than Microsoft Internet Explorer, see the online help for detailed instructions on how to configure the proxy.

Tip: The browser used for recording can be set in **Window** → **Preferences** → **Test** → **TPTP URL** → **URL Recorder**.

- ▶ Recording has now started.
- ▶ Start the selected Web application by entering the following URL in the browser:

`http://localhost:9080/RAD75BankBasicWeb/`

Note that the port (9080) may be different in your installation.

Important: For Internet Explorer 7.0 you must use the IP-address to run the Web application: `http://<ip-address>:9080/RAD75BankBasicWeb/`. No recording is produced when using `http://localhost:9080/...`

For Firefox 2.0, you must first configure the network settings: Select **Tools** → **Options** → **Advanced** → **Network**. Click **Settings** and select **Auto-detect proxy settings for the network**.

- ▶ We record a money transfer from a customer's account to another one, and verify that the required transactions have been created.
 - Select the **redbank** link on the ITSO RedBank welcome page, type **333-33-3333** as customer ID (SSN), and click **Submit**.
 - Click account number **003-999000777** and on the next page select **Transfer**, enter **500** in the Amount field and **003-999000888** in the To Account field, and click **Submit**.
 - Verify that **List transactions** is selected and click **Submit**. One Debit transaction is listed.
 - Click **Account Details** and then click **Customer Details**.
 - Click account number **003-999000888**, verify that **List transactions** is selected and click **Submit**. One Credit transaction is listed.
 - Click **Account Details**, click **Customer Details**, and finally click **Logout**.
- ▶ Close the browser to stop recording, or click **Stop Recording** in the toolbar of the Recorder Control view (Figure 23-13).

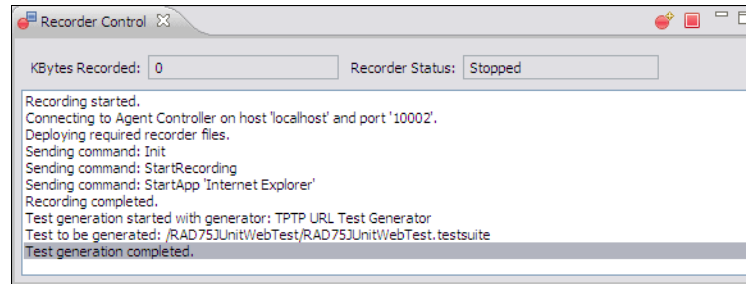

Figure 23-13 Recorder Control view

- ▶ When prompted to Confirm Open Editor, click **Yes**.
- ▶ Notice the messages Recording completed and Test generation completed in the Recorder Control view after closing the browser.
- ▶ The wizard generates automatically a TPTP URL Test. The Recorder Control view informs you with the message Test generation completed when the test is successfully generated.

Editing the test

The TPTP URL Test appears under the RAD75JUnitWebTest project and is open in the editor. We can inspect and modify it before compiling and running it. The test is not Java code yet, but we can check the requests and modify them.

- ▶ Enter the following data in the **Overview** tab (Figure 23-14):
 - Source Folder: /RAD75JUnitWebTest/src
 - Package Name: itso.rad75.bank.test
 - Class Name: RAD75JUnitWebTest

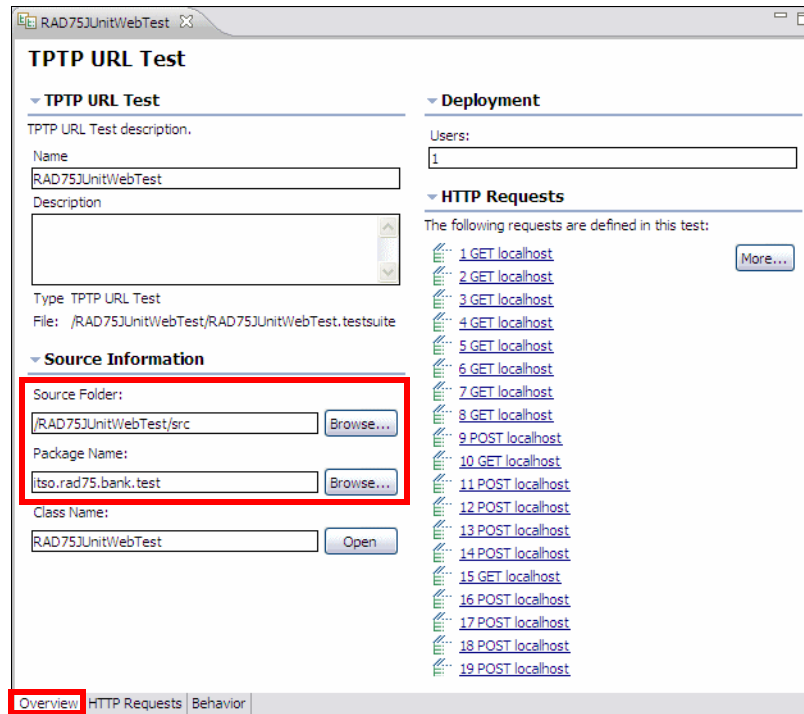

Figure 23-14 TPTP URL Test dialog: Overview tab

- ▶ Select the **Behavior** tab of the TPTP URL Test editor.
- ▶ Change the behavior of the test. For example, we adjust the number of iterations (Figure 23-15). Save and close the Test Editor.

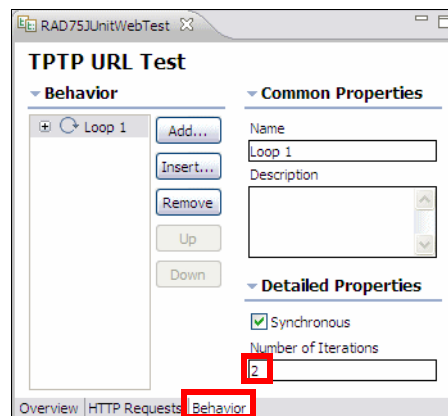

Figure 23-15 TPTP URL Test dialog: Behavior tab

Generating an executable test

Before a test can be run, the Java source code for the test must be generated and compiled. This process is called *code generation*. The compiled code is stored in the RAD75JUnitWebTest project.

To start the code generation of the RAD75JUnitWebTest, do these steps:

- ▶ Right-click **RAD75JUnitWebTest** TPTP URL Test in the RAD75JUnitWebTest project and select **Generate**.
- ▶ In the TPTP URL Test Definition Code Generation dialog, accept the project and source folder and click **Finish** to start the code generation.
- ▶ To examine the generated Java code, switch to the Java or Web perspective, and open the `itso.rad75.bank.test.RAD75JUnitWebTest` class.

Running the test

To run the RAD75JUnitWebTest, do these steps:

- ▶ Switch to Test perspective.
- ▶ Right-click **RAD75JUnitWebTest** TPTP URL Test in the RAD75JUnitWebTest project and select **Run As** → **Test**.
- ▶ The test executes and creates a result.

Analyzing the test results

When the test run is finished, the execution result  appears in the Test Navigator view. To analyze the test results, do these steps:

- ▶ Double-click the execution result  **RAD75JUnitWebTest[<timestamp>]** file in the Test Navigator view. The Test Log Overview tab is displayed (Figure 23-16).
- ▶ The test log gives the test verdict and the starting and stopping time of the test run. The verdict can be one of the following:
 - *fail*: One or more requests returned a HTTP code of 400 or greater, or the server could not be reached during playback.
 - *pass*: No request returned a code of 400 or greater.
 - *inconclusive*: The test did not run to completion.
 - *error*: The test itself contains an error.

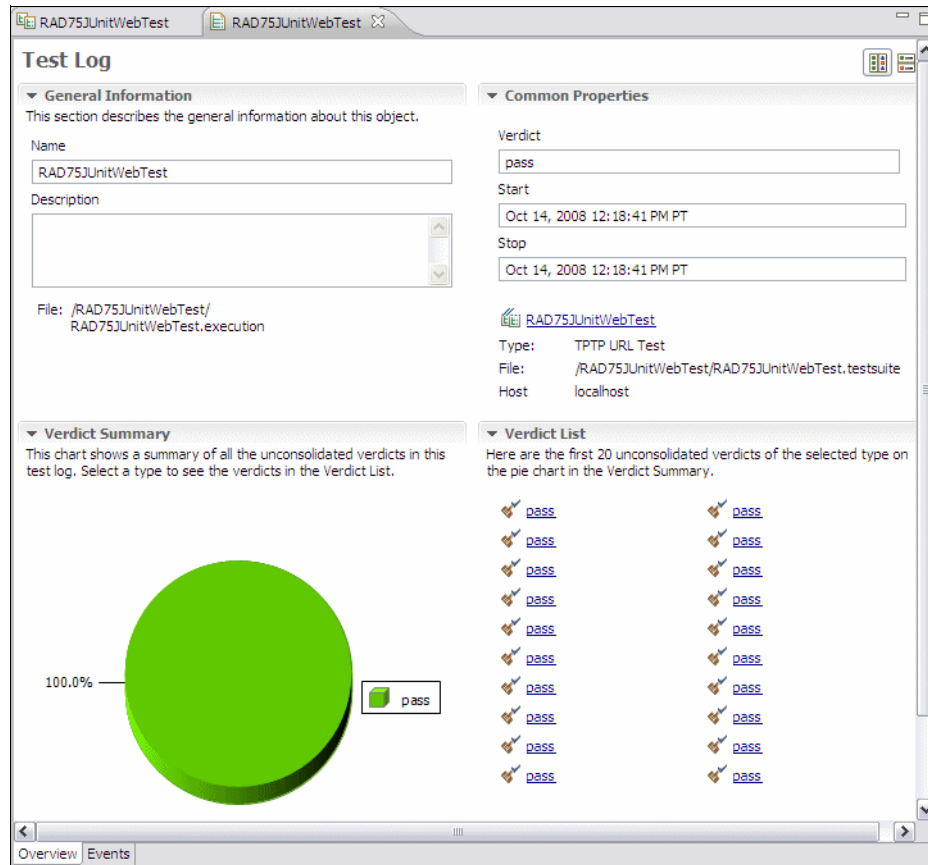

Figure 23-16 Test Log Overview tab

Note: In applications that use session data you can run into errors because the session ID is stored in the generated test case. When you rerun such test cases, a new session ID is created by the server, and it does not match the recorded session ID.

The problem is a known Eclipse issue and there are a few discussions in the following two defects:

https://bugs.eclipse.org/bugs/show_bug.cgi?id=128613

https://bugs.eclipse.org/bugs/show_bug.cgi?id=139699

- ▶ Click the **Events** tab to get detailed information about each single HTTP request (Figure 23-17).

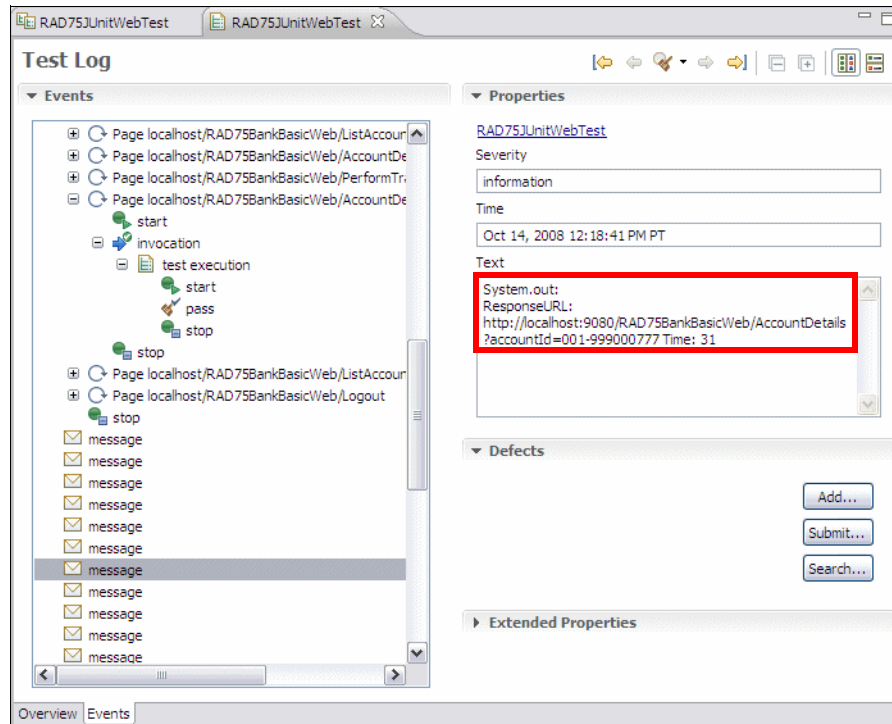

Figure 23-17 Test Log Events tab

Generating test reports

Based on a test execution results file, you can generate different kinds of analysis reports:

- ▶ **HTTP Page Response Time report:** Bar graph showing the seconds required to process each page in the test and the average response time for all pages.
- ▶ **HTTP Page Hit Rate report:** Bar graph showing the hits per second to each page and the total hit rate for all pages.

You can also generate the Test Pass report in the same way as for the basic JUnit tests.

Note: To view the reports, you have to install the Scalable Vector Graphics (SVG) browser plug-in.



Debug local and remote applications

The debugging features included with IBM Rational Application Developer V7.5 can be used to debug a wide range of applications in several languages running either on local test environments (including local Web applications) or on remote servers such as WebSphere Application Server or WebSphere Portal.

In this chapter, the main debugging features are described and two examples of how to use the debugger are provided. The new debug tooling features present in Rational Application Developer v7.5 are introduced: these include the ability to transfer Java-based debug sessions between Rational Team Concert team members. Two examples of debug session transfer are described. Finally, a list of potential sources for further information is supplied.

The chapter is organized into the following sections:

- ▶ Summary of new features in v7.5
- ▶ Overview of Application Developer debugging tools
- ▶ Debugging a Web application on a local server
- ▶ Debugging a Web application on a remote server
- ▶ Jython debugger
- ▶ Debug extension for Rational Team Concert Client (Team Debug)
- ▶ More information

Summary of new features in v7.5

The debugging facilities available with Rational Application Developer v7.5 are very similar to those available in the previous version. The main new feature introduced in v7.5 is *collaborative debugging*, available when using Rational Team Concert Client. This feature is described in detail in the sections:

- ▶ Collaborative debugging using Rational Team Concert Client
- ▶ Debug extension for Rational Team Concert Client (Team Debug)

Overview of Application Developer debugging tools

This section provides an overview of the basic debug tooling features included in Application Developer v7.5.

The topics covered here are:

- ▶ Supported languages and environments
- ▶ Basic Java debugging features
- ▶ XSLT debugging
- ▶ Remote debugging
- ▶ Stored procedure debugging for DB2 V9
- ▶ Collaborative debugging using Rational Team Concert Client

Supported languages and environments

Application Developer includes support for debugging many different languages and environments. These are as follows:

- ▶ Java
- ▶ JavaScript
- ▶ DB2 stored procedures (either in Java or SQL)
- ▶ XSL transformations (XSLT)
- ▶ SQLJ
- ▶ Jython Scripts for WebSphere Application Server administration
- ▶ Mixed language applications (for example XSLT called from Java)
- ▶ WebSphere Application Server (servlets, JSPs, EJBs, Web services)
- ▶ WebSphere Portal (portlets)

Applications in all these languages and environments can be debugged within Application Developer using a similar process of setting breakpoints, running the application in debug mode and within the Debug perspective stepping through the code to track variables and logic and hopefully find and fix problems.

Furthermore, the interface for debugging within the Debug perspective is intended to be consistent across all these languages and environments.

Basic Java debugging features

The following section gives a brief description of the main debugging features available within Application Developer for Java applications and explains how they would typically be used. Although this description focuses mainly on the tools available for Java, most of the features are available when debugging other languages.

Views within the Debug perspective

When running an application in debug mode and a breakpoint is reached, the user is prompted to see if they want to move to the Debug perspective. Note that it is possible to do debugging in other perspectives, however the Debug perspective provides the full set of views available for debugging.

By default, when debugging Java, the views shown in the Debug perspective are as follows:

- ▶ **Source view**—Shows the file of the source code that is being debugged, highlighting the current line being executed.
- ▶ **Outline view**—Contains a list of variables and methods for the code listing shown in the display view.
- ▶ **Debug view**—Shows a list of all active threads, and a stack trace of the thread that is currently being debugged.
- ▶ **Servers view**—Useful if the user wants to start or stop test servers while debugging.
- ▶ **Variables view**—Given the selected source code file shown in the Debug view, the Variables view shows all the variables available to that class and their values. The variables view is, by default, structured into columns. The use of columns can be toggled from the **Layout** → **Show Columns** menu option from the drop-down arrow menu in the Variables view. Also, step-by-step debugging variables that change value are highlighted in a different color.
- ▶ **Breakpoints view**—Shows all breakpoints in the current workspace and gives a facility to activate/de-activate them, remove them, change their properties, and to import/export a set of them to other developers.
- ▶ **Display view**—Allows the user to execute any Java command or evaluate an expression in the context of the current stack frame.

- ▶ **Expressions view**—During debugging, the user has the option to inspect or display the value of expressions from the code or even evaluate new expressions. The Expressions view contains a list of expressions and values which the user has evaluated and then selected to track.
- ▶ **Console view**—Shows the output to System.out.
- ▶ **Tasks view**—Shows any outstanding source code errors, warnings or informational messages for the current workspace.
- ▶ **Error Log**—Shows all errors and warnings generated by plug-ins running in the work space.

Figure 24-1 shows an application stopped at a breakpoint in the Debug perspective.

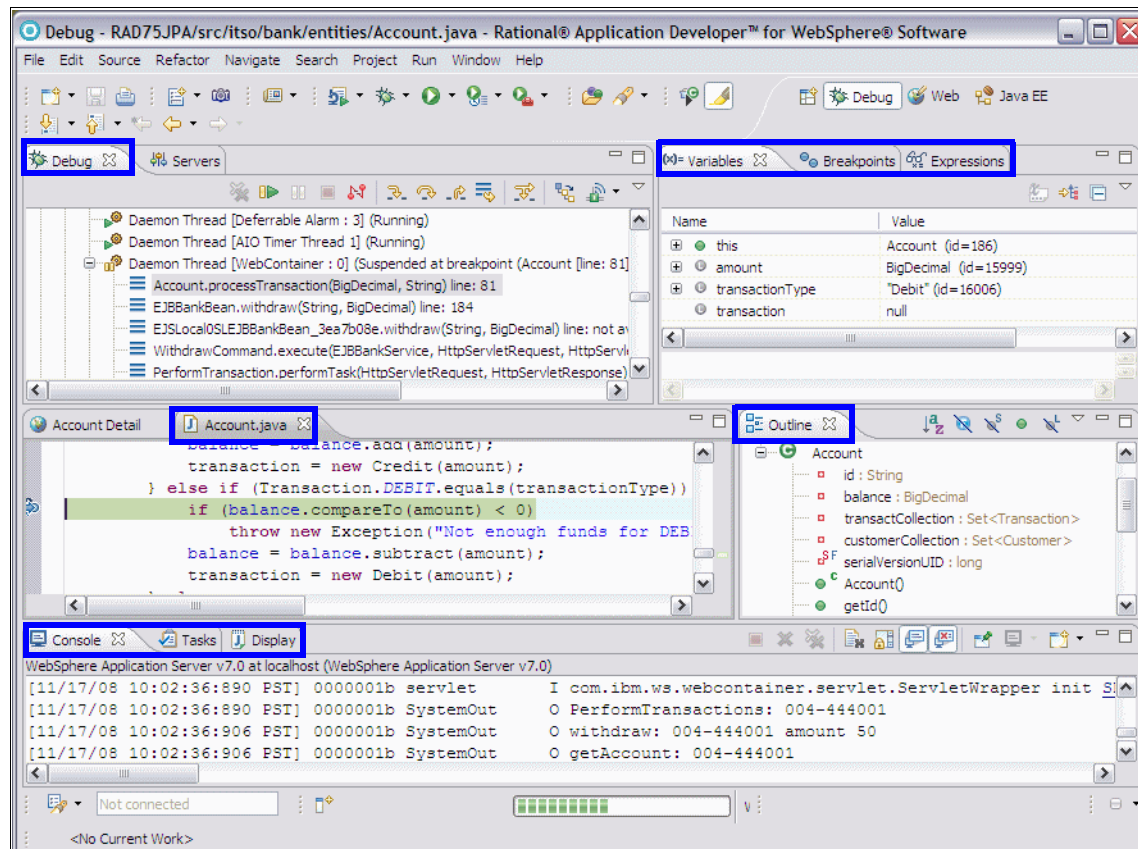















Figure 24-1 Typical application running in the Debug perspective

Debug functions

From the Debug view, you can use the functions available from the icon bar to control the execution of the application. The following icons are available:

- ▶  **Resume** (F8): Runs the application to the next breakpoint.
- ▶  **Suspend**: Suspends a running thread.
- ▶  **Terminate**: Terminates a process.
- ▶  **Disconnect**: Disconnects from the target when debugging remotely.
- ▶  **Remove All Terminated Launches**: Removes terminated executions from the Debug view.
- ▶  **Step Into** (F5): Steps into the highlighted statement.
- ▶  **Step Over** (F6): Steps over the highlighted statement.
- ▶  **Step Return** (F7): Steps out of the current method.
- ▶  **Drop to Frame**: Provides the facility to reverse back to a higher method call in the current stack frame.
- ▶  **Use Step Filters/Step Debug** (Shift-F5): Enable/disable the filtering for the *step debug* functions.
- ▶  **Step-By-Step Mode**: Once the step-by-step debug feature is enabled in the Run/Debug preferences, this icon can also be used to toggle the feature.
- ▶  **Show Qualified Names** (from drop-down menu): Toggle option to show the full package name.
- ▶  or  **Debug UI demon**: Provides a drop-down list for controlling the debugging of XSL transforms that are invoked by WebSphere applications.

Show Running Threads filter

When debugging, there are often many extra threads shown in the Debug view that are not useful for finding a fault in an application under development. This is especially the case when debugging Web applications, where the Application Server starts several threads that are very unlikely to be the cause of an application problem. To show only threads that are suspended, bring up the context menu of the thread being debugged in the Debug view and toggle the **Show Running Threads** filter.

Using these buttons, menus and the information shown in the various views available in the Debug perspective, it should be possible to debug most problems.

Enable/disable Step Filter/Step Debug in the Debug view

In the Debug view toolbar, there is a **Use Step Filters** icon. This feature allows users to filter out Java classes that do not have to be stepped into while debugging. For example, usually it is not necessary for programmers to step into code from the classes within the Sun and IBM Java libraries when step-by-step debugging, and by default these classes are in the step filter list. The facility is provided to add any class or package to this list.

To add new Java package to the Step Filter/Step Debug feature in the Debug view, do these steps:

- ▶ Select **Window** → **Preferences**.
- ▶ Expand **Run/Debug** → **Java and Mixed Language Debug** → **Step Filters**.
- ▶ Click **Add Filter**.
- ▶ Enter the new package or class you want to filter out and click **OK**.

The Step Filter/Step Debug feature can be toggled on and off by clicking **Step Filter** () in the Debug view.

Prior to Version 7.0, the `java.*` and `javax.*` packages were not visible from the Step Filters preferences and were always filtered. Now these packages appear in the step filter list and it is possible to de-select them and therefore, when debugging, it is possible to step into classes from this package. The default setting is to leave these classes remaining filtered.

Drop to Frame

The drop-to-frame feature allows the control of an application to be reversed back to a previously executed line of code. This feature is available when debugging Java applications and Web applications running on WebSphere Application Server and is useful when you want to test a block of code using a range of values.

For example, if a developer wants to test a method with the minimum and maximum permitted values for a given parameter, a breakpoint can be added at the end of the method, and the drop-to-frame feature can be used to back up the control of the application to the start of the method, change the parameters, and run it again.

When running an application in the Debug perspective, the stack frame can be seen in the Debug view (Figure 24-2). Drop to frame allows you to back up your application's execution to previous points in the call stack by selecting the desired method level from within the Debug view and then clicking **Drop To Frame** () . This moves the control of the application to the top of the method selected in the Debug view.

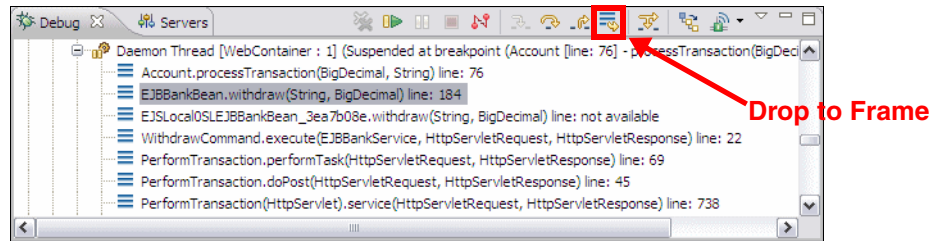

Figure 24-2 Drop to Frame Button in the Debug view.

XSLT debugging

XSL (EXtensible Stylesheet Language) Transformations (XSLT) is a language for transforming XML documents into XHTML or other XML documents. It is a declarative language expressed in XML and provides mechanisms to match tags from the source document to templates (similar to methods), store values in variables, basic looping/code branching and invoke other templates in order to build up the result document.

Also, XSLT files can use templates stored in other files and it is possible for XSLT files to become complicated. Application Developer features a full-featured XSL transformation debugger, and XSLT files can be debugged using a similar set of tools to that available for Java.

To launch a debugging session for a XSLT file and its source XML file, simply select both files on the Enterprise Explorer, right-click and select **Debug As** → **XSLT Transformation**:

- ▶ For example, If you have gone through Chapter 10, “Develop XML applications” on page 185, select **Accounts.xml** and **Accounts.xsl**, right-click, and select **Debug As** → **XSLT Transformation**.
- ▶ This action steps into the first line of the XSL file, and from there, debugging can continue. The debug launch configuration window (from the Context Window use **Debug As** → **Debug**) allows the user to configure dependent files (both XSLT and Java) and other settings to guide the XSLT debugging. These configurations can then be saved to make launching the debugging quicker in the future.

Figure 24-3 shows the Debug perspective when debugging XSLT. From the Debug perspective, the user can step through the XSLT file and the source XML and watch the result XML being built element by element.

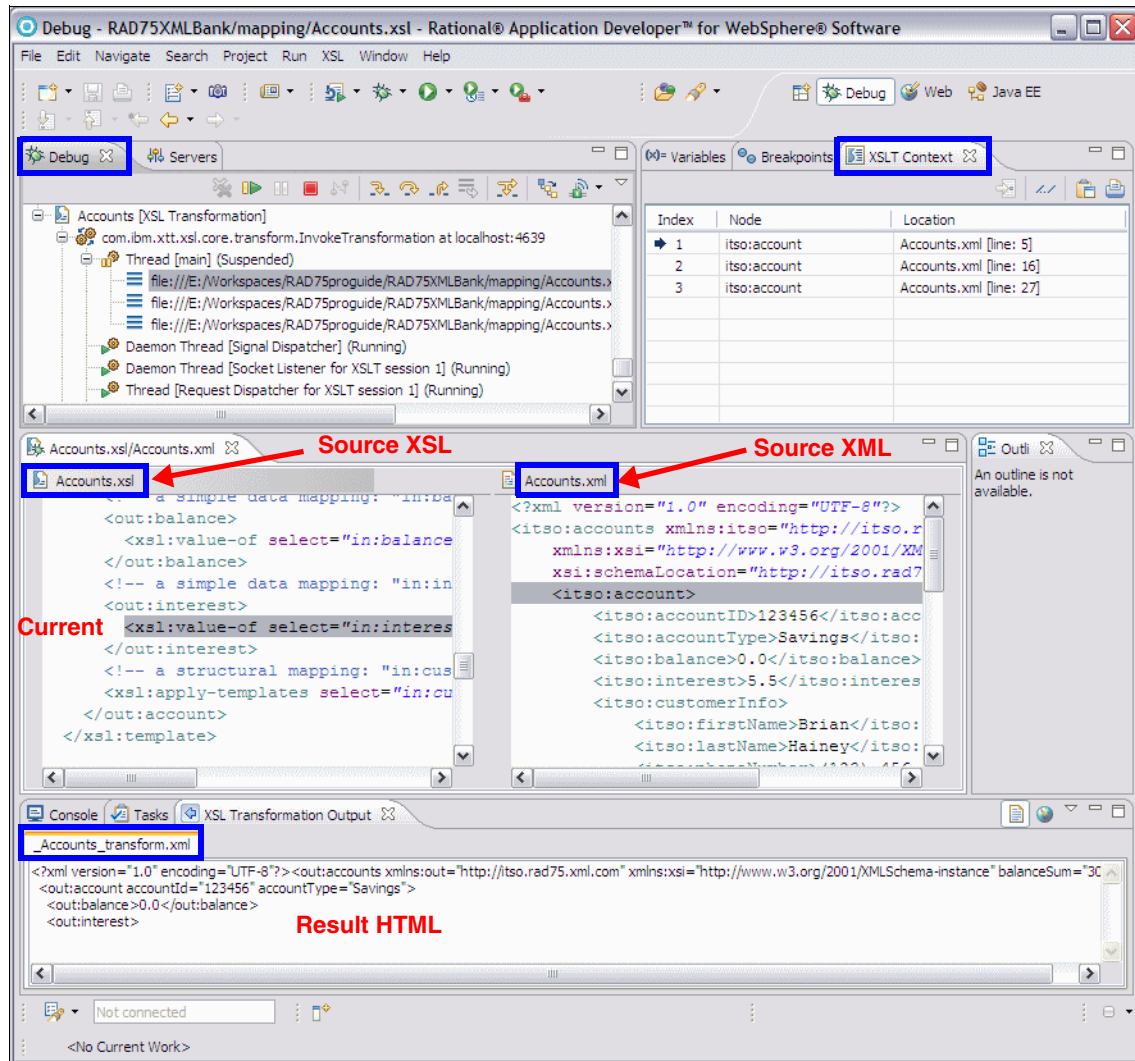

Figure 24-3 Debugging XSLT

The following views are useful when debugging XSLT:

- ▶ **Debug view**—Shows the XSL transformation running as an application with the stack frame for the current execution point.
- ▶ **XSLT Context view**—Shows the current context of the XML input for the selected stack frame.
- ▶ **Expressions view**—Can be used to show the value of XSL expressions, including XPath expressions in the current context.

- ▶ **Variables view**—Currently visible XSLT variables.
- ▶ **XSL Transformation Output view**—Shows the serialized output of the transformation as it is produced.
- ▶ **Display view**—Shows the XSL file on the left side and the input XML file on the right. The line being executed for each is highlighted.
- ▶ **Breakpoints view**—Shows all breakpoints in the workspace, including those placed in an XSLT file. In an XSL file there are several places where a breakpoint has no effect, for example blank lines, `<xsl:output>` lines and XML declarations. When the user attempts to add a breakpoint to an invalid line they receive the message *Cannot Add Breakpoint*.

It is also possible to debug a XSLT transformation called from a Java application. The easiest way to do this is to add a breakpoint in the Java code before the XSL transformation is called (typically from the `javax.com.transform.Transformer` `transform` method). Then use the **Debug** → **Java And Mixed Language Application** option for the Java class from the context menu. When the debugger stops at the breakpoint, use the **Step Into** icon, and the debugger moves to debugging the XSL file and stops at the first line in the transformation.

Finally, it is also possible to debug Java code called from the XSL file. To do this you must use the launch configuration window and make sure that the Class path tab includes the projects that contain the Java code to be debugged. When stepping through the XSLT debugger, it will be possible to Step Into the call to the Java method.

Remote debugging

The debugger provided with Application Developer allows a programmer to attach to a Java application running on a remote machine and control its execution. This is particularly useful when debugging an application that cannot be run on the development machine.

The application that is debugged remotely must be compiled with debug information on (within Application Developer select **Window** → **Preferences**, and look at **Java** → **Compiler** and the Classfile Generation attributes), and when the application is launched, the appropriate JVM parameters must be supplied to configure the IP address and port for the debugger machine. This setting varies between different JVMs.

When starting the debug session, use **Debug As** → **Debug** (from the Enterprise Explorer context menu) and create a new configuration for Remote Java Application.

Make sure the Host and Port are configured for the target machine and that the source tab is filled out with the appropriate source code, then click Debug and the remote debugging session will start.

The **Debug UI daemon** is a feature available from the toolbar of the Debug view which allows developers to debug XSL transformations which are invoked by a WebSphere application.

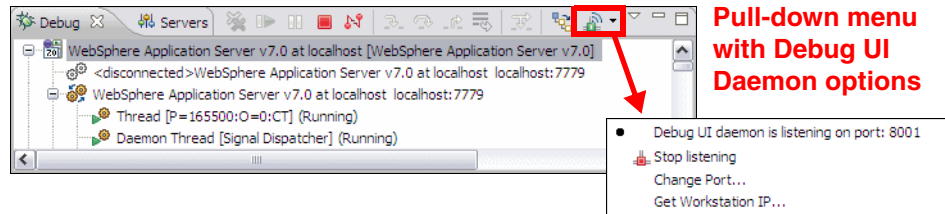

Figure 24-4 Setting Debug UI Daemon options

When enabled, the daemon listens on a port (which you can configure) and if during the WebSphere debug session the application invokes an XSL transformation, Application Developer will step into the XSLT file and debugging continues. You can disable the feature by selecting the appropriate option from the drop-down menu in the Debug view.

The debug daemon must also be started and ready to accept incoming debug session for working with the Debug extension for Rational Team Concert Client (Team Debug).

Stored procedure debugging for DB2 V9

This feature allows a user to debug Java and DB2 stored procedures running on a local or remote DB2 server. The Debug Launch configuration editor provides fields to specify a stored procedure on a DB2 database to debug, arguments to pass to the procedure and the associated source code. If the database server is configured correctly, the debugger will launch and allow debugging to continue. Application Developer has a detailed help chapter on this feature.

Collaborative debugging using Rational Team Concert Client

Rational Application Developer provides:

- ▶ Rational Team Concert Client
- ▶ Debug Extension for Rational Team Concert Client
- ▶ Team Debug Service Extension for Rational Team Concert server

This allows teams members to share debugging sessions including breakpoints and session status. It is possible to send the session to a selected user or to park it in a team repository for later retrieval. It is even possible to share the session by dragging and dropping it onto a chat window provided that the messaging service is enabled. For a detailed description see Debug extension for Rational Team Concert Client (Team Debug)

Debugging a Web application on a local server

This section steps through a Web application scenario where a sample application is run on the local Application Developer test server and the debugging facilities are used to step through the code and watch the behavior of the application.

The debug example includes the following tasks to demonstrate the debug tooling:

- ▶ Importing the sample application
- ▶ Running the sample application in debug mode
- ▶ Setting breakpoints in a Java class
- ▶ Watching variables
- ▶ Evaluating and watching expressions
- ▶ Working with breakpoints
- ▶ Set breakpoints in a JSP
- ▶ Debugging a JSP

Importing the sample application

The following instructions show how to set up your workspace for the sample application. We use the ITSO RedBank Web application sampled developed in Chapter 14, “Develop EJB applications” on page 387 to demonstrate the debug facilities.

If you have the necessary projects (RAD75EJBWebEAR, RAD75EJBWeb, RAD75EJB, and RAD75JPA) in the workspace, you can skip this step.

To import the ITSO RedBank EJB Web application, follow these steps:

- ▶ In the Web perspective select **File** → **Import** → **Other** → **Project Interchange** and click **Next**.
- ▶ In the Import Projects screen click **Browse** to locate the file:
`C:\7672code\zInterchange\ejb\RAD75EJBWeb.zip`
- ▶ Select the projects that are not in the workspace, and click **Finish**.

To run this application you have to configure a database as described in “Setting up the ITSOBANK database” on page 1154 and “Configuring the data source in WebSphere Application Server” on page 1155.

Running the sample application in debug mode

To verify that the sample application was imported properly, run the sample Web application on the WebSphere Application Server V7 test server in debug mode as follows:

- ▶ In the Enterprise Explorer, expand **RAD75EJBWeb** → **WebContent**.
- ▶ Right-click **index.jsp** and select **Debug As** → **Debug on Server**.
- ▶ If the Server Selection dialog opens, select **Choose an existing server**, select **WebSphere Application Server v7**, and click **Finish**. This will start the server, publish the application to the server, and bring up a browser showing the Index page.
- ▶ If the server is already running in normal (non-debug) mode, you are prompted to switch mode. Click **OK**, and the server restarts in debug mode.
- ▶ When the Index page is displayed, click **RedBank**, enter 444-44-4444 in the Customer SSN field, and click **Submit**.
- ▶ The list of accounts for that customer are displayed (Figure 24-5). If you can see these results, then the application is working fine in debug mode.

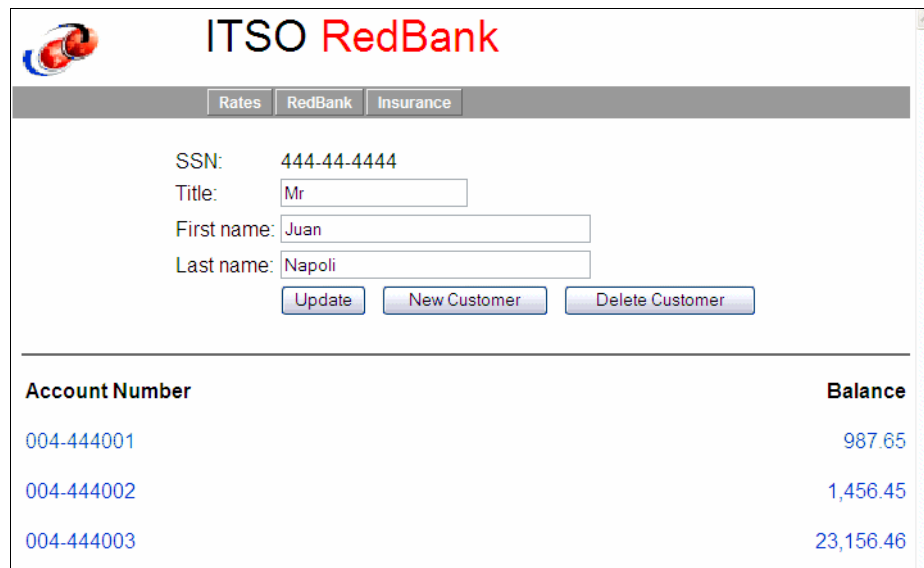

The screenshot shows the ITSO RedBank application interface. At the top left is a logo with two overlapping circles. The title "ITSO RedBank" is displayed in red. Below the title is a navigation bar with three tabs: "Rates", "RedBank", and "Insurance". The "RedBank" tab is selected. The main content area displays customer details for SSN 444-44-4444. The fields are: Title (Mr), First name (Juan), and Last name (Napoli). Below these fields are three buttons: "Update", "New Customer", and "Delete Customer". A horizontal line separates the customer details from a table of accounts. The table has two columns: "Account Number" and "Balance".

Account Number	Balance
004-444001	987.65
004-444002	1,456.45
004-444003	23,156.46

Figure 24-5 Customer details for the RedBank application

Setting breakpoints in a Java class

Breakpoints are indicators to the debugger that it should stop execution at that point in the code and let the user inspect the current state and step through the code. Breakpoints can be set to always trigger when the execution point reaches it or when a certain condition has been met.

In the ITSO RedBank sample application, before the balance of an account is updated after withdrawal of funds from an account, the new balance is compared to see if it goes below zero. If there are adequate funds, the withdrawal will complete. If there are not enough funds in the account, an Exception is thrown from the Account class and the showException.jsp is displayed to the user showing an appropriate message.

In this example, we set a breakpoint where the logic tests that the amount to withdraw does not exceed the amount that exists in the account.

- ▶ In the Enterprise Explorer select and expand **RAD7JPA** → **src** → **itso.bank.entities**, and open **Account.java** in the Java editor.
- ▶ Locate the processTransaction method.

Tip: You can use the Outline view or expand Account.java in the Enterprise Explorer to find the processTransaction method quickly in the source code.

- ▶ Place the cursor in the gray bar (along the left edge of the editor area) on the following line of code in the processTransaction method:

```
if (balance.compareTo(amount) < 0)
```

- ▶ Double-click to set a breakpoint marker (Figure 24-6).

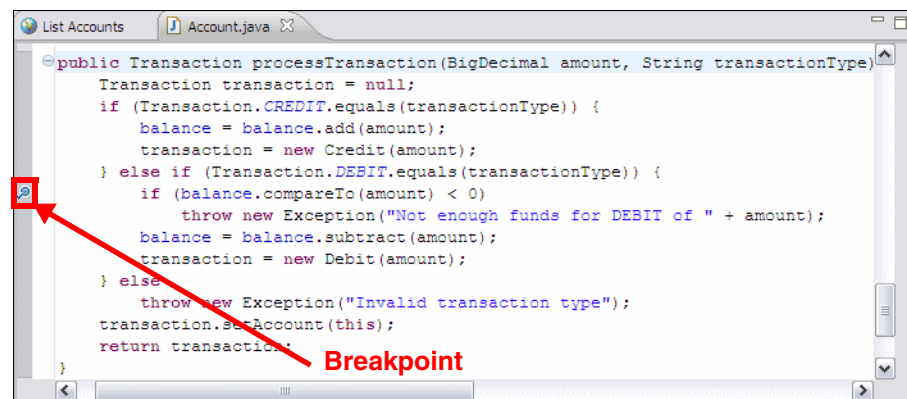

Figure 24-6 Setting a breakpoint in Java

Note: Enabled breakpoints are indicated with a blue circle. Installed breakpoints have an additional check mark overlay. A breakpoint can only be installed when the class the breakpoint is located in has been loaded by the VM.

- ▶ Right-click the breakpoint and select **Breakpoint Properties**.
- ▶ In the Breakpoint Properties window, you can change the details of the breakpoint (Figure 24-7).

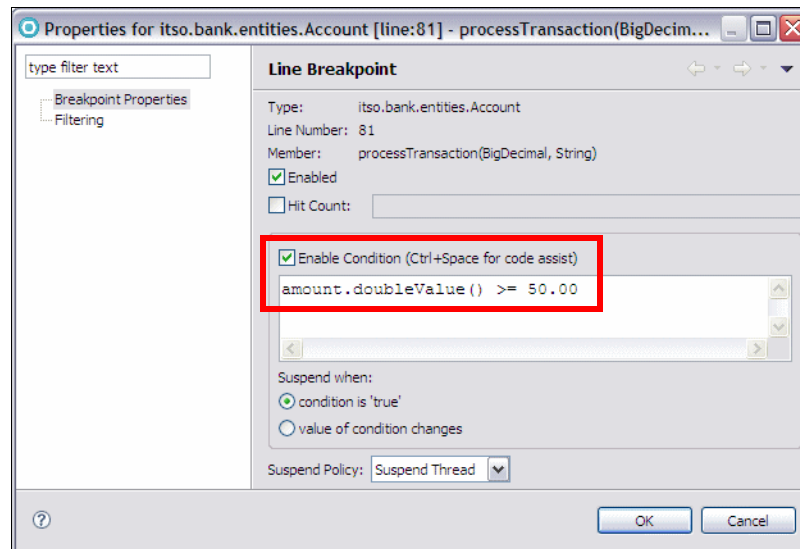

Figure 24-7 Breakpoint properties

- If the **Hit Count** property is set, it causes the breakpoint to be triggered only when the line has been executed as many times as the hit count specified. Once triggered, the breakpoint is disabled.
- Selecting **Enable Condition** allows breakpoints to trigger only when the condition specified in the entry field evaluates to *true*. This condition is a Java expression. Note that you can use code assist (Ctrl+Space) to see the fields and methods that you can use in this expression. When this condition is enabled, the breakpoint is marked with a question mark on the breakpoint, which indicates that it is a conditional breakpoint.

For example, select **Enable Condition**, enter the expression `amount.doubleValue() >= 50.00`, select **condition is 'true'**. Now the breakpoint will only trigger on transactions over \$50.00.

- ▶ Click **OK** to close the breakpoint properties.

It should now be possible to run the application and trigger the breakpoint. Note that it is not necessary to restart the Application Server for the new breakpoint to work.

To trigger the breakpoint, perform the following steps:

- ▶ In the home page, click on the **RedBank** tab, enter 444-44-4444 as the customer number and click **Submit**.
- ▶ In the List Accounts page, click on the first account (004-444001).
- ▶ In the Account Details page, select **Withdraw** and enter 50 in the Amount field.
- ▶ Click **Submit**. The `processTransaction` method is executed and the new breakpoint triggered.

Debug perspective

Depending on the preferences set in **Windows** → **Preferences** → **Run/Debug** → **Perspectives** you may be prompted to open the Debug perspective. In most cases the Debug perspective opens.

If the Debug perspective does not open automatically, select **Window** → **Open Perspective** → **(Other)** → **Debug**.

The Debug perspective shows the source code where the execution stopped at the breakpoint (refer to Figure 24-1 on page 864):

- ▶ The Debug view shows the threads, currently stopped in `Account.processTransaction`.
- ▶ The source code of the `Account` class shows the current line (at the breakpoint).
- ▶ The Outline view shows the current method (`processTransaction`).
- ▶ The Variables view shows the account (`this`), the amount (`BigDecimal`), the transaction type (`Debit`), and the transaction (`null`).
- ▶ The Breakpoints view shows the breakpoint (`Account [line: 81]`).
- ▶ The Console view shows the server console. You may see time-out errors because we stopped the execution in the middle of an EJB call.

In this perspective it is possible to step through the code, and to watch and edit variables.

Watching variables

The Variables view displays the current values of the variables in the selected stack frame (Figure 24-6):

- ▶ Expand **this** and verify the value of `id`. You can also expand the `balance` and see the value (for example, 98765 with scale 2 = 987.65).
- ▶ Expand **amount**. Although `amount` is of type `BigDecimal`, a string representation of its value is shown in the bottom section of the window.

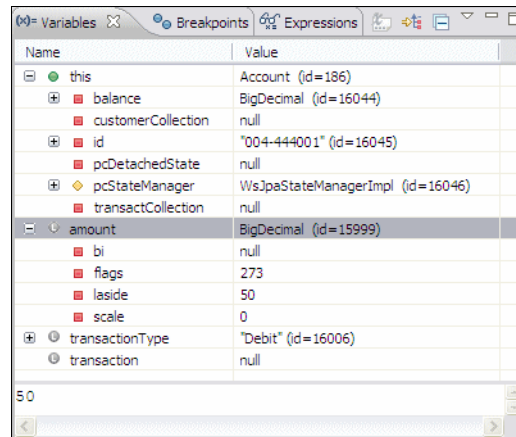



Figure 24-8 Displaying variables

The plus sign (+) next to a variable indicates that it is an object. By clicking on the plus sign, it is possible to look into instance variables associated with the object.

Follow these steps to see how you can track the state of a variable, while debugging the method:

- ▶ Click **Step Over**  in the Debug view (or press F6) to execute the current statement.
- ▶ Click **Step Over** again and the `balance` is updated. Note that the color of `balance` changes in the Variables view.

It is possible to test the code with some other value for any of these instance variables; a value can be changed by selecting **Change Value** from its context menu. A dialog opens where the value can be changed. For objects such as `BigDecimal`, you have to use a constructor to set the value.

For example, right-click **balance** and select **Change Value**. In the Change Object Value dialog, type **new java.math.BigDecimal(900.00)**, and click **OK**.

Evaluating and watching expressions

When debugging, it is often useful to be evaluate an expression made up of several variables within the current application context.

To view the value of an expression within the code:

- ▶ Select the expression (for example, `balance.compareTo(amount)` in the breakpoint line), right-click, and select **Inspect**. The result opens in a pop-up window showing the value (Figure 24-9).

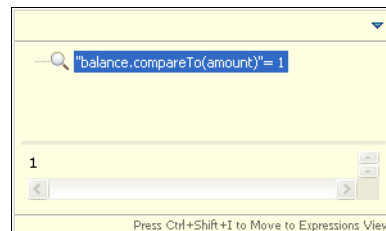

Figure 24-9 Inspect Pop-up window

- ▶ To move the results to the Expressions view (Figure 24-10) so that the value of the expression can continue to be monitored, press **Ctrl+Shift+I**.
- ▶ To watch an expression, right-click in the Expressions view and select **Add Watch Expression**. In the Add Watch Expression dialog, enter an expression, such as, `balance.doubleValue()`.

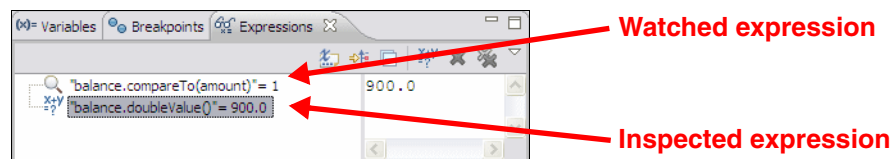



Figure 24-10 Inspecting a variable in Expressions view

Note: The Expressions view contains a list of watched expressions (marked by a  symbol) and a list of inspected expressions marked by a  symbol (Figure 24-10). The difference between these is that the value shown for watched expressions changes with the underlying value as the user steps through the code, while an inspected expression will remain showing the value it held when it was first inspected.

Using the Display view

To evaluate an expression in the context of the currently suspended thread which does not come from the source code, use the Display view.

- ▶ Set a new breakpoint on the line: `transaction.setAccount(this);`
- ▶ Click **Step Return** until you reach that line.
- ▶ From the Workbench, select **Windows** → **Show View** → **Display**.
- ▶ Type the expression **`transaction.getTransTime()`** in the Display View, then highlight the expression, right-click, and select **Display** (Figure 24-11).

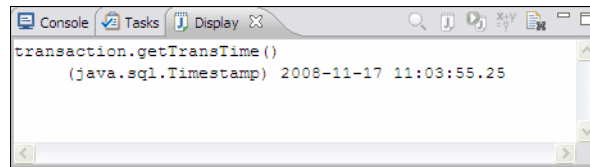

Figure 24-11 Expression and evaluated result in display view

Tip: When entering an expression in the Display Panel, it is possible to use code assist (Ctrl+Space).

- ▶ Each expression is executed, and the result is displayed as shown in Figure 24-11. This is a useful way to evaluate Java expressions or even call other methods during debugging, without having to make changes in your code and recompile.
- ▶ You can also highlight any expression in the source code, right-click, and select **Watch** (or **Inspect**). The result is shown in the Expressions view.
- ▶ Select **Remove** from the context menu to remove expressions or variables from the Expressions views. In the Display view, just select the text and delete it.

Working with breakpoints

To enable a breakpoint in the code, double-click in the grey area of the left frame (or use the context menu on the left side of the frame) for the line of code the breakpoint is required for. To remove double-click on it again, and to disable the breakpoint, right-click and select **Disable Breakpoint**.

Alternatively, once they have been created, the breakpoints can be enabled and disabled from the Breakpoints view (Figure 24-12). If the breakpoint is un-selected in the Breakpoints view, it is skipped during execution.

To disable or enable all breakpoints, click the **Skip All Breakpoints** icon. If this option is selected then all breakpoints are skipped during execution.

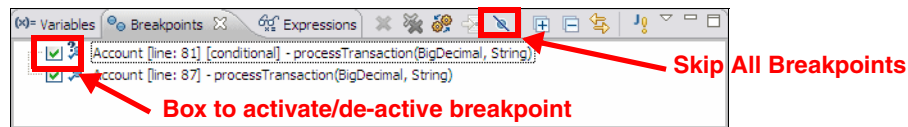



Figure 24-12 Enabling/Disabling Breakpoints

It is possible to export a set of breakpoints, including the conditions and hit count properties so that they can be shared across a development team. To do this, from the context menu of the Breakpoints view select **Export Breakpoints** and the breakpoints are saved as a bkpt file to the selected location.

Before continuing with debugging of JSPs, do the following:

- ▶ Remove the breakpoints by clicking the **Remove All Breakpoints** icon .
- ▶ Click **Resume**  to continue execution.

Note that you do not see the Web page automatically in the Debug perspective. Click the view with the World icon (in the same pane as the source code) to see the resulting Web page. Alternatively, switch to the Web perspective.

If you waited too long, the thread has been terminated in the server and you have to restart the application from the `index.jsp`.

Tip: Java exception breakpoints are a different kind of breakpoint that are triggered when a particular exception is thrown. These breakpoints can be set by selecting **Run** → **Add Java Exception Breakpoint**.

Set breakpoints in a JSP

You can also set breakpoints in JSPs. Within the source view of a JSP page, you can set breakpoints inside JSP scriptlets, JSP directives, and lines which use JSP tag libraries. You cannot set breakpoints in lines with only HTML code.

In the following example, we set a breakpoint in the `listAccounts.jsp` at the point where the JSP displays a list of accounts for the customer.

- ▶ In the Web Perspective expand **RAD75EJBWeb** → **WebContent** and open the **listAccounts.jsp** in the editor. Select the **Source** tab.
- ▶ Set a breakpoint by double-clicking in the grey area next to the desired line of code (Figure 24-13).
- ▶ Note that the Breakpoint properties are also available for JSPs from the context menu. These share the same features as Java breakpoints with the exception that content assist is not available in the breakpoint condition field.

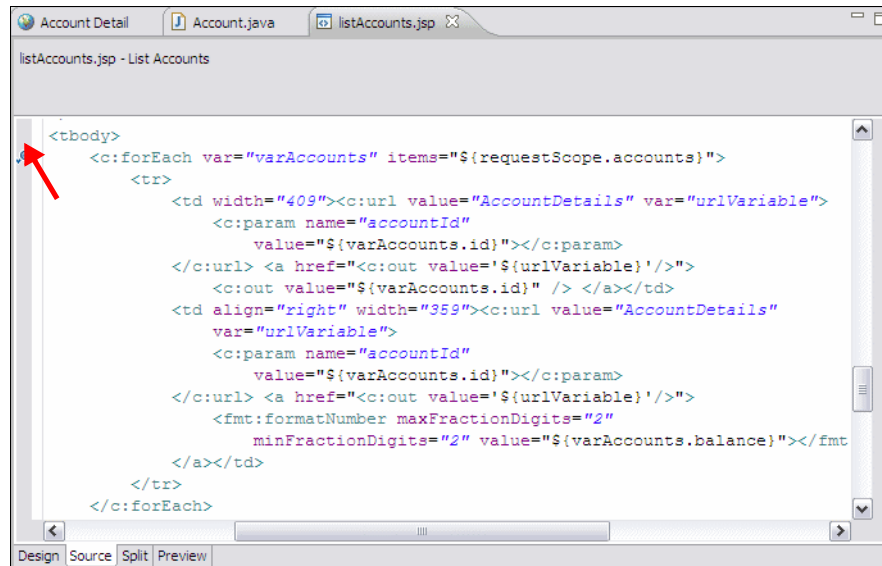

Figure 24-13 Adding a breakpoint to a JSP page

Debugging a JSP

When a new breakpoint is added, it is not necessary to redeploy the Web application:

- ▶ From the RedBank index page, select the **RedBank** tab.
- ▶ On the redbank page, enter a Customer ID of 444-44-4444, and click **Submit**. This executes the `listAccounts.jsp` file and hits the new breakpoint.
- ▶ In the Confirm Perspective Switch dialog, click **Yes** to switch to the Debug perspective.
- ▶ Execution should stop at the breakpoint set in the `listAccounts.jsp`, because clicking **Submit** in the application attempts to display the accounts by executing this JSP. The thread is suspended in debug, but other threads might still be running (Figure 24-14).

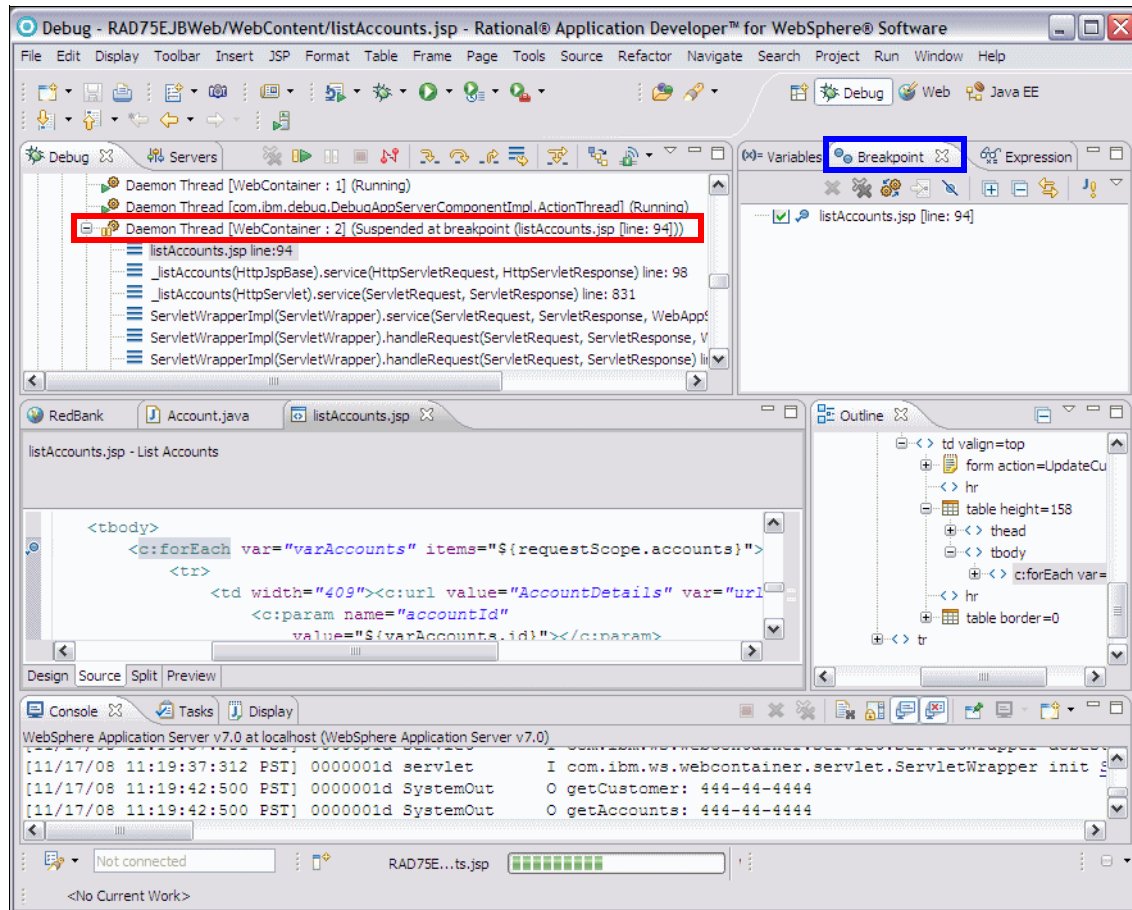

Figure 24-14 Debugging a JSP

Note: If you have two JSPs with the same name in multiple Web applications, the wrong JSP source might be displayed. Open the correct JSP to see its source code.

- ▶ Once a breakpoint is hit, you can analyze variables and step through lines of the JSP code. The same functions available for Java classes are available for JSP debugging. The difference is that the debugger shows the JSP source code and not the generated Java code.
- ▶ The JSP variables are shown in the Variables view. Note that the JSP implicit variables are also visible, and it is possible to look at things such as request parameters or session data (Figure 24-15).

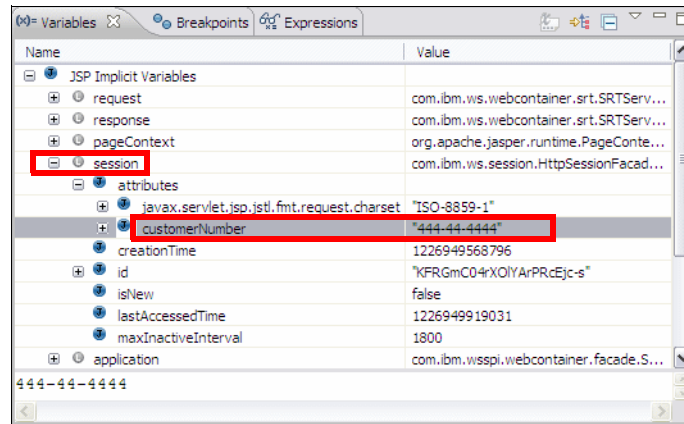

Figure 24-15 JSP Implicit variables in Variable view

- ▶ Step over the lines within the JSP by pressing the **F6** key (Step Over). Note that the debugger will skip any lines with only HTML code.
- ▶ Note the change in the variables view. Expand **JSP Implicit Variables** → **pageContext** → **page_attributes** and select **varAccounts**, which is the variable in the `<c:forEach var="varAccounts" ...>` loop:

```
Account: 004-444001 balance 987.65
```
- ▶ The customer and the accounts are visible under **JSP Implicit Variables** → **pageContext** → **request_attributes**.
- ▶ Click **Resume** (▶) allow the application to continue with the JSP page generation.
- ▶ Remove the breakpoint.

This concludes the section on debugging a local test environment.

Debugging a Web application on a remote server

It is possible to connect to and debug a Java Web application that has been launched in debug mode on a remote application server. When debugging a remote program the Debug perspective has the same features as when debugging locally—the difference lies in the fact that the application is on a remote JVM and the debugger must attach to the JVM through a configured debug port. The debugging machine must also map the debug information to its locally stored copy of the source code, so it is important that the source code on the debugger machine matches what is deployed.

This following example scenario includes a node where Application Developer v7.5 is installed (Developer node), and a separate node where IBM WebSphere Application Server v7 is installed (Application Server node). The developer node attaches to the Application Server Node and controls it through a debugger.

Tip: If you defined a second server profile in (AppSRV02) in Chapter 22, “Servers and server configuration” on page 777, then you can use this server for debugging on a remote server.

Exporting the RedBank as an EAR file

This section describes how to export the RedBank to an Ear file so that it can be deployed on a remote WebSphere Application Server.

- ▶ In the Enterprise Explorer, right-click **RAD75EJBWebEAR** and select **Export** → **EAR file**.
- ▶ In the EAR Export dialog enter the following and then click **Finish**:
 - EAR application: RAD75EJBWebEAR
 - Destination: C:\temp\RAD75EJBWebEAR.ear

Deploying the RedBank application

The following steps show how to deploy the RedBank application to a remote system where IBM WebSphere Application Server v7 has been installed:

- ▶ Ensure that the target WebSphere Application Server - server1 application server is started.
- ▶ Start the WebSphere Application Server Administrative Console by entering the following in a Web browser and logging on:

`https://<hostname>:9043/ibm/console` <=== port 9048 in our case

Note: For the <hostname> it is sufficient to use the IP address of the machine running WebSphere Application Server. Run the command `ipconfig` from the command line to determine this. Note that the remote server may run on a different set of ports.

- ▶ From the Administration Console, expand **Applications** and click **New Enterprise Application**.
- ▶ Select **Local file system** and click **Browse** and locate the generated EAR file (C:\temp\RAD75EJBWebEAR.ear).
- ▶ Select **Fast Path** and click **Next**.

- ▶ In Step 1, select **Precompile JavaServer Pages files**, and click **Next**.
- ▶ In Step 2, click **Next**.
- ▶ In Step 3 (Summary), accept the defaults and click **Finish**.

You should see a screen showing the progress of the installation. After a short time, the following message will be displayed if the application is successfully deployed:

```
Application RAD75EJBWebEAR installed successfully.
```

- ▶ Click **Save** directly to the master configuration link URL.
- ▶ Navigate to the **Applications** → **Application** → **Types WebSphere enterprise Application**. Select **RAD75EJBWebEAR** and click **Start**.
- ▶ Click **Close Page** and **Logout**.
- ▶ Verify the application is working properly by opening a Browser and navigating to the following URL of the target machine:

```
https://<hostname/address>:9443/RAD75EJBWeb/ <=== 9448 for us
```

Configuring debug on a remote WebSphere Application Server

The following steps explain how to configure WebSphere Application Server V6.1 to start in debug mode:

- ▶ If it is not already running, start the application server.

```
<was_home>\bin\startServer.bat server1
```
- ▶ Start the WebSphere Administrative Console by entering the following in a Web browser and then logging in:

```
https://<hostname>:9043/ibm/console <=== port 9048 in our case
```
- ▶ In the left-hand frame expand **Servers** → **Server Types** → **WebSphere Application Servers**.
- ▶ In the Application Servers page, click **server1**.
- ▶ On the Configuration tab, select **Debugging Service** in the Additional Properties section at the bottom right, to open the Debugging Service configuration page.
- ▶ In the General Properties section of the Configuration tab, select **Enable service at startup**. This enables the debugging service when the server starts.

Note: The value of the JVM debug port is required when connecting to the application server with the debugger. The default value is **7777**; in our case the server used port **7782**.

- ▶ Click **OK** to make the changes to your local configuration.
- ▶ Save the configuration changes.
- ▶ Click **Logout**.
- ▶ You must restart the application server before the changes that have been made take effect.
- ▶ Again, verify the application is working properly by navigating to the following URL:

`https://<hostname/IPaddress>:944x/RAD75EJBWeb/`

Attaching to the remote server in Application Developer

Assuming that the target server is running in debug mode, complete the following steps to attach to the remote WebSphere Application Server v7 from within Application Developer v7.5. Note that the workspace used must contain the RAD75EJBWeb project.

- ▶ In the Enterprise Explorer, right-click **RAD75EJBWeb**, and select **Debug As** → **Debug Configurations**.
- ▶ Create a new remote Debug configuration for WebSphere Application Server v7 server.
 - On the **Create, Manage, and run configurations** page, double-click **WebSphere Application Server** (or right-click and select **New**).
 - Verify the name for this Debug configuration (RAD75EJBWeb).
 - In the **Connect** tab, make sure the project is RAD75EJBWeb, select **WebSphere v7 Server** for the IBM WebSphere Server type, enter the IP address or target machine name for the Host name, and **7777** (7782 in our case) as the JVM debug port.
 - Click **Apply** (Figure 24-16).

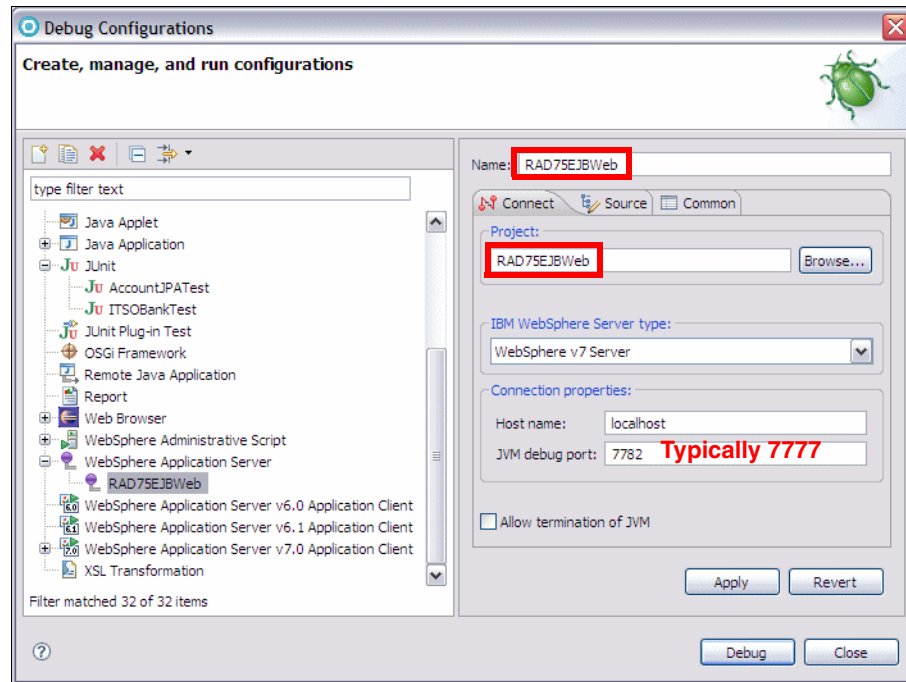

Figure 24-16 Debug config for Remote debugging

- On the **Source** tab expand the Default folder. Note that about halfway down is the RAD75EJBWeb project. This lets the debugger know where the source code is.
- On the **Common** tab are standard options for debug configuration, including where to save the configuration and where to output the SystemOut file.
- Click **Debug** to attach the debugger to the remote server.

The Debug perspective now shows the Remote debugger running in the Debug view, as shown in Figure 24-17. The debugger is waiting for a breakpoint to be triggered. Note that clicking the Disconnect icon (🔌) stops the debugging.

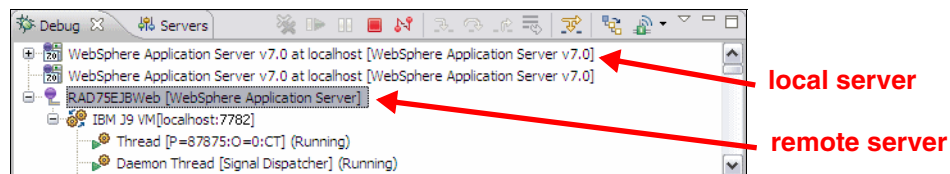

Figure 24-17 Debugging perspective while remote debugging

Note: When attaching to a local Application Developer's WebSphere instance, you must start the application server in debug mode, then open the Debug perspective, and disconnect the debug instance started by Application Developer automatically when the server was started in debug mode.

After that you can start a remote debug instance using **localhost** as the host name and port **7777** (or the correct port, such as **7782**). This will attach to the test application server and allow the user to perform all the usual debugging facilities.

Debugging a remote application

From a Web browser, navigate to the URL where hostname is the IP address or name of the target machine:

```
https://<hostname/IPaddress>:944x/RAD75EJBWeb/
```

You can now debug the remotely running application in the same way as a locally deployed application:

- ▶ Set breakpoints (Java or JSP).
- ▶ Step through the code.
- ▶ Watch variables.
- ▶ Execute expressions.

To terminate the debugging session, select the remote debugging instance and click **Disconnect** .

Uninstalling the remote application

You might want to remove the RAD7BankBasicEAR application from the remote server. In the administrative console under **Applications** → **Application Types** → **WebSphere Enterprise Applications**, select **RAD7EJBWebEAR** and click **Uninstall**. Then save the configuration. Optionally, stop the remote server.

Jython debugger

The Jython debugger enables you to detect and diagnose errors in Jython script (with extension .py or .jy) that is used for WebSphere Application Server administration. With the debugger, you can control the execution of your code by setting line breakpoints, suspending execution, stepping through your code, and examining the contents of variables. (Note that variable values cannot be changed in Jython.)

The Jython debugger only supports debugging of script that are running on WebSphere Application Server Version v6.1 or v7.

You can debug a Jython script that has been developed or imported into a Jython project. When you are debugging a Jython script, you can set line breakpoints.

When the workbench is running the script and encounters a breakpoint, the script temporarily stops running. Execution suspends at the breakpoint before the script is executed, at which point you can check the contents of variables. You can then step over (execute) and see what effect the statement has on the script.

Using the Debug Launch configuration, you can launch a debugging session for a given Jython script on either the local test server or a server running on a remote machine. If the target environment is on a remote machine, then the host and port numbers must be configured in the **wsadmin arguments** field. Refer to the Application Developer online help for details on this feature.

Tip: To debug a Jython script, the server does not have to run in Debug mode.

Debugging a sample Jython script

In this section we debug the **listJDBCProviders** script that was described in “Developing automation scripts” on page 810:

- ▶ Open the **listJDBCProviders.py** Jython script file in the RAD75Jython project.
- ▶ Set a breakpoint in the `showJdbcProviders` function at the line:

```
        for provider in providerEntryList
```
- ▶ Select **listJDBCProviders.py** and **Run** → **Debug As** → **Administrative Script**.
- ▶ In the Debug Configurations dialog (Figure 24-18):
 - Verify **listJDBCProviders.py** as Name.

- Select **WebSphere Application Server v7** as Scripting runtime and **was70profile1** as the WebSphere profile.
- Specify a User ID and password if security is enabled.
- Click **Apply**, then click **Debug**.

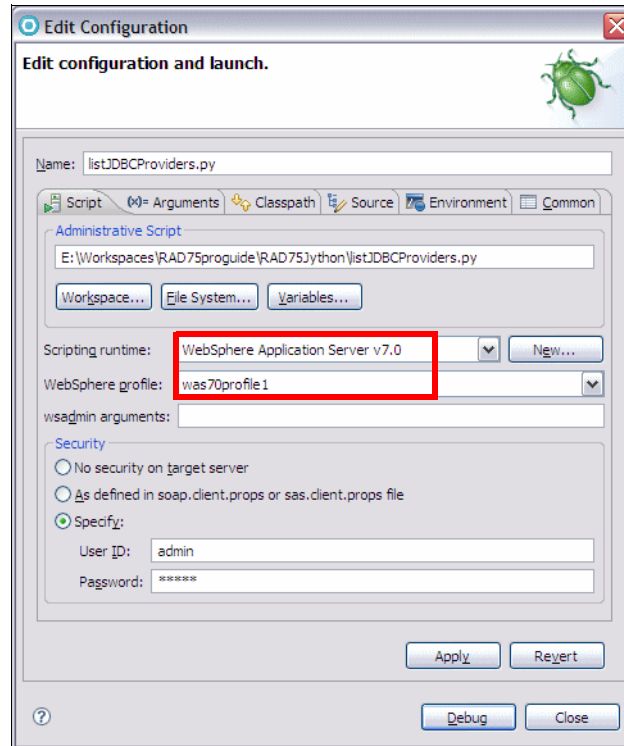

Figure 24-18 Jython debugging configuration

- ▶ Execution of the script starts and when the breakpoint is encountered execution is suspended.
- ▶ When prompted, switch to the Debug perspective.
- ▶ The Debug perspective opens and displays the familiar views (Figure 24-19):
 - The Debug view shows the thread and is used to step through the code.
 - The editor shows the source code and where we currently are.
 - The Variables view shows the Jython variables, which cannot be changed.
 - The Breakpoints view shows the breakpoints.
 - The Outline view shows the outline of the script.
 - The Console shows the output of the script.

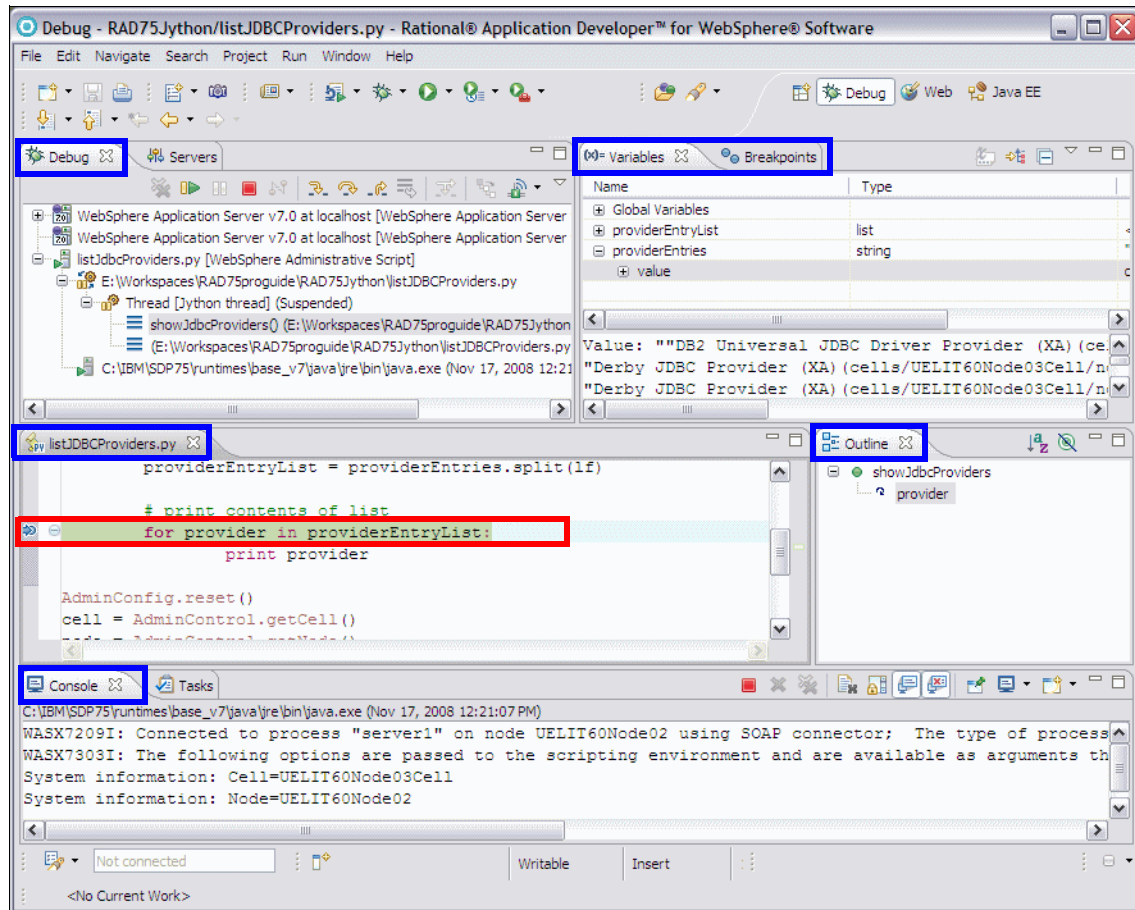

Figure 24-19 Debug perspective when debugging a Jython script

- ▶ Step through the Jython code and watch the variables.

The Jython debugger is very useful when you encounter errors in your Jython scripts. Run the script in debug mode, without having to restart the server.

Debug extension for Rational Team Concert Client (Team Debug)

Application Developer v7 includes a debug extension for Rational Team Concert.

Introduction

While debugging complex applications, any given team member may require the expertise of a specialist to understand and correct a specific part of code. However, recreating a debug session to reproduce a particular scenario can be quite time consuming, so Application Developer offers the capability to share the complete state of an existing debug session with another user, including any breakpoints already set.

There are two main modes of operation:

- ▶ If both users are logged on the Team Concert server at the same time, one user can add a debug session to the team repository and then transfer the debug session to the other user (Figure 24-20).
- ▶ Alternatively, the debug session can be parked on the Team Concert server, so that it can be retrieved later by any user. It is also possible to drag and drop a link to a debug session onto a messaging system, if messaging has been configured to integrate with Team Concert.

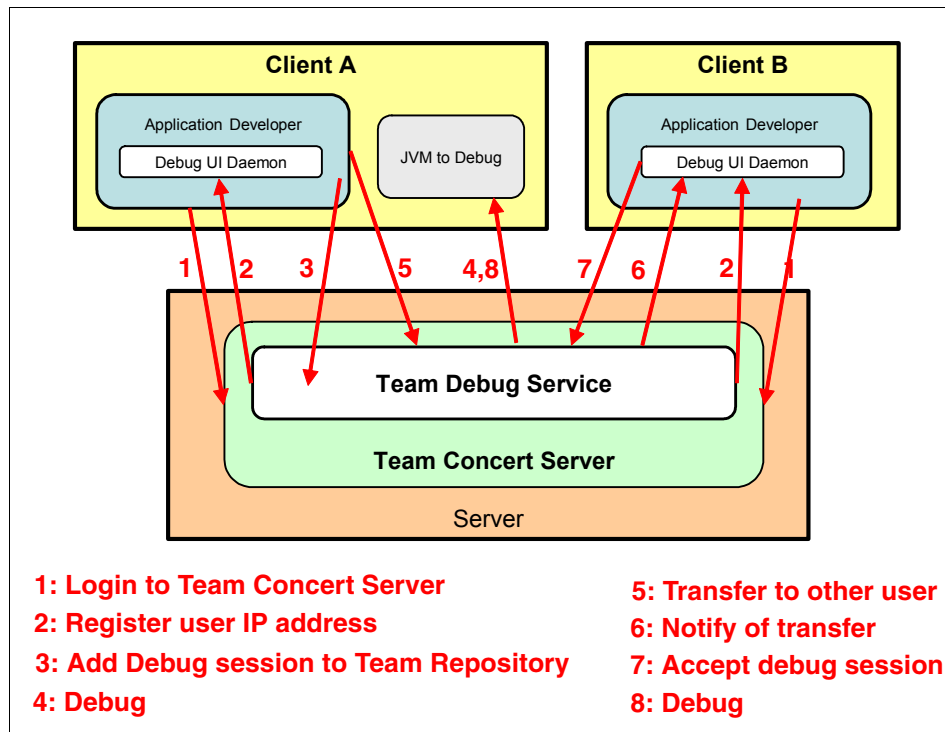

Figure 24-20 Workflow for transferring Java Debug session

Supported environments

Team Debug launchers only support Java 1.5 and higher as the target JRE. The supported versions of Websphere Application Server are v6.0, v6.1, and v7.0.

The supported types of launch configurations are the following:

- ▶ Debug on Server
- ▶ Eclipse application
- ▶ Java applet
- ▶ JUnit
- ▶ JUnit plug-in test
- ▶ Remote Java application
- ▶ Java application

While the Team Debug Client supports multiple languages, the Team Debug Service is English only, so the user could receive error messages from the server in English.

Prerequisites

The following prerequisites must be satisfied:

- ▶ This feature leverages Team Concert and requires an installation of additional features on the Team Concert Server as well as on Application Developer (Team Concert Client). For installation instructions, “Installing IBM Rational Team Concert” on page 1139.
- ▶ Two Rational Application Developer users must be logged in to the same Rational Team Concert server, either at the same time in case of a direct transfer, or potentially at different times if the debug session is parked on the server.
- ▶ The two users should have imported the same versions of the project to be debugged into the Application Developer workspace. Refer to Chapter 29, “Rational Team Concert” on page 1077 for details on how to share a project in Rational Team Concert.
- ▶ In Application Developer, the **Debug UI daemon** (refer to “Remote debugging” on page 869) must be active and listening for inbound connections.
- ▶ When the user logs onto the Team Concert server, the user’s IP address and the debug daemon port are registered with the team debug service. This information is needed to identify the users and send them notifications when they are sent a debug session or they are requested to transfer their debug session.

If users do not receive notifications, check the user IP address and debug daemon settings. The IP address of the client can be determined in the Debug view by clicking on the **Debug UI daemon** icon and selecting **Workstation IP**. After verifying the IP address, debug port, and status of the daemon, try to logout and login again to Team Concert. This way the user is registered again with the team debug service with the correct information. If the problem persists, part the debug session and use the Team Debug view to transfer the session.

- ▶ If you test this functionality using two Application Developer instances running on the same machine, remember to change the default value of the Debug UI daemon port (8001) for at least one of the two instances.

Sharing a Java debug session by transferring it to another user

This example will show to share the debug session of a Java application. The following scenario can be executed if you have completed the steps in “Source control scenarios” on page 1099 (Chapter 29, “Rational Team Concert”). If you are unsure whether the two users have the same versions of the projects imported, you can revert back to a known baseline that contains the desired sources.

To replace the contents of each user’s workspace with a known baseline, perform these steps:

- ▶ Right-click **My Repository Workspaces** in the Team Artifacts view.
- ▶ Select the personal workspace of the user.
- ▶ Right-click **Java Prototype Component**.
- ▶ Select **Replace With** → **Baseline**.
- ▶ Select the Baseline **Imported prototype**.
- ▶ Look at the Pending Changes view.
- ▶ Right-click on the Incoming Changes and select **Accept**.

To initiate the debug session and transfer it to another user, Lara performs the following actions:

- ▶ Open **BankClient.java**.
- ▶ Place a breakpoint on the line `executeCustomerTransactions(iTS0Bank);`.
- ▶ Right-click **BankClient.jav** and select **Debug As** → **Debug Configurations**.
- ▶ Create a new Java Application Configuration (Figure 24-21):
 - Name: **RAD75 Team Debug Configuration**
 - Project: RAD75Java
 - Main class: `itso.rad75.bank.client.BankClient`
 - In the **Team** tab select **Add debug session to team repository**.

- Select a team repository: hostname (rcsnl-cc.rcsnl.ams.nl.ibm.com)
 - Ensure that at the bottom of the page you see Using Team Java Launcher.
- Click **Debug**.

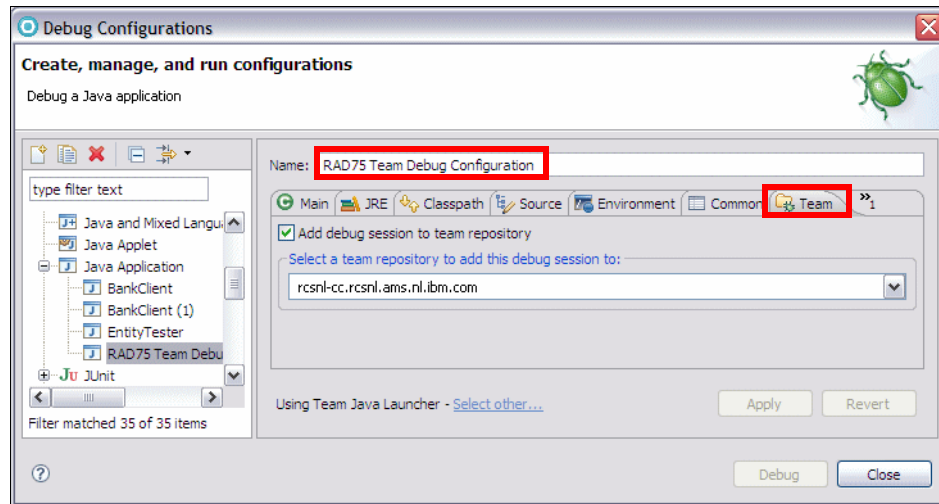

Figure 24-21 Debug configuration for a Java Application to be added to team repository

Note that the Team Java Launcher starts the JVM to debug with the following parameters:

```
-agentlib:jdwp=transport=dt_socket,suspend=y,server=y,address=hostname:debugPort -Dfile.encoding=<codepage> -classpath <path>
<MainClass>
```

You cannot use the Eclipse JDT Launcher for this purpose because it starts the JVM to debug without the **server=y** parameter.

Observe the Debug perspective (Figure 24-22). The Debug view should show line referring to the virtual machine decorated with the following text:

```
[Team] VM [hostname:debugPort]
```

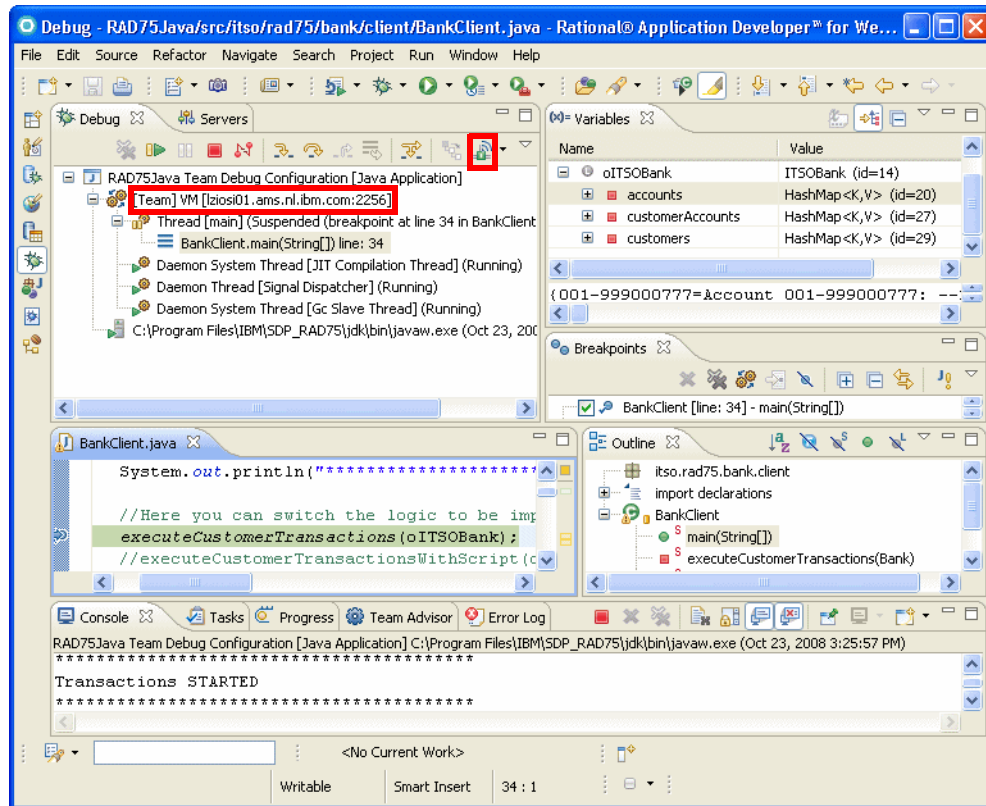

Figure 24-22 Team Debugging

To transfer the debug session to Patrick, Lara performs these actions:

- ▶ In the Debug perspective, right-click on the line:
 - [Team] VM [hostname:debugPort]
- ▶ Select **Transfer to User**.
- ▶ Enter the user name or a space followed by the last name to find Patrick.
- ▶ A dialog shows the attempt to transfer the debug session.

Note: The presence of firewalls between the Team Concert server and Application Developer may prevent this functionality from working. A symptom of such situation would be a message stating:

```
Unable to add debug session to repository
Reason: Cannot connect to IP_address:debugPort
```

The IP address and port in the error message are those of the JVM to be debugged (typically on the Team Concert client). The port is randomly chosen by the Team Launcher, which means that you cannot easily open this port on the firewall. One way of fixing the value of the debug port is to start the Java program in debug server mode instead of using the Team Launcher. Note however that it is currently not possible to fix the value of the port used by the Team Debug Service on the Team Concert Server. This is considered an enhancement for a future release.

To launch the Java program in debug server mode:

- ▶ Create a new Java launch configuration, and add this in the VM argument:

```
-agentlib:jdwp=transport=dt_socket,suspend=y,server=y,address=hostname:debugPort
```

Note that the hostname used must be recognizable by the Jazz server (do not specify localhost, use the full hostname or IP address).

- ▶ Launch this session in Run mode.
- ▶ Create a Remote Java Application debug configuration and connect to this running JVM for debug.
- ▶ Once connected, add the debug session to the Jazz server.

In his workspace, Patrick sees a dialog with the title Incoming Debug Session (Figure 24-23):

- ▶ Select **Import Breakpoints**.
- ▶ Click **Yes**.

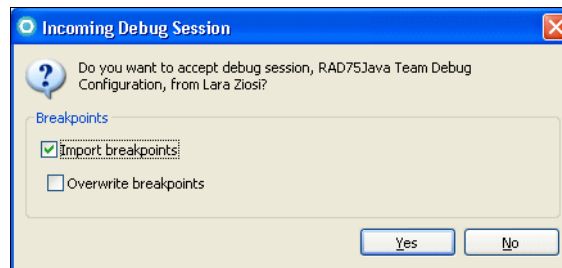

Figure 24-23 Invitation to accept an incoming debug session from another user

Lara's debug session is suspended at the same line where she left it and Patrick can step into the application from the point where Lara transferred it.

If Patrick has imported the breakpoints, they will be grouped in a Working Set named after Lara's user on the Team Concert Server. The debug output and input streams will be directed to the console of the user that receives the debug session.

Patrick can decide to transfer the session back to Lara at some later stage in the execution. Alternatively, Lara can also request the session back by doing the following:

- ▶ In the Team Artifacts view, expand the Debug node under the Project Area.
- ▶ Expand **Search Team Debug Session** → **Started by Me**.
- ▶ Identify the session started by Lara and currently being debugged by Patrick.
- ▶ Right-click the session, and select **Debug**.
- ▶ Patrick receives a notification that the debug session is requested by Lara.
- ▶ When Patrick accepts, Lara will be asked if she wants to import Patrick breakpoints.
- ▶ A new debug session appears in Lara's Debug view.

Sharing a WebSphere Application Server Debug session by parking it on the server

This example shows how a developer can share a WebSphere Application Server v7 debug session with another user by first parking the session in Rational Team Concert. A parked debug session has no owner and can be retrieved by another user at a later time.

In this example, Patrick has loaded into his repository workspace the contents on the Web Development Component. Patrick performs these actions:

- ▶ Start the WebSphere Application Server in debug mode.
- ▶ Add the project RAD75EJBWebEAR to the server.
- ▶ Set a breakpoint in Account.java on the line:

```
if (balance.compareTo(amount) < 0)
```
- ▶ In the Debug view, right-click **WebSphere Application Server v7.0 at localhost localhost:7777**, and select **Add to Team Repository**.
- ▶ Note that the Team decoration is added and you should now see:

```
[Team] VM [hostname:7777]
```

Patrick can now proceed to debug the application. He will follow the steps listed in “Running the sample application in debug mode” on page 872, and attempt to withdraw a large amount until he hits the breakpoint. At this point Patrick decides to park the debug session by doing the following:

- ▶ Right-click **[Team] VM [Team-Concert-server-hostname:7777]**, and select **Park Debug Session**.

Parked debug sessions are stored on the Team Concert Server and nobody owns them. Anyone can retrieve them and regain control.

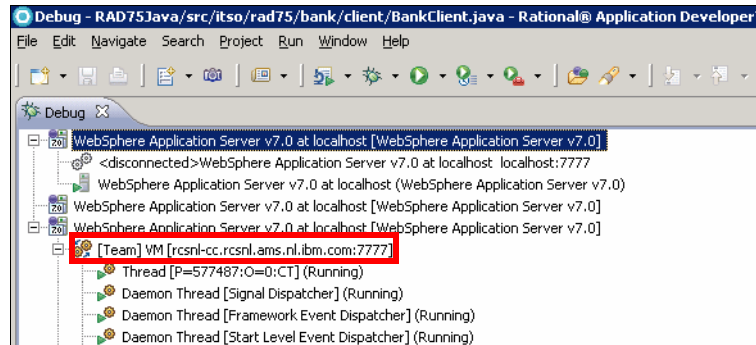

Figure 24-24 Appearance of a debug session added to a Team Repository

Possibly at a later time, Lara decides to continue Patrick’s debug session. She performs these actions:

- ▶ In the Team Artifacts view, expand the node Debug under the Project Area.
- ▶ In the node Search Team Debug Sessions, select **Parked Debug Sessions** (Figure 24-25)

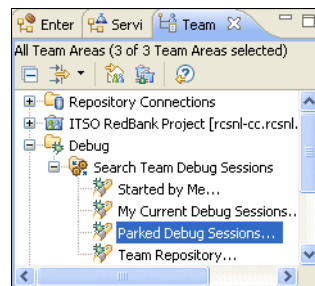

Figure 24-25 Search for parked debug sessions

- ▶ In the Team Debug view, identify the session started by Patrick, right-click on the session, and select: **Debug** (Figure 24-26).

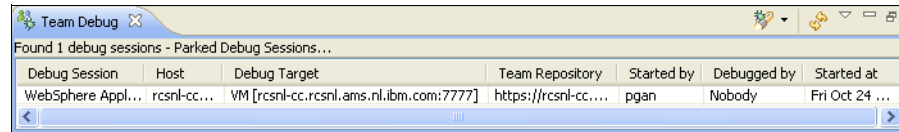

Figure 24-26 Team Debug view showing a parked debug session

- ▶ A dialog prompts whether you want to import breakpoints. Click **Yes**.

At this point Lara will see in the Debug perspective the code that contains the breakpoint. The variables view shows the contents as determined by the workflow previously followed by Patrick. Lara will also see a copy of the standard output and standard error streamed to the console (the same keep being streamed to the console of Patrick's instance of Application Developer). While Lara steps through the code, Patrick will see the results in the Web browser opened on his machine. Lara can then decide to transfer the session back to Patrick, or to park it again on the server.

More information

The online help provided with Application Developer has a large section on debugging applications and is a good starting point. It has information on the following topics:

- ▶ Java development tools (JDT) debugger.
- ▶ Java and mixed language debugger
- ▶ J2EE/Web application debugging
- ▶ Jython debugger
- ▶ XSLT debugger
- ▶ Debug extensions for Rational Team Concert Client
- ▶ DB2 stored procedure debugger
- ▶ SQLJ debugger
- ▶ Installing Rational Debug extensions for Rational Team Concert Client
<http://publib.boulder.ibm.com/infocenter/radhelp/v7r5/topic/com.ibm.debug.team.client.ui.doc/topics/cbtovrvw.html>
- ▶ Installing Rational Debug Extension for Rational Team Concert Server
http://publib.boulder.ibm.com/infocenter/radhelp/v7r5/index.jsp?topic=/com.ibm.rad.install.doc/topics/t_install_teamdebug.html

- ▶ Rational Team Concert InfoCenter

<http://publib.boulder.ibm.com/infocenter/rtc/v1r0m0/index.jsp>

Finally, IBM developerWorks has a number of tutorials and articles to explain debugging for various situations, including the following topics:

- ▶ Debugging and Testing Java Applications:

<http://www.ibm.com/developerworks/edu/i-dw-r-radcert2556.html>

- ▶ Getting Started with the New Rational Application Developer XSLT Debugger:

http://www-128.ibm.com/developerworks/rational/library/05/614_debug/



Part 7

Deploy and profile applications

In this part of the book, we describe the tooling and technologies provided by Application Developer for automatic builds, deployment, and profiling.



Build applications with Ant

Traditionally, application builds are performed by using UNIX/Linux shell scripts or Windows batch files in combination with tools such as *make*. While these approaches are still valid, new challenges exist when developing Java applications, especially in a heterogeneous environment. Traditional tools are limited in that they are closely coupled to a particular operating system. With Ant, you can overcome these limitations and perform the build process in a standardized fashion regardless of the platform.

This chapter provides an introduction to the concepts and features of Ant within IBM Rational Application Developer v7.5. The focus of the chapter is to demonstrate how to use the Ant tooling included in Rational Application Developer to build applications.

The chapter is organized into the following sections:

- ▶ Introduction to Ant
- ▶ Ant features in Application Developer
- ▶ Building a simple Java application
- ▶ Building a Java EE application
- ▶ Running Ant outside of Application Developer
- ▶ Using the Rational Application Developer Build Utility

Introduction to Ant

Ant is a Java-based, platform-independent, open source build tool. It was formerly a sub-project in the Apache Jakarta project, but in November 2002 it was migrated to an Apache top-level project. Ant's function is similar to the *make* tool. Since it is Java-based and does not make use of any operating system-specific functions, it is platform independent, thus allowing you to build your projects using the same build script on any Java-enabled platform.

The Ant build operations are controlled by the contents of the XML-based script file. This file not only defines what operations to perform, but also defines the order in which they should be performed, and any dependencies between them.

Ant comes with a large number of built-in tasks sufficient to perform many common build operations. However, if the tasks included are not sufficient, you also have the ability to extend Ant's functionality by using Java to develop your own specialized tasks. These tasks can then be plugged into Ant.

Not only can Ant be used to *build* your applications, it can also be used for many other operations such as retrieving source files from a version control system, storing the result back in the version control system, transferring the build output to other machines, deploying the applications, generating *Javadoc*, and sending messages when a build is finished.

Ant build files

Ant uses XML *build files* to define what operations must be performed to build a project. Here is a list of the main components of a build file:

- ▶ **Project:** A build file contains build information for a single project. It can contain one or more *targets*.
- ▶ **Target:** A target describes the *tasks* that must be performed to satisfy a goal. For example, compiling source code into class files might be one target, and packaging the class files into a JAR file might be another target.

Targets can depend upon other targets. For example, the class files must be up-to-date before you can create the JAR file. Ant can resolve these dependencies.

- ▶ **Task:** A task is a single step that must be performed to satisfy a target. Tasks are implemented as Java classes that are invoked by Ant, passing parameters defined as attributes in the XML. Ant provides a set of standard tasks (core tasks), a set of optional tasks, and an API, which allows you to write your own tasks.

- ▶ **Property:** A property has a name and a value pair. Properties are essentially variables that can be passed to tasks through task attributes. Property values can be set inside a build file, or obtained externally from a properties file or from the command line. A property is referenced by enclosing the property name inside `${}`, for example `${basedir}`.
- ▶ **Path:** A path is a set of directories or files. Paths can be defined once and referred to multiple times, easing the development and maintenance of build files. For example, a Java compilation task can use a path reference to determine the classpath to use.

Ant tasks

A comprehensive set of built-in tasks is supplied with the Ant distribution. The tasks that we use in our example are as follows:

- ▶ `delete`: Deletes files and directories
- ▶ `echo`: Outputs messages
- ▶ `jar`: Creates Java archive files
- ▶ `javac`: Compiles Java source
- ▶ `mkdir`: Creates directories
- ▶ `tstamp`: Sets properties containing date and time information

To find out more about Ant, visit the Ant Web site at:

<http://ant.apache.org/>

This chapter provides a basic outline of the features and capabilities of Ant. For complete information, you should consult the Ant documentation included in the Ant distribution or available on the Internet at:

<http://ant.apache.org/manual/index.html>

Note: Application Developer v7.5 includes Ant v1.7.

Ant features in Application Developer

Application Developer includes the following features to aid in the development and use of Ant scripts:

- ▶ It provides the ability to create and run Ant buildfiles in the Workbench and run the build process in a background task like other tasks within Application Developer.
- ▶ The Ant editor also offers content assist (including Ant specific templates) with the ability to insert snippets and syntax highlighting.

- ▶ The Ant editor has a format function that allow you to format your Ant files base on your preferences.
- ▶ The Ant editor also offers annotations support.
- ▶ It provides the ability to add new Ant task and types that will be available for build files.
- ▶ A Problems view is available in the Ant editor to highlight syntax errors in your Ant files.

In this section, we highlight the following Ant-related features in Application Developer:

- ▶ Content assist
- ▶ Code snippets
- ▶ Formatting an Ant script
- ▶ Defining the format of an Ant script
- ▶ Problems view

Preparing for the sample

To demonstrate the basic concepts of Ant, we provide a very simple Java application named HelloAnt, which prints a message to the console.

We use a simple Java project (RAD75Ant) and class (HelloAnt) for this example.

To create a new Java project, do these steps:

- ▶ In the Workbench, select **File** → **New** → **Project**.
- ▶ In the New Project dialog, select **Java** → **Java Project** and click **Next**.
- ▶ When prompted for the project name, enter **RAD75Ant** for the project name field, and click **Finish**.
- ▶ If the current perspective is not the Java perspective when you create the project, Application Developer prompts you to switch to the Java perspective. Click **Yes**.

To import the HelloAnt class into the RAD75Ant Java project, do these steps:

- ▶ Right-click the **RAD75Ant** project and select **New** → **Package**.
- ▶ In the New Package dialog, type `itso.rad75.ant.hello` for the Name, and click **Finish**.
- ▶ Right-click **itso.rad75.ant.hello** and select **Import**.
- ▶ In the Import dialog, select **General** → **File System**, and click **Next**.

- ▶ In the File System dialog, click **Browse** and select `c:\7672code\ant\` as directory, select `HelloAnt.java`, and click **Finish** (Figure 25-1).

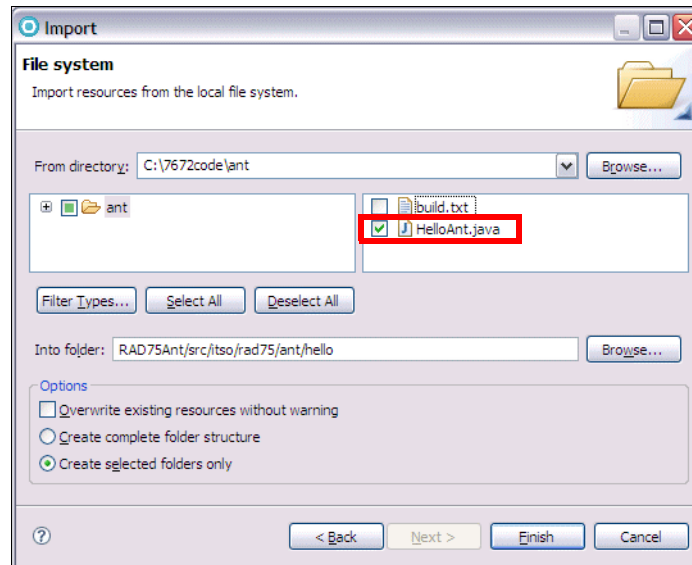

Figure 25-1 Import a Java class

Creating a build file

To create the simple build file, do these steps:

- ▶ Right-click the **RAD75Ant** project. and select **New** → **File**.
- ▶ In the New File dialog, type **build.xml** as the file name, and click **Finish** (Figure 25-2).

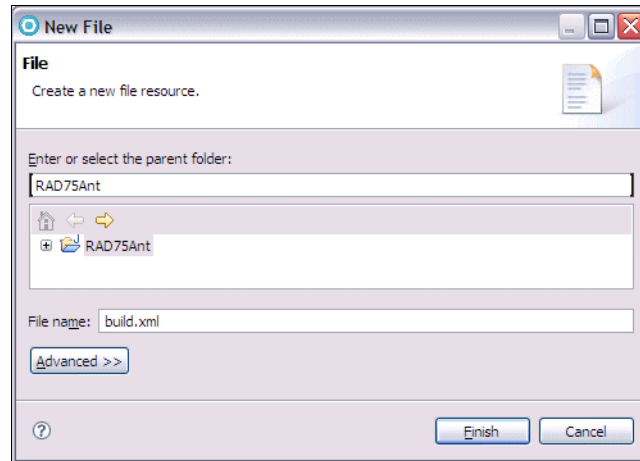

Figure 25-2 Create the `build.xml` file

Note: Application Developer has the ability to link to external files on the file system. The **Advanced** button on the New File dialog allows you to specify the location on the file system that the new file is linked to.

- ▶ Double-click the **build.xml** file to open it in the Ant editor. Copy and paste the text in `c:\7672code\ant\build.txt` into the `build.xml` file.

We now walk you through the various sections of this file, and provide an explanation for each section.

Project definition

The `<project>` tag in the `build.xml` file defines the project name and the default target. The project name is an arbitrary name; it is not related to any project name in your Application Developer workspace.

```
<project name="HelloAnt" default="dist" basedir=".">
```

The project tag also sets the working directory for the Ant script. All references to directories throughout the script file are based on this directory. A dot (`.`) means to use the current directory, which, in Application Developer, is the directory where the `build.xml` file resides.

Global properties

Properties that will be referenced throughout the whole script file can be placed at the beginning of the Ant script. Here we define the property `build.compiler` that tells the `javac` command what compiler to use. We tell it to use the Eclipse compiler.

We also define the names for the source directory, the build directory, and the distribute directory. The source directory is where the Java source files reside. The build directory is where the class files end up, and the distribute directory is where the resulting JAR file is placed:

- ▶ We define the source property as `."`, which means that it is the same directory as the base directory specified in the project definition above.
- ▶ The build and distribute directories will be created as `c:\temp\build` and `c:\temp\RAD75Ant` directories.

Properties can be set as shown below, but Ant can also read properties from standard Java properties files or use parameters passed as arguments on the command line:

```
<!-- set global properties for this build -->
<property name="build.compiler"
    value="org.eclipse.jdt.core.JDTCompilerAdapter"/>
<property name="source" value="."/>
<property name="build" value="c:\temp\build"/>
<property name="distribute" value="c:\temp\RAD75Ant"/>
<property name="outFile" value="helloant"/>
```

Build targets

The build file contains four build targets:

- ▶ `init`
- ▶ `compile`
- ▶ `dist`
- ▶ `clean`

Initialization target (`init`)

The first target we describe is the `init` target. All other targets (except `clean`) in the build file depend upon this target. In the `init` target, we execute the `tstamp` task to set up properties that include timestamp information. These properties are then available throughout the whole build. We also create a build directory defined by the `build` property.

```

<target name="init">
  <!-- Create the time stamp -->
  <tstamp/>
  <!-- Create the build directory structure used by compile -->
  <mkdir dir="${build}"/>
</target>

```

Compilation target (compile)

The compile target compiles the Java source files in the source directory and places the resulting class files in the build directory.

```

<target name="compile" depends="init">
  <!-- Compile the java code from ${source} into ${build} -->
  <javac srcdir="${source}" destdir="${build}"/>
</target>

```

With these parameters, if the compiled code in the build directory is up-to-date (each class file has a timestamp later than the corresponding Java file in the source directory), the source will not be recompiled.

Distribution target (dist)

The dist target creates a JAR file that contains the compiled class files from the build directory and places it in the lib directory under the dist directory. Because the distribution target depends on the compile target, the compile target must have executed successfully before the distribution target is run.

```

<target name="dist" depends="compile">
  <!-- Create the distribution directory -->
  <mkdir dir="${distribute}/lib"/>

  <!-- Put everything in ${build} into the output JAR file -->
  <!-- We add a time stamp to the filename as well -->
  <jar jarfile="${distribute}/lib/${outFile}-${DSTAMP}.jar"
      basedir="${build}">
    <manifest>
      <attribute name="Main-Class"
        value="itso.rad75.ant.hello.HelloAnt"/>
    </manifest>
  </jar>
</target>

```

Cleanup target (clean)

The last of our standard targets is the clean target. This target removes the build and distribute directories, which means that a full recompile is always performed if this target has been executed.

```

<target name="clean">
  <!-- Delete the ${build} and ${distribute} directory trees -->

```

```

    <delete dir="${build}"/>
    <delete dir="${distribute}"/>
</target>

```

Note that the `build.xml` file does not call for this target to be executed. It has to be explicitly specified when running Ant.

Content assist

To access the content assist feature in the Ant editor, do these steps:

- ▶ Open the **build.xml** in an editor (if not already open).
- ▶ Place the cursor in the file and enter `<pro`, and then press **Ctrl+Spacebar**.
- ▶ The content assist dialog is presented (Figure 25-3). You can then use the up and down arrow keys to select the tag that you want.

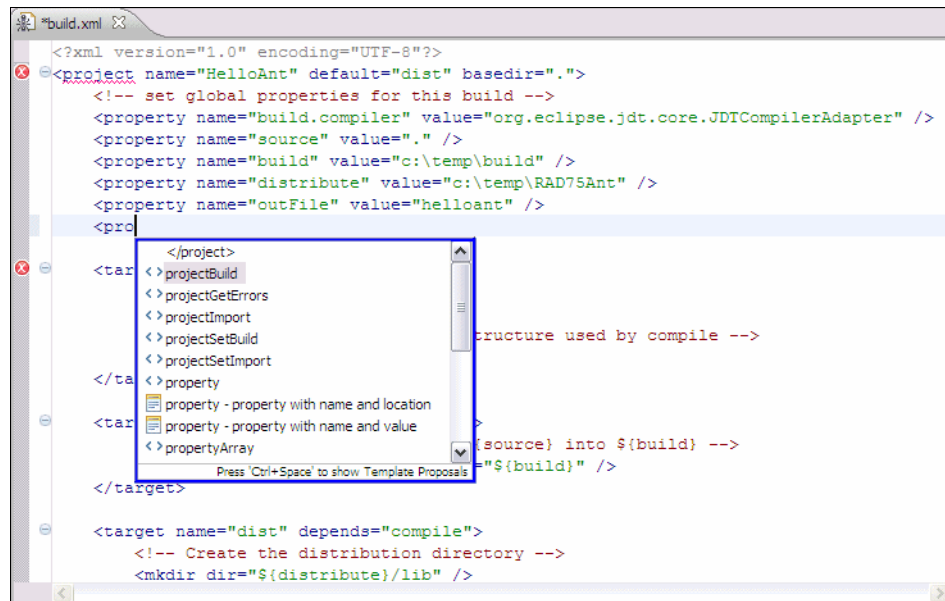

Figure 25-3 Content assist in Ant editor

Code snippets

Application Developer v7.5 provides the ability to create code snippets that contain commonly used code to be inserted into files rather than typing the code in every time.

To create code snippets, do these steps:

- ▶ Open the Snippets view by selecting **Window** → **Show View** → **Other**, and in the Show View dialog expand the **General** folder, select the **Snippets** view, and click **OK**.
- ▶ Right-click the Snippets view and select **Customize** (Figure 25-4).

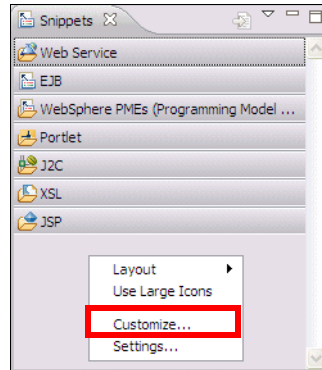

Figure 25-4 Customizing snippets

- ▶ In the Customize Palette dialog, select **New** → **New Category**.
- ▶ In the New Customize Palette dialog (Figure 25-5), do these steps:
 - Name: **Ant**
 - Description: **Ant Snippets**
 - Select **Custom**.
 - Click **Browse** next to Custom, select **Ant Buildfiles** for Content Type Selection, and click **OK** to return to the Customize Palette dialog.

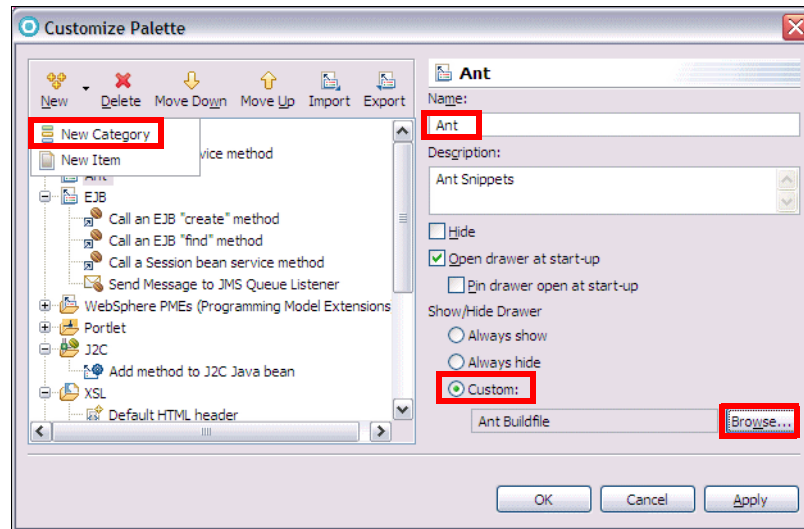

Figure 25-5 New Customize Palette dialog

- ▶ In the Customize Palette dialog, select **New** → **New Item**.
- ▶ In the Unnamed Template dialog, enter the following items:
 - Name: **Comment Tag**
 - Click **New** in the variables section
 - Variable Name: **comment**
 - Template Pattern: `<!-- ${comment} -->`
- ▶ Click **OK** in the Customize Palette dialog.
- ▶ The Ant category with the Comment Tag entry is added to the Snippets view.

Using the code snippet

Now that you have created a code snippet, you can use it in any Ant build file. To use a code snippet, do these steps:

- ▶ Open the **build.xml** file.
- ▶ Add an empty line under the `<project>` tag, place the cursor there, double-click the **Comment Tag** in the Snippets view, and the Insert Template dialog is displayed (Figure 25-6 on page 914).

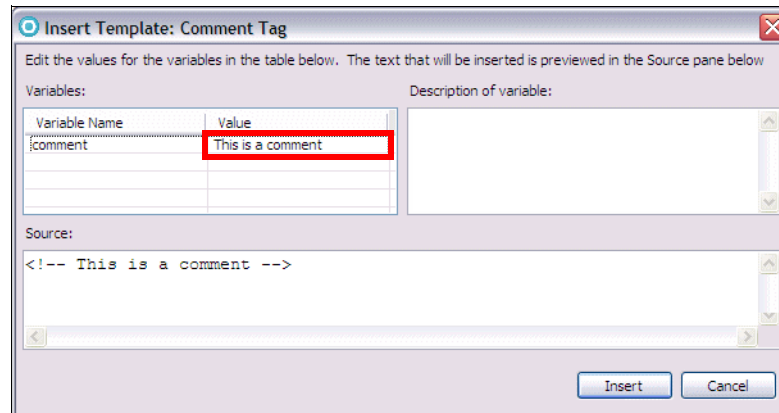

Figure 25-6 Insert Template dialog

- ▶ In the variables table, type **This is a comment** in the comment variable.
- ▶ Click **Insert**.
- ▶ The comment line is inserted. Save the file.

```
<project name="HelloAnt" default="dist" basedir=".">
  <!-- This is a comment -->
  <!-- set global properties for this build -->
```

Formatting an Ant script

Application Developer offers you the ability to format Ant scripts in the Ant editor. To format the Ant script, do these steps:

- ▶ Open the **build.xml** file.
- ▶ Right-click the editor and select **Format**, or press **Ctrl+Shift+F**.

Defining the format of an Ant script

To define the format of an Ant script, do these steps:

- ▶ Select **Window** → **Preferences**.
- ▶ In the Preferences dialog, select and expand **Ant**.
- ▶ In the Ant preferences dialog, you can specify the console colors (Figure 25-7).

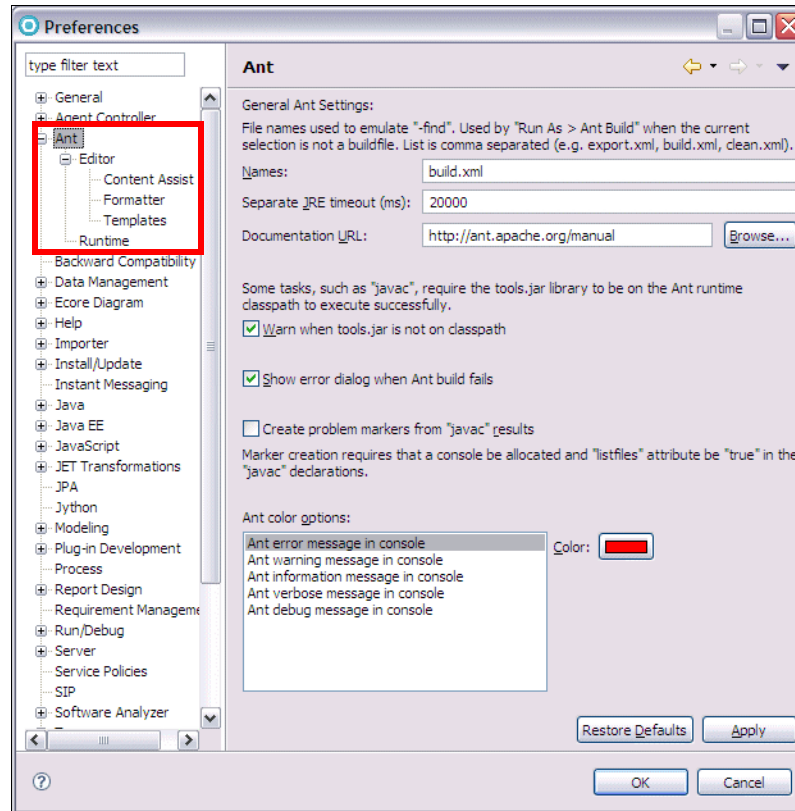

Figure 25-7 Ant preferences

- ▶ Expand the **Ant** folder and select **Editor**.
 - In the Appearance tab, you can change the layout preferences of your Ant file.
 - In the Syntax tab, you can change the syntax highlighting preferences with a preview of the results, and on the Problems tab you can define how certain problems should be handled.
 - In the Problems tab, you can change the severity levels for the buildfile problems.
 - In the Folding tab, you can enable folding when opening a new editor and specify which region types should be folded.
- ▶ Expand **Editor**.
 - In the Content Assist window, you can define the content assist preferences.

- In the Formatter window, you can define the preferences for the formatting tool for the Ant files.
- In the Templates window, you can create, edit, delete, import and export templates for Ant files.
- ▶ Select **Runtime**.
In this dialog, you can define your preferences such as classpath, tasks, types, and properties.

Problems view

Application Developer offers you the Problems view for the Ant file. The editor presents an error in the view by placing a *red X* on the left of the line with the problem as well as a line marker in the file on the right of the window (Figure 25-8). The Problems view lists the problems as seen in Figure 25-9.



Figure 25-8 Problems in the Ant editor

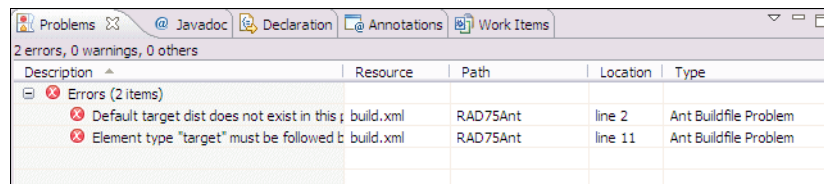

Figure 25-9 Problems view displaying Ant problems

Building a simple Java application

We created a simple build file that compiles the Java source for our HelloAnt application and generates a JAR file with the result. The build file is called `build.xml`, which is the default name assumed by Ant if no build file name is supplied.

The example simple build file has the following targets:

- ▶ **init**: Performs build initialization tasks. All other targets depend upon this target.
- ▶ **compile**: Compiles Java source into class files.
- ▶ **dist**: Creates the deliverable JAR for the module, and depends upon the compile target.
- ▶ **clean**: Removes all generated files. Used to force a full build.

Each Ant build file can have a default target. This target is executed if Ant is invoked on a build file and no target is supplied as a parameter. In our example, the default target is `dist`, as specified in the `<project>` tag. The dependencies between the targets are illustrated in Figure 25-10.

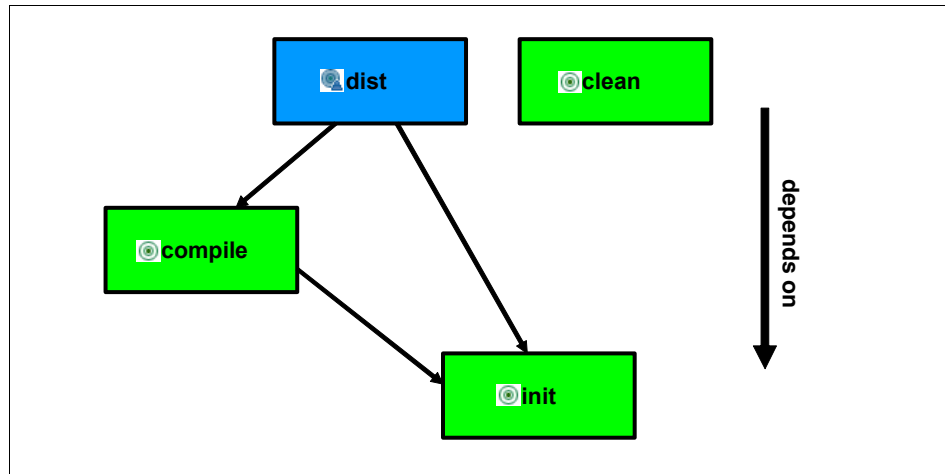

Figure 25-10 Ant example dependencies

Running Ant

Ant is a built-in function to Application Developer. You can launch it from the context menu of any XML file, although it will run successfully only on valid Ant XML build script files. When launching an Ant script, you are given the option to select which targets to run.

To run the build script:

- ▶ Open the Java perspective.
- ▶ Expand the **RAD75Ant** project.
- ▶ Right-click **build.xml** and select **Run As** → **3 Ant Build...**
- ▶ In the Edit Configuration dialog (Figure 25-11), select the desired attributes:
 - In the **Targets** tab you can see that the **dist** target is executed by default. If you select multiple targets, the execution order is shown under Target execution order, and the order can be changed by clicking **Order**. For now, only select the **dist** target.

Note: Because the **dist** target depends on **compile**, even if you only select **dist**, the **compile** target is executed as well.

- In the **JRE** tab, select **Run in the same JRE as the workspace**.
- Click **Apply** if you make any changes.

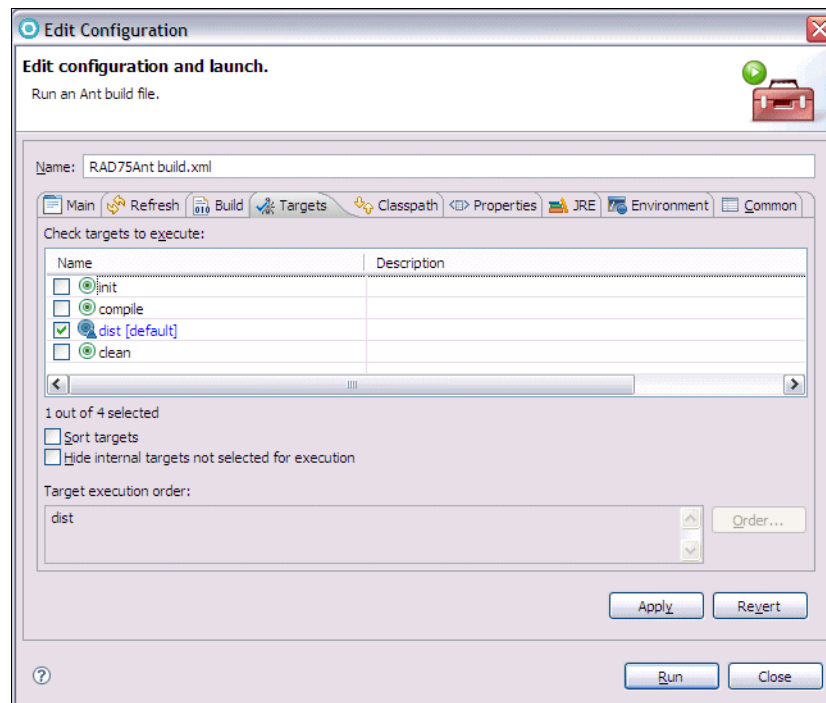
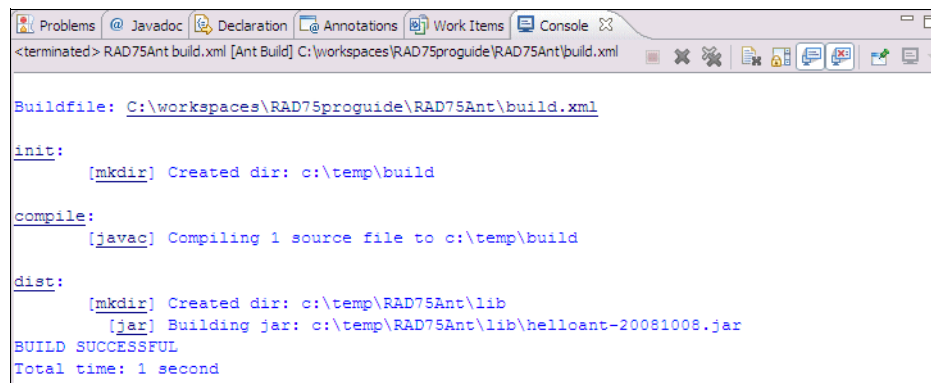

Figure 25-11 Selecting Ant targets to run

- ▶ The Run Ant wizard gives you several tabs to configure or run the Ant process. The tabs allow you to do the following operations:
 - **Main:** This tab allows you to select the build file, base directory, and arguments to pass to the Ant process.
 - **Refresh:** This tab allows you to set some refresh options when the Ant process has finished running.
 - **Build:** This tab allows you to set some build options before the Ant process is run.
 - **Targets:** This tab allows you to select the targets and the sequences the targets are to run.
 - **Classpath:** This tab allows you to customize the classpath for the Ant process.
 - **Properties:** This tab allows you to add, edit, or remove properties to be used by the Ant process.
 - **JRE:** This tab allows you to select the Java Runtime Environment to use to run the Ant process.
 - **Environment:** This tab allows you to define environmental variables to be used by the Ant process. This tab is only relevant when running in an external JRE.
 - **Common:** This tab allows you to define the launch configuration for the Ant process.
- ▶ Click **Run** to execute the Ant build.
- ▶ The output is in the Console (Figure 25-12).

The image shows a screenshot of an IDE's console window. The title bar includes tabs for Problems, Javadoc, Declaration, Annotations, Work Items, and Console. The console text shows the output of an Ant build process. It starts with a terminated message, followed by the buildfile path. The process includes an 'init' phase with a 'mkdir' task creating a directory, a 'compile' phase with a 'javac' task, and a 'dist' phase with 'mkdir' and 'jar' tasks. The build concludes with 'BUILD SUCCESSFUL' and a total time of 1 second.

```
<terminated> RAD75Ant build.xml [Ant Build] C:\workspaces\RAD75proguide\RAD75Ant\build.xml

Buildfile: C:\workspaces\RAD75proguide\RAD75Ant\build.xml

init:
    [mkdir] Created dir: c:\temp\build

compile:
    [javac] Compiling 1 source file to c:\temp\build

dist:
    [mkdir] Created dir: c:\temp\RAD75Ant\lib
    [jar] Building jar: c:\temp\RAD75Ant\lib\helloant-20081008.jar
BUILD SUCCESSFUL
Total time: 1 second
```

Figure 25-12 Ant output in the Console

Ant console

The Console view opens automatically when running Ant, but if you want to open it manually, select **Window** → **Show view** → **Console**.

The Console shows that Ant has created the `c:\temp\build` directory, compiled the source files, created the `c:\temp\RAD75Ant\lib` directory, and generated a JAR file (`helloant-20081008.jar`).

Rerun Ant

If you launch Ant again with the same target selected, Ant skips creating the directories, but the class and JAR files are created.

Forced build

To generate a complete build, select the **clean** target as the first and the **dist** target as the second target to run. You have to clear `dist`, select `clean`, and then select `dist` again to get the execution order right (Figure 25-13). Alternatively you can click **Order** to change the execution order. Click **Apply** and **Run**.

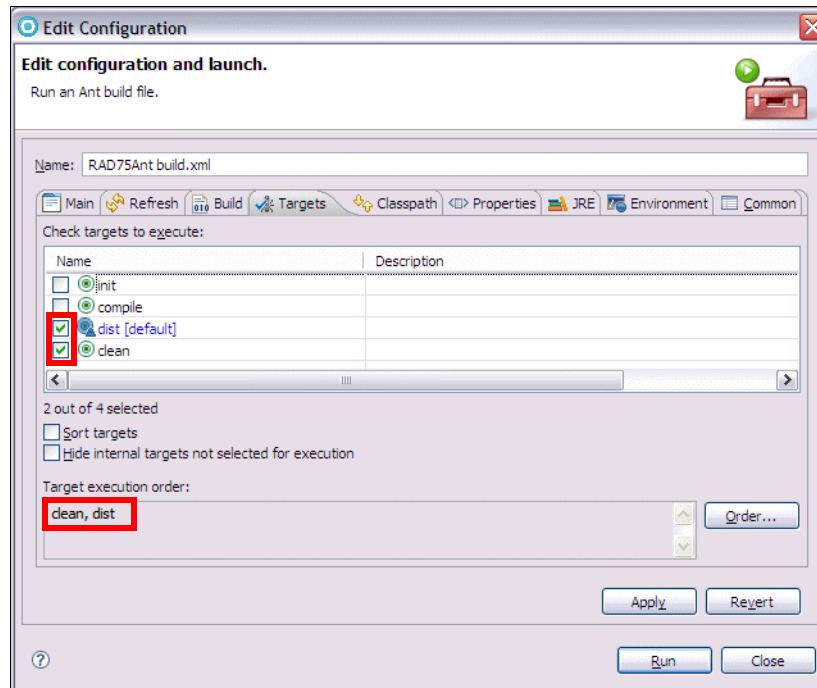

Figure 25-13 Launching Ant to generate complete build

Classpath problem

The classpath specified in the Java build path for the project is not available to the Ant process. If you are building a project that references another project, the classpath for the javac compiler must be set up in the following way:

```
<javac srcdir="${source}" destdir="${build}" includes="**/*.java">
  <classpath>
    <pathelement location="../MyOtherProject"/>
    <pathelement location="../MyThirdProject"/>
  </classpath>
</javac>
```

Running the sample application to verify the Ant build

Now that you have completed the Ant build, we recommend that you verify the build by running the sample application as follows:

- ▶ Open a Windows command window.
- ▶ Navigate to the output directory of the Ant build (for example, `c:\temp\RAD75Ant\lib`).
- ▶ Set the Java path by entering the following command:
Enter the location of the installation directory (for example, our installation directory is found in `c:\IBM\SDP75`).

```
set PATH=c:\IBM\SDP75\jdk\bin;%PATH%
```
- ▶ Run the following command:

```
java -jar helloant-20081008.jar
```

Note that the timestamp in the JAR filename is dependent on when it is built.
- ▶ You should see the following output:

```
Hello from Turkey!
```

Building a Java EE application

As we have just demonstrated in the previous section, building a simple Java application using Ant is quite easy. In this section we demonstrate how to build a Java EE application from existing Java EE related projects.

This section is organized as follows:

- ▶ Java EE application deployment packaging
- ▶ Preparing for the sample

- ▶ Creating the build script
- ▶ Running the Ant Java EE application build

Java EE application deployment packaging

EAR, WAR, and EJB JAR files contain a number of deployment descriptors that control how the artifacts of the application are to be deployed onto an application server. These deployment descriptors are mostly XML files and are standardized within the Java EE specification.

While working in Application Developer, some of the information in the deployment descriptor is stored in XML files. The deployment descriptor files also contain information in a format convenient for interactive testing and debugging. This is one of the reasons that it is so quick and easy to test Java EE applications in the integrated WebSphere Application Server V7 Test Environment included with Application Developer.

The actual EAR being tested, and its supporting WAR, EJB, and client application JARs, are not actually created as a standalone file. Instead, a special EAR is used that simply points to the build contents of the various Java EE projects. Since these individual projects can be anywhere on the development machine, absolute path references are used.

When an enterprise application project is exported, a true standalone EAR is created, including all the module WARs, EJB JARs, JPAs and Java utility JARs it contains. Therefore, during the export operation, all absolute paths are changed into self-contained relative references within that EAR, and the internally optimized deployment descriptor information is merged and changed into a standard format. To create a Java EE-compliant WAR or EAR, we therefore have to use Application Developer's export function.

Preparing for the sample

For the purposes of demonstrating how to build a J2EE application using Ant, we use the Java EE applications developed in Chapter 14, "Develop EJB applications" on page 387.

To import the RAD75EJB.zip project interchange file containing the sample code into Rational Application Developer, do these steps:

- ▶ Open the Java EE perspective Enterprise Explorer view.
- ▶ Select **File** → **Import**.
- ▶ Expand the **Other** folder and select **Project Interchange** and then click **Next**.

- ▶ In the Import Projects dialog, click **Browse** next to the zip file, navigate to and select the **RAD75EJB.zip** from the `c:\7672code\zInterchange\ejb` folder, and click **Open**.

Note: For information on downloading the sample code, refer to Appendix B, “Additional material” on page 1149.

- ▶ Click **Select All** to select all projects and then click **Finish**.
- ▶ After importing the two project interchange files, you have the following projects:
 - RAD75EJB
 - RAD75EJBEAR
 - RAD75EJBTestWeb
 - RAD75JPA

Creating the build script

To build the RAD75EJBEAR enterprise application, we created an Ant build script (`build.xml`) that utilizes the Java EE Ant tasks provided by Application Developer.

To add the Ant build script to the project, do these steps:

- ▶ Open the Java EE perspective Enterprise Explorer view.
- ▶ Expand **RAD75EJBEAR**, and select **META-INF**.
- ▶ Select **File** → **New** → **Other**.
- ▶ In the New File dialog, select **General** → **File**, and click **Next**.
- ▶ Type **build.xml** in the File name field, and click **Finish**.
- ▶ Double-click the **build.xml** file to open it in the editor. Copy and paste the text in `c:\7672code\ant\j2ee\build.txt` into the `build.xml` file.
- ▶ Modify the value for the `work.dir` property to match your desired working directory (for example, `c:/temp/RAD7AntEE`), as highlighted in Example 25-1.

Example 25-1 J2EE Ant build.xml script

```
<?xml version="1.0" encoding="UTF-8"?>
<project name="ITSO RAD Pro Guide Ant" default="Total" basedir=".">

  <!-- Set global properties -->
  <property name="work.dir" value="c:/temp/RAD75AntEE" />
  <property name="dist" value="${work.dir}/dist" />
  <property name="project.ear" value="RAD75EJBEAR" />
```

```
<property name="project.ejb" value="RAD75EJB" />
<property name="project.war" value="RAD75EJBTestWeb" />
<property name="type" value="incremental" />
<property name="debug" value="true" />
<property name="source" value="true" />
<property name="meta" value="false" />
<property name="noValidate" value="false" />
```

The `build.xml` script includes the following Ant targets, which correspond to common Java EE application build:

- ▶ **deployEjb**: This generates the deploy code for all EJBs in the project.
- ▶ **buildEjb**: This builds the EJB project (compiles resources within the project).
- ▶ **buildWar**: This builds the Web project (compiles resources within the project).
- ▶ **buildEar**: This builds the Enterprise Application project (compiles resources within the project).
- ▶ **exportEjb**: This exports the EJB project to a JAR file.
- ▶ **exportWar**: This exports the Web project to a WAR file.
- ▶ **exportEar**: This exports the Enterprise Application project to an EAR file.
- ▶ **buildAll**: This invokes the `buildEjb`, `buildWar`, and `buildEar` targets.
- ▶ **exportAll**: This invokes the `exportEjb`, `exportWar`, and `exportEar` targets to create the `RAD7EJBEAR.ear` used for deployment.

The additional targets are:

- ▶ **init**: Initialize and create a directory.
- ▶ **info**: Print out the properties.
- ▶ **Total**: Invokes `buildAll` and `exportAll`.
- ▶ **clean**: Delete the output files.

EJB specification level

If you have enterprise beans at 1.1, 2.0, or 2.1 specification-level, you have to generate deployment code for the enterprise beans. The `ejbDeploy` tool executed under the `deployEjb` target generates deployment code for these artifacts.

When you install the WebSphere Application Server V6.1 with Feature Pack for EJB 3.0 or WebSphere Application Server v7.0, you can utilize the EJB 3.0 specification at runtime. For EJB 3.0 specification-level, you no longer have to generate the EJB deployment code. So, the `ejbdeploy` command does not generate deployment code for artifacts at Java EE 5 specification-level.

The following lists the general behavior of the `ejbdeploy` command when issued with the presence of Java EE 5 artifacts:

- ▶ Tolerates EAR 5.0 files and EJB 3.0 JAR files.
- ▶ Tolerates EAR files with Java 2 Platform Enterprise Edition (J2EE) 1.4 deployment descriptors that contain EJB 3.0 JAR files. Deployment code is generated only for EJB at 1.1, 2.0, or 2.1 specification-level. However, deployment code is not generated for EJB beans at 3.0 specification-level.
- ▶ If the `-complianceLevel` option for the `ejbdeploy` command is not specified, in any of the following cases the default `-complianceLevel` setting is Java developer kit V5.0, "5.0":
 - An EAR or JAR file that contains Java EE 5 or EJB 3.0 deployment descriptor files
 - An EAR file without any deployment descriptor files

All other cases, the `-complianceLevel` setting defaults to Java developer kit V1.4, "1.4".

If you are generating deployment code for J2EE 1.4 EAR or JAR files that contain source code files which make use of the new language features in Java developer kit 5.0, you must specify the following parameter when running the `ejbdeploy` command: `-complianceLevel "5.0"`.

In the global properties for this build script, we define a number of useful variables, such as the project names and the target directory. We also define a number of properties that we pass on to the Application Developer Ant tasks. These properties allow us to control whether the build process should perform a full or incremental build, whether debug statements should be included in the generated class files, and whether Application Developer's metadata information should be included when exporting the project.

When launching this Ant script, we can also override these properties by specifying other values in the arguments field, allowing us to perform different kinds of builds with the same script.

Running the Ant Java EE application build

When launching the `build.xml` script, you can select which targets to run and the execution order.

To run the Ant `build.xml` to build the Java EE application, do these steps:

- ▶ Right-click **build.xml** (in RAD75EJBEAR/META-INF), and select **Run As** →  **3 Ant Build...**

Note: From the content menu for the Ant build script, the following two build options exist:

- ▶ 2 Ant Build: This invokes the default target for the Ant build. In our example, this is the Total target, which in turn invokes buildAll and exportAll targets.
- ▶ 3 Ant Build: This will launch a dialog where you can select the targets and order, and provide parameters, as seen in Figure 25-14.

- ▶ The Edit configuration and launch dialog opens (Figure 25-14).

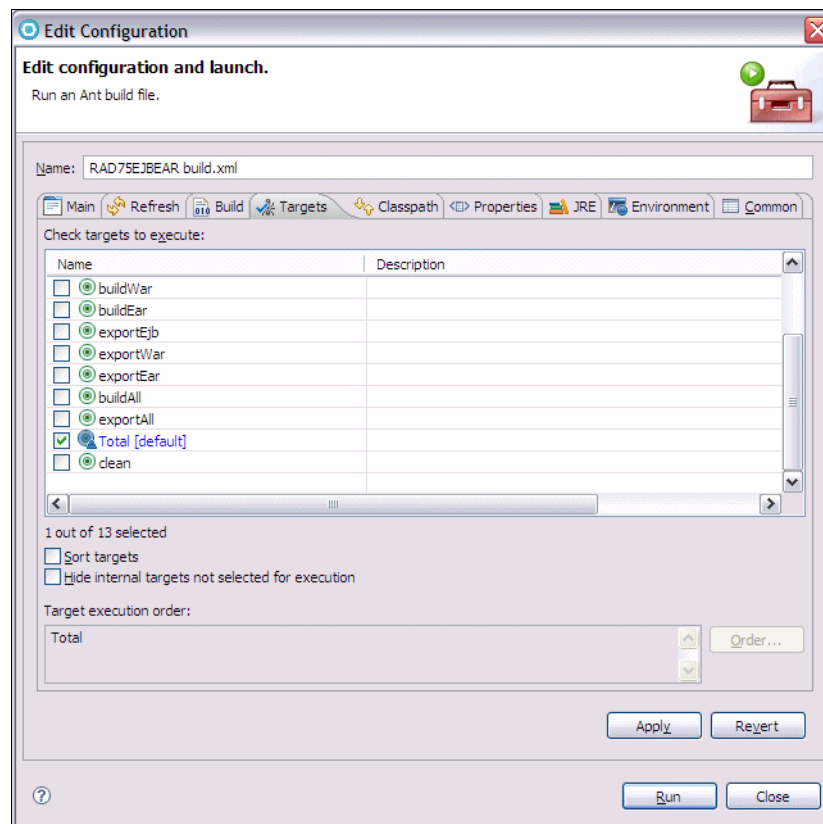

Figure 25-14 Launch Ant to build and export a J2EE project (EAR)

- ▶ Select the **Main** tab:
 - To build the Java EE EAR file with debug, source files, and metadata, enter the following values in the Arguments text area:
`-DDebug=true -Dsource=true -Dmeta=true`
 - To build the Java EE EAR for production deployment (without debug support, source code, and meta data), enter the following value in the Arguments text area:
`-Dtype=full`
- ▶ Select the **Targets** tab. Ensure that **Total** is selected (default).
- ▶ Select the **JRE** tab. Select **Run in the same JRE as the workspace**.
- ▶ Click **Apply** and then click **Run**.
- ▶ Verify in the `c:\temp\RAD75AntEE\dist` output directory that the `RAD7EJBEAR.ear`, `RAD75EJB.jar`, and `RAD75EJBTestWeb.war` files were created.

The Console view displays the operations performed and their results.

Running Ant outside of Application Developer

To automate the build process even further, you might want to run Ant outside of Application Developer by running Ant in *headless mode*.

Preparing for the headless build

Application Developer includes a `runAnt.bat` file that can be used to invoke Ant in headless mode and passes the parameters that you specify. This have to be customized for your environment.

The `runAnt.bat` file included with Application Developer is located in the following directory (for example, our `<rad_home>` directory is found in `c:\IBM\SDP75`):

```
<rad_home>\bin
```

To create a headless Ant build script for J2EE project, do these steps:

- ▶ Copy the `runAnt.bat` file to a new file called `itsoRunAnt.bat`.
- ▶ Modify the `WORKSPACE` value in the `itsoRunAnt.bat` so that it points to your current workspace (Example 25-2):

```
set WORKSPACE=C:\workspaces\RAD75proguide
```

Example 25-2 Snippet of the itsoRunAnt.bat (modified runAnt.bat)

```

.....
set JAVAEXE="C:\IBM\SDP75\jdk\jre\bin\java.exe"
.....
set INSTALL_DIRECTORY="C:\IBM\SDP75"
.....
set LAUNCHER_JAR="C:\IBM\SDP75Shared\plugins\org.eclipse.equinox.launcher_1.0
                                     .100.v20080509-1800.jar"

REM #####
REM ##### you must edit the "WORKSPACE" setting below #####
REM #####
REM ***** The location of your workspace *****
set WORKSPACE=C:\workspaces\RAD75proguide

:workspace
if not %$WORKSPACE%==$ goto check
.....

```

Running the headless Ant build script

Attention: Prior to running Ant in headless mode, Application Developer must be closed. If you do not close Application Developer, you will get build errors when attempting to run Ant build in headless mode.

To run the `itsoRunAnt.bat` command file, do these steps:

- ▶ Ensure that you have closed Application Developer.
- ▶ Open a Windows command prompt.
- ▶ Navigate to the location of the `itsoRunAnt.bat` file.
- ▶ Run the command file by entering the following command:

```

itsoRunAnt -buildfile
           c:\workspaces\RAD75proguide\RAD75EJBEAR\META-INF\build.xml clean Total
           -DDebug=true -Dsource=true -Dmeta=true

```

The `-buildfile` parameter specifies the fully qualified path of the `build.xml` script file. We can pass the targets to run as parameters to `itsoRunAnt` and we can also pass Java environment variables by using the `-D` switch.

In this example, we run the `clean` and `Total` targets, and we include the debug, Java source, and metadata files in the resulting EAR file.

- ▶ There are several build output files, which can be found in the `c:\temp\RAD75AntEE\dist` directory: `RAD75EJB.jar`, `RAD75EJBEAR.ear`, and `RAD75EJBTestWeb.war`.

Note: We have included `itsRunAnt.bat` and `output.txt` files in the `c:\7672code\ant\j2ee` directory. The `output.txt` file contains the output from the headless Ant script for review purposes.

Verify that the installation directory (see Example 25-2 on page 928, bold) points to the correct directory on your system.

Using the Rational Application Developer Build Utility

Application Developer v7.5 introduces a new feature, called *build utility*, that can be installed standalone on a build server running on Windows, Linux, or z/OS. The build utility has a smaller footprint than Application Developer itself, as it does not contain any user interface code. The inputs to the build utility are the projects developed in Application Developer and the outputs are JAR, WAR, and EAR files.

Note: For information on installing the build utility, refer to “Installing Rational Application Developer Build Utility” on page 1148.

In the following we assume that the build utility was installed on Windows in the folder `C:\IBM\BuildUtility`.

The build utility includes a `runAnt.bat` file that can be used to invoke Ant in headless mode the same way as Application Developer does.

The `runAnt.bat` file included with the build utility is located in the directory `C:\IBM\BuildUtility\eclipse\bin`.

When you invoke a build on a build server, typically you use Ant to create a workspace containing the projects before you build them. In the following example, we modify the Ant build script so that it first imports the projects into a new workspace and then builds them.

Example of using the build utility

We use the `RAD75EJBWebEAR` enterprise application for the build utility example. This application is similar to the `RAD75EJBWAR` application that we used for the Ant headless build.

- ▶ Extract the project interchange file into a directory on the source server:

```
C:\7672code\z\Interchange\ejb\RAD75EJBWeb.zip ==> C:\sources
```

Create the build file (BUbuild.xml)

To create the build file, we copy the build file from the headless Ant example and modify it for the RAD75EJBWebEAR enterprise application.

- ▶ Copy the RAD75EJBWebEAR\META-INF\build.xml file to c:\sources\BUbuild.xml.
- ▶ Modify the **BUbuild.xml** as highlighted in Example 25-3. The changes to the original build.xml file are:
 - Project names are different
 - Import the projects into the workspace before the build
 - Full build instead of incremental build

Example 25-3 BUbuild.xml for the build utility

```
<?xml version="1.0" encoding="UTF-8"?>
<project name="ITSO RAD Pro Guide Ant Build Utility" default="Total"
        basedir=".">

  <!-- Set global properties -->
  <property name="work.dir" value="c:/temp/RAD75BU" />
  <property name="dist" value="${work.dir}/dist" />
  <property name="project.ear" value="RAD75EJBWebEAR" />
  <property name="project.ejb" value="RAD75EJB" />
  <property name="project.war" value="RAD75EJBWeb" />
  <property name="project.jpa" value="RAD75JPA" />
  <property name="type" value="full" />
  <property name="debug" value="true" />
  <property name="source" value="true" />
  <property name="meta" value="false" />
  <property name="noValidate" value="false" />

  <target name="init">...

  <target name="info">
    <!-- Displays the properties for this run -->
    <echo message="debug=${debug}" />
    <echo message="type=${type}" />
    <echo message="source=${source}" />
    <echo message="meta=${meta}" />
    <echo message="noValidate=${noValidate}" />
    <echo message="Output directory=${dist}" />
    <echo message="project.ear=${project.ear}" />
    <echo message="project.ejb=${project.ejb}" />
    <echo message="project.war=${project.war}" />
    <echo message="project.jpa=${project.jpa}" />
  </target>

  <target name="importJPA">
    <projectImport projectName="${project.jpa}" />
  </target>
</project>
```

```

        <eclipse.refreshLocal resource="${project.jpa}" />
    </target>
    <target name="importEJB">
        <projectImport projectName="${project.ejb}" />
        <eclipse.refreshLocal resource="${project.ejb}" />
    </target>
    <target name="importWAR">
        <projectImport projectName="${project.war}" />
        <eclipse.refreshLocal resource="${project.war}" />
    </target>
    <target name="importEAR">
        <projectImport projectName="${project.ear}" />
        <eclipse.refreshLocal resource="${project.ear}" />
    </target>
    <target name="importAll"
        depends="importJPA,importEJB,importWAR,importEAR">
        <!-- Import all projects and exports all files -->
        <echo message="Import All projects" />
    </target>

    <target name="deployEjb">...
    <target name="buildEjb" depends="deployEjb">...
    <target name="buildJPA">
        <!-- Builds the JPA project -->
        <projectBuild projectName="${project.jpa}" BuildType="${type}"
            DebugCompilation="${debug}" />
    </target>
    <target name="buildWar">...
    <target name="buildEar">...
    <target name="exportEjb" depends="init">...
    <target name="exportWar" depends="init">...
    <target name="exportEar" depends="init">...
    <target name="buildAll" depends="buildJPA,buildEjb,buildWar,buildEar">
        <!-- Builds all projects -->
        <echo message="Built all projects" />
    </target>

    <target name="exportAll" depends="exportEjb,exportWar,exportEar">...
    <target name="Total" depends="importAll,buildAll,exportAll">...
    <target name="clean">...
</project>

```

- The projects are imported into the Eclipse workspace from the workspace directory itself, using targets such as:

```

<target name="importEJB">
    <projectImport projectName="${project.ejb}"/>
    <eclipse.refreshLocal resource="${project.ejb}" />
</target>

```

- ▶ Because we do not specify the attribute `projectLocation` for the `projectImport` task, it is assumed that the projects to import are in the workspace directory. Note that `projectImport` does not make a physical copy of the projects, it just imports a reference to the projects.

Create the command file for execution

To run the `buildi` utility, we create a batch command file.

- ▶ Create a command file as `C:\sources\itsoBUBuild.bat` with the following content (Example 25-4):

Example 25-4 Contents of ITSOBUBuild.bat

```
@echo on
setlocal
set WORKSPACE=C:\sources

C:\IBM\BuildUtility\eclipse\bin\runant.bat
        -buildfile C:\sources\BUBuild.xml clean Total
```

- ▶ Execute the build using the commands:
cd C:\sources
itsoBUBuild.bat >BUoutput.txt
- ▶ Review the `BUoutput.txt` file. You should see these lines towards the end:
[ejbExport] EJBExport completed to c:/temp/RAD75BU/dist/RAD75EJB.jar
[warExport] WARExport completed to c:/temp/RAD75BU/dist/RAD75EJBWeb.war
[earExport] EARExport completed to c:/temp/RAD75BU/dist/RAD75EJBWebEAR.ear
- ▶ Verify the files created in the folder `c:/temp/RAD75BU/dist`.

Note: We have included the files `BUBuild.xml`, `itsoBUBuild.bat`, and `BUoutput.txt` in `C:\7672code\ant\buildutility`.

More information on Ant

For more information on Ant, we recommend the following resources:

- ▶ *Automatically generate project builds using Ant*, white paper found at:
<http://www.ibm.com/developerworks/library/ar-autotask/>



Deploy enterprise applications

The term *deployment* can have many different meanings depending on the context. In this chapter we start out by defining the concepts of application deployment. The remainder of the chapter provides a working example for packaging and deploying the ITSO Bank enterprise application to a standalone IBM WebSphere Application Server v7.0.

The application deployment concepts and procedures described in this chapter apply to Application Server v7.0 (Base, Express, and Network Deployment editions). In Application Developer v7.5, the configuration of the integrated Application Server v7.0 for deployment, testing, and administration is the same for the separately installed Application Server v7.0.

The chapter is organized into the following sections:

- ▶ Introduction to application deployment
- ▶ Preparing for the deployment of the EJB application
- ▶ Packaging the application for deployment
- ▶ Manual deployment of enterprise applications
- ▶ Automated deployment using Jython based wsadmin scripting

Introduction to application deployment

Deployment is a critical part of the Java EE application development cycle. Having a solid understanding of the deployment components, architecture, and process is essential for the successful deployment of the application.

In this section we review the following concepts of the Java EE and WebSphere deployment architecture:

- ▶ Common deployment considerations
- ▶ Java EE application components and deployment modules
- ▶ Preparing for the deployment of the EJB application
- ▶ WebSphere deployment architecture
- ▶ Java and WebSphere class loader

Note: Further information on the IBM Application Server deployment can be found in the following sources:

- ▶ *WebSphere Application Server V6.1: Planning and Design*, SG24-7305
- ▶ *WebSphere Application Server V6.1: Systems Management and Configuration*, SG24-7304
- ▶ *WebSphere Application Server V6: Scalability and Performance*, SG24-6392
- ▶ IBM WebSphere Application Server v7.0 InfoCenter, found at:
<http://publib.boulder.ibm.com/infocenter/wasinfo/v7r0/index.jsp>

Common deployment considerations

Some of the most common factors that impact the deployment of a Java EE application are as follows:

- ▶ **Deployment architecture:** How can you create, assemble, and deploy an application properly if you do not understand the deployment architecture?
- ▶ **Infrastructure:** What are the hardware and software constraints for the application?
- ▶ **Security:** What security will be imposed on the application and what is the current security architecture?
- ▶ **Application requirements:** Do they imply a distributed architecture?
- ▶ **Performance:** How many users are using the system (frequency, duration, and concurrency)?

Java EE application components and deployment modules

Within the Java EE application development life cycle, the application components are created, assembled, and then deployed. In this section, we explore the application component types, deployment modules, and packaging formats to gain a better understanding of what is being packaged (assembled) for deployment.

Application component types

In Java EE 5, there are four application component types supported by the runtime environment:

- ▶ Application clients: Run in the Application client container.
- ▶ Applets: Run in a browser (or a stand-alone applet container).
- ▶ Web applications (servlets, JSPs, HTML pages): Run in the Web container.
- ▶ EJBs: Run in the EJB container.

Deployment modules

The Java EE deployment components are packaged for deployment as modules:

- ▶ Web module
- ▶ EJB module
- ▶ Resource adapter module
- ▶ Application client module

Packaging formats

Each module is packaged on a specific jar file format:

- ▶ Web modules in Web Application Archive (WAR)
- ▶ EJB and Application client modules in JAR files
- ▶ Resource adapter modules in Resource Application Archive (RAR)

Enterprise Application Archive (EAR) can be used to package EJB modules, resource adapter modules, application client modules, and Web modules.

Deployment descriptors

In J2EE 1.4 and earlier, information describing a J2EE application and how to deploy it into a J2EE container was stored in XML files called deployment descriptors. An EAR file normally contained multiple deployment descriptors, depending on the modules it contains. Figure 26-1 shows a schematic overview of a J2EE EAR file. In this figure the various deployment descriptors are designated with DD after their name.

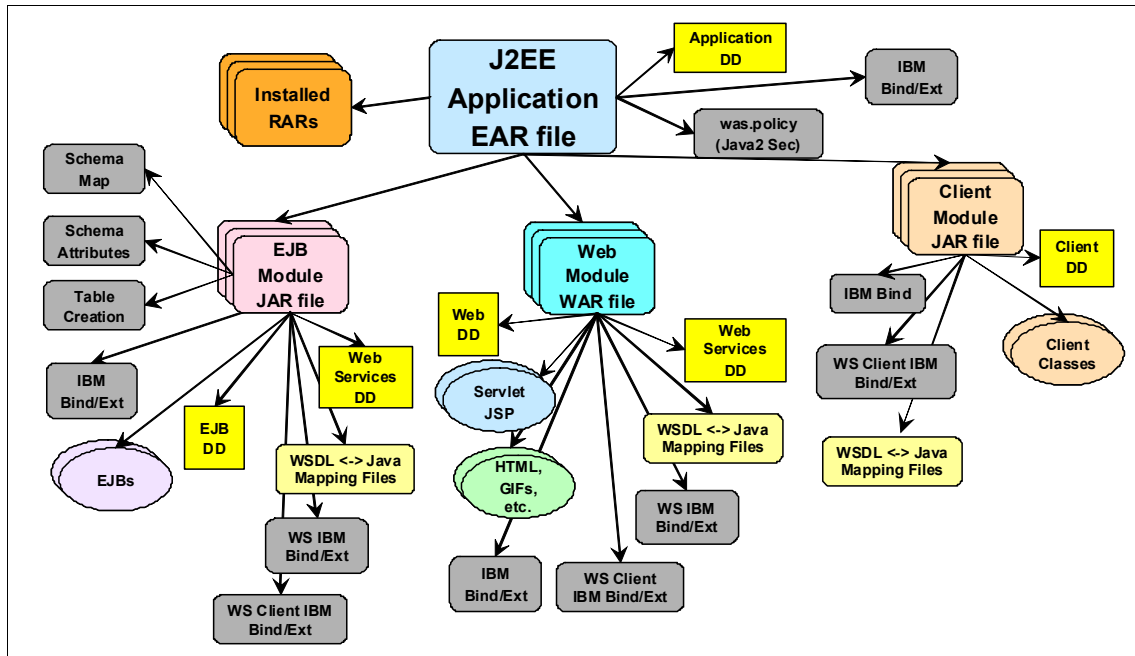

Figure 26-1 J2EE EAR file structure

The deployment descriptor of the EAR file itself is stored in the META-INF directory in the root of the EAR and is called `application.xml`. It contains information about the modules making up the application.

The deployment descriptors for each module are stored in the META-INF directory of the module and are called `web.xml` (for Web modules, actually in WEB-INF), `ejb-jar.xml` (for EJB modules), `ra.xml` (for resource adapter modules), and `application-client.xml` (for Application client modules). These files describe the contents of a module and allow the Java EE container to configure servlet mappings, JNDI names, and so forth.

Classpath information, specifying which other modules and utility JARs are needed for a particular module to run, is stored in the `manifest.mf` file, also in the META-INF directory of the modules.

Deployment descriptors in Java EE 5

However, with Java EE 5, deployment descriptors become optional and an Enterprise Application can be deployed using annotations to replace the information previously contained into deployment descriptors.

To generate the standard deployment descriptor for a Java EE module, either select **Generate deployment descriptor** in the Create Project dialog, or right-click an existing project and select **Java EE** → **Generate Deployment Descriptor Stub**.

Whether you use standard Java EE deployment descriptors or not, Application Developer can also generate additional WebSphere-specific information used when deploying applications to WebSphere environments. This supplemental information is stored in XMI files, also in the META-INF (or WEB-INF) directory of the respective modules. Examples of information in the IBM-specific files are IBM extensions, such as servlet reloading and EJB access intents. To use these extension files you need first to generate them.

To do so:

- ▶ Right-click on the project you want to add the WebSphere-specific deployment descriptor.
- ▶ Select **Java EE** → **Generate WebSphere XXX Deployment Descriptor**, depending on the kind of descriptor you want to generate. The available kinds of deployment descriptor (XXX) are:
 - Bindings—Creates `ibm-web-bnd.xml` or `ibm-ejb-jar-bnd.xml` or similar
 - Extensions—Creates `ibm-web-ext.xml` or `ibm-ejb-jar-ext.xml` or similar
 - Programming Model Extensions—Creates `ibm-web-ext-pme.xml` or `ibm-ejb-jar-ext-pme.xml` or similar

Deployment Descriptor editors

Application Developer has easy-to-use editors for working with the deployment descriptors. The information that goes into the different files is accessible from one page in the IDE, eliminating the need to be concerned about what information is put into what file. However, if you are interested, you can click the Source tab of the Deployment Descriptor editor to see the text version of what is actually stored in that descriptor.

For example, if you open the EJB deployment descriptor, you have access to settings that are stored across multiple deployment descriptors for the EJB module, including:

- ▶ EJB deployment descriptor, `ejb-jar.xml`
- ▶ Bindings file, `ibm-ejb-jar-bnd.xml`
- ▶ Extensions deployment descriptor, `ibm-ejb-jar-ext.xml`

The deployment descriptors can be modified in Application Developer by double-clicking the file to open the Deployment Descriptor Editor (Figure 26-2).

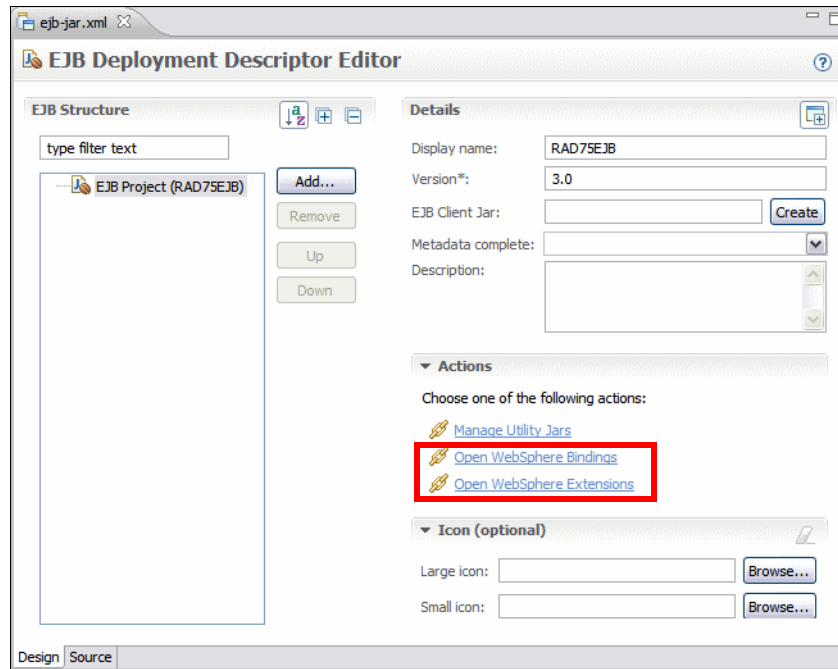

Figure 26-2 Deployment Descriptor editor for an EJB project

While the editor allows you to modify the content of the `ejb-jar.xml`, the links under Actions allow you to open the IBM bindings and extensions stored in the WebSphere-specific deployment descriptor files (Figure 26-3). The descriptor files are kept in the `META-INF` directory of the module you are editing. Clicking the **Source** tab allows you to access and modify the XML source of the deployment descriptor.

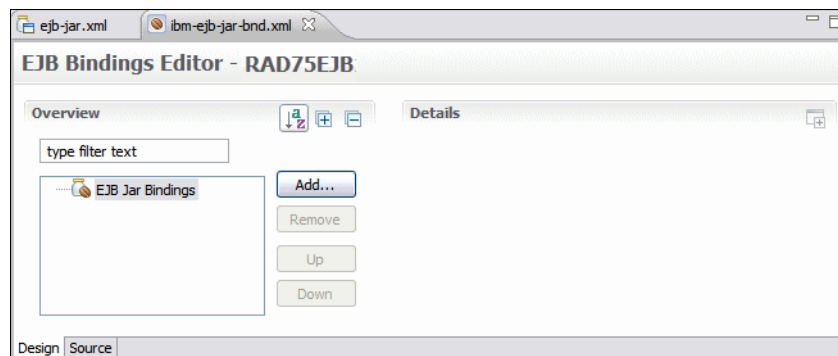

Figure 26-3 Deployment Descriptor editor for Bindings

WebSphere deployment architecture

This section provides an overview of the IBM WebSphere Application Server v7.0 deployment architecture.

Application Developer v7.5 includes an integrated Application Server v7.0. Administration of the server and applications is performed by using the WebSphere Administrative Console for such configuration tasks as:

- ▶ J2C authentication aliases
- ▶ Data sources
- ▶ Service buses
- ▶ JMS queues and connection factories

Due to the loose coupling between Application Developer and Application Server, applications can deploy in the following ways:

- ▶ Deploy from an Application Developer project to the integrated Application Server v7.0.
- ▶ Deploy from an Application Developer project to a separate Application Server runtime environment.
- ▶ Deploy through an EAR to an integrated Application Server v7.0.
- ▶ Deploy through an EAR to a separate Application Server runtime environment.

Administration of the application server is performed through the WebSphere Administrative Console that runs in a Web browser.

In addition, the Application Server v7.0 can obtain an EAR from external tools and be loaded into Application Developer v7.5 or **Application Developer Assembly and Deployment (RAD-AD)**. Application Developer or RAD-AD optimize the EAR and a new EAR is saved to deploy to the application server.

The RAD Assembly and Deploy function replaces the former Application Server Toolkit (AST) v6.1 function. Assembly and Deploy is licensed as part of the WebSphere Application Server v7.0. It includes a superset of the older AST functionality and is fully integrated within the Application Developer v7.5 tooling. The remaining Application Developer v7.5 functions are included on a trial basis and can be easily purchased through a downloadable license key.

A diagram of the deployment architecture and the various mechanisms to deploy out an application are provided in Figure 26-4.

Details on how to configure the servers in Application Developer v7.5 are documented in Chapter 22, “Servers and server configuration” on page 777.

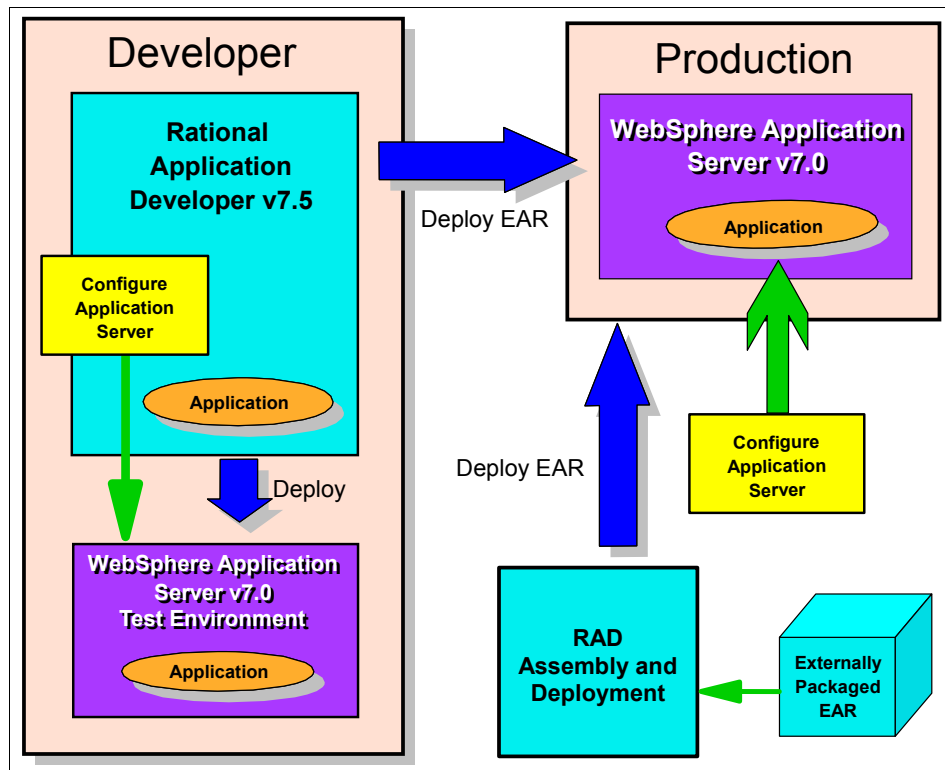

Figure 26-4 Deployment architecture

WebSphere profiles

Application Server v6.0 introduced the concept of WebSphere profiles. It has been split into two separate components:

- ▶ A set of shared product files—Runtime files
- ▶ A set of configuration files known as WebSphere profiles—Configurable files

A WebSphere profile includes Application Server configuration, applications, and properties files that constitute a new application server. Having multiple profiles equates to having multiple Application Server instances for use with a number of applications.

In Application Developer v7.5, this allows a developer to configure multiple application servers for various applications that they might be working with. Separate WebSphere profiles can then be set up as test environments in Rational Application Developer (see Chapter 22, “Servers and server configuration” on page 777).

WebSphere enhanced EAR

WebSphere Application Server v6 also introduced the **enhanced EAR** feature. The enhanced EAR information, which includes settings for the resources required by the application, is stored in an **ibmconfig** subdirectory of the enterprise application (EAR file) META-INF directory.

The enhanced EAR feature provides an extension of the Java EE EAR with additional configuration information for resources typically required by Java EE applications. This information is not mandatory to be supplied at packaging time, but it can simplify the deployment of applications to Application Server for selected scenarios.

The Enhanced EAR editor can be used to edit several WebSphere Application Server specific configurations, such as JDBC providers, data sources, class loader policies, substitution variables, shared libraries, virtual hosts, and authentication settings. The configuration settings can be made simply within the editor and published with the EAR at the time of deployment.

The upside of the tool is that it makes the testing process simpler and repeatable, since the configurations can be saved to files and then shared within a team's repository. Even though it does not let you configure every possible runtime setting, it is a good tool for development purposes because it eases the process of configuring the most common ones.

The downside is that the configurations are attached to the EAR, and are not available server- or system-wide. In the WebSphere Administrative Console you can navigate to the enhanced EAR deployment information (select **Applications** → **WebSphere enterprise applications**, select the application, then click the **Application scoped resources** link), but you cannot modify the settings. You can only edit settings that belong to the cluster, node, and server contexts.

When you change a configuration using the Enhanced EAR editor, these changes are made within the application context. The deployer can still make changes to the EAR file using the RAD Assembly and Deployment (RAD-AD), but it still requires a separate tool. Furthermore, in most cases these settings are dependent on the node the application server is installed in anyway, so it might not make sense to configure them at the application context for production deployment purposes.

Table 26-1 lists the supported resources that the enhanced EAR provides and the scope in which they are created.

Table 26-1 Enhanced EAR resources supported and their scope

Scope	Resources
Application	JDBC providers, data sources, substitution variables, class loader policies
Server	Shared libraries
Cell	JAAS authentication aliases, virtual hosts

To open the Enhanced EAR, right-click an enterprise application and select **Java EE** → **Open WebSphere Application Server Deployment** (Figure 26-5).

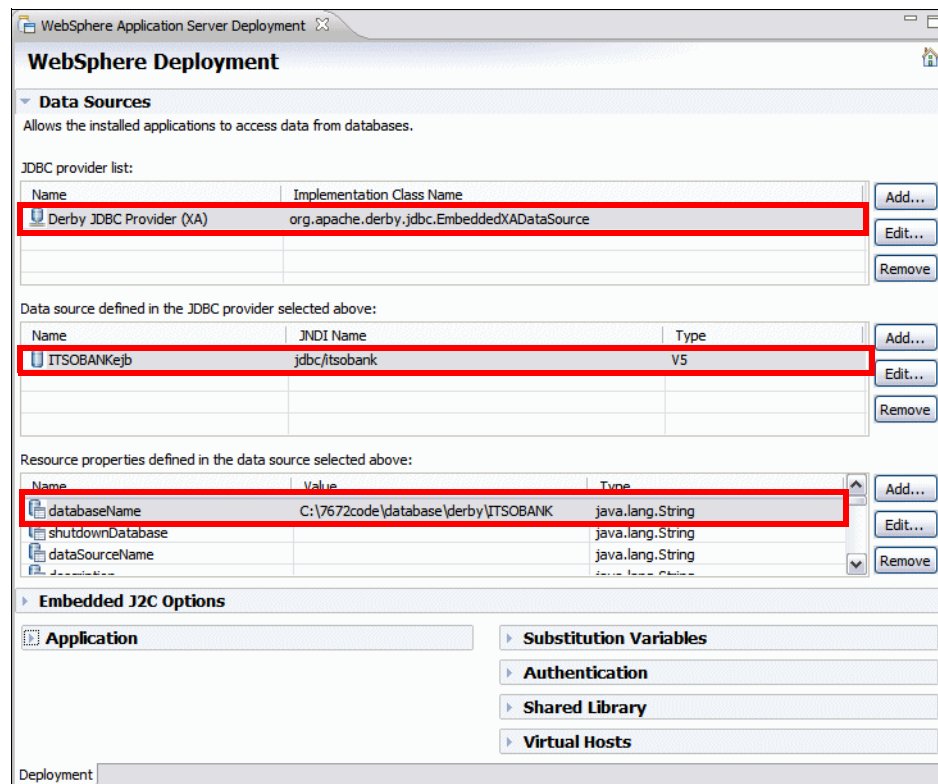

Figure 26-5 Enhanced EAR Deployment Descriptor Editor

Figure 26-5 displays the JDBC provider (Derby JDBC Provider (XA)), a configured data source (ITSOBANKejb) with properties (databaseName). Select a JDBC provider to see the list of data sources. This example of defining a data source using the Enhanced EAR editor was created in “Creating a data source in the enhanced EAR” on page 802.

Figure 26-6 displays the contents of the `resources.xml` file that is part of the enhanced EAR information stored in:

```
ibmconfig/cells/defaultCell/applications/defaultApp/deployments/defaultApp
```

Notice that in the `ibmconfig` directory are the well-known directories for a WebSphere cell configuration. The XML editor of Application Developer displays the configuration contents for the Derby JDBC Provider (XA) and the data source.

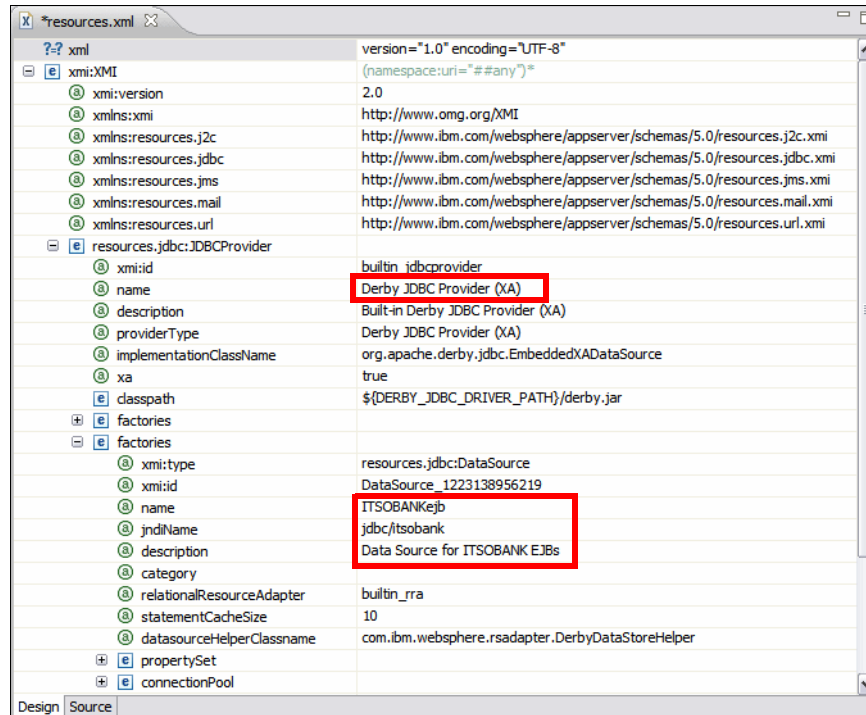

Figure 26-6 Enhanced EAR: resources.xml

Note: For more detailed information and an example of using the WebSphere enhanced EAR, refer to these sources:

- ▶ *Packaging applications* chapter in the *WebSphere Application Server V6.1: Systems Management and Configuration*, SG24-7304
- ▶ IBM WebSphere Application Server v7.0 Info Center, found at:
<http://publib.boulder.ibm.com/infocenter/wasinfo/v7r0/index.jsp>

WebSphere Rapid Deployment

WebSphere Rapid Deployment is a collection of tools and technologies introduced in IBM WebSphere Application Server v6.1 to make application development and deployment easier than ever before.

WebSphere Rapid Deployment consists of the following elements:

- ▶ Rapid deployment tools
- ▶ Fine-grained application updates

Rapid deployment tools

Using the rapid deployment tools part of WebSphere Rapid Deployment, you can accomplish the following tasks:

- ▶ Create a new Java EE application quickly without the overhead of using an integrated development environment (IDE).
- ▶ Package Java EE artifacts quickly into an EAR file.
- ▶ Deploy and test Java EE modules and full applications quickly on a server.

For example, you can place full Java EE applications (EAR files), application modules (WAR files, EJB JAR files), or application artifacts (Java source files, Java class files, images, and JSPs) into a configurable location on your file system, referred to as the *monitored*, or *project*, directory. The rapid deployment tools then automatically detect added or changed parts of these Java EE artifacts and perform the steps necessary to produce a running application on an application server.

There are two ways to configure the monitored directory, each performing separate and distinct tasks (as shown in Figure 26-7):

- ▶ Free-form project
- ▶ Automatic application installation project

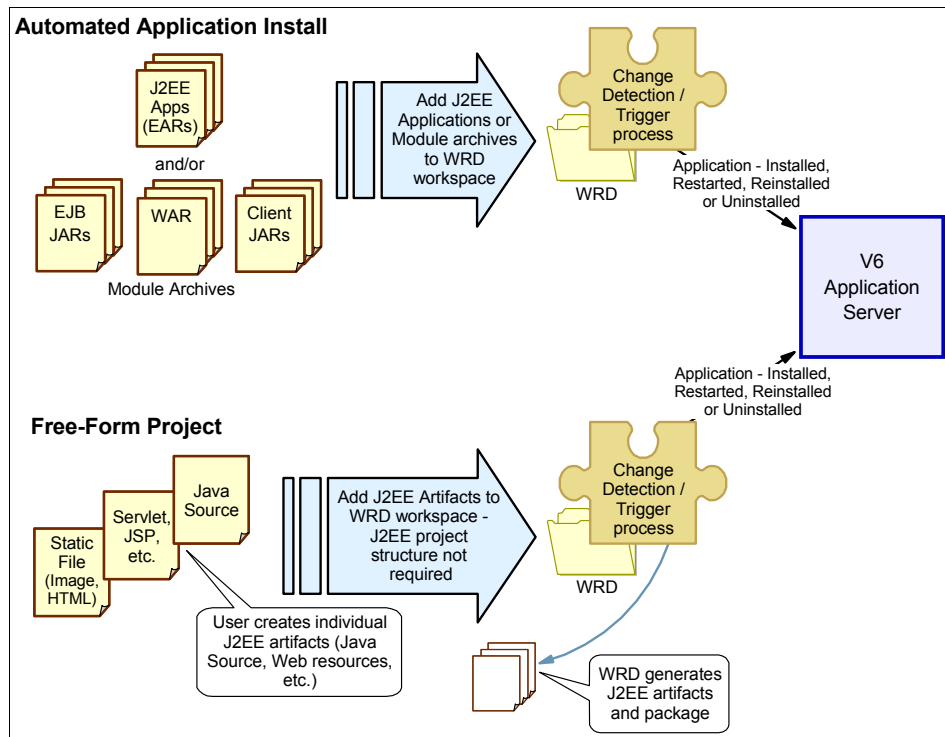

Figure 26-7 WebSphere Rapid Deployment modes

With the **free-form project** approach, you can place in a single project directory the individual parts of your application, such as Java source files that represent servlets or enterprise beans, static resources, XML files, and other supported application artifacts. The rapid deployment tools then use your artifacts to automatically place them in the appropriate Java EE project structure, generate any additional required artifacts to construct a Java EE-compliant application, and deploy that application on a target server.

The advantage of using a free-form project is that you do not have to know how to package your application artifacts into a Java EE application. The free-form project takes care of the packaging part for you. The free-form project is suitable when you just want to test something quickly, perhaps write a servlet that performs a task.

The **automatic application installation project** allows you to quickly and easily install, update, and uninstall Java EE applications on a server. If you place EAR files in the project directory, they are automatically deployed to the server. If you delete EAR files from the project directory, the application is uninstalled from the server. If you place a new copy of the same EAR file in the project directory, the

application is reinstalled. If you place WAR or EJB JAR files in the automatic application installation project, the rapid deployment tool generates the necessary EAR wrapper and then publishes that EAR file on the server. For RAR files, a wrapper is not created. The standalone RAR files are published to the server.

An automatic application installation project simplifies management of applications and relieves you of the burden of going through the installation panels in the WebSphere Administrative Console or developing wsadmin scripts to automate your application deployment.

The rapid deployment tools can be configured to deploy applications either onto a local or remote WebSphere Application Server.

Note: For more detailed information on WebSphere Rapid Deployment, refer to these sources:

- ▶ *WebSphere Application Server V6.1: Planning and Design*, SG24-7305
- ▶ *WebSphere Application Server V6.1: Systems Management and Configuration*, SG24-7304
- ▶ IBM WebSphere Application Server v7.0 InfoCenter, found at:
<http://publib.boulder.ibm.com/infocenter/wasinfo/v7r0/index.jsp>

Java and WebSphere class loader

Class loaders are responsible for loading classes, which can be used by an application. Understanding how Java and WebSphere class loaders work is an important element of Application Server configuration needed for the application to work properly after deployment. Failure to set up the class loaders properly will often result in class loading exceptions such as `ClassNotFoundException` when trying to start the application.

Java class loader

Java class loaders enable the Java virtual machine (JVM) to load classes. Given the name of a class, the class loader should locate the definition of this class. Each Java class must be loaded by a class loader.

When the JVM is started, three class loaders are used:

- ▶ **Bootstrap class loader:** The bootstrap class loader is responsible for loading the core Java libraries (that is, `core.jar`, `server.jar`) in the `<JAVA_HOME>/lib` directory. This class loader, which is part of the core JVM, is written in native code.

Note: Beginning with JDK 1.4, the core Java libraries in the IBM JDK are no longer packaged in `rt.jar` as was previously the case (and is the case for the Sun JDKs), but instead split into multiple JAR files.

- ▶ **Extensions class loader:** The extensions class loader is responsible for loading the code in the extensions directories (`<JAVA_HOME>/lib/ext` or any other directory specified by the `java.ext.dirs` system property). This class loader is implemented by the `sun.misc.Launcher$ExtClassLoader` class.
- ▶ **System class loader:** The system class loader is responsible for loading the code that is found on `java.class.path`, which ultimately maps to the system `CLASSPATH` variable. This class loader is implemented by the `sun.misc.Launcher$AppClassLoader` class.

Delegation is a key concept to understand when dealing with class loaders. It states that a custom class loader (a class loader other than the bootstrap, extension, or system class loaders) delegates class loading to its parent before trying to load the class itself. The parent class loader can either be another custom class loader or the bootstrap class loader. Another way to look at this is that a class loaded by a specific class loader can only reference classes that this class loader or its parents can load, but not its children.

The Extensions class loader is the parent for the System class loader. The Bootstrap class loader is the parent for the Extensions class loader. The class loaders hierarchy is shown in Figure 26-8.

If the System class loader has to load a class, it first delegates to the Extensions class loader, which in turn delegates to the Bootstrap class loader. If the parent class loader cannot load the class, the child class loader tries to find the class in its own repository. In this manner, a class loader is only responsible for loading classes that its ancestors cannot load.

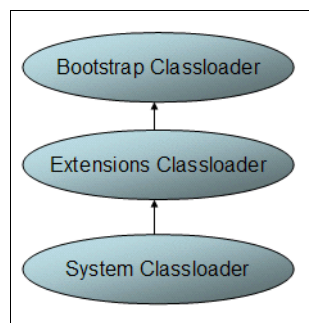

Figure 26-8 Java class loaders hierarchy

WebSphere class loader

It is important to keep in mind when reading the following material on WebSphere class loaders, that each Java Virtual Machine (JVM) has its own setup of class loaders. This means that in a WebSphere environment hosting multiple application servers (JVMs), such as a Network Deployment configuration, the class loaders for the JVMs are completely separated even if they are running on the same physical machine.

WebSphere provides several custom delegated class loaders, as shown in Figure 26-9. The top box represents the Java (Bootstrap, Extension, and System) class loaders. WebSphere does not load much here, just enough to get itself bootstrapped and initialize the WebSphere extension class loader.

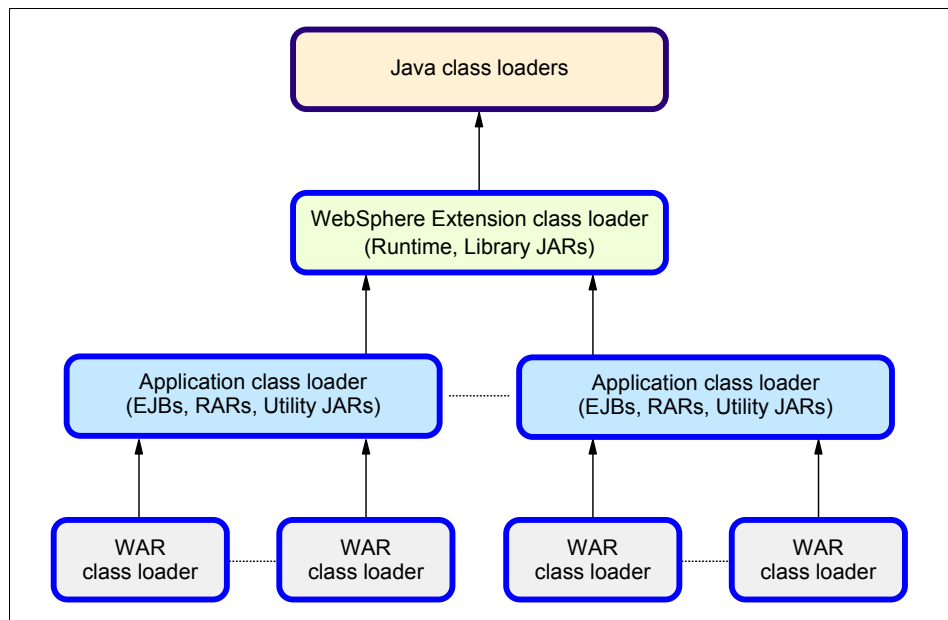

Figure 26-9 WebSphere class loaders hierarchy

The WebSphere extensions class loader is where WebSphere itself is loaded. It uses the following directories to load the required WebSphere classes:

```

<JAVA_HOME>\lib
<WAS_HOME>\classes           (Runtime Class Patches directory, or RCP)
<WAS_HOME>\lib               (Runtime class path directory, or RP)
<WAS_HOME>\lib\ext           (Runtime Extensions directory, or RE)
<WAS_HOME>\installedChannels
  
```

The WebSphere runtime is loaded by the WebSphere extensions class loader based on the `ws.ext.dirs` system property, which is initially derived from the `WS_EXT_DIRS` environment variable set in the `setupCmdLine.bat` file. The default value of `ws.ext.dirs` is as follows:

```
SET WAS_EXT_DIRS=%JAVA_HOME%\lib;%WAS_HOME%\classes;%WAS_HOME%\lib;  
%WAS_HOME%\installedChannels;%WAS_HOME%\lib\ext;%WAS_HOME%\web\help;  
%ITP_LOC%\plugins\com.ibm.etools.ejbdeploy\runtime
```

The RCP directory is intended to be used for fixes and other APARs that are applied to the application server runtime. These patches override any copies of the same files lower in the RP and RE directories. The RP directory contains the core application server runtime files. The bootstrap class loader first finds classes in the RCP directory, then in the RP directory. The RE directory is used for extensions to the core application server runtime.

Each directory listed in the `ws.ext.dirs` environment variable is added to the WebSphere extensions class loaders class path. In addition, every JAR file and/or ZIP file in the directory is added to the class path.

You can extend the list of directories and files loaded by the WebSphere extensions class loaders by setting a `ws.ext.dirs` custom property to the Java virtual machine settings of an application server.

Application and Web module class loaders

Java EE applications consist of five primary elements: Web modules, EJB modules, application client modules, resource adapters (RAR files), and utility JARs. Utility JARs contain code used by both EJBs and/or servlets. Utility frameworks (such as `log4j`) are a good example of a utility JAR.

EJB modules, utility JARs, resource adapters files, and shared libraries associated with an application are always grouped together into the same class loader. This class loader is called the application class loader. Depending on the application class loader policy, this application class loader can be shared by multiple applications (EAR) or be unique for each application (the default).

By default, Web modules receive their own class loader (a WAR class loader) to load the contents of the `WEB-INF/classes` and `WEB-INF/lib` directories. The default behavior can be modified by changing the application's WAR class loader policy (the default being *Module*). If the WAR class loader policy is set to *Application*, the Web module contents are loaded by the *application class loader* (in addition to the EJBs, RARs, utility JARs, and shared libraries). The application class loader is the parent of the WAR class loader.

The application and the Web module class loaders are reloadable class loaders. They monitor changes in the application code to automatically reload modified classes. This behavior can be altered at deployment time.

Handling JNI code

Due to a JVM limitation, code that has to access native code through a Java Native Interface (JNI) must not be placed on a reloadable class path, but on a static class path. This includes shared libraries for which you can define a native class path, or the application server class path. So if you have a class loading native code through JNI, this class must not be placed on the WAR or application class loaders, but rather on the WebSphere extensions class loader.

It might make sense to break out just the lines of code that actually load the native library into a class of its own and place this class on a static class loader. This way you can have all the other code on a reloadable class loader.

Preparing for the deployment of the EJB application

This section describes the steps required to prepare the environment for the deployment sample. We will use the ITSO Bank enterprise application developed in Chapter 14, “Develop EJB applications” on page 387, to demonstrate the deployment process.

This section includes the following tasks:

- ▶ Reviewing the deployment scenarios
- ▶ Installing the prerequisite software
- ▶ Importing the sample application project interchange files
- ▶ Sample database

Reviewing the deployment scenarios

Now that the Application Developer integration with Application Server is managed the same as a standalone Application Server, the procedure to deploy the ITSO Bank sample application is nearly identical to that of a standalone Application Server.

There are several possible configurations in which our sample can be installed, but in this chapter we will deploy the ITSO Bank application to a separate production IBM Application Server v7.0. This scenario uses two nodes (developer node, application server node).

Installing the prerequisite software

The application deployment sample requires that you have the software mentioned in this section installed. Within the example, you can choose between DB2 Universal Database or Derby as your database server. We used Derby for this chapter and our deployment exercises.

The sample for the working example environment consists of two nodes (see Table 26-2 for product mapping):

- ▶ Developer node—This node will be used by the developer to import the sample code and package the application in preparation for deployment.
- ▶ Application server node—This node will be used as the target server where the enterprise application will be deployed.

Table 26-2 Product mapping for deployment

Software	Version
Developer node	
Microsoft Windows	XP + Service Pack 2 + Critical fixes and security patches.
IBM Application Developer * Integrated IBM Application Server V7.0	v7.5
Derby (installed by default)	v10.2
Application server node	
Microsoft Windows	XP + Service Pack 2 + Critical fixes and security patches.
IBM Application Server (Base stand-alone)	v7.0
Derby (installed by default)	v10.2

Note: For detailed information on installing the required software for the sample, refer to Appendix A, “Product installation” on page 1121.

Tip: DB2 Universal Database or Derby

You can use DB2 or Derby as database server. Because Derby is installed by default as part of the Application Server (integrated and stand-alone), we used Derby as the database for this chapter and the deployment exercises.

Importing the sample application project interchange files

This section describes how to import the project interchange files into Application Developer. The RAD75EJB.zip contains the following projects for the ITSO Bank enterprise application developed in Chapter 14, “Develop EJB applications” on page 387:

- ▶ **RAD75JPA**—This is the Java project that contains persistence JPA classes.
- ▶ **RAD75EJB**—This is the EJB project with session beans.
- ▶ **RAD75TestWeb**—This is the web project that is used to test the EJB beans.
- ▶ **RAD75EJB EAR**—This is the EAR project for the enterprise application; it includes the above modules.

A second project interchange file, RAD75EJBWeb.zip, contains the Web application that uses the EJBs:

- ▶ **RAD75EJBWeb**—This is a Web project (JSP and servlets) for the front-end application.
- ▶ **RAD75EJBWebEAR**—This is the EAR project for the Web application. Note that this EAR also references the RAD75EJB and RAD75JPA projects.

To import the RAD75EJB.zip project interchange file, do these steps:

- ▶ In the Java EE (or Web) perspective, Enterprise Explorer, select **File** → **Import**.
- ▶ Select **Other** → **Project Interchange** from the list of import sources and then click **Next**.
- ▶ In the Import Projects dialog, click **Browse** for the zip file, navigate to and select the **RAD75EJB.zip** from the C:\7672code\zInterchangeFiles\ejb folder, and click **Open**.
- ▶ Click **Select All** to select all projects and then click **Finish**.
- ▶ Repeat this sequence for the RAD75EJBWeb.zip file, and select the RAD75EJBWeb and RAD75EJBWebEAR projects.

Sample database

The ITSO Bank application are based on the ITSOBANK database. Refer to “Setting up the ITSOBANK database” on page 1154 for instructions on how to create the ITSOBANK database. You can either use the DB2 or Derby database. For simplicity we chose to use the built-in Derby database in this chapter.

To make it even simpler, we have placed the Derby database as part of the file you have downloaded for this chapter. The ITS0BANK folder under the C:\7672code\Database\Derby folder constitutes the Derby database. Therefore, the complete path or location of the database is:

```
C:\7672code\Database\Derby\ITS0BANK
```

This value has to be configured for the databaseName resource property for the data source we will define in the server (see “Configuring the data source in the application server” on page 956). Therefore, if you configure this location in the data source, you do not have to set up a sample Derby database, as it has already been done for you. Make sure that you test the data source connection.

Packaging the application for deployment

This section describes the steps in preparation for packaging, as well as how to export the enterprise application from Application Developer to an EAR file, which is used to deploy on the application server.

This section includes the following procedures:

- ▶ Removing the enhanced EAR data source
- ▶ Generating the deploy code
- ▶ Exporting the EAR files

Removing the enhanced EAR data source

As explained earlier, the application deployment descriptor contains enhanced EAR information for the JDBC Provider and data source configuration. These settings are useful when running the application within Application Developer.

As we are deploying the application to a remote application server system and because the enhanced EAR data source configuration overrides the administrative console configuration, the enhanced EAR data source settings must be removed.

To remove the enhanced EAR data source settings, do these steps:

- ▶ Right-click the **RAD75EJBEAR** project and select **Java EE → Open WebSphere Application Server Deployment**.
- ▶ The WebSphere Deployment editor opens.
- ▶ Select **Derby JDBC Provider (XA)** from the JDBC provider list and click **Remove**.
- ▶ Save the deployment descriptor.

Generating the deploy code

Previously to Java EE 5, deployment code had to be generated to be able to deploy the EJBs to an application server. This is no more necessary for Java EE 5 application. So if you EAR contains only Java EE 5 applications you do not have to generate deployment code. However, if you have a mix of EJB 2.x and EJB 3.0 in your EAR then deployment code would need to be generated for the EJB 2.x projects.

Generating the deploy code is as follows:

- ▶ Make sure that you have selected the correct backend folder in the deployment descriptor of the EJB 2.x projects, either Derby or DB2. Deployment code is generated for the selected mapping (backend folder).
- ▶ Deployment is required for EJBs 2.x. This can be performed in the IDE now, or when installing the application on the server.
- ▶ In the Enterprise Explorer, right-click the EAR project and select **Prepare for Deployment**. For a Java EE 5 EAR project deployment code is only generated for the EJB 2.x modules it contains.

You can also directly right-click the EJB 2.x projects and select **Prepare for Deployment** (the Web modules do not require deployment).

Exporting the EAR files

We have two enterprise applications for the EJB sample in the workspace: RAD75EJBEAR and RAD75EJBWebEAR. We have to export both of these enterprise projects as EAR files.

To export the enterprise applications from Application Developer to EAR files, do these steps:

- ▶ In the Enterprise Explorer, right-click **RAD75EJBEAR** and select **Export** → **EAR file**.
- ▶ In the EAR Export dialog, enter the destination path (for example, C:\7672code\deployment\RAD75EJB.ear) and click **Finish** (Figure 26-10). As we are deploying the application to IBM WebSphere Application Server v7.0, select **Optimize for a specific server runtime** and set to **was.base v7**.

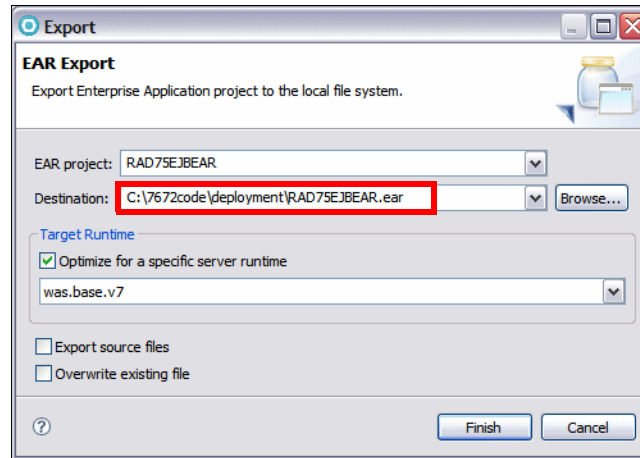

Figure 26-10 Choices for exporting an EAR file

- ▶ Repeat the export for the project RAD75EJBWebEAR.

Filtering the content of an EAR

It is possible to exclude certain files from the exported EAR, for example, diagrams and Javadoc.

To filter (exclude) files from an EAR, do these steps:

- ▶ Right-click a Java, Web, or EJB project and select **Properties**.
- ▶ On the **Source** tab, expand the source folder (typically **src**), select **Excluded** and click **Edit**.
- ▶ In the Inclusion and Exclusion Patterns dialog, click **Add** to exclude files of a given extension (for example, ****/*.dtx** to exclude diagrams).
- ▶ Click **Finish** and then **OK**.

Manual deployment of enterprise applications

Both enterprise applications have been packaged as an EAR file and can be deployed to the application server. This section describes the steps required to configure the target Application Server and install the two enterprise applications.

Note: You can either use the EAR files exported in the previous section for deployment to the target Application server, or alternatively use the solution EAR files from the C:\7672code\jython directory of the sample code.

Configuring the data source in the application server

The data source for the application server can be created in several ways, including these:

- ▶ Enhanced EAR—This is the ideal option for deploying the application to the Integrated Application Server in Application Developer, but because we are deploying to the stand-alone server, we are not using the enhanced EAR functionality.
- ▶ Scripting using wsadmin command line interface—For details, refer to the Application Server v7.0 InfoCenter. This is also covered in the second part of this chapter, which is about the automated deployment using Jython-based wsadmin scripting.
- ▶ WebSphere Administrative Console—For our example, we create and configure the data source for the ITSO Bank application using the administrative console of the target stand-alone Application Server v7.0.

The high-level configuration steps to configure the data source within Application Server for the ITSO Bank application sample are as follows:

- ▶ Start the application server.
- ▶ If you configured the stand-alone application server as a Windows service, you can start the server by starting its service.
- ▶ Configure the JDBC provider.
- ▶ Create the data source.

Start the application server

Ensure that the application server where you want to deploy the applications is started. You can use any WebSphere Application Server, stand-alone or configured as a profile in Application Developer.

If the server is not running, start the server in any of these ways:

- ▶ Use the Windows start menu. For example, select **Start** → **Programs** → **IBM WebSphere** → **Application Server V7** → **Profiles** → **default** → **Start server**.
- ▶ If you followed the instructions in Chapter 22, “Servers and server configuration” on page 777 and installed a second WebSphere profile, you can start that server from the Servers view of Application Developer.
- ▶ An application server can also be started using the **startServer server1** command in the **bin** folder where the server profile is installed, for example:

```
C:\Program Files\IBM\WebSphere\AppServer\profiles\default\bin  
<RAD_HOME>\runtimes\base_v7\profiles\was70profile1\bin
```

- ▶ If you configured the stand-alone application server as a Windows service, you can start the server by starting its service.

Tip: You can also use the WebSphere Application Server v7.0 test environment to go through the enterprise application installation dialogs.

However, make sure that the RAD75EJBEAR and RAD75EJBWebEAR applications are removed from the server (right-click the server and select **Add and Remove Projects**).

Note: To verify that the server has started properly, you can look for the message **Server server1 open for e-business** in the SystemOut.log found in the <was_profile_root>\logs\server1 directory.

Start the administrative console

We use the WebSphere Administrative Console to define the data source and install the applications. When using a server from Application Developer, you can start the administrative console by right-clicking the server and selecting **Administration** → **Run administrative console**. However, we recommend to perform the configuration in an external browser to simulate a real deployment environment.

- ▶ To start the administrative console, open a Web browser (Internet Explorer, Firefox) and use this URL:

```
http://<hostname>:<port>/ibm/console
http://localhost:9060/ibm/console      test environment
http://localhost:9062>/ibm/console    alternate profile
```

- ▶ For a stand-alone server, you can also select **Start** → **Programs** → **IBM WebSphere** → **Application Server V6** → **Profiles** → **default** → **Start administrative console**.
- ▶ Click **Login** (without security, no user ID is required).
- ▶ Figure 26-11 shows the Welcome page.

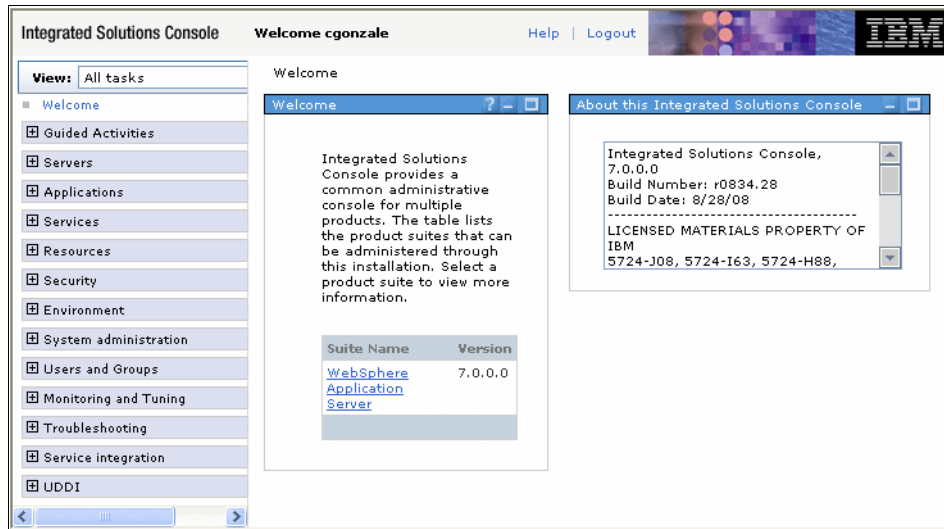

Figure 26-11 Welcome page of the administrative console

Create the JDBC driver variable

If you are using Derby, verify that the WebSphere variable for the Derby JDBC driver (DERBY_JDBC_DRIVER_PATH) is defined.

- ▶ Select **Environment** → **WebSphere Variables**. Verify that DERBY_JDBC_DRIVER_PATH is defined (Figure 26-12).

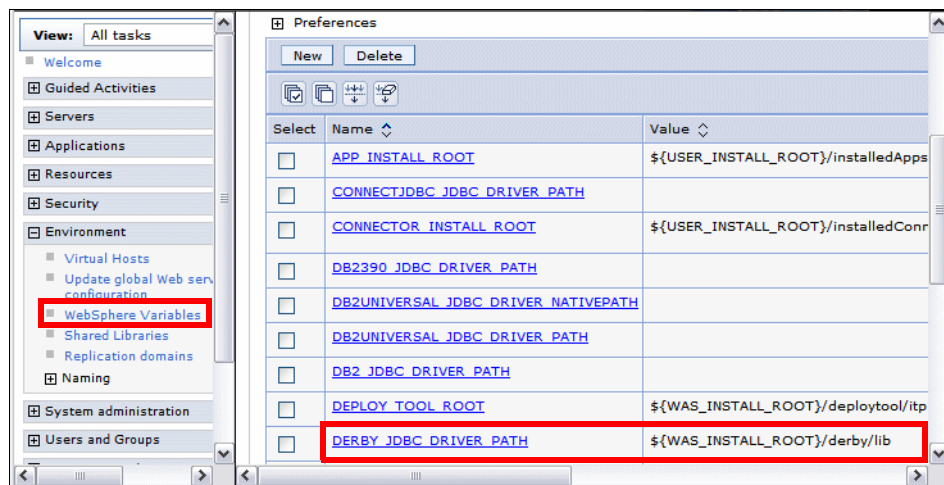

Figure 26-12 WebSphere Variable: DERBY_JDBC_DRIVER_PATH \

Configure the JDBC provider

This section describes how to configure the JDBC provider for the selected database type. The following procedure demonstrates how to configure the JDBC Provider for Derby:

- ▶ Select **Resources** → **JDBC** → **JDBC providers**.
- ▶ Select the server scope: **Node=<hostname>Node<xx>**, **Server=server1**
- ▶ Click **New**.
- ▶ In the Create new JDBC Providers page (Figure 26-13), do these steps:
 - For Database type, select **Derby**.
 - For JDBC Provider, select **Derby JDBC Provider**.
 - For Implementation type, select **XA data source**.
 - Accept the default name of Derby JDBC Provider (XA).
 - Click **Next**.

The screenshot shows a wizard titled "Create a new JDBC Provider". On the left, there are three steps: "Step 1: Create new JDBC provider" (selected), "Step 2: Enter database class path information", and "Step 3: Summary". The main area is titled "Create new JDBC provider" and contains the following fields:

- Scope:** cells:UELIT60Node03Cell:nodes:UELIT60Node02:servers:server1
- * Database type:** Derby
- * Provider type:** Derby JDBC Provider
- * Implementation type:** XA data source
- * Name:** Derby JDBC Provider (XA)
- Description:** Derby embedded XA JDBC Provider. This provider is only configurable in version 6.0.2 and later nodes

At the bottom, there are "Next" and "Cancel" buttons. The "Next" button is highlighted in yellow.

Figure 26-13 Create a JDBC provider

- ▶ For Derby, Step 2 is skipped (the class path is set correctly), and in Step 3: Summary page, click **Finish**.
- ▶ Click **Save** to the master configuration.

Create the data source

We create the data source for the ITSOBANK database for the selected JDBC provider:

- ▶ Select **Derby JDBC Provider (XA)** for Derby or **DB2 Universal JDBC Driver Provider (XA)** for DB2.
- ▶ Under Additional Properties (right-hand side of page), click **Data sources**.
- ▶ In the Data source page, click **New**.
- ▶ Enter the basic configuration for the new Data source (Figure 26-14).

Figure 26-14 Basic configuration for the data source

- Name: **RAD75DS for ITSOBANK** (this can be anything).
- JNDI name: **jdbc/itsobank** (this must match the JNDI name that was given in the EAR enhanced deployment descriptor (refer to Figure 26-5 on page 942).

If you already configured a data source with the JNDI name `jdbc/itsobank`, use another name, such as `jdbc/itsobank1`.

- ▶ In the next page (Figure 26-15), enter the database name.
 - Make sure that you enter the complete path of the database file. For example, in our case this value is:

```
C:\7672code\database\derby\ITSOBANK
```
 - Clear **Use this data source in container managed persistence (CMP)**. This is for EJB 2.x only.
 - Click **Next**.

Create a data source

Step 1: Enter basic data source information

→ Step 2: Enter database specific properties for the data source

Step 3: Setup security aliases

Step 4: Summary

Enter database specific properties for the data source

Set these database-specific properties, which are required by the database vendor JDBC driver to support the connections that are managed through the datasource.

Name	Value
* Database name	C:\7672code\database\derby

Use this data source in container managed persistence (CMP)

Previous Next Cancel

Figure 26-15 Enter the database path or name

- ▶ Leave the next page blank (no authentication aliases are required for Derby) and click **Next**.
- ▶ In the summary page, verify the configuration information you entered for the data source and click **Finish**.
- ▶ Click **Save** to the master configuration.
- ▶ Verify the database connection for the new data source (Figure 26-16):
 - Select the data source (check box)
 - Click **Test connection** and a message indicates success or failure.

JDBC providers

Messages

The test connection operation for data source RAD75DS for ITSOBANK on server server1 at node TPCGONZALENode04 was successful.

JDBC providers > Derby JDBC Provider (XA) > Data sources

Use this page to edit the settings of a datasource that is associated with your selected JDBC provider. The datasource object supplies your application with connections for accessing the database. Learn more about this task in a [guided activity](#). A guided activity provides a list of task steps and more general information about the topic.

Preferences

New Delete **Test connection** Manage state...

Select	Name	JNDI name	Scope	Provider	Description	Category
<input checked="" type="checkbox"/>	RAD75DS for ITSOBANK	jdbc/itsobank	Node=TPCGONZALENode04,Server=server1	Derby JDBC Provider (XA)	New JDBC Datasource. This Datasource type is only configurable in version 6.0.2 and later nodes	

Total 1

Figure 26-16 Test connection of the data source

Tip: If the connection fails, make sure that no connection is active from Application Developer (in the Data perspective disconnect from ITSOBANK).

Installing the enterprise applications

To install the two enterprise applications to the target application server, do these steps:

- ▶ Copy the RAD75EJBEAR.ear and RAD75EJBWebEAR.ear files from the developer node (where you exported the files from Application Developer) to the application server node, typically into the installableApps directory:

```
<AppServer_HOME>/installableApps
<RAD_HOME>/runtimes/base_v7/profiles/<profile>/installableApps
```

- ▶ In the WebSphere Administrative Console select **Applications** → **New Application**.
- ▶ Click **New Enterprise Application**.
- ▶ Enter the following items (Figure 26-17):
 - Select **Local file system**.
 - Specify path: C:\.....\installableApps\RAD75EJBEAR.ear

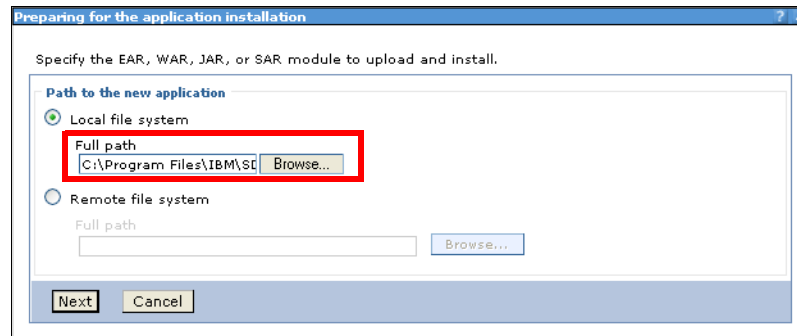

Figure 26-17 Enterprise application installation: Specify the path to the EAR file

- ▶ Click **Next**
- ▶ Ensure that **Fast Path** is checked and click **Next**. This starts the installation wizard.
- ▶ In the Select installation options page, accept the default values and click **Next** (Figure 26-18). Optionally select **Precompile JavaServer Pages files** for applications with a Web module with JSPs.

Install New Application

Specify options for installing enterprise applications and modules.

→ **Step 1: Select installation options**

[Step 2: Map modules to servers](#)

[Step 3: Summary](#)

Select installation options

Specify the various options that are available to prepare and install your application.

Precompile JavaServer Pages files

Directory to install application

Distribute application

Use Binary Configuration

Deploy enterprise beans

Application name

Create MBeans for resources

Override class reloading settings for Web and EJB modules

Reload interval in seconds

Deploy Web services

Validate Input off/warn/fail

Process embedded configuration

Figure 26-18 Enterprise application installation: Installation options

- In the Map modules to servers page, accept the default values and click **Next** (Figure 26-19).

Install New Application

Specify options for installing enterprise applications and modules.

[Step 1: Select installation options](#)

→ **Step 2: Map modules to servers**

[Step 3: Summary](#)

Map modules to servers

Specify targets such as application servers or clusters of application servers where you want to install your application. Modules can be installed on the same application server or dispersed among servers as targets that serve as routers for requests to this application. The plug-in configuration is generated, based on the applications that are routed through.

Clusters and servers:

Select	Module	URI	Server
<input type="checkbox"/>	RAD75EJB	RAD75EJB.jar,META-INF/ejb-jar.xml	WebSphere:cell=TPCGONZALENode04Cell,node=TPCGONZALENode04,server=server1
<input type="checkbox"/>	RAD75EJBTestWeb	RAD75EJBTestWeb.war,WEB-INF/web.xml	WebSphere:cell=TPCGONZALENode04Cell,node=TPCGONZALENode04,server=server1

Figure 26-19 Enterprise application installation: Map modules to servers

- In the summary page, verify the configuration information for the new enterprise application and click **Finish** to confirm (Figure 26-20).

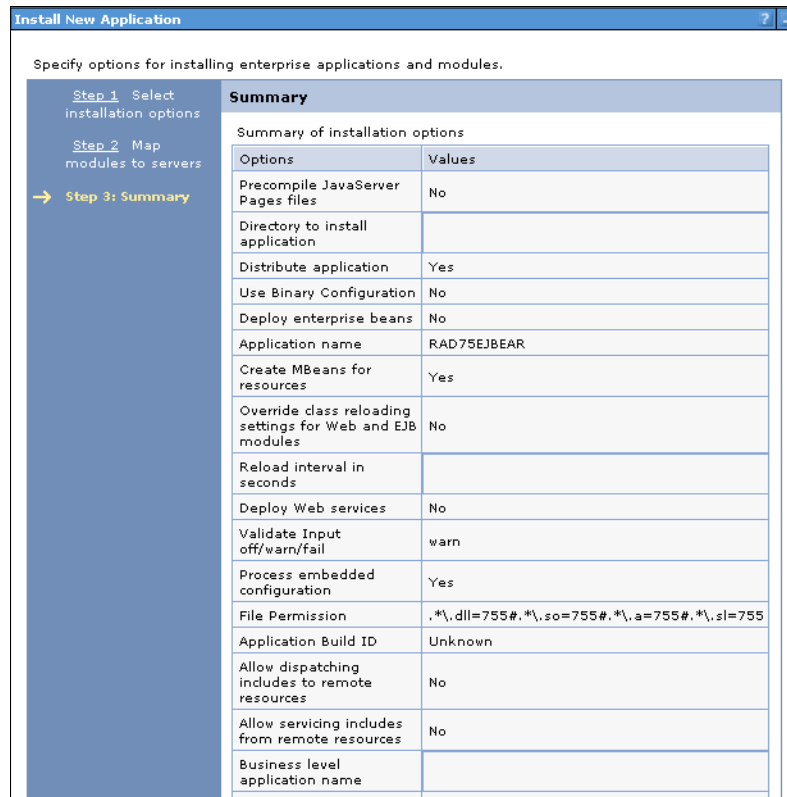

Figure 26-20 Summary page for the Install Application wizard

- You will see a number of messages, concluded by successful installation:

Installing...

If there are enterprise beans in the application, the EJB deployment process can take several minutes. Do not save the configuration until the process completes.

Check the SystemOut.log on the deployment manager or server where the application is deployed for specific information about the EJB deployment process as it occurs.

```
ADMA5016I: Installation of RAD75EJBEAR started.
```

```
.....
```

```
ADMA5005I: The application RAD75EJBEAR is configured in the WebSphere
Application Server repository.
```

```
.....
```

```
Application RAD75EJBEAR installed successfully.
```

- ▶ Click **Save** directly to the master configuration.
- ▶ Repeat the installation steps to install the RAD75EJBWebEAR.ear enterprise application:
 - In the installation options page, select **Precompile JavaServer Pages files**.
 - The rest of the steps are the same.

Starting the enterprise applications

To start the enterprise applications, do these steps:

- ▶ In the administrative console, select **Applications** → **Application Types** → **WebSphere enterprise applications**.
- ▶ Select the **RAD75EJB** and **RAD75EJBWebEAR** applications and click **Start** (Figure 26-21).

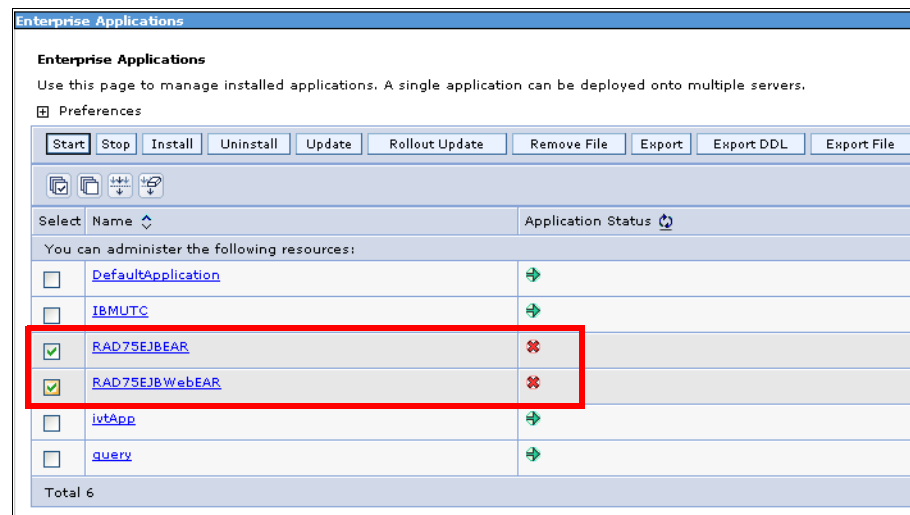
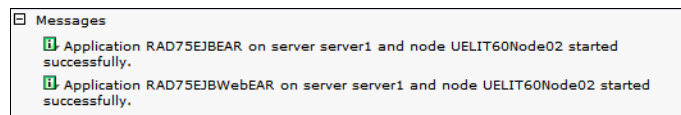

Figure 26-21 Start the newly deployed Enterprise application

- ▶ The status for the applications changes to a green arrow, and two messages about the successful start are displayed at the top.



Verifying the application after manual installation

To verify that the ITSO Bank sample is deployed and working properly, do these steps:

- ▶ Enter the following URL in a browser to access the ITSO Bank application:

http://<hostname>:9080/RAD75EJBWeb/ stand-alone server
http://localhost:9081/RAD75EJBWeb/ WebSphere profile

- ▶ The ITSO RedBank home page is displayed (Figure 26-22).



Figure 26-22 ITSO RedBank: Home page

- ▶ Click **redbank** and the login page is displayed. Enter a customer ID, for example, 555-55-5555, and click **Submit** (Figure 26-23).

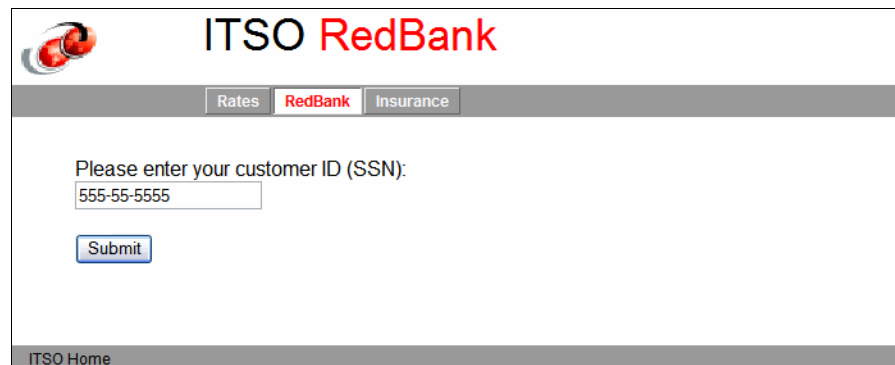

Figure 26-23 ITSO RedBank: Login page

- ▶ The accounts page lists the accounts of the customer with their balance. (Figure 26-24).

ITSO RedBank

Rates RedBank Insurance

SSN: 555-55-5555
 Title: Mr
 First name: Brian
 Last name: Hailey

Update New Customer Delete Customer

Account Number	Balance
005-555001	65.89
005-555002	72,213.41
005-555003	897.55

Add Account Logout

ITSO Home RedBank

Figure 26-24 ITSO RedBank: Accounts page

- ▶ This concludes our testing, though you can further experiment with the application:
 - Update the customer name or title.
 - Click on one of the account numbers to get the account maintenance page.
 - Submit banking transactions, such as deposit, withdraw, and transfer.
 - List the transactions.
 - Logout.

Uninstalling the application

We also want to show deployment using automation scripts, so after testing we uninstall the applications. This is necessary if you want to use the same server for the automation scripts.

- ▶ In the WebSphere Administrative Console, select **Applications** → **Application Types** → **WebSphere enterprise applications**.
- ▶ Select the two **RAD75EJBxxx** applications and click **Stop**.

- ▶ Select the two **RAD75EJBxxx** applications and click **Uninstall**. Click OK when prompted to remove the applications.
- ▶ Wait for the uninstall successful messages, then click **Save**.

Automated deployment using Jython based wsadmin scripting

In this section we will introduce you to the WebSphere scripting client called *wsadmin*, and the new scripting language used in the client, called *Jython*.

WebSphere Application Server's administration model is based on the Java Management Extensions (JMX) framework. JMX enables you to wrap hardware and software resources in Java and expose them in a distributed environment. WebSphere's administrative services provides functions that use the JMX interfaces to manipulate the application server configuration, which is stored in a XML based repository in the server's file system. Application Server provides the following tools that aid in administration of its configuration:

- ▶ WebSphere Administrative Console—A Web application.
- ▶ Command-line commands—These executable commands can be found in the `<was_install_root>/bin` folder and also in the `<was_profile_root>/bin` folder.
- ▶ wsadmin scripting client—A command-line interface. Scripts can be used to automate the administration of multiple application servers and nodes.
- ▶ Thin client—A lightweight runtime package that enables you to run the wsadmin tool or a standalone administrative Java program remotely.

Overview of wsadmin

The **wsadmin** tool is a scripting client that has a command-line interface. It is targeted towards advanced administrators. It provides extra flexibility that is available through the Web based administrative console and helps make the administration much quicker. It is primarily used to automate administrative activities that can consist of several administrative commands and need to be executed repetitively.

The **wsadmin** client uses the Bean Scripting Framework (BSF). The BSF allows using a variety of scripting languages. Prior to WebSphere Application Server V6, only one scripting language was supported, Java Command Language (Jacl). Application Server now supports two languages: Jacl and Jython (or jpython).

Jython is the strategic direction. New tools in WebSphere Application Server v7.0, RAD Assembly and Deployment (RAD-AD), and Rational Application Developer v7.5 are available to help create scripts using Jython. A Jacl-to-Jython migration tool is included with the Application Server.

There are five **wsadmin** objects that are available to use in the scripts:

- ▶ **AdminControl**— This object is used to run operational commands.
- ▶ **AdminConfig**—This object is used to create or modify Application Server configurational elements.
- ▶ **AdminApp**—This object is used to administer applications.
- ▶ **AdminTask**—This object is used to run administrative commands.
- ▶ **Help**—This object is used to obtain general help.

Overview of Jython

Jython is an implementation of the Python language. The **wsadmin** tool uses Jython V2.1. The J in Jython represents its Java-like syntax. But Jython is also quite different than Java or C++ syntax. Though like Java, Jython is a typed, case-sensitive, and object-oriented language, but unlike Java it is an indentation based language, which means that it does not have any mandatory statement termination characters (like a semi-colon in Java), and code blocks are specified by indentation. To begin a code block, you have to indent in, and to end a block, indent out. Statements that expect an indentation level end in a colon (:). Functions are declared with the **def** keyword, and comments start with a pound sign (#). Example 26-1 shows a Jython code snippet.

Example 26-1 Jython snippet

```
def listAllApps # This function lists all application
    apps = AdminApp.list()
    if len(apps) == 0:
        print "Inside if block - No enterprise applications"
    else:
        print "Inside the else block"
        appsList = apps.split(1Sep)
        for app in appsList:
            print app

# This is a comment - Main section starts here
1Sep = java.lang.System.getProperty('line.separator')
listAllApps # call the listAllApps function defined above
```

Structure of a Jython script

A Jython script usually consists of method definitions and a main section. The outline view of the Application Developer lists the methods of the script file for easy code navigation. The main section is at the end of the Jython script and consists of declaration of global variables, which can be used across all the methods. The main section then calls functions (Figure 26-25).

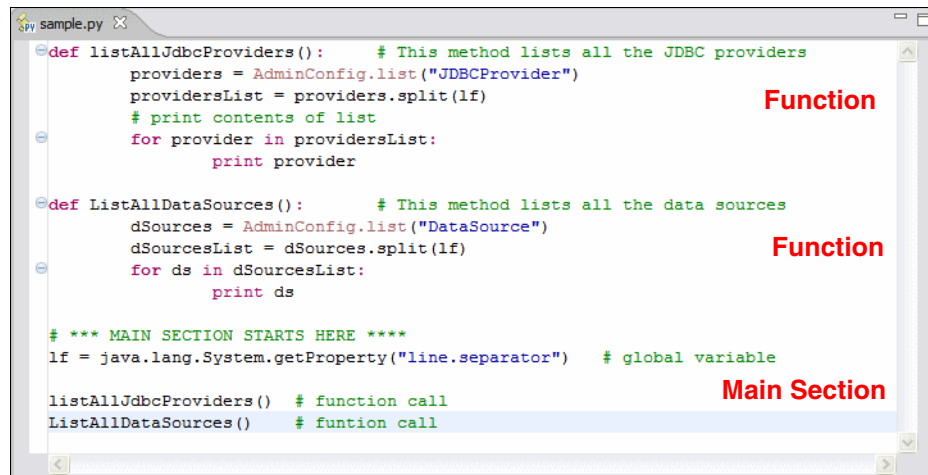

```

sample.py
def listAllJdbcProviders():      # This method lists all the JDBC providers
    providers = AdminConfig.list("JDBCProvider")
    providersList = providers.split(lf)
    # print contents of list
    for provider in providersList:
        print provider
Function

def ListAllDataSources():      # This method lists all the data sources
    dSources = AdminConfig.list("DataSource")
    dSourcesList = dSources.split(lf)
    for ds in dSourcesList:
        print ds
Function

# *** MAIN SECTION STARTS HERE ****
lf = java.lang.System.getProperty("line.separator") # global variable
listAllJdbcProviders() # function call
ListAllDataSources() # function call
Main Section

```

Figure 26-25 Structure of a Jython script

Developing a Jython script to deploy the ITSO Bank

In this section we follow a step by step process and complete a Jython script that deploys the RAD75EJBWebEAR and RAD75EJBEAR files as enterprise applications to a target v7.0 application server. Here are the steps that have to be executed:

- ▶ Create a JDBC provider.
- ▶ Create and configure a data source.
- ▶ Install the ITSO Bank Web application.
- ▶ Install the ITSO Bank EJB application.
- ▶ Start both applications.

Note: We also have a section on Jython in Chapter 22, “Servers and server configuration” in “Developing automation scripts” on page 810.

Preparation

In this section we create a Jython project and a Jython script in Application Developer:

- ▶ The RAD75EJBEAR.ear and RAD75EJBWebEAR.ear files are available in the C:\7672code\deployment folder (where you exported the files), or you can use the solution files from C:\7672code\jython.
- ▶ Create a Jython project in Application Developer. If you followed the instructions in Chapter 22, “Servers and server configuration” on page 777, you already have this project, otherwise you can create it as follows:
 - Click **File** → **New** → **Project** and the New Project wizard opens. Select **Jython** → **Jython Project** and click **Next**.
 - For the Project name, type **RAD75Jython** and click **Finish**.
- ▶ Create a Jython script to deploy the ITSO Bank application:
 - Select **File** → **New** → **Other** → **Jython** → **Jython Script File** and click **Next**.
 - In the Parent folder field, specify /RAD75Python, and for the File name, type **deployITSOBankApp.py**.
 - Click **Finish** to create the Jython script file.
- ▶ In the Servers view, decide which server to use for testing. You can use the test environment or the server profile you defined in Chapter 22, “Servers and server configuration” on page 777.

Main section of the script

Let us define our global variables first.

- ▶ Open the Jython script (if you closed it).
- ▶ Add the following four global variables:

```
global AdminConfig
global AdminControl
global AdminApp
global AdminTask
```

- ▶ Define a global variable for the deployment server node name and the deployment server:

```
nodeName = AdminControl.getNode()
srvrInfo=AdminConfig.list('Server')
srvr=AdminConfig.showAttribute(srvrInfo, 'name')
```

- ▶ Define a global variable for the name of the new JDBC provider, the data source, and the database:

```
jdbcProv = "ITSO Derby JDBC Provider (XA)"
```

```

dataSourceName = "RAD75JythonDS"
jndiDS = "jdbc/itsobank2"
dbasname="C:/7672code/database/derby/ITSOBANK"

```

- ▶ Define a global variable to store the name of the new connection factory (used for EJB container-managed persistence):

```
cfname = "RAD75JythonDS_CF"
```

- ▶ Define global variables to store the path of the EAR files and the enterprise application names:

```

webappEAR = "C:/7672code/jython/RAD75EJBWebEAR.ear"
ejbappEAR = "C:/7672code/jython/RAD75EJBEAR.ear"
webappEARName = "RAD75EJBWebEAR" # display name of the enterprise App
ejbappEARName = "RAD75EJBEAR" # display name of the enterprise App

```

- ▶ Create function calls for the six deployment steps:

```

createProvider()           # Step 1 - Create the JDBC provider
createDS()                 # Step 2 - Create the data source
installApp(webappEAR, webappEARName) # Step 3 - Install ITSO Bank Web App
installApp(ejbappEAR,ejbappEARName) # Step 4 - Install ITSO Bank EJB App
startApp(ejbappEARName)   # Step 5 - Start ITSO Bank EJB
startApp(webappEARName)   # Step 6 - Start ITSO Bank Web App

```

Next we define the six functions. Note that the function code goes before the main section.

Creating a JDBC provider

We create a function named **createProvider** for this purpose:

- ▶ This statement defines the function `createProvider`, which will encapsulate the code for creating a new JDBC provider:

```
def createProvider():
```

- ▶ This code snippet checks if the JDBC provider we want to create already exists, and if it does, then we simply return. Make sure that rest of the code for this method is indented:

```

prov = AdminControl.completeObjectName("name=" + jdbcProv +
    ",type=JDBCProvider,Server="+srvr + ",node="+nodeName + ",*")
if len(prov) > 0:
    return
#endif

```

- ▶ Define local variables for attributes required to create a new JDBC provider:

```

provName=['name',jdbcProv]
impClass=['implementationClassName',
    'org.apache.derby.jdbc.EmbeddedXADataSource']
jdbcAttrs=[]
jdbcAttrs.append(provName)

```

```
jdbcAttrs.append(impClass)
```

- ▶ We are using a template to create the JDBC provider:

```
tplName = 'Derby JDBC Provider (XA)'
templates =
    AdminConfig.listTemplates("JDBCProvider",tplName).split(lineSeparator)
tpl = templates[0]
serverId = AdminConfig.getid("/Node:" + nodeName + "/Server:" + srvr + "/")
```

- ▶ Create the JDBC provider using the template, save the configuration, and end:

```
AdminConfig.createUsingTemplate("JDBCProvider",serverId,jdbcAttrs,tpl)
AdminConfig.save()
#enddef
```

The complete code for this function is shown in Example 26-2.

Example 26-2 Create a JDBC provider using the template for Derby JDBC Provider (XA)

```
def createProvider():
    prov = AdminControl.completeObjectName("name="+jdbcProv + ",
        type=JDBCProvider,Server="+srvr + ",node="+nodeName + ",*")
    if len(prov) > 0:
        return
    #endif

    provName=['name',jdbcProv]
    impClass=['implementationClassName',
              'org.apache.derby.jdbc.EmbeddedXADataSource']

    jdbcAttrs=[]
    jdbcAttrs.append(provName)
    jdbcAttrs.append(impClass)
    tplName = 'Derby JDBC Provider (XA)'
    templates = AdminConfig.listTemplates("JDBCProvider", tplName)
                                .split(lineSeparator)

    tpl = templates[0]
    serverId = AdminConfig.getid("/Node:" + nodeName + "/Server:" + srvr + "/")
    AdminConfig.createUsingTemplate("JDBCProvider",serverId,jdbcAttrs,tpl)
    AdminConfig.save()
#enddef
```

Creating a data source

We create a function named **createDS** for this purpose:

```
def createDS():
```

- ▶ The following code snippet checks if the data source we want to create already exists, and if it does, then we simply return. Once again, make sure that rest of the code for this method is indented:

```

dsId = AdminConfig.getid("/JDBCProvider:"+jdbcProv + "/DataSource:"+
    dataSourceName + "/")
if len(dsId) > 0:
    return
#endif

```

- ▶ Define local variables for attributes required to create a data source:

```

dsname=['name',dataSourceName]
jndiName=['jndiName',jndiDS]
description=['description','ITS0Bank Data Source']
dsHelperClassname=['datasourceHelperClassname',
    'com.ibm.websphere.rsadapter.DerbyDataStoreHelper']
dsAttrs=[]
dsAttrs.append(dsname)
dsAttrs.append(jndiName)
dsAttrs.append(description)
dsAttrs.append(dsHelperClassname)
provId = AdminConfig.getid("/Node:"+nodeName + "/Server:"+srvr +
    "/JDBCProvider:"+jdbcProv + "/")

```

- ▶ Create the data source and save the configuration:

```

AdminConfig.create('DataSource',provId,dsAttrs)
AdminConfig.save()

```

- ▶ We have to configure the data source and add resource property set attributes, such as database name, password, description, and login timeout. Because this piece of code is more than a few lines, we put the code into a separate function. Let us define a function call:

```

modifyDS()

```

- ▶ The last step is to enable the use of this data source in container-managed persistence. We use a separate method as well:

```

useDSinCMP()

```

- ▶ The code for this function is shown in Example 26-3.

Example 26-3 Create a data source

```

def createDS():
    dsId = AdminConfig.getid("/JDBCProvider:"+jdbcProv + "/DataSource:"+
        dataSourceName + "/")
    if len(dsId) > 0:
        return
    #endif
    dsname=['name',dataSourceName]
    jndiName=['jndiName',jndiDS]
    description=['description','ITS0Bank Data Source']
    dsHelperClassname=['datasourceHelperClassname',
        'com.ibm.websphere.rsadapter.DerbyDataStoreHelper']

```

```

dsAttrs=[]
dsAttrs.append(dsname)
dsAttrs.append(jndiName)
dsAttrs.append(description)
dsAttrs.append(dsHelperClassname)
provId = AdminConfig.getid("/Node:"+nodeName + "/Server:"+srvr +
    "/JDBCProvider:"+jdbcProv + "/")
    AdminConfig.create('DataSource',provId,dsAttrs)
AdminConfig.save()
modifyDS() # modify DS to add the poperties (databaseName)
useDSinCMP() # enable this DS in Container Managed Persistence (CMP)
#enddef

```

Modify the data source with properties

Even though we have already written the code to create the data source, we still have to add a resource property set with attributes such as the database name, password, description, and login time out. The code in Example 26-4 is the complete code for the **modifyDS** function.

Example 26-4 Add resource property set to the data source

```

def modifyDS() :
    dsId = AdminConfig.getid("/JDBCProvider:"+jdbcProv + "/DataSource:"+
        dataSourceName + "/")
    dbnameAttrs = [{"name", "databaseName"}, {"value", dbname}, {"type",
        "java.lang.String"}, {"description", "This is a required property"}]
    descrAttrs = [{"name", "description"}, {"value", ""}, {"type",
        "java.lang.String"}]
    passwordAttrs = [{"name", "password"}, {"value", ""}, {"type",
        "java.lang.String"}]
    loginTimeOutAttrs = [{"name", "loginTimeout"}, {"value", 0}, {"type",
        "java.lang.Integer"}]

    propset = []
    propset.append(dbnameAttrs)
    propset.append(descrAttrs)
    propset.append(passwordAttrs)
    propset.append(loginTimeOutAttrs)
    pSet = ["propertySet", [{"resourceProperties", propset}]]
    attrs = [pSet]
    AdminConfig.modify(dsId, attrs)
    AdminConfig.save()
#enddef

```

Use the data source in container-managed persistence (CMP)

We have to configure this data source for use in container-managed persistence of entity EJBs. This is quite a simple and easy thing to do when using the administration console (Figure 26-26), but when using a script, this is a multiple step process. Note that for EJB 3.0 and JPA we do not have to do this.

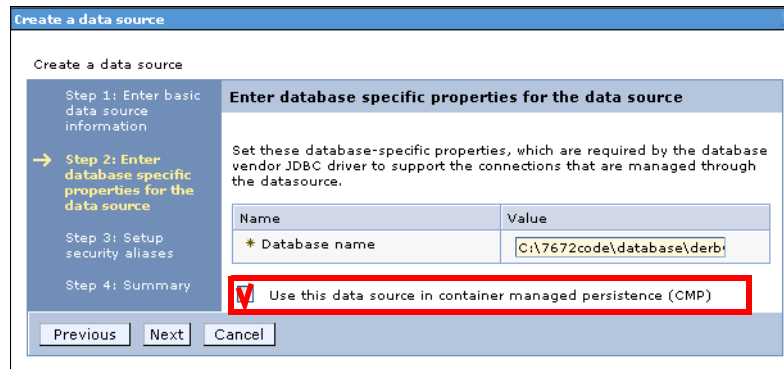

Figure 26-26 Enabling a data source to be used in CMP

The code in Example 26-5 is the complete code for the `useDSinCMP` function.

Example 26-5 Enable the data source for container-managed persistence

```
def useDSinCMP():
    dsId = AdminConfig.getid("/JDBCProvider:"+jdbcProv +
        "/DataSource:"+dataSourceName + "/")
    rra = AdminConfig.getid("/Node:"+nodeName+"/Server:"+srvr
        +"/J2CResourceAdapter:WebSphere Relational Resource Adapter/")
    nameAttr = ["name", cfname]
    authmechAttr = ["authMechanismPreference", "BASIC_PASSWORD"]
    cmpdsAttr = ["cmpDatasource", dsId]
    attrs = []
    attrs.append(nameAttr)
    attrs.append(authmechAttr)
    attrs.append(cmpdsAttr)
    newcf = AdminConfig.create("CMPConnectorFactory", rra, attrs)
    AdminConfig.save()
    # Modify the CMPConnectionFactory to add the Mapping attributes
    mapAuthAttr = ["authDataAlias", ""]
    mapConfigAliasAttr = ["mappingConfigAlias", ""]
    mapAttrs = []
    mapAttrs.append(mapAuthAttr)
    mapAttrs.append(mapConfigAliasAttr)
    mappingAttr = ["mapping", mapAttrs]
    attrs2 = []
    attrs2.append(mappingAttr)
```



```

    cfId = AdminConfig.getid("/CMPConnectorFactory:"+cfname+"/")
    AdminConfig.modify(cfId, attrs2)
    AdminConfig.save()
    AdminConfig.modify(dsId, attrs2)
    AdminConfig.save()
#enddef

```

Install the enterprise applications

We are at the point where we have written the code required to create a JDBC provider and a data source for the ITSO Bank applications. Therefore, we are ready to start installing the EAR files. The best practice is to create a generic method that encapsulates the code to install any EAR file when provided with the location of the EAR file and the display name of the application.

The code in Example 26-6 is the complete code for the **installApp** function.

Example 26-6 Install or update an enterprise application

```

def installApp(appEAR, appName):
    try:
        app = AdminApp.view(appName)
    except:
        options = "-appname " + appName
        AdminApp.install(appEAR, options)
        AdminConfig.save()
    else:
        if app > 1:
            options = "-operation update -contents " + appEAR
            contentType = 'app'
            AdminApp.update(appName, contentType, options)
            AdminConfig.save()
#enddef

```

In the main section we had already defined variables that contain the complete path of the EAR files and also their display names. Therefore, we can use these variables as parameters and use the `installApp` function to install the RAD75EJBEAR and RAD75EJBWebEAR applications:

```

installApp(webappEAR, webappEARName)
installApp(ejbappEAR, ejbappEARName)

```

Start the enterprise applications

After installing the applications, we have to start both enterprise applications. Again, it makes sense to create a generic function that can start any enterprise application when provided with the display name of that application.

The code in Example 26-7 is the complete code for the **startApp** function.

Example 26-7 Start an enterprise application

```
def startApp(appName):
    app = AdminControl.completeObjectName
        ("type=Application,name="+appName+",*")
    if len(app) > 1:
        return

    appMgr = AdminControl.queryNames
        ("node="+nodeName+",type=ApplicationManager,process="+srvr+",*")

    AdminControl.invoke(appMgr, 'startApplication', appName)
#enddef
```

Once again, we can use the global variables that contain the display name of both applications and pass them as parameters to the startApp function:

```
startApp(ejbappEARName)
startApp(webappEARName)
```

Tip: The complete code of the **deployITSOBankApp.py** Jython script is available in the sample code:

```
C:\7672code\jython\deployITSOBankApp.py
```

Import this file into the RAD75Jython project (or copy/paste from Windows Explorer into Application Developer. In addition to the logic discussed above, the script has many comments and produces test output to the console (print statements) so that the execution can be followed.

Executing the Jython script

We plan to execute the Jython script against the application server that is already configured in Application Developer.

Note that we used a JNDI name of **jdbc/itsobank2** for the new data source, so that we do not have a conflict with an existing data source in the server.

To execute the Jython script, do these steps:

- ▶ Make sure that the target server is started.
- ▶ Right-click **deployITSOBankApp.py** and select **Run As** → **Administrative Script**.

- ▶ In the Modify attributes and launch dialog:
 - Select **WebSphere Application Server V7.0** for the Scripting runtime.
 - Select the WebSphere profile (**was70profile1**, or **AppSrv01**).
 - Specify user ID and password if the server runs with security enabled.
 - Click **Run** to execute the Jython script (Figure 26-27).

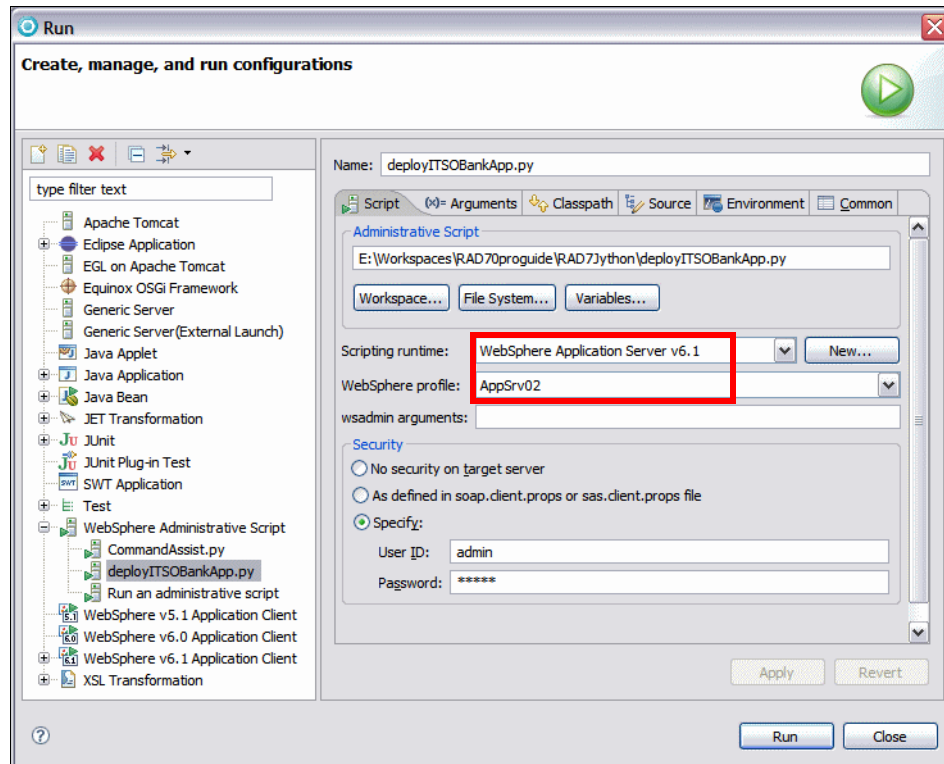

Figure 26-27 Select the runtime and the WebSphere profile

The console view shows the result of the execution (Example 26-8).

Example 26-8 Output of the Jython script

```
WASX7209I: Connected to process "server1" on node UELIT60Node02 using SOAP
connector; The type of process is: UnManagedProcess
```

```
***** STEP 1 completed - The ITSO Derby JDBC Provider (XA) has been created
Done creating the DS. Config saved ..
Done modifying the DS. Config Saved ..
```

```
***** STEP 2 completed - Done creating the DS. Config saved ..
```

```
***** App not found: RAD75EJBWebEAR. Installing it now

ADMA5016I: Installation of RAD75EJBWebEAR started.
ADMA5058I: Application and module versions are validated with versions of
          deployment targets.
ADMA5005I: The application RAD75EJBWebEAR is configured in the WebSphere
          Application Server repository.
ADMA5053I: The library references for the installed optional package are
          created.
ADMA5005I: The application RAD75EJBWebEAR is configured in the WebSphere....
ADMA5001I: The application binaries are saved in C:\<WAS_HOME>\profiles
          \AppSrv02\wstemp\Script1144d386b1d\workspace\cells\<cell>
          \applications\RAD75EJBWebEAR.ear\RAD75EJBWebEAR.ear
ADMA5005I: The application RAD75EJBWebEAR is configured in the WebSphere ...
SECJ0400I: Successfully updated the application RAD75EJBWebEAR with the
          appContextIDForSecurity information.
ADMA5011I: The cleanup of the temp directory for application RAD75EJBWebEAR is
          complete.
ADMA5013I: Application RAD75EJBWebEAR installed successfully.

***** Done installing App: RAD75EJBWebEAR. Config saved ..
***** App not found: RAD75EJBEAR. Installing it now

ADMA5016I: Installation of RAD75EJBEAR started.
.....
ADMA5013I: Application RAD75EJBEAR installed successfully.

***** Done installing App: RAD75EJBEAR. Config saved ..

***** The startApplication operation for RAD75EJBEAR completed.

***** The startApplication operation for RAD75EJBWebEAR completed.
```

Verifying the application after automatic installation

You can find the ITSO Derby JDBC Provider (XA) and the RAD75Jython data source using the Administrative Console.

To verify that the ITSO Bank sample is deployed and working properly, follow the instructions in “Verifying the application after manual installation” on page 966.

The verification concludes this chapter, as we have successfully deployed our enterprise applications, both manually by using the WebSphere Administrative Console, and also by using the Jython scripting with the Jython tooling provided by Application Developer v7.5.

Generation Jython source code for wsadmin commands

WebSphere Application Server provides a WebSphere Administration Command assist tool that can be used to generate the Jython source code for administrative activities. For further information and an example of using this tool, refer to “Generating WebSphere admin commands for Jython scripts” on page 813.

More information

For more information on application deployment, refer to these resources:

- ▶ WebSphere Application Server v7.0 Information Center:
http://publib.boulder.ibm.com/infocenter/wasinfo/v6r1/index.jsp?topic=/com.ibm.websphere.base.doc/info/welcome_base.html
- ▶ Understand WebSphere Extended Deployment:
<http://www.ibm.com/developerworks/autonomic/library/ac-webxd/>
- ▶ Learn how to publish an enterprise application with WebSphere Application Server and Application Server Toolkit, v6.1:
<http://www.ibm.com/developerworks/edu/wes-dw-wes-hellowas.html>



Profile applications

Profiling is a technique used by developers to collect runtime data and detect application problems such as memory leaks, performance bottlenecks, excessive object creation, and exceeding system resource limits during the development phase.

This chapter introduces the features, architecture, and process for profiling applications using the profiling features of IBM Rational Application Developer v7.5. We have included an example for basic memory analysis, execution time analysis, and method code coverage analysis.

The chapter is organized into the following sections:

- ▶ Introduction to profiling
- ▶ Preparing for the profiling sample
- ▶ Profiling a Java application
- ▶ Profiling a Web application running on the server

Introduction to profiling

Traditionally, performance analysis is performed once an application is getting close to deployment or after it has already been deployed. The profiling tools included with Application Developer allow the developer to move the performance analysis to a much earlier phase in the development cycle, thus providing more time for changes to the application that might effect the architecture of the application before they become critical production environment issues.

The types of problems that Application Developer profiling tooling can assist in detecting include:

- ▶ Memory usage problems
- ▶ Performance bottlenecks
- ▶ Excessive object creation
- ▶ System resource limits

The profiling tools can be used to gather data on applications that are running:

- ▶ Inside an application server, such as WebSphere Application Server
- ▶ As a standalone Java application
- ▶ On the same system as Application Developer
- ▶ On a remote WebSphere Application Server with the IBM Rational Agent Controller installed
- ▶ In multiple JVMs

Profiling features

Within Application Developer, there are several analysis types. Each analysis type includes associated views that provides the user with the ability to concentrate on particular types of analysis such as memory leaks, performance bottlenecks, and excessive object creation while profiling an application.

The following analysis types and their associated views are described in this section:

- ▶ Basic memory analysis
- ▶ Execution time analysis
- ▶ Method code coverage analysis
- ▶ Probekit analysis

Basic memory analysis

Basic memory analysis displays statistics about the application heap. It is used to detect memory management problems. Memory analysis can help developers identify memory leaks as well as excessive object allocation that might cause performance problems. Basic memory analysis has been enhanced with the views described in Table 27-1.

Table 27-1 Basic memory analysis views

View name	Description
Memory statistics	Displays statistics about the application heap. It provides detailed information such as the number of classes loaded, the number of instances that are alive, and the memory size allocated by every class.
Object references	Displays references by a set of objects. This is useful to study data structures, to find memory leaks, and to find unexpected references.

Execution time analysis

Execution time analysis is used to detect performance problems by highlighting the most time intensive areas in the code. This type of analysis helps developers identify and remove unused or inefficient coding algorithms. Execution time analysis has been enhanced with the views described in Table 27-2.

Table 27-2 Execution time analysis views

View name	Description
Execution statistics	Displays statistics about the application execution time.
Call tree	Displays information about method calls during the profiling session in a form that lets easily identify a hot spot. It consists of two parts , the execution flow call tree and call stack view.
Method invocation	Displays a graphical representation of the entire course of a program's execution and also provides the ability to navigate through the methods that invoked the selected method.
Method invocation details	Displays statistical data on a selected method.
Object references	Displays references by a set of objects. This is useful to study data structures, to find memory leaks, and to find unexpected references.
UML2 trace interactions	Displays execution flow of an application according to the notation defined by UML.

Method code coverage analysis

Method code coverage analysis is used to detect areas of code that have not been executed in a particular scenario that is tested. This capability is a useful analysis tool to integrate with component test scenarios and can be used to assist in identifying test cases that might be missing from a particular test suite or code that is redundant. Method code coverage analysis has been enhanced with the view described in Table 27-3.

Table 27-3 Method code coverage view

View name	Description
Coverage statistics	Displays usage statistics for a selected type of object.

Probekit analysis

Probes are reusable Java code fragments that you write to collect detailed runtime data about a program's objects, instance variables, arguments, and exceptions. *Probekit* provides a framework on the Eclipse platform to help you create and use probes. One common use of Probekit is to create lightweight profilers that collect only the data developers are interested in.

A probekit file can contain one or more probes, with each containing one or more probe fragments. These probes can be specified when to be executed or on which program they will be used. The probe fragments are a set of Java methods that are merged with standard boilerplate code with a new Java class generated and compiled. The functions generated from the probe fragments appear as static methods of the generated probe class.

The probekit engine—also called the byte-code instrumentation (BCI) engine—is used to apply probe fragments by inserting the calls into the target programs. The insertion process of the call statements into the target methods is referred to as *instrumentation*. The data items requested by a probe fragment are passed as arguments (for example, method name and arguments). The benefit of this approach is that the probe can be inserted into a large number of methods with small overhead.

Probe fragments can be executed at the following points:

- ▶ At method entry or exit time
- ▶ At exception handler time
- ▶ Before the original code in the class static initializer
- ▶ Before every executable code when source code is available
- ▶ When specific methods are called, not inside the called method

Each of the probe fragments can access the following data:

- ▶ Package, class, and method name
- ▶ Method signature
- ▶ this object
- ▶ Arguments
- ▶ Return value

There are two major types of probes available to the user (Table 27-4).

Table 27-4 Types of probes available with Probekit

Type of probe	Description
Method probe	Probe can be inserted anywhere within the body of a method with the class or jar files containing the target methods instrumented by the BCI engine.
Callsite probe	Probe is inserted into the body of the method that calls the target method. The class or jar files that call the target instrumented by the BCI engine.

Profiling architecture

The profiling architecture that exists in Application Developer is based on the Eclipse Test & Performance Tools Platform (TPTP) project. More detailed information on the Eclipse TPTP project can be found at:

<http://www.eclipse.org/tptp/>

In the past TPTP workbench users required the services of the standalone Agent Controller before they could use the function in the Profiling and Logging perspective and in the Test perspective. Even when the user tried to profile a Java application locally or to run TPTP tests locally, the Agent Controller would have to be installed on the local machine.

The *Integrated Agent Controller* is a new feature in the TPTP workbench, which allows users to profile a Java application locally and to run a TPTP test locally without requiring the standalone Agent Controller on the local machine. Profiling on a remote machine or running a TPTP test on a remote machine still requires the Agent Controller on that remote machine.

This feature is packaged in the TPTP runtime install image and therefore no separate install step is required. The Integrated Agent Controller does not require any configuration at all. Unlike the Agent Controller, which requires the user to enter information, such as the path for the Java executable, the Integrated Agent Controller determines the required information from the Eclipse workbench during startup.

TPTP provides the Agent Controller daemon with a process for enabling client applications to launch host processes and interact with agents that exist within host processes. Figure 27-1 shows the profiling architecture.

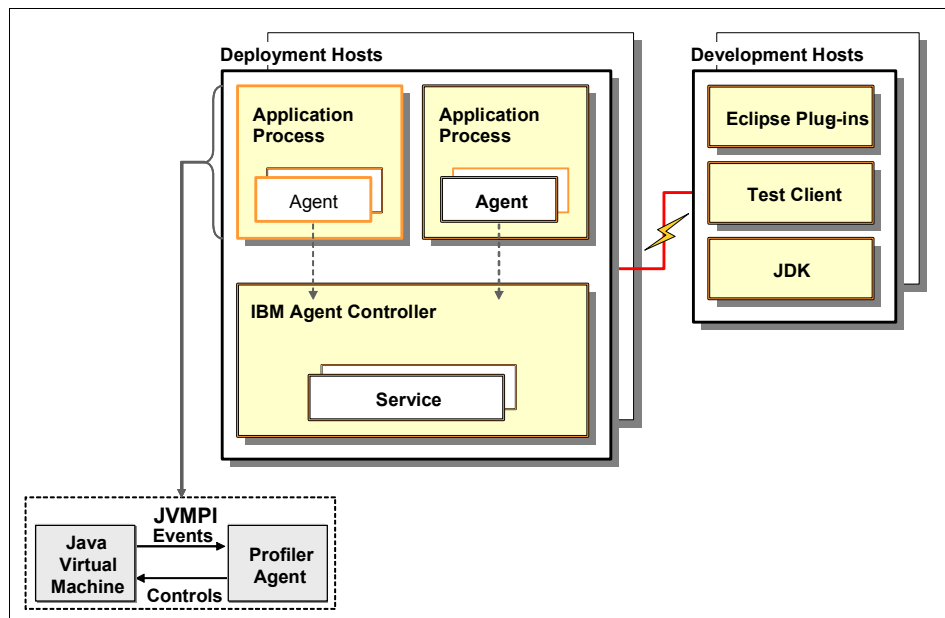

Figure 27-1 Profiling architecture of IBM Rational Application Developer V7.0

The definitions for the profiling architecture are as follows:

- ▶ **Application process:** The process that is executing the application consisting of the Java Virtual Machine (JVM) and the profiling agent.
- ▶ **Agent:** The profiling component installed with the application that provides services to the host process, and more importantly, provides a portal by which application data can be forwarded to attached clients.
- ▶ **Test Client:** A local or remote application that is the destination of host process data that is externalized by an agent. A single client can be attached to many agents at once, but does not always have to be attached to an agent.
- ▶ **Agent Controller:** A daemon process that resides on each deployment host providing the mechanism by which client applications can either launch new host processes, or attach to agents coexisting within existing host processes. The Agent Controller can only interact with host processes on the same node. Application Developer comes with an *integrated agent controller*, therefore, a separate install of the agent controller is not required.
- ▶ **Deployment hosts:** The host that an application has been deployed to and is being monitored for the capture of profiling agent.

- ▶ **Development hosts:** The host that runs an Eclipse-compatible architecture such as Application Developer to receive profiling information and data for analysis.

Each application process shown in Figure 27-1 represents a JVM that is executing a Java application that is being profiled. A profile agent will be attached to each application to collect the appropriate runtime data for a particular type of profiling analysis. This profiling agent is based on the Java Virtual Machine Profiler Interface (JVMPi) architecture. More details on the JVMPi specification can be found at:

<http://java.sun.com/j2se/1.4.2/docs/guide/jvmpi>

The data collected by the agent is then sent to the Agent Controller, which then forwards this information to Application Developer for analysis and visualization.

There are two types of profiling agents available in Application Developer:

- ▶ **Java Profiling Agent:** This agent is based on the JVMPi architecture and is shown in Figure 27-1. This agent is used for the collection of both standalone Java applications as well as applications running on an application server.
- ▶ **J2EE Request Profiling Agent:** This agent resides in an application server process and collects runtime data for J2EE applications by intercepting requests to the EJB or Web containers.

Note: There is only one instance of the J2EE Request Profiling agent that is active in a process that hosts WebSphere Application Server.

Profiling and Logging perspective

The Profiling and Logging perspective can be accessed by selecting **Window** → **Open Perspective** → **Other** → **Profiling and Logging** and then clicking **OK**. If it is not listed, click **Show all**.

If Profiling and Logging is not enabled in the workspace, you are prompted to enable this capability. Click **OK**.

There are many supporting views for the Profiling and Logging perspective. To see the supporting views select **Window** → **Show View** → **Other** under Profiling and Logging (Figure 27-2):

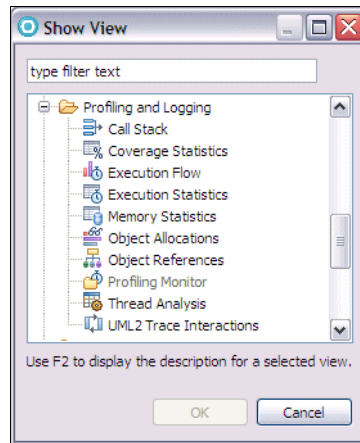

Figure 27-2 Profiling and Logging views

Preparing for the profiling sample

This section describes the tasks that have to be completed prior to profiling the sample Web application. We use the Web application developed in Chapter 14, “Develop EJB applications” on page 387, as our sample application for profiling.

Complete the following tasks in preparation for the profiling sample:

- ▶ Prerequisite software installation
- ▶ Enabling the Profiling and Logging capability

Prerequisite software installation

The working example requires the following software be installed:

- ▶ IBM Rational Application Developer v7.5
- ▶ Integrated Agent Controller

This feature is packaged in the Application Developer install image and therefore no separate install step is required.

Enabling the Profiling and Logging capability

To enable the Profiling and Logging capability in the preferences, do these steps:

- ▶ Select **Window** → **Preferences**.
- ▶ In the Preferences dialog expand **General** → **Capabilities** and click **Advanced** (Figure 27-3).

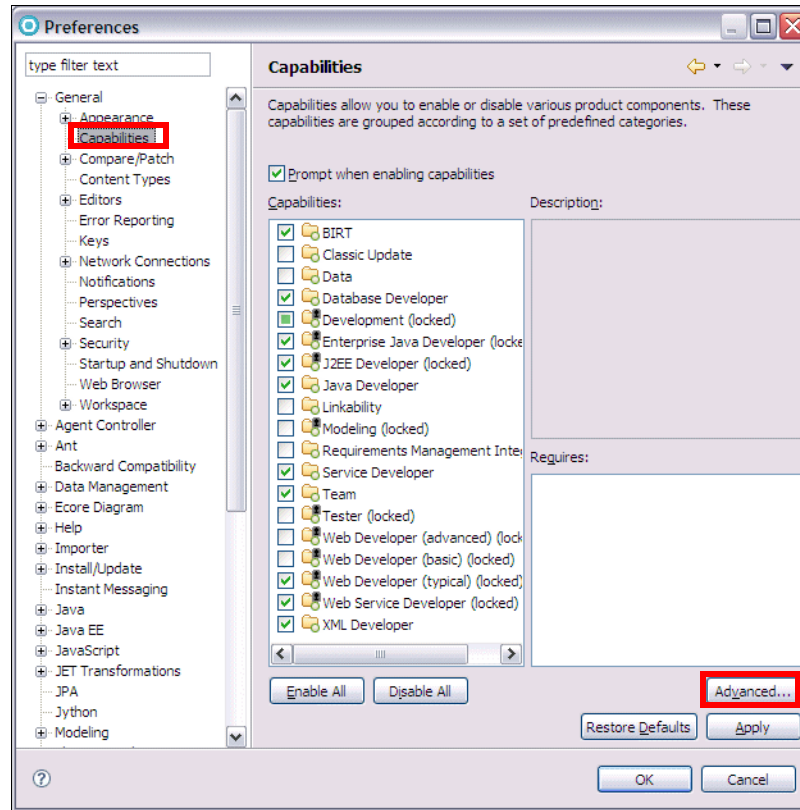

Figure 27-3 Enable Profiling and Logging capability (1)

- In the Advanced dialog expand **Tester**, and select **Profiling and Logging** (Figure 27-4) and click **OK**.

Note: If you want to use the Probekit, you have to enable this capability by selecting **Probekit** (Figure 27-4).

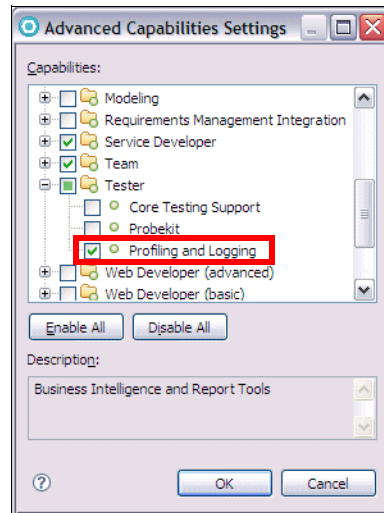

Figure 27-4 Enable Profiling and Logging capability (2)

Profiling a Java application

In this section we profile a Java application. We import the sample code and run the application in profiling mode.

Importing the sample project interchange file

Tip: If you have the sample JPA application (RAD75JPA and RAD75JPATest projects) already in the workspace, skip this step.

To import the JPA application project interchange file, do these steps:

- ▶ Open the Java EE perspective.
- ▶ Select **File** → **Import**.
- ▶ In the Import dialog, select **Project Interchange** and click **Next**.
- ▶ In the Import Projects dialog, click **Browse** and locate the file:
c:\7672code\zInterchange\jpa\RAD75JPA.zip
- ▶ Select the **RAD75JPA** and **RAD75JPATest** projects, and click **Finish**.

Alternatively you can run the Java application (BankClient) in the RAD75Java project in profiling mode.

Important: If you do not already configured the data source settings for the ITSOBANK database, follow the steps in “Configuring the data source for the ITSOBANK” on page 413 before publishing and running the sample application.

Creating a profiling configuration

We use the **EntityTester** class (in `RAD75JPATest\itso.bank.entities.test`) as sample application. Refer to “Testing JPA entities” on page 295 for a description of the `EntityTester` class.

- ▶ Right-click **EntityTester** and select **Profile As** → **Profile Configurations**.
- ▶ In the Profile Configurations dialog, double-click **Java Application**, and an entry named **EntityTester** is added and opened.
- ▶ In the **Arguments** tab, type **333-33-3333** as Program arguments, and **-javaagent:<RAD_HOME>/runtimes/base_v7/plugins/com.ibm.ws.jpa.jar** as VM arguments (Figure 27-5).

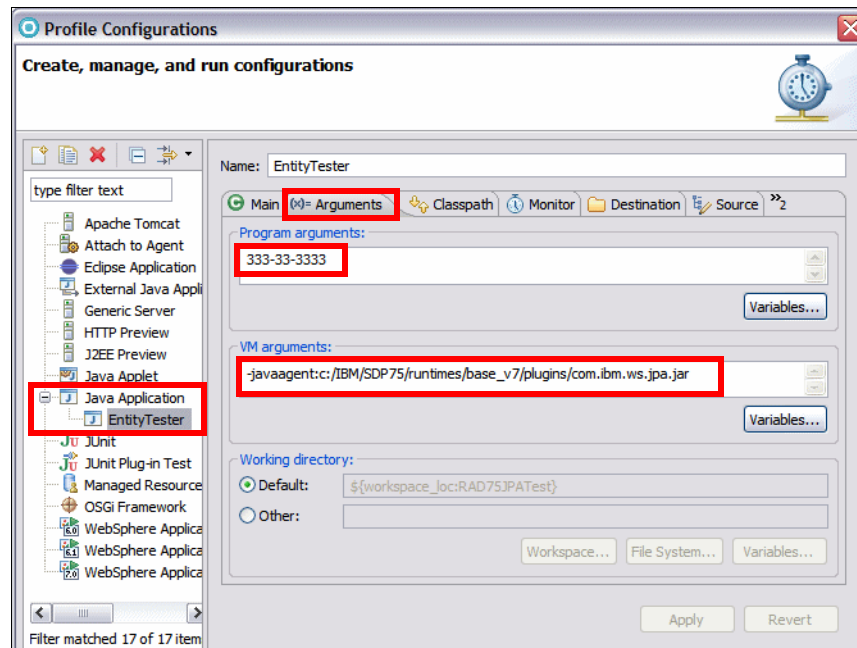

Figure 27-5 Profile Configuration: Arguments

- ▶ In the **Monitor** tab, select **Execution Time Analysis** (Figure 27-6). Note that you can only select one of the four options.

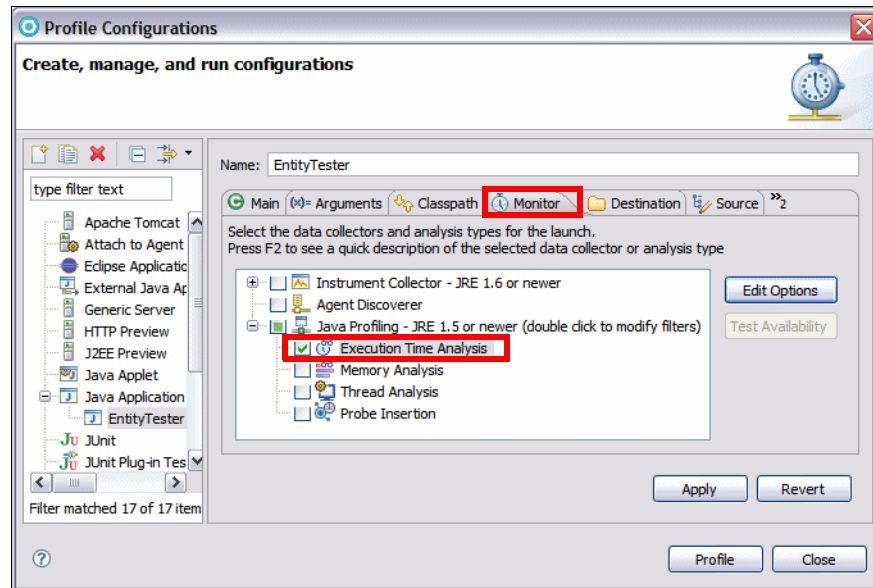

Figure 27-6 Profile Configuration: Monitor

Note: You can only select one analysis type. Refer to the technote:

<http://www-01.ibm.com/support/docview.wss?uid=swg21328379>

- ▶ Click **Edit Options**, and in the Edit Profiling Options dialog, select **Collect method CPU time information**, and click **Finish** (Figure 27-7).

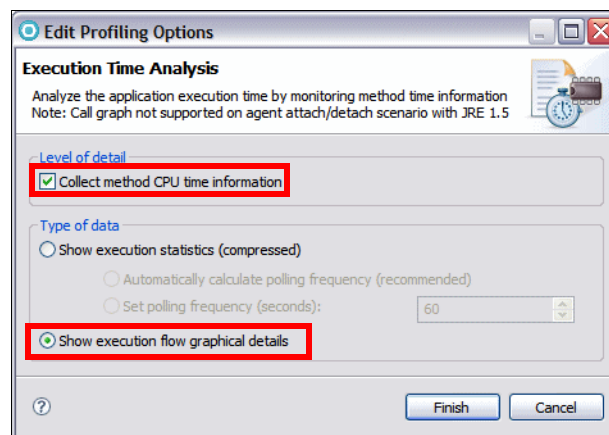

Figure 27-7 Profiling options for execution time analysis

- ▶ Click **Apply** to save the configuration.

Running the EntityTester application

To run the application, click **Profile**.

- ▶ When prompted, click **Yes** to switch to the Profiling and Logging perspective.
- ▶ In the Profiling Monitor view you can see that Execution Time is being measured.
- ▶ In the Console view you can see that program running through its parts and displaying the output (Figure 27-8).

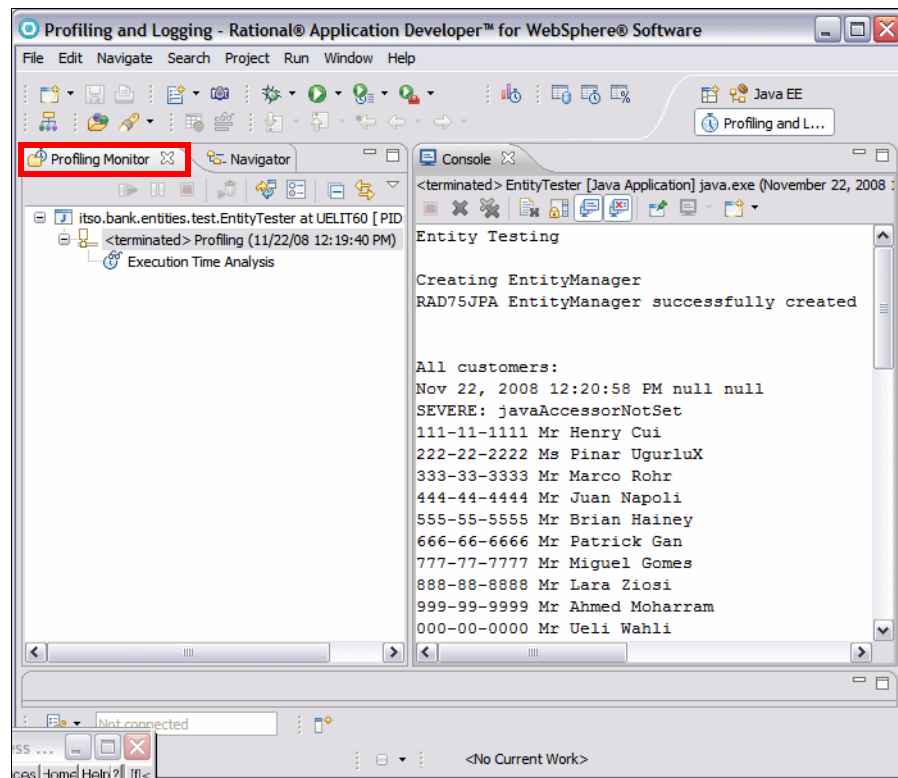

Figure 27-8 EntityTester run in profiling mode

Analyzing profiling data

We have now run the sample application that we want to collect data for. In this section, we analyze the collected data for execution statistics.

To display the collected data, we use the toolbar icons (Figure 27-9). Alternatively, you can right-click the process and select **Open With** → statistic:

- ▶ Open Execution Flow
- ▶ Open Memory Statistics
- ▶ Open Execution Statistics
- ▶ Open Coverage Statistics
- ▶ Open Object References



Figure 27-9 Profiling statistics icons

Execution statistics

The Execution Statistics view displays statistics about the application execution time. It provides data such as the number of methods called, and the amount of time taken to execute every method. Execution statistics are available at the package, class, method and instance level.

To analyze the execution statistics, in the Profiling Monitor view, double-click **Execution Time Analysis**, or click the  icon, or right-click the entry and select **Open With** → **Execution Statistics**.

- ▶ The **Session summary** and the **Execution Statistics** tab show the same data, using different filters. On the **Execution Statistics** tab you can set the filter, for example, **No filter** (our selection), **Highest 10 base time** (which is the filter for the Session summary), **Highest 10 cumulative time**, and so forth (Figure 27-10).

>Package	Base Time (sec...)	Average Base ...	Cumulative Tim...	Calls
itso.bank.entities	2.009680	0.002230	2.009680	901
itso.bank.entities.test	16.957411	16.957411	18.967091	1

Figure 27-10 Execution time Statistics: Summary

- ▶ Expand the packages and classes to see the accumulated values per class or per method (Figure 27-11).

Notice the icons  to switch to package, class, method, and instance views, to open the source, to display data as percentages, and to add delta columns.

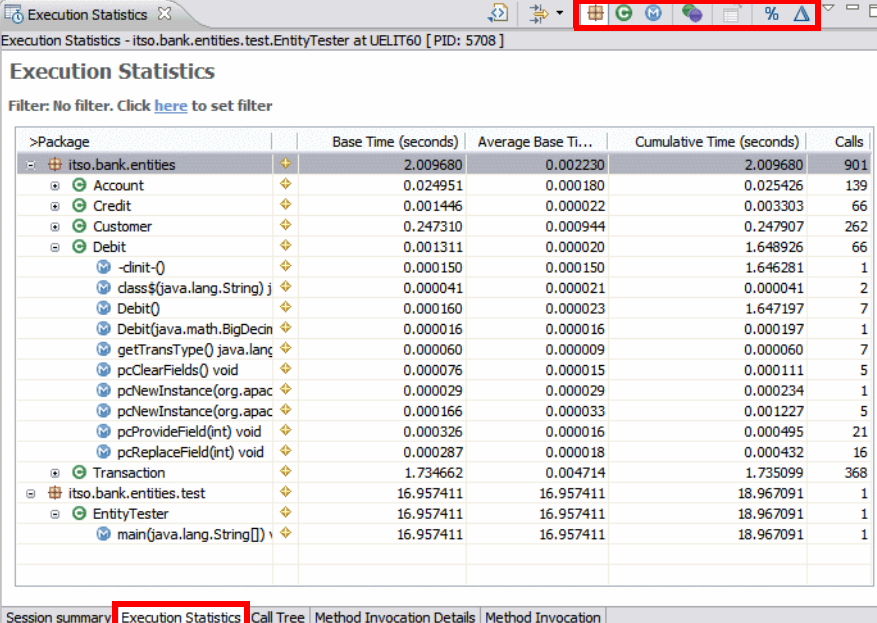

>Package	Base Time (seconds)	Average Base Ti...	Cumulative Time (seconds)	Calls
itso.bank.entities	2.009680	0.002230	2.009680	901
Account	0.024951	0.000180	0.025426	139
Credit	0.001446	0.000022	0.003303	66
Customer	0.247310	0.000944	0.247907	262
Debit	0.001311	0.000020	1.648926	66
-dinit-()	0.000150	0.000150	1.646281	1
class\$(java.lang.String) ;	0.000041	0.000021	0.000041	2
Debit()	0.000160	0.000023	1.647197	7
Debit(java.math.BigDecimal)	0.000016	0.000016	0.000197	1
getTransType() java.lang	0.000060	0.000009	0.000060	7
pcClearFields() void	0.000076	0.000015	0.000111	5
pcNewInstance(org.apac	0.000029	0.000029	0.000234	1
pcNewInstance(org.apac	0.000166	0.000033	0.001227	5
pcProvideField(int) void	0.000326	0.000016	0.000495	21
pcReplaceField(int) void	0.000287	0.000018	0.000432	16
Transaction	1.734662	0.004714	1.735099	368
itso.bank.entities.test	16.957411	16.957411	18.967091	1
EntityTester	16.957411	16.957411	18.967091	1
main(java.lang.String[])	16.957411	16.957411	18.967091	1

Figure 27-11 Execution Time Statistics: Expanded

- ▶ For each object type, the following statistics are displayed:
 - **Base Time:** The time taken to execute the invocation (excluding time spent in called methods).
 - **Average Base Time:** The base time divided by the number of calls.
 - **Cumulative Time:** The time taken to execute the invocation (including time spent in called method).
 - **Calls:** The number of calls made to the package, class, or method.

Note: The JPA entity classes include a number of generated methods with the **pc** prefix that are generated for database access.

Call Tree

Select the **Call Tree** tab. Expand **main** → **main** → **processTransaction** → **Credit** to analyze the call tree and the percent of time spent in each method of the tree (Figure 27-12).

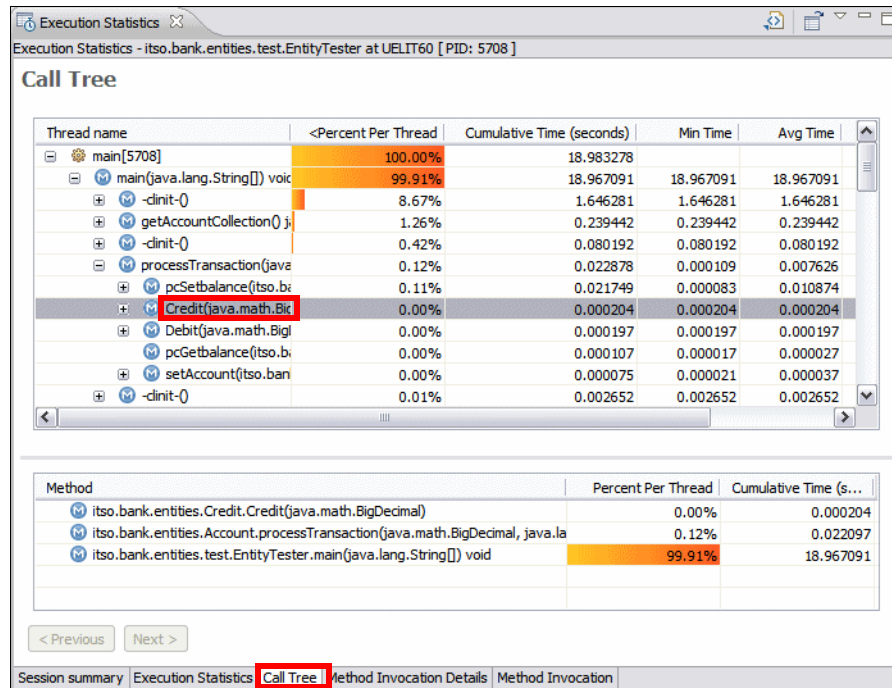

Figure 27-12 Execution Time Analysis: Call Tree

Method invocation details

Expand **Account** to see the methods of the Account class. Select **processTransaction** and select **Method Invocation Details** (Figure 27-13).

The Method Invocation Details view provides statistical data on a selected method. The following data is displayed for the selected method:

- ▶ **Selected method** (Account.processTransaction): Shows details including the number of times the selected method is called, the class and package information, and the time taken by this method.
- ▶ **Selected method invoked by:** Shows details of each method that calls the selected method, including the number of calls to the selected method, and the number of times the selected method is invoked by the caller. In our case, the main method invokes the processTransaction method.
- ▶ **Selected method invokes:** Shows details of each method invoked by the selected method, for example, Credit and Debit constructors, setAccount of the Transaction class, and internal JPA methods.

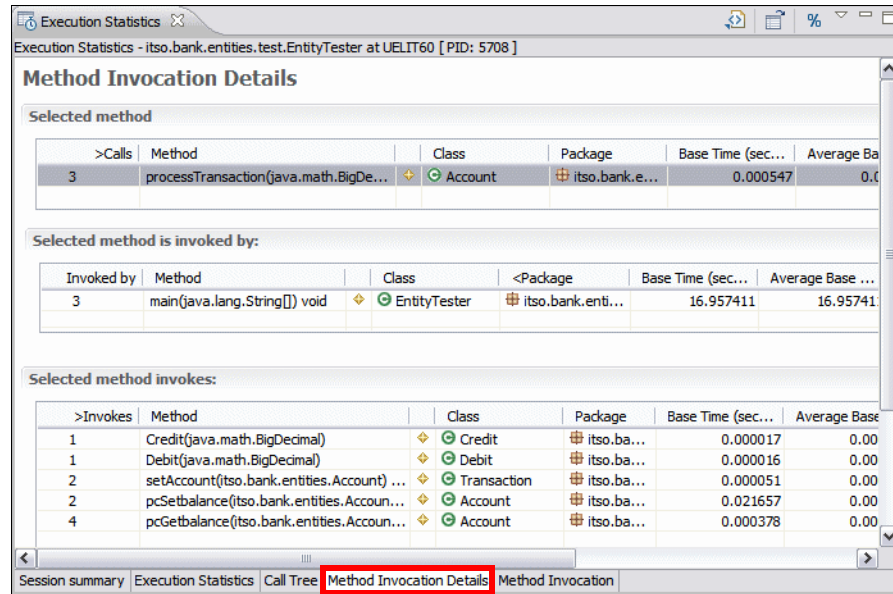

Figure 27-13 Execution Time Analysis: Method Invocation Details

- ▶ Select the **Method Invocation** tab to see a graphical representation of the calls (Figure 27-14).

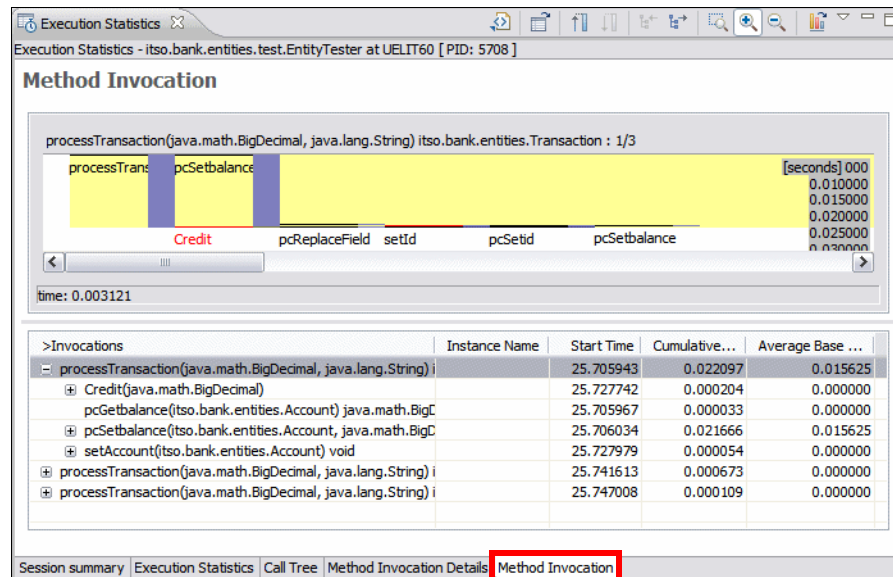



Figure 27-14 Execution Time Analysis: Method invocation

Execution flow

The Execution Flow view and table both show a representation of the entire program execution. In this view, the threads of the program fit horizontally, and time is scaled so that the entire execution fits vertically. In the table, the threads are grouped in the first column and time is recorded in successive rows.

In the Profiling Monitor view, click the **Open Execution Flow** icon , or select **Open With** → **Execution Flow** (Figure 27-29).

- ▶ The bottom pane displays the action sequence. Expand **main** and select the first **main** method.
- ▶ The top pane shows the execution stripes (Figure 27-15).

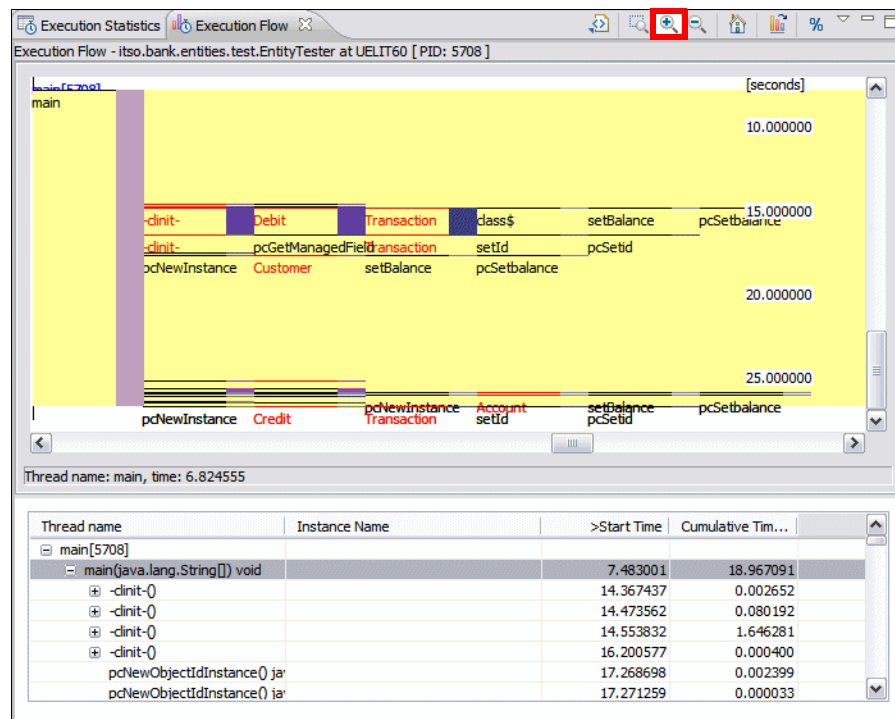

Figure 27-15 Execution Flow

- ▶ Select the **Zoom In** icon  and click into the column to see more details.

UML sequence diagrams

You can also analyze the graphical details of the execution flow using the data collected with Execution Time Analysis. These graphical details are displayed using the UML sequence diagram notation. The representation of time in these diagrams helps in determining bottlenecks in application performance as well as network communication. The following types of diagrams are available:

- ▶ **UML2 Class Interactions:** Shows interactions of classes that participate in the execution of an application.
- ▶ **UML2 Object Interactions:** Shows interactions of objects that participate in the execution of an application.
- ▶ **UML2 Thread Interactions:** Shows interactions of methods that execute in different threads, which participate in the execution of an application.

To display UML2 interaction diagrams, do these steps:

- ▶ In the Profiling Monitor view, right-click the entry and select **Open With** → **UML2 Class interactions** (Figure 27-16). You have to scroll to find suitable interactions.

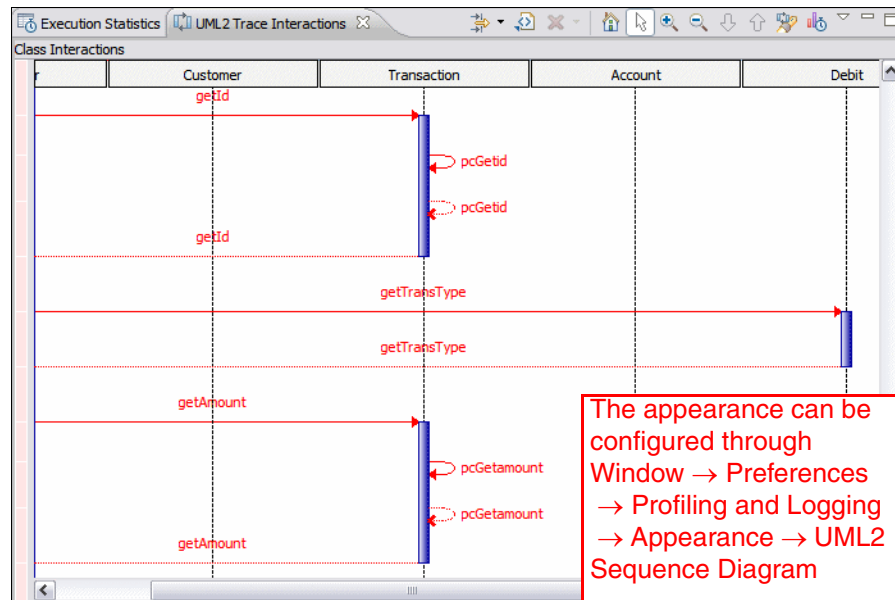

Figure 27-16 UML2 Interaction

The other two UML diagrams are very similar: UML2 Object Interactions and UML2 Thread Interactions.

You can drill down into a lifeline that allows you to view all the trace interactions within a particular lifeline (right-click the class and select **Drill down into selected lifeline**). This feature helps to trace the root cause of a problem from a host, to a process, to a thread, and eventually to a class or an object.

You can highlight a call stack to view all the methods invocations in a call stack by right-clicking a method and selecting **Highlight call stack**.

Memory statistics

The Memory Statistics view displays statistics about the application heap. It provides detailed information such as the number of classes loaded, the number of instances that are alive, and the memory size allocated by every class. Memory statistics are available at the package, class, and instance level.

To analyze the memory consumption, we have to rerun the application with another profiling option.

- ▶ Select **Run** → **Profile Configurations**. In the Profile Configurations dialog, select the **EntityTester** (preselected).
- ▶ In the **Monitor** tab, select **Memory Analysis**.
- ▶ Click **Edit Options** and select **Track object allocation sites**. Click **Finish**.
- ▶ Click **Apply**, then click **Profile**.
- ▶ A new entry opens in the Profiling Monitor view. The Console view shows the application output while it runs to completion.
- ▶ Double-click **Memory Analysis**, or click the **Open Object Allocations view** icon .
- ▶ The Object Allocations view displays live and total instances, active and total size, and average age (Figure 27-17).

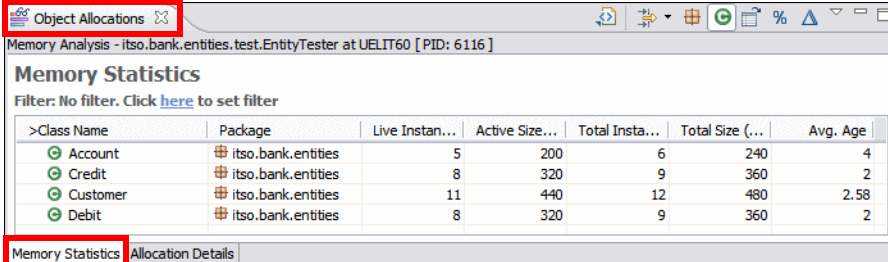

>Class Name	Package	Live Instan...	Active Size...	Total Insta...	Total Size (...)	Avg. Age
Account	itso.bank.entities	5	200	6	240	4
Credit	itso.bank.entities	8	320	9	360	2
Customer	itso.bank.entities	11	440	12	480	2.58
Debit	itso.bank.entities	8	320	9	360	2

Figure 27-17 Object Allocations

- ▶ Select a class (**Credit**) and select the **Allocation Details** tab (Figure 27-18).

Object Allocations

Memory Analysis - itso.bank.entities.test.EntityTester at UELIT60 [PID: 6116]

Allocation details for 'itso.bank.entities.Credit'

>Method	Line ...	Class	Package	Live Instan...	Active Size...	Total Insta...	Total Size (...)	Avg. Age
-clinit-	79	Credit	itso.b...	1	40	1	40	17

Memory Statistics Allocation Details

Figure 27-18 Object Allocation Details

- ▶ Click the **Open Memory Statistics** icon .
- ▶ The Memory Statistics (Figure 27-19) displays:
 - **Total Instances:** Shows the total number of instances that had been created of the selected package, class, or method.
 - **Live Instances:** Shows the number of instances of the selected package, class, or method, where no garbage collection has taken place.
 - **Collected:** Shows the number of instances of the selected package, class, or method, that were removed during garbage collection.
 - **Total Size:** Shows the total size in bytes of the selected package, class, or method, of all instances that were created for it.
 - **Active Size:** Shows the total number of size of all live instances.

Memory Statistics

Memory Statistics - itso.bank.entities.test.EntityTester at UELIT60 [PID: 6116]

>Package	Total Instances	Live Instances	Collected	Total Size (bytes)	Active Size (bytes)
itso.bank.entities	36	32	4	1440	1280
Account	6	5	1	240	200
Credit	9	8	1	360	320
Customer	12	11	1	480	440
Debit	9	8	1	360	320
java.lang	0	0	0	0	0

Figure 27-19 Memory Statistics

- ▶ Click the **Open Object References** icon  (Figure 27-20).

Object References

Object References Table - itso.bank.entities.test.EntityTester at UELIT60 [PID: 6116]

<Show Reference By	Package	Size (bytes)	Number of References	Details
Debit	itso.bank.entities	320		
Customer	itso.bank.entities	440		
Credit	itso.bank.entities	320		
Class	java.lang	0		
Account	itso.bank.entities	200		

Figure 27-20 Object References

Thread analysis

To analyze the threads, we have to rerun the application with another profiling option.

- ▶ Select **Run** → **Profile Configurations**.
- ▶ For the **EntityTester** class, in the **Monitor** tab, select **Thread Analysis**.
- ▶ Click **Edit Options** and select **Contention analysis**. Click **Finish**.
- ▶ Click **Apply**, then click **Profile**.
- ▶ A new entry opens in the Profiling Monitor view (Figure 27-21).

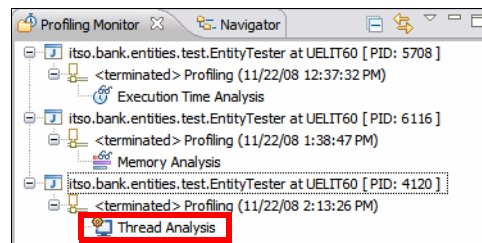



Figure 27-21 profiling Monitor with three runs

- ▶ Double-click **Thread Analysis**, or click the **Open Thread Analysis view** icon .
- ▶ The **Thread Statistics** tab shows the state, running and waiting time of the threads (Figure 27-22).

 The screenshot shows the 'Thread Analysis' window with the 'Thread Statistics' tab selected. The tab title is 'Threads Analysis - itso.bank.entities.test.EntityTester at UELIT60 [PID: 4120]'. Below the title is a table with columns: Thread Name, Class Name, >State, Running Time, and Waiting Time. The table lists several threads, including 'Finalizer thread', 'main', 'Thread-2', 'Thread-3', 'Thread-4', and 'unknown0'. The 'Thread Statistics' tab name at the bottom is highlighted with a red box.

Thread Name	Class Name	>State	Running Time	Waiting Time
Finalizer thread	java.lang.Thread	Stopped	00:15:299	
main	java.lang.Thread	Stopped	00:12:852	
Thread-2	java.lang.Thread	Stopped	00:12:855	
derby.antigc	java.lang.Thread	Stopped	00:00:000	00:11:650
Thread-3	java.util.Timer\$TimerImpl	Stopped	00:00:000	00:10:857
derby.rawStoreDae	java.lang.Thread	Stopped	00:00:000	00:10:658
DestroyJavaVM hel	java.lang.Thread	Stopped	00:00:000	
Thread-1	com.ibm.misc.SignalDispatcher\$1	Stopped	00:00:000	
Thread-4	java.util.logging.LogManager\$4\$1	Stopped	00:00:000	
unknown0	java.lang.Thread	Unknown		

Figure 27-22 Thread Analysis: Thread Statistics

- ▶ The **Monitor Statistics** tab shows the details of a selected thread, including the Java classes involved.

- ▶ The **Thread Visualizer** tab shows the threads that were active, and the time when they were active (Figure 27-23). we can see two threads for the Derby database and 5 threads for the application code.

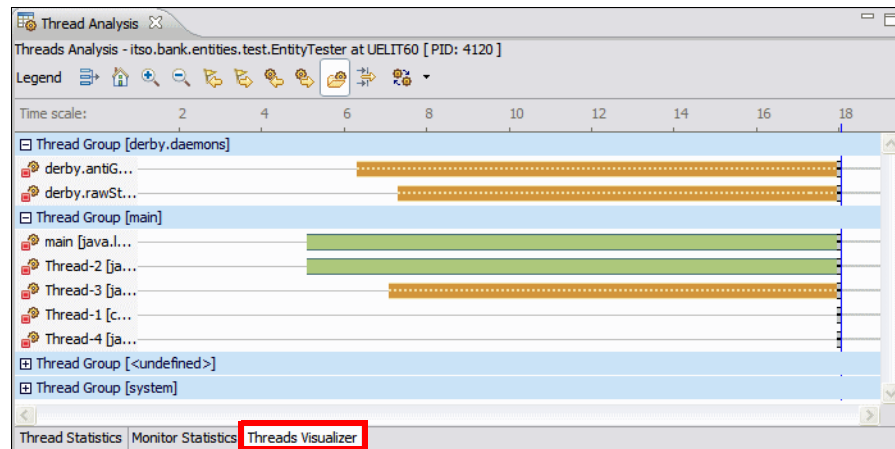

Figure 27-23 Thread Analysis: Visualizer

Reports

For several statistics you can create a report in comma-separated-values (CSV), HTML, or XML format by clicking the **New Report** icon .

Clean up

You can remove measurements by right-clicking an entry in the Profiling Monitor view and selecting **Delete**.

Profiling a Web application running on the server

In this section we run a Web application in the WebSphere Application Server v7.0 in profiling mode.

Importing the sample project interchange file

Tip: If you have the ITSO RedBank Web application (RAD75EJBEAR and dependent projects) already in the workspace, skip this step.

To import the ITSO RedBank Web application project interchange file, do these steps:

- ▶ Open the Java EE perspective.
- ▶ Select **File** → **Import**.
- ▶ In the Import dialog, select **Project Interchange** and click **Next**.
- ▶ In the Import Projects dialog, click **Browse** and locate the file:
c:\7672code\zInterchange\ejb\RAD75EJB.zip
- ▶ Select the **RAD75JPA** and **RAD75EJB** projects, and click **Finish**.
- ▶ Repeat the import for the interchange file:
c:\7672code\zInterchange\ejb\RAD75EJBWeb.zip
- ▶ Select the **RAD75EJBWeb** and **RAD75EJBWebEAR** projects, and click **Finish**.

Publishing and running sample application

The sample application has to be published to the WebSphere Application Server, prior to running the application server in profile mode.

Important: If you do not already configured the data source settings for the ITSOBANK database, follow the steps in “Configuring the data source for the ITSOBANK” on page 413 before publishing and running the sample application.

To publish and run the sample application on the WebSphere Application Server v7 test server, do these steps:

- ▶ In the Web perspective, Enterprise Explorer, expand **RAD75EJBWeb** → **WebContent**.
- ▶ Right-click **index.jsp** and select **Run As** → **Run on Server**.
- ▶ In the Run on Server dialog, select **Choose an existing server**, select **WebSphere Application Server v7 at localhost**, and click **Finish**.

This operation will start the server and publish the application to the server. The **index.jsp** page is displayed in a Web browser.

Starting the server in profiling mode

To start the WebSphere Application Server v7 in profiling mode, you would click the **Profile Restart** icon  in the Servers view:

However, the server start fails after a short time with this message in the Console view:

```
ADMU3011E: Server launched but failed initialization
```

In addition, the native_stderr.log file (in <RAD_HOME>\runtimes\base_v7\profiles\was70profile1\logs\server1), displays the following error message:

```
JVMJ9TI001E Agent library JPIBootLoader could not be opened (The specified
module could not be found. )
JVMJ9VM015W Initialization error for library j9jvmti24(-3): JVMJ9VM009E
J9VMD11Main failed
Could not create the Java virtual machine.
```

If you get this error, it means environment variables do not contain the required libraries for profiling on the server.

Setting up profiling environment variables

To setup the required environment variables, do these steps:

- ▶ Locate the installation directories for Application Developer and the shared SDP:

```
<SDP75>      = C:\IBM\SDP75           or similar
<SDPShared> = C:\IBM\SDP75Shared    or similar
```

- ▶ Create a command file in <SDP75>, for example, profiling.bat:

```
SET JAVA_PROFILER_HOME=C:\IBM\SDP70Shared\plugins\org.eclipse.tptp.
platform.jvmti.runtime_4.4.200.v200809231141\agent_files\win_ia32
```

```
SET PROBEKIT_HOME=C:\IBM\SDP70Shared\plugins\org.eclipse.hyades.
probekit_4.2.400.v200809150100
```

```
SET TPTP_AC_HOME=C:\IBM\SDP70Shared\plugins\org.eclipse.tptp.platform.
ac.win_ia32_4.4.1.v200808290100\agent_controller
```

```
SET PATH=%JAVA_PROFILER_HOME%;%TPTP_AC_HOME%\bin;%TPTP_AC_HOME%\lib;
%PROBEKIT_HOME%;%PATH%
```

```
start eclipse.exe -product com.ibm.rational.rad.product.v75.ide
```

- ▶ Stop the server in Application Developer, then close Application Developer.
- ▶ Start Application Developer using the **profiling.bat** command file.

Note: This issue is addressed in the following technote:

<http://www-01.ibm.com/support/docview.wss?rs=0&uid=swg21319688>

If you are using WebSphere Application Server v6.1 for profiling, see:

<http://www-01.ibm.com/support/docview.wss?uid=swg21288832>

Profile on server: Execution Time Analysis

Once Application Developer is started, start the server in profiling mode. Right-click the server and select  **Profile**.

- ▶ After a while, the Profile on Server dialog opens (Figure 27-24). Select **Execution Time Analysis**.

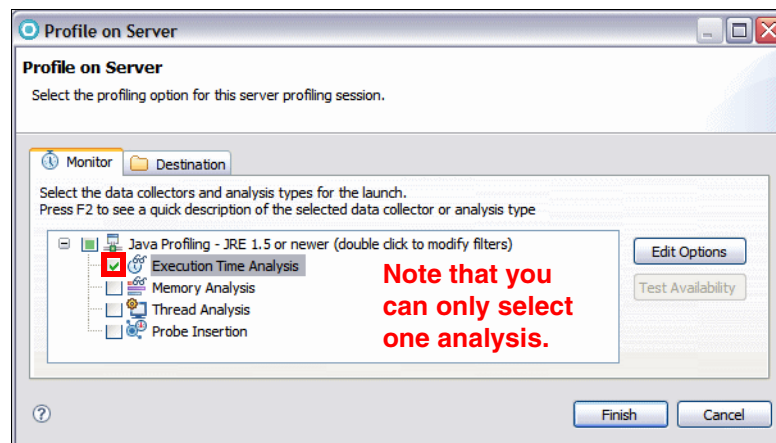

Figure 27-24 Profile on server

- ▶ Click **Edit Options**. In the Edit profiling options dialog, select **Collect method CPU time information** and **Show execution flow graphical details**. Click **Finish** (refer to Figure 27-7 on page 994).
- ▶ When prompted, switch to the Profiling and Logging perspective.
- ▶ When the server is started, the Profiling Monitor shows the active monitor (Figure 27-25).

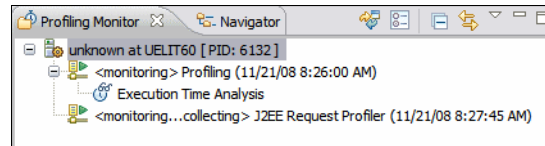

Figure 27-25 Profiling Monitor

Run the sample application to collect profiling data

Note: This step requires that you have published the project to the server as described in “Publishing and running sample application” on page 1006.

To collect data, we display the accounts of one customer, run a debit and a credit transaction, list the transactions, and update the customer name:

- ▶ In the Java EE perspective, right-click **RAD75EJBWeb** and select **Profile As** → **Profile on Server**. Click **Finish** to publish the application.
- ▶ In the RedBank home page, click **RedBank**. If the heading and footing do not display, right-click the **redbank.jsp** and **Profile on Server**.
- ▶ In the Login page, enter **222-22-2222** in the customer SSN field and click **Submit**.
- ▶ Select the last account.
- ▶ In the Account Details page, select **Withdraw** and withdraw an amount of \$25.
- ▶ In the Account Details page, select **Deposit** and deposit \$33.
- ▶ In the Account Details page, select **List Transactions**.
- ▶ In the List Transactions page, click **Account Details**.
- ▶ In the Account Details page, click **Customer Details**.
- ▶ In the Customer page, change the last name, and click **Update**.
- ▶ In the Customer page, click **Logout**.

Pause monitoring

In the profiling Monitor view, pause monitoring by selecting both processes and clicking the Pause Monitoring icon  (or right-click and select **Pause Monitoring**).

You can also keep the profiling running while you analyze the accumulated data.

Statistic views

The statistic views are the same as for profiling the Java application and are not described in detail in this section.

Execution statistics

To analyze the execution statistics, in the Profiling Monitor view, select the **<attached> Profiling** process and click the  icon, or select **Open With** → **Execution Statistics** (Figure 27-26).

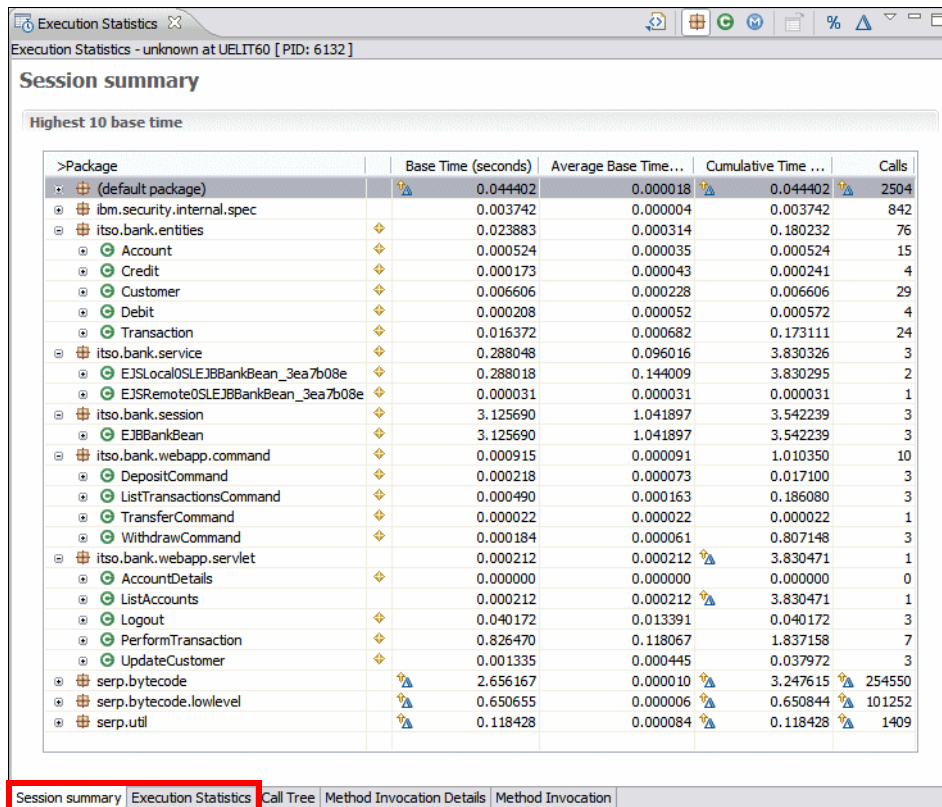

Execution Statistics - unknown at UELIT60 [PID: 6132]

Session summary

Highest 10 base time

>Package	Base Time (seconds)	Average Base Time...	Cumulative Time ...	Calls
(default package)	0.044402	0.000018	0.044402	2504
ibm.security.internal.spec	0.003742	0.000004	0.003742	842
itso.bank.entities	0.023883	0.000314	0.180232	76
Account	0.000524	0.000035	0.000524	15
Credit	0.000173	0.000043	0.000241	4
Customer	0.006606	0.000228	0.006606	29
Debit	0.000208	0.000052	0.000572	4
Transaction	0.016372	0.000682	0.173111	24
itso.bank.service	0.288048	0.096016	3.830326	3
EJSLocalOSLEJBBean_3ea7b08e	0.288018	0.144009	3.830295	2
EJSRemoteOSLEJBBean_3ea7b08e	0.000031	0.000031	0.000031	1
itso.bank.session	3.125690	1.041897	3.542239	3
EJBBean	3.125690	1.041897	3.542239	3
itso.bank.webapp.command	0.000915	0.000091	1.010350	10
DepositCommand	0.000218	0.000073	0.017100	3
ListTransactionsCommand	0.000490	0.000163	0.186080	3
TransferCommand	0.000022	0.000022	0.000022	1
WithdrawCommand	0.000184	0.000061	0.807148	3
itso.bank.webapp.servlet	0.000212	0.000212	3.830471	1
AccountDetails	0.000000	0.000000	0.000000	0
ListAccounts	0.000212	0.000212	3.830471	1
Logout	0.040172	0.013391	0.040172	3
PerformTransaction	0.826470	0.118067	1.837158	7
UpdateCustomer	0.001335	0.000445	0.037972	3
serp.bytecode	2.656167	0.000010	3.247615	254550
serp.bytecode.lowlevel	0.650655	0.000006	0.650844	101252
serp.util	0.118428	0.000084	0.118428	1409

Session summary | Execution Statistics | Call Tree | Method Invocation Details | Method Invocation

Figure 27-26 Execution Statistics

You can expand a class to see the statistics for each method (Figure 27-27).

Execution Statistics - unknown at UELIT60 [PID: 6132]

Session summary

Highest 10 base time

>Package	Base Time (seconds)	Average Base Time...	Cumulative Time ...	Calls
(default package)	0.044402	0.000018	0.044402	2504
ibm.security.internal.spec	0.003742	0.000004	0.003742	842
itso.bank.entities	0.023883	0.000314	0.180232	76
itso.bank.service	0.288048	0.096016	3.830326	3
itso.bank.session	3.125690	1.041897	3.542239	3
EJBBankBean	3.125690	1.041897	3.542239	3
deposit(java.lang.String, java.math)	0.004848	0.004848	0.008232	1
EJBBankBean()	0.000028	0.000014	0.000028	2
getAccount(java.lang.String) itso.b	0.000000	0.000000	0.000000	0
getAccounts(java.lang.String) itso.i	0.000000	0.000000	0.006154	0
getCustomer(java.lang.String) itso.	3.125662	3.125662	3.536057	1
getTransactions(java.lang.String) it	0.172291	0.172291	0.178705	1
updateCustomer(java.lang.String, j	0.000570	0.000570	0.003089	1
withdraw(java.lang.String, java.ma	0.013897	0.013897	0.046443	1
itso.bank.webapp.command	0.000915	0.000091	1.010350	10
itso.bank.webapp.servlet	0.000212	0.000212	3.830471	1
serp.bytecode	2.656167	0.000010	3.247615	254550
serp.bytecode.lowlevel	0.650655	0.000006	0.650844	101252
serp.util	0.118428	0.000084	0.118428	1409

Session summary | Execution Statistics | Call Tree | Method Invocation Details | Method Invocation

Figure 27-27 Execution Statistics by methods of a class

Method invocation details

Expand **itso.bank.entities** → **Account** to see the methods of the Account class. Right-click **processTransaction** and select **Show Method Invocation Details** (Figure 27-28).

The Method Invocation Details view provides statistical data on a selected method. The following data is displayed for the selected method:

- ▶ **Selected method** (Account.processTransaction): Shows details including the number of times the selected method is called, the class and package information, and the time taken by this method.
- ▶ **Selected method invoked by**: Shows details of each method that calls the selected method, including the number of calls to the selected method, and the number of times the selected method is invoked by the caller. In our case, the deposit and withdraw methods of the EJBBankBean class invoke the selected method.
- ▶ **Selected method invokes**: Shows details of each method invoked by the selected method, for example, Credit and Debit constructors, setAccount of Transaction class, and internal JPA methods.

Execution Statistics - unknown at UELIT60 [PID: 6132]

Method Invocation Details

Selected method

>Calls	Method	Class	Package	Base Time (sec...)	Average Base ...
2	processTransaction(java.math.BigDe...	Account	itso.bank.ent...	0.000276	0.000138

Selected method is invoked by:

>Invoked by	Method	Class	Package	Base Time (sec...)	Average Base ...
1	deposit(java.lang.String, java.math....	EJBBankBean	itso.bank.ses...	0.004848	0.004848
1	withdraw(java.lang.String, java.mat...	EJBBankBean	itso.bank.ses...	0.013897	0.013897

Selected method invokes:

>Invokes	Method	Class	Package	Base Time (sec...)	Average Base ...
1	Debit(java.math.BigDecimal)	Debit	itso.bank.ent...	0.000010	0.000010
1	Credit(java.math.BigDecimal)	Credit	itso.bank.ent...	0.000010	0.000010
2	pcSetbalance(itso.bank.entities.Acco...	Account	itso.bank.ent...	0.000026	0.000013
2	setAccount(itso.bank.entities.Accoun...	Transaction	itso.bank.ent...	0.000039	0.000019
3	pcGetbalance(itso.bank.entities.Acco...	Account	itso.bank.ent...	0.000000	0.000000

Session summary | Execution Statistics | Call Tree | **Method Invocation Details** | Method Invocation

Figure 27-28 Method Invocation Details

Execution flow

The Execution Flow view and table both show a representation of the entire program execution. In this view, the threads of the program fit horizontally, and time is scaled so that the entire execution fits vertically. In the table, the threads are grouped in the first column and time is recorded in successive rows.

In the Profiling Monitor view, select the **<attached> J2EE Request Profile** process and click the  icon, or select **Open With** → **Execution Flow** (Figure 27-29).

- ▶ The bottom pane displays the action sequence. Expand the Web Container and select the first **doPost** method.
- ▶ The top pane shows the execution stripes. Select the **Zoom In** icon  and click into the Web Container column, near the start time of the method, until you see the graphic diagram appear.

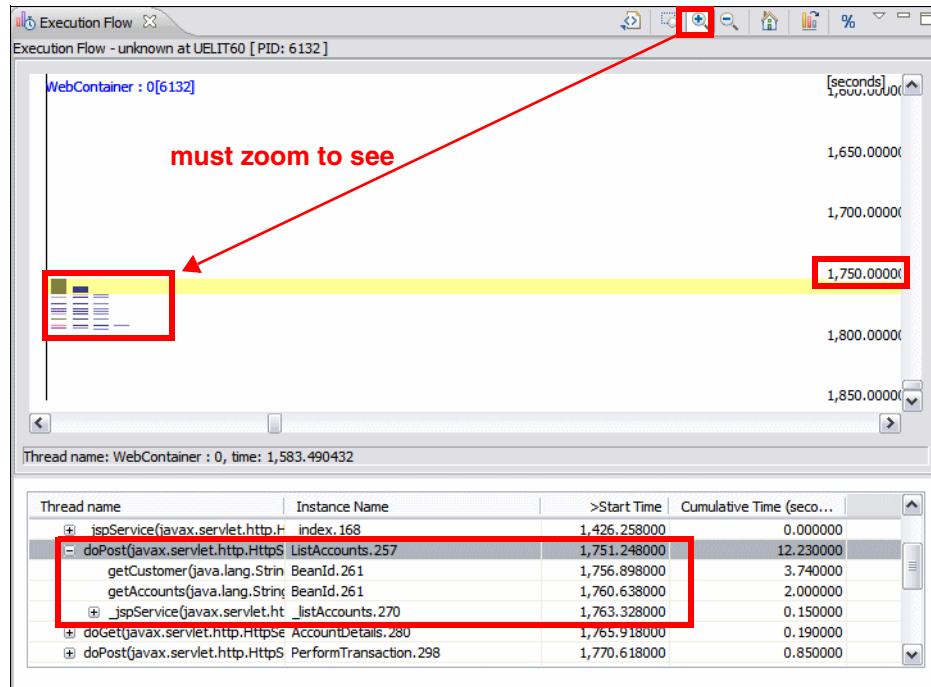

Figure 27-29 Execution Flow

Zoom into the top pane using the **Zoom In** icon  to see methods and their times (Figure 27-30).

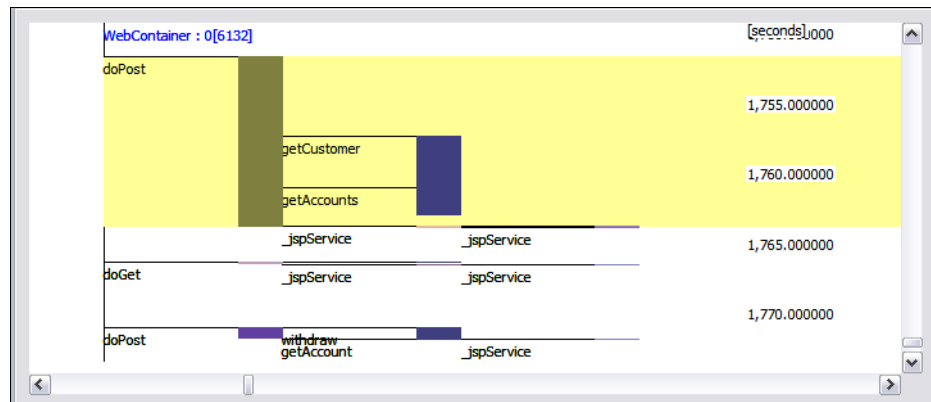

Figure 27-30 Execution Flow zoomed in

UML sequence diagrams

To display an UML2 interaction diagram, do these steps:

- ▶ In the Profiling Monitor view, right-click the **<attached> J2EE Request Profiler** process and select **Open With** → **UML2 Class interactions** (Figure 27-31). You have to scroll to find suitable interactions.

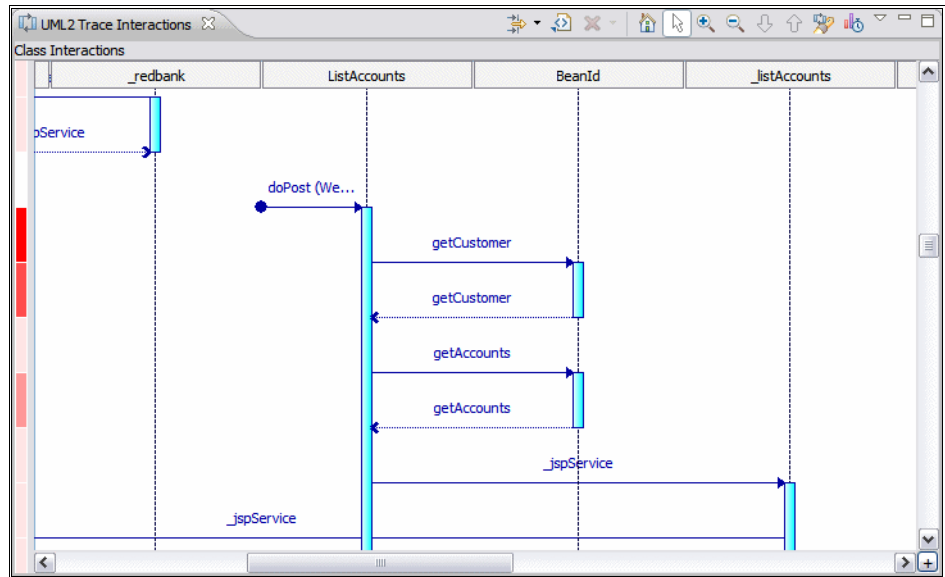



Figure 27-31 UML2 Class Interactions

You can drill down into a lifeline that allows you to view all the trace interactions within a particular lifeline (right-click the class and select **Drill down into selected lifeline**). This feature helps to trace the root cause of a problem from a host, to a process, to a thread, and eventually to a class or an object.

You can highlight a call stack to view all the methods invocations in a call stack by right-clicking a method and select **Highlight call stack**.

Refreshing the views and resetting data

You can keep the profiling running while you analyze the views. Now and then you might want to refresh the views with the latest data, or reset the data:

- ▶ Click the **Refresh Views** icon  to refresh the views.
- ▶ Right-click the profiling process and select **Reset Data** to start a new collection of data and subsequent analysis.

Ending the profiling session

To end the profiling session, click the Terminate icon . To remove the profiling agent, right-click the agent and select **Delete**. You are prompted if you want to delete the data in the file system. The connection to the server is removed.

Profile on server: Memory and thread analysis

To profile the application on the server for memory or thread analysis, you have to stop the server, change the profiling options, and restart the server:

- ▶ Stop the server.
- ▶ Start the server in profiling mode, and wait for the Profile on Server dialog.
 - Select **Memory Analysis** (Figure 27-24 on page 1008) and click **Edit Options**.
 - Or select **Thread Analysis** and click **Edit Options**.
 - In the Profile on server dialog, click **Finish**.
- ▶ Click **Yes** in the Confirm Perspective switch dialog.
- ▶ The Profiling and Logging perspective opens and the agent is displayed in the Profiling Monitor view.

Run the sample application

In the Java EE perspective, right-click **redbank.jsp** and select **Profile As** → **Profile on Server**. You do not have to republish the application.

Run the sample sequence of operations as described in “Run the sample application to collect profiling data” on page 1009.

Display memory and thread analysis

Open the appropriate views from the Profiling Monitor view to perform the analysis.

More information

In the Application Developer Online Help, select **Developing** → **Monitoring, profiling, and analyzing applications**.



Part 8

Management and team development

In this part of the book, we describe the tooling and technologies provided by Application Developer for managing and developing applications in a team environment, using Concurrent Versions System (CVS), and Rational Team Concert.



CVS integration

This chapter provides an introduction to the widely adopted open source version control system known as Concurrent Versions System (CVS) and the tools within Application Developer V7.5 to integrate with it. Through an example installation and implementation of CVS followed by usage scenarios, including two developers working on a simulated project, we demonstrate the main features of using CVS within Application Developer.

The chapter is organized into the following sections:

- ▶ Introduction to CVS
- ▶ CVSNT Server installation and implementation
- ▶ CVS client configuration for Application Developer
- ▶ Configuring CVS in Application Developer
- ▶ Development scenario
- ▶ CVS resource history
- ▶ Comparisons in CVS
- ▶ Annotations in CVS
- ▶ Branches in CVS
- ▶ Working with patches
- ▶ Disconnecting a project
- ▶ Team Synchronizing perspective
- ▶ More information

Introduction to CVS

Concurrent Versions System (CVS) is a popular open source Software Configuration Management (SCM) system for source code version control. It can be used by individual developers or very large teams and can be configured to run across the Web or any configuration where the users have TCP/IP access to a CVS server. CVS allows users to work on the same file simultaneously without locking and provides a facility to merge changes and resolve conflicts when they arise. For these main reasons and the fact that it is free and relatively easy to install and configure, CVS has become very popular both for open source and commercial projects.

The Microsoft Windows version of CVS—known as CVSNT—while still retaining the original functionality has split off from the original UNIX version and has been enhanced even further, to the extent that enhancements in CVSNT have been ported back to the UNIX version. It can be run on any Windows NT® or later system and allows clients to connect to the CVS server from many different environments.

Finally, it is important to note that CVS only implements version control and does not handle other aspects of SCM, such as requirements management, defect tracking, and build management. There are other open source projects for performing these functions, and also, the IBM Rational suite of products has a large set of tools that perform the same functions in an integrated way.

CVS features

Some of the main features of CVS are as follows:

- ▶ Multiple client-server protocols over TCP/IP, a feature that allows developers access to the latest code from a wide variety of clients located anywhere with access to the CVS server.
- ▶ All the versions of a file are stored in a single repository file using forward-delta versioning, which stores only the differences between sequential versions.
- ▶ Developers are insulated from each other. Every developer works in their own directory, and CVS merges the work in the repository when they are ready to commit. Conflicts can be resolved as development progresses (using synchronize) and must be resolved before any piece of work is committed to the repository.

Important: CVS and Application Developer have a slightly different interpretation of what the term conflict means:

- ▶ In CVS, a conflict means that two changes have been made to the same line or set of lines in the same source code file. In these cases an automatic merge is not possible and some manual merging is required.
 - ▶ For Application Developer, a conflict means only that there exists a locally modified version of a resource for which a more recent revision is available in the branch in the repository. In these cases an automatic merge might resolve the issue, or if there are changes to the same set of lines then (as is the case for resolving CVS conflicts), manual merging is required.
-
- ▶ CVS uses an unreserved checkout approach to version control that helps avoid artificial conflicts common when using an exclusive checkout model.
 - ▶ CVS keeps shared project data in repositories. Each repository has a root directory on the file system.
 - ▶ CVS maintains a history of the source code revisions. Each change is stamped with the time it was made and the user name of the person who made it. We recommend that developers also provide a description of the change. Given this information, CVS can help developers find answers to questions such as: Who made the change, when was it made, the reasons why, and what specifically was changed.

CVS support within Application Developer

Application Developer provides a fully integrated CVS client, the main features of which are demonstrated throughout this chapter. At the highest level, there are two perspectives in Application Developer that are important when working with CVS:

- ▶ **CVS Repository Exploring perspective**—Provides an interface for creating new links to a repository, browsing the content of the repository, and checking out content (files, folders, projects) to the workspace.
- ▶ **Team Synchronizing perspective**—Provides an interface for synchronizing code on the workspace with code in a repository. The perspective is also used by other version control systems, including IBM Rational ClearCase.

In addition to these two perspectives, there are numerous menu options, context menu options, and other features throughout Application Developer to help users work with a CVS repository.

Application Developer v7.5 supports four authentication protocols when establishing a connection to a CVS server:

- ▶ **pserver (password server)**—This is the simplest but least secure communication method. Using this mechanism the user name and password is passed to the CVS server using a defined protocol. The downside is that the password is transmitted in clear text over the network, making it vulnerable to network sniffing tools.
- ▶ **ext (external)**—This method allows the user to specify an external program to connect to the repository. On the preferences page **Window → Preferences → Team → CVS → Ext Connection Method**, a user can specify the local application to run, to send commands to the CVS server and the parameters to pass to it. Each CVS operation performed is then done through this executable, and passwords are encrypted using whatever mechanism the executable uses. Generally this mechanism requires shell accounts on the server machine so that the clients can make use the remote shell applications.
- ▶ **extssh (external program using secure shell)**—This method is similar to the **ext** method from above, but uses a built-in SSH client supplied with Application Developer to perform encryption. The preferences page **Window → Preferences → General → Network Connections → SSH2** provides a set of options for configuring the ssh security including the ssh application path and some private keys.
- ▶ **pserverssh2 (password server using secure shell)**—This method uses the **pserver** mechanism of storing the users and passwords within the CVS server as above, but uses ssh encryption (as configured in the SSH2 connection method preferences page) to communicate the user and password information to the server.

For more information on these configurations, refer to the CVS home page and Application Developer help. The option **pserver** is the easiest to configure and is used in the example in this chapter.

CVSNT Server installation and implementation

The following CVSNT Server installation and implementation section is organized as follows:

- ▶ Installing the CVS server
- ▶ Configuring the CVS server repository
- ▶ Creating the Windows users and groups used by CVS
- ▶ Verifying the CVSNT installation
- ▶ Creating CVS users

Installing the CVS server

The CVS server distribution for Linux, UNIX, and Windows platforms is available at the CVS project site, as is installation and usage documentation:

<http://www.march-hare.com/cvspro/>

At the time of writing, the CVSNT branch 2.5.x branch was the most stable version.

Note: Application Developer does not directly support CVSNT (version 2.5.03), and therefore CVSNT has to be configured to act like a standard CVS server by setting the **Compatibility** options. This is done in the sample under the step titled “Configuring the CVS server repository” on page 1024.

We used CVSNT V2.5.03.2382 for the sample because all of our sample applications were developed on the Windows platform, and the CVS home page stated that this was the most stable recent version. We found CVSNT easy to use and did not experience any significant problems using CVSNT, however, the correct configuration was required.

For information on CVS compatibility with Eclipse versions, refer to the following URL:

http://wiki.eclipse.org/index.php/CVS_FAQ

To install CVS on the Windows platform, do these steps:

- ▶ Before installing CVSNT, refer to these useful installation tips:
<http://www.cvsnt.org/wiki/InstallationTips>
- ▶ Download the CVSNT Server V2.5.03 (cvsnt-2.5.03.2382.msi) from the above URL to a temporary directory (for example, c:\temp).

Important: The CVSNT software requires a user performing the installation has local system privileges to install and configure a service in Windows.

- ▶ Execute the CVSNT installer by double-clicking the downloaded cvsnt-2.5.03.2382.msi file from the temporary directory.
- ▶ In the Welcome dialog, click **Next**.
- ▶ In the License Agreement dialog, review the terms, select **I accept the terms in the Licence Agreement**, and click **Next**.
- ▶ In the Choose Setup Type dialog, click **Typical**.

- ▶ In the Ready to Install dialog, click **Install**.
- ▶ In the Completing the CVSNT 2.5.03.2382 Setup Wizard dialog, click **Finish**.

When the installation is complete, the installation program prompts to see if you want to perform a restart. We recommend that you restart your system. This step guarantees that the environment variables are set up properly and the CVSNT Windows services are started.

Configuring the CVS server repository

After you have installed the CVS server and restarted the system, do the following steps to create and configure the CVS server repository:

- ▶ Manually create the common root directory. For example, the directory `c:\rep7672` can be created using Windows Explorer.
- ▶ Select **Start** → **Programs** → **CVSNT** → **Service control panel** to start the CVSNT control application.
- ▶ The CVS services must be stopped to create a new repository. In the CVSNT control panel window, click **Stop** under CVSNT Service and CVSNT Lock Service (Figure 28-1).

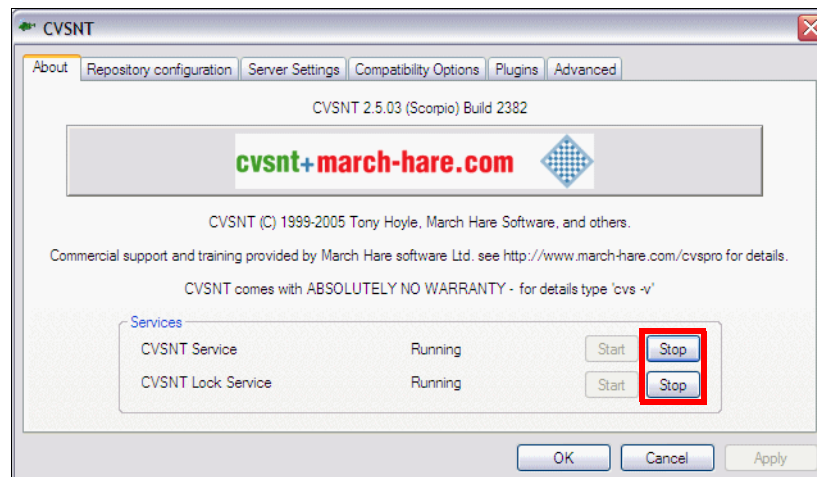

Figure 28-1 Stop the CVSNT services

- ▶ Select the **Repository configuration** tab, and click **Add**.
- ▶ In the Server Settings dialog, enter the following values (Figure 28-2):
 - Location: `c:/rep7672` (we created this directory manually)
 - Name: `/rep7672` (default)
 - Description: RAD 7.5 Redbook CVS repository

- Leave the other selections with their defaults.
- Click **OK**.

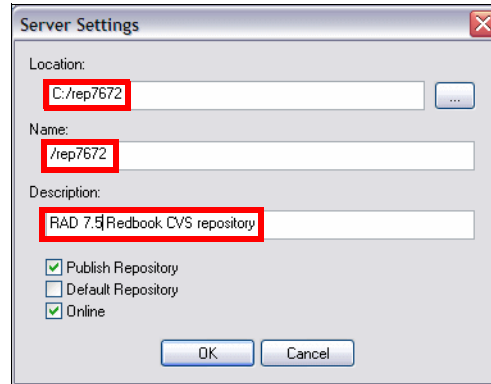

Figure 28-2 Add repository

- ▶ When prompted with the message *c:/rep7672 exists, but is not a valid CVS repository. Do you want to initialize it?*, click **Yes** and then **Apply**.
- ▶ Select the **Compatibility Options** tab (Figure 28-3). For both type of clients:
 - Select **Respond as cvs 1.11.2 to version request**.
 - Select **Emulate '-n checkout' bug**.
 - Select **Hide extended log/status information**.
 - Clear **Ignore client-side force -k options**
- For Clients allowed to connect, select **Any CVS/CVSNT** (default).

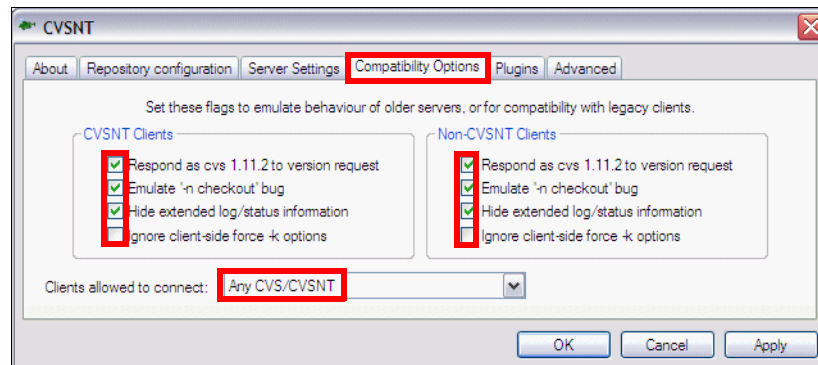

Figure 28-3 Compatibility options

These settings ensure that CVSNT is compatible with clients such as Application Developer and other CVS clients.

- ▶ Click **Apply** and then **OK** to close the CVS control panel.

Creating the Windows users and groups used by CVS

The following instructions configure the user account for CVSNT and associate the CVSNT application with that user.

Add a Windows user (cvsadmin)

To add a Windows CVS administrator user, do these steps:

- ▶ In the Windows desktop, right-click **My Computer** (or whatever the label of the computer is on the desktop), and select **Manage**.
- ▶ In the Computer Management dialog, select **Local Users and Groups** → **Users**.
- ▶ Select **Action** → **New User**.
- ▶ In the New User dialog, enter the following values:
 - User name: cvsadmin
 - Password: <password>. Remember this password for later!
 - Leave full name blank.
 - Description: User account for the CVSNT application.
 - Clear **User must change password at next logon**.
 - Clear **User cannot change password**.
 - Clear **Password never expires**.
 - Clear **Account is disabled**.
 - Click **Create** and click **Close**.
- ▶ Do not exit the Computer Management tool.

Add Windows user (cvsadmin) to the Administrators group

To add the Windows user to a group that has the sufficient permissions, do these steps:

- ▶ In the Computer Management application, select **Groups** and double-click **Administrators**.
- ▶ Click **Add**.
- ▶ Type **cvsadmin** in the Enter the object names to select field, and click **Check Names**. The user name is verified and prefixed by the local machine name. Click **OK** to add cvsadmin to the Administrators group.
- ▶ Click **Apply** and then **OK** to exit the Administrators Properties window.
- ▶ Close the Computer Management dialog.

We created a new administrative user for the CVS server machine to start and stop the CVS administration processes.

Configure the CVS administration user

The CVS services have to be associated with the cvsadmin user to complete the configuration. Do these steps:

- ▶ Restart the CVSNT Control Panel application, **Start** → **Programs** → **CVSNT** → **CVSNT Control Panel**.
- ▶ Select the **Server Settings** tag and select **cvsadmin** (prefixed by the CVS server machine name) for Run as user, and the local machine name for Default domain (Figure 28-4).

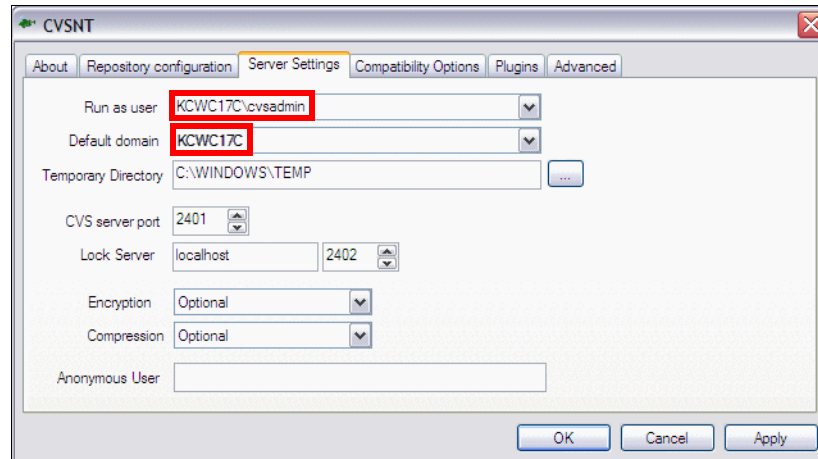

Figure 28-4 CVSNT Server Settings

- ▶ Click **Apply** and **OK**.

Verifying the CVSNT installation

To verify that the CVSNT installation is running as required, do these steps:

- ▶ Restart the system, which ensures that the environment variables are loaded and the CVSNT services are started.
- ▶ After the system has been restarted, verify that the following CVSNT Windows services have started, by starting the **CVSNT Control Panel**, viewing the **About** tab and checking the status of the following services:
 - CVSNT
 - CVSNT Lock Service

Both of these services should show as running.

Creating CVS users

To create CVS users to access the files in the repository, do these steps:

- ▶ Open a Windows command prompt.
- ▶ Set the `cvsroot` environment variable with the following command:

```
set cvsroot=:pserver:cvsadmin@KCWC17C.itsosj.sanjose.ibm.com:/rep7672
```

Where `KCWC17C.itsosj.sanjose.ibm.com` is the host name of the CVS server and `/rep7672` is the directory the repository is located on the host machine.

Note: The full host name must be specified, `localhost` does not work. To find the host name of a machine, right-click the **My Computer** icon on the Windows desktop, select **Properties**, and select the **Computer Name** tab. The full computer name is shown on this page.

- ▶ Log on to the CVS repository machine to manage the users, using the following command:

```
cvs login cvsadmin
```

- ▶ You are prompted to enter the CVS password.

Enter the password for the `cvsadmin` user created in “Creating the Windows users and groups used by CVS” on page 1026.

- ▶ Enter the following CVS commands to add users:

```
cvs passwd -a -r cvsadmin <cvs-user-id>
```

- `cvs passwd -a` is the command to add a new user and password, or change a password if that user already exists.
- `-r cvsadmin` indicates the alias or native user name that the user will run under when connecting to the repository (we set this to be `cvsadmin` for the user created in “Creating the Windows users and groups used by CVS” on page 1026).
- `<cvs-user-id>` is the user ID to be added.

For example, to add user `cvsuser1`, enter the following command:

```
cvs passwd -a -r cvsadmin cvsuser1
```

Note: The first occurrence of a user being added creates the file `passwd` in the directory, `c:\rep7672\CVSR00T`. The new user is appended to this file. We recommend that this file not be edited directly by a text editor. It also must not be placed under CVS control.

- ▶ A prompt opens to enter the password:

```
Adding user cvsuser1@KCWC17C.itsosj.sanjose.ibm.com
New password: *****
Verify password: *****
```

Note that the user ID and password created is completely specific to the CVS repository and is unrelated to the windows password.

- ▶ Repeat the previous step for an additional CVS user: cvsuser2. We need two users for the example.
- ▶ Provide the development team members their CVS account information, host name, and connection type to the CVS server, so that they can establish a connection from Application Developer. For example:
 - Account info: Developer CVS user ID (for example, cvsuser1)
 - CVS server host name: (for example, KCWC17C.itsosj.sanjose.ibm.com)
 - Connection type: pserver
 - Password: <password>
 - Repository path: /rep7672

Any subsequent changes to the users or passwords must be done by the administrator using the same commands.

CVS client configuration for Application Developer

This section describes how to create a client connection within Application Developer to a CVS server. Typically these activities are done in Application Developer from a new workspace.

Configuring the CVS team capability

Verify that team capabilities CVS support is enabled by doing these steps:

- ▶ Select **Windows** → **Preferences**.
- ▶ Select and expand the **General** and select **Capabilities**.
- ▶ Select the **Team** capability.
- ▶ Click **Advanced**.
- ▶ Expand the **Team** and verify that **CVS Support** is selected (Figure 28-5).
- ▶ Click **OK**.
- ▶ Click **Apply** and **OK** to close the Preferences dialog.

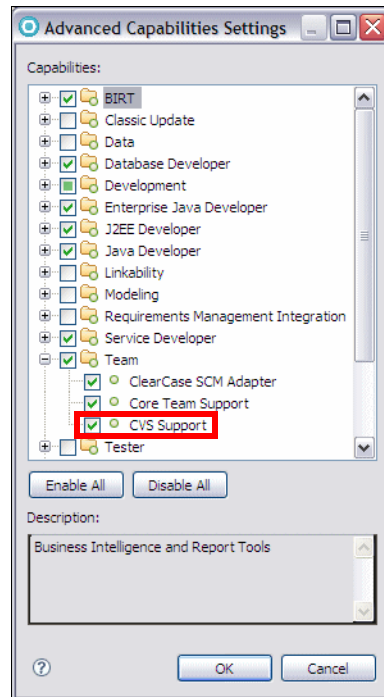

Figure 28-5 Verify Team capability CVS Support is enabled

Accessing the CVS repository

To access a repository that has been configured on a server for users to perform their version management, do these steps:

- ▶ Select **Windows** → **Open Perspective** → **Other** → **CVS Repository Exploring**. Click **OK**.
- ▶ In the CVS Repositories view, right-click, and select **New** → **Repository Location**.
- ▶ Add the parameters for the repository location as shown in Figure 28-6, where Host and Repository path should reflect where the CVS repository is, and User and Password are the name of the user of the workspace. Select **pserver** as the connection type.
- ▶ Select **Validate Connection Finish** and **Save Password**, and then click **Finish**.
- ▶ Click **No** in the Secure Storage dialog (unless you want to establish the password recovery feature).

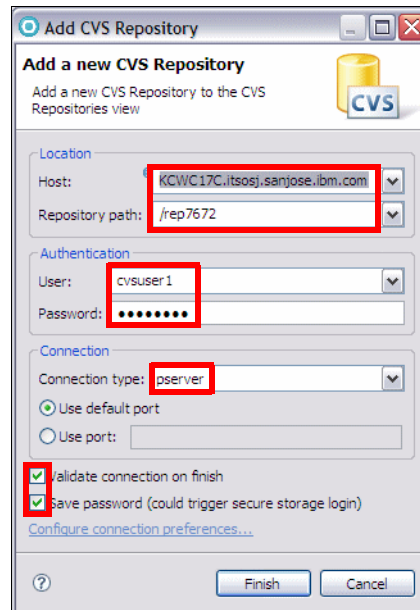

Figure 28-6 Add the CVS repository to the workspace

If everything worked correctly, you can see a repository location in the CVS Repositories view. The entry can be expanded to show HEAD, Branches, Versions, and Dates (Figure 28-7).

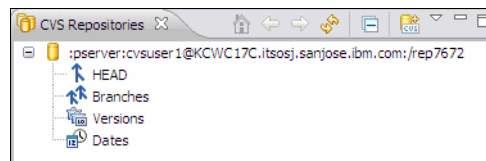

Figure 28-7 CVS Repositories view

Configuring CVS in Application Developer

Within Application Developer, it is possible to set the following CVS related settings to guide the integration of CVS:

- ▶ Label decorations
- ▶ File content
- ▶ Ignored resources
- ▶ CVS-specific settings
- ▶ CVS keyword substitution

Label decorations

Label decorations are set to be on for CVS by default. This means that the CVS properties of a particular file are shown on its label or icon. For example, if a file has changed from the version in the repository, it will have a > symbol next to its file name.

To view or change the label decorations, select **Windows** → **Preferences** and expand **General** → **Appearance** and select **Label Decorations**. By default, the **CVS** labels are selected (Figure 28-8).

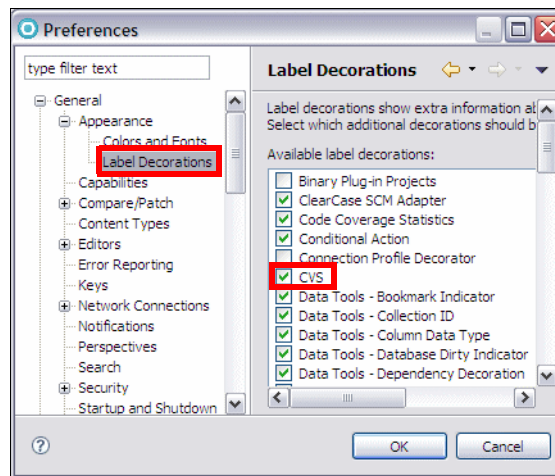

Figure 28-8 CVS Label Decoration preferences

File content

The file content of resources can be configured to be stored as either ASCII or binary. When working with a file extension that is not defined in the file content list stored in Application Developer, files of this type are saved into the repository as binary by default. When a resource is stored as a binary, CVS cannot show line-by-line comparisons between versions. However, files that have binary content cannot be stored as ASCII CVS files. Once a file is created as one type, it cannot be changed. Therefore, it is important to make sure that each file content type is configured correctly in Application Developer before adding a new project to the repository.

To verify that a resource in the workspace is stored in the repository correctly, select **Windows** → **Preferences** and expand **Team** → **File Content** (Figure 28-9). Verify that the file extensions that you are using are present and stored in the repository as desired.

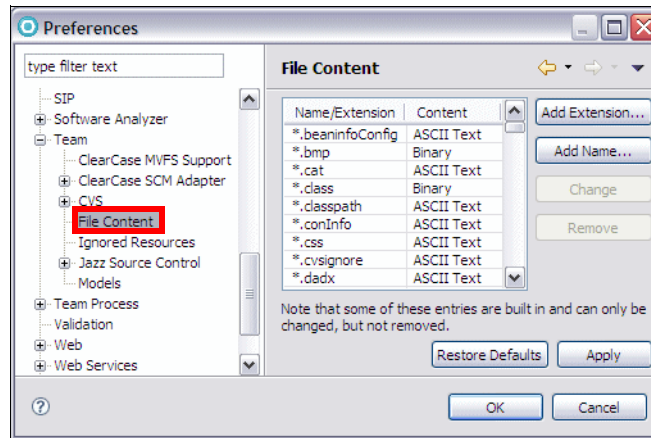

Figure 28-9 Team File Content preferences

If a particular file extension is not in the list, then this extension has to be added, unless the resource is stored in the default binary format. Application Developer prompts the user for the resource type when performing the first check-in (see Figure 28-16 on page 1043) if it encounters a new type, or the new type can be added manually in the Preferences page.

A common file that is often supplied with a source code distribution is a `Makefile.mak` file, which is usually an ASCII file.

To demonstrate adding this file type extension (that is not present in this list), do these steps:

- ▶ Select **Windows** → **Preferences** and expand **Team** → **File Content**.
- ▶ Click **Add Extension**.
- ▶ Enter the extension name `mak` and click **OK**.
- ▶ Find the extension in the list, and in the Content column, and select **ASCII Text** from the drop-down.

Tip: The content can also be changed by highlighting the extension and clicking **Change**. This toggles the setting between ASCII Text and Binary.

- ▶ Click **Apply** and then **OK**.

Ignored resources

Resources that are created or changed dynamically through mechanisms such as compilation or builds are not recommended to be saved in the repository. This can include class files, executables, and Enterprise JavaBean stubs and implementation codes.

Application Developer stores a list of these resources that are ignored when performing CVS operations. This is accessed by selecting **Windows** → **Preferences** and expanding **Team** → **Ignored Resources**.

Resources can be added to this list by specifying the pattern that will be ignored. The two wild card characters are an asterisk (*)—which indicates a match of zero or many characters—and a question mark (?)—which indicates a match of one character. For example, a pattern of `_EJS*.java` would match any file that begins with `_EJS` and had zero to many characters and ends in `.java`.

The following example shows the addition of the filename pattern `*.tmp` to the ignored resources list:

- ▶ Select **Windows** → **Preferences** and expand **Team** → **Ignored Resources**.
- ▶ Click **Add Pattern**.
- ▶ Enter the pattern `*.tmp` and click **OK**.
- ▶ Ensure that the resource (`*.tmp`) is selected and added to the **Ignored Resources** list (Figure 28-10). `*.tmp` resources are now ignored by CVS in Application Developer.

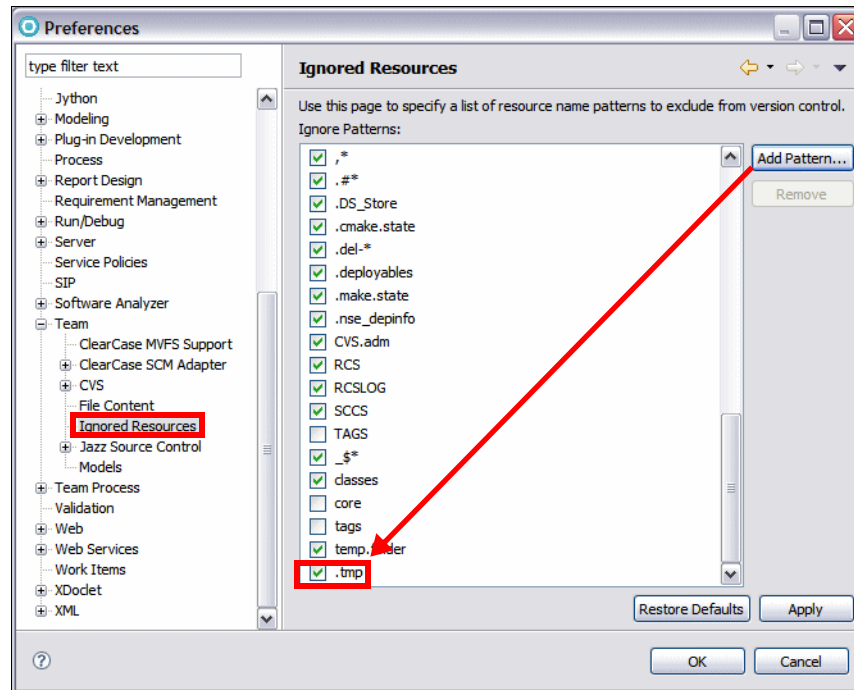

Figure 28-10 Resources that will be ignored when saving to the repository

To remove a pattern from the ignore list, select it and click **Remove**. To temporarily disable ignoring a file pattern clear its check box in the list.

Additionally, there are two further facilities that can be used to exclude a file from version control:

- ▶ Resources marked as derived are automatically not checked into the CVS repository by Application Developer. This field is set by builders in the Eclipse framework, such as the Java builder. To determine if a resource is derived or not, right-click the resource and select **Properties**, or look in the Properties view. The Derived field is shown under Info. It is also possible to change the Derived field value in the properties dialog.
- ▶ Use of a `.cvsignore` file. This file contains a list of files or directories that should not be placed into the repository. CVS checks this file and does not add to CVS any files which are in this list.

A file can be added to the list by right-clicking the file in the Enterprise Explorer and selecting **Team** → **Add to .cvsignore**.

Further details on the syntax of `.cvsignore` can be found at:

<http://www.cvsnt.org/manual/html/cvsignore.html>

CVS-specific settings

The CVS settings in Application Developer are extensive and cannot be covered in full here. Some of the more important settings are highlighted in Table 28-1 with short descriptions. A complete description of the remaining settings can be obtained from the Application Developer help system.

Table 28-1 Category of CVS settings available

Category	Window Preferences	Description
General CVS Settings	Team → CVS	Settings for the behavior in communicating with CVS, handling the files and projects received from CVS and when to prompt the user for certain activities.
Annotate	Team → CVS → Annotate	Switch on or of annotating of binary files.
Comment Templates	Team → CVS → Comment Templates	Let you create, edit or remove comment templates which can be used while checking in a file.
Console	Team → CVS → Console	Various settings for the CVS console view including a flag to for whether to display CVS commands to the console.
Ext Connection Method	Team → CVS → Ext Connection Method	Settings to identify the ssh external program and associated parameters when using the ext protocol to communicate with the CVS server.
Label Decorations	Team → CVS → Label Decorations	Settings for how to display the CVS state of resources in Application Developer.
Password Management	Team → CVS → Password Management	Manages which repositories have passwords saved within Application Developer.
Synchronize/Compare	Team → CVS → Synchronize/Compare	Various settings for comparison
Update/Merge	Team → CVS → Update/Merge	Settings for guiding the Application Developer process when merging is required during synchronization.
Watch/Edit	Team → CVS → Watch/Edit	Settings for the CVS watch and edit functionality which allows users to be informed (via e-mail) when a file has been edited or committed by another user.

CVS keyword substitution

In addition to storing the history of changes to a given source code file in the CVS repository, it is also possible to store meta-information (such as author, date/time, revision and change comments) in the contents of the file. Typically a standard header template is configured in Application Developer, which is then applied to each file when CVS operations (usually check-in and checkout) are performed. The template can include a set of CVS keywords inside a heading, which are expanded out when a file is checked in or out. This is known as keyword expansion.

Keyword expansion is an effective mechanism for developers to quickly identify what version a resource is in the repository versus what a user has checked out locally on their workspace.

Application Developer, by default, has the keyword substitution set to *ASCII with keyword expansion (-kkv)* under the selection **Windows** → **Preferences** → **Team** → **CVS** and the **File and Folders** tab (Figure 28-11). This setting expands out keyword substitution based on the interpretation by CVS, and is performed wherever the keywords are located in the file.

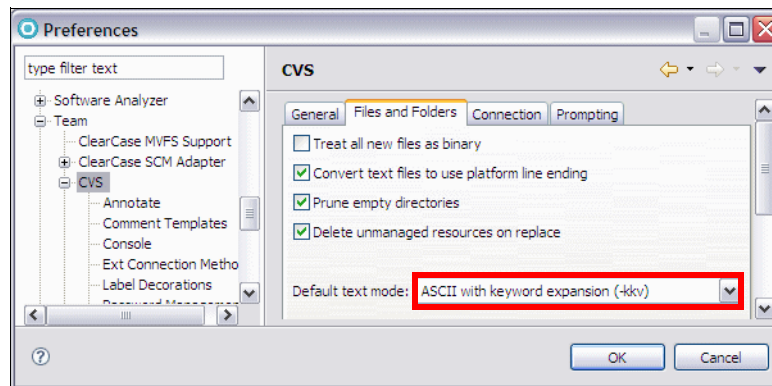

Figure 28-11 CVS Keyword expansion setting

Some of the available keywords (case sensitive) are listed in Table 28-2.

Table 28-2 CVS keywords

Keyword	Description
\$Author\$	Expands to the name of the author of the change in the file, for example: \$Author: itsodev \$
\$Date\$	Expands to the date and time of the change in UTC, for example: \$Date: 2008/10/14 18:21:32 \$
\$Header\$	Contains the CVS file in repository, revision, date (in UTC), author, state and locker, for example: \$Header: /rep7672/XMLExample/.project,v 1.1 2008/10/14 18:21:32 itsodev Exp itso \$
\$Id\$	Like \$Header\$ except without the full path of the CVS file, for example: \$Id: .project,v 1.1 2008/10/14 18:21:32 itsodev Exp itso \$
\$Log\$	The log message of this revision. This does not get replaced but gets appended to existing log messages.
\$Name\$	Expands to the name of the sticky tag, which is a file retrieved by date or revision tags, for example: \$Name: version_1_3 \$
\$Revision\$	Expands to the revision number of the file, for example: \$Revision: 1.1 \$
\$Source\$	Expands to the full path of the RCS file in the repository, for example: \$Source: /rep7672/XMLExample/.project,v \$

To ensure consistency between multiple users working on a team, it is recommended that a standard header is defined for all Java source files. A simple example is shown in Example 28-1.

Example 28-1 Example of CVS keywords used in Java

```

/**
 * Class comment goes here.
 *
 * <pre>
 * Date $Date
 * Id $Id
 * </pre>
 * @author $Author
 * @version $Revision
 */

```

To ensure consistency across all files created, each user would have to cut and paste this into their document. Fortunately, Application Developer offers a means to ensure this consistency.

To set up a standard template, do these steps:

- ▶ Select **Windows** → **Preferences** → **Java** → **Code Style** → **Code Templates**.
- ▶ Expand **Comments** → **Files** and click **Edit**.
- ▶ Cut and paste or type what comment header you require (Figure 28-12).

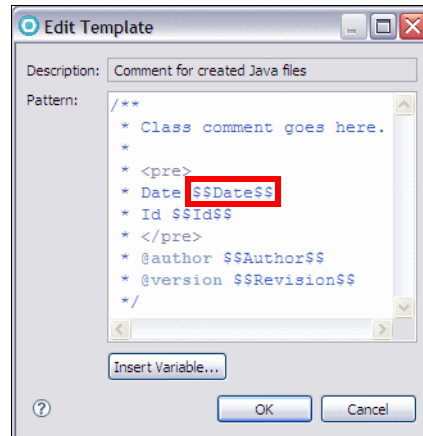

Figure 28-12 Setup of a common code template for Java files

- ▶ Click **OK** to complete the editing, then click **Apply** followed by **OK**.

Note: The double dollar sign (\$\$) is required because Application Developer treats a single dollar (\$) as one of its own variables. \$\$ is used as a means of escaping the single dollar so that it can be post processed by CVS.

This sets up a standard CVS template. The next time a new class is created, checked in, and then checked out, the header is displayed (Example 28-2).

Example 28-2 Contents of Java file after check in and check out from CVS

```
/**
 * class comment goes here.
 *
 * <pre>
 * Date $Date: 2004/10/29 18:21:32 $
 * Id $Id: $Id: Example.java,v 1.1 2004/10/29 18:21:32 itsodev Exp itso $
 * </pre>
 * @author $Author: itsodev $
 * @version $Revision: 1.1 $
 */
```

Development scenario

Note: The example in this chapter calls for two simulated developer systems. For demonstration purposes, this can be accomplished by having two workspaces on the same machine. Refer to “Workbench basics” on page 76 for detailed instructions on setting up multiple workspaces.

To show you how to work with CVS in Application Developer, we follow a simple but typical development scenario, shown in Table 28-3.

Two developers, *cvsuser1* and *cvsuser2*, work together to create a servlet `ServletA` and a view bean `View1`.

Table 28-3 Sample development scenario

Step	Developer 1 (<i>cvsuser1</i>)	Developer 2 (<i>cvsuser2</i>)
1	Creates a new Dynamic Web Project <code>RAD75CVSGuide</code> and a servlet <code>ServletA</code> in it and adds it to the version control and the repository.	
2	2b: Updates the servlet <code>ServletA</code> .	2a: Imports the <code>RAD75CVSGuide</code> CVS module as a Workbench project. Creates a view bean <code>View1</code> , adds it to the version control, and synchronizes the project with the repository.
3	3a: Synchronizes the project with the repository to commit the changes to repository (servlet) and receives changes from the repository (view bean).	3b: Synchronize the project with the workspace to receive the servlet.
4	4a: Continues changing and updating the servlet. Synchronizes the project with the repository to commit his changes to repository and merges changes. 4c: Synchronize with the repository to pick up the merged servlet.	4a: Begins changes to servlet in parallel with developer 1. 4b: Synchronizes the project after <i>cvsuser1</i> has committed and has to merge code from the workspace and the CVS repository.
5	Assigns version number the project.	

Steps 1 through 3 are serial development with no parallel work on the same file being done. During steps 4 and 5 both developers work in parallel, resulting in conflicts. These conflicts are resolved using the CVS tools in Application Developer.

In the sections that follow, we perform each of the steps and explain the team actions in detail.

Important: Always work in the workspace of the correct user (cvsuserX).

Create and share the project (step 1 - cvsuser1)

Application Developer offers a perspective specifically designed for viewing the contents of CVS servers: The CVS Repository Exploring perspective.

Add a CVS repository

For this section, ensure that you have completed, “CVSNT Server installation and implementation” on page 1022 and “Accessing the CVS repository” on page 1030.

- ▶ The CVS Repositories view now contains the repository location (Figure 28-13).

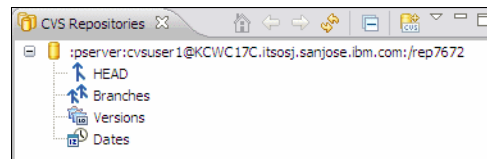

Figure 28-13 CVS Repositories view

Expanding a location in the CVS Repositories view reveals branches and versions. A special branch, called HEAD, is shown outside the main branches folder because of its importance. It is the main integration branch, holding the project's current development state.

The CVS Repositories view can be used to check out repository resources as projects on the Workbench. You can also configure branches and versions, view resource histories, and compare resource versions and revisions.

First, a project must be created and shared before full use can be made of the repository.

Create a project and servlet

To create a project and a servlet, do these steps:

- ▶ Switch to the Web perspective and create a new Dynamic Web Project by selecting **File** → **New** → **Dynamic Web Project**.
- ▶ Type **RAD75CVSGuide** as the name of the project, keep the defaults for all the other options, and click **Finish**.
- ▶ In the Enterprise Explorer, right-click **RAD75CVSGuide** and select **New** → **Servlet**.
- ▶ In the Create Servlet dialog (Figure 28-14):
 - Type **itso.rad75.teamcvs.servlet** for the Java package.
 - Type **ServletA** for the Class name.
 - Click **Finish**.

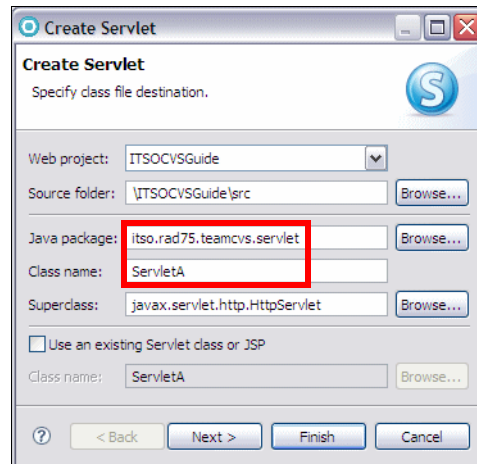

Figure 28-14 Create Servlet wizard

Add the project to the repository

To add the Web project source code to the repository, do these steps:

- ▶ In the Enterprise Explorer, right-click **RAD75CVSGuide** and select **Team** → **Share Project**.
- ▶ In the Share Project dialog, select **CVS**, and click **Next**.
- ▶ In the Share Project with CVS Repository dialog, select **Use existing repository location**, select the repository, and click **Next**.
- ▶ In the Enter Module Name dialog, select **Use project name as module name** (default), and click **Next**. A status window might appear as the resources are added to the repository.

- ▶ The Share Project Resources dialog (Figure 28-15) opens, listing the resources to be added. Click **Finish**.

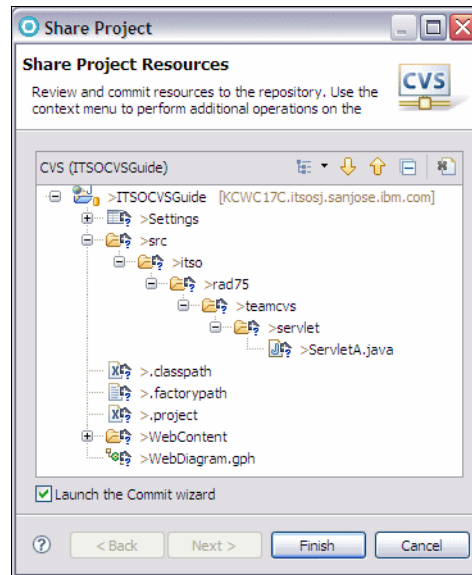

Figure 28-15 Verification of resources add under CVS revision control

- ▶ A dialog opens, informing you that new file types are being added, which are not configured as types in the Application Developer preferences. Those files are meta informations of the project and must be ASCII Text (Figure 28-16). Set these file types to **ASCII Text**, and click **Next**.

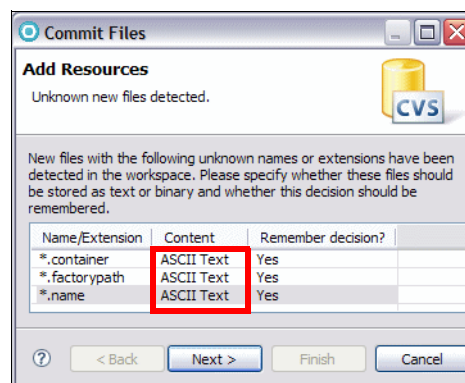

Figure 28-16 Adding new file types on check-in

- ▶ In the commit files dialog, type **Initial version** in the comment field and click **Finish**.
- ▶ A status window opens, showing the progress as the initial versions of a new project are checked into the repository. Because RAD75CVSGuide is a relatively small project, this process should only take a few seconds. For larger projects where the initial check-in might take some time, the **Run Background** button allows the user to continue working in their workspace while the CVS check-in process completes.

After this has been completed, the RAD75CVSGuide project is checked into the repository and available for other developers to use.

Adding a shared project to the workspace (step 2a - cvsuser2)

The purpose of any source code repository is to allow multiple developers to work as a team on the same project. The RAD75CVSGuide project has been created in one developer's workspace and shared using CVS.

Now we want to add the same project to a second developer's workspace.

- ▶ The second developer must add the CVS repository location to their workspace using the CVS Repositories view in the CVS Repository Exploring perspective, as described in "Add a CVS repository" on page 1041.

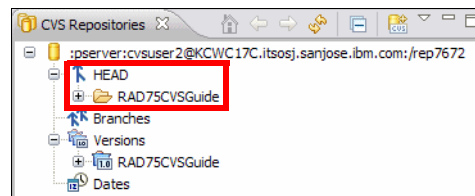

The difference is that the HEAD branch in the repository contains the RAD75CVSGuide project.

- ▶ Right-click the **RAD75CVSGuide** module, and select **Check Out**. The current project in the HEAD branch is checked out to the workspace.

Develop the view bean

Now that both developers have exactly the same synchronized HEAD branch of the RAD75CVSGuide project on their workspaces, it is time for the second developer to create the view bean `View1`.

- ▶ Open the Web perspective.
- ▶ In the Enterprise Explorer, right-click **RAD75CVSGuide** and select **New** → **Class**.

- ▶ In the New Class dialog (Figure 28-17):
 - Type **itso.rad75.teamcvs.bean** for the Package.
 - Type **View1** for the Name.
 - Select **Generate comments**.
 - Click **Finish**.

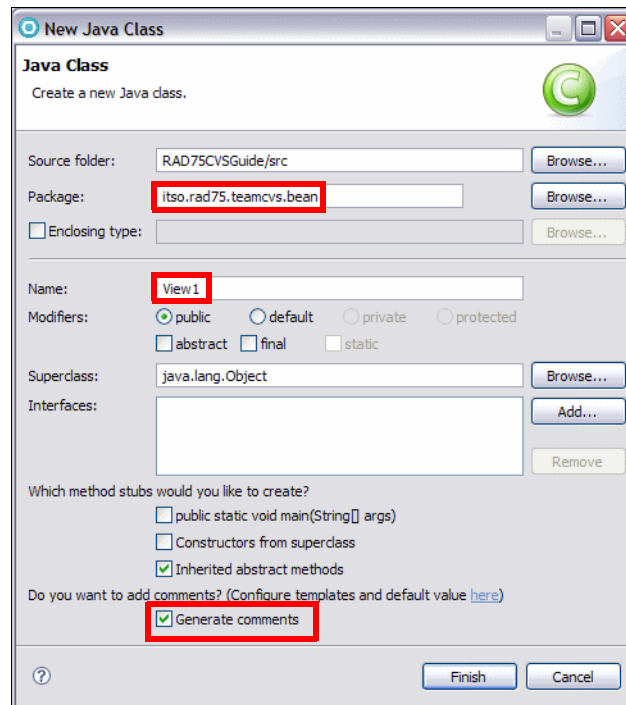

Figure 28-17 Creating the View1 view bean

- ▶ Add the highlighted two private attributes in the View1 class (Example 28-3).

Example 28-3 Add two private attributes to the View1 class

```
package itso.rad75.teamcvs.bean;

public class View1 {
    private int count;
    private String message;
}
```

- ▶ In the Java Editor, right-click and select **Source** → **Generate Getters and Setters**, select **Select All**, and verify that the Access modifier is set **public** (Figure 28-18). Click **OK**.

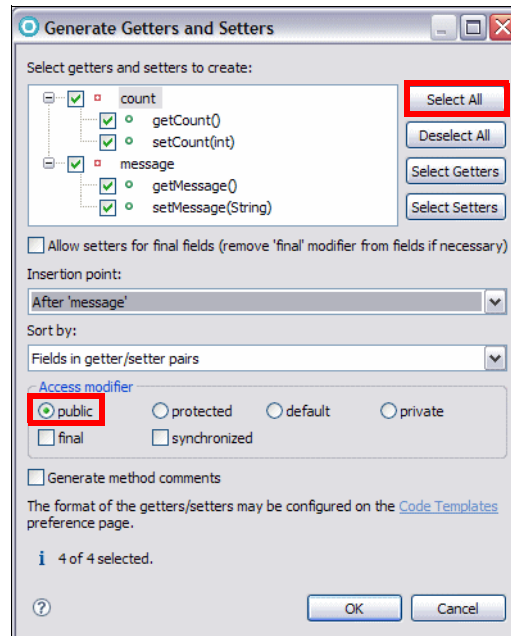

Figure 28-18 Creating setters and getters for class View1

- ▶ Save and close the View1 class.

Tip: In the Enterprise Explorer view, the greater than sign (>) in front of a resource name means that the particular resource is not synchronized with the repository. The question mark symbol (?) indicates that the file is not in the repository. These visual cues can be used to determine when a project requires synchronization.

Synchronizing with the repository

To update the repository with these changes, do these steps:

- ▶ Right-click **RAD75CVSGuide** and select **Team** → **Synchronize with Repository**.
- ▶ A dialog prompts you to change to the Team Synchronizing perspective. Select **Remember my decision** and click **Yes**. The project is compared with the repository, and the differences are displayed in the Synchronize view (Figure 28-19).

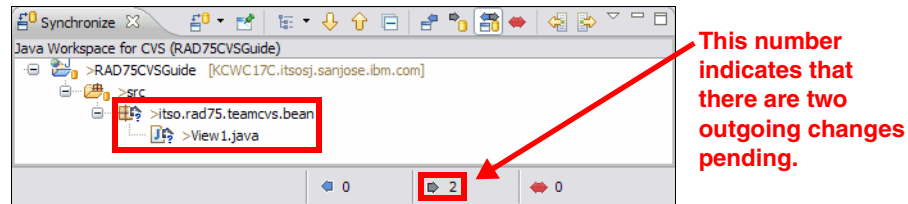



Figure 28-19 Synchronizing RAD75CVSGuide after creating the viewbean View1

This view allows you to update resources in the Workbench with newer content from the repository (*incoming*), commit resources from the Workbench to the repository (*outgoing*), and resolve conflicts that might occur in the process.

The arrow icons with a plus sign  indicate that the files do not exist in the repository. Because the package `itso.rad75.teamcvs.bean` and the class `View1.java` are new and not yet checked in, they show the plus sign.

- ▶ To add these new resources to version control, right-click **RAD75CVSGuide** in the Synchronize view, and select **Commit**.
- ▶ In the Commit Files dialog, type **View bean itso.rad75.teamcvs.bean.View1 added** for the commit comment and check the files displayed on bottom half of the window to make sure the changes are as expected (Figure 28-20).
- ▶ Click **Finish** and the changes are committed to the repository.

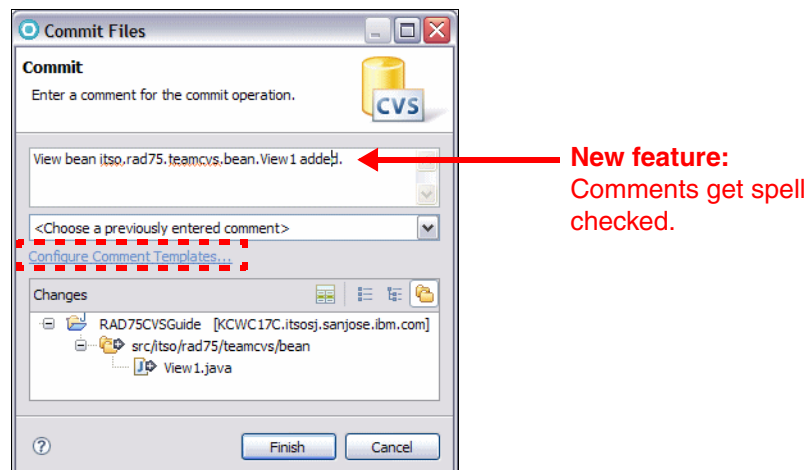

Figure 28-20 Verifying committing of resources into repository

Note: The user can specify some common text within commit comments, and re-use the same format for all commits. To create such comments, click **Configure Comment Template** to create a comment, then select it from the drop-down list in this dialog.

Modifying the servlet (step 2b - cvsuser1)

While activities in “Adding a shared project to the workspace (step 2a - cvsuser2)” occur, our original user, cvsuser1, is working on developing the servlet further.

In the first workspace created for cvsuser1, do these steps:

- ▶ In the Enterprise Explorer, open **ServletA.java** (in RAD75CVSGuide/Java Resources/src/itso.rad75.teamcvs.servlet).
- ▶ Create a static attribute called `totalCount` of type `int` and initialized to zero as highlighted in Example 28-4. Save and close the servlet.

Example 28-4 ServletA gets a static attribute

```
package itso.rad75.teamcvs.servlet;

.....

public class ServletA extends HttpServlet {
    private static final long serialVersionUID = 1L;
    private static int totalCount = 0;

    public ServletA() {
        super();
    }
    .....
}
```

Synchronizing with the repository (step 3a - cvsuser1)

User cvsuser1 now synchronizes with the repository and receives the changes of cvsuser2 (adding the View1 bean) and provides the opportunity to check-in the changes made to ServletA. Do these steps:

- ▶ In the Enterprise Explorer, right-click the **RAD75CVSGuide** project and select **Team** → **Synchronize with Repository**.
- ▶ Select **Remember my decision** and click **Yes** to switch to the Synchronize view.

- ▶ Expand the **RAD75CVSGuide** → **src** trees to view the changes (Figure 28-21).

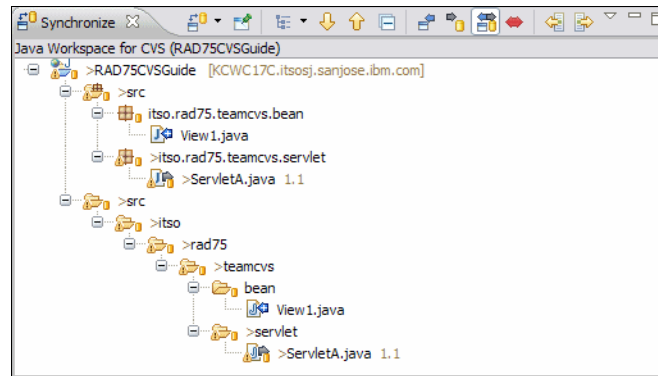



Figure 28-21 User cvsuser1 merging with CVS repository

Note: The symbol  in the diagram indicates that an existing resource differs from what is in the repository. The symbol  indicates that a new resource is in the repository that does not exist on the local workspace.

- ▶ To obtain updated resources from the CVS repository, right-click the **RAD75CVSGuide** project and select **Update**. This brings a copy of the `View1.java` file into this workspace.

Note: When using Application Developer v7.5, sometimes a Java file that has been changed appears twice in the Synchronize view. It might appear under the representation of the Java package and also under a folder representation of the packages. Figure 28-21 shows an example of this with both `View1.java` and `ServletA.java` showing twice. While this looks untidy, if either of the representations of the file are updated, then both disappear from the Synchronize view as expected.

- ▶ Verify that the changes do not cause problems with existing resources in the local workspace, by checking the Problems View. In this case, there are none. Right-click the **RAD75CVSGuide** project and select **Commit**.
- ▶ In the Commit dialog, add the comment **Static variable totalCount added to ServletA** and click **Finish** (Figure 28-22). This checks the changes made to `ServletA` into the repository.

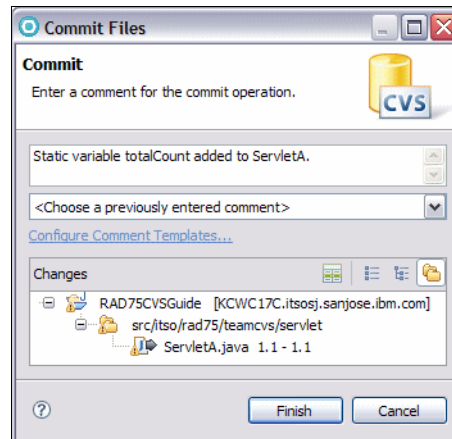

Figure 28-22 Adding comment for changes to ServletA

The repository now has the latest changes to the code from both developers. The user `cvsuser1` is in sync with the repository; however, `cvsuser2` has not yet received the changes to the `ServletA`.

Synchronizing with the repository (step 3b - `cvsuser2`)

The second workspace used by `cvsuser2` should also synchronize (update) with the repository and receive the changes of `cvsuser1`.

This brings the changes made to `ServletA` into the workspace and makes sure that both workspaces are completely up to date.

Parallel development (step 4 - `cvsuser1` and `cvsuser2`)

The previous steps have highlighted development and repository synchronization with two people working on two parts of a project. It highlights the need to synchronize between each phase in the development before further work is performed.

The following scenario demonstrates two developers working simultaneously on the same file, starting from the same revision. Each user's sequence of events is described in the sections below; and a summary is shown in the time-line in Figure 28-23.

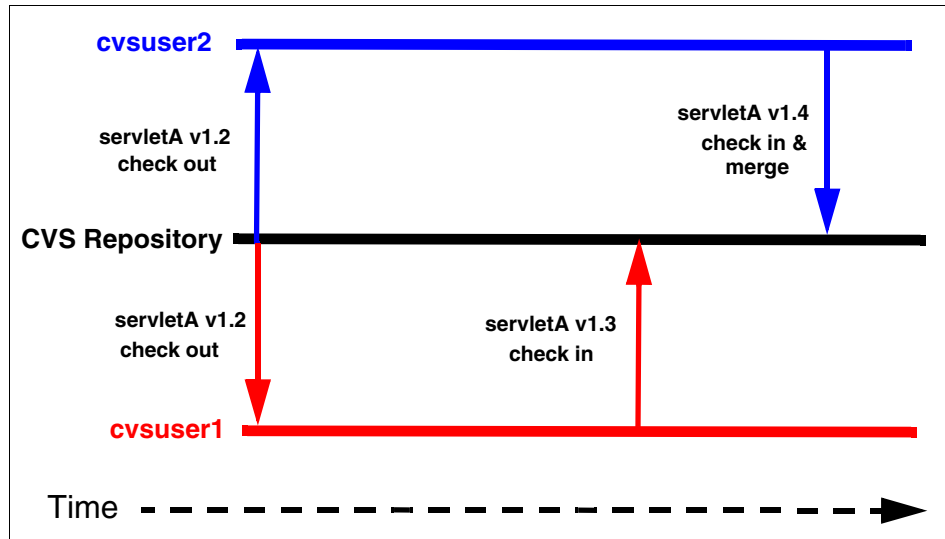

Figure 28-23 Parallel concurrent development of same resource by multiple developers

User cvsuser1 updates and commits changes

In this scenario, user cvsuser1 modifies the doPost method to log information for an attribute. The following procedure demonstrates how to synchronize the source code and commit the changes to CVS.

- ▶ In the Enterprise Explorer, open **ServletA** (in RAD75CVSGuide/Java Resources/src/itso.rad75.teamcvs.servlet).
- ▶ Generate Getter- and Setter-method for static variable `totalCount`.
- ▶ Navigate to the doPost method by scrolling down the file and adding the code to count the number of post requests received:

```
protected void doPost(HttpServletRequest request,
    HttpServletResponse response) throws ServletException, IOException {
    ServletA.setTotalCount(ServletA.getTotalCount() + 1);
    System.out.println("The total number of requests is: " +
        ServletA.getTotalCount());
}
```

- ▶ Save and close the file.
- ▶ Synchronize the project with the repository by right-clicking and selecting **Team** → **Synchronize with Repository**.
- ▶ Fully expand out the tree in the Synchronize view. The servlet should be the only change.
- ▶ Right-click the project and select **Commit**, add the comment **doPost method implemented by cvsuser1**, and click **Finish** to commit.

The developer cvsuser1 has now completed the task of adding code into the servlet. Changes can now be picked up by other developers in the team.

User cvsuser2 updates and commits changes

To complete the scenario, the second developer also makes changes to doPost method of ServletA. This is done in the workspace of cvsuser2 and assumes that the workspace was synchronized before this scenario was started.

To make the changes, do these steps:

- ▶ In the Enterprise Explorer, open **ServletA**.
- ▶ Generate Getter- and Setter-method for static variable totalCount.
- ▶ Add the highlighted code of Example 28-5 to the ServletA. An instance variable for the view bean is added and the doPost method gets implemented. Save and close the file.

Example 28-5 cvsuser2 completes the ServletA as well

```
package itso.rad75.teamcvs.servlet;
.....

public class ServletA extends HttpServlet {
    private static final long serialVersionUID = 1L;
    private static int totalCount = 0;
    private View1 myViewBean;
    .....

    protected void doPost(HttpServletRequest request,
        HttpServletResponse response) throws ServletException, IOException {
        this.myViewBean = new View1();
        this.myViewBean.setCount(ServletA.getTotalCount());

        switch (ServletA.getTotalCount()) {
        case (0):
            System.out.println("No hits on page");
            break;
        case (1):
            System.out.println("One hit on page");
            break;
        default:
            System.out.println("Hits are greater than one");
        }
    }

    .....
}
```

- ▶ Synchronize with the repository by right-clicking the **RAD75CVSGuide** project and selecting **Team** → **Synchronize with Repository**.
- ▶ Expand the tree in the Synchronize view to see the changes (Figure 28-24).

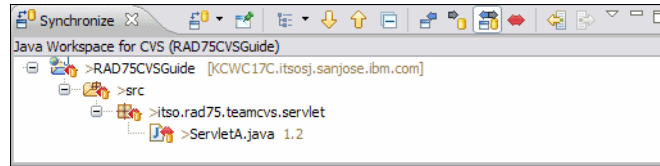



Figure 28-24 Synchronize view with conflicting changes

Note: The symbol  indicates that the file has conflicting changes that requires merging.

- ▶ Double-click **ServletA.java** to see the changes (Figure 28-25):
 - On the left side are the changes made by the current user `cvsuser2` and on the right side is the code in the repository (checked in by user `cvsuser1`).
 - Use the arrow icons at the top  to move from change to change.
 - Black lines between the panes indicate identical blocks.
 - Red lines indicate changes (inserts or conflicts).
 - Red bars on the right indicate conflicts.

Merging in this case requires consolidation between the two developers as to the best solution. In our example, we assume that the changes in the repository (right side) have to be placed sequentially before changes performed by `cvsuser2` (left side).

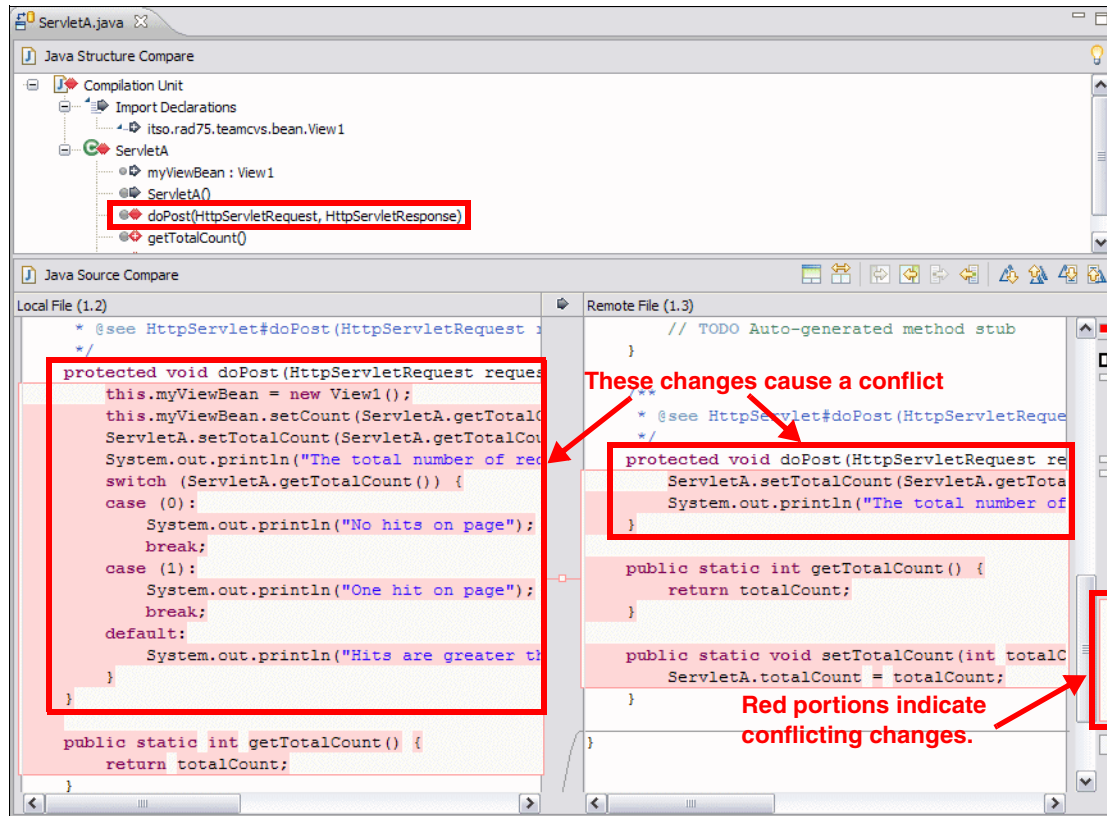



Figure 28-25 The changes between the local and remote repository

- ▶ Double-click the **doPost** method in the Java Structure Compare view.
- ▶ Step 1: Click the **Copy Current Change from Right to Left** icon . This places the change of the conflicting section on the right-hand panel to the bottom of the section in the left-hand panel (Figure 28-26).
- ▶ Step 2: In the left pane, highlight the two lines of code which were added and move them to the correct location in the method.

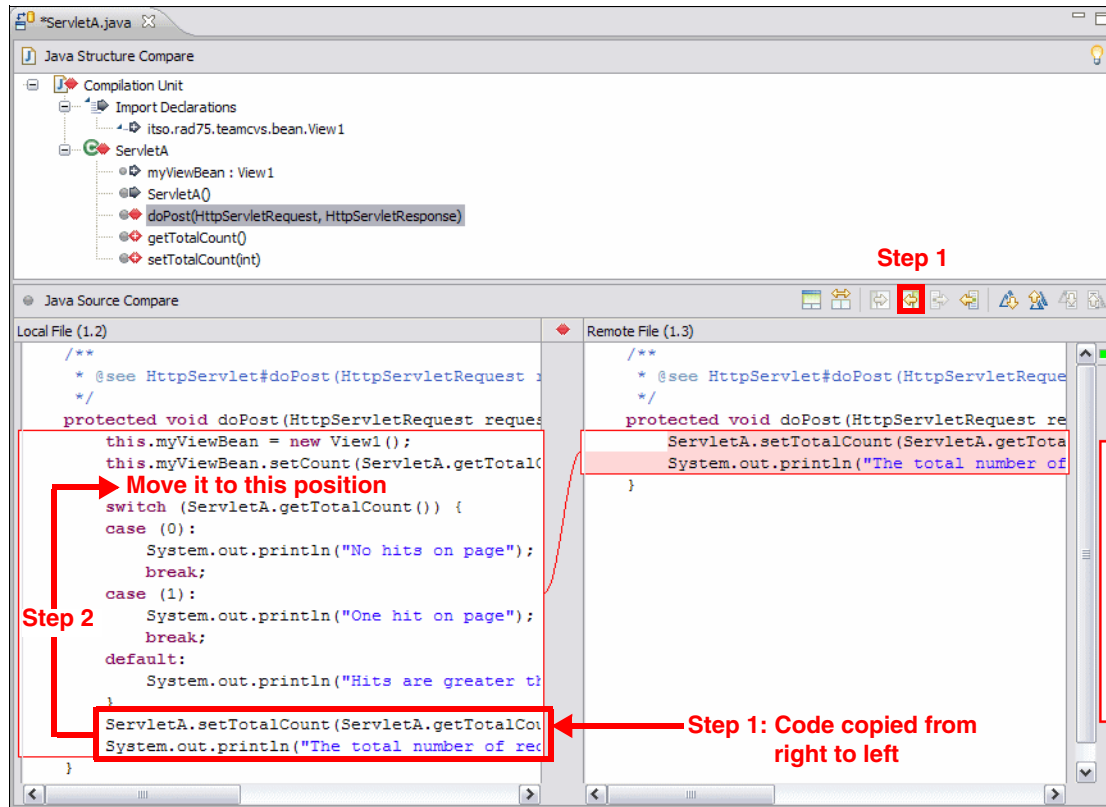

Figure 28-26 Merging changes from right to left

- ▶ Verify that the code is exactly as agreed by the developers, and save the new merged change by selecting **File** → **Save**.
- ▶ Re-synchronize the file using **Team** → **Synchronize With Repository**.
- ▶ In the Synchronize view, verify that the changes are correct, right-click **ServletA.java** and select **Mark as Merged**, then right-click again and select **Commit**.
- ▶ In the Commit dialog, enter the comment **ServletA changed and doPost method merged with cvsuser1**.

This operation creates a revision of the file, revision 1.4, which contains the merged changes from users cvsuser1 and cvsuser2. This is the case even though both developers originally checked out revision 1.2.

User cvsuser1 synchronizes

The workspace for cvsuser1 should also be synchronized with the repository at this stage to pick up the merged code of the ServletA.

Creating a version (step 5 - cvsuser1)

Now that the changes for both users are committed and cvsuser1 has synchronized with the repository, we want to create a version to milestone our work. Perform the following in the workspace of cvsuser1:

- ▶ Right-click **RAD75CVSGuide** and select **Team** → **Tag as Version**. The Tag Resources dialog opens (Figure 28-27).

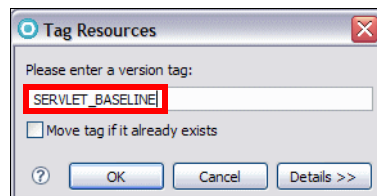

Figure 28-27 Tagging the project as a version

- ▶ Type **SERVLET_BASELINE** as the version tag and click **OK**.
- ▶ Verify that the tag has been performed by switching to the CVS Repository Exploring perspective and expand **Versions** (Figure 28-28).

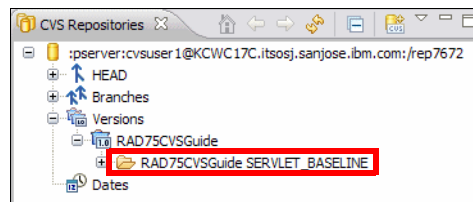

Figure 28-28 Repository view showing new project revision

CVS resource history

Within Application Developer, a developer can view the resource history of any file in a shared project. This is done in the CVS resource History view, which shows a list of all the revisions of a resource in the repository. From this view you can also compare two revisions, revert the existing workspace file to a previous revision, or open an editor to show the contents of a revision.

To demonstrate this feature, do these steps:

- ▶ In the Enterprise Explorer, right-click **ServletA.java** and select **Team** → **Show History**, and the History view opens (Figure 28-29).

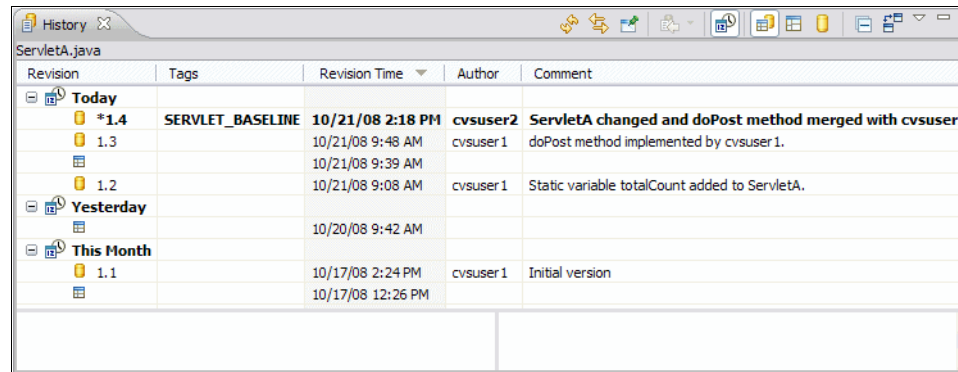





Figure 28-29 CVS History view for ServletA.java





The CVS resource history displays the columns described in Table 28-4.

Table 28-4 CVS resource history terminology

Column	Description
Revision	The revision number of each version of the file in the repository. An asterisk (*) indicates that this is the current version in the workspace.
Tags	Any tags which have been associated with the revision.
Revision Time	The date and time when the revision was created in the repository.
Author	The name of the user that created and checked in the revision into the repository.
Comments	The comment (if any) supplied for this revision at the time it was committed.

The following icons are available at the top of the History view:

- ▶  **Refresh**—Refreshes the history shown for the currently shown resource.
- ▶  **Link Editor with Selection**—A toggle switch which automatically shows the history of the resource currently being shown in the main editor.
- ▶  **Pin the History View**—Locks the history view into showing just the currently selected resource's history. When this is toggled on then the **Link Editor with Selection** is automatically switched off.

- ▶  **Group Revisions by date**—This changes the view to show the revisions ordered by date rather than by logical revision number. It is also possible to order the items in the History View by clicking on the column headers.
- ▶    **Local Revisions, Local and Remote Revisions, Local Revisions**—These boxes provide three options, which type of revisions to show for the selected resource.
- ▶  **Compare Mode**—If this toggle is on then double-clicking on a line in the history view shows a comparison between the selected repository file and the file in the workspace. If this is switched off then double-clicking displays the contents of that file revision.
- ▶ **Filters**—This feature is available from the drop-down menu in the History view. It allows a user to filter the History view by author, date, or text within the check-in comments.

Comparisons in CVS

Often developers have to view what changes have been made to a file and in which revision. Application Developer provides a mechanism to graphically display two revisions of a file and their differences. Two types of comparison are possible, users can compare the version in their workspace with any version in the CVS repository, or any two files in the CVS repository can be compared with each other.

The Resource History view provides these mechanisms and the following scenario has an example of how to do this.

Comparing a workspace file with the repository

The user `cvsuser1` has Version 1.4 of the `ServletA` file in the workspace and wants to compare the differences between the current version and Version 1.1. To do this, do these steps:

- ▶ In the Enterprise Explorer, right-click **ServletA.java** and select **Compare with** → **History**, and the History view opens.
- ▶ Double-click **revision 1.1** and the Comparison Editor opens (Figure 28-30):
 - In the top half the outline view of the changes are shown. This includes attribute changes and which methods that have been changed.
 - In the bottom two panes the actual code differences are highlighted. The left pane has the revision in the workspace and the right pane has the revision 1.1 from the repository.

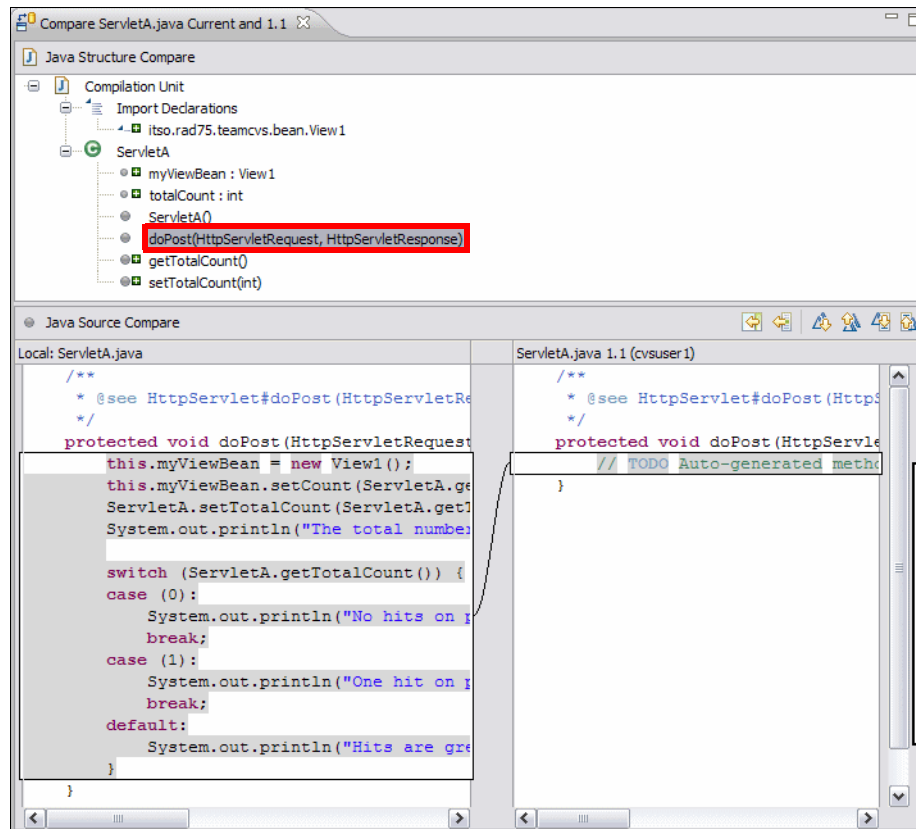

Figure 28-30 Comparison between current ServletA.java and revision 1.1

Note: The bars in the bottom pane on the right-hand side indicate the parts of the file which are different. By clicking a bar, Application Developer positions the panes to highlight the changes. This can assist in quickly moving around large files with many changes.

Comparing two revisions in repository

In this case, the developer wants to compare the differences between revision 1.1 and 1.3 in the repository of the ServletA file, but version 1.4 is in the workspace and the developer does not want to remove it.

The procedure to compare these two files is as follows:

- ▶ Open the CVS Resource History using the procedure in “CVS resource history” on page 1056, which displays the view shown in Figure 28-31.

- ▶ First click the  icon to only show remote revisions.
- ▶ Select the row of the first revision to compare, for example revision 1.1, and then, while pressing the Ctrl key, select the row of the second version, which is 1.3.
- ▶ Right-click, ensuring that the two revisions remain highlighted, and select **Compare With Each Other** (Figure 28-31).

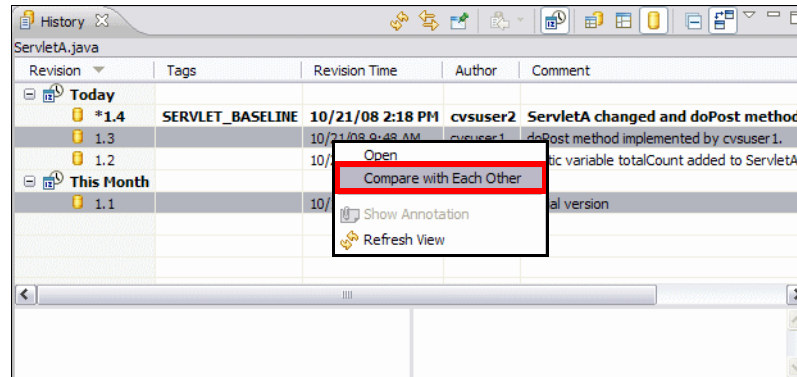

Figure 28-31 Highlight the two versions to compare

- ▶ The result appears as in Figure 28-32. The higher version always appears in the left-hand pane and the lower version to the right.

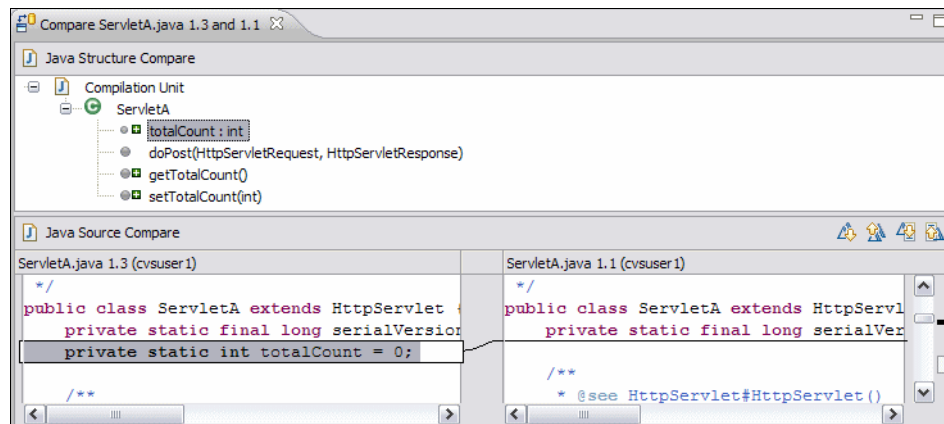

Figure 28-32 Comparisons of two revisions from the repository

Annotations in CVS

The Annotation view allows a user to view all the changes that have been performed on a particular file in a single combination of workspace views. It displays what lines were changed in particular revisions, the author responsible for the change, when the file was changed and the change description entered at the time. By showing this information across all revisions of a file and in the same set of connected views, developers can quickly determine the origin of changes and the explanation behind them.

To demonstrate annotations, we can go back to our example of looking at ServletA and see what the information the Annotations feature provides:

- ▶ In the Enterprise Explorer, right-click **ServletA.java** and select **Team** → **Show Annotation**. If the Changing Quick Diff Reference dialog appears, select **OK**.
- ▶ Application Developer opens the ServletA in a Java Editor, where a colored line is displayed on the left bar of the source code. When you hover the mouse over the colored line, a pop-up displays which CVS revision was last responsible for changing that line (Figure 28-33). In the History view the revision associated with the line of source code selected, is highlighted.

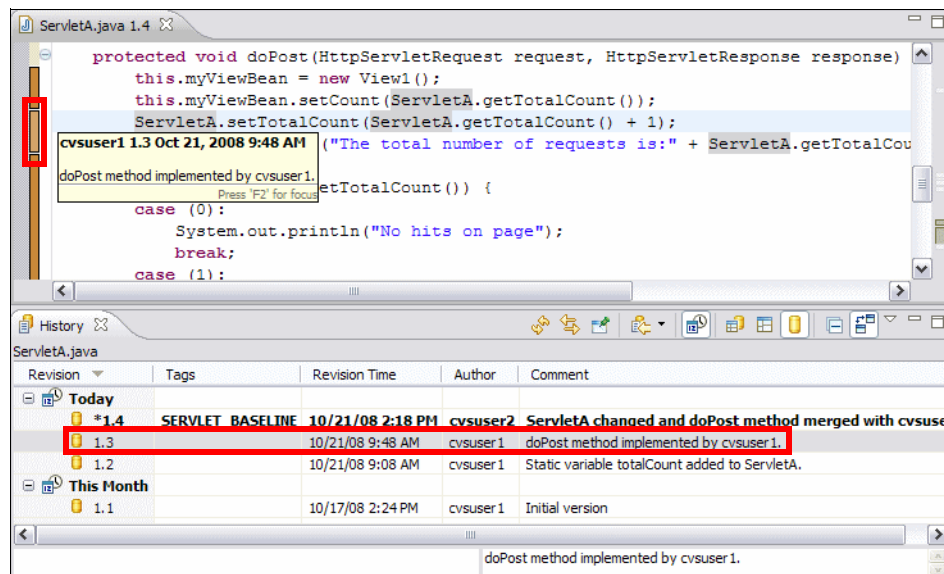

Figure 28-33 CVS Annotation view

Branches in CVS

Branches are a source control technique to allow development on more than one baseline in the repository.

In CVS, the HEAD branch always refers to the latest or current work that is being performed in a team environment. This is only sufficient for a development team that works on one release, which contains all the latest developments, including major enhancements and bug fixes. The real-world situation is usually that at least two streams are required. One main stream to manage the development, and a maintenance stream for the version that is in currently production. This allows new versions of the production build to be created without fear of being affected by the changes made to the main development stream. This scenario is when branches can be useful and where CVS baselines and parallel streams of work should be created.

At some point the development and maintenance streams have to be merged together to provide a new baseline to be a production version. This process ensures that any fixes or enhancements made in the maintenance stream make it into the development stream. This is known as a merge, and the CVS tools within Application Developer provide features to facilitate this process. A representation of this is shown in Figure 28-34.

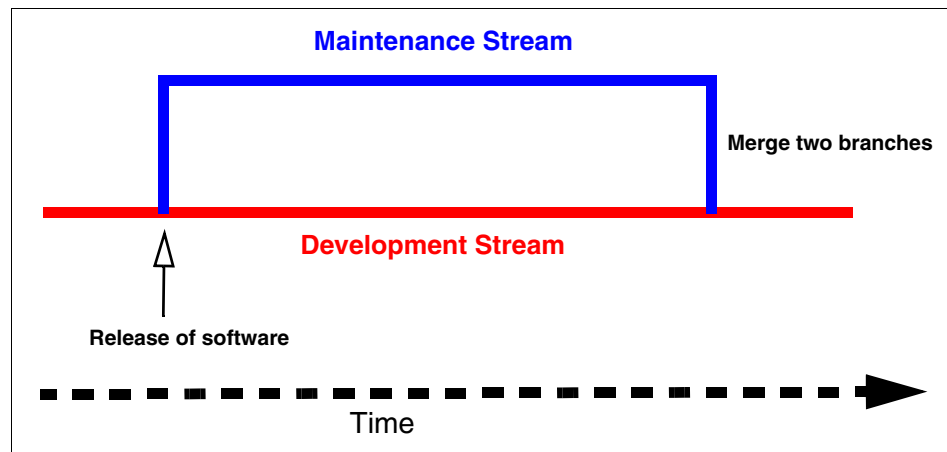

Figure 28-34 Branching with two streams

Branching

Creating a branch is useful when you want to maintain multiple streams of the software being developed or supported and when they are in different stages of delivery (usually development and production support).

The scenario demonstrated here is that a particular release has been deployed to the production environment, and a new project has started to enhance the application. In addition to this, the existing production release has to be maintained so that problems identified are fixed quickly. Branching provides the mechanism to achieve this and the following example outlines how this might be done.

Perform the following steps for the first workspace for cvsuser1:

- ▶ In the Enterprise Explorer of the Web perspective, right-click **RAD75CVSGuide** and select **Team** → **Tag as Version**. Type **BRANCH_ROOT** in the tag version field, and click **OK**.
- ▶ Right-click **RAD75CVSGuide** again, and select **Team** → **Branch**.
- ▶ In the Create a new CVS Branch dialog (Figure 28-35), enter **Maintenance** as the branch name and **BRANCH_ROOT** for the version name. Verify that **Start working on the branch** is selected so that the workspace automatically sets itself up for development on the new branch. Click **OK**.

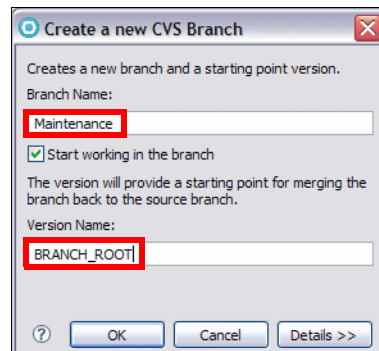

Figure 28-35 Creating a new CVS Branch

Attention: Remember the version name entered here, as it is important. It identifies the point at which the branch was created and is required later when the branches are merged.

- ▶ Right-click **RAD75CVSGuide**, select **Properties**, and select the **CVS** tab. A view is displayed with the tag name displayed as Maintenance (Branch). This indicates that the project is now associated with the CVS Maintenance branch and any changes checked in go to that branch (Figure 28-36).

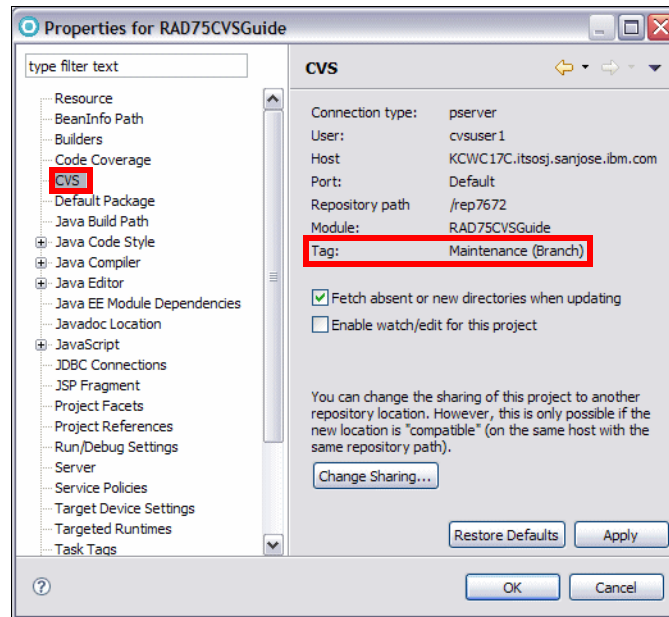

Figure 28-36 Branch information for a project in the local workspace

- ▶ Open the CVS Repository Explorer window by clicking **Window** → **Open Perspective** → **Other** → **CVS Repository Explorer**.
- ▶ Right-click the repository and click **Refresh View**.
- ▶ Expand the tree to verify that the branch has been created in the repository (Figure 28-37).

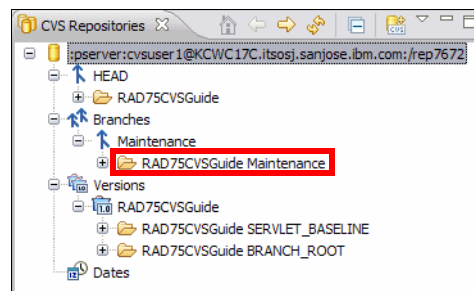

Figure 28-37 List of branches

Refreshing branching information

The CVS Repositories view does not automatically receive a list of all branches from the server. If a branch has been created on the CVS server, the user of a workspace must perform a refresh to receive the name of the new branch. In our sample case, `cvsuser2` should perform a refresh to receive information about the new maintenance branch.

From the `cvsuser2` workspace, do these steps:

- ▶ To refresh the branches in a repository, open the CVS Repository Exploring perspective.
- ▶ Select the repository and expand the tree. Select and right-click the **Branches** node, and select **Refresh Branches**.
- ▶ In the Refresh Branches dialog, click **Select All** followed by **Finish**.
- ▶ The Maintenance branch is now shown under the Branches folder (Figure 28-38).

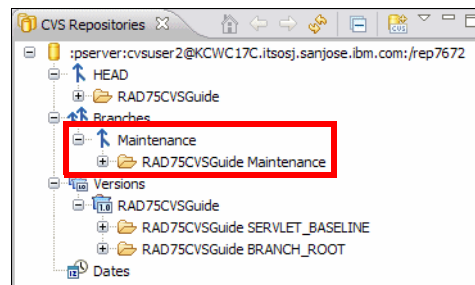

Figure 28-38 Refreshed Branch list

Updating branch code

Assume now that there are changes required to be made to `ServletA` and a new view bean (`View2`) must be created. This scenario demonstrates the merge process with the changes being made in the maintenance branch and then moved into the main branch.

In the workspace of `cvsuser1`, do these steps:

- ▶ From the Enterprise Explorer open **ServletA.java**.
- ▶ Navigate to the `doPost` method and at the top add the statement:

```
System.out.println("Added in some code to demonstrate branching");
```
- ▶ Save and close the file.
- ▶ Right-click the `itso.rad75.teamcvs.beans` package and select **New** → **Class**.

- ▶ Type **View2** for the name of the class and click **Finish**.
- ▶ Right-click **RAD75CVSGuide** and select **Team** → **Synchronize With Repository**.
- ▶ In the Synchronize view, right-click **RAD75CVSGuide** and select **Commit**.
- ▶ In the Commit dialog, type **Branching example** as the revision comments, and click **Finish**.
- ▶ In the CVS Repository Explorer perspective, expand the tree below the Maintenance branch (Figure 28-39).

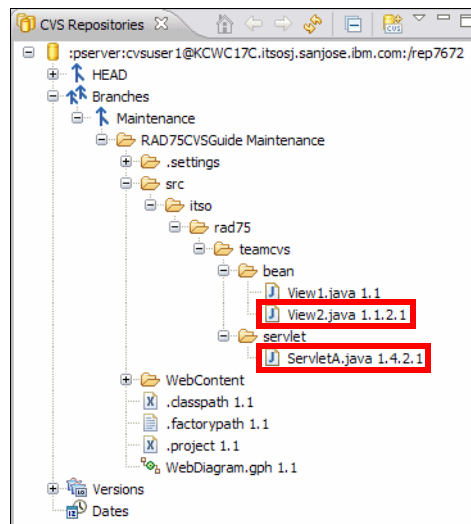

Figure 28-39 Code checked into the branch

Note: Note that the logical revision for `View2.java` is 1.1.2.1 and for `ServletA.java` is 1.4.2.1. The extra two numbers in the logical revision are added by CVS when a branch is created. The first two numbers indicate the logical revision where the branch was created, the third indicates which branch the change from that logical revision (currently the second one if we count the HEAD branch) and the final number is the logical revision within this branch. In this case both files are the first revision in the Maintenance branch, and so the last digit is the number one.

The changes have now been committed into the Maintenance branch, which now has different content than the main branch. These changes are not seen by developers working on the HEAD branch, which is the development stream in our scenario.

Merging

Merging of branches occurs when it is decided that code from one branch should be incorporated into another branch. This might be required for several reasons, such as if a major integration release is about to be released for testing, or if bug fixes are required from the maintenance branch to resolve certain issues.

The scenario here is that development on the main CVS branch has completed and any production fixes made to the Maintenance branch are required in the main branch as a new production build is planned.

To merge the two branches, the following information is required:

- ▶ The name of the branch or version that contains your changes.
- ▶ The version from which the branch was created. This is the version name that you supplied when branching.

In our case, the branch is called **Maintenance**, and the version from which we created the branch was called **BRANCH_ROOT**.

Merging requires that the target or destination branch be loaded into the workspace before merging in a branch. Because in our scenario the changes are merged to HEAD, the HEAD branch must be loaded in the workspace.

Perform the following on the cvsuser1 workspace:

- ▶ In the Web perspective right-click **RAD75CVSGuide** and select **Replace With** → **Another Branch or Version**.
- ▶ In the dialog, select **HEAD** and click **OK** to load the latest (HEAD) version of the **RAD75CVSGuide** project into the workspace.
- ▶ Right-click **RAD75CVSGuide** and select **Team** → **Merge**. This displays the dialog shown in Figure 28-40, which prompts the user for the start and end points of the merge.

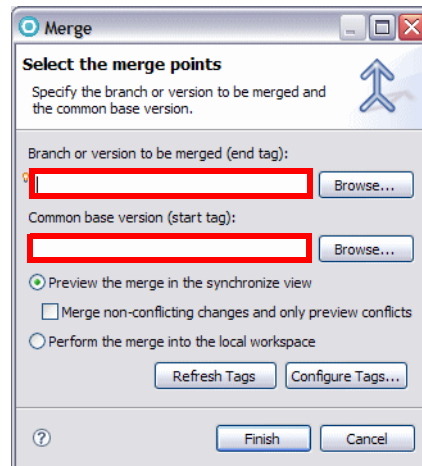

Select a start and end branch or revision in these two boxes

Figure 28-40 Selection of the merge start point

- ▶ Click **Browse** for the Common base version (start tag) field, expand Versions, select **BRANCH_ROOT** and click **OK**.
- ▶ Click **Browse** for the Branch or version to be merged (end tag) field, expand Branches, select **Maintenance** and click **OK**.
- ▶ The Select the Merge Points dialog (Figure 28-40) now shows the start and end tags of the merge, which will be applied to the version in the workspace.
- ▶ The options to **Preview Merge in the synchronize view** and **Perform the merge into the local workspace** provide the facility to select where to perform the merge:
 - Previewing it in the Synchronize view allows the user to review and make changes to each file as required.
 - Performing the merge into the local workspace applies the changes immediately into the workspace based on preferences selected in the workspace preferences.
- ▶ For the example, select **Preview Merge in the synchronize view** and clear **Merge non-conflicting changes and only preview conflicts**.
- ▶ Click **Finish** to start the merging.
- ▶ Expand the tree in the Synchronize view to display changes. Verify that there are no conflicts. If there are, then the developer has to resolve these conflicts. In our case, the merge is simple and there are no conflicts (Figure 28-41).

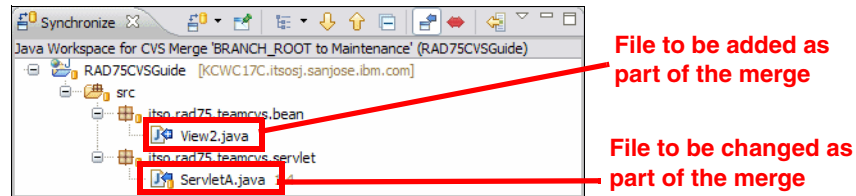

Figure 28-41 Files required to be merged

- ▶ Right-click **RAD75CVSGuide** and select **Merge**.
This attempts to bring the changes from the branch into the main stream, and because there are no conflicts it completes successfully.
- ▶ Right-click **RAD75CVSGuide** and select **Team** → **Synchronize with Repository**.
- ▶ Expand the Synchronize view to display the changed files `ServletA.java` and `View2.java` (Figure 28-42).

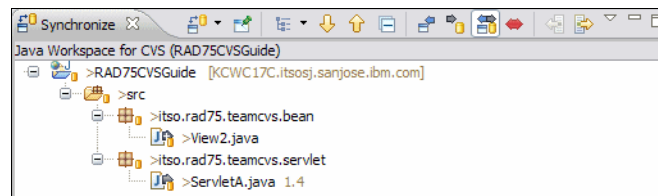

Figure 28-42 CVS updates to HEAD from the merge

This view shows that the file `View2.java` is a new file to be added to the repository and that the file `ServletA.java` has been changed. This is consistent with the changes that were made in the Maintenance branch and now have to be added to the main branch.

- ▶ Right-click the project and select **Commit**. In the Commit dialog, add the comment **Merged changes from Maintenance branch**, and click **OK**.

The changes from the branch have now been merged into the main development branch.

This scenario, although a simple one, highlights the technique required by users to work with branches. In a real scenario there would be conflicts, and this would require resolution between developers. Be aware that branching and concurrent development is a complex process and requires communication and planning between the two teams.

Application Developer provides the tools to assist developers when merging; however, equally important are procedures for handling situations such as branching and merging of code, which should be established among the team early in a project life cycle.

Working with patches

Application Developer provides the facility for developers to be able to share work when they only have read access to a CVS repository. In this circumstance the developer that does not have full access to the repository can create a patch and forward it to another developer with write access, and the patch can be applied to the project and the changes committed.

Such a configuration is useful when access to the source code repository has to be restricted to a small number of users to prevent uncoordinated changes corrupting the quality of the code. Any number of users can then contribute changes and fixes to the repository using patches, but only through designated code minders who can commit the work and who have the opportunity to review changes before applying them to the repository.

This is done through the **Team** → **Create Patch** and **Team** → **Apply patch** options available from a project context menu. A patch can contain a single file, a project or any other combination of resources on the workspace. The Application Developer online help has a complete description of how to work with CVS patches.

Disconnecting a project

For many reasons (for example, to disassociate a project from one repository to allow it to be added to another repository) a developer might want to disconnect a project from the current CVS repository. To perform this task, complete the following steps:

- ▶ In the Web perspective, right-click **RAD75CVSGuide** and select **Team** → **Disconnect**.
- ▶ A prompt opens, asking to confirm the disconnect from CVS and if the CVS control information should be deleted (Figure 28-43).
Select **Do not delete the CVS meta information** and click **OK**.

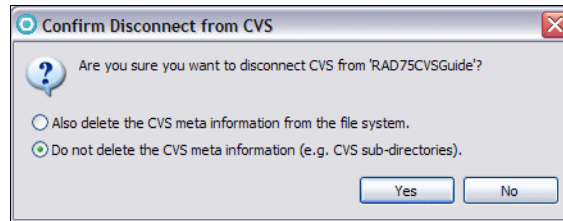

Figure 28-43 Disconnect confirmation

By not deleting the CVS meta information, we can reconnect the project with the CVS repository later more easily. If the meta information is removed, CVS cannot determine which revision in the repository a particular file is associated with.

Reconnect

You can reconnect a project to the repository by selecting **Team** → **Share Project**. Reconnecting is easier if the CVS meta information was not deleted:

- ▶ If the meta information was deleted, the user is prompted to synchronize the code with the an existing revision in the repository.
- ▶ If the meta information is still available, select **Team** → **Share Project**, select **CVS** in Share Project dialog and click **Next**. The original CVS repository information is shown (Figure 28-44). Click **Finish** to re-connect.

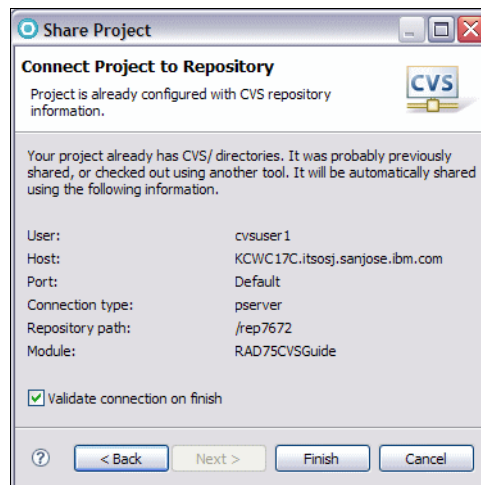

Figure 28-44 Reconnect to repository with original CVS meta information

Team Synchronizing perspective

The Team Synchronizing perspective in Application Developer has been used in the examples in this chapter but has not yet described in detail. The purpose of this perspective is to provide to the user with a tool to identify changes repository compared with what is on the local workspace, and assist in synchronizing the two together.

Features provided with the Team Synchronize perspective include:

- ▶ Provide a comparison of changes in the workspace (as described in “Comparisons in CVS” on page 1058).
- ▶ Committing the changes made to the repository (as described in the previous scenarios).
- ▶ Create custom synchronization of a subset of resources in the workspace.
- ▶ Schedule checkout synchronization.

Custom configuration of resource synchronization

The Synchronize view provides the ability to create custom synchronization sets for the purpose of synchronizing only identified resources that a developer might be working on. This allows the developer to focus on changes that are part of their scope of work and ensure they are aware of the changes that occur without worrying about changes to other areas.

The developer can make changes to the other areas or someone else might check-in changes to these parts, but only the resources in the defined set are synchronized.

This is handy if the changes being worked on are localized and other areas of the code are changing in ways not important for the work at hand. On the other hand, problems can occur with this mode of operation as well. Developers have to be careful that important changes to the non-synchronized parts are not ignored for long periods of time.

Important: Custom synchronization is most effective when an application is designed with defined interfaces, where the partitioning of work is clear. However, even in this scenario, it should be used with caution because it can introduce additional work in the development cycle for final product integration. Procedures have to be documented and enforced to ensure that integration is incorporated as part of the work pattern for this scenario.

The example scenario (again using the **RAD75CVSGuide** project) demonstrates custom synchronization, through two procedures:



- ▶ Full synchronization of the project **RAD75CVSGuide**
- ▶ Partial synchronization of the `ServletA.java`

To perform the example, complete the following for the `cvsuser1` workspace:

- ▶ Open the **Team Synchronizing** perspective.
- ▶ Click the Synchronize button  at the top the Synchronize view and click **Synchronize** to add a new synchronization definition.
- ▶ In the Synchronize dialog, select **CVS** and click **Next**.
- ▶ Expand the Workspace tree to view the contents and note that all resources in the workspace are selected. Accept the defaults for the Synchronize CVS dialog, and click **Finish**.

Note: When using Application Developer v7.5, the list of resources shows a **Workspace** and a **Java Workspace** folder. If a customized resource set is required, it can be selected from either folder with the same final result.

If there are no changes, then a dialog box opens, saying Synchronizing: No changes found, and in the Synchronize view a message of No changes in 'CVS (Workspace)'. Click **OK** in the dialog box.

- ▶ To preserve this synchronization, click **Pin Current Synchronization** .
- ▶ Add a new synchronization by clicking the Synchronize icon  at the top of the Synchronize view.
- ▶ In the Synchronize dialog, select **CVS** and click **Next**.
- ▶ Expand the project tree under `JavaSource` to view the contents, click **Deselect All** to deselect all the resources, and select only **ServletA.java**.

The Synchronize CVS dialog appears as shown in Figure 28-45.

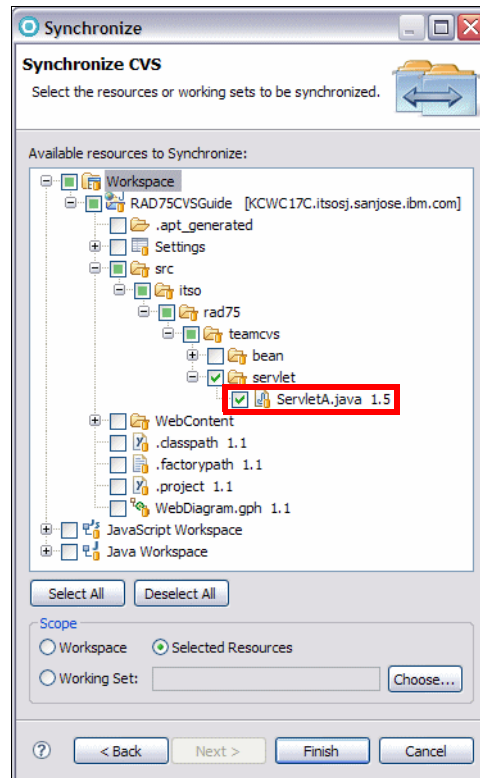



Figure 28-45 Selecting ServletA.java for synchronization

- ▶ Click **Finish**.
- ▶ If there are no changes, then a dialog box opens, saying Synchronizing: No changes found, and in the Synchronize view a message of No changes in 'CVS (Workspace)'. Click **OK** in the dialog box.
- ▶ To preserve this synchronization, click **Pin Current Synchronization** .
- ▶ Click the  icon at the top of the Synchronize view. There are now two CVS Synchronizations in the list (Figure 28-46).

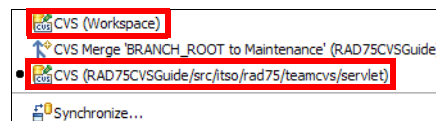

Figure 28-46 List of synchronizations created

Schedule synchronization

Application Developer allows the scheduling synchronization of the workspace. This feature follows on from “Custom configuration of resource synchronization” on page 1072, in which a user would like to schedule the synchronization that has been defined. Scheduling a synchronization can only be performed for synchronizations that have been pinned.

To demonstrate this feature, assume that the **RAD75CVSGuide** project is loaded in the workspace and a synchronization has been defined for this project and pinned. Scheduling of this project for synchronization is then performed using the following steps:

- ▶ In the Synchronize view select **Schedule** from the drop-down list (Figure 28-47).

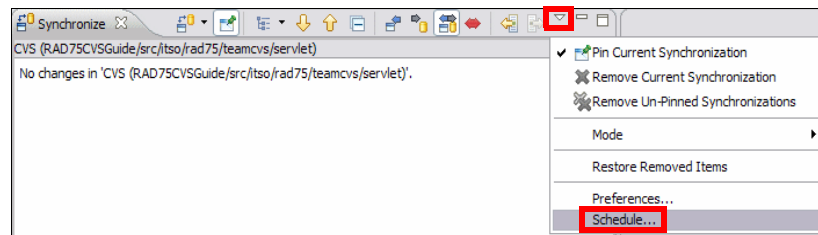

Figure 28-47 Drop-down selection for scheduling synchronization

- ▶ In the Configure Synchronize Schedule dialog, select **Using the following schedule:** and the time period that you want to synchronize (Figure 28-48). Click **OK**.

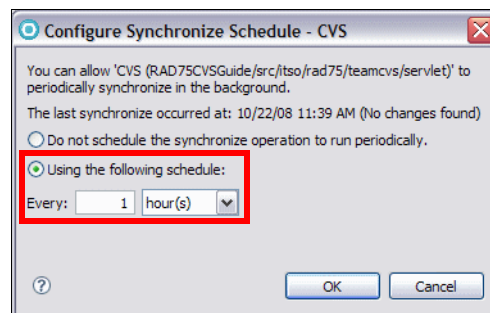

Figure 28-48 Setting synchronization schedule

- ▶ The user might be prompted to pin the current CVS synchronization, if it is not already pinned. Click **Yes**.

Assuming that one hour is chosen, the RAD75CVSGuide project is synchronized every hour to ensure that the latest updates are available. This action performs the synchronize operation and shows any changes available in the synchronize view, where the user can accept or postpone integrating the changes as appropriate.

More information

The help feature provided with Application Developer has a large section on using the Team Synchronizing and the CVS Repository Exploring perspective and describes all the features covered in this chapter.

In addition, the following URLs provide further information for the topics covered in this book:

- ▶ **CVS home page**—The main source of information for CVS:
<http://www.nongnu.org/cvs/>
- ▶ **CVSNT home page**—This is the main source of information for CVSNT, which is the CVS server implementation for Windows machines and the CVS server software used in this chapter. See the following URL:
<http://cvsnt.org/wiki>
- ▶ **Eclipse CVS information**—The CVS features available in Application Developer V7.5 come from Eclipse 3.4. The following link is the main information page for this project. It contains documentation, downloads, and even the source code:
<http://wiki.eclipse.org/ CVS>
- ▶ **Tortoise CVS home page**—This is another CVS client that lets users perform CVS operations from Windows Explorer. It provides most of the features of Application Developer and is available under the GNU public license. This can come in handy when CVS operations are required outside Application Developer. See the following URL:
<http://www.tortoise cvs.org>
- ▶ **CVS command line reference**—Some operations on the CVS server (for example changing the password of a user) is best done from the command line. The following URL provides a quick reference for the CVS command line interface:
<http://refcards.com/docs/forda/cvs/cvs-refcard-a4.pdf>



Rational Team Concert

This chapter describes the capabilities of the Rational Team Concert Client included with Rational Application Developer. The main goal of the chapter is to show how a team of Application Developer users can get started using Team Concert by defining the team composition and the project iterations, choosing a development process among various proven best practices, sharing existing projects, managing code and conflicts, tracking defects, tasks and other work items and generating reports. We show how you can run automated builds and debug collaboratively using additional features provided by Application Developer.

This chapter is organized into the following sections:

- ▶ Introduction to IBM Rational Team Concert
- ▶ Getting started: Setup a project area
- ▶ Source control scenarios
- ▶ Building with Team Concert and the Application Developer Build Utility
- ▶ Running reports (Standard edition only)
- ▶ Collaborative Debugging
- ▶ More information

Introduction to IBM Rational Team Concert

Team Concert is a scalable platform for collaborative development based on the the Jazz Open Source platform (<http://jazz.net>). The major features of Team Concert include:

- ▶ Customizable processes
- ▶ Agile planning
- ▶ Work item tracking
- ▶ Source code management
- ▶ Build management

From an architectural standpoint, Team Concert is built upon an application server, which could be Tomcat or IBM WebSphere Application Server and a relational database, which could be Derby, IBM DB2, or Oracle.

Editions

Team Concert is provided in three different editions. Smaller teams can get started using the **Express-C** edition which supports up to 10 users and provides access for the first three users free of charge.

Note: Refer to “Installing IBM Rational Team Concert” on page 1139 for instructions on how to install Team Concert Express-C edition and the Team Concert Client, which is an optional component of Application Developer.

Larger teams may want to use or upgrade to the **Express** or **Standard** editions, which support up to 50 and 250 users. All editions provide integration with Subversion and LDAP authentication, while the Standard edition provides connectors for IBM Rational ClearCase and IBM Rational ClearQuest. Team Concert also integrates with IBM Lotus® Sametime® and Jabber for instant messaging. Refer to <http://jazz.net> for information about additional planned integrations. For a full description of the features offered by each edition, see Table 29-1 on page 1079.

Note: The scenarios described in this chapter have been tested with Team Concert Standard Edition, Tomcat and DB2. Features that are specific to the Standard Edition have been highlighted and most scenarios are applicable to the Express-C edition. The source code management and item tracking features described in this chapter are those of Team Concert itself, so no installation of ClearCase, Subversion or ClearQuest is required to follow the proposed scenarios.

Table 29-1 Feature Comparison of the three editions of Rational Team Concert

Edition	Express-c	Express	Standard
Maximum users	10	50	250
Database included (optional)	Derby only	IBM DB2 Express (DB2, Oracle)	IBM DB2 Express (DB2, Oracle)
Application server included (optional)	Apache Tomcat only	Tomcat (IBM WebSphere)	Tomcat (IBM WebSphere)
Source code management	Yes	Yes	Yes
Work item tracking	Yes	Yes	Yes
Build management	Yes	Yes	Yes
Agile planning	Yes	Yes	Yes
Subversion integration	Yes	Yes	Yes
Server-level permissions	Yes	Yes	Yes
LDAP authentication	Yes	Yes	Yes
Customizable process	Yes	Yes	Yes
Customizable work item attributes and workflow	No	No	Yes
Reports	No	No	Yes
Dashboard	No	No	Yes
Role-based process permissions	No	No	Yes
Rational ClearCase connector	No	No	Yes
Rational ClearQuest connector	No	No	Yes
LDAP import	No	No	Yes

Architecture

The architecture of the Team Concert server comprises kernel and optional components, described in (Figure 29-1):

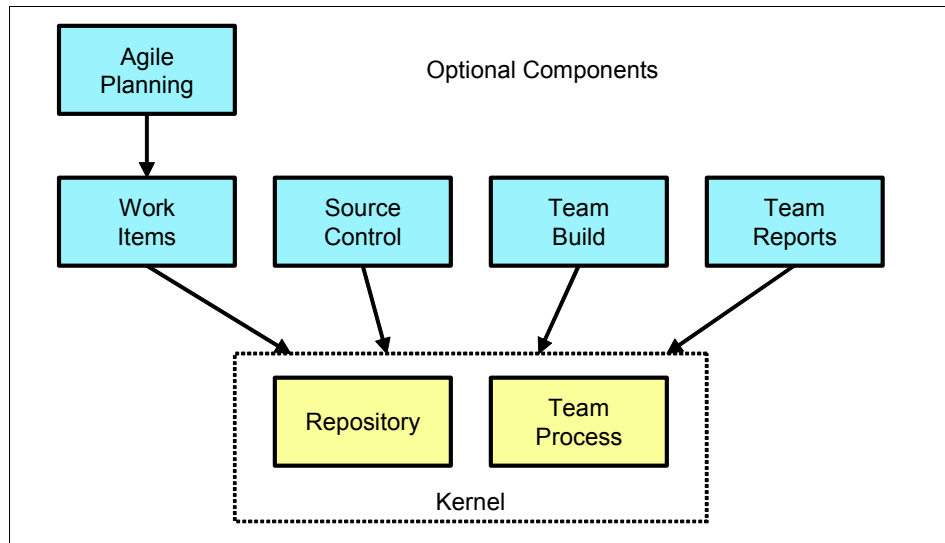

Figure 29-1 Kernel and Optional components

Kernel components

The kernel components are the repository and the team process.

Repository

The repository contains *items* that can be identified by *universally unique identifiers* (UUID). *Item states* and *values* also have such unique identifiers. There are auditable item types, which maintain an audit trail consisting of the past states of the item, the user who saved the item, and the time of the change.

- ▶ The repository component provides a server-side CRUD API for the items in the repository. The repository is supported by a relational database. The top-level items stored in the repository are *project areas*, which typically correspond to software development projects and contain references to artifacts (deliverables), team members, process, and schedule.
- ▶ A project area may contain multiple *development lines*, for example one for new development and one for maintenance.
- ▶ Each development line has its own deliverables, members, process and schedule, which may be structured in multiple *iterations*.

- ▶ Within a project area, members can be organized into *Team Areas*, which define the users, their roles, the development line they work on, and any process customizations that applies to that specific group.

Team process

Team Concert is process-aware but does not impose a particular process. The selected process can actively modify the behavior of the tool by defining user roles, permissions, preconditions for client and server-side operations, predefined reports and queries.

The process is hierarchical: It can be defined at the project area level and then customized for each team area belonging to the project. When creating a new project area, you can select among the following *process templates* (Table 29-2) that are shipped with the product and can be further customized:

- ▶ Agile
- ▶ The Eclipse Way
- ▶ OpenUp
- ▶ Cloudburst
- ▶ Scrum
- ▶ SimpleTeam

Out of these process templates, OpenUp, developed by the Eclipse Process Framework (<http://www.eclipse.org/epf/>) includes typical characteristics of the Rational Unified Process.

Table 29-2 Main features of Team Concert process templates

Process	Development Lines	Iteration types	Roles	Work Item categories
Agile	Main development	Development Stabilization	Project lead Team member	Defect Retrospective Story Task
The Eclipse Way	Main development	Development Stabilization	Contributor Team lead	Defect Enhancement Plan Item Retrospective Story Task Track Build Item

Process	Development Lines	Iteration types	Roles	Work Item categories
OpenUp	Main development	Inception Elaboration Construction Transition	Analyst Architect Developer Project manager Stakeholder Tester	Defect Enhancement Risk Task Use Case
Cloudburst	Development Maintenance	Development End game Maintenance Ready to ship	Project lead Team member	Defect Enhancement Task
Scrum	Main development	Sprint1 Sprint2	Product owner Scrum master Team member Stakeholder	Defect Impediment Retrospective Story Task
Simple Team	Development		Team member	Defect Enhancement Task

Optional components

The optional components are listed below.

Work items

Each process defines categories of *work items* that can be assigned to team member, worked on and queried. Each work item type has a *state transition model* that defines the available states and the actions that users can take to move a work item from one state to another.

Some types of work items, such as *Defect* or *Enhancement* are suitable for being associated to source code *change sets*. Other types of work items such as *Retrospective* (in the Eclipse way and Agile processes), are used to record what went well and what did not go well in the recently completed iteration, and so forth.

Agile planning

The Agile planning component allows team leads and members to create *iteration plans* and to distribute work items to them according to the chosen process.

Source control

The source control component is based on *repository workspaces*, and *streams*. Team Concert bases source control on *change sets*, not on files. Change sets contain the before and after states of versionable items, an optional comment, and can be linked to a work item.

In Application Developer (and in Eclipse) there is a *local* workspace, contained in the Eclipse workspace, which mirrors the *repository* workspace of that particular user. A repository workspace is similar to an Application Developer or Eclipse workspace because it contains the artifacts developed by one particular user, but it is very different because it is stored in the repository, on the Team Concert server.

- ▶ Change sets are pushed from the local workspace onto the repository workspace by the *check in* operation. Conversely, files can be imported into a local workspace from the repository workspace by using the *load* operation.
- ▶ The fact of having a repository workspace allows each user to make a backup of their work on the server. Once a particular user is satisfied with the changes, the user can make them available to the team by using the *deliver* operation.
- ▶ Change sets are delivered from the repository workspace (which belongs to one user) to the *stream* (which belongs to a team).
- ▶ A stream holds a common shared copy of the files, and it is also stored on the server.
- ▶ A user can *accept* changes made by other team members and available in the stream *change history*. Each workspace or stream keeps a change history that permits to creation of the current version of the items from the accumulated changes.

In complex projects, streams and workspaces can be partitioned into components that have their own change history, change sets and configuration (Figure 29-2).

To initialize streams and workspaces, it is possible to create a *baseline*, which is an immutable copy of a component in a given workspace or stream. A *snapshot* is an immutable collection of one baseline for each workspace component, which can be used to recreate the entire workspace configuration (typically for reproducing a build).

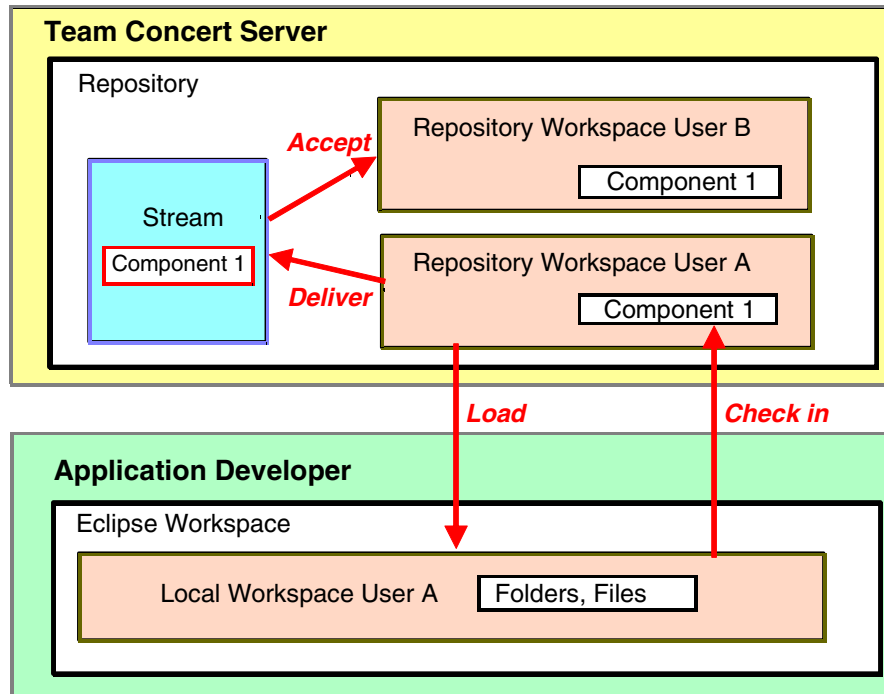

Figure 29-2 Local and Workspace Repository and their relationship to a Stream

Team build

Team Concert includes the Jazz Build Engine and an Ant build toolkit that can publish build information to the Jazz repository. The repository contains:

- ▶ **Build definition** items, representing a particular build, such as a weekly project-wide integration build;
- ▶ **Build engine** items, representing a particular build system running on a build server;
- ▶ **Build request** items, representing a particular request to run a build;
- ▶ **Build result** items, representing the outputs from a particular run.

The installation of Team Concert provides two components: Jazz Build Engine and Build Toolkit.

- ▶ The Jazz Build Engine can be used to run continuous builds or to request builds at a particular point in time. While the build items described above are optimized for use with the Jazz Build Engine, they can also be used with other build engines such as IBM Rational BuildForge or CruiseControl.

- ▶ The Build Toolkit is a set of Ant Tasks that can be used to perform the following tasks:
 - Publishing build results and contributions
 - Enabling progress monitoring
 - Working with Jazz source control
 - Controlling the build life cycle

There are four types of available *build templates* that can be selected when creating a new build definition:

Ant - Jazz Build Engine	A build using Ant and the Jazz Build Engine
Command Line - Jazz Build Engine	A build that invokes a command line using the Jazz Build Engine
Generic	A generic build
Maven - Jazz Build Engine	A build using Maven 2 and the Jazz Build Engine

Team reports

The reports component applies only to the Standard edition and it consists of the *data warehouse* and the *reports engine*. The data warehouse stores read-only snapshots of the repository data in a non-normalized form that is optimized for efficient queries and quick response times. The report engine is based on the Eclipse BIRT (Business Intelligence and Reporting Tools) project.

Getting started: Setup a project area

This section is a practical introduction to the Team Concert Client shipped with Application Developer. We will work primarily in two Perspectives:

- ▶ Work Items
- ▶ Jazz Administration

The section is organized in the following topics:

- ▶ Creating a repository connection and project area
- ▶ Predefined work items: Define team members
- ▶ Predefined work items: Define iterations and iteration plans
- ▶ Process configuration: Define preconditions
- ▶ New work item: Create components
- ▶ Creating a repository workspace
- ▶ Setting up team areas

Creating a repository connection and project area

You can perform the setup of a new Project Area from Application Developer following these steps:

- ▶ Select **Windows** → **Open Perspective** → **Work Items** (Figure 29-3).

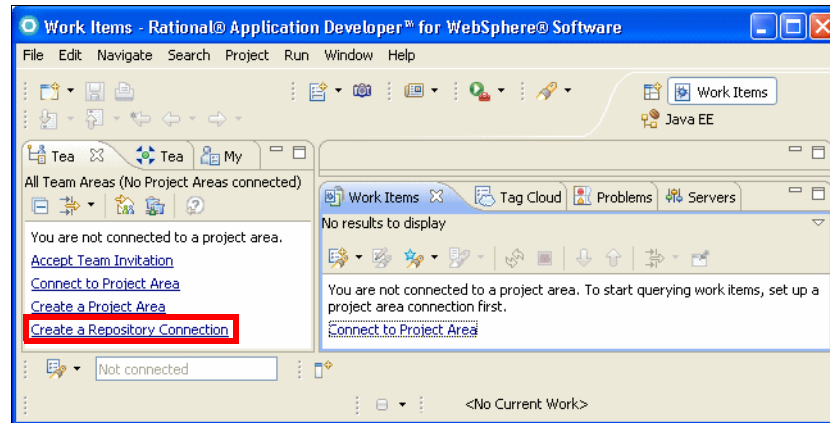

Figure 29-3 Work Items perspective

- ▶ Select **Create a Repository Connection** (Figure 29-4):

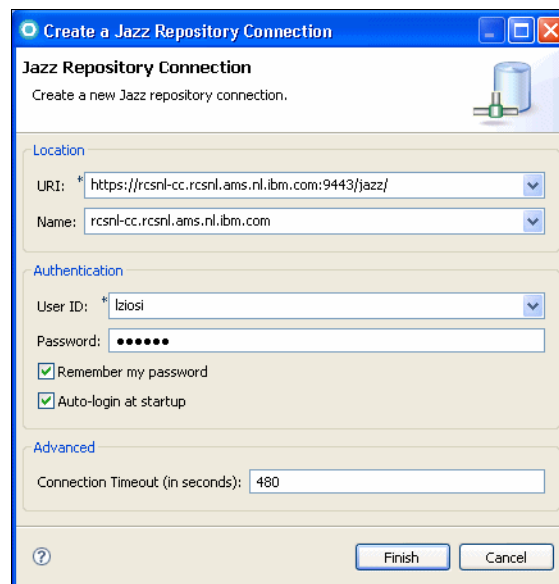

Figure 29-4 Create a Jazz repository connection

- Enter the URI that you defined when you installed the server:
https://hostname:port/jazz/
- Enter the Connection Name: hostname
- Enter the user ID and password of a user that has been defined on the server at installation time

If Team Concert is installed on the same machine as Application Developer, you will see the URI corresponding to localhost in the URI drop down list

- ▶ Right-click on the Repository Connection in the Team View.
- ▶ Select **New** → **Project Area** (Figure 29-5)
 - Enter the name: ITSO RedBank Project
 - Enter the Description: Project Area for ITSO Redbank Application
 - Click **Next**.

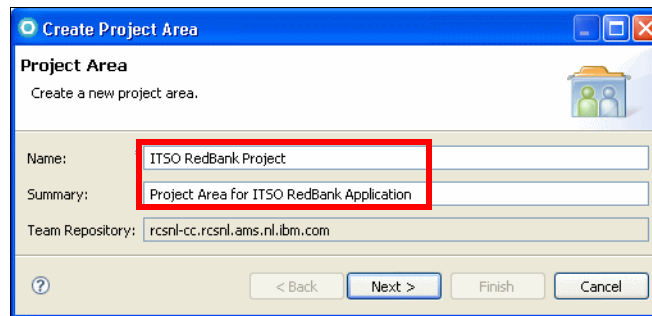

Figure 29-5 Create RedBank project area

- ▶ Select the Process Template that you want to apply to this Team process Area, in this case we select **OpenUp Process** (Figure 29-6).

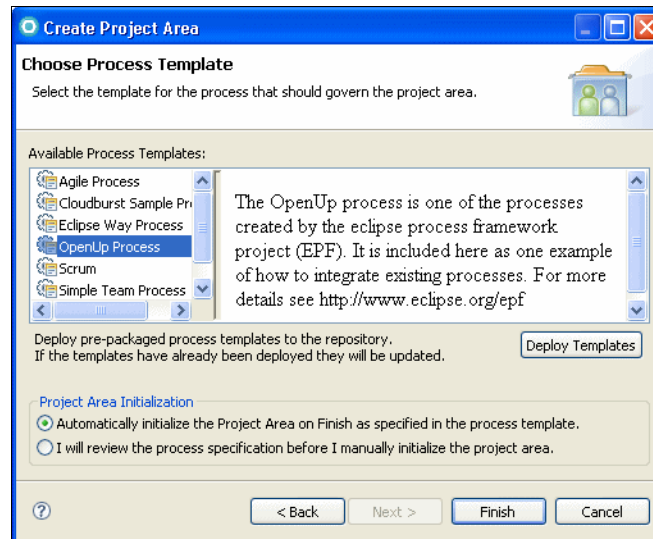

Figure 29-6 Select the OpenUp process for the project area

- ▶ The Project Area editor opens. Here you can define the team members, their roles, the iterations of the project, process customizations, work item types, and releases.

Predefined work items: Define team members

In the Work Items view you find some predefined work items that guide you to get started (Figure 29-7). You will assign a few of them to yourself to prepare the project.

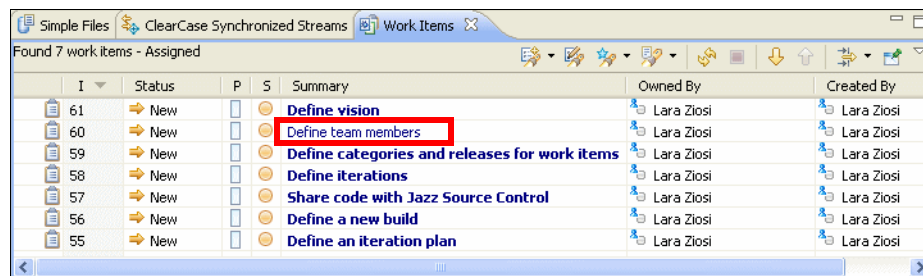

Figure 29-7 View of work items initially created

- ▶ Select the **Define team members** work item. This opens the Work Item Editor, where you can find a description of what you have to do to complete this task (Figure 29-8). Select some appropriate values:
 - Change status from New to **Start Working**.
 - Severity: **Major**
 - Owned by: yourself
 - Planned for: **Inception**
 - Due: today's date
- ▶ Save (note that the status changes from Start Working to In progress).

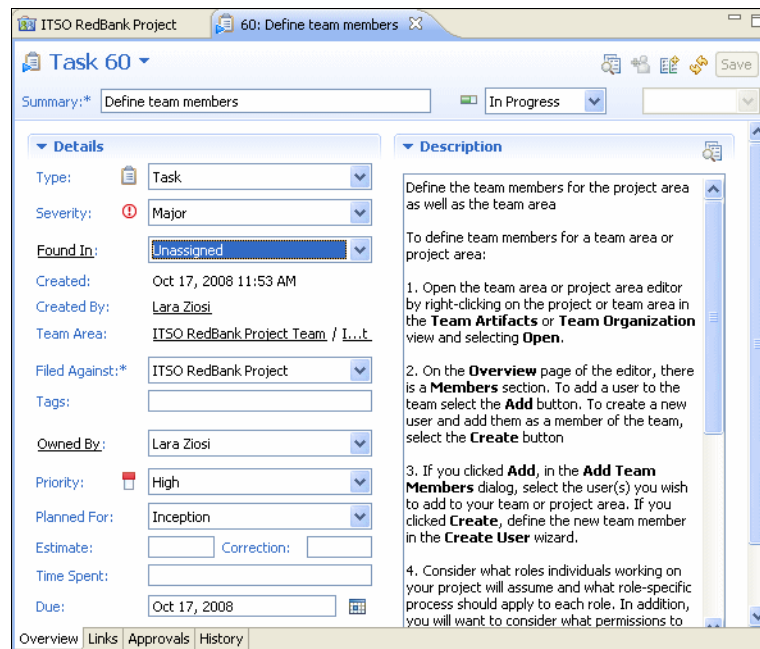

Figure 29-8 Work Item view

- ▶ As described in the work item, open the Project Area editor:
 - Locate the **Members** section.
 - Select **Create**.
 - Select **Create a new User**.
 - Fill in the user information.
 - Assign to a Repository group (JazzUsers)
 - Assign a Rational Concert - Developer license.
 - Click **Finish**.
 - Assign some of the available process roles to the members (Figure 29-9).

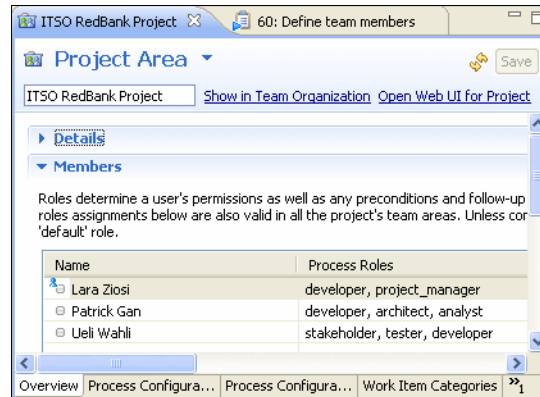

Figure 29-9 Assign members to the project and process roles to the members

- ▶ When you are done adding the members and save the project area editor, you are prompted for sending an invitation e-mail the new members, assuming that the e-mail service has been configured on the server (Figure 29-10). If the Mail service is not configured, you will see an exception that you can ignore.



Figure 29-10 Send Team Invitation to new members of a project area

The new team members receive an e-mail (Example 29-1).

Example 29-1 E-mail generated by Team Concert to invite new team member

You have been invited to join the Jazz team ITSO RedBank Project.

You can explore the related project area via the web UI at
[https://rcsnl-cc.rcsnl.ams.nl.ibm.com:9443/jazz/web/projects/ITSO%20RedBank%20P
 roject](https://rcsnl-cc.rcsnl.ams.nl.ibm.com:9443/jazz/web/projects/ITSO%20RedBank%20P%20roject).

Use File>Accept Team Invitation within the Rational Team Concert client to open the Accept Team Invitation dialog.

Copy the invitation below and paste into the Accept Invitation text field.

```
teamRepository=https://rcsn1-cc.rcsn1.ams.nl.ibm.com:9443/jazz/  
userId=lziosi  
userName=Lara Ziosi  
projectAreaName=ITSO RedBank Project
```

- ▶ The other team members can accept the invitation as described in the e-mail.
- ▶ If e-mail notification was not configured on the server, then you will see an exception that can be ignored.
- ▶ However, you will have to provide the above connection details to the users in some way. With that information the users will do the following:
 - Open the Work Items Perspective and select **Connect to the Repository**.
 - Right-click on the repository connection in the Team Artifacts view and select **Connect to Project Areas**.
 - In the dialog that opens, select the project area name to connect to.
- ▶ In the Work Item editor for Define Team Members, select **Resolve** and **Fixed**.

Predefined work items: Define iterations and iteration plans

To define the iterations and iteration plans, to the following:

- ▶ Open the work item **Define Iterations** and select **Start Working**. Save it.
 - In the Project Area editor, Overview tab, look at the Process Iterations:
 - Set dates for the iterations defined in the four phases: Inception, Elaboration, Construction, Transition by selecting **Edit Properties** (Figure 29-11).
 - Here you could create additional development lines (for example, one for maintenance) and remove or add iterations.
- ▶ In the Work Item editor for Define Iterations select **Resolve**, and **Fixed**.
- ▶ Open the work item **Define an iteration plan** and select **Start Working**. Following the description, perform these steps:
 - Select the **Plans** node under the Project Area in the Team Artifacts view.
 - Right-click **Inception Iteration I1**.
 - Select **New** → **Iteration Plan**.
 - Name the iteration plan **InceptionIterationPlan**.
 - In the editor that opens, in the Planned Items tab, you can see the folders Top Items and Defects and Enhancements.

- Drag and drop all the predefined work items from the Work Item View onto the Top Items folder. This assigns the work items to the current iteration.
- ▶ In the Work Item editor for Define an Iteration plan, select **Resolved** and **Fixed**.

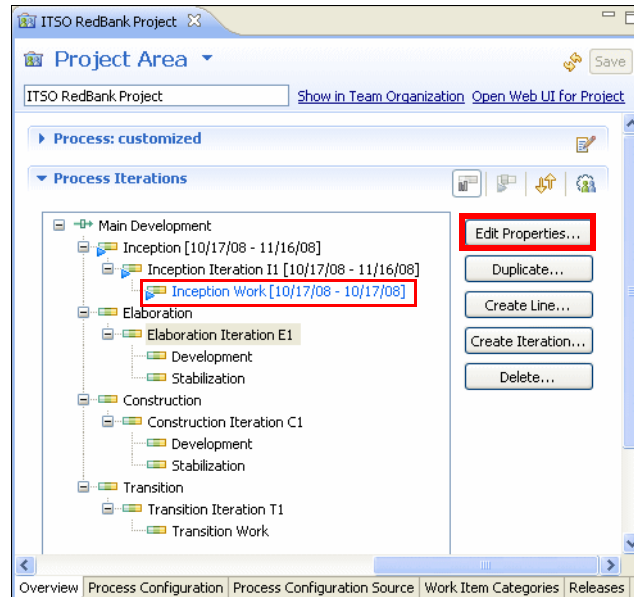

Figure 29-11 Define development lines, iterations, dates for the phases of the project

- ▶ Open the view called My Work.
- ▶ Select the project area **ITSO RedBank Project**.
- ▶ You should see the work you have already completed and the planned work (Figure 29-12).

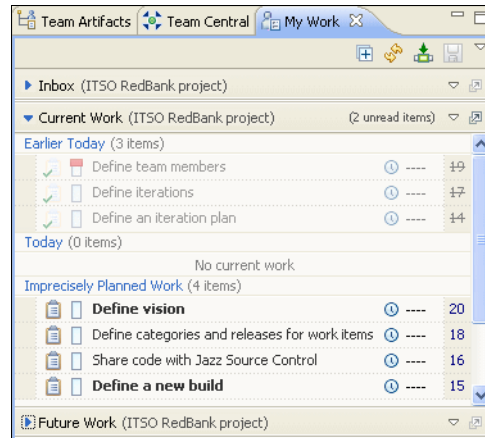

Figure 29-12 My Work View after completing a few work items

Process configuration: Define preconditions

Team Concert allows you to associate preconditions to certain actions, in order to enforce desirable behavior. You can specify different preconditions for different phases of a project. By default the Open Up process template specifies rules on the delivery operation during the Stabilization phase of the Elaboration Iteration. We will add the rule that every delivery operation must be associated with a Work Item:

- ▶ In the Project Area editor, select the **Process Configuration** tab.
- ▶ Under **Configuration** → **Team Configuration**, select **Operation Behavior**.
- ▶ For the user: Everyone (default) select the operation: **Source Control** → **Deliver (client)**.
- ▶ Note that **Preconditions and follow-up actions are configured for this operation** is selected.
- ▶ The following preconditions are already selected:
 - Clean Workspace
 - Descriptive Change Sets

Remove Descriptive Change Sets (we will replace it with a more restrictive condition).

- ▶ Click **Add** in the Preconditions (7 available) group (Figure 29-13).

Multiple select (use the Ctrl key) the following preconditions: **Prohibit Unused**, **Java imports**, and **Require Work items and Comments**.

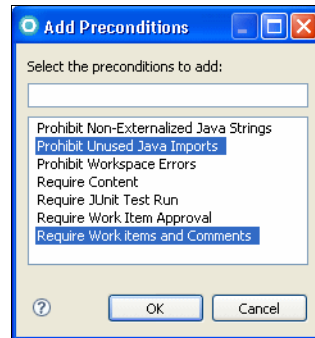

Figure 29-13 Available preconditions

Figure 29-14 shows the resulting Operations behavior.

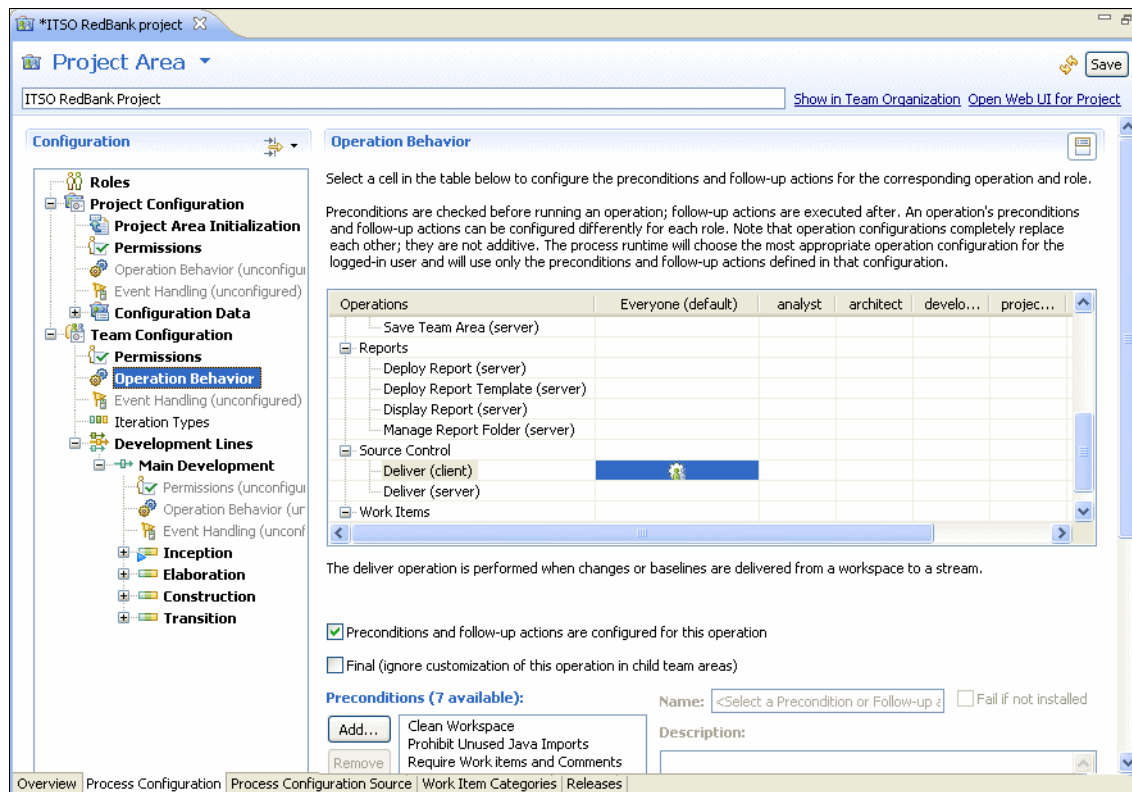

Figure 29-14 Preconditions on Operation Behavior in the project area

New work item: Create components

We want to be able to manage different parts of the project in different components owned by different teams. We first create a work item to track this task. Note that you can also create work items from the iteration plan.

- ▶ Select **File** → **New** → **Work Item**.
- ▶ Project Area: ITS0 RedBank project
- ▶ Work Item Type: **Task**
- ▶ Enter the following information:
 - Summary: Create Components
 - Filed against: ITS0 RedBank Project
 - Owned by: yourself
 - Planned for: Inception
 - Due: today's date
- ▶ Save the Work Item. Select **In progress**. Save again.
- ▶ Open the Team Artifacts View (Figure 29-15).

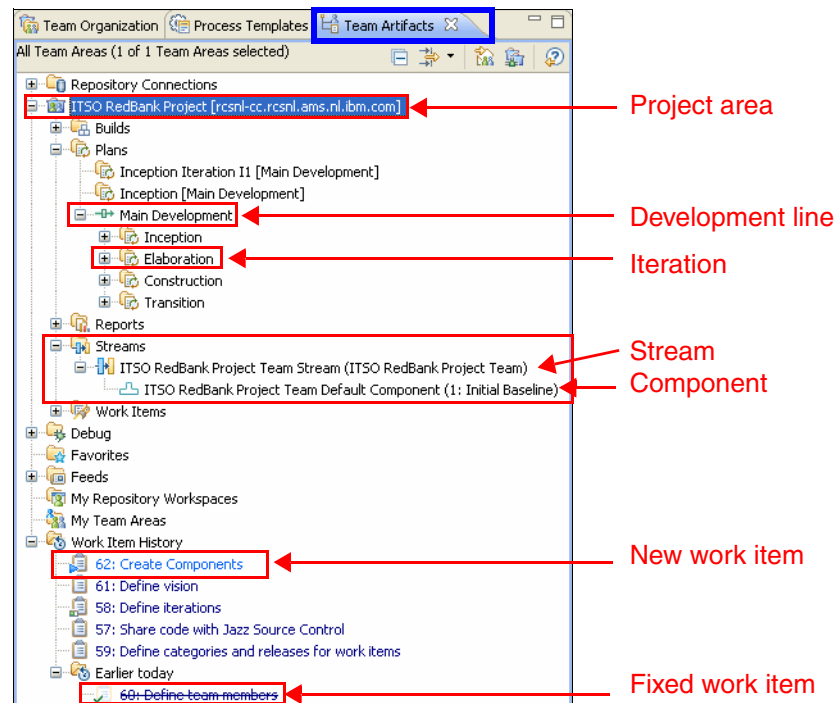

Figure 29-15 Team Artifacts view showing stream, component and work item history

Expand the Project Area node **ITSO RedBank Project**. Inside the node streams there is the stream called ITSO RedBank Project Team Stream, which contains the component ITSO RedBank Project Team Default Component.

- ▶ Right-click on the Stream and select **Open**.
- ▶ In the Components list select **New**. Enter the following names:
 - Java prototype Component
 - Web Application Component
- ▶ When you select **Save**, the component initial baselines are created (Figure 29-16).

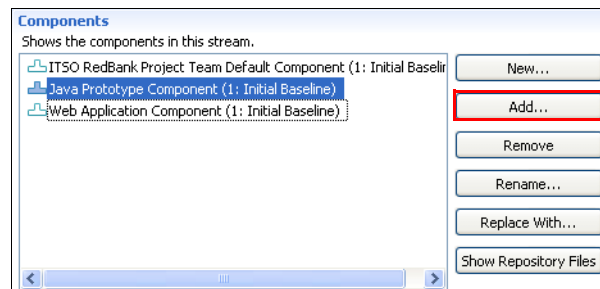

Figure 29-16 Creation of additional components

- ▶ In the Work Item editor for Create Components, select **Resolve** and **Fixed**.
- ▶ Associate this work item with the **inceptioniterationplan** (drag and drop it on the Top Items folder).

Creating a repository workspace

Create a repository workspace for the current user:

- ▶ Select the Team Artifacts view.
- ▶ Right-click on **My Repository Workspaces** → **New Repository Workspace**. The New Repository Workspace dialog opens (Figure 29-17).
- ▶ Select **Flow with a stream** (select the only available stream).
- ▶ Type the name **ITSO Redbank Lara's Workspace**.
- ▶ In Components to Add:
 - Select all the components.
 - Select **Load Repository Workspace after creation** to copy the selected components from the repository workspace to the local workspace after the repository workspace has been created.

- ▶ Click **Finish**.

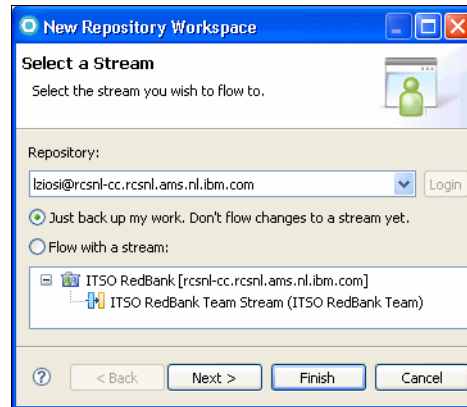

Figure 29-17 Create a repository workspace for the current user

- ▶ In the Load Repository Workspace dialog:
 - Select: **Browse the components to select the folders to be loaded.**
 - Select all three components.

Setting up team areas

We want to create two team areas to distinguish development of a Java application prototype from the main development of the RedBank application.

- ▶ Open the **Team Organization** view (in the Jazz Administration perspective).
- ▶ Right-click on the default Team Area (ITSO RedBank ProjectTeam) and select **New → Team Area**.
- ▶ Type the Name **Java Prototype Team** and an optional Summary (Figure 29-18).

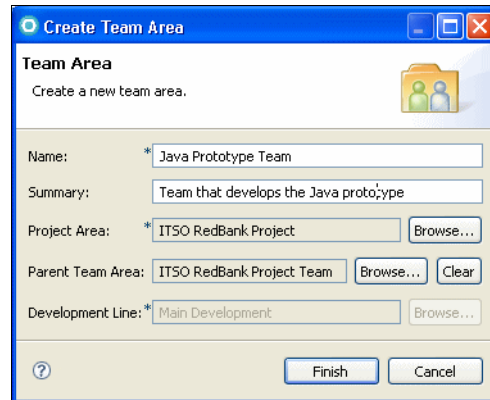

Figure 29-18 Creation of new Team Area for the Java Team

- ▶ Repeat the same steps to create the team area **Web Development Team**.
- ▶ Distribute members among the two teams (Figure 29-19).
- ▶ Assign the ownership of the Java Prototype component to the Java Prototype Team:
 - Open the Team Area editor for Java Prototype Team.
 - Select **Artifacts** → **Stream**.
 - Right-click and select **Search Components**.
 - Find the Java Prototype component.
 - Change owner to the Java Prototype Team.
- ▶ Assign the ownership of the Web Application Component to the Web Development Team.

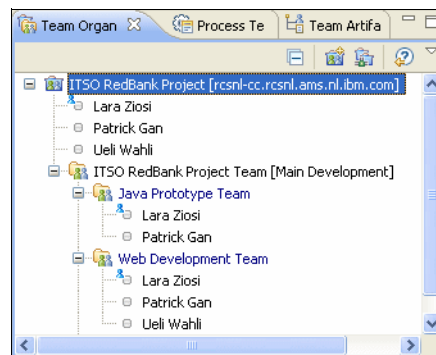

Figure 29-19 Team Organization view with team areas and team members

Source control scenarios

In this section we describe some common development scenarios using various source control features.

- ▶ Sharing existing projects
- ▶ Connecting to the repository and loading projects
- ▶ Managing conflicts

Sharing existing projects

In this section we share a Java project and a Web project.

Sharing the Java project

To seed the project area we want to import a Java prototype of the RedBank application. We also want to store it in a dedicated component. Only the Java Team will be concerned with this project.

- ▶ Select **Start working** on the work item Share code with Jazz Source Control.
- ▶ Open the **Java Perspective**.
- ▶ Select **File** → **Import** → **Project Interchange** and locate the `C:\7672code\zInterchange\java\RAD75Java.zip` file.
- ▶ Right-click the **RAD75Java** project in the Package Explorer, and select **Team** → **Share Project** → **Jazz source Control**.
- ▶ In the Share Project dialog click **Next** (Figure 29-20).

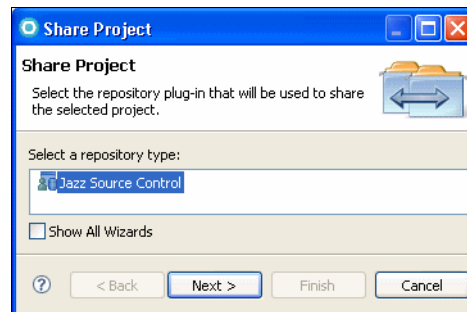

Figure 29-20 Share an existing project with Jazz Source Control

- ▶ In the Share Project in Jazz dialog (Figure 29-21):
 - Select: **Select a component in an existing repository workspace.**
 - Select **ITSO RedBank Lara's Workspace.**
 - Select **Java Prototype Component.**

- Click **Next**.

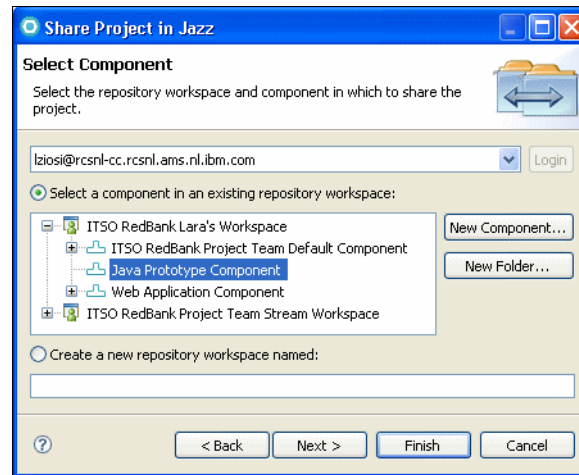

Figure 29-21 Select a component from a repository workspace to share a project

- ▶ In the Review Ignored Resources page, you can see that `.class` files and the `bin` folder are not added to source control. Click **Finish**.
- ▶ Expand the project in the Package Explorer. Notice that files and packages are decorated by black arrows oriented left to right, indicating outgoing changes (Figure 29-22).

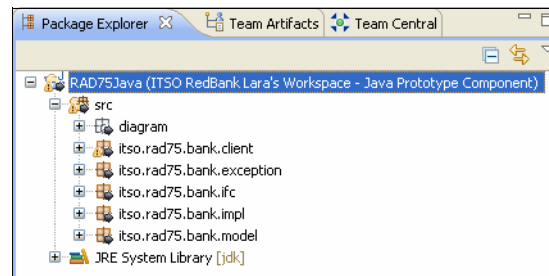

Figure 29-22 Package Explorer after sharing a project

- ▶ Expand the contents of the **Pending Changes** view. This view shows the incoming/outgoing changes between the workspace (ITSO Redbank Lara's Workspace) and the stream (ITSO RedBank Project Team Stream). The component Java Prototype Component has one outgoing change set called *Share projects*, which contains all files and folders to be added to source control.

- ▶ Right-click on the **Share projects** change set and select **Associate Work Item**.
- ▶ Select the work item **Share Code with Jazz Source Control** (Figure 29-23).

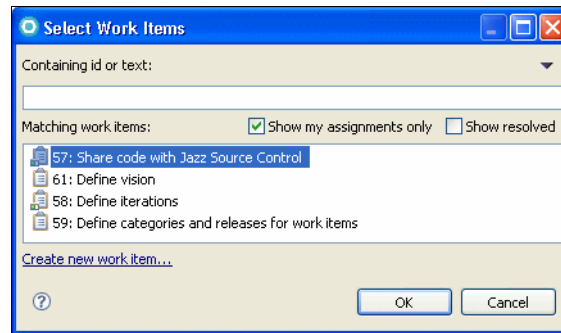

Figure 29-23 Associate a work item to a change set

- ▶ Notice that the change set is now called **Share Code with Jazz Source Control - Share projects** (Figure 29-24).

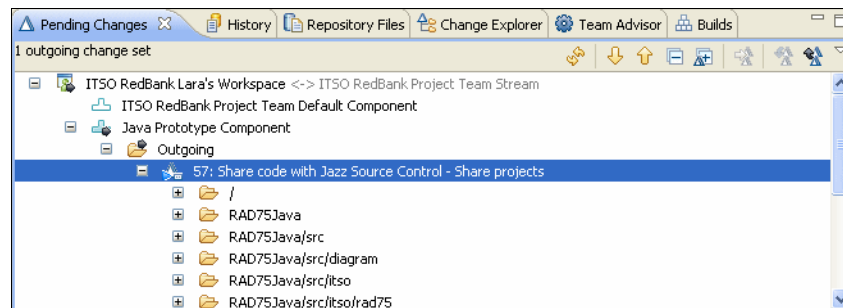

Figure 29-24 Pending changes view after sharing a project

- ▶ Right-click on the change set and select **Deliver**. This places the project in the team repository and removes all the outgoing changes from the Pending Changes view.
- ▶ If you right-click on the **Java Prototype Component** in the Pending Changes view you can select **Show Repository Files**.
- ▶ The Repository Files view opens and you can verify that all the project files and folders are stored in the repository.
- ▶ In the Team Artifacts view, locate the stream **ITSO RedBank Project Team Stream**.

- ▶ Right-click on the stream and select **Show Repository Files**. This action shows that the deliver operation has made the projects available in the Stream where the team can access them.
- ▶ Since this is the initial state of the project and we want to be able to go back to it if required, we create a new baseline for the Java Prototype Component. Note that the existing baseline (Initial Baseline) was created as soon as the component was created, and it is not associated to any source files.
- ▶ Right-click **Java Prototype Component** in the Pending Changes view and select **New** → **Baseline**. Name the baseline **Imported prototype**.
- ▶ Right-click on the outgoing change and select **Deliver**.
- ▶ To verify, right-click **Java Prototype Component** in the Pending Changes view and select **Show Baselines**. The History View opens and you can right-click on each baseline and select **Show Repository Files** (Figure 29-25).

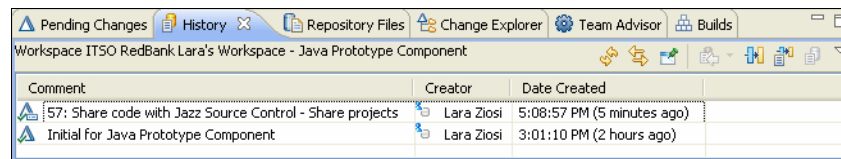

Figure 29-25 History view shows the baselines of the component

Sharing a Web application

We now repeat the above steps for the Web application.

- ▶ Select **File** → **Import** → **Project Interchange** and locate the `C:\7672code\zInterchange\ejb\RAD75EJBWeb.zip` file.
- ▶ Right-click the **RAD75EJBWeb** project in the Package Explorer and select **Team** → **Share Project** → **Jazz source Control**.
 - Select all four available projects.
 - Share them into the component **ITSO RedBank Lara's Workspace** → **Web Application Component**.
- ▶ In the Pending Changes View:
 - Right-click on the Change Set and select **Associate Work Item**.
 - Select the work item **Share Code with Jazz Source Control**.
 - Right-click on the change set and select **Deliver**.
- ▶ In the Team Artifacts view, Work Item history node:
 - Select the work item **Share Code with Jazz Source Control**.
 - Mark it as **Resolved** and **Fixed**.

Connecting to the repository and loading projects

Now that the project has been delivered to the Team Repository it can be accessed by another user. The following steps are performed in an empty Application Developer workspace. Perform these actions to start working on the Java project as user Patrick:

- ▶ Create a repository connection.
- ▶ Connect to the project area **ITSO RedBank Project**.
- ▶ Create a new repository workspace:
 - Load all components from the stream.
 - In the Load Repository Workspace dialog (Figure 29-26), select **Find and Load Eclipse projects**.

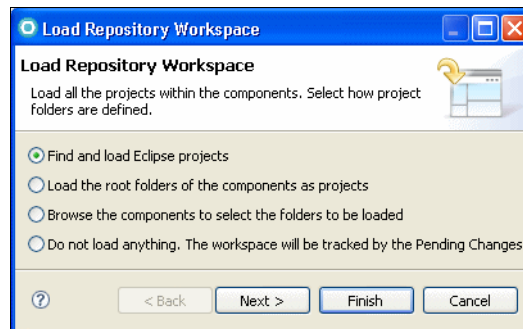

Figure 29-26 Methods to load existing projects from a repository workspace

- The RAD75Java Project appears under **Java Prototype Component** (Figure 29-27).

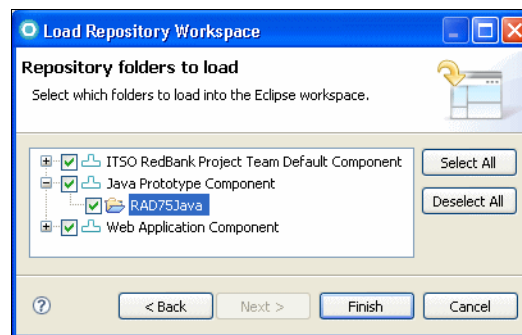

Figure 29-27 Loading specific projects into the local Eclipse workspace

- ▶ Patrick finds that there are warnings (Figure 29-28) and corrects them by removing two unused methods from `BankClient.java`. Patrick saves the file.
 - Open the Pending Changes view.
 - Select the file **BankClient.java**.
 - Right-click and select **Check-in** → **New Change set**.

Note that the *Check-in* operation is only going to store the changes in Patrick's own repository workspace. The other team members have no access to the changed file until Patrick actually *delivers* the change set to the team repository.

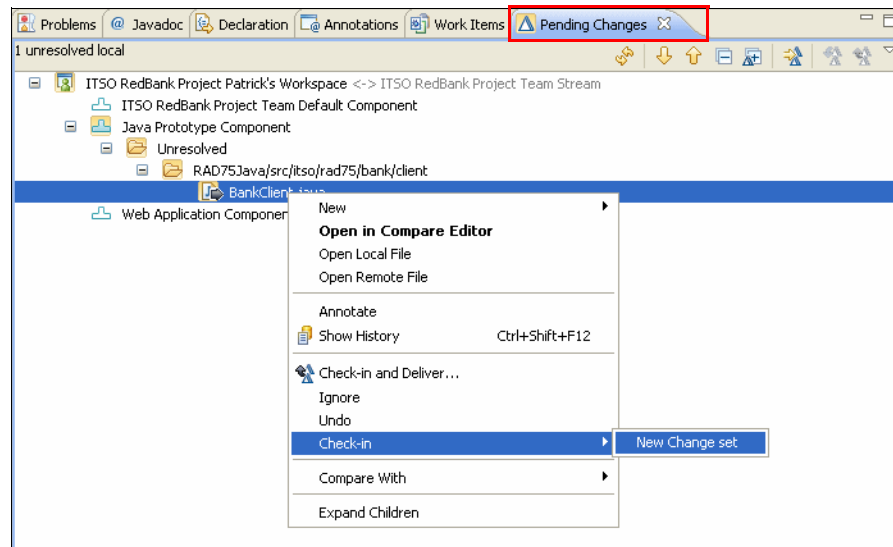

Figure 29-28 Check-in operation from Pending Changes view

- The change set appears under the Outgoing header with the label: <Enter a Comment>.
- Click once on the label and type **Resolve Warnings** (Figure 29-29).

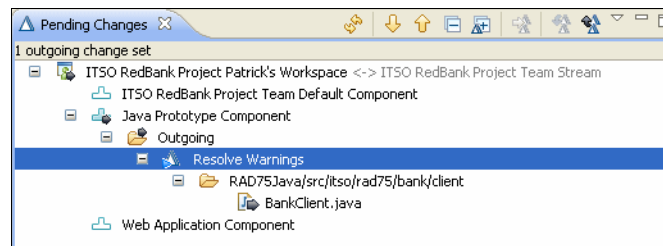

Figure 29-29 Pending Changes view after check-in and change set creation

**Standard
Edition only?**
See PMR
05183,211,788

- ▶ Finally Patrick decides that it is best to make the changes available to the whole team right away. Right-click on the change set and select **Deliver**.
- ▶ The Team Advisor View appears and informs Patrick that he cannot deliver the changes (Figure 29-30). Due to the preconditions set in the project process, Patrick will not be able to deliver a change set that is not associated to a work item and that introduces unused imports. The latter issue is due to the fact that after deleting the two methods, some existing imports have become unused.

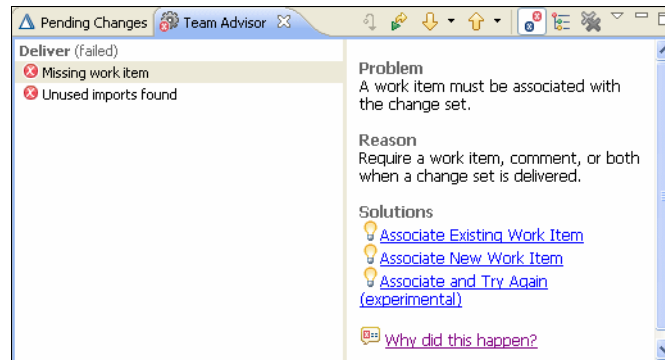

Figure 29-30 Team Advisor with reasons why a deliver operation is not completed

- ▶ To resolve the first problem Patrick can click select **Associate New Work Item**, naming the work item a [space].
- ▶ To resolve the second problem, it is enough to select **Source** → **Organize Imports** (or press **CTRL+SHIFT+O**) with the `BankClient.java` open in the Java source editor.
- ▶ Now it is possible for Patrick to deliver the change to the team repository.
- ▶ After opening the work item **Clean Java Prototype**, the Links folder should contain a link to the change set **Resolve Warnings**.

Managing conflicts

For the purpose of demonstrating how conflicts can be managed in Team Concert, we describe what happens if Lara—unaware of the changes made by Patrick—decides to change the implementation of the Java prototype, switching to the use of JavaScript (refer to “Using scripting inside the JRE” on page 116).

While logged on as Lara, perform the following:

- ▶ In the Java Perspective, Package Explorer view, expand the package `itso.rad75.bank.client`. Note that `BankClient.java` is decorated with an arrow from right to left indicating an incoming change.

- ▶ Open **BankClient.java**.

- ▶ Change the lines:

```
//Here you can switch the logic to be implemented in Java or Scripting
    executeCustomerTransactions(oITSOBank);
    //executeCustomerTransactionsWithScript(oITSOBank);
```

to use Java Script instead of Java:

```
//Here you can switch the logic to be implemented in Java or Scripting
    //executeCustomerTransactions(oITSOBank);
    executeCustomerTransactionsWithScript(oITSOBank);
```

- ▶ Save the file.
- ▶ Right-click on the file in Package Explorer and select **Team** → **Check in**. Remember that this action pushes the change set onto Lara's private workspace repository.
- ▶ Open the Pending Changes view if it is not visible.
- ▶ You will see an outgoing change set with the label Enter a Comment.
- ▶ Click on the label and type **Switch To Java Script**.
- ▶ You will see orange double headed arrows indicating conflicts (Figure 29-31).

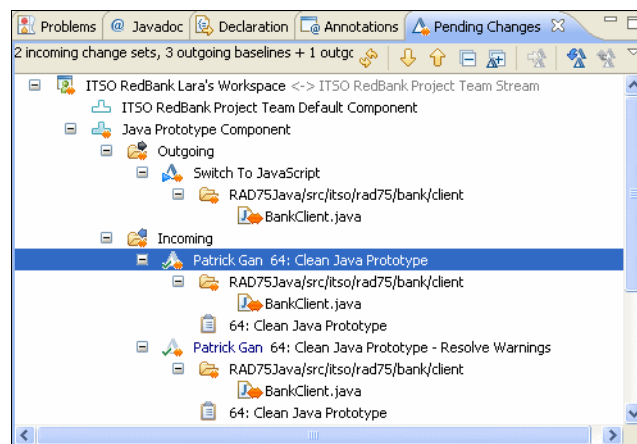

Figure 29-31 Conflicts in the pending Changes view

- ▶ Lara tries to **Deliver**.

- ▶ (Standard edition only) Lara is prompted to associate a work item with the change set.
- ▶ Lara creates the new work item called **Switch to JavaScript**.
- ▶ When Lara tries to **Deliver** again, the Team Advisor reports:

Problem
An error occurred during "Deliver".
Cannot deliver changes since they would create conflicts for
"/RAD75Java/src/itso/rad75/bank/client/BankClient.java". Try accepting all
incoming changes, resolve the conflicts, then deliver again.
- ▶ As a result Lara right-clicks on the incoming changes and selects **Accept**.
- ▶ When Lara tries to **Deliver** the change set Switch to JavaScript, the following dialog box appears (Figure 29-32).

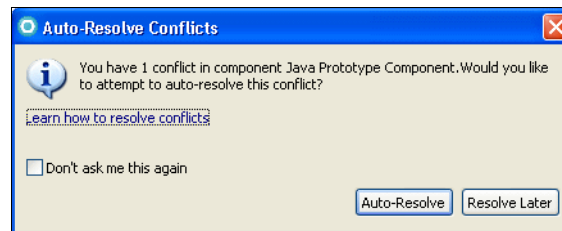

Figure 29-32 Auto-Resolve Conflicts dialog

- ▶ Click **Resolve Later** to explore all possibilities for conflict resolution.
- ▶ Because the conflict was left unresolved, it appears in the Pending Changes view in the Unresolved section for the component (Figure 29-33).

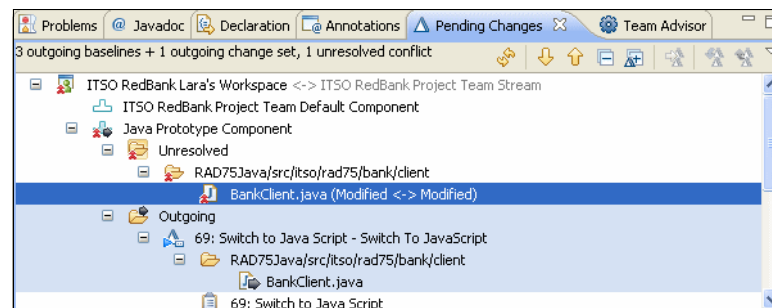

Figure 29-33 Unresolved conflict in Pending Changes view

- ▶ By right-clicking on **BankClient.java** in the Unresolved category, options for resolving the conflict are displayed (Figure 29-34).

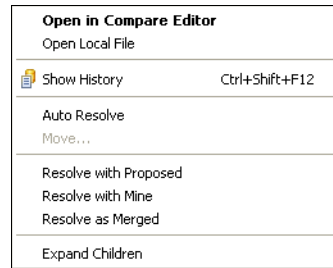

Figure 29-34 Possible options for resolving conflicts

- Auto Resolve** Works by merging nonconflicting changes such as simple additions or removals (but not intra-line differences).
- Resolve with proposed** Replaces the file in your workspace with the one that contains the conflicting changes.
- Resolve with Mine** Replaces the file that contains the conflicting changes with the file that is currently in your workspace.
- Resolve as Merged** Indicates that you have finished merging.
- ▶ Before deciding which option to use, Lara selects **Open in Compare Editor**.
 - ▶ In Java Structure Compare (Figure 29-35) you can see that the change made by Lara to the main function is seen as *outgoing*. The changes made by Patrick (deletion of import statements and of two methods) are seen as *incoming*, and they cannot be overruled using this editor.

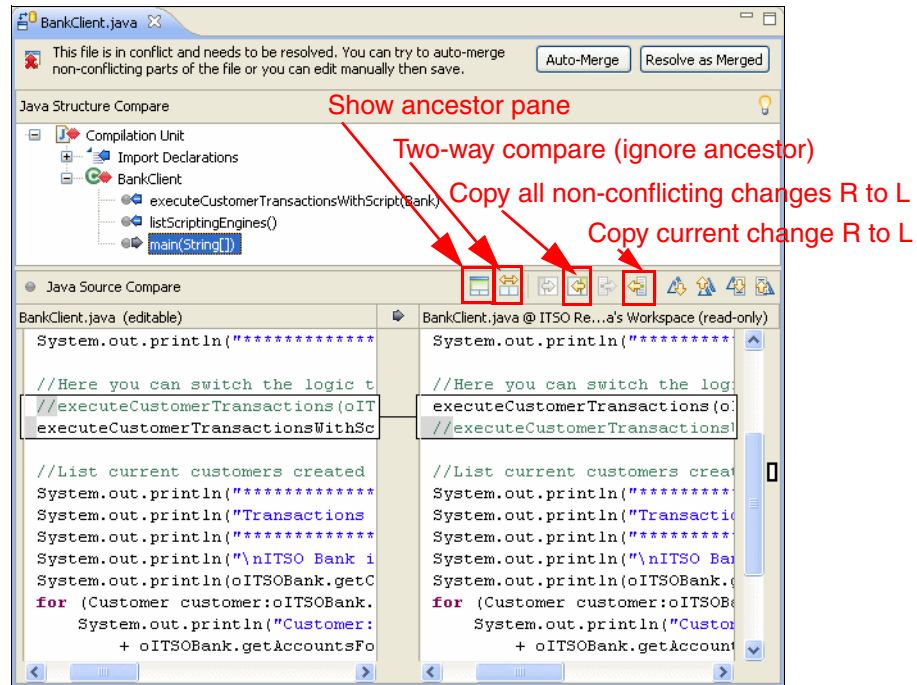

Figure 29-35 Compare Editor

- ▶ Lara decides that she wants to preserve her changes, so she right-clicks on **BankClient.java** in the Unresolved category in the pending Changes view and selects **Resolve with Mine**.
- ▶ The Pending Changes view shows the conflict as resolved.
- ▶ Lara selects **Deliver and Resolve Work Item**.
- ▶ When Patrick refreshes the Pending Changes view, he will see the incoming change associated to the work item **Switch to Java Script**.
- ▶ After review of the work item description Patrick accepts the incoming change.
- ▶ Patrick then opens the work item **Clean Java prototype** and selects **Resolve, Won't Fix**, because in this case the warnings about unused methods had to be preserved to allow a different choice of implementation in this Java prototype.

Building with Team Concert and the Application Developer Build Utility

Note: Before you can run the steps in this section you should have installed the Rational Team Concert Build System and the Rational Application Developer Build Utility on the computer that runs the Rational Team Concert server, as described in Appendix A, “Product installation” on page 1121.

In this section we show how you can request builds on the Team Concert Build engine invoking the Application Developer Build Utility introduced in “Using the Rational Application Developer Build Utility” on page 929. This section is organized in the following parts:

- ▶ Creating a build user
- ▶ Creating a repository workspace owned by the build user
- ▶ Starting the Jazz build engine
- ▶ Preparing the Ant build file
- ▶ Creating a build engine and a build definition
- ▶ Requesting a build

Creating a build user

In order to run builds in Team Concert, you need a dedicated user added to the team area. This user must be assigned a special license type and must own the repository workspace used for the build.

- ▶ Create a work item called **Create Build User** and select **Start Working**.
- ▶ Right-click on the project area in the Team Artifacts view and select **Create** from the Members section.
- ▶ Set the `userId` and the `userName` as **build**.

Note that by default the password of this user is set to be equal to its user ID. You will need the user ID and password of this user to start the build engine.

- ▶ Assign a Build System license to the build user (Figure 29-36).

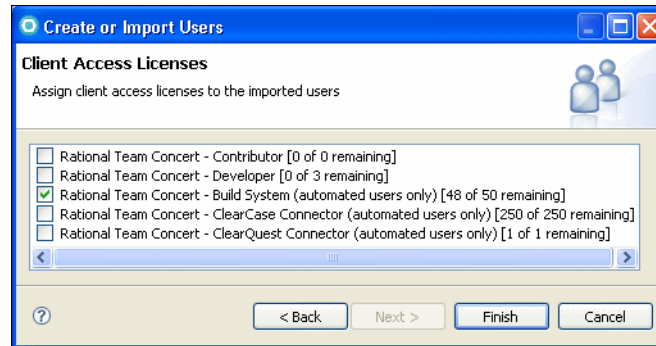

Figure 29-36 Assign a Build System license to the build user

Creating a repository workspace owned by the build user

Perform the following steps in the Team Artifacts view to create a new repository workspace:

- ▶ Select **My Workspaces** → **New Repository Workspace**.
- ▶ Select **Flow with a stream** → **ITSO RedBank Project Team Stream**.
- ▶ Type the Name as **ITSO RedBank Project Build Workspace**.
- ▶ Accept to load the four projects from the Web Application Component.

Change the owner of the new workspace to be the build user:

- ▶ Right-click **ITSO RedBank Project Build Workspace** and select **Open**.
- ▶ Select **Browse** on the Owned By field and type **build** to select the build user.

Notice that the new workspace disappears from the node My Workspaces.

Starting the Jazz build engine

On the Team Concert server you must start the Jazz build engine before you can request any builds. The build engine is an executable at:

```
<RTC_Build_installation>\buildsystem\buildengine\eclipse\jbe
```

The required arguments for the Jazz build engine are:

```
repository <repository address> (address of a Jazz repository)
userId <user id> (user id of a user defined in the Jazz repository)
```

You can launch **jbe** without any arguments to see the full list of optional arguments. Note that in order to launch the build engine, a JDK version 1.5 or higher must be on the system path. If that is not the case, you can supply the location of a suitable JDK as a command line argument introduced by **-vm**.

The following batch file (Example 29-2) illustrates how you could start the build engine on a Team Concert server and a build engine installed in:

```
C:\Program Files\ibm\JazzTeamServer
C:\Program Files\ibm\TeamConcertBuild\buildsystem
```

Example 29-2 Sample batch file to start the Team Concert Build Engine

```
@echo on
setlocal
set RTC_SERVER_HOME="C:\Program Files\ibm\JazzTeamServer"
set JAVA_HOME=%RTC_SERVER_HOME%\server\win32\ibm-java2-i386-50\jre\bin
set RTC_BUILD_HOME="C:\Program Files\ibm\TeamConcertBuild"
cd %RTC_BUILD_HOME%\buildsystem\buildengine\eclipse
jbe -repository https://rcsn1-cc.rcsn1.ams.nl.ibm.com:9443/jazz -userId build
-pass build -sleepTime 3 -verbose -vm %JAVA_HOME%\java.exe
```

Note that the password of the build user is passed as an optional command line argument introduced by **-pass**. An alternative to providing the password on the command line is to launch **jbe** once with the optional argument **-createPasswordFile**. If you execute:

```
<RTC_Build_installation>\buildsystem\buildengine\eclipse\jbe
    -createPasswordFile passwordFile.txt
```

you will be prompted to enter the password for the build user, which will be stored encrypted in the file provided on the command line. It is recommended that you protect the file itself with appropriate operating system permissions.

Preparing the Ant build file

A suitable Ant build file has been developed in “Create the build file (BUbuild.xml)” on page 930. To share this Ant file, perform these steps:

- ▶ Create a project using **File** → **New** → **Project** → **General** → **Project**, and set the project name as **AntScripts**.
- ▶ Import the Ant build file using **File** → **Import** → **File System**, and import the file C:\7672code\ant\j2ee\BuildUtility\BUbuild.xml.
- ▶ Share this project directly in the ITSO RedBank Project Team Workspace.
- ▶ **Deliver** the Change set.

- ▶ Review the Pending Changes view and **accept** the incoming change sets into the build workspace and Lara's workspace.

Creating a build engine and a build definition

In this section we describe how to configure the build engine in Application Developer. Subsequently we create a new build definition and associate it to this build engine.

- ▶ In the Team Artifacts view, expand the **Project Area** node.
- ▶ Right-click on **Builds** → **Build Engines**.
- ▶ Select **New Build Engine**.
- ▶ In the Build Engine editor set the following values:
 - ID: **default** (if you change this value, you need to pass an optional argument `engineID` when you start `jbe`)
 - Team Area: **ITSO RedBank Project Team**
 - Save the Build Engine editor.

If the build engine is not currently running you will see a warning in the editor.

We are now ready to create a new build definition of type Command Line - Jazz Build Engine.

- ▶ Expand the **Project Area** in the Team Artifacts view.
- ▶ Right-click on the **Builds** node, select **New Build definition**, and enter the following values (Figure 29-37):
 - Team Area: **ITSO RedBank Project Team**
 - Select **Create a new build**.
 - Among the available build templates, select **Command Line - Jazz Build Engine**.
 - Click **Next**.

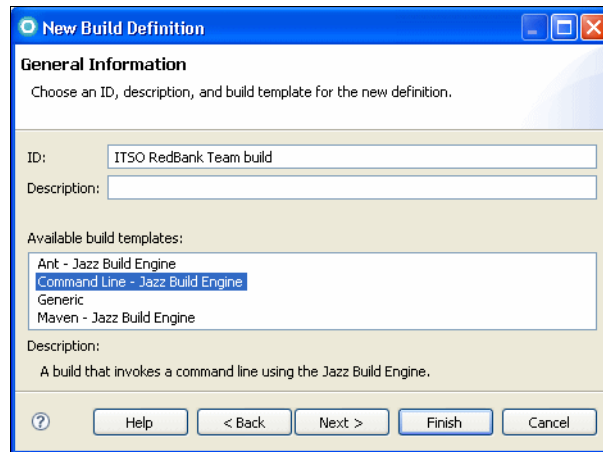

Figure 29-37 New build definition of type Command Line - Jazz Build Engine

- Select **Jazz Source Control**. You do this when you want to load files from a repository workspace before the build starts.
- Click **Finish**.

Now we need to provide a command based on the contents of the script:

```
C:\IBM\BuildUtility\eclipse\bin\runAnt.bat
```

The above script uses some operating system environment variables, such as `WORKSPACE`. In the Build Definition editor you cannot access operating system environment variables, but you can set up properties. Property values can be defined in the Properties tab of the editor and can be referenced from any tabs using the syntax `${propertyName}`. For clarity, because the term workspace is overloaded in this context, we will replace the `WORKSPACE` environment variable used in `runAnt.bat` with the `BU_WORKSPACE` property in the Build Definition editor.

To get started, try and save the Build Definition editor. You will see that there are three errors detected:

- ▶ A command must be specified
- ▶ A load directory must be specified
- ▶ A repository workspace must be specified

If you click on any of the errors you are taken to the field of the editor that misses a required value.

- ▶ Workspace: **ITSO Redbank Project Build Workspace** (this is the repository workspace owned by the build user with the latest sources to build)
- ▶ Load directory: **`${BU_WORKSPACE}`**

► **Command:**

```
{JAVA_HOME}\java.exe -Dwtp.autotest.noninteractive=true
-Dwas.runtime={BASE_DIR}..\..\runtimes -cp {BASE_DIR}\startup.jar
org.eclipse.core.launcher.Main -application com.ibm.etools.j2ee.ant.RunAnt
```

Remain in the **Command Line** tab of the Build Definition editor and enter Arguments as:

```
-data {BU_WORKSPACE} -buildfile {BU_WORKSPACE}\AntScripts\BUBuild.xml
```

Switch to the **Properties** tab of the Build Definition editor and enter the following Property Name and Value pairs:

► **BASE_DIR:** C:\IBM\BuildUtility\eclipse

Note that `BASE_DIR` is defined as the `eclipse` subfolder of the installation directory of the Application Developer Build Utility. You might have to change this value to match your installation of the build utility.

► **JAVA_HOME:** \${BASE_DIR}\jdk\bin

► **BU_WORKSPACE:** C:\builds

`{BU_WORKSPACE}` is used as value of the Team Concert load directory and as value of the Eclipse workspace used by the build utility.

The load directory is a temporary storage on the build server where the contents of the repository workspace owned by the build user will be copied when the build starts.

Because we pass the value of this variable as the **-data** argument to the build utility, the build utility will create an empty Eclipse workspace in that same directory. It will be the responsibility of the Ant build script to actually import the projects into the empty workspace. This is done by using the Ant task `projectImport` without any specified `projectLocation` as we have already seen in “Create the build file (BUbuild.xml)” on page 930.

Because we have previously shared the Ant script, it will be copied to the load directory, and we can therefore provide its location using **-buildfile**.

Requesting a build

In the Team Artifacts view, do the following:

- Expand the **Project Area** node.
- Expand the **Builds** node.
- Right-click on the build definition **Itso Redbank Project Team**.
- Select **Request Build**.
- Select **Submit**.

This queues the build request and you can monitor its status from the Builds view (Figure 29-38).

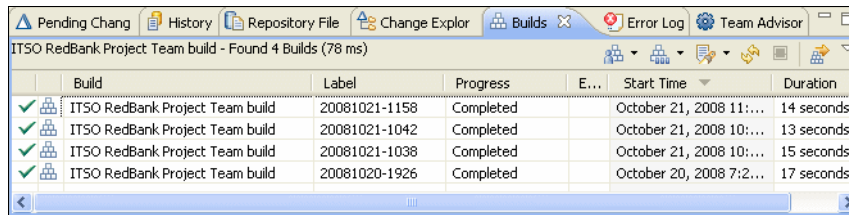

Build	Label	Progress	E...	Start Time	Duration
✓ ITSO RedBank Project Team build	20081021-1158	Completed		October 21, 2008 11:...	14 seconds
✓ ITSO RedBank Project Team build	20081021-1042	Completed		October 21, 2008 10:...	13 seconds
✓ ITSO RedBank Project Team build	20081021-1038	Completed		October 21, 2008 10:...	15 seconds
✓ ITSO RedBank Project Team build	20081020-1926	Completed		October 20, 2008 7:2...	17 seconds

Figure 29-38 Builds view after completion of some builds

At any time you can right-click on the Build Description and select **Open Latest Build Details**. From the Build Details editor you can access the build log, associate the build with an existing work item, create a new work item, or create a release associated to the build (Figure 29-39).

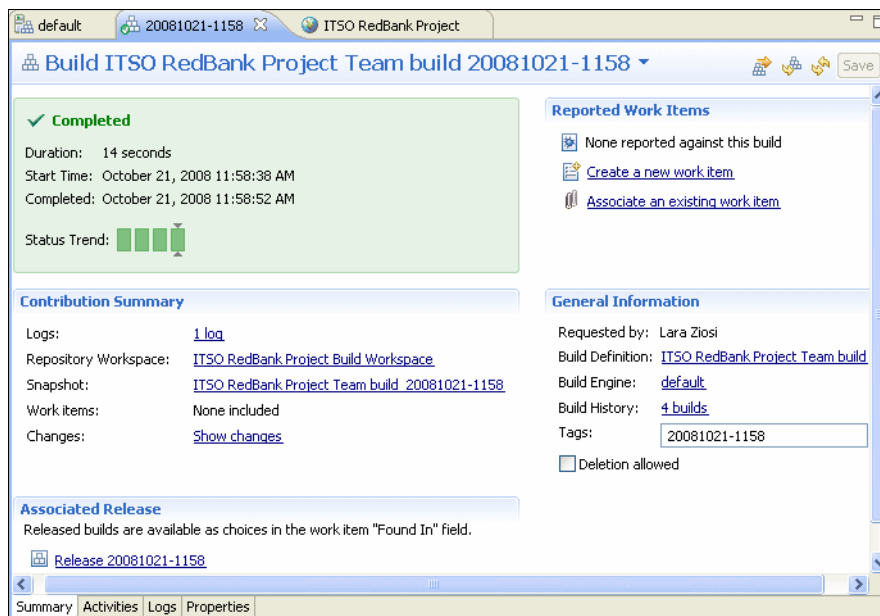

Build ITSO RedBank Project Team build 20081021-1158

✓ **Completed**

Duration: 14 seconds
 Start Time: October 21, 2008 11:58:38 AM
 Completed: October 21, 2008 11:58:52 AM

Status Trend: █ █ █ █ █

Reported Work Items

- None reported against this build
- [Create a new work item](#)
- [Associate an existing work item](#)

Contribution Summary

Logs: [1 log](#)
 Repository Workspace: [ITSO RedBank Project Build Workspace](#)
 Snapshot: [ITSO RedBank Project Team build 20081021-1158](#)
 Work items: None included
 Changes: [Show changes](#)

General Information

Requested by: Lara Ziosi
 Build Definition: [ITSO RedBank Project Team build](#)
 Build Engine: [default](#)
 Build History: [4 builds](#)
 Tags:
 Deletion allowed

Associated Release

Released builds are available as choices in the work item "Found In" field.

[Release 20081021-1158](#)

Summary | Activities | Logs | Properties

Figure 29-39 Build Details editor

Running reports (Standard edition only)

If you are using Standard edition, the Team Artifacts view shows a node called *Reports* under the Project Area. To see how you can create a report, do the following:

- ▶ Expand **Reports** → **Report templates**.
- ▶ Right click on **Open vs Closed Work Items**.
- ▶ Select **Create Report**.
- ▶ Select the destination folder as **My Reports**.

A new report based on the selected template is created under My Reports. To run the report, do the following:

- ▶ Double click on **Open vs Closed Work Items** under My Reports.
- ▶ Expand the Parameters section. Select appropriate parameters values.
- ▶ Click **Run**.
- ▶ Save the report.
- ▶ You can also export the report as PDF, Postscript, Excel®, Word, PowerPoint®.
- ▶ As soon as you select the export format, the corresponding tool opens.

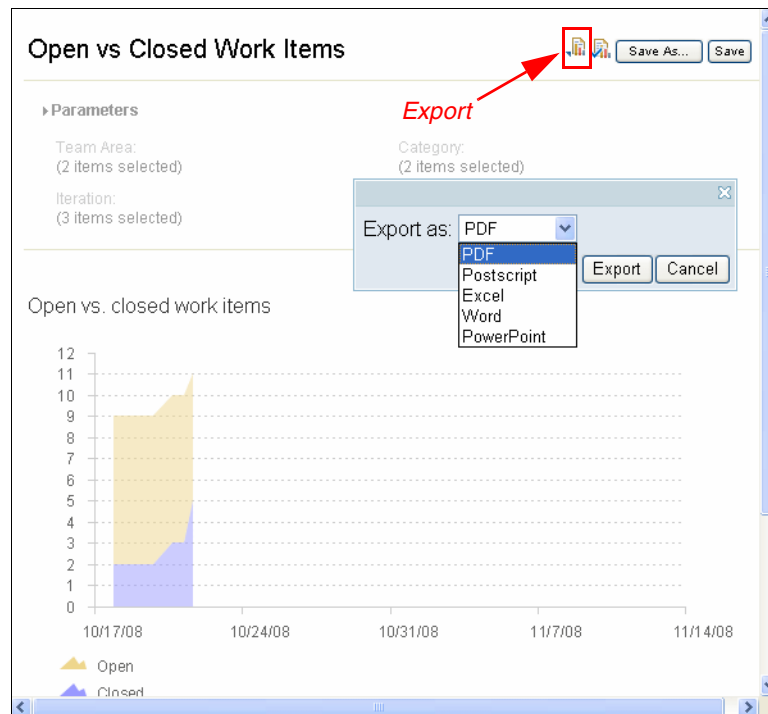

Figure 29-40 Report based on the open vs closed work items template

Collaborative debugging

Collaborative debugging is a feature provided by Application Developer that allows users logged onto the same Team Concert repository to share a debug session including all status information and breakpoints. This feature is described in Chapter 24, “Debug local and remote applications” on page 861.

More information

For more information on Team Concert and its integration with Application Developer, refer to these resources:

- ▶ Rational Team Concert enablement roadmap (login to <http://jazz.net>):
http://www.ibm.com/developerworks/rational/roadmaps/rtcroadmap/?S_TACT=105A_GX63&S_CMP=JAZZ&ca=ddc-
- ▶ Jazz platform technical overview (login to <http://jazz.net>):
<https://jazz.net/learn/LearnItem.jsp?href=content/docs/platform-overview/index.html>
- ▶ How to use the Scrum project management method with IBM Rational Team Concert and the Jazz platform:
http://www.ibm.com/developerworks/rational/library/08/0701_ellingsworth/
- ▶ *Collaborative Application Lifecycle Management with Rational Products*, SG24-7622
- ▶ Application Developer: select **Help** → **Help Contents**, under:
 - Product overview → Introduction to Rational Team Concert
 - Installing and upgrading → Installing Rational Team Concert
 - Migrating → Migrating the Jazz Team Server
 - Collaborating
 - Developing → Debugging Applications → Debug extension for Rational Team Concert Client
 - Administering → Managing the Jazz Team Server through the Web interface
 - Managing change and releases
 - Tutorials → Do and Learn → Tutorial: Get started with Rational Team Concert
 - Troubleshooting and support → Rational Team Concert troubleshooting and support
- ▶ Application Developer: select **Help** → **Cheat Sheets**, then select Team/Jazz → Setup a new Jazz Project Area and Team Area



Part 9

Appendixes



Product installation

The objective of this appendix is to highlight the key installation considerations and options, identify components installed while writing this book, and provide a general awareness regarding the use of IBM Installation Manager to install IBM Rational Application Developer v7.5.

The appendix is organized into the following sections:

- ▶ IBM Installation Manager
- ▶ Installing IBM Rational Application Developer
- ▶ Installing the WebSphere Portal v6.1 test environment
- ▶ Installing IBM Rational Team Concert
- ▶ Installing Rational Application Developer Build Utility

Launchpad

There are a number of scenarios that you can follow when installing Rational Application Developer:

- ▶ Installing from the CDs
- ▶ Installing from a downloaded electronic image on your workstation
- ▶ Installing from an electronic image on a shared drive
- ▶ Installing from a repository on an HTTP or HTTPS server

While writing this Redbooks publication, we installed IBM Rational Application Developer v7.5 from a downloaded electronic image on the workstation. The steps are listed as follows:

After you download all the components of Application Developer v7.5, unzip the files into an installation folder. From there start the Launchpad by executing `RAD_SETUP\1 launchpad.exe`:

- ▶ On the first panel, select the language, for example, **English**, and click **OK**.
- ▶ The Launchpad opens (Figure A-1)

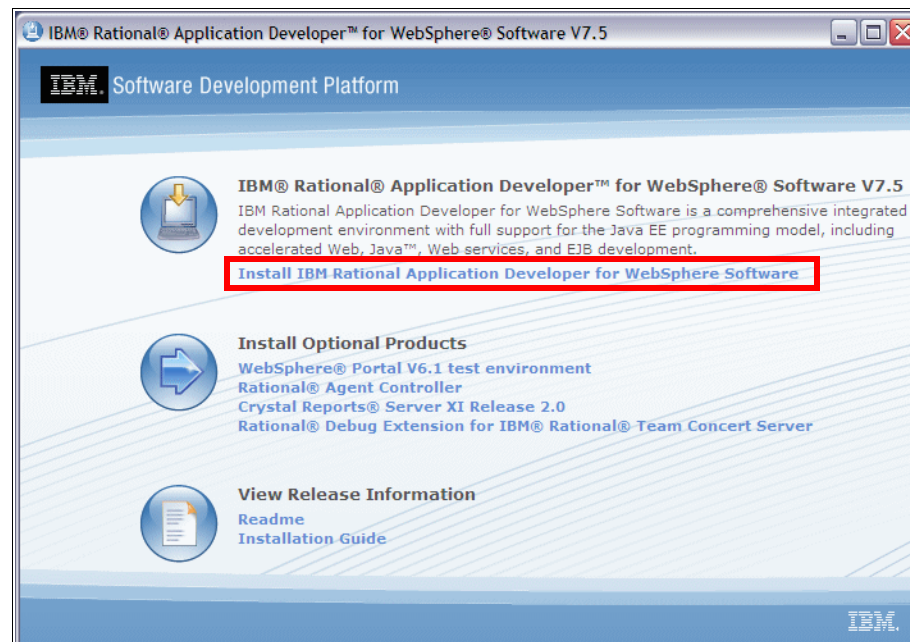

Figure A-1 Launchpad

Click **Install UBM Rational Application Developer for WebSphere Software**.

IBM Installation Manager

IBM Installation Manager is used to install Rational Application Developer. IBM Installation Manager is a program that helps you install the Rational desktop product packages on your workstation. It also helps you update, modify, and uninstall this and other packages that you install. A package can be a product, a group of components, or a single component that is designed to be installed by Installation Manager.

The first step is to install Version 1.2 of Installation Manager:

- ▶ Select **IBM Installation Manager Version 1.2**.
- ▶ Accept the license agreement.
- ▶ Select the installation directory: C:\IBM\Installation Manager\eclipse.
- ▶ Click **Install**, wait for the installation to finish, and click **Restart Installation Manager**.

There are six wizards in the Installation Manager that make it easy to maintain your package through its lifecycle (Figure A-2).

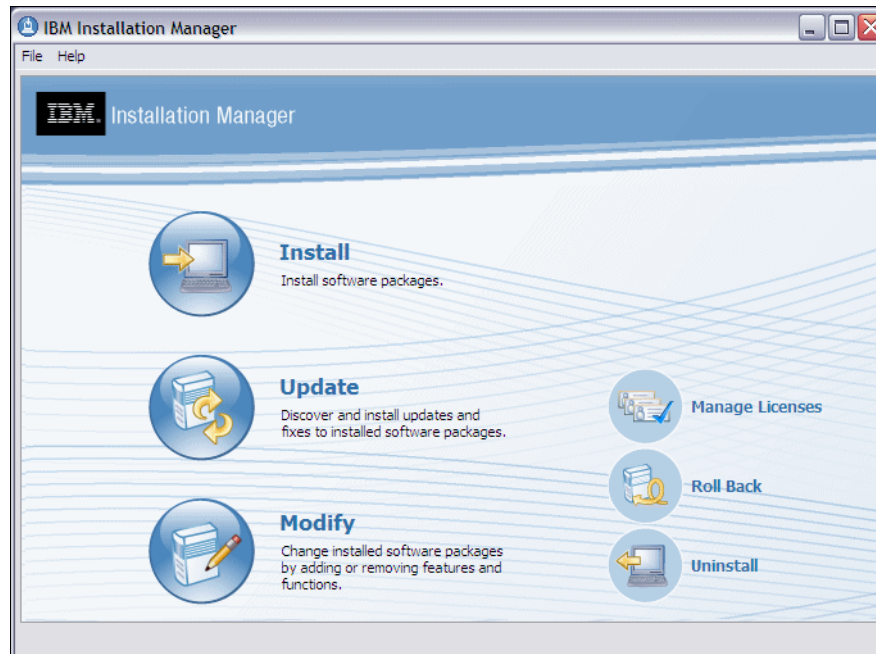

Figure A-2 Installation Manager

These are the six wizards:

- ▶ The **Install** wizard walks you through the installation process.
- ▶ The **Update** wizard searches for available updates to packages you have installed.
- ▶ With the **Modify** wizard, you can modify certain elements of a package you have already installed.
- ▶ The **Manage Licenses** wizard helps you set up the licenses for your packages.
- ▶ Using the **Roll Back** wizard, you can revert back to a previous version of a package.
- ▶ The **Uninstall** wizard removes a package from your computer.

Installing IBM Rational Application Developer

From the Installation Manager, click **Install** to install Application Developer:

- ▶ In the Install Packages dialog, select Application Developer and the webSphere servers that you want to install. Select **WebSphere Application Server v7.0** and optionally **WebSphere Application Server v6.1** (Figure A-3). Click **Next**.

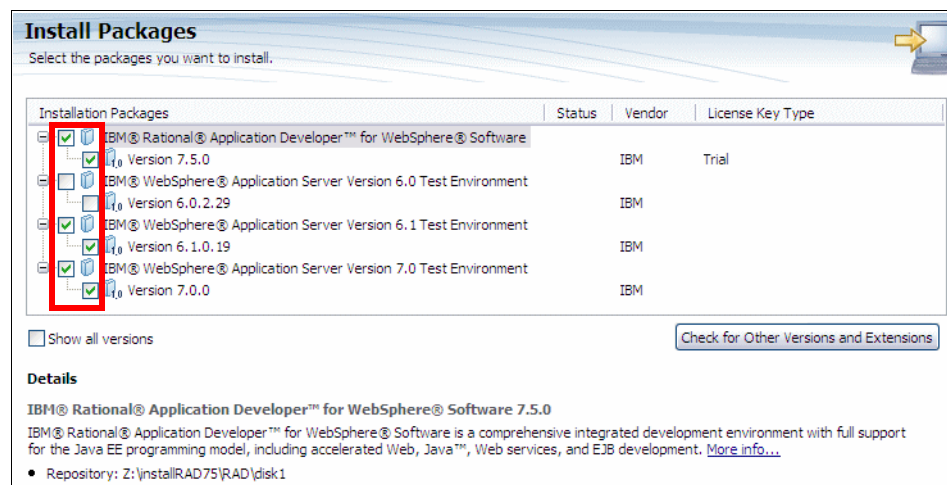

Figure A-3 Install Packages

- ▶ Click **Check for Other Versions or Extension** to see if newer versions are available.

- ▶ Select **I accept the terms in the license agreements** and then click **Next**.
- ▶ In the Select a location for the shared resources directory page, change the Shared Resource Directory from C:\Program Files\IBM\SDPShared to **C:\IBM\SDP75Shared** (Figure A-4). Click **Next**.

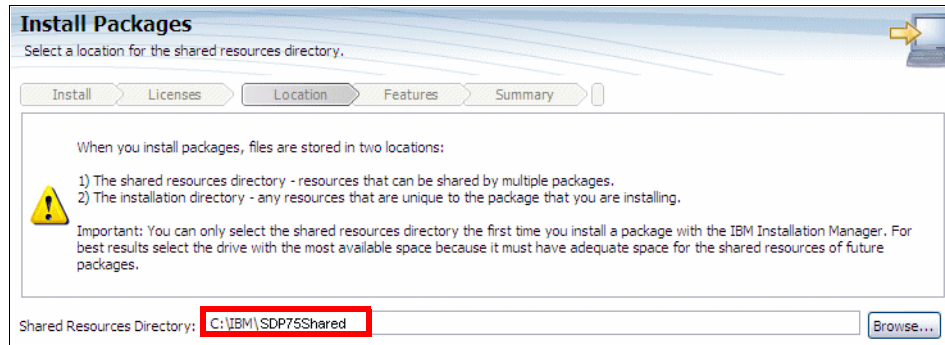

Figure A-4 Shared Resource Directory

- ▶ In the Package Group page, select **Create a new package group**, and set the installation directory for the package group to **C:\IBM\SDP75** (Figure A-5), and click **Next**.

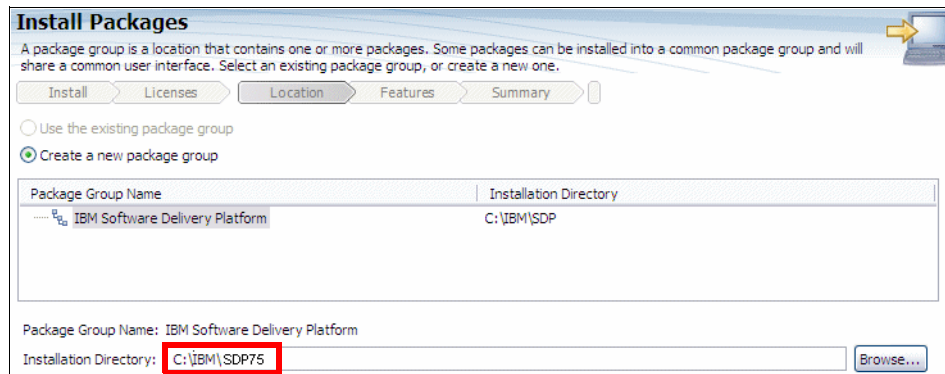

Figure A-5 Installation location for package group

- ▶ In the Extend an existing Eclipse page, we do not want to extend an existing Eclipse. Leave this page as default and click **Next**.
- ▶ In the Select the languages you want to install page, select your language and click **Next**.
- ▶ In the Select the features you want to install page, select the package features that you want to install. If you want to complete all the chapters for this Redbooks publication, you have to select the features shown in Figure A-6. Click **Next**.

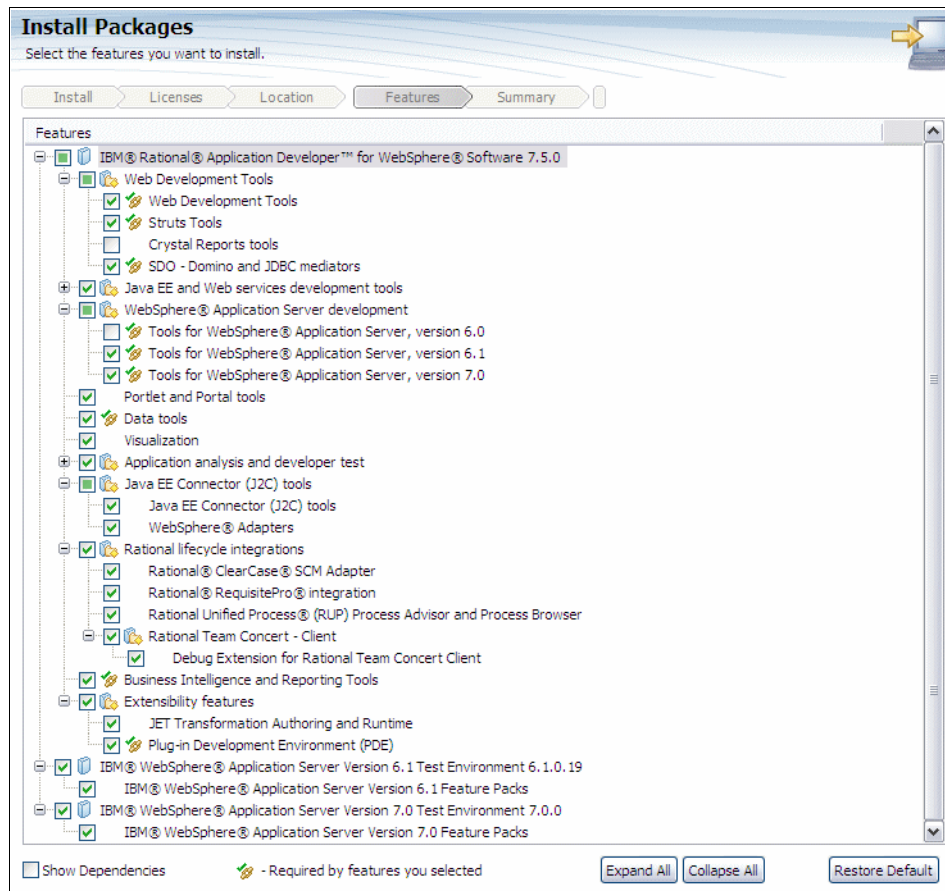

Figure A-6 Select the features you want to install

Note: You only need the **WebSphere Adapters** for the JCA examples accessing CICS and SAP.

- ▶ In the configurations page (Figure A-7):
 - Select how to access the Help system (Web, download for local access, or intranet server).
 - Select the name of the WebSphere Application Server profile, and the user ID and password for administrative security.

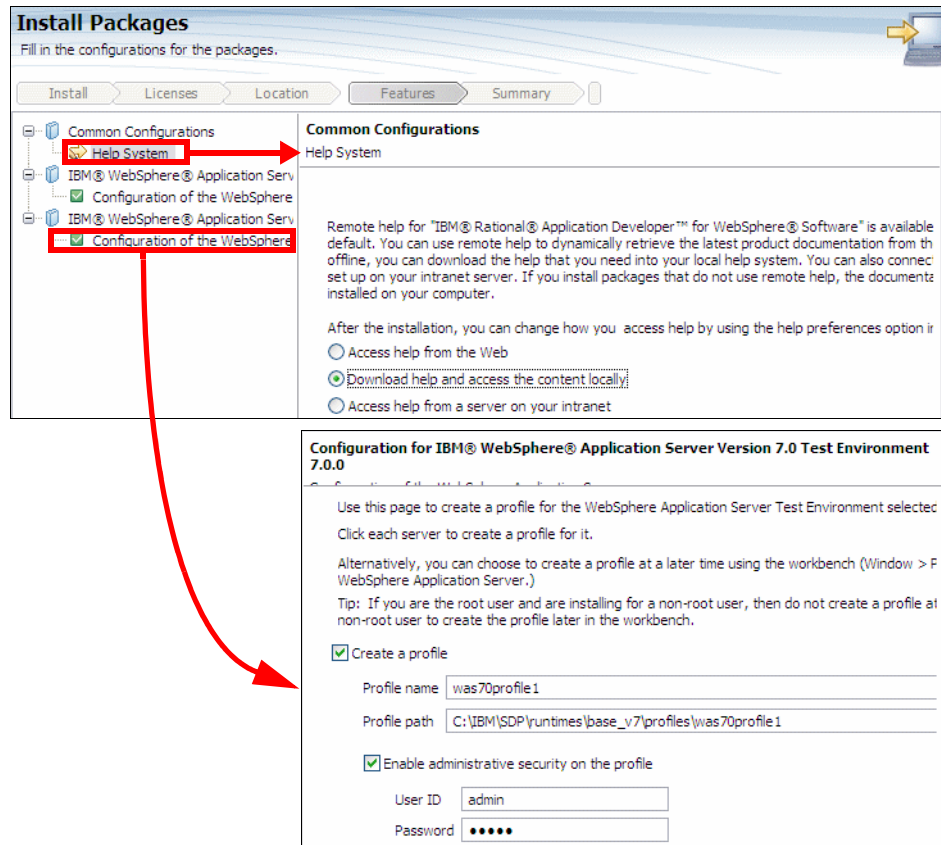

Figure A-7 Configuration options

- ▶ In the Summary page, review your choices, and click **Install**.
- ▶ The installation proceeds with install Application Developer and the selected server runtimes.
- ▶ When the installation process is completed, a message confirms the success of the process. Click **View log file** to open the installation log file for the current session in a new window. Close the Installation Log window to continue.
- ▶ In the Install Package wizard, do not start IBM Rational Application Developer when you exit. Click **Finish** to close the Install Package wizard, and you are returned to the Start page of Installation Manager.

Installing the license for Rational Application Developer

You have two options on how to enable licensing for Rational Application Developer:

- ▶ Importing a product activation kit
- ▶ Enabling Rational Common Licensing to obtain access to floating license keys

In this section, we show you how to import a product activation kit:

- ▶ Start IBM Installation Manager.
- ▶ On the main page, click **Manage Licenses**.
- ▶ The Manage Licenses dialog opens. Select **Application Developer Version 7.5** and **Import product Activation Kit**. Click **Next**.
- ▶ In the Import Activation Kit page, browse to the path of the download location for the kit, then select the appropriate Java archive (JAR) file and click **Open**. Click **Next**.

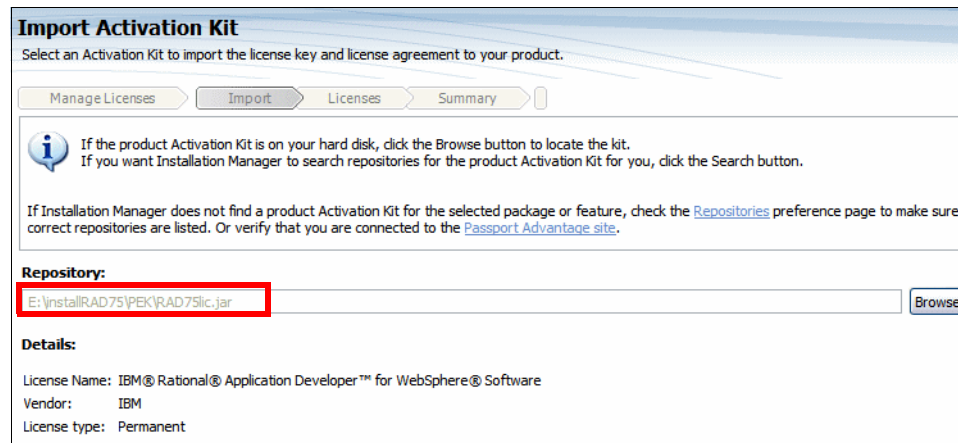

Figure A-8 Import Activation Kit

- ▶ In the Licenses page, select **I accept the terms in the license agreements**. Click **Next**.
- ▶ In the summary page, click **Finish**.
- ▶ The product activation kit with its permanent license key is imported to Application Developer. The Manage Licenses wizard indicates whether the import is successful.

Updating Rational Application Developer

Once Application Developer has been installed, the Installation Manager provides an interface to update the product.

In the Installation Manager overview, select **Update Packages** (see Figure A-2 on page 1123).

Selecting Update Packages takes you to the dialogue shown in Figure A-9. You can select **Update all** to update all products installed, or you can be explicit about a particular product. Clicking **Next** searches for the updates to the products selected.

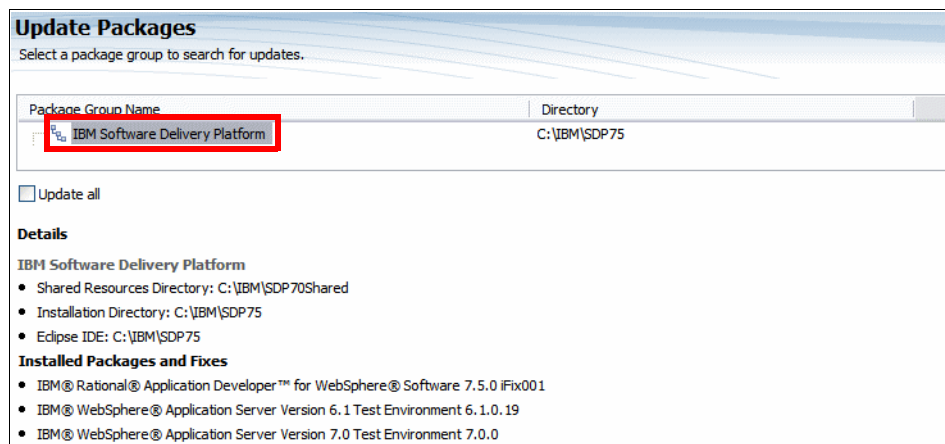

Figure A-9 Update Packages

Uninstalling Rational Application Developer

Application Developer V7.0 can be uninstalled interactively through the IBM Installation Manager.

Before uninstallation of any products, ensure to terminate the programs that you installed using Installation Manager.

In the Installation Manager overview select **Uninstall Packages** (see Figure A-2 on page 1123).

In the Uninstall Packages page, select the Rational Application Developer product package that you want to uninstall (Figure A-10). Click **Next**.

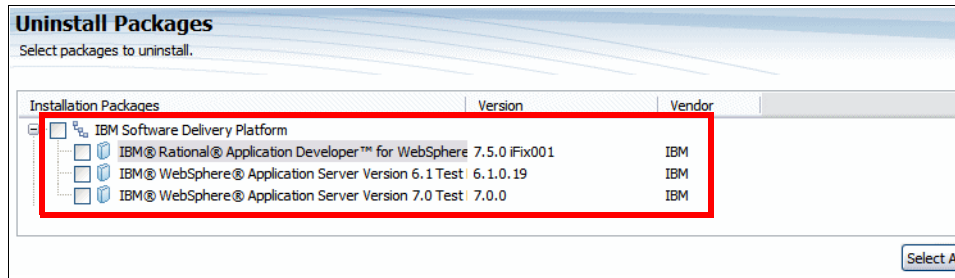

Figure A-10 Uninstall Application Developer

In the Summary page review the list of packages that will be uninstalled and then click **Uninstall**. The Complete page is displayed after the uninstallation finishes. Click **Finish** to exit the wizard.

Installing the WebSphere Portal v6.1 test environment

In this section we describe how to install WebSphere Portal v6.1, add it to Application Developer v7.5, and configure the portal test environment for performance.

Installing WebSphere Portal v6.1

If you have already installed Portal Server v6.1 on the same machine where you are about to install Rational Application Developer, the installation wizard of Application Developer automatically integrates the installed Portal Server as a target runtime.

Most of you are installing the Portal test environment after you have installed Application Developer. The best way to do this is to use the Launchpad for Rational Application Developer v7.5 (Figure A-1 on page 1122).

- ▶ In the Launchpad dialog, click **WebSphere Portal V6.1 test environment**.
- ▶ A dialog prompts the user to insert the Disk 1, which is the setup disk for WebSphere Portal v6.1. You can either do this or extract all the downloaded zip files for Application Developer v7.5 into a temporary directory and specify the path of that folder in this dialog (Figure A-11).

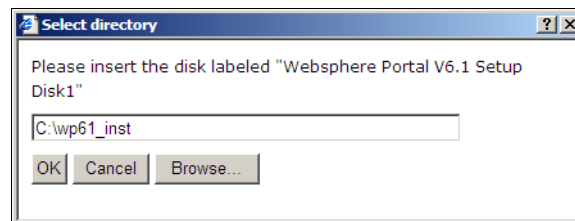

Figure A-11 Location of the install image of WebSphere Portal Setup Disk 1

- ▶ Click **Next** on the Welcome Page.
- ▶ Click **Next** on the Software license agreement (if you agree).
- ▶ In the next page, select **Administration** as the Installation type and click **Next** (Figure A-12).

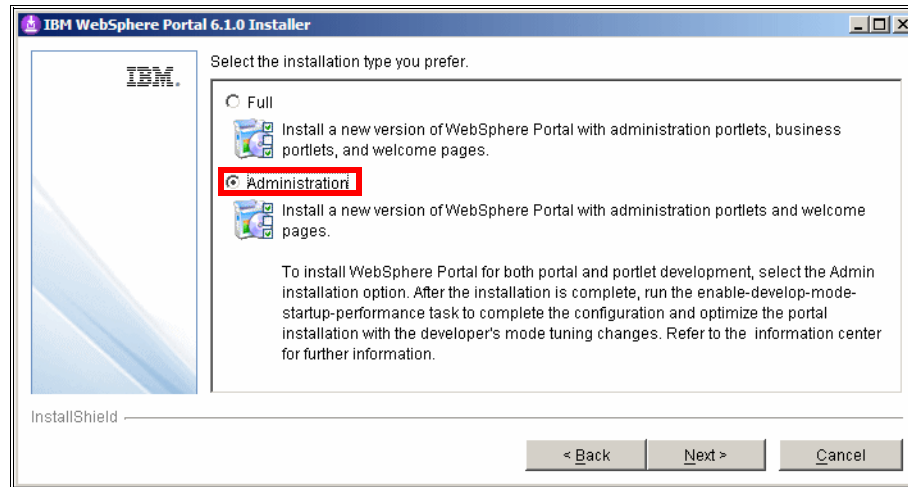

Figure A-12 Installing the WebSphere Portal v6.1 test environment

- ▶ In the next page, specify the WebSphere Portal installation directory. Accept the default (C:\IBM\WebSphere), and click **Next**.
- ▶ In the next page, you have to select if you want to install a new instance of WebSphere Application Server or use an existing instance. We use an existing server installed with Application Developer v7.5.
Select **Install on top of an existing instance** and click **Next**.
- ▶ In the next page, select the location of the existing WebSphere Application Server (for example, C:\IBM\SDP75\runtimes\base_v61), and click **Next**.
- ▶ In the next page, specify the node name and the fully qualified hostname of the machine). Accept the defaults, and click **Next**.
- ▶ In the next page, enter the user ID and password for the Portal Server administrator user. Type the values that were used for the servers installed with Application Developer v7.5 (admin/admin), and click **Next**.
- ▶ In the next page, optionally select to start the server as a Windows Services. We suggest to clear the option. Click **Next**.
- ▶ In the next page (Figure A-13), the wizard displays the summary screen. Read and verify, and if everything is as desired, and click **Next** to start the install process. This can take a long time (up to 2 hours), depending on the machine resources.
- ▶ When the wizard has completed installing the product, it displays the final summary dialog. Click **Finish**.

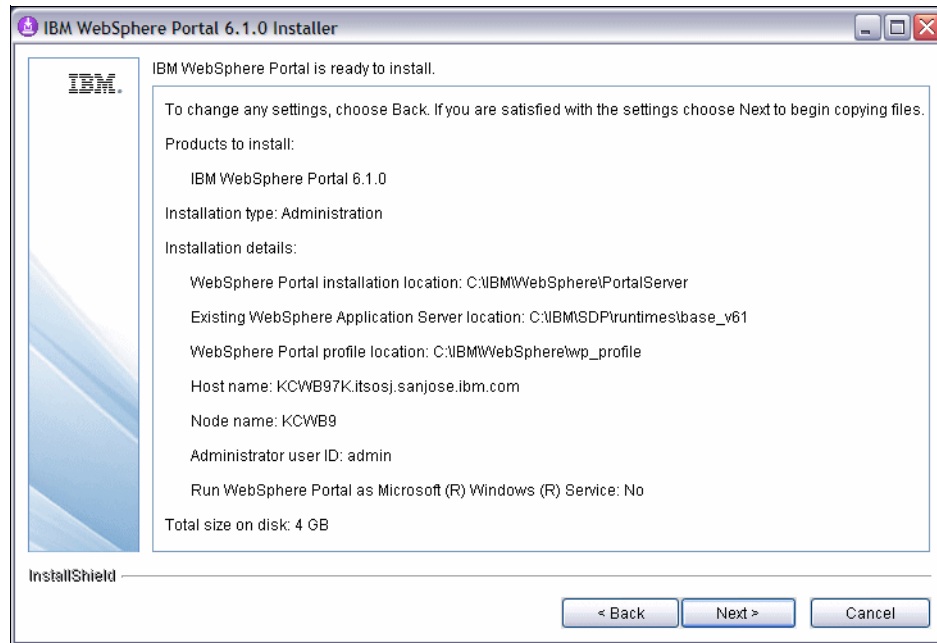

Figure A-13 WebSphere Portal v6.1 summary

Adding WebSphere Portal v6.1 to Application Developer

To execute the portal and portlet applications, we have to create a new server in Application Developer for the installed Portal Server as the target runtime.

- ▶ Start Application Developer.
- ▶ In the Servers view, right-click and select **New** → **Server** to start the New Server dialog (Figure A-14).

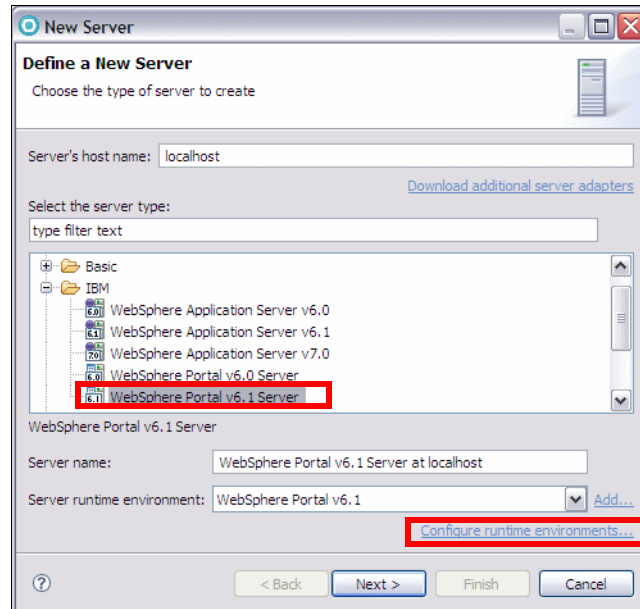

Figure A-14 Define a Portal Server

- ▶ In the New Server dialog, select **WebSphere Portal v6.1 Server** as the server type and click **Configure runtime environments** to verify if the install wizard has configured the newly installed Portal Server correctly.
- ▶ The dialog displays the list of installed server runtime environments (Figure A-15). You should see an entry for WebSphere Portal v6.1. You can also bring up this dialog by selecting **Window** → **Preferences**, and select **Server** → **Installed Runtimes**.

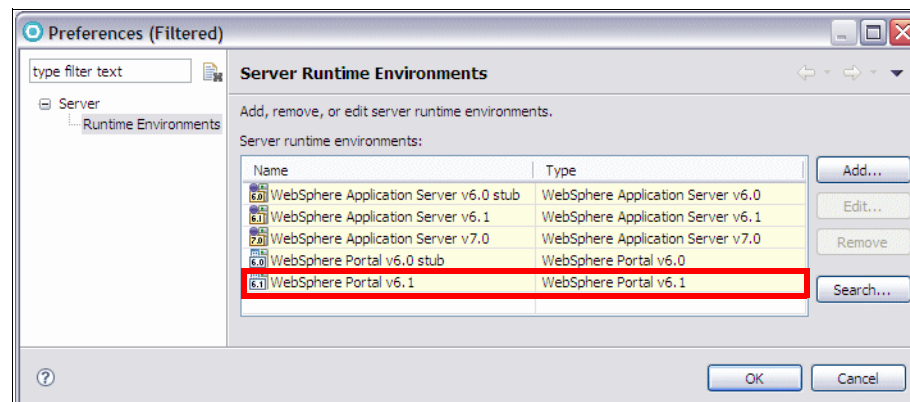

Figure A-15 List of Installed Server Runtime Environments

- ▶ Select **WebSphere Portal v6.1** and click **Edit**, if the Edit button is enabled. If the Edit button is disabled, Application Developer recognized automatically the new Portal Server.

In the Edit Server Runtime dialog, verify that the install path locations of Portal and Application Servers are correct. Click **Finish** to close this dialog

- ▶ Close the Installed Server Runtime Environments dialog.
- ▶ In the New Server dialog, click **Next**.
- ▶ In the WebSphere Settings dialog (Figure A-16), select **SOAP** as the server connection type, and click **Next**.

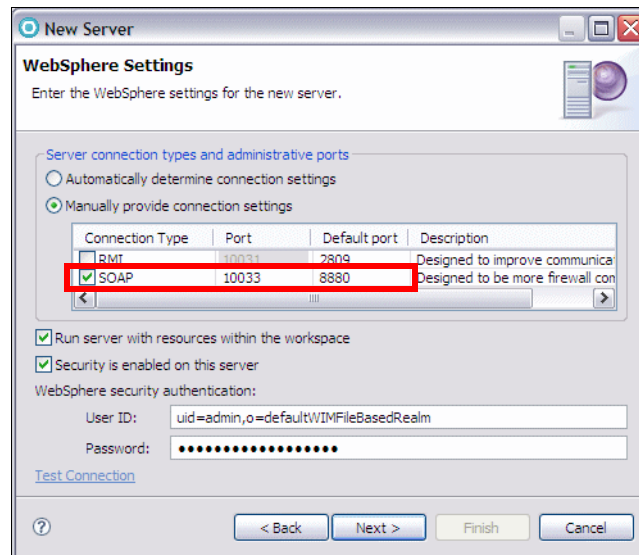

Figure A-16 WebSphere Settings

- ▶ In the WebSphere Portal Settings dialog (Figure A-17), verify the portal settings, such as context root, default, and personalized home, and the install location of Portal Server.

In the same dialog, enter the user ID and password for the Portal Server administrator, for example `admin/admin` (overtyping the values that are here). Decide if you want to enable the automatic login of a particular user when the Portal test environment starts. Click **Next**.

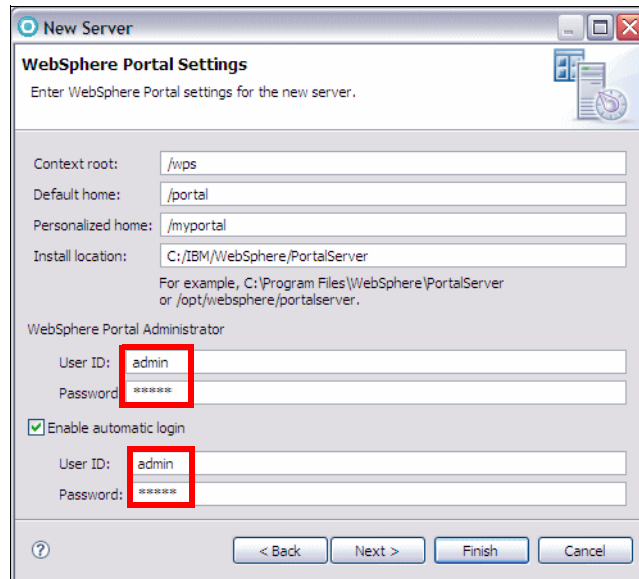

Figure A-17 WebSphere Portal Settings

- ▶ In the Properties Publishing Properties dialog, select the default value of **Local Copy** for the transfer method. Click **Next**. (Figure A-18)

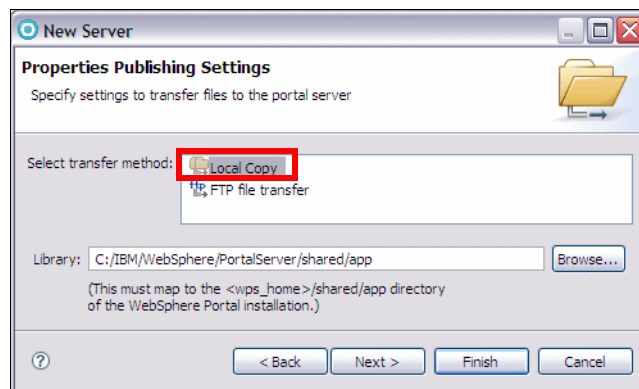

Figure A-18 Publishing Settings

- ▶ In the Add and Remove Projects dialog, click **Next** (you do not have any portal or portlet projects to add to this server).
- ▶ In the Tasks dialog, click **Finish**. This should install a new test server. You can verify this in the Servers view that displays a new entry for WebSphere Portal v6.1 Server (Figure A-19).

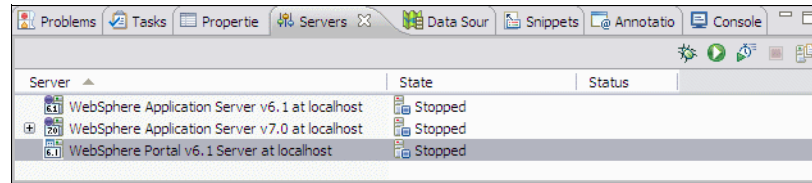

Figure A-19 Portal Server added to Application Developer

- ▶ Do not start the server yet, we have to optimize the server first.

Optimizing the Portal Server for development

To optimize the WebSphere Portal for development and to improve the start up performance, run the task described in the InfoCenter at:

http://publib.boulder.ibm.com/infocenter/wpdoc/v6r1m0/index.jsp?topic=/com.ibm.wp.ent.doc/install/inst_opt.html

Run the **ConfigEngine** command in `<Portal_Profile-HOME>/ConfigEngine`:

```
ConfigEngine.bat enable-develop-mode-startup-performance
```

The task should end with a 0 return code. If some problems occur during the execution of the task, you can find a problem resolution at:

<http://www-01.ibm.com/support/docview.wss?uid=swg21316233>

Verify development mode

In Application Developer, do these steps:

- ▶ Right-click the Portal Server and select **Start** (or click the **Start** icon) which starts the server, and change its status to Started and its state to Synchronized. Note that it takes a while to start the Portal Server.
- ▶ Right-click on the portal server entry in the Servers view, and select **Administration** → **Run administrative console**. This opens a browser session with administrative console of the Portal Server.
- ▶ Enter user ID and password (admin).
- ▶ Navigate to **Server** → **Application Servers** → **WebSphere_Portal** and verify that **Run in development mode** is selected (Figure).
- ▶ If you make changes, click **Apply**, and then click **Save** to apply changes to the master configuration.

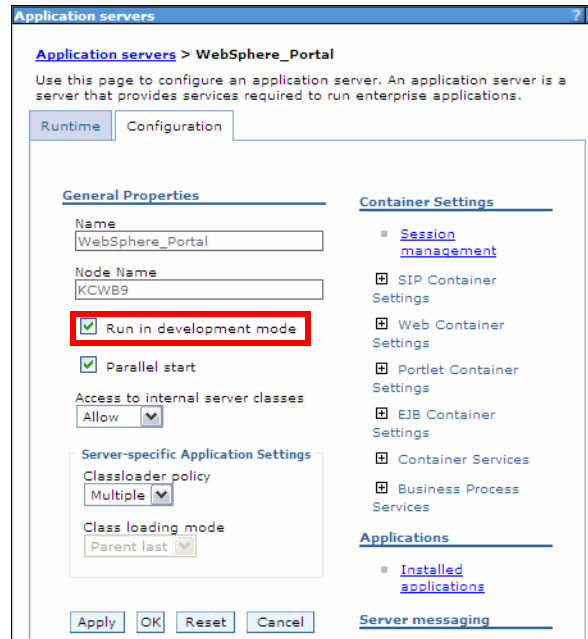

Enable debugging service

If you are using a remote Portal Server without using the Rational tools, and you intend to use this Portal Server for debugging purposes, then you might want to enable the debugging service for this server during its startup process.

Select **Server** → **Application Servers** → **WebSphere_Portal** → **Debugging Service** (under Additional properties):

- ▶ Select **Enable service at server startup**.
- ▶ Click **Apply**, and click **Save** to apply changes to the master configuration.

Stop the server

We are done with installation and configuration. Stop the server.

Besides these basic changes, there are more tips that you can implement to increase the performance of the Portal Server during the development mode or to reduce its startup time. Refer to “More information” on page 774.

Installing IBM Rational Team Concert

The complete instructions for installing any of the three editions of Rational Team Concert can be found in the product help under **Installing and upgrading** → **Installing Rational Team Concert**.

Installing Rational Team Concert Express-c server

In this section we show how you can get started with the installation of Rational Team Concert Express-C edition on Windows. For other editions and platforms refer to product help. You can obtain IBM Rational Team Concert Express-c edition for free from <http://jazz.net>.

The server license is free and you are provided with three free Developer licenses. Note that you are required to register to access the download page.

- ▶ After you download the file, extract the archive to a directory on your file system with a short path, such as:

```
C:\IBM
```

- ▶ As a result, you should have the directories:

```
C:\IBM\jazz\buildsystem
```

```
C:\IBM\jazz\client
```

```
C:\IBM\jazz\repotools
```

```
C:\IBM\jazz\scmtools
```

```
C:\IBM\jazz\server
```

- ▶ At this point you can start the provided Apache Tomcat server. For instructions on how to change the default server ports and the default launch directory refer to the product help.

- Open a command window.

- Change directory to the server directory:

```
cd C:\IBM\jazz\server
```

- Run the command to start the server:

```
server.startup.bat
```

Running the setup wizard

To configure the team server, perform these steps:

- ▶ Open a Web browser with the URL:

```
https://localhost:9443/jazz/setup
```

Provide the default Username and Password of ADMIN/ADMIN (Figure A-20).

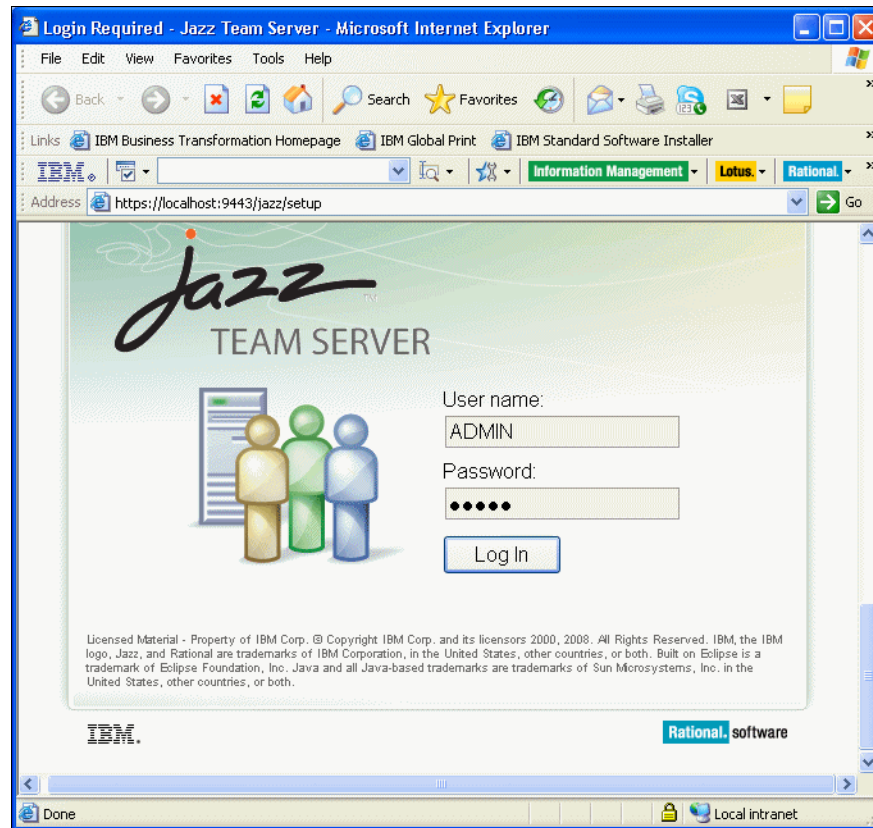

Figure A-20 Running the setup after starting Tomcat

- ▶ To select a setup path click **Fast Path Setup**, which skips the configuration of the mail server for e-mail notification and uses the built-in Derby database (Figure A-21). Refer to the product help for information on using the **Custom Setup** option.

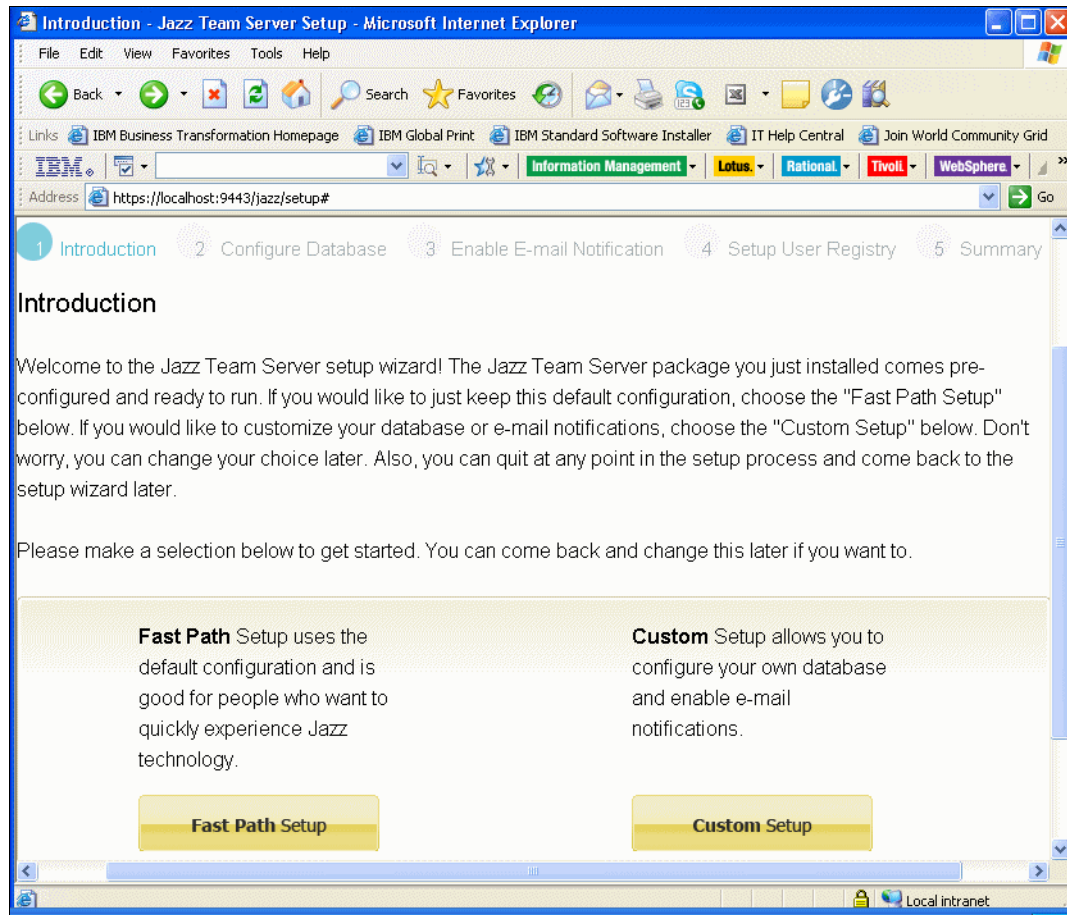

Figure A-21 Selecting Fast Path Setup

- ▶ In the Setup User Registry page (Step 1), select **Tomcat User Database** (Figure A-22).

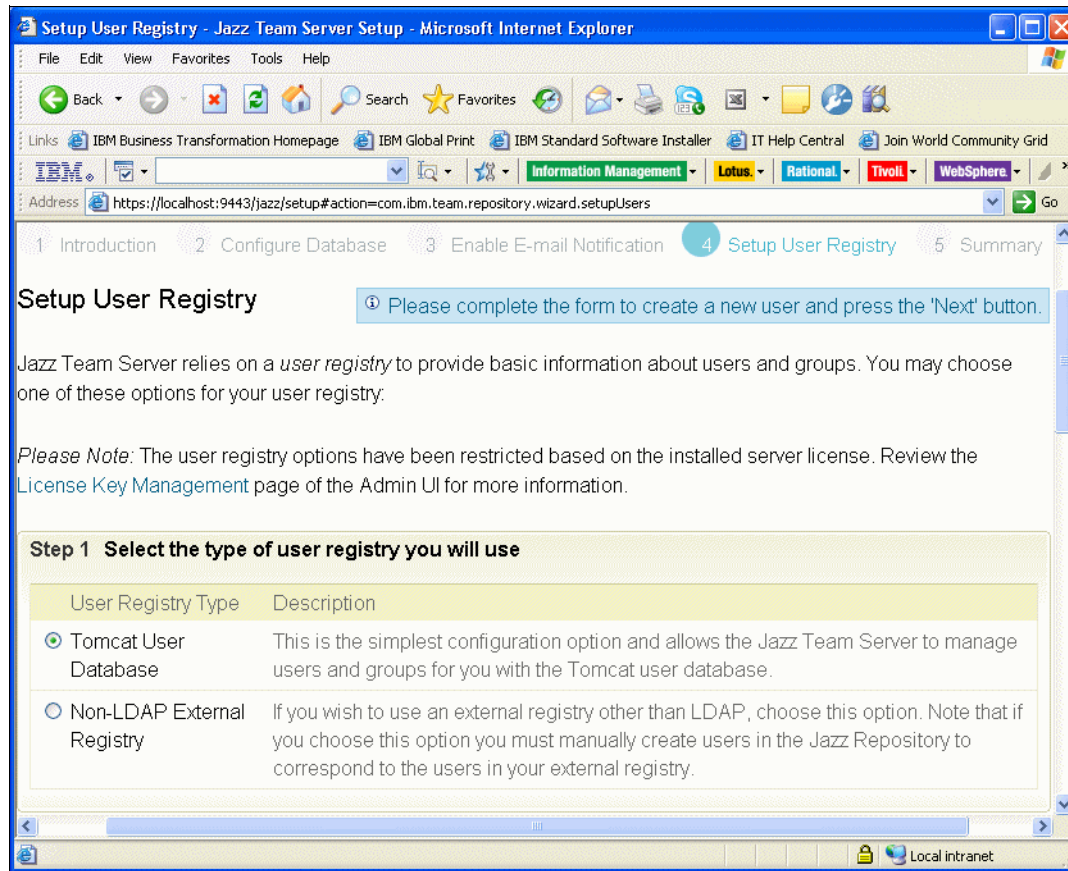

Figure A-22 Setting up the user Registry

- ▶ In the Setup User Registry page (Step 2), enter user ID, name, password and e-mail address of the user (Figure A-23).

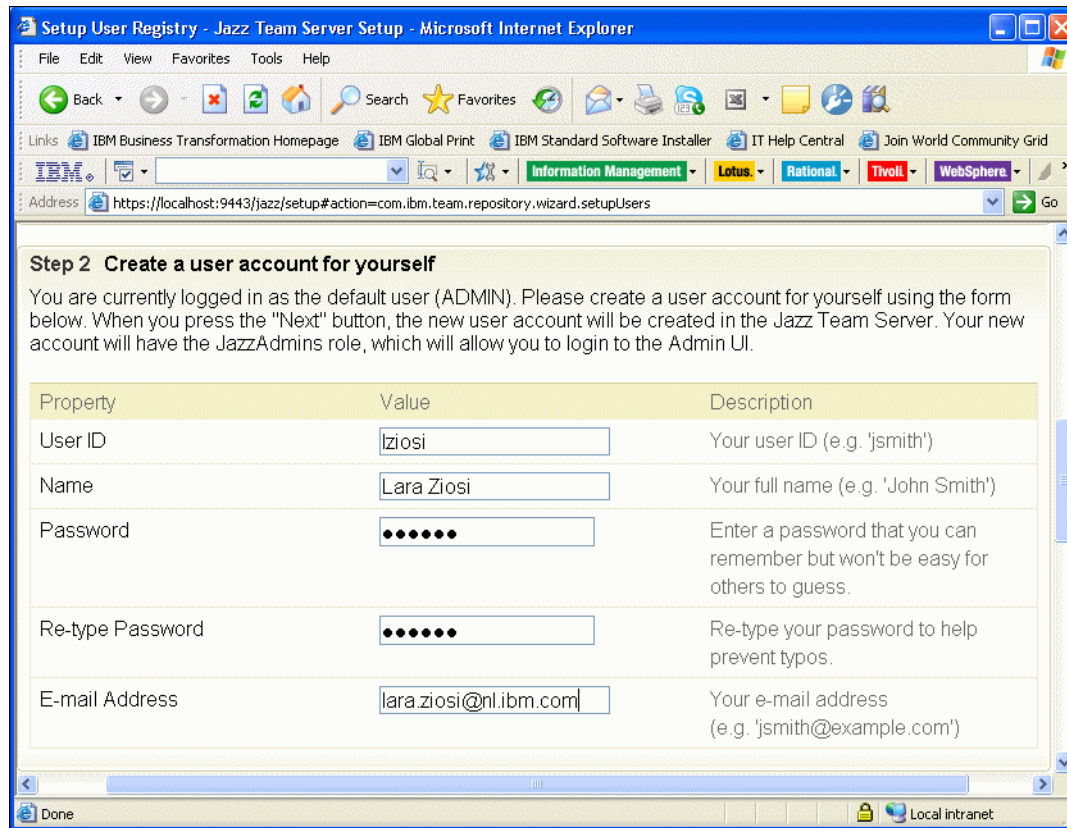

Figure A-23 Creating the first user account

- ▶ In the Setup User Registry page (Step 3), you can disable the ADMIN user used to log on to the setup wizard (Figure A-24).
- ▶ In the Setup User Registry page (Step 4), you can see three available Developer licenses. Assign one license to the user you just created.

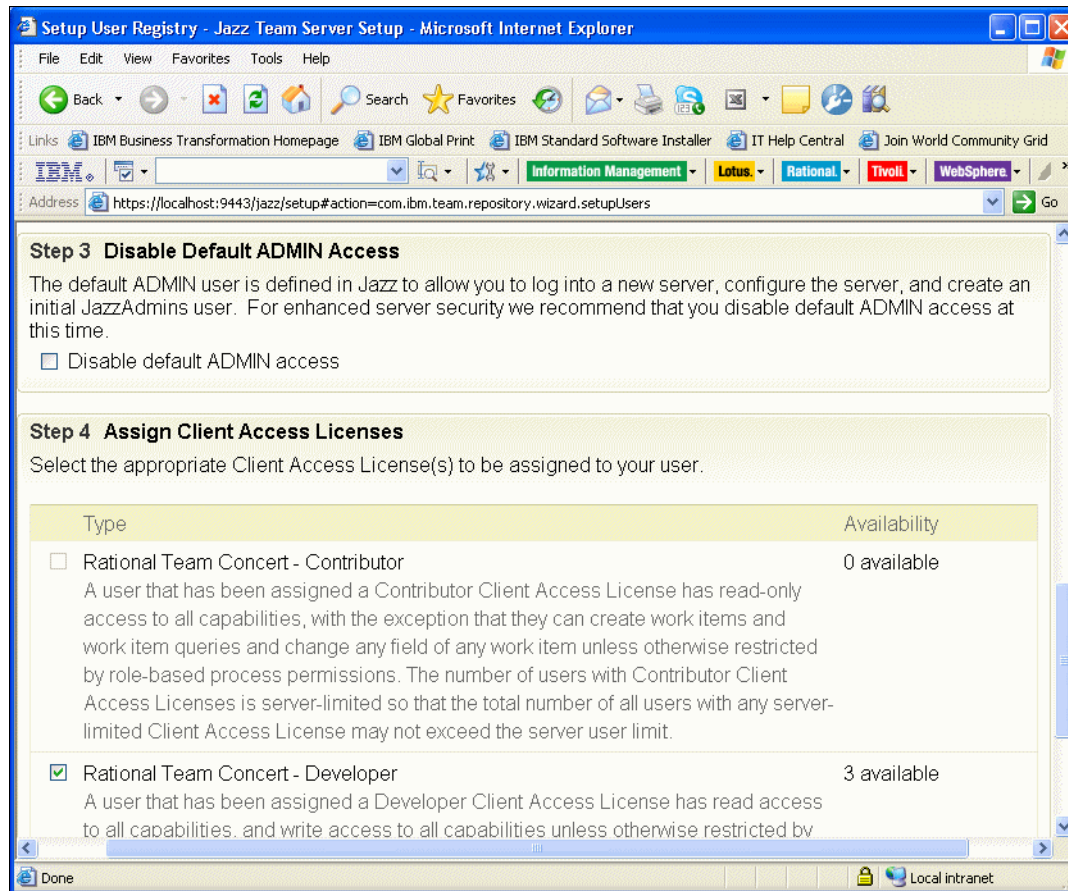

Figure A-24 Assigning developer licenses

- ▶ Click **Next** and you see a summary page from which you can terminate the Setup wizard (Figure A-25).

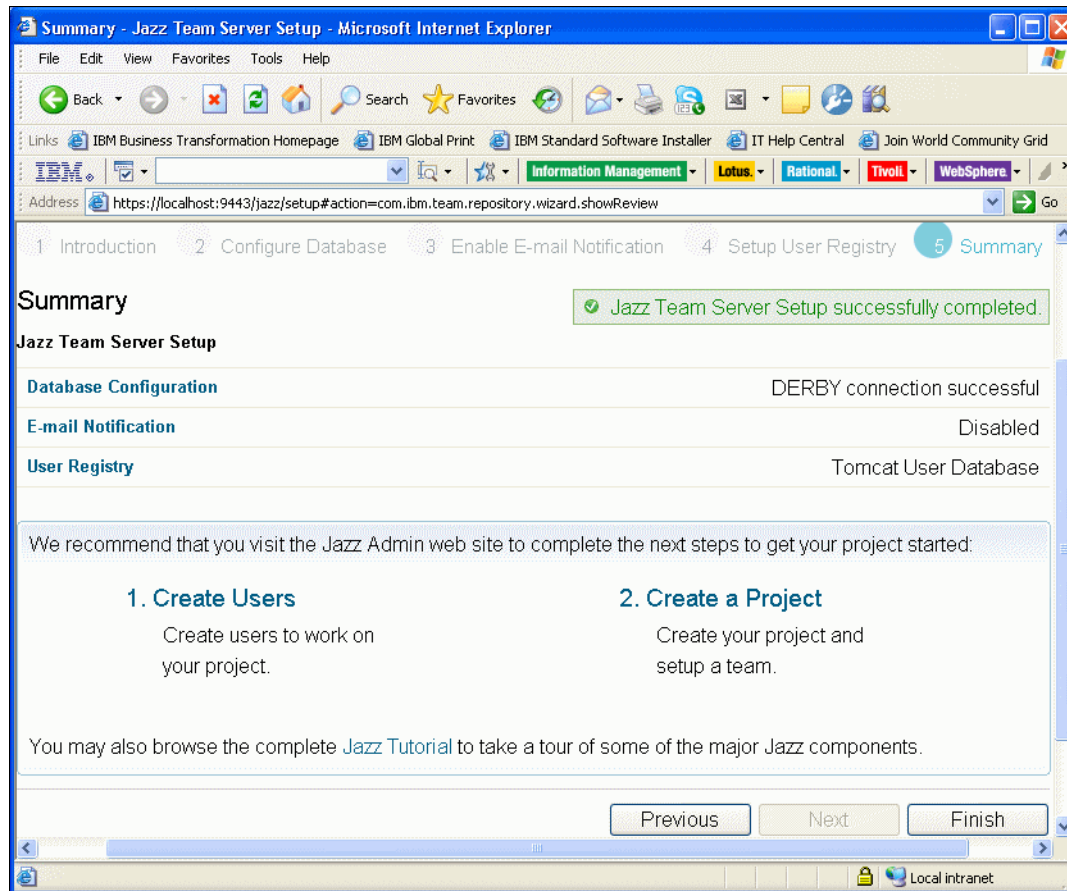

Figure A-25 Summary

- ▶ Verify that the setup is correct by launching the Team Server Admin Web UI opening the following URL:
<https://localhost:9443/jazz/admin>
- ▶ If you do not want to have passwords in clear in any files on the file system, inspect the contents and then remove the backup property files contained in:
`C:\IBM\jazz\server\teamserver-<digits>backup.properties`
- ▶ You are now ready to connect to the server with the Rational Team Concert client or a Web browser.
- ▶ You can stop the server from a command window by running the command:
`C:\IBM\jazz\server.shutdown.bat`

- ▶ The server was started as an application. You can make it become a service so that it starts automatically at boot time. Refer to the following Jazz technote for instructions:

https://jazz.net/learn/LearnItem.jsp?href=content/tech-notes/jazz-team-server-0_6-running-jazz-team-server-in-tomcat-as-a-windows-service/index.html

Installing Rational Team Concert Build Engine and Build Toolkit

Installing the Build Engine and Build Toolkit from the Express-C.zip file consists of simply uncompressing the archive and verifying that the following directories were extracted:

```
C:\IBM\jazz\buildsystem
C:\IBM\jazz\buildsystem\buildengine
C:\IBM\jazz\buildsystem\buildtoolkit
```

Installing the client and the debug extensions

There are three required components besides the Rational Team Concert server:

- ▶ Rational Team Concert Client
- ▶ Debug Extension for Rational Team Concert Client
- ▶ Team Debug Service Extension for Rational Team Concert Server

Rational Team Concert Client and debug extensions

The first two components are optional features of Rational Application Developer that can be installed using IBM Installation Manager. They are contained in the Rational Application Developer core disks. An existing installation can be modified to include these features as follows:

- ▶ Stop Rational Application Developer if it is running.
- ▶ Launch **IBM Installation Manager**.
- ▶ Click **Modify**.
- ▶ Select the Package group that contains Rational Application Developer.
- ▶ Click **Next** on the page that shows the languages.
- ▶ In the Features page, select:
 - **Rational lifecycle integrations** → **Rational Team Concert - Client**
 - **Rational lifecycle integrations** → **Rational Team Concert - Client** → **Debug Extensions for Rational Team Concert Client**
- ▶ Click **Next** and **Finish**.

For more information see the product Help under: **Developing** → **Debugging Applications** → **Debug Extensions for Rational Team Concert Client** → **Overview**.

Rational Team Concert server debug extensions

The Rational Team Concert Server has to be configured with the Team Debug Service Extension, which is found in the Rational Application Developer optional disk `C:\N16ML: IBM Rational Debug Extension for IBM Rational Team Concert Server`.

The installation of the Debug Extension is described in the product Help under: **Installing and Upgrading** → **Installing Rational Application Developer** → **Installing Supporting Software** → **Installing Rational Debug Extension for Rational Team Concert Server**.

To verify that the installation is correct, connect to the Rational Team Concert server with a Web browser and verify that the following service is active (Figure A-26):

```
com.ibm.debug.team.common.service.ITeamDebugService
```

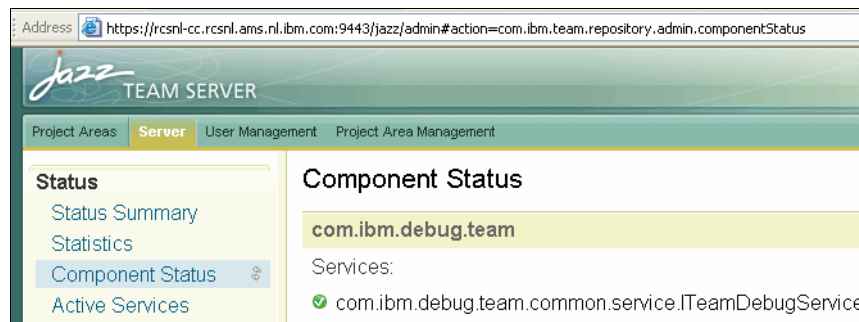

Figure A-26 Verify that the debug extension is active on the Team Concert Server

Installing Rational Application Developer Build Utility

The build utility can be used to execute builds on a build server without having Application Developer, WebSphere Application Server or Portal Server installed. It does not contain any user interface code, and it allows you to create ANT scripts for running the available Ant Tasks in headless mode.

The build utility maintains three sets of two archives, for the operating systems: Windows, Linux, or z/OS.

Here we show only how to install on Windows the core files and the WebSphere Application Server v7 stub files. The corresponding sources can be found in the download image: **C1LYOML** (IBM Rational Application Developer for WebSphere Build Utility V7.5 Multilingual Multiplatform Part 2). For a complete description of the other platforms and supported application servers, see the product Help under: **Installing and Upgrading** → **Installing Supporting Software** → **Installing Rational Application Developer for WebSphere Software build utility**.

- ▶ From the electronic image #2 or CD #2, extract the following files to a temporary directory:
RAD-75_BuildUtility_v70Stub_windows-<yyyymmdd_tttt>.zip
RAD-75_BuildUtility_windows-<yyyymmdd_tttt>.zip
- ▶ Unzip the files to a root directory of your choice. We recommended that you select a root directory with a short path without any spaces (such as, C:\IBM), otherwise the sample in BuildUtility\eclipse\samples\AutoBuild will fail.

The archives create the following directory structure:

```
<root>/BuildUtility/eclipse (core installation files)
<root>/BuildUtility/runtimes (WebSphere Application Server v7.0 stub files)
```

**B**

Additional material

The additional material is a Web download of the sample code for this book. This appendix describes how to download, unpack, describe the contents, and import the project interchange file. In some cases the chapters also require database setup; however, if needed, the instructions will be provided in the chapter in which they are needed.

The appendix is organized into the following sections:

- ▶ Locating the Web material
- ▶ Unpacking the sample code
- ▶ Description of the sample code
- ▶ Setting up the ITSOBANK database
- ▶ Configuring the data source in WebSphere Application Server
- ▶ Importing sample code from a project interchange file

Locating the Web material

The Web material associated with this book is available in softcopy on the Internet from the IBM Redbooks Web server. Enter the following URL in a Web browser, and then download the two ZIP files from:

<ftp://www.redbooks.ibm.com/redbooks/SG247672>

Alternatively, you can go to the IBM Redbooks Web site at:

<http://www.ibm.com/redbooks>

Select the **Additional materials** and open the directory that corresponds with the Redbooks publication form number, SG24-7672.

The additional Web material that accompanies this Redbooks publication includes the following files:

<i>File name</i>	<i>Description</i>
7672code.zip	Zip file containing sample code
7672codesolution.zip	Zip file containing solution interchange files

System requirements for downloading the Web material

The following system configuration is recommended:

Hard disk space:	20 GB minimum
Operating System:	Windows or Linux
Processor:	2 GHz
Memory:	2 GB

Using the sample code

In this section we provide a description of the sample code and how to use it.

Unpacking the sample code

After you have downloaded the two ZIP files, unpack the files to your local file system using WinZip, PKZip, or similar software. For example, we unpacked the 7672code.zip and 7672codesolution.zip files to the C:\ drive, which creates **C:\7672code**. Throughout the samples, we reference the sample code as if you have unpacked the files to the C drive.

Description of the sample code

Table B-1 describes the contents of the sample code after unpacking. The 7672code folder has two major sections:

- ▶ Code sample to follow the instructions in a chapter
- ▶ Interchange files with the solution of each chapter

Table B-1 Sample code description

Directory	Sample code for which chapter
c:\7672code	Root directory after unpacking the sample code
..\java	Chapter 8, “Develop Java applications” on page 69
..\patterns	Chapter 9, “Accelerate development using patterns” on page 157
..\xml	Chapter 10, “Develop XML applications” on page 185
..\database	Chapter 11, “Develop database applications” on page 227 Also includes the code to setup the ITS0BANK database in either Derby or DB2
..\jpa	Chapter 12, “Persistence using the Java Persistence API (JPA)” on page 267
..\webapp	Chapter 13, “Develop Web applications using JSPs and servlets” on page 317
..\ejb	Chapter 14, “Develop EJB applications” on page 387
..\struts	Chapter 15, “Develop Web applications using Struts” on page 445
..\jsf	Chapter 16, “Develop Web applications using JSF” on page 493
..\appclient	Chapter 17, “Develop Java EE application clients” on page 543
..\webservice	Chapter 18, “Develop Web services applications” on page 563
..\web20	Chapter 19, “Develop Web applications using Web 2.0” on page 649
..\jca	Chapter 20, “Develop applications to connect to enterprise information systems” on page 697
..\portal	Chapter 21, “Develop portal applications” on page 739
..\junit	Chapter 23, “Test using JUnit” on page 819
..\ant	Chapter 25, “Build applications with Ant” on page 903
..\jython	Chapter 26, “Deploy enterprise applications” on page 933
..\zInterchange	Directory with an interchange file for most chapters containing the final code

Interchange files with final code

The directory C:\7672code\z**Interchange** contains the final applications for most chapters:

```
..\java\RAD75Java.zip
..\patterns\RAD75Patterns.zip
..\xml\RAD75XML.zip
..\database\RAD75Database.zip
..\jpa\RAD75JPA.zip
..\webapp\RAD75BankBasicWeb.zip
..\ejb\RAD75EJB.zip RAD75EJBWeb.zip
..\struts\RAD75Struts.zip RAD75Struts-Tiles.zip
..\jsf\RAD75JSF.zip
..\appclient\RAD75AppClient.zip
..\webservice\RAD75WebService.zip
..\web20\RAD75Web20-Ajax.zip RAD75Web20-Dojo.zip
..\jca\RAD75JCACICS.zip RAD75JCACICSChannel.zip RAD75JCASAP.zip
..\portal\RAD75PortalEvent.zip RAD75PortalEventAjax.zip
..\junit\RAD75JUnit.zip RAD75JUnitWebTest.zip
..\ant\RAD75Ant.zip
..\jython\RAD75Jython.zip
```

Importing sample code from a project interchange file

This section describes how to import the Redbooks publication sample code project interchange zip files into Application Developer. This section applies for each of the chapters containing sample code that have been packaged as a project interchange zip file.

Tip: After importing an interchange file for the RAD7EJB project, you have to deploy the code again. Right-click the **RAD7EJB** project and select **Prepare for Deployment**.

To import a project interchange file, do these steps:

- ▶ From the Workbench, select **File** → **Import**.
- ▶ From the Import dialog, select **Other** → **Project Interchange**, and then click **Next** (Figure B-1).

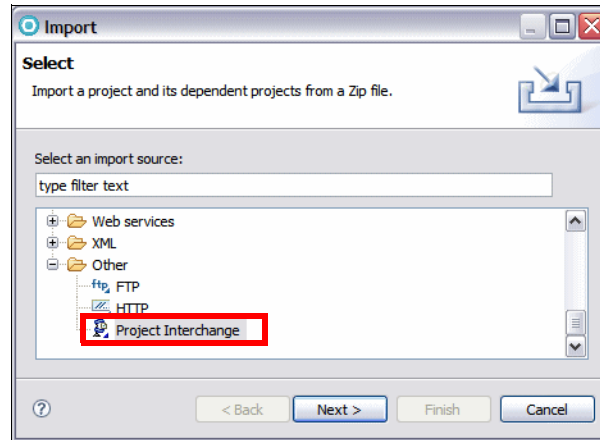

Figure B-1 Import a project interchange file

- ▶ When prompted for the path and file name, enter the following:
 - From zip file: Click **Browse** and locate the path and the zip file (for example, C:\7672code\zInterchange\java\RAD7Java.zip).
 - Project location root: Leave the default workspace location.
- ▶ After locating the zip file, the projects contained in the interchange file are listed. Select the project(s) that you want to import, and click **Finish**.

For example, we select **RAD7Java** and clicked **Finish** (Figure B-2).

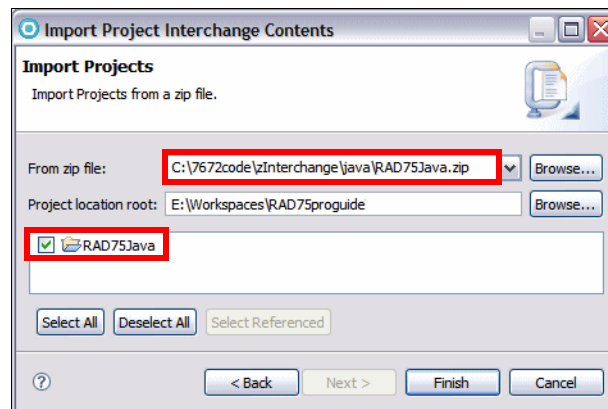

Figure B-2 Import projects from an interchange file

Setting up the ITSOBANK database

We provide two implementations of the ITSOBANK database, Derby and DB2. You can choose to implement either or both databases and then set up the enterprise applications to use one of the databases. The Derby database system is shipped with the WebSphere Application Server. We tested the application on DB2 Version 8.2, but it should work on DB2 v9.1 as well.

Derby

Command files to define and load the ITSOBANK database in Derby are provided in the `C:\7672code\database\derby` folder:

- ▶ **DerbyCreate.bat**, **DerbyLoad.bat** and **DerbyList.bat** files assume that you installed Application Developer in `C:\IBM\SDP75\` folder. You have to edit these files to point to your Application Developer installation directory if you installed the product in a different folder.
- ▶ In the `C:\7672code\database\derby` directory:
 - Execute the **DerbyCreate.bat** file to create the database and table.
 - Execute the **DerbyLoad.bat** file to delete the existing data and add records.
 - Execute the **DerbyList.bat** file to list the contents of the database.

These command files use the SQL statements and helper files provided in:

- ▶ `itsobank.ddl`—Database and table definition
- ▶ `itsobank.sql`—SQL statements to load sample data
- ▶ `itsobanklist.sql`—SQL statement to list the sample data
- ▶ `tables.bat`—Command file to execute `itsobank.ddl` statements
- ▶ `load.bat`—Command file to execute `itsobank.sql` statements
- ▶ `list.bat`—Command file to execute `itsobanklist.sql` statements

The Derby ITSOBANK database is created under:

`C:\7672code\database\derby\ITSOBANK`

DB2

DB2 command files to define and load the ITSOBANK database are provided in **C:\7672code\database\db2** folder:

- ▶ Execute the **createbank.bat** file to define the database and table.
- ▶ Execute the **loadbank.bat** file to delete the existing data and add records.
- ▶ Execute the **listbank.bat** file to list the contents of the database.

These command files use the SQL statements provided in:

- ▶ `itsobank.ddl`—Database and table definition
- ▶ `itsobank.sql`—SQL statements to load sample data
- ▶ `itsobanklist.sql`—SQL statement to list the sample data

Configuring the data source in WebSphere Application Server

This section shows how to configure the data source in the WebSphere administrative console. We configure the data source against the WebSphere Application Server v7.0 test environment shipped with Application Developer.

Here are the high-level configuration steps to configure the data source within WebSphere Application Server for the ITSOBANK database:

- ▶ Starting the WebSphere Application Server
- ▶ Configuring the environment variables
- ▶ Configuring J2C authentication data
- ▶ Configuring the JDBC provider
- ▶ Creating the data source

Starting the WebSphere Application Server

If you are using a stand-alone WebSphere Application Server v7.0, enter the following commands in a command window:

```
cd \IBM\WebSphere\AppServer\profiles\AppSrv01\bin
startServer.bat server1
```

If you are using the WebSphere Application Server v7.0 test environment shipped with Application Developer, in the Servers view, right-click **WebSphere Application Server v7.0 at localhost** and select **Start**.

Configuring the environment variables

Prior to configuring the data source, ensure that the environment variables are defined for the desired database server type. This step does not apply to Derby because we are using the embedded Derby, which already has the variables defined. For example, if you choose to use DB2 Universal Database, you must verify the path of the driver for DB2 Universal Database.

- ▶ Launch the WebSphere administrative console:
 - If you are using the WebSphere Application Server v7.0 test environment shipped with Application Developer, you can simply right-click **WebSphere Application Server v7.0** and select **Administration** → **Run administrative console**.
 - For a stand-alone server, type the following URL in a Web browser:
<http://localhost:9062/ibm/console>
You may use a different port other than 9062. The administrative console port number was chosen during the installation of the server profile.
- ▶ Click **Log in**. If you installed WebSphere with administrative security enabled, use the user ID and password chose at installation time (for example, admin/admin).
- ▶ Expand **Environment** → **WebSphere Variables**.
- ▶ Scroll down the page and click the desired variable and update the path accordingly for your installation.

For Derby:

- DERBY_JDBC_DRIVER_PATH—By default this variable is already configured because Derby is installed with WebSphere Application Server:

```
{WAS_INSTALL_ROOT}/derby/lib
```

For DB2:

- DB2UNIVERSAL_JDBC_DRIVER_PATH
Edit the value and provide the DB2 installation directory, for example, C:\IBM\SQLLIB\java, or C:\SQLLIB\java.
- ▶ Click **Save** (at the top).

Configuring J2C authentication data

This section describes how to configure the J2C authentication data (database login and password) for WebSphere Application Server from the WebSphere administrative console. This step is required for DB2 UDB and optional for Derby.

If using DB2 UDB, configure the J2C authentication data (database login and password) for WebSphere Application Server from the Administrative Console:

- ▶ Select **Security** → **Global security**.
- ▶ Under the Authentication properties, expand **Java Authentication and Authorization Service** and select **J2C Authentication data**.
- ▶ Click **New**.
- ▶ Enter the Alias, User ID, and Password in the JAAS J2C Authentication data page. For example, create an alias called **db2user** with the user ID and password used when installing DB2.
- ▶ Click **Save**.

Configuring the JDBC provider

This section describes how to configure the JDBC provider for the selected database type. The following procedure demonstrates how to configure the JDBC provider for Derby, with notes on how to do the equivalent for DB2 UDB.

To configure the JDBC provider from the WebSphere administrative console, do these steps:

- ▶ Select **Resources** → **JDBC** → **JDBC Providers**.
- ▶ Select the scope settings.
 - Select the server scope from the drop-down menu. In our case, we select **Node=<machine>NodeXX, Server=server1**.
- ▶ Click **New**.
- ▶ From the New JDBC Providers page, do these steps and then click **Next**:
 - Select the Database Type: Select **Derby**.
Note: For DB2 UDB, select **DB2**.
 - Select the JDBC Provider: Select **Derby JDBC Provider**.
Note: For DB2 UDB, select **DB2 Universal JDBC Driver Provider**.
 - Select the Implementation type: Select **XA data source**.
Note: For DB2 UDB, select **XA data source**.
- ▶ Click **Next**.
- ▶ Click **Finish**.

Creating the data source

To create the data source for Derby, do these steps:

- ▶ Select the **Derby JDBC Provider (XA)**.
- ▶ Under Additional Properties, select **Data sources**.
- ▶ Click **New**.
- ▶ Type **ITSOBANKderby** as Data source name, and **jdbc/itsobank** as JNDI name. Click **Next**.
- ▶ Type **C:\7672code\database\derby\ITSOBANK** as the Database name. Clear **Use this data source in container managed persistence (CMP)**, because JPA does not use CMP. Click **Next**.
- ▶ Skip the Setup security aliases page. Click **Next**.
- ▶ Click **Finish** and then click **Save**.
- ▶ Verify the connection by selecting **ITSOBANKderby** (the check box) and then click **Test connection**. You should get the message:

The test connection operation for data source ITSOBANKderby on server server1 at node xxxxxNodexx was successful with 1 warning(s).

If you are using DB2, create a data source for **JDBC Providers → DB2 Universal JDBC Provider Driver (XA)**:

- ▶ Select **Data sources**, then click **New**.
- ▶ Type **ITSOBANKdb2** as Data source name, and **jdbc/itsobankdb2** as JNDI name.
- ▶ Type **ITSOBANK** as Database name and **localhost** as Server name. Leave 4 as Driver type and 50000 as Port number. Clear **Use this data source in container managed persistence (CMP)**.
- ▶ Select the **db2user** alias for Authentication alias for XA recovery and for Component-managed authentication alias.
- ▶ Click **Next**, then **Finish** and then **Save**.
- ▶ Verify the connection by selecting **ITSOBANKdb2** (the check box) and then click **Test connection**. You should get the successful message.

Note: If you always want to use DB2 for the ITSOBANK database, set the JNDI name for the DB2 data source to **jdbc/itsobank** and for Derby to **jdbc/itsobankderby**. The sample application uses **jdbc/itsobank** to access the database, and it can be Derby or DB2.

Abbreviations and acronyms

Ajax	Asynchronous JavaScript and XML	DDL	data definition language
AOP	aspect-oriented programming	DMS	database management system; data mediator services
API	Application Programming Interface	DOM	domain object model
AST	Application Server Toolkit	DTD	document type definition
ATM	automatic teller machine	DTO	data transfer object
AWT	Abstract Window Toolkit	EAI	enterprise application integration
BCI	byte-code instrumentation	EAR	Enterprise Application Archive
BIRT	Business Intelligence and Reporting Tools	EGL	Enterprise Generation Language
BMP	bean-managed persistence	EJB	Enterprise JavaBean
BPEL	Business Process Execution Language	EJS	Enterprise Java Server
BSF	Bean Scripting Framework	EL	expression language
BVT	build verification test	EMF	Eclipse Modeling Framework
CBE	Common Base Event	FK	foreign key
CCI	Common Client Interface	FTP	File Transfer Protocol
CDT	C/C++ Development Tooling	FVT	function verification test
CMP	container managed persistence	GEF	Graphical Editing Framework
CMR	container managed relationship	GIF	Graphic Interchange File
CORBA	Common Object Request Broker Architecture	GMF	Graphical Modeling Framework
CRUD	create, retrieve, update and delete	GUI	graphical user interface
CSS	cascading style sheet	HTML	HyperText Markup Language
CSV	comma separated values	HTTP	Hypertext Transfer Protocol
CVS	Concurrent Versions System	IBM	International Business Machines
DADX	document access definition extension	IDE	integrated development environment
DAO	data access object	ITSO	International Technical Support Organization
DB	database	J2C	Java EE Connector

J2EE	Java 2 Platform Enterprise Edition	JVMPI	Java Virtual Machine Profiler Interface
J2SE™	Java 2 Platform Standard Edition	JWL	JSF Widget Library
JAAS	Java Authentication and Authorization Service	LDAP	Lightweight Directory Access Protocol
JAF	Java Activation Framework	MDB	message-driven bean
JAR	Java archive	MFS	Message Format Service
JAXB	Java API for XML Binding	MIME	Multipurpose Internet Mail Extensions
JAX-RPC	Java API for XML RPC	MTOM	Message Transmission Optimization Mechanism
JAX-WS	Java API for XML Based Web Services	MVC	model-view-controller
JAXP	Java API for XML Processing	OASIS	Organization for the Advancement of Structured Information Standards
JAXR	Java API for XML Registries	ODBC	Open DataBase Connectivity
JCA	J2EE Connector Architecture	OMG	Object Management Group
JCP	Java Community Process	OO	object-oriented
JDBC	Java DataBase Connectivity	ORB	Object Request Broker
JDK	Java Development Kit	PDA	personal digital assistant
JDT	Java development tools	PDE	Plug-in Development Environment
JET	Java Emitter Templates	POJI	plain old Java interface
JMS	Java Message Service	POJO	plain old Java object
JMX	Java Management Extensions	PTP	point-to-point
JNDI	Java Naming and Directory Interface	QL	query language
JNI	Java Native Interface	RA	resource adapter
JOnAS	Java Open Application Server	RAD	rapid application development
JPA	Java Persistence API	RAMP	Reliable Asynchronous Messaging Profile
JPQL	Java persistence query language	RAR	resource adapter archive
JRE	Java Runtime Environment	RDB	relational database
JSF	JavaServer Faces	RMI	remote method invocation
JSON	JavaScript Object Notation	RUP	Rational Unified Process
JSP	JavaServer Pages	SAX	Simple API for XML
JSR	Java Specification Request	SCM	software configuration management
JSTL	JSP Standard Tag Library	SDK	Software Developer Kit
JTA	Java Transaction API		
JVM	Java Virtual Machine		

SDO	Service Data Objects	UTC	Universal Test Client
SDP	Software Delivery Platform	UUID	universally unique identifier
SEI	service endpoint interface	VM	virtual machine
SGML	Standard Generalized Markup Language	VOB	versioned object base
SIP	Session Initiation Protocol	VOIP	voice over IP
SLED	SUSE Linux Enterprise Desktop	W3C	World Wide Web Consortium
SLES	SUSE Linux Enterprise Server	WAR	Web Application Archive
SOA	service oriented architecture	WML	Wireless Markup Language
SOAP	Simple Object Access Protocol	WS-I	Web Services Interoperability Organization
SPF	Struts Portal Framework	WSDL	Web Service Description Language
SPI	Service Programming Interfaces	WSRP	Web Services for Remote Portlet
SQL	Structured Query Language	WSS	Web services security
SQLJ	Structured Query Language for Java	WTP	Web Tools Platform
SSI	server side include	WYSIWYG	what-you-see-is-what-you-get
SSL	secure socket layer	XML	eXtensible Markup Language
SSN	social security number	XOP	XML-binary Optimized Packaging
SSO	single sign-on	XSD	XML Schema Definition
SVG	scalable vector graphics	XSL	eXtensible Stylesheet Language
SVT	system verification test	XSLT	XSL transformations
SWT	Standard Widget Toolkit		
TLA	term license agreement		
TLD	tag library descriptor		
TPTP	Test & Performance Tools Platform		
UCM	Unified Change Management		
UDB	Universal Database		
UDDI	Universal Description, Discovery, and Integration		
UI	user interface		
UML	Unified Modeling Language		
URI	Uniform Resource Identifier		
URL	Uniform Resource Locator		

Related publications

The publications listed in this section are considered particularly suitable for a more detailed discussion of the topics covered in this book.

IBM Redbooks

For information about ordering these publications, see “How to get Redbooks” on page 1164. Note that some of the documents referenced here may be available in softcopy only.

- ▶ *WebSphere Application Server V7.0: Technical Overview*, REDP-4482
- ▶ *Experience Java EE! Using WebSphere Application Server Community Edition 2.1*, SG24-7639
- ▶ *Rational Application Developer V7 Programming Guide*, SG24-7501
- ▶ *WebSphere Application Server Version 6.1 Feature Pack for EJB 3.0*, SG24-7611
- ▶ *Web Services Feature Pack for WebSphere Application Server V6.1*, SG24-7618
- ▶ *Building Dynamic Ajax Applications Using WebSphere Feature Pack for Web 2.0*, SG24-7635
- ▶ *Topics on Version 7 of Rational Developer for System z and WebSphere Developer for System z*, SG24-7482
- ▶ *Using Rational Performance Tester Version 7*, SG24-7391
- ▶ *Web Services Handbook for WebSphere Application Server 6.1*, SG24-7257
- ▶ *Building SOA Solutions Using the Rational SDP*, SG24-7356
- ▶ *Patterns: Extended Enterprise SOA and Web Services*, SG24-7135

Online resources

These Web sites are also relevant as further information sources:

- ▶ WebSphere and Rational software
<http://www.ibm.com/software/websphere>
<http://www.ibm.com/software/rational>

- ▶ WebSphere Information Center
<http://publib.boulder.ibm.com/infocenter/wasinfo/v7r0/index.jsp>
- ▶ IBM Education Assistant
<http://www.ibm.com/software/info/education/assistant>
- ▶ developerWorks
<http://www.ibm.com/developerworks>
- ▶ alphaWorks
<http://www.ibm.com/alphaworks>
- ▶ Eclipse
<http://www.eclipse.org>
- ▶ Sun Java
<http://java.sun.com>
- ▶ Java Community Process
<http://www.jcp.org>
- ▶ Apache Derby database
<http://db.apache.org/derby>
- ▶ OASIS
<http://www.oasis-open.org>
- ▶ Jython
<http://www.jython.org>
- ▶ Web Services Interoperability Organization
<http://www.ws-i.org>

How to get Redbooks

You can search for, view, or download Redbooks, Redpapers, Technotes, draft publications and Additional materials, as well as order hardcopy Redbooks, at this Web site:

ibm.com/redbooks

Help from IBM

IBM Support and downloads

ibm.com/support

IBM Global Services

ibm.com/services

Index

The index has not been updated yet

Symbols

.jspPersistence 378
 .metadata directory 85
 @PersistenceContext 419
 @viz.diagram 131

A

Abstract Window Toolkit 31
 acceptance test 822
 access CVS repository 1030
 Account class 114
 account template 174
 AccountDetails 337
 action
 bar 30
 class 448
 servlet 448
 action code 518
 ActionForm 47
 ActionServlet 47
 add a project to a server 797
 addCustomer method 424
 additional material 1149
 AJAX 51
 Analyze Model wizard 265
 Annotation view 1061
 Ant 903
 build
 files 904
 path 905
 project 904
 property 905
 target 904
 task 904
 build J2EE application 921
 create build script 923
 deployment packaging 922
 run Ant build 925
 build simple Java application 917

build targets 909
 classpath problem 921
 clean 910
 compile 910
 forced build 920
 global properties 909
 init 909
 project definition 908
 rerun Ant 920
 run Ant 917
 content assist 911
 documentation 905
 example 906
 headless build 927
 introduction 904
 build files 904
 new features 905
 tasks 905
 J2EE
 applications 921
 build script 923
 Javadoc 130
 new features
 code assist 911
 code snippets 911
 define format of an Ant script 914
 format an Ant script 914
 Problems view 916
 run 917
 Run Ant wizard 919
 run headless build 928
 run outside Application Developer 927
 runAnt.bat 927
 script 130, 908
 tasks 904–905
 delete 905
 echo 905
 jar 905
 javac 905
 mkdir 905
 tstamp 905
 Web service 622
 Web site 905
 Apache

- OpenJPA
 - persistence provider 277
- Apache Geronimo 779
- Apache Jakarta 851
 - Ant 904
- Apache Tiles 485
- Apache Tomcat 779
- appearance
 - of Java elements 100
 - preferences 100
- applet 32
- application
 - classloader 949
 - client module 320, 935
 - deployment 934
 - flow 407
 - installation wizard 962
 - logging 182
 - profiling 983
 - resources 464
 - samples 180
- Application Client for WebSphere Application Server 545
- Application Client project 177
- Application Developer
 - Ant support 903
 - CVS support 1021
 - database tools 228
 - debug 862
 - Log and Trace Analyzer 84
 - portal development 744
 - portal test environment 745
 - Struts support 450
 - Tiles framework 485
- Application Server
 - installation directory 784
- Application Server profile 782
- Application Server Toolkit 969
- application-client.xml 936
- ApplicationResources.properties 457, 464
- ApplicationServlet 322
- Assert class 829
- association relationship 106
- Asynchronous JavaScript 51
- attribute
 - derived 166
- autoboxing 27
- automatic
 - build 87

- automatic build 87
- automation scripts 810
- AWT
 - See Abstract Window Toolkit

B

- BankClient class 112
- BankClient.java.jet 179
- BankFacadeJava 184
- BEA WebLogic Server 779
- Bean Scripting Framework 968
- bookmarks 134–135
- Bookmarks view 135
- bootstrap 946
- breakpoint
 - conditional 874
 - JSP 879
 - marker 873
 - properties 874
 - set 873
- Breakpoints view 137, 863
- browse diagram 23, 49
- build 87, 903
 - Ant build file 904
 - applications 903
 - compiler 909
 - targets 909
 - verification test 821
- build.xml 907, 917
 - J2EE application 923

C

- C 26
- C++ 26
- Cactus 851
- calibration 823
- Call Hierarchy view 76
- capabilities 88
- cascading style sheets 38, 331
- change
 - variable value 876
- class diagram
 - EJB 34
 - J2EE client 546
- class loader 946
 - WebSphere 948
- classloaders 949–950
 - WebSphere classloaders

- RCP directory 948
- RE directory 948
- RP directory 948
- classpath
 - Ant classpath 921
 - variables 98
- CLASSPATH variable 947
- classpath.jet 172
- clean build 88
- closeAccount method 424
- Cloudscape 229
- code assist 111, 113
- code coverage analysis 986
- code formatter 105
 - blank lines 108
 - braces 107
 - comments 109
 - control statements 109
 - indentations 107
 - line wrapping 109
 - new lines 108
 - preferences 101–102
 - white space 107
- code snippet
 - Ant 912
- code style 102
 - and formatting 102
- code visualization 22
- coding conventions 103
- Colors view 326
- column alias 242
- combined fragments 60
- command
 - design pattern 339
- Common Annotations for the Java Platform 578
- Common Object Request Broker Architecture 29
- CommonBaseEvents.xml 85
- Compare view 1058
- compare with 95
- compare with local history 94
- compilation target 910
- compiler options 114
 - preferences 114
- component
 - test 820
- concatenation mapping 213
- Concurrent Versions System 1019
- condition
 - breakpoint 874
- conflict 1021
- connection
 - database 229
 - server 793
- Connector project 176, 178
- Console view 133
- constructor 104
- container-managed relationships 60
- content assist 111, 145
 - Ant 911
- context root 320, 343
- cookies 36
- CORBA
 - See Common Object Request Broker Architecture
- Core Java APIs 27
- Craig Larmann 66
- create
 - static Web resources 358
 - test case 833
 - Web Project 340
- Create Servlet wizard 369
- Credit class 115
- Crystal Reports perspective 130
- Crystal Reports Web project 177
- CSS
 - See Cascading Style Sheets
- CSS Designer 331
- CSS File wizard 333
- custom
 - profile 782
- Customer class 114
- CustomerManager 517
- CVS 1019
 - administrator 1026
 - annotations 1061
 - branch 1062
 - merging 1067
 - client configuration 1029
 - access CVS repository 1030
 - enable CVS Team capability 1029
 - comparison 1058
 - conflict 1021
 - development scenario 1040
 - features 1020
 - introduction 1020
 - keyword substitution 1037
 - merge 1053
 - parallel development 1050

- patches 1070
 - preferences
 - CVS specific settings 1036
 - file content 1032
 - ignored resources 1034
 - label decorations 1032
 - Repositories view 1041
 - repository 1024
 - add 1041
 - synchronization 1050
 - scenario 1040
 - shared project 1044
 - Synchronize 1046
 - team capability 1029
 - version 1056
 - Web site 1023
 - CVS Annotation view 132
 - CVS Repositories view 131, 1065
 - CVS Repository Exploring perspective 130, 1021
 - CVS Resource History view 132
 - CVSNT 1020
 - control panel 1024
 - create CVS users 1028
 - Server 1022
 - server implementation 1023
 - server installation 1023
 - server repository configuration 1024
 - verify installation 1027
- D**
- data 960
 - Data Definition project 177
 - Data Design project 177, 256
 - Data Development project 177, 235
 - Data Diagram Editor 134
 - data diagrams 260
 - data graph 49, 222
 - data mediator 50
 - data modeling 255
 - data object 49
 - Data Output view 133
 - Data perspective 132, 134–135
 - Data Project Explorer view 132
 - data source
 - container-managed persistence 976
 - enhanced EAR 802
 - ITSOBANK 960
 - SDO 499, 658
 - database
 - connection 229
 - Database Explorer view 132
 - DB2 stored procedure debugging 899
 - DB2 Universal JDBC Driver Provider (XA) 802
 - DDL generation 263
 - Debit class 116
 - debug 862
 - expressions 877
 - features
 - breakpoints 878
 - drop to frame 866
 - JSP 880
 - Jython 888
 - port 885
 - remote 869
 - Web application on local server
 - debug functions 865
 - set breakpoint in JSP 879
 - set breakpoint in servlet 873
 - watch variables 876
 - Web application on remote server
 - attach to remote server 885
 - configure debug in server 884
 - export project to WAR file 883
 - Debug perspective 136, 862–863
 - debug tooling
 - supported environments
 - WebSphere Application Server 862
 - WebSphere Portal 862
 - supported languages
 - EGL 862
 - Java 862
 - mixed language 862
 - SQL stored procedures 862
 - SQLJ 862
 - XSLT 862
 - Debug UI daemon 870
 - Debug view 137, 863
 - debugging
 - icons 865
 - Declaration view 75
 - default
 - workspace 83
 - delegate method generator 148
 - deleteCustomer method 424
 - delta versioning 1020
 - dependency relationship 26
 - deployITSOBankApp.py 971

- deployment 933
 - architecture 934
 - common considerations 934
 - deploy the enterprise application
 - configure data source in the server 956
 - descriptor 937
 - descriptors 935
 - J2EE application components
 - applets 935
 - application clients 935
 - EJBs 935
 - Web applications 935
 - J2EE deployment modules
 - application client module 935
 - EJB module 935
 - resource adapter module 935
 - Java and WebSphere class loader 946
 - package an application 953
 - prepare for sample
 - deployment scenario 950
 - import sample code 952
 - install prerequisite software 951
 - scenario 950
 - WebSphere deployment architecture 939
 - WebSphere Rapid Deployment 944
 - Deployment Manager
 - profile 782
 - deposit
 - method 422
 - Derby 228
 - ITSOBANK database 229
 - JDBC Provider (XA) 802
 - stored procedure 235
 - derived
 - attribute 166
 - design time template 331
 - Design view 190
 - desktop applications 26
 - developerWorks
 - Rational 66
 - samples 181
 - diagrams
 - external 62
 - disconnected data graphs 49
 - Display view 863, 878
 - doGet 365
 - doPost 365
 - drop to frame 865–866
 - DTD 187
 - DTD editor 189
 - dynamic behavior diagrams 28
 - dynamic page template 331
 - Dynamic Web project 179
 - dynamic Web project 175, 178
 - Struts support 454
 - Dynamic Web Project wizard 333
 - dynamic Web resources 361
- ## E
- EAR 922
 - filtering 955
 - EAR file 319
 - Eclipse
 - CVS information 1076
 - Java Development Tools 580
 - Test and Performance Tools Platform 819
 - Web Tools Platform 779
 - Editing JSP 370
 - editors 121
 - EJB 387
 - application 407
 - capability 409
 - class diagram 34
 - deployed code 954
 - inheritance 35
 - JAR 165
 - JARs 922
 - local and remote interfaces 61
 - module 320, 935
 - new features 405
 - overview 388
 - project 176–177, 409
 - create 410
 - query language 60
 - relationships 35
 - security roles 37
 - session facade 415
 - Timer Service 61
 - Universal Test Client 426
 - visualize 35
 - EJB 3.0
 - Web application 433
 - EJB application
 - prepare for development 408, 729
 - configure data source 413
 - create EJB project 409
 - testing with UTC 426

- ejb-jar.xml 937
- embedded SQL 253
- enabling transcoding for development 748
- encapsulation 407
- enhanced EAR 414, 800, 941
 - data source 802, 953
- Enhanced EAR Editor 941
- Enhanced Faces Components palette 509
- enterprise application 320
- Enterprise Application project 175, 178
- Enterprise JavaBeans 56, 387
 - see EJB
 - types
 - message-driven 59
- entityMgr.createNamedQuery 420
- entityMgr.find 420
- entityMgr.remove 424
- environment 822
- Error Log view 148
- evaluate an expression 878
- example projects 182
- exception breakpoints 879
- executable test 856
- Execution Flow view 1000, 1012
- Execution Statistics view 996
- execution time analysis 985
 - views 985
- exemplar analysis 159
- exemplar authoring 158
- export
 - EAR 954
 - Java application 125
- expression
 - debugging 877
 - evaluation 877
 - language 44
- Expression Builder wizard 240
- Expressions view 864
- extends relationship 106
- Extensible Markup Language 33
- Extensible Style Language 188
- extensions classloader 949
- external diagrams 62

F

- facade 184
 - pattern 183
 - transformation 183

- Faces Action 506
- faces-config.xml 496, 506
- FacesServlet 496
- facets 169
- fast view 126
- file associations 92
- File Creation wizard 332
- Filter Mapping wizard 333
- Filter wizard 333
- filters 44
- folding 112
- framework
 - JUnit 834
- function
 - expression 240
 - verification test 821

G

- Gallery view 157, 326
- getAccount method 421
- getAccounts method 421
- getCustomer method 420
- getCustomers method 420
- getTransactions method 422
- Graphical Modeling Framework 450
- graphical user interfaces 30
 - Abstract Window Toolkit 31
 - Java components 32
 - Standard Widget Toolkit 31
 - Swing 31

H

- HEAD branch 1044
- headless
 - Ant build 927
- headless build 927
- Hierarchy view 72
- history 93
- History view 1056
- hit count 874
- HTML 37
- HTTP 35, 38
 - recording 852
 - See Hypertext Transfer Protocol
 - status codes 36
 - test 852
- HTTP Page Hit Rate report 858–859
- HTTP Page Response Time report 858

HttpJspServlet 322
 HttpRequest 322
 HttpResponse 322
 HttpServlet 322
 HttpSession 322
 HyperText Markup Language 35, 37
 Hypertext Transfer Protocol 35
 see HTTP

I

IBM Installation Manager 1123
 IBM WebSphere Portal 54, 743
 ibm-portal-topology.xml 752
 icons for debugging 865
 IDE
 See integrated development environment
 ignored resources 1034
 implements relationship 106
 import
 JAR file 127
 import generation 145
 indentation 107
 Informix 229
 initialization target 909
 injector
 business interface 429
 inline mapping 213
 installation
 CVS for NT 1023
 WebSphere Portal 1131
 WebSphere Portal V5.0 Test Environment
 1131
 Installation Manager 1123
 Installed JREs
 preferences 115
 integrated
 development environment 120
 Integrated Agent Controller 987
 interaction
 operators 61
 use element 62
 Interface Definition Language 29
 internal 34
 Internet
 preferences 97
 Internet preferences 97
 proxy settings 97
 Web Browser settings 96

InvalidateSession 337
 ITSO Bank
 export 125
 Struts 452
 ITSO Bank application
 Bank interface 104, 108
 export 125
 methods 83
 overview 78
 packages 78–79
 step-by-step development 86
 UML class diagram 85
 ITSOBank class 113
 ITSOBANK database 228
 setup 1154
 ITSOCVSGuide 1042

J

J2EE
 perspective 140
 Request Profiling Agent 989
 specification 319
 Web APIs 322
 J2EE Application Client 62, 544
 JAAS
 authentication 802
 Jacl 810
 Jakarta 851
 Java
 application
 debug 122
 export 125
 build path 172
 class loader 946
 classpath variables 98
 debugging features 863
 development
 preferences 98
 development preferences
 appearance of Java elements 100
 code style and formatting 102
 Java classpath variables 98
 development settings 48
 Editor
 preferences 109
 language 26
 packages 92, 94, 96
 project 178

- Runtime Environment 115
- scrapbook 122
- search 139
- servlet 317
- source folder 344
- stored procedure 244
- utility JAR 922
- Java 2 Platform Enterprise Edition 162
- Java API for XML Processing 34
- Java Browsing perspective 139, 70, 76
- Java class loader
 - extensions class loader 947
 - hierarchy 947
 - system class loader 947
- Java Editor settings 109
- Java EE
 - Module Dependencies 172
- Java Emitter Templates 159
- Java Management Extensions 968
- Java Message Service 71, 544
- Java Naming and Directory Interface 29, 63, 544
- Java Native Interface 31
- Java perspective 138, 70
- Java Portlet specification 55
- Java Profiling Agent 989
- Java Python 810
- Java Remote Method Invocation 29
- Java Runtime Environment 124
- Java Tcl 810
- Java Type Hierarchy perspective 142, 70, 77
- Java Virtual Machine 28
- JavaBean
 - annotation 578
- Javadoc 128
 - Ant 130
 - Ant script 131
 - diagrams 131–132
 - generate 128
 - tooling 128
 - view 128
- JavaServer Faces 48
 - overview 494, 650
 - see also JSF
- JavaServer Pages 41, 317
- JavaServer Pages Standard Template Library 323
- JAXP 34
- JBoss 779
- JDBC 29
 - driver
 - variable 958
 - provider
 - Jython 816
 - jdbc/itsobankdb2 805
 - jdbc/itsobankejb 960
 - JDT 580
 - JET 159
 - JET Transform project 161
 - JMS 71
 - JMX 968
 - JNDI
 - See Java Naming and Directory Interface
 - JNI 950
 - See Java Native Interface
 - join 240
 - JPA
 - manager bean 514
 - JPA Manager Bean wizard 514
 - JRE 115
 - JSF
 - action 506
 - add connection for action 508
 - add navigation rules 508
 - add simple validation 512
 - add static navigation to page 513
 - add UI components 509
 - add variables 510
 - application architecture 495
 - Application Developer 497
 - benefits 494
 - components 497
 - configuration file 496
 - create connection between JSF pages 504
 - create Faces Action 506
 - expression builder 498
 - features 494
 - form 511
 - JPA entity object 520
 - managed bean 500
 - overview> 494
 - Quick Edit view 498
 - resource bundles 498
 - servlet 496
 - specification 494
 - validators 496
 - variable 511
 - Web application 503, 660
 - JSF and SDO Web application
 - configure data source via enhanced EAR 499,

- 658
- JSP 41
 - breakpoint 879
 - debugging 880
 - include 485
 - Tag libraries 43
 - tag libraries 323
 - variables 881
- JSP Page Designer 451
- JSP Standard Tag Library 44
- JSR 168 746
- JSR 175 578
- JSR 181 578
- JSR 224 578
- JSR 235 49
- JSR 250 578
- JSTL 44, 323
- JUnit
 - Assert class 829
 - framework 834
 - introduction 819
 - library 831
 - methods 835
 - run 837
 - sample 830
 - test
 - case 831
 - test suite 835
 - testing 825
 - view 837
- JVM
 - debug port 885
 - See Java Virtual Machine
- Jython 810
 - create data source 973
 - create JDBC provider 972
 - debugger 888
 - execute 978
 - generate 981
 - install enterprise application 977
 - overview 969
 - project 178, 810, 971
 - script 970
 - deploy ITSO Bank 970
 - file 810
 - start enterprise application 977

- K**
 - keyword
 - substitution 1037
- L**
 - label decorations 1032
 - launchClient command 64
 - LibraryFacadeJava 184
 - life cycle
 - events 44
 - Life-cycle Listener wizard 333
 - lifeline 56
 - links 358
 - Links view 326
 - Linux 903
 - ListAccounts 337
 - listeners 44
 - local
 - history 93
 - local history 93
 - compare with 95
 - replace with 95
 - restore from 95
 - Log Console view 920
 - log files 84

- M**
 - make 903–904
 - mapping
 - concatenate 213
 - inline 213
 - substring 214
 - mark occurrences 112, 138
 - MDB 59
 - See Message Driven Bean
 - Members view 139
 - Memory Statistics view 149, 1002
 - memory usage problems 984
 - merging 1067
 - from a stream 1067
 - Message Transmission Optimization Mechanism 623
 - message-driven EJBs 59, 71
 - Method Invocation Details view 998, 1011
 - migration
 - considerations 24
 - MIME 623
 - modeling assistant 30

model-view-controller 46, 323
 Struts Web application 447
 MTOM 623
 multiprotocol binding 613
 Multipurpose Internet Mail Extensions 43
 MVC
 See model-view-controller
 Struts 447
 MySQL 229

N

navigate Java code 134
 navigation
 candidate 349
 root 349
 rule 506
 static 513
 navigation rules 508
 Navigator view 132
 Network Deployment 781

O

OASIS 633
 Object Management Group 66
 Object References view 149
 ObjectWeb Java Open Application Server 779
 online help 127
 openAccount method 423
 OpenJPA
 persistence provider 277
 Oracle 229, 779
 Organization for the Advancement of Structured Information Standards 633
 Outline view 137, 73, 326, 863
 owned element association 27

P

Package Explorer view 71
 Page Data view 157, 326, 469
 Page Designer 326, 329
 page template 330, 351
 create static 352
 customize 353
 Palette
 view 326
 parallel development 1050
 patches 1070

pattern
 apply 179
 command 339
 facade 183
 implementation 157
 specification 158
 performance
 bottlenecks 984
 test 821
 PerformTransaction 337
 persistence
 provider 276
 personal digital assistant 54
 perspectives 120
 available 129
 Crystal Reports 130
 customizing 124
 CVS Repository Exploring 130
 CVS Repository Exploring perspective 130
 Data 132, 134–135
 Debug 136
 J2EE 140
 Java Browsing 139, 76
 Java perspective 138
 Java Type Hierarchy 142, 77
 layout 122
 Plug-in Development 147
 preferences 95
 Profiling and Logging 149
 Report Design 150
 Resource 152
 specify default 124
 switching 123
 Team Synchronizing 153
 Test 154
 Web 155
 physical data model 256–257
 Physical Data Model editor 259
 Plug-in Development perspective 147
 Plug-ins view 143, 145, 147–148, 151, 159
 portal
 applications 54
 development strategy
 JavaServer Faces 748
 introduction 740
 samples and tutorials 746
 tools
 Portal Import wizard 749
 Portal Project wizard 750

- skin and theme design 753
- concepts and definitions
 - portal page 740
 - portlet 741
 - portlet application 741
 - portlet events 742
 - portlet modes 742
 - portlet states 742
- development 744
- page 740
- preferences 750
- samples and tutorials 746
- skin 753
- technology 740
- test environments
 - WebSphere Portal V5.0 745
- theme 754
- Portal Designer 752
- Portal Import Wizard 749
- Portal Project wizard 750–751
- portlet 741
 - API 746
 - applications 739
 - development 744
 - events
 - action events 742
 - message events 743
 - Window events 743
 - JSF 748
 - modes
 - configure 742
 - edit 742
 - help 742
 - states 742
 - maximized 742
 - minimized 742
 - normal 742
 - portlet modes 742
 - Struts 749
- Pramati Server 779
- preferences 86
 - appearance 100
 - braces 107
 - capabilities 88
 - classpath variables 99
 - code style 102
 - compiler 115
 - file associations 92
 - folding 112
 - formatter 105
 - indentation 107
 - installed JREs 116
 - Internet 97
 - Java Editor 110
 - local history 94
 - mark occurrences 112
 - perspectives 95
 - Process 10
 - startup and shutdown 83
 - templates 113
 - Web browser 96
 - white space 108
- probekit analysis 986
- Problems view 137, 916
- Process Advisor 7
- Process Browser 7
- Process Preferences 10
- product
 - activation kit 1128
- profile
 - application server 782
 - WebSphere Application Server 940
- Profile Management Tool 779, 784
- profiling
 - agent types
 - J2EE Request Profiling Agent 989
 - Java Profiling Agent 989
 - analyze data 995
 - architecture 987
 - agent 988
 - Agent Controller 988
 - application process 988
 - deployment hosts 988
 - development hosts 989
 - test client 988
 - example 990
 - features
 - code coverage 986
 - execution time analysis 985
 - memory analysis 985
 - introduction 984
 - prepare for profiling sample
 - enable Profiling and Logging capability 990
 - publish and run sample application 1006
 - profile the sample application
 - start server in profile mode 1007
 - profiling sets 984
- Profiling and Logging capability 91

- Profiling and Logging perspective 149, 989
- Profiling Monitor view 149
- programming technologies 25
 - desktop applications 26
 - dynamic Web applications 38
 - Enterprise JavaBeans 56
 - J2EE Application Clients 62
 - messaging systems 70
 - static Web sites 35
 - Web Services 65
- project
 - close 173
 - directory structure 344
 - disconnect from CVS 1070
 - EJB 409
 - facets 169
 - interchange file 173, 1152
 - properties 171–172
 - version 1056
- Properties view 511
- Proxy Settings 97
- Python 969

Q

- query condition 242
- quick assist 144
- Quick Edit view 326, 513
- quick fix 73, 142

R

- RAD7Ant 906
- RAD7BankBasicEAR 341
- RAD7BankBasicWeb 340
- RAD7DataDesign 256
- RAD7DataDevelopment 236
- RAD7Java 87, 362
- RAD7JavaImport 127
- RAD7JUnitWebTest 852
- RAD7Jython 810, 971
- RAD7Patterns 160
- RAD7PatternsClient 160
- RAD7PatternsFacade 183
- RAD7PatternsFacadeTransform 183
- RAD7SQLJ 250
- RAD7StrutsWeb 454
- RAD7WebServiceAnt 622
- RAD7WebServiceJSFClient 598
- RAD7XMLBank 190

- RAD7XMLBankJava 216
- rapid application development 133
- Rational Application Developer
 - configure CVS 1031
 - editors 121
 - folders 172
 - installation 1121, 1124
 - JavaServer Faces support 497
 - license 1128
 - local vs remote test environment 780
 - log files 84
 - new EJB features 405
 - new server 789
 - online help 127
 - perspectives 120
 - preferences 86
 - projects 166
 - Connector project 176
 - Dynamic Web project 175
 - EJB project 176
 - Enterprise Application project 175
 - Java project 176
- Rational Unified Process 7
 - samples 179
 - server configuration 777
 - startup parameters 82
 - Struts 450
 - Struts support
 - Struts Component wizard 450
 - Struts Configuration Editor 450
 - Web Project Struts enabled 450
 - supported test servers 779
 - test server introduction 778
 - UML visual editing 22
 - uninstall 1129
 - views 121
 - Web services tools 574
 - XML tools 189
- Rational Edge 66
- Rational Function Tester 821
- Rational Manual Tester 821
- Rational Performance Tester 822
- Rational Software UML Resource Center 66
- RCP directory 948
- RE directory 948
- realized node 503
- RedBank
 - application design 335
 - application test 381

- class diagram 336
 - controller layer 337
 - home page 358
 - html pages 352
 - implementation 339
 - model 345
 - site navigation 348
 - user interface 351
 - view layer 336
 - Web Diagram 328
 - Redbooks Web site 1164
 - Contact us lx
 - refactor 99, 151
 - actions 152
 - refactoring servlets 369
 - Regular Expression wizard 193
 - related elements 32
 - remote
 - debugging 869
 - remove project from a server
 - via Rational Application Developer 798
 - Report Design perspective 150–151
 - Report project 177
 - request sequence 449
 - RequestDispatcher 322
 - resource
 - synchronization 1072
 - resource adapter 949
 - module 935
 - Resource perspective 152
 - result set 240
 - reverse engineering 257
 - RMI
 - See Remote Method Invocation
 - row action 529
 - RP directory 948
 - rule
 - violation 121
 - Rule Builder perspective 153
 - Run Ant wizard 919
 - run configuration 110
 - runAnt.bat 927, 929
 - RUP
 - life cycle 6
- S**
- sample code 1149
 - description by chapter 1151
 - locate 1150
 - project interchange files 1152
 - Scalable Vector Graphics 849
 - schema validation 199
 - scrapbook 122
 - SDO
 - access XML 220
 - search dialog 138
 - security
 - Workbench 809
 - Security Configuration wizard 808
 - Security Constraint wizard 333
 - Security Role wizard 333
 - select statement 237
 - sequence diagrams 54
 - preferences 64
 - server
 - add project 797
 - configuration
 - export 796
 - connection type 793
 - customization 792
 - remove project 798
 - resources 799, 806
 - Servers view 137, 327, 425
 - service
 - client 565
 - provider 564
 - requester 565
 - service broker 564–565
 - Service Data Objects 49
 - XML 220
 - service provider 564
 - service requester 564
 - service-oriented architecture 563–564
 - service
 - requester 565
 - service broker 565
 - service provider 564
 - servlet 39, 362
 - add to Web Project 362–363
 - container 321
 - create 363
 - Servlet Application Programming Interface 40
 - Servlet Mapping wizard 333–334
 - Servlet wizard 333
 - ServletContext 44
 - servlets 362
 - session

- scope variable 510
- session bean 415
 - business methods 419
 - create 416
- session facade 415
- set breakpoint 873
- showcase samples 180
- Simple API for XML Parsing 34
- Simple Object Access Protocol 566
- SIP project 178
- site
 - appearance 346
 - navigation 340, 346
 - template 347
- smart compile 138
- smart insert 137
- Snippets view 327
- SOA 563
- SOAP
 - over JMS 613
- Software Configuration Management 1020
- source code analysis 118
- Source Code Comparison editor 154
- source folding 136
- Source view 863
- SQL
 - query 243
 - statement 235
- SQL Builder 134
- SQL Server 229
- SQLJ 228
 - applications 249
 - file 253
 - serialized profile 249
 - test 254
 - translator 249
 - wizard 250
- staging environment 822
- Standard Widget Toolkit 31
- start server in profile mode 1007
- startup parameters 82
- stateful session EJB 59
- stateless 415
- stateless session EJB 58
- static analysis 121
 - configuration 118
 - result 121
- static method sequence diagram 23, 63
- static navigation 513
- static pages
 - create a list 360
 - create tables 359
 - links 358
 - text 358
- Static Web project 176, 179
- Static Web Project wizard 334
- static Web sites 35
- step
 - filter 866
 - into 865
 - over 865, 876
- step over 865
- step-by-step mode 865
- stored procedure 244
 - deployment 248
 - run 249
- Stored Procedure wizard 244
- structural diagrams 27
- Struts 445
 - action classes 448
 - action form 448
 - architecture 446
 - Component wizards 450
 - Configuration Editor 450
 - configuration file 448
 - configuration file editor 473
 - controller 447
 - create action 458
 - create components 457
 - Struts Action 458
 - Struts Form Bean 459
 - Struts Web Connection 462
 - create form bean 459
 - create Web connection 462
 - create Web page 461
 - development 457
 - development capabilities 451
 - errors tag 469
 - introduction 446
 - ITSO Bank 452
 - model 447
 - model-view-controller 447
 - MVC 447
 - Portlet framework 450
 - portlets 749
 - resource files 448
 - tag libraries 468
 - tag library 467

- validation framework 462, 465
 - validators 451
 - view 447
 - Web application 448
 - prepare for sample 452
 - run sample
 - run sample application 482
 - Struts enabled project 454
 - Web application using Tiles 485
 - Web Diagram editor 450
 - Struts-bean tags 468
 - struts-config.xml 47, 448
 - Struts-html tags 467
 - Struts-logic tags 468
 - Struts-nested tags 468
 - Struts-template tags 468
 - Struts-tiles tags 468
 - style sheets
 - customize 355
 - Styles view 327
 - substring mapping 214
 - suspend 865
 - Swing 31
 - SWT
 - See Standard Widget Toolkit
 - Sybase 229
 - synchronization
 - schedule 1075
 - Synchronize view 153, 1072
 - system verification test 821
- T**
- tables 359
 - tag libraries 43
 - tag library descriptor 43
 - Tasks view 132, 327
 - TCP/IP Monitor 575, 595
 - TCP/IP Monitor view 596
 - team capability 89
 - Team Synchronizing perspective 153, 1021, 1072
 - technology samples 180
 - templates 113
 - patterns 170
 - terminate 865
 - test 822
 - benefits 823
 - case 823
 - concepts 820
 - framework 824
 - phases 820
 - results 848
 - strategy 824
 - suite
 - class 830
 - Test & Performance Tools Platform 819, 825, 987
 - test environment
 - configuration 778
 - local and remote 780
 - Test Log view 154
 - Test Navigator 154
 - Test Pass report 850
 - Test perspective 154
 - text 358
 - Thumbnails view 327
 - Tiles 485
 - configuration file 488
 - run application 490
 - runtime behavior 489
 - Web pages 488
 - tiles-def.xml 486
 - Time Frame Historic report 850
 - topic diagrams 23, 51
 - TPTP 819
 - JUnit run 848
 - JUnit test 844
 - JUnit Test editor 846
 - test results 849
 - URL Test 854
 - transaction
 - class 115
 - template 175
 - transfer method 423
 - transformation 184
 - facade 183
 - model 164
 - templates 170
 - TSO Bank application
 - run 109
 - type hierarchy 137
 - Types view 139
- U**
- UDDI registry 566
 - UML
 - class diagram 23, 28
 - diagram settings 48

- lifelines 56
- more information 66
- relationships 26
- sequence diagram 54
- topic diagrams 23
- visual editing 22
- WSDL 38
- WSDL message 43
- WSDL operations 46
- UML2 Class Interactions view 1001
- UML2 Object Interactions view 1001
- UML2 Thread Interactions view 1001
- uninstall 1129
- unit test 820
- Universal Description, Discovery, and Integration 67
- Universal Test Client 426
 - EJB 426
 - Web services testing 575
- UNIX 903
- UpdateCustomer 337
- updateCustomer method 421
- URL mapping 365
- User Function Library 177
- UTC 426
- Utility project 178

V

- validation 512
- variable
 - change value 876
- variables
 - debugging 876
 - JSP 881
- Variables view 137, 863
- version
 - project 1056
- versioning 1056
- view
 - add and remove 125
 - Page Data 510
 - Properties 511
 - Quick Edit 513
- views 121
 - Annotation 1061
 - Bookmarks 135
 - Breakpoints 137, 863
 - Call Hierarchy 76

- Colors 326
- Compare 1058
- Console 133
- CVS Annotation 132
- CVS Repositories 131, 1041, 1065
- CVS Resource History view 132
- Data Definition view 132
- Data Project Explorer 132
- Debug 137, 863
- Declaration 75
- Design 190
- Display 863, 878
- Error Log 148
- Execution Flow 1000, 1012
- Execution Statistics 996
- Expressions 864
- Gallery 157, 326
- Hierarchy 72
- History 1056
- Javadoc 128
- JUnit 837
- Links 326
- Members 139
- Memory Statistics 149, 1002
- Method Invocation Details 998, 1011
- Navigator 132
- Object References 149
- Outline 137, 326, 863
- Page Data 157, 326
- Page Designer 326
- Palette 326
- Plug-ins 143, 145, 147–148, 151, 159
- Problems 137
- Profiling Monitor 149
- Quick Edit 326
- Servers 137, 327
- Snippets 327
- Source 863
- Styles 327
- Synchronize 153, 1072
- Tasks 132, 327
- TCP/IP Monitor 596
- Test Log 154
- Thumbnails 327
- Types 139
- Variables 137, 863
- XSLT Context 868
- XSLT Transformation Output 869
- VoiceXML 43

W

- WAR 922, 935
 - classloader 949
- watch variables 876
- Web
 - content folder 344
- Web application
 - debug on local server 871
 - debug on remote server 882
 - module 935
 - testing
 - example 854
 - using JSF and SDO 493, 649
- Web applications 38
- Web archive
 - See WAR
- Web development tooling 324
 - CSS Designer 331
 - file creation wizard 332
 - Page Designer 329
 - page templates 330
 - Web Site Designer 327
- Web Diagram 328
 - actions 534
 - Editor 503
 - create JSF page 503
 - toolbar 509
 - Tiles actions 491
- Web Diagram Editor 450
- Web Diagram wizard 334
- Web module 320
- Web Page Template wizard 334
- Web Page wizard 334
- Web perspective 155, 325
- Web project
 - directory structure 340
- Web Service Discovery Dialog 575, 598
- Web Service wizard 574, 586
- Web services 65, 563
 - client development 575
 - create with Ant tasks 622
 - development 573
 - EJB from WSDL 574
 - interoperability 568
 - introduction
 - related standards 567
 - service-oriented architecture 564
 - SOA implementation 565
 - Java client proxy from WSDL 575
 - JavaBean from WSDL 574
 - JSF client 598
 - prepare for development 576
 - runtime 587
 - Sample Web application from WSDL 575
 - security 568, 633
 - test tools 575
 - TCP/IP Monitor 575
 - test environment 575
 - Universal Test Client 575
 - Web Services Explorer 575
 - tools 574
 - top-down from WSDL 614
 - UML 40
 - using annotations 578
- Web Services Description Language 67, 566
- Web Services Explorer 575, 590
- Web Services Interoperability Organization 69, 568
- Web Services Metadata for the Java Platform 578
- Web Site Designer 327, 346
- Web Tools Platform 779
- web.xml 321, 936
- WEB-INF directory 321
- WebLogic Server 779
- WebSphere
 - admin commands 813
 - administrative console 787
 - administrative scripting tool 810
 - class loader 948
 - JPA persistence provider 277
 - Network Deployment 781
 - profile
 - sharing 795
 - test 787
 - Profiles
 - application server profile 782
 - custom profile 783
 - deployment manager profile 783
 - profiles 781, 940
 - sample applications 782
 - scripting client 968
- WebSphere Administration Command assist tool 813
- WebSphere Application Server 778
 - Base Edition 933
 - deployment architecture 939
 - enable debug 884
 - Express Edition 933
 - installation 783

- Network Deployment Edition 933
 - profile creation 784
 - Profiles 781
 - profiles 940
 - WebSphere class loader
 - application class loader 949
 - extensions to class loader 948
 - handling JNI code 950
 - hierarchy 948
 - Web module class loader 949
 - WebSphere enhanced EAR 941
 - WebSphere Portal 743
 - installation 1131
 - V5.0 test environment 1131
 - WebSphere Profile wizard 784
 - WebSphere Rapid Deployment
 - modes 945
 - tools 944
 - Welcome page 76
 - preferences 78
 - Wireless Markup Language 43
 - withdraw method 422
 - wizard
 - JPA Manager Bean 514
 - Workbench
 - basics 76, 79
 - preferences 86
 - working set 141
 - workspace 79
 - World Wide Web Consortium 623
 - ws.ext.dirs 949
 - wsadmin 810, 968
 - WSDL 566
 - dynamic 584
 - editor 615
 - messages
 - UML 43
 - UML class diagrams 38
 - WS-I 69
 - Basic Profile 568
 - compliance 596
 - WTP 779
 - WYSIWYG 329
- X**
- XML 33, 186
 - and relational data 190
 - binary Optimized Packaging 623
 - constraints 193
 - editor 189, 200
 - mapping editor 190, 208
 - namespaces 188
 - overview 186
 - path language 188
 - processor 186
 - schema
 - editor 189
 - generate JavaBeans 216
 - generate XML file 200
 - Service Data Objects 220
 - tools
 - DTD editor 189
 - XML editor 189
 - XML Schema editor 189
 - XPath Expression wizard 189
 - XSL editor 189
 - transform 207
 - validator 198
 - XOP 623
 - XPath 188–189
 - expression 208, 215
 - expression wizard 189
 - XSL 188
 - debugging and transformation 190
 - editor 189
 - file 202
 - transformation 207
 - XSL Transformation Output view 869
 - XSL Transformations 34, 188
 - XSL-FO 188
 - XSLT 188
 - Context view 868
 - debugger 867
 - templates 208
 - transformation 867



Draft Document for Review December 30, 2008 1:05 pm

Rational Application Developer V7.5 Programming Guide



Develop application using Java EE 5

Test, debug, and profile with local and remote servers

Deploy applications to WebSphere servers

IBM Rational Application Developer for WebSphere Software v7.5 (for short, Application Developer) is the full function Eclipse 3.4 based development platform for developing Java Standard Edition Version 6 (Java SE 6) and Java Enterprise Edition Version 5 (Java EE 5) applications with a focus on applications to be deployed to IBM WebSphere Application Server and IBM WebSphere Portal. Rational Application Developer provides integrated development tools for all development roles, including Web developers, Java developers, business analysts, architects, and enterprise programmers.

Rational Application Developer is part of the IBM Rational Software Delivery Platform (SDP), which contains products in four life cycle categories:

- ▶ Architecture management, which includes integrated development environments
- ▶ Change and release management
- ▶ Process and portfolio management
- ▶ Quality management

This publication is a programming guide that highlights the features and tooling included with Rational Application Developer v7.5. Many of the chapters provide working examples that demonstrate how to use the tooling to develop applications, as well as achieve the benefits of visual and rapid application development. This publication is an update of Rational Application Developer V7 Programming Guide, SG24-7501.

INTERNATIONAL TECHNICAL SUPPORT ORGANIZATION

BUILDING TECHNICAL INFORMATION BASED ON PRACTICAL EXPERIENCE

IBM Redbooks are developed by the IBM International Technical Support Organization. Experts from IBM, Customers and Partners from around the world create timely technical information based on realistic scenarios. Specific recommendations are provided to help you implement IT solutions more effectively in your environment.

For more information:
ibm.com/redbooks

SG24-7672-00

ISBN