

INSTRUCTIONS

BTE-10B

Direct FM Multiplex Exciter

ES-27278

LIST OF EQUIPMENT

BTE-10B FM Exciter (ES-27278)		
<i>Quantity</i>	<i>Description</i>	<i>Reference</i>
1	FM Exciter Unit	MI-34501
1	Crystal Unit (Spare to be ordered separately)	MI-34509*
1	Set of Operating Tubes	MI-34510
	Set of FCC Spare Tubes (Not supplied—to be ordered separately).....	
2	Instruction Books	IB-30262-1

* See table of crystals and frequencies.

RECOMMENDED SPARE PARTS

<i>Description</i>	<i>Symbol</i>	<i>Quantity</i>	<i>Stock No.</i>
Capacitor, ceramic, .01 μf	C106, C113, C114, C115, C122, C124, C126, C130, C132, C135, C138, C140, C145, C152, C153, C157, C169, C172, C180, C184, C209, C211, C212	5	73960
Capacitor, feed thru — .001 μf	C107, C120, C127, C129, C131, C134, C143, C144, C146, C147, C150, C166	5	99177
Capacitor, ceramic, 5 μf	C133, C155, C156	5*	77688
Capacitor, ceramic, 2,200 μf	C148	1	77953
Capacitor, ceramic, 10 μf	C214, C171, C177, C183, C207, C208, C109, C110, C149, C160, C164	5*	77865
Crystal diode, 1N34A	CR101, CR102, CR104	2	59395
Lamp, neon	DS101, DS102	5*	101857
Fuse, 0.5 amp	F101, F102	2	212327
Mount, shock mount		1	57692

* 5—minimum quantity shipped.

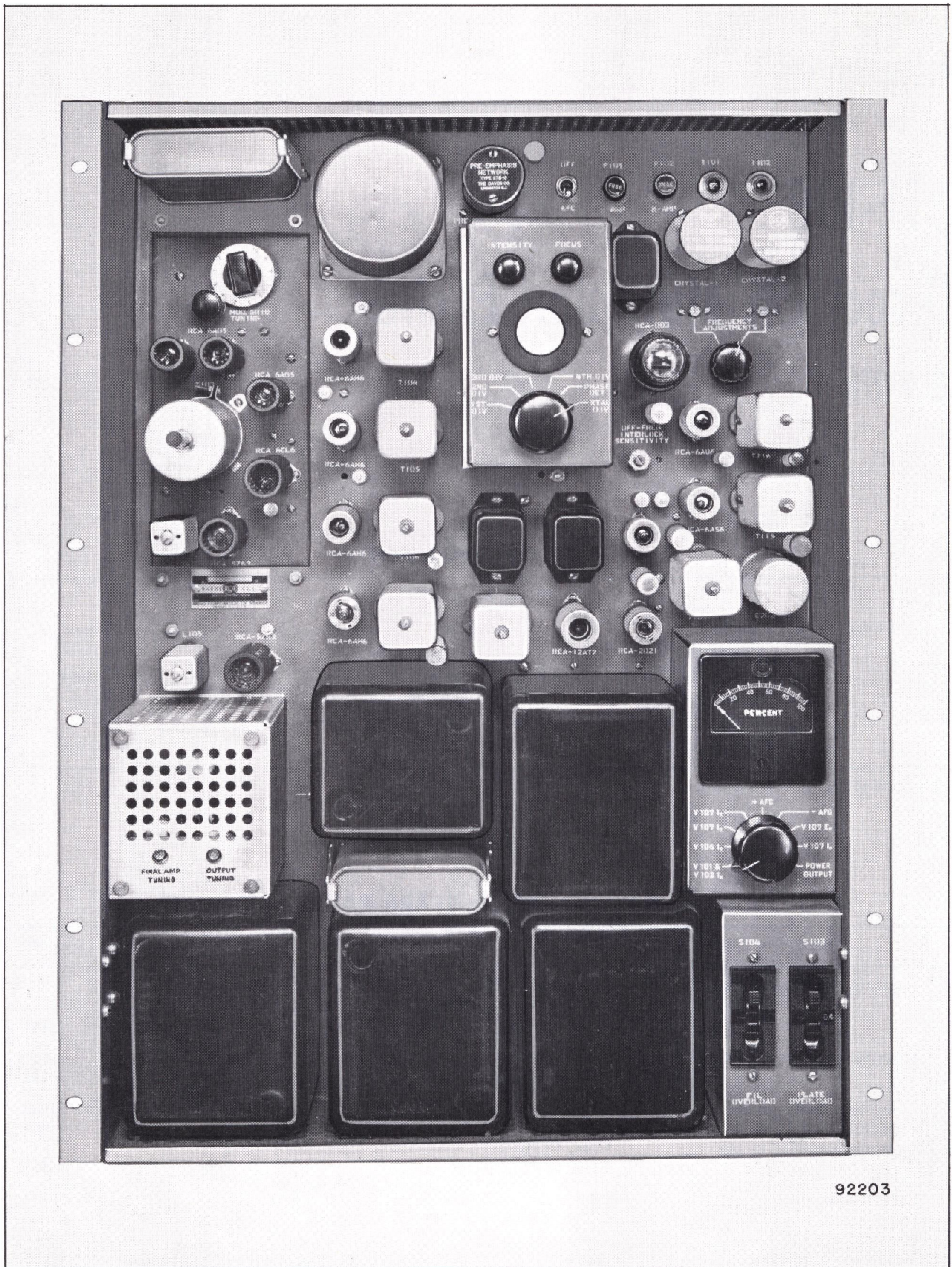

92203

Figure E-1. BTE-10B FM Multiplex Exciter

TECHNICAL SUMMARY

ELECTRICAL CHARACTERISTICS

Type of Emission	F3
Frequency Range	88-108 mc/s
Power Output	10 watts
Output Impedance	50 ohms
Frequency Deviation for 100% mod.	±75 kc/s
Modulation Capability	±100 kc/s min.
Carrier Frequency Stability	±1000 cps max.
Audio Input Impedance	600/150 ohms
Audio Input Level (100% mod.)	+10 ±2 dbm ¹
Audio Frequency Response (30-15000 cps)	±1 db max. ²
Harmonic Distortion (30-15000 cps)	0.5% max. ³
FM Noise Level (referred to 100% FM mod.)	-65 db max.
AM Noise Level (referred to carrier voltage)	-50 db max.
Sub-carrier Input Level (30% mod. of carrier)	5v max. ⁴
Sub-carrier Input Impedance	10,000 ohms
Sub-carrier Center Frequency Range	30 to 67 kc/s
Main-to-Sub-channel Crosstalk	-55 db ⁵
Sub-to-Main-channel Crosstalk	-65 db ⁶
Power Line Requirements	240/208 or 117 V, single phase 50/60 cps
Slow Voltage Variations	±5%
Power Consumption	300 watts, Approx.
Crystal Heaters	117 volts, 50-60 cps, 10 watts each
Altitude	7500 ft. max.
Ambient Temperature Range	-20°C to +45°C

MECHANICAL SPECIFICATIONS

	<i>Height</i>	<i>Width</i>	<i>Depth</i>
Overall Dimensions	24½"	19"	11"
Weight	80 lbs.		

¹Level measured at input (J101) using 400 cps tone.

²Audio frequency response referred to 75 μs pre-emphasis curve.

³Distortion includes all harmonics up to 30 kc/s and is measured following a standard 75 μs de-emphasis network.

⁴Subcarrier modulation percentage can be brought to 50% if required. (See Subcarrier Modulation in text.)

⁵Reference shall be ±7.5 kc/s deviation of the subcarrier by a 400 cps tone. Main channel modulation 70% by 30-15000 cps tones.

⁶Reference shall be ±75 kc deviation of the main carrier by a 400 cps tone. Sub-channel modulated 100% (±7.5 kc/s) by 30-6000 cps tones. Subcarrier modulated 30% on main carrier.

TUBE COMPLEMENT

<i>Symbol</i>	<i>Type</i>	<i>Function</i>	<i>Symbol</i>	<i>Type</i>	<i>Function</i>
V101	6AQ5	Reactance Modulator	V109	6AH6	Frequency Divider (1/4)
V102	6AQ5	Reactance Modulator	V110	6AH6	Frequency Divider (1/4)
V103	6AQ5	Master Oscillator	V111	6AH6	Frequency Divider (1/5)
V104	6CL6	Subcarrier Modulator	V112	6AU6	Crystal Oscillator
V105	5763	Frequency Tripler	V113	6AH6	Crystal Frequency Divider (1/5)
V106	5763	Frequency Tripler	V114	12AT7	Cathode Follower
V107	6146	Frequency Doubler and Power Amplifier	V115	6AS6	Off-Frequency Detector
V108	6AH6	Frequency Divider (1/3)	V116	2D21	Off-Frequency Control
			V117	OD3	Voltage Regulator
			V118	1EP1	Cathode Ray Tube

DESCRIPTION

The RCA BTE-10B, ES-27278, is a frequency modulated exciter which provides an r-f output of ten watts at any specified frequency in the 88 to 108 megacycle band. The compact unit incorporates a subcarrier modulator stage which can be fed from a subcarrier generator such as the RCA BTX-1A to provide for multiplexing one or two subcarriers on the main FM channel. Thus, it is designed especially to provide for various applications of FM multiplex such as background music, and, if it should become authorized, stereophonic sound.

The BTE-10B is the exciter used in the RCA BTF-5B 5KW FM Transmitter. It can be used to replace the exciter units of previous RCA FM transmitters, or that of any other FM transmitters where an exciter power output of ten watts is adequate. The unit incorporates features which make it easy to adjust, easy to maintain and very reliable in operation.

All r-f multipliers, including the output stage, employ single-tuned circuits. The exciter can be housed in a standard cabinet rack together with a subcarrier generator. Employing miniature tubes throughout, the BTE-10B is a self-contained unit with built-in power supplies and an oscilloscope to facilitate alignment.

The BTE-10B when properly adjusted, and used in conjunction with the BTX-1A Subcarrier Generator, will provide subchannel performance comparable to the main FM channel with regard to signal-to-noise ratio and distortion. The frequency response of the subcarrier will be somewhat limited when programming the subcarrier separately.

R-f multiplier and power amplifier stages of the BTE-10B use relatively broadband, single-tuned circuits, thus simplifying adjustment. A built-in meter can be switched to read the following voltages and currents: Modulator cathode current; second and third multiplier grid currents; PA cathode and plate current; AFC control voltage; and plate voltage.

The monitor oscilloscope incorporated in the exciter simplifies adjustment and maintenance of the AFC frequency dividers. A switch permits instantaneous checking and adjustment of all five dividers, and a check of the control action of the phase detector. Displays are in the form of Lissajous' figures, with the advantages that lock-in of the dividers can be observed easily. Checks can be made during operation without disturbing the AFC circuit in any way. This type display requires no synchronization or other adjustments.

Power supplies employ semiconductor rectifiers. The high voltage regulated supply which furnishes d-c plate and screen voltage utilizes a bridge type germanium rectifier. Modulator and oscillator filaments are supplied by a d-c supply employing a full wave silicon rectifier.

All components of the BTE-10B are mounted on a vertical chassis. Special hinge-type mounting pins at the bottom corners permit the top of the chassis to be swung out for access to the wiring and circuit components on the underneath side.

CIRCUITS

A block diagram of the BTE-10B Exciter is shown in Figure 2. Circuits consist of: A master oscillator which operates at 1/18th of the carrier frequency; two reactance modulators to provide modulation for the main channel; a third reactance modulator for the subcarrier; three frequency multipliers including the output stage to bring the output frequency up to the 88 to 108 mc range; automatic frequency control circuitry; and power supplies to furnish a-c and d-c voltages for these stages.

The master oscillator is a 6AQ5 Hartley type oscillator which operates at a frequency between approximately five and six mc., depending upon the desired output frequency. The plates of the two 6AQ5 reactance modulators are connected to the oscillator plate, and the grids, which are in push-pull, are inductively coupled to the plate tank. R-f voltages on the two modulator grids are 180 degrees out of phase with respect to each other, and each is 90 degrees out of phase with the oscillator plate. Thus, one tube appears as a capacitive reactance and the other appears as an inductive reactance across the oscillator tank. The magnitude of the reactive component presented to the tank coil varies with the audio voltage applied to the modulator grids, and the frequency of the oscillator is varied accordingly. The mean frequency is controlled by the bias voltage applied to one grid. This bias voltage is supplied by the automatic frequency control circuit to be described in a later paragraph.

The third reactance modulator, an RCA Type 6CL6, provides for modulation of the subcarrier on the main r-f carrier. This reactance tube is coupled to only a part of the oscillator coil since the required deviation of the r-f carrier by the subcarrier is small.

Use of the pushpull modulator and the inductive coupling circuit results in a highly linear operation

BTE-10B EXCITER CRYSTALS

<i>MI No.*</i>	<i>Carrier Frequency (MC)</i>	<i>Crystal Frequency (KC)</i>	<i>MI No.*</i>	<i>Carrier Frequency (MC)</i>	<i>Crystal Frequency (KC)</i>
34509-1	88.1	101.9676	34509-51	98.1	113.5417
-2	88.3	102.1991	-52	98.3	113.7731
-3	88.5	102.4306	-53	98.5	114.0046
-4	88.7	102.6620	-54	98.7	114.2361
-5	88.9	102.8935	-55	98.9	114.4676
-6	89.1	103.1250	-56	99.1	114.6991
-7	89.3	103.3565	-57	99.3	114.9306
-8	89.5	103.5880	-58	99.5	115.1620
-9	89.7	103.8194	-59	99.7	115.3935
-10	89.9	104.0509	-60	99.9	115.6250
-11	90.1	104.2824	-61	100.1	115.8565
-12	90.3	104.5139	-62	100.3	116.0880
-13	90.5	104.7454	-63	100.5	116.3194
-14	90.7	104.9769	-64	100.7	116.5509
-15	90.9	105.2083	-65	100.9	116.7824
-16	91.1	105.4398	-66	101.1	117.0139
-17	91.3	105.6713	-67	101.3	117.2454
-18	91.5	105.9028	-68	101.5	117.4769
-19	91.7	106.1343	-69	101.7	117.7083
-20	91.9	106.3657	-70	101.9	117.9383
-21	92.1	106.5972	-71	102.1	118.1713
-22	92.3	106.8287	-72	102.3	118.4028
-23	92.5	107.0602	-73	102.5	118.6343
-24	92.7	107.2917	-74	102.7	118.8657
-25	92.9	107.5231	-75	102.9	119.0972
-26	93.1	107.7546	-76	103.1	119.3287
-27	93.3	107.9861	-77	103.3	119.5602
-28	93.5	108.2176	-78	103.5	119.7917
-29	93.7	108.4491	-79	103.7	120.0231
-30	93.9	108.6806	-80	103.9	120.2546
-31	94.1	108.9120	-81	104.1	120.4861
-32	94.3	109.1435	-82	104.3	120.7176
-33	94.5	109.3750	-83	104.5	120.9491
-34	94.7	109.6065	-84	104.7	121.1806
-35	94.9	109.8380	-85	104.9	121.4120
-36	95.1	110.0694	-86	105.1	121.6435
-37	95.3	110.3009	-87	105.3	121.8750
-38	95.5	110.5324	-88	105.5	122.1065
-39	95.7	110.7639	-89	105.7	122.3380
-40	95.9	110.9954	-90	105.9	122.5694
-41	96.1	111.2269	-91	106.1	122.8009
-42	96.3	111.4583	-92	106.3	123.0324
-43	96.5	111.6898	-93	106.5	123.2639
-44	96.7	111.9213	-94	106.7	123.4954
-45	96.9	112.1528	-95	106.9	123.7268
-46	97.1	112.3843	-96	107.1	123.9583
-47	97.3	112.6157	-97	107.3	124.1898
-48	97.5	112.8472	-98	107.5	124.4213
-49	97.7	113.0787	-99	107.7	124.6528
-50	97.9	113.3102	-100	107.9	124.8843

* Suffixes 1 to 100 designate channel number. Add 200 to suffix to get FCC channel number, e.g., MI-34509-75 designates FCC channel 275, frequency 102.9 mc.

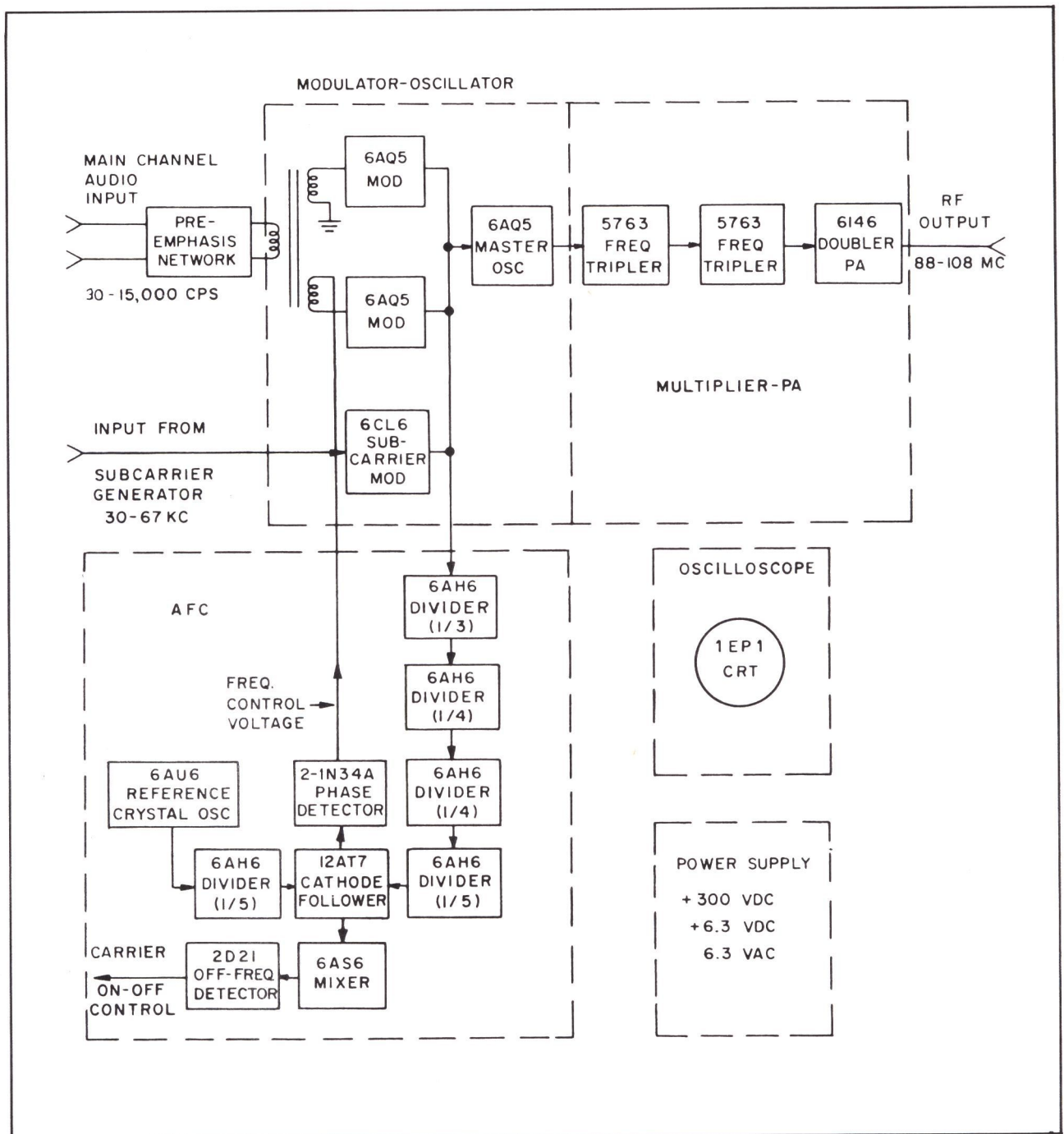

Figure E-2. Block Diagram, BTE-10B FM Exciter

with very low harmonic distortion. Each tube is almost a pure reactance, and loading of the oscillator is greatly reduced, providing better AFC action. Moreover, the pushpull modulator automatically balances out temperature and supply-voltage changes. Modulating circuits are very effectively decoupled, thus minimizing the possibility of cross-talk between the main channel and subchannel, and vice versa.

Automatic Frequency Control

The automatic frequency control circuitry of the BTE-10B Exciter is characterized by a long record of dependable operation. A phase detector is used to develop a control voltage which establishes and maintains a phase lock between a reference crystal oscillator and the derived signal. Thus the system is actually an automatic phase control system which

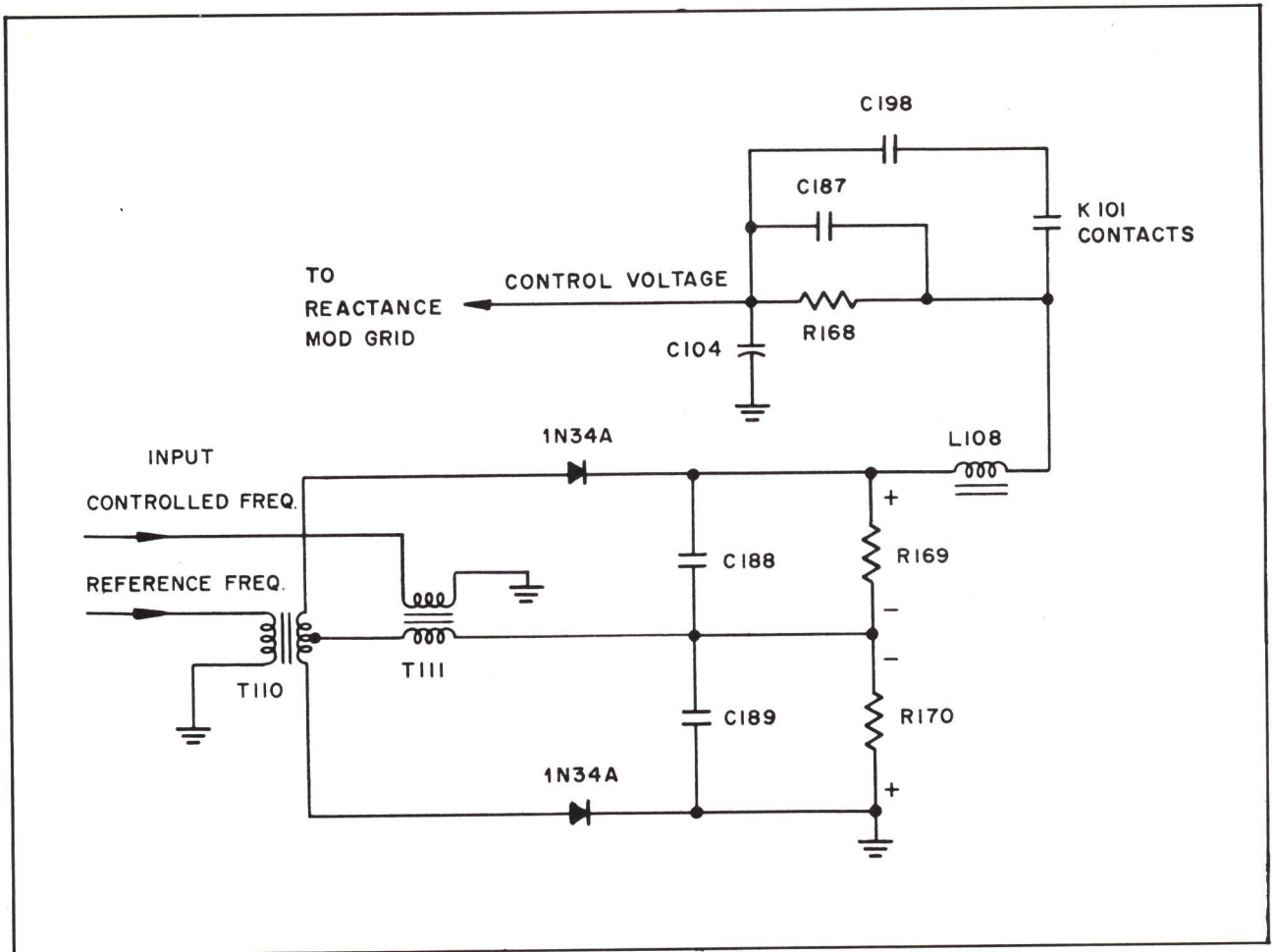

Figure E-3. Simplified Schematic, BTE-10B Phase Detector

achieves a stability precisely matching that of the crystal reference source. To confine the phase deviations of the master oscillator signal to within range of the phase detector, and in order not to exceed the possible speed of the low pass network in the AFC circuit, the master oscillator frequency and swing must be reduced. This is accomplished in locked-oscillator type dividers with an overall division of 240. Thus the maximum phase deviation at the lowest audio frequency (30 cps) is ± 58 degrees (at ± 100 kc deviation of the final frequency), and well within the limits of linearity of the phase detector.

The limited pull-in range normally associated with precise frequency control is overcome by the use of an off-frequency circuit which extends the pull-in range to ± 400 kc (at the final frequency), and simultaneously provides a safeguard against uncontrolled and possible off-frequency operation.

Circuits of the AFC system are diagrammed in Figure 2. A small r-f voltage is fed from the master

oscillator circuit to the divider chain where it is divided by 240 to a range of 20 to 25 kc. It should be noted that, at the same time, deviation due to modulation is reduced from a maximum of ± 5 kc to ± 20 cps. From the dividers, this voltage is fed through a cathode follower to a phase detector employing two 1N34A diodes. A reference voltage of the same frequency, fed into the phase detector, is obtained by dividing by five the frequency of the reference crystal oscillator.

Operation of the phase detector is illustrated in the simplified diagram of Figure 3, and by the vector diagram of Figure 4. Assuming that the master oscillator is exactly on frequency, with no correction bias applied to its grid, the two input signals applied to T110 and T111 therefore are of the same frequency but 90 degrees out of phase. The reference frequency signal is applied to T110, and the voltage developed across the top half of the secondary is represented by vector BA in Figure 4 (a), while the voltage across the lower half is represented by vector BC.

These two voltages are equal in magnitude and 180 degrees out of phase. The controlled frequency signal is applied to T111, and the voltage developed across its secondary is represented by vector BD, which is 90 degrees out of phase with each of the other two. The voltage impressed across each 1N34A crystal rectifier and its associated load (R169 and R170) is then the vector sum of the series voltages E_1 and E_2 respectively. Since the magnitudes of E_1 and E_2 are equal, the d-c voltages across R169 and R170 will be equal and of the polarity shown. Hence, the voltage as measured from the top of R169 to ground will be zero.

If, however, the frequency of the master oscillator should *decrease*, the relative phase of the two input signals and their vector relationships will change as shown in Figure 4 (b). Since the magnitude of E_1 is now greater than that of E_2 , the d-c voltage across R169 will be greater than that across R170 and a net *positive* correction voltage appearing at the top of R169 will be applied to the reactance tube grid, correcting the frequency. Accordingly, if the oscillator frequency should *increase*, the vector relationships change as shown in Figure 4 (c), and a net *negative* correcting voltage is applied to the reactance tube grid. Thus any departure from the 90-degree phase relationship between the two signals is instantaneously corrected by a proper error voltage. High frequency components of the input signals are filtered out of the control voltage by the capacitors C188 and C189 and the choke L108.

The network consisting of capacitors C104, C187, C198 and resistor R168 extends the control range of the phase detector beyond the ± 90 degree phase difference limit that would otherwise be imposed, by feeding a small amount of the beat frequency back to the reactance tube grid. This beat frequency then causes the master oscillator frequency to swing in both directions at the difference frequency rate. The amount of frequency deviation is proportional to the amplitude of the signal at the reactance tube grid; and in order to produce sufficient swing without objectionable audio frequency feedback, capacitor C187 is made small and is paralleled by a larger capacitor C198 which is switched in only when the master oscillator is "hunting." The switching is done automatically by the off-frequency detector described in a later paragraph.

If the signal at the reactance tube grid is sinusoidal, there will be no d-c component and the mean frequency of the master oscillator will remain unchanged. However, the beat frequency at the phase detector output, when it is not locked in, is non-symmetrical and has a d-c component of the proper polarity to change the mean frequency of the master oscillator toward its correct frequency.

To illustrate how the non-symmetrical waveform is developed, take an example in which the frequency of the master oscillator is such as to produce a signal at T111 which is 0.1 kc low. A difference frequency of 0.1 kc will be fed to the reactance tube grid, and

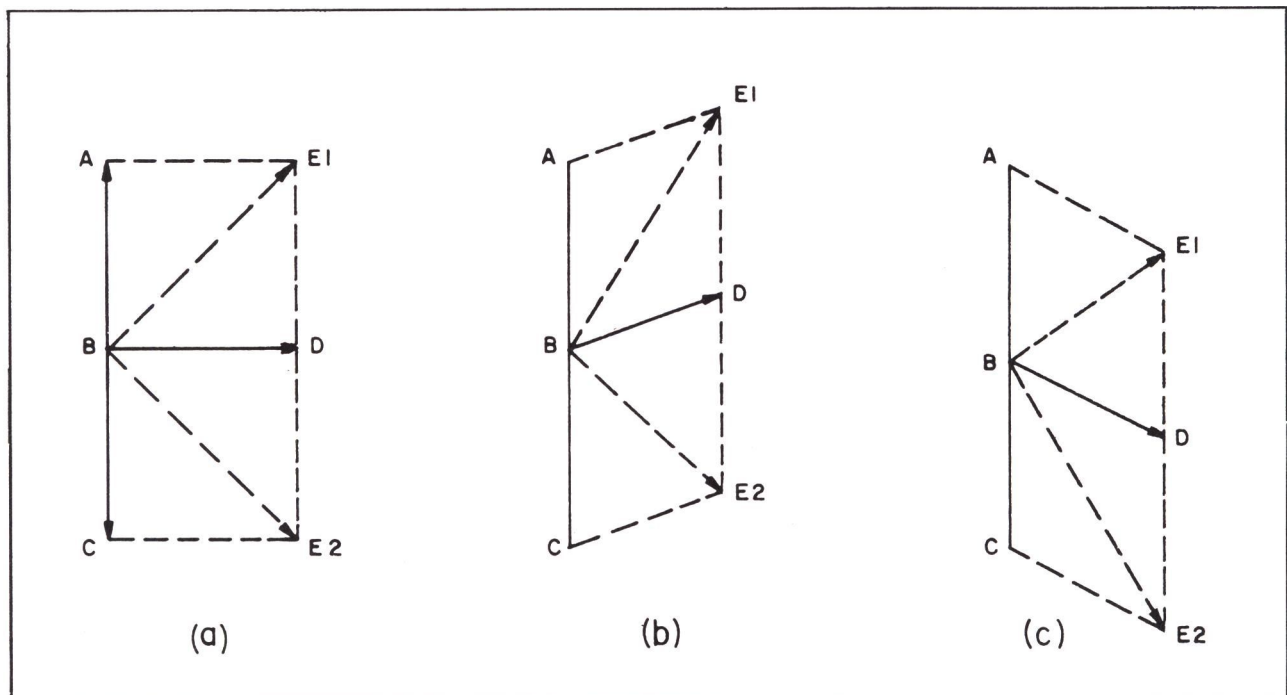

Figure E-4. Phase Detector Signal Voltages

the master oscillator will then swing above and below the tuned frequency one hundred times per second. The dashed line curve of Figure 5 (a) is the waveform of the beat frequency which would appear at the junction of L108 and R168 if C104 were shorted. If this waveform was fed back to the reactance tube through a blocking capacitor, the solid line waveform would appear at the same point. Note that the solid line waveform is slightly distorted so that its axis no longer represents zero d-c voltage.

The positive peak of the solid line waveform in Figure 5 (a) is produced as the master oscillator frequency swings further away from its frequency, and the negative peak is produced as it approaches its correct frequency. As the controlled frequency approaches the reference frequency, the beat becomes increasingly slower, and the distorted waveform is produced. The d-c component produced across C104 is of such polarity as to change the master oscillator frequency toward its correct frequency.

Figures 5 (b) through (d) are the same as (a) except for the frequency of the beat. Note that as the beat frequency becomes lower, the distortion becomes greater, producing a corresponding increasing d-c component. The waveforms shown can be produced by blocking the d-c component from the reactance tube and by tuning the master oscillator for the desired beat frequency. However, when the d-c component is fed to the reactance tube grid, the beat frequency automatically decreases until it is zero. The system is then "locked in" and the d-c voltage maintains that condition.

Off-Frequency Detector

Protection against loss of control by the automatic frequency control system, and possible off-frequency operation, is provided by the off-frequency detector circuit shown in Figure 6. V115 is a 6AS6 mixer stage which is fed from the last divider in each chain as shown in Figure 2. The plate load of the stage is by-passed by capacitor C193, which is a low impedance to the beating frequencies and to the sum of the beating frequencies, eliminating these signals in the output.

When the master oscillator is on frequency there is no difference frequency produced in V115, and therefore the output of the stage is zero. If for any reason a difference occurs in the two beating frequencies, however, the difference frequency component appears across the plate load and hence across the thyatron grid resistor R172. If the positive half of this alternating voltage exceeds the fixed cathode bias applied to the thyatron V116, the tube conducts, energizing relay K101. One (normally closed) set of contacts on relay K101 operates the transmitter interlock circuit, preventing plate power from being applied to the PA; another set of contacts (normally open) switches in the feedback capacitor C198, shown in Figure 3, for purposes previously described.

Sensitivity of the circuit is adjusted by the thyatron bias resistor R174. This adjustment is set so that the low modulating frequencies will not trigger the thyatron but so that the beat frequencies will cause it to fire.

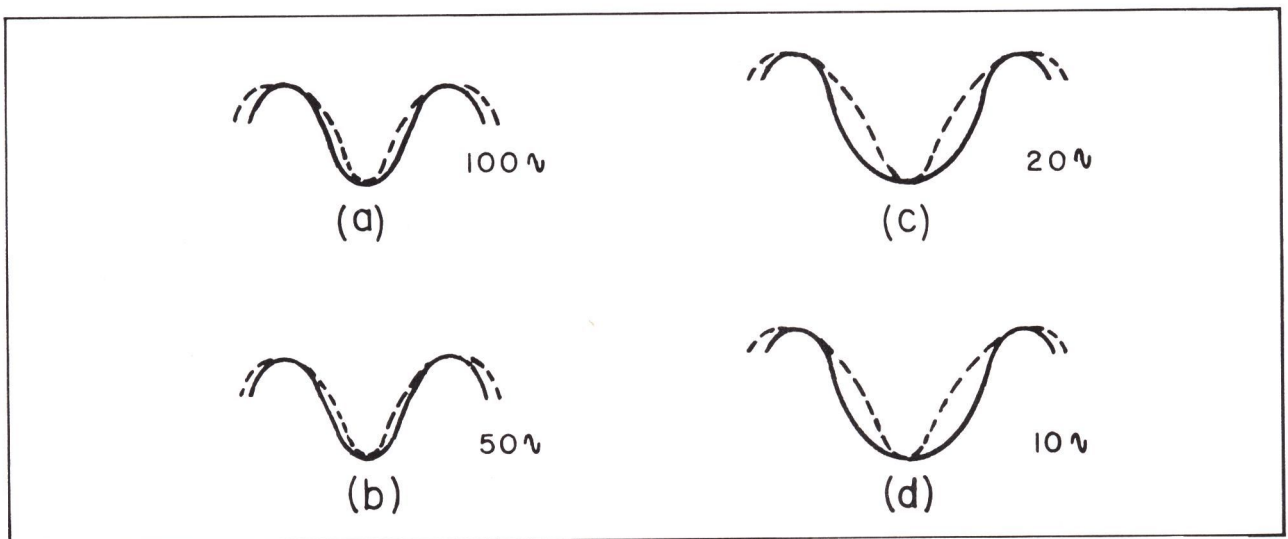

Figure E-5. Phase Detector Output Waveforms

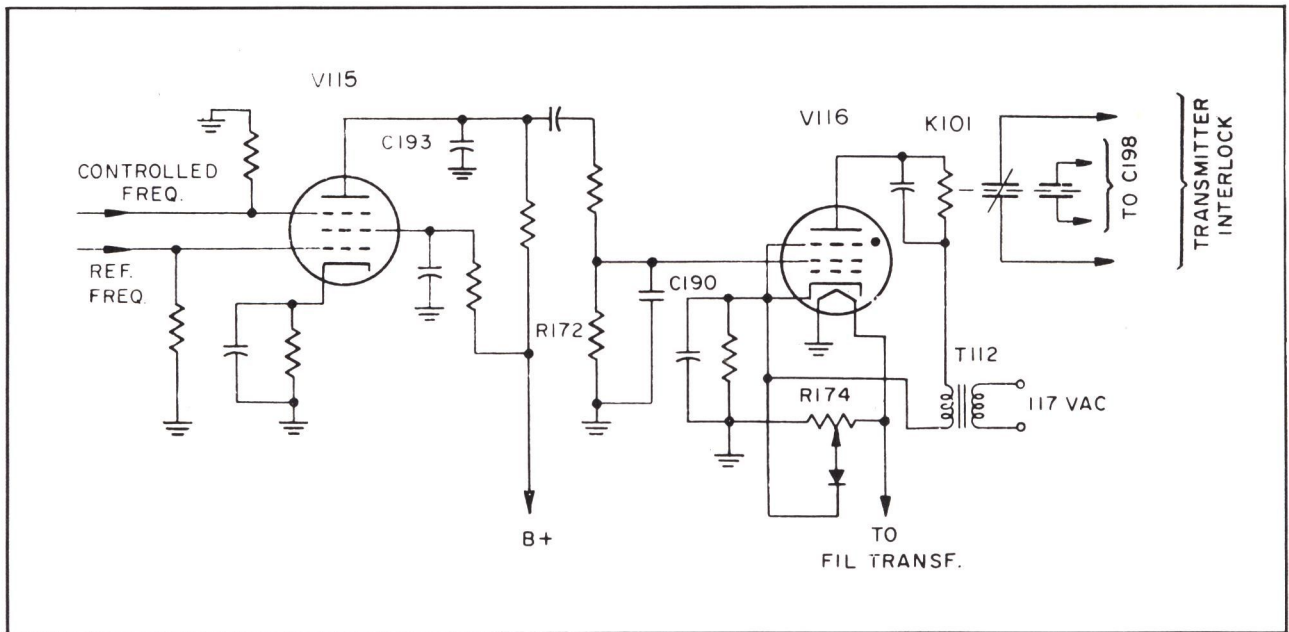

Figure E-6. Simplified Schematic, Off-Frequency Detector

INSTALLATION

Carefully unpack and inspect the equipment to make certain that no damage has been incurred during shipment. Any damages or shortages should be immediately reported to RCA and to the transportation company in order that lost or damaged material may be recovered.

The equipment is shipped complete in one container, excepting tubes and crystals which are packed separately. All internal wiring is done at the factory, only external cables and wiring need be prepared and connected to the equipment at installation. Reference should be made to the interconnection diagram of this book which designates the cables and wiring to be used and the proper connections.

A-C Power Line Connections

The primaries of the plate transformer (T113) and the filament transformer (T114) are each tapped for operation from either 120-volt or 240-volt single-phase a-c lines. The equipment is shipped with the

taps set for 240-volt use. *The crystal beaters must be connected only to a 120-volt a-c source.* Particular care must be taken to insure that proper connections are made before power is applied to the equipment. Reference should be made to the overall schematic diagram and to the table *Transformer Primary Taps* for making connections. *If 240 volts is used, be sure not to disconnect T112 (black leads) from the 120-volt terminals 4 and 2 of T113.*

The a-c overload switch (S104) can be used as a "Power Off-On" switch, if desired, and the d-c overload switch (S103) for "Standby" plate switching. The connections of these circuit-breakers are shown in the overall schematic diagram.

Tubes should be inserted in their proper sockets by reference to the type number designations printed near the appropriate sockets. Crystal Units MI-34509 should be inserted into the sockets marked "CRYSTAL 1" and "CRYSTAL 2."

TRANSFORMER PRIMARY TAPS

Power Line Voltage:	106	117	128	197	208	219	229	240	251
Taps to be Used:	3-4	2-4	1-4	3-5	2-5	1-5	3-6	2-6	1-6
	Tap C of "AC OVERLOAD" Circuit Breaker			Tap B of "AC OVERLOAD" Circuit Breaker					

After tubes and crystals are in place, and all connections are properly made, a-c power can be applied to the equipment. Allow sufficient time for tubes and the crystals heaters to reach operating temperature before following the tune-up procedure below. Indicators DS101 and DS102 will light when the crystal oven heaters are on.

Tune-Up Procedure

The oscilloscope patterns illustrated in these pages were obtained on the built-in CRO during tune-up of an exciter unit. These patterns should be considered as typical of those to be expected; slight deviations from these displays may occur in individual units.

1. With the equipment operating and indicators "DS101" and "DS102" extinguished, indicating that the crystal heaters have reached operating temperature, switch "AFC-OFF" switch to "OFF" position. With the CRO Switch (S106) in any position, advance the "INTENSITY" control (R185) clockwise until a trace appears on the face of the tube (V118). Then adjust "FOCUS" (R183) for proper sharpness. Switch meter-switch (S102) to "V107 E_p " position and check plate voltage. (Reading should be between 54 and 66.) Turn "OFF-FREQUENCY INTER-LOCK SENSITIVITY" (R176) to extreme clockwise position.

2. Turn CRO switch to "XTAL DIV" position. Adjust top screw of L112 for maximum horizontal size of CRT pattern. (1/8" to 3/16" will be satisfactory).

3. Adjust top screw of T115 to obtain stationary Lissajous' figure indicating a division ratio of 1/5. (Pattern should have five left-hand loops and five right-hand loops.) Adjust top screw of T109 for maximum vertical size of pattern. See Figure 7 a.

4. Set the master oscillator to the approximate operating frequency which is 1/18 of the final carrier frequency. E.g., 88.1 mc corresponds to 4894 kc master oscillator frequency. Use grid-dipper, calibrated receiver or frequency meter. Use bottom screw of T103 to make this adjustment setting the top (fine) adjustment to a mid-position.

5. Turn CRO-Switch to "1ST DIV" position and adjust T14 for a stationary Lissajous' figure and a division ratio of 1/3. See Figure 7 b.

NOTE: Too high an inductance, when the adjusting screw is all the way in, means a low frequency and a possible division ratio of 1/4 or 1/5 or more. Too low an inductance may result in a 1/2 division ratio.

6. Turn CRO-Switch to "2ND DIV" position and adjust T105 for a stationary Lissajous' figure and a division ratio of 1/4 (Figure 7 c).

7. Turn CRO-Switch to "3RD DIV" position and adjust T106 for a stationary Lissajous' figure and a division ratio of 1/4 (Figure 7 d).

8. Turn CRO-Switch to "4TH DIV" position and adjust T107 for stationary Lissajous' figure and a division ratio of 1/5. Adjust T108 for maximum horizontal size of pattern (Figure 7 e).

9. Turn CRO-Switch to "PHASE DET" position. A square of medium brightness should be seen representing an unstationary Lissajous' circle. The rate of change of the circle depends on the frequency-difference between the reference signal and the divided master oscillator signal. Rotate the bottom screw of T103 slowly in both directions trying to find the point where both signals agree in frequency resulting in a slowly changing Lissajous' circle. During the variation of T103 make sure as you change frequency that all dividers (T104-T107) are still locked in. If a nearly stationary circle cannot be obtained, try again starting on a somewhat higher or lower frequency.

10. If a slowly changing circle was obtained, switch meter switch (S102) to "V101 & V102 I_p " position and adjust "MODULATOR GRID TUNING" (C105) for peak indication. Slight resetting of T103 bottom adjustment may be required to obtain slowly moving Lissajous' circle. Then switch "AFC" switch (S101) to "ON" position. The circle should "jump" into a completely stationary circle now. (See Figure 7 f.) In addition to the CRO the phase detector output voltage can be observed also on the built-in meter, with the meter switch in "+ or -AFC" position. With AFC on, both positions should give nearly zero readings. With AFC off, frequency differences at the phase detector up to a few cps can be observed with the meter.

11. A more sensitive adjustment of "MODULATOR GRID TUNING" (C105) can be made by applying 50 cps at approximately +10 db to the audio input connector (J101), and adjusting C105 for maximum indication on the modulation percentage meter of a modulation monitor.

12. Tune L104 to maximum indication of the meter (M101) with meter switch (S102) in "I, V106" position.

13. Steps 11 and 12 may slightly change the master oscillator frequency. So, AFC should be switched off and with CRO switch in "PHASE DET" position the circle should be made near-stationary by tuning T103 with the fine control knob on top of the can. Then throw "AFC-OFF" switch back to "AFC" position.

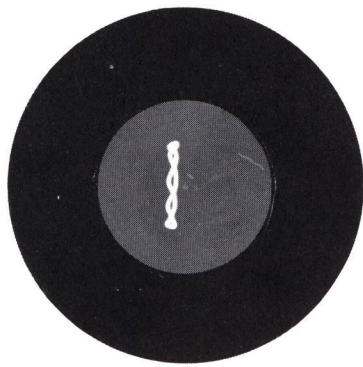

(a) Switch Position:
"XTAL DIV." (1/5)



(b) Switch Position:
"1st DIV." (1/3)



(c) Switch Position:
"2nd DIV." (1/4)



(d) Switch Position:
"3rd DIV." (1/4)



(e) Switch Position:
"4th DIV." (1/5)



(f) Switch Position:
"PHASE DET."

Figure E-7. BTE-10B Oscilloscope Patterns

NOTE: T104 to T107 stay locked in over a certain frequency range. It is desirable to have T104-T107 adjusted so that they normally operate in the middle of their lock-in range. In order to assure this, switch CRO-Switch to "1ST DIV" position. Now turn tuning screw on top of T104 to the left until the divider unlocks (Lissajous' figure gets "fuzzy"). Start turning screw to the right and observe the number of revolutions until it unlocks at the other end of the range. Turn screw back half the number of revolutions counted. Repeat this for T105, T106, T107, and T115.

14. Tune L105 to maximum indication of meter; meter switch in "I_c V107" position.

NOTE: Remove C214 for center frequencies above 100 mc.

15. Tune C137 "PLATE TUNING" to dip on meter, meter switch in "I_k V107" or better in "I_p

V107" position. Adjust C139 "OUTPUT TUNING" to obtain proper grid current in following amplifier or desired output, then retune C137 for dip or maximum output. (If a Micromatch or Reflectometer is used in the output transmission line, the developed DC voltage may be fed into the exciter via pin 8, of plug T105 and indicated on the meter, meter switch in "POWER OUTPUT" position.)

16. Adjust the sensitivity of the off-frequency detector (V116) as described in the following paragraphs.

NOTE CAREFULLY: This adjustment is important to assure sufficient pull-in range of the exciter.

Then proceed with Steps 17, 18, 19 and 20.

"OFF-FREQUENCY INTERLOCK" Adjustment

Sensitivity of the off-frequency detector (V116) is controlled by the setting of the "OFF-FREQUENCY INTERLOCK SENSITIVITY" potentiometer (R174) in the cathode circuit of this stage. Proper adjustment can be obtained by use of either a 35 cps or 50 cps tone source, although the methods differ slightly as follows:

Using a 35-cycle tone, modulate the exciter 130%. An input signal of approximately +13 db is required. Turn R174 counter-clockwise until relay K101 is energized, as observed by listening for the closing of the relay or by operation of the PA plate or screen cutout. The point at which relay K101 is energized will be the correct setting for R174.

If a 35 cps source is not available, an alternate method using a 50-cycle tone source may be used. Modulate the exciter 130% with the 50-cycle tone, and turn R174 counter-clockwise to the point where K101 is energized. Note this setting. Then turn R174 clockwise until K101 is de-energized, noting this setting. Then set R174 halfway between these energized and de-energized positions, which will be the

correct adjustment. Check for proper off-frequency control action by switching the "AFC SWITCH" (S101) to "OFF" and slightly detuning the vernier control on the top of T103. This should energize relay K101. Retune T103 to original setting.

17. Set CRO-Switch (S106) to "PHASE DET" position and reduce "INTENSITY" (R185) to prevent burn-in of the pattern.

18. Finally, using the station frequency monitor tune the crystal "FREQUENCY ADJUSTMENT" trimmer capacitors (C205) and (C206) to the assigned center frequency. (C205 or C206 will vary final frequency approximately ± 15 kc.)

NOTE: Frequency can be changed slightly by adjustment of L112 also. Do not change more than ± 2 kc.

19. Reduce "INTENSITY" (R185) as much as possible to prevent CRT "burn-in".

20. Multiplex Operation. Best crosstalk will be obtained with all multiplier and amplifier stages tuned for maximum grid current in the following stage or for maximum power.

OPERATION

In daily operation of the equipment, the crystal heaters should be left on continuously. Then after application of power to the exciter, and allowing a short warm-up period, performance can be checked by observing the patterns on the oscilloscope while the exciter is on the air.

The oscillograms shown with the tuning procedure in the INSTALLATION section of this book represent the desired adjustment of the various stages of the exciter for proper operation of the AFC system. These oscilloscope patterns may be observed during regular operation without affecting performance of the exciter.

The 75 μ s pre-emphasis network is a plug-in unit and can be removed if it is desired to apply pre-emphasis at some other point in the system. If this unit is removed, an 18 db pad should be inserted in place of the pre-emphasis network. Such an attenuator can be made up in accordance with Figure 8. Numbers on the diagram identify the octal pins of the socket XZ101. The use of $\pm 5\%$ tolerance, $\frac{1}{2}$ watt resistors is recommended.

Output Frequency Conversion

A conversion coil (MI-34501-2) is supplied with the exciter to modify the last stage to a straight-

through amplifier, providing an output frequency in the range of 44 to 54 mcs. If the exciter is to be used with previously designed FM transmitters incorporating a frequency doubler, this modification should be made in the exciter.

If it is necessary that the exciter operate on one-half of the final frequency, modification of the output stage should be made in accordance with the following procedure using the conversion coil.

1. Remove all power from the exciter unit. Remove the cover enclosing components of the final stage, and remove the 6146 tube (V107).

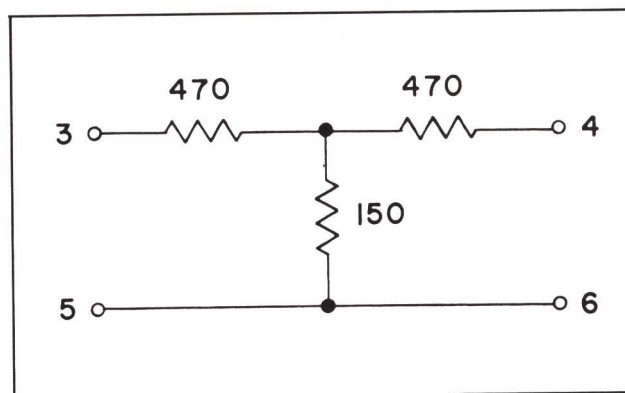

Figure E-8. Schematic, 18 db Attenuator

2. Unsolder the r-f choke (L107) from the feed-through capacitor (C146), and remove units that hold the plate component mounting bracket in place. The bracket can then be turned to gain access to screws holding the plate coil (L106). Remove this coil, and install the new coil (MI-34501, Item 2) in its place.

3. Put mounting bracket back in place, making sure all mounting screws are tight. Re-solder L107 and C146 in such a way that there will be at least 1/2-inch clearance between L107 and the cover when the cover is in position.

4. Reinsert tube V107 in its socket, and install the cover in place. This completes the modification. Filament and plate power can now be applied. With the modification made, power output will be between 10 and 15 watts.

NOTE: In an emergency, the RCA 6146 (V107) may be replaced by an RCA 2E26, at somewhat reduced power output, should the latter tube be more readily available. No change in connections is required.

Main Carrier Deviation by the Subcarrier

Approximate deviation of the main carrier can be set without a monitor, using only a subcarrier generator and the chart shown in Figure 9. The chart indicates the amount of subcarrier voltage necessary

at the input of the BTE-10B Exciter (J-102 or J-106) to produce the required deviation.

As indicated on the chart, the higher subcarrier frequencies require slightly more voltage than the lower frequencies. To obtain a ± 10 kc deviation of the main carrier at 67 kc, 3.6 volts should be selected. At a 32.5 kc, 2.6 volts will produce the same main channel deviation.

The above method is approximate and subject to tolerances in the order of ± 25 percent. It is recommended that the reactance tube V-104 be compared with 2 or 3 other 6CL6 tubes. One method of doing so is by measuring relative subcarrier voltage. A multiplex receiver (with main program off) should produce a voltage of 0.1 to 0.2 volts at the discriminator with ± 15 kc deviation of the main by the subcarrier. Using several 6CL6 tubes this voltage should remain the same.

Proper setting of L-104 in the BTE-10B (maximum grid current into the 2nd tripler) will coincide with minimum subcarrier deviation of the main channel. Detuning of L-104 will increase crosstalk as well as subcarrier deviation of the main carrier. Therefore, L-104 should be set to maximum grid current into the following tripler stage for minimum crosstalk.

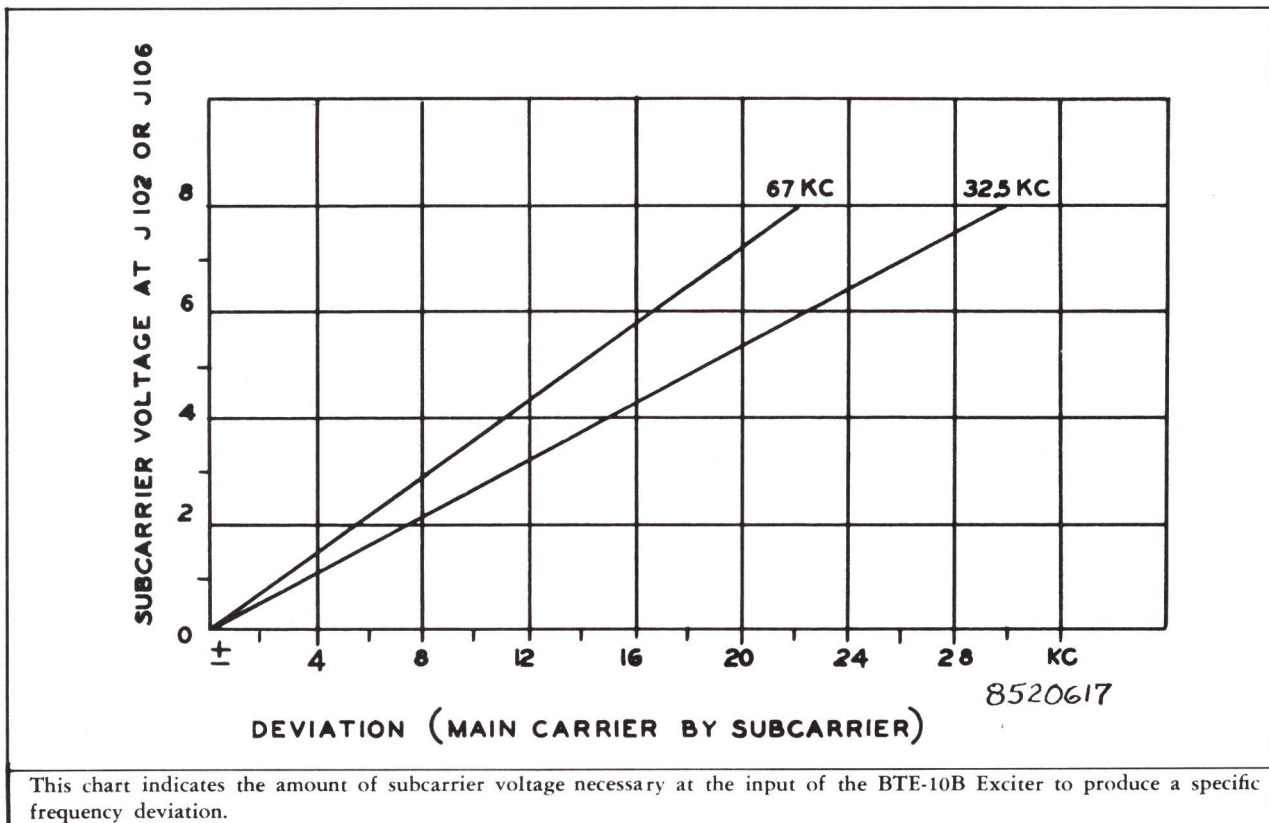

This chart indicates the amount of subcarrier voltage necessary at the input of the BTE-10B Exciter to produce a specific frequency deviation.

Figure E-9. Main Carrier Deviation by the Subcarrier (Chart)

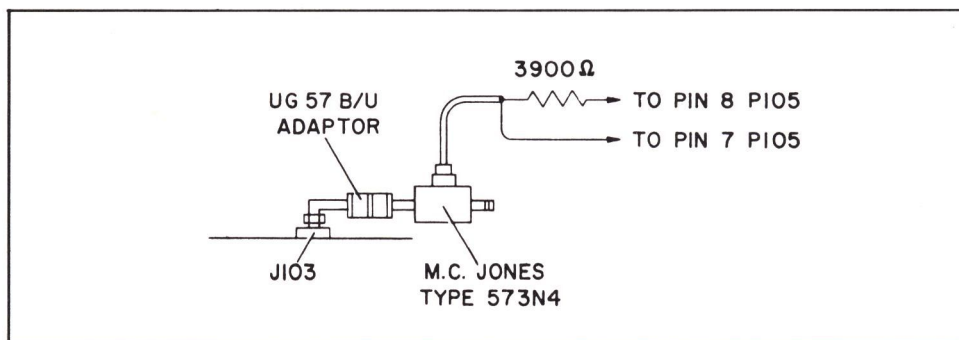

Figure E-10. Connections for Measuring Power Output

Subcarrier Modulation

To increase subcarrier modulation percentage, a 47K ohm, 1/2 watt resistor should be connected in parallel to R195 or R197.

Use of Control Tones

The exciter can be modulated by control tones if

desired. These control tones, which are generally in the range between 20 kc and 35 kc, should be fed into one of the subcarrier input jacks (J106) on the exciter. With approximately 5 volts as measured at this point, 30% modulation of the main carrier will be obtained.

MAINTENANCE

With normal care, no maintenance should be required except a periodic check of all tubes and replacement of defective ones with new tubes of the same type.

Failure of automatic frequency control due to the failure of a tube or other component will be evidenced by operation of the relay K101 in the off-frequency detector circuit, opening the contacts (Terminals No. 5 and No. 6 of J105) that control the PA stage of the transmitter. If failure is due to a defective tube, proper operation of the exciter will be restored by replacement of the defective tube without need for readjustment. However, if replacement of circuit components is made, it will be necessary to realign the exciter following the procedure for tuning presented under INSTALLATION.

Emergency Operation

Provision is made for maintaining frequency control should tubes or components associated with the automatic frequency control fail. The operator will be warned of the loss of control by loss of carrier, or by the erratic performance of the carrier frequency monitor.

Tube or component failure can be found in some cases by switching the meter switch (S102) through each of its positions until an abnormal reading is found identifying the difficulty. The oscilloscope switch (S106) may also be helpful in locating trouble in the AFC circuits.

If the master oscillator is functioning, the output carrier frequency can be controlled manually as follows, until such time as repairs can be made:

1. Remove the 2D21 "OFF-FREQUENCY" control tube (V116).
2. Turn the "AFC-OFF" switch (S101) to "OFF".
3. Slowly rotate the top adjustment screw of T103 in first one direction and then the other to bring the output frequency to its assigned value as indicated by the frequency monitor.

Stability of the master oscillator without AFC is such that after sufficient warm-up it maintains frequency to ± 1 kc (at the final frequency) for short periods of time. Possible drift can be corrected by adjustment of T103 top screw.

CAUTION: The voltage of the filament d-c power supply will vary with load. Therefore, care should be taken not to remove more than two of the tubes having d-c on the filament. Otherwise, damage to the remaining d-c heated tubes or to C202 may result.

Power Output Measurements

Power output indications can be obtained conveniently by use of the meter (M101) and a suitable coupler such as the M. C. Jones Micromatch. With the meter switch (S102) in the "POWER OUTPUT" position, the positive terminal of the meter is connected to Pin No. 7 (ground) of P105 and the negative terminal to Pin No. 8 of P105. Readings obtained

will depend upon the type of coupler used. With an M. C. Jones Type 573N4 and a UG57B/U adaptor, a 3900-ohm resistor in series with the meter will provide mid-scale reading of the meter at ten watts output. Connections should be made as shown in Figure 10.

The parasitic suppressor R138-L113 is not required whenever tube V107 is operated as a doubler. In an application where maximum possible output power is desired, R138-L113 may be removed.

Additional power may be obtained by shorting out R132. Under such conditions, however, V107 should not be operated without r-f excitation. Lack of excitation will increase the plate current of V107 to a point where S103 will be energized.

To make tuning more practical, a switch should be placed across R132. This switch will be closed

only after sufficient drive has been obtained, as indicated by M101 in the V107 I position.

TYPICAL METER READINGS

Meter (M101) Position	Function	Reading	
		88 mc	108 mc
V101 & V102 I _k	Modulators	63	64
V106 I _c	2d Freq. Tripler	39	35
V107 I _c	Doubler & PA	41	35
V107 I _k	Doubler & PA	68	66
+AFC	Control Voltage	<10	<10
-AFC	Control Voltage	<10	<10
V107 E _p	Doubler & PA	62	62
V107 I _p	Doubler & PA	49	48
POWER OUTPUT	PA	(see text)	

TYPICAL TUBE SOCKET VOLTAGES*

BTE-10B FM Exciter

Tube		P i n N o .										
Symbol	Type	1	2	3	4	5	6	7	8	9	10	11
V101	6AQ5	.2	15.5	0	6.4	150	150	.2	—	—	—	—
V102	6AQ5	0 ¹	15.5	0	6.4	150	150	0 ¹	—	—	—	—
V103	6AQ5	-17	0	0	6.4	150	70	-17	—	—	—	—
V104	6CL6	7.6	0	150	0	6.4	150	7.6	150	0	—	—
V105	5763	320	—	10	0	6.0	270	10	-25	-25	—	—
V106	5763	320	—	10	0	5.9AC	270	10	-2.2 ²	-2.2 ²	—	—
V107	6146	48	6.3AC	225	48	-2.8 ³	48	0	0	—	—	—
V108	6AH6	-4.5	75	0	6.3AC	75	75	0	—	—	—	—
V109	6AH6	-8	90	0	6.3AC	90	90	0	—	—	—	—
V110	6AH6	-13	95	0	6.3AC	95	95	0	—	—	—	—
V111	6AH6	-7	100	0	6.4	100	100	0	—	—	—	—
V112	6AU6	-9.5	0	0	6.3AC	145	70	0	—	—	—	—
V113	6AH6	-7	88	0	6.4	88	-7	0	—	—	—	—
V114	12AT7	240	.5	4.3	0	0	240	-1	4.2	6.4	—	—
V115	6AS6	0	2.2	0	6.3AC	120	85	0	—	—	—	—
V116	2D21	0 1.5AC ⁴	2.7 ⁵	0	6.3AC	2.7 ⁵	145AC ⁴ -100	2.7 ⁵	—	—	—	—
V117	OD3	- ⁶	2.4	—	150	150	—	—	—	—	—	—
V118	1EP1	0	6.3AC	2.5 ⁷	9	80 ⁸	- ⁶	320	320	- ⁶	320	—

* Voltages measured with VTVM against ground; values are positive except where marked otherwise.

¹May vary ±1V due to AFC. If more than +1V or -1V, correct setting of T103.

²Measure at junction of R126 and R127.

³Measure at junction of R130 and R131.

⁴Figures above line: relay de-energized; below line: relay energized.

⁵Depends on setting of R174, Typical value shown.

⁶Do not take reading.

⁷Depends on setting of R185, Typical value shown.

⁸Depends on setting of R183, Typical value shown.

⁹Reading difficult, due to large value of R187 and R188.

TROUBLE SHOOTING HINTS

RECOMMENDED TROUBLE SHOOTING EQUIPMENT

<i>Equipment</i>	<i>Type</i>
Vacuum Tube Voltmeter with RF Probe	RCA Voltomyst WV-98A with WG-301A Probe or Heath V-7A with Probe # 309C or Equivalent
Audio Oscillator	Hewlett-Packard 206A or Heath AG-9A or Equivalent
Oscilloscope	RCA WO-88A with WG-300A Probe or Heath 0-12 with Probe PK-1 or Equivalent
Receiver	National NC-109 or Equivalent
Grid Dip Meter	Measurements Corp. # 56 Heath GD-1B

The BTE-10B Exciter consists of the sub-units listed below; trouble shooting the exciter should follow in the order as given below.

- (1) Power Supply (V117)
- (2) RF Portion (Tubes V101 to V107)
- (3) Oscilloscope (V118)
- (4) AFC (Tubes V108 to V114)
- (5) Off Frequency Control (Tubes V115 and V116)

1. Power Supply

With S104 closed, check voltage at pin 5 of XC202. This voltage should be 6.3 volts DC $\pm 5\%$, and positive with relation to ground.

The AC voltage at pins 10 and 11 of T114 should be 6.3 volts, and between pins 7 and 9, 22 volts.

With S103 closed, check voltage at pin 5 of V117. It should read +150 volts. To check current through V117, measure the DC voltage across R194. Multiply this reading by 10 to get the current through the tube. This current should be between 15 and 25 ma. The voltage across R194 should be 1.5 to 2.5 V DC. The voltage across C200 can be read on M101 with switch S102 in the V107 E_p position. Multiply the reading on M101 by 5 to get the actual voltage. The AC voltage at pins 7 and 8 of T113 should be 370 volts.

S103 will trip at approximately 400 ma through control winding (C to D).

If proper voltages are available from the power supplies, proceed to the next section.

2. R-F Section

Switch S101 to AFC-OFF position.

Check pin voltages of V103 as given in table of Typical Tube Socket Voltages for BTE-10B FM

Exciter. The voltage on pin 1 should be measured using a 1 megohm isolation resistor (this resistor is part of the DC probe of the VTVM recommended in the Trouble Shooting Equipment Chart). If the voltage across R116 is very small the tube is not oscillating and another tube should be tried.

Next, measure the r-f voltage across pins A and D of coil T103. Approximately 2 V rms should be present. Use VTVM with RF-probe. Tune C105 for a peak reading on M101 with the selector switch in the V101 and V102 I_k position. When peaked, 7 V rms (r-f voltage) should be present on pins 1 and 7 of V101 and of V102.

The r-f voltage on pin 5 of V101, V102, and V103 is 100 volts. On terminal E of T103 the voltage is 35 volts. These voltages cannot be measured with the recommended VTVM since there is a limitation of 20 V rms for the r-f probe.

Check pin voltages of V104. There is no adjustment that will effect these voltages.

Check pin voltages of V105. If there is no voltage on pin 8 and 9, try a new tube and check C121. Tune L104 for maximum grid current into V106. If no grid current can be obtained, try a new V106 or check whether L104 and C125 resonate at 3 times the oscillator frequency. Use grid dip meter (exciter plate voltage off and dip meter in CW position) or use the receiver tuned to 3 times the oscillator frequency, and couple the antenna input loosely to pin 1 of V105. Set IF gain of the receiver such that the S2 reading is obtained on the S-Meter. Try to increase this indication by tuning L104.

Proceed in the same way with the second tripler V106. For frequencies above 100 mc, C214 should be removed.

To check the PA, a 10 watt dummy load should be made up using 5 resistors (composition type) of 270 ohm, 2 watts in parallel.

At 10 watts output the r-f voltage across this 54 ohm load should be 23 volts rms.

Refer to Off-Frequency Detector section for test with modulation on.

3. Oscilloscope

It should be possible to get some trace on the face of V118 irrespective of the setting of S106. Check V118 pin voltages if necessary, and make sure that the tube is properly inserted in the tube socket. Adjust R185 and R183. If it is not possible to reduce the intensity to zero with R185, a 1.5 megohm 1 watt resistor should be connected from pin 4 to pin 8 of V118.

4. AFC

Check the pin voltages of tube V112. In order to oscillate, L112 and the associated capacitors (C176, C204, and C203) should resonate at a frequency approximately 50% higher than the crystal used. (See table for BTE-10B Exciter Crystals.) When V112 is properly oscillating, the following r-f voltages (measure with VTVM and r-f probe) should be measured: 3.5 volts rms at terminal B of L112; 6.5 volts rms at pin 5 of V112, and 1.5 volts rms at pin 1 of V112.

The above voltages are nearly sinusoidal in character. Once V112 oscillates properly, the crystal divider can be locked in. This will produce a steady pattern on the oscilloscope with S106 in the CRYSTAL DIV position.

The following waveforms and voltages can be observed: Pin 1 of V113 should be 17 volts peak-to-peak, somewhat resembling a negative half wave; and a 140 volt peak-to-peak distorted sinewave at pin 5 of V113. At terminal A of T109 a 27 volt rms sine-wave can be measured. The VTVM in the AC position should be used since the frequency at T109 is between 20 and 25 kc. The voltage at terminal D of T109 is 7 volts rms. This signal can be followed to terminal 1 of T110 where 5 volts rms should be read.

The same procedure should be followed for the other divider chain, V108 through V111. The waveform appearing at the plate of all tubes will be symmetrical and look like a distorted sinewave. All grid waveforms are clipped sinewaves with only the negative portion remaining. The clipping and distortion is less pronounced in the first and second dividers. The peak-to-peak AC voltages at the grids of the first, second, etc., dividers are: 5.0, 14, 28 and 24 volts respectively. The plate AC peak-to-peak voltages of the dividers are 50, 140, 220 and 160 volts respectively.

At terminal D of T108, 14 volts peak-to-peak should be measured; at terminal 1 of T111 the rms voltage should be 3 volts.

With the master oscillator right on frequency, the DC voltage at the junction of L108 and R168 should be very close to zero with the AFC switch in the ON position. With AFC off, and S106 in the PHASE DET. Position, a slowly turning circle will be obtained at the CRT. In synchronism with the slowly turning circle a very low-frequency AC voltage should appear across the phase detector output. This voltage can be observed at M101 with S102 in the plus or minus AFC position. If the final frequency (the assigned frequency of the station) is off center by 4320 cps, Meter M101 will swing from maximum

positive to maximum negative and return to maximum positive indication in 1 second. The meter should show a maximum reading of $\pm 80\%$ on its dial, representing ± 8 volts at the junction of L108 and R168. If less than ± 8 volts is obtained, check the AC voltages into T110 and T111, and if these voltages are correct, check diodes CR101 and CR102.

With the AFC ON, it should be possible to detune T103 (rear adjustment) up to a point where M101 reads steadily $\pm 80\%$ in the \pm AFC position without loss of AFC action.

If control is lost before reading a $\pm 80\%$ indication check, (without retuning T103) which divider is unlocked and retune the particular divider slightly; then bring T103 back to center frequency and try detuning again.

Once control is lost, the exciter will not pull back on frequency unless T103 is tuned back to nearly "zero" frequency. To widen the range of pull-in action, an off-frequency detector has been added which is covered in the following section.

5. Off-Frequency Detector

With the AFC operating properly, the two frequencies fed to the grids (pins 1 and 7) of V115 will be identical, and no difference frequency appears at the plate. The original frequencies and the sum of the two original frequencies are eliminated by C193.

If control is lost, a difference beat appears which triggers V116 and then closes K101. This will cause a low frequency sweep of the oscillator to lock the AFC in.

The pull-in range of the AFC system with Off-Frequency Detector inoperative is ± 100 kc at the final frequency, and with the Off-Frequency Detector operating it is ± 350 kc.

To test the operation of the Off-Frequency Detector, switch AFC to the off position and adjust T103, (top adjustment) for stationary circle on the CRT in phase detector position. Then detune T103 (top adjustment) to give a circle "moving around" several times per second. This should close K101; if necessary adjust R174. With AFC ON, detune T103 until a reading of +40 is obtained on M101 in the +AFC position. Switch AFC OFF and then ON again. The AFC should be re-established within a few seconds. When the circle becomes stationary, the opening of K101 will cause a slight "jump" which can easily be observed. Repeat the above step in the negative direction. As a final check, modulate the transmitter 130% with 50 cycle tone. This should *not* close K101.

To check the range of the vernier control (top of T103), bring it all the way in and read \pm AFC volt-

age (e.g., +25) then take it all the way out and read AFC voltage again (e.g., -15). The sum of the absolute value of both readings should be 40 or more. If this range is not obtained, loosen lock-nut on handle and unscrew the handle to allow deeper penetration of vernier core. Then reset locknut.

To check quickly whether V101 and V102 are properly modulating the carrier, feed a +10 db sig-

nal at 30 cps to J101. (This will produce 2.45 volts across J101; .62 volts from pins 5 to 3 at XZ101; .08 volts from terminal 6 to 15 of T101; and .245 volts from terminal 4 to 14 or 10 to 13 of T101.) This modulation should cause very noticeable broadening of the circle on the CRT in the PHASE DET. position. A 30 cps voltage can also be found (use Oscilloscope) at junction of L108-R168 as well as at pin 5 of V115.

NOTES

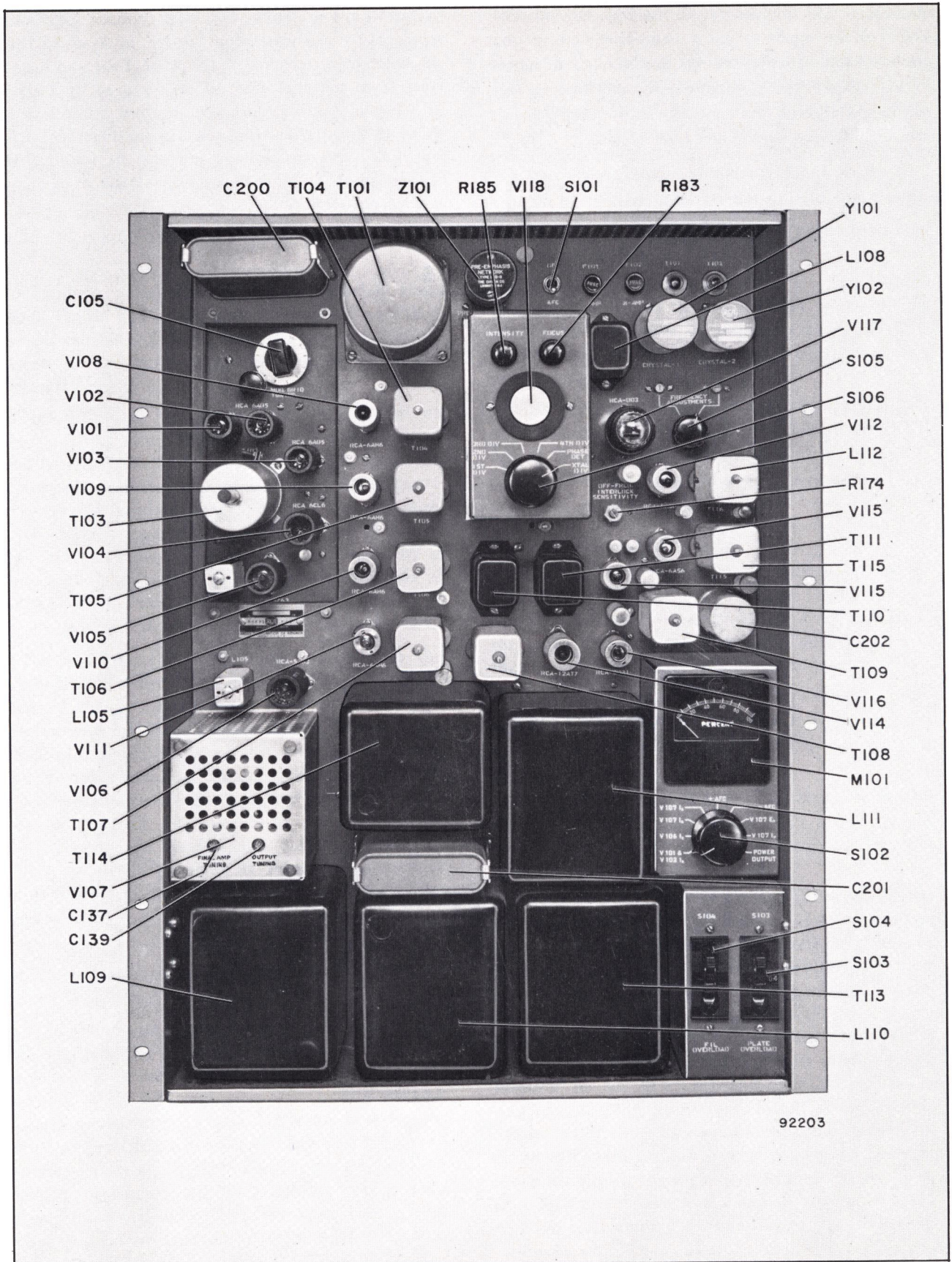

92203

Figure E-11. BTE-10B FM Exciter, Front View

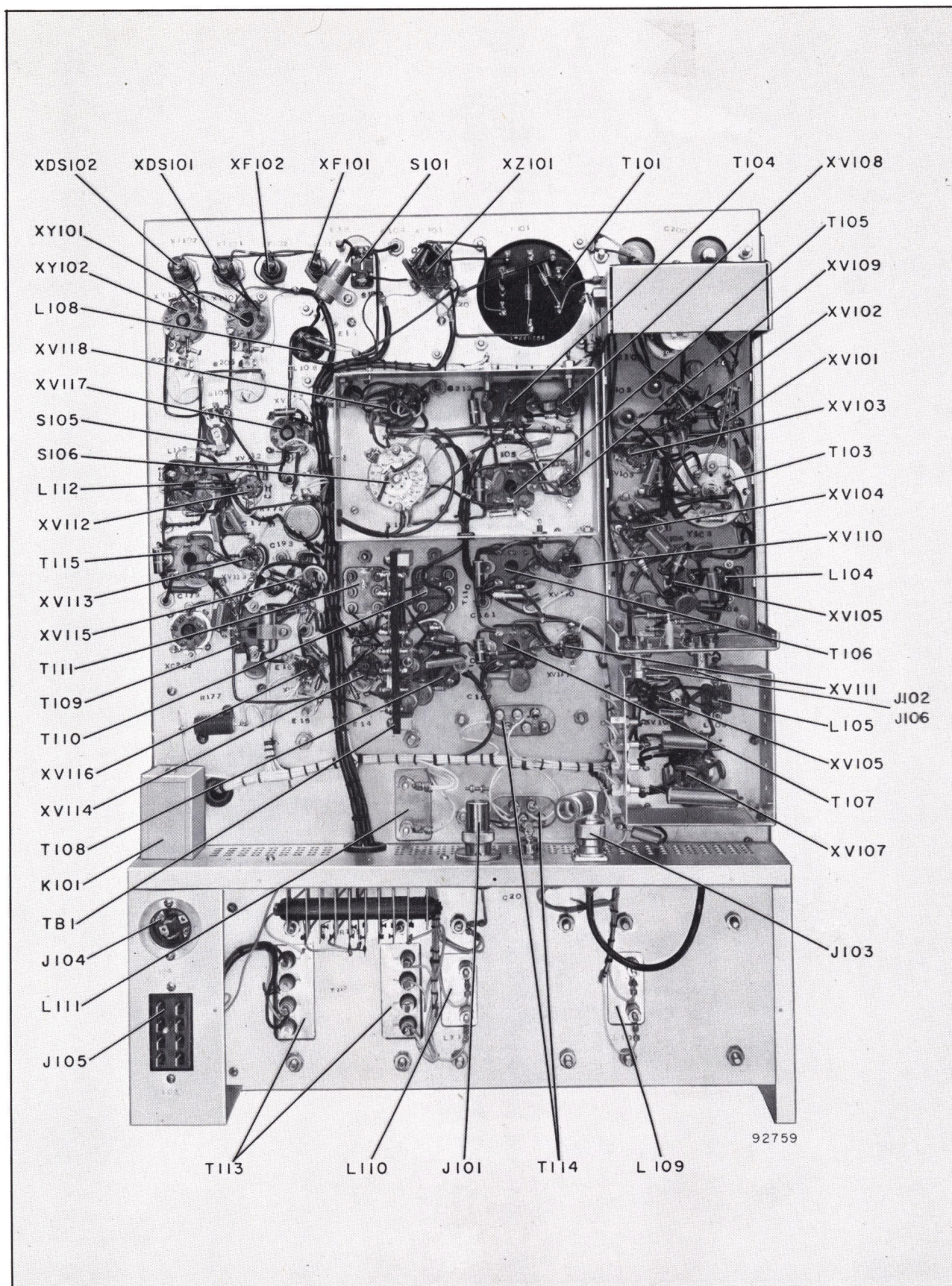

Figure E-12. BTE-10B FM Exciter, Rear View

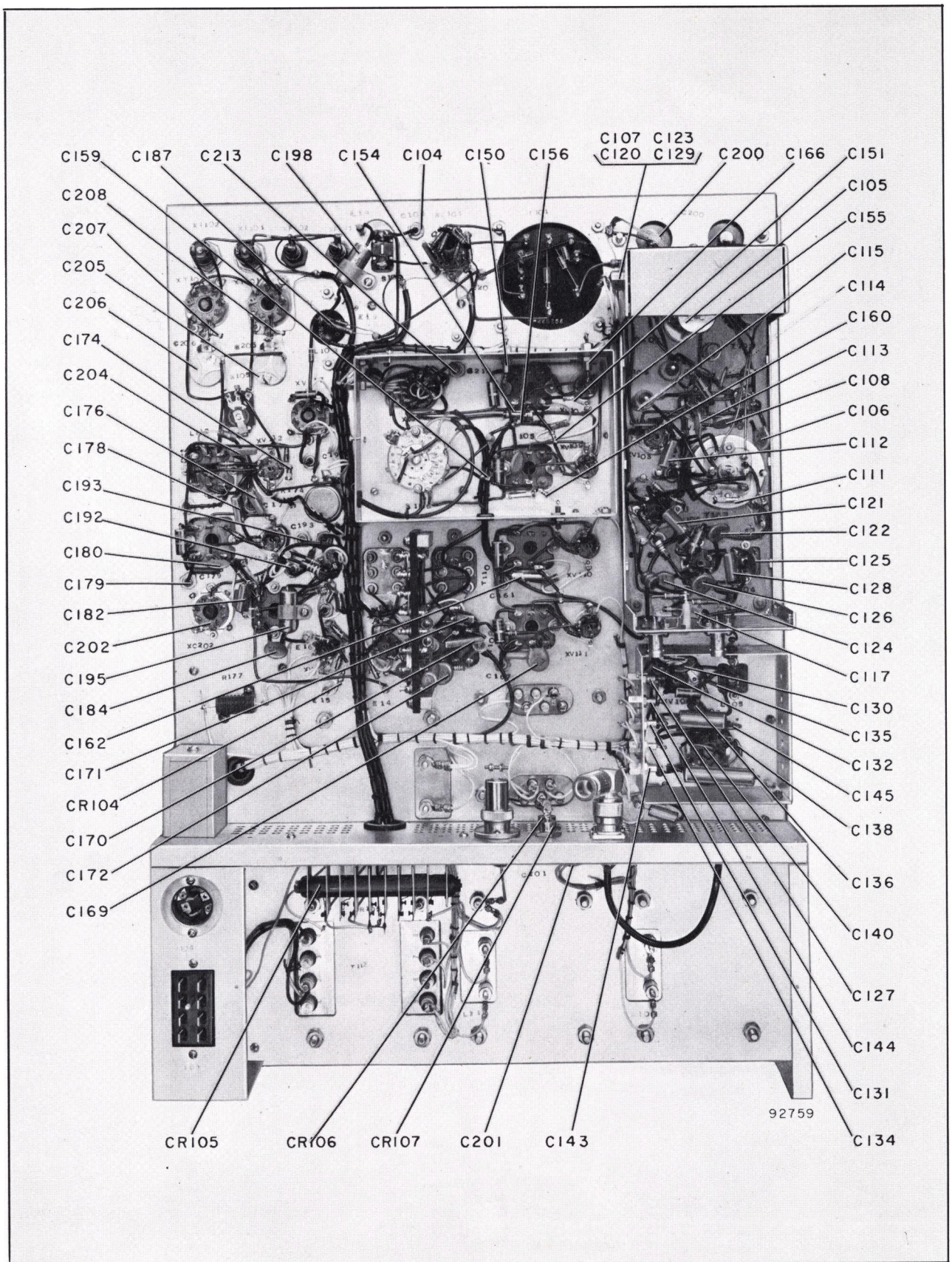

Figure E-13. BTE-10B FM Exciter, Rear View

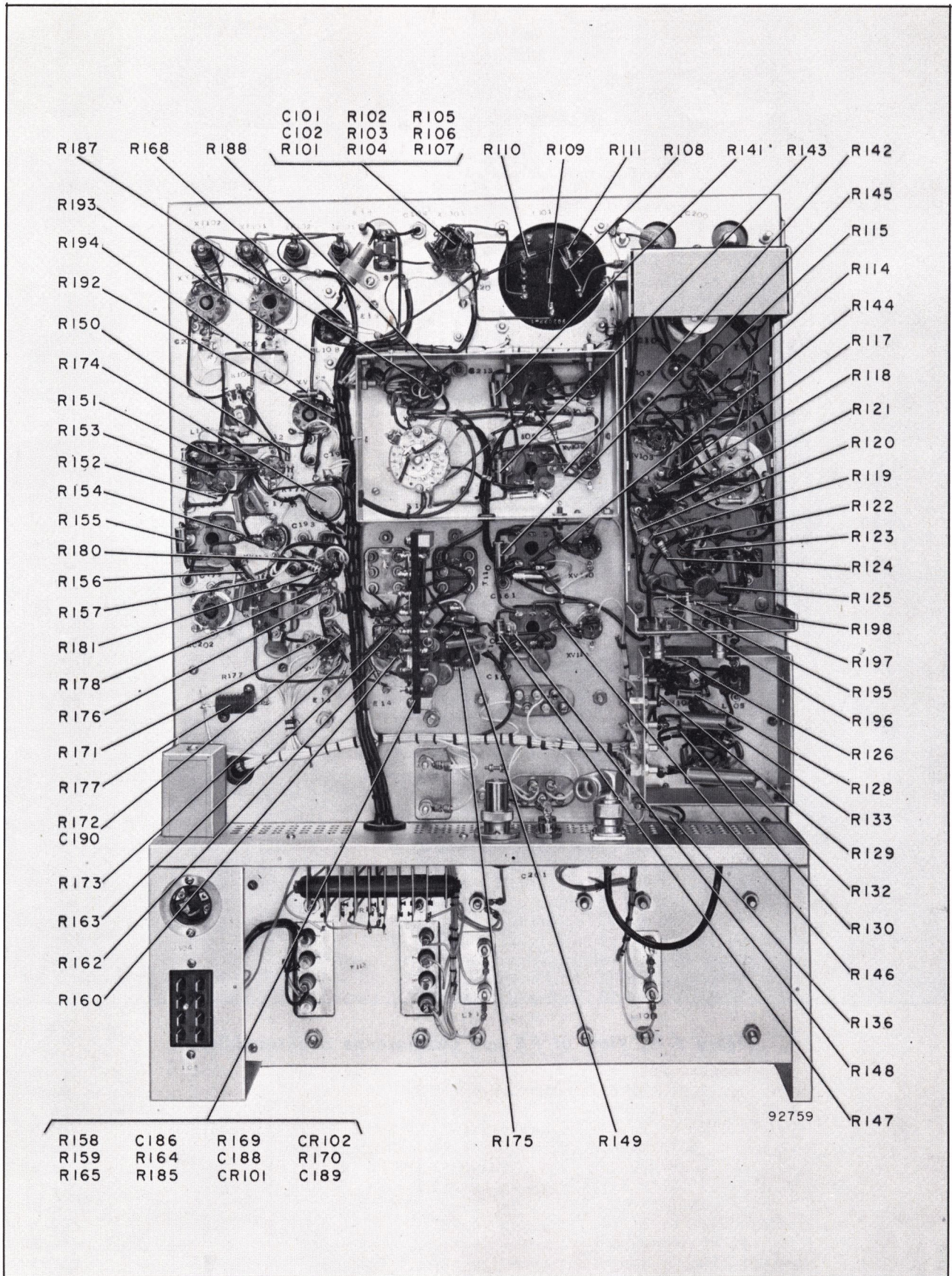

Figure E-14. BTE-10B FM Exciter, Rear View

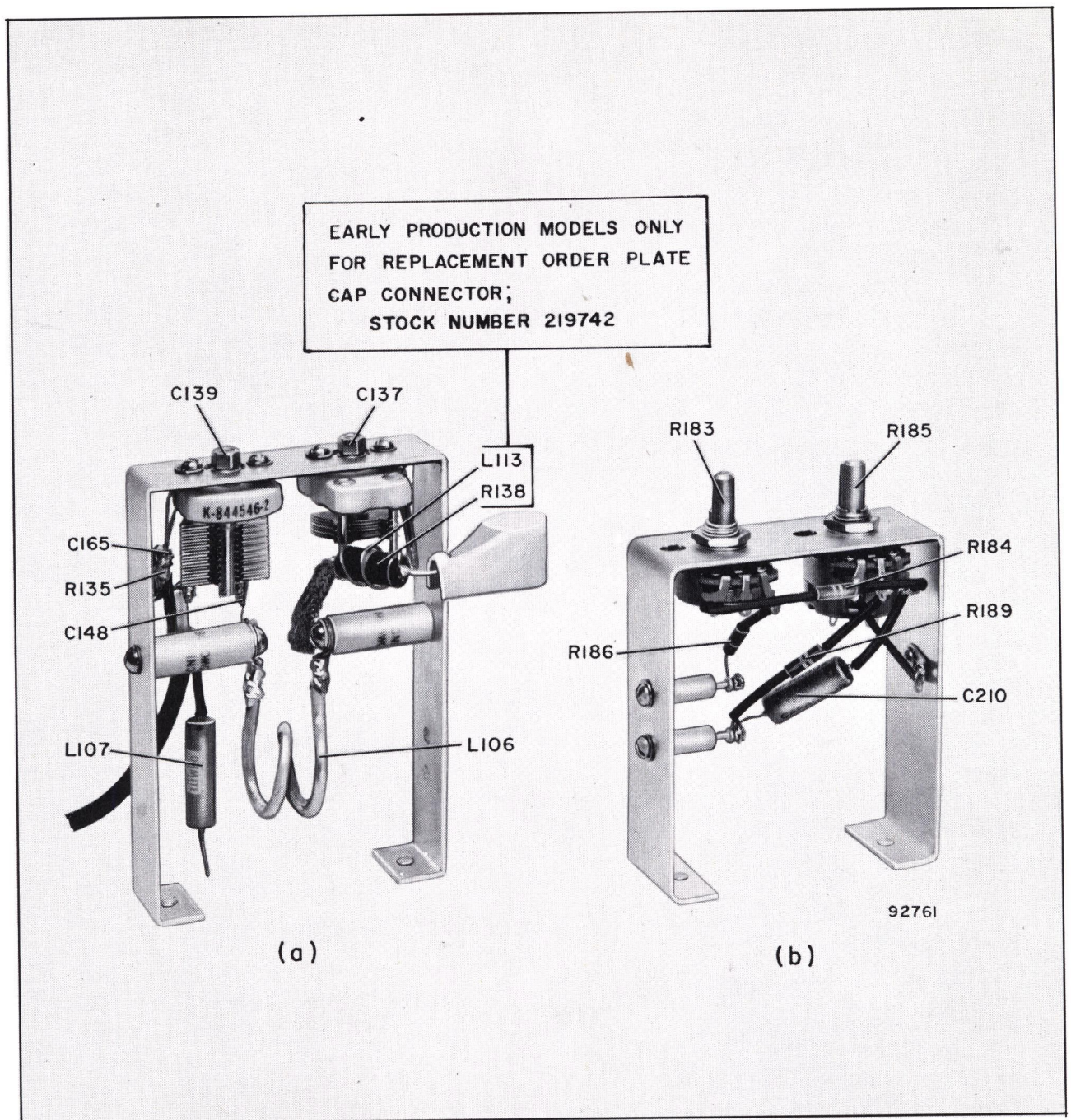

Figure E-15. View of PA and Oscilloscope Subassemblies

LIST OF PARTS

Symbol No.	Stock No.	Drawing No.	Description
EXCITER, MI-34501			
			<i>CAPACITORS:</i>
C101, C102	211170	737883-15	fixed, paper, .015 μ f \pm 10%, 100 v
C103		727856-131	fixed, mica, 220 μ mf \pm 10%, 500 v
C104	211169	737863-87	fixed, paper, 1 μ f \pm 20%, 100 v
C105	45362	882321-1	variable, 6-140 μ mf
C106	73960	990167-19	fixed, ceramic, .01 μ f -0 +100%, 500 v
C107	99177	8825449-1	feed-thru, .001 μ f, 500 v
C108	73960	990167-19	fixed, ceramic, .01 μ f -0 +100%, 500 v
C109, C110	77865	90575-309	fixed, ceramic, 10 μ mf \pm 1 μ mf, 500 v
C111	217541	90575-129	fixed, ceramic, 68 μ mf \pm 2.5%, 500 v
C112		727856-145	fixed, mica, 820 μ mf \pm 10%, 300 v
C113 to C115	73960	990167-19	fixed, ceramic, .01 μ f -0 +100%, 500 v
C116	217537	737863-25	fixed, paper, .1 μ f \pm 10%, 100 v
C117		727856-131	fixed, mica, 220 μ mf \pm 10%, 500 v
C118	77252	990167-13	fixed, ceramic, .001 μ f -0 +100%, 600 v
C119		90575-315	fixed, ceramic, 18 μ mf \pm 10%, 500 v
C120	99177	8825449-1	feed-thru, .001 μ f, 500 v
C121		727856-131	fixed, mica, 220 μ mf \pm 10%, 500 v
C122	73960	990167-19	fixed, ceramic, .01 μ f -0 +100%, 500 v
C123	99177	8825449-1	feed-thru, .001 μ f, 500 v
C124	73960	990167-19	fixed, ceramic, .01 μ f -0 +100%, 500 v
C125	217565	458528-203	fixed, ceramic, 110 μ mf \pm 5%, 500 v
C126	73960	990167-19	fixed, ceramic, .01 μ f -0 +100%, 500 v
C127	99177	8825449-1	feed-thru, .001 μ f, 500 v
C128		727856-133	fixed, mica, 270 μ mf \pm 10%, 500 v
C129	99177	8825449-1	feed-thru, .001 μ f, 500 v
C130	73960	990167-19	fixed, ceramic, .01 μ f -0 +100%, 500 v
C131	99177	8825449-1	feed-thru, .001 μ f, 500 v
C132	73960	990167-19	fixed, ceramic, .01 -0 +100%, 500 v
C133		990575-359	fixed, ceramic, 5 μ mf \pm 1 μ mf, 500 v
C134	99177	8825449-1	feed-thru, .001 μ f, 500 v
C135	73960	990167-19	fixed, ceramic, .01 μ f -0 +100%, 500 v
C136		727856-133	fixed, mica, 270 μ mf \pm 10%, 500 v
C137	44369	844546-10	variable, 4 - 25 μ mf
C138	73960	990167-19	fixed, ceramic, .01 μ f -0 +100%, 500 v
C139	43368	844546-2	variable, 5- 75 μ mf
C140	73960	990167-19	fixed, ceramic, .01 μ f -0 +100%, 500 v
C141, C142	73473	990167-17	fixed, ceramic, .0047 μ f -0 +100%, 500 v
C143, C144	99177	8825449-1	feed-thru, .001 μ f, 500 v
C145	73960	990167-19	fixed, ceramic, .01 μ f -0 +100%, 500 v
C146, C147	99177	8825449-1	feed-thru, .001 μ f, 500 v
C148	77953	990167-15	fixed, ceramic, 2200 μ mf -0 +100, 500 v
C149	77865	990575-309	fixed, ceramic, 10 μ mf \pm 1 μ mf, 500 v
C150	99177	8825449-1	feed-thru, .001 μ f, 500 v
C151		90575-217	fixed, ceramic, 22 μ mf \pm 5%, 500 v
C152, C153	73960	990167-19	fixed, ceramic, .01 μ f -0 +100%, 500 v
C154		90575-227	fixed, ceramic, 56 μ mf \pm 5%, 500 v
C155, C156		90575-359	fixed, ceramic, 5 μ mf \pm 1 μ mf, 500 v
C157	73960	990167-19	fixed, ceramic, .01 μ f -0 +100%, 500 v
C158		90575-227	fixed, ceramic, 56 μ mf \pm 5%, 500 v
C159	78928	90575-404	fixed, ceramic, 1.5 μ mf \pm .25 μ mf, 500 v
C160	77865	90575-309	fixed, ceramic, 10 μ mf \pm 1 μ mf, 500 v
C161	206332	737863-375	fixed, paper, .1 μ f \pm 20%, 400 v
C162	44700	90575-335	fixed, ceramic, 120 μ mf \pm 10%, 500 v
C163	79992	90575-405	fixed, ceramic, 2 μ mf \pm .25 μ mf, 500 v
C164	77865	90575-309	fixed, ceramic, 10 μ mf \pm 1 μ mf, 500 v
C165		90575-321	fixed, ceramic, 33 μ mf \pm 10%, 500 v
C166	99177	8825449-1	feed-thru, .001 μ f, 500 v
C167	213643	737863-381	fixed, paper, .33 μ f \pm 20%, 400 v
C168		727856-243	fixed, mica, 680 μ mf \pm 5%, 500 v
C169	73960	990167-19	fixed, ceramic, .01 μ f -0 +100%, 500 v
C170		727860-248	fixed, mica, 1100 μ mf \pm 5%, 300 v
C171	77865	90575-309	fixed, ceramic, 10 μ mf \pm 1 μ mf, 500 v

Symbol No.	Stock No.	Drawing No.	Description
C172	73960	990167-19	fixed, ceramic, .01 μ f -0 +100%, 500 v
C173	206332	737863-375	fixed, paper, .1 μ f \pm 20%, 400 v
C174		90575-225	fixed, ceramic, 47 μ mf \pm 5%, 500 v
C175	206332	737863-375	fixed, paper, 1 μ f \pm 20%, 400 v
C176		727856-235	fixed, mica, 330 μ mf \pm 5%, 500 v
C177	77865	90575-309	fixed, ceramic, 10 μ mf \pm 1 μ mf, 500 v
C178		727856-121	fixed, mica, 82 μ mf \pm 10%, 500 v
C179	213643	737863-381	fixed, paper, .33 μ f \pm 20%, 400 v
C180	73960	990167-19	fixed, ceramic, .01 μ f -0 +100%, 500 v
C181		727856-243	fixed, mica, 680 μ mf \pm 5%, 300 v
C182		727860-248	fixed, mica, 1100 μ mf \pm 5%, 300 v
C183	77865	90575-309	fixed, ceramic, 10 μ mf \pm 1 μ mf, 500 v
C184	73960	990167-19	fixed, ceramic, .01 μ f -0 +100%, 500 v
C185, C186	211171	737883-75	fixed, paper, .1 μ f \pm 20%, 100 v
C187 to C189	211170	737883-15	fixed, paper, .015 μ f \pm 10%, 100 v
C190		727856-115	fixed, mica, 47 μ mf \pm 10%, 500 v
C191	217539	737863-277	fixed, paper, .15 μ f \pm 20%, 300 v
C192	211169	737863-87	fixed, paper, 1 μ f \pm 20%, 100 v
C193	217564	737863-267	fixed, paper, .022 μ f \pm 20%, 300 v
C194	206332	737863-375	fixed, paper, .1 μ f \pm 20%, 400 v
C195	210909	737883-275	fixed, paper, .1 μ f \pm 20%, 300 v
C196	211169	737863-87	fixed, paper, 1 μ f \pm 20%, 100 v
C197	207757	442901-58	tubular electrolytic, 20 μ f -10 +100%, 150 v
C198	210874	737883-83	fixed, paper, .47 μ f \pm 20%, 100 v
C199	213643	737863-381	fixed, paper, .33 μ f \pm 20%, 400 v
C200, C201	211225	450184-5	fixed, paper, 16 μ f, 400 v
C202	211167	735712-6	fixed, electrolytic, 1500 μ f, 15 v
C203		727856-236	fixed, mica, 360 μ mf \pm 5%, 500 v
C204		727856-145	fixed, mica, 820 μ mf \pm 10%, 300 v
C205, C206	204066	258851-6	variable, ceramic, 6 - 25 μ mf
C207, C208	77865	90575-309	fixed, ceramic, 10 μ mf \pm 1 μ mf, 500 v
C209	73960	990167-19	fixed, ceramic, .01 μ f -0 +100%, 500 v
C210	211171	737883-75	fixed, paper, .1 μ f \pm 20%, 100 v
C211, C212	73960	990167-19	fixed, ceramic, .01 μ f -0 +100%, 500 v
C213	210495	737863-371	fixed, paper, .047 μ f \pm 20%, 400 v
C214	77865	90575-309	fixed, ceramic, 10 μ mf \pm 1 μ mf, 500 v
CR101, CR102	59395	1N34A	Crystal - diode
CR103			Not Used
CR104	59395	1N34A	Crystal - diode
CR105	210347	8908824-4	Rectifier - plate
CR106, CR107	217571	8971903-2	Rectifier - filament
DS101, DS102	101857	872291-9	Lamp - neon
F101, F102	212327	8858508-6	Fuse:- 0.5 amp
J101	211510	481799-2	Connector - female
J102	54890	445813-2	Connector - coaxial
J103	92180	433647-1	Receptacle - type N
J104	32660	889482-3	Receptacle
J105	55806	727969-7	Connector - male
J106	54890	445813-2	Connector - coaxial
K101	217572	627511-55	Relay - telephone type
L101	44679	862943-1	Choke - R.F.
L102	217573	8886161-13	Choke - R.F.
L103	44679	862943-1	Choke - R.F.
L104	211238	481715-4	Coil - R.F.
L105	217361	481715-6	Coil - R.F.
L106	217570	8959095-501	Coil - (Silver plated)
L107	57259	8886161-7	Choke - R.F.
L108	211164	8917198-1	Choke - R.F.
L109, L110	210637	476457-1	Reactor - filter
L111	210703	476473-1	Reactor - filter
L112	217356	728446-18	Coil - I.F.
M101	217558	477920-2	Meter - 0-100 microamps. D.C.
P101	211509	481799-1	Connector - male
P102	214186	427992-1	Connector - coaxial, male
P103	212885	8905991-1	Connector - male, coaxial

Symbol No.	Stock No.	Drawing No.	Description
P104	32661	878243-1	Connector - female
P105	55808	727969-8	Connector - female
P106	214186	427992-1	Connector - coaxial, male
			<i>RESISTORS:</i>
			<i>Fixed, Composition - unless otherwise specified</i>
R101, R102		82283-141	180 ohms $\pm 5\%$, $\frac{1}{2}$ w
R103		82283-147	330 ohms $\pm 5\%$, $\frac{1}{2}$ w
R104, R105		82283-141	180 ohms $\pm 5\%$, $\frac{1}{2}$ w
R106, R107		82283-133	82 ohms $\pm 5\%$, $\frac{1}{2}$ w
R108		82283-76	15,000 ohms $\pm 10\%$, $\frac{1}{2}$ w
R109, R110		82283-66	2200 ohms $\pm 10\%$, $\frac{1}{2}$ w
R111		82283-76	15,000 ohms $\pm 10\%$, $\frac{1}{2}$ w
R112, R113		82283-67	2700 ohms $\pm 10\%$, $\frac{1}{2}$ w
R114		90496-63	1200 ohms $\pm 10\%$, 1 w
R115		82283-147	330 ohms $\pm 5\%$, $\frac{1}{2}$ w
R116		82283-77	18,000 ohms $\pm 10\%$, $\frac{1}{2}$ w
R117		90496-86	100,000 ohms $\pm 10\%$, 1 w
R118		82283-80	33,000 ohms $\pm 10\%$, $\frac{1}{2}$ w
R119		82283-79	27,000 ohms $\pm 10\%$, $\frac{1}{2}$ w
R120		82283-74	10,000 ohms, $\pm 10\%$, $\frac{1}{2}$ w
R121		82283-64	1500 ohms $\pm 10\%$, $\frac{1}{2}$ w
R122		90496-85	82,000 ohms $\pm 10\%$, 1 w
R123		99126-55	270 ohms $\pm 10\%$, 2 w
R124	55186	867970-305	wire wound, 0.43 ohms $\pm 10\%$, $\frac{1}{2}$ w
R125		90496-76	15,000 ohms $\pm 10\%$, 1 w
R126		90496-85	82,000 ohms $\pm 10\%$, 1 w
R127		82283-163	1500 ohms $\pm 5\%$, $\frac{1}{2}$ w
R128		99126-55	270 ohms $\pm 10\%$, 2 w
R129		90496-76	15,000 ohms $\pm 10\%$, 1 w
R130		90496-79	27,000 ohms $\pm 10\%$, 1 w
R131		82283-159	1000 ohms $\pm 5\%$, $\frac{1}{2}$ w
R132	93933	458574-36	wire wound, 400 ohms $\pm 5\%$, 10 w
R133	217563	458572-85	wire wound, 16,000 ohms $\pm 5\%$, 5 w
R134		90496-121	27 ohms $\pm 5\%$, 1 w
R135		82283-74	10,000 ohms $\pm 10\%$, $\frac{1}{2}$ w
R136	217602	99316-3	wire wound, 5 ohm $\pm 1\%$, $\frac{1}{2}$ w
R137	55186	867970-305	wire wound, 0.43 ohms $\pm 10\%$, $\frac{1}{2}$ w
R138		99126-1	10 ohms $\pm 20\%$, 2 w
R139	217604	990185-395	film, 9530 ohms $\pm 1\%$, $\frac{1}{2}$ w
R140		82283-62	1000 ohms $\pm 10\%$, $\frac{1}{2}$ w
R141		99126-73	8200 ohms $\pm 10\%$, 2 w
R142		82283-62	1000 ohms $\pm 10\%$, $\frac{1}{2}$ w
R143		99126-73	8200 ohms $\pm 10\%$, 2 w
R144		82283-66	2200 ohms $\pm 10\%$, $\frac{1}{2}$ w
R145		99126-73	8200 ohms $\pm 10\%$, 2 w
R146		82283-66	2200 ohms $\pm 10\%$, $\frac{1}{2}$ w
R147		99126-73	8200 ohms $\pm 10\%$, 2 w
R148		82283-82	47,000 ohms $\pm 10\%$, $\frac{1}{2}$ w
R149		82283-84	68,000 ohm $\pm 10\%$, $\frac{1}{2}$ w
R150		82283-98	1 meg ohm $\pm 10\%$, $\frac{1}{2}$ w
R151		82283-86	100,000 ohms $\pm 10\%$, $\frac{1}{2}$ w
R152		82283-72	6800 ohms $\pm 10\%$, $\frac{1}{2}$ w
R153		82283-56	330 ohms $\pm 10\%$, $\frac{1}{2}$ w
R154		82283-66	2200 ohms $\pm 10\%$, $\frac{1}{2}$ w
R155		99126-73	8200 ohms $\pm 10\%$, 2 w
R156		82283-82	47,000 ohms $\pm 10\%$, $\frac{1}{2}$ w
R157		82283-84	68,000 ohms $\pm 10\%$, $\frac{1}{2}$ w
R158	78907	941799-17	wire wound, 4000 ohms $\pm 5\%$, 5 w
R159	93466	458572-97	wire wound, 40,000 ohms $\pm 5\%$, 5 w
R160 to R162		82283-50	100 ohms $\pm 10\%$, $\frac{1}{2}$ w
R163		82283-86	100,000 ohms $\pm 10\%$, $\frac{1}{2}$ w
R164, R165		82283-59	560 ohms $\pm 10\%$, $\frac{1}{2}$ w
R166		82283-50	100 ohms $\pm 10\%$, $\frac{1}{2}$ w
R167		82283-86	100,000 ohms $\pm 10\%$, $\frac{1}{2}$ w

Symbol No.	Stock No.	Drawing No.	Description
R168		82283-98	1 meg ohm $\pm 10\%$, $\frac{1}{2}$ w
R169, R170		82283-183	10,000 ohms $\pm 5\%$, $\frac{1}{2}$ w
R171		82283-90	220,000 ohms $\pm 10\%$, $\frac{1}{2}$ w
R172, R173		82283-86	100,000 ohms $\pm 10\%$, $\frac{1}{2}$ w
R174	56596	458575-108	varibale, carbon, 2500 ohms $\pm 10\%$, 2 w
R175		82283-92	330,000 ohms $\pm 10\%$, $\frac{1}{2}$ w
R176		82283-82	47,000 ohms $\pm 10\%$, $\frac{1}{2}$ w
R177	217546	8914834-3	wire wound, 2000 ohms $\pm 3\%$, 25 w
R178		82283-82	47,000 ohms $\pm 10\%$, $\frac{1}{2}$ w
R179		82283-92	330,000 ohms, $\pm 10\%$, $\frac{1}{2}$ w
R180		82283-78	22,000 ohms $\pm 10\%$, $\frac{1}{2}$ w
R181		90496-81	39,000 ohms $\pm 10\%$, 1 w
R182		82283-61	820 ohms $\pm 10\%$, $\frac{1}{2}$ w
R183	206044	433196-3	variable, .25 meg ohms $\pm 10\%$, 2 w
R184		82283-88	150,000 ohms $\pm 10\%$, $\frac{1}{2}$ w
R185	52837	433196-5	variable, 50,000 ohms $\pm 10\%$, 2 w
R186		82283-98	1 meg ohm $\pm 10\%$, $\frac{1}{2}$ w
R187, R188		82283-100	1.5 meg ohm $\pm 10\%$, $\frac{1}{2}$ w
R189		82283-95	560,000 ohm $\pm 10\%$, $\frac{1}{2}$ w
R190	217603	990185-468	carbon, film, 49,900 ohms $\pm 1\%$, $\frac{1}{2}$ w
R191	214810	990187-668	film, 4.99 megohms $\pm 1\%$, 1 w
R192		82283-175	4700 ohm $\pm 5\%$, $\frac{1}{2}$ w
R193		82283-206	91,000 ohm $\pm 5\%$, $\frac{1}{2}$ w
R194		90496-50	100 ohm $\pm 10\%$, 1 w
R195		82283-82	47,000 ohms $\pm 10\%$, $\frac{1}{2}$ w
R196		82283-74	10,000 ohm $\pm 10\%$, $\frac{1}{2}$ w
R197		82283-82	47,000 ohms $\pm 10\%$, $\frac{1}{2}$ w
R198		82283-74	Resistor - fixed, composition, 10,000 ohms $\pm 10\%$, $\frac{1}{2}$ w
S101	211166	8907253-2	Switch: toggle
S102	217560	8436501-1	Switch: rotary
S103	217566	849370-8	Switch: D.C. O.L.
S104	217552	8434096-1	Switch: A.C. O.L.
S105	52980	442389-2	Switch: rotary
S106	217559	8436500-1	Switch: rotary
T101	52685	902022-1	Transformer: input
T102	211180	897903-502	Coil Assembly
T103	219740	727590-507	Coil Assembly
T104	51738	728446-17	Transformer: 42.8 microhenry
T105	211182	728446-13	Transformer: 471 microhenry
T106	211183	728446-14	Transformer: 5652 microhenry
T107 to T109	211184	728446-15	Transformer: 34,500 microhenry
T110, T111	51734	442511-1	Transformer: input
T112	210660	481743-1	Transformer: power
T113	217362	8434093-1	Transformer: plate
T114	217357	8434095-1	Transformer: filament
T115	211184	728446-15	Transformer: 34,500 microhenry
XC202	217561	99390-3	Socket: octal, red
XDS101, XDS102		8856946-2	Socket: lamp
	94121		Jewel only
	56610		Socket only
XF101, XF102	48894	99088-2	Holder: fuse
XV101 to XV103	94879	737867-18	Socket: 7 pin miniature
XV104 to XV106	94880	737870-18	Socket: 9 pin miniature
XV107	54414	99390-1	Socket: octal
XV108 to XV113	94879	737867-18	Socket: 7 pin miniature
XV114	94880	737870-18	Socket: 9 pin miniature
XV115, XV116	94879	737867-18	Socket: 7 pin miniature
XV117	54414	99390-1	Socket: octal
XV118	217548	8944202-1	Socket: 11 pin
XY101, XY102	75061	746002-7	Socket: crystal
Y101, Y102			Crystal
XZ101	59919	746048-1	Socket: vector
Z101	219730	481755-3	Network: pre-emphasis
	219742	8815313-9	Miscellaneous: Connectbr: plate cap

<i>Symbol No.</i>	<i>Stock No.</i>	<i>Drawing No.</i>	<i>Description</i>
	211248	8817922-1	Dial: (C105)
	211244	8917263-1	Drive Unit: (tunes C105)
	208116	426765-12	Insulator: steatite, 3/8" dia. x 1" lg.
	30075	737820-507	Knob: 1" dia. (for S105)
	215877	737820-505	Knob: 1-1/2" dia. (for S102 and S106)
	213996	69916-10	Knob: 3/4" dia. (for R185)
	57692	8896313-1	Mount: shock mount
	217574	483884-9	Shield: tube, 7 pin (for 6AQ5)
	215853	483884-12	Shield: tube, 9 pin (for 6CL6, 5763)
	53016	99369-1	Shield: tube, 7 pin (for 6AS6)
	54521	99369-2	Shield: tube, 7 pin (for 6AU6)
	56359	8888549-2	Shield: tube, 9 pin, (for 12AT7)

NOTES

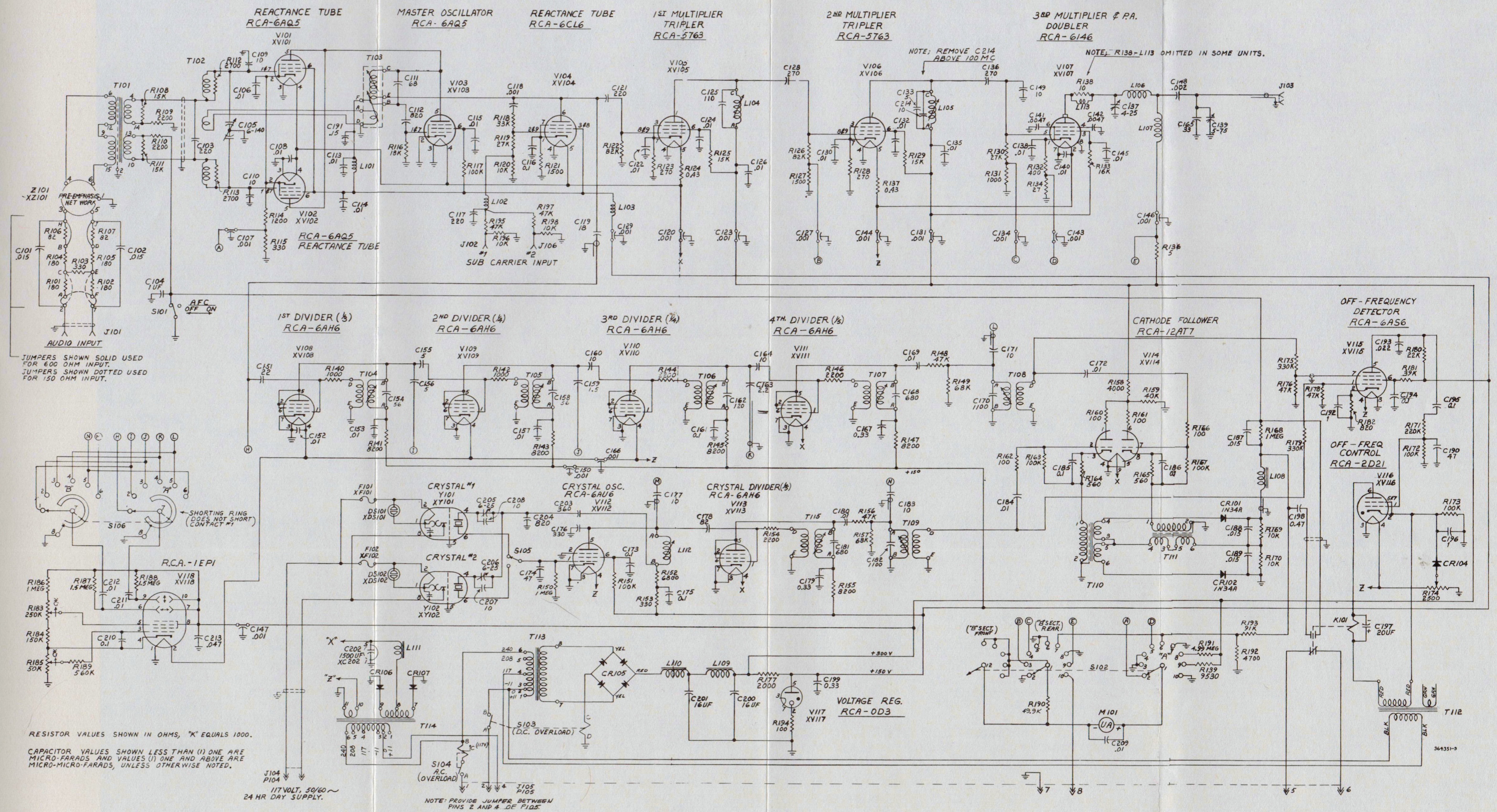
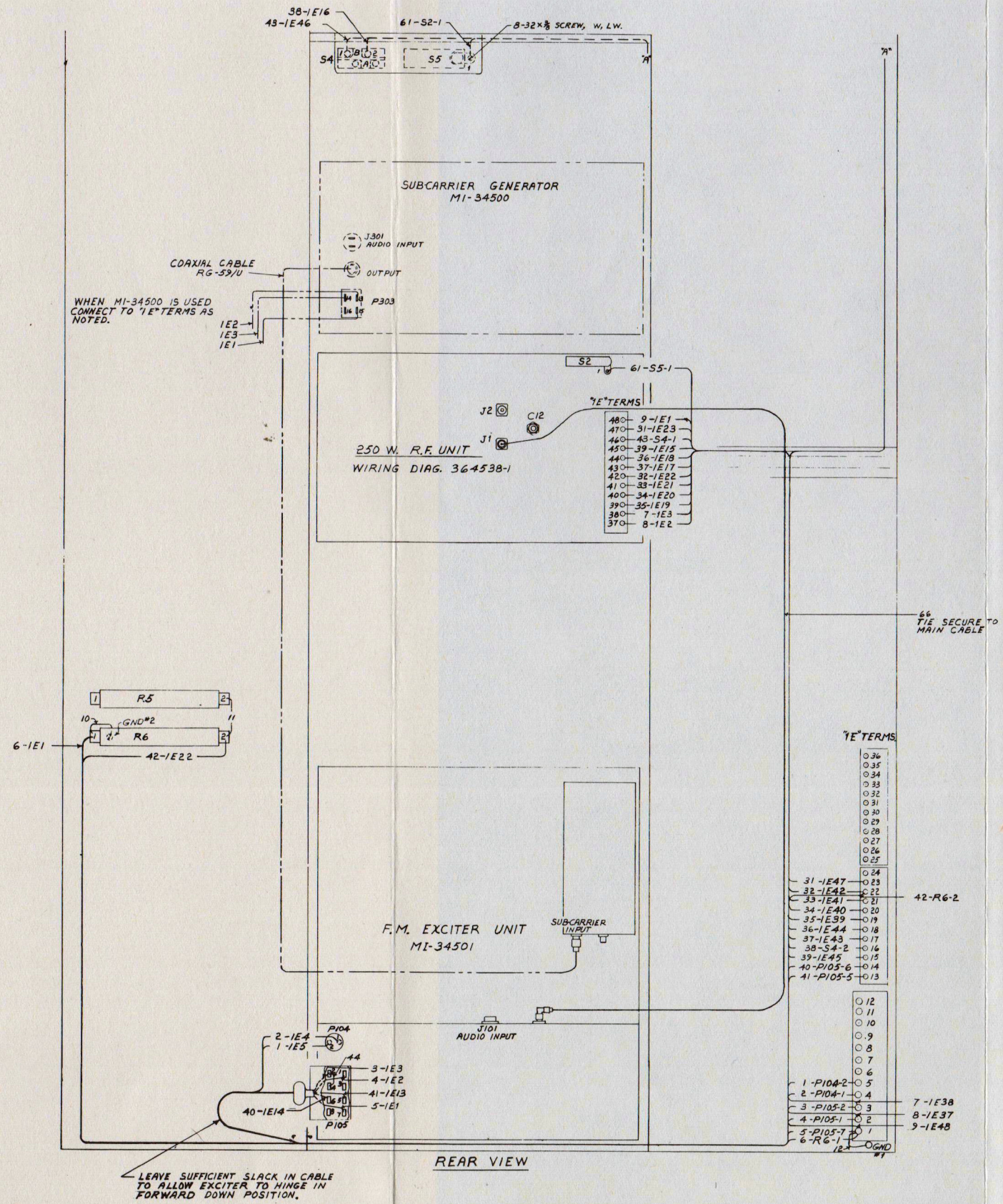

Figure E-16. Overall Schematic Diagram, BTE-10B FM Exciter (364351)



WIRE TABLE			
WIRE NO'S INCLUSIVE	DESCRIPTION	8959092 ITEM NO	WIRE NUMBERS NOT USED
1 TO 12	WIRE 2010592-33 BLK 300V. #16AWG	69	
31 TO 44	WIRE 2010592-32 BLK 300V. #18AWG	70	
61	WIRE 2010853-141 WHT 15KV.DC.#14AWG	71	

Figure E-17. Interconnection Diagram,
BTE-10B/BTX-1A (364539)