

## SHARP

## SERVICE MANUAL / SERVICE-ANLEITUNG / MANUEL DE SERVICE

S3532RTW600HS

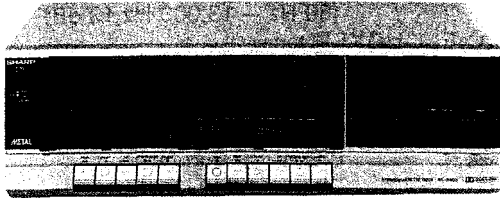
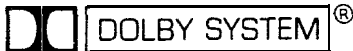

PHOTO: RT-W600H(S)



# RT-W600H(S)

# RT-W600H(BK)

- Noise reduction system manufactured under license from Dolby Laboratories Licensing Corporation. "Dolby" and the double-D symbol are trademarks of Dolby Laboratories Licensing Corporation.
- Geräuschunterdrückungssystem unter Lizenz von Dolby Laboratories Licensing Corporation hergestellt. Das Wort "Dolby" und das Symbol des doppelten D sind die Warenzeichen von Dolby Laboratories Licensing Corporation.
- Réducteur de bruits Dolby: Circuit fabriqué sous licence des Dolby Laboratories Licensing Corporation. Le mot "Dolby" et le symbole double D sont des marques déposées des Dolby Laboratories Licensing Corporation.

- In the interests of user-safety the set should be restored to its original condition and only parts identical to those specified be used.
- Im Interesse der Benutzer-Sicherheit sollte dieses Gerät wieder auf seinen ursprünglichen Zustand eingestellt und nur die vorgeschriebenen Teile verwendet werden.
- Dans l'intérêt de la sécurité de l'utilisateur, l'appareil devra être reconstitué dans sa condition première et seules des pièces identiques à celles spécifiées, doivent être utilisées.

## INDEX TO CONTENTS

(E)	Page	Page
SPECIFICATIONS .....	2-4	
NAMES OF PARTS .....	2-4	
BLOCK DIAGRAM .....	.5	
DISASSEMBLY .....	6, 7	
VOLTAGE SELECTOR ADJUSTMENT .....	6, 7	
CIRCUIT ADJUSTMENT .....	8, 9	
MECHANICAL ADJUSTMENT .....	10, 11	
TEST TAPES FOR MEASUREMENT .....	10, 11	
		Page
		NOTES ON SCHEMATIC DIAGRAM .....
		WIRING SIDE OF P.W. BOARD .....
		SCHEMATIC DIAGRAM .....
		EXPLODED VIEW .....
		REPLACEMENT PARTS LIST .....
		EQUIVALENT CIRCUIT
		(BLOCK DIAGRAM) OF IC .....

## INHALTSVERZEICHNIS

(D)	Seite	Seite
TECHNISCHE DATEN .....	2-4	
BEZEICHNUNG DER TEILE .....	2-4	
BLOCKSCHALTPLAN .....	.5	
ZERLEGEN .....	6, 7	
EINSTELLUNG DES SPÄNNUNGSWÄHLERS .....	6, 7	
SCHALTUNGSZEINSTELLUNG .....	8, 9	
MECHANISCHE EINSTELLUNG .....	10, 11	
TESTBÄNDER FÜR MESSUNG .....	10, 11	
		Seite
		ANMERKUNGEN ZUM SCHEMATISCHEN
		SCHALTPLAN .....
		VERDRAHTUNGSSEITE DER
		LEITERPLATTE .....
		SCHEMATISCHER SCHALTPLAN .....
		EXPLOSIONSDARSTELLUNG .....
		ERSATZTEILLISTE .....
		ERSATZSCHALTKREIS (BLOCKSCHALTPLAN)
		DES INTEGRIERTENSCHALTKREISES .....

## TABLE DES MATIÈRES

(F)	Page	Page
CARACTÉRISTIQUES .....	2-4	
NOMENCLATURE .....	2-4	
DIAGRAMME SYNOPTIQUE .....	.5	
DÉMONTAGE .....	6, 7	
RÉGLAGE DU SÉLECTEUR DE TENSION .....	6, 7	
RÉGLAGE DU CIRCUIT .....	8, 9	
RÉGLAGE DE MÉCANIQUE .....	10, 11	
BANDES D'ESSAI POUR MESURE .....	10, 11	
		Page
		REMARQUES CONCERNANT LE DIAGRAMME
		SCHÉMATIQUE .....
		CÔTÉ CÂBLAGE DE LA PLAQUETTE
		DE MONTAGE IMPRIMÉ .....
		DIAGRAMME SCHÉMATIQUE .....
		VUE EN ÉCLATE .....
		LIST DES PIÈCES DE RECHANGE .....
		CIRCUIT EQUIVALENTS
		(DIAGRAMME SYNOPTIQUE) DE CI .....

# RT-W600H(S)

E

FOR A COMPLETE DESCRIPTION OF THE OPERATION OF THIS UNIT,  
PLEASE REFER TO THE OPERATION MANUAL.

## SPECIFICATIONS

Power source:	AC 110V/127V/220V/240V, 50/60 Hz	TDK Metal tape;	40 Hz — 15,000 Hz (DIN 45 51 1)
Power consumption:	11 W		(50 Hz — 13,000 Hz ±3dB)
Semiconductors:	7 ICs 32 Transistors 26 Diodes 10 LEDs	S/N ratio (MAXELL UDXLII tape):	
Dimensions:	Width; 430 mm (17") Height; 129 mm (5-1/16") Depth; 218 mm (8-9/16")	Dolby NR off;	52 dB
Weight:	3.6 kg (7.9 lbs.)	Dolby NR effect;	10 dB (at over 5 kHz)
Tape:	Compact cassette tape	Input sensitivity and input impedance:	
Tape speed:	4.75 cm/sec. (1-7/8 ips.)	Microphones;	0.2 mV (2.2 kohms)
Wow & flutter:	0.09% (WRMS) 0.15% (DIN 45 511)	Line In;	50 mV (50 kohms)
Frequency response:		Din In;	0.2 mV (2.2 kohms)
Normal tape;	40 Hz — 12,000 Hz (DIN 45 511) (50 Hz — 11,000 Hz ±3dB)	Output level and loaded impedance:	
MAXELL UDXLII tape;	40 Hz — 13,000 Hz (DIN 45 511) (50 Hz — 12,000 Hz ±3dB)	Headphones;	0.2 mW ("0" dB), 8 ohms
		Line Out;	550 mV ("0" dB), 50 kohms
		Din Out;	550 mV ("0" dB), 50 kohms

Specifications for this model are subject to change without  
prior notice.

## NAMES OF PARTS

1. Power Switch
2. Deck 1: Cassette Compartment
3. Deck 2: Cassette Compartment
4. Record Muting Button
5. Deck 2: Digital Tape Counter and Reset Button
6. Dolby NR Switch
7. Dubbing Speed Selector Switch
8. Source Selector Switch
9. Deck 1: Tape Selector Switch
10. Deck 2: Tape Selector Switches
11. Level Display Meter
12. Record Level Controls
13. Microphon Jacks
14. Headphones Jack
15. Deck 2: Pause Button
16. Deck 2: Stop/Eject Button
17. Deck 2: Fast Forward Button
18. Deck 2: Play Button
19. Deck 2: Rewind Button
20. Deck 2: Record Button
21. Deck 1: Pause Button
22. Deck 1: Stop/Eject Button
23. Deck 1: Fast Forward Button
24. Deck 1: Play Button
25. Deck 1: Rewind Button
26. Line Output Sockets
27. Line Input Sockets
28. Input Selector Switch
29. DIN Record/Playback Socket
30. AC Voltage Selector
31. AC Power Supply Cord

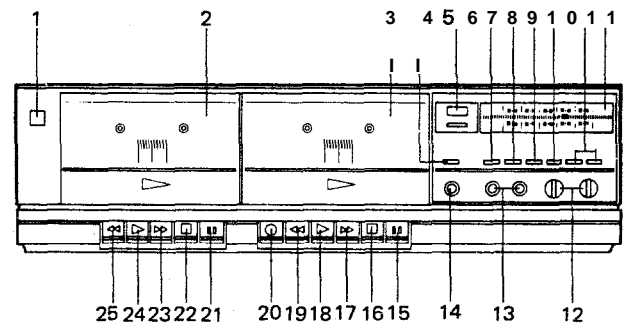

Figure 2-1

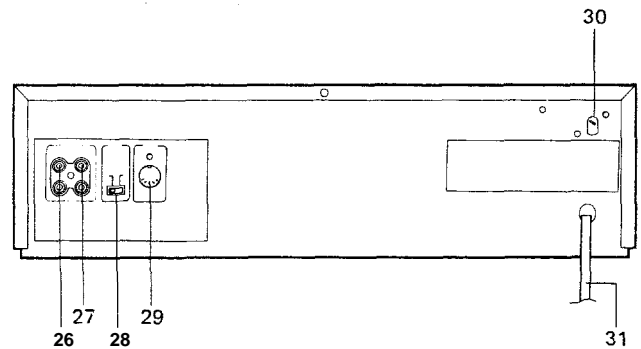

Figure 2-2



EINE VOLLSTÄNDIGE BESCHREIBUNG DER BEDIENUNG DIESES GERÄTES IST IN DER BEDIENUNGSANLEITUNG ENTHALTEN.

## TECHNISCHE DATEN

Spannungsversorgung:	Netzspannung 110V/127V/220V/ 240V, 50/60Hz	TDK-	40 – 15 000 Hz (DIN 45 511)
Leistungsaufnahme:	11W	Reineisenband;	(50 – 13 000 Hz ±3 dB)
Bestückung:	7 integrierte Schaltkreise	Rauschabstand (MAXELL UDXLII-Band):	
	26 Transistoren	Dolby NR Aus;	52 dB
	10 Leuchtdioden	Dolby NR Effekt;	10 dB (bei über 5 kHz)
Abmessungen:	Breite; 430mm	Eingangsempfindlichkeit und -impedanz	
	Höhe; 129mm	Mikrofoneingang;	0,2mV (2,2 kOhm)
	Tiefe; 218mm	Direkteingang,	50mV (50kOhm)
Gewicht:	3,6 kg	DIN-Dingang;	0,2mV (2,2 kOhm)
Cassette:	Kompaktcassette	Angangspegel und Belastungsimpedanz:	
Bandgeschwindigkeit:	4,75cm/s	Kopfhörerausgang;	0,2mV ("0" dB), 8 Ohm
Gleichlaufschwankungen:	0,09% (WRMS) 0.15% (DIN 45 511)	Direktausgang;	550mV ("0" dB), 50 kOhm
Frequenzgang:		D I N-Ausgang;	550mV ("0" dB), 50 kOhm
Normalband;	40 – 12 000 Hz (DIN 45 511) (50 – 11000 Hz ±3 dB)		
MAXELL UDXLII-Band;	40 – 13 000 Hz (DIN 45 511) (50 – 12 000 Hz ±3 dB)		

Die technischen Daten für dieses Modell können ohne vorherige Ankündigung Änderungen unterworfen sein.

## BEZEICHNUNG DER TEILE

1. Netzschalter
2. Deck 1: Cassettenfach
3. Deck 2: Cassettenfach
4. Aufnahme-Stummschaltungstaste
5. Deck 2: Digitaleandzählwerk und Rückstelltaste
6. Dolby NR-Schalter
7. Überspielgeschwindigkeits-Wahlschalter
8. Programmquellenschalter
9. Deck 1: Wahlschalter für Band 1
10. Deck 2: Wahlschalter für Band 2
11. Pegelanzeige
12. Aufnahmenpegelsteller
13. Mikrofonbuchsen
14. Kopfhörerbuchse
15. Deck 2: Pausentaste
16. Deck 2: Stopp-/Auswurf Taste
17. Deck 2: Schnellvorlauf Taste
18. Deck 2: Wiedergabe Taste
19. Deck 2: Rückspul Taste
20. Deck 2: Aufnahme Taste
21. Deck 1: Pausentaste
22. Deck 1: Stopp-/Auswurf Taste
23. Deck 1: Schnellvorlauf Taste
24. Deck 1: Wiedergabe Taste
25. Deck 1: Rückspul Taste
26. Ausgangsbuchsen
27. Eingangsbuchsen
28. Eingangswahlschalter
29. DIN-Anschluß für Aufnahme/Wiedergabe
30. Netzspannungswähler
31. Netzkabel

POUR LA DESCRIPTION COMPLETE DU FONCTIONNEMENT DE CET APPAREIL, SE REPORTER AU MODE D'EMPLOI.

**CARACTÉRISTIQUES**

Alimentation:	CA 110V/127V/220V/240V 50/60Hz	Bande TDK métal;	40 à 15 000 Hz (DIN 45 511)
Consommation:	11W		(50 à 15 000 Hz $\pm 3$ dB)
Semi-conducteurs:	7 CI 32 transistors 26 diodes 10 LED	Rapport S/B: (Bande MAXELL UDXLII)	
		Dolby RB coupe;	52 dB
		Effet Dolby RB;	10 dB (à plus de 5 kHz)
Dimensions:	Largeur; 430mm Hauteur; 129mm Profondeur; 218mm	Sensibilité d'entrée et impédance d'entrée:	
		Microphones;	0,2mV (2,2 kohms)
		Entrée de ligne;	50mV (50 kohms)
		Entrée DIN;	0,2mV (2,2 kohms)
Poids:	3,6 kg	Niveau de sortie et impédance de charge:	
Bande:	Bande cassette compacte	Casque;	0,2mW ("0" dB), 8 ohms
Vitesse de défilement	4,75cm/s	Sortie de ligne;	550mV ("0" dB), 50 kohms
Pleurage et scintillement:	0,09% (efficace) 0,15% (DIN 45 511)	Sortie DIN;	550mV ("0" dB), 50 kohms
Réponse de fréquence:		Les caractéristiques de ce modèle sont sujettes à modification sans préavis.	
	Bande normale;	40 à 12 000 Hz (DIN 45 511)	
		(50 à 11 000 Hz $\pm 3$ dB)	
	Bande MAXELL UDXLII.		
		40 à 13 000 Hz (DIN 45 511)	
		(50 à 12 000 Hz $\pm 3$ dB)	

**NOMENCLATURE**

1. Commutateur d'alimentation
2. Platine 1: Compartiment de cassette
3. Platine 2: Compartiment de cassette
4. Bouton de réglage silencieux d'enregistrement
5. Platine 2: Commutateur numérique de bande et bouton de remise à zéro
6. Commutateur Dolby NR
7. Commutateur de sélection de vitesse de copie
8. Commutateur de sélection de source
9. Platine 1: Commutateur de sélection de bande 1
10. Platine 2: Commutateur de sélection de bande 2
11. Compteur d'affichage de niveau
12. Commandes de niveau d'enregistrement
13. Douilles de microphones
14. Douille de casque
15. Platine 2: Bouton de pause
16. Platine 2: Bouton d'avance rapide
17. Platine 2: Bouton d'arrêt/éjection
18. Platine 2: Bouton de lecture
19. Platine 2: Bouton de rebobinage
20. Platine 2: Bouton d'enregistrement
21. Platine 1: Bouton de pause
22. Platine 1: Bouton d'arrêt/éjection
23. Platine 1: Bouton d'avance rapide
24. Platine 1: Bouton de lecture
25. Platine 1: Bouton de rebobinage
26. Douilles de sortie de ligne
27. Douilles d'entrée de ligne
28. Commutateur de sélection d'entrée
29. Douille d'enregistrement/lecture DIN
30. Sélecteur de tension de secteur
31. Cordon d'alimentation

**Ⓓ ZERLEGEN**

**Vorsichtsmassregeln für das zerlegen**  
 Beim Zerlegen und Zusammenbauen des Gerätes die folgenden Anweisungen befolgen, um dessen **Betriebs-sicherheit** und ausgezeichnete Leistung aufrechtzuerhalten.

1. **Cassette aus dem cassettenhalter entfernen.**
2. Bevor mit dem Zerlegen des **Gerätes** begonnen wird, unbedingt den **Netzkabelstecker aus der Netzsteckdose ziehen.**
3. **Nylonbänder** oder **Leitungshalter** entfernen, falls dies beim Zerlegen des **Gerätes** erforderlich ist. **Nach Warten des Gerätes** darauf achten, die Leitungen wieder so zu verlegen, wie sie vor dem Zerlegen angeordnet waren.
4. Beim **Ausführen** von **Wartungsarbeiten** auf **statische Elektrizität** der integrierten Schaltkreise und anderen Schaltungen achten.

**Ⓕ DÉMONTAGE**

**Précautions pour le démontage**  
 Lors du **démontage** de l'appareil et de son remontage, suivre les **précautions ci-dessous**, pour maintenir la **sécurité** et d'excellentes performances.

1. **Déposer la bande cassette du porte-cassette**
2. S'assurer de retirer la **fiche d'alimentation secteur** de la prise murale avant de **démarrer le démontage** de l'appareil.
3. **Déposer les bandes de nylon ou les serre-câbles si nécessaire** lors du démontage de l'appareil. **Après la réparation** de l'appareil, **s'assurer de redispser les fils tel qu'ils étaient avant le démontage.**
4. **Faire attention à l'électricité statique** des circuits **intégrés** et des autres circuits lors de la **réparation.**

SCH-RITT	ENTFERNEN	VERFAHREN	AB-BILDUNG
1	Gehäuse	Schraube. . . . . (A)x5	6-1
2	Bodenplatte	Schraube. . . . . (B)x2	6-3
3	Frontplatte	1. Schalterhebel . . . (C)x7 2. Buchse. . . . . (D)x5 3. Schraube . . . . . (E)x3 4. Knopf . . . . . (F)x2	6-2 6-3
4	Cassettendeck-laufwerk	1. Zählwerkriemen. . . (G)x1 2. Schraube. . . . . (H)x6	6-3, 6-4

ÉTAPE	DÉPOSE	PROCÉDÉ	FIGURE
1	Coffret	Vis . . . . . (A)x5	6-1
2	Plaque de base	Vis . . . . . , (B)x2	6-3
3	Panneau avant	1. Levier de cammutateur . . (C)x7	6-2
		2. Douille . . . . . (D)x5 3. Vis. . . . . (E)x3 4. Bouton . . . . . (F)x2	6-3
4	Mécanisme du magnétophone	1. Courroie de campteur . . . (G)x1 2. Vis. . . . . (H)x6	6-3, 6-4

**RÉGLAGE DU SÉLECTEUR DE TENSION**

Der Spannungswähler befindet sich an der Rückseite des Gerätes. Falls eine Änderung der Spannung notwendig sein sollte, benutzen Sie dazu einen Schraubenzieher. Drehen Sie den Spannungswähler in beliebiger Richtung, bis die gewünschte Spannungszahl im Fensterneben der Einstellschraube erscheint.

**EINSTELLUNG DES SPANNUNGSWÄHLERS**

Le sélecteur de tension est situé sur le panneau arrière de l'appareil. Si le réglage est nécessaire, utiliser un tournevis pour tourner le sélecteur dans un sens ou dans l'autre **jusqu'à** ce que le chiffre de la tension **appropriée** soit affiché dans la **fenêtre** voisine de la vis de réglage.

## CIRCUIT ADJUSTMENT

SETTING POSITION OF SWITCH AND KNOB	Dolby NR Switch: off Dubbing Speed: Normal Deck 1 Tape Selector Switch: Normal Deck 2 Tape Selector Switch: Normal Source Switch: Line		
ITEM	INPUT	ADJUSTMENT POINT	REMARKS (CHECK)
BIAS OSCILLATOR FREQUENCY	—	L301	105 ± 5 kHz
BIAS CURRENT	—	L: VR301 R: VR302	Normal: 11.4V (Metal: 29.0V ± 3.0V) (CrO <sub>2</sub> : 17.5V ± 2.5V)
ERASE CURRENT	—		Metal : 36 ± 4V
DECK 1 PLAY BACK SENSITIVITY	Test tape MTT-150	L: VR102 R: VR202	Normal: 530 mV
DECK 2 PLAYBACK SENSITIVITY	Test tape MTT-150	—	See that the electronic voltmeter reading is within the range from 473 mV to 594 mV. If not, take the procedures shown in the Table • 1.
RECORD/PLAY BACK SENSITIVITY	Non-recorded tape (MTT-502) 400 Hz - 13 dB (1V = 0 dB)	L: VR103 R: VR203	1. Adjust the record level knobs so that the electronic voltmeter reads 375 mV. 2. Playback the normal tape recorded and adjust the semi-variable resistor so that the electronic voltmeter read 375 mV.

Table \* 1

Voltmeter reads	Procedures
More than 594 mV	Cut the resistor R111, R211
Less than 473 mV	Cut the resistor R109, R209

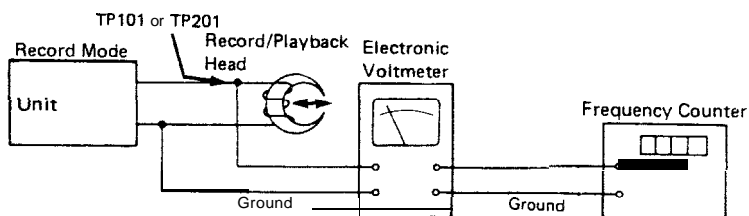

Figure 8-1 BIAS OSCILLATOR FREQUENCY

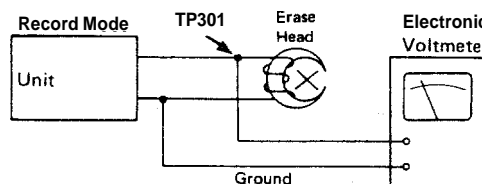

Figure 8-2 BIAS/ERASE CURRENT

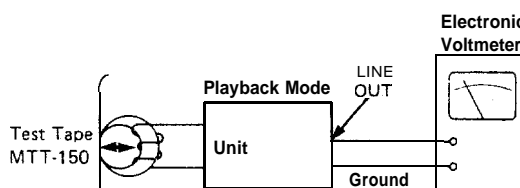

Figure 8-3 DECK 1/DECK 2 PLAYBACK SENSITIVITY

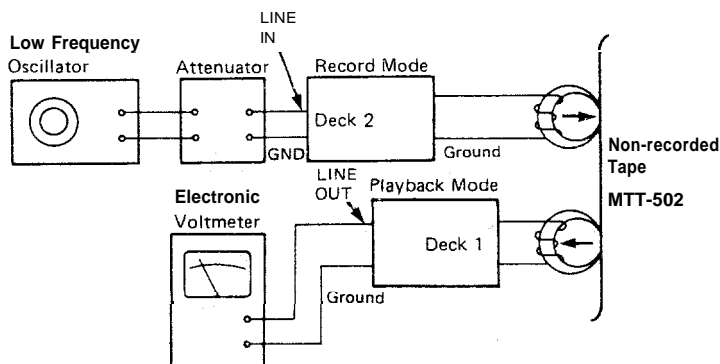

Figure 8-4 RECORD/PLAYBACK SENSITIVITY

**Ⓓ SCHALTUNGSEINSTELLUNG**

<b>SCHALTER-UND STELLER-EINSTELL-POSITION</b>	Dolby-N R-Schalter: Aus Überspielgeschwindigkeit: Normal Deck 1 Wahlschalter: Normal Deck 2 Wahlschalter: Normal Programmquellenwahlschalter: LINE		
<b>BENENNUNG</b>	<b>EINGANG</b>	<b>INSTELL-PUNKT</b>	<b>BEMERKUNGEN (PRÜFUNG)</b>
VORMAGNETISIERUNGSSCHWINGFREQUENZ		L301	105 ± 5 kHz
VORMAGNETISIERUNGSTROM		L: VR301 R: VR302	Normalband: 11,4V (Reineisenband: 29,0V ±3,0V) (CrO <sub>2</sub> -Band: 17,5V ±2,5V)
LÖSCHSTROM			Reineisenband: 36 ± 4V
WIEDERGABEMPFFINDLICHKEIT VON DECK 1	Testband MTT-150	L: VR102 R: VR202	Normalband: 530 mV
WIEDERGABEMPFFINDLICHKEIT VON DECK 2	Testband MTT-150		Überprüfen, ob der elektronische Spannungsmesser 473 mV bis 594 mV anzeigt. Wenn es nicht so ist, die Nachstellung gemäß Tabelle "2" vornehmen.
AUFNAHME-/WIEDERGABEMPFFINDLICHKEIT	Unbespieltes Band (MTT-502) -13 dB (1 V = 0 dB)	L: VR103 R: VR203	1. Den Aufnahmepegelsteller so einstellen, daß der elektronische Spannungsmesser 375 mV anzeigt. 2. Das bespielte Normalband wiedergeben und den Trimmer so einstellen, daß der elektronische Spannungsmesser 375 mV anzeigt.

Tabelle \* 1

Anzeige des Spannungsmessers	Verfahren
Mehr als 594 mV	Den Widerstand R111 oder R211 trennen.
Weniger als 473 mV	Den Widerstand R109 oder R209 trennen.

**Ⓕ RÉGLAGE DU CIRCUIT**

<b>RÉGLAGE DE LA POSITION DES COMMUTEURS ET DES BOUTONS</b>	Commutateur Dolby NR: Coupe Vitesse de copie: Normale Platine 1: Commutateur de sélection: Normale Platine 2: Commutateur de sélection: Normale Commutateur de sélection de source: LINE		
<b>ARTICLE</b>	<b>ENTRÉE</b>	<b>POINT DE RÉGLAGE</b>	<b>REMARQUES (VÉRIFICATION)</b>
FREQUENCE DE L'OSCILLATION DE POLARISATION	—	L301	105 ± 5 kHz
COURANT DE POLARISATION	—	G: VR301 D: VR302	Normal: 11,4V Metal: 29,0V ±3,0V CrO <sub>2</sub> : 17,5V ±2,5V
COURANT D'EFFACEMENT		—	Metal : 36 ± 4V
SENSIBILITÉ DE LECTURE DE LA PLATINE 1	Bande d'essai MTT-150	G: VR102 D: VR202	Normal: 530 mV
SENSIBILITÉ DE LECTURE DE LA PLATINE 2	Bande d'essai MTT-150	—	Voir si l'indication du voltmètre électronique se situe entre 473 mV et 594 mV. Sinon, effectuer les procédés indiqués dans le Tableau *1.
SENSIBILITÉ D'ENREGISTREMENT/LECTURE	Bande non enregistrée MTT-502 -20 dB (1 V = 0 dB)	G: VR103 D: VR203	1. Régler la bouton de commande de niveau du disque de telle sorte que le voltmètre électronique indique 375 mV 2. Lire une bande normale enregistrée et régler la résistance semi-variable de telle sorte que le voltmètre électronique indique 375 mV.

Tableau \*1

Indication du voltmètre	Procédés
Supérieure à 594 mV	'Couper la résistance R111 ou R211
Inférieure à 473 mV	Couper la résistance R 109 ou R209

## MECHANICAL ADJUSTMENT

ITEM	USING JIG	ADJUSTMENT POINTS	REMARKS (CHECK)
Driving power	Tape tension measuring cassette TW-2412		More than 180g
Torque	Torque meter Play TW-211 Fast-forward TW-223 1 Rewind TW-223 1		(Play : 35-60g-cm) (Fast-forward : 70-110g-cm) (Rewind : 70-110g-cm)
Azimuth	Test tape MTT-114	Azimuth adjusting screw	Sine waveform attains the maximum
Tape speed	Test tape Normal speed MTT-111 High speed MTT-111	Normal speed Deck 1: VR402 Deck 2: VR404 High speed Deck 1: VR401 Deck 2: VR403	Normal speed $2990 \pm 20$ Hz High speed $5980 \pm 50$ Hz

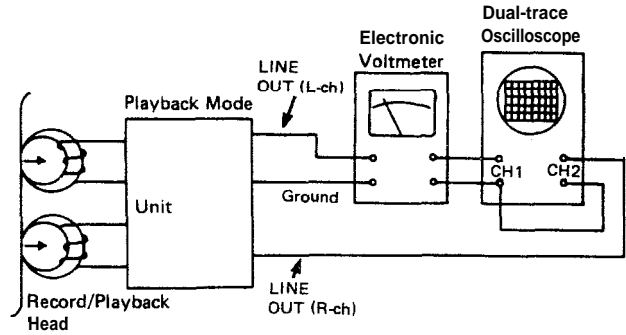

Figure 10-1 AZIMUTH

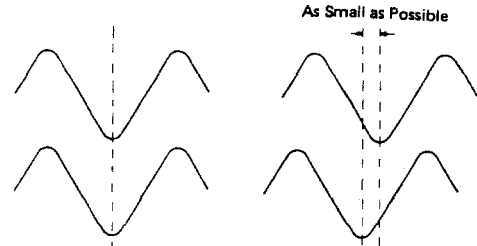

Figure 10-2 AZIMUTH WAVEFORM

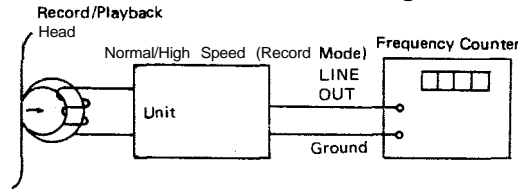

Figure 10-3 TAPE SPEED

## TEST TAPES FOR MEASUREMENT

COMPACT CASSETTE TYPE			
TITLE	MODEL	FREQUENCY/LEVEL	APPLICATION
FLUTTER	MTT-111	3 kHz, -10 dB	Tape speed, Wow and flutter check
AZIMUTH	MTT-113 MTT-113C MTT-114	6.3 kHz, -10 dB 8 kHz, -10 dB 10 kHz, -10 dB	Head azimuth adjustment
DISTORTION	MTT-118	1 kHz, -10 dB	Distortion check level adjustment
DOLBY LEVEL CALIBRATION	MTT-150	Dolby B-Type Tone 200 nwb/m	Dolby NR B-type level adjustment
BLANK	MTT-502	--	Record frequency check

TORQUE METER FOR COMPACT CASSETTE		
MODEL	MEASUREMENT RANGE	APPLICATION
TW-2111	10 - 100 g-cm	Normal : Playback torque
	1.5 - 10 g-cm	Normal : Back-tension
TW-2121	10 - 100 g-cm	Reverse : Playback torque
	1.5 - 10 g-cm	Reverse : Back tension
TW-223 1	30 - 200 g-cm	Fast-forward, Rewind torque
TW-2412	0 - 300 g	Normal : Driving power
TW-2422	0 - 300 g	Reverse : Driving power

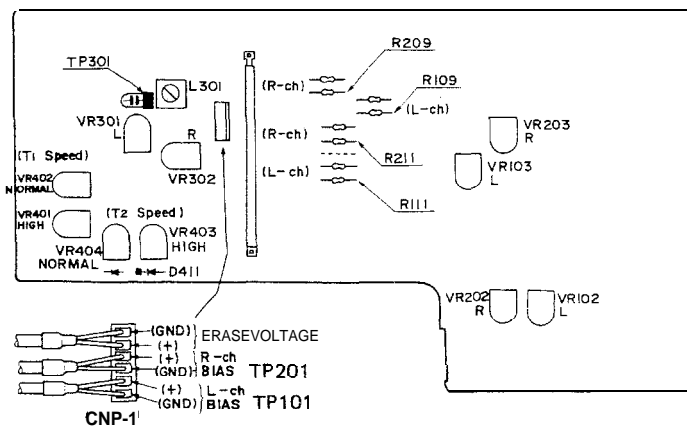

Figure 10-4 ADJUSTMENT POINTS

**ⓓ MECHANISCHE EINSTELLUNG**

BEIENNUNG	FÜHRUNG-SLEHRE	EINSTELL-PUNKT	BEMERKUNGEN (PRÜFUNG)
Antriebskraft	Bandzug-Meßcassette TW-2412	—	Mehr als 180 g
Drehmoment	Drehmomentmesser Weidergabe TW-2111 Schnellvorlauf TW-2231 Rückspulung TW-2231	—	(Wiedergabe: 35 – 60 g-cm) (Schnellvorlauf: 70 – 110 g-cm) (Rückspulung: 70 – 110 g-cm)
Azimut	Testband MTT-1 14	Azimuteinstellschraube	Sinuswellenform wird maximal.
Bandgeschwindigkeit	Testband MTT-1 11	Normal Geschwindigkeit Deck 1: VR402 Deck 2: VR404 Hohe Geschwindigkeit Deck 1: VR401 Deck 2: VR403	Normal Geschwindigkeit 2 990 ± 20 Hz Hohe Geschwindigkeit 5 980 ± 50 Hz

**TESTBÄNDER FÜR MESSUNG**

KOMPAKTCASSETTENTYP			
BENENNUNG	MODE LL	FREQUENZ/ PEGEL	ANWENDUNG
GLEICHLAUF-SCHWANKUNGEN	MTT-111	3 kHz, -10 dB	Überprüfung der Bandgeschwindigkeit und Gleichlaufschwankungen
AZIMUT	MTT-113 MTT-113C MTT-114	6,3 kHz, -10 dB 8 kHz, -10 dB 10 kHz, -10 dB	Kopfazimuteinstellung
KLIRRFAKTOR	MTT-118	1 kHz, -10 dB	Verzerrungspegel-einstellung
DOLBY-PEGEL-EICHUNG	MTT-150	Ton von Dolby B-Typ 2 0 0 nwb/m	Dolby-NR B-Typ-Pegel-einstellung
LEER-CASSETTE	MTT-502	—	Überprüfung der Aufnahme-frequenz

**TESTBÄNDER**

DREHMOMENTMESSER FÜR KOMPAKTCASSETTE		
MODELL	MESSBEREICH	ANWENDUNG
TW-2111	10 – 100 g-cm	Normal : Wiedergabedrehmoment
	1,5 – 10 g-cm	Normal : Rückzug
TW-2121	10 – 100 g-cm	Rücklauf : Wiedergabedrehmoment
	1,5 – 10 g-cm	Rücklauf : Rückzug
TW-2231	30 – 200 g-cm	Schnellvorlauf-, Rückspul-drehmoment
TW-2412	0 – 300 g	Normal : Antriebskraft
TW-2422	0 – 300 g	Rücklauf: Antriebskraft

**ⓕ RÉGLAGE DE MÉCANISME**

ARTICLE	GABARIT	POINTS DE RÉGLAGE	REMARQUES (VÉRIFICATION)
Puissance d'entraînement	Cassette de mesure de tension de la bande TW-2412	—	Plus de 180 g
Couple	Compteur de couple Lecture: TW-2111 Avance rapide: TW-2231 Rebobinage: TW-2231	—	(Lecture: 35 à 60g-cm) (Avance rapide: 70 – 110 g-cm) (Rebobinage: 70 – 110 g-cm)
Azimuth	Bande d'essai MTT-114	Vis de réglage de l'azimuth	La forme d'onde sinusoïdale atteint le maximum.
Vitesse de la bande	Bande d'essai MTT-111	Vitesse normale Platine 1: VR402 Platine 2: VR404 Grande vitesse Platine 1: VR401 Platine 2: VR403	Vitesse normale 2 990 ± 20 Hz Grande vitesse 5 980 ± 50 Hz

**BANDES D'ESSAI POUR MESURAGE**

TYPE CASSETTE COMPACTE			
TITRE	MODÈLE	FRÉQUENCE/ NIVEAU	APPLICATION
PLEURAGE	MTT-111	3 kHz, -10 dB	Vérification de la vitesse de bande et du pleurage et scintillement
AZIMUTH	MTT-113 MTT-113C MTT-114	6,3 kHz, -10 dB 8 kHz, -10 dB 10 kHz, -10 dB	Réglage de l'azimuth de la tête
DISTORSION	MTT-118	1 kHz, -10 dB	Réglage de niveau de distorsion
CALIBRAGE DU NIVEAU DOLBY	MTT-150	Tonalité Dolby type B, 200 nwb/m	Réglage du niveau type B Dolby NR
ESPACE VIERGE	MTT-502	—	Vérification de la fréquence d'enregistrement

**BANDES D'ESSAI**

JAUGE DE COUPLE POUR CASSETTE COMPACTE		
MODÈLE	GAMME DE MESURE	APPLICATION
TW-2111	10 – 100 g-cm	Normal : Lecture d'enroulement
	1,5 – 10 g-cm	Normal : Tension arrière
TW-2121	10 – 100 g-cm	Retour : Lecture d'enroulement
	1,5 – 10 g-cm	Retour : Tension arrière
TW-2231	30 – 200 g-cm	Couple d'avance rapide et de rebobinage
I-W-241 2	0 – 300 g	Normal : Puissance d'entraînement
TW-2422	0 – 300 g	Retour : Puissance d'entraînement

## NOTES ON SCHEMATIC DIAGRAM

- Resistor:  
To differentiate the units of resistors, such symbols as **K** and **M** are used: the symbol **K** means 1000 ohm and the symbol **M** means 1000K ohm and the resistor without any symbols is **ohm-type** resistor.  
Capacitor:  
To indicate the unit of capacitor, a symbol **P** is used; this symbol **P** means micro-microfarad and the unit of the capacitor without such symbol is microfarad.
- Parts marked with "**Δ**" (  ) are important for maintaining the safety of the set. Be sure to replace these with specified ones for maintaining the safety and performance of the set.
- The indicated voltage in each section is the one measured by electronic voltmeter between such a section and the chassis with no **signal** given.
- Schematic diagram and wiring side of **P.W.Board** for this model are subject to change for improvement without prior notice.

## ANMERKUNGEN ZUM SCHEMATISCHEN SCHALTPLAN

## Widerstände:

Um die Einheiten der Widerstände unterscheiden zu können, werden Symbole wie **K** und **M** benutzt. Das Symbol **K** bedeutet 1000 Ohm und das Symbol **M** 1 000 Kilo ohm; Bei Widerständen ohne Symbol handelt es sich um ohmsche Widerstände. Außerdem sind die mit "Fusible" bezeichneten Widerstände Schmelzsicherungstypen.

## Kondensatoren:

Zum Bezeichnen der Kondensatoreinheit wird das Symbol **P** benutzt; dieses Symbol **P** bedeutet Nanofarad. Die Einheit eines Kondensators ohne Symbol ist Mikrofarad. Für Elektrolytkondensatoren wird die Bezeichnung "Kapazität/-Stehspannung" benutzt.

- Die mit **Δ** (  ) bezeichneten Teile sind besonders wichtig für die Aufrechterhaltung der Sicherheit. Beim Wechseln dieser Teile sollten die vorgeschriebenen Teile immer verwendet werden, um sowohl die Sicherheit als auch die Leistung des Gerätes aufrechtzuerhalten.
- Die in den einzelnen Teilen angegebenen Spannungen werden mit einem elektronischen Voltmeter zwischen dem betreffenden Teil und dem Chassis ohne Signalzuleitung gemessen.
- Änderungen der technischen Daten oder Verdrahtungspläne dieses Modells im Sinne der Verbesserung jederzeit vorbehalten.

## REMARQUES CONCERNANT LE DIAGRAMME SCHÉMATIQUE

## Résistance:

Pour différencier les unités de résistances, on utilise des symboles tels que **K** et **M**: le symbole **K** signifie 1000 ohms, le symbole **M** 1000 Kohms, et la résistance donnée sans symbole est une résistance de type ohm. En outre, celle qui est dotée de "Fusible" est de type à fusible.

## Condensateur:

Pour indiquer l'unité de condensateur, on utilise le symbole **P**; ce symbole **P** signifie micro-microfarad, et l'unité de condensateur donnée sans ce symbole est le microfarad. En ce qui concerne le condensateur électrolytique, on utilise l'expression "tension de régime/capacité";

- Les pièces portant la marque **Δ** (  ) sont particulièrement importantes pour le maintien de la sécurité. S'assurer de les remplacer par des pièces du numéro de pièce spécifié pour maintenir la sécurité et la performance de l'appareil.
- La tension indiquée dans chaque section est celle mesurée par le voltmètre électronique entre la section en question et le châssis, en l'absence de tout signal.
- Les caractéristiques ou diagrammes de câblage sont susceptibles d'être modifiés, à des fins d'amélioration, sans aucun préavis.

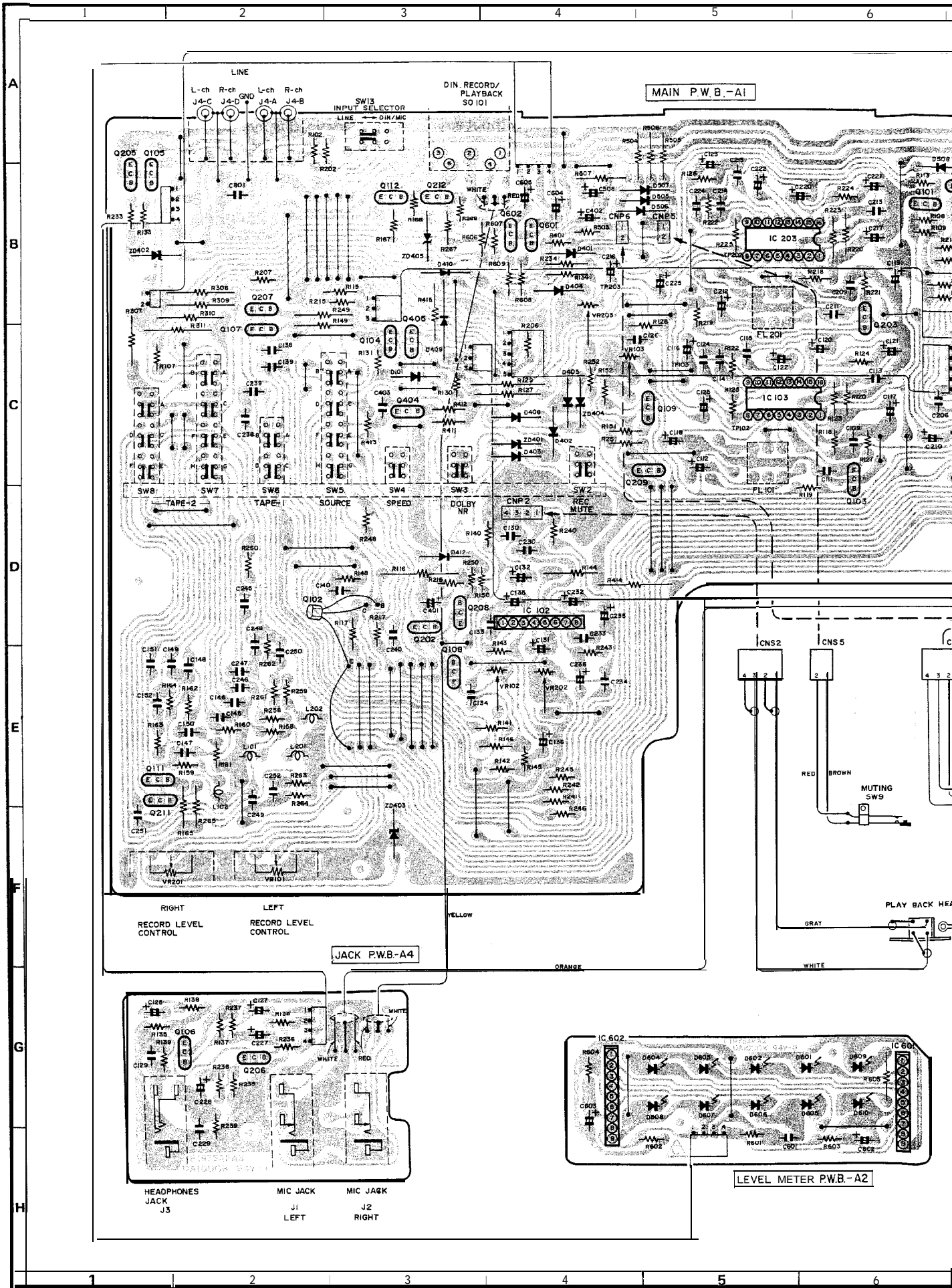
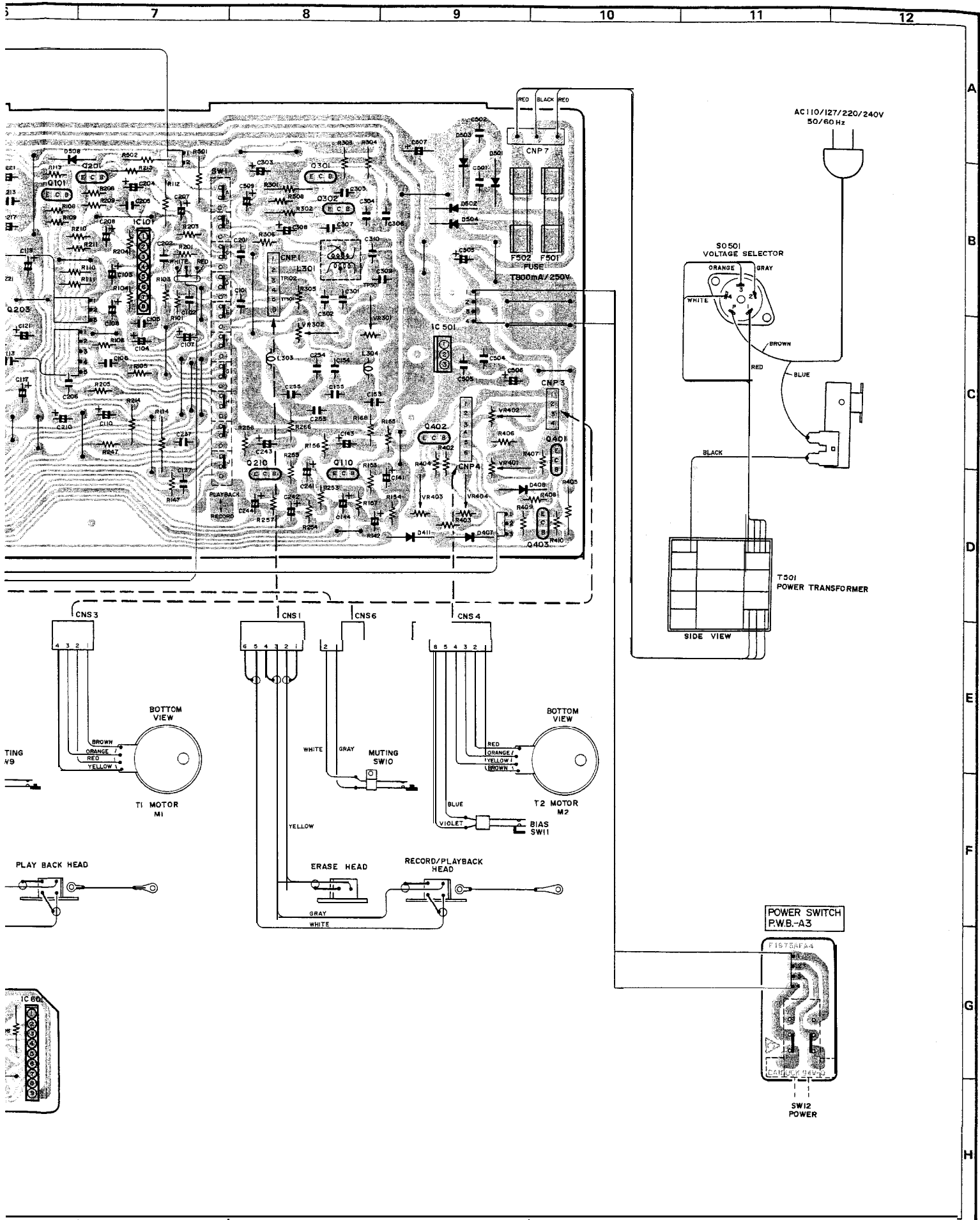
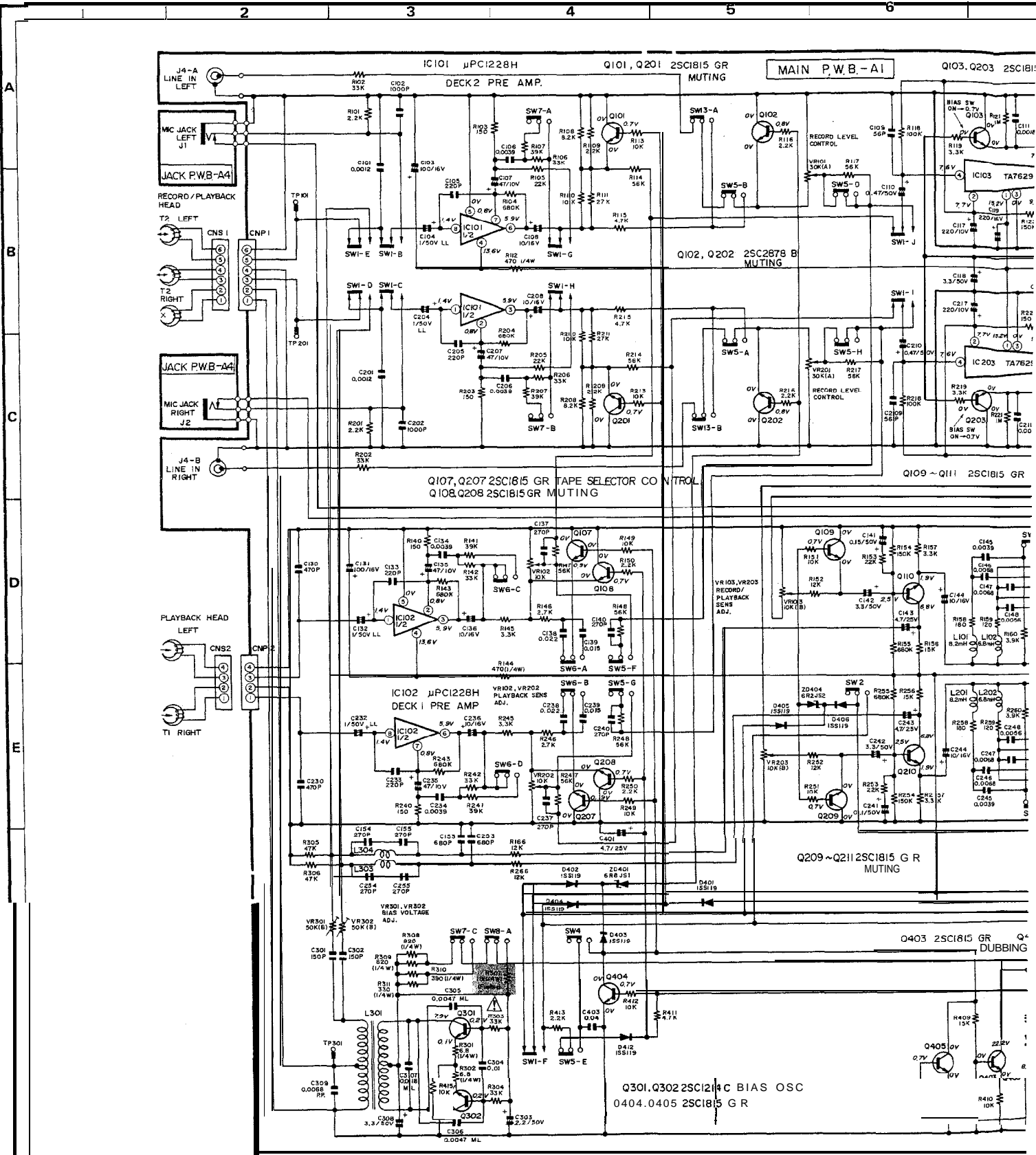

Figure 13 WIRINGSII

# RT-W600H(S)



WIRING SIDE OF P.W. BOARD



SW. NO	FUNCTION	POSITION	LINE/DIN-TI/MIC
SW1 (A-F)	REC/ PB - SW	PLAYBACK - RECORD	NORMAL - METAL/CR0
SW2	RECORD MUTING	OFF - ON	OTHER - METAL
SW3 (A,B)	DOLBY	OFF - ON	OTHER - METAL
SW4 (A-C)	DUBBING SPEED	NORMAL - HIGH	OFF - ON

SW5 (A-F)	SOURCE SW	LINE/DIN-TI/MIC
SW5 (A-D)	DECK 1 TAPE SELECTOR	NORMAL - METAL/CR0
SW7 (A-H)	DECK 2 TAPE SELECTOR	NORMAL - CR02
SW8 (A-F)	DECK 2 TAPE SELECTOR	OTHER - METAL
SW9	DECK 1 MUTING	OFF - ON

  

SW10	DECK 2 MUTING	OFF - ON
SW11 <td>DECK 2 BIAS</td> <td>OFF - ON</td>	DECK 2 BIAS	OFF - ON
SW12 <td>POWER</td> <td>STAND BY - ON</td>	POWER	STAND BY - ON
SW13 (A,B)	INPUT SELECTOR	LINE - DIN(MIC)

- NOTES ON SCHEMATIC DIAGRAM can be found on page 12.
- ANMERKUNGEN ZUMSCHEMATISCHEN SCHALTPLAN stehen auf Seite 12.
- REMARQUES CONCERNANT LEDIAGRAMME SCHEMATIQUE sont indiquées à la page 12.

Figure 15 SCHEMATIC I

# H(S) RT-W600H(S)

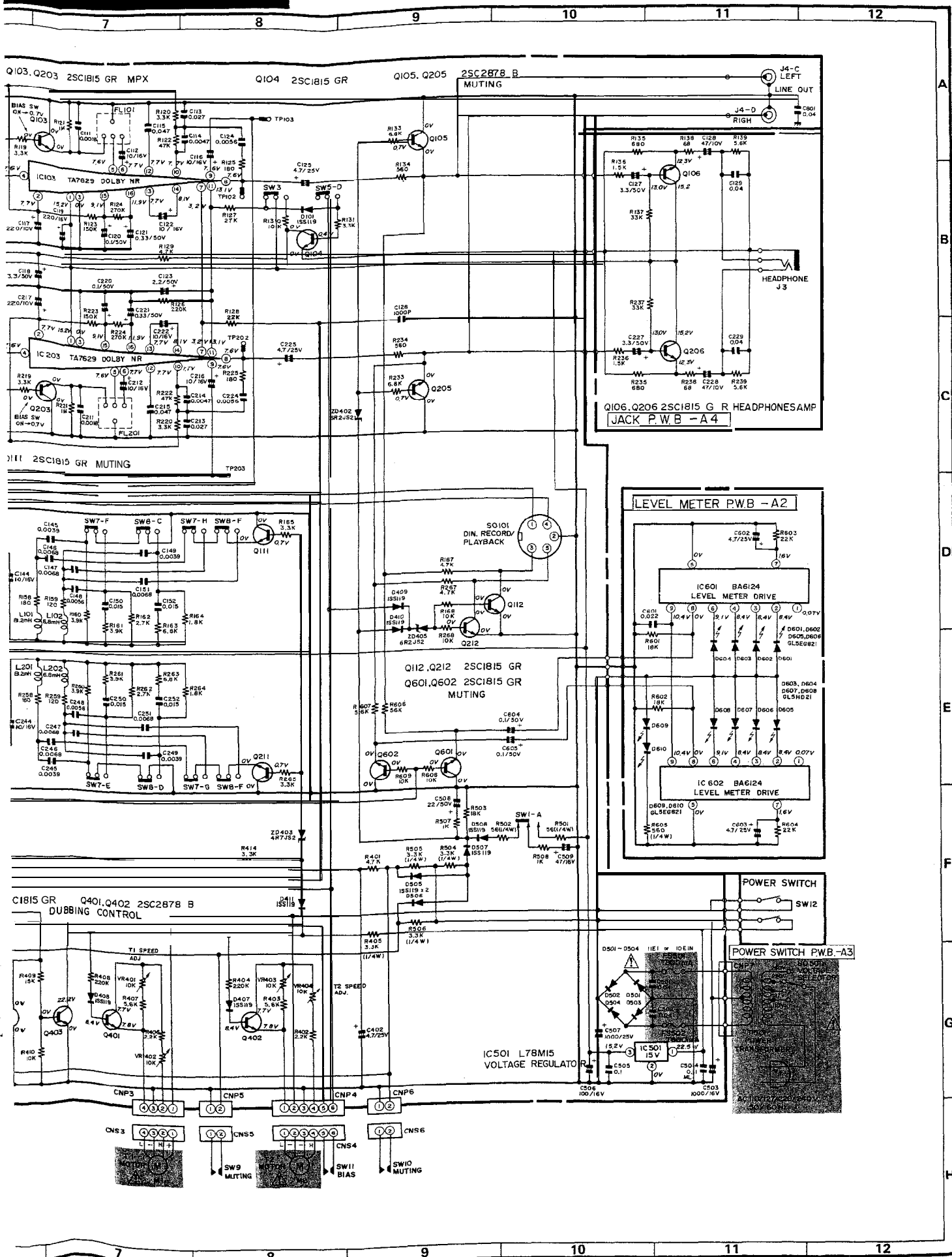

HEMATIC DIAGRAM

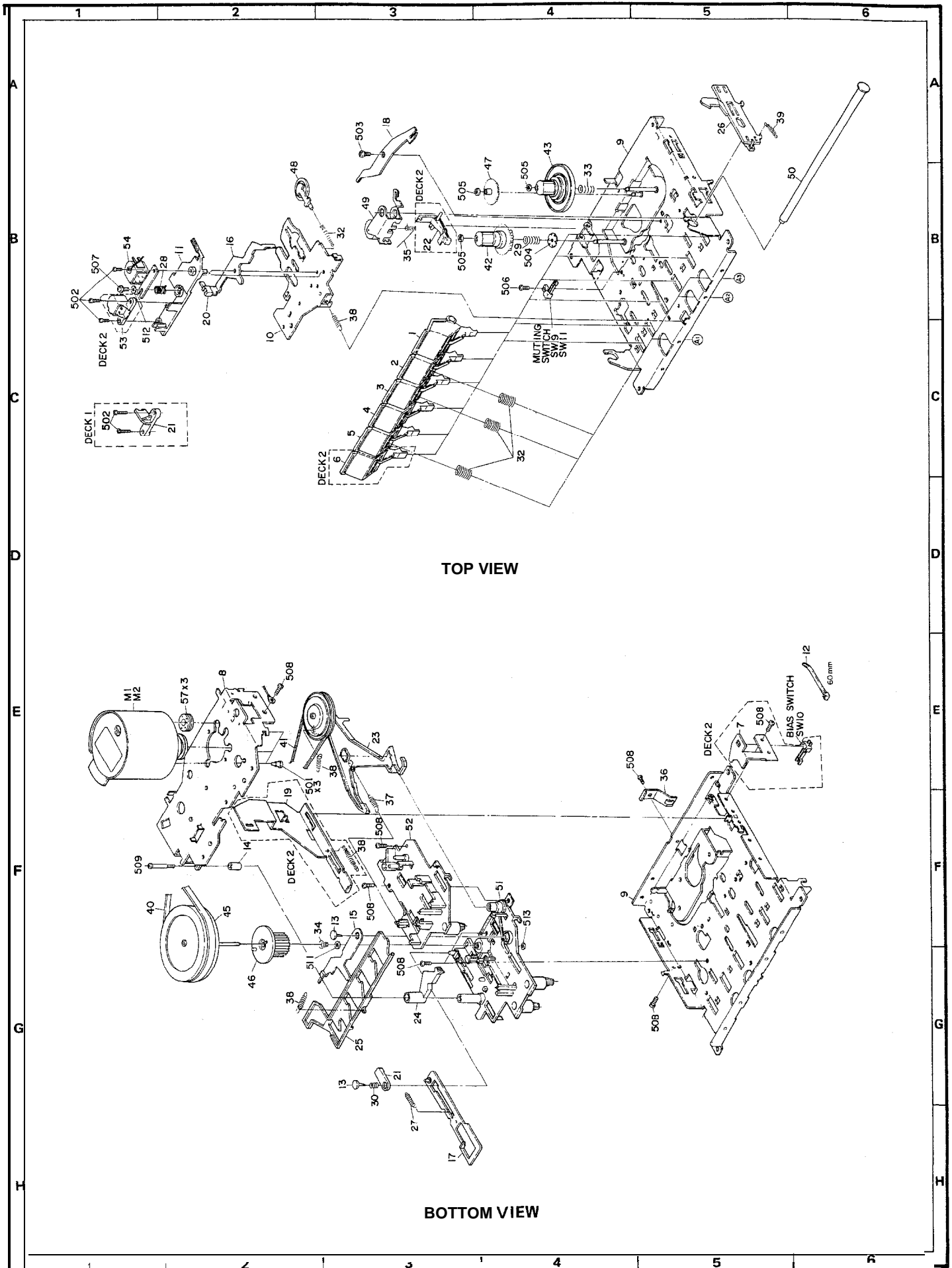

Figure 17 EXPLODED VIEW (MECHANSIM)

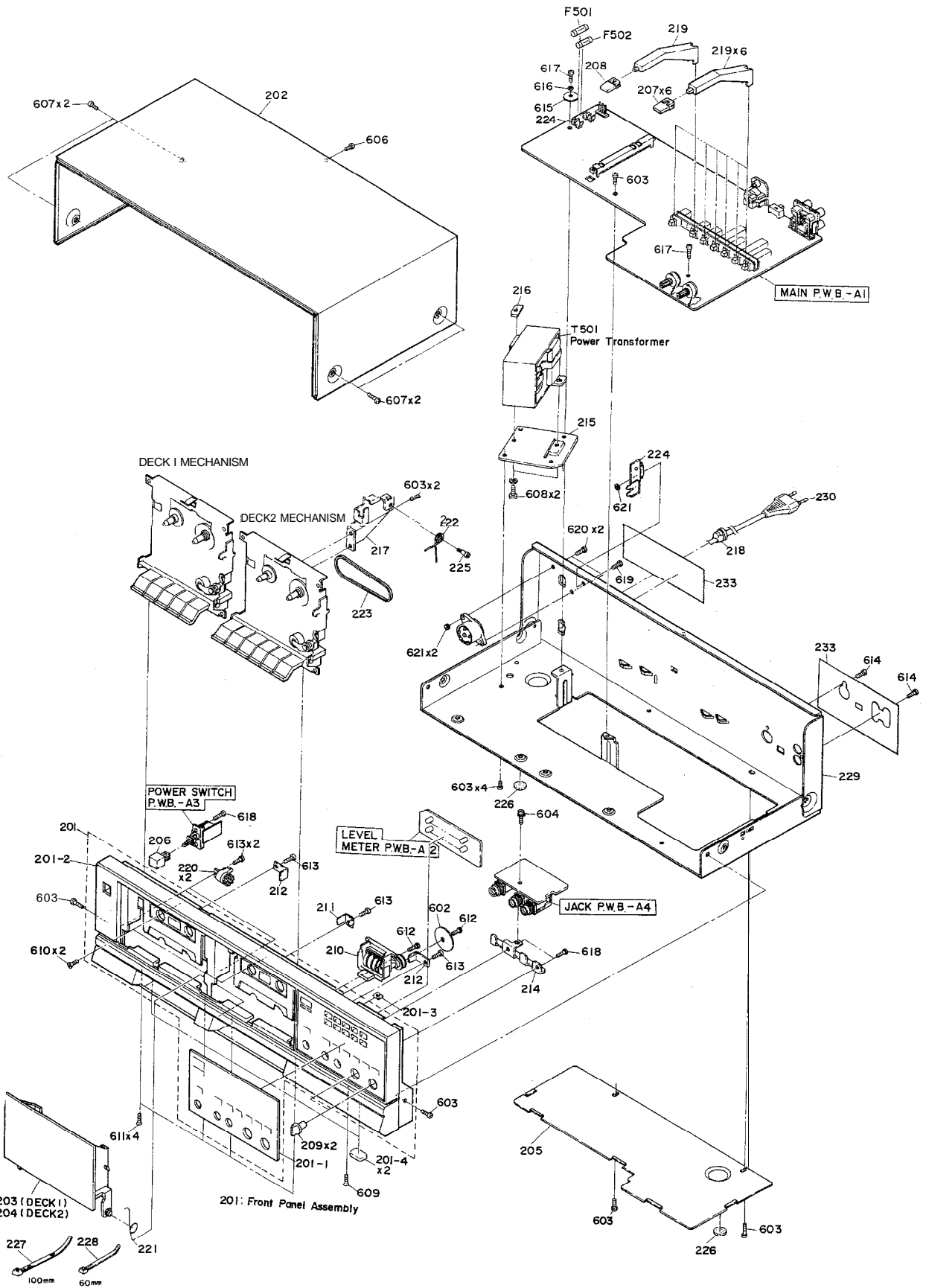

Figure 18 EXPLODED VIEW (CABINET)

**(E) REPLACEMENT PARTS LIST**

**(D) ERSATZTEILLISTE**

**(F) LISTE DES PIÈCES DE RECHANGE**

**"HOW TO ORDER REPLACEMENT PARTS"**

To have your order filled promptly and correctly, please furnish the following information.

1. MODEL NUMBER
2. REF. NO.
3. PART NO.
4. DESCRIPTION

**"BESTELLEN VON ERSATZTEILEN"**

Um Ihren Auftrags schnell und richtig ausführen zu können, bitten wir um die folgenden Angaben.

1. MODELLNUMMER
2. REF. NR.
3. TEIL NR.
4. BESCHREIBUNG

**"COMMENT COMMANDER DES PIÈCES DE RECHANGE"**

Pour voir votre commande exécutée de manière rapide et correcte, veuillez fournir les renseignements suivants.

1. NUMÉRO DU MODÈLE
2. N° DE REFERENCE
3. N° DE LA PIÈCE
4. DESCRIPTION

**NOTE:**  
Parts marked with "△" are important for maintaining the safety of the set. Be sure to replace these parts with specified ones for maintaining the safety and performance of the set.

**ANMERKUNGEN:**  
Die mit △ bezeichneten Teile sind besonders wichtig für die Aufrechterhaltung der Sicherheit. Beim Wechseln dieser Teile sollten die vorgeschriebenen Teile immer verwendet werden, um sowohl die Sicherheit als auch die Leistung des Gerätes aufrechtzuerhalten.

**NOTE:**  
Les pièces portant la marque △ sont particulièrement importantes pour le maintien de la sécurité. S'assurer de les remplacer par des pièces du numéro de pièce spécifié pour maintenir la sécurité et la performance de l'appareil.

REF.NO.	PART NO.	DESCRIPTION	CODE
<b>INTEGRATED CIRCUITS</b>			
ICI 01	VHiUPC1 228HA1	Pre Amp. $\mu$ PC1288H	AE
ICI 02	VHiUPC1 228HA1	Pre Amp. $\mu$ PC1288H	AE
IC103	VHiTA7629P/-1	Dolby NR Circuit, TA7629P	AL
IC203	VHiTA7629P/-1	Dolby NR Circuit, TA7629P	AL
IC501	VHiL78M15// -1	15V, Voltage Regulator, L78M15	AG
IC601	VHiBA6124// -1	Level Meter Driver, BA6124	AG
IC602	VHiBA6124// -1	Level Meter Driver, BA6124	AG
<b>TRANSISTORS</b>			
Q101	VS2SC1815GR-1	Silicon, NPN, 2SC1815GR	AB
Q102	VS2SC2878B/-1	Silicon, NPN, 2SC2878B	AC
Q103	VS2SC1815GR-1	Silicon, NPN, 2SC1815GR	AB
Q104	VS2SC1815GR-1	Silicon, NPN, 2SC1815GR	A8
Q105	VS2SC2878B/-1	Silicon, NPN, 2SC2878B	AC
Q106	VS2SC1815GR-1	Silicon, NPN, 2SC1815GR	AB
Q107	VS2SC1815GR-1	Silicon, NPN, 2SC1815GR	AB
Q108	VS2SC1815GR-1	Silicon, NPN, 2SC1815GR	AB
Q109	VS2SC1815GR-1	Silicon, NPN, 2SC1815GR	A8
Q110	VS2SC1815GR-1	Silicon, NPN, 2SC1815GR	AB
Q111	VS2SC1815GR-1	Silicon, NPN, 2SC1815GR	AB
Q112	VS2SC1815GR-1	Silicon, NPN, 2SC1815GR	AB
Q201	VS2SC1815GR-1	Silicon, NPN, 2SC1815GR	A8
Q202	VS2SC2878B/-1	Silicon, NPN, 2SC2878B	AC
Q203	VS2SC1815GR-1	Silicon, NPN, 2SC1815GR	AB
Q205	VS2SC2878B/-1	Silicon, NPN, 2SC2878B	AC
Q206	VS2SC1815GR-1	Silicon, NPN, 2SC1815GR	AB
Q207	VS2SC1815GR-1	Silicon, NPN, 2SC1815GR	AB
Q208	VS2SC1815GR-1	Silicon, NPN, 2SC1815GR	AB
Q209	VS2SC1815GR-1	Silicon, NPN, 2SC1815GR	AB
Q210	VS2SC1815GR-1	Silicon, NPN, 2SC1815GR	AB
Q211	VS2SC1815GR-1	Silicon, NPN, 2SC1815GR	AB
Q212	VS2SC1815GR-1	Silicon, NPN, 2SC1815GR	AB
Q301	VS2SC1214-C-1	Silicon, NPN, 2SC1214C	AC
Q302	VS2SC1214-C-1	Silicon, NPN, 2SC1214C	AC
Q401	VS2SC2878B/-1	Silicon, NPN, 2SC2878B	AC
Q402	VS2SC2878B/-1	Silicon, NPN, 2SC2878B	AC
Q403	VS2SC1815GR-1	Silicon, NPN, 2SC1815GR	AB
Q404	VS2SC1815GR-1	Silicon, NPN, 2SC1815GR	AB
Q405	VS2SC1815GR-1	Silicon, NPN, 2SC1815GR	AB
Q601	VS2SC1815GR-1	Silicon, NPN, 2SC1815GR	AB
Q602	VS2SC1815GR-1	Silicon, NPN, 2SC1815GR	AB

REF.NO.	PART NO.	DESCRIPTION	CODE
<b>DIODES</b>			
D101	VHD1SS119// -1	Silicon, 1SS119	AA
D401	VHDI SS119// -1	Silicon, 1 SS119	AA
D402	VHD1SS119// -1	Silicon, 1 SS119	AA
D403	VHD1 SSI 19// -1	Silicon, 1 SS119	AA
D404	VHD1SS119// -1	Silicon, 1 SS119	AA
D405	VHD1SS119// -1	Silicon, 1 SS119	AA
D406	VHD1SS119// -1	Silicon, 1 SS119	AA
D407	VHD1SS119// -1	Silicon, 1 SS119	Ah
D408	VHD1SS119// -1	Silicon, 1 SS119	AA
D409	VHD1SS119// -1	Silicon, 1 SS119	AA
D410	VHD1SS119// -1	Silicon, 1 SS119	AA
0411	VHD1SS119// -1	Silicon, 1 SS119	AA
D412	VHD1SS119// -1	Silicon, 1 SS119	AA
D501	VHD11 EI TA2/-1	Silicon, 1 1 EI	AB
D502	VHD11 EI TA2/-1	Silicon, 1 1 EI	AB
D503	VHD11 EI TA2/-1	Silicon, 1 1 EI	AB
D504	VHD11 EI TA2/-1	Silicon, 1 1 EI	AB
D505	VHDI SS119// -1	Silicon, 1 SS119	Ah
D506	VHD1SS119// -1	Silicon, 1 SS119	AA
D507	VHD1SS119// -1	Silicon, 1 SS119	Ah
D508	VHD1SS119// -1	Silicon, 1 SS119	AA
D601	VHPGL5EG821-1	LED, Green, GL-5EG821	AC
D602	VHPGL5EG821-1	LED, Green, GL-5EG821	AC
D603	VHPGL5HD21/-1	LED, Red, GL-5HD21	AC
D604	VHPGL5HD21/-1	LED, Red, GL-5HD21	AC
D605	VHPGL5EG821-1	LED, Green, GL-5EG821	AC
D606	VHPGL5EG821-1	LED, Green, GL-5EG821	AC
D607	VHPGL5HD21/-1	LED, Red, GL-5HD21	AC
D608	VHPGL5HD21/-1	LED, Red, GL-5HD21	AC
D609	VHPGL5EG821-1	LED, Green, GL-5EG821	AC
D610	VHPGL5EG821-1	LED, Green, GL-5EG821	AC
ZD401	VHERD6R8JS2-1	Zener, 6.8V, RD6.8JS1	AB
ZD402	VHERD6R2JS2-1	Zener, 6.2V, RD6.2JS2	AB
ZD403	VHERD4R7JS2-1	Zener, 4.7V, RD4.7JS2	A8
ZD404	VHERD6R2JS2-1	Zener, 6.2V, RD6.2JS2	AB
ZD405	VHERD6R2JS2-1	Zener, 6.2V, RD6.2JS2	AB

<b>FILTERS</b>			
FL1 01	RCiLL0086AFZZ	Multiplex	AF
FL201	RCiLL0086AFZZ	Multiplex	AF

# RT-W600H(S)

REF.NO.	PART NO.	DESCRIPTION	CODE	REF.NO.	PART NO.	DESCRIPTION	CODE
<b>COILS</b>							
L101	RCiLZ0087AFZZ	8.2 mH, Record Equalizer	AC	C228	RC-EZA476AF1A	4 7 $\mu$ F, 10V	AB
L102	RCiLZ0086AFZZ	6.8 mH, Rec. Equalizer	AC	C232	VCEALAI HW105M1	1 $\mu$ F, 50V	AB
L201	RCiLZ0087AFZZ	8.2 mH, Record Equalizer	AC	C235	RC-EZA476AF1A	4 7 $\mu$ F, 10V	AB
L202	RCiLZ0086AFZZ	6.8 mH, Rec. Equalizer	AC	C236	RC-EZA106AF1C	10 $\mu$ F, 16 V	AB
L301	RCiLB0747AFZZ	Bias Oscillator	AF	C241	RC-EZA154AF1H	0.15 $\mu$ F, 50 V	AB
L303	RCiLZ0120AFZZ	15 mH, Bias Trap	AC	C242	RC-EZA335AF1H	3.3 $\mu$ F, 50 V	AB
L304	RCiLZ0120AFZZ	15 mH, Bias Trap	AC	C243	RC-EZA475AF1E	4.7 $\mu$ F, 25 V	AB
<b>TRANSFORMER</b>							
△ T501	RTRNP1130AFZZ	Power		C244	RC-EZAI 06AF1C	10 $\mu$ F, 16 V	AB
<b>CONTROLS</b>							
VR101	RVR-A0196AFZZ	30 kohms (A)	AD	C303	RC-EZA225AF1H	2.2 $\mu$ F, 50 V	AB
VR102	RVR-M0391 AFZZ	10 kohm (B)	AB	C308	RC-EZA335AF1H	3.3 $\mu$ F, 50 V	AB
VR1 03	RVR-M0391 AFZZ	10 kohm (B)	AB	C401	RC-EZV475AF1E	4.7 $\mu$ F, 25 V	AB
VR201	RVR-A0196AFZZ	30 kohms (A)	AD	C402	RC-EZA475AF1E	4.7 $\mu$ F, 25 V	AB
VR202	RVR-M0391 AFZZ	10 kohm (B)	AB	C503	RC-EZV1 08AFI C	10 0 0 $\mu$ F, 16V	AD
VR203	RVR-M0391 AFZZ	10 kohm (B)	AB	C506	RC-EZA107AF1C	100 $\mu$ F, 16 V	AB
VR301	RVR-M0394AFZZ	50 kohms (B)	AB	C507	RC-EZW108AF1E	1 0 0 0 $\mu$ F, 2 5 V	AD
VR302	RVR-M0394AFZZ	50 kohms (B)	A8	C508	RC-EZA226AF1E	22 $\mu$ F, 25 V	AB
VR401	RVR-M0391 AFZZ	10 kohm (B)	AB	C509	RC-EZA476AF1C	4 7 $\mu$ F, 16 V	A8
VR402	RVR-M0391 AFZZ	10 kohm (B)	AB	C602	RC-EZA475AF1E	4.7 $\mu$ F, 25 V	AB
VR403	RVR-M0391 AFZZ	10 kohm (B)	AB	C603	RC-EZA475AF1E	4.7 $\mu$ F, 25 V	AB
VR404	RVR-M0391 AFZZ	10 kohm (B)	AB	C604	RC-EZA104AF1H	0.1 $\mu$ F, 5 0 V	AB
<b>ELECTROLYTIC CAPACITORS</b>							
(Unless otherwise specified electrolytic capacitors are $\pm 20\%$ type.)							
CI 03	RC-EZAI 07AF1C	100 $\mu$ F, 16 V	AB	C605	RC-EZA104AF1H	0.1 $\mu$ F, 50 V	AB
C104	VCEALAI HW105M1	1 $\mu$ F, 50 V	AB	<b>CAPACITORS</b>			
C107	RC-EZA476AF1A	4 7 $\mu$ F, 10V	AB	There are two types of capacitors available and they can be identified from each other by reading their Part Numbers.			
CI 08	RC-EZAI 06AF1C	10 $\mu$ F, 16 V	AB	• Ceramic type capacitor:			
C110	RC-EZA474AF1H	0.47 $\mu$ F, 50 V	AB	A symbol "C" or "K" is given at the 3rd digit of its Part Number like "VCC(or K)●●●●●●J."			
C112	RC-EZA106AF1C	10 $\mu$ F, 16 V	AB	• Semiconductor type capacitor;			
C116	RC-EZA106AF1C	10 $\mu$ F, 16 V	AB	A symbol "T" is given at the 3rd digit of its Part Number like "VCT●●●●●●J."			
CI 17	RC-EZA227AF1 A	220 $\mu$ F, 10V	AB	The capacitance error of each capacitor is indicated by the symbol given at the 13th digit of the Part Number as follows: "J" ( $\pm 5\%$ ), "K" ( $\pm 10\%$ ), "M" ( $\pm 20\%$ ), "N" ( $\pm 30\%$ ), "C" ( $\pm 0.25$ pF), "D" ( $\pm 0.5$ pF), "Z" ( $+80-20\%$ ).			
C118	RC-EZA335AF1H	3.3 $\mu$ F, 50 V	AB	CI 01	VCTYPAI EX122J	0.0012 $\mu$ F, 25 V	AA
CI 19	RC-EZA227AF1C	220 $\mu$ F, 16 V	AB	CI 02	VCTYPAI EX102J	0.001 $\mu$ F, 25 V	AA
CI 20	RC-EZA104AF1 H	0.1 $\mu$ F, 50 V	AB	CI 05	VCCSPA1 HL221J	220 pF, 50 V	AA
CI 21	RC-EZA334AF1H	0.33 $\mu$ F, 50 V	AB	CI 06	VCTYPAI EX392J	0.0039 $\mu$ F, 25 V	AA
CI 22	RC-EZA106AF1C	10 $\mu$ F, 16 V	AB	CI 09	VCCSPA1 HL560J	56 pF, 50 V	AA
CI 23	RC-EZA225AF1H	2.2 $\mu$ F, 50 V	AB	CI 11	VCTYPAI EX182 J	0.0018 $\mu$ F, 25 V	AA
CI 25	RC-EZA475AF1E	4.7 $\mu$ F, 25 V	AB	C113	VCTYPAI EX273J	0.027 $\mu$ F, 25 V	AB
CI 27	RC-EZA335AF1H	3.3 $\mu$ F, 50 V	AB	C114	VCTYPAI EX472J	0.0047 $\mu$ F, 25 V	AA
CI 28	RC-EZA476AF1A	4 7 $\mu$ F, 10V	AB	C115	VCTYPAI EX473J	0.047 $\mu$ F, 2 5 V	AB
CI 31	RC-EZAI 07AFI C	100 $\mu$ F, 16 V	AB	CI 124	VCTYPAI EX562J	0.0056 $\mu$ F, 25 V	AA
CI 32	VCEALAI HW105M1	1 $\mu$ F, 50 V	A8	CI 126	VCTYPAI EX102J	0.001 $\mu$ F, 2 5 V	AA
CI 35	RC-EZA476AF1 A	4 7 $\mu$ F, 10V	AB	C129	VCKZPA1HF403Z	0.04 $\mu$ F, 5 0 V	AA
CI 36	RC-EZAI 06AF1C	1 0 $\mu$ F, 16V	AB	CI 30	VCCSPA1HL471 J	470 pF, 50 V	AA
CI 41	RC-EZA154AF1H	0.15 $\mu$ F, 50 V	AB	CI 33	VCCSPA1 HL221J	220 pF, 50 V	AA
CI 42	RC-EZA335AF1H	3.3 $\mu$ F, 50 V	AB	CI 34	VCTYPAI EX392J	0.0039 $\mu$ F, 2 5 V	AA
CI 43	RC-EZA475AF1E	4.7 $\mu$ F, 25 V	AB	CI 37	VCCSPA1HL271J	270 pF, 50 V	AA
C144	RC-EZA106AF1C	10 $\mu$ F, 16 V	AB	CI 38	VCTYPAI EX223J	0.022 $\mu$ F, 2 5 V	AA
C204	VCEALAI HW105M1	1 $\mu$ F, 50 V	AB	CI 39	VCTYPAI EX153J	0.015 $\mu$ F, 2 5 V	AA
C207	RC-EZA476AF1A	4 7 $\mu$ F, 10V	AB	C140	VCCSPA1 HI-271 J	270 pF, 50 V	AA
C208	RC-EZA106AF1C	10 $\mu$ F, 16V	AB	CI 45	VCTYPAI EX392J	0.0039 $\mu$ F, 25 V	AA
C210	RC-EZA474AF1H	0.47 $\mu$ F, 50 V	AB	CI 46	VCTYPAI EX682J	0.0068 $\mu$ F, 25 V	AA
c212	RC-EZA106AF1C	10 $\mu$ F, 16 V	AB	CI 47	VCTYPAI EX682J	0.0068 $\mu$ F, 25 V	AA
C216	RC-EZAI 06AF1C	10 $\mu$ F, 16 V	AB	CI 48	VCTYPAI EX562J	0.0056 $\mu$ F, 25 V	AA
C217	RC-EZA227AF1 A	220 $\mu$ F, 10V	AB	CI 49	VCTYPAI EX392J	0.0039 $\mu$ F, 50 V	AA
C220	RC-EZAI 04AF1H	0.1 $\mu$ F, 50 V	AB	CI 50	VCTYPAI EX153 J	0.01 5 $\mu$ F, 25 V	AA
C221	RC-EZA334AF1H	0.33 $\mu$ F, 50 V	AB	C151	VCTYPAI EX682J	0.0068 $\mu$ F, 25 V	AA
c222	RC-EZA106AF1C	10 $\mu$ F, 16 V	AB	CI 52	VCTYPAI EX1 53J	0.015 $\mu$ F, 2 5 V	AA
C225	RC-EZA475AF1E	4.7 $\mu$ F, 25 V	AB	CI 53	VCCSPA1HL681J	680 pF, 50 V	AA
C227	RC-EZA335AF1H	3.3 $\mu$ F, 50 V	AB	CI 54	VCCSPA1HL271J	270 pF, 50 V	AA
				CI 55	VCCSPA1 HL271 J	270 pF, 50 V	AA
				C201	VCTYPAI EX1 22J	0.0012 $\mu$ F, 25 V	AA
				C202	VCTYPAI EX102J	0.001 $\mu$ F, 25 V	AA
				C205	VCCSPA1 HL221J	220 pF, 50 V	AA
				C206	VCTYPAI EX392J	0.0039 $\mu$ F, 2 5 V	AA
				C209	VCCSPA1 HL560J	5 6 pF, 5 0 V	AA

REF.NO.	PART NO.	DESCRIPTION	CODE	REF.NO.	PART NO.	DESCRIPTION	CODE
24	MLEVPO539AF00	Release Lever, Arm Lock	AB	204	GFTAC1505AFSA	Cassette Holder, (Deck 2).	AL
25	MLEVPO541 AF00	Lever, Release	AB			(BK)	
26	MLEVPO580AF00	Lever, Cassette Holder Lock	AB	205	GiTAU0029AFZZ	Bottom Plate	AH
27	MSPRC0455AFFJ	Spring, Lever Return	AA	206	JKNBM0428AFSB	Button, Power Switch	AB
28	MSPRC0456AFFJ	Spring, Azimuth	AA	207	JKNBM0547AFSA	Button, Black	AC
29	MSPRC0457AFFJ	Spring, Back Tention	AA	208	JKNBM0547AFSE	Button, Blue	AB
30	MSPRC0458AFFJ	Spring, Pause Lock Lever	AA	209	JKNBN0483AFSB	Knob, Record Level Balance	AA
31	MSPRC0467AFFJ	Spring, Button	AA			Control	
32	MSPRC0468AFFJ	Spring, Idler	AA	210	KCoUB0176AFZZ	Tape Counter	AG
33	MSPRC0489AFFJ	Spring, Back Tention	AA	211	LANGF0923AFZZ	Bracket, Cassette Holder	AC
34	MSPRC0497AFFJ	Spring, Flywheel	AA	212	LANGF0926AFZZ	Bracket, Cassette Holder	AC
35	MSPRD0570AFFJ	Spring, Pinch Roller	AA	214	LANGQ0965AFZZ	Bracket, Microphone Shield	AC
36	MSPRP0370AFFW	Plate Spring, Cassette Press	AA	215	LANGQ0966AFZZ	Bracket, Power Transformer	AD
37	MSPRT1076AFFJ	Spring, Fast-Forward/Rewind	AA	216	LANGR0546AFZZ	Bracket, Power Transformer	AB
		Lever				Retaining	
38	MSPRT1077AFFJ	Spring, Lock Lever	AA	217	LANGR0562AFZZ	Bracket, Record Action	AD
39	MSPRT1 078AFFJ	Spring, Arm Lock Release	AA	△ 218	LBSHC0004AGZZ	Bushing, AC Power Supply	AB
		Lever				Cord	
40	NBLTH0103AFZZ	Belt, Flywheel	AC	219	MLEVPO594AFZZ	Lever, Switch	AK
41	NBLTK0290AF00	Belt, Take-Up/Supply	AB	220	MLIFP0040AFZZ	Dumper	AC
		Turntable		221	MSPRD0650AFFJ	Spring, Cassette Holder	AB
42	NDAiRO186AF00	Supply Turntable	AB	222	MSPRD0651 AFFJ	Spring, Record Action Lever	AC
43	NDAiRO187AFZZ	Take-Up Turntable	AE	223	NBLTK0329AFZZ	Belt, Tape Counter	AB
44	NFLYCO131 AFZZ	Flywheel	AH	△ 224	QFSDH1054AFZZ	Holder, Fuse	AA
45	NGERHO144AF00	Gear, Flywheel	AB	△ 224	QLUGL0152AFZZ	Lug Terminal	AD
46	NGERHO149AF00	Gear, Fast- Forward	AB	225	NPLYCO101 AFFD	Pully, Record Action Lever	AA
47	NGERHO149AF00	Gear, Fast- Forward	AB			Spring Retaining	
48	NiDR-0089AFZZ	Idler, Playback	AD	226	PFLT-0369AFZZ	Felt, Rear Leg	AA
49	NRoLY0065AFZZ	Pinch Roller Assembly	AE	227	LHLDW1068AFZZ	Nylon Band, 100mm	AA
50	NSFTT0308AFFD	Shaft, Button	AC	228	LHLDW1 075AFZZ	Nylon Band, 60mm	AA
51	PGiDM0120AFZZ	Lever Guide (Right)	AE	229	LCHSM0546AFZZ	Main Chassis	—
52	PGiDM0125AF00	Lever Guide (Left)	AB	△ 230	QACCVO001 AGZZ	AC Power Supply Cord	AL
53	RHEDA01 25AFZZ	Head, Erase (Deck 2)	AH	233	TSPC-1359AFZZ	Label, Specification, (S) SEEG	
54	RHEDFO090AFZZ	Playback Head (Deck 1)	AM			DV	
54	RHEDH0135AFZZ	Head, Record/Playback	AM	233	TSPC-1360AFZZ	Label, Specification, (S) SEEG	
		(Deck 2)				SNS	
55	MLEVPO482AFZZ	Deck 1 Head, Dummy	AB	233	TSPC-1390AFZZ	Label, Specification, (BK)	
57	LBSHZ0086AFZZ	Cushion, Motor	AA			SEEG DV	
501	LX-BZ0451 AFFD	Screw, 2mm Dia. × 6mm	AA	233	TSPC-1391 AFZZ	Label, Specification, (BK)	
502	LX-HZ01 42AFFD	Screw, φ2 × 9mm	AA			SEEG SNS	
503	LX-HZ0151 AFFD	Screw, φ4 × 6 mm	AB	602	LX-WZ1088AFZZ	Washer, \$3.2 × φ25mm	A A
504	LX-WZ1076AF00	Washer, Supply Turn Table	AA	603	XHBSD30P06000	Screw, φ3 × 6 mm	AA
505	LX-WZ1086AFZZ	Stop Washer, φ1.5 × \$3.5	AA	604	XHBSD30P08R00	Screw with Washer, φ3	AA
		× 0.5mm				× 8mm	
506	XBPSD16 P04000	Screw, φ1.6 × 4 mm	AA	606	XHBSN30P08000	Screw, φ4 × 8mm, (S)	AA
507	XBPSD20W08000	Screw, φ2 × 8mm	AA	606	XHBSF30P08000	Screw, φ4 × 8mm, (BK)	AA
508	XHPSD26P04000	Screw, \$2.6 × 4 mm	AA	607	XHBSN40P08000	Screw, φ4 × 8mm, (S)	AA
509	XHPSD26P26000	Screw, φ2.6 × 23 mm	AA	607	XHBSF40P08000	Screw, φ4 × 8mm, (BK)	AA
511	XWHJZ23-05044	Washer, q52.3 × q54.4	AA	608	XHMSF40P10K00	Screw, φ4 × 10mm	AA
		× 0.5mm		609	XHSSD30P08000	Screw, φ3 × 8mm	AA
512	XWHSD21-05065	Washer, \$2.1 × φ6.5	AA	610	XHSSN30P10000	Screw, φ3 × 10mm	AA
		× 0.5mm		610	XHSSF30P10000	Screw, φ3 × 10mm	AA
513	XWHJZ21-05040	Washer, \$2.1 × φ4	AA	611	XHSS330P08000	Screw, φ3 × 8mm	AA
		× 0.5mm		612	XJBSD26P10000	Screw, 2.6mm Dia. × 10mm	AA
				613	XJBSD30P10000	Screw, φ3 × 10mm	AA
				614	XJBSF30P08000	Taptite Screw, φ3 × 8mm, AA	
						Black	
				615	XWHSD35-10150	Washer, φ3.5 × φ15	AA
						× 1 mm	
				676	XWSSJ30-07000	Washer, φ3 × 0.7mm	AA
				617	XHBSD30P08000	Screw, φ3 × 8mm	AA
				618	XHBSD30P08000	Screw, φ3 × 8mm	AA
				619	XBBSF30P08000	Screw, φ3 × 8mm	AA
				620	XBBSF30P10000	Screw, φ3 × 10mm	AA
				621	XNESD30-24000	Nut	AA

### CABINET PARTS

201	CPNLC1652AF01	Front Panel Assembly, (S)	
201	CPNLC1652AF01	Front Panel Assembly, (BK)	
201-1	HDECP0333AFSA	Decoration Plate, (S)	AK
202-1	HDECP0333AFSB	Decoration Plate, (BK)	
201-2		Front Panel	—
201-3	LX-NZ0052AFFD	Nut	AA
201-4	PFLT-0494AFZZ	Felt, Front Leg	AA
202	GCAB-3184AFSA	Cabinet, (S)	
202	GCAB-3184AFSB	Cabinet, (BK)	
203	GFTAC1468AFSA	Cassette Holder, (Deck 1). (S)	AL
203	GFTAC1504AFSA	Cassette Holder, (Deck 1).	AL
		(BK)	
204	GFTAC1 469AFSA	Cassette Holder, (Deck 2), (S)	AL

### ACCESSORIES/PACKING PARTS

QCNW-0727AFZZ	Connecting Cord, (DIN Type)	AP
SPAKA1374AFZZ	Packing Add., Right	

# RT-W600H(S)

REF.NO.	PART NO.	DESCRIPTION	CODE	REF.NO.	PART NO.	DESCRIPTION	CODE
R239	VRD-ST2CD562J	5.6 kohms, 1/6W	AA	R607	VRD-ST2CD563J	56 kohms, 1/6W	AA
R240	VRD-ST2CD151J	150 ohms, 1/6W	AA	R608	VRD-ST2CD103J	10 kohm, 1/6W	AA
R241	VRD-ST2CD393J	39 kohms, 1/6W	AA	R609	VRD-ST2CD103J	10 kohm, 1/6W	AA
R242	VRD-ST2CD333J	33 kohms, 1/6W	AA	<b>CIRCUIT PARTS</b>			
R243	VRD-ST2CD684J	680 kohms, 1/6W	AA	CNS1	QCNW-2989AFZZ	6 Pin Socket Assembly	AG
R245	VRD-ST2CD332J	3.3 kohms, 1/6W	AA	CNS2	QCNW-2986AFZZ	4 Pin Socket Assembly	AG
R246	VRD-ST2CD272J	2.7 kohms, 1/6W	AA	CNS3	QCNW-2987AFZZ	4 Pin Socket Assembly	AD
R247	VRD-ST2CD563J	56 kohms, 1/6W	AA	CNS4	QCNW-2990AFZZ	6 Pin Socket Assembly	AE
R248	VRD-ST2CD563J	56 kohms, 1/6W	AA	CNS6	QCNW-2991 AFZZ	2 Pin Socket Assembly	AC
R249	VRD-ST2CD103J	10 kohm, 1/6W	AA	CNS9	QCNW-2988AFZZ	2 Pin Socket Assembly	AC
R250	VRD-ST2CD222J	2.2 kohms, 1/6W	AA	CNP1	QCNCM663FAFZZ	6 Pin Plug	AC
R251	VRD-ST2CD103J	10 kohm, 1/6W	AA	CNP2	QCNCM663DAFZZ	4 Pin Plug	AC
R252	VRD-ST2CD123J	12 kohms, 1/6W	AA	CNP3	QCNCM663DAFZZ	4 Pin Plug	AC
R253	VRD-ST2CD223J	22 kohms, 1/6W	AA	CNP4	QCNCM663FAFZZ	6 Pin Plug	AC
R254	VRD-ST2CD154J	150 kohms, 1/6W	AA	CNP5	QCNCM663BAFZZ	2 Pin Plug	AC
R255	VRD-ST2CD684J	680 kohms, 1/6W	AA	CNP6	QCNCM663BAFZZ	2 Pin Plug	AC
R256	VRD-ST2CD153J	15 kohms, 1/6W	AA	CNP7	QCNCM553CAFZZ	3 Pin Plug	AA
R257	VRD-ST2CD332J	3.3 kohms, 1/6W	AA	△ F501	QFS-C801EAFNi	Fuse, T800mA/250V	AD
R258	VRD-ST2CD181J	180 ohms, 1/6W	AA	△ F502	QFS-C801EAFNi	Fuse, T800mA/250V	AD
R259	VRD-ST2CD121J	120 ohms, 1/6W	AA	J1	QJAKE0111 AFZZ	Jack, Microphone	AD
R260	VRD-ST2CD392J	3.9 kohms, 1/6W	AA	J2	QJAKE0111 AFZZ	Jack, Microphone	AD
R261	VRD-ST2CD392J	3.9 kohms, 1/6W	AA	J3	QJAKJ0146AFZZ	Jack, Headphone	AD
R262	VRD-ST2CD272J	2.7 kohms, 1/6W	AA	J4A-D	QSöCJ0498AFZZ	Socket, Tepe Input/Output	AE
R263	VRD-ST2CD682J	6.8 kohms, 1/6W	AA	SO101	QSoCD4507AF.Z	Socket, DIN, Record/Playback	AE
R264	VRD-ST2CD182J	1.8 kohms, 1/6W	AA	△ SO501	QSöCE0607AFZZ	AC Voltag Selector	AF
R265	VRD-ST2CD332J	3.3 kohms, 1/6W	AA	△ M1	RMöTV0195AF05	Deck 1 Motor	AY
R266	VRD-ST2CD123J	12 kohms, 1/6W	AA	△ M2	RMöTV0195AF05	Deck 2 Motor	AY
R267	VRD-ST2CD472J	4.7 kohms, 1/6W	AA	SW1	QSW-S0465AFZZ	Switch, Slide Type	AC
R268	VRD-ST2CD103J	10 kohm, 1/6W	AA	SW2~8	QSW-P0587AFZZ	Switch, Assembly, Push Lock Type	AS
R301	VRD-ST2EE6R8J	6.8 ohms, 1/4W	AA	SW9	QSW-F0203 AFZZ	Switch, Leaf Type	AC
R302	VRD-ST2EE6R8J	6.8 ohms, 1/4W	AA	SW10	QSW-F0203AFZZ	Switch, Leaf Type	AC
R303	VRD-ST2CD333J	33 kohms, 1/6W	AA	SW11	QSW-F0203 AFZZ	Switch, Leaf Type	AC
R304	VRD-ST2CD333J	33 kohms, 1/6W	AA	SW12	QSW-P0365AFZZ	Switch, Slide Type	AF
R305	VRD-ST2CD473J	47 kohms, 1/6W	AA	SW13	QSW-S0427AFZZ	Switch, Slide Type	AD
△ R306	VRD-ST2CD473J	47 kohms, 1/6W	AA	<b>MECHANICAL PARTS</b>			
△ R307	VRG-ST2EC180J	18 ohms, 1/4W, ±5%, Fusible	AB	1	JKNBRO455AFSB	Button, Pause, (S)	AD
R308	VRD-ST2EE821J	820 ohms, 1/4W	AA	1	JKNBRO455AFSC	Button, Pause, (BK)	AD
R309	VRD-ST2EE821J	820 ohms, 1/4W	AA	2	JKNBRO456AFSB	Button, Stop, (S)	AC
R310	VRD-ST2EE391J	390 ohms, 1/4W	AA	2	JKNBRO456AFSC	Button, Stop, (BK)	AC
R311	VRD-ST2EE331J	330 ohms, 1/4W	AA	3	JKNBRO457AFSB	Button, Fast- Foward, (S)	AD
R401	VRD-ST2CD472J	4.7 kohms, 1/6W	AA	3	JKNBRO457AFSC	Button, Fast- Foward, (BK)	AD
R402	VRD-ST2CD222J	2.2 kohms, 1/6W	AA	4	JKNBRO458AFSB	Button, Play, (S)	AC
R403	VRD-ST2CD562J	5.6 kohms, 1/6W	AA	4	JKNBRO458AFSC	Button, Play, (BK)	AC
R404	VRD-ST2CD224J	220 kohms, 1/6W	AA	5	JKNBRO459AFSB	Button, Rewind, (S)	AD
R405	VRD-ST2EE332J	3.3 kohms, 1/4W	AA	5	JKNBRO459AFSC	Button, Rewind	AD
R406	VRD-ST2CD222J	2.2 kohms, 1/6W	AA	6	JKNBRO460AFSB	Button, Record (Deck 2), (S)	AC
R407	VRD-ST2CD562J	5.6 kohms, 1/6W	AA	6	JKNBRO460AFSD	Button, Record (Deck 2), (BK)	AC
R408	VRD-ST2CD224J	220 kohms, 1/6W	AA	7	LANGF0910AFFW	Bracket, Switch (Deck 2)	AC
R409	VRD-ST2CD153J	15 kohms, 1/6W	AA	8	LANGF0864AFZZ	Bracket, Flywheel	—
R410	VRD-ST2CD103J	10 kohm, 1/6W	AA	9	—————	Main Chassis	—
R411	VRD-ST2CD472J	4.7 kohms, 1/6W	AA	10	LCHSS0204AFFW	Plate, Head	AD
R412	VRD-ST2CD103J	10 kohm, 1/6W	AA	11	LDAiH0063AF00	Head Base	AB
R413	VRD-ST2CD222J	2.2 kohms, 1/6W	AA	12	LHLDW1 075AFZZ	Nylon Band	AA
R414	VRD-ST2CD332J	3.3 kohms, 1/6W	AA	13	LRTNPO058AFZZ	Retaining Stopper	AA
R415	VRD-ST2CD103J	10 kohm, 1/6W	AA	14	LSLVMOI 78AFFD	Sleeve, Arm	AC
R501	VRD-ST2EE560J	56 ohms, 1/4W	AA	15	MLEVf1637AFFW	Lever, Eject	AB
R502	VRD-ST2EE560J	56 ohms, 1/4W	AA	16	MLEVf1638AFFW	Lever, Auto-Stop	AB
R503	VRD-ST2CD183J	18 kohms, 1/6W	AA	17	MLEVf1737AFZZ	Lever, Pause	AC
R504	VRD-ST2EE332J	3.3 kohms, 1/4W	AA	18	MLEVf1738AFFW	Lever, Play Release	AA
R505	VRD-ST2EE332J	3.3 kohms, 1/4W	AA	19	MLEVf1761 AFFW	Lever, Record (Deck 2)	AE
R506	VRD-ST2EE332J	3.3 kohms, 1/4W	AA	20	MLEVPO433AFZZ	Chip, Sensor	AA
R507	VRD-ST2CD102J	1 kohm, 1/6W	AA	21	MLEVPO502AFZZ	Lever, Pause Lock	AB
R508	VRD-ST2CD102J	1 kohm, 1/6W	AA	22	M LEVPO527 AFOO	Lever, Erase Prevention (Deck 2)	AA
R601	VRD-ST2CD1 83J	18 kohms, 1/6W	AA	23	MLEVPO602AFZZ	Lever, Fast-Forward/Rewind	AE
R602	VRD-ST2CD183J	18 kohms, 1/6W	AA				
R603	VRD-ST2CD223J	22 kohms, 1/6W	AA				
R604	VRD-ST2CD223J	22 kohms, 1/6W	AA				
R605	VRD-ST2EE561J	560 ohms, 1/4W	AA				
R606	VRD-ST2CD563J	56 kohms, 1/6W	AA				

REF.NO.	PART NO.	DESCRIPTION	CODE	REF.NO.	PART NO.	DESCRIPTION	CODE
C211	VCTYPA1 EX182 J	0.0018 $\mu$ F, 25V	AA	R128	VRD-ST2CD223J	22 kohms, 1/6W	AA
C213	VCTYPA1 EX273J	0.027 $\mu$ F, 25V	AB	R129	VRD-ST2CD472J	4.7 kohms, 1/6W	AA
C214	VCTYPA1 EX472J	0.0047 $\mu$ F, 25V	AA	R130	VRD-ST2CD103J	10 kohm, 1/6W	AA
C215	VCTYPA1 EX473 J	0.047 $\mu$ F, 25V	AB	R131	VRD-ST2CD332J	3.3 kohms, 1/6W	AA
C224	VCTYPA1 EX562J	0.0056 $\mu$ F, 25V	AA	R133	VRD-ST2CD682J	6.8 kohms, 1/6W	AA
c229	VCKZPA1HF403Z	0.04 $\mu$ F, 50V	AA	R134	VRD-ST2CD561J	560 ohms, 1/6W	AA
C230	VCCSPA1 HL471 J	470 pF, 50V	AA	R135	VRD-ST2CD681J	680 ohms, 1/6W	AA
C233	VCCSPA1 HL221J	220 pF, 50V	AA	R136	VRD-ST2CD152J	1.5 kohms, 1/6W	AA
C234	VCTYPA1 EX392J	0.0039 $\mu$ F, 25V	AA	R137	VRD-ST2CD333J	33 kohms, 1/6W	AA
C237	VCCSPA1 HL271J	270 pF, 50V	AA	R138	VRD-ST2CD680J	68 ohms, 1/6W	AA
C238	VCTYPA1 EX223J	0.022 $\mu$ F, 25V	AA	R139	VRD-ST2CD562J	5.6 kohms, 1/6W	AA
c239	VCTYPA1 EX153J	0.015 $\mu$ F, 25V	AA	R140	VRD-ST2CD151J	150 ohms, 1/6W	AA
C240	VCCSPA1 HL271J	270 pF, 50V	AA	R141	VRD-ST2CD393J	39 kohms, 1/6W	AA
C245	VCTYPA1 EX392J	0.0039 $\mu$ F, 25V	AA	R142	VRD-ST2CD333J	33 kohms, 1/6W	AA
C246	VCTYPA1 EX682J	0.0068 $\mu$ F, 25V	AA	R143	VRD-ST2CD684J	680 kohms, 1/6W	AA
C247	VCTYPA1 EX682J	0.0068 $\mu$ F, 25V	AA	R144	VRD-ST2EE471J	470 ohms, 1/4W	AA
C248	VCTYPA1 EX562J	0.0056 $\mu$ F, 25V	AA	R145	VRD-ST2CD332J	3.3 kohms, 1/6W	AA
c249	VCTYPA1 EX392 J	0.0039 $\mu$ F, 25V	AA	R146	VRD-ST2CD272J	2.7 kohms, 1/6W	AA
C250	VCTYPA1 EX153J	0.015 $\mu$ F, 25V	AA	R147	VRD-ST2CD563J	56 kohms, 1/6W	AA
C251	VCTYPA1 EX682J	0.0068 $\mu$ F, 25V	AA	R148	VRD-ST2CD563J	56 kohms, 1/6W	AA
C252	VCTYPA1 EX153J	0.015 $\mu$ F, 25V	AA	R149	VRD-ST2CD103J	10 kohm, 1/6W	AA
C253	VCCSPA1 HL681J	680 pF, 50V	AA	R150	VRD-ST2CD222J	2.2 kohms, 1/6W	AA
C254	VCCSPA1 HL271J	270 pF, 50V	AA	R151	VRD-ST2CD103J	10 kohm, 1/6W	AA
C255	VCCSPA1 HL271J	270 pF, 50V	AA	RI 52	VRD-ST2CD123J	12 kohms, 1/6W	AA
C301	VCCSPA1 HL151 J	150 pF, 50V	AA	R153	VRD-ST2CD223J	22 kohms, 1/6W	AA
C302	VCCSPA1 HL151 J	150 pF, 50V	AA	R154	VRD-ST2CD154J	150 kohms, 1/6W	AA
C304	VCTYPA1 EX103J	0.01 $\mu$ F, 25V	AA	R155	VRD-ST2CD684J	680 kohms, 1/6W	AA
C305	VCQYKA1 HM472J	0.0047 $\mu$ F, 50V, M L	AB	RI 56	VRD-ST2CD153J	15 kohms, 1/6W	AA
C306	VCQYKA1 HM472J	0.0047 $\mu$ F, 50V, M L	AB	R157	VRD-ST2CD332J	3.3 kohms, 1/6W	AA
C307	VCQYKA1 HM183J	0.018 $\mu$ F, 50V, $\pm$ 5%, M L	AB	R158	VRD-ST2CD181J	180 ohms, 1/6W	AA
C309	VCQPKQ2A A682J	0.0068 $\mu$ F, 100V, Polypropylene	AB	RI 59	VRD-ST2CD121J	120 ohms, 1/6W	AA
C403	VCKZPA1HF403Z	0.04 $\mu$ F, 50V	AA	R160	VRD-ST2CD392J	3.9 kohms, 1/6W	AA
△ C501	VCKZPA1HF403Z	0.04 $\mu$ F, 50V	AA	R161	VRD-ST2CD392J	3.9 kohms, 1/6W	AA
△ C502	VCKZPA1HF403Z	0.04 $\mu$ F, 50V	AA	R162	VRD-ST2CD272J	2.7 kohms, 1/6W	AA
C504	VCQYKW1 HM104M	0.1 $\mu$ F, 50V, $\pm$ 20%, M L	AB	R163	VRD-ST2CD682J	6.8 kohms, 1/6W	AA
C505	VCTYPA1 EX104M	0.1 $\mu$ F, 25V	AB	RI 64	VRD-ST2CD182J	1.8 kohms, 1/6W	AA
C601	VCKZPV1 HF223Z	0.022 $\mu$ F, 50V	AA	R165	VRD-ST2CD332J	3.3 kohms, 1/6W	AA
C801	VCKZPA1HF403Z	0.04 $\mu$ F, 50V	AA	RI 66	VRD-ST2CD123J	12 kohms, 1/6W	AA
				RI 67	VRD-ST2CD472J	4.7 kohms, 1/6W	AA
				R168	VRD-ST2CD103J	10 kohm, 1/6W	AA
				R201	VRD-ST2CD222J	2.2 kohms, 1/6W	AA
				R202	VRD-ST2CD333J	33 kohms, 1/6W	AA
				R203	VRD-ST2CD151J	150 ohms, 1/6W	AA
				R204	VRD-ST2CD684J	680 kohms, 1/6W	AA
				R205	VRD-ST2CD223J	22 kohms, 1/6W	AA
				R206	VRD-ST2CD333J	33 kohms, 1/6W	AA
				R207	VRD-ST2CD393J	39 kohms, 1/6W	AA
				R208	VRD-ST2CD822J	8.2 kohms, 1/6W	AA
				R209	VRD-ST2CD223J	22 kohms, 1/6W	AA
				R210	VRD-ST2CD103J	10 kohm, 1/6W	AA
				R211	VRD-ST2CD273J	27 kohms, 1/6W	AA
				R213	VRD-ST2CD103J	10 kohm, 1/6W	AA
				R214	VRD-ST2CD563J	56 kohms, 1/6W	AA
				R215	VRD-ST2CD472J	4.7 kohms, 1/6W	AA
				R216	VRD-ST2CD222J	2.2 kohms, 1/6W	AA
				R217	VRD-ST2CD563J	56 kohms, 1/6W	AA
				R218	VRD-ST2CD104J	100 kohm, 1/6W	AA
				R219	VRD-ST2CD332J	3.3 kohms, 1/6W	AA
				R220	VRD-ST2CD332J	3.3 kohms, 1/6W	AA
				R221	VRD-ST2CD105J	1 Mohms, 1/6W	AA
				R222	VRD-ST2CD473J	47 kohms, 1/6W	AA
				R223	VRD-ST2CD154J	150 kohms, 1/6W	AA
				R224	VRD-ST2CD274J	270 kohms, 1/6W	AA
				R225	VRD-ST2CD181J	180 ohms, 1/6W	AA
				R233	VRD-ST2CD682J	6.8 kohms, 1/6W	AA
				R234	VRD-ST2CD561J	560 ohms, 1/6W	AA
				R235	VRD-ST2CD681J	680 ohms, 1/6W	AA
				R236	VRD-ST2CD152J	1.5 kohms, 1/6W	AA
				R237	VRD-ST2CD333J	33 kohms, 1/6W	AA
				R238	VRD-ST2CD680J	68 ohms, 1/6W	AA

**RESISTORS**

(Unless otherwise specified, resistors are 1/6W,  $\pm$ 5%, carbon type.)

RI 01	VRD-ST2CD222J	2.2 kohms, 1/6W	AA
R102	VRD-ST2CD333J	33 kohms, 1/6W	AA
R103	VRD-ST2CD151J	150 ohms, 1/6W	AA
R104	VRD-ST2CD684J	680 kohms, 1/6W	AA
R105	VRD-ST2CD223J	22 kohms, 1/6W	AA
R106	VRD-ST2CD333J	33 kohms, 1/6W	AA
R107	VRD-ST2CD393J	39 kohms, 1/6W	AA
R108	VRD-ST2CD822J	8.2 kohms, 1/6W	AA
R109	VRD-ST2CD223J	22 kohms, 1/6W	AA
R110	VRD-ST2CD103J	10 kohm, 1/6W	AA
R111	VRD-ST2CD273J	27 kohms, 1/6W	AA
RI 12	VRD-ST2EE471J	470 ohms, 1/4W	AA
RI 13	VRD-ST2CD103J	10 kohm, 1/6W	AA
R114	VRD-ST2CD563J	56 kohms, 1/6W	AA
R115	VRD-ST2CD472J	4.7 kohms, 1/6W	AA
R116	VRD-ST2CD222J	2.2 kohms, 1/6W	AA
R117	VRD-ST2CD563J	56 kohms, 1/6W	AA
R118	VRD-ST2CD104J	100 kohm, 1/6W	AA
R119	VRD-ST2CD332J	3.3 kohms, 1/6W	AA
R120	VRD-ST2CD332J	3.3 kohms, 1/6W	AA
R121	VRD-ST2CD105J	1 Mohm, 1/6W	AA
R122	VRD-ST2CD473J	47 kohms, 1/6W	AA
R123	VRD-ST2CD154J	150 kohms, 1/6W	AA
R124	VRD-ST2CD274J	270 kohms, 1/6W	AA
R125	VRD-ST2CD181J	180 ohms, 1/6W	AA
R126	VRD-ST2CD224J	220 kohms, 1/6W	AA
R127	VRD-ST2CD273J	27 kohms, 1/6W	AA

# RT-W600H(S)

REF.NO.	PART NO.	DESCRIPTION	CODE	REF.NO.	PART NO.	DESCRIPTION	CODE
	SPAKA1 399AFZZ	Packing Add., Left			SSAKH0054AGZZ	Polyethylene Bag, Unit	AB
	SPAKC3372AFZZ	Packing Case, (S) SEEG DV			TGANG1054AFZZ	Warranty Card, SEEG DV	AA
	SPAKC3373AFZZ	Packing Case, (S) SEEG SNS			TiNSZ0782AFZZ	Operation Manual	
	SPAKC3461 AFZZ	Packing Case, (BK) SEEG DV			TLABM0184AFZZ	Label, Special Feature (Deck 1)	AC
	SPAKC3462AFZZ	Packing Case, (BK) SEEG SNS			TLABM0187AFZZ	Label, Special Feature (Deck 2)	AB
	SPAKP0274AFZZ	Protection Sheet, Panel, (S) AA					
	SPAKP0601 AFZZ	Protection Sheet, Panel, (BK) AA					
	SSAKA0024AFZZ	Polyethylene Bag, Accessories	AA				

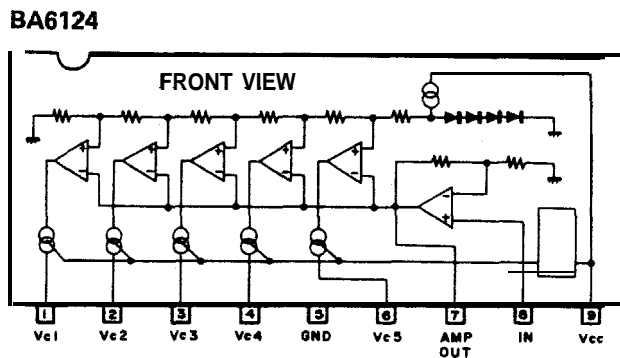
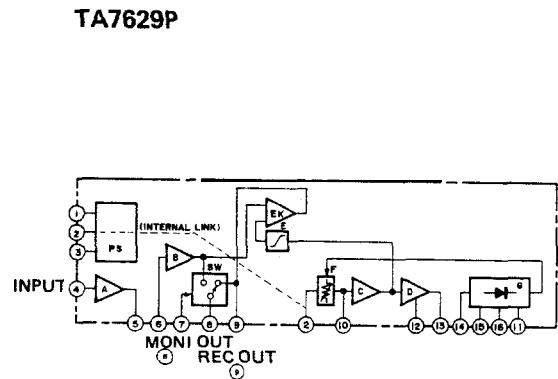
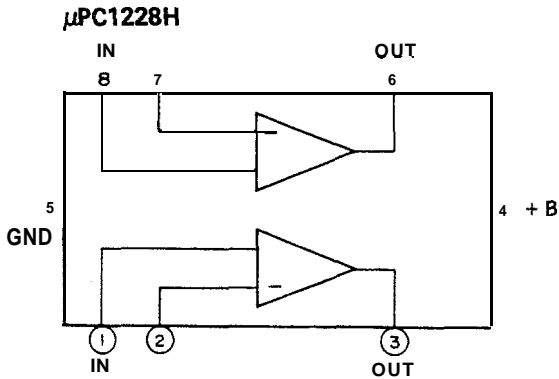

Figure 24-1 EQUIVALENT CIRCUIT (BLOCK DIAGRAM) OF IC

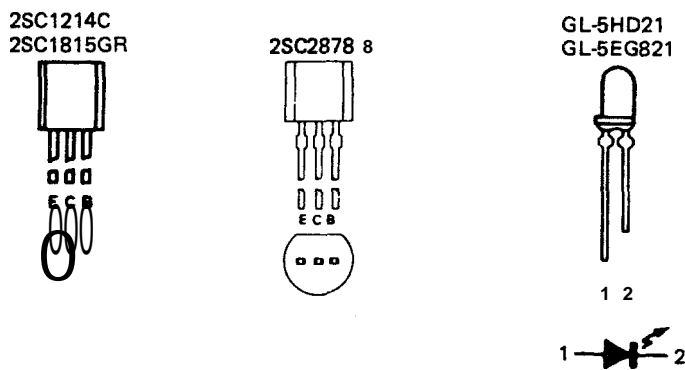

Figure 24-2 TYPES OF TRANSISTOR AND LED

A8503-4891H·KI·K

Printed in Japan  
In Japan gedruckt  
Imprimé au Japon