

**Radiotron  
UV-201-A**  
The super-amplifier  
tube \$6.50



**Radiotron UV-199**  
The little tube of big  
performance \$6.50



**Radiotron UV-209**  
The long distance de-  
tector \$5.00

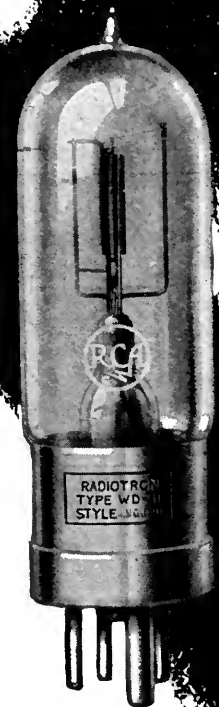

**Radiotron WD-11**  
The ideal dry battery  
detector \$6.50



**Radiotron  
WD-12**  
The standard base  
dry cell tube  
\$6.50



This symbol  
of quality is  
your protec-  
tion



# Radiotrons

## To Get Distance— and Get it Clearly

For quality of reception and length of service, every fellow wants a RADIOTRON. Experienced amateurs and broadcast listeners know the sensitivity and dependable performance of these tubes. UV-199 for portable sets because it operates on flashlight batteries, WD-11 and WD-12, the dry cell tubes, for use everywhere—especially on farms and at the summer bungalow—UV-200 and UV-201-A for use with a storage battery. There is a Radiotron for every need.

Look for the RCA trade mark, and the name RADIOTRON. Each is a guarantee of satisfaction.

**Radio Corporation of America**

Sales Dept., Suite 2066  
233 Broadway, New York  
District Sales Offices

10 So. LaSalle St.  
Chicago, Ill.

433 California St.  
San Francisco, Cal.

# Radiotrons

REG. U. S. PAT. OFF.

★ Tested and approved by RADIO BROADCAST ★

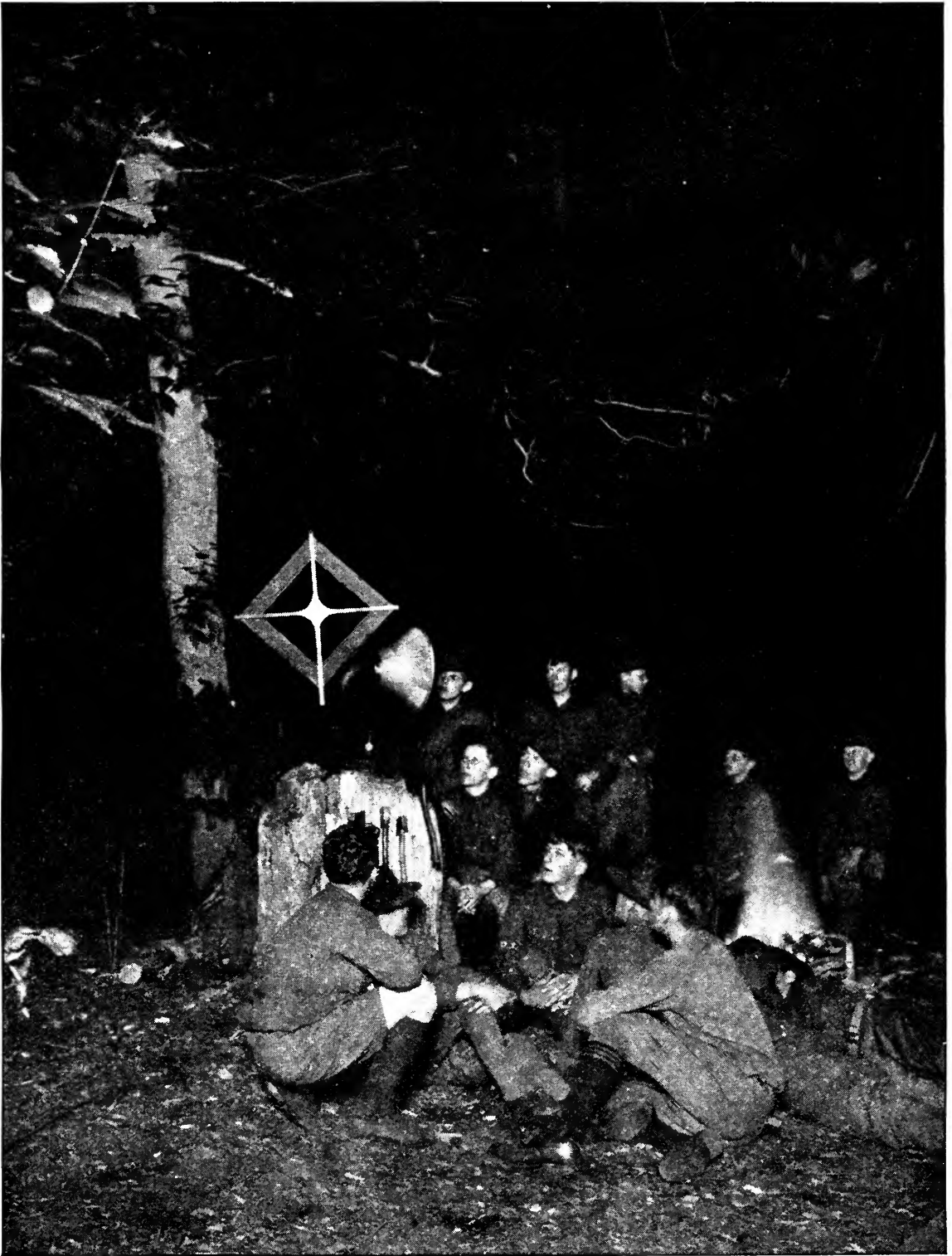

Photograph by Roger B. Whitman

“HEARIN’ THINGS AT NIGHT”

This clearing in the woods was filled with music from a four-tube reflex receiver perched on a tree-stump. The Scouts are members of Troop 55, Garden City, L. I.

# RADIO BROADCAST

Vol. 3 No. 5



September, 1923

## The March of Radio

### PRESIDENT HARDING OVER WIRE AND RADIO

**T**HE coöperation of wire and radio is undoubtedly a development which will prove of inestimable importance in putting the vast multitudes of this country in close touch with its important events. Many important happenings occur where there is no radio station, events which cannot be brought to the studio. But few and far between are the events which the telephone engineer cannot reach, if the occasion demands. The vast network of wires throughout the country is of such fine mesh that few places where anything important is likely to happen are more than a few miles from wire connection. With a good wire connection, the distant radio station is enabled to broadcast its message almost as well as if the event transpired in the studio.

We said "a good wire connection," and this means more than the average reader probably surmises. The ordinary telephone and telegraph wires are entirely unsuited for sending the voice currents to the broadcasting station. Their transmission is much too poor in quality, and in addition they pick up much extraneous "electrical noise." The engineers of the American Telephone and Telegraph Company have studied this problem in its most minute details: both theoretically and experimentally the staff has attacked the question as to what good voice transmission really is, and how to get it. They can tell you all about the different "energy levels" of

noise and voice currents for different kinds of telephone lines, and they have found out that only the highest grade telephone lines may be used in their long-distance, transcontinental circuits. Even these best quality lines must be improved before they are suitable for carrying the voice currents to a broadcasting station. The wires must be "balanced" to get rid of disturbing noises, fitted with "repeaters" which will amplify the voice currents and yet keep the original quality of the voice unimpaired, and equipped with duplicate apparatus to ensure continuity of service. All these items are being worked out in such a way that before long the telephone company will have a network of high grade "radio wires" available for operating the various broadcasting stations it will probably erect.

An excellent test and illustration of the value of this service was recently given when President Harding's speech was sent from St. Louis to New York, and there broadcasted from station WEAf. The voice currents had to travel about a thousand miles before actuating the control of the radio transmitter, yet the articulation was excellent, considering the long route taken by the voice before it reached the listener-in.

This is one of the marvels which radio engineers, with vision, have been predicting for a year or two—the President addressing his countrymen—not a few hundred or thousand in the most capacious hall obtainable,



#### SPEAKING TO THE NATION FROM ST. LOUIS

In his address of June 21st at the St. Louis Coliseum, President Harding said: "It has seemed to me that nearly every city and village, from the Potomac to the Pacific, has bestowed an invitation and a tender of hospitality. I would like to say to you, because in saying it to you I am speaking to many others in this marvelous age of communication, that I very genuinely regret the impossibility of accepting all of them. Quite apart from the personal satisfaction and renewed assurance in direct contact with our people, I think that there is vast benefit in bringing the Government a little closer to the people, and the people a little closer to the Government and closer to those temporarily charged with official responsibility."

but actually millions of them. While a conservative estimate would put the number of the President's audience at a few hundred thousand, it seems quite possible that at least a million people heard him speak. If so many did not hear him, they could have done so had they desired.

In this experiment, only a few broadcasting stations transmitted the President's speech but as soon as the high-grade telephone network can be developed economically, such a

speech will be sent out on different wavelengths by enough powerful radio stations, strategically located, so that it will be possible actually, not figuratively, for the Chief Executive to address *all* of his countrymen.

#### Still Trouble from Interference?

**I**N OUR last issue we gave out the glad tidings that "interference had been done away with"—that the new schedule of frequencies which the Department of Commerce had allotted to the various broadcasting stations has remedied all the trouble which, for so long, had harassed the radio listener.

The opinion was based first, on our general knowledge of what should interfere and what should not, and next, and more important, on the basis of our observations. As we mentioned in last month's editorial, the better class of amateurs have been able to get rid of interference even when the stations were only ten meters apart, or only five (even this very small margin being a frequency separation of about fifteen kilocycles) but these listeners were not considered when we gave it out as welcome news that the wavelength separation for closely adjacent stations in the new assignment was about fifty meters. With a good regenerative receiver this is about five times the margin necessary for non-interfering signals, but of course a good many people do not have regenerative receivers, and many of them who do are not able to make them perform as they should. With this idea in mind we investigated the interference, with the new schedule, on a non-regenerative receiver, using a triode detector and two circuits for tuning. The antenna has tuning of its own, by means of a step coil and variable condenser, and coupled to the antenna circuit (by a vario-coupler) is the second tuned circuit to which the detector is connected. At a distance of about ten miles from three stations, rated at 405, 455, and 492 meters respectively, there is no interference! Using a loud speaker, and adjusting the set to give a signal from one of the stations loud enough to be audible throughout the house, by means of the audio-frequency amplifier, the signals from the other stations were so weak that the ear had to be held quite close to the loud speaker before they were even audible. That's what we called "no interference".

In talking with one of our well known radio inspectors, however, we found that many

people still report interference; in fact, some go so far as to say the old schedule was better—that only one station should be allowed to send at a time. Of course, this is nonsense, the new schedule is a real step in advance and the Department of Commerce is to be commended in having taken it. What, then, is the matter with these people reporting interference? In general, we can say their sets are certainly not operating as they should, or else the set is too crude to be considered as a real radio receiver. Those sets made of a few turns of wire on an oatmeal box, with a crystal and telephone shunted around the coil, are not considered in this argument. Interference undoubtedly does occur in many sets of this kind, but complaints from such sources should receive but little consideration from the radio inspector trying to satisfy the public. Radio to-day has advanced sufficiently to warrant a fairly selective receiver; if the set is non-regenerative, two tuned circuits should be used, with comparatively weak coupling, and if a regenerative set is used, those operating them must study their action sufficiently to get reasonable selectivity.

To be sure, there are a few listeners who will undoubtedly report interference, even after observing all precautions. A few members of the radio audience live within a stone's throw of one of the broadcasting stations. They are really "out of luck," because the signal from the neighboring station will be able to drown out the distant stations even if the two signals are a hundred meters apart. In such cases only expert adjustment of an especially selective set, and the use of absorbing circuits, can eliminate interference. Fortunately only a small percentage of the radiolistseners are so situated.

### Preparing for Long Distance

**D**ESPITE all arguments to the contrary, we are of the belief that a great deal of the enjoyment which is to be

had from a radio receiver is found in our ability to astound our friends by tuning in a program a thousand or more miles away for their particular benefit. This mild method of "showing off" is sure to find disciples among us mortals for some little time to come.

There is something fascinating about hearing a concert from a long way off, and the pleasure does not seem to wane with familiarity. Some of the old ship operators spend much of their spare time listening for distant broadcast stations, much as the proverbial letter carrier, on his day off, takes a little walk. Among the radio manufacturers, merchants, and writers whom it is our privilege to know, there are many who feel a holiday or a vacation incomplete unless they have a radio receiver with them in order to compare the reception at distant points with the results they obtain at home.

And now, when the days are still long and there is more time for us to devote to radio than is possible in winter, would it not be wise for us to give a thought to the long-distance receiver we will want for use when the weather makes the care of a good fire and radio a most attractive pair of indoor sports?

Now is the time to begin work on that power amplifier, or super-heterodyne, or reflex receiver for use at home or in connection with various jamborees to be held by the sons or daughters



AN INTERESTED GROUP AT LONG BEACH, L. I.

Frank M. Squire, Chief Engineer of the De Forest Company, (standing just behind the bulldog) is trying a new model receiver, developed by him, which works a loud speaker from the small circular loop shown just to the left of the horn

of Something-or-Other to be given in the fire house or the town school next winter. Dancing to music played by an orchestra a thousand miles away is now possible—if you have the proper receiver in good shape. Are you putting your radio house in order for the good times that are coming?

### “Deaf Ears Hear Again”

**T**HERE have recently appeared several reports to the effect that people who have been deaf all their lives have been able to hear by means of radio apparatus; and the achievement was heralded as one of radio's greatest triumphs. We pointed out that a mistake had surely been made—sound was sound, and after the sound waves had left the diaphragm of the telephone it was a matter of no consequence to the ear drum whether the vibration of the diaphragm was caused by a radio signal or by ordinary wire telephone currents.

It seems worth while to point out this fact again in view of the importance given by

reliable newspapers to such articles as the one before us—“Deaf ears hear again through the magic of radio.” As the article consists largely of an interview with a deaf person who *had* heard radio signals the article is apparently a confirmation of the idea conveyed by the headlines.

How then does radio help these deaf people? Simply in this way: in the development of radio it has been found necessary to have amplifiers, the same kind of amplifiers as have been used for the past ten years by the telephone engineers in all their long-distance lines; by means of these amplifiers, which the average person naturally thinks of as radio, extremely loud sounds can be produced, as witness the loud speakers frequently used in large lecture halls by the “public address” engineers of the telephone companies. Now evidently amplifier systems are exactly what the average deaf person needs. Probably many “deaf” people are not absolutely deaf—loud enough signals might well be audible to them no matter how hard of hearing they might be. This is what radio

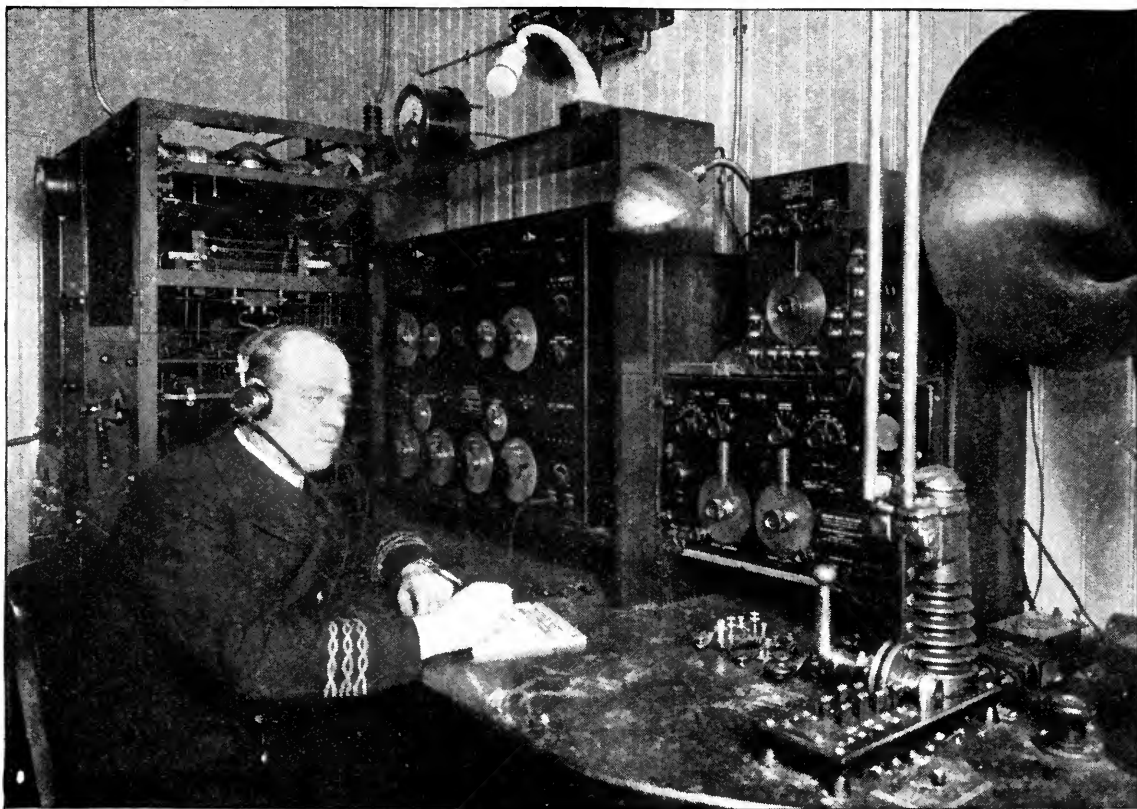

CHIEF RADIO OFFICER E. N. PICKERILL IN THE OPERATING ROOM OF THE “LEVIATHAN”  
Uninterrupted service with points 3,000 miles away is claimed for this ship's radio apparatus



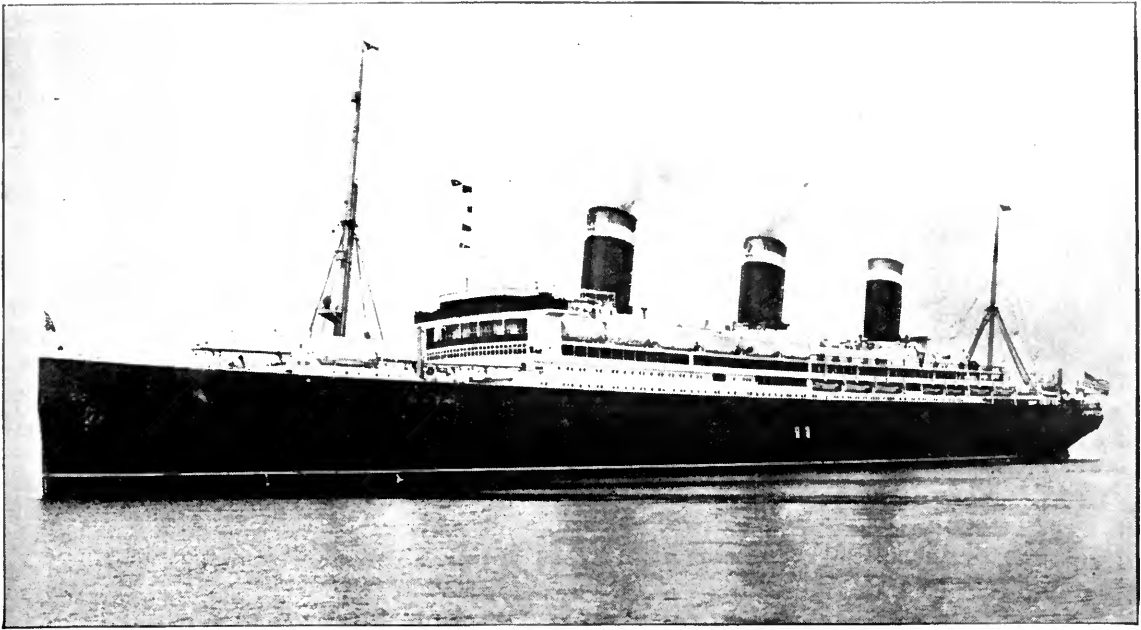

© Underwood &amp; Underwood

THE "LEVIATHAN"—SHE CARRIES THE MOST POWERFUL RADIO EQUIPMENT OF ANY SHIP

The "duplex" system of radio telephony, whereby conversations may be carried on as over a land line—without changing from "send" to "receive"—has been installed on this floating hotel by the Radio Corporation

is doing for the deaf; enabling them to apply to their ear drums signals perhaps ten thousand times as loud as the ordinary person requires for normal hearing. Such amplifying systems are entirely apart from radio in the strict sense of the term, however. The same apparatus attached to the ordinary telephone line would permit the deaf to hear ordinary telephone conversation perfectly well, and yet this would evidently not be an achievement of radio.

We must remember, however, that radio makes available to the deaf, concerts, programs, and speeches, in such form that the amplifying apparatus is able to strengthen it sufficiently for their hearing. Thus even though the radio waves, as such, do nothing to make the deaf hear, the apparatus associated with radio has no doubt proved a great boon to them. If one is very deaf, a good deal of amplification is necessary; one person known to us has a five-tube amplifier, and wears head phones! As he says, "it costs money if you're very deaf." So delighted was he actually to hear that he burned up two of his tubes the first hour, trying to increase this amplification.

A real advantage of this use of the amplifier is that by using the head phones, the deaf person can have his signals as loud as he wants them; yet people around him are not disturbed,

or even aware of the extremely loud signal to which he is listening.

It is possible, too, that the continued use of greatly amplified signals beating upon the ear drums will cause the organs associated with hearing to improve, due to exercise. We know, for instance, that a broken arm or leg, after being held in a plaster cast for a long period is difficult or impossible to use immediately after the cast has been removed. But when the newly knitted member is exercised periodically, the muscles gradually become stronger and we find that the member may be used quite as well as it could before the period of inaction began. Some interesting experiments are being carried on, taking advantage of this method for improving hearing, and some favorable reports of the results obtained have reached us. It is a very worth-while undertaking and should be encouraged.

#### Marconi Making Progress With His Short Waves

**A**BOUT a year ago Senator Marconi reported before a joint meeting of radio and electrical engineering societies, at a meeting in New York City, his interesting and apparently promising experi-



A COIN-BOX BROADCAST RECEIVER IN PARIS

In some of the Parisian cafes, movie houses, hotels, and other public places are now found "Radio-Automatic" stations at which any one may listen-in on broadcasting programs for a few centimes, at times indicated on a chart hung near the instrument

ments in short-wave radio. He showed experimentally how the short waves could be reflected by an "electrical mirror" and sent in any desired direction, like light waves, and how easily they might be absorbed. There was nothing new in these special experiments, Hertz having done exactly similar ones in his laboratory thirty-odd years previously, but the experiments did indicate to the large and enthusiastic audience how Hertz's laboratory experiments on short waves might be turned to practical use. It was evident to every one that if radio waves could be confined to one direction, instead of spreading out in all directions, much less power would be required and much interference would surely be eliminated.

From a recent interview given by Marconi to the London press it appears that he has been applying himself to the problem with very successful results. Although he did not mention short waves as the means he employed, reading between the lines of his interview, we are forced to conclude that such was the case. "We have transmitted messages up to a distance of 2,500 miles, not only with much smaller power, but also far more cheaply than with the ordinary system of long-distance

wireless," he said. "To send the message 2,500 miles took less power than the ordinary message from London to Paris. . . ."

Our best wishes are extended to the radio pioneer in this new field he is developing. We should ourselves be doing more, in this country, to open up this unexplored, but very promising, field of radio transmission.

### Radio an Auto Accessory in Jolly Old England

EVERY potential buyer of a modern motor car knows that long list of "accessories." They bristle all over the specification; they crop up in the selling price; but in the car itself they are models of unobtrusiveness. Some of them are absolute necessities: a good many of them are not. Attractive accessories, contrived to add just a degree more of comfort and convenience for the user, are constantly being devised by makers who see in them an additional something to sell.

It was therefore to be expected that with the recent rapid development of wireless broadcasting and the perfection of portable "listening-in" sets, motor car manufacturers would soon be considering the adaptability of yet another luxurious accessory. The Daimler Company was quick to realize the possibilities of carrying a portable wireless set on its cars, and the Marconi Company, doubtless with business prospects also in mind, has combined with it to overcome some of the technical problems involved.

In October of last year two Daimler landaulettes made a reasonably successful experimental run from London to Chelmsford and back, fitted with an installation which appears crude in comparison to recent achievements. Their biggest problem was, of course, the antenna. As everyone who is interested in wireless is aware, the height of the antenna which picks up the transmitting station's signals has a great bearing upon the ability of the vacuum tube to produce clear sounds in the receiver. A traveling motor car is, obviously, no place for an antenna of more than insignificant height, so that the first experiments were made with an ingenious contrivance, shaped rather like a catherine-wheel, and mounted pivotally to the roof of the car. This was actuated by a small hand wheel which rotated the antenna through a certain number of degrees, and so



was able to obtain the best results from signals coming from all points of the compass. By this means a directional value was given to it, which compensated for loss of height. When not in use it could be folded down to lie flat upon the roof of the car.

In any case, the antenna was unsightly and very much in the way, so the experimenters quickly evolved a flat antenna consisting of a copper plate, suspended and insulated from the luggage rail on the car top at eight points. This, it was found, overcame all the receiving difficulties and proved actually more efficient than the frame antenna. Later it was found possible to build it into the car between the coachwork of the roof and the upholstery. From the centre of the lower side of the copper plate, lead-in wires passed down to the receiving set within the car.

In the earlier models, the tuning apparatus was in the form of a vertical projection, rather awkwardly placed, and having three

controls. This has been replaced by an eight-tube receiving set (five radio-frequency, a detector, and two A. F. amplifiers), neatly and compactly enclosed in a small upholstered box to the left of the back seat. Four people can listen-in on this set at the same time, using either one of the light single earpiece receivers provided, or, if they prefer it, the ordinary double head-phones.

Another problem was the disturbing influence set up by the ignition apparatus of the car itself. Each spark-plug was found to be a miniature transmitter, throwing off waves which could plainly be heard in the receivers. This has been overcome by enclosing the magneto in a copper box, and each spark plug in a copper sheath. Moreover, each high tension wire is run through a flexible copper casing, the copper in every case serving to ground the disturbing waves and minimize their effect.

As a motor car is insulated from the roadway by its tires, the next problem was to devise an

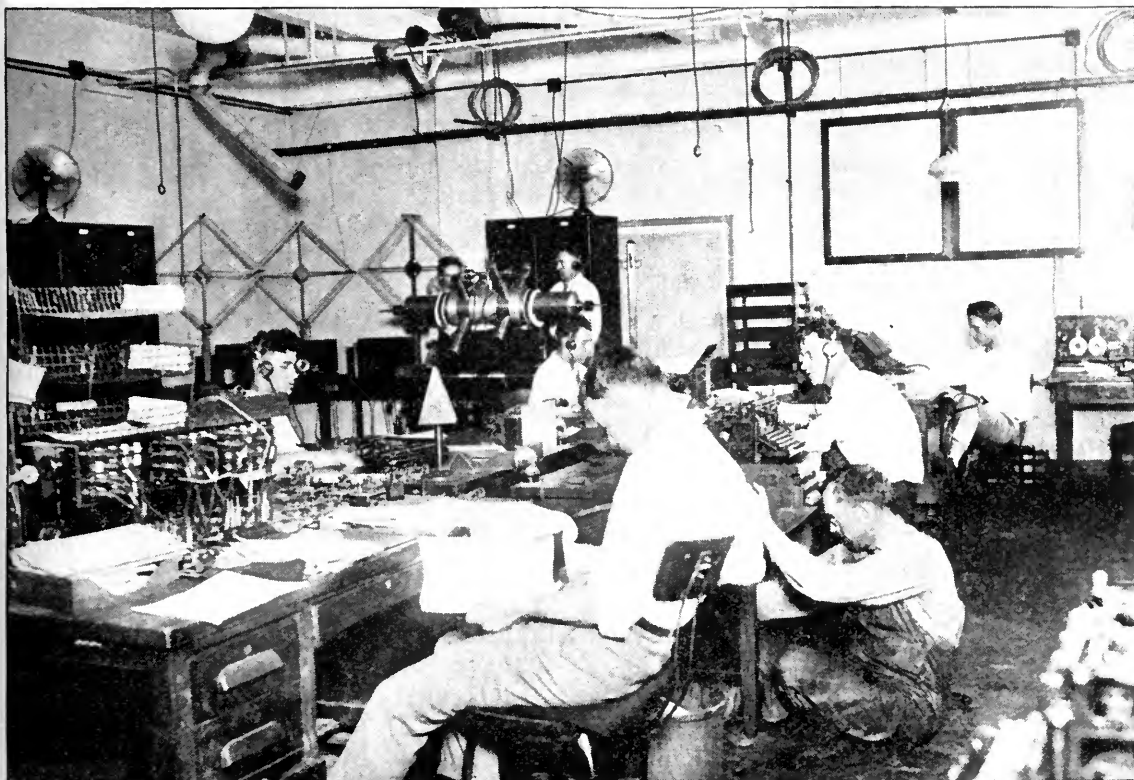

© Harris & Ewing

#### HERE MESSAGES ARE SENT AND RECEIVED THROUGHOUT THE WORLD

The Radio Central room of the U. S. Navy Department. Communications are transmitted to Lyons, London, Balboa, and to fleets operating near Constantinople. This station has picked up a message from Cairo, Egypt. The "clarophone," or static eliminator, invented by W. J. Scott of the Navy Department, is seen in the background (small cylinders projecting from a large horizontal cylinder)

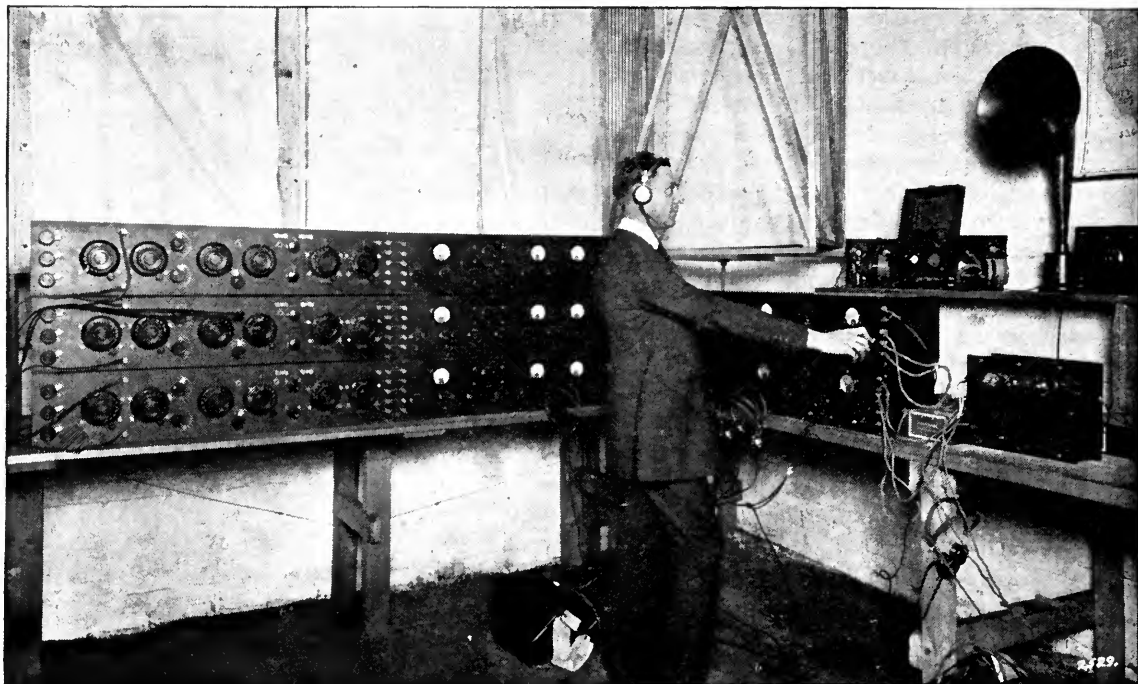

#### RECEIVING FIVE CONCERTS AT ONCE WITH SUPER-HETERODYNES

Claude Golden in the Research Laboratory of the Experimenters' Information Service, New York, tuning in on Pittsburgh, Chicago, Schenectady, New York, and Cleveland

efficient "ground." They soon found that the frame of the car made what is called a "capacity ground," which, although not so efficient as a true "ground," served the purpose very well indeed.

The A and B batteries and valve panel are neatly and cleverly put away out of sight between the floor-board and the chauffeur's seat. No technical knowledge whatever is required to operate the tuning controls contained in the small upholstered box to the left of the back seat: only the simplest operations are necessary to achieve excellent results.

So efficient has this apparatus proved that the Daimler Company proposes to build plate antenna into the roofs of all their cars as standard fittings, so that the purchaser who wants to install a wireless will have his antenna ready at hand.

The Daimler Hire Ltd., of London, has already installed sets in fifteen of its fleet of 250 cars, and so great has the demand been for them, that the company is busily engaged in fitting more. "2LO," the London station of the British Broadcasting Company has been heard clearly and distinctly from Southampton on one of these cars, while only the other day

a car on the road in the neighborhood of Uxbridge picked up signals from a station at Newcastle.

As an "attractive accessory," the wireless set has undoubtedly come to stay: how soon the portable transmission set follows it remains to be seen. At the present rate of development, what is now but an ingenious pastime may soon pass into the sphere of commercial usefulness.

#### "Frate Sole" Is Carried Across Continent to Composer's First Instructor

PROBABLY not more than a dozen persons were cognizant of the drama of the air that, according to the *San Francisco Chronicle*, was enacted recently, when Giuseppe Bartalo, aged teacher of Luigi Mancinelli, author of the motion picture opera "Frate Sole," which was presented at the Civic Auditorium in San Francisco, heard in New Orleans his pupil's last composition, broadcasted from station KPO in San Francisco.

It was Bartalo who, many years ago, shaped the musical foundation of Luigi Mancinelli in far-off Milan, when the little boy with the

serious eyes came to him for his initial instruction. Proudly he watched the fruits of his labors, as Mancinelli developed into a composer whose operatic and symphonic scores were familiar to thousands.

While Mancinelli was climbing to fame, Bartalo was establishing himself in America. The roads of pupil and teacher parted. Mancinelli rose high in his profession, but he never forgot the instructor to whom he owed his early training and encouragement. Frequently he wrote him, and sent him copies of his newest scores. And Bartalo's breast would swell with pride, and he would tell his friends tales of his Luigi as he always remembered him.

In 1922, Mancinelli died. Bartalo was heart broken. He collected all of his pupil's works that he could find. But some of the latest works he overlooked, among them, "Frate Sole," which he had never heard. No more had America. When arrangements were made to bring "Frate Sole" to this country, no one thought of little Bartalo, down in New Orleans.

When a special concert was arranged through station KPO, so that the radio world might hear a fragment of the dead composer's work, friends recalled the aged maestro. Telegrams were exchanged between San Francisco and New Orleans. As a result of them, little, old, bent Giuseppe Bartalo sat at a receiving set half across the continent, and with tears streaming down his cheeks, as he later explained by telegram to KPO and to his friends, heard again the living fire of "Little Luigi."

### Private Radiophone Communication

A RECENT announcement from the Bell System's engineers states that the famous radio link in their telephone network, connecting Los Angeles with Catalina Island, is soon to be abolished, as the radio service is not as economical as the cable service between these points. Having found the Key West-Havana cable service satisfactory, the telephone company has decided to put a cable to Catalina. But before dismantling the radio plant the engineers have been experimenting with a scheme for private radio telephone transmission—a scheme such that any one not "in the know" could not decipher it. The experiments are said to have been successful to the extent that the average receiving set could hear nothing intelligible from the station. It seems, however, that one skilled in the art

could soon adjust his set to pick it up. The system, we judge from the interview the engineers gave, is not similar to Marconi's directive radiation scheme but probably one which broadcasts the radio signal without the carrier wave; as this is necessary to make an intelligible signal it must be put back into the signal at the receiving station and if one did not appreciate this fact, the speech would indeed be "private." If our guess is correct, this scheme is far from being private because it would not take long for the average listener to learn what to do to his set to put the requisite carrier wave back in to the received signal.

### Service is Necessary

IN YOUR own sphere of acquaintances how many people have you known, who, after procuring a radio receiver, could secure anything like satisfactory results before you or some other person versed in operation showed them how to adjust the knobs properly? Again, how many of these same acquaintances could make head or tail out of the instruction book they received with their outfit—if, indeed, they received one?

Inquiries of this nature among our own acquaintances have brought home the need for reliable service with every radio receiver put in the home. We believe that the reliable radio dealer a year or two from to-day will find that the sale of one or two standard lines of complete receivers will pay him well enough to allow a fair profit above his expenditures and permit him to give the desired service at a comparatively low figure. As in the automobile business, it will be possible for him to make a definite charge for service after the guarantee period has passed. And it is more than likely that the cost of supplying service on newly installed machines may be kept down to a minimum by sending a representative, capable of instructing the purchaser, to check up each installation and show its owner how to secure the best results from it.

Along with the idea of service comes the thought that much of the high-class radio business of the future will be done on the time payment plan, and the merchant who can secure proper financing and is willing to convert service from a liability to an asset by advertising it properly has his finger on the latch that will open the door to prosperity for him.

J. H. M.



CHRISTMAS DAY AT THE HOME OF 6KW  
Office building at the Tuinucu Sugar Company plantation

## Set-Backs and Come-Backs at 6KW

A Story of the Building and Operating of the Well-Known Amateur Broadcasting Station in Tuinucu, Cuba

By FRANK H. JONES

**I**N 1920, when the Westinghouse Company first started broadcasting from KDKA and WJZ for local listeners, I surprised them as well as myself by picking them up clearly here at Tuinucu, Cuba—a distance of 1,250 miles—with a single-tube regenerative circuit. Later, I added audio-frequency amplifiers and we were dancing to music transmitted by these stations before they could believe they were reaching out more than a few hundred miles at best. But the joke was really on me, for I thought they must be using at least five or maybe ten kilowatts, and you can imagine my surprise when I found that they were not using more than  $\frac{1}{2}$  kw. We heard them so well at times that for all the 1,250 miles from KDKA and 1,375 miles from WJZ, the

thought took root in my mind that maybe I could reach out half that far with a set, say, of 100 watts, carefully constructed and accurately adjusted.

In December, 1921, I decided to make the plunge and thought that all I had to do was order what I wanted, set it up, and proceed to startle the world. I ordered all the necessary apparatus to make a 100-watt set, using Kenotron-rectified current on the plates—that is, two 50-watt oscillator tubes and two 50-watt Kenotron rectifier tubes, planning to use magnetic modulation, this being considered simple and easy to operate.

This was about the time when broadcasting started to boom, and I then had my first of a series of disappointments. It was almost

exactly a year before I was able to get together, down here in Cuba, all the necessary parts for that first transmitter. First a few sockets came, and some transformers; then a long wait and some condensers and Kenotrons; then another long wait and some more condensers and the Radiotrons. Then I would find that one tube had arrived with a broken grid and another with a broken filament. It's a long way down here and the boxes receive lots of rough handling. It seemed as though the fates were against me, but finally the great day arrived when I had all the stuff I needed *at the same time!*

Of course I had already put up an antenna, having planned to transmit on about 300 meters. I used an inverted L 200 feet long with a series condenser to get down to 300 meters. I did not have a thermal galvanometer wavemeter, but just a buzzer device which I had used to calibrate my receivers, and I had expected to be able to employ this by using my calibrated tube receiver as a wavemeter with phones. It was truly an exciting moment when I first turned on the current with fond expectations of having to buy a new antenna ammeter so the reading wouldn't go off the scale (I had a meter reading 0-5 amperes.)

I was glad I had no expectant audience, for the meter needle never budged a hair's breadth.

Then followed industrious retracing out of circuits and rechecking approximate calculations I had made on the various values of capacitance and inductance to give me the 300-meter wave. The circuits all checked up O. K. From then on I sweat blood. I'll bet, if I tried one combination of capacitance and inductance in the various high-frequency parts of the circuit, I tried 999,999. Remember, I had no laboratory testing meters and apparatus and so had to try various combinations—and try them carefully—so as not to burn up any apparatus. Well, to cut this part of the story shorter, I'll say that I finally made a very slight change in the inductance value of one of the coils, and lo and behold, I had a radiation of about two measly tenths of an ampere! Eureka, I was getting along.

But what was the wavelength?

I could hear the ding thing *all over* my receiving tuner.

"*Que pasa?*" as we say in Spanish.

Had the manufacturer forgot to send the wavelength, or had there, somehow or other, sneaked in too many?

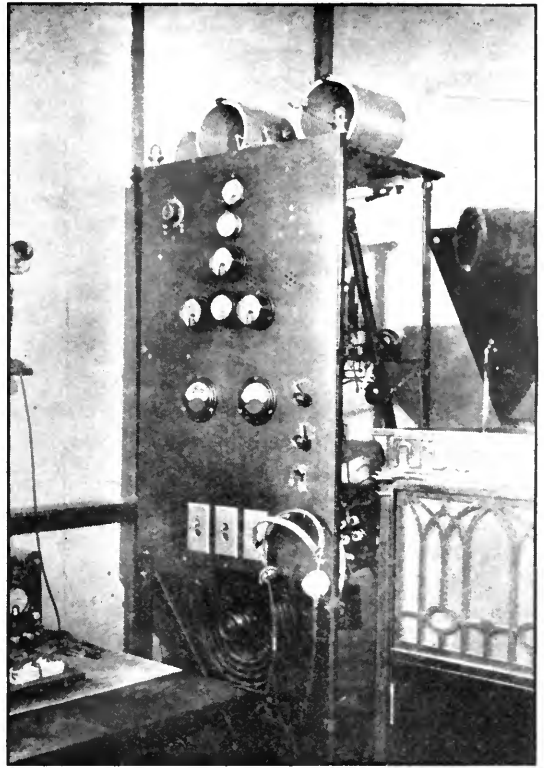

THE TRANSMITTER PANEL AT TUINUCU

Well, finally, after deep, heavy, thinking, I decided my radiation (?) was principally on a wave somewhere around 228 meters. I asked a friend living about 1,000 feet away, if he could hear me, and he said yes, so then after calibrating his receiver, I asked him to let me know what wave I was radiating. He said he didn't think it was a wave at all, but sounded more like a buzz-saw.

Some people always try to be funny when you're serious.

I finally wrote to my good friend Pierri of R. C. A. and upon his advice got a thermal galvanometer wavemeter. Oh boy, that's the finest piece of testing apparatus I ever had my hands on—quick and easy to operate—but they sure dent your pocket-book. With it I began to get somewhere. I found I was really radiating fairly sharply on 250 meters. It's some satisfaction to know where you're at, even if you don't know how you got there nor where you go from there.

After making 'steen thousand more trials and combinations (incidentally burning out only two 50-watters), I finally boosted my current in the antenna to  $1\frac{1}{2}$  amperes.





MR. JONES AT HIS RECEIVING STATION

From here the telegraph transmitter, located in another room, is operated by remote control. I.C.W. (interrupted continuous wave) transmission is carried on under the call letters 6XJ, on 275 meters

*Viva Cuba, viva yo, viva everybody!*

I then seemed to be stumped. But I came across an article in a magazine that said an earth was the poorest kind of a ground, or something like that. My pocket-book was already getting flat and I couldn't think of importing any special dirt from U. S. dealers who "guarantee" everything to add 100 per cent. efficiency to everything. We had lots of dirt here, and I had always thought it was pretty dirty dirt; but apparently as a ground it didn't speak the right language for radio.

Curtain after great gloom.

Scene Two: Same as before.

Enters the hero, "Jack Counterpoise."

Well, to come down to earth (grounds) again—I read many lines on how *not* to construct a counterpoise and then discovered I would have to cut down all the nice trees around our bungalow, and move the house away and level off the ground.

I consulted my wife.

Result: house stays where it is and trees also. Then I wished that my little son Vincente would turn out to be a second G. W. Without giving him any hints, for one has to be honor-

able with one's wife, I gave him a nice nickle-plated hatchet for his birthday and told him he mustn't cut the trees. (Tough luck, he obeyed.)

My wife said she had read lots of things in books that she knew were not true, so maybe the ones who wrote about counterpoises didn't know everything, either. She said, "Why don't you put up your old counterpoise contraption *over* the trees and *over* the house."

So I did.

I don't know by experience what a theoretically good counterpoise could do to my set, but anyway, the one I put up over trees 'n everything, boosted my antenna current right off the bat to  $3\frac{1}{2}$  amperes on straight C. W., on 275 meters; and then to around  $4\frac{1}{2}$  on 342 meters after I had made a few thousand more adjustments.

Now I connected in the magnetic modulator which brought the current down to around 3 amperes after re-tuning. The phonograph was then started and my friend about 1,000 feet away was asked how it sounded. He said it didn't sound at all, it buzzed. I asked him if it buzzed like a saw-mill and he said no . . . it buzzed like about ten saw-mills.



I then wrote down in my log, "Communication just received from one thousand feet away saying we are coming in loud—'Can hear you all over the house.'"

I was surely "radiating" now.

"Can you hear the music?" I asked him.

"Yes, maybe," he came back, "if you could shut down the saw mills."

Some people are so unappreciative.

Well, naturally, I decided the filter circuit must be leaking, so I added more condensers and filter coils, took some out here and put them there and after trying many combinations I finally found I could eliminate most of the 60-cycle hum by proper adjustment of the filament-tap return on the tank inductance. I was then using circuit No. 5 of the R. C. A. catalogue.

My first report was from a sugar mill about 80 miles from Tuinucu, using 342 meters. My friend, Mr. Leonard Fox, the manager there, and a fellow radio fan, said he heard me fairly loud with quite a bit of hum.

With this arrangement I experimented and transmitted for about two months, finally greatly improving the modulation by bridging a variable condenser around the secondary of the magnetic modulator with a value of

about .003 mfd. This, also, cut out a lot of the remaining 60-cycle hum. I was then being heard all over Cuba, with maximum distances in Cuba from Tuinucu being around 300 miles.

Friend Pierri of the R. C. A. then suggested that I try the same set using one 50-watt tube as oscillator and one 50-watt tube as modulator, adding the necessary choke coils and making a slight change in the wiring circuit. This gave me  $2\frac{1}{2}$  to 3 amperes in the antenna on 310 meters, and letters began to come in from points in Florida, U. S. A. saying they were hearing me quite clearly. After that, I added a 5-watt tube as speech amplifier in front of the modulator tube and all during December of 1922 and January, February, and to March 1, 1923, my 50-watter, so arranged, was heard quite consistently all through the Southeastern states with a goodly number of reports from Pennsylvania, New Jersey, New York, and Porto Rico.

While I was still fussing around trying to get rid of my 60-cycle hum, an enthusiastic (?) listener wrote me in Spanish asking if I would kindly do my transmitting during the "madrugada" (midnight to morning) as he wanted to listen to KDKA and my battery of saw mills "distracted" his attention.

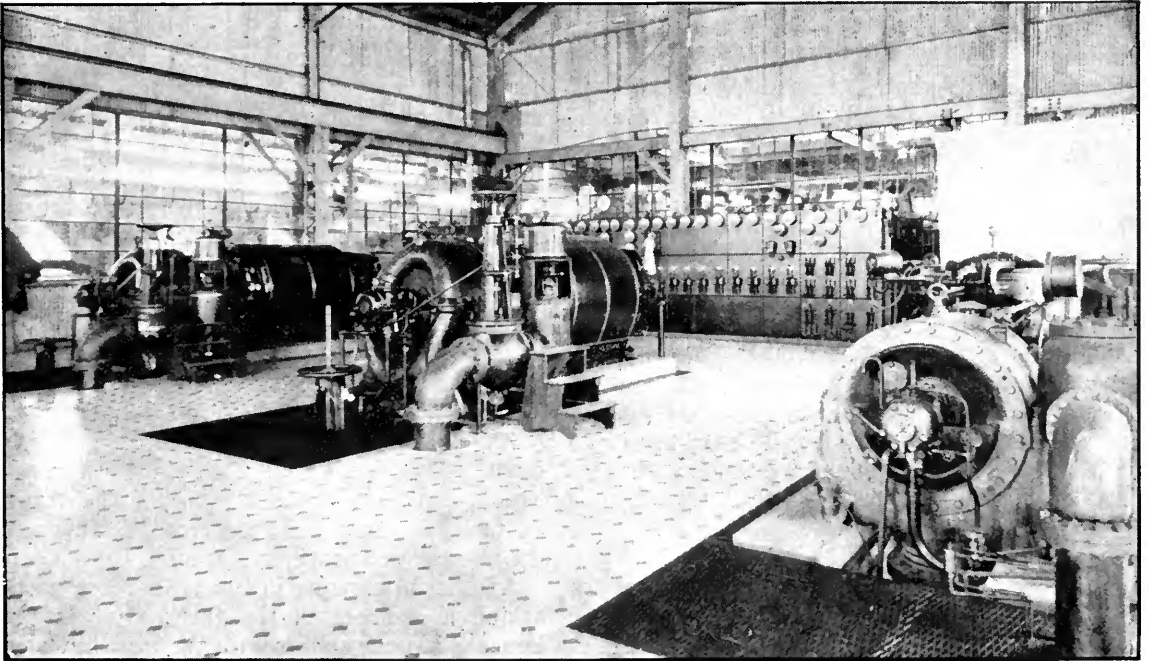

THIS IS WHERE THE "JUICE" ORIGINATES FOR 6KW

As the power plant of an amateur's broadcasting station, this would indeed be imposing, but it is first and foremost the power plant of the Tuinucu Sugar Company, of which Mr. Jones is chief electrical engineer

These Spanish people are *very* polite.

*Caramba, pensé yo, mi idea original era tener un trasmisora de 100 vatios. Voy!!*

So I squeezed my pocket-book again and bought some more tubes, coils, condensers—and a 1000-volt D. C. generator. No more 60-cycle hum for me, and with 'D. C. you don't have any hum to filter out, oh, of *course* not!

More waiting.

I swear to goodness, from the time it takes to get this kind of apparatus down here, one would think that every one of a million people in the U. S. A. were building transmitters also.

Considerable difficulty was encountered at first in eliminating the hum caused by the commutator ripple of the D. C. generator, but this was finally almost perfectly accomplished by using about 9 mfd's across the D. C. and some additional filter coils as shown in the circuit (page 374).

The antenna current on 315 meters with 900 volts on the plates is  $3\frac{1}{2}$  amperes, and this increases to  $4\frac{1}{2}$  during speech or music. I now transmit concerts on 315 meters and my broadcasting license, under Cuban laws, allows me to use from 300 to 360. The call letters of this license are 6KW. It is a Cuban class "C" station.

I am also a member of the American Radio Relay League and this summer I hope to open up traffic between Porto Rico and Cuba and amateurs in the U. S. A. I have also a class "B" license which down here is for amateur phone and C. W. telegraph. No spark transmitters are to be allowed in Cuba. Move along, you rock-crusher operators in the States and don't let Cuba lead too long. Don't try to sell it to some newcomer, just bury it and stand the loss and your new C. W. set will more than pay you. I know—I used to have a spark set way back in 1907. My class "B" license call number is 6XJ, and I shall use I. C. W. on 275 meters. Next winter I shall use straight C. W. for work with England and France.

Ye Gods, when I think back. . . . With my old spark set of 1 K. W. rating, I used to get 50 to 75 miles when she was "good" and I take off my hat to the boys who get such fine DX work on only 20 watts.

I first tested out my new 100-watt set on March 9, 1923, and had previously advised a

friend, Mr. Donald Hutchinson of North Tarrytown, N. Y. to be listening for me. He cabled next morning that he heard me so loud and clear that he couldn't comfortably use the headphones.

The modulation of Station 6KW has been reported good from Dakota to St. Johns, Newfoundland, signals clear, wave steady, and good volume. Literally, thousands of letters have been received from enthusiastic listeners, and I do think that for 100 watts it gets out very well.

I have many letters from Canada. Hundreds up there have reported 6KW louder and clearer than some of their good-sized local stations. I don't pretend to explain this. Perhaps someone will come along and explain away the mystery. 6KW has been heard many times with consistent volume and clearness in every state east of the Rocky Mountains; in Canada, in every province from Saskatchewan to Newfoundland.

St. John's is 2,500 miles from Tuinucu. Reports have come from all over Cuba, of course, Porto Rico, Hayti, Jamaica, Mexico, Central America, and throughout the Panama Canal Zone. I don't believe they have any receiving sets in the northern part of South America, for from there to Tuinucu it is only 900 miles, and I have no report as yet from South America.

The koo'ing of a cuckoo bird is reproduced between numbers during concerts and the slogan which I adopted is "If you hear the 'koo' of the cuckoo, you are in tune with Tuinucu, Cuba."

A perusal of the letters received by a broadcasting station reveals some curious phases of psychology. On one night when I transmitted nothing but phonograph records, I only announced "phonograph record" after one particular selection. A man wrote in saying that he liked all the orchestra selections, but that he did not like "the phonograph record" and never did like phonograph records over the radio. My experience is that eight out of ten people can't tell the difference, if the transmitter is working well, the record is new, and the microphone properly placed.

Another man wrote in from the frozen north asking if I operated the transmitter in pajamas! No one suffers with the heat in Cuba. Sunstroke is practically unknown. One is usually comfortable at night with a light blanket on the bed.





THE STUDIO IN MR. JONES'S HOME

Many listeners-in pleaded to have me open a bottle of champagne in front of the microphone and let them just hear the "pop."

We have winds here in Cuba that play havoc at times. You may look at your antenna in the morning and think what a beauty it is; and the next night it's on the ground, maybe, masts and all. Then we just heave to, and put it up again and "nothing to do till to-morrow."

And lightning during the summer months, WOW! Several times I have seen all the incandescent street lamps light up with a heavily charged atmosphere here during storms. You can open your antenna grounding switch  $\frac{1}{4}$  inch many times with a clear sky and a continuous stream of  $\frac{1}{4}$ -inch sparks will flow from antenna to ground. Once my antenna was found all tangled up in a tree a quarter of a mile from its home.

The Cuban government first assigned me 5KW and after I had been announcing this for about a week they changed it to 6KW. The numbers refer to the Provinces. No. 1—Pinar del Rio; Nos. 2, 3, and 4, Havana; No. 5, Matanzas; No. 6, Santa Clara; No. 7, Camaguey; and No. 8, Oriente.

I transmitted for several months before I had call letters, but I had a special permit, so, while I was OK legally, it caused many dis-

cussions in the States as to why the station of "Frank H. Jones" never signed off with call letters.

Naturally musical talent is hard to obtain here in the "woods" as one might say, but we very frequently have orchestras here from nearby towns for dances in the "*Sociedad*", "*Escuela*", or the manager's house on the plantation. I have put up private metallic circuits to all these places running to my house and also from our "park" and all the concerts and dances and "doings" in these places I can transmit.

The Cuban Government also authorized 6KW to broadcast officially the weather report which is telegraphed to me daily from the National Observatory. I pick up also in the early evening, many bits of news by radio from the States and sometimes I broadcast these.

Tuinucu (pronounced Too-e-nu-koo) has been spelled no fewer than hundreds of different ways, some listeners even addressing their cards "Stoni-cove," "Cuni-kuk," "Cookuticuk," "Punicu," "Sonnicu" and "Boomicu." My wife gets the most fun reading these addresses. Tuinucu is the plantation town and home of the Tuinucu Sugar Company cane-sugar mill. It is located almost exactly in the centre of the island of Cuba about eight miles

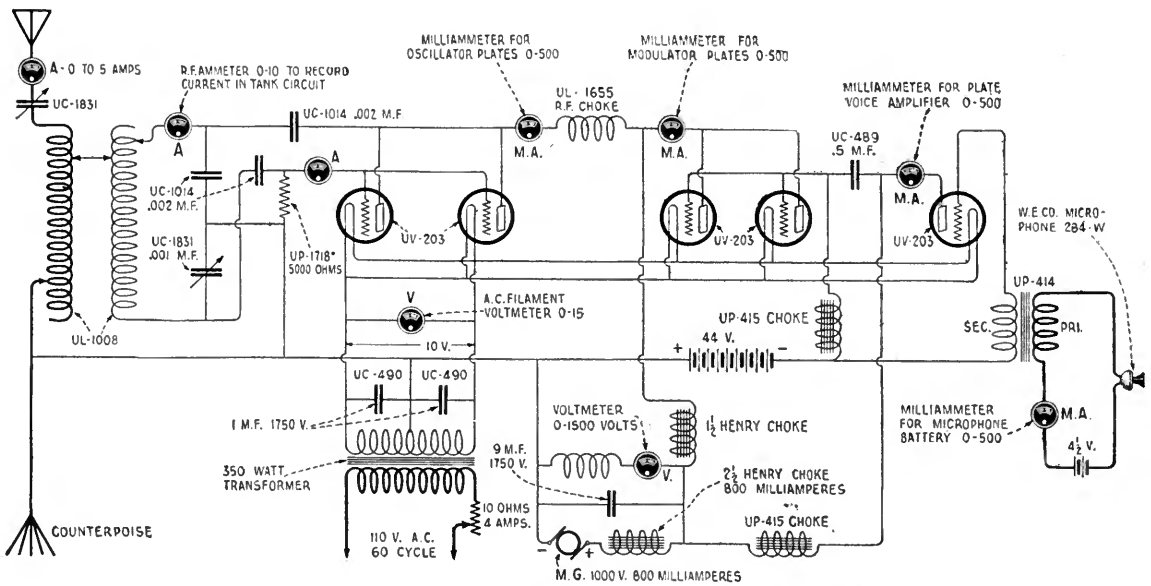

DIAGRAM OF THE TRANSMITTER CIRCUIT USED AT 6KW

northeast of Sancti Spiritus and about a mile west of Zaza del Medio, both of these latter towns usually being found on maps, although Tuinucu may not be shown. Tuinucu is 200 miles by air line east of Havana.

Some operating data on the transmitter when using the 315-meter wave may be of interest. The current in the tank circuit may be around 8 amperes when  $4\frac{1}{2}$  is being radiated. Under these conditions, the oscillator tubes show about 280 to 350 milliamperes in the plate circuit; the modulator tubes 100 to 400 milliamperes on plates, and amplifier tube plate from 25 to 125 milliamperes; these currents applying when the plate voltage is 900 volts.

In eliminating parasitic sounds in a transmitter, one has to be as careful in the wiring as in a good receiver. All the leads liable to produce feed-back effects are run in lead-covered wire with the casings grounded. I first had the  $1\frac{1}{2}$ -henry choke near the modulating and oscillating tubes, but its strong flux made it necessary to place it farther away. I found that it is also well to mount the tubes on several thicknesses of felt. All mechanical vibrations have to be carefully guarded against. I first had my motor generator in the same room as the transmitter, but even its slight vibration was picked up by the amplifier tube and tremendously amplified. I then mounted the motor generator in another room about 30 feet from the operating room and on a concrete base extending from the ground up through the floor of the house but *not touching* the floor.

Just a word about my receiving apparatus. I have built and tried out almost every circuit I ever saw described, but for good, reliable work, both near and DX, I use either my G. E. Company single-circuit or my Westinghouse R.C. Either of these is generally sufficiently selective with a fairly short antenna and plenty of tickler coupling and low filament voltage.

I began playing the game of "Radio Golf" a couple of years ago, and after I had made a score of more than 100,000 miles I quit keeping track. My real object in starting the game was to get people really to know how to use their detectors. My watchword was always: "What I can't hear on detector alone can't be heard on audio amplification."

I built a radio-frequency set with 3 stages of R. F. and detector (page 370), this set being arranged with various combinations to use antenna or 18" loop alone or in combination with the well-known three-circuit regenerative tuner, using vario-coupler, grid variometer and plate variometer. On the loop, I have heard everything I have been able to pick up on the antenna with the detector alone in the regenerative set. Generally speaking, however, I prefer to use my single-circuit sets. With them I can usually pick up a station and tune it in (if it's possible) in a few seconds, while to pick up and tune in well a station 1,000 miles away on the R. F. set, requires a lot of time and more patience. Of course, in the case of a real, "dye in the wool" radio amateur, his middle name is patience.

# The Thoriated Tungsten Filament



Characteristics of the New X-L Filament, Used in the UV-201-A and UV-199 Tubes. Comparisons with the Older Pure Tungsten Type



By W. C. WHITE

General Electric Company

The papers of the Radio Club of America are being published exclusively in RADIO BROADCAST. Mr. White's discussion in this number is the second of the Club's articles to appear. The first, "Eighteen Years of Amateur Radio," by George E. Burghard, was published last month.—THE EDITOR.

**I**N THE design, manufacture, and use of high-vacuum receiving tubes, the electron source, in most cases, has always been the chief problem.

By far the greatest amount of scientific work on vacuum tubes and also a considerable part of the manufacturing development has been devoted to this question of the production of electrons.

Until quite recently, the pure tungsten filament and the coated filament were the only two types of electron-emitting sources in extended use in receiving tubes. Although each of these sources met the requirements of practical use, it has been found possible to reduce the filament energy and secure other characteristics equal or better than that formerly obtained.

The important desirable features which the ideal electron-emitting filament for a high-vacuum receiving tube should have, some of which are self-evident, can be listed as follows:

- (1) Long operating life.
- (2) Low filament energy to supply the necessary electron emission.
- (3) Uniformity of electron emission during life.
- (4) Uniformity of electron emission among different tubes of the same type.
- (5) Quietness of operation.
- (6) "Electrical robustness" of the filament.

Another most desirable feature, if not the most important, but which is not so self-evident, is the necessity for low electron emission per unit of length or, expressed in another way, the greatest length possible within reason for a given amount of electron emission and filament energy. These features of long filament length combined with long life and low filament energy were always the difficult problems in tungsten filament design for receiving tubes.

The new X-L tungsten filament meets these

many, and it would almost seem, divergent requirements in a most admirable way, and although, of course, it is probably not the final development in electron-emitting sources, still it is such a big advance, particularly over the old type of pure tungsten filament, that it meets to a considerable extent the ideal requirements.

The outstanding features of this new X-L tungsten filament considered from the viewpoint of the desirable features of the ideal and in comparison with the old pure tungsten filament are as follows:

- (1) For the same life, the X-L filament can have several times the electron emission, and only a fraction of the same amount of energy is required for excitation. This is best brought out by a comparison between the old UV-201 and the new UV-201-A tubes, the latter tube utilizing this new X-L tungsten filament. This comparison is a convenient one to bring out these points because the two tubes are made to be interchangeable and to operate from the same filament voltage.

Type	Volts	Filament Amperes	Watts	Electron Emission Milliamperes
UV-201	5	1	5	7.5
UV-201-A	5	.25	1.25	45

- (2) The uniformity of electron emission from the X-L filament is the same as from the old tungsten filament. This can be brought out by the fact that in the UV-199 tube, which also uses the X-L filament, measurement of electron emission has been made on every tube leaving the factories. The minimum allowable limit is six milliamperes. The average of thousands of tubes is eight milliamperes, and practically the highest that is found among the standard product is twelve milliamperes.
- (3) Tube noise, a troublesome feature in the older type of tungsten tube, is practically eliminated with the X-L filament, largely because of the much lower operating temperature.

- (4) The feature of increased electron emitting length is well brought out by the following tabulation, again a comparison between the UV-201 and the UV-201-A tubes:

Type	Approximate Life	Filament Length	Approximate Mutual Conductance	Relative Delivered Energy
UV-201	1000	38 mm.	300	1
UV-201-A	1000	48 mm.	475	2

From the foregoing tabulation it will be seen that there is more than fifty per cent. increase in mutual conductance due to the longer filament which allows also the use of larger plate areas. The figures under the column "Relative Delivered Energy" imply that under similar conditions the increased mutual conductance allows the UV-201-A tube to give about double the energy output as an amplifier. The figures for mutual conductance given above refer to these constants measured at rated filament voltage, a plate voltage of forty and a grid voltage of zero.

Probably this feature of increased electron emitting area with the X-L filament can be more clearly brought out by the statement that if an X-L filament tube were built operating at the same filament temperature as the UV-201-A but having the same volts and amperes as the UV-201 and the same life, the electron emission from the X-L filament would be twenty-four times as great and the length approximately double that of the pure tungsten filament.

- (5) The X-L filament has a long life. Life in this case is not terminated by a burnout, but by loss of electron emission. This drop of emission does not occur continuously during the life of the filament, but quite suddenly, and in a very pronounced way at the end of its useful life. The relation between life and filament voltage is not a simple relation, because operation at abnormally high voltage will destroy electron emission which, however, can be renewed by the proper procedure in the hands of the user. This question of life of the tube and the fundamental causes allowing this possibility of renewing electron emission, or reactivation, as it is termed, will be discussed more fully in the following paragraphs.

The electron emission from a given material can be expressed by a fairly simple formula and is determined by two factors, one of which is a constant that is typical of that material and the second is a function of the temperature; the electron emission increasing very rapidly with temperature. In the case of a coated filament, the constant of the material indicates

a high emission, but the allowable temperature is low. In the case of the pure tungsten filament, the constant of the material indicates a relatively low electron emission at a given temperature, but there is the practicability of operating at relatively high temperatures.

It has been found that in general in the case of suitable electron emitting substance the more stable and homogeneous the material the lower the electron emission and, conversely, the lower the temperature at which the material evaporates or disintegrates the higher the electron emission. Another factor found experimentally was that in most cases the more active the material, that is, the greater the electron emission at low temperature, the more subject the material was to loss of electron emission from contamination and insufficient vacuum; certain gases or vapors in particular being very fatal to this electron emission. The problem, therefore, was one of finding a compromise between these divergent factors.

The X-L filament is a tungsten filament in which there is a small percentage, considerably under five per cent. of a material that has high electron activity. This active material in the case of the X-L filament as at present used is thorium and a chemical compound of this thorium is mixed with the tungsten early in the stage of the manufacture of the metal from which the filament wire is drawn.

When the completed filament containing this active material is operated in a vacuum at a certain high temperature, there is a change from the chemical compound to pure thorium. At another certain lower temperature, there is a constant diffusion of this thorium toward the surface of the filament. By this process, a layer of these thorium atoms one atom deep, (and only one atom deep) is formed on the surface of the filament. This atomic layer of thorium is of high electron emissivity so that ample electron emission is obtained from it at temperatures that would give practically no useful electron emission from a pure tungsten filament.

Thorium cannot remain indefinitely, however, on the surface of a hot filament, because in comparison with tungsten, it has a higher rate of evaporation, this rate, of course, increasing rapidly with the temperature. At the temperature at which the X-L filament is operated, this evaporation is relatively slow, but is quite appreciable. The instant that an





atom of thorium evaporates from the surface there is a movement of atoms inside the body of the material which places another atom in the surface layer in the position occupied by the former atom after which movement there is again equilibrium of thorium inside the filament.

A rough analogy to the actions just described is the case of a jar of liquid which is capable of forming bubbles. The production of pure thorium can be likened to the formation of air bubbles at the bottom of the jar and the diffusion of these thorium atoms to the surface of the filament can be likened to these air bubbles rising to the surface of the liquid. As in the case of the thorium atoms, these small air bubbles will distribute themselves so that the entire surface is covered with bubbles one layer deep. If more bubbles are then formed at the bottom of the jar, they will rise until they strike the under surface of the surface layer of bubbles and there will remain stationary and it is possible to thus form a thick mass of the bubbles, all stationary. The evaporation of the thorium from the surface of the filament may be likened to the evaporation of the film of some of the bubbles in the surface layer which causes these bubbles to burst and immediately other bubbles from beneath rise to the surface taking the place of the bubbles just destroyed.

In the case of the filament, the higher the temperature the greater the evaporation of the thorium from the surface which would correspond in this analogy to the bubbles in the surface layer of the liquid bursting at more frequent intervals.

The bubble analogy is in one respect not a good one, and this point is that the volume occupied by the thorium atoms is only a very small portion of the total volume of the material near the surface of the filament, whereas, in the case of the bubbles in the jar of liquid the volume of these bubbles under the surface is much greater than the volume occupied by the liquid. Therefore, in the bubble analogy

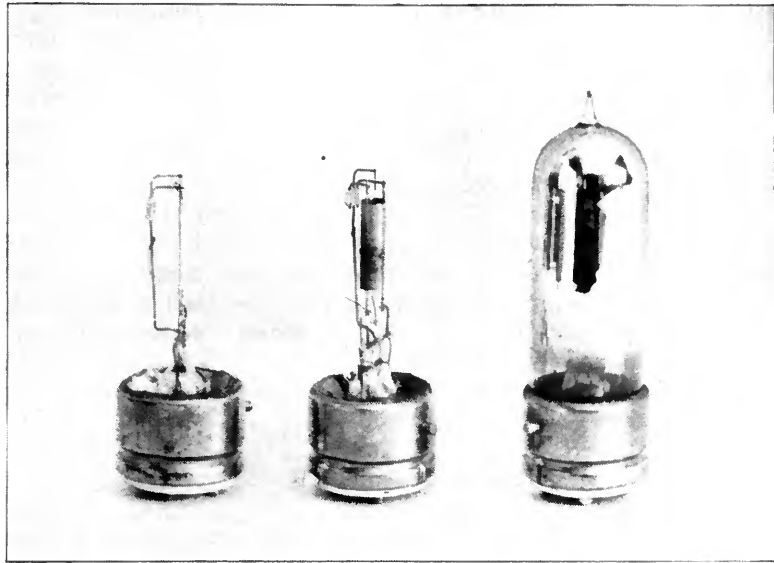

FIG. 1

The UV-199 dry-cell tube. It uses the new thoriated tungsten filament

the layer of atoms one atom deep is not clearly portrayed because the bubbles underneath crowd toward the surface displacing practically all the liquid.

The reactions inside of the X-L filament when operating at its normal temperature are such that the production of thorium in the interior and the rate of its diffusion to the surface are proportioned so that at normal rated temperature they amply compensate for the loss of thorium atoms by evaporation.

There is one effect, however, which tends to prevent the practical utilization of the process in the simple form here outlined.

In an earlier paragraph it was stated that one of the disadvantages of an active electron emitting material was its liability to contamination. This contamination consists of the chemical combination of some gaseous or vapor impurity in the vacuum with the thorium at the surface of the filament, which is emitting the electrons. The X-L filament would be very sensitive to such contamination and this chemical compound formed at the surface by this contamination would not emit any electrons and would require an exceedingly high temperature, up to near the melting point of the tungsten, to remove it and leave free the surface area for the pure active material. Therefore, in the case of the X-L filament, unless some precautionary measures were taken, the electron emission would

last only a few seconds or a few minutes during which time the active surface would become so contaminated that the emission would drop to practically zero.

This problem of keeping the active surface of the filament "clean" was solved by first finding out what the contaminating agents were and then by placing inside the bulb certain substances that would have a more active chemical combination with these contaminating agents than the thorium surface on the filament. The presence of such substances prevents contamination of the filament by previously combining with the contaminating agents. It does not in any way increase the electron emission from the filament directly, but simply protects the thorium film so that the full electron emission characteristic, as would be obtained in practically a perfect vacuum, is more conveniently realized.

Keeping in mind the phenomena just described, the various characteristics of the X-L filament as an electron emitting source are explainable.

For instance, if the filament is operated at an abnormally high temperature, the electron emission at first will be very large, but the higher this abnormal temperature the quicker will this high electron emission fall off until it is below even normal value. This rapid falling of electron emission is due to the fact that the rate of evaporation of thorium from the surface is more rapid than the diffusion to the surface and, therefore, the surface of the filament is no longer covered with the active thorium, but only with pure tungsten, the electron emission from which at a given temperature is far below that from thorium. If then the filament is operated at normal temperature for a short period of time, the evaporation of thorium is reduced to normal and the diffusion from the interior rebuilds the electron emitting layer at the surface. As the surface of the filament becomes more and more completely covered with thorium, the electron emission rises until, when it has become fully covered, it returns to normal.

This brings out the point that there is an optimum temperature for operation of the X-L filament, or more properly speaking, a restricted range of temperature for satisfactory operation. If the temperature is maintained above this range, the electron emission sooner or later falls off as explained, but there is no

permanent injury to the filament unless this misuse is continued, and operation again at normal value soon brings back normal electron emission. If the operation is below this useful temperature range, the electron emitting efficiency is unnecessarily low.

Under rare operating conditions, the supply of thorium in the interior of the filament might become deficient, which would reduce the supply of thorium arriving at the surface and fail to keep a complete layer at the filament surface. Under these circumstances, there is usually still a supply of the thorium compound present which was originally put into the filament metal and by operation of the filament at approximately three times normal voltage for a fraction of a minute there will be a new production of pure thorium. Then, after this new production of thorium has occurred, operation of the filament at normal temperature for a reasonable period of time will cause this new thorium to be diffused to the surface and a new complete active electron emitting layer will be formed.

Also, under abnormal conditions, such as overload of the plate, the contaminating agents may be so plentiful inside the bulb that the substances placed inside to absorb these contaminating vapors and gases may not take them up rapidly enough and so allow a contamination of the filament. Again, the cure for this condition is to operate the filament for a few seconds at about three times normal voltage which decomposes this contaminated thorium from the surface of the filament and then by operation at normal temperature for a reasonable time the normal thorium layer and normal electron emission are regained.

The length of time that the filament must be operated at normal temperature under these different conditions described in order to regain normal emission varies widely, depending upon whether or not the thorium just below the surface has been removed. If the thorium has been removed a considerable distance below the surface, a longer time is required for it to diffuse through this distance to the surface than would be required if simply the surface layer were destroyed. Therefore, if the filament has been operated at an abnormally high voltage for ten to twenty-five hours, it may require this same length of time at normal rated operating voltage in order to obtain



normal electron emission. It is, therefore, apparent that an X-L filament contains a certain amount of stored-up or potential electron capacity which under normal conditions is continuously brought to the surface and utilized in an efficient manner so as to give long life. If abnormal conditions occur, this orderly procedure is disturbed so as to cause a failure of electron emission. However, as pointed out, this potential source of electron emission is seldom permanently destroyed before the end of filament life, and the proper procedure should bring back normal electron emission.

X-L FILAMENT RADIOTRON TUBES

THE Model UV-199 Radiotron tube utilizes the X-L filament and brings out in a most striking manner its unusual characteristics and, therefore, it is of interest to describe briefly this tube and some of its characteristics and properties. The general appearance of this Radiotron tube is shown in Fig. 1. The overall length of this tube from the tip of the bulb to the bottom of the contact pins of the base is  $3\frac{1}{2}$ " and its maximum diameter 1". One of the first features noted in an inspection of this tube is the fact that the bulb is opaque so that the electrodes are not visible. This opaqueness is caused by the materials used to prevent contamination of the filament in the manner previously described.

The outstanding advantages of this new tube are its low filament energy which is only about 75 per cent. of that of any other tube in use at the present time, its small size and excellent detector and amplifier characteristics.

The filament is operated at three volts and requires only sixty milliamperes.

The tabulation shown below indicates what service can be obtained from a set employing one, two, three, or four of these tubes in parallel operated from three good quality No. 6 dry cells connected in series. This tabulation is based on the use of the tubes two hours out of each twenty-four hours.

No. of tubes in set	Total hours	Days	Months
1	387	193	$6\frac{1}{2}$
2	200	100	$3\frac{1}{2}$
3	126	63	2
4	92	46	$1\frac{1}{2}$

The extremely low filament current of this UV-199 tube makes it possible to operate from flashlight cells. Operation from such

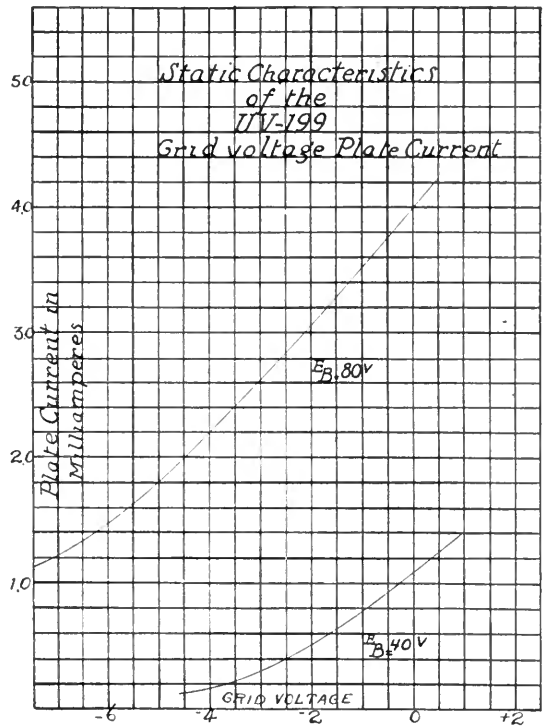

FIG. 2  
The "characteristic curve" of the UV-199

small size cells is not as economical as from the six-inch size of cells. However, for portable equipments, this difference is more than offset by the light weight and small size of these flashlight cells.

One UV-199 tube may be operated from a three cell flashlight battery one hour out of each day for a little over a month. A longer period of daily operation than one hour will shorten somewhat the total useful battery life.

For portable sets containing more than one UV-199 tube one three cell flashlight battery should be used for each tube operated. Operation of the filaments of more than one tube from a single flashlight battery is not only poor economy, but the voltage drop of the cell while in use under this heavier current drain is after a short time so rapid that operation of the set is unsatisfactory.

This size of unit flashlight cell is approximately  $1\frac{3}{8}$ " in diameter and  $2\frac{5}{16}$ " long. Smaller sizes of flashlight cells have not been found satisfactory for use with these filaments, because not only is the economy poor but their voltage drops so rapidly that in a regenerative circuit difficulty is experienced in satisfactorily holding an adjustment.

This use of flashlight cells combined with the small size of the tube gives the possibility of making up extremely sensitive, small, and light weight portable receiving equipments.

The characteristic curve of this tube is shown in Fig. 2, and is very similar to that of the old UV-201.

In this connection, it should be kept in mind that the UV-201-A tube has a higher amplification constant and lower impedance than the UV-199 tube, and, therefore, has a greater mutual conductance so that it is inherently a better amplifier. This is to be expected, because the UV-201-A requires almost seven times as much filament energy and has bigger electrodes. The higher electron emission of the UV-201-A and the fact that it can be operated at a higher plate voltage than the UV-199 combined with its better characteristic curve make it a much better tube to use for the operation of loud speakers where an exceedingly large volume of sound is required. However, where it is desired to build a multi-tube set, the UV-199 is, of course, superior because a dry battery can be used for the filaments, whereas, the same number of UV-201-A tubes would make dry battery operation rather out of the question.

The UV-199 tube is also very suitable for radio-frequency amplification, because the capacity between electrodes, owing to their small size, is considerably below that of any other tube available to the experimenter at the present time. To get the full advantage of this low capacity, a socket designed for the tube rather than an adapter to a standard socket should be used. Attention should also be directed to the set wiring so as to keep capacity effects at a minimum.

The arrangement of the contacts on the base of this UV-199 tube (Fig. 3) is not the same as in the case of the standard bases. This change has been made so that the wiring of the filament leads as well as the plate and grid leads can be more conveniently arranged and with less capacity effects between them than in the former pin arrangement.

One of the principal precautions to be observed in the use of the Radiotron Model UV-199 is to be certain that the rheostat used

is such that the voltage of the filament source can be reduced to the proper value of three volts for the filament.

Inasmuch as three new dry cells for a very short time have a voltage of 4.5 volts, this means that 1.5 volts must at first be absorbed by the filament rheostat. A filament rheostat of thirty ohms maximum resistance is recommended for a single tube. In the case of two tubes, the filaments of which are in parallel and controlled from a single rheostat, the resistance should be fifteen ohms, and in the case of three tubes, ten ohms.

If for any reason it is desired to operate these tubes from a three cell storage battery and a connection for the voltage from two cells cannot be obtained, the rheostat resistance should be at least sixty ohms for one tube, thirty ohms for two tubes, and twenty ohms for three tubes.

In a great majority of cases, if due to improper operation these tubes show low electron emission, this electron emission can be regained by operation at normal filament voltage for a period of time roughly proportioned to the time during which the tubes were operated at an over-voltage. It is preferable during this reactivation of the filament and often hastens its



FIG. 3  
Showing arrangement of contacts on the UV-199

recovery to disconnect the B battery so that there is no plate voltage on the tube. If this treatment fails to reactivate the filament, the tube filament may be flashed at eight to nine volts for about ten seconds and followed by a run of several hours at rated voltage. This should, in practically all cases, cause the return of normal electron emission. These methods of reactivation will not, of course, be successful if the tube has run its normal life or has been consistently operated at excess temperature or misused.

Under normal operating conditions, these methods of reactivation are not necessary during the life of the tube.

Many modern vacuum tube receiving circuits are of extreme sensitivity, and vibration often causes the tube to introduce into the receivers a disturbing sound. This is termed microphonic effect of the tube and is a factor which must be taken care of in multi-tube UV-199 circuits in the same way as it has been

taken care of in the use of other tubes, that is, by proper cushioning of the sockets.

A plate voltage higher than that obtained from four standard block cells should not be used on this tube, as it reduces seriously the factor of safety against overload and will shorten the life. With eighty volts on the plate a negative bias of three to 4.5 volts should be used on the grid. This is conveniently obtained by two or three small flashlight cells.

It is an interesting fact that with a plate voltage as obtained from four block cells and with the proper negative bias, the plate current is approximately 2.5 milliamperes which at eighty volts gives a dissipation of energy on the plate of approximately .2 watt. As the normal filament energy is only .18 watt, this fact that the plate energy is more than the filament energy is rather a striking example of the great improvement that has been made in these tubes in regard to filament operation and electron emitting efficiency.

A fairly comprehensive examination of tubes that have become inoperative due to actual filament burnout has disclosed the fact that a very large majority of these tubes were burned out by the filament becoming connected across the plate battery. It is a common custom, but dangerous to the tubes, to make changes in the wiring or connections of the set while it is in operation or while the tubes are in the sockets and the B battery in circuit. A mistaken connection which puts the filament of a UV-199 or UV-201-A tube across a B battery

of forty volts or more that is in good condition usually destroys the filament so quickly that a flash is not noticeable unless the tube is directly in the line of vision.

In view of these facts, it is particularly to be urged that wherever possible tubes be removed from their sockets or the B battery disconnected while experimenting with the circuit arrangement. An even preferable arrangement and one which allows the convenience of trying various arrangements without the preceding precaution is to insert in one lead of the B battery at one battery terminal a ten-watt, 110-volt Mazda lamp. The cold resistance of such a lamp is so low that in the great majority of circuits there will be no ill effects, but such a lamp has the valuable characteristic of increasing its resistance so that at operating temperatures it is ten or twelve times as high as when cold. A ten-watt lamp used in such a manner even with a plate voltage of eighty or more will limit the current to less than 100 milliamperes which can do absolutely no harm to even such a small filament as that used in the UV-199. A lamp used in this manner also is convenient in that it shows up, by the filament becoming incandescent, a B battery short circuit or leakage that might otherwise go unnoticed and very quickly run down this battery.

The X-L tungsten filament is not only useful in receiving tubes, but is alike applicable to the smaller sizes of transmitting tubes, resulting in a much lower requirement of filament energy.

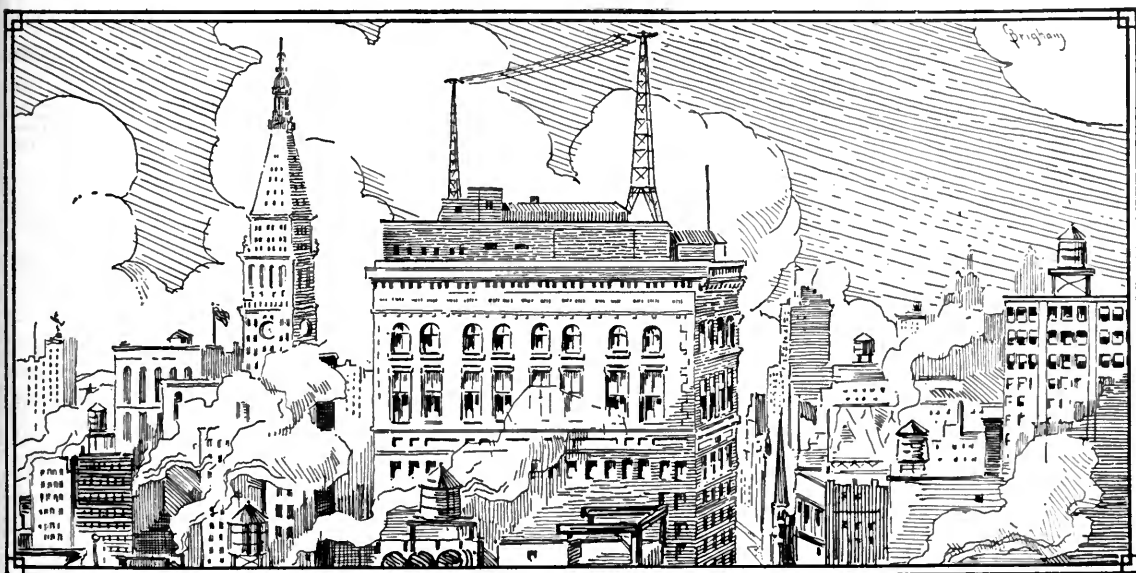

# 10,000 Miles of Radio Lectures in China

By C. H. ROBERTSON

Science Lecturer, Educational Dept., National Committee Y. M. C. A. of China

Back in 1902, Professor Robertson was asked to give up his work on the Engineering Faculty at Purdue University and go to China to carry on, under the auspices of the Y. M. C. A., the work he had been doing in the United States. Except for the war period, when he was on a special mission in Russia and Siberia, Professor Robertson has spent most of the intervening years in China. Concerning the purpose and results of these years of work in the Orient, he said, in 1920: "I have been back on the field but four months after returning from furlough, and perhaps the most encouraging thing has been the constantly increasing industrial development in mining and manufacturing. In all this, the Association (Y. M. C. A.) has been a constantly increasing factor in *helping the people to assert themselves*, in pointing out and studying new and difficult problems that the rising industrial life presents, and has been particularly helpful in encouraging right educational ideals and methods. In the face of these and other things, there should be no retrenchment, we should advance."

Professor Robertson's account of his radio lectures in China is especially interesting as a revelation both of the widespread interest in modern scientific progress evidenced by Chinese of intelligence, and of the rapidity with which knowledge of radio communication is being assimilated and turned to practical account.

—THE EDITOR.

THE radio telephone as a lecture subject has gripped China more powerfully than any other subject in the twenty years of lecture experience of the writer in the "Middle Flowery Peoples Government Country."

The first radio lecture was in Tientsin in 1906. The audience was the staff of the great Government Educational Museum, established in a confiscated temple. Building after building had been filled with modern educational equipment of the Western type to supplant the recently abolished "Literati" or classical educational system dating from before the time of Columbus. A part of this equipment was a wireless telegraph station. No one on the staff knew how to operate it, and so, at their request, the writer put it in order, gave them a lecture and started this group in radio.

Later, the writer constructed, in the "Y" Lecture Laboratory at Shanghai, a spark station

that was completely dissectible and connectable in a great number of ways. This did several years' service until superseded by a modern vacuum-tube outfit.



PROFESSOR ROBERTSON'S LICENSE

Title page of document issued for radio lecture campaigns. As will be noted, this is "Number One." It happens that Dr. Robertson holds another "One", also issued by the Republic of China, with a date ten years earlier—in 1912

THE PORTABLE STATION RECENTLY USED

THIS station (shown in the picture on the opposite page) was used in the Victory Day celebration in New York in 1919, and a year later was built into a traveling lecture unit in our Shanghai Laboratory. It has power, sending, receiving, and amplifying units. It uses two five-watt W. E. "E" power tubes, one as oscillator, the other as modulator on the Heising system. For reception W. E. "J" tubes are used, a detector and two stages of audio-frequency amplification. For the loud speaker three stages of amplication are added, the last through an "E" tube to handle the greatly increased energy. The panels turn back and down into the base which shuts up like a jack-knife, completely enclosing the panels. The tables



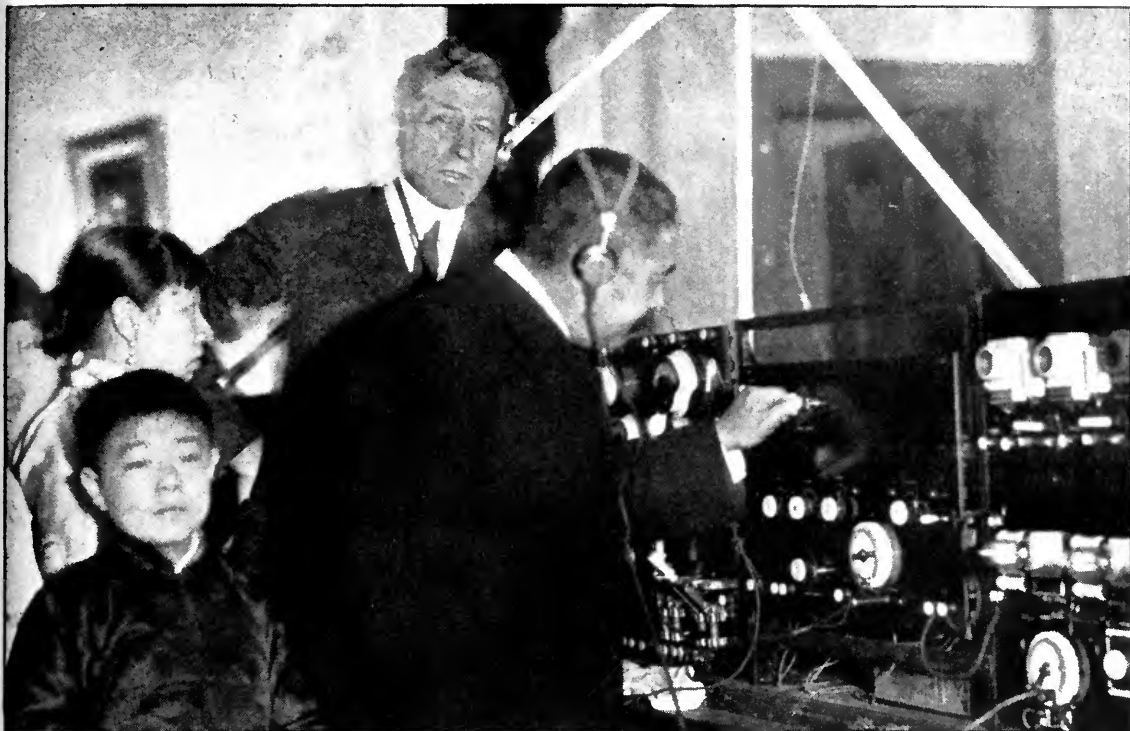

LI YUAN HUNG, RECENT PRESIDENT OF THE REPUBLIC OF CHINA, AN ENTHUSIASTIC PATRON OF THE POPULAR SCIENTIFIC LECTURES

He is shown with his son and daughter and Professor Robertson. The apparatus in the picture was built for this lecture work and was mounted on panels so as to be accessible from front and rear, allowing every detail to be followed out. Two 5-watt tubes were used for transmitting, and for reception, a detector and two stages of A. F. amplification were used, three more stages being added when the loud speaker was employed

in front turn back and lock together making the cover, and the outfit becomes a strong trunk ready for the road.

The energy is supplied by two 175-ampere storage batteries which in turn drive a motor generator giving 350 volts plate current. A suitable switch enables one voltmeter to read all pressures. All supply current passes through one ammeter, so by subtraction, the consumption of any unit of the station is determined. The station can be opened or closed in about ten minutes. A folding frame giving a 10-foot square loop provides for short distance transmission and reception, while a switch throws over to an antenna with which long distances can be had on both transmission and reception. An exact duplicate of this station in another trunk provides for complete two-way demonstrations over short or long distances.

This quite possibly was the first radio telephone station mounted on a Chinese wheelbarrow, and in this form our preliminary tests were made between the laboratory and various

positions on the streets of Shanghai. The temporary loop may be seen supported by the mast from the front end of the barrow (page 384.)

On the opposite page is shown the title page of the amateur license issued to the writer. Of course all the lecturing has to be done in Chinese. The radio lecture generally begins: "Wo-men chin-tien wan-shang-ti ti-mu shih wu hsien-tien-hwa." "The subject of our lecture to-night is the radio telephone."

With the portable apparatus described, we started down the hundreds of miles of coast-line to South China and began at Hongkong. The British Navy gave fine coöperation and we installed our broadcasting station on one of their cruisers. To our delight, we found that it worked across the spacious harbor and could be amplified and made clearly audible to the large audiences gathered in the "Y" auditorium on the precipitous mountainside upon which the city is built.

In Canton, the first lecture was before the

officials of the South China Government. Our old friend, Premier Wu Ting Fang (whom many of you will remember as China's Minister to America) was present and just as keen and penetrating in his questions as when he fascinated so many American audiences in years gone by.

The Canton "Y" has a fine new plant, and to the auditorium came three audiences per day. Of all I enjoyed none so much as the group of seventy students in a technical series on "Radio," with a view to the further development of the spirit and method of science in the city of Canton.

At Amoy, the smallest city on the whole trip, C. J. Wang, the able Chinese Secretary, and John Bradshaw, his American associate,

have a tremendous grip on the town. They put up a special auditorium seating over 2,000 people, and to this on one day came 7,800, with a total for the first four days of 17,800, supplemented by a later four-day campaign of over 10,000, making a total of more than 27,000 people. Not only were there large numbers, but the character and appreciation of the audiences were of a high order.

A unique event was made with the cooperation of the Chinese Navy, on a cruiser on which we installed our broadcasting radio-telephone. The other apparatus we erected seven miles up the bay at a new educational centre called "Chi Mei" (The Assemblage of the Beautiful). Here I was privileged to speak to an audience of 1,600, and great was their delight to hear the voice of my associate, Mr. Han, and then a musical program coming across the seven miles of mountain and sea.

The occasion was the opening of a new department of what is building into Amoy's two million dollar University, the gift of Mr. Tang Ka Ki, now a wealthy rubber grower who, in times of business depression, has even worked as a ric-sha coolie, and who, out of these great octaves of humanizing experience, is now devoting himself and all that he has to the putting forward of education in his native province after years of strenuous business at Singapore.

In Foochow, I found my old friend Governor Li Hou Chi. He was immensely interested in the lecture message. He appointed his chief officials to attend, got up a fine dinner in his palace, urged me to get to him as soon as possible data for linking up the different cities of his province by wireless telephone, and then provided a contribution sufficient to cover the local expenses of the lecture campaign.



EXPERIMENTING WITH A LOOP TRANSMITTING AND RECEIVING STATION IN SHANGHAI

But even greater was the appreciation of a mission college student who sat in the front seat at every lecture and afterward wrote: "O! my teacher. I am very grateful toward you for having come to us. I have got lots of things from you. My schoolmates wish me to speak on what you have taught in the special wireless telephone class, so may I see your book on the Audion for I not yet understand it. I desire to be your student or servant after have graduated from college this year, whereby I have the opportunity to learn from you the electricity. . . . You are very kind and have done big service." How many others were interested as much as this young fellow I do not know, but that it was a great many I am sure.

#### A TRIP TO THE NORTH

**I**N PAOTINGFU is the great Military Academy, the West Point of China, and it was a fine show to see the 1,200 students come marching through the city as twelve companies of one hundred each. Their officers all came to the stage and examined the equipment, and



PROFESSOR CHARLES H. ROBERTSON

then we had a most appreciated presentation, ending up with exchange of messages with one of their wireless telephone squads outside the East Gate. Each following day they brought the whole radio corps to the technical lectures, and good times we had! The initial meeting was followed up by two big audiences each day from the schools, merchants, gentry, and other classes of that interesting old capital.

The unusual campaign in Peking was initiated by working day and night in the laboratory of the China Electric Company, where, with the help of their radio engineer, Mr. F. R. Lack, our equipment was brought up to date. The meetings were held in that fairy-land-like group of buildings, in the centre of the city, that has been erected by the Rockefeller Foundation for the Union Medical College. It ranks high among the medical training institutions of the world, and in its beautiful auditorium all the meetings of the Peking campaign were held. But better even than the fine surroundings was the coöperation of the Peking Board of Education in gathering the audiences, made up of picked students from about fifty of the schools and colleges of the city.

After a long trip through the wide plains of Manchuria we tackled the Yangtze Valley.

Our ton of radio and lecture equipment was put on board the steamer *Kiang Shun*. We



C. H. HAN DEMONSTRATING MONORAIL APPARATUS

Mr. Han has been associated with Dr. Robertson for 18 years

started up river at daybreak. Plains gave way to mountains, and steaming by pagodas, lumber rafts, sailing junks, big steamers, and many walled cities, we debarked four days later, six hundred miles from the sea on the wide swift flowing Yangtze at Hankow, with waves so big that my demonstrating mechanics were sea-sick as we shifted by sailing junk to a Japanese steamer for the next leg of the journey to Changsha.

We crossed the Tung Ting Lake, the "Bull's-eye" of China, and after an all-day run up the beautiful Hsiang River, arrived at Changsha (Long Sand), the thriving, bustling capital of the agricultural and mining province of Hunan.

We had to hustle to get our radio telephone stations up and working for the official meeting at seven o'clock with Governor Chao Hung Ti in the chair, and the principal high officials and gentry present. It was an appreciative audience, and the Governor was especially gracious. We effected a fine exchange of messages with the American Navy ship *Villalobos* (One of

Admiral Dewey's prizes from the Battle of Manila Bay). Our radio reached through to them strongly and their signals were amplified by our receiving set loud enough for an audience of 50,000 people. When the meeting ended, I took the Governor for a look at our auxiliary radiophone in a closed room on the other side of a big compound.

When we were through, I escorted him to his sedan chair at the door. He was soon seated and I followed, according to Chinese courtesy, to the gate. He had just gained the street, thickly surrounded by his armed bodyguard, when—*Bang!!*—a heavy explosion, and I saw the chair careening through the smoke, and stepping over the threshold found nine wounded people moaning and crying on the stone flagging, from the missiles of the bomb thrown from somewhere in the darkness. The soldiers grabbed the shafts and got away with the Governor unharmed to his palace. Later we learn that seventeen were wounded. One of his chair coolies died shortly after. How harrowing an experience this is one doesn't

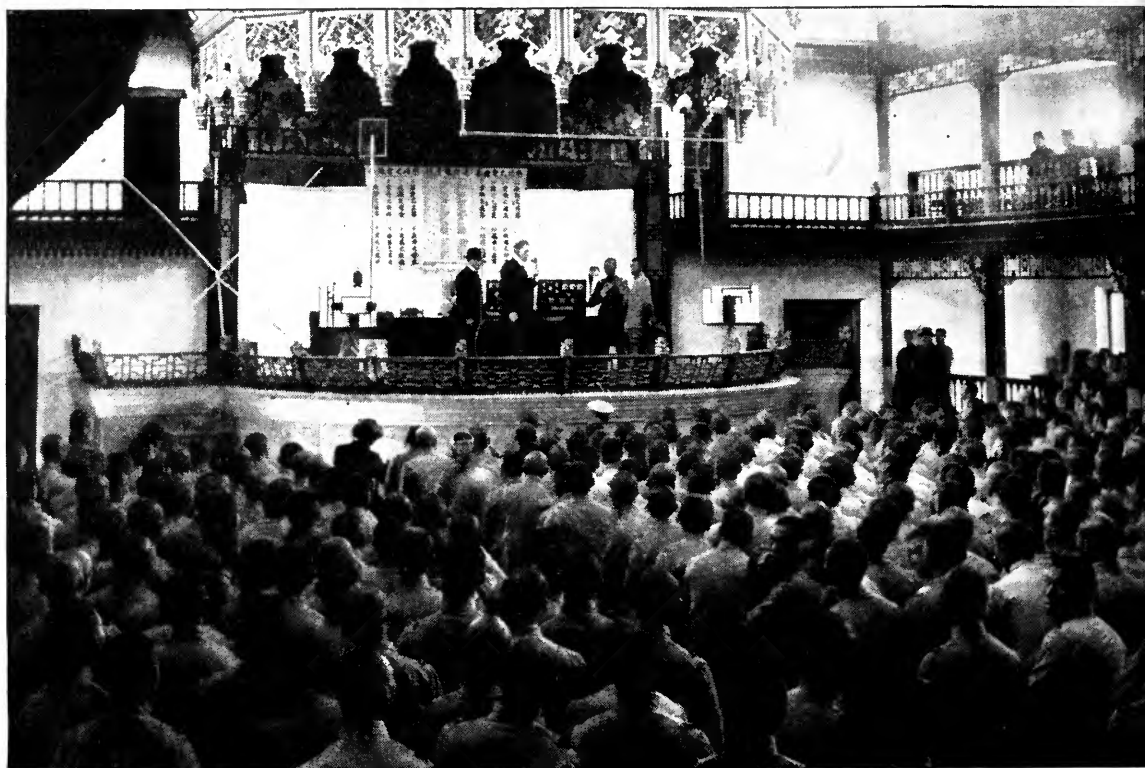

CADETS OF THE WEST POINT OF CHINA IN THE TEMPLE OF THE GOD OF WAR IN PAHOTINGFU  
Two officers of the Military Radio Telephone squad are on the stage. The charts in Chinese at the back of the stage summarize the applications of radio. During the last two years about four hundred such audiences have gathered for these radio lectures in China



## PART OF AN AUDIENCE IN FOOCHOW

This was a combination meeting, at which Eddy spoke on religion and Robertson on science

realize until, after having gotten the wounded on stretchers to the Red Cross Hospital, one washes off the blood and grime and turns in late at night.

The next day the pressure began. Popular lectures at 10:00 and 4:00, technical radio

lecture at 2:00 and science and religion forum at 7:00 with an attendance for the day just beyond 3,000. There was a keen interest shown by the audiences and fine coöperation by Kallam, the American navy operator who was with us. He especially appreciated the en-



FOOCHOW OFFICIALS WHO ATTENDED LECTURES BY PROFESSOR ROBERTSON





AN OFFICIAL RECEPTION BY THE MILITARY AND CIVIL GOVERNORS OF KIANGSI PROVINCE

thusiastic applause of the audience transmitted to him by radiophone, and replied with an apt Chinese phrase—"Ting Hao" (Very good).

On the last day of our tour came a final address before a group of faculty members of a great Chinese college. Paul Kwei, Head of the Department of Physics, got his big impetus for scientific educational work in two of our lectures in St. John's University at Shanghai, ten years ago. The total attendance in Changsha was 16,705.

A trying twenty-hour railway trip in day coaches brought us back again to Hankow, just in time to catch the night steamer for Kiukiang, twelve hours down, and there we made close connections for the train to Nanchang, the capital of Kiangsi, seventy miles interior on the south bank of the river.

Again a week of eager faces, and I found a Purdue-trained engineer, C. E. Draper, arranged to take charge of the students from the technical radio series part of the program and to lead them in their studies in actual experimental contact with this fascinating subject.

Twenty-four hours down river brought us to Anking, the proud capital of Anhwei Province. Here we found the American Navy Flagship *Isabel* equipped with a radiophone, so we had

beautifully clear communications by voice, as well as by telegraph, to the immense delight of the audiences in the provincial educational Association lecture hall.

Another week of eager faces—three meetings with Governor Hsu, an old-time friend, and his official family, a three-page poem in Chinese from one of the auditors, and we started with light hearts for a sail past a mile-long flock of wild ducks down the Yangtze.

Here we arrived home in Shanghai again; and a strenuous time it had been. The cities visited were twenty-seven, the distance more than 13,000 miles, and the attendance 184,242. Not only were there great numbers but also personalities. Twelve provincial Governors and twenty-five national and ex-national officials, including two national ex-presidents, graced the meetings with their presence, and were stirred by the vision of science in the future of China, and of the contributions to science in the world that China would sometime make.

A friend said: "It looks easy, but we know it is not." And that is the truth. The journeys took us into four main regions of China. In one were bandits, in another famine, in the third pirates and in the fourth mutinous and looting soldiers. Shortly after I left the City of



Wuchang, the "Long" street was looted and burned. The Governor permitted the looters to get away, but laid an ambush for them on the railroad, and when their long train pulled in, turned on the artillery and shot the train and its contents to pieces.

#### A RADIO TRIP TO THE MAN-CHURIAN FRONTIER

**A**FTER a series of travel adventures on the disorganized railways of China, early this year, I drew near to Mukden. Major Gao, aide of General Chang (whose guest I was to be in Mukden), met me two stations out and on disembarking I found motor cars and army transport waiting.

In a motor placed at my disposal for the visit, and in the crisp, sharp northern winter morning I went to the provincial assembly building. The army radio telephone corps had erected the antenna masts. In less than an hour we were set up, all ready for the lecture except for the testing. Throwing in the switches, I said: "Wo-men tsai che-pien hswo hua ni-men tsai n-pien ting teh lai la ma"—

"We here speaking you there hear, eh?" Immediately came back the reply from their radio corps in a temple outside the city: "Wo-men che-pien ting teh heng hao"—"We here hear extremely well." After a little more testing, they said: "If you will listen in we will call Chang Chun." I heard them calling and in a moment back came the reply from Chang Chun, 200 miles away.

At 10 o'clock in came my first audience, a half regiment of sturdy Manchurian soldiers. We had a fine time together! Immediately following this, came the first of a series of eight daily lectures with laboratory work for the radio corps.

That same afternoon, came a group of



THE GOVERNMENT RADIO ENGINEERING SCHOOL AT SHANGHAI

In the centre, "X", is Professor T. C. Chang, Dean of the School. With him are some special radio students. The building is finely equipped with class rooms, and "labs," and an operating room in which are various types of phone and telegraph sending and receiving apparatus

important business men gathered by Joe Platt, our wonder-working "Y" secretary, who is so esteemed in Manchuria's capital. In the evening a small group gathered in General Chang's headquarters office, made up of staff officers and influential civilians, for an informal chatty hour. Some subjects discussed were 1, The Stroboscope and Its Revelations; 2, Glimpses Into Astronomy; 3, Molecular Motions; 4, Curious Right-angle Gyroscopic Reactions; and so on for eight days in succession!

The life of Mukden often reminded me of pioneer days in the Dakotas. It is an immense prairie land bordered on the east by the Pacific, on the west by mountains and deserts



THE "BRIDGE OF TEN THOUSAND AGES" AND FOOCHOW HARBOR—

A typical panorama of the "old and populous land," which, according to Professor Robinson, is now beginning—

and on the north by the great rivers and forests of Siberia. The streets are crowded with traffic coming in from the country, big two-wheel carts (rims recently broadened by law) drawn by three to six horses. Markets filled with furs from muskrat to tiger. One day my soldier-audience failed me. They were out suppressing a bandit uprising. Everywhere a great stir of life. Plans for agricultural development on quantity scale, companies for exploiting forests, promoters of mines, of electric-service monopolies and of new railways. I felt I ought to be staking out a claim, organizing a lumber camp or opening a mine!

On the last day General Chang gave us and his staff a banquet in the great North Camp four miles out. It was a stinging cold day, yet the big military band marched out for the occasion. The next morning, escorted again by the ever-courteous Major Gao, we got our 1,500 lbs. of lecture equipment on the train and started back again for the Yangtze and home.

It was a great experience, but of it all nothing seemed to me more significant than the quiet evenings with General Chang and his keen, intelligent group of officers, holding informal discussions on science, on religion, and on the moral issues of life. They all seemed to enjoy it immensely, and so did I. How much all this will count in the potential struggle between Russia, Japan and China of which Manchuria is the future stage, I know not, but that it was in the right direction, and that it has given another link with some of the personalities that will loom large in the future of China, I am confident.

Without doubt, the greatest handicap to the progress of radio education in China to-day is the bureaucratic monopoly of the military

party who have not yet raised the war embargo against the importation of radio equipment into China. It took me no less than two months to get through the Customs at Shanghai the lecture equipment for educational purposes—and then only after special authority had been secured from Peking.

One of our keenest supporters and patrons has been President Li Yuan Hung. Our first meeting with him in our lecture work came when, as a Colonel of a local regiment in Wuchang, in 1911, he attended a science lecture. A few weeks later he was instrumental in starting the revolution that upset the Ching Dynasty after its 267 years' rule, helped to establish the Republic of China, became its first Vice-President, and then President of China.

In the early days of the lecture work, it was extremely difficult to secure the coöperation of American business men and firms. Not so, however, with the Germans, who through their agents in China were glad to provide fine coöperation in equipment and publicity. A visit of the writer to America in 1919 helped to increase American support. There is need however, of far greater foresight and vision and more extended coöperation of American radio and scientific organizations.

Returning to Shanghai I found that "broadcasting" had arrived and was producing that tidal wave of interest and enthusiasm with which all of you in America are so familiar.

Now is the time for constructive propaganda; a Radio Corporation broadcasting station has been started in Shanghai, and daily programs of Western and Chinese selections are sent out and the same great enthusiasm and unanswerable demand for receiving equipment has



—WITH KUSHANG MOUNTAIN IN THE BACKGROUND

—to throb with interest and activity in applying the fruits of modern science to its social and industrial life

developed in Shanghai that so many of you are familiar with in America.

In getting ready for big developments, it is the plan of the National "Y" Educational Department to initiate special training insti-

tutes with the provision for amateur teacher training, literature supply, equipment, etc., so that there may increasingly come to China the great blessings that radio will engender in this old and populous land.

## Wanted: A Desert Island!

The Story of an Attempt to Forget Radio and All Its Dreadful Associations

By ZEH BOUCK

**T**HERE was a time, when to isolate myself from radio—from its inducements and extravagances—was farthest from my desires; and occasionally, even now, I am not altogether antagonistic to it. I don't mind writing a radio article now and then—it returns to me a fraction of the money I have squandered on everything from coherers to power tubes—or listening-in once in a while to WLC handling traffic in a way that shakes the dust from a thousand memories!— But one can have too much of a good thing, and the time came, not very long ago, when radio and I decided to see less of each other (I'd laugh, were it not so tragic!).

After disposing of a motor-generator and sundry apparatus, I presented an incipient lunatic next door with my antenna, on condition that he swing the unsightly lead across the courtyard into his own window. Feeling more or less like an emancipated drug addict, I looked forward to an enjoyable freedom. But I was sadly mistaken. Generosity may be a virtue—but virtue has always been my stumb-

ling block. My neighbor apparently considered that services went with the aerial, and he dogged my steps and my telephone with an implacable demand for a crystal regenerative set! With the usual malignancy of neighbors across the court, he recommended me to some dozen of his fanatic friends, with the result that instead of being divorced from radio I was all the more embroiled in its iniquities! Deciding to finish my next door neighbor once and for all, I sold him an electrolytic interrupter with which to light his filaments. When his three tubes blew out (as I knew they would the second he turned them on), instead of being disgusted and forever through with me, the leech came around and demanded, not my life as I had hoped, but a scientific explanation of why his tubes had blown!

That finished me—pitifully so. I determined to leave the city, to seek new parts, (no, no, I mean new places), some virgin land; vowing to shun radio in every form however innocuous it might appear! But the question was, *where* to go; in what direction lay my escape?

"Finding an unpolluted spot is going to be

like searching for a catwhisker in a haystack!" I thought; which paraphrasing of the old aphorism well indicates my disordered state of mind.

*Haystack!* A-a-ah! The very thing! Back to nature—farm-life, cows, sleepy pigs—back to those far regions where they have yet to learn the value of silos as antenna masts! And visualizing the peace and antiquity that I desired, Schoharie, N. Y., my ancestral village, flashed to mind. Schoharie, backward and somnolent, lying in the valley of the same name, between slopes that farther south and east run into the less lazy majesty of the Catskills. Schoharie! A great soft country, like a sleeping cat, indolently beautiful, with hills of green and tilled gold squares isolating it from "civilization." Down in the centre of the valley runs the twisty, slow Schoharie River, emptying later into the Mohawk, and beside the river, the twisty, slow Schoharie train. In my mind's eye I saw myself alighting from that train at the little station. . . .

Without more ado I telegraphed the Mackeys, with whom I had previously boarded. It was not until I had finished packing my bag that I noticed that I had thrown in a pair of phones, by force of habit.

The next day, on the observation platform of train 51, I breathed a sigh of relief as she slowly pulled out of Grand Central Terminal. Good-bye to radio! But fifteen minutes later I was dizzy with counting antennas! I was actually ill by the time we passed the old De Forest tower at Highbridge. As we sped through Yonkers, I cast a final, half fascinated glance at a huge umbrella type aerial (2ZS, I think), and turned to my paper, carefully folding *inside* the page that gave the broadcasting programs.

At Albany, I changed to the Binghamton

Local, a fairly comfortable train when stopped at stations, or, as is quite often the case, between them. I had barely settled myself in the old D. & H. smoker, when a native son of the soil dropped into the seat beside me. I wiggled over to the window, partly to give him room and partly to escape the hazard of a heavy basket which he balanced on the rack above me. My companion looked me over with disconcerting deliberateness, and taking a preliminary chew from a package of Old Cottage, spat and spoke.

"Going out far this way?"

I beamed on him with a sudden realization of where I was. At last I could converse with some one in a language in which "coil" could mean rope and spaghetti was something to eat.

"Oh not very far. I'm getting off at the Junction. It's a great free country out here!"

"Uh huh," and he chewed away unimpressed, for all the world like the ruminating stock he doubtless owned. He evidently figured it was my turn, so I ventured:

"Goin' very far yourself?"

"No, I'm jest going to Delanson."

"Delanson, eh? You don't happen to remember Dick Mackey, do you?" Dick, years ago, had there proprietored the best hotel in the county. He taught the bartender the ramifications of his art, until his license was voted away, when he took to farming.

"Dick! I should say I do reck'lect him. Beint he up in Schoharie now?"

"Right-o. That's where I'm going. . . . Out on his farm."

"Yep, Dick's a good fellow. D'ye know Russ Deyo up in Schoharie?"

"Russ? Sure! He has the Ever-ready Storage Battery agency, hasn't he?"

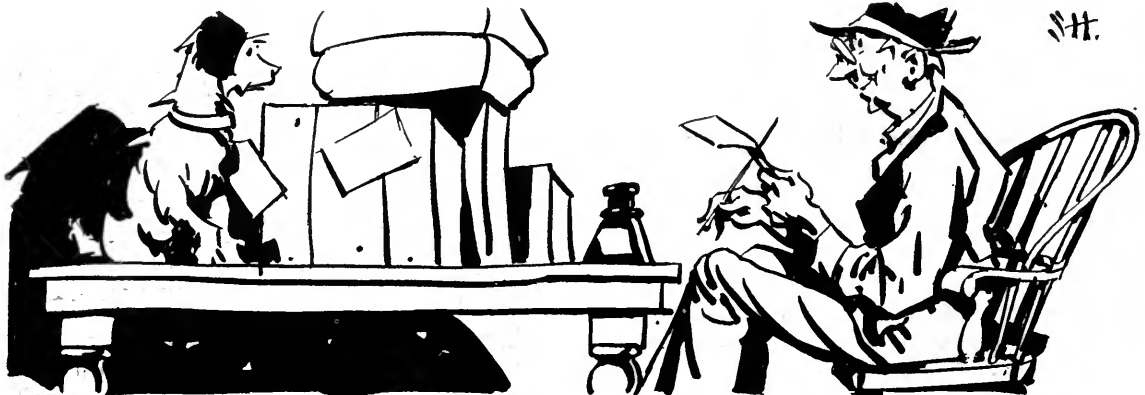

I CAUGHT A GLIMPSE OF JED WILKINS IN THE EXPRESS OFFICE

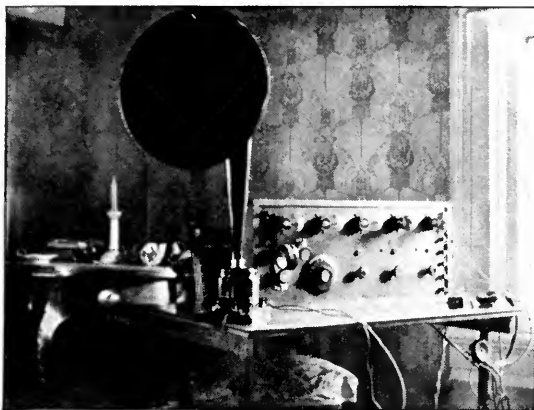

RUSSELL DEYO'S FIVE-BULB SET  
Which gave the writer a surprise

"Reckon he has. Russ is a lively boy, Russ be. Got one of these here radios now, and he's selling 'em all over the county. Farmer down by Delanson got one the other day offin him!"

My heart sank. I made a mental note to keep away from Russ Deyo. It was a darn shame, too, for we've always been the best of friends. "Radio all over the county!" That was discouraging. Well, anyway, I knew that Dick had two hundred acres of virgin hillside, and I consoled myself with the thought of my coming isolation.

Then my curiosity, whetted by fourteen years' environment, got the better of my discretion, and I asked:

"What do you farmers think of this radio, anyhow?"

"Well, to be frank with ye, we don't think a hell of a lot of it——"

I nodded and beamed approvingly, almost asking him for a chew of tobacco.

"Well," I pursued, "doesn't it do you any good? Don't you derive any benefit from the market quotations and the crop reports, and all that sort of stuff? There's the weather forecasts—and then, don't you enjoy the concerts?"

"Weather reports? Huh! I reckon I kin gen'rally figure out the weather 'thout anybody's assistance. The music's all right for them as likes it. My wife, she kinda takes to sech tripe . . . but then she ain't responsible. And then that there crop report. Well, half the farmers don't get it anyway, 'cause it's sent out at the wrong time, 'round seven in the evening when we're doing chores. The farmer ain't got the time to listen to sech stuff; he's got work to do, and when that's done,

he goes to bed. The only chanct he's got is in the winter when work's slack, and then those market reports don't do him any good 'cause there ain't no crops!"

I was beginning to understand what was meant by "agricultural depression." My acquaintance continued.

"The trouble is, I guess, "he closed his eyes as he became philosophical, "that most of us are too old. It's a thing for the *young* people. There ain't no doubt in my mind that when they perfect it, radio's goin' to be a wonderful thing. There's heaps of opportunity in it. There's lots of fortunes that's goin' to be made. There's a chanct, now, for a young man like you——"

I excused myself, rather abruptly I fear, and stood on the platform until we had jerked out of Delanson.

Manly Bellinger, an old friend of mine, met me at the Junction, and I settled back in his Ford delighted to abandon the Schoharie Express and its attendant evils. But while Manly was turning over the engine, I caught a glimpse of Jed Wilkins in the Express Office, checking over a collection of boxes and packages, half of which displayed the labels of some radio company. Well we started off, and I was soon breathing deeply of the fresh valley air. As my spirits rose, I asked Manly for the village scandal, which he gladly furnished *ad infinitum*. But my heart sank again as my chauffeur mentioned a new small-town iniquity, RADIO; and he enthusiastically proclaimed that Schoharie's aristocracy had capitulated to it!

Prompted by the instinct of self-preservation, I directed my chauffeur to raise the dust of the *back* street when running through the town, and under no condition to stop, whether for



"VAN"—A RADIO TRAGEDY

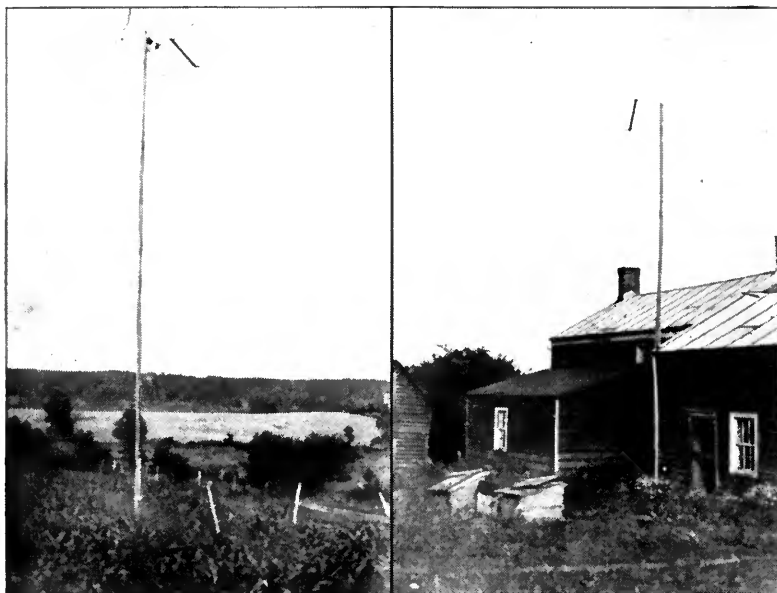

MR. SPADEHOLTZ'S ANTENNA SYSTEM IN THE SCHOHARIE HILLS

blowout or earthquake. Manly was somewhat taken back.

"Well," said he, obviously disappointed, "I kinda told Russ Deyo that I might bring you around to his store before I took you up to the farm——" Manly paused, daunted for the moment by my pallor and the contrasting danger in my eyes. "——yes yes, I know you didn't particularly want me to tell any one that you were coming up this time, but I just figured it out to myself, I did, being that you and Russ are such good friends. . . . And then there's Pert—Pert Badgely at the Newsroom. He's got the agency for the Specific Electric Radios, and he sorta reckoned on seein' you.

He said he had a couple of questions he calculated to ask——"

"That's all very interesting," I broke in ironically, "but it's contrary to orders. You steer clear of Main Street, and when you see Pert and Russ, you just pass it along that I changed my mind and went to Bermuda—no, better yet, to the South Sea Islands!"

**B**UT the farm was Paradise! The weather was lazy and perfect, not a single stretch of wire polluting the blue depths of the sky. The trees, light with the soft verdure of early summer, swung their green laurels unstayed or weighted by

unsightly insulators and spreaders. Not even a telephone or electric-light wire did I see, and I rejoiced in my perfect isolation. I settled down to a quiet existence, and read extensively—*The Dairyman's League News*, *The Schoharie Republican* and *County Democrat*, and the Sears & Roebuck Company catalogue (this last only until I came to the radio department). But such tranquility could not last, and it came to a tragic conclusion two days after my arrival, when Russ Deyo drove up, and burst in on me.

"Well, well, Jack! I sort of thought I'd find you up here, though Manly didn't like to admit it. Well I suppose you came up here to dope out some new radio ideas all by your lonesome!"

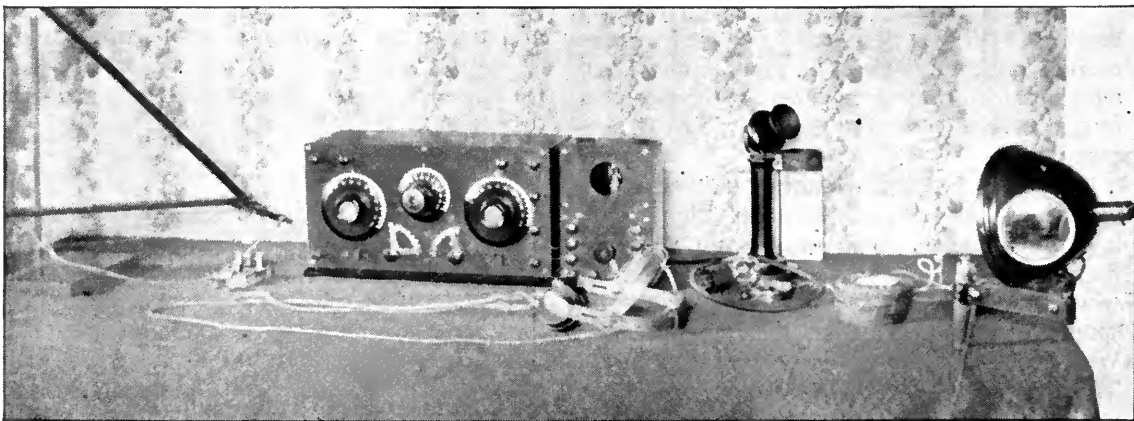

THE NEAT APPARATUS OF MR. SPADEHOLTZ

Both cabinets, the honeycomb coils, loop, and key were all made by him in his amateur workshop



I shook hands with him, though his words had somewhat rubbed my fur the wrong way, and before I could denounce such calumny, Russ elaborated on his delusion.

"I bet you miss your set out here. Nothing to do, no signals to listen to. Well, I think we can make up for that a little bit. I've got a peach of a little set down at the house you can fool around with."

I began to protest, but my friend cut me short.

"Not at all, Jack. It's not the least trouble. I'm only too glad to let you play with the set. To tell you the truth I'm rather proud of that little instrument, and I'd like to have you look 'er over. Come, you're not doing anything this afternoon, why not let me run you to town and show it to you?"

"No, no, Russ," I expostulated (rather feebly), "I don't want—well to tell you the truth, I didn't come out here to—"

"Now, I told you before, Jack, it's not the least bit of trouble, and the Missus'll be glad to see you."

I capitulated; I couldn't offend Russ, so, letting him continue to think that he was doing me a favor, I made up my mind to get it over with as soon as possible. As we drove past the stables, Russ called back to the folks that I would not return to supper, and before I could assure them that I most certainly would be back in one half hour, we were around the corner and out of range. I sat glumly in the car, watching the little dashboard ammeter jump back and forth as we lurched over the hillside road. But the little instrument soon called forth unpleasant memories, so I wrenched my eyes from it, and made a sorry endeavor to be pleasant.

"I suppose WGY is about all you can get around here on a crystal set," I suggested, trying to show an interest in the apparatus which he was taking me to see.

"Yes, that's about all we can get."

"Crystals don't work very well on single-circuit sets, do they?"

"No, I guess not."

I was deciding that Russ didn't know a great deal about receivers, but nevertheless I persevered in talking intelligently about a simple set.

"Do you use a synthetic crystal?" I asked.

"No; no, I never heard of them. What are they?"

Quite discouraged, I said a few thing about



THE LAYOUT OF MARSTON VROOMAN

In Middleburg, N. Y. A set that takes one back to pre-war amateur days

metal sulphides, wondering, for the want of something more cheerful to do, what sort of a mineral he used under the bent safety-pin, which contrivance I was now convinced constituted his "little instrument."

Five minutes later Russ Deyo introduced me to his *five-bulb, two radio, detector, and two audio* set! I was simultaneously introduced to his dog, Van (whom I renamed Pan, as being short for Pandemonium), and I spent the next ten minutes between pretending to enthuse over the apparatus (which really deserved commendation) and warding off the attacks of the mongrel who was sedulously destroying my right trouser leg. I looked first at the glowing bulbs, and then at the dark circles under my friend's eyes, and comprehended. I determined, at least, to save his reason. As Russ left the room for a moment, I called to Van, who had relinquished my ankle in favor of the pedals on the piano, and sicked him on the radio set.

"Get 'em, Van!" I hissed, pointing to the five tubes. "Rats! Eat 'em!"

Van cocked his eye that was airdale (the other was partly fox terrier), and threw one comprehending glance at the apparatus. He yelped pitifully, and flew from the room, his tail between his legs. That dog was the only male member of the Deyo family with sense enough to be scared of the thing. (Poor Van, well might he fear it! He is now dead, and his



THE UNASSUMING SHOP OF MR. DEYO  
From which he dispenses radio equipment to  
Schoharie, N. Y., and throughout the county

spirit flown at a speed which I hope is greater than 186,000 miles a second. He ran into a moving automobile one night in a precipitate rush to escape from the loud-speaker.)

Russ returned a moment later, his face beaming. "Come on, Jack, we're off! I've got a treat for you. We're going up to Spadeholtz's farm on the hill. He's got one of the neatest little sets, and he made every bit of it himself on the farm. He's got antenna masts, and——"

"I'm sorry, Russ, but I must get back to the Mackeys'. Supper, you know, and besides——" But my protests were futile.

"Nonsense, you're eating with me. Come on!" By this time I was prepared to look for something better than a crystal set, and under happier circumstances I should have admired the ingenuity of the lad who built his set on the lonely hillside. A year before, I could have appreciated the antenna and its supports, the cleancut appearance of the apparatus, the audion sockets, transmitting key, loop, honeycomb coils and omnigraph, *all home made!* As

it was, I assimilated these details quite dispassionately, and made not the slightest protest when Russ announced that he was now going to show me another station located somewhere in Middleburg owned by one Marston Vrooman. I was led, unresisting, much after the manner that a criminal is conducted to and from the scenes of his crime.

Young Vrooman's station brightened me a little, for in appearance and layout, it was reminiscent of the old amateur days before the war. But my retrospective thoughts brought the evils of to-day into a more prominent relief, and I soon sank back into my "slough of despond."

I WAS depressed the next day, and in my melancholy, the blue sky seemed hidden behind a network of a thousand antennas. I went to town that evening, hoping to lose myself, mentally and physically, in the motion picture theater. But Russ saw me first.

"Hello there, Jack!" he beamed. "I've been wanting to get up to you all day, but I've been as busy as the deuce. I'm going to take you down to Charlie Holmes's, you remember him. He's got quite a set, and I know you'll be interested in it. I'll get the car——"

"No! No you won't, Russ!" This time I would be firm. "Impossible! I'm going to the show, and nowhere else." But Russ smiled as cheerfully as ever.

"All right, fine!" he assented. "Hattie Meyers has a set there in the theater. It's the same as Charlie Holmes's, in fact he installed it. . . ." and in half swoon I heard only vaguely the details of ". . . Westinghouse . . . two step . . . Western . . . loud-speaker. . . ."

As we left the theater, two tortured hours later, Russ, always painfully enthusiastic, grabbed my arm.

"Now, I'm coming up for you to-morrow night, Jack. The firemen are giving a combined party and radio dance, and I know you'll want to be there. In fact you can operate the set. Well good night, Jack!"

"Good-bye, Russ," I said, "*Adieu!*"

The next morning Manly Bellinger made what reparation he could, and in his Ford, he sneaked me away from Schoharie before the sun was fairly up. I didn't dare brave the train. I had just been reading about the receiving experiments on the Lackawana Railroad and Heaven only knows what atrocities Russ might have committed on the Schoharie Limited.

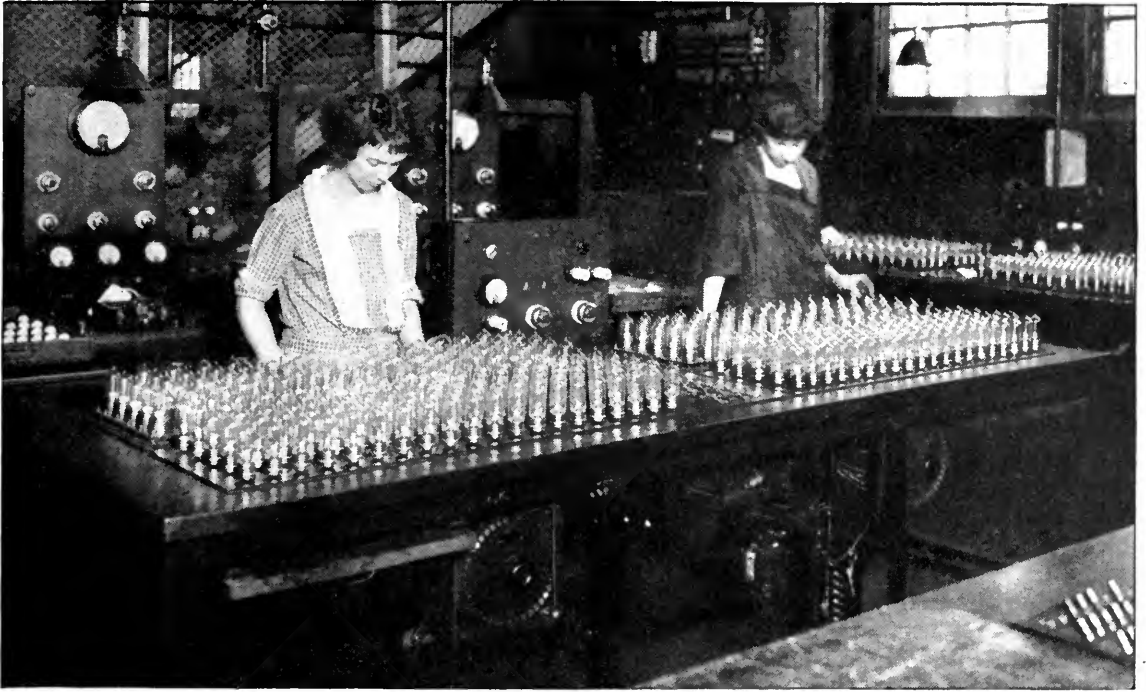

WD-11's and WD-12's on the aging table. The tubes are kept on this table one hour to increase the possible electron emission and to test for the degree of vacuum

## How Vacuum Tubes are Made

Following the WD-11's and WD-12's Through One of the Plants in Which They are Made

By W. W. RODGERS

Westinghouse Electric and Manufacturing Company

This is the first time that an article has been published in a radio magazine describing and illustrating the important steps in the manufacture of vacuum tubes. Except for minor modifications and a difference in the exhausting process, all vacuum tubes are made in a way much like the dry-cell tubes here described by Mr. Rodgers.—THE EDITOR.

**I**F ONE were asked what single factor has made radio universally popular in America, the answer might not be as difficult as it first seems. For, of the many things introduced into the radio market for the benefit of amateur and fan, the dry-cell vacuum tube stands supreme in the number of radio enthusiasts it has added to the list of those who nightly listen-in. Thousands of new fans were created as soon as the dry-cell tube began to be sold in quantities.

This little tube eliminated a sharp class distinction in the radio world. Before it came there were the crystal detector users and the vacuum-tube users. Crystal detector sets were numerically superior to vacuum-tube sets when

all that could be obtained was the six-volt tube operated from a heavy and expensive storage battery. People who could not afford these items had to be content with crystal detectors, and thus were very limited in their range of radio entertainment.

Then came the dry-cell tube, changing this condition. The purchaser of the one-volt tube could procure his current from a 40-cent dry cell; whereas the storage battery needed for a six-volt tube cost from ten to twenty dollars. There was such a rush on the part of the public to buy, that for a time the manufacturers were swamped. In fact, two great shortages have occurred in the vacuum tube supply since they were first placed on sale.

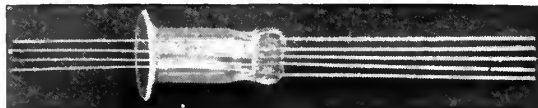

FIG. 1

The short glass tube has a flare on one end and its other end has been melted and pressed down around the five wires, which are imbedded firmly in the glass. Note that there are five wires in the glass press, but only four leads come through the flared opening. The fifth wire is a blind which acts as a support, later, for the plate

These shortages are not likely to occur again as they occurred with a type of tube made by one company, which at the time was the only concern in America capable of producing these tubes in quantities. There are now two companies making such vacuum tubes, and thus with their increased facilities a much larger production is available.

The first commercial dry-cell vacuum tube, the WD-11, is a product of the Research Laboratories of the Westinghouse Electric and Manufacturing Company at East Pittsburgh, Pa. It was here that the need for such a tube was first seen and the research work necessary to the perfection of the finished tube carried on.

Early in radio telephone broadcasting history, after the public had indicated its interest in the concerts and the possibilities of the industry were realized, the need for a vacuum tube which could be operated at low cost was clearly seen. It was apparent to the men who had the problem to solve that the first cost of the tube was not what prevented an almost universal interest in radio, but that it was due to the upkeep, as they say in the automobile world. Storage batteries cost money to buy and to keep charged.

Long before the first order was given the Research Laboratory to start experimenting on the proper material for a low-voltage filament, preliminary work had been started by the research engineers. It had been discovered that a new filament was necessary. This filament must consume a very small amount of current yet have a satisfactory electron emission.

However, in spite of the preliminary experimenting on the tube, it was nearly eight months before the Research Laboratory, which received its order from the Company officials to start developing a tube having the WD-11 characteristics in March, 1921, was able to furnish the perfected tube. The first commercially

practical tube was completed October, 1921. During the eight months intervening a new oxide-coated filament was perfected and the WD-11 type designed.

At first there was some trouble in securing the proper type of worker—one who required no small degree of skill in the various stages of assembly. Girls had been decided upon for a large number of the manufacturing operations, and a few thought that it would require a long period of training to fit them for the work.

While the organization was being perfected the Research Laboratory undertook the construction of 400 tubes. This order came in October, 1921. With an augmented force the 400 tubes were completed in a short time. Then another order for 400 tubes was placed with the Research Laboratory and upon its completion, another and still other orders. The tube became popular at once and the demand for it by the public exceeded expectations.

At the time the tubes were being assembled in the Research Laboratory, a section of the factory in East Pittsburgh was being equipped to build the tubes. The men and girls trained by the research engineers formed the nucleus of the larger force required in the department of the Main Works where the tubes are now assembled. Soon this department was building tubes in daily increasing quantities.

Since the vacuum tube department was given the task, production has so increased that

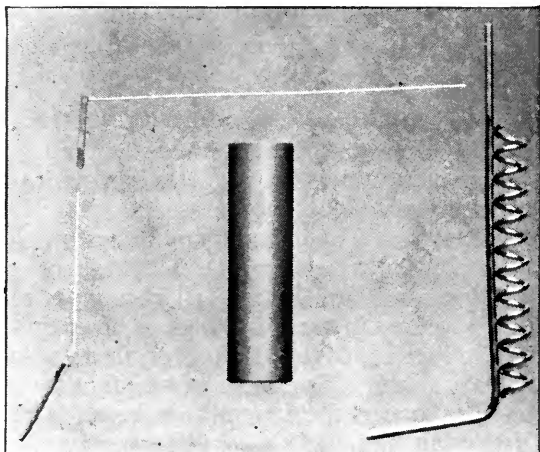

FIG. 2

The filament, plate, and grid of the WD-11 and WD-12 dry-cell tube. Note that the ends of the filament are held by two clips and that there is a support running from the upper clip. These attachments are provided so that the filament may be spot-welded to its support

now the average number of tubes assembled daily is 7,500. This is quite a large quantity when one considers the care necessary in their assembly and the number of tests each tube is required to pass before it is considered ready for the purchaser.

The WD-11 and WD-12 tubes, which are identical except for their bases, despite the fragile character of the materials used and the great care and skill necessary to their proper assembly, are sturdy bits of apparatus, well adapted to withstand fair handling and give efficient service during a long life. Much attention has been given to constructing them so that they might be small yet not at all delicate. This does not mean

that they are dropped on the ground to test the strength of the glass, nor that they will come up smiling after having  $22\frac{1}{2}$  volts connected across their filaments. How many users have burned out their dry-cell tubes because of this error! The filament voltage should not be more than one and one-tenth volts.

There are two main units in these tubes—the outer tube, from which the air is removed, and the assembled inner unit. If this is kept in mind and if it is understood that all assembly is done on the inner unit which is then inserted in the outer tube, sealed in and the outer tube exhausted of air, the various stages of manufacture may be followed very easily.

There are 13 steps or processes through which the parts go before they emerge as the complete vacuum tube. There is a test made after each stage of the assembly and still further tests after the tube is completed. The tests are so severe that a tube after it passes through them is rarely returned from a customer for failure to operate correctly.

The raw materials from which the completed tube is made consists of the glass blank, which is purchased from the glass manufacturer already shaped—this forms the glass walls of the tube; a thin glass stem; a short tube of glass, which is later shaped and which holds



FIG. 3

Mounting the filament—step seven in the assembly. The operator is holding the assembled inner unit in her hand while she spot-welds the top of the filament to its support

the wires in place in the tube; the filament, cut to size and coated at the East Pittsburgh plant; the plate; and the grid. The plates are shaped from a rectangular piece of metal, and the grid wires are wound into the spiral form they take in the completed tube.

All these units can be seen in the photographs of the assembly process.

The first step in the process is the making of the flare. This consists in heating the small tube on one end to soften it and then spinning on the flare.

It will be noted, if one looks closely (Fig. 1) that there are five wires in the press or inner unit of which four run through. The fifth wire is merely a blind inserted to act as a support for the plate. These wires are white at the top but red where they adhere to the glass in making the seal tight. Dumet wire is used for the seal, nickel being welded to it at the top. A copper covering is necessary so that when the press is melted to hold the wires at its top, a gas-tight joint is formed.

The placing of the five wires in the press is the second operation of the assembly. What this resembles with the five wires imbedded in is clearly shown in the photograph.

Next the stems are cut to the proper length so that when the plate, grid, and filament



FIG. 4

The assembled inner unit complete, with grid, plate, and filament mounted. The flare at the end of the glass mount is used for sealing in this assembled inner unit to the glass blank

FIG. 5  
The glass blank as it is received from the glass factory

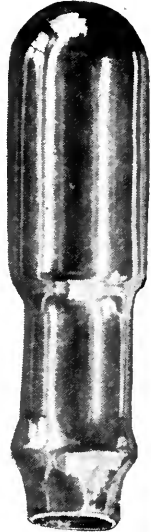

(Fig. 2) are inserted they will fit in their proper places. This makes the fourth step in the operation.

Step five consists of mounting the plate. This is spot-welded to its support by a girl who has a special machine for the task.

Step six consists in mounting the grid. This is also spot-welded at the top and bottom to its mounting.

The next step is mounting the filament (Fig. 3). This filament, which is a platinum iridium alloy, coated with an oxide of barium and strontium, comes to the girls already cut to the right length, properly tested and with its ends ready for mounting. Mounting the filament is probably the most delicate task in the assembly of the tube.

There is a good reason for using an alloy for the vacuum-tube filament. Ordinary metals are not used because they are not as strong at the temperature to which they are subjected as is the alloy. Making the tube strong enough to stand the wear and tear of daily use was ever a problem before the research department. All sorts of metals were tried. The WD-11 filament has a long life which accounts for the fact that it will give service for a period often ranging between 2,000 and 3,000 hours.

Step seven is completed with the mounting of the filament (Fig. 4). The weld press is completed and is ready to be placed in the glass blank (Fig. 5), which first must be prepared for exhausting.

Step eight in the process is called tubulating the glass blank (Fig. 7). A thin point of flame is blown against the rounded end of the glass blank, so that a tiny hole is melted through. Then the glass tube is welded around this hole. The blank now has a glass tube running

from its end (Fig. 6). This glass tube is attached for the purpose of exhausting the tube. As the other end of the tube is sealed this end remains so that it can be attached to the pumping machines.

The next step, number nine, is termed sealing-in (Fig. 8). When it is finished, the glass weld with its mounted plate, grid and filament and the four wires, running out of its end, is firmly sealed to the glass blank. The flare, first spun on the press, is used to make this joint.

At this point, the tube resembles a completed vacuum tube except that it has no base and has a long glass tube mounted on its top.

When the sealing is completed, the tube is tested for leaks in any part of it. It is also tested for short circuits from filament to grid and from grid to plate.

Step ten—exhausting the air from the tube—is a very important one (Fig. 9). Before arriving at this stage, a getter has been painted on the base of the glass weld. It can be seen as the white dab on the press holding the five wires in place. From 10 to 15 minutes are required to exhaust each tube.

In exhausting the tube, the glass stem at the top is inserted in a piece of rubber tubing which leads directly to the pumps. These are two in number, an oil pump and a mercury-vapor pump.

A covering is pulled down over the tubes. This covering serves as an oven to bake them at a temperature of 400° Centigrade and thus reduce the gas content.

Then the pumps are turned on and the tubes exhausted to a pressure of one-millionth of a millimeter of mercury. This is a much higher point of exhaustion than that given the electric lamp.

As the tube sits in the holder, it is surrounded



FIG. 6

The glass blank with its stem attached. This stem is used in the process of removing the air from the tube



by a coil of heavy copper wire. The covering is now pulled up and a high-frequency spark is thrown on this surrounding coil to test the tube for cracked glass.

After this, the plate is heated red hot by an oscillating current having a frequency of 1,000,000 cycles—these are generated by two 250-watt tubes similar to those used for transmitting purposes—to remove the gas from the plates and metal supports.

Next in order is the turning off of the plate oscillations and heating the filament to obtain the proper chemical reaction on the filament oxide and thus increase the possible electron emission.

The tip is now sealed off by the machine operator using a gas flame, which he runs around the bottom of the glass tube until it melts off and forms the tip.

Finally the tube, properly exhausted is removed from the machine, complete now except for the base (Fig. 10).

The tube now passes through several stages of inspection before the bases are cemented on. During this inspection, the tube is carefully looked over for appearance and poor tips, and for degree of vacuum. Opposite the inspectors who take the tube at this stage there is a box into which the rejected tubes are tossed and smashed to fine bits.

Step number eleven is cementing the base to the tube. Just before "basing," a small glass stem is slipped over each of the four leads to prevent any shorts at this point. The base is filled with a cement, an operator draws the four wires through the stems in the bottom of it, and the tube with its base attached is placed in a machine which bakes the base on firmly. Included in the basing operation is the soldering of the bottom of the tips on the base and rounding off the ends of the stems. An operator dips the stems in a solder pot so that the wires running through the stems are soldered firmly

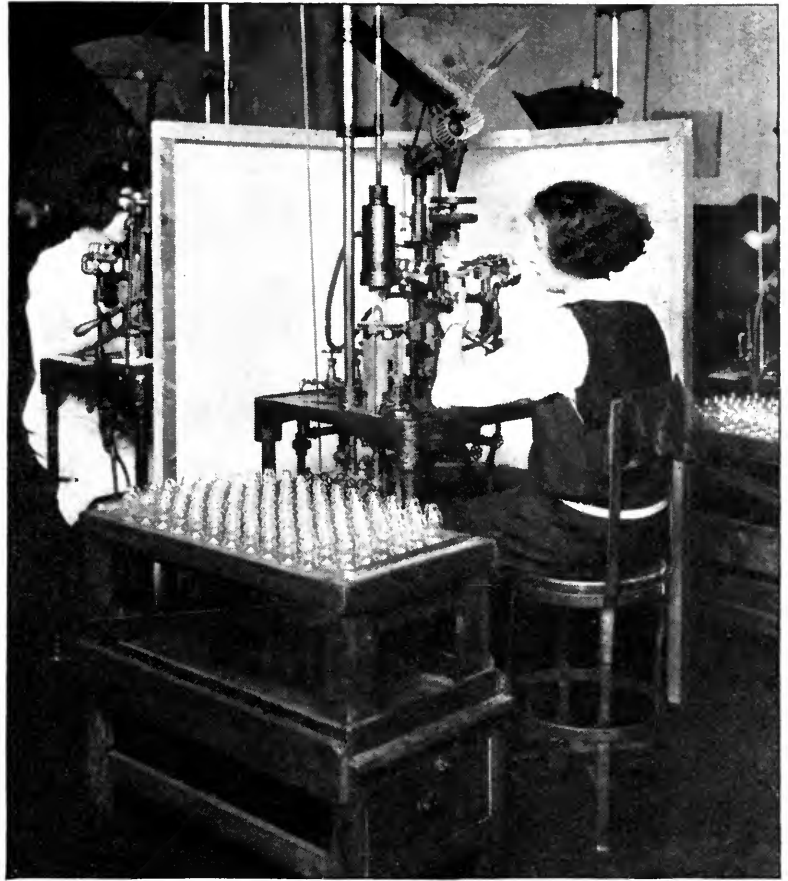

FIG. 7  
Tubulating the blank. A tiny hole is melted in the rounded end of the glass blank and around this hole is sealed a glass stem

in place. To make a neat job, the stems are next placed in a machine so that they are rounded off properly. Just look at the tips on the base of your vacuum tube to understand this operation.

Thus when the tube reaches this stage it resembles the one used in the receiving set. But it still has some tests and processes to go through before it can be called completed.

The next step is a test, and while it is given no number in the order of assembly, it is important. This test is termed lighting out the tube (Fig. 11). An operator places the tube in a base connected to three electric lamps; one red, one blue, and one white. The red lamp is in series with the grid, the blue lamp is in series with the plate and the white lamp is in series with the filament. If, when the tube is placed in this base, one of the lamps glows, it is discarded, for it plainly can be seen that the wires are short-circuited and the tube is unfit for use.

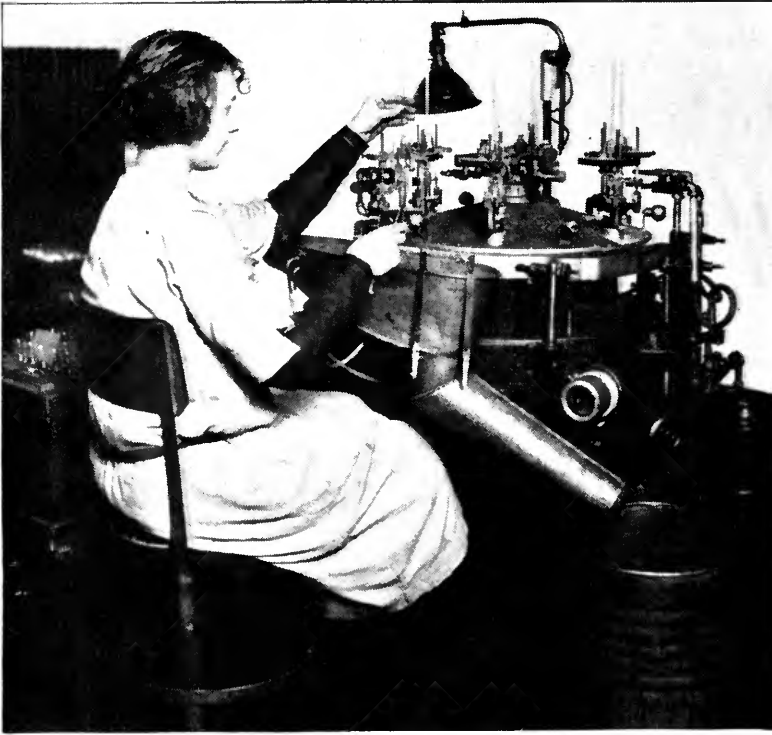

FIG. 8

In this process, the assembled inner unit is sealed by means of its flare to the bottom of the glass blank

Those of the tubes which pass this test go on to the next stage. This is a test and a process combined for developing more efficiency in the tube. It is step twelve, otherwise known as the aging process. In it the tubes are placed upright, several hundred at a time, on a table, with their leads connected to circuits which are slightly stronger in voltage than the tube is subjected to in normal use (photo p. 397). The tubes are kept on this table one hour to see if any faults develop and to obtain the maximum electron emission from the filament. During this aging test, sometimes the degree of vacuum is found to be insufficient. This condition can be determined by a measurement of the nega-

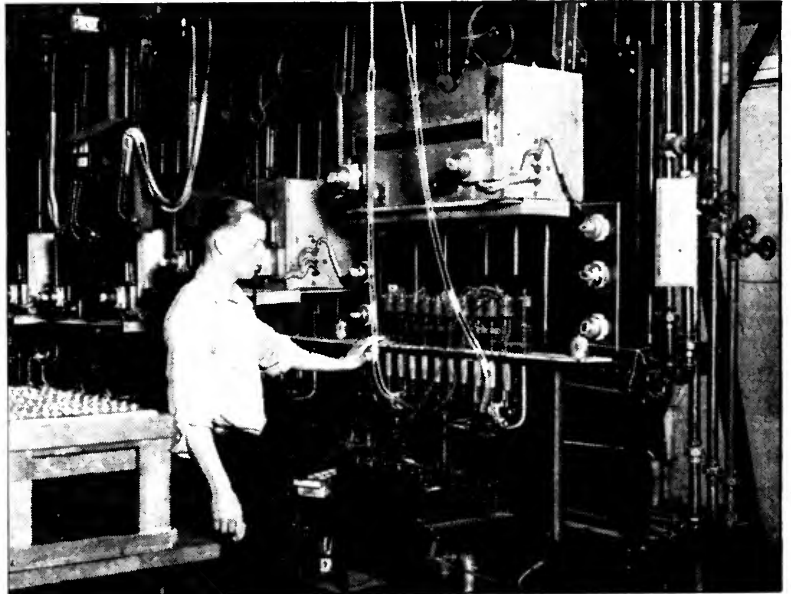

FIG. 9

Exhausting the tube—step ten. Ten tubes are exhausted simultaneously in this machine. Each one is surrounded by a coil, described in the article, and its glass stem is attached to a rubber tube (seen underneath the shelf) which leads to the pumps. The white box-like affair just above the row of tubes is the oven. It is pulled down over the tubes to bake them as a part of the exhausting process

tive grid current. During the aging process, the getter absorbs such gases as might remain in the tube.

After leaving the aging table, the tubes are stored for three days. This is time enough to determine whether there are any air leaks. After this final storage, they are again tested for all circuits, filament emission, degree of vacuum and appearance and are ready for shipping.

The final stage is the packing. Those who have purchased the WD-11 know how carefully it is packed in its cardboard box with many layers of packing material wrapped around it.

The process of assembling these tubes is one that is long and tedious, calling for the utmost skill on the part of the various operators. In assembling the

plate, grid and filament, girls do the task. They do, also, most of the preliminary tests. Men operate the exhausting machines and do the final testing.

A visit to the vacuum-tube department at East Pittsburgh is a revelation of the efficiency of the workers. The recruits are trained by skilled operators a number of weeks before they are placed at the task of doing the actual assembling. Some difficulty is experienced in obtaining girls who are dexterous enough to do the work properly. The employment department thinks that if one girl out of ten or fifteen sent to it is found satisfactory, it is doing well. All these things must be considered in the assembling process. The skill of the worker is largely responsible for the efficiency of the tube.

Dry-cell tubes have been brought to a high point of efficiency, and experiments are constantly being carried on to develop this efficiency further. The point now has been reached where it costs much less to operate the filament of a vacuum tube than it does to light the electric lamp above the head of the radio enthusiast operating his receiver.

Each tube is a monument to masterful research, inventive genius, the wizardry of modern machinery and a perfect organization of workers and officials.

It is certain that further experiments now going on will reduce this operating cost and still further lengthen the life of the dry cell. The Research Laboratory which first developed the tube is constantly working on various forms of low-voltage tubes. These stories, however, must wait until the tubes are perfected.

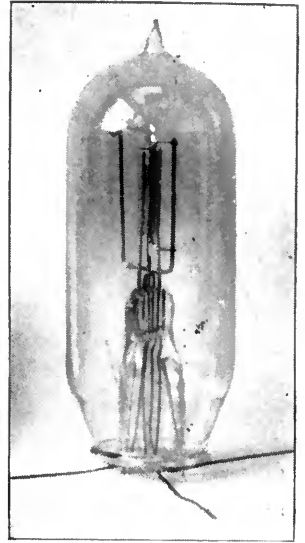

FIG. 10

After the tube has been exhausted and the glass stem sealed off, it resembles the completed tube except that it has no base

FIG. 11

"Lighting out." The tube is placed in a holder leading to the three lights in series with the grid, plate, and filament. If one of the lamps lights when a tube is placed in the holder, the operator knows that the tube has developed a short circuit



# Some Notes on Tuned Circuits

Inductance and Capacity—The Two Factors that Affect the Wavelength of Any Circuit

By M. B. SLEEPER

**A**FTER all the years that we have had radio experimenters, there are still inquiries pouring in concerning the wavelength of a coil or a variometer. Strangely enough, in spite of the great importance of tuned circuits, comparatively little has been written to give the sort of detailed explanation of them that have been given for vacuum tubes and various other phases of radio equipment and circuits.

In order to have the right idea about wavelength and tuned circuits you must first realize that a coil has no inherent wavelength other than its natural period—a useless factor in tuning. It would be just as incorrect to talk about the wavelength of a variable condenser as of a coil or variometer, for wavelength depends upon inductance *and* capacity. You would not speak of the area of a length. You think of area as depending upon length and width. In the same way wavelength is determined by the amount of inductance of a coil and the capacity of a condenser.

Perhaps one of the reasons for this confusion is that the nature of the capacity in a tuned circuit is not always apparent. Consider the circuit in Fig. 1, that of an ordinary loose-coupled set. It is divided into a primary or antenna circuit and a secondary circuit. You might think off-hand that there is only the inductance of the coil in the antenna circuit.

Actually, the antenna provides the capacity, because, just as you have in the secondary circuit a coil connected to the two sets of plates of a condenser, so in the primary you have the upper end of the coil going to wires strung over the ground, and at the other end a lead to the earth. The antenna wires and the ground serve as condenser plates and the air separating them as the dielectric. Therefore, the wavelength of the primary circuit is not determined merely by the inductance of the coil, but by that inductance and also the capacity of the antenna-ground condenser.

If, then, you use the primary coil of an ordinary variocoupler in the antenna circuit and your antenna is very small, perhaps a single 50-foot wire, the antenna-ground capacity will be very small and the wavelength correspondingly short. When you increase the antenna to one of four wires, each 100 ft. long, the capacity will be much increased, and, as a result, the wavelength in the primary circuit will be greater than before.

Frequently experimenters complain that they cannot tune down to the 200-meter stations. Investigation usually shows either that the antenna is too large or the minimum tap on the coil gives an inductance so great that the wavelength at the lowest is above 200 meters.

The antenna tuning is not so important as the tuning of the secondary circuit, for the reason that the resistance of the antenna, the ground lead-in, and the ground connection is very high, and consequently tuning is not very sharp in the antenna circuit.

New types of receiving equipment for wavelengths from 150 to 1000 meters are often made with untuned primaries. This is entirely practical, unless the antenna is so large that its capacity and the inductance of the lead-in and ground connection is sufficient to give a wavelength, regardless of the inductance of the tuning coil, very much above the minimum wavelength to be received. A loose coupler, or, as it is more often called, a fixed coupler, with a non-adjustable primary winding relies largely upon shock excitation of the secondary

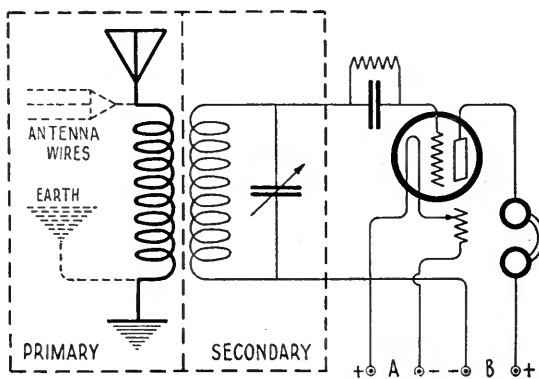

FIG. 1

The antenna-to-ground circuit in any receiver provides capacity as well as inductance

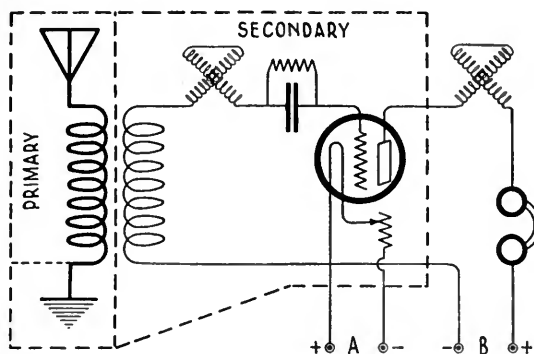

FIG. 2

Capacity in the secondary circuit is supplied by the elements of the tube and by the coils themselves

rather than on tuning the primary to the exact wavelength of the incoming signals.

One method of reducing the wavelength in the antenna circuit is to connect a variable or fixed condenser in series with the lead from the antenna to the coil, or from the coil to the ground. This reduces the wavelength because the total capacity of two condensers in series, in this case the antenna-ground condenser and the condenser in the set decreases the total capacity of the circuit. On the other hand, the wavelength can be increased by shunting a condenser around the coil, for it is then in parallel with the antenna-ground capacity. Two condensers in parallel give a total capacity equal to the sum of the two.

The secondary circuit is quite simple in an outfit such as that shown in Fig. 1. The wavelength is determined simply by the inductance of the coil and the capacity of the condenser. Sometimes a fixed inductance is employed with a variable condenser; or the coil is tapped so that the number of turns in the circuit, and correspondingly the inductance, can be varied.

The absurdity of saying that the coil is a 300-meter inductance is evident from the fact that the wavelength of the circuit varies according to the adjustment of the condenser. Tables are available for determining the wavelength of any circuit according to the inductance of the coil and the particular setting of the condenser. If honeycomb coils are used, the wavelength can be found from tables or charts supplied by the manufacturers.

It should be noted that, in any circuit, the wavelength does not change in direct proportion to the inductance or capacity, but according to the square root of either factor. In

other words, if the condenser capacity is increased four times, the wavelength is only doubled. A very simple formula gives the exact wavelength:  $\lambda = 59.6 \sqrt{LC}$ , where  $\lambda$  is the wavelength in meters,  $L$  is the inductance in centimeters, and  $C$  the capacity in microfarads. Remember that one million centimeters is equal to one millihenry of inductance.

Fig. 2 is rather puzzling. It shows the circuit of the familiar two-variometer receiving set. At first, you might say that there is no capacity in the secondary circuit, but only the inductance of the coil in the variocoupler and the inductance of the grid variometer. There is capacity, however, for the grid of the tube acts as one plate of a very small condenser and the filament and plate of the tube serve as the other plate, not to mention the distributed capacity found between adjacent turns of the coils themselves. For that reason a much higher inductance is required than would be needed if the circuits were tuned by a variable condenser.

Often the question is asked whether or not the plate circuit is tuned also to the wavelength of the incoming signals. It is not necessary to do this, for the plate variometer gives only an approximate adjustment.

Some manufacturers have attempted to rate their variometers for wavelength, and in that way have encouraged experimenters to think of the wavelength ranges of variometers. This is a misleading practice, for the wavelength is considerably altered by the size of the secondaries used in different types of variocouplers. Moreover the capacity of vacuum tubes varies considerably, the capacity of the UV-199 being very

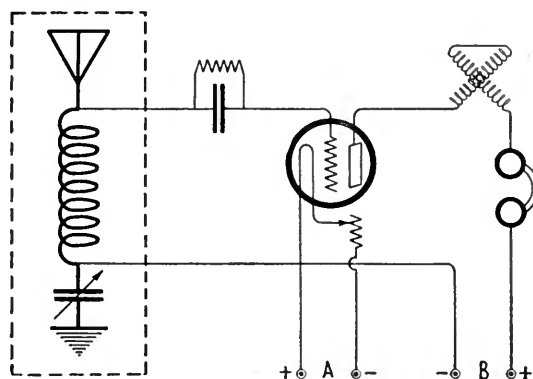

FIG. 3

This single-circuit hook-up depends upon the antenna capacity, inductance of the coil, and capacity of the tuning condenser for its wavelength

low and of the UV-201-A or VT-1 comparatively high. However, a manufacturer can say that his variometer, when used with a particular type of variocoupler and vacuum tube, tunes over a certain wavelength range.

If the antenna capacity is specified, the primary circuit can also be rated for wavelength. That, however, is not a very useful rating because antenna capacities vary greatly: they are not determined merely by the dimensions of the wires. Trees, buildings and metal roofs or large chimneys increase or decrease the capacity. An antenna erected over dry earth does not have the same capacity as one stretched over moist earth, for example.

A single-circuit receiver, such as the one shown in Fig. 3, depends upon the antenna capacity, the inductance of the coil, and the capacity of the tuning condenser, for its wavelength. Since all the tuning is done in the antenna circuit, which, as explained before, has too high a resistance to give sharp tuning, more or less trouble from interference is often

experienced. You will find, too, that the setting of the plate coupling coil or plate variometer will affect the wavelength, for it introduces another value, that of mutual inductance between the two coils, altering the effective inductance in the circuit. Thus, altering the antenna circuit requires a new setting of the plate variometer, or vice versa until a suitable balance is reached.

If you want to design your equipment accurately, you must measure the antenna capacity. This, however, is not at all necessary in installing or operating a bought receiver, for most of that work has been done for you. The method is simple, and details of the process can be found in a number of radio books. You will need to find out as much as you can about the constants of your coils and condensers so that you can determine the wavelength range with some degree of accuracy. In any case, do not go by wavelength ratings of coils, vario-couplers, or variometers, and above all do not learn to think of inductance in terms of wavelength.

## A Little Foresight and a Big Success

How a Knowledge of Radio, Combined with Good Business Principles, Enabled A. J. Haynes, of the Haynes-Griffin Radio Service, Inc. to Increase His Business a Thousandfold and Give Customers Better Values and Service

By ALFRED M. CADDELL

**W**HEN a man starts in business with a very small capital and is obliged to seek larger store-space twice within a year, and his assets increase a thousandfold during the same period; and especially when he makes his money on your money—you are interested in him. You want to learn some of the things he knows about the commercial end of radio, something about his business methods and why he has succeeded when countless others, who jumped into the business with both feet, have failed.

An uphill story, or a story that starts from scratch, is generally a good one. It is likely to be a story of faith, determination, and a combination of knowledge and good will toward the business itself. Besides, somewhere in the story, may lie the so-called "secret" of success which others may perceive—and apply.

Artemas J. Haynes has long been in the radio

business, either as an amateur purchasing equipment, an engineer developing new apparatus or, as at present, a business man who brings together the sources of supply and the customer demand. He became interested in radio while a student in preparatory school back in 1910. Like a lot of amateurs, he commenced with a coherer—with which he received very little. His first successful receiving set was an indoor aerial, crystal detector and a pair of 75-ohm phones through which he could hear the local high-power spark stations and occasionally a ship.

He wasn't very different from the average radio amateur of those days and now—every odd moment out of school and college found him building and experimenting with radio apparatus. He had sets and fragments of sets, mounted high on a table and strung around his room—batteries, switches, odd parts, and wire. He went through the regular



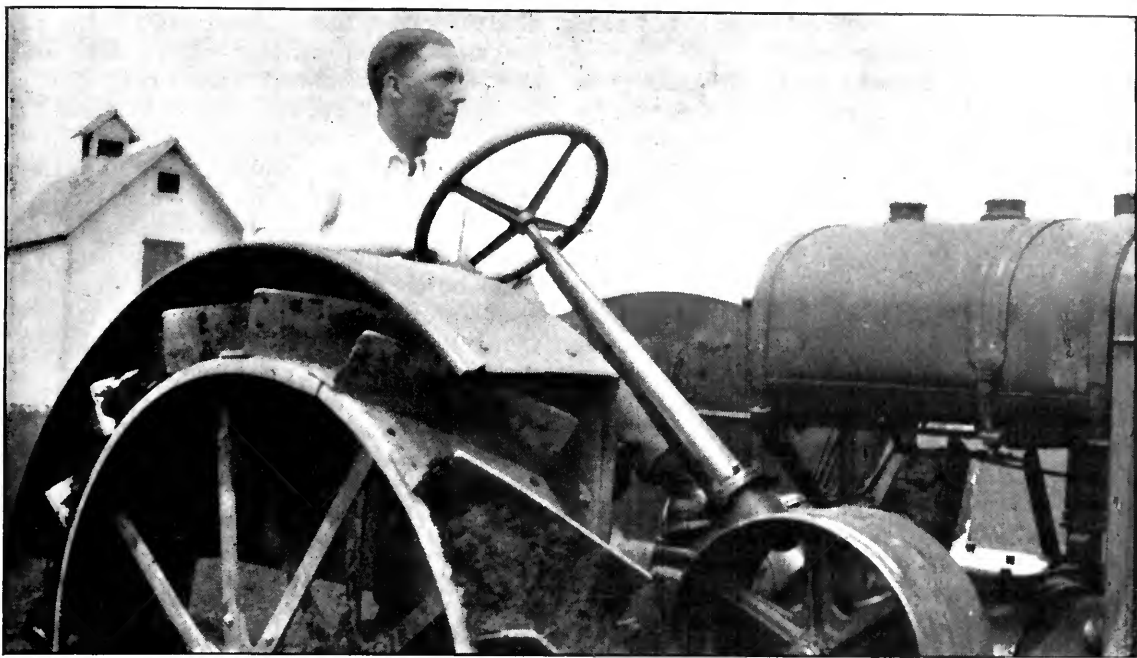

MR. HAYNES, LIKE PRESIDENT HARDING, DRIVES A TRACTOR NOW AND THEN

run of coherers, magnetic, crystal, and electrolytic detectors, tuning coils, loose couplers, and finally ended up with the De Forest Audion, a little round bulb that screwed into a miniature socket, with a small square plate and grid and two carbon filaments—a wonderfully big feature in those days.

“We were all a bit skeptical of that little bulb at first,” says Mr. Haynes. “The promises made for it sounded too good to be true and it wasn’t until after much hesitancy that I finally purchased one and compared it with my prize galena crystal that I realized with a heartfelt sigh that my interminable search for the most sensitive spot on the most sensitive crystal was over.”

When the United States entered the World War in 1917, Mr. Haynes was a student at Yale University. Immediately after the declaration of war he enlisted in the Naval Reserve, and was among the first to attend the Brooklyn Navy Yard Radio School. Things were moving fast in those days, and new orders went flying about, so he quickly found himself assigned as radio operator to the U. S. *Shubrick*, a hastily converted coal-burning destroyer that was pressed into service for patrol and convoy work. Then he went to the naval radio station at New Haven, after which he was suddenly transferred as radio instructor to

Yale University, where he taught many of the boys their first principles of radio.

So much for his pre-business days, which had proved to be a wonderful combination of learning and teaching, resulting in a solid foundation in radio. Now came employment with the De Forest Radio Company as engineer, a year or more in the laboratory and then a position placing him in charge of foreign sales. But in the early part of 1920, when radio as a means of livelihood seemed uncertain, he took a look into the retail music field. Not for long, however. Indeed, he was permitted only a passing glance, for the dawn of radio broadcasting appeared on horizon in 1920-21.

“I think most of us who had followed the business,” said Mr. Haynes, “realized that sooner or later radio broadcasting was bound to become a big thing, and notwithstanding the long, almost impatient wait, it really came much quicker than I expected. As it was, the suddenness of its coming found me in the woods of Maine, but I returned to New York as soon as I could. During the winter of 1920-21 I operated the De Forest experimental station at Highbridge (2XG) which was used primarily for test and demonstration work between Highbridge and 2XX, our other experimental station, operated by Robert F. Gowan of honeycomb coil fame, located at his home in

Ossining. I spent many evenings at old 2XG testing with amateur stations and playing phonograph records to entertain listeners in and around New York. In fact, we staged a good many dances this way in the homes of radio amateurs who were equipped with loud speakers.

"And then the big broadcasting storm broke over the land. Previously, the interest in radio had been comparable to the few drops of rain that announce a cloudburst. Hundreds of wild schemes followed in the aftermath. It was the beginning of the Radio Age. Dealers who had no previous experience with radio or electrical equipment began selling radio apparatus like so many nuts and bolts. Factories soon lagged far behind in filling their orders, a fact which led dealers to duplicate their requirements with many jobbers and manufacturing concerns. But after the first heat of the race, the public called a halt and began analyzing the situation. They became wary of radio sets sold over the books-and-stationery counters, and at the drug store. They began to discriminate between the cheaply built apparatus and that which was more reliable. Meanwhile, manufactures had been led to increase their production, but they had hardly begun turning out the rush equipment when the buying demand fell off. The lure of 'money in radio' soon showed its face—inexperienced dealers who had placed large orders for cheap apparatus found themselves loaded with stock which suddenly had lost half its retail value. Exit from the radio business seemed to many to be the only way out of such an unprecedented situation.

"Fortunately, I had seen a lot of discouragement in trying to get radio broadcasting started, and this operated to make me proceed most cautiously. Would the present flurry last? I saw permanence in radio, but at a distance. As the public now knows, the radio business was encumbered by men with no knowledge foundation whatever, who like get-rich-quick promoters were riding on the back of free publicity. How to avoid the pitfalls that were bound to react from such a situation? How to get into the retail business and make progress at the same time? How to make it known that I had the technical experience, that I knew radio goods, that I had a desire to fit the customer's pocketbook and

needs together, that I aimed to be in the business to stay and was more than willing to cooperate with customers to see that they got the very best out of their outfits to which they were entitled?

"Skimming the cream off milk and expecting that milk to retain its full value presented an altogether incompatible viewpoint. There was only one way to go into a permanent retail radio business and that was to take counsel with customers, talk frankly to them, tell them that you aimed to stay and grow in the business and offer to be of assistance then and thereafter. Reconciling the situation as best I could, I borrowed a little money and opened up a small store known as the Haynes Radio Shop on Lexington Avenue, New York, in the spring of 1922.



"At first, I barely paid the rent on the place out of the income of the business. But gradually I began to get more customers—young lads who were anxious to have sets installed in their homes. I hired one man, then two, and the little business began to look up. At times the gross receipts amounted to less than \$100 a day, which barely allowed me to make both ends meet. Then it commenced a steady upward climb as the summer slump of 1922 began to draw toward its end. Private installations now became more in demand, one job attracting another. When Johnny Smith or Bobby Jones got in trouble, if I couldn't explain it away when he called at the shop, with a perplexed look on his face, I went over to his place, diagnosed the ailment and set his apparatus in order. After that, it very seldom got out of order, for he was getting accustomed to it and manipulated it only in the way he should.

"During this baby growth of the business I advertised very little, for the simple reason that I had no available funds. But had I had extra money at the time I hardly think I would have plunged into the business any heavier just then. Liquidation, elimination, controversy over the permanence of radio, and confusion were in the air. But at various turns radio broadcasting gave healthy signs of surmounting its troubles. The curve on the chart that I kept and an auditing of my accounts left no doubt about this.

"During radio's inevitable slump in the summer of 1922, I was one of the organizers of the first Radio Dealers' Association of New

York, and served as Vice-President as long as that organization lasted. Mr. Griffin, now my partner in the firm of Haynes-Griffin Radio Service, Inc., was President. Personally, I consider the greatest benefit derived from that association was the bringing of Mr. Griffin and myself together. Mr. Griffin's whole training and experience over a period of more than six years had been in advertising and merchandising with one of the leading advertising organizations in the country. He brought to the organization a breadth of vision and experience which most retail merchants acquire only after years of hard work and hard knocks. This, supported by my own training in the technical side of radio, gave the new organization a combination of experience seldom found in any business conducted solely by one man whose training and inclination generally lies along one particular line.

"Mr. Griffin had been in the radio retail business in rather a small way by himself. But each of us realized that we had progressed as far as we could by ourselves, for in order for either one of us to take care of any more business it meant increased organization. Besides, our individual locations just then were not ideal for expansion—we felt it necessary to locate in a more transient section of the city which offered greater contact with the radio public."

The results of that merger speak for themselves. The two young business men, as partners, began to forge ahead very rapidly. Locating midway between Times Square and the Grand Central Terminal, New York, a more strategic spot for transient accommodation could not be had. It was the one thing needed to assure their success. Shortly after the partnership was effected, the opportunity came to purchase the Lexington Radio & Electric Company, and not only the stock and good-will of that company was taken over but the entire personnel as well. This, therefore, made the Haynes-Griffin Radio Service, Inc. a combination of three of the oldest and best known radio stores in New York City, and the many regular customers which the additional store immediately brought to the combination helped toward the great expansion which has since taken place.

But before this article appears in print, Mr. Haynes and his associates will have given even more tangible evidence of the success which

has followed in the wake of their business methods and ideals. For during July they opened the largest radio store in New York City, which probably also means the largest in the world. Space and facilities are more than tripled in the new store. More than 4,000 square feet are devoted to the sale of radio apparatus alone. In this store are incorporated several new ideas in the merchandising of radio. On the ground floor where parts and accessories are carried there are in effect, three radio stores in one. For the stock of the store is duplicated in three different locations so that customers may be served efficiently and quickly without either salesmen or customers being obliged to move about from counter to counter in order to secure everything that may be desired. On the second

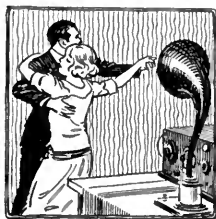

floor there are several small sound-proof demonstration booths similar to those in phonograph shops, where practically every make of proven, well-known radio receiver is on display; while in the basement will be located a repair and service department which, from an adjunct of the radio retail business, has grown to be a department of the first importance.

Many stories of how service and attention resulted in further business abound about the shop. A short time ago a man from Connecticut came into the store to buy an insulator for a receiving antenna. He had been sent in by his employer who thought what he wanted was a very large insulator. However, he was assured that a midget insulator costing twenty-five cents would do as well, and reassured that if it proved unsatisfactory to his employer the twenty-five cents would be refunded and a larger insulator substituted in its place. Furthermore, the salesman obtained the employer's name and saw to it that a letter was written to him that night, explaining to the employer why his man had been persuaded to take the midget insulator. The result of this attention to such a small purchase is almost unbelievable—since then the employer, although he has never been inside the store and is not personally acquainted with the organization has bought more than \$3,000 worth of radio merchandise.

Another instance was that of a young office man in Brooklyn who bought a "Haynes Circuit" receiving set, the development of Mr.

Haynes. He knew little or nothing about the radio art, and was obliged to come into the store on several occasions to get pointers. As a result of the attention given him, he has been instrumental in selling thirty-six sets to fellow office workers and officials in the company where he was employed. All of them were "Haynes Circuits."

A case of a somewhat different type may also be cited. A woman came into the shop, saying that a friend was going to sing that evening at one of the broadcasting stations, and she had been given to understand that if she came to the shop she could hear her sing. Just how, she knew not, but that's what she had been told. Would they be open that evening? Ordinarily they would not, yet this time most assuredly they would. More than that, they invited the woman to ask all her friends—the shop would be a regular receiving station that evening. Eight women came, and listened throughout the whole performance, and eight women had the mysterious something explained to them—that is, explained so that they felt confident they could hear the same kind of music in their own homes. And so eight more enthusiasts, soon to become customers, were introduced into the radio fold that evening.

"I consider that I sell good-will and service more than radio equipment," says Mr. Haynes. "And I think you will find this to be the case with every successful dealer in the radio field. Radio is such a large proposition and so entirely new to most people—a scientific thing made popular—that real merchandising consists of individual education. In the beginning, both dealer and customer were like two strangers who spoke a strange tongue in a strange land. They understood each other very little. Unlike the clothing business, for example, which is as old as man himself, radio burst upon the world as a brand new creation. Customers knew so little about it that they wonderingly asked: 'How much do you charge for an ohm?' and things like that. You couldn't laugh at them—you simply had to explain what an ohm was.

"It was due to this prevailing lack of knowledge that many customers were victimized by unscrupulous dealers who probably didn't know much more themselves but who sold them anything in order to get their money. But it

was also due to this lack of knowledge that we owe our success. It was a wonderful chance to gain a customer's confidence. Each customer, of course, presented an individual problem, but we have yet to meet the problem in the customer line that we have not been able to solve. The sales we have lost by being—as some might consider it—too frank in our advice, have been more than made up in almost every case by the confidence and ultimate business we have enjoyed from those same customers. So much has been written about the 'straight and narrow' way of doing business that I am afraid the eye slides right over it without ever seeing—at least not focussing attention on it sufficiently long. But of this I am sure: that the radio retail dealer who sells service and attention first and equipment afterward will have a larger credit balance at the end of the year than the dealer who sells equipment only."

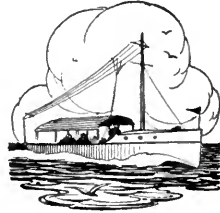

The speaker led the way to the rear of his shop, opened a locker door, picked out his tennis racket, and prepared to "call it a day." Tennis is one of his standby recreations, and one can see the effects of it in his eye and step. Next comes swimming, and sport with the rod and gun. As is evidenced by the healthy state of equilibrium in which he keeps himself, he knows how to mix pleasure with business and not keep himself too near the saturation point. Besides, his wife won't let him become over-concerned with his hobby, even though it is the radio business.

Like many others in the commercial field who have kept their ears close to the ground and their eyes on the progress of radio, both Mr. Haynes and Mr. Griffin maintain that the possibilities of the art, especially in the way of a quickening of intelligence in all classes of people, are only beginning to be realized. The biggest thing, of course, is the proper control of broadcasting. As one who has seen the broadcasting art develop from "Station 2XG, calling—1, 2, 3, 4; Station 2XG calling—1, 2, 3, 4" to the present high state of efficiency, Mr. Haynes has confidence that broadcasting will develop equally as much again; that the day will come when broadcasting will be subsidized by the government for the unlimited use of everybody—not a local or state affair, but national, as an investment in education, recreation, and good citizenship.

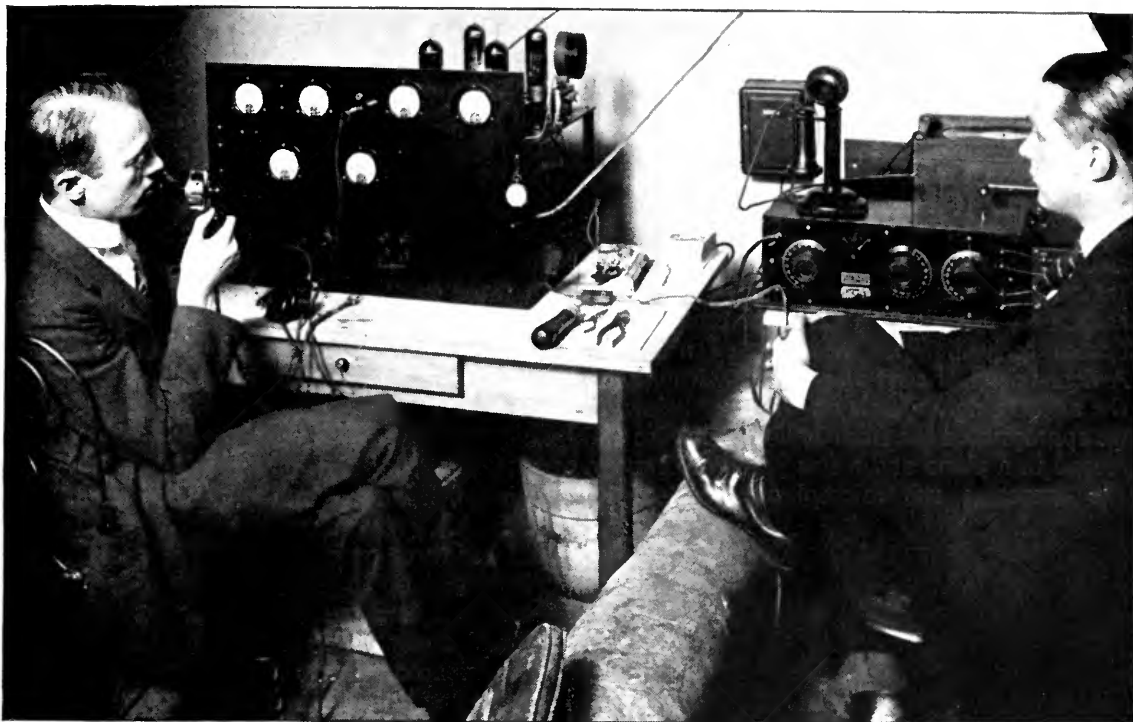

ELLIOTT JENKINS (LEFT) AND THORNE DONNELLEY (RIGHT) TESTING THEIR WRIGLEY TOWER OUTFIT

## Highlights in the History of WDAP

The Chicago Broadcasting Station that Plays Dance Music for Half a Continent

By J. ELLIOTT JENKINS

I CANNOT make up my mind whether this brief history of WDAP, which I am writing at the request of the Editor of *RADIO BROADCAST*, will be a confession or a biography. However, it should be somewhat amusing, especially to those familiar with broadcasting stations. It certainly is to me.

Thorne Donnelley and I, though we had never worked together before, had been perfectly good hams in the days of Morse and carborundum, when you used part of your father's automobile for your transmitter, and your initials were your call. My early training in the art of making the cook's favorite rolling pin into a tuning inductance came from Paul Godley, then an operator on the Great Lakes. But in 1921, when the Local Westinghouse station first opened up with the Chicago Opera, the trouble began. Donnelley came up to my house one evening to consider a Morehead

tube hooked to a loose coupler tuner. Strains of Aida were faintly audible. This was too much. The following week, I was summoned to his house, where he had collected most of the receiving apparatus in Chicago. It covered the floor and the grand piano, and a certain amount of it would function. A few days later came a hurry call on the arrival of a 20-watt Paragon transmitter. This gave room for a lot of thought.

A few days later, riding past the Wrigley Tower on Michigan Avenue, I said I thought it would make a good place for an experimental laboratory. About a week later, Donnelley came bursting into my own laboratory on Van Buren Street, followed by three men, two boys, and several dozen boxes. I said, "What's this?" and he replied, "Our broadcasting station for the Wrigley Building. I'm going over there now and string the antenna while

you put this stuff together." He shoved some papers at me, original art drawings by Charlie Logwood, then in Chicago, of a 100-watt, grid-modulated oscillator, and I went at it.

In about a week the thing was up, perched in the penthouse among huge water tanks and steel pipes. It led into a sort of cage antenna which hung at an angle to the tower. It radiated four amperes and sounded like nothing the air had ever heard before. We worked it as 9CT for a while, and then our broadcasting license arrived. This necessitated a studio. A dear friend of ours was experimenting with the advertising business on the floor below, so we appropriated the front half of the office and moved in a piano and a few yards of drapery. We overcame the microphone problem by

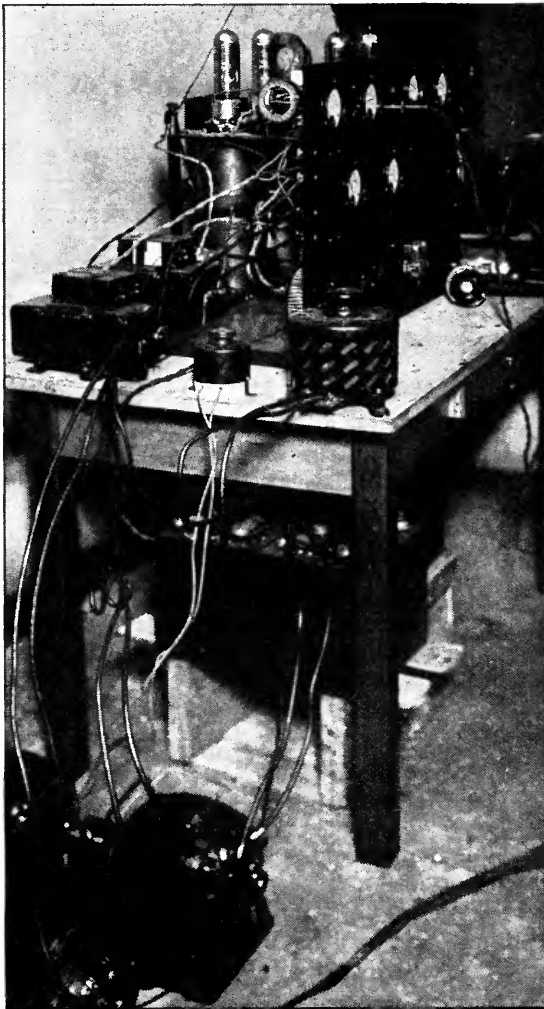

THE STATION IN THE WRIGLEY TOWER  
Showing generators, inductances, "hay wire," etc.

packing a four-button carbon affair into a fibre waste basket and hanging it on a pale blue parrot-cage support. I shall never forget the general effect. On top of the piano sat a loud speaker, connected to a hand microphone in the operating room. When the operator—it required just one to run the transmitter and the concert—would announce the station and the next number, it would be fairly audible to those in the studio. Then he would turn and bellow—"All right, *shoot!*" and the temperamental talent below would recover as rapidly as possible and do its best at the waste basket. It was a great way to run a station, and I wish we could return to it.

"WDAP, located on the Wrigley Building, Chicago, Illinois (it's a wonder we left off the U. S. A.), ground out her closing quotations and her three concerts a week all through the winter and up to July, 1922, steadily growing worse. It is a curious thing, that process of natural decay which a station, put up by the inexperienced, always undergoes. It just gets worse, despite your increasing knowledge and your violent efforts, and nothing will save it. So one afternoon in late July, a fortunate thing occurred. The sky turned a peculiar green, lightning flashed, and windows in the "Loop" blew in. A moment later the sun shone. With mingled feelings I drove to the Wrigley Building. It had a curious bare appearance in the sunshine. Pieces of our antenna were picked up in all directions for weeks. As I remember, we had used acid flux when putting it up originally.

But sometime before this, Donnelley and I had realized that it is almost impossible to put up a decent antenna on a tower-like building, so we began making overtures to the Drakes, deeply affected by thoughts of the reinforced concrete understructure the deep courts, and the sixty-foot steel masts on the corners of the roof. One of the directors of the Whitestone Company, which operates the Drake Hotel, had unfortunately heard the old station, but the idea went over regardless. So immediately after the windstorm, we moved an astounding collection of junk into the two handball courts and dressing room on top of the Drake. These were not in much demand, and would make marvelous studios and transmitter room. The dressing-room faced the south court, so we set the old 100-watt job up there and with tremendous effort strung a huge T antenna between the southeast and southwest flag masts.





THE ORIGINAL STUDIO EQUIPMENT AT THE DRAKE HOTEL

The pale blue parrot cage support is visible. It holds the signal lamp

Sixty feet under it we rigged a fan counterpoise. This was a success from the start. One ampere sent into it would raise the dead.

In the meantime I had been working as I never intend to again, building a one-kilowatt set. This was of the power amplifier type for the simple reason that it cost just half as much as the usual type of large transmitter for the given rated output, using half as many tubes and half as much current. It had a 50-watt grid modulated driver and room for four  $\frac{1}{4}$ -KW tubes. Excepting our good friend E. K. Oxner, Donnelley and I were our own authorities on large power amplifiers, so when the new transmitter simply refused to work, we could go nowhere for help. After a three weeks' struggle, we gave a Sunday night concert with three amperes in the antenna. People in town phoned us to shut the rotten thing off, but a few crystal set owners called up wild with enthusiasm. They were hearing us without their antennas, and our modulation was perfect. For the next three days the mail rolled in, coming from everywhere but the West

Coast. It seems that our small output was so concentrated on just one wavelength that all tube sets within twenty miles began to back-fire when tuned to it. For some time after that, listeners with tube sets anywhere near us found it necessary to turn their tube filaments way down to get us properly.

We felt that we had something unusual, and went to work hard on the set, adding tubes and working up the radiation, half an ampere at a time. Finally the West Coast mail began to come in. It was a nightly occurrence to have listeners in the Eastern states get excited and call us on the phone, relaying our signals back to us over the land line. I recall one night when I was particularly impressed with the speed of ether wave transmission. I was at the transmitter, and the doors to the studio were open. A gentleman in Seabright, N. J. called us up and I took the call. He complimented us on the station and put one of his headphones to the telephone mouthpiece. The notes of the piano number in progress went through our broadcasting microphone and

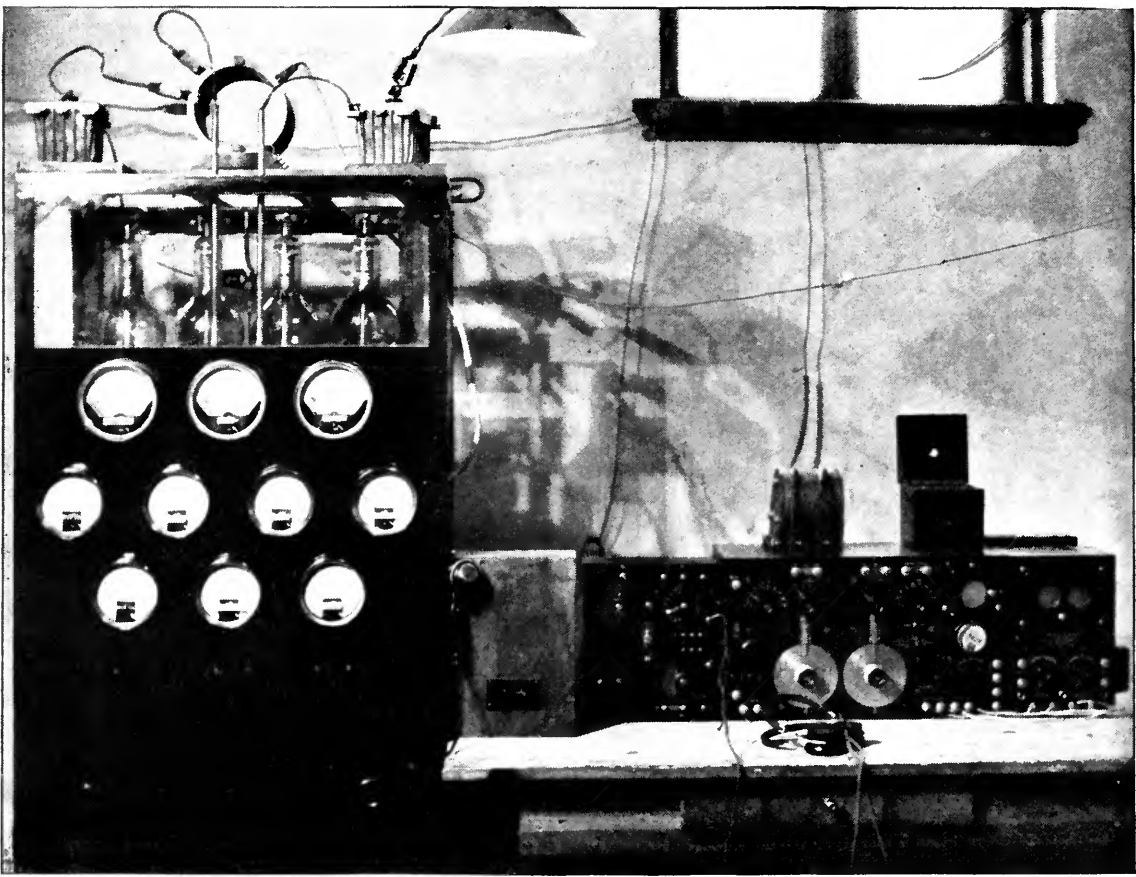

THE FIRST TRANSMITTER AT THE DRAKE HOTEL

It got its concerts as far as Surrey, England, Rio de Janeiro, Wrangel, Alaska, and to a ship 300 miles this side of Honolulu

the set to Seabright, and back to my left ear over the wires so much more quickly than they came through the air from the studio to my right ear that the difference was easily noticeable. In one case they traveled 1,800 miles; in the other, 40 feet.

I will never forget the first night we broadcasted Jack Chapman's orchestra. Our lines to the main floor had just been installed, and I went down with a microphone and put it on Jack's piano. When I got back to the transmitter room I found Donnelley and the first operator dancing violently around the place dragging a crystal monitoring set after them. Apparently everyone listening felt the same way, as our mail went from 200 to around 800 letters a day.

WDAP went off the air recently for several weeks, and all hands turned to for the completion of the new transmitter. This takes up the entire other handball court on the floor. It is in the form of a single unit of two-inch

pipings and conduit work. All the generators are at one end. Then come the filter systems, input control panels, circuit breakers, and field rheostats. There are three transmitter cases in a row, the middle one containing a hundred-watt driver circuit. This may be coupled to either of the outside cabinets, which contain separate power amplifiers. In front of all this is the operating desk, with remote controls for everything and microphone lines. Way up above the structure are the tuning variometers, of  $\frac{3}{4}$  inch copper tubing. The lead-in comes through the skylight for an antenna of four long cages in the form of an X. Under the antenna is a vast counterpoise covering the entire roof of the hotel.

We went on the air with the new station Saturday, June 29th, 1923. We have great hopes for it, and letters received thus far indicate that the two years of hard work we have spent on power amplifiers was more than justified.

# “Music Hath Charms—”

BUT NOT TO SOOTHE THE TOO-SAVAGE BREAST

Of this royal prisoner at the Bronx Zoological Park, in New York. When music from a broadcasting station was turned on, Chief Keeper John Toomey was glad he was on the outside, looking in. Not all the animals lacked the musical appreciation of this lion however

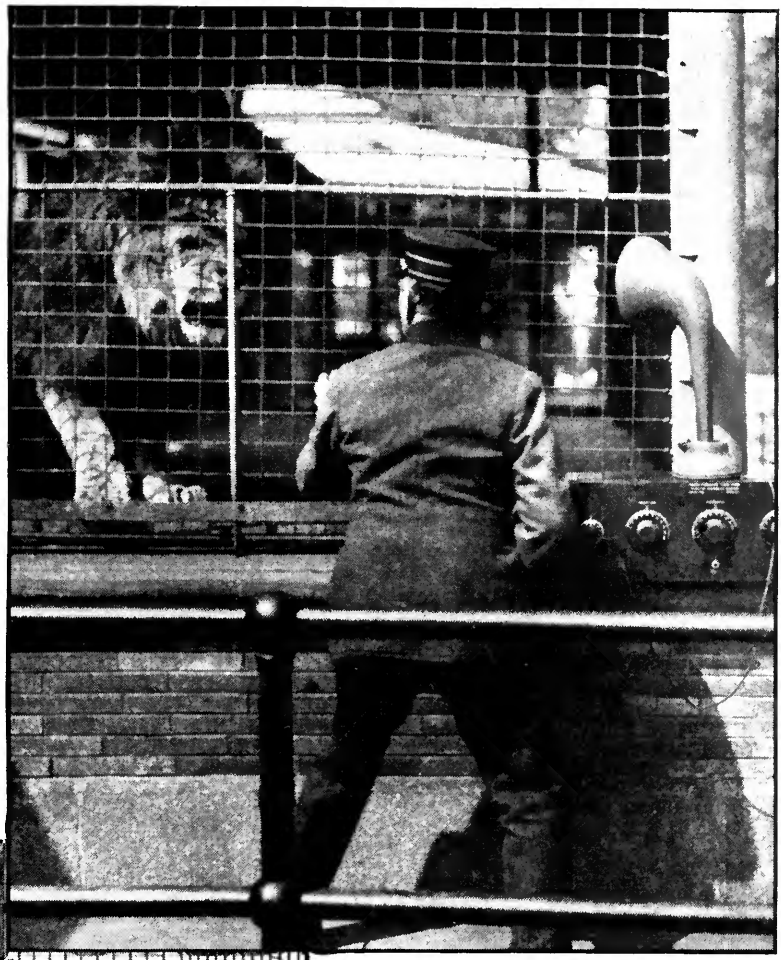

(LEFT) TRYING IT ON THE BEARS  
They liked it—especially the organ music—and were inspired to stand on their hind legs and crowd up close to the loud speaker

(RIGHT) “GRANDPA” FELT 600 YEARS YOUNGER

And seemed decidedly pleased with the radio music. It is estimated that “Grandpa” celebrated his 269th birthday about the year Columbus came over

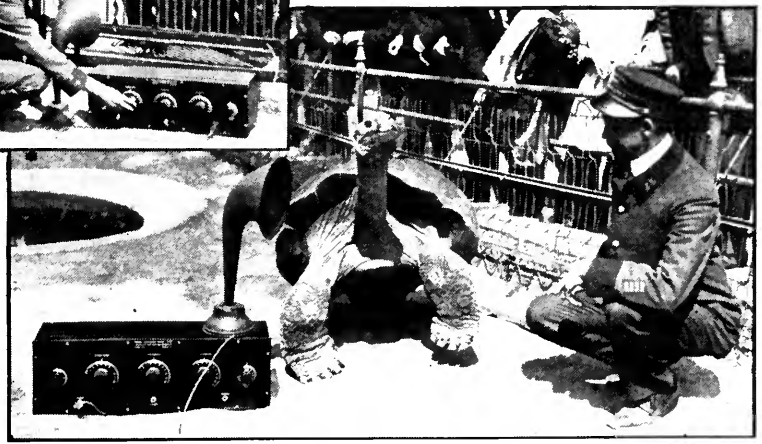

# Receiving Contest Winners



Infinite Painstaking, Excellent Workmanship and Great Originality Evidenced by the Successful Contestants. *Miss White Wins Third Place.* Three Complete Articles by the Winners. Next Month Will Appear Much "Dope" and Many Interesting Illustrations from Other Entrants—also "Honorable Mentions" and Summary

## FIRST

**Richard Bartholomew, of Garrochales, Porto Rico.** He has been sent the first prize, a De Forest D-10, 4-tube Reflex Loop Receiver. (For his article, see pp. 305-311 in the August number.)

## SECOND

**Eric G. Shalkhauser of Peoria, Illinois.** Mr. Shalkhauser wins the 150-3000-meter Grebe Tuned Radio-Frequency Amplifier. His clear and complete article on a portable Grimes "Inverse Duplex" loop receiver is full of practical help for the experimenter. His aggregate mileage of 48,745 is excellent for *loop* reception.

## THIRD

**Miss—get that!—Miss Abbye M. White, Baer Avenue, Hanover, Pennsylvania.** The originality of her home-made set and the excellent description, photos, and diagrams which she submitted were unanimously awarded the Third Prize—three vacuum tubes (choice of UV-201's, UV-199's, WD-11's or WD-12's), although her total mileage—60,595 on an outdoor antenna (96 stations more than 150 miles away of which 18 were more than 1,000 miles)—was considerably below the records of several others whose contributions did not fulfil the other requirements so well.

## FOURTH

**Harry Blumenfeld, of Cleveland, Ohio.** The winner of this prize, the Timmons Loud Speaking Unit, did all his DX work with an Armstrong three-circuit regenerative set.

Now we'll let the winners tell their own stories, and we hope that each of you will find something of particular interest and definite suggestion which you can use in your own radio work.

**L**AST month we published the winning article in the long-distance receiving contest "held to determine who has done the best with any number of tubes and any type of receiver."

This month, we announce the winners of the second, third, and fourth prizes, and print their articles in full.

The great pile of manuscripts, photos, diagrams, etc., that flooded the editorial office of RADIO BROADCAST has been very carefully gone over during the last four weeks, and a rich mine of data has resulted, which, we are sure, is going to help many an enthusiast to solve his own radio difficulties and to build his own apparatus more effectively.

Some of you, unfortunately, fell down on one or more of the requirements—omitted photos, for instance, or neglected to include adequate data on the construction and operation of your sets. It was stated in the Rules of the Contest, that "manuscripts should include the following: description of set, directions or advice for constructing and operating it; any 'wrinkles' or makeshifts which you have used to advantage; photograph of your apparatus; circuit diagram; in general, anything you have to tell that will make your story more interesting and helpful." Thus in judging contributions, "the quality and interest of photographs, text, and drawings, and the originality and general effectiveness of the apparatus described" had "greater weight than the list of stations heard," although a long list of distant stations distinctly helped.

The contest winners and the prizes they have won are as follows:

# In Tune with the Infinite

The Description of a Practical, Portable, "Inverse Duplex" Receiver, with Some Interesting Remarks About its Construction and Behavior

By ERIC G. SHALKHAUSER

(SECOND PRIZE)

Articles describing the theory, construction, and operation of the Grimes "Inverse Duplex" circuit have appeared in the April, July, and August issues of RADIO BROADCAST. What Mr. Shalkhauser does in this article is to show how he has developed the Grimes circuit in a four-tube loop outfit that is portable, dependable, and rugged. Anyone who has experimented with the "Inverse Duplex" or who has had experience in building his own radio-frequency outfits, should be able to construct a set similar to Mr. Shalkhauser's from the circuit diagram and the several clear photographs published with this article. We should like to hear from those of our readers who undertake to develop outfits of this kind.—THE EDITOR.

THE receiver shown in the photographs as assembled in permanent form, has gone through many stages of experimental work before the very best results were obtained. A four-tube set was finally chosen in preference to a two- or three-tube set, primarily because the small percentage of energy that a loop antenna will pick up in comparison with an out-door type necessitates much more amplification to assure satisfactory results at all times. The average listener does not realize what obstacles the radio man has to overcome and cannot understand why so many sets operate spasmodically. With this loop receiver it has been comparatively simple to tune in the West Coast



THE RUGGED CARRYING CASE

Everything is inside: 4-tube Inverse Duplex, loop, all batteries and phones. Unlike many so-called portable sets, this one is precisely what the name implies

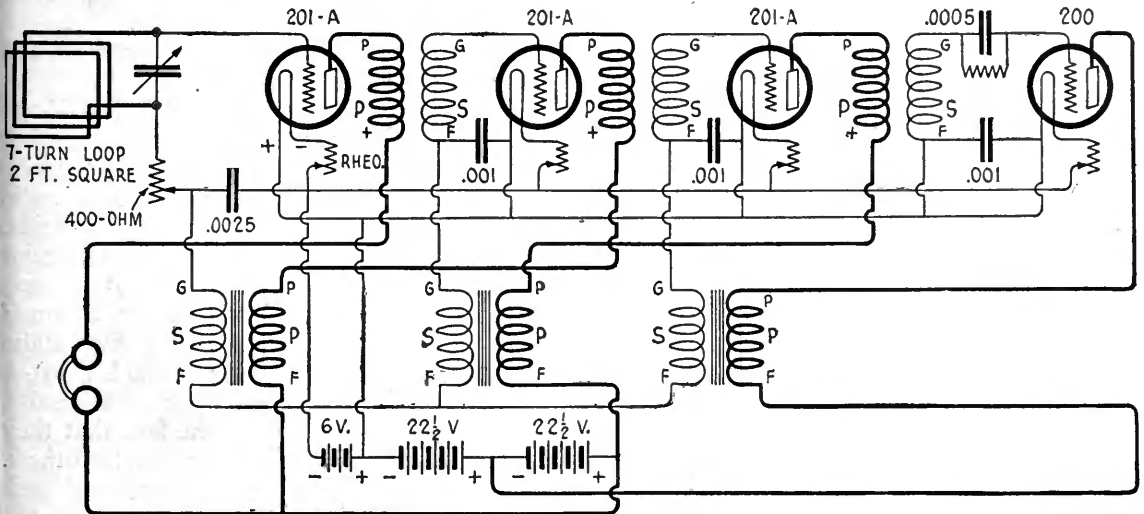

THREE RADIO AND THREE AUDIO STAGES

With a tube detector, they make up Mr. Shalkhauser's 4-tube circuit which he operates from a two-foot loop

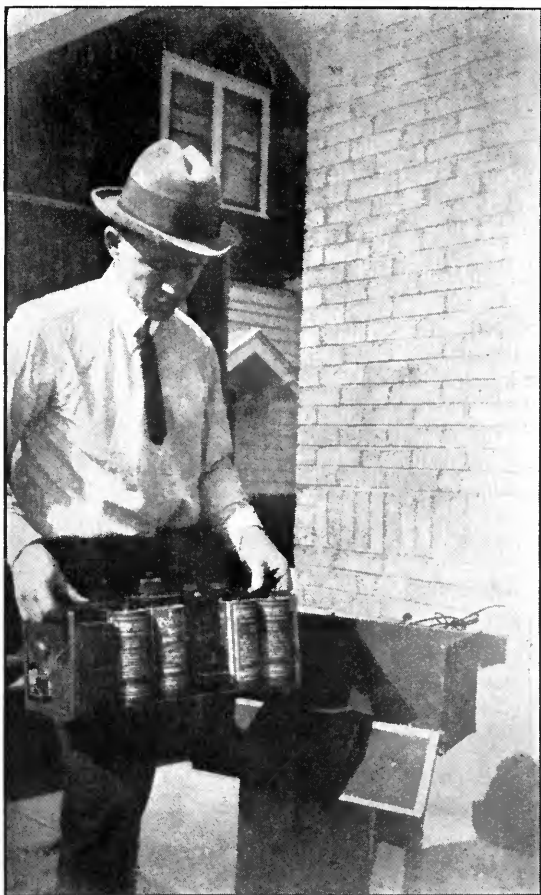

THE RECEIVER CAN BE LIFTED RIGHT OUT

Mr. Shalkhauser showing how easy it is to get at the "works"

stations most any evening of the week, from Peoria, Ill. The distance is about 2,000 miles.

The receiver was constructed with the idea that it must be:

- 1 Easily portable (of the one-man type).
- 2 Simple yet efficient in tuning.
- 3 Rugged but sensitive.

The receiver was assembled in January of this year. Four months of experimenting with radio apparatus found on the market to-day, resulted in the combination of parts shown in the photographs. All makes and types of radio- and audio-frequency transformers available were given a trial. The various makes of tubes showed a great deal of difference when combined with these transformers.

The hook-up as at present used in the set is the Grimes "Inverse Duplex," a modification of the French Latour circuit used during the war. Using the regular Latour circuit good

results can be expected if the tubes in the second and third stages of amplification are not overloaded. This, however, is difficult to avoid with the ordinary vacuum tube, and the modification according to Grimes proves a decided advantage.

Many types of loops were tried with varying results. The size finally decided upon was a loop two feet square wound with seven turns of large-size lamp-cord wire  $\frac{3}{8}$ -inch spacing is used between the centres of adjacent turns. Connection is made with the receiving set through a plug and jack arrangement, making it possible to swing the loop in any direction desired. Good contact is assured at the same time. Not only is it possible to select stations lying in the same plane with the loop, but directional effects are experienced depending on which end of the loop is connected to the grid of the first amplifier tube. The grid end pointing to the station desired gives stronger signals than when the loop is rotated through 180 degrees. WBAD at Minneapolis lies in the same plane with Atlanta, Georgia and Peoria, Illinois. Yet by swinging the loop through 180 degrees, when both stations were sending on identically the same wavelength at the same hour, either one could be received in preference to the other. This property of the loop is not generally known.

With the potentiometer in series as shown in the diagram, selectivity is greatly increased. Stations sending close by have a tendency to paralyze the set. Putting resistance into the circuit will prevent this as the energy effecting the first amplifier tube is decreased.

The loop itself folds up in compact form and is carried in the cabinet.

Experiments were carried on with the UV-200 the UV-201, the UV-201-A, the French amplifier, the old Moorhead, and the UV-199. In connection with these tubes the various types of radio and audio-frequency transformers were tried. Since the apparatus used in the duplex circuit has fixed values almost throughout, it was necessary to choose such combinations as would give proper balancing of radio and audio currents. The UV-200, UV-201 and UV-201-A tubes have given the best all-around results. This can be explained by the fact that they have been on the market longer than the others, are manufactured under standard and well established principles and were used in the design of the transformers to meet their particular characteristics. The WD-11 and



UV-199 tubes will need specially designed transformers for best operation.

Acme radio transformers R-2, R-3 and R-4 were used for the first, second and third radio-frequency stages, respectively, and gave by far the best results. The Atwater-Kent audio transformers served best in the audio-frequency circuits. For the first and second stages the 10-1 ratios were used, for the third the 5-1 ratio. No by-pass condensers were necessary across the secondary of the audio transformers, the distributed capacity being amply large to allow the radio-frequency currents to pass.

Critical adjustments for the amplifier tubes are not essential, although it has been found desirable to place separate rheostats in each filament circuit. The detector tube has a vernier control for best results. For long distance reception the vernier adjustment is particularly useful.

Following is the list of parts used:

3 UV-201 or UV-201-A tubes . . . . .	\$19.50
1 UV-200 tube . . . . .	5.00
3 Cutler-Hammer rheostats . . . . .	3.00
1 Cutler-Hammer rheostat, vernier . . . . .	1.50
1 Kellogg .001 mfd. vernier condenser . . . . .	8.75
2 Atwater-Kent 10-1 ratio audio transformers . . . . .	10.00
1 Atwater-Kent 5-1 ratio audio transformer . . . . .	4.00
3 Acme radio transformers, R-2, R-3, R-4 . . . . .	15.00
3 Micadon .001 fixed condensers . . . . .	1.20
1 Micadon .0025 fixed condenser . . . . .	.40
1 Grid leak and condenser .0005 . . . . .	.50
2 Single-circuit jacks . . . . .	1.40
1 Acme potentiometer . . . . .	1.50
2 Round plugs . . . . .	3.00
1 Dictograph headset . . . . .	8.00
4 Dry cells . . . . .	1.80
2 22½-volt Burgess B batteries . . . . .	4.50
1 Panel . . . . .	2.40
4 Sockets . . . . .	3.00
4 Binding posts . . . . .	.20
75 feet single lamp cord . . . . .	.75
	<hr/>
	\$95.40

The most remarkable advantage of this receiver over all others lies in its simple yet very efficient tuning properties. After proper adjustment of the rheostats the condenser is the only tuning device used. Absolutely none of the characteristic whistling noises can be heard. The station tuned to merely swings in and out again as the wave is passed. Very little static interference is in evidence. It is a pleasure to work with this circuit after having been accustomed to one which is more noisy and in which every beat note can be heard through the head-phones. Using an .001 mfd. vernier condenser, the longer range of wavelengths used since May 15th can be tuned in properly. The entire set, including dry cells,

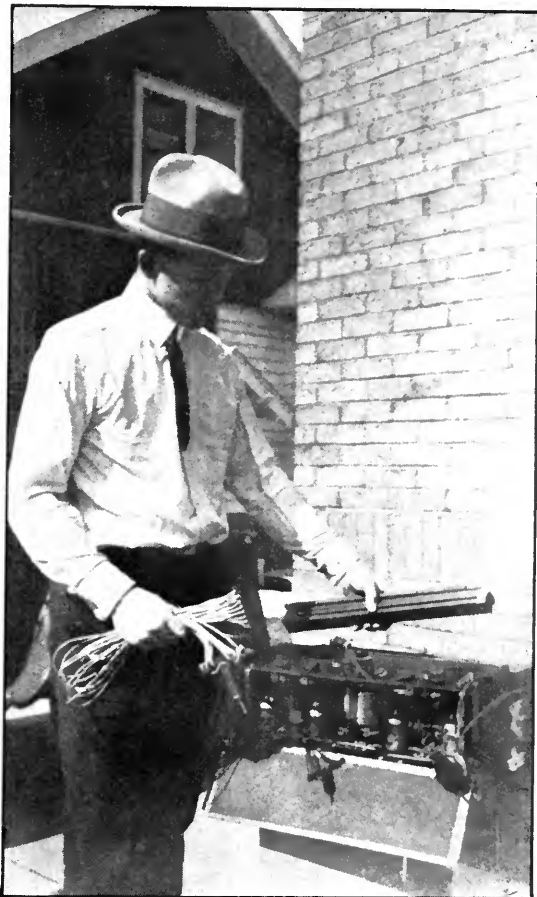

UNPACKING THE LOOP

A place is provided for it at the back of the horizontal tuning panel

weighs less than the ordinary 80-ampere-hour storage battery. It is ideal for camping trips and automobile use.

Hints for proper construction and operation:

1. Above all, avoid the ordinary kind of flux when soldering connections. Use pure rosin and good solder. This set functioned about 15 per cent. of normal the first time it was assembled after experimenting. Acid had gotten into several of the parts, particularly the by-pass condensers and jacks, and ruined them for further use. All connections must be soldered well unless good contact can be made through jacks or binding posts.
2. Use large size wire. There is a world of difference between No. 18 bell wire and No. 14 copper wire in connecting up the parts. Avoid as much as possible running wires parallel. If it is done, keep them at least one-half to one inch apart.
3. Set all radio- and audio-frequency transformers so



#### THE LOOP IS QUICKLY SET UP

The fact that with a set of this type you have no antenna-wire to stretch from tree to tree, or ground connection to make, is an additional argument for using the loop on a portable set

- that they stand at right angles to each other and at least four inches apart. Shielding is desirable but not essential.
4. Follow the circuit diagram when assembling the parts. I have assembled this set dozens of times and have never experienced any trouble in getting at least a few stations at the first trial made.
  5. Not all tubes function alike. The mere changing about of two amplifier tubes will often make a decided change in the signal strength.
  6. The UV-201-A amplifier is used when operating with dry cells on the filaments. Special binding posts are provided for storage battery operation with the UV-201 amplifiers.
  7. If the set is functioning properly a decided click can be heard in the head-phones when the grid connection to the first amplifier tube is touched with the moistened finger. The tubes must of

course be turned on. This is also true when the grid of the detector tube is touched.

The following is a list of stations<sup>1</sup> heard during the months of February, March, April and part of May, 1923, on the four-tube portable loop receiver, all stations having been received with such signal strength that little doubt remains about mistakes having been made:

KHJ, KWH, KYJ	Los Angeles	1,955
KUO	San Francisco	2,015
WBZ	Springfield, Mass.	1,045
WGI	Medford Hillside, Mass.	1,040
KNJ	Roswell, N. M.	1,190
PWX	Havana	1,500
KDYS	Great Falls, Mont.	1,420
WOAI	San Antonio, Tex.	1,160
WDAE	Tampa, Fla.	1,160

<sup>1</sup>EDITOR'S NOTE: As there is not space to print Mr. Shalkhauser's complete list, only the stations over 1,000 miles from Peoria, Ill. are given here.

#### THE OUTFIT READY FOR USE

The hinged front side of the cabinet might well be provided with a support and used as a desk

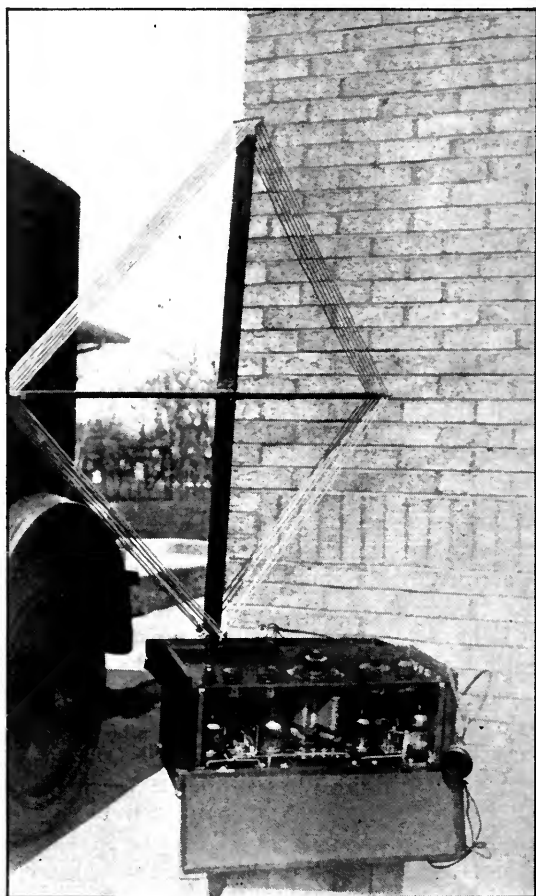

# Hearing North America

An ingenious arrangement of apparatus permitting any one of five circuits to be used

By MISS ABBYE M. WHITE

(THIRD PRIZE)

**R**ATHER fearfully I venture into your contest, for I do not know if we of the fair sex are allowed in or not. But your rules say nothing against it—so here I am.

The set I am going to describe is not so unusual except that I have at instant command any one of five different circuits—all efficient—and each having a different purpose. My set is entirely homemade—and I had great fun in constructing it.

When I first made my set I used the Reinartz circuit alone—and then, finding in it some shortcomings, I modified it to use a double-circuit which is far more selective although slightly more difficult to adjust. The original cabinet was made to accommodate a panel 8"x 10", being 5" in depth. I thus had a very compact receiver. Upon modifying it I did not change the cabinet but simply added additional binding posts on the rear—and used three spider-web coils and one extra condenser for my other hook-ups.

Before going into the actual construction of the set I wish to say something of the circuits used. The Reinartz as we all know is fairly selective as long as there is no local interference. It is particularly efficient on amateur waves—and amateur stations from every district have been copied by its use. The circuit I used has a wavelength range that goes up beyond six hundred meters, for many ships in the Atlantic have also been copied. The reason for my looking for another circuit is that station 3ACY is located about three blocks away and he is "pounding brass" with a  $\frac{1}{2}$ -KW spark all day long—hence I needed something more selective. The spider-

web coils appealed to me because they were easily constructed and offered a tuning element which had very little distributed capacity and the resistance could be much reduced and hence the tuning made very sharp. So I made three of these coils and mounted them. I tried two different circuits—one the ordinary two-circuit tuner employing tickler feed-back, and the second a modification of the efficient Weagant circuit. The latter is my favorite, but offers one objection in that the impedance of the phones enters into the tuning and an additional pair of phones cannot be added or an amplifier hooked in without retuning. The optional circuit shown by dotted lines in Fig. 1 overcomes this objection in that any number of phones can be connected or taken out without detuning.

Thus far I have described only three circuits, and you may wonder where the other two come in. They are formed by simply disconnecting the primary spider-web coil P and hooking the aerial lead to the switch lever on coil S and the ground lead to the opposite side of the same



MISS ABBYE M. WHITE

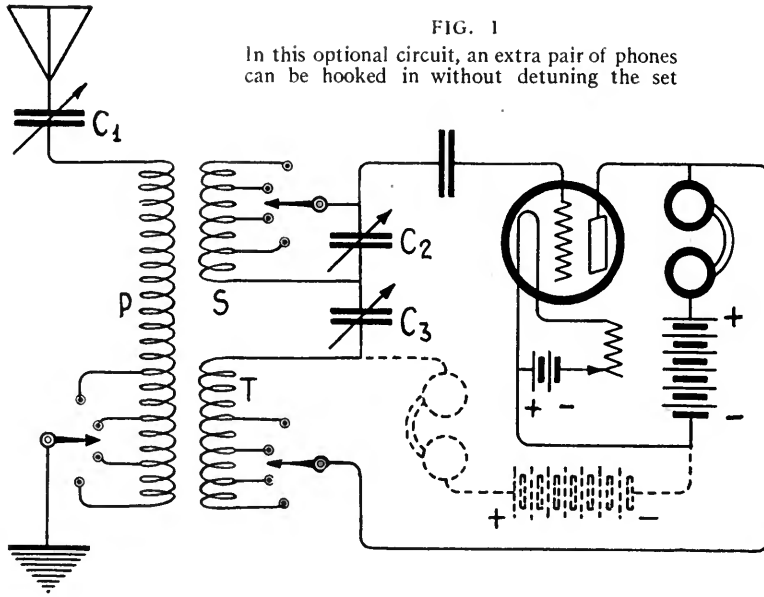

FIG. 1  
In this optional circuit, an extra pair of phones  
can be hooked in without detuning the set

circuit and show a coil mounted to one side of the condensers or the condensers mounted close together, I contend that the arrangement I have adopted is best for selective tuning and to eliminate body capacity. I arrived at this conclusion after much experimental work and feel justified in what I say. In the mounting shown I have my variable condensers well spaced—and not too close to the spider-web coil. As you will note from the picture of the rear view of the cabinet, (page 424) the coil stands upright and close to the panel—this arrangement

coil. Thus I now have a single circuit tuner—which can be connected in either of the two methods described before. I employ the tuner in this manner late at night or when little interference is experienced, to do DX work—for I have found nothing as efficient as the single-circuit tuner for distant work. Of course, during the evening (or when 3ACY is working) I do not employ the single-circuit but use the two-circuit, since it is more selective.

Now as to the materials needed for the construction of the set.

- 1 formica panel 8" x 10"
  - 1 tube socket
  - 1 UV-200 or any other good detector tube
  - 24 binding posts
  - 2 porcelain knobs
  - 6 switch levers
  - 1 box brass-headed upholstery tacks
  - 1 pair phones
  - 1 6-volt A battery  
(unless dry cell tubes are used)
  - 1 B battery
  - 1 vernier rheostat
  - 2 23-plate variable condensers
  - 1 13-plate variable condenser
  - 1 pair hinges
- Odd pieces of cardboard, wood, screws, tinfoil, etc.

The approximate cost of the above, including an 80-ampere-hour A battery is about thirty-five dollars.

First I will take up the construction of the original Reinartz unit. As said, the panel was 8" x 10". The photographs will give quite an effective view of the manner in which the various units are mounted. Although many magazine articles give descriptions of this

also adds to selective and sharp tuning by eliminating long leads to switch points. When I made my original set I made the switch levers out of sheet brass—the knobs were turned from walnut and the shaft made of  $\frac{3}{16}$ " brass. The contacts or switch points were of brass tacks—which are cheap and almost as effective as the regular article. I will not give any definite dimensions of the panel layout, for it is best to lay it out in accordance with the sizes of the condensers used, make of rheostat, switch lever lengths, etc., but the general plan shown in the photo should be followed for best results. The binding posts originally used were the five lower ones shown in the photo mounted on a strip of formica.

Now as to a few specific instructions about the component parts. The spider-web coil was made on a wood form—inside diameter  $2\frac{1}{2}$ " and outside diameter  $6\frac{1}{4}$ " and had seven spokes. The material was what is known as five-ply veneer wood. The slots were cut with a hack saw and edges smoothed with a file to allow easy winding. Photo-mounting cardboard could have been used for the form. The wire used was number 23 D.C.C. and as Fig. 2 will show, the inside section of winding—the "feed-back" coil—consists of 45 turns, tapped at 0, 15, 30, and 45. Then the wire was cut and the antenna and grid winding put on. Taps were taken out at the following points, of this second winding: on 0, 1, 2, 3, 4, 5, 6, 7, 8, 9, 10, 26, 33, and 40. The first four taps from the feed-back coil were attached to the

four switch points on the right side of the panel looking at it from the front—above and to the right was mounted the 23-plate feed-back condenser  $C_3$ . Then the taps for the antenna tuning were attached to the central switch points. The 10th tap is connected as shown in Fig. 2. The last three taps—at 26, 33, and 40—were attached to three of the points on the left switch which is the grid tuning switch (a fourth point was added to make the panel symmetrical). The condenser in the left upper corner is the 13-plate one which serves to tune the receiver to the desired wavelength. The coil in mounting was not supported by any means other than the leads to the switch points themselves, this being sufficient.

As will be noticed the grid condenser is mounted on a short piece of formica fastened on porcelain knobs seen along the right side in the photograph of the rear of the cabinet. This grid condenser was one of a series made and so arranged that they were easy to change. Two brass machine screws were mounted on the formica strip and the condensers were made by wrapping tin foil with a paper dielectric on a cardboard form, one sheet of tinfoil extending beyond the paper dielectric at one end of the form and the other sheet of foil extending from the other end. Thus the connections for the condenser were made at each end by soldering to the tinfoil brass washers so spaced that the holes would be the same distance apart as were the two brass machine screws mounted on the formica. In this manner the condenser could be slipped over the screws and locked into place with a knurled nut. I found that a condenser which had about two square inches of effective area on each sheet of foil worked best. An ordinary grid condenser could be used here. The leak, when used, consisted of a strip of paper placed on the same bolts before tightening the nuts. Pencil lines were then drawn until the correct resistance was obtained. The two binding posts on the front of the panel are for connecting the phones. In making connections avoid running leads parallel—and

keep them separated as far as possible. Fig. 3 gives a view of the binding posts and the accompanying table on page 424 will show what leads are connected to the various posts. The view of the posts is shown as looking on them from the rear of the cabinet. The table also tells which posts to connect together to use the various circuits. The 13-plate condenser is always connected across from the side of the grid condenser, away from the grid to the positive of the filament and in each of the circuits serves as a tuning condenser. To eliminate to a large extent the effect of body capacity in tuning, condensers should be connected so that the movable plates are connected to the filament. Then, too, I use, instead of the dials for tuning, a rod with an insulated handle attached to the knob of the condenser—the length serving in a manner like a vernier—in that it moves over a considerable distance before the condenser plates rotate much, thus making tuning easy.

The cabinet was made of odd pieces of wood picked up and finished with walnut stain, shellac, and wax.

Now as to the three spider-web coils. The mounting is almost self explanatory from the photo—the wood used was odd bits picked up and cut to shape. The only thing different in the spider-web coils I used is that they are tapped—thus permitting sharper tuning and a broader range. The outside diameter of the forms is 6 inches, inside diameter of the primary is 2 inches, of secondary  $1\frac{3}{4}$  inches, of

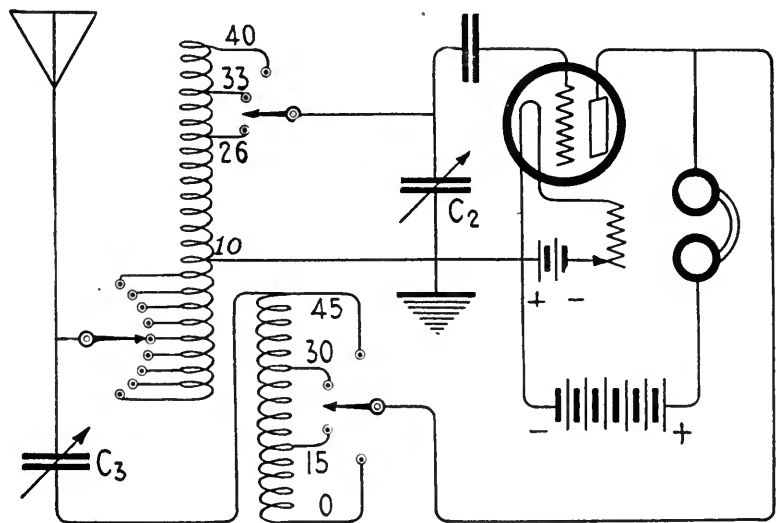

FIG. 2

The wiring diagram used by Miss White. Various circuit arrangements are produced from this by changing connections at binding posts mounted at the back of the cabinet

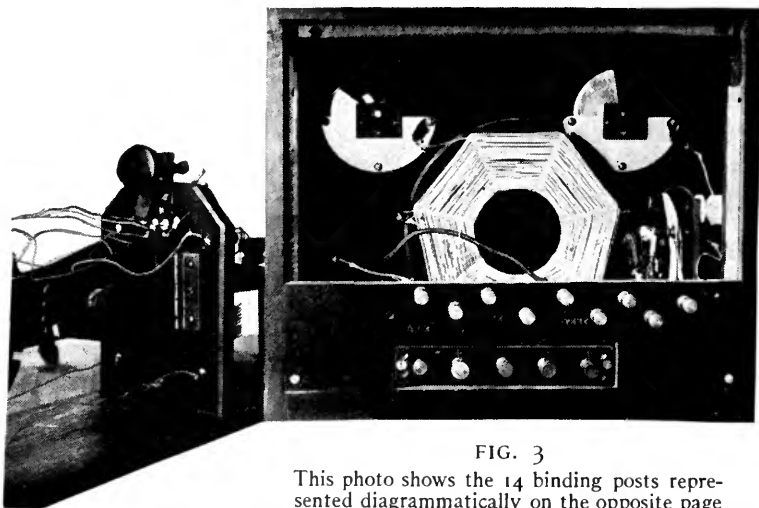

FIG. 3

This photo shows the 14 binding posts represented diagrammatically on the opposite page

tickler  $2\frac{1}{4}$  inches. All wire used in winding the coils is 23 D.C.C. and the number of spokes is 15. The forms were made of photo-mount cardboard, each having been given several coats of shellac to add stiffness and to insulate. The primary winding consisted of 50 turns—taps taken out at the 35th, 40th, 45th, and 50th turns. The secondary consisted of 60 turns—taps at 45, 50, 55, and 60. The tickler coil had 40 turns—taps at 25, 30, 35, and 40.

As will be noted, the switch levers and points on the two outside coils, which are the primary and tickler, were mounted directly on the wooden hinged arm, and the switch points for the central coil were mounted on the support on which the hinges for the other two coils are fastened. The central coil was fastened by wire supports one on each side of the coil—the lower extremities of these supports being fastened to the base of the instrument. A word of warning in making any kind of coils: never use shellac on the windings unless absolutely necessary—for it adds largely to the distributed capacity and thus “broadens” the tuning.

You will note that, when the set was modified, the additional binding posts were mounted directly on the wood, which is satisfactory if the wood is entirely dry; and it is a good plan to place the whole set and spider-web coils after mounting, near the stove or some other warm place, so as to dry the wood and the alcohol out of the shellac used to cover the woodwork.

My antenna consists of two wires about 90 feet long at a height of about 35 feet. The

earth is used as a ground but excellent results are also obtained by using the ungrounded side of the house lighting circuit as a counterpoise.

Connections made to posts shown in Figs. 3 and 4.

- No. 1 to one phone post on front of cabinet
- 2 to No. 4
- 3 to rheostat—other side of rheostat to one side of filament
- 4 to other side of filament
- 5 to antenna switch in Reinartz circuit
- 6 to fixed plates of 13-plate condenser and to one side of grid condenser—other side of grid condenser goes to grid
- 7 to grid switch in Reinartz circuit
- 8 to plate of vacuum tube
- 9 to 10th turn tap in Reinartz circuit
- 10 to plate switch in Reinartz circuit
- 11 to other phone post on front of cabinet
- 12 to 45th turn tap on feed-back winding of Reinartz circuit
- 13 to fixed plates in 23-plate condenser
- 14 to movable plates of 23-plate condenser

#### To connect Reinartz circuit:

- Connect post 7 to post 6
- 4 to 9 and to plus A and ground
- 8 to 10 and to 11
- 2 to minus of B battery
- 1 to plus of B battery
- 12 to 13
- 14 to 5 and to aerial
- 3 to minus of A battery

#### To connect Weagant circuit:

- Connect 8 to 11 and to one side of tickler coil
  - 1 to plus of B battery
  - 2 to minus of B battery
  - 4 to plus of A battery
  - 3 to minus of A battery
  - 4 to 14 and to one side of secondary
  - 6 to other side of secondary
  - 13 to other side of tickler
- Primary as shown in diagram, Fig. 1.

#### To connect to optional circuit shown in Fig. 1, having made the above connections:

- Change 11 from 8 to 13.

A little should be said about the tuning of the receiver. In the Reinartz circuit, the feed-back condenser is set so that it is about half its maximum capacity in the circuit—and the feed-back switch placed on the point to which the 15th tap is connected. Now, then, the grid switch is placed on the 40th tap and the antenna switch tried on various points, while the circuit is tuned with the tuning condenser—the 13-plate one—final tuning being done with the feed-back condenser. If signals



do not come through, another antenna tap is tried and the same procedure followed. For amateur waves, the 33-turn grid tap is used. It may be found that a different tap on the feed-back coil will work better. After a little experimenting tuning will be easy.

With the spider-web coils it may be found that on first connecting them, the set may not regenerate. If this is the case, change the leads to the tickler or feed-back coil and the set should work properly. For general work, a rather loose coupling on the coils is desirable, thus giving less interference—with but little decrease in signal strength. The circuit can be tuned by moving the coils closer or farther apart, although it is easier and better to use the condensers as the tuning elements. The spider-web coils cover a wave range considerably above 700 meters, for NAA comes pounding through on 712.

I have on various trials been able to receive phone from as far as Chicago, Atlanta, and other places with only a piece of wire strung

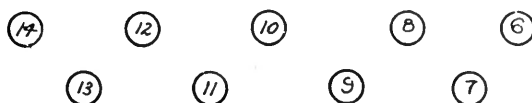

FIG. 4

The arrangement of binding posts referred to in the table of connections on the opposite page

around on the floor of the room as an aerial, using the Weagant circuit connected as a single circuit. On the whole, my set has afforded me much pleasure and has not given the trouble that sets seem to give most people in the radio game. I can travel over the United States and yet remain at home. Nightly I visit most of the larger cities in the U. S. and get much interesting entertainment and instruction.

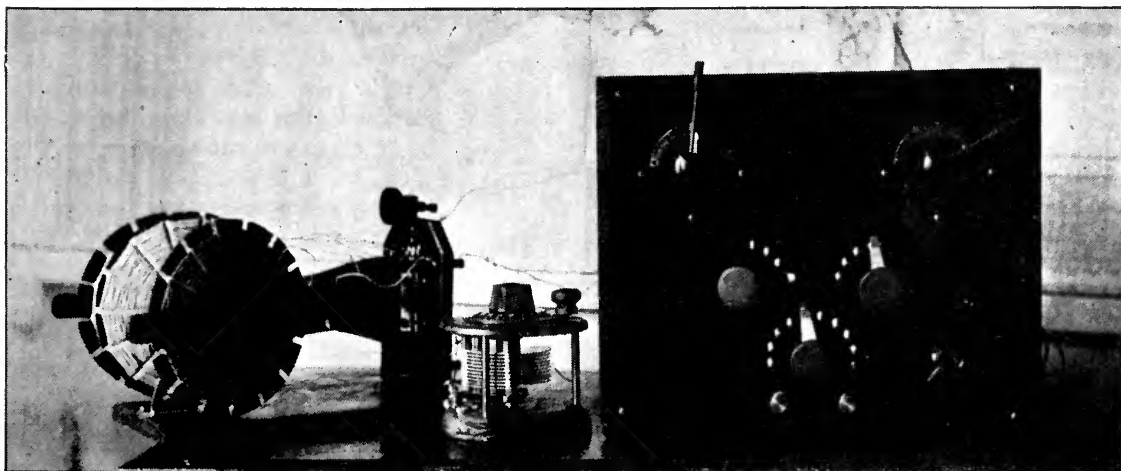

FIG. 5

Miss White's complete receiver, showing home-made spider-webs and mounting. Note also the tuning rods attached to the two condenser knobs on the panel

## In Radio Broadcast's "Lab"

While trying the many receivers sent us by various manufacturers and while experimenting with all sorts of trick hook-ups, we find out some interesting things. If you are of an experimental nature, you must find similar circumstances in your own radio laboratory—whether it be a neat, well-equipped workshop, or a table of junk in one corner of your room.

Each month we are going to describe our findings in a new department which we expect will suggest to you many interesting lines along which to conduct your own experiments, as well as to give definite reports of the performance of all manner of radio apparatus.—THE EDITOR.

# The World at Your Finger Tips

After All is Said and Done, the Receiver for the Fellow Who Wants Real Results for a Limited Expenditure is the Good Old Armstrong Three-Circuit Regenerator

By H. BLUMENFELD

(FOURTH PRIZE)

**B**OY! Page the radio bug who sits up night after night and twirls dials until his fingers ache and his wrist is all bent out of shape, yet doesn't get a thing. For I have something to tell him.

Do you want a real DX receiver? Then spare a few moments and read the following:

After experimenting for more than a year on various types of hook-ups—single-circuit, two-circuit, three-circuit, super-regenerative, Flewelling, reflex, Reinartz, and various types of radio-frequency circuits, I have at last settled down on the simple, but *ultra-efficient* three-circuit regenerative circuit.

We are now going to work by the process of elimination. You may argue that the three-circuit set is pretty complicated for the amateur to operate as there are too many controls. Of course this set is practical, but since May 15th, 1923, when all stations went on separate wavelengths, all of these controls became unnecessary.

So why not be economical and get the same, if not better re-

sults? The super-regenerative and the Flewelling sets are only in their early stages of development, and seem to produce results, but they are not very stable in DX work, as yet.

The reflex set is another set that is hard to build (although very satisfactory if built properly.) Therefore, for the novice the only set that it is advisable to stick to and experiment with is one employing the Armstrong single- or three-circuit system of regeneration.

The single-circuit set is not very selective for DX work, therefore there is but one *good* circuit left, and that is the famous Armstrong three-circuit receiver.

It is very selective and brings in nearly all the important broadcasting stations you can think of.

The advantages of this circuit are:

- (1) Ease in tuning in distant stations.
- (2) Economical.
- (3) Only 4 controls necessary. (Condenser, Coupler, Variometer, and Rheostat.)
- (4) Not complicated.

But there is a small phrase behind this efficient set that makes it work wonderfully well on local and distant stations.

It is, "Use the right parts in their right places."

The following are the complete



OUT OF THE WAY, YET HANDY

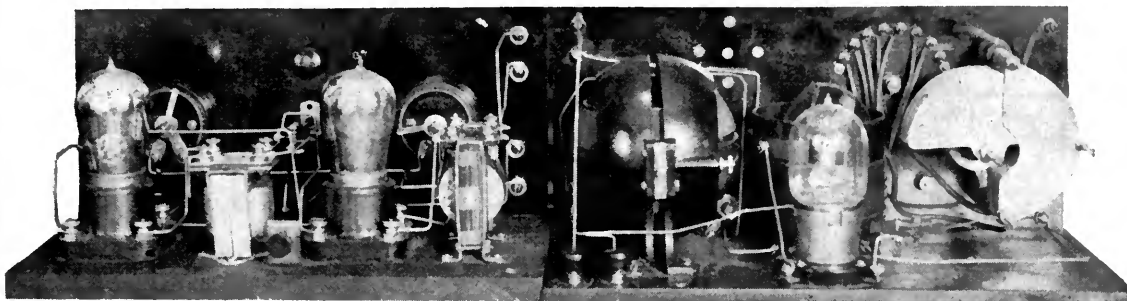

MR. BLUMENFELD'S COMPLETE RECEIVER

It is a three-circuit regenerator with two stages of audio amplification

parts needed to build this set which is equipped with a two-stage amplifier for additional volume:

## PARTS NEEDED FOR DETECTOR AND TUNER

- 1 Coupler
- 1 Variable condenser
- 1 Variometer
- 1 Rheostat (vernier type)
- 1 Socket
- 1 Vacuum tube
- 8 Binding posts
- 1 Panel (7 x 12 x  $\frac{3}{8}$ ) (Formica or Bakelite)
- 1 Base (6 x 12 x  $\frac{3}{8}$ ) (mahogany)
- 1 Grid leak and condenser (.00025 Mfd.)
- 1 Switch arm
- 8 Taps and 2 stops
- 1 Jack (closed circuit)

## PARTS NEEDED FOR AMPLIFIER

- 2 Audio-frequency transformers
- 2 Vacuum tubes (UV-201-A recommended)
- 2 Rheostats
- 2 Sockets
- 2 Jacks (one double-circuit and one open-circuit)
- 1 Panel (7 x 12 x  $\frac{3}{8}$ )
- 1 A battery switch
- 5 Binding Posts

## ACCESSORIES

- 25 Ft. tinned copper wire
- 1 Doz. flat head wood screws (brass)
- 1 Storage B battery of 68 volts. or 3 22½-volt dry B batteries
- 1 80- to 120-ampere-hour storage A battery (6 volts) or dry cells if dry-cell tubes are used
- 1 Pair of phones and horn
- 5 Clips for A and B batteries

## OPTIONAL

- 1 Book case as shown in photograph
- 1 Dozen small flexible cords for connecting set to back of cabinet.

In the detector circuit I have found a variometer in the grid circuit unnecessary.

The panel is a very important factor in your set. Bakelite is handsome and glossy and

will last for years. Keep in mind that every radio bug takes a great pride in the looks of his set.

Bear in mind, if you buy cheap parts, you will get cheap results; and if you buy high grade parts, you will get results accordingly. This does not mean that you must buy high priced parts. By no means. But buy shrewdly and carefully. You won't be sorry.

The condenser is one of the most essential parts for this circuit unless a variometer is used to tune the secondary circuit. So, when you get one, get a good one. And then purchase a vernier of the button type which has a little beveled edge (rubber) which meets the bevel side of the dial.

Any good variometer may be used.

So much for the detector. The amplifier:

Most any transformer can amplify of course. Never doubt it. But many of them will cause howling, hissing, produce distortion, in fact everything but real music.

So a good transformer is very essential to any set.

Two steps of amplification are required on this set, which will work a loud-speaker in excellent shape.

Make all connections as short as possible, and solder them carefully. Do not run any wires parallel for any long distance. The aerial should be a single wire at least 75 feet long and not more than 150 feet long and about 30 or more feet high.

On a cold, clear night this set reaches out its long hand and simply grabs the distant stations.

On local stations, the signals should roar in with terrific volume. In three months I have heard 196 stations 150 or more miles from my home in Cleveland. My total mileage is 145,179 miles.

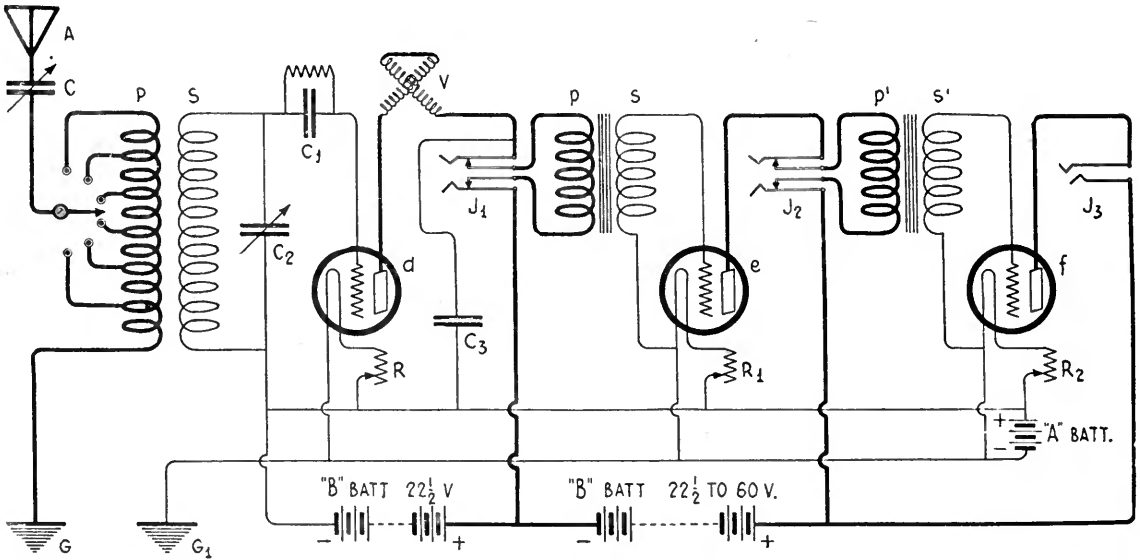

THE THREE-CIRCUIT REGENERATIVE CIRCUIT

It is very common and quite old, but it is still delivering the goods. The two stages of audio amplification make possible the use of a loud speaker. The parts include A, antenna; C, antenna series condenser (.0005 mfd); P, primary of variocoupler; G, ground; S, secondary of variocoupler; C<sub>2</sub>, secondary tuning condenser (.0005 mfd); C<sub>1</sub>, grid condenser and leak; d, detector tube; R, R<sub>1</sub>, and R<sub>2</sub>, rheostats; G<sub>1</sub>, ground from negative of A battery; V, plate variometer; C<sub>3</sub>, telephone condenser; (.002 mfd); J<sub>1</sub> and J<sub>2</sub>, circuit-closing jacks; J<sub>3</sub>, open-circuit jack

The enclosed photos speak for themselves. There is no need for the reader to have a panel layout. Perhaps the layout does not suit him. But, for the radio bug who does not want to take the time to lay out a set, the photo shows very clearly how to do it, as well as how to mount the set, which when finished will look as well, especially to its maker, as the highest priced set on the market.

In the B battery circuit will be seen a .25-ampere fuse. This is used because the A and B battery wires might become crossed accidentally and burn out the tube. This is very expensive in the end as a tube costs quite a bit of money nowadays. So with this method,

the fuse will burn out instead of the tube and the former is much the less expensive.

A variable condenser of .005 mfd. may be put across the secondary of the variocoupler for greater selectivity, although this is not necessary.

If possible, use a separate ground for the negative filament.

This set when finished and put into a cabinet as shown, will look very well.

You will just blush with pride when a person looking at the set says, "My, what a beautiful set."

And not only that—but it works, and it works well.

## In the Wake of the Winners

The response to the Receiving Contest was not limited by the boundaries of the United States. Reports from Canada, England, Porto Rico, and ships at sea poured into the editorial office. Some of these were almost undecipherable scribbles on both sides of small slips of paper; others were neatly typewritten sheets accompanied by excellent photos and full of material that is bound to intrigue the interest of any broadcast fan. Next month, we will announce the Honorable Mention contestants, and will print as much of their contributions as space permits. A summary of the contest results, together with some general conclusions about broadcast receiving, will also appear.

—THE EDITOR.

# Broadcasters in New York, Paris, and Los Angeles

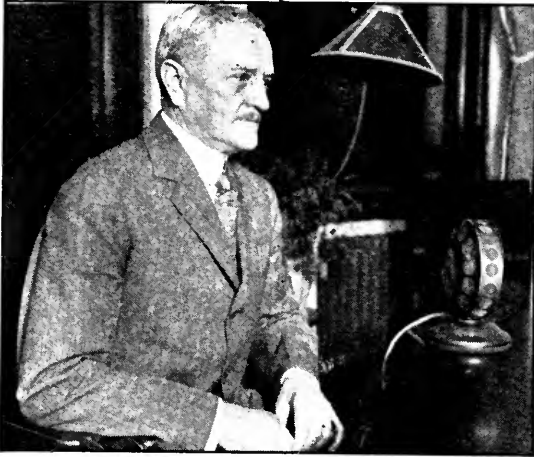

GENERAL PERSHING TALKS TO A MILLION

At least that number, it is estimated, heard his recent speech given at WEAf (New York) and rebroadcast by WCAP (Washington, D. C.) and WMAF (Dartmouth, Mass.)



A SPANISH POET AT A FRENCH STATION

M. Carnido is shown broadcasting some of his own poetry through the Eiffel Tower station, in the town called Paris

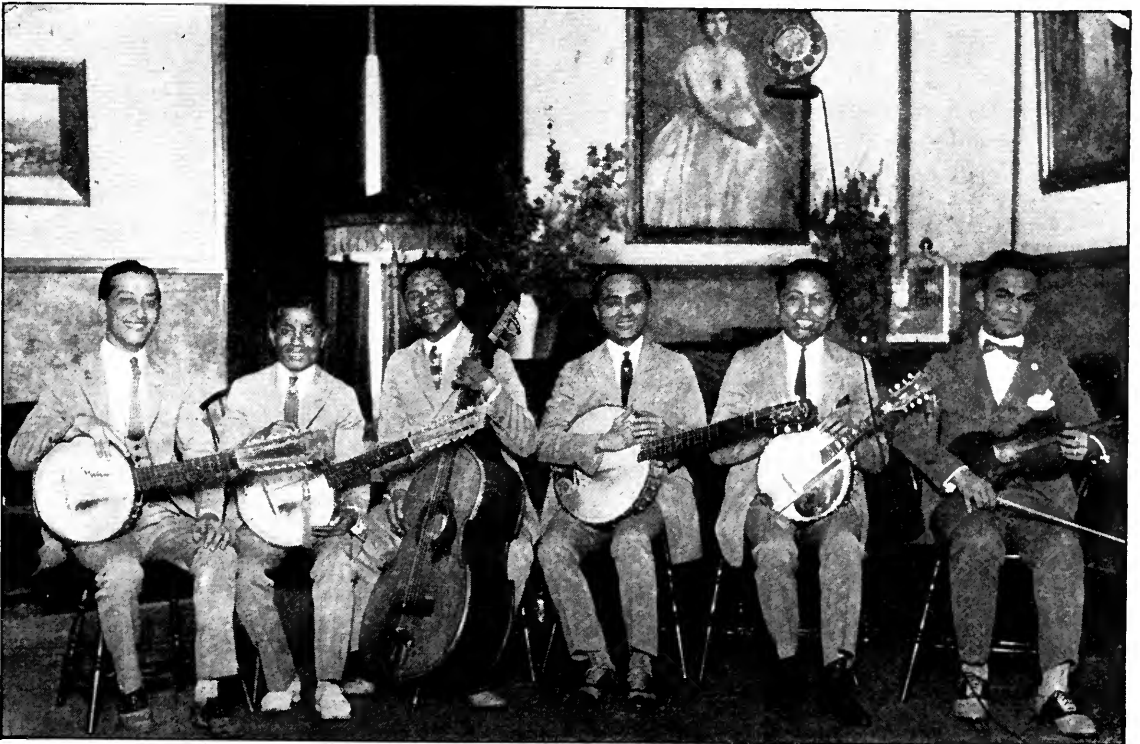

THIS SEXTETTE FURNISHES IRRESISTIBLE DANCE MUSIC FOR KHJ'S AUDIENCES

It is the Filipino String Sextette from the Bluebird Cafeteria in Los Angeles. The four steps of banjo-frequency amplification, violin detector, and one base guitar form a hook-up that is exceedingly popular throughout the West

# What You Should Know About Condensers

Molecules, Elements, Conductors, and Dielectrics. The Action of Electrons at Condenser Plates. Capacity, Inductance, and Resistance

By ALLEN D. CARDWELL

## PART I

If receiving set owners would buy their variable condensers after a survey of the mechanical and electrical characteristics of the types on sale, rather than from a comparison merely of general appearance, hearsay and price, there would be less trouble with thousands of receiving sets and less apparatus of inferior quality on the market. Of course, to the uninitiated, a 43-plate condenser, for instance, is simply one unit in a collection of junk that he has to buy and connect up before he can hear the evening programs. So he trots down to the store, looks at his list and buys, among other things, "1 variable condenser (43-plate)." Now, when we are dealing in electrical circuits passing inconceivably weak currents, *the best is none too good* in a condenser to be used in these circuits. It seems to us, then, that a familiarity with good and bad condenser construction is worth any enthusiast's while to obtain; and we feel sure that any one who reads the two installments of this article by Mr. Cardwell, will find the knowledge he has gained to be of practical dollar-and-cents value to him.—THE EDITOR.

**R**ECENT research into the nature of electrical phenomena has given us substantial ground work on which to rationalize the rather complex theory of condensers and their effects. We no longer say that electricity is a

"current" and do not have to avoid specifying what it is. To-day we understand electricity to be a characteristic movement of electrons. We can explain practically all radio problems on the electron theory, and it is hardly possible to understand the action of condensers without some general idea of electron currents and their characteristic effects.

### THE CHEMICAL BASIS OF ELECTRICAL ENERGY

**T**HE first approach toward electron study begins with chemistry. If we take any substance, we can break it down into certain chemical units which are called molecules. The molecule is the smallest unit of the material which will look, taste, smell, or react with the characteristic effects of the substance as a whole. For example, pure water always looks the same, tastes the same, and will interact in the same way with other given substances. The material we call water is a liquid, the smallest unit of which is the molecule. If we break

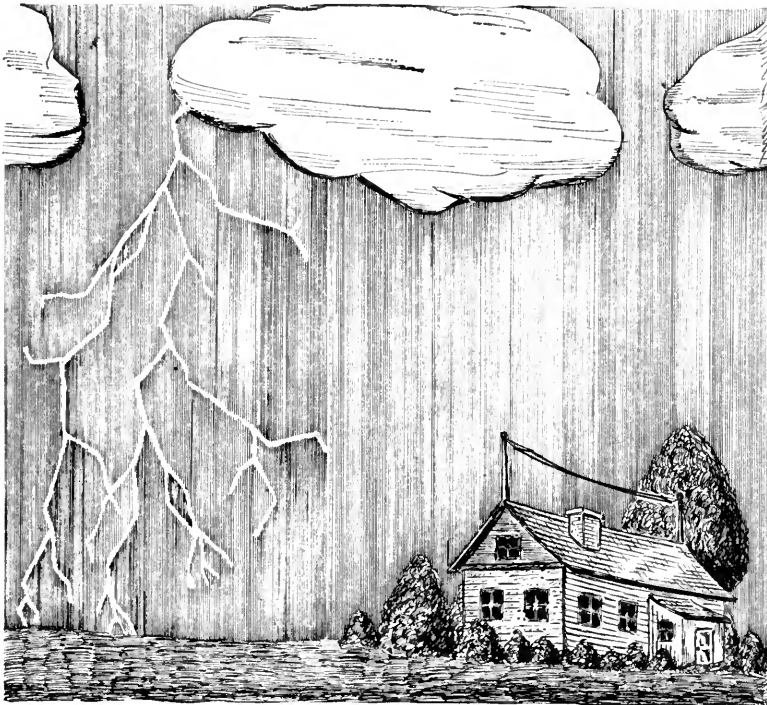

NATURAL CONDENSERS—STORM CLOUDS

The lightning discharge illustrates the rupture of the dielectric



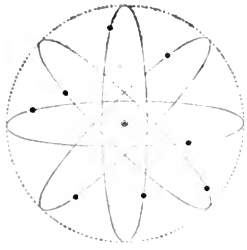

FIG. 1  
Electron orbits about an atom. A theoretical illustration to visualize the general idea. The orbits are not necessarily in the same circumference, nor has it been proven that they revolve, some asserting that the electrons have a reciprocating motion

up the molecule by proper chemical agencies, we can further reduce its component units into indivisible particles which we call elements. There are some 80-odd elements that have been discovered thus far, from which we build up the entire physical universe—rocks, trees, animal life, metals, etc. Some of the elements are found in nature in a pure state; for example, a diamond is nearly pure carbon. Gold, silver, lead, etc., are 'metallic' elements often found isolated or uncombined with other elements. The elements are the units which give us by characteristic combinations, molecules and the molecules in turn give us the distinguishing qualities of any uniform or homogeneous substance such as sugar, water, air, granite, iron ore, etc. (Homogeneous does not include mixtures such as plaster, sealing wax, glass, etc.) We can go further, however, and break up the molecules into groups of atoms and these in turn we find are composed of characteristic combinations of electrons. The number of electrons in a characteristic group determines the atom, and the groups of atoms determine the molecule. All electrons are identical regardless of what molecule or element they may be a part of. The only distinguishing characteristic of an electron is its electrical state, it may either possess an electrical charge or it may be lacking in electrical energy. The average number of electrons without charges are counterbalanced by a like number with charges in the normal conductor which possesses no difference of potential between any given points. A preponderance of charged electrons or non-charged electrons will cause a difference of potential and a flow of electrical energy. Electrons which are similarly charged tend to repel one another so that in a conductor which possesses a preponderance of charged electrons this phenomena of mutual repulsion causes an equal distribution of current-carrying electrons, inasmuch as wherever there is a greater gathering of similarly charged electrons there is also a greater tendency to disperse them. It may

seem absurd to reduce all forms of matter to one common base, but science has vindicated the conception of the atom as an aggregation of electrons revolving in fixed orbits about a neutral centre.

Electrons have these peculiarities:

1. They revolve about the neutral centre of the atom in fixed orbits (Fig. 1) at very high velocities (50 miles a second approximately.)
2. They are affected by heat and their speed increases at higher temperatures.
3. Some electrons are positive and some are negative in their electrical charge.
4. The weight of an electron has been calculated. Hence, electrical energy has weight!
5. The tension with which the electrons are bound together in the atom combination determines the relative "conductivity" or "insulation strength" of the substance formed by the electrons of the atoms in the molecules of the material.

CONDUCTORS AND DIELECTRICS

WE FIND that substances which are classed as "conductors" are such because some electrons in the atoms composing the material can be dislodged. That is, certain groups of electrons in each atom are revolving in outer orbits of the atoms and can be made to jump from atom to atom or into space. Elements, such as iron, aluminum, copper and silver, etc. are good conductors. The atomic weights are relatively high, and there are a larger number of electrons per atom. This gives us more active or floating electrons to serve as current carriers, but in all cases where these electrons are charged, they are called negative electrons. The positive electrons are not detachable from their atom base or centre. If by chemical or mechanical means, we withdraw some of these

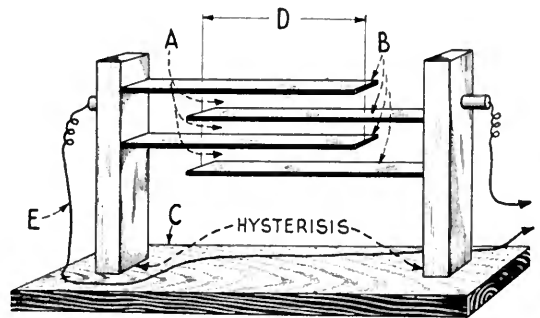

FIG. 2

Factors in condenser ratings: A—dielectric, its character and thickness; B—area and number of plates; C—insulator; D—surfaces opposed; E—stray fields

negative electrons from a conductor, such as a wire, we make a current flow because there is created a shortage of electrons along the wire. The actual movement of the electrons is not direct along the wire. The electrons are measured in billions per inch of wire and their normal motions are very erratic so that a difference in potential at two points on a circuit creates only an "average" movement in



FIG. 3

Showing the gradient of current pressure (electron density) on a wire. At A the electrons are excessive and a current will flow to B until the common level is on line X. The density is obviously a "cone" field about the wire, but for purposes of simplicity it is shown only as a vertical plane above the wire

one direction. This may be illustrated by the movement of a mob of people about a theatre or ball park entrance who may push and jam toward the doors, but a relatively small number actually pass in, during a given interval of time although the average or "net" push of the crowd can be tremendous, especially for those who happen to be near the gates or wall. The electrons in a conductor which can thus be used to set up an electric current are termed free electrons. Their speed, or average movement, depends upon the steepness of the "grade" created by an impressed force or shortage of electrons created at any point (Fig. 3) just as the speed with which a car will roll down hill depends upon the slope of the hill. It has been pointed out that approximately only one in 5,000 electrons resident in a conductor actually is used when a current is flowing through the conductor. In conductors the electrons are moving in all directions freely and wherever an electron dislodges another from an atom, the space left by the dislodged electron is filled by another electron from some other part of the conductor.

In non-conducting materials, so called, we have electrons which relatively are not free. They are so tightly bound to the neutral or centre of the atom that only extreme pressures can dislodge them. Such materials as hard rubber, air, Formica, Bakelite, etc. are of this type. There are no free electrons in insulators although electrical pressure can be applied and its effect noticed at a distance in the insulator,

much in the same manner as a group of billiard balls may transmit the power of the impact of the cue ball providing a group of balls are already in physical contact. It is by forcing them out of their normal locations that we can make a condenser store electrical energy.

#### THE ACTION OF ELECTRONS AT CONDENSER PLATES

ASSUME that a potential of positive polarity is applied to one of the opposing plates. That means that one wall of the condenser will become crowded with free electrons and the other wall will be lacking in a sufficient number of electrons to satisfy the atoms in the conducting material (Fig. 4). Accordingly there will be an effect transferred to the dielectric between the plates which is an electrostatic strain or displacement. Although the electrons of the dielectric are not free to move permanently they can shift out of place. At the positive plate, they will be pushed back by the accumulation of electrons there. At the negative side they will be pulled toward the plate. Yet in neither case will they actually move out of the dielectric to the conductor or out of the conductor to the dielectric, otherwise the current would move immediately in one direction and not store up energy. This congestion or concentration of the electrostatic strains or lines of force exerted by the accumulation of electrons within a restricted area accounts for the term "condenser."

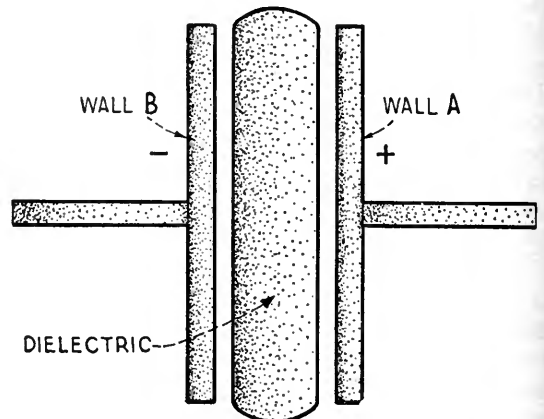

FIG. 4

Condition of electron congestion of a charged condenser. (The dielectric is shown as a separated "unit" in the centre, but actually is in contact with the wall surfaces A and B.) The stipling illustrates how the electrons crowd up on the inside wall of the A plate, thus pushing the dielectric electrons toward, *but not to*, the B plate, where the strain causes the electrons in the B plate to move away from the dielectric

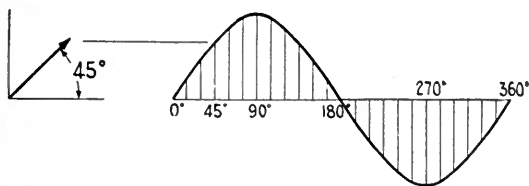

FIG. 5

Showing how a counter clockwise rotating voltage or current, or both, can be made to represent a "sine" curve when plotted against time. Each position on the curve thus has an "angular" value, used constantly in mathematical calculation

The closer the conducting walls and the greater the areas of their opposing surfaces, the greater their capacity to hold electrical energy. A condenser cannot exist without a dielectric or insulating medium. If the opposing surfaces are separated by air, air is the dielectric. If separated by mica, then mica is the dielectric. The dielectric must necessarily be a non-conductor. This explains why the electron theory is vital to the proper understanding of condensers.

The dielectric, therefore, absorbs a certain amount of electricity and holds it in suspension until the potential used to move the free electrons is removed or reduced.

When the condenser walls are short circuited, the stored energy is permitted to discharge itself and a current is set up in an opposite direction to that of the original charge. Note that there are thus two currents: the current of free electrons in the conductor and the current of the movable but restricted electrons in the dielectric. The first is a conduction current and the second a displacement current. This distinction is fundamental.

If the impressing electromotive force (the push or pull of electrons along the circuit) is great, it may cause such a strain upon the electrons in the dielectric that the free electrons will break through the dielectric and flash as a spark discharge, in which case they pass physically through the dielectric whether it be glass, air, mica or what not and actually "puncture" the insulating medium. Thus storm clouds accumulate electric potentials which are built up until they are so great that they break down the insulation of the air and lightning is discharged from cloud to cloud or to the ground.

In radio receiving circuits we are dealing with extremely small voltages, so minute that it is practically impossible to construct a condenser with walls so close together that a spark could

be passed by the voltage set up from a received signal. The "puncture voltage" of a receiving condenser is therefore not important. (Static charges, however, even on small aerials, will build up potentials of a thousand volts or more and cause considerable sparking across the condenser walls.) It is of vital importance, however, to preserve all the variations in voltage and current of the received signal regardless of how weak it may be. This involves certain resistance effects of high-frequency, alternating currents, and only by understanding them can we appreciate the importance of correct condenser design.

CAPACITY, INDUCTANCE, AND RESISTANCE

EVERY alternating current circuit exhibits three properties in variable proportions. There will be some capacity, some resistance and some inductance regardless of whether they are wanted or not. We find, also, that every circuit will respond or be most easily disturbed by an alternating current of one definite frequency more readily than by any other frequency. The frequency may be ten oscillations (charges and discharges) of the current through the circuit in one second, or it may be one million oscillations in one second.

An excellent analogy may be drawn from the use of a tuning fork (Fig. 8). If struck, it vibrates and emits a note. The tines thus represent three physical effects: (1) the compression swing which we may call the condenser, (2) the inertia pull at the end of each swing which is typical of the inductance drag, and (3) the air resistance equal to the circuit resistance. If the fork is put in a sealed tube and the air pumped out, the fork will oscillate for a much

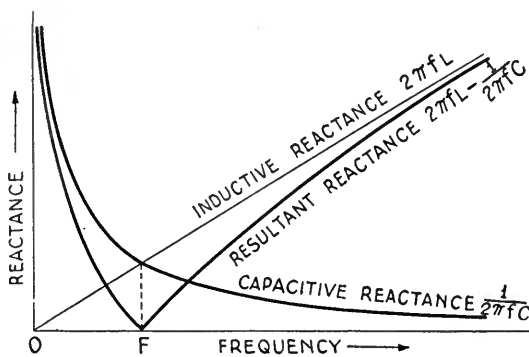

FIG. 6

Reactance curves, showing how the capacitive reactance and the inductive reactance are neutralized at resonance, shown at point F

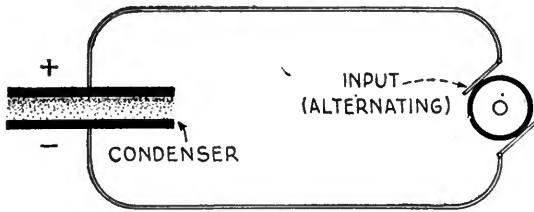

FIG. 7

Condition of electron displacement in the dielectric on one phase in an alternating current

longer period although no sound can be heard from it. The frequency with which the fork vibrates depends upon the length, weight and elasticity of the tines.

If we mount two tuning forks of the same frequency on a board, we can strike one and its vibrations carried through the air or along the board will cause the second fork to begin to vibrate. This is due to the fact that a slight disturbance of the same frequency as that of the fork causes it to vibrate and if the disturbance is prolonged, the two forks vibrate continuously for some time.

If, therefore, we wish to secure a signal from a certain station, we adjust our receiving circuit so that it will oscillate or alternate in potential and current with the exact frequency of the wave used by the transmitter. Then any variation in the amount of current sent from the transmitting antenna and to the receiving circuit is acting upon a highly sensitive mechanism which is so critically balanced that it will oscillate.

In this resonant circuit we must hold the resistances down in every way. Hence, we will return to the condenser part of the circuit and limit the discussion to a definite range of frequencies.

For wavelengths of 220 meters we are detecting currents that alternate at 1,363,500 alternations per second. For waves up to 700, the frequency is down to 428,600 alternations per second. For 350 meters our condenser must

charge and discharge 857,100 times a second.

#### LOSSES IN CONDENSERS

THE first thing we observe when a condenser is used in a high-frequency circuit is that the current may be dissipated in the dielectric. Thus, if we force 1 ampere of current into a condenser and when it discharges we only get back .9 amperes, there has been a dielectric loss of .1 amperes due to the creepage across the space between the plates. Some of the current must have "leaked" through the dielectric or have been absorbed in the dielectric itself. These losses are normally too small to measure when the dielectric is only dry air, but under certain conditions the leakage can increase to an appreciable extent. In a solid dielectric, this loss is always appreciable and accounts in one way for the preference of radio engineers in using air as a dielectric wherever possible

FIG. 8

When the tuning fork is moving as in A, its spring is compressing, but its momentum is decreasing. In B, its spring is released and the momentum forces the lines to swing outward and accumulate an opposite spring tension. In C, the momentum and the spring effects are at the neutralized point where spring effect equals momentum, and the direction of motion changes with the spring effect inward exceeding the momentum outward. Any piece of steel or other springy material has a natural period of vibration just as an electrical circuit

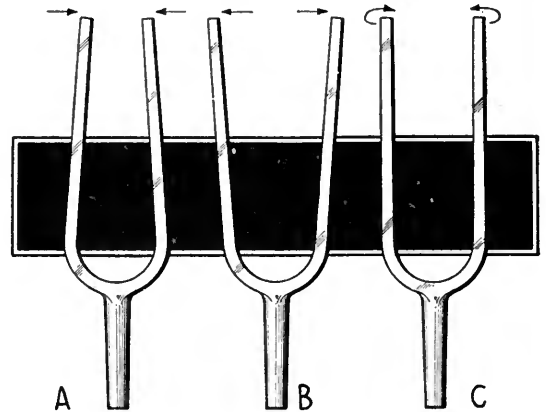

*The second and final part of this article will appear next month. It will deal with further kinds of losses in condensers, variable air condensers for radio use, disadvantages of the conventional form of condenser, the best materials for condensers, and condenser ratings.*



# The Grid

## QUESTIONS AND ANSWERS

The Grid is a Question and Answer Department maintained especially for the radio amateurs. Full answers will be given wherever possible. In answering questions, those of a like nature will be grouped together and answered by one article. Every effort will be made to keep the answers simple and direct, yet fully self-explanatory. Questions should be addressed to Editor, "The Grid," RADIO BROADCAST, Garden City, N. Y.

### ADAPTING YOUR THREE-CIRCUIT RECEIVER TO THE NEW WAVELENGTHS

THE allotment of higher waves to broadcasting stations has made necessary the loading of many receivers in order to preserve efficient reception over the entire wave range. The majority of enthusiasts have found it a comparatively simple matter to load up the single-circuit sets. Generally their own ingenuity has pointed out the necessity of adding merely a few more turns of wire to the main inductance. The wave shift with the honeycomb sets is less complicated and is effected by using slightly larger coils in primary, secondary, and if necessary, in the tickler.

The variocoupler-twin-variometer set, however, presents somewhat of a problem, and RADIO BROADCAST has been the recipient of numerous inquiries as to the most efficient method of loading apparatus of this type.

There are two basic ways in which this may be accomplished: by the addition of inductance, and by the addition of capacity. The first method is perhaps the most efficient and at the same time most simple. The loading coil consists of ten turns of wire on a two and a half inch diameter tube (or simply wound about the fingers), inserted in series with the grid variometer and secondary, as is shown in Fig. 1. A small panel switch is included across

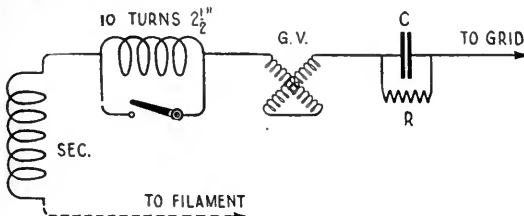

FIG. 1

A loading coil—10 turns of wire on a 2½-inch tube, raises the wavelength of the secondary circuit. If the antenna is a fairly long one, it is generally unnecessary to load the primary circuit

the extra inductance for shorting during short-wave reception. The loading coil may be placed within the cabinet, care being taken to locate it in such a manner that it is not in inductive relation (near and parallel) to other coils of the set. If placed too near other inductances, the load may absorb energy when shorted and lessen the general efficiency of the apparatus.

The addition of a small capacity across the secondary of the variocoupler and the grid variometer (Fig. 2) will also boost the wave well above the broadcasting frequencies, and into the path of six hundred meter traffic, a wave-

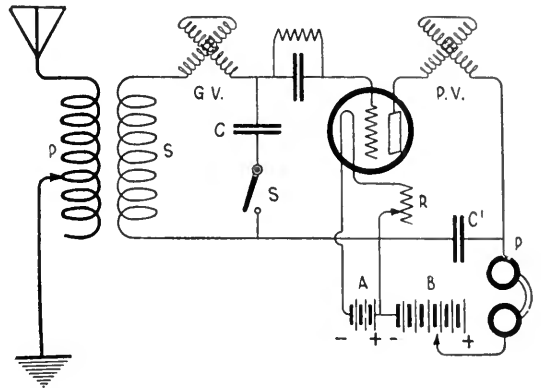

FIG. 2

A small condenser, C, across the secondary of the variocoupler and the grid variometer will also raise the wavelength of the secondary circuit

length worth investigating by enthusiasts mastering the code. The condenser is most easily made from a standard .0005 grid condenser (minus the leak), by unrolling and clipping off one half of the copper foil, and firmly rebinding the remaining foil and waxed paper. A switch is again provided for eliminating the condenser on waves which

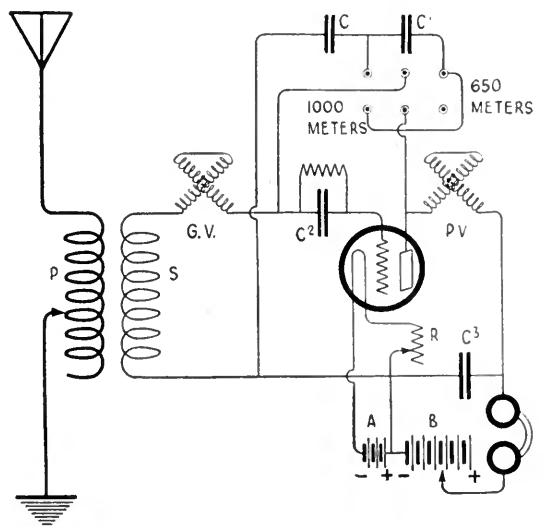

FIG. 3

This system of capacity load permits a wide tuning range—from the amateur wavelengths up to about 1000 meters

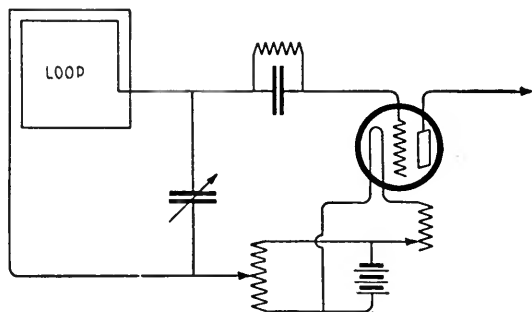

FIG. 4

Here a loop antenna, shunted by a variable condenser, is substituted for the outdoor antenna, ground and variocoupler of the standard receiver

can be received with the variocoupler and variometer alone.

A second system of capacity load, which is used by a well-known manufacturer of variometer receivers, is shown in Fig. 3. This system enables the operator to proceed in overlapping jumps from short waves (up to four hundred and fifty meters) to medium waves (in the neighborhood of six hundred), and high waves (up to one thousand meters), by the three different positions (right, open, and left) of a double-pole double-throw switch. The extra capacities, C and C<sup>1</sup>, may be made in the same manner as that for the circuit shown in Fig. 2, except that only one third of the foil is cut from the standard condenser. This is due to the fact that on medium waves, the condensers are in series, which gives a total extra capacity across the variometer and secondary, of one half that of a single condenser. On the thousand meter adjustment, the capacity (one condenser) is increased across the grid circuit, while the remaining condenser couples the grid and plate elements of the tube, maintaining regeneration by capacity feed-back over the entire scale of wavelengths.

Using an aerial of generous proportions, it is seldom necessary to load the primary circuit. However, if following the instructions given in the preceding paragraphs avails little improvement on the higher waves, a small load (about ten turns of wire on a three-inch tube) should be placed in series with the antenna, and provided with the usual short-circuiting switch.

Some readers have found it difficult to receive the higher wavelengths on the set described by Mr. Seager in the March RADIO BROADCAST. This difficulty is very easily remedied by adding eight turns of wire to the primary, and ten turns to the secondary, adding the wire in each case between the last two high-wave taps. That is, if at present there are twelve turns of wire between the last two (on the high end) primary taps, there will be twenty turns after the addition of the extra inductance. If the set does not oscillate with the additional turns in the circuit, it will be necessary to shunt the tickler with a small condenser (similar to that described for use in Fig. 2) with a switch for disconnecting it.

#### SUBSTITUTING LOOPS ON STANDARD RECEIVERS

*I was much interested in Mr. Herts's article on adding two steps to an Aeriola Sr., in the May number of RADIO BROADCAST. Mr. Herts said that he used a loop on this set. In common with your other numerous readers, I should be obliged if you would show Mr. Herts's hook-up using a loop.*

J. W. T. P., TRURO, NOVA SCOTIA.

ANY circuit operating from an open antenna can be successfully converted for loop reception providing that the nearness of broadcasting stations or the presence of radio-frequency amplification justifies the change. It will merely be necessary to rearrange the grid circuit, eliminating the original tuning apparatus, and replace it by the loop with a shunted condenser, as per the diagram in Fig. 4. The notable exception to this procedure is the tickler regenerative circuit, which is not well adapted to loop reception due to the necessity of introducing, in series with the loop, a separate load with a tickler, thus cutting down the number of turns active in the picking up of radio signals.

In the circuit to which J. W. T. P. refers, the loop will be substituted for the first variometer, and the series condenser placed in shunt with it—in other words, as shown in Fig. 4.

#### ANTENNA CORROSION AND RESISTANCE

*I have read that an aerial should be re-wired every year or so, due to the fact that the surface corrodes, increasing its resistance to high-frequency radio currents which I am also informed travel on the surface of the wire. (Why is this?) My antenna has been up nine months, and the signals of late seem weaker than usual. Do you think that it is due to surface corrosion?*

M. A. C., ALBANY, N. Y.

LOSS of signal strength in the above case is doubtless due to some cause other than that which the writer suggests. It is, however, quite possible that corrosion or oxidization at unsoldered joints, if such exist in his antenna, has become so far advanced as to almost cut off or completely isolate certain portions of his aerial system. The decrease in loudness due to surface variations of the wire is seldom sufficient to be noticeable. Before this stage is reached, the wire generally weakens in one or more places and breaks. The voltage drop which our communicant suggests is due to resistance (as are practically all electrical and mechanical losses), and the loss is at all times proportional to the strength of the current. As the received energy is minute in the extreme, it follows that the current would not be sufficiently strong to occasion a perceptible loss.

High-frequency currents, such as radio oscillations, tend to travel on the surface of the wire due to a phenomenon known as "surface" or "skin effect", the study of which takes one quite deeply, but interestingly, into the science of high-frequency alternating currents.

The path or wire of all electric currents is surrounded by a magnetic field which varies in intensity as the current strengthens or weakens. When the amperage (measure of current) rises, the magnetic field spreads out farther from the wire—when it drops, the magnetic field contracts. In alternating electricity the strength of the current is constantly varying from zero to maximum. Hence it goes without saying that the resulting magnetic field is continually jumping in and out from the wire, totally disappearing into the centre of the wire from which it apparently springs, when the current is at zero.

Whenever a moving magnetic field, such as that expanding and contracting about a wire carrying alternating current, cuts another conductor, electricity, or a current, is "induced" therein. This is merely the theory of the dynamo which is nothing more than a machine for cutting a conductor by a magnetic field.

The current induced in a conductor by a near-by alternating current is in a direction *always opposite to that of the*



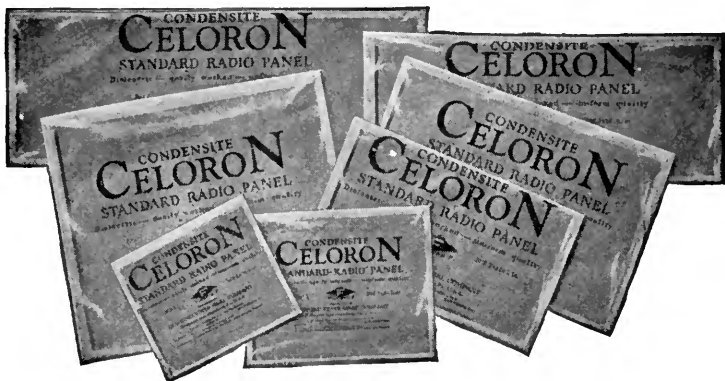

## Just pick out the size you want

**C**ELORON Radio Panels, ready-cut in standard sizes, save you the trouble and delay of having your panel cut to order. Just go to a nearby radio dealer who sells Celoron panels and pick out the size you want. Then you are sure of getting a panel that is neatly trimmed and finished, and something more—you get the necessary insulation for successful receiving.

Condensite Celoron has high dielectric strength and great insulation resistance. Its moisture-repelling properties prevent warping.

### Easy to work

You will like the "workability" of Celoron panels. They are easy to drill, tap, saw, and mill, and will engrave evenly without feathering. Each panel is wrapped in glassine paper to protect the surface. On

every one are complete instructions for working and finishing.

One of these standard sizes will fit the set you intend to build:

- |                          |                            |
|--------------------------|----------------------------|
| 1—6 x 7 x $\frac{1}{8}$  | 4—7 x 18 x $\frac{3}{16}$  |
| 2—7 x 9 x $\frac{1}{8}$  | 5—9 x 14 x $\frac{3}{16}$  |
| 3—7 x 12 x $\frac{1}{8}$ | 6—7 x 21 x $\frac{3}{16}$  |
|                          | 7—12 x 14 x $\frac{3}{16}$ |

If your dealer cannot supply you, ask him to order for you, or write direct to us. Indicate by number the size you want. Celoron is also furnished in full-sized sheets, and we can cut panels in any sizes desired.

### Write for this free booklet

Our booklet, "Tuning in on a New World," contains lists of the leading broadcasting stations in the United States and Canada, an explanation of symbols used in radio diagrams, and several efficient radio hook-ups. It will be sent free, on request.

To radio dealers: Send for special dealer price list showing standard assortments

## Diamond State Fibre Company

BRIDGEPORT

(near Philadelphia)

PENNSYLVANIA

Offices in Principal Cities

In Canada: Diamond State Fibre Company of Canada, Limited, 245 Carlaw Ave., Toronto



CONDENSITE  
**CELORON**  
STANDARD RADIO PANEL

★ Tested and approved by RADIO BROADCAST ★

*original current.* But, as mentioned before, the magnetic lines of force apparently emanate from the infinite dead centre of the wire. It would then follow that, in expanding, they must cut the wire itself, and induce therein a current always opposing the current that induces it! This is precisely what occurs, and in every alternating current line there is a counter electro-motive force that tends to buck or stop the first current. (This is, of course, not the counter E. M. F. (electro-motive force) generally referred to in an inductive circuit.)

In expanding out of the wire, or in contracting back into

the wire, *more lines of force, in a given time, cut the centre and the inside of the wire than cut the surface.* This is necessarily so, because some of the lines never expand so far as the surface. In other words, this counter E. M. F. is greater at the centre of the wire than at its surface, and the surface being the less opposed and freer path, is taken by the current!

This skin effect, however, is only noticeable with high-frequency currents where the field expands and contracts many thousands of times a second, and the "centre opposition" is practically constant.

## Supplemental List of Broadcasting Stations in the United States

LICENSED FROM JUNE 16 TO JULY 13 INCLUSIVE

CALL SIGNAL	STATION	FREQUENCY (Kilocycles)	WAVE-LENGTH
KFHS	Nelson, Robert Washington, Hutchinson, Kansas . . . . .	1310	229
KFHU	Sateren, M. G., Mayville, N. D. . . . .	1150	261
KFHY	Mc Ewan, R. S., Trinidad, Col. . . . .	1240	242
KFIU	Alaska Elect. Light & Power Co., Juneau, Alaska . . . . .	1330	226
KFIV	Broyles, V. H., Pittsburg, Kansas . . . . .	1250	240
KFIK	Reorganized Church of Jesus Christ, Independence, Kansas. . . . .	1250	240
WCAP	Chesapeake & Potomac Tel. Co., Washington, D. C. . . . .	640	469
WKAD	Looff, Charles E., Providence, R. I. . . . .	1250	240
WRAZ	Radio Shop of Newark, Newark, N. J. . . . .	1290	233
WSAG	Davis, Loren V., St. Petersburg, Fla. . . . .	1230	244
WSAK	Daily News, The, Middleport, Ohio . . . . .	1160	258
WSAN	Allentown Radio Club, Allentown, Pa. . . . .	1310	229
WSAQ	Round Hills Radio Corp., Dartmouth, Mass. . . . .	1070	280
WSAR	Doughty & Welch Elect. Co., Fall River, Mass. . . . .	1180	254
WTAB	Fall River Daily Herald, Fall River, Mass. . . . .	1210	248

### DELETIONS FROM JUNE 1 TO JUNE 30

KDZG . . . . .	San Francisco, Calif.	WGAM . . . . .	Orangeburg, S. C.
KDZX . . . . .	San Francisco, Calif.	WHAE . . . . .	Sioux City, Iowa
KFBD . . . . .	Hanford, Calif.	WHAW . . . . .	Tampa, Fla.
KFBH . . . . .	Marshfield, Ore.	WIAE . . . . .	Vinton, Iowa
KFCB . . . . .	Phoenix, Ariz.	WKAH . . . . .	West Palm Beach, Fla.
KFEB . . . . .	Taft, Calif.	WKAK . . . . .	Okemah, Okla.
KFGB . . . . .	Pueblo, Colo.	WKAL . . . . .	Orange, Texas
KJJ . . . . .	Sunnyvale, Calif.	WKN . . . . .	Memphis, Tenn.
KNI . . . . .	Eureka, Calif.	WLK . . . . .	Indianapolis, Ind.
KNN . . . . .	Los Angeles, Calif.	WMAG . . . . .	Liberal, Kansas
KOA . . . . .	Denver, Colo.	WMAR . . . . .	Waterloo, Iowa
KSL . . . . .	San Francisco, Calif.	WMAX . . . . .	Ann Arbor, Mich.
WAAL . . . . .	Minneapolis, Minn.	WOAS . . . . .	Middletown, Conn.
WAAY . . . . .	Youngstown, Ohio	WOAU . . . . .	Evansville, Ill.
WCAB . . . . .	Newburgh, N. Y.	WOU . . . . .	Omaha, Neb.
WCAC . . . . .	Fort Smith, Ark.	WPAA . . . . .	Wahoo, Neb.
WCAW . . . . .	Quincy, Ill.	WPAY . . . . .	Bangor, Maine
WCN . . . . .	Worcester, Mass.	WPE . . . . .	Independence, Mo.
WEAV . . . . .	Rushville, Neb.	WPO . . . . .	Memphis, Tenn.
WEAX . . . . .	Little Rock, Ark.	WRAC . . . . .	Mayville, N. D.
WEH . . . . .	Tulsa, Okla.	WRAK . . . . .	Escanaba, Mich.
WEY . . . . .	Wichita, Kansas	WRAM . . . . .	Galesburg, Ill.
WFAC . . . . .	Superior, Wis.	WSAV . . . . .	Houston, Tex.
WFAW . . . . .	Miami, Fla.	WWAY . . . . .	Chicago, Ill.
WFAZ . . . . .	Charleston, S. C.		

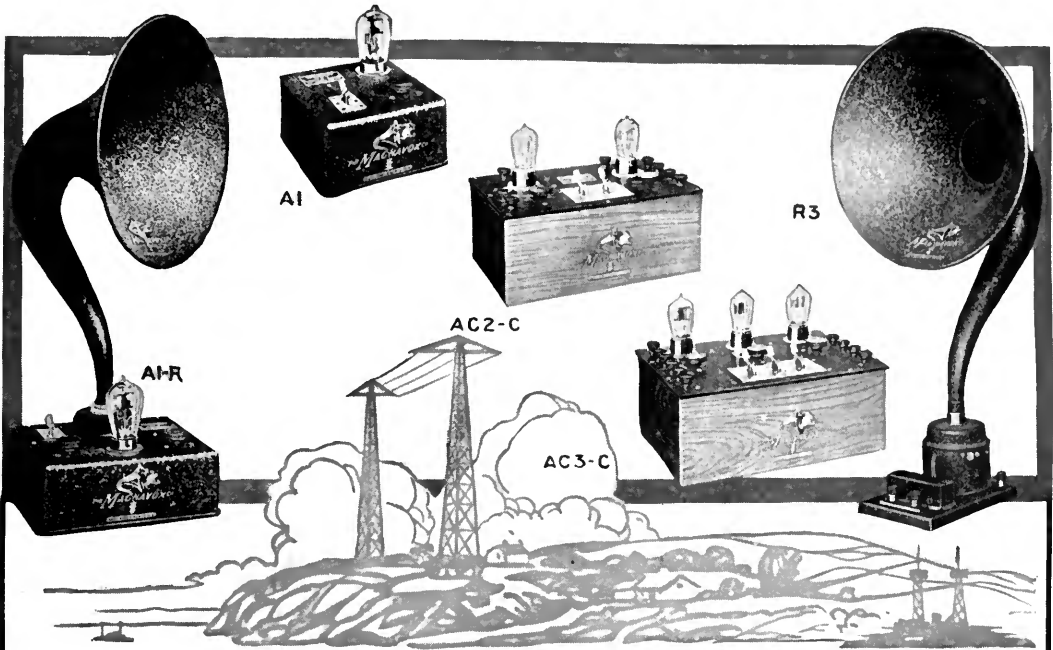

## ★ Radio Takes Another Step Forward

THE new Magnavox models (rapidly being distributed to the trade) extend and supplement the already famous Magnavox line, which now includes a Magnavox for every receiving set.

A brief summary of Magnavox products is given below:

<i>Magnavox Reproducers</i>		<i>Magnavox Power Amplifiers</i>	
R-2 with 18-inch curvex horn. . .	\$60.00	A2-M same as A2-R but with Reproducer M1 . . . . .	85.00
R-3 with 14-inch curvex horn. . .	35.00	<i>Magnavox Power Amplifiers</i>	
M1 with 14-inch curvex horn; requires no battery for the field. .	35.00	A1—new 1-stage Power Amplifier. . . . .	\$27.50
<i>Magnavox Combination Sets</i>		AC-2-C—2-stage Power Amplifier. . . . .	55.00
A1-R consisting of Reproducer R3 and 1 stage of amplification. . . . .	\$59.00	AC-3-C—3-stage Power Amplifier. . . . .	75.00
A2-R consisting of Reproducer R3 and 2 stages of amplification. . . . .	85.00	<i>Ask your dealer for demonstration. Interesting booklet will be sent on request.</i>	
A1-M same as A1-R but with Reproducer M1 . . . . .	59.00	<b>THE MAGNAVOX COMPANY</b>	
		Oakland, California	
		New York Office: 370 Seventh Avenue	

# MAGNAVOX PRODUCTS

The only complete line of Reproducers and Power Amplifiers

8-T

★ Tested and approved by RADIO BROADCAST ★

# New Equipment

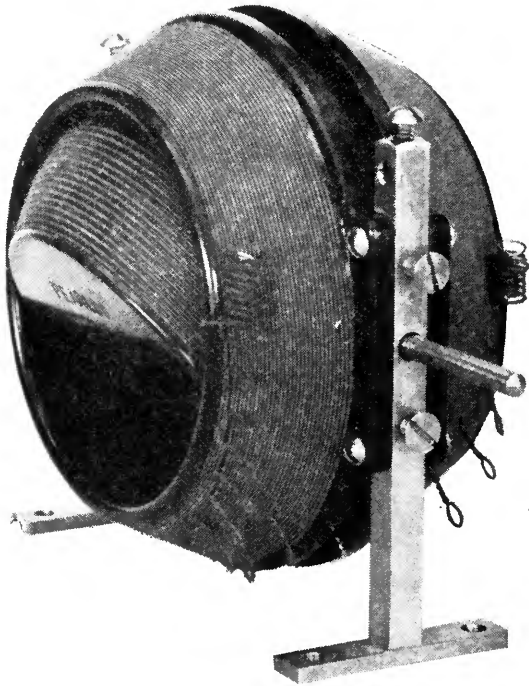

## A FRICTION-CONTACT VARIOCOUPLER

The Pearlco molded variocouplers and variometers are well made and may be used in various broadcast receiving circuits with success. Pearl Radio Corporation, 1033 Race St., Philadelphia, Pa.



## FOR CUTTING OUT INTERFERENCE

This new product of the Malone-Lemmon Laboratories, Madison Ave. & 44th St., New York City, is particularly valuable to those employing single-circuit receivers as an aid in cutting out interference. It is tuned to the interfering station which is thus eliminated. Spark interference is not entirely eliminated at close range, though it is greatly reduced

A TWO-IN-ONE SOCKET  
WD-11's or standard-based tubes may be used with this new socket without altering the wiring. Alden-Napier Co., Springfield, Mass.

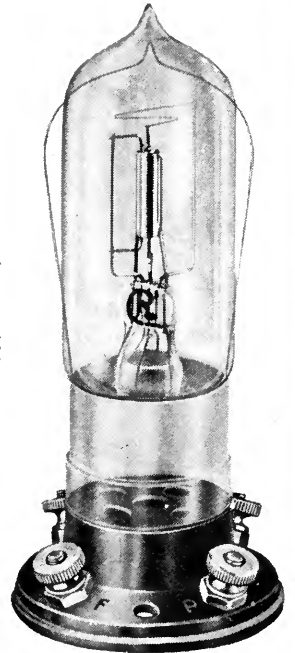

## THE LATEST GREBE PRODUCT

The CR-12 is a four-tube receiver, designed especially for broadcast reception, and may be operated from either dry or storage A batteries. Any type of tubes or combination of tubes may be used. A. H. Grebe & Co., Inc., Richmond Hill, N. Y.



## THE SYMPHONY RECEIVER

A three-circuit regenerator, with three stages of audio amplification. It permits loud-speaker operation of great volume over comparatively long distances and is very selective. Kellogg Switchboard & Supply Co., Adams St., Chicago, Illinois

In this department last month, it was said that the new Burgess B battery "takes less than half the space required by the older forms of equal capacity." This should have read—"half the base area—"