

Euphonix System



Installation Guide

Document Revision: 2.6
Part Number: 840-07591-04
Release Date: August 2006



Euphonix, Inc.

220 Portage Ave.
Palo Alto, California 94306
Phone: 650-855-0400
Fax: 650-855-0410
Web: <http://www.euphonix.com>
e-mail: info@euphonix.com



In the interest of continued product development, Euphonix reserves the right to make improvements in this manual and the products it describes at any time, without notice or obligation.

System 5, S-5, PatchNet, eMix, EuCon, R-1, Audio Deck, Studio Hub are trademarks of Euphonix, Inc.

©2006 Euphonix, Inc. All rights reserved worldwide. No part of this publication may be reproduced, transmitted, transcribed, stored in a retrieval system, or translated into any language in any form by any means without written permission of Euphonix, Inc.

Revision History

V2.6: Added Power Status (DE-9) pinout info for dual power supplies for DF64, CM401, CM402, CM408, CM403 CM409HTP, SC262, PC254d, PC254i, SH612.

Table of Contents

Revision History	ii
List of Figures	v
List of Tables	vii
Chapter 1: System 5 Overview	9
Introduction to System 5	9
Digital Signal Processing (DSP)	9
The System 5 Console	9
Analog and Digital I/O	10
Mic Inputs	11
Monitoring	11
Power	11
Digital Sync	11
System Control Connections	12
Estimating System Requirements	14
Number of DF64 Digital Frames	14
Number of CM408 Eight-channel Sections	14
I/O Specification	15
Chapter 2: Interconnecting System Components	17
Component Specifications	17
Typical Room and Equipment Layout for System 5	20
Typical Console Layout	20
Console Dimensions	21
Suggested Rack Elevations	23
Audio Hookup	25
Synchronization Hookup	26
MADI Hookup	27
Control Hookup	31
Chapter 3: System 5 Components	33
DF64 Digital Frame	33
FC631 Frame Controller	35

MM641 MADI Interface Card.....	35
SP661 Signal Processor	35
System 5 Console.....	35
SC262 System Computer	37
PC254d Digital Pilot Computer	38
PC254i Interface Computer	39
MC524 Monitor Interface	40
Input/Output Connections.....	41
ML530 Mic/Line Interface	46
SH612 Studio Hub	48
AM713 Analog to MADI Converter.....	49
Front Panel	49
Rear Panel	50
MA703 MADI to Analog Converter.....	52
Front Panel	52
Rear Panel	53
DM714 AES/EBU to MADI Converter.....	55
Front Panel	55
Rear Panel	56
MD704 MADI to AES/EBU Converter.....	58
Front Panel	58
Rear Panel	59
FC726 Format Converter	61
GP132	68
Front Panel Functions	68
25-pin D-sub connectors RT1-RT4	68
MIDI Connections	69
Input and Output Connections	69
Connector Pinouts (DB-25 RT1-RT4)	69
TT007.....	71
Setup	71
Capabilities	71
Using the TT007	72
Index	73

List of Figures

2-1	Typical Room and Equipment Layout for System 5	20
2-2	System 5 Console	20
2-3	Console Dimensions - Top	21
2-4	Console Dimensions - Side	21
2-5	CM40x Module Dimensions	22
2-6	One- and Two-frame Systems	23
2-7	Three-frame System	24
2-8	Four-frame System	24
2-9	Audio Hookup	25
2-10	Synchronization Hookup (Word Clock shown, AES/EBU may be used)	26
2-11	MADI hookup: one DF64 core, 10 or 11 DSP cards, one SH612	27
2-12	MADI hookup for two DF64 cores and one SH612 Studio Hub	28
2-13	MADI hookup for three DF64 cores and two SH612 Studio Hubs	29
2-14	MADI hookup for four DF64 cores and two SH612 Studio Hubs	30
2-15	Control Hookup	31
3-1	DF64 Digital Frame Front and Rear Panels	33
3-2	FC631, MM641, and SP661 Cards	34
3-3	CM401 Expansion Port: DB-25 Female pinout	36
3-4	Typical Talkback Wiring	36
3-5	SC262 Front and Rear Panels	37
3-6	PC254d Front and Rear Panels	38
3-7	PC254i Front and Rear Panels	39
3-8	MC524 Front and Rear Panels	40
3-9	Elco 38 Connector	41
3-10	Elco 90 Connector	42
3-11	Elco 90 Connector	43
3-12	Elco 90 Connector	44
3-13	DB-25 Connector	45
3-14	ML530 Front and Rear Panels	46
3-15	ML530 In 1/In 2 Pinout: Elco 38 Socket	47
3-16	ML530 Out 1/Out 2 Pinout: Elco 38 Socket	47

3-17	SH612 Studio Hub	48
3-18	AM713 Front Panel	49
3-19	AM713 Rear Panel	50
3-20	MA703 Front Panel	52
3-21	MA703 Rear Panel	53
3-22	DM714 Front Panel	55
3-23	DM714 Rear Panel	56
3-24	DM714 Parallel AES/EBU Digital Inputs: Female DB-25	57
3-25	MD704 Front Panel	58
3-26	MD704 Rear Panel	59
3-27	DM704 Parallel AES/EBU Digital Outputs: Female DB-25	60
3-28	FC726 Front and Rear Panels	61
3-29	GP132 Front and Rear Panels	68
3-30	GP132 Input and Output Connections	69
3-31	TT007 front and rear panels	72

List of Tables

1-1	DF64 Requirements	14
1-2	Summary of System 5 Components	16
2-1	System 5 Components: Dimensions, Power Consumption, Heat Dissipation	17
2-2	Fuse Ratings for System 5 Components	19
3-1	Switch Functions	36
3-2	In 1 Elco 38 Pinout	41
3-3	In 2 Elco 90 Pinout	42
3-4	Out 1 Elco 90 Pinout	43
3-5	Out 2 Elco 90 Pinout	44
3-6	Out 3 DB-25 Pinout	45
3-7	AES/EBU DB-25 Pinout	63
3-8	Common DD-50 Connector Pinout and Usage With Third-party Devices	64
3-9	FC726 TDIF Cable Wiring Specification	65
3-10	FC726 Pro Tools Cable Wiring Specification	66
3-11	FC726 SDIF Cable Wiring Specification	67
3-12	GP132 Outputs	69
3-13	GP132 Inputs	70

Chapter 1: System 5 Overview

This chapter explains the basic elements of any digital audio mixing system and introduces the components of System 5. It concludes with a section explaining how to estimate your system's requirements.

Chapter 2: *Interconnecting System Components* illustrates how to connect the components, where to locate them, and lists technical information about the components.

Chapter 3: *System 5 Components* presents relevant details about each component's connectors and cables.

Introduction to System 5

Digital Signal Processing (DSP)

The DF64 Digital Frame is a rack-mounted unit that performs all audio processing in System 5: dynamics and EQ, mix buses, record buses, aux sends, and monitor buses. Up to four DF64s can be specified in a single system and their DSP can be allocated, using factory-supplied *Mixer Model* files, to provide different numbers of buses and channels for each project. The number of DF64s required in a system depends on the number of *logical channels* desired: a mono input uses one logical channel, a stereo input uses two, and a 7.1 input uses eight.

The System 5 Console

The System 5 console must contain the CM401 and CM402 center section modules and a variable number of CM408 Eight-channel Modules, each providing eight physical faders. Several optional sections can be included:

- CM403: Houses the dual joystick panner and film monitor panel;
- CM409F: Blank section the size of a CM408;

Facilities often install a larger console frame than is initially filled with modules and panels. This can be due to plans for future expansion or to fulfill physical requirements for console access. The blank sections merely fill in the space to avoid having a hole across part of the console width;

- CM409H: Half-width blank section;
- CM409HTP: Half-width section that contains a trackball panner

The following sections discuss important concepts necessary to specify a console layout.

Inputs

System 5 inputs may be mono, stereo, or any format up to 7.1, which means that a single input may use one to eight logical channels.

Physical Faders

Each CM408 Eight-channel Module contains eight physical faders. Each fader can control two inputs using a **Swap** button that switches the fader between the Swap and Main inputs.

Layouts

Inputs are assigned to physical faders by using *Layouts*. Numerous Layouts can be easily stored and recalled to remap the console surface. To understand Layouts, consider the following examples:

- A console fitted with one CM408 has eight physical faders that can control up to 16 inputs (Swap and Main per input). One Layout can assign 16 stereo inputs to the faders for a total of 32 logical channels.
- Another Layout for the same system with eight faders can assign 7.1 inputs to the Main and Swap layers. This yields 16 inputs each with eight channels for a total of 128 logical channels.
- To make the situation even more interesting, these two examples can be combined! Assuming the DSP processing is available in the DF64s, the first 32-channel Layout can be assigned and left connected to the mix buses while the second Layout is recalled. If none of the channels between the Layouts are the same, there are now 160 logical channels feeding the mix buses at the same time, although they cannot be controlled simultaneously from the console surface.

Layouts may also be used to place the inputs most often used on the top fader layer, or inputs that should be grouped together (i.e., drums).

Analog and Digital I/O

All audio signals are converted to and from the MADI format through analog and digital converters. All MADI devices are connected to the SH612 Studio Hub which is connected to the DF64 Digital Frames. A system may have one or two SH612s:

- **one SH612:** connect up to six output and eight input devices.
- **two SH612s:** connect up to 12 input devices to one and up to 12 output devices to the second.

Analog I/O

All analog I/O is converted between analog and MADI formats via the AM713 Analog to MADI Converter, and the MA703 MADI to Analog Converter. Each unit's main I/O handles 24 signals and also contains an auxiliary stereo analog input or output, and an auxiliary stereo digital input or output (AES/EBU and S/PDIF).

Digital I/O

All digital I/O is converted to and from MADI format via the DM714 AES/EBU to MADI Converter, and the MD704 MADI to AES/EBU Converter. Each unit's main I/O handles 24 signals (12 AES/EBU pairs) and also contains an auxiliary stereo analog input or output, and an auxiliary stereo digital input or output (AES/EBU and S/PDIF). All digital inputs have built in Sample Rate Converters.

Format Conversion

The FC726 is a bidirectional device with 56 channels of sample-rate-converted I/O. All inputs and outputs are converted to and from MADI which are connected to the connected to the MADI I/O on the DF64 MADI card or through the optional SH612 Studio Hub. In addition to AES/EBU I/O, the FC726 allows direct connection to several third-party digital formats. Formats supported by the unit are TDIF, SDIF-2, and ADAT Optical. AES/EBU outputs are always active even when using third-party formats.

Mic Inputs

Mic inputs are handled by the ML530 Mic/Line Interfaces. Each unit contains 24 remote control mic preamps. Each ML530 is connected to a dedicated AM713 Analog to MADI Converter. Up to five ML530s may be deployed in a system.

Monitoring

Monitoring is handled by the MC524 Monitor Interface. This unit provides Main (7.1), Alt 1 (5.1), and Alt 2 (stereo) control room monitoring, SLS (7.1), and Cues 1–3 (each stereo) studio monitoring, 2 talkback preamps, and 4 listen mic preamps. The MC524 is connected to a dedicated MA703 MADI to Analog Converter.

Power

Some of the System 5 console components have dual power entry connectors for redundant power supplies. We recommend deriving the two power supplies from different sources to maximize the failsafe capabilities of the system. The best case is to connect one power supply to a UPS (Uninterruptable Power Supply) and the other to a clean technical power source. If a UPS is not used, the power supplies should be connected to separately protected clean technical power circuits.

Digital Sync

A high quality digital sync source is required for the System 5 console. Some facilities may already have a digital master clock or house reference in place but others may require one. Euphonix has tested several digital sync generators and distribution amplifiers and can supply these devices with the console. Contact a Euphonix sales representative for further information.

We recommend following these guidelines:

- It is important to minimize the timing differences between signal paths to avoid cumulative timing errors. It is good system engineering practice to send sync signals to all system components from one source.
- Sync signals should not be looped and each distribution amplifier should be fed directly from the master clock source.
- Drawings in this installation guide show the use of Word Clock. The user may use either AES/EBU sync or Word Clock.

NOTE: *The SH612's sync connections are designed to be used for in-house factory testing and should not be used in the final installation.*

System Control Connections

Ethernet

Several intelligent system components are connected via RJ45 Ethernet through a EuCon Ethernet hub. These devices include:

- SC262 System Computer
- PC254d Digital Pilot Computers
- PC254i Interface Computer
- CM408 Eight-channel Modules
- CM401 Master Fader Module (console center section)
- CM402 Expanded Channel Module (console center section)
- CM403 Film and Joystick Panels

KVM Extender

The KVM Extender cable is a Category 5 UTP cable, however it does not carry Ethernet data like the system components. The KVM Extender requires its own dedicated cable. Its maximum length is 400 ft (120 m).

Monitor, Trackball, and Keyboard

The SC262 System Computer provides master control for the entire system. A monitor, trackball, and keyboard located in the control room connect to this computer and control mixing, routing, and file management. A KVM Extender is typically used which routes these signals from the machine room to the control room through a single multipair cable built into the console ethernet harness.

Firewire

Each DF64 Digital Frame requires an PC254d Digital Pilot computer. These computers require no user interaction and configure the individual DF64s on startup. Each are connected to their respective DF64s via firewire.

TCC Control

The PC254i Interface computer also requires no user interaction. It connects to the MC524 Monitor Interface and up to seven ML530 Mic/Line Interfaces via TCC connection.

Machine Control

The TT007 provides machine control of three serial 9-pin devices, MTC, and LTC. The TT007 connects via MIDI in and out to a MOTU MIDI I/F. This interface is connected to the PC254i Interface Computer, MMC, LYNX Net, and ESBUS via the parallel port.

GPIO Control

The GP132 provides GPIO control for the system. The GP132 connects via MIDI in and out to a MIDI Interface (supplied). This interface is connected to the SC262 system computer, MMC, LYNX Net, and ESBUS via the USB port.

Estimating System Requirements

This section helps estimate the system requirements for a particular installation. Contact a Euphonix representative for an exact specification. Use following categories to determine the System 5 components necessary for your studio. Most of the studio details considered here are relevant to any digital mixing system.

Number of DF64 Digital Frames

Some examples of Mixer Models and their relationship to the number of DF64s are shown below.

Table 1-1 DF64 Requirements

Number of DF64s	Sample Rate	Logical Channels	Record Buses	Mix Buses	Aux Sends
1	48 kHz	58	48	8	12
1	48 kHz	70	24	12	16
1	48 kHz	46	32	32	8
2	48 kHz	154	24	12	8
2	48 kHz	94	48	8	12
2	96 kHz	64	24	12	8
3	48 kHz	166	48	16	12
3	48 kHz	166	24	24	12
3	96 kHz	94	12	48	16
4	48 kHz	226	24	32	24
4	48 kHz	112	48	12	12
4	96 kHz	136	24	12	8

NOTE: Table 1-1 refers to logical audio channels not inputs. See Inputs on page 10 to see how to count logical channels based on the number and type of inputs.

Number of CM408 Eight-channel Sections

One application may require a small, powerful console to control many inputs from a small number of faders. Other applications may trade console size for the power of accessing each input quickly without having to swap the fader or recall a Layout. Specify enough physical faders to conveniently control the required number of inputs.

I/O Specification

When considering I/O requirements, count the number of analog and AES/EBU inputs and outputs required to hook up all equipment and auxiliary panels for extra equipment. Do not specify I/O from the console perspective. For example, it is not efficient to specify one analog input and one analog output to be used as an insert point for each channel input. For microphone preamps, count the maximum number of preamps required including extras rather than one preamp for every channel.

Number of ML530 Mic-Line Interfaces

Each ML530 contains 24 remote-controlled microphone preamps. Note that each ML530 requires one dedicated AM713 Analog to MADI Converter.

$$\text{Total} = (\text{Microphone Preamps required} / 24)$$

Number of AM713 Analog to MADI Converters

Each AM713 contains 24 analog to MADI converters (equipment outputs).

$$\text{Total} = (\text{Analog inputs required} / 24) + (1 \text{ per ML530})$$

Number of MA703 MADI to Analog Converters

Each MA703 contains 24 MADI to analog converters (equipment inputs).

$$\text{Total} = (\text{Analog outputs required} / 24) + (1 \text{ for MC524})$$

Number of DM714 AES/EBU to MADI Converters

Each DM703 contains 24 (12 pairs) AES/EBU to MADI converters (equipment outputs).

$$\text{Total} = (\text{AES/EBU inputs required} / 24)$$

Number of MD704 MADI to AES/EBU Converters

Each MD704 contains 24 MADI to AES/EBU converters (equipment inputs).

$$\text{Total} = (\text{AES/EBU outputs required} / 24)$$

Number of FC726 Format Converters

Each FC726 is a bidirectional device that contains 56 sample-rate selectable AES/EBU inputs and outputs (112 signals). It also enables format conversion of 56 third-party format digital channels.

$$\text{Total} = (\text{Format-converted Inputs or Outputs} / 56)$$

The following chart summarizes this section:

Table 1-2 Summary of System 5 Components

Component	Function	Number	Notes
CM401 Master Module	These two modules make up the center section of the S5 console.	1 of each required	Ethernet devices. CM401 includes a TB Mic and expansion port for TB external switches wiring.
CM402 Expanded Channel Module			
CM403 Powered Console Module	Allows installation of joystick panner panel and film monitor panel.	optional	Ethernet device
CM408 8-channel Module	Contains 8 physical faders that control two layers of 8 inputs.	1 required	Ethernet device
CM409HTP Track Panner Module	Half-width console section with trackball panner.	optional	Serial device
PC254i Interface Computer	Computer for MC524 and ML530	1 required	Ethernet device. Connects to MC524 and up to 7 ML530s via TCC. Connects to MIDI I/F via parallel port. Connects to SH612(s) via serial port.
PC254d Digital Pilot	Configures DF64	1 required for each DF64	Ethernet device. Connects to DF64 via firewire.
TT007	Machine control Interface; Synchronizer	1 required	Requires video sync and MIDI connection to MIDI Express..
GP132 Input/Output and Relay System	Provides up to 32 input/output relay closures	Optional (4 max)	MIDI device connects to MIDI Express.
MIDI Express XT	MIDI communication between console and GP132/TT007	1 required	Connects to SC262 system computer through USB port.
MC524 Monitor Interface	Analog monitor output controller	1 required	TCC connection to Interface Pilot. 1 MA703 is required (standard).
ML530 Mic/Line Interface	24 remote-control mic preamps	7 max	1 AM713 is required per ML530
SC262 System Computer	Master system computer	1 required	Ethernet device. Connects to control room display monitor, keyboard, and trackball.
DF64 Digital Frame	Performs all system DSP	1 required (4 max)	The DF64 comes with its own PC254d Digital Pilot.
SH612 Studio Hub	MADI routing hub	1 required (2 max)	Requires digital sync reference. Connects to PC254i via control port.
AM713 Analog to MADI Converter	Provides 24 Analog to MADI Converters, Stereo Aux Digital Input (AES/EBU or S/PDIF available), and Aux Stereo Analog Input.	1 required for each ML530 specified.	Requires digital sync reference.
MA703 MADI to Analog Converter	Provides 24 MADI to Analog Converters, Stereo Aux Digital Output (AES/EBU or S/PDIF available), and Aux Stereo Analog Output.	1 required for the MC524.	Requires digital sync reference.
DM714 AES/EBU to MADI Converter	Provides 24 AES/EBU to MADI Converters, Stereo Aux Digital Input (AES/EBU or S/PDIF available), and Aux Stereo Analog Input.	Optional	Requires digital sync reference.
MD704 MADI to AES/EBU Converter	Provides 24 MADI to AES/EBU Converters, Stereo Aux Digital Output (AES/EBU or S/PDIF available), and Aux Stereo Analog Output.	Optional	Requires digital sync reference.
FC726 Digital Format Converter	Provides 56 channels of format converted inputs and outputs (112 channels total). Supports MADI, AES/EBU, T-DIF, ADAT Optical, S-DIF2.	Optional	Requires digital sync reference.

Chapter 2: Interconnecting System Components

This chapter summarizes technical information for System 5's components, including size, weight, power consumption, cooling, and fuse requirements and shows their interconnections. To plan an installation, examine Figure 2-1 to learn about suggested equipment locations. The Sync, MADl, and Control hookup diagrams (Figure 2-10 through Figure 2-13) all show maximum cable distances.

Component Specifications

Table 2-1 System 5 Components: Dimensions, Power Consumption, Heat Dissipation

Component	Height	Width	Depth	Weight	Power Consumption	Heat Dissipation
CM401	13.25" 34 cm	12" 30 cm	33.5" 84 cm	35 lb 16 kg	120 W	410 BTU/hr
CM402	13.25" 34 cm	12" 30 cm	33.5" 84 cm	35 lb 16 kg	120 W	410 BTU/hr
CM403	13.25" 34 cm	12" 30 cm	33.5" 84 cm	35 lb 16 kg	120 W	410 BTU/hr
CM408	13.25" 34 cm	12" 30 cm	33.5" 84 cm	35 lb 16 kg	120 W	410 BTU/hr
CM409F	13.25" 34 cm	12" 30 cm	33.5" 84 cm	16 lb 7 kg	NA	NA
CM409H	13.25" 34 cm	6" 15 cm	33.5" 84 cm	9 lb 4 kg	NA	NA
CM409HTP	13.25" 34 cm	6" 15 cm	33.5" 84 cm	10 lb 4.5 kg	NA	NA
CM424 Producer's Module with Writing Surface	13.25" 34 cm	24" 60 cm	33.5" 84 cm	35 lb 16 kg	NA	NA
Console Frame 6 ft	39.5" 1 m	6'10" 2.08 m	41" 1.04 m	245 lb 111 kg	NA	NA
Console Frame 9 ft	39.5" 1 m	9'10" 3 m	41" 1.04 m	300 lb 136 kg	NA	NA
Console Frame 12 ft	39.5" 1 m	12'10" 3.9 m	41" 1.04 m	380 lb 172 kg	NA	NA
MC524 Monitor Interface	3.5" 89 mm 2RU	17"/432 mm (19"/483 mm faceplate)	18.5" 470 mm	17 lb 7.7 kg	70 W	240 BTU/hr

ML530 Mic/Line Interface	3.5" 89 mm 2RU	17"/432 mm (19"/483 mm faceplate)	18.5" 470 mm	17 lb 7.7 kg	100 W	345 BTU/hr
SC262 System Computer	3.5" 89 mm 2RU	17"/432 mm (19"/483 mm faceplate)	22" 560 mm	23 lb 10.5 kg	200 W	685 BTU/hr
PC254i Digital Pilot	3.5" 89 mm 2RU	17"/432 mm (19"/483 mm faceplate)	18.5" 470 mm	23 lb 10.5 kg	200 W	685 BTU/hr
PC254d Digital Pilot	3.5" 89 mm 2RU	17"/432 mm (19"/483 mm faceplate)	18.5" 470 mm	23 lb 10.5 kg	200 W	685 BTU/hr
DF64 Digital Frame	15.75" 400 mm	19" 483 mm	17.3" 440 mm	≈80 lb 36.4 kg	300 W	1025 BTU/hr
SH612 Studio Hub	3.5" 89 mm 2RU	17"/432 mm (19"/483 mm faceplate)	18.5" 470 mm	12 lb 7.7 kg	100 W	345 BTU/hr
TT007 Machine Control Interface	1.75" 44.5 mm 1RU	19" 483 mm	12" 305 mm	4 lb 1.8 kg	15 W	NA
GP132 General Purpose Input/Output and Relay System	1.75" 44.5 mm 1RU	19" 483 mm	6.4" 163 mm	3.5 lb 1.6 kg	15 W	NA
MIDI Express XT MIDI Communication	1.75" 44.5 mm 1RU	19" 483 mm	5.5" 140 mm	3 lb 1.4 kg	10 W	NA
AM713 Analog to MADI Con- verter	3.5" 89 mm 2RU	17"/432 mm (19"/483 mm faceplate)	18.5" 470 mm	17 lb 7.7 kg	50 W	175 BTU/hr
MA703 MADI to Analog Con- verter	3.5" 89 mm 2RU	17"/432 mm (19"/483 mm faceplate)	18.5" 470 mm	17 lb 7.7 kg	50 W	175 BTU/hr
DM714 AES/EBU to MADI Converter	3.5" 89 mm 2RU	17"/432 mm (19"/483 mm faceplate)	18.5" 470 mm	17 lb 7.7 kg	25 W	90 BTU/hr
MD704 MADI to AES/EBU Converter	3.5" 89 mm 2RU	17"/432 mm (19"/483 mm faceplate)	18.5" 470 mm	17 lb 7.7 kg	25 W	90 BTU/hr
FC726 Digital Format Converter	3.5" 89 mm 2RU	17"/432 mm (19"/483 mm faceplate)	18.5" 470 mm	13.5 lb 6 kg	50 W	175 BTU/hr

Table 2-2 Fuse Ratings for System 5 Components

Component	100/115/120 VAC	220/230/240 VAC	How to Change Voltage Setting
CM401	T5 A	T5 A	autoranging
CM402	T5 A	T5 A	autoranging
CM403	T5 A	T5 A	autoranging
CM408	T5 A	T5 A	autoranging
MC524 Monitor Interface	6 A	3 A	autoranging
ML530 Mic/line Interface	6 A	3 A	autoranging
SC262 System Computer	6 A	3 A	autoranging
PC254i Digital Pilot	6 A	3 A	autoranging
PC254d Digital Pilot	6 A	3 A	autoranging
DF64 Digital Frame	5 A breaker	5 A breaker	autoranging
SH612 Studio Hub	F2.5 A	F1.25 A	autoranging
TT007 Machine Control Interface	2 mA	2 mA	autoranging
GP132 General Purpose Input/ Output and Relay System	2 mA	2 mA	autoranging
MIDI Express XT MIDI Communication Interface	125 mA	125 mA	side panel selector switch
AM713 Analog to MADi Converter	630 mA	315 mA	rear panel selector switch
MA703 MADi to Analog Converter	630 mA	315 mA	rear panel selector switch
DM714 AES/EBU to MADi Converter	630 mA	315 mA	rear panel selector switch
MD704 MADi to AES/EBU Converter	630 mA	315 mA	rear panel selector switch
FC726 Digital Format Converter	T2.5 A	T2.5 A	autoranging

Typical Room and Equipment Layout for System 5

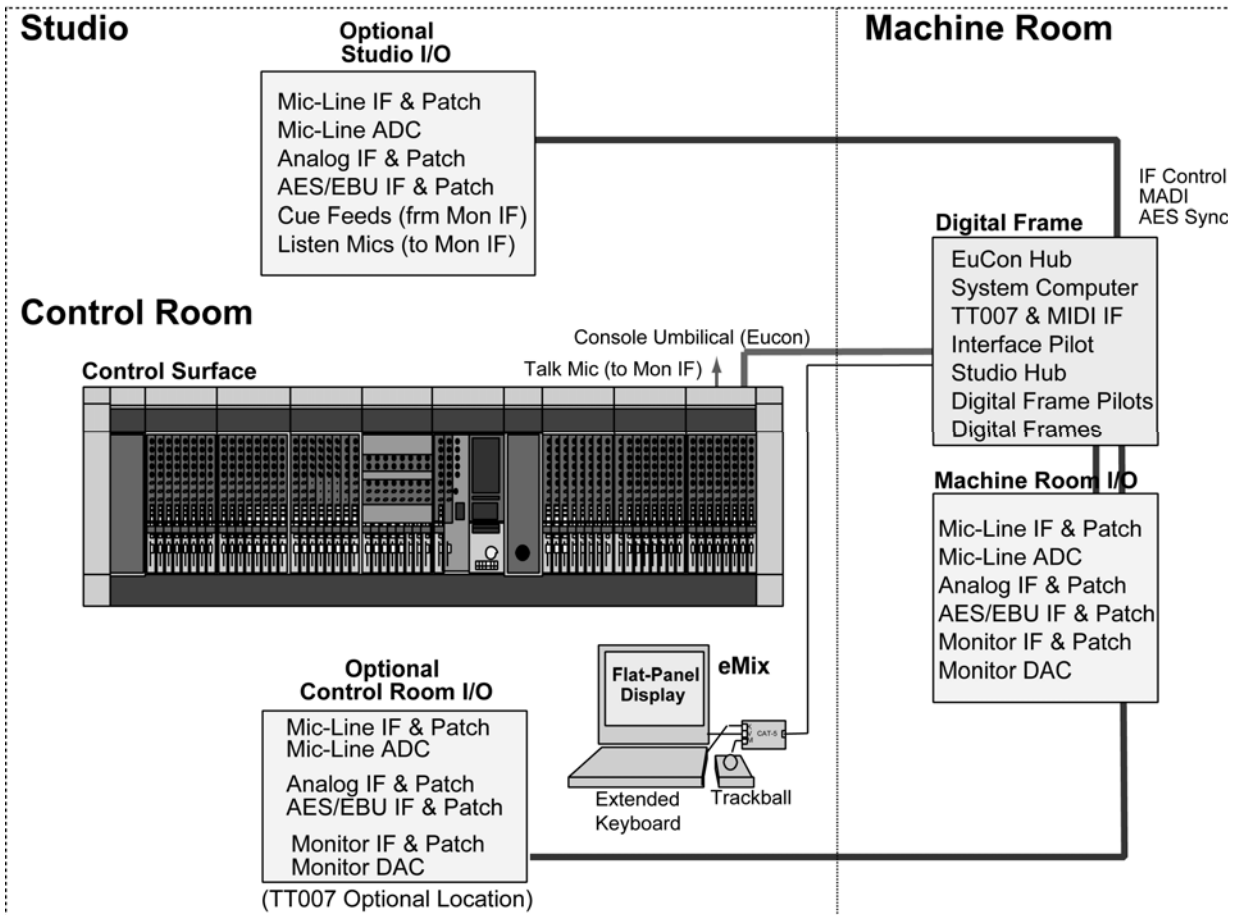

Figure 2-1 Typical Room and Equipment Layout for System 5

Typical Console Layout

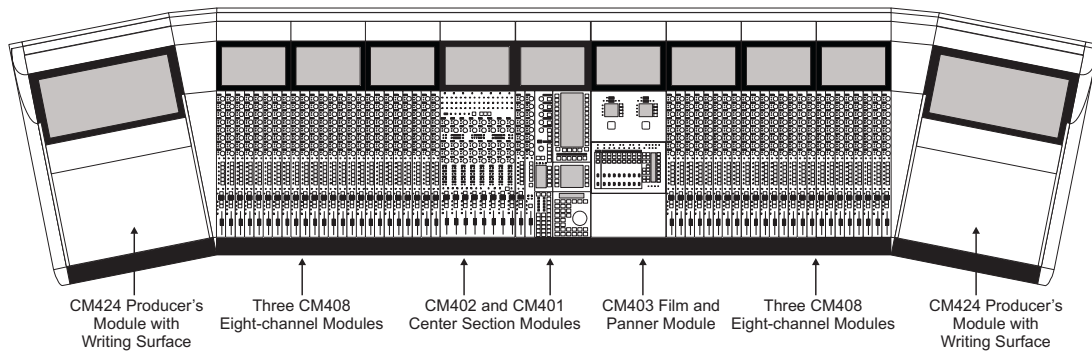

Figure 2-2 System 5 Console

Console Dimensions

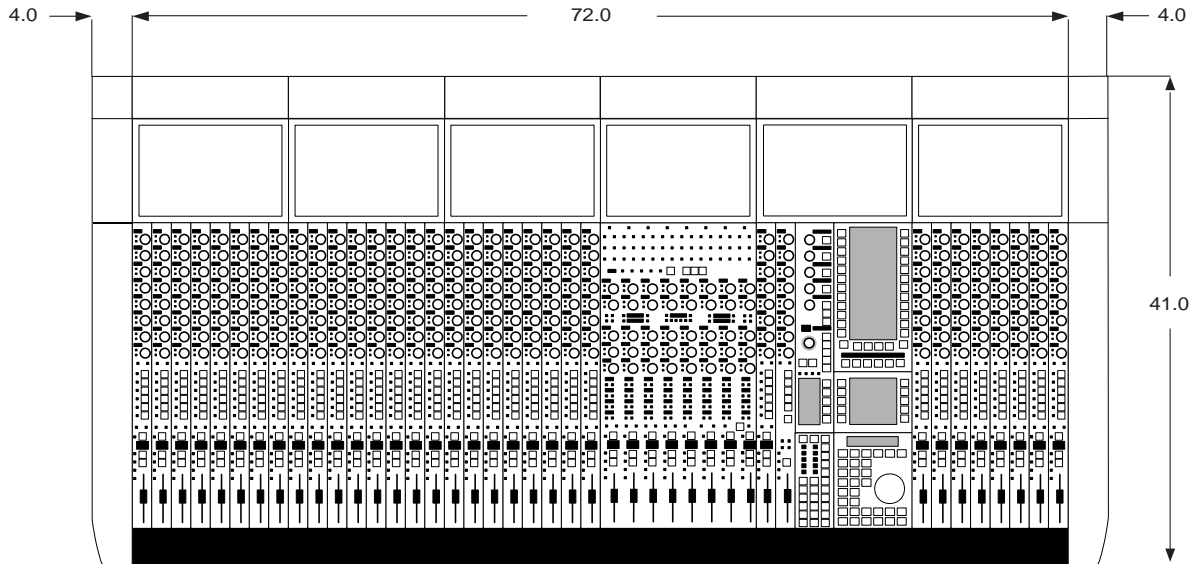

Figure 2-3 Console Dimensions - Top

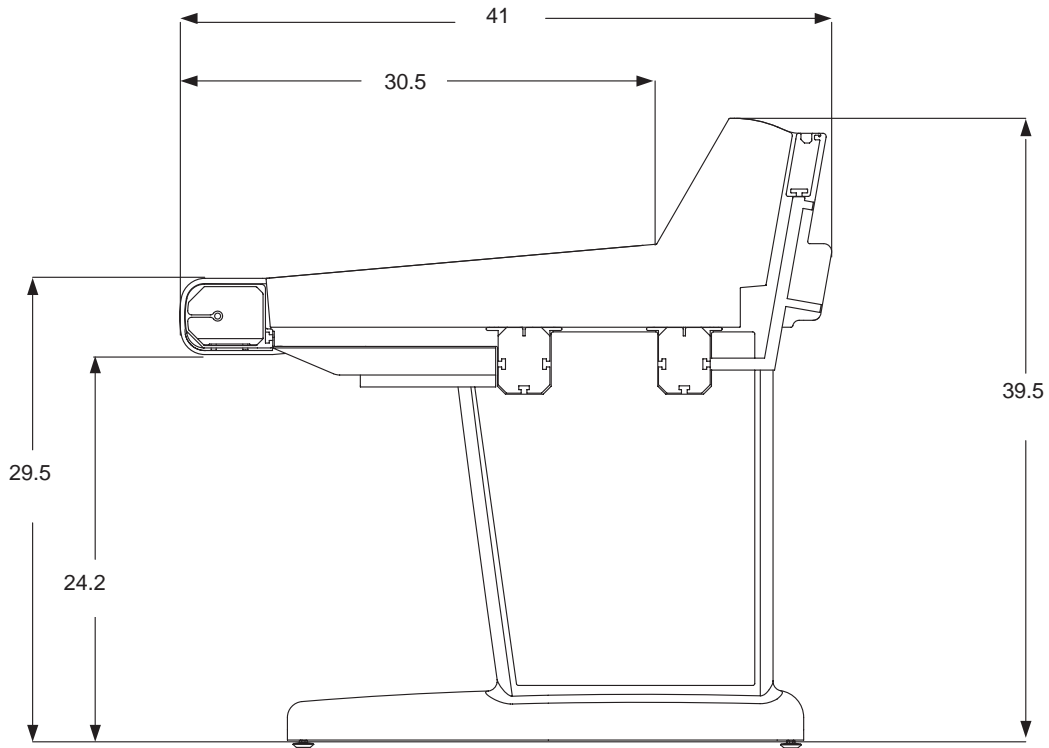

Figure 2-4 Console Dimensions - Side

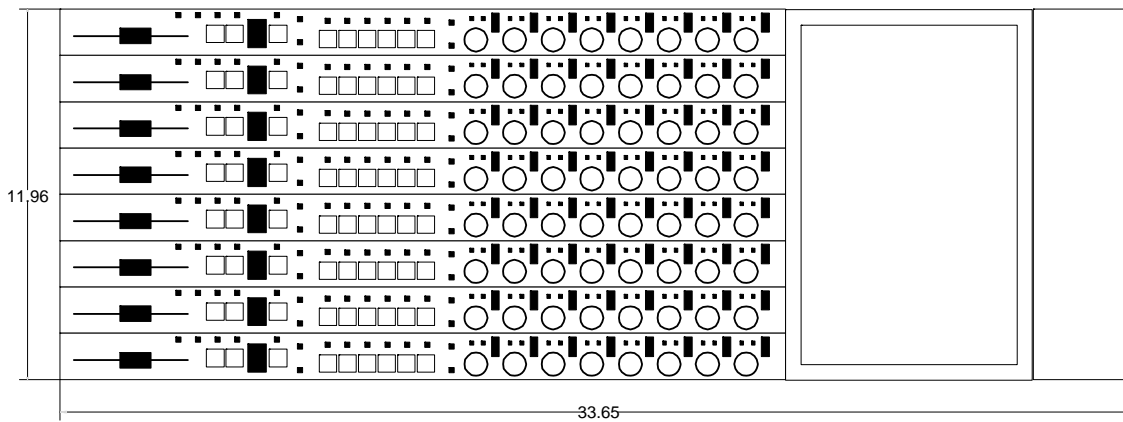
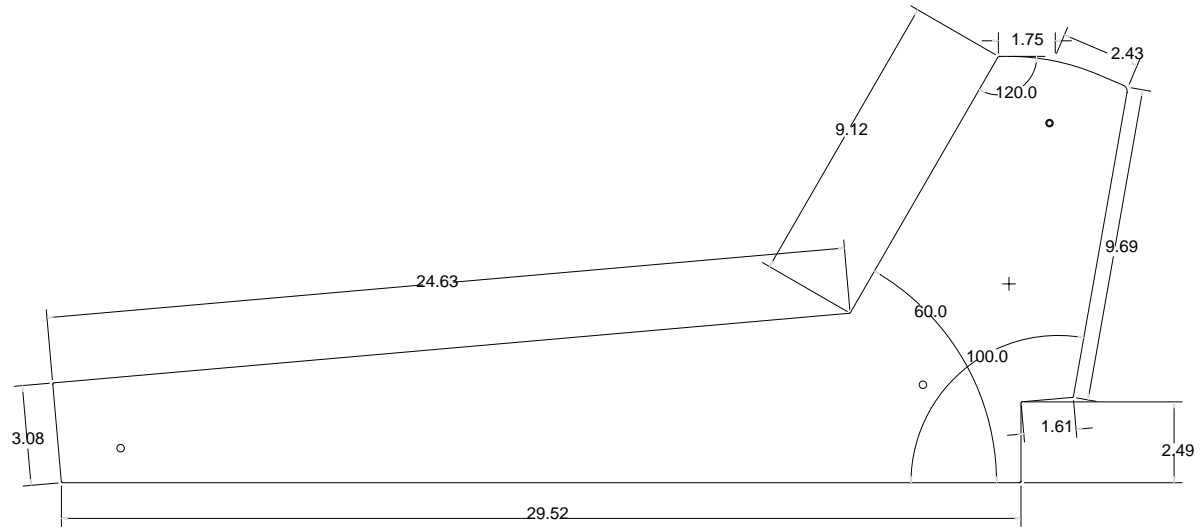

Figure 2-5 CM40x Module Dimensions

Suggested Rack Elevations

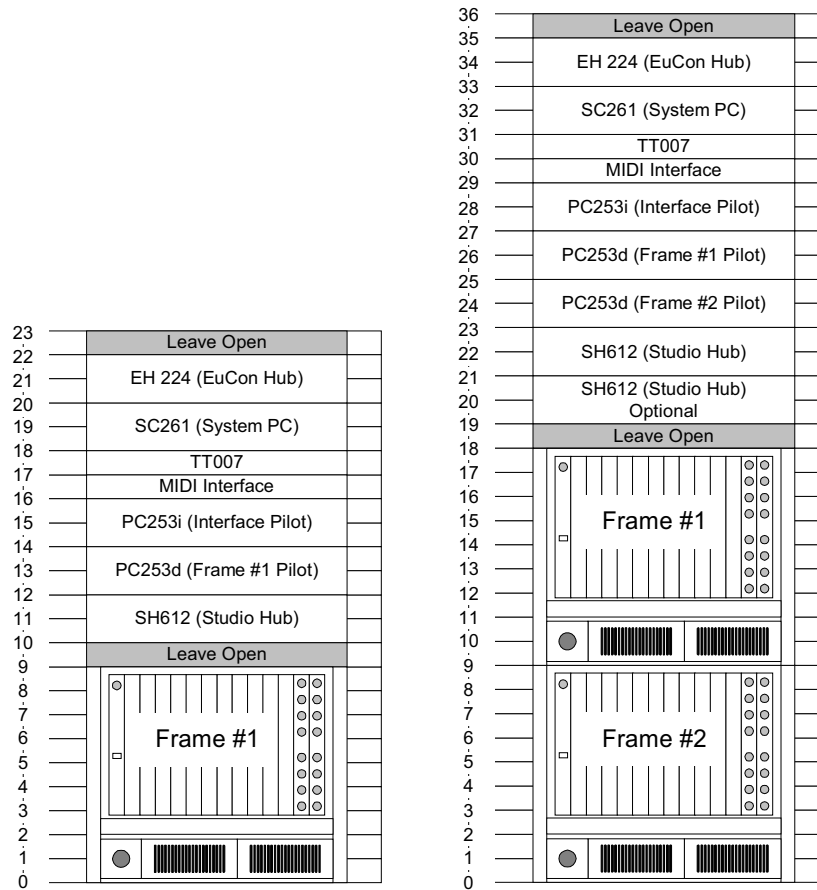

Figure 2-6 One- and Two-frame Systems

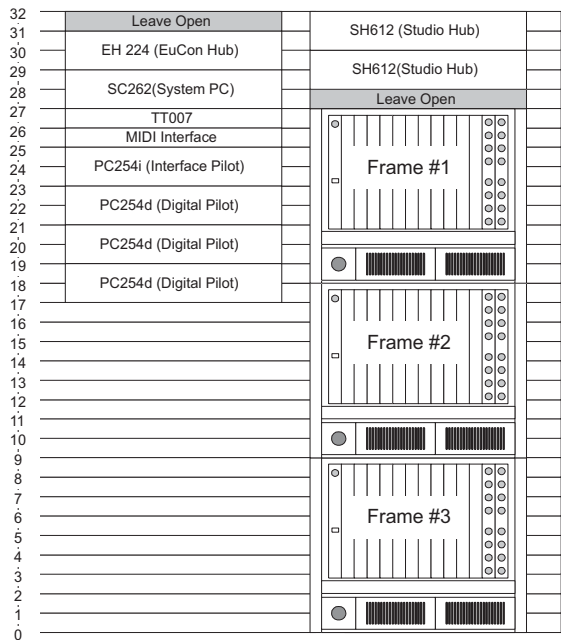

Figure 2-7 Three-frame System

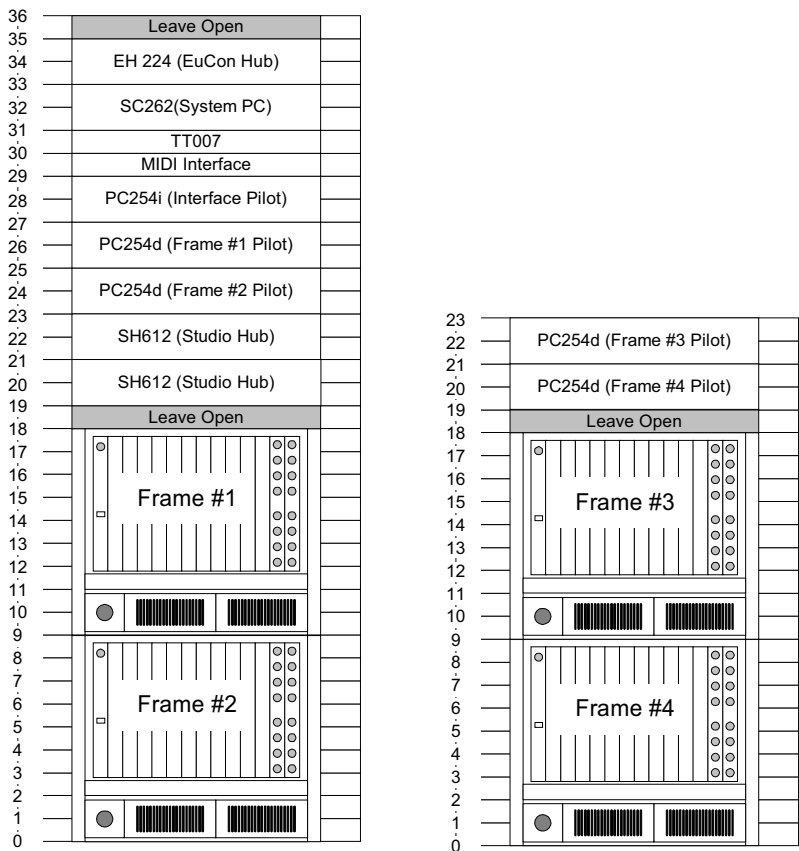

Figure 2-8 Four-frame System

Audio Hookup

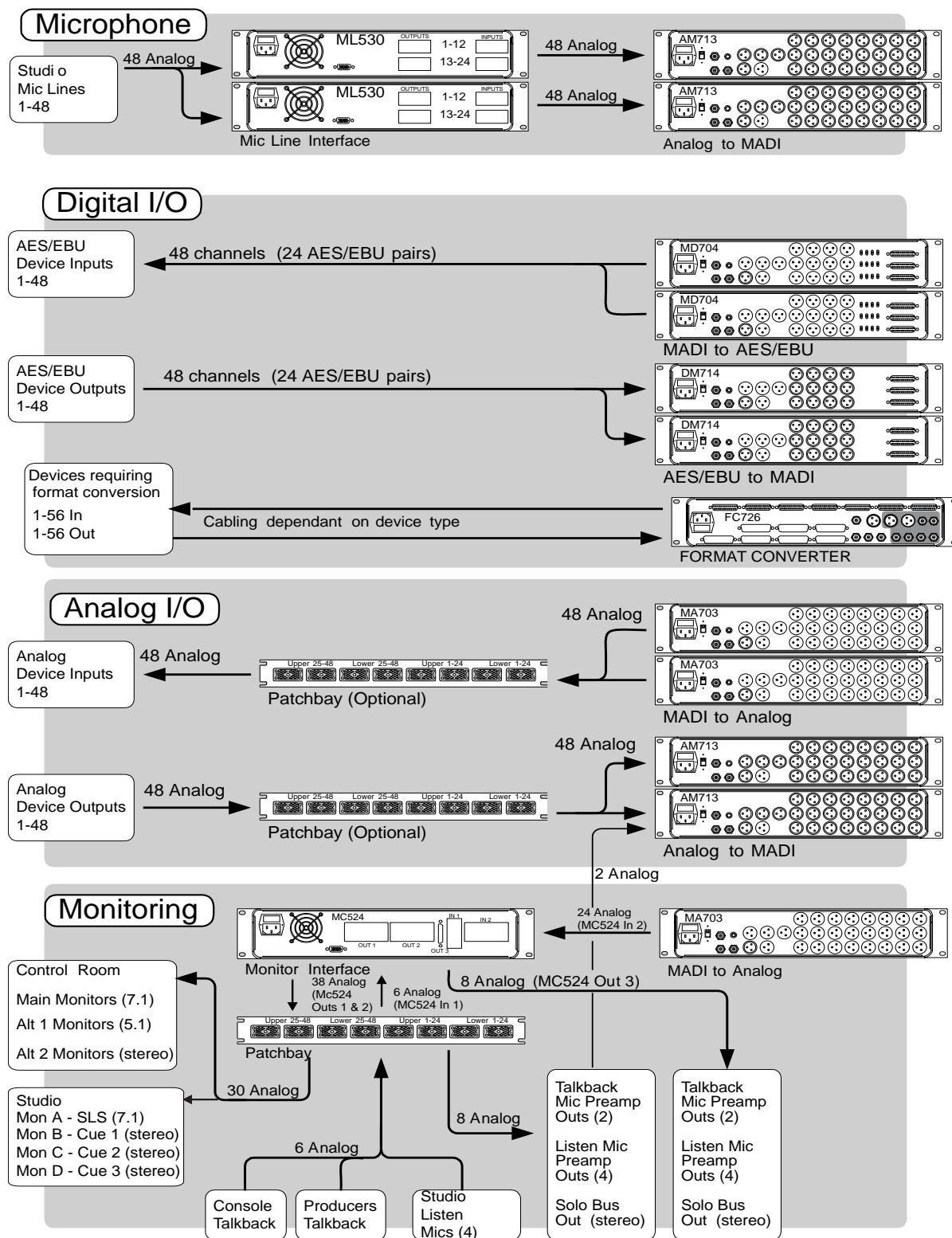

Figure 2-9 Audio Hookup

Synchronization Hookup

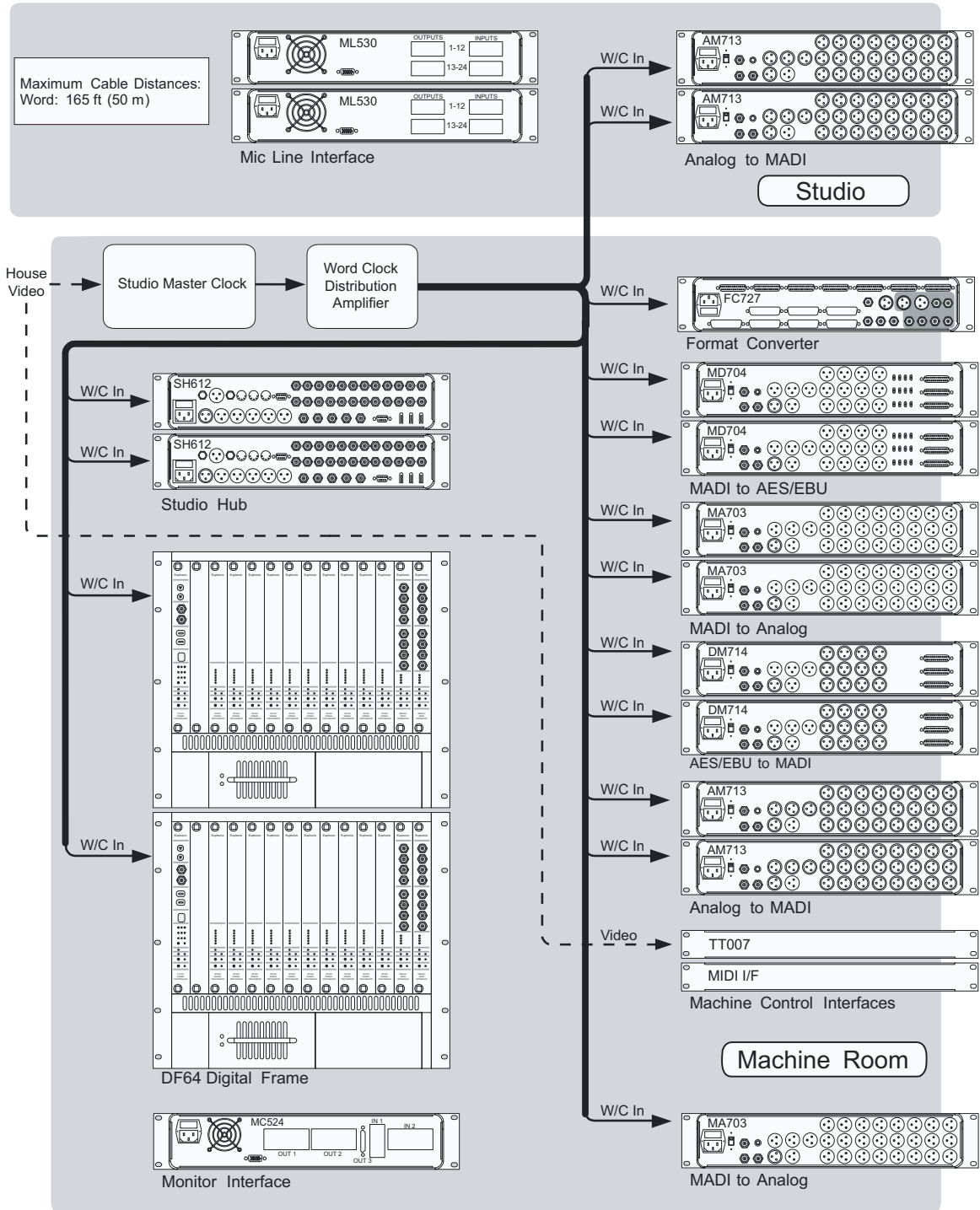

Figure 2-10 Synchronization Hookup (Word Clock shown, AES/EBU may be used)

NOTE: Each component receives a separate word clock feed from the Word Clock Distribution Amplifier. DO NOT LOOP THE WORD CLOCK FROM COMPONENT TO COMPONENT!

MADI Hookup

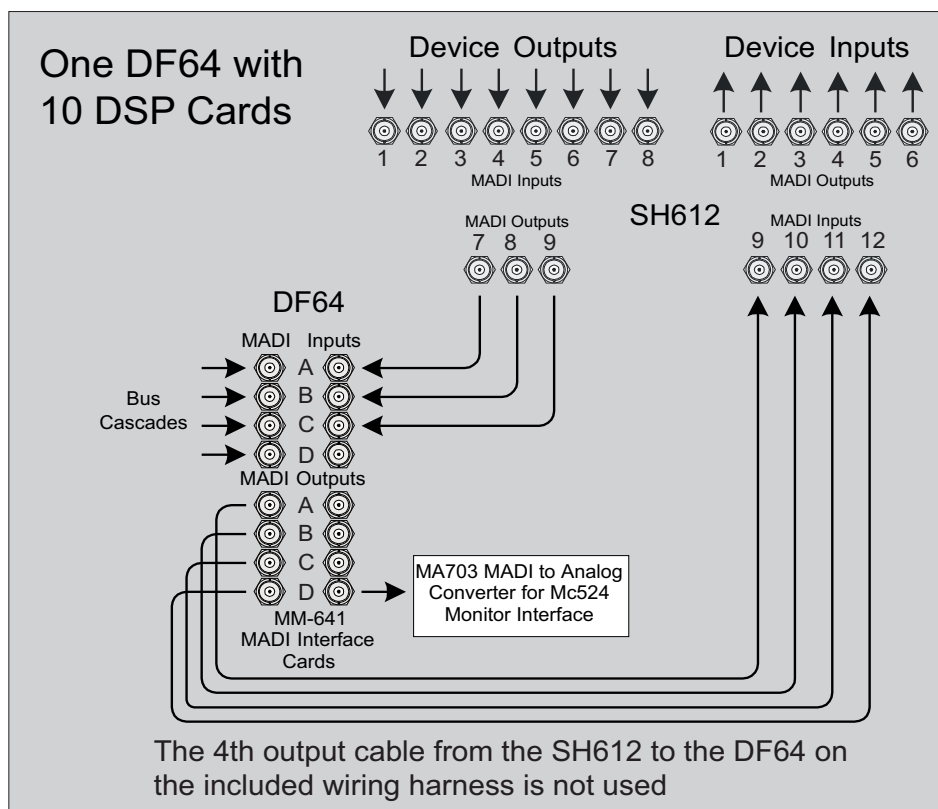
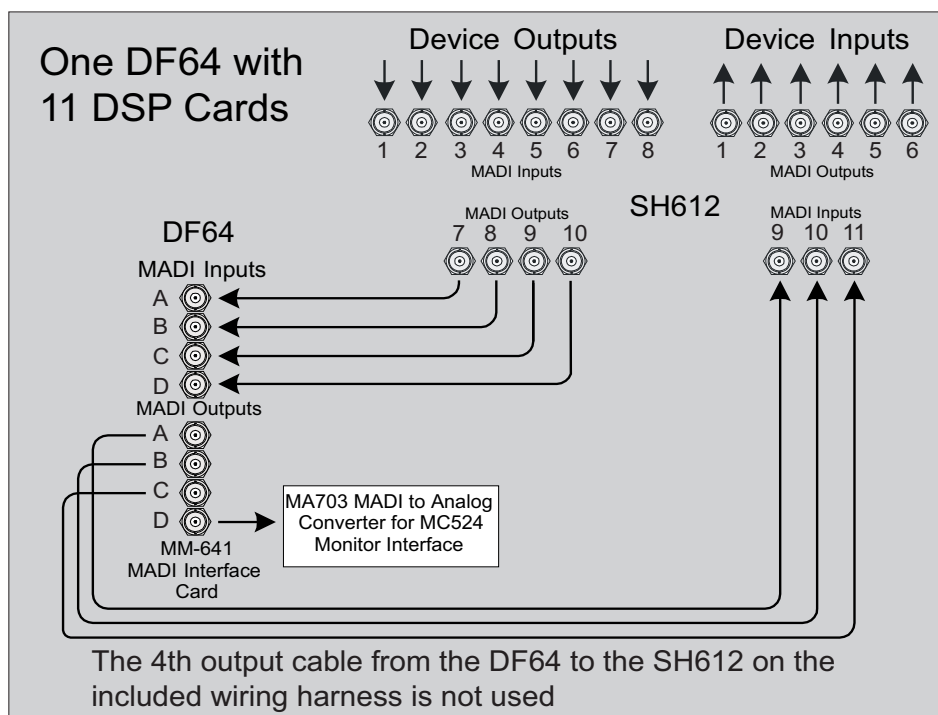

Figure 2-11 MADI hookup: one DF64 core, 10 or 11 DSP cards, one SH612

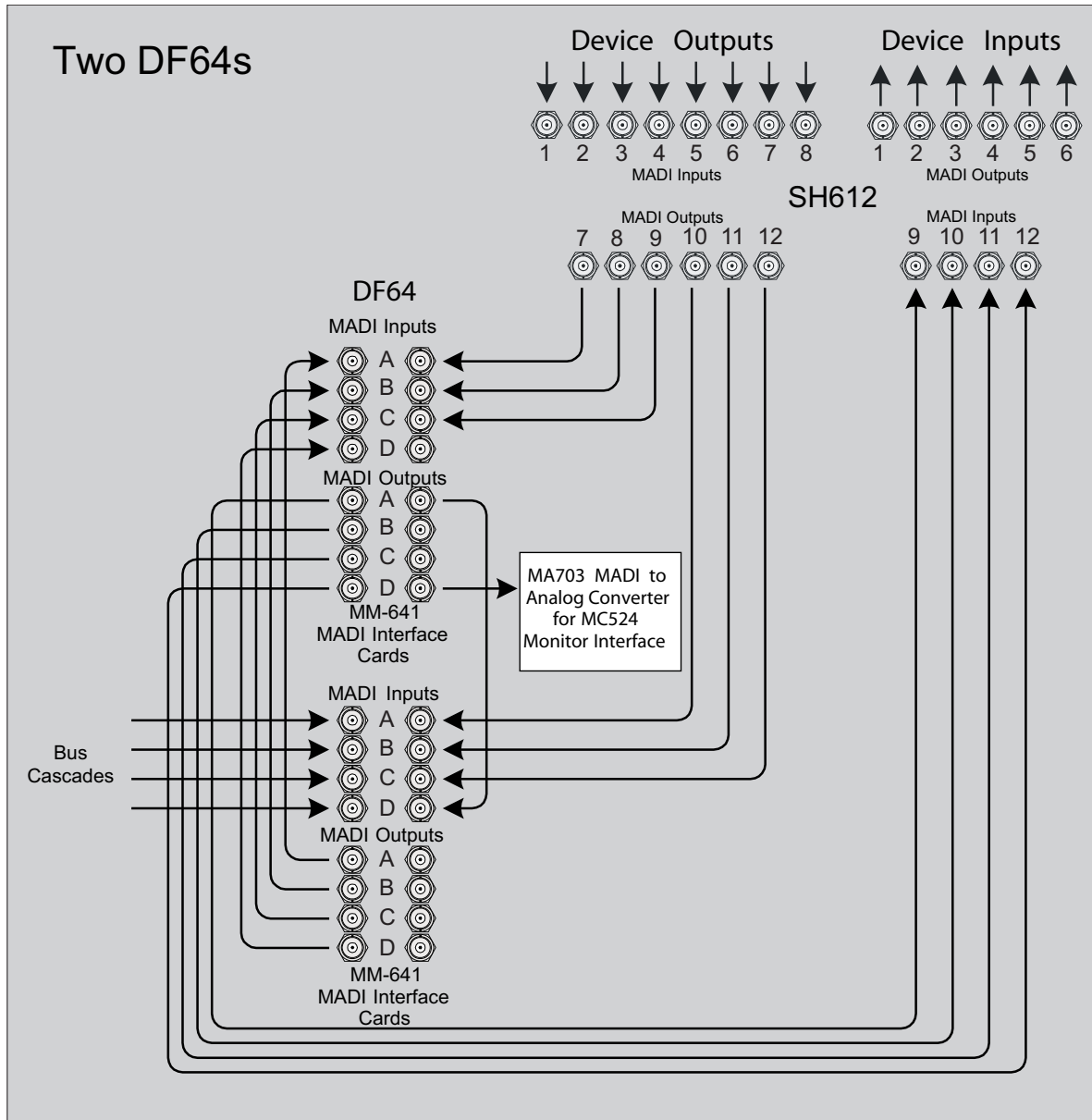

Figure 2-12 MADI hookup for two DF64 cores and one SH612 Studio Hub

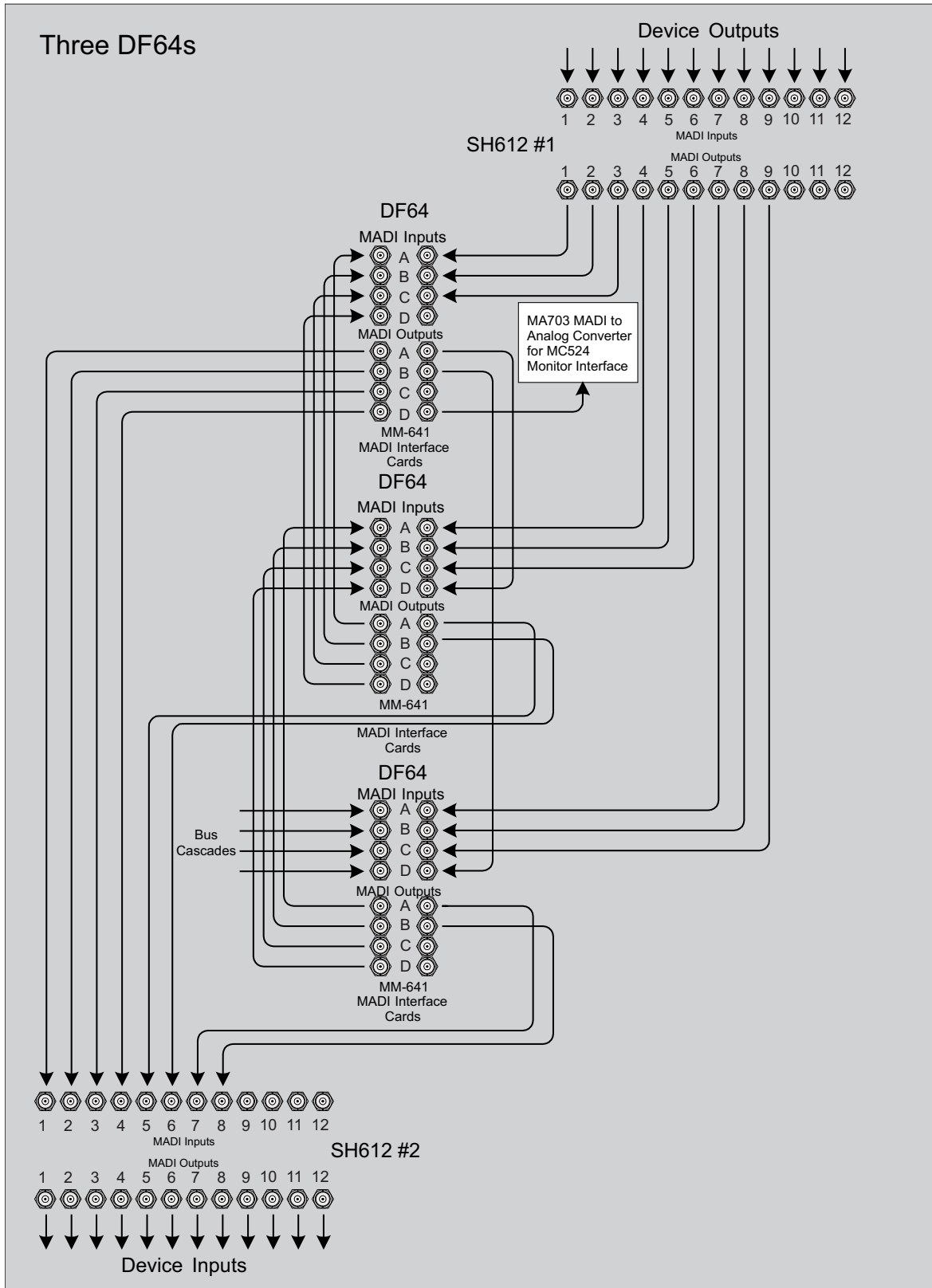

Figure 2-13 MADI hookup for three DF64 cores and two SH612 Studio Hubs

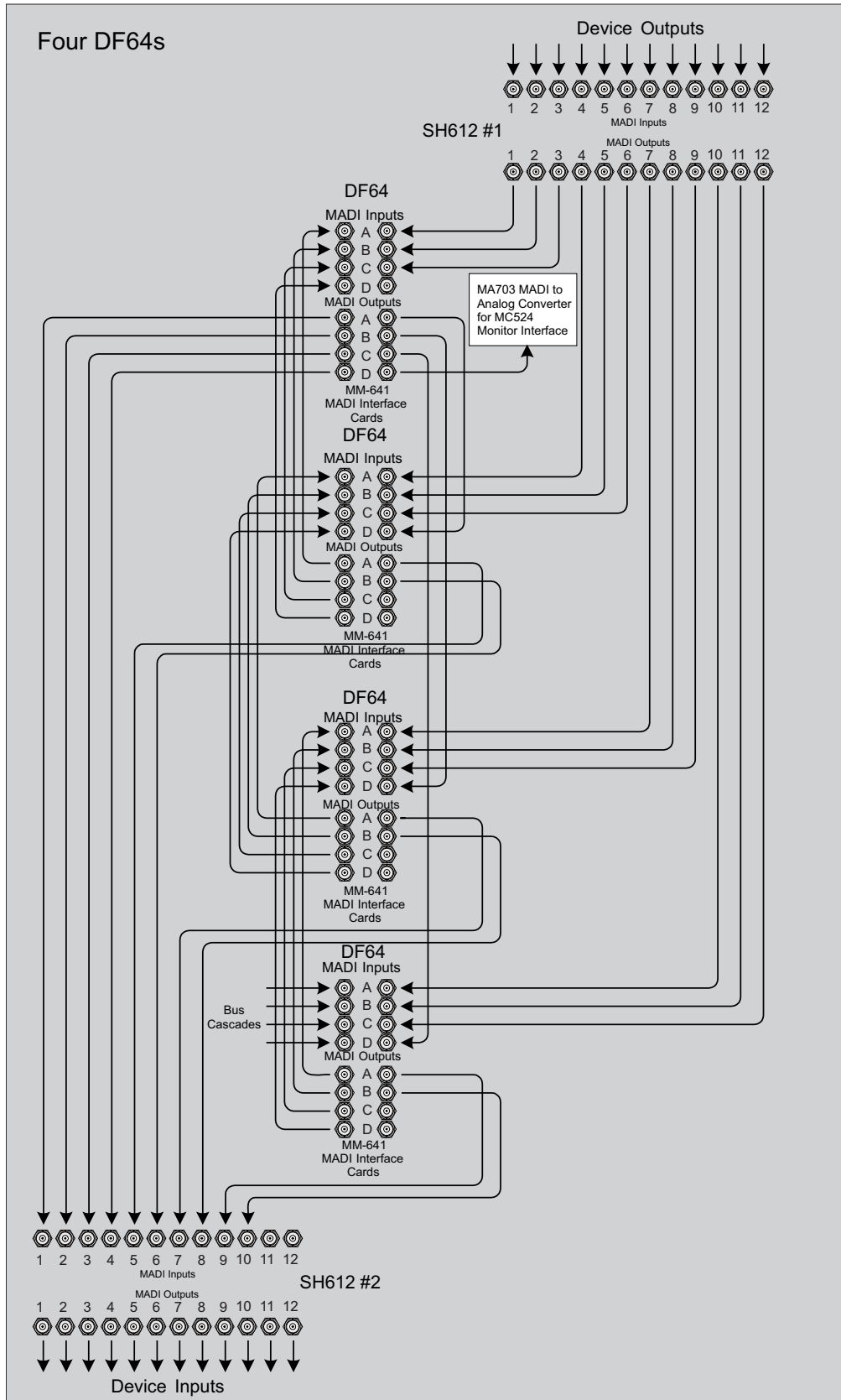

Figure 2-14 MADI hookup for four DF64 cores and two SH612 Studio Hubs

Control Hookup

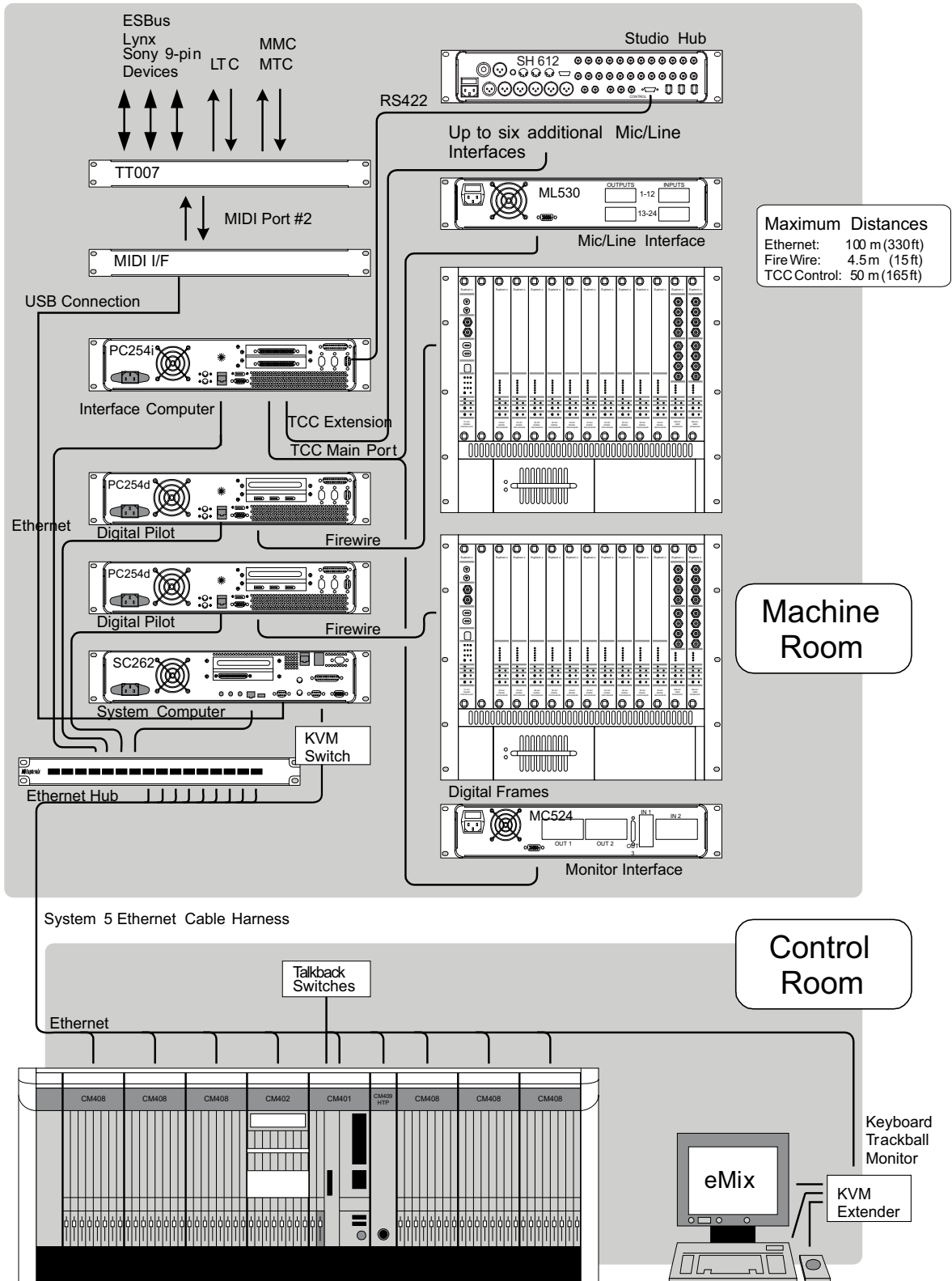

Figure 2-15 Control Hookup

Chapter 3: System 5 Components

This chapter discusses the System 5 components and all connectors necessary for operation. Pinouts for user-wired connections are shown for each component, along with the cables and connectors provided by Euphonix.

DF64 Digital Frame

The DF64 contains three types of cards: FC631 Frame Controller, MM641 MADI Interface, and SP661 Signal Processor (all three shown in Figure 3-2).

Power Connectors (IEC): Accepts two standard IEC power cords (provided). Two autoranging switching supplies accept voltages between 100–240 VAC, 50–60 Hz.

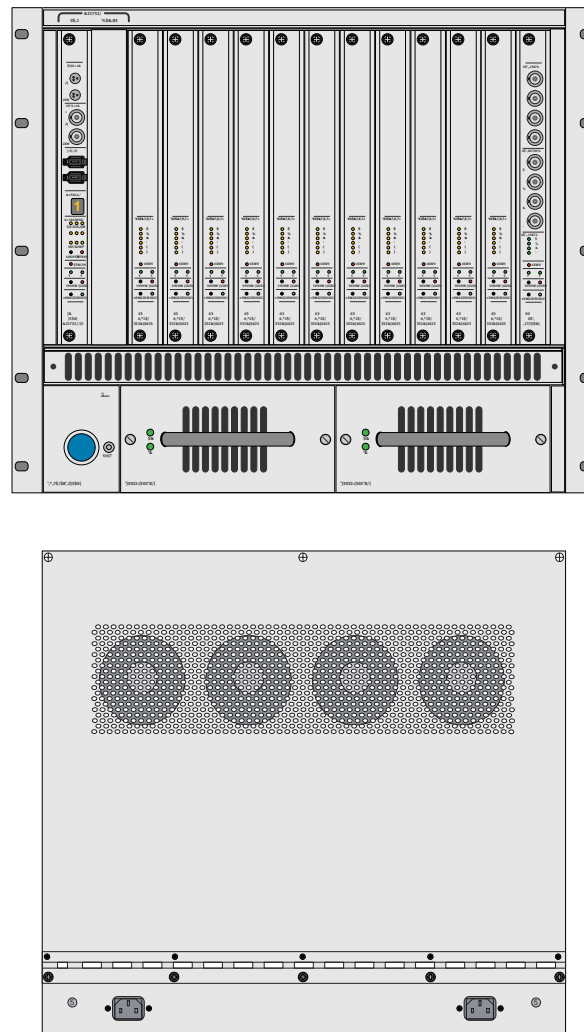

Figure 3-1 DF64 Digital Frame Front and Rear Panels

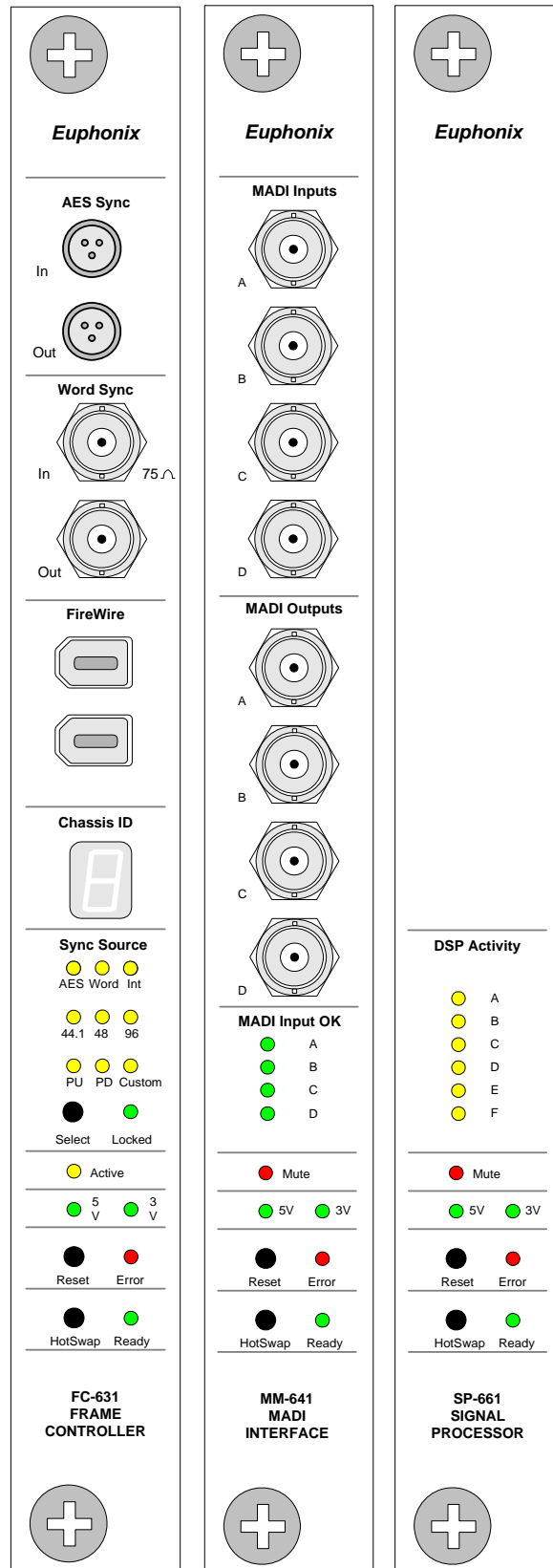

Figure 3-2 FC631, MM641, and SP661 Cards

FC631 Frame Controller

AES Sync In (3-pin Lemo Female): The DF64 Digital Frame clocks to the signal at this port when the sync source is set to AES Sync. Connect this port to a digital sync reference.

AES Sync Out (3-pin Lemo Male): This signal is active regardless of the selected sync source.

Word In (BNC): The DF64 clocks to the signal at this port when the sync source is set to Word Clock. Connect this port to a digital sync reference.

Word Out (BNC): This signal is active regardless of selected sync source.

IEEE 1394 ports (2 ports, 6-pin IEEE 1394): High speed communication interface to the PC254d Digital Pilot Computer. This interface carries real-time control and metering data between the PC254d and the DF64. Connect either port to any of the IEEE 1394 ports on the dedicated PC254d for this frame via provided IEEE-1394 (Firewire) cables.

MM641 MAD I Interface Card

MADI In (4) and **MADI Out** (4) (8 BNC): Digital audio in and outs. See the MADI Hookup diagrams beginning on page 26 for details on these connections.

SP661 Signal Processor

This card has no connections.

System 5 Console

The System 5 Console consists of several modular components: the CM401 and CM402 (console center section), the CM408 (contains eight physical faders and controls), the CM403 (contains the joystick panner panel and film monitor panel), and the CM409HTP Track Panner Module. Each component has the following connections:

Power Connectors (IEC): Accepts two standard IEC power cords (provided). Two autoranging switching supplies accept voltages between 100–240 VAC, 50–60 Hz.

Power Status (DE-9): Offers two open-collector, optically-isolated power status feeds. Pins 1/2 reference the primary power supply, and pins 3/4 the secondary. These outputs are capable of switching a maximum of 20 mA at 24 VDC.

Network Port (RJ45): Connect to EuCon Network Hub via RJ45 through the console ethernet harness (provided).

Expansion Port (DB-25): Active on the CM401 only. Connect talkback switches here.

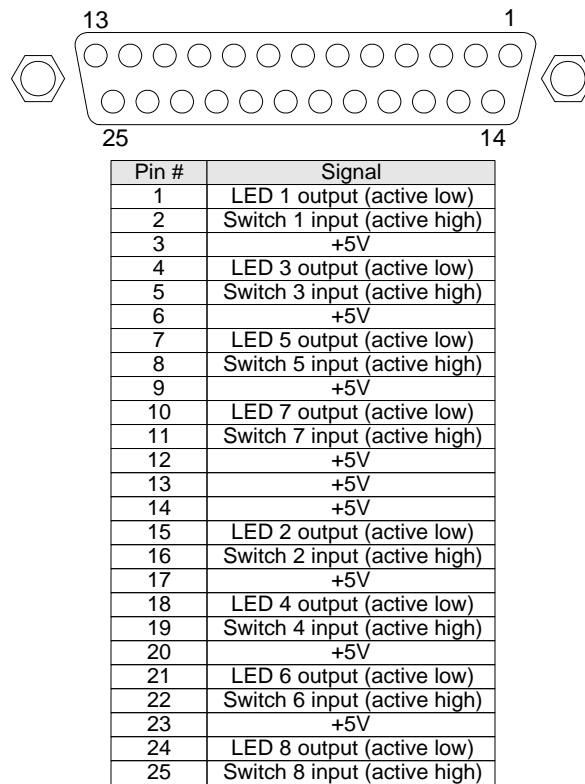

Figure 3-3 CM401 Expansion Port: DB-25 Female pinout

Table 3-1 Switch Functions

Function	Switch	Talley
Talkback to Mon A (SLS)	Switch 1 (pin 2)	LED 1 (pin 1)
Talkback to Mon B (Cue 1)	Switch 2 (pin 16)	LED 2 (pin 15)
Talkback to Mon C (Cue 2)	Switch 3 (pin 5)	LED 3 (pin 4)
Talkback to Mon D (Cue 3)	Switch 4 (pin 19)	LED 4 (pin 18)

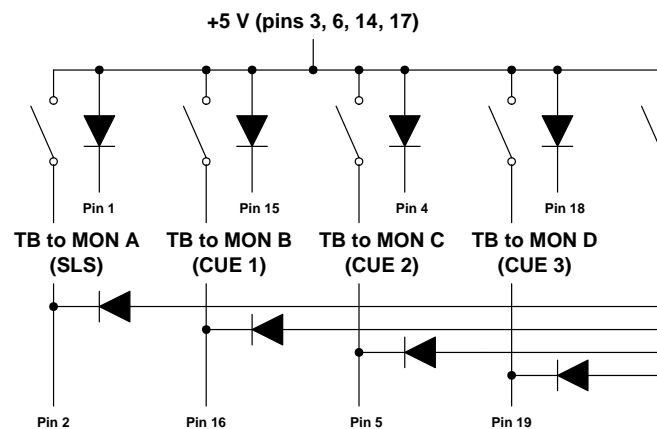

Figure 3-4 Typical Talkback Wiring

SC262 System Computer

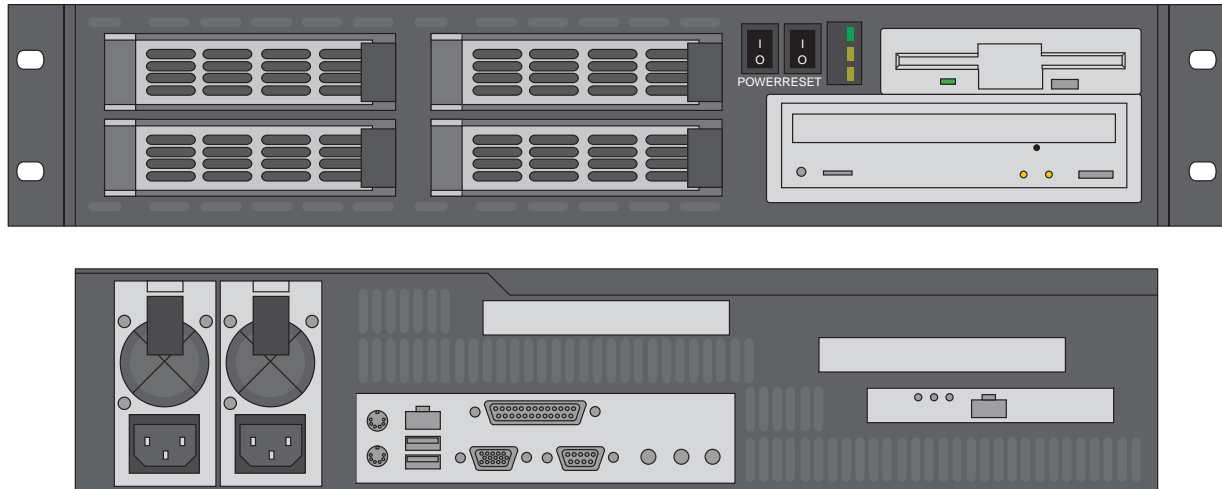

Figure 3-5 SC262 Front and Rear Panels

VGA Connector (DA-15): Main video monitor connection.

Keyboard (PS/2): Main keyboard connection.

Mouse (PS/2): Main trackball connection.

Serial Port 1 (DE-9): Touchscreen control connection.

Connect the machine room KVM extender to the VGA, keyboard, and mouse connectors on the rear panel of the SC262. A second KVM extender is located at the console. The KVM extenders are connected by a single cable built into the console ethernet harness (provided).

LAN Port 1 (Onboard RJ45): Connect to EuCon Network Switch via RJ45 (provided).

LAN Port 2 (Auxiliary RJ45): Optional connection for external network.

Power Connectors (IEC): Accepts two standard IEC power cords (provided). Two autoranging switching supplies accept voltages between 100–240 VAC, 50–60 Hz.

PC254d Digital Pilot Computer

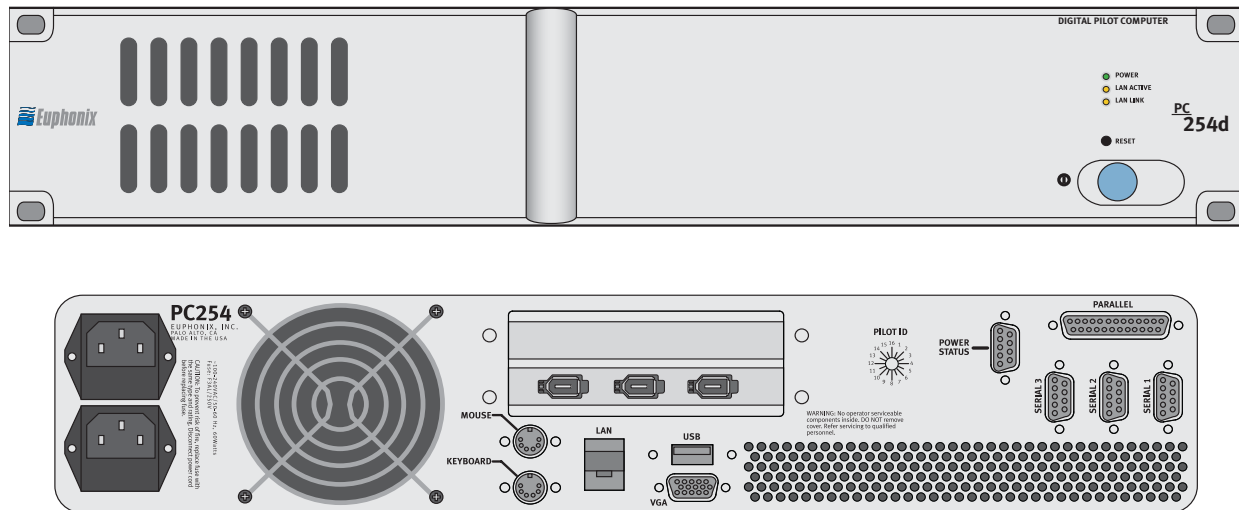

Figure 3-6 PC254d Front and Rear Panels

IEEE 1394 Ports (3 6-pin IEEE 1394 connectors): Connect any port to IEEE 1394 connector on the FC631 card in the respective DF64 via provided IEEE 1394 cables (Firewire).

Network Port (RJ45): Connect to EuCon Network Switch via RJ45 (provided).

Power Connectors (IEC): Accepts two standard IEC power cords (provided). Two autoranging switching supplies accept voltages between 100–240 VAC, 50–60 Hz.

Power Status (DE-9): Offers two open-collector, optically-isolated power status feeds. Pins 1/2 reference the primary power supply, and pins 3/4 the secondary. These outputs are capable of switching a maximum of 20 mA at 24 VDC.

PC254i Interface Computer

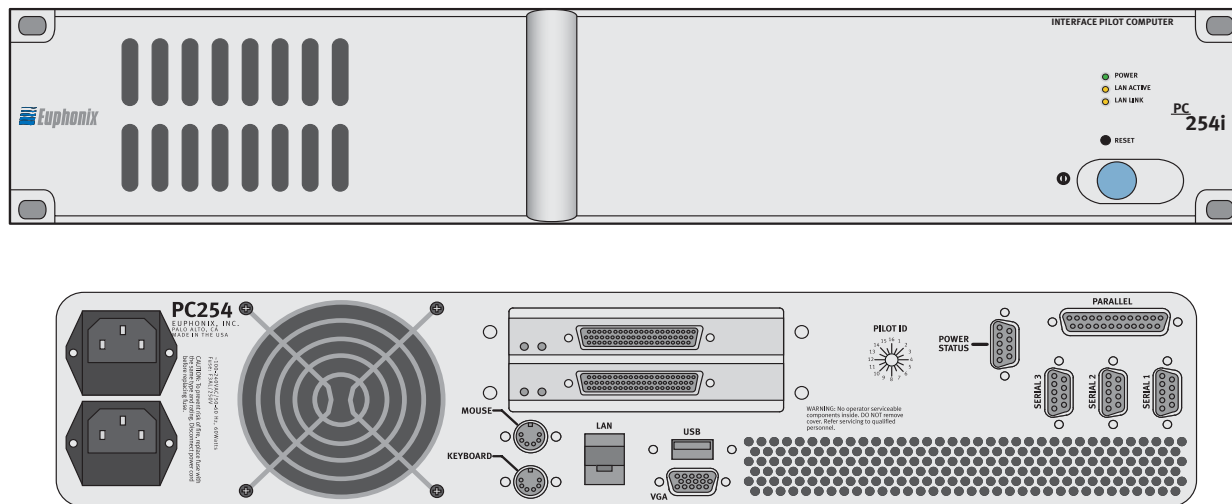

Figure 3-7 PC254i Front and Rear Panels

Parallel Port (DB-25): Currently unused..

TCC Main Port (Lower DC-62HD): Connect TCC breakout cable (provided) to this port. This cable breaks out to four DB-15 connectors that provide control hookup for the MC524 Monitor Interface and three ML530 Mic/Line Interfaces.

TCC Extension Port (Upper DC-62HD): Connect a second TCC breakout cable (provided) to this port to connect up to four additional ML530 Mic/Line Interfaces.

Network Port (RJ45): Connect to the EuCon Network Switch via the RJ45 cable (provided).

Serial Port 1 (DE-9): Connect to control port on first SH612.

Serial Port 2 (DE-9): Connect to control port on second SH612 (optional)

Power Connectors (IEC): Accepts two standard IEC power cords (provided). Two autoranging switching supplies accept voltages between 100–240 VAC, 50–60 Hz.

Power Status (DE-9): Offers two open-collector, optically-isolated power status feeds. Pins 1/2 reference the primary power supply, and pins 3/4 the secondary. These outputs are capable of switching a maximum of 20 mA at 24 VDC.

USB Port (any): Connect to MOTU MIDI I/F via USB A-to-B cable.

MC524 Monitor Interface

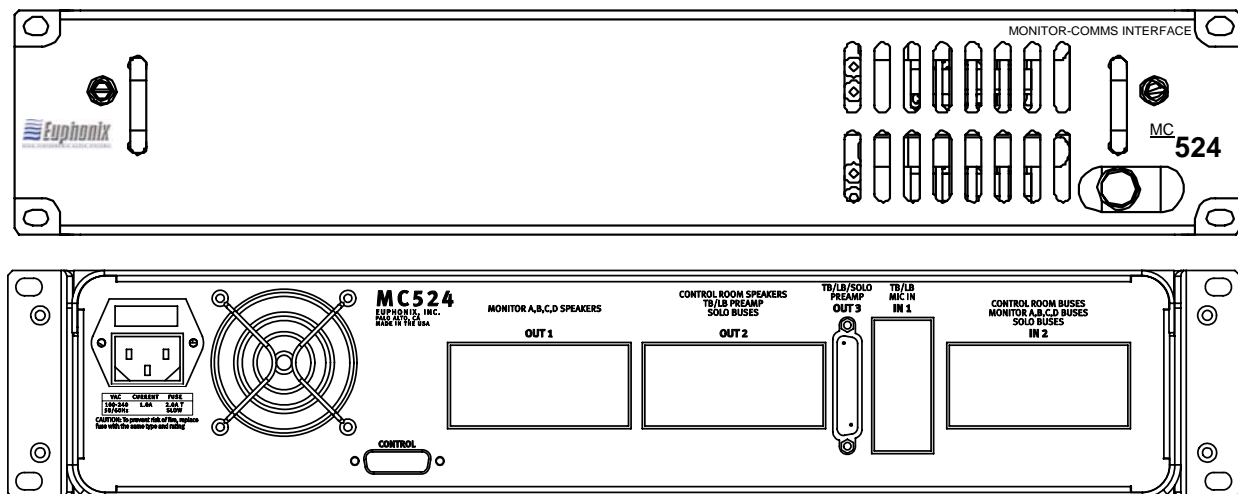

Figure 3-8 MC524 Front and Rear Panels

Power Switch: Powers the unit off/on.

In 1 (38-pin ELCO): Talk Back, Listen Back and Mic inputs. This connector receives four stereo listen channels and two stereo talk mic inputs. Signals can be boosted or attenuated. In a standard patch configuration, input cable fans out to 12 female XLRs.

In 2 (90-pin ELCO): Control Room Buses, Monitor A, B, C, D, and Solo buses inputs. This connector receives eight Monitor A channels, and two channels each for Monitor B, C, D. These signals can be attenuated only and are typically fed from the AM713.

Out 1 (90-pin ELCO): Monitor A, B, C, D Speaker outputs. This connector outputs eight Control Room channels, eight Monitor A channels, and two channels each for Monitor B, C, D, and Solo. The output cable fans out to two 38-pin ELCO/Edak connectors for the Euphonix Patchbay.

Out 2 (90 pin ELCO): Control Room Speakers, Talk Back and Listen Back Preamp, and Solo Buses outputs. This connector outputs eight Control Room Main channels, six Control Room Alt 1 channels, two Control Room Alt 2 channels, four Listen pre, two talk pre and two Solo channels. The output cable fans out to two 38-pin ELCO/Edak connectors for the Euphonix Patchbay.

Out 3 (female DB-25): Talk Back, Listen Back, and Solo Preamp outputs. This connector outputs four Listen pre, two Talk Back pre and two Solo channels. Output cable fans out to eight male XLRs.

Control (DA-15): Input for digital control signal from Digital Pilot (Euphonix TCC bidirectional serial protocol). All patching, switching, and gain controls are communicated via this connection as well as MC524 IP address.

AC Line In (IEC) and **Fuse Tray**: Accepts standard IEC power cord (provided). An autoranging switching supply accepts voltages between 90–250 VAC, 50–60 Hz.

Input/Output Connections

Table 3-2 In 1 Elco 38 Pinout

Crk #	Designator	24 X 32	High	Low	Gnd
1	M1	Talk 1	A	E	L
2	M2	Talk 2	B	F	M
3	M3	Listen 1	C	H	N
4	M4	Listen 2	D	J	P
5	M5	Listen 3	DD	JJ	PP
6	M6	Listen 4	EE	KK	RR
7			FF	LL	SS
8			HH	MM	TT
9			R	S	V
10			T	U	W
11			X	Z	AA
12			Y	BB	CC

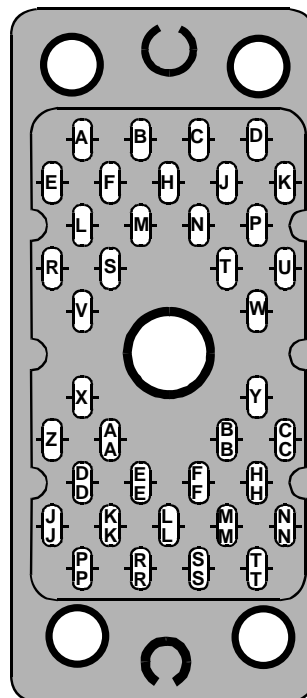

Figure 3-9 Elco 38 Connector

Table 3-3 In 2 Elco 90 Pinout

Crk #	Designator	24 X 32	High	Low	Gnd
1	L3	Cntrl Rm (L)	A	H	R
2	L4	Cntrl Rm (C)	B	J	S
3	L5	Cntrl Rm (R)	C	K	T
4	L6	Cntrl Rm (Si)	D	L	U
5	L7	Cntrl Rm (Sr)	E	M	V
6	L8	Cntrl Rm (B)	F	N	W
7	L9	Cntrl Rm (Li)	X	AE	AM
8	L10	Cntrl Rm (Ri)	Y	AF	AN
9	L11	Mon A (L)	Z	AH	AP
10	L12	Mon A (C)	AA	AJ	AR
11	L13	Mon A (R)	AB	AK	AS
12	L14	Mon A (Si)	AC	AL	AT
13	L15	Mon A (Sr)	BJ	BS	BY
14	L16	Mon A (B)	BK	BT	BZ
15	L17	Mon A (Li)	BL	BU	CA
16	L18	Mon A (Ri)	BM	BV	CB
17	L19	Mon B (L)	BN	BW	CC
18	L20	Mon B (R)	BP	BX	CD
19	L21	Mon C (L)	CF	CN	CW
20	L22	Mon C (R)	CH	CP	CX
21	L23	Mon D (L)	CJ	CR	CY
22	L24	Mon D (R)	CK	CS	CZ
23	L1	Solo (L)	CL	CT	DA
24	L2	Solo (R)	CM	CU	BD

**Figure 3-10 Elco 90 Connector**

Table 3-4 Out 1 Elco 90 Pinout

Crk #	Designator	24 X 32	High	Low	Gnd
1	BO11	Mon A (L)	A	H	R
2	BO12	Mon A (C)	B	J	S
3	BO17	Mon A (R)	C	K	T
4	BO18	Mon A (Sl)	D	L	U
5	BO19	Mon A (Sr)	E	M	V
6	BO20	Mon A (B)	F	N	W
7	BO21	Mon A (Li)	X	AE	AM
8	BO22	Mon A (Ri)	Y	AF	AN
9	BO23	Mon B (L)	Z	AH	AP
10	BO24	Mon B (R)	AA	AJ	AR
11	BO25	Mon C (L)	AB	AK	AS
12	BO26	Mon C (R)	AC	AL	AT
13	BO27	Mon D (L)	BJ	BS	BY
14	BO28	Mon D (R)	BK	BT	BZ
15			BL	BU	CA
16			BM	BV	CB
17			BN	BW	CC
18			BP	BX	CD
19			CF	CN	CW
20			CH	CP	CX
21			CJ	CR	CY
22			CK	CS	CZ
23			CL	CT	DA
24			CM	CU	BD

**Figure 3-11 Elco 90 Connector**

Table 3-5 Out 2 Elco 90 Pinout

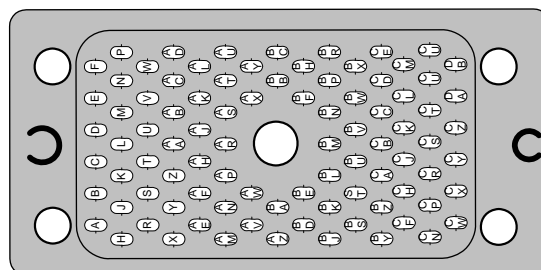
Crk #	Designator	24 X 32	High	Low	Gnd
1	BO31	Solo L	A	H	R
2	BO32	Solo R	B	J	S
3	TL1	Talk 1	C	K	T
4	TL2	Talk 2	D	L	U
5	TL3	Listen 1	E	M	V
6	TL4	Listen 2	F	N	W
7	TL5	Listen 3	X	AE	AM
8	TL6	Listen 4	Y	AF	AN
9	BO3	CR main (L)	Z	AH	AP
10	BO4	CR main (C)	AA	AJ	AR
11	BO5	CR main (R)	AB	AK	AS
12	BO6	Cntrl Rm (Sl)	AC	AL	AT
13	BO7	Cntrl Rm (Sr)	BJ	BS	BY
14	BO8	CR main (B)	BK	BT	BZ
15	BO9	CR main (Li)	BL	BU	CA
16	BO10	CR main (Ri)	BM	BV	CB
17	BO13	CR Alt 1 (L)	BN	BW	CC
18	BO14	CR Alt 1 (C)	BP	BX	CD
19	BO15	CR Alt 1 (R)	CF	CN	CW
20	BO16	CR Alt 1 (Sl)	CH	CP	CX
21	BO29	CR Alt 1 (Sr)	CJ	CR	CY
22	BO30	CR Alt 1 (B)	CK	CS	CZ
23	BO1	CR Alt 2 (L)	CL	CT	DA
24	BO2	CR Alt 2(R)	CM	CU	BD

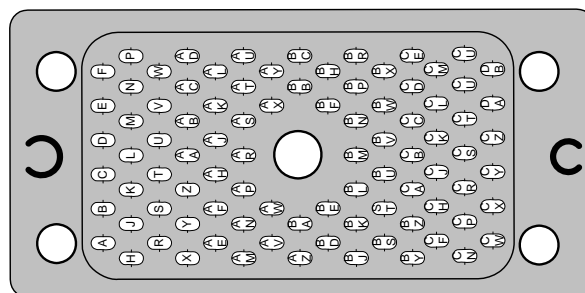
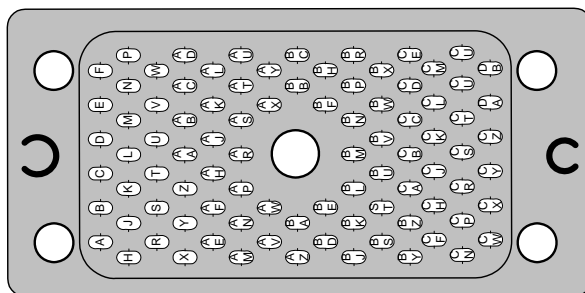
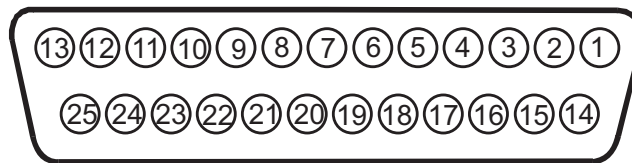

Figure 3-12 Elco 90 Connector

Table 3-6 Out 3 DB-25 Pinout

Crk #	Designator	24 X 32	High	Low	Gnd
1		T1	24	12	25
2		T2	10	23	11
3		L1	21	9	22
4		L2	7	20	8
5		L3	18	6	19
6		L4	4	17	5
7		Solo L	15	3	16
8		Solo R	1	14	2

**Figure 3-13** DB-25 Connector

ML530 Mic/Line Interface

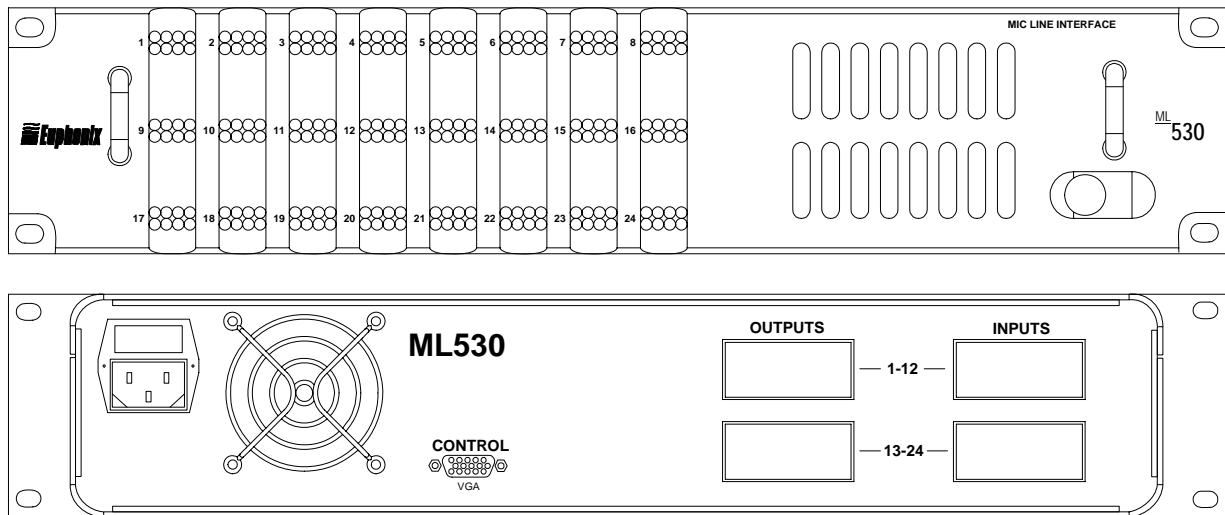

Figure 3-14 ML530 Front and Rear Panels

Inputs (two 38-pin ELCO sockets): A total of 24 microphone inputs are received on two 38-pin ELCO connectors (connectors and pins provided).

Outputs (two 38-pin ELCO sockets): A total of 24 outputs are provided on two 38-pin ELCO connectors. These outputs feed an AM713 Analog to MADI Converter (a 24 male XLR to 38-pin ELCO cable is provided).

Control (DA-15): Connect to PC254d Digital Pilot Computer via TCC breakout cable (provided). All patching, switching and gain controls are communicated via this connection.

AC Line In (IEC) and **Fuse Tray**: Accepts standard IEC power cord (provided). An autoranging switching supply accepts voltages between 90–250 VAC, 50–60 Hz.

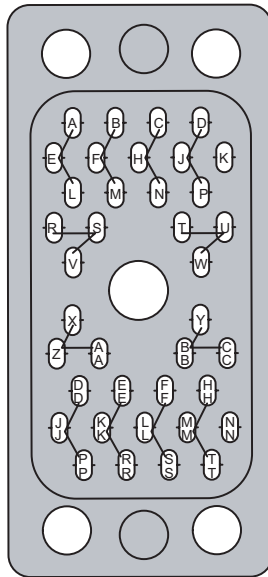

Num	Signal	Wiring Instruction & Description	+	-	G
1	Mic In 1 / Mic In 13	From studio Mic 1 / 13	A	E	L
2	Mic In 2 / Mic In 14	From studio Mic 2 / 14	B	F	M
3	Mic In 3 / Mic In 15	From studio Mic 3 / 15	C	H	N
4	Mic In 4 / Mic In 16	From studio Mic 4 / 16	D	J	P
5	Mic In 5 / Mic In 17	From studio Mic 5 / 17	DD	JJ	PP
6	Mic In 6 / Mic In 18	From studio Mic 6 / 18	EE	KK	RR
7	Mic In 7 / Mic In 19	From studio Mic 7 / 19	FF	LL	SS
8	Mic In 8 / Mic In 20	From studio Mic 8 / 20	HH	MM	TT
9	Mic In 9 / Mic In 21	From studio Mic 9 / 21	R	S	V
10	Mic In 10 / Mic In 22	From studio Mic 10 / 22	T	U	W
11	Mic In 11 / Mic In 23	From studio Mic 11 / 23	X	Z	AA
12	Mic In 12 / Mic In 24	From studio Mic 12 / 24	Y	BB	CC

Figure 3-15 ML530 In 1/In 2 Pinout: Elco 38 Socket

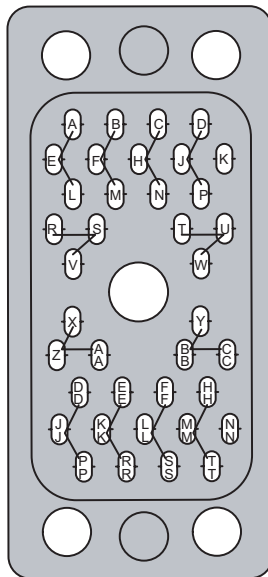

Num	Signal	Wiring Instruction & Description	+	-	G
1	Mic Pre Out 1 / Out 13	To AM713 Analog In 1 / In 13	A	E	L
2	Mic Pre Out 2 / Out 14	To AM713 Analog In 2 / In 14	B	F	M
3	Mic Pre Out 3 / Out 15	To AM713 Analog In 3 / In 15	C	H	N
4	Mic Pre Out 4 / Out 16	To AM713 Analog In 4 / In 16	D	J	P
5	Mic Pre Out 5 / Out 17	To AM713 Analog In 5 / In 17	DD	JJ	PP
6	Mic Pre Out 6 / Out 18	To AM713 Analog In 6 / In 18	EE	KK	RR
7	Mic Pre Out 7 / Out 19	To AM713 Analog In 7 / In 19	FF	LL	SS
8	Mic Pre Out 8 / Out 20	To AM713 Analog In 8 / In 20	HH	MM	TT
9	Mic Pre Out 9 / Out 21	To AM713 Analog In 9 / In 21	R	S	V
10	Mic Pre Out 10 / Out 22	To AM713 Analog In 10 / In 22	T	U	W
11	Mic Pre Out 11 / Out 23	To AM713 Analog In 11 / In 23	X	Z	AA
12	Mic Pre Out 12 / Out 24	To AM713 Analog In 12 / In 24	Y	BB	CC

Figure 3-16 ML530 Out 1/Out 2 Pinout: Elco 38 Socket

SH612 Studio Hub

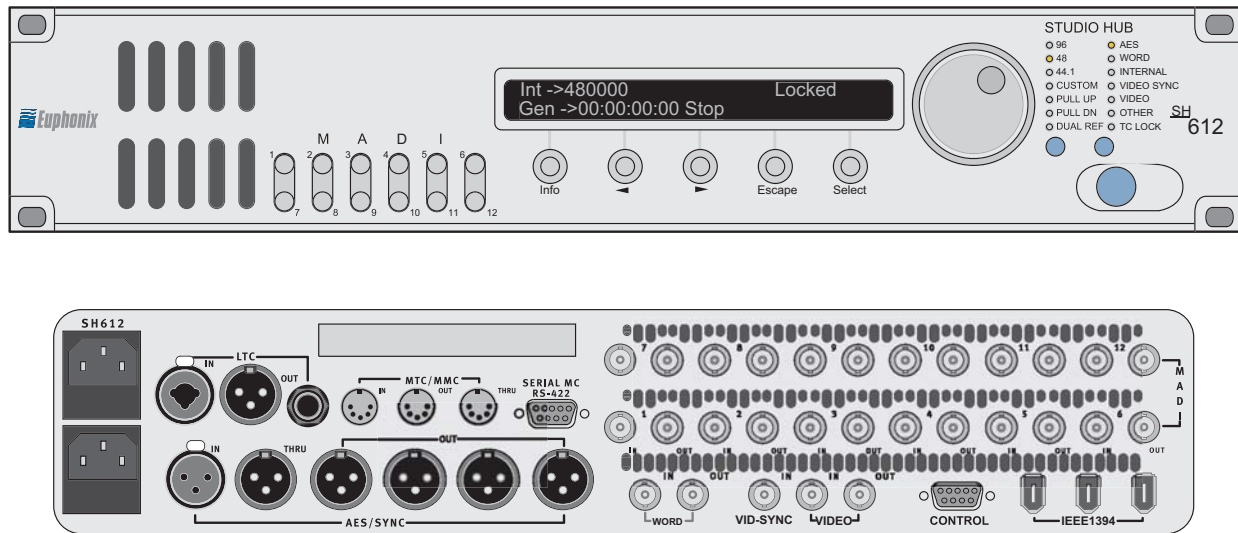

Figure 3-17 SH612 Studio Hub

Video In (BNC): Accepts signal from house blackburst or composite sync.

AES Sync In (female XLR): Accepts signal from a digital sync reference.

AES Sync Out Ports (four male XLR): This signal is active regardless of selected sync source.

Word In (BNC): Accepts signal from a digital sync reference.

Word Out (BNC): This signal is active regardless of selected sync source.

MADI In / Out Ports (24 BNC): Digital audio in and outs. See the MADI Hookup diagrams (beginning on page 26) for details on these connections.

Control Port (DE-9): Connect to Serial Port 1 on PC254i Interface Computer.

Power Connectors (IEC): Accepts two standard IEC power cords (provided). Two autoranging switching supplies accept voltages between 100–240 VAC, 50–60 Hz.

NOTE: The connections described above pertain only to a System 5 console configuration. The other connections on the SH612 are used when installed with the now-discontinued R-1 Digital Audio Multitrack Recorder.

AM713 Analog to MADI Converter

Front Panel



Figure 3-18 AM713 Front Panel

Signal Strength LEDs: Each of the 28 channels has a four-segment LED that represents the following signal levels: -42 dB, -18 dB, -6 dB (green), -0.05 dB (red).

Trim Pots Access: Three trim pots adjust the maximum analog input level of channels 1–8, 9–16, and 17–24 in 2-dB steps between +12 and +26 dBu.

SR Conv: This indicates sample-rate conversion activity on the auxiliary digital inputs.

Sample Rate LEDs: These LEDs indicate the sample rate to which the converter is currently locked. Sample rates are auto-sensed but can be manually selected on the AM713. Supported sample rates are 96 kHz, 88.2 kHz, 48 kHz, 44.1 kHz, and Custom rates from external sources.

Sample Rate Source LEDs: These LEDs indicate the format of the Sample Rate Source to which the converter is currently locked. Sample Rate Source can be auto-sensed or manually selected. If an external source is not detected, the AM713 reverts to Internal sync. If a manually selected source is not present, the Sample Rate Source indicator blinks.

- **AES:** Sample Rate locked to AES Input.
- **Word:** Sample Rate locked to Word Clock Input.
- **Internal:** Sample Rate locked to its own internal crystal.
- **Auto:** Sample Rate Source has been auto-sensed.

These LEDs appear in the same order in which signals are tested for their presence. This detection procedure occurs when the converters are powered on. The Sample Rate and Sample Rate Source can also be selected manually.

Manual Selection Buttons: The button below each Sample Rate LED row manually selects the sample rate. Also allows manual selection of the Sample Rate Source.

Power Switch: On/Off switch.

Rear Panel

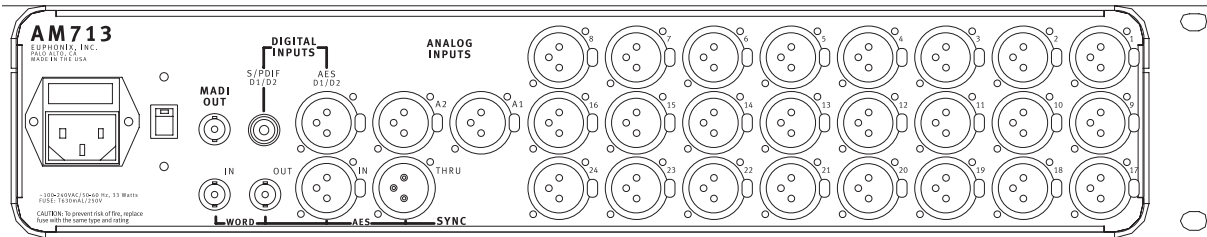

Figure 3-19 AM713 Rear Panel

Input Voltage Selector: This red switch allows operation in either 100/110/115 VAC or 220/230/240 VAC environments. A fuse must also be changed for 220/230/240 VAC operation. Units are shipped set and fused for 100/110/115 VAC.

Power Connector (IEC) and Fuse Tray: The IEC power connector accepts standard IEC power cords. The fuse tray contains both the active fuse and a spare for 220/230/240 VAC operation.

Analog Inputs (female XLR): 24 balanced, analog inputs on XLR connectors. Input sensitivity is set from the front panel.

Auxiliary Analog Inputs (female XLR): Two balanced analog inputs on XLR connectors. Input sensitivity is set from the front panel.

AES/EBU Digital Input (female XLR): Stereo AES/EBU digital input on one XLR connector. Functions in parallel with the auxiliary S/PDIF input and the two inputs should not be used simultaneously.

S/PDIF Digital Input (RCA): Stereo S/PDIF digital input on one RCA connector. Functions in parallel with the auxiliary AES/EBU input and the two inputs should not be used simultaneously.

AES Sync In (female XLR): Master clock input for the converter when using AES as Sample Rate Source.

AES Sync Thru (male XLR): Outputs the same signal connected to AES Sync In.

Word In (BNC): Master clock input for the converter when using Word Clock as Sample Rate Source.

Word Out (BNC): Outputs a Word clock signal synchronized to the Sample Rate Source. In the presence of an external Word clock input, this connector provides a regenerated version of that input signal. Without an external sample rate source, this connector outputs the internally generated clock signal.

MADI Out (BNC): Outputs the digital audio signal.

- **1–24:** Analog inputs
- **25–26:** Aux analog inputs
- **27–28:** Aux digital inputs

NOTE: 28 channels are always transmitted; dual channels are not used.

Trim Pots: Four detented trim pots, accessed from the front panel, adjust the analog input level of channels 1–8, 9–16, 17–24, and auxiliary analog in 3 dB steps between +6 and +27 dBU.

MA703 MADI to Analog Converter

Front Panel



Figure 3-20 MA703 Front Panel

Signal Strength LEDs: Each of the 28 channels has a four-segment LED that represents the following signal levels: -42 dB, -18 dB, -6 dB (green), -0.05 dB (red).

Trim Pots Access: Three trim pots adjust the maximum analog output level of channels 1–8, 9–16, and 17–24 in 2-dB steps between +12 and +26 dBu.

SR Conv: This indicates sample-rate conversion activity on the auxiliary digital inputs.

Sample Rate LEDs: These LEDs indicate the sample rate to which the converter is currently locked. Sample rates are auto-sensed. Supported sample rates are 96 kHz, 88.2 kHz, 48 kHz, 44.1 kHz, and Custom rates from external sources.

Sample Rate Source LEDs: These LEDs indicate the format of the Sample Rate Source to which the converter is currently locked. Sample Rate Source can be auto-sensed or manually selected. If an external source is not detected, the MA703 mutes its outputs. If a manually selected source is not present, the Sample Rate Source indicator blinks.

- **AES:** Sample Rate locked to AES Input.
- **Word:** Sample Rate locked to Word Clock Input.
- **MADI:** Sample Rate locked to MADI.
- **Auto:** Sample Rate Source has been auto-sensed.

These LEDs appear in the same order in which signals are tested for their presence. This detection procedure occurs when the converters are powered on. The Sample Rate Source can also be selected manually.

Manual Selection Buttons: The button below each Sample Rate LED row manually selects the sample rate.

Power Switch: On/Off switch.

Rear Panel

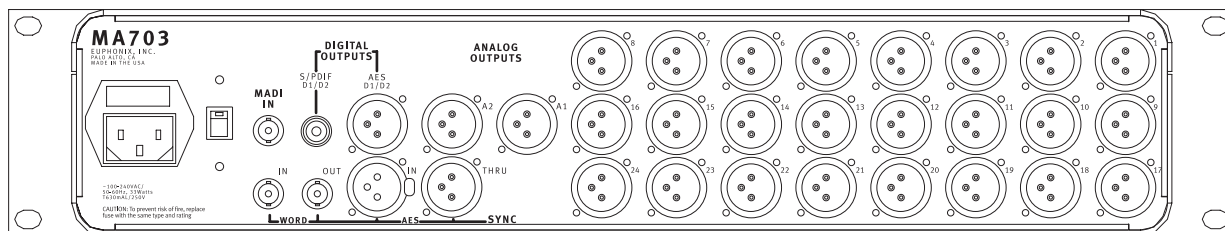

Figure 3-21 MA703 Rear Panel

Input Voltage Selector: This red switch allows operation in either 100/110/115 VAC or 220/230/240 VAC environments. A fuse must also be changed for 220/230/240 VAC operation. Units are shipped set and fused for 100/110/115 VAC.

Power Connector (IEC) and Fuse Tray: The IEC power connector accepts standard IEC power cords. The fuse tray contains both the active and spare fuses.

Analog Outputs (male XLR): 24 balanced analog outputs on XLR connectors. Output level is set from the front panel.

Auxiliary Analog Outputs (male XLR): Two balanced analog outputs on XLR connectors. Output level can be set from the front panel.

AES/EBU Digital Outputs (male XLR): Stereo AES/EBU digital outputs on one XLR connector. Functions in parallel with the auxiliary S/PDIF output and the two inputs should not be used simultaneously.

S/PDIF Digital Outputs (RCA): Stereo S/PDIF digital output on one RCA connector. Functions in parallel with the auxiliary AES/EBU output and the two inputs should not be used simultaneously.

AES Sync In (female XLR): Master clock input for the converter when using AES as the Sample Rate Source.

AES Sync Thru (male XLR): Outputs the same signal connected to AES Sync In.

Word In (BNC): Master clock input for the converter when using Word Clock as Sample Rate Source.

Word Out (BNC): Outputs a Word Clock signal synchronized to the Sample Rate Source. In the presence of an external Word clock input, this connector provides a regenerated version of the input signal. Without an external sample rate source, this connector outputs an internally generated clock signal.

MADI In (BNC): Digital audio signal input.

- **1–24:** analog outputs
- **25–26:** aux analog outputs
- **27–28:** aux digital outputs.

DM714 AES/EBU to MADI Converter

Front Panel



Figure 3-22 DM714 Front Panel

Signal Strength LEDs: Each of the 28 channels has a four-segment LED that represents the following signal levels: -42 dB, -18 dB, -6 dB (green), -.05 dB (red).

Trim Pot: A trim pot adjusts the analog output level of channels A1 and A2 between +12 and +26 dBu in 2-dB steps.

SR Conv: The sample rate of all digital inputs is automatically detected and, if asynchronous, converted to the system Sample Rate. This process is independently applied to each stereo pair such that a combination of synchronous and asynchronous signals can be connected to the DM714. Sample-rate conversion is switched off when synchronous signals are detected. The range of sample-rate conversion is 32–56 kHz. 88.2 or 96 kHz signals cannot be sample-rate converted and are passed through if synchronous. If non-synchronous 88.2 or 96 kHz signals are detected, the upper signal strength LED flashes red to warn the user that the sample rate for those channels is not in sync with the system settings. Sample-rate conversion reduces the bit depth in a 24-bit signal to 20 bits.

Sample Rate LEDs: These LEDs indicate the Sample Rate to which the converter is currently locked. Sample Rates are auto-sensed but can be manually selected. Supported Sample Rates are 96 kHz, 88.2 kHz, 48 kHz, 44.1 kHz and Custom Rates from external sources.

Sample Rate Source LEDs: These LEDs indicate the format of the Sample Rate Source to which the converter is currently locked. Sample Rate Source can be auto-sensed or manually selected. If an external source is not detected, the DM714 reverts to Internal sync. If a manually selected source is not present, the Sample Rate Source indicator blinks.

- **AES:** Sample Rate locked to AES Input.
- **Word:** Sample Rate locked to Word Clock Input.
- **Internal:** Sample Rate locked to its own internal crystal.
- **Auto:** Sample Rate Source has been auto-sensed.

These LEDs appear in the same order in which signals are tested for presence. This detection procedure occurs when the converters are powered on. The Sample Rate and Sample Rate Source can also be selected manually.

Manual Selection Buttons: The button below each Sample Rate LED row manually selects the Sample Rate Source. The DM714 also allows manual selection of the Sample Rate.

Power Switch: On/Off switch.

Rear Panel

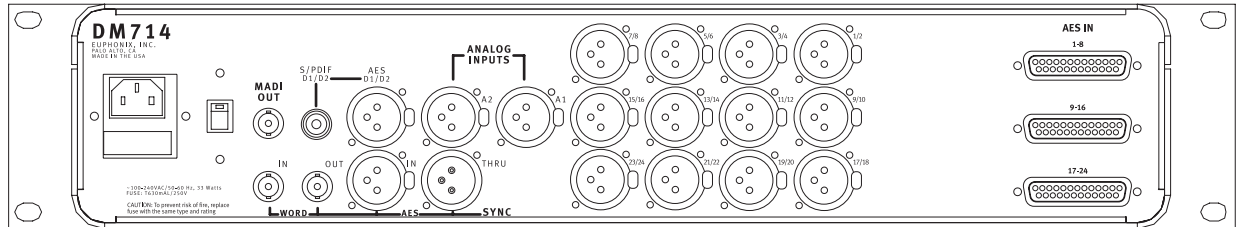

Figure 3-23 DM714 Rear Panel

Input Voltage Selector: This red switch allows operation in either 100/110/115 VAC or 220/230/240 VAC environments. A fuse must also be changed for 220/230/240 VAC operation. Units are shipped set and fused for 100/110/115 VAC.

Power Connector (IEC) and Fuse Tray: The IEC power connector accepts standard IEC power cords. The fuse tray contains both the active fuse and a spare for 220/230/240 VAC operation.

AES/EBU Digital Inputs (female XLR): 12 AES/EBU stereo inputs.

Parallel AES/EBU Digital Inputs (female DB-25): Three 8-channel digital connectors function in parallel with XLR digital inputs, and should not be used simultaneously with the XLR inputs. See Figure 3-24 on page 57 for pinout diagram.

Auxiliary Analog Inputs (female XLR): Two balanced analog inputs on XLR connectors. Input sensitivity is set from the front panel.

Auxiliary AES/EBU Digital Input (female XLR): Stereo AES/EBU digital input on one XLR connector. Functions in parallel with the auxiliary S/PDIF input and the two inputs should not be used simultaneously.

Auxiliary S/PDIF Digital Input (RCA): Stereo S/PDIF digital input on one RCA connector. Functions in parallel with the auxiliary AES/EBU input and the two inputs should not be used simultaneously.

AES Sync In (female XLR): Master clock input for the converter when using AES as Sample Rate Source.

AES Sync Thru (male XLR): Outputs the same signal connected to AES Sync In.

Word In (BNC): Master clock input for the converter when using Word Clock as Sample Rate Source.

Word Out (BNC): Outputs a Word clock signal synchronized to the Sample Rate Source. In the presence of an external Word clock input, this connector provides a regenerated version of that input signal. Without an external sample rate source, this connector outputs the internally generated clock signal.

MADI Out (BNC): Outputs the digital audio signal.

- **1–24:** Main digital inputs
- **25–26:** Aux analog inputs
- **27–28:** Aux digital inputs

NOTE: 28 channels are always transmitted; dual channels are not used.

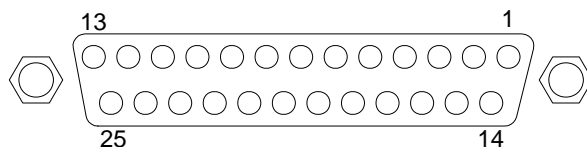

Pin #	Connector 1	Connector 2	Connector 3
1	N/C	N/C	N/C
2	N/C	N/C	N/C
3	N/C	N/C	N/C
4	N/C	N/C	N/C
5	N/C	N/C	N/C
6	N/C	N/C	N/C
7	Digital In 7/8+	Digital In 15/16+	Digital In 23/24+
8	GND	GND	GND
9	Digital In 5/6-	Digital In 13/14-	Digital In 21/22-
10	Digital In 3/4+	Digital In 11/12+	Digital In 19/20+
11	GND	GND	GND
12	Digital In 1/2-	Digital In 9/10-	Digital In 17/18-
13	N/C	N/C	N/C
14	N/C	N/C	N/C
15	N/C	N/C	N/C
16	N/C	N/C	N/C
17	N/C	N/C	N/C
18	N/C	N/C	N/C
19	N/C	N/C	N/C
20	Digital In 7/8-	Digital In 15/16-	Digital In 23/24-
21	Digital In 5/6+	Digital In 13/14+	Digital In 21/22+
22	GND	GND	GND
23	Digital In 3/4-	Digital In 11/12-	Digital In 19/20-
24	Digital In 1/2+	Digital In 9/10+	Digital In 17/18+
25	GND	GND	GND

Figure 3-24 DM714 Parallel AES/EBU Digital Inputs: Female DB-25

MD704 MADI to AES/EBU Converter

Front Panel



Figure 3-25 MD704 Front Panel

Signal Strength LEDs: Each of the 28 channels has a four-segment LED that represents the following signal levels: -42 dB, -18 dB, -6 dB (green), -.05 dB (red).

Trim Pot: A trim pot adjusts the analog output level of channels A1 and A2 between +12 and +26 dBu in 2-dB steps.

Sample Rate LEDs: These LEDs indicate the Sample Rate to which the converter is currently locked. Sample Rates are auto-sensed but can be manually selected on the DM714. Supported Sample Rates are 96 kHz, 88.2 kHz, 48 kHz, 44.1 kHz and Custom Rates from external sources.

Sample Rate Source LEDs: These LEDs indicate the format of the Sample Rate Source to which the converter is currently locked. Sample Rate Source can be auto-sensed or manually selected. If an external source is not detected, the MD704 mutes its outputs. If a manually selected source is not present, the Sample Rate Source indicator blinks.

- **AES:** Sample Rate locked to AES Input.
- **Word:** Sample Rate locked to Word Clock Input.
- **MADI:** Sample Rate locked to MADI.
- **Auto:** Sample Rate Source has been auto-sensed.

These LEDs appear in the same order in which signals are tested for presence. This detection procedure occurs when the converters are powered on. The Sample Rate (DM714 only) and Sample Rate Source can also be selected manually.

Manual Selection Buttons: The button below each Sample Rate LED row manually selects the Sample Rate Source.

Power Switch: On/Off switch.

Rear Panel

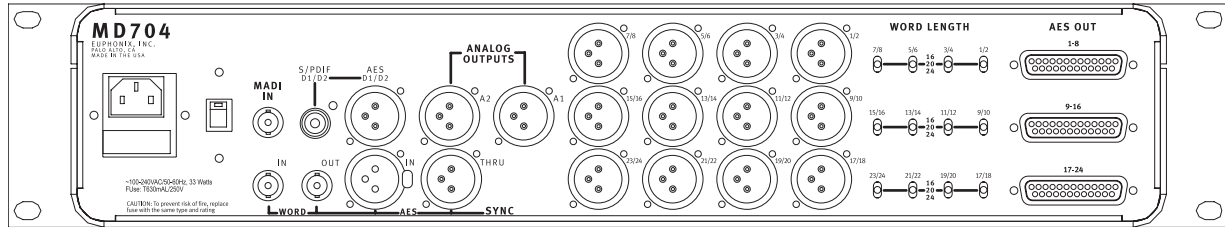

Figure 3-26 MD704 Rear Panel

Input Voltage Selector: This red switch allows operation in either 100/110/115 VAC or 220/230/240 VAC environments. A fuse must also be changed for 220/230/240 VAC operation. Units are shipped set and fused for 100/110/115 VAC.

Power Connector (IEC) and Fuse Tray: The IEC power connector accepts standard IEC power cords. The fuse tray contains both the active and spare fuses.

AES/EBU Digital Outputs (female XLR): 12 AES/EBU stereo outputs.

Parallel AES/EBU Digital Outputs (female DB-25): Three 8-channel digital connectors function in parallel with XLR digital outputs and the two outputs should not be used simultaneously. See Figure 3-27 on page 60 for pinout diagram.

Auxiliary Analog Outputs (male XLR): Two balanced analog outputs on XLR connectors. Output level can be set from the front panel.

AES/EBU Digital Outputs (male XLR): Stereo AES/EBU digital outputs on one XLR connector. Functions in parallel with the auxiliary S/PDIF output and the two outputs should not be used simultaneously.

S/PDIF Digital Outputs (RCA): Stereo S/PDIF digital output on one RCA connector. Functions in parallel with the auxiliary AES/EBU output and the two outputs should not be used simultaneously.

AES Sync In (female XLR): Master clock input for the converter when using AES as the Sample Rate Source.

AES Sync Thru (male XLR): Outputs the same signal connected to AES Sync In.

Word In (BNC): Master clock input for the converter when using Word Clock as Sample Rate Source.

Word Out (BNC): Outputs a Word Clock signal synchronized to the Sample Rate Source. In the presence of an external Word clock input, this connector provides a regenerated version of the input signal. Without an external sample rate source, this connector outputs an internally generated clock signal.

MADI In (BNC): Digital audio signal input.

- **1–24:** main digital outputs
- **25–26:** aux analog outputs
- **27–28:** aux digital outputs

Bit-Depth Reduction: Sets the resolution to 16, 20, or 24 bits for the main AES/EBU channels.

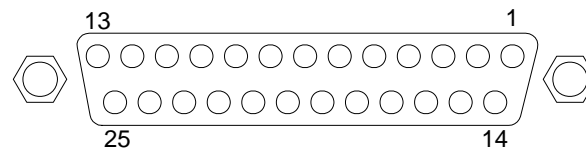

Pin#	Connector 1	Connector 2	Connector 3
1	Digital out 7/8+	Digital Out 15/16+	Digital Out 23/24+
2	GND	GND	GND
3	Digital out 5/6-	Digital Out 13/14-	Digital Out 21/22-
4	Digital out 3/4+	Digital Out 11/12+	Digital Out 19/20+
5	GND	GND	GND
6	Digital out 1/2-	Digital Out 9/10-	Digital Out 17/18-
7	N/C	N/C	N/C
8	N/C	N/C	N/C
9	N/C	N/C	N/C
10	N/C	N/C	N/C
11	N/C	N/C	N/C
12	N/C	N/C	N/C
13	N/C	N/C	N/C
14	Digital out 7/8-	Digital Out 15/16-	Digital Out 23/24-
15	Digital out 5/6+	Digital Out 13/14+	Digital Out 21/22+
16	GND	GND	GND
17	Digital out 3/4-	Digital Out 11/12-	Digital Out 19/20-
18	Digital out 1/2+	Digital Out 9/10+	Digital Out 17/18+
19	GND	GND	GND
20	N/C	N/C	N/C
21	N/C	N/C	N/C
22	N/C	N/C	N/C
23	N/C	N/C	N/C
24	N/C	N/C	N/C
25	N/C	N/C	N/C

Figure 3-27 DM704 Parallel AES/EBU Digital Outputs: Female DB-25

FC726 Format Converter

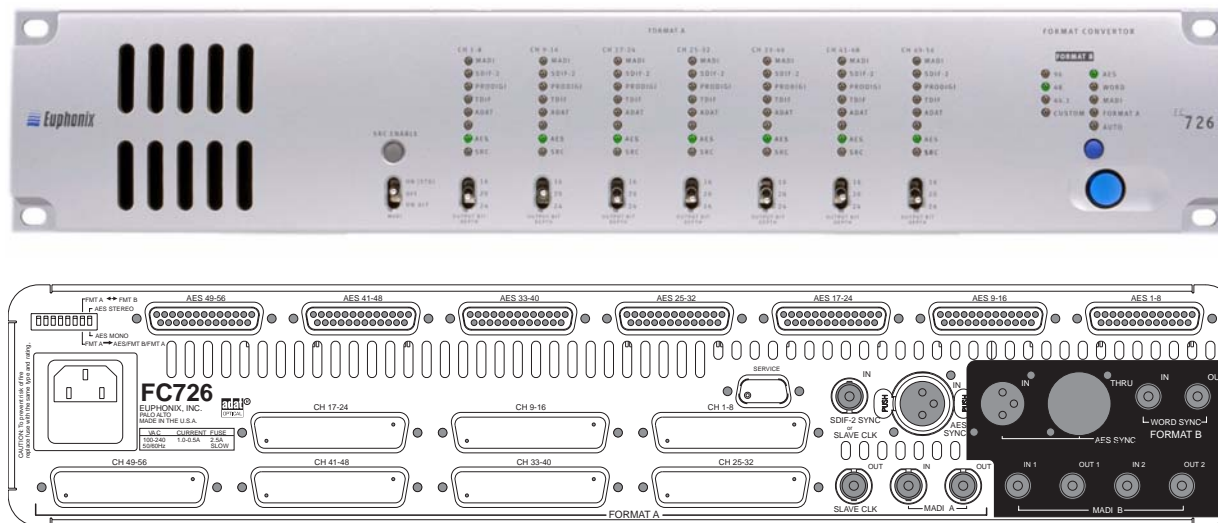

Figure 3-28 FC726 Front and Rear Panels

The FC726 Format Converter provides 56 sample-rate selectable, AES/EBU inputs and outputs. It also allows direct connection to the following third-party digital formats: TDIIF, SDIF-2, and ADAT Optical.

Power Connector (IEC): Accepts standard IEC power cord (provided). An autoranging switching supply accepts voltages between 100–240 VAC, 50–60 Hz.

Format A Common Connectors (seven DD-50): Connects to third-party devices. Each connector provides eight bidirectional channels. Appropriate adapters must be used for each format to connect the third-party devices. Specify cable requirements at time of order. See Table 3-8 through Table 3-11 for pinout specifications.

Format A AES Connectors (seven DB-25): Connects to AES devices. Each connector provides eight bidirectional channels (four AES pairs). Specify cable requirements at time of order.

MADI A In 1 / MADI A Out 1 (two BNC): The MADI A In/Out Ports interface with non-Euphonix MADI devices. At 48 kHz, MADI A provides 56 channels of 24-bit audio; at 96 kHz, 28 channels of 24-bit audio channels (cable not provided).

Format A AES Sync In (female XLR): Connect an AES Sync signal to this XLR connector to synchronize the Format A MADI signal. According to the AES specification, to operate correctly the AES sync signal must use the same sample rate as the incoming MADI signal (cable not provided).

SDIF-2 or Slave Clock In (BNC): This connector can receive either an SDIF or Slave Clock Sync signal (the FC726 automatically detects the signal type). An SDIF device must send a Word Sync signal to this connector to interface properly. Slave Clock is a sync signal (commonly implemented in Pro Tools systems and referred to as a *super-clock*) that runs at 256 times the sample rate. Cable not provided.

MADI B In 1 / MADI B Out 1 (two BNC): Connect these MADI Ports to the DF64 or optional SH612 Studio Hub (cable provided).

Format B AES Sync In (female XLR): Connect this port to a digital sync reference.

Format B AES Sync Thru (male XLR): This signal is active regardless of selected sync source.

Format B Word In (BNC): Connect this port to a digital sync reference.

Format B Word Out (BNC): This signal is active regardless of selected sync source.

Table 3-7 AES/EBU DB-25 Pinout

Pin	Description
Pin 1	N/C
Pin 2	Channel 1 / 2 In (COLD)
Pin 3	Channel 3 / 4 In (GND)
Pin 4	Channel 3 / 4 In (HOT)
Pin 5	Channel 5 / 6 In (COLD)
Pin 6	Channel 7 / 8 In (GND)
Pin 7	Channel 7 / 8 In (HOT)
Pin 8	Channel 1 / 2 Out (COLD)
Pin 9	Channel 3 / 4 Out (GND)
Pin 10	Channel 3 / 4 Out (HOT)
Pin 11	Channel 5 / 6 Out (COLD)
Pin 12	Channel 7 / 8 Out (GND)
Pin 13	Channel 7 / 8 Out (HOT)
Pin 14	Channel 1 / 2 In (GND)
Pin 15	Channel 1 / 2 In (HOT)
Pin 16	Channel 3 / 4 In (COLD)
Pin 17	Channel 5 / 6 In (GND)
Pin 18	Channel 5 / 6 In (HOT)
Pin 19	Channel 7 / 8 In (COLD)
Pin 20	Channel 1 / 2 Out (GND)
Pin 21	Channel 1 / 2 Out (HOT)
Pin 22	Channel 3 / 4 Out (COLD)
Pin 23	Channel 5 / 6 Out (GND)
Pin 24	Channel 5 / 6 Out (HOT)
Pin 25	Channel 7 / 8 Out (COLD)

NOTE: *In and Out are from the FC726's perspective.*

Table 3-8 Common DD-50 Connector Pinout and Usage With Third-party Devices

Pin #	Common Connector (DB50 Female)	SDIF usage	TDIF usage	ProDigi usage	ADAT usage	ProTools
1	In 1+	In 1+	NC	In 1+	In 1/2	In 1/2+
2	In 1-	In 1-	In 1/2	In 1-	NC	In 1/2-
3	In 2+	In 3+	NC	In 3+	In 3/4	In 3/4+
4	In 2-	In 3-	In 3/4	In 3-	NC	In 3/4-
5	In 3+	In 5+	NC	In 5+	In 5/6	In 5/6+
6	In 3-	In 5-	In 5/6	In 5-	NC	In 5/6-
7	In 4+	In 7+	NC	In 7+	In 7/8	In 7/8+
8	In 4-	In 7-	In 7/8	In 7-	NC	In 7/8-
9	GND	GND	GND	GND	GND	GND
10	In 5+/GP In A	In 2+	NC	In 2+	Error In	ICR_WC+
11	In 5-	In 2-	NC	In 2-	NC	ICR_WC-
12	In 6+/GP In B	In 4+	NC	In 4+	User0 In	ICR_BC+
13	In 6-	In 4-	NC	In 4-	NC	ICR_BC-
14	In 7+/GP In C	In 6+	NC	In 6+	User1 In	ICR_SD+
15	In 7-	In 6-	NC	In 6-	NC	ICR_SD-
16	In 8+/GP In D	In 8+	NC	In 8+	Mstr/Slv IN	ICR_AD+
17	In 8-	In 8-	NC	In 8-	NC	ICR_AD-
18	Cable ID2	0 (tie to pin 23)	0 (tie to pin 23)	0 (tie to pin 23)	1 (NC)	1 (NC)
19	Cable ID1	0 (tie to pin 23)	1 (NC)	1 (NC)	0 (tie to pin 23)	0 (tie to pin 23)
20	Cable ID0	1 (NC)	0 (tie to pin 23)	1 (NC)	0 (tie to pin 23)	1
21	Bit Clk In+	NC	NC	Bit Clk In+	Bit Clk In	Bit Clk In+
22	Bit Clk In-	NC	NC	Bit Clk In-	NC	Bit Clk In-
23	GND	GND	GND	GND	GND	GND
24	Word Clk In+	NC	In LR Clk	Word Clk In+	Word Clk In	Word Clk In+
25	Word Clk In-	NC	NC	Word Clk In-	GND	Word Clk In-
26	Out 1+	Out 1+	NC	Out 1+	Out 1/2	Out 1/2+
27	Out 1-	Out 1-	Out 1/2	Out 1-	NC	Out 1/2-
28	Out 2+	Out 3+	NC	Out 3+	Out 3/4	Out 3/4+
29	Out 2-	Out 3-	Out 3/4	Out 3-	NC	Out 3/4-
30	Out 3+	Out 5+	NC	Out 5+	Out 5/6	Out 5/6+
31	Out 3-	Out 5-	Out 5/6	Out 5-	NC	Out 5/6-
32	Out 4+	Out 7+	NC	Out 7+	Out 7/8	Out 7/8+
33	Out 4-	Out 7-	Out 7/8	Out 7-	NC	Out 7/8-
34	Out 5+/GP Out A	Out 2+	FS0 out	Out 2+	Mute Out	NC
35	Out 5-	Out 2-	NC	Out 2-	NC	NC
36	Out 6+/GP Out B	Out 4+	FS1 out	Out 4+	NC	NC
37	Out 6-	Out 4-	NC	Out 4-	NC	NC
38	Out 7+/GP Out C	Out 6+	Emph Out	Out 6+	NC	NC
39	Out 7-	Out 6-	NC	Out 6-	NC	NC
40	Out 8+/GP Out D	Out 8+	NC	Out 8+	NC	NC
41	Out 8-	Out 8-	NC	Out 8-	NC	NC
42	Bit Clk Out+	NC	NC	Bit Clk Out+	Bit Clk Out	Bit Clk Out+
43	Bit Clk Out-	NC	NC	Bit Clk Out-	GND	Bit Clk Out-
44	GND	GND	GND	GND	GND	GND
45	Word Clk Out+	NC	Out LR Clk	Word Clk Out+	Word Clk Out	NC
46	Word Clk Out-	NC	NC	Word Clk Out-	GND	NC
47	Extra In/GP In E+	NC	NC	NC	DVCO In	NC
48	Extra In/GP In E-	NC	NC	NC	NC	NC
49	NC	NC	NC	NC	Vcc	NC
50	GND	GND	GND	GND	GND	GND

Table 3-10 FC726 Pro Tools Cable Wiring Specification

Connector	Pin	Connection	Description
J1	1	J2-17	In 1/2+
J1	2	J2-42	In 1/2-
J1	3	J2-16	In 3/4+
J1	4	J2-41	In 3/4-
J1	5	J2-1	In 5/6+
J1	6	J2-26	In 5/6-
J1	7	J2-18	In 7/8+
J1	8	J2-43	In 7/8-
J1	9	J2-2	GND
J1	10	J2-5	ICR_WC+
J1	11	J2-30	ICR_WC-
J1	12	J2-3	ICR_BC+
J1	13	J2-28	ICR_BC-
J1	14	J2-21	ICR_SD+
J1	15	J2-46	ICR_SD-
J1	16	J2-23	ICR_AD+
J1	17	J2-48	ICR_AD-
J1	18	NC	Cable ID
J1	19	J1-23	Cable ID
J1	20	NC	Cable ID
J1	21	J2-19	Bit Clk In+
J1	22	J2-44	Bit Clk In-
J1	23	J1-19,J2-13	GND
J1	24	J2-11	Word Clk In+
J1	25	J2-36	Word Clk In-
J1	26	J2-7	Out 1/2+
J1	27	J2-32	Out 1/2-
J1	28	J2-8	Out 3/4+
J1	29	J2-33	Out 3/4-
J1	30	J2-25	Out 5/6+
J1	31	J2-50	Out 5/6-
J1	32	J2-24	Out 7/8+
J1	33	J2-49	Out 7/8-
J1	34	NC	
J1	35	NC	
J1	36	NC	
J1	37	NC	
J1	38	NC	
J1	39	NC	
J1	40	NC	
J1	41	NC	
J1	42	J2-9	Bit Clk Out+
J1	43	J2-34	Bit Clk Out-
J1	44	J2-38	GND
J1	45	NC	
J1	46	NC	
J1	47	NC	
J1	48	NC	
J1	49	NC	
J1	50	J2-27	GND

Notes:

J1 = DB-50 male

J2 =50-pin high density SCSI-2-style female

Jx-x	<i>denotes twisted pair</i>
Jx-x	

In and Out are from the FC726's perspective.

Table 3-11 FC726 SDIF Cable Wiring Specification

Connector	Pin	Connection	Description
J1	1	J4-2	In 1+
J1	2	J4-1	In 1-
J1	3	J4-6	In 3+
J1	4	J4-5	In 3-
J1	5	J4-10	In 5+
J1	6	J4-9	In 5-
J1	7	J4-14	In 7+
J1	8	J4-13	In 7-
J1	9	NC (GND)	
J1	10	J4-4	In 2+
J1	11	J4-3	In 2-
J1	12	J4-8	In 4+
J1	13	J4-7	In 4-
J1	14	J4-12	In 6+
J1	15	J4-11	In 6-
J1	16	J4-16	In 8+
J1	17	J4-15	In 8-
J1	18	J1-23	Cable ID
J1	19	J1-23	Cable ID
J1	20	NC	Cable ID
J1	21	NC	
J1	22	NC	
J1	23	J1-18,19	GND
J1	24	NC	
J1	25	NC	
J1	26	J5-2	Out 1+
J1	27	J5-1	Out 1-
J1	28	J5-6	Out 3+
J1	29	J5-5	Out 3-
J1	30	J5-10	Out 5+
J1	31	J5-9	Out 5-
J1	32	J5-14	Out 7+
J1	33	J5-13	Out 7-
J1	34	J5-4	Out 2+
J1	35	J5-3	Out 2-
J1	36	J5-8	Out 4+
J1	37	J5-7	Out 4-
J1	38	J5-12	Out 6+
J1	39	J5-11	Out 6-
J1	40	J5-16	Out 8+
J1	41	J5-15	Out 8-
J1	42	NC	
J1	43	NC	
J1	44	NC	
J1	45	NC	
J1	46	NC	
J1	47	NC	
J1	48	NC	
J1	49	NC	
J1	50	NC	

Notes:

J1, J2, J3 = DB-50 male

J4 = DB-50 male

J5 = DB-50 female

Jx-x

denotes twisted pair

Jx-x

In and Out are from the FC726's perspective.

GP132

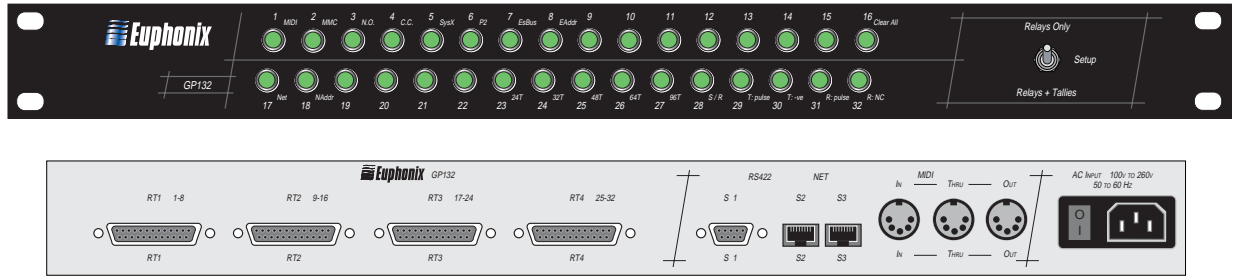

Figure 3-29 GP132 Front and Rear Panels

Front Panel Functions

While the toggle is in the Setup position, pressing button 16 clears all relays. Holding 14, 15, and 16 resets the GP132.

The GP132 has a three-state toggle switch on the right of the front panel:

Setup

For operation with Max Air, select **1-MIDI** and **2-MMC** on the front panel. All other selections should be turned off except for **23-24T** which remain on.

Relays Only

The front panel displays the state of the relays (outputs) and allows control of the relay closures manually from the buttons on the front panel.

Relays + Tallies

The front panel displays the state of the inputs and allows control of the relay closures manually from the buttons on the front panel.

25-pin D-sub connectors RT1-RT4

Each connector has eight relay outputs and eight opto-isolated tally inputs. Since both outputs and inputs share common lines, you cannot use the same number connection for an output and input simultaneously, and be careful when connecting multiple devices to the same connector.

Tally inputs accept 5–24 VDC/AC. (Contact Euphonix Customer Service before applying over 24 V.) The relays are rated at 500 mA maximum; an additional driver circuit is required to drain more current.

NOTE: The maximum length for any MIDI cable is 10 m. Cables over this length may cause data loss (this is the MIDI specification).

MIDI Connections

Connect the GP132's MIDI ports to **Port 2** (In and Out) on the console's MIDI Interface. Up to four GP132s can be connected (ins and outs) to ports 2–5.

Input and Output Connections

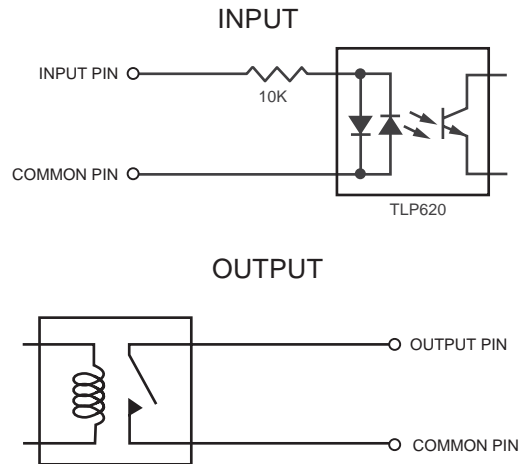

Figure 3-30 GP132 Input and Output Connections

Connector Pinouts (DB-25 RT1–RT4)

Table 3-12 GP132 Outputs

RT1	RT2	RT3	RT4	PIN
1	9	17	25	2
2	10	18	26	16
3	11	19	27	5
4	12	20	28	19
5	13	21	29	8
6	14	22	30	22
7	15	23	31	11
8	16	24	32	25
Common	Common	Common	Common	13

Table 3-13 GP132 Inputs

RT1	RT2	RT3	RT4	PIN
1	9	17	25	1
2	10	18	26	15
3	11	19	27	4
4	12	20	28	18
5	13	21	29	7
6	14	22	30	21
7	15	23	31	10
8	16	24	32	24
Common	Common	Common	Common	3,6,9,12,14, 17,20,23

WARNING: *If power fails on the GP132, none of the relays will function. After restoring power, the GP132 resets ALL relays.*

TT007

Setup

Connect the IEC power cable (included) to your studio power. Then connect MIDI Port 2 In and Out on the TT007 to MIDI Port 1 In and Out on the System 5 MIDI Interface.

Capabilities

The TT007 is an optional rack-mount device that provides machine control for all Euphonix consoles. The TT007 allows the console to become the single, centralized machine control hub within any studio. Virtually every machine, in or out of the control room, can be remotely controlled from the console at the press of a button. The flexibility gained from the addition of the TT007 is unprecedented. These are a few of the many features that can be seamlessly implemented with the TT007:

- Entire machine networks can be configured and set into motion directly from the console.
- user nameable, instantly accessible locate points
- automatic transport cycling
- jogging and variable shuttle
- control tape decks, DAWs, and other synchronizers

All timecode formats and frame rates are supported, including MIDI Time Code (MTC) and external video sync. MIDI Machine Control (MMC), the TimeLine Lynx™ network, and Sony 9-pin (P2) protocols work right “out of the box” to insure that starting to work with the TT007 is quick and easy. Three MIDI and three serial machine ports are available. The TT007 also has a built-in timecode generator and LTC reader.

Using the TT007

The TT007's front panel is very easy to master. Dedicated Port buttons instantly access individual assignments for each machine control Port. Any Port can be defined as a master, controller, or slave. A single master acts as the synchronization source for all machines in the network.

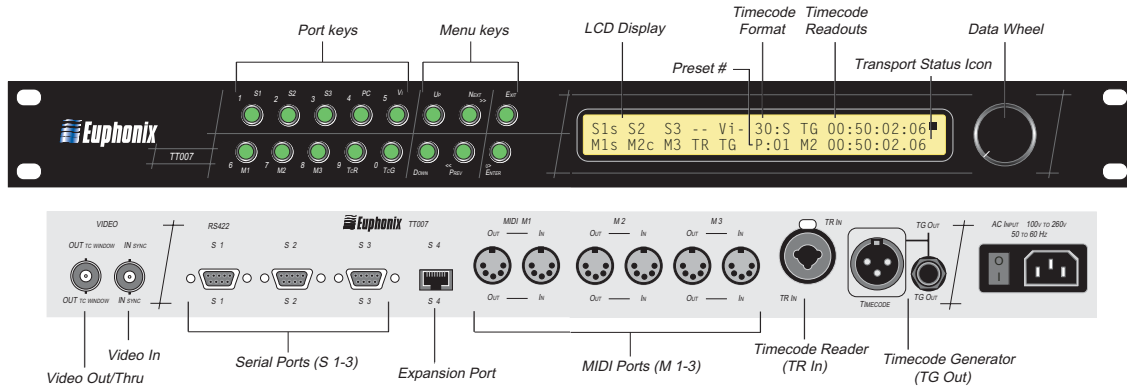

Figure 3-31 TT007 front and rear panels

The transport controls of the master machine can drive the network but the TT007 is unique in its ability to accept transport commands from additional control surfaces and relay those commands to the master machine. Any controller device in the studio defined as a controller (and on-line) has direct access to the master machine. This gives the engineer new freedom to issue commands from the most convenient place in the studio at any given moment: Hit Play on the sequencer, turn around and press **Stop** on the workstation to make an edit, then pull forward and hit Play on the console to continue the mix!

The built-in SMPTE/EBU generator can supply the master timecode source when random access machine control is desired, or for machines unable to generate their own timecode. Two readouts on the front panel LCD display incoming timecode from any selected Port. Additionally, a video burn-in window can be set to display one of the eight available timecode sources. The burn-in window can be superimposed on a video monitor by simply passing a composite video signal through the TT007 video reference input.

The TT007 stores 50, user-defined presets that are instantly recalled when needed. The presets store customized machine control configurations including Port configurations, timecode formats, sync preferences, and window displays.

The transport controls on the TT007 are similar to most tape machines: Play, Stop, Fast Forward and Rewind are all clearly marked on the front panel. Transport mode allows control of any one of the seven ports or the timecode generator from the transport keys and the front panel Data Wheel.

Index

A

Analog I/O 10
Audio Hookup 25

C

CM401 9
CM402 9
CM403 9
CM408 9
CM409F 9
Console Dimensions 21
Console Layout 20
Converters
 AM713 Analog to MADI 49
 DM714 AES/EBU to MADI 55
 FC726 61
 MA703 MADI to Analog 52
 MD704 MADI to AES/EBU 58

D

DF64 Digital Frame 14
Digital I/O 11
Digital Sync 11

E

Ethernet 12

F

Faders 10
FC631 Frame Controller 35
Firewire 13
Format Conversion 11

G

GP132 68
GPIO Control 13

I

Inputs 10

K

KVM Extender 12

L

Layouts 10

M

Machine Control 13
MC524 Monitor Interface 40
Mic Inputs 11
ML530 Mic/Line Interface 46
MM641 MADI Interface Card 35
Monitoring 11
 MC524 Monitor Interface 11

P

PC254d Digital Pilot Computer 38
PC254i Interface Computer 39

R

Rack Elevations 23

S

SC262 System Computer 37
SH612 Studio Hub 48
SP661 Signal Processor 35
Synchronization Hookup 26
System 5 Components
 Dimensions 17
 Fuse Rating 19
 Heat Dissipation 17
 Power Consumption 17

T

TCC Control 13
TT007 13, 71

