

SA800/801
Diskette
Storage Drive

OEM Manual

 **Shugart**

TABLE OF CONTENTS

1.0 Introduction	1
1.1 General Description	1
1.2 Specification Summary	2
1.2.1 Performance Specifications	2
1.2.2 Functional Specifications	2
1.2.3 Physical Specifications	2
1.2.4 Reliability Specifications	3
2.0 Functional Characteristics	5
2.1 General Operation	5
2.2 Read/Write and Control Electronics	5
2.3 Drive Mechanism	5
2.4 Positioning Mechanism	5
2.5 Read/Write Head	5
2.6 Recording Format	6
2.7 Optional Features	6
2.8 Model Differences	6
3.0 Functional Operations	7
3.1 Power Sequencing	7
3.2 Drive Selection	7
3.3 Track Accessing	7
3.3.1 Step Out	7
3.3.2 Step In	7
3.4 Read Operation	7
3.5 Write Operation	9
3.6 Sequence of Events	9
4.0 Electrical Interface	13
4.1 Signal Interface	13
4.1.1 Input Lines	13
4.1.1.1 Input Line Termination	15
4.1.1.2 Drive Select 1-4	15
4.1.1.3 Direction Select	15
4.1.1.4 Step	15
4.1.1.5 Write Gate	15
4.1.1.6 Write Data	16
4.1.1.7 Head Load (Alternate Input)	16
4.1.1.8 In Use (Alternate Input)	16
4.1.2 Output Lines	16
4.1.2.1 Track 00	16
4.1.2.2 Index	16
4.1.2.3 Sector (SA801 only)	17
4.1.2.4 Ready	17
4.1.2.5 Read Data	17
4.1.2.6 Sep Data	17
4.1.2.7 Sep Clock	17
4.1.2.8 Write Protect (Optional on SA800)	17
4.1.2.9 Disk Change (Alternate Output)	18
4.1.3 Alternate I/O Pins	18
4.2 Power Interface	18
4.2.1 AC Power	18
4.2.2 DC Power	19



5.0 Physical Interface	21
5.1 J1/P1 Connector	21
5.2 J5/P5 Connector	22
5.3 J4/P4 Connector	22
6.0 Drive Physical Specifications	23
6.1 Drive Dimensions	23
6.2 Mounting Recommendations	23
6.2.1 Vertical Mounting	23
6.2.3 Upright Mounting	23
6.3 Chassis Slide	25
6.4 Decorative Face Plate	25
7.0 Customer Installable Options	27
7.1 Drive Select - One to Eight Drives	30
7.2 Select Drive Without Loading Head or Enabling Stepper Motor	31
7.3 Select Drive and Enable Stepper Without Loading Head	32
7.4 Load Head Without Selecting Drive or Enabling Stepper	32
7.5 Radial Ready	33
7.6 Radial Index/Sector	34
7.7 Eight, 16, Or 32 Sectors	35
7.8 In Use Alternate Input (Activity LED)	36
7.9 Write Protect Optional Use	36
7.10 Disk Change (Alternate Output)	37
8.0 Operation Procedures	38
8.1 Diskette Loading and Handling	38
8.2 Write Protecting a Diskette	39
9.0 Error Detection and Correction	40
9.1 Write Error	40
9.2 Read Error	40
Appendix A - Models and Features	41

LIST OF ILLUSTRATIONS

Figure 1. SA800/801 Diskette Storage Drive	iv
2. SA800/801 Functional Diagram	4
3. Track Access Timing	8
4. Read Initiate Timing	8
5. Read Signal Timing	9
6. Write Initiate Timing	10
7. Write Data Timing	10
8. General Control and Data Timing Requirements	11
9. Interface Connections	14
10. Interface Signal Driver/Receiver	16
11. Index Timing	16
12. Sector Timing	17
13. J1 Connector Dimensions	21
14. J5 Connector	22
15. J4 Connector	22
16. Interface Connectors - Physical Location Diagram	22
17. Head Load Actuator Mounting Prerequisites	23
18. SA800/801 Diskette Storage Drive Dimensions	24
19. Slide Mounting Dimensions	25
20. SA800/801R Dimensions	26
21. Component Locations Standard PCB	28
22. Component Locations LSI PCB	29
23. Drive Select Circuitry	30
24. Select Drive Without Loading Head Circuit	31
25. Stepper Motor Enable Circuit	32
26. Load Head Without Selecting Drive or Enabling Stepper Circuit	33
27. Radial Ready Circuit	34
28. Radial Index/Sector Circuit	34
29. Sector Timing Relationships	35
30. Sector Divide Circuit	35
31. In Use/Activity LED Circuit	36
32. Write Protect Circuit	36
33. Disk Change Timing	37
34. Disk Change Circuit	37
35. Loading SA800/801	38
36. Diskette Write Protected	39
37. Write Inhibit Notch Specifications	39

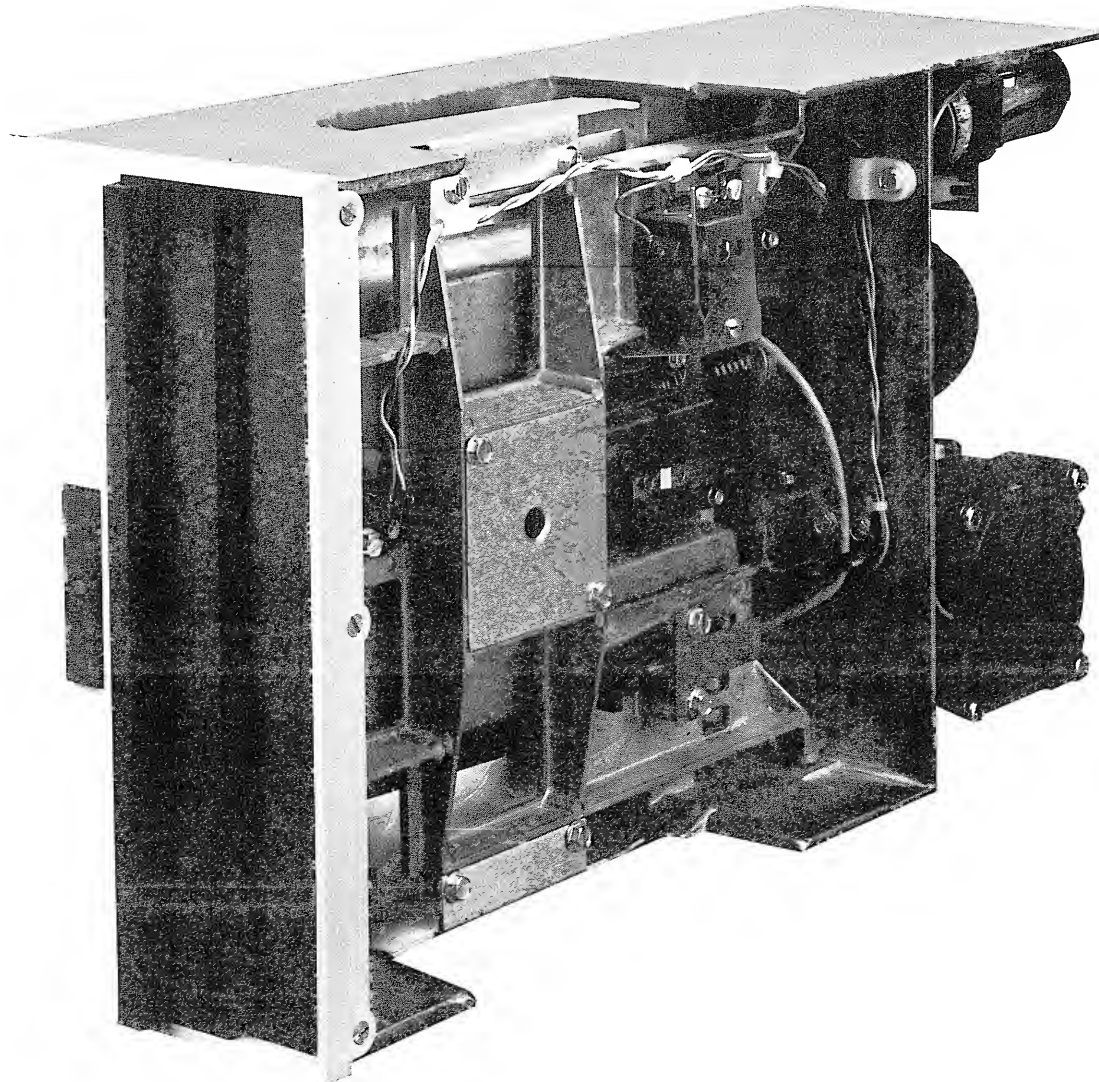

Figure 1. SA800/801 Diskette Storage Drive



1.0 INTRODUCTION

1.1 General Description

The SA800/801 are enhanced versions of the successful SA900/901 Diskette Storage Drive. The SA800/801 provides the customer with a mature and reliable product, manufactured to the same high standard of excellence as the 900/901, but with additional features.

The SA800 Diskette Storage Drive can read and write diskettes for interchange with other SA800's, the SA900, IBM 3741, 3742 or 3540 and with the IBM System 32.

The SA801 provides the same features as the SA800 with additional flexibility for those requirements which preclude IBM compatibility.

The SA800/801 Diskette Storage Drives have as standard features: a patented diskette clamping/registration design which eliminates the possibility of damage to the diskette due to misregistration and guarantees over 30,000 interchanges with each diskette; single and double density capability on the same drive for the same price; a proprietary ceramic R/W head designed and manufactured by Shugart Associates to provide media life exceeding 3.5 million passes/track and head life exceeding 15,000 hours; an activity light which indicates drive in use; and ribbon cable or twisted pair connector for ease of packaging. All of these features and more are available with the SA800/801.

SA800/801 Diskette Storage Drive provide the system designer solutions to his applications requirements with greater performance and reliability than cassette or cartridge drives, and lower cost with increased function over I/O and reel-to-reel tape drives.

Applications for the SA800/801 Diskette Storage Drive are key entry systems, point of sale recording systems, batch terminal data storage microprogram load and error logging, minicomputer program and auxiliary data storage, word processing systems and data storage for small business systems.

The SA100 Diskette, IBM Diskette or equivalent, can be read and written interchangeably between any SA800 and IBM 3741/42, 3747 and 3540. The SA101 Diskette can be read or written interchangeably on any SA801. The SA102 and SA103 are used for double density applications.

As a product enhancement, to improve reliability and serviceability, Shugart is incorporating into the SA800 serves drives a PCB Large Scale Integration (LSI) components. These components are:

- Control Chip
- Write Channel
- Read Channel

The LSI Control chip performs the following functions:

- TRK 00 detector
- Index detector
- Stepper logic
- FM clock/data separator and data window
- Sector separator
- Write Protect detector
- Door open/close detector
- Disk change circuit
- Ready signal

The functions listed above are either detected from the drive mechanics or from the Host Interface. As a result, the proper logic generated by the LSI chip either will be used within the drive electronic circuit to perform stepping, read/write operations or will be fed back to the Host Interface.

Also, an internal FM data separator is incorporated inside the chip. A jumper option will allow the user to select the data separator to perform as its predecessor SA800 (jumper FS) or to select the separator to be compatible with the IBM System 3740 data separator (jumper TS). Thus IBM compatibility will allow direct interfacing with LSI single chip floppy disk controllers.



1.2 Specification Summary

1.2.1 Performance Specifications

	Single Density	Double Density
Capacity		
Unformatted		
Per Disk	3.2 megabits	6.4 megabits
Per Track	41.7 kilobits	83.4 kilobits
IBM Format		
Per Disk	2.0 megabits	n/a
Per Track	26.6 kilobits	n/a
Transfer Rate	250 kilobits/sec.	500 kilobits/sec
Latency (average)	83 ms	83 ms
Access Time		
Track to Track	8 ms	8 ms
Average	260 ms	260 ms
Settling Time	8 ms	8 ms
Head Load Time	35 ms	35 ms

1.2.2 Functional Specifications

	Single Density	Double Density
Rotational Speed	360 rpm	360 rpm
Recording Density		
(inside track)	3200 bpi	6400 bpi
Flux Density	6400 fci	6400 fci
Track Density	48 tpi	48 tpi
Tracks	77	77
Physical Sectors		
SA800	0	0
SA801	32/16/8	32/16/8
Index	1	1
Encoding Method	FM	MF ² M
Media Requirements		
SA800	SA100/IBM Diskette	SA102/IBM Diskette
SA801	SA101	SA103

1.2.3 Physical Specifications

	Operating	Shipping	Storage
Environmental Limits			
Ambient Temperature	= 40°F to 115°F (4.4° to 46.1°C)	-40°F to 144°F	-8°F to 117°F
Relative Humidity	= 20% to 80%	1 to 95%	1 to 95%
Maximum Wet Bulb	= 78°F (25°C)	No Condensation	No Condensation
AC Power Requirements			
50/60 Hz ± 0.5 Hz			
100/115 VAC Installations	= 85 to 127V @ .3A typical		
200/230 VAC Installations	= 170 to 253V @ .18A typical		
DC Voltage Requirements			
+ 24 VDC ± 5% 1.3A typical			
+ 5 VDC ± 5% 0.8A typical			
-5 VDC ± 5% .05A typical (option -7 to -16 VDC)			
Mechanical Dimensions (Reference Figures 18 and 20)			
Width	= 4 5/8 in. (11.75 cm)		
Height	= 9 1/2 in. (24.13 cm)		
Depth	= 14 1/4 in. (36.20 cm)		
Weight	= 13.0 lbs. (5.91 kg)		
Heat Dissipation	= 271 BTU/hr. typical (80 Watts)		



1.2.4 Reliability Specifications

MTBF:	5000 POH under heavy usage 8000 POH under typical usage
PM:	Every 5000 POH under heavy usage Every 15,000 under typical usage
MTTR:	30 minutes
Component Life:	15,000 POH
Error Rates:	
Soft Read Errors:	1 per 10^9 bits read
Hard Read Errors:	1 per 10^{12} bits read
Seek Errors:	1 per 10^6 seeks.
Media Life:	
Passes Per Track	3.5×10^6
Insertions:	30,000 +

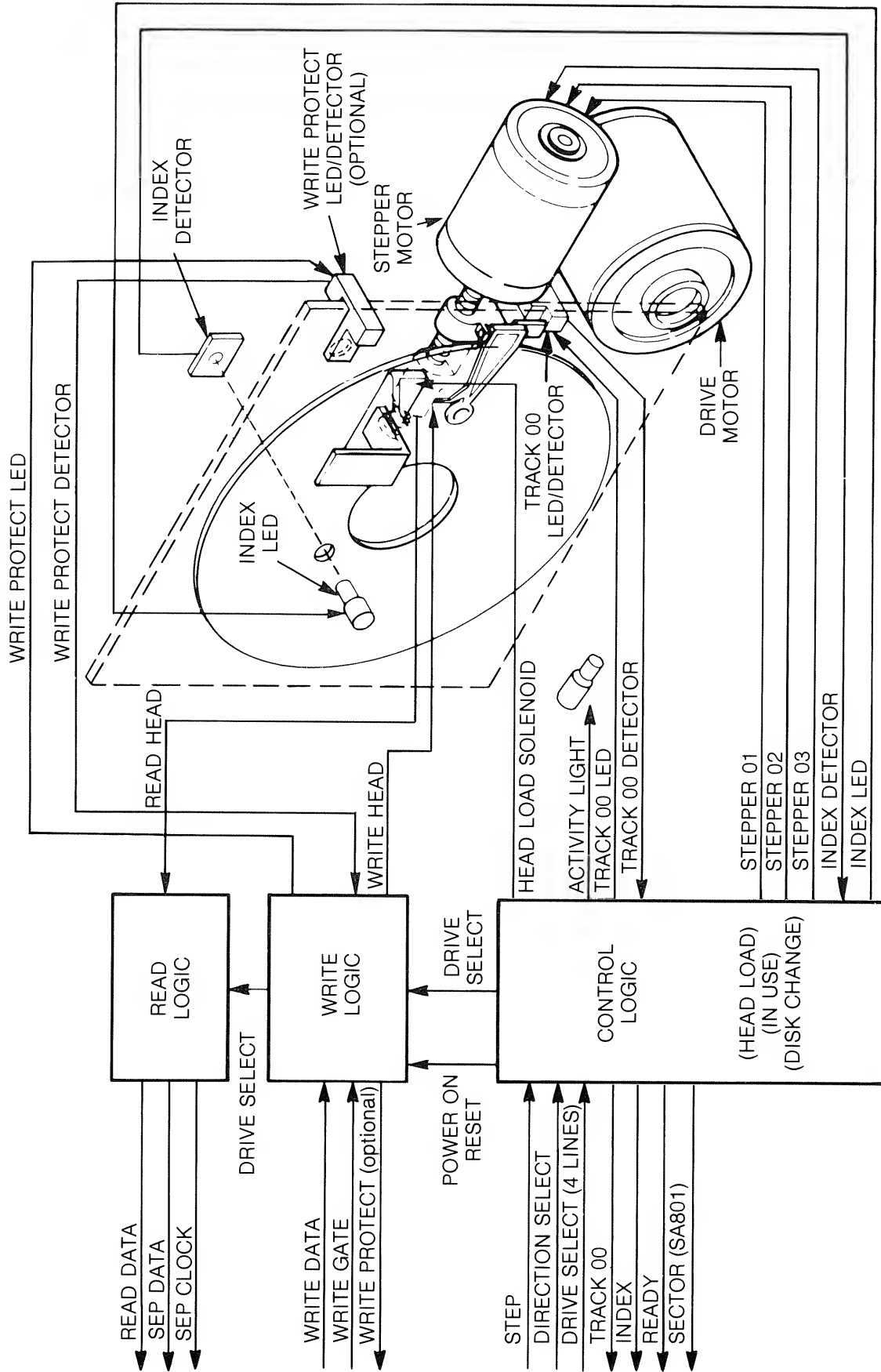

Figure 2. SA800/801 Functional Diagram



2.0 FUNCTIONAL CHARACTERISTICS

2.1 General Operation

The SA800/801 Diskette Storage Drive consists of read/write and controls electronics, drive mechanism, read/write head, track positioning mechanism, and the removable diskette. These components perform the following functions:

- Interpret and generate control signals.
- Move read/write head to the selected track.
- Read and write data.

The relationship and interface signals for the internal functions of the SA800/801 are shown in Figure 2.

The Head Positioning Actuator positions the read/write head to the desired track on the diskette. The Head Load Actuator loads the diskette against the read/write head and data may then be recorded or read from the diskette.

2.2 Read/Write and Control Electronics

The electronics are packaged on one PCB. The PCB contains:

1. Index Detector Circuits. (Sector/Index for 801).
2. Head Position Actuator Driver.
3. Head Load Actuator Driver.
4. Read/Write Amplifier and Transition Detector.
5. Data/Clock Separation Circuits.
6. Write Protect.
7. Drive Ready Detector Circuit.
8. Drive Select Circuits.

2.3 Drive Mechanism

The Diskette drive motor rotates the spindle at 360 rpm through a belt-drive system. 50 or 60 Hz power is accommodated by changing the drive pulley and belt. A registration hub, centered on the face of the spindle, positions the Diskette. A clamp that moves in conjunction with the cartridge guide fixes the Diskette to the registration hub.

2.4 Positioning Mechanism

An electrical stepping motor (Head Position Actuator) and lead screw positions the read/write head. The stepping motor rotates the lead screw clockwise or counterclockwise in 15° increments. A 15° rotation of the lead screw moves the read/write head one track position. The using system increments the stepping motor to the desired track.

2.5 Read/Write Head

The SA800/801 head is a single element ceramic read/write head with straddle erase elements to provide erased areas between data tracks. Thus normal interchange tolerances between media and drives will not degrade the signal to noise ratio and insures Diskette interchangeability.

The read/write head is mounted on a carriage which is located on the Head Position Actuator lead screw. The Diskette is held in a plane perpendicular to the read/write head by a platen located on the base casting. This precise registration assures perfect compliance with the read/write head. The Diskette is loaded against the head with a load pad actuated by the head load solenoid.

The read/write head is in direct contact with the Diskette. The head surface has been designed to obtain maximum signal transfer to and from the magnetic surface of the Diskette with minimum head/Diskette wear.

2.6 Recording Format

The format of the data recorded on the disk is totally a function of the host system, and can be designed around the users application to best take advantage of the total available bits that can be written on any one track.

For a detailed discussion of various recording formats, the systems designer should read one of the following:

1. IBM Compatibility Manual.
2. Shugart Associates Double Density Design Guide.
3. SA801/901 Track Formats.

2.7 Optional Features

1. -12 to -15 Volt DC to replace -5 Volt DC requirement.
2. Dust Cover, Not available on "R" series.
3. Write Protect for SA800. Standard on SA801.
4. Door Lock. Will lock the door when drive is selected or through alternate I/O pin.
5. Horizontal mounting with door opening up.
6. SA800/801 "R" Series. Allows two drives to be horizontally installed in a standard 19" Ret-
ma rack. Reference figure 20.

2.8 Model Differences

- 800-1 - Soft Sected with an FM (single density) data separator.
- 800-2 - Soft Sected without data separator.
- 800-4 - Mechanics only (No PCB).
- 801 - Hard Sected with an FM (single density) data separator and sector separator.

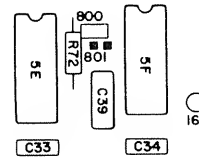

NOTE:

To convert a 801 to a 800 move the shorting plug from the 801 position to the 800 position. A 800 cannot be converted to a 801.

3.0 FUNCTIONAL OPERATIONS

3.1 Power Sequencing

Applying AC and DC power to the SA800/801 can be done in any sequence, however, once AC power has been applied, a 2 second delay must be introduced before any Read or Write operation is attempted. This delay is for stabilization of the Diskette rotational speed. Also, after application of DC power, a 90 millisecond delay must be introduced before a Read, Write, or Seek operation or before the control output signals are valid. After powering on, initial position of the R/W head with respect to data tracks is indeterminant. In order to assure proper positioning of the R/W head prior to any read/write operation after powering on, a Step Out operation should be performed until the Track 00 indicator becomes active.

3.2 Drive Selection

Drive selection occurs when a drive's Drive Select line is activated. Only the drive with this line active will respond to input lines or gate output lines. Under normal operation, the Drive Select line will load the R/W head, apply power to the stepper motor, enable the input lines, activate the output lines and light the Activity LED on the front of the drive. Optional modes of operation are available. Reference section 7 for these user installable features.

3.3 Track Accessing

Seeking the R/W head from one track to another is accomplished by:

- a. Activating Drive Select line.
- b. Selecting desired direction utilizing Direction Select line.
- c. Write Gate is being inactive.
- d. Pulsing the Step line.

Multiple track accessing is accomplished by repeated pulsing of the Step line until the desired track has been reached. Each pulse on the Step line will cause the R/W head to move one track either in or out depending on the Direction Select line. Head movement is initiated on the trailing edge of the Step Pulse.

3.3.1 Step Out

With the Direction Select line at a plus logic level (2.5V to 5.25V) a pulse on the Step line will cause the R/W head to move one track away from the center of the disk. The pulse(s) applied to the Step line and Direction Select line must have the timing characteristics shown in Figure 3.

3.3.2 Step In

With the Direction Select line at a minus logic level (0V to .4V), a pulse on the Step line will cause the R/W head to move one track closer to the center of the disk. The pulse(s) applied to the Step line must have the timing characteristics shown in Figure 3.

3.4 Read Operation

Reading data from the SA800/801 Diskette Storage drive is accomplished by:

- a. Activating Drive Select line.
- b. Write Gate being inactive.

The timing relationships required to initiate a read sequence are shown in Figure 4. These timing specifications are required in order to guarantee that the R/W head position has stabilized prior to reading.

The timing of the read signals, Read Data, Separated Data, and Separated Clock are shown in Figure 5.

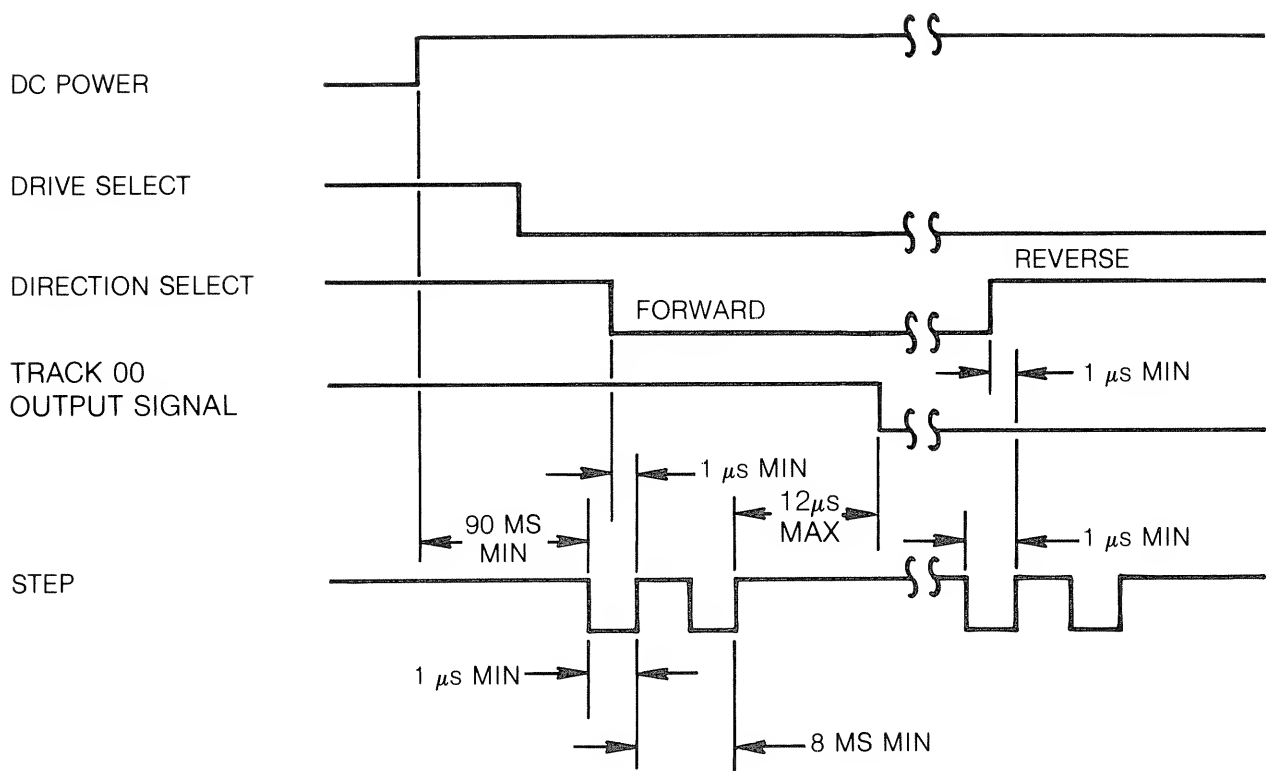
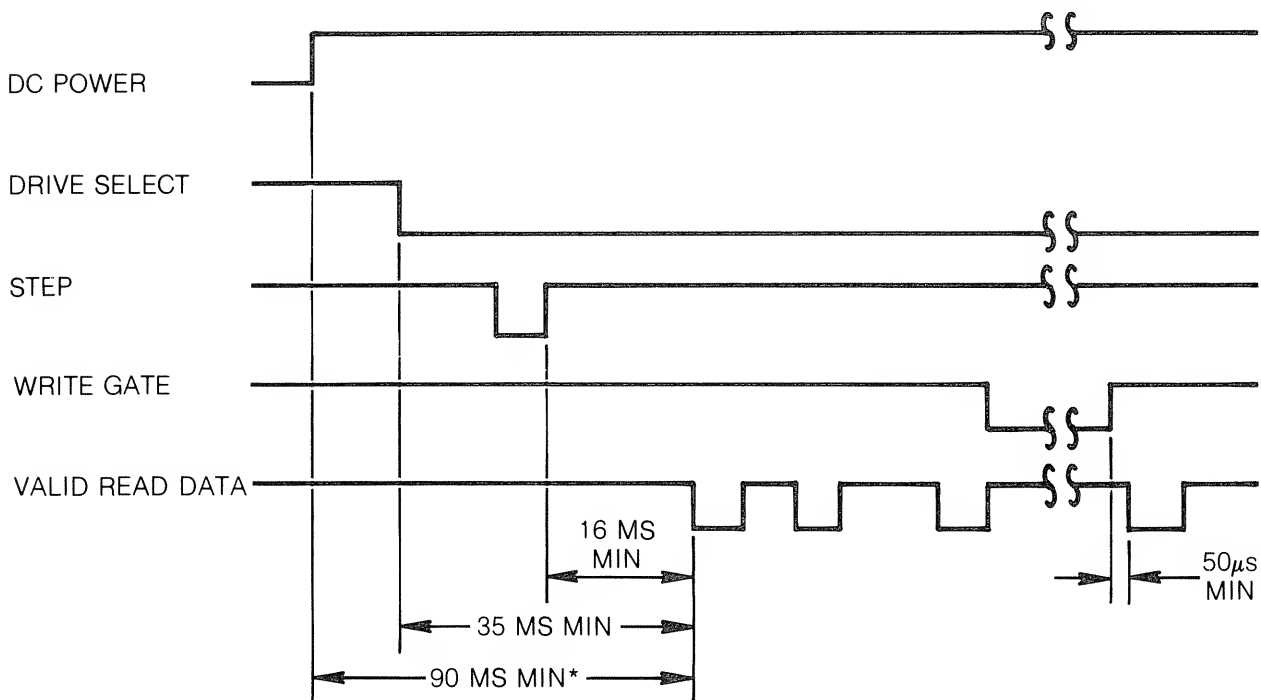
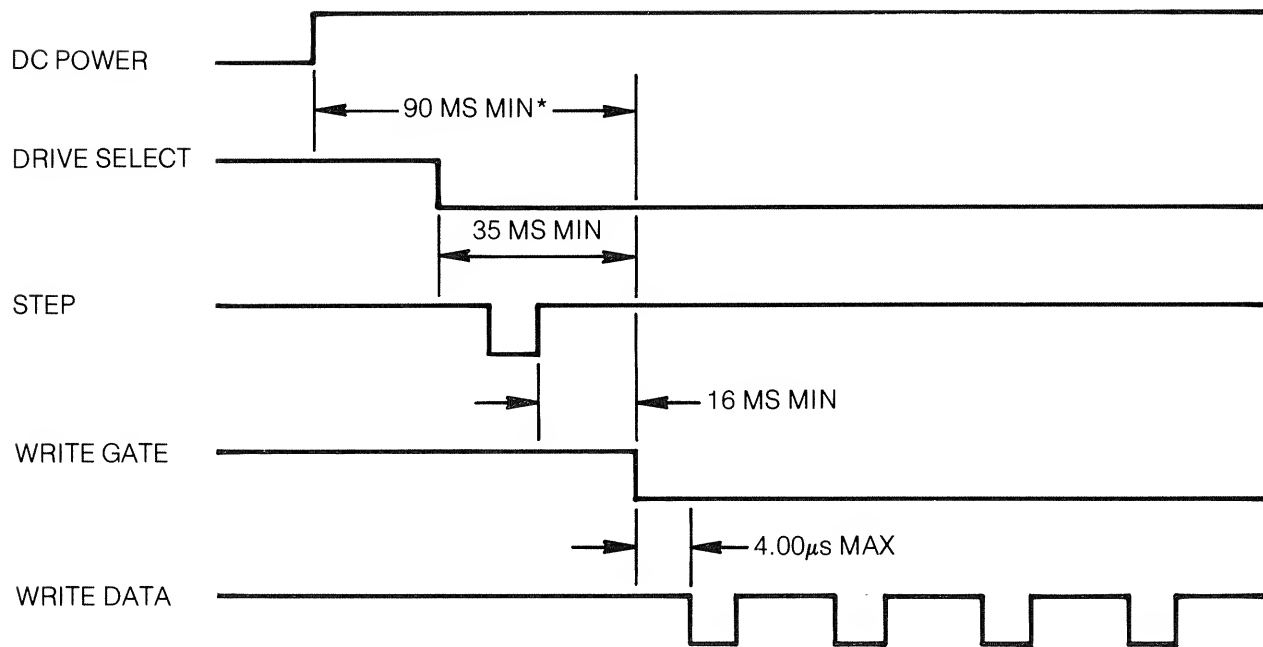

Figure 3. Track Access Timing



* 2 SECONDS IF AC AND DC POWER ARE APPLIED AT SAME TIME

Figure 4. Read Initiate Timing



* 2 SECONDS IF AC AND DC POWER ARE APPLIED AT SAME TIME.

Figure 6. Write Initiate Timing

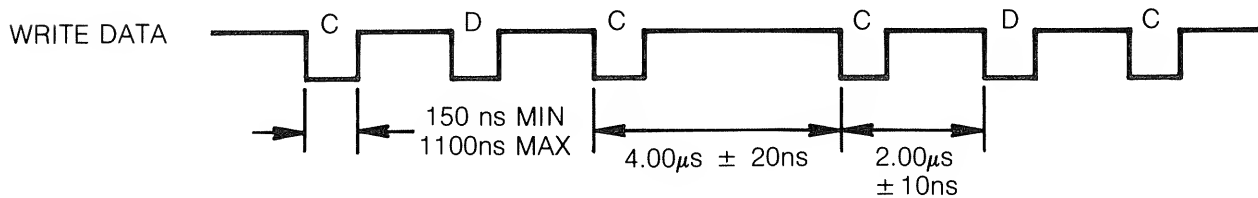
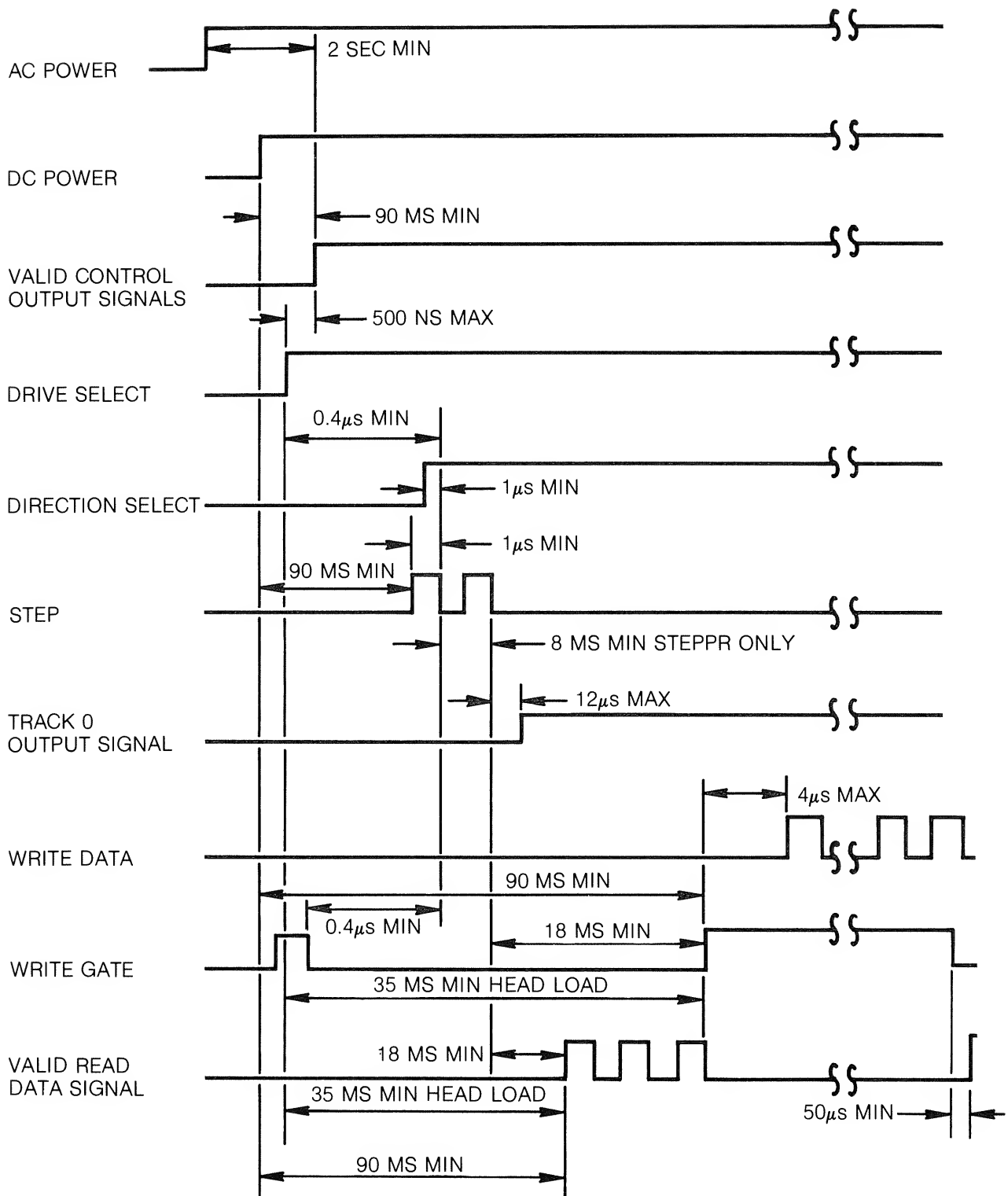

Figure 7. Write Data Timing



NOTE 1: 35ms minimum delay must be introduced after Drive Select to allow for proper head load settling. If stepper power is to be applied independent of Head Load, then an 8ms minimum delay must be introduced to allow for stepper settling. See Section 7 on optional customer installable features.

Figure 8. General Control and Data Timing Requirements





4.0 ELECTRICAL INTERFACE

The interface of the SA800/801 Diskette drive can be divided into two categories:

1. Signal
2. Power

The following sections provide the electrical definition for each line.

Reference Figure 9 for all interface connections.

4.1 Signal Interface

The signal interface consists of two categories:

1. Control
2. Data Transfer

All lines in the signal interface are digital in nature and either provide signals to the drive (input), or provide signals to the host (output), via interface connector P1/J1.

4.1.1 Input Lines

There are ten signal input lines, eight are standard and two are user installable options (reference section 7).

The input signals are of two types, those intended to be multiplexed in a multiple drive system and those which will perform the multiplexing. The input signals to be multiplexed are:

1. Direction Select
2. Step
3. Write Data
4. Write Gate

The input signals which are intended to do the multiplexing are:

1. Drive Select 1
2. Drive Select 2
3. Drive Select 3
4. Drive Select 4

The input lines have the following electrical specifications. Reference Figure 10 for the recommended circuit.

True = Logical zero = $V_{in} \pm 0.0V$ to $+ 0.4V$
@ $I_{in} = 40$ ma (max)

False = Logical one = $V_{in} + 2.5V$ to $+ 5.25V$
@ $I_{in} = 0$ ma (open)

Input Impedance = 150 ohms

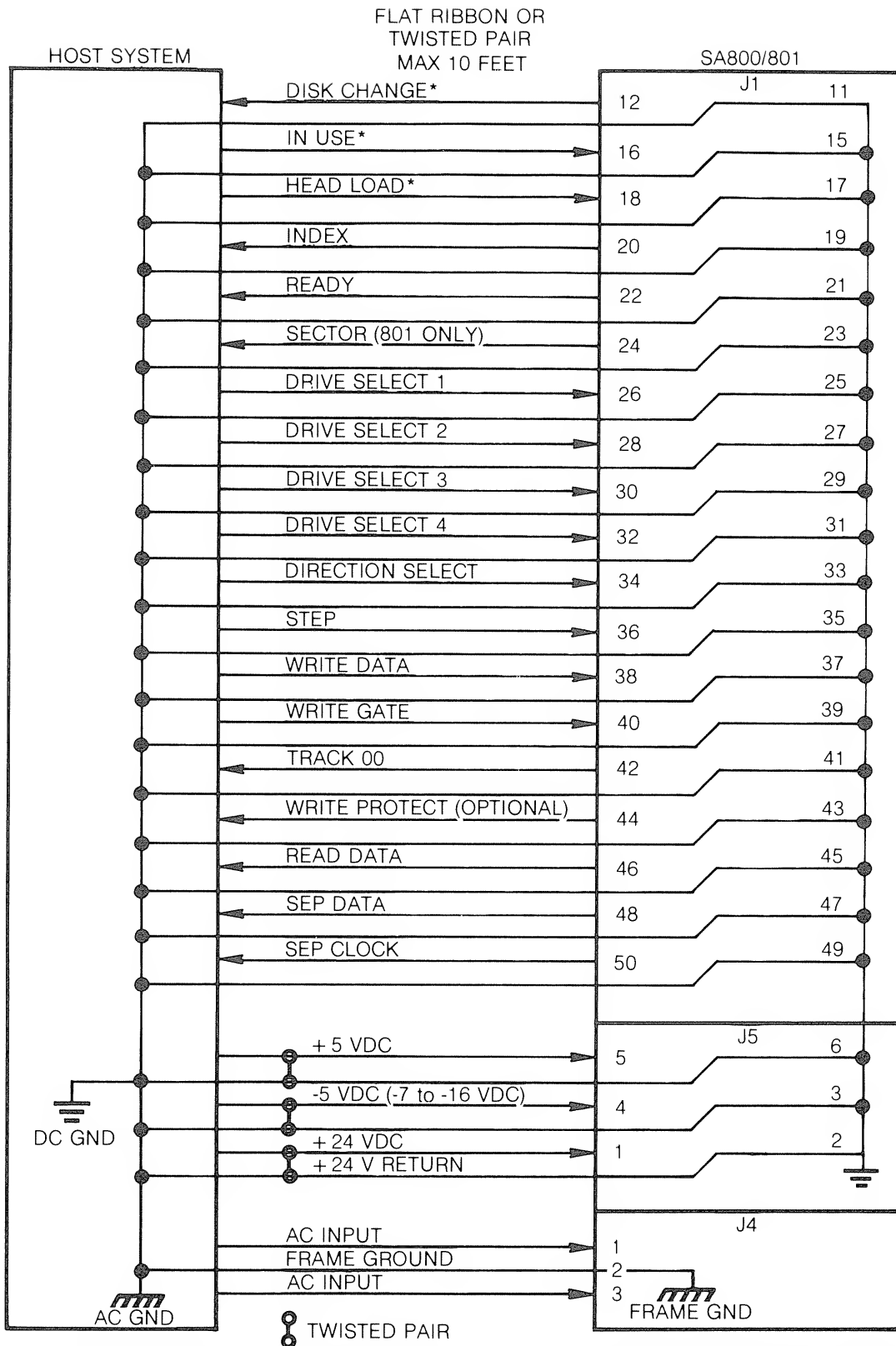

NOTE: Not shown are 5 of the 9 Alternate I/O connections. The connections for these lines are on pins 2, 4, 6, 8, 10 and 14. Signal return for these lines are on pins 1, 3, 5, 7, 9 and 13 respectively. Reference Section 7 for uses of these lines.

*These lines are alternate input/output lines and they are enabled by jumper plugs. Reference Section 7 for uses of these lines.

Figure 9. Interface Connections

4.1.1 Input Line Termination

The SA800/801 has been provided with the capability of terminating the four input lines, which are meant to be multiplexed, by jumpering traces. The four lines and their respective jumpering traces are:

1. Direction Select Trace "T3"
2. Step Trace "T4"
3. Write Data Trace "T5"
4. Write Gate Trace "T6"

In order for the drive to function properly, the last drive on the interface must have these four lines terminated. Termination of these four lines can be accomplished by either of two methods.

1. As shipped from the factory, jumpers are installed on the terminator posts T3, T4, T5, and T6. Remove these shorting plugs from all drives except the last one on the Interface.
2. External termination may be used provided the terminator is beyond the last drive. Each of the four lines should be terminated by using a 150 ohm, ¼ watt resistor, pulled up to +5 VDC.

4.1.1.2 Drive Select 1-4

Drive Select when activated to a logical zero level, activates the multiplexed I/O lines and loads the R/W head. In this mode of operation only the drive with this line active will respond to the input lines and gate the output lines.

Four separate input lines, Drive Select 1, Drive Select 2, Drive Select 3, and Drive Select 4, are provided so that up to four drives may be multiplexed together in a system and have separate Drive Select lines. Traces 'DS1', 'DS2', 'DS3', and 'DS4' have been provided to select which Drive Select line will activate the interface signals for a unique drive. As shipped from the factory, a shorting plug is installed on 'DS1'. To select another Drive Select line, this plug should be moved to the appropriate 'DS' pin. For additional methods of selecting drives, see section 7.1.

4.1.1.3 Direction Select

This interface line is a control signal which defines direction of motion the R/W head will take when the Step line is pulsed. An open circuit or logical one defines the direction as "out" and if a pulse is applied to the Step line the R/W head will move away from the center of the disk. Conversely, if this input is shorted to ground or a logical zero level, the direction of motion is defined as "in" and if a pulse is applied to the step line, the R/W head will move towards the center of the disk.

4.1.1.4 Step

This interface line is a control signal which causes the R/W head to move with the direction of motion as defined by the Direction Select line.

The access motion is initiated on each logical zero to logical one transition, or the trailing edge of the signal pulse. Any change in the Direction Select line must be made at least 1 μ s before the trailing edge of the Step pulse. The read/write head may be prevented from stepping past track 00 by using the "NFO" trace option on LSI PCB. Refer to Figure 3 for these timings. **Note:** When going from a reverse seek to a forward seek or vice versa and additional 8 ms delay must be induced before changing direction.

4.1.1.5 Write Gate

The active state of this signal, or logical zero, enables Write Data to be written on the diskette. The inactive state, or logical one, enables the read data logic (Separated Data, Separated Clock, and Read Data) and stepper logic. Refer to Figure 6 for timings.

4.1.1.6 Write Data

This interface line provides the data to be written on the diskette. Each transition from a logical one level to a logical zero level, will cause the current through the R/W head to be reversed thereby writing a data bit. This line is enabled by Write Gate being active. Refer to Figure 7 for timings.

4.1.1.7 Head Load (Alternate Input)

This customer installable option, when enabled by jumpering Trace 'C' and activated to a logical zero level and the diskette access door is closed, will load the R/W head load against the diskette. Refer to section 7 for uses and method of installation.

4.1.1.8 In Use (Alternate Input)

This customer installable option, when enabled by jumpering Trace 'D' and activated to a logical zero level will turn on the Activity LED in the door push button. This signal is an "OR" function with Drive Select. Refer to section 7.8 for uses and method of installation.

4.1.2 Output Lines

There are six standard and one optional output lines from the SA800, and eight output lines from the SA801. Also, there is one Alternate Output available from the drive. The output signals are driven with an open collector output stage capable of sinking a maximum of 40 ma at a logical level or true state with a maximum voltage of 0.4V measured at the driver. When the line driver is off and the collector current is a maximum of 250 microamperes.

Refer to Figure 10 for the recommended circuit.

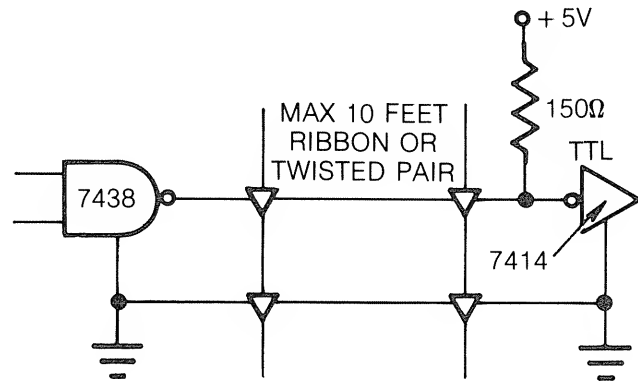

Figure 10. Interface Signal Driver/Receiver

4.1.2.1 Track 00

The active state of this signal, or a logical zero indicates when the drives R/W head is positioned at track zero (the outermost track) and the access circuitry is driving current through phase one of the stepper motor. This signal is at a logical one level, or false state, when the selected drives R/W head is not at track 00.

4.1.2.2 Index

This interface signal is provided by the drive once each revolution of the diskette (166.67 ms) to indicate the beginning of the track. Normally this signal is a logical one and makes the transition to the logical zero level for a period of 1.7 ms (0.4 ms on SA801) once each revolution. The timing for this signal is shown in Figure 11.

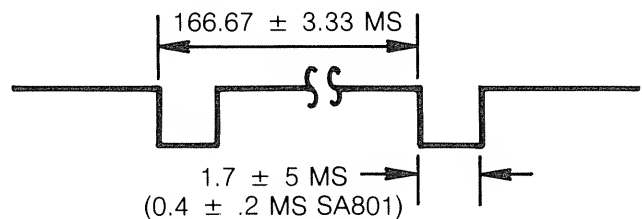

Figure 11. Index Timing

To correctly detect Index at the Host Index should be false at Drive Select time, that is, the Host should see the transition from false to true after the drive has been selected.

For additional methods of detecting Index, refer to section 7.6.

4.1.2.3 Sector (SA801 only)

This interface signal is provided by the drive 32 times each revolution. Normally, this signal is a logical one and makes the transition to a logical zero for a period of 0.4 ms each time a sector hole on the Diskette is detected. Figure 12 shows the timing of this signal and its relationship to the Index pulse.

For additional methods of detecting Sector refer to section 7.7.

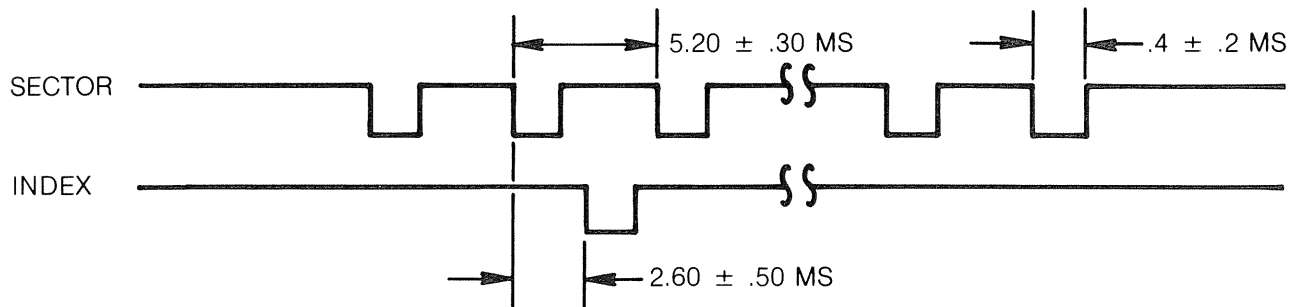

Figure 12. Sector Timing

4.1.2.4 Ready

This interface signal indicates that two index holes have been sensed after properly inserting a diskette and closing the door, or that two index holes have been sensed following the application of +5V power to the drive.

For additional methods of using the Ready line, refer to section 7.5.

4.1.2.5 Read Data

This interface line provides the "raw data" (clock and data together) as detected by the drive electronics. Normally, this signal is a logical one level and becomes a logical zero level for the active state. Reference Figure 5 for the timing and bit shift tolerance within normal media variations.

4.1.2.6 Sep Data

This interface line furnishes the data bits as separated from the "raw data" by use of the internal data separator. Normally, this signal is a logical one level and becomes a logical zero level for the active state. Reference Figure 5 for the timing. This line is available on the SA801 and 800 Model 1.

4.1.2.7 Sep Clock

This interface line furnishes the clock bits as separated from the "raw data" by use of the internal data separator. Normally, this signal is a logical one level and becomes a logical zero level for the active state. Reference Figure 5 for the timing. This line is available on the SA801 and 800 Model 1 and PCB 25136.

NOTE: True separation internally inserting up to three missing clock bits to maintain synchronization, is available on the LSI PCB by using trace option "TS".

4.1.2.8 Write Protect (Optional on SA800)

This interface signal is provided by the drive to give the user an indication when a Write Protected Diskette is installed. The signal is logical zero level when it is protected. Under normal operation, the drive will inhibit writing with a protected diskette installed in addition of notifying the interface.

For other methods of using Write Protect, refer to section 7.9.

4.1.2.9 Disk Change (Alternate Output)

Reference section 7.10.

4.1.3 Alternate I/O Pins

These interface pins have been provided for use with customer installable options. Refer to section 7 for methods of use.

4.2 Power Interface

The SA800/801 Diskette Storage Drive requires both AC and DC power for operation. The AC power is used for the spindle drive motor and the DC power is used for the electronics and the stepper motor.

4.2.1 AC Power

The AC power to the drive is via the connector P4/J4 located to the rear of the drive and below the AC motor capacitor. The P4/J4 pin designations are outlined below for standard as well as optional AC power.

P4 PIN	60 Hz		50 Hz	
	115 V (Standard)	208/230 V	110V	220V
1	85-127 VAC	170-253 VAC	85-127 VAC	170-253 VAC
2	Frame Gnd	Frame Gnd	Frame Gnd	Frame Gnd
3	85-127 V Rtn	170-253 V Rtn	85-127 V Rtn	170-253 V Rtn
MAX CURRENT	0.35 Amps	0.23 Amps	0.35 Amps	0.23 Amps
FREQ TOLERANCE	± 0.5 Hz		± 0.5 Hz	

4.2.2 DC Power

DC power to the drive is via connector P5/J5 located on non-component side of PCB near the P4 connector. The three DC voltages and their specifications along with their P5/J5 pin designators, are outlined below.

P5 PIN	DC VOLTAGE	TOLERANCE	CURRENT	MAX RIPPLE (p to p)
1	+ 24 VDC	± 1.2 VDC	1.7 A Max** 1.3 A Typ	100 mv
2	+ 24 V Return*			
3	- 5 V Return			
4	- 5 VDC	± 0.25 VDC	0.07 A Max 0.05 A Typ	50 mv
	Optional -7 to -16 VDC (trace 'L')***	NA	0.10 A Max 0.07 A Typ	NA
5	+ 5 VDC	± 0.25 VDC	1.0 A Max 0.8 A Typ	50 mv
6	+ 5 V Return			

*The +24 VDC power requires a separate ground return line. It, and all other DC grounds must be connected together at the power supply. One line from this common DC connection must go to one common Frame Ground connection near the power supply.

**If either customer installable option described in sections 7.2 and 7.4 are used, the current requirement for the + 24 VDC is a multiple of the maximum of + 24V current times the number of drives on the line.

***If the shorting plug is in the vertical position the -7 to -16 VDC option can be used. If the shorting plug is in the horizontal position, -5 VDC must be used.

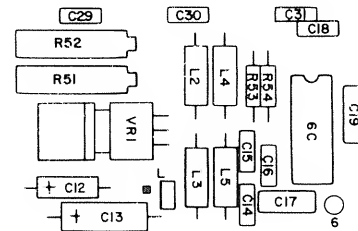



5.0 PHYSICAL INTERFACE

The electrical interface between the SA800/801 and the host system is via three connectors. The first connector, J1, provides the signal interface; the second connector, J5, provides the DC power; and the third connector, J4, provides the AC power and frame ground.

This section describes the physical connectors used on the drive and the recommended connectors to be used with them. Refer to Figure 16 for connector locations.

5.1 J1/P1 Connector

Connection to J1 is through a 50 pin PCB edge card connector. The dimensions for this connector are shown in Figure 13. The pins are numbered 1 through 50 with the even numbered pins on the component side of the PCB and the odd numbered pins on the non-component side. Pin 2 is located on the end of the PCB connector closest to the AC motor capacitor and is labeled 2. A key slot is provided between pins 4 and 6 for optional connector keying.

The recommended connectors for P1 are tabulated below.

TYPE OF CABLE	MANUFACTURER	CONNECTOR P/N	CONTACT P/N
Twisted Pair, #26 (crimp or solder)	AMP	1-583717-1	583616-5 (crimp) 58354-3 (solder)
Twisted Pair, #26 (solder term.)	VIKING	3VH25/1JN-5	NA
Flat Cable	3M "Scotchflex"	3415-0001	NA

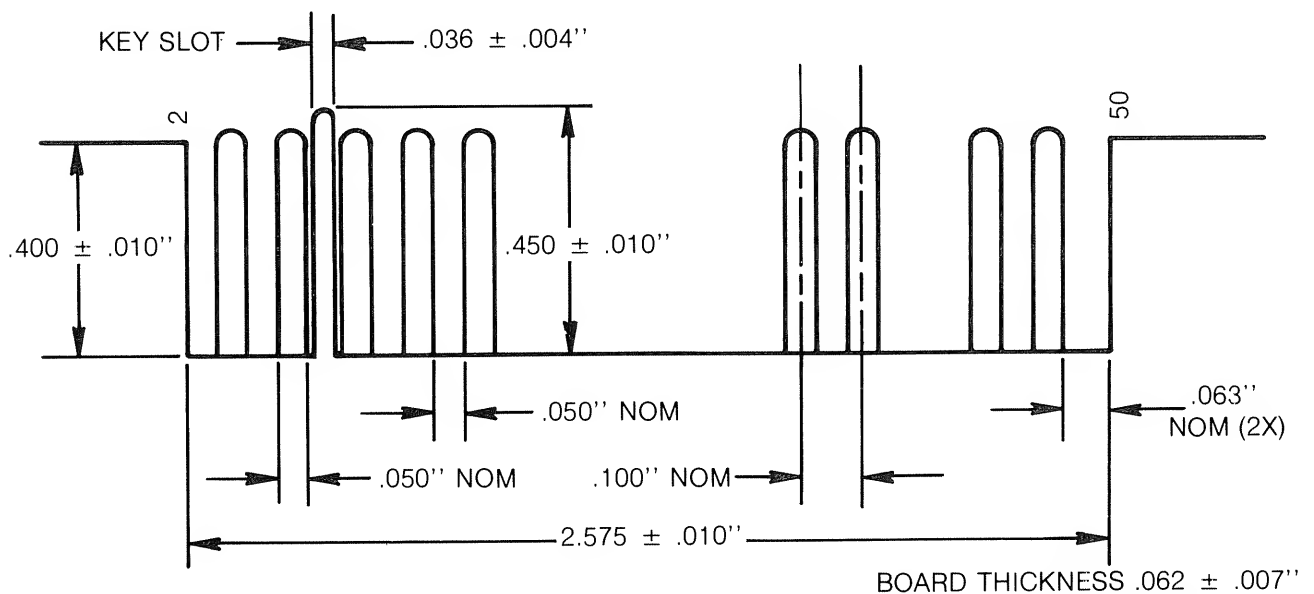

Figure 13. J1 Connector Dimensions

5.2 J5/P5 Connector

The DC power connector, J5, is mounted on the non-component side of the PCB and is located below the AC motor capacitor. J5 is a 6 pin AMP Mate-N-Lok connector P/N 1-380999-0. The recommended mating connector (P5) is AMP P/N 1-480270-0 utilizing AMP pins P/N 60619-1. J5 pins are labeled on the component side of the PCB with pin 5 located nearest J1/P1. Figure 14 illustrates J5 connector as seen on the drive PCB from non-component side.

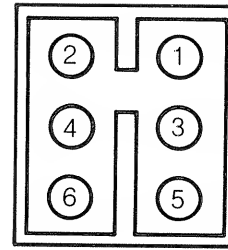

Figure 14. J5 Connector

5.3 J4/P4 Connector

The AC power connector, J4 is mounted on the AC motor capacitor bracket and is located just below the capacitor. J4 connector is a 3 pin connector AMP P/N 1-480305-0 with pins P/N 60620-1. The recommended mating connector (P4) is AMP P/N 1-480303-0 or 1-480304-0 both utilizing pins P/N 60619-1. Figure 15 illustrates J4 connector as seen from the rear of the drive.

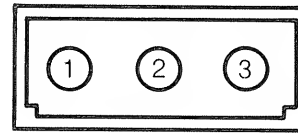

Figure 15. J4 Connector

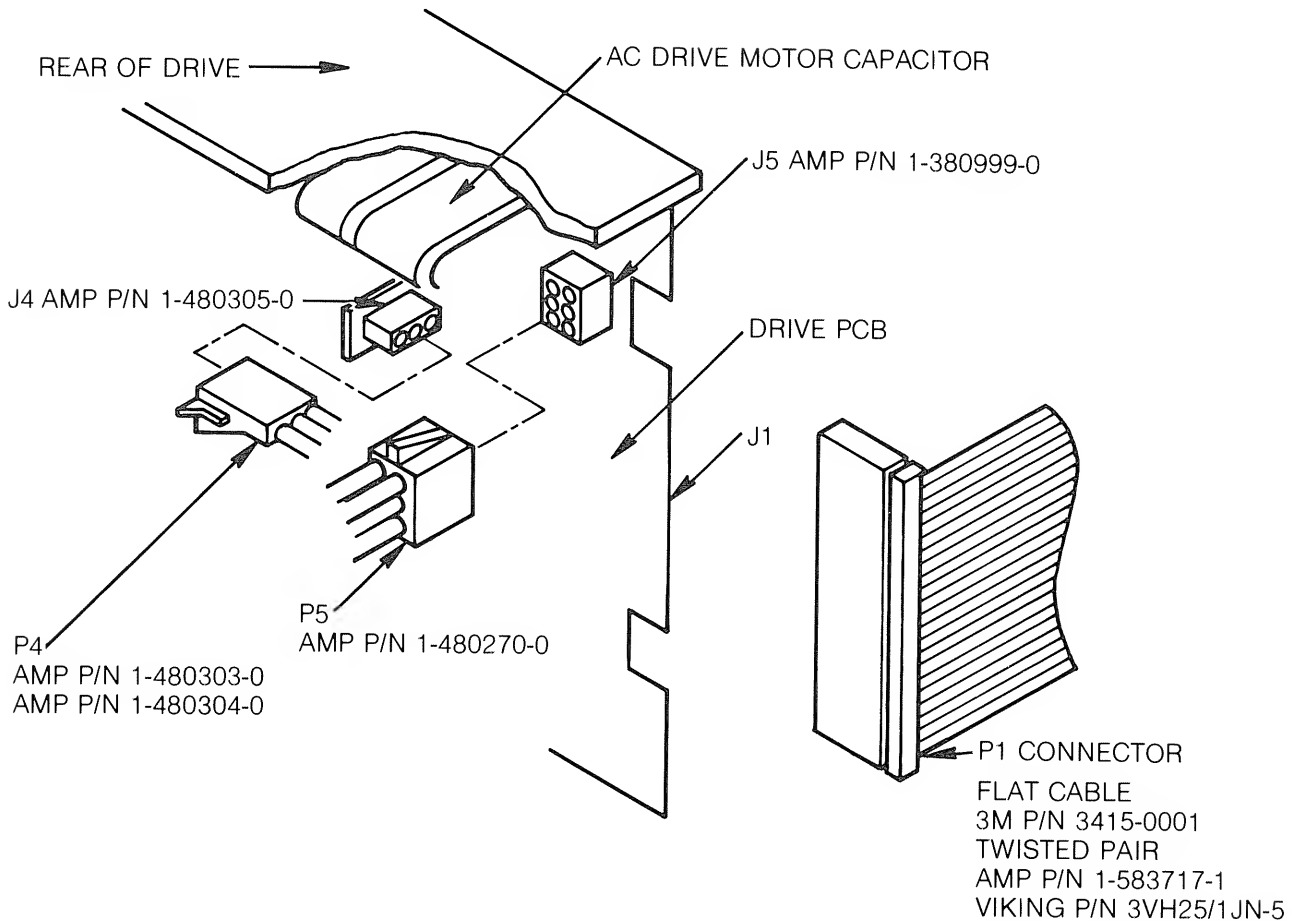

Figure 16. Interface Connectors - Physical Location Diagram

6.0 DRIVE PHYSICAL SPECIFICATIONS

This section describes the mechanical dimensions and mounting recommendations for the SA800/801.

6.1 Drive Dimensions

Reference Figure 18 for dimensions of the SA800/801.

6.2 Mounting Recommendations

The SA800/801 is capable of being mounted in one of the following positions:

1. Vertical-Door opening to the left or right.
2. Horizontal-Door opening up or down.
3. Upright-Door opening towards the front or rear.

6.2.1 Vertical Mounting

The drive, as shipped from the factory, is ready to be mounted in the vertical position, door opening left or right, without any adjustments.

Horizontal Mounting

If the drive is to be mounted horizontally with the door opening down (PCB up), the head load actuator return spring must be repositioned to compensate for gravity. Reference Figure 17 for the proper spring position on the actuator.

If the door is to open up (PCB down), it must be specified when ordering. This feature provides a heavier door opening spring. In addition, the head load actuator return spring will be repositioned to compensate for gravity. Reference Figure 17 for the proper position for the spring on the actuator.

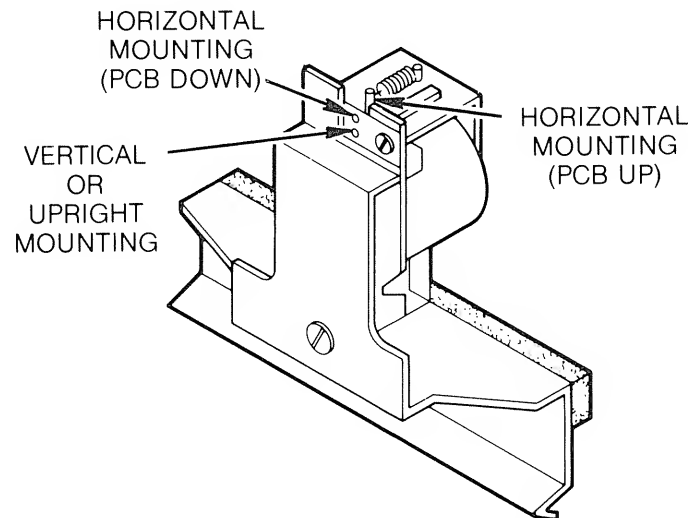
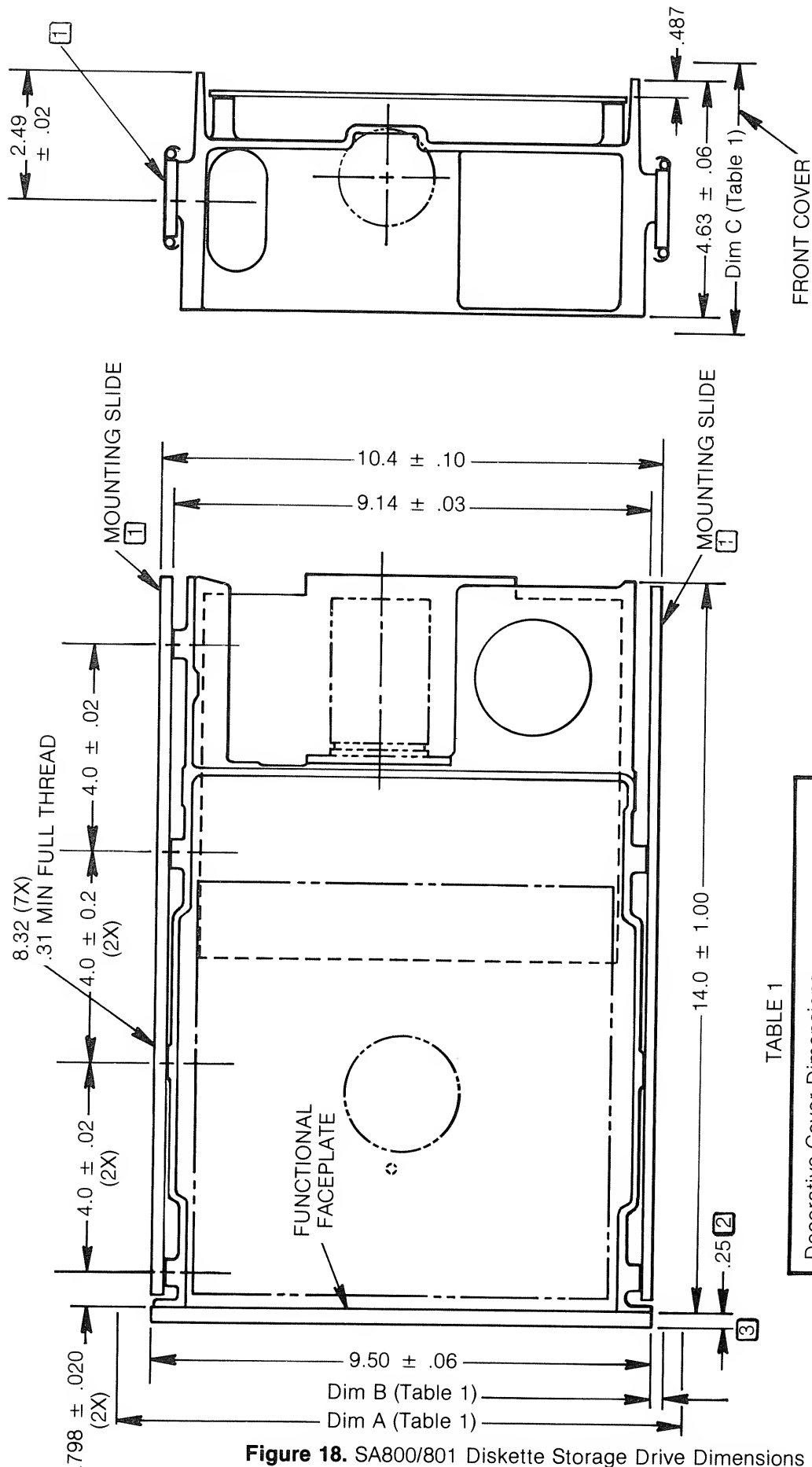

Figure 17. Head Load Actuator Mounting Prerequisites

6.2.3 Upright Mounting

If the Drive is to be mounted in the upright position (IBM 3740 fashion), the spring hook attached to the eject mechanism must be removed and then attach the eject spring to the place the hook was on.



- 1 If file is mounted on slides, file will extend 14 inches from operating position for servicing.
- 2 With decorative cover this dimension is .38.
- 3 Handle extends .375 beyond faceplate.
- 4 All dimensions are in inches.

TABLE 1

Decorative Cover Dimensions			
Cover Size	Dim A	Dim B	Dim C
4-5/8 X 10-1/2	10.50	.240	4.62
5-1/4 X 10	10.00	.240	5.25
5-1/4 X 11	11.00	.740	5.25
Tolerance	± .03	± .030	± .03

Figure 18. SA800/801 Diskette Storage Drive Dimensions

6.3 Chassis Slide

Available as an optional accessory is a chassis slide kit P/N 50239. This kit contains two slides, one locking and one non-locking, and seven screws. Dimensions of the slide are shown in Figure 19. For use on the standard casting only.

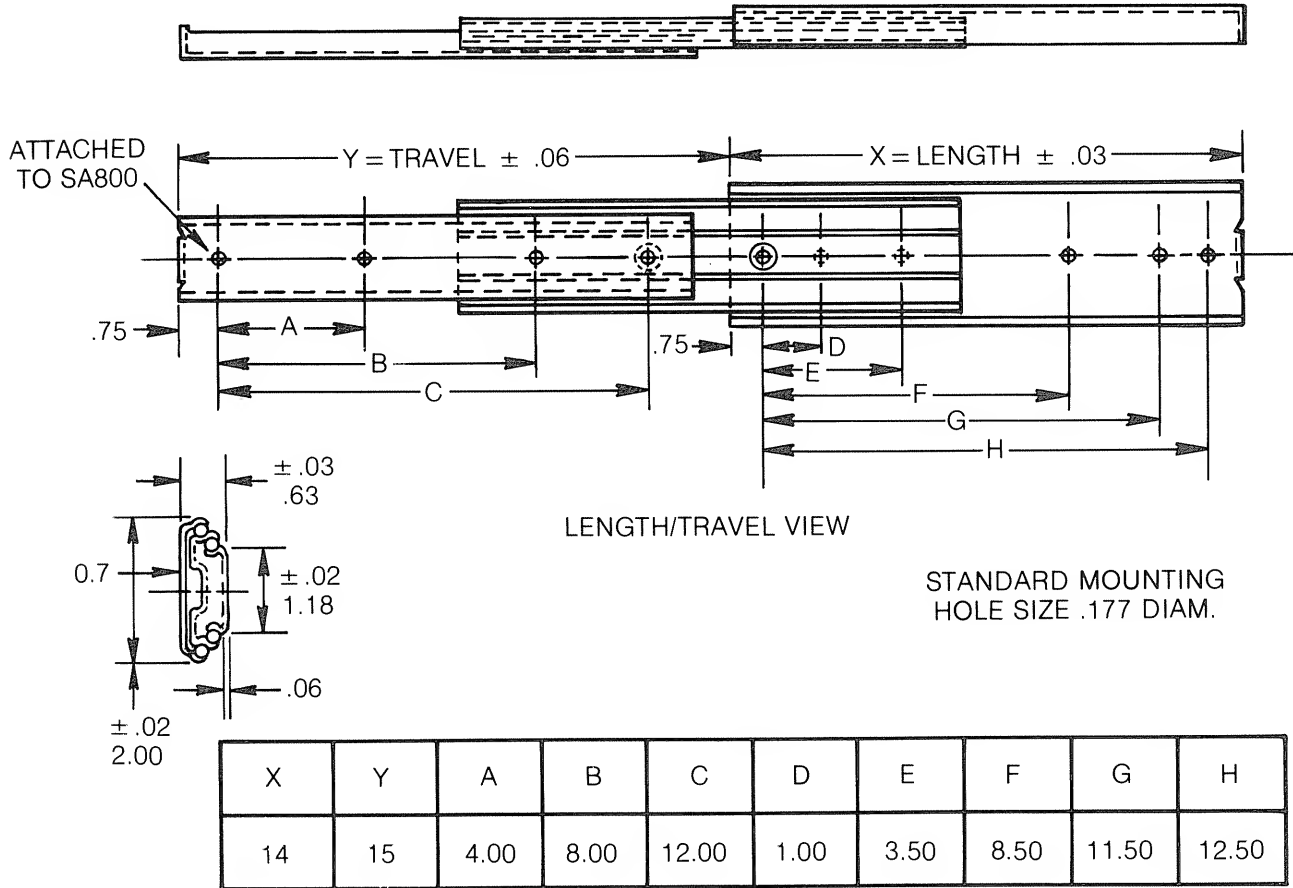

Figure 19. Slide Mounting Dimensions

6.4 Decorative Face Plate

The SA800/801 may be ordered with one of the following decorative face plates:

SIZE	COLOR	PART NO.
4 5/8 × 10 1/2	Tan	50264
4 5/8 × 10 1/2	White	50263
5 1/4 × 10	Tan	50261
5 1/4 × 10	White	50260
5 1/4 × 11	Tan	50258
5 1/4 × 11	White	50257
"R" Series-4 5/8 × 8 11/16	Tan	50675

If another color is required to match the system's color scheme, the face plate may be painted. The following information should be utilized to avoid potential problems in the painting process.

1. The front cover is made from GE's LEXAN. Dimensional stability of LEXAN exists from -60°F + 250°F. If the type paint used requires baking, the temperature should not exceed + 250°F, including any hot spots which can contact the cover.
2. LEXAN is a polycarbonate. Any paint to be used should be investigated to insure that it does not contain chemicals that are solvents to polycarbonates.

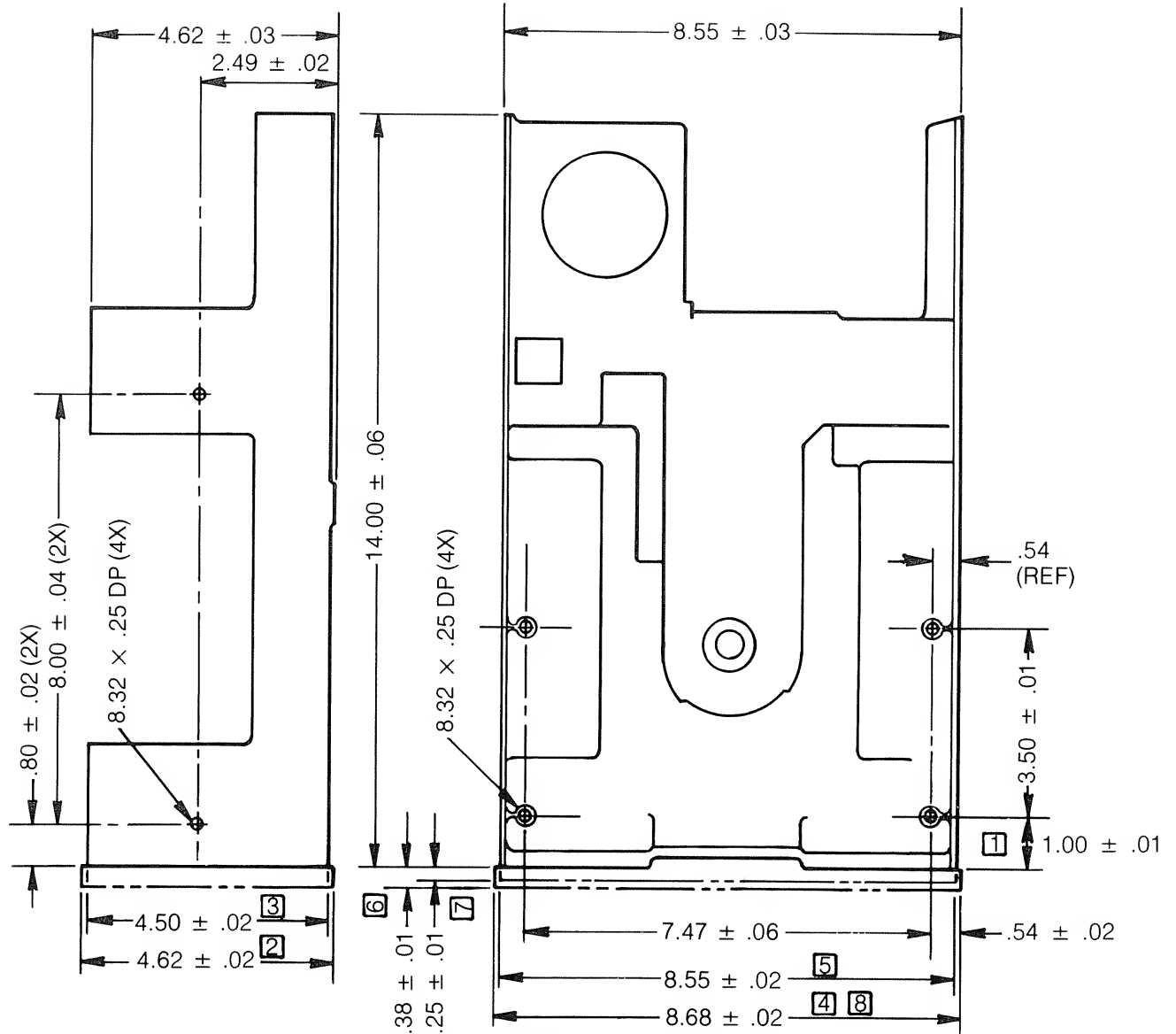

- 1 Dimension is from end of base casting.
- 2 Cosmetic front cover height.
- 3 Functional front plate height.
- 4 Cosmetic front cover width.
- 5 Functional front plate width.
- 6 Cosmetic front cover thickness.
- 7 Functional front plate thickness.
- 8 Cosmetic front cover color comes only in tan.

Figure 20. SA800/801R Dimensions

7.0 CUSTOMER INSTALLABLE OPTIONS

The SA800/801 can be modified by the user to function differently than the standard method as outlined in sections 3 and 4. These modifications can be implemented by adding or deleting traces and by use of the Alternate I/O pins. Some traces are capable of being connected by use of a shorting plug, Shugart P/N 15648 or AMP P/N 530153-2. This section will discuss a few examples of modifications and how to install them. The examples are:

1. Drive Select one to eight drives.
2. Select drive without loading head or enabling stepper.
3. Select drive and enable stepper without loading the head.
4. Load head without selecting drive or enabling stepper.
5. Radial Ready.
6. Radial Index/Sector.
7. Eight, 16, or 32 Sector option.
8. In Use (Activity L.E.D.) optional input.
9. Write Protect options.

Tabulated below are the trace options with the condition of the trace as it is shipped from the factory. Figure 21 shows the location of these traces on the PCB.

CUSTOMER CUT/ADD TRACE OPTIONS

TRACE DESIGNATOR	DESCRIPTION	SHIPPED FROM FACTORY	
		OPEN	SHORT
T3,T4,T5,T6	Terminations for Multiplexed Inputs		Plugged
T1	Terminator for Drive Select		Plugged
T2	Spare Terminator for Radial Head Load	X	
DS1,DS2,DS3,DS4	Drive Select Input Pins	X	DS1 is Plugged
RR	Radial Ready		X
RI	Radial Index and Sector		X
R,I,S	Ready, Index, Sector Alternate Output Pads		X
HL	Stepper Power From Head Load		Plugged
DS	Stepper Power From Drive Select	X	
WP	Inhibit Write When Write Protected		X
NP	Allow Write When Write Protected	X	
8,16,32	8, 16, 32 Sectors (SA801 Only)	8 & 16	32
D	Alternate Input-In Use	X	
2,4,6,8,10,12,14,16,18	Nine Alternate I/O Pins	X	
D1,D2,D4,DDS	Customer Installable Decode Drive Select Option	X	
A,B,X	Radial Head Load		Plugged
C	Alternate Input-Head Load	X	
Z	In Use from Drive Select		Plugged
Y	In Use from HD LD	X	
DC	Alternate Output-Disk Change	X	
NFO	Non Force Out	X	
TS	True FM Data Separation	X	

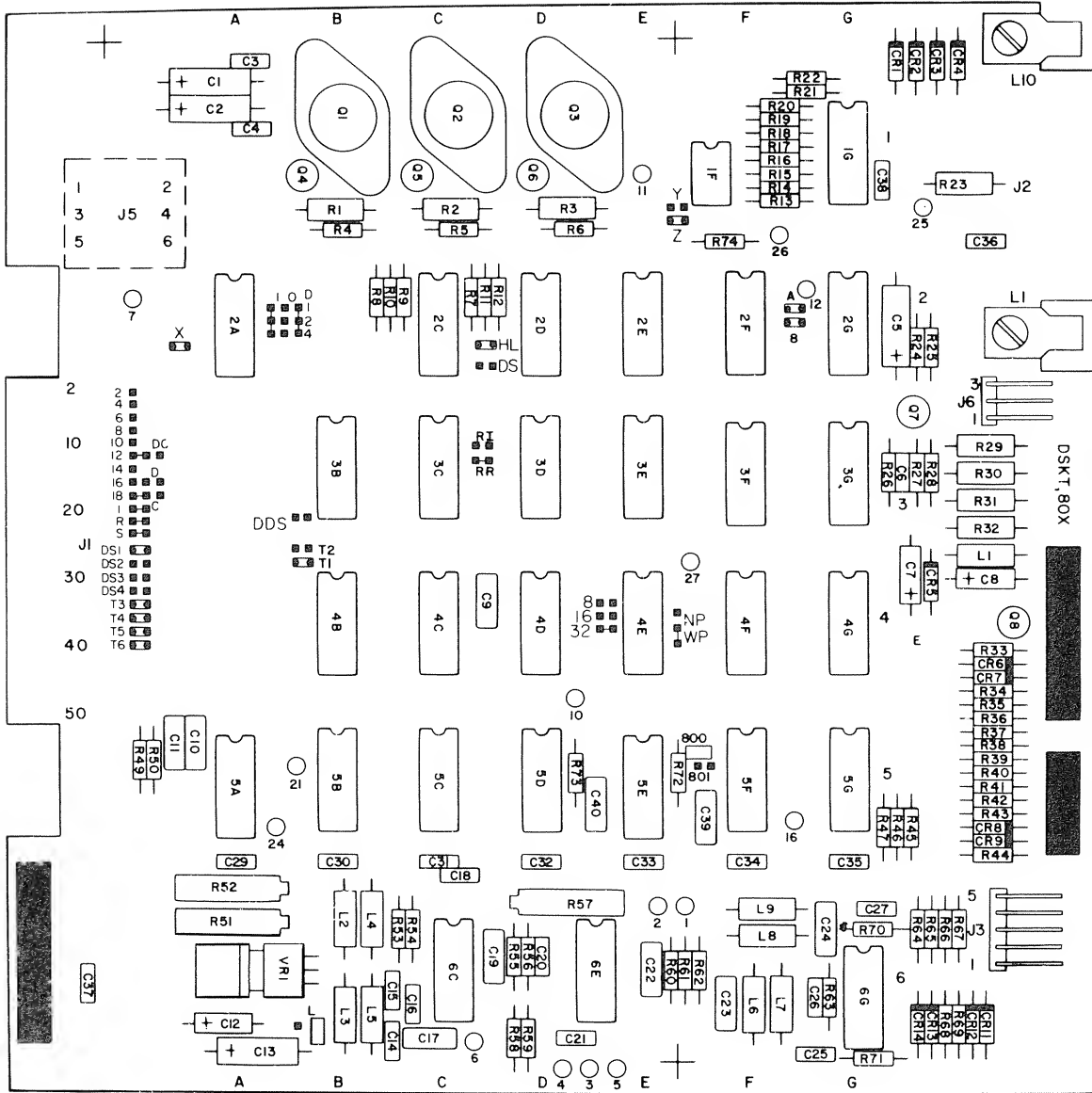

- ▣ Jumper Plug Installed as Shipped
- Test Point

Figure 21. Component Locations Standard PCB

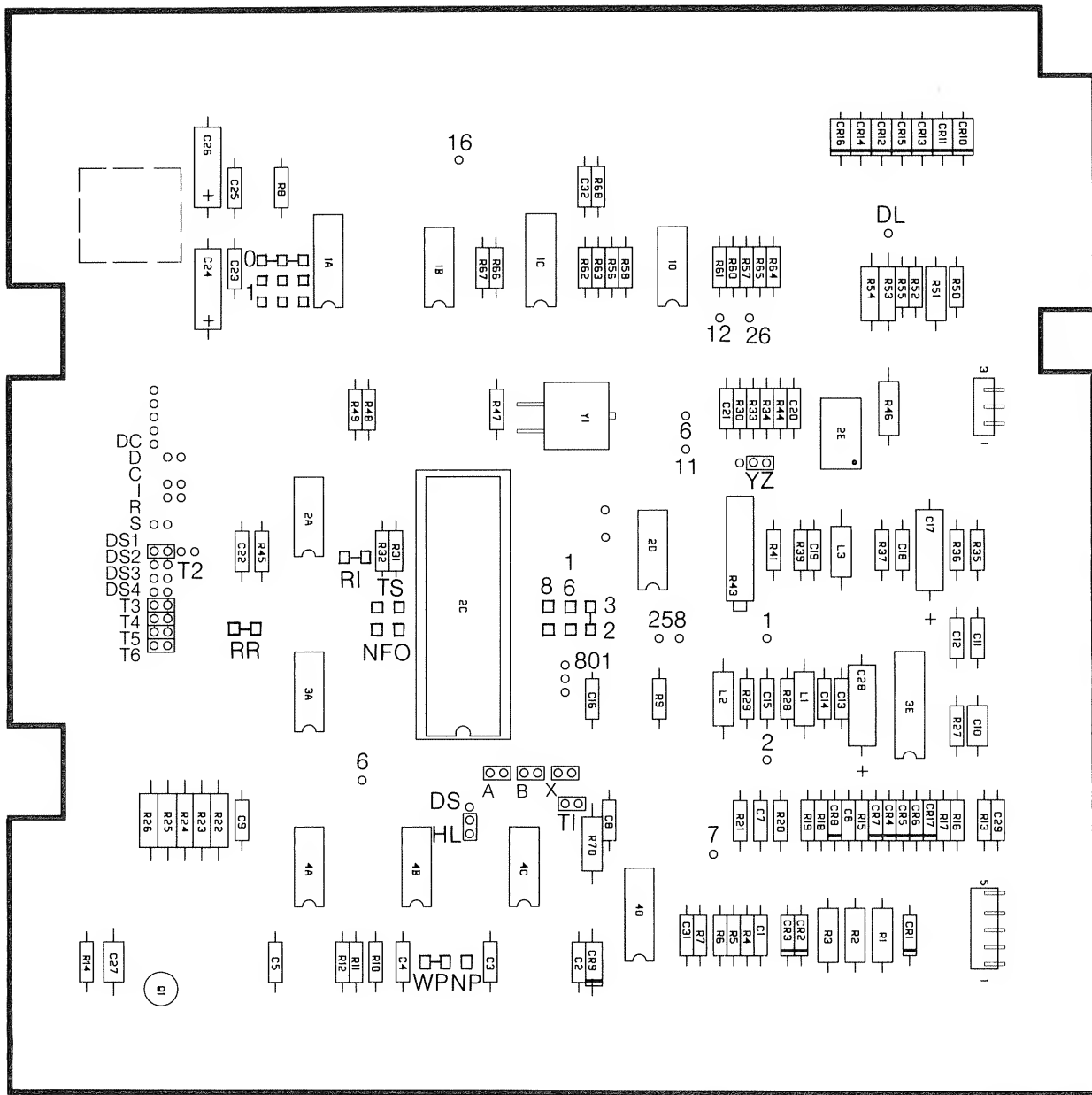

Figure 22. Component Locations LSI PCB

7.1 Drive Select - One to Eight Drives

Customer installed option allows up to eight drives to be multiplexed together. This method of drive selection uses a binary address to select a drive.

To install this feature on a standard drive, the following traces should be added or deleted:

1. Add a 74L85, 4 bit comparator (Motorola P/N MC 14585, National Semiconductor P/N MM 74c85) into position 2B on PCB, (1A on PCB 25136).
2. Connect trace 'DDS'.
3. Insure traces 'DS1' - 'DS4' are plugged.
4. Jumper traces 'D1', 'D2', and 'D4' according to table below for address of each drive.

The four Drive Select lines are to be used for addressing the drives. Pin 26 is used as Drive Select enable and pins 28 (binary 1), 30 (binary 2), and 32 (binary 4), are the address lines. Figure 23 illustrates the circuitry. The table below shows the logical state each line must be at to select each of the drives.

Figure 23 illustrates the circuitry.

ADDRESS	TRACE		
	D1	D2	D4
0	0	0	0
1	1	0	0
2	0	1	0
3	1	1	0
4	0	0	1
5	1	0	1
6	0	1	1
7	1	1	1

DRIVE	INTERFACE PIN			
	26	28	30	32
0	0	1	1	1
1	0	0	1	1
2	0	1	0	1
3	0	0	0	1
4	0	1	1	0
5	0	0	1	0
6	0	0	1	0
7	0	0	0	0

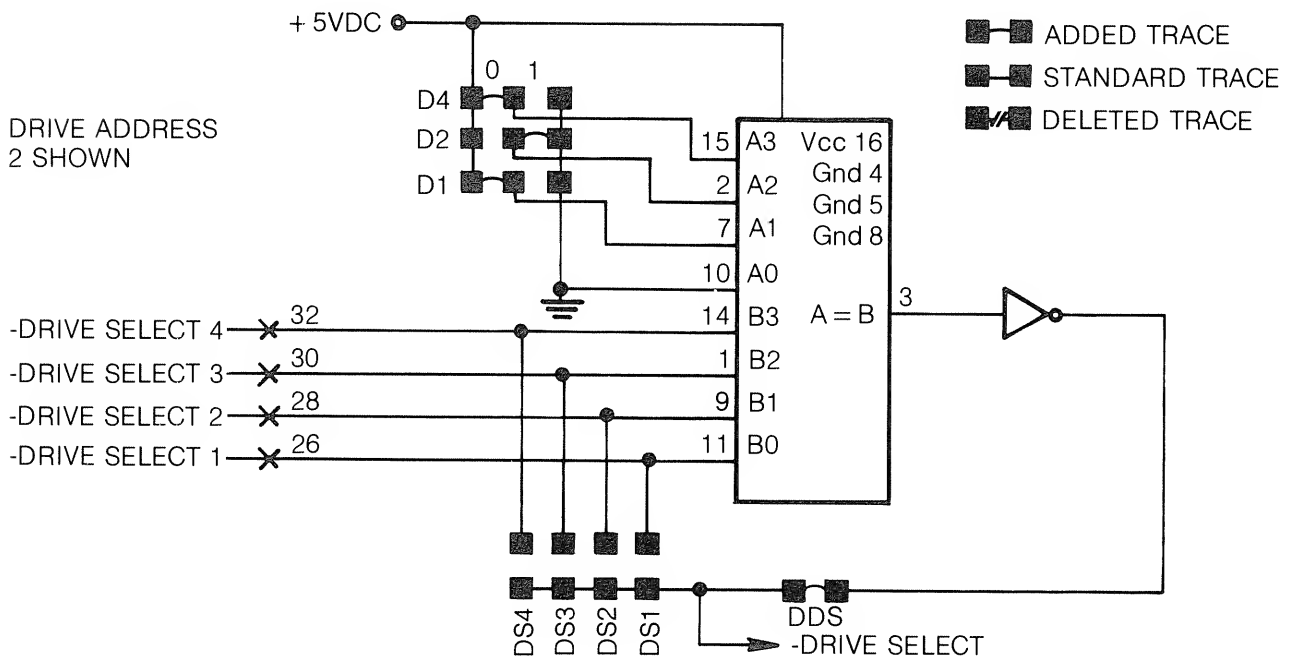

Figure 23. Drive Select Circuitry

7.2 Select Drive Without Loading Head Or Enabling Stepper Motor

This option would be advantageous to the user who requires a drive to be selected at all times. Normally, when a drive is selected, its head is loaded and the stepper motor is energized. The advantage of this option would be that the output control signals could be monitored (with the exception of Track Zero, which requires the stepper to be energized) while the head was unloaded thereby extending the head and media life. When the system requires the drive to perform a Read, Write, or Seek, the controller would activate the Head Load line (pin 18) which in turn would load the head and energize the stepper motor. After the Head Load line is activated, a 35 ms delay must be introduced before Write Gate and Write Data may be applied or before Read Data is valid.

To install this option on a standard drive, the following traces should be added or deleted:

1. Jumper trace 'T2'.
2. Remove jumper from trace 'X'.
3. Jumper trace 'C'.

Figure 24 illustrates the circuitry.

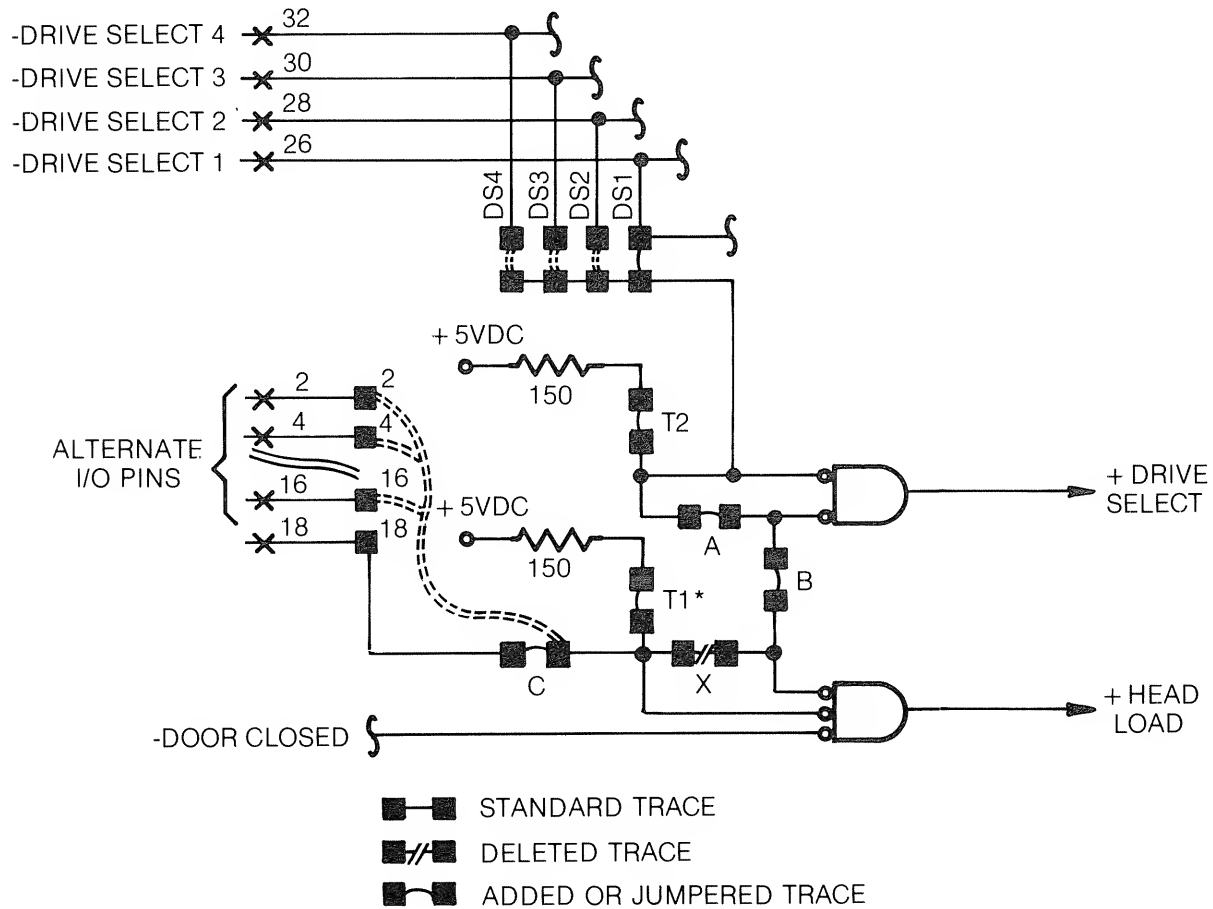

*NOTE: If the -Head Load line is multiplexed, terminator 'T1' jumper must be removed from each drive except the last one on the line. Also, the current requirement for the + 24 VDC supply should be a multiple of the maximum + 24 volt current times the number of drives on the line that have Head Load active.

Figure 24. Select Drive Without Loading Head Circuit

7.3 Select Drive and Enable Stepper Without Loading Head

This option is useful to the user who wishes to select a drive and perform a seek operation without the head being loaded or with door open. An example use of this option is that at power on time, an automatic recalibrate (reverse seek to track zero) operation could be performed with the drive access door open. Normally for a seek to be performed, the door must be closed and the head loaded. Other advantages are those listed in section 7.2 in addition to being able to monitor Track Zero. When a Read or Write operation is to be performed, the head must be loaded (pin 18). After the Head Load line is activated, a 35 ms delay must be introduced before Write Gate and Write Data may be applied or before Read Data is valid.

To install this option on a standard drive, the following traces should be added or deleted:

1. Jumper trace 'T2'.
2. Remove jumper from trace 'B'.
3. Remove jumper from trace 'HL'.
4. Jumper trace 'DS'.
5. Jumper trace 'C'.

Figures 24 and 25 illustrate the circuitry.

7.4 Load Head Without Selecting Drive Or Enabling Stepper

This option is useful in disk to disk copy operations. It allows the user to keep the heads loaded on all drives thereby eliminating the 35 ms head load time. The head is kept loaded on each drive via an Alternate I/O pin. Each drive may have its own Head Load line (Radial or Simplex) or they may share the same line (Multiplexed). When the drive is selected, an 8 ms delay must be introduced before a Read or Write operation can be performed. This is to allow the R/W head to settle after the stepper motor is energized. With this option installed, a drive can only be selected with both Drive Select and Head Load active.

To install this option on standard drive, the following traces should be added or deleted:

1. Jumper trace 'T2'.
2. Remove jumper from trace 'A'.
3. Remove jumper from trace 'HL'.
4. Jumper trace 'DS'.
- *5. Jumper trace 'C'.

*If the -Head Load line is multiplexed, terminator 'T1' jumper must be removed from each drive except the last one on the line.

Figures 25 and 26 illustrate the circuitry.

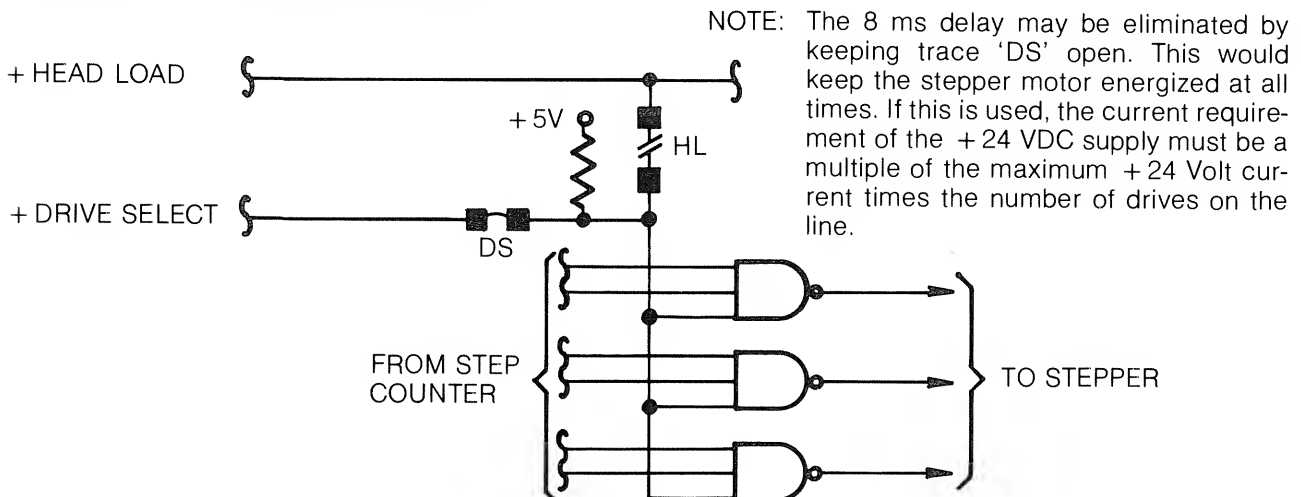
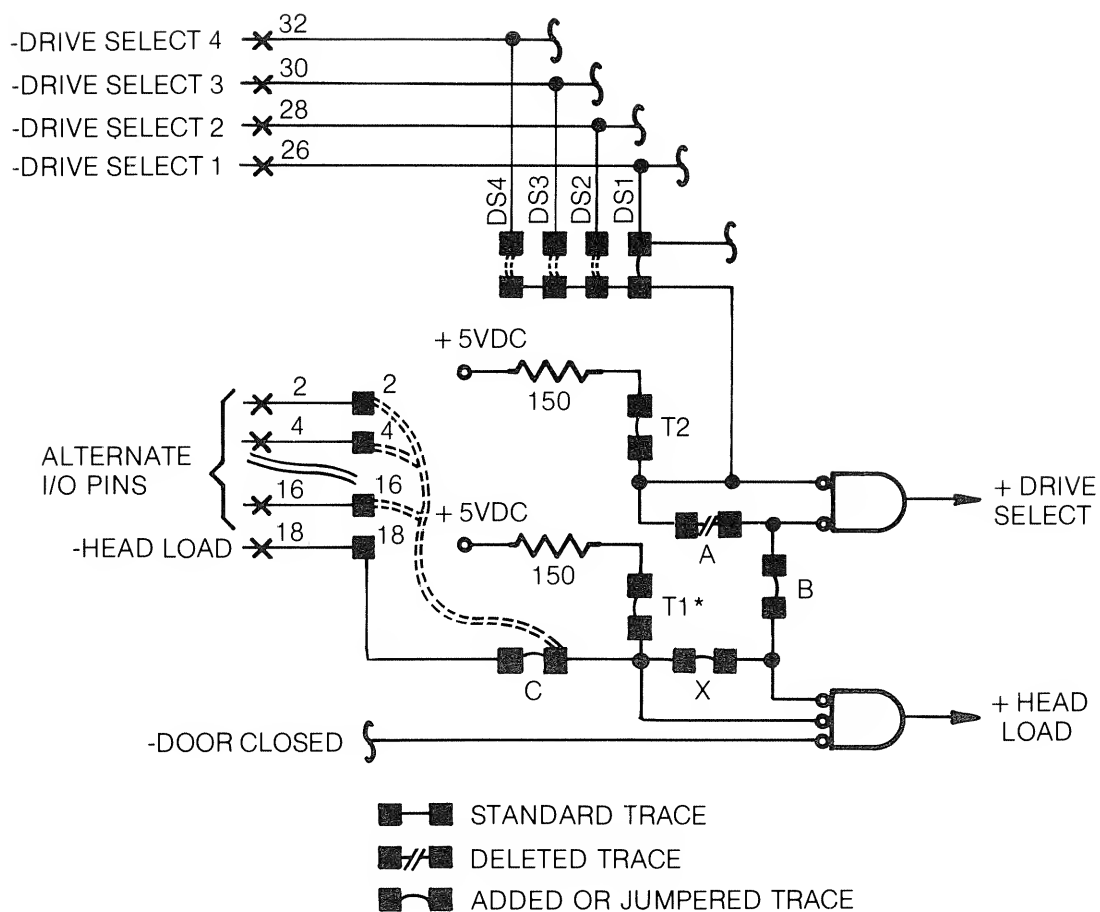

Figure 25. Stepper Motor Enable Circuit



*IF THE -HEAD LOAD LINE IS MULTIPLEXED; TERMINATOR 'T1' JUMPER MUST BE REMOVED FROM EACH DRIVE EXCEPT THE LAST ONE ON THE LINE.

Figure 26. Load Head Without Selecting Drive or Enabling Stepper Circuit

7.5 Radial Ready

This option enables the user to monitor the Ready line of each drive on the interface. This can be useful in detecting when an operator has removed or installed a Diskette in any drive. Normally, the Ready line from a drive is only available to the interface when it is selected.

To install this option on a standard drive, the following traces should be added or deleted:

1. Cut trace 'RR'.
- *2. Cut trace 'R'.
- *3. Add a wire from pad 'R' to one of the Alternate I/O pins.

*One of the drives on the interface may use pin 22 as its Ready line, therefore, steps 2 and 3 may be eliminated on this drive. All the other drives on the interface must have their own Ready line, therefore steps 2 and 3 must be incorporated.

Figure 27 illustrates the circuitry.

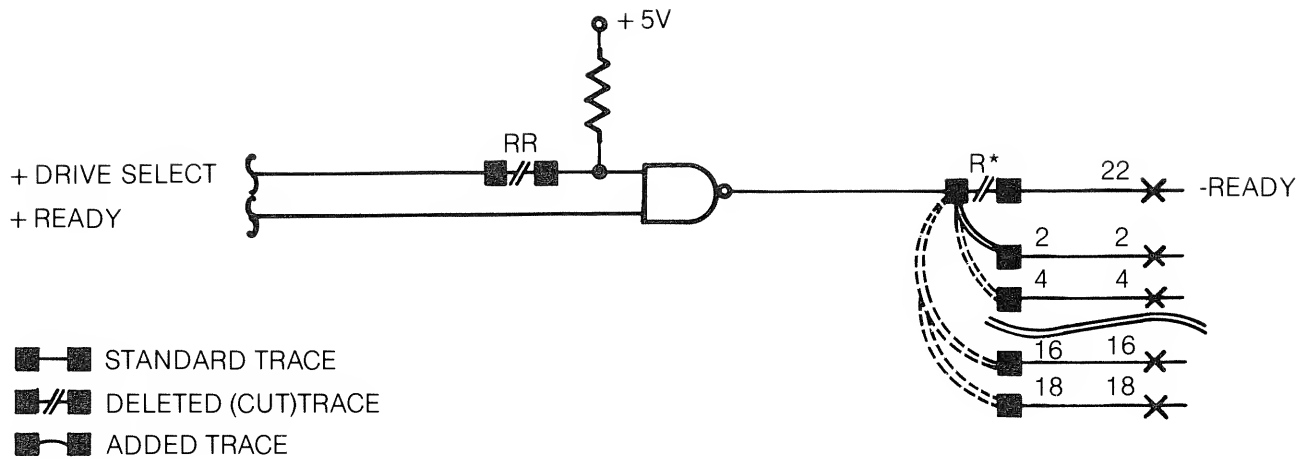

Figure 27. Radial Ready Circuit

7.6 Radial Index/Sector

This option enables the user to monitor the Index and Sector lines at all times so that the drive may be selected just prior to the sector that is to be processed. This option can be used to reduce average latency.

To install this option on a standard drive the following traces should be added or deleted:

1. Cut trace 'RI'.
- *2. Cut trace 'I'.
- *3. Cut trace 'S'.
- *4. Add a wire from trace 'I' to one of the Alternate I/O pins.
- *5. Add a wire from trace 'S' to one of the Alternate I/O pins.

*One of the drives on the interface may use pin 20 (-Index) and pin 24 (-Sector) as its Index and Sector lines, therefore, steps 2-5 may be eliminated for this drive. All other drives on the interface must have their own Index and Sector lines, therefore, steps 2-5 must be incorporated.

Figure 28 illustrates the circuitry.

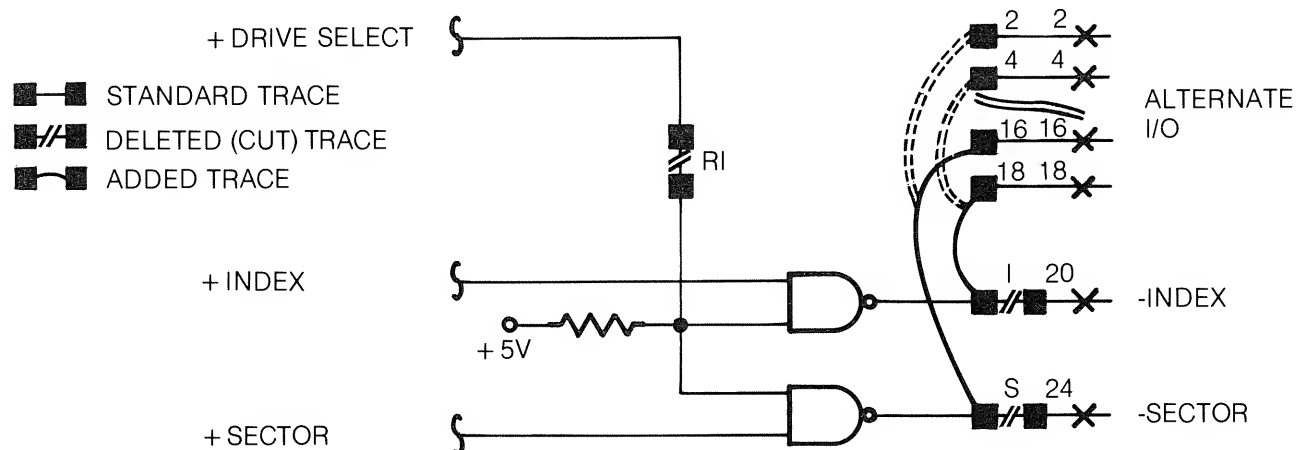

Figure 28. Radial Index/Sector Circuit

7.7 Eight, 16, Or 32 Sectors

The SA801, as shipped from the factory, is set up to provide 32 Sector pulses per revolution of the Diskette onto the interface. This option is provided for the user who wishes to have eight or 16 Sectors per revolution. The logic divides the Sector pulses by two or four. Reference Figure 29 for the timing relationships.

To install this option on a standard drive (SA801), the following traces should be added or deleted:

1. Cut trace '32'.
2. Connect trace '16' for 16 Sectors or connect trace '8' for eight Sectors.

Figure 30 illustrates the circuitry.

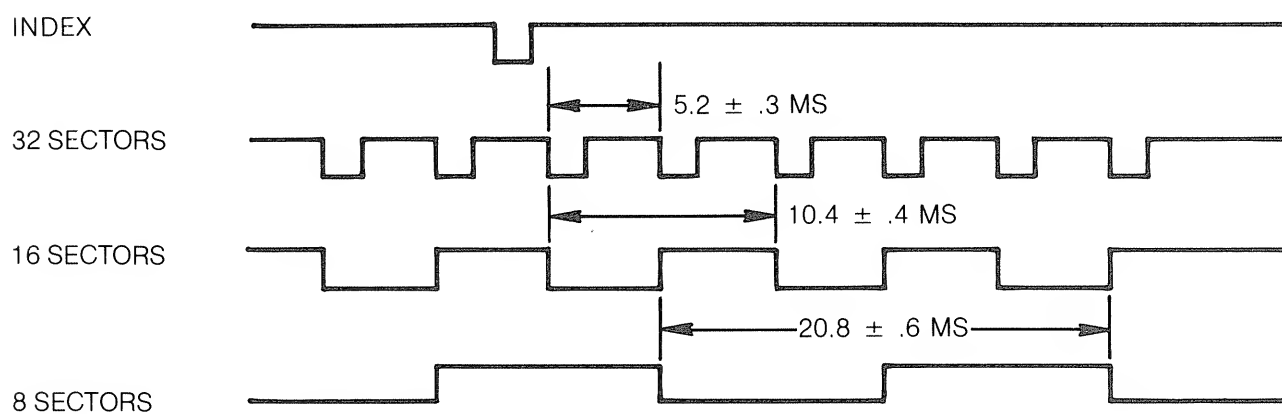

* INDICATES BEGINNING OF SECTOR 1 IN RELATIONSHIP TO INDEX

Figure 29. Sector Timing Relationships

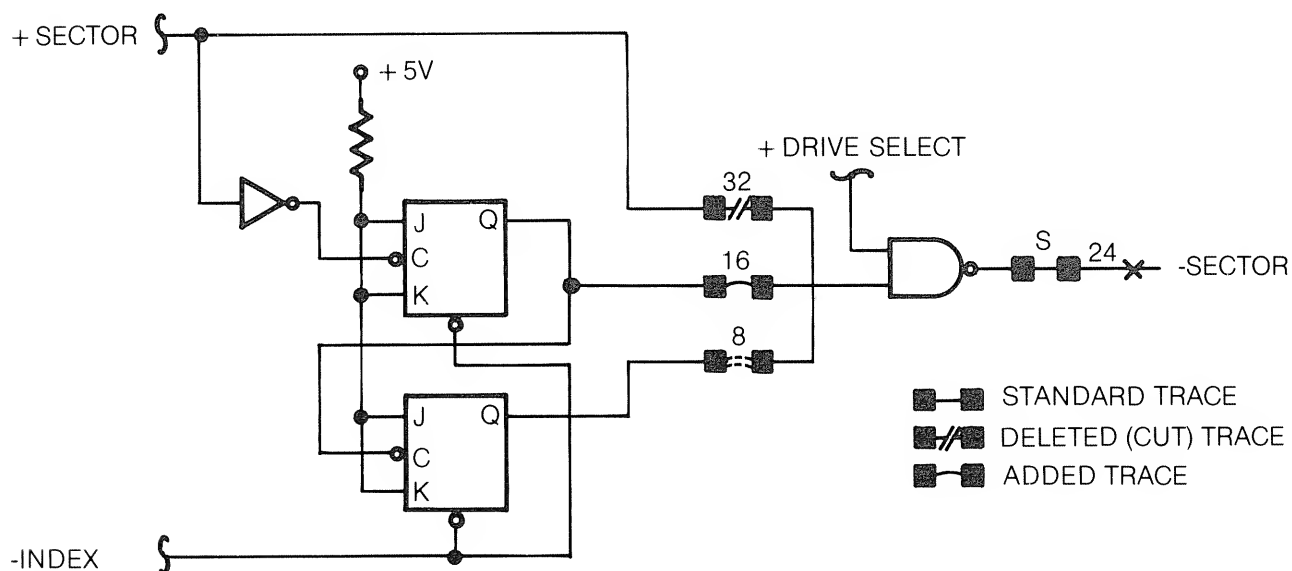

Figure 30. Sector Divide Circuit

7.8 In Use Alternate Input (Activity LED)

This alternate input, when activated to a logical zero level, will turn on the Activity LED mounted in the push bar on the front panel of the drive. It can be used as an indicator to the operator. Examples of some indications are:

1. Write protected Diskette is installed.
2. Drive in which the diskette is to be changed.
3. The operating system drive.
4. Drive with a special configuration.

To install this option on standard drive, jumper trace 'D' and activate the interface line pin 16.

This signal is an "OR" function with Drive Select or Head Load. Figure 31 illustrates the circuitry.

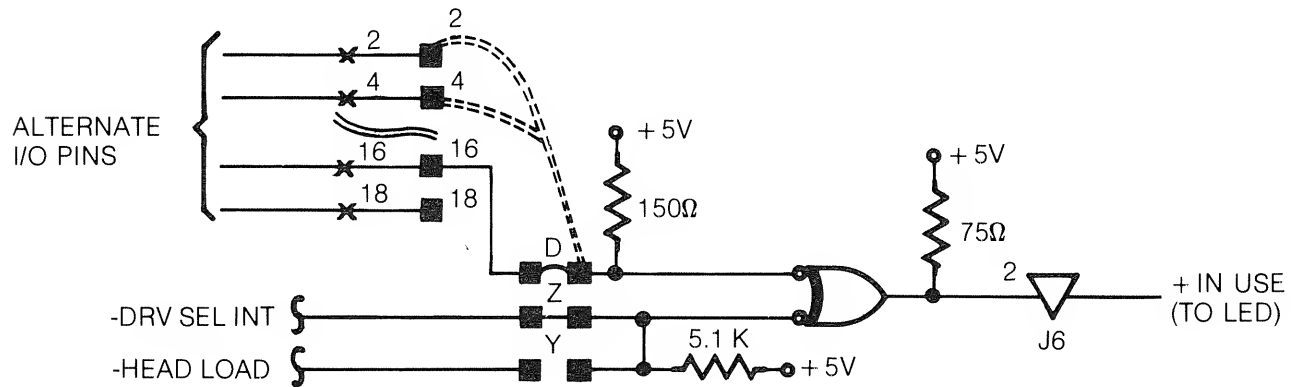

Figure 31. In Use/Activity LED Circuit

7.9 Write Protect Optional Use

As shipped from the factory, the optional Write Protect feature will internally inhibit writing when a Write Protected Diskette is installed. With this option installed, a Write Protected Diskette will not inhibit writing, but it will be reported to the interface. This option may be useful in identifying special use Diskettes.

To install this option on a drive with the Write Protect feature, the following traces should be added or deleted:

1. Cut trace 'WP'.
2. Connect trace 'NP'.

Figure 32 illustrates the circuitry.

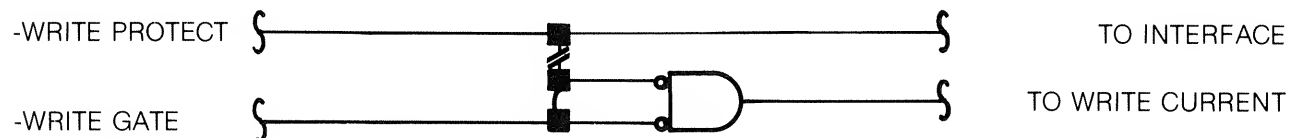

Figure 32. Write Protect Circuit



7.10 Disk Change (Alternate Output)

This customer installable option is enabled by jumpering trace 'DC'. It will provide a true signal (logical zero) onto the interface (pin 12) when Drive Select is activated if while deselected the drive has gone from a Ready to a Not Ready (Door Open) condition. This line is reset on the true to false transition of Drive Select if the drive has gone Ready. Timing of this line is illustrated in Figure 33. The circuitry is illustrated in Figure 34.

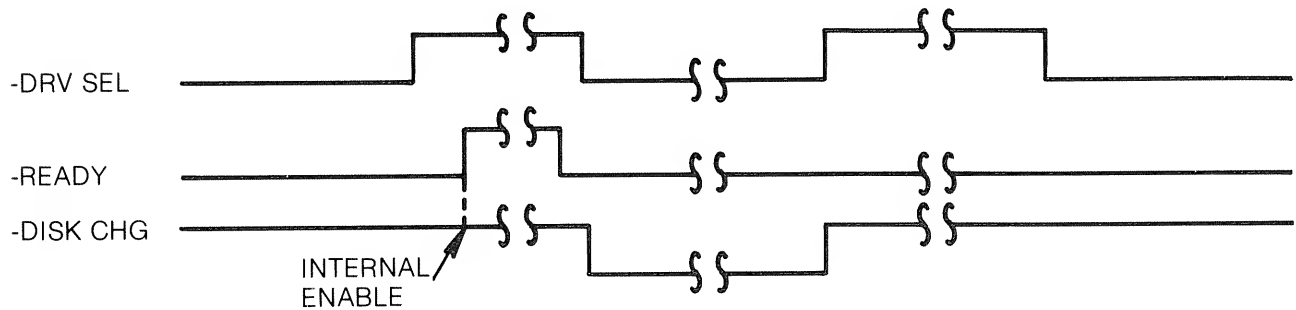

Figure 33. Disk Change Timing

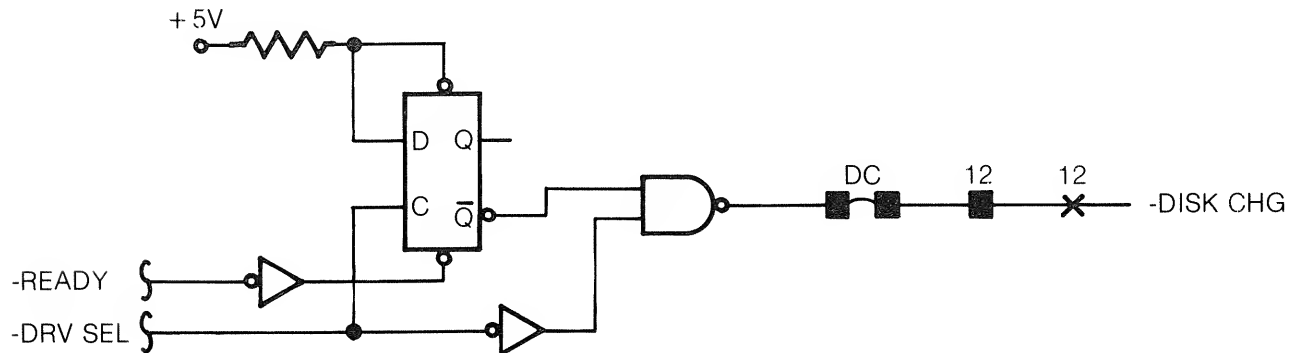

Figure 34. Disk Change Circuit

8.0 OPERATION PROCEDURES

The SA800/801 was designed for ease of operator use to facilitate a wide range of operator oriented applications. The following section is a guide for the handling and error recovery procedures on the diskette and diskette drive.

8.1 Diskette Loading and Handling

The diskette is a flexible disk enclosed in a plastic jacket. The interior of the jacket is lined with a wiping material to clean the disk of foreign material. Figure 35 shows the proper method of loading a diskette in the SA800/801 Diskette Storage Drive. To load the diskette, depress latch, insert the diskette with the label facing out. (See Figure 35). Move the latch handle to the left to lock diskette on drive spindle. The diskette can be loaded or unloaded with all power on and drive spindle rotating.

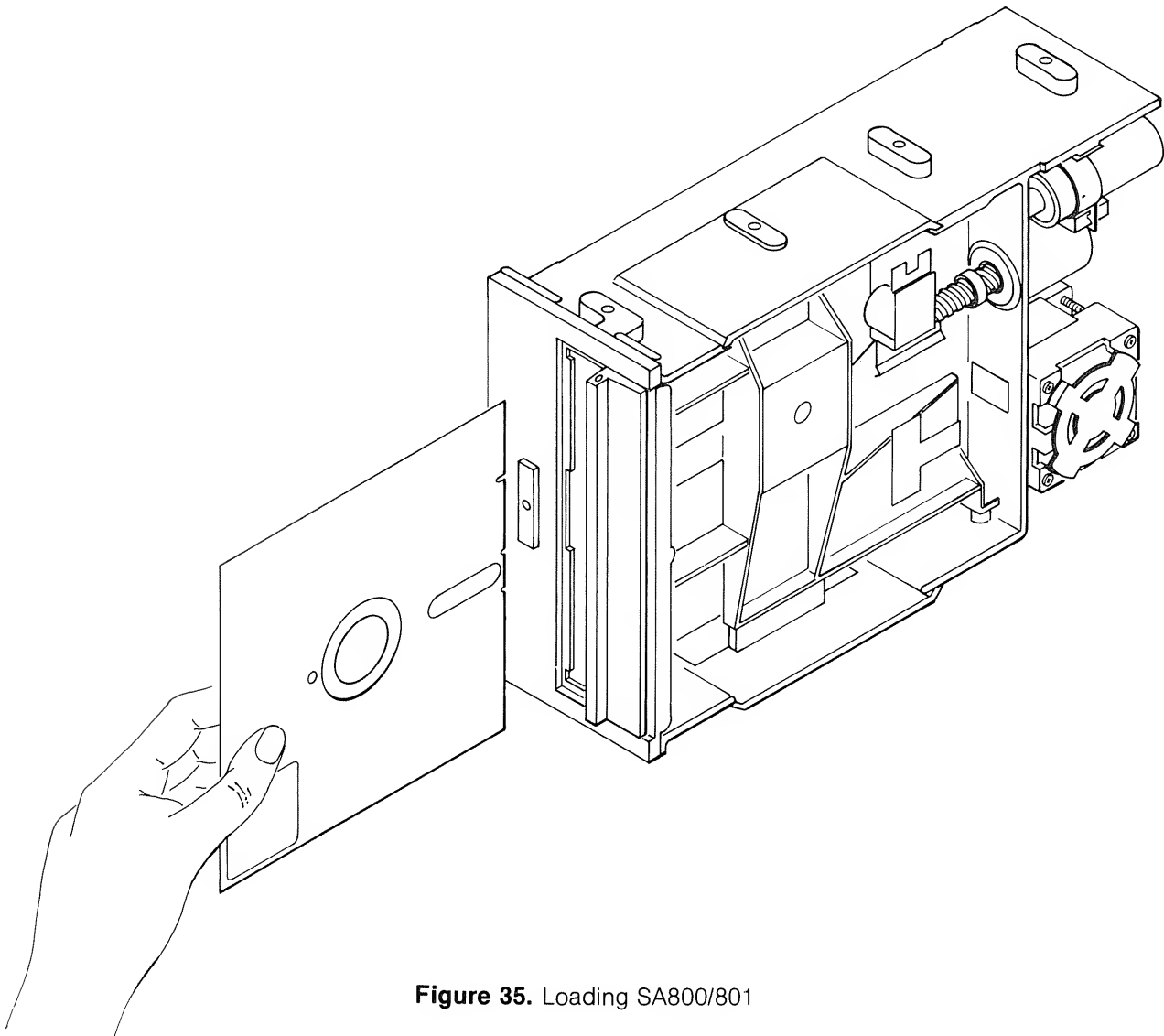

Figure 35. Loading SA800/801

When removed from the drive, the diskette is stored in an envelope. To protect the diskette, the same care and handling procedures specified for computer magnetic tape apply. These precautionary procedures are as follows:

1. Return the diskette to its storage envelope.
2. Keep cartridges away from magnetic fields and from ferromagnetic materials which might become magnetized. Strong magnetic fields can distort recorded data on the disk.
3. Replace storage envelopes when they become worn, cracked or distorted. Envelopes are designed to protect the disk.
4. Do not write on the plastic jacket with a lead pencil or ball-point pen. Use a felt tip pen.
5. Heat and contamination from a carelessly dropped ash can damage the disk.
6. Do not expose diskette to heat or sunlight.
7. Do not touch or attempt to clean the disk surface. Abrasions may cause loss of stored data.

8.2 Write Protecting a Diskette

Shugart Media has the capability of being write protected. The write protect feature is selected by the notch in the media. When the notch is open it is protected; when covered, writing is allowed. The notch is closed by placing a tab over the front of the notch, and the tab folded over covering the rear of the notch. The Diskette can then be write protected by removing the tab. Refer to Figures 36 and 37.

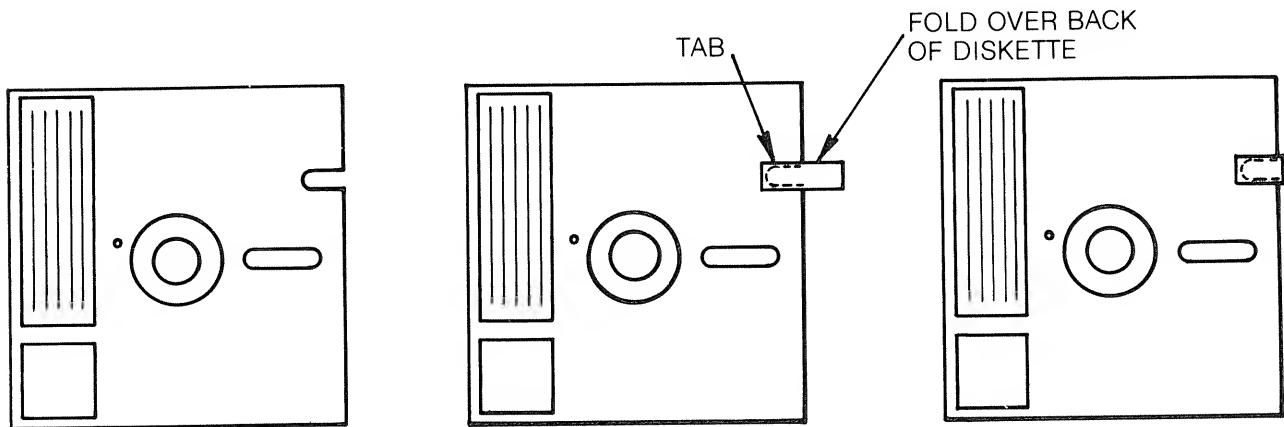

Figure 36. Diskette Write Protected

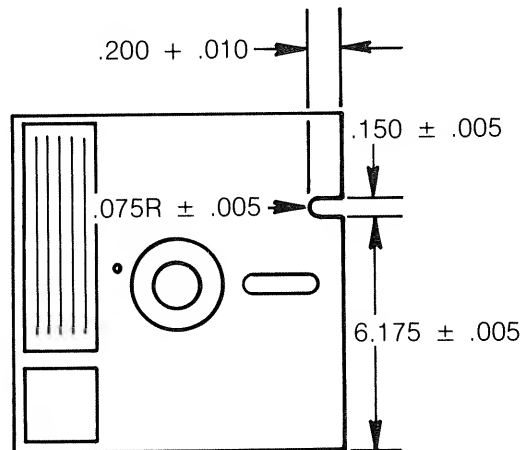

Figure 37. Write Inhibit Notch Specifications

9.0 ERROR DETECTION AND CORRECTION

9.1 Write Error

If an error occurs during a write operation, it will be detected on the next revolution by doing a read operation, commonly called a "write check." To correct the error, another write and write check operation must be done. If the write operation is not successful after ten attempts have been made, a read operation should be attempted on another track to determine if the media or the drive is failing. If the error still persists, the disk should be considered defective and discarded.

9.2 Read Error

Most errors that occur will be "soft" errors; that is, by performing an error recovery procedure the data will be recovered.

Soft errors are usually caused by:

1. Airborne contaminants that pass between the read/write head and the disk. These contaminants will generally be removed by the cartridge self-cleaning wiper.
2. Random electrical noise which usually lasts for a few μsec .
3. Small defects in the written data and/or track not detected during the write operation which may cause a soft error during a read.

The following procedures are recommended to recover from the above mentioned soft errors:

1. Reread the track ten times or until such time as the data is recovered.
2. If data is not recovered after using step 1, access the head to the adjacent track in the same direction previously moved, then return to the desired track.
3. Repeat step 1.
4. If data is not recovered, the error is not recoverable.

APPENDIX A - MODELS AND FEATURES

MODEL DIFFERENCES

- 800-1 - Soft Sectorred with an FM (single density) data separator.
- 800-2 - Soft Sectorred without data separator.
- 801 - Hard Sectorred with an FM (single density) data separator and sector separator.

NOTE: To convert a 801 to a 800 move the shorting plug from the 801 position to the 800 position. A 800 cannot be converted to a 801.

DRIVE MODEL	MEDIA	
	SINGLE DENSITY	DOUBLE DENSITY
800-1	SA100	SA102
800-2	SA100	SA102
801	SA101	SA103

MEDIA DESCRIPTION

DISKETTE MODEL	PART NUMBER	DESCRIPTION
SA100	50417	IBM 3740 Compatible, Single Density
SA101	50418	32 Sector, Single Density
SA102	50646	Double Denisty M ² FM
SA103	50708	32 Sector, Double Density

AC VOLTAGE/FREQUENCY CONVERSION

PRIMARY VOLTAGE AND FREQUENCY	PART NUMBERS		
	MOTOR ASM*	MOTOR PULLEY	BELT
115VAC,60HZ	50443	50358	50356
115VAC,50HZ	50443	50357	50355
230VAC,60HZ	50444	50358	50356
230VAC,50HZ	50444	50357	50355

*Motor assemblies include - motor, capacitor and connector.

DECORATIVE FACEPLATES

Size	Color	Part Numbers
4-5/8 × 10-1/2	Tan	50264
4-5/8 × 10-1/2	White	50263
5-1/4 × 10	Tan	50261
5-1/4 × 10	White	50260
5-1/4 × 11	Tan	50258
5-1/4 × 11	White	50257
Rack Mount 4-5/8 × 8-11/16	Tan	50675





7

8



9

10



© Copyright 1977

475 Oakmead Parkway Sunnyvale, California 94086
Telephone: (408) 733-0100 TWX: 910 339 9355 SHUGART SUVL