

Automotive Solutions

EMC Test Systems for
Automotive Electronics



SCHAFFNER

SCHAFFNER EMC SYSTEMS

www.schaffner.com

Page Description

2 EMC Test System for Automotive Electronics Introduction

3 Pulse Tests with the System 5000 NSG 5000

4 Pulse / Burst Generators NSG 5001A / 5003

5 High Energy Pulse Generators NSG 5005A / 5005B

6 Accessories INA 5025 / CDN 500

7 Accessories INA 5020 / 5024

8 Modular EMC Test System System 5200

9 / 10 Plug-in modules CTR 5210 / ARB 5220 / 5221

11 / 12 Plug-in modules DCS 5230 / AMP 5240 / CSW 5250

13 / 14 AUTOSTAR™ software AUTOSTAR™

15 42 Volt - High Current Coupler CDN 5010

16 Battery Simulators - Voltage Sources NSG 5004A

17 Typical Configurations - Rack Systems

18 Standards for Conducted Immunity Requirements &
System Configurations Standards

19 RF Immunity and Emission Testing ProfLine 5100 series

20 ProfLine RF EMC Test Systems ProfLine 5110 / 5120

21 ProfLine RF EMC Test Systems ProfLine 5130 / 5140

22 ProfLine RF EMC Test Systems ProfLine 5150 / 5160

23 ProfLine RF EMC Test Systems ProfLine 5170 / 5180

24 Index by Product Number Index

EMC test system for automotive electronics



The use of electronic and electrical sub-systems in automobiles continues to escalate as manufacturers exploit the technology to optimise performance and add value to their products.

With automobile operation and safety increasingly dependent on the reliable functioning of complex control and monitoring systems, integrity in the face of electromagnetic interference is of vital importance. The electromagnetic compatibility (EMC) test standards with which automobile manufacturers must comply are determined by bodies such as ISO, SAE and DIN. Additionally, most manufacturers also develop and specify their own custom EMC tests to meet a wide-ranging - and fast evolving - set of requirements. The need for a flexible test resource has never been greater.

Building on Strength

Schaffner has been at the forefront of the pioneering work to establish EMC tests for motor vehicle electronics. Automotive manufacturers and suppliers world-wide have come to trust test systems from Schaffner. Active involvement in the standardisation committees ensures that the latest advances are continuously reflected in our test systems.

International and In-house Standards

Well-proven system architecture and a modular concept ensure that the test systems keep pace with changes in demands required by the standards, as well as with the special needs of vehicle manufacturers. The system's test specifications exceed the conditions set down in relevant standards, which results in the requisite flexibility for the user and the necessary test margins. The pulse parameters are so broadly dimensioned that many company-specific test specifications are covered automatically, eliminating the need to take any additional action.

New Requirements

Besides the classical pulse tests, variations and disturbances on a vehicle's power supply lines are assuming greater significance. Currently, simulations are insufficiently reflected in international standards with the result that a broad range of manufacturer-specific specifications has become established.

Magnetic field tests and tests with conducted sinusoidal oscillations are becoming important in view of the increasing utilisation of sensors and peripheral sub-assemblies.

Schaffner has expanded the test system with new components in order to fulfil these applications in an optimal and future-secure manner. The forthcoming use of 42 Volt technology in passenger cars will have a profound influence on test equipment. The new generation of test equipment has been appropriately specified and adequately dimensioned to cope with the expected higher supply levels. The software implemented is the key element in ensuring the efficient utilisation of complex test systems.



Schaffner's AUTOSTAR offers more than just a control package. AUTOSTAR is an open test management platform with a graphical interface and flexible test report production.

Complete customer solutions with fully integrated installations are possible through the complementary range of test systems for radiated interference immunity and emission measurements.

Pulse tests with the System 5000

The compact and modular System 5000 offers all the generators necessary for tests with pulsed interference as well as voltage variations as called for by ISO and SAE. The established test specifications for passenger cars together with the new standards for commercial vehicles published by the ISO, SAE, DIN and other bodies are fully covered, as are the many company-specific standards from larger vehicle manufacturers. The construction adopted enables trends in the standards and changing market requirements to be followed consistently through the introduction of new developments or upgrades to the generator modules. Hence, investments in test equipment are optimally protected.

NSG 5000 System Chassis

This compact mainframe houses the common system components and accommodates all the standard pulse generators. A high performance processor controls all the real-time tasks, takes care of system integrity, assures the monitoring of the EUT path and handles communication with the Windows-based user interface. Besides the control unit, the power supply, high voltage unit and control electronics for the EUT are all housed in a package mounted at the rear of the mainframe. This modularity provides the flexibility to adapt to changing requirements. The front of the chassis is available for the insertion of various pulse generators and for the connection and practical handling of test objects. Interrupt-free test sequences comprising all types of pulse at one and the same EUT connector are made possible through the use of a high voltage pulse bus configuration.



An electronic switch to connect and disconnect the battery supply is incorporated in the NSG 5000. Furthermore, the processor also controls the external battery substitute power source.

In its standard configuration, the equipment is rated for testing objects at up to 30V / 25A dc or 48V / 10A dc. The test rig and the power sources are protected by built-in, over-current trip switches.

Additional inputs and outputs are located on the rear panel for test execution control purposes and the monitoring of error signals, oscilloscope triggers, gate start/stop commands, etc.

Larger systems can be created by installing further generators in an expansion chassis and these generators are instantly recognised by the software and are embodied automatically in the system.

Overall control is effected via a PC running under Windows. The new version of the operating system, AUTOSTAR, integrates all the individual components into a uniform and clear test rig control platform.

Technical Specifications

NSG 5000

Instrument power supply	Dimensions	EUT supply	Computer interface	Control connections
100 to 120Vac $\pm 10\%$, 47-63Hz 220 to 240Vac $\pm 10\%$, 47-63Hz	19" benchtop housing, can also be rack mounted Height 31cm (12.2") Depth 51cm (20")	From an external source, e.g. battery or NSG 5004A battery simulator 48Vdc, 25A max. continuous Sensor for voltage correction Program-controlled switching 30A safety cut-out	RS 232C or IEEE 488	EUT failure/Start-Stop/Test end/ Trigger for oscilloscope

Pulse generators

Surge Pulse Generator

NSG 5001A

Switching actions with inductive loads on the vehicle supply harness, dc motors that operate as generators when the vehicle supply is switched off and the effects that occur when an ignition coil is switched off can all create disturbances that have to be simulated and their consequences checked. ISO and SAE have specified these tests under pulse designation 1/2/6. The NSG 5001A produces these test pulses in conformance with the relevant standard. In order to be able to cope with a company's own test methods, the generator module also provides a much greater range of selectable parameters, considerably higher test voltages, additional impedances and further pulse widths. The switch type INA 5020 provides the often required automatic battery switch-off and restore functions.

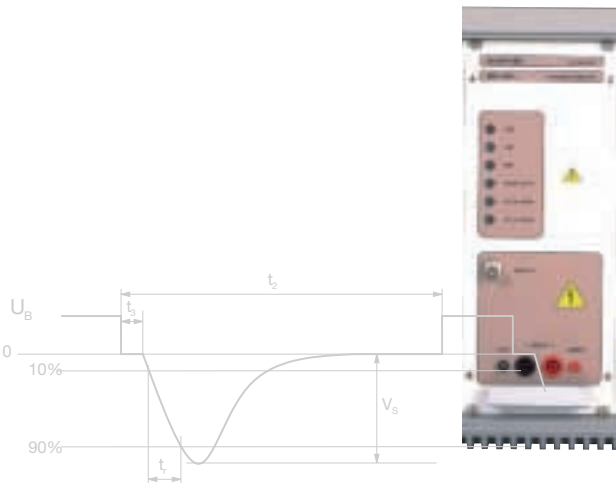

Burst Pulse Generator

NSG 5003

Fast transient interference signals injected onto a vehicle's wiring harness through switching of associated peripheral devices can affect the correct functioning of adjacent electronic units. In conformance with the standards (ISO/SAE pulse 3a/3b), the NSG 5003 simulates these interference phenomena by means of pulse bursts. The vibrant development of electronic devices for the automotive industry means that better and faster test methods are required. The burst generator more than meets these increasing demands; its technical properties exceeding the specifications laid down in the standards by several factors. Higher pulse voltages, burst frequencies and pulse burst specifications are just part of it; there are also automated functions for weak spot analyses and long-term trials.

The EUT connection, as well as the separate connector for the coupling clamp used in data line tests, has been optimised to suit the high frequency conditions prevailing in such a fast pulse environment.

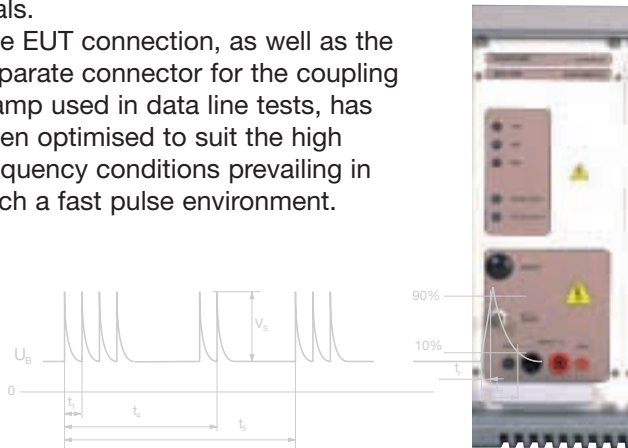

Technical Specifications

NSG 5003

Pulse amplitude	Impedance	Pulse rise time	Pulse duration	Burst frequency	Pulses per burst	Burst repetition	Pulse modes
20 to 800V in 1V steps	50Ω	5ns	100ns (into 50Ω)	1 to 100kHz in 0.1kHz steps	1 - 200	90ms to 99.9 seconds in 10ms steps	Single, continuous, programmed 1 to 99999

Technical Specifications

NSG 5001A

Pulse amplitude	Impedance	Pulse rise time	Pulse duration	Pulse modes	Repetition	Battery supply activation	Pulse Monitor
10 to 600V in 1V steps	2/4/10/50Ω and external (pulse 1/2) 10/30Ω (pulse 6)	1/3μs (pulse 1/2) 60μs (pulse 6)	50/200/500/1000/2000μs (pulse 1/2) 300μs (pulse 6)	Single, continuous, programmed 1 to 99999	0.2 - 15s	Program-controlled / Voltage-controlled	1:100, BNC

Pulse generators

High Energy Pulse Generator

NSG 5005A

Alternators produce a high-energy (load dump) pulse on a vehicle's power harness when the battery is disconnected. The NSG 5005A simulates the corresponding pulse 5, specified by both ISO and SAE, the clamped load dump pulse 5b, as well as the additional pulse 7 defined by the ISO.

Some vehicle manufacturers have expanded upon these specifications - in most cases by making them more stringent. The generator takes this into account. Contrary to the classic concept, the unit is built around an active amplifier circuit. This enables much greater variability of the pulse parameters to be achieved and facilitates better reproducibility. Impedances are emulated electronically by dynamic current limiting, ensuring that the required pulse energy is driven

optimally into the EUT. An impedance box is available as an option (INA 5025) which sets up the generator impedance by means of hardware, using power resistors.

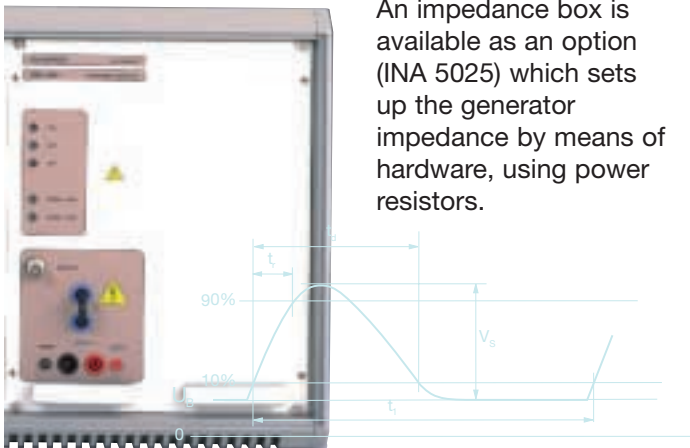

High Energy Pulse Generator

NSG 5005B

Some American laboratories tend to prefer the current load dump approach that is incorporated in the standards set down by the SAE. This view is taken because alternators are considered to behave rather as 'hard' current sources.

This requirement is reflected in the NSG 5005B, which offers a practical and proven solution for use in the field of passenger vehicles and light duty trucks.

The module also employs an active amplifier circuit, providing the user with considerable advantages in terms of test parameter flexibility.

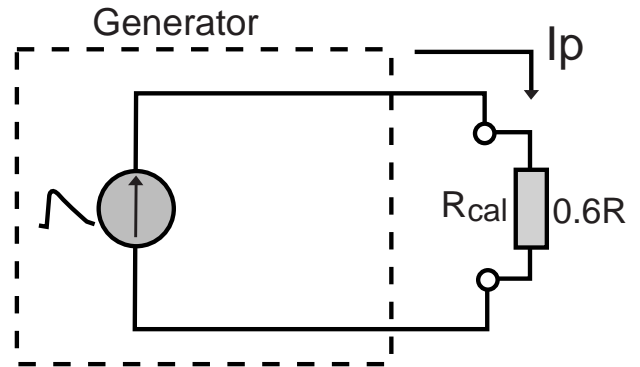

Technical Specifications

NSG 5005A

Pulse amplitude	Impedance	Pulse rise time	Pulse duration	Pulse repetition	Pulse modes	Pulse monitor	INA 5025, hardware impedance
20 to 200V in 0.5V steps	According to resistor fitted	0.1 to 10ms	30 - 700ms	15 to 600s in 0.1s steps	Single, continuous, programmed 1 to 99999	1:100, BNC	0.5 to 10Ω in 0.25Ω steps
Clamping: 20-180V							

Technical Specifications

NSG 5005B

Energy source	Pulse amplitude	Pulse rise time	Pulse duration	Pulse repetition	Pulse modes
200mF capacitor charged to 60V	20 to 120A, in 1A steps (84A into 0.6Ω reference load)	5 - 10ms	40/100/150/200/250/300/350/400ms	25 to 600s in 0.1s steps	Single, continuous, programmed 1 to 99999

Accessories

Capacitive Coupling Clamp

CDN 500



The coupling clamp CDN 500 is manufactured exactly in accordance with the drawings and specifications of ISO 7637/3. It is, above all, the fast nanosecond pulse bursts (ISO 3a and 3b) that are injected on cable

runs. The characteristic impedance of the unit is 50Ω . The CDN 500 coupling clamp is connected to the generator via a coaxial cable. The far side of the clamp has to be terminated with a 50Ω load resistor. A suitable terminating load is available as an accessory under the type number INA 5030 which also provides a measurement output via a 40dB attenuator. The coupling clamp will accept ribbon cables as well as round cables of up to 40mm diameter. The effective coupling capacitance depends on the cross section and the material of the cable used; a typical value being around 100pF.

Hardware Impedance Module

INA 5025



Enables resistors to be added to the high-energy pulse generator type NSG 5005A to modify the generator's impedance. Impedances of 0.5Ω to 10Ω , in steps of 0.25Ω are selectable under software control. The INA 5025 can be operated in either the NSG 5000 basic

system chassis, the expansion chassis type INA 5000 or in a special housing type INA 5026.

Expansion Chassis

INA 5000

Additional generator modules can be accommodated in the expansion chassis to permit the assembly of larger systems. All the control functions remain effective and the system incorporates the modules in the INA 5000 through an auto-configuration feature.

Interface Option

INA 5002

The System 5000 is generally operated via the RS 232 serial interface. To increase the interference immunity of the PC interface, the connection can be effected alternatively by means of an opto-link type INA 30xA. The optional INA 5002 is available to embed the System 5000 within an IEEE 488 laboratory communications system.

Technical Specifications

INA 5025

Selectable impedances	0.5 to 10Ω , programmable in steps of 0.25Ω
Dimensions W x H x D mm	225 x 311 x 220

Technical Specifications

CDN 500

Typical coupling capacitance	100pF approx. (200pF max.)
Active length	1000mm (39")
Diameter of round cables	40mm (1.6") max.
Breakdown voltage	>500V
Characteristic impedance (without cable inserted)	$50\Omega \pm 10\%$
Connectors	50 Ω BNC (1 each side)
Dimensions L x W x H mm	1300 x 300 x 106 (51.2 x 11.8 x 4.2")
Weight	11.5kg (25lbs) approx.
Construction	Brass, with plated surface; coupling panel with roller hinges for precise positioning

Accessories

Battery Switch

INA 5020

The INA 5020 provides a means for pulse-controlled (as required by the ISO) or program-controlled on and off switching of the power supply to the EUT from a battery or an appropriate source such as the battery simulator NSG 5004A. The switch is a rearward-facing module in the NSG 5000 system chassis and, hence, takes up no generator module space.



Pulse 4 Driver Board

INA 5024

This driver board is required to control external sources for the simulation of the pulse 4 voltage variation as specified by ISO and SAE. When more complex and freely programmable voltage variations are required, System 5200 should be used.

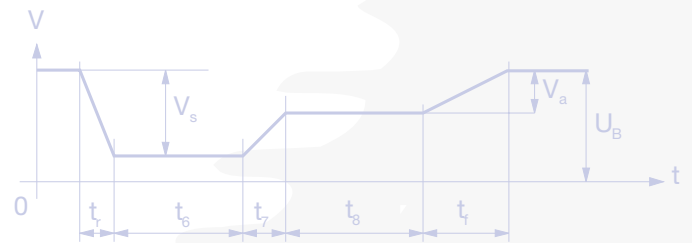

Technical Specifications

INA 5020

Input DC voltage range	0 to 30V (48V max with derated current to 10A)
DC current	30A max
Switch On/OFF time	2µs
Max. voltage drop	2.5V @ 25A
MCB rating	30A

Complex voltage variations Magnetic field tests Sinusoidal burst with System 5200

A complementary system part is available that is optimally designed to cope with the demands imposed by the newer and multiple requirements met today especially in matters of voltage variation.

Again, great importance is placed on modularity to ensure that systems can be ideally configured, expansions are possible at any time and a solid platform is provided to cater for future developments in this test arena. The software integrates the various system components seamlessly into the overall system concept with uniform operating procedures and user guidance together with a comprehensive test result reporting facility.



System 5200 Concept

A 19" system chassis serves as the basis for all test configurations. Control of the chassis is assured by a controller module that takes care of communication with the PC on the one hand while, on the other hand, it serves the bus to which all modules have access. All the generators and function units are designed for plug-in mounting in the front of the chassis. As a result, all the connections to the EUT and to the sources are brought out on the front to the test rig and the items under test. Where necessary, the individual modules are further modularised through a concept of motherboards and plug-in functional units.

Basic Chassis

The 19" basic chassis contains all the power supply components and, if required, the burst-transformer, the rear-facing fans, the control and signal bus boards as well as the common inputs and outputs for the safety circuits and signals for the expanded control and monitoring of the test procedures.

The CAN-bus, already well-known in automotive technology circles, is used as the system bus. Additionally, the NSG 5202 contains the transformer sub-assembly required for sinusoidal-burst tests. A chassis type NSG 5201 can also have this transformer sub-assembly added subsequently at any time by a Schaffner Service Center.

NSG 5201 and NSG 5202

Technical Specifications	NSG 5200
AC Operating Voltage & Frequency Ranges	100V/120V/220V/240V 47 to 63Hz
Dimensions	Width 84HP Height 6U Depth 500mm
Rack Weight	18Kg (NSG 5201) 26Kg (NSG 5202)
Control Bus	CAN
Safety Interlocks	Yes
Auxiliary Input Signals	DUT FAIL / EXT / PAUSE/ RESUME
Auxiliary Output Signals	CRO-TRIG / TEST-END

plug-in modules

Controller

CTR 5210



The controller controls all the addressing, real-time and synchronisation tasks on the CAN-bus as well as maintaining communication with the PC and, hence, with the AUTOSTAR user-software. RS 232C and IEEE 488 interfaces are available as standard. Designed as a motherboard, the unit can have other interfaces added as required. As a further facility, line waveforms can be measured

and stored on a digital oscilloscope and downloaded to the ARB 5220 / 5221 modules for subsequent regeneration.

Function Generators

ARB 5220 / ARB 5221



ARB 5220

The function generator is used universally throughout the System 5200 for the control of sources, battery simulators and amplifiers. The task definition in the Autostar application software specifies the necessary voltage/frequency conditions. The controller converts this information into algorithms for the ARB (Arbitrary waveform generator) which creates an image of the requirements in its own processor and memory and then generates the output signals for the addressed power modules during the test run. All the requisite curve forms can be

created numerically from the basic functions.

By loading a bit map, e.g. a table of results from a storage oscilloscope, the ARB also generates curve forms that can be difficult to describe mathematically.

Basic functions:

SINE
TRIANGLE
SQUARE
RAMP (Including DC)

Ramping Capabilities:

Amplitude
Frequency
DC offset

Every card incorporates a second channel for the control of a further source with a programmable, steady state voltage as well as an output for current limiting one of the sources. The main output signal consists of analogue voltage of -10 to + 10V - a standard that is used by the majority of voltage sources. Limits are only imposed by the sources used for a particular application.

Technical Specifications

CTR 5210

Module width	8HP
Control Bus	CAN
Interfaces	IEEE488 (GPIB) & RS 232

Plug-in modules

ARB 5220

The ARB 5220 is a module equipped with a function generator board. A second board can be added subsequently at any time. The ARB 5221 is delivered equipped with two function generators. Two of these modules can be used in a system, i.e. up to four function generators are available to control the relevant number of sources. All the generators used are programmed separately and run synchronously based on a master-slave relationship.



ARB 5221

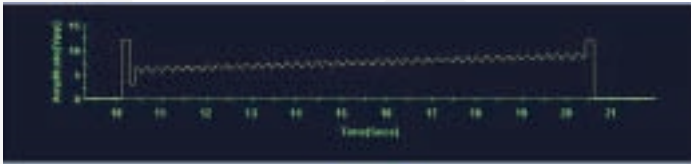
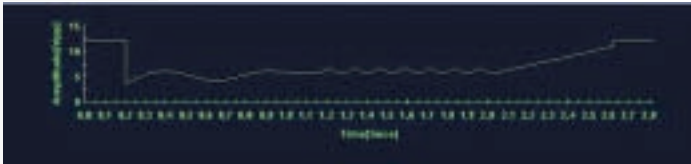

Technical Specifications		ARB 5220
Output	Voltage	-10 to + 10V
	Resolution	10mV
	Accuracy	±10mV
	Impedance	10Ω
	Short circuit protection	Yes
	Standard segment types	Sine, Square, Triangle & Ramp (including DC)
	Number of segments per waveform	1 to 100
Frequency range	Sine	0.01Hz to 300KHz
	Square / Triangle	0.01Hz to 100KHz
	Frequency resolution	0.01Hz
	Amplitude & offset ramping	Linear
	Frequency ramping	Sine / Square / Triangle
	Phase angle	Linear, Log (Base 10)
	Rectification	0 to 360° in 15° steps
	Test duration	None, Positive, Negative
		1ms to 100 hours
		1 to 9999 cycles
Module width		4HP

Plug-in modules

DC Switch

DCS 5230



The DCS 5230 switches the voltage source through to the EUT connection under program-control. The primary input and the auxiliary connection enable two sources to be used. The DCS switching capacity of 70V/75A is capable

of coping with high power requirements and is ready for the 42V era.

The selectable switching conditions are:

- Output (EUT) to primary source
- to auxiliary source
- switched off (open)
- switched off (short-circuit to 0V)
- dip and drop from primary to auxiliary source and back again
- to primary source with 2Ω extra impedance (SAEJ1113/11 pulse 2b)

Current and voltage at the output can be measured at any point during a test and be recorded in the test report. Due to the rapid switching times, the requirements of every standard that calls for drop-outs and voltage jumps in the μs range can be fulfilled by using a battery simulator and an auxiliary source.

Technical Specifications		DCS 5230
Primary	Input Voltage	-4V to 70V
	Current	0 to 75A (derate for inductive loads > 300mH)
	Voltage Drop	1V max @ 75A
Auxiliary input voltage	Current	0 to 70V
	Current	0 to 75A
Switch time	ON	0.2 to 1.5μs
	OFF	0.5 to 1.5μs (13.5 to 0V, 1KΩ load)
Pulse 2 output impedance	Current	approx.2Ω
	Current	25A
Overvoltage protection		75V
Overcurrent protection		>75A
Module width		40HP

Power Amplifier

AMP 5240



Up to ±15V and 5A can be delivered by the power amplifier module which means that for many applications – namely for component and sub-assembly testing – the use of an external battery simulator is unnecessary. The frequency range and bipolarity ensure that the module will find a wide range of applications. The EUT current can be

measured and a program-controlled current limit can be specified.

The AMP 5240 also serves as a power driver for the electromagnetic coils used in magnetic field tests and as an amplifier for conducted sinusoidal frequency tests. Separate current measurements for the two types of test ensure correct control of the test conditions.

Technical Specifications		AMP 5240
Operating Modes		Constant Voltage / Constant Current
Output	Voltage	-15 to +15V
	Resolution	0.1V
	Accuracy	± 0.1V
Current	Current	-5 to +5A
	Impedance	0.5Ω
Current limit	Range	0.1 to 5A
	Resolution	0.1A
	Accuracy	± 0.1A
Frequency	Range	0 to 300 KHz
	Resolution	± (0.1% + 1Hz)
	Accuracy	± (0.1% + 1Hz)
Short circuit protection		Yes
Module width		20HP

Plug-in modules

Magnetic Field Tests

The 5200 system configuration is expanded by the addition of magnetic field antennae for the execution of magnetic field tests. Either simple current loops or Helmholtz coils are used depending on the relevant test standard. The AMP 5240 is equipped with a control input for the connection of a magnetic field measuring sensor for the precise regulation of the field generated.

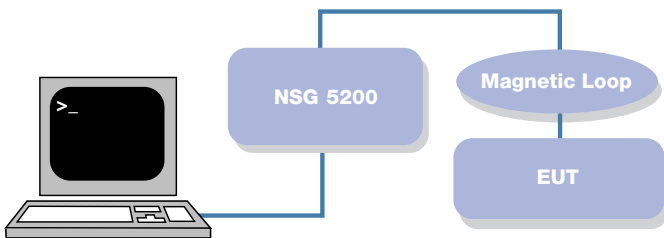

Sinusoidal-burst Module

CSW 5250



Conducted sinusoidal shaped interference simulations are described in various standards with differing conditions pertaining to them. The CSW 5250 module contains the necessary circuitry for pulse superimposition, selectable impedances and the connection mechanism to the transformer. The pure, non-superimposed sinusoidal signal can be monitored at output sockets. External impedances can be connected as required for further applications.

Technical Specifications	Helmholtz Coil
Coil radius	1.2m
Frequency range	0.01 to 30KHz
Magnetic field density	170dBpT
Max. DUT side length	0.8m

Technical Specifications	Radiating Loop Solution
Frequency range	0.01 to 100KHz
Magnetic field density	180dBpT (@ 10A)
Loop diameter	12cm
No. of Turns	20
Sensor diameter	4cm
No. of Turns	51

Technical Specifications	CSW 5250
Waveform types	Sine / Square / Triangle / Pulse
Amplifier frequency	0.01 to 300KHz
Resolution	1Hz
Accuracy	± (1% +1Hz)
Current	-5 to +5A
Source impedance	< 0.5Ω
Battery DC current	0 to 25A
Transformer turns ratio	2 :1
Connection	Positive or negative lead
Bypass capacitor, switchable	100μF
MCB protection	25A
Module width	8HP

AUTOSTAR™ software

AUTOSTAR is more than just an operating program for test routines – it is, in fact, a Test Management Platform. Based on the concept of an open system, it integrates all the generators and other circuitry present in the installation into a consistent presentation and a uniform graphical user interface. Additional components can be incorporated as required through the support of 'Active-X' elements and drivers. AUTOSTAR presents the operator with a clear, structured, visual interface with menubars, test lists, test sequence information and, when appropriate, with graphical pulse representations.

The test management platform AUTOSTAR sends strings of commands to the system chassis control computer, receives test and measurement data for further processing and undertakes all necessary coordination tasks. All hardware associated tasks, together with time-critical and safety related control matters, are managed at the chassis controller level.

Graphical presentations are particularly informative in applications with complex supply voltage variations. The linear or logarithmic scaling and a zoom function ensure a clear overview of the whole test sequence and an opportunity to check details.

Test program

Test programs are grouped together as follows:

Surge – Class 1, 2, 3

Burst

Load dump

Supply voltage variations – type 4c, 4d, 2b.

Power magnetics

Conducted sine wave

The test library contains not only the pre-programmed test routines in accordance with international standards such as ISO and SAE, but also test

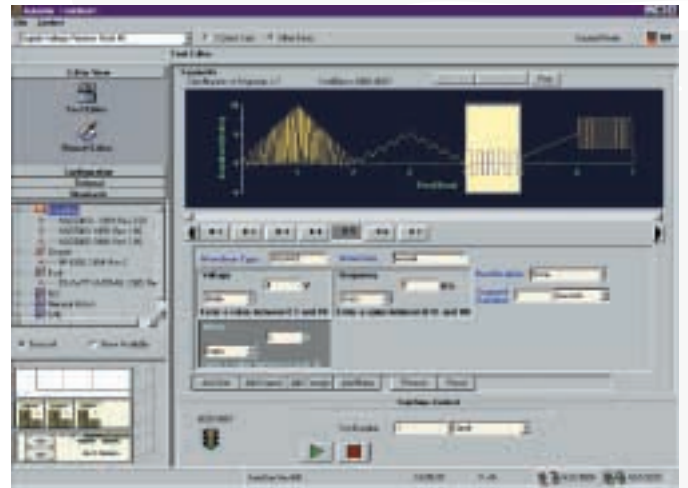

conditions that conform to manufacturers' in-house standards.

The user can implement these tests directly, modify them and store them under a new designation or create new test definitions from the ground up and include them in the list as well.

Sequences consisting of tests of the same or differing categories can be arbitrarily merged and then also be stored for later re-use.

The user-guidance facility contains not only information regarding limiting values but also a protective feature against prohibited parameter combinations with appropriate warning flags.

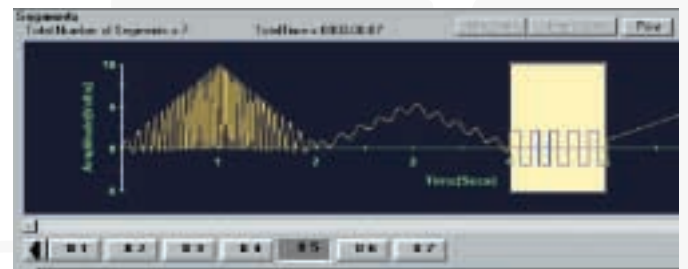

AUTOSTAR™ software

Test Evaluation and Reporting

Reports concerning individual tests and test sequences are produced automatically and are in a form which can be used for technical files and quality assurance documents. The user is provided with a range of editable fields for remarks and specification of the task in hand. The test data and results are stored in a database form that can be retrieved by macro-programming into applications such as WORD, Excel, Access, etc.

Auto-configuration

At start-up, the software automatically detects and recognises the generators and other elements that are present in the system. This auto-configuration feature is bound up with a number of self-tests and provides the user with all the available functions automatically. A choice of communication mode via either the RS 232C or IEEE 488 port is provided. The test configuration can also be created manually which is used to make a conscious limitation on the functions available and particularly for off-line operation. This mode of operation enables arbitrary test routines to be prepared in the office without having to connect up the test system.

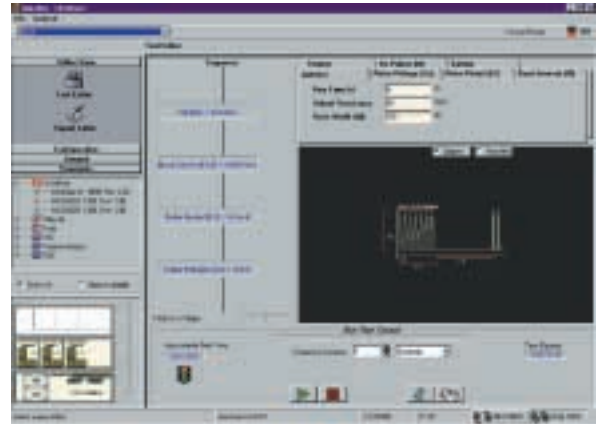

PC Requirements

AUTOSTAR

The recommended minimum PC configuration for working with AUTOSTAR consists of:

- PC with Pentium II 233MHz or greater
- Microsoft Windows 95/98/2000/NT
- 64MB RAM
- 100MB harddisk space
- Super VGA - 1024 x 768 resolution
- CD-ROM - drive
- Microsoft mouse or compatible pointing device
- 1/2 free RS 232 ports or the PCI-GPIB controller from National Instruments

42Volt

High Current Coupler

CDN 5010

There is considerable progress in the 42 Volt vehicle supply concept and hybrid 14V/42V installations which will soon be market-ready. The need for higher power devices is also developing in step with the introduction of the higher supply voltage.

The permissible EUT voltage of 45V for the NSG 5000 system chassis at a reduced current rating of 10A is sufficient for many applications concerning component and sub-assembly tests.

The System 5000 can be expanded with a high current coupler for pulse tests on installations with a high current requirement.

The high current coupler type CDN 5010, equipped with both a switch and decoupling filter rated at 48V and 60A, is controlled by the system controller. The pulses are fed to the CDN 5010 via a cable from the output of the generator module in the System 5000 and are there superimposed on the battery voltage. All the functions, such as battery switch off before pulse triggering, etc, are also applied to the high current path and are controlled by the software in an unmodified manner.

The System 5200 with its rating of 70V / 75A for the switched EUT connection is well equipped and offers ample margins to cope with future demands.

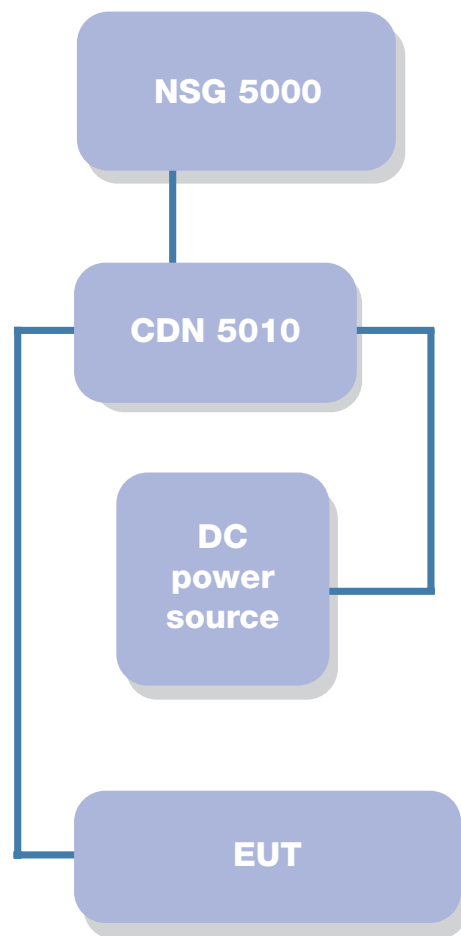

Technical Specifications

CDN 5010 High Current Coupler

Instrument power supply

100 to 120Vac ± 10%, 47 to 63Hz
220 to 240Vac ± 10%, 47 to 63Hz

EUT power supply

From an external source
4 to 48 Vdc/60A max. continuous
Switching under software control
60A safety cut-out

Load inductance

300mH max.

Dimensions

19" benchtop housing, can also be rack-mounted
Height 19cm (7.5")
Depth 51cm (20")

Battery simulators

Current sources

Battery simulators replace the vehicle battery in the test environment. These sources have to fulfil various criteria concerning power rating, voltage, slew-rate, impedance, etc. depending on the particular application. Bi-polar current sources are called for in certain cases. Furthermore, reactions to the EUT's characteristics regarding such matters as in-rush current, spikes and damping have to be taken into account. Regulation with sense-lines in a closed loop is often required. Simulation of rapid voltage changes may require the use of two sources with the DCS 5230 power switch commutating between the two. This can represent an economic solution since the sources used need only have a modest specification, especially the second source as it would only have to deliver a considerably lower static power output.

The open architecture of the hardware and AUTOSTAR software permits arbitrary sources to be integrated with control being effected by means of a 0 - 10V analogue signal. The control units, INA 5024 in the System 5000 and ARB in the System 5200, are precise and fast enough to fulfil the test requirements.

NSG 5004A

Schaffner offers a standard solution for all applications in the classic voltage and current fields using this battery simulator. The bipolar source, with its low impedance, current limiting function and fast regulation provides the maximum flexibility for tests involving voltage variations. Sense-lines permit automatic correction for voltage losses in the cabling. The battery simulator NSG 5004A outputs 12.5A at -30V to +30V and can be delivered as a cascaded unit with a current rating of 25A.



Other Sources

Other sources can be used according to the test requirements. This encompasses simple power supplies as well as highly specified dc amplifiers with extended bandwidth, extra high current capabilities, enhanced stability or other features.

As long as the source accepts an analogue control signal ($\pm 10V$), it can be integrated seamlessly into the system 5200 and the AUTOSTAR software package.

The technical data published by the manufacturers must be taken as being decisive when determining the suitability and limits for specific tests and the particular EUT.

Technical Specifications				NSG 5004A	Battery Simulator
Output voltage	Current	Impedance	Regulation response	Current limiting	
0 to $\pm 30V_{dc}$, stabilized via sensor connections	12.5A/25A, short-term 3 x I for 100ms	0.01 Ω eff.	$\leq 30V/ms$	0.1A to I _{max} . adjustable in 0.1A steps	

Typical configurations

Rack systems

Typical Configurations

The modular instruments can be used either as free-standing units or they can be installed in a 19" crate or rack/cabinet. Schaffner offers instrument housings with suitable internal cabling and mains control panel as accessories. Starting with three basic configurations, the rack systems are configured and equipped in accordance with each customer's specifications.

System 5200 Configurations

Voltage variation configuration

NSG 5201 / CTR 5210 / ARB 5220 / DCS 5230 / Autostar software / NSG 5004

Pulsed magnetic configuration

NSG 5201 / CTR 5210 / ARB 5220 / DCS 5230 / AMP 5240 / Autostar software

Conducted sine wave configuration

NSG 5202 / CTR 5210 / ARB 5220 / DCS 5230 / AMP 5240 / CSW 5250 / Autostar Software / NSG 5004 or other DC source

Rack Systems

The modular instruments (NSG 5000 / NSG 5200 / NSG 5004A) can be used either as free-standing units or they can be installed in a 19" cabinet. Schaffner offers instrument housings with suitable internal cabling and mains control panel as accessories. Starting with basic configurations, the rack systems are configured and equipped in accordance with each customer's specifications.



Examples of Standards for Conducted Immunity Requirements and System Configurations

	Standard	System Requirements	Notes
ISO	ISO/WD 7637-2 1999	NSG 5000, NSG 5001A, NSG 5003, NSG 5004A, NSG 5005A, NSG 5201, CTR 5210, ARB 5220, DCS 5230	
SAE	J1113/11 Jun 1995	NSG 5000, NSG 5001A, NSG 5003, NSG 5004A, NSG 5005A, NSG 5005B, NSG 5201, CTR 5210, ARB 5220, DCS 5230	Passenger cars only for Current Load Dump (NSG 5005B)
SAE	J1113-2 Sep 1996	NSG 5202, CTR 5210, ARB 5220, DCS 5230, AMP 5240, CSW 5250, Aux Source	
SAE	J1113/22 Feb 1995	NSG 5201, CTR 5210, ARB 5220, DCS 5230, AMP 5240, NSG 5004A, Helmholtz Coil	
DIN	DIN 40838 Part 1 1992	NSG 5000, NSG 5001A, NSG 5003, NSG 5004A, NSG 5005A	
Jaso	D 001-94 1994	NSG 5202, CTR 5210, ARB 5220, DCS 5230, NSG 5004A, AMP 5240, CSW 5250, Aux Source, Helmholtz Coil	Except §5.7 Transient Voltage Characteristics
MIL	MIL-STD-462 Jan 1993	NSG 5201, CTR 5210, ARB 5220, DCS 5230, AMP 5240, NSG 5004A, Radiating Loop	
BMW	N 600 13.0 Part 2 May 1996	NSG 5000, NSG 5001A, NSG 5003, NSG 5004A, NSG 5005A, NSG 5201, CTR 5210, ARB 5220, DCS 5230	
Chrysler	PF-9326 Rev C Dec 1999	NSG 5000, NSG 5001A, NSG 5003, NSG 5004A, NSG 5005A, , NSG 5202, CTR 5210, ARB 5220, DCS 5230, AMP 5240, CSW 5250, Aux Source, Helmholtz Coil	
Fiat	7-Z0450	NSG 5201, CTR 5210, ARB 5220, DCS 5230, AMP 5240, NSG 5004A, Helmholtz Coil	
Ford	ES-XW7T-1A278-AB Apr 1999 Rev B	NSG 5000, NSG 5001A, NSG 5003, NSG 5004A, NSG 5005A, NSG 5201, CTR 5210, ARB 5220, DCS 5230, AMP 5240, Radiating Loop	Additional Resistor Box required
General Motors	GM9105P Nov 1996	NSG 5000, NSG 5001A, NSG 5003, NSG 5004A, NSG 5005A, NSG 5005B, NSG 5201, CTR 5210, ARB 5220, DCS 5230	
	GM9113P May 1993	NSG 5201, CTR 5210, ARB 5220, DCS 5230, AMP 5240, NSG 5004A, Helmholtz Coil	
	GM9117P May 1993	NSG 5201, CTR 5210, ARB 5220, DCS 5230, NSG 5004A	
	GM9123P Jan 1997	NSG 5201, CTR 5210, ARB 5220, DCS 5230, NSG 5004A	
	GMW3100 Feb 2000	NSG 5000, NSG 5001A, NSG 5003, NSG 5004A, NSG 5005A, LISN, NSG 5201, CTR 5210, ARB 5220, DCS 5230	
Mercedes	A 000 000 71 99 Nov 1993	NSG 5000, NSG 5001A, NSG 5003, NSG 5004A, NSG 5201, CTR 5210, ARB 5220, DCS 5230	
Mazda	MES PW 67600 Jul 1995	NSG 5000, NSG 5001A, NSG 5003, NSG 5004A, NSG 5005A, NSG 5202, CTR 5210, ARB 5220, DCS 5230, AMP 5240, CSW 5250, Aux Source, Radiating Loop	
Nissan	28400 NDS02 Feb 1997	NSG 5201, CTR 5210, ARB 5220, DCS 5230, NSG 5004A	Source for §4 to be defined
Renault	36.00.400 / C Jan 1998	NSG 5201, CTR 5210, ARB 5220, DCS 5230, NSG 5004A	Source for §3.4.2.3.1 & §3.4.2.3.2 to be defined
	36-00-804/ - B 1996	NSG 5000, NSG 5001A, NSG 5003, NSG 5004A, NSG 5005A, NSG 5201, CTR 5210, ARB 5220, DCS 5230, AMP 5240, Helmholtz Coil	
Volkswagen	TL-VW 820 66	NSG 5000, NSG 5001A, NSG 5003, NSG 5004A, NSG 5005A, NSG 5201, CTR 5210, ARB 5220, DCS 5230	
Volvo	Doc. No. 300 Aug 1992	NSG 5000, NSG 5001A, NSG 5003, NSG 5004A, NSG 5005A, NSG 5201, CTR 5210, ARB 5220, DCS 5230	Except §5.1 Pulses 5c (12v) and 5d (24v)

RF immunity and emission testing

- Simple turnkey systems
- Fully automated report generation
- Integrated systems
- Compliant to international standards
- Training

To complement the test instrumentation for pulsed and conducted tests, Schaffner also offers a complete range of RF test systems for immunity and emission checks. The test installations range from direct coupling, strip transmission lines and TEM-cells right through to various types of absorber cells and chambers. The product range includes all the necessary instruments such as modulators, amplifiers, probes, couplers, networks, antennae, measuring receivers, etc. and, naturally, the accompanying user-friendly application software providing comprehensive test reports.

The software has been specially adapted from the well-proven CIS9942 RF immunity IEC 61000-4-3 package to meet the specific requirements of the automotive component standards. These include conditional levelling on net forward power, levelling to the peak level of the modulated signal and the requirement to reduce the RF level during frequency stepping.

Detailed information about the ProfLine 5000 Automotive RF EMC Test Systems is available in separate specialist publications.



ProfLine	Frequency Range	Test Method	Standard Met	
			ISO	SAE
5110	250kHz - 500MHz	Direct Injection	11452-7	J1113/3
5120	1MHz - 400MHz	Bulk Current Injection	11452-4	J1113/4
5130	10kHz - 200MHz	Radiated in Chamber	11452-6	J1113/21
5140	200MHz - 1GHz	Radiated in Chamber	11452-2	J1113/21
5150	1GHz - 18GHz	Radiated in Chamber	11452-2	J1113/21
5160	10kHz - 200MHz	Strip Line	11452-5	J1113/23
5170	10kHz - 500MHz	Tri Plate	-	J1113/25
5180	10kHz - 200MHz	TEMCELL	11452-3	J1113/24

ProfLine RF EMC test systems

ProfLine 5110

Direct Injection Method

- 250kHz - 500MHz
- Complies with ISO 11452-7 Level 6 (250kHz - 400MHz)
- Complies with SAE J1113/3 Level IV (250kHz - 500MHz)
- Turnkey system with optional report generation

Test levels supported in standard package

Test severity level SAE J1113/3	Test severity level ISO 11452-7	Value Watts
L1		0.05
L2	I	0.1
L3	II	0.2
L4	III	0.3
L5	IV	0.4
L6	V	0.5

BAN

A Broadband Artificial Network (BAN) is a network which presents a controlled impedance to the EUT over the specified frequency range of the test thus ensuring repeatability and comparability of results.

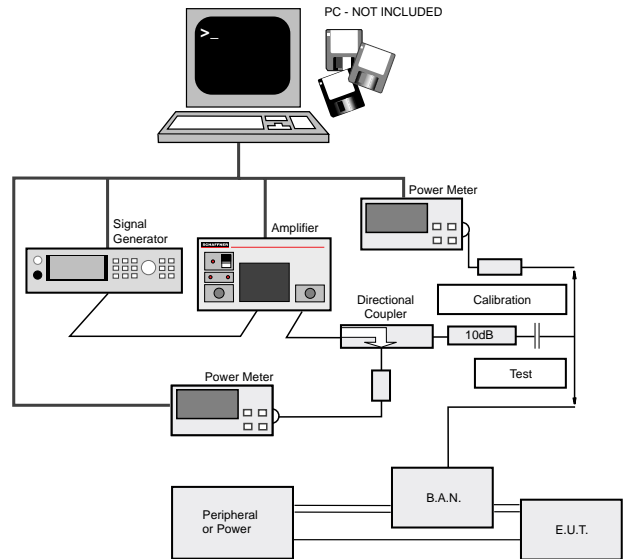

ProfLine 5120

Bulk Current Injection Method

- 1MHz - 400MHz
- Complies with ISO 11452-4 Level IV (1MHz - 400MHz)
- Complies with SAE J1113/4 Level L5 (1MHz - 400MHz)
- Turnkey system with optional report generation

Test levels supported in standard package

Test severity level SAE J1113/4	Test severity level ISO 11452-4	Value mA
L1	I	25
L2	II	40
L3	III	60
L4	IV	80
L5	IV	100

Bulk Current Injection (BCI) Probe

Bulk Current Injection is a method of carrying out immunity tests by inducing disturbance signals directly into the wiring harness by means of a current injection probe. The injection probe is a current transformer

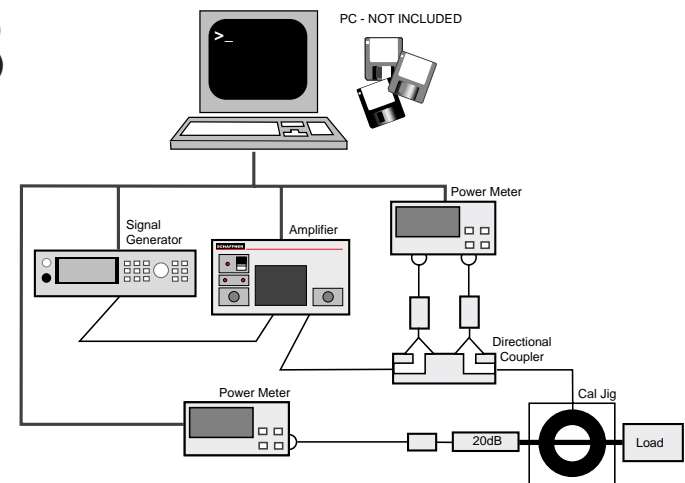

through which the cabling of the EUT is passed. Immunity tests are carried out by varying the test severity level and frequency of the induced disturbance. (ISO 11452-4 sect 4.1)

ProfLine 5130

Radiated in an Absorber Lined Chamber

- 10kHz - 200MHz
- Compliant with ISO 11452-6 to Level L6 (10kHz - 200MHz)
- Compliant with SAE J1113/21-6 to Level IV (10kHz - 200MHz)
- Turnkey system with optional report generation

Test levels supported in standard package

Test severity level SAE J1113/21	Test severity level ISO 11452-6	Value V/m
L1	I	25
L2		40
L3	II	50
L4		60
L5	III	75
L6	IV	100

Higher levels available

The Parallel Plate Antenna

The parallel plate antenna is basically a parallel balanced transmission line (antenna) that is capable of generating a uniform electric field over a useful physical area. The antenna is designed to interface to a 50Ω power source and a 50Ω load in order to achieve good matching characteristics. The test configuration may be designed to test equipment with their associated wiring harnesses.

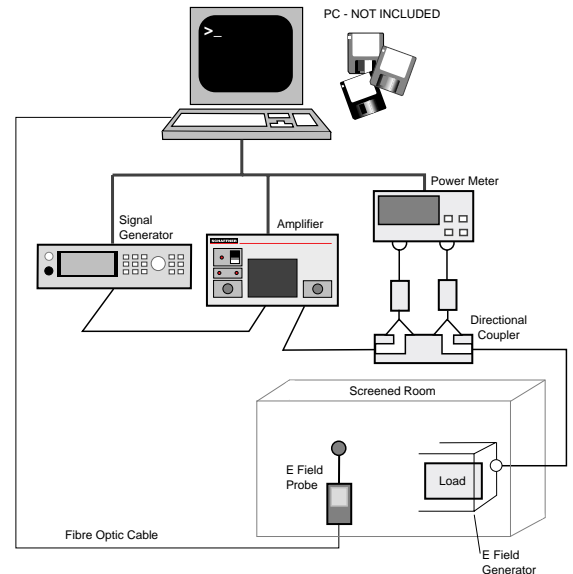

The maximum size of the EUT should not be larger than the width of the antenna.

The user is cautioned that, since the test apparatus will generate undesirable electromagnetic radiation into the environment, the test may need to be performed in a shielded enclosure. (ISO 11452-6 sect 4.3.1)

ProfLine 5140

Radiated in a Chamber

- 200MHz - 1GHz
- Complies with SAE J1113/21 Level L6 (200MHz-1GHz)
- Complies with ISO 11452-2 Level IV (200MHz-1GHz)
- Turnkey system with optional report generation

Test levels supported in standard package

Test severity level SAE J1113/21	Test severity level ISO 11452-2	Value V/m
L1	I	25
L2		40
L3	II	50
L4		60
L5	III	75
L6	IV	100

Higher levels available

Field Generating Device

The Field Generating Device shall be an antenna. Any commercially available antenna set (including high power baluns if appropriate) which is capable of

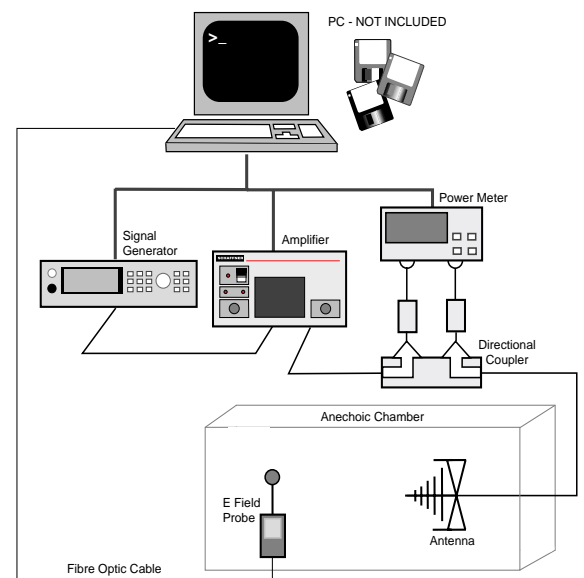

radiating the specified field strengths at the EUT with the available power may be used. (ISO 11452 sect 4.2.1)

ProfLine 5150

Radiated in a Chamber

- 1GHz - 18GHz
- Complies with ISO 11452-2 Level IV (1GHz - 18GHz)
- Complies with SAE J1113/21 Level L6 (1GHz - 18GHz)
- Turnkey system with optional report generation

Test levels supported in standard package

Test severity level SAE J1113/21	Test severity level ISO 11452-2	Value V/m
L1	I	25
L2		40
L3	II	50
L4		60
L5	III	75
L6	IV	100

Higher levels available

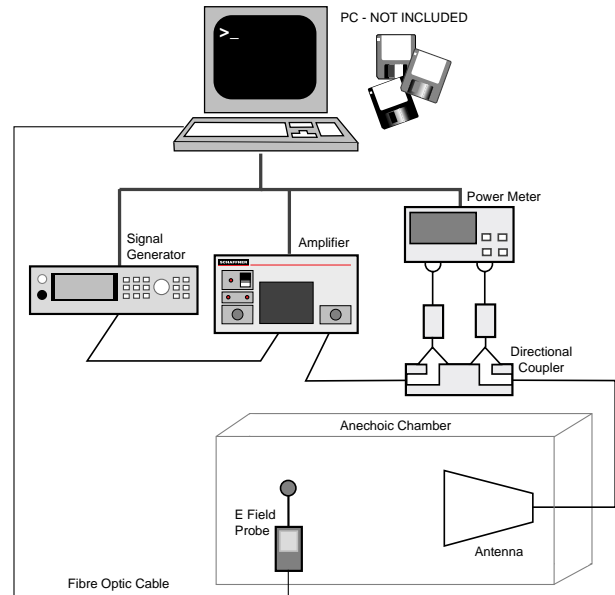

Field Generating Device

The Field Generating Device shall be an antenna. Any commercially available antenna set (including high power baluns if appropriate) which is capable of

radiating the specified field strengths at the EUT with the available power may be used. (ISO 11452 sect 4.2.1)

ProfLine 5160

Strip Line Method

- 10kHz - 200MHz
- Complies with ISO 11452-5 to Level IV (10kHz - 200MHz)
- Complies with SAE J1113/23 to Level 4 (10kHz - 200MHz)
- Turnkey system with optional report generation

Test levels supported in standard package

Test severity level SAE J1113/23	Test severity level ISO 11452-5	Value V/m
L1	I	50
L2	II	100
L3	III	150
L4	IV	200

Higher levels available

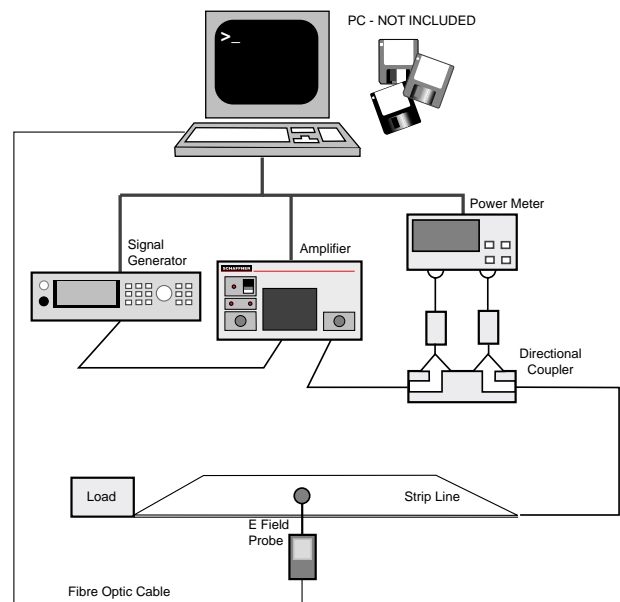

The Strip Line

The Strip Line ideally sets up a region of uniform electromagnetic field. The primary usage of this stripline is to expose at least 1.5 metres of the wiring harness to RF fields. In practice, the fields generated will be uniform only below the TEM multi-mode

frequency. The use of a straight length of cable or harness of 1.5 metres is required to integrate fields above the multi-mode frequencies along the length of the harness. (ISO 11452-5 sect 4.1)

ProfLine 5170

Tri-Plate Method

- 10kHz - 500MHz
- Complies with SAE J1113/25 Level 4 (10kHz - 500MHz)
- Turnkey system with optional report generation

Test levels supported in standard package

Test severity level SAE J1113/25	Value V/m
L1	50
L2	100
L3	150
L4	200

Higher levels available

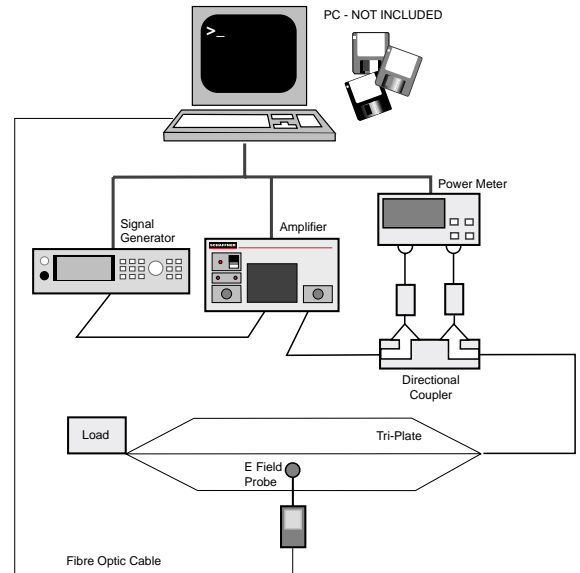

The Tri-Plate

A Tri-Plate is a variation of a TEM cell which is constructed without sides to a cell. The Tri-Plate sets up a region of uniform electric and magnetic fields between the centre septum and the top and bottom ground plates. The lack of side walls means that the

Tri-plate must be used within a shielded room to prevent radiation from the Tri-plate from interfering with nearby electronic devices. The possibility of room resonances and reflected waves distorting the measurements must be ignored. (SAE J 1113/25)

ProfLine 5180

TEM Cell Method

- 10kHz - 200MHz
- Complies with ISO 11452-3 Level IV (10kHz - 200MHz)
- Complies with SAE J1113/24 Level 4 (10kHz - 200MHz)
- Turnkey system with optional report generation

Test levels supported in standard package

Test severity level SAE J1113/24	Test severity level ISO 11452-3	Value V/m
L1	I	50
L2	II	100
L3	III	150
L4	IV	200

Higher levels available

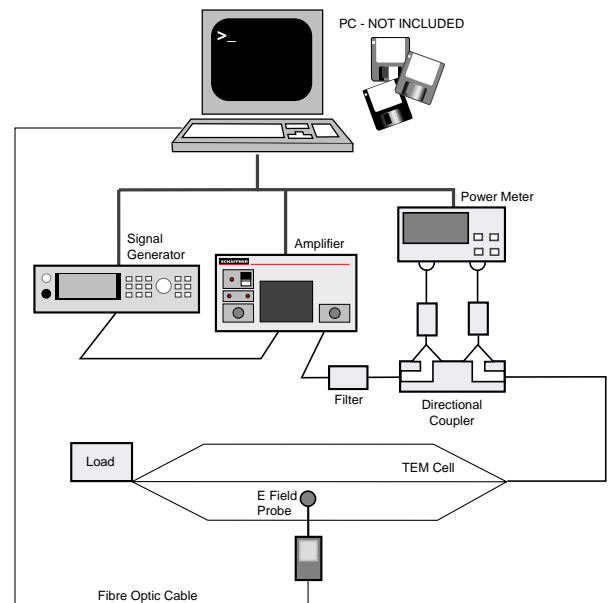

The TEM Cell

The TEM cell used in this test method is a rectangular coaxial line with 50Ω characteristic impedance. The EUT is exposed to a uniform TEM field. The TEM cell method cannot be used to determine

absolute test field levels, polarization and frequency for device immunity. Only comparative measurements can be made. The TEM cell has the major advantage of not radiating energy into the surrounding space.

AMP 5240	11
ARB 5220	9
ARB 5221	9
AUTOSTAR	13 / 14
CDN 5010	15
CDN 500	6
CSW 5250	12
CTR 5210	9
DCS 5230	11
INA 5020	7
INA 5024	7
INA 5025	6
NSG 5000	3
NSG 5001A	4
NSG 5003	4
NSG 5004A	16
NSG 5005A	5
NSG 5005B	5
ProfLine 5100 series	19
ProfLine 5110	20
ProfLine 5120	20
ProfLine 5130	21
ProfLine 5140	21
ProfLine 5150	22
ProfLine 5160	22
ProfLine 5170	23
ProfLine 5180	23
System 5200	8

© 2001 Schaffner EMC Systems Specifications
subject to change without notice.

This catalogue is only intended as a guide.
For full technical specifications and up to date
information, please visit our website at;

www.schaffner.com

All trademarks recognised.

Schaffner group manufacturing companies are
ISO-registered. Their products are designed
and manufactured under the strict quality
requirements of the ISO 9000 standard.

This document has been carefully checked.
However, Schaffner does not assume any
liability for errors or inaccuracies.



SCHAFFNER

HEADQUARTERS

Schaffner EMV AG

CH-4542 Luterbach

Switzerland

Tel: [+41] 32 6816 626

Fax: [+41] 32 6816 641

E-mail: sales@schaffner.com

SALES SUBSIDIARIES

China

Schaffner Beijing Liaison Office

Tel: [+86] 10 6510 1761

E-mail: chinasales@schaffner.com

Japan

Schaffner EMC KK

Tel: [+81] 3 3418 5822

E-mail: japansales@schaffner.com

UK

Schaffner EMC Ltd

Tel: [+44] 118 977 0070

E-mail: uksales@schaffner.com

France

Schaffner EMC S.A.S.

Tel: [+33] 1 34 34 30 60

E-mail: francesales@schaffner.com

Singapore

Schaffner EMC Pte Ltd

Tel: [+65] 377 3283

E-mail: singapore@schaffner.com

USA

Schaffner EMC Inc

Tel: [+1] 732 225 9533

E-mail: usasales@schaffner.com

Germany

Schaffner EMC Systems GmbH

Tel: [+49] 30 5659 8835

E-mail: mebsales@schaffner.com

Sweden

Schaffner EMC AB

Tel: [+46] 8 5792 1121

E-mail: swedensales@schaffner.com

Italy

Schaffner EMC Srl

Tel: [+39] 02 66 04 30 45

E-mail: italysales@schaffner.com

Switzerland

Schaffner EMV AG

Tel: [+41] 32 6816 626

E-mail: switzerlandsales@schaffner.com

690-680A / March 2001

www.schaffner.com