



SD Range Installation and Operation Guide



Contents

Introduction	3
Features	4
Important Safeguards	5
Installing the Unit	7
Installation	10
Remote Control	12
Configuring the Unit	21
Status	22
General	23
Cameras	24
Schedule	26
Recording	27
Network	32
Alarms	35
Activity	38
Serial	43
Audio	44
Text	45
Admin	47
Maintain	49
Demos	50
Help	51
Unit Operation	52
Event List	58
Copy Menu	60
Problem Solving	62
Appendix A	66
Appendix B	67
Appendix C	69

Whilst every attempt is made to ensure these manuals are accurate and current, Dedicated Micros reserve the right to alter or modify the specification of the machine described herein without prejudice.

Introduction



What is ...

SD Range ?

A comprehensive, digital recording solution, the SD Range allows customers to improve the functionality of their CCTV solution without increasing their budget. Offering either JPEG or MPEG-4 recording at scalable quality settings in PAL or NTSC format, the SD Range provides the user with both high quality video images and minimum storage consumption.

Available with either 8, 12, 16 or 32 camera inputs and offering telemetry control, the SD range has built in Alarm functionality and onboard Activity detection software. The **MultiMode recording feature** enables different recording rates, resolutions and compression formats to be set across scheduled, normal, and alarm modes for each individual camera.*

Its size and design enables it to be an ideal desktop solution, a perfect replacement for an existing VCR/Mux installation, or an outstanding first-time CCTV solution.

The user interface has a colour coded 'Softkey' interface and the configuration menus are common to both the local monitor and web interface, making for easy set-up and operation.

The SD Range includes both an integrated CD-R Writer and USB ports for video archiving. The unit also offers integrated text support, allowing users to connect with cash registers in retail applications to monitor Point Of Sale (POS) locations. Capturing and associating video with the relevant text information allows the user to search video footage by time, event, and text data to provide evidence of fraud or to aid identification of regular offenders.

*Among the many other features included as standard on the SD Range are: multiway display, picture in picture viewing, remote monitoring using NetVu ObserVer, which uses DM's unique **TransCoding** capabilities to provide fluent live and replay images, plus Dedicated Micros' trademark plug and play set-up with a user-friendly interface to keep installation and operator training to a minimum.*

With telemetry control of up to 32 cameras, including coax telemetry, control of dome cameras, audio recording and activity detection. The SD Range is the ideal product for single site and small to medium sized businesses wishing to deploy a fully functional digital recording solution.

** 4 camera input model available after future development.*

For further information, please visit the website:

www.dedicatedmicros.com

or contact customer services in your region.

Features

- 8, 12, 16 or 32 camera input options (*4 camera input model available after future development*)
- Field serviceable hard drives
- Telemetry support (Coax & Serial)
- All DVR functions fully supported by Keyboard/IR Remote Control
- Scalable recording settings of either 50pps 75pps or 100pps
- **MultiMode** Recording - Dynamically-switchable resolution, record-rate & compression (MPEG4/JPEG) per camera
- Single, Picture in Picture and Multiway displays
- Live and playback viewing locally and over Ethernet
- Built in activity detection
- JPEG or MPEG-4 recording and transmission
- Built in CD-R writer and USB ports for download of video archive to external flash memory
- Web pages provide easy remote configuration
- Alarm Inputs & Outputs
- Easy to use on-screen, colour coded soft keys
- BS8418 compliant
- Text support and text search features ideal for retail installations
- Optional external keyboard available
- Configuration via USB mouse and USB QWERTY keyboard.

Design of the manual

The manual has three parts:

1. Installation Shows details of how to install the unit and connect external devices.
2. Configuration Shows details of the units menus.
3. Operation Shows quick reference details on how to control the unit.

The order and layout of these pages has been designed to help the setup process. It is recommended that the menus are edited sequentially (as they appear on the page), to enable accurate, easy and efficient setup.

Important Safeguards

Read Instructions

All the safety and operating instructions should be read before the unit is operated.

Power Sources

This unit should be operated only from the type of power source indicated on the manufacturer's label.

Servicing

Do not attempt to service this unit yourself as opening or removing covers may expose you to dangerous voltage or other hazards.

Refer all servicing to qualified service personnel.

Ventilation

Ensure unit is properly ventilated to protect from overheating.

All the safety and operating instructions should be read before the unit is operated.



To prevent fire or shock hazard, do not expose this equipment to rain or moisture. The lightning flash with arrowhead symbol within an equilateral triangle is intended to alert the user of this equipment that there are dangerous voltages within the enclosure which may be of sufficient magnitude to constitute a risk of electric shock.

WARNING

This is a class A product. In a domestic environment this product may cause radio interference in which case the user may be required to take adequate measures.

Lightning Strike

The unit has some inbuilt protection for lightning strike, however it is recommended that isolation transformers be fitted to the system in areas where lightning is a common occurrence.

Regulatory Notes and FCC and DOC Information

(USA and Canadian Models Only)

Warning: This equipment has been tested and found to comply with the limits for a Class A digital device, pursuant to part 15 of the FCC rules. These limits are designed to provide reasonable protection against harmful interference when the equipment is operated in a commercial environment. This equipment generates, uses, and can radiate radio frequency energy and, if not installed and used in accordance with the instruction manual, may cause harmful interference to radio communications. Operation of this equipment in a residential area is likely to cause harmful interference in which case the user will be required to correct the interference at their own expense.

If necessary, the user should consult the dealer or an experienced radio/television technician for corrective action. The user may find the following booklet prepared by the Federal Communications Commission helpful: "How to Identify and Resolve Radio-TV Interference Problems".

This booklet is available from the US Government Printing Office, Washington, DC20402, Stock No. 004-000-00345-4.

This reminder is provided to call the CCTV system installer's attention to Art. 820-40 of the NEC that provides guidelines for proper grounding and, in particular, specifies that the cable ground shall be connected to the grounding system of the building, as close to the point of cable entry as practical.

CE Mark



If this product is marked with the CE symbol it indicates compliance with all applicable directives.

Directive 89/336/EEC.

A 'Declaration of Conformity' is held at Dedicated Micros Ltd.,

1200 Daresbury Park, Daresbury, Cheshire, WA4 4HS, UK.

Laser



The unit supports an integrated CD writer, the following are additional warnings associated with installing and operating the CD writer, please pay particular attention to this information.

- Caution - Use of controls or adjustments or performance of procedures other than those specified herein may result in hazardous radiation exposure.
- To prevent exposure to laser emanations (harmful to the eyes), do not attempt to disassemble this unit.

Installing the Unit

Before you start

Check the contents of the box

The following items are included in the box:

Remove all items from the packaging and check the items listed below are present.

- SD DVR (either 8, 12, 16 or 32 input)
- IR Remote Control (x 2)
- IR Remote Control Extender
- Power Leads
- SD Range Software CD

If any of these items are missing please contact Dedicated Micros Technical Support team.

Note: Before installing the SD DVR, carefully read all Safety Instructions and the following information on where the unit should be located.

Choosing a location for installation

- The SD is designed to be desk, shelf or rack mounted. Rack mounting brackets are available as an optional accessory.
- Ensure the SD unit is properly ventilated to protect from overheating.
- Ensure there is a 3cm gap on both sides of the unit.
- Ensure the IR receiver on the front of the unit faces the operator position, and is not more than 10 feet (3 metres) from the operator. An IR Remote Control Extender is also available.
- Ensure the unit is not located anywhere it could be subject to mechanical shocks.
- The unit should be located in an area with low humidity and a minimum of dust. Avoid places like damp basements or loft spaces.
- If the unit is to be installed in a closed assembly, the maximum operating temperature must not exceed 40°C (104°F).
- Ensure there is reliable earthing of the mains outlet when fitted to supply connections (other than direct connection to the branch circuit).
- Any branch circuit supplying the unit must be rated at 15Amps.
- It is recommended that an uninterruptable power source be connected to the unit in case of power failure (to ensure continuous operation of the unit).

Electrical Connections

Please ensure the following are available and have been tested prior to the installation:

- Mains point
- Network point
- Network cable
- Active video signals i.e. at least one working camera feed
- PC with CD ROM drive and connection to the same network as the SD unit (Recommended).

Quick Overview Of Default SD Record Settings

SD units provide out of the box:

High performance recording on ALL cameras with minimal configuration.

Consistent recording duration and smooth motion video per camera regardless of the number of cameras.

The product range has Normal, Medium and Low record rate models.

Normal

Continuous 5pps MPEG4 recording on all cameras, on all channel variants (default out of the box).

Medium

Continuous 2pps MPEG4 recording on all cameras, on all channel variants (default out of the box)

Low

Continuous 1pps MPEG4 recording on all cameras, on all channel variants (default out of the box)

Complete Flexibility

The picture quality can be increased if less than 30 or 60 days standard recording is required.

The advanced record menu can be used to configure individual cameras to suit specific requirements e.g. Entry/Exit routes. Various storage sizes are available dependant on the combination of the number of cameras, the 30 or 60 day storage options, and the Normal, Medium and Low record rates selected.

With Global record rates of up to 100pps (PAL) and 120pps (NTSC), the SD Range offers recording of up to 5pps on each camera, out of the box, at a record duration of 7, 14, 30 or 60 days (the default is 14 or 30 days depending on variant).

Note: *It is the Installer/Owner's responsibility to ensure that the record duration is set to the necessary requirements of the application.*

MultiMode Recording

The unit supports MultiMode recording, which is a storage technology developed by Dedicated Micros. This offers the ability to set different recording rates, resolutions and compression formats across scheduled, normal and alarm modes for each individual camera.

By varying the quality, bit rate and file size of the recorded images, the MultiMode function can increase recording capabilities of the unit.

MultiMode offers:

- Ability to set different recording resolutions.
- Ability to set and switch MPEG or JPEG compression recording as required.
- Ability to set PPS recording rate per camera.
- Dynamically switchable resolution when switching from Normal to Event recording.
- Dynamically switchable compression between MPEG4 and JPEG from Normal to Event recording.

Differences between MPEG-4 and MJPEG(JPEG)

JPEG (short for Joint Photographic Experts Group) is an ISO/IEC standard algorithm for the compression of digital still images. It can reduce files sizes to five percent of the original size although some detail is lost at that level of compression. Ratios of 10:1 to 20:1 may provide little noticeable loss. The more the loss can be tolerated, the more the image can be compressed.

A video sequence of a scene consists of a number of pictures or frames. In a static scene, the initial frame contains an image. If there is no movement in the scene, all subsequent frames will contain the same data. MJPEG recording will record and compress each image individually.

MPEG-4 is used primarily to compress audio and visual (AV) digital data (moving images and sound). MJPEG is an informal name for multimedia recording where each video frame is separately compressed as a JPEG image.

If this redundancy were removed and only the changes in scene were recorded, it would be possible to get a better compression ratio.

MPEG-4 recording uses a keyframe (I-Frame) to record the full scene, then uses the following frames to record the differences between the I-Frame and each subsequent frame (P-Frames) i.e. the difference between I-Frame and frame 1, then the difference between frame 1 and frame 2, etc. These frames enable the true picture to be recorded but the time between I frames determines the step back/forward interval that can be used.

The advantage of MPEG-4 recording is that, in static scenes, it requires less disk space to record a time period than the equivalent JPEG recording. It is important to select an I-frame rate sufficient for accurate recording whilst maintaining the lower recording requirement of MPEG-4. Note that I-frame rates are auto set on the SD.

MPEG-4 is better suited to recording static scenes with little or no movement.

Motion JPEG (MJPEG) uses intraframe coding technology similar to the I-frame part of MPEG-4, but does not use the P-Frame interframe prediction. This makes the degree of compression capability independent of the amount of motion in the scene as each scene is recorded entirely. This means that more storage space is required to record a given scene, but there is a lower processor overhead, and each frame is an individual separate image.

MJPEG is better suited to recording high motion scenes, or scenes during an alarm state.

Note: *Dedicated Micros recommends using MPEG4 as a background recording setting; switching to MJPEG on event or alarm.*

Installation

Front Panel connections



Data

- Socket Can be used to connect an external IR receiver to replace the internal unit
- IR Infra-Red receiver for use with Remote Control
- USB USB2.0 connector
- LED Four LEDs show the unit status
 Green - Unit working normally
 Flash Orange - IR being received
 Solid Red - Unit working but outside normal parameters
 Flashing Red - System not operational (i.e. in boot up)
 No LED - Power Failure

Rear Panel connections

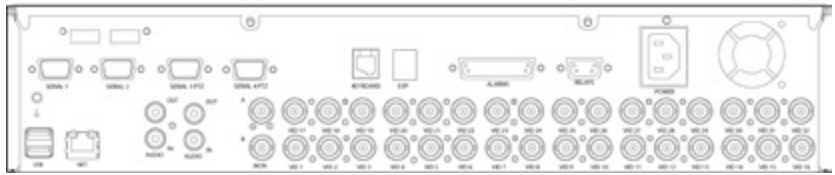

32 Input model

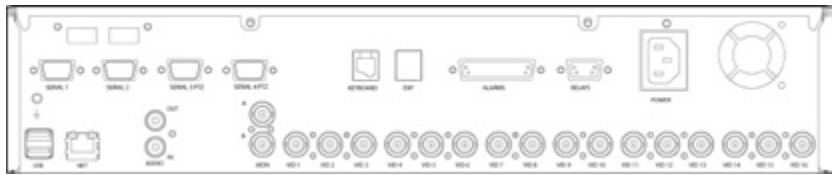

16 Input model

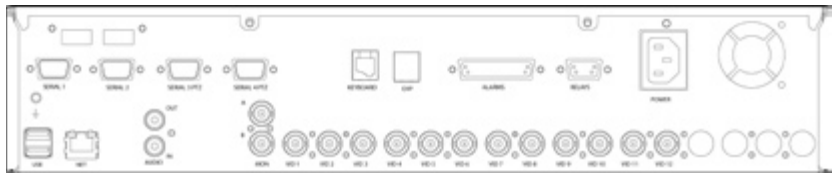

12 Input model



8 Input model

Video

VID1 to VID8/VID10/

VID16/VID32

MON A

MON B

75Ω BNC composite video input, 1V pk-pk.

75Ω BNC composite monitor output, 1V pk-pk

Spot Monitor output

Audio

Audio IN

RCA (phono) socket, 8KHz/16KHz/22KHz sampling 75Ω input impedance, 1V pk-pk

Audio OUT

RCA (phono) socket, line level <100Ω output impedance, 1V pk-pk amplification required

Note: The 32 input model has two Audio IN / Audio OUT connections.

Data

SER 1

RS-232 (3 wire & 9 wire)

SER 2

RS-232 (3 wire & 9 wire)

SER 3 PTZ

RS-485 (2 wire & 4 wire) or RS232 (3 wire)

SER 4 PTZ

RS-485 (2 wire & 4 wire) or RS232 (3 wire)

USB

2x USB2.0 connectors

NET

RJ45 Ethernet network connector, 10/100 Mb/s Ethernet Network

KBD

RJ12 connector for use with KBC01 or KBC02 telemetry keyboards.

EXP

RJ12 expansion port for future use

Power

POWER

IEC mains socket

Alarms and relays

ALARMS IN

25 way (female) D Type 24V 200mA

Range of Alarm states are

- i. 0 – 800R = Short circuit
- ii. 800R – 2K = closed contact
- iii. 2k – 12k = open contact
- iv. > 12K = open circuit.

RELAYS

9 way (female) D Type rated at 24V 200mA

Remote Control

The IR Remote Control offers all the control functionality traditionally available via front panel navigation.

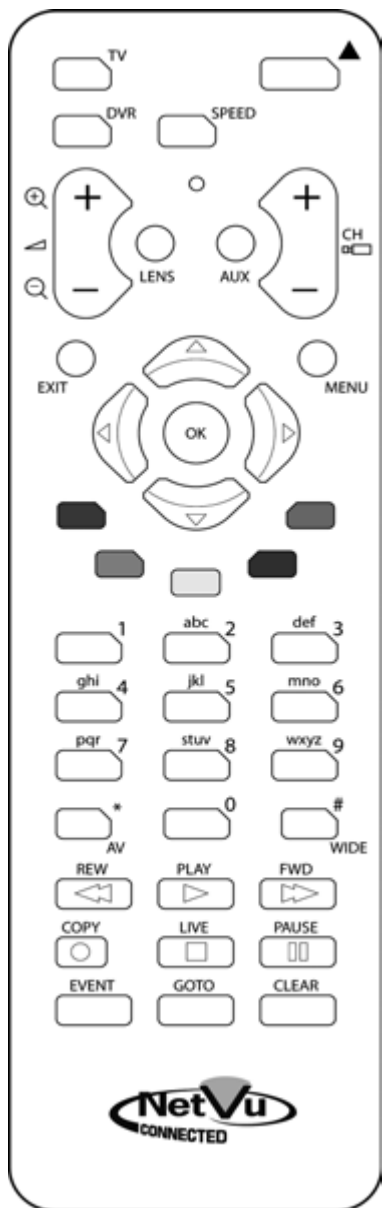



Button Guide

Key **Function**

- 

Switches the Remote Control to 'TV' mode and sends codes understood by common TV sets.
- 

Switches the Remote Control to 'DVR' mode. Note the DVR mode is the default mode of operation.
- 

Toggle the speed of PTZ camera movement (two speeds available).
- 

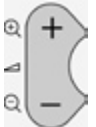
This button puts the unit into Panic Alarm, sending all cameras into Global alarm. Press again to cancel (alarm will cancel after three mins).
- 

Use the Zoom Keys to zoom in/out with a selected camera. Also used to zoom (x2) into Live or Playback images.
- 

This button will change the Zoom Keys operation to focus or iris functions (when available).
- 

Use this button to cycle through available cameras.
- 

This button should be pressed to carry out auxiliary actions on a PTZ camera.
- 

Press the Menu button to enter the Configuration menus.
- 

Press the Exit button to exit the Configuration menus.



Use the Directional and OK buttons to navigate through the menu screens and accept changes. Also use for PTZ telemetry control of cameras.



Use the Softkeys (Red, Green, Yellow, Purple) to directly access the corresponding function displayed on the menu screen.



The Number pad should be used to select specific cameras and preset positions when available.



Use the Playback buttons to interrogate recorded images. Use the LIVE button to switch from Playback or menu to a LIVE display.

How to navigate the pages

Using the IR Remote Control

Press the Menu button to access configuration menus. The menu will have a red indicator highlighting the first option. Press the Down Directional button to highlight the next menu item, press OK to open the highlighted menu item.

Press the Right Directional button to highlight the first editable parameter on the screen.

Use the Left/Right/Up/Down Directional buttons to move between fields.

Select OK to start editing an editable field. The field turns green.

Use the Up/Down Directional buttons to change the settings within an editable field.

Use the OK button to accept a new setting. The field turns blue again. Press Exit to leave a drop-down menu without changing the setting.

Press any coloured Softkey to open the softkey menu.

Use the coloured Softkeys to select the accompanying colour option on screen i.e. red key to select the red option.

To edit a field, select using the OK button.

Numeric fields can be edited with the Directional buttons. Use the UP/Down Directional buttons to increase/decrease by an increment of 1, use the Left/Right Directional buttons to increase/decrease by an increment of 10.

Using a USB Mouse or the webpages

Navigate the pages by clicking on the tabs on the left of the main page.

Highlight an editable field by clicking directly on it.

Use the drop down menu to change settings.

Note: A selected item in the drop down list will appear highlighted.

Navigating away from a page (clicking on a different tab on the side panel) will automatically save any changed settings.

Installing the SD Unit

This procedure shows the sixteen camera input version.

Step 1 Connecting Video

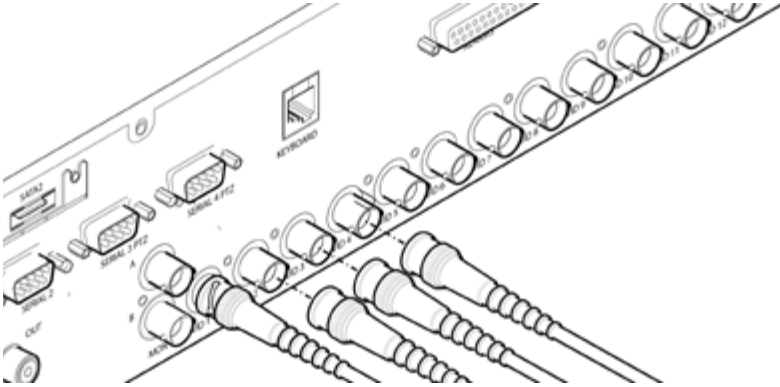

The SD supports up to 8, 12, 16 or 32 connected Video Inputs (dependant on model) via the 75Ω BNC connectors. Connect cameras to the video inputs, starting from input 1.

Step 2 Monitor

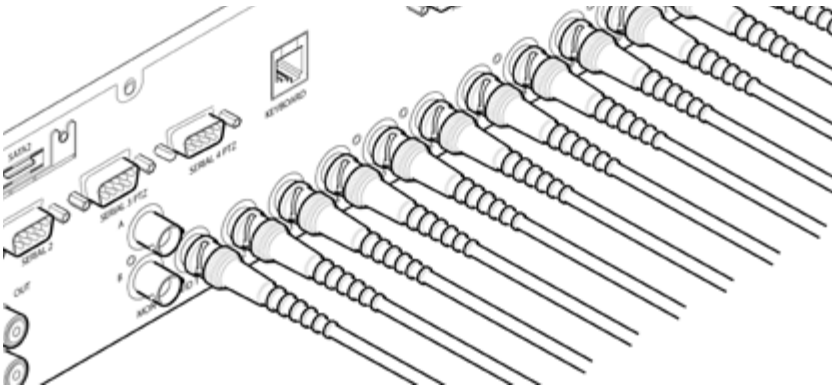

The SD supports a main monitor via BNC 'A' and a spot monitor via BNC labelled 'B'.

Step 3 Connecting Audio

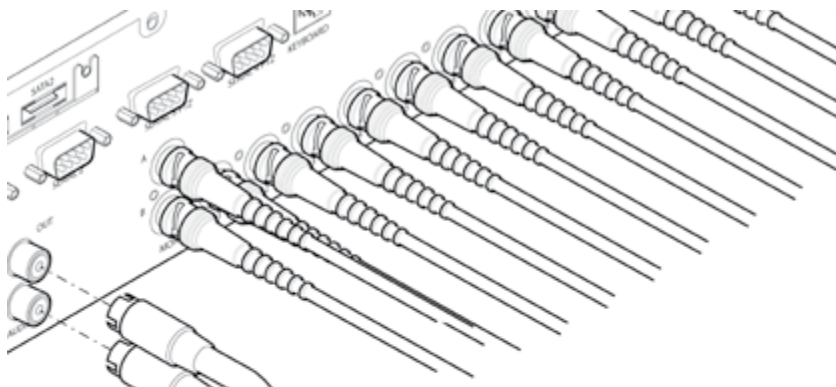

The SD supports either one or two channels of bi-directional audio*, accessible through NetVu Observer. Connect the audio equipment to the phono sockets AUDIO IN and AUDIO OUT. The audio channel defaults to recording camera 1.

- * *32 input model supports two channels of bi-directional audio, 8, 12 and 16 input models support one.*

The following modes of operation are supported:

- Challenge – intruders from an RVRC.
- Listen – to local audio from a site at the RVRC.
- Record - local audio from a site with the video.
- Replay - all audio through a local Audio output (not supported when Audio out is used as a challenge/PA source).

Note: *The Audio output can be configured as a challenge output or as a replay output.*

Step 4 Connecting to the Network

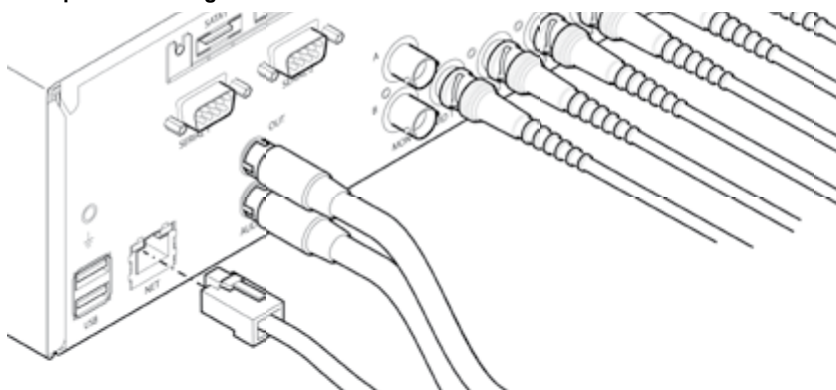

The SD supports a 10/100Mbps auto-detecting network port. Use a CAT5 cable to connect the unit to the network.

By default the unit is configured for DHCP where the unit is automatically allocated an IP address from the network DHCP server.

DNS (Dynamic Name Servers) is supported and therefore the unit can be assigned a name. This removes the need for the unit to have a fixed IP address and makes it easier for a remote user to locate.

Step 5 Relays

RELAYS

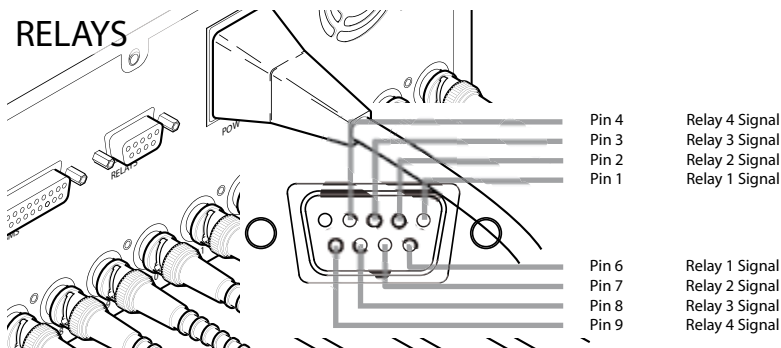

The SD supports up to four 24V 200mA relays.

Relay Connector

Pins	Connection
1 & 6	Relay 1 signal
2 & 7	Relay 2 signal
3 & 8	Relay 3 signal
4 & 9	Relay 4 signal

Step 6 Alarms

ALARMS

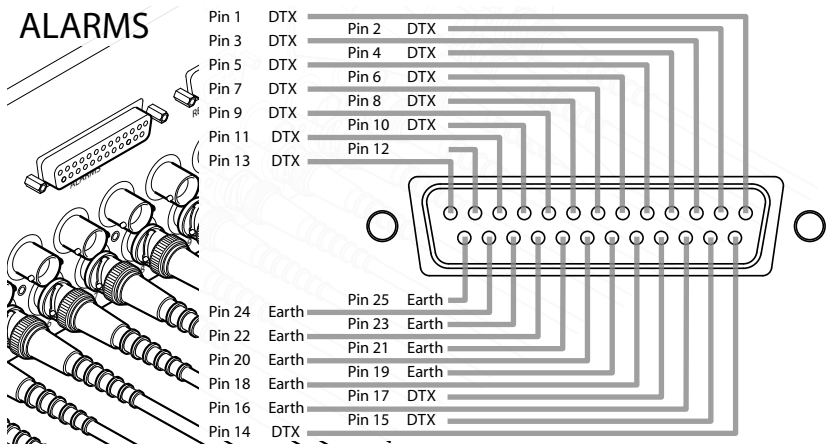

The SD supports 16 normally open/closed tamper proof alarm inputs via the back panel, or one Global keyswitch input with camera specific inputs configurable as entry/exit alarms. The Alarms support tamper proof detection using 1k in line and 5K end of line resistance. The SD detects short circuit, open circuit and contact closure. This functionality is part of the advanced alarms supported on NetVu Connected products and included features required for Central Monitoring and is compatible with the British Standard BS8418.

Relay Connector

Pin	Alarm Input Connection
1 - 17	1-17
18-25	Earth Common

End Of Line Circuitry

The following describes the EOL tamper alarms circuitry needed when EOL has been configured. There should be two resistive values within the tamper alarm circuitry. These must be located inside the alarm device (furthest point from the unit).

The alarm state could be Normally Open or Normally closed however the tamper states are the same for both settings.

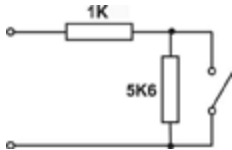

Open, the resistive value is 6.8K ohms (1K + 5.6K).

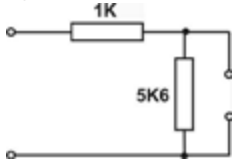

Closed, the resistive value is 1K ohms, as the circuit does not see the 5.6K ohm resistor.

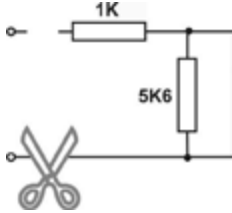

Open Circuit Tamper, the resistive value is infinity as the circuit has been cut and therefore is 'open'.

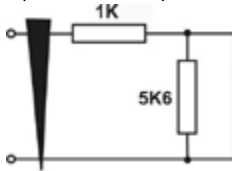

Short Circuit Tamper, the resistive value is 0 Ohms.

Step 7 Connecting Serial Ports

Serial ports have two main uses:

1. Connecting twisted pair telemetry for PTZ cameras.
2. Providing text data recorded with the video e.g. Point of Sale.

Note: *Telemetry cameras should be connected to Serial 3 and 4. Text data can be retrieved from any serial port.*

RS232

RS-232	Serial 1 & 2 Pin Allocation	Serial 3 & 4 Pin Allocation
Data Carrier Detect (DCD)	1	-
Receive Data (RX)	2	2
Transmit Data (TX)	3	3
Data Terminal Ready (DTR)	4	-
Ground (GND)	5	5
Data Set Ready (DSR)	6	-
Ready To Send (RTS)	7	7
Clear To Send (CTS)	8	8
Ring Indicate (RI)	9	-

RS485

RS-485	Serial 3 & 4 Pin Allocation
Transmit Data (TX+)	1
Transmit Data (TX-)	9

Step 8 Connecting a Keyboard

The SD supports Dedicated Micro keyboards DM/KBC1 and DM/KBC2. Connect either of these keyboards via the KBD connector socket on the rear panel.

Note: Refer to the Unit Operation section of this manual for further guidance regarding the supported keyboards.

Step 9 Connecting Dennard 2060 & 2040 Domes

A Dennard 2040/2060 Dome can be connected via either co-axial telemetry or RS485 twisted pair. If using co-axial the address switches should be set as:

Blue switch - F

Yellow switch - D

If the dome is being connected using RS485, the dome address should be set according to the camera number of the SD (1-32).

Pin connections for RS485 connection to a Dennard dome on serial port 3/4 are:

Dome Cable	SD Serial Connector
Yellow	1 TX+
Green	9 TX-

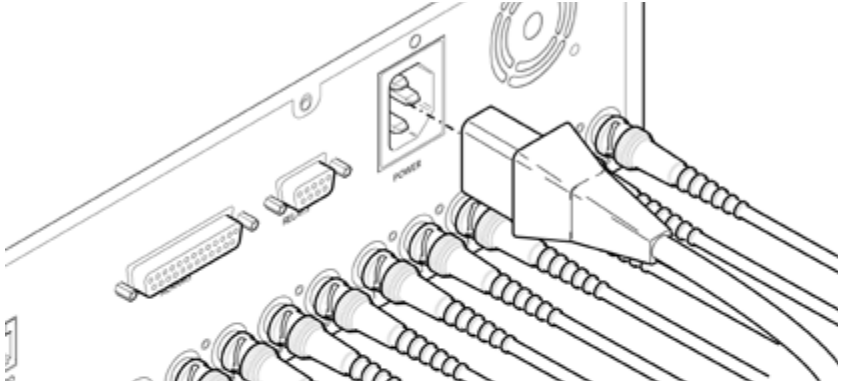
Step 10 Connecting Power

The SD has an internal power supply unit. Connect the mains lead to the unit and then to the wall socket, or to a fused spur connection. To be compliant with wiring regulations in some countries, an Alarm/Security device should be connected to a fused spur and not a wall outlet socket (check local regulations before installation).

Configuring the Unit

The unit can be configured either on the local monitor or over the network using a PC with Internet Explorer or similar browser. Both methods have identical interfaces.

Accessing the menus on a local monitor

1. The Configuration pages can be displayed on the local monitor by pressing the MENU button on the Remote Control.

Note: If the IR Remote Control does not open the menu, press the DVR button on the Remote to make sure it is in DVR mode, then press the MENU button again.

Please refer to section; 'How to navigate the pages', for guidance on navigating the local monitor configuration pages.

Accessing the menus on a PC web browser

Locating the Unit IP address

The IP address of the unit is required to access these pages. The SD unit's IP address can be identified from the local menu pages. Using the local monitor, press the MENU button and then navigate to the Network menu to find the DHCP assigned IP address.

If DNS is not to be used, it is important to set a fixed IP address so that the same URL can be entered to contact the unit every time.

If a permanent IP address is not assigned to the unit, it will attempt to contact the DHCP server every time it starts up. If for any reason, a DHCP server cannot allocate an IP address to the unit, the encoder will use a default IP address. It is recommended that DNS (Domain Name Server) be used as assigning a name makes it easier for a remote user to locate the unit.

Accessing the Configuration Web Pages

The unit can be configured using on the on-board web pages. To access these:

1. Launch Internet Explorer (or other web browser package).
2. Type the URL for the unit (IP address or domain and unit name).

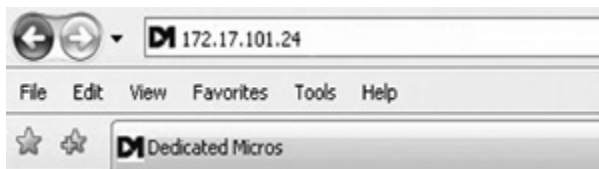

3. The Main Menu page will be displayed.

Status

This page shows the general information about the unit, including the version of software installed and the adopted video standard.

CONFIGURATION		SD Range
Status	Status	
General	Record duration	
Cameras	Estimate (Days)	85
Schedule	Camera fail	
Recording	Alarmed cameras	
Network	MAC address	00-D0-D9-06-5B-41
Alarms	Software version	04.2 (06.2)
Activity	Webpage version	02.0 (01.28) - 10/08/2007
More..	Codec version	01.4 (018) C2DM
	Hard disk size	475750
	SD model	

The configuration pages are navigable using the menu on the left hand side of the page.

Note: Any changes made on the web pages are automatically saved when the page is closed. To 'manually' save changes, select the Save button. Use the 'Cancel' button to exit a page without saving any changes made.

Note: The Save button is only displayed when accessing the menus via the web interface.

Note: Some pages may be displayed differently on the web browser than the local monitor.

General

This page enables configuration of the time, date, local region and language used to display text.

The screenshot shows a web interface for configuring a device. The main heading is 'CONFIGURATION' with a sub-heading 'SD Range'. On the left is a navigation menu with options: Status, General, Cameras, Schedule, Recording, Network, Alarms, Activity, and More... The 'General' tab is selected. The 'General' configuration area includes: Language (English), Set time (10:17) with a 'Set_time' button, Set date (22/08/2007) with a 'Sync unit time from PC' button, Date format (dd/mm/yy), and Time zone (GMT +0 - Greenwich Mean Time : Dublin, Edinburgh, Lisb...). A note states 'Change to timezone require system restart, Use Maintain page'. At the bottom are 'Maintain' and 'Cancel' buttons.

- | | |
|---------------------------------|---|
| Language | This will allow selection of the appropriate local language. The unit currently supports five languages (English, French, Italian, Spanish and German). |
| Set time | Enter the current local time. |
| Set date | Enter the current local date. |
| Set_time (Green) | Use this button to accept any changes made to the time and date parameters. |
| Sync unit time from PC (Yellow) | Use this button to synchronise the time of the unit with that of the PC being used to view the menu pages. |
| Date Format | As default, the date is entered dd/mm/yy. It can also be displayed as mm/dd/yy or yy/mm/dd. |
| Maintain (Red) | This button navigates to the Maintain page. |
| Cancel (Purple) | Settings are automatically saved when the page is closed. Use this button to cancel any changes before navigating away from the page. |
| Save | To 'manually' save changes whilst in a menu page, select the Save button. |

Note: Any changes made on the web pages are automatically saved when the page is closed. To 'manually' save changes, select the Save button. Use the 'Cancel' button to exit a page without saving any changes made.

Note: The Save button is only displayed when accessing the menus via the web interface.

Cameras

This page allows the connected cameras to be configured.

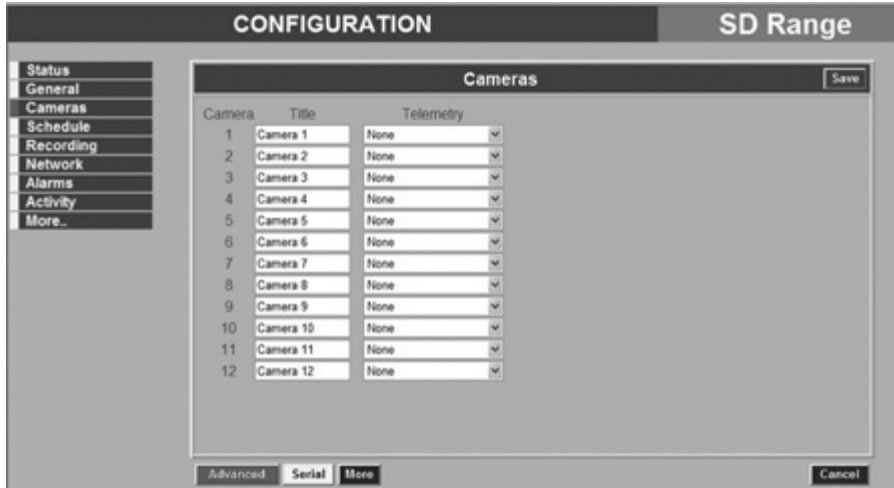

Camera

This column shows all the cameras that are currently connected and can be edited.

Title

Each of the camera titles can be edited to describe the camera location or view. On the Local monitor, Press OK on the item to edit and display a virtual keyboard. When using the remote web pages, utilise the PC keyboard to enter text.

Note: If a camera title is entered via the local monitor, an on-screen virtual keyboard will be displayed to aid text entry.

Telemetry

If a Dome or PTZ camera is used; the appropriate control protocol should be selected.

Advanced (Green)

Opens the Advanced Setup page (see overleaf).

Serial (Yellow)

Opens the Serial Settings page (refer to Serial section of this manual). The Serial page is used to define which serial port is used to connect telemetry cameras.

Cancel (Purple)

Settings are automatically saved when the page is closed. Use this button to cancel any changes before navigating away from the page.

More/Back (Blue)

Only eight cameras can be displayed on the local monitor. If required, access additional camera settings via the More button. Return to the previous page via the Back button. These buttons are only displayed if more than eight cameras are connected.

Save

To 'manually' save changes whilst in a menu page, select the Save button.

Note: Any changes made on the web pages are automatically saved when the page is closed. To 'manually' save changes, select the Save button. Use the 'Cancel' button to exit a page without saving any changes made.

Note: The Save button is only displayed when accessing the menus via the web interface.

Advanced

The **Advanced** button on the cameras page will access the **Advanced settings** page, allowing more of the camera settings to be edited.

Camera	Camera type	Contrast adjust	Termination
1	Colour	0	On
2	Colour	0	On
3	Mono	0	On
4	Mono	0	On
5	Mono	0	On
6	Mono	0	On
7	Mono	0	On
8	Mono	0	On
9	Mono	0	On
10	Mono	0	On
11	Mono	0	On
12	Mono	0	On

- Camera** This column shows all the cameras that are currently connected and can be edited.
- Camera Type** The settings will default to Colour. If Monochrome cameras are used, select Mono. This removes colour patterning when mono cameras are displayed. If a particular channel is not in use, this should be set to OFF. This will disable the camera fail on this channel and also enable the record calculator to display the best estimate of record duration.
- Contrast Adjust** This option enables the contrast settings of the selected camera to be changed. Select from 1 - 99 (default is 50).
- Termination** The SD DVR will automatically terminate the camera input with 75Ω. This can be switched off here to enable a local monitor to be tee'd off.
- Camera (Red)** This button navigates back to the main Cameras page.
- Cancel (Purple)** Settings are automatically saved when the page is closed. Use this button to cancel any changes before navigating away from the page.
- More/Back (Blue)** Only eight cameras can be displayed on-screen. If required, access additional camera settings via the More button. Return to the previous page via the Back button. These buttons are only displayed if more than eight cameras are connected.
- Save** To 'manually' save changes whilst in a menu page, select the Save button.

Schedule

The SD DVR recording quality is controlled by three factors; the time of day, the quality of image that has been set to record during that time, and whether the unit is in alarm. These factors combine to produce a recording profile. Each of these parameters can be adjusted individually. The schedule configuration can also be used to determine when the alarm contacts are active on the unit.

This page allows the schedule settings on the unit to be edited.

Enable	Mode	Start	End/day
<input type="checkbox"/>	Night	00:00	00:00
<input type="checkbox"/>	Weekend	Sun 00:00	Sun 00:00
<input type="checkbox"/>	Keyswitch (alarm input 17)		

- | | |
|-----------|---|
| Enable | The schedule can quickly be enabled or disabled by ticking the accompanying textbox of the options outlined below. |
| Mode | This lists the three available modes that can be used when setting camera schedules. |
| Night | Select to establish start and end times for Night schedule settings. |
| Weekend | Select to establish start day/time and end day/time for Weekend schedule settings. |
| Start | These text boxes control what time the Day and Night profiles will become active. During the Day period, the camera settings for 'Day' will be active (<i>refer to Recording - Advanced</i>). |
| End/Day | These text boxes control what time the Day and Night profiles will become inactive. |
| Keyswitch | A Keyswitch can be used to switch from Night profile to Day, or to disable the alarms. It can be attached via the Alarms connector using alarm in 17. |

Note: Use of a Keyswitch precludes the use of schedules.

- | | |
|-----------------|---|
| Cancel (Purple) | Settings are automatically saved when the page is closed. Use this button to cancel any changes before navigating away from the page. |
| Save | To 'manually' save changes whilst in a menu page, select the Save button. |

Recording

The SD has a range of pre-defined configurations available. As standard the unit can record at 5pps MPEG4 and at a duration of 7, 14, 30 or 60 days (the default is 14 days). Alternatively the unit can be configured for 1pps JPEG recording on each camera or can be configured for **MultiMode** operation so that it switches from 5pps MPEG to 5pps JPEG on Event (Note that this will result in the record duration being determined by the amount of time the unit is in alarm). The Apply button updates the system record duration calculator which calculates the actual duration capable of being held on the drive. If specific requirements are needed on a camera, the Advanced configuration can be used to configure the exact requirement.

The screenshot shows the 'CONFIGURATION' window for 'SD Range'. On the left is a vertical menu with items: Status, General, Cameras, Schedule, Recording, Network, Alarms, Activity, and More.. The main window is titled 'Record Setup' and contains the following elements:

- 'Record duration (days)' text box with the value '65'.
- 'Preset configuration' dropdown menu showing 'Normal rate - MPEG4 5pps'.
- 'Reduce duration / enhance quality (days)' dropdown menu showing '30', with a note '(Settings apply to full system)' below it.
- 'Apply?' button.
- 'Save' button in the top right corner.
- 'Advanced' and 'Record_options' buttons at the bottom left.
- 'Cancel' button at the bottom right.

Record duration	This text box will display the record duration possible using the current configuration.
Preset configuration	Select the rate of non alarm recording to be used from the range of preset recording profiles; via Normal, Medium and Low Rate options utilising MPEG4, JPEG or MultiMode recording.
Record duration/enhance quality	The recording duration can be limited to 7, 14, 30 or 60 days; allowing the machine to enhance the recording quality to suit.
Apply? (Green)	If the settings have been changed then Apply will configure these and override any individual settings. The Record calculator will then update.
Advanced (Red)	This button opens the Advanced Setting page (<i>see later</i>).
Record options (Yellow)	This button opens the Record options page (<i>see later</i>).
Cancel	Settings are automatically saved when the page is closed. Use this button to cancel any changes before navigating away from the page.
Save	To 'manually' save changes whilst in a menu page, select the Save button.

Advanced Settings

CONFIGURATION
SD Range

Status

General

Cameras

Schedule

Recording

Network

Alarms

Activity

More..

Advanced
Save

Camera 1
Copy_to_all
Record duration (days) 85

	Compression	Quality	KBits/s	pps
Day normal	MP 2CIF	180	KBits/s	5
Day event	MP 2CIF	180	KBits/s	5
Night normal	MP 2CIF	180	KBits/s	5
Night event	MP 2CIF	180	KBits/s	5
Weekend normal	MP 2CIF	180	KBits/s	5
Weekend event	MP 2CIF	180	KBits/s	5

Note: Quality setting defines JPEG file size in K bytes, or MPEG Kbits /second dependent on the Compression type selected. Compression type selects MPEG or JPEG and a selected image size (4CIF, 2CIF, CIF or QCIF)

Transmission
Record_options
Cancel

Camera	Enables selection of a specific camera for editing.
Copy to all (Blue)	Select this button to apply this record configuration to ALL connected cameras.
Record Duration (days)	This text box will display the record duration possible using the current configuration.
Day/Night/Weekend Normal	This column shows the recording profile used by the camera if no schedules are applied and the camera is operating under Normal (non Event) conditions.
Day/Night/Weekend Event	This column shows the recording quality that will be used by the camera during an Alarm or Event. Note that Night and Weekend schedules will be used only when schedules are applied.
Compression	Selects MPEG or JPEG and a selected image size (4CIF, 2CIF, CIF or QCIF).
Quality	If JPEG is selected, the figure entered in this text box will be the size of the JPEG transmitted (in Kbytes). If MPEG4 is selected, the figure will be the bit rate allocated. A higher bit rate will provide better quality. JPEG file sizes can be configured in the range of 5-45Kbytes and MPEG bit rates in the range of 45-2500 K bits/second.
PPS	This shows the pictures per second that will be recorded.
Transmission (Green)	This button opens the Transmission settings page (<i>see later</i>).
Record options (Yellow)	This button opens the Record options page (<i>see later</i>).
Cancel (Purple)	Settings are automatically saved when the page is closed. Use this button to cancel any changes before navigating away from the page.
Save	To 'manually' save changes whilst in a menu page, select the Save button.

Transmission

The NetVu Connected remote viewing software (NetVu ObserVer) will use the settings configured on this page as the defaults for JPEG & MPEG; High, Medium and Low settings. The SD transmits live images using JPEG or MPEG image formats utilising the soft codec architecture (VISP). The SD features **TransCoding** which enables recorded JPEG images to be **Transcoded to low bit rate MPEG4** for transmission over limited bandwidth links. This is essential for efficient, 'fast update' remote viewing of recorded video in central monitoring applications. The SD can also **Transcode** from recorded high bit rate MPEG4 to low bit rate MPEG4.

Transmission			
JPEG transmission			
Quality	Display Res	Size KB	PPS
High	704 x 256	25	6
Med	704 x 256	20	3
Low	176 x 128	5	3
MPEG4 transmission			
Quality	Resolution	Bit rate	PPS
High	704 x 256	1024	15
Med	352 x 256	512	5
Low	176 x 128	128	3

- JPEG/MPEG4 Quality** This shows the remote viewing settings being configured. These will be used by the remote viewing client as default settings.
- Display Res** There are four display resolutions available; 704x512, 704x256, 352x256 & 176x128
- Size KB** In the JPEG settings, the figure entered in this text box will be the size of JPEG transmitted (in Kbytes). In the MPEG4 settings, the figure will be the bit rate allocated. A higher bit rate will include more detail, but will take up more bandwidth on remote viewing, or more storage space on a hard drive.
- PPS** This shows the pictures per second that will be transmitted. On JPEG, the actual images per second transmitted will depend on the bandwidth of the link, increasing the PPS may introduce time lag if bandwidth is not sufficient. On MPEG transmission increasing the PPS will also reduce the quality of the images, as more images are transmitted for the defined bit rate.
- Advanced (Red)** This button opens the Advanced Record Setting page (see below).
- Cancel (Purple)** Settings are automatically saved when the page is closed. Use this button to cancel any changes before navigating away from the page.
- Save (Grey)** To 'manually' save changes whilst in a menu page, select the Save button.

Record Options



Timed expiry (days) Images recorded onto disk can be programmed to expire after a user-defined number of days and hours. This option has been designed to assist where the installation requirements define that recorded images must adhere to legislation on retaining images for a maximum record time, for example 31 days.

Warning: All images older than the selected timed expiry will no longer be available.

Alarm protection Alarm images can be protected from overwriting.

Alarm protection duration (days) This drop down sets how long Alarm images will be protected

4CIF interface enable This can be switched On if the system will be used to record using the 4CIF settings, and will eliminate the comb effect that may be visible in a high motion recording environment. It is not required if not using 4CIF, and may not be required if not recording high motion.

Manual Image protection It is possible to protect images stored on the unit hard drives. These images will not be overwritten (see overleaf for further details).

Advanced (Red) This button opens the Advanced Setting page.

Cancel (Purple) Settings are automatically saved when the page is closed. Use this button to cancel any changes before navigating away from the page.

Save To 'manually' save changes whilst in a menu page, select the Save button.

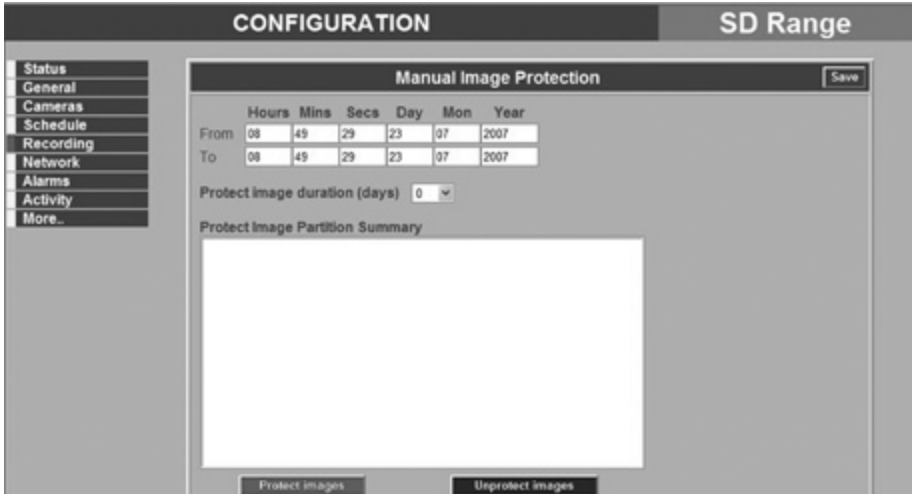

- From Enter the date and start time for the period containing the recorded images.
- To Enter the date and end time for the period to be protected.
- Protect image duration (days) Select how long, in days, the images will be protected for.
- Protect Image Partition Summary This shows all protected images.
- Protect images (Red) Once the time and date information has been entered, select the 'Protect Images' option. The entries within the list section will be preserved.
- Note:** It may take some time to add protected images to the list.
- Unprotect Images (Blue) It is possible to manually un-protect images that have either been automatically protected or manually protected. Once the time and date information has been entered, select the 'Unprotect Images' option. The entries within the list section will be removed.
- Note:** It may take some time to remove protected images from the list.
- Record Options (Yellow) Use this button to return to the Record Options page.
- Cancel (Purple) Settings are automatically saved when the page is closed. Use this button to cancel any changes before navigating away from the page.
- Save To 'manually' save changes whilst in a menu page, select the Save button.

Network

This page allows configuration of the network settings for the unit. Note that the unit is initially configured for DHCP.

DHCP

DHCP service will automatically interrogate any DHCP server when a machine boots up and assign a free IP address, subnet and gateway. This can be used to ensure an IP address is unique to this machine. However, this could result in the machine having a different IP address every time it boots. The IP address should be noted and then DHCP disabled. Alternatively the unit can be configured for DNS which enables DHCP to be maintained.

DHCP IP

This is the IP address the DHCP server has allocated to the unit.

DHCP Subnet

This is the subnet of the network the unit is on that was automatically allocated by the DHCP server on power up.

DHCP Gateway

This is the IP address of the default gateway (router) assigned by the DHCP server.

DHCP Name

This is the name of the DHCP server.

DNS Sys name

This field can be edited to assign a name to the unit which would be displayed in NetVu ObserVer.

Primary DNS

This is the primary DNS server IP address for applications that are utilising domain names.

Email (Red)

This Button will open the Email Page (*see later*).

Maintain button (Green)

When IP configuration changes have been made, it is necessary to reset and restart the SD unit This can be done via the Maintain menu.

Email settings

The unit can send an email when it registers an event. The settings for this email can be edited by clicking the Edit button, refer to Email Settings.

Bandwidth selection

It is possible to set maximum limits for the bandwidth utilisation on the Network port of the unit. The settings can be edited by clicking the Edit button, refer to 'Bandwidth selection'.

Cancel (Purple)

Settings are automatically saved when the page is closed. Use this button to cancel any changes before navigating away from the page.

Save

To 'manually' save changes whilst in a menu page, select the Save button.

Email Settings



Mail Server

This is the IP address or URL of the SMTP Server that the e-mail from the unit will be sent to. The SMTP server will then forward this onto the recipient.

Recipient address

This is the e-mail address and display name of the intended recipient of the e-mailed image.

Recipient display name

This is the addressee name that will be shown in the email name field.

Reply to address

This field must be configured if the recipient is to reply to an e-mail. The unit does not accept e-mails so this must be a valid e-mail address.

Reply to display name

This is the reply to name that will be shown in the email name field.

Sender address

These optional fields indicate the source of the e-mail notification. If the fields are left blank the unit will use the system name & DNS name to create a sender name.

Sender display name

This is the sender name that will be shown in the email name field.

E-mail Logging

A log can be created for every e-mail transaction that the unit issues.

Network (Red)

This button will open the Network page (see Network).

Cancel (Purple)

Settings are automatically saved when the page is closed. Use this button to cancel any changes before navigating away from the page.

Save

To 'manually' save changes whilst in a menu page, select the Save button.

Bandwidth Selection

The screenshot shows a web-based configuration interface. At the top, there are two tabs: 'CONFIGURATION' and 'SD Range'. On the left, a vertical menu lists various system settings: Status, General, Cameras, Schedule, Recording, Network, Alarms, Activity, and More... The main area is titled 'Bandwidth' and contains several input fields and a dropdown menu. The 'Type' dropdown is set to 'LAN'. Below it, 'Max trans rate (kBits/sec)' is set to '10000', 'Tx image buffers' is set to '3', 'Ethernet MTU' is set to '1500', and 'Ethernet re-tx t/o (ms)' is set to '250'. At the bottom of the main area, there are three buttons: 'Network', 'Cancel', and 'Save'.

- | | |
|-------------------------|---|
| Type | This option ensures the speed of the data from the unit matches the speed of the network the data is being transmitted across. These are default settings and are configured as:
LAN – 10000 Kilobits/second
WAN – 256 Kilobits/second
ISDN – 64 Kilobits/second |
| Max Transmission Rate | This shows the maximum transmission speed for the type of network selected. |
| Tx image buffers | This is used in order to improve the picture delivery over Ethernet when using a slow connection, i.e. 256Kbps. Options available are 1, 2 or 3 buffers. |
| Ethernet MTU | This is the maximum transmit unit for the Ethernet packet. The MTU is the largest physical packet size measured in bytes, that the network can transmit. By default this figure is set to 1500bytes. |
| Ethernet rx-tx t/o (ms) | This is the time the unit will wait to re-send a packet if an acknowledgement is not received.
When making a connection across a WAN link this figure should be increased and should match the timeout figure for the router. |
| Network (Red) | This button will open the Network page (<i>see Network</i>). |
| Cancel (Purple) | Settings are automatically saved when the page is closed. Use this button to cancel any changes before navigating away from the page. |
| Save | To 'manually' save changes whilst in a menu page, select the Save button. |

Alarms

This page allows configuration of the alarm settings. For hardware installation information, refer to 'Installing the SD DVR'.

The alarms are associated with cameras by default. There is a panic alarm available using the panic button on the remote, or on a connected SD keyboard. This will put all cameras into alarm recording. There is also a contact alarm that is configured as a keyswitch via Alarm input 17.

Alarms support tamper proof detection to detect short circuit, open circuit and contact closure.

Alarm	This box specifies which alarm response profile is being configured.
Source	Use the drop down to select whether the contact is normally open (N/O), normally closed (N/C) or disabled.
Pulse (secs)	The pulse extension is used to prevent double triggers on a single alarm. The pulse extension time starts on an alarm trigger. If that contact is triggered again after the first alarm has finished but within the pulse extension, the second trigger will not restart the alarm, but will extend the current alarm duration.
EOL contact	The End Of Line (EOL) is part of the advanced alarm feature and enables the inputs to detect any changes in the input electronic resistance, e.g. 0 – 800Ω. A change will result in a Tamper Alarm (short circuit) being detected and the system switching to alarm mode (refer to 'End Of Line Circuitry' in the 'Installing The SD' section). By default the EOL contacts are disabled for each input.
Primary camera	An alarm can activate two cameras if required. The primary camera will take the still image used for e-mailing on alarm and adding to the event database. It is also the camera that is displayed first on the Operator monitor.
Preset	If the Primary camera is enabled for telemetry, it can be sent on alarm to the preset nominated here.
Secondary camera	If the alarm triggers two cameras, the second camera should be defined here.

Enable	This shows when the alarm is enabled, and can be set for OFF, 24 hours, Schedule Day, Schedule Night and Weekend. Note that if a Keyswitch is utilised: Keyswitch OFF uses Schedule Day and Keyswitch ON uses Schedule Night).
Entry route	This creates deferred alarms along a specified route while the entry time is active in compliance with BS8418, the British Standard for remote monitoring stations. The entry/exit time period is set on the Global Page. Diverting from the entry route during the count down will result in the alarm being triggered immediately. This allows staff entry without triggering an alarm, prior to switching the system to Day mode.
Exit route	This creates deferred alarms along a specified route while the exit time is active in compliance with BS8418, the British Standard for remote monitoring stations. The entry/exit time period is set on the Global Page. Diverting from the exit route during the count down will result in the alarm being triggered immediately. This allows staff to leave without triggering an alarm.
Activate relay mode	The alarm can be used to trigger one of the four available relays. The alarm will trigger the selected relay until the alarm ends.
Remote alarm reporting	Enable this to send a report to an RVRC on receipt of an alarm. Ensure that the Report Settings have been configured in the Alarms -> Remote Reporting menu
Email on Alarm	Enable this to send an email on receipt of an alarm. Ensure that the email settings have been configured in Network->Email settings.
Log event	The SD DVR can record all Events, both Alarms and Activity. Enable this to have the event written to the log.
Switch to camera	The SD DVR can display the primary camera associated with this alarm on the operator monitor.
Sounder	The unit has a buzzer which can sound for five seconds when an alarm or activity are detected.
Global (Red)	This button will open the Global Alarms settings (see Global Alarms below).
Remote Reporting (Yellow)	This button will open the Remote Reporting settings (see Remote Alarm Reporting below).
Cancel (Purple)	Settings are automatically saved when the page is closed. Use this button to cancel any changes before navigating away from the page.
Save (Grey)	To 'manually' save changes whilst in a menu page, select the Save button.

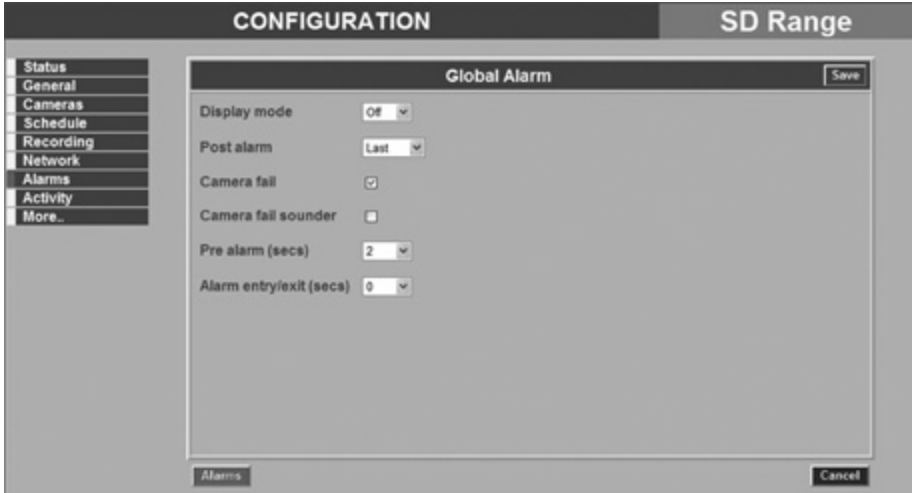

- Display mode A monitor can be configured to switch to display mode on alarm activation.
- Post Alarm Post alarm defines what happens when an alarm condition has completed. Select Last to leave the last alarmed camera displayed. Select Revert to return the display to its state prior to the alarm being raised.
- Camera fail A relay can be assigned to activate if a camera fail is registered by the DVR. This is hard defined as Relay 3.
- Camera fail sounder The on board sounder can be set to activate if a camera fail is registered by the DVR.
- Pre alarm (secs) This is the period of time, prior to the alarm start that will be included along with the alarm recording for archive. These images will be protected from being overwritten with the alarm images. The unit places a 'marker' in the regular recording that acts as the start of the pre-alarm recording, the number of images available will be dependant on the pre-alarm time set.
- Alarm entry/exit (secs) The alarm entry/exit timer is the time interval between an entry initiator being activated and alarms being triggered, or the alarm keyswitch being tripped and the exit initiator being activated. This timer will allow a key holder sufficient time to enter or exit the premises without triggering an alarm. This is set in seconds.
- Alarms (Red) This button will navigate back to the main Alarms page.
- Cancel (Purple) Settings are automatically saved when the page is closed. Use this button to cancel any changes before navigating away from the page.
- Save To 'manually' save changes whilst in a menu page, select the Save button.

Activity

This page allows configuration of the activity detection settings.

The unit can detect changes in the image received from a camera. This detection can be refined to specify certain areas of the image using an overlay grid. This grid can be edited.

Camera	This shows which camera settings are currently being edited.
Detection	Detection can be deactivated or activated using this drop down menu.
Pulse	The pulse extends the trigger period to avoid double triggers of Activity detection occurring, i.e. If a second incident is received, after the first alarm is finished but within this period, the unit will not create a new even, but will extend the current event duration.
Enable	This option defines when the activity detection is enabled
Activate relay	The alarm can be used to trigger one of the four available relays.

Note: When setting the sensitivity it is recommended that an Activity test is run to ensure the correct sensitivity is selected.

Sensitivity	There are five levels of sensitivity for activity detection to ensure any scene environment can be covered. Select the sensitivity level to suit the camera location: <ul style="list-style-type: none"> External cameras where there may be a lot of background movement, such as cloud shadow or rain, should be set to Outdoor high, Outdoor low or very low sensitivity. Cameras sited indoors where there is very little background movement can be set to Indoor high or Indoor low sensitivity.
-------------	---

The sensitivity levels are:

- Indoor High (most sensitive setting).
- Indoor Low.
- Outdoor High.

	<ul style="list-style-type: none">• Outdoor Low.• Very Low (lowest sensitivity level)
Display activity area	Use this option to test and tune the sensitivity and activity grid configuration for each camera. When activity is detected on the camera, a yellow box is displayed on-screen. Press the MODE button to exit the test.
Remote Alarm Reporting	This must be enabled for the unit to automatically connect on alarm, it must also be configured on the Alarm option. Ensure that the Report settings have been configured in Alarms -> Remote Reporting menu.
Email on activity	Enable this to send an email on receipt of an alarm. Ensure that the email settings have been configured in Network-> Advanced-> Email settings.
Log event	The SD DVR can record all Events, both Alarms and Activity. Enable this to have the event written to the log.
Switch to camera	The SD DVR can display the primary camera associated with this alarm on the operator monitor.
Sounder	The unit has a buzzer which can sound for five seconds when an alarm or activity are detected.
Edit grid (Red)	This button will open the Activity Grid editor for this camera (see Activity Grid below).
Cancel (Purple)	Settings are automatically saved when the page is closed. Use this button to cancel any changes before navigating away from the page.
Save	To 'manually' save changes whilst in a menu page, select the Save button.

Activity Grid



The alarm detection area can be edited via the Activity Grid. The Activity Grid can be used to exclude areas where there may be continuous movement (i.e. trees or bushes) which lead to false triggers. The camera view can be overlaid by a grid of up to 16x16 cells. Each cell can be individually enabled or disabled.

Select a camera via the Activity Detection screen, then select the Edit Grid option (Red Softkey). Use the up/down/left/right Directional buttons to navigate between cells. To add cells, press the OK button on an area of the image that does not presently contain any cells. A cell will be added. Use the Directional buttons to add more cells. When the required number of cells have been added, press the OK button again. If cells need to be removed, highlight a cell and press the OK button. Use the Directional buttons to move around the image deleting other cells. Press the OK button when all required cells have been deleted. If only a small area of the camera view may be subject to false triggers. Use the Default_grid feature (Yellow Softkey) to fill the screen with a full 16x16 cell grid, then highlight the required cell(s) to be removed via the OK button.

Activity (Red)	This button will navigate back to the Activity settings page.
Clear cells (Green)	This button will clear all entered cells.
Default grid (Yellow)	This button will insert a default square of 16 x 16 cells across the displayed video image.
Cancel (Purple)	Settings are automatically saved when the page is closed. Use this button to cancel any changes before navigating away from the page.
Save	To 'manually' save changes whilst in a menu page, select the Save button.

Remote Alarm Reporting

CONFIGURATION **SD Range**

Remote Alarm Reporting Save

Primary host: 172.17.100.16
 Secondary host: 172.17.101.27
 Public (NAT) IP address:
 Video server port: 80
 Unit alarm name: CIM SD ALARM
 alarm reporting:
 camfail reporting:
 tamper reporting:
 startup reporting:
 Dial retry time (secs): 20
 Dial count: 3
 Dial limit: 5
 Alarm telnet server port: 23
 ARC ping: Multi

Alarms Activity Cancel

Primary Host	This is the IP address or name of the initial host that the unit will transmit an alarm message to.
Secondary Host	If the unit is unable to contact the primary host, an alternative route can be identified via a secondary host. If there is only one alarm receiving IP address, you must enter the details in both the primary and secondary connection settings.
Public (NAT) IP Address	This is the public IP (or domain name) for a unit connected to the Internet via a NAT Router or Firewall. This field should be left blank if NAT is not used e.g. on a private network.
Video server port	This field allows the ARC to connect to the unit through a router that is using port forwarding e.g. if the video server does not appear on port 80 (HTTP) to the external network.
Unit alarm name	This is the name that will be presented to the remote alarm viewing application. It should therefore have some significance to the Operator. This name must match the defined folder name in the Viewer PC folder tree.
Alarm reporting	This must be enabled for the unit to automatically connect on alarm. It must also be enabled in the Alarm Zone option.
Camfail reporting	If the unit identifies camera failure on any of the inputs, enabling this option will force the unit to connect to the remote alarm station.
Tamper reporting	The unit supports Tamper alarm inputs, if a tamper is detected, this will activate a tamper alarm on that input. The alarm response is the same as if the alarm had activated.
Startup reporting	This will send an alarm report when the unit starts up. Any system resets will be identified.
Dial retry time (secs)	If the initial connection attempt fails, the unit will wait for the specified time period before attempting to re-connect.
Dial count	This details the number of attempts the unit has made to connect to the remote alarm monitoring station.

Dial limit	This identifies the number of times the unit will attempt to connect to the remote alarm monitoring station after a failed attempt. A setting of '0' means no limit and the unit will continue to try and connect until it is successful.
Alarm telnet server port	This specifies the network port number to use for reporting to the alarm server. This should normally left at the default value.
ARC ping	This will send a single wake up ping across a network to a specified ARC server. If no reply is received, the unit will wait for the Dial Retry Time before sending another ping (until it reaches the Dial Limit).

Serial

This page allows configuration of the two Serial ports on the rear of the unit. For installation information, refer to 'Installing the SD DVR'.

CONFIGURATION **SD Range**

Serial Save

Port Summary

Serial 1	Text in Image
Serial 2	Disabled
Serial 3	Text in Image
Serial 4	Disabled

Port Configuration

Port: Serial 1

Function: Text in Image

Mode: RS232

Baud rate: 115200

Data bits: 8

Stop bits: 1

Parity: None

Main Camera Cancel

Serial Port 1/2/3/4

Select the serial port to be edited

Function

Each serial port can be Disabled, set to Debug (serial communications), Text in Image, or a number of supported telemetry products.

Mode, Baud Rate, Parity, Data Bits, Stop Bits This allows the communication settings to be configured.

Note: When a telemetry protocol is selected these settings will be set to the default to pre-determined values for the protocol, and should not normally be altered manually.

Main (Red)

This button will navigate to the Main page.

Camera (Green)

This button will navigate to the Camera settings page.

Cancel (Purple)

Settings are automatically saved when the page is closed. Use this button to cancel any changes before navigating away from the page.

Save

To 'manually' save changes whilst in a menu page, select the Save button.

Audio

The settings for any available audio stream can be edited on this page. For hardware installation information, refer to 'Installing the SD DVR'.

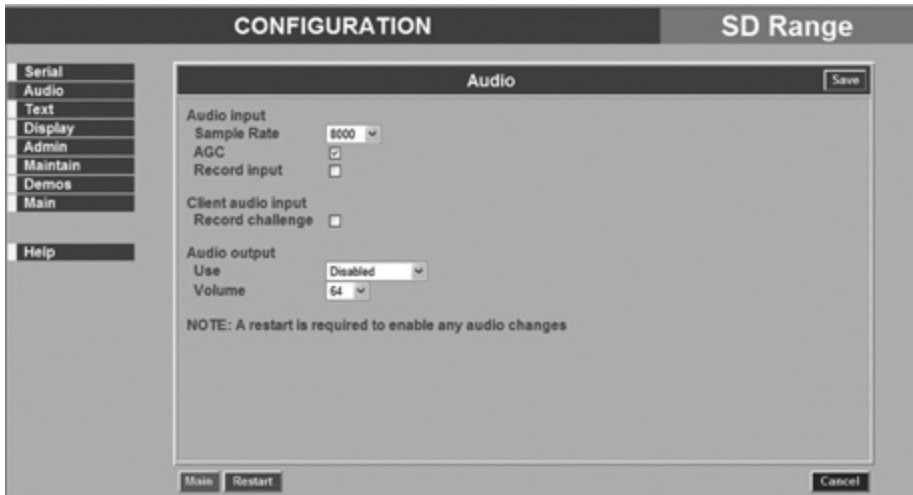

Audio Input

Sample Rate

The sample rate related to the quality of the audio being processed. A higher figure will require more storage space but will provide higher quality audio. It is selectable between 8000 Hz (phone quality), 11025 Hz, 16000 Hz and 22050 Hz (half CD quality).

AGC

Enables the Automatic Gain Control feature.

Record Input

Select whether the Audio input is to be recorded or not.

Client audio input

Enables audio from NetVu ObserVer. If the output is enabled for Challenge, it can be used for PA (Public Address purposes to challenge intruders).

Record challenge

Enables recording of the Audio input from NetVu ObserVer.

Audio Output

If the audio is being used as a challenge output or PA, then this option enables the client audio to be recorded as well as being output to the local audio output.

Use

The Audio channel can be used for Challenge or Local playback.

Volume

Adjustable level between 0 and 64.

Main (Red)

Navigate to the Main menu page.

Cancel (Purple)

Settings are automatically saved when the page is closed. Use this button to cancel any changes before navigating away from the page.

Save

To 'manually' save changes whilst in a menu page, select the Save button.

Text

The SD DVR can handle POS text data within the unit. This menu enables control of the data, how it is displayed on the monitor and recorded on the DVR. Dedicated Micro's can provide a range of text solutions for Retail, ATM or other applications, for details on how to use Text to enhance your security and video management system, talk to your DM Sales or Technical support contact.

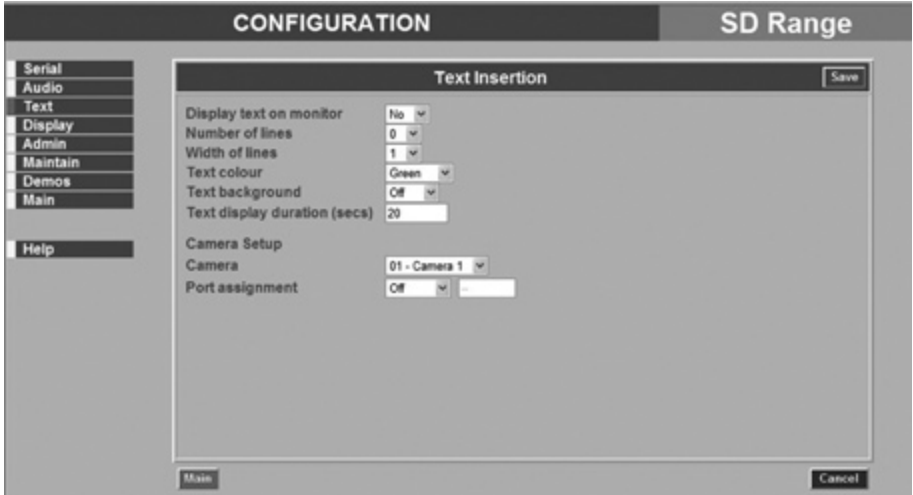

Display text on monitor	This setting allows the Text in Image to be disabled or enabled as required.
Number of lines	This is the number of lines that will be displayed in live and replay mode on the main monitor, along with the relevant images. The default setting is 20 lines.
Width of lines	This identifies the length of the lines that will be stored with the image. The default setting is 50 characters (typically the full screen).
Text colour	It is possible to select which colour the text from the peripheral serial device will be displayed within the image. The options are; Black, White, Yellow, Magenta, Red, Cyan and Green.
Text background	A background can be applied to the text within the image. This is disabled by default. The options available are; Black or White.
Text duration	The text can be wiped from the monitor after a set period, programmable between 0-999 seconds. A zero entry will keep the text on screen indefinitely.
Camera	Select the camera input to be configured from drop down list.
Port assignment	Text can be input either via a serial port or over a network port. Select either a serial port or a network port, ensuring that the serial port is configured for Text input on the Serial Menu.
Main (Red)	This button will navigate to the Main page.
Cancel (Purple)	Settings are automatically saved when the page is closed. Use this button to cancel any changes before navigating away from the page.
Save	To 'manually' save changes whilst in a menu page, select the Save button.

Display

This page allows configuration of the Monitor settings.

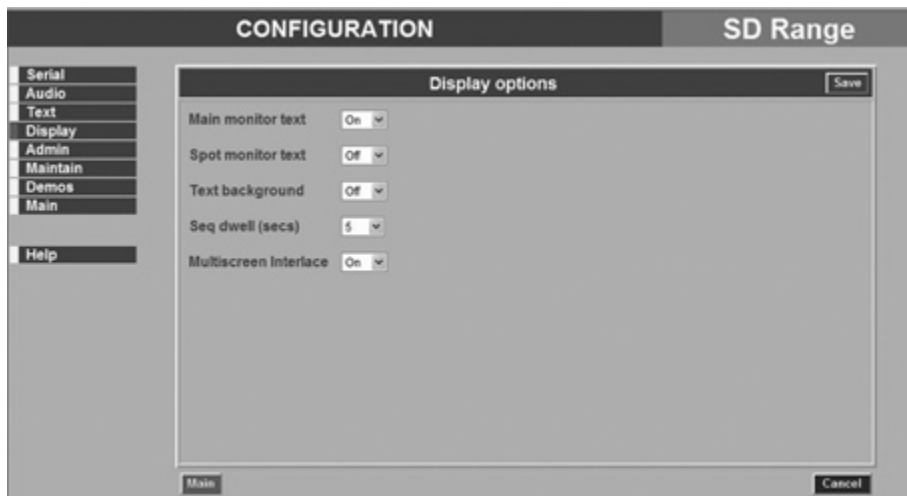

Main monitor text	It is possible to select text to be displayed on the main monitor. The text displayed will include; time, date, mode of operation (Day, Night or Weekend), camera number and camera title.
Spot monitor text	It is possible to select text to be displayed on the spot monitor. The text displayed will include; time, date, camera number and camera title.
Text Background	A black box appears by default behind the text. It is possible to switch this box off.
Seq dwell (secs)	The sequence dwell time can be set from 1 to 99 seconds. The dwell time is the length of time a camera is displayed before switching to the next camera in the sequence.
Multiscreen Interface	Improves the display on multiscreen views to remove flicker.
Main (Red)	This button will navigate to the Main page.
Cancel (Purple)	Settings are automatically saved when the page is closed. Use this button to cancel any changes before navigating away from the page.
Save	To 'manually' save changes whilst in a menu page, select the Save button.

Admin

The unit can protect access to the configuration options by setting passwords. These can be set individually for access to the menus and access to the recorded data.

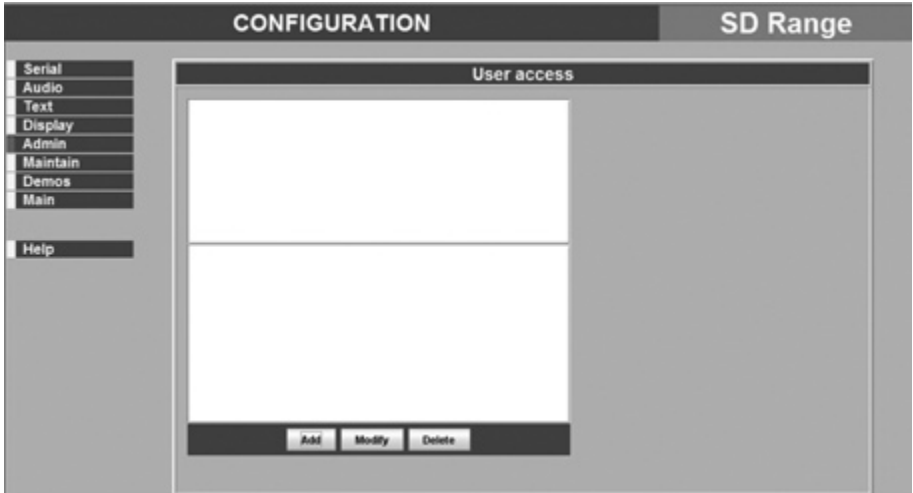

Add/Modify/Delete

Select Add and enter the new User Name, Password and which cameras on the system will be available to the user in Live and Playback mode. To modify or delete a user's settings, highlight the user in the list and press the relevant button to modify or delete. This button will navigate to the Main page.

Main (Red)

Cancel (Purple)

Settings are automatically saved when the page is closed. Use this button to cancel any changes before navigating away from the page.

Local Admin Passwords

Please note that if the Configuration pages are accessed via the local monitor GUI, the menu screen shown below will be displayed.

The screenshot shows a configuration window titled 'CONFIGURATION' for the 'SD Range' unit. On the left is a vertical menu with options: Serial, Audio, Text, Display, Admin, Maintain, Demos, and Main. The 'Admin' option is selected. The main area contains two sections for password configuration:

- Menu password:** A label 'Menu password' is followed by a dropdown menu set to 'Password' and a text input field containing 'XXXX'.
- Playback password:** A label 'Playback password' is followed by a dropdown menu set to 'Password' and a text input field containing 'XXXX'.

At the bottom of the window are two buttons: 'Main' on the left and 'Cancel' on the right.

Menu password

It is possible to configure a four digit password to enable / disable access to the local menu configuration pages. To enable this, enter the password in the box provided. When accessing menus, the password will be requested via a pop up box.

Playback password

It is also possible to configure a four digit password to disable access to playback images on the unit. In the configuration page enter a password in the box provided. If a playback function is requested on the local monitor, the operator will be challenged for a password. The operator will remain logged in as a Supervisor (Playback functionality enabled) until the EXIT button is pressed or the menu system entered.

Maintain

This page can be used to view the software details the unit is utilising. The unit can be shut down and reset from this point, while all settings can be returned to their original factory release state via the Default button.

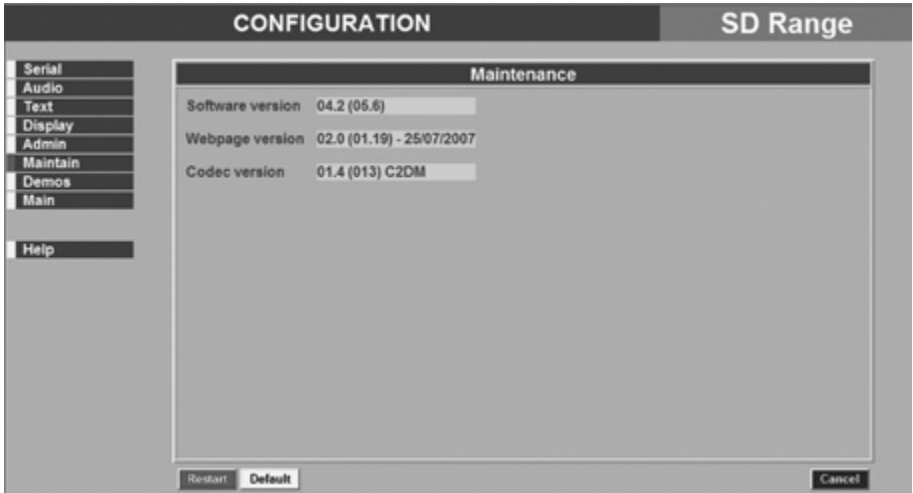

Software version	Details the version of software the unit is running.
Webpage version	Details the version of the webpage software the unit is utilising.
Codec version	Highlights the codec version the unit is using.
Restart (Red)	This button will shutdown and restart the unit.
Upgrade	This button looks for an upgrade file on a connected USB storage device or inserted CD. If any are found, the upgrade process will begin. Contact DM or search the DM website for details of software upgrade availability.
Note: The Upgrade button is only available via the Local monitor menu.	
Default (Yellow)	This button will return all option settings to their factory release default settings.
Cancel (Purple)	Settings are automatically saved when the page is closed. Use this button to cancel any changes before navigating away from the page.

Demos

The Demo section details several short tutorials on how to carry out common procedures via the IR Remote Control.

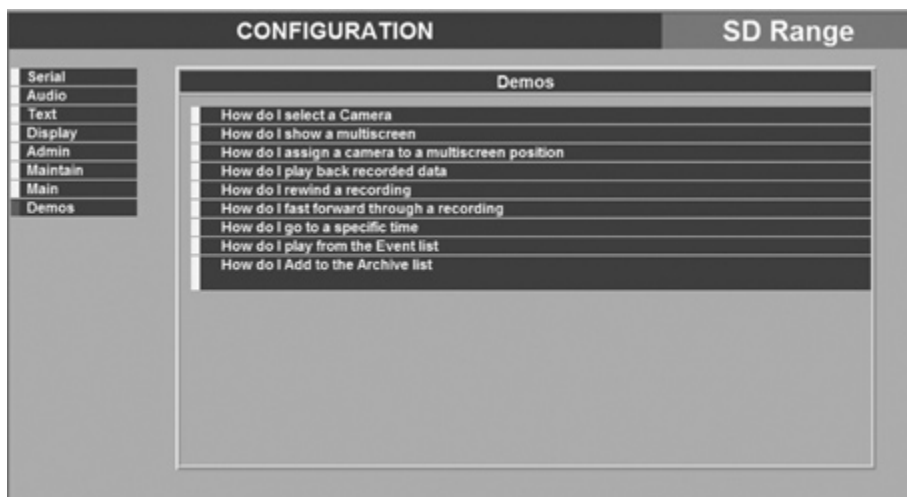

Select from the various options shown in the menu screen above. When the chosen Demo has been selected, a short tutorial will be displayed, showing which buttons, and in which sequence, should be pressed on the IR Remote Control.

Help

The Help section provides quick and easy guidance to currently displayed menu screens.

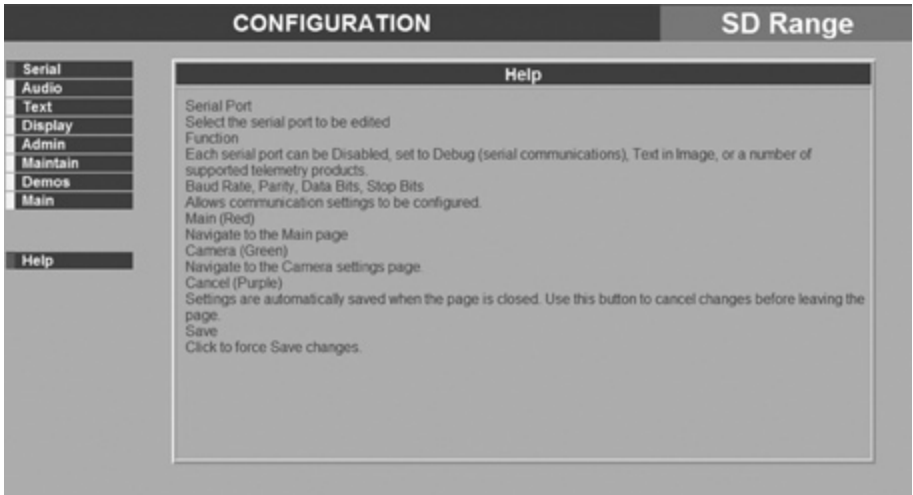

As shown in the above example, firstly select the required menu screen; then select the Help option. both the chosen menu heading and the Help heading will be accompanied by a red tab.

Then displayed on screen is a detailed description of the various options contained within the displayed menu.

Unit Operation

The SD unit can be operated using the enclosed IR Remote Control, via the optional keyboard or using a USB mouse.

Using the IR Remote Control

By default, the Keyboard/ Remote Control will be in "DVR" mode. If the unit does not respond to commands from the Remote Control, pressing the "DVR" button will always return the Keyboard/ Remote Control to "DVR" mode. Pressing the "TV" button will switch to "TV" mode and send codes understood by common television sets (when pre-programmed to do so; see Appendix B).

Pressing any of the coloured Softkeys at any time will display the 'coloured' keys first and then access the equivalent 'coloured' option displayed in the menus.

For a description of the button commands available on the Keyboard/Remote Control, refer to the IR Remote Control section (page 12).

Using the Optional touch keyboard

The unit can also be controlled using either the optional; DM/KBC1 or DM/KBC2 keyboard. This is connected via the KBD connector on the rear of the SD and provides the same control functions as the Keyboard/Remote Control.







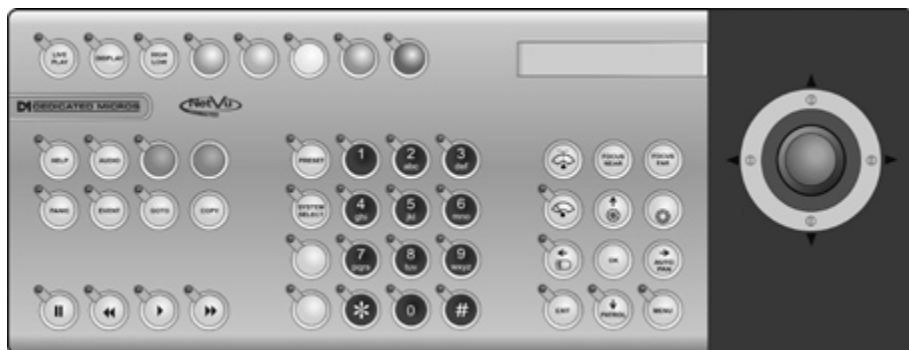

DM/KBC1 Keyboard



DM/KBC2 Keyboard



Note: Not all buttons detailed below are relevant for both models of keyboard.

Key	Function
	Displays the Softkeys menu if not currently on screen. Selects the colour coded item displayed on screen.
	Toggles between Live and Playback modes
	Removes the Softkeys from view if they are on screen. Toggles the visibility of on-screen text and status bar if no Softkeys are on screen. (For future use).
	For future use
	Displays the Softkey options for the Audio functions (for future use).
	Forces all the cameras to record in alarm mode for three minutes, or until the button is pressed again.
	Displays the archiving options
	Live mode - No functionality Play mode - Starts fast forwarding from play time. Rewind mode - Starts fast forwarding from play time. Pause mode - Steps forward one frame



Live mode - Puts unit into reverse playback from current time
 Play mode - Starts rewinding from play time.
 Rewind mode - Increases the rewind speed.
 Pause mode - Steps back one frame.



Live mode - Freezes the current display window
 Play mode - Pauses video in playback.



Live mode - puts the unit into playback using the last stored playback time



Displays the Events list menu.



Opens the GOTO menu



For future use.



Toggles control from Main to Spot monitor.



Allows the numeric selection of a camera (numeric selection defaults to camera selection).



Allows entry of camera and Preset and numbers.



For future use.



For future use.



Triggers the wash function on a telemetry camera.



Triggers the wipe function on a telemetry camera.



Switches on the lamp on a telemetry camera



Adjusts the focus to objects nearer the camera.



Adjusts the focus to objects further from the camera.



Closes the Iris on a Telemetry camera.



Opens the Iris on a Telemetry camera.



Zooms in on a telemetry camera and also provides electronic zoom out.



Zooms out on a telemetry camera and also provides electronic zoom in.



Sends a Patrol command to a telemetry camera.



Instructs the selected telemetry camera to automatically pan (on cameras that support this function).

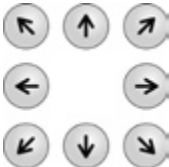

Used as menu and on-screen navigation keys
Pan and tilt control for telemetry cameras



In Play mode: Used to Mark Start/End positions.
In Live mode: Displays the Copy List and archive controls.



Exits menus.

Softkey Guidance

The IR Remote Control, KBC1 and KBC2 have a common user interface to control the SD. In addition to the direct action keys (rewind, fast forward etc.), there are coloured Softkeys that are context sensitive and enable rapid access to required functions.

To bring up context sensitive Softkey functions at any time, press any of the coloured keys on the keyboard or IR Remote Control.

To select cameras

Cameras can be selected either by using the numeric number buttons on the keypad or via the Up/Down camera CH key on the IR Remote Control. For numeric entries that require two digit entry, ensure both digits are entered within the one second time out

Electronic Zoom

If the DVR is in Live or Playback mode, pressing the Zoom IN button will Zoom (x2) into the image. Once 'zoomed in', it is possible to navigate within the image using the Directional buttons.

Note: Electronic zoom is possible on Dome cameras, however the unit must be in Live or Replay mode (not Telemetry mode - TELEM (displayed in the status bar).)

To control PTZ dome cameras

When a Dome or PTZ camera is selected, the Directional buttons will control the dome movements, putting the unit in Telemetry mode. There are two speeds supported on the IR Remote control and these can be selected via the Speed key.

Note: To zoom in with the camera, use the Zoom IN button.

If the camera requires the focus or iris functions to be altered, pressing the Lens button will change the operation of the +/- button to that of focus and iris (this is indicated in the status bar).

On the KBC2; a PTZ camera is controlled via the Joystick.

A home (Preset 1) position is supported on the IR Remote Control/keyboards. This is accessed by pressing the OK button when in telemetry mode.

To select preset positions on a Dome camera, press the coloured Softkeys when in telemetry mode and the following bar will be displayed:



Select Preset (blue softkey) followed by the preset number (2 digits).

To select Multiscreen

Press a coloured Softkey and the following menu will be displayed:



To display images in a Quad layout, press the green softkey.

To display images in multiscreen format, press the yellow softkey to display two further menus:



To change the camera in a specific segment of a multiscreen:

Select 'Segment', this will display a flashing '+' symbol in the first segment on the screen. Sequence through the segments by pressing the OK button. When the segment that requires changing is displayed, enter the camera number (2 digits) or use the CH +/- keys. The selected camera is then shown. To exit Segment, press the colour keys and then press the Blue Segment button again.

To select a Sequence

Select a sequence by pressing a coloured Softkey, the following menu will be displayed:



Press the Next button and the following menu will be displayed



Press the sequence key and a sequence will start on the main monitor. The dwell time for the sequence can be adjusted in the Display menu. The sequence will display all cameras that are available and not assigned as hidden cameras.

To control a spot monitor

To control a spot monitor press the MONITOR key on the remote or keyboard. The status display will show SPOT on the main monitor. Any camera selections or Sequence selections will now apply to the spot monitor. Note: The spot monitor is only capable of displaying live full screen images.

To Copy cameras to an archive

Refer to the Copy Menu section of this manual.

To Investigate events

Refer to the Event List section of this manual.

Event List

Alarms and activity detection are tagged and stored in the Event list for easy retrieval along with System events such as system start data and camera fails. Each event is labelled with an event type (alarm, activity or system) and its time and date. To view an event from the Event list:

SD 8 Camera 8 12-Jul-2007 4:06:29 PM GMT

Date	Time	Description
12/07/2007	15:58:33	Alarm 2
12/07/2007	15:58:10	Alarm 1
12/07/2007	15:57:48	Alarm 3
12/07/2007	15:57:44	Alarm 1
12/07/2007	15:57:41	Alarm 2
12/07/2007	15:57:38	Alarm 3
12/07/2007	15:57:35	Alarm 1
12/07/2007	15:57:33	Alarm 2
12/07/2007	15:57:24	Alarm 3
12/07/2007	15:57:11	Alarm 2
12/07/2007	15:56:41	System Startup
12/07/2007	15:55:39	System Halt (BAD)
12/07/2007	15:54:57	Alarm 3
12/07/2007	15:54:47	Alarm 2
12/07/2007	15:54:38	Alarm 1



12/07/2007 16:02:14 Camera 2

Event Filter

Start: 16 02 12 07 2007
End: 16 02 12 07 2007

Alm Act Sys

Filter Page - Page + Range Search

- Press the Event button on the Keyboard/RC Interface.
- Use the Up/Down Directional buttons to select the event required, the selected event is displayed in the preview window.
- To view any additional pages of Event data, press the Blue Softkey. Press the Yellow Softkey to view previous pages.
- Press PLAY to view the event in full screen.
- Press EXIT or LIVE to exit the Event List.

Event Search Filter

It is possible to filter the event search by time. Use the Directional buttons on the Keyboard/IR Remote Control to move to the Event Filter textbox. Enter the required Start and End time for the search and select the Blue search option. If required, also select via the checkbox options which specific events are to be searched. It is also possible to filter the search by type (alarm, activity or system) by pressing the corresponding coloured Softkey:

Alarm - Red

Activity - Green

System - Yellow

SD 8 Camera 8 12-Jul-2007 4:28:39 PM GMT

Date	Time	Description
12/07/2007	15:56:41	System Startup
12/07/2007	15:55:39	System Halt (BAD)
12/07/2007	14:21:00	RTC reset (Webpage)
12/07/2007	12:42:31	System Startup
12/07/2007	12:41:27	System Halt (GOOD)
12/07/2007	12:35:11	Camera Restored
12/07/2007	12:33:54	Camera fail
12/07/2007	12:13:51	Camera Restored
12/07/2007	12:13:47	Camera fail
12/07/2007	12:01:47	System Startup
12/07/2007	12:00:41	System Halt (BAD)
12/07/2007	10:17:39	System Startup
12/07/2007	10:16:37	System Halt (BAD)
12/07/2007	08:30:00	System unset (TIMER)
11/07/2007	18:30:00	System set (TIMER)

12/07/2007 16:00:32 Camera 1

Event Filter

Start: 16 23 12 07 2007
 End: 16 23 12 07 2007

Alm Act Sys

Alarm Activity System Search Next

Play an event back full screen

Highlight the relevant event and press PLAY. Tap the EVENT button to return to the Event list.

Copy Events To The Archive List

To copy events to the Archive list, select the event and Press the COPY button. The duration of the event will be copied to the Archive list. To archive to CD/USB, refer to the Copy Menu section on the following page.

Start a new search

If you wish to start a new search filter, tap the EVENT button to exit the Event list, then re-enter data in the Event Search Filter menu

Copy Menu

Copy Images to CD or USB device

Using the Copy Menu

Images and events can be copied to CD or USB Media for reviewing remote from the unit for evidential or monitoring purposes.

Images can be sent to the Copy List in two ways:

- 1) Manually review the recorded video, marking the start and end points of each segment of video to be copied. Please note that numerous segments can be added via the addition of start and end points before navigating to view them in the Copy List.
- 2) Open the Event list and select which events will be added to the Copy List.

Using the Copy option during Playback

It is possible to add playback images to the Copy List while reviewing the images. This provides the user with a simple process of selecting images that are of interest to be automatically sent to the Copy List.

1. Press the REWIND button or use the GOTO facility to return to the start of the recorded files that are to be copied.
2. Press PLAY and immediately press the COPY button, the message; 'Mark Start' will appear in the lower right segment of the screen. Continue playing, using Fast Forward if required.
3. When the end of the required segment to be copied is reached, press the COPY key again to mark the segment end.
4. Repeat the above step to add all required segments.
5. Press the LIVE button, then COPY to navigate to the Copy list to archive to USB or CD.

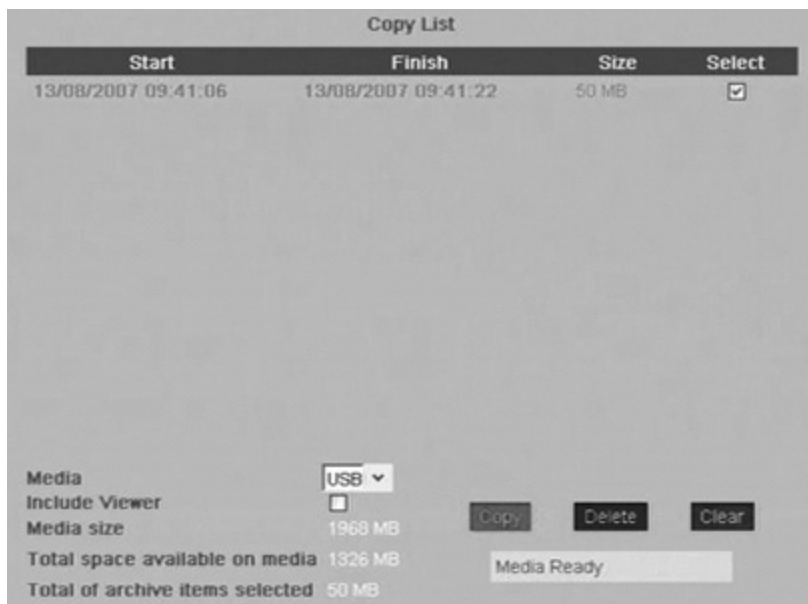

Using the Copy option within Event list

Within the Event list it is possible to highlight an event and send to the Copy List.

1. Press the EVENT button to display the Event list screen.
2. Use the Up/Down Directional buttons to highlight the event to be copied.
3. Press the COPY button, the event is then sent to the Copy List.

To Copy Events/Images to CD

1. Insert a blank CDR into the CD drive of the unit.
2. Select CD from the Media textbox.
3. Select the Copy option (Red) to start archive.
4. Selected items are then saved to disc. Please note that if the CD is not ready or is not empty, 'status' will be displayed on screen. Whilst data is writing to CD, the following status information will be displayed on screen:

Please Wait

Watermarking

LeadIn

Writing

Verifying

5. On completion the CD will be ejected from the unit.

To Copy Events/Images to a USB Device

1. Insert a USB Device into the USB port on the front of the SD unit.
2. Select USB from the Media textbox.
3. Select the Copy option (Red) to start archive.
4. Selected items are then saved to the USB device.
5. The USB export status is displayed as a %. On completion the status will read 'Finished'.

Note: *The SD range will support most USB Flash and USB HDD media for export, a summary of known supported items is displayed in Appendix C.*

Selecting/Deselecting Copy items

1. To clear copy list, press Clear button
2. To delete individual items from copy list, select items to be deleted by selecting them and pressing OK. Check all items to be removed and choose Delete (blue softkey)

Problem Solving

This is a list of common problems encountered using Digital Video recording technology in a CCTV environment; and suggested solutions for each scenario.

I keep getting two alarms for one event. How can I prevent this ?

A pulse extension extends the trigger period to avoid double alarm triggers from occurring, i.e. If a second trigger occurs on the same alarm input within the pulse extension time period, the unit will not create a new event.

Answer Extend the Pulse Extension via the 'Installer' menus. Go to the 'Alarms and Presets' menu and increase the extension parameter.

My images are feint/dark ?

Ensure the camera has been set up correctly. Signals from the cameras can be adjusted within the DVR to compensate for a variety of conditions. The contrast can be altered.

Answer Modify the camera settings via the 'Installer' menus. Go to the 'Camera Advance' menu and modify the contrast parameters.

Also If the camera feed was previously looped through and then disconnected, check the camera has been correctly terminated. Check the Input Termination parameter is set to 'On'.

How do I identify which unit I am viewing over a network ?

Each unit can be allocated a relevant 20 character name to identify the unit to the Operator or System Administrator.

Answer Check the settings via the 'Installer' menus. Go to the menu and check the Unit name parameters.

How do I make sure I delete images after a certain time period ?

Images recorded onto disk can be made unavailable after a user-defined number of days and hours. This is designed to help operators comply with legislation on the retention of images for a set period of time. Once the timed expiry has been set, all images older than the selected time will be no longer available.

Answer Modify the settings via the Installer menus. Go to the Record Options menu and modify the Timed expiry parameters.

How do I protect images from being overwritten ?

It is possible to protect images stored on the unit hard drives. These images will not be overwritten.

Answer Modify the settings via the 'Installer' menus. Go to the 'Record Options' menu and utilise the Image Protection function.

How do I see all system alarms, failed cameras, the amount of available storage and earliest protected recording on my unit ?

All of these parameters are available via the Status Page. This should be checked every day to ensure the system is operating well and there are no obvious imminent problems.

Answer View the information by pressing the MENU button once.

There is no response from the unit when I try to navigate the menus

Most likely solution is that the unit is in spot mode (the word SPOT will be displayed on the bottom of the screen and the SPOT LED is lit).

Answer Press the MONITOR button on the Keyboard.

The cable could have been connected incorrectly.

Answer Check the monitor is not plugged into output monitor B.

I cannot select a specific camera

Answer Check that the camera video input in the 'Camera Advanced' menu is set to connected.

Answer Check that the camera has not been disabled (made covert) in the 'Camera Viewing' menu.

Cannot display any other cameras apart from the one currently displayed

Answer Check that the monitor is connected to the Monitor A output, and that the spot light is not lit.

I have a white screen with a selected camera and an image displayed of a 'crossed out' camera

The camera has failed.

Answer Check that the video signal level is one volt peak to peak, even if the camera works when plugged directly into a monitor.

All of my cameras are being displayed in monochrome

Answer Check that the monitor being used is a colour monitor.

Answer Reboot the unit (using the menus) with a camera connected to input one, as the unit may have started in NTSC mode if no cameras were connected when it was initially booted.

Answer Check that the camera is defined in the Advanced Camera menu as Colour and not Mono.

I have a single camera being displayed in monochrome

Answer Check that the camera type is set as colour in the 'Camera Advanced' menu.

My camera image is either too bright or too dark.

The solution can either be a hardware or software issue.

Answer Toggle the state of input termination in the 'Camera Advanced' menu.

Answer Check the contrast settings in the individual 'Camera Advanced' menu.

My unit is not recording.

Answer Check in the 'Recording Advanced' menu that the record configuration is set to record at 1 or more pictures per second.

Answer Check that the 'Protected %' is not 100%.

Answer Reboot the unit using the 'Maintenance' menu. If this fails; restore the unit to Factory Default settings via the Maintenance page. Warning: Any configuration settings will be lost.

I have a specific camera that will not record

The most likely solution is a configuration error in the system setup.

Answer Check that the camera is selected to be recorded in the 'Recording Advanced' menu.

I have no serial or co-axial telemetry control

The most likely solution is a configuration error.

Answer Check that correct type of telemetry is selected in the 'Camera' menu.

Answer Check that the Dome/PTZ is addressed correctly as per the camera manufacturer's manual.

I have no serial telemetry

The most likely solution is a communications error

Answer Check that your RS485 telemetry wiring is connected to pins 1 & 9 on the serial port selected in the 'Serial' menu.

Erratic camera movement/camera moves on its own

Over time, the calibration between the joystick and unit could deteriorate

Answer Re-calibrate the keyboard joystick by pressing and holding the button to the right of the Audio button while re-powering the keyboard. Now move the joystick in all directions until the LEDs in the centre of the keyboard no longer flash.

Telemetry works when using the keyboard but not over the LAN/Internet

Signals from the unit are being interrupted or blocked'

Answer Check Routers/Firewalls to ensure that port 1025 UDP is not being blocked.

I cannot playback the recorded CD on my DVR

Recorded CDs and DVDs can only be played back on a Windows based PC.

Answer Use a Windows based PC to play back the recorded disk

I get a message 'No CD in requested device' message, yet there is a disk in the drive

Disk may be dirty, scratched or not blank.

Answer Try a new disk.

I get a message 'Nothing to Archive'

No images have been recorded during the times you have selected to be archived to disk.

Answer Check the Configuration settings on the Archive pages.

My audio works live, but is not being recorded

Live feed means the physical connections are correct, therefore it is probably a configuration error.

Answer Check that audio recording has been enabled in the 'Audio' menu page.

Audio can be heard on a PC connected over a LAN, but not over a WAN or the Internet

There is a firewall configuration problem.

Answer Check Routers/Firewalls to ensure that ports 2074 & 2075 UDP are not being blocked.

Audio recorded is too quiet

The audio feed signal is too low.

Answer Connect the microphone to a suitable pre-amp; connect the pre-amp to the line-in socket of the unit.

I cannot find my unit on the network, it cannot be connected to or even 'pinged'

Network connection problems can be difficult to diagnose due to the nature of network connections. There are a few common solutions presented below.

Answer Check that the unit has been assigned a valid IP address, subnet mask and gateway, in the 'Network Settings' page.

Answer Check that you have used the correct type of Ethernet lead. Use a straight through lead when connecting the unit into a Hub or Router, and a crossover cable when connecting the unit directly to a PC.

Answer Check that the PC you are using has been assigned an IP address.

I cannot connect to the unit with Internet Explorer, but the unit can be pinged. I can even connect with NetVu Observer

Answer Open Internet Explorer, and check the settings by opening 'Tools->Internet Options->Connections->LAN Settings' and ensure that it is not trying to use a proxy server.

Why does my unit keep timing out.

Answer Check the MTU Value in the 'More Network Options->Network Options' menu. Typical values are 576 for ISDN, 1458 for a WAN and 1500 for a LAN.

What is the username and password when trying to enter configuration options?

Answer The defaults are username = **dm**, and password = **web**. If these do not work, then the passwords have been customised for your installation. Check with the IT department, or with your installer. Lost passwords cannot be reset, if the passwords are not recoverable, the unit will have to be returned to Dedicated Micros for resetting.

Alarms inputs and/or Activity are not being registered or logged.

Answer Check that 'Events Active' is set to either Alarms, Activity or both. If it is set to none, the unit will just ignore all alarm activations.

I was performing a walktest and the unit stopped sending alarms.

There is a feature that will disable a repeatedly tripping contact. If this has been activated, it can effect walktests.

Answer Check on the General Contacts. menu to see if Nuisance Count has been set up.

Appendix A

Alarm & Relay Pin Outs

Using Serial Ports

It is possible to connect a variety of telemetry cameras to the unit, using the following table as a guide to the serial port connections.

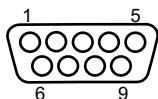

RS485 Connectivity (2 wire) (Serial 3, 4)

Pin	Description
1	RS485 + (A)
9	RS485 - (B)

RS232 Connectivity (Serial 1, 2)

Pin	Description	Desc
1	Data Carrier Detect	DCD
2	Receive Data	RX
3	Transmit Data	TX
4	Data Terminal Ready	DTR
5	Ground	GND
6	Data Set Ready	DSR
7	Ready to Send	RTS
8	Clear to Send	CTS
9	Ring Indicate	RI

RS232 Connectivity (Serial 3, 4)

Pin	Description	Desc
2	Receive Data	RX
3	Transmit Data	TX
5	Ground	GND
7	Ready to Send	RTS
8	Clear to Send	CTS

Appendix B

Using the Keyboard/RC Interface Control To Control A Common Television Set

To use the Keyboard/RC Interface Control as a common television remote handset, it is necessary to input a code specific to the relevant television. Below are detailed the procedures to follow and a listing of the codes associated with common television brands.

How to Program The SD IR Remote Control

1. Turn the TV you wish to control ON.
2. Press and hold the TV button on the Keyboard/RC Interface.
3. Press and hold the PANIC button until the LED on the Keyboard/RC Interface Control turns ON.
4. Release both buttons, the LED will stay ON.
5. Press and release the PLAY button.
6. Enter the required code (see list below and overleaf). Please note that up to 10 codes can be entered at any one time. For many makes of television it will be necessary to try several codes before the user is able to pinpoint the relevant one for the TV model.
7. Press PLAY. The IR Remote Control will search the stored codes. Note that if more than one code has been entered, it will be necessary to press the REV button to cycle individually through the stored codes. To view which code has successfully accessed the TV, simply note when the TV turns OFF.
8. Press STOP. The LED turns OFF and the code is stored.

Codes Relevant To Common Televisions.

TV Brand	Code(s)
Alba	2003/2009/2010/2021/2022/2041/2045/2052/2093/2255/2278/2293/2306/2492/2497/2498/2521/2527/2541/2545/2564/2605/2609/2614/2618/2622/2631/2633/2636
Amstrad	2002/2009/2010/2012/2024/2045/2492/2498/2515/2515/2515/2521/2540/2605/2609/2610/2618/2621/2633
Baird	2068/2081/2504/2517/2518/2618
Bang & Olufsen	2000
Bauer	2617
Beko	2007/2027/2052/2180/2191/2228/2242/2269/2498/2588/2589/2616/2637
Binatone	2003
Blaukpunkt	2008/2079/2519/2625 /2636
Brandt	2029/2033/2034/2075/2076/2081/2117/2174/2272/2332/2535/2536
Brother	2610
Daewoo	2003/2009/2037/2039/2060/2070/2105/2128/2148/2224/2492/2498/2521/2551/2565/2566/2570/2592/2605/2609/2633/2636
Ferguson	2028/2029/2036/2038/2050/2068/2076/2089/2093/2143/2173/2517/2518/2536/2560/2618/2619/2620/2625/2627/2637
Goldline	2498
Goldstar	2003/2009/2011/2037/2053/2059/2077/2093/2094/2492/2498/2527/2542/2605/2608/2616/2624/2629/2632/2636/2637
Goodmans	2002/2004/2009/2021/2022/2037/2045/2059/2068/2070/2076/2093/2259/2369/2492/2496/2497/2498/2504/2516/2548/2551/2554 2605/2609/2610/2614/2633/2635/2636
Hitachi	2003/2004/2014/2017/2021/2026/2031/2033/2034/2035/2054/2081/2082/2083/2169/2175/2199/2201/2202/ 2253/2260/2380/2385/2396/2414/2426/2427/2441/2448 /2450/2469/2470/2471/2472/2497/2498/2499/2500/2504/2509/2512/2522/2524/2549/2551/2575/579/608/620/627/629/636

JVC	2021/2037/2045/2050/2210/2216/2239/2240/2267/2276/2280/2282/2298/2333/2377/2397/2497/2502/2507/ 2517/2518/2521/ 2557/2563/ 2572/2577/2597/2609/2615/2616/2622/2636/2646
LG	2003/2009/2011/2037/2053 /2055/2059/2077/2084/2093/2094/2195/2200/2237 /2245/2261/2262/2263/2274/2287/2312/2330/2355/2356/2359/2364/2381/2389 /2451/2452/2492/2498/2527/2542/2580/2581/2582/2594/2596/2598/2600/2605/ 2608/2616/2645/2647/649
Panasonic	2042/2043/2044/2063/2074/2085/2086/2100/2107/2114/2123/2130/2134/2136/2138/2168/2187/2226/2252/2324/2357/2361/2388/2408/2415/2416/2428/2429/2473/2474/2475/2498/2511/2520/2523/2528/2562/2578/2585/2599/ 2601/2603/2620/2636/640/ 648
Philips	2000/2003/2031/2032/2037/2055/2056/2068/2070/2087/2093/2108/2109/2112/2115/2119/2122/2126/2129/2131/2132/2133/2141/2146/2147/2149/2150 2152/2154/2155/2157/2163/2170/2182/2183/2190/2192/2197/2206/2214/2215/2229/2231/2246/2248 2249/251/254/257/264/275/277/283/291/297/323 /338/339/343 /383/384/393/398/436/453/454/476/477/478/479/480/481/495/498/499/554/567/568573/604/623/624 /627/629/ 635 /636/637/643/644
Pioneer	2029/2037/2081 /2093/2379/2382/2387/2390/2392/2444/2449/2498/2584/2627/2627/2637
Sanyo	2003/2004/2006/2014/2016/2021/2023/2024/2025/2030/2032/2076/2088/2161/2220/2223/2290/2292/2401/2442/2443/2492/2494/2497/2501/2504/2513/2532/2605/ 2627/2629/2633
Sharp	2001/2005/2023/2040/2101/2102/2127/2139/2160/2162/2186/2193/2207/2219/2335/2352/2354/2360/2365/2366/2368/2372/2373/2376/2403/2407/2417/2422/2423 /2424/2430/2431/2432/2433/2434/2455/2456/2457/2458/2459/2460/2461/2462/2463/2483/497/502/506/513/533
Sony	2004/2009/2021/2023/2024/2047/2067/2076/2078/2091/2097/2098/2110/2111/2118/2121/2125/2135 /2142/2166/2177/2185/2204/2234/2236/2326/2344 /2345/2346/2349/2363/ 2400/2402/2404/2405/2410 /2413/2418/2420/2439//2493/ 2494/2497/2508 /2569/2571/587/602/603/607/639
Technics	2043
Toshiba	2015/2021/2051 /2069/2090/2103/2137/2158/2159/2165/2179/2188/2194 /2208/2211/2213/2217 /2218/2222/2243/2244/2250/2271/2284/2288/2294 /2303 /2304/2313/2318/2319/2320/2321/2322/2328/2347/2350/2370/2375/2394/2409/2421/2435/2437/2440/2465/466/467/485/487/489/490/496/497/503/508 /526/574/54/ 591/595/606/607/632/642

Appendix C

Unit Specification

LANGUAGES

Including: English, French, Italian, German & Spanish.

SUPPORTED USB DEVICES

Crucial High Speed USB SD/MMC Card Reader (CTR2MMPU2) with SanDisk Standard SD Card 2GB (SDSDB-2048)
Crucial High Speed USB Compact Flash Card Reader (CTR2ADPU2) with SanDisk Standard CompactFlash Card 4GB (SDCFB-4096).
Crucial 40x Speed USB Flash Drive 512MB (CT512MBUFD).
SanDisk Cruzer Micro USB Flash Drive 4GB.
Buffalo RUF-C/U2 128MB/256MB USB stick.

CAMERAS

8, 12, 16 and 32 camera inputs available. Auto detection on power up. Non-looping BNC connectors provided for each camera input. Alarm on Camera Fail.

Option to view all or selected cameras without effecting recording.

MONITOR VIEWING

Main monitor:

Full screen, picture in picture, quad viewing and multiscreen.

Mon A: Composite video BNC connector.

Spot monitor:

Full screen, sequence.

Mon B: Composite video BNC connector.

ACTIVITY DETECTION

Each activity detection will switch the selected camera from normal record profile to alarm record profile. This feature can also; log the event, activate a relay, trigger a sounder, switch camera or link to an alarm.

Individual configurable alarm responses include: move camera to preset, activate a relay, remote alarm reporting, email on alarm, log event, switch camera, activate sounder.

ALARMS & RELAYS

16 normally open/closed tamper proof alarm inputs via back panel.

Keyswitch alarm.

4 relay outputs.

AUDIO

The user has the option to record and play back audio through the unit in real time. Recorded with images, audio can be played back directly from the unit via powered external speakers.

Audio output for on site PA/Challenge.

Connections:

Line in: 1V pk-pk, RCA phono socket.

Line out: 1V pk-pk, RCA phono socket.

SEARCH AND PLAYBACK

- Frame advance/rewind, fast picture search and pause keys.
- Event list, including event list filter with unique quadrant preview facility.
- GOTO time and date.
- Playback in quad, multiscreen, picture in picture and full screen.

MultiMode RECORDING

MultiMode recording gives you the ability to set different record rates, resolutions and compression algorithms (MPEG-4/JPEG) across scheduled, normal and alarm modes dynamically on individual cameras.

RECORDING

Playback and record to hard disk simultaneously.

Alarmed or manually selected images can be protected from being overwritten.

Timed expiry option allows images to be held for a selected number of days.

EVENT COPYING

Event sequences and user defined recorded sequences can be saved to a CD via the integrated CD-writer or to an external flash drive through the USB port.

TEXT SUPPORT

Through the inclusion of Text Support, the SD can search captured transaction data for specific goods purchased, transaction numbers, credit card references, keywords etc. and jump straight to the associated video sequence.

NETWORKING CAPABILITIES

A standard Ethernet connection allows live and recorded viewing on a networked PC using DM's NetVu ObserVer software. Web pages are available for configuration using a standard internet browser.

KEYBOARD/RC INTERFACE CONTROL

Offering full system control.

OPTIONAL KEYBOARDS

Supports Dedicated Micros keyboards:

- DMKBC1
- DMKBC2

TELEMETRY

Built-in RS485/Twisted pair protocols provide direct control of the numerous domes including but not limited to the following:

- Dedicated Micros Serial
- AD Matrix/AD 168-Matrix
- Baxall C
- BBV C/RS485/Matrix
- Dennard/Dennard C
- Ermitec
- JVC
- Kalatel
- MarkMercer
- Panasonic WV-CS600/WV-CS850
- Pelco C
- Philips/Philips 232
- Samsung
- Sanyo
- Sensormatic
- Ultrak
- Vantage
- VCL/VCL-Matrix
- Vicon
- Vista

COLOUR RESOLUTION

Sampling rate: 13.5 MHz to CCIR 601.

Number of pixels: PAL 704h x 256v 288 TVL resolution.

NTSC 704h x 240v.

16.8 million colours 256 levels of grey, 8-bit luma.

COMPRESSION

JPEG & MPEG-4 format files.

JPEG: 4CIF, 2CIF, CIF & QCIF resolution.

MPEG-4: 2CIF, CIF & QCIF.

User definable file size and bit rate.

SD RANGE DATA

Serial Ports: 4 - 2 xRS232 (9 wire) or (3 wire), 2 x RS232 (3 wire), RS485.

Ethernet: 1x Ethernet RJ-45 10/100 Ethernet connection.

USB: 3 x USB 2.0 Connector (1 positioned on the front panel).

TEMPERATURE RANGE

5 - 40°C

RELATIVE HUMIDITY

10% - 85% Non-condensing.

UNIT DIMENSIONS

435mm deep, 440mm wide, 98mm high.





Notes

Index

Accessing the Configuration Web Pages.....	21
Accessing the menus on a local monitor	21
Accessing the menus on a PC web browser	21
Activity.....	38
Activity Grid.....	40
Admin.....	47
Advanced.....	25
Advanced Settings.....	28
Alarm & Relay Pin Outs.....	66
Alarms.....	35
Alarms and relays.....	11
Appendix A.....	66
Appendix B.....	67
Appendix C.....	69
Audio.....	44
Audio recorded is too quiet.....	64
Bandwidth Selection.....	34
Cameras.....	24
Check the contents of the box.....	7
Choosing a location for installation.....	7
Codes Relevant To Common Televisions.....	67
Complete Flexibility.....	8
Configuring the Unit.....	21
Copy Events To The Archive List.....	59
Copy Images to CD or USB device.....	60
Copy Menu.....	60
Data.....	10
Demos.....	50
Design of the manual.....	4
Differences between MPEG-4 and MJPEG(JPEG).....	8
DM/KBC1 Keyboard.....	52
Electrical Connections.....	7
Electronic Zoom.....	56
Email Settings.....	33
Erratic camera movement/camera moves on its own.....	63
Event List.....	58
Event Search Filter.....	59
Features.....	4
Front Panel connections.....	10
General.....	23
Global Alarms.....	37
How to navigate the pages.....	13
I cannot playback the recorded CD on my DVR.....	64
I cannot select a specific camera.....	62
I get a message 'Nothing to Archive'.....	64
displayed of a 'crossed out' camera.....	63
I have no serial or co-axial telemetry control.....	63
I have no serial telemetry.....	63
Important Safeguards.....	5
Installation.....	10
Installing the SD Unit.....	15
Installing the Unit.....	7
Introduction.....	3
I was performing a walktest and the unit stopped sending alarms.....	65
Laser.....	6
Lightning Strike.....	5
Local Admin Passwords.....	48
Locating the Unit IP address.....	21
Maintain.....	49
Manual Image Protection.....	31
MultiMode Recording.....	8

My audio works live, but is not being recorded.....	64
My camera image is either too bright or too dark.....	63
My images are feint/dark ?.....	62
My unit is not recording.....	63
Network.....	32
Play an event back full screen.....	59
Power.....	11
Power Sources.....	5
Problem Solving.....	62
Quick Overview Of Default SD Record Settings.....	8
Rear Panel connections.....	10
Recording.....	27
Record Options.....	30
Remote Control.....	12
RS232.....	19
RS485.....	19
Schedule.....	26
Selecting/Deselecting Copy items.....	61
Serial.....	43
Servicing.....	5
Softkey Guidance.....	56
Start a new search.....	59
Status.....	22
To control a spot monitor.....	57
To control PTZ dome cameras.....	56
To Copy cameras to an archive.....	57
To Copy Events/Images to a USB Device.....	61
To Investigate events.....	57
To select a Sequence.....	57
To select cameras.....	56
To select Multiscreen.....	56
Transmission.....	29
Unit Operation.....	52
Unit Specification.....	69
Using a USB Mouse or the webpages.....	13
Using Serial Ports.....	66
Using the Copy Menu.....	60
Using the Copy option during Playback.....	60
Using the Copy option within Event list.....	61
Using the IR Remote Control.....	52
Using the Keyboard/RC Interface Control To Control A Common Television Set.....	67
Using the Optional touch keyboard.....	52
Ventilation.....	5
Video.....	11
What is the username and password when trying to enter configuration options?.....	64
Why does my unit keep timing out.....	64



Dedicated Micros Ltd.
1200 Daresbury Park, Daresbury,
Cheshire, WA4 4HS, UK

Dedicated Micros France
9-13 rue du Moulinet
75013 Paris, France

Dedicated Micros Slovenia
Delavska cesta 26,
4208 Sencure, Slovenia

Dedicated Micros Benelux
Joseph Chantraineplantsoen 1,
3070 Kortenberg, Belgium

Dedicated Micros USA.
14434 Albemarle Point Place, Suite 100,
Chantilly, Virginia 20151 USA

Dedicated Micros USA.
23456 Hawthorne Blvd.
Suite 100, Torrance,
CA 90505, USA

Dedicated Micros, Australia PTY.
5/3 Packard Avenue, Castle Hill,
NSW 2154, Australia

Dedicated Micros, Asia PTY
16 New Industrial Road,
#03-03 Hudson Techno Centre,
Singapore 536204

Dedicated Micros Middle East
Building 12, Suite 302, P.O. Box 500291, Dubai Internet
City, Dubai, United Arab Emirates

Dedicated Micros (Malta) Ltd.
BLB017, Bulebel Industrial Estate,
Zejtun, ZTN3000, Malta

Installed by

