

# SERVICE MANUAL

STEREO GRAPHIC EQUALIZER

## SANSUI SE-8X

(Silver & Black Model)

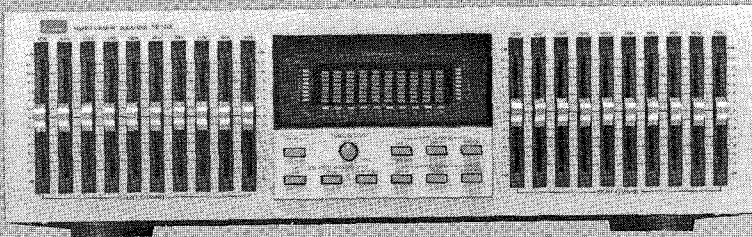

### CAUTION

1. Use only replacement parts recommended by the manufacturer.
2. Measure insulation resistance before returning the appliance to the customer to prevent electrical shock.

**Sansui**

SANSUI ELECTRIC CO., LTD.

### •SPECIFICATIONS

<b>Input impedance</b> (1,000 Hz)	
INPUT.....	30 kilohms
<b>Output level</b> (1,000 Hz)	
OUTPUT.....	1V into 30 kilohms
	(Maximum output level: 4V at 0.5% total harmonic distortion)
<b>Total harmonic distortion</b> (20 Hz to 20 kHz)	
INPUT.....	less than 0.005%
<b>Frequency response</b>	
(at rated output, Equalizer level controls: "0" position)	
.....	10 to 100,000 Hz
	+0 dB, -1 dB
<b>Equalizer frequency</b> .....	32 Hz, 63 Hz, 125 Hz,
	250 Hz, 500 Hz, 1 kHz,
	2 kHz, 4 kHz, 8 kHz, 16 kHz
<b>Level variation range</b> .....	±12 dB
<b>Signal to noise ratio</b> (short-circuit, A-network)	
.....	110 dB
<b>Gain</b> (1,000 Hz, Equalizer level controls: "0" position)	
.....	0 dB

### Others

#### Power requirements

Power voltage..... 120, 220, 240V  
(50/60 Hz)

For USA and Canada

..... 120 V (60 Hz)

Power consumption... 12 watts

#### Dimensions.....

430 mm (16-15/16") W

130 mm (5-1/8") H

277 mm (10-15/16") D

Using rack mounting adaptors

..... 480 mm (18-15/16") W

130 mm (5-1/8") H

302 mm (11-15/16") D

**Weight**..... 4.4 kg (9.7 lbs.) net

5.3 kg (11.7 lbs.) packed

\* Design and specifications subject to change without notice for improvements.

# 1. BLOCK DIAGRAM

1-1.

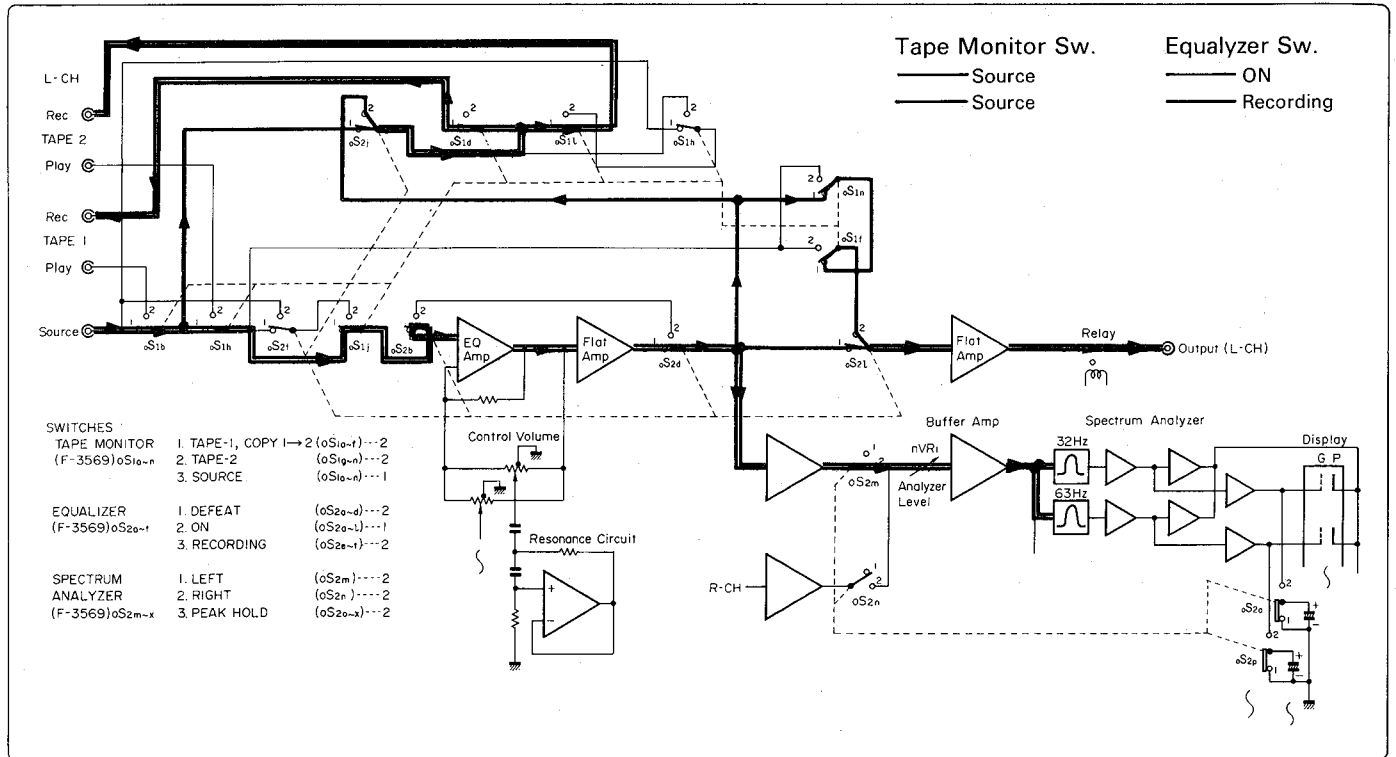

1-2.

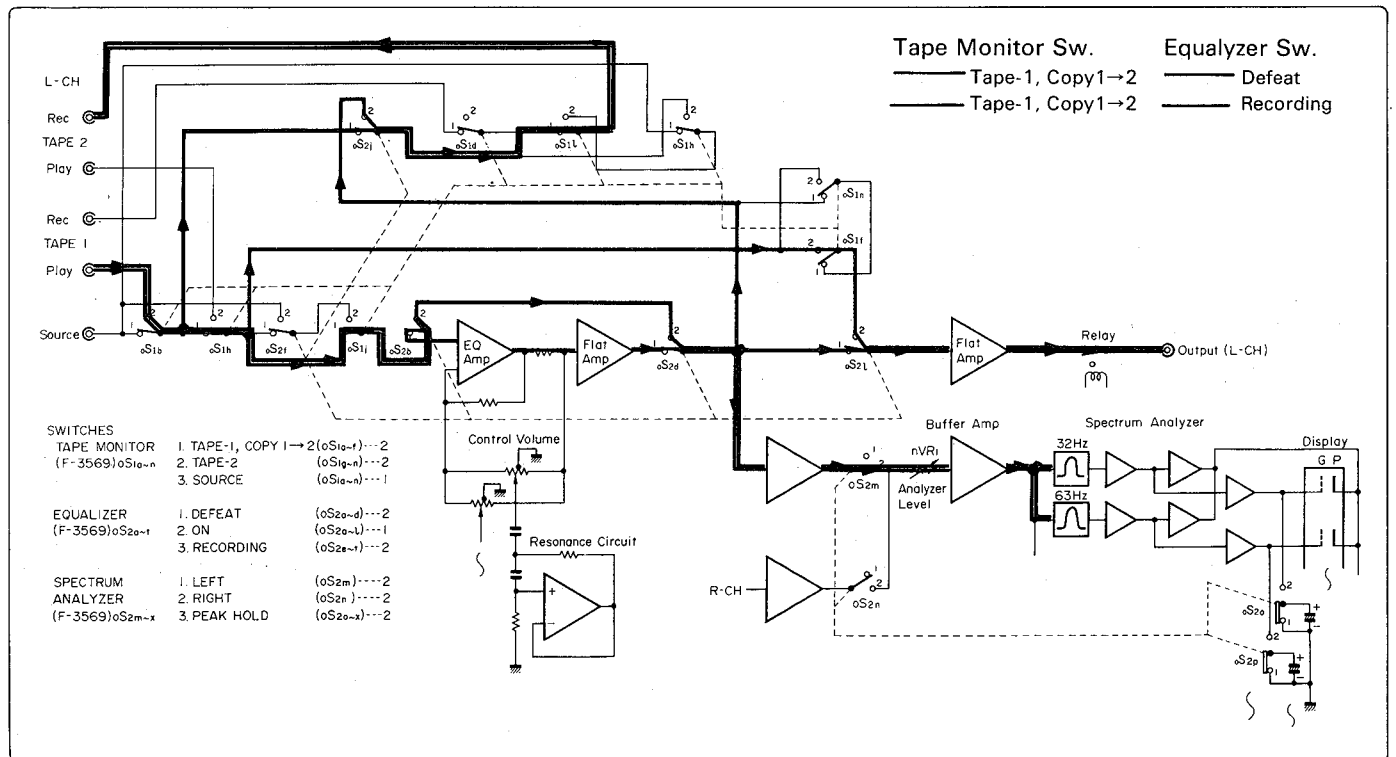

1-3.

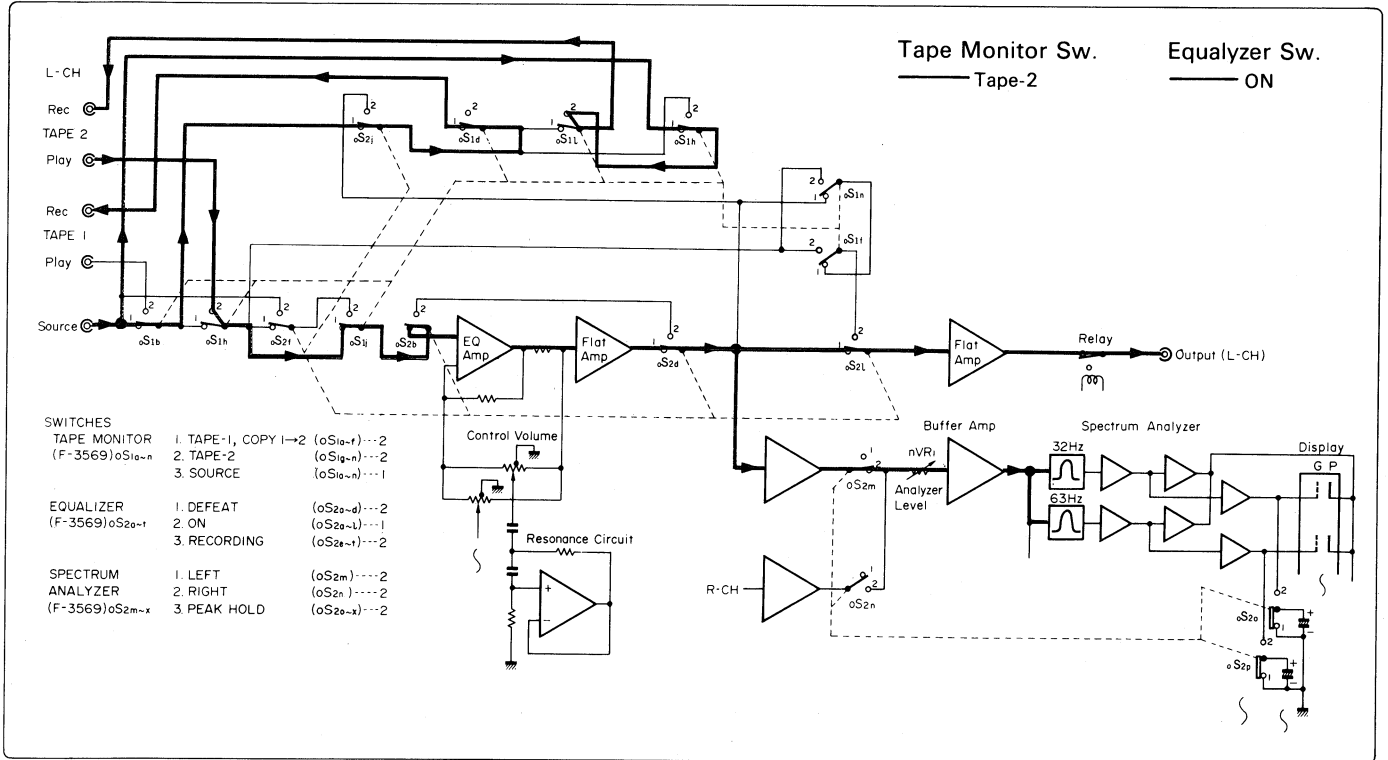

1-4.

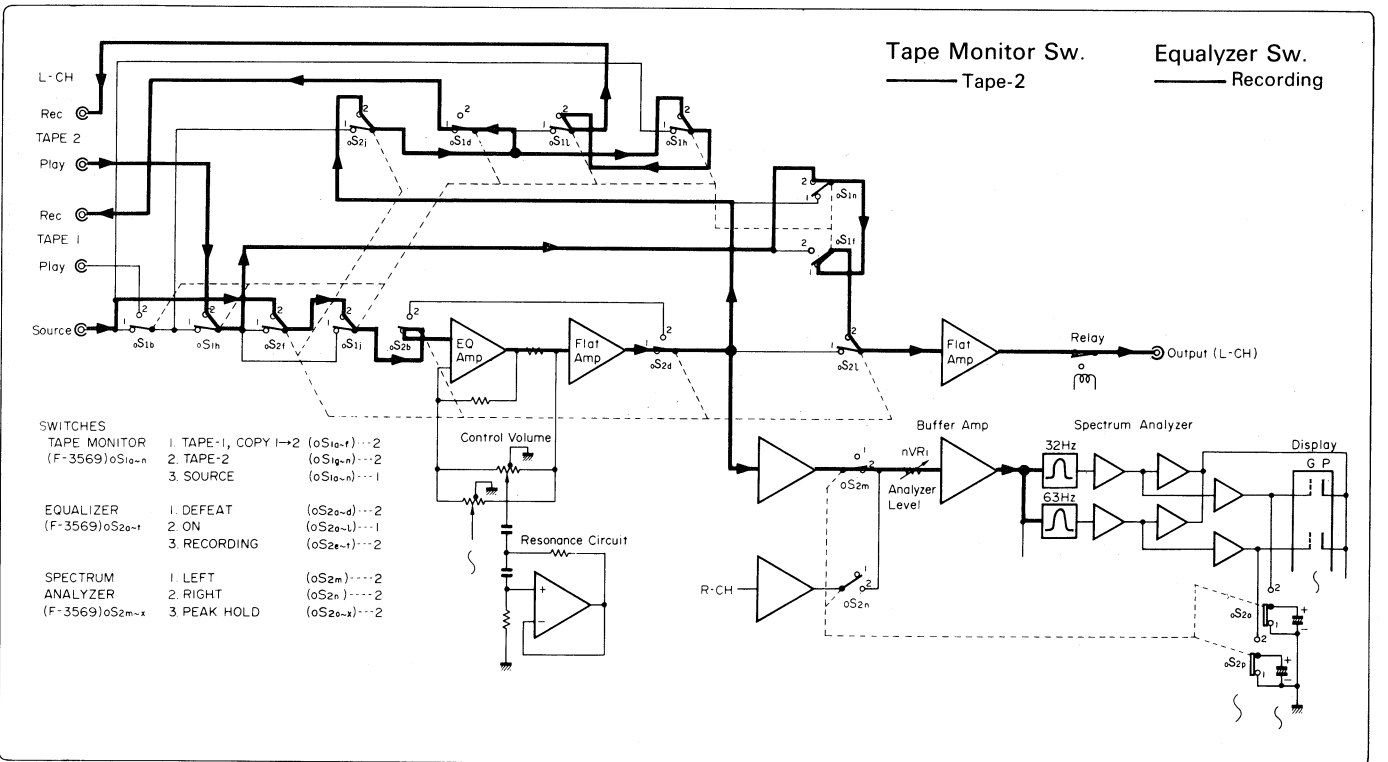



## 2. PARTS LOCATION & PARTS LIST

### 2-1. F-3569 Control & Switch Circuit Board (Stock No. 00759601)

•Since some of capacitors and resistors are omitted from parts lists in this service manual, refer to the Common Parts List for capacitors & resistors, which was issued on February 1983.

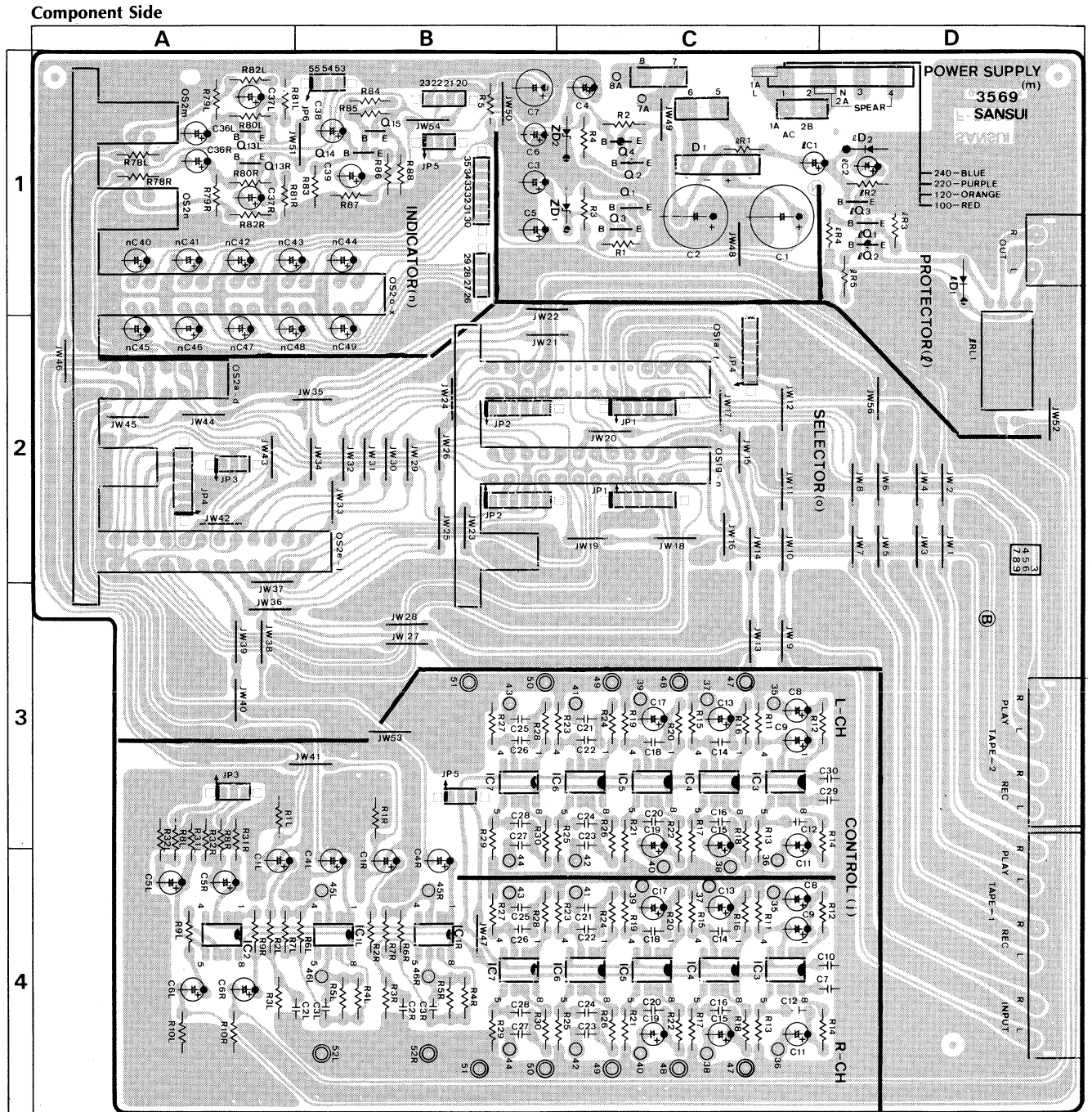

•Abbreviations

C.R. : Carbon Resistor	E.B. : Bi-Polar Electrolytic Capacitor
S.R. : Solid Resistor	E.B.L. : Low Leak Bi-Polar Electrolytic Capacitor
Ce.R. : Cement Resistor	Ta.C. : Tantalum Capacitor
M.R. : Metal Film Resistor	F.C. : Film Capacitor
F.R. : Fusing Resistor	M.P. : Metalized Paper Capacitor
N.I.R. : Non-Inflammable Resistor	P.C. : Polystyrene Capacitor
A.R. : Array Resistor	G.C. : Gimmic Capacitor
C.C. : Ceramic Capacitor	A.C. : Array Capacitor
C.T. : Ceramic Capacitor, Temperature Compensation	V.R. : Variable Resistor
E.C. : Electrolytic Capacitor	S.V.R. : Semi Variable Resistor
E.L. : Low Leak Electrolytic Capacitor	SW. : Switch



Parts List <F-3569>

Parts No.	Stock No.	Description
<b>•IC</b>		
jIC1	46673800	M5218P
jIC2	07208900	NJM4558D-X
	or 46673800	M5218P
jIC3	03607700	NJM4558D
	or 07265800	MB3607M
	or 46580100	M5218P
jIC4	03607700	NJM4588D
	or 07265800	MB3607M
	or 46580100	M5218P
jIC5	03607700	NJM4558D
	or 07265800	MB3607M
	or 46580100	M5218P
jIC6	03607700	NJM4558D
	or 07265800	MB3607M
	or 46580100	M5218P
jIC7	03607700	NJM4558D
	or 46580100	M5218P
<b>•Transistor</b>		
IQ1	03059501	2SC945
	or 03068301	2SC2320
	or 07194801	2SC1815
	or 46125901	KTN5014
IQ2	03012701	2SA999
	or 07194701	2SA1015
	or 07197001	2SA733A
	or 46126001	KTP5514
IQ3	03059501	2SC945
	or 03068301	2SC2320
	or 07194801	2SC1815
	or 46125901	KTN5014
<b>•Diode</b>		
ID1	03117600	1S2473T77
	or 46086000	1S1588TP-3
	or 46092700	US1035TB
ID2	03117600	1S2473T77
	or 46086000	1S1588TP-3
	or 46092700	US1035TB
IRL1	11504700	Relay

Parts No.	Stock No.	Description
<b>•Transistor</b>		
mQ1	03086101	2SD357
mQ2	03034401	2SB527
mQ3	03059501	2SC945
	or 03068301	2SC2320
	or 07194801	2SC1815
	or 46125901	KTN5014
mQ4	03012701	2SA999
	or 07194701	2SA1015
	or 07197001	2SA733A
	or 46126001	KTP5514
<b>•Diode</b>		
mD1	03117000	PB-152
<b>•Zener Diode</b>		
mDZ1	03179200	RD15E-B
	or 46114400	05Z15-X
	or 46114500	05Z15-Y
mDZ2	03179200	RD15E-B
	or 46114400	05Z15-X
	or 46114500	05Z15-Y
<b>•Transistor</b>		
nQ13	03059501	2SC945
	or 03068301	2SC2320
	or 07194801	2SC1815
	or 46125901	KTN5014
nQ14	03059501	2SC945
	or 03068301	2SC2320
	or 07194801	2SC1815
	or 46125901	KTN5014
nQ15	03059501	2SC945
	or 03068301	2SC2320
	or 07194801	2SC1815
	or 46125901	KTN5014
nPL1	07234400	Pilot Lamp, 8V 150mA
oS1	46133200	Push SW., TAPE MONITOR
	or 46133201	Push SW., TAPE MONITOR
oS2	46133100	Push SW., EQUALIZER/SPECTRUM ANALYZER
	07249000	2P Output Terminal
	07249100	4P TAPE-2 Terminal
	07249200	6P TAPE-1 Terminal

Parts List <F-3567>

Parts No.	Stock No.	Description
<b>•Transistor</b>		
nQ1	03059501	2SC945
	or 03068301	2SC2320
	or 07194801	2SC1815
	or 46125901	KTN5014
nQ2	03059501	2SC945
	or 03068301	2SC2320
	or 07194801	2SC1815
	or 46125901	KTN5014
nQ3	03059501	2SC945
	or 03068301	2SC2320
	or 07194801	2SC1815
	or 46125901	KTN5014
nQ4	03059501	2SC945
	or 03068301	2SC2320
	or 07194801	2SC1815
	or 46125901	KTN5014
nQ5	03059501	2SC945
	or 03068301	2SC2320
	or 07194801	2SC1815
	or 46125901	KTN5014
nQ6	03059501	2SC945
	or 03068301	2SC2320
	or 07194801	2SC1815
	or 46125901	KTN5014
nQ7	03059501	2SC945
	or 03068301	2SC2320
	or 07194801	2SC1815
	or 46125901	KTN5014
nQ8	03059501	2SC945
	or 03068301	2SC2320
	or 07194801	2SC1815
	or 46125901	KTN5014
nQ9	03059501	2SC945
	or 03068301	2SC2320
	or 07194801	2SC1815
	or 46125901	KTN5014
nQ10	03059501	2SC945
	or 03068301	2SC2320
	or 07194801	2SC1815
	or 46125901	KTN5014
nQ11	03012701	2SA999
	or 07194701	2SA1015
	or 07197001	2SA733A
	or 46126001	KTP5514
nQ12	03012701	2SA999
	or 07194701	2SA1015
	or 07197001	2SA733A
	or 46126001	KTP5514
<b>•IC</b>		
nIC1	03607700	NJM4558D
	or 07265800	MB3607M
	or 46580100	M5218P
nIC2	07205200	NJM2902N
	or 07258300	MB3614M
	or 46500800	NJM2058D
nIC3	07205200	NJM2902N
	or 07258300	MB3614M
	or 46500800	NJM2058D
nIC4	07205300	NJM2901N
	or 07246300	MB4204M
	or 46727100	M51209P
nIC5	07205300	NJM2901N
	or 07246300	MB4204M
	or 46727100	M51209P
nIC6	07205300	NJM2901N
	or 07246300	MB4204M
	or 46727100	M51209P
nIC7	03607700	NJM4558D
	or 07265800	MB3607M
	or 46580100	M5218P
nIC8	07205300	NJM2901N
	or 07246300	MB4204M
	or 46727100	M51209P
nIC9	07205400	MSM4017RS
	or 46727200	M4017BP
nPL2	07203400	FL.Display Tube FG80SB6

2-2. F-3567 Spectram Analyzer Circuit Board (Stock No. 00759501)

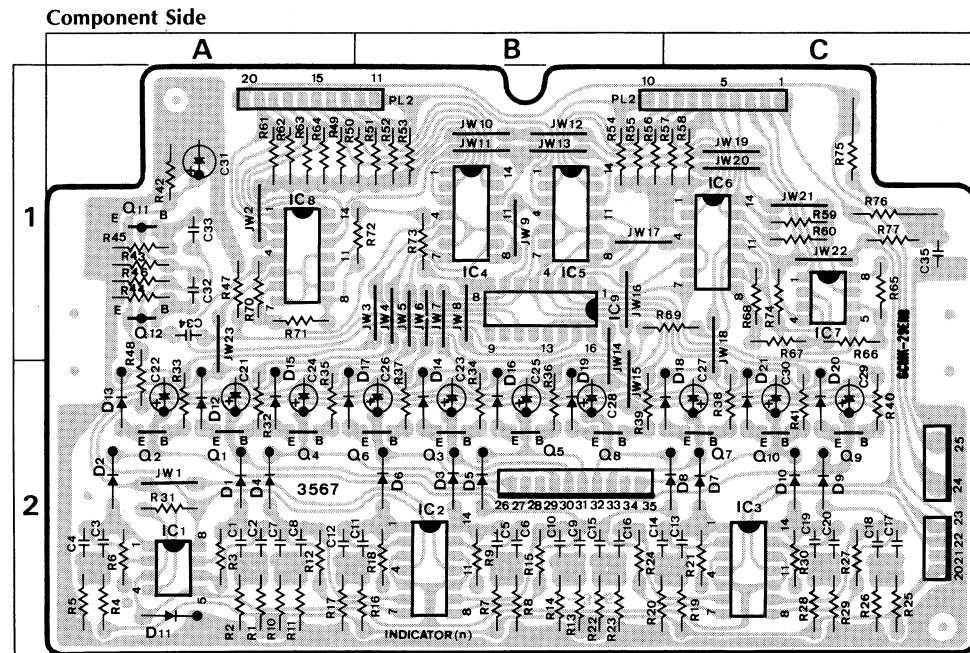

•Note: The Circuit Boards F-4370 & F-4371 are not supplied as the assembled, However the individual parts on the circuit board are provided for orders.

2-3. F-4370 Control Circuit Board

Component Side

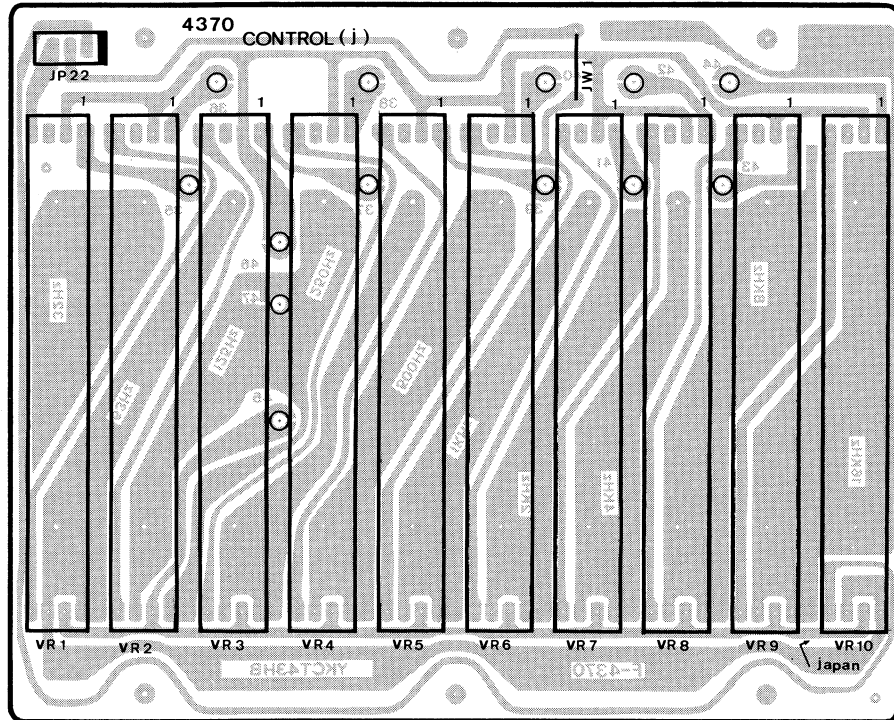

Parts List

Parts No.	Stock No.	Description
jVR1	46708200	250kΩ Slide VR with LED 32Hz
jVR2	46708200	250kΩ Slide VR with LED 63Hz
jVR3	46708200	250kΩ Slide VR with LED 125Hz
jVR4	46708200	250kΩ Slide VR with LED 250Hz
jVR5	46708200	250kΩ Slide VR with LED 500Hz

Parts No.	Stock No.	Description
jVR6	46708200	250kΩ VR., 1kHz
jVR7	46708200	250kΩ VR., 2kHz
jVR8	46708200	250kΩ VR., 4kHz
jVR9	46708200	250kΩ VR., 8kHz
jVR10	46708200	250kΩ VR., 16kHz

2-4. F-4371 Ripple Filter Circuit Board

Component Side

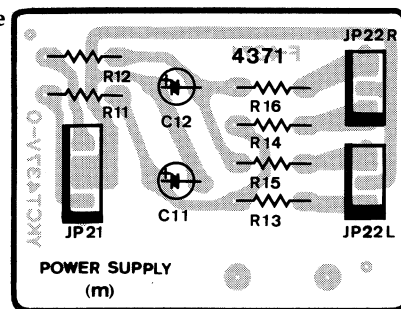

Parts List

Parts No.	Stock No.	Description
mR11	46682800	180Ω 1/4W F.R.
mR12	46682800	180Ω 1/4W F.R.

3. OTHER PARTS

3-1. Front View

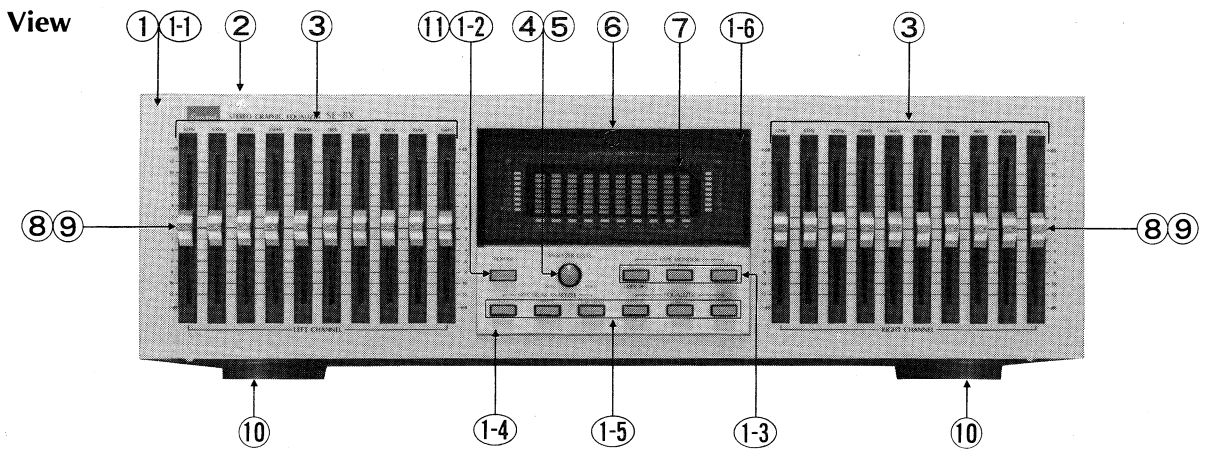

3-2. Top View

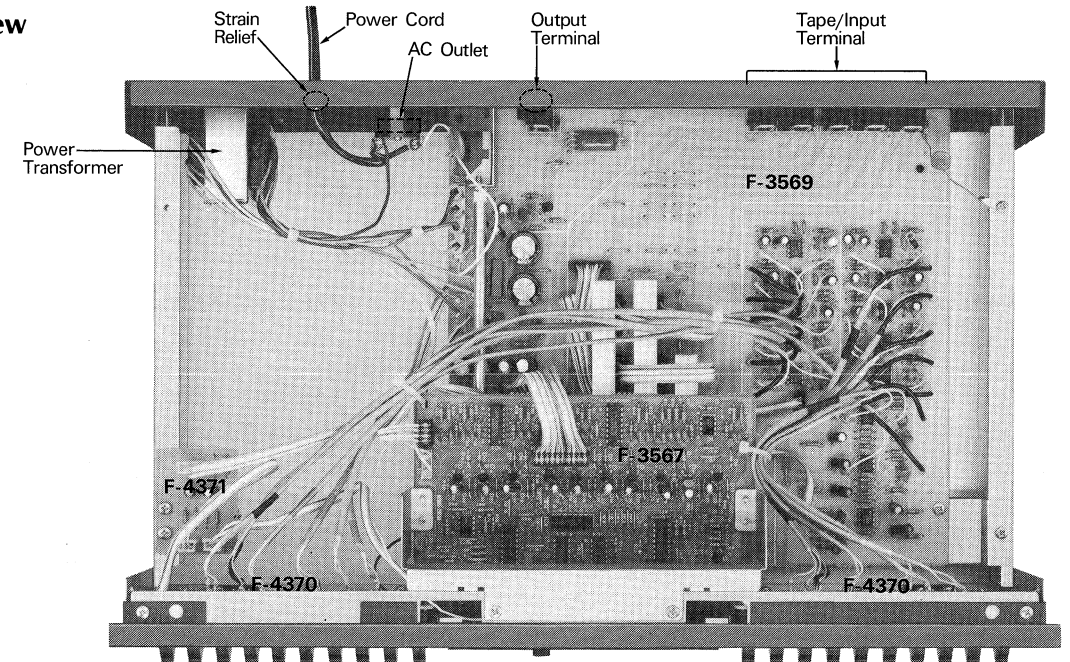

Parts List < Front View >

Parts No.	Stock No.	Description
1	47303100	Front Panel Ass'y < Silver Model >
1-1		Front Panel
1-2	07630800	Push Switch Knob
1-3	07800900	Push Switch Knob
1-4	47317800	Sub Panel
1-5	07801000	Push Knob Ass'y
1-6	07798300	Dial Window
1	47303200	Front Panel Ass'y < Black Model >
1-1		Front Panel
1-2	07630900	Push Switch Knob
1-3	07630900	Push Switch Knob
1-4	47317900	Sub Panel
1-5	07554000	Push Switch Knob
1-6	07798300	Dial Window
2	07610900	Bonnet < Silver Model >
	07611000	Bonnet < Black Model >
3	47305100	Slide Volume Hood < Silver Model >
	47311700	Slide Volume Hood < Black Model >
4	46089800	100kΩ, Analyzer Level Volume Knob, Analyzer < Silver Model >
5	07614300	Knob, Analyzer < Silver Model >
	07680600	Knob, Analyzer < Black Model >

Parts No.	Stock No.	Description
6	07234400	Pilot Lamp, 8V 150mA
7	47303000	Dial Plate
8	47317700	Slide Volume Knob < Silver Model >
	47317600	Slide Volume Knob < Black Model >
9	46708200	250kΩ Slide Volume, control volume
10	07662900	Leg
11	46360300	Power Switch

Parts List < Top View >

Parts No.	Stock No.	Description
mT1	15004401	Power Transformer
pC1	46425800	10000pF 400V C.C.
	38004700	Power Cord
	39106000	Strain Relief
	07249000	2P Output Terminal
	07249100	4P TAPE-2 Terminal
	07249200	6P TAPE-1 Terminal
	07189600	AC Outlet

4. SCHEMATIC DIAGRAM

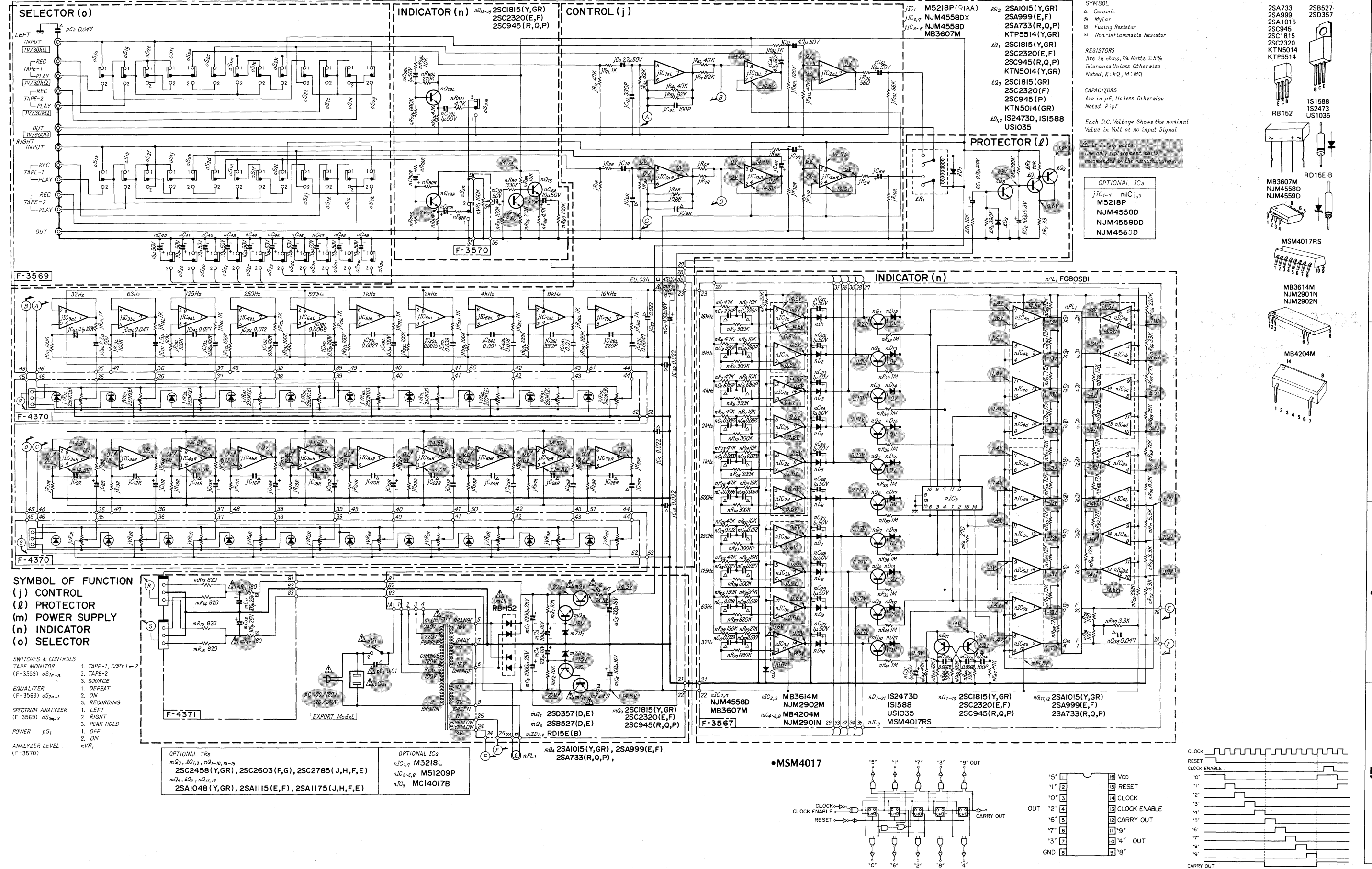

1  
2  
3  
4  
5



### 5. PACKING LIST

Parts No.	Stock No.	Description
1	91167620	Vinyl Bag
2	07822500	Styrofoam Packing
3	47304800	Carton Case <Silver Model>
	47304700	Carton Case <Black Model>

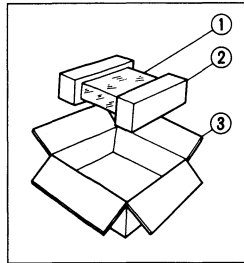

### 6. ACCESSORY LIST

Stock No.	Description
38103300	PJP Cord
46606900	Operating Instructions

### SCHMATIC DIAGRAM < Power Supply Section >

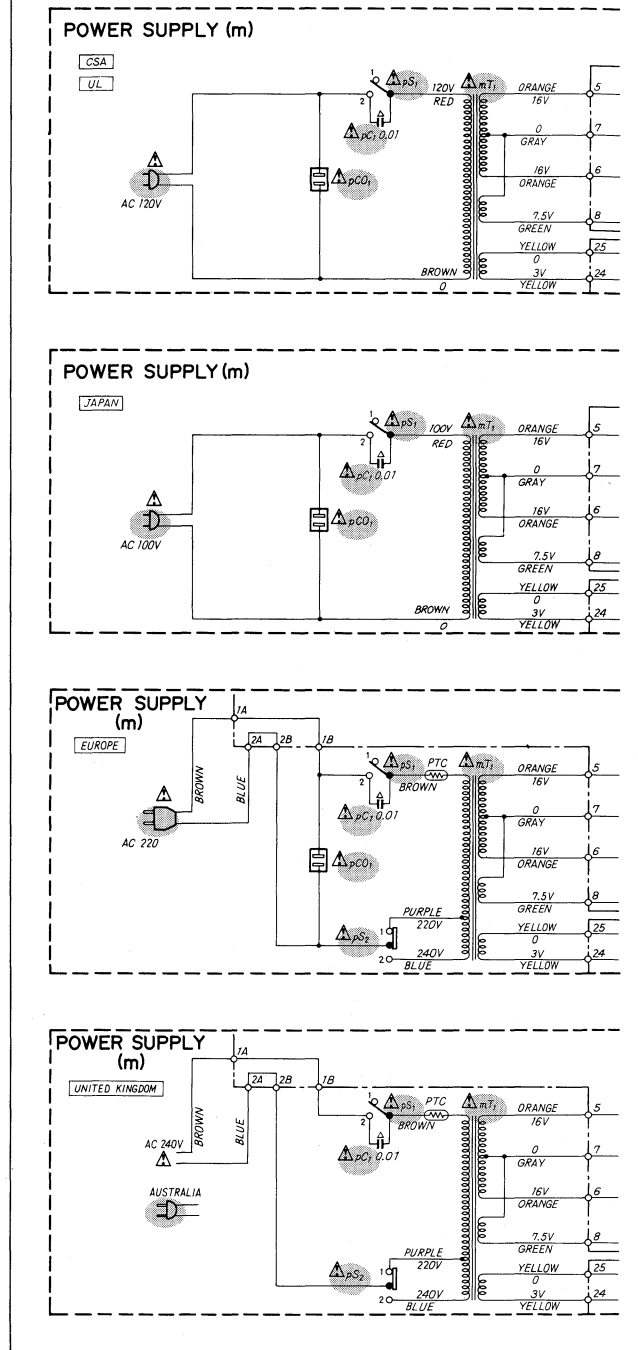

SANSUI ELECTRIC CO., LTD.: 14-1, Izumi 2-chome, Suginami-ku, Tokyo 168 Japan  
 SANSUI ELECTRONICS CORPORATION: 1250 Valley Brook Ave. Lyndhurst, N.J. 07071 U.S.A.  
 333 West Alondra Blvd. Gardena, California 90247 U.S.A.  
 3036 Koapaka 5t. Honolulu, Hawaii 96819 U.S.A.  
 SANSUI ELECTRONICS (U.K.) LTD.: Unit 10A, Lyon Industrial Estate, Rockware Avenue, Greenford, Middx UB6, OAA, England  
 SANSUI ELECTRONICS G.M.B.H.: Paul Ehrlich Strasse 8, 6074 Rödermark 2, West Germany