

For the best **SHENZHEN I/O** experience, we highly recommend printing this manual and assembling a binder that you can refer to as you play. To assemble the binder, simply follow these instructions:

- Get a 0.5-inch 3-ring binder (such as [this one](#)) and a set of 5-part tabbed dividers (such as [this one](#)).
- Print this PDF, ensuring that the "Fit to page" option is *unchecked*.
- Place the Cover Sheet in the front of the binder.
- Fold or cut the Reference Card into quarters.
- Place the three Story Documents (two emails and one visa application form) in the inside front pocket.

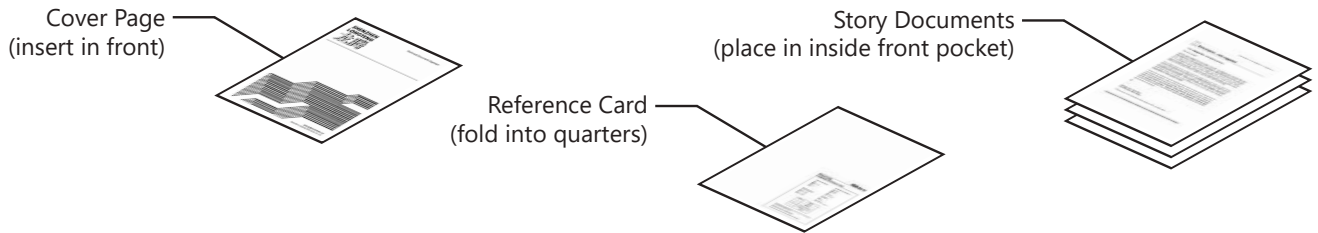

- Three-hole punch the remaining sheets and place in the binder in the following order:

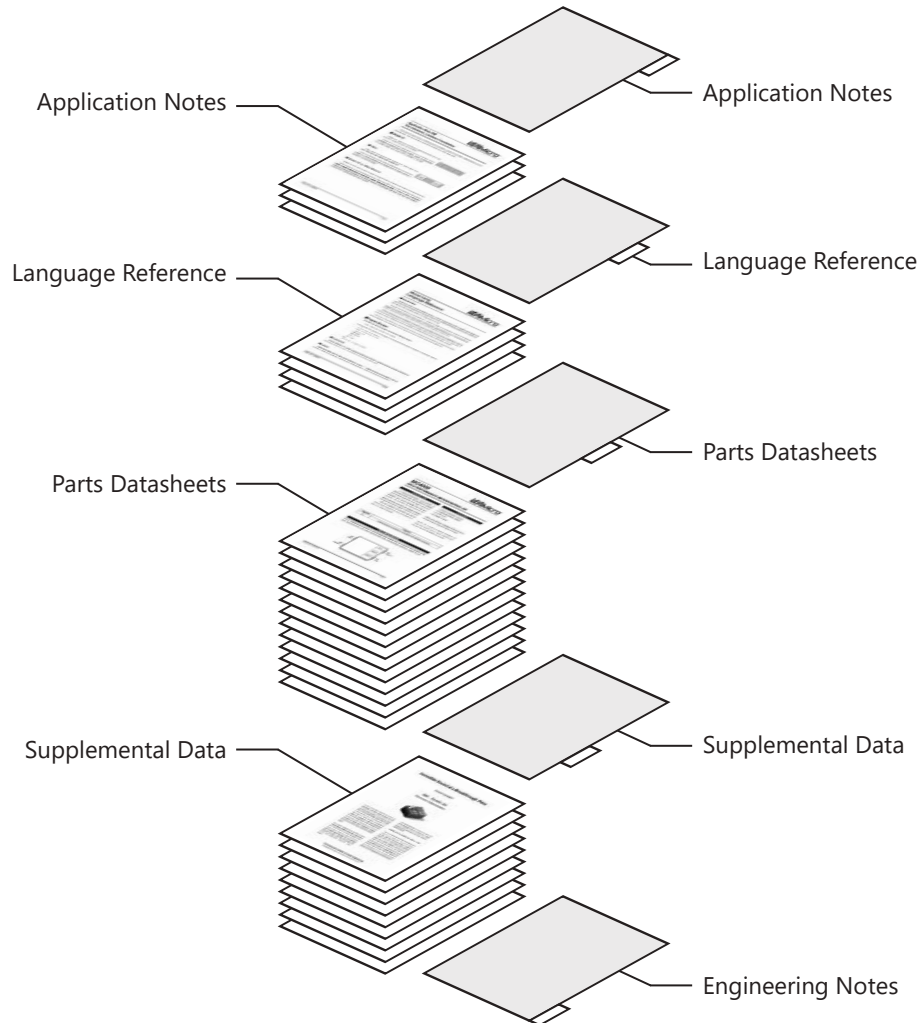

- If you obtained Avery® 11110 dividers, re-print the tab insert page on the tab paper. Otherwise, cut, fold, and place the tab inserts into the section tabs you are using.
- For the Engineering Notes section, use whatever engineering paper you prefer.

**SHENZHEN  
LONGTENG**  
**龙腾**

*Technical Document Organizer*

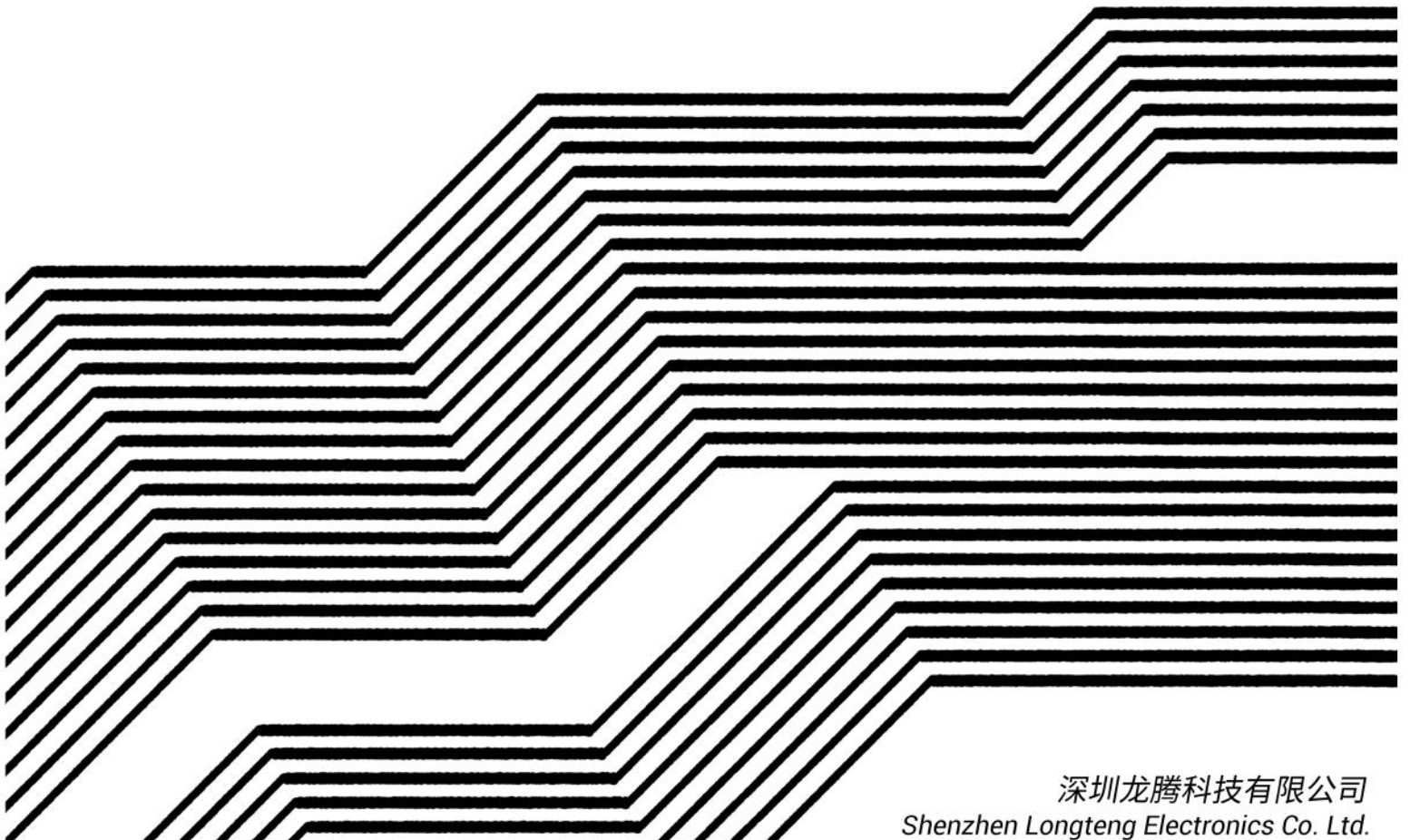

深圳龙腾科技有限公司  
*Shenzhen Longteng Electronics Co. Ltd.*

*These tab inserts are formatted for Avery® Big Tab™ Insertable Dividers (5 Tabs), 11110.*

Application Notes

Application Notes

Language Reference

Language Reference

Parts Datasheets

Parts Datasheets

Supplemental Data

Supplemental Data

Engineering Notes

Engineering Notes

## MCxxxx Family Language Reference Card

### Basic Instructions

**nop**  
**mov** R/I R  
**jmp** L  
**slp** R/I  
**slx** P

### Test Instructions

**teq** R/I R/I  
**tgt** R/I R/I  
**tlt** R/I R/I  
**tcp** R/I R/I

### Arithmetic Instructions

**add** R/I  
**sub** R/I  
**mul** R/I  
**not**  
**dgt** R/I  
**dst** R/I R/I

### Registers

**acc**  
**dat** [1]  
**p0, p1** [1]  
**x0, x1, x2, x3** [1]

Notation	Meaning
R	Register
I	Integer [2]
R/I	Register or integer [2]
P	Pin register (p0, p1, etc.)
L	Label [3]

[1] Not all registers are available on all microcontrollers. Refer to the parts datasheets for pin diagrams and register information.

[2] Integer values must be in the range -999 to 999.

[3] Labels used as operands must be defined elsewhere in the program.



## Some progress... and a suggestion

---

From: **Margie Fish** <mfish@fish.partners>

Good morning!

Just a quick update for you today. First off, I've placed your resume with two new agencies. They specialize in industries a little different from yours, but you never know where a match might be made! I've also reached out to a few more of my colleagues across the country, letting them know to get in touch if they hear of anything. Finally, I followed up with Electromotiv again, but they keep stalling. At this point I think it's safe to say an offer won't be coming.

You've been with us for a while now and I appreciate your trust, so I want to be honest: The likelihood of us finding you something that genuinely makes use of your skills in the foreseeable future is rather low. This isn't because of any lack of qualifications on your part... It is simply a reflection of the realities of the time. We'll keep trying, of course! I just wanted to ensure you kept some realistic expectations in mind going forward.

I know you've said you were hoping to stay in the country, but it may be time to reconsider that stance. Many of the people we represent have done stints overseas and report that it is an eye-opening, and in some cases, career-enhancing move. I don't have a lot of contacts in that particular arena, but I can point you in the direction of someone I know who has some experience working with Chinese electronics firms. Let me know if that sounds interesting to you and I'll get you two introduced.

M.

-----

Margie Fish, President  
**Fish Partners Recruiting**

*"The journey of a thousand miles begins with a single step..."*



## Great chatting with you

---

From: **Jessie Huang** <hhuang@huang.associates>

Hey, just wanted to follow up on our call. As I mentioned, the company is called Longteng Electronics. They're not exactly one of the biggest players, but they've been running a stable business for a while now, and that's always a good sign. Up until now they've mostly done manufacturing subcontracts, so traditionally their design engineering team has been relatively small. But they're looking to grow the department because they want to create new products in-house, for both domestic and international markets.

The position is located in Shenzhen, China, which is just across the border from Hong Kong. The pay is competitive for the area, which I think you'll find more than adequate for living there. I forgot to ask if you had family... but whatever your situation is, you'll find Shenzhen is a modern, fairly international city. There's even a McDonald's right downtown! If there's anything I might be able to do help you feel more comfortable about the idea of relocating, let me know. I have helped many engineers like yourself find opportunities in China and I am pretty familiar with the ins and outs.

Looking forward to hearing from you once you've had a chance to chew it over!

Jess

//

Jessie H. Huang  
Huang & Associates  
*"Connecting talent across the Pacific since 2021!"*

# Visa Application Form of the People's Republic of China

Applicant should fill out this form truly and completely. Please write your answer in capital English letters in the space provided or cross the appropriate box to select.

1.1	Full English name as in passport	
1.2	Legal sex	<input type="checkbox"/> M <input type="checkbox"/> F
1.3	Name in Chinese characters (if given)	
1.4	Other names you are known by	
1.5	Current nationality	
1.6	Date of birth (yyyy-mm-dd)	
1.7	Place of birth (city, province, country)	
1.8	Marital status	
1.9	Current occupation	Embedded systems engineer
2.1	Major purpose of visit to China	Employment
2.2	Date of your first entry (yyyy-mm-dd)	2026/09/28
2.3	Residence during your stay in China	1210 Baoan Nan Road Apt. 2109
2.4	Name and address of your inviter / point of contact / employer in China	Shenzhen Longteng Electronics Co.Ltd. No.44A Donghuan Road Luohu District, Shenzhen, Guangdong, CHINA
3.1	Detailed home mailing address	
3.2	Contact person in case of emergency	
3.3	Contact person's phone number	
4.1	Have you ever been refused entry to China?	
4.2	Do you have a criminal record?	

I have read and understood all the questions in this application. I shall be fully responsible for the answers, which are true and correct. I understand that whether to issue a visa, type of visa, number of entries, validity and duration of each stay will be decided by consular officers, and any false, misleading or incomplete statement may result in a refusal of a visa for or denial of entry into China.

Applicant's signature: \_\_\_\_\_ Date (yyyy-mm-dd): \_\_\_\_\_

Replace this page with the "Application Notes" section divider.



## Application Note 268

### Two Interfaces, Limitless Possibilities

There are two types of pins on MCxxxx microcontrollers: simple I/O and XBus. Note that they are not interoperable, and can only be connected to another pin of the same type.

#### ■ Simple I/O

Simple I/O values are continuous signal levels from 0 to 100, inclusive. Simple I/O pins are unmarked.

Simple I/O is used for applications such as connecting a microcontroller to a simple input, such as a button, switch, or microphone, or a simple output, such as an LED, a speaker, or a motor.



#### ■ XBus

XBus values are discrete data packets from -999 to 999, inclusive. XBus pins are marked with a yellow dot.

XBus is commonly used to transmit data between two microcontrollers or a microcontroller and complex input or output, such as a keypad or numeric display.



#### ■ Simple I/O vs. XBus Behavior

Simple I/O pins can be read or written at any time with no regard to the state of connected devices.

XBus, however, is a synchronized protocol. Data over XBus pins is only transferred when there is **both a reader attempting to read and a writer attempting to write**. If a read or write is attempted *without* a corresponding operation on a connected device, the operation will block.

## Application Note 393 Make Sure To Get Enough Sleep!

- CPUs are typically much faster than the signals they are reading and writing.
- A CPU can execute a very large number of instructions within one **time unit**.
- To advance to the beginning of the next time unit, a CPU can go to **sleep**.
- To put a CPU to sleep, use the `slp` instruction and specify the number of time units to sleep.

### EXAMPLE CIRCUIT

#### SQUARE WAVE GENERATOR

The following program generates a square wave on simple I/O pin p1 that is on (100) for 3 time units and off (0) for 3 time units.

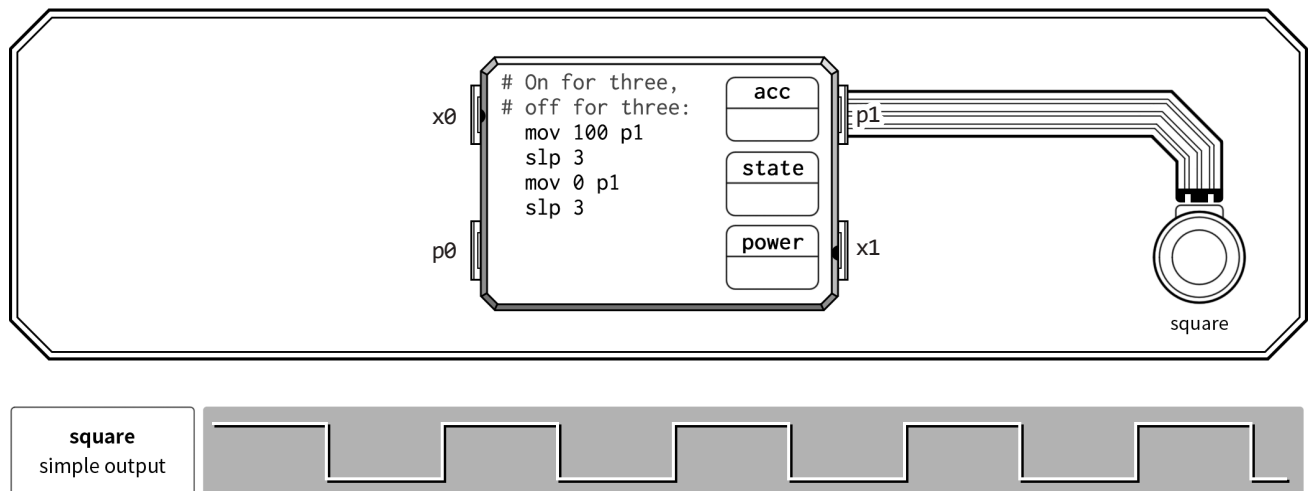

## Application Note 650

### Reference Design: Touch-Activated Light Controller

#### EXAMPLE CIRCUIT

The following circuit is a reference design for a touch-activated light controller. When a user touches a capacitive switch, the controller will detect the rising edge and advance the light to the next intensity level, from off, to 50%, to 100%, and back to off.

The circuit consists of two MC4000 microcontrollers that communicate over XBus:

- The first microcontroller reads from the capacitive switch on simple I/O pin p0 and sends either a 0 or 1 over XBus to the second microcontroller every time unit, where a value of 0 means that the switch wasn't touched and a value of 1 means that the switch was touched. By storing the previous reading from the capacitive switch in acc, the first microcontroller can detect a transition from low (0) to high (100).
- The second microcontroller stores the current state of the light in its acc register. It waits for an XBus value from the first microcontroller using the slx instruction, and then increments acc by 50 if the value is 1. When acc is incremented past 100, it resets acc back to 0. The resulting value is then used to drive the light using simple I/O pin p1.

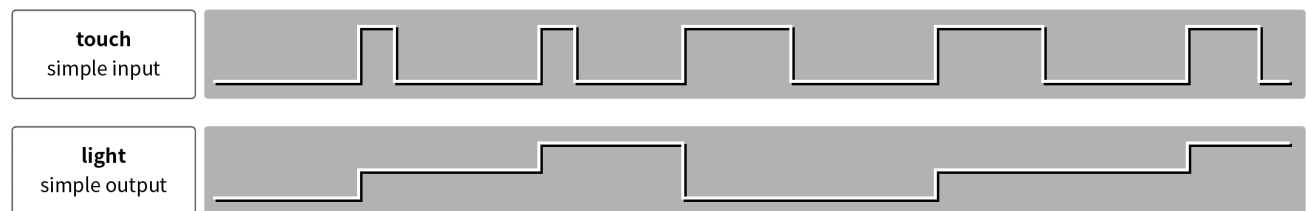
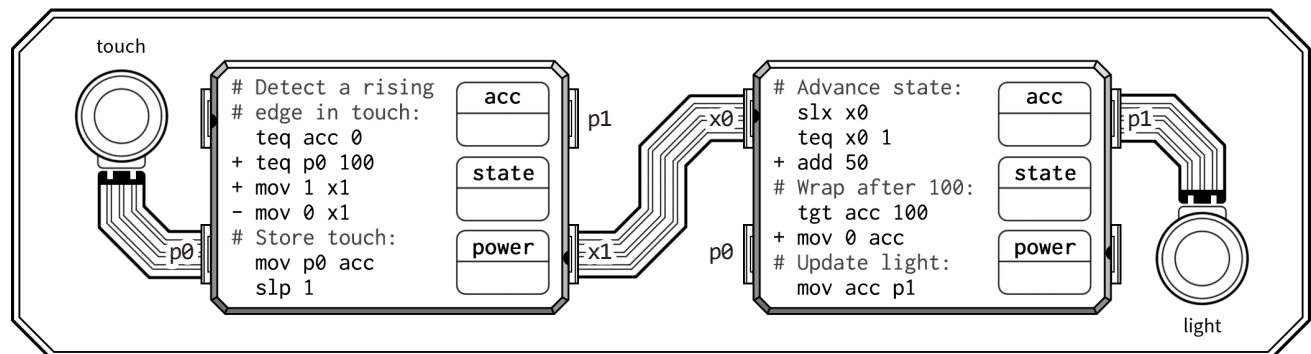

Replace this page with the "Language Reference" section divider.

---

## MCxxxx Family Language Reference

---

### ■ Introduction

The MCxxxx family of microcontrollers employs a common programming system to simplify system design and reduce new product development time. A program written for one member of the MCxxxx family can be re-used in any other MCxxxx microcontroller with few or no changes (see note [1]).

Programs for the MCxxxx are assembled from a small but versatile set of operations. Each line of an MCxxxx program can contain an instruction, which consists of the instruction's name followed by zero or more instruction operands. Detailed descriptions of the available instructions and their usage are provided below.

MCxxxx microcontrollers are designed to be used in power-constrained environments and applications, and the MCxxxx programming system has been designed accordingly. While a MCxxxx microcontroller is in a sleep state, it consumes no power. Otherwise, power consumption is proportional to the number of instructions executed.

*[1] MCxxxx microcontrollers have varying features, pinouts, and program space limitations, described in the model-specific datasheets. Some adaptation may be required to account for these model-specific differences.*

### ■ Program Structure

Each line of an MCxxxx program must have the following structure:

```
LABEL CONDITION INSTRUCTION COMMENT
```

All components are optional, but must appear in the specified order if present. Examples of syntactically valid lines:

```
# This line is a comment.  
loop: # until ACC is ten  
    teq acc 10  
    + jmp end  
    mov 50 x2  
    add 1  
    jmp loop  
end:  
    mov 0 acc # reset counter
```

### ■ Comments

Any text following a “#” symbol is ignored until the end of the line. Comments improve developer productivity by allowing the behavior of code to be described in-line with the program itself.

### ■ Labels

Labels must appear first on a line, and are followed by a colon (“:”). Labels are used as jump targets by the `jmp` instruction. Labels must begin with a letter and may contain alphabetic, numeric, and underscore characters.

## ■ Conditional Execution

All instructions in the MCxxxx programming language are capable of **conditional execution**. Prefixing an instruction with a “+” or “-” symbol will cause that instruction to be enabled or disabled by **test instructions**. When an instruction is disabled by a test instruction, it will be skipped and will not consume power. Instructions with no prefix are never disabled and always execute normally. All conditional instructions start in a disabled state. A test instruction must be executed to enable conditional instructions.

For an example of conditional instructions in use, see **Application Note 650: Touch-Activated Light Controller**.

## ■ Registers

Registers are used as sources and destinations for data manipulated by MCxxxx instructions. The set of registers varies between MCxxxx models. It is an error to use a register in a microcontroller program if that register is not present on that microcontroller.

**acc** is the primary general-purpose register used for internal computation on MCxxxx family microcontrollers. All arithmetic operations implicitly use and modify the value of **acc**.

**dat** is a second register available on some MCxxxx family members. It can be used in most contexts where **acc** is permitted.

The internal registers of MCxxxx microprocessors (**acc** and **dat**, if available) are initialized to the value 0.

The pin registers (**p0**, **p1**, **x0**, **x1**, **x2**, **x3**) are used when reading from or writing to the pins of MCxxxx microcontrollers. Reading and writing through the pins allows a single MCxxxx microcontroller to communicate and coordinate with other connected, compatible devices. Each pin on an MCxxxx family microcontroller functions as either a simple I/O or XBus interface. Refer to the appropriate datasheet for details on pin functionality.

**null** is a pseudo-register. Reading from the **null** register produces the value 0. Writing to the **null** register has no effect.

## ■ Instruction Operands

Each type of instruction requires a fixed number of operands. If an instruction has any associated operands, they must appear following the instruction name, separated by spaces. For the benefit of development productivity, the MCxxxx programming system does not require the use of redundant punctuation to separate instruction operands.

Instruction operands are described with the following notation:

Notation	Meaning
R	Register
I	Integer [1]
R/I	Register or integer [1]
P	Pin register (p0, p1, etc.)
L	Label [2]

[1] Integer values must be in the range -999 to 999.

[2] Labels used as operands must be defined elsewhere in the program.

## Basic Instructions

### **nop**

This instruction has no effect.

### **mov** R/I R

Copy the value of the first operand into the second operand.

### **jmp** L

Jump to the instruction following the specified label.

### **slp** R/I

Sleep for the number of time units specified by the operand.

### **slx** P

Sleep until data is available to be read on the XBus pin specified by the operand.

## Arithmetic Instructions

Registers can store integer values between -999 and 999, inclusive. If an arithmetic operation would produce a result outside this range, the closest allowed value is stored instead. For example, if acc contains the value 800 and the instruction `add 400` is executed, then the value 999 will be stored in acc.

### **add** R/I

Add the value of the first operand to the value of the acc register and store the result in the acc register.

### **sub** R/I

Subtract the value of the first operand from the value of the acc register and store the result in the acc register.

### **mul** R/I

Multiply the value of the first operand by the value of the acc register and store the result in the acc register.

### **not**

If the value in acc is 0, store a value of 100 in acc. Otherwise, store a value of 0 in acc.

### **dgt** R/I

Isolate the specified digit of the value in the acc register and store the result in the acc register.

### **dst** R/I R/I

Set the digit of acc specified by the first operand to the value of the second operand.

Examples of the `dgt` and `dst` instructions:

acc	Instruction	acc'
596	<code>dgt 0</code>	6
596	<code>dgt 1</code>	9
596	<code>dgt 2</code>	5

acc	Instruction	acc'
596	<code>dst 0 7</code>	597
596	<code>dst 1 7</code>	576
596	<code>dst 2 7</code>	796

## ■ Test Instructions

For more information on conditional execution and the “+” or “-” symbols, see *Conditional Execution*, page 2.

**teq** R/I R/I

Test if the value of the first operand (A) is equal to the value of the second operand (B).

Condition	Effect on ‘+’ Instructions	Effect on ‘-’ Instructions
A is equal to B	Enabled	<i>Disabled</i>
A is not equal to B	<i>Disabled</i>	Enabled

**tgt** R/I R/I

Test if the value of the first operand (A) is greater than the value of the second operand (B).

Condition	Effect on ‘+’ Instructions	Effect on ‘-’ Instructions
A is greater than B	Enabled	<i>Disabled</i>
A is not greater than B	<i>Disabled</i>	Enabled

**tlt** R/I R/I

Test if the value of the first operand (A) is less than the value of the second operand (B).

Condition	Effect on ‘+’ Instructions	Effect on ‘-’ Instructions
A is less than B	Enabled	<i>Disabled</i>
A is not less than B	<i>Disabled</i>	Enabled

**tcp** R/I R/I

Compare the value of the first operand (A) to the value of the second operand (B).

Condition	Effect on ‘+’ Instructions	Effect on ‘-’ Instructions
A is greater than B	Enabled	<i>Disabled</i>
A is equal to B	<i>Disabled</i>	<i>Disabled</i>
A is less than B	<i>Disabled</i>	Enabled



Replace this page with the "Parts Datasheets" section divider.

## MC4000 HIGH PERFORMANCE MICROCONTROLLER

### DESCRIPTION

A reduced-functionality microcontroller to help lower BOM costs, the MC4000 is a flexible and versatile alternative to its larger cousin, the MC6000. Don't let its diminutive size fool you, however: The MC4000 can easily hold its own with its generous nine lines of program memory, one general-purpose register, and four I/O pins.

We are confident the MC4000 will find its way into your designs and into your heart! Contact us to request samples.

### FEATURES

- (9) lines of program memory
- (1) general-purpose register
- (2) XBus pins
- (2) simple I/O pins

Refer to the *MCxxxx Language Reference* for information about programming the MC4000.

*NOTE: As a result of customer feedback, an XBus-only variant will be made available later this year with the MC4000X part number.*

### PIN CONFIGURATION

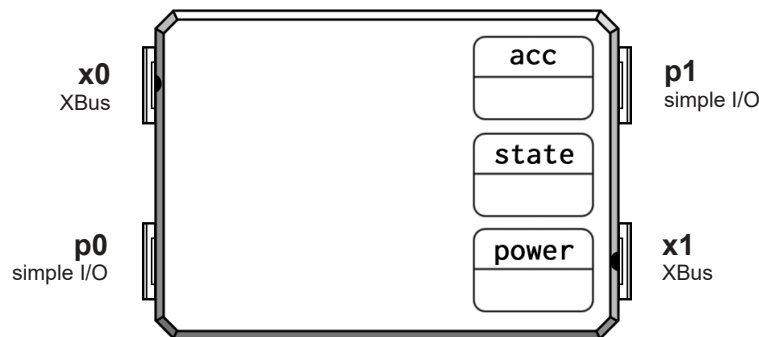

Register	Purpose
acc	General purpose accumulator; is the target of all arithmetic instructions

*NOTE: At any given time, a simple I/O pin is either in **input mode** or **output mode**. Writing a value to a pin register will put the corresponding pin into **output mode** with the specified output value. Reading a value from a pin register will put the corresponding pin into **input mode**, clearing any previously set output value.*

## MC6000

### HIGH PERFORMANCE MICROCONTROLLER

#### DESCRIPTION

Offering maximum power so you can achieve a minimum chip count, the MC6000 is the centerpiece of 诚尚Micro's MCxxxx microcontroller family. With plenty of room for complex instructions in its expansive fourteen-line program memory, two general-purpose registers, and six pins for I/O, the MC6000 can be at the center of even your most demanding embedded applications! Contact us to request samples.

#### FEATURES

- (14) lines of program memory
- (2) general-purpose registers
- (4) XBus pins
- (2) simple I/O pins

Refer to the *MCxxxx Language Reference* for information about programming the MC6000.

#### PIN CONFIGURATION

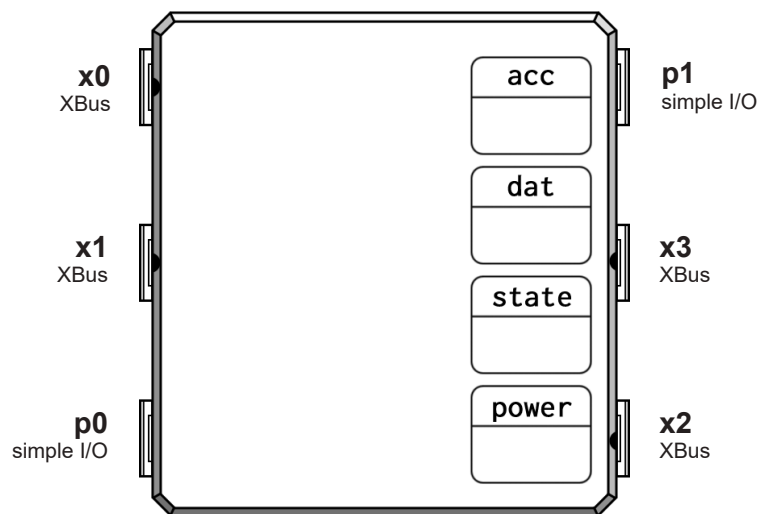

Register	Purpose
acc	General purpose accumulator; is the target of all arithmetic instructions
dat	General purpose data register; used for additional on-chip storage

**NOTE:** At any given time, a simple I/O pin is either in **input mode** or **output mode**. Writing a value to a pin register will put the corresponding pin into **output mode** with the specified output value. Reading a value from a pin register will put the corresponding pin into **input mode**, clearing any previously set output value.

## DX300 DIGITAL I/O EXPANDER

### DESCRIPTION

Control the world with the DX300 digital I/O expander! This unique and useful part can read or write up to three on/off signals at once over simple I/O or XBus.

It is sure to find its ideal application in answering many of your control and signal processing needs. Contact us to request samples.

### PIN CONFIGURATION

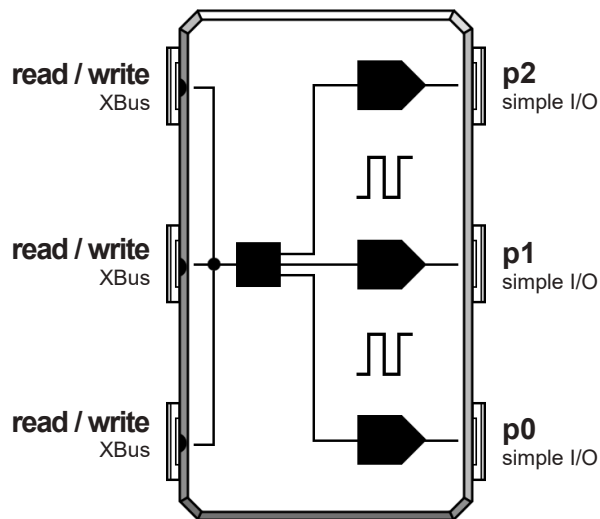

*NOTE: At any given time, the DX300 is either in **input mode** or **output mode**. Writing an XBus value to the DX300 will put its simple I/O pins into **output mode** with the specified output values. Reading an XBus value from the DX300 will put its pins into **input mode**, clearing any previously set output values.*

### USAGE

- **Write** a 3-digit number to any XBus pin to change the state of the simple I/O pins. The three digits of the value written will be used to turn the simple I/O pins on (100) or off (0) depending on if the digit is a 1 or a 0.
- **Read** from any XBus pin to get a 3-digit number that captures the state of the simple I/O pins. The digits of the resulting XBus value will be set to either a 1 or a 0 depending on if the simple I/O pin is on (100) or off (0).
- When representing the state of the simple I/O pins, the value in the ones column corresponds to p0, while the tens column corresponds to p1, and the hundreds column corresponds to p2.

### EXAMPLE TABLE

XBus Value	p0	p1	p2
100	0	0	100
011	100	100	0
000	0	0	0

## DX300 EXAMPLE CIRCUIT

### STEPPER MOTOR CONTROLLER

The following circuit controls a stepper motor using 诚尚Micro's DX300 digital I/O expander to control the **motor-0**, **motor-1**, and **motor-2** signals and built-in simple I/O pin **p0** to control the remaining **motor-3** signal.

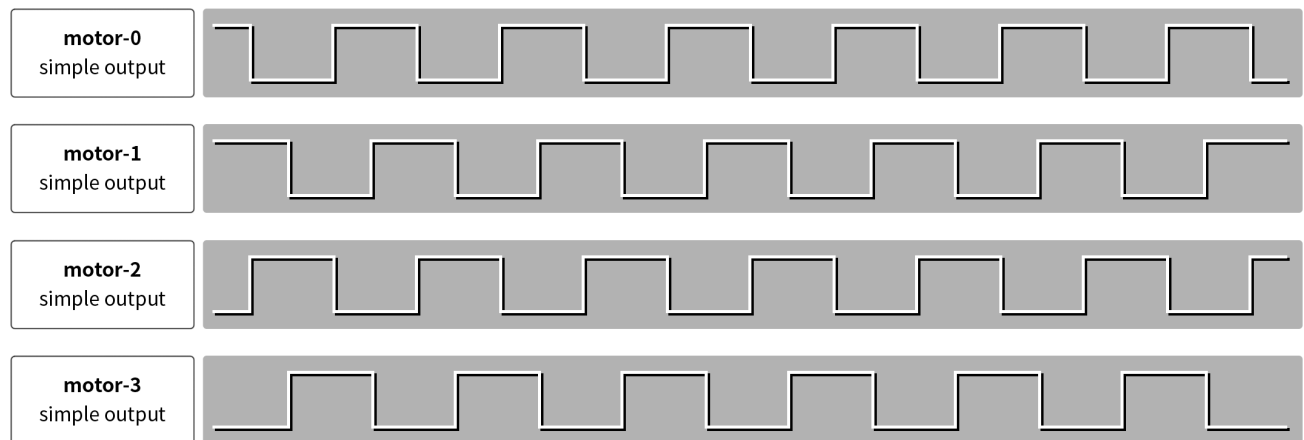
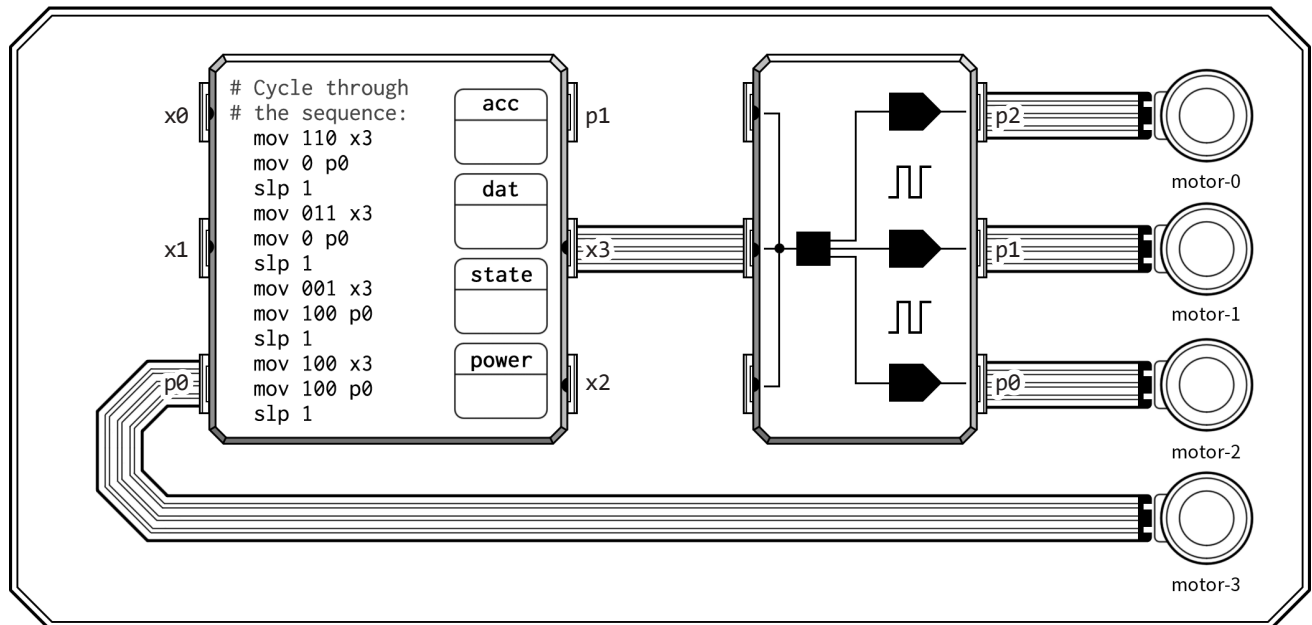

# RANDOM-ACCESS MEMORY

## General Description

**100P-14** random-access memory by Pingda Co. Ltd. offers embedded system engineers additional storage for today's increasingly data-driven world with a whopping fourteen memory cells. With its convenient auto-increment feature, you won't have to waste precious registers keeping track of memory addresses.

## Features

- (14) random-access memory cells
- (2) independent, auto-incrementing memory pointers

## Usage

- All memory *cells* initialize to a value of 0.
- All memory *pointers* initialize to point at the first memory cell (address 0).
- Memory pointers can be read and written over XBus with the **a0** and **a1** **address** pins.
- Memory values referenced by pointers can be read and written over XBus with the **d0** and **d1** **data** pins.
- After reading from or writing to a data pin, the corresponding memory pointer will *automatically* increment to the next memory location.

## Example Circuit: Data Packet Reverser

The following example circuit reads in 3-value packets from **input** and writes them back out to **output** in reverse order, using a **100P-14** to temporarily store the values.

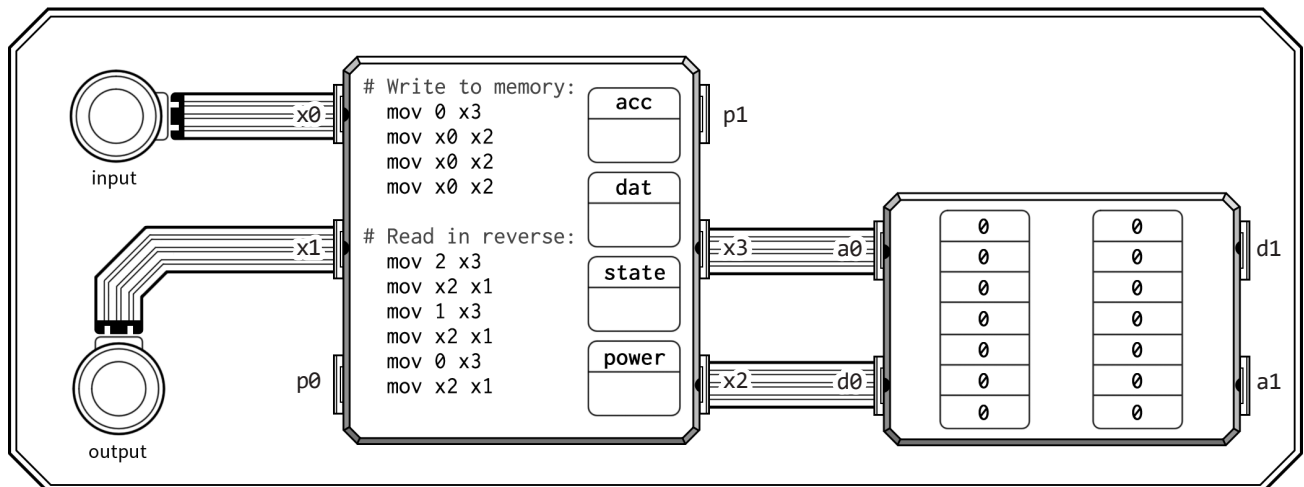

# READ-ONLY MEMORY

## General Description

200P-14 read-only memory by Pingda Co. Ltd. offers embedded system engineers the ability to easily access up to fourteen factory-programmed memory cells for a wide range of diverse applications. With its convenient auto-increment feature, you won't have to waste precious registers keeping track of memory addresses.

## Features

- (14) read-access memory cells
- (2) independent, auto-incrementing memory pointers

## Usage

- All memory cell values are set in advance by the design engineer.
- All memory *pointers* initialize to point at the first memory cell (address 0).
- Memory pointers can be read over XBus with the a0 and a1 **address** pins.
- Memory values referenced by pointers can be read over XBus with the d0 and d1 **data** pins.
- After reading from a data pin, the corresponding memory pointer will *automatically* increment to the next memory location.

## Example Circuit: Data Packet Generator

The following circuit sends a data packet with a predetermined set of values to **output** every time unit that **trigger** is high.

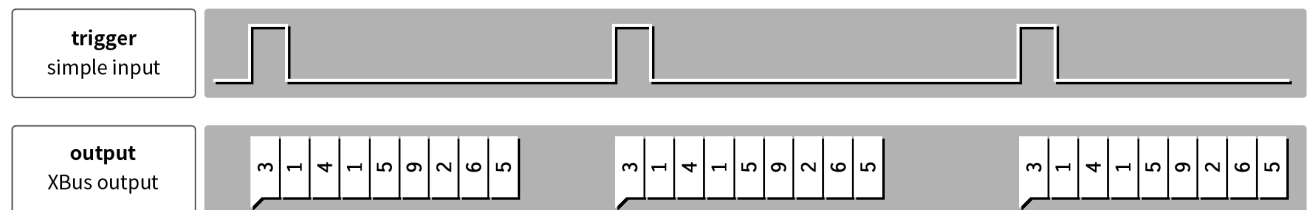
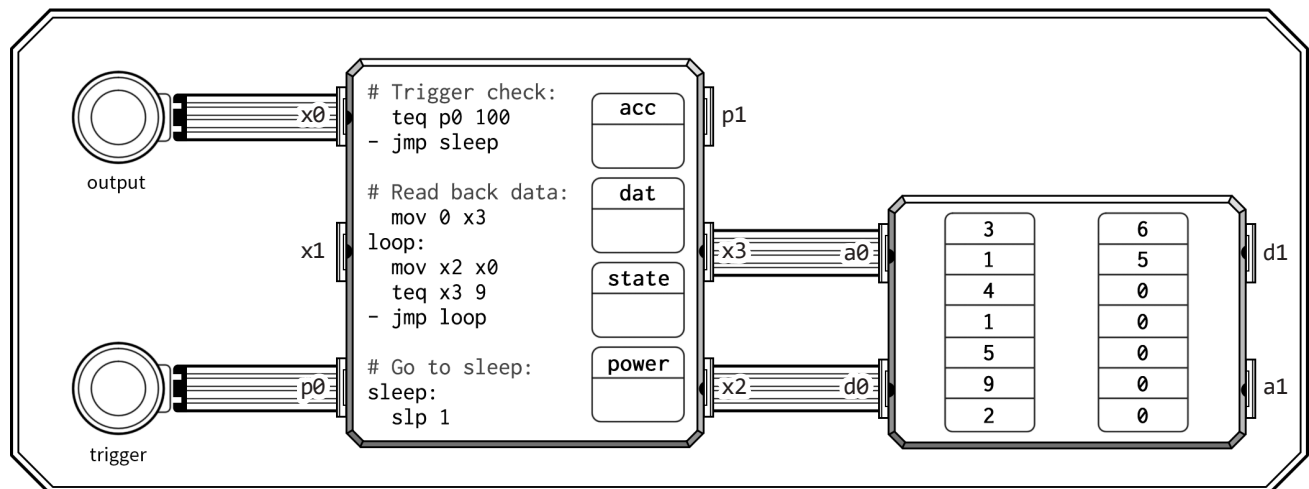

## LC70GXX SIMPLE I/O LOGIC GATE FAMILY

LC70G04 / LC70G08 / LC70G32 / LC70G86

*We could all use a little more logic in our lives...*

The **LC70Gxx** logic gate family from The Logic Company™ offers that bit of extra logic you've been wanting— and for not a lot of money. With the **LC70Gxx** family you can rest assured your logical operations will be performed quickly, accurately, and with a minimum of extra "fuss."

Embedded systems engineers the world over trust The Logic Company™ with logical operations every day... *day in and day out!*

- **LC70G04** is a one-input, one-output inverter.
- **LC70G08** is a two-input, one-output AND gate.
- **LC70G32** is a two-input, one-output OR gate.
- **LC70G86** is a two-input, one-output XOR gate.

When measuring inputs, signals less than 50 are interpreted as "off", while signals greater than or equal to 50 are interpreted as "on".

## PIN LOCATIONS

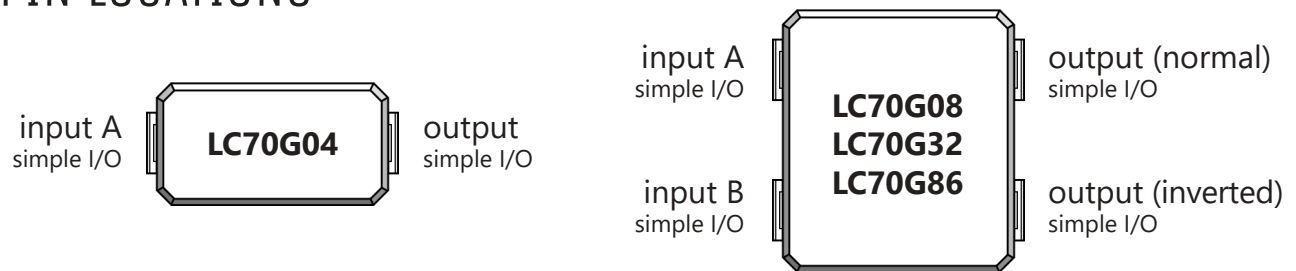

## OUTPUT TABLE

A	B	Inverter LC70G04	AND LC70G08	OR LC70G32	XOR LC70G86
0	0	1	0	0	0
0	1	1	0	1	1
1	0	0	0	1	1
1	1	0	1	1	0



# Denver Timekeeping

---

## DT2415 Incremental Clock

### Key Features

- Emits a simple I/O signal that corresponds to the number of 15-minute increments since midnight
- Includes a built-in backup battery so that the time is kept, even when power is not available

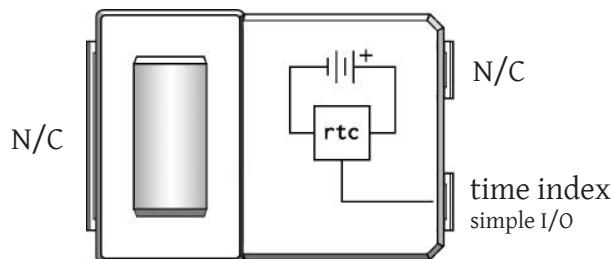

### Example Output

<i>Time</i>	00:00 - 00:14	00:15 - 00:29	00:30 - 00:44	00:45 - 00:59	...	23:45 - 23:59
<i>Index</i>	0	1	2	3	...	95

### The Denver Timekeeping Story

When Denver Timekeeping founders Chad and Becca set up their small-batch chip fab in the mountain town of Denver, Colorado, there were many who were dubious, to say the least. “You can’t manufacture in America anymore,” they said. “It’s too expensive, and hasn’t all that expertise left the country anyhow?”

But Chad and Becca persistently stuck to their vision of inexpensive, reliable, and American-made timekeeping chips manufactured the old way. And, after many trials and tribulations, they are proud to announce the Denver Timekeeping DT2415. Made in the cool air and with the pure water of the Rocky Mountains, this real-time clock includes a backup battery that ensures the time is kept even when power is not— a must-have for ruggedized devices.

We hope you enjoy this chip. And if you’re ever in Denver, drop us a line. Chad and Becca love to show customers around the fab.

---

# C2S

## CHENNAI COMMS SOLUTIONS

### **PRESENTING THE C2S-RF901**

If you need an easy and effective wireless solution for your embedded system design, Chennai Comms Solutions has the answer in the form of the C2S-RF901. A low-power RF transceiver with a built-in antenna and auto-sensing RF switch, the C2S-RF901 sends and receives data over a reliable wireless link using a dual XBus connection.

### **NON-BLOCKING BUFFER!**

All data received is passed through an internal non-blocking buffer. Reading from the C2S-RF901 when no data is available will yield a value of -999 instead of blocking until data arrives (which is typical XBus behavior). With the C2S-RF901, you can keep working while you wait for data to arrive!

### **CONVENIENT PIN LOCATIONS!**

With transmit and receive pins located on the same side of the part, you will never find yourself moving components in an awkward way to accommodate the C2S-RF901 in your designs. Just place it down and don't worry.

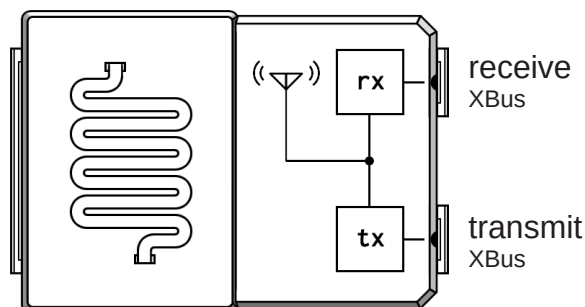

### **YOUR BEST SOLUTION FOR WIRELESS**

Indeed, the C2S-RF901 is a true turnkey solution for wireless communications that you will find yourself using every day.

*“When it comes to wireless, don't be a protozoan.  
Just get yourself a C2S-RF901!”*

# FM/iX Sound Module FM BLASTER

## DESCRIPTION

The FM/iX FM Blaster is a versatile FM-based tone generator applicable to a diverse set of devices from PC-compatible sound cards to video game consoles to consumer keyboards. The FM/iX comes with 10 professionally designed, stunningly realistic preset patches that cover a wide range of musical directions including classical, rock, plastic, gasp, and techno.

## FEATURES

- 1 voice of polyphony (new note or instrument change will stop current note)
- 10 preset instruments with built-in envelopes
- Industry standard tuning (equal temperament)
- Includes bass drum and snare/hihat combination!

## NOTE VALUES

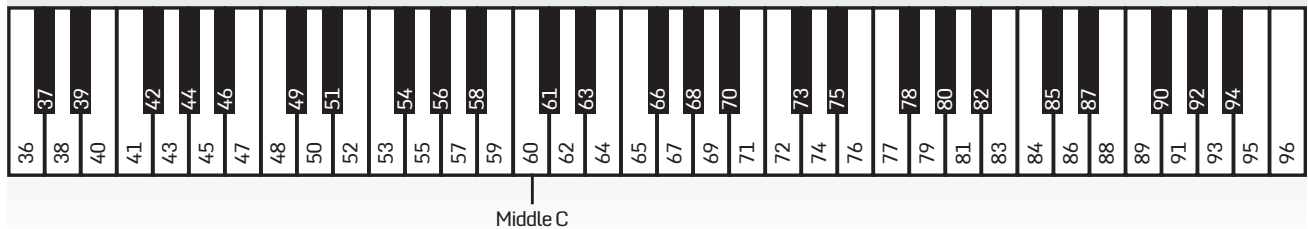

## INSTRUMENT LIST

- |                 |                  |
|-----------------|------------------|
| 00. Harpsiclav  | 05. Bellrimba    |
| 01. Plucktar    | 06. Reso Strings |
| 02. Tines       | 07. Glass Pad    |
| 03. Hollow Bass | 08. Hi-Snare     |
| 04. Rubber Bass | 09. Bass Drum    |

## PINOUT DIAGRAM

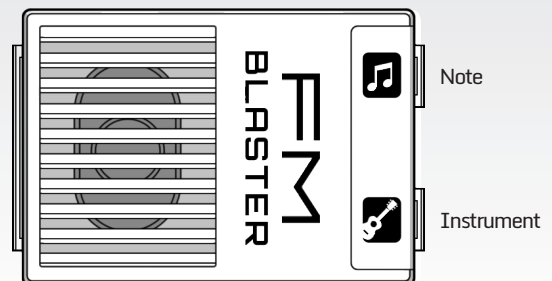

**MOUNTLEAF**  
SOUND CONCEPTS

## N4PB-8000 Push-Button Controller

¥3/ea.

- Push-button array controller with support for up to 8 buttons
- 4 non-blocking XBus pins
- Great quality and price

Direction	Value	Result
Read	[button]	[button] down event
Read	-[button]	[button] up event
Read	-999	No new button events

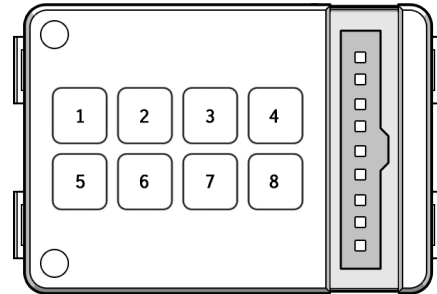

## LuX Industry LX700

¥4/ea.

- 7-segment numerical display with 2.5 digits and bonus minus sign
- Displays the full range of XBus values from -199 to 199

Direction	Value	Result
Write	-199 to 199	display [value]
Write	-999	Turn off all segments

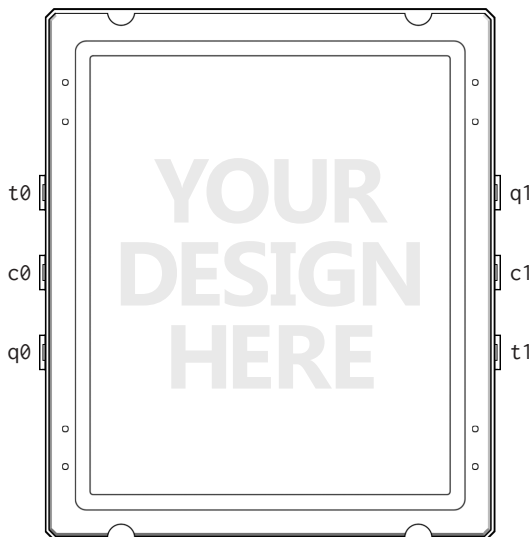

## LuX Industry LX910C

¥8/ea.

- Custom-manufactured for your unique application's display needs
- Now with integrated segment-based touchscreen controller!

Pin	Direction	Value	Result
cN	Write	[segment]	Turn on [segment]
cN	Write	-[segment]	Turn off [segment]
cN	Write	999	Turn on all segments
cN	Write	-999	Turn off all segments
tN	Read	[segment]	[segment] touch event
tN	Read	-[segment]	[segment] release event
tN	Read	-999	No new touch events
qN	Write/ Read	[segment]	Query [segment] state; Subsequent read yields 1 or 0 if [segment] is on or off

## MC4010 MATH CO-PROCESSOR

### USAGE

Write a **command sequence** to any pin to instruct the MC4010 to perform a calculation. A **command sequence** (see table, right) consists of an **operation code** followed by one or two values. Once a complete **command sequence** is written to the MC4010, the result register is updated with the result of the specified calculation.

Reading from any pin retrieves the value stored in the result register. result can be read any number of times.

In the following example, the **command sequence** 50 20 4 is sent to the MC4010 to perform the calculation  $20 / 4 = \underline{\quad}$ . The result, 5, is stored in the result register and read back into the accumulator.

```
# x0 is connected to an MC4010 input pin
mov 50 x0 # op code for division
mov 20 x0 # write first value
mov 4 x0 # write second value
mov x0 acc # read back result (5)
```

### COMMAND LIST

Operation	Command sequence	result is set to:
Set	10 A	A
Add	20 A B	A + B
Subtract	30 A B	A - B
Multiply	40 A B	A x B
Divide	50 A B	A / B
Remainder	51 A B	Remainder of (A / B); negative if A was negative
Modulus	60 A B	A mod B; negative if B was negative
Exponent	70 A B	A <sup>B</sup>
Square root	80 A	Square root of A, rounded down
Min	90 A B	Smaller of A and B
Max	91 A B	Larger of A and B

### PIN CONFIGURATION

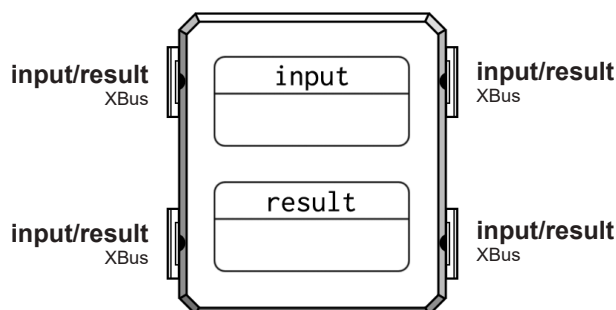

### PRICING

The price can be obtained with samples purchased for MC6000 microprocessors. Please contact us today to discuss pricing. We will be happy to assist you.

*This part is for prototyping ONLY!  
- Carl*

Register	Purpose
input	Holds operations and values until a complete <b>command sequence</b> has been sent.
result	Holds the result of the last executed command. The value is limited to the range -999 to 999.

## D80C010-F

### /// KEY FEATURES

- Stores a unique identification value that can be read over industry-standard XBus
- Hardened against reverse engineering, radiation, and electromagnetic pulse (EMP) weapons
- Temperature range of -40°C to +95°C, supporting usage in a wide range of environments

### /// PIN DIAGRAM

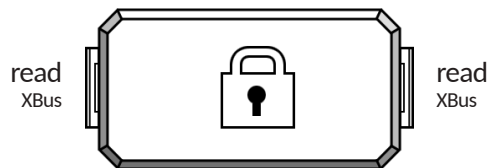

### /// CEO'S NOTE

## SECURITY FOR TODAY'S WORLD

Dear Fellow Engineer,

In today's world, the only guarantee is that there are no guarantees. Uncertainty is the norm and the potential for conflict, or even chaos, lurks around every corner. In this world of multiple and difficult to predict threat vectors, how can assets and secret information be protected? Decisive Pty's comprehensive D80 family of security solutions provides the answer.

The D80 family is designed for the needs of today's security industry, where secret and sensitive information must often interoperate with outside data— without compromising the security boundary. At Decisive, we engineer security from the ground up, starting with tamper-resistant enclosures for all of our components. Our multi-layered proprietary authentication protocol, built with formally-verified methods, ensures an inviolable separation between trusted and untrusted environments. And, with active intrusion detection built into the lowest level of our architecture, your cybersecurity team can be notified immediately as soon as a potential threat is encountered. When implemented correctly across all of your devices, the D80 family keeps the good guys in and the bad guys out.

With top engineered solutions and rigorous quality control, you can count on Decisive to add the security you need for the projects that need it most— we guarantee it!

**Ronan R. Dornan**  
Chief Executive Officer

## ABOUT KU-JI

KU-JI was founded in 1992 by Shushin Yukawa. We create a variety of electronic devices. In addition to world-leading accelerometers and gyroscopes, our company has pioneered the miniaturization of divination and other spiritual techniques using easily integrated microelectromechanical systems. This new kind of "spiritual computation," or "spiritation," combines ancient learning with modern manufacturing and engineering, and promotes understanding of the true nature of reality.

## EK1 "ORACLE ENGINE"

Since time immemorial, the divination method known as I Ching has provided guidance, wisdom, and insight to practitioners and laypeople alike. However, the traditional method using yarrow stalks is not commonly performed today and people who wish to receive the insights of the I Ching use later-developed methods such as tossing coins or even use programs based on the common random number generator (RNG) of modern computer systems.

Pained by this situation, our founder Shushin Yukawa has developed the EK1 which painstakingly recreates the traditional yarrow stalk I Ching divination method in miniature with advanced MEMS technology.

- Includes built-in piezoelectric generator that converts a user's mechanical energy into electrical energy to conduct the divination process.
- Generates an I Ching hexagram represented as a stream of 6 digital values over 6 time units, starting with the lowermost line. A value of 100 corresponds to a solid line and a value of 0 corresponds to a broken line.
- Contains 50 microscopic precision-milled Achillea millefolium stalks to recreate the oldest and truest method of hexagram generation.

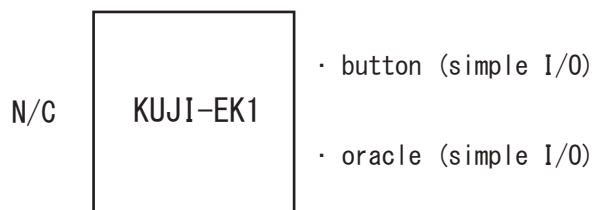

Other "Spiritation" Products by KU-JI GK LTD:

KUJI-TU1 Palmistry  
 KUJI-SS1 "Four Pillars of Destiny"  
 KUJI-AS1 Western Astrology  
 KUJI-SH1 Onomancy  
 KUJI-FS1 Feng Shui

Product demonstrations are available at KU-JI headquarters in Yamagata City, Yamagata Prefecture, Japan. Please contact us via e-mail to schedule an appointment.

# 崇信电子有限公司

## PGA33X6

有时我们会遇到不能用常规部件或者正常手段解决的情况，出于这种缘由，我们开发了PGA33X6，它拥有一个灵活而强大的逻辑结构，能够提升任何装置的运行能力。

亮点：

- (3) 简易的带缓冲输入引脚
  - (3) 简易的带缓冲输出引脚
  - (6) 过渡区乘法纵列
  - (1) 具备反馈以及直接输出能力的设置/重置触发器
- 
- 已用一个“积之和”的通断配置组织，以便任意地将输入映射至输出
  - 能够替换上百个分立的逻辑门
  - 不适宜用于低功耗应用

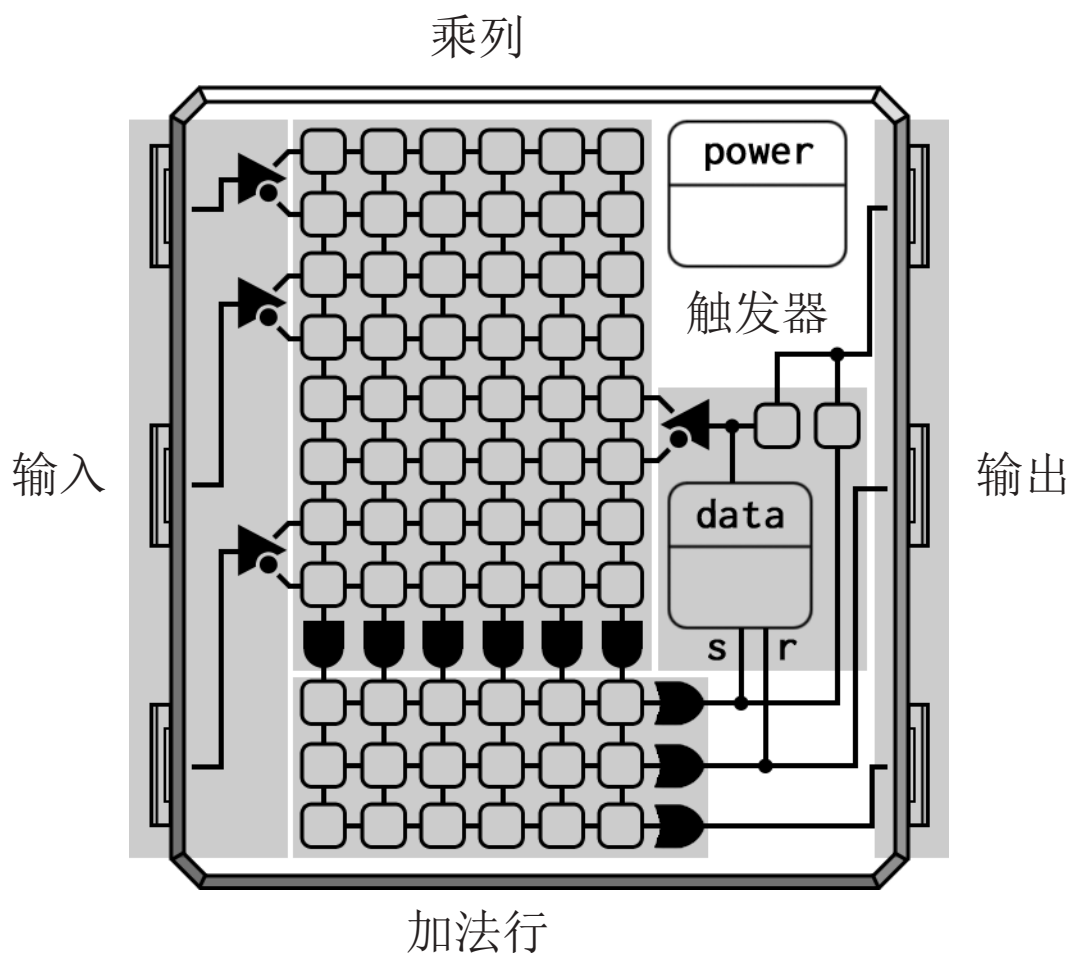



## Recognize Words Quickly And Easily With Raven Dynamics!

Natural language control is a critical part of any modern interface, yet cost and complexity of implementation has slowed its adoption in low-power embedded environments. Raven Dynamics is about to change this state of affairs with solutions based on its newly developed NEME Slice™ technology. By pre-encoding words and phrases as sets of small “slices” which are then associated with a hashed key, NEME Slice™ can positively identify a dictionary’s worth of spoken content with an over 92% accuracy rate.

The **Raven Dynamics NLP2** is the first widely available implementation of NEME Slice™ technology. NLP2 references an extensive built-in English language index that was created in partnership with top linguists, computer scientists, and product design experts. With its built-in microphone and audio pass-through feature, NLP2 will easily fit into your existing designs to add voice control to even the simplest device.

### NLP2 Key Features:

- Built-in support for the English language with mapping to a predefined keyword set.
- Captures audio using built-in binaural microphones and processes spoken keywords as they are detected in the audio stream.
- Keywords are reported over XBus as pairs of 3-digit values and are buffered through an internal non-blocking buffer that yields a value of -999 when attempting to read when no data is available.
- Raw audio pass-through is available in addition to the keyword stream.

271 390	RAVEN
109 874	DYNAMICS

*Figure 1. Words and phrases are hashed into a six-digit number. In this example, the words “Raven” and “Dynamics” are displayed, along with their hashed equivalents.*

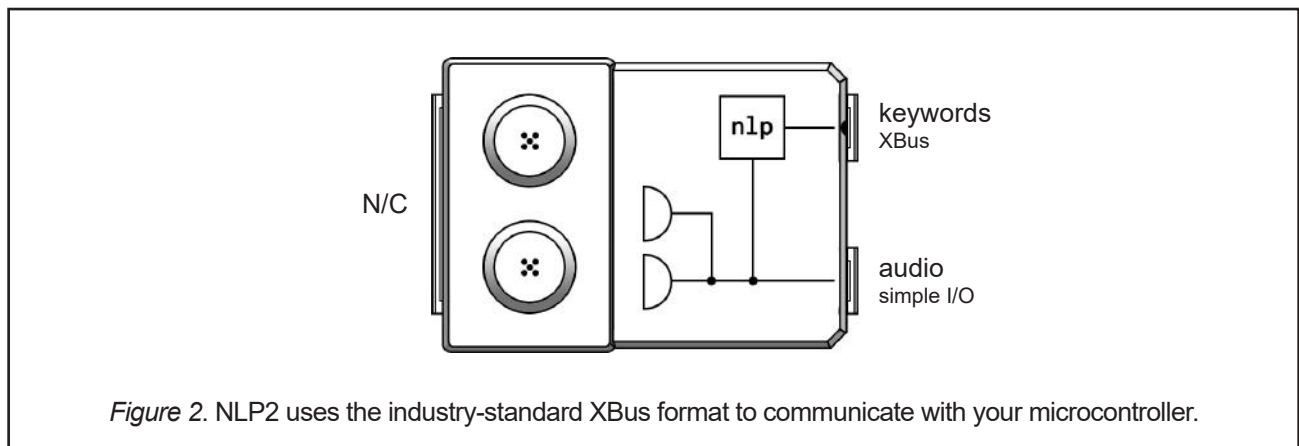

Replace this page with the "Supplemental Data" section divider.

# Incredible Sound at a Breakthrough Price.

Sounds Impossible?

Nah... Sounds Like  
*Harmonic Maximization.*

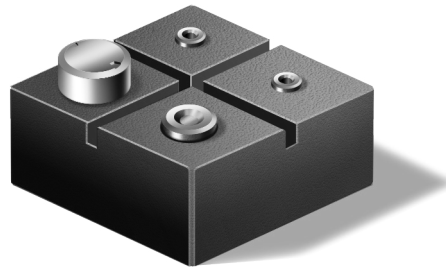

At the Sunnyvale Institute for Audio Engineering, we have done decades of advanced audio research. But even we know that a truly breakthrough audio device only comes around once in a generation. So it was with no small amount of trepidation when our scientists in the lab introduced us to something they'd been working on for the last few years. Would this be just another piece of "audio gear" destined to gather dust on the shelves of your local electronics store?

Our minds changed once we took a listen. Everything sounded more alive, more present, more real to us than anything we'd heard before. Whereas before the harmonies would float through the air listlessly towards our ears, with this technology the sound was heightened, improved... *maximized.*

The propellerheads in back won't like that we're showing it to you, but go on— have a peek at the proprietary Harmonic Maximization formula:

$$\text{AUDIO\_OUT} = (\text{AUDIO\_IN} - 50) \times 4 + 50$$

"Yes, but what does all that mumbo-jumbo mean?" you might ask. It may be Greek to you and me, but don't worry— what it means for us is crisp highs and booming lows, all in perfect balance. As for all that math, well, we'll just have to trust that our world-class acoustics engineers know what to do with it! And it's a good thing we do, because they've taken that little algorithm and miniaturized it into an ingenious little device you can plug into *any* audio source.

**The Sunnyvale Institute for Audio Engineering**  
*Changing the Way You Hear, from Ear to Ear™*

**POSEIDON-779 // THORIUM MINING UNIT  
 ACTUATOR CONTROL SUBSYSTEM  
 2A27 GEOMETRIC SPECIFICATIONS**

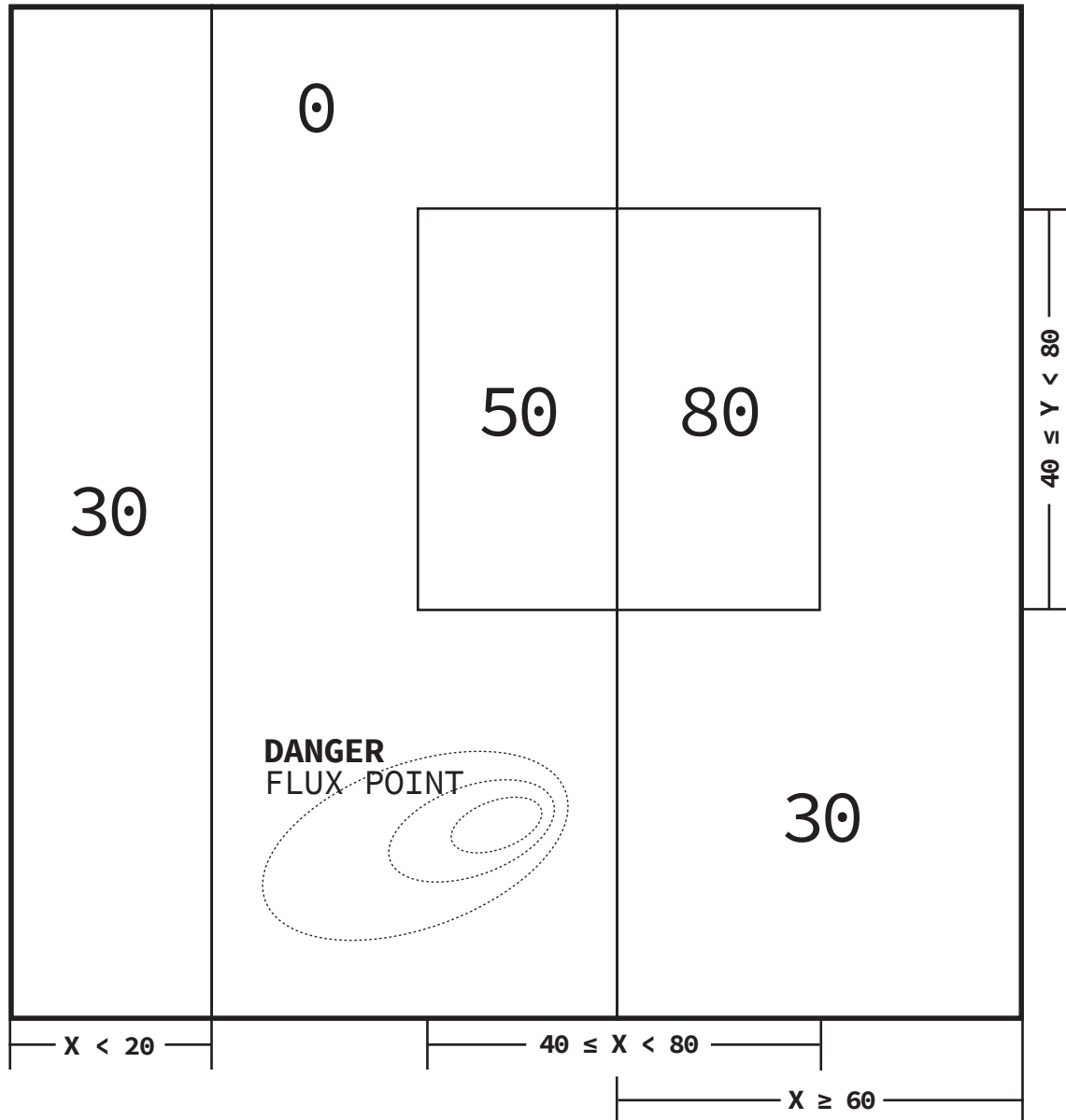

**UNDERSTAND:** This is a geometric visualization of a state space. The 2A27 actuator control must take a value as shown in specifications dependent on inputs as described.

**UNDERSTAND:** The 0 value area in the middle is required so that the actuator avoids the flux point.

**ACT:** Create a device that maps given coordinates to the corresponding power value as specified in this geometric visualization.

# Welcome to DarkLord555's Creepy Sound Effects Page

This page was designed for Internet Explorer 3.0 or better  
You are the 1792th visitor to this page

=====

You have found yourself in a dark wood...

In a huge forest with no beginning or end...

## What is that noise??

Before you know it, the darkness has taken you...!!!

=====

These sound effects were recorded and modified by me, [DarkLord555](#). They are free to use. You can use these sound effects to scare your little sister or whatever else, I don't care:

### Sinister Giggle ([giggle.wav](#)):

100	80	41	14	14	41	69	74	54	27	19	40	75
-----	----	----	----	----	----	----	----	----	----	----	----	----

### Unsettling Laugh ([laugh.wav](#)):

20	76	11	30	17	27	48	81	29	74	24	19
----	----	----	----	----	----	----	----	----	----	----	----

### Blood-Curdling Cry ([cry.wav](#)):

16	36	42	14	10	58	100	76	26	28	70	80	42
----	----	----	----	----	----	-----	----	----	----	----	----	----

### Startling Crash ([crash.wav](#)):

39	44	95	67	17	38	39	24	30
----	----	----	----	----	----	----	----	----



### Creepy Singing, *Ring Around the Rosie* ([ring.wav](#)):

90	33	86	64	97	98	87	32	13	45	36	50	80
----	----	----	----	----	----	----	----	----	----	----	----	----

# PP-221

## CARBINE TARGET ILLUMINATOR

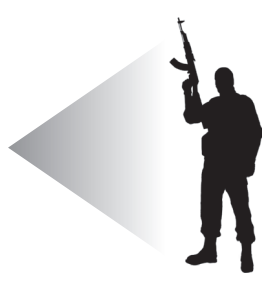
Don't let your operators get caught fiddling with rangefinder settings at the wrong moment. Today's aiming devices for individual carbine weapons often feature complex illuminators with multiple switches and dials, which can be difficult to operate in the dark, or worse— during an engagement. The PP-221 eliminates these issues by automatically snapping to three predefined settings optimized for common engagement distances.

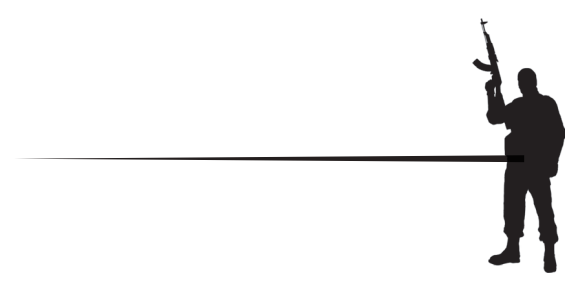
Radar Range	Diagram	Laser	20° Flood	60° Flood
1-2 time units		0%	---	On
3-4 time units		50%	On	---
5-6 time units		100%	---	---

**Short range mode.** For close-quarters situations and room-to-room engagements, short range mode sets the flood light to a wide diffusion to illuminate the largest possible area without wasting power on an aiming laser.

**Mid range mode.** For use in a wide variety of urban environments, the flood light is adjusted to a narrower cone in order to project illumination towards the target area, while the laser point enables precise aiming.

**Long range mode.** The highest-power laser point with the lowest divergence used for outdoor situations or in situations with excessive non-natural ambient illumination.

# The Assembled Meat Primer

## Sample Specifications

Now that you have your meat assembler up and running, it's time to put the device through its paces! You'll find, as many have, that assembled meat isn't just a convenient, cost-effective solution for a commercial dining facility— it can also be a versatile culinary tool in the hands of an experienced operator. Use the meat patterns below to get started with some familiar servings. Don't be afraid to experiment, however!

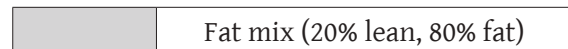

### CUTLET-STYLE MEAT

A traditional cutlet of meat with fat around the edges that will crisp nicely when broiled.

Valve	First						Last
valve-0							
valve-1							
valve-2							

#### Nutrition Facts

Serving size: 100 grams  
 Calories 217  
 Fat (g) 16  
 Carbs (g) 0  
 Protein (g) 19

### STEAK-STYLE MEAT

This lean “steak” was inspired by the fine marbling that can be found in high-grade beef.

Valve	First						Last
valve-0							
valve-1							
valve-2							

#### Nutrition Facts

Serving size: 100 grams  
 Calories 176  
 Fat (g) 4  
 Carbs (g) 0  
 Protein (g) 34

### BACON-STYLE MEAT

Rashers of good streaky bacon are never far when you have this pattern queued up!

Valve	First						Last
valve-0							
valve-1							
valve-2							

#### Nutrition Facts

Serving size: 100 grams  
 Calories 227  
 Fat (g) 18  
 Carbs (g) 0  
 Protein (g) 16

Hey there! I've picked out some keywords for the biggest shows currently on television. Xiaomei had some ideas too, so between the two of us I'm sure we've come up with a pretty comprehensive list. Of course, you can just start with "Get the Throne" for the first product. Thanks for all your hard work!

— David 戴维

## David & Xiaomei's List of Spoiler-Related Keywords

### TRUTH INVESTIGATORS | 盘根究底

102 113 MURDER  
325 475 BASEMENT  
526 367 TENNIS RACKET  
520 817 BIRTHDAY  
352 559 MOTHER-IN-LAW  
815 628 MUSHROOM BURGER

### GET THE THRONE | 权力的战争

711 573 EMPEROR  
495 160 CENTURIONS  
575 645 POISON MASTER  
712 917 MIDWIFE  
356 361 DWARF REBELLION  
138 420 SHADOW ZONE

### MEMORIES OF TOMORROW | 明日记忆

238 458 PODCAST  
902 197 BOYFRIEND  
814 228 TROLLEY BUS  
944 156 SHRUB  
873 873 AQUARIUM  
821 345 COLLECTOR'S EDITION

### MY ROOMMATE IS A LAMIA | 我的室友是蛇精

870 707 LAMIA  
901 711 SUCCUBUS  
832 502 BASS GUITAR  
599 884 SEAT BELT  
410 266 TISSUE PAPER  
877 876 DENTAL INSURANCE



### Wavelength-Based Colour Classification

Light Colour	Light Wavelength	Min Value	Max Value	SmartDye Colour
Red	620nm - 750nm	20	39	.blood
Orange	590nm - 620nm	40	49	Deep Nacho
Yellow	570nm - 590nm	50	59	Chartreuse Abuse
Green	495nm - 570nm	60	69	Ballistic Viridian
Blue	450nm - 495nm	70	79	Cool Dad®
Violet	380nm - 450nm	80	89	HyPURPLE

### iNK SmartDye™ Colour Space

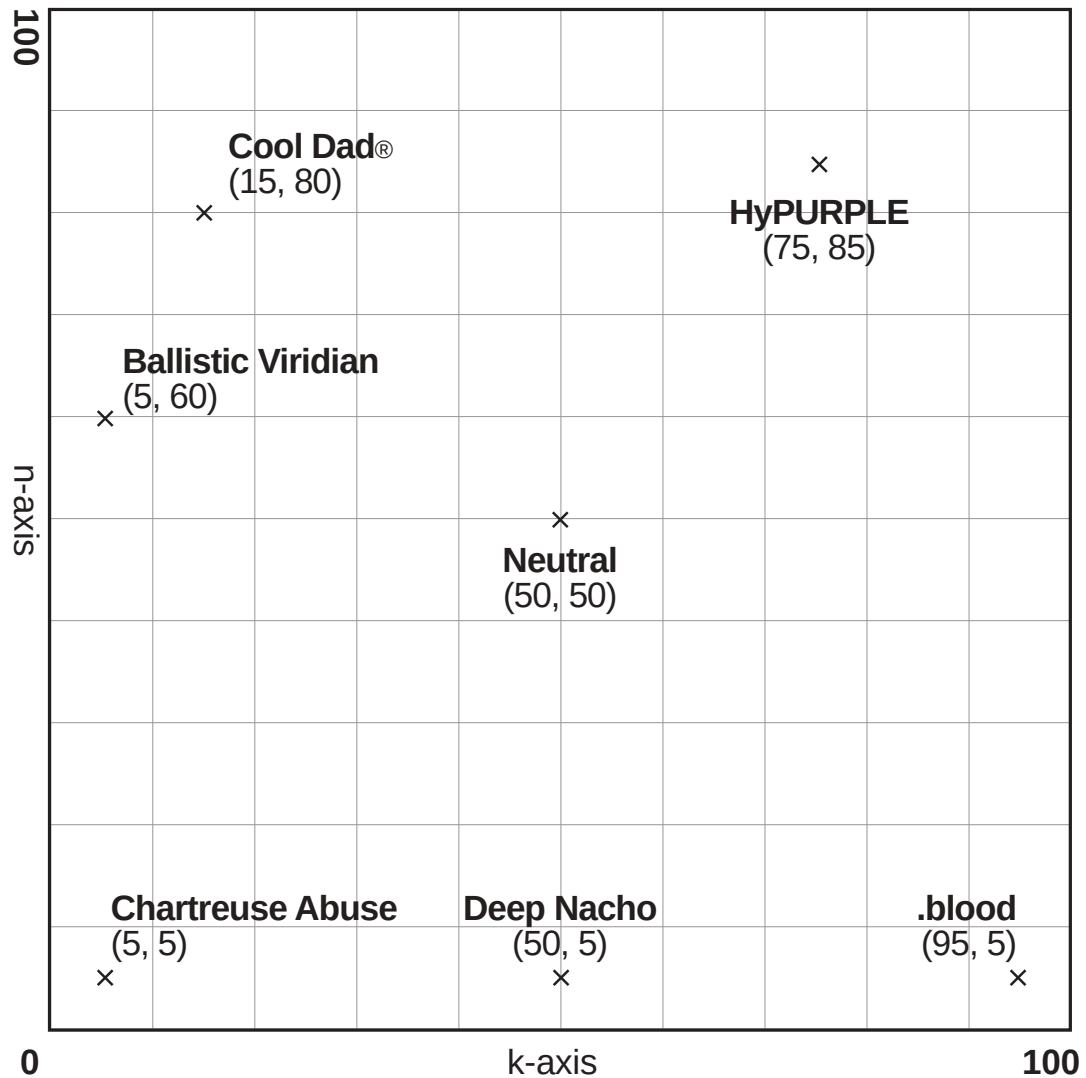

## Making the Most of a Few Simple Ingredients

It is a given that the elegant bachelor will have a wet bar for entertaining friends or that very special guest. But stocking all of the various liquors needed to fully equip a bar can be quite expensive, a cost that would easily run into the thousands of dollars. Fortunately, the science of mixology has shown us that a respectable variety of drinks can be made with a few key ingredients: vodka, gin, and dry vermouth in the alcohol department, and sweetened lemon, lime, and cranberry for the mixes.

With just these six components, a number of classic cocktails are eminently possible for the elegant bachelor to serve to his evening company. Here we present them, along with sample talking points.

### VODKA SHOT

*"This is sure to get the party started."*

- 1.5 oz. vodka

### LEMON DROP

*"When life hands you lemons, make Lemon Drops, is what I always say."*

- 3 oz vodka
- 1 oz. lemon mix

### COSMOPOLITAN

*"Now here's a sophisticated drink for a discerning [gentleman or lady]."*

- 2 oz. vodka
- 1 oz. lime mix
- 1 oz. cranberry mix

### CAPE COD

*"Did you know that cranberries used to be called craneberries? It's true."*

- 2 oz. vodka
- 2 oz. cranberry mix

### VODKA MARTINI

*"Here's an ingenious variation on the classic martini."*

- 3 oz. vodka
- 1 oz. dry vermouth

### GIMLET

*"The perfect cocktail for a fine evening with good company."*

- 3 oz. gin
- 1 oz. lime mix

### GIN MARTINI

*"The martini is one of those drinks that has simply never gone out of style."*

- 3 oz. gin
- 1 oz. dry vermouth

**Figure 7G: Sector Map**

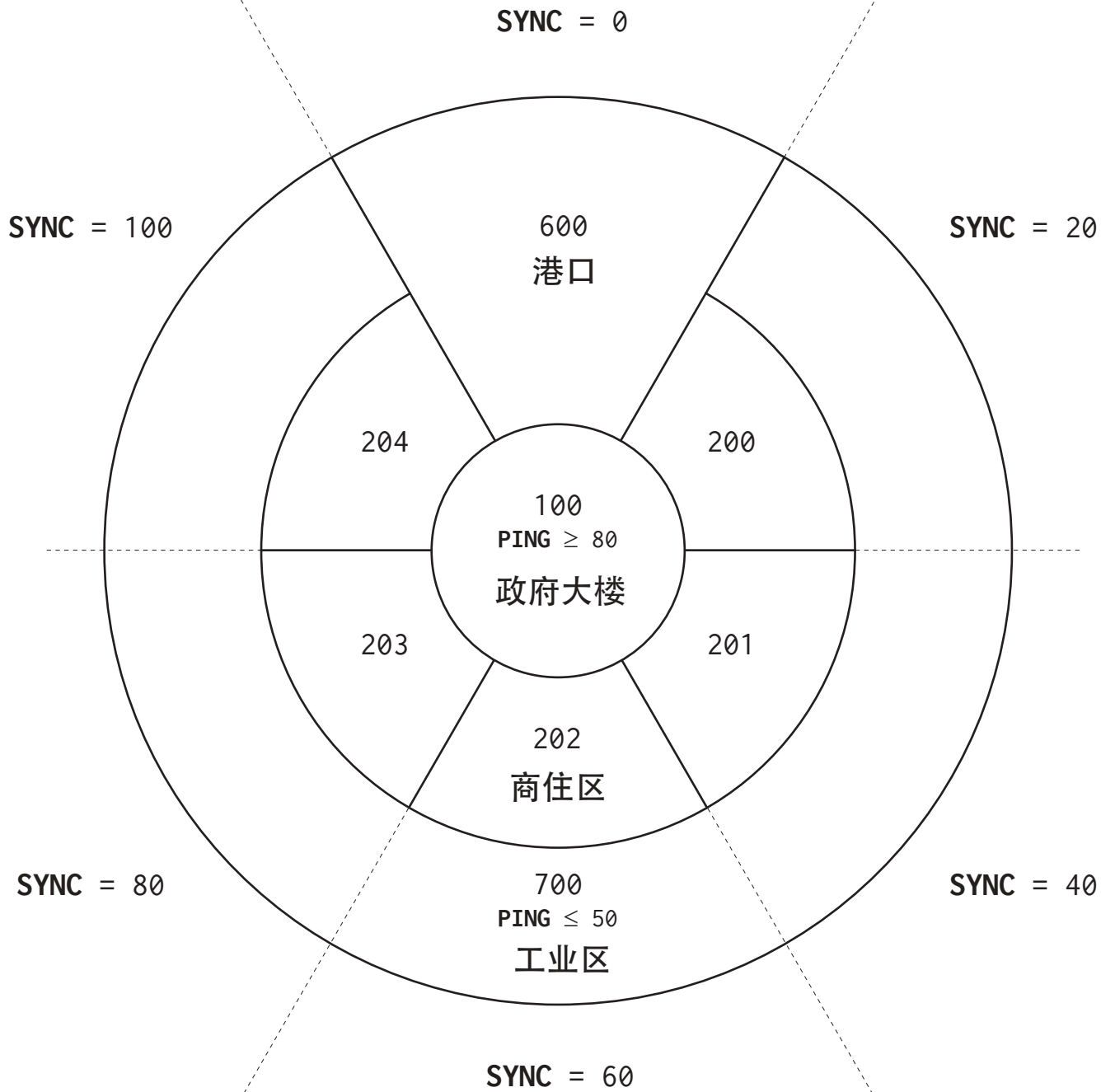

AWH	W DEPTH		CONFIGURATION
AVG	ANCR		MOTION AMPLITUDE

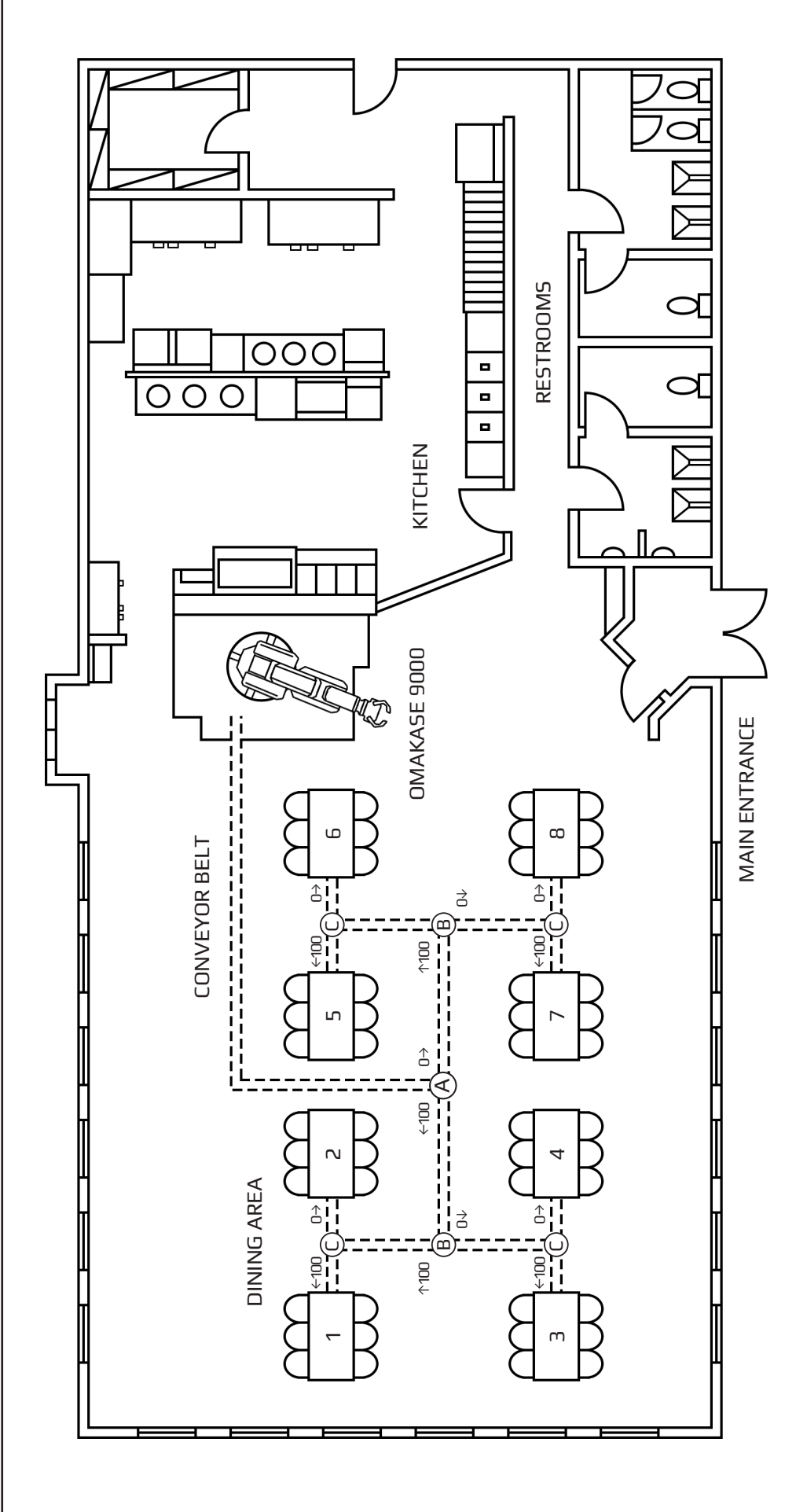

PROJECT:  
**SUSHIROBO**  
 RESTAURANT / KITCHEN  
 PRELIMINARY DESIGN  
 STUDIO COMPLEX, BUILDING 8

DESIGN BY:  
 SEKOVA  
 ENGINEERING BY:  
 INFRASTRUCTURE UNIT 2



# LuX Industry Custom LCD Spec (Revision 3)



1. Place the design you want in the marked area below.
2. Mark regions CLEARLY with whole numbers 1-998.
3. Questions? Call Chuck.

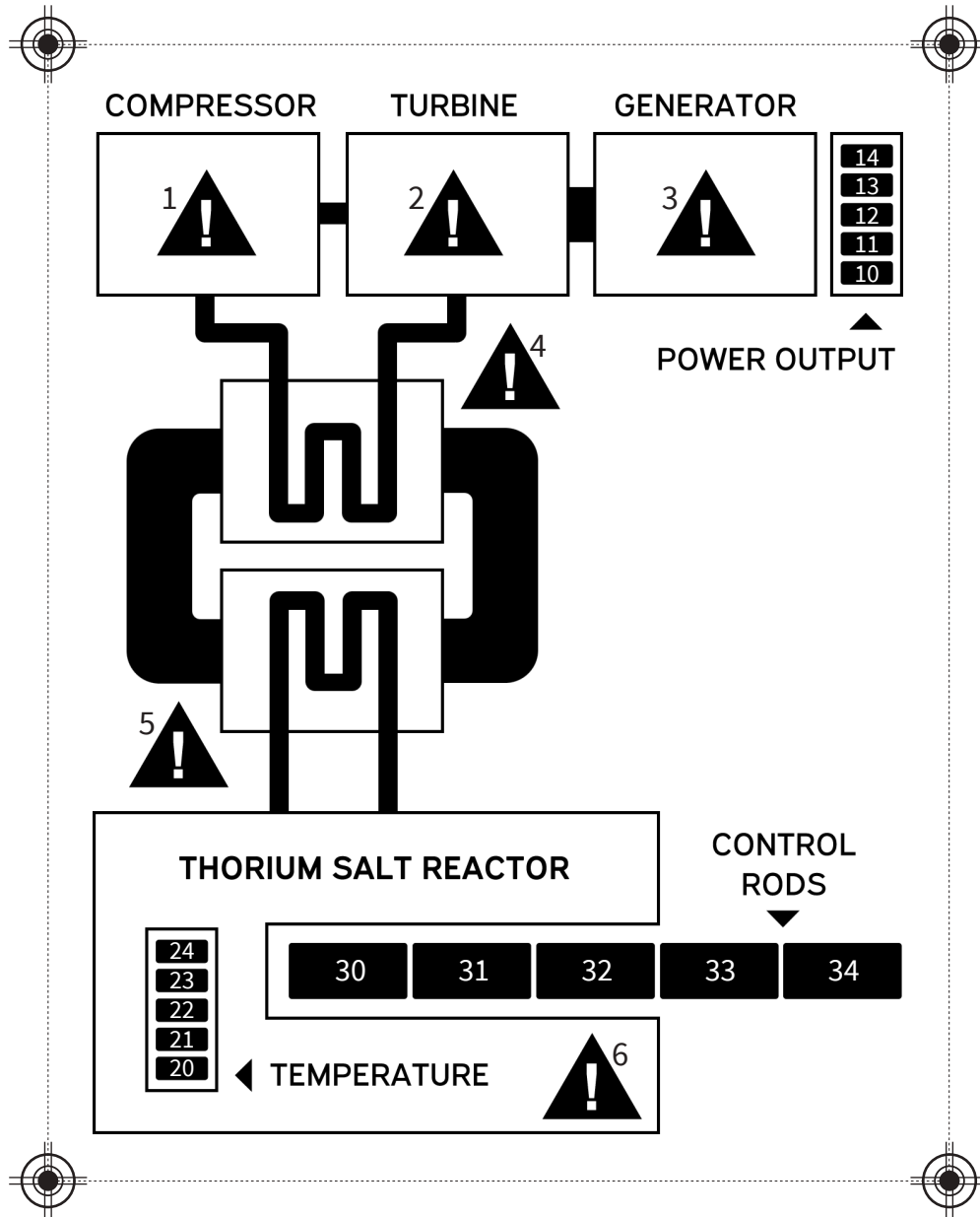

Notes:

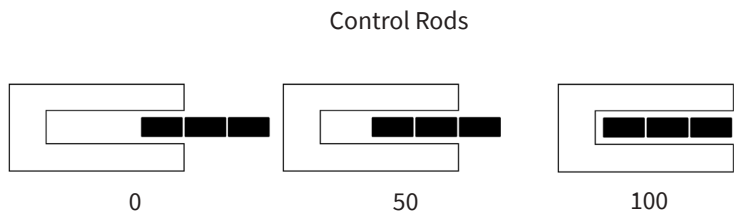
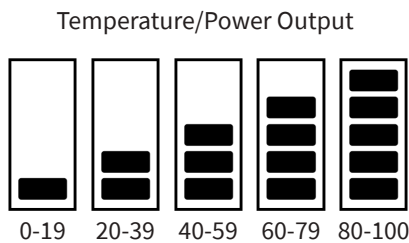

# Mass Production of a Neural Processing Lattice

Suemura, L.<sup>1</sup>, Zhao, F.<sup>1</sup>, Grinnell, G.<sup>1</sup>, Farzan, K.<sup>2</sup>, Webb, C.<sup>2</sup>

<sup>1</sup>Biological Research Group <sup>2</sup>Neuroscience Research Group

There has been considerable interest in creating lattice-like structures to facilitate the growth of cells of various types in highly ordered configurations.<sup>[1]</sup> In particular, one exciting potential use of such a structure would be to harness the computational power of neurons. In this paper, we present a method for quickly and inexpensively creating lattices suitable for neuron growth by depositing layers of substrate in predefined patterns. Mass-produced lattices could have considerable utility in computational neuroscience and beyond.<sup>[2][3]</sup>

## Template-Based Layering

0	–	–	–	–	–	–
1	α	α	α	α	α	α
2	β	β	β	β	β	β
3	α	β	α	β	α	β
4	ψ	α	α	ψ	α	ψ
5	–	α	α	–	α	–
6	ψ	–	–	ψ	–	ψ
7	–	α	–	–	–	–
8	–	–	–	–	β	–

Fig. 1: The master scaffold layer templates.

Our approach centers around the use of three main substrates: α-MSH, β-P2, and ψ(HG). These substrates are indexed for easy translation into “sheets” of patterns of 6 cells each [Fig 1]. Because of the modularity of the substrate, a surprisingly small number of predefined patterns can be used to create a wide range of possible substrate designs, making them well-suited to both research and commercial applications. Quality tests indicate that the resulting substrates are comparable to those created by previously described methods.<sup>[4][5]</sup>

<b>Pattern: 1, 4, 6, 6, 0, 0</b>	<b>Pattern: 2, 1, 2, 4, 7, 7</b>
– – – – – –	– α – – – –
– – – – – –	– α – – – –
ψ – – ψ – ψ	ψ α α ψ α ψ
ψ – – ψ – ψ	β β β β β β
ψ α α ψ α ψ	α α α α α α
α α α α α α	β β β β β β

Fig. 2: Example patterns and resulting substrates from the lattice “printer.”

The cell-based “printer” assembles scaffolds in 6 x 6 chunks, from bottom to top [Fig 2]. By using the printer to create patterns up to 6 layers deep, scaffolds can be assembled and then delivered to the culture lab for neuron growth.

Replace this page with the "Engineering Notes" section divider.