

STANDARD STRIKER[®] (SKR-STD) TRACKED STRIKER (SKR-TRK) USER MANUAL

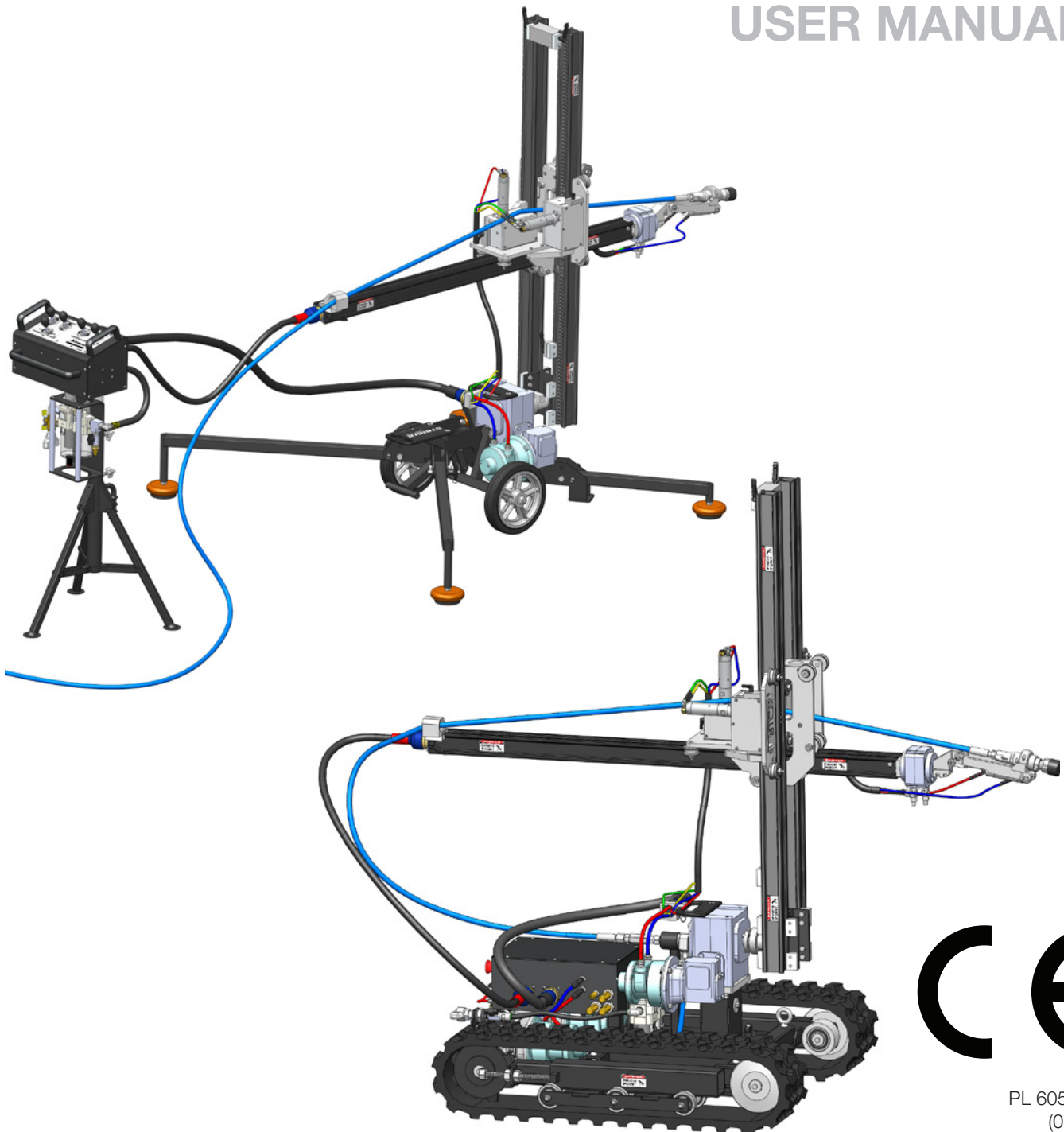

TABLE OF CONTENTS

MANUFACTURER'S INFORMATION 4

STANDARD STRIKER® (SKR-STD) SPECIFICATIONS.....	4
STANDARD STRIKER® (SKR-STD) DESCRIPTION OF EQUIPMENT AND INTENDED USE.....	4
STANDARD STRIKER® (SKR-STD) KEY FEATURES.....	4
TRACKED STRIKER® (SKR-TRK) SPECIFICATIONS.....	5
TRACKED STRIKER® (SKR-TRK) DESCRIPTION OF EQUIPMENT AND INTENDED USE.....	5
TRACKED STRIKER® (SKR-TRK) KEY FEATURES.....	5
CE DECLARATION OF INCORPORATION STANDARD STRIKER® (SKR-STD)....	6
CE DECLARATION OF INCORPORATION STANDARD STRIKER® (SKR-TRK)....	7

WARNING AND SAFETY INSTRUCTIONS 8

OPERATOR TRAINING.....	8
PERSONAL PROTECTIVE EQUIPMENT REQUIREMENTS.....	8
SAFETY LABEL DEFINITIONS.....	8
PRE-RUN SAFETY CHECK.....	9

STRIKER® (SKR-STD) SYSTEM ASSEMBLY - OVERVIEW 10

STRIKER (SKR-STD) AND CONTROL BOX.....	10
--	----

STRIKER® (SKR-STD) WITH CART- ASSEMBLY 11

POSITIONING AND RELOCATING THE STRIKER (SKR-STD).....	11
SWITCHING OUTRIGGER TO DOWNRIGGER LEG ASSEMBLIES.....	12
INSTALLING THE HORIZONTAL RAIL TO WRIST.....	13
RAIL AND CARRIAGE STOPS.....	14
BCK-20 BARRACUDA AND HIGH-PRESSURE HOSE.....	15
WRIST SPEED AND RESISTANCE ADJUSTMENTS.....	16

STRIKER® (CB-SKR) CONTROL BOX - OVERVIEW 17

CONTROL BOX ASSEMBLY.....	18
CONTROL BOX AIR SUPPLY FITTING AND FOOT PEDAL DUMP.....	19
CONTROL BOX TO STRIKER® (SKR-STD) ASSEMBLY CONNECTION.....	20

STRIKER® (SKR-STD) OPERATION..... 21

CONTROL BOX, TEST RUN, AND RUN PROCEDURES.....	21
--	----

STRIKER® (SKR-STD) MAINTENANCE 22

STRIKER® (SKR-STD) STORAGE, TRANSPORTATION, AND HANDLING 22

CONVERTING STANDARD TO TRACKED BASE	23
SWITCHING 20K AND 40K SWIVEL ASSEMBLIES	26
STRIKER® (SKR-TRK) SYSTEM ASSEMBLY - OVERVIEW	36
STRIKER® (SKR-TRK) WITH WIRELESS REMOTE CONTROLLER	36
STRIKER® (SKR-TRK) - ASSEMBLY	37
UNPACKING AND HORIZONTAL RAIL INSTALLATION	37
RAIL STOP INSTALLATION	38
HIGH-PRESSURE HOSE AND TOOL INSTALLATION	39
WRIST SPEED AND RESISTANCE ADJUSTMENTS	40
CONTROL LINE UMBILICAL CONNECTION	41
AIR AND WATER SUPPLY AND LUBRICATOR SETTING	42
TRACKED BASE ORIENTATIONS	43
CHANGING TRACKED STRIKER ORIENTATIONS	44
WIRELESS CONTROL BOX	45
WIRELESS REMOTE CONTROLLER ACTIVATION	45
WIRELESS REMOTE CONTROLLER OPERATION	46
ASSOCIATING WIRELESS REMOTE CONTROLLER TO RECEIVER UNIT	47
WIRELESS REMOTE CONTROLLER TETHERED CONNECTION	48
STRIKER® (SKR-TRK) OPERATION	48
TEST RUN PROCEDURES	48
SAFE AND DANGER ZONES	49
STRIKER® (SKR-TRK) MAINTENANCE	50
STRIKER® (SKR-TRK) STORAGE, TRANSPORTATION, AND HANDLING	50
STRIKER® (SKR-TRK) TROUBLESHOOTING	51
STRIKER® (SKR-STD) AND (SKR-TRK) PARTS DIAGRAMS	52
TERMS AND CONDITIONS	70

MANUFACTURER'S INFORMATION

StoneAge Inc.
466 S. Skylane Drive
Durango, CO 81303, USA
Phone: 970-259-2869
Toll Free: 866-795-1586
www.stoneagetools.com

StoneAge Europe
Unit 2, Britannia Business Centre
Britannia Way
Malvern WR14 1GZ
United Kingdom
Phone: +44 (0) 1684 892065

STRIKER® SKR-STD AND CB-SKR CONTROL BOX SYSTEM

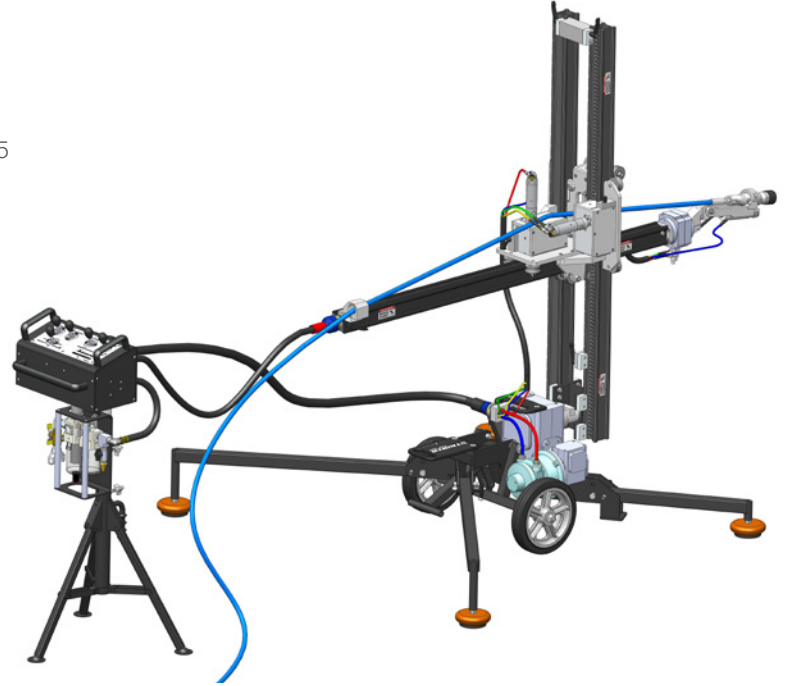

This manual must be used in accordance with all applicable national laws. The manual shall be regarded as a part of the machine and shall be kept for reference until the final dismantling of the machine, as defined by applicable national law(s).

Updated manuals can be downloaded at:
<https://www.stoneagetools.com/manuals>

STANDARD STRIKER® SPECIFICATIONS	IMPERIAL SYSTEM	METRIC SYSTEM
Weight	260 pounds	118 kilograms
Control Box Weight (includes Control Box, FRL and Stand)	43 pounds	19.5 kilograms
Product Size / Footprint Extended	63 in Wide x 55 in Long x 66 in High	1600 mm Wide x 1397 mm Long x 1676 mm High
Product Size / Footprint Collapsed	25 in Wide x 31 in Long x 66 in High	635 mm Wide x 787 mm Long x 1676 mm High
Cleaning Window	84 in Wide x 54 in Long x 60 in High	2134 mm Wide x 1372 mm Long x 1524 mm High
Maximum Air Supply Pressure	125 PSI	0.86 MPa
Maximum Air Consumption	100 CFM at 100 PSI	2.8 Meters ³ /Minute at 0.70 MPa
System Air Operating Pressure	80 PSI min, 100 PSI max	0.55 Mpa min, 0.70 Mpa max
Recommended Operational Temperature Range	-20 °F to 140 °F	-29 °C to 60 °C
Recommended Operational Relative Humidity Range	15 % RH to 100 % RH	15 % RH to 100 % RH
Reaction Force	Up to 70 pounds	Up to 32 KG

DESCRIPTION OF EQUIPMENT AND INTENDED USE

STANDARD STRIKER® AND CONTROL BOX

The powerful and responsive STRIKER® (SKR-STD) combines a rotary shotgun arm and positioning system for precise remote shotgunning in tough to reach locations.

KEY FEATURES:

STANDARD STRIKER® (SKR-STD)

- Modular system designed for portability and easy assembly
- Lightweight components for single operator setup and use
- Wheeled base for easy maneuverability
- Fully pneumatic
- Portable control box allows cleaning visibility.
- Affordable alternative to complicated robotic systems

STANDARD CONTROL BOX (CB-SKR)

- Small, lightweight, ergonomic design that includes a Portable stand and filter-regulator-lubricator assembly
- Body controls: In/Out, Up/Down, and Rotation
- Wrist controls: Rotation and Flex
- OPTIONAL Pneumatic Foot Pedal Dump Control for the non-wireless control box.

**TRACKED STRIKER® SKR-TRK AND
WIRELESS REMOTE CONTROL SYSTEM**

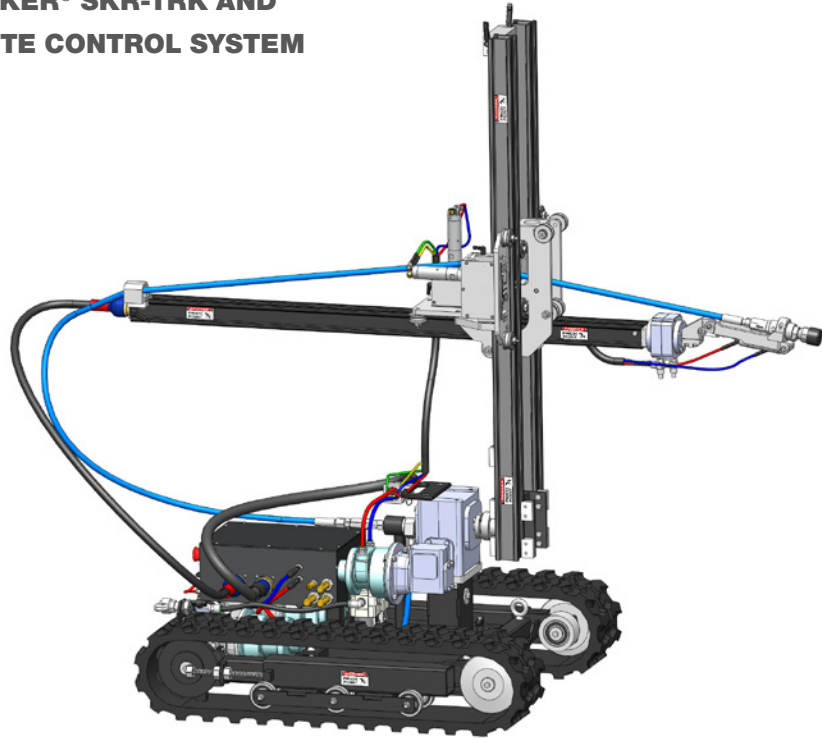

TRACKED STRIKER® SPECIFICATIONS	IMPERIAL SYSTEM	METRIC SYSTEM
Weight	570 pounds	259 kilograms
Wireless Remote Control Weight	4.5 pounds	2 kilograms
Product Size / Footprint	34.5 in Wide x 44 in Long x 66 in High	876 mm Wide x 1118 mm Long x 1676 mm High
Cleaning Window	84 in Wide x Unlimited Long x 66 in High	2134 mm Wide x Unlimited Long x 1676 mm High
Maximum Air Supply Pressure	125 PSI	0.86 MPa
Maximum Air Consumption	120 CFM at 100 PSI	3.4 Meters ³ /Minute at 0.70 MPa
System Air Operating Pressure	80 PSI min, 100 PSI max	0.55 Mpa min, 0.70 Mpa max
Recommended Operational Temperature Range	-20 °F to 140 °F	-29 °C to 60 °C
Recommended Operational Relative Humidity Range	15 % RH to 100 % RH	15 % RH to 100 % RH
Reaction Force	Up to 100 pounds	Up to 45 KG

DESCRIPTION OF EQUIPMENT AND INTENDED USE

TRACKED STRIKER® AND WIRELESS CONTROLLER

The TRACKED STRIKER® (SKR-TRK) is an automated shotgunning tool, mounted to a rubber tracked base, wireless controlled, for blast pad work on structure walkways and platforms, inside tanks and boilers.

KEY FEATURES:

TRACKED STRIKER® (SKR-TRK)

- Pneumatic powered track base and articulation for easy maneuverability
- Optional 20,000 or 40,000 PSI Swivel
- Capable of handling jet reaction force up to 100 pounds
- Can be easily and rapidly disassembled for transportation or installation inside vessels.

WIRELESS REMOTE CONTROL

- Wireless remote controller allows increased mobility.
- Body controls: In/Out, Up/Down, and Rotation
- Wrist controls: Rotation and Flex

EU DECLARATION OF CONFORMITY

Manufacturer: StoneAge Incorporated
466 South Skylane Drive
Durango, CO 81303
USA

Authorized Representative: StoneAge Europe
Unit 2, Britannia Business Centre
Britannia Way
Malvern WR14 1GZ
United Kingdom
Steve Ellis, Director StoneAge Europe

Declare that: **STRIKER® (SKR-STD) Standard Base Assembly and Control Box (CB-SKR)**
for high pressure water cleaning of system parts.

Is compliant with the following Directives and Standards:

Directive 2006/42/EC (Machinery Directive)

EN ISO 12100:2010 (E) Safety of machinery – General principles for design – Risk assessment and risk reduction

The Technical File for STRIKER® (SKR-STD) Standard Base Assembly and Control Box (CB-SKR) is maintained at: StoneAge Incorporated, 466 South Skylane Drive, Durango, CO 81303, USA and was compiled by the Engineering Manager. The Technical File is available through the Authorized Representative.

This Declaration of Conformity is issued under the exclusive responsibility of StoneAge Incorporated.

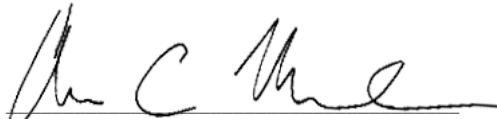

StoneAge Incorporated, Durango, CO, USA
Adam Markham, Engineering Manager, Robotics

02/11/2019
Date



EU DECLARATION OF CONFORMITY

Manufacturer: StoneAge Incorporated
466 South Skylane Drive
Durango, CO 81303
USA

Authorized Representative: StoneAge Europe
Unit 2, Britannia Business Centre
Britannia Way
Malvern WR14 1GZ
United Kingdom
Steve Ellis, Director StoneAge Europe

Declare that: **STRIKER[®] (SKR-TRK) Tracked Base Assembly and Wireless Controller
for high pressure water cleaning of system parts.**

Is compliant with the following Directives and Standards:

Directive 2006/42/EC (Machinery Directive)
EN ISO 12100:2010 (E) Safety of machinery – General principles for design – Risk assessment and risk reduction
ETSI EN 300 328 V1.9.1 (Article 3.2 of R&TTE Directive) - Base Unit
ETSI EN 300 328 V1.9.1 (Article 3.2 of R&TTE Directive) - Console Box
ETSI EN 301 489-1 V1.9.2 (2008-4) & ETSI EN 301 489-17 (Article 3.1(b) of R&TTE Directive) - Console Box

The Technical File for STRIKER[®] (SKR-TRK) Tracked Base Assembly and Wireless Controller is maintained at:
StoneAge Incorporated, 466 South Skylane Drive, Durango, CO 81303, USA and was compiled by the Engineering Manager.
The Technical File is available through the Authorized Representative.

This Declaration of Conformity is issued under the exclusive responsibility of StoneAge Incorporated.

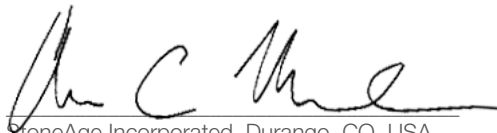

StoneAge Incorporated, Durango, CO, USA
Adam Markham, Engineering Manager, Robotics

02/11/2019
Date



WARNING AND SAFETY INSTRUCTIONS

OPERATOR TRAINING

Managers, Supervisors, and Operators MUST be trained in Health and Safety Awareness of High-pressure Water Jetting and hold a copy the Water Jetting Association (WJA) Code of Practice, or equivalent (see www.waterjetting.org.uk).

Operators MUST be trained to identify and understand all applicable standards for the equipment supplied. Operators should be trained in manual handling techniques to prevent bodily injury.

StoneAge has designed and manufactured this equipment considering all hazards associated with its operation. StoneAge assessed these risks and incorporated safety features in the design. StoneAge **WILL NOT** accept responsibility for the results of misuse.

IT IS THE RESPONSIBILITY OF THE INSTALLER/OPERATOR to conduct a job specific risk assessment prior to use. Job specific risk assessment MUST be repeated for each different set up, material, and location.

The risk assessment MUST conform to the Health and Safety at Work Act 1974 and other relevant Health and Safety legislation.

PERSONAL PROTECTIVE EQUIPMENT REQUIREMENTS

Use of Personal Protective Equipment (PPE) is dependent on the working pressure of water and the cleaning application. Managers, Supervisors, and Operators MUST carry out a job specific risk assessment to define the exact requirements for PPE. See Protective Equipment for Personnel (Section 6) of WJTA-IMCA's Recommended Practices For The Use Of High-pressure Water Jetting Equipment for additional information.

Hygiene - Operators are advised to wash thoroughly after all waterjetting operations to remove any waterblast residue which may contain traces of harmful substances.

First aid provision - users MUST be provided with suitable first aid facilities at the operation site.

SAFETY LABEL DEFINITIONS

The STRIKER® (SKR-STD) and TRACKED STRIKER® (SKR-TRK) have the potential to cause serious injury to fingers or hands if they become caught between the rollers or rotating connections.

The STRIKER® (SKR-STD) and TRACKED STRIKER® (SKR-TRK) have the potential to cause serious injury if fingers or hands become caught between the carriage and rails.



Operators MUST read, understand, and follow the Operational and Training Requirements (Section 7.0) of WJTA-IMCA's Recommended Practices For The Use Of High-pressure Water Jetting Equipment, or equivalent.

Operators MUST read, understand and follow the Warnings, Safety Information, Assembly, Installation, Connection, Operation, Transport, Handling, Storage, and Maintenance Instructions detailed in this manual.

The risk assessment MUST consider potential material or substance hazards including:

- Aerosols
- Biological and microbiological (viral or bacterial) agents
- Combustible materials
- Dusts
- Explosion
- Fibers
- Flammable substances
- Fluids
- Fumes
- Gases
- Mists
- Oxidizing Agents

PPE may include:

- **Eye protection:** Full face visor
- **Foot protection:** Kevlar® brand or steel toe capped, waterproof, non-slip safety boots
- **Hand protection:** Waterproof gloves
- **Ear protection:** Ear protection for a minimum of 85 dBA
- **Head protection:** Hard hat that accepts a full face visor and ear protection
- **Body protection:** Multi-layer waterproof clothing approved for water jetting
- **Hose protection:** Hose shroud
- **Respiratory protection:** May be required; refer to job specific risk assessment

The STRIKER® (SKR-STD) and TRACKED STRIKER® (SKR-TRK) have a maximum operating air pressure of 100 psi (0.7 MPa). Never exceed 125 psi (0.86 MPa) supply pressure. Exceeding 125 psi (0.86 MPa) supply pressure may result in injury to the Operator and/or damage to the equipment.

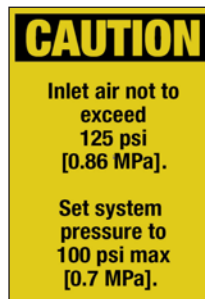

▲ WARNING

Operations with this equipment can be potentially hazardous. Caution MUST be exercised prior to and during machine and water jet tool use. Please read and follow all of these instructions, in addition to the guidelines in the WJTA Recommended Practices handbook, available online at www.wjta.org. Deviating from safety instructions and recommended practices can lead to severe injury and/or death.

- Do not exceed the maximum operating pressure specified for any component in a system.
- Inspect the equipment for visible signs of deterioration, damage, and improper assembly. Do not operate until repaired. Make sure all threaded connections are tight and free of leaks.
- The immediate work area MUST be marked off to keep out untrained persons.
- Users of the STRIKER® (SKR-STD) and TRACKED STRIKER® (SKR-TRK) MUST be trained and/or experienced in the use and application of high-pressure technology and cleaning, as well as all associated safety measures, according to the WJTA Recommended Practices for the use of High-pressure Water jetting Equipment.
- The Control Box should be located in a safe location where the Operator has good visibility of the placement of the tool. The STRIKER® (SKR-STD) and TRACKED STRIKER® (SKR-TRK) and Control Box MUST be supervised at all times and should never be left unattended.
- STAY BEHIND THE VERTICAL RAIL ASSEMBLY AND OUT OF THE SPRAY ZONE WHEN OPERATING THE STRIKER®. Failure to do so **will** result in death or serious injury..
- Always de-energize the system before servicing or replace any parts. Failure to do so can result in severe injury and/or death.
- When moving the STRIKER® (SKR-STD) lift with care to prevent bodily injury.

PRE-RUN SAFETY CHECK

Refer to WJTA-IMCA's, Recommended Practices For The Use Of High-pressure Waterjetting Equipment and/or The Water Jetting Association's, WJA Code of Practice for additional safety information.

- Complete a job specific risk assessment and act on the resulting actions.
- Adhere to all site specific safety procedures.
- Ensure the waterblasting zone is properly barricaded and that warning signs are posted.
- Ensure the work place is free of unnecessary objects (e.g. loose parts, hoses, tools).
- Ensure all Operators are using the correct Personal Protective Equipment (PPE).
- Check that the air hoses are properly connected and tight.
- Check all hoses and accessories for damage prior to use. Do not use damaged items. Only high quality hoses intended for waterblast applications should be used as high-pressure hoses.
- Check all high-pressure threaded connections for tightness.
- Test the controls before operating the STRIKER® (SKR-STD) and TRACKED STRIKER® (SKR-TRK) with high-pressure water to verify the control valves move the Tool in the intended directions.
- Operate the high-pressure water at full pressure and use the Pneumatic Foot Pedal Dump Control to verify that the dump valve is working properly.
- Ensure that Operators never connect, disconnect, or tighten hoses, adapters, or accessories with the high-pressure water pump unit running.
- Ensure no personnel are in the hydroblasting zone.

**STRIKER® SKR-STD AND
CB-SKR CONTROL BOX SYSTEM**

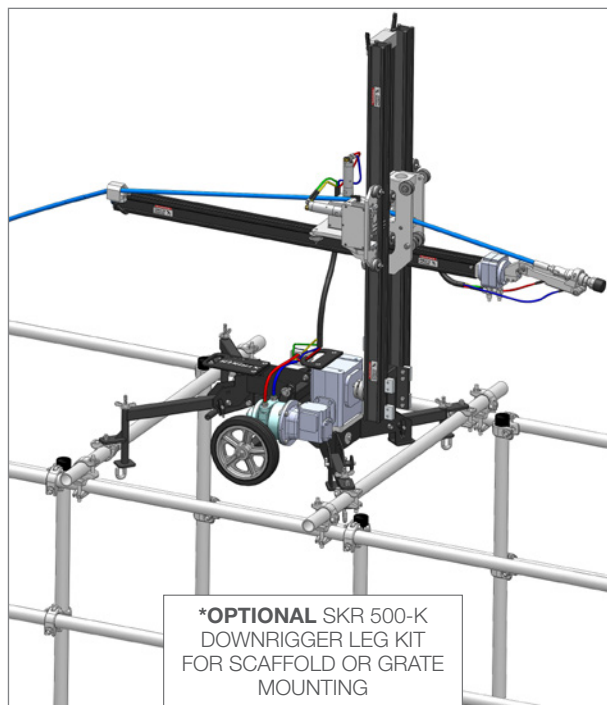
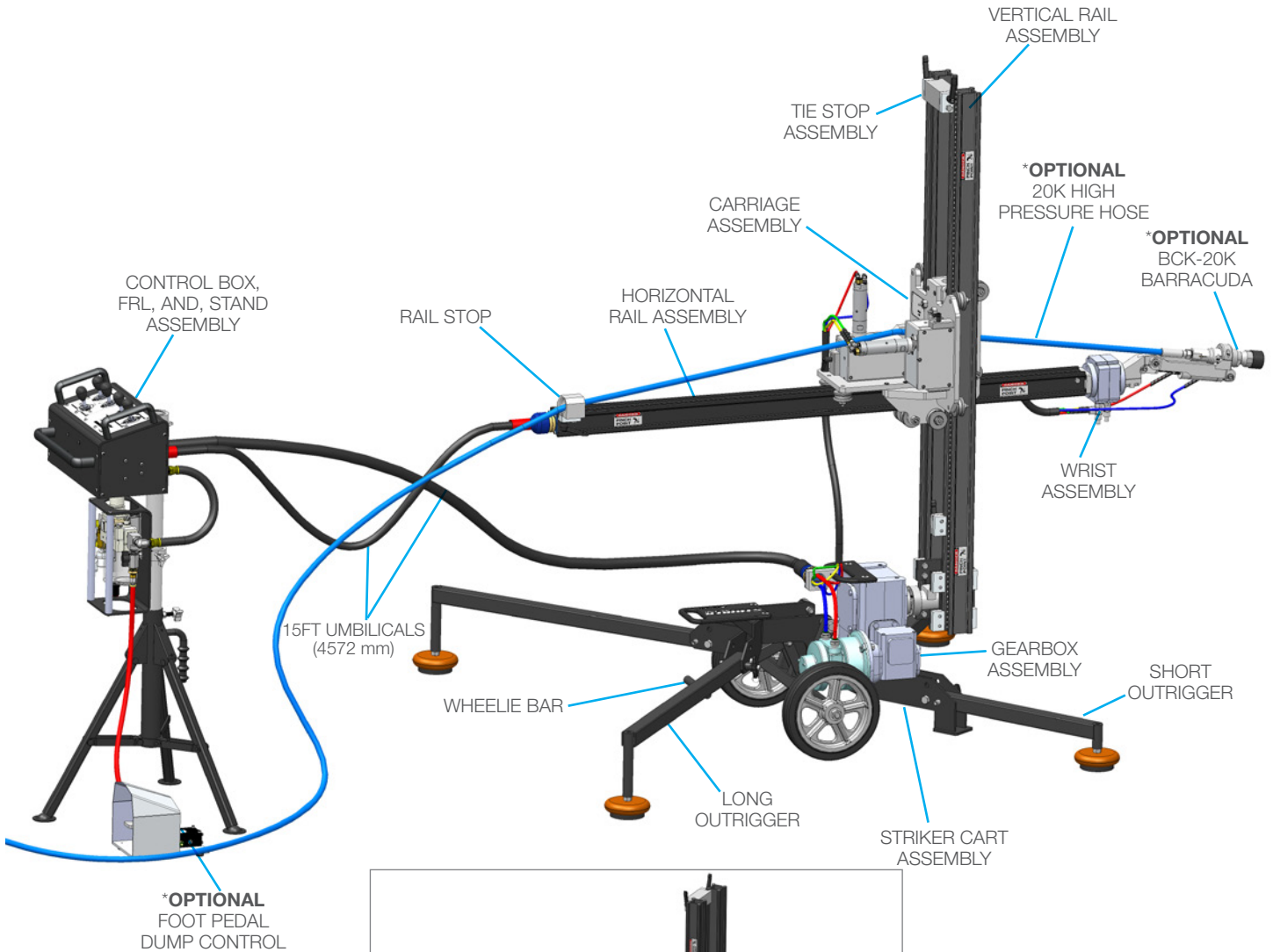

LEG BASE SET-UP

The leg base on the Striker may come with the legs folded upright.

1. Lift the Lever Bar up, use the longer legs as handles, tilt the Striker back, and roll into place. Once in place, pull the 4 Quick Release Pins out of the leg assemblies. **(Figure 1)**

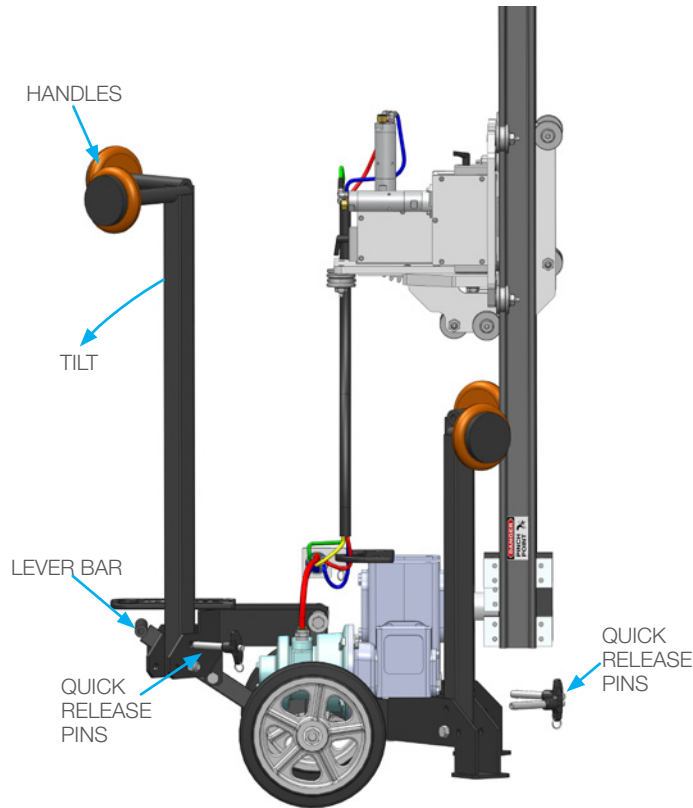

FIGURE 1

2. Pull the leg assemblies down and insert the Quick Release Pins through the cart and leg base. Push down on the Lever Bar to raise the wheels and foot plates off the ground. The Striker can be stabilized by screwing the feet in or out. **(Figure 2)**

⚠ CAUTION

All four adjustable feet **MUST** be level to the ground and the lever bar **MUST** be pressed firmly down to lift the wheels and foot plates off the ground. **(Figure 2)** Failure to do so may allow the Striker to slide around on the ground during operation.

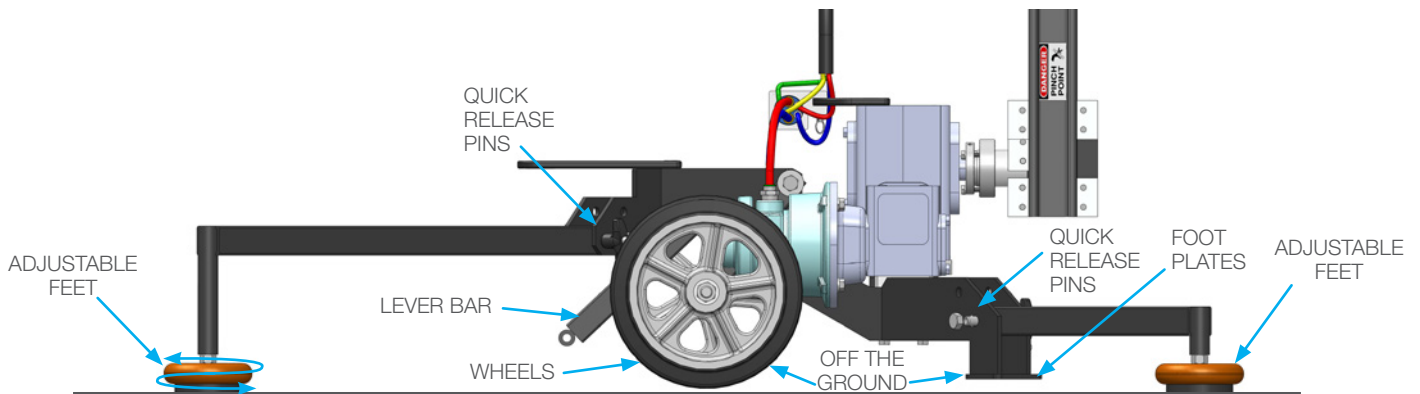

FIGURE 2

SKR-100 SET-UP - SWITCHING OUTRIGGER TO DOWNRIGGER LEGS

CHANGING FROM THE OUTRIGGER LEG ASSEMBLIES TO THE DOWNRIGGER LEG ASSEMBLIES

The Downrigger Leg Kit is designed to allow the user to mount the Striker onto scaffolding. It comes with two short and two long leg inserts.

1. Remove the 1/2" Bolts, Lock Nuts, and the Quick Release Pins from the Outrigger Leg Assembly and Cart. **(Figure 1)**
2. Insert the Downrigger Leg Assembly and secure with the 1/2" Bolt, Lock Nut, and Quick Release Pins as shown in **(Figure 2)**.

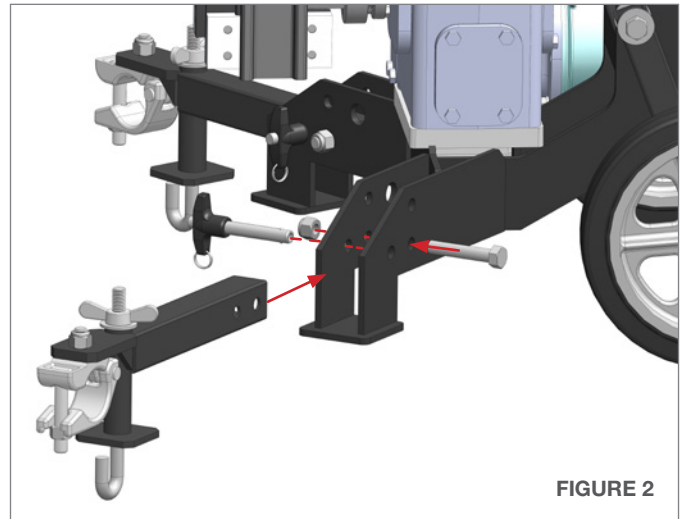
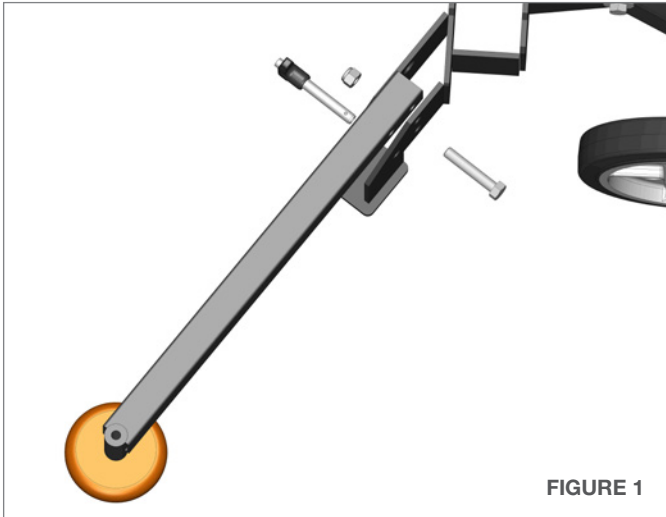

3. Confirm that the Short and Long Downrigger Legs are Installed where shown in **(Figure 3)**.

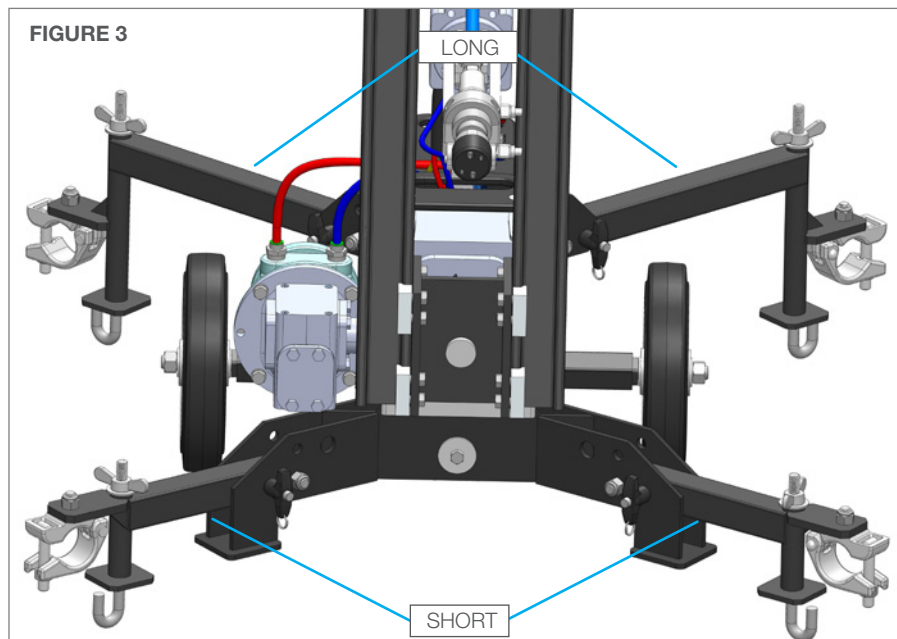

INSTALLING THE HORIZONTAL RAIL AND WRIST ASSEMBLY INTO THE VERTICAL RAIL ASSEMBLY

1. Install the Horizontal Rail Assembly with Wrist through the Carriage Assembly located on the Vertical Rail Assembly. **(Figure 1)**
Center the Horizontal Rail between the four rollers on the Carriage Assembly **(Figure 2)** and slide in about half way.

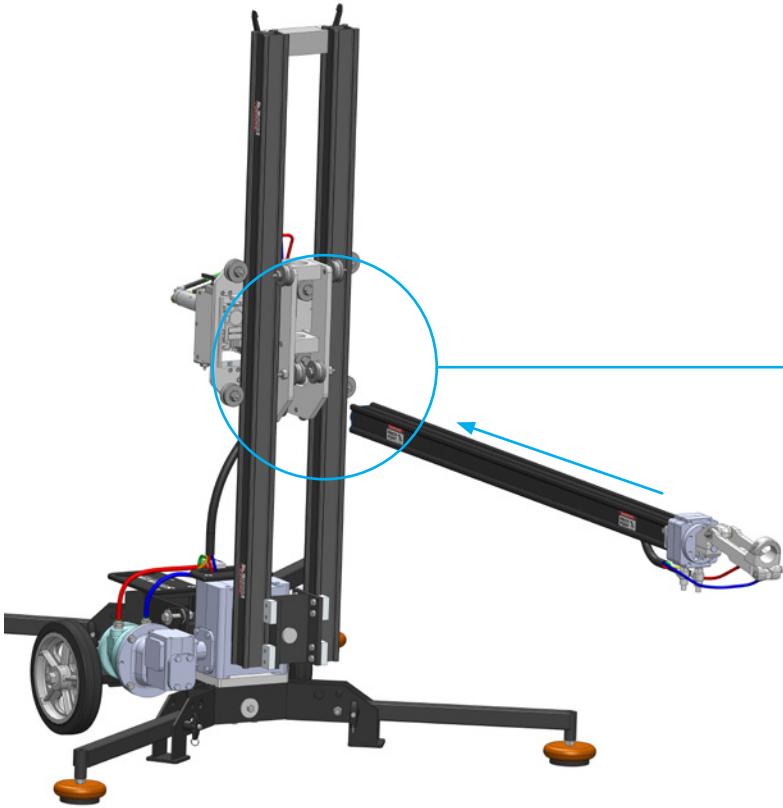

FIGURE 1

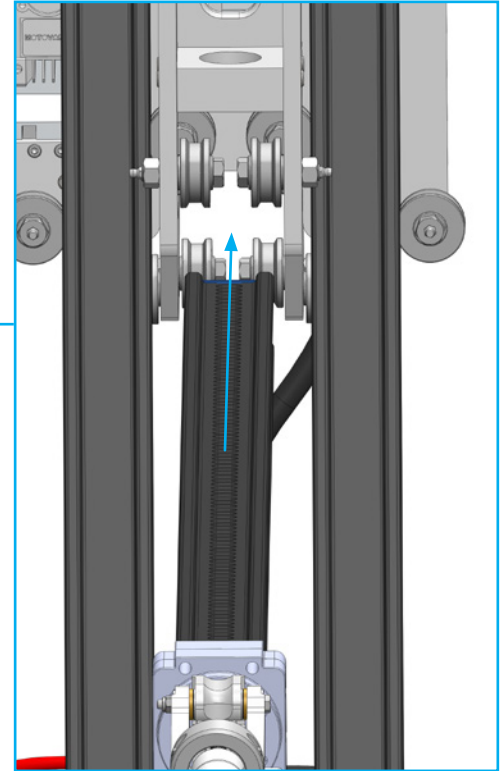

FIGURE 2

NOTICE

The Horizontal Rail Assembly is slotted on both sides. Flipping the Horizontal Rail allows the 270° rotational spray pattern to be directed up or down. **(Figure 3)**

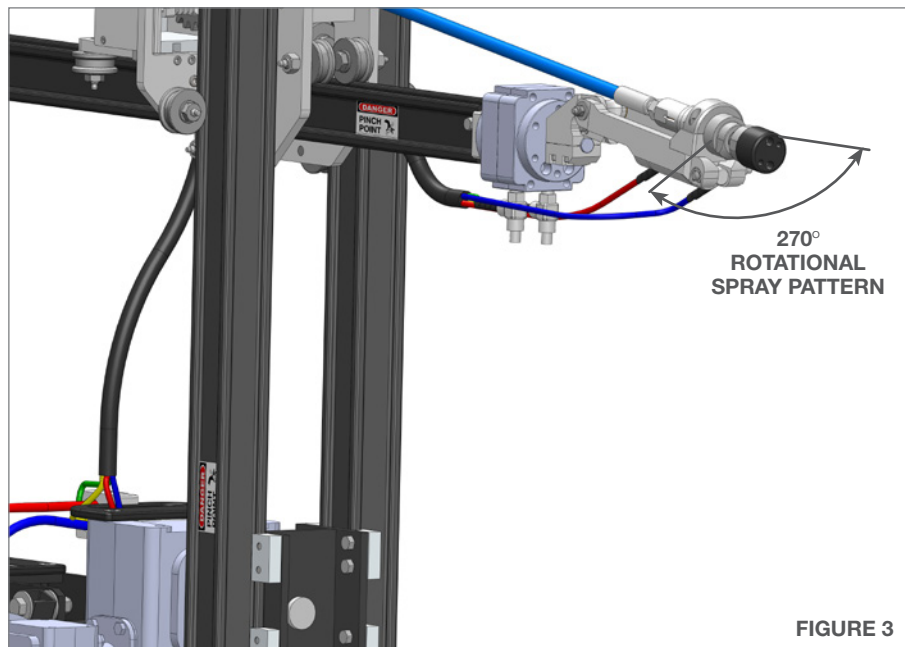
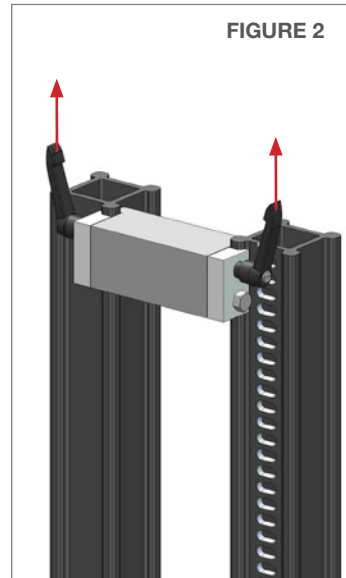
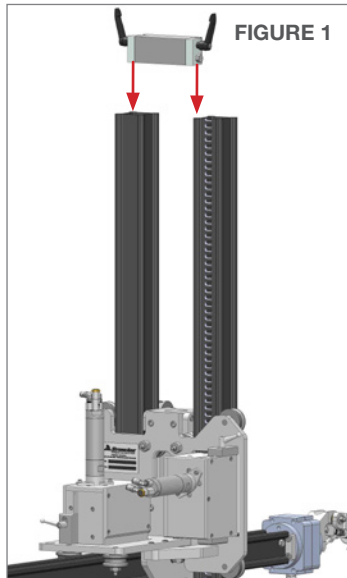

FIGURE 3

SKR-STD SET-UP - RAIL AND CARRIAGE STOPS

INSTALLING THE RAIL STOPS

1. Slide the Tie Rail Stop onto the end of the Vertical Rail Assembly. **(Figure 1)** Orient and tighten the Release Levers away from the Carriage Assembly. **(Figure 2)**



2. Slide the Rail Stop onto the end of the Horizontal Rail Assembly. **(Figure 3)** Orient and tighten the Release Lever away from the Carriage Assembly. **(Figure 4)**

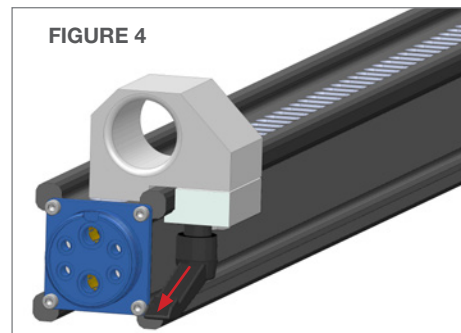
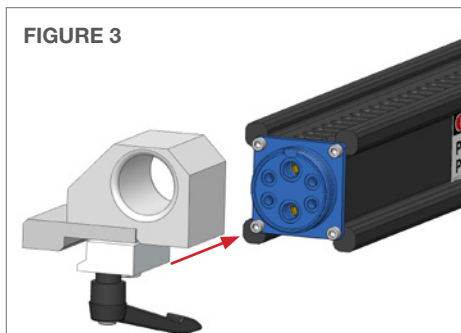

3. Slide the Carriage Stop along the Vertical Rail Assembly until the top of the block is 12" (305 mm) from the bottom of the Vertical Rail. Orient and tighten the Release Lever away from the Carriage Assembly.

NOTICE

Setting the Carriage Stop at a minimum of 12" (305 mm) ensures the carriage and horizontal rail will clear the gearbox and the base.

If the Carriage Stop is placed lower to gain range of motion, the Operator must pay attention to the horizontal rail and carriage assembly to ensure that they DO NOT make contact with the gearbox or base. Failure to do so will result in damage to the motors on the carriage assembly.

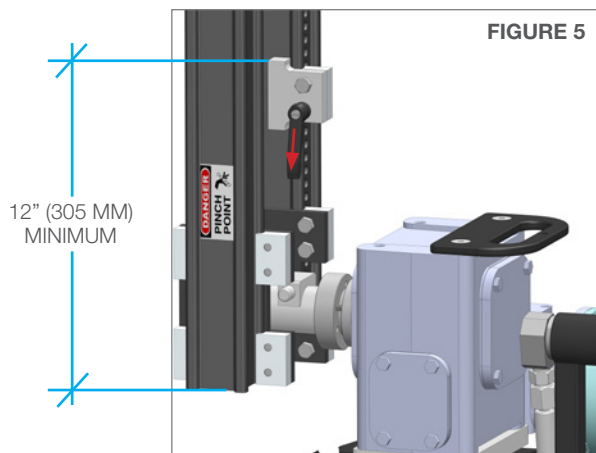

CONNECTING HIGH PRESSURE HOSE AND FITTINGS TO BCK-20K

1. Feed the male connector on the High Pressure Hose through the Rear Rail Stop on the end of the Horizontal Rail, then through the Carriage towards the BCK-20K Holder. **(Figure 1)**

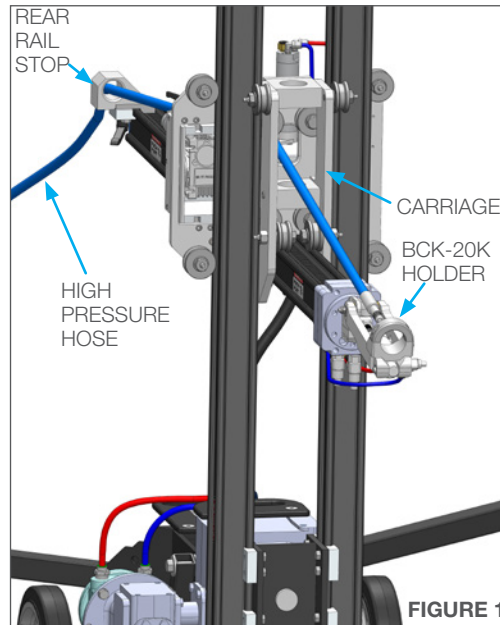

2. Fasten High Pressure Hose to BCK-20K Barracuda **(Figure 2)**. The hose end is a 9/16" medium pressure connection, with a modified gland nut and standard collar.

NOTICE

It is recommended to use BLUE GOOP, A SWAGELOK brand anti-seize, or an equivalent on threaded fittings to avoid galling.

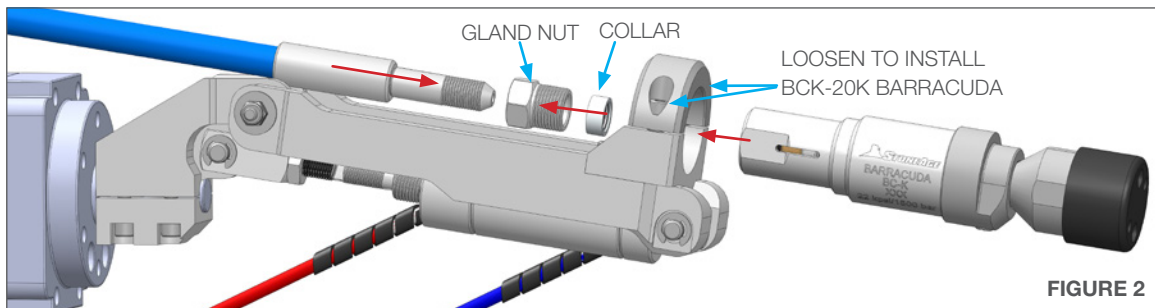

3. Tighten BCK-20K Barracuda to Gland Nut on the High Pressure Hose (A) and tighten the Wrist Clamp to BCK-20K Barracuda (B). **(Figure 3)**

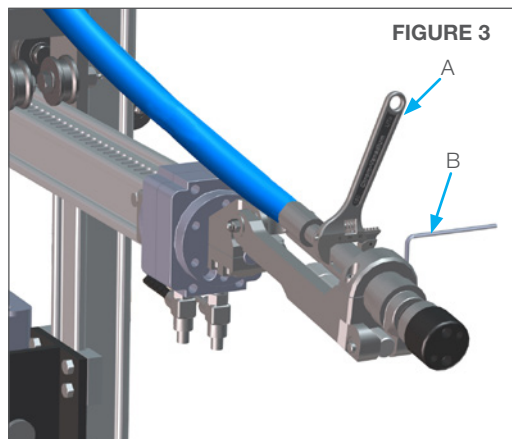

WRIST SPEED CONTROL ADJUSTMENTS

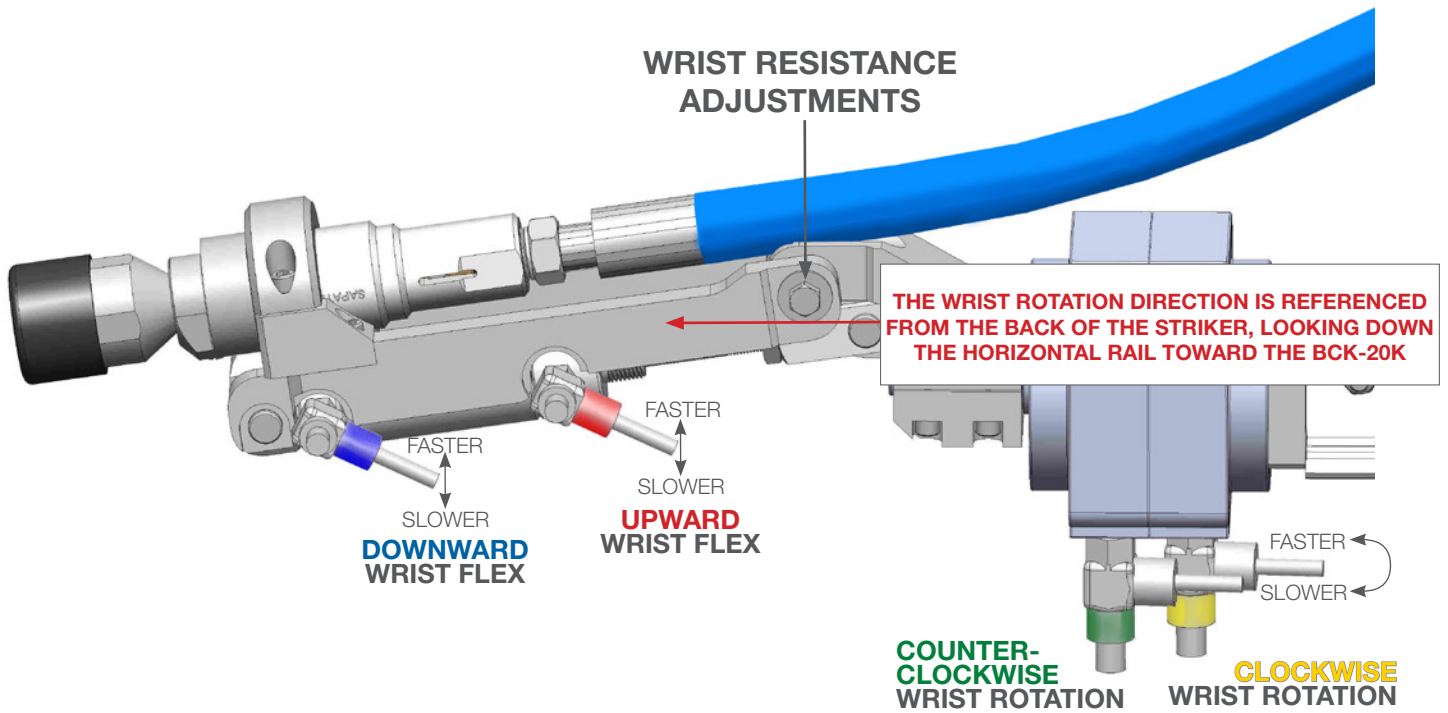

WRIST RESISTANCE ADJUSTMENTS

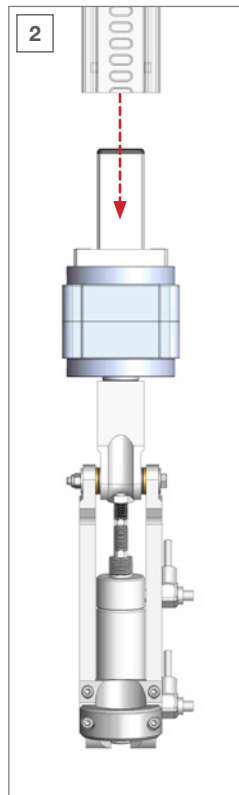
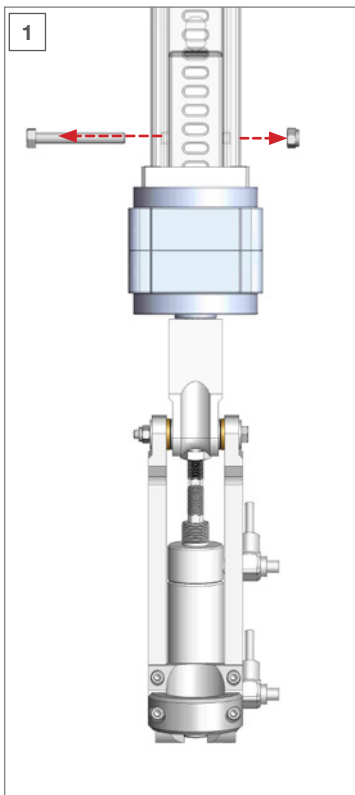

1. Remove Bolt and Lock Nut From the Rail and Wrist Assembly.
2. Pull the Wrist Assembly free of the Rail.
3. Remove the black plastic end cap from the end of the Wrist Assembly.
4. Remove the Friction Torque Limiter and Shaft
5. Loosen set screws.
6. Adjust nut to the left for less resistance and tighten to the right for increased resistance.

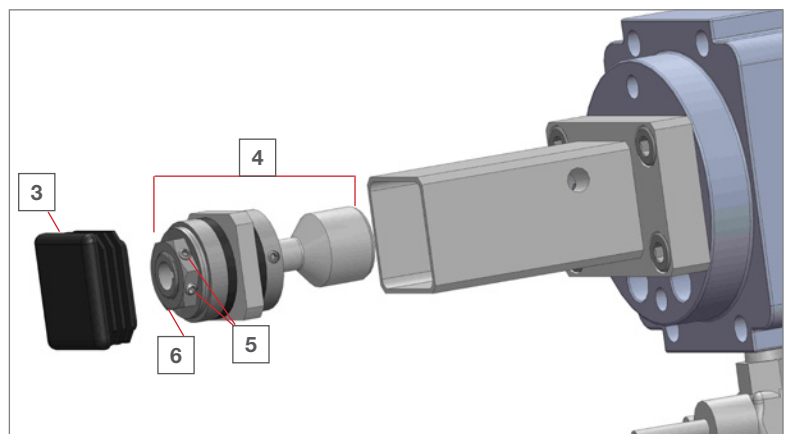

CONTROL BOX
TOP VIEW



CONTROL BOX
FRONT VIEW

CONTROL BOX
REAR VIEW

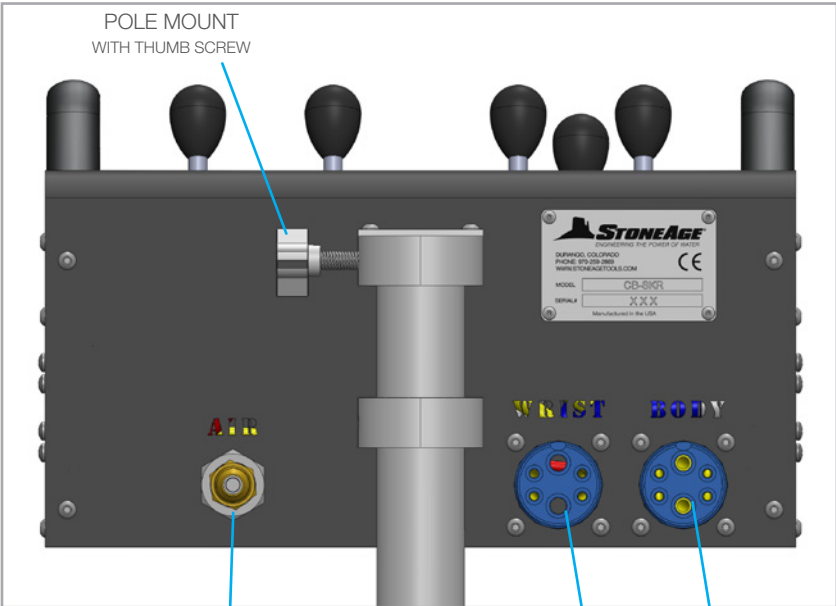
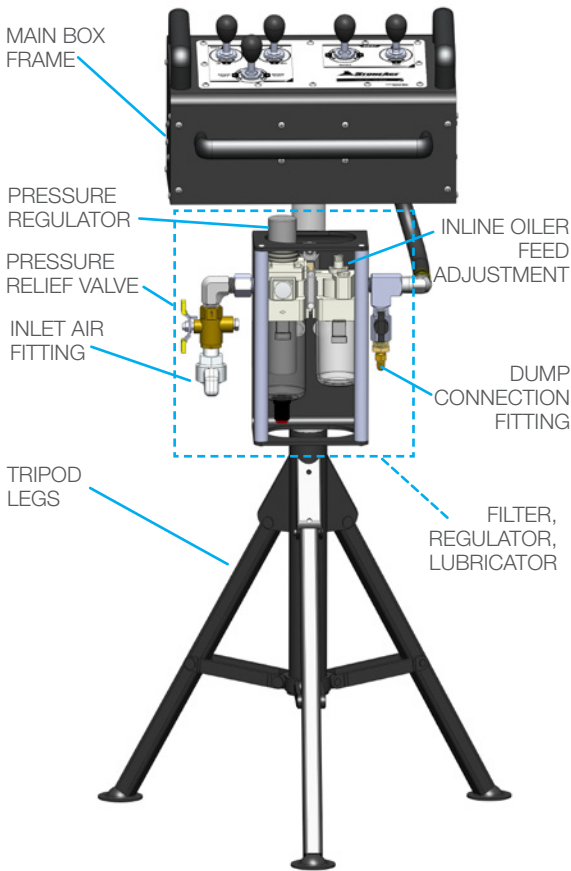

AIR SUPPLY FITTING WITH DUST CAP

WRIST UMBILICAL PORT RED

SYSTEM UMBILICAL PORT BLUE

CONTROL BOX ASSEMBLY

ASSEMBLE CONTROL BOX, FRL, AND TRIPOD BASE

1. Setup the tripod base in a location with good visibility to the cleaning site, but at a safe distance away from waterblast zone.
2. Slide the vertical tube into the tripod base. Secure with the supplied thumbscrew knob. Note: The vertical tube has a hole through one wall that the thumbscrew must engage.
3. Slide the Filter, Regulator, Lubricator (FRL) assembly over the vertical tube down to the tripod base. Secure with the supplied thumbscrew knob.
4. Slide the Control Box over the vertical tube. The Control Box has a stop that keeps it located at the top of the vertical tube. Secure with the supplied thumbscrew knob.
5. Install the short 1/2 in. (13 mm) I.D. hose between the FRL and the Control Box.

NOTICE

The vertical tube has a hole through one wall that the thumbscrew must engage.

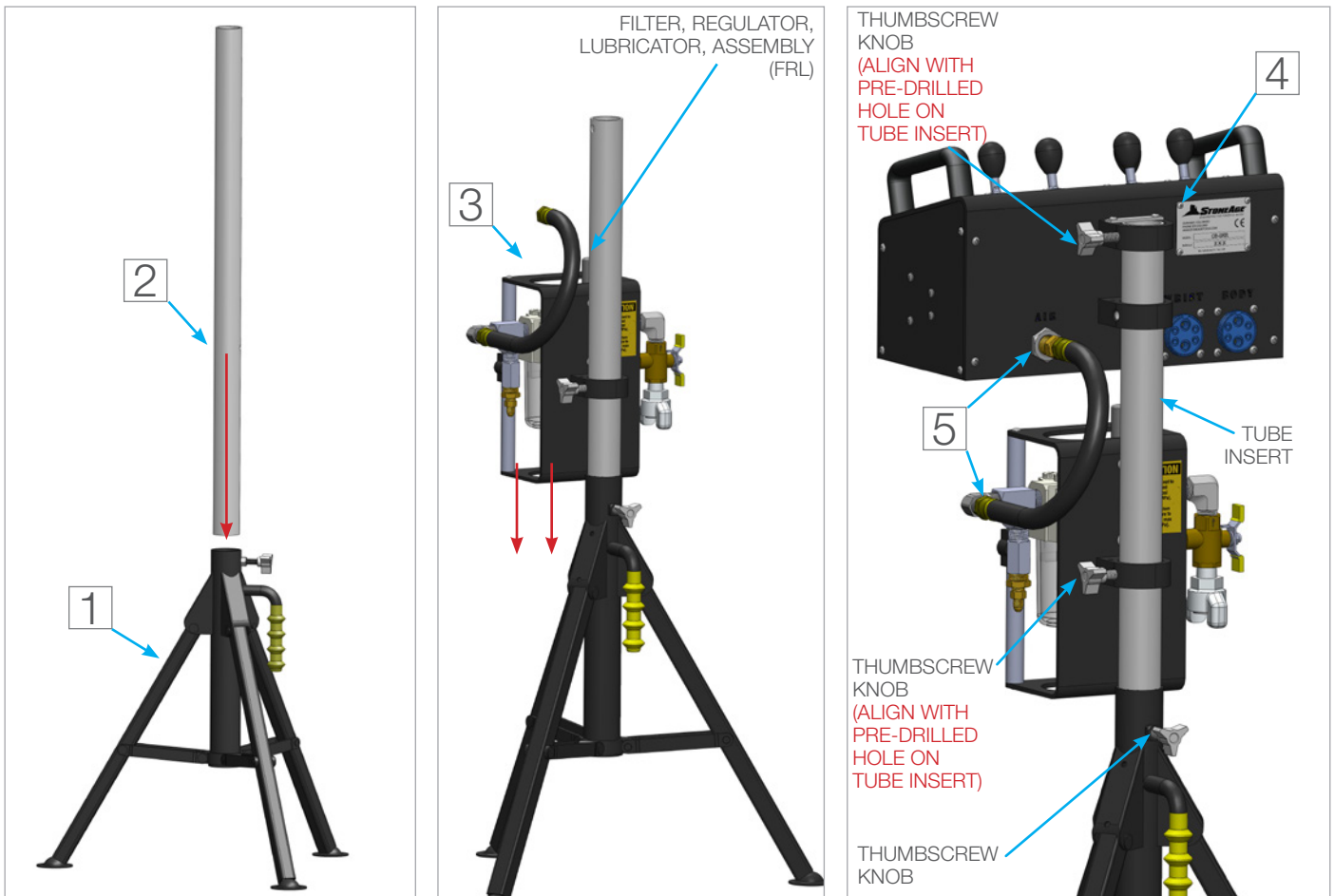

AIR SUPPLY AND LUBRICATOR SETTING

1. The Control Box is supplied with a twist claw style inlet coupling (Chicago style) located on the side of the FRL Assembly. Connect a compatible compressed air line (not included) according to the Manufacturer's instructions. If another pneumatic connection is preferred, this fitting can be removed and any male 1/2 in. NPT fitting may be used.
2. Using the regulator adjust the operating pressure to 110 psi (0.76 MPa) for the application.

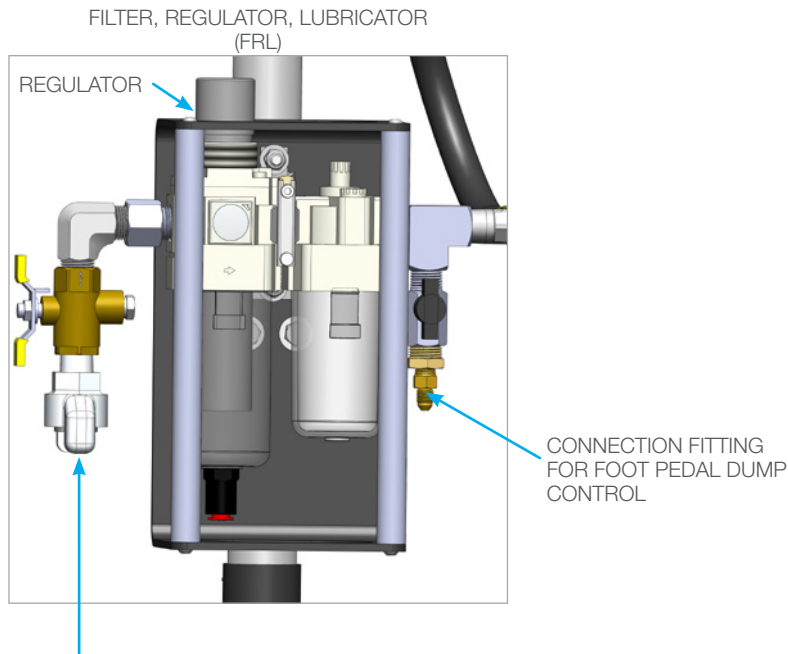

AIR SUPPLY FITTING

A universal **AIR SUPPLY FITTING** (Chicago style) is located on the side of the FRL. Connect a compatible compressed air line (not included) according to the manufacturer's instructions. If another pneumatic connection is preferred, this fitting can be removed and any male 1/2 in. NPT fitting may be used.

⚠ WARNING

Minimum operating pressure is 80 psi (0.55 MPa). Maximum operating air pressure is 100 psi (0.7 MPa). Exceeding 125 psi (0.86 MPa) supply pressure may result in injury to the Operator and/or damage to the equipment.

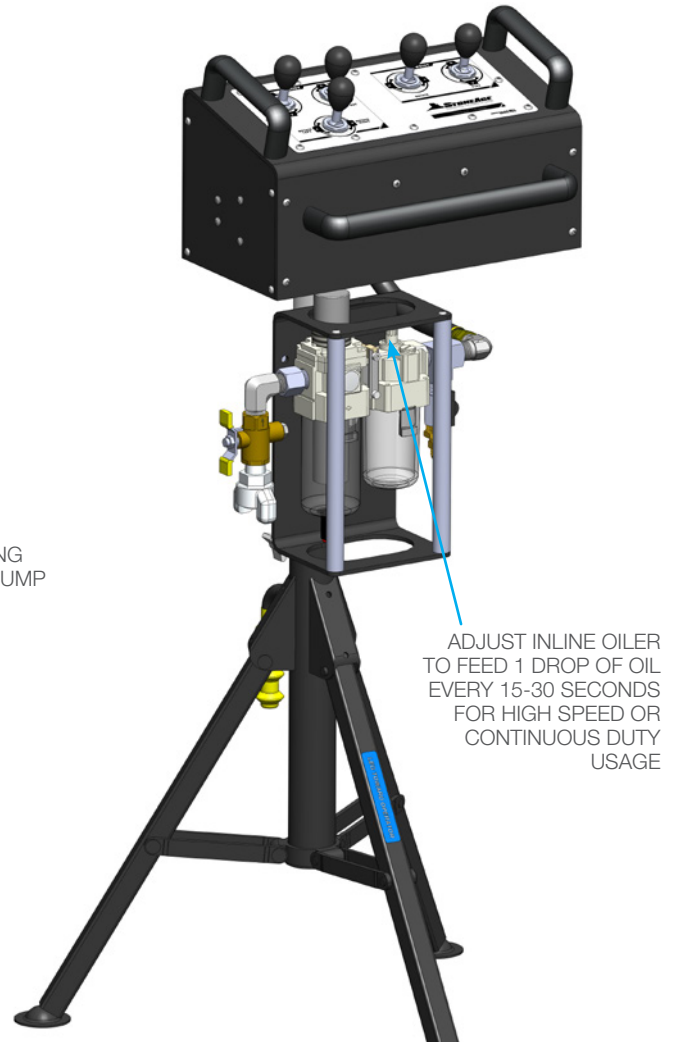

PNEUMATIC FOOT PEDAL DUMP CONTROL NOT INCLUDED IN THE STRIKER® PACKAGE

An optional Pneumatic Foot Pedal Dump Control with Air Line package is available for purchase through StoneAge Tools®.

To install the Pneumatic Foot Pedal Dump Control package, connect one end of the Air Line to the fitting on the Foot Pedal Dump marked "SUPPLY" and the other end to the Connection Fitting on the Control Box (See diagram above).

To connect to the Dump Valve, the Operator will need to install 1/4 in. O.D. Nylon tubing (Not Included in the FPA-SKR package) between the push fitting on the Foot Pedal Dump marked "DUMP" and the pneumatic dump valve.

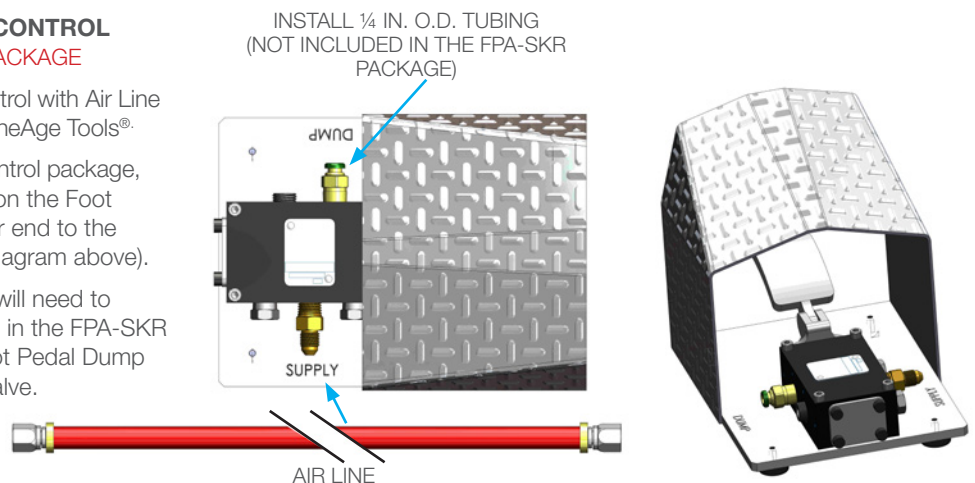

CONTROL BOX TO STRIKER (SKR-STD) SYSTEM ASSEMBLY CONNECTION

PNEUMATIC SUPPLY LINE CONNECTIONS

1. Remove the dust caps from both plugs on the Control Box and the STRIKER® (SKR-STD).
2. Connect the STRIKER® (SKR-STD) to the Control Box by plugging the **RED** umbilical into the plug marked "Wrist" and the **BLACK** umbilical into the plug marked "Body". Verify the Control Box rotates, flexes, raises, and lowers, the wrist and rotates the assembly left and right correctly.
3. Familiarize yourself with the Control Box functions by hooking up to air, before operating the STRIKER® (SKR-STD) with high pressure water.

 WRIST

 BODY

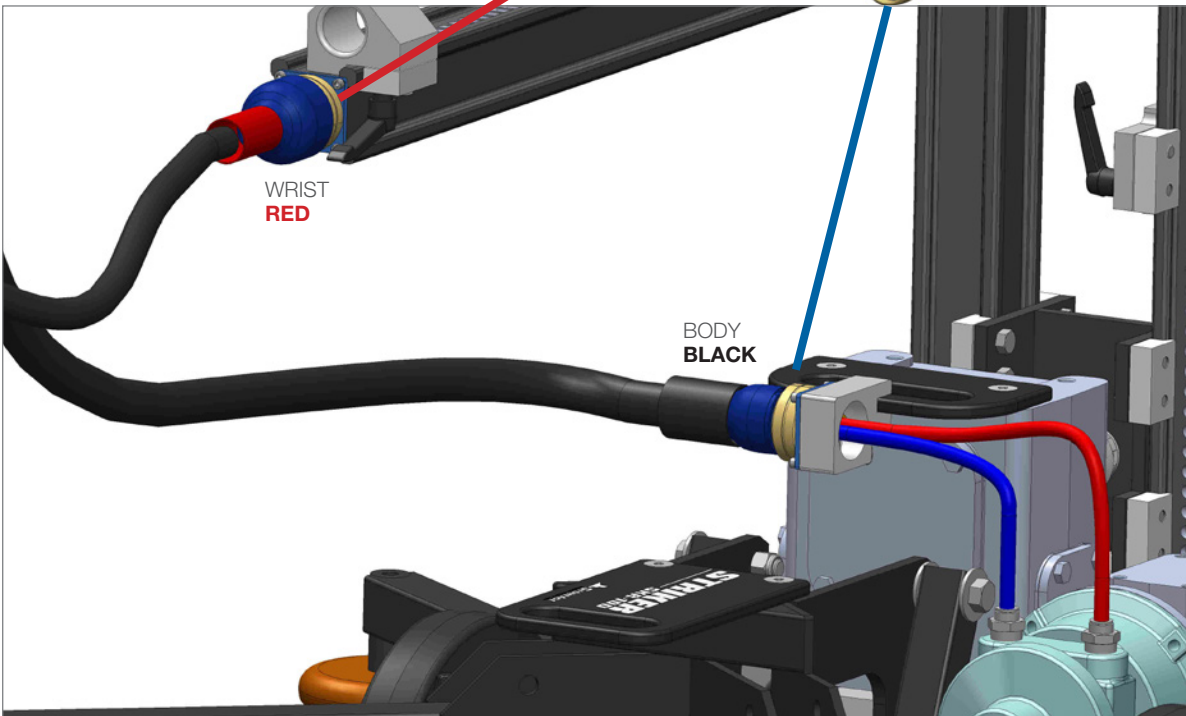
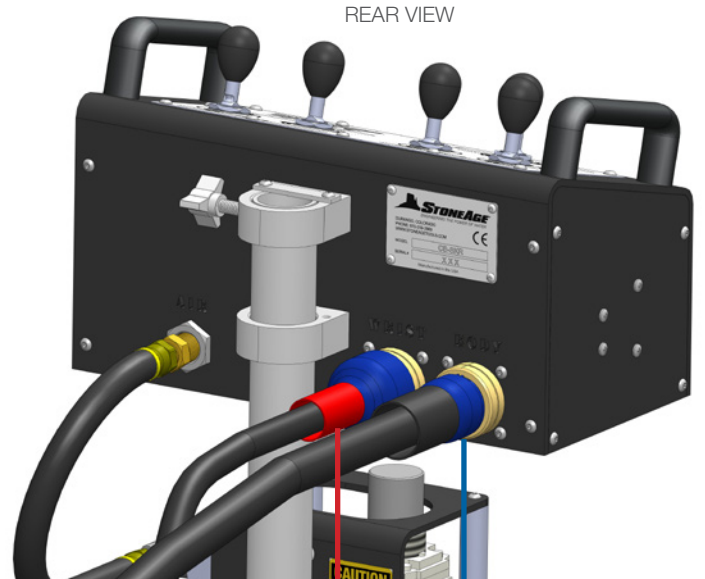
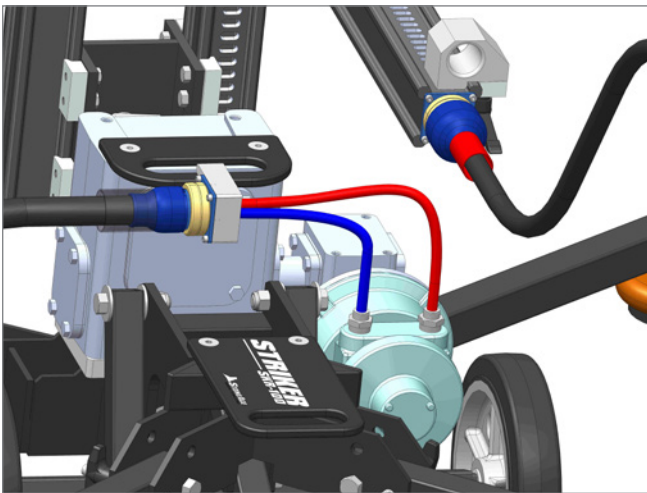

CONTROL BOX

- There are three levers that control the **BODY** of the STRIKER® (SKR-STD).
 - The **IN/OUT LEVER** will move the Horizontal Rail Assembly in the In (extending) and Out (retracting) directions.
 - The **UP/DOWN LEVER** will move the Carriage Assembly Up and Down the Vertical Rail Assembly.
 - The **ROTATE LEFT/RIGHT LEVER** will rotate the Vertical Rail Assembly from the Spline at the bottom in a windshield wiper motion.
- There are two levers that control the **WRIST** of the STRIKER® (SKR-STD).
 - The **ROTATE LEVER** rotates the BCK-20K BARRACUDA tool from the Wrist in a maximum 270° radius.

NOTE: The Horizontal Rail is slotted on top and bottom to allow the center of the Wrist rotation point to be pointed upward or downward.
 - The **FLEX LEVER** flexes the BCK-20K BARRACUDA tool 90° from the Wrist.
- The **WRIST** speed controls are located on the STRIKER® (SKR-STD) The wrist will operate differently while it is under high pressure water versus operating with air only. See the Wrist Speed and Resistance Adjustment page in this manual to adjust the wrist settings.
- The **OFF** position for all levers is at the spring centered middle position.
- To de-energize the system, remove foot from the **PNEUMATIC FOOT PEDAL DUMP CONTROL** . This will stop the Carriage Assembly and BCK-20K BARRACUDA tool from moving and reroute the high-pressure water away from the STRIKER® (SKR-STD).

▲ WARNING

Crush Hazard. Keep hands, hair, and clothing, clear of Carriage Rollers, Wrist joints, Spline Hub, and out of all travel limit zones. Contact with moving parts can result in severe injury

▲ DANGER

STAY BEHIND THE VERTICAL RAIL ASSEMBLY AND OUT OF THE SPRAY ZONE WHEN OPERATING THE TRACKED STRIKER. Failure to do so **will** result in death or serious injury.

TEST RUN PROCEDURE

- Perform the **PRE-RUN SAFETY CHECK (SEE PAGE 8)**.
- Test the Control Box before operating the STRIKER® (SKR-STD) with high-pressure water to verify the control valves move the Horizontal and Vertical Rail Assemblies in their intended directions, and the **PNEUMATIC FOOT PEDAL DUMP CONTROL** is working properly. Ensure that the High Pressure Water System cannot be energized while making adjustments.
- Operate the high-pressure water at full pressure and use the **PNEUMATIC FOOT PEDAL DUMP CONTROL** to verify that the dump valve is working properly. To activate dump, remove foot from the pedal.
- Operate the high-pressure system and waterjet tool at full pressure to test the Speed and Resistance settings on the Wrist. Properly setting up the Wrist will provide good control of the BCK-20K BARRACUDA tool in Rotation and Flex directions. Detailed adjustment instructions can be found on the Wrist Speed and Resistance Adjustment page in this manual.
- The STRIKER® (SKR-STD) has been engineered to stay in position with a maximum reaction force of 70lbs when all outriggers are deployed. The STRIKER® (SKR-STD) may slide on smooth, oily, or slippery surfaces during operation. Anchoring the STRIKER® (SKR-STD) to the floor, heavy duty scaffolding, or similar components will aid in keeping the unit in position. The anchoring method **MUST** be capable of withstanding a minimum of 70 lbs of reaction force from the STRIKER® (SKR-STD). Operate the high-pressure hose and waterjet tool at full pressure to test the anchoring method.

RUN PROCEDURE

- After completing the setup, and taking all safety precautions the STRIKER® (SKR-STD) system is ready for operation.
- To line up the STRIKER® (SKR-STD) with the area to be cleaned, lift up on the Wheelie Bar to engage wheels, counter balance the unit, and move into place. Push down on the Wheelie Bar to set Outriggers down on the floor.
- Operate the in/out, up/down and rotation functions on the upper rail assembly and the rotate and flex functions on the Wrist, to begin high pressure cleaning at the preferred location.
- The STRIKER® (SKR-STD) **MUST** be supervised at all times.

HIGH-PRESSURE HOSE

- The TRACKED STRIKER is designed to be used with a 12ft (3658 mm) SPIR STAR® HP 8mm Hose and SPIR STAR® standard 9/16"-18 Medium Pressure 8-4 male end at the BC-K 20 KPSI BARRACUDA and a SPIR STAR® 3/4"-16 Type M Swivel Female End at the coupler on the STRIKER assembly.
- Only high quality hoses intended for waterblast applications should be used as high-pressure hoses. Pressure rating of high-pressure hoses **MUST NEVER** be exceeded.
- Verify that the high-pressure hose is properly installed through the Carriage Assembly.
- Inspect high-pressure hoses for damage or wear before each use. Do not use damaged or worn high-pressure hose.

MAINTENANCE

MAINTENANCE		
Maintenance Item	Frequency	Maintenance Required
All Air Fittings	After each use	Reinstall all dust caps to protect from dirt and moisture.
Carriage rollers	Every 100 Hours of use	Lubricate Zerks on all Carriage Rollers using any multipurpose NLGI 2 grease.
Gearbox oil level	Every 100 Hours of use	Fill with Mobil SHC™ 634 synthetic gear oil. See individual part diagram pages for gearbox fill orientations.
Lubricator of Control Box	Before each use	Add oil when fluid drops below minimum level marking. Fill with a quality air tool oil.
Vertical and Horizontal Rails	As Needed	Inspect for wear that would allow Carriage Rollers to slip off. Replace Rail as needed.
Waterblast Tool	After each use	Remove tool, blow out water, lubricate, and store in clean container.

Contact StoneAge for Safety Data Sheets for material usage, a complete list of spare part numbers, and service instructions for the STRIKER® (SKR-STD) and Control Box.

STORAGE, TRANSPORTATION, AND HANDLING

When moving the STRIKER® (SKR-STD), lift with care to prevent bodily injury. When the Rear (Long) Outriggers are folded upright, and the wheels on the cart are lowered, the STRIKER® (SKR-STD) can be moved as a two wheeled dolly. Two 3/4" (19 mm) holes, are provided in the Front (Short) Outrigger mount plates on the cart weldment. They are intended for Clevis Pins to allow for lifting by crane.

The STRIKER® (SKR-STD) is shipped in a custom wooden crate and may be stored upright in the same crate between jobs.

When storing the unit, use compressed air to blow out the air lines to remove debris and moisture. Use mild soapy water to clean the machine in order to remove corrosive materials.

Apply a small amount of air tool oil directly into the forward and reverse fittings. Then, briefly operate the controls at slow speed for a short duration in each direction to coat the interior parts of the motor. Install the dust caps onto all three fittings to keep moisture and dirt out.

CONVERTING STANDARD STRIKER TO TRACKED STRIKER BASE

USE THIS SECTION OF THE MANUAL TO CONVERT A STANDARD STRIKER TO A TRACKED BASE.

REMOVE THE VERTICAL RAIL ASSEMBLY

1. Using the Control Box rotate the Vertical Rail Assembly into a horizontal position as shown in **(Figure 1)**.
2. Disconnect the High Pressure Hose from the BC-20K tool and pull all the way out through the Rear Rail Stop. **(Figure 2)**
3. Disconnect the Control Box Umbilical from the end of the Horizontal Rail. **(Figure 3)**
4. Remove the Rear Rail Stop **(Figure 4)** from the Horizontal Rail and the Tie Rail Stop from the Vertical Rails. **(Figure 5)**

⚠ WARNING

Always de-energize the system before servicing or replacing any parts. Failure to do so can result in severe injury and/or death. Keep hands, hair, and clothing clear of moving parts.

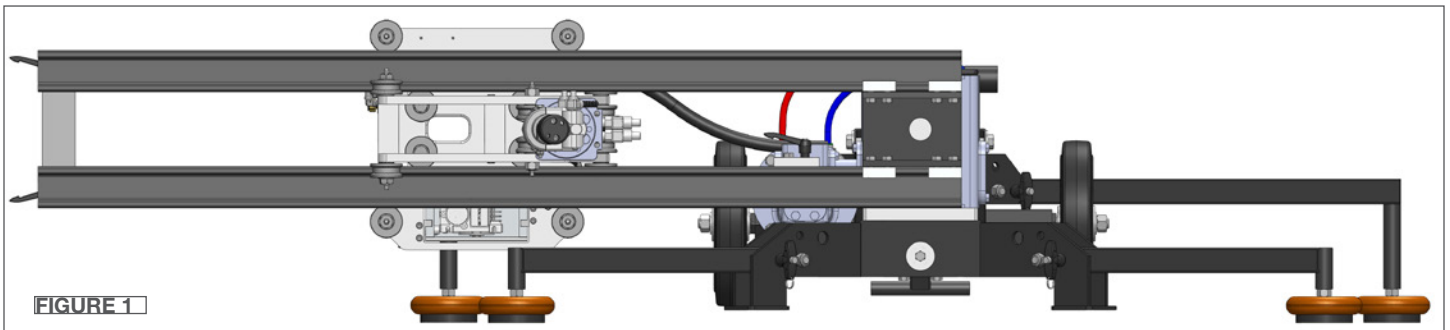

FIGURE 1

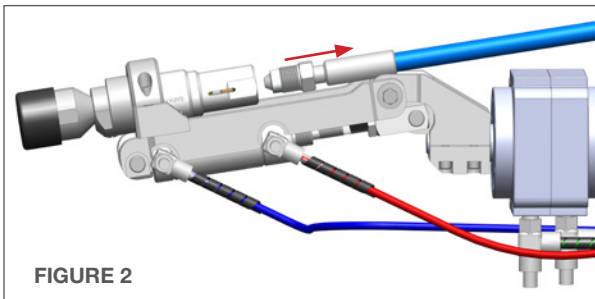

FIGURE 2

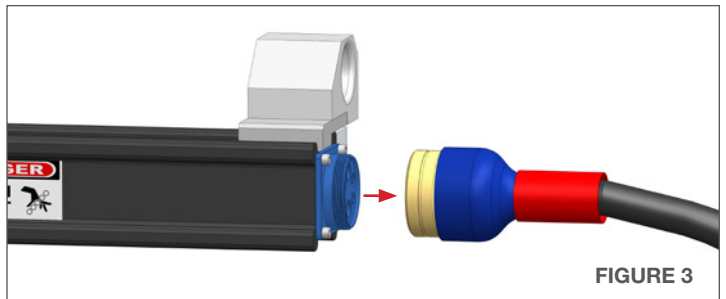

FIGURE 3

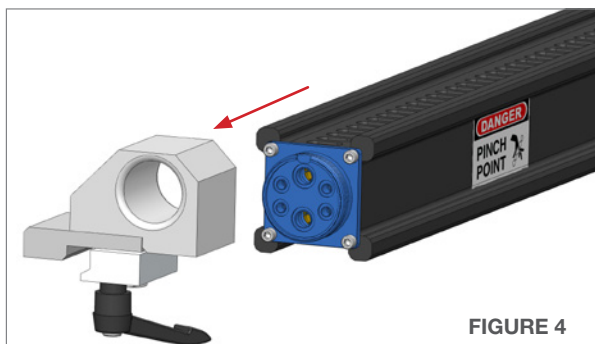

FIGURE 4

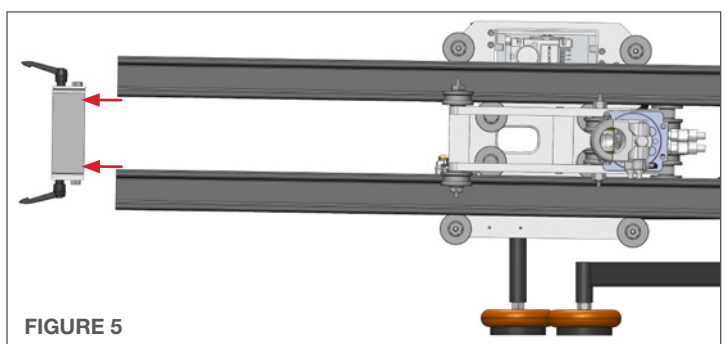

FIGURE 5

CONVERTING STANDARD STRIKER TO TRACKED STRIKER BASE

REMOVING THE HORIZONTAL RAIL AND CARRIAGE ASSEMBLY

- Slide the Horizontal Rail Assembly with Wrist out of the Carriage Assembly. **(Figure 6)**



FIGURE 6

- Disconnect the Control Box Umbilical from the QD Hanger. **(Figure 7)**
- Depress the pushlock fittings on the air motor and pull out the red and blue 1/4" tubing. **(Figure 8)**
- Pull out the quick release pin on the QD Hanger and slide the assembly off the Gearbox handle. **(Figure 9)**

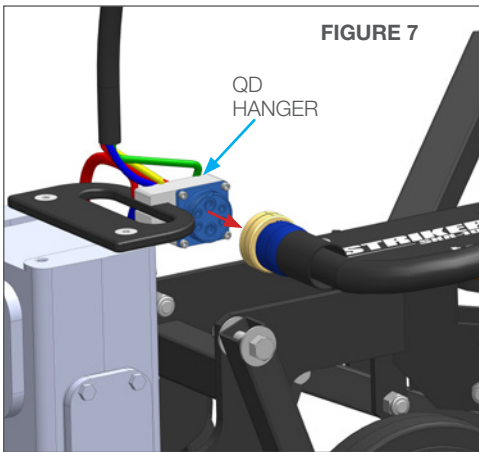

FIGURE 7

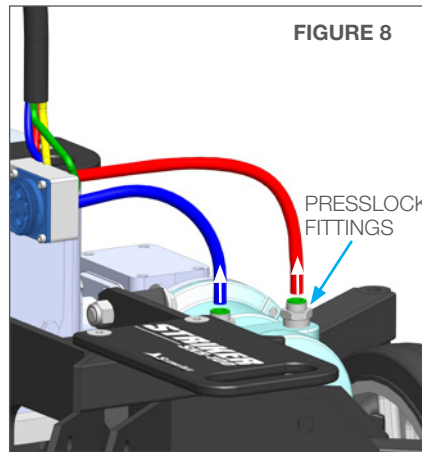

FIGURE 8

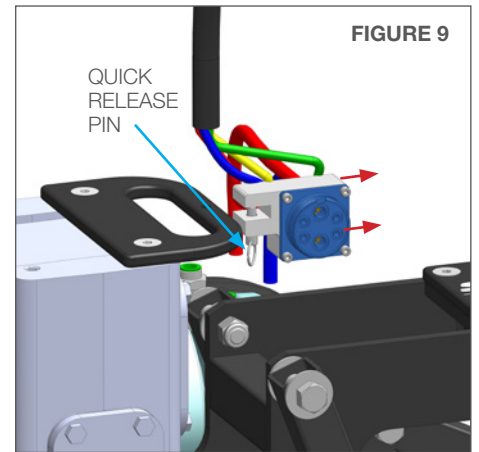

FIGURE 9

- Disengage the drive gear from the slotted rail by releasing the lever on the motor. **(Figure 10)**
- Roll the Carriage off rails with caution so as not to drop it. **(Figure 11)**

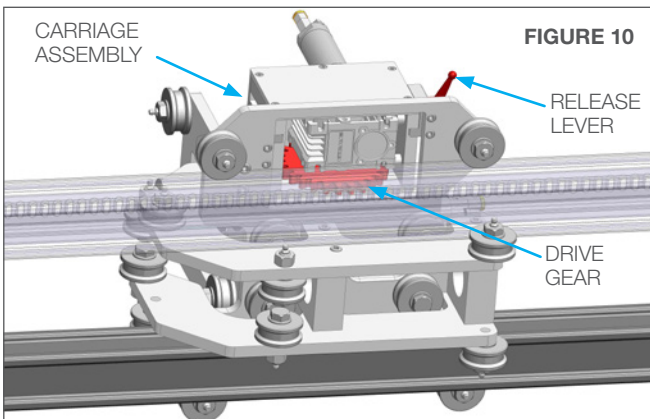

FIGURE 10

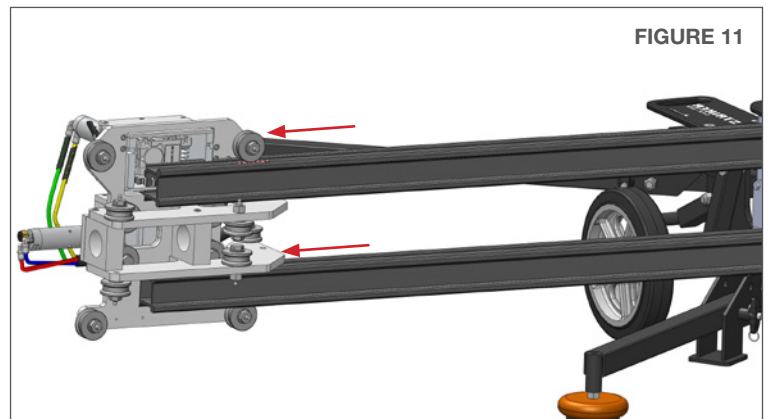
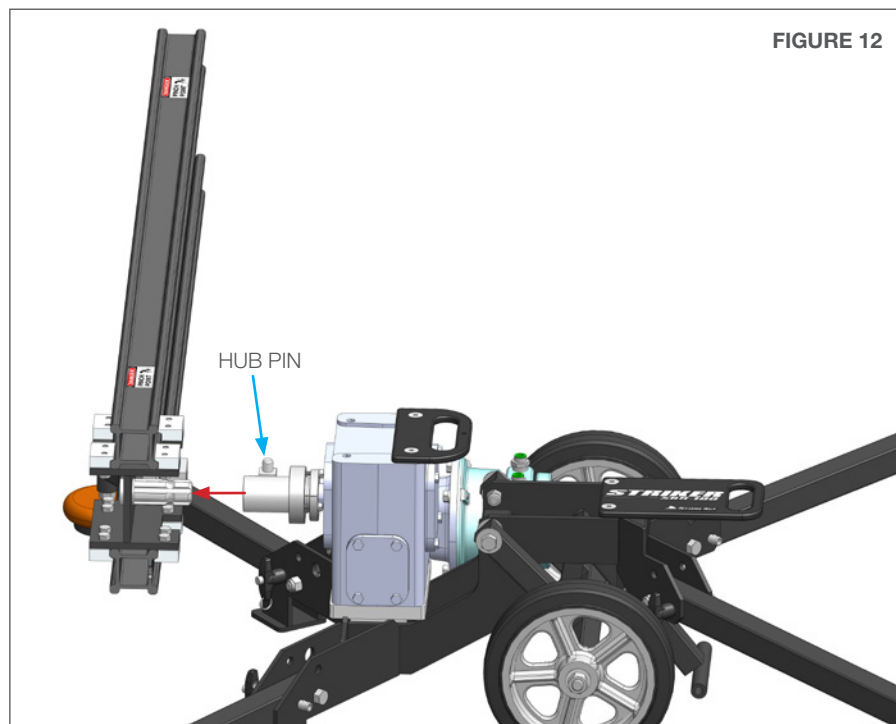

FIGURE 11

REMOVING THE VERTICAL RAIL AND THE GEARBOX ASSEMBLY

12. Slide the Vertical Rail Assembly off the Spline by depressing the Hub Pin on the Spline coupling. **(Figure 12)**



13. Remove the Wedge Bolt from the mounting plate and lift the Gearbox Assembly out of the cart. **(Figure 13)**

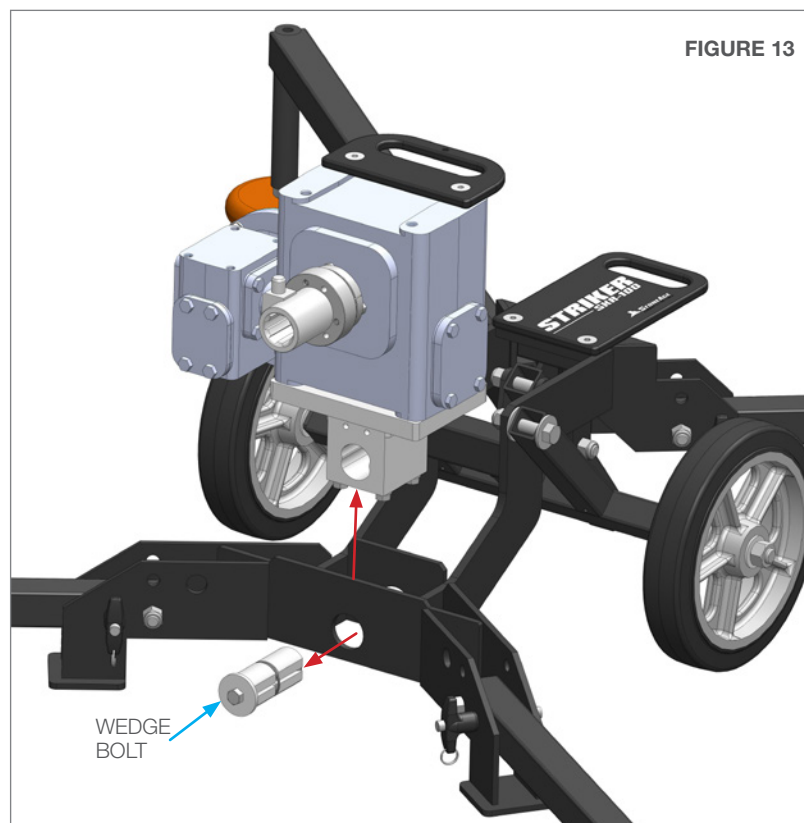

CONVERTING STANDARD STRIKER TO TRACKED STRIKER BASE

PREPARING THE TRACKED BASE

14. The Tracked Striker Base comes with either a 20K (1500 bar) or 40K (2000 bar) Swivel and Inlet assembly. Additional swivel assemblies are sold separately through StoneAge Tools®. (Figure 14)

NOTICE

Verify if the Tracked Striker Base is set up with the 20k or 40k. The 20k swivel is an MP9 and the 40k swivel is the H9.

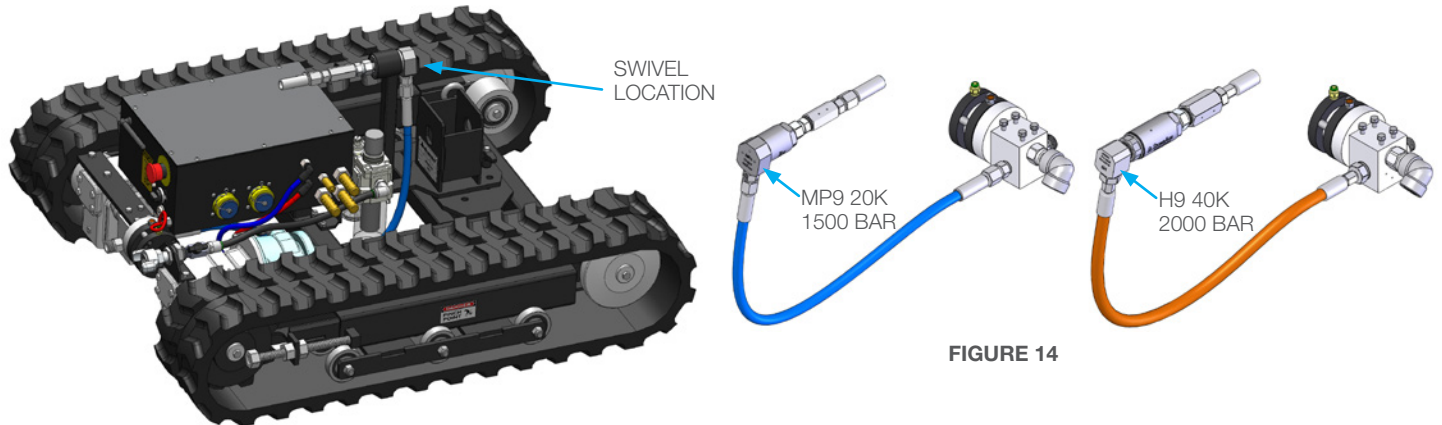

SWITCHING SWIVEL ASSEMBLIES

The following steps are only necessary if changing the pressure rating of the Tracked Striker. Skip to Step 19 if the base is already assembled with the desired swivel.

15. Remove and retain the four 1/4" hex bolts and washers from the mounting plate. Depress the presslock fitting to release the red tubing. (Figure 15)
16. Loosen the swivel fitting with two adjustable end wrenches and slide the swivel out from the holder. (Figure 16)

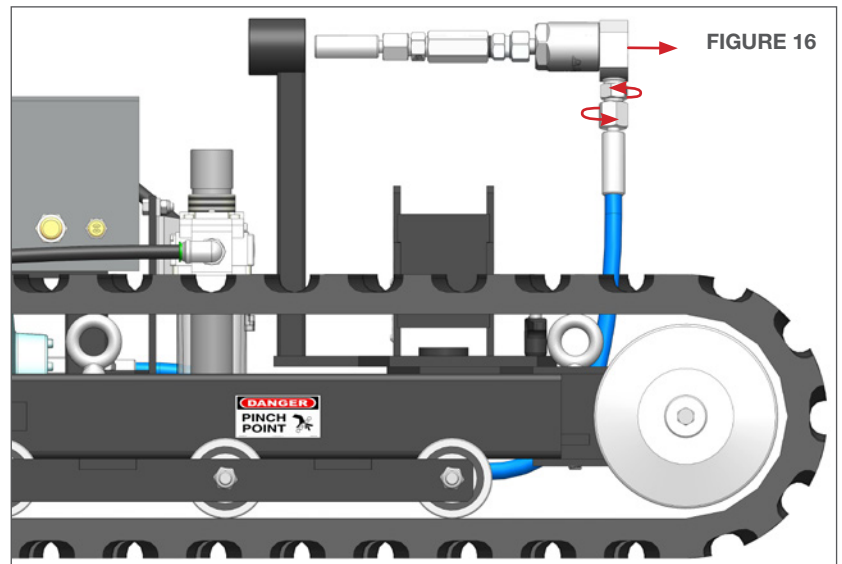
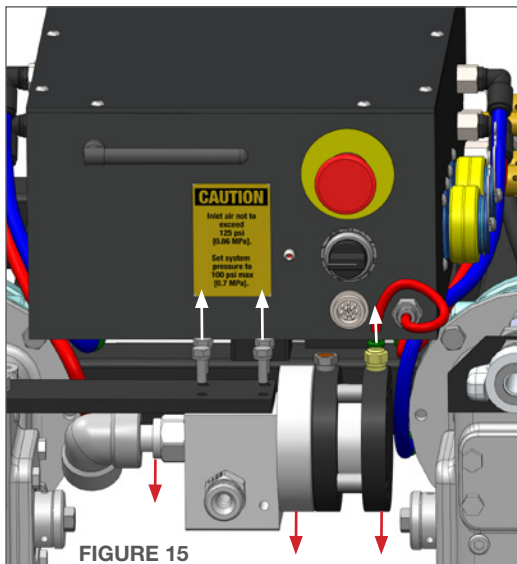

INSTALLING THE SWIVEL

17. Install the four retained 1/4" hex bolts and washers through the base plate into the dump valve. Depress the presslock fitting to insert the red tubing. Pull on the tubing to ensure it is securely fastened. **(Figure 17)**
18. Tighten the swivel fitting with two adjustable end wrenches and slide into the holder. **(Figure 18)**

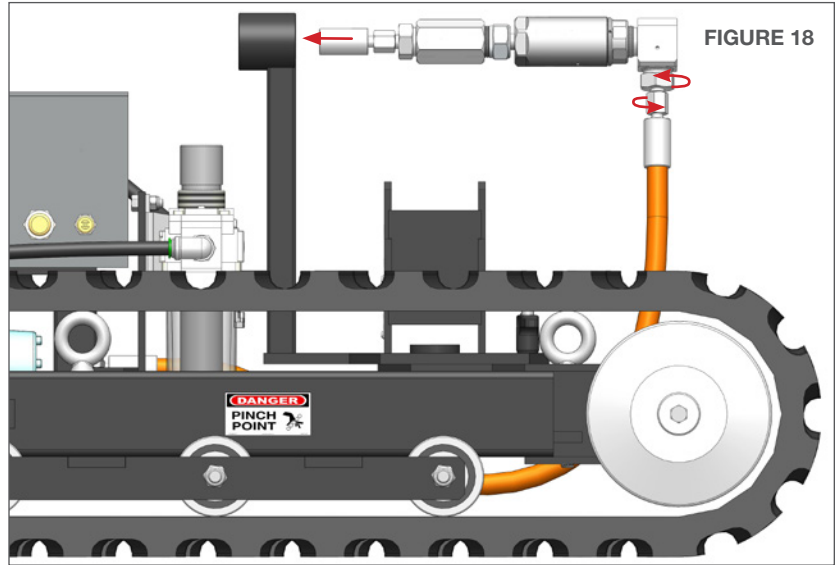
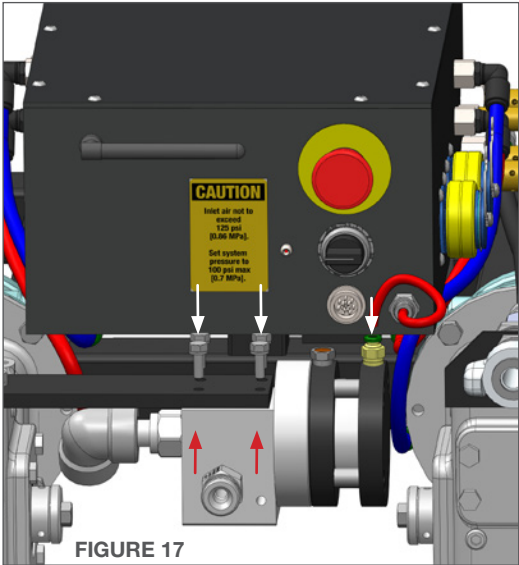

NOTICE

At this point it is best to determine the desired orientation of the Tracked Striker. The job location will determine if the Parallel or Perpendicular position will allow for easier access to the object to be cleaned. The diagrams below illustrate the differences between the two positions.

PARALLEL ORIENTATION

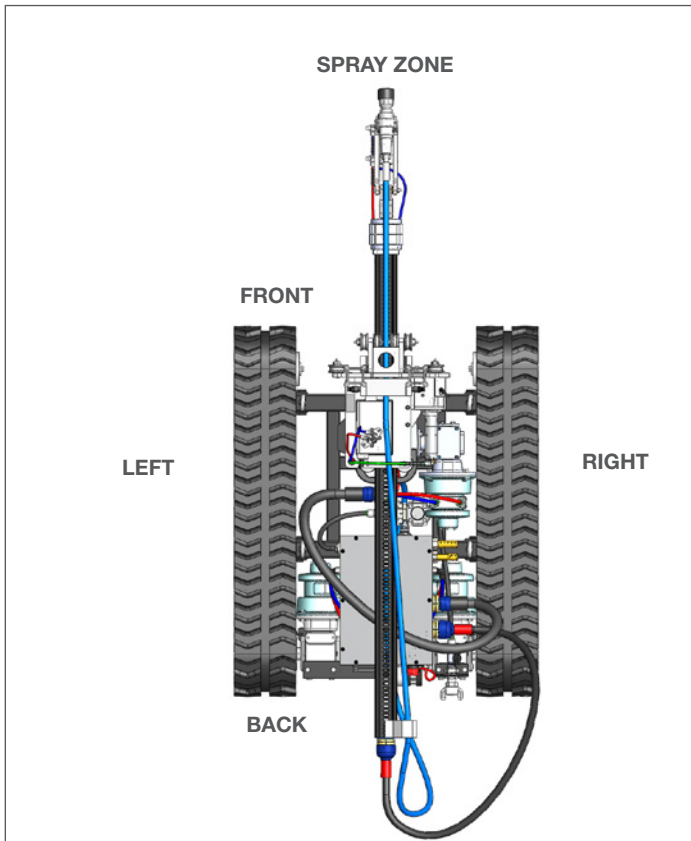

PERPENDICULAR ORIENTATION

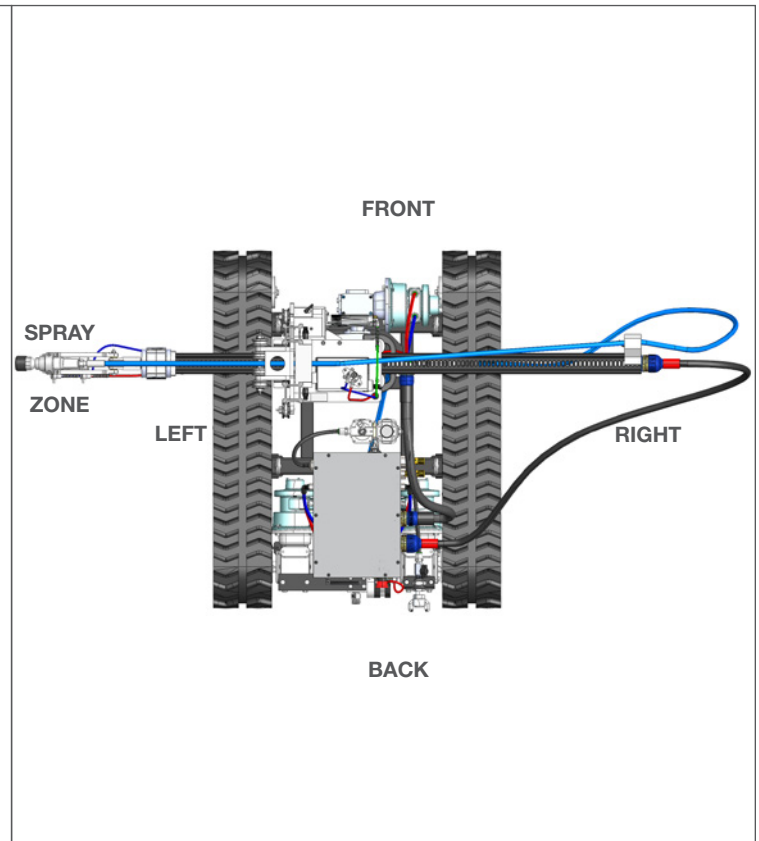

CONVERTING STANDARD STRIKER TO TRACKED STRIKER BASE

ROTATING THE POSITION OF THE PIVOT

The instructions below are for rotating the position of the pivoting gearbox mount from Parallel to Perpendicular. If the Parallel position is the desired orientation then skip to Step 23.

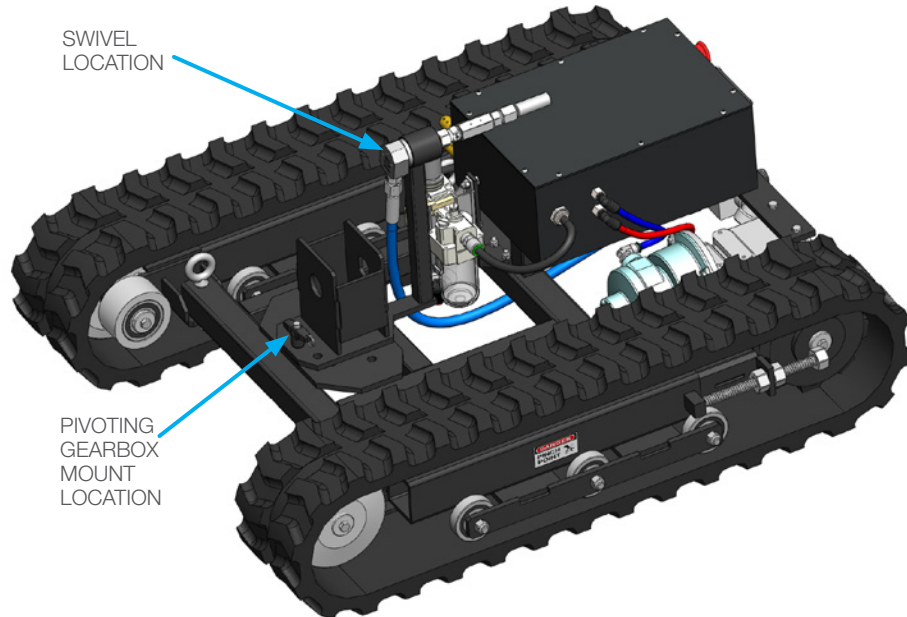

PARALLEL ORIENTATION

19. Loosen the swivel fitting with two adjustable end wrenches to allow the hose to rotate when changing positions. **(Figure 19)**

20. Pull out the Quick Release Pin and rotate the pivoting gearbox mount in the direction shown. **(Figure 20)**

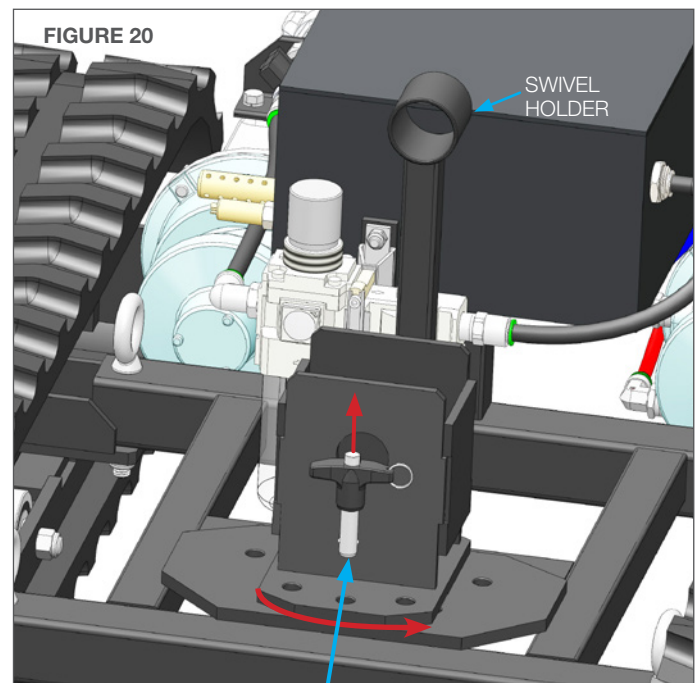
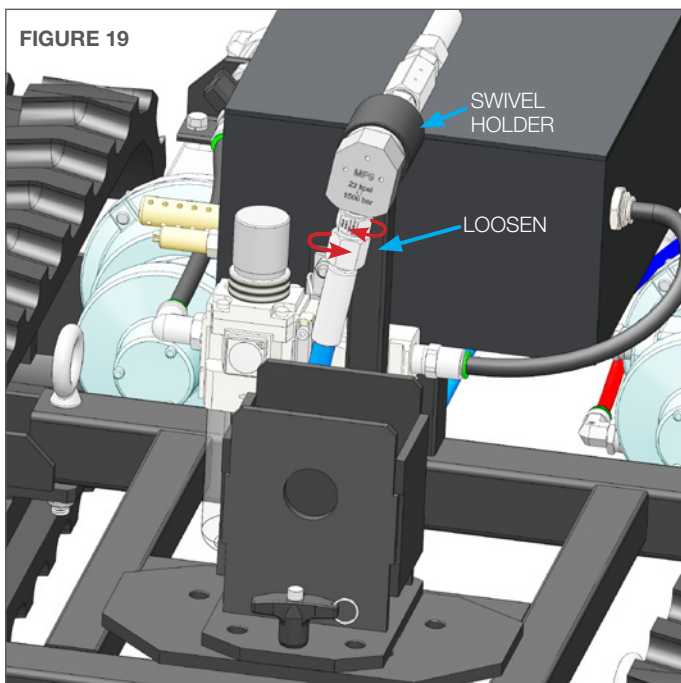

PARALLEL ORIENTATION

QUICK RELEASE PIN

ROTATING THE POSITION OF THE PIVOT (CONTINUED)

- 21. Insert the Quick Release Pin in the 3 O'Clock position. (Figure 21)
- 22. Tighten the swivel fitting with two adjustable end wrenches. (Figure 22)

PERPENDICULAR ORIENTATION

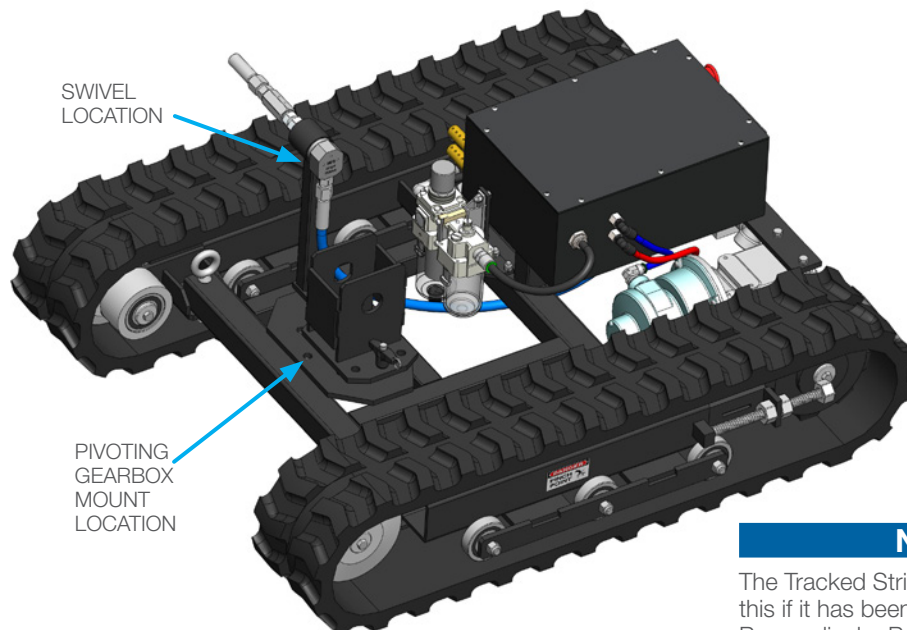
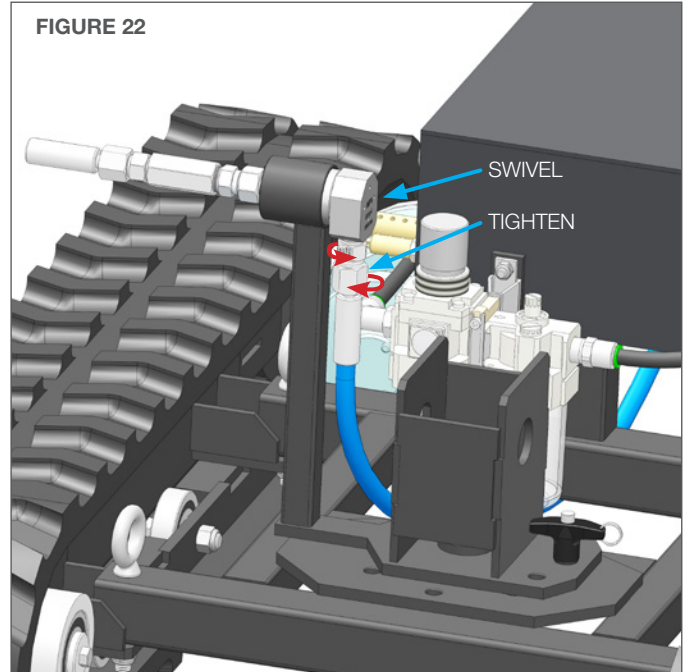
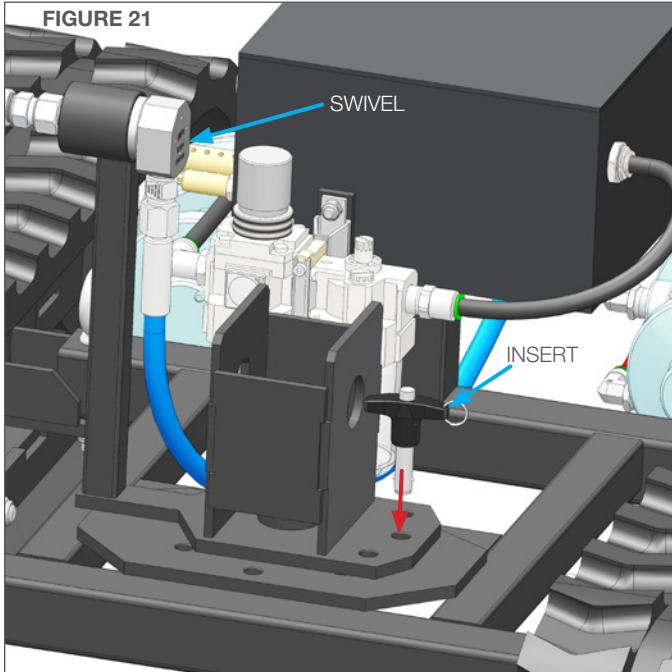

NOTICE

The Tracked Striker should appear like this if it has been rotated properly into the Perpendicular Position

PERPENDICULAR ORIENTATION

CONVERTING STANDARD STRIKER TO TRACKED STRIKER BASE

MOUNTING GEARBOX ASSEMBLY ONTO TRACKED BASE

The following assembly instructions are shown with the Tracked Striker in the **PERPENDICULAR ORIENTATION**.

23. Place the Gearbox Assembly into the mount as shown in **(Figure 23)**. Install Wedge Bolt with the flats lined up through both inboard and outboard plates and the Gearbox Assembly. Tighten Wedge Bolt with two 9/16" wrenches on both sides until secure.

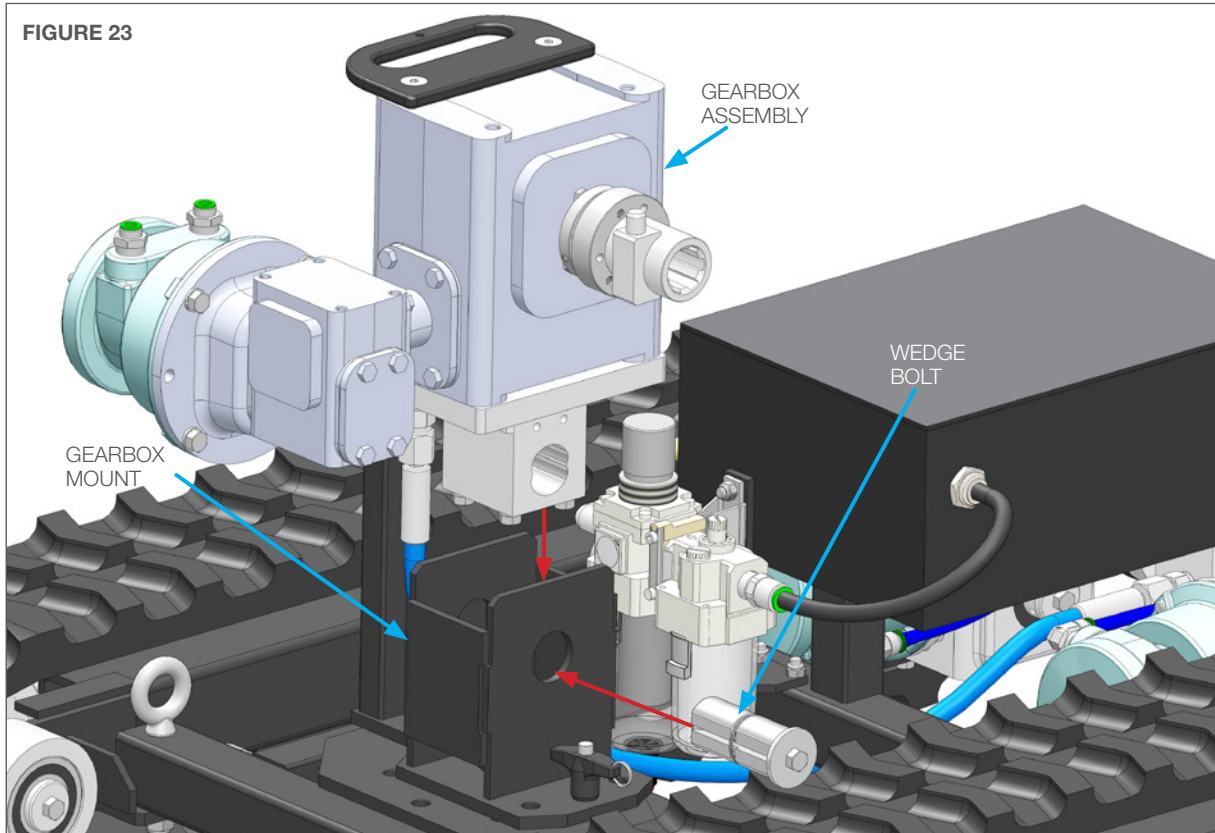

24. Slide the Vertical Rail Assembly onto the Spline by depressing the Hub Pin on the Spline coupling. **(Figure 24)**
The Hub Pin should be fully engaged and positioned between Rail Clamps as shown. **(Figure 24.1)**

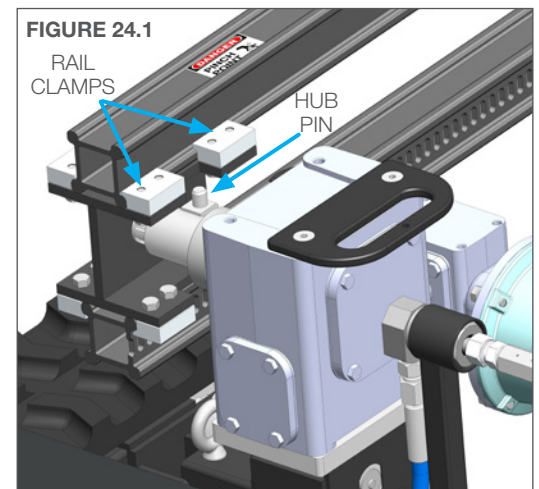
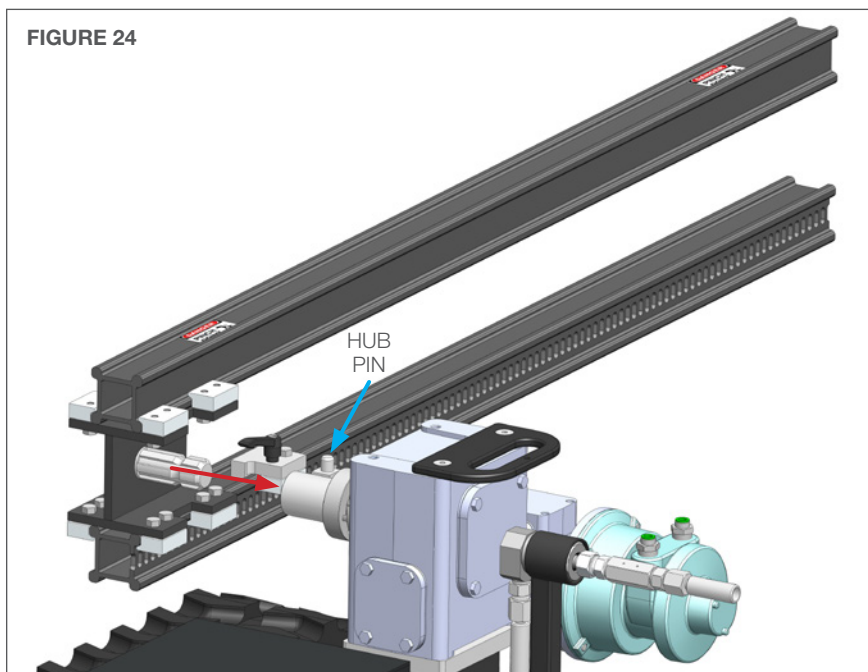

INSTALLING THE CARRIAGE ASSEMBLY

25. Slide the Carriage onto the Vertical Rails (**Figure 25**) and disengage the drive gear from the slotted rail by releasing the lever on the motor. This will allow the carriage to move along the rails. (**Figure 25.1**) Continue to slide the Carriage about half way down the rails and tighten the lever on the Carriage to engage the drive gear.

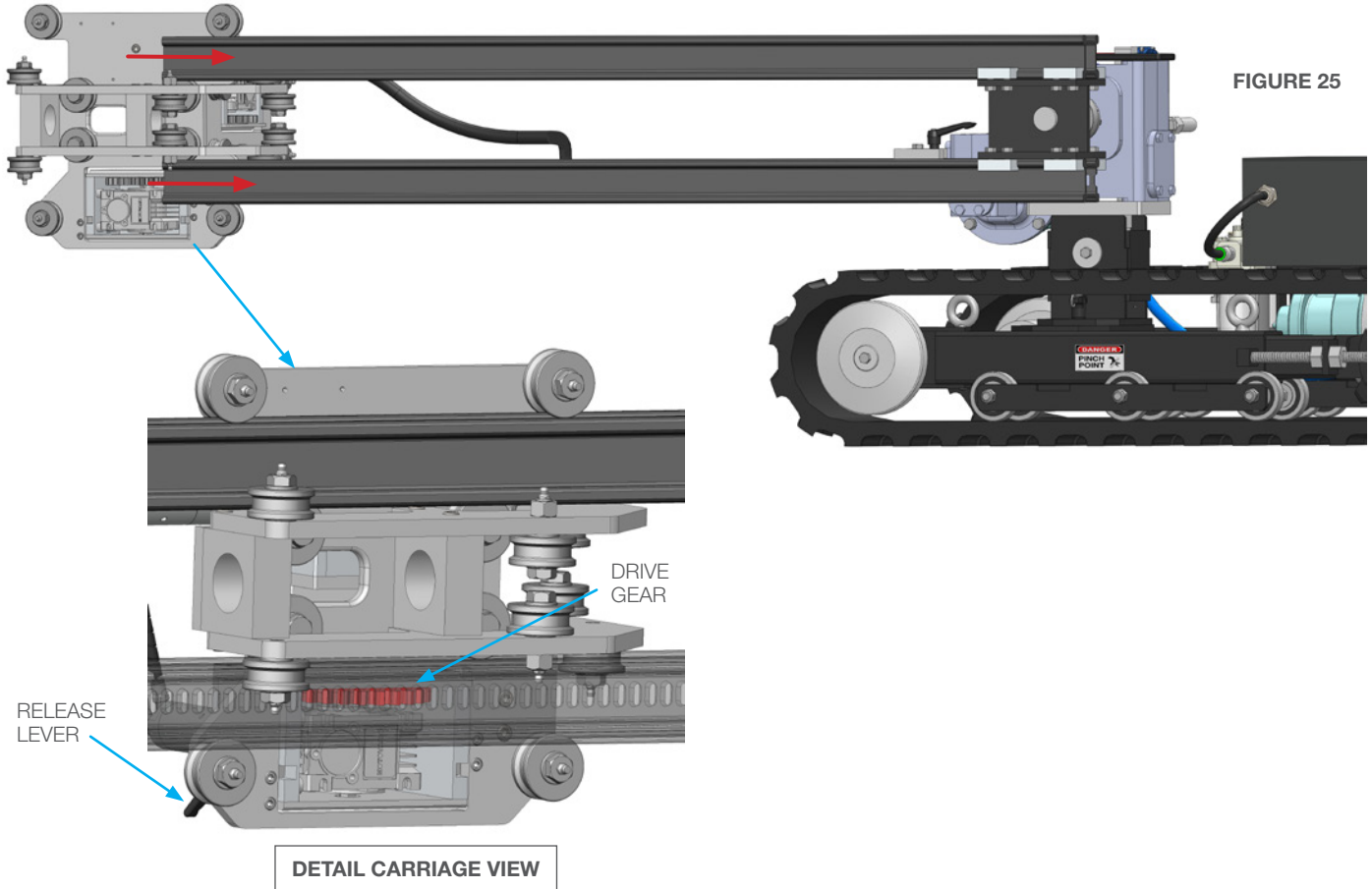

26. Connect the QD Hanger to the Gearbox handle by pulling out the quick release pin on the QD Hanger and sliding the pin into the center hole on the handle. (**Figure 26**)
27. Depress the pushlock fittings on the air motor and push in the red and blue 1/4" tubing lines as shown. IT IS CRITICAL TO FUNCTION that the red and blue lines be inserted in the exact positions shown. Pull back on both lines to ensure they are securely connected. (**Figure 27**)

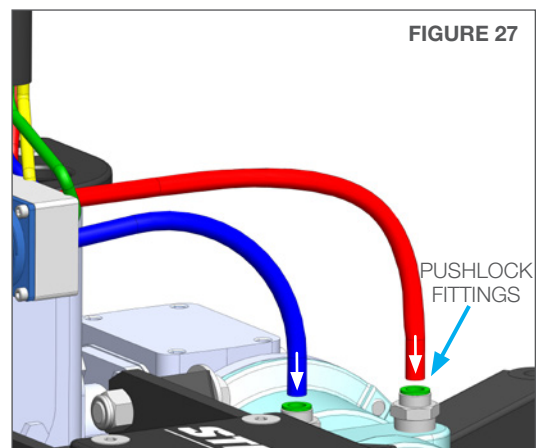
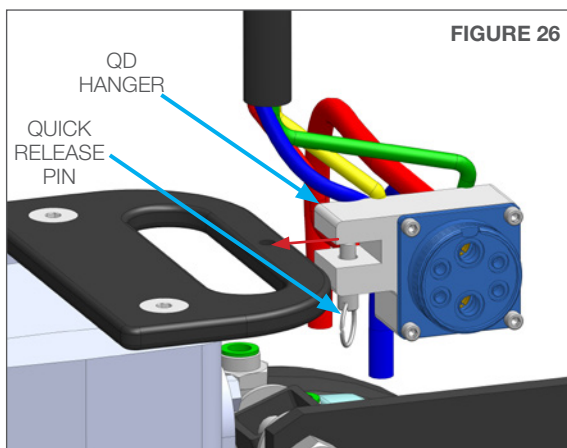

CONVERTING STANDARD STRIKER TO TRACKED STRIKER BASE

INSTALLING THE HORIZONTAL RAIL INTO THE CARRIAGE ASSEMBLY

28. Slide the Horizontal Rail Assembly into the Carriage Assembly. (Figure 28) Line up the box rail with the rollers. (Figure 28.1)

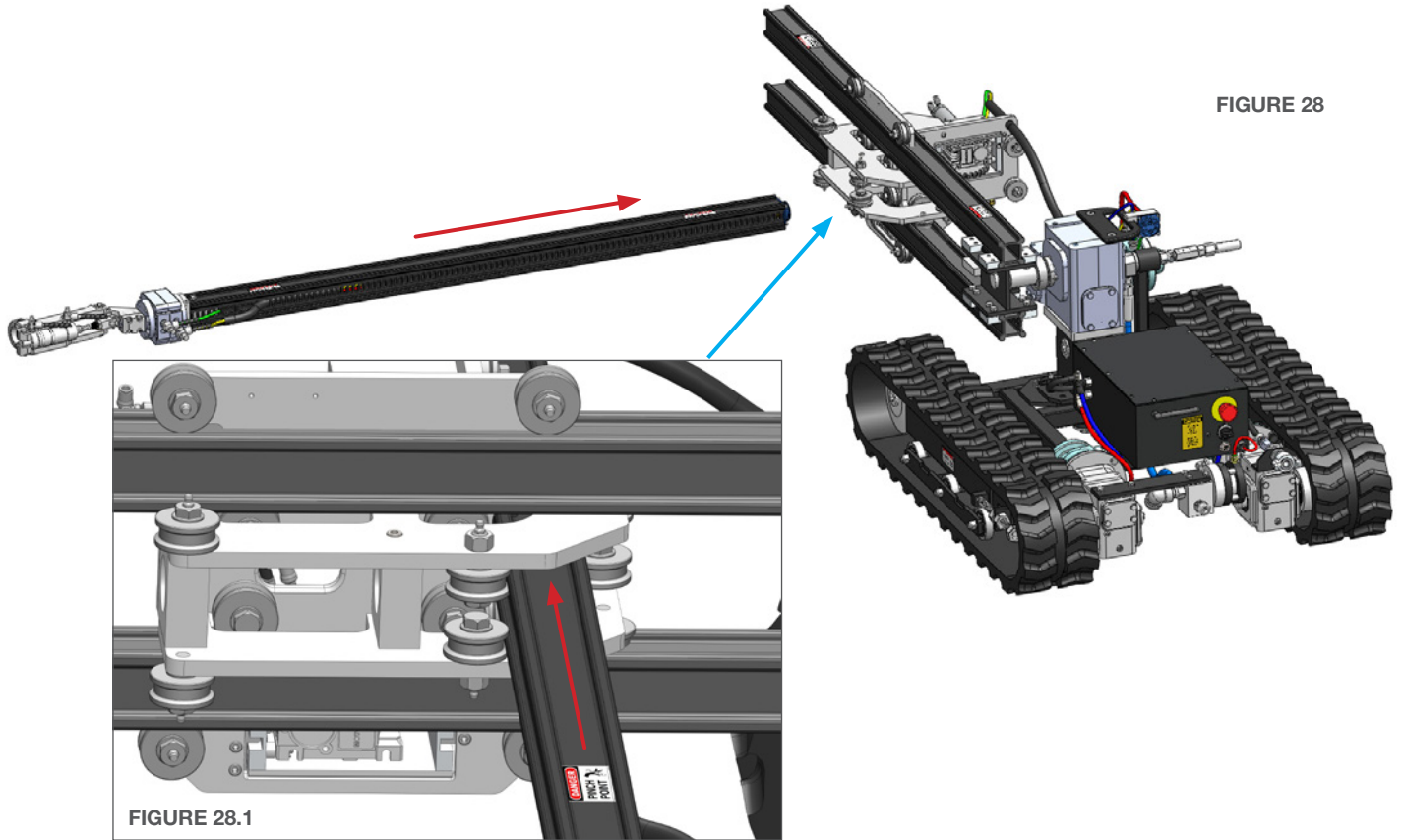

FIGURE 28

FIGURE 28.1

DETAIL CARRIAGE VIEW

NOTICE

The Horizontal Rail Assembly is slotted on both sides. Flipping the Horizontal Rail allows the 270° rotational spray pattern to be directed up or down.

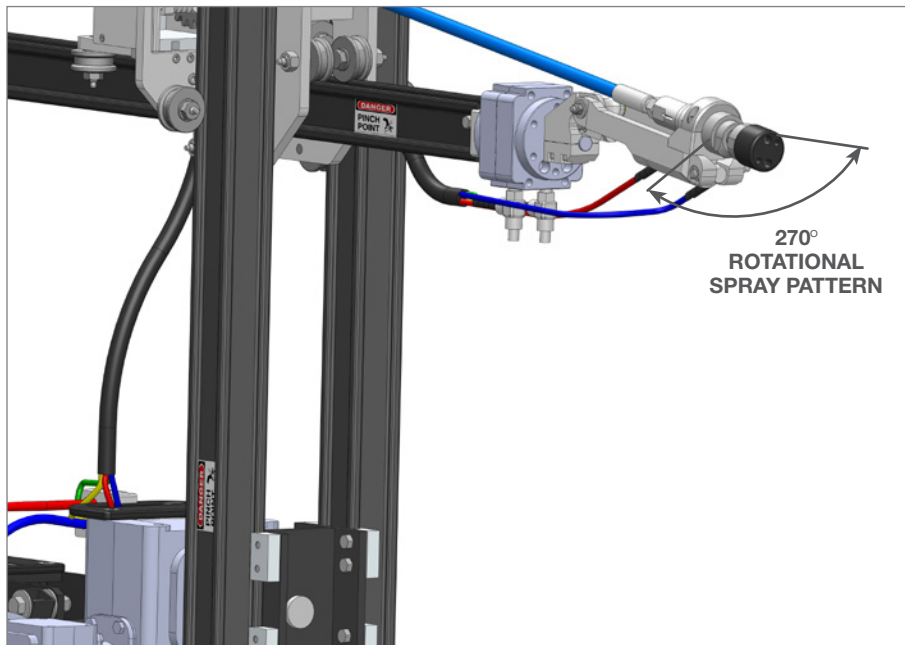

270°
ROTATIONAL
SPRAY PATTERN

INSTALLING THE RAIL STOPS

29. Slide the Tie Rail Stop onto the ends of the Vertical Rail Assembly. **(Figure 29)** Orient and tighten the Release Levers away from the Carriage Assembly. **(Figure 29.1)**

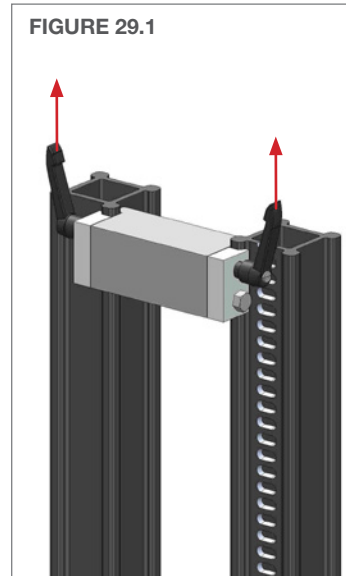
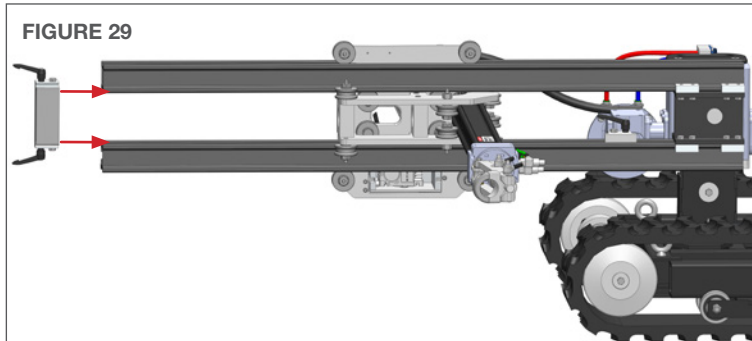

30. Slide the Rail Stop onto the end of the Horizontal Rail Assembly. **(Figure 30)** Orient and tighten the Release Lever away from the Carriage Assembly. **(Figure 30.1)**

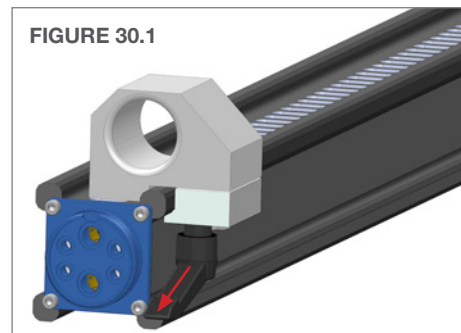
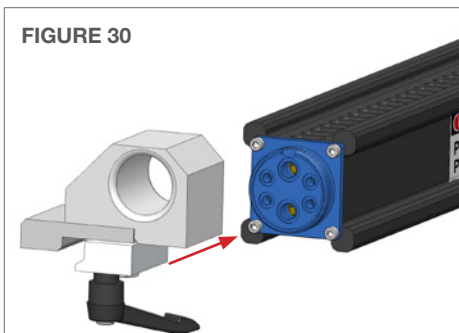

31. Slide the Carriage Stop along the Vertical Rail Assembly until the top of the block is 12" (305 mm) from the bottom of the Vertical Rail. Orient and tighten the Release Lever away from the Carriage Assembly.

NOTICE

Setting the Carriage Stop at a minimum of 12" (305 mm) ensures the carriage and horizontal rail will clear the gearbox and the base.

If the Carriage Stop is placed lower to gain range of motion, the Operator must pay attention to the horizontal rail and carriage assembly to ensure that they DO NOT make contact with the gearbox or base. Failure to do so will result in damage to the motors on the carriage assembly.

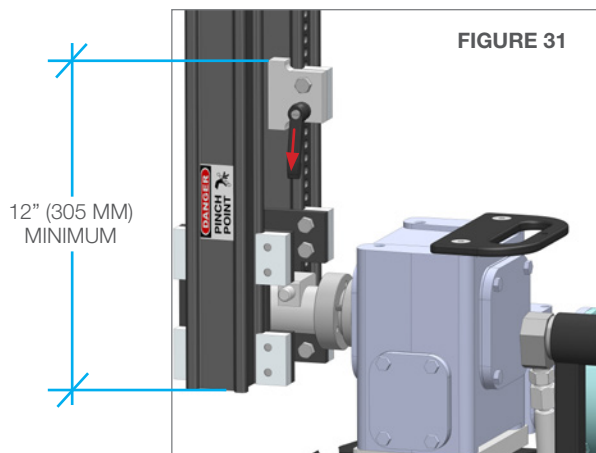

CONVERTING STANDARD STRIKER TO TRACKED STRIKER BASE

CONNECTING HIGH PRESSURE HOSE AND FITTINGS TO BCK-20K

32. Connect the female connector on the High Pressure Hose to the Swivel Connection. **(Figure 32)** Feed the male connector on the High Pressure Hose through the Rear Rail Stop on the end of the Horizontal Rail, then through the Carriage towards the BCK-20K Holder. **(Figure 32.1)**

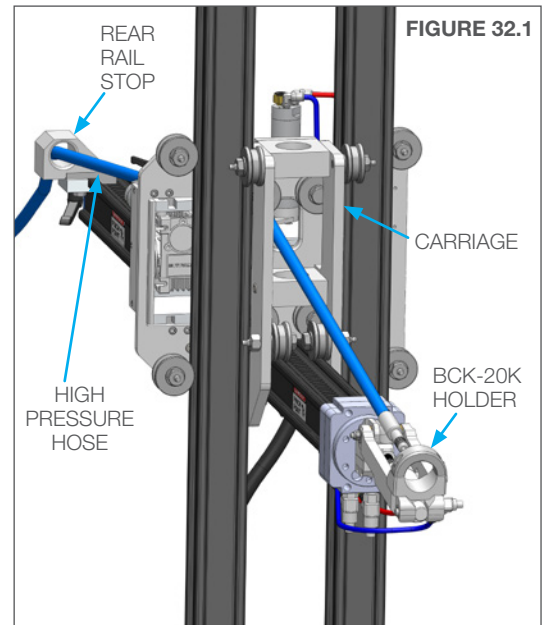
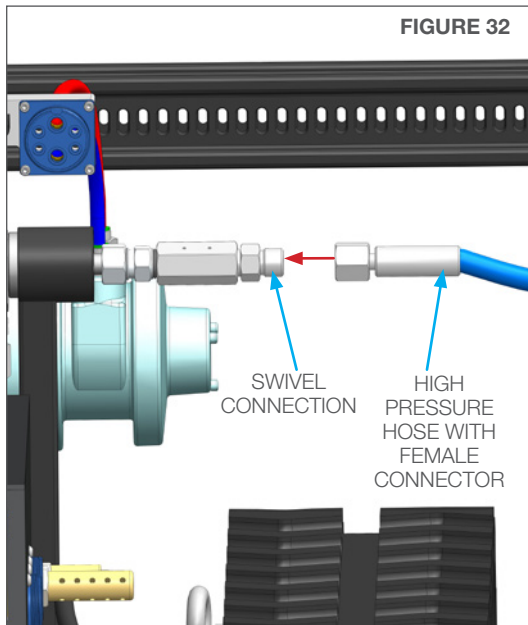

33. Fasten High Pressure Hose to BCK-20K Barracuda by loosening the two 1/4" square head cap screws and sliding the BCK-20 into the holder until the shoulder hits the collar. **(Figure 33)** The hose end is a 9/16" medium pressure connection, with a modified gland nut and standard collar.

NOTICE

It is recommended to use BLUE GOOP, A SWAGELOK brand anti-seize, or an equivalent on threaded fittings to avoid galling.

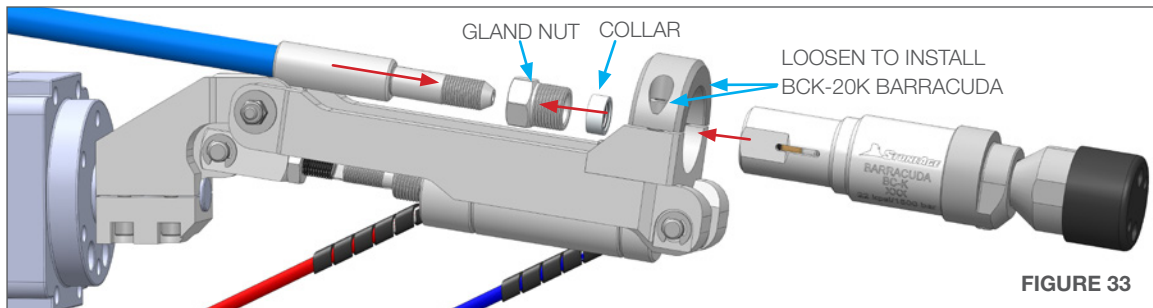

34. Tighten the BCK-20K Barracuda to Gland Nut on the High Pressure Hose (A) and tighten the Wrist Clamp to BCK-20K Barracuda (B). **(Figure 34)**

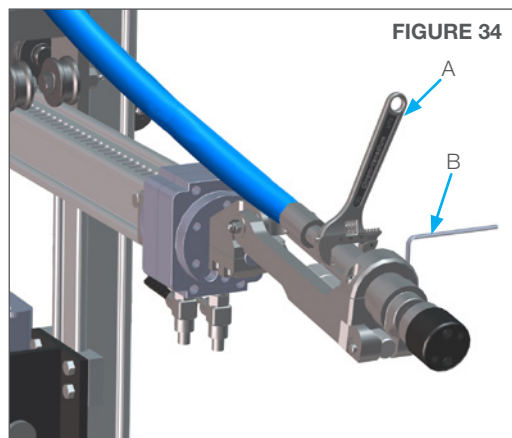

PNEUMATIC SUPPLY LINE CONNECTIONS

Remove the dust caps from the connectors on the Wireless Control Receiver, the Horizontal Rail, and the Gearbox Assembly.

36. Connect the **RED** umbilical into the Right plug on the Wireless Control Receiver and the end of the Horizontal Rail.
Connect the **BLACK** umbilical into the Left plug on the Receiver Box and the QD Hanger. **(Figure 36)**

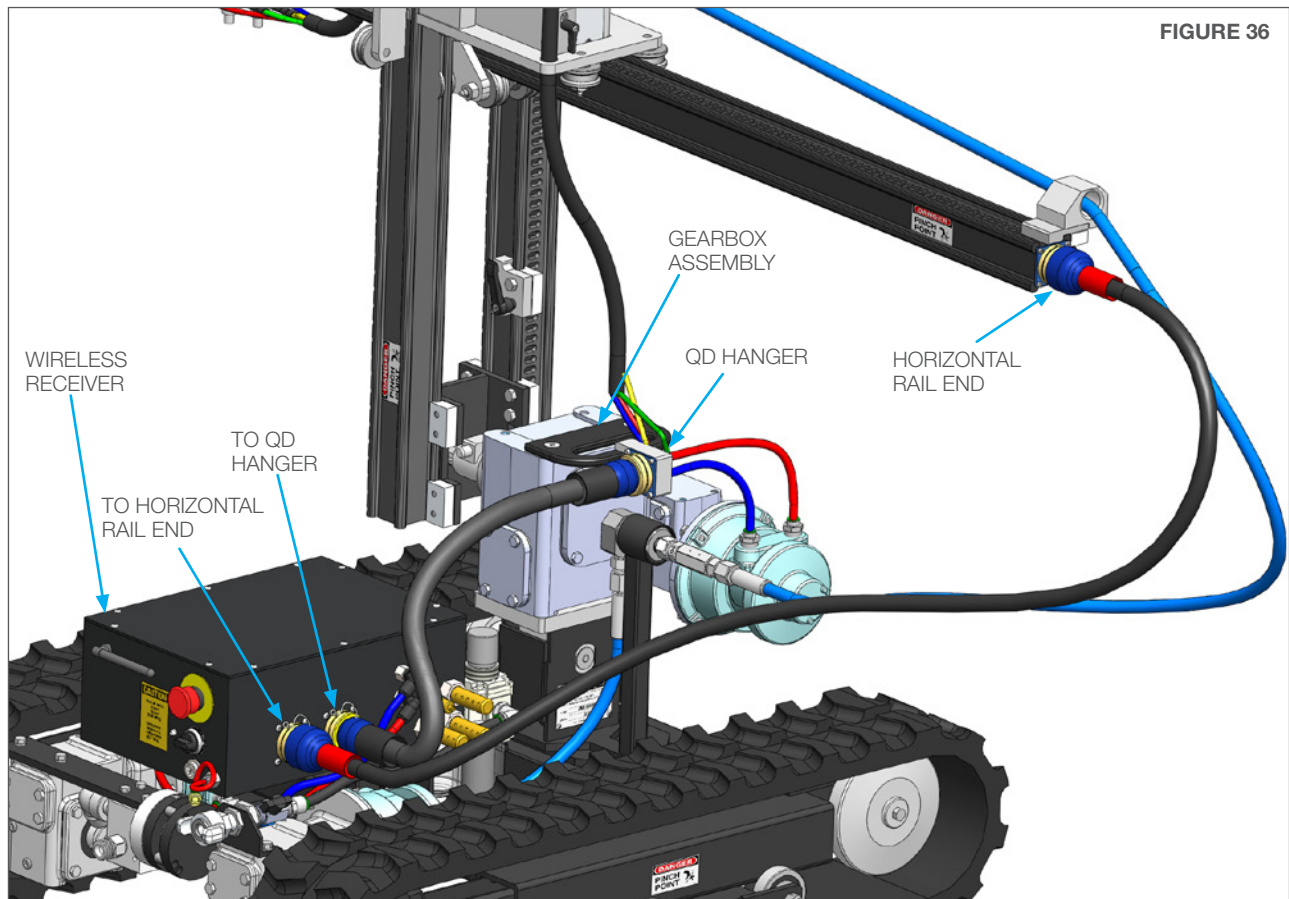

NOTICE

TO COMPLETE THE SET-UP OF THE TRACKED STRIKER (SKR-TRK), SKIP FORWARD TO THE
“AIR AND WATER SUPPLY AND LUBRICATOR SETTING”
IN THE TRACKED STRIKER SECTION OF THIS MANUAL.
FOLLOW THE INSTRUCTIONS THROUGH TO OPERATION.

TRACKED STRIKER® SKR-TRK AND WIRELESS REMOTE CONTROL SYSTEM

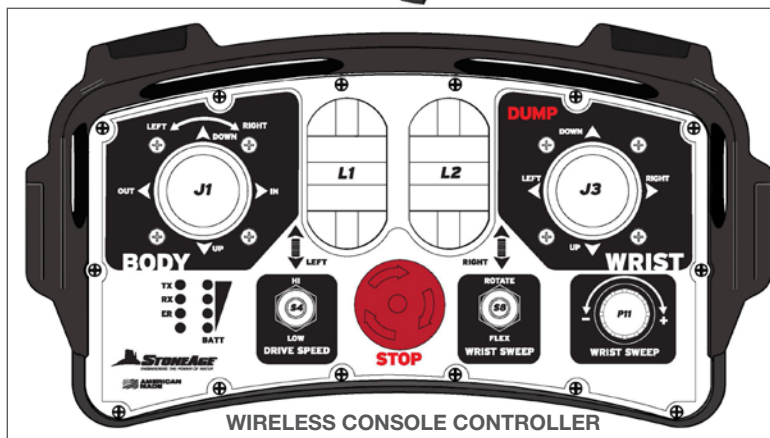
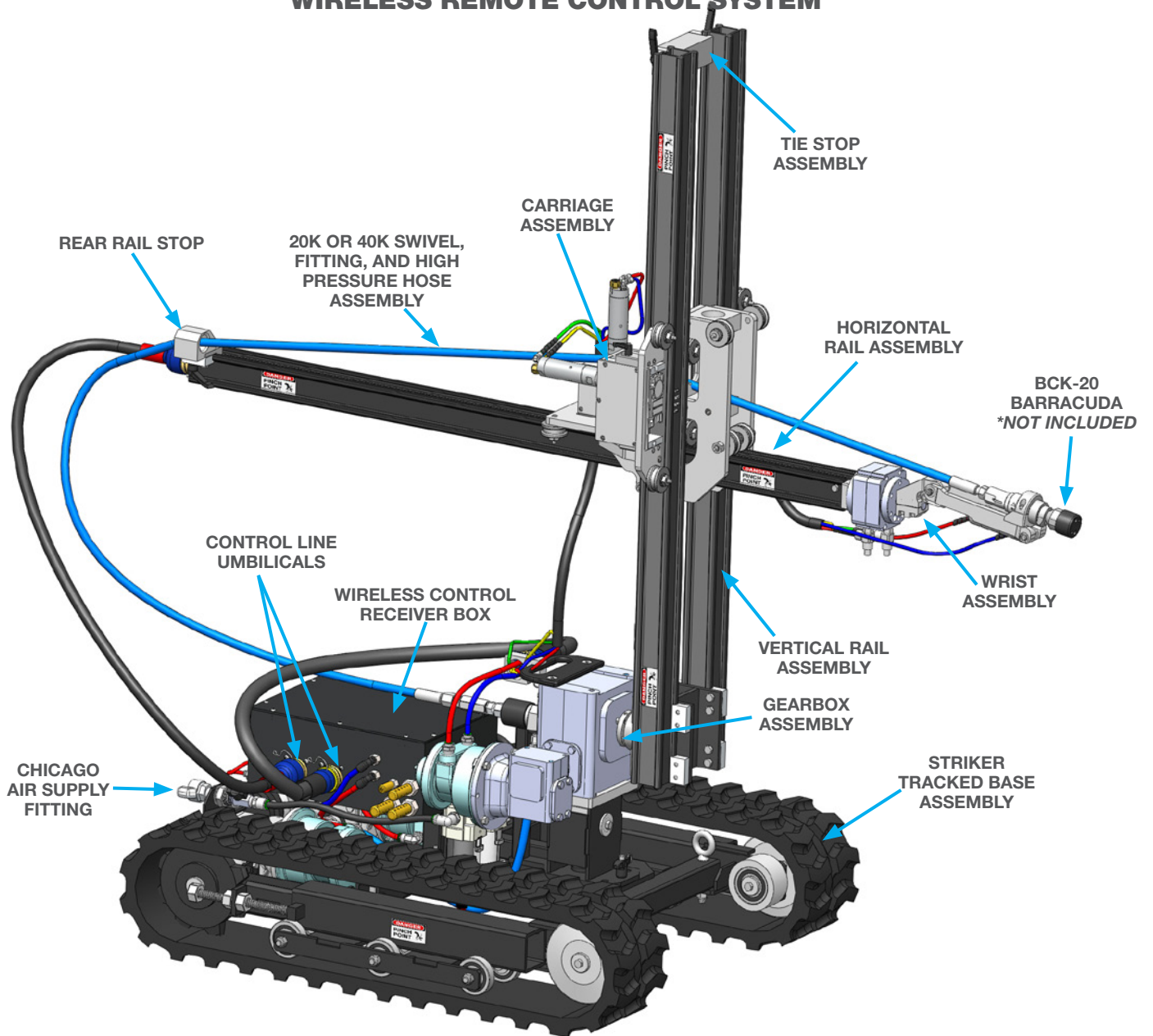

REMOVING THE TRACKED BASE FROM THE CRATE

The Tracked Striker is shipped with the Remote Control associated to the Tracked Base. This allows the Operator to drive the tracked base out of the crate and into location.

- Pull up on the EMERGENCY STOP BUTTONS on both the RECEIVER UNIT and REMOTE CONTROL.
- Stand near the RECEIVER UNIT with the REMOTE CONTROL in hand. Activate the REMOTE CONTROL by flipping the ON/OFF switch UP.
- When the TX lights blink at a rate of once per second on the REMOTE CONTROL, turn ON the power on the RECEIVER UNIT by rotating the ON/OFF knob clockwise.
- The TX (Transmit) and RX (Receive) LEDs on the REMOTE CONTROL should be active indicating that the communication link is established.

If the unit fails to move, shut both the Remote Control and the Receiver down and follow the association steps on Page 44. See Page 45 for detailed Remote Controller operating instructions.

INSTALLING THE HORIZONTAL RAIL INTO THE CARRIAGE ASSEMBLY

1. Install the Horizontal Rail Assembly with Wrist through the Carriage Assembly located on the Vertical Rail Assembly. **(Figure 1)** Center the Horizontal Rail between the four rollers on the Carriage Assembly **(Figure 1.1)** and slide in about half way.

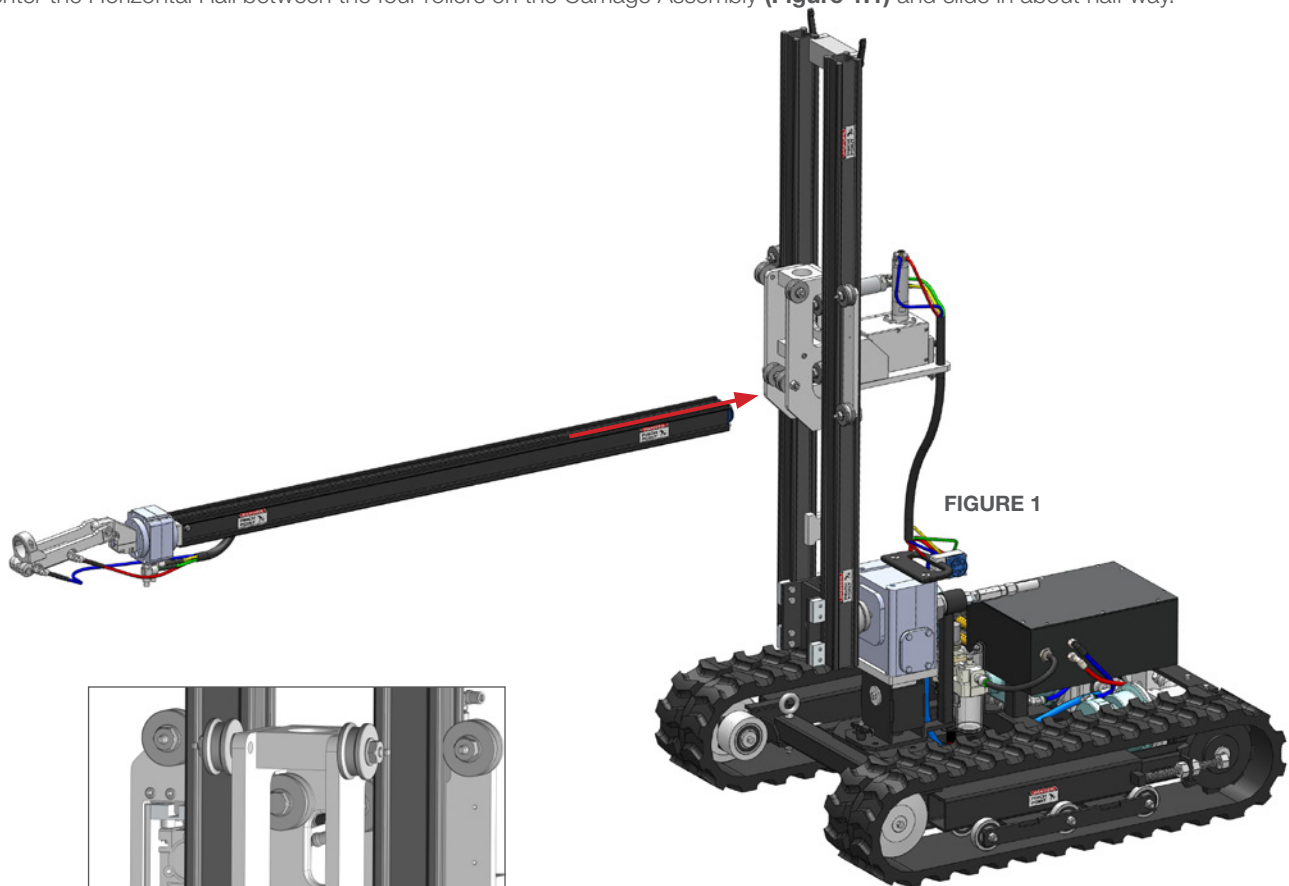
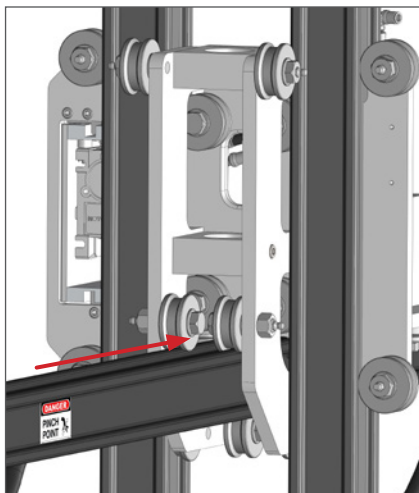
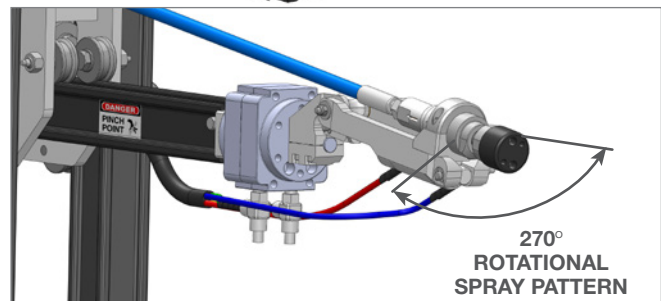

FIGURE 1



DETAIL CARRIAGE VIEW FIGURE 1.1



270°
ROTATIONAL
SPRAY PATTERN

NOTICE

The Horizontal Rail Assembly is slotted on both sides. Flipping the Horizontal Rail allows the 270° rotational spray pattern to be directed up or down.

SKR-TRK SET-UP - RAIL STOP INSTALLATION

INSTALLING THE RAIL STOPS

- Slide the Rail Stop onto the end of the Horizontal Rail Assembly. **(Figure 2)** Orient and tighten the Release Lever away from the Carriage Assembly. **(Figure 2.1)**

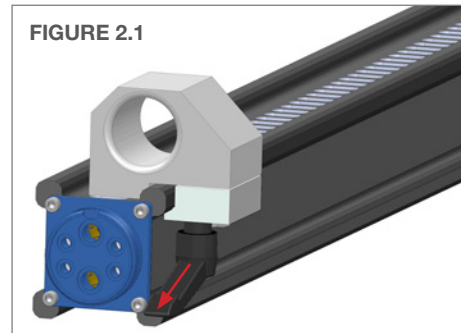
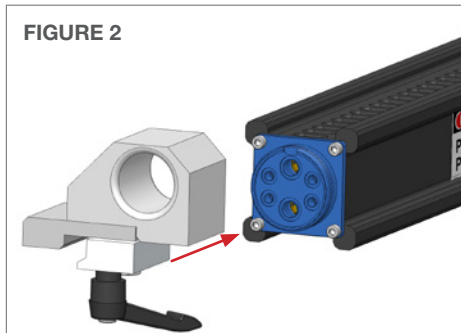

- Slide the Carriage Stop along the Vertical Rail Assembly until the top of the block is 12" (305 mm) from the bottom of the Vertical Rail. Orient and tighten the Release Lever away from the Carriage Assembly.

NOTICE

Setting the Carriage Stop at a minimum of 12" (305 mm) ensures the carriage and horizontal rail will clear the gearbox and the base.

If the Carriage Stop is placed lower to gain range of motion, the Operator must pay attention to the horizontal rail and carriage assembly to ensure that they DO NOT make contact with the gearbox or base. Failure to do so will result in damage to the motors on the carriage assembly.

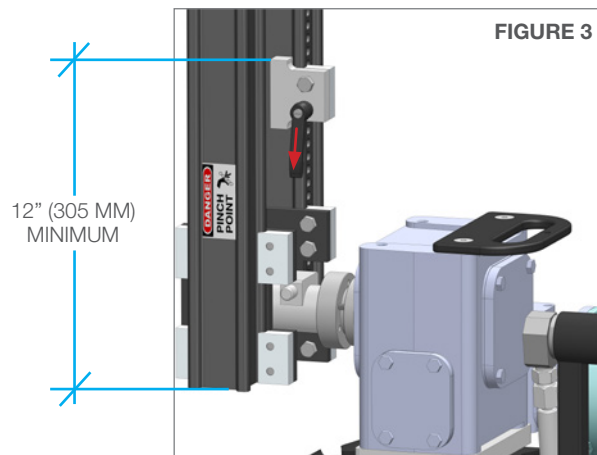

CONNECTING HIGH PRESSURE HOSE AND FITTINGS TO BCK-20K

32. Connect the female connector on the High Pressure Hose to the Swivel Connection. **(Figure 4)** Feed the male connector on the High Pressure Hose through the Rear Rail Stop on the end of the Horizontal Rail, then through the Carriage towards the BCK-20K Holder. **(Figure 4.1)**

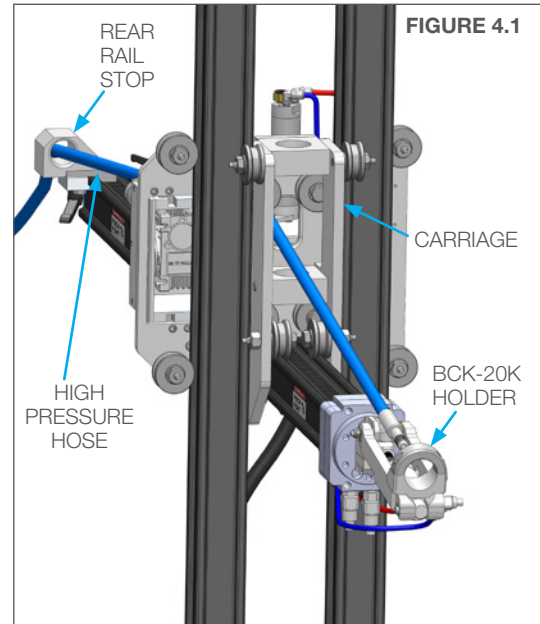
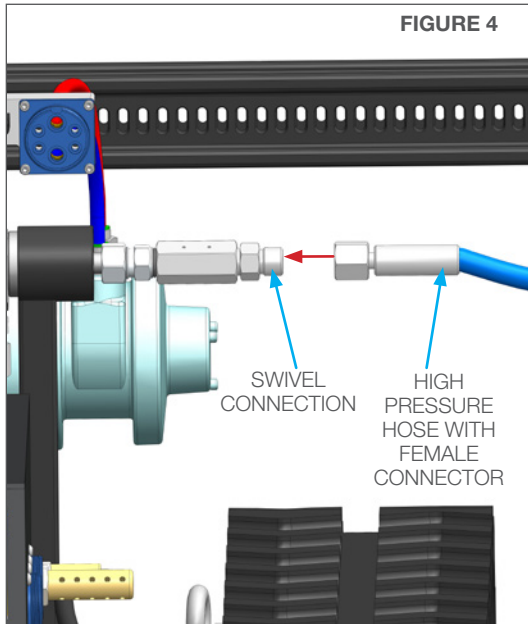

33. Fasten High Pressure Hose to BCK-20K Barracuda by loosening the two 1/4" square head cap screws and sliding the BCK-20 into the holder until the shoulder hits the collar. **(Figure 5)** The hose end is a 9/16" medium pressure connection, with a modified gland nut and standard collar.

NOTICE

It is recommended to use BLUE GOOP, A SWAGELOK brand anti-seize, or an equivalent on threaded fittings to avoid galling.

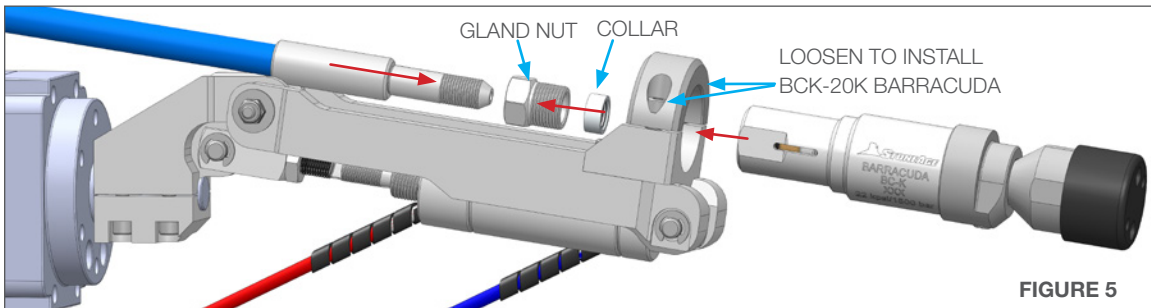

34. Tighten the BCK-20K Barracuda to Gland Nut on the High Pressure Hose (A) and tighten the Wrist Clamp to BCK-20K Barracuda (B). **(Figure 6)**

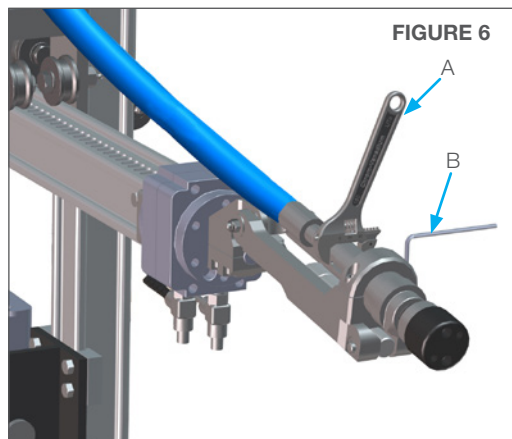

WRIST SPEED CONTROL ADJUSTMENTS

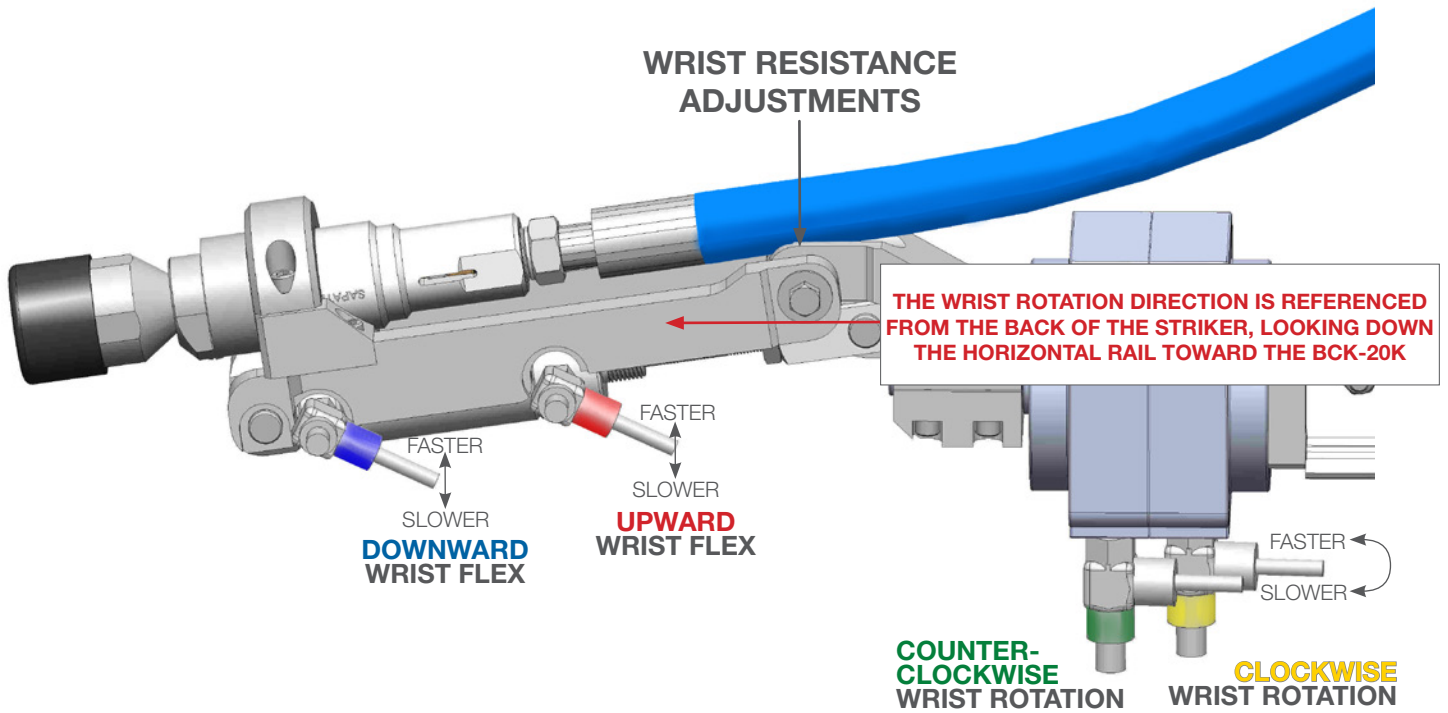

WRIST RESISTANCE ADJUSTMENTS

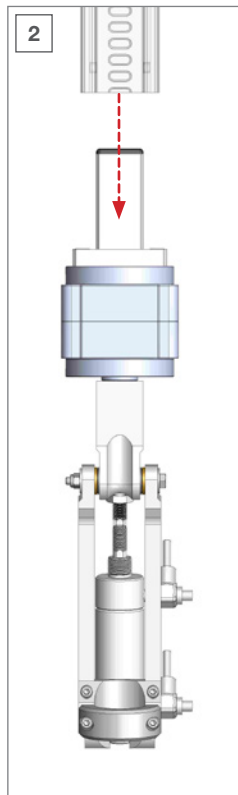
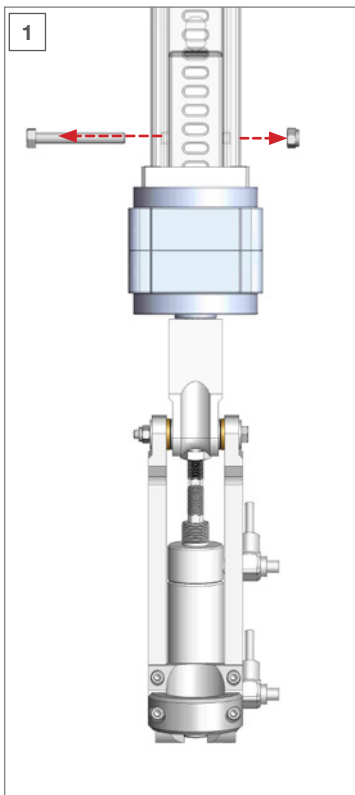

1. Remove Bolt and Lock Nut From the Rail and Wrist Assembly.
2. Pull the Wrist Assembly free of the Rail.
3. Remove the black plastic end cap from the end of the Wrist Assembly.
4. Remove the Friction Torque Limiter and Shaft
5. Loosen set screws.
6. Adjust nut to the left for less resistance and tighten to the right for increased resistance.

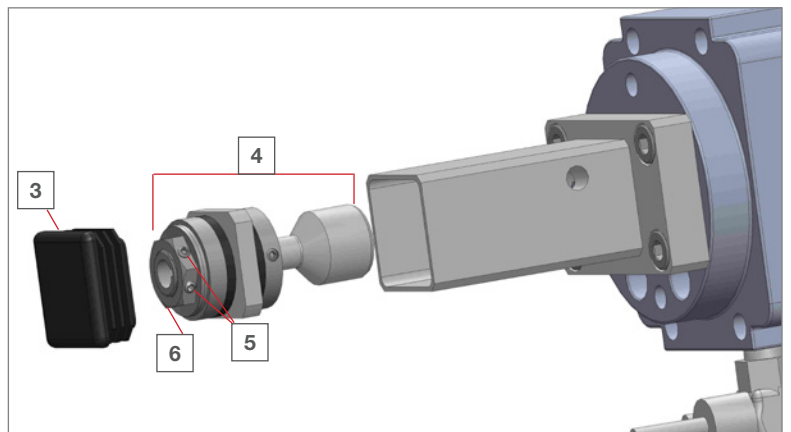

PNEUMATIC SUPPLY LINE CONNECTIONS

Remove the dust caps from the connectors on the Wireless Control Receiver, the Horizontal Rail, and the Gearbox Assembly.

36. Connect the **RED** umbilical into the Right plug on the Wireless Control Receiver and the end of the Horizontal Rail.
Connect the **BLACK** umbilical into the Left plug on the Receiver Box and the QD Hanger.

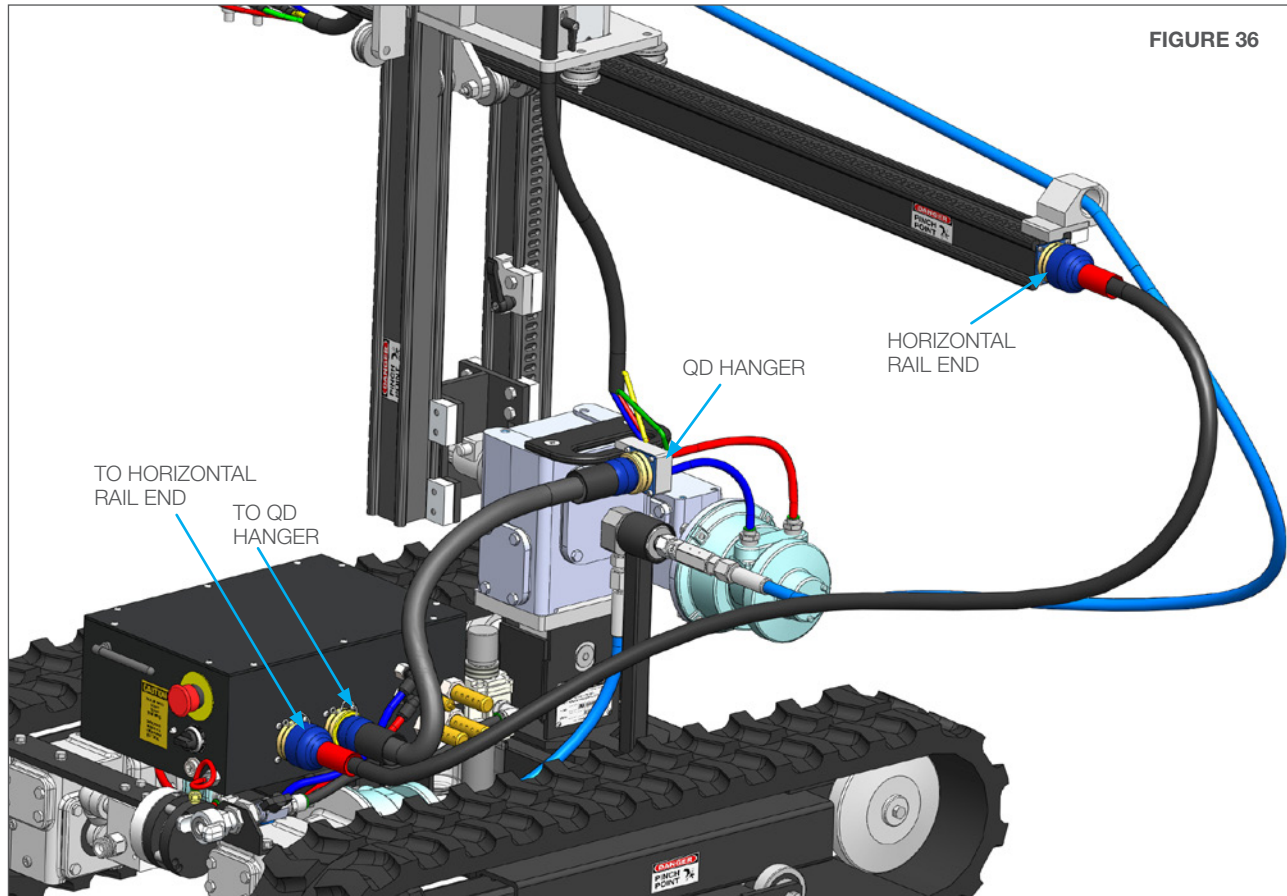

SKR-TRK SET-UP - AIR AND WATER SUPPLY AND LUBRICATOR SETTING

AIR AND WATER SUPPLY AND LUBRICATOR SETTING

1. The Tracked Striker is supplied with a twist claw style inlet coupling (Chicago style) located to the right of the Emergency Shut Off button. **(Figure 1)** Connect a compatible compressed air line (not included) according to the Manufacturer's instructions. If another pneumatic connection is preferred, this fitting can be removed and any male 1/2 in NPT fitting may be used. Connect the water supply hose to the Main Water Inlet/Outlet connection to the left of the Air Supply fitting.
2. Use the Regulator on the Filter, Regulator, Lubricator (FRL) to adjust the operating pressure to 110 psi (0.76 MPa) for the application. **(Figure 3)**
3. Adjust inline oiler on the FRL to feed 1 drop of oil every 15-30 seconds for high speed or continuous duty usage. **(Figure 3)**

⚠ WARNING

Minimum operating pressure is 80 psi (0.55 MPa). Maximum operating air pressure is 125 psi (0.86 MPa). Exceeding 125 psi (0.86 MPa) supply pressure may result in injury to the Operator and/or damage to the equipment.

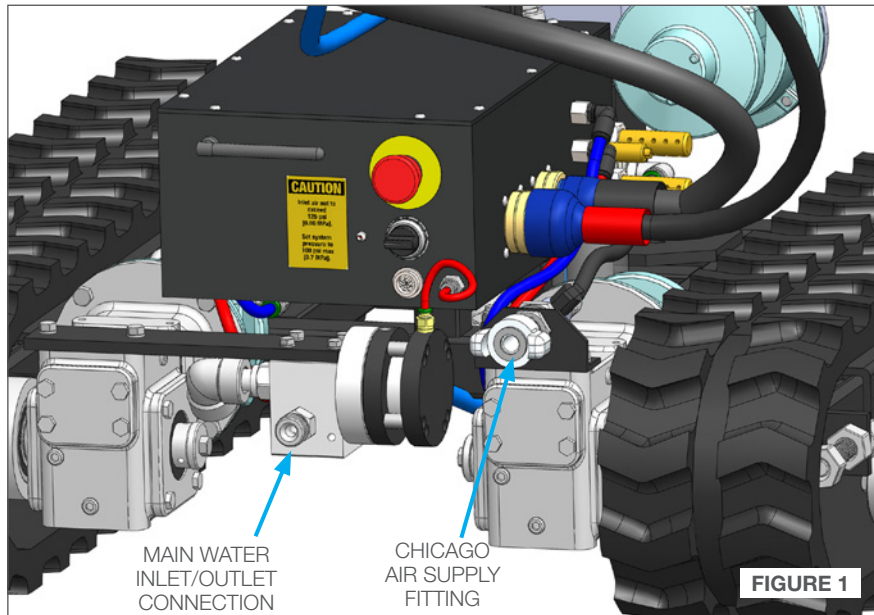

FIGURE 1

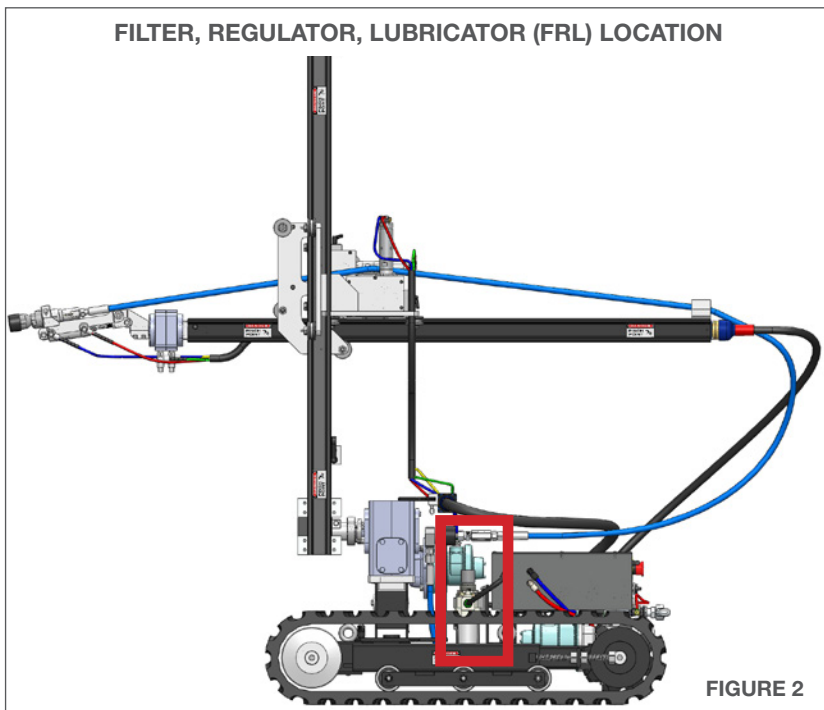

FIGURE 2

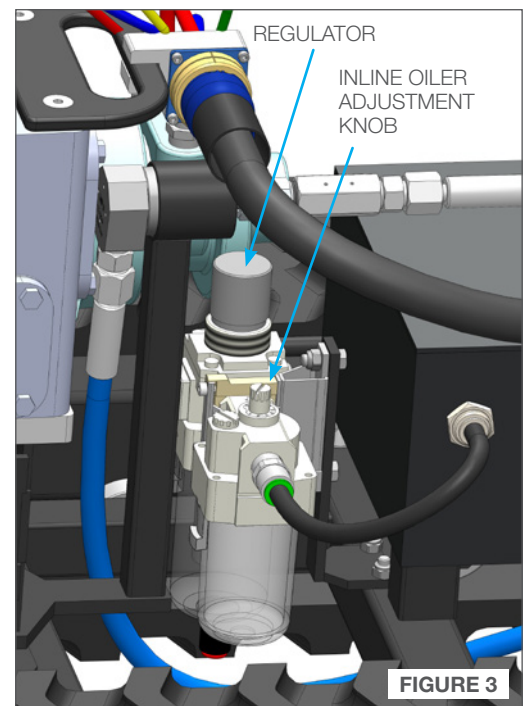

FIGURE 3

RAIL ASSEMBLY ORIENTATION

There are two ways to position the rail assembly on the Tracked Striker base. The diagrams below illustrate the differences between the two positions.

The Tracked Striker is shown in the left column in the **Parallel Orientation**. The Tracked Striker is in the Parallel Orientation when the horizontal rail is running parallel with the tracks.

The Tracked Striker is shown in the right column in the **Perpendicular Orientation**. The Tracked Striker is in the Perpendicular Orientation when the horizontal rail is running perpendicular to the tracks.

PARALLEL ORIENTATION

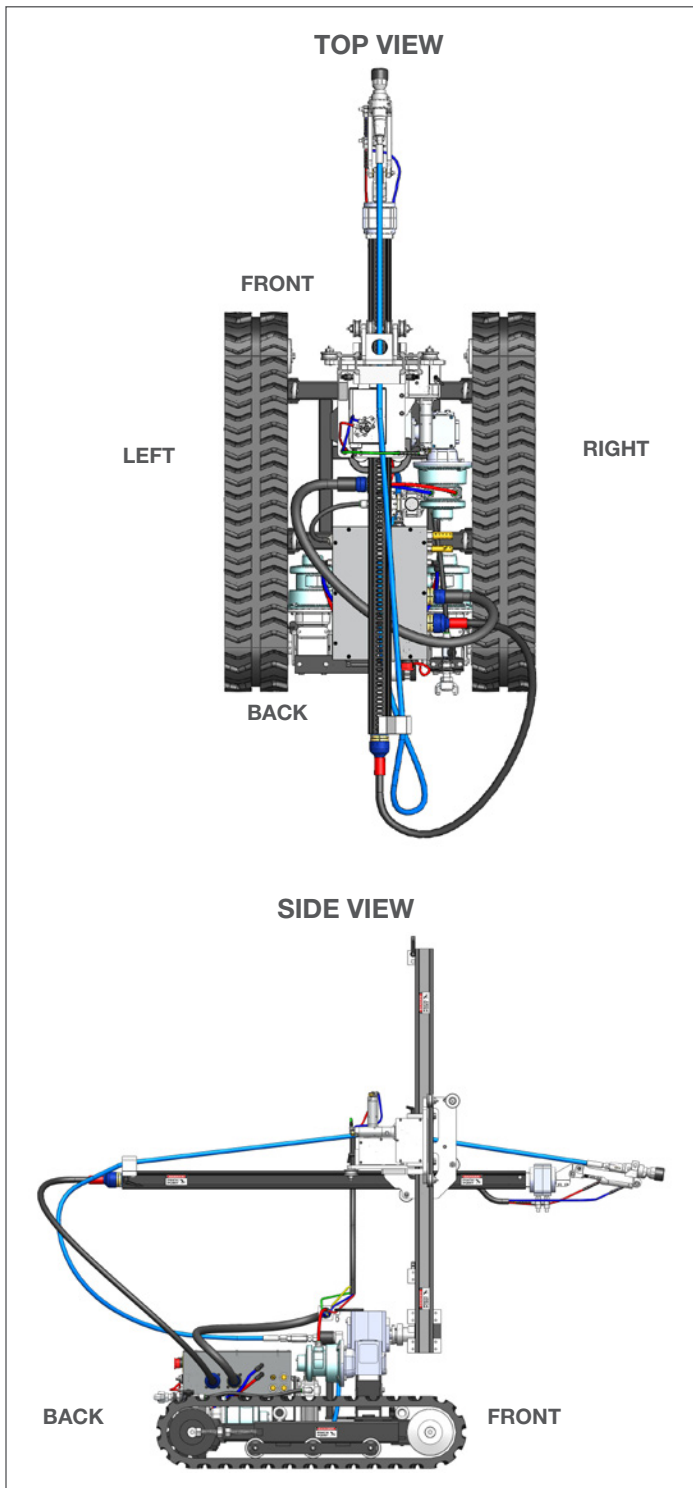

PERPENDICULAR ORIENTATION

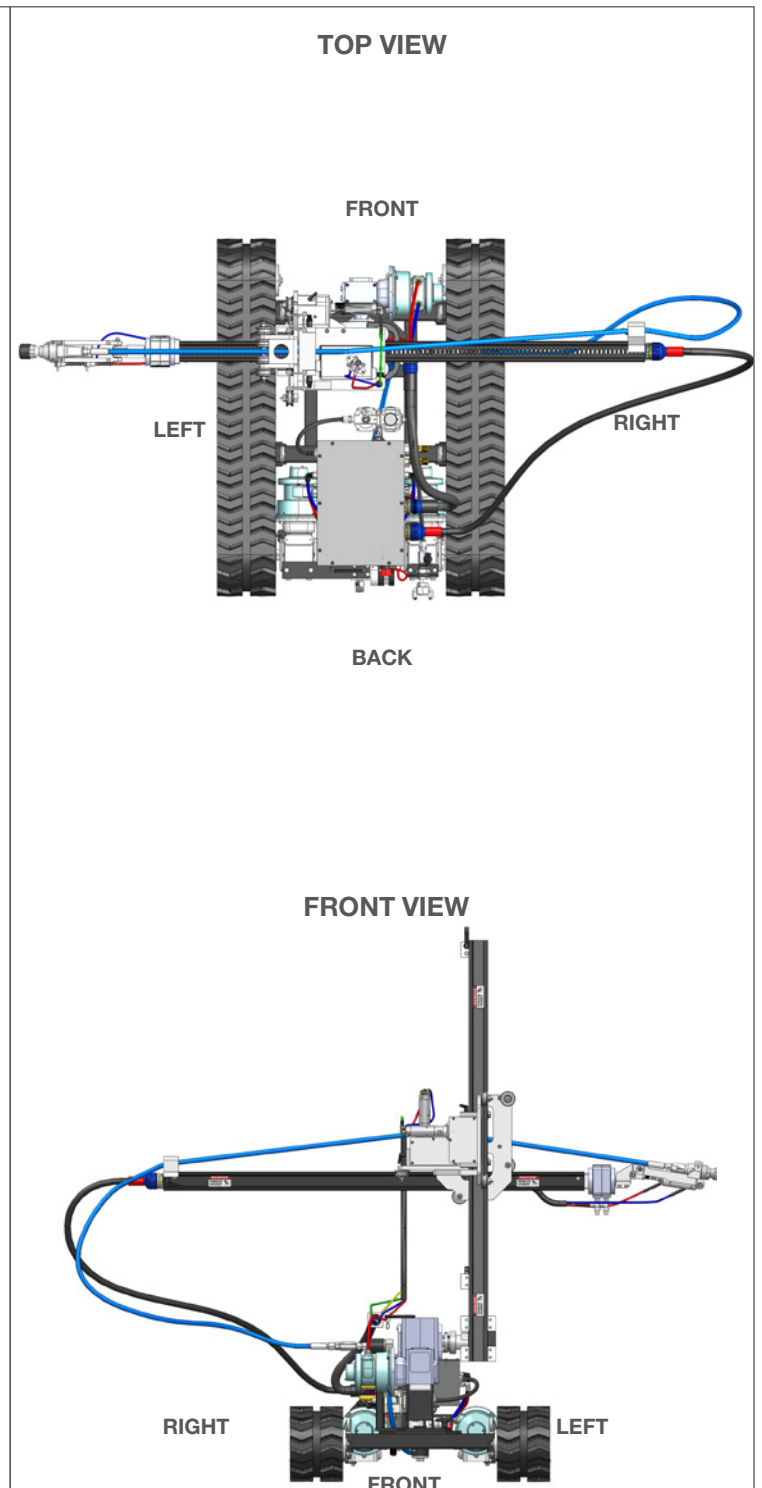

SKR-TRK SET-UP - CHANGING TRACKED STRIKER ORIENTATION

ROTATING THE TRACKED STRIKER ORIENTATION

The job location will determine if the Parallel or Perpendicular position will allow for easier access to the object to be cleaned. Changing the orientation requires rotating the upper rail and gearbox assembly. The Tracked Striker has an easy pivot mechanism located under the gearbox. The following instruction is to rotate the Tracked Striker from the Parallel Orientation to the Perpendicular Orientation.

⚠ WARNING

Always de-energize the system before servicing or replacing any parts. Failure to do so can result in severe injury and/or death. Keep hands, hair, and clothing clear of rotating parts.

1. Dump and shut down the main water supply to the Tracked Striker.
2. Disconnect high pressure water hose from the swivel.
3. Loosen the nut on the swivel fitting with two adjustable end wrenches to allow the swivel to rotate with the Pivot Base.
4. Pull out the quick release pin on the pivot mechanism.
5. Rotate the upper rail and gearbox assembly in the counterclockwise direction with 12 O'Clock being located at the Front of the Tracked Striker.

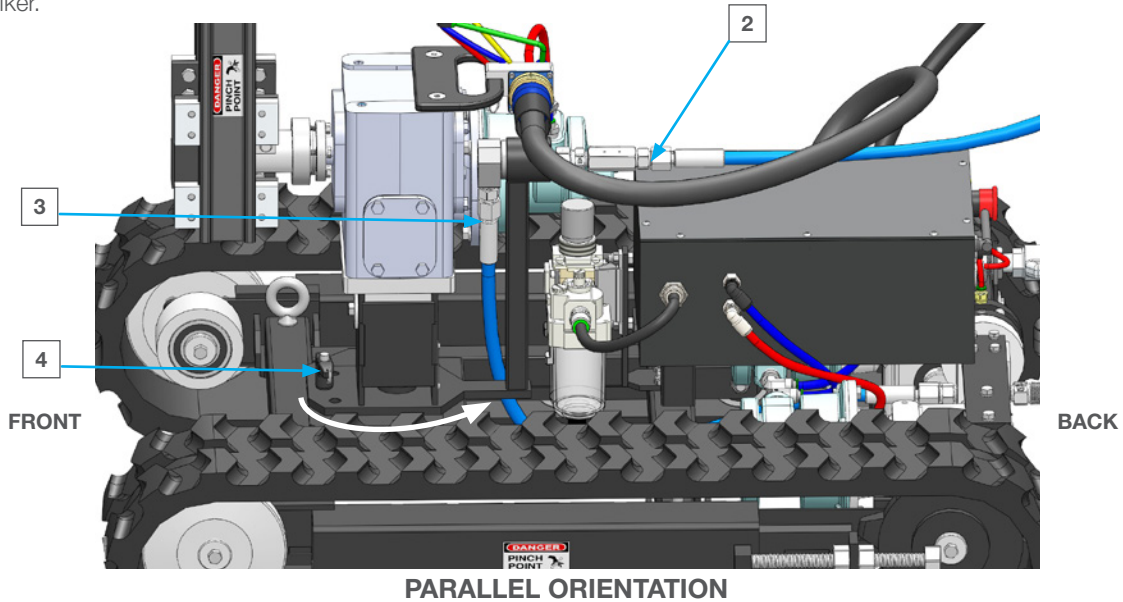

PARALLEL ORIENTATION

6. Replace the Quick Release Pin.
7. Tighten the swivel fitting with two adjustable end wrenches.
8. Connect the high pressure hose to the swivel. Ensure that the it is securely tightened.

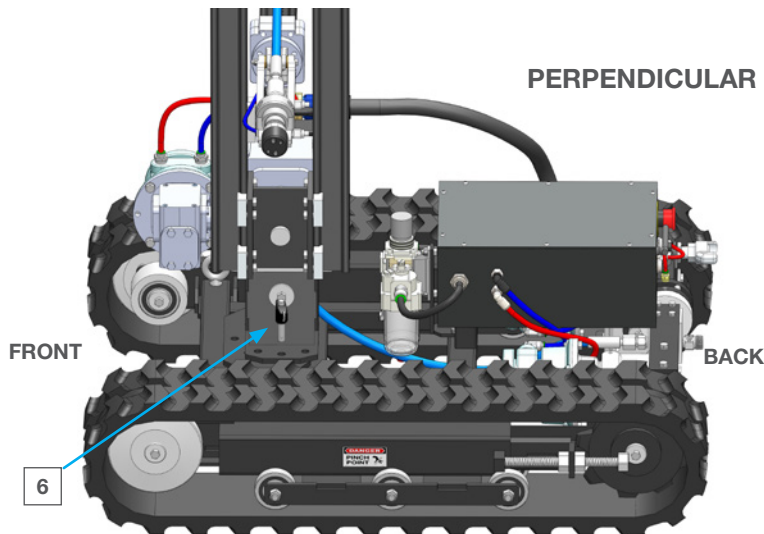

PERPENDICULAR ORIENTATION

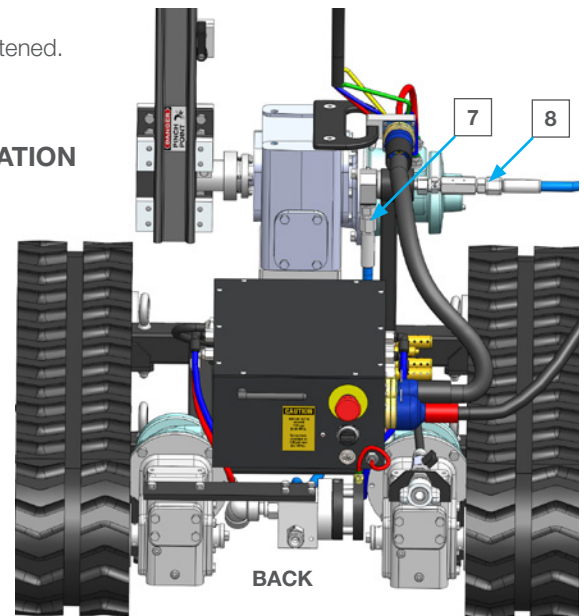

TRACKED STRIKER ACTIVATION

- Push in both the large red EMERGENCY STOP BUTTONS on both the RECEIVER UNIT and REMOTE CONTROL.
- Turn the Air Ball Valve connected to the Chicago Fitting on the Striker parallel to the air line or the “ON” position.
- Check the gauge on the Filter Regulator on the Striker to make sure it reads 80-120 PSI.
- On the REMOTE CONTROL, rotate “Wrist Sweep” knob counterclockwise to “-” or OFF
- Turn the RECEIVER UNIT on and listen for the charger to stop (approximately 20 seconds).
- Pull out the large red EMERGENCY STOP BUTTON out on the RECEIVER UNIT. The green light on the RECEIVER UNIT should be on.
- On the REMOTE CONTROL UNIT, pull up on the EMERGENCY STOP BUTTON.
- On the REMOTE CONTROL, hold the ON/OFF Power Switch in the up position for 2-3 seconds.
- On the REMOTE CONTROL, the TX (Transmit) and RX (Receive) LEDs should be active, indicating that the communication link has been established.
- Test the Striker’s directional movements with the REMOTE CONTROL.

NOTICE

If the ER LED flashes, the Tracked Striker may need to be re-associated. The Association instructions are on PAGE 47. If a connection issue remains after following the Association instructions, call StoneAge Tools for technical assistance.

WIRELESS RECEIVER UNIT ON TRACKED STRIKER

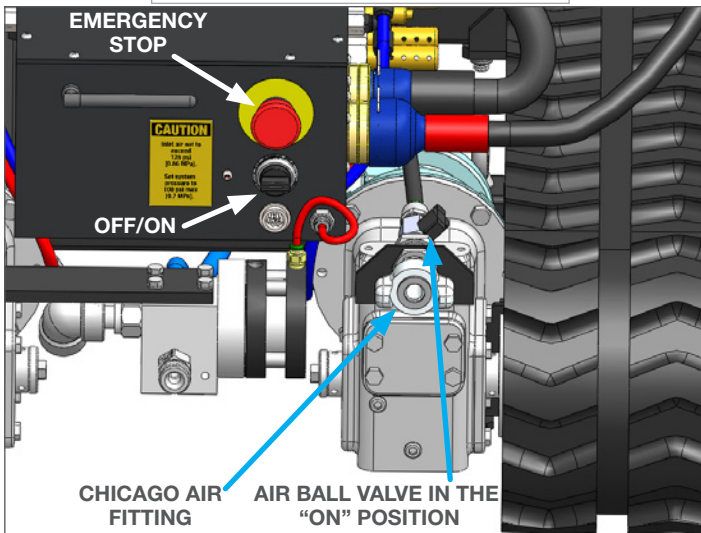

REMOTE CONTROL LEFT SIDE VIEW

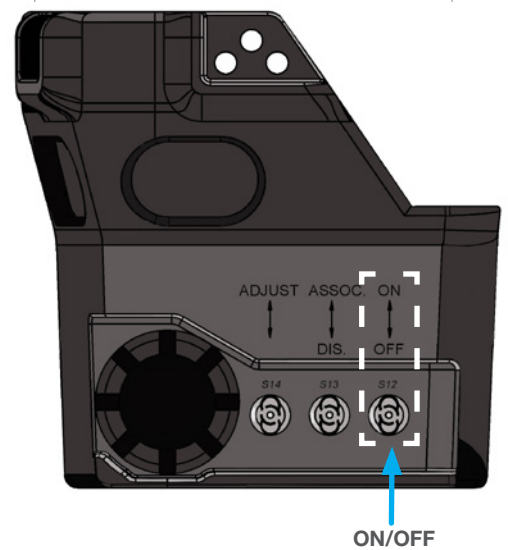

REMOTE CONTROL CONSOLE

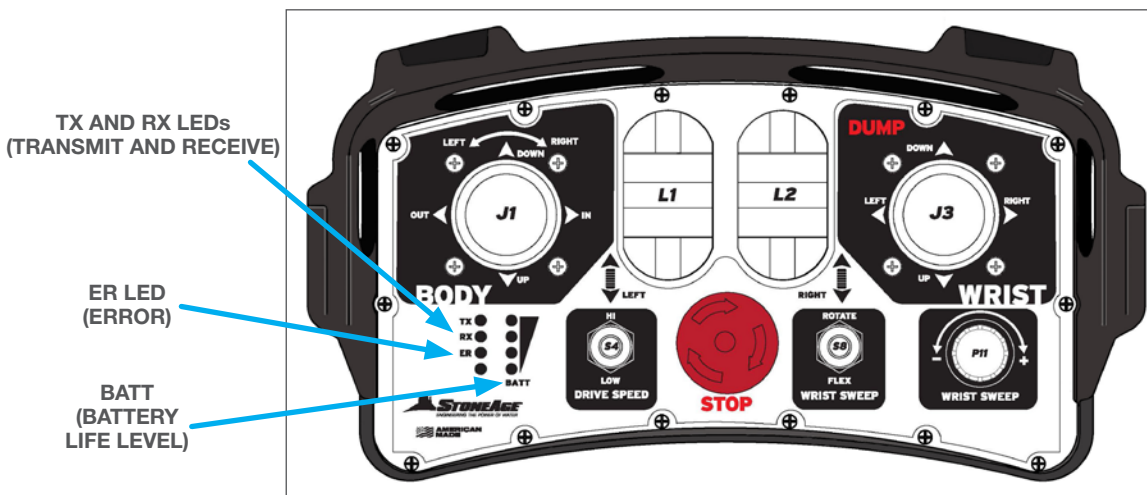

WIRELESS REMOTE CONTROLLER- OPERATION

WIRELESS REMOTE CONTROLLER

NOTICE

The Remote Control performs the functions below with different control mechanisms. The directional markings on the wireless console controller are based on the Operator standing behind the Tracked Striker in the Parallel Orientation. It is recommended to practice with the controller before operating the Tracked Striker with high pressure water. The controls will feel slightly different when operating the Tracked Striker in the Perpendicular orientation.

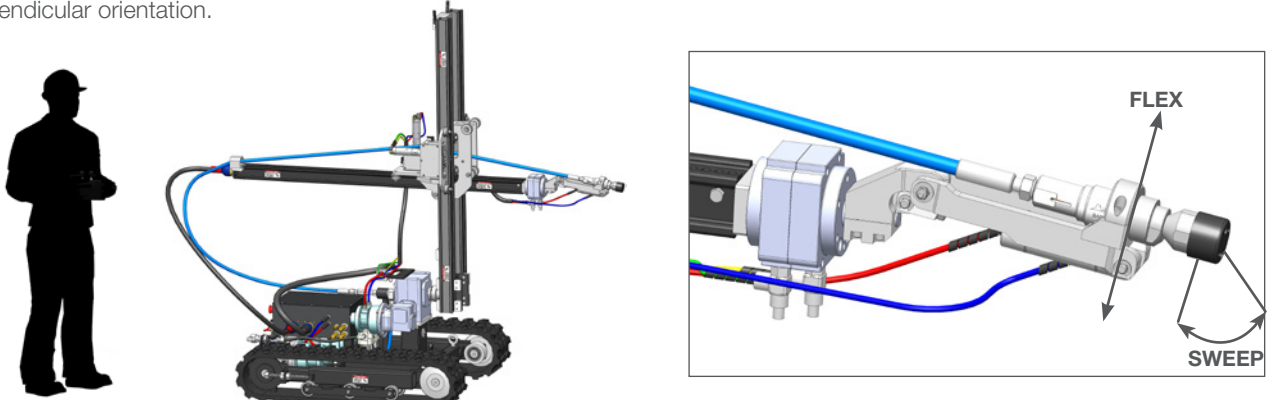

- The **TRACKED BASE** of the TRACKED STRIKER is controlled with three controls in the six following directions.
 - **L1 FORWARD/REVERSE** will move the tracked base in forward and reverse directions.
 - **L2 ROTATE LEFT/RIGHT** will operate the left or right tracks so the assembly can turn.
 - **S4 HI/LOW SPEED** adjustment allows the user to preset the speed at which the TRACKED STRIKER will move in the FORWARD/ REVERSE directions.
- The **BODY** of the TRACKED STRIKER is controlled in the six following directions.
 - **J1 IN/OUT** will move the Horizontal Rail Assembly in the In (extending) and Out (retracting) directions.
 - **J1 UP/DOWN** will move the Carriage Assembly Up and Down along the Vertical Rail Assembly.
 - **J1 ROTATE LEFT/RIGHT** will rotate the Vertical Rail Assembly from the Spline at the bottom in a windshield wiper motion.
- The **WRIST** of the TRACKED STRIKER is controlled in the four following directions.
 - **J3 ROTATE** rotates the BCK-20K BARRACUDA tool from the Wrist in a maximum 270° radius. The Horizontal Rail is slotted on top and bottom to allow the center of the Wrist rotation point to be pointed upward or downward.
 - **J3 FLEX** flexes the BCK-20K BARRACUDA tool 90° from the Wrist.
 - **S8 FLEX/ROTATE SWEEP** switches the wrist between a sweeping rotation motion and a flexing up and down motion
 - **P11 SWEEP +/-** adjusts the speed of the sweeping or flexing motion
- The **WRIST** speed controls are located on the TRACKED STRIKER See the “Wrist Speed and Resistance Adjustment” page for adjustment instructions. Wrist Speed and Resistance settings will operate differently when operating with high pressure water versus air only.
- The **OFF** position for all levers is at the spring centered middle position.
- To de-energize the system, depress the **DUMP CONTROL** . This will stop the Carriage Assembly and BCK-20K BARRACUDA tool from moving and reroute the high-pressure water away from the TRACKED STRIKER.

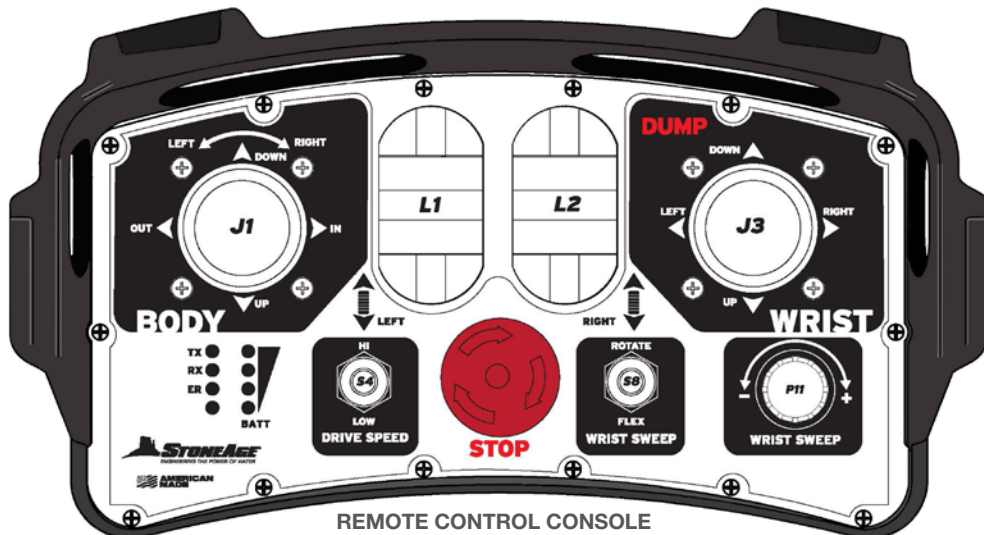

WIRELESS CONTROL SYSTEM- ASSOCIATING REMOTE CONTROL TO RECEIVER UNIT

ASSOCIATING REMOTE CONTROL TO RECEIVER UNIT

The REMOTE CONTROL must be “associated” or linked to the RECEIVER UNIT on the TRACKED STRIKER before the system can be used. Follow the steps below to properly associate the wireless control system.

STEP 1: Turn air on; confirm 100 psi on FRL.

STEP 2: Engage E-Stop (press in) on tumble box; release E-stop on control box.

STEP 3: Switch on tumble box; wait for system to charge (noise stops); release E-Stop on tumble box (green LED will light).

STEP 4: Place control box on tumble box or hold level. Ensure Wrist Sweep is turned fully counterclockwise.

STEP 5: With the E-Stop released, hold switches on left side of control box up, to ASSOC and ON positions; do not release.

STEP 6: Wait for TX LED to blink on control box while continuing to hold switches on.

NOTE: If LEDs are blinking randomly check controls on control box to ensure they are in the neutral position.

STEP 7: While continuing to hold switches and TX LED is blinking, push and release E-Stop on tumble box.

STEP 8: Release switches on left side of control box.

STEP 9: Wait a few moments for TX and RX LED to start blinking; control box is now associated with tumble box

NOTICE

If the ER LED flashes, go through the association steps again. If there is a connection issue after, call StoneAge Tools for technical assistance.

WIRELESS RECEIVER UNIT ON TRACKED STRIKER

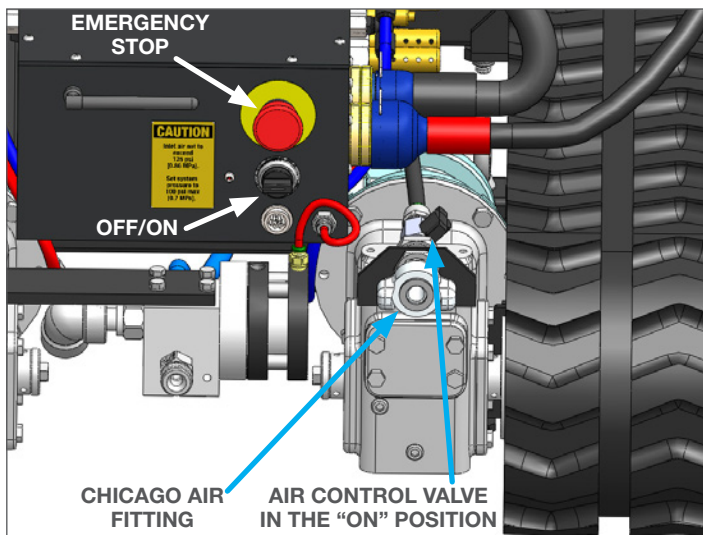

REMOTE CONTROL LEFT SIDE VIEW

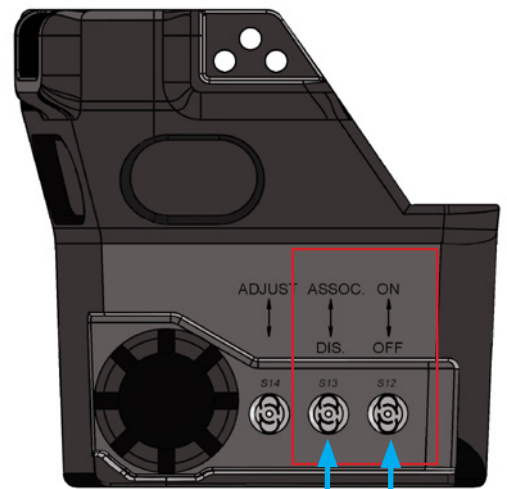

ASSOCIATE ON/OFF

REMOTE CONTROL CONSOLE

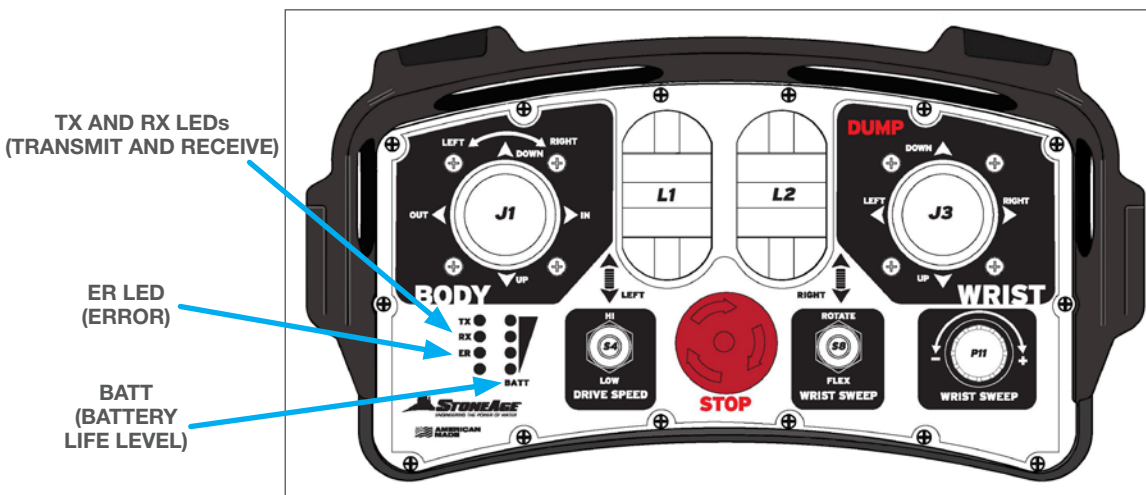

WIRELESS REMOTE CONTROLLER- TETHERED CONNECTION

TETHERED CONNECTION FOR WIRELESS REMOTE CONTROLLER

The TRACKED STRIKER can be connect to the WIRELESS RECEIVER BOX with a tether if wireless signal is not permitted. There is a port on the right side of the WIRELESS REMOTE CONTROLLER. Remove the dust cap and connect the tether to this port and the other side to the port on the WIRELESS RECEIVER BOX.

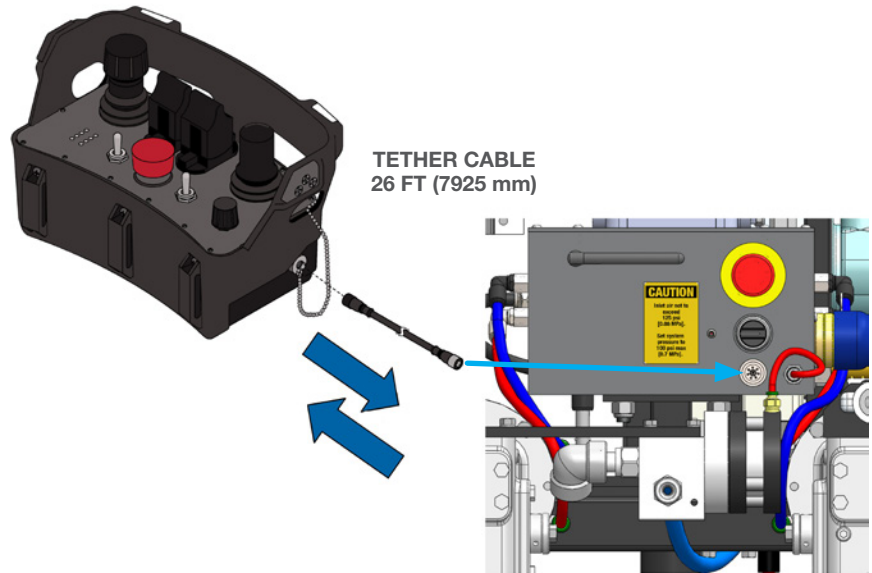

OPERATION

TEST RUN PROCEDURE

- Perform the **PRE-RUN SAFETY CHECK SEE PAGE 8.**
- Test the Control Box before operating the TRACKED STRIKER with high-pressure water to verify the control valves move the Horizontal and Vertical Rail Assemblies in their intended directions, and the **DUMP CONTROL** is working properly. Ensure that the High Pressure Water System cannot be energized while making adjustments.
- Operate the Track drive with both high and low speed selection.
- Operate the in/out, up/down and rotation functions on the body and the rotate and flex functions on the Wrist, to begin high pressure cleaning at the preferred location.
- Operate the high-pressure water at full pressure and use the **DUMP CONTROL** to verify that the dump valve is working properly.
- Operate the high-pressure system and waterjet tool at full pressure to test the Speed and Resistance settings on the Wrist. Properly setting up the Wrist will provide good control of the BC-K 20KPSI BARRACUDA tool in Rotation and Flex directions. Detailed adjustment instructions can be found within this manual in both the SKR-STD and SKR-TRK "SET-UP" sections under "WRIST SPEED AND RESISTANCE ADJUSTMENTS."
- Test the emergency stop, verifying that it shuts off the system and activates the high pressure dump valve.
- The TRACKED STRIKER has been engineered to stay in position with a maximum reaction force of 100 lbs. The TRACKED STRIKER may slide on smooth, oily, or slippery surfaces during operation. Anchoring the TRACKED STRIKER to the floor will aid in keeping the unit in position. The anchoring method **MUST** be capable of withstanding a minimum of 100 lbs of reaction force from the TRACKED STRIKER. Operate the high-pressure hose and waterjet tool at full pressure to test the anchoring method.
- Verify that the work environment has been properly marked off and it is a safe environment to operate within. Refer to the WJTA Recommended Practices and page 7 and 8 of this manual for more safety information.
- The TRACKED STRIKER **MUST** be supervised at all times.

▲WARNING

Crush Hazard. Keep hands, hair, and clothing, clear of Carriage Rollers, Wrist joints, Spline Hub, and out of all travel limit zones. Contact with moving parts can result in severe injury.

HIGH-PRESSURE HOSE

- The TRACKED STRIKER is designed to be used with a 12ft (3658 mm) SPIR STAR[®] HP 8mm Hose and SPIR STAR[®] standard 9/16"-18 Medium Pressure 8-4 male end at the BC-K 20KPSI BARRACUDA and a SPIR STAR[®] 3/4"-16 Type M Swivel Female End at the coupler on the STRIKER assembly.
- Only high quality hoses intended for waterblast applications should be used as high-pressure hoses. Pressure rating of high-pressure hoses **MUST NEVER** be exceeded.
- Verify that the high-pressure hose is properly installed through the Carriage Assembly.

⚠ DANGER

STAY BEHIND THE VERTICAL RAIL ASSEMBLY AND OUT OF THE SPRAY ZONE WHEN OPERATING THE TRACKED STRIKER.
Failure to do so **will** result in death or serious injury.

Operators MUST read and follow, Pre-Operating Procedures (Section 9.0) of WJTA-IMCA's Best Practices For The Use Of High-pressure Water jetting Equipment, or equivalent.

StoneAge also recommends following the ACH Waterjet Technology (France) (Section 7.6):

7.6. Layout (workstation)

Distances:

The boundary must be at least 6 meters from the nozzle or (where the water exits the tool). This distance determination is also valid for any upper or lower floors. The determination of the distance must therefore be three-dimensional.

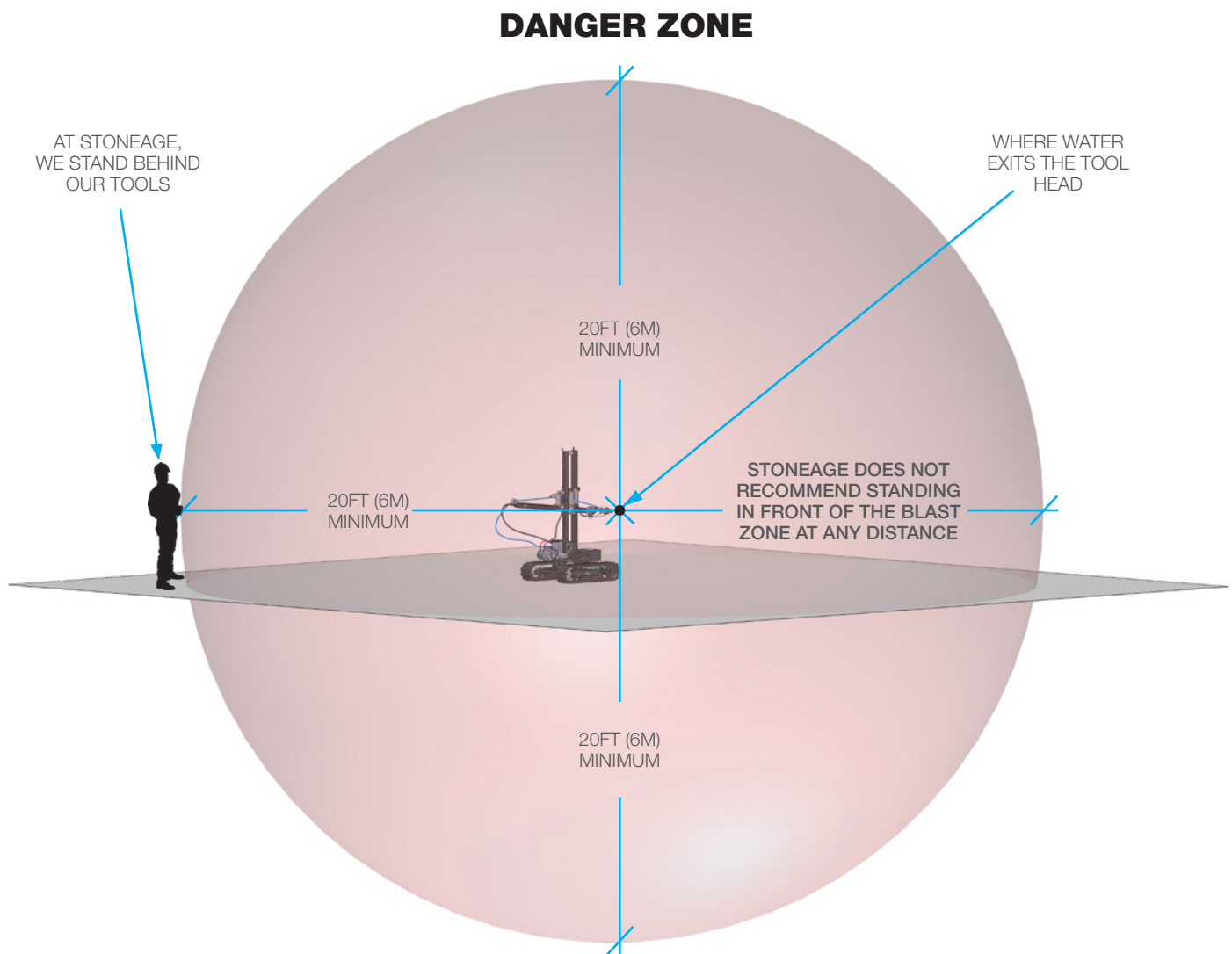

SKR-TRK MAINTENANCE

MAINTENANCE		
Maintenance Item	Frequency	Maintenance Required
All Air Fittings	After each use	Reinstall all dust caps to protect from dirt and moisture.
Carriage rollers	Every 100 Hours of use	Lubricate Zerks on all Carriage Rollers using any multipurpose NLGI 2 grease.
Gearbox oil level	Every 100 Hours of use	Fill with Mobil® and SCH™ 634 synthetic gear oil. See individual part diagram pages for gearbox fill orientations.
Lubricator by the Tumblebox	Before each use	<ul style="list-style-type: none"> • Add a quality air tool oil when fluid drops below minimum level marking. • Check Drip Rate • Empty Water
Tumblebox	After each use	Disconnect umbilical hose with air supply connected and run each function to purge any collected water from the system. Be careful to protect the umbilical o-rings
Tumblebox	Every 6 months or after opening box for service.	Inspect, Clean, and, lubricate the gasket on the Tumblebox. StoneAge recommends using Molykote 111 or equivalent.
Vertical and Horizontal Rails	As Needed	Inspect for wear that would allow Carriage Rollers to slip off. Replace Rail as needed.
Waterblast Tool	After each use	Remove tool, lubricate and store in clean container.
Wireless Controller	When battery indicator light is blinking	Replace 2 C Cell alkaline batteries
Wireless Receiver	Every 600 hours Every 200-300 hours in humidity	Replace desiccant pack inside the receiver box

Contact StoneAge for Safety Data Sheets for material usage, a complete list of spare part numbers, and service instructions for the TRACKED STRIKER® (SKR-TRK) and Wireless Remote Controller.

STORAGE, TRANSPORTATION, AND HANDLING

When storing the TRACKED STRIKER® (SKR-TRK), use compressed air to blow out the air lines to remove debris and moisture. Use mild soapy water to clean the machine in order to remove corrosive materials. DO NOT USE HIGH PRESSURE WATER TO CLEAN THE MACHINE. Follow the “**After** each use” instructions in the maintenance chart above.

TROUBLESHOOTING	
Problem	Solution
No air is delivered to tool	<ul style="list-style-type: none"> • Check that shut-off valve near the air supply connection is open • Check that regulator is set to 110 psi
Tool is not rotating	<ul style="list-style-type: none"> • Make sure tool is cleaned and serviced per the specifications within the respective tool manual
Tool is not cleaning effectively	<ul style="list-style-type: none"> • Check rotation speed, the tool may be spinning too fast or too slow
Wireless Remote Controller is not working moving the Striker	<ul style="list-style-type: none"> • Make certain all controls are set at “0”, or the neutral positions when associating the controller to the receiver box. • Check the antenna on the tumblebox for proper connection and no visible damage. • Replace batteries (2 C Cell alkaline Batteries) in the wireless remote controller even if showing a charge. • Re-associate Wireless Remote Controller to the receiver
Wireless Remote Controller lights are not on	<ul style="list-style-type: none"> • Replace batteries (2 C Cell alkaline Batteries) re-associate the wireless remote controller to the wireless receiver. • Ensure that the E-Stop is not activated.
Striker is not moving in any direction but has air flow	<ul style="list-style-type: none"> • Check batteries in the wireless remote controller. Replace if necessary and re-associate the wireless remote controller to the wireless receiver. • Check air connections to the motors on the Carriage Assembly • Check the air connections to the main motor on the gearbox assembly
Striker is not moving in one direction but has air flow	<ul style="list-style-type: none"> • Check for a nonfunctional valve in the wireless receiver box. Nonfunctional valves will have blinking lights. Go to the “Part Diagram” section in the back of this manual for part numbers and replacement instructions

This page is intentionally left blank.

PARTS DIAGRAM

STRIKER® (SKR 109) CART BASE ASSEMBLY



#	PART NUMBER	QTY.
1	GB 550-11 BOLT, HEX .50-13 X 2.75	4
2	GB 550-10 BOLT, HEX .50-13 X 2.50	4
3	GN 550-H HEX NUT	4
4	GN 550-L NYLOK NUT	8
5	GN 562-H HEX NUT	2
6	GSF 337-03 FHCS .37-16 X .75 LG SS	2
7	GW 550-F FLAT WASHER	4
8	SKR 110 CART	1
9	SKR 130 AXLE FRAME WELDMENT	1

10	SKR 140 WHEELIE BAR WELDMENT	1
11	SKR 150 GEAR LINK WELDMENT	2
12	SKR 160 FWD OUTRIGGER WELDMENT	2
13	SKR 170 AFT OUTRIGGER WELDMENT	2
14	SKR 185 HANDLE	1
15	SKR 305 WHEEL 10.0	2
16	SKR 312 WASHER .750	4
17	SKR 330 FOOT, OUTRIGGER	4
18	SKR 331-001 STUD .5 X 2.5	4
19	SKR 335 QR PIN, T-HANDLE .50 X 2.25	4

STRIKER® (SKR 501)
FORWARD DOWNRIGGER ASSEMBLY

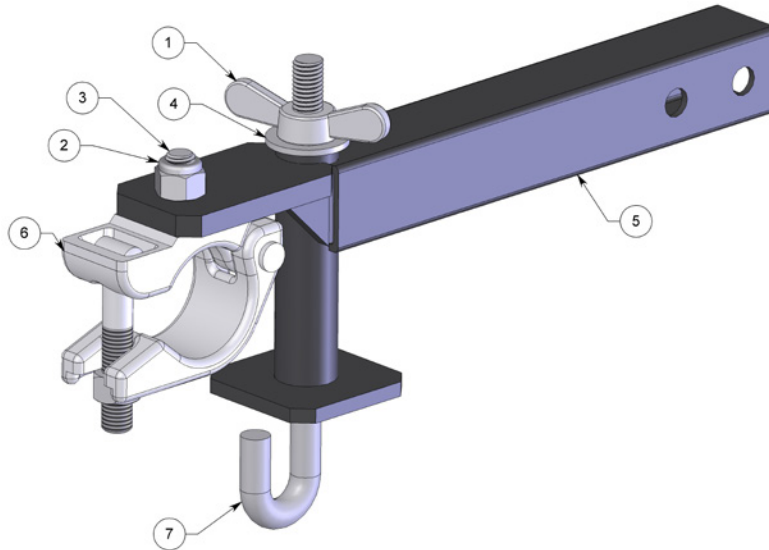

#	PART NUMBER	QTY.
1	SKR 509 WING NUT	1
2	GN 550-L NYLOK NUT	1
3	GSF 550-06 FHCS .50-13 X 1.50 LG Z	1
4	GW 550-F FLAT WASHER	1
5	SKR 501.1 FWD DOWNRIGGER WELDMENT	1
6	SKR 510 SCAFFOLD CLAMP ASSY	1
7	SKR 511 J BOLT FRONT MODIFIED	1

STRIKER® (SKR 502)
AFT DOWNRIGGER ASSEMBLY

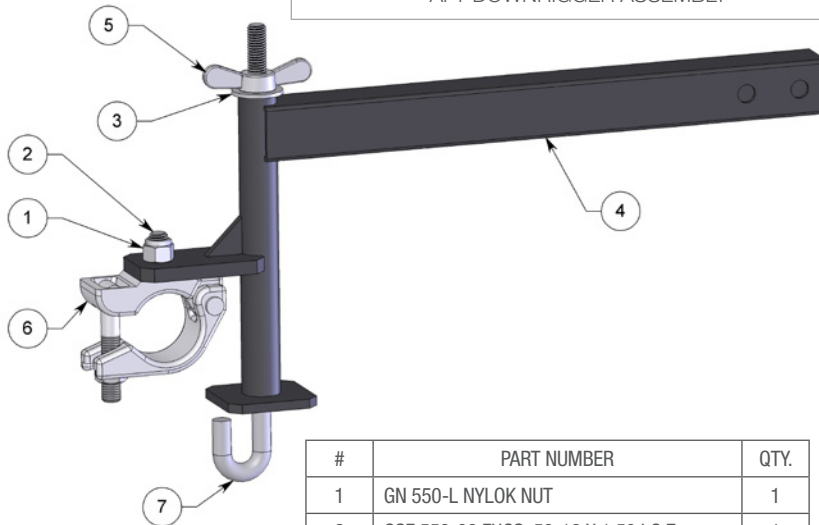

#	PART NUMBER	QTY.
1	GN 550-L NYLOK NUT	1
2	GSF 550-06 FHCS .50-13 X 1.50 LG Z	1
3	GW 550-F FLAT WASHER	1
4	SKR 502.1 AFT DOWNRIGGER WELDMENT	1
5	SKR 509 WING NUT	1
6	SKR 510 SCAFFOLD CLAMP ASSY	1
7	SKR 512 J BOLT REAR	1

PARTS DIAGRAM

STRIKER® (SKR 800-XX) TRACKED BASE ASSEMBLY

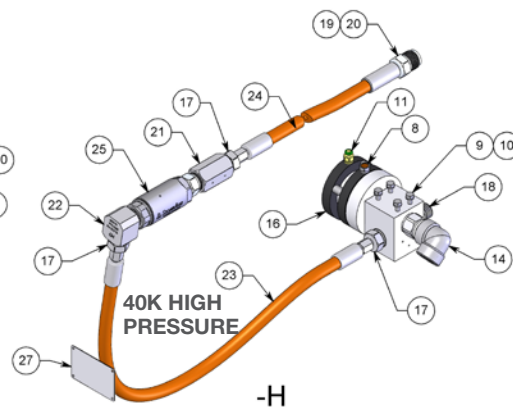
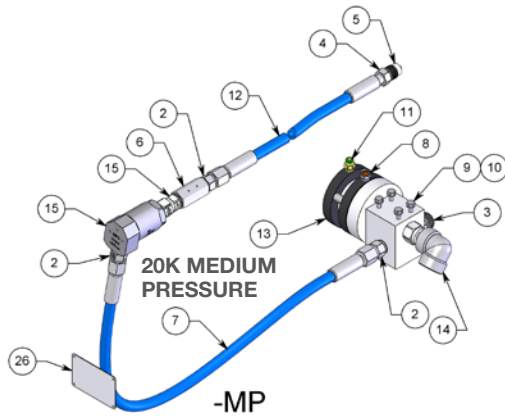
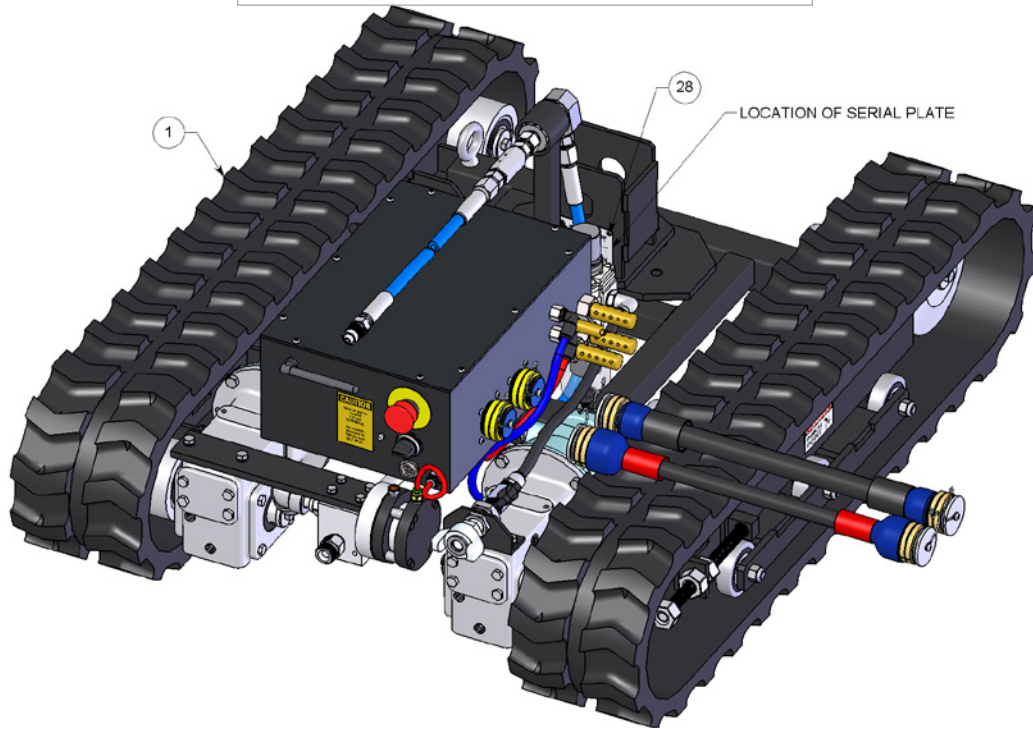

#	PART NUMBER	-MP QTY.	-H QTY.
1	SKR 800.1 TRACK BASE	1	1
2	AF 061-MP9 ADAPTER .75 TYPE M TO MP9	3	-
3	AF 063-MP9 ADAPTER 1.00 TYPE M TO MP9	1	-
4	AF 070-MP9 GLAND	1	-
5	AF 071-MP9 COLLAR .56 MP	1	-
6	AF 073-MP9 COUPLER	1	-
7	BRLM 268-003 HP HOSE 8-4 31IN OAL	1	-
8	DB 026 MUFFLER .250 NPT, DUMP VALVE	1	1
9	GB 525-03 BOLT, HEX .25-20 X .75	4	4
10	GW 525-L LOCK WASHER	4	4
11	SM 309 FITTING, BUSHING P4M PL4	1	1
12	SKR 822 HP HOSE 8-4 12FT OAL	1	-
13	SKR 823 DUMP VALVE 20K	1	-
14	SKR 824 DUMP ELBOW	1	1

15	SL-MP9AV9-90 SWIVEL	1	-
16	ACDU 610400072 DUMP VALVE 40K	-	1
17	AF 060-H9 ADAPTER .56 TYPE M TO H9	-	3
18	AF 062-H9 ADAPTER .88 TYPE M TO H9	-	1
19	AF 071-H9 COLLAR	-	1
20	AF 072-H9 GLAND ASSY, ANTIVIBE	-	1
21	AF 073-H9 COUPLING	-	1
22	SA 050-H9H9-90 ELBOW	-	1
23	SKR 831 HP HOSE 6UHP 31IN OAL	-	1
24	SKR 832 HP HOSE 6UHP 12FT OAL	-	1
25	UHS-H9H9 ASSY	-	1
26	SKR 803-MP9 SERIAL PLATE	1	-
27	SKR 803-H9 SERIAL PLATE	-	1
28	GSB 313-0075 BHCS 6-32 X .188 LG SS	4	4

STRIKER® (SKR 800.1)
TRACKED BASE ASSEMBLY

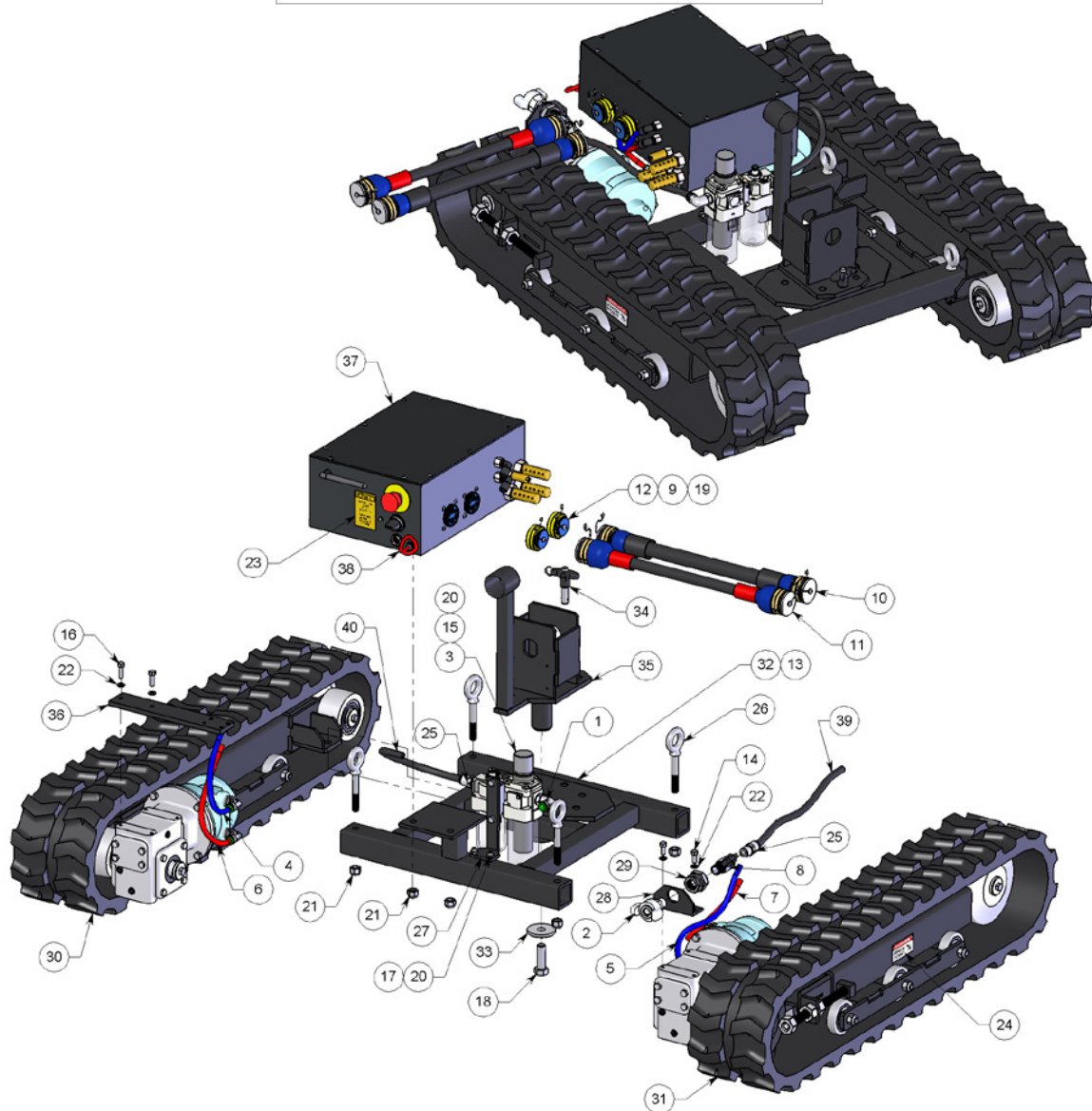

#	PART NUMBER	QTY.
1	BUD 142 FITTING 90° SWIVEL P8MPL8	1
2	CB 114 INLET FITTING	1
3	CB 312 GEN3 FILTER-REGULATOR-LUBRICATOR WITH GEN2 CLAMP	1
4	CB 359-B TUBING 1, .38 BLUE	1
5	CB 359-B TUBING 2, .38 BLUE	1
6	CB 359-R TUBING 1, .38 RED	1
7	CB 359-R TUBING 2, .38 RED	1
8	CB 393 P8 BALL VALVE	1
9	CB 429 LANYARD ASSY UMBILICAL	2
10	CB 450-50 UMBILICAL 4PL4 2PL6 50 INCH	1
11	CB 451-100 UMBILICAL 4PL4 100 INCH	1
12	CB 461 SEALED SOCKET COVER	2

13	FS 004-0 ZERK, STRAIGHT	1
14	GB 531-03 BOLT, HEX .31-18 X .75	4
15	GB 531-035 BOLT, HEX .31-18 X .88	2
16	GB 531-04 BOLT, HEX .31-18 X 1.00	2
17	GB 531-11 BOLT, HEX .31-18 X 2.75	2
18	GB 562-04 BOLT, HEX .62-11 X 1.00	1
19	GMS 319-015-32 PHMS .19-32X.38 LG PH-SS	2
20	GN 531-L NYLOK NUT	4
21	GN 550-L NYLOK NUT	4
22	GW 531-L LOCK WASHER	6
23	PL 156-125 CAUTION INLET AIR, 125PSI MAX	1
24	PL 160 PINCH POINT 1.5X3.0 DECAL	2
25	SBT 362 FTG P8MPL8 BUSHING	2

26	SKR 806 LIFTING EYE	4
27	SKR 811 FRL BRACKET WELDMENT	1
28	SKR 812 INLET BRACKET	1
29	SKR 814 FTG, P8P8 BULKHEAD	1
30	SKR 833 LEFT TRACK ASSY	1
31	SKR 843 RIGHT TRACK ASSY	1
32	SKR 870 CHASSIS WELDMENT	1
33	SKR 872 WASHER, PIVOT	1
34	SKR 873 QUICK RELEASE PIN	1
35	SKR 874 PIVOT BASE	1
36	SKR 879 DUMP MOUNT BRACKET	1
37	SKR 880 CERVIS BOX FULL ASSEMBLY	1
38	SKR TUBE 1 .250	1
39	SKR TUBE 1 .500	1
40	SKR TUBE 2 .500	1

PARTS DIAGRAM

STRIKER® (SKR 100) UPPER ASSEMBLY

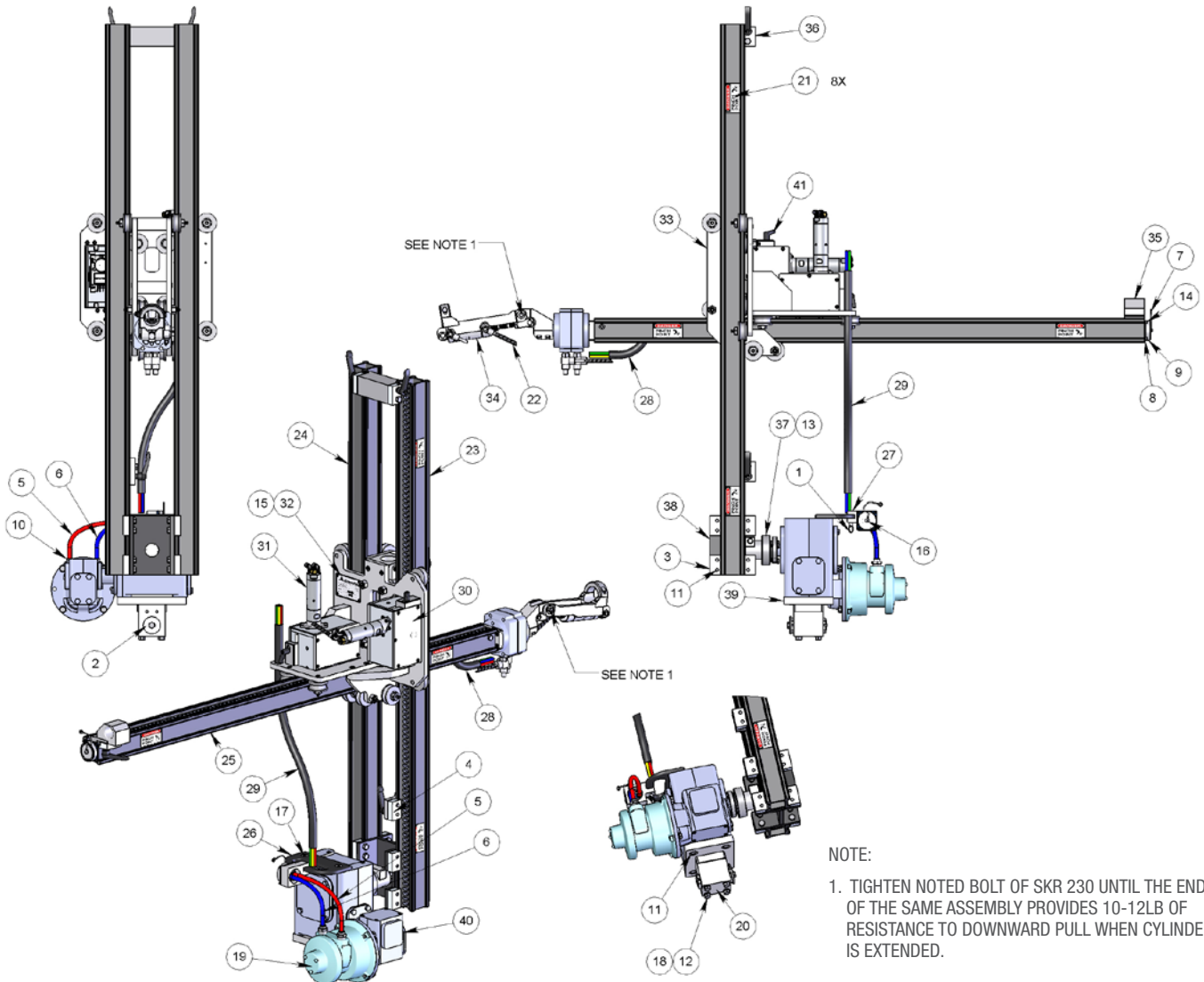

NOTE:

1. TIGHTEN NOTED BOLT OF SKR 230 UNTIL THE END OF THE SAME ASSEMBLY PROVIDES 10-12LB OF RESISTANCE TO DOWNWARD PULL WHEN CYLINDER IS EXTENDED.

#	PART NUMBER	QTY.	15	16	17	18	19	20	21	22	23	24	25	26	27	28	29	30	31	32	33	34	35	36	37	38	39	40	41								
1	ABX 566 SPRING PLUNGER, PULL RING LOCKING	1	GSB 313-0075 BHCS 6-32 X .188 LG SS	GMS 319-015-32 PHMS .19-32X.38 LG PH-SS	GSF 337-04 FHCS .37-16 X 1.00 LG SS	GW 537-L LOCK WASHER	LM 016-6 AIR MOTOR	LP 095-001 CORNER POST	PL 160 PINCH POINT 1.5X3.0 DECAL	SBT 511.1 SPIRAL WRAP, .375	SKR 180-56 BOX RAIL, 2.5 SLOTTED, 56IN VT	SKR 181-56 BOX RAIL, 2.5, 56IN VT	SKR 182-56 BOX RAIL, 2.5 DUAL SLOTTED, 56IN HZ	SKR 186 GBX HANDLE	SKR 188 QD HANGER	SKR 189-6.17 TUBE BUNDLE, 4PL4 74IN WRIST	SKR 189-5.75 TUBE BUNDLE, 4PL4 69IN BODY	SKR 203-L MOTOVARIO DRIVE ASSY	SKR 203-R MOTOVARIO DRIVE ASSY	SKR 204 CE SERIAL PLATE	SKR 210 RIBBED CARRIAGE ASSEMBLY	SKR 230 3 PIECE PALM	SKR 250 REAR STOP W HOSE GUIDE	SKR 260 TIE STOP ASSEMBLY	SKR 270 SPLINE HUB WELDMENT	SKR 280 RAIL CLAMP BASE WELDMENT	SKR 290 GBX MOUNT PLATE	SKR 302 GEARBOX MODIFIED	SRT 557 ADJUSTABLE HANDLE .25-20 X 1.19 SS								
2	BR 008-BU-001 WEDGE BOLT	1																																			
3	BR 060 RAIL CLAMP	8																																			
4	BU 152 RAIL STOP ASSY	1																																			
5	CB 359-R TUBING, .38 RED	1																																			
6	CB 359-B TUBING, .38 BLUE	1																																			
7	CB 430 LANYARD ASSY BOX	2																																			
8	CB 452.2 FTG TWINTEC SOCKET	2																																			
9	CB 459 SOCKET COVER	2																																			
10	DB 072 FITTING PUSH CONNECT	2																																			
11	GB 537-04 BOLT, HEX .37-16 X 1.00	24																																			
12	GB 537-16 BOLT, HEX .37-16 X 4.00	4																																			
13	GK 250-250-1000-SE KEY (SG 072)	1																																			
14	GS 316-015 SHCS .16-32 X .38 SS	8																																			

STRIKER® (SKR 210)
CARRIAGE ASSEMBLY

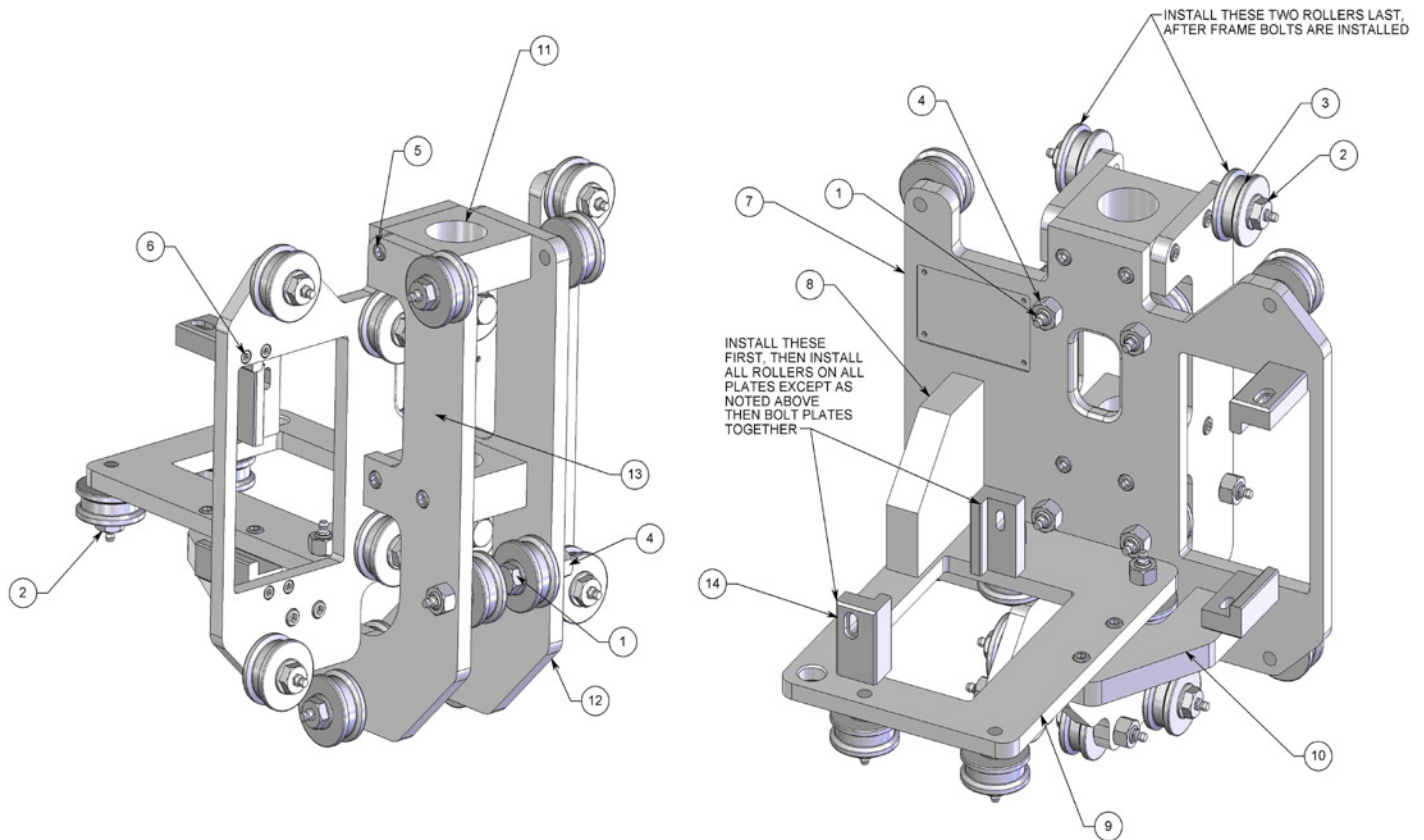

#	PART NUMBER	QTY.
1	BR 051-2.0-0 AXLE-ZERK	10
2	BR 052-1.5 AXLE-ZERK	10
3	BR 055 ROLLER ASSY	20
4	GN 350-H HEX NUT SS	10
5	GS 331-03 SHCS .31-18 X .75 SS	22
6	GS 325-03 SHCS .25-20 X .75 SS (TB 050)	8
7	SKR 211 VERTICAL FLAT PLATE	1
8	SKR 212 CORNER BRACKET	1
9	SKR 213 HORIZONTAL CARRIAGE PLATE	1
10	SKR 214 CORNER BONE	1
11	SKR 215 TOP CROSS BLOCK	2
12	SKR 216 LH VERTICAL PLATE	1
13	SKR 217 RH VERTICAL PLATE	1
14	SRT 546 HANDLE MOUNT BLOCK	4

PARTS DIAGRAM

STRIKER® (SKR 203-X) MOTOVARIO DRIVE ASSEMBLY, -R OR -L

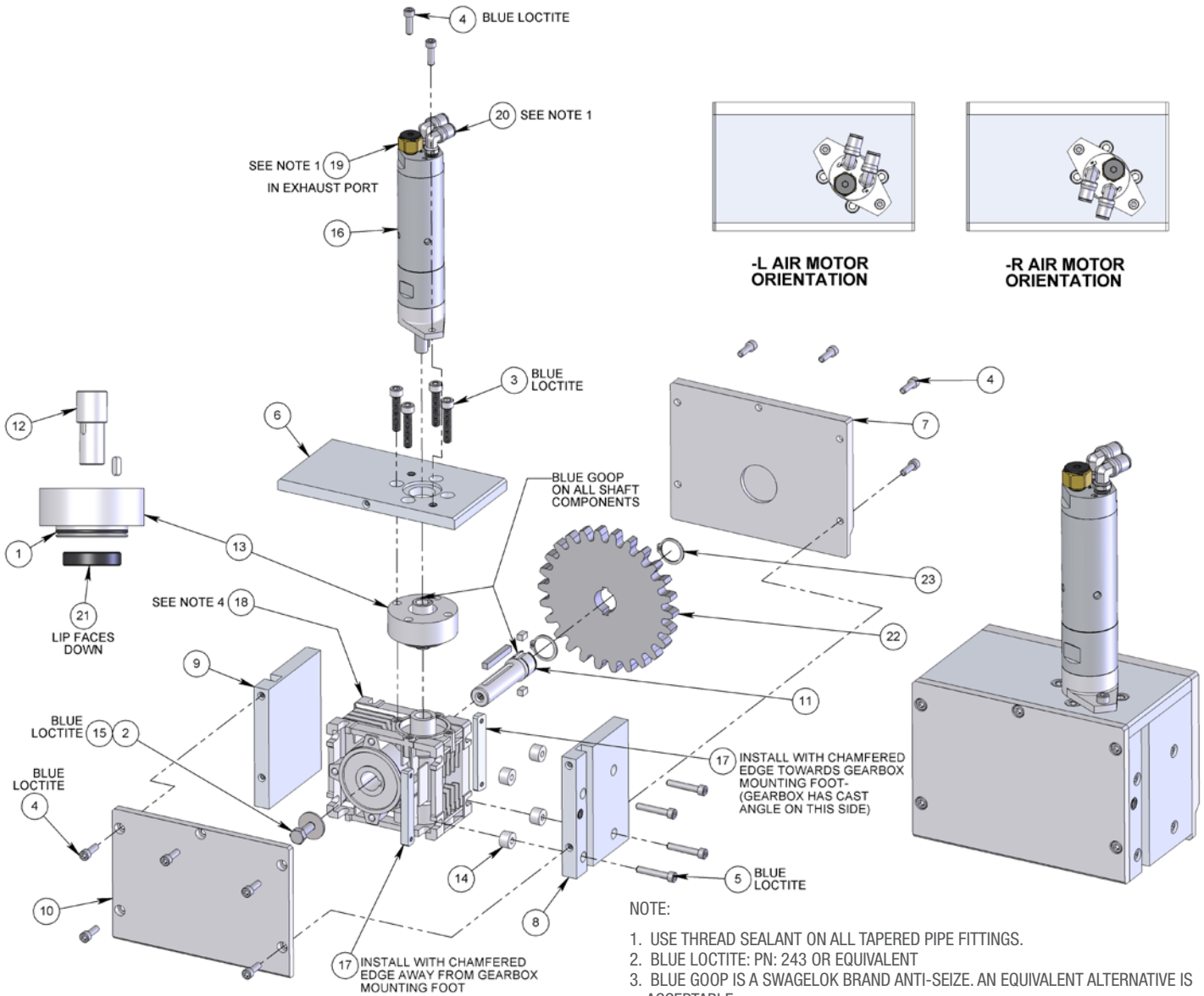

NOTE:

1. USE THREAD SEALANT ON ALL TAPERED PIPE FITTINGS.
2. BLUE LOCTITE: PN: 243 OR EQUIVALENT
3. BLUE GOOP IS A SWAGelok BRAND ANTI-SEIZE. AN EQUIVALENT ALTERNATIVE IS ACCEPTABLE.
4. REMOVE MOUNTING FLANGE THAT COMES WITH GEARBOX. KEEP INPUT SHAFT FACING UP TO PREVENT OIL LEAKAGE.

#	PART NUMBER	-L/QTY.	-R/QTY.
1	DB 169 O-RING, PISTON	1	1
2	GB 325-03 BOLT, HEX .25-20 X .75 SS	1	1
3	GS 3M6-30-1.0 SHCS M6X1.0 X 30 SS	4	4
4	GS 319-025 SHCS .19-24 X .62 SS	12	12
5	GS 319-045 SHCS .19-24 X 1.125 SS	4	4
6	LWP 504 TOP MOTOR MOUNT PLATE	1	1
7	LWP 505 GEAR COVER	1	1
8	LWP 506 HANDLE SIDE MOUNTING PLATE	1	1
9	LWP 507 IDLE SIDE MOUNTING PLATE	1	1
10	LWP 508 REAR COVER	1	1
11	LWP 509 MOTOVARIO SHAFT	1	1

12	LWP 510-001 STEP SHAFT	1	1
13	LWP 511 TOP GEARBOX SPACER	1	1
14	LWP 515 SPACER	4	4
15	LWP 516 WASHER, OVERSIZED	1	1
16	LWP 520-001 AIR MOTOR	1	1
17	LWP 542 NUT PLATE	2	2
18	LWP 550 MOTOVARIO NMRV030301600_625IN	1	1
19	LWP 557 EXHAUST PROTECTOR, P2M	1	1
20	SKR 382 FTG, ELBOW SWIVEL 90 P2MPL4	2	2
21	SL 010 SEAL	1	1
22	SRT 520 SPUR GEAR SS (6 DP, 14.5 PA, 26 T)	1	1
23	SRT 537 RETAINING RING, SS EXTERNAL	2	2

STRIKER® (SKR 230)
3 PIECE WRIST ASSEMBLY

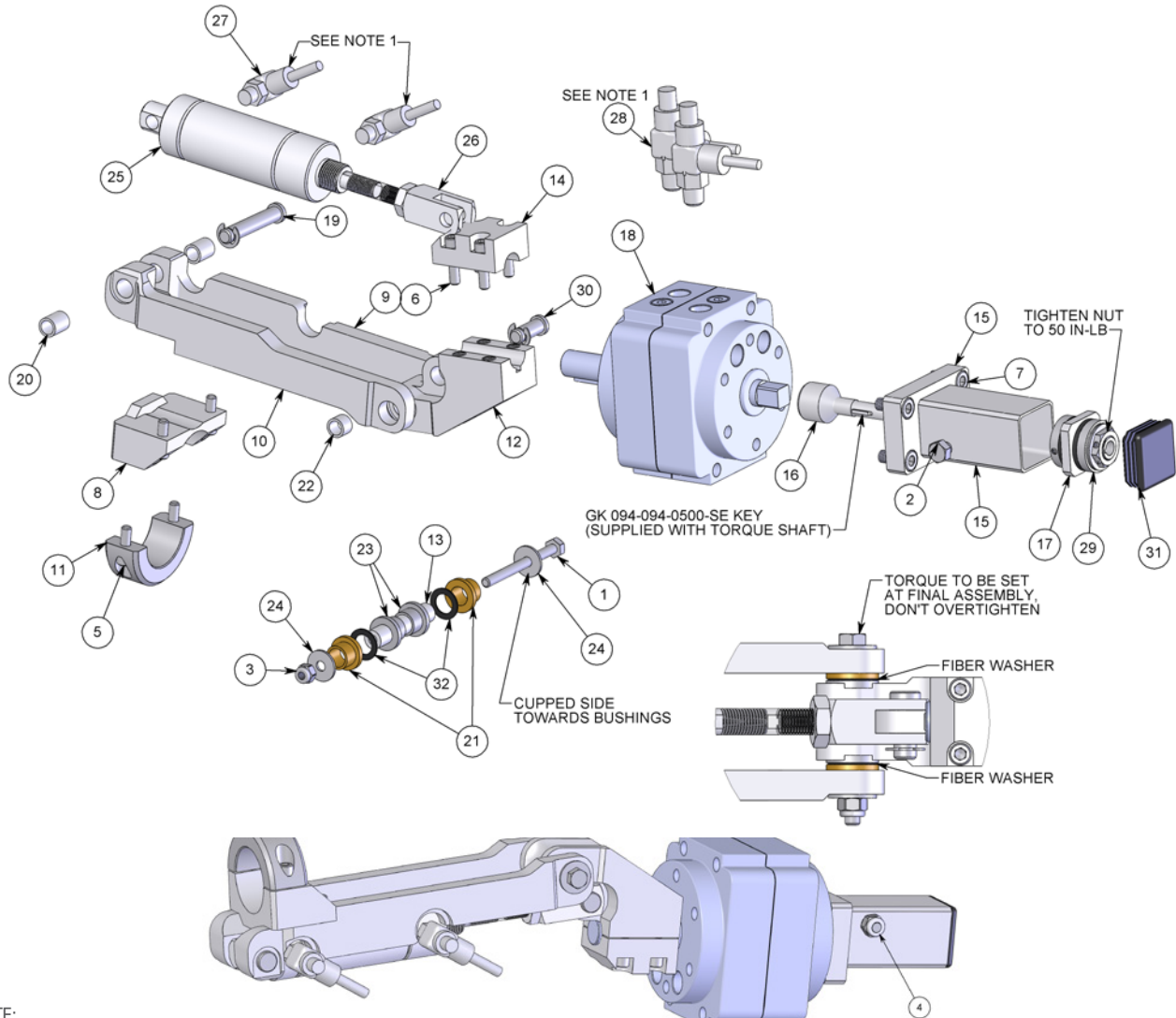

NOTE:

1. SET EACH NEEDLE VALVE TO 2 TURNS FROM CLOSED. TIGHTENING THE ADJUSTMENT SCREW CLOSES THE VALVE.
2. APPLY BLUE GOOP TO ALL THREADS OF STAINLESS STEEL FASTENERS
3. APPLY ANTI-SEIZE TO SHAFTS AND KEYS

#	PART NUMBER	QTY.
1	GB 325-12 BOLT, HEX .25-20 X 3.00 SS (HC 024)	1
2	GB 331-09 BOLT, HEX .31-18 X 2.25 SS	1
3	GN 325-L NYLOK NUT SS (TB 044.1)	1
4	GN 331-L NYLOK NUT SS	1
5	GS 325-03 SHCS .25-20 X .75 SS (TB 050)	4
6	GS 325-04 SHCS .25-20 X 1.00 SS (BC 053)	4
7	GS 3M8-16-1.25 SHCS M8X1.25 X 16 SS	4
8	SKR 231 TOOL HOLDER BC	1
9	SKR 232 ULNA FORK	1

10	SKR 233 RADIUS FORK	1
11	SKR 235 COLLAR UPPER HALF	1
12	SKR 237 PALM	1
13	SKR 238 WRIST BONE	1
14	SKR 240 SQUARE COLLAR HALF	1
15	SKR 241 END ROTARY MOUNT	1
16	SKR 242 TORQUE SHAFT W KEY	1
17	SKR 245 TORQUE PLATE	1
18	SKR 301 ROTARY AIR CYLINDER	1
19	SKR 340 PIN .375 X 2.25	1
20	SKR 341 BUSHING .375 X .625	2
21	SKR 342 BUSHING, FLANGE SOFT .5 X .5	2
22	SKR 343 BUSHING .375 X .375	1

23	SKR 344 BUSHING, FLANGE .5 X .5	2
24	SKR 345 WASHER, SPRING .265 X .812	2
25	SKR 350 AIR CYLINDER 1.5 DIA 1.5 STROKE	1
26	SKR 351 ROD END 1.5 CYL	1
27	SKR 355 FTG, BIMBA P2 PUSHLOCK NEEDLE VALVE	2
28	SKR 356 FTG, BIMBA P4 PUSHLOCK NEEDLE VALVE	2
29	SKR 360 FRICTION TORQUE LIMITER	1
30	SKR 365 CLEVIS .375 X .8125	1
31	SKR 366 RIBBED PLUG	1
32	SKR 370 FIBER WASHER	2

PARTS DIAGRAM

STRIKER® (SKR 260) TIE STOP ASSEMBLY

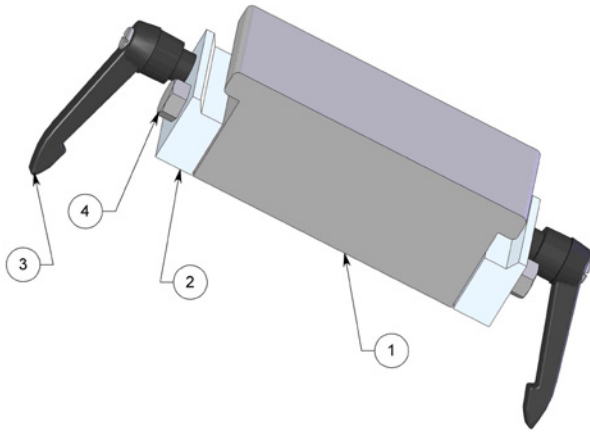

#	PART NUMBER	QTY.
1	SKR 261 TIE STOP	1
2	BR 060-D RAIL CLAMP, DRILLED	2
3	BU 151 HANDLE	2
4	GB 537-05 BOLT, HEX .37-16 X 1.25	2

STRIKER® (SKR 250) REAR STOP WITH HOSE GUIDE ASSEMBLY

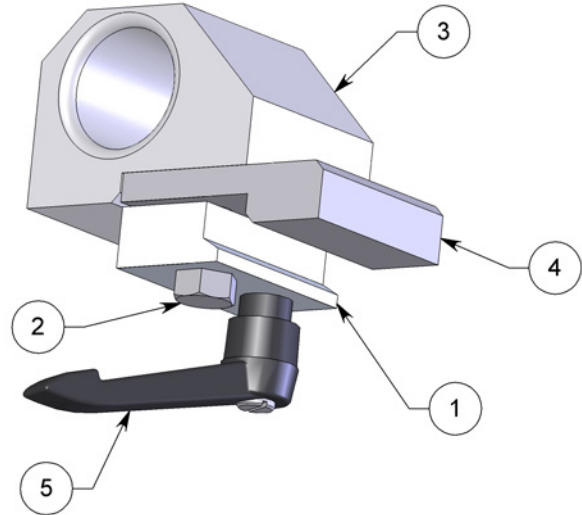

#	PART NUMBER	QTY.
1	BR 060-D RAIL CLAMP, DRILLED	1
2	GB 537-06 BOLT, HEX .37-16 X 1.50	1
3	SKR 251 REAR STOP	1
4	SKR 252 HOSE BRACKET SPACER PLATE	1
5	SKR 253 HANDLE	1

STRIKER® (BU 152) RAIL STOP ASSEMBLY

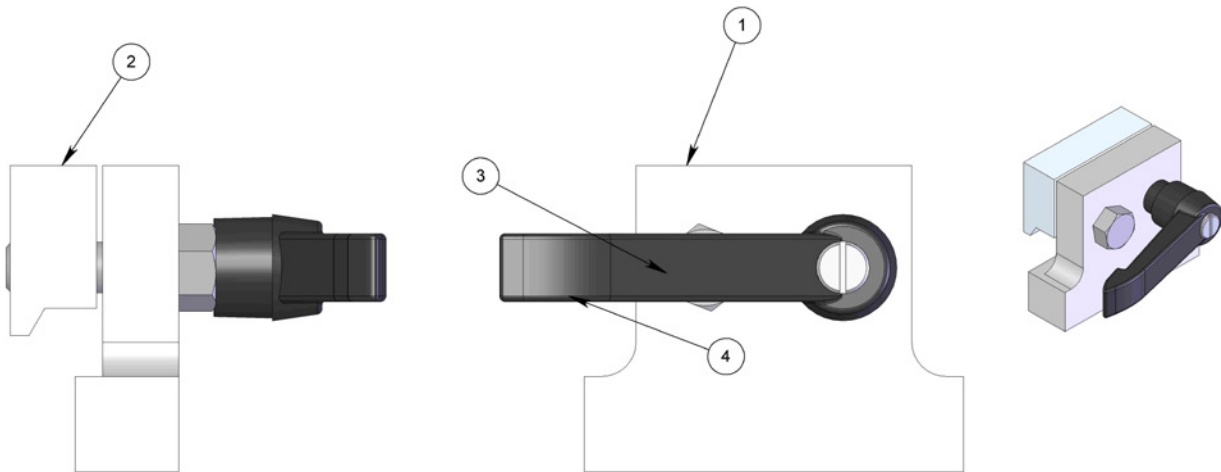

#	PART NUMBER	QTY.
1	BU 149 PLATE, RAIL STOP	1
2	BR 060 RAIL CLAMP	1
3	GB 537-05 BOLT, HEX .37-16 X 1.25	1
4	BU 151 HANDLE	1

STRIKER® (CB-SKR)
CONTROL BOX

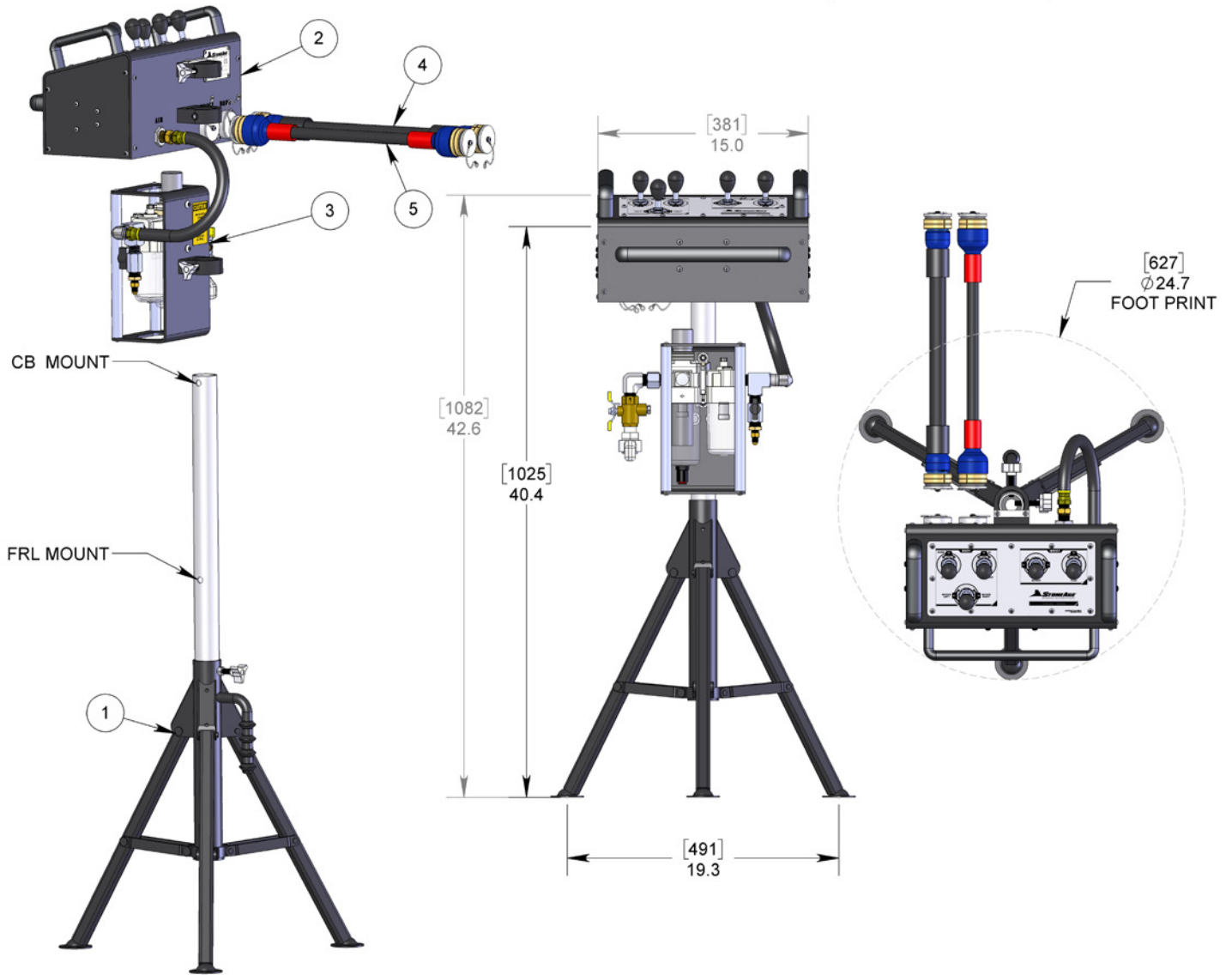

#	PART NUMBER	QTY.
1	CB 301 CB STAND ASSEMBLY	1
2	CB 400 CONTROL BOX ASSY	1
3	CB 403 FRL ASSY	1
4	CB 450 UMBILICAL 4PL4 2PL6	1
5	CB 451 UMBILICAL 4PL4	1

PARTS DIAGRAM

STRIKER® (CB 301) CB STAND ASSEMBLY



#	PART NUMBER	QTY.
1	CB 303 MTG POLE	1
2	CB 314 3-LOBE KNOB	1
3	CB 301.1 TRIPOD	1

STRIKER® (FPA-SKR) FOOT PEDAL DUMP CONTROL NOT INCLUDED IN PACKAGE

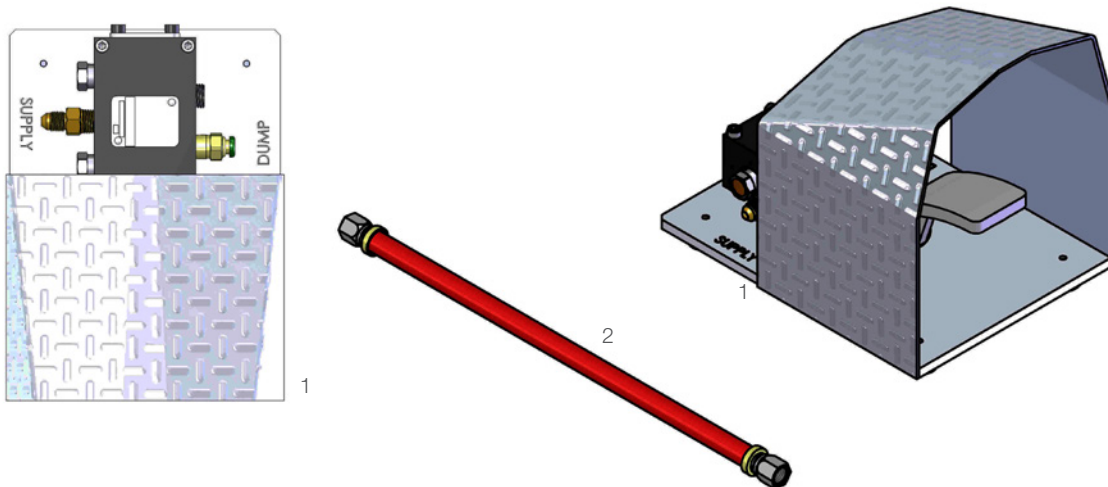

#	PART NUMBER	QTY.
1	FPA-100 FOOT PEDAL ASSEMBLY	1
2	FPA 102 HOSE ASSEMBLY	2

STRIKER® (CB 400)
CONTROL BOX ASSEMBLY (PAGE 1 OF 2)

CB 615 ORING REPLACEMENT KIT FOR TWINTEC SOCKETS	
PART NUMBER	QTY.
BJ 016 ORING	2
TR 127 ORING	4

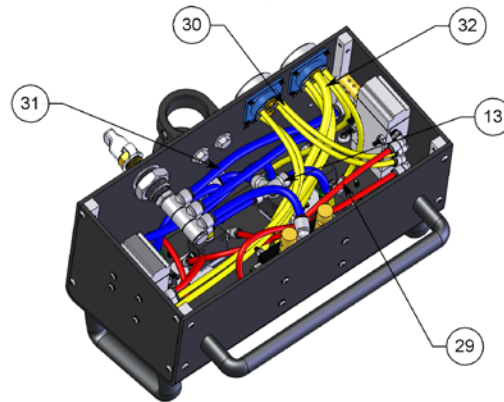
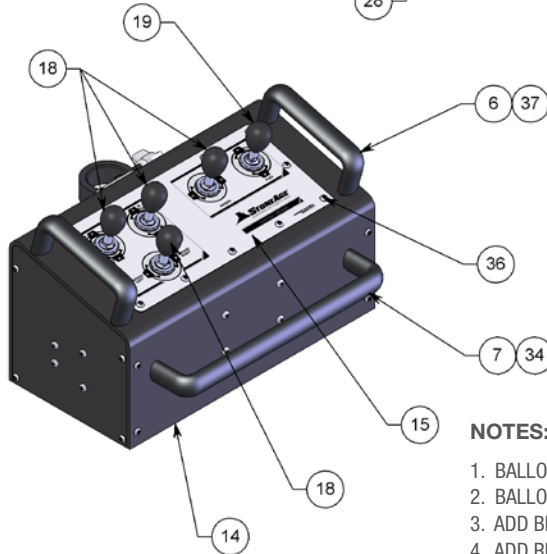
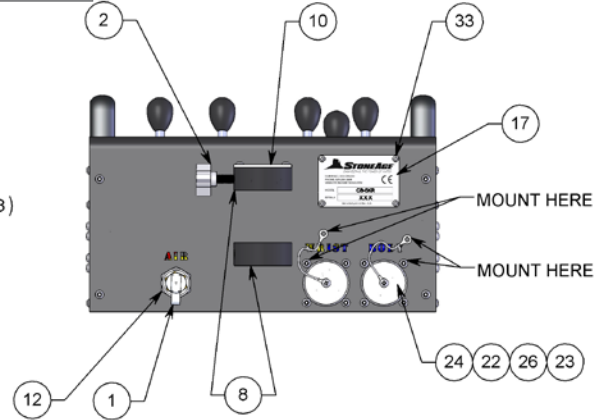
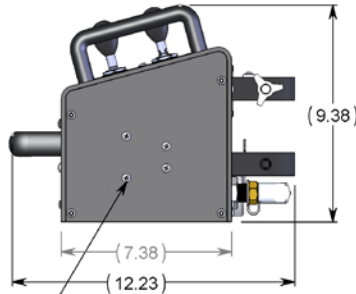
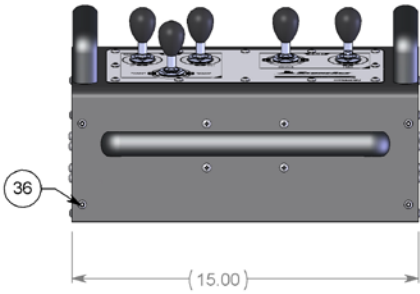

NOTES:

1. BALLOONS ON PAGE 2 IDENTIFY INTERNAL COMPONENTS.
2. BALLOONS ON PAGE 1 IDENTIFY EXTERNAL COMPONENTS.
3. ADD BLUE LOCTITE: PN 242 OR EQUIVALENT TO ALL THREADED HARDWARE UNLESS OTHERWISE NOTED.
4. ADD RED LOCTITE: PN 262 OR EQUIVALENT.

#	PART NUMBER	QTY.
1	BR 167 DUST CAP	1
2	CB 314 3-LOBE KNOB	1
6	CB 325 HANDLE TOP	2
7	CB 326 HANDLE FRONT	1
8	CB 328-001 POLE MOUNT	2
10	CB 347 CAP PLATE	1
12	CB 380 FTG P8 BULK HEAD CONNECTOR	1
13	CB 382 FTG PL6-T	
14	CB 401 CB FRAME	1
15	CB 402 GRAPHIC OVERLAY_AUTOSHOTSYS	1
18	CB 419-HD PNEUM3WAYASSY_NDT	4
19	CB 420-HD PNEUM3WAYASSY_DT	1

22	CB 430 LANYARD ASSY BOX	2
23	CB 452.2 FTG TWINTEC SOCKET	2
24	CB 459 SOCKET COVER	2
26	GMS 319-015-32 PHMS .19-32X.38 LG PH-SS	2
28	GPH 319-08 PHPMS 10-24 X 2.00 SS	12
29	GPTB 0250-PUR95A-RD	5FT
30	GPTB 0250-PUR95A-YL	6FT
31	GPTB 0375-PUR95A-BL	6FT
32	GPTB 0375-PUR95A-YL	2FT
33	GR 125-SS-188-250 RIVET	4
34	GSB 3M8-16-1.25 BHCS M8X1.25 X 16 SS	2
36	GTB 319-02-32 BHTS .19-32 X .50 LG TORX-SS	38
37	GTB 331-025 BHTS .31-18 X .63 LG TORX-SS	4

PARTS DIAGRAM

STRIKER® (CB 400) CONTROL BOX ASSEMBLY (PAGE 2 OF 2)

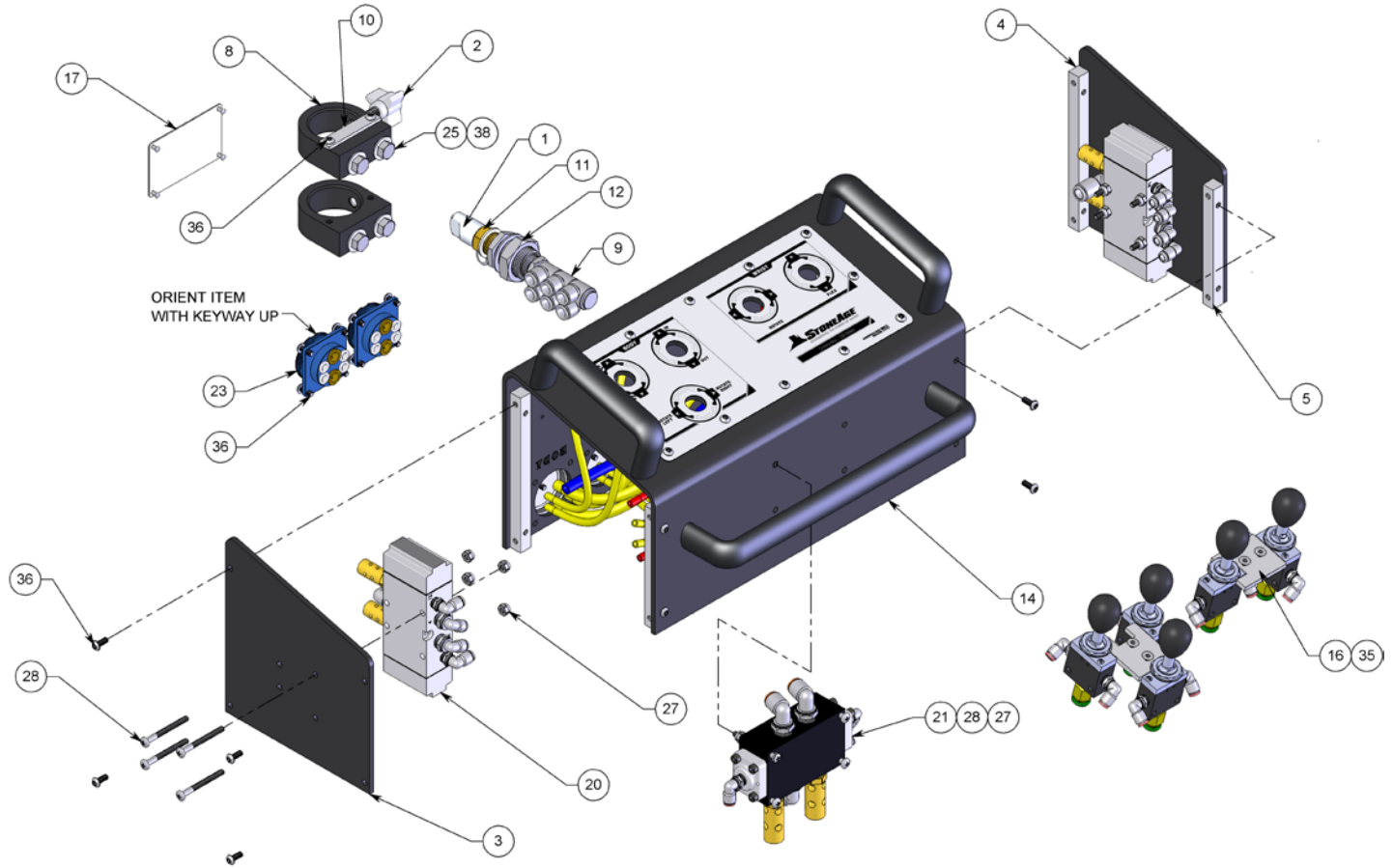

#	PART NUMBER	QTY.
1	BR 167 DUST CAP	1
2	CB 314 3-LOBE KNOB	1
3	CB 322 SIDE PLATE	2
4	CB 323 BRACE REAR	2
5	CB 324 BRACE FRONT	2
8	CB 328-001 POLE MOUNT	2
9	CB 331 P8PL6 6-WAY MANIFOLD	1
10	CB 347 CAP PLATE	1
11	CB 355 FTG P8J8 BRASS MALE TO MALE	1
12	CB 380 FTG P8 BULK HEAD CONNECTOR	1
14	CB 401 CB FRAME	1

16	CB 407 VALVEBRACE	2
17	CB 408 CE SERIAL PLATE	1
20	CB 421 FESTOPILOTEDASSY	2
21	CB 422 RY3 AAA PILOTED SPOOL VALVE ASSY	1
23	CB 452.2 FTG TWINTEC SOCKET	2
25	GB 337-03 BOLT, HEX .37-16 X .75 SS	4
27	GN 319-L NYLOK NUT SS (HC 025.1)	12
28	GPH 319-08 PHPMS 10-24 X 2.00 SS	12
35	GSF 319-02 FHCS .19-24 X .50 LG SS	4
36	GTB 319-02-32 BHTS .19-32 X .50 LG TORX-SS	38
38	GW 337-F FLAT WASHER	4

STRIKER® (CB 403)
(FILTER, REGULATOR, LUBRICATOR) FRL ASSEMBLY

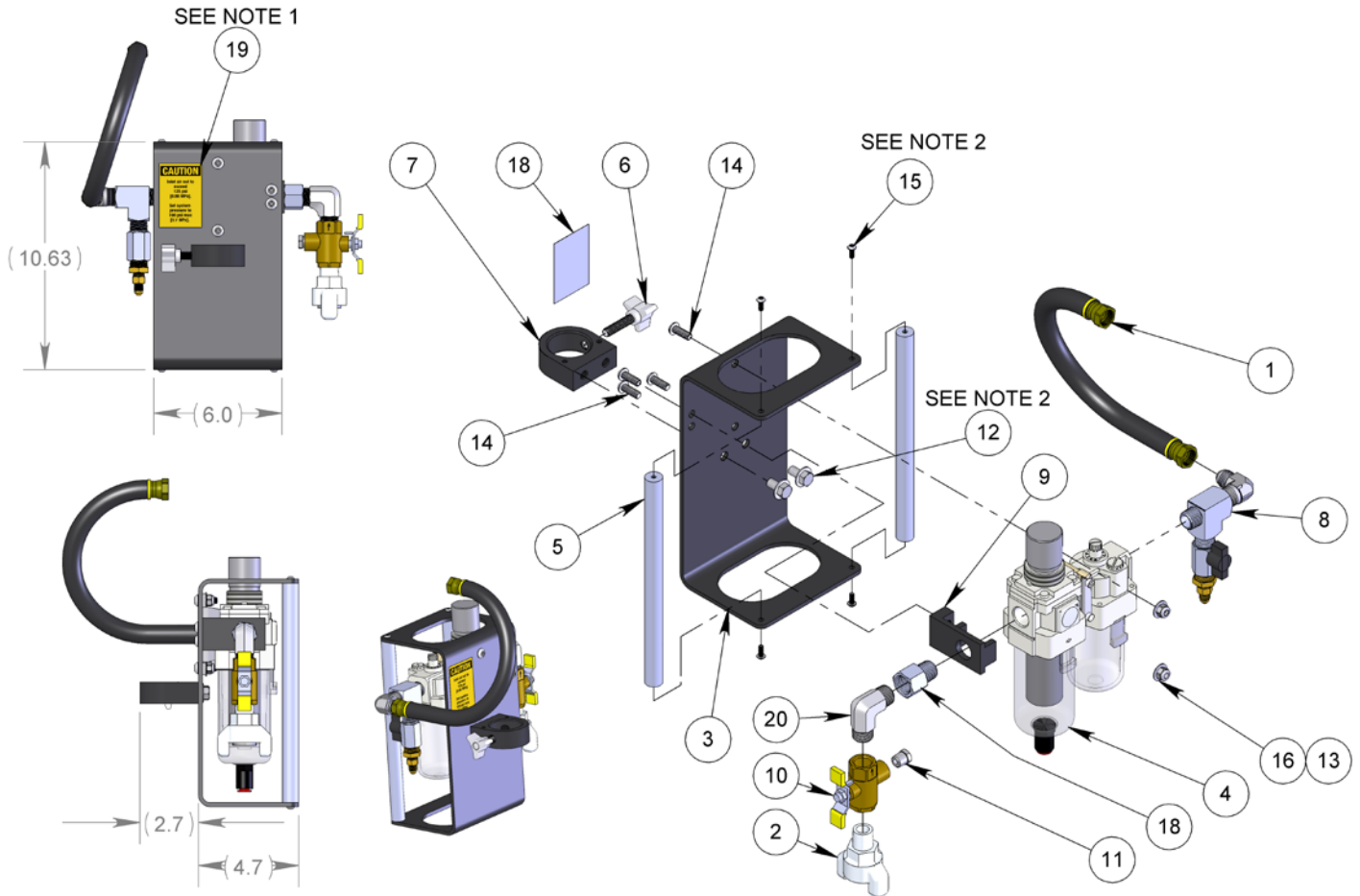

NOTES:

1. CLEAN ALL DEBRIS & OILS BEFORE INSTALLING. INSTALL AT APPROXIMATE ORIENTATION AND LOCATION & AT ROOM TEMP.
2. ADD BLUE LOCTITE® 242 OR EQUIVALENT TO ALL NOTED HARDWARE.
3. ADD LOCTITE THREAD SEALANT ® 567 TO ALL NPT THREADS. AN EQUIVALENT ALTERNATIVE IS ACCEPTABLE.
4. ADD BLUE GOOP WHICH IS A SWAGelok BRAND ANTI-SEIZE TO ALL OTHER THREADED HARDWARE OR AN EQUIVALENT ALTERNATIVE IS ACCEPTABLE.

#	PART NUMBER	QTY.
1	CB 052-14 HOSE ASSY (FOR CB PDT)	1
2	CB 114 INLET FITTING	1
3	CB 311 FRL FRAME	1
4	CB 312 GEN3 FILTER-REGULATOR-LUBRICATOR WITH GEN2 CLAMP	1
5	CB 313 ROD	2
6	CB 314 3-LOBE KNOB	1
7	CB 328-001 POLE MOUNT	1
8	CB 390 FRL DUMP SUPPLY ASSY	1
9	CB 395 FRL BRACKET	

10	CB 792 VALVE, AUTO DRAIN, P8	1
11	CB 793 BREATHER, SINTERED BRONZE, P4	1
12	GB 337-03 BOLT, HEX .37-16 X .75 SS	2
13	GN 331-L NYLON NUT SS	2
14	GSB 331-035 BHCS .31-18 X .88 LG SS	4
15	GTB 319-02-32 BHTS .19-32 X .50 LG TORX-SS	4
16	GW 331-F FLAT WASHER SS	2
17	GW 337-F FLAT WASHER SS	2
18	ML 077-P8 BUSHING	1
19	PL 156-125 CAUTION INLET AIR, 125PSI MAX	1
20	SBT 292.1 FTG 90° ELBOW P8MP8M	1

PARTS DIAGRAM

AUTOBOX® (CB 312)
GEN 3 FILTER, REGULATOR, LUBRICATOR WITH GEN 2 CLAMP

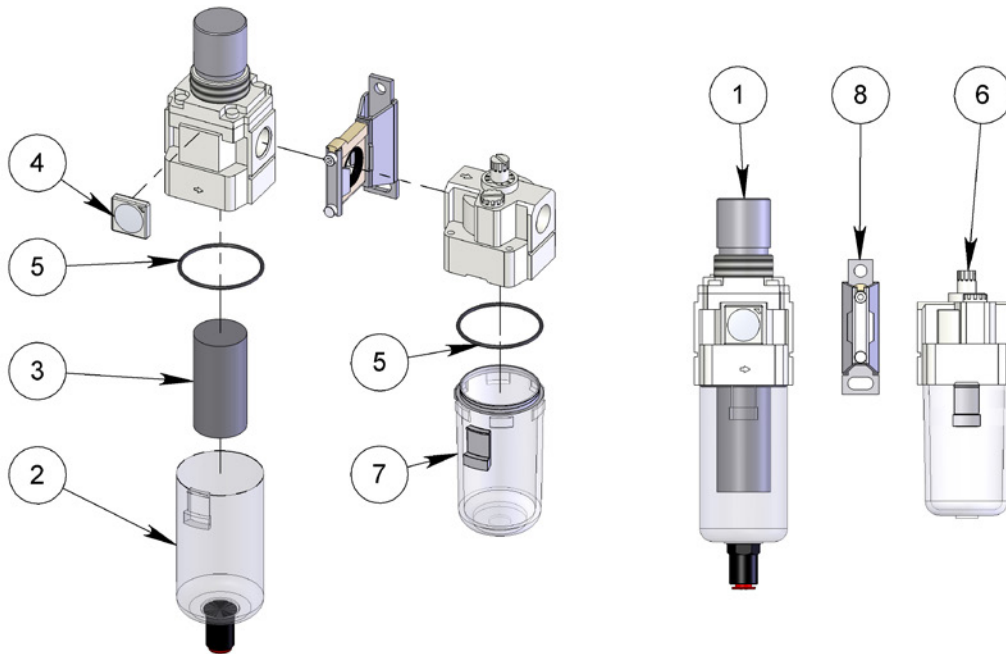
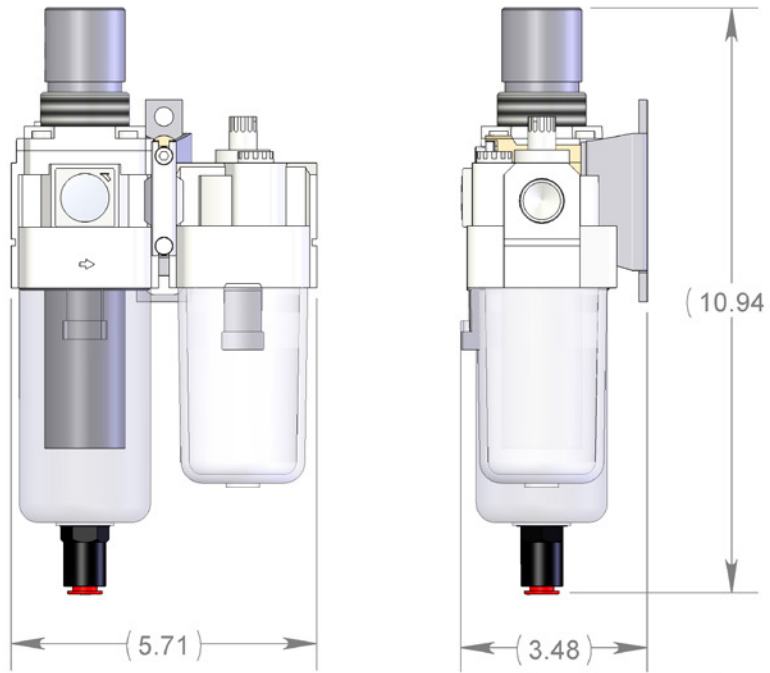

#	PART NUMBER	QTY.
1	CB 312.1 FILTER REGULATOR ASSEMBLY	1
2	CB 312.1.1 FILTER REGULATOR BOWL	1
3	CB 312.1.6 FILTER	1
4	CB 312.1.7 GAUGE WITH LENS	1
5	CB 312.1.8 ORING	2
6	CB 312.2 LUBRICATOR ASSEMBLY	1
7	CB 312.2.2 LUBRICATOR BOWL	1
8	CB 312.3 SPACER W BRACKET	1

STRIKER® (SKR 880.1)
REMOTE CONTROL CONSOLE

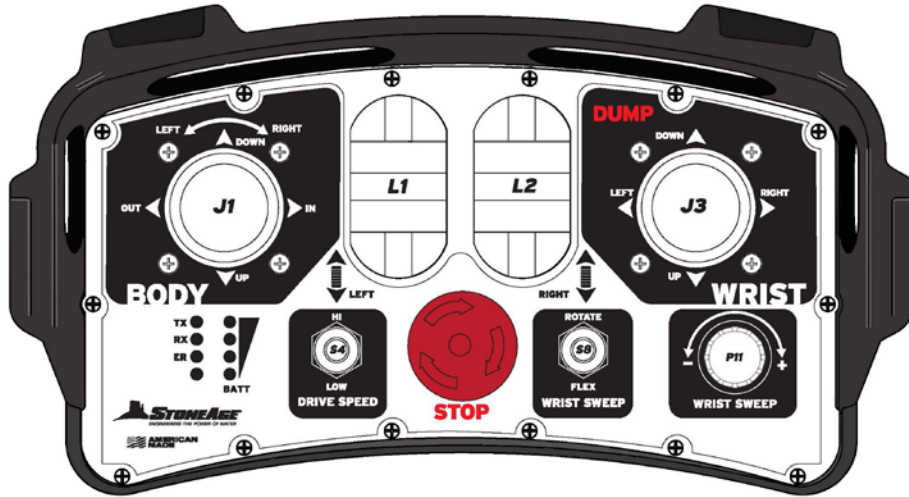

TOP VIEW

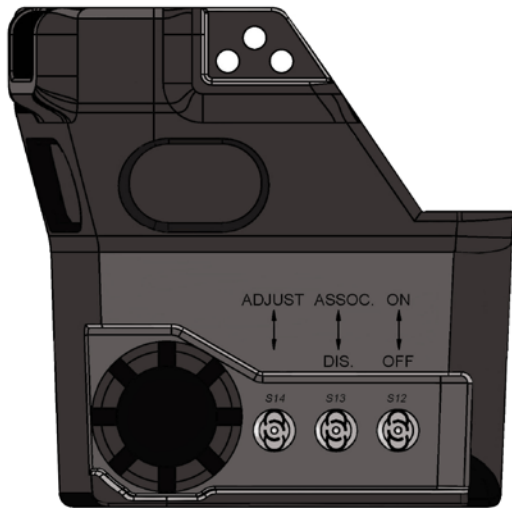

LEFT SIDE SWITCH DETAIL

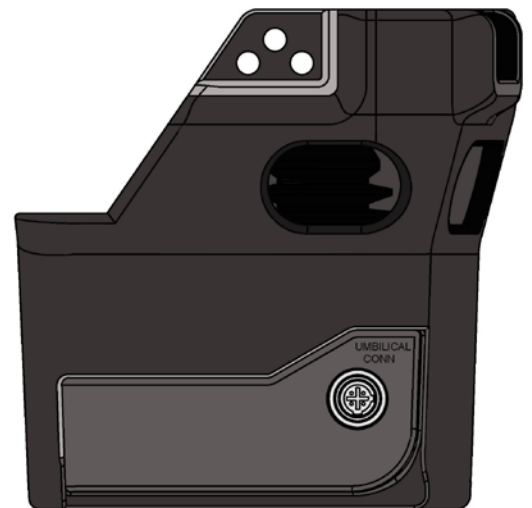

RIGHT SIDE SWITCH DETAIL

PARTS DIAGRAM

STRIKER® (SKR 880.10.XX)
REPLACEMENT VALVES FOR WIRELESS RECEIVER

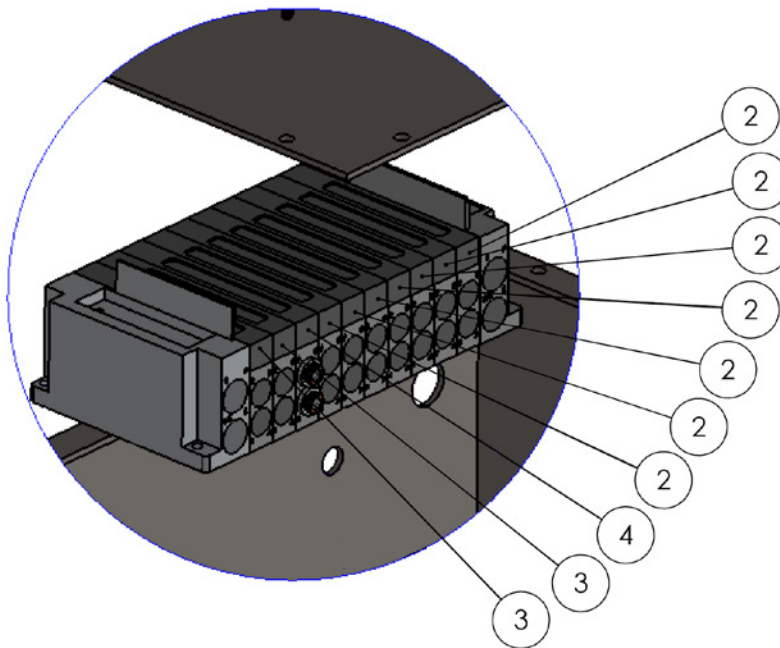

#	PART NUMBER	QTY.
2	SKR 880.10.10 SY5300T-6Z1 VALVE	7
3	SKR 880.10.11 SY5500T-6Z1 VALVE	2
4	SKR 880.10.12 SY5C00T-6Z1 VALVE	1

NOTICE

Replace any valve that has a blinking light. When replacing the cover plate, ensure that the gasket is seated properly and screws are tightened in a cross pattern.

REMOVE THE TWO
OFFSET STARLOCK
SCREWS AND LIFT THE
VALVE OUT



This page is intentionally left blank.

TERMS AND CONDITIONS

1. Acceptance of Terms and Conditions. Receipt of these Terms and Conditions of Sale ("Terms and Conditions") shall operate as the acceptance by StoneAge, Inc. ("Seller") of the order submitted by the purchaser ("Buyer"). Such acceptance is made expressly conditional on assent by Buyer to these Terms and Conditions. Such assent shall be deemed to have been given unless written notice of objection to any of these Terms and Conditions (including inconsistencies between Buyer's purchase order and this acceptance) is given by Buyer to Seller promptly on receipt hereof.

Seller desires to provide Buyer with prompt and efficient service. However, to individually negotiate the terms of each sales contract would substantially impair Seller's ability to provide such service. Accordingly, the product(s) furnished by Seller are sold only according to the terms and conditions stated herein and with the terms and conditions stated in any effective StoneAge Dealer Agreement or StoneAge Reseller Agreement, if applicable. Notwithstanding any terms and conditions on Buyer's order, Seller's performance of any contract is expressly made conditional on Buyer's agreement to these Terms and Conditions unless otherwise specifically agreed to in writing by Seller. In the absence of such agreement, commencement of performance, shipment and/or delivery shall be for Buyer's convenience only and shall not be deemed or construed to be an acceptance of Buyer's terms and conditions.

2. Payment/Prices. Unless other arrangements have been made in writing between Seller and Buyer, payment for the product(s) shall be made upon receipt of invoice. The prices shown on the face hereof are those currently in effect. Prices invoiced shall be per pricelist in effect at the time of shipment. Prices are subject to increase for inclusion of any and all taxes which are applicable and which arise from the sale, delivery or use of the product(s), and the collection of which Seller is or may be responsible to provide to any governmental authority, unless acceptable exemption certificates are provided by Buyer in accordance with applicable law. Buyer shall pay all charges for transportation and delivery and all excise, order, occupation, use or similar taxes, duties, levies, charges or surcharges applicable to the product(s) being purchased, whether now in effect or hereafter imposed by any governmental authority, foreign or domestic.

3. Warranty. SELLER MAKES NO WARRANTIES OR REPRESENTATIONS AS TO THE PERFORMANCE OF ANY PRODUCT EXCEPT AS SET FORTH IN THE STONEAGE LIMITED WARRANTY PROVIDED WITH THE PRODUCT.

4. Delivery. Seller is not obligated to make delivery by a specified date, but will always use its best efforts to make delivery within the time requested. The proposed shipment date is an estimate. Seller will notify Buyer promptly of any material delay and will specify the revised delivery date as soon as practicable. UNDER NO CIRCUMSTANCES SHALL SELLER HAVE ANY LIABILITY WHATSOEVER FOR LOSS OF USE OR FOR ANY DIRECT OR CONSEQUENTIAL DAMAGES RESULTING FROM DELAY REGARDLESS OF THE REASON(S).

All product(s) will be shipped F.O.B. point of origin, unless specifically agreed otherwise, and Buyer shall pay all shipping costs and insurance costs from that point. Seller, in its sole discretion, will determine and arrange the means and manner of transportation of the product(s). Buyer shall bear all risk of loss commencing with the shipment or distribution of the product(s) from Seller's warehouse. Order shortages or errors must be reported within fifteen (15) business days from receipt of shipment to secure adjustment. No product(s) may be returned without securing written approval from Seller.

5. Modification. These Terms and Conditions are intended by Seller and Buyer to constitute a final, complete and exclusive expression of agreement relating to the subject matter hereof and cannot be supplemented or amended without Seller's prior written approval.

6. Omission. Seller's waiver of any breach or Seller's failure to enforce any of these Terms and Conditions at any time, shall not in any way affect, limit or waive Seller's right thereafter to enforce and compel strict compliance with every term and condition hereof.

7. Severability. If any provision of these Terms and Conditions is held to be invalid or unenforceable, such invalidity or unenforceability shall not affect the validity or enforceability of the other portions hereof.

8. Disputes. Seller and Buyer shall attempt in good faith to promptly resolve any dispute arising under these Terms and Conditions by negotiations between representatives who have authority to settle the controversy. If unsuccessful, Seller and Buyer shall further attempt in good faith to settle the dispute by nonbinding third-party mediation, with fees and expenses of such mediation apportioned equally to each side. Any dispute not so resolved by negotiation or mediation may then be submitted to a court of competent jurisdiction in accordance with the terms hereof. These procedures are the exclusive procedures for the resolution of all such disputes between the Seller and Buyer.

9. Governing Law. All sales, agreements for sale, offers to sell, proposals, acknowledgments and contracts of sale, including, but not limited to, purchase orders accepted by Seller, shall be considered a contract under the laws of the State of Colorado and the rights and duties of all persons, and the construction and effect of all provisions hereof shall be governed by and construed according to the laws of such state.

10. Jurisdiction and Venue. Seller and Buyer agree that the state or federal courts located within the City and County of Denver, Colorado shall have sole and exclusive jurisdiction over any litigation concerning any dispute arising under these Terms and Conditions not otherwise resolved pursuant to Section 9 as well as any alleged defects of any Products or damages sustained as a result of such alleged defects. Seller and Buyer further agree that should any litigation be commenced in connection with such a dispute, it shall only be commenced in such courts. Seller and Buyer agree to the exclusive jurisdiction of such courts and neither will raise any objection to the jurisdiction and venue of such courts, including as a result of inconvenience.

11. Attorney's Fees. If any litigation is commenced between Seller and Buyer, or their personal representatives, concerning any provision hereof, the party prevailing in the litigation shall be entitled, in addition to such other relief that is granted, to a reasonable sum as and for their attorneys' fees and costs in such litigation or mediation.

STONEAGE TRADEMARK LIST

View the list of StoneAge's trademarks and service marks and learn how the trademarks should be used. Use of StoneAge trademarks may be prohibited, unless expressly authorized.

<http://www.StoneAgetools.com/trademark-list/>

STONEAGE PATENT DATA

View the list of StoneAge's current U.S. patent numbers and descriptions.

<http://www.sapatents.com>

STONEAGE TERMS AND WARRANTY

View StoneAge's Terms and Warranty Conditions online.

<http://www.stoneagetools.com/terms>

<http://www.stoneagetools.com/warranty>

Warranties set forth herein extend only to End-Users, meaning customers acquiring, or that have previously acquired, a product manufactured by StoneAge ("Product") for their own use and not for resale, either directly from StoneAge Inc. ("StoneAge") or from a StoneAge Authorized Dealer or Reseller ("Dealer"). No warranty of any kind or nature is made by StoneAge beyond those expressly stated herein.

1. LIMITED WARRANTY PERIOD. Subject to the limitations and conditions hereinafter set forth, StoneAge warrants its Product to be free from defects in workmanship and material for a period of one (1) year from the date of purchase by the End-User, provided that the end of the limited warranty period shall not be later than eighteen (18) months from the date of shipment of the Product to the Dealer or the End-User by StoneAge ("Limited Warranty Period"). All replacement parts which are furnished under this Limited Warranty and properly installed shall be warranted to the same extent as the original Product under this Limited Warranty if, and only if, the original parts were found to be defective within the original Limited Warranty Period covering the original Product. Replacement parts are warranted for the remainder of the original Limited Warranty Period. This Limited Warranty does not cover any component part of any Product not manufactured by StoneAge. Any such component part is subject exclusively to the component manufacturer's warranty terms and conditions.

2. LIMITED WARRANTY COVERAGE. StoneAge's sole obligation under this Limited Warranty shall be, at StoneAge's option and upon StoneAge's inspection, to repair, replace or issue a credit for any Product which is determined by StoneAge to be defective in material or workmanship. StoneAge reserves the right to examine the alleged defective Product to determine whether this Limited Warranty is applicable, and final determination of limited warranty coverage lies solely with StoneAge. No statement or recommendation made by a StoneAge representative, Dealer or agent to End-User shall constitute a warranty by StoneAge or a waiver or modification to any of the provisions hereof or create any liability for StoneAge.

3. WARRANTY SERVICE PROVIDERS. Service and repair of the Product is to be performed only by StoneAge authorized service representatives, including Dealers who are authorized repair centers, with StoneAge approved parts. Information about StoneAge authorized service representatives can be obtained through the StoneAge website at www.stoneagetools.com/ service. Unauthorized service, repair or modification of the Product or use of parts not approved by StoneAge will void this Limited Warranty. StoneAge reserves the right to change or improve the material and design of the Product at any time without notice to End-User, and StoneAge is not obligated to make the same improvements during warranty service to any Product previously manufactured.

4. WARRANTY EXCLUSIONS. This Limited Warranty does not cover, and StoneAge shall not be responsible for the following, or damage caused by the following: (1) any Product that has been altered or modified in any way not approved by StoneAge in advance in writing; (2) any Product that has been operated under more severe conditions or beyond the rated capacity specified for that Product; (3) depreciation or damage caused by normal wear and tear, failure to follow operation or installation instructions, misuse, negligence or lack of proper protection during storage; (4) exposure to fire, moisture, water intrusion, electrical stress, insects, explosions, extraordinary weather and/or environmental conditions including, but not limited to lightning, natural disasters, storms, windstorms, hail, earthquakes, acts of God or any other force majeure event; (5) damage to any Product caused by any attempt to repair, replace, or service the Product by persons other than StoneAge authorized service representatives; (6) costs of normal maintenance parts and services; (7) damage sustained during unloading, shipment or transit of the Product; or (8) failure to perform the recommended periodic maintenance procedures listed in the Operator's Manual accompanying the Product.

5. REQUIRED WARRANTY PROCEDURES. To be eligible for warranty service, the End-User must: (1) report the Product defect to the entity where the Product was purchased (i.e. StoneAge or the Dealer) within the Limited Warranty Period specified in this Limited Warranty; (2) submit the original invoice to establish ownership and date of purchase; and (3) make the Product available to a StoneAge authorized service representative for inspection to

determine eligibility for coverage under this Limited Warranty. This Limited Warranty shall not extend to any person or entity who fails to provide proof of original purchase from StoneAge or a Dealer. No Product may be returned for credit or adjustment without prior written permission from StoneAge.

6. DISCLAIMER OF IMPLIED WARRANTIES AND OTHER REMEDIES. EXCEPT AS EXPRESSLY STATED HEREIN (AND TO THE FULLEST EXTENT ALLOWED UNDER APPLICABLE LAW), STONEAGE HEREBY DISCLAIMS ALL OTHER WARRANTIES, EXPRESS OR IMPLIED, INCLUDING WITHOUT LIMITATION ALL IMPLIED WARRANTIES OF MERCHANTABILITY OR FITNESS FOR A PARTICULAR PURPOSE, AND ANY AND ALL WARRANTIES, REPRESENTATIONS OR PROMISES AS TO THE QUALITY, PERFORMANCE OR FREEDOM FROM DEFECT OF THE PRODUCT COVERED BY THIS LIMITED WARRANTY. STONEAGE FURTHER DISCLAIMS ALL IMPLIED INDEMNITIES.

7. LIMITATION OF LIABILITY. End-User specifically acknowledges that the Product may be operated at high speeds and/or pressures, and that as such it may be inherently dangerous if not used correctly. End-User shall familiarize itself with all operation materials provided by StoneAge and shall at all times use and require its agents, employees and contractors to use all necessary and appropriate safety devices, guards and proper safe operating procedures. In no event shall StoneAge be responsible for any injuries to persons or property caused directly or indirectly by the operation of the Product if End-User or any agent, employee, or contractor of End-User: (1) fails to use all necessary and appropriate safety devices, guards and proper safe operating procedures; (2) fails to maintain in good working order such safety devices and guards; (3) alters or modifies the Product in any way not approved by StoneAge in advance in writing; (4) allows the Product to be operated under more severe conditions or beyond the rated capacity specified for the Product; or (5) otherwise negligently operates the Product. End-User shall indemnify and hold StoneAge harmless from any and all liability or obligation incurred by or against StoneAge, including costs and attorneys' fees, to or by any person so injured.

TO THE FULL EXTENT ALLOWED BY APPLICABLE LAW, STONEAGE SHALL NOT BE LIABLE FOR ANY INDIRECT, SPECIAL, INCIDENTAL, CONSEQUENTIAL, OR PUNITIVE DAMAGES (INCLUDING WITHOUT LIMITATION, LOSS OF PROFITS, LOSS OF GOODWILL, DIMINUTION OF VALUE, WORK STOPPAGE, INTERRUPTION OF BUSINESS, RENTAL OF SUBSTITUTE PRODUCT, OR OTHER COMMERCIAL LOSS EVEN TO THE EXTENT SUCH DAMAGES WOULD CONSTITUTE DIRECT DAMAGES), WITH RESPECT TO THE COVERED STONEAGE PRODUCT, OR OTHERWISE IN CONNECTION WITH THIS LIMITED WARRANTY, REGARDLESS OF WHETHER STONEAGE HAS BEEN ADVISED OF THE POSSIBILITY OF SUCH DAMAGES.

IT IS UNDERSTOOD THAT STONEAGE'S LIABILITY, WHETHER IN CONTRACT, IN TORT, UNDER ANY WARRANTY, IN NEGLIGENCE, OR OTHERWISE SHALL NOT EXCEED THE AMOUNT OF THE PURCHASE PRICE PAID BY THE END-USER FOR THE PRODUCT. STONEAGE'S MAXIMUM LIABILITY SHALL NOT EXCEED, AND END-USER'S REMEDY IS LIMITED TO EITHER (1) REPAIR OR REPLACEMENT OF THE DEFECTIVE WORKMANSHIP OR MATERIAL OR, AT STONEAGE'S OPTION, (2) REFUND OF THE PURCHASE PRICE, OR (3) ISSUANCE OF A CREDIT FOR THE PURCHASE PRICE, AND SUCH REMEDIES SHALL BE END-USER'S ENTIRE AND EXCLUSIVE REMEDY.

YOU, THE END-USER, UNDERSTAND AND EXPRESSLY AGREE THAT THE FOREGOING LIMITATIONS ON LIABILITY ARE PART OF THE CONSIDERATION IN THE PRICE OF THE STONEAGE PRODUCT YOU PURCHASED.

Some jurisdictions do not allow the limitation or exclusion of liability for certain damages, so the above limitations and exclusions may not apply to you. This Limited Warranty gives you specific legal rights, and you may also have other rights which vary from jurisdiction to jurisdiction. If any provisions of this Limited Warranty is held to be invalid or unenforceable, such invalidity or unenforceability shall not affect the validity or enforceability of the other portions hereof.



1-866-795-1586 • www.STONEAGETOOLS.com

© 2015 StoneAge, Inc. All Rights Reserved