

Service Manual



Compact Disc Player SL-P770



Color

(K) Black Type

SPECIFICATIONS

Audio

No. of channels: 2 (left and right stereo)
Frequency response: 2~20.000 Hz \pm 0.2 dB
Output voltage: 2.5 rms V (at 0 dB)
Dynamic range: 100 dB
S/N ratio: 113 dB
Harmonic distortion: 0.0013% (1 kHz, 0 dB)
Total harmonic distortion: 0.0025% (1 kHz, 0 dB)
Channel separation: 110 dB
Wow and flutter: Below measurable limit
Low-pass filter: High Resolution Digital Filter
Output impedance: Approx. 600 Ω
Load impedance: More than 10 k Ω
Headphone output level: 100 mW max. 32 Ω (adjustable)

Signal format

Sampling frequency: 44.1 kHz
Correction system: Technics Super Decoding Algorithm
D-A conversion: 16-bit inner

Pickup

Type: Fine-focus one beam
Light source: Semiconductor laser
Wavelength: 780 nm
Traverse system: High-speed linear access system
Spindle system: Brushless DD motor

Infrared remote control transmitter

Dimensions (W×H×D): 73 × 22 × 181 mm
(2-7/8" × 7/8" × 7-1/8")
Batteries: UM-4 "AA" batteries or IEC-R03
or equivalent (1.5 V × 2)
Weight: 130 g (including batteries)
(0.28 lbs)

General

Power supply: For U.S.A. and Canada:
AC 120 V, 60 Hz
For United Kingdom and Australia:
AC 240 V, 50 Hz
For Continental Europe:
AC 220 V, 50 Hz
For Others:
AC 110~127 V/ 220~240 V,
50/60 Hz
Power consumption: 16 W
Dimensions (W×H×D): 430 × 129 × 333 mm
(16-15/16" × 5-3/32" × 13-1/8")
Weight: 8.1 kg
(17.9 lbs)

Specifications are subject to change without notice.
 Weight and dimensions are approximate.
 Measured by EIAJ (CP-307).

Color	Area
(K)	[M] U.S.A.
(K)	[MC] ... Canada.
(K)	[E] Continental Europe.
(K)	[EK] United Kingdom.
(K)	[XL] Australia.
(K)	[EG] ... F.R.Germany.
(K)	[EB] Belgium.
(K)	[EH] Holland.
(K)	[EF] France.
(K)	[Ei] Italy.
(K)	[XA] Asia, Latin America, Middle Near East, Africa and Oceania.
(K)	[XB] Saudi Arabia.
(K)	[PA] Far East PX.
(K)	[PE] European Military.
(K)	[PC] European Audio Club.

SL-P770

CONTENTS

	Page	Page	
SAFETY PRECAUTIONS	2	SCHMATIC DIAGRAM	28~34
PRECAUTION OF LASER DIODE	3	PRINTED CIRCUIT BOARD AND CONNECTION DIAGRAM	35~38
BEFORE USING THIS UNIT	3	REPLACEMENT PARTS LIST (Electric parts)	39~40
FRONT PANEL CONTROLS AND FUNCTIONS	4~5	EXPLODED VIEWS	41~43
REMOTE CONTROL TRANSMITTER	6	REPLACEMENT PARTS LIST (Mechanical parts)	44
CONNECTIONS	6	REMOTE CONTROL UNIT PARTS	45
OPERATION	7~9	PACKING	46
CONVENIENT FUNCTIONS	10	RESISTORS AND CAPACITORS	47~49
RECORDING FROM COMPACT DISCS	12	BLOCK DIAGRAM	50~52
HANDLING PRECAUTIONS FOR OPTICAL PICKUP	15	TERMINAL FUNCTION OF LSI	53~57
DISASSEMBLY INSTRUCTIONS	16~19	INTERNAL CONNECTION OF FL	58
MEASUREMENTS AND ADJUSTMENTS	20~26		
SCHEMATIC DIAGRAM OF REMOTE CONTROL UNIT	27		

SAFETY PRECAUTION (This "safety precaution" is applied only in U.S.A.)

1. Before servicing, unplug the power cord to prevent an electric shock.
2. When replacing parts, use only manufacturer's recommended components for safety.
3. Check the condition of the power cord. Replace if wear or damage is evident.
4. After servicing, be sure to restore the lead dress, insulation barriers, insulation papers, shields, etc.
5. Before returning the serviced equipment to the customer, be sure to make the following insulation resistance test to prevent the customer from being exposed to a shock hazard.

INSULATION RESISTANCE TEST

1. Unplug the power cord and short the two prongs of the plug with a jumper wire.
2. Turn on the power switch.
3. Measure the resistance value with ohmmeter between the jumpered AC plug and each exposed metal cabinet part, such as screwheads antenna, control shafts, handle brackets, etc. Equipment with antenna terminals should read between 3M Ω and 5.2M Ω to all exposed parts. (Fig. A) Equipment without antenna terminals should read approximately infinity to all exposed parts. (Fig. B)

Note: Some exposed parts may be isolated from the chassis by design. These will read infinity.

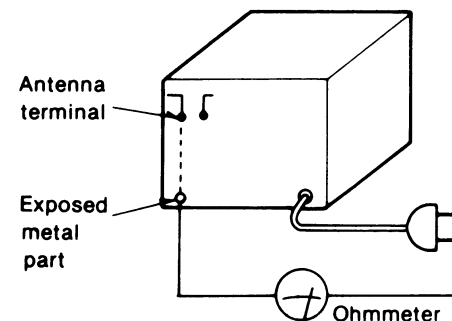

(Fig. A)

Resistance = 3M Ω —5.2M Ω

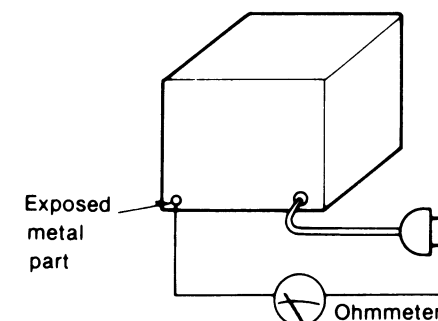

(Fig. B)

Resistance = Approx ∞

4. If the measurement is outside the specified limits, there is a possibility of a shock hazard. The equipment should be repaired and rechecked before it is returned to the customer.

Technics

Matsushita Services Company
50 Meadowland Parkway,
Secaucus, New Jersey 07094

Panasonic Sales Company,
Division of Matsushita Electric
of Puerto Rico, Inc.
Ave. 65 De Infanteria, Km. 9.7
Victoria Industrial Park
Carolina, Puerto Rico 00630

Panasonic Hawaii, Inc.
91-238, Kauhii Street, Ewa Beach
P.O. Box 774
Honolulu, Hawaii 96808-0774

Matsushita Electric
of Canada Limited
5770 Ambler Drive, Mississauga,
Ontario, L4W 2T3

Matsushita Electric Trading Co., Ltd.
P.O. Box 288, Central Osaka Japan

Panasonic Tokyo Office
Matsushita Electric Trading Co., Ltd.
6th Floor, World Trade Center Bldg.,
No. 4-1, Hamamatsu-cho 2-Chome,
Minato-ku, Tokyo 105, Japan

PRECAUTION OF LASER DIODE

Caution: This product utilizes a laser diode.
 ADVARSEL: I dette a apparat anvendes laser.

• Use of caution labels Note ○ Mark is used, × Mark is not used.

Areas	SQWD45	SQWD10	SQWD7	SQWD19
[MC]	×	○	×	×
[E]	○	×	○	○
[EK], [XL], [EG], [EB], [EH], [EF], [Ei], [XA], [XB]	○	×	○	○

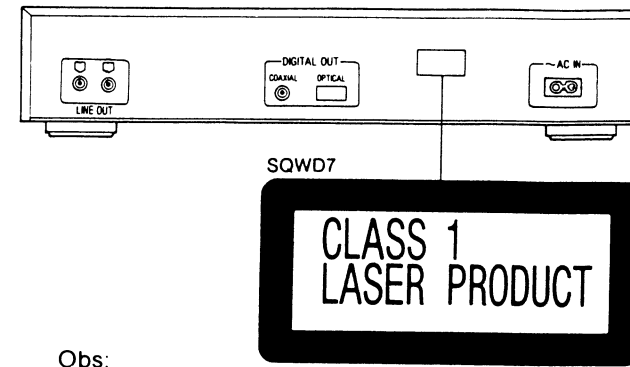

Obs:
 Apparaten innehåller laser
 Komponent av höger laserklass
 än klass 1.

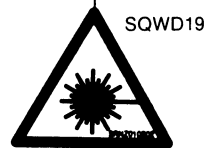
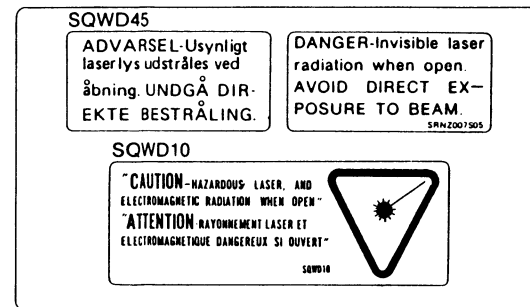

VAROITUS! Laite sisältää laserdiodin,
 joka lähettää näkymätöntä silmille
 vaarallista lasersäteilyä

BEFORE USING THIS UNIT

- Place a softcloth under the unit to protect it from scratches.
- Press the lock shaft on the bottom panel to the in (FREE) position (FREE).

NOTE:
 IF THE UNIT IS TRANSPORTED AGAIN, PERFORM THE FOLLOWING STEPS:
 1) Remove the disc from the holder.
 2) Pull the lock shaft to the out (LOCK) position (LOCK).
CAUTION:
 Do not transport the unit without locking the lock shaft.
SEVERE DAMAGE WILL RESULT.

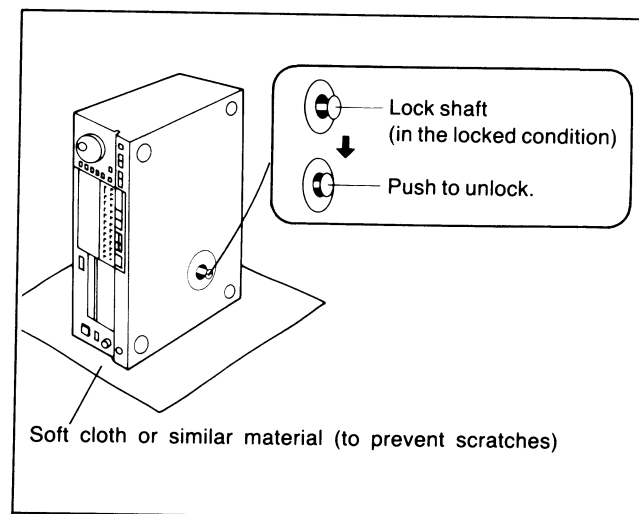

Soft cloth or similar material (to prevent scratches)

FRONT PANEL CONTROLS AND FUNCTIONS

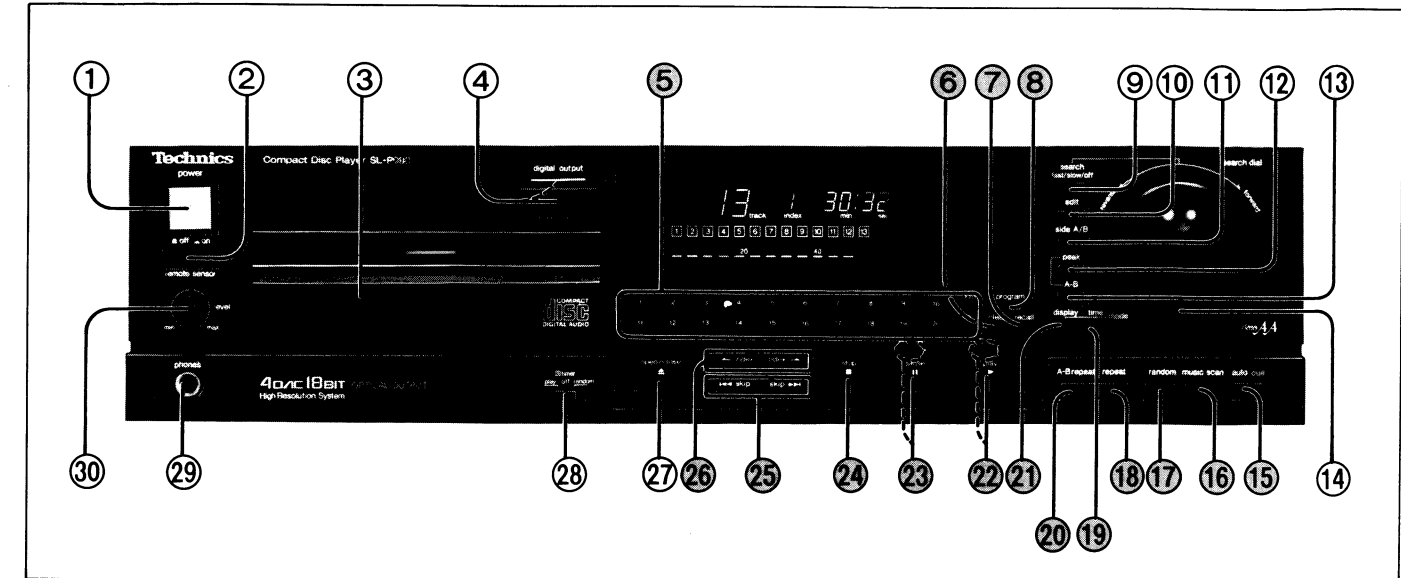

Control section

- Power switch (power)**
- Remote-control signal receptor (remote sensor)**
- Disc holder**
- Digital output button/indicator (digital output)**
 While this indicator illuminates, compact-disc sounds can be output (as digital signals) from the digital output terminals on the rear panel of this unit.
- Numeric buttons (1~20, +10, 0)**
 These buttons can be used to select the track numbers and the recording time.
- Clear button (clear)**
- Recall button (recall)**
- Programmed-play button (program)**
- Search-speed select button (fast/slow/off)**
 This button can be used to select the speed when using the search dial to locate the beginnings of tracks.
fast:
 Set to this position to search at high speed. (One turn of the dial is equivalent to about 25 seconds.)
slow:
 Set to this position to search at slow speed. (One turn of the dial is equivalent to about 1 second.)
off:
 Set to this position when the search dial is not being used.
- Compact-disc edit button (edit)**
 When compact-disc sounds are to be recorded to tape, this button can be used to calculate the number of tracks that can be recorded on the two sides of the tape, considering the length of the cassette tape used, so that there is no interruption of tracks.
- Tape-side select button (side A/B)**
- Peak-level search button (peak)**
 This button can be used to locate the maximum signal level (peak level) for the signals on the disc. This is a convenient feature that helps when adjusting the recording level when compact-disc sounds are to be recorded to tape.
- A-B peak-level search button (A-B)**
- Search dial (search dial)**
- Automatic play stand-by button (auto cue)**
- Music scan button (music scan)**
 This button can be used to play the first part of each track in order.
- Random-play button (random)**
 This button can be used to select "random" play (the unit's microcomputer selects the sequence of track play in a random order).
- Repeat button (repeat)**
- Time-display select button (time mode)**
- A-B repeat button (A-B repeat)**
- Display-mode select button (display mode)**
 This button can be used to select, each time it is pressed, either the display of the play position of the disc, or the display of the output level, by the indicator.
- Play button/indicator (play/▶)**
- Pause button/indicator (pause/||)**
- Stop button (stop/■)**
 This button can be used to stop the disc play, as well as to cancel the various play modes.
- Skip buttons (◀◀ skip/skip ▶▶)**

The functions indicated by the shaded frames can also be activated by using the remote-control transmitter's controls.

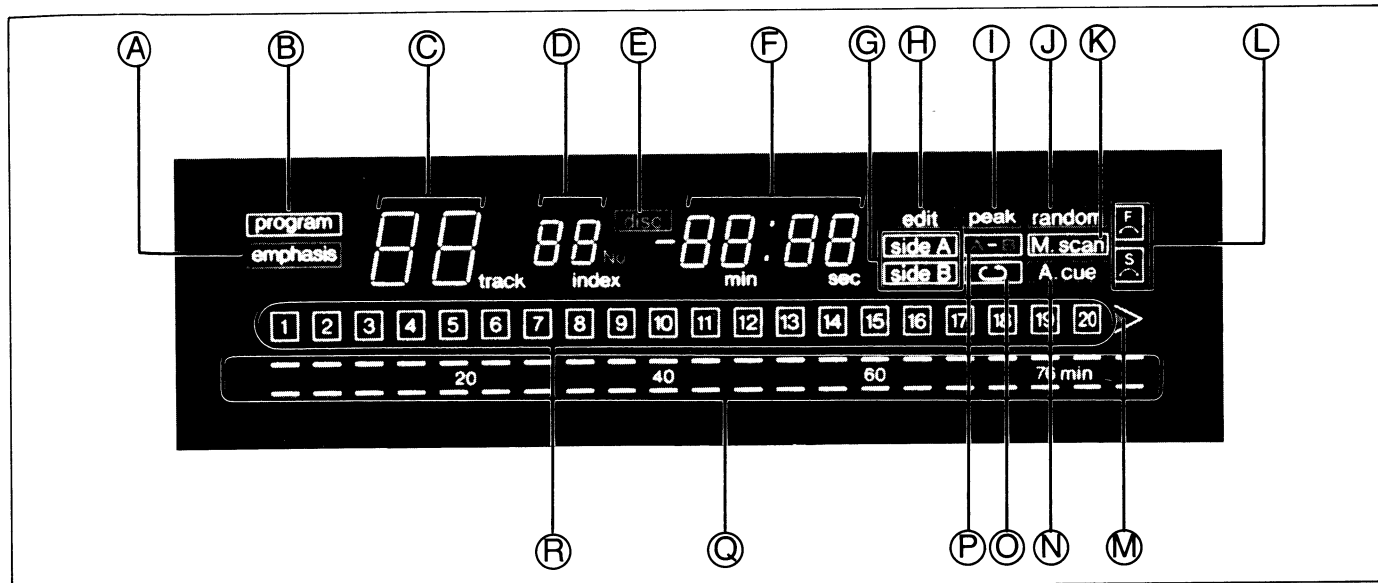

26 Index-skip buttons (← index/index →)
 These buttons can be used to skip to any desired index number, after which play begins from that point.

What index numbers are...
 Index numbers are sub track numbers used to subdivide tracks into smaller parts for reference purposes. Compact discs that have such subdivisions are indicated by the symbol on the notes and commentary that accompany the disc.

- 27 Disc holder open/close button (open/close/▲)**
- 28 Timer stand-by switch (□ timer)**
- 29 Headphones jack (phones)**
- 30 Headphones volume control (level)**
- 31 Search buttons (◀◀ search ▶▶)**
 These buttons can be used to locate a desired part of the disc at high speed (forward or reverse) during disc play. (The search speed is slow when the button is first pressed, and becomes faster if the button is pressed and held continuously.)
 (For the remote-control transmitter only.)

Indicators section

- A Emphasis indicator (emphasis)**
 The sounds on some compact discs are sounds that are re-recordings (as digital signals) of a sound source originally recorded as analog signals. For some discs of this type, the signal characteristics have been corrected (emphasized), and this indicator illuminates when such discs are loaded in this unit. For such discs, the output level will be displayed as slightly higher than for analog signals.
- B Programmed-play indicator (program)**

- C Track number display (track)**
- D Index-number display (No./index)**
 This display shows the index number as well as the sequence of programmed play.
- E Disc indicator (disc)**
 This indicator illuminates when a disc is loaded.
- F Time display**
- G Tape side indicator (side A, side B)**
- H Compact-disc edit indicator (edit)**
- I Peak-level search indicator (peak)**
- J Random-play indicator (random)**
- K Music scan indicator (M.scan)**
- L Search-speed indicators (F, S)**
- M "Over" mark (▶)**
 The "▶" indicator illuminates if the total number of tracks on the disc is 21 tracks or more. When the play reaches the 21st track and thereafter, the "▶" begins flashing.
- N Automatic play stand-by indicator (A.cue)**
- O Repeat indicator (◁)**
- P A-B repeat indicator (A-B)**
- Q Play-position/digital output-level indicator**
- R Music matrix (1~20)**
 The numbers of the tracks on the disc are displayed up to a maximum of 20.

REMOTE CONTROL UNIT PARTS

EUR64712 For U.S.A. and Canada
 EUR64713 For others

- 31 Search buttons (◀◀ search ▶▶)**
 (For the remote-control transmitter only.)
- 5 Numeric buttons (1~20, +10, 0)**
- 8 Programmed-play button (program)**
- 20 A-B repeat button (A-B repeat)**
- 18 Repeat button (repeat)**
- 17 Random-play button (random)**
- 16 Music scan button (music scan)**
- 15 Automatic play stand-by button (auto cue)**
- 21 Display-mode select button (display mode)**
- 19 Time-display select button (time mode)**
- 24 Stop button (■ stop)**
- 23 Pause button**
- 22 Play button (▶ play)**
- 25 Skip buttons (◀◀ skip ▶▶)**
- 6 Clear button (clear)**
- 7 Recall button (recall)**
- 26 Index-skip buttons (← index skip →)**

CONNECTIONS

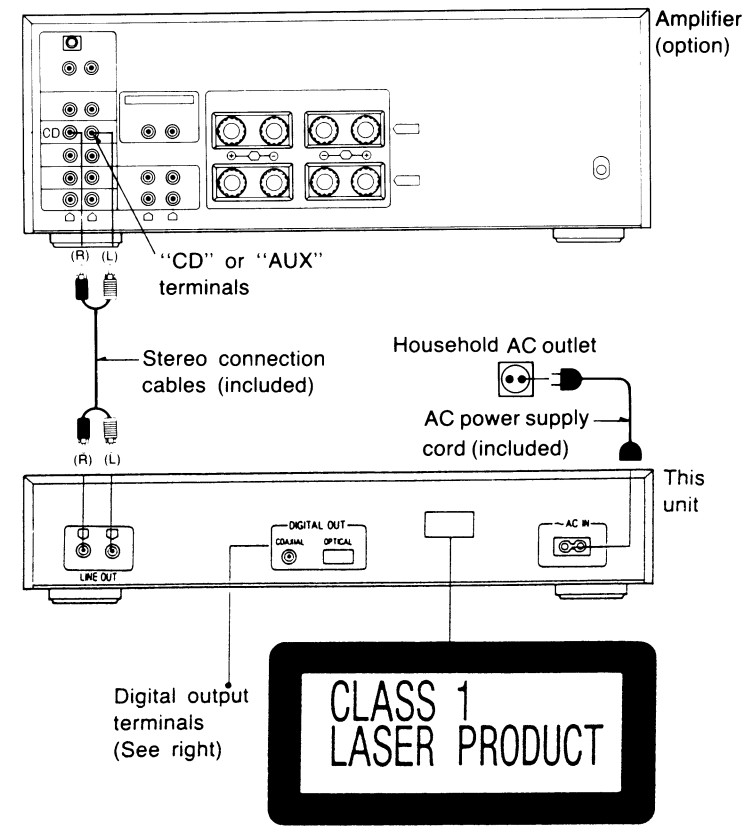

Digital output terminals (DIGITAL OUT)

The output signals of this unit are output from these terminals as digital signals.

• Coaxial terminal (COAXIAL)
 This terminal can be used for connection with other equipment that has a digital input terminal, such as an amplifier, by using a coaxial cable. (included)

• Optical terminal (OPTICAL)
 This terminal can be used for connection with other equipment that has a digital input terminal, such as an amplifier, by using an optical cable (included). A dust-protection cap is inserted in this terminal. Remove this cap only when a connection is to be made to this terminal.

CAUTION
 When using the optical cable, please keep the following points in mind:

1. The maximum length of optical cable to be used with this unit is 3 m (approx. 10 ft.).
2. Always make sure the plug is fully inserted. If the plug is not inserted all the way, an imperfect connection will result.
3. The optical cable must never be bent or coiled tightly. Doing so will permanently damage the optical fiber in the cable and, therefore, prevent proper data transmission. If the cable must be coiled (for storage, etc.), the diameter of the loop should be at least 15 cm (approx. 6 inches).
4. Handle the optical cable's plug very carefully. Keep the plug free from dust or damage. Dust can be removed by wiping the plug with a soft cloth. Do not use any cleaners or solvents to clean the plug.

OPERATION

The following explanation will use, as an example, a compact disc on which are recorded 13 tracks, with a total playing time of 30 minutes and 32 seconds.

Listening a disc from beginning (automatic play)

The track will be played from the first track to the final track in order. The operations described below are the basic operations when listening to a compact disc. Follow steps 1, 2, 3 and 4 in the same way for another performance.

Note: Have you released the lock shaft?

- 1 "off"
- 2 Reduce the volume level (at the amplifier), and then switch ON the power.
- 3 Press **open/close**, and insert the disc. (See 1 below).
- 4 Press **open/close**. (See 2 below). (The holder will close, and the disc will begin to rotate.)
- 5 Press **play**. (See 3 below). (Play indicator will illuminate and play will start.)

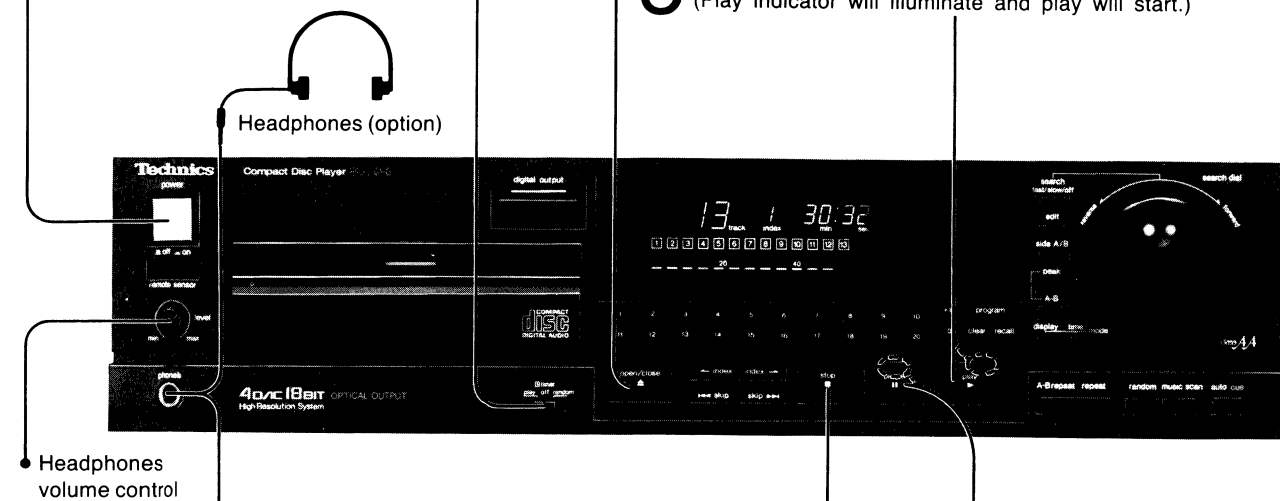

When listening through headphones

- Set the headphones volume control to low position before connecting headphones.
- Use the headphones volume control to adjust the volume while listening to music.

To stop disc play

Press the **stop** button. (Some play modes will be cancelled.)

After use

- Remove the disc from the disc holder.
- Close the disc holder.
- Turn off the power.

To temporarily stop disc play

Press the **pause** button. (The pause indicator will illuminate.) Press the **play** button again to resume the play. (The pause indicator will go out.)

1 To insert a disc:

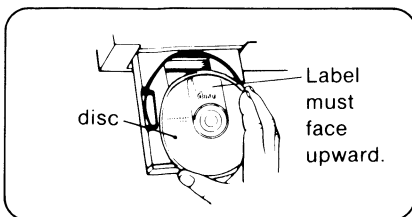

Do not try to insert a disc until the holder has opened completely, because the disc may be scratched if it is inserted sooner. Discs of the 8-cm (3") size and 12-cm (5") size cannot be used together.

2 The indicator will display:

The total number of tracks and the total play time will be displayed.

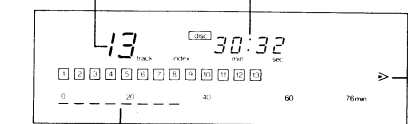

Total play time is also indicated by the number of bars.

Note:

You may notice that there is a slight difference (a few seconds) between the time displayed for each track and the time shown in the notes included with the disc. This is because the displayed time includes the time between tracks.

Illuminates when there are 21 or more tracks.

3 The indicator will display:

The track number and the elapsed play time will be displayed.

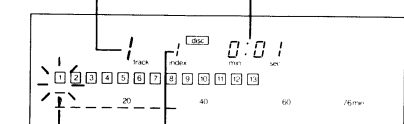

For discs without index numbers, "1/" will be continuously displayed.

The track number flashes during play, and then disappears when play finishes.

Programmed play

The functions indicated by the shaded frames can also be activated by using the remote-control transmitter's controls.

- To listen in any desired order. (The explanation below shows when the 7th track is first, the 4th track second, the 2nd track last.)
- A maximum of 32 tracks can be programmed.

1 Press program.

(The programmed-play indicator will illuminate.)

2 Select the track numbers in the desired sequence of play by using the numeric buttons.

(See 1 below).

(If a track number not included on the disc is programmed, it won't operate. If 33 tracks or more are programmed, the "1/" display will appear, and the programming cannot be made.)

3 Press play.

(Play will start in order.) (See 2 below).

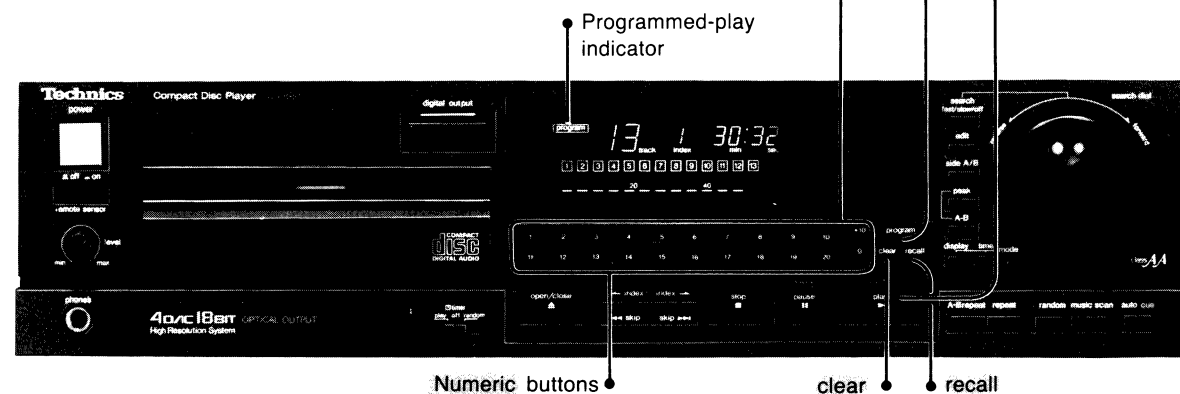

To verify the programmed sequence

Press the **recall** button. (Each time the button is pressed, the programmed sequence and the track number will alternately be displayed.)

To add a programmed selection during disc play

Use the **numeric** buttons to select and program the desired track.

Each time the button is pressed, the number of the specified track and the programmed sequence will be displayed. After 2 seconds, the display returns to show the current time.

1 The indicator will display:

(Display after programming)

Total time of programmed tracks

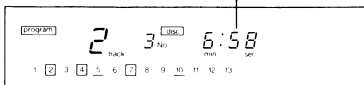

The total time of programmed tracks will appear in the time display; if the total exceeds 99 minutes the "--:--" display will appear.

To cancel or change the programmed track in the previous step

Stop the disc play first.

- 1 Press the **recall** button until the number corresponding to the track to be cancelled appears on the display.
- 2 Press the **clear** button. (The music matrix corresponding to the programmed track recalled in the previous step will stop illumination, and the selection will be cancelled.)
- 3 Use the **numeric** buttons to select and program some other desired track. (It will be added as the final track.)

Notes:

- To select the 21st and subsequent tracks: Press the **+10** button to select the "tens" digit, and then press (one of) the **0-9** buttons to select the "units" digit. **Example: to select the 32nd track** Press the **+10** button three times to select 3, and then press the **2** button.

To cancel or change the most recently programmed track

Stop the disc play first.

- 1 Press the **clear** button. (The music matrix corresponding to the most recently programmed track will be disappeared, and the selection will be cancelled.)
- 2 Use the **numeric** buttons to select and program some other desired track.

2 To cancel:

Press the **program** button. (The programmed-play indicator will go out.)

The functions indicated by the shaded frames  can also be activated by using the remote-control transmitter's controls.

To listen immediately to certain track (direct play)

A one-touch selection permits the immediate play of, for example, the 3rd track on the disc.

Press to select the track number desired.

(See **1** below.)
(The play indicator will illuminate, and play will begin.)



Play indicator

To listen to tracks in random sequence (random play)

The unit's microcomputer selects the sequence of play in random order. This feature can, moreover, be combined with the repeat play feature (described at the right) for repeated random sequence play of all tracks (or of only the programmed tracks), making these two features ideal for background music play.

Press the random button.

(The random-play indicator will illuminate, and the play will begin.)
(See **2** below.)

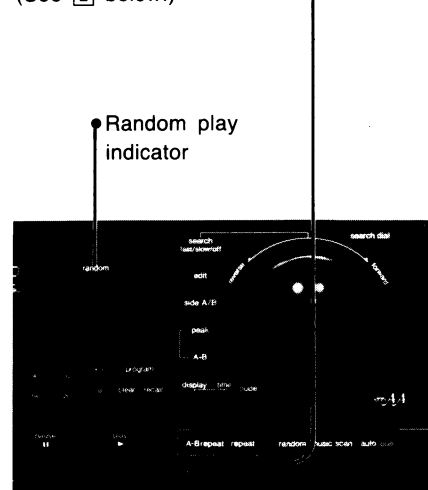

Random play indicator

To listen to tracks repeatedly (repeat-play)

To repeat all tracks or certain programmed tracks...

Repeat play is possible:

- Of all tracks (during automatic play and random play).
- Of programmed tracks (during programmed play).
- From the specified track to the final track (during direct play), after which there is a return to the first track, and then all tracks are repeatedly played.

Press the repeat button before or during play. (See **3** below.)

(The repeat indicator illuminates.)

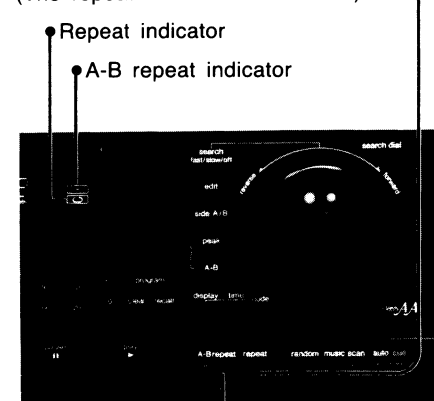

Repeat indicator
A-B repeat indicator

To repeat desired places (A-B repeat play)

- 1 Press **A-B repeat** at the place where you want the repeat performance to begin (to select point A). (The "A-" portion of the A-B repeat indicator will illuminate.)
- 2 Press **A-B repeat** at the point where you want to end the repeat play (to select point B). (The "A-B" portion of the A-B repeat indicator, and the repeat indicator will then illuminate.)
(See **4** below.)

3 To cancel:

Press the **repeat** button again.
(The illumination of the repeat indicator will stop.)

4 To cancel:

Press the **A-B repeat** button again.
(The illumination of the A-B and repeat indicators will stop.)
The A-B repeat play feature does not function during the programmed play mode.

CONVENIENT FUNCTIONS

To listen to certain tracks in random order (skip play)

When, while a track is playing, you decide you want to listen to the next track, or to listen once again to the track now playing, either track can be quickly and easily located for play.
While watching the track number display, press until the number of the desired track appears.

Note:

When a skip button is pressed during the A-B repeat play mode, A-B repeat play will be cancelled.

To skip tracks

- Press the **skip** button to listen to the track now playing, or to a track already played.
- Press the **skip** button to listen to the next track.

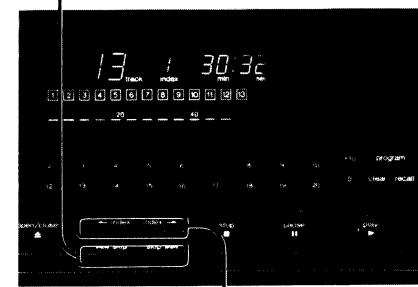

To skip index numbers

- Press the **index** button to listen to the index now playing, or to a index already played.
- Press the **index** button to listen to the next index.

Note:

Skip play of index numbers is limited to those compact discs that include index numbers.
(Whether or not a disc includes such index numbers is noted in the notes and commentary accompanying the disc.)

- 1 Although the search speed will vary according to the speed at which the dial is turned, the speed will not exceed the speed set for each mode.
- During the programmed play mode it is only possible to search and locate from among the tracks being played. To go to some other track, use the

To search for a certain track (search play)

Using the main unit controls for search

The beginning of a track can be located with a high degree of precision by using the search dial to listen to the play sounds. The unit can, moreover, be set to the play stand-by mode by press the **pause** button after locating the beginning of a desired track.

1 Select the speed mode by the fast/slow/off:

(The respective indicator will then illuminate.) (See **1** below.)

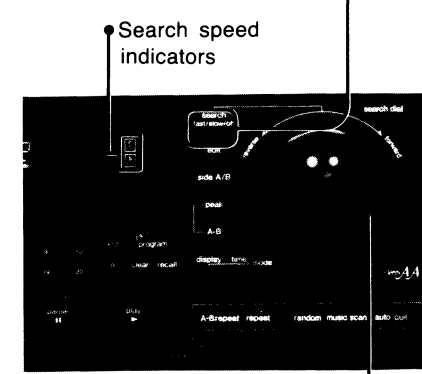

Search speed indicators

2 Search for the desired position.

Turn to the right to move forward on the disc.
Turn to the left to move backward on the disc.

Using the remote-control transmitter for search

By using the search buttons, the desired track(s) can be located while listening to the disc's sounds (at a level about 1/4 of the level during ordinary play).

- To move backward quickly on the disc, press and hold **◀**, and then release it at the desired position.
- To move forward quickly on the disc, press and hold **▶**, and then release it at the desired position.

- skip function to find its beginning.
- For A-B repeat play, it is possible to search outside the A-B pattern. Then, when **play** button is pressed, there will be a return to between the A-B points originally selected.

The functions indicated by the shaded frames  can also be activated by using the remote-control transmitter's controls.

To locate a desired track (music scan)

The first part (about 15 seconds) of each track is played in sequence one after another.

This feature is convenient if you do not know the title of a track you want to listen to, and if you do not know the track number.

Press the music scan button.

(The music scan indicator will illuminate, and play will begin.)
(See **2** below.)

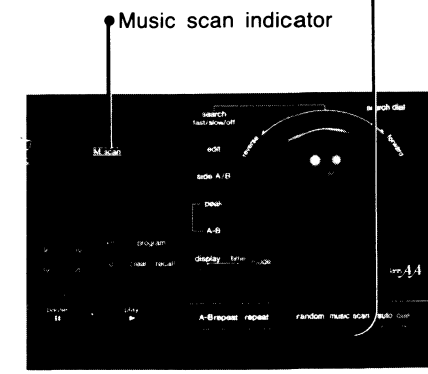

Music scan indicator

1 When the playing of the specified track has finished.

Next recorded track will be played.

Notes:

- If a selection is made while programmed tracks are being played, the selected track will be added to those already programmed.
(The direct play does not function.)
- If a track number not included on a disc is specified, it won't accept.

2 To cancel:

Press the **random** button once again.
(The illumination of the random play indicator will stop, and the unit will resume ordinary play.)

3 To cancel:

Press the **repeat** button again.
(The illumination of the repeat indicator will stop.)

4 To cancel:

Press the **A-B repeat** button again.
(The illumination of the A-B and repeat indicators will stop.)
The A-B repeat play feature does not function during the programmed play mode.

- 2 When the music scanning finishes, it will be automatically cancelled, and play will begin from the beginning of the first track.
- If the **play** button is pressed during music scanning, there will be a change to play at that point (the music scanning will be cancelled.)

Automatic disc play stand by setting (automatic cueing)

Each time a track finishes playing, the play pauses (in the stand-by, or "cue", mode) at the beginning of the next track scheduled for play. This feature can be conveniently used for such uses as starting the track's play after first making an announcement (at a party for example) or to start play at a precise moment for some reason.

Press the auto cue button.

(See 1 below).
(The automatic play stand-by indicator will then illuminate.)

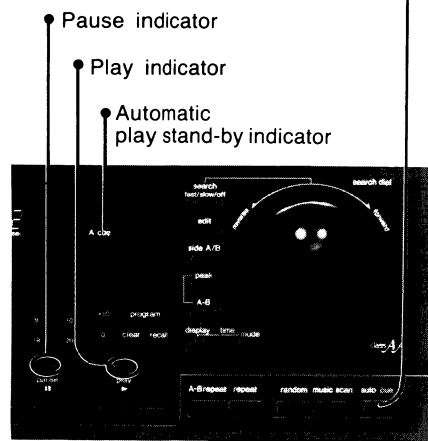

To resume the play:
Press the play button.

Changing the indications shown by the display

The display can be used for display of the play position and for display of the output level.

Press display mode button.

[The displays change as shown below (2) each time the button is pressed.]

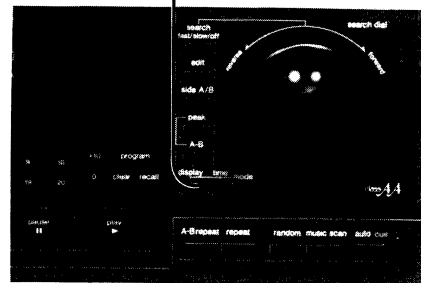

Display of the play position

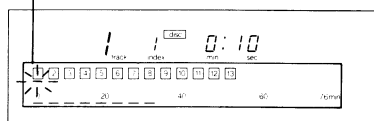

Display of the output level

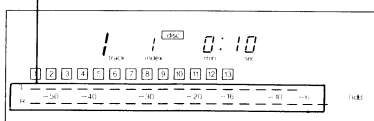

1 When the unit goes to the beginning of the next track scheduled for play, the unit goes on the pause mode; pause indicator will illuminate and play indicator will go out.

To cancel:

Press the **autocue** button.
(The illumination of the automatic play stand-by indicator will then stop.)

2 Play-position display

The total play time will be indicated by a broken bar-line type of display. Each bar segment represents about four minutes. The relative position (on the disc) now playing is indicated by the flashing of the bar segment.

Output-level display

The digital output level is displayed, and the maximum output level at any given time remains displayed for about two seconds. (This is the "peak-hold" function.)

The functions indicated by the shaded frames can also be activated by using the remote-control transmitter's controls.

Changing the indications of the time mode display

Press time mode button.

(During play mode or pause mode.)
(See 3 below).
The displays change as shown below each time the button is pressed.

•Track number and elapsed play time of track currently being played.
(Condition before button is pressed.)

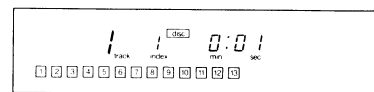

•Total remaining time on the disc



During the programmed play mode, the total remaining play time of programmed tracks. When the compact-disc editing function is being used, the remaining time available on the side (A or B) of the tape being used for recording.

•Track number remaining time of track now playing

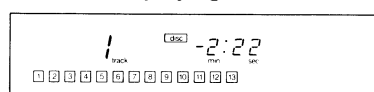

•Total elapsed play time

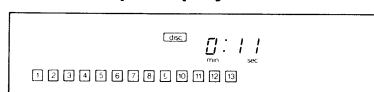

During the programmed play mode, the total elapsed play time of programmed tracks. When the compact-disc editing function is being used, the tape-travel time.

3 Notes:

- The "---" display will appear;
- When the 33rd track (or higher) is played.
- When the 33rd track (or higher) is programmed.
- When the total programmed time exceeds 99 minutes.
- During the random play mode.

RECORDING FROM COMPACT DISCS

The functions indicated by the shaded frames can also be activated by using the remote-control transmitter's controls.

To edit while recording from compact discs

If the editing function of this unit is used when recording from compact discs to tape, the tracks can be recorded on the two sides (sides A and B) of the tape, considering the length of the tape used, so that there is no interruption of tracks at the end of one tape side. In addition, an unrecorded space (of three seconds in length) is automatically made after the play of each track is finished. (This is the automatic-spacing feature.)

Automatic editing (recording in the sequence in which tracks are recorded on the compact disc or in the sequence in which desired tracks are programmed for play)

For automatic editing, the unit automatically calculates which tracks can be recorded on both sides of the tape (in the sequence in which they are recorded on the compact disc, or in the sequence in which certain desired tracks are programmed for play) and, after making this calculation, the unit programs those tracks for play.

1 Set the tape deck to the recording stand-by mode.

2 Select the tracks you want to record.
(See 1 below.)

3 Press the **edit** button, and then select the length (C-46, C-60, C-90 or C-0) of the tape to be used for recording.

4 When the tape deck begins recording, press the play button of this unit at the same time.
(Play indicator will illuminate, and play will start.)

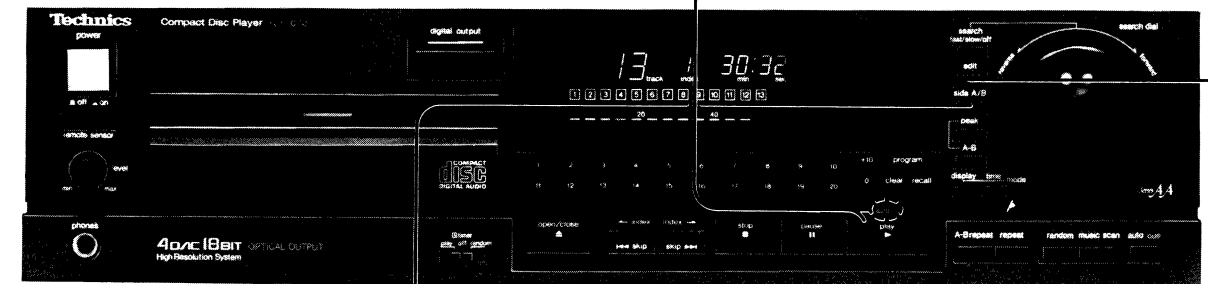

To verify the tracks to be recorded on side B (during the stop mode)

Press the side A/B button.

(The **side B** indicator will illuminate, and the track numbers to be recorded on side B, and the total play time, will be displayed.)

When the play of tracks programmed for side A has finished

Locate the beginning of the tracks programmed for side B, and then change to the pause mode.

- Prepare the tape deck (in the recording stand-by mode) so that it can be recorded to side B of the tape.
- Follow step 4 above.

1 When the tape length is selected (in step 3) after a total programmed time exceeding 99 minutes is programmed and the symbol "---" appears in the display, the symbol "-E" will then appear, and further programmings can not be made.

When 33 or more tracks are programmed, the letter "-F" (full) will be displayed, and programming will not thereafter be accepted.

Note:

The only operation-control buttons that can be used during disc play while the editing function is being used are the **digital output**, **open/close** and **stop** buttons; all others are non-operational at this time.

2 The indicator will display:

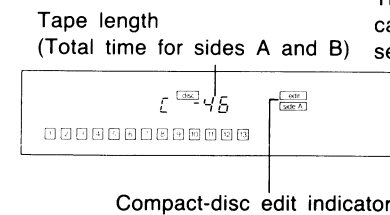

The play time is calculated about several seconds later...
Track numbers to be recorded on side A

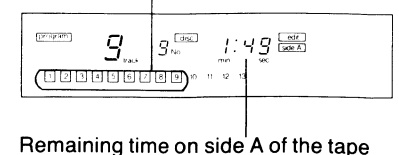

The functions indicated by the shaded frames can also be activated by using the remote-control transmitter's controls.

Manual editing (maximum recording efficiency according to remaining tape time)

For manual editing, the amount of time remaining available for recording is automatically calculated after each track to be recorded is programmed, and that remaining time is displayed in the time display. This makes it possible to select tracks that most nearly match the tape length (remaining time on the tape).

- 1 Set the tape deck to the recording stand-by mode.
- 2 Press the **edit** button, and then select the length (C-46, C-60, C-90 or C-0) of the tape to be used for recording.

- 3 Press the **clear** button so that "0" appears in the track number display. (See [5] below.)
(The track numbers programmed by the automatic editing function will be erased from the memory.)

- 4 Using the numeric buttons, program the numbers of the tracks to be recorded. (See [6] below.)

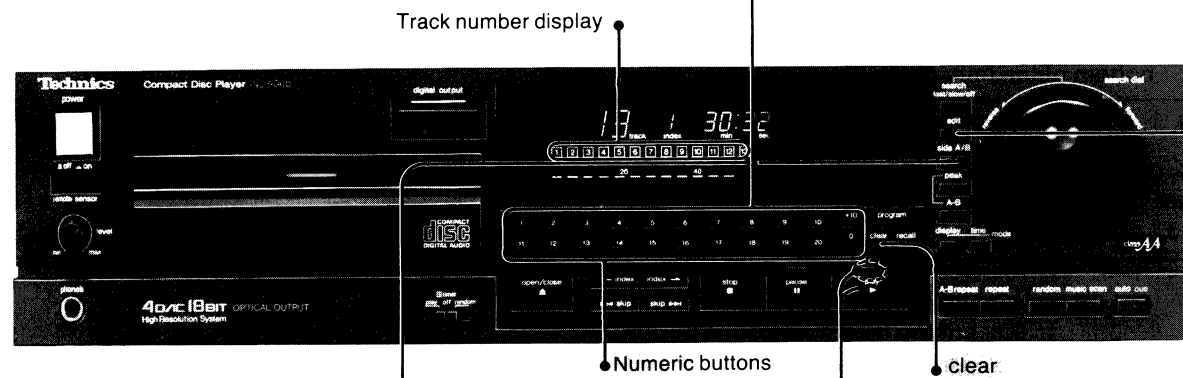

- 5 Press the **side A/B** button so that the display for side B of the tape appears, and then follow steps 3 and 4 above.

Notes:

- If the tape length is insufficient at steps 4 and 5 and the recording is made anyway, the track being recorded when side A of the tape reaches its end will be interrupted, and the recording on side B of the tape will begin from the first track already programmed for side B.
- To change the track, follow the steps on page 10.

- 6 When the tape deck begins recording, press the **play** button of this unit at the same time. (Play indicator goes on and the recording from the compact disc will begin.)

- 3 Select **C-0** if the recording time is to be other than 46, 60 or 90 minutes.

Using the numeric buttons, select the total recording time (1 to 99 minutes) for sides A and B of the tape.

- 1 For a recording of 20 minutes on each side (A and B) of the tape, press the +10 button four times, and then press the 0 button.
- 2 For a recording of 40 minutes on side A, press the +10 button eight times, and then press the 0 button. (If an error is made, select **C-0** and then repeat the procedure correctly.)

- 4 **To cancel:** Press the **stop** button. (Press once if a disc is in the stop mode and press twice if a disc is playing.)

- 5 **The indicator will display:** (The display of track numbers displayed during automatic editing is erased in sequence, and the recording time for side A of the tape is displayed.)

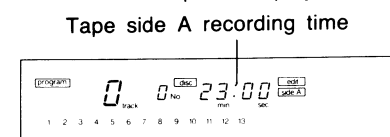

- 6 **The indicator will display:** The remaining time is displayed in sequence.

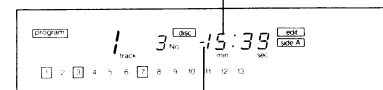

Illuminates when the tape length is insufficient.

For precise adjustment of the recording level (peak-level search function)

The peak-level search function is a feature that makes it possible to locate the maximum signal level (peak level) among all tracks or between any two selected points (between points A and B on the disc), and then to repeatedly play that portion (including approximately three seconds before and after the peak level, so,

total of six seconds), thus making it conveniently easy to preset the recording level to the correct level before beginning the recording.

To check the output level, press the **display mode** button to change the indicator to display of the output level.

- 1 Set the tape deck to the recording stand-by mode.

- 2 Press the **peak** button while the unit is in the stop mode.

Detects the peak level (from among all tracks or among programmed tracks); after completion, there is repeat play of about six seconds.

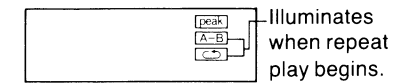
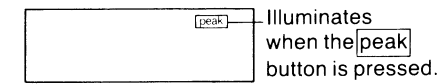

- 3 Adjust the recording level by using the recording-level control on the tape deck.

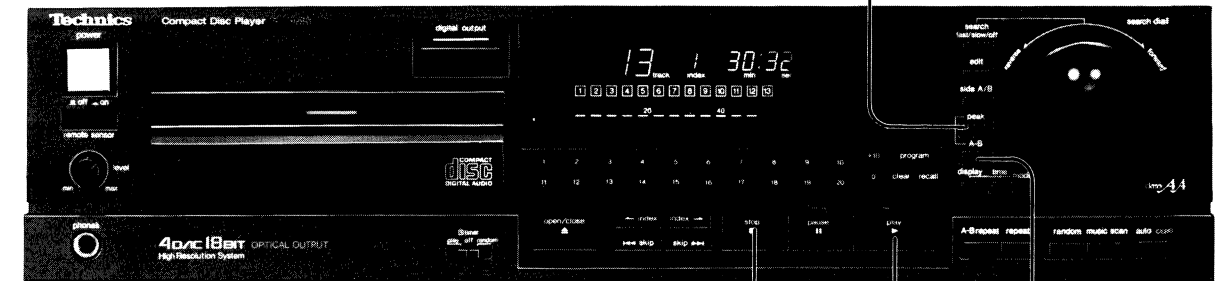

Notes:

- The search for the peak level will begin from the first track, so about three minutes will be required until the detection finishes.
- It is possible that the peak-level position will change, because the detection of the peak level is an approximate reading of the digital level of the sounds on the compact disc.

- 4 Press the **stop** button to stop the six second repeat play. (The peak-level search indicator and A-B repeat indicator and repeat indicator will go out.)

- 5 Set the tape deck to start recording.

- 6 Press the **play** button. (The recording from the compact disc will begin.)

To find the peak level with even greater precision (during play mode)

While following the steps described above, substitute the follow on step 2.

- 1 Press the **A-B** button at the point where you want the detection of the peak level to start.

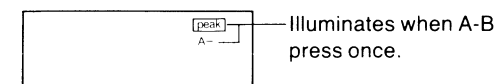

- 2 Press the **A-B** button at the point where you want the detection of the peak level to stop. (Six-second repeat play will start.)

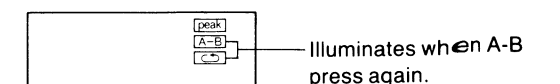

To cancel the recording-level adjustment

- Press the **stop** button. (The illumination of the peak-level indicator stops, and play stops.)

1. Do not attempt to perform such operations as search play or skip play during the peak-level search mode - (Correct peak levels cannot be located.)
2. If the B position (the position at which the search is to end) is not designated for A-B peak-level search, the search will continue through the final track.

HANDLING PRECAUTIONS FOR OPTICAL PICKUP

The laser diode in the optical pickup may break down due to potential difference caused by static electricity of clothes or human body. So, be careful of electrostatic breakdown during repair of the optical pickup.

Handling of optical pickup

1. Do not give excessive shock to the optical pickup because it is of extremely precise structure.
2. To prevent the breakdown of the laser diode, an anti-static shorting pin is inserted into the flexible board. (FPC board)
When removing or connecting the short pin, finish the job in as short time as possible.
3. Take care not to apply excessive stress to the flexible board. (FPC board)
4. Do not turn the variable resistor (laser power adjustment). It has already been adjusted.

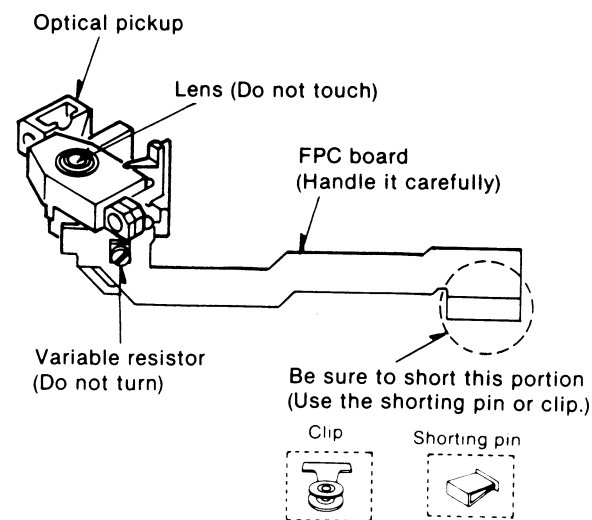

Grounding for electrostatic breakdown prevention

1. Human body grounding
Use the anti-static wrist strap to relieve the static electricity from your body.
2. Work table grounding
Put a conductive material (sheet) or steel sheet on the area where the optical pickup is placed, and ground the sheet.

Caution:

The static electricity of your clothes will not be grounded through the wrist strap. So, take care not to let your clothes touch the optical pickup.

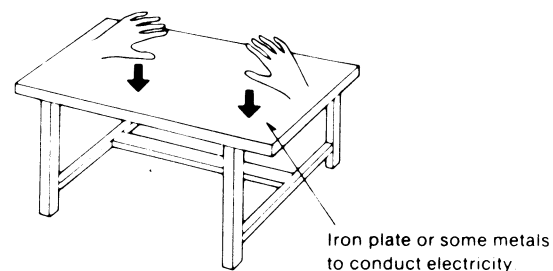
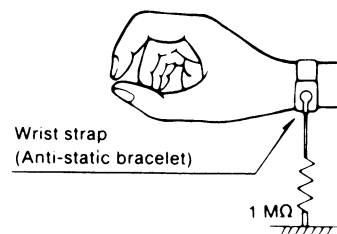

DISASSEMBLY INSTRUCTIONS

CAUTION:

- It is very dangerous to look at or touch laser radiation. (Laser radiation is invisible.)
- With the unit turned "on", laser radiation is emitted from the pickup lens.
- When removing the cabinet and disc clamer of this unit, be sure to turn the power supply off.

- This unit uses FPC and care should be taken during assembly and disassembly.

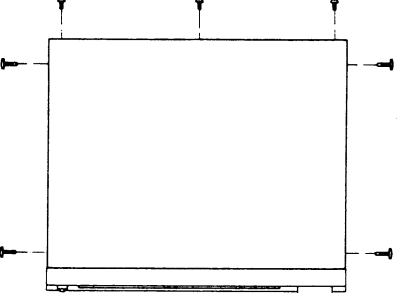
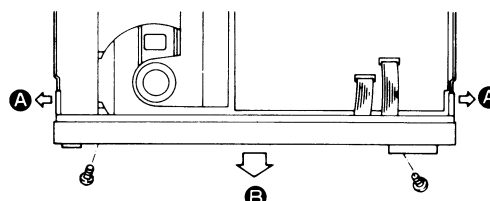
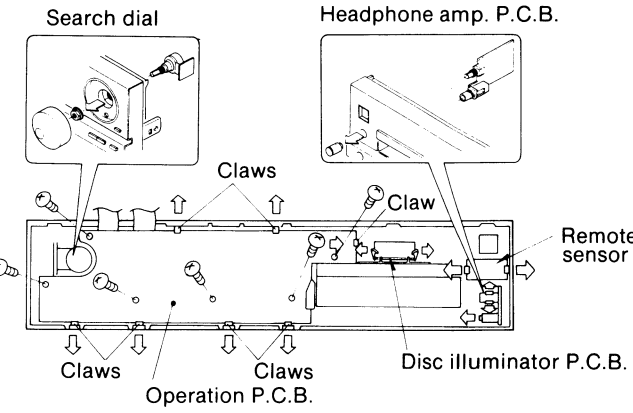
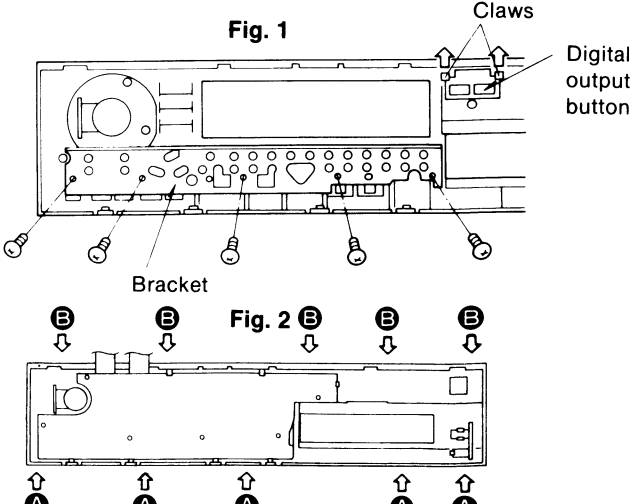
Ref. No. 1	How to remove the cabinet	Ref. No. 2	How to remove the front panel
Procedure 1	1. Remove the 7 screws.	Procedure 1 → 2	1. Remove the 2 screws. 2. Slightly pull the tabs outwards (arrows A). 3. Remove the front panel in the direction of the arrow B.
 <p>Note: When servicing, lock the lock shaft at the bottom of the unit. (See page 3.)</p>			
Ref. No. 3	How to remove the operation P.C.B., headphone amp. P.C.B., search dial, remote sensor and disc illuminator P.C.B.		
Procedure 1 → 2 → 3	<p>A. Operation P.C.B.</p> <ol style="list-style-type: none"> 1. Remove the 6 screws. 2. Release the 7 claws. <p>B. Headphone amp. P.C.B.</p> <ol style="list-style-type: none"> 1. Pull out the level control knob. 2. Release the 3 claws. <p>C. Search dial</p> <ol style="list-style-type: none"> 1. Pull out the search dial. 2. Remove the nut. <p>D. Remote sensor</p> <ol style="list-style-type: none"> 1. Release the 2 claws. <p>E. Disc illuminator P.C.B.</p> <ol style="list-style-type: none"> 1. Release the 2 claws. 		
			
Ref. No. 4	How to remove the front grille and the operation buttons.		
Procedure 1 → 2 → 3 → 4	<p>A. Main operation button (Fig. 1)</p> <ol style="list-style-type: none"> 1. Remove the 5 screws. 2. Remove the bracket. <p>B. Digital output button (Fig. 1)</p> <ol style="list-style-type: none"> 1. Release the 2 claws. <p>C. Front grille (Fig. 2)</p> <ol style="list-style-type: none"> 1. First release the 5 claws A at the bottom of the front panel. 2. Then release the 5 claws B at the top of the front panel. 		

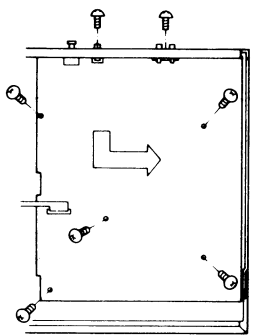
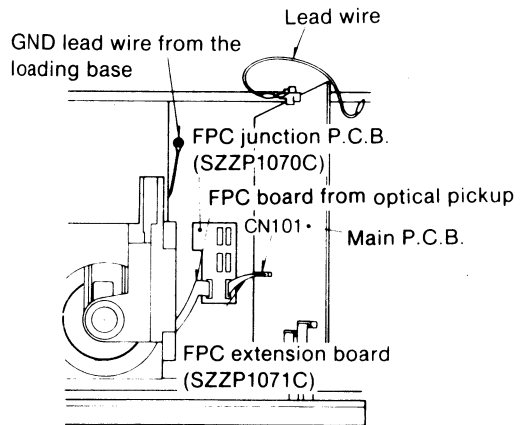
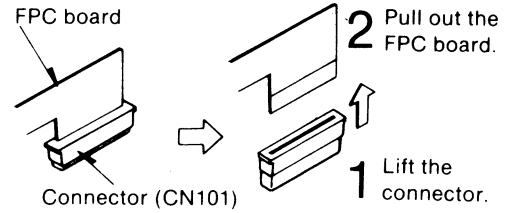
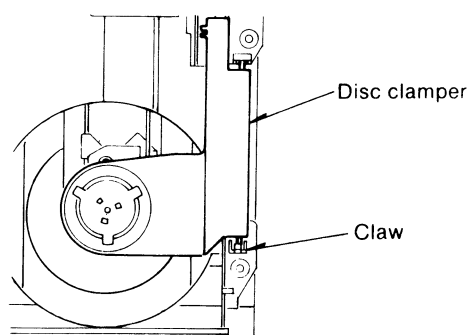
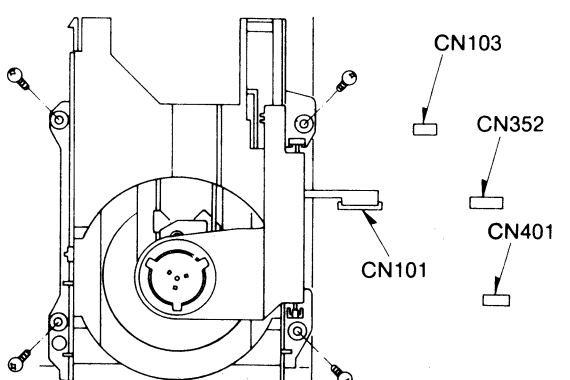
<p>Ref. No. 5</p>	<p>How to remove the main P.C.B.</p>	<p>How to check the main P.C.B.</p>	
<p>Procedure 1 → 5</p> <ol style="list-style-type: none"> 1. Remove the 7 screws. 2. Lift the P.C.B. to remove it from the chassis tab. 3. Remove the P.C.B. in the direction of the arrow.  	<p>Procedure 1 → 2 → 7</p> <ol style="list-style-type: none"> 1. Remove the main P.C.B. 2. Remove the FPC board (CN101).  <p>Caution: Insert the shorting pin into the FPC board in order to prevent breakdown of laser diode. (See page 15.)</p> <ol style="list-style-type: none"> 3. Connect FPC board from optical pickup to FPC junction P.C.B. (SZP1070C). <p>Caution: Cover the foil of the FPC junction P.C.B. with friction tape to prevent a short-circuit between the foil and the chassis.</p> <ol style="list-style-type: none"> 4. Connect FPC extension board (SZP1071C) to FPC junction P.C.B. and CN101 of the main P.C.B. 5. Place the main P.C.B. as shown in the figure. <p>Cautions:</p> <ul style="list-style-type: none"> • Be sure to connect the P.C.B. ground terminal (line out terminal) and the chassis with a lead wire. • Be sure to connect the GND lead wire from the loading base to the chassis. 		
<p>Ref. No. 6</p>	<p>How to remove the disc clamber</p>	<p>Ref. No. 7</p>	<p>How to remove the loading base</p>
<p>Procedure 1 → 6</p> <ul style="list-style-type: none"> • Release the claw. 	<p>Procedure 1 → 2 → 7</p> <ol style="list-style-type: none"> 1. Pull out the 3 connectors (CN103, CN352 and CN401). 2. Remove the FPC board (CN101). 3. Remove the 4 screws. <p>Refer to "HANDLING PRECAUTIONS FOR OPTICAL PICKUP" on page 15.</p> 		

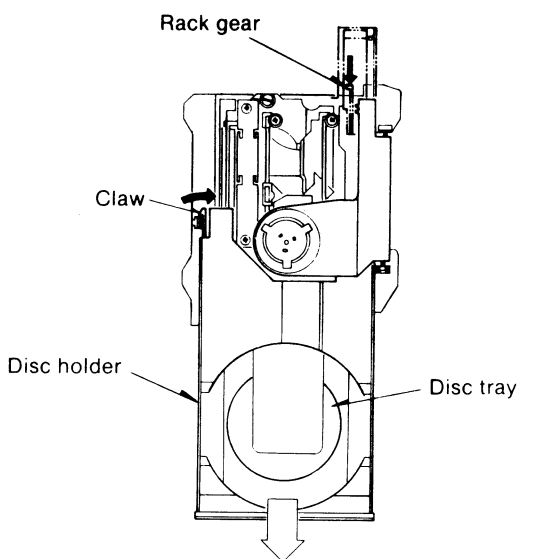
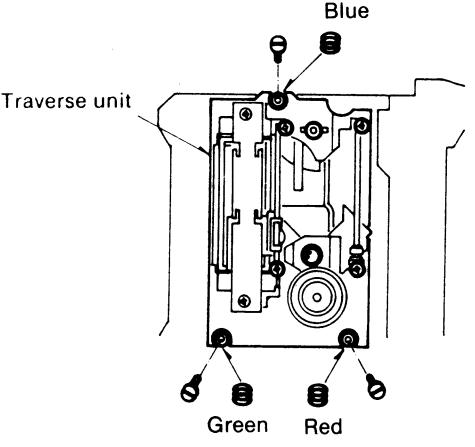
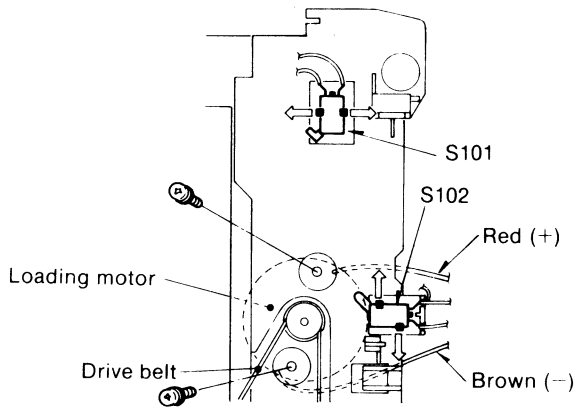
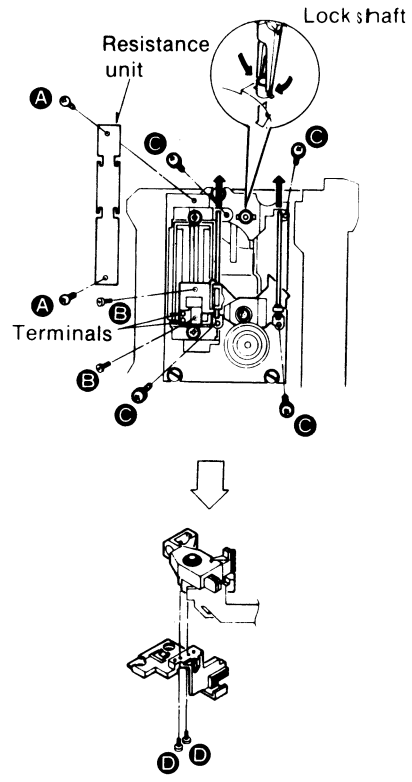
<p>Ref. No. 8</p>	<p>How to remove the disc holder</p>	<p>Ref. No. 10</p>	<p>How to remove the traverse unit</p>
<p>Procedure 1 → 2 → 8</p> <ol style="list-style-type: none"> 1. Push the rack gear slowly in the direction of the arrow until the disc tray comes up. 2. Pull the disc holder until it stops. 3. Release the claw. 4. Pull out the disc holder further to remove it. 		<p>Procedure 1 → 2 → 6 → 7 → 8 → 10</p> <ul style="list-style-type: none"> • Remove the 3 screws.  <p>Caution: Note the color of the 3 springs, they must be reinstalled to their original positions.</p>	
<p>Ref. No. 9</p>	<p>How to remove the loading motor</p>	<p>Ref. No. 11</p>	<p>How to remove the optical pickup</p>
<p>Procedure 1 → 2 → 7 → 8 → 9</p> <ol style="list-style-type: none"> 1. Remove the drive belt. 2. Remove the 2 screws. <p>Note: Red lead wire.....(+) terminal (close to the slit of the motor) Brown lead wire.....(-) terminal</p>  <p>How to remove the switches (S101, S102)</p> <ul style="list-style-type: none"> • Release the claws. • Note the fitting direction before remove it. 		<p>Procedure 1 → 2 → 6 → 7 → 8 → 11</p> <ol style="list-style-type: none"> 1. Remove the 2 screws (A) and the resistance unit. 2. Unsolder the 2 terminals and 2 screws (B). 3. Release the claws by using pliers to remove the lock shaft. 4. Remove the 4 screws (C). 5. Pull out the optical pickup from the 2 guide shafts. 6. Remove the 2 screws (D) to separate the holder from the optical pickup. 	

Ref. No. 12	How to remove the spindle motor
Procedure 1 → 6 → 7 → 8 → 12	<ol style="list-style-type: none"> Loosen the screw ① by using a 1.27 mm hexagonal wrench and remove the turntable. Remove the 2 screws (②, ③). <p>Caution:</p> <ol style="list-style-type: none"> Turntable height adjustment is necessary any time the turntable or spindle motor is replaced. The (+) terminal of the spindle motor is indicated by the red mark.

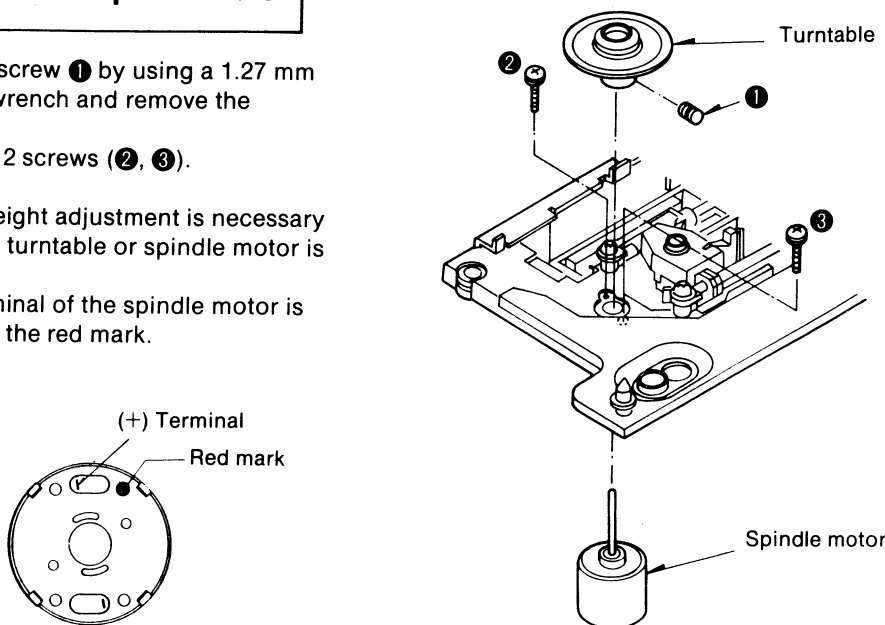

Ref. No. 13	How to remove the power transformer
Procedure 1 → 2 → 8 → 13	<ol style="list-style-type: none"> Remove the connector (CN11). Remove the 2 screws. Lift the power transformer to remove it from the chassis tab (arrow A). Remove the power source P.C.B. in the direction of arrow B. <p>• How to remove the power switch rod</p> <ol style="list-style-type: none"> Set the power switch in the "OFF" position. Remove the power switch rod by using a screwdriver.

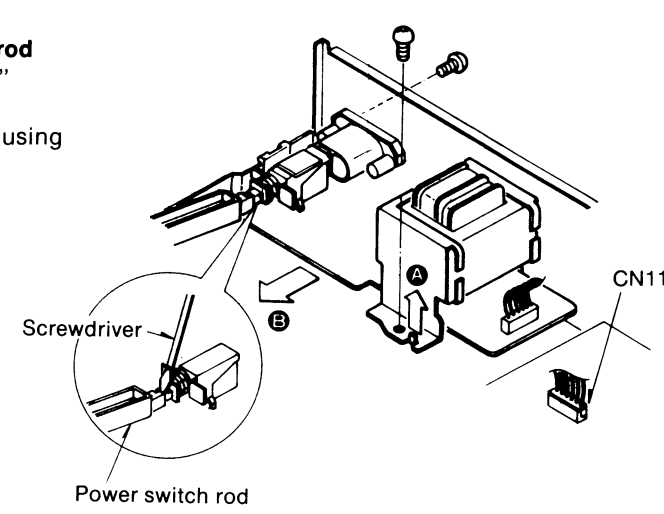

MEASUREMENTS AND ADJUSTMENTS

Caution:

- It is very dangerous to look at or touch the laser beam. (Laser radiation is invisible.)
- With the unit turned "on", laser radiation is emitted from the pickup lens.
- Avoid exposure to the laser beam, especially when performing adjustments.

ADJUSTMENT POINTS

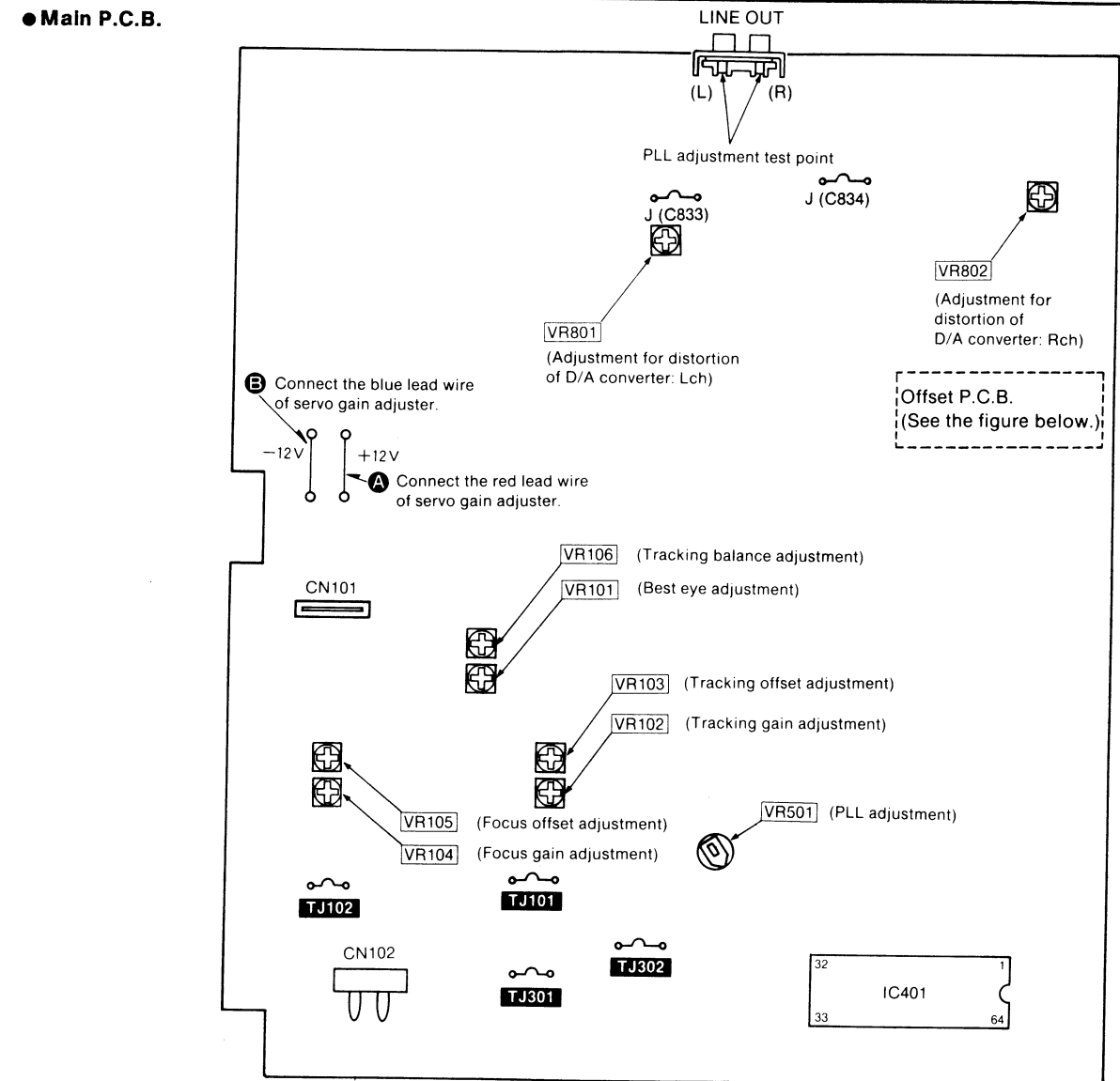

● **Filter for turntable height adjustment**

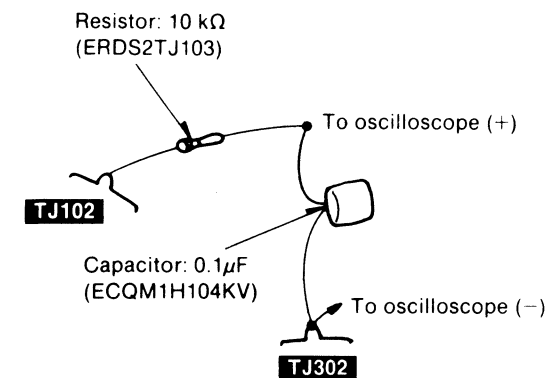

● **Offset P.C.B.**

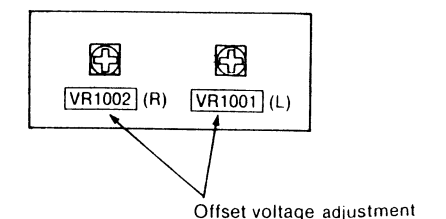

ELECTRICAL ADJUSTMENT

Measuring Instruments and Special Tools

- Servo gain adjuster (SZZP1017F)
- Test discs
 - Test disc (SZZP1014F) old or new type
 - Inspection test disc (SZZP1054C)
 - Uneven disc (SZZP1056C)
 - Black band disc (SZZP1057C)
- Ordinary disc
- Two-channel oscilloscope (with trigger) of 30MHz or over
- Low frequency oscillator
- Conversion connector(SZZP1032F)

Adjustment Procedure

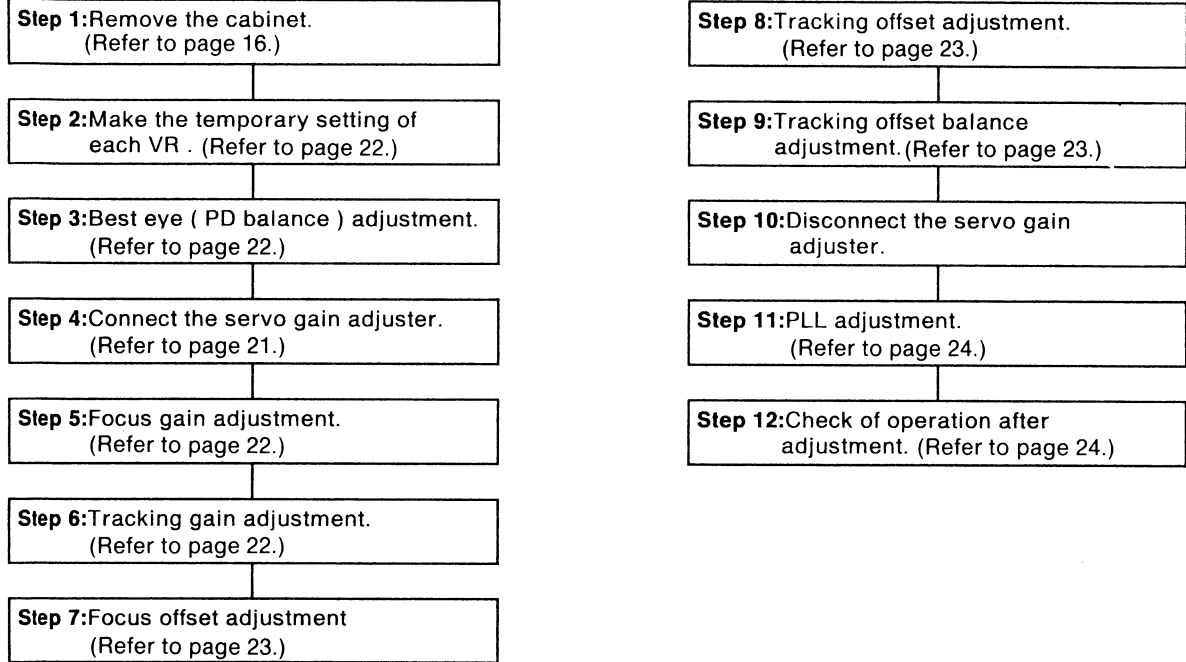

Connection of Servo Gain Adjuster

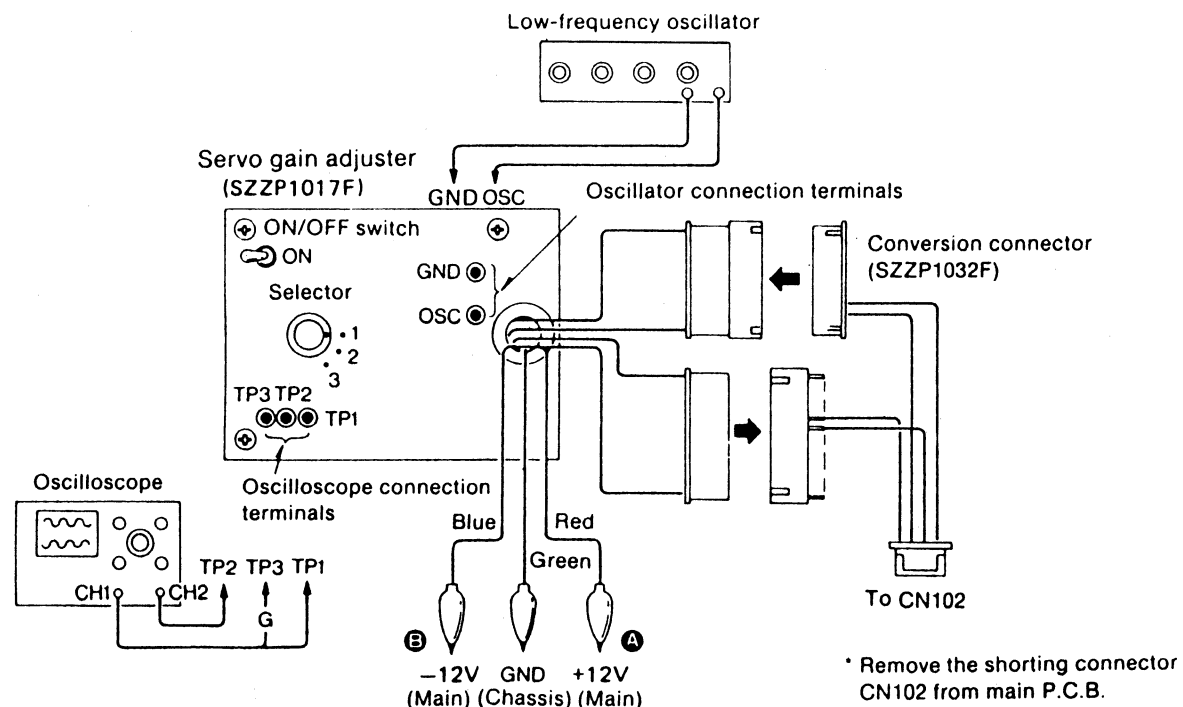

TEMPORARY SETTING OF EACH VR

Note :
If a disc skips or can not be played back , adjust each VR temporarily, as shown.

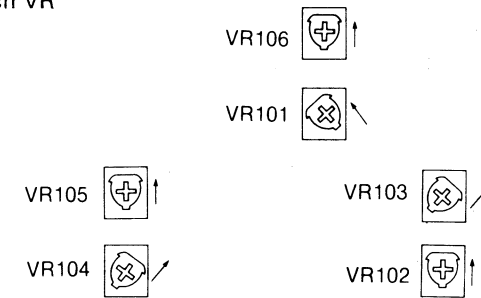

BEST EYE(PD BALANCE) ADJUSTMENT

1. Connect CH1 of the oscilloscope to **TJ301 (+)** and **TJ302 (-)** of the main P.C.B.
Oscilloscope setting: VOLT.....200mV
 SWEEP.....0.5μsec.
 INPUT.....AC
2. Turn **ON** the power switch of the player and insert a test disc (SZZP1014F or SZZP1054C).
3. Set the player to the play mode.
4. Adjust **VR101** so that the eye pattern of RF signal is stretched to maximum.
5. Turn **OFF** the power switch of the player.

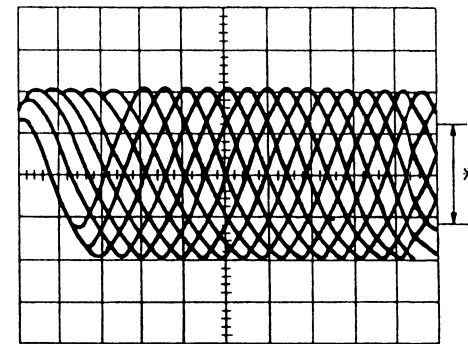

FOCUS GAIN ADJUSTMENT

1. Connect the servo gain adjuster. (Refer to page 21.)
2. Set the selector switch of the servo gain adjuster to **2** and ON-OFF switch to **ON**.
3. Set the low frequency oscillator to a frequency of **750Hz** and an output voltage of **100mVp-p**. Then connect the oscillator to **OSC (+)** and **GND (-)** terminals of the servo gain adjuster.
4. Connect CH1 and CH2 of the oscilloscope to **TP1** and **TP2** of the servo gain adjuster. (**TP3** is the ground terminal.)
Oscilloscope setting: VOLT.....200mV(both channels)
 SWEEP.....1msec.
 INPUT.....DC
5. Turn **ON** the power switch of the player and insert a test disc (SZZP1014F or SZZP1054C).
6. Set the player to the play mode.
7. Set the selector switch of the servo gain adjuster from **"2"** to **"3"**.
8. **750Hz** signals will be displayed on the oscilloscope. Adjust **VR104** until the waveform amplitudes of both channels are equal.
9. Shift the selector switch of the servo gain adjuster from **"3"** to **"2"**.

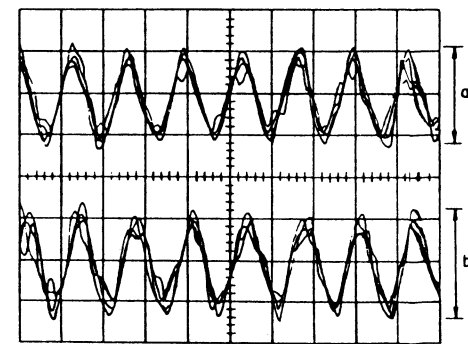

TRACKING GAIN ADJUSTMENT

1. Oscilloscope setting and connection are same as above.
2. Set the low frequency oscillator to a frequency of **1.0kHz** and an output voltage of **100mVp-p**.
3. Set the selector switch of the servo gain adjuster from **"2"** to **"1"**.
4. **1.0kHz** signals will be displayed on the oscilloscope. Adjust **VR102** until the waveform amplitudes of both channels are equal.
5. Shift the selector switch of the servo gain adjuster from **"1"** to **"2"**.
6. Turn **OFF** the power switch of the player.

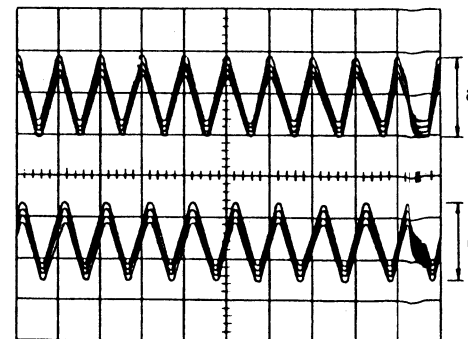

FOCUS OFFSET ADJUSTMENT

1. Connect CH1 of the oscilloscope to **TJ301 (+)** and **TJ302 (-)** of the main P.C.B.
Connect CH2 of the oscilloscope to **TJ102 (+)** and **TJ302 (-)** of the main P.C.B.
Oscilloscope setting: VOLT.....200mV(both channels)
SWEEP.....0.5msec.
INPUT.....AC(CH1),DC(CH2)
MODE.....NORM
(Triggering via CH1)
2. Turn **ON** the power switch of the player and insert the test disc (SZZP1057C).
3. Set the player to the play mode.
4. Check the waveform of CH1 and CH2 on the oscilloscope and adjust **VR105**, so that the waveform around the triggering point becomes as shown in the illustration.

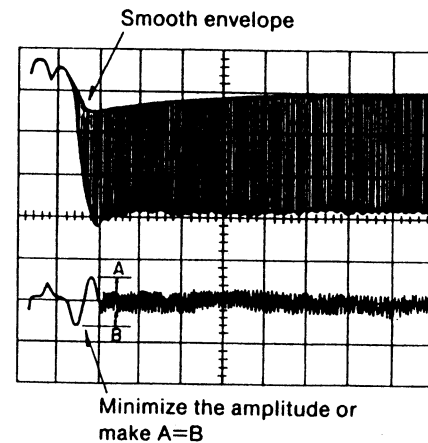
**TRACKING OFFSET ADJUSTMENT**

1. Connect CH1 of the oscilloscope to **TJ301 (+)** and **TJ302 (-)** of the main P.C.B.
Connect CH2 of the oscilloscope to **TJ101 (+)** and **TJ302 (-)** of the main P.C.B.
Oscilloscope setting: VOLT.....200mV(both channels)
SWEEP.....0.5msec.
INPUT.....AC(CH1),DC(CH2)
MODE.....NORM
(Triggering via CH1)
2. Turn **ON** the power switch of the player and insert the test disc (SZZP1057C).
3. Set the player to the play mode.
4. Check the waveform of CH1 and CH2 on the oscilloscope and adjust **VR103**, so that the waveform around the triggering point becomes as shown in the illustration.

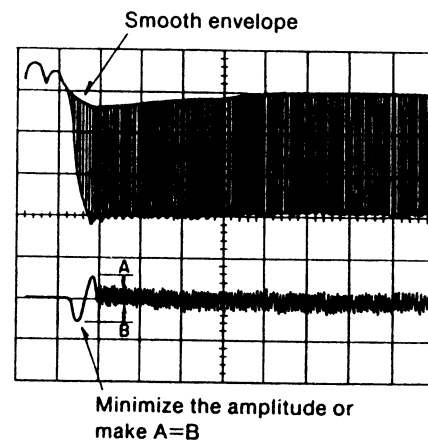
**TRACKING OFFSET BALANCE ADJUSTMENT**

1. Set the low frequency oscillator to a frequency of **1kHz** and an output voltage of **200mVp-p**. Then connect the oscillator to **OSC (+)** and **GND (-)** terminals of the servo gain adjuster.
2. Connect CH1 of the oscilloscope to **TJ301 (+)** and **TJ302 (-)** of the main P.C.B.
Oscilloscope setting: VOLT.....500 mV
SWEEP.....0.5msec.
INPUT.....AC
3. Turn **ON** the power switch of the player and insert a test disc (SZZP1014F or SZZP1054C).
4. Set the player to the play mode.
5. Set the selector switch of the servo gain adjuster from "2" to "1".
6. Adjust **VR106**, so that the output waveform is as shown (jitter is minimized).
7. Shift the selector switch of the servo gain adjuster from "1" to "2".
8. Turn **OFF** the power switch of the player.
9. Disconnect the servo gain adjuster, and insert the shorting connector of CN102 to the original position.

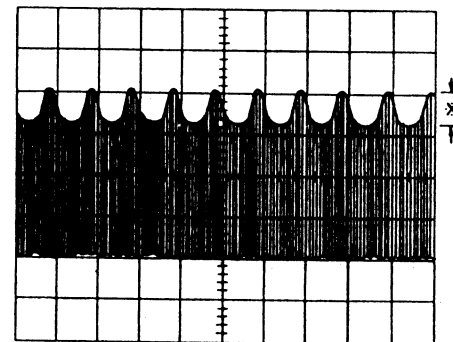
**PLL ADJUSTMENT**

1. Connect CH1 of the oscilloscope to the **LINE OUT terminal** (either of Lch or Rch) and **ground**.
Oscilloscope setting: VOLT.....1V
SWEEP.....1msec.
INPUT.....DC
2. Turn **ON** the power switch of the player and insert the test disc (SZZP1054C).
3. Play **Track No.6 (wedge 0.7mm)** of the test disc.
4. Check the waveform displayed on the oscilloscope and adjust **VR501** in the following steps.
Step 1. Turn **VR501** clockwise slowly and observe the point at which the waveform on the oscilloscope begins to be disturbed.
Step 2. Turn **VR501** counterclockwise slowly and observe the point at which the waveform on the oscilloscope begins to be disturbed.
Step 3. Set **VR501** in the middle between the points observed in the above steps "1" and "2".

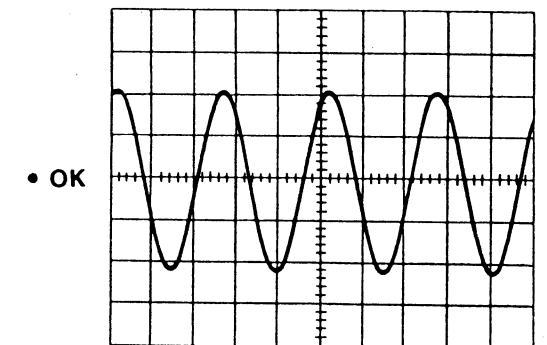
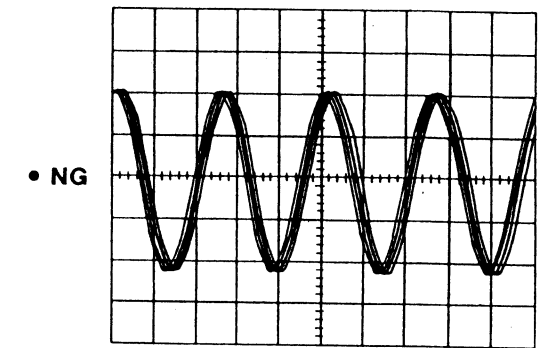
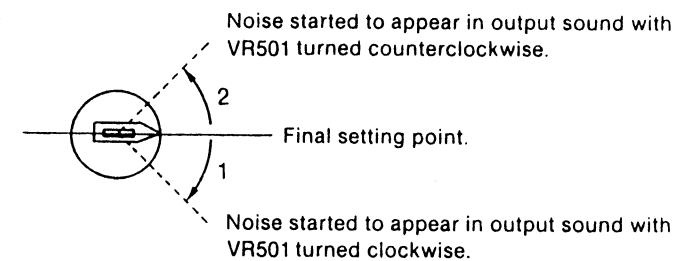
**CHECK OF PLAY OPERATION AFTER ADJUSTMENT****Check of skip search**

1. Play an ordinary disc.
2. Press the skip button and verify skip search operation (forward and reverse).

Check of manual search

1. Play an ordinary disc.
2. Press the manual search button and verify that smooth manual search can be performed at low and high speeds (forward and reverse).

Check of playability

1. Play the test disc (SZZP1054C).
2. Play the track No.6 (wedge 0.7mm) and verify that there is no skip sound or noise.
3. Play the track No.13 (black dot 0.7mm) and verify that there is no skip sound or noise.

OPTICAL PICKUP ADJUSTMENT**Measuring Instruments and Special Tools**

- Two-channel oscilloscope (with trigger) of 30MHz or over
- Test discs
Test disc (SZZP1014F) old or new type
Inspection test disc (SZZP1054C)
Uneven disc (SZZP1056C)
- Hexagonal wrench (SZZP1044C....1.5mm)
- Screw lock paint (RZZ0L01)
- Hexagonal wrench (1.27mm)
- Feeler gauge (RZZ0297)
- Filter (Refer to page 20.)

Adjustment Procedure

- If the optical pickup and spindle motor are replaced, adjust it according to the following procedure.

Step 1: Make the temporary of each VR. (Refer to page 22.)

Step 2: Turntable height adjustment. (Refer to page 25.)

Step 3: Mechanical adjustment. (Refer to page 25.)

Step 4: Electrical adjustment. (Refer to page 21.)

TURNABLE HEIGHT ADJUSTMENT

1. Connect CH1 of the oscilloscope to **TJ102 (+)** and **TJ302 (-)** of the main P.C.B. through the filter. (Refer to page 20.)
Oscilloscope setting: VOLT.....50mV
 SWEEP.....1msec.
 INPUT.....DC

2. Set the oscilloscope to DC zero balance.
3. Turn **ON** the power switch of the player and insert a test disc (SZZP1014F or SZZP1054C).
4. Set the player to the play mode.
5. Measure the DC level (AmV) displayed on the oscilloscope.

If the value of A is within the range of $\pm 60\text{mV}$, the turntable height is correct. If it is not within this range, make the necessary adjustments using the 0.9mm feeler gauge (RZZ0297). If A is more than $+60\text{mV}$, make the turntable lower. If A is less than -60mV , make the turntable higher.

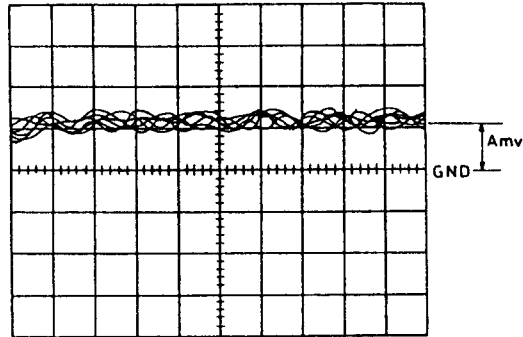

Adjust the turntable height as follow:

- A. Insert the 0.9mm feeler gauge (RZZ0297) as shown below.

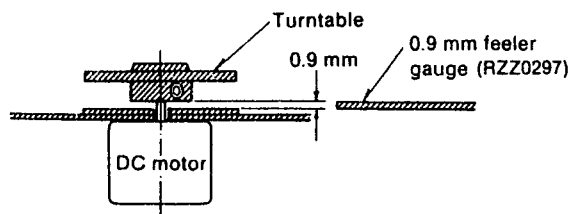

- B. Loosen the turntable set-screw.
- C. Adjust the turntable height to 0.9 mm with the feeler gauge as shown above.
- D. Tighten the turntable set-screw by using the 1.27mm hexagonal wrench.
- E. Check the turntable height adjustment by following steps 1 ~ 5 above.

MECHANICAL ADJUSTMENT

1. Connect CH1 of the oscilloscope to **TJ301 (+)** and **TJ302 (-)** of the main P.C.B.
Oscilloscope setting: VOLT.....200mV
 SWEEP.....0.5μsec.
 INPUT.....AC

2. Turn **ON** the power switch of the player and insert the test disc (SZZP1056C).
3. Using the manual search buttons, move the pickup so that the mechanical adjustment screws line up with the adjustment holes in the bottom panel.

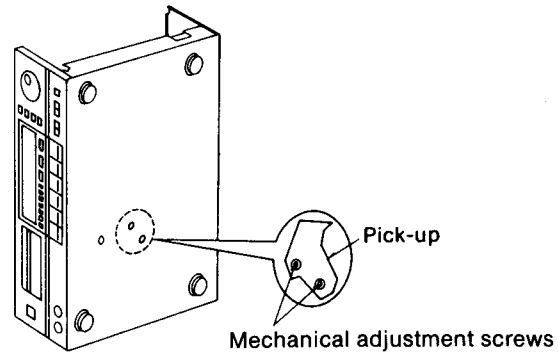

Note: The mechanical adjustment screws have been already locked with screw lock paint at the factory. It might be hard to turn them.

4. Monitoring RF signal on the oscilloscope, adjust the **two adjusting screws** alternately with the 1.5mm hexagonal wrench (SZZP1044C) so that the vertical fluctuation of RF signal is minimized and the eye pattern is most stretched.
5. Turn **OFF** the power switch of the player.
6. After the adjustment, apply **screw lock paint (RZZ0L01)** to the adjusting screws.

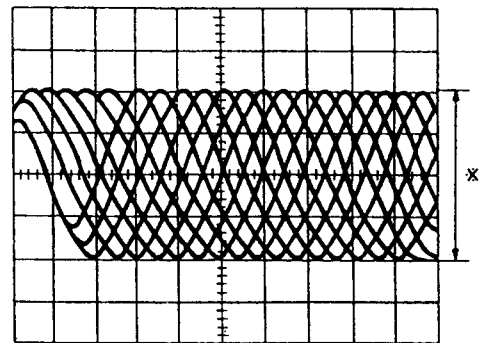

ADJUSTMENT FOR DISTORTION OF D/A CONVERTER

Measuring Instruments and Special Tools

- Distortion meter
- Test disc
- Test disc (SZZP1014F) old or new type

1. Connect (+) terminal of the distortion meter to output terminal (Lch or Rch) and (-) terminal to the chassis.
2. Turn ON the power switch of the player and insert the test disc (SZZP1014F).
3. Playback 1 kHz, -24 dB signal.
4. Adjust VR801 (Lch) or VR802 (Rch) so that the distortion ratio is minimized.

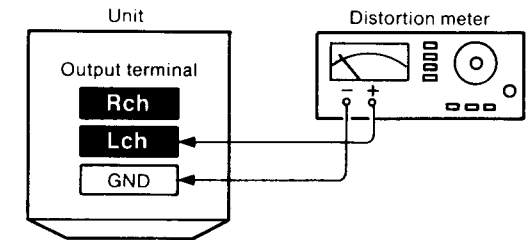

OFFSET VOLTAGE ADJUSTMENT

Measuring Instrument

- Digital voltmeter

1. Press "STOP" button and set the player in "STOP MODE".
2. Connect the digital voltmeter to jumper wire mounted in J (C833) (Lch) (+) or J (C834) (Rch) (+) and output terminal (GND) (-).
3. Adjust VR1001 (Lch) or VR1002 (Rch) so that the voltage is $\pm 1\text{ mV}$.

ADJUSTMENT FOR DISTORTION OF D/A CONVERTER

Measuring Instruments and Special Tools

- Distortion meter
- Test disc
- Test disc (SZZP1014F) old or new type

1. Connect (+) terminal of the distortion meter to output terminal (Lch or Rch) and (-) terminal to the chassis.
2. Turn ON the power switch of the player and insert the test disc (SZZP1014F).
3. Playback 1 kHz, -24 dB signal.
4. Adjust VR801 (Lch) or VR802 (Rch) so that the distortion ratio is minimized.

OFFSET VOLTAGE ADJUSTMENT

Measuring Instrument

- Digital voltmeter

1. Press "STOP" button and set the player in "STOP MODE".
2. Connect the digital voltmeter to jumper wire mounted in J (C833) (Lch) (+) or J (C834) (Rch) (+) and output terminal (GND) (-).
3. Adjust VR1001 (Lch) or VR1002 (Rch) so that the voltage is ± 1 mV.

■ SCHEMATIC DIAGRAM OF REMOTE CONTROL UNIT

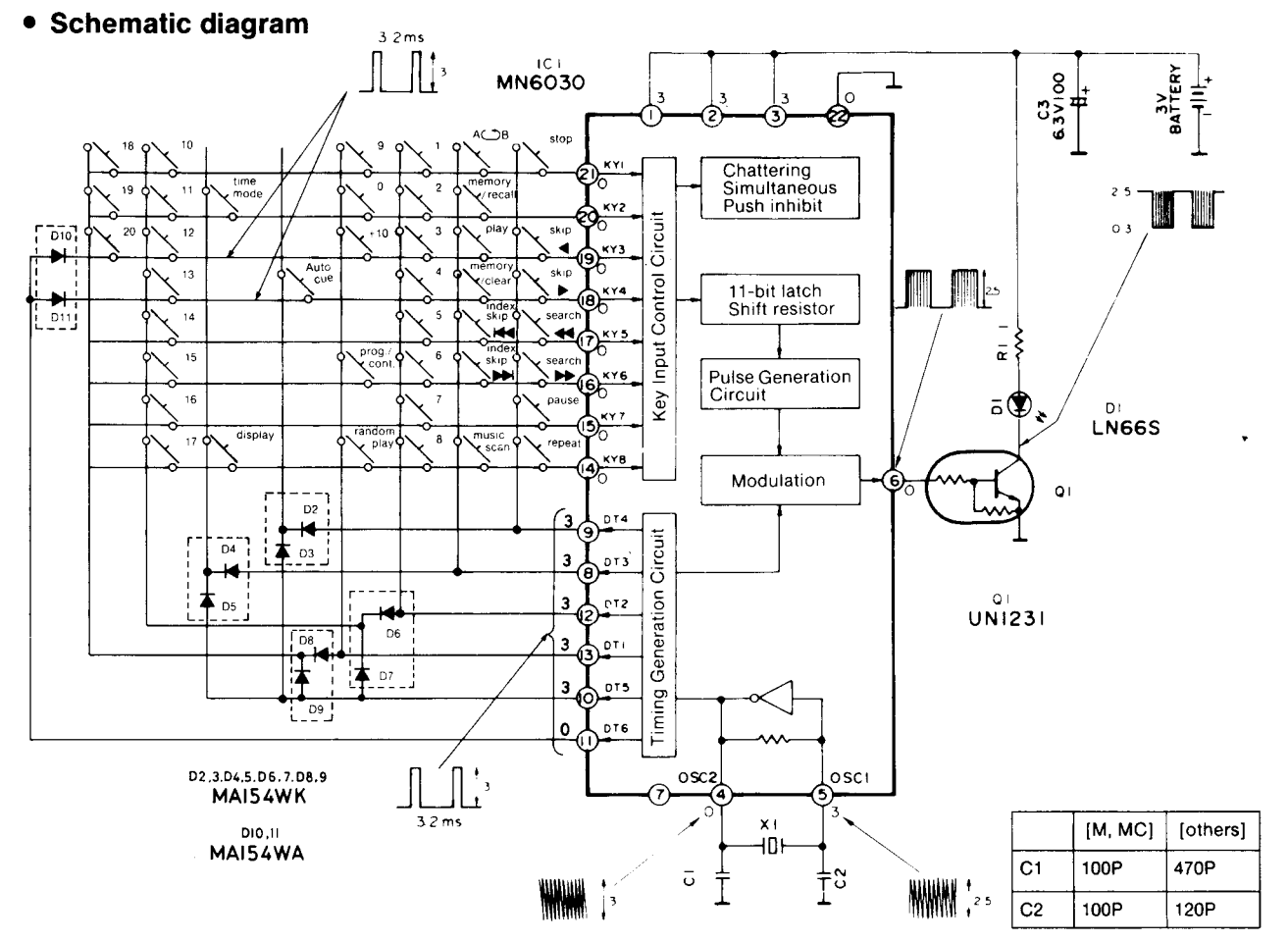

• Key number description and data code

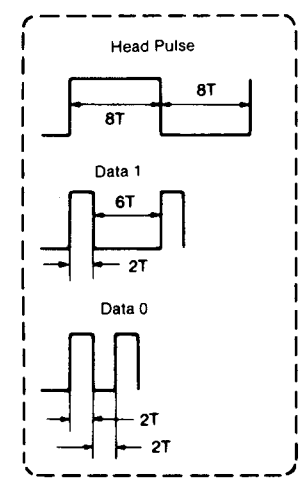
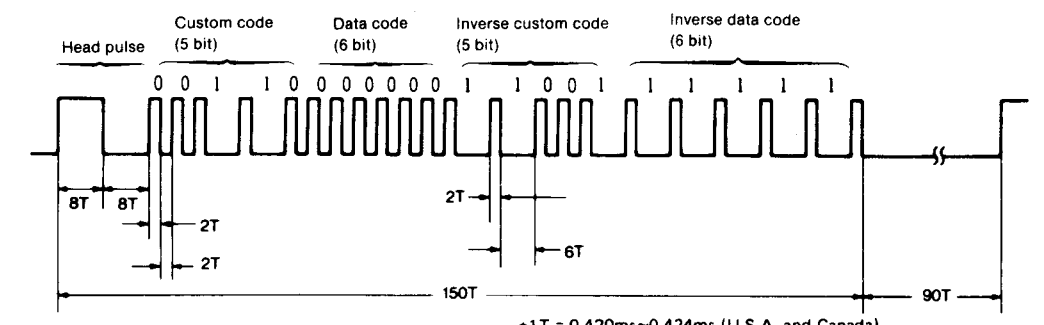

Function	Data Code	Function	Data Code	Function	Data Code
stop	0 0 0 0 0 0	1	0 0 0 0 1 0	auto cue	1 1 0 0 0 1
skip ◀	0 1 0 0 0 0	2	1 0 0 0 1 0	time mode	1 0 0 1 0 1
skip ▶	1 1 0 0 0 0	3	0 1 0 0 1 0	display	1 1 1 1 0 1
search ◀◀	0 0 1 0 0 0	4	1 1 0 0 1 0	10	0 0 0 0 1 1
search ▶▶	1 0 1 0 0 0	5	0 0 1 0 1 0	11	1 0 0 0 1 1
pause	0 1 1 0 0 0	6	1 0 1 0 1 0	12	0 1 0 0 1 1
repeat	1 1 1 0 0 0	7	0 1 1 0 1 0	13	1 1 0 0 1 1
A-B repeat	0 0 0 1 0 0	8	1 1 1 0 1 0	14	0 0 1 0 1 1
memory recall	1 0 0 1 0 0	9	0 0 0 1 1 0	15	1 0 1 0 1 1
play	0 1 0 1 0 0	0	1 0 0 1 1 0	16	0 1 1 0 1 1
memory clear	1 1 0 1 0 0	-10	0 1 0 1 1 0	17	1 1 1 0 1 1
index skip ◀◀	0 0 1 1 0 0	program/continue	1 0 1 1 1 0	18	0 0 0 1 1 1
index skip ▶▶	1 0 1 1 0 0	random play	1 1 1 1 1 0	19	1 0 0 1 1 1
music scan	1 1 1 1 0 0			20	0 1 0 1 1 1

Z0297) as shown
 0.9 mm feeler gauge (RZZ0297)

with the feeler gauge
 using the 1.27mm
 ment by following

ope, adjust the two
 1.5mm hexagonal
 tical fluctuation of
 e pattern is most
 er.
 ck paint(RZZ0L01)

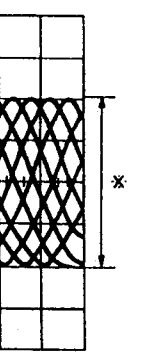

SCHEMATIC DIAGRAM

(This schematic diagram may be modified at any time with development of new technology.)

Notes:

- 1. **S1** : Power switch in "on" position.
- 2. **S2** : Voltage selector switch.
(For [EK], [XA], [XB], [PA], [PE] and [PC] only.)
- 3. **S101** : Disc holder open/close detection switch.
- 4. **S102** : Disc holder open/close detection switch.
- 5. **S601** : Open/close switch.
- 6. **S602** : Stop switch.
- 7. **S603** : Pause switch.
- 8. **S604** : Play switch.
- 9. **S605** : Program switch.
- 10. **S606** : Recall switch.
- 11. **S607** : Time mode switch.
- 12. **S608** : Music scan switch.
- 13. **S609** : Side A-B switch.
- 14. **S611~615** : Numeric (1~20) switches.
- 15. **S616** : Clear switch.
- 16. **S617** : Forward skip switch.
- 17. **S619** : Edit switch.
- 18. **S626** : Numeric (0) switch.
- 19. **S627** : Backward skip switch.
- 20. **S629** : A-B peak level search switch.
- 21. **S636** : Numeric (+10) switch.
- 22. **S637** : Forward index skip switch.
- 23. **S638** : A-B repeat switch.
- 24. **S639** : Peak level search switch.
- 25. **S647** : Backward index skip switch.
- 26. **S648** : Repeat switch.
- 27. **S649** : Display mode selector switch.
- 28. **S651** : Timer switch.
- 29. **S653** : Digital output switch.
- 30. **S654** : Random play switch.
- 31. **S655** : Auto cue switch.
- 32. **S656** : Search speed selector switch.

33. The voltage value and waveforms are the reference voltage of this unit measured by DC electronic voltmeter (high impedance) and oscilloscope on the basis of chassis. Accordingly, there may arise some error in voltage values and waveforms depending upon the internal impedance of the tester or the measuring unit.
* The parenthesized are the values of voltage generated during playing (Test disc 1 kHz, L+R, 0 dB), others are voltage values in stop mode.

25. Important safety notice:
Components identified by Δ mark have special characteristics important for safety. When replacing any of these components, use only manufacturer's specified parts.

26. : Positive voltage lines and negative voltage lines.
 : Audio signal lines.

Caution!

- IC and LSI are sensitive to static electricity. Secondary trouble can be prevented by taking care during repair.
- Cover the parts boxes made of plastics with aluminum foil.
- Ground the soldering iron.
- Put a conductive mat on the work table.
- Do not touch the pins of IC or LSI with fingers directly.

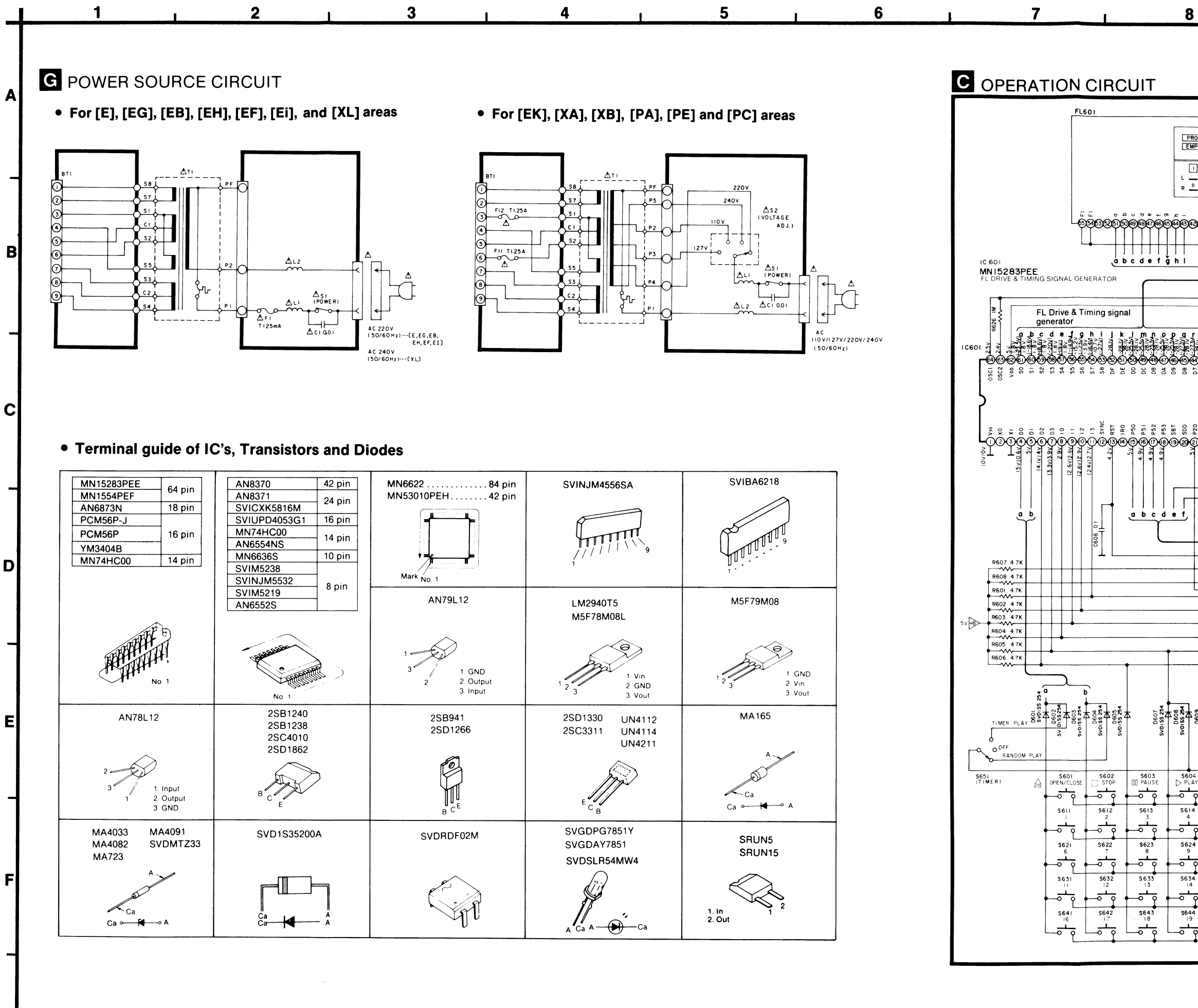

CIRCUIT

[EF], [Ei], and [XL] areas

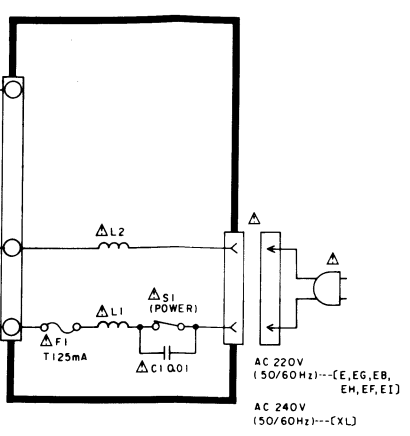

• For [EK], [XA], [XB], [PA], [PE] and [PC] areas

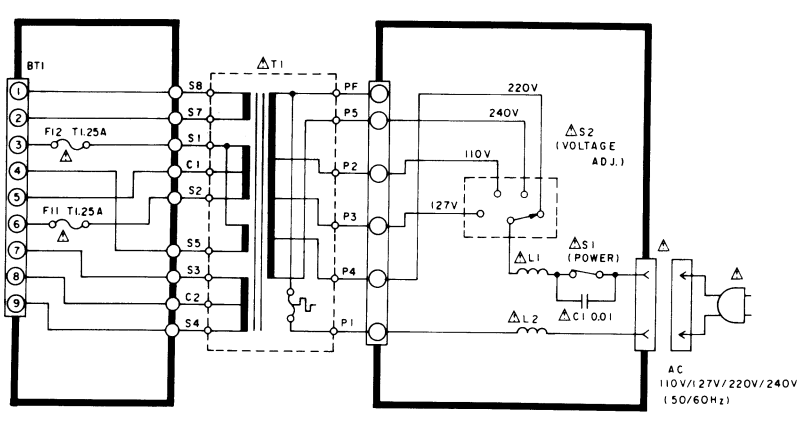

Transistors and Diodes

AN8370 AN8371 SVICKX5816M SVIUPD4053G1 MN74HC00 AN6554NS MN6636S SVIM5238 SVINJM5532 SVIM5219 AN6552S	42 pin 24 pin 16 pin 14 pin 10 pin 8 pin	MN6622 84 pin MN53010PEH 42 pin	SVINJM4556SA SVIBA6218
2SB1240 2SB1238 2SC4010 2SD1862	2SB941 2SD1266	2SD1330 2SC3311	UN4112 UN4114 UN4211
SVD1S35200A	SVDRDF02M	SVGDPG7851Y SVGDAY7851 SVDSL54MW4	SRUN5 SRUN15

C OPERATION CIRCUIT

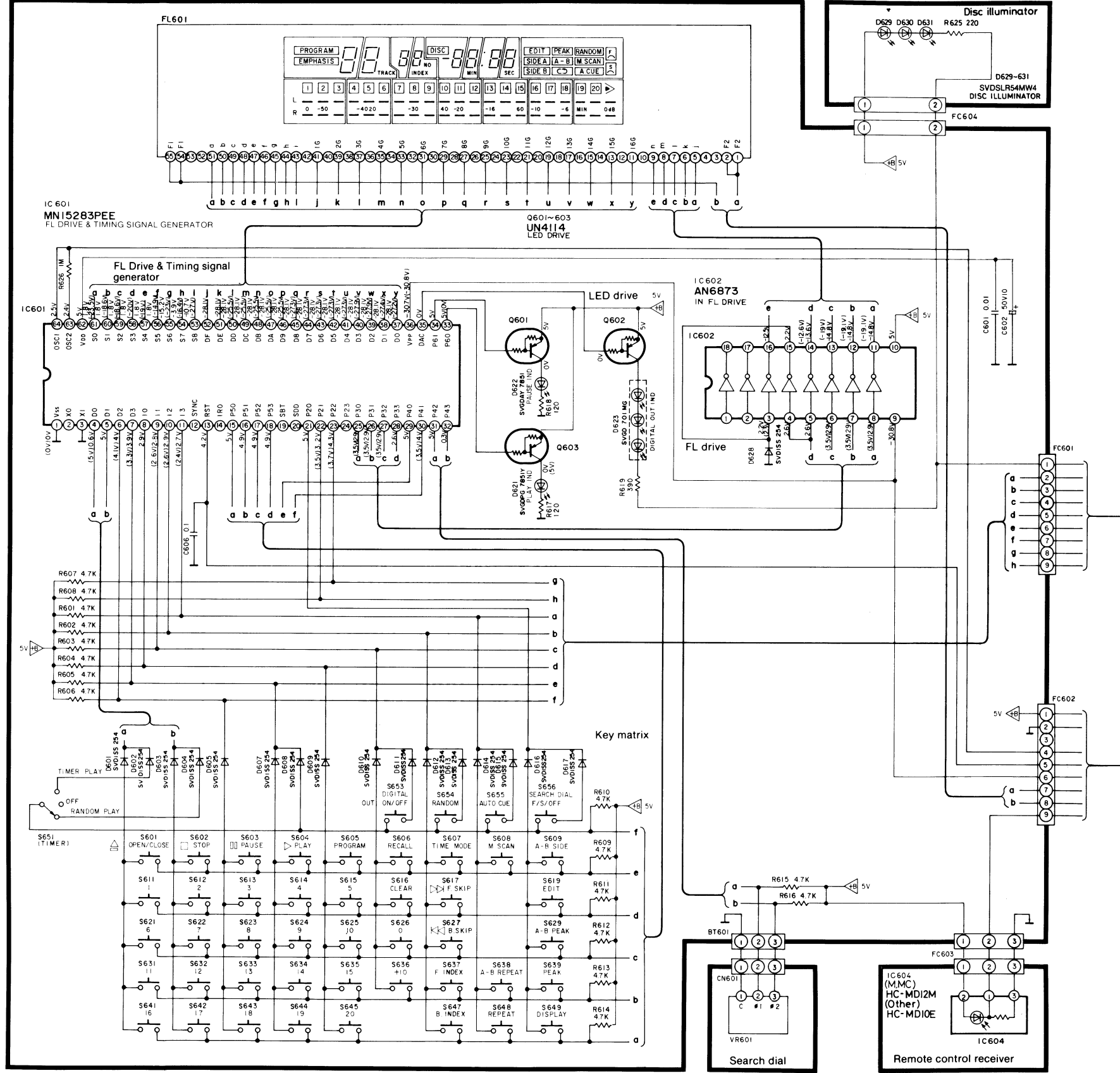

E DISC ILLUMINATOR CIRCUIT

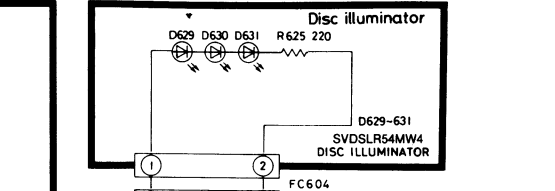

B SEARCH DIAL CIRCUIT

F REMOTE SENSOR CIRCUIT

A MAIN CIRCUIT

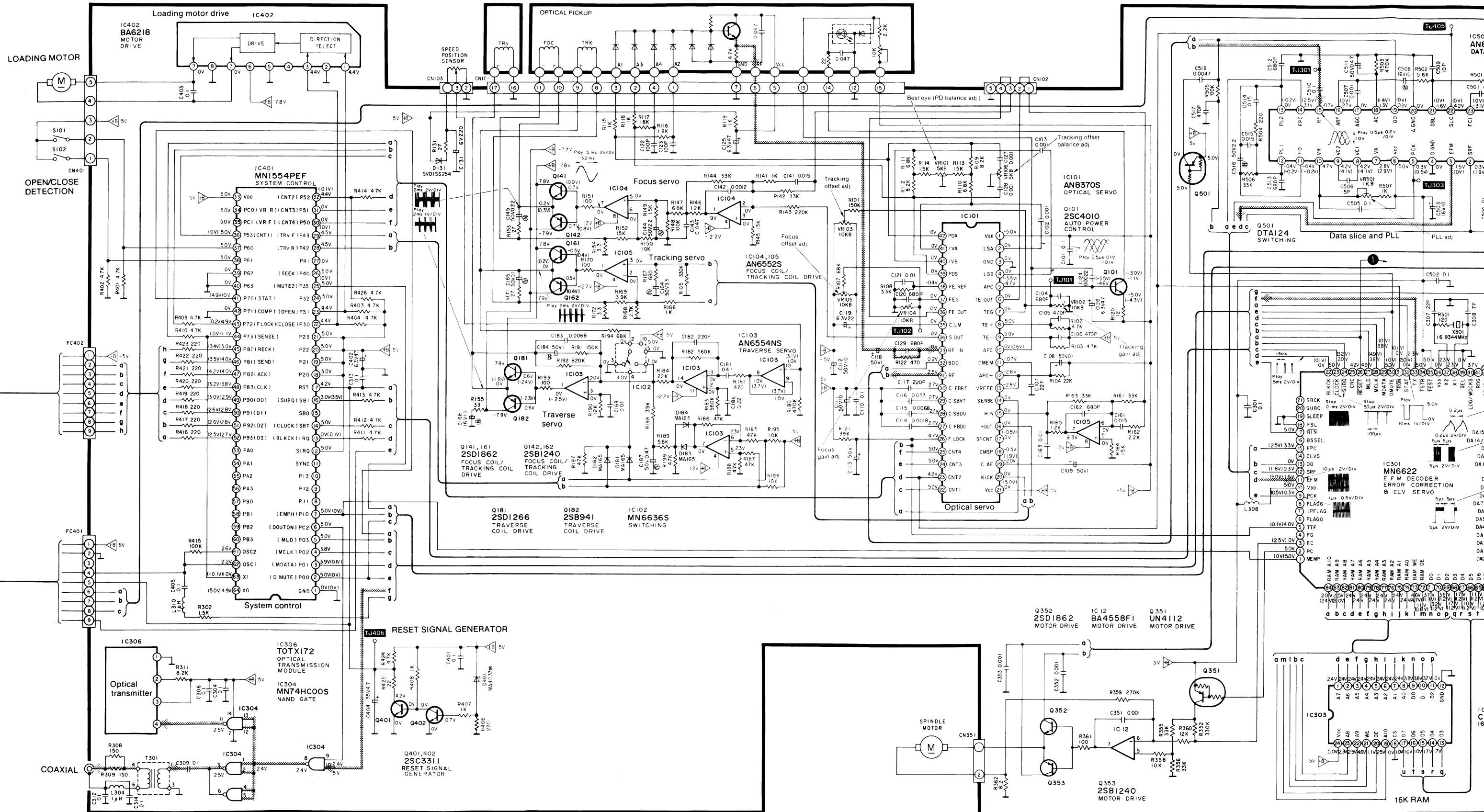

G POWER SOURCE CIRCUIT

• For [M] and [MC] areas
(For other areas, refer to page 28.)

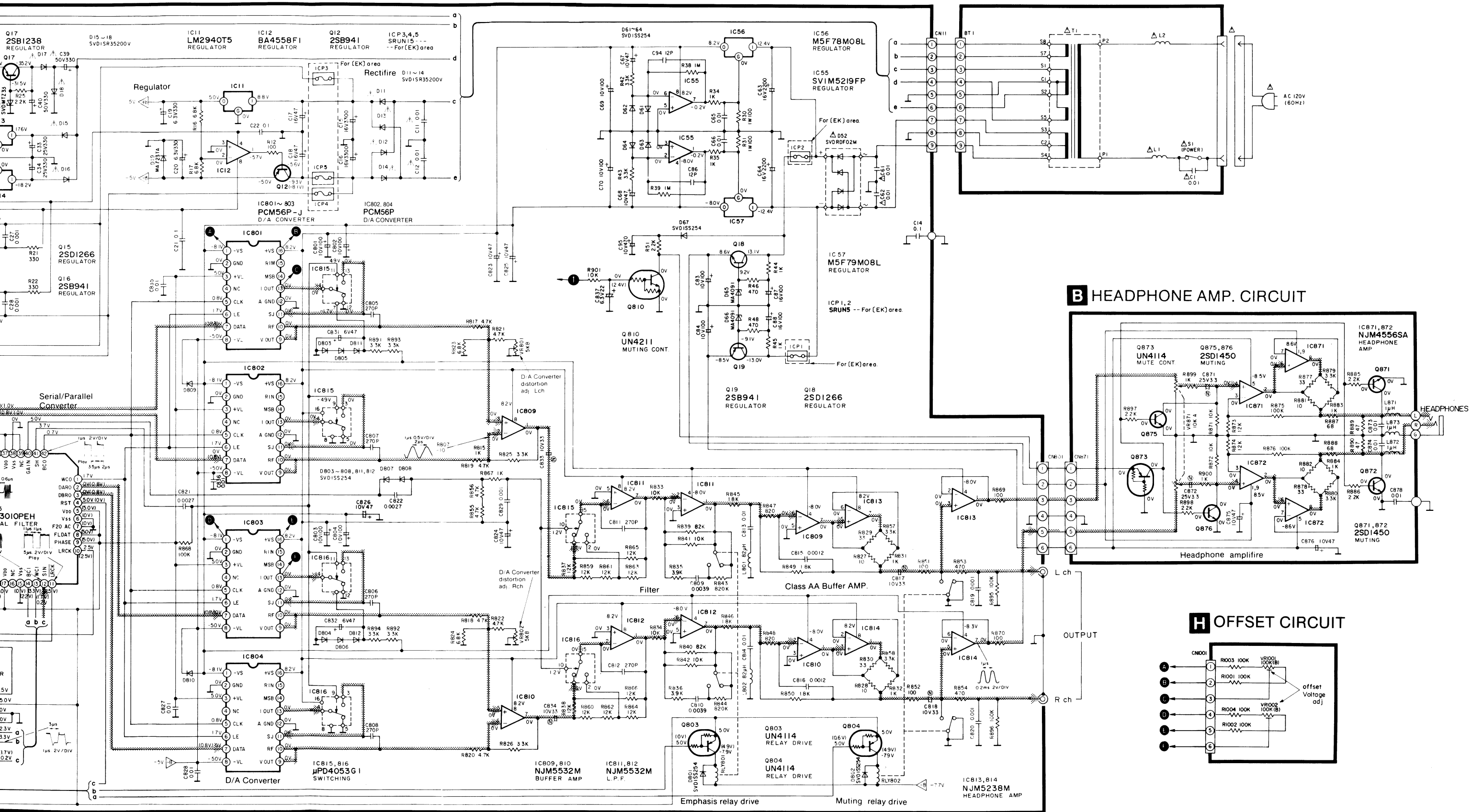

B HEADPHONE AMP. CIRCUIT

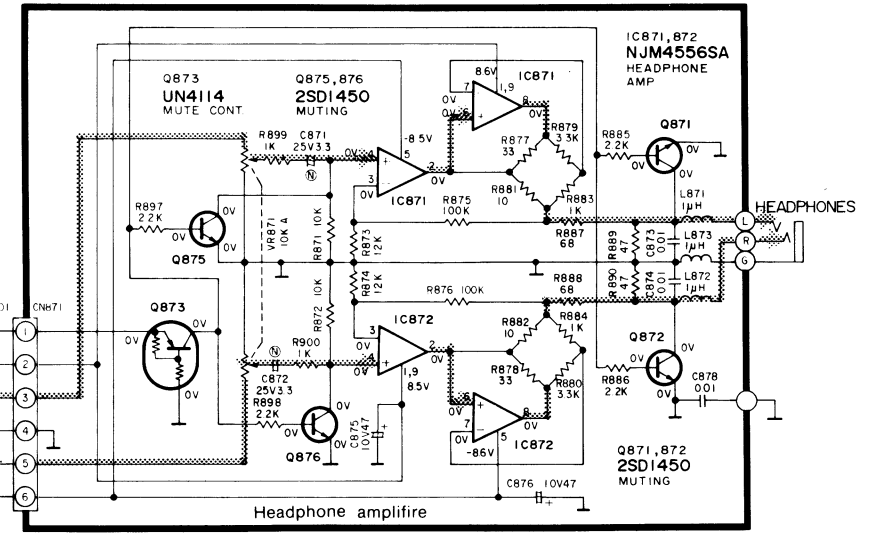

H OFFSET CIRCUIT

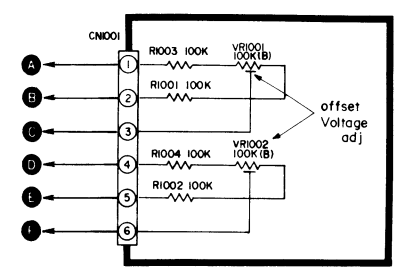

PRINTED CIRCUIT BOARD AND WIRING CONNECTION DIAGRAM

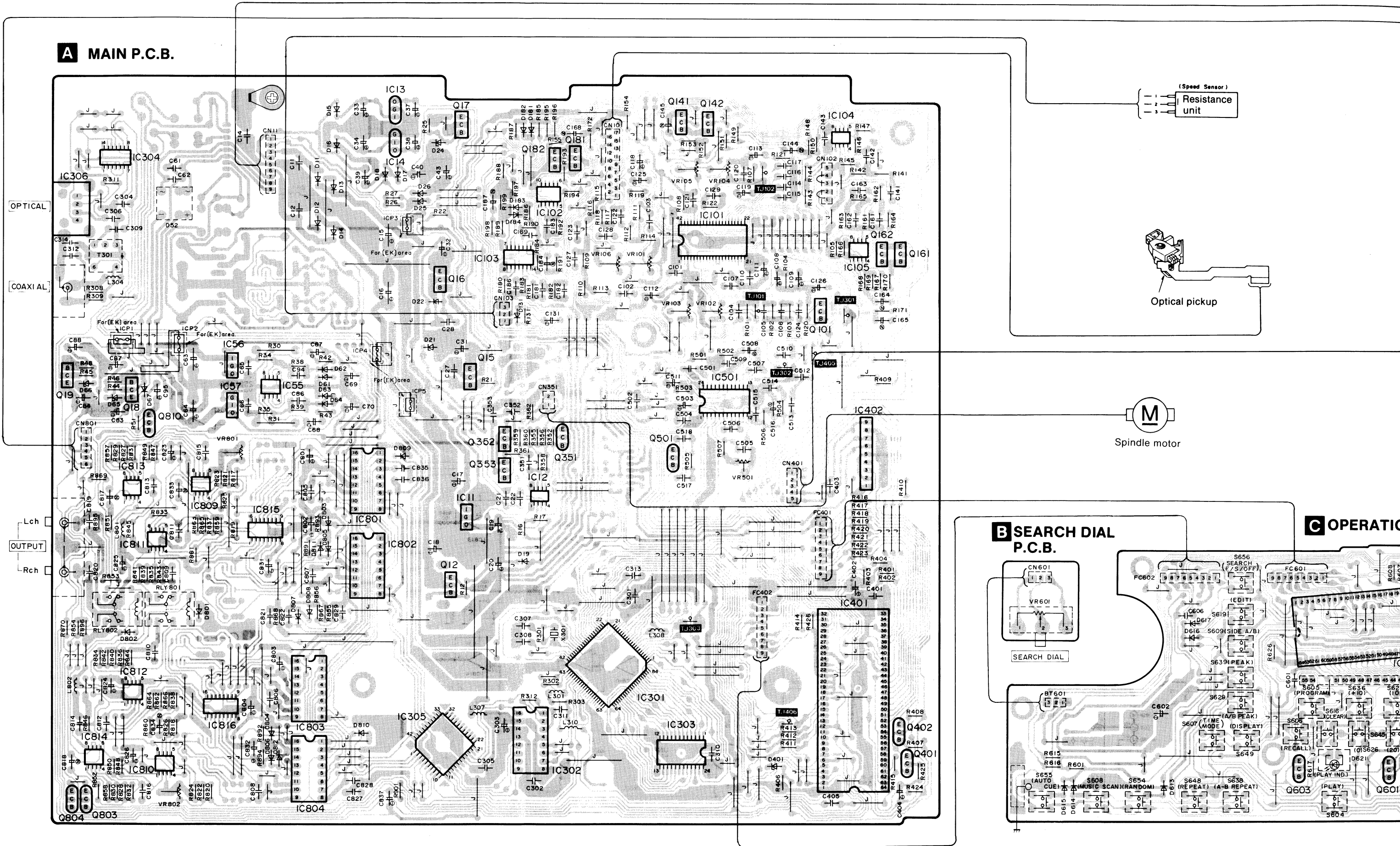

A MAIN P.C.B.

B SEARCH DIAL P.C.B.

C OPERATIONAL P.C.B.

(Speed Sensor)
Resistance unit

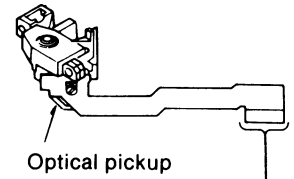

Spindle motor

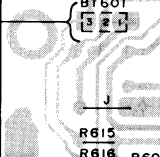
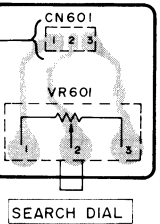

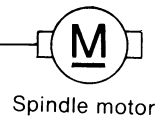
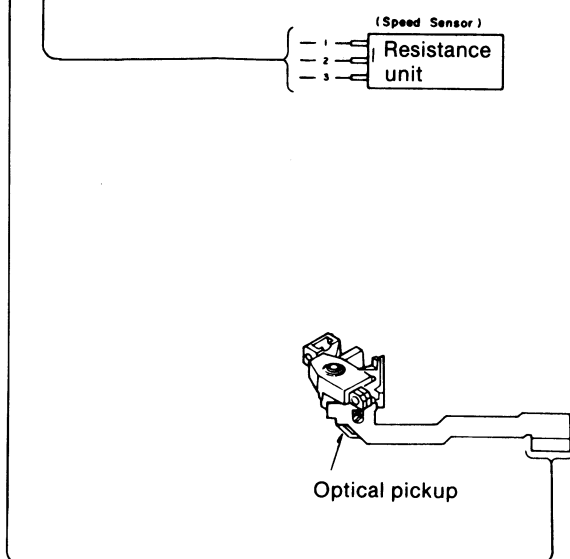
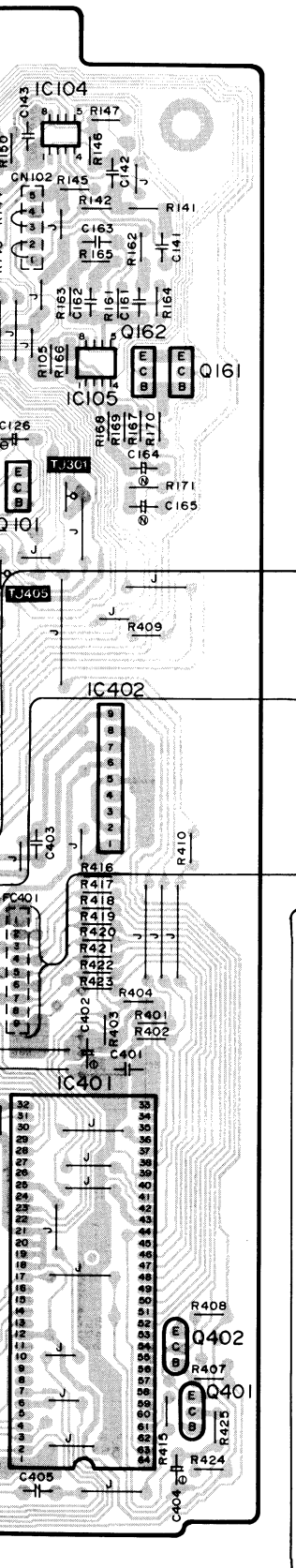

D HEADPHONE AMP. P.C.B.

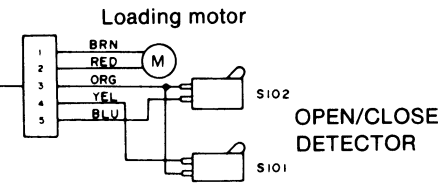
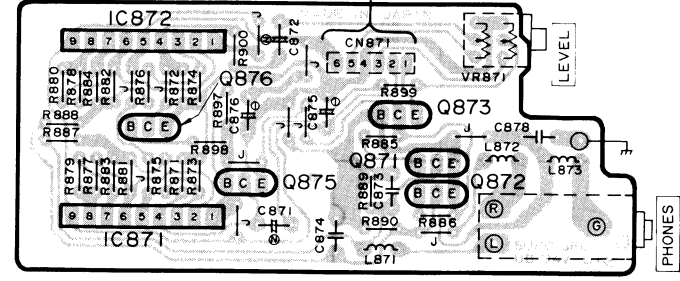

G POWER SOURCE P.C.B.
• For [M] and [MC] areas

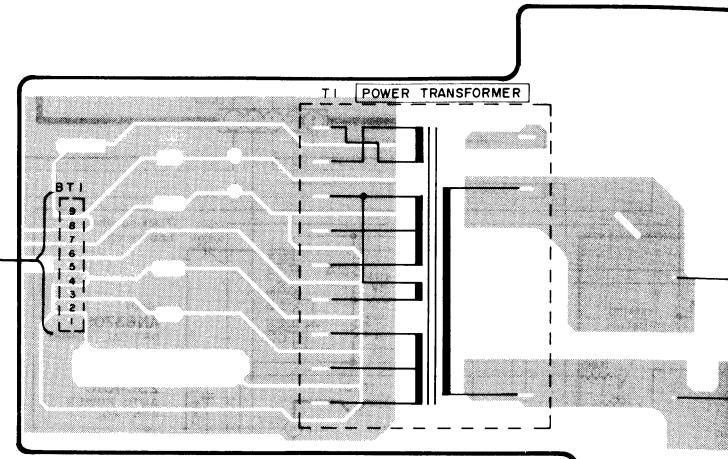

C DISC ILLUMINATOR P.C.B.

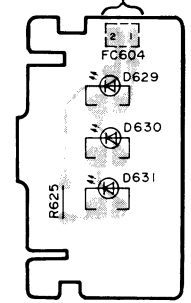

B SEARCH DIAL P.C.B.

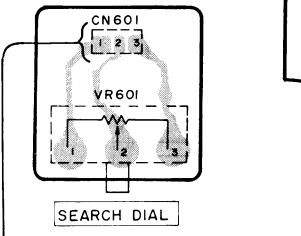

C OPERATION P.C.B.

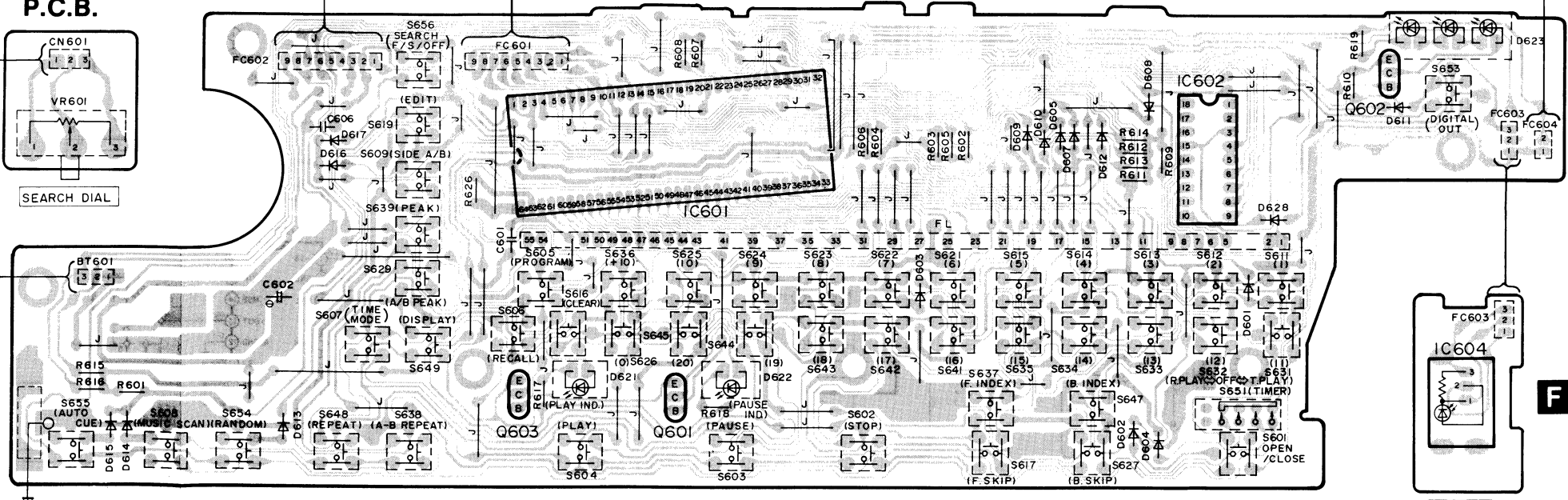

F REMOTE SENSOR P.C.B.

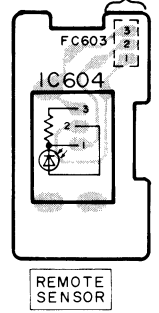

H OFFSET P.C.B.

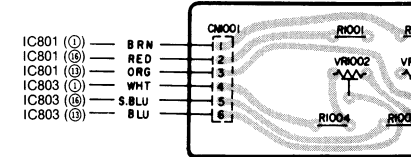

- IC801 (⊖) — BRN
- IC801 (⊖) — RED
- IC801 (⊖) — ORG
- IC803 (⊖) — WHT
- IC803 (⊖) — S.BLU
- IC803 (⊖) — BLU

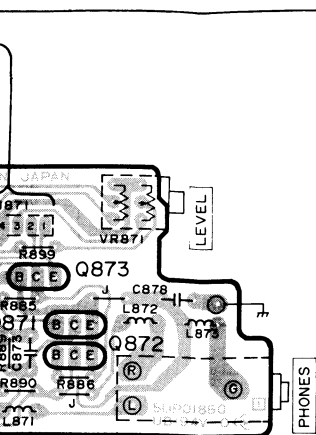

C DISC ILLUMINATOR P.C.B.

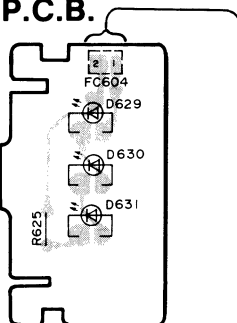

OPEN/CLOSE DETECTOR

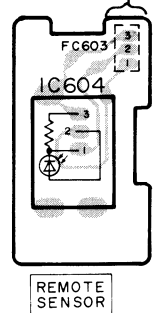
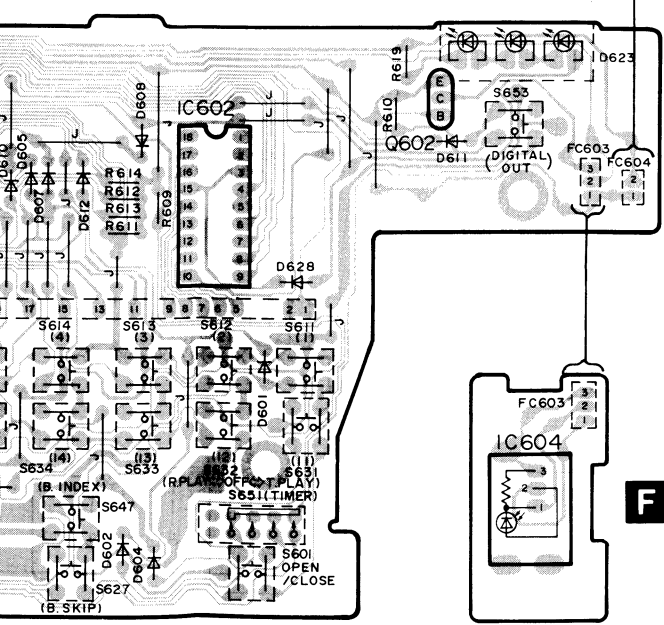

F REMOTE SENSOR P.C.B.

G POWER SOURCE P.C.B.
• For [M] and [MC] areas

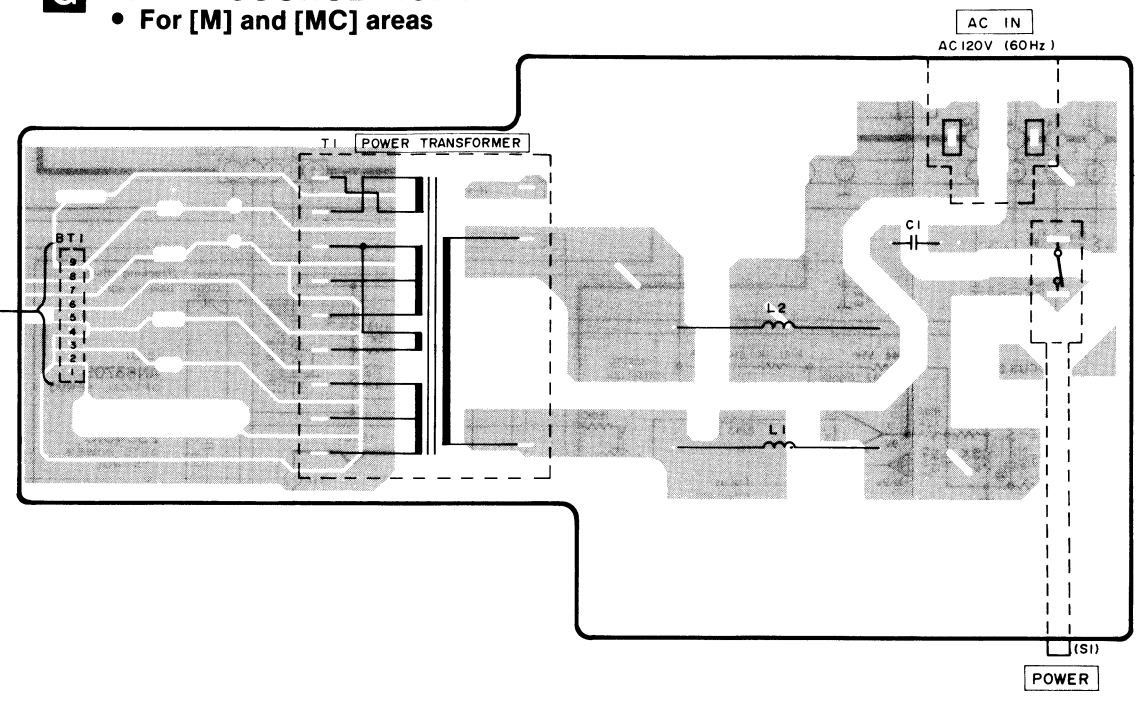

G POWER SOURCE P.C.B.
• For [EK], [XA], [XB], [PA], [PE] and [PC] areas

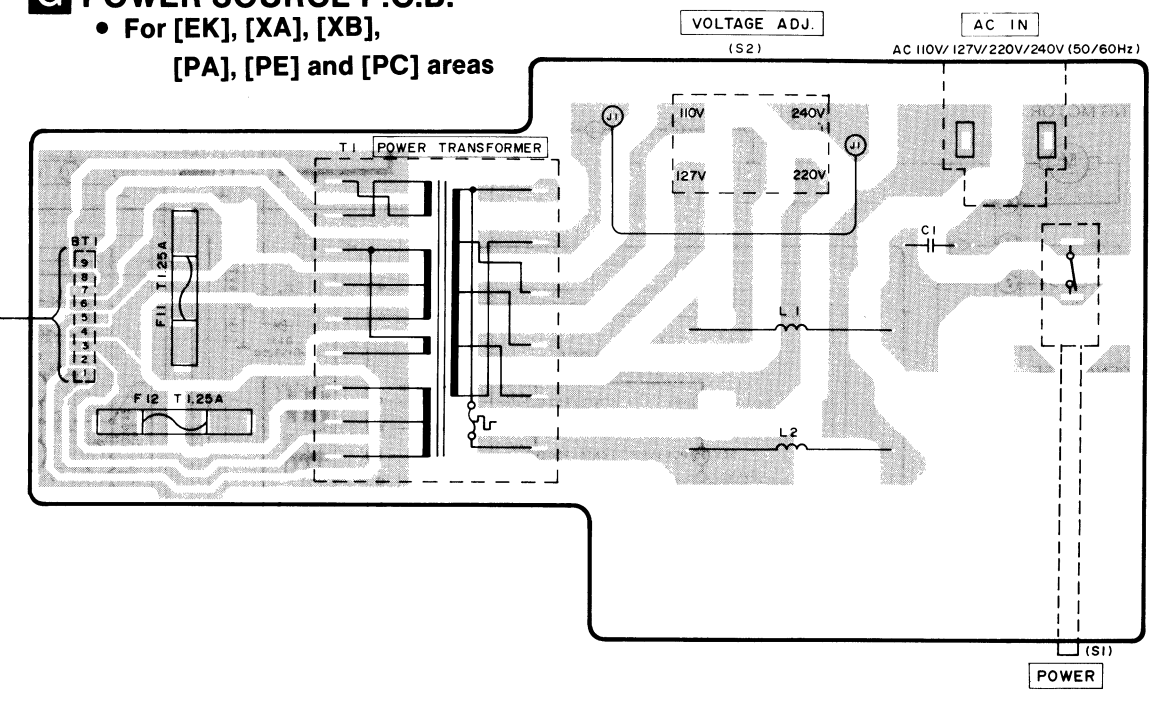

H OFFSET P.C.B.

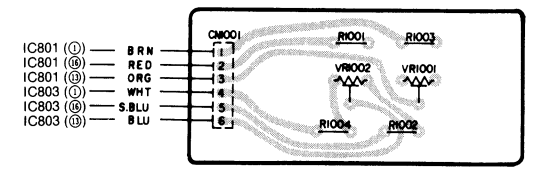

G POWER SOURCE P.C.B.
• For [E], [EG], [EB], [EH], [EF], [Ei] and [XL] areas

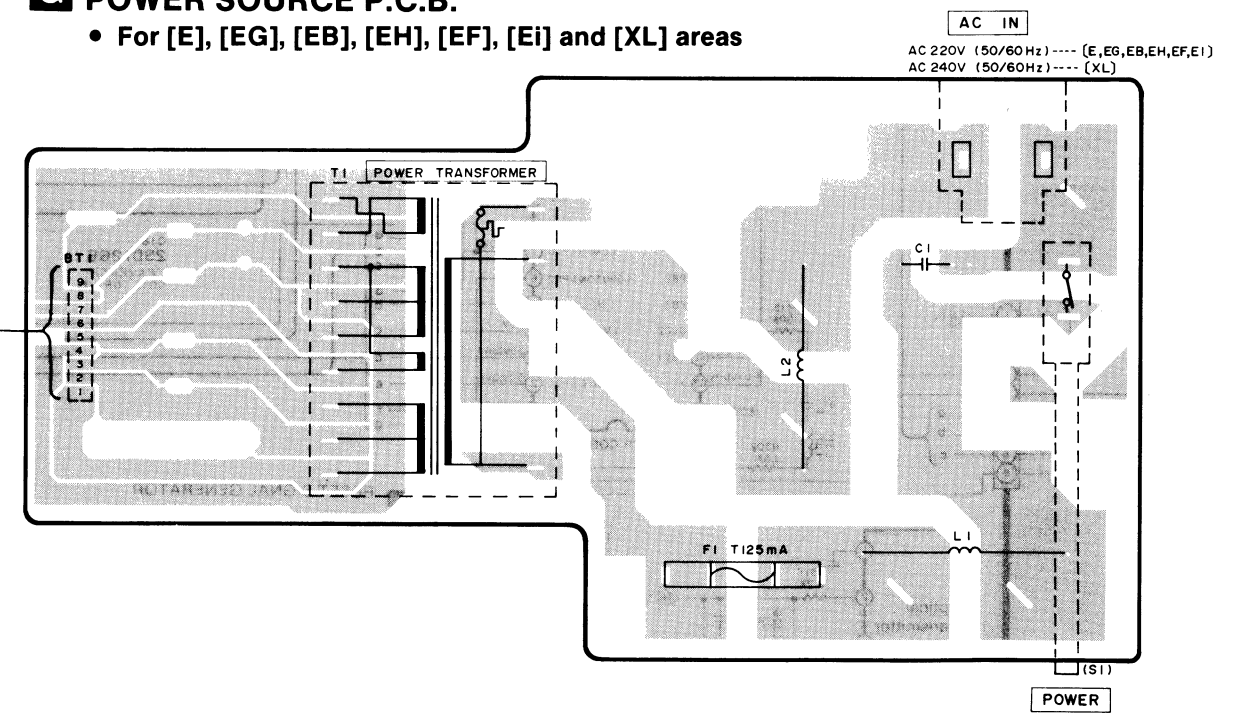

EXPLODED VIEWS

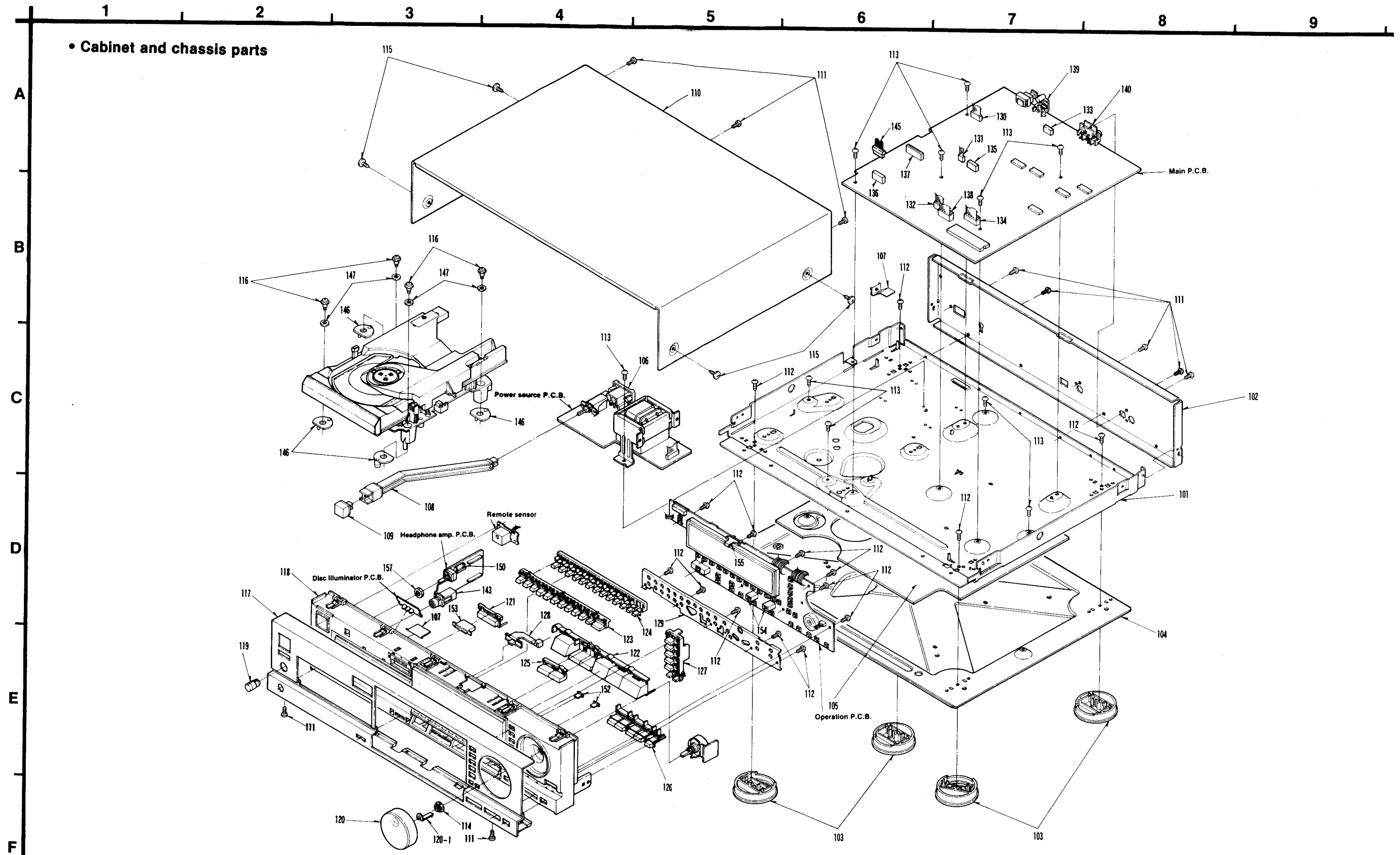

101~130	116	117	118	119	111	120	109	116	108	107	120-1	114	111	121	125	128	113	123	106	129	112	110	111	112	115	105	112	113	107	112	113	130	113	113	139	112	113	113	103	112	130	139	112	133	111	102							
131~157	146	147	146	157	147	153	143	150	146	152	152	155	154	136	145	137	132	138	135	134	133	139	140	145	137	136	132	138	135	134	133	139	140	145	137	136	132	138	135	134	133	139	140	145	137	136	132	138	135	134	133	139	140

REPLACEMENT PARTS LIST (Mechanical parts)

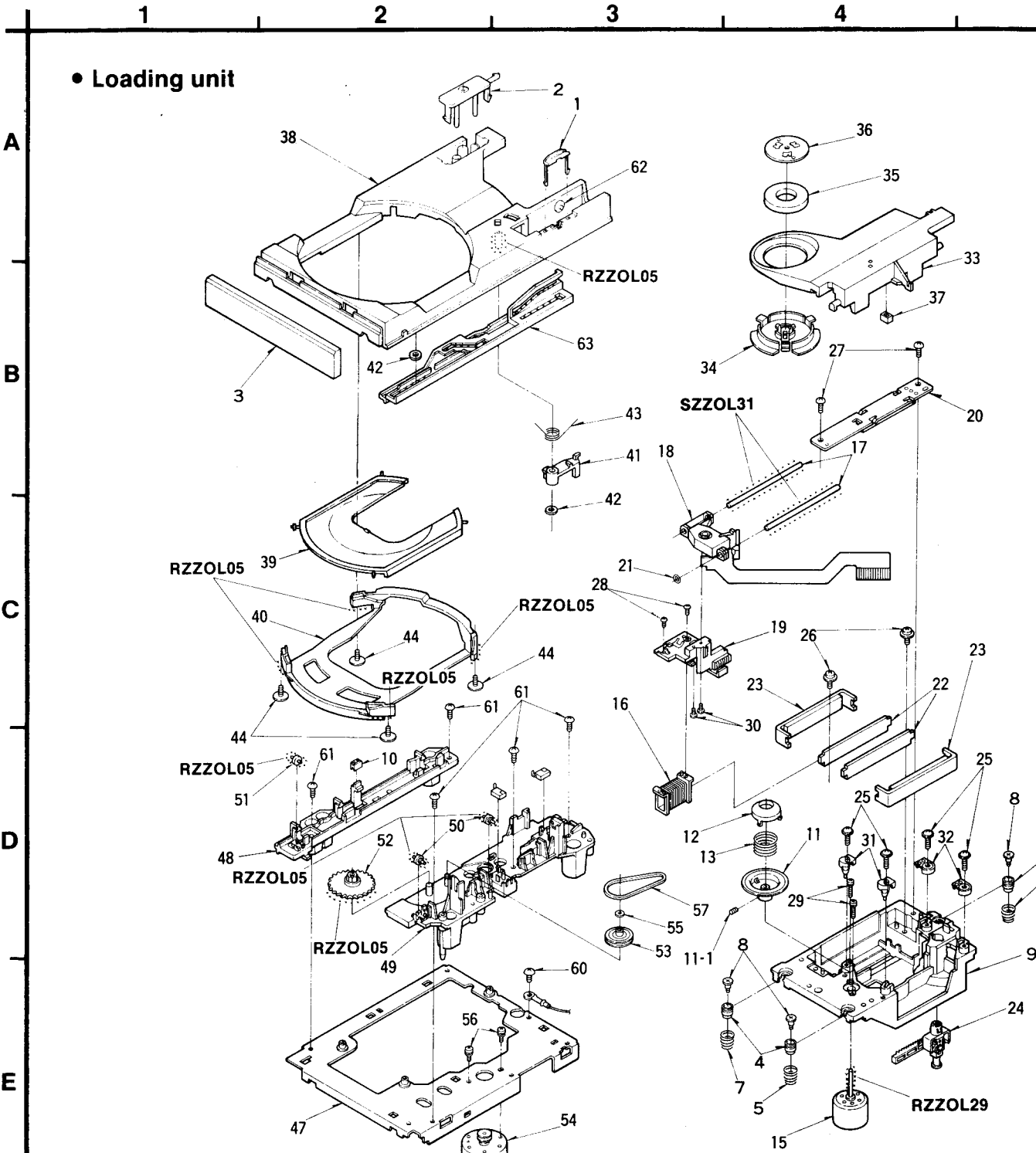

Note: When changing mechanism parts, apply the specified grease to the areas marked "XX" as shown in the drawing.

1~20	3	10	2	1	16	18	12	13	8	4	19	11	17	15	20	8	4
							11-1	7	5	14						9	6
21~40	38		28										36	37	33		
	39			21		34		23		29	26	27	25	35	22	23	24
	40							30					31		32	25	
41~63	44	42	44	50	61	44	63	42	62			57					
	51	61	52	54	56	54	54	43	55								
	48	47	49			60	41	53					58				

Ref. No.	Part No.	Description	Ref. No.	Part No.	Description
CABINET AND CHASSIS					
101	SKUD191ZF0A	CHASSIS	113	XTV3+8J	SCREW
102 (M, MC)	SGPD720ZF0D	REAR PANEL	114	SNE4021	NUT
102 (XA)	SGPD720ZF1B	REAR PANEL	115	SNE2129-1	SCREW
102 (E)	SGPLP770-KE	REAR PANEL	116	SHDD4	SCREW
102 (EB, EH, EF)	SGPLP770-KEB	REAR PANEL	117	SGWLP770-KM	FRONT PANEL
102 (E1)	SGPLP770-KEG	REAR PANEL	118	SGYLP990-KM	FRONT GRILLE
102 (EG)	SGPLP770-KEK	REAR PANEL	119	SBN1161-2	KNOB, HEADPHONES LEVEL
102 (PA, PE, PC)	SGPLP770-KPA	REAR PANEL	120	SBND70MM0A	SEARCH DIAL
102 (XB)	SGPLP770-KXB	REAR PANEL	120-1	SHR9541-1	SPACER
102 (XL)	SGPLP770-KXL	REAR PANEL	121	SBCD4750ZK0A	BUTTON, DIGITAL OUTPUT
103	SKLD8-E	FOOT	122	SBCD4760ZK0B	BUTTON, MAIN
104	SKUD170KF0A	BOTTOM BOARD	123	SBCD4770ZK0B	BUTTON, NUMERIC(A)
105	SHGD139	CUSHION SPACER	124	SBCD4780ZK0B	BUTTON, NUMERIC(B)
106 (M, MC, XL)	SJSD16	AC INLET	125	SBCD4790ZK0B	BUTTON, INDEX
106 (E, EK, EG, EB)	SJS9236	AC INLET	126	SBCD4811ZK0A	BUTTON, REPEAT
106 (EH, EF, E1)			127	SBCD4840ZK0A	BUTTON, EDIT
106 (XA, XB, PA)			128	SBDD91ZK0A	KNOB, TIMER
106 (PE, PC)			129	SUWD94	BRACKET, BUTTON
107	SUWD116	BRACKET	130	EMCS0950Z	CONNECTOR (CN11)
108	SUBD12	POWER SWITCH ROD	131	EMCS0350Z	CONNECTOR (CN103)
109	SBC666-5	BUTTON, POWER	132	EMCS0550Z	CONNECTOR (CN401)
110	SYQD530KME1	CABINET	133	EMCS0650Z	CONNECTOR (CN801)
111	XTV3+8JFZ	SCREW	134	SJSD0905	CONNECTOR (FC402)
112	XTV3+8G	SCREW	135	EMCS0250Z	CONNECTOR (CN351)
			136	EMCS0552M	CONNECTOR (CN102)
			137	SJSD1709	CONNECTOR (CN101)
			138	SJSD0905	CONNECTOR (FC401)
			139	SJFD7-1	JACK (DIGITAL OUTPUT)
			140	SJFD4-1	TERMINAL PLATE (PHONE)
			142	EMCS0650ZL	CONNECTOR (CN871)
			143	SJJD17B	JACK, HEADPHONES
			145	SRD001N14E	SHORTING CONNECTOR (CN102)
			146	SHGD122-1	CUSHION RUBBER
			147	SHGD123	CUSHION RUBBER
			152	SHRD133	LED BLOCK
			153	SHRLP990-KN	LED BLOCK
			154	SHRD169	LED HOLDER
			155	SHGD142	FL HOLDER
			157	XNS7	NUT
			160	SHRD51-1	HOLDER

Ref. No.	Part No.	Description	Ref. No.	Part No.	Description
LOADING MECHANICAL					
1	SHRD150	ROLLER HOLDER	29	XYM2+C12	SCREW
2	SHRD144	COVER WITH CLAW	30	XQN17+C6	SCREW
3	SGXD3150ZK0B	ORNAMENT PANEL	31	SHRD136	GUIDE SHAFT HOLDER(A)
4	SHGD110	CUSHION RUBBER	32	SHRD137	GUIDE SHAFT HOLDER(B)
5	SUSD126	SPRING (RED)	33	S1RD42-2	CLAMPER
6	SUSD127	SPRING (BLUE)	34	S1RD51	HOLDER
7	SUSD128	SPRING (YELLOW)	35	SOMD4	MAGNET
8	SFXGB20-01	SCREW	36	SOYD2	YOKE
9	S1SD13-3	TRAVERSE BASE	37	SHGD119	CUSHION RUBBER
10	SFGZB63M51	CUSHION RUBBER	38	S1RLP990-KM	DISC HOLDER
11	SDOD28-1E	TURNTABLE	39	S1RD98	DISC TRAY
11-1	XXE26D5	SCREW	40	S1RD99	TRAY BASE
12	SDOD29-2	RING	41	S1RD96	LOCK LEVER
13	SRQA010N04	SPRING	42	SFUMZ15R61	WASHER
15	SJGDRF310T	SPINDLE MOTOR	43	SUSD83	SPRING
16	SORD21E-1	TRAVERSE COIL	44	SFXGQ06N01	SCREW
17	SUXD78-2	GUIDE SHAFT	46	XTV3+8BFN	SCREW
18	SOAD60A-1	OPTICAL PICKUP	47	S1WLP320-KM	LOADING BASE
19	EWSL11A00000	COIL HOLDER	48	S1RD43-3	BRACKET(A), LOADING BASE
20	EWS7G0A00Q53	RESISTANCE UNIT	49	S1RLP320KM3	BRACKET(B), LOADING BASE
21	SHGD131	STOPPER	50	SDRD2	ROLLER
22	SOYD8E-1	YOKE (A)	51	SDRD6	ROLLER
23	SOYD9	YOKE (B)	52	SDGD38	MAIN GEAR
24	SHRD23-2	LOCK SHAFT	53	SDGD39-2	PULLEY GEAR
25	XTV3+12GFZ	SCREW	54	SMNLP320-KM	LOADING MOTOR
26	SNSD27	SCREW	55	SHWD20	WASHER
27	XTV3+8G	SCREW	56	XYN26+T4	SCREW
28	XTV2+4G	SCREW	57	SMBD3	DRIVE BELT
			61	XTV3+8JFZ	SCREW
			62	SDRD12	ROLLER
			63	S1RD40-2	RACK GEAR

■ REMOTE CONTROL UNIT PARTS

■ PACKING

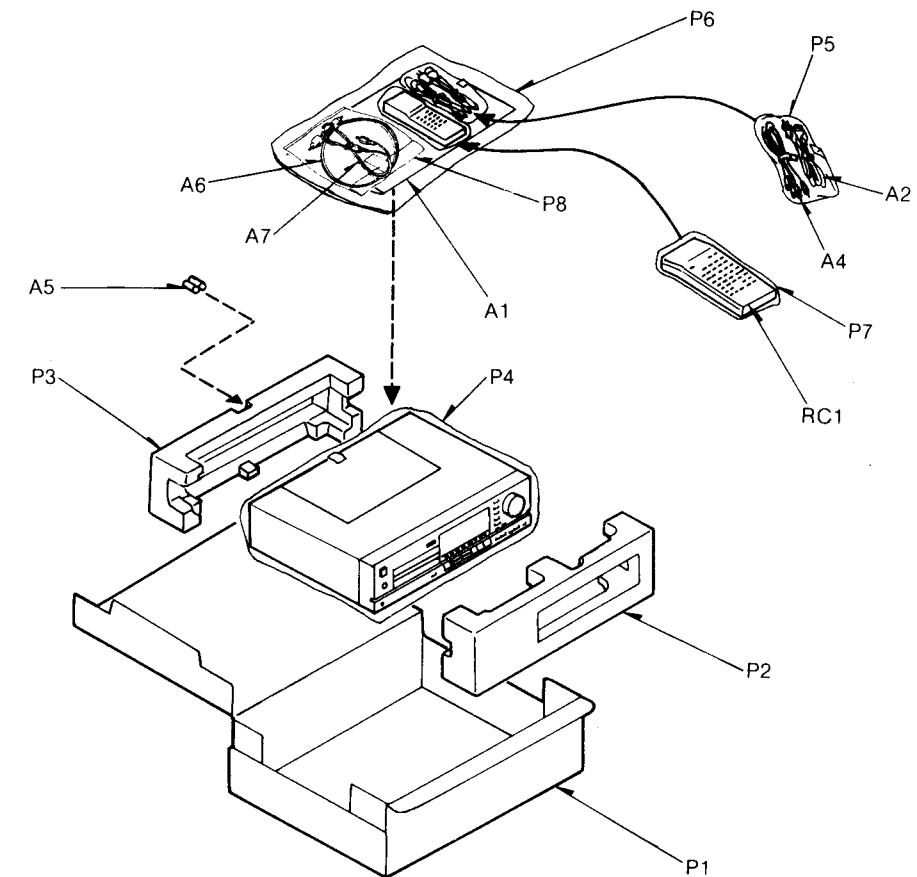
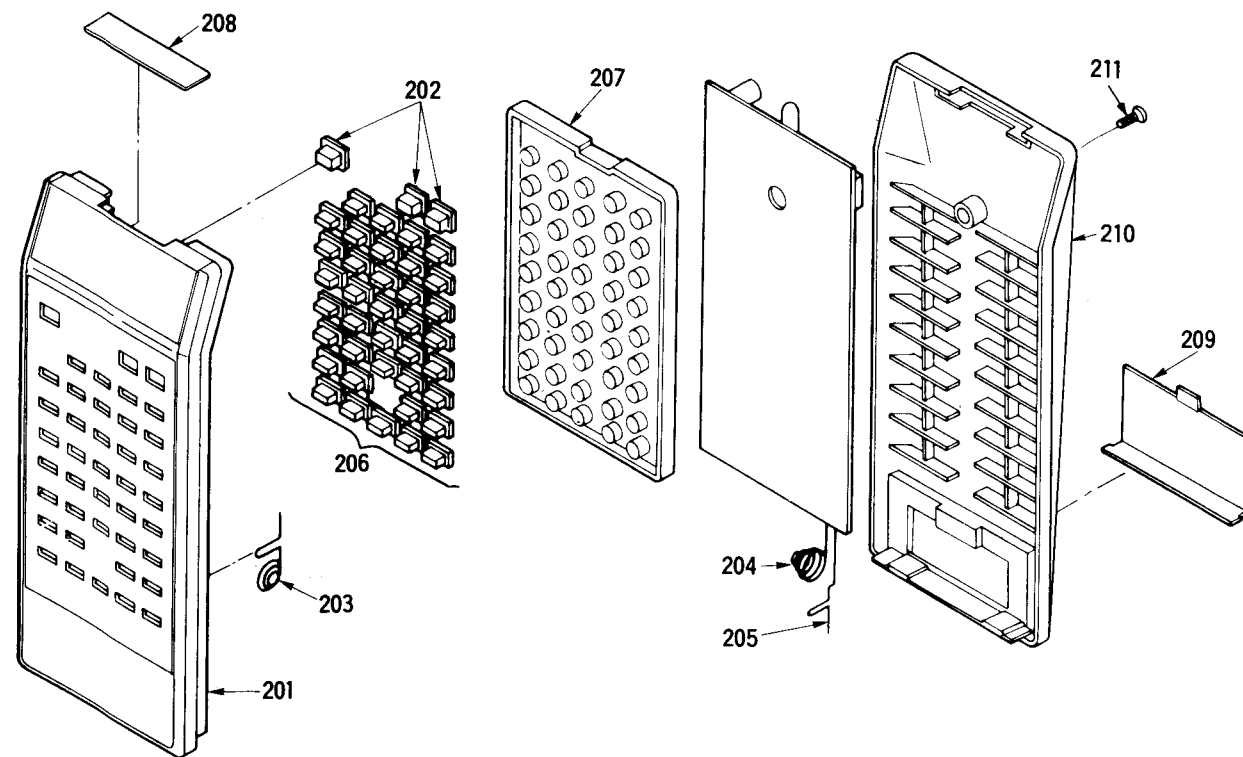

Ref. No.	Part No.	Description	Ref. No.	Part No.	Description
INTEGRATED CIRCUITS					
IC1 (E, EK, XL, EG) (EB, EH, EF) (E1, XA, XB) (PA, PE, PC)	MN6030B	I.C. REMOTE SIGNAL	(E1, XA, XB) (PA, PE, PC)	ECKD1H101KB	CERAMIC, 100PF, 50V
IC1 (M, MC)	MN6030CA	I.C., REMOTE SIGNAL	C2 (M, MC)	ECKD1H121KB	CERAMIC, 120PF, 50V
TRANSISTORS					
Q1	UN1231	TRANSISTOR	C2 (E, EK, XL, EG) (EB, EH, EF) (E1, XA, XB) (PA, PE, PC)	ECEA0GK101	ELECTROLYTIC, 6.3V100µF
DIODES					
D1	1N66	L.E.D	MECHANISM PARTS		
D2	MA154WK	DIODE	201 (M, MC)	UR64VCS425	UPPER CABINET
D4	MA154WK	DIODE	201	UR64VCS426	UPPER CABINET
D6	MA154WK	DIODE	(E, EK, XL, EG) (EB, EH, EF) (E1, XA, XB) (PA, PE, PC)	202	SBCLP990-KN1
D8	MA154WK	DIODE	203	UR64TD374	BATTERY TERMINAL
D10	MA154WA	DIODE	204	UR64TD373	BATTERY TERMINAL (-)
OSCILLATOR					
X1 (E, EK, XL, EG) (EB, EH, EF) (E1, XA, XB) (PA, PE, PC)	CSB420PB1	OSCILLATOR	205	UR64TD372	BATTERY TERMINAL (+)
X1 (M, MC)	CSB455EB1	OSCILLATOR	206	SBCLP990-KN2	BUTTON(B)
RESISTORS					
R1	ERDS2TJ1R0	CARBON, 1Ω, 1/4W	207	UR64CT369	RUBBER CONTACT
CAPACITORS					
C1 (M, MC)	ECKD1H101KB	CERAMIC, 100PF, 50V	208	UR52SB327	PLATE
C1 (E, EK, XL, EG) (EB, EH, EF)	ECKD1H471KB	CERAMIC, 470PF, 50V	209	UR64EC366	BATTERY COVER
			210	UR64CS365A	LOWER CABINET
			211	XTS26+10GFZ	SCREW
			REMOTE CONTROL ASS'Y		
			RC1 (M, MC)	EUR64712	REMOTE CONT.(REF TO NOTE)
			RC1 (E, EK, XL, EG) (EB, EH, EF) (E1, XA, XB) (PA, PE, PC)	EUR64713	REMOTE CONT.(REF TO NOTE)

Ref. No.	Part No.	Description	Ref. No.	Part No.	Description
PACKING MATERIAL					
P1 (M, E, EK, XL) (EG, EB, EH) (E1, XA, XB) (PA, PE, PC)	SPND244	CARTON BOX	A1 (PA, PE, PC)	SQULP770-KPA	INSTRUCTION MANUAL
P1 (MC)	SPND245	CARTON BOX	A1 (XB)	SQULP770-KXB	INSTRUCTION MANUAL
P1 (EF)	SPND246	CARTON BOX	A2 Δ	SFDAC05G02	POWER CORD
P2	SPSD133	PAD (FRONT)	(EK)	SJA168	POWER CORD
P3	SPSD134	PAD (REAR)	A2 Δ	SJA172	POWER CORD
P4	XZB60X60A010	PROTECT ION COVER (UNIT)	(XA, PA, PE) (PC)	SJA172-1	POWER CORD
P5	XZB26X17C03	PROTECT ION BAG (CORDS)	A2 Δ	SJA173	POWER CORD
P6	XZB23X35C03	PROTECT ION BAG (INST. MANUAL)	(M)	SJA183	POWER CORD
P7	XZB23X20C03	PROTECT ION BAG (CORDS)	A2 Δ	SJA187	POWER CORD
P8	SRHZJ02N01	PROTECT ION BAG (REMOTE CONT.)	(XL)		
ACCESSORIES					
A1 (M)	SQU0269	INSTRUCTION MANUAL	A2 Δ	SJA187	POWER CORD
A1 (EK, XL, EF) (XA)	SQU0271	INSTRUCTION MANUAL	(E, EG, EB, EH) (EF, E1)	RJP120ZBS-H	AC PLUG ADAPTOR
A1 (EG)	SQU0273	INSTRUCTION MANUAL	A3 Δ	SJP2249-2	OUTPUT CORD BATTERY
A1 (E1)	SQU0275	INSTRUCTION MANUAL	(XA, XB, PA) (PE, PC)		
A1 (E, EB, EH)	SQULP770-KE	INSTRUCTION MANUAL	A4		
A1 (M, MC)	SQULP770-KMC	INSTRUCTION MANUAL	A5		
			(E, EK, XL, EG) (EB, EH, EF) (E1, XA, XB) (PA, PE, PC)		
			A5 (M, MC)		BATTERY
			A6	SJPD16	OPTICAL OUTPUT CORD
			A7	SJPD19	DIGITAL OUTPUT CORD

RESISTORS AND CAPACITORS

Notes: * Important safety notice:

Components identified by Δ mark have special characteristics important for safety. When replacing any of these components use only manufacturer's specified parts.

* Bracketed indications in Ref. No. columns specify the area.

Parts without these indications can be used for all areas.

Numbering System of Resistor

Example

ERD	25	F	J	102
Type	Wattage	Shape	Tolerance	Value
ERX	2	AN	J	471
Type	Wattage	Shape	Tolerance	Value
				47x10 ¹ (ohm)

Numbering System of Capacitor

Example

ECKD	1H	102	Z	F
Type	Voltage	Value	Tolerance	Peculiarity
ECEA	50	M		330
Type	Voltage	Peculiarity		Value
				(33x10 ⁰ microfarad)

Resistor Type	Wattage	Tolerance
ERD : Carbon	10 : 1/8W	J : ±5%
ERG : Metal Oxide	12 : 1/2W	F : ±1%
ERX : Metal Film	25 : 1/4W	G : ±2%
ERQ : Fuse Type Metal	1A : 1W	K : ±10%
ERD [] L : Carbon (chip)	18 : 1/8W	
ERD [] K : Metal Film (chip)	S2 : 1/4W	
ERC : Solid	S1 : 1/2W	
	2F : 1/4W	
	50 : 1/2W	
	2A : 2W	

Capacitor Type	Voltage	Tolerance
ECE : Electrolytic	0J : 6.3V	C : ±0.25pF
ECCD : Ceramic	1A : 10V	J : ±5%
ECKD : Ceramic	1C : 16V	K : ±10%
ECQM : Polyester	1E : 25V	Z : +80%
	1H : 50V	-20%
ECQP : Polypropylene	1V : 35V	P : +100%
	50 : 50V	-0%
ECG : Ceramic	05 : 50V	M : ±20%
ECEA [] ON : Non Polar Electrolytic	2H : 500V	
QCU [] : Ceramic (Chip Type)	2A : 100V	D : ±0.5pF
ECUX : Ceramic (Chip Type)	1 : 100V	G : ±2%
ECF : Semiconductor	KC : 400V AC	
	KC : 125VAC (U.L)	
EECW : Liquid electrolyte double layer capacitor	1J : 63V	

Ref. No.	Part No.	Value.	Ref. No.	Part No.	Value.	Ref. No.	Part No.	Value.
RESISTORS(VALUE,WATTAGE)								
R12	ERDS2TJ101	100 1/4	R107	ERDS2TJ683	68K 1/4	R170	ERDS2TJ101	100 1/4
R16	ERDS2TKG6801	6.8K 1/4	R108	ERDS2TJ332	3.3K 1/4	R171	ERDS2TJ270	27 1/4
R17	ERDS2TKG6801	6.8K 1/4	R109	ERDS2TJ822	8.2K 1/4	R172	ERDS2TJ3R3	3.3 1/4
R21	ERDS2TJ331	330 1/4	R110	ERDS2TJ682	6.8K 1/4	R180	ERDS2TJ474	470K 1/4
R22	ERDS2TJ331	330 1/4	R111	ERDS2TJ682	6.8K 1/4	R181	ERDS2TJ471	470 1/4
R25	ERDS2TJ222	2.2K 1/4	R112	ERDS2TJ822	8.2K 1/4	R182	ERDS2TJ564	560K 1/4
R26	ERDS2TJ392	3.9K 1/4	R113	ERDS2TJ152	1.5K 1/4	R183	ERDS2TJ564	560K 1/4
R27	ERDS2TJ392	3.9K 1/4	R114	ERDS2TJ152	1.5K 1/4	R184	ERDS2TJ223	22K 1/4
R30	ERDS2TJ101	100 1/4	R115	ERDS2TJ102	1K 1/4	R185	ERDS2TJ473	47K 1/4
(M, MC, E, XL)			R116	ERDS2TJ182	1.8K 1/4	R186	ERDS2TJ473	47K 1/4
(EG, EB, EH)			R117	ERDS2TJ182	1.8K 1/4	R187	ERDS2TJ473	47K 1/4
(EF, EI, XA)			R118	ERDS2TJ102	1K 1/4	R188	ERDS2TJ473	47K 1/4
(XB, PA, PE)			R119	ERDS2TJ102	1K 1/4	R189	ERDS2TJ562	5.6K 1/4
(PC)			R120	ERDS2TJ120	12 1/4	R190	ERDS2TJ123	12K 1/4
R30	ERGS1J101P	100 1	R121	ERDS2TJ333	33K 1/4	R191	ERDS2TJ154	150K 1/4
(EK)			R122	ERDS2TJ471	470 1/4	R192	ERDS2TJ824	820K 1/4
R31	ERDS2TJ101	100 1/4	R131	ERDS2TJ270	27 1/4	R193	ERDS2TJ101	100 1/4
(M, MC, E, XL)			R141	ERDS2TJ102	1K 1/4	R194	ERDS2TJ683	68K 1/4
(EG, EB, EH)			R142	ERDS2TJ333	33K 1/4	R195	ERDS2TJ103	10K 1/4
(EF, EI, XA)			R143	ERDS2TJ124	120K 1/4	R196	ERDS2TJ103	10K 1/4
(XB, PA, PE)			R144	ERDS2TJ333	33K 1/4	R197	ERDS2TJ473	47K 1/4
(PC)			R145	ERDS2TJ153	15K 1/4	R198	ERDS2TJ473	47K 1/4
R31	ERGS1J101P	100 1	R146	ERDS2TJ122	1.2K 1/4	R199	ERDS2TJ473	47K 1/4
(EK)			R147	ERDS2TJ682	6.8K 1/4	R301	ERDS2TJ121	120 1/4
R34	ERDS2TJ102	1K 1/4	R148	ERDS2TJ104	100K 1/4	R302	ERDS2TJ152	1.5K 1/4
R35	ERDS2TJ102	1K 1/4	R149	ERDS2TJ152	1.5K 1/4	R303	ERDS2TJ391	390 1/4
R38	ERDS2TJ105	1M 1/4	R150	ERDS2TJ103	10K 1/4	R308	ERDS2TJ151	150 1/4
R39	ERDS2TJ105	1M 1/4	R151	ERDS2TJ101	100 1/4	R309	ERDS2TJ151	150 1/4
R42	ERDS2TJ332	3.3K 1/4	R152	ERDS2TJ153	15K 1/4	R311	ERDS2TJ822	8.2K 1/4
R43	ERDS2TJ332	3.3K 1/4	R153	ERDS2TJ270	27 1/4	R312	ERDS2TJ104	100K 1/4
R44	ERDS2TJ102	1K 1/4	R154	ERDS2TJ3R3	3.3 1/4	R352	ERDS2TJ334	330K 1/4
R45	ERDS2TJ102	1K 1/4	R155	ERDS2TJ330	33 1/4	R355	ERDS2TJ333	33K 1/4
R46	ERDS2TJ471	470 1/4	R161	ERDS2TJ333	33K 1/4	R356	ERDS2TJ333	33K 1/4
R48	ERDS2TJ471	470 1/4	R162	ERDS2TJ222	2.2K 1/4	R358	ERDS2TJ103	10K 1/4
R51	ERDS2TJ222	2.2K 1/4	R163	ERDS2TJ333	33K 1/4	R359	ERDS2TJ274	270K 1/4
R101	ERDS2TJ154	150K 1/4	R164	ERDS2TJ153	15K 1/4	R360	ERDS2TJ123	12K 1/4
R102	ERDS2TJ472	4.7K 1/4	R165	ERDS2TJ122	1.2K 1/4	R361	ERDS2TJ101	100 1/4
R103	ERDS2TJ472	4.7K 1/4	R166	ERDS2TJ102	1K 1/4	R362	ERDS2TJ8R2	8.2 1/4
R104	ERDS2TJ223	22K 1/4	R166	ERDS2TJ102	1K 1/4	R401	ERDS2TJ472	4.7K 1/4
R105	ERDS2TJ334	330K 1/4	R167	ERDS2TJ681	680 1/4	R402	ERDS2TJ472	4.7K 1/4
			R168	ERDS2TJ272	2.7K 1/4	R403	ERDS2TJ472	4.7K 1/4
			R169	ERDS2TJ392	3.9K 1/4	R404	ERDS2TJ472	4.7K 1/4

Ref. No.	Part No.	Value.	Ref. No.	Part No.	Value.	Ref. No.	Part No.	Value.
R406	ERDS2TJ221	220 1/4	R845	ERDS2TJ182	1.8K 1/4	C32	ECEA1AU101	100 10
R407	ERDS2TJ102	1K 1/4	R846	ERDS2TJ182	1.8K 1/4	C33	ECEA25V330V	330 25
R408	ERDS2TJ102	1K 1/4	R847	ERDS2TJ821	820 1/4	C34	ECEA25V330V	330 25
R409	ERDS2TJ472	4.7K 1/4	R848	ERDS2TJ821	820 1/4	C37	ECEA1HK010	1 50
R410	ERDS2TJ472	4.7K 1/4	R849	ERDS2TJ182	1.8K 1/4	C38	ECEA1HK010	1 50
R411	ERDS2TJ472	4.7K 1/4	R850	ERDS2TJ182	1.8K 1/4	C39	ECEA50V330V	330 50
R412	ERDS2TJ472	4.7K 1/4	R851	ERDS2TJ101	100 1/4	C40	ECEA50V330V	330 50
R413	ERDS2TJ472	4.7K 1/4	R852	ERDS2TJ101	100 1/4	C43	ECEA1HK010	1 50
R414	ERDS2TJ472	4.7K 1/4	R853	ERDS2TJ471	470 1/4	C61	Δ ECFTD103KXL	0.01 25
R415	ERDS2TJ104	100K 1/4	R854	ERDS2TJ471	470 1/4	C62	Δ ECFTD103KXL	0.01 25
R416	ERDS2TJ221	220 1/4	R855	ERDS2TJ472	4.7K 1/4	C63	UKS1C222M1AA	0.0022 16
R417	ERDS2TJ221	220 1/4	R856	ERDS2TJ472	4.7K 1/4	C64	UKS1C222M1AA	0.0022 16
R418	ERDS2TJ221	220 1/4	R857	ERDS2TJ332	3.3K 1/4	C65	ECQM1H103JZ	0.01 50
R419	ERDS2TJ221	220 1/4	R858	ERDS2TJ332	3.3K 1/4	C66	ECQM1H103JZ	0.01 50
R420	ERDS2TJ221	220 1/4	R859	ER010TKD1202	12K 10	C67	ARA1A470MOT	47 10
R421	ERDS2TJ221	220 1/4	R860	ER010TKD1202	12K 10	C68	ARA1A470MOT	47 10
R422	ERDS2TJ221	220 1/4	R861	ER010TKD1202	12K 10	C69	REC1A101MOT	100 10
R423	ERDS2TJ221	220 1/4	R862	ER010TKD1202	12K 10	C70	REC1A101MOT	100 10
R424	ERDS2TJ472	4.7K 1/4	R863	ER010TKD1202	12K 10	C83	ECEA1AU101	100 10
R425	ERDS2TJ220	22 1/4	R864	ER010TKD1202	12K 10	C84	ECEA1AU101	100 10
R426	ERDS2TJ472	4.7K 1/4	R865	ER010TKD1202	12K 10	C86	ECCD1H120KC	12P 50
R501	ERDS2TJ224	220K 1/4	R866	ER010TKD1202	12K 10	C87	REC1C101MOT	100 16
R502	ERDS2TJ562	5.6K 1/4	R867	ERDS2TJ102	1K 1/4	C88	REC1C101MOT	100 16
R503	ERDS2TJ474	470K 1/4	R868	ERDS2TJ104	100K 1/4	C94	ECCD1H120KC	12P 50
R504	ERDS2TJ221	220 1/4	R869	ERDS2TJ101	100 1/4	C95	ECEA1CU331	330 16
R505	ERDS2TJ104	100K 1/4	R870	ERDS2TJ101	100 1/4	C101	ECQV1H104JZ	0.1 50
R506	ERDS2TJ333	33K 1/4	R871	ERDS2TJ103	10K 1/4	C102	ECKD1H102KB	0.001 50
R507	ERDS2TJ102	1K 1/4	R872	ERDS2TJ103	10K 1/4	C103	ECKD1H102KB	0.001 50
R601	ERDS2TJ472	4.7K 1/4	R873	ERDS2TJ123	12K 1/4	C104	ECKD1H681K	680P 50
R602	ERDS2TJ472	4.7K 1/4	R874	ERDS2TJ123	12K 1/4	C105	ECKD1H471KB	470P 50
R603	ERDS2TJ472	4.7K 1/4	R875	ERDS2TJ104	100K 1/4	C106	ECKD1H471KB	470P 50
R604	ERDS2TJ472	4.7K 1/4	R876	ERDS2TJ104	100K 1/4	C107	ECCD1H220K	22P 50
R605	ERDS2TJ472	4.7K 1/4	R877	ERDS2TJ330	33 1/4	C108	ECEA1HK0R1	0.1 50
R606	ERDS2TJ472	4.7K 1/4	R878	ERDS2TJ330	33 1/4	C109	ECEA1HK010	1 50
R607	ERDS2TJ472	4.7K 1/4	R879	ERDS2TJ332	3.3K 1/4	C110	ECQV1H104JZ	0.1 50
R608	ERDS2TJ472	4.7K 1/4	R880	ERDS2TJ332	3.3K 1/4	C111	ECEA1HK100	10 50
R609	ERDS2TJ472	4.7K 1/4	R881	ERDS2TJ100	10 1/4	C112	ECEA1CKS100	10 16
R610	ERDS2TJ472	4.7K 1/4	R882	ERDS2TJ100	10 1/4	C113	ECEA1HK010	1 50
R611	ERDS2TJ472	4.7K 1/4	R883	ERDS2TJ102	1K 1/4	C114	RCBS1C182MXY	0.0018 16
R612	ERDS2TJ472	4.7K 1/4	R884	ERDS2TJ102	1K 1/4	C115	ECKD1H682KB	0.0068 50
R613	ERDS2TJ472	4.7K 1/4	R885	ERDS2TJ222	2.2K 1/4	C116	ECQM1H333JZ	0.033 50
R614	ERDS2TJ472	4.7K 1/4	R886	ERDS2TJ222	2.2K 1/4	C117	RCBS1H221KBY	220P 50
R615	ERDS2TJ472	4.7K 1/4	R887	ERDS2TJ680	68 1/4	C118	ECEA1HK010	1 50
R616	ERDS2TJ472	4.7K 1/4	R888	ERDS2TJ680	68 1/4	C119	ECEA0JK220	22 6.3
R617	ERDS2TJ121	120 1/4	R889	ERDS2TJ470	47 1/4	C120	ECKD1H681K	680P 50
R618	ERDS2TJ121	120 1/4	R890	ERDS2TJ470	47 1/4	C121	ECFTD103KXL	0.01 25
R619	ERDS2TJ391	390 1/4	R891	ERDS2TJ332	3.3K 1/4	C122	ECBT1H101KB5	100P 50
R625	ERDS2TJ221	220 1/4	R892	ERDS2TJ332				

Tolerance	
J	: ±5%
F	: ±1%
G	: ±2%
K	: ±10%

Tolerance	
C	: ±0.25pF
J	: ±5%
K	: ±10%
Z	: +80%
	-20%
P	: +100%
	-0%
M	: ±20%
D	: ±0.5pF
G	: ±2%

Value.	
100	1/4
27	1/4
3.3	1/4
470K	1/4
470	1/4
560K	1/4
560K	1/4
22K	1/4
47K	1/4
47K	1/4
47K	1/4
5.6K	1/4
12K	1/4
150K	1/4
820K	1/4
100	1/4
68K	1/4
10K	1/4
10K	1/4
47K	1/4
47K	1/4
47K	1/4
120	1/4
1.5K	1/4
390	1/4
150	1/4
150	1/4
8.2K	1/4
100K	1/4
330K	1/4
33K	1/4
33K	1/4
10K	1/4
270K	1/4
12K	1/4
100	1/4
8.2	1/4
4.7K	1/4
4.7K	1/4
4.7K	1/4
4.7K	1/4

Ref. No.	Part No.	Value.	Ref. No.	Part No.	Value.	Ref. No.	Part No.	Value.	
R406	ERDS2TJ221	220 1/4	R845	ERDS2TJ182	1.8K 1/4	C32	ECEA1AU101	100 10	
R407	ERDS2TJ102	1K 1/4	R846	ERDS2TJ182	1.8K 1/4	C33	ECEA25V330V	330 25	
R408	ERDS2TJ102	1K 1/4	R847	ERDS2TJ821	820 1/4	C34	ECEA25V330V	330 25	
R409	ERDS2TJ472	4.7K 1/4	R848	ERDS2TJ821	820 1/4	C37	ECEA1HK010	1 50	
R410	ERDS2TJ472	4.7K 1/4	R849	ERDS2TJ182	1.8K 1/4	C38	ECEA1HK010	1 50	
R411	ERDS2TJ472	4.7K 1/4	R850	ERDS2TJ182	1.8K 1/4	C39	ECEA50V330V	330 50	
R412	ERDS2TJ472	4.7K 1/4	R851	ERDS2TJ101	100 1/4	C40	ECEA50V330V	330 50	
R413	ERDS2TJ472	4.7K 1/4	R852	ERDS2TJ101	100 1/4	C43	ECEA1HK010	1 50	
R414	ERDS2TJ472	4.7K 1/4	R853	ERDS2TJ471	470 1/4	C61	ECFTD103KXL	0.01 25	
R415	ERDS2TJ104	100K 1/4	R854	ERDS2TJ471	470 1/4	C62	ECFTD103KXL	0.01 25	
R416	ERDS2TJ221	220 1/4	R855	ERDS2TJ472	4.7K 1/4	C63	UKS1C222M1AA	0.0022 16	
R417	ERDS2TJ221	220 1/4	R856	ERDS2TJ472	4.7K 1/4	C64	UKS1C222M1AA	0.0022 16	
R418	ERDS2TJ221	220 1/4	R857	ERDS2TJ332	3.3K 1/4	C65	ECQM1H103JZ	0.01 50	
R419	ERDS2TJ221	220 1/4	R858	ERDS2TJ332	3.3K 1/4	C66	ECQM1H103JZ	0.01 50	
R420	ERDS2TJ221	220 1/4	R859	ER010TKD1202	12K 10	C67	ARATA470MOT	47 10	
R421	ERDS2TJ221	220 1/4	R860	ER010TKD1202	12K 10	C68	ARATA470MOT	47 10	
R422	ERDS2TJ221	220 1/4	R861	ER010TKD1202	12K 10	C69	REC1A101MOT	100 10	
R423	ERDS2TJ221	220 1/4	R862	ER010TKD1202	12K 10	C70	REC1A101MOT	100 10	
R424	ERDS2TJ472	4.7K 1/4	R863	ER010TKD1202	12K 10	C83	ECEA1AU101	100 10	
R425	ERDS2TJ220	22 1/4	R864	ER010TKD1202	12K 10	C84	ECEA1AU101	100 10	
R426	ERDS2TJ472	4.7K 1/4	R865	ER010TKD1202	12K 10	C86	ECCD1H120KC	12P 50	
R501	ERDS2TJ224	220K 1/4	R866	ER010TKD1202	12K 10	C87	REC1C101MOT	100 16	
R502	ERDS2TJ562	5.6K 1/4	R867	ERDS2TJ102	1K 1/4	C88	REC1C101MOT	100 16	
R503	ERDS2TJ474	470K 1/4	R868	ERDS2TJ104	100K 1/4	C94	ECCD1H120KC	12P 50	
R504	ERDS2TJ221	220 1/4	R869	ERDS2TJ101	100 1/4	C95	ECEA1CU331	330 16	
R505	ERDS2TJ104	100K 1/4	R870	ERDS2TJ101	100 1/4	C101	ECQV1H104JZ	0.1 50	
R506	ERDS2TJ333	33K 1/4	R871	ERDS2TJ103	10K 1/4	C102	ECKD1H102KB	0.001 50	
R507	ERDS2TJ102	1K 1/4	R872	ERDS2TJ103	10K 1/4	C103	ECKD1H102KB	0.001 50	
R601	ERDS2TJ472	4.7K 1/4	R873	ERDS2TJ123	12K 1/4	C104	ECKD1H681K	680P 50	
R602	ERDS2TJ472	4.7K 1/4	R874	ERDS2TJ123	12K 1/4	C105	ECKD1H471KB	470P 50	
R603	ERDS2TJ472	4.7K 1/4	R875	ERDS2TJ104	100K 1/4	C106	ECKD1H471KB	470P 50	
R604	ERDS2TJ472	4.7K 1/4	R876	ERDS2TJ104	100K 1/4	C107	ECCD1H220K	22P 50	
R605	ERDS2TJ472	4.7K 1/4	R877	ERDS2TJ330	33 1/4	C108	ECEA1HK0R1	0.1 50	
R606	ERDS2TJ472	4.7K 1/4	R878	ERDS2TJ330	33 1/4	C109	ECEA1HK010	1 50	
R607	ERDS2TJ472	4.7K 1/4	R879	ERDS2TJ332	3.3K 1/4	C110	ECQV1H104JZ	0.1 50	
R608	ERDS2TJ472	4.7K 1/4	R880	ERDS2TJ332	3.3K 1/4	C111	ECEA1HK100	10 50	
R609	ERDS2TJ472	4.7K 1/4	R881	ERDS2TJ100	10 1/4	C112	ECEA1CKS100	10 16	
R610	ERDS2TJ472	4.7K 1/4	R882	ERDS2TJ100	10 1/4	C113	ECEA1HK010	1 50	
R611	ERDS2TJ472	4.7K 1/4	R883	ERDS2TJ102	1K 1/4	C114	RCBS1C182MXY	0.0018 16	
R612	ERDS2TJ472	4.7K 1/4	R884	ERDS2TJ102	1K 1/4	C115	ECKD1H682KB	0.0068 50	
R613	ERDS2TJ472	4.7K 1/4	R885	ERDS2TJ222	2.2K 1/4	C116	ECQM1H333JZ	0.033 50	
R614	ERDS2TJ472	4.7K 1/4	R886	ERDS2TJ222	2.2K 1/4	C117	RCBS1H221KBY	220P 50	
R615	ERDS2TJ472	4.7K 1/4	R887	ERDS2TJ680	68 1/4	C118	ECEA1HK010	1 50	
R616	ERDS2TJ472	4.7K 1/4	R888	ERDS2TJ680	68 1/4	C119	ECEA0JK220	22 6.3	
R617	ERDS2TJ121	120 1/4	R889	ERDS2TJ470	47 1/4	C120	ECKD1H681K	680P 50	
R618	ERDS2TJ121	120 1/4	R890	ERDS2TJ470	47 1/4	C121	ECFTD103KXL	0.01 25	
R619	ERDS2TJ391	390 1/4	R891	ERDS2TJ332	3.3K 1/4	C122	ECBT1H101KB5	100P 50	
R625	ERDS2TJ221	220 1/4	R892	ERDS2TJ332	3.3K 1/4	C123	ECBT1H101KB	100P 50	
R626	ERDS2TJ105	1M 1/4	R893	ERDS2TJ332	3.3K 1/4	C124	ECKD1H222KB	0.0022 50	
R817	FSR25TG472	4.7 1/4	R894	ERDS2TJ332	3.3K 1/4	C125	ECEA0JK470	47 6.3	
R818	FSR25TG472	4.7 1/4	R895	ERDS2TJ104	100K 1/4	C126	ECEA0JK470	47 6.3	
R819	FSR25TG472	4.7 1/4	R896	ERDS2TJ104	100K 1/4	C127	ECKD1H102KB	0.001 50	
R820	FSR25TG472	4.7 1/4	R897	ERDS2TJ222	2.2K 1/4	C128	ECKD1H102KB	0.001 50	
R821	FSR25TG472	4.7 1/4	R898	ERDS2TJ222	2.2K 1/4	C129	ECKD1H681K	680P 50	
R822	FSR25TG472	4.7 1/4	R899	ERDS2TJ102	1K 1/4	C131	ECEA0JK221	220 6.3	
R823	FSR25TG682	6.8 1/4	R900	ERDS2TJ102	1K 1/4	C141	ECQM1H153JZ	0.015 50	
R824	FSR25TG682	6.8 1/4	R901	ERDS2TJ103	10K 1/4	C142	ECQM1H122JZ	0.0012 50	
R825	FSR25TG332	3.3K 1/4	R1002	ERDS2TKG1003	100K 1/4	C143	ECQM1H473JZ	0.047 50	
R826	FSR25TG332	3.3K 1/4	R1003	ERDS2TKG1003	100K 1/4	C144	ECEA1HKNR22	2.2 50	
R827	ERDS2TJ100	10 1/4	R1004	ERDS2TKG1003	100K 1/4	C145	ECEA1HKNR22	0.22 50	
R828	ERDS2TJ100	10 1/4	CAPACITORS(VALUE,VOLTAGE)						
R829	ERDS2TJ330	33 1/4	C1	△	ECKDKC103PF2	0.01 125	C161	ECQM1H153JZ	0.015 50
R830	ERDS2TJ330	33 1/4	C11	△	ECFTD103KXL	0.01 25	C162	ECKD1H681K	680P 50
R831	ERDS2TJ102	1K 1/4	C12	△	ECFTD103KXL	0.01 25	C163	ECQM1H103JZ	0.01 50
R832	ERDS2TJ102	1K 1/4	C14		ECFF1E104ZF	0.1 25	C164	ECEA1HKNR3R	3.3 50
R833	ERDS2TJ103	10K 1/4	C15		ECEA1CU332	3300 16	C165	ECEA1HKNR01	0.1 50
R834	ERDS2TJ103	10K 1/4	C16		ECEA1CU332	3300 16	C168	ECEA1CKN100	10 16
R835	ERDS2TJ392	3.9K 1/4	C17		ECEA1CU470	47 16	C169	RCBS1C103MYY	0.01 16
R836	ERDS2TJ392	3.9K 1/4	C18		ECEA1CU470	47 16	C181	ECQM1H474JZ	0.47 50
R837	ER010TKD1202	12K 10	C19		ECEA0JS331	330 6.3	C182	RCBS1H221KBY	220P 50
R838	ER010TKD1202	12K 10	C20		ECEA0JS331	330 6.3	C183	ECQM1H682JZ	0.0068 50
R839	ERDS2TJ823	82K 1/4	C21		ECFF1E104ZF	0.1 25	C184	ECEA1HKNR010	1 50
R840	ERDS2TJ823	82K 1/4	C22		ECFF1E104ZF	0.1 25	C186	ECQM1H224JZ	0.22 50
R841	ERDS2TJ103	10K 1/4	C27		ECKD1H102KB	0.001 50	C187	ECEA1HKNR47	0.47 50
R842	ERDS2TJ103	10K 1/4	C28		ECKD1H102KB	0.001 50	C301	ECFF1E104ZF	0.1 25
R843	ERDS2TJ824	820K 1/4	C31		ECEA1AU101	100 10	C302	ECFF1E104ZF	0.1 25
R844	ERDS2TJ824	820K 1/4					C303	ECEA0JK470	47 6.3
							C304	ECFF1E104ZF	0.1 25

Ref. No.	Part No.	Value.	Ref. No.	Part No.	Value.	Ref. No.	Part No.	Value.
C305	ECFF1E104ZF	0.1 25	C510	ECQM1H104JZ	0.1 50	C815	ECQP1122JZ	0.0012 100
C306	ECFF1E104ZF	0.1 25	C511	ECEA1HUR47	0.47 50	C816	ECQP1122JZ	0.0012 100
C307	ECCD1H220K	22P 50	C512	ECKD1H681K	680P 50	C817	ARAIAN330MOT	330 10
C308	ECCD1H700CC	7P 50	C513	ECKD1H681K	680P 50	C818	ARAIAN330MOT	330 10
C309	ECFF1E104ZF	0.1 25	C514	ECQM1H154JZ	0.15 50	C819	ECQP1102JZ	0.001 100
C310	ECFF1E104ZF	0.1 25	C515	ECQM1H153JZ	0.015 50	C820	ECQP1102JZ	0.001 100
C311	ECFTD103KXL	0.01 25	C516	ECEA1HKNR22	2.2 50	C821	ECKD1H272KB	0.0027 50
C312	ECFF1E104ZF	0.1 25	C517	ECKD1H471KB	470P 50	C822	ECKD1H272KB	0.0027 50
C313	ECFF1E104ZF	0.1 25	C518	ECKD1H472KB	0.0047 50	C823	ARAI470MOT	47 10
C314	ECFF1E104ZF	0.1 25	C601	RCBS1C103MYY	0.01 16	C824	ARAI470MOT	47 10
C351	ECKD1H102KB	0.001 50	C602	ECEA1HKS100	10 50	C825	ARAI470MOT	47 10
C352	ECKD1H102KB	0.001 50	C606	ECFF1E104ZF	0.1 25	C826	ARAI470MOT	47 10
C353	ECKD1H102KB	0.001 50	C801	REC1A101MOT	100 10	C827	ECFTD103KXL	0.01 25
C401	ECFF1E104ZF	0.1 25	C802	REC1A101MOT	100 10	C828	ECFTD103KXL	0.01 25
C402	ECEA0JK470	47 6.3	C803	REC1A101MOT	100 10	C829	ECKD1H102KB	0.001 50
C403	ECFF1E104ZF	0.1 25	C804	REC1A101MOT	100 10	C831	REC0J470MOT	470 6.3
C405	ECFF1E104ZF	0.1 25	C805	ECQP2A271J	270P 100	C832	REC0J470MOT	470 6.3
C501	ECQM1H104JZ	0.1 50	C806	ECQP2A271J	270P 100	C835	ECFTD103KXL	0.01 25
C502	ECQP2A271J	270P 100	C807	ECQP2A271J	270P 100	C836	ECFTD103KXL	0.01 25
C503	ECEA1CKS100	10 16	C808	ECQP2A271J	270P 100	C837	ECEA0JK220	22 6.3
C504	ECFF1E104ZF	0.1 25	C809	ECQP2A392J	0.0039 100	C871	ARAIEN3R3M0	3.3 25
C505	ECQP2A392J	0.0039 100	C810	ARAIEN3R3M0	0.0039 100	C872	ARAIEN3R3M0	3.3 25
C506	ECCD1H150KC	15P 50	C811	ECQP1271JZ	270P 100	C873	ECQM1H103KF	0.01 50
C507	ECKD1H102KB	0.001 50	C812	ECQP1271JZ	270P 100	C874	ECQM1H103KF	0.01 50
C508	ECEA1CKN100	10 16	C813	ECQP1103JZ	0.01 100	C875	ARAI470MOT	47 10
C509	ECCD1H100KC	10P 50	C814	ECQP1103JZ	0.01 100			

■ BLOCK DIAGRAM

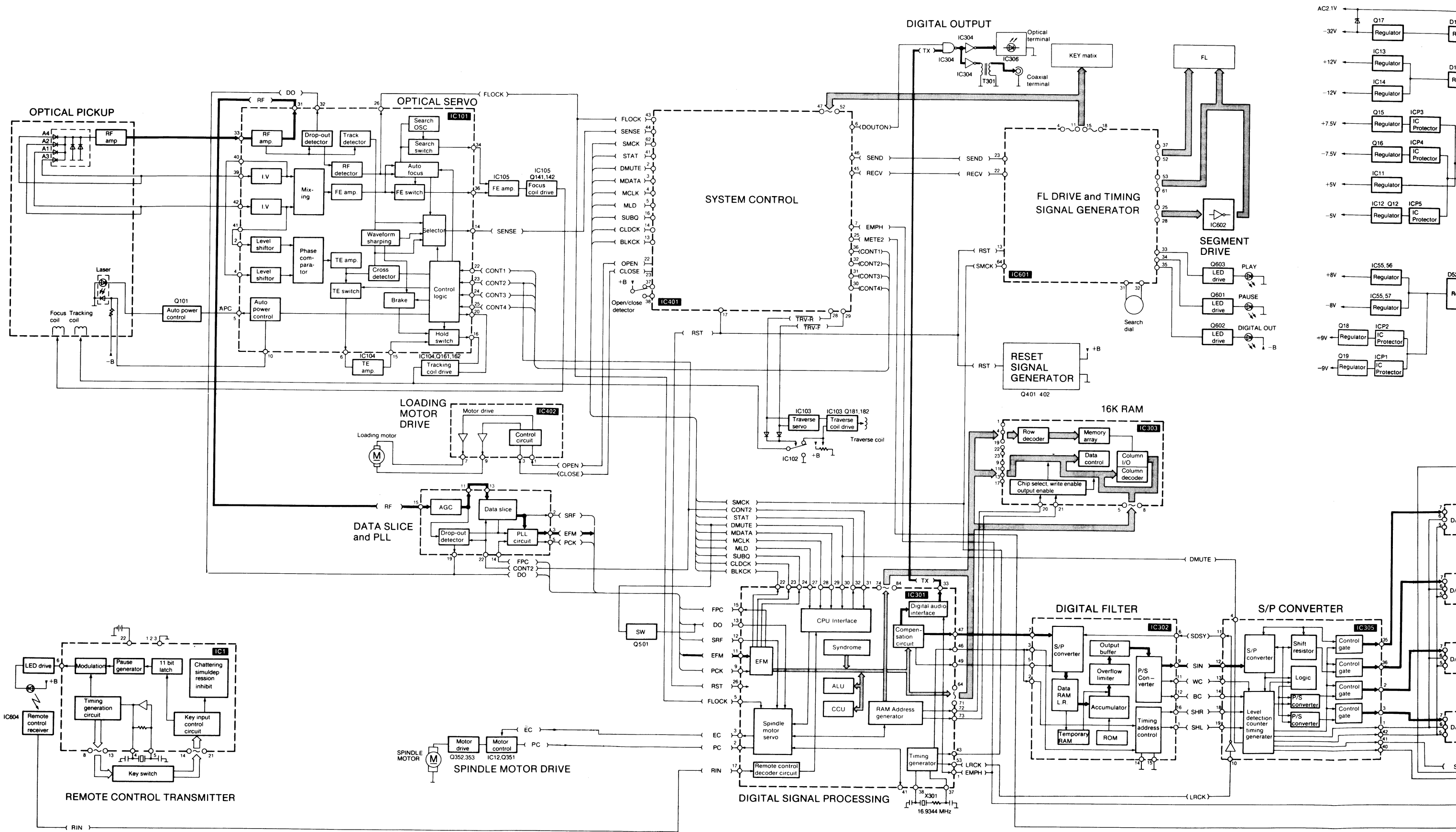

■ TERMINAL FUNCTION OF LSI

● MN6622 (Digital Signal Processing: EFM Decoder, Error Correction, CLV Servo)

Pin No.	Mark	I/O	Function	Pin No.	Mark	I/O	Function
1	MEMP	I	Emphasis signal input	34	TSTR	I	Not used (connected to +5V)
2	PC	O	Spindle motor "ON" signal(ON at "L")	35	TEST	I	Not used (connected to +5V)
3	EC	O	Spindle motor drive signal	36	VSS	I	GND terminal
4	FG	I	Not connected	37	X2	O	Clock output (16.9344MHz)
5	TTF	I	Spindle motor free run	38	X1	I	Clock input (16.9344MHz)
6	FLAG0	O	Not connected	39	SEL	I	Not used (connected to GND)
7	IPFLAG	O	Not connected	40	LDG/ WDCKS	O	Degitch signal at Lch/ word clock for serial DAC
8	FLAG6	O	Not connected	41	RDG	O	Not connected
9	PCK	I	PLL extract clock input(4.2336MHz)	42	DEMPH	O	Not connected
10	VDD	I	Power supply (connected to +5V)	43	SMCK	O	Clock output (4.2336MHz)
11	EFM	I	EFM signal input (PLL)	44	WS	O	Not connected
12	SRF	I	EFM signal input (DSL)	45	SRCK	O	Not connected
13	DO	I	Drop-out signal ("H" at drop-out)	46	XCK	O	Clock output (16.9344MHz)
14	CLVS	O	Not connected	47	DA15/ SRDATA	O	DA parallel output(MSB)/ Serial data output(MSB FIRST)
15	EPC	O	PLL frequency comparison signal	48	DA14/ SRDATA	O	Not connected
16	BSSEL	O	Not connected	49	DA13/ SCK	O	DA Parallel output/ serial data output bit clock
17	RIN	I	Remote control signal input	50	DA12/ WDCK	O	Not connected
18	FSL	I	Not used (connected to GND)	51	DA11/ BYTCK	O	Not connected
19	SLEEP	I	Not used (connected to GND)	52	VSS	I	GND terminal
20	SUBC	O	Not connected	53	DA10/R/L	O	DA parallel output/ R/L signal (R at "H")
21	SBCK	I	Not connected	54	DA9	O	Not connected
22	BLKCK	O	Sub-code block(Q-data) clock (75Hz)	56	DA7	O	Not connected
23	CLDCK	O	Sub-code frame(Q-data) clock (7.35kHz)	57	DA6	O	Not used (connected to GND)
24	SUBQ	O	Sub-code(Q-data) output	58	DA5	O	Not connected
25	CRC	O	Not connected	63	DA0	O	Not connected
26	RST	O	Reset signal input ("L" = Reset)	64	D7	I/O	16K RAM DATA
27	MLD	I	Data input (command load)	71	D0	I/O	16K RAM DATA
28	MCLK	I	Data clock input (command clock)	72	RAMOE	O	16K RAM OE signal
29	MDATA	I	Data input (command data)	73	RAMWE	O	16K RAM WE signal
30	DMUTE	I	Muting control (Not used, connected to GND)	74	RAMA0	O	16K RAM address
31	TRON	I	Tracking servo "ON" signal (ON at "L")	84	RAMA10	O	16K RAM address
32	STAT	O	Processing condition (CRC,OTC,CLVOK,TT,STOP) output				
33	TX	O	Digital output signal				

● MN53010PEH (Serial/Parallel converter)

Pin No.	Mark	I/O	Function
1	WCO	O	Output data word clock (DALO,DBLO,DARO,DBRO)
2	DARO	O	Rch data output, (+)terminal
3	DBRO	O	Rch data output, (-)terminal
4	RST	O	Reset output data to "0"
5	VDD	I	Power supply (connected to +5V)
6	VSS	I	GND terminal
7	F2DAC	I	"H": 2DAC 18-bit "L": 2DAC 17-bit
8	FLOAT	I	"H": 4DAC 18-bit "L": 4DAC 17-bit
9	PHASE	I	"H": Phase inversion "L": Normal mode
10	LRCK	I	Inverter input
11	LRCK	O	LRCK signal inverter output
12	SIN	I	Data input
13	WCI	I	Input data word clock
14	BCI	I	Input data bit clock
15	VSS	I	GND terminal
16	NC	---	Not connected
17	VDD	I	Power supply (connected to +5V)
18	SHR	I	Rch Deglitcher signal

Pin No.	Mark	I/O	Function
18	SHR	I	Rch Deglitcher signal
19	SHL	I	Lch Deglitcher signal
20	NC	---	Not connected
31			
			NORMAL MODE delay: 180ms
			TEST MODE delay: 1.45ms
			TEST MODE delay: 0.73ms
			TEST MODE delay: 0ms
32	NTEST1	I	H L H L
33	NTEST2	I	H H L L
34	NTEST3	I	"H": Normal mode "L": Reset
35	DALO	O	Lch data output, (+)terminal
36	DBLO	O	Rch data output, (-)terminal
37	VDD	I	Power supply (connected to +5V)
38	VSS	I	GND terminal
39	NC	---	Not connected
40	GAIN	O	Gain selector signal H: 0~-12dB L: below -12dB
41	SH	O	Deglitch signal H: Sample L: Hold
42	BCO	O	Output data bit clock

● AN8371S (Data slice and PLL)

Pin No.	Mark	I/O	Function
1	VEE	I	Power supply (connected to -5V)
2	SRF	O	RF signal output data-sliced into digital value
3	EFM	O	EFM signal output synchronized with PCK
4	D.GND	I	GND terminal (digital system)
5	PCK	O	Clock output extracted from SRF
6	VCC	I	Power supply (connected to +5V)
7	VA	I	VCO free run frequency adjusting current input (not connected)
8	VC1	I	Capacitor connection for VCO oscillator frequency
9	VC2	I	Capacitor connection for VCO oscillator frequency
10	VR	I	Resistor connection for VCO oscillator frequency
11	PD	I	Capacitor connection for PLL DO protection
12	PL1	I	PLL loop filter connection

Pin No.	Mark	I/O	Function
13	PL2	I	PLL loop filter connection
14	FPC	I	Frequency comparison error signal input
15	RF	I	RF signal input
16	ARF	O	RF signal output with AGC output
17	AGC	I	ARF signal input for AGF drop-out detection input
18	AC	I	Loop filter for AGC connection
19	DO	O	Drop-out detection pulse output
20	A.GND	I	GND terminal (analog system)
21	DSL	I	RF signal input for data slicing
22	SLC	I	Slicing level control signal input
23	FC1	I	Filter capacitor for data slice connected
24	FC2	I	Filter capacitor for data slice connected

● AN8370S (Optical Servo Control)

Pin No.	Mark	I/O	Function
1	VEE	I	Power supply (connected to -5V)
2	LSA	I	Phase difference input (A)
3	GND	I	GND terminal
4	LSB	I	Phase difference input (B)
5	APC	O	Auto laser power control output
6	TEOUT	O	Tracking error signal output
7	TEG	I	Tracking error gain adjusting input
8	TE(+)	I	Phase difference to voltage conversion (+)
9	TE(-)	I	Phase difference to voltage conversion (-)
10	APC(-)	I	Laser power inversion input
11	C.MEM	I	Capacitor connection for phase difference memory
12	APC(+)	I	Laser power non inversion input
13	VREFE	O	Reference current generation
14	SENSE	O	Selector output (track-crossed)
15	HIN	I	Tracking hold circuit input
16	HOUT	O	Tracking hold circuit output
17	SPCNT	O	Trackcrossing speed control output (not used, (Not connected))
18	C.MSP	I	Trackcrossing reference speed setting capacitor connection (Not connected)
19	C.AF	I	Auto focus timer capacitor connection
20	KICK	O	Track kick signal output
21	VCC	I	Power supply (connected to +5V)
22	CNT1	I	Control input (FOON Focus servo "ON" signal)

Pin No.	Mark	I/O	Function
23	CNT2	I	Control input (TRON Tracking servo ON signal)
24	CNT3	I	Control input (KICKF Kick direction [Forward] command)
25	CNT4	I	Control input (KICKR Kick direction [Reverse] command)
26	F.LOCK	O	Focus lock signal output
27	C.FBDO	O	Capacitor connection for inversion RF high detection
28	C.SBDO	O	Capacitor connection for inversion RF low detection
29	C.SBRT	O	Capacitor connection for non-inversion RF slow detection
30	C.FBRT	O	Capacitor connection for non-inversion RF fast detection
31	RF OUT	O	RF signal output
32	BDO	O	Drop-out detection output
33	RF IN	I	RF signal input
34	S.OUT	O	Focus search signal output
35	C.LW	I	Capacitor connection for triangular wave generation
36	FE.OUT	O	Focus error signal output
37	FEG	I	Focus error gain adjusting input
38	FE.REF	I	Focus error comparison voltage generation
39	PDB	I	Photo detection current input (B)
40	IVB	O	Current/ voltage conversion (B)
41	IVA	O	Current/ voltage conversion (A)
42	PDA	I	Photo detection current input (A)

● YM3404 (Digital filter)

Pin No.	Mark	I/O	Function
1	SHL	O	1DAC(ST="L"): Lch Deglitcher signal 2DAC(ST="H"): L/Rch Deglitcher signal
2	X0	O	Clock output
3	X1	I	Clock input
4	VDD2	I	Power supply (connected to +5V)
5	BCI	I	Bit clock input (input data)
6	SDSY	I	R/L signal
7	SDI	I	Data input
8	VCC1	I	Power supply (connected to +5V)

Pin No.	Mark	I/O	Function
9	DLO	O	1DAC(ST="L"): L/Rch data output terminal 2DAC(ST="H"): Lch data output terminal
10	RDO	O	Rch data output (not connected)
11	WCO	O	Output data word clock
12	BCO	O	Bit clock output (output data)
13	VSS	I	GND terminal
14	ST	I	1DAC/2DAC selector terminal
15	FEN	I	System clock selector terminal
16	SHR	O	1DAC(SP="L"): Rch deglitch signal

● MN1554PEF (System Control)

Pin No.	Mark	I/O	Function
1	GND	I	GND terminal
2	DMUTE	O	Muting control
3	MDATA	O	Command data output
4	MCLK	O	Data clock output (command clock)
5	MLD	O	Data output (command load)
6	DOUTION	O	Optical output control signal
7	EMPH	O	Emphasis signal output
8	P11	I	Not connected
9	P12	I	Not connected
10	P13	I	Not connected
11	SYNC	O	Not connected
12	SIRQ	I	Not used (connected to +5V)
13	BLKCK	I	Sub-code block(Q data) clock input (75Hz)
14	CLDCK	I	Sub-code block(Q data) clock input (7.35KHz)
15	SBO	I	Not connected
16	SUBQ	I	Sub-code(Q data) input
17	RST	I	Reset signal input
18	P20	O	Not used (connected to +5V)
19	P21	O	Not used (connected to +5V)
20	P22	O	Not used (connected to +5V)
21	P23	O	Not used (connected to +5V)
22	CLOSE	O	Loading motor "Close" command
23	OPEN	O	Loading motor "Open" command
24	P32	O	Not connected
25	MUTE2	O	Muting control
26	SEEK	O	Traverse servo control
27	P41	O	Not connected
28	TRV.R	O	Traverse "Reverse" command signal
29	TRV.F	O	Traverse "Forward" command signal
30	CNT4	O	Optical servo IC control signal (KICKR: Kick direction [reverse] command)
31	CNT3	O	Optical servo IC control signal (KICKF: Kick direction [forward] command)
32	CNT2	O	Optical servo IC control (TRON: Tracking servo)

Pin No.	Mark	I/O	Function
33	VDD	I	Power supply (connected to +5V)
34	VR.R	O	Not connected
35	VR.F	O	Not connected
36	CNT1	O	Optical servo IC control signal (FOON: Focus servo)
37	P60	I	Disc holder "Open/close" detection
38	P61	I	Disc holder "Open/close" detection
39	P62	I	Not used (connected to GND)
40	P63	I	Not used (connected to GND)
41	STAT	I	Processing status input from signal processing LSI
42	COMP	O	TOC reading control (ON at "L")
43	FLOCK	I	Optical servo condition(focus) input
44	SENSE	I	Optical servo condition(track cross) input
45	RECK	I	Data receipt command signal
46	SEND	I	Data transmission command
47	ACK	I	Data discrimination signal
48	CLK	I	Data lock signal
49	D0	I	Key scan
50	D1	I	Key scan
51	D2	I	Key scan
52	D3	I	Key scan
53	PA0	I	
54	PA1	I	Not connected
55	PA2	I	
56	PA3	I	Not connected
57	PB0	I	Not connected
58	PB1	I	Key scan
59	PB2	I	Key scan
60	PB3	I	Key scan
61	OSC2	I	Clock terminal
62	OSC1	I	Clock input
63	X1	I	Optical servo condition input
64	X0	O	Not connected

● MN15283PEE (FL Drive and Timing Signal Generator)

Pin No.	Mark	I/O	Function
1	VSS	I	GND terminal
2	XO	---	Not connected
3	X1	I	Not used (connected to GND)
4	D0	I	Key scan input
7	D3		
8	11	I	Key scan input
11	13		
12	SYNC	---	Not connected
13	RST	I	Reset signal input
14	IRO	---	Not connected
15	50	I	Key scan input
18	53		
19	SBT	---	Not connected
20	SDD	---	Not connected
21	20	I	Key scan input
22	RECV	O	Receiving data command signal
23	SEND	O	Receiving data command signal
24	P23	---	Not connected

Pin No.	Mark	I/O	Function
25	P30	O	FL anode signal
28	P33		
29	P40	I	Key scan input
30	P41	I	Key scan input
31	P42	I	Not connected
32	P43	I	Not connected
33	PLAY	O	"Play" indicator LED drive signal
34	PAUSE	O	"Pause" indicator LED drive
35	DIGITAL OUT	O	Digital output indicator LED drive
36	VPP	I	Connected to -32V
37	D0	O	FL grid signal
52	DF		
53	S8	O	FL anode signal
61	S0		
62	VDD	I	Connected to +5V
63	OSC2	I	Clock terminal
64	OSC1	I	Clock input

INTERNAL CONNECTION OF FL

Grid connection diagram

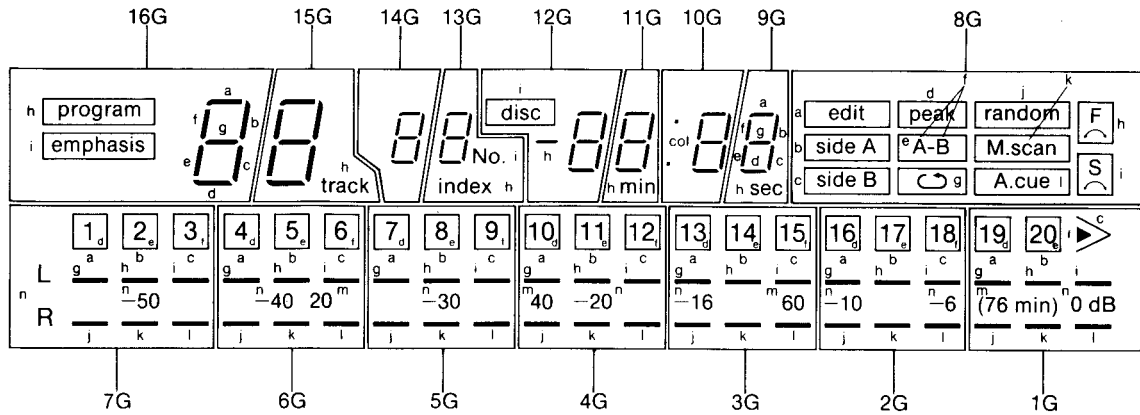

Anode connection table

	16G	15G	14G	13G	12G	11G	10G	9G	8G	7G	6G	5G	4G	3G	2G	1G			
a	a	a	a	a	a	a	a	a	edit	1	4	7	10	13	16	19			
b	b	b	b	b	b	b	b	b	side A	2	5	8	11	14	17	20			
c	c	c	c	c	c	c	c	c	side B	3	6	9	12	15	18	>			
d	d	d	d	d	d	d	d	d	peak	1	4	7	10	13	16	19			
e	e	e	e	e	e	e	e	e	A-	2	5	8	11	14	17	20			
f	f	f	f	f	f	f	f	f	B	3	6	9	12	15	18	▶			
g	g	g	g	g	g	g	g	g	↻	1	4	7	10	13	16	19			
h	program	track	-	index	-	min	col	sec	F	2	5	8	11	14	17	20			
i	emphasis	-	-	No.	disc	-	-	-	S	3	6	9	12	15	18	21			
j	-	-	-	-	-	-	-	-	random	22	25	28	31	34	37	40			
k	-	-	-	-	-	-	-	-	M.scan	23	26	29	32	35	38	41			
l	-	-	-	-	-	-	-	-	A.cue	24	27	30	33	36	39	42			
m	-	-	-	-	-	-	-	-	-	-	20	-	40	60	-	76 min			
n	-	-	-	-	-	-	-	-	-	L	R	-50	-40	-30	-20	-16	-10	-6	0 dB

Compact Disc Player

SL-P770

DEUTSCH

ELEKTRISCHE JUSTIERUNG

Meßinstrumente und Spezialwerkzeuge

- Servo-Verstärkungs-Justierer (SZZP1017F)
- Testplatten
 Testplatte (SZZP1014F) alter oder neuer Typ
 Inspektions-Testplatte (SZZP1054C)
 Ungleichmäßige Platte (SZZP1056C)
 Schwarzbandplatte (SZZP1057C)
- Gewöhnliche Platte
- Zweikanal-Oszilloskop (mit Trigger) von 30 MHz oder mehr
- Niederfrequenz-Oszillator
- Zwischenstecker (SZZP1032F)
- Filter

Justierverfahren

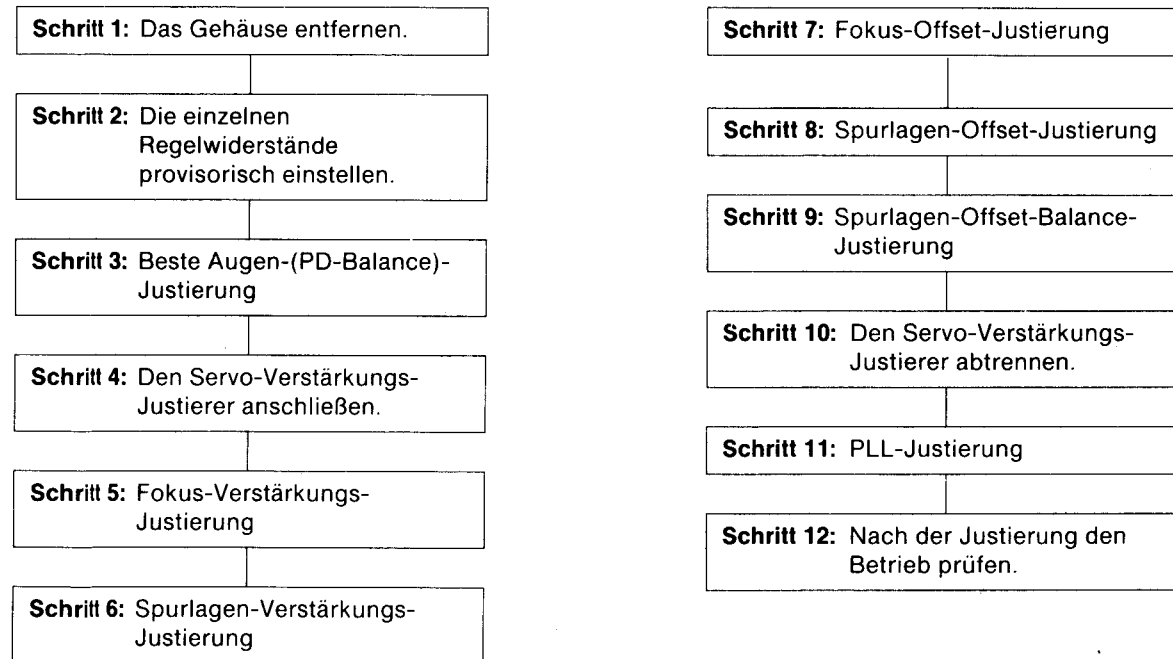

PROVISORISCHE JUSTIERUNG DER EINZELNEN REGELWIDERSTÄNDE

Hinweis:
 Wenn bei einer Platte Überspringungen auftreten oder Wiedergabe nicht möglich ist, die einzelnen Regelwiderstände wie abgebildet provisorisch einstellen.

BESTE AUGEN-(PD-BALANCE)-JUSTIERUNG

1. Kanal 1 des Oszilloskops an **TJ301 (+)** und **TJ302 (-)** der Hauptplatine anschließen.
Oszilloskop-Einstellung:
 VOLT 200 mV
 KIPP 0,5 μ sec.
 EINGANG Wechselstrom
2. Den Netzschalter des Spielers einschalten und eine Testplatte (SZZP1014F oder SZZP1054C) einsetzen.
3. Den Spieler auf Wiedergabe schalten.
4. **VR101** so justieren, daß das Augenmuster des HF-Signals maximal gestreckt ist.
5. Den Netzschalter des Spielers ausschalten.

FOKUS-VERSTÄRKUNGS-JUSTIERUNG

1. Den Servo-Verstärkungs-Justierer anschließen.
2. Den Wahlschalter des Servo-Verstärkungs-Justierers auf **2** und den ON-OFF-Schalter auf **ON** stellen.
3. Den Niederfrequenz-Oszillator auf eine Frequenz von **750 Hz** und eine Ausgangsspannung von **100 mVs-s** einstellen. Dann den Oszillator an **OSC (+)** und **GND (-)** des Servo-Verstärkungs-Justierers anschließen.
4. Kanal 1 und Kanal 2 des Oszilloskops an **TP1** und **TP2** des Servo-Verstärkungs-Justierers anschließen. (**TP3** ist die Masseklemme.)
5. Den Netzschalter des Spielers einschalten und eine Testplatte (SZZP1014F oder SZZP1054C) einsetzen.
6. Den Spieler auf Wiedergabe schalten.
7. Den Wahlschalter des Servo-Verstärkungs-Justierers von **"2"** auf **"3"** stellen.
8. Auf dem Oszilloskop werden **750 Hz**-Signale angezeigt. **VR104** justieren, bis die Wellenform-Amplituden beider Kanäle identisch sind.
9. Den Wahlschalter des Servo-Verstärkungs-Justierers von **"3"** auf **"2"** stellen.

Oszilloskop-Einstellung:

VOLT 200 mV (beide Kanäle)
 KIPP 1 msec.
 EINGANG Gleichstrom

SPURLAGEN-VERSTÄRKUNGS-JUSTIERUNG

1. Die Oszilloskop-Einstellung und der Anschluß sind die gleichen wie oben.
2. Den Niederfrequenz-Oszillator auf eine Frequenz von **1,0 kHz** und eine Ausgangsspannung von **100 mVs-s** stellen.
3. Den Wahlschalter des Servo-Verstärkungs-Justierers von **"2"** auf **"1"** stellen.
4. Auf dem Oszilloskop werden **1,0 kHz**-Signale angezeigt. **VR102** justieren, bis die Wellenform-Amplituden beider Kanäle identisch sind.
5. Den Wahlschalter des Servo-Verstärkungs-Justierers von **"1"** auf **"2"** stellen.
6. Den Netzschalter des Spielers ausschalten.

FOKUS-OFFSET-JUSTIERUNG

1. Kanal 1 des Oszilloskops an **TJ301 (+)** und **TJ302 (-)** der Hauptplatine anschließen. Kanal 2 des Oszilloskops an **TJ102 (+)** und **TJ302 (-)** der Hauptplatine anschließen.
2. Den Netzschalter des Spielers einschalten und die Testplatte (SZZP1057C) einsetzen.
3. Den Spieler auf Wiedergabe schalten.
4. Die Wellenform von Kanal 1 und Kanal 2 auf dem Oszilloskop prüfen und **VR105** so justieren, daß die Wellenform um den Triggerpunkt so wie in der Abbildung wird.

Oszilloskop-Einstellung:

VOLT 200 mV (beide Kanäle)
 KIPP 0,5 msec.
 EINGANG Wechselstrom (Kanal 1),
 Gleichstrom (Kanal 2)
 BETRIEBSART ... NORM
 (Schaltgriff auf Kanal 1)

SPURLAGEN-OFFSET-JUSTIERUNG

1. Kanal 1 des Oszilloskops an **TJ301 (+)** und **TJ302 (-)** der Hauptplatine anschließen. Kanal 2 des Oszilloskops an **TJ101 (+)** und **TJ302 (-)** der Hauptplatine anschließen.
2. Den Netzschalter des Spielers einschalten und die Testplatte (SZZP1057C) einsetzen.
3. Den Spieler auf Wiedergabe schalten.
4. Die Wellenform von Kanal 1 und Kanal 2 auf dem Oszilloskop prüfen und **VR103** so justieren, daß die Wellenform um den Triggerpunkt so wie in der Abbildung wird.

Oszilloskop-Einstellung:

VOLT 200 mV (beide Kanäle)
 KIPP 0,5 msec.
 EINGANG Wechselstrom (Kanal 1),
 Gleichstrom (Kanal 2)
 BETRIEBSART ... NORM
 (Schaltgriff auf Kanal 1)

SPURLAGEN-OFFSET-BALANCE-JUSTIERUNG

1. Den Niederfrequenz-Oszillator auf eine Frequenz von **1 kHz** und eine Ausgangsspannung von **200 mVs-s** einstellen. Dann den Oszillator an **OSC (+)** und **GND (-)** des Servo-Verstärkungs-Justierers anschließen.
2. Kanal 1 des Oszilloskops an **TJ301 (+)** und **TJ302 (-)** der Hauptplatine anschließen.
3. Den Netzschalter des Spielers einschalten und eine Testplatte (SZZP1014F oder SZZP1054C) einsetzen.
4. Den Spieler auf Wiedergabe schalten.
5. Den Wahlschalter des Servo-Verstärkungs-Justierers von **"2"** auf **"1"** stellen.
6. **VR106** so justieren, daß die Ausgangs-Wellenform wie abgebildet wird (Jitter ist minimiert).
7. Den Wahlschalter des Servo-Verstärkungs-Justierers von **"1"** auf **"2"** stellen.
8. Den Netzschalter des Spielers ausschalten.
9. Den Servo-Verstärkungs-Justierer abtrennen und den Kurzschlußstecker von CN102 an der Ursprünglichen Position einstecken.

Oszilloskop-Einstellung:

VOLT 500 mV
 KIPP 0,5 msec.
 EINGANG Wechselstrom

PLL-JUSTIERUNG

1. Kanal 1 des Oszilloskops an die **LINE OUT-Buchse** (entweder linker oder rechter Kanal) und an **Masse** anschließen.
Oszilloskop-Einstellung:
VOLT 1 V
KIPP 1 msec.
EINGANG Gleichstrom
2. Den Netzschalter des Spielers einschalten und die Testplatte (SZZP1054C) einsetzen.
3. **Spur Nr. 6 (Keil 0,7 mm)** der Testplatte abspielen.
4. Die auf dem Oszilloskop angezeigte Wellenform prüfen und **VR501** in den folgenden Schritten justieren.
Schritt 1. **VR501** langsam im Uhrzeigersinn drehen und den Punkt beobachten, an dem die Wellenform auf dem Oszilloskop anfängt zu verzerren.
Schritt 2. **VR501** langsam entgegen dem Uhrzeigersinn drehen und den Punkt beobachten, an dem die Wellenform auf dem Oszilloskop anfängt zu verzerren.
Schritt 3. **VR501** auf die Mitte zwischen den in den obigen Schritten "1" und "2" beobachteten Punkten einstellen.

PRÜFUNG DES WIEDERGABEBETRIEBS NACH DER JUSTIERUNG

- Prüfung des Überspring-Suchlaufs**
1. Eine gewöhnliche Platte abspielen.
 2. Die Skip-Taste drücken, um den Überspring-Suchlauf zu prüfen (in Vorwärts- und Rückwärtsrichtung).
- Prüfung des manuellen Suchlaufs**
1. Eine gewöhnliche Platte abspielen.
 2. Die Taste für manuellen Suchlauf drücken und prüfen, ob einwandfreier manueller Suchlauf mit niedriger und hoher Geschwindigkeit möglich ist (in Vorwärts- und Rückwärtsrichtung).
- Prüfen auf Defekte**
1. Die Testplatte (SZZP1054C) abspielen.
 2. Die **Spur Nr. 6 (Keil 0,7 mm)** wiedergeben und prüfen, daß kein Tonausfall oder Rauschen auftritt.
 3. Die **Spur Nr. 13 (schwarzer Punkt 0,7 mm)** wiedergeben und prüfen, daß ein Tonausfall oder Rauschen auftritt.

JUSTIERUNG DES OPTISCHEN ABTASTERS

Meßinstrumente und Spezialwerkzeuge

- Zweikanal-Oszilloskop (mit Trigger) von 30 MHz oder mehr
- Testplatten
Testplatte (SZZP1014F) alter oder neuer Typ
Inspektions-Testplatte (SZZP1054C)
Ungleichmäßige Platte (SZZP1056C)
- Sechskantschlüssel (SZZP1044C... 1,5 mm)
- Sechskantschlüssel (1,27 mm)
- Fühlerlehre (RZZ0297)
- Filter
- Schrauben-Versiegelungsfarbe (RZZ0L01)

Justierverfahren

- Wenn der optische Abtaster und der Spindelmotor ausgetauscht werden, die Justierung nach dem folgenden Verfahren durchführen.

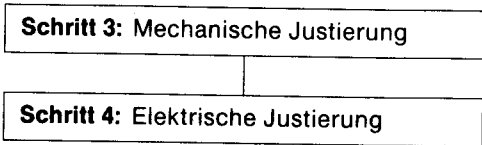
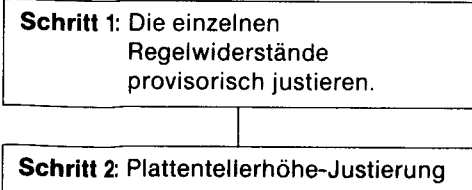

PLATTENTELLERHÖHE-JUSTIERUNG

1. Kanal 1 des Oszilloskops an **TJ102 (+)** und **TJ302 (-)** der Hauptplatine durch das Filter anschließen.
Oszilloskop-Einstellung:
VOLT 50 mV
KIPP 1 msec.
EINGANG Gleichstrom
2. Das Oszilloskop auf Gleichstrom-Nullbalance einstellen.
3. Den Netzschalter des Spielers einschalten und eine Testplatte (SZZP1014F oder SZZP1054C) einsetzen.
4. Den Spieler auf Wiedergabe schalten.
5. Den auf dem Oszilloskop angezeigten Gleichstrompegel (A mV) messen.
Wenn der Wert von A under ± 60 mV liegt, ist die Plattentellerhöhe korrekt. Wenn er nicht in diesem Bereich liegt, die erforderlichen Justierungen unter Verwendung der 0,9 mm Fühlerlehre (RZZ0297) durchführen. Wenn A mehr als $+60$ mV beträgt, den Plattenteller absenken. Wenn A weniger als -60 mV beträgt, den Plattenteller anheben.

Die Plattentellerhöhe wie folgt justieren:

- A. Die 0,9 mm Fühlerlehre (RZZ0297) wie unten gezeigt einführen.
- B. Die Plattenteller-Stellschraube lösen.
- C. Die Plattentellerhöhe durch geringfügiges Bewegen der Fühlerlehre in die entsprechende Richtung justieren.
- D. Die Plattenteller-Stellschraube mit dem 1,27 mm Sechskantschlüssel anziehen.
- E. Die Plattentellerhöhe-Justierung nach den obigen Schritten 1~5 überprüfen.

MECHANISCHE JUSTIERUNG

1. Kanal 1 des Oszilloskops an **TJ301 (+)** und **TJ302 (-)** der Hauptplatine anschließen.
Oszilloskop-Einstellung:
VOLT 200 mV
KIPP 0,5 μ sec.
EINGANG Wechselstrom
2. Den Netzschalter des Spielers einschalten und die Testplatte (SZZP1056C) einsetzen.
3. Mit den Tasten für manuellen Suchlauf den Abtaster so positionieren, daß die Schrauben für mechanische Justierung mit den Justieröffnungen in der Bodenplatte ausgerichtet sind.
4. Unter Beobachtung des HF-Signals auf dem Oszilloskop die **beiden Justierschrauben** abwechselnd mit dem 1,5 mm Sechskantschlüssel (SZZP1044C) so einstellen, daß die vertikalen Schwankungen des HF-Signals minimal und das Augenmuster am weitesten gestreckt wird.
5. Den Netzschalter des Spielers ausschalten.
6. Nach der Justierung **Schrauben-Versiegelungsfarbe** (RZZ0L01) auf die Justierschrauben auftragen.

JUSTIERUNG FÜR VERZERRUNG DES D/A-UMWANDLERS

Meßinstrumente und Spezialwerkzeuge

- Verzerrungsmeter
- Testplatte
Testplatte (SZZP1014F) alter oder neuer Typ

1. Die Klemme (+) des Verzerrungsmeters an die Ausgangsbuchse (linker oder rechter Kanal) und die Klemme (-) an das Chassis anschließen.
2. Den Netzschalter des Spielers einschalten und die Testplatte (SZZP1014F) einsetzen.
3. Ein 1 kHz, -24 dB Signal wiedergeben.
4. **VR801** (linker Kanal) oder **VR802** (rechter Kanal) so justieren, daß das Verzerrungsverhältnis minimal wird.

OFFSET-AUSGANGSSPANNUNG-JUSTIERUNG

Meßinstrument

- Digital-Voltmeter
1. Die Taste "STOP" drücken und den CD-Spieler auf "STOP MODE" stellen.
 2. Den Digital-Voltmeter an den Überbrückungsdraht anschließen, der sich in J (C833) (linker Kanal) (+) oder J (C834) (rechter Kanal) (+) befindet, und an die Ausgangsklemme (GND) (-) anschließen.
 3. VR1001 (linker Kanal) oder VR1002 (rechter Kanal) so einstellen, daß die Spannung ± 1 mV beträgt.

FRANÇAIS

REGLAGES ELECTRIQUES

Appareils de mesure et outillage spécial

- Boîte de réglage du gain de la boucle d'asservissement (SZZP1017F)
- Disques d'essai
 - Disque d'essai (SZZP1014F) nouveau ou ancien modèle
 - Disque de vérification (SZZP1054C)
 - Disque voilé (SZZP1056C)
 - Disque à bande noire (SZZP1057C)

- Disque ordinaire
- Oscilloscope double track à déclenchement, 30 MHz (ou mieux)
- Générateur basse fréquence
- Adaptateur (SZZP1032F)
- Filter

Procédure de réglage

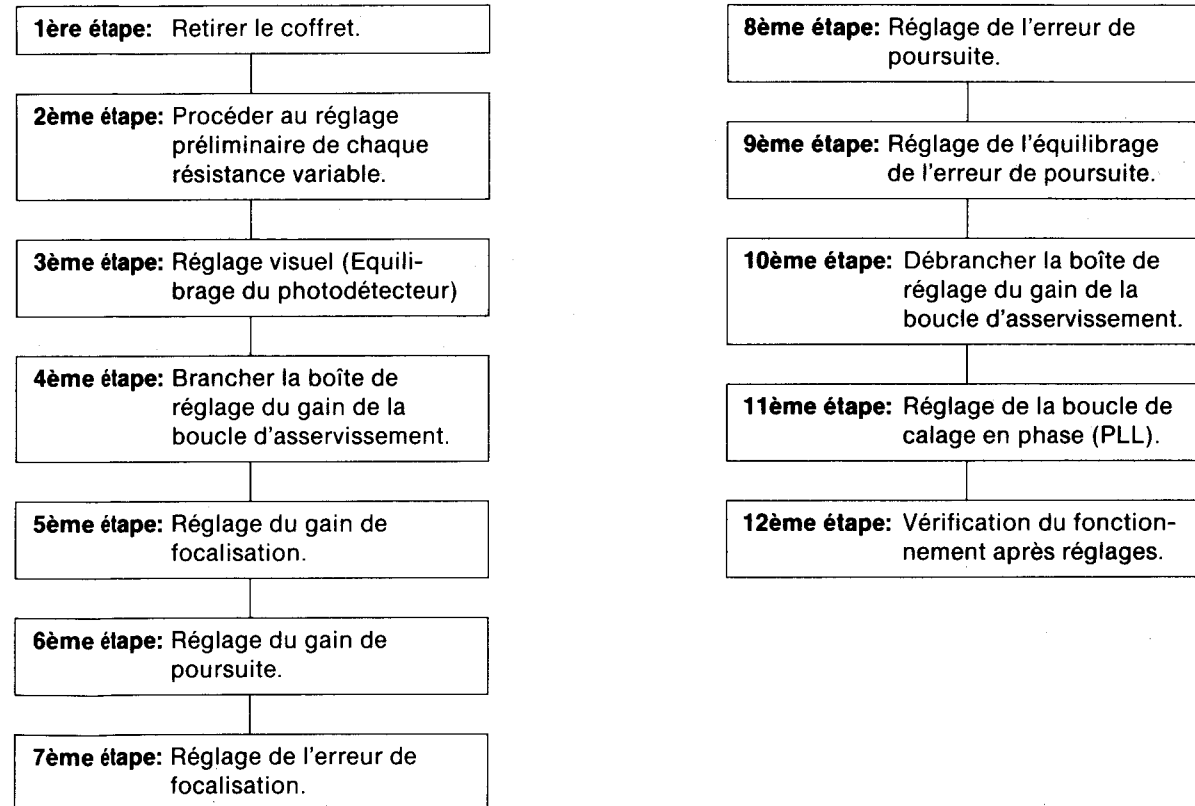

Réglage préliminaire de chaque résistance variable

Remarque:

Si la lecture du disque est impossible ou que des sauts de portions enregistrées apparaissent, procéder au réglage de chaque résistance variable comme il est indiqué ci-après.

REGLAGE VISUEL (EQUILIBRAGE DU PHOTO-DETECTEUR)

1. Relier l'entrée 1 (CH1) de l'oscilloscope aux bornes **TJ301 (+)** et **TJ302 (-)** du circuit imprimé principal.

Réglages de l'oscilloscope:

TENSION200 mV
BALAYAGE0,5 μs
ENTREECA

2. Placer l'interrupteur d'alimentation du lecteur sur la position **ON** et mettre en place un disque d'essai (SZZP1014F ou SZZP1054C).
3. Procéder à la lecture du disque.
4. Régler **VR101** de sorte que la figure du signal radiofréquence soit aussi étirée que possible.
5. Placer l'interrupteur d'alimentation du lecteur sur la position **OFF**.

REGLAGE DU GAIN DE FOCALISATION

1. Brancher la boîte de réglage du gain de la boucle d'asservissement.
2. Placer le commutateur de cette boîte sur la position **2** et l'interrupteur d'alimentation sur la position **ON**.
3. Régler le générateur basse fréquence de sorte que le signal de sortie soit à la fréquence de **750 Hz** avec une amplitude de **100 mV crête à crête**. Brancher ce générateur entre les bornes **OSC (+)** et **GND (-)** de la boîte de réglage.
4. Relier les entrées (CH1 et CH2) de l'oscilloscope aux bornes **TP1** et **TP2** de la boîte de réglage. (**TP3** est la borne de masse.)

Réglages de l'oscilloscope:

TENSION200 mV (sur les deux entrées)
BALAYAGE1 ms
ENTREECC

5. Placer l'interrupteur d'alimentation du lecteur sur la position **ON** et mettre en place un disque d'essai (SZZP1014F ou SZZP1054C).
6. Procéder à la lecture du disque.
7. Basculer le commutateur de la boîte de réglage de la position **2** à la position **3**.
8. Deux traces du signal à **750 Hz** apparaissent sur l'écran de l'oscilloscope. Régler **VR104** de sorte que les amplitudes des deux traces soient identiques.
9. Basculer le commutateur de la boîte de réglage de la position **3** à la position **2**.

REGLAGE DU GAIN DE POURSUITE

1. Les raccordements et les réglages de l'oscilloscope sont identiques à ceux du réglage précédent.
2. Régler le générateur basse fréquence de sorte que le signal de sortie soit à la fréquence de **1,0 kHz** avec une amplitude de **100 mV crête à crête**.
3. Basculer le commutateur de la boîte de réglage de la position **2** à la position **1**.

4. Deux traces du signal à **1,0 kHz** apparaissent sur l'écran de l'oscilloscope. Régler **VR102** de sorte que les amplitudes des deux traces soient identiques.
5. Basculer le commutateur de la boîte de réglage de la position **1** à la position **2**.
6. Placer l'interrupteur d'alimentation du lecteur sur la position **OFF**.

REGLAGE DE L'ERREUR DE FOCALISATION

1. Relier l'entrée 1 (CH1) de l'oscilloscope aux bornes **TJ301 (+)** et **TJ302 (-)** du circuit imprimé principal. Relier l'entrée 2 (CH2) de l'oscilloscope aux bornes **TJ102 (+)** et **TJ302 (-)** du circuit imprimé principal.

Réglages de l'oscilloscope:

TENSION200 mV (sur les deux entrées)
BALAYAGE0,5 ms
ENTREECA (CH1), CC (CH2)
MODENORM (le déclenchement est commandé par CH1)

2. Placer l'interrupteur d'alimentation du lecteur sur la position **ON** et mettre en place un des disques d'essai (SZZP1057C).
3. Procéder à la lecture du disque.
4. Observer les deux traces et régler **VR105** de sorte que l'allure des courbes au voisinage du point de déclenchement soit celle de l'illustration.

REGLAGE DE L'ERREUR DE POURSUITE

1. Relier l'entrée 1 (CH1) de l'oscilloscope aux bornes **TJ301 (+)** et **TJ302 (-)** du circuit imprimé principal. Relier l'entrée 2 (CH2) de l'oscilloscope aux bornes **TJ101 (+)** et **TJ302 (-)** du circuit imprimé principal.

Réglages de l'oscilloscope:

TENSION200 mV (sur les deux entrées)
BALAYAGE0,5 ms
ENTREECA (CH1), CC (CH2)
MODENORM (le déclenchement est commandé par CH1)

2. Placer l'interrupteur d'alimentation du lecteur sur la position **ON** et mettre en place un des disques d'essai (SZZP1057C).
3. Procéder à la lecture du disque.
4. Observer les deux traces et régler **VR103** de sorte que l'allure des courbes au voisinage du point de déclenchement soit celle de l'illustration.

REGLAGE DE L'EQUILIBRE DE L'ERREUR DE POURSUITE

- Régler le générateur basse fréquence de sorte que le signal de sortie soit à la fréquence de **1 kHz** avec une amplitude de **200 mV crête à crête**. Brancher ce générateur entre les bornes **OSC (+)** et **GND (-)** de la boîte de réglage.
- Relier l'entrée 1 (CH1) de l'oscilloscope aux bornes **TJ301 (+)** et **TJ302 (-)** du circuit imprimé principal.
Réglages de l'oscilloscope:
TENSION500 mV
BALAYAGE0,5 ms
ENTREECA
- Placer l'interrupteur d'alimentation du lecteur sur la position **ON** et mettre en place un disque d'essai (SZZP1014F ou SZZP1054C).
- Procéder à la lecture du disque.
- Basculer le commutateur de la boîte de réglage de la position **2** à la position **1**.
- Régler **VR106** de sorte que l'allure du signal soit celle de l'illustration (l'instabilité de phase est minimale).
- Basculer le commutateur de la boîte de réglage de la position **1** à la position **2**.
- Placer l'interrupteur d'alimentation du lecteur sur la position **OFF**.
- Débrancher la boîte de réglage et replacer le connecteur de court-circuit de CN102 dans la position d'origine.

REGLAGE DE LA BOUCLE DE CALAGE EN PHASE

- Brancher l'entrée (CH1) de l'oscilloscope entre la borne de sorte ligne (**LINE OUT**) de la voie droite ou gauche et la **masse**.
Réglages de l'oscilloscope:
TENSION1 V
BALAYAGE1 ms
ENTREECC
- Placer l'interrupteur d'alimentation du lecteur sur la position **ON** et mettre en place un des disques d'essai (SZZP1054C).
- Lire la **plage No. 6** du disque (**coin 0,7 mm**).
- Observer l'allure du signal sur l'oscilloscope et régler **VR501** de la manière suivante:
1ère étape: Tourner **VR501** doucement dans le sens des aiguilles d'une montre et noter le moment où le signal commence à être perturbé.
2ème étape: Tourner **VR501** doucement dans le sens contraire des aiguilles d'une montre et noter le moment où le signal commence à être perturbé.
3ème étape: Régler **VR501** au milieu des deux positions notées au cours des opérations **1** et **2** ci-dessus.

VERIFICATION DU FONCTIONNEMENT APRES REGLAGES**Vérification du saut de plage**

- Lire un disque ordinaire.
- Appuyer sur la touche de commande de saut de plage et s'assurer que le fonctionnement est correct dans les deux sens.

Vérification de la recherche manuelle

- Lire un disque ordinaire.
- Appuyer sur la touche de recherche manuelle et s'assurer que le fonctionnement s'effectue sans à-coups dans les deux vitesses possibles.

Vérification de la lecture

- Mettre en place un des disques d'essai (SZZP1054C).
- Lire la **plage No. 6 (coin 0,7 mm)** et s'assurer qu'il n'y a ni bruit ni perte de signal.
- Lire la **plage No. 13 (point noir 0,7 mm)** et s'assurer qu'il n'y a ni bruit ni perte d'information.

REGLAGE DU CAPTEUR OPTIQUE**Appareils de mesure et outillage spécial**

- Oscilloscope double trace à déclenchement, 30 MHz (ou mieux)
- Disques d'essai
Disque d'essai (SZZP1014F) nouveau modèle ou ancien modèle
Disque de vérification (SZZP1054C)
Disque voilé (SZZP1056C)
- Clé hexagonale (SZZP1044C...1,5 mm)
- Clé hexagonale (1,27 mm)
- Jauge d'épaisseur (RZZ0297)
- Filtre
- Vernis de blocage (RZZ0L01)

Procédure de réglage

- Si le capteur optique ou le circuit imprimé du moteur de rotation sont remplacés, procéder aux réglages en suivant la procédure décrite ci-dessous.

1ère étape: Procéder au réglage préliminaire de chaque résistance variable.

2ème étape: Réglage de la hauteur de la platine.

3ème étape: Réglage mécanique.

4ème étape: Réglage électrique.

REGLAGE DE LA HAUTEUR DE LA PLATINE

- Relier l'entrée 1 (CH1) de l'oscilloscope aux bornes **TJ102 (+)** et **TJ302 (-)** du circuit imprimé principal.
Réglages de l'oscilloscope:
TENSION50 mV
BALAYAGE1 ms
ENTREECC
- Régler l'oscilloscope de sorte que la trace soit au centre lorsque l'entrée est égale à 0 V.
- Placer l'interrupteur d'alimentation du lecteur sur la position **ON** et mettre en place un disque d'essai (SZZP1014F ou SZZP1054C).

- Procéder à la lecture du disque.
- Mesurer la tension continue (A mV) du signal apparaissant sur l'oscilloscope.
Si la valeur A est à l'intérieur de la fourchette ± 60 mV, la hauteur de la platine est correcte. Dans le cas contraire, procéder aux réglages requis en employant la jauge de profondeur (RZZ0297). Si A est supérieure à **+60 mV**, diminuer la hauteur de la platine. Si A est inférieure à **-60 mV**, augmenter la hauteur de la platine.

Réglage de la hauteur de la platine:

- Introduire la jauge de 0,9 mm (RZZ0297) comme il est indiqué ci-dessous.
- Dévisser la vis de positionnement de la platine.
- Régler la hauteur de la platine en déplaçant légèrement la jauge dans la direction voulue.

- Resserrer la vis de positionnement au moyen de la clé de 1,27 mm.
- Vérifier la hauteur de la platine en procédant aux opérations 1 à 5 décrites ci-dessus.

REGLAGE MECANIQUE

- Relier l'entrée 1 (CH1) de l'oscilloscope aux bornes **TJ301 (+)** et **TJ302 (-)** du circuit imprimé principal.
Réglages de l'oscilloscope:
TENSION200 mV
BALAYAGE0,5 μ s
ENTREECA
- Placer l'interrupteur d'alimentation du lecteur sur la position **ON** et mettre en place un des disques d'essai (SZZP1056C).
- A l'aide des touches de recherche, déplacer le capteur de telle manière que les vis de réglage mécanique apparaissent à travers les trous pratiqués sur le fond de l'appareil.

- Observer l'allure du signal radiofréquence sur l'oscilloscope et agir alternativement sur les **deux vis** à l'aide de la clé hexagonale (SZZP1044C) de sorte que la fluctuation verticale des courbes soit minimale et que leur forme soit aussi étirée que possible.
- Placer l'interrupteur d'alimentation du lecteur sur la position **OFF**.
- Le réglage terminé, appliquer une **goutte de vernis de blocage** (RZZ0L01) sur la vis de réglage.

REGLAGE DE LA DISTORSION DU CONVERTISSEUR D/A**Appareils de mesure et outillage spécial**

- Distorsiomètre
- Disque d'essai
Disque d'essai (SZZP1014F) nouveau ou ancien modèle

- Relier la borne (+) du distorsiomètre une borne de sortie (voie droite ou voie gauche) et la borne (-) au châssis.
- Placer l'interrupteur d'alimentation du lecteur sur la position **ON** et mettre en place un des disques d'essai (SZZP1014F).

- Procéder à la lecture (1 kHz, -24 dB).
- Régler **VR801** (voie gauche) ou **VR802** (voie droite) de sorte que la distorsion soit minimale.

COMPENSATION DU NIVEAU DE SORTIE**Reglage audio**

- Voltmètre digital
- Appuyer sur la touche "STOP" pour amener le lecteur à l'arrêt.
 - Brancher le voltmètre digital entre J (C833) (Voie gauche) (+) ou J (C834) (Voie droite) (+) et la borne de sortie (GND) (-).
 - Régler VR1001 (Voie gauche) ou VR1002 (Voie droite) de sorte que la tension soit égale à ± 1 mV.

ESPAÑOL

AJUSTE ELECTRICO

Instrumentos de medición y herramientas especiales

- Ajustador de servogancia (SZZP1017F)
- Discos de prueba
 - Disco de prueba (SZZP1014F) tipo antiguo o nuevo
 - Disco de prueba de inspección (SZZP1054C)
 - Disco desperejo (SZZP1056C)
 - Disco de banda negra (SZZP1057C)
- Disco común
- Osciloscopio de dos canales (con disparador) de 30 MHz o más
- Oscilador de baja frecuencia
- Conector de conversión (SZZP1032F)
- Filtro

Procedimiento de ajuste

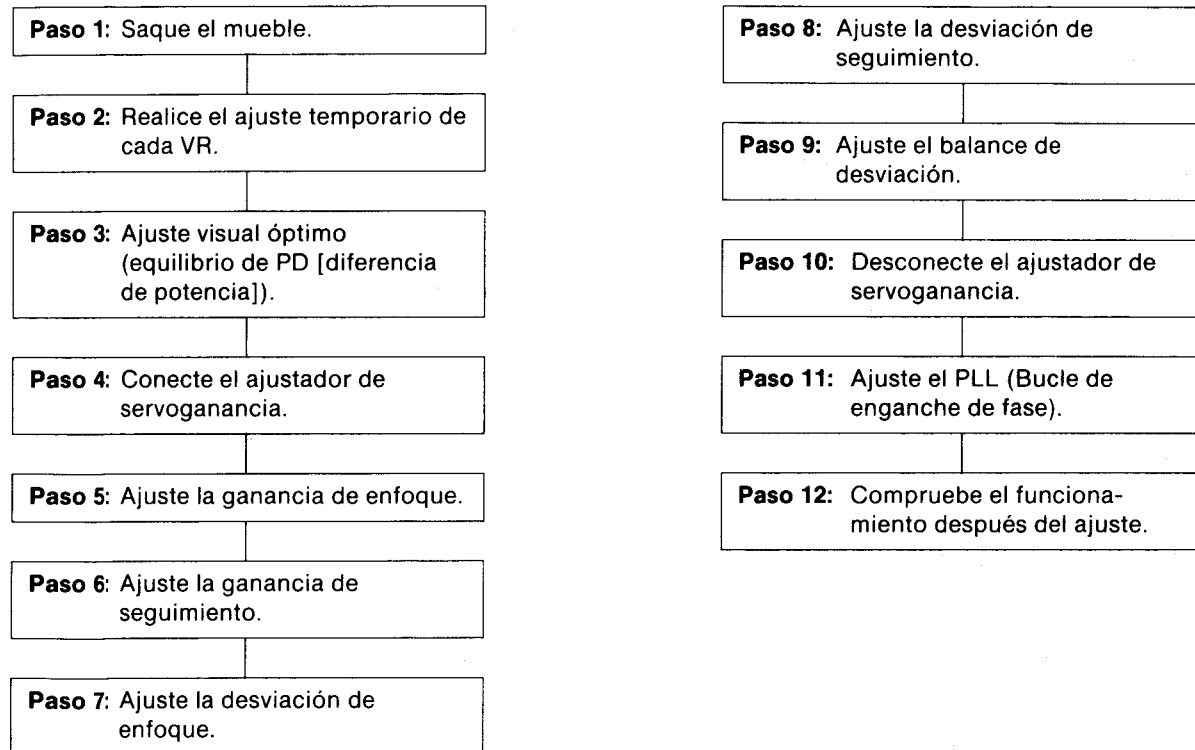

AJUSTE TEMPORARIO DE CADA VR

Nota:
Si el disco salta o no puede reproducirse, ajuste temporariamente cada VR como se muestra.

AJUSTE VISUAL OPTIMO (EQUILIBRIO DE PD)

1. Conecte CH1 del osciloscopio a **TJ301 (+)** y **TJ302 (-)** del P.C.B. (tablero de circuitos impresos) principal.
Puesta de osciloscopio: VOLT200 mV
Barrido0,5 μseg.
EntradaCA
2. Ponga el interruptor de alimentación del reproductor en **ON** e inserte un disco de prueba (SZZP1014F o SZZP1054C).
3. Ponga el reproductor en la modalidad de reproducción.
4. Ajuste **VR101** de modo que el patrón visual de la señal de RF se ensanche al máximo.
5. Ponga el interruptor de alimentación del reproductor en la posición **OFF**.

AJUSTE DE LA GANANCIA DE ENFOQUE

1. Conecte el ajustador de servogancia.
2. Ponga el conmutador selector del ajustador de servogancia en **2** y el interruptor ON-OFF en **ON**.
3. Ajuste el oscilador de baja frecuencia a la frecuencia de **750 Hz** y voltaje de salida a **100 mVp-p**. Luego conecte el oscilador a los terminales **OSC (+)** y **GND (-)** del ajustador de servogancia.
4. Conecte CH1 y CH2 del osciloscopio a **TP1** y **TP2** del ajustador de servogancia (**TP3** es el terminal de puesta a tierra).
Puesta de osciloscopio:
VOLT200 mV (ambos canales)
BARRIDO1 mseg.
ENTRADACC
5. Ponga el interruptor de alimentación del reproductor en **ON** e inserte un disco de prueba (SZZP1014F o SZZP1054C).
6. Ponga el reproductor en la modalidad de reproducción.
7. Cambie el conmutador selector del ajustador de servogancia de **"2"** a **"3"**.
8. En el osciloscopio se visualizarán señales de **750 Hz**. Ajuste **VR104** hasta que las amplitudes de la forma de onda de ambos canales sean iguales.
9. Cambie el conmutador selector del ajustador de servogancia de **"3"** a **"2"**.

AJUSTE DE LA GANANCIA DE SEGUIMIENTO

1. La puesta del osciloscopio y las conexiones son las mismas que las indicadas anteriormente.
2. Ponga el oscilador de baja frecuencia a **1,0 kHz** y voltaje de salida de **100 mVp-p**.
3. Cambie el conmutador selector del ajustador de servogancia de **"2"** a **"1"**.
4. En el osciloscopio se visualizarán señales de **1,0 kHz**. Ajuste **VR102** hasta que las amplitudes de la forma de onda de ambos canales sean iguales.
5. Cambie el conmutador selector del ajustador de servogancia de **"1"** a **"2"**.
6. Ponga en **OFF** el interruptor de alimentación del reproductor.

AJUSTE DE LA DESVIACION DE ENFOQUE

1. Conecte CH1 del osciloscopio a **TJ301 (+)** y **TJ302 (-)** del P.C.B. principal.
Conecte CH2 del osciloscopio a **TJ102 (+)** y **TJ302 (-)** del P.C.B. principal.
Puesta de osciloscopio:
VOLT200 mV (ambos canales)
Barrido0,5 mseg.
EntradaCA (CH1), CC (CH2)
ModalidadNORM (Disparo vía CH1)
2. Ponga el interruptor de alimentación del reproductor en **ON** e inserte un disco de prueba (SZZP1057C).
3. Ponga el reproductor en la modalidad de reproducción.
4. Verifique la forma de onda de CH1 y CH2 en el osciloscopio, y ajuste **VR105** de modo que la forma de onda alrededor del punto de disparo sea como la que se muestra en la figura.

AJUSTE DE LA DESVIACION DE SEGUIMIENTO

1. Conecte CH1 del osciloscopio a **TJ301 (+)** y **TJ302 (-)** del P.C.B. principal.
Conecte CH2 del osciloscopio a **TJ101 (+)** y **TJ302 (-)** del P.C.B. principal.
Puesta de osciloscopio:
VOLT200 mV (ambos canales)
Barrido0,5 mseg.
EntradaCA (CH1), CC (CH2)
ModalidadNORM (Disparo vía CH1)
2. Ponga el interruptor de alimentación del reproductor en **ON** e inserte un disco de prueba (SZZP1057C).
3. Ponga el reproductor en la modalidad de reproducción.
4. Verifique la forma de onda de CH1 y CH2 en el osciloscopio y ajuste **VR103** de modo que la forma de onda alrededor del punto de disparo sea como la que se muestra en la figura.

AJUSTE DEL EQUILIBRIO DE DESVIACION DEL SEGUIMIENTO

1. Ajuste el oscilador de baja frecuencia a la frecuencia de **1 kHz** y voltaje de salida de **200 mVp-p**. Luego conecte el oscilador a los terminales **OSC (+)** y **GND (-)** del ajustador de servogancia.
2. Conecte CH1 del osciloscopio a **TJ301 (+)** y **TJ302 (-)** del P.C.B. principal.
Puesta de osciloscopio: VOLT500 mV
Barrido0,5 mseg.
EntradaCA
3. Ponga el interruptor de alimentación del reproductor en **ON** e inserte un disco de prueba (SZZP1014F o SZZP1054C).
4. Ponga el reproductor en la modalidad de reproducción.
5. Cambie el conmutador selector del ajustador de servogancia de **"2"** a **"1"**.
6. Ajuste **VR106** de modo que la forma de onda de la salida sea como se muestra (la fluctuación se hace mínima).
7. Lleve el conmutador selector del ajustador de servogancia de **"1"** a **"2"**.
8. Ponga en **OFF** el interruptor de alimentación del reproductor.
9. Desconecte el ajustador de servogancia, inserte el conector de cortocircuito de CN102 en la posición original.

AJUSTE DEL PLL (BUCLE DE ENGANCHE DE FASE)

1. Conecte CH1 del osciloscopio al terminal **LINE OUT** (del canal L o del R) y a **tierra**.

Puesta de osciloscopio: VOLT1 V
Barrido1 mseg.
EntradaCC

2. Ponga el interruptor de alimentación del reproductor en **ON** e inserte un disco de prueba (SZZP1054C).
3. Reproduzca el **surco No. 6 (cuña de 0,7 mm)** del disco de prueba.

4. Verifique la forma de onda que se visualiza en el osciloscopio y ajuste **VR501** de acuerdo con los siguientes pasos.

Paso 1. Gire lentamente **VR501** en el sentido de las manecillas del reloj y observe el punto en el que la forma de onda del osciloscopio comienza a deformarse.

Paso 2. Gire lentamente **VR501** en el sentido contrario a las manecillas del reloj y observe el punto en que la forma de la onda del osciloscopio comienza a deformarse.

Paso 3. Fije **VR501** en la posición intermedia entre los puntos observados en los pasos anteriores "1" y "2".

COMPROBACION DEL FUNCIONAMIENTO DE RE-PRODUCCION DESPUES DEL AJUSTE**Comprobación de exploración de salto**

1. Reproduzca un disco común.
2. Pulse el botón de salto para comprobar la exploración de salto (tanto en la modalidad directa como en la inversa).

Comprobación de exploración manual

1. Reproduzca un disco común.
2. Pulse el botón de exploración manual para comprobar si la exploración manual se puede realizar suavemente a velocidades bajas y altas (tanto en la modalidad directa como en la inversa).

Comprobación de reproducibilidad

1. Reproduzca el disco de prueba (SZZP1054C).
2. Reproduzca el **surco No. 6 (cuña de 0,7 mm)** y verifique si no hay salto de sonido o ruido.
3. Reproduzca el **surco No. 13 (punto negro de 0,7 mm)** y verifique si no hay salto de sonido o ruido.

AJUSTE DE LA TOMA OPTICA**Instrumentos de medición y herramientas especiales**

- Osciloscopio de dos canales (con disparador) de 30 MHz o más
- Discos de prueba
Disco de prueba (SZZP1014F) tipo antiguo o nuevo
Disco de prueba de inspección (SZZP1054C)
Disco desparejo (SZZP1056C)

- Llave de tuercas hexagonal (SZZP1044C...1,5 mm)
- Llave de tuercas hexagonal (1,27 mm)
- Calibre de espesor (RZZ0297)
- Filtro
- Adherencia de cierre de tornillo (RZZ0L01)

Procedimiento de ajuste

- Si se cambia la toma óptica y el motor del eje, ajústelos de acuerdo con el siguiente procedimiento.

Paso 1: Ajustar temporariamente cada VR.

Paso 2: Ajuste la altura del plato giradiscos.

Paso 3: Ajuste mecánico.

Paso 4: Ajuste eléctrico.

AJUSTE DE LA ALTURA DEL PLATO GIRADISCOS

1. Conecte CH1 del osciloscopio a **TJ102 (+)** y **TJ302 (-)** del P.C.B. principal a través del filtro.

Puesta de osciloscopio: VOLT50 mV
Barrido1 mseg.
EntradaCC

2. Ajuste el equilibrio cero de CC del osciloscopio.
3. Lleve el interruptor de alimentación del reproductor a **ON** e inserte un disco de prueba (SZZP1014F o SZZP1054C).
4. Ponga el reproductor en la modalidad de reproducción.

5. Mida el nivel de CC (AmV) que se visualiza en el osciloscopio.

Si el valor de A está dentro de la gama de ± 60 mV, la altura del plato giradiscos es correcta. Si no está dentro de esta gama, realice los ajustes necesarios utilizando el calibre de espesor (RZZ0297). Si A es mayor que $+60$ mV, baje el plato giradiscos. Si A es menor que -60 mV, levante el plato giradiscos.

Ajuste la altura del plato giradiscos de la siguiente forma:

- A. Inserte el calibre de espesor de 0,9 mm (RZZ0297), como se muestra abajo.
- B. Afloje el tornillo de ajuste del plato giradiscos.
- C. Ajuste la altura del plato giradiscos moviendo el calibre levemente en la dirección apropiada.

- D. Apriete el tornillo de ajuste del plato giradiscos usando la llave de tuerca hexagonal de 1,27 mm.
- E. Compruebe el ajuste de la altura del plato giradiscos siguiendo los pasos 1~5 anteriores.

AJUSTE MECANICO

1. Conecte CH1 del osciloscopio a **TJ301 (+)** y **TJ302 (-)** del P.C.B. principal.

Puesta de osciloscopio: VOLT200 mV
Barrido0,5 μ seg.
EntradaCA

2. Lleve el interruptor de alimentación del reproductor a **ON** e inserte el disco de prueba (SZZP1056C).
3. Utilizando los botones de exploración manual, mueva la toma de modo que los tornillos de ajuste mecánico se alineen con los orificios de ajuste del panel inferior.

4. Mientras comprueba la señal de RF del osciloscopio, apriete los **dos tornillos de ajuste** alternativamente con la llave hexagonal de 1,5 mm (SZZP1044C) de modo que la fluctuación vertical de la señal de RF se haga mínima y que el patrón visual se ensanche al máximo.

5. Lleve el interruptor de alimentación del reproductor a **OFF**.
6. Después del ajuste, aplique **adherencia de cierre de tornillo** (RZZ0L01) a los tornillos de ajuste.

AJUSTE DE LA DISTORSION DEL CONVERTIDOR D/A**Instrumentos de medición y herramientas especiales**

- Medidor de distorsión
- Disco de prueba
Disco de prueba (SZZP1014F) tipo antiguo o nuevo

1. Conecte el terminal (+) del medidor de distorsión al terminal de salida (canal L o R) y al terminal (-) del chasis.
2. Lleve el interruptor de alimentación del reproductor a **ON** e inserte el disco de prueba (SZZP1014F).

3. Reproduzca la señal 1 kHz, -24 dB.
4. Ajuste **VR801** (canal L) o **VR802** (canal R) de modo que la relación de distorsión sea mínima.

ADJUSTE DEL AUDIO**Instrumento de medición**

- Voltímetro digital
1. Pulse el botón de parada (STOP) y ponga el reproductor en la modalidad de parada.
 2. Conecte el voltímetro digital al cable de conexión montado en J (C833) (Lch) (+) o J (C834) (Rch) (+) y al terminal de salida (GND) (-).

3. Ajuste VR1001 (Lch) o VR1002 (Rch) de modo que el voltaje sea ± 1 mV.

Service Manual

Supplement



Compact Disc Player
SL-P770

Color	Area
(K)	[M] U.S.A.
(K)	[MC] Canada.
(K)	[E] Continental Europe.
(K)	[EK] United Kingdom.
(K)	[XL] Australia.
(K)	[EG] F.R.Germany.
(K)	[EB] Belgium.
(K)	[EH] Holland.
(K)	[EF] France.
(K)	[Ei] Italy.
(K)	[XA] Asia, Latin America, Middle Near East, Africa and Oceania.
(K)	[XB] Saudi Arabia.
(K)	[PA] Far East PX.
(K)	[PE] European Military.
(K)	[PC] European Audio Club.

Please file and use this supplement manual together with the service manual for Model No. SL-P770, Order No. HAD8801018C0.

Note: This supplement has been issued to inform you that the service manual for Model No. SL-P770 contains some incorrect information in "MEASUREMENTS AND ADJUSTMENTS" on page 24 and 25. Please kindly correct your service manual as follows.

(over)

Technics

Matsushita Services Company
50 Meadowland Parkway,
Secaucus, New Jersey 07094

**Panasonic Sales Company,
Division of Matsushita Electric
of Puerto Rico, Inc.**
Ave. 65 De Infanteria, Km. 9.7
Victoria Industrial Park
Carolina, Puerto Rico 00630

Panasonic Hawaii, Inc.
91-238, Kauhū Street, Ewa Beach
P.O. Box 774
Honolulu, Hawaii 96808-0774

**Matsushita Electric
of Canada Limited**
5770 Ambler Drive, Mississauga,
Ontario, L4W 2T3

Matsushita Electric Trading Co., Ltd.
P.O. Box 288, Central Osaka Japan

**Panasonic Tokyo Office
Matsushita Electric Trading Co., Ltd.**
6th Floor, World Trade Center Bldg.,
No. 4-1, Hamamatsu-cho 2-Chome,
Minato-ku, Tokyo 105, Japan

CORRECTION

■ MEASUREMENTS AND ADJUSTMENTS

OPTICAL PICKUP ADJUSTMENT

INCORRECT

CORRECT

(On page 24.)

Measuring Instruments and Special Tools

- Two-channel oscilloscope (with trigger) of 30MHz or over
- Test discs
 - Test disc (SZZP1014F) old or new type
 - Inspection test disc (SZZP1054C)
 - Uneven disc (SZZP1056C)
- Hexagonal wrench (SZZP1044C.....1.5mm)
- Screw lock paint (RZZ0L01)
- Hexagonal wrench (1.27mm)
- Feeler gauge (RZZ0297)
- Filter (Refer to page 20.)

Measuring Instruments and Special Tools

- Two-channel oscilloscope (with trigger) of 30MHz or over
- Test discs
 - Test disc (SZZP1014F) old or new type
 - Inspection test disc (SZZP1054C)
 - Uneven disc (SZZP1056C)
- **Hexagonal wrench (2.0mm)**
- Screw lock paint (RZZ0L01)
- Hexagonal wrench (1.27mm)
- Feeler gauge (RZZ0297)
- Filter (Refer to page 20.)

(On page 25.)

MECHANICAL ADJUSTMENT

1. Connect CH1 of the oscilloscope to **TJ301 (+)** and **TJ302 (-)** of the main P.C.B.
Oscilloscope setting: VOLT.....200mV
 SWEEP.....0.5μsec.
 INPUT.....AC
2. Turn **ON** the power switch of the player and insert the test disc (SZZP1056C).
3. Using the manual search buttons, move the pickup so that the mechanical adjustment screws line up with the adjustment holes in the bottom panel.
4. Monitoring RF signal on the oscilloscope, adjust the **two adjusting screws** alternately with the 1.5mm hexagonal wrench (SZZP1044C) so that the vertical fluctuation of RF signal is minimized and the eye pattern is most stretched.
5. Turn **OFF** the power switch of the player.
6. After the adjustment, apply **screw lock paint(RZZ0L01)** to the adjusting screws.

MECHANICAL ADJUSTMENT

1. Connect CH1 of the oscilloscope to **TJ301 (+)** and **TJ302 (-)** of the main P.C.B.
Oscilloscope setting: VOLT.....200mV
 SWEEP.....0.5μsec.
 INPUT.....AC
2. Turn **ON** the power switch of the player and insert the test disc (SZZP1056C).
3. Using the manual search buttons, move the pickup so that the mechanical adjustment screws line up with the adjustment holes in the bottom panel.
4. Monitoring RF signal on the oscilloscope, adjust the **two adjusting screws alternately with the 2.0 mm hexagonal wrench so that the vertical fluctuation of RF signal is minimized and the eye pattern is most stretched.**
5. Turn **OFF** the power switch of the player.
6. After the adjustment, apply **screw lock paint(RZZ0L01)** to the adjusting screws.