

**140 HYDROSTATIC TRACTOR**  
**(Serial No. 30,001- ..**  
**Service Manual**  
**SM-2093-(Jul-73)**

**John Deere Horicon Works**  
**SM2093 (JUL-73)**  
LITHO IN U.S.A.  
**ENGLISH**

# 140 HYDROSTATIC TRACTOR

(Serial No. 30,001- )

## Service Manual

### SM-2093-(Jul-73)

#### CONTENTS

##### SECTION 10 - GENERAL

- Group 5 - Tractor Identification
- Group 10 - Specifications
- Group 15 - Tune-up and Adjustment
- Group 20 - Fuel and Lubricants

##### SECTION 20 - ENGINE

- Group 5 - General Information
- Group 10 - Cylinder Head, Valves and Breather
- Group 15 - Piston, Crankshaft, Main Bearings, Balance Gears, and Flywheel
- Group 20 - Camshaft, Tappets, and Governor

##### SECTION 30 - FUEL SYSTEM

- Group 5 - General Information
- Group 10 - Carburetor
- Group 15 - Air Cleaner
- Group 20 - Fuel Strainer and Gas Tank

##### SECTION 40 - ELECTRICAL SYSTEM

- Group 5 - General Information
- Group 10 - Cranking System
- Group 15 - Ignition System
- Group 20 - Charging System
- Group 25 - PTO Clutch, Lights and Accessories

##### SECTION 50 - POWER TRAIN

- Group 5 - General Information
- Group 10 - Clutch, Neutral-Return and Drive Shaft H-1 (Serial No. 30,001-38,000) and H-3 (Serial No. 30,001-46,883)
- Group 11 - Neutral Return and Drive Shaft H-1 (Serial No. 38,001- ) and H-3 (Serial No. 46,884- )
- Group 12 - Brakes
- Group 15 - Hydrostatic Transmission
- Group 20 - Control Cam and Linkage
- Group 25 - Differential and Axle

##### SECTION 60 - HYDRAULIC LIFT SYSTEM

- Group 5 - General Information
- Group 10 - Hydraulic Circuits
- Group 15 - Hydraulic Control Valves
- Group 20 - Hydraulic Cylinders

##### SECTION 70 - MISCELLANEOUS

- Group 5 - General Information
- Group 10 - Steering Assembly
- Group 15 - Front Wheels and Axle (Serial No. 30,001-38,000)
- Group 16 - Front Wheels and Axle (Serial No. 38,001- )
- Group 20 - Fender-Deck and Seat Assembly

*(All information, illustrations and specifications contained in this service manual are based on the latest information available at the time of publication. The right is reserved to make changes at any time without notice.)*

Copyright © 1970  
DEERE & COMPANY  
Moline, Illinois  
All rights reserved

## INTRODUCTION

This service manual contains service and maintenance information for the John Deere 140 Hydrostatic Tractor, (Serial No. 30,001- ).

The manual is divided into sections. Each section pertains to a certain component or operational system of the tractor. The information is divided into groups within each section.

All sections of this service manual should be carefully studied by the serviceman. Much basic information such as the principles of 4-cycle engine operation, carburetion and ignition can be found in any good library and is recommended reading for the new serviceman before consulting this manual for service procedures.

Emphasis is placed on diagnosing malfunctions, analysis and testing. Diagnosing malfunctions in-

cludes possible troubles, their causes and how to correct them. Under specific components these troubles are analyzed to help the serviceman understand what is causing the problem. In this way, he can eliminate the cause rather than just replace parts and have the same problem keep recurring.

Specifications and special tools are found at the end of the Groups for easy reference.

This manual can be kept in its own cover, or it can be removed and filed in your service manual rack or placed behind the service manual tab in your Consumer Products Parts and Service Binder.

Whenever new or revised pages are provided, insert them into your manual as soon as you receive them. Your service manual will always be up-to-date and be a valuable asset in your service department.



This safety alert symbol identifies important safety messages in this manual. When you see this symbol, be alert to the possibility of personal injury and carefully read the message that follows.

# Section 10 GENERAL

## Group 5 TRACTOR IDENTIFICATION

### TABLE OF CONTENTS

	Page		Page
<b>GROUP 5 - TRACTOR IDENTIFICATION</b>		<b>GROUP 15 - TUNE-UP AND ADJUSTMENT</b>	
Serial Numbers .....	5-2	Preliminary Engine Testing .....	15-1
Identification Codes .....	5-2	Minor Tune-Up Guide .....	15-1
Tractor Codes .....	5-2	Major Tune-Up Guide .....	15-2
Tire Codes .....	5-2	Common Adjustments .....	15-2
Hydraulic System Codes .....	5-2		
<b>GROUP 10 - SPECIFICATIONS</b>		<b>GROUP 20 - FUEL AND LUBRICANTS</b>	
Engine Specifications .....	10-1	Fuel .....	20-1
Capacities .....	10-1	Lubricants .....	20-1
Tractor Specifications .....	10-2	Capacities .....	20-1
Bolt Torque Chart .....	10-3	Type of Lubricant .....	20-2
Set Screw Seating Torque Chart .....	10-3	Service Intervals .....	20-2
Rear Wheel Weight Bolt Size Chart .....	10-4	Changing Crankcase Oil .....	20-2
		Changing Hydrostatic Drive Filter .....	20-3
		Changing Hydrostatic Drive Oil .....	20-3
		Grease Fitting Locations .....	20-4



## SERIAL NUMBERS

Each 140 Hydrostatic Tractor is assigned an individual serial number. This number is found below the instrument panel assembly.

Below is a typical serial number plate from a 140 Tractor.

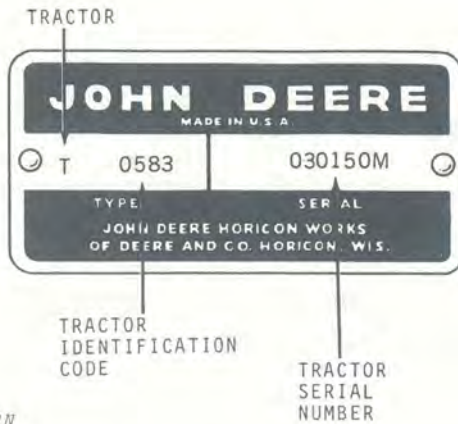

M9382N

Fig. 1-Serial Number Plate

## IDENTIFICATION CODES

### Tractor Codes

Six tractor codes are used for the 140 Tractor and they refer to base color and type of hydraulic system.

Base Color	Type Hydraulics	Serial Number	
		Tractor Code	Tractor No.
Green	H-1	T0581	030001
White	H-1	T0582	030001
Green	H-3	T0583	030001
White	H-3	T0584	030001
Green	H-1	T0585	046501
Green	H-3	T0586	046501

## Tire Codes

John Deere 140 Tractors are available with five different combinations of tires as follows:

Tire Code	Size Front	Size Rear	Tubeless	PR*	Tread
GT-3	16x6.50-8	23x8.50-12	Yes	2	High-Flotation
GT-4	4.80/4.00-8 -----	-----	No	4	Studded
		23x8.50-12	Yes	2	Traction
GT-5	16x16.50-8	23x10.50-12	Yes	2	High-Flotation
GT-6	16x6.50-8 -----	-----	Yes	2	High-Flotation
		23x8.50-12	Yes	2	Traction
GT-7	4.80/4.00-8 -----	-----	No	4	Studded
		23x8.50-12	Yes	2	High-Flotation

\* Ply rating

## Hydraulic System Codes

John Deere 140 Tractors are available with two different hydraulic systems as follows:

**H-1 Tractors** have one single spool hydraulic control valve, offering simultaneous operation of equipment with one lever. These tractors cannot be modified for three-lever operation, but may be equipped with lock-out arms, additional circuits and couplers to increase their versatility.

**H-3 Tractors** have one 3-spool control valve. Three levers permit individual control of each of three separate circuits. For example, with H-3 Tractors, you can operate the 3-point hitch, raise and lower a front-mounted blade and angle the blade. Each operation is independent of the others and is controlled by a separate circuit and lever.

A center hydraulic rockshaft permits use of center-mounted equipment such as rotary mowers and center blades, independently of front or rear applications.

## Group 10

# SPECIFICATIONS

ENGINE SPECIFICATIONS	
Engine Model No. . . . .	K321AS
Manufacturer . . . . .	Kohler
Cylinders . . . . .	One
Cycle . . . . .	Four
Bore & Stroke . . . . .	3.50 x 3.25
Displacement . . . . .	31.27 cu. in.
Speeds (fast) No load . . . . .	3800 rpm
Speeds (idle) . . . . .	1500 rpm
Horsepower (Engine Manufacturer's Rating)* . . . . .	14 @ 3600 rpm
Normal Compression . . . . .	110-120 psi
Valve Clearance:	
(Intake) Cold . . . . .	0.010 in.
(Exhaust) Cold . . . . .	0.020 in.
Ignition . . . . .	Battery
Spark Plug Gap . . . . .	0.025 in.
Breaker Point Gap . . . . .	0.020 in.

\* The horsepower rating shown is established by the engine manufacturer in accordance with Standard Internal Combustion Engine Institute procedure. It is corrected to 60°F. and 29.92 in. Hg. Barometer and is developed from laboratory test engines equipped with standard air cleaner and muffler, less alternator equipment.

## CAPACITIES

Component	Quantity
Fuel Tank	1-3/4 U.S. Gallons
Crankcase	3 U.S. Pints*
Transmission	5 U.S. Quarts*

\* Initial capacity or after complete disassembly.  
 See page 20-3 of this section.



### TRACTOR SPECIFICATIONS



Item	140 Tractor with GT-3 Tires	140 Tractor with GT-4 Tires	140 Tractor with GT-5 Tires
<b>WHEEL TREAD</b>			
Front .....	31-1/4 in.	29-1/2 in.	31-1/4 in.
Rear .....	29 or 34-1/2 in.	29 or 34-1/2 in.	30-1/2 or 33 in.
<b>TIRE SIZES (Also see Group 5)*</b>			
Front .....	16x6.50-8 2 ply	4.80/4.00-8 4 ply	16x6.50-8 2 ply
Rear .....	23x8.50-12 2 ply	23x8.50-12 2 ply	23x10.50-12 2 ply
<b>TIRE INFLATION*</b>			
Front .....	6 to 16 psi	12 to 40 psi	6 to 16 psi
Rear .....	8 to 10 psi	8 to 10 psi	8 to 10 psi
<b>DIMENSIONS</b>			
Wheel Base .....	46 in.	46 in.	46 in.
Over-all Length .....	67-1/2 in.	67-1/2 in.	67-1/2 in.
Over-all Height .....	43 in.	43 in.	43 in.
Over-all Width:			
(min.) .....	38 in.	38 in.	40-1/2 in.
(max.) .....	42-1/2 in.	42-1/2 in.	43 in.
<b>CURB WEIGHT</b> .....	740 lbs.	740 lbs.	740 lbs.
<p>FUEL SYSTEM - See Section 30 for detailed specifications.</p> <p>ELECTRICAL SYSTEM - See Section 40 for detailed specifications.</p> <p>TRANSMISSION - See Section 50 for detailed specifications.</p> <p>DIFFERENTIAL - See Section 50 for detailed specifications.</p> <p>CLUTCH, ENGINE DISCONNECT OR NEUTRAL RETURN - See Section 50 for detailed specifications.</p> <p>BRAKES - See Section 50 for detailed specifications.</p> <p>STEERING AND WHEEL BEARINGS - See Section 70 for detailed specifications.</p>			

\* The GT-6 and GT-7 tire combinations are available as options.  
 They are as follows:

GT-6 ----- GT-3 Front High-Flotation Tires and GT-4 Traction Rear Tires.

GT-7 ----- GT-4 Front Tires and GT-5 High-Flotation Rear Tires.

### BOLT TORQUE CHART

Grade of Bolt		SAE-2	SAE-5	SAE-8	Socket or Wrench Size	
Min. Tensile Strength		64,000 PSI	105,000 PSI	150,000 PSI		
Grade Marking on Bolt						
U.S. Standard		TORQUE IN FOOT POUNDS			U.S. Regular	
Bolt Dia.	U.S. Dec. Equiv.				Bolt Head	Nut
1/4	.250	6	10	14	7/16	7/16
5/16	.3125	13	20	30	1/2	1/2
3/8	.375	23	35	50	9/16	9/16
7/16	.4375	35	55	80	5/8	11/16
1/2	.500	55	85	120	3/4	3/4
9/16	.5625	75	130	175	13/16	7/8
5/8	.625	105	170	240	15/16	15/16
3/4	.750	185	300	425	1-1/8	1-1/8
7/8	.875	* 160	445	685	1-5/16	1-5/16
1	1.000	250	670	1030	1-1/2	1-1/2

Multiply readings by 12 for inch pound values.

\* "B" Grade bolts larger than 3/4-inch are sometimes formed hot rather than cold which accounts for the lower recommended torque.

NOTE: Allow a tolerance of plus or minus 10% on all torques given in this chart.

### SET SCREW SEATING TORQUE CHART

Screw Size	Cup Point	Square Head
Torque in Inch Pounds		
#5	9	--
#6	9	--
#8	20	--
#10	33	--
1/4	87	212
5/16	165	420
3/8	290	830
7/16	430	--
1/2	620	2100
9/16	620	--
5/8	1225	4250
3/4	2125	7700

Divide readings by 12 for foot pound values

NOTE: Allow a tolerance of plus or minus 10% on all torques given in this chart.

**REAR WHEEL WEIGHT BOLT SIZE CHART**

Tire/Wheel Option	Wheel Position	No. of Weights	Bolt Size
GT-3*	Narrow	1	1/2 x 4-3/4
GT-3*	Narrow	2	1/2 x 7
GT-3	Wide	1	1/2 x 5-1/4
GT-3	Wide	2	1/2 x 7-1/2
GT-5	Narrow	1	1/2 x 5-3/4
GT-5	Narrow	2	1/2 x 8
GT-5	Wide	1	1/2 x 5-1/4
GT-5	Wide	2	1/2 x 7-1/2
Adjustable	Not Reversible	1	1/2 x 2-1/2
Adjustable	Not Reversible	2	1/2 x 4-3/4

\* Raised portion of wheel weight out.



## Group 15 Tune-up and Adjustment

**IMPORTANT:** Before attempting to tune-up the 140 Tractor engine, first determine if it is in a condition whereby performance can be restored by tune-up. Do this by making the preliminary engine tests below.

### PRELIMINARY ENGINE TESTING

Operation	Specification	Reference
Cylinder compression	110-120 psi (1000 rpm)	Section 20, Group 5
Crankcase vacuum	5-10 inches of water column	Section 20, Group 5
Battery hydrometer test	1.260-1.280 sp. gr. 100% charged at 80° F.	Section 40, Group 10

### MINOR TUNE-UP GUIDE

Operation	Specification	Reference
Change oil	Summer above 32° F.— SAE 30 (AM30730) Winter below 32° F.— SAE 5W-20 (AM30710)	Section 10, Group 20
Clean and regap spark plug	Clean electrodes Clean insulation Replace gasket Set gap at 0.025 in.	Section 40, Group 15
Remove air cleaner and clean by tapping lightly against flat surface	Check air cleaner condition Replace if necessary	Section 30, Group 15
Adjust carburetor	High speed mixture needle Idle mixture needle	Section 30, Group 10
Adjust governor speed	Speed (fast)— 3800 rpm no load; Speed (idle)— 1200-1700 rpm	Section 20, Group 15
Check and clean fuel tank and strainer	Regular gasoline only	Section 30, Group 20

### MAJOR TUNE-UP GUIDE

**IMPORTANT:** Major tune-up should include all items listed for "Minor Tune-Up" on page 15-1 in addition to the following:

Operation	Specification	Reference
Recondition carburetor	Install carburetor kit	Section 30, Group 10
Inspect and clean breather assembly	Replace parts as necessary. Install new gaskets. Check crankcase vacuum after assembly	Section 20, Group 10
Remove shrouding, clean engine and cylinder head fins	.....	Section 20, Group 10
Test condenser	See Manufacturer's Specifications	Section 40, Group 15
Test coil	See Manufacturer's Specifications	Section 40, Group 15
Replace breaker points	Point gap 0.020 in.	Section 40, Group 15
Retime ignition	"S" mark on flywheel at 1200-1800 rpm	Section 40, Group 15

### COMMON ADJUSTMENTS

*NOTE: The following common adjustments are recommended after engine tune-up is completed.*

Adjustment	Specification	Reference
Engine disconnect	.....	Section 50, Group 10
Steering linkage	.....	Section 70, Group 10
Brakes	.....	Section 50, Group 10
Speed control cam and linkage	.....	Section 50, Group 20



## Group 20 FUEL AND LUBRICANTS

### FUEL

Use regular grade gasoline of a recognized brand. Avoid using stale gasoline or gasoline that has been stored a long time. Stale gasoline does not vaporize properly and causes hard starting.

Premium grade gasoline (ethyl) is not recommended for small tractor engines. The engine compression ratio is not high enough to require premium grade, which can cause a buildup of lead deposits. These deposits cause a loss of power and shorten engine life.

Do not mix oil with gasoline. Do not use white gasoline.

### LUBRICANTS

Effective use of lubricating oils and greases is perhaps the most important step toward low upkeep cost, long tractor life and satisfactory service. Use only the lubricants specified in this group at the proper intervals.

We recommend John Deere Torq-Gard Supreme engine oil for use in the engine crankcase. Torq-Gard Supreme is compounded specifically for use in John Deere engines and provides superior lubrication under all conditions. NEVER PUT ADDITIVES IN THE CRANKCASE. Torq-Gard Supreme oil was formulated to provide all the protection your engine needs. Additives could reduce this protection rather than help it.

If oil other than Torq-Gard Supreme is used, it must conform to one of the following specifications:

#### SINGLE VISCOSITY OILS

API Service CD/SE, CD/SD, CC/SD or SD  
MIL-L-46152, MIL-L-2104C\*

#### MULTI-VISCOSITY OILS

API Service CC/SE, CC/SD or SD  
MIL-L-46152

\* As further assurance of quality, the oil should be identified as suitable for API Service Designation SD.

The charts below and on the next page indicate the lubricant, capacities and service intervals recommended for 140 Tractors beginning with Serial No. 30,001.

### CAPACITIES

Fuel Tank .....	1.75 U.S. Gallons
Crankcase .....	3.0 U.S. Pints*
Transmission/Rear Axle .....	5.0 U.S. Quarts*

\* Initial capacity or after complete disassembly. See page 20-3 of this section.



## TYPE OF LUBRICANT

### Crankcase

Depending on the expected prevailing temperature for the fill period, use the proper viscosity oil listed in the following chart.

Air Temperature	John Deere Torq-Gard Oil	Other Oils	
		Single Viscosity Oil	Multi-Viscosity Oil
Above 32°F.	SAE 30	SAE 30	Not Recommended
-10°F. to 32°F.	SAE 10W-20*	SAE 10W	SAE 10W-30*
Below -10°F.	SAE 5W-20* *	SAE 5W* *	SAE 5W-20* *

\* SAE 5W-20 oil can also be used to insure optimum lubrication at starting, particularly when engine is subjected to -10°F. or lower temperatures for several hours.

\*\* Some increase in oil consumption may be expected when SAE 5W-20 or SAE 5W oils are used. Check oil level more frequently.

Transmission/Rear Axle . . . John Deere All-Weather Hydrostatic Fluid or Automatic Transmission Fluid Type "F"  
 Tractor Grease Fittings and Front Wheel Bearings . . . . . John Deere Multipurpose Lubricant or SAE Multipurpose-Type Grease

## SERVICE INTERVALS

Crankcase (Oil Change)  
 Break-in . . . . . First 2 hours  
 Regular . . . . . Every 25 hours  
 Dusty Conditions . . . . . Every 8 hours  
 Transmission/Rear Axle  
 Oil Change and Filter . . . . . 500 hours or 2 years  
 Tractor Grease Fittings  
 (See page 10-20-4 for locations) . . Spring and Fall  
 Front Wheel Bearings (Repack) . . . . . 250 hours

### Air Cleaner

Clean (Normal Conditions) . . . . . 25 hours  
 Clean (Dusty Conditions) . . . . . 5 hours  
 Replace . . . . . 100 hours

## CHANGING CRANKCASE OIL

*NOTE: The best time to drain the crankcase is when the oil is hot. Dirt and foreign material in the crankcase is in suspension and is easier to drain out.*

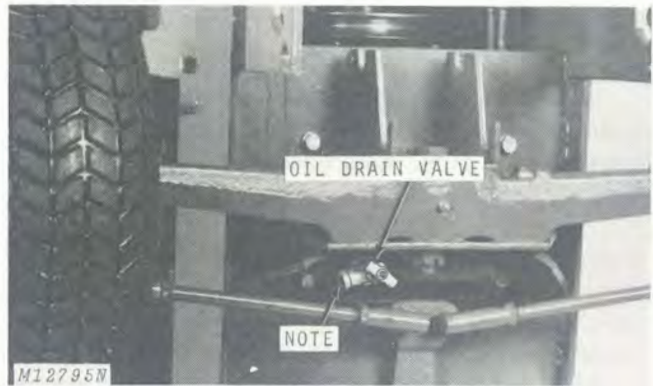

Fig. 1-Draining Crankcase (Serial No. 56,001- )

Open oil drain valve and allow oil to drain into a container, Figure 1.

*NOTE: For convenience a suitable length of 5/8-inch garden hose or plastic tubing may be installed on the drain valve to allow oil to be drained into a container away from the tractor.*

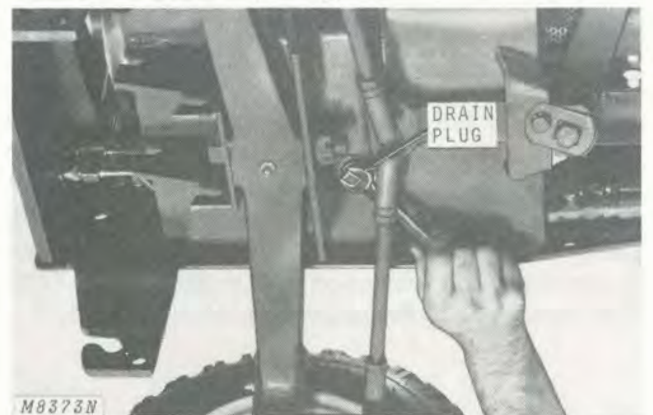

Fig. 2-Draining Crankcase (Serial No. 30,001-56,000)

Remove drain plug and allow oil to drain into container, Figure 2.



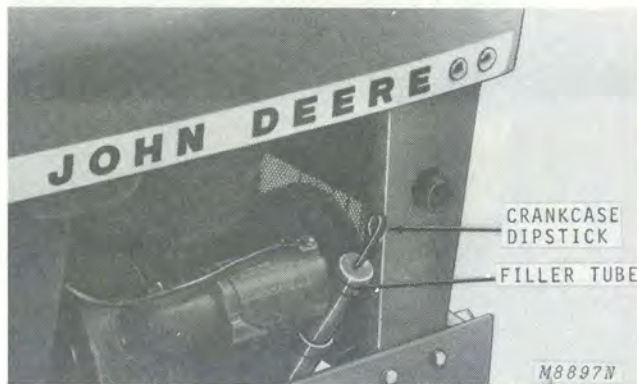

Fig. 3-Dipstick and Filler Tube

After the oil has drained, install drain plug and add 2-1/2 pints of the proper viscosity oil through filler tube, Figure 3. Check dipstick and add another half-pint if dipstick reading indicates necessity.

### CHANGING HYDROSTATIC DRIVE FILTER

**IMPORTANT:** Be extremely careful to prevent dirt or foreign material from entering the hydraulic system when changing filter. Clean dust and dirt from the edges of the filter before removing.

Unscrew and discard oil filter, Figure 4. If removal is difficult, a filter removal tool can be used.

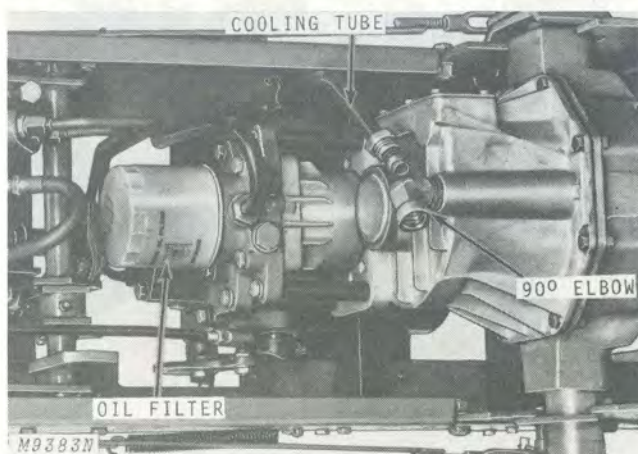

Fig. 4-Changing Transmission Oil Filter

Install a new John Deere oil filter. Moisten rubber gasket with transmission oil prior to installation. **IMPORTANT:** Tighten only hand tight.

### CHANGING HYDROSTATIC DRIVE OIL

To drain transmission drive oil, remove filter and disconnect cooling tube. Turn 90 degree elbow counter-clockwise until it points down, Figure 4. When drained, turn 90 degree elbow to original position and connect cooling tube. Install a new oil filter.

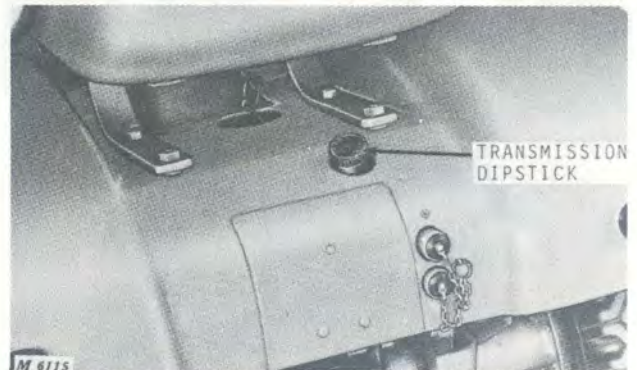

Fig. 5-Transmission Filler Tube and Dipstick

Add 3 quarts of oil. Check dipstick. Then add up to 2 additional quarts until level is to midpoint of "SAFE" range on dipstick, Figure 5. Use only John Deere All-Weather Hydrostatic Fluid or Automatic Transmission Fluid Type "F." Make final check with engine running and transmission control lever in neutral.



## GREASE FITTING LOCATIONS

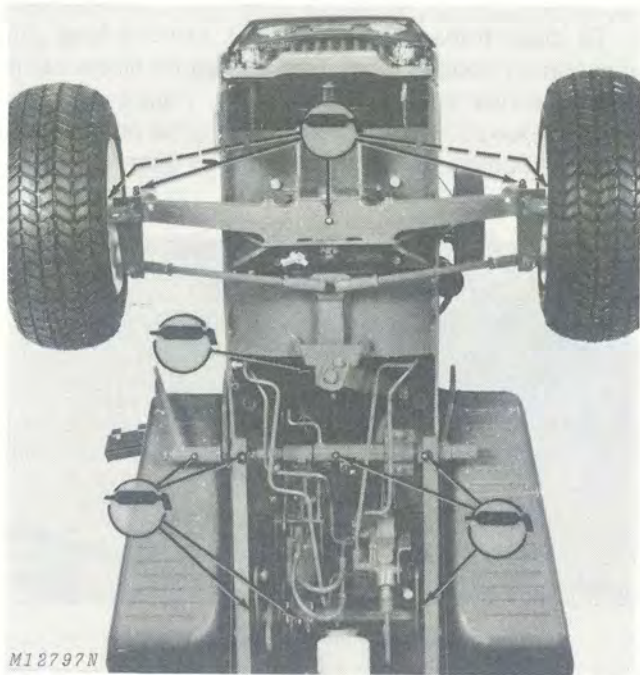

Fig. 6-Fittings on Front Axle, Steering Arm, Brake and Lift Linkage

Lubricate the grease fittings shown above, Figure 6, using a John Deere Pisto-Luber or hand grease gun containing John Deere Multipurpose Lubricant or an equivalent SAE multipurpose-type grease. Wipe fittings clean before and after lubrication.

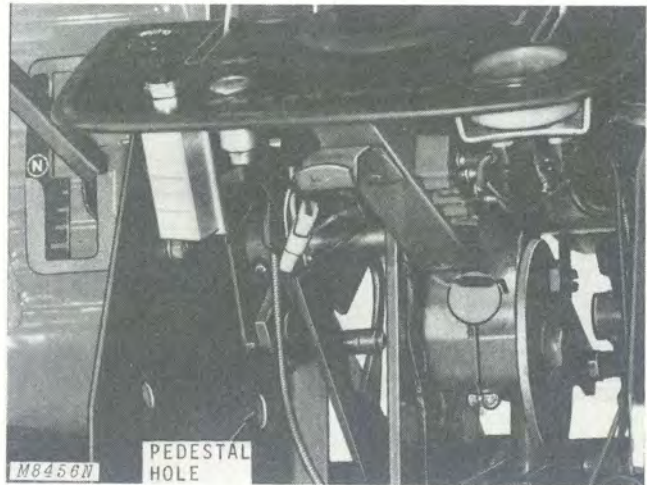

Fig. 7-Lubricating Steering Column

Insert grease gun through hole provided on right-hand side of pedestal, Figure 7, to lubricate steering column. Also lubricate grease fitting on hydraulic lever shaft, below.

**IMPORTANT: Do not overlubricate steering column fitting. Do not use a high-pressure grease gun on this fitting.**

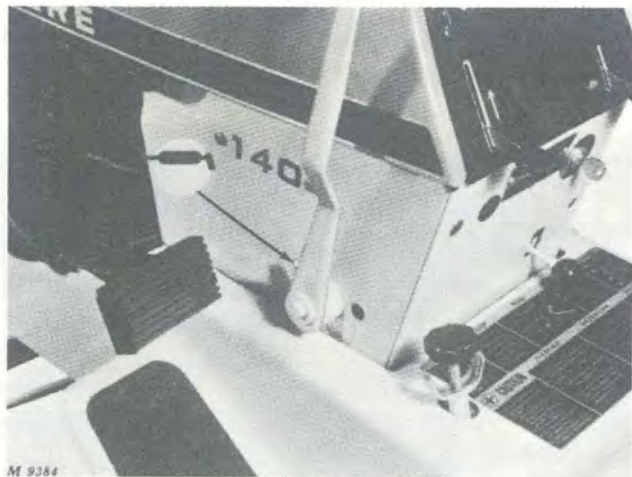

Fig. 8-Lubricating Hydraulic Lever Shaft



# Section 20 ENGINE

## Group 5 GENERAL INFORMATION

### TABLE OF CONTENTS

<b>GROUP 5 - GENERAL INFORMATION</b>		<b>GROUP 15 - PISTON, CRANKSHAFT, MAIN BEARINGS, BALANCE GEARS, AND FLYWHEEL</b>	
Description .....	5-3	General Information .....	15-1
Engine Analysis .....	5-4	Dynamic Engine Balancing System .....	15-2
Preliminary Engine Checks .....	5-4	Repair .....	15-3
Preliminary Engine Tests .....	5-5	Removing Engine .....	15-4
Diagnosing Malfunctions .....	5-7	Engine Service Support Stand .....	15-4
<b>GROUP 10 - CYLINDER HEAD, VALVES AND BREATHER</b>		Disassembling Engine .....	15-5
General Information .....	10-1	Removing Ring Gear .....	15-5
Valve Analysis .....	10-2	Removing Piston Rings .....	15-6
Repair .....	10-3	Piston Ring Analysis .....	15-6
Removing Valves .....	10-4	Inspecting Piston .....	15-8
Inspecting Cylinder Head .....	10-4	Piston Analysis .....	15-9
Inspecting Breather .....	10-5	Inspecting Crankshaft .....	15-11
Testing Valve Springs .....	10-5	Connecting Rod and Cap Analysis .....	15-11
Inspecting Valves .....	10-5	Inspecting and Repairing Block .....	15-12
Reconditioning or Replacing Valves .....	10-6	Deglazing Cylinder Bore .....	15-13
Replacing Valve Guides .....	10-7	Boring Cylinder Block .....	15-13
Replacing Valve Inserts .....	10-8	Inspecting Camshaft .....	15-13
Checking Valve Clearance .....	10-8	Inspecting Main Bearings .....	15-13
Installation .....	10-9	Bearing Analysis .....	15-13
Installing Valve Springs, Retainers and Keepers .....	10-9	Assembly .....	15-15
Assembling Breather .....	10-9	Replacing PTO End Main Bearing .....	15-15
Installing Cylinder Head .....	10-9	Replacing Balance Gear Stub Shafts .....	15-15
Installing Carburetor .....	10-10	Replacing Balance Gear Bearings .....	15-15
Checking Air Filter .....	10-10	Timing Balance Gears Without Special Tool .....	15-15
Spark Plug Gap .....	10-10	Timing Balance Gears With Special Tool .....	15-17
Breaker Point Gap .....	10-10	Assembling Bearing, Bearing Plate and Oil Seals .....	15-18
Specifications .....	10-11	Assembling Connecting Rod and Piston .....	15-18
Table of Clearances .....	10-11	Checking Piston Ring End Gap .....	15-19
Torque for Hardware .....	10-11	Installing Rings and Piston .....	15-19
Tune-Up Data .....	10-11	Attaching Rod to Crankshaft .....	15-20
Special Tools .....	10-12	Assembling Oil Pan on Block .....	15-20
		Assembling Ring Gear on Flywheel .....	15-20
		Installing Flywheel .....	15-21
		Assembling Shrouding .....	15-21
		Assembling Exterior Components .....	15-21
		Installation .....	15-22
		Installing Engine .....	15-22

*Continued on next page*

### TABLE OF CONTENTS - Continued

Adjustment .....	15-23	Installation .....	20-4
Throttle Linkage Adjustment .....	15-23	Installing Governor .....	20-4
Governor Speed Adjustment .....	15-23	Installing Camshaft .....	20-5
Specifications .....	15-24	Installing Governor Arm .....	20-5
Table of Clearances .....	15-24	Specifications .....	20-6
Torques for Hardware .....	15-24	Table of Clearances .....	20-6
Maintenance Data .....	15-24	Torque for Hardware .....	20-6
Special Tools .....	15-25	Special Tools .....	20-6
 GROUP 20 - CAMSHAFT, TAPPETS, AND GOVERNOR			
General Information .....	20-1		
Automatic Compression Release			
Camshaft .....	20-2		
Repair .....	20-3		
Removing Camshaft and Tappets .....	20-3		
Removing Governor .....	20-4		
Inspecting Camshaft .....	20-4		
Inspecting Governor Gear .....	20-4		



## DESCRIPTION

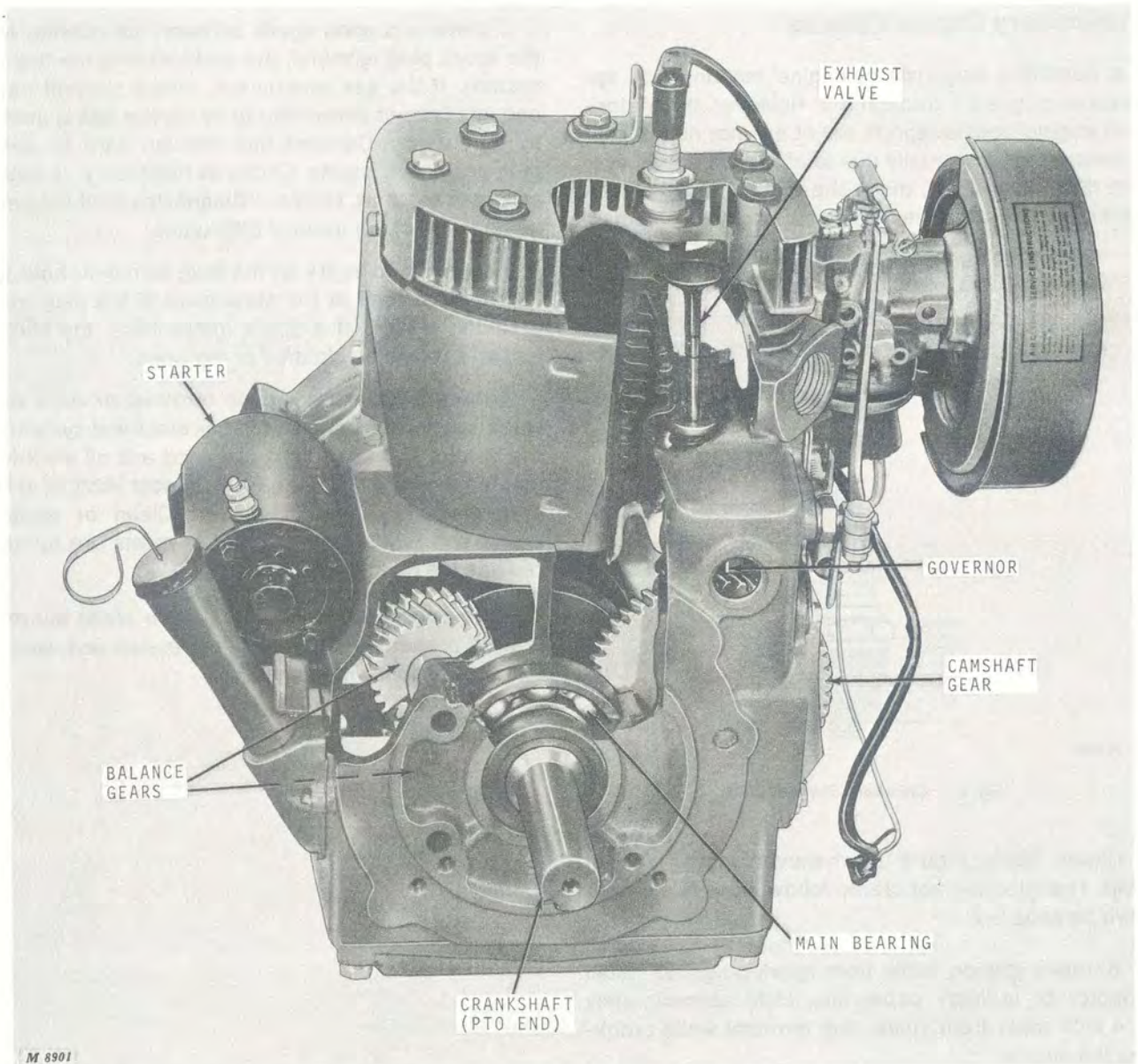

Fig. 1 - Cutaway View of Kohler K321AS Engine (PTO Shaft End)

140 Hydrostatic Tractors are equipped with a Kohler K321AS, four-cycle, L-head, single-cylinder internal-combustion engine. It has a cast-iron block with large bore - short stroke design.

The engine is air-cooled, has anti-friction ball bearings, oil bath lubrication and an internal flyweight governor.

Other features are a dynamic balancing system and battery ignition.

Detailed specifications are covered in Section 10, "General," and at the end of each group in this section.

## ENGINE ANALYSIS

### Preliminary Engine Checks

A complete diagnosis of engine malfunctions appears on pages 5-7 through 5-9. However, the majority of engine trouble reports are of a minor non-chronic nature and are usually due to electrical or fuel system difficulties. First, make the checks listed on the next page to isolate the majority of engine problems.



M 8502

Fig. 2 - Checking Spark at Plug

Check spark, Figure 2, whenever engine will not start. If engine will not crank, follow diagnosis procedure on page 5-7.

Remove ignition cable from spark plug and install adaptor or ordinary paper clip. Hold approximately 1/4 inch away from spark plug terminal while cranking the engine.

If there is a good spark between the adaptor and the spark plug terminal, the problem is in the fuel-air system. If the gas tank is full, check shut-off valve and gas lines to carburetor to be certain gas is getting to carburetor. Connect high-tension wire to spark plug and crank engine. Choke as necessary. If engine still does not start, refer to "Diagnosing Malfunctions" guide to check for internal difficulties.

If there is no spark at the plug terminal, hold the high-tension lead at the steel base of the plug while cranking engine. If a spark jumps here, the plug is bad and should be cleaned or replaced.

If there is no spark at the terminal or base or a weak spark, the trouble is in the electrical system. If the battery and spark plug are good and all electrical connections are tight, the trouble most likely is in the breaker points and condenser. Clean or replace points and adjust gap. If breaker points are burned, replace the condenser also.

If the engine still does not start, or starts but does not run properly, make the compression and vacuum tests on the following pages.



## Preliminary Engine Tests.

The following preliminary engine tests are recommended to detect and isolate possible malfunctions before proceeding with further diagnosis. These tests are especially important when the engine is burning oil, losing power or running erratically and when carburetion and ignition adjustments do not correct the condition.

### Compression Test

The 140 Tractor engine features an automatic compression release camshaft (ACR). Because ACR relieves compression pressure during slower cranking speeds (650 rpm and below), it is important to crank the engine at 1000 rpm or more to obtain an accurate test unless, however, the engine is cranked backward.

With the engine installed in the tractor, test compression as follows.

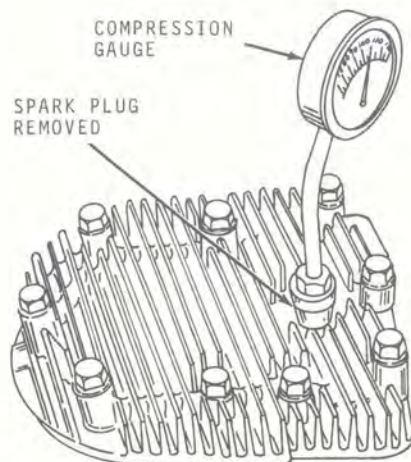

M 8503

Fig. 3 - Testing Engine Compression

Place hydrostatic control lever in neutral, depress brake pedals and set parking brake. Be sure oil in crankcase is at proper level.

*NOTE: Be sure tractor drives are all disengaged. Run engine until warm, then stop the engine.*

Remove spark plug. Also remove air filter for most accurate test.

Set throttle and choke valve in wide open position by raising throttle lever all the way and lowering choke lever.

Wind a 1/4-inch starter rope around flywheel sheave in the opposite direction of crankshaft rotation. Have a helper hold the compression gauge in the spark plug hole, Figure 3. Pull starter rope and record reading. Repeat procedure to insure correct reading.

### Test Conclusions

An engine in top operating condition will have a compression gauge reading of 110 to 120 psi.

A compression test reading above 120 psi indicates excessive deposits in the combustion chamber or on the piston.

A reading lower than 100 psi indicates leakage at the cylinder head gasket, piston rings or valves. *The engine should be repaired or reconditioned if compression falls below 100 psi.*

To determine whether the rings or the valves are at fault, pour about one tablespoonful of heavy oil into the spark plug hole. Crank the engine several revolutions to spread the oil and repeat the compression test.

The oil will temporarily seal leakage around the piston rings. If the same approximate compression reading is obtained, the rings are satisfactory, but the valves are leaking or the piston is damaged. If the compression has increased considerably over the original readings, there is leakage past the rings.



### Crankcase Vacuum Test

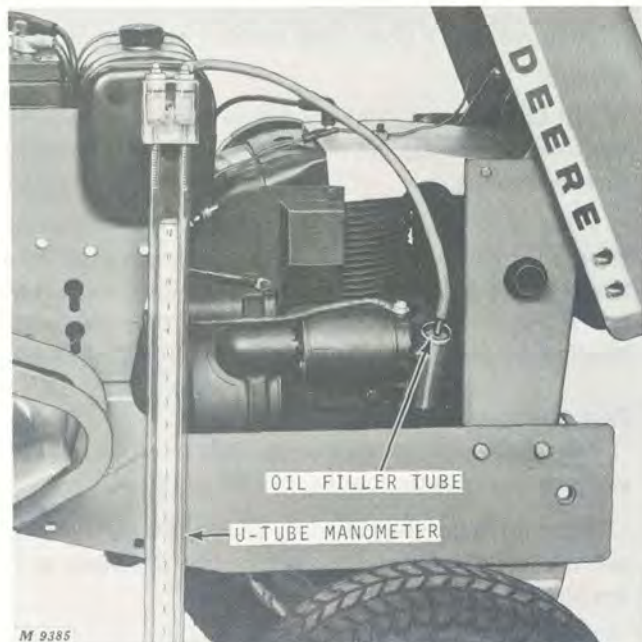

Fig. 4 - Checking Crankcase Vacuum

The crankcase breather maintains a partial vacuum in the crankcase when engine is operating properly.

To determine proper operation of the breather, connect a water U-tube manometer to the oil filler tube, Figure 4. The tester must hang vertically as shown. Start and run engine at 1200 to 1700 rpm. Allow engine to warm up and observe reading on scale. Follow manufacturer's recommendations for installation, testing and compensation for the effect of altitude on the gauge reading.

### Test Conclusions

Proper crankcase vacuum is a 5-inch to 10-inch water column.

A crankcase vacuum reading lower than indicated above is most likely due to a leaking breather valve or improperly assembled breather. See Group 10 and carefully reassemble all breather parts. A low vacuum reading may also be caused by leaky valves, engine blow-by, or worn oil seals.

If the crankcase is found to be pressurized rather than have a vacuum, chances are that the breather filter is plugged.

Engines with zero vacuum or pressurized crankcase will likely be pumping oil into the combustion chamber or out the breather or oil seals. This can be detected by watching for excessive exhaust smoke, engine overheating or oil leakage outside the engine.

## DIAGNOSING MALFUNCTIONS

### Engine

#### Engine Will Not Crank

- Hydrostatic control lever not in neutral.
- Battery discharged or defective.
- Neutral-start switch and bracket loose or not properly adjusted.
- PTO drive engaged.
- Defective safety switch (es).
- Defective starter.
- Defective solenoid.
- Loose electrical connections.
- Defective key switch
- Engine seized

#### Engine Cranks But Will Not Start

- Empty fuel tank.
- Restricted fuel tank vent.
- Fuel shut-off valve closed (valve below fuel tank).
- Clogged, restricted or air-locked fuel line.
- Breaker points worn or pitted.
- Spark plug fouled or pitted.
- Battery not fully charged.
- Loose electrical connections.
- Faulty condenser.
- Defective ignition coil.
- Dirt in fuel system.
- Frayed wire (s) causing ground (s).

#### Engine Starts Hard

- Spark plug pitted or fouled.
- Breaker points worn, pitted or out of adjustment.
- High-tension wire shorted.
- High-tension wire loose at spark plug or coil.
- Loose electrical connections.
- Restricted fuel tank vent.
- Clogged fuel line or air lock.
- Broken choke or throttle cable.
- Dirt or water in fuel system.
- High speed and idle mixture needles not properly adjusted.
- Wrong valve clearance.
- Head gasket leaking.
- Low compression.

#### Engine Starts But Fails to Keep Running

- Restricted fuel tank vent.
- High speed and idle mixture needles not properly adjusted.
- Broken choke cable.
- Dirt or water in fuel system.
- Carburetor float leaking or not properly adjusted.
- High-tension wire loose at spark plug or coil.
- High-tension wire shorted.
- Breaker points not properly adjusted.
- Loose connections.
- Defective head gasket.
- Faulty condenser.



## DIAGNOSING MALFUNCTIONS - Continued

### Engine Runs But Misses

- High-tension wire loose from spark plug or coil.
- Breaker points out of adjustment or worn and pitted.
- Spark plug fouled or pitted, incorrect gap.
- Loose electrical connections.
- Carburetor float leaking or not properly adjusted.
- Dirt or water in fuel system.
- Wrong valve clearance.
- Faulty coil.
- Engine shrouding plugged (overheats).

### Engine Misses Under Load

- Spark plug fouled or pitted, incorrect gap.
- High speed and idle mixture needles not properly adjusted.
- Incorrect spark plug.
- Breaker points out of adjustment or worn and pitted.
- Ignition out of time.
- Dirt or water in fuel system.
- Stale fuel.

### Engine Will Not Idle

- Idle speed too slow.
- Idle mixture needle not properly adjusted.
- Dirt or water in fuel system.
- Restricted fuel tank filler cap.
- Spark plug fouled or pitted, incorrect gap.
- Wrong valve clearance.
- Low engine compression.

### Engine Misses When Advancing Throttle

- Cold engine.
- High speed and idle mixture needles not properly adjusted.
- Spark plug fouled or pitted, incorrect gap.
- Linkage misaligned (throttle arm-to-governor).

### Engine Loses Power

- Crankcase low on oil.
- Engine shrouding plugged (overheats).
- Excessive engine load.
- Restricted air filter.
- Dirt or water in fuel system.
- High speed and idle mixture needle not properly adjusted.
- Spark plug fouled or pitted (incorrect gap).
- Too much oil in crankcase.
- Low engine compression.
- Worn cylinder bore.

### Engine Overheats

- Dirty or plugged shrouding and engine fins.
- High speed and idle mixture needles not properly adjusted.
- Too much oil in crankcase.
- Crankcase low on oil.
- Excessive engine load.

### Engine Knocks

- Engine out of time.
- Excessive engine load.
- Crankcase low on oil.

### Engine Backfires

- High speed and idle mixture needles not properly adjusted.
- Loose cylinder head or blown head gasket.
- Intake valve sticking in guide.
- Ignition out of time.

## DIAGNOSING MALFUNCTIONS—Continued

### Engine Uses Excessive Amount of Oil

- Clogged breather assembly.
- Breather not assembled properly.
- Worn or broken piston rings.
- Worn cylinder bore.
- Clogged oil holes in piston.
- Wrong size piston rings.
- Worn valve stems and/or valve guides.
- Incorrect oil viscosity.
- Faulty breather causing low crankcase vacuum.

### Engine Runs Erratically or Surges

- Dirt or water in fuel system.
- High speed and idle mixture needles not properly adjusted.
- Idle speed too slow.
- Spark plug fouled or pitted (incorrect gap).
- Poor compression.
- Faulty breather causing low crankcase vacuum.
- Carburetor leaking at gaskets or at connection.
- Restricted fuel tank vent.
- Throttle-to-governor linkage misassembled.
- Throttle-to-governor linkage improperly adjusted.
- Breaker points out of adjustment, worn or pitted.

### Gasoline in Crankcase

- Carburetor float not properly adjusted or leaking.
- Float valve and/or seat leaking.

### Excessive Vibration

- Engine balance gears timed wrong.
- Bolts holding engine to engine base are loose.
- Misalignment or excessive drive shaft wear.
- Loose PTO pulley.
- Loose or improperly balanced flywheel.
- Worn clutch coupling.
- Engine out of time.
- Loose flexible coupling between drive shaft and hydrostatic transmission.



## Group 10 CYLINDER HEAD, VALVES, AND BREATHER

### GENERAL INFORMATION

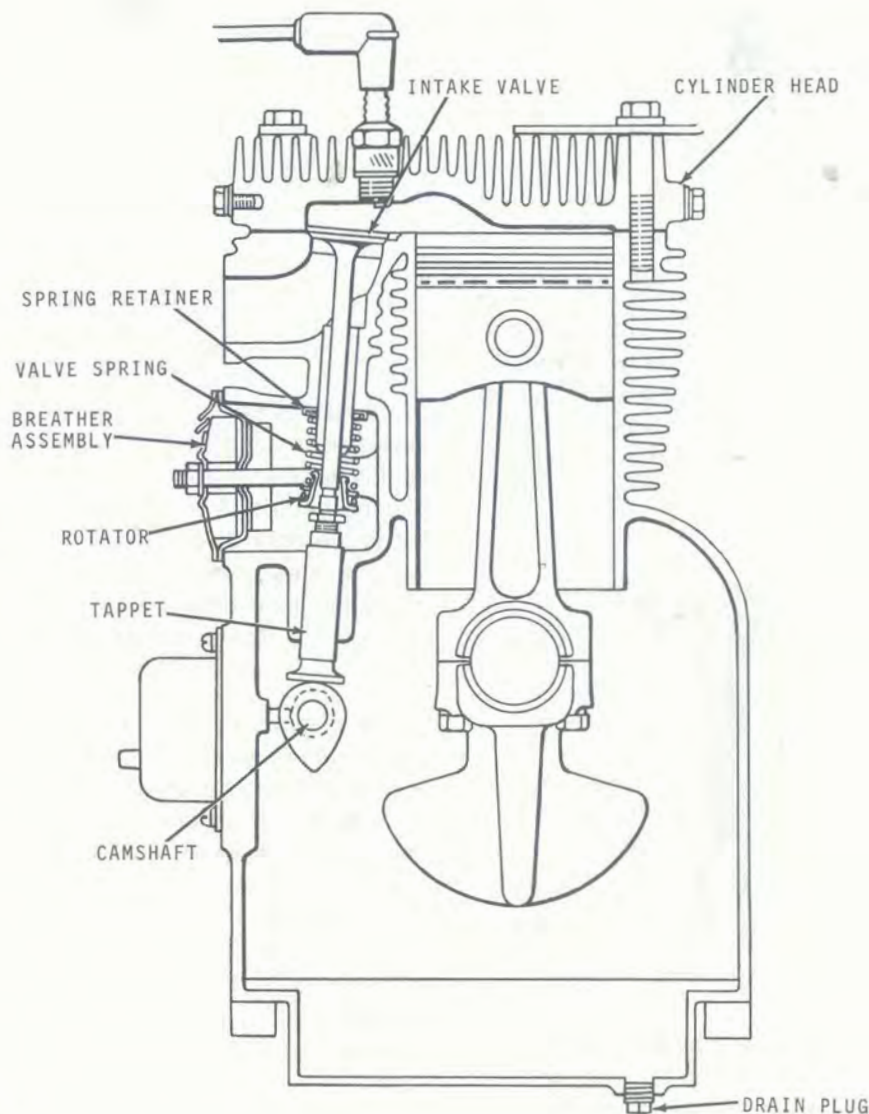

M 9386

Fig. 1-Schematic View of Intake Valve, Tappet, and Breather Assembly

It is not necessary to remove the engine from the tractor to grind valves and valve seats or to service the breather assembly.

The 140 Tractor has valve rotators on both the intake and exhaust valves (15, Figure 6). Both valves also feature replaceable inserts (29, 30, Figure 6) which are pressed into the block.

Valve guides can be replaced when wear tolerances are exceeded.

The breather assembly is mounted in front of the valve spring chamber below the carburetor.



## VALVE ANALYSIS



Fig. 2 - Lead Deposits on Leaky Intake Valve

Lead deposits on the intake valve consist mostly of lead and some metal which comes from the lubricating oil. It is caused by a small amount of leakage of exhaust gases back into the intake port area. This indicates that the valve is not seating properly. Grind the valve and reface the seat to correct this condition. **NOTE:** Be sure to correct valve-to-tappet clearance after grinding valves. See page 10-8.



Fig. 3 - Valve Stem Corrosion

Valve stem corrosion is caused by moisture finding its way into the engine. Moisture in the fuel-air mixture can condense inside the engine when engine is stopped before it has had a chance to warm up.

Valve corrosion can also occur during storage when the engine has not been run for some time. Fogging or pouring oil in the combustion chamber before storing will prevent valve corrosion.

Corroded and pitted valves tend to collect deposits which in turn causes valve sticking. Always replace badly corroded or pitted valves with new valves.



Fig. 4 - Exhaust Valve Running Too Hot

Exhaust valves are designed to function in temperatures exceeding 5000° F. However, when operating at this temperature for long periods of time, valve burning occurs. A tell-tale sign of valves running too hot is the dark discoloration of the valve stem down into the area protected by the valve guide. Another indication is disfiguration of the valve margin and valve face. Valve inserts may also begin to burn away.

The most common cause of an overheated engine and valves is poor cooling due to dirt or obstructions inside the intake shrouding. Remove and clean shrouding and all cooling fins on the engine if this condition is noticed. **NOTE:** Never run engine with shrouding removed.

Also check for improper valve timing by checking and correcting valve clearance.

Worn valve guides or valve springs can also cause overheated valves.

Valves running hot also can be caused by a lean fuel mixture, improper spark plug or over-heated spark plugs which cause pre-ignition.



Fig. 5 - Gummy Valve Causing Valve to Stick

Using gasoline which has been left in the tank a long time is a common cause of sticking valves.

Sometimes this gummy substance can be seen on the valve. When this condition is found, it is also likely that the carburetor also contains gum deposits and will require a complete cleaning.

Advise customer always to use fresh gasoline and always to drain gas from all fuel lines and carburetor before storing tractor.

## REPAIR

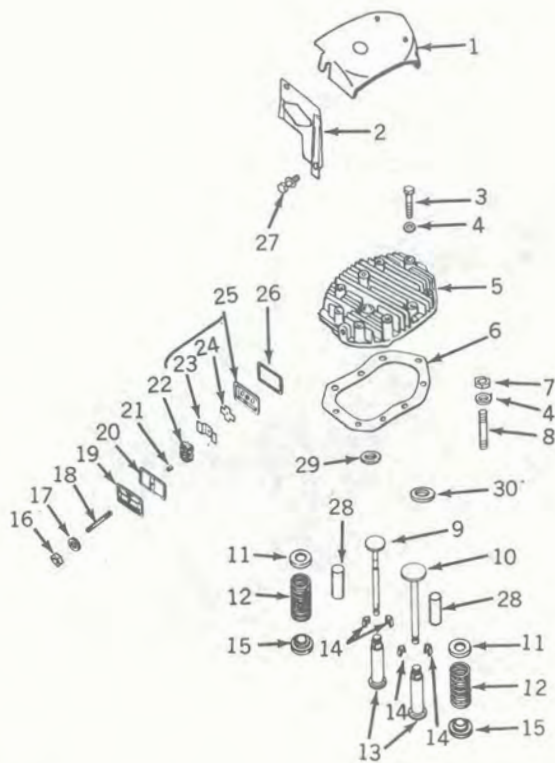

- 1 - Head Baffle
- 2 - Side Baffle
- 3 - Cap Screw (8 used)
- 4 - Washer (9 used)
- 5 - Cylinder Head
- 6 - Head Gasket
- 7 - Hex. Nut
- 8 - Stud
- 9 - Exhaust Valve
- 10 - Intake Valve
- 11 - Upper Spring Retainer (2 used)
- 12 - Valve Spring, Intake and Exhaust (2 used)
- 13 - Tappet (2 used)
- 14 - Spring Keeper (4 used)
- 15 - Rotator, Intake and Exhaust (2 used)
- 16 - Hex. Nut
- 17 - Lock Washer
- 18 - Stud
- 19 - Cover
- 20 - Outer Gasket
- 21 - Seal
- 22 - Filter
- 23 - Baffle
- 24 - Reed
- 25 - Breather Plate Assembly
- 26 - Inner Gasket
- 27 - Cap Screw (4 used)
- 28 - Valve Guides (2 used)
- 29 - Exhaust Valve Insert
- 30 - Intake Valve Insert

M 9387

Fig. 6 - Exploded View of Cylinder Head, Valves and Breather



## REPAIR - Continued

It is not necessary to remove the engine from the tractor when servicing the cylinder head, head gasket, muffler, breather assembly, valves and valve seats.

Disconnect choke conduit and cable at carburetor. Remove carburetor, breather assembly, head baffle, cylinder head and head gasket.

### Removing Valves

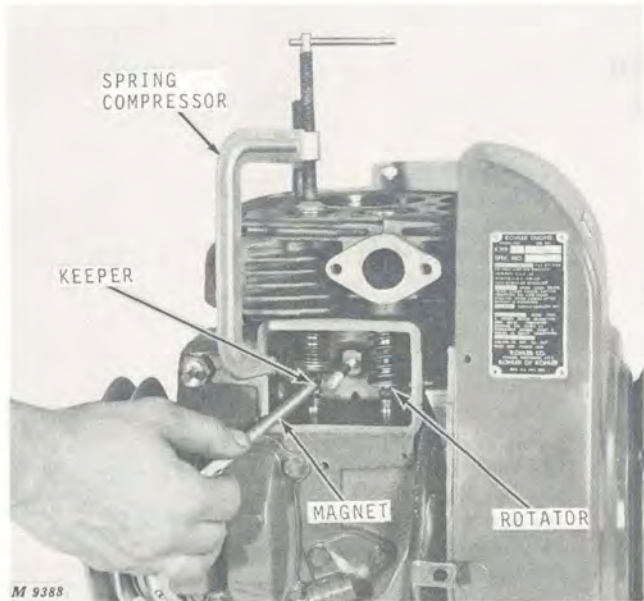

Fig. 7 - Removing Valves

Use a valve spring compressor to compress valve springs, Figure 7. Remove keepers from valve stem and lift valves from engine block.

Remove valve spring retainers, rotators, and valve springs from valve chamber.

### Inspecting Cylinder Head

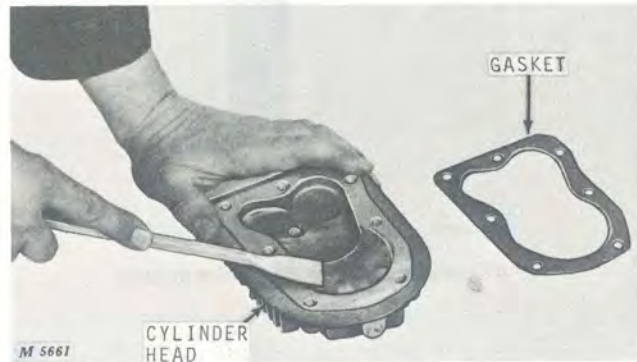

Fig. 8 - Cleaning Cylinder Head

Remove all deposits from combustion chamber and gasket surface of head with a scraper and a wire brush, Figure 8.

Be careful not to damage the cylinder head gasket surface. Use a safe cleaning solvent to remove dirt, grease and other deposits.



Fig. 9 - Checking Surface of Cylinder Head

Check the cylinder head for cracks and broken cooling fins and inspect the gasket surface for burrs and nicks. Replace the head if any of these conditions are found.

When a cylinder head is removed because of gasket leaks, check the flatness of the cylinder head by placing it on a surface plate, Figure 9. Check to see that gasket surfaces make contact at all points. Replace the cylinder head if it is warped.

**NOTE:** Always use new head gasket after removing cylinder head.

### Inspecting Breather

Clean all breather parts in solvent. Blow out filter contamination with compressed air or replace with new filter as necessary.

Inspect reed valve to be certain it is flat and not damaged.

Be sure small drain hole in breather plate is not clogged. Refer to Figure 24 when reassembling breather.

### Testing Valve Springs

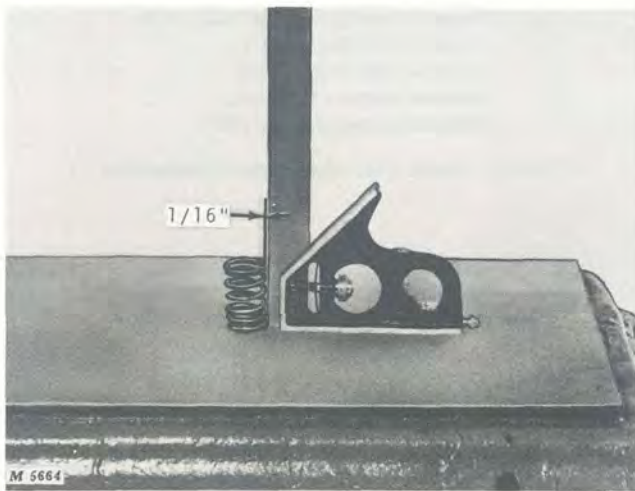

Fig. 10 - Valve Spring Squareness

Check valve spring for squareness, using a steel square and a surface plate, Figure 10. Stand the spring and square on end on the surface plate. Slide the spring up to the square. Revolve the spring slowly and observe the space between the top coil of the spring and the square. See "Specifications," page 10-11, for out-of-square limits.



Fig. 11 - Valve Spring Tension

Check valve spring for proper pressure, Figure 11. Refer to "Specifications," page 10-11, for free length of the spring and the pressure in pounds that the spring should exert when it is compressed to a measured length.

### Inspecting Valves

Remove carbon from valve head, face, and stem with a power-operated wire brush. Be sure carbon is removed and not merely burnished. Any carbon left on the stem will affect accurate alignment in the valve refacer collet.

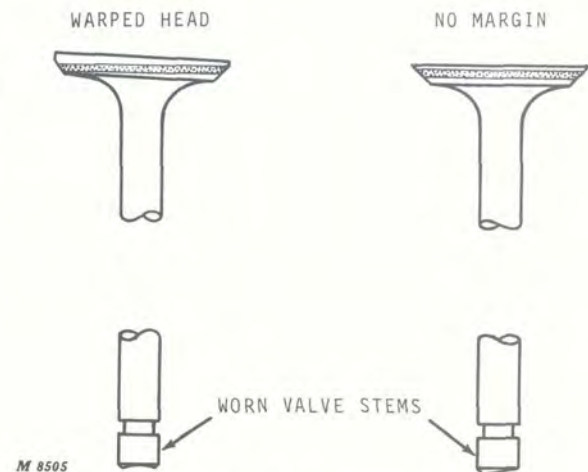

Fig. 12 - Faulty Valves

Check valve faces, heads and stems, Figure 12, for defects. Also look for bent valve stems and excessive corrosion causing pits on valve face or stem. Replace valves with warped head. Recondition or replace valves with less than 1/32-inch margin. Valve stem ends should be ground square before checking valve tappet clearance.



## Reconditioning or Replacing Valves

### Valve Guides

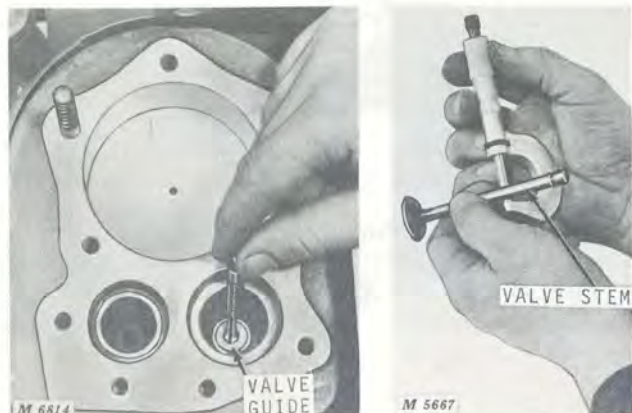

Fig. 13 - Measuring Valve Guides and Stems

Clean the valve guides first to assure valve alignment when cutting valve seats.

Use valve guide cleaner to clean inside of valve guide. Then measure I.D. of valve guide, and O.D. of valve stem, Figure 13. Refer to "Specifications," page 10-11, for clearance. Replace and ream guides as necessary.

### Valve Seats

Broken or worn valve seats (inserts) may be replaced. See page 10-8. They are either stellite or molybdenum nickel.

The valve seating surface "A," Figure 14, should be held as close to 1/32 inch as possible. Seats with more than 1/16-inch seating surface should be narrowed (cut back) with 30 degree cutters, Figure 15.

The valve seat angle "B" depends upon valve face angle "C." New valves have a 45 degree face. Recondition valve seats with 45 degree cutters and lap valves. See opposite page.

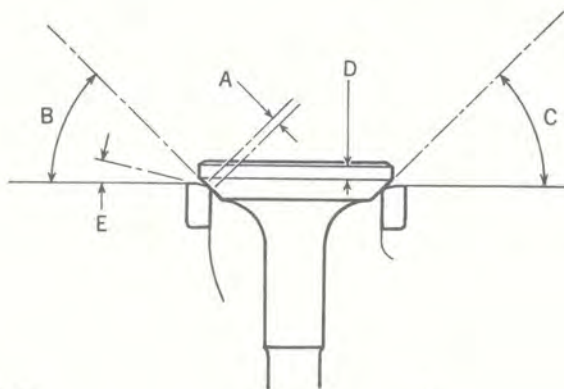

M 5567

- A-Valve Seating Surface (1/32 inch)
- B-Valve Seat Angle (45°)
- C-Valve Face Angle (45°)
- D-Valve Margin (1/16 inch)
- E-Seat Narrowing Angle (30°)

Fig. 14 - Valve Seat and Surface Dimensions

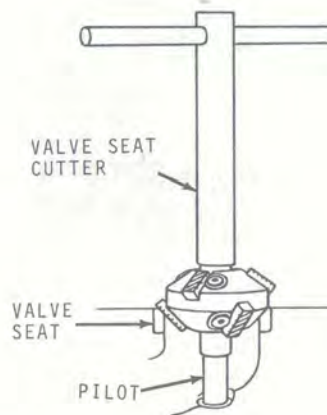

M 5568

Fig. 15 - Valve Seat Cutter

This valve seat cutter will cut a 45 degree valve seat and narrow the seat to 30 degrees. See "Special Tools," page 10-12, for tool manufacturer.

When reconditioning valves, be sure there is no less than 1/32-inch margin "D" on the valve, Figure 14.

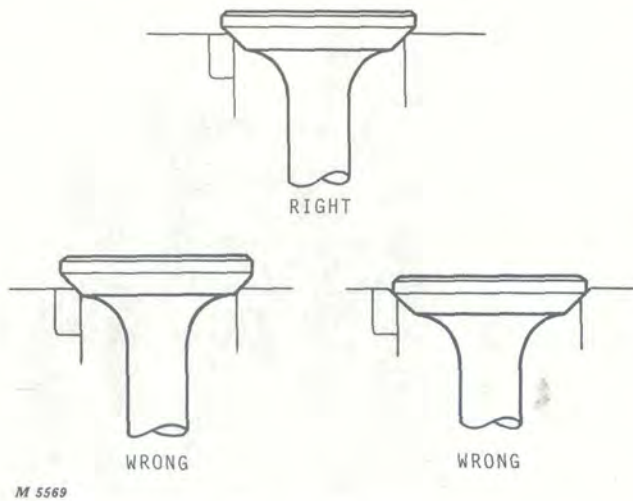

Fig. 16 - Valve and Seat Relationship

When matching valves to seats, be sure valve seat is very nearly centered on the valve face. The position of the valve in the seat is clearly evident after lapping the valve, Figure 16.

### Valve Lapping

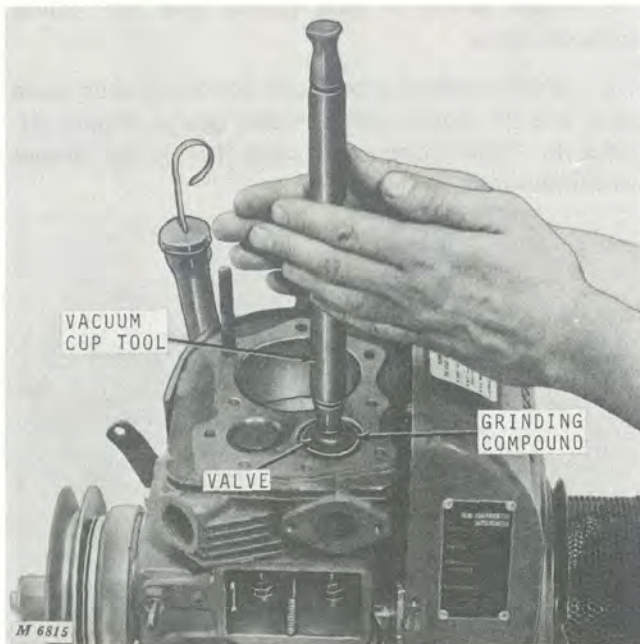

Fig. 17 - Lapping Valves

Coat face of valve sparingly with a fine grade of valve grinding compound. Use a vacuum cup tool, Figure 17, to grip top of valve and rotate valve in an oscillating circular motion on valve seat.

Lift valve from seat every eight or ten strokes to keep compound equalized on surface of valve seat.

Continue valve lapping operation until a uniform lapping ring appears around entire surface of valve face. When a good surface is attained, wash all parts with solvent to remove all traces of lapping compound. Dry parts thoroughly.

Note position of valve seat marked on valve face. The lapping mark made by the seat after lapping should appear on or near the center of the valve face.

### Replacing Valve Guides

If valve guide clearance exceeds maximum tolerance, replace the guide.

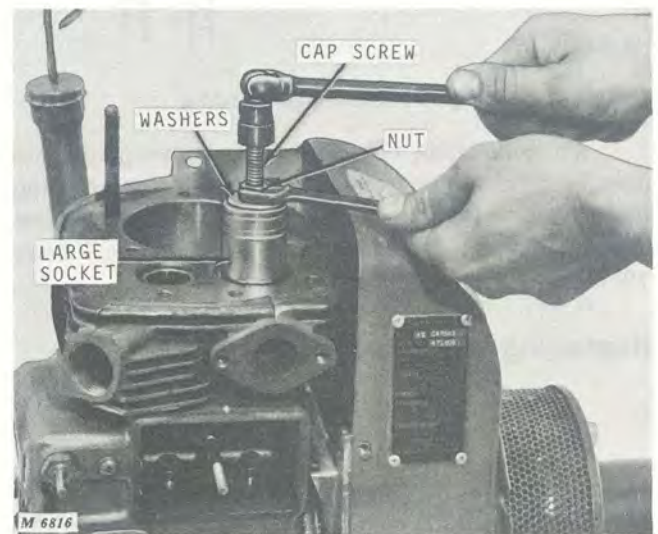

Fig. 18 - Removing Valve Guides

Tap the valve guide its full length using a 3/8-inch N.C. tap and tapping compound or oil to prevent tap from breaking off in valve guide.

Thread a 3/8-N.C. x 6-inch cap screw its full length.

Install a nut, washer and spacer on the cap screw; then, turn the cap screw into the valve guide the full length of the valve guide.

Hold cap screw and keep turning nut against washer until valve guide is completely free from cylinder block, Figure 18.

**NOTE:** Valve guides can also be removed by driving them down into the valve spring chamber and carefully breaking them. Use care not to damage the cylinder block.



## Replacing Valve Guides-Continued

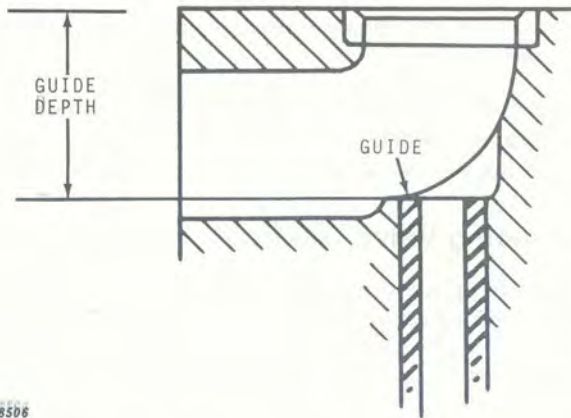

Fig 19 - Installing Valve Guides

Thoroughly clean hole and press valve guide into hole 1-15/32 inches from top of block. After installing new guide, ream hole as required for necessary valve clearance in guide. Refer to "Specifications," page 10-11, for valve guide clearances.

## Replacing Valve Inserts

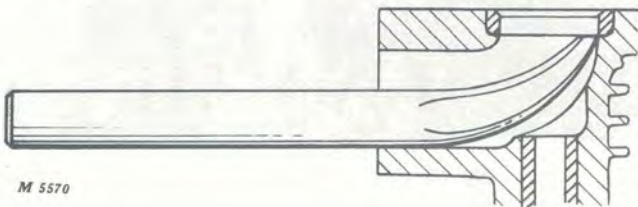

Fig. 20 - Removing Exhaust Valve Insert

To remove valve seat inserts, use extractor, Figure 20, or a valve seat puller. See "Special Tools," page 10-12. Clean seat area thoroughly before installing new insert. If extractor is not available, break insert and drive out.

Valve inserts are retained by press fit only. Chill both the insert and driving tool in dry ice before pressing insert into block.

## Checking Valve Clearance

Valve grinding changes the tappet and valve clearance. After grinding or installing new valves, check clearance as follows:

1. Rotate crankshaft until piston is at top dead center (end of compression stroke) and crankshaft keyway is at exactly 12 o'clock (top) position. If breaker points are properly adjusted, they will be



Fig. 21 - Checking Valve Clearance

opening at this time. It is important that this procedure be followed to insure that the exhaust tappet is NOT riding on the automatic compression release mechanism.

2. Grind off tip of valve stem in a valve resurfacing machine set to grind a perfectly square face.

3. Insert valves in their guides and hold valves firmly on seats.

4. Check clearance between bottom of each valve stem and its tappet with a feeler gauge, Figure 21. Refer to "Specifications," page 10-11, for proper valve clearance.

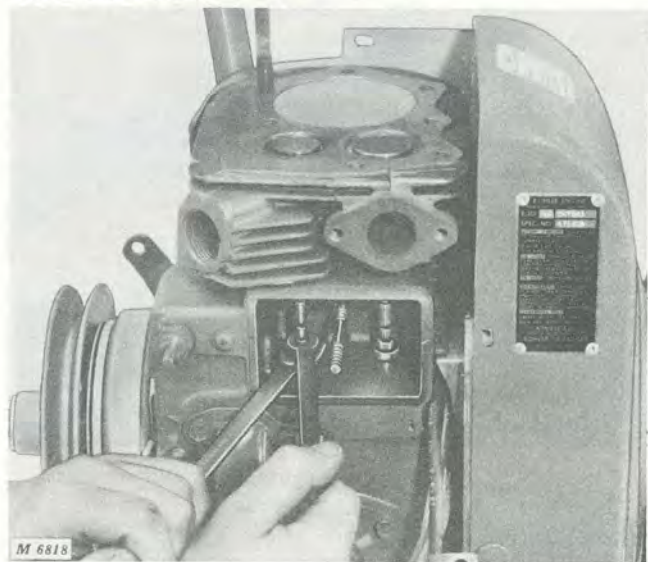

Fig. 22 - Adjusting Tappet Clearance

5. With a wrench on the flat area of the tappet and a wrench on the tappet adjusting screw, Figure 22, turn the screw up or down until the proper setting is obtained when checking with a feeler gauge.



## INSTALLATION

### Installing Valve Springs, Retainers and Keepers

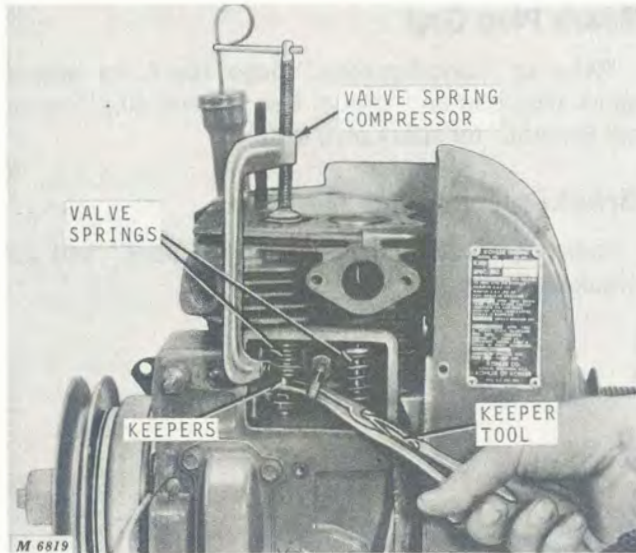

Fig. 23-Installing Valve Springs, Retainers and Keepers

Place upper retainers, valve springs, and rotators into valve chamber.

Install valves in guides working them back and forth to make sure they slip through the guides easily. Using a spring compressor, compress the springs and install keepers on valve stem with keeper tool, Figure 23. If tool is not available, apply grease to keepers to hold them on the valve stem and insert them by hand.

### Assembling Breather

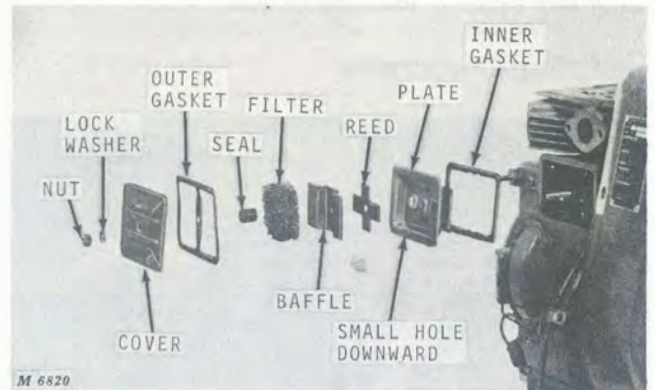

Fig. 24-Breather Parts

The correct order of breather assembly is very important. For correct assembly, refer to Figure 24. Always use new gaskets. Place breather plate so that small hole at bottom of plate is down. If breather plate is reversed, engine will pump oil out of the breather chamber and engine damage will soon occur.

### Installing Cylinder Head

Always install a new head gasket when head has been removed for service. This will assure a gas-tight fit.

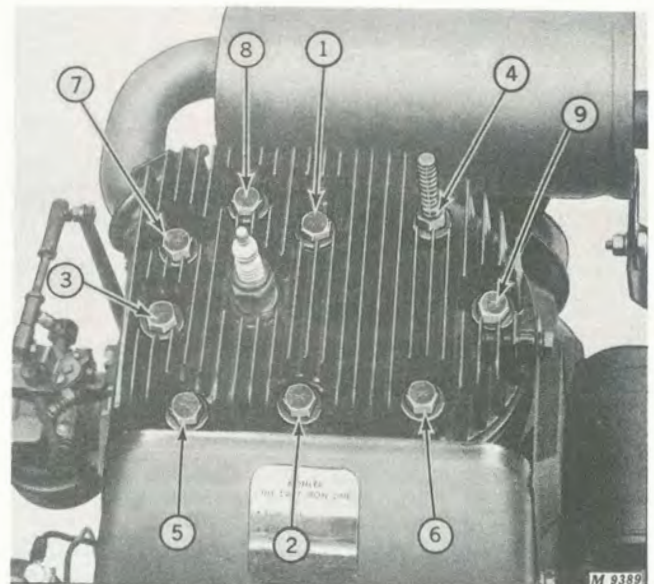

Fig. 25-Cylinder Head Bolt Tightening Sequence

It is important to tighten all cylinder head bolts with an even pressure and in their correct order, Figure 25, so that uneven stresses will not be set up in the cylinder wall. Refer to "Specifications," page 10-11, for proper cylinder head bolt torque.

### Installing Carburetor

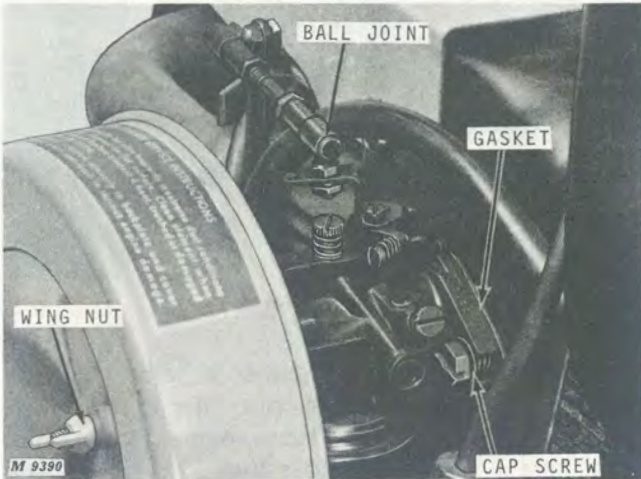

Fig. 26-Carburetor Assembly

Using a new gasket, mount carburetor, Figure 26, on engine block and tighten bolts firmly. Connect fuel line to carburetor. Install head baffle. Connect throttle rod between governor arm and throttle shaft arm.

### Checking Air Filter

Be sure air filter is clean. Remove filter and tap out dust or replace if necessary. See Section 30, Group 15.

### Spark Plug Gap

Refer to "Specifications," page 10-11, for proper spark plug gap and torque. See Section 40, "Electrical System," for spark plug testing.

### Breaker Point Gap

Refer to Section 40, "Electrical System," and set breaker point gap.



## SPECIFICATIONS

### K321AS Kohler Engine

Component	New Part Dimension	Wear Tolerance
Valve stem diameter-Intake	0.3105/0.3110 inch	.....
Exhaust	0.3090/0.3095 inch	.....
Valve seat width	3/64 inch	1/32 inch
Valve face width	3/32 inch	.....
Valve margin	1/16 inch	1/32 inch
Valve spring squareness	1/32-1/16 inch	3/32 inch
Valve spring compressed tension	43-49 lbs. at 1-5/16-inch length	.....
Valve spring free length with rotator	1-7/8-inch	.....
Cylinder head flatness	Contact at all points	Replace if warped

### Table of Clearances

Item	Clearances
Intake valve stem in guide	0.0010 to 0.025 inch
Exhaust valve stem in guide	0.0025 to 0.0040 inch
Valve clearance-intake (cold)	0.008 to 0.010 inch
Valve clearance-exhaust (cold)	0.017 to 0.020 inch

### Torque for Hardware

Location	Torque
Cylinder head bolts	25-30 ft-lbs
Spark plug	27 ft-lbs

### Tune-Up Data

Item	Specifications
Engine compression	110-120 psi (1000 rpm)
Spark plug gap	0.025 inch
Valve face angle	45°, see page 10-6
Valve seat angle	45°, see page 10-6
Crankcase vacuum	
(A) U-tube manometer	5 to 10-inch water column
(B) Mercury gauge	1/2 to 1-inch mercury



### SPECIAL TOOLS

Name	Part No.	Use
Extractor	K.O. LEE R95	To remove valve seat inserts.
Valve Spring Tester	STURTEDANT Model SPT	To check valve spring pressure.
Adjustable Reamers	QUICK SET 43	Ream valve guides after installation.
Valve Grinding Compound	B-K 1896	To lap valve seat and valve face.
Valve Keeper Replacer	KD 608	To install keepers on valve stem.
Valve Lifter	SNAP ON CF19	To compress valve springs.
U-Tube Manometer	DWYER Model 1211-24	Check crankcase vacuum.
Valve Seat Cutter Kit for Kohler Engines	NEWAY No. 102S Kit, NEWAY Sales Inc., Corunna, Michigan	Recondition valve seat.

## Group 15 PISTON, CRANKSHAFT, MAIN BEARINGS, BALANCE GEARS, AND FLYWHEEL

### GENERAL INFORMATION

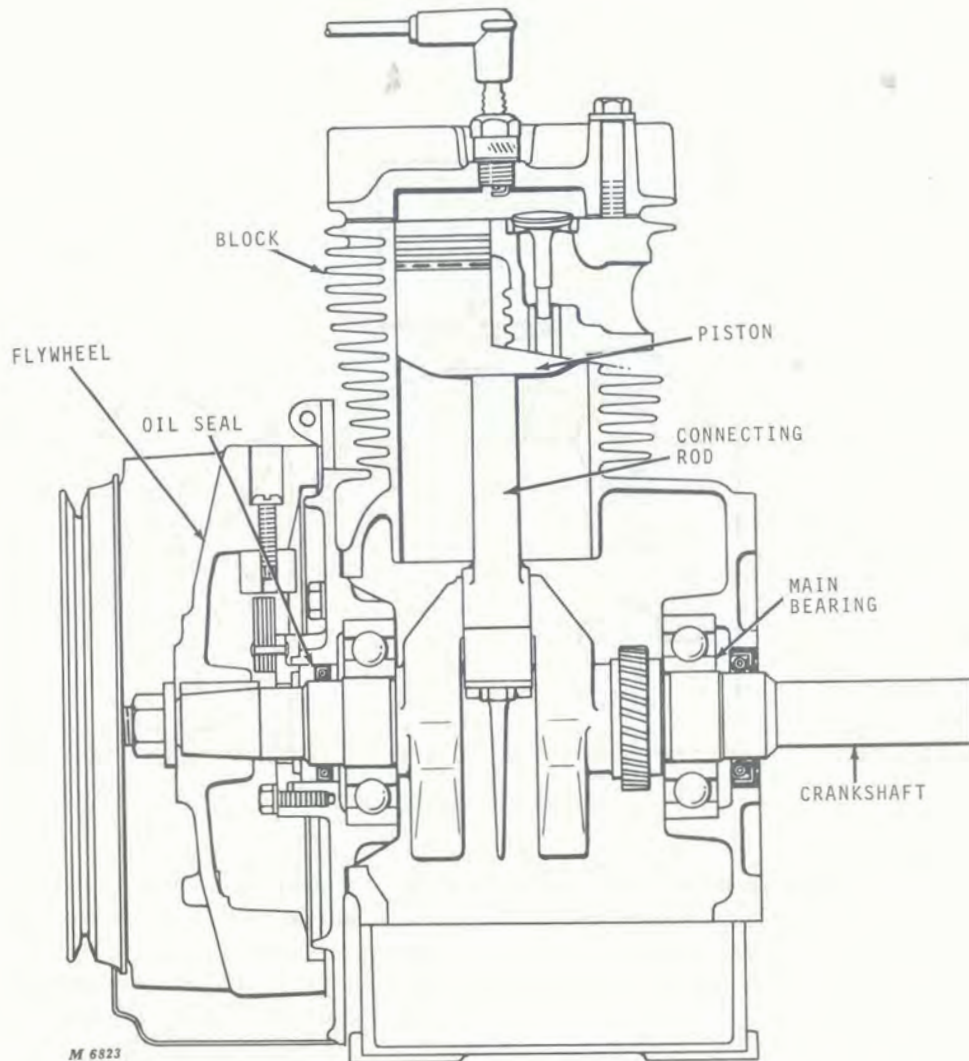

Fig. 1-Cutaway View of Kohler K321AS Engine

Oversize pistons and rings are available for the K321AS Kohler Engine, Figure 1. An undersize connecting rod is also available.

Both a short block and a complete engine are available for service on the 140 Tractor.

If many internal parts are worn beyond repair, it may be less expensive to install one of these engines rather than rebore the cylinder block, grind the crankshaft, and replace parts.



### Dynamic Engine Balancing System

The K321AS Engine balancing system consists of two balance gears, which run on needle bearings. Snap rings hold these on stub shafts, which are press-fitted into special bosses in the crankcase. Spacer washers control end play. The gears are driven by the crankgear in the opposite direction of crankshaft rotation.

The crankshaft counterweights alone cannot effectively control engine vibration. If the counterweights were designed to exactly balance the maximum force, they would create an unbalance when this maximum force dropped to zero at the 90 and 270 degree positions.

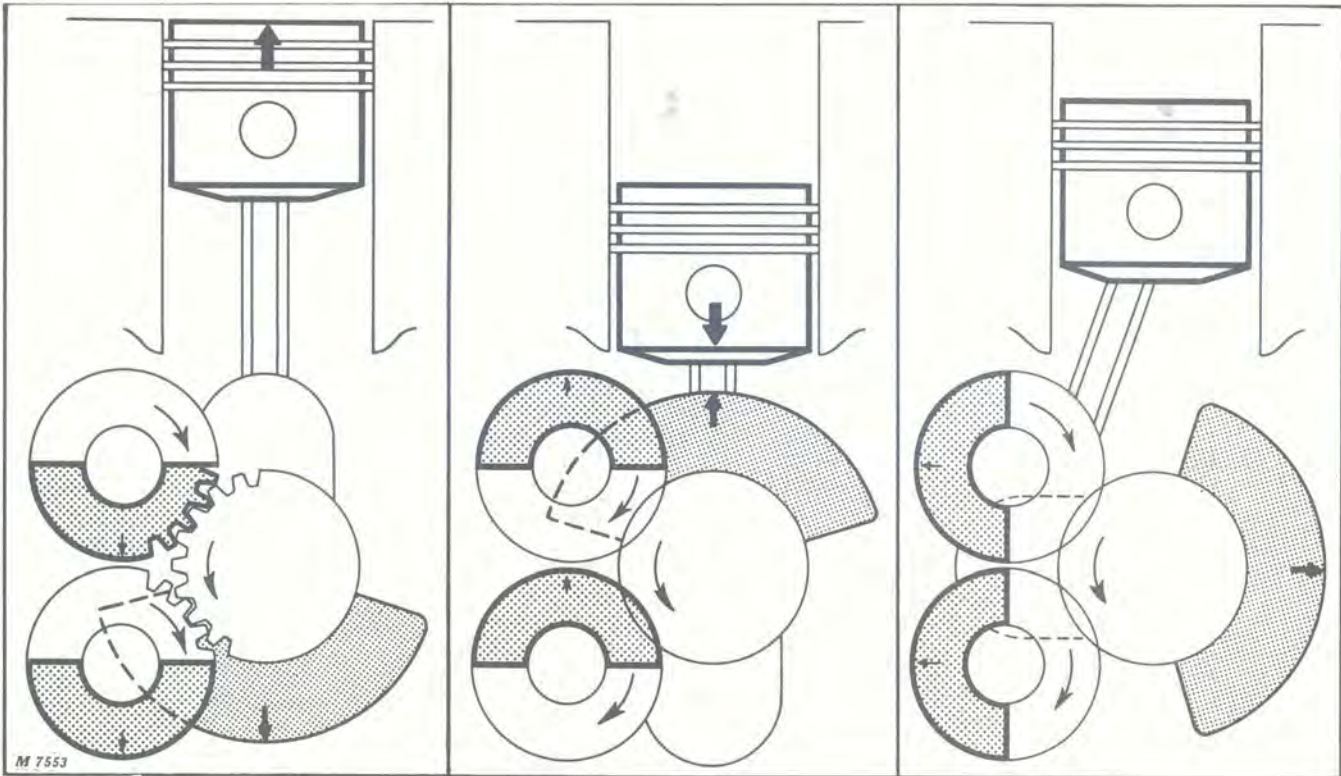

Fig. 2-Piston at Top Dead Center (TDC)

Fig. 3-Piston on Bottom Dead Center (BDC)

Fig. 4-Piston Midway in Cylinder

The balance gears oppose and then add to the force exerted by the crankshaft counterweights to effectively reduce vibration. Both horizontal and vertical forces are thus reduced, resulting in smoother operation with less vibration.

Figure 2 shows how the reciprocating weights (piston, piston pin and connecting rod) exert maximum force upward (large arrow) while the crankshaft counterweights exert force (medium arrow) in the opposite direction.

In this position, the balance gears (small arrows) each add to the force of the crankshaft counterweights to balance the opposing forces.

This same balancing effect is evident when the piston reaches bottom dead center, Figure 3. However, now the two forces are directed toward each other.

When the piston is midway in the cylinder, Figure 4, no vertical inertial force is exerted. The crankshaft counterweights now exert a force horizontally. The balance gears exert force in the opposite direction to counteract the force of the counterweights.

When the crankshaft has rotated another 180 degrees and the piston is again midway in the cylinder, the force of the balance gears is directed inward while that of the counterweights is outward.

When working on dynamically-balanced engines, be sure you obtain the proper balance gear end play and have the gears properly timed to the engine.



## REPAIR

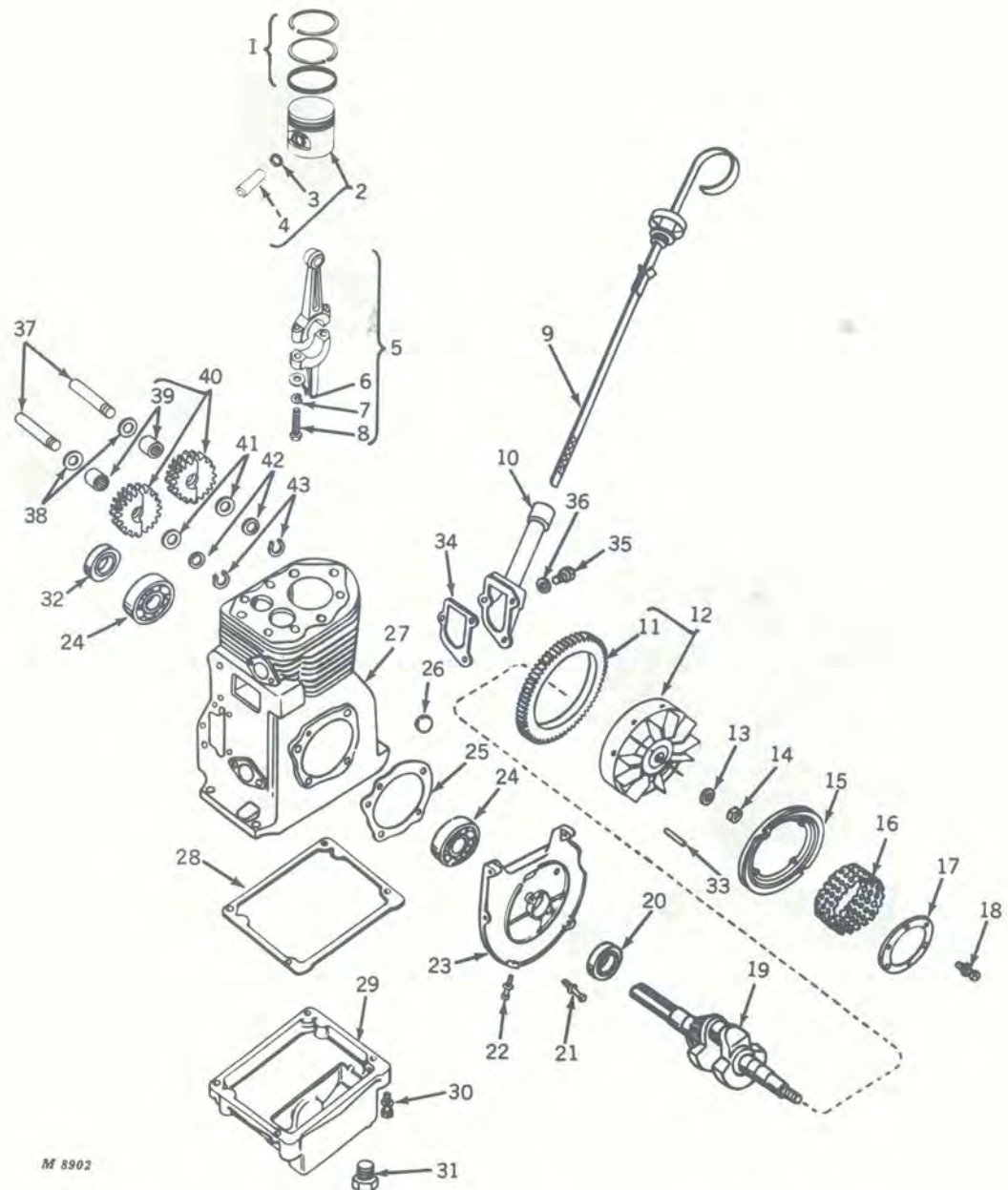

M 8902

- |                            |                          |                              |
|----------------------------|--------------------------|------------------------------|
| 1-Ring Set                 | 15-Pulley                | 29-Oil Pan                   |
| 2-Piston Assembly          | 16-Grass Screen          | 30-Cap Screw (4 used)        |
| 3-Retainer (2 used)        | 17-Cover                 | 31-Pipe Plug                 |
| 4-Piston Pin               | 18-Mach. Screw (4 used)  | 32-Oil Seal, 2-3/8" O.D.     |
| 5-Rod Assembly             | 19-Crankshaft            | 33-Key, 3/16" x 3/16" 1-3/8" |
| 6-Washer (2 used)          | 20-Oil Seal, 2" O.D.     | 34-Fill Tube Gasket          |
| 7-Lock Washer (2 used)     | 21-Cap Screw (8 used)    | 35-Cap Screw                 |
| 8-Screw (2 used)           | 22-Cap Screw (6 used)    | 36-Lock Washer               |
| 9-Dipstick                 | 23-Bearing Plate         | 37-Gear Stud (2 used)        |
| 10-Oil Fill Tube           | 24-Ball Bearing (2 used) | 38-Spacer (2 used)           |
| 11-Ring Gear               | 25-Bearing Plate Gasket  | 39-Bearing (2 used)          |
| 12-Flywheel with Ring Gear | 26-Plug Button           | 40-Balance Gear (2 used)     |
| 13-Washer                  | 27-Cylinder Block        | 41-Shim                      |
| 14-Hex. Nut                | 28-Oil Pan Gasket        | 42-Spacer                    |
|                            |                          | 43-Snap Ring                 |

Fig. 5-Exploded View Showing Piston, Connecting Rod, Crankshaft, Flywheel, Main Bearings and Oil Seals

## Removing Engine

Loosen four bolts from tractor frame and remove hood and grille components as a unit.

Shut off the fuel below the gas tank, disconnect the fuel lines and remove the tank. Also remove the battery and battery base.

Disconnect all electrical wires at engine. Disconnect ground cable and starter cable. Remove choke and throttle cables from engine.

Remove two cap screws to free flex-coupling on front of drive shaft from clutch cone. Remove four cap screws securing engine to engine base.

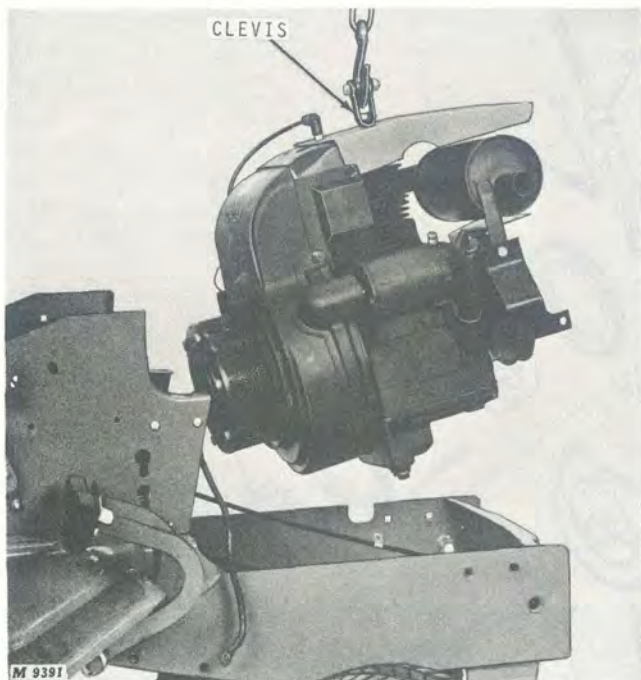

Fig. 6-Removing Engine From Tractor

Bolt a clevis or lifting strap to an engine head bolt, and secure chain hoist. Hoist engine upward until clear of tractor, Figure 6.

## Engine Service Support Stand

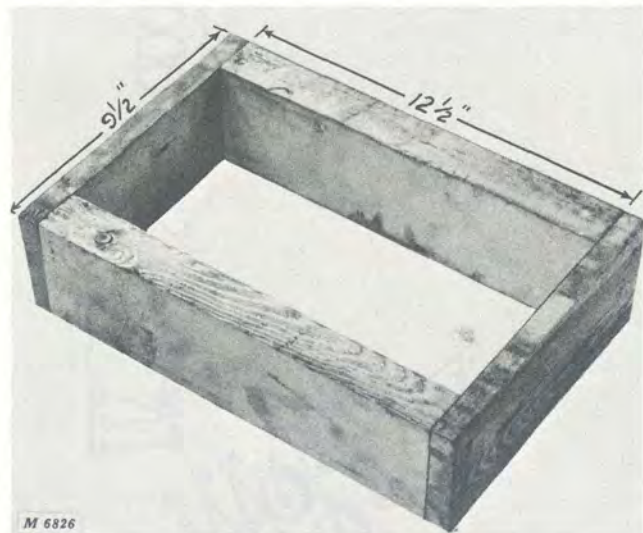

Fig. 7-Engine Service Support Stand

Using two 2 x 4-inch boards, 12-1/2 inches long and two 1 x 4-inch boards, 9-1/2 inches long, construct a stand for servicing the engine.

A stand such as the one shown in Figure 7 will permit servicing the engine without resting it on the crankshaft and provides a stable support for the engine while servicing components.



## Disassembling Engine

Remove engine shrouding, air cleaner and carburetor.

Remove cylinder head, breather assembly and valves. See Group 10 of this section.

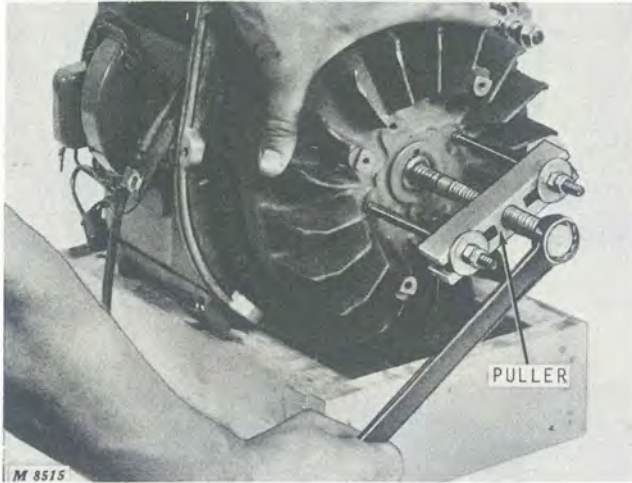

Fig. 8-Removing Flywheel

Break flywheel nut loose with a shock tool or use a long handle nut spinner and a strap wrench. The flywheel is mounted on a tapered shaft and should be removed with a puller, Figure 8.

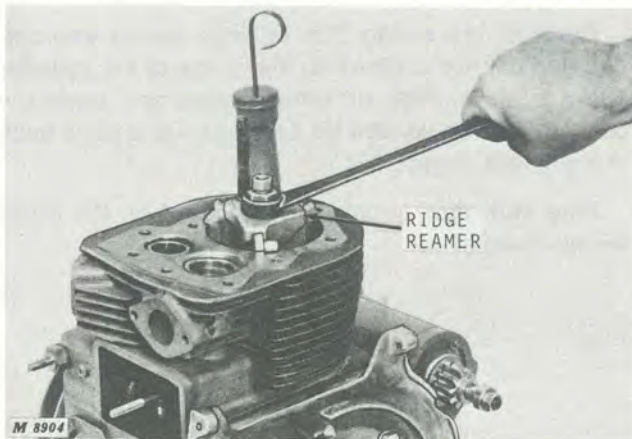

Fig. 9-Removing Ridge with Ridge Reamer

Remove oil pan and dipstick. Turn engine upside down and remove cap screws, and rod cap from connecting rod.

**IMPORTANT: Use proper tools to prevent oil slinger damage when removing rod cap screws.**

Before removing piston, check for carbon or ridge at top of cylinder bore. Remove carbon and ridge with ridge reamer, Figure 9. Push piston and rod out top of block.

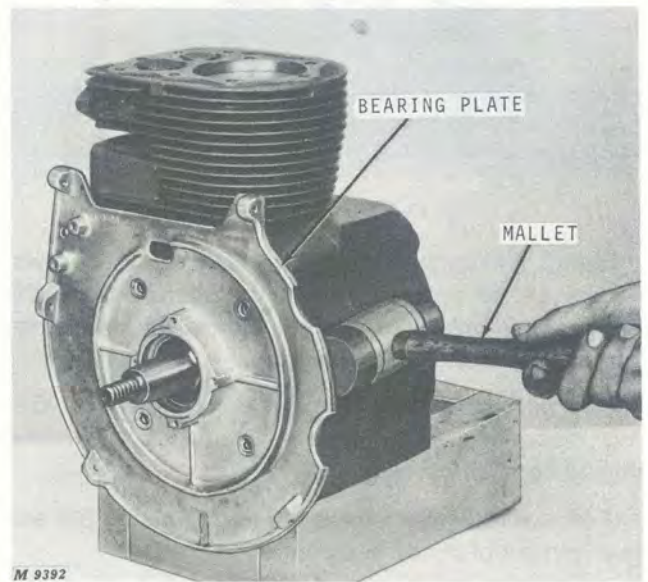

Fig. 10-Removing Bearing Plate

Remove bearing plate, Figure 10. Be sure key is removed from end of crankshaft before removing plate. Cover keyway with tape to prevent cutting seal when removing and replacing plate.

Using a small snap ring pliers, remove snap ring from lower balance gear. Be careful not to lose spacer washers. Remove lower balance gear.

Remove crankshaft. It may be necessary to press crankshaft out of other bearing.

Remove snap ring, spacer washers and upper balance gear.

## Removing Ring Gear

Inspect ring gear for broken, worn or damaged teeth. If ring gear is damaged, break it into sections to remove it from flywheel. Use a cold chisel and/or hack saw or heat the ring gear with a torch and drive it off the flywheel. If heat is used, let flywheel cool before installing new ring gear.



## Removing Piston Rings

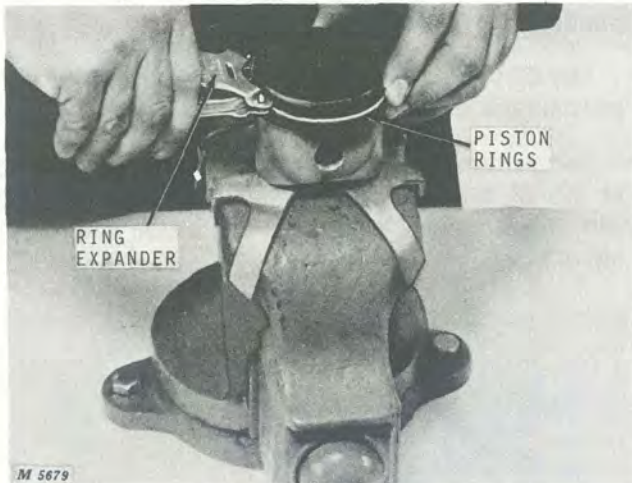

Fig. 11-Removing Piston Rings

Clamp the connecting rod in vise with soft jaws, Figure 11, to prevent damaging rod. **IMPORTANT: Tighten vise only tight enough to hold the assembly. Too much pressure will bend rod.**

Use ring expander to remove rings, Figure 11. Before discarding, analyze their condition to determine engine condition. See below.

Remove retainers from each end of piston pin and push pin out of piston and connecting rod.

If camshaft or governor must be removed, see Group 20 of this section.

## Piston Ring Analysis

Light scuffing or scoring of both rings and piston occurs when unusually high friction and combustion temperatures approach the melting point of piston material, Figure 12.

When this condition is found check and correct the following probable causes:

1. Cooling fins on block and head plugged with dirt.
2. Lack of cylinder lubrication.
3. Improper combustion.
4. Wrong bearing or piston clearance.
5. Too much oil in crankcase causing fluid friction.



Fig. 12-Scored Piston and Rings Caused by Overheating as Temperatures Reach Melting Point of the Materials



Fig. 13-Piston Rings in Alignment

Rings of the wrong size or rings having improper end gap cannot conform to the shape of the cylinder. This results in high oil consumption and excessive blowby. This could also be caused by end gaps being in alignment, Figure 13.

Ring end gaps should be staggered on the piston during installation.



## Piston Ring Analysis—Continued

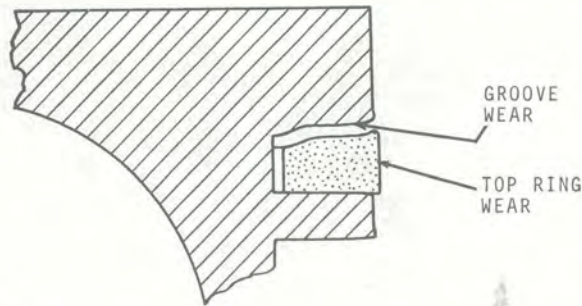

Fig. 14-Top Ring and Groove Side Wear

Check wear of ring grooves carefully, Figure 14, especially the top groove. The top ring and groove is exposed to most combustion temperature and pressure as well as airborne abrasives which enter the combustion chamber.



Fig. 15-Piston Rings Stuck and Broken Because of Lacquer, Varnish and Carbon Build-up

Any condition which causes the engine to operate at abnormally high temperatures may cause varnish and lacquer gum deposits, Figure 15, as well as carbon deposits to form in the piston grooves making the rings stick. When this happens excessive oil consumption and blowby will occur.

Engine heating and ring sticking are most often caused by:

1. Overloading.
2. Over-advanced ignition.
3. Lean fuel mixture.
4. Dirty cooling fins.
5. Incorrect oil.
6. Low oil supply.
7. Stale fuel.



Fig. 16-Scratched Ring Faces Caused by Abrasives in the Engine

Vertical scratches across the faces of piston rings, Figure 16, are the result of an abrasive entering the engine. Abrasives may be airborne, may have been left in during overhaul, or are loose lead and carbon deposits.

When this condition is found, always check and correct the source of abrasives to prevent premature ring failure.

Common causes for abrasives in the engine are:

1. Damaged, collapsed or improperly installed air filter.
2. Loose connection or damaged gasket between air filter and carburetor.
3. Air leak around carburetor-to-cylinder block gasket.
4. Air leakage around throttle shaft.
5. Failure to properly clean cylinder bore during overhaul.





Fig. 17-Worn Oil Rings Which Cannot Provide Oil Control

Rails of the oil ring are worn down to the oil drain hole spacer and the ring surface is worn flat, Figure 17. This can come from cylinder wall contact after much use and possible entry of abrasives. Compression rings will also be worn thin.

Badly worn oil rings will have:

1. Extra large gap.
2. Low tension.

### Inspecting Piston

Remove deposits from piston surfaces. Clean gum and varnish from the piston skirt.

**IMPORTANT: Do not use a caustic solution or a wire brush to clean pistons.**

Be sure the oil ring holes are clean.

Clean carbon from piston ring grooves with a ring groove cleaner. If cleaning tool is not available, break an old ring and use it to clean groove, Figure 18.

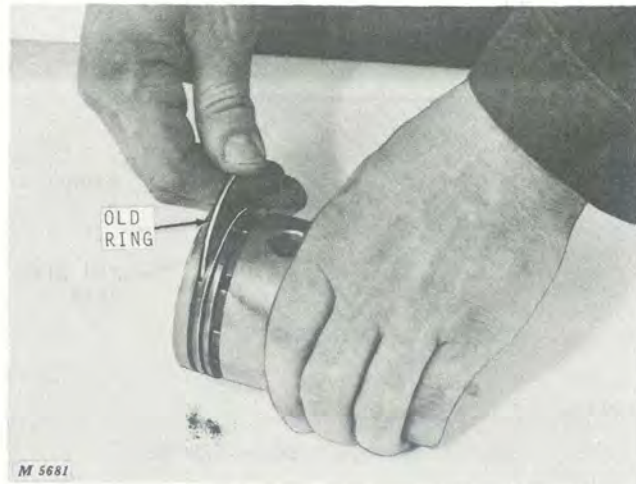

Fig. 18-Cleaning Ring Grooves

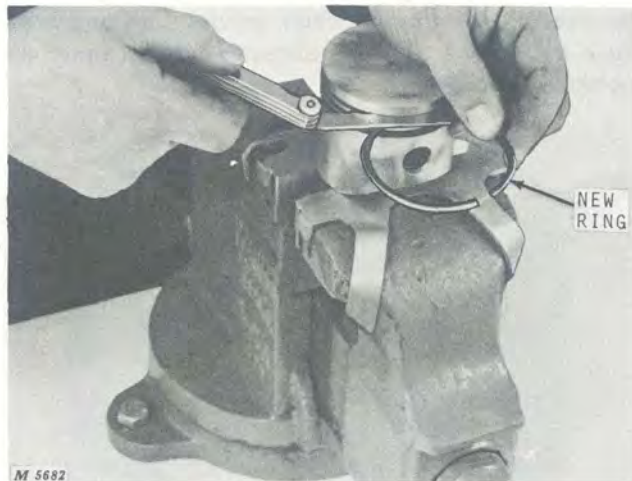

Fig. 19-Measuring Ring Clearance

Check ring grooves for excessive wear by inserting a new ring in the proper groove at several points around the piston. Measure clearance between ring and groove with a feeler gauge, Figure 19. Refer to "Specifications," page 15-24, for ring groove side clearance. Replace piston having ring clearance beyond wear limits.

Inspect piston for fractures at the ring lands, skirts and ring bosses and for rough or scored skirts.

Analyze the condition of the piston by studying the illustrations beginning on page 15-9. Replace faulty pistons.





Fig. 20-Measuring Piston Pin and Piston

Measure piston-to-pin clearance, Figure 20, with micrometer. Replace parts as necessary. See "Specifications", page 15-24.



Fig. 21-Measuring Piston

Check the piston-to-cylinder bore clearance by measuring the piston and bore diameters, Figures 21 and 29.

Measure the outside diameter of the piston with a micrometer at the centerline of the piston pin bore and at 90 degrees to the pin bore axis.

If piston-to-cylinder bore clearance is less than 0.005 inch over specifications, deglaze the cylinder walls and install a set of heavy-duty rings.

If cylinder-to-bore clearance is more than 0.005 inch over specifications, the cylinder will have to be rebored and oversize piston and rings installed.

Oversize pistons and rings are available in 0.010 inch, 0.020 inch and 0.030 inch sizes for service.

See page 15-13 for deglazing and boring information.

## Piston Analysis



Fig. 22-Piston Top Land Burning Caused by Detonation

Detonation is a form of abnormal combustion causing excessive temperature and pressure in the combustion chamber. Commonly called carbon knock, spark knock or timing knock, detonation occurs as compressed air-fuel mixture ignites spontaneously to interrupt the normal ignition flame front. When detonation is detected check and correct the following possible causes:

1. Lean fuel mixtures.
2. Low octane fuels.
3. Over-advanced ignition timing.
4. Engine lugging.
5. Build-up of carbon deposits on piston and cylinder head causing excessive compression.
6. Wrong cylinder head or milling of head increasing compression ratio.





Fig. 23-Hole Burned in Piston Caused by Pre-Ignition

Pre-ignition is the igniting of the fuel-air mixture prior to the regular ignition spark. Pre-ignition causes severe internal shock resulting in pings, vibration, detonation and power loss. Severe damage to piston, rings and valves results from pre-ignition, Figure 23.

When pre-ignition is suspected and detected, check and correct the following possible causes:

1. Internal carbon deposits which remain incandescent.
2. Incorrect spark plug (high heat range)
3. Broken ceramic in spark plug.
4. Sharp edges on valves or elsewhere in the combustion chamber.



Fig. 24-Diagonal Piston Wear Pattern Caused by Bent or Twisted Connecting Rod

Check rod and piston alignment when a piston shows a diagonal wear pattern extending across the skirt of the piston, Figure 24. Contact with cylinder wall shows on bottom of skirt at left and ring lands on the right.

A cylinder bored at an angle to the crankshaft could also cause improper ring contact with the cylinder wall.

This condition can cause:

1. Rapid and uneven piston wear.
2. Rapid piston ring wear.
3. Excessive oil consumption.

## Piston Analysis-Continued



Fig. 25-Piston Damage Caused by Piston Pin Retainer Coming Loose

In Figure 25 a piece of the piston pin retainer found its way into the oil ring.

Pin retainers loosen or break due to:

1. Rod misalignment.
2. Excessive crankshaft end play.
3. Crank pin taper.
4. Weak pin retainers.
5. Pin retainers incorrectly installed.

Inertia can cause the retainer or loose object inside the piston pin to beat out the piston and cylinder in the pin boss area. Damage to both piston and cylinder occurs.

## Inspecting Crankshaft

Wipe crankshaft dry and check general condition. Clean up threads on end of shaft if necessary. If crankshaft journal, Figure 26, indicates wear beyond specified limits or if journal is scored, take the crankshaft to a competent automotive shop to turn the journal down 0.010-inch. An undersize connecting rod and cap must then be installed. **THIS IS IMPORTANT.** Do not just replace a crankshaft having a bad journal. Turning down the journal and installing a new rod will likely be the least expensive method of repair.

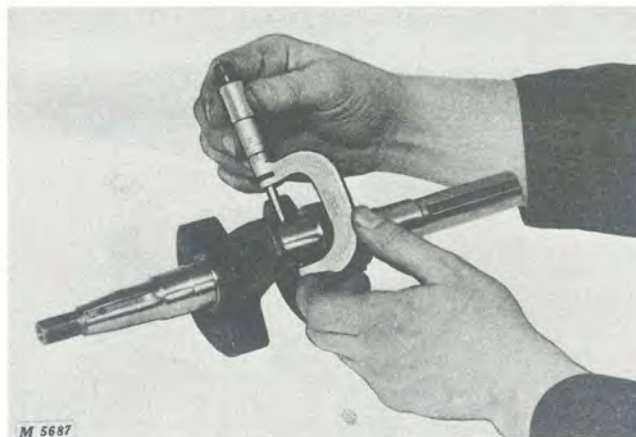

Fig. 26-Measuring Crankshaft Journal

## Connecting Rod and Cap Analysis

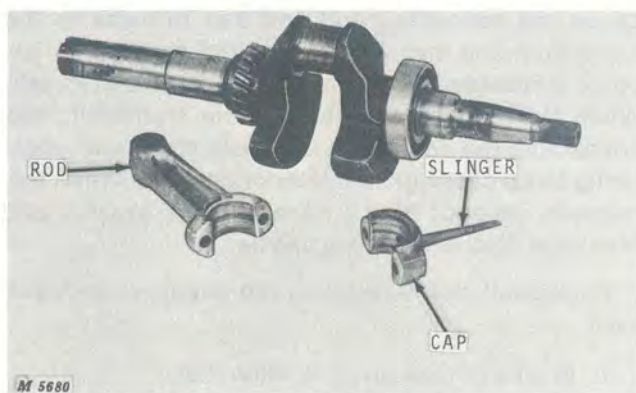

Fig. 27-Crankshaft Connecting Rod and Cap

After cleaning and drying parts, check rod and cap for signs of bending, cracking or unusual wear patterns, Figure 27.



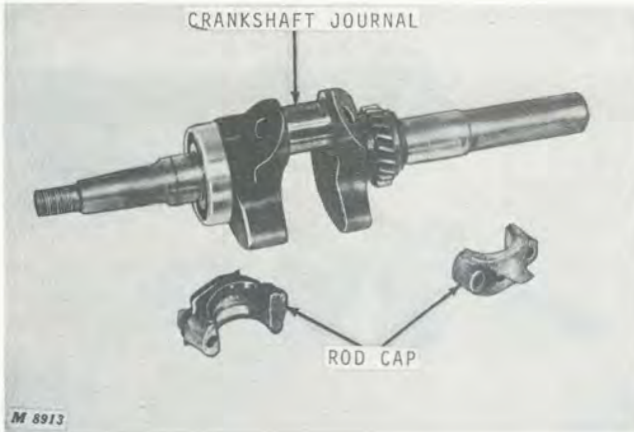

Fig. 28-Scored and Galled Crankshaft Journal and Rod Cap Caused by Lack of Lubrication

Lack of lubrication or improper lubrication can cause the connecting rod and cap to seize to the crankshaft and may even cause rod particles to become embedded in the hardened steel crankshaft. When the rod and cap seize to the crankshaft, the connecting rod and piston may both break with shattering force causing other interior damage. When this happens inspect block carefully for cracks and breakage before rebuilding engine.

Crankshaft and connecting rod damage can result from:

1. Engine run low on oil or without oil.
2. Oil slinger broken off bearing cap.
3. Oil hole in connecting rod plugged with sludge.
4. Oil not changed regularly.
5. Bearing cap installed incorrectly.

**Note** especially the condition of the rod and cap bearing area. Evidence of score marks on these areas indicates impurities in the oil or engine run without oil. Replace rod showing scratch marks or deep scores in the bearing area. Bent rods can be straightened with a rod aligner. Be sure slinger on rod cap is intact—not cracked, bent or chipped. This is important. **NOTE:** *New rods and caps are available only as a matched set for service. If either is damaged, both must be replaced.*

Measure fit of rod and cap to crankshaft bearing. Also measure fit of piston pin in piston and rod. See "Specifications," page 15-24, for wear tolerances.

An undersize rod and cap (0.010-inch) is available for service.

### Inspecting and Repairing Block

After thoroughly cleaning the block, check it for cracks. Cracks not visible to the naked eye may be detected by coating the suspected area with a mixture of 25 per cent kerosene and 75 per cent light engine oil.

Wipe the part dry and immediately apply a coating of zinc oxide dissolved in wood alcohol. If a crack is present, the coating will become discolored at the defective area. Replace the block if cracked. **NOTE:** *A short block is available for service.*

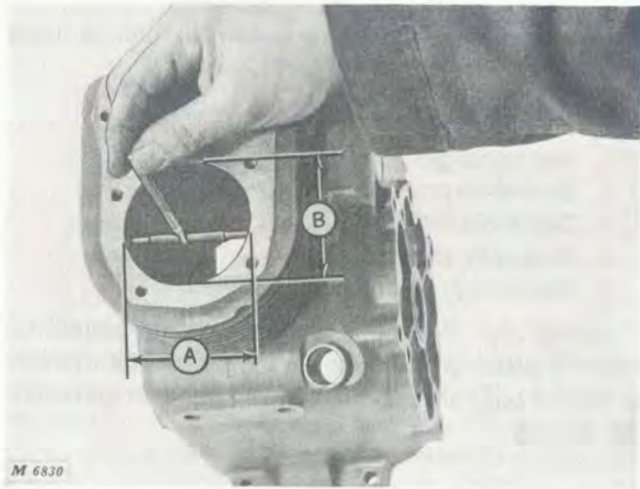

Fig. 29-Measuring Cylinder Bore

Use a telescoping gauge, Figure 29, and micrometer to measure bore in two places at top and bottom of ring travel area. Out-of-round dimension is the difference between dimensions "A" and "B." Cylinder wall taper is the difference between dimension "A" at the top and dimension "A" at the bottom of cylinder bore. See "Specifications," page 15-24, for wear tolerance.



## Deglazing Cylinder Bore

Deglazing is not intended to remove any appreciable amount of metal from the bore, but rather to clean up and provide the proper surface. A proper bore surface feels smooth but has a cross-hatch pattern of micro-scratches which can be seen. This finish will allow the new rings to seat or run-in properly. This finish also retains a small film of oil to provide ring lubrication for the ring surface and prevent scoring.

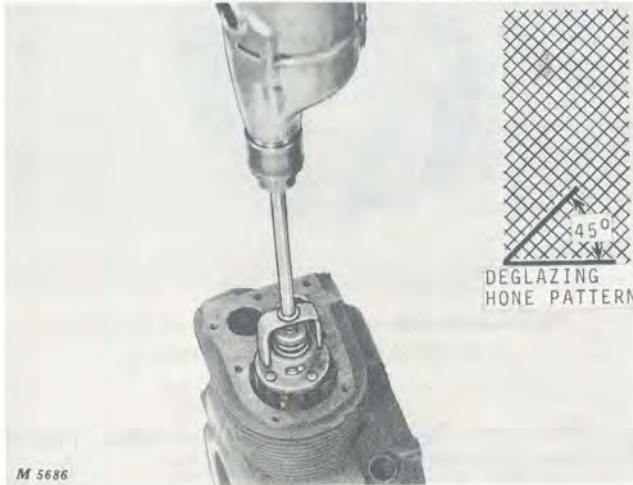

Fig. 30-Deglazing Cylinder Bore

Use a deglazing tool to break glaze, Figure 30. Follow manufacturer's recommendations.

A 200 to 280 grit tool is generally preferred for deglazing. A cross hatch pattern of approximately 45 degrees should be obtained by operating the tool vertically during deglazing.

## Boring Cylinder Block

If block is to be bored as determined on page 15-9, clean and dry block thoroughly. Reboring can be done by machining at a reliable automotive repair shop or by electric drill and honing tool. See "Special Tools", page 15-25.

Honing to 0.010-inch oversize to accommodate oversize piston and rings can also be done with a coarse stone in the deglazing tool, Figure 30, and finishing with finer grit stone(s).

**IMPORTANT:** If block is jugged in a drill press for honing, be sure honing tool and block are in true alignment.

## Inspecting Camshaft

Check camshaft for broken or cracked gear teeth. Check operation of ACR assembly making sure all parts are intact and operate freely. Check condition of flyweight springs. If camshaft needs attention, see Group 20 for camshaft and governor service.

## Inspecting Main Bearings

Main bearings turn in an oil mist and will not normally require replacing. Check for unusual signs of wear such as race turning with bearing or bearing deflection caused by excessive engine lugging. Refer to "Bearing Analysis" below.

## Bearing Analysis

The causes of bearing failure must be identified and understood in order to apply the proper corrective measures.

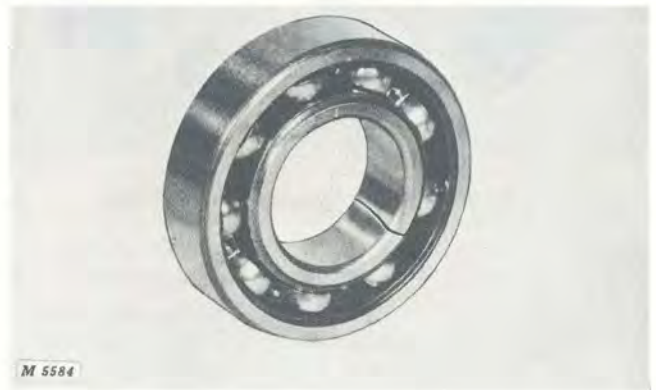

Fig. 31-Broken Races Caused by Misaligned Bearing During Installation

Bearings allowed to cock while inserting or pressing them over a burr may cause the bearing to crack, Figure 31. Always use bearing driver tool and remove burrs before installing bearings.



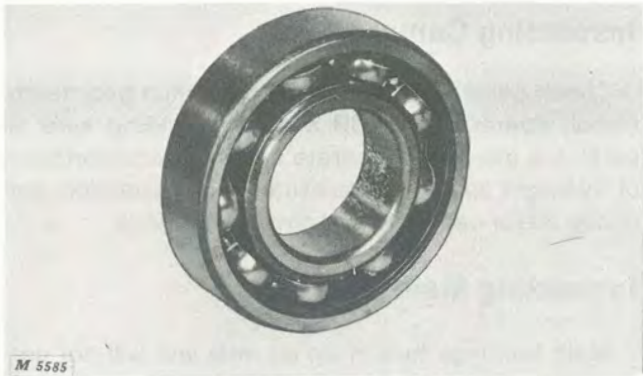

Fig. 32-Bearing Wear Caused by Crack or Looseness on Shaft

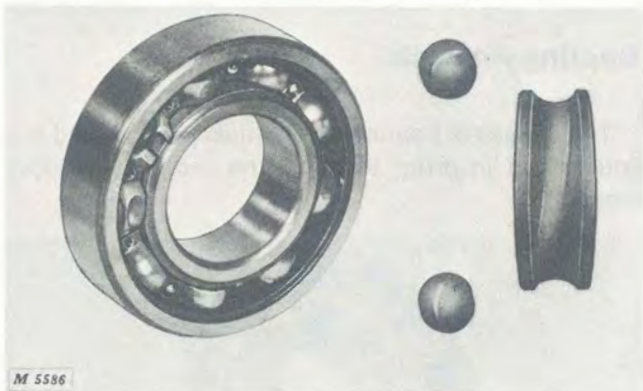

Fig. 33-Bearing Wear Caused by Misalignment

If inner ring is a loose fit on the rotating shaft, rotation of the shaft within the inner ring can scuff loose small particles of metal. These eventually get into the bearing causing wear on the balls and races. This makes for noisy operation and shortened bearing life and failure. The condition is easily identified by scoring or abrasion on the bore of inner ring, Figure 32.

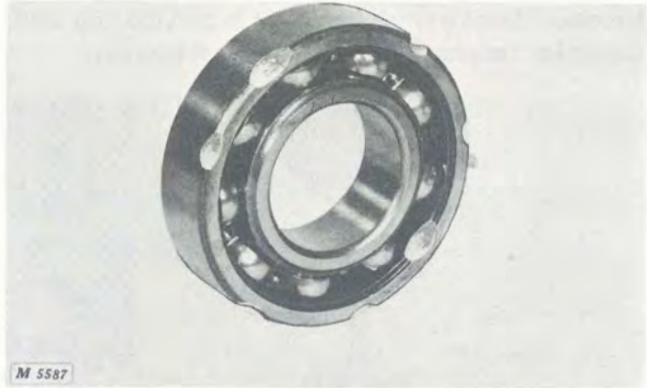

Fig. 34-Nicks in Outer Race Caused by Using Chisel or Driftpin to Remove or Install Bearing

Misaligned bearings cause undue wear, heat by friction and eventual failure, Figure 33.

Note the crooked ball paths in the raceways and the oval appearance of the balls and wear on the separator caused by rubbing against the race.

## ASSEMBLY

### Replacing PTO End Main Bearing

If a new main bearing is required, install it by pressing it into cylinder block. Press on outer race of bearing. Be certain bearing is not cocked in bore.

### Replacing Balance Gear Stub Shafts

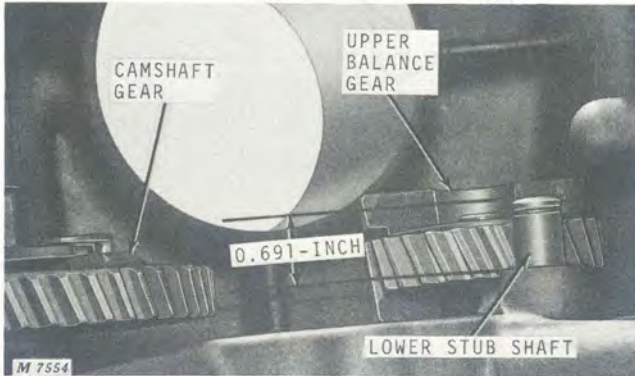

Fig. 35-Installing Stub Shafts

If new stub shafts are required, press into block until they extend 0.691 inch above the surface of the boss, Figure 35.

### Replacing Balance Gear Bearings



Fig. 36-Installing Needle Bearing in Gear

Press new bearings into balance gears if necessary, Figure 36.

### Timing Balance Gears Without Special Tool

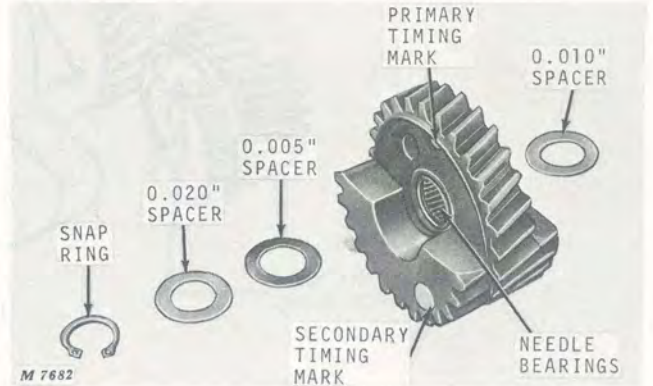

Fig. 37-Balance Gear Assembly

Slip one 0.010-inch spacer on upper stub shaft and install upper balance gear. Be sure timing marks are toward flywheel side of engine. Next place a 0.010-inch spacer on stub shaft, followed by a 0.005 and 0.020-inch spacer, and install snap ring, Figure 37.

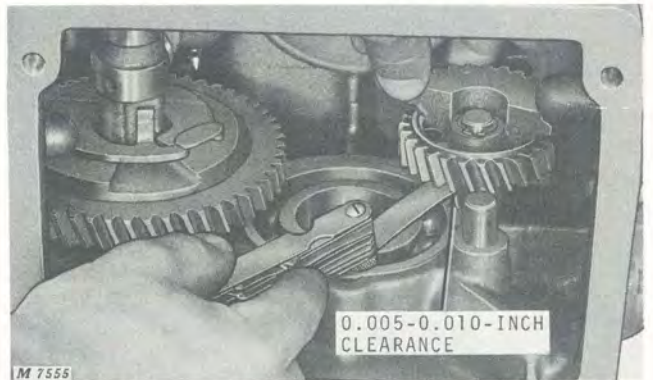

Fig. 38-Checking Balance Gear End Play

Check end play of balance gear and adjust to 0.005 to 0.010 inch by adding or removing 0.005-inch spacers, Figure 38.



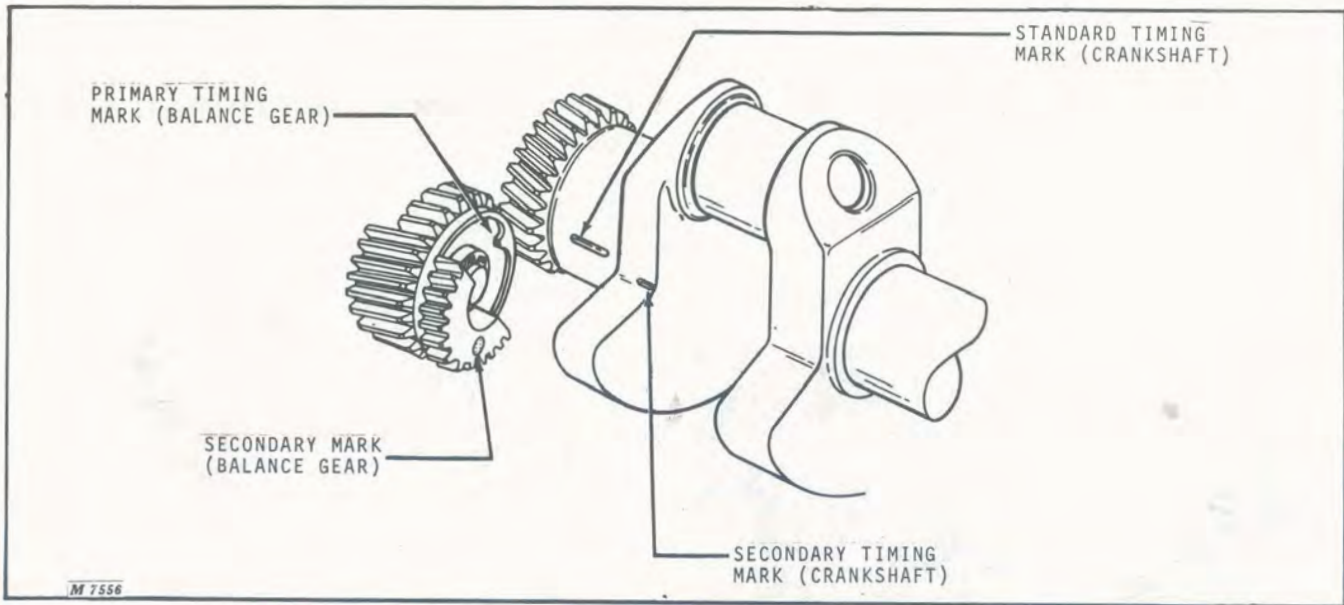

Fig. 39-Timing Marks for Installing Dynamic Balance Gears

Align crankshaft so the primary timing mark on top balance gear; Figure 39, lines up with standard timing mark on the crankshaft.

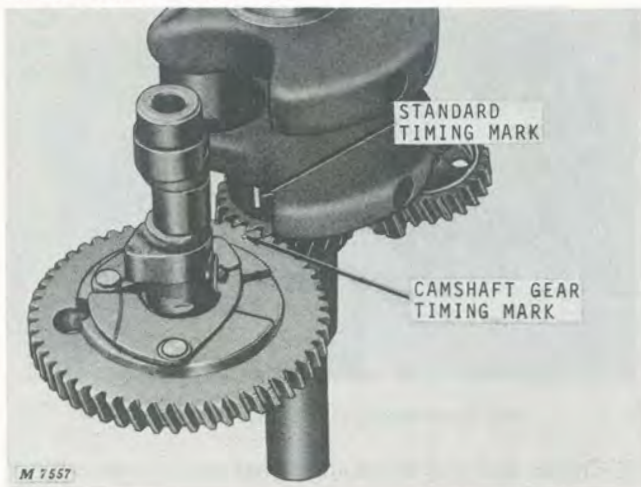

Fig. 40-Aligning Crankshaft and Camshaft Gears

Slide the crankgear approximately 1/16 inch into the wide side of the upper balance gear. Rotate the crankshaft to align standard timing mark (next to crankgear) with dot (timing mark) on face of camshaft gear, Figure 40. Press crankshaft remainder of the way into block. Camshaft, crankshaft and upper balance gear are now correctly aligned.

Rotate crankshaft until it is approximately 15 degrees past bottom dead center. Slip one 0.010-inch spacer over lower stub shaft, and install lower balance gear.

Align secondary mark, Figure 39, on lower balance gear with the secondary timing mark on the crankshaft counterweight. Gears will turn slightly as they engage, causing the secondary timing mark on the lower balance gear to line up with the standard timing mark on the crankshaft.

Add one 0.005 and one 0.020-inch spacer and install snap ring retainer. Check and adjust end play to 0.005 to 0.010 inch by adding or removing 0.005-inch spacers, Figure 38.

**NOTE:** Turn crankshaft until counterweights are in position indicated in Figure 41. A straight line should be formed by the half-moon sections of the balance gears, Figure 41. If this line is not straight, one of the balance gears was inserted into the wrong tooth of the crankshaft gear. Review timing procedure described above if the straight line is not formed and correct the timing.

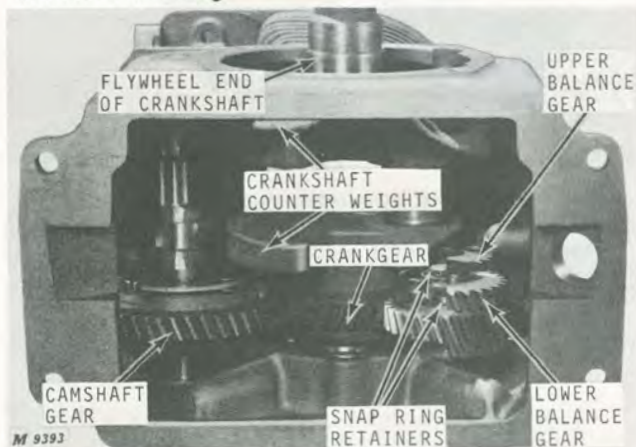

Fig. 41-Correctly Installed Balance Gears



## Timing Balance Gears with Special Tool

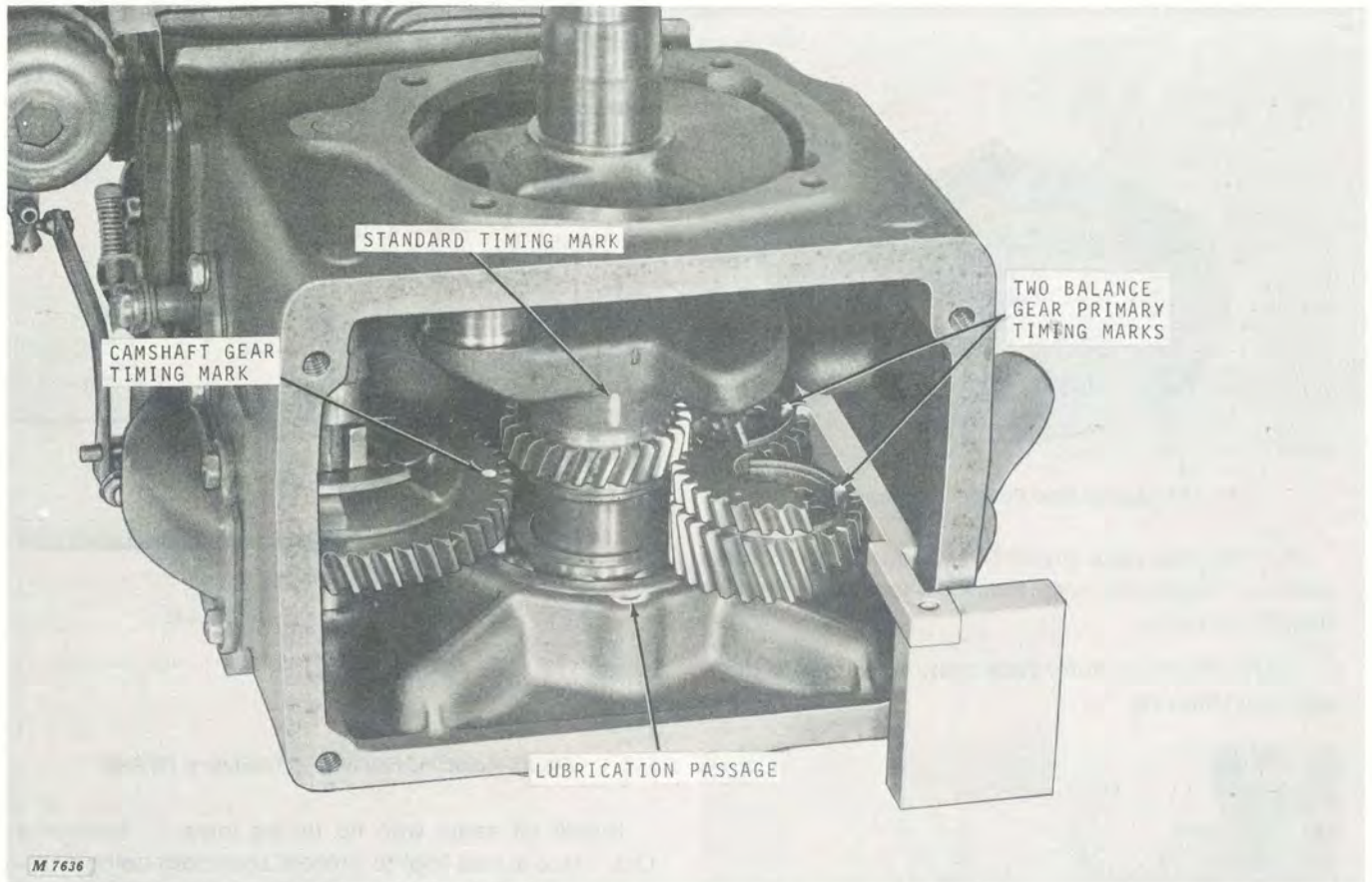

Fig. 42-Timing Balance Gears with Special Tool

A special time-saving tool can be used to install and time the balance gears.

A plastic timing tool may be purchased at low cost. See page 15-25.

Install both balance gears on the stub shafts; using spacers and snap rings as instructed on pages 15-15 and 15-16 of this section. Insert special tool inside block with two teeth toward balance gears. Position primary timing mark on each gear so that it lines up with its respective tooth on the side of the tool, Figure 42.

Install crankshaft so that counterweights are toward balance gear side of engine, Figure 42. Turn crankshaft so that standard timing mark on crankshaft is in line with lubrication passage in engine block, Figure 42.

Drive crankshaft 1/16-inch into the wide side of balance gears. Remove tool and turn crankshaft until standard timing mark on crankshaft aligns with timing mark on camshaft gear.

Engage crankshaft gear and camshaft gear. Tap crankshaft into place with plastic hammer.

Gears now should be in proper alignment. When properly timed, balance gears will form a straight line when counterweights are to either side, as in Figure 41.



## Assembling Bearing, Bearing Plate and Oil Seals



Fig. 43-Installing Main Bearing in Bearing Plate

With bearing plate properly supported, press main bearing, Figure 43, into bearing plate until bearing bottoms in bore.

**NOTE:** Press on outer race only, so as not to damage main bearing.

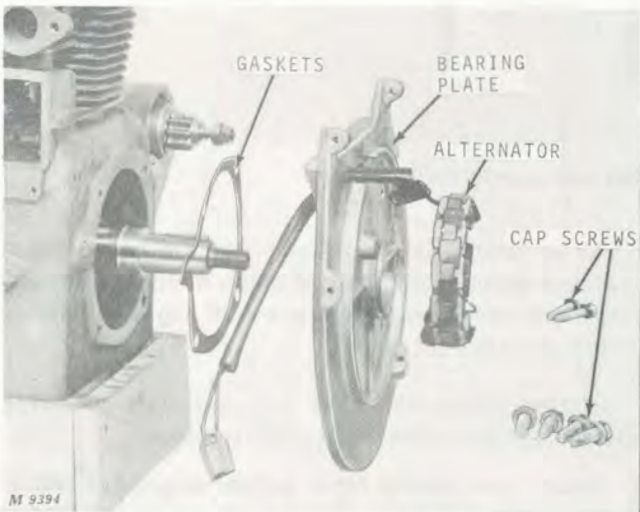

Fig. 44-Installing Bearing Plate with Bearing on Cylinder Block

Install three .010 inch thick gaskets and bearing plate over crankshaft. Using two 3/8 x 1-3/4-inch cap screws, draw bearing plate toward block. Insert two of the four 3/8 x 1-inch cap screws in other two holes in plate. Remove the two long cap screws and replace with shorter screws provided, Figure 44. Draw cap screws up evenly until correct torque is obtained. See "Torque Chart," Section 10.

Seat the bearings by first tapping the tapered end of crankshaft with a mallet. Then tap PTO end of crankshaft. Check distance between bearing ring and crankshaft shoulder with a feeler gauge, Figure 45. Proper clearance is 0.003 to 0.020 inches. Add or remove gaskets from between block and bearing plate as required, to obtain correct crankshaft end clearance.

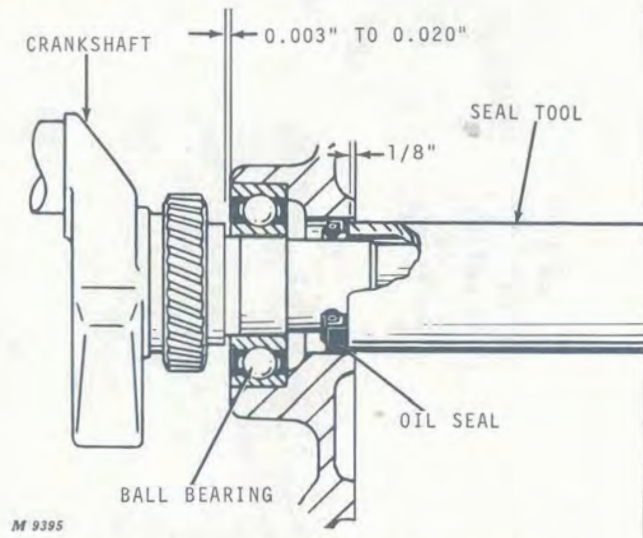

Fig. 45-Adjusting End Play and Installing Oil Seal

Install oil seals with lip facing inward, "Numbers Out." Use a seal tool to protect seal from being damaged during installation. On PTO end of engine, drive seal into seal bore until outer face of seal is recessed 1/8 inch, Figure 45. On bearing plate end of engine, seal must be recessed approximately 3/8 inch into seal bore.

## Assembling Connecting Rod and Piston

Support connecting rod in a bench vise and slip piston down over connecting rod. Coat piston pin with a light film of oil. Insert piston pin through piston bore and connecting rod and on into opposite piston bore. A properly fitted piston can be pressed into position with hand pressure. Install retainer in both ends of piston pin bore, making sure that snap rings are securely seated in retainer grooves in piston bore.

Use a commercial rod aligner to check rod and piston alignment. Follow manufacturers' recommendations for checking and correcting alignment.



## Checking Piston Ring End Gap

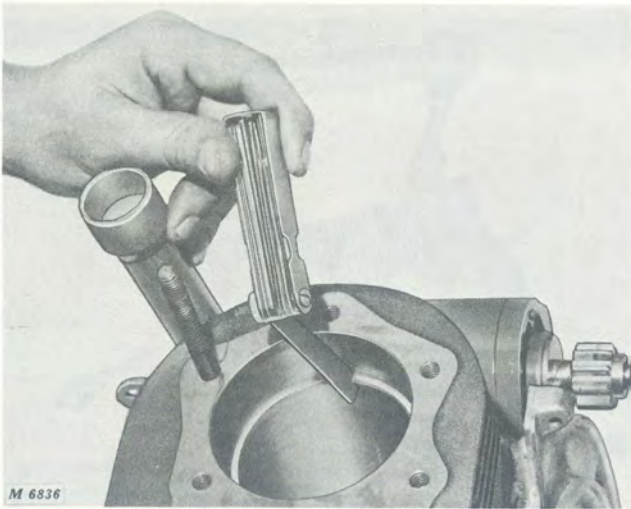

Fig. 46-Checking Ring End Gap

Always check ring end gap whenever new rings are installed. Use an inverted piston without rings to push the ring squarely to a point in the bore which is approximately the center of piston ring travel.

Measure the ring end gap by inserting a feeler gauge between the ends of the ring, Figure 46. Ring gap should be in the 0.010 to 0.020 inch range. See "Specifications," page 15-24, for additional information.

Minor increase in gap clearance can be made by filing the ends of the ring but this must be done accurately on equipment made for this purpose.

Too much end clearance indicates that wrong rings are being used or cylinder is worn too large.

## Installing Rings and Piston

Install expander in lower ring slot, Figures 47 and 48. Spiral lower chrome steel rail into groove. Install cast iron spacer above rail and spiral second chrome steel rail into groove above spacer.

Install expander in center ring slot. Spiral chrome steel rail into groove and install cast iron ring above rail with scraper groove down.

Install top ring with bevel up.

Adjust rings in slots so ring gaps are staggered and not in alignment with each other.

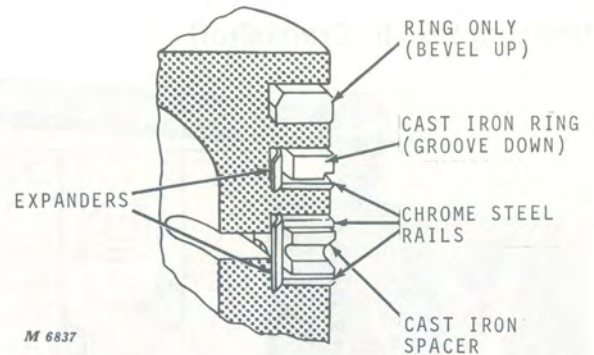

Fig. 47-Piston Ring Assembly

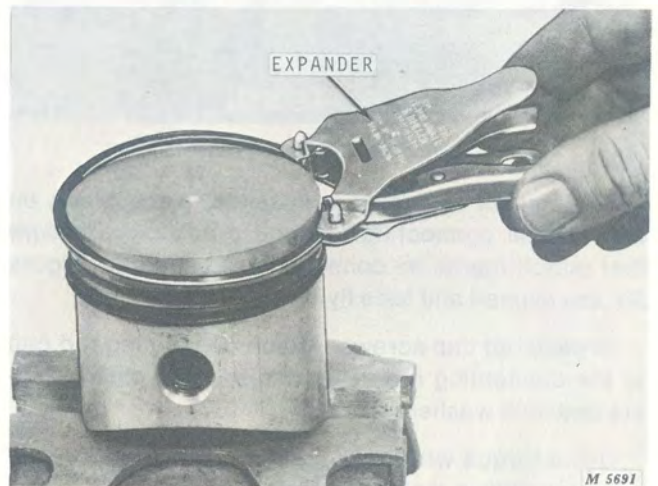

Fig. 48-Installing Rings

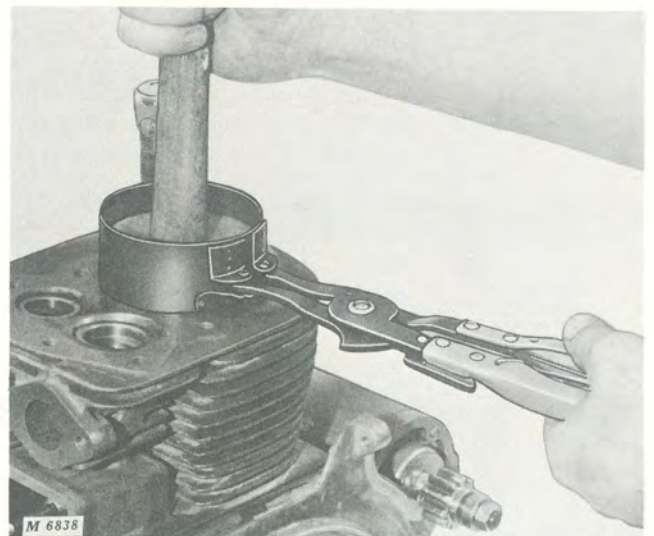

Fig. 49-Installing Piston in Cylinder

Coat piston and ring generously with light oil and insert complete assembly into cylinder bore using ring compressor, Figure 49.

**NOTE:** Be sure match marks on connecting rod and rod cap are aligned and face flywheel side of engine, Figure 50.



### Attaching Rod to Crankshaft

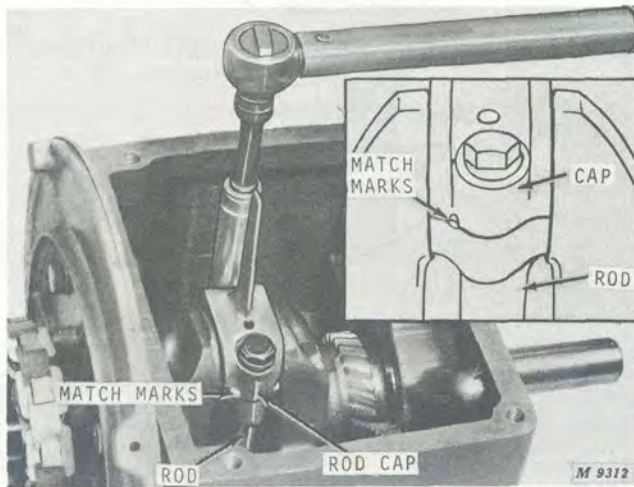

Fig. 50-Rod and Crankshaft Assembly

After piston assembly is installed, place block on end and oil connecting rod and crank pin. Be sure that match marks on connecting rod and cap, Figure 50, are aligned and face flywheel side of engine.

Grease rod cap screws. Attach connecting rod cap to the connecting rod using cap screws, plain washers and lock washers.

Use a torque wrench to tighten connecting rod cap screws to 300 in-lbs or 25 ft-lbs.

### Assembling Oil Pan on Block

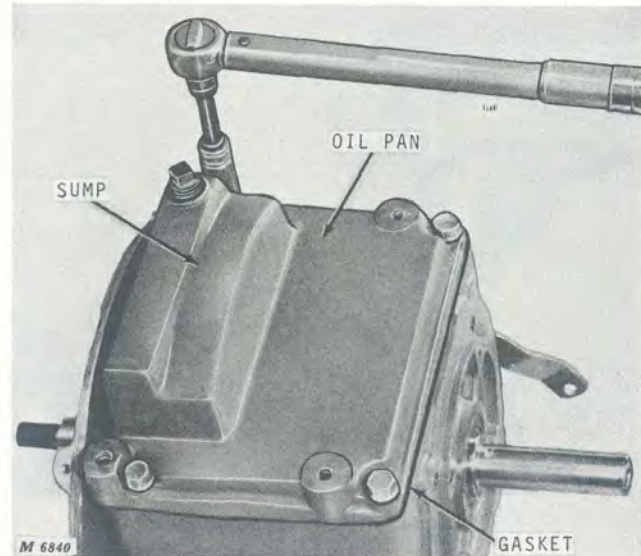

Fig. 51-Oil Pan and Gasket Assembly

Place a new gasket on oil pan and install on engine block, being sure rod slinger goes into sump on oil pan, Figure 51. Refer to "Torque Chart," Section 10, and torque cap screws accordingly.

### Assembling Ring Gear on Flywheel

The ring gear must be pressed into the recess on the outer perimeter of the flywheel. To do this, heat the new gear in an oven or submerge it in hot oil.

Position the heated gear on the flywheel, making sure it isn't cocked. Press the gear on the flywheel with an arbor press or drive it on with a soft-head hammer. Be sure chamfer is on the starter drive side.

As the gear cools, it will contract to form a tight press fit on the flywheel.

## Installing Flywheel

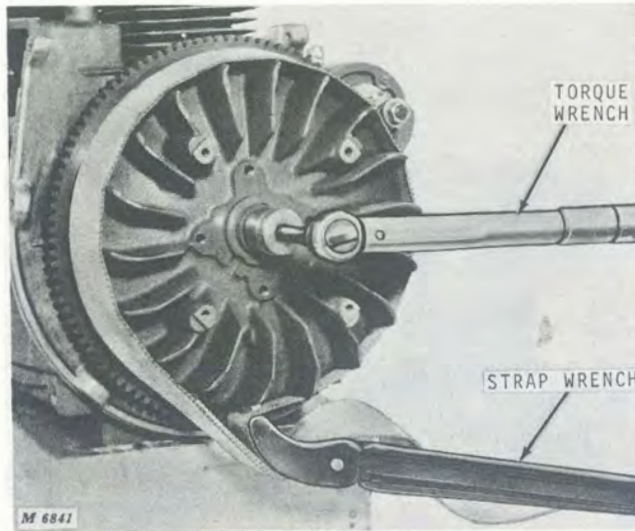

Fig. 52-Flywheel Assembly

Place square key in crankshaft keyway.

Assemble flywheel, washer and nut on end of crankshaft and tighten nut.

Place bar between flywheel fins or use strap wrench, Figure 52, while torquing nut to between 60 and 70 ft-lbs.

Refer to Group 10 and install valves, breather and cylinder head.

## Assembling Shrouding

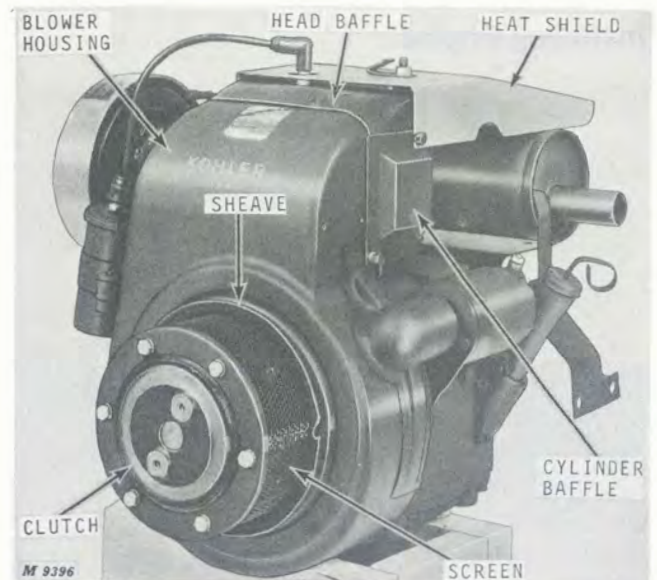

Fig. 53-Installing Engine Shrouding

Install sheave, blower housing, cylinder baffle, head baffle, and heat shield, Figure 53. Install clutch and screen (see Section 50, Group 10). Tighten cap screws firmly.

## Assembling Exterior Components

Install coil and condenser. Attach leads to their respective terminals. See Section 40, "Electrical System."

Be sure breaker point push rod is in place. Also inspect, clean and adjust breaker points if necessary. See Section 40, "Electrical System."

Refer to page 10-10 of this section and install the carburetor and related linkage.



## INSTALLATION

### Installing Engine

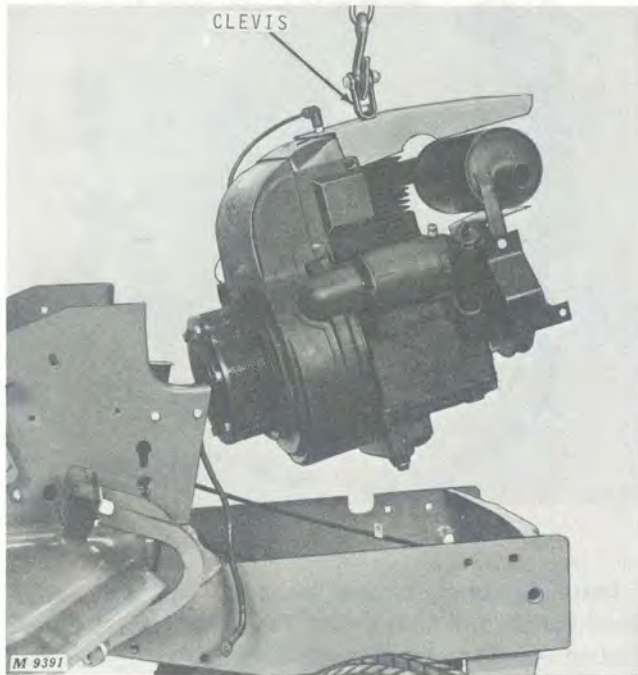

Fig. 54-Installing Engine in Tractor

Attach hoist to engine. Swing hoist over tractor and lower engine into position on engine base, Figure 54.

Fasten engine to engine base with four bolts. Torque to specifications, Section 10. Remove hoist.

Attach flex-coupling on drive shaft to clutch cone. Inspect clutch adjustment for proper free travel. Adjust as necessary (see Section 50, Group 10).

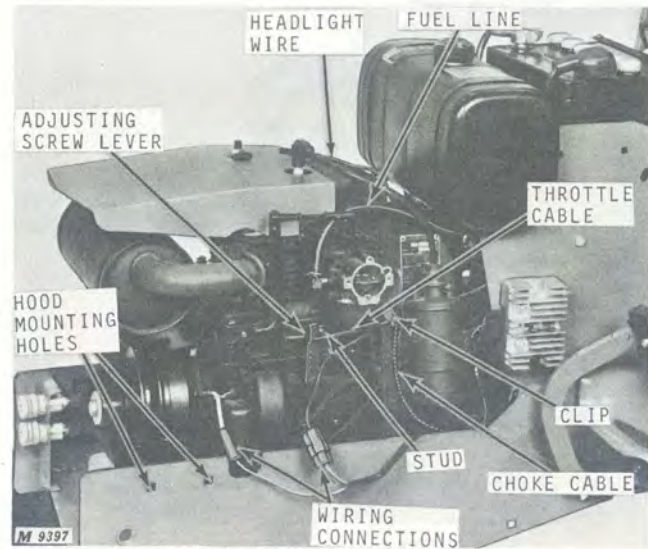

Fig 55-Fuel and Wiring Connections

Install battery, battery base and gas tank.

Connect fuel line to carburetor (Fig. 55). Attach choke cable. Insert throttle cable in lower hole of adjusting screw lever. (The air cleaner is removed for illustration purposes only.)

**NOTE:** To properly adjust throttle cable, hold the adjusting screw lever rearward against stud while installing throttle cable clip on choke bracket.

Connect all electrical wires, Figure 55. Install hood and grille components. Fill crankcase with oil of recommended viscosity.

## ADJUSTMENT

### Throttle Linkage Adjustment

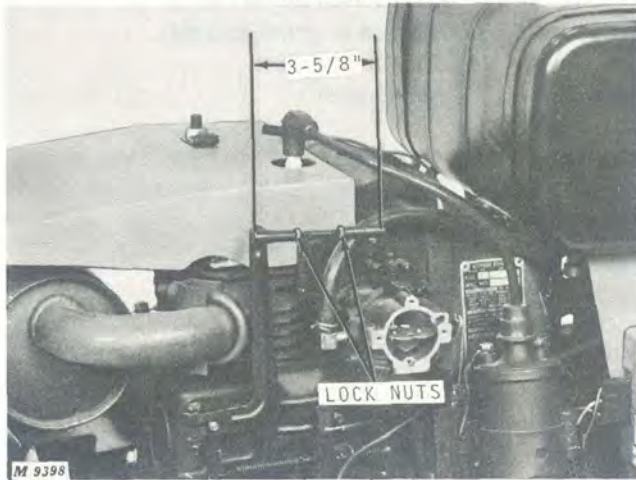

Fig. 56-Adjusting Throttle Linkage

Overall length of throttle linkage is 3-5/8 inches as shown in Figure 56. To obtain this dimension, loosen lock nuts and turn ends on or off threaded link until correct length is reached. Tighten lock nuts.

### Governor Speed Adjustment

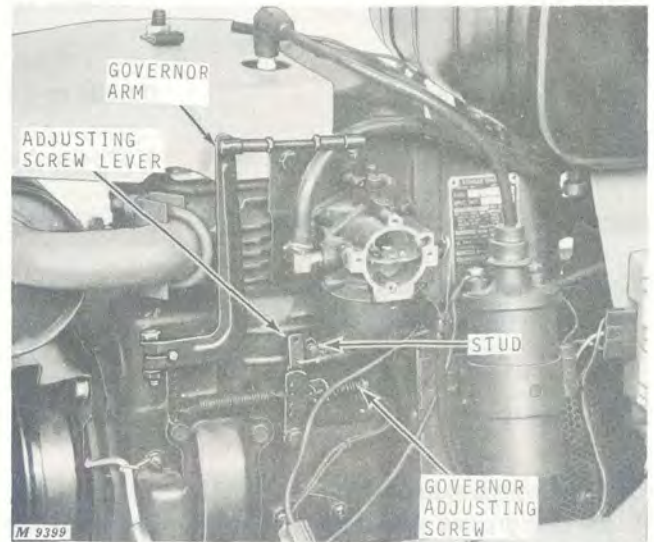

Fig. 57-Adjusting Governor Speed

To adjust governor, Figure 57, stop engine and set throttle control in run (high speed) position. Position cable so that side of adjusting screw lever strikes breather stud.

Start engine. Adjust engine speed to 3600 to 3800 rpm. Turn governor adjusting screw clockwise to decrease maximum rpm. Turn screw counterclockwise to increase maximum rpm:

Check engine rpm using a tachometer. See "Special Tools," page 15-25.

**IMPORTANT: Engine speed should not exceed 3800 rpm at no load.**



**SPECIFICATIONS**  
**K321AS Kohler Engine**

Component	New Part Dimension	Wear Tolerance
Crankshaft journal size	1.5000 to 1.4995 inch	0.0025 inch out of round Replace or grind journal
Piston pin diameter	0.8752 to 0.8754 inch	0.8747 inch
Piston pin bore	0.8754 to 0.8757 inch	0.8767 inch
Piston pin bore in connecting rod	0.8757 to 0.8760 inch	.....
Piston diameter top of skirt (just below oil ring groove) at 90° to piston pin bore	3.4900 to 3.4930 inch	3.4870 inch
Cylinder bore	3.500 inch	0.005 inch Taper (Top to bottom) 0.004 inch out of round
Top ring groove side clearance	0.002 to 0.004 inch	.....
Middle ring groove side clearance	0.002 to 0.004 inch	.....
Oil ring groove side clearance	0.001 to 0.003 inch	.....

**Table of Clearances**

Item	Clearances
Crankshaft end play	0.003 to 0.020 inch
Connecting rod to crankshaft journal clearance	0.001 to 0.002 inch
Connecting rod—journal end play	0.007 to 0.016 inch
Piston skirt clearance at thrust face top of skirt	0.0070 to 0.0100 inch
Piston ring end gap	0.010 to 0.020 inch

**Torques for Hardware**

Location	Torque
Connecting rod cap screws	300 in-lbs
Flywheel nut	60 to 70 ft-lbs
Misc. hardware	Refer to "Torque Chart," Section 10

**Maintenance Data**

Item	Specifications
Crankcase lubricant	Refer to Section 10 for proper crankcase lubricant
Oil change	Every 25 hours of operation or every 8 hours under extremely dusty conditions

## SPECIAL TOOLS

Name	Part No.	Use
Puller	OTC No. 515	To remove flywheel
Strap wrench	Ridgid-5	To remove flywheel
Micrometer 1-inch	Starrett 230 RL	Check piston pin diameter
Micrometer 2-inch	Starrett 2 RL	Check crank pin diameter
Micrometer 4-inch	Starrett 436 XRL	Check piston diameter
Inside telescoping gauge 5/16-6-inch	Starrett S579H	Check cylinder bore
Feeler gauge	OTC 860 A	Check end clearances
Cylinder hone	AMMCO 500	Deglazing and boring engine block
Ring groove cleaner	OTC 846	Clean piston grooves
Fine-Stone for AMMCO 500 cylinder hone	AMMCO 621	Finish cut
Finishing-Stone for AMMCO 500 cylinder hone	AMMCO 3933	Finish and deglazing
Medium-Stone for AMMCO 500 cylinder hone	AMMCO 620	Semi-finish
Coarse-Stone for AMMCO 500 cylinder hone	AMMCO 619	For roughing cylinder (Primary cut)
Piston ring expander	KD 875	To remove and install rings
Piston ring band handle	KD 850	Tighten piston ring compressor
Piston ring compressor	KD 850 B-1	To compress piston rings
Ridge/Reamer	AMMCO Model 2100	To remove top ridge from cylinder bore
Treysit Vibrator Engine Tachometer	670156	Measure engine rpm. Order from Lauson Power Products, Parts Depot, Grafton, Wisconsin, 53024
Balance Tool	JDST-3	Timing balance gears to crankshaft gear. Order from Service Tools, Inc. 1901 Indiana Avenue Chicago, Illinois 60616



**20** Engine  
**15-26** Piston, Crankshaft and Flywheel

Tractor, Hydrostatic-140 (Serial No. 30,001- )  
SM-2093-(Sep-70)

---

## Group 20 CAMSHAFT, TAPPETS, AND GOVERNOR

### GENERAL INFORMATION

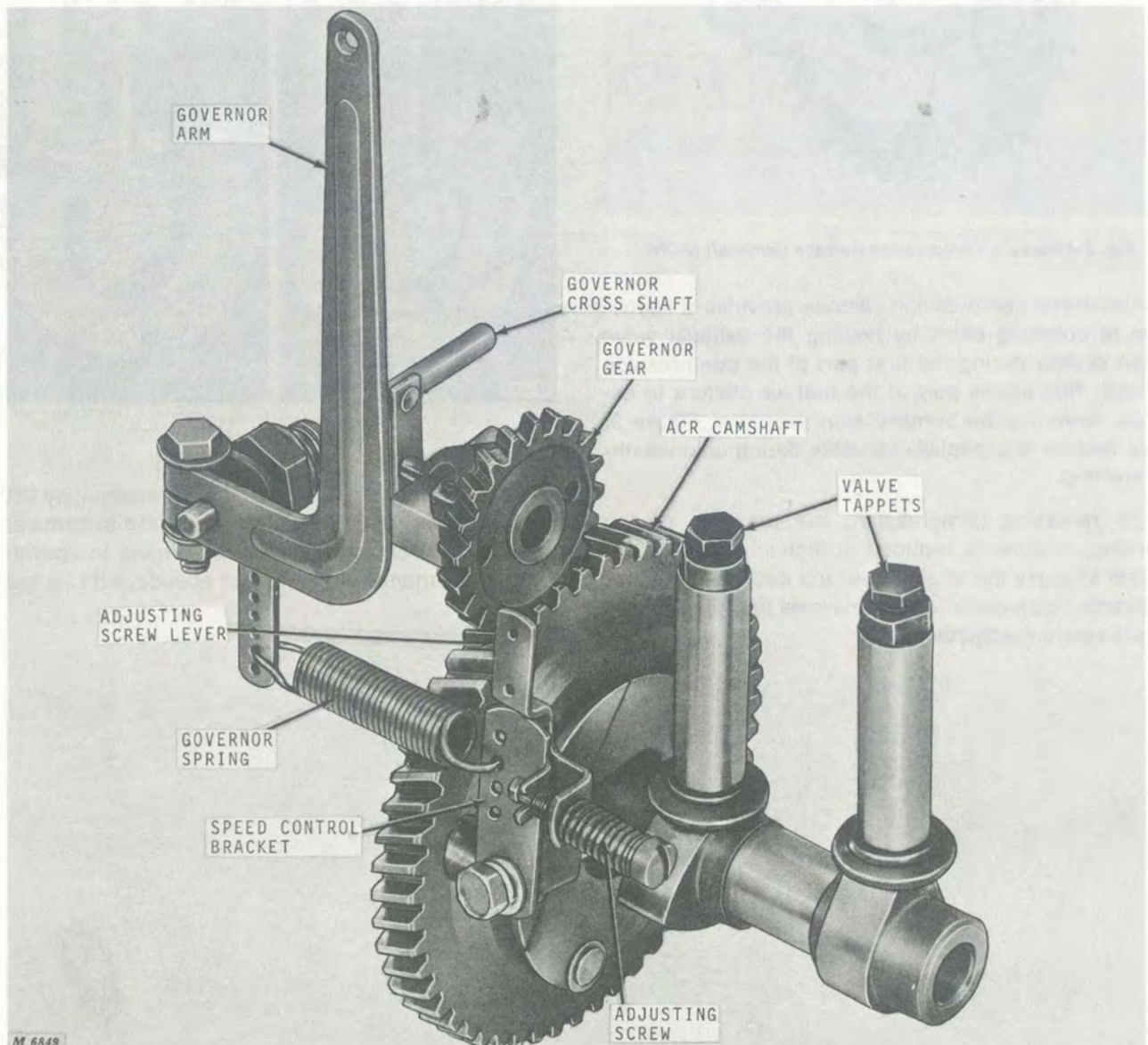

Fig. 1 - Assembled View of Camshaft, Tappets and Governor

The camshaft-driven governor maintains constant engine speed under varying loads and serves as a top speed limiting device.

The engine in the 140 Tractor features the automatic compression release camshaft, Figures 1 and 2.



### Automatic Compression Release Camshaft

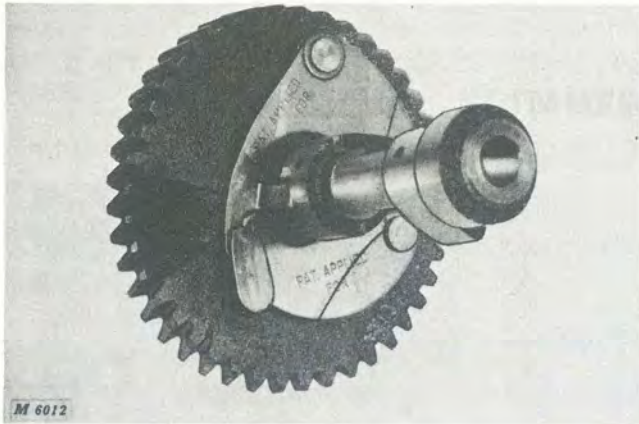

Fig. 2-Automatic Compression Release Camshaft (ACR)

Automatic compression release provides a reduction in cranking effort by holding the exhaust valve open slightly during the first part of the compression stroke. This allows part of the fuel-air mixture to escape, lowering the compression pressure, Figure 3. This feature is especially valuable during cold weather starting.

By releasing compression, the pressure of the burning mixture is reduced sufficiently for the flywheel to carry the engine over top dead center. This prevents "kick-back" and eliminates the need for the spark retard mechanism.

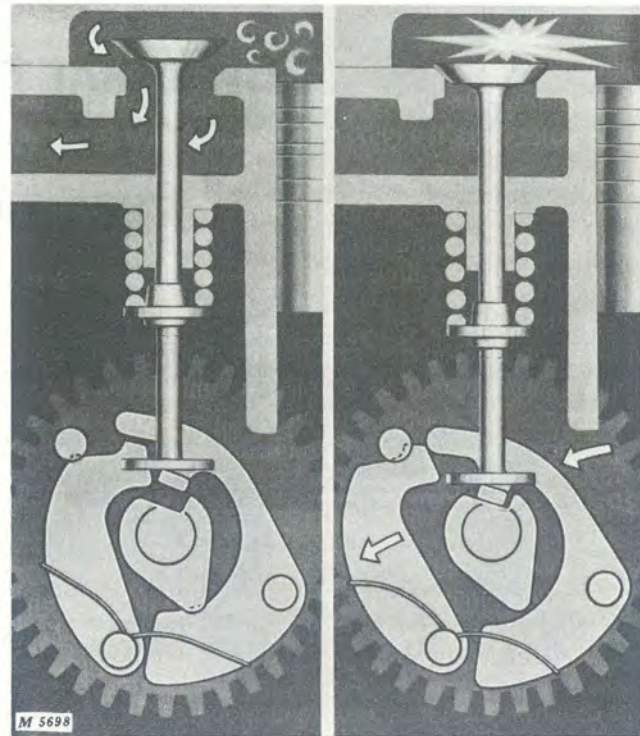
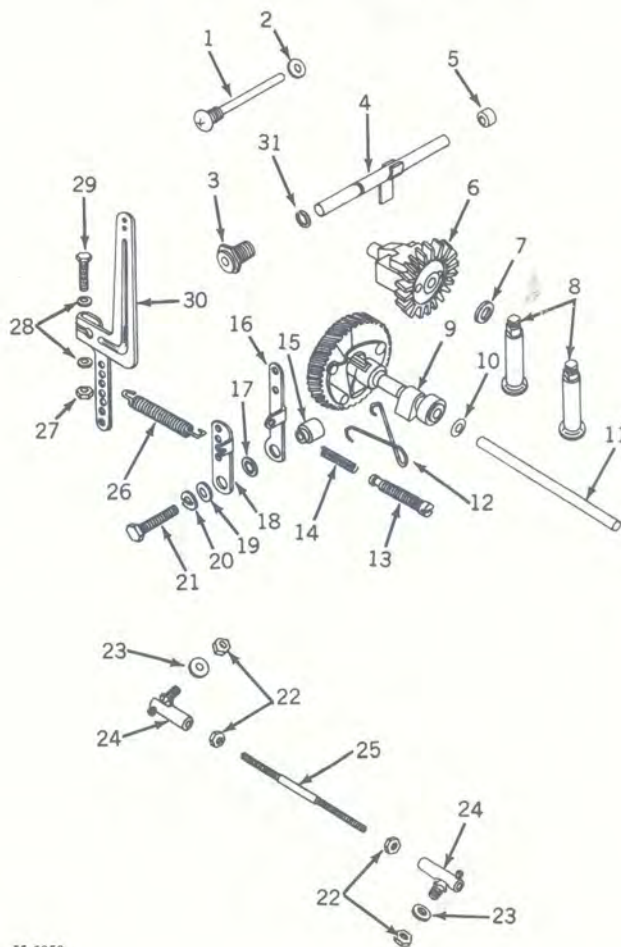

Fig. 3-ACR Operation

When the engine speed reaches approximately 650 rpm, centrifugal force disengages the automatic compression release allowing the engine to operate in the usual manner at all higher speeds, with no loss of power.

## REPAIR



- 1-Governor Stop Pin
- 2-Governor Stop Pin Washer
- 3-Governor Bushing
- 4-Governor Cross Shaft
- 5-Needle Bearing
- 6-Governor Gear
- 7-Thrust Washer
- 8-Tappets (2 used)
- 9-ACR Camshaft
- 10-Spacer (0.005 or 0.010 inch as Required)
- 11-Camshaft Pin
- 12-ACR Camshaft Spring
- 13-Adjusting Screw
- 14-Adjusting Screw Spring
- 15-Spacer
- 16-Adjusting Screw Lever
- 17-Tension Washer
- 18-Speed Control Bracket
- 19-Washer
- 20-Lock Washer
- 21-Cap Screw
- 22-Hex. Nut (4 used)
- 23-Washer (2 used)
- 24-Ball Joint (2 used)
- 25-Throttle Rod
- 26-Governor Spring
- 27-Hex. Nut
- 28-Washer (2 used)
- 29-Cap Screw
- 30-Governor Lever
- 31-Snap Ring

M 6850

Fig. 4-Exploded View of Camshaft and Governor

### Removing Camshaft and Tappets

Remove engine and all component parts covered in Group 15.

Use a blunt punch to drive camshaft pin out of block, Figure 5.

**NOTE:** Drive pin out from power take-off side of cylinder block only. Pin will slide out easily after it is driven free from this side of block, Figure 5. Removing or installing pin incorrectly will damage engine block.

Lift out camshaft.

**IMPORTANT:** Watch for and save thin camshaft shim(s) when removing camshaft.

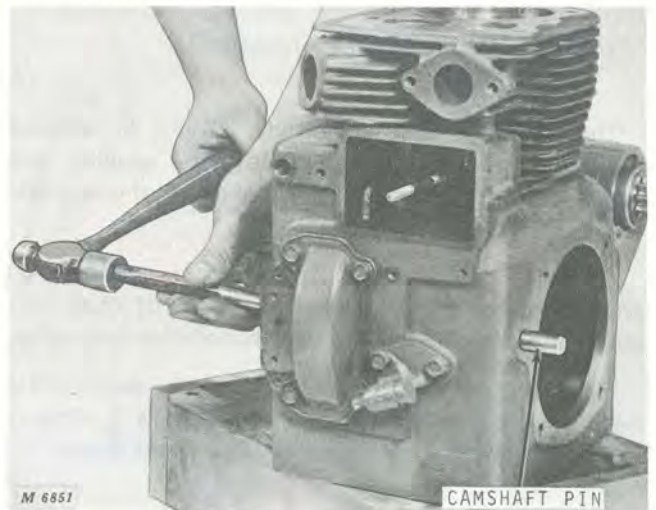

Fig. 5-Removing Camshaft Pin

Mark tappets before removing to be sure they are returned to same tappet hole. Lift tappets out.



## Removing Governor

Loosen nut on governor arm shaft and slide off all external parts.

*NOTE: Do not attempt to remove governor cross shaft from outside of engine. It must be removed from the inside.*

Turn block upside down and remove governor stop pin (1, Fig. 4) and copper washer. Governor assembly, thrust washer, and cross shaft (4, Fig. 4) may now be removed.

## Inspecting Camshaft

Wash governor and camshaft in a safe cleaning solvent and wipe parts dry.

Check camshaft for cracked, worn or broken gear teeth.

Check operation of ACR camshaft and weights, making sure all parts are intact and operate freely.

## Inspecting Governor Gear

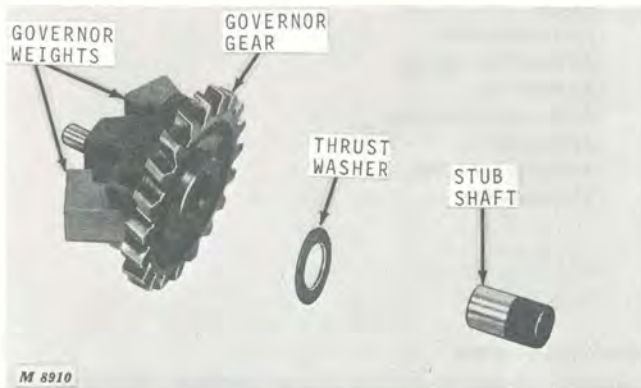

Fig. 6-Governor Gear Assembly

The governor gear assembly, Figure 6, will not normally show much wear. Be sure weights and governor center pin operate freely and that gears and teeth are in good condition.

The stub shaft is replaceable. Remove expansion plug from block and press replacement shaft into block until it protrudes 11/32 inch from the boss area.

Be sure cross shaft arm is not loose on shaft and is positioned perpendicular to shaft, Figure 7. This is important. If arm is loose, install new cross shaft.

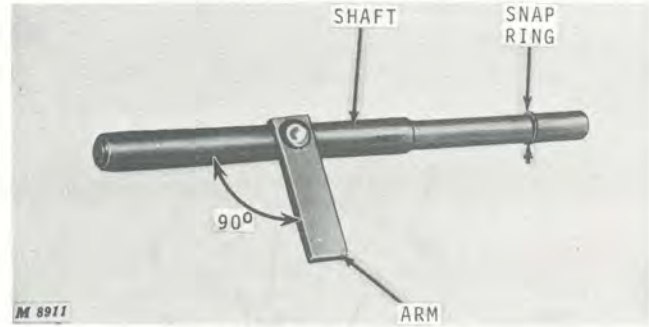

Fig. 7-Governor Cross Shaft

## INSTALLATION

### Installing Governor

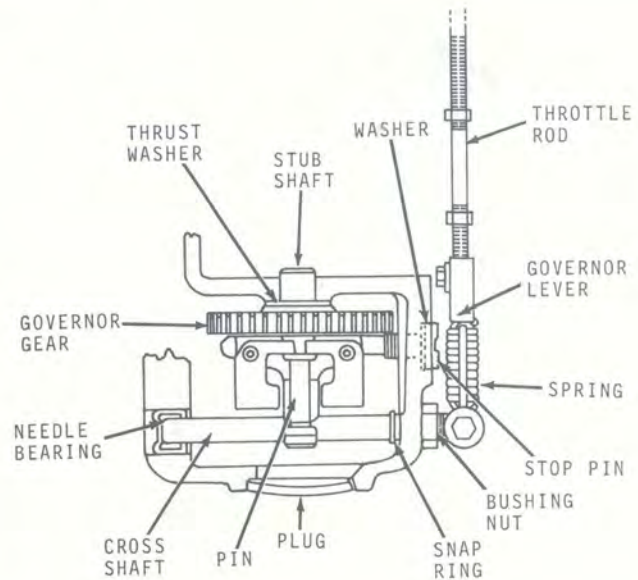

Fig. 8-Cross-Section of Governor Assembly

Place cylinder block on its side. Install cross shaft from inside of block. Place thrust washer and governor gear assembly on stub shaft, Figure 8. Place expansion washer on stop pin and turn in from outside of engine block.

Thread bushing nut into block. Tighten nut lightly.



Grasp end of cross shaft and work cross shaft in and out to determine end clearance. Cross shaft should be free to move in and out approximately 1/64 to 1/32 inch. Adjust for more or less end clearance by tapping needle bearing either in or out of block, Figure 8.

**NOTE:** To prevent damage, tap needle bearing at depressed center area only.

Spin the governor gear assembly to be sure it rotates freely.

### Installing Camshaft

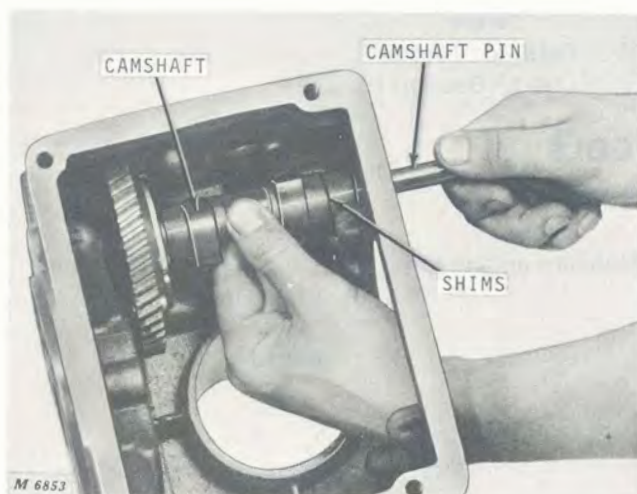

Fig. 9-Installing Camshaft

Install tappets in holes from which removed.

While holding camshaft assembly, Figure 9, insert camshaft pin. Be sure to install thin shim washer(s) on shaft next to bearing plate side of block. Drive pin into block until end of pin is flush with block exterior (flywheel side of block).

Use feeler gauge to check camshaft end clearance. Camshaft end clearance should be 0.005 to 0.010 inch. Use spacer washers as required to obtain correct clearance.

Spin camshaft to be sure governor and camshaft turn freely.

### Installing Governor Arm

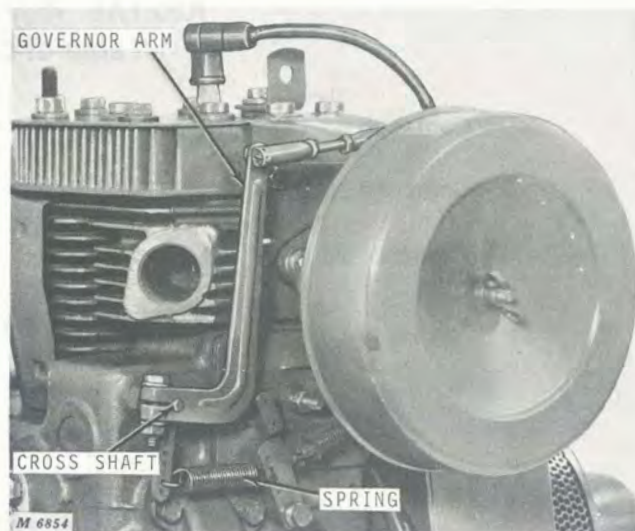

Fig. 10-Positioning Governor Arm

Turn block upright and slide governor arm and bolt assembly on end of cross shaft, Figure 10.

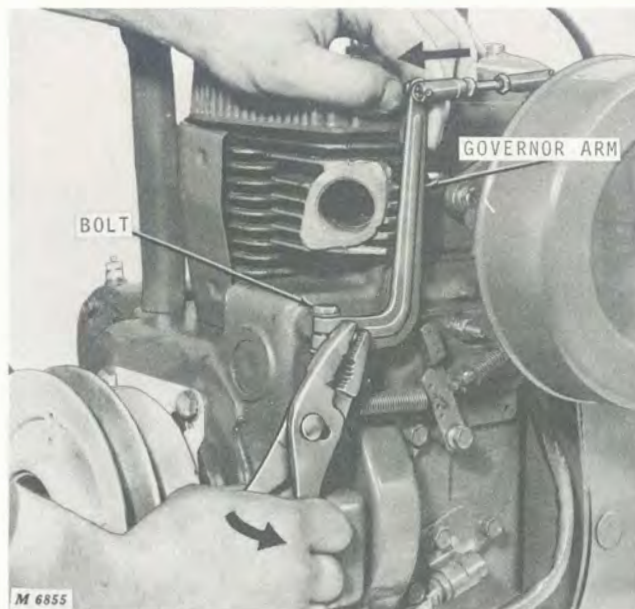

Fig. 11-Adjusting Governor Arm

Before tightening bolt on cross shaft, turn governor shaft counterclockwise as far as possible. While holding cross shaft in this position, move governor arm to the left (away from carburetor) and tighten bolt, Figure 11. Move governor through its full arc of travel to be sure it operates loosely. Relieve pressure on bushing nut if too tight.

Refer to "Assembly," page 15-15, to complete engine assembly.



### SPECIFICATIONS

#### K321AS KOHLER ENGINE Table of Clearances

Item	Clearances
Camshaft pin to camshaft	0.001 to 0.0035 inch
Camshaft end play	0.005 to 0.010 inch
Tappet in block	0.0008 to 0.0023 inch

#### Torque for Hardware

Location	Torque
Miscellaneous hardware	Refer to "Torque Chart," Section 10

### SPECIAL TOOLS

Name	Part No.	Use	Order From
Treysit Vibrator Engine Tachometer	670156	Measure engine rpm	Lauson Power Products Parts Depot Grafton, Wisconsin 53024

# Section 30 FUEL SYSTEM

## Group 5 GENERAL INFORMATION

### TABLE OF CONTENTS

GROUP 5 - GENERAL INFORMATION	Page	GROUP 15- AIR CLEANER	Page
Principle of Operation .....	5-2	General Information .....	15-1
Diagnosing Malfunctions .....	5-3	Service .....	15-1
GROUP 10 - CARBURETOR		Heavy-Duty Air Cleaner .....	15-2
General Information .....	10-1	GROUP 20 - FUEL STRAINER AND GAS TANK	
Repair .....	10-1	Fuel Strainer .....	20-1
Disassembling Carburetor .....	10-1	Gas Tank .....	20-1
Cleaning Carburetor .....	10-1	Special Tools .....	20-1
Inspecting Carburetor .....	10-2		
Assembly .....	10-3		
Installing Float Valve .....	10-3		
Installing Float and Float Shaft .....	10-3		
Installation .....	10-3		
Adjustment .....	10-4		
Carburetor .....	10-4		
Governor and Throttle .....	10-4		



### PRINCIPLE OF OPERATION

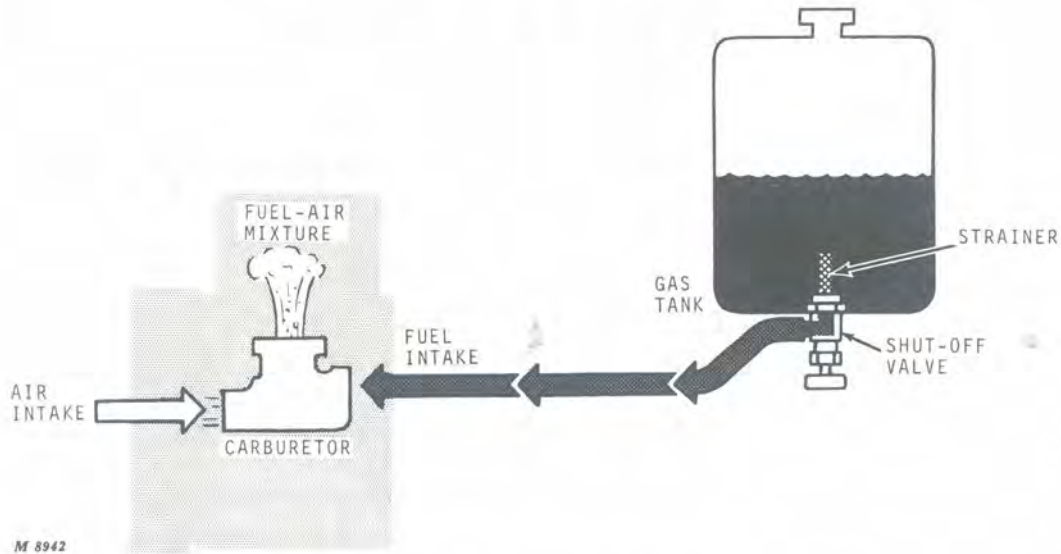

Fig. 1-Gravity Flow Fuel System for 140 Tractor

The gas tank is mounted above the engine and carburetor to allow gravity feed of the fuel, eliminating the need for a fuel pump.

Gasoline flows from the tank through an in-line strainer to the fuel shut-off valve. When the valve is

open, fuel is free to flow through the gas line to the carburetor.

The side-draft carburetor used on the 140 Hydrostatic Tractor has three adjustments: high speed and idle mixture needles, and an idle stop screw.

## DIAGNOSING MALFUNCTIONS

### Carburetor

#### Hard Engine Starting

- Engine flooded.
- Restricted gas tank vent.
- High speed and idle mixture needles not properly adjusted.
- Float valve leaking.
- Choke control not properly adjusted.
- Fuel shut-off valve closed.
- Water, rust or stale fuel in gas tank.
- Dirty carburetor.
- Restricted air filter element.

#### Engine Stalling

- High speed and idle mixture needles not properly adjusted.
- Dirt, water or ice in fuel system.
- Restricted gas tank vent.
- Choke control not properly adjusted.
- Restricted fuel line.
- Air lock in fuel line.
- Restricted air filter element.

#### Rough idle

- High speed and idle mixture needles not properly adjusted.
- Loose engine mounting bolts.
- Incorrect float setting.
- Restricted air filter element.
- Dirt, water, or ice in fuel system.
- Damaged gasket between carburetor body and cylinder block.
- Choke control not properly adjusted.

#### Poor Acceleration

- High speed and idle mixture needles not properly adjusted.
- Restricted air filter element.
- Arm loose on governor cross shaft.
- Choke control not properly adjusted.
- Sticky fuel inlet needle.
- Dirty or damaged high-speed mixture needle.

#### Engine Surging

- High speed and idle mixture needles not properly adjusted.
- Too low on fuel.

#### Flooding or Leaking Carburetor

- Sticky float valve.
- Incorrect float setting.
- Leaking float.

#### Gas Drips from Carburetor

- Loose fuel fitting.
- Fuel line loose on fuel fittings.

### Fuel Strainer

#### No Fuel Reaches Carburetor

- Empty gas tank.
- In-line strainer clogged.
- Restricted gas tank vent.

Also see "Diagnosing Malfunctions," page 5-7 of Section 20, "Engines," for other solutions.





## Group 10 CARBURETOR

### GENERAL INFORMATION

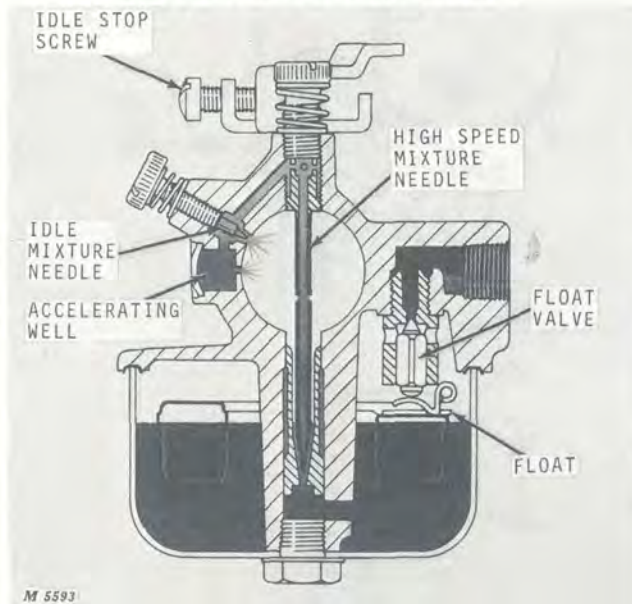

Fig. 1-Cutaway View of Carburetor

Fuel enters the bowl through a valve controlled by the float, Figure 1. Air entering the carburetor is controlled by the choke valve when starting. The air-fuel mixture entering the engine is regulated by the throttle valve which maintains uniform engine speed under varying loads, by increasing or decreasing air-fuel flow.

Whenever the throttle is opened quickly to give extra power for a sudden load, an extra amount of fuel is required for a momentarily richer air-fuel mixture. The accelerating well, Figure 1, provides the extra fuel.

The carburetor has two adjusting needles (one for high speed and the other for low or idle speeds, Figure 1) and an idle stop screw.

The high speed mixture needle controls the amount of fuel entering the venturi at high engine speeds.

The idle mixture needle controls the amount of fuel entering the venturi when engine is idling or when throttle valve is in the full closed position

The idle stop screw controls the throttle setting for correct idle position

### REPAIR

When diagnosis indicates the carburetor should be cleaned, disassemble the carburetor before placing it in the cleaning solution to make sure the solution reaches all surfaces and parts.

Always install all the parts in the repair kit when the carburetor needs servicing. Always install new gaskets whenever the carburetor is disassembled.

### Disassembling Carburetor

Remove governor throttle rod from carburetor throttle lever.

Remove carburetor from engine and remove air cleaner base.

Remove fuel bowl, float valve, and seat.

Remove high speed and idle mixture needles.

*NOTE: Do not attempt to remove choke or throttle valves, because screws holding valves to shafts are peened. Should valves require service, it is less expensive to replace the carburetor body than to repair the valves.*

### Cleaning Carburetor

Clean all parts in a carburetor cleaning solvent.

**IMPORTANT: Never clean holes or passages with small drill bits or wire, because a slight enlargement or burring of these holes will change the performance of the carburetor. No method of cleaning other than solvent should be used.**

Place carburetor parts in a suitable basket and immerse basket in a container of carburetor cleaning solution.

*NOTE: Good carburetor cleaning solutions can be obtained from most jobbers. Agitating the basket up and down in the solution will speed up action of the solvent and aid in dissolving deposits in small drilled passages.*



Allow parts to remain in the solution from one to two hours. Then remove and rinse with fresh cleaning solvent. Dry with compressed air, making sure all holes are open and free of carbon and dirt. Never use rags or waste paper to dry the parts. Any lint may plug jets or channels and affect operating efficiency of carburetor.

**IMPORTANT: Never use compressed air to clean a completely assembled carburetor. To do so may cause the float to collapse.**

### Inspecting Carburetor

Inspect float and float valve assembly for defects or wear. If either is noticed, replace parts as required.

Float valves and seats are available only as matched sets and should never be interchanged.

For a positive leak test, immerse the float in hot water. Any leak can be detected at once by air bubbles escaping from the float. Do not attempt to repair the float if it leaks. Replace it.

Check float pin and replace if worn.

Inspect tapered ends of mixture needles. If a ring has been cut in the tapered surface of either because the needle has been turned too tightly against the seat, replace the needle.

The seats for the high speed and idle mixture adjusting needles are an integral part of the carburetor body casting and therefore cannot be removed or replaced.

Inspect carburetor body casting and fuel bowl for cracks or damaged sealing surface. Examine threaded holes for damaged threads.

Inspect jets for damaged or plugged holes. Replace if damaged.

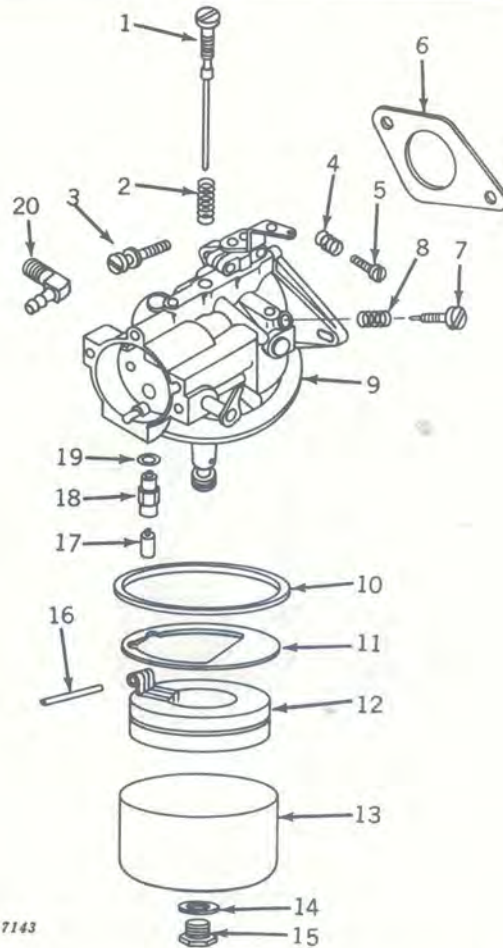

M 7143

- |   |                        |
|---|------------------------|
| 1-High Speed Mixture Needle                 | 10-Bowl Ring Gasket    |
| 2-Spring                                    | 11-Bowl Gasket         |
| 3-Cap Screw                                 | 12-Float               |
| 4-Spring                                    | 13-Bowl                |
| 5-Idle Stop Screw                           | 14-Bowl Screw Gasket   |
| 6-Gasket                                    | 15-Bowl Screw          |
| 7-Idle Mixture Needle                       | 16-Float Pin           |
| 8-Spring                                    | 17-Float Valve         |
| 9-Carburetor with Choke and Throttle Valves | 18-Seat                |
|   | 19-Gasket              |
|   | 20-Fuel Line Connector |

Fig. 2-Exploded View of Carter Carburetor Components

**IMPORTANT: Never clean holes or passages with small drill bits or wire. Dissolve all particles with carburetor solvent only.**

Inspect throttle and choke valves for bends, cracks or other damage.



## ASSEMBLY

Install the carburetor repair kit whenever the carburetor is disassembled for service and parts show wear.

### Installing Float Valve

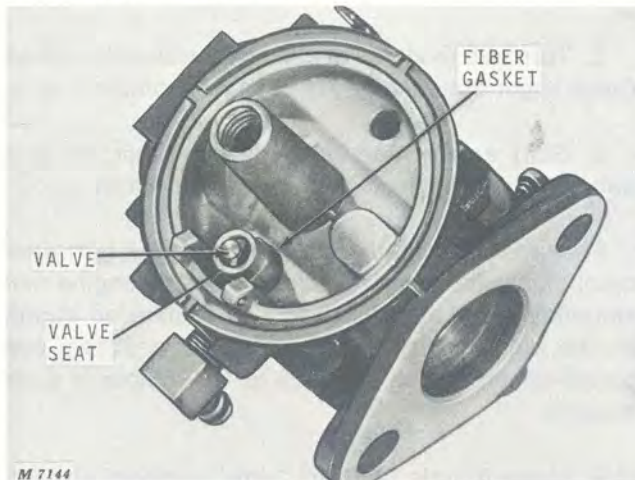

Fig. 3-Installing Float Valve Seat and Valve

The valve seat, valve and fiber gasket are packaged together for service. Never replace one part without replacing the other parts.

Screw valve seat assembly (18, Fig. 2) into carburetor housing.

Insert valve (17, Fig. 2) with tapered end against valve seat, Figure 3.

### Installing Float and Float Shaft

Assemble float (12, Fig. 2), to carburetor housing with float pin (16). Invert carburetor, Figure 4. With float resting lightly on float valve, the distance between float and machined surface of carburetor body should be  $\frac{13}{64}$  inch. To increase or decrease the distance, bend lip on float. Dimension should be made on free end of float (opposite valve seat), Figure 4.

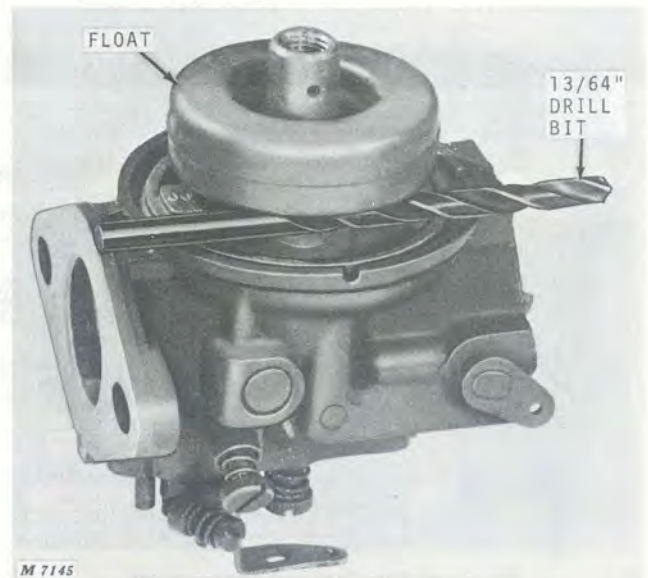

Fig. 4-Adjusting Float

Position bowl gasket (11), fuel bowl (13), bowl screw gasket (14) and bowl screw (15). Tighten screw firmly.

Install idle mixture needle (7), through spring (8) and high speed mixture needle (1) through spring (2) and into carburetor body.

**IMPORTANT: Do not force needles too firmly against seat because it will groove needle point and cause carburetor malfunction.**

## INSTALLATION

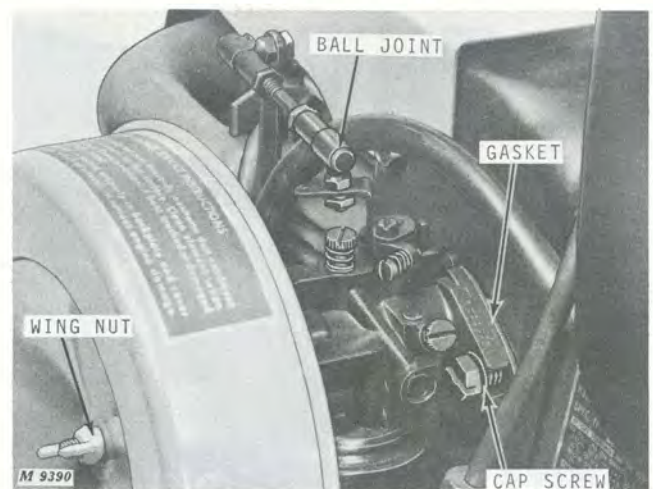

Fig. 5-Installing Carburetor Assembly on Cylinder Block

Place new gasket between carburetor flange and cylinder block and bolt carburetor to cylinder block, Figure 5.

Install throttle rod ball joint to throttle lever, Figure 5.



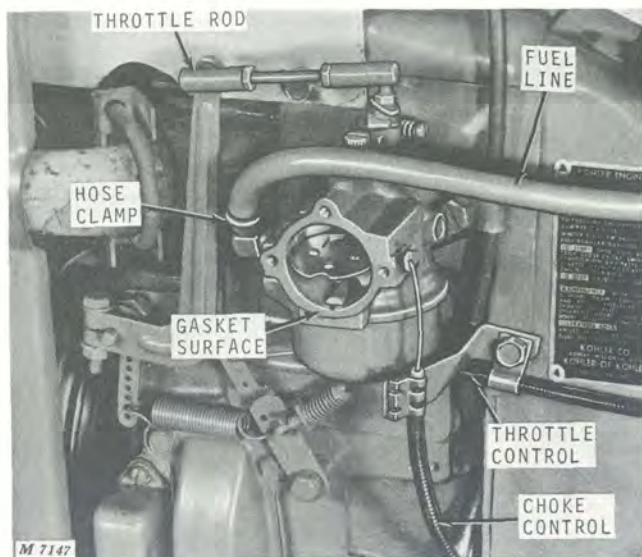

Fig. 6-Installing Carburetor Components

Attach fuel line and choke and throttle control cables to carburetor, Figure 6. Secure conduit clamps to supporting brackets.

Place new gasket on carburetor body, Figure 6, and attach air cleaner base to carburetor.

Place filter element on base making sure it seats tightly around base. Install cover and tighten wing nut finger tight, Figure 5.

## ADJUSTMENT

### Carburetor

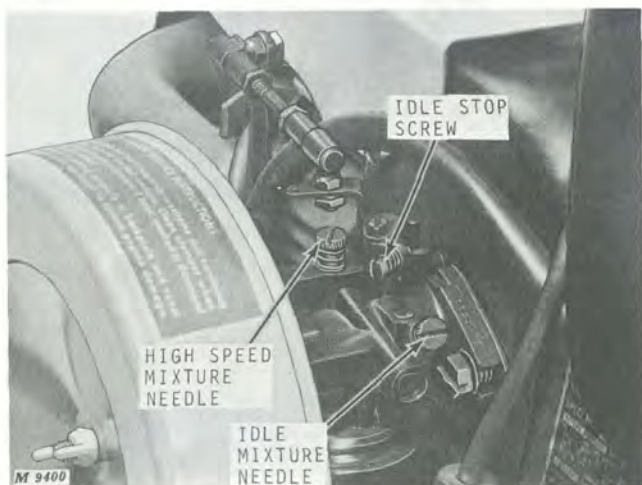

Fig. 7-Carburetor Adjustments

Idle adjustment and high speed adjustment must be made at the same time as each affects the other. Adjust as follows:

1. Be sure choke lever is down (choke open). Turn high speed mixture needle clockwise until closed. Close finger tight only. Then open one and one-half turns.
2. Turn idle mixture needle clockwise until closed. Close finger tight only. Then open two complete turns.
3. Start engine and raise throttle lever on dash panel to "fast" position. Allow engine to warm up.
4. Turn high speed mixture needle 1/8 turn each time, clockwise or counterclockwise until engine runs smoothly at full throttle. Keep needle position slightly on the rich side (open) when operating tractor with power-driven equipment such as the mower or snow thrower.
5. Move throttle lever to "slow" position and turn idle mixture needle 1/8 turn each time, clockwise or counterclockwise until engine idles smoothly.
6. Advance throttle lever quickly to check for uniform acceleration. If engine misses, gas-air mixture is too lean. Turn high speed mixture needle counterclockwise until positive acceleration can be obtained.

If excess exhaust smoke is noticed, mixture is too rich. Readjust idle mixture needle if necessary, until good balance is achieved and engine idles smoothly between 1200 to 1700 rpm. The idle stop screw adjusts the speed at which the engine idles. This is factory-adjusted and will not normally require adjustment.

### Governor and Throttle

Instructions for adjusting the governor and throttle are found on page 15-23 of Section 20.



## Group 15 AIR CLEANER

### GENERAL INFORMATION

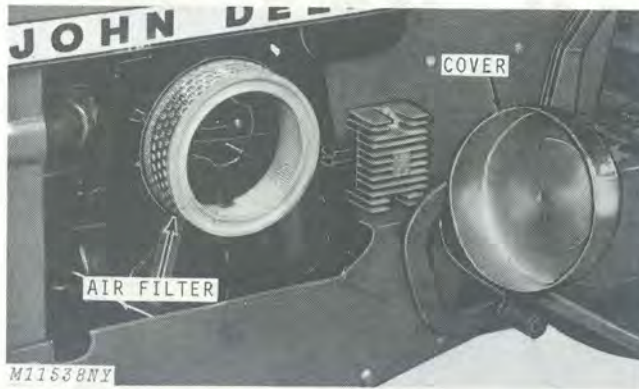

Fig. 1-Air Cleaner

The air cleaner consists of the base mounted on the carburetor, an air filter element and a cover that fits over the filter element. The filter element is made of treated paper with a soft sealing edge.

Care of the air cleaner is important since all the air that enters the engine goes through the air filter element. A clogged air filter element restricts air flow and reduces engine efficiency. A damaged air filter element allows dirt to enter the engine and causes immediate damage to internal working parts.

### SERVICE

The most damaging engine wear can be traced to entry of dirt or dust through an improperly serviced air filter element.

#### Cleaning

Under normal conditions the air filter element should be cleaned every 25 hours of operation. However, under extremely dusty conditions, it should be cleaned every 5 hours of operation.

Tap the filter lightly against a flat surface and brush out dust.

Do not dip filter into a liquid cleaner of any type. Replace filter if bent, crushed or damaged. Replace if extremely dirty. Under extremely dusty conditions, replace every 100 hours of operation. When in doubt, replace filter. This is inexpensive insurance to protect the engine.

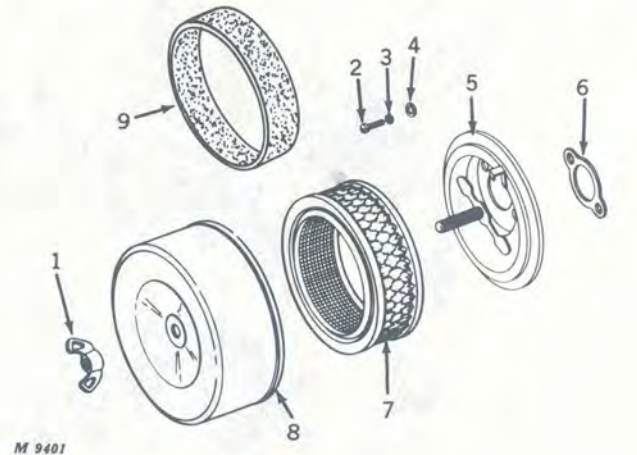

- M 9401
- 1-Wing Nut
  - 2-Machine Screw
  - 3-Lock Washer
  - 4-Plain Washer

- 5-Base
- 6-Air Cleaner Gasket
- 7-Air Filter Element
- 8-Air Filter Cover
- 9-Polyurethane Pre-cleaner (Optional)

Fig. 2-Exploded View of Air Cleaner Components

**IMPORTANT: Never run engine with air filter element removed.**

Wipe air cleaner base and inside of air cleaner cover with a clean cloth dampened with water. Install air filter element making sure it seats around base. Assemble cover and tighten wing nut on cover finger tight, Figure 2.

#### Pre-Cleaner

A polyurethane band pre-cleaner (9, Figure 2) is available as an option, and should be recommended to customers operating in extremely dry and dirty conditions. This pre-cleaner will increase air filter element life four to eight times under these conditions.

The pre-cleaner fits over the element and inside the air filter cover.

To service the pre-cleaner, wash it in water and squeeze dry.

**IMPORTANT: Never soak pre-cleaner in oil. The pre-cleaner must be used dry.**



## HEAVY-DUTY AIR CLEANER

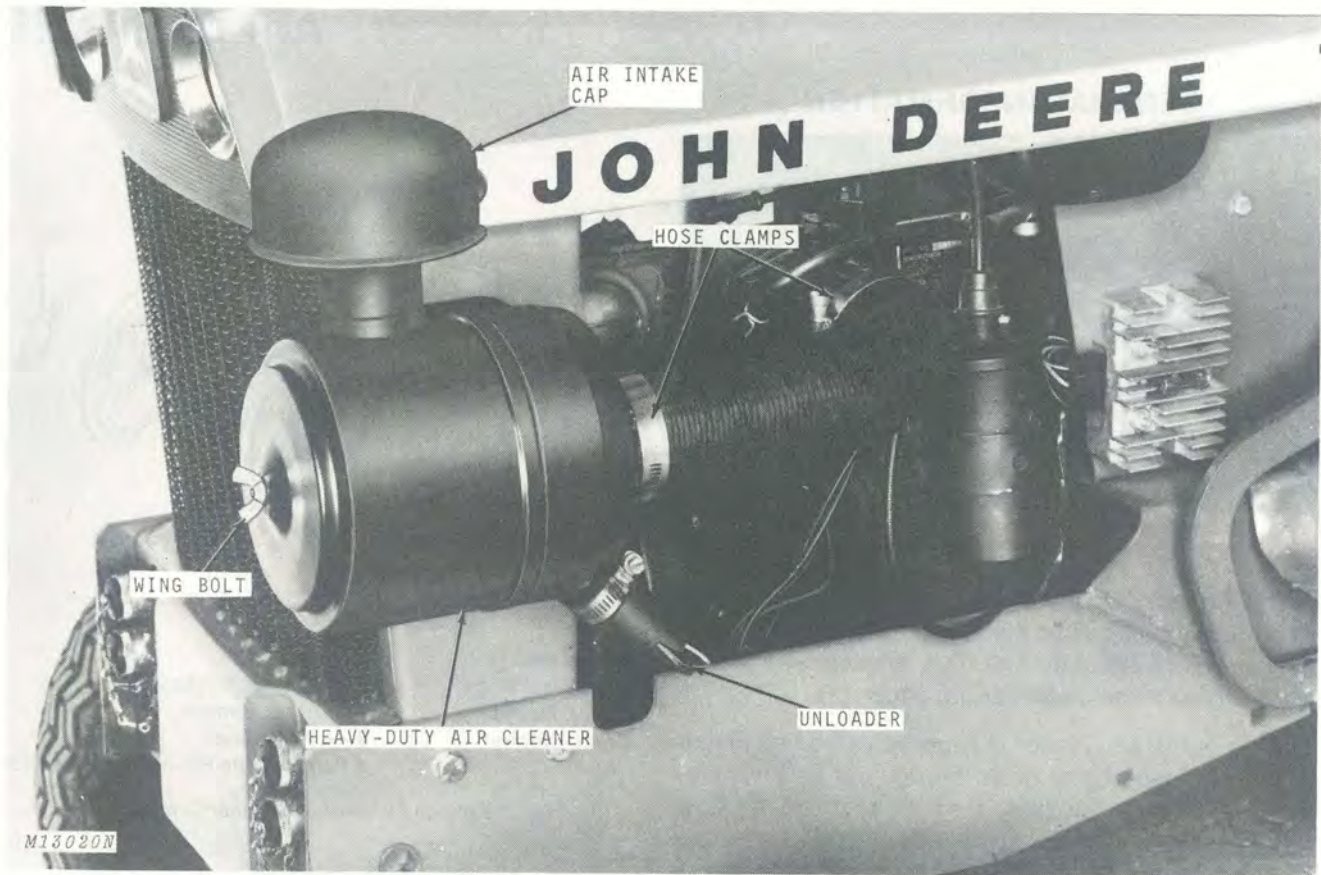

Fig. 3-Heavy-Duty Air Cleaner

### GENERAL INFORMATION

The heavy-duty air cleaner is available as extra equipment for customers operating in extremely dusty conditions.

The air cleaner features a large capacity cleanable filter element, a self-unloader for dirt accumulation discharge, and turbo-airflow design.

### SERVICE

Under normal conditions, the filter element should be cleaned every 50 hours.

Clean the filter element by tapping it gently on a flat surface or clean it with water until water runs clear. Shake off excess water and dry element. Wipe out inside of air cleaner housing with a clean damp cloth.

Replace the filter element after 10 cleanings or after one year of service, whichever comes first. Replace the element any time damage is noted.

Inspect the gasket between the support and air cleaner housing and replace it if damaged. Check the hose clamp connections and the gasket and screws securing the carburetor adapter to carburetor, Figure 3. Check the unloader for obstructions or damage and clean it if necessary. Install element and tighten wing bolt by hand.

## Group 20 FUEL STRAINER AND GAS TANK

### FUEL STRAINER

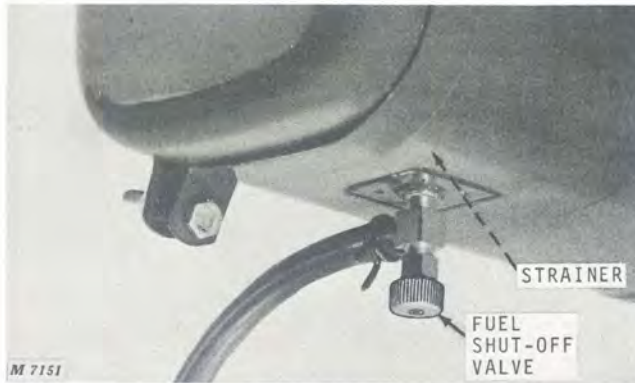

Fig. 1-In-Line Fuel Strainer

An in-line fuel strainer is used to prevent foreign particles from entering the carburetor. Should the strainer become plugged, it can be removed for cleaning.

Shut off fuel by turning thumb screw on fuel shut-off valve. Remove gas line from carburetor, open fuel shut-off valve, and drain gas tank.

Unscrew fuel shut-off valve and strainer assembly from tank. Clean strainer with gasoline and compressed air. Replace in tank. Fill tank with gasoline. Open fuel shut-off valve and bleed air from fuel line. Attach fuel line to carburetor.

### GAS TANK

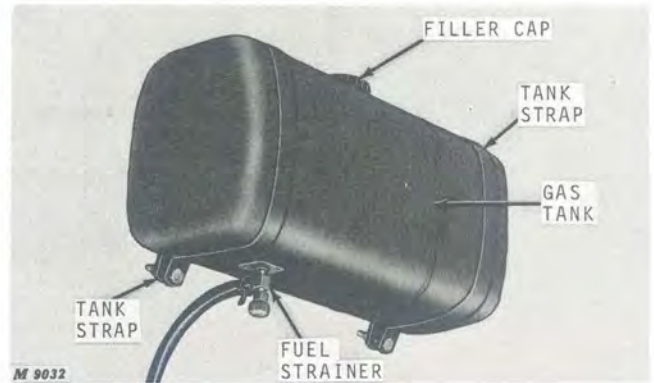

Fig. 2-Gas Tank

Clean gas tank and fuel strainer whenever gum deposits are detected in gas tank or when dirty fuel has obviously been used.

Do not attempt to solder the gas tank unless proper precautions are taken. Because of the size of the tank (1.75 U.S. gal.) it may be more desirable to replace the tank rather than attempt to repair it.

### SPECIAL TOOLS

No.	Name	Use
OTC KC18	Hose Clamp Pliers	To remove gas line hose clamps.





# Section 40

# ELECTRICAL SYSTEM

## Group 5

## GENERAL INFORMATION

### TABLE OF CONTENTS

	Page		Page
<b>GROUP 5 - GENERAL INFORMATION</b>		Inspection .....	15-6
Principle of Operation .....	5-2	Spark Plug .....	15-6
Wiring Diagram .....	5-3	Ignition Coil .....	15-6
Testing .....	5-4	Condenser .....	15-6
Diagnosing Malfunctions .....	5-4	Repair .....	15-6
<b>GROUP 10 - CRANKING SYSTEM</b>		Spark Plug .....	15-6
Principle of Operation .....	10-1	Ignition Coil .....	15-7
Battery .....	10-1	Condenser .....	15-7
Starting Motor .....	10-2	Breaker Points .....	15-8
Key Switch .....	10-3	Adjustments .....	15-8
Solenoid .....	10-3	Adjusting Breaker Points .....	15-8
Testing .....	10-4	Timing Engine .....	15-8
Battery .....	10-4	Specifications .....	15-10
Ignition Switch .....	10-5	Special Tools .....	15-10
Solenoid .....	10-5	<b>GROUP 20 - CHARGING SYSTEM</b>	
Safety Switches .....	10-5	Principle of Operation .....	20-1
Starter .....	10-6	Alternator .....	20-1
Armature .....	10-6	Rectifier-Regulator .....	20-2
Analysis .....	10-7	Testing .....	20-2
Battery .....	10-7	<b>GROUP 25 - PTO CLUTCH, LIGHTS AND ACCESSORIES</b>	
Starter .....	10-7	PTO Clutch .....	25-1
Repair .....	10-8	Testing .....	25-1
Battery .....	10-8	Servicing .....	25-2
Solenoid .....	10-8	Lights .....	25-3
Neutral-Start Switch .....	10-9	Circuit Breaker .....	25-4
Starter .....	10-9	Ammeter .....	25-4
<b>GROUP 15 - IGNITION SYSTEM</b>		Cigarette Lighter .....	25-4
Principle of Operation .....	15-1		
Ignition Coil .....	15-2		
Breaker Points .....	15-2		
Condenser .....	15-2		
Spark Plug .....	15-3		
Ignition Switch .....	15-3		
Testing .....	15-4		
Ignition Coil .....	15-4		
Condenser .....	15-5		
Spark Plug .....	15-5		



### PRINCIPLE OF OPERATION

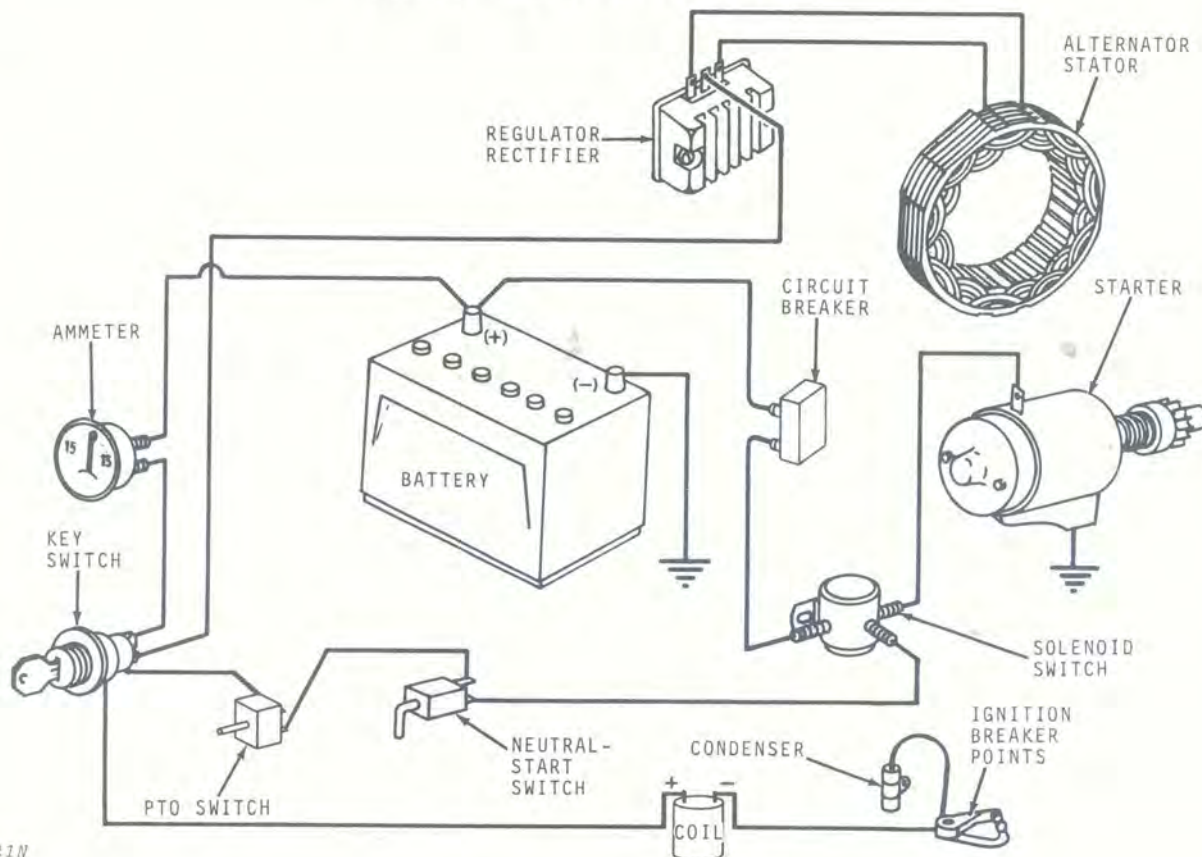

M13021N

Fig. 1-Electrical System of 140 Tractor

The electrical system used in the 140 Tractor, Figure 1, is an alternator system. It utilizes solid-state (no moving parts) electronic devices for converting alternating current to direct current for charging the 12-volt storage battery. A compact permanent magnet starter is used for cranking purposes.

When the key switch is turned to the far right, (start position), the solenoid is energized through a pair of safety switches. Continuity through these switches is made only when the hydrostatic control lever is in the neutral position and the PTO clutch is disengaged.

Once the solenoid is energized, electrical energy from the battery is relayed to the starter. The starter engages the flywheel ring gear and turns the engine crankshaft.

When the key switch is in the "START" or "RUN" position it also energizes the ignition coil. This coil is a transformer which increases the voltage from 12-volts to 25,000-volts. The ignition coil voltage build-up is necessary to fire the spark plug and ignite the fuel-air mixture.

The voltage build-up and collapse is accomplished with the use of breaker points and a condenser.

Once the engine begins operating, the key switch returns to the "RUN" position. In this position the charging circuit is completed. Current moves from the alternator to the electrical system or battery through the rectifier-regulator and ammeter.

When the key switch is turned to the "OFF" position, electrical current no longer flows to the coil, causing the engine to stop.

Complete information on servicing the circuit breaker, ammeter, headlights, cigarette lighter and the electromagnetic PTO clutch is contained in Group 25 of this section.

### WIRING DIAGRAM

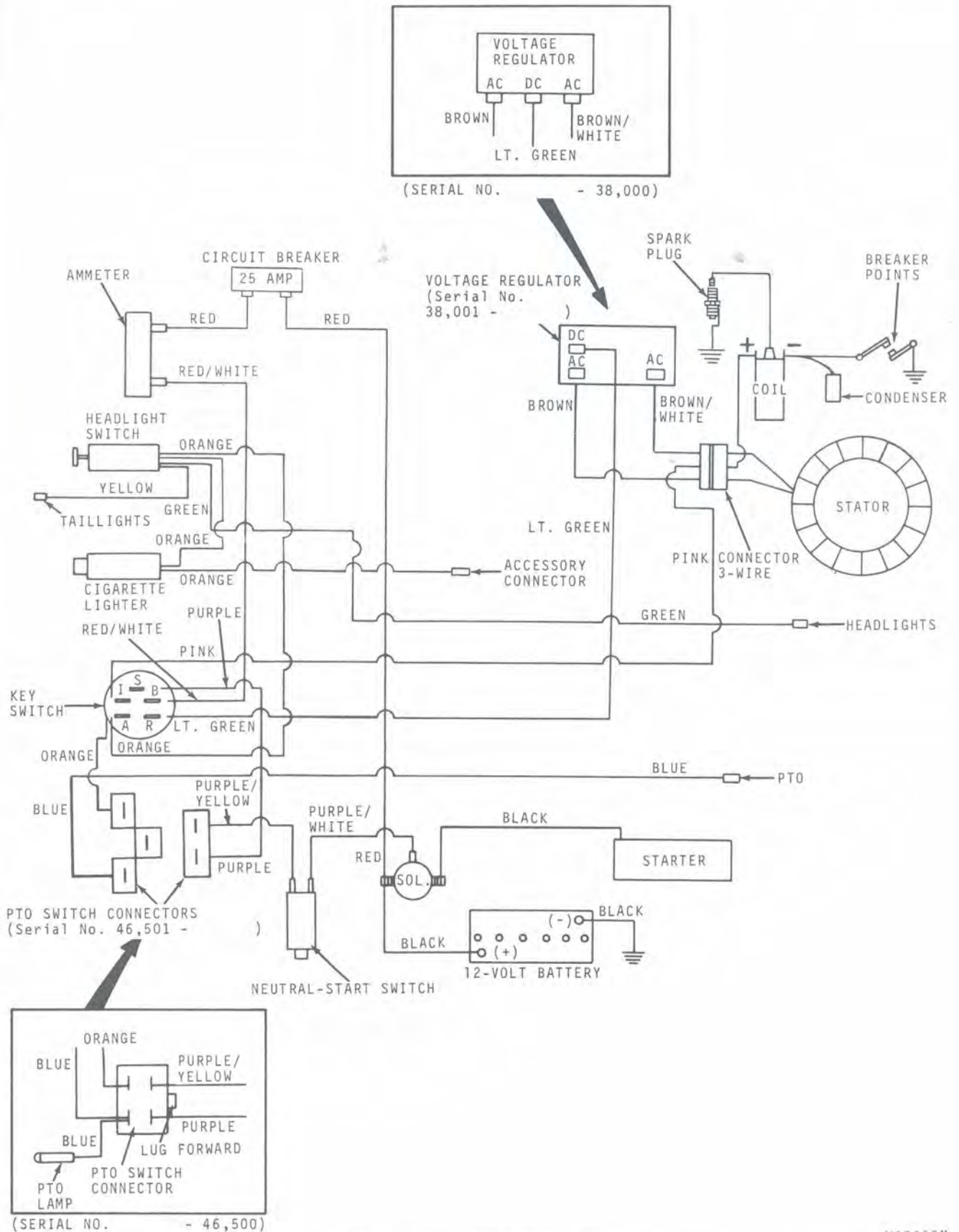

Fig. 2-Electrical System of 140 Tractor

M13022N



## TESTING

Instructions are provided in each group for testing electrical components on and off the tractor. The purpose of the tests is to isolate the cause of trouble in the cranking, ignition or charging system.

Adequate approved electrical test equipment is required to accurately test electrical circuits and intelligently diagnose unsatisfactory performance.

Many servicemen prefer to have their electrical components tested by professionals using highly complex test equipment. Automotive repair centers can provide this service. The coil, rectifier-regulator, solenoid, condenser, starter, and alternator used on the 140 Hydrostatic Tractor can be tested on automotive test equipment.

Recommended test procedures for dealers having their own test equipment are outlined in Groups 10, 15, and 20.

**IMPORTANT:** Because there are many manufacturers of test equipment, each with their own specific operating instructions, it is important to follow the manufacturer's recommendations if the procedures in this test section should contradict those of the manufacturer.

## DIAGNOSING MALFUNCTIONS

### Engine

#### Engine Is Hard to Start

- Breaker points burned or pitted.
- Incorrect breaker point gap.
- Ignition out of time.
- Defective or loose spark plug.
- Loose or corroded electrical connections.
- Condenser or coil faulty.

#### Engine Misfires

- Incorrect spark plug gap.
- Defective or loose spark plug.
- Incorrect spark plug.
- Breaker points pitted or corroded.
- Incorrect breaker point gap.
- Loose wire in primary circuit.
- Leaking or broken high tension wire.
- Defective coil or condenser.
- Defective ignition switch.

#### Engine Backfires or Knocks

- Cracked spark plug porcelain.
- Ignition out of time.

#### Engine Pre-Ignition

- Ignition out of time.
- Spark plug electrodes burned.
- Excessive carbon build-up in cylinder.

#### Engine Loses Power

- Faulty ignition.
- Spark plug faulty.
- Condenser or coil faulty.

#### Engine Overheating

- Ignition out of time.

## DIAGNOSING MALFUNCTIONS—Continued

### Starter

#### Starter Fails to Energize

- Hydrostatic control lever not in "NEUTRAL" or PTO clutch is engaged.
- Corroded or loose electrical connections.
- Defective solenoid.
- Defective starter.
- Weak or defective battery.
- Corroded battery terminals.
- Defective safety switches.
- Poor battery ground.
- Shorted armature.

#### Starter Turns Too Slowly

- Weak or defective battery.
- Worn brushes or dirty commutator.
- Armature binding.

#### Starter Spins Without Engaging

- Drive pinion gear damaged.
- Ring gear on flywheel has broken teeth.

#### Starter Drawing Excessive Current

- Broken or jammed starter drive.
- Shorted or grounded armature.
- Engine resistance.
- Worn armature shaft bushings.
- Misaligned starting motor.
- Bent armature shaft.

### Battery

#### Battery Uses Too Much Water

- Defective rectifier-regulator.
- Cracked or damaged battery case.
- Electrolyte spewing through filler caps.

#### Battery Discharges Rapidly

- Loose or corroded battery terminals and cable ends.
- Low water level.
- Electrical system over-load.
- Low or no alternator output.
- Loose connections or damaged wires.

#### Battery Remains Low or Discharged

- Electrolyte, moisture and dirt on case.
- Loose or corroded battery terminals and cable ends.
- Tractor not operated long enough to charge battery.
- Loose or damaged wires.
- Defective ignition switch.
- Defective battery.
- Continuous loads in excess of alternator capacity.
- Low or no alternator output.
- Defective rectifier-regulator.

#### Battery Spewing

- Battery overfilled.
- Loose battery hold down bolts.

#### Battery Leaking

- Cracked or damaged battery case.
- Loose or damaged cell cover.



## Alternator

### No Alternator Output

Loose connections or damaged wires.  
Ground, open or short in stator.

### Unsteady or Low Alternator Output

Loose connections or damaged wires.  
Shorting of AC leads to regulator.

### Excessive Alternator Output

Test rectifier-regulator. Replace if necessary.

### Ammeter Shows Discharging When Engine Idles

At low (idle) engine rpm battery voltage is higher than alternator voltage. This should be considered normal.

### Ammeter Shows Discharging Condition Continually

Loose connections or damaged wires.

### Regulator Fuse Burned Out

Polarity reversed through battery.

## Cigarette Lighter

### Cigarette Lighter Will Not Function

Loose or damaged lead.  
Unit not properly grounded.  
Circuit breaker open.  
Reset circuit breaker.

## Lights

### Lights Will Not Light

Circuit breaker defective.  
Loose or damaged wires.  
Poor ground.  
Sealed beams burned out.

## PTO Clutch

### Clutch Will Not Engage

Faulty switch.  
Loose or shorted wire to coil.  
Shorted or defective field coil.

## Group 10 CRANKING SYSTEM

### PRINCIPLE OF OPERATION

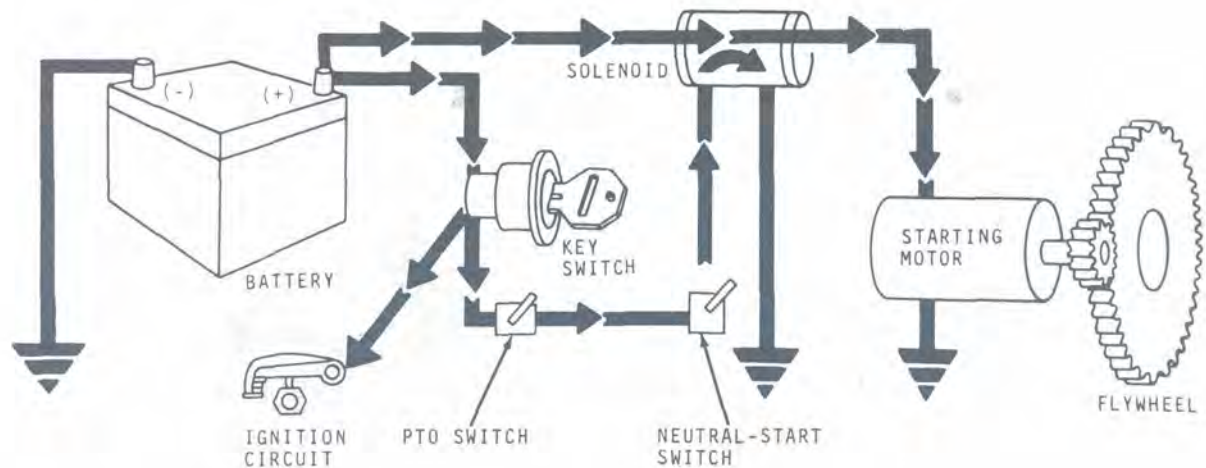

M13023N

Fig. 1-Cranking Circuit of Tractor

The cranking system consists of a 12-volt storage battery, a key switch, two neutral-start safety switches, a solenoid, and a compact starting motor, which engages and disengages with the engine ring gear through a Bendix-type drive.

#### Battery

The storage battery is of the lead-acid variety. Lead is used in the construction of the cell plates and a sulfuric acid solution serves as the electrolyte.

Tractors are shipped from the factory with dry-charged batteries. This means, the plates are charged, but electrolyte must be added just before using.

The 12-volt battery has a hard rubber case with six individual cells. Each cell contains a specific number of sets of negative and positive plates.

All plates of like charge are interconnected so that the accumulative charges are present at the positive and negative battery terminals.

As a battery discharges and the energy is not replenished, the sulfuric acid is withdrawn from the electrolyte and the lead sulfate deposits build up on the plates. This causes the specific gravity of the electrolyte to diminish. Charging the battery reverses the chemical reaction, restoring the electrolyte to original potential.

**IMPORTANT: Avoid battery damage by charging at the manufacturer's recommended ampere-hour charging rate.**



## Starting Motor

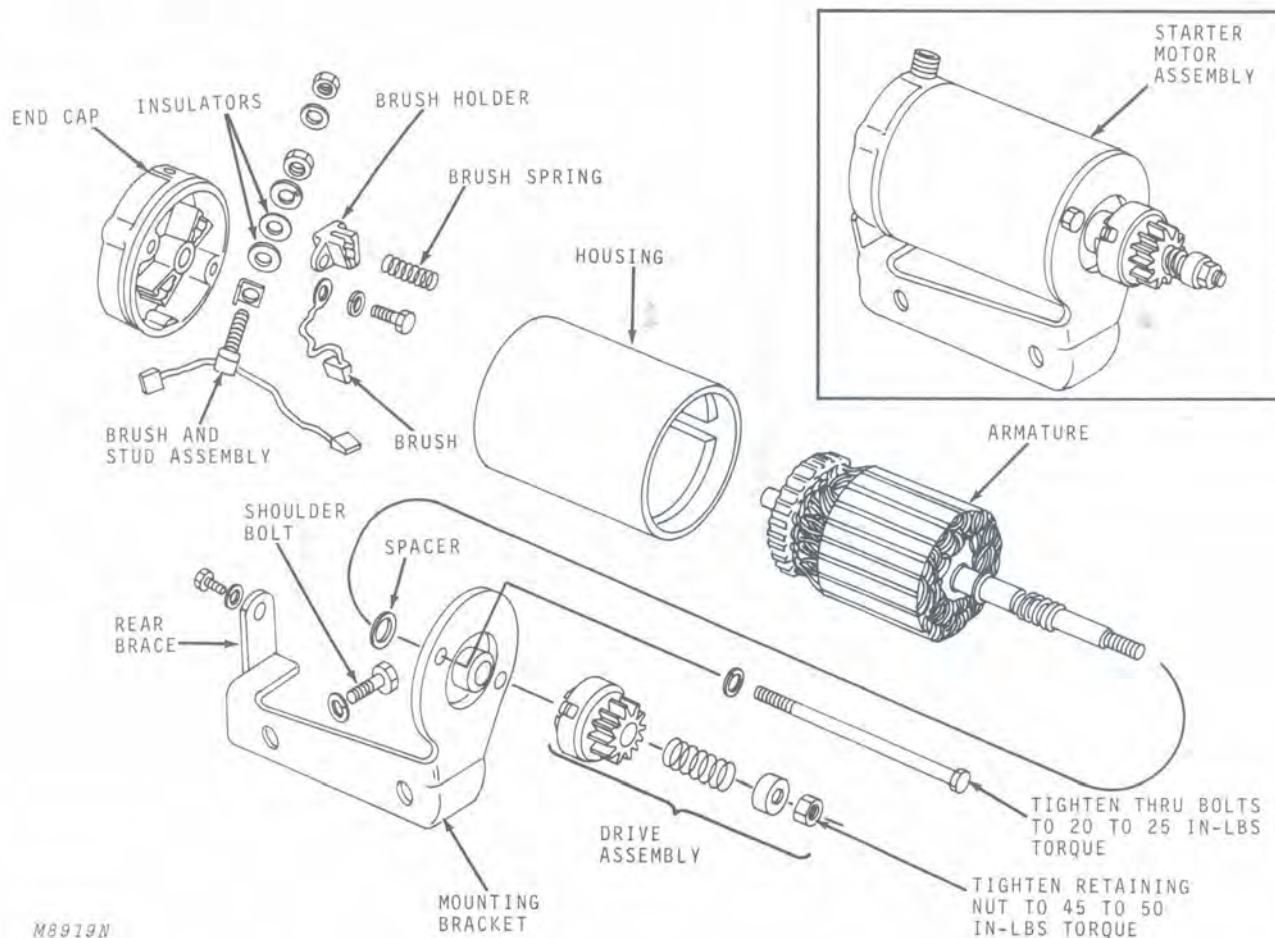

Fig. 2- Starting Motor Components

The permanent magnet starting motor, Figure 2, requires considerably less current to operate than conventional wire-wound starters. The lower current demand means lower operating temperatures, longer brush life and "starts" even with poorly charged batteries.

The permanent magnet starting motor needs current only for the armature in order to set up opposing magnetic fields to start it turning. This current is induced into the starter in the usual manner with the ignition switch, battery, solenoid and four brushes.

The drive consists of only three parts; a drive gear, anti-drift spring, and spring cup. When the armature turns, the drive gear moves laterally into mesh with the flywheel. As the engine fires and speeds up, the armature is overrun causing the drive gear to disengage.

## Key Switch

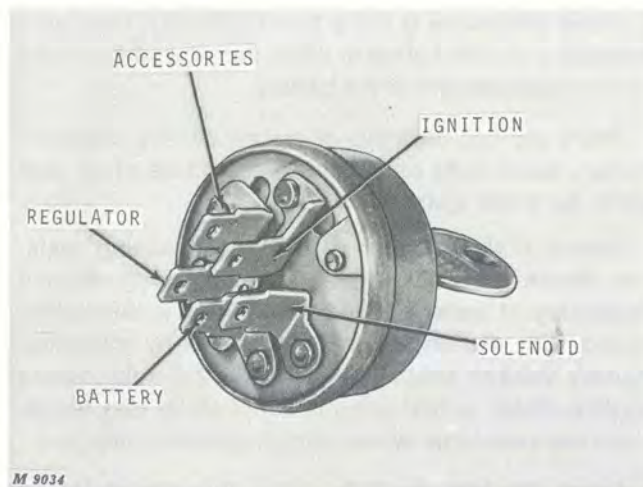

Fig. 3-Key Switch

The key switch, Figure 3, is nothing more than a flow divider which directs the flow of electricity from the battery to the proper circuit.

In the case of the cranking circuit, when the switch is in the "START" position, current is directed to flow from the battery to the solenoid.

When the switch is returned to "RUN" position following engine start, current is diverted from the solenoid and routed instead to the accessories, charging circuit, and ignition system.

## Solenoid

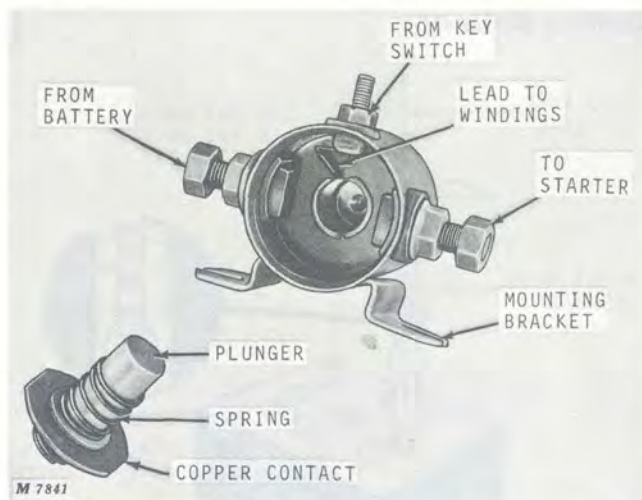

Fig. 4-Solenoid Components

The solenoid, Figure 4, is a sealed electric switch, composed of an electromagnet and spring-loaded plunger.

When the ignition switch is turned to the "START" position, current from the switch flows to the solenoid windings forming a complete circuit with the grounded case and setting up an electromagnetic field.

This draws the cylindrical plunger into the center of the field, overcoming a spring around the plunger. A copper contact on the end of the plunger closes the circuit between the battery and starter contact points, energizing the starter.

Once the engine starts, the key switch is permitted to return to the "Run" position, cutting off the energy to the solenoid and collapsing the electromagnetic field. The spring-loaded plunger moves out of the magnetic field, breaking contact between the battery and starter terminals.



## TESTING

### Testing Battery

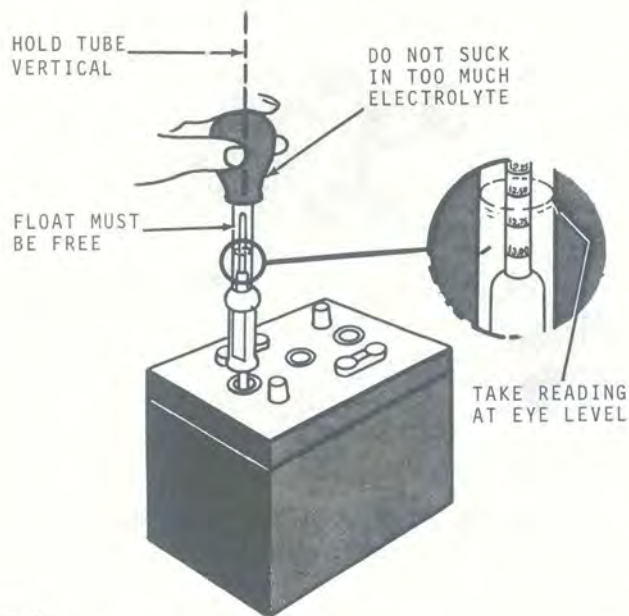

M 7843

Fig. 5-Testing Specific Gravity

### Checking Specific Gravity

To determine whether the battery is capable of meeting the requirements of the starting motor, it is necessary to duplicate operating conditions by subjecting the battery to a load test. To obtain a true test, the battery should be at least 75% charged. This can be determined by taking a hydrometer reading, Figure 5.

The following table illustrates typical ranges of specific gravity (amount of unused sulfuric acid remaining in the solution) for a cell in various states of charge, with respect to its ability to crank the engine at 80°F. with initial full-charge specific gravity at either 1.260 or 1.280.

Specific Gravity	Capacity
1.260 to 1.280	100%
1.230 to 1.250	75%
1.200 to 1.220	50%
1.170 to 1.190	25%
1.140 to 1.160	Very little useful capacity
1.110 to 1.130	Discharged

### Checking Battery Voltage

With a battery in good condition, each cell contributes approximately 1.95 to 2.08 volts. If battery charge is low and less than 0.05 volt difference is noted between the highest and lowest cells, the battery may be recharged.

If this difference is more than 0.05 volts, this could indicate a cracked plate or other damage which could call for replacement of the battery.

There are two methods of testing battery capacity. Battery electrolyte temperature should be at or near 80°F. for these tests.

Before making either of the two following tests, first check electrolyte level in battery. Add water if necessary. If water is added, be sure it is thoroughly mixed with the underlying electrolyte by charging. Battery voltage should be 11.5 to 12.6 volts before testing. Refer to instructions supplied by test equipment manufacturer when using high-rate equipment.

Using the first method, crank the engine for 15 seconds with the starting motor and measure the battery voltage. If voltage is less than 9.6 volts at the end of 15 seconds replace battery.

As a second method, use high-rate discharge test equipment, Figure 6.

Discharge the battery by means of a heavy-duty carbon pile at a rate 3 times the ampere-hour capacity.

If after 15 seconds the battery voltage is less than 9.0 volts, the battery fails to meet the load test, indicating loss of capacity or internal short circuits. Any battery that passes the load test is a good battery and can be relied upon to fulfill the requirements of the starting motor under normal conditions.

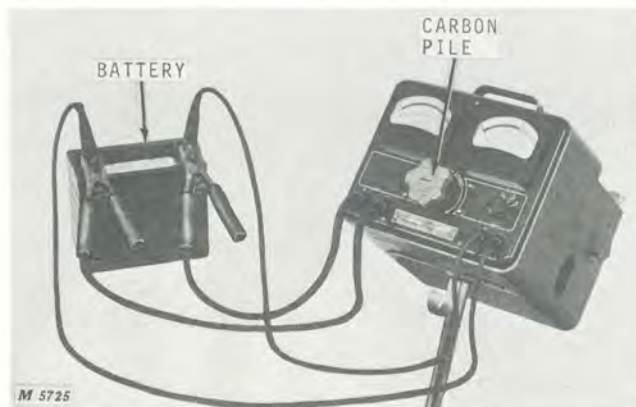

Fig. 6-Testing Battery Capacity



## Testing Ignition Switch

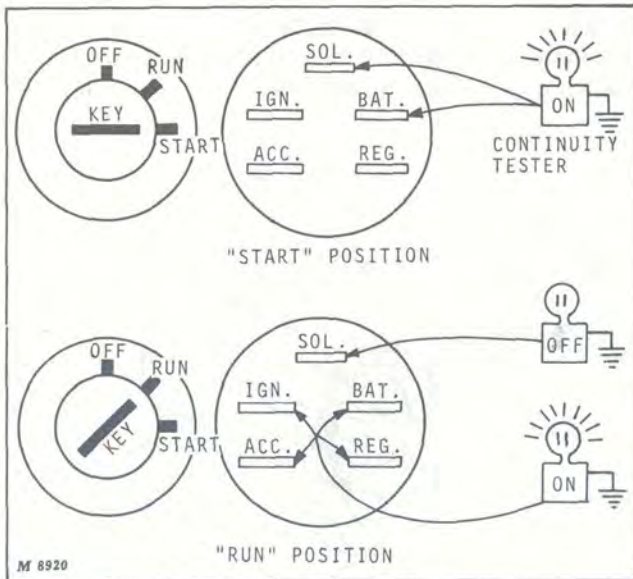

Figure 7, Testing Ignition Switch

Test for electrical continuity between switch terminals using the same procedure as shown in Figure 7.

The starter energizing terminal is the only terminal that will show no continuity when switch is in the "Run" position. It should show continuity however when the switch is held in the "START" position.

## Testing Solenoid

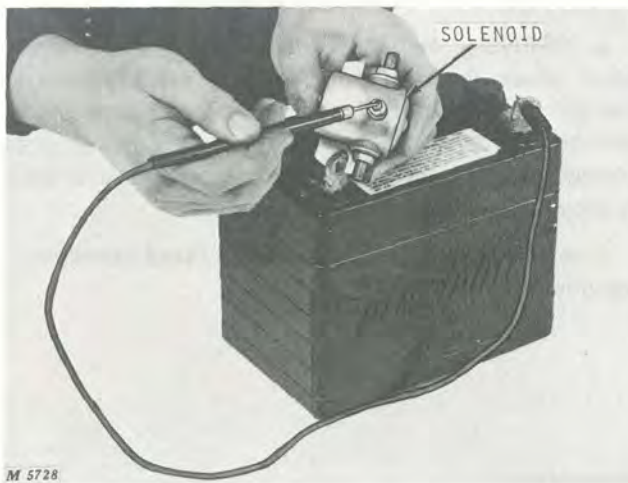

Fig. 8-Solenoid Test

The solenoid (magnetic switch) is a sealed unit and cannot be repaired.

With a continuity tester and a battery of correct voltage, connected as shown in Figure 8, momentarily touch jumper lead to solenoid terminal. If solenoid is in good condition, the plunger will snap in and close the main contacts.

The solenoid can be tested in the tractor. Removal as shown in Figure 8, is optional.

Failure of the above test indicates a defective solenoid. Replacement will be necessary.

## Testing Switches

### Neutral-Start and Safety Switches

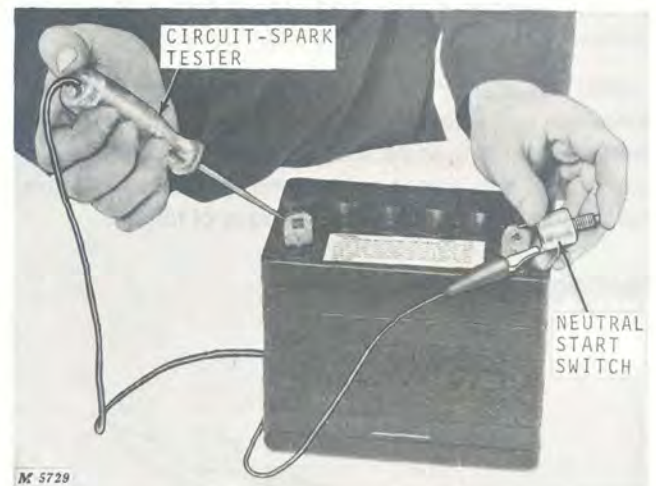

Fig. 9-Testing Safety Switches

Neutral-start switch failure is sometimes the wrong diagnosis for a switch which needs only a simple adjustment or cleaning.

Before removing the neutral-start switch for testing, be sure switch plunger is being depressed sufficiently by the hydrostatic lever.

If engine still does not crank, remove switches from tractor and test electrically as follows.

The following test can be used on the neutral-start and PTO clutch switches.

1. Connect circuit test light lead to switch terminal. Place switch and tester on battery terminals, Figure 9.

2. Push switch plunger down on neutral-start switch. If circuit tester light does not go ON, switch is defective.

3. To test PTO clutch switch, connect an ohmmeter to the two forward terminals on the switch. With the switch in the "OFF" position, continuity should be shown. No continuity should be indicated with the switch in the "ON" position.



## Testing Starter

If the starter fails to crank properly, check for poor electrical connections, a low battery, or a faulty solenoid.

Refer to page 10-4 to determine battery condition. Be sure hydrostatic control lever is in "NEUTRAL" and PTO clutch is disengaged. If the starter still fails to crank, jump around solenoid with a heavy jumper cable. If the starter operates, the trouble can be isolated by further testing of the switches or the solenoid.

If the starter still fails to operate, either the starter or the engine is at fault. To determine if the engine is at fault, remove starter and repeat test with jumper cables.

With the starter removed from the engine, check armature for freedom of operation by turning the shaft. A bent armature shaft or badly worn bushings can cause the armature to bind. Disassemble the starter and inspect and test for cause of failure.

## Testing Armature

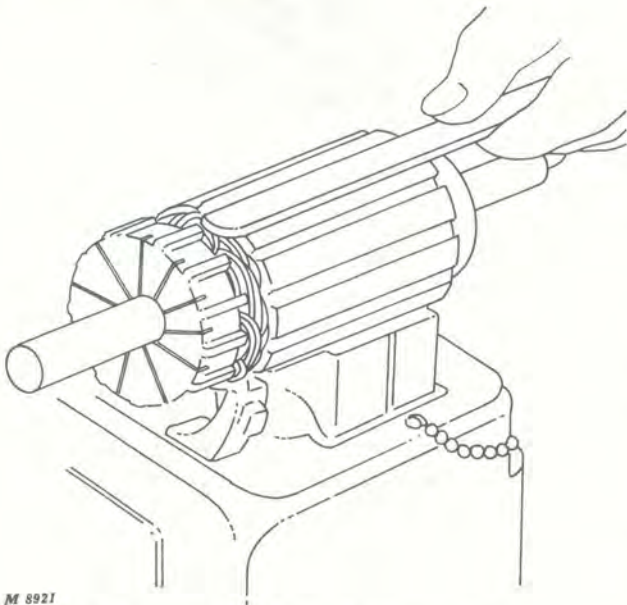

M 8921

Fig. 10-Checking Armature for Short Circuits

If inspection does not reveal the cause of failure, test the armature for opens, shorts and grounds as follows:

1. SHORTS - A burned commutator bar indicates a shorted armature. Short circuits are located by rotating the armature on a growler with a steel strip (hacksaw blade) held on the armature, Figure 10. The steel strip will vibrate on the area of the short circuit.

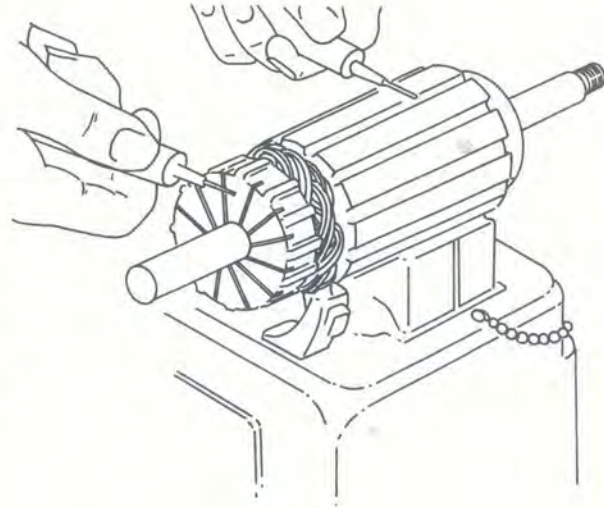

M 8922

Fig. 11-Checking Armature for Grounds

2. GROUNDS - Grounds in the armature can be detected with a test lamp and probes, Figure 11. If the lamp lights when one test probe is placed on the commutator and the other probe on the armature core or shaft, the armature is grounded.

3. OPENS - Inspect for loose connections at the point where the armature windings are attached to the commutator bars. Poor connections cause arcing and burning of the commutator. Resolder any poor connections and turn armature commutator in a lathe to provide a good surface for brushes.

If tests reveal any of the above listed conditions, replace the armature.

## ANALYSIS

### Battery

#### Cracked Case

If a cracked battery case is found, install new battery and advise customer to keep battery electrolyte at specified level and to keep battery fully-charged in freezing weather.

Other causes could be rough handling of battery or pounding cables onto terminals.

#### Pitted Battery Terminals

If battery terminals are severely pitted, the probable cause is tractor operation with loose cable connections. This results in arcing across terminal-to-cable gap.

#### Low Battery Condition

Several causes of low battery condition could exist, including:

1. Improper electrolyte level.
2. Excessive use of accessories without engine operating.
3. Ignition switch left in "run" position.
4. Faulty regulator or alternator.
5. Loose battery connections.
6. Dirty battery case.
7. Short in electrical system.

### Starter

#### Overheating

Overheating of starter can result from armature binding or long duration cranking of a hard starting engine.

#### Poor Starter Performance

This could be caused by a number of conditions, including:

1. Excessive lubrication of end cap bushing, resulting in gum formation and high resistance at the commutator.
2. Armature binding.
3. Dirty or damaged starter drive assembly.
4. Badly worn brushes or weakened brush springs.
5. Excessive voltage drop in cranking circuit.
6. Battery or wiring defects.
7. Shorts, opens or grounds in armature.



## REPAIR

### Battery

#### Removing Battery

Loosen bolts through terminal clamps. Use a terminal puller to remove clamps. If terminal puller is not available, spread clamps before prying them off battery posts.

To avoid injury from a spark or short circuit, disconnect cable from the negative battery terminal first. Then remove boot from positive terminal and disconnect cable from positive terminal.

#### Servicing Battery

Good battery servicing in the tractor should include the following 8 items:

1. Clean battery.
2. Inspect cables including ground connections.
3. Clean terminals.
4. Inspect hold-downs.
5. Inspect case for leaks.
6. Make hydrometer test.
7. Add water if necessary. Use caution to protect tractor from electrolyte damage.
8. Recharge battery if less than 75% charged.

#### Cleaning Battery

Corrosion around the battery terminals is normal. However, an accumulation of corrosion over a long period can shorten the life of the battery. It is therefore important to keep battery terminals as clean as possible.

To clean terminals, remove battery from tractor. Remove all corrosion using a wire brush. Wash terminals using a solution of one part ordinary baking soda to four parts water. Do not permit cleaning solution to enter battery cells. Flush battery with clear water.

Wash entire battery case, battery base, and hold down strap with clear water. Do not get water on switches and wiring connections.

Coat terminals with petroleum jelly or a light film of oil to protect against corrosion. Be sure vent holes in cell caps are open.

When installing battery, connect cable to positive terminal first. Be sure to slide rubber boot down on cable until terminal and clamp are completely covered.

#### Activating New Battery

When activating a new battery, remove from tractor before filling with electrolyte. This will prevent damage to tractor in case electrolyte spills.

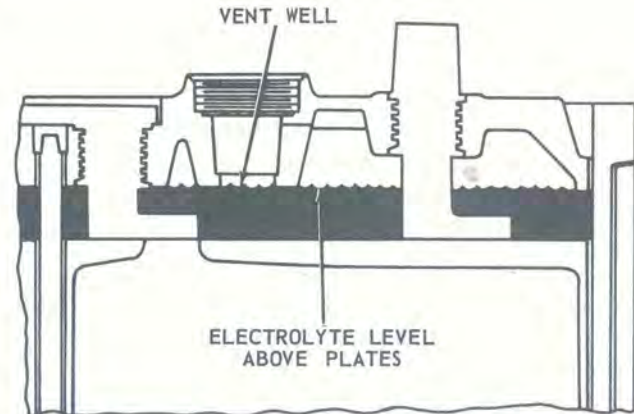

Fig. 12-Proper Level of Electrolyte in Battery Cells

Add electrolyte until plates are just covered. Then charge at 30 to 40 amps for 10 minutes or 15 amps for 30 minutes.

Charging the battery will increase battery temperature and raise the electrolyte level. If electrolyte is still below the ring in the battery neck, add enough electrolyte to fill to the bottom of the ring. See Figure 12.

Advise customers to add water as recommended in the operator's manual. A healthy battery will consume about one teaspoon of water per cell each month.

**CAUTION:** After the battery is activated, hydrogen and oxygen gases in the battery are very explosive. Therefore, it is necessary to keep open flames and sparks away from battery.

#### Solenoid

The solenoid is a sealed unit; replace when tests prove it defective.

Fasten solenoid to pedestal with bolts, washers and nuts and tighten firmly.

Leads should always be connected correctly. Refer to Group 5 Wiring Diagram, for correct lead connections.



### Neutral-Start Switch

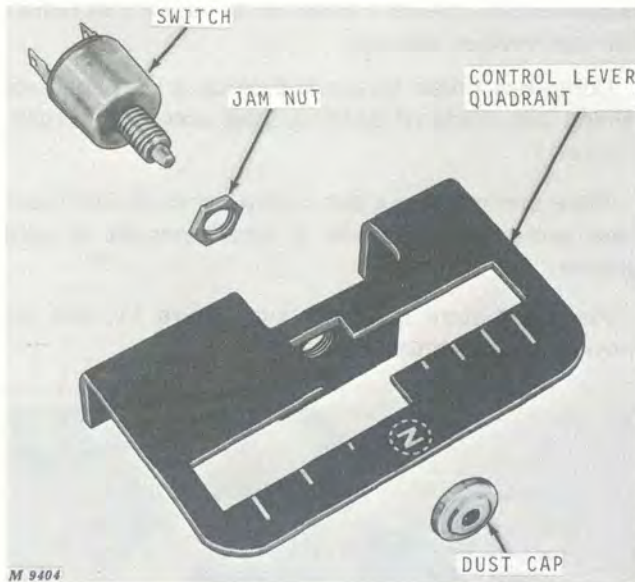

Fig. 13-Neutral-Start Switch Components

Before replacing or repairing the neutral-start switch, be sure to test the switch as explained on page 10-5. A simple adjustment or cleaning may correct the problem.

To adjust switch, loosen threaded cap and jam nut, Figure 13, to allow switch plunger to contact arm of actuating lever. Tighten nut and cap.

### Starter

Repair to the starter is limited to the brushes, end cap, armature and starter drive assembly. Any of these parts can be replaced if found to be defective. Fields in this starter are permanent magnets and no service is required or possible. Any serious defect in the magnets will require a complete starter replacement.

#### Removing Starter

Disconnect negative cable from battery.

Disconnect solenoid-to-starter cable from starter terminal.

Remove two mounting bolts holding starter to engine block.

### Disassembling Starter Drive

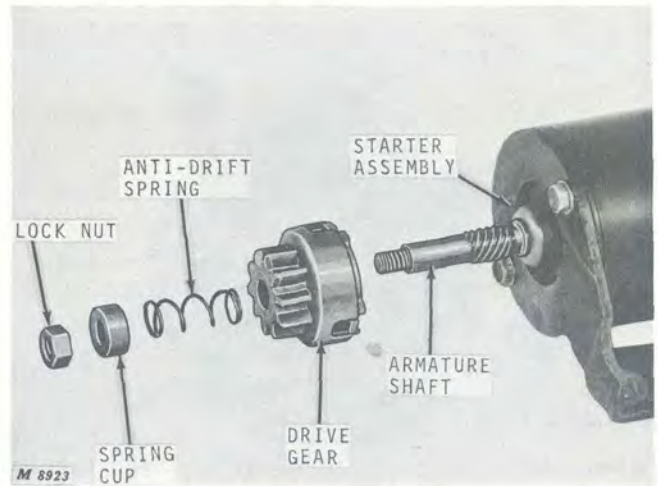

Fig. 14-Starter Drive

Hold drive gear and unscrew 3/8-inch lock nut. Remove drive parts from armature shaft.

### Disassembling Starter

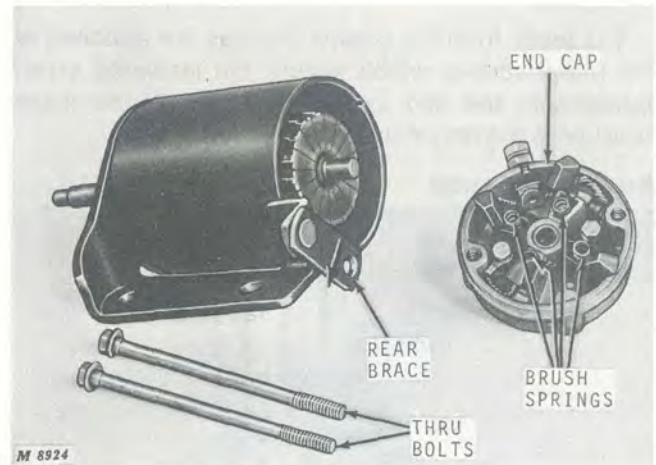

Fig. 15-Disassembling Starter

Remove the two thru bolts which hold the end caps to starter housing. Remove 1/4 x 5/8-inch cap screw from rear brace. Tap rear brace downward (see arrow) to provide room for removal of end cap.

Remove end cap carefully, Figure 15, to avoid losing brush springs which will pop out when end cap is removed.



### Replacing Brushes

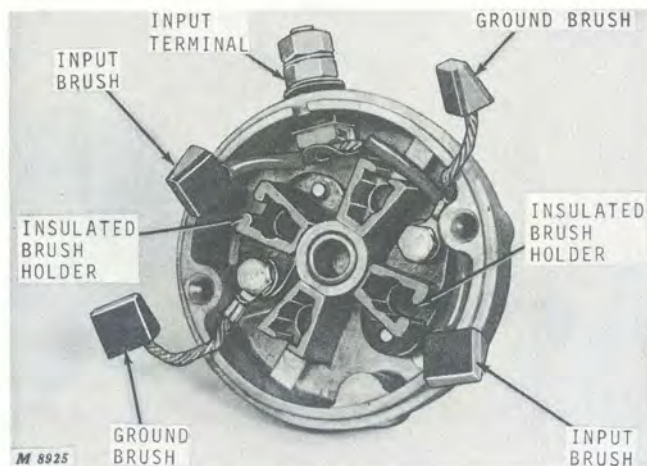

Fig. 16-Replacing Brushes

Replace brushes whenever they show any appreciable amount of wear. To replace input brush assembly, remove nuts and washers from terminal and pull the brushes out through the inside of cap. When assembling, place the input brushes into the insulated brush holders.

The leads from the ground brushes are attached to the metal screws which secure the insulated brush holders to the end cap, Figure 16. Place these brushes in the non-insulated brush holders.

### Assembling Starter

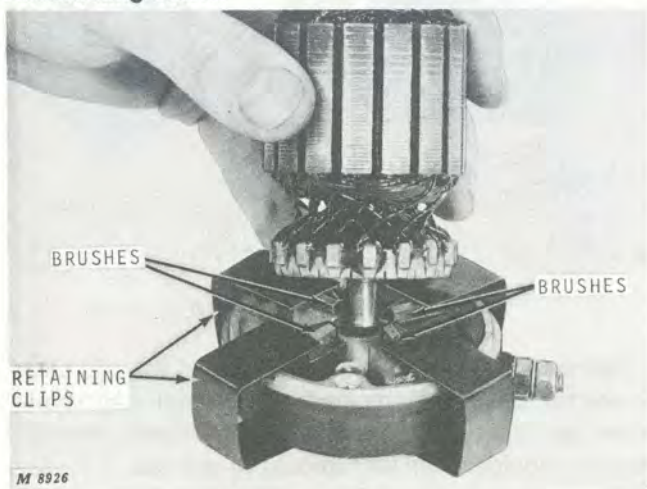

Fig. 17-Installing Brushes

The preparation of the starter end cap is the first step in the assembly of the starter.

First, place brush springs into brush holders. Then, in succession, place a brush in its respective holder with the beveled side up.

Compress brush spring and place a U-shaped retaining clip made of banding steel onto each brush, Figure 17.

Wipe commutator clean with a dry cloth and lubricate armature shaft with a small amount of light grease.

Place armature into end cap, Figure 17, and remove U-shaped brush retaining clips.

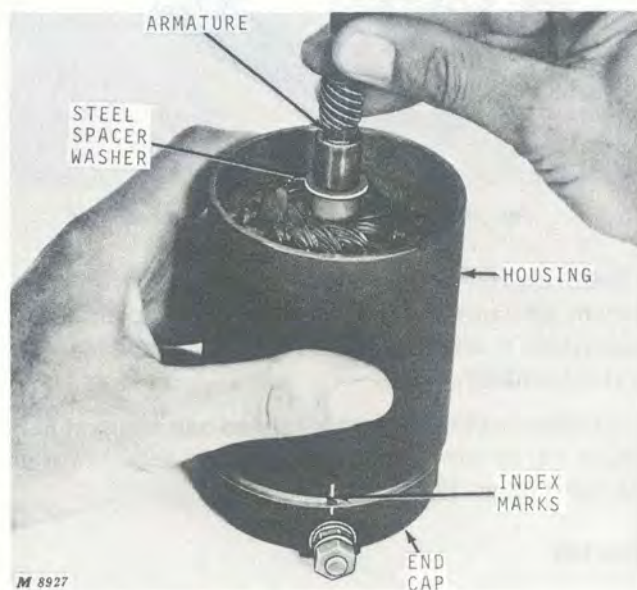

Fig. 18-Aligning Index Marks

Place starter housing over armature while exerting down pressure on the armature. This prevents brush springs from pushing armature up and away from end cap. If this occurs, reload brushes into end cap and reassemble.

Align housing with end cap using the index marks on cap and housing as a guide, Figure 18.

*NOTE: The starter housing has a mark and an indentation on the inside which must fit into the two indentures on the drive end cap.*

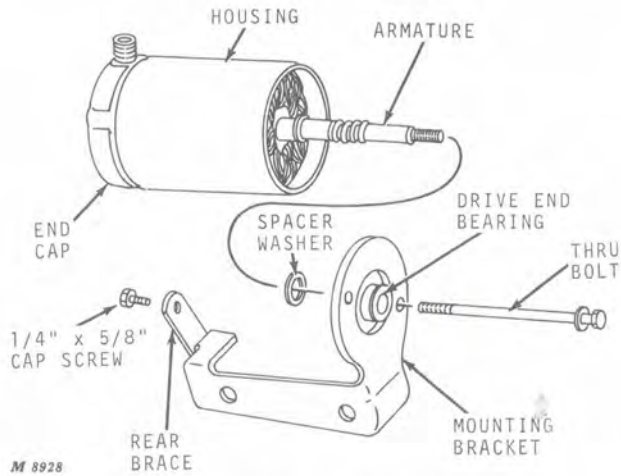

Fig. 19-Assembling Starter to Bracket

Place steel spacer washer onto armature shaft and insert armature shaft through drive end bearing of mounting bracket, Figure 19.

Insert thru bolts and torque to 20 to 25 inch-pounds.

Position rear brace and install 1/4 x 5/8-inch cap screw and tighten firmly.

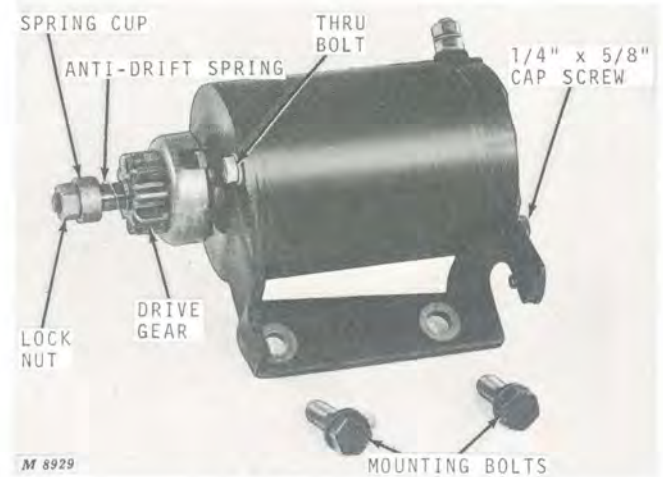

Fig. 20-Installing Drive Assembly

Install starter drive gear, anti-drift spring, spring cup, and lock nut on armature shaft. Torque lock nut to 45 to 50 inch-pounds, Figure 20.

Install starter on engine, using the two shoulder bolts previously removed. Attach solenoid to starter wire and tighten all bolts firmly.





## Group 15 IGNITION SYSTEM

### PRINCIPLE OF OPERATION

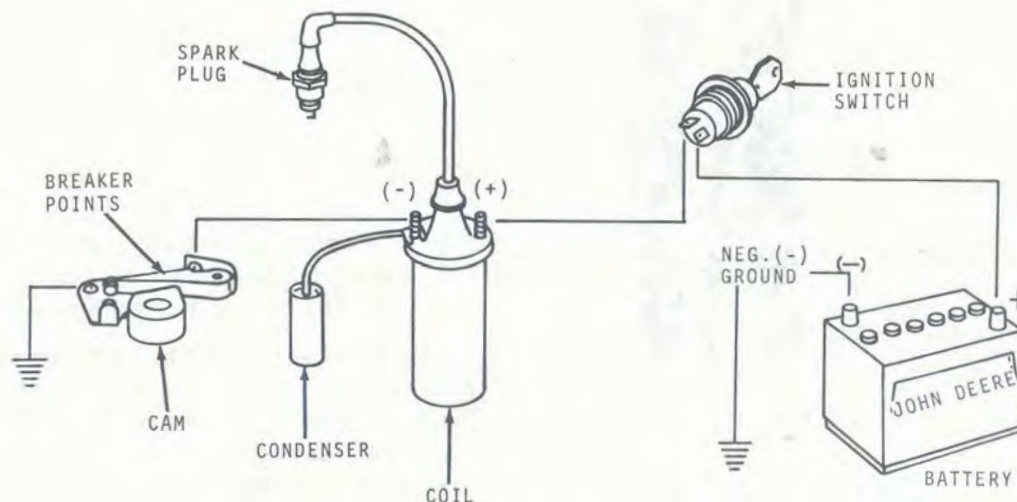

M 8605

Fig. 1-Ignition System Components

The battery ignition system differs from the magneto ignition in two ways.

1. Current is supplied to the ignition coil from the battery rather than from a permanent magnet self-powered magneto.

2. The ignition switch must be closed in the battery system for the current to flow through the coil. Magneto systems require an open circuit type switch.

The function of any ignition system is the same, and that is to produce a hot spark at the plug at the right time for ignition of the fuel mixture.

Here is how the battery ignition works:

With the ignition switch closed, current flows from the battery to the primary windings of the coil, and through the closed breaker points to ground.

At the point when the piston is near top dead center on the compression stroke, the breaker points are opened by the cam and push rod.

When the points are opened, the primary electric circuit is broken and the magnetic field breaks down.

With the collapse of the primary field, the magnetic lines of force cut across the conductor coil windings and a high voltage is induced in the secondary windings. The high voltage developed in the secondary coil causes the current to jump across the spark plug electrode gap, thus making a spark.

The residual current in the primary winding is absorbed by the condenser. This eliminates arcing at the points and aids in producing a stronger spark at the spark plug.



### Ignition Coil

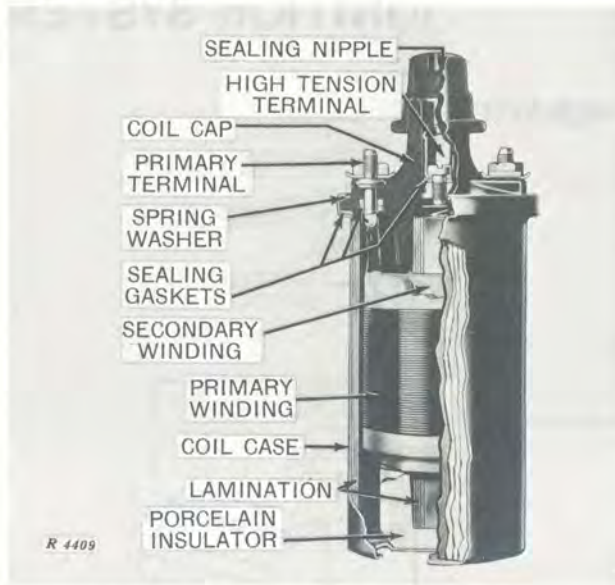

Fig. 2-Ignition Coil

The ignition coil is a pulse transformer that transforms or steps up the low battery or alternator voltage to the high-voltage necessary to ignite the fuel-air mixture at the gap of the spark plug.

The ignition coil contains three basic parts: a primary winding consisting of a few hundred turns of relatively heavy wire; a secondary winding consisting of many thousand turns of very fine wire and laminated soft iron which serves to concentrate the magnetic field. The primary winding is assembled around the outside of the secondary winding and the laminated iron provides both a core and outside shell about both the windings. These three units are placed in the coil case and immersed in oil. The coil cap with its necessary attachments to the windings completes the entire coil.

When the primary circuit is energized (the breaker points are closed), a magnetic field is built up around both the primary and secondary coils. When the primary circuit is de-energized (the breaker points are opened), the magnetic field collapses about the coils inducing a voltage within both of the coils. The voltage developed within the primary coil is absorbed and dissipated by the condenser. The voltage developed within the secondary coil (possibly 25,000 volts or more) is distributed to the spark plug for igniting the fuel-air mixture within the cylinder.

### Breaker Points

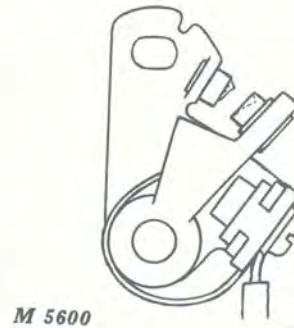

Fig. 3-Breaker Points

Engine operation is greatly affected by the condition and adjustment of the breaker points, Figure 3, which time the firing of the spark plug.

The points are tripped by the breaker rod, operated by a lobe on the camshaft. A specific time is required for the magnetic field within the ignition coil to build up to sufficient value. Unless the points are adjusted to specification, weak, early or late sparking occurs.

### Condenser

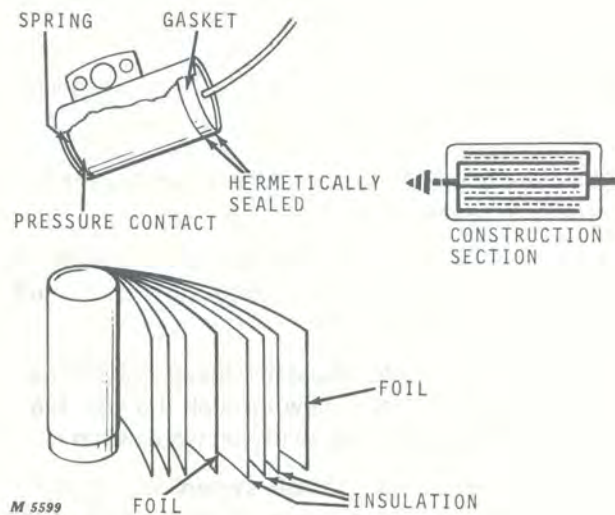

Fig. 4-Cutaway View of Condenser

When the magnetic field in the coil collapses, voltage much higher than the original voltage is induced into the primary winding. As the breaker points open, the current tends to continue flowing across the points. The resulting arc would damage the points in a short time. The condenser, by absorbing the surge of high-voltage, dampens the tendency of current to arc across the points. The condenser also allows the magnetic field to collapse rapidly which contributes to high-voltage induced into the secondary windings.

## Spark Plug

A spark plug consists mainly of two electrodes separated from each other by a specific gap. The side electrode is connected to the shell of the spark plug. The center electrode is completely insulated from the shell. The high-voltage, produced in the secondary winding of the coil, is applied to the center electrode and causes a spark to jump the gap to the side electrode. This spark, inside the cylinder, ignites the fuel-air mixture and starts the combustion process in the combustion chamber of the cylinder.

The gap spacing between electrodes is critical for efficient engine operation. Correct spark plug gap affects the entire range of performance of the engine; starting, idling, accelerating, power and top speed.

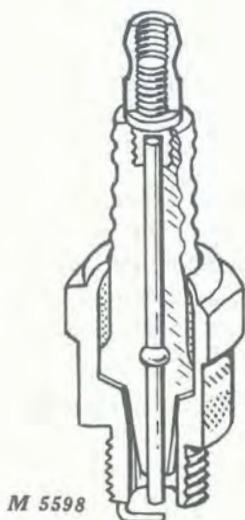

Fig. 5-Spark Plug

Spark plugs must operate within a certain temperature range to give good performance. The ability of the spark plug to conduct heat away from the center electrode and its insulating material is controlled by the design of the shell and insulator. The path for heat escape is through the insulating material, the plug shell, the gasket and threads to the cylinder head. By varying the construction of the insulator, the spark plug manufacturer is able to produce spark plugs of different heat dissipating characteristics.

## Ignition Switch

The ignition switch in the battery ignition system routes the electrical current from the battery to the coil in both "start" and "run" positions. Since electrical current is needed to operate the ignition coil, a switch with a closed ignition circuit is required. This means that opening the circuit will stop the ignition function. Magneto and solid state systems are just the opposite, as they operate when the ignition switch is open, and stop when the switch is closed.



## TESTING

Instructions are provided for testing electrical components on and off the tractor. The purpose of the tests is to isolate the cause of trouble in the ignition system. A complete diagnosis guide is in Group 5 of this Section.

Adequate approved electrical test equipment is required to accurately test electrical circuits and intelligently diagnose unsatisfactory performance.

Many servicemen prefer to have their electrical components tested by professionals using highly complex test equipment. Good automotive repair centers provide this service. The coil, voltage regulator, solenoid and alternator stator used on the 140 Hydrostatic Tractor can be tested on automotive test equipment.

The following test procedures are recommended for dealers having their own test equipment. Equipment needed is listed on page 15-10.

*NOTE: Because there are many manufacturers of test equipment, each with their own specific operating instructions, it is important to follow the manufacturer's recommendations if the procedures in this test section should contradict those of the manufacturer.*

### Testing Battery

Refer to page 10-4 of this section to test the battery.

### Testing Coil



Fig. 6-Testing Coil Power

The ignition coil is either in a satisfactory condition or it is not. Coil failure occurs all at once, much as an electric light bulb. It does not degenerate gradually.

When coil failure is suspected, use an analyzer, Figure 6, to test coil. The analyzer will also test the condenser and solenoid as well as checking voltage and amperage. See equipment manufacturers operators hand book for specifications for particular unit being tested.

Follow manufacturer's recommendations to test the following:

1. Coil power test
2. Coil high speed test
3. Coil surface insulation test
4. Coil continuity test
5. Coil ground test.

### Testing Condenser

If the condenser shorts out, the coil will be unable to produce output voltage. On the other hand, if it opens or decreases in capacity, the output voltage will be greatly reduced and the ignition points will burn excessively.

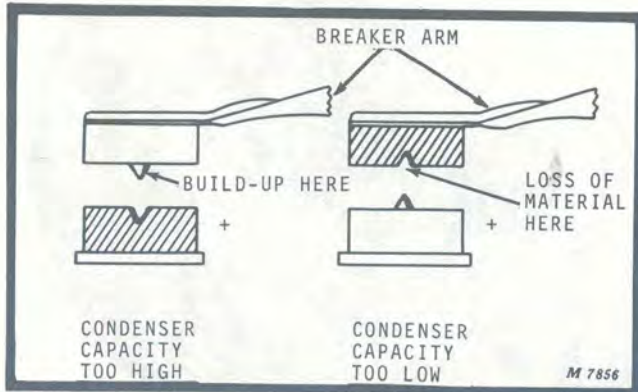

Fig. 7-Breaker Point Build-Up

If badly burned breaker points occur frequently, the condition of the condenser should be suspected. If condenser has too small capacity, metal will transfer from the stationary contact to the movable contact. If capacity is too large, the metal will build up on stationary contact, Figure 7.

Condensers can be tested off the tractor on test units such as shown in Figure 8. Follow manufacturer's recommendations to make the following condenser tests:

1. Capacity
2. Leakage
3. Short
4. Series resistance



Fig. 8-Testing Condenser Capacity

### Testing Spark Plug

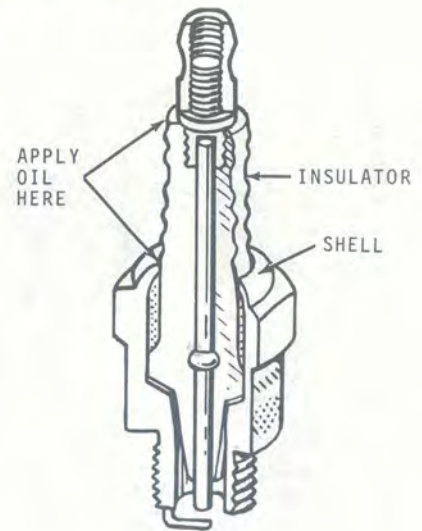

Fig. 9-Spark Plug

Test the plug, Figure 9, for compression leakage at the insulator seal. Apply a coating of oil to the shoulder of the plug where the insulator projects through the shell, and to the top of the plug, where the center electrode and terminal project from the insulator.

Place the spark plug under pressure, either by turning the engine over the compression stroke or in a commercial tester. Disconnect the high tension wire during the test.

Leakage is indicated by air bubbling through the oil. If the test indicates compression leakage, replace plug.



## INSPECTION

## REPAIR

### Spark Plug

### Spark Plug

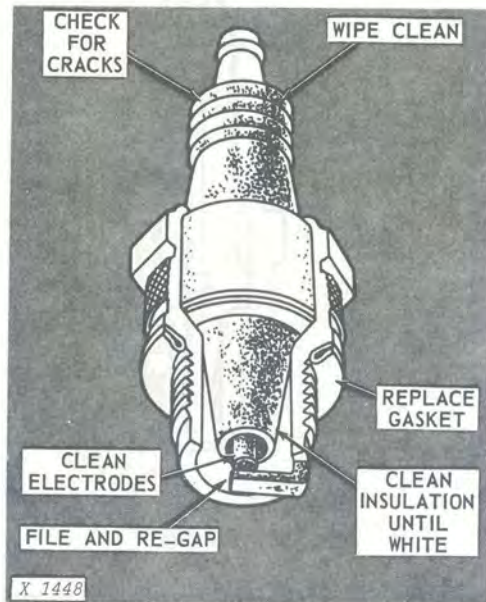

Fig. 10-Maintenance of Spark Plugs

Fig. 11-Checking Spark Plug Gap

Engine misfire or generally poor operation is often caused by a spark plug in poor condition or by one with improper gap setting. Plugs fail for various reasons. Check to see if the porcelain insulator is cracked or is coated with oil, carbon or other deposits, Figure 10.

This can cause the high voltage ignition impulse to pass from the center electrode to ground without jumping the plug gap. As an engine operates, the electrodes are gradually burned or worn away. Check the gap to see if it has become so wide that the available ignition voltage cannot jump the gap, causing the engine to miss.

### Ignition Coil

Inspect coil assembly for damage that may affect its operation. Look especially for cracks, evidence of overheating or other damage.

### Condenser

Inspect condenser for visible damage. Look especially for damaged terminal lead, dents or gouges in can, or broken mounting clip.

Remove, inspect and regap spark plug to 0.025-inch every 100 hours, Figure 11. Bend only the outer electrode when setting gap.

Do not sandblast, wire brush, scrape or otherwise service plug in poor condition—best results are obtained with a new plug.

Use a spark plug wrench to remove old plug. Always use a new spark plug gasket when replacing plug. Tighten plug to 27 foot-pounds torque.

Good operating conditions are indicated if plug has light coating of gray or tan deposit. A dead white, blistered coating could indicate overheating.

A black (carbon) coating may indicate an over-rich fuel-mixture caused by clogged air cleaner or improper carburetor adjustment.



## Ignition Coil

### Coil Polarity

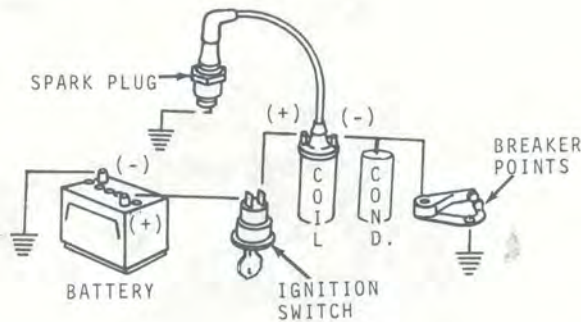

M8606N

Fig. 12-Correct Polarity Diagram

Wrong polarity of the coil is not a serious problem, but can cause damage over a long period of time. A coil that is connected incorrectly will require an extra 4000 to 8000 volts to create a spark.

A coil that is wired correctly will have the same polarity as the battery, Figure 12. If the battery has a negative ground, the coil negative terminal should be connected to the breaker point lead. If the battery has a positive ground, the coils positive terminal should be connected to the breaker point lead.

The wrong coil polarity makes the center electrode of the spark plug have the wrong polarity. This can cause misfiring as voltage requirements increase.

### Checking Coil Polarity

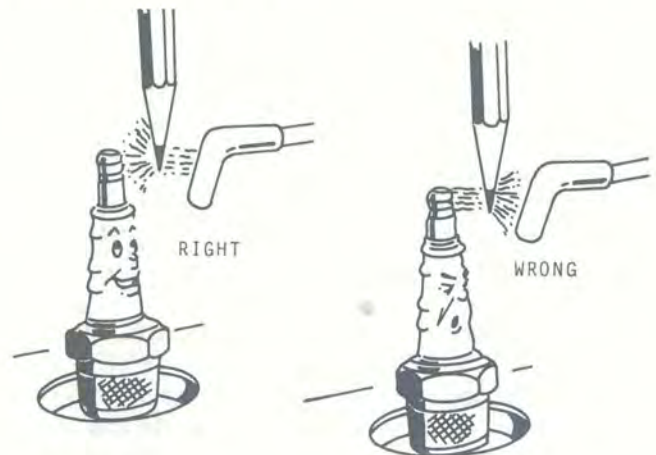

M8607N

Fig. 13-Testing Polarity at the Spark Plug

One method of checking polarity is to connect the negative lead of a volt meter to the spark plug terminal. With the engine running, momentarily touch positive voltmeter lead to a ground. The coil polarity is correct if the meter reads up scale.

Another method is to hold the spark plug wire terminal about 1/4 inch from the spark plug. Insert the lead point of a wooden pencil between lead and spark plug, Figure 13. Spark should flare and turn orange on the plug side of pencil lead if polarity is correct.

A loss of engine power is also evidenced if coil polarity is reversed. Refer to illustrations in Group 5 for detailed electrical wiring diagrams.

### Servicing Coil

The only service required on the coil is to keep the terminals and connections clean and tight. The coil itself should be kept reasonably clean.

Rubber nipples used on the high voltage terminal must be in good condition to prevent leakage at this point.

There is no repair on the coil. If it is cracked or has bad wiring, it must be replaced.

### Condenser

If inspection or tests disclose a defective condenser, replace. Install a new condenser whenever condition of points indicate need.



## Breaker Points

Engine operation is greatly affected by breaker point condition and adjustment. If points are burned or badly oxidized, little or no current will pass. As a result, the engine may not operate at all or may miss, particularly at full throttle.

Adjusting breaker point gap affects the time that the contacts are opened and closed. A definite time is required for the magnetic field within the ignition coil to build up to sufficient value.

If the contact points are closed for too short a time, a weak spark will be produced by the coil. If the points are set too wide, they will open before the primary current reaches maximum value. On the other hand, if set too close, they will open after the primary current has passed its maximum value.

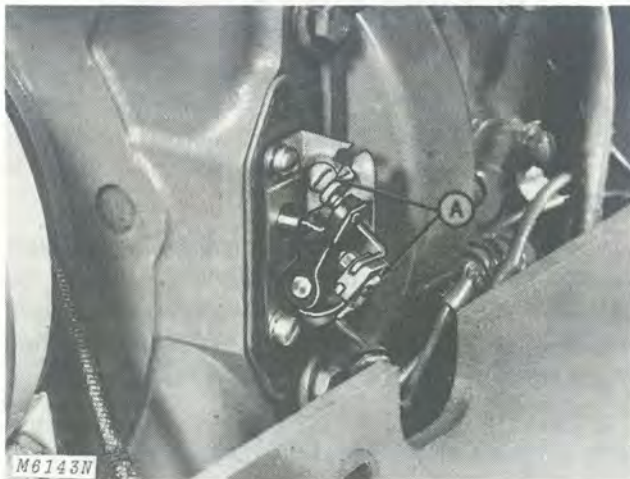

Fig. 14-Replacing Breaker Points

Replace badly burned or pitted points, Figure 14. If slightly pitted points have been dressed down with a point file as a temporary field fix, replace points at first opportunity. If points are oxidized, rub a piece of coarse cloth across surfaces. Clean dirty or oily points with cloth, but make sure no particles of lint are left between surfaces.

To replace points, remove screws "A". Be sure lockwashers are in place when installing new points.

## ADJUSTMENTS

### Adjusting Breaker Points

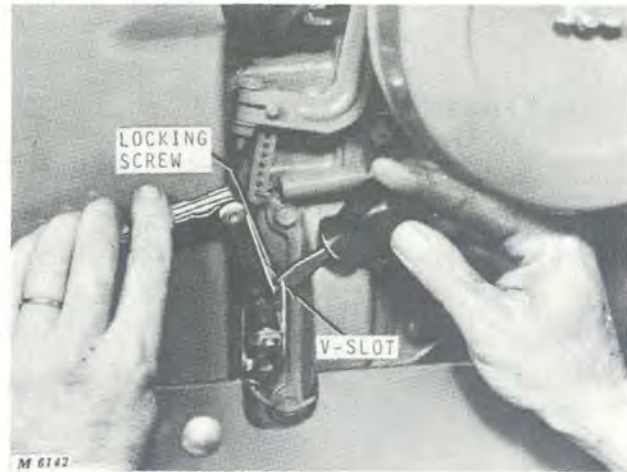

Fig. 15-Adjusting Breaker Points

Rotate engine until "TDC" mark on flywheel lines up with indicator, Figure 16. Measure gap with feeler gauge, Figure 15. Gap should be 0.020 inch when fully open, Figure 15.

If necessary, loosen locking screw and move screwdriver in "V" slot until gap is 0.020 inch. Maximum gap setting can vary from 0.018 to 0.022 inch, to achieve smoothest running. Securely tighten locking screw after adjusting gap.

### Timing Engine

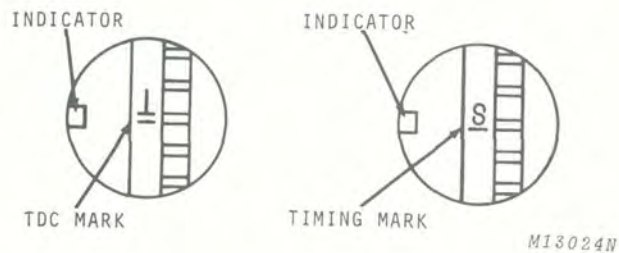

Fig. 16-Timing Sight Hole

The engine is equipped with a timing sight hole in the blower housing, Figure 16. Two timing marks are stamped on the flywheel. The "T" mark indicates top dead center (TDC) while the "S" mark indicates the spark point, which is 20 degrees before top dead center. Line under timing marks should line up with indicator.



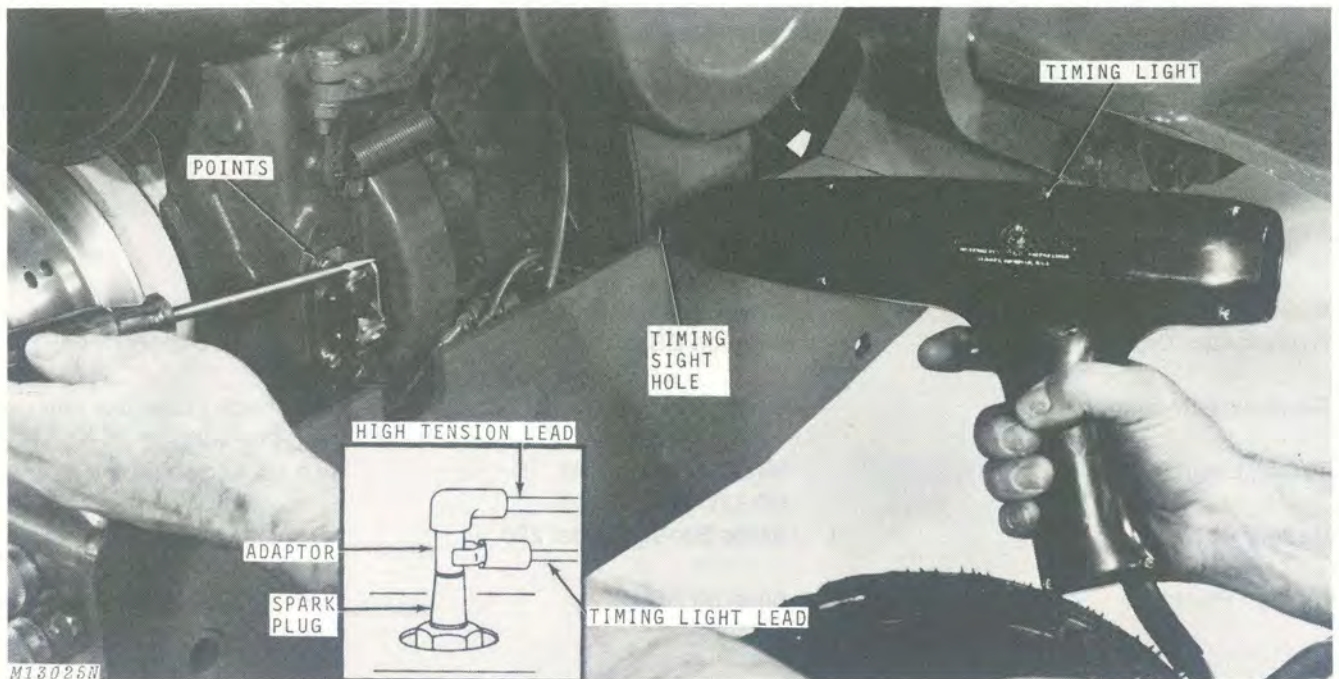

Fig. 17-Timing Sight Hole

Several different types of timing lights are available. Follow the manufacturer's instructions for the type used. The following timing procedure can be used with most timing lights.

Remove high tension lead at spark plug. Install a spark plug adaptor and re-connect high tension lead.

Connect one timing light lead to the spark plug adaptor, see inset Figure 17.

Connect second timing light lead to the positive battery terminal. See timing light instructions for battery size, wiring, etc.

Connect third timing light lead to ground.

Rotate engine by hand until "S" mark is visible through timing sight hole, Figure 16. Chalk "S" line for easy reading.

Start engine. Run engine at 1200 to 1800 rpm. Aim timing light into sight hole. The light should flash as "S" mark on flywheel housing lines up with indicator in timing sight hole.

If timing is off, remove breaker point cover, loosen locking screw and shift breaker plate until "S" mark is exactly lined up with indicator in timing sight hole. Re-tighten locking screw before replacing breaker point cover.



## SPECIFICATIONS

Spark Plug Gap ..... 0.025 inch  
Breaker Point Gap ..... 0.018 to 0.022 inch

## SPECIAL TOOLS

Name	Manufacturer and No.	Use
Hydrometer-Thermometer	Snap on BB-4A	To check battery condition.
Generator-Regulator Tester	Snap on MT-401B	To check generator output and voltage
Timing Light	Mercotronic Model 65-12DC	To set engine timing.
Battery Charger	Silver Beauty model 220	For initial charge and to recharge batteries.
Ignition Point File	Snap on HB-5	To file breaker points and spark plug electrodes.
Feeler Gauge	OTC No. 860-A	To gap breaker points.
Spark Plug Wire Gauge	OTC No. 866	To check gap and regap spark plug.
Test Lamp	Snap on CT-6	Test circuits.
Magneto Analyzer	Mercotronic Model 98 Mercotronic Instruments Corporation 215 Branch St. Almont, Michigan	Test coil, condenser, solenoid, battery voltage and check continuity.

## Group 20 CHARGING SYSTEM

### PRINCIPLE OF OPERATION

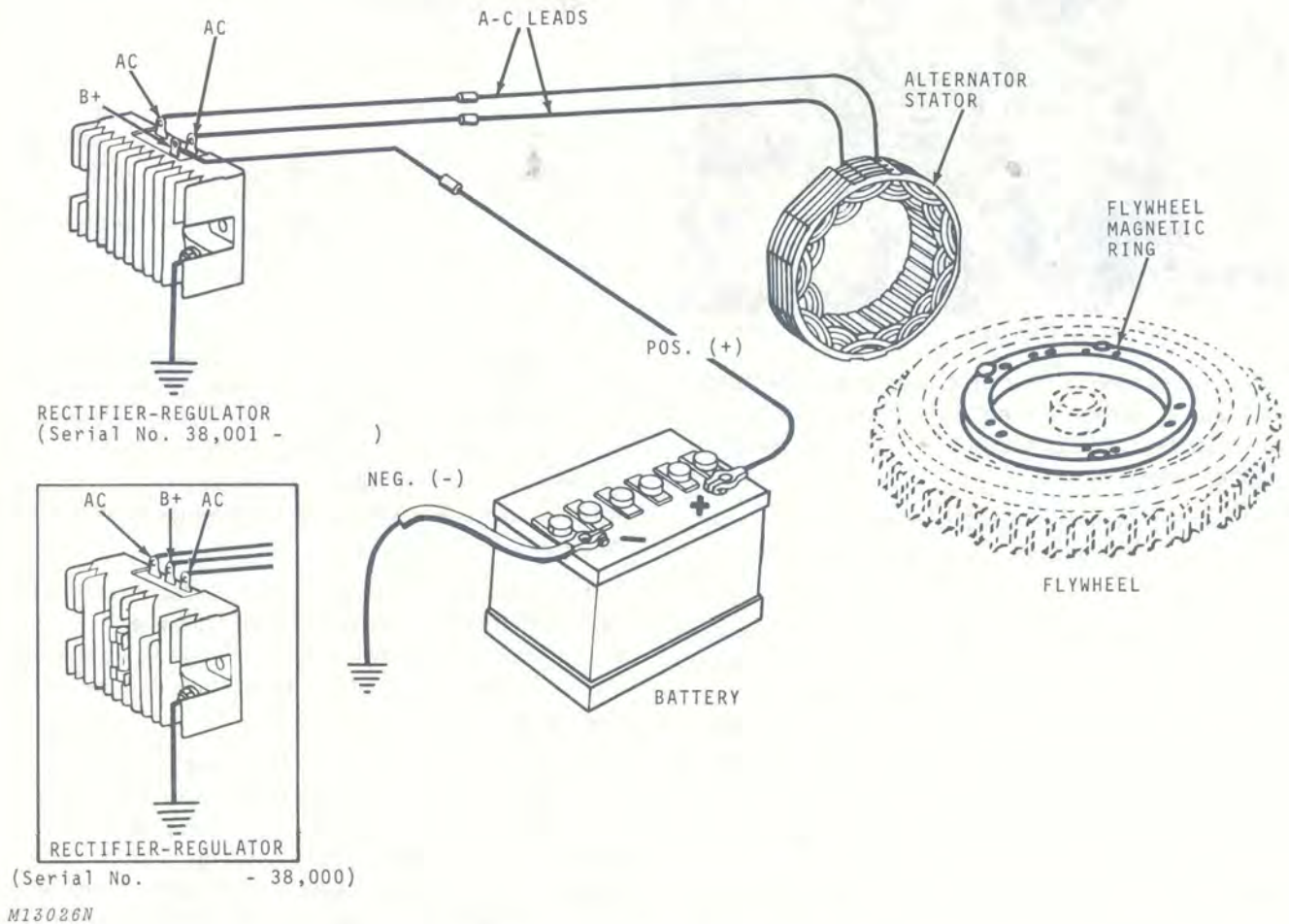

Fig. 1-Principle of Alternator Operation

### Alternator

An alternator system, Figure 1, supplies electrical energy to charge the 12-volt battery. The battery, in turn, furnishes energy for cranking, lights, and other accessories.

The alternator features (1) a permanent magnetic ring bolted to the inside rim of the flywheel; (2) an alternator stator assembly bolted to the engine bearing plate and (3) a rectifier-regulator unit mounted externally on the tractor.

The magnetic ring is composed of 12 permanent magnets imbedded in a cast ring. These high-strength magnets are arranged between pole pieces providing an equal number of north and south magnetic poles.

The magnetic ring, bolted to the inside rim of the flywheel rotates around the stator.

As the magnetic ring rotates about the stator, an alternating current is generated in the stator windings. This alternating current is routed to a rectifier-regulator where it is converted to direct current. Direct current conversion is required as the battery will not accept alternating current because of its electrical polarity.

With this system, the battery and alternator work hand-in-hand to supply the needs of the engine and accessories—each one being dependent upon the other.



## Rectifier-Regulator

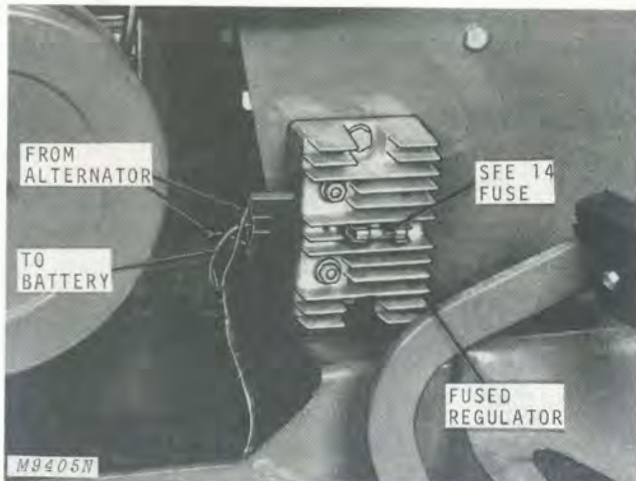

Fig. 2-Fused Rectifier-Regulator (Serial No. -38,000)

The alternating current produced in the alternator is changed to direct current in the rectifier-regulator unit, Figure 2. Direct current is necessary for charging the battery.

This change is accomplished through the use of solid state electronic devices which are arranged to form a full-wave bridge rectifier.

Regulation is also provided by electronic devices (Zener diodes) which "sense" the counter-voltage created by the battery to control or limit the charging rate. Since these devices generate heat in operation, the regulator is equipped with finned surfaces to provide a greater cooling surface.

When the battery is in a low state of charge, the regulator permits a higher charge rate to the battery. When battery is fully charged, the devices limit the charging rate.

## TESTING

The following tests are designed to isolate the cause of trouble in the charging system. A complete diagnosis guide appears in Group 5 of this section.

Adequate, approved electrical test equipment is required to accurately test electrical circuits and intelligently diagnose unsatisfactory performance.

Many servicemen prefer to have their electrical components tested by professionals using highly complex test equipment. Good automotive repair centers provide this service.

The following test procedures are recommended for dealers having their own test equipment. Equipment needed is listed at the end of this section.

**NOTE:** Because there are many manufacturers of test equipment, each with their own specific operating instructions, it is important to follow the manufacturer's recommendations if the procedures in this test section contradict those of the manufacturer.

## Testing Circuit Wiring

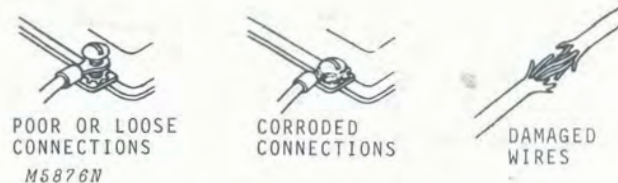

Fig. 3-Faulty Wiring

The wiring, Figure 3, in the circuit is just as important a part of the charging system as the electrical units themselves. Undersize wire or loose connections between the regulator and battery or poor ground connections between the battery and alternator will cause a lowering of the charging rate to the battery.

High resistance resulting from loose or corroded connections in the charging circuit between the alternator and regulator will result in a high voltage at the alternator and may cause premature failure of the regulator.

A visual inspection will often reveal much useful information relative to the condition of the charging system. All wiring should be inspected periodically for damaged insulation. Faulty wiring should be replaced. All terminals should be checked for loose or corroded connections, and cleaned and tightened, as necessary.

Unwanted resistance in the circuit results in unwanted voltage losses or drops. EXCESSIVE voltage drop in the charging circuit tends to keep the battery in an undercharged condition.



## Testing Alternator and Regulator

When testing the alternator be sure the battery is in a full state of charge. See page 10-4 of this section.

**IMPORTANT: When testing the charging system, be sure battery polarity is correct. Prevent alternator (AC) leads from touching or shorting, because this could permanently damage the stator.**

### Quick Check of Charging System

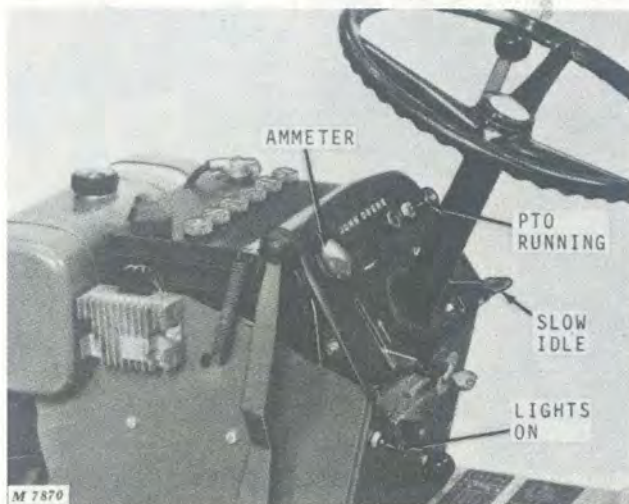

Fig. 4-Quick-Testing Charging System

Remove spark plug wire and crank engine 15 seconds to partially discharge battery. Reinstall spark plug wire and start engine.

Run at slow idle, Figure 4. Place load on charging system by turning on lights and PTO switch. Tractor ammeter will show a discharge condition.

Increase engine rpm by lifting up on throttle lever. As engine speed increases, discharge condition will disappear; ammeter will show a charging condition at full rpm.

If this does not occur, proceed to make the following tests to determine electronic component which has failed.

When testing the charging system of the tractor, use the following sequence:

### Checking Rectifier-Regulator Fuse (Serial No. -38,000)

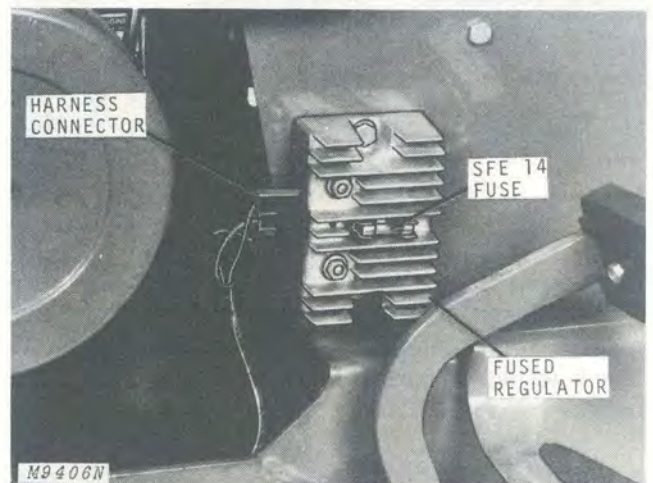

Fig. 5-Checking for Blown Fuse

140 Tractors (Serial No. -38,000) have a rectifier-regulator with a fuse.

It is important to inspect for a blown SFE-14 fuse in the rectifier-regulator, Figure 5, before proceeding to test the charging system.

Replace fuse and inspect for original cause of system short or overload.



## TESTING—Continued

### Testing AC Voltage

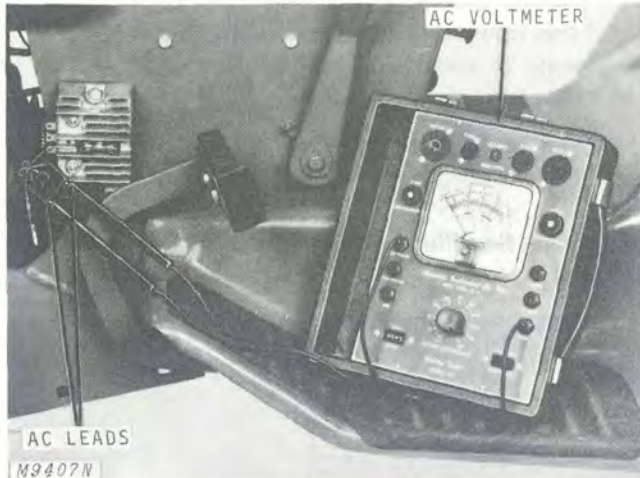

Fig. 6-Testing AC Voltage

Start engine. Remove 3-prong connector from rectifier-regulator unit. Insert leads from AC voltmeter into the two outer AC plug connections, Figure 1. Check voltage recorded with engine running at full speed (no load), Figure 6.

Alternator should supply 28 to 32 volts to the regulator.

If no charge is being received by the battery (0 ammeter reading) and voltage is substantially below 28 volts, follow procedure for testing AC leads and windings, Figure 7.

If no charge is being received by the battery (0 ammeter reading) and voltage is more than 25 to 28 volts, the stator is producing properly. Follow the procedure for testing DC amperes on the next page.

### Testing AC Leads and Windings

Check if stator is shorted to bearing plate by checking continuity between bearing plate and one AC lead from stator, Figure 7. Continuity would indicate a shorted stator.

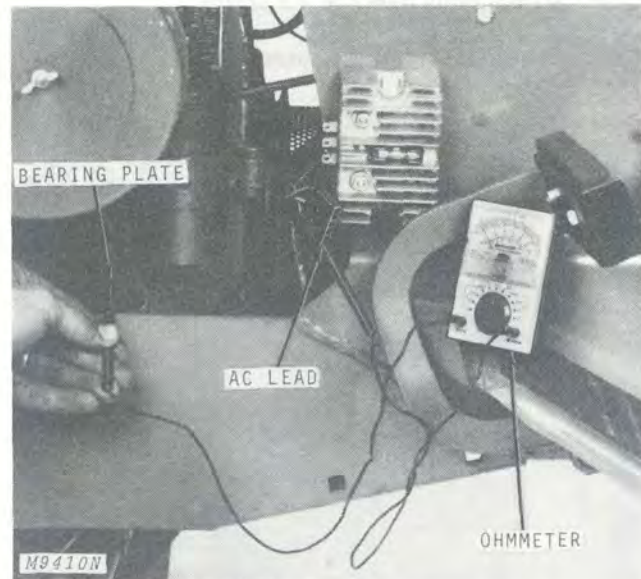

Fig. 7-Using Ohmmeter To Test Stator For Short

Use a test light or an ohmmeter to check for continuity in the stator coil by attaching test leads to the stator leads. An infinity reading would indicate an open in the stator coil.

No adjustments are possible on the alternator system and field service on this system is not recommended.

A faulty alternator should be replaced with a new unit if testing proves it defective.

To remove alternator, see Section 20 for instructions on engine removal and disassembly. Remove flywheel, which houses rotating magnetic field. Remove screws holding stator to bearing plate.



## Testing DC Amperes

To check amperage, the battery must be in need of some charge value. If battery is partially discharged, proceed. If not, remove spark plug wire and crank engine 15 seconds to partially discharge battery. Install spark plug wire.

**CAUTION:** Do not ground connections or make contact between the loose leads when making this test.

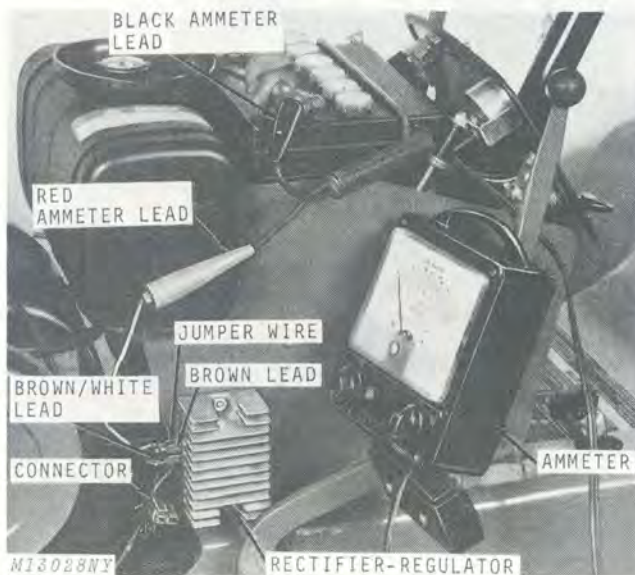

Fig. 8-Testing DC Amperes

Disconnect rectifier-regulator and remove the brown and brown/white leads from connector, Figure 8. Install loose leads on correct (AC) terminals of rectifier-regulator and a jumper wire on remaining (B+) terminal. Install red ammeter lead on jumper wire and black ammeter lead on positive battery terminal and start engine.

Adjust polarity on meter. Ampere reading should be from 8 to 10 amps on tractors (Serial No. 38,000) and from 12 to 15 amps on tractors (Serial No. 38,001- ), depending on battery condition.

If ampere reading is below these ranges, the rectifier-regulator is not functioning properly. Replace rectifier-regulator.

If ampere reading is within or above these ranges, and no charge is being received by the battery, follow the procedure for testing DC charging circuit at right.

## Testing DC Circuit

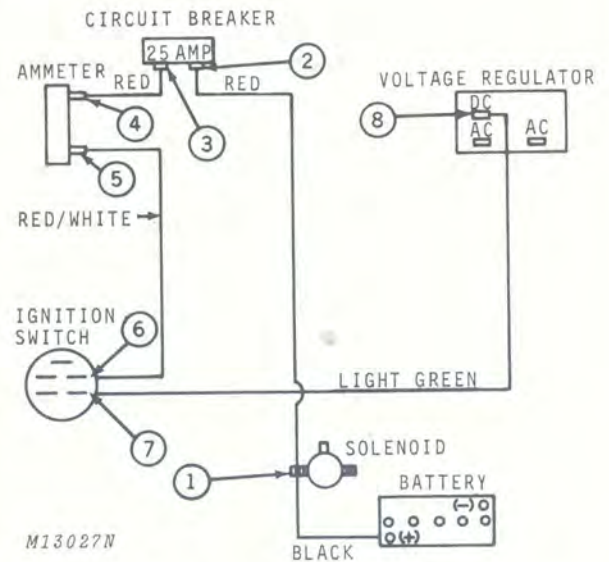

Fig. 9-Testing DC Circuit

Disconnect the positive battery terminal and turn the key switch to the "RUN" position. Connect one lead from a continuity tester to the disconnected battery cable and the other lead to each of the eight check points shown in Figure 9, in the following order.

1. Solenoid post. This eliminates a faulty battery cable.
2. Circuit breaker terminal. This eliminates a faulty red lead.
3. Circuit breaker terminal. This eliminates a faulty circuit breaker.
4. Ammeter terminal. This eliminates a faulty red lead.
5. Ammeter terminal. This eliminates a faulty ammeter.
6. Ignition switch terminal. This eliminates a faulty red/white lead.
7. Ignition switch terminal. This eliminates a faulty ignition switch.
8. Regulator end of light green lead. This eliminates a faulty light green lead.

Replace any faulty components.

Reinstall positive battery cable.

If no faulty components were discovered, follow procedure for testing DC voltage on the next page.



## Testing DC Voltage

To check rectifier-regulator output, check the positive terminal to ground with a direct current voltmeter, Figure 10. Run engine at full speed (no load) and observe tractor ammeter until it reaches a "0" reading, then check voltmeter reading.

If voltmeter reading is not in the 13.5 to 14.7 range, the rectifier-regulator is not functioning properly. Replace rectifier-regulator.



Fig. 10-Checking Battery and Regulator Condition

## Group 25 PTO CLUTCH, LIGHTS, AND ACCESSORIES

### PTO CLUTCH

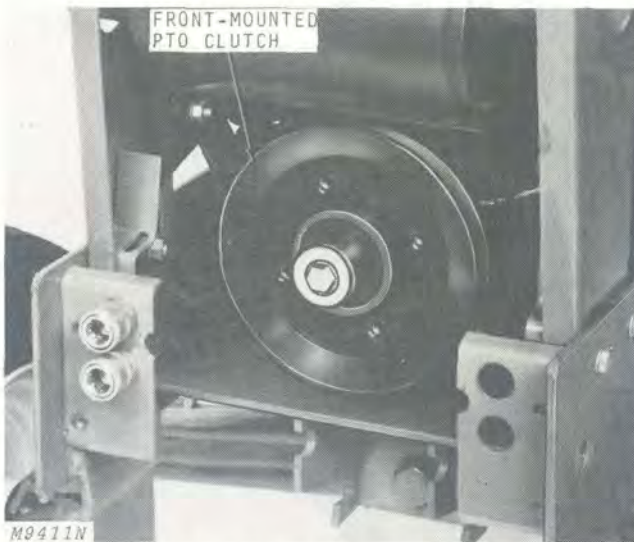

Fig. 1-Front-Mounted Electromagnetic PTO Clutch

The electro-magnetic front PTO clutch, Figure 1, actuated by a switch on the dash panel, will normally require no service. Any difficulty with the clutch can usually be corrected by checking the electrical circuit.

#### Testing The PTO Clutch

A faulty clutch switch, loose wiring or short circuit will appear to be a clutch failure. Test in the following manner if PTO clutch fails to operate.

With the clutch mounted on the tractor, disconnect field coil wire on left side of engine.

Connect one terminal of a 12-volt test lamp into the connector on the wire leading from the dash to the field coil wire. Ground the second test lamp wire to tractor frame. Start tractor and engage PTO switch. If lamp lights, the PTO is either defective or connection between the terminal and field coil wire was poor. Check for wear where input wire enters coil to see that pulley and rotor do not rub on wire.

If lamp fails to light, the problem rests in the PTO clutch safety switch, indicator light or other electrical components, rather than in the PTO itself.

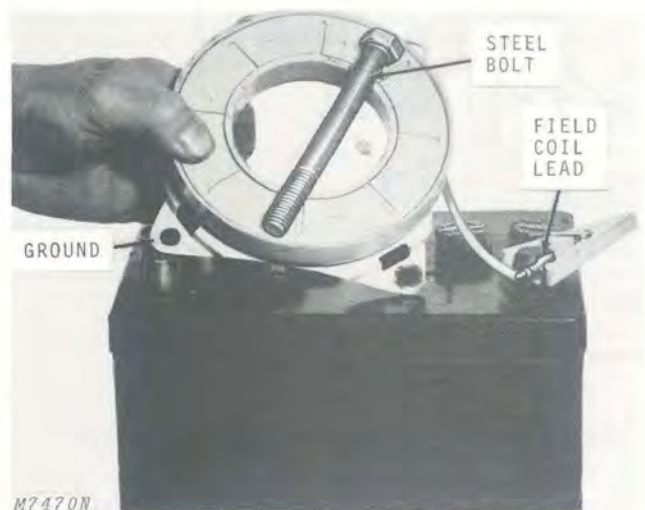

Fig. 2-Testing PTO Field Coil

Reconnect wire from dash to PTO field wire. With engine running, engage PTO switch once again. If PTO does not engage, shut off engine and remove the field from the tractor. Place field coil wire on positive terminal of a 12-volt battery. Set field coil frame on negative post.

Set steel bolt across coil as shown in Figure 2. Electromagnetic action will hold bolt to coil if PTO field is in good condition. If bolt will not stick to field coil, coil is defective and must be replaced.



### Servicing the PTO Clutch

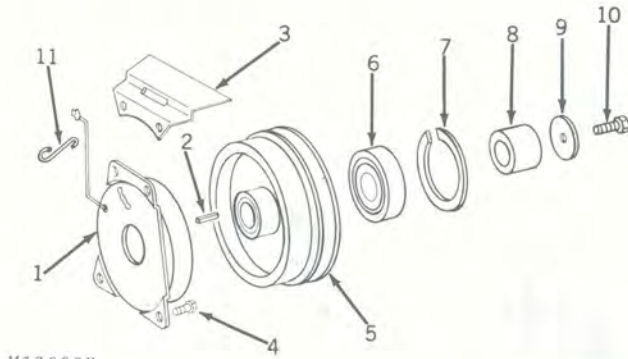

M13029N

- |                       |                |
|-----------------------|----------------|
| 1-Field Coil Assembly | 6-Ball Bearing |
| 2-Shaft Key           | 7-Snap Ring    |
| 3-Belt Shield         | 8-Bushing      |
| 4-Cap Screw           | 9-Washer       |
| 5-Rotor and Pulley    | 10-Cap Screw   |
|                       | 11-Wire Clamp  |

Fig. 3-PTO Clutch Components (Serial No. 30,001-30,275)

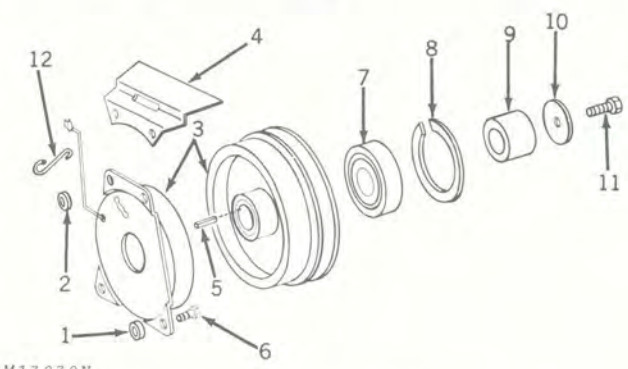

M13030N

- |                         |                |
|-------------------------|----------------|
| 1-Thick Spacer (Bottom) | 7-Ball Bearing |
| 2-Thin Spacer (Top)     | 8-Snap Ring    |
| 3-Clutch Complete       | 9-Bushing      |
| 4-Belt Shield           | 10-Washer      |
| 5-Shaft Key             | 11-Cap Screw   |
| 6-Cap Screw             | 12-Wire Clamp  |

Fig. 4-PTO Clutch Components (Serial No. 30,276-46,500)

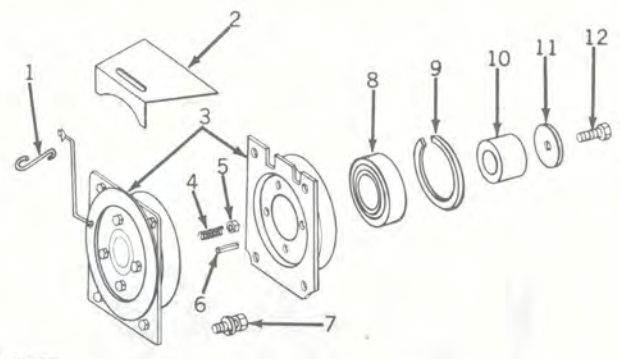

M13031N

- |                   |                |
|-------------------|----------------|
| 1-Wire Clamp      | 7-Cap Screw    |
| 2-Belt Shield     | 8-Ball Bearing |
| 3-Clutch Complete | 9-Snap Ring    |
| 4-Spring (4 used) | 10-Bushing     |
| 5-Nut (4 used)    | 11-Washer      |
| 6-Shaft Key       | 12-Cap Screw   |

Fig. 5-PTO Clutch Components (Serial No. 46,501- )

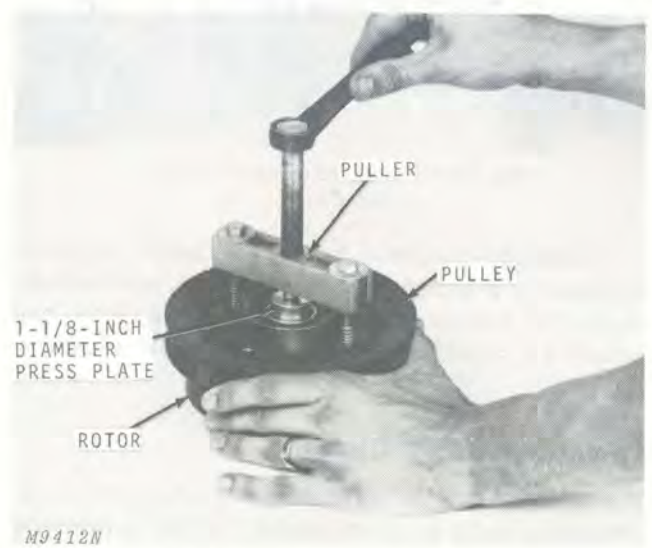

M9412N

Fig. 6-Removing Pulley from Rotor

Replacement of the bearing in the rotor and pulley assembly is the only service recommended for the PTO clutch.

To remove bearing, separate rotor and pulley using a small puller, Figure 6. Remove snap ring and press old bearing out from back side by pressing on inner race. To install new bearing, press into bore and insert snap ring.

**IMPORTANT: When installing replacement bearing, press on outer race only. Be sure the pulley is properly supported during the pressing operation.**

Assemble rotor and pulley by pressing them together. Press on inner race of bearing.

A slight audible noise is considered normal as the clutch engages. Never lubricate the clutch.

To prevent unnecessary clutch wear, keep the clutch switch off (clutch disengaged) when operating the tractor without power-driven equipment.

## LIGHTS

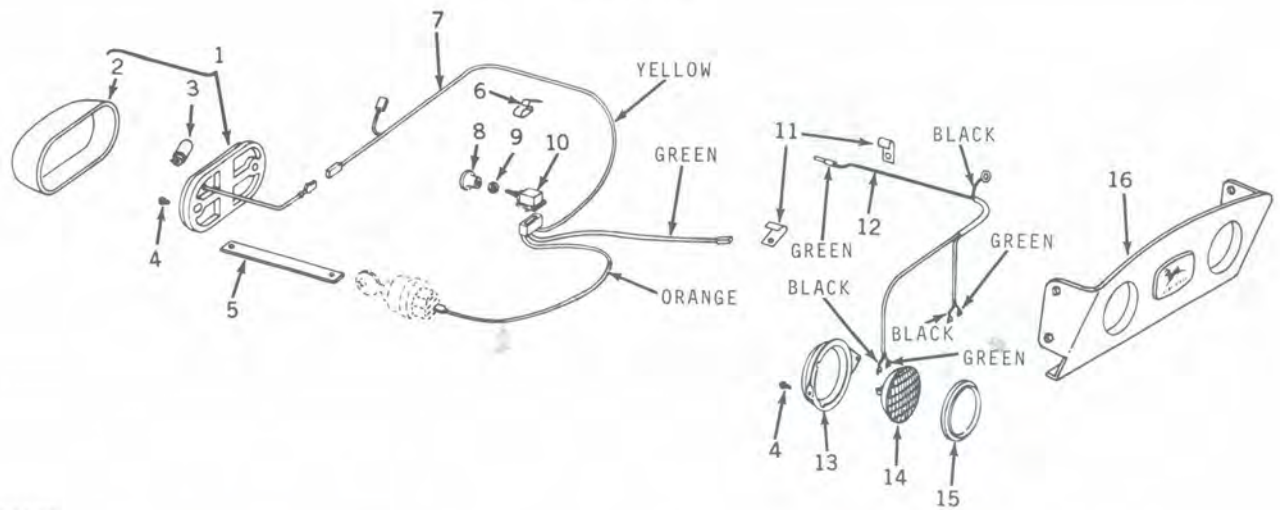

M9413N

- 1-Taillight (Complete)
- 2-Taillight Lens
- 3-Taillight Bulb
- 4-Self-Tapping Screw
- 5-Ground Strap
- 6-Frame Clip

- 7-Taillight Harness
- 8-Switch Knob
- 9-Face Nut
- 10-Light Switch
- 11-J-Clamp

- 12-Headlight Harness
- 13-Headlight Flange
- 14-Sealed Beam Headlight
- 15-Headlight Ring
- 16-Headlight Panel

Fig. 7-Headlight and Taillight Components

### Replacing Headlights

Before replacing sealed beam headlights, Figure 7, be sure light switch is off. Open hood. Remove two self-tapping screws holding headlight flange in place. Disconnect wiring harness leads from sealed beam and remove faulty unit.

Replace beam in headlight ring. Install flange making sure screws are not tightened excessively. Connect harness leads to sealed beam.



### CIRCUIT BREAKER

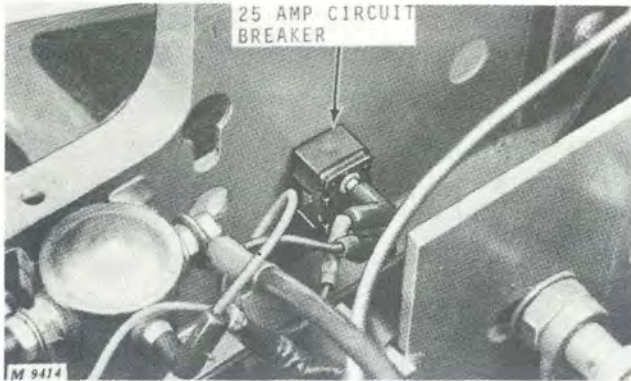

Fig. 8-Location of Circuit Breaker

One master 25-ampere circuit breaker protects the complete electrical system on the 140 Tractor. The circuit breaker is located below the battery base, inside the pedestal on the right-hand side of the tractor, Figure 8.

The circuit breaker will automatically reset itself in case of a short circuit or electrical overload.

If the circuit breaker does not operate properly, replace it with new circuit breaker.

### AMMETER

Prevent accidental short circuit between the ammeter terminals behind the dash by keeping terminal covers in place during tractor service.

### CIGARETTE LIGHTER

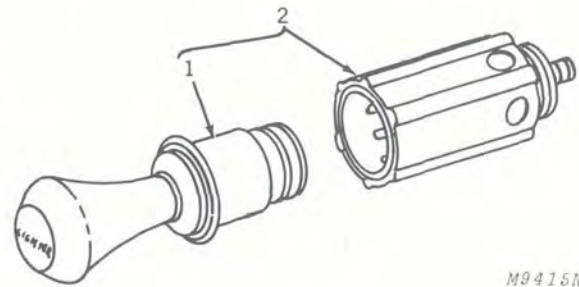

1-Lighter Element  
2-Complete Lighter

Fig. 9-Cigarette Lighter Components

The cigarette lighter, Figure 9, has no fuse, but is protected by a circuit breaker at the rear of the lighter base.

If lighter fails to operate, because of an overload, reset circuit breaker by raising tractor hood and pushing a small wire into the hole at the rear of the lighter housing, Figure 10. Remove wire after resetting circuit breaker.



Fig. 10-Resetting Circuit Breaker in Cigarette Lighter

# Section 50 POWER TRAIN

## Group 5 GENERAL INFORMATION

### TABLE OF CONTENTS

	Page		Page
<b>GROUP 5 - GENERAL INFORMATION</b>		<b>GROUP 15 - HYDROSTATIC TRANSMISSION</b>	
Description .....	5-3	General Information .....	15-1
<b>GROUP 10 - CLUTCH, NEUTRAL RETURN AND   DRIVE SHAFT H-1 TRACTORS (Serial   No. 30,001-38,000) AND H-3 TRAC-   TORS (Serial No. 30,001-46,883)</b>		Two Basic Principles of Hydraulics .....	15-1
Principle of Operation .....	10-1	Principle of Operation .....	15-2
Diagnosing Malfunctions .....	10-3	Diagnosing Malfunctions .....	15-4
Clutch Repair .....	10-4	Testing .....	15-5
Disassembly .....	10-5	Implement Circuit Pressure Test .....	15-5
Analysis .....	10-6	Charge Pressure Test .....	15-5
Assembly .....	10-7	Removing Transmission from Tractor .....	15-5
Clutch Adjustment .....	10-8	Repair .....	15-6
Specifications .....	10-9	Making Transmission Repair Stand .....	15-7
Torque for Hardware .....	10-9	Disassembling Transmission .....	15-7
Special Tools .....	10-9	Removing Charge Pump .....	15-7
<b>GROUP 11 - NEUTRAL RETURN AND DRIVE   SHAFT H-1 TRACTORS (Serial No. 38,   001- ) AND H-3 TRACTORS   (Serial No. 46,884- )</b>		Removing Front Housing .....	15-7
Principle of Operation .....	11-1	Removing Valve Plates .....	15-8
Diagnosing Malfunctions .....	11-3	Removing Cylinder Blocks .....	15-8
Drive Shaft Repair .....	11-4	Removing Motor Swashplate .....	15-8
Disassembly .....	11-5	Removing Pump Swashplate .....	15-8
Assembly .....	11-6	Inspecting Transmission Parts .....	15-9
<b>GROUP 12 - BRAKES</b>		Pump Shaft .....	15-9
Principle of Operation .....	12-1	Cylinder Block Bore and Pistons .....	15-9
Diagnosing Malfunctions .....	12-3	Slipper Retainer .....	15-9
Brake Repair .....	12-4	Pistons and Slippers .....	15-9
Removing Brake Shoes and Drum .....	12-5	Cylinder Block Face .....	15-10
Inspecting Brake Parts .....	12-5	Valve Plates .....	15-10
Assembly .....	12-5	Swashplates .....	15-10
Brake Adjustment .....	12-6	Charge Pump .....	15-11
Torque for Hardware .....	12-6	Check Valves .....	15-11
Special Tools .....	12-6	Relief Valves .....	15-11
		Housing Bearings .....	15-11
		Housing Seals .....	15-11

*(Continued on next page)*



**TABLE OF CONTENTS—Continued**

	Page		Page
GROUP 15 - HYDROSTATIC TRANSMISSION—		GROUP 25 - DIFFERENTIAL AND AXLE	
Continued		Description .....	25-1
Assembling Transmission .....	15-12	Axle Repair .....	25-2
Seals and Bearings .....	15-12	Disassembling Axle .....	25-2
Variable Swashplate .....	15-13	Inspecting Axle Parts .....	25-3
Motor Swashplate .....	15-13	Roller Bearings .....	25-3
Cylinder Block and Pistons .....	15-13	Axles .....	25-3
Installing Cylinder Blocks in Housing .....	15-14	Oil Seals .....	25-3
Check Valves .....	15-14	Wheel Hubs .....	25-3
Relief Valves .....	15-14	Assembling Axle .....	25-3
Valve Plates .....	15-15	Differential Repair .....	25-4
Installing Front Housing .....	15-15	Removing Differential .....	25-4
Installing Control Cam Assembly .....	15-15	Disassembling Differential .....	25-5
Installing Charge Pump .....	15-15	Inspecting Differential Parts .....	25-9
Installing Transmission .....	15-16	Bearings .....	25-9
Specifications .....	15-17	Gears .....	25-9
Torque for Hardware .....	15-17	Axle Housings .....	25-9
Special Tools .....	15-17	Differential Case .....	25-9
		Assembling Differential .....	25-9
GROUP 20 - CONTROL CAM AND LINKAGE		Adjusting Ring Gear and Pinion .....	25-12
General Information .....	20-1	Installing Rear Axle .....	25-14
Diagnosing Malfunctions .....	20-1	Specifications .....	25-15
Removing Cam and Linkage .....	20-2	Torque for Hardware .....	25-15
Inspecting Parts .....	20-2	Special Tools .....	25-15
Cam Assembly .....	20-2		
Linkage .....	20-2		
Hydrostatic Control Lever .....	20-2		
Assembling Cam and Linkage .....	20-3		
Adjusting Cam and Linkage .....	20-3		

## DESCRIPTION

### H-1 Tractors (Serial No. 30,001-38,000) and H-3 Tractors (Serial No. 30,001-46,883)

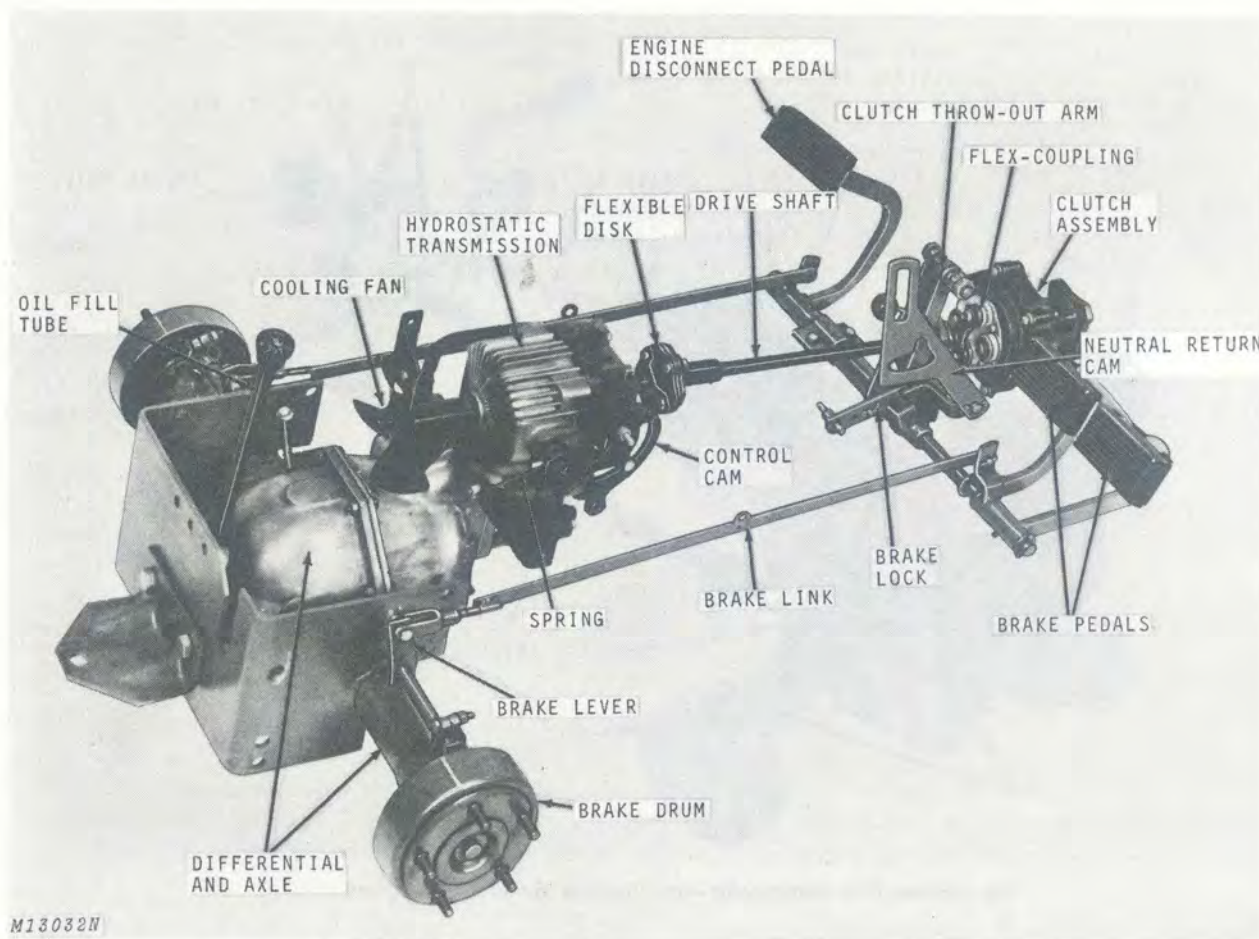

Fig. 1—Power Train Components—H-1 Tractors (Serial No. 30,001-38,000) and H-3 Tractors (Serial No. 30,001-46,883)

The power train of these 140 Hydrostatic Tractors, Figure 1, consists of a cone-type clutch connected to the engine, a hydrostatic transmission, and a heavy-duty differential and axle. A drive shaft, attached to a flex-coupling at the front and a flexible disk at the rear, connects the clutch and hydrostatic transmission. Power from the transmission is transmitted to the rear wheels by the heavy-duty differential and axle.

The cooling fan, Figure 1, blows air over the fins in the aluminum transmission housing to cool the oil in the hydrostatic circuit. This oil also operates the tractor-implement hydraulic lift system and lubricates all parts in the transmission, differential, and axle.

A dipstick in the oil fill tube, Figure 1, is used to check the transmission oil level.

Depressing the engine disconnect pedal disengages the engine from the transmission and returns the hydrostatic control lever to neutral.

The engine disconnect feature aids cold weather starting because it eliminates any drag imposed by the transmission components.

The individual drum-type brakes can be locked together for parking, or used individually for making tight turns.



## DESCRIPTION—Continued

### H-1 Tractors (Serial No. 38,001-46,603)

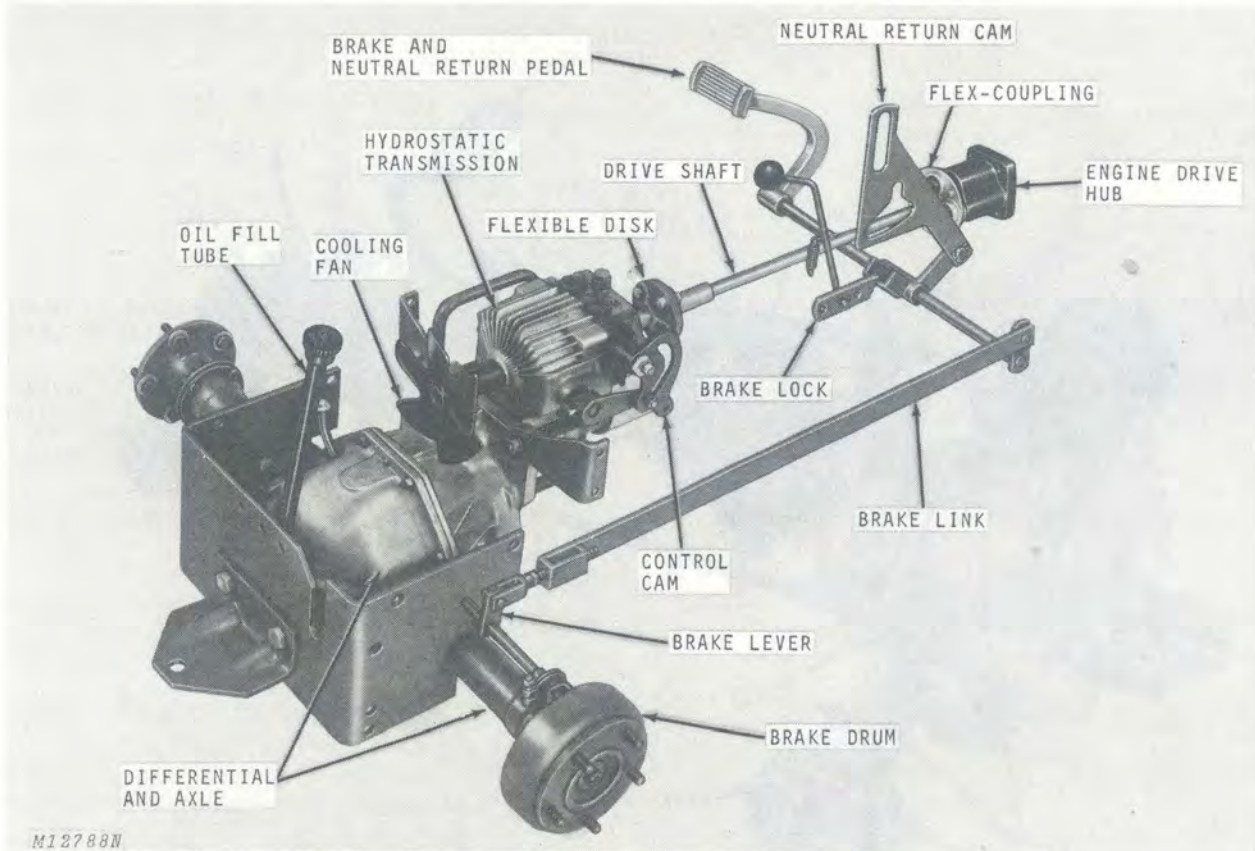

Fig. 2—Power Train Components—H-1 Tractors (Serial No. 38,001-46,603)

The power train of these 140 Hydrostatic Tractors, Figure 2, consists of an engine, a hydrostatic transmission, and a heavy-duty differential and axle. A drive shaft, attached to a flex-coupling at the front and a flexible disk at the rear, connects the engine and hydrostatic transmission. Power from the transmission is transmitted to the rear wheels by the heavy-duty differential and axle.

The cooling fan, Fig. 2, blows air over the fins on the aluminum transmission housing to cool the oil in the hydrostatic circuit. This oil also operates the tractor-implement hydraulic lift system and lubricates all parts in the transmission, differential, and axle.

A dipstick in the oil fill tube, Fig. 2, is used to check the transmission oil level.

Depressing the brake and neutral return pedal returns the hydrostatic control lever to neutral and applies the brake.

## DESCRIPTION

**H-1 Tractors (Serial No. 46,604- ) and H-3 Tractors (Serial No. 46,884- )**

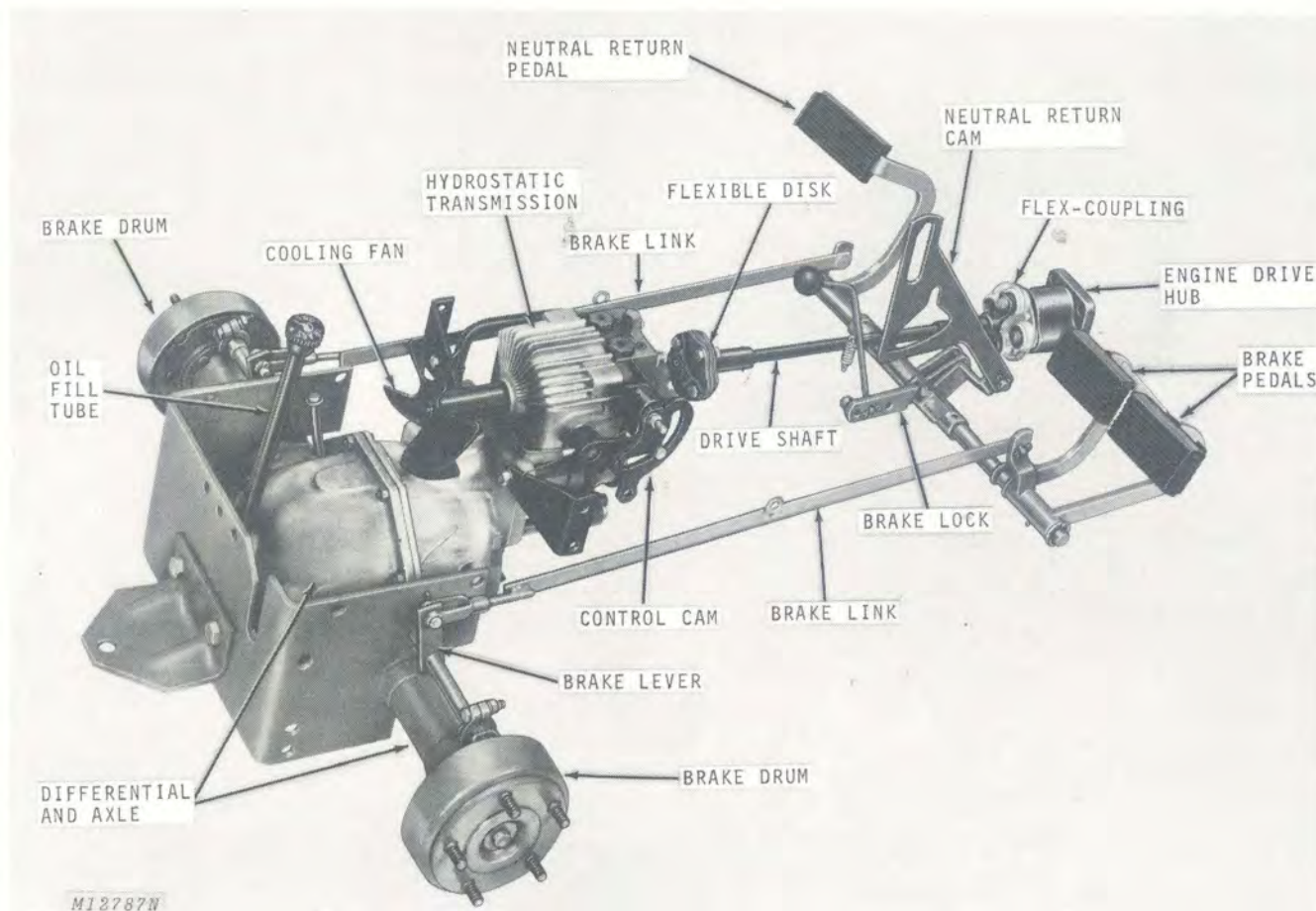

Fig. 3—Power Train Components—H-1 Tractors (Serial No. 46,604- ) and H-3 Tractors (Serial No. 46,884- )

The power train of these 140 Hydrostatic Tractors, Figure 3, consists of an engine, a hydrostatic transmission, and a heavy-duty differential and axle. A drive shaft, attached to a flex-coupling at the front and a flexible disk at the rear, connects the engine and hydrostatic transmission. Power from the transmission is transmitted to the rear wheels by the heavy-duty differential and axle.

The cooling fan, Fig. 3, blows air over the fins on the aluminum transmission housing to cool the oil in the hydrostatic circuit. This oil also operates the tractor-implement hydraulic lift system and lubricates all parts in the transmission, differential, and axle.

A dipstick in the oil fill tube, Fig. 3, is used to check the transmission oil level.

Depressing the neutral return pedal returns the hydrostatic control lever to neutral.

The individual drum-type brakes can be locked together for parking, or used individually for making tight turns.





## Group 10 CLUTCH, NEUTRAL RETURN, AND DRIVE SHAFT H-1 TRACTORS (SERIAL NO. 30,001-38,000) AND H-3 TRACTORS (SERIAL NO. 30,001-46,883)

### PRINCIPLE OF OPERATION

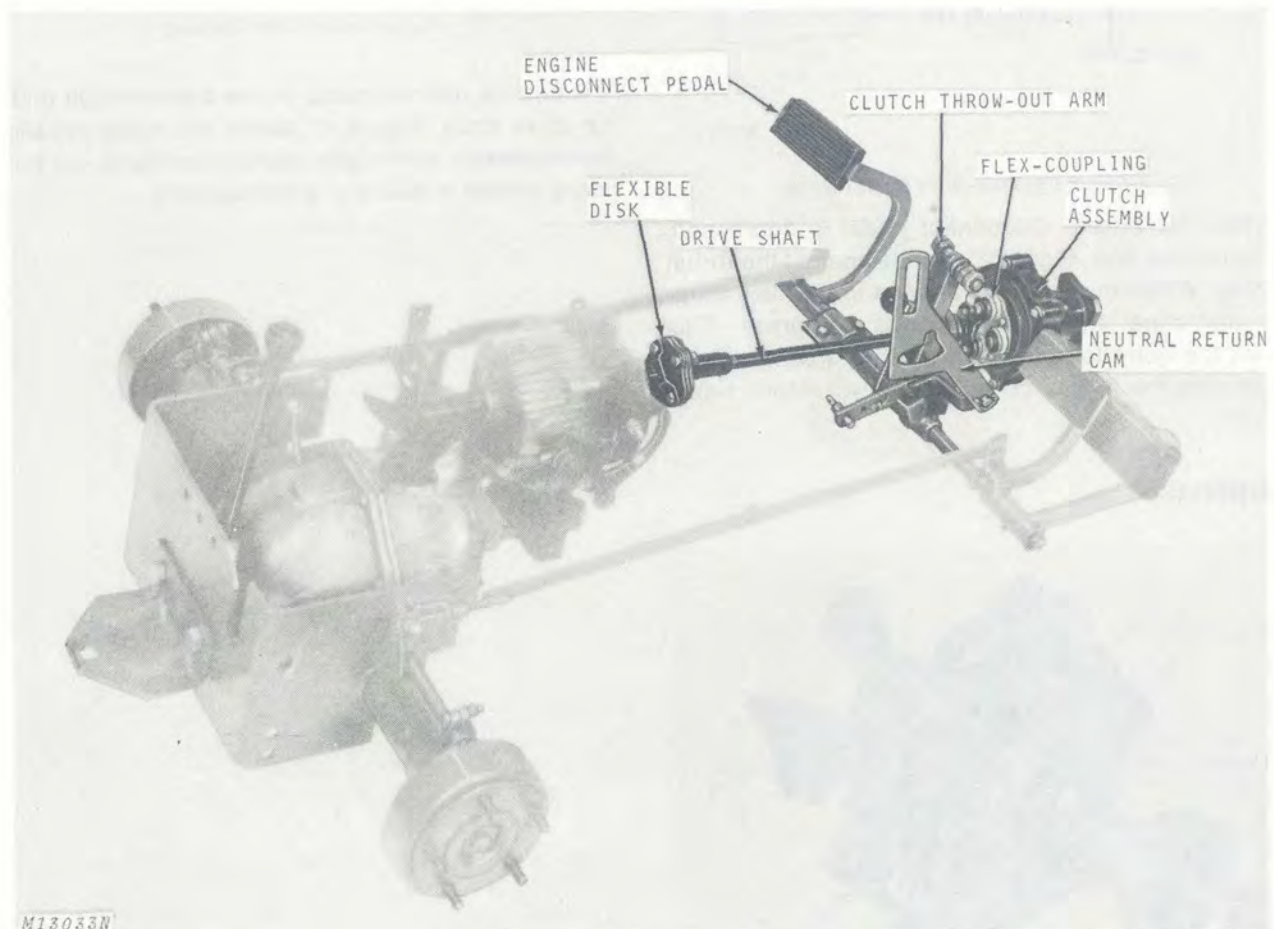

Fig. 1-Clutch, Neutral Return and Drive Shaft

The engine disconnect pedal, Figure 1, engages and disengages the clutch on the engine flywheel. Depressing the pedal also returns the hydrostatic control lever to neutral, preventing the tractor from lurching forward or rearward when the engine disconnect pedal is released.

When the clutch is engaged, Figure 2, four springs push against the clutch cone, wedging it against the clutch and cup lining. This wedging action forces the clutch cone to turn, rotating the drive shaft flex-coupling, the drive shaft, drive disks and internal transmission parts. The transmission regulates the speed and direction of rotation of the differential gears and the axle shafts, propelling the tractor.



## Clutch

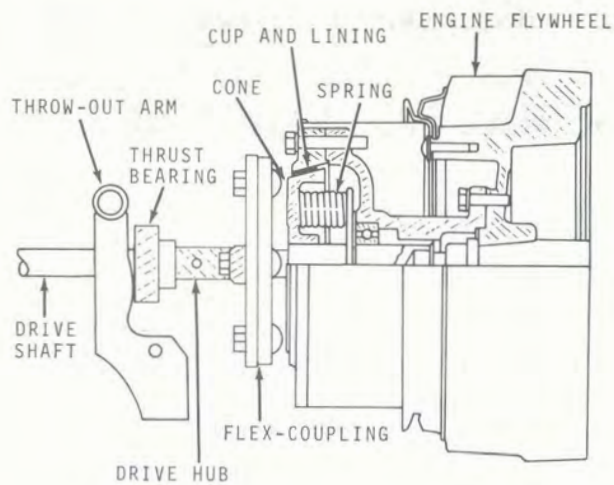

Fig. 2-Clutch Engaged-Drive Shaft Turning

When the engine disconnect pedal is depressed, the throw-out arm, Figure 2, pushes against the thrust bearing. When this thrust is applied to the flex-coupling and cone, the clutch springs compress. This forces the cone to separate from the drive cup, disconnecting the flow of power to the hydrostatic transmission.

## Couplings

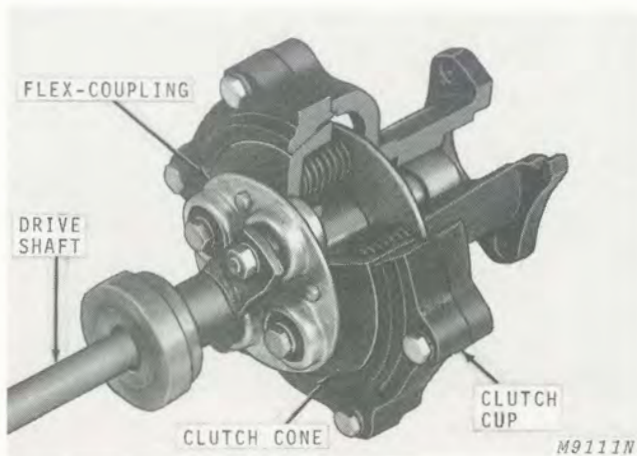

Fig. 3-Flex-Coupling and Cutaway of Clutch Assembly

A flex-coupling, Figure 3, connects the clutch cone to the drive shaft and also serves as a vibration dampener.

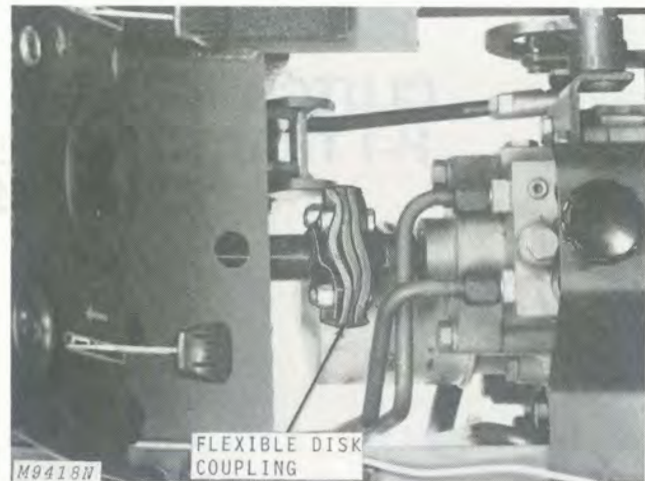

Fig. 4-Flexible Disk Coupling

A flexible disk coupling on the transmission end of the drive shaft, Figure 4, allows for some misalignment between the engine and transmission. Its function is similar to that of a universal joint.

## DIAGNOSING MALFUNCTIONS

### Clutch

#### Clutch Will Not Disengage.

- Groove pin on engine disconnect shaft sheared.
- Clutch out of adjustment.
- Groove pin on engine disconnect pedal sheared.
- Pilot shaft rusted or seized in pilot bearings.
- Roller on throw-out arm worn or broken.

#### Clutch Will Not Engage.

- Broken or weak spring on engine disconnect shaft.
- Lining on clutch cup worn.
- Pilot shaft rusted or seized in pilot bearings.
- Clutch springs weak or broken on inside of clutch.

#### Clutch Engages, But Will Not Drive Tractor.

- Free wheeling valves open.
- Grease on clutch lining.
- Lining on clutch cup worn.
- Weak or broken clutch springs.
- Pins in drive shaft hubs sheared.
- Internal damage to transmission.  
See Group 15 in this section.

#### Clutch is Noisy When Disengaged.

- Bronze pilot bushing loose in drive hub.



### CLUTCH REPAIR

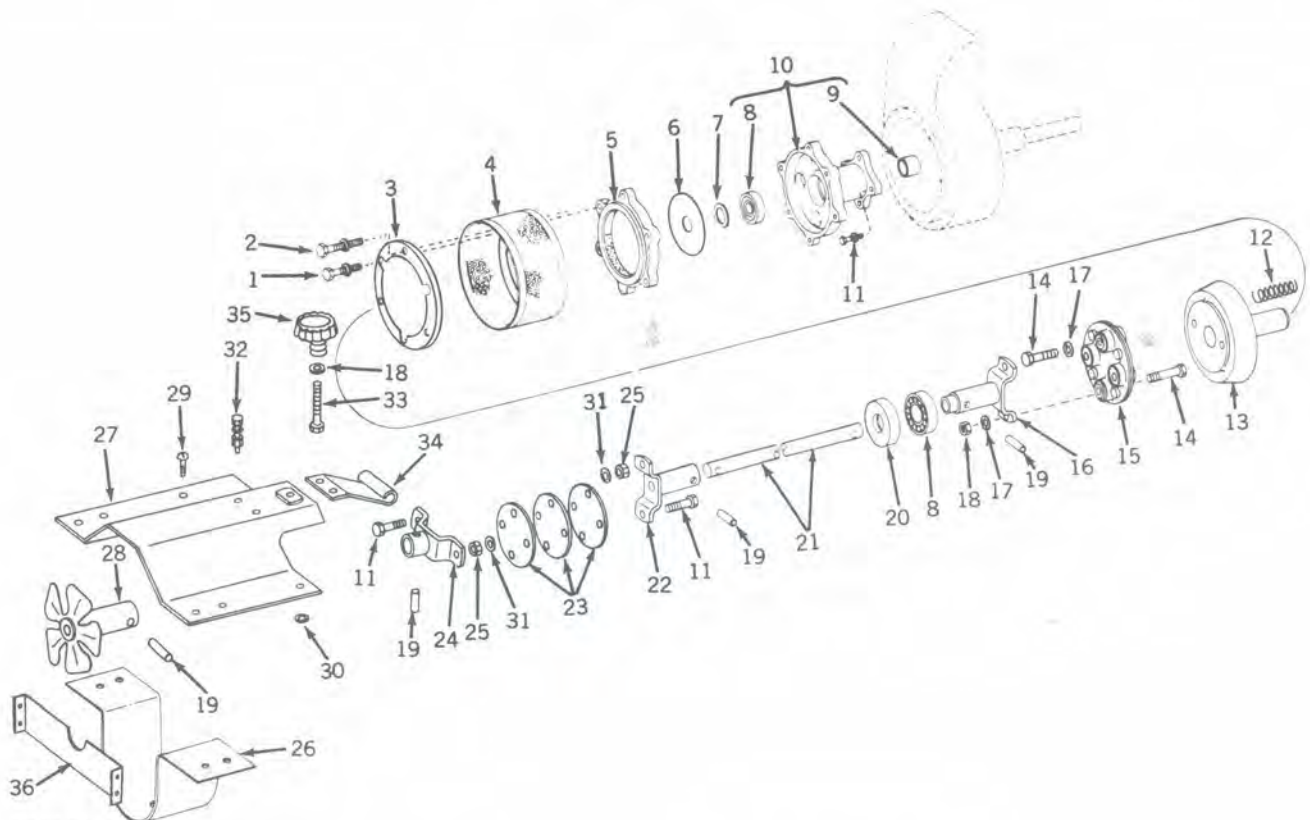

M9420N

- |   |   |
|---|---|
| 1. Cap Screw, 5/16" x 1-1/4" (3 used)     | 19. Spring Pin                                |
| 2. Cap Screw, 5/16" x 1-3/4" (3 used)     | 20. Bearing Retainer                          |
| 3. Screen End Cap                         | 21. Drive Shaft                               |
| 4. Engine Air Intake Screen               | 22. Drive Hub (Rear)                          |
| 5. Cup with Lining                        | 23. Drive Disk (3 used)                       |
| 6. Large Washer, 1-1/32" x 3-3/4" x .120" | 24. Transmission Drive Hub                    |
| 7. Small Washer, 1-1/32" x 1-3/8" x .060" | 25. Lock Nut, Elastic, 5/16" (4 used)         |
| 8. Throw-out Bearing                      | 26. Lower Fan Shield                          |
| 9. Bushing                                | 27. Upper Fan Shield                          |
| 10. Drive Hub Assembly                    | 28. Fan                                       |
| 11. Cap Screw; 5/16" x 1" (8 used)        | 29. Self-tapping Screw 1/4" x 3/8" (6 used)   |
| 12. Release Spring                        | 30. Flat Washer, 1/4" x 1/2" x .060" (2 used) |
| 13. Clutch Cone                           | 31. Washer, .344" x .688" x .060" (4 used)    |
| 14. Cap Screw; 5/16" x 1-1/2" (4 used)    | 32. Machine Screw, 3/16" x 1/2" (2 used)      |
| 15. Flex-coupling                         | 33. Free-wheeling Valve Screw                 |
| 16. Drive Hub (Front)                     | 34. Valve Actuating Plate                     |
| 17. Lock Washer, 5/16" (4 used)           | 35. Knob                                      |
| 18. Nut, 5/16" (2 used)                   | 36. Fan Guard                                 |

Fig. 5-Clutch, Drive Shaft and Couplings

### Disassembly

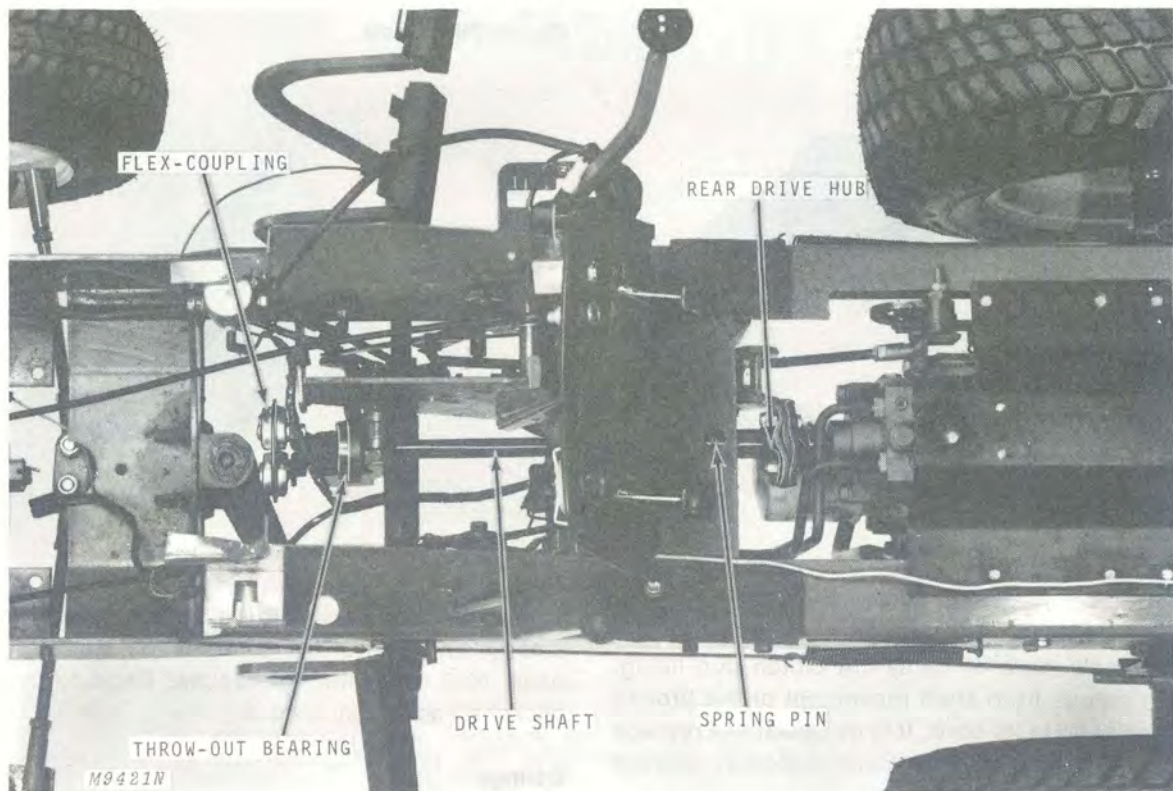

Fig. 6-Removing Drive Shaft Assembly

To service the clutch and drive shaft assembly, it is recommended that the engine and clutch be removed as a unit from the tractor. To do so, first remove the engine mounting bolts. Disconnect fuel lines, electrical wiring, and control cables. Remove battery, battery base, and fuel tank. Disconnect flex-coupling from clutch cone. Attach hoist and lift complete engine and clutch assembly forward and up.

Remove clutch assembly from engine by removing the four cap screws. Disassemble and inspect internal components.

Drive out spring pin securing rear drive hub to drive shaft, Figure 6. Remove drive shaft and throw-out bearing assembly by moving shaft forward and out.



### Analysis

#### Clutch Cup Lining



Fig. 7-Badly Worn Lining

An unevenly worn or badly cut clutch cup lining, Figure 7, results from shaft movement or the bronze bushing rotating in its bore. It is necessary to replace the cup and bushing if the lining indicates uneven wear.

#### Clutch Bushing

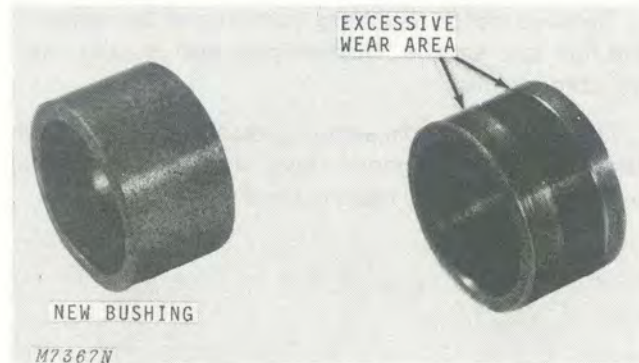

Fig. 8-Bushing Wear Due to Movement in Bore

Circular rings on the clutch bushing, Figure 8, and varying micrometer measurements on the outside diameter of the bushing indicate the bushing has been rotating in its bore. Replacement is necessary. See "Specifications" on page 10-9.

#### Clutch Pilot Shaft

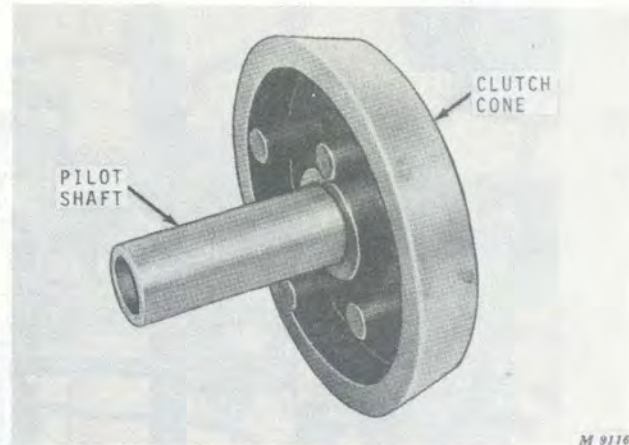

Fig. 9-Checking Pilot Shaft

Inspect pilot shaft, Figure 9. The shaft should be smooth and free of burrs. Refer to "Specifications", page 10-9, for shaft tolerances. Replace cone and pilot shaft assembly if worn.

#### Springs

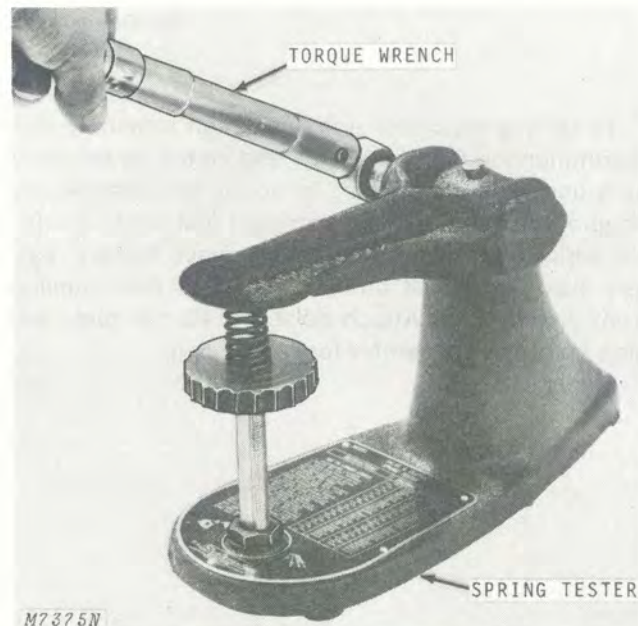

Fig. 10-Testing Clutch Springs

Check each clutch spring in a valve spring tester similar to the one shown in Figure 10. See "Specifications" on page 10-9 for proper spring tension.

Replace any springs that are not to proper specifications.

## Assembly

### Drive Hub

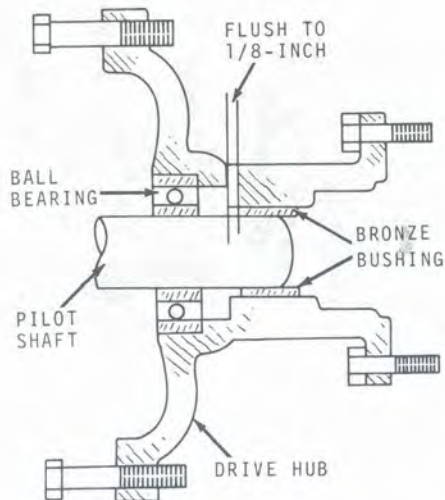

M 7376

Fig. 11-Installing Bearings In Drive Hub

With the proper size arbor or round shaft, press the bronze pilot bushing into drive hub flush to 1/8 inch from inside edge of drive hub as shown in Figure 11. Invert the hub and press the ball bearing into the hub until it bottoms on the outer ring.

*NOTE: When pressing in bronze bushing from the front of clutch drive hub, be sure to adequately support casting around ball bearing bore to prevent cracking the casting. When pressing ball bearing into place, press on outer ring only.*

### Cone

Install four clutch springs on cone studs Figure 12. Install a 3-3/4-inch washer, then a 1-3/8-inch washer on pilot shaft. Install cone and pilot shaft assembly into drive hub, being sure springs are in their proper position.

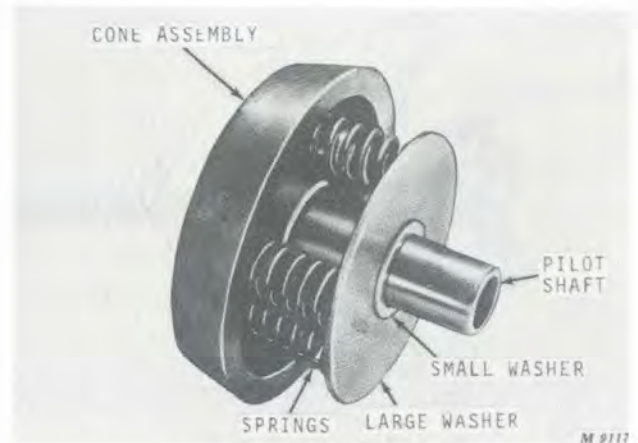

Fig. 12-Installing Clutch, Springs and Washers

### Cup and Screen

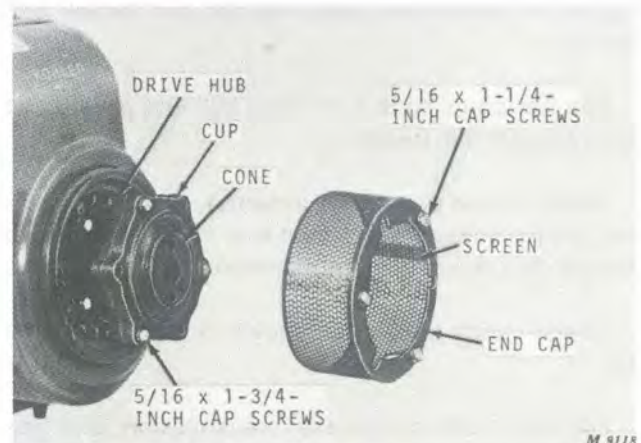

Fig. 13-Installing Cup and Screen

Align drive hub on flywheel, Figure 13. Install four 5/16 x 1-inch cap screws in drive hub and flywheel. Tighten cap screws to 20 ft-lbs torque.

Install cup on drive hub with three 5/16 x 1-3/4-inch cap screws and lock washers equally spaced as shown in Figure 13. The long cap screws are to pull the cup and drive hub together because the short cap screws would not reach the drive hub. Assemble the screen and end cap with three 5/16 x 1-1/4-inch cap screws and lock washers. Tighten all 5/16-inch cap screws to 20 ft-lbs torque.



### Drive Shaft

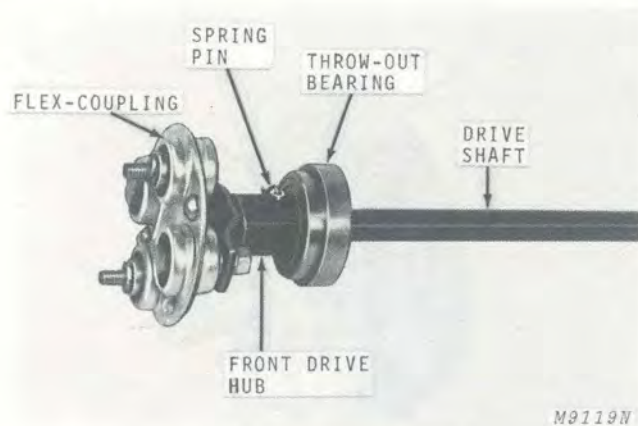

Fig. 14-Assembling Drive Shaft

To install drive shaft assembly with the engine removed, install throw-out bearing on front drive hub, Figure 14. Insert drive shaft into hub and secure with spring pin.

Bolt flex-coupling to front drive hub and place drive shaft assembly in tractor.

Install engine and clutch assembly in tractor. Connect clutch linkage and attach rear drive shaft hub to flexible disk coupling on transmission.

Adjust clutch linkage as shown in Figures 15 and 16.

Fill the engine crankcase, transmission, and gas tank. Replace the battery.

### CLUTCH ADJUSTMENT

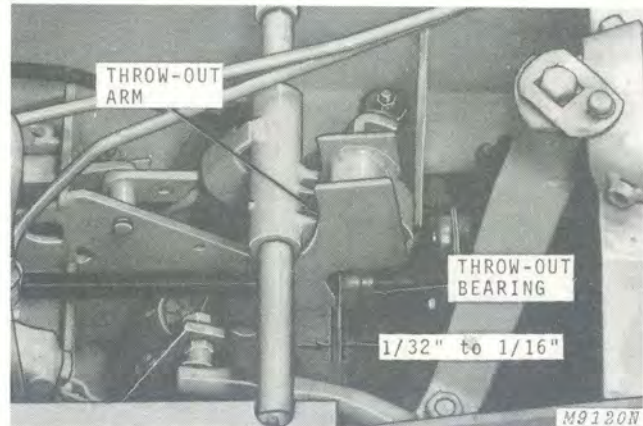

Fig. 15-Clutch Adjustment Dimensions

The clutch linkage is properly adjusted when the distance between the throw-out arm and the throw-out bearing is between 1/32 to 1/16-inch, Figure 15, with clutch pedal in released (up) position.

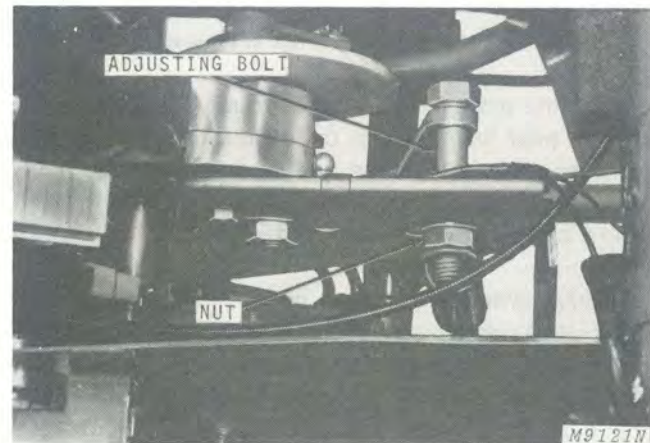

Fig. 16-Clutch Adjusting Bolt (Battery Removed)

Adjust clutch when the above dimension exceeds 1/16-inch as follows:

1. Remove battery and battery base.
2. Loosen nut and move adjusting bolt, Figure 16, in slotted hole until correct adjustment is obtained, Figure 15.
3. Tighten nut securely.

### SPECIFICATIONS

Component	New Part Dimension
Clutch Spring, Compressed (64 to 71 pounds load) .....	1.25 inches
Bronze Bushing, I.D. ....	1.004 inches
Bronze Bushing, O.D. ....	1.054 inches
Pilot Shaft, O.D. ....	0.999 inch

### TORQUE FOR HARDWARE

Location	Torque
Clutch Cup-to-Drive Hub .....	20 ft-lbs
Drive Hub-to-Flywheel .....	20 ft-lbs

### SPECIAL TOOLS

Name	Part No.	Use
Slide Hammer .....	OTC-954 .....	To pull bronze bushing from drive hub





## Group 11 NEUTRAL RETURN AND DRIVE SHAFT H-1 TRACTORS (SERIAL NO. 38,001- ) AND H-3 TRACTORS (SERIAL NO. 46,884- )

### PRINCIPLE OF OPERATION

#### H-1 Tractors (Serial No. 38,001-46,603)

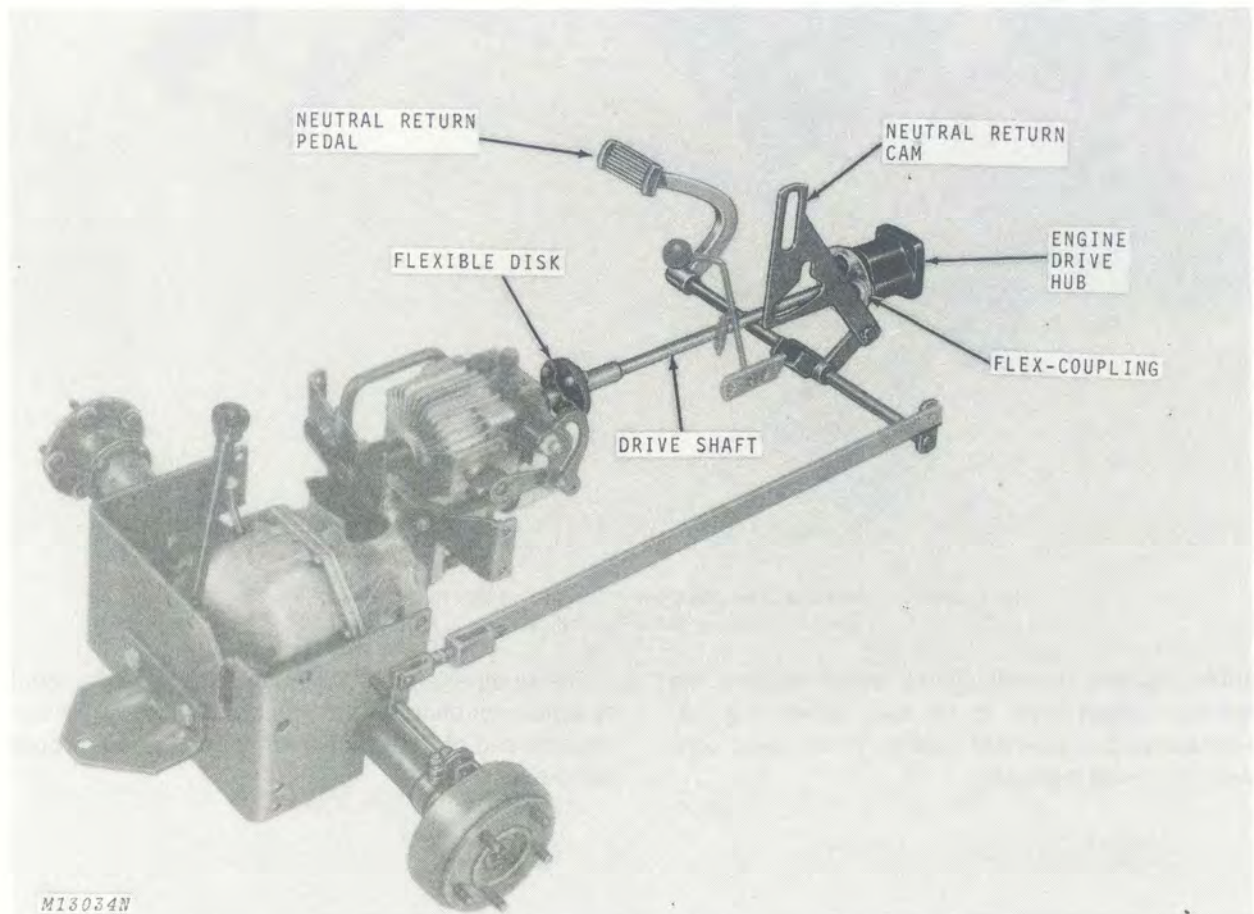

Fig. 1-Neutral Return and Drive Shaft—H-1 Tractors (Serial No. 38,001-46,603)

Depressing the neutral return pedal and brake pedal returns the hydrostatic control lever to neutral, preventing forward or rearward movement until the hydrostatic control lever is moved manually.

The drive shaft is connected directly to the engine by a flex-coupling on the engine drive hub. The transmission end of the drive shaft is connected through a flexible disk.



### PRINCIPLE OF OPERATION—Continued

H-1 Tractors (Serial No. 46,604- ) and H-3 Tractors (Serial No. 46,884- )

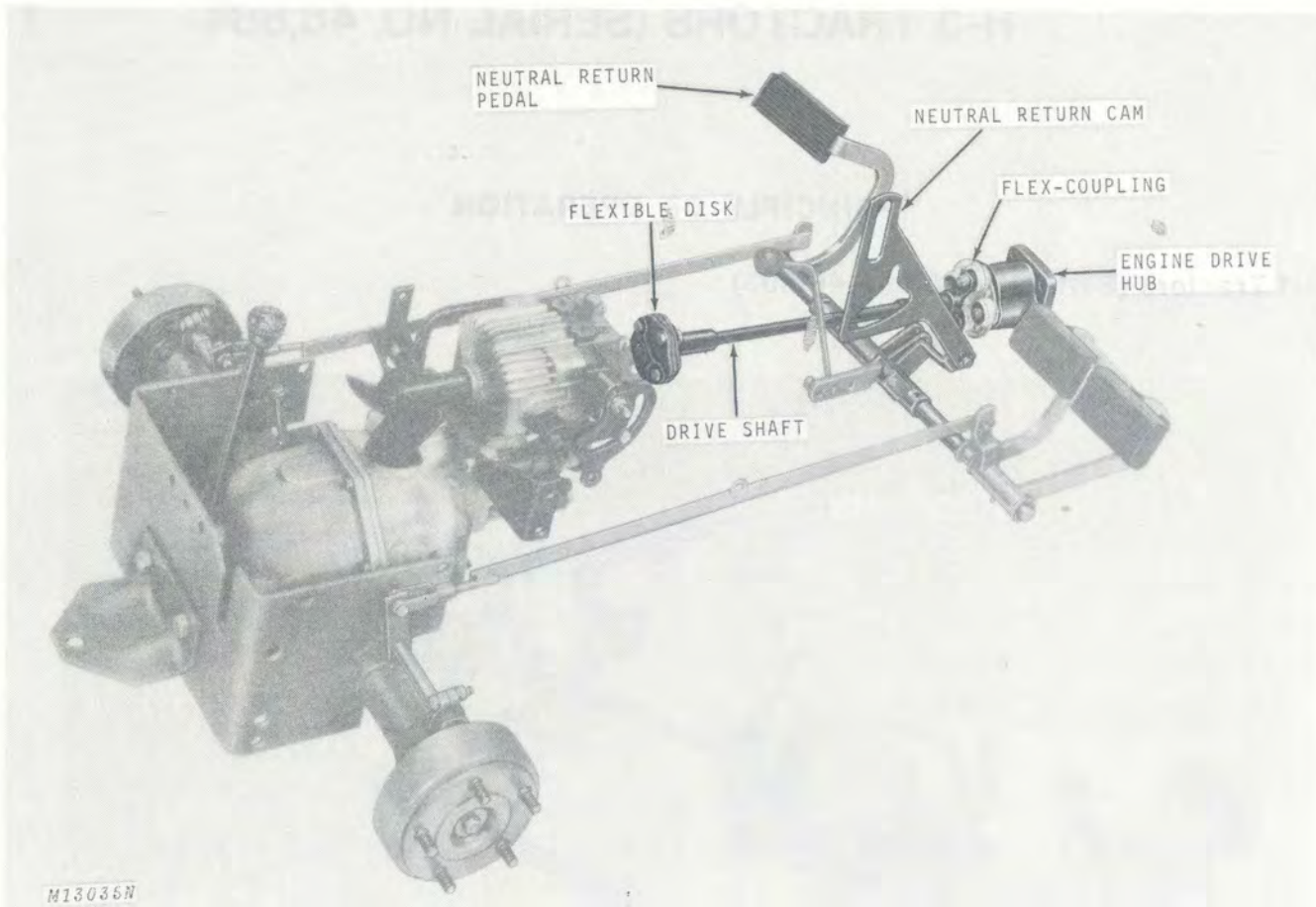

Fig. 2—Neutral Return and Drive Shaft—H-1 Tractors (Serial No. 46,604- )  
and H-3 Tractors (Serial No. 46,884- )

Depressing the neutral return pedal returns the hydrostatic control lever to neutral, preventing forward or rearward movement until the hydrostatic control lever is moved manually.

The drive shaft is connected directly to the engine by a flex-coupling on the engine drive hub. The transmission end of the drive shaft is connected through a flexible disk.

## Couplings

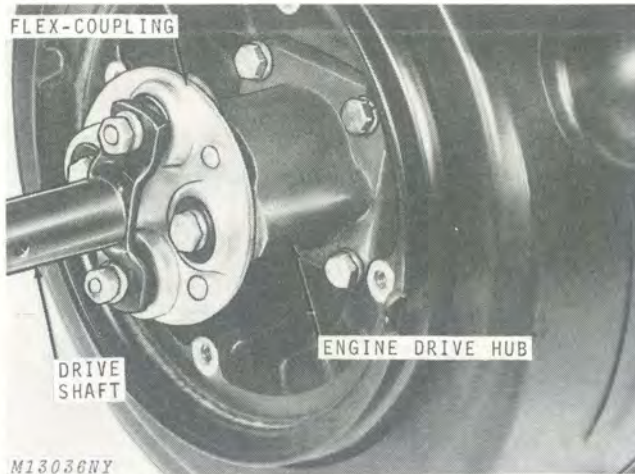

Fig. 3-Flex-Coupling and Engine Drive Hub

A flex-coupling, Figure 3, connects the engine drive hub to the drive shaft and also serves as a vibration dampener.

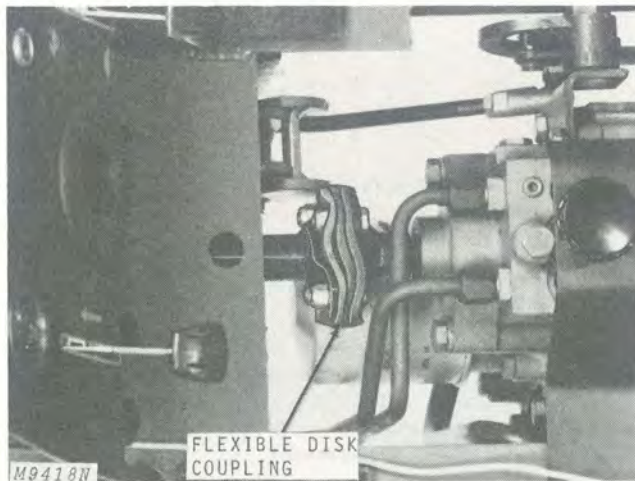

Fig. 4-Flexible Disk Coupling

A flexible disk coupling on the transmission end of the drive shaft, Figure 4, allows for some misalignment between the engine and transmission. Its function is similar to that of a universal joint.

## DIAGNOSING MALFUNCTIONS

### Neutral Return Pedal Will Not Return Hydrostatic Control Lever to Neutral.

- Groove pin on neutral return pedal sheared.
- Groove pin on neutral return shaft sheared.
- Hydrostatic control lever out of adjustment.
- Neutral cam malfunctioning.

### Neutral Return Pedal Will Not Disengage.

- Weak or broken return spring.
- Shaft requires lubrication.
- Neutral cam malfunctioning.



### DRIVE SHAFT REPAIR

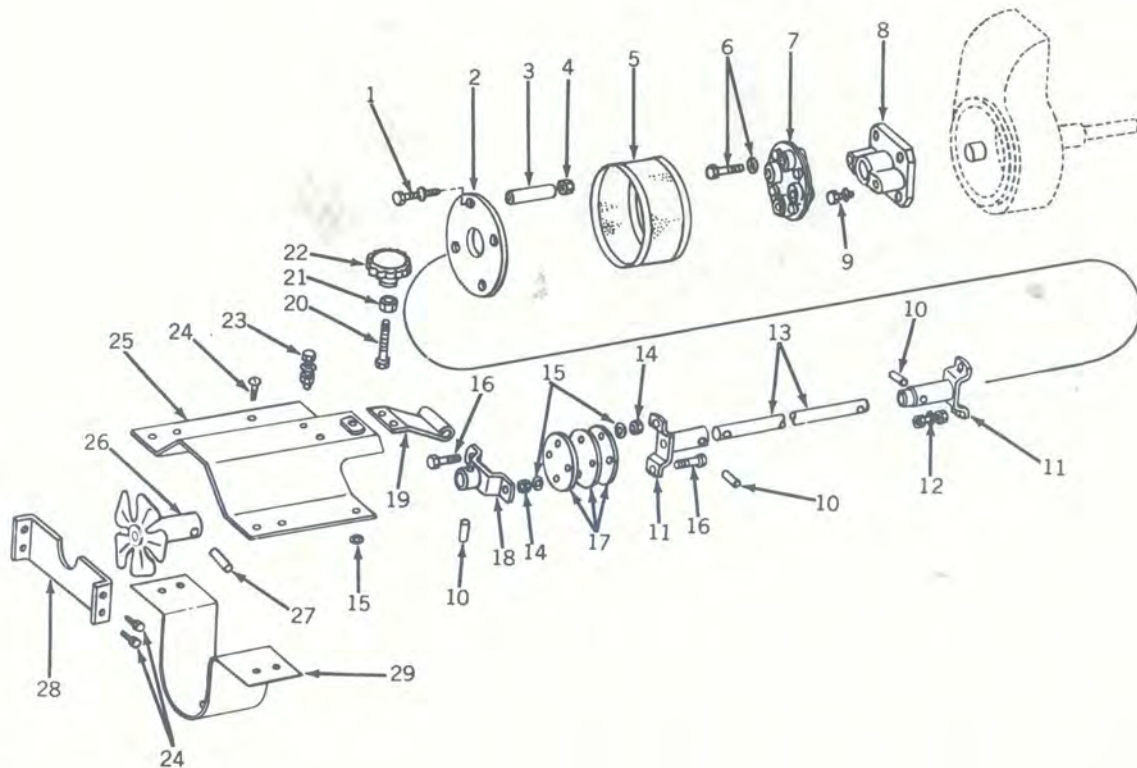

M13037N

- |                                       |   |
|---------------------------------------|---|
| 1-Cap Screw                           | 16-Cap Screw (4 used)                     |
| 2-Cap                                 | 17-Drive Disk (3 used)                    |
| 3-Spacer (4 used)                     | 18-Transmission Shaft Hub                 |
| 4-Speed Nut (4 used)                  | 19-Spring Plate                           |
| 5-Screen                              | 20-Cap Screw                              |
| 6-Cap Screw and Washer (2 used)       | 21-Nut                                    |
| 7-Flex-Coupling                       | 22-Knob                                   |
| 8-Engine Drive Hub                    | 23-Machine Screw, Washer and Nut (2 used) |
| 9-Cap Screw and Washer (4 used)       | 24-Screw                                  |
| 10-Spring Pin (3 used)                | 25-Fan Shield                             |
| 11-Drive Shaft Hub (2 used)           | 26-Fan and Hub Assembly                   |
| 12-Cap Screw, Washer and Nut (2 used) | 27-Spring Pin                             |
| 13-Drive Shaft                        | 28-Fan Guard                              |
| 14-Nut (4 used)                       | 29-Fan Shield                             |
| 15-Washer (6 used)                    |   |

Fig. 5-Drive Shaft and Couplings

## Disassembly

To service the drive shaft assembly, it is recommended that the engine and drive shaft be removed from the tractor as a unit. To do so, first remove the hood, grille and front panel. Disconnect fuel line, electrical wiring and control cables. Remove battery, battery base and fuel tank. Remove the engine mounting bolts.

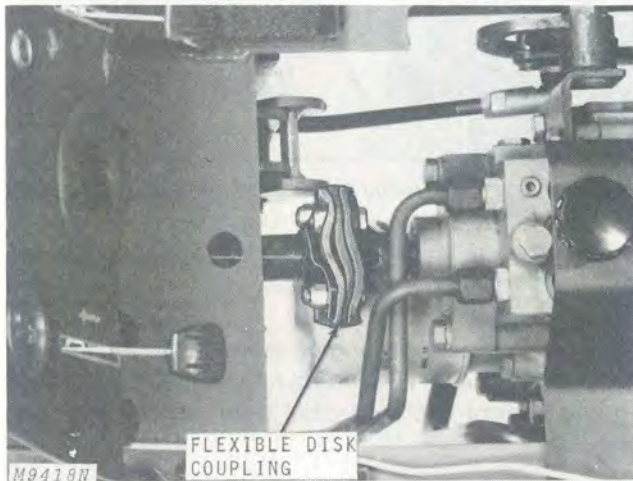

Fig. 6-Disconnecting Drive Shaft

Remove the two bolts connecting the drive shaft to the flexible coupling, Figure 6, and remove engine and drive shaft.

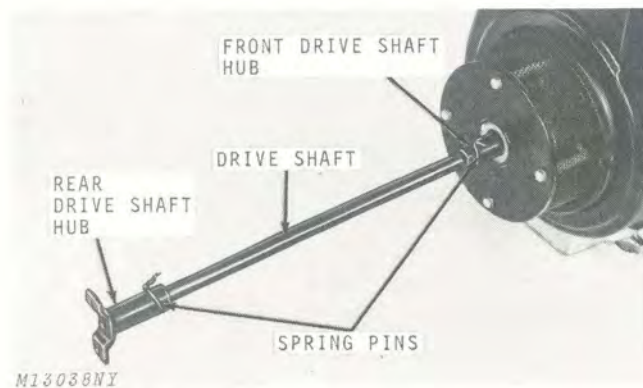

Fig. 7-Removing Drive Shaft Hub

Either drive shaft hub can be removed by untwisting the wire and driving out the spring pin, Figure 7.

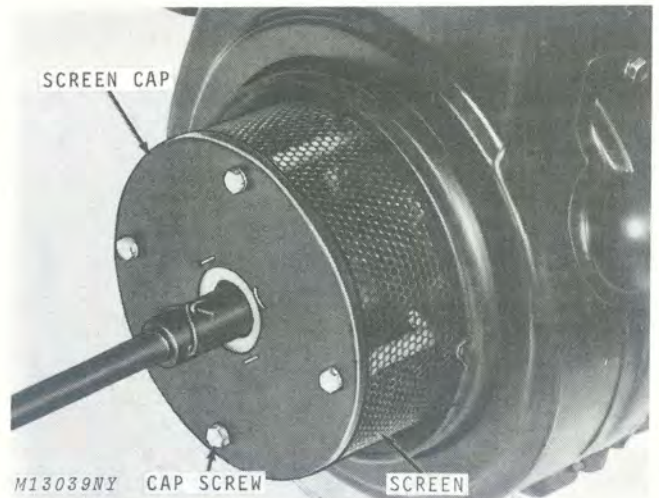

Fig. 8-Removing Flex-Coupling and Engine Drive Hub

The flex-coupling and engine drive hub, Figure 8, can be serviced by removing the four cap screws securing the screen cap and screen.



## Assembly

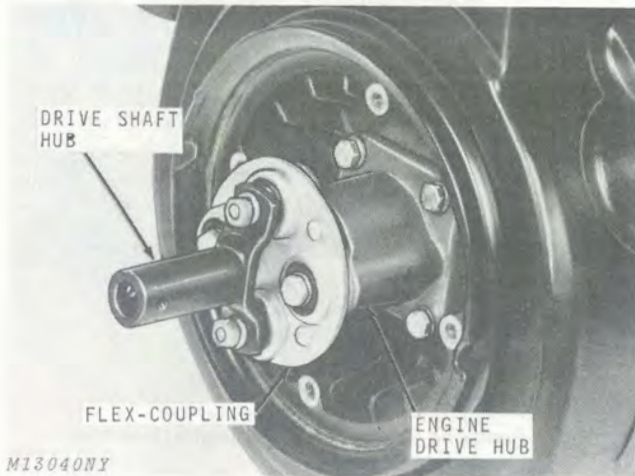

Fig. 9-Installing Flex-Coupling

Install engine drive hub and secure it with four cap screws, Figure 9. Install flex-coupling on engine drive hub and secure it with two cap screws. Install drive shaft hub on flex-coupling and secure it with two cap screws, washers and nuts.

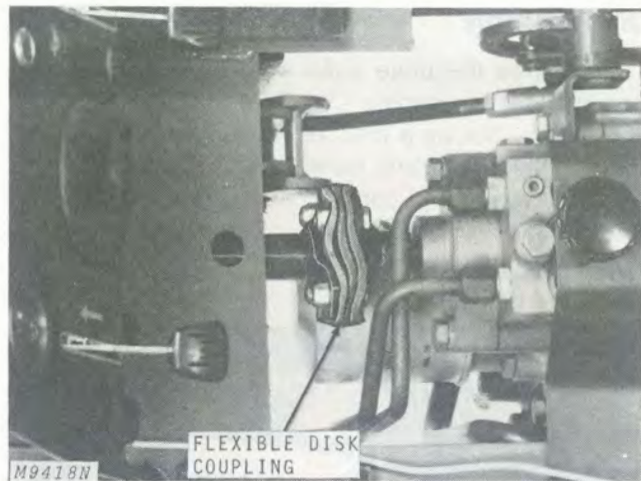

Fig. 11-Installing Engine and Drive Shaft

Guide engine and drive shaft into frame and secure drive shaft to flexible disk, Figure 11.

Secure engine mounting bolts. Install battery base, fuel tank and battery. Connect fuel line, electrical wiring and control cables. Install front panel, grille and hood.

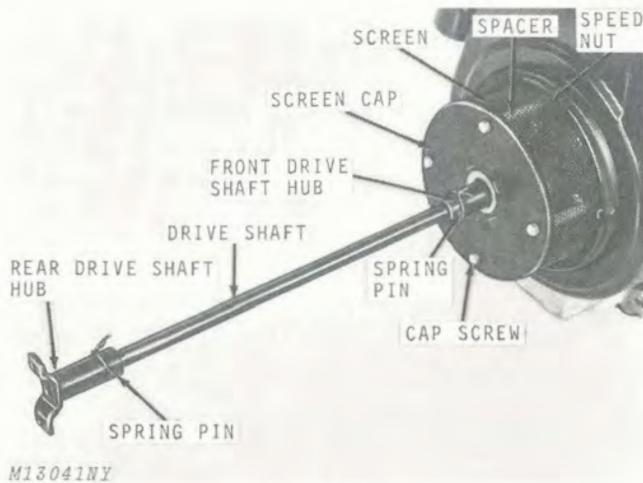

Fig. 10-Installing Screen

Install four cap screws through screen cap and spacers and hold with speed nuts. Secure screen with screen cap and four cap screws, Figure 10. Install drive shaft in front drive shaft hub and secure it with a spring pin. Install rear drive shaft hub and secure it with a spring pin. Secure spring pins in front and rear drive shaft hubs with a small piece of heavy wire.

## Group 12 BRAKES

### PRINCIPLE OF OPERATION

H-1 Tractors (Serial No. 30,001-38,000) and (Serial No. 46,604- )  
H-3 Tractors (Serial No. 30,001- )

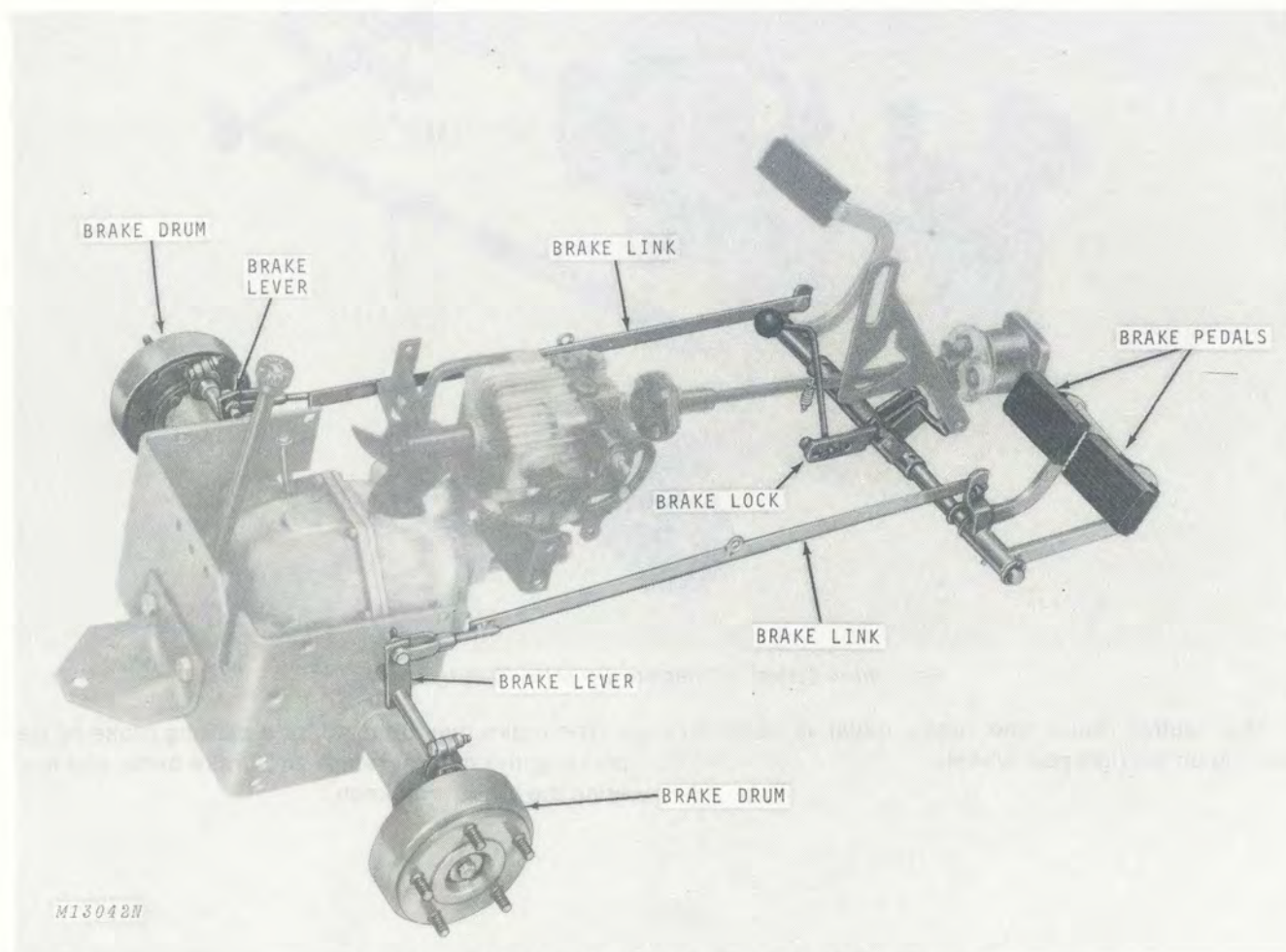

Fig. 1-Brake System H-1 Tractors (Serial No. 30,001-38,000) and (Serial No. 46,604- ), also H-3 Tractor (Serial No. 30,001- )

Separate brake pedals are used for braking; one for each rear wheel. They can be used separately to assist in sharp turns or locked together.

The brakes may be used as a parking brake by locking brakes together, depressing brake pedals and lowering parking brake knob.



## PRINCIPLE OF OPERATION—Continued

### H-1 Tractors (Serial No. 38,001-46,603)

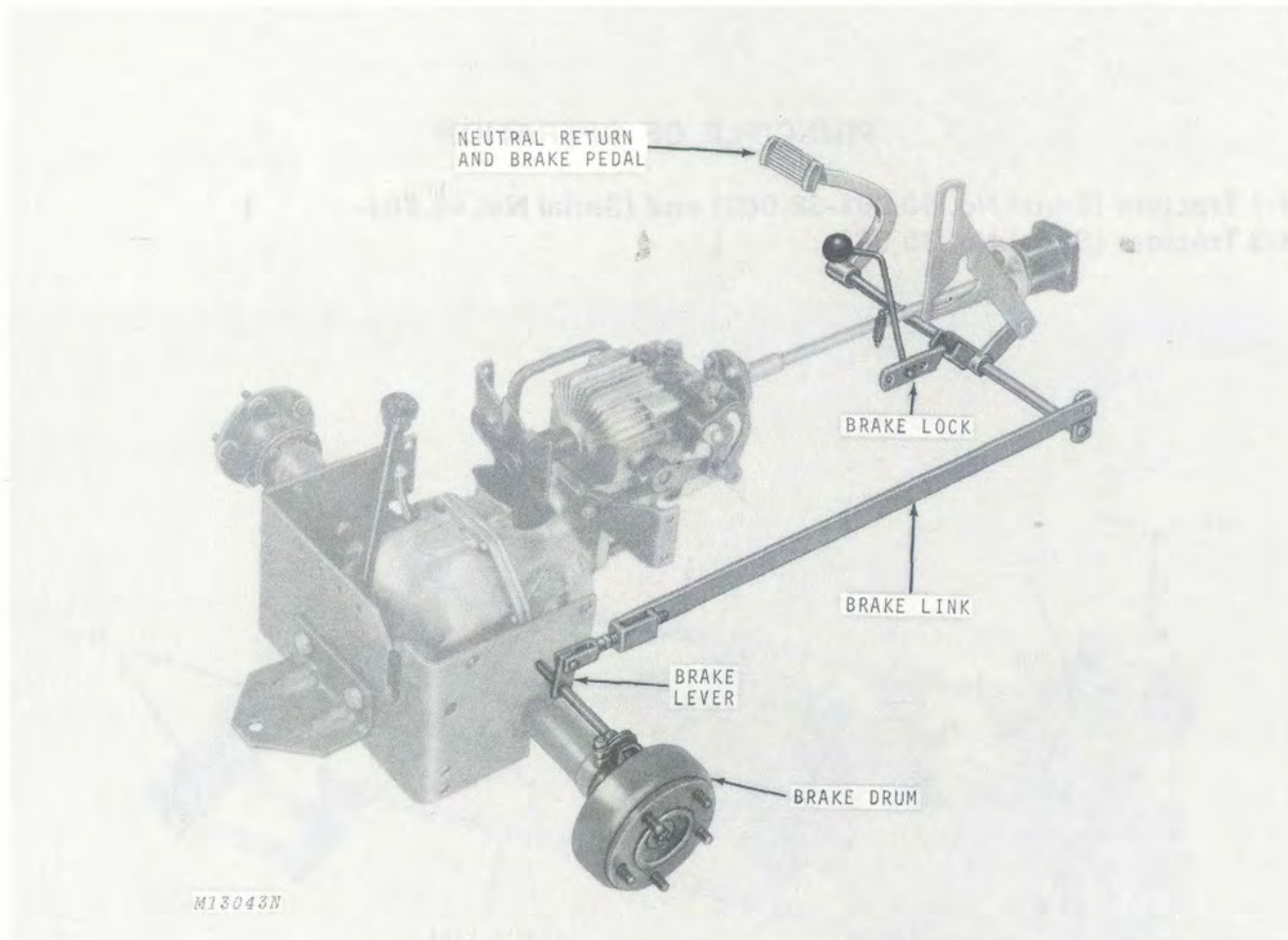

Fig. 2-Brake System H-1 Tractors (Serial No. 38,001-46,603)

The neutral return and brake pedal is used for braking on the right rear wheel.

The brake may be used for a parking brake by depressing the neutral return and brake pedal and lowering the brake lock knob.

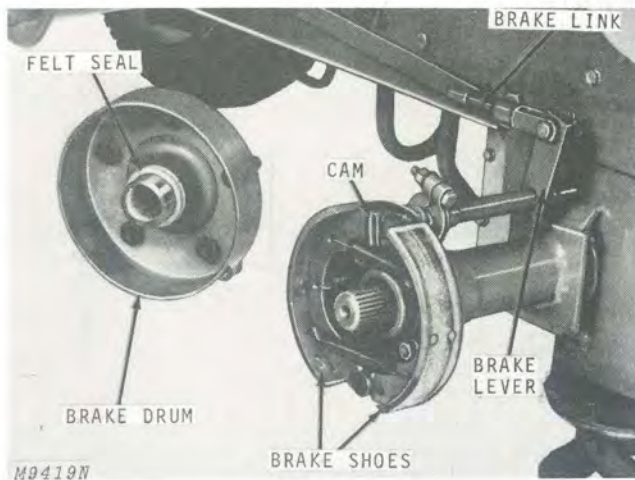

Fig. 3-Brake

When the brake pedals are depressed, the brake levers move forward. The forward movement of the brake levers rotates the cams which force the brake shoes outward against the brake drums, slowing and stopping the tractor.

## DIAGNOSING MALFUNCTIONS

### Brakes Not Effective

- Brakes not properly adjusted.
- Groove pins on brake shaft sheared.
- Worn brake lining.
- Grease on lining.



**BRAKE REPAIR**

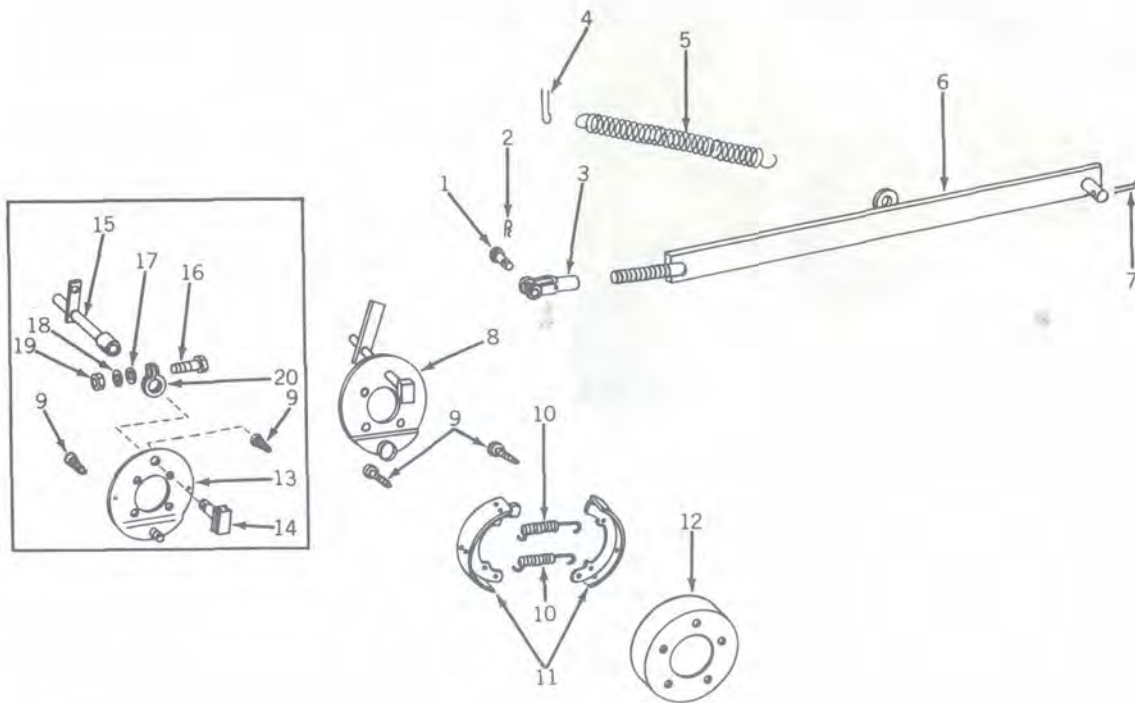

M13044N

- |                                    |                                     |
|------------------------------------|-------------------------------------|
| 1-Drilled Pin                      | 12-Brake Drum                       |
| 2-Cotter Pin                       | 13-Back Plate (Serial No. -48,903)  |
| 3-Yoke                             | 14-Camshaft (Serial No. -48,903)    |
| 4-Cotter Pin                       | 15-Brake Shaft (Serial No. -48,903) |
| 5-Pedal Return Spring              | 16-Cap Screw (Serial No. -48,903)   |
| 6-Brake Link                       | 17-Washer (Serial No. -48,903)      |
| 7-Cotter Pin                       | 18-Lock Washer (Serial No. -48,903) |
| 8-Back Plate (Serial No. 48,904- ) | 19-Nut (Serial No. -48,903)         |
| 9-Hold-down Springs (2 used)       | 20-Clamp (Serial No. -48,903)       |
| 10-Pull-back Springs (2 used)      |                                     |
| 11-Brake Shoes (2 used)            |                                     |

Fig. 4-Exploded View of Brake Linkage

NOTE: Figure 4 shows the single brake used on H-1 Tractors (Serial No. 38,001-46,603). Quantities of the parts will double for all other Tractors, that is H-1 (Serial No. 30,001-38,000) and (Serial No. 46,604- ) and H-3 (Serial No. 30,001- ).

## Removing Brake Shoes and Drum

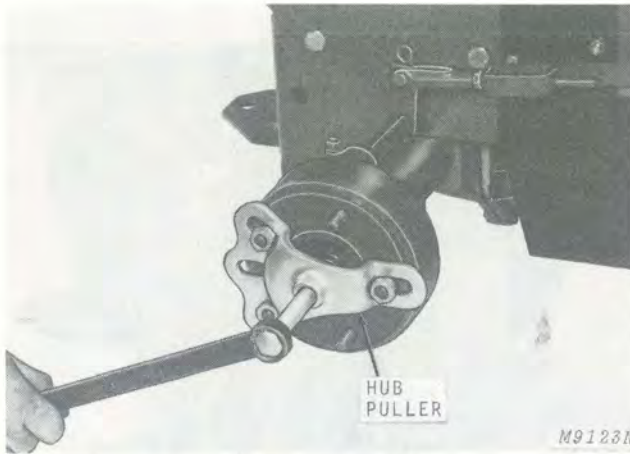

Fig. 5-Removing Brake Drum

Remove wheel hub retaining cap screw and washer. Install a puller similar to the one shown in Figure 5. If the puller being used does not have a broad push point, be sure to use a spacer of some sort to protect the axle threads. With puller properly attached, remove drum.

To remove brake shoes, Figure 6, disconnect shoe pull-back springs and unhook hold-down springs.

## Inspecting Brake Parts

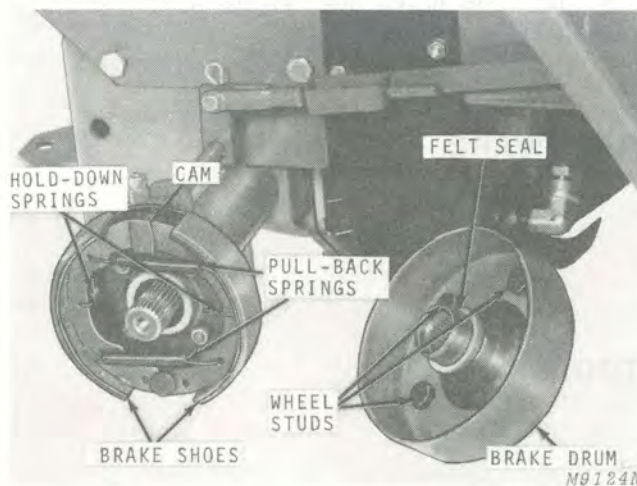

Fig. 6-Inspecting Brake Lining

Examine lining on brake shoes for wear and oil contamination. Replace shoes and linings if worn badly.

Replace axle oil seals if oil contamination is found on linings. See page 25-3 of this section.

## Brake Drum

Replace brake drums if they are found to be worn or damaged.

To replace brake drum, press wheel studs out of drive hub, Figure 6. Press wheel studs through new brake drum and drive hub.

## Springs

Replace springs that appear to be stretched or in any way damaged.

## Assembly

Assemble shoes and springs to back plate, Figure 6. Pull hub and drum onto axle shaft using a 7/16 x 2-inch NF cap screw, nut, and washer, Figure 7.

*NOTE: Be certain felt seal is in place on hub, Figure 6.*

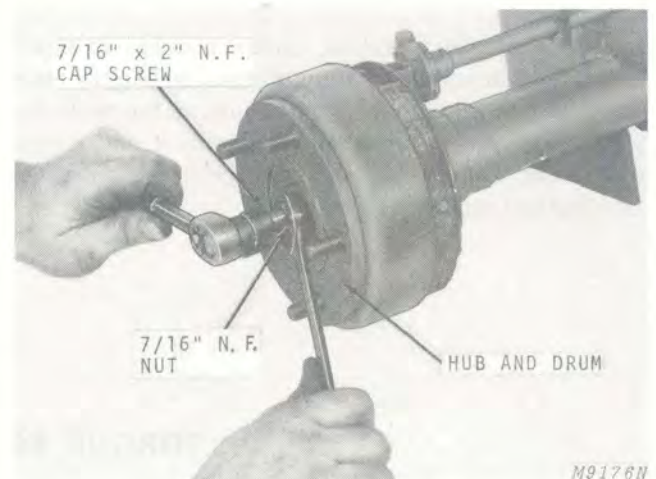

Fig. 7-Installing Hub and Drum

Remove this cap screw and nut and replace with original cap screw when hub is in place. Torque to 35 to 40 ft-lbs.

*NOTE: Do not hammer hub onto axle because the bearing could be damaged.*



### BRAKE ADJUSTMENT

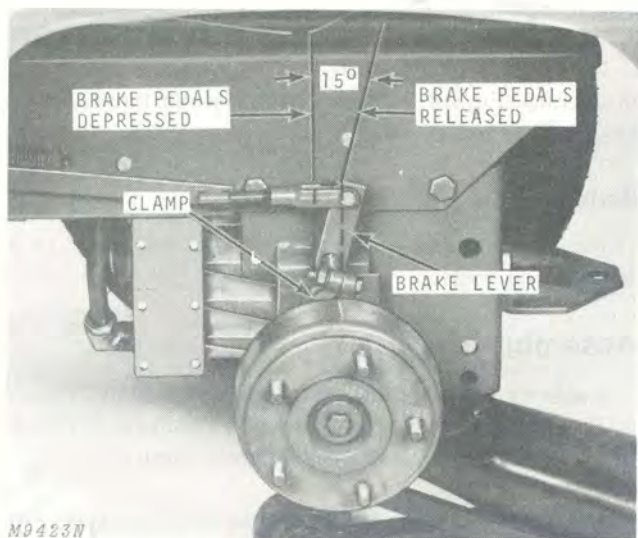

Fig. 8-Adjusting Brake Lever

Before applying brakes, check position of brake levers. Brake levers should be adjusted slightly rearward so that brakes are applied just as the brake levers reach vertical position, Figure 8. If not, loosen clamp and rotate lever and shaft on brake camshaft until correct position is obtained.

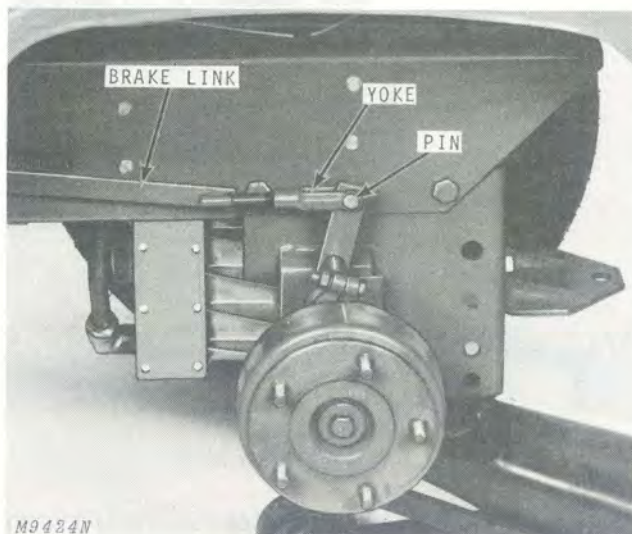

Fig. 9-Adjusting Brake Link

Lock the two brake pedals together with the locking strap. Lower the parking brake knob and depress the pedals until they engage in the second notch.

The brake should be adjusted so that both rear wheels are locked with the pedals in this position.

Unlock brake and adjust by removing pin and turning yoke onto brake link, Figure 9, to shorten or lengthen brake link.

### TORQUE FOR HARDWARE

Location	Torque
Brake Back Plate .....	15 ft-lbs
Brake Hub-to-Axle Shaft .....	35 to 40 ft-lbs

### SPECIAL TOOLS

Name	Part No.	Use
Puller .....	OTC-967 .....	To remove brake hub and drum

## Group 15 HYDROSTATIC TRANSMISSION

### GENERAL INFORMATION

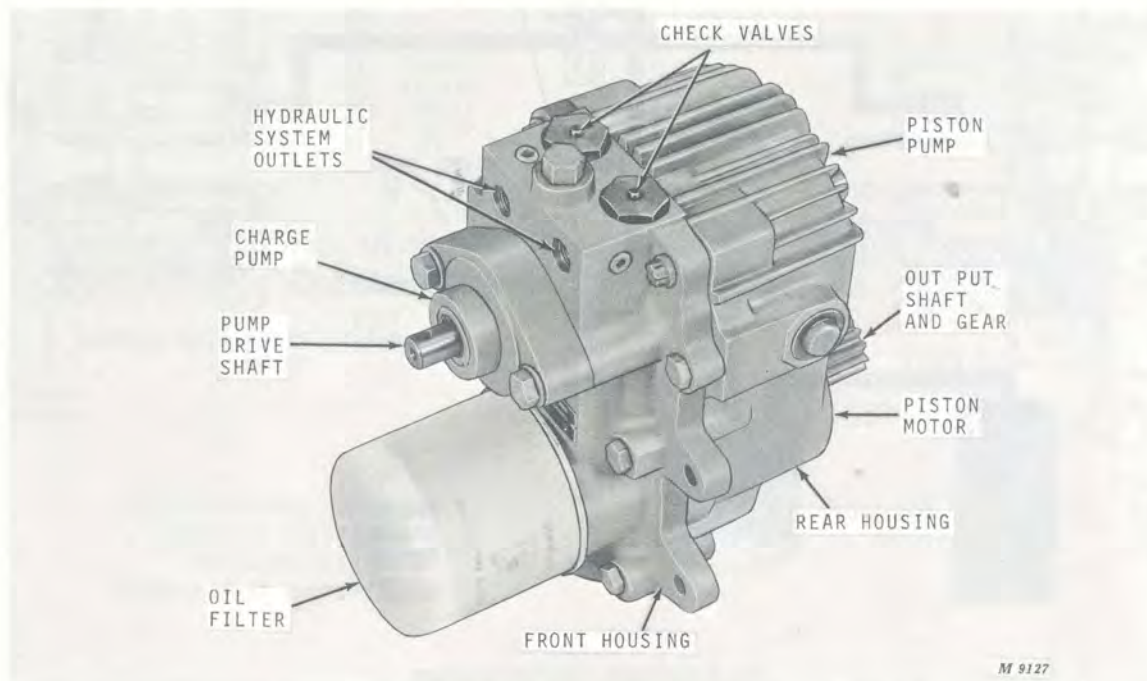

Fig. 1-Hydrostatic Components

The hydrostatic transmission, Figure 1, is a compact unit which consists of a charge pump, piston pump, piston motor, and valve system.

The charge pump performs three principle functions: First, it supplies oil under low pressure to the hydrostatic piston pump; second, it supplies oil and pressure for the hydraulic lift system; and third, it furnishes oil to make up for internal leakage. It also circulates oil for cooling.

A piston pump driven by the engine delivers oil under high pressure to the piston motor. This high pressure causes the piston motor to rotate, transmitting power to the differential through the output shaft and gear.

Forward or reverse operation of the transmission is controlled by a single lever. This control lever changes the distance the pistons of the piston pump travel, increasing or decreasing transmission output shaft speed.

Reducing the piston travel applies a braking effort to the piston motor which will slow or stop tractor travel.

Any excessive oil pressure which develops from directional changes in the transmission operation, is controlled by the charge relief and check valve system.

### Two Basic Principles of Hydraulics

A knowledge of two basic principles of hydraulics is required to understand the hydrostatic system.

1. Liquid has no shape of its own. Therefore, in any hydraulic system, the liquid (oil) may be directed into passages of any size or shape.

2. Liquid is incompressible. Being incompressible, pressure applied to a confined liquid will be transmitted equally in all directions throughout the liquid.



### Principle of Operation

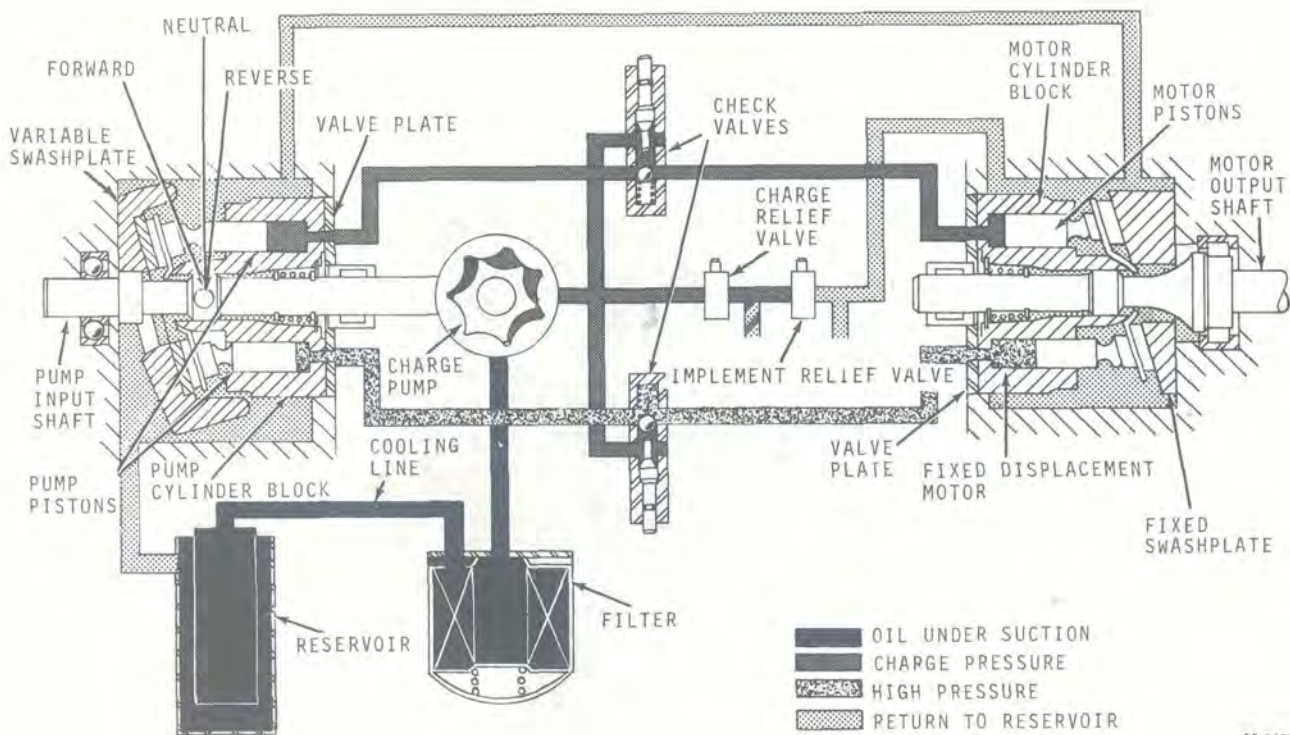

Fig. 2-Hydrostatic Oil Flow Diagram

#### Charge Pump

A rotor type charge pump Figure 2, supplies oil to the piston pump and circulates oil for cooling. The pump also supplies high pressure oil for the hydraulic lift system.

#### Piston Pump

The piston pump input shaft Figure 2 is coupled to the engine drive shaft. A cylinder block with nine pistons is connected to the input shaft. As the cylinder block revolves, the pistons move back and forth. The angle of the swashplate on which the piston slippers ride controls the distance the pistons travel, varying the volume of oil displaced to the piston motor.

The variable swashplate is mounted on trunnions supported by needle bearings in the transmission case. The swashplate does not rotate but merely tilts back and forth from a vertical position. The vertical position is neutral or "Zero Output" because the pistons do not reciprocate when the swashplate is in this position. This results in no oil flow from pump to motor.

Moving the hydrostatic control lever forward tilts the swashplate forward. This results in forward rotation of the fixed displacement motor, causing the tractor to move forward.

Reversing the tilt of the pump swashplate reverses the flow through the oil delivery ports. This results in reverse rotation of the fixed displacement motor, causing the tractor to back up.

**IMPORTANT: To prevent hydrostatic transmission damage during WINTER weather, RUN engine until the hydraulic lift system functions before moving hydrostatic lever from neutral position.**

Extremely cold weather can cause charge pump cavitation for a short period of time. If the piston motor is put in stroke during this time, the slippers and the slipper retainer can be damaged.



### Piston Motor

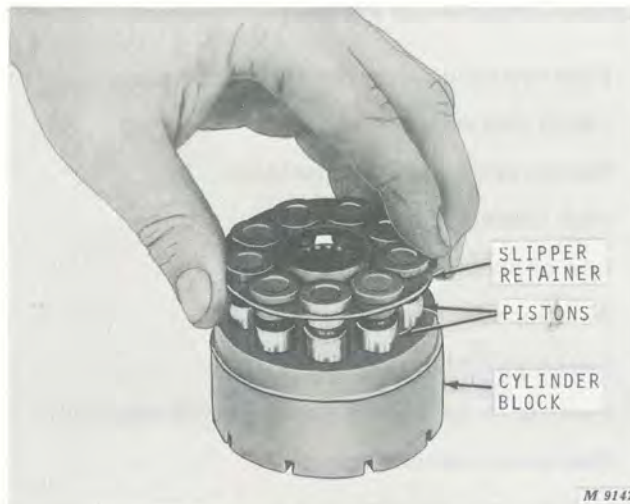

Fig. 3-Piston Motor Assembly

The piston motor Figure 3, is an axial piston, fixed displacement motor of the same design as the piston pump. A splined output shaft is connected to the cylinder block and is driven by it. As oil pressure is introduced from the piston pump, force is exerted against the pistons of the motor. Since the fixed swashplate of the motor is inclined, the pistons slide on the incline and cause the cylinder block to rotate. As the cylinder block continues to rotate, oil is expelled and returned to the reservoir for re-use and cooling.

The speed the cylinder block rotates is dependent upon the volume of oil being displaced by the piston pump. Therefore, the greater the variable swashplate angle in the pump, the faster the cylinder block in the motor will revolve. Likewise, reducing swashplate angle in the pump slows motor rotation. This produces a braking effect which will slow or stop tractor travel.

### Valve System

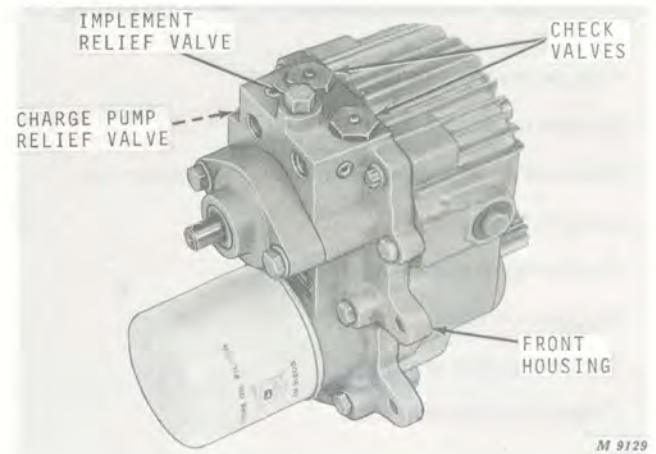

Fig. 4-Front Housing and Valves

The valve system in the transmission front housing, Figure 4, contains the passages necessary to deliver oil for each hydraulic function.

Implement and charge pump relief valves relieve hydraulic pressure at preset limits within the hydraulic lift and transmission circuits.

The two check valves permit pressure to build to workable limits within the system, and provide directional control for oil entering and leaving the piston pump. The two check valves can be opened manually to relieve pressure so the tractor can be pushed by hand for short distances.



## DIAGNOSING MALFUNCTIONS

### Transmission Will Not Operate In Either Direction.

- Free wheeling valves not closed.
- Broken control linkage.
- Sheared charge pump drive pin.
- System low on oil.
- Check valve spools stuck open.
- Plugged oil filter.
- Suction oil line leaking.
- Charge pump cavitation.

**IMPORTANT:** To prevent hydrostatic transmission damage during WINTER weather, RUN engine until the hydraulic lift system functions before moving hydrostatic lever from neutral position.

### Transmission Operates in One Direction Only.

- Faulty control linkage.
- One check valve spool stuck open or leaking badly.

### Transmission Operates Erratically.

- Check valves sticking open momentarily.
- Charge pump relief valve sticking open momentarily.

### Transmission Leaking Oil.

- Gasket between transmission and differential not sealing.
- Trunnion seals cracked or damaged.
- Charge pump seal or O-ring faulty or damaged.
- Gasket between front and rear transmission housing faulty.
- Check valve sealing O-rings faulty.
- Relief valve O-rings faulty.
- Hydraulic lines leaking.
- Bolts on pump case loose.
- Case plugs leaking.

### Loss of Transmission Power.

- Free wheeling valves not closed completely.
- Faulty free wheeling valve.
- Pistons sticking in cylinder block.
- High internal leakage.
- Low oil supply.
- Air trapped in system.
- Leaking oil intake pipe.
- Pump or motor pistons sticking in cylinder block.
- Bent piston retainer ring.

### Transmission Overheating.

- Reservoir low on oil.
- Pump or motor worn internally.
- Free wheeling valves leaking.
- Excessive dirt on pump housing and differential.
- Improper transmission fluid used.

*NOTE: Refer to Section 60 for Hydraulic Lift System Malfunctions.*

## TESTING

### Implement Circuit Pressure Test

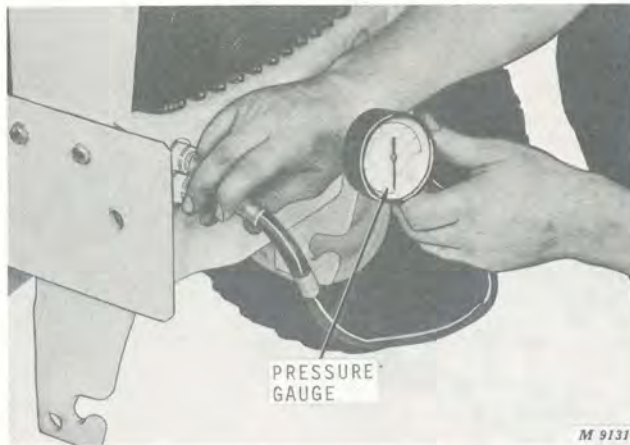

Fig. 5-Checking Implement Circuit Pressure.

Using a 0 to 1000 psi pressure gauge, check implement pressure at the front hydraulic outlets, Figure 5. The gauge should read 500 psi  $\pm$  50 psi when hydraulic lift lever is actuated fully. If readings fall below 450 psi, inspect implement relief valve and spring. Replace spring and cone, if required, or shim up spring with shim kit, and retest. If pressure is still inadequate, charge pump service is required.

### Charge Pressure Test

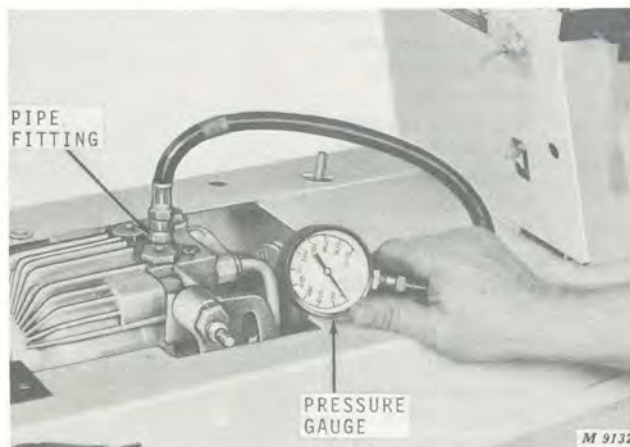

Fig. 6-Checking Charge Pump Pressure

Remove pipe plug and install a pipe fitting and pressure gauge, Figure 6. At half throttle, pressure should be in the 75 to 110 psi range. This test is not necessary unless relief valves have been changed.

## REMOVING TRANSMISSION FROM TRACTOR

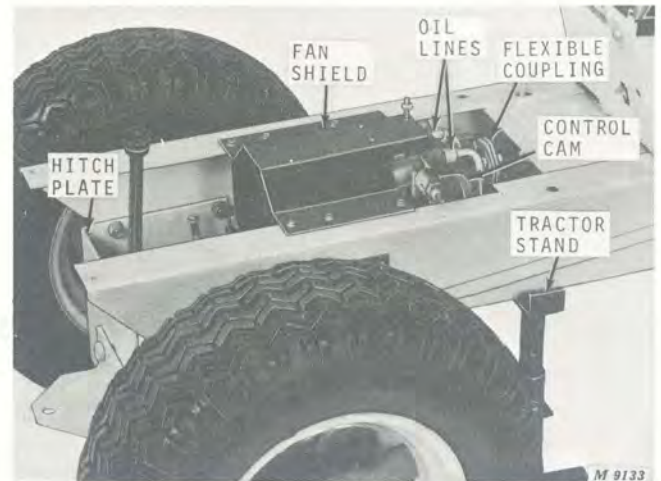

Fig. 7-Removing Transmission

**NOTE:** The transmission does not have to be removed to service check valves, relief valves, trunion shaft oil seals, charge pump or rear PTO oil seal. Before removing and disassembling the transmission, read "Diagnosing Malfunctions" and the "Testing" information in this group.

Remove fender-deck assembly. Wipe dirt and grass from the transmission and the area around it. Remove fan shield and transmission fan.

**CAUTION:** Keep hands and tools away from transmission fan when operating tractor with fender deck removed.

Disconnect drive shaft at flexible coupling and PTO shaft extension, if so equipped. Disconnect control rod at cam. Disconnect brake links at brake levers.

Disconnect hydraulic oil lines.

Remove hitch plate cap screws and transmission mounting bracket cap screws.

With tractor properly supported and with the wheels still in place, roll axle, transmission, and hitch plate assembly rearward away from tractor.

Disconnect oil intake pipe from transmission and remove the four cap screws securing transmission to axle.

Use a safe cleaning solvent and thoroughly clean the outside of the transmission. Move the transmission to a clean, well lighted work area and use clean tools for the service procedure.



REPAIR

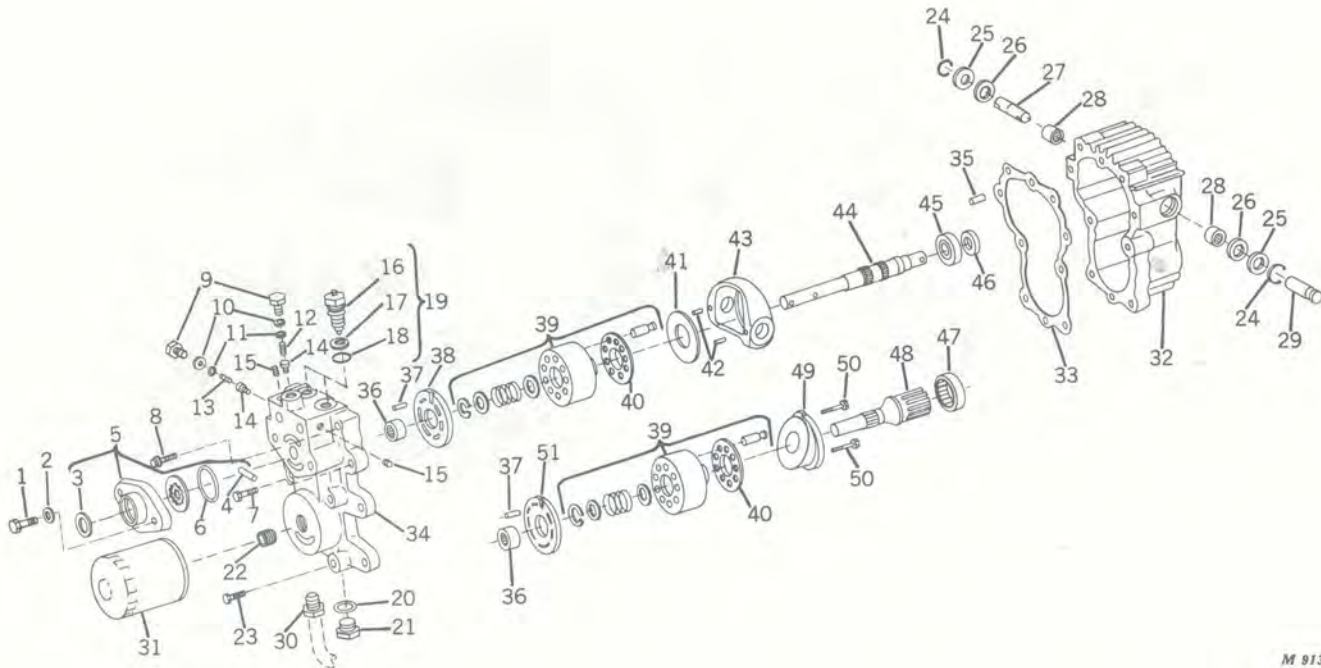

M 9130

- |                                  |                                 |
|----------------------------------|---------------------------------|
| 1-Cap Screw, 7/16" x 2" (2 used) | 26-Trunnion Shaft Seal (2 used) |
| 2-Washer (2 used)                | 27-Trunnion Control Shaft       |
| 3-Bearing Seal                   | 28-Trunnion Bearing (2 used)    |
| 4-Pump Drive Pin                 | 29-Trunnion Shaft               |
| 5-Charge Pump Assembly           | 30-Tube Nut, 5/8"               |
| 6-O-ring                         | 31-Oil Filter                   |
| 7-Cap Screw, 3/8" x 1-1/2"       | 32-Rear Assembly Housing        |
| 8-Cap Screw, 12 Point (2 used)   | 33-Housing Gasket               |
| 9-Plug, Hex. (2 used)            | 34-Front Housing                |
| 10-O-ring (2 used)               | 35-Dowel Pin                    |
| 11-Shim Kit                      | 36-Bearing (2 used)             |
| 12-Spring, Implement Relief      | 37-Plate Pin (2 used)           |
| 13-Spring, Charge Pump Relief    | 38-Pump Valve Plate             |
| 14-Relief Valve Cone (2 used)    | 39-Cylinder Block Kit (2 used)  |
| 15-Pipe Plug (4 used)            | 40-Slipper Retainer             |
| 16-O-ring                        | 41-Thrust Plate                 |
| 17-Backup Ring                   | 42-Roll Pin (2 used)            |
| 18-O-ring                        | 43-Variable Swashplate          |
| 19-Check Valve Assembly (2 used) | 44-Pump Drive Shaft             |
| 20-O-ring (2 used)               | 45-Bearing                      |
| 21-Plug, Hex. (2 used)           | 46-Pump Shaft Seal              |
| 22-Filter Union                  | 47-Output Shaft Bearing         |
| 23-Cap Screw, 3/8" x 2" (4 used) | 48-Output Drive Shaft           |
| 24-Retaining Ring (3 used)       | 49-Stationary Swashplate        |
| 25-Washer, Special (2 used)      | 50-Swashplate Screws            |
|                                  | 51-Motor Valve Plate            |

Fig. 8-Hydrostatic Transmission Components

## Making Transmission Repair Stand

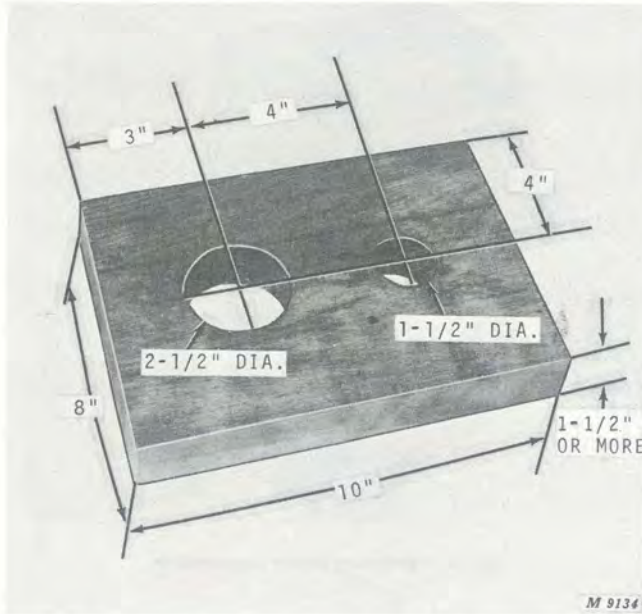

Fig. 9-Wood Repair Stand for Servicing Transmission

Make a wood fixture as shown in Figure 9 to facilitate transmission disassembly and assembly.

## Disassembling Transmission

The outside of the transmission must be thoroughly clean.

Many internal parts have highly polished surfaces. Extreme care must be taken to prevent damage during disassembly and assembly.

To minimize the possibility of rust, coat your hands with transmission oil before handling polished parts.

Also refer to Figure 8 for parts description and location.

## Removing Charge Pump

Remove cap screws securing the charge pump, Figure 10, to the transmission front housing. Carefully slide pump assembly off input shaft.

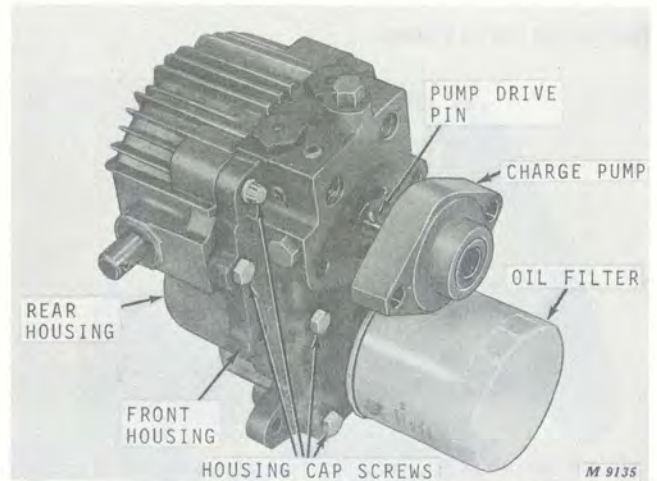

Fig. 10-Removing Charge Pump

Remove pump drive pin from input shaft.

Remove oil filter.

## Removing Front Housing

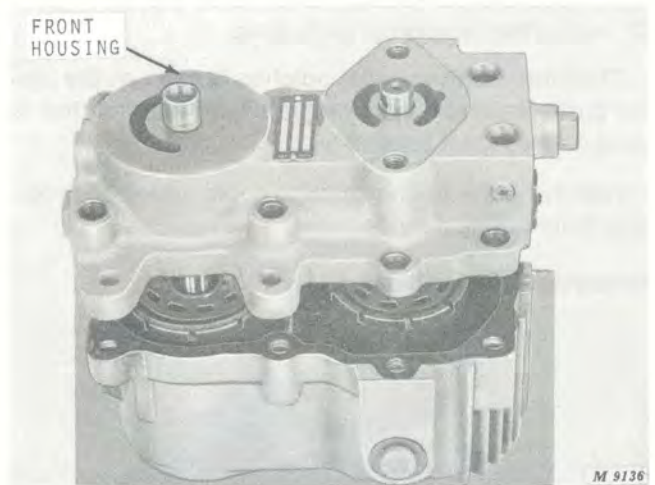

Fig. 11-Removing Front Housing

Remove the eight cap screws Figure 10 which retain the front housing to the rear housing.

Lift front housing from rear housing, Figure 11.



### Removing Valve Plates

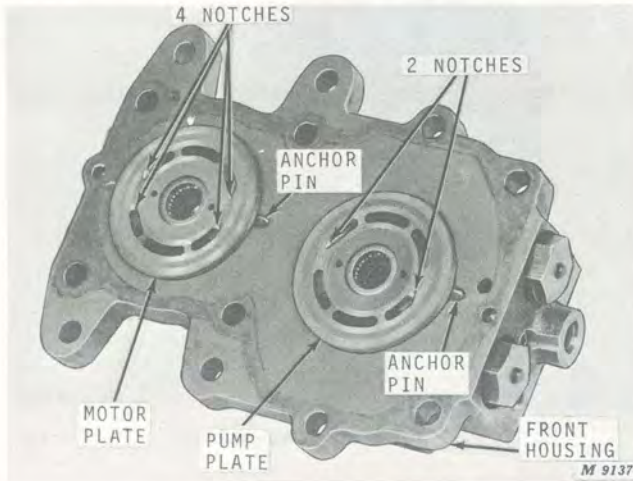

Fig. 12-Removing Valve Plates

**IMPORTANT:** The valve plates may stick to the front housing. Be extremely careful not to drop them.

Remove the pump and motor valve plates, Figure 12, noting the location of each plate.

The plate with two relief notches is used on the piston pump assembly and the plate with four notches is used on the motor assembly.

Remove plate anchor pins to avoid losing or dropping them during service.

### Removing Cylinder Block

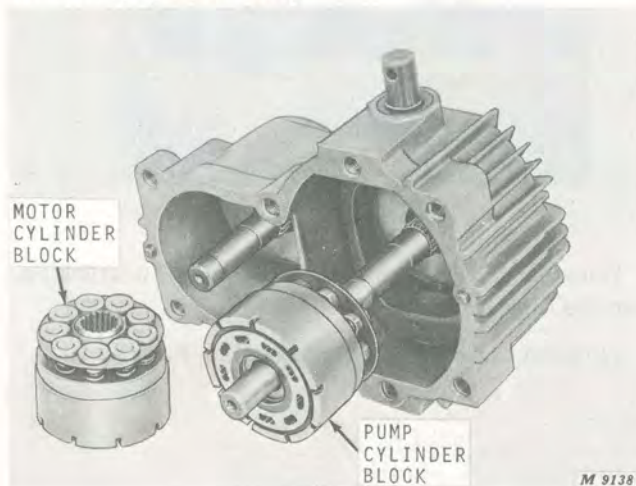

Fig. 13-Removing Cylinder Blocks

Tip the rear transmission housing, Figure 13, when the blocks are being removed to prevent piston assemblies from falling out of the cylinder blocks.

Grasp the cylinder blocks and gently slide them off the shafts. Handle them carefully to avoid dropping and damaging the units.

### Removing Motor Swashplate

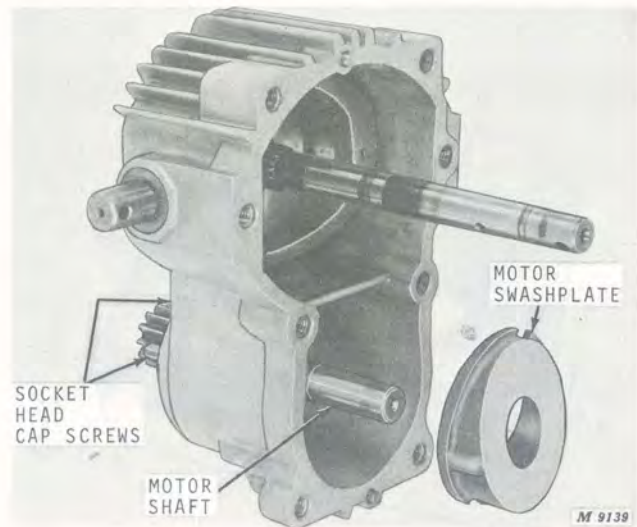

Fig. 14-Removing Motor Swashplate

Remove the two socket head cap screws retaining the motor swashplate, Figure 14.

Tip housing on its side and remove swashplate and motor shaft.

### Removing Pump Swashplate

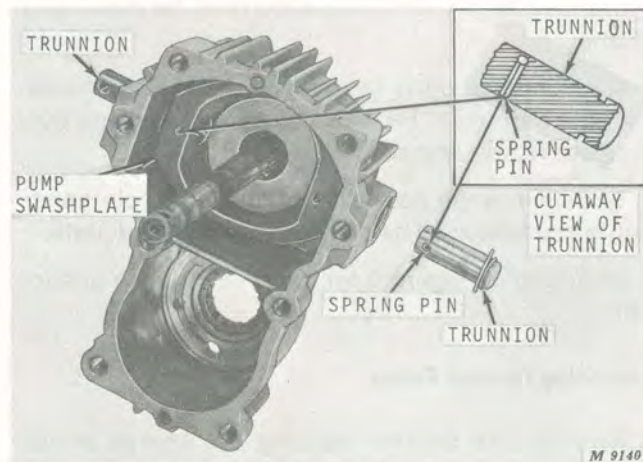

Fig. 15-Removing Pump Swashplate

To remove the pump swashplate, Figure 15, drive spring pins into trunnion shafts until they are flush with the shaft surface.

**IMPORTANT:** DO NOT drive spring pins more than 1/16-inch below surface of trunnion shaft. If pins are driven too deep, further disassembly will be difficult.



## Inspecting Parts

### Pump Shaft

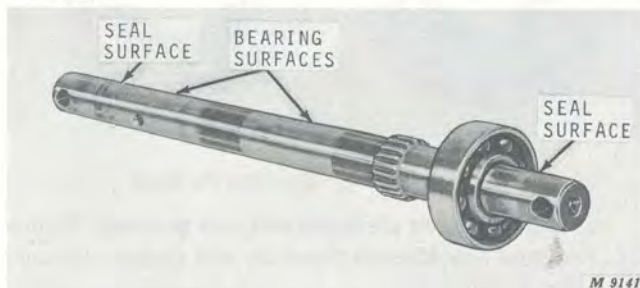

Fig. 16-Inspecting Pump Shaft and Bearing

Remove and inspect pump shaft and bearing assembly, Figure 16. Replace bearing if rough or worn.

Inspect pump shaft bearing and seal surfaces. If shaft is found to be rough or grooved, replace shaft.

### Cylinder Block Bore and Pistons

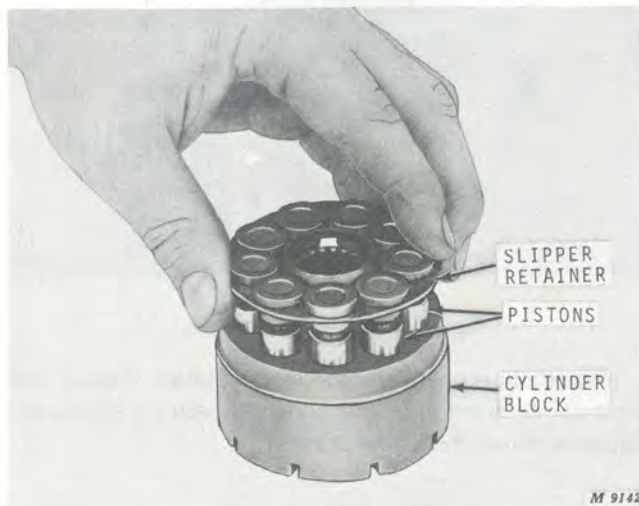

Fig. 17-Inspecting Cylinder Block

Gently lift all pistons as shown in Figure 17. Check for free movement of pistons in cylinder block bores.

A scored piston or cylinder block bore will require replacement of the complete assembly.

**IMPORTANT: Do not interchange pistons between cylinder blocks. Pistons and cylinder blocks are matched.**

### Slipper Retainer

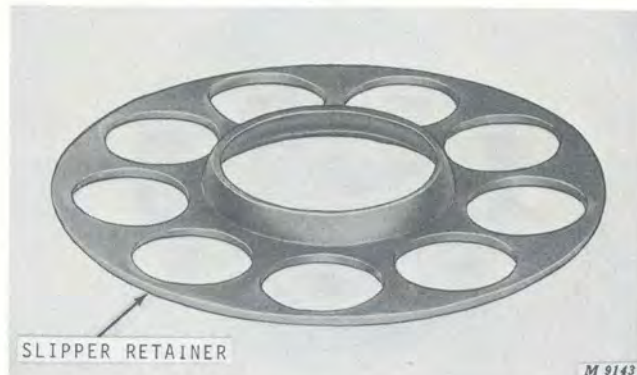

Fig. 18-Inspecting Slipper Retainer

Check slipper retainer Figure 18, for flatness. Replace retainer if bent. Reusing a bent retainer can cause pistons to bind, scoring the cylinder block.

If slipper retainer is bent, check for the following possible causes:

1. Charge pump inoperative.
2. Wrong viscosity oil.
3. Oil filter plugged.
4. Air leaking into intake line.

### Pistons and Slippers

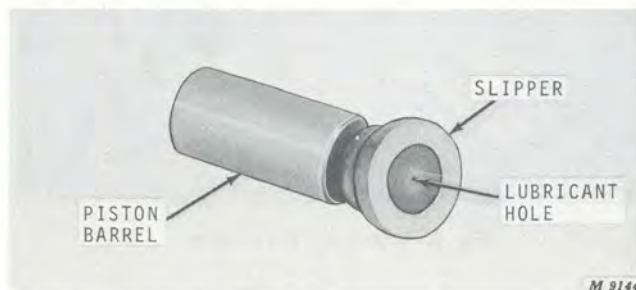

Fig. 19-Inspecting Piston and Slippers

If pistons have scored barrels or slippers have edges rounded more than 1/32-inch, replace the entire cylinder block assembly.

Inspect lubricant hole for blockage. If blocked, open with compressed air.

Individual pistons and cylinder blocks are not available for service because of the close tolerance-match fitting required for proper operation. A new cylinder block assembly complete with pistons must be installed.



### Cylinder Block Face

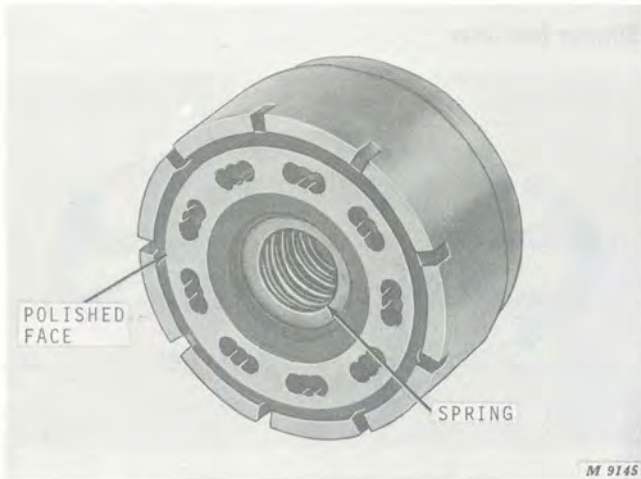

Fig. 20-Inspecting Cylinder Block Face

Inspect polished face of cylinder block, Figure 20, for scoring. Replace cylinder block assembly if scored.

Check spring for breakage. If broken, replace cylinder block assembly.

### Valve Plates

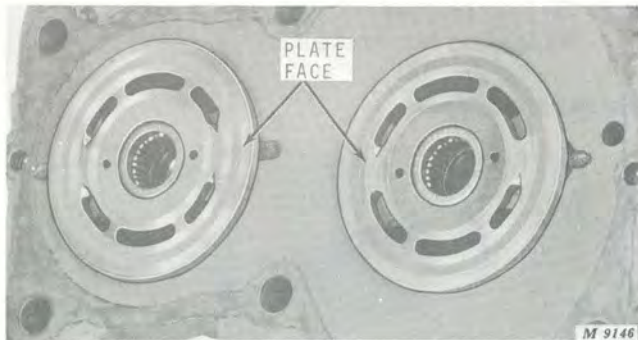

Fig. 21-Inspecting Valve Plates

Thoroughly clean valve plates, Figure 21, and dry with compressed air.

Inspect valve plates for scratches, excessive wear or erosion. A worn or scored valve plate reduces pump efficiency.

**NOTE:** To check valve plates for wear, run your finger nail across face of plate. If wear is felt, replace the plate.

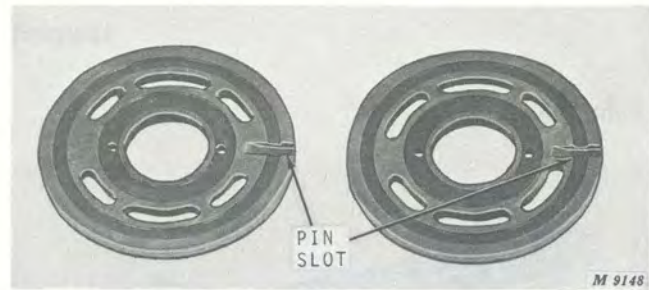

Fig. 22-Inspecting Valve Plate Pin Slots

Inspect the valve plate pin slot and grooves, Figure 22. Remove any foreign material and deburr the surface, if necessary.

### Swashplates

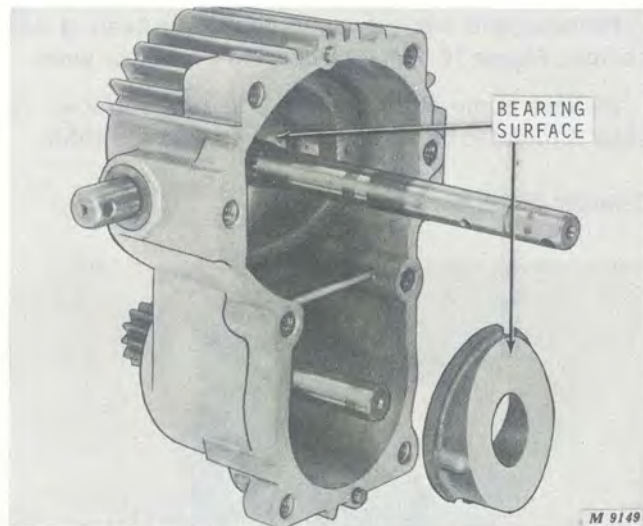

Fig. 23-Inspecting Swashplates

Inspect pump and motor swashplates, Figure 23, for wear or scoring of the polished bearing surfaces. Replace plates if worn or scored.

### Charge Pump

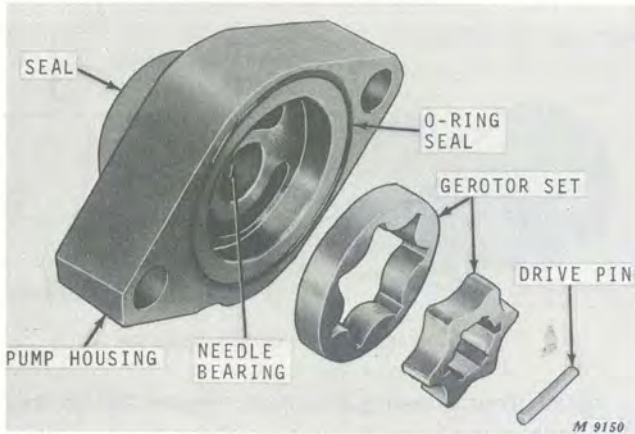

Fig. 24-Inspecting Charge Pump

Inspect gerotor set, pump housing, and needle bearing, Figure 24, for wear or damage. Replace entire charge pump if wear or damage is evident.

Always replace O-ring and pump seal before reassembling charge pump to transmission.

### Check Valves

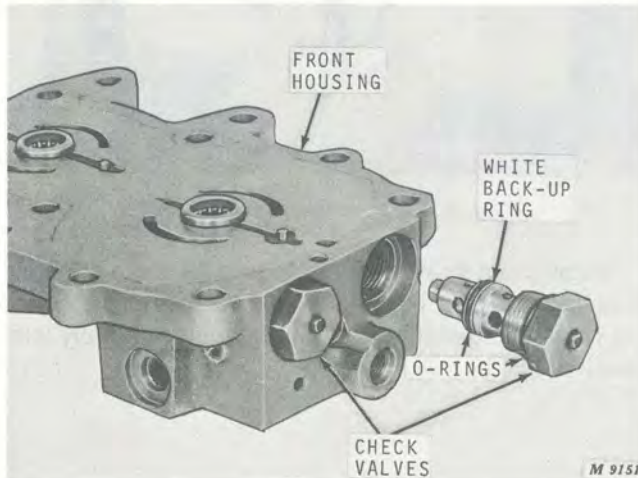

Fig. 25-Inspecting Check Valves

Remove and inspect both check valves for free movement of check ball, Figure 25.

Use new O-rings when reinstalling check valves. Note position of white back-up ring in lower O-ring groove. Replace this ring if damaged.

### Relief Valves

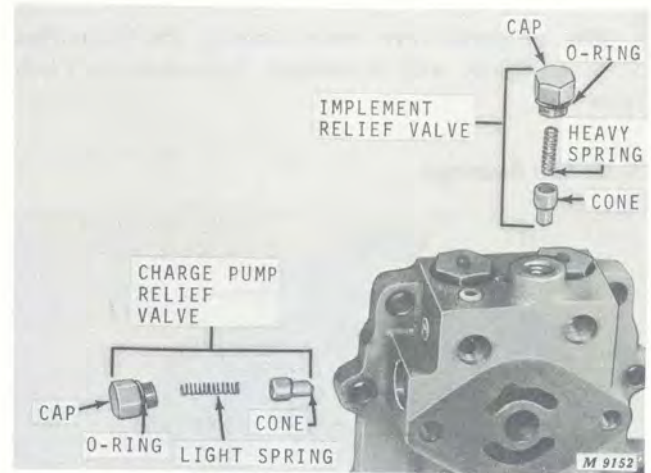

Fig. 26-Inspecting Relief Valves

Remove and inspect implement and charge pump relief valve cones and springs, Figure 26.

Check for rust and pitting of springs. Inspect cone points for wear. Replace springs and cones if worn, pitted, or rusty.

### Housing Bearings

Inspect housing bearings for wear and loose bearing rollers. Replace any questionable bearings.

### Housing Seals

To prevent costly rework, install new seals when assembling the transmission.



## Assembling Transmission

After all parts have been cleaned and inspected, oil them lightly with Automatic Transmission Fluid-Type "F."

### Seals and Bearings

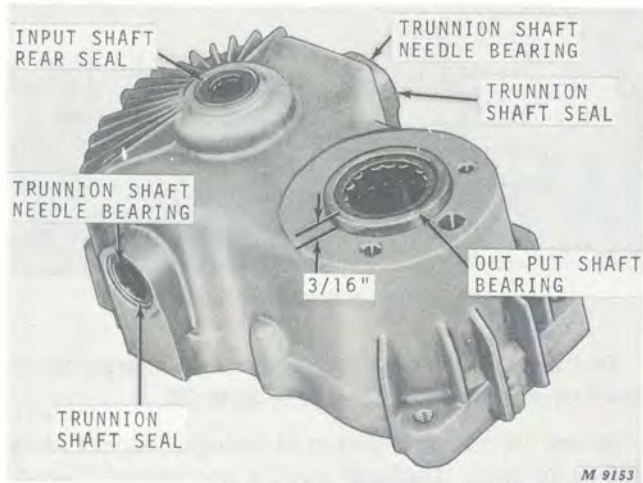

Fig. 27-Installing Seals and Bearings

Install trunnion shaft needle bearings, Figure 27, by pressing the bearings into the housing from the outside until they bottom in the bore.

Start trunnion shaft seals into housing bore by hand. Complete installation with a seal driver or pipe of the same diameter. Drive seals in until they bottom against needle bearings.

When installing a new output shaft bearing, Figure 27, press bearing into housing until  $3/16$  inch of outer race remains extended above mounting flange.

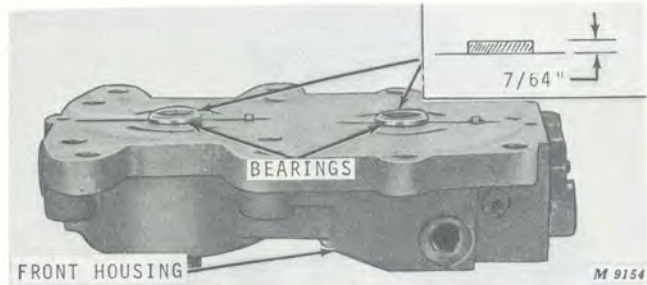

Fig. 28-Installing Front Housing Bearings

Install front housing bearings, Figure 28, so that  $7/64$  inch of the bearing remains above the machined surface. This is important because these two bearings pilot the valve plates when unit is assembled.

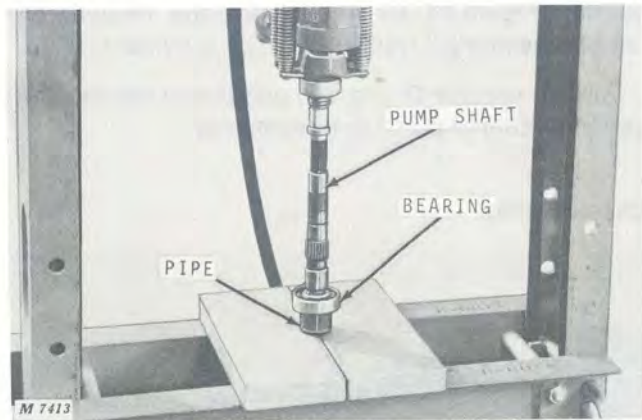

Fig. 29-Installing Input Shaft Bearing

Install input shaft bearing, Figure 29, onto shaft by pressing on inner bearing race only. Lubricate bearing with oil and place shaft and bearing assembly into rear housing.

### Variable Swashplate

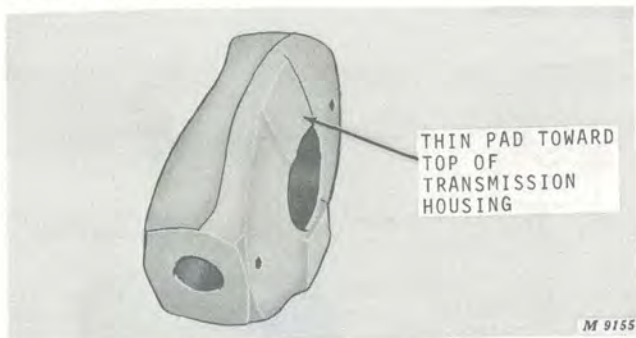

Fig. 30-Variable Swashplate Pads

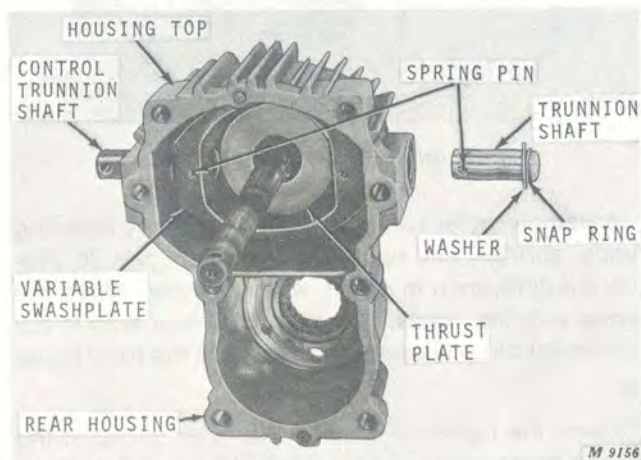

Fig. 31-Installing Trunnion Shafts

Place pump swashplate, Figure 30, into rear housing with the thin pad toward top of housing.

Position trunnion shafts, Figure 31. Tap shafts into swashplate using a soft metal hammer. Be careful to align spring pin holes in swashplate and shaft to facilitate installation of spring pins. Use a small drift punch to align the two parts before installing spring pins. Drive spring pins flush with the top of swashplate casting.

Place thrust plate into machined recess of swashplate with the highly polished surface of plate facing outward.

### Motor Swashplate

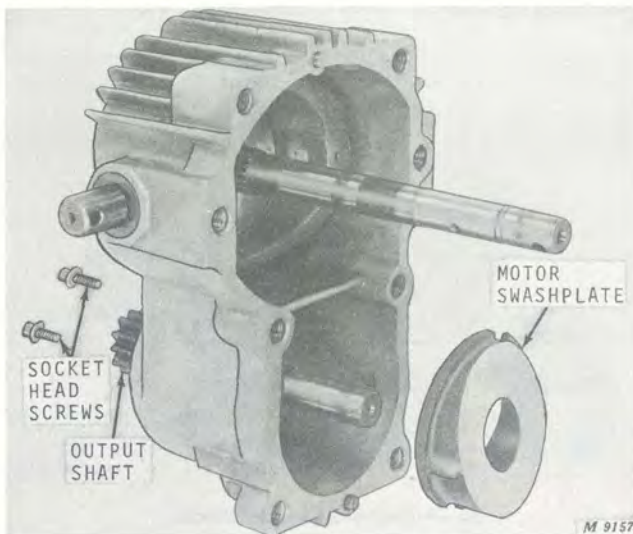

Fig. 32-Installing Motor Swashplate

Place output shaft into housing and insert motor swashplate, Figure 32, with the thin edge toward center of housing. Secure plate with two socket head screws. Tighten screws to 100 in-lbs torque.

### Cylinder Block and Pistons

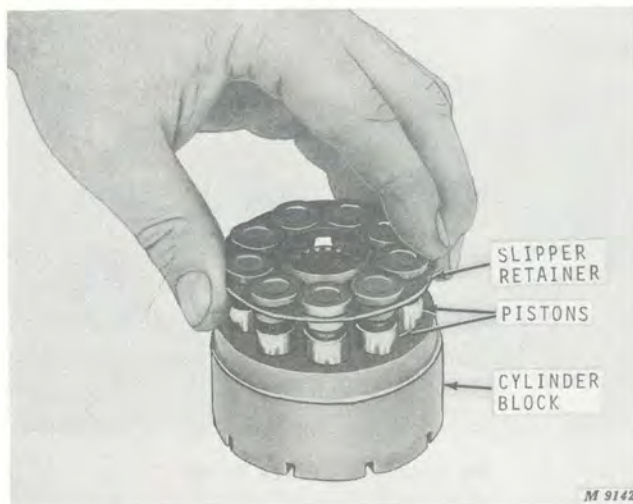

Fig. 33-Cylinder Block Assembly

Lubricate the pistons. Put the slipper retainer and pistons into the cylinder block, Figure 33. Be sure each piston moves freely in its bore.

**IMPORTANT: DO NOT interchange pistons between cylinder blocks. Pistons and cylinder blocks are matched.**



### Installing Cylinder Blocks in Housing

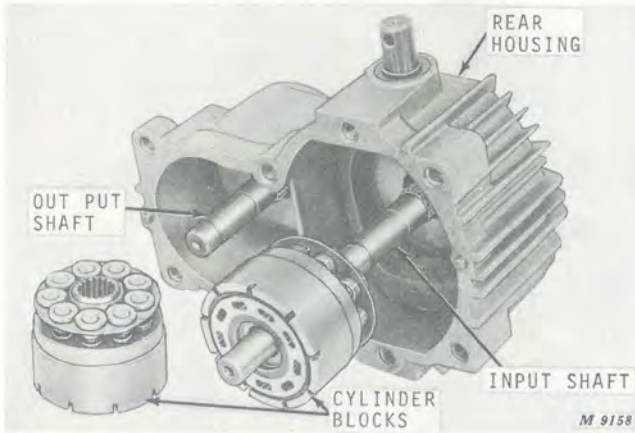

Fig. 34-Installing Cylinder Blocks

Place rear housing on its side as shown in Figure 34. Install cylinder blocks. Pistons will then remain in their proper position until slippers are in contact with the swashplates.

### Check Valves

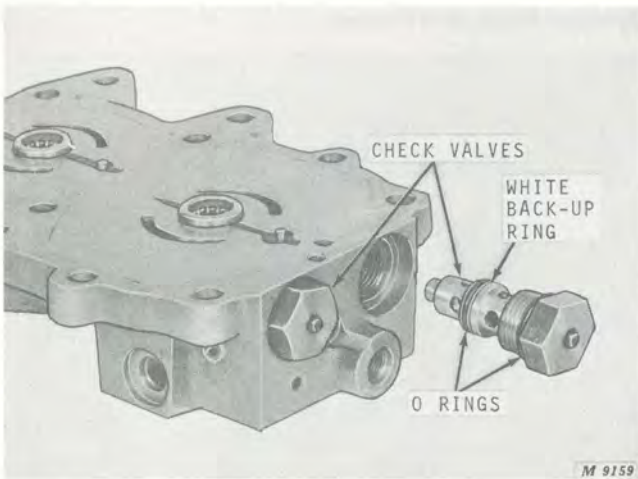

Fig. 35-Installing Check Valves

Place new O-rings on check valves, Figure 35. Note position of white nylon back-up ring on lower end of valve. Be sure this ring is positioned correctly.

Dip check valves into clean transmission oil and install in housing. Both valves are alike and can be interchanged.

### Relief Valves

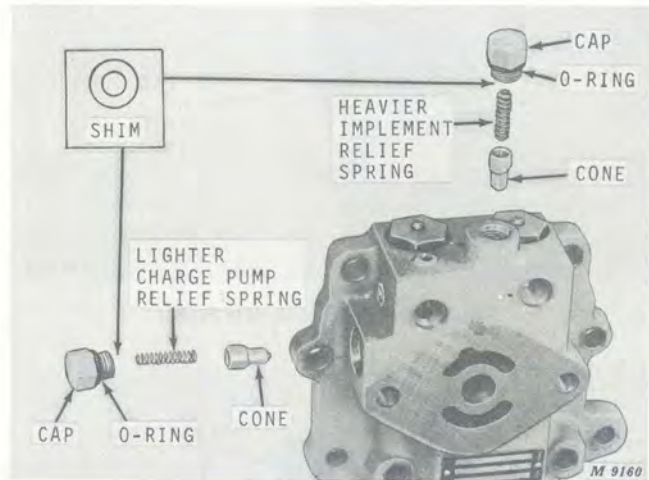

Fig. 36-Installing Pressure Relief Valves

Assemble relief valves in front housing by inserting cones, springs, and caps as shown in Figure 36. Notice the difference in spring wire diameter. Place the spring with the heavier or larger diameter wire in the implement circuit, located at the top of the front housing.

Insert the lighter or smaller diameter spring in the charge pump relief circuit, located at the side of the front housing.

Place new O-rings on caps. Install and tighten caps firmly.

Shim kits are available to increase relief spring tension if testing reveals pressure readings below 75 to 110 psi for the charge pump and 500 psi for the implement circuit. See "Testing", page 15-5.



### Valve Plates

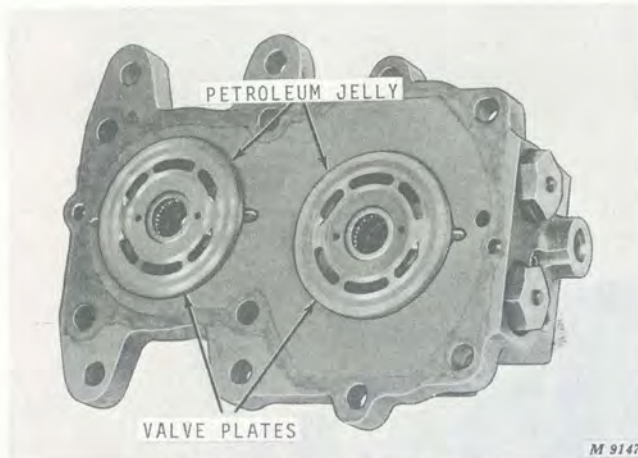

Fig. 37-Installing Valve Plates

Position valve plates on front housing, Figure 37. Apply a small amount of petroleum jelly between plate and front housing to hold plates in place during assembly.

### Installing Front Housing

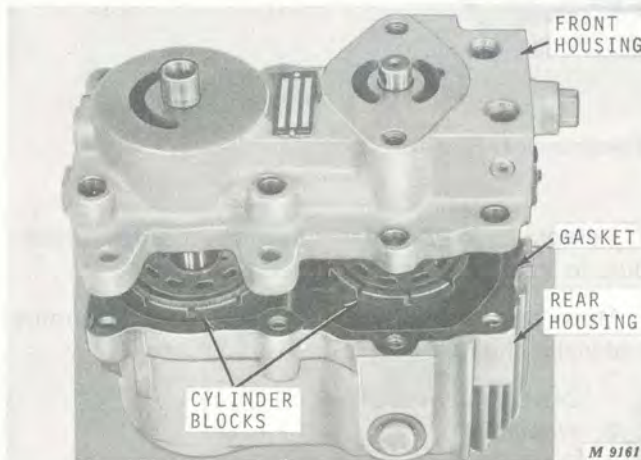

Fig. 38-Installing Front Housing

Place gasket on rear housing, Figure 38, and carefully lower front housing until valve plates and cylinder blocks meet. Observe valve plates before bolting housings together to be sure valve plates are positioned properly.

### Installing Control Cam Assembly

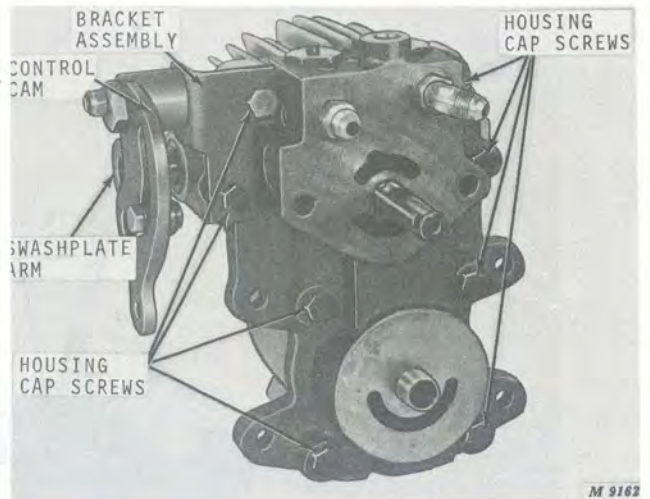

Fig. 39-Installing Control Cam

Install swashplate arm, Figure 39, and cam spring on trunnion shaft and insert spring pin. The cam spring is illustrated in Figure 2, Key 27, on page 20-2 of this Section.

Position control cam and bracket assembly on housing and secure with housing cap screws. After tightening all housing cap screws to 35 ft-lbs torque, check for free movement of control cam. If binding is noted, loosen bracket cap screws and reposition bracket to relieve binding.

### Installing Charge Pump

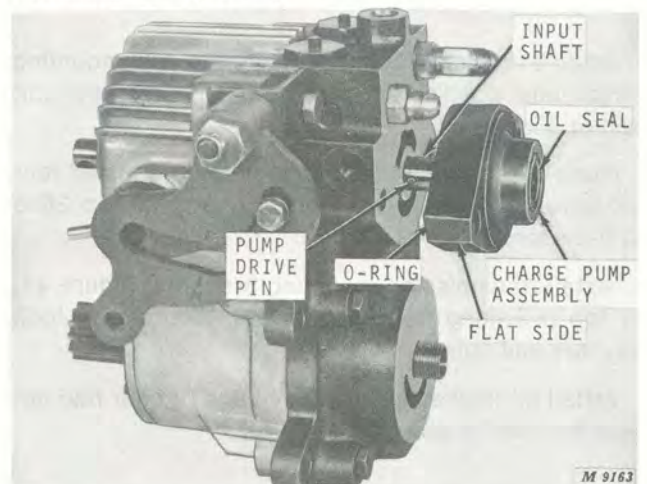

Fig. 40-Installing Charge Pump

Install a new pump shaft oil seal, Figure 40, prior to installing pump on the front housing. Position O-ring on pump face and insert pump drive pin in shaft.

Slide charge pump assembly with gerotor set in place on input shaft. Be sure flat side of casting is on relief valve side.

Carefully position charge pump on front housing being careful not to dislodge O-ring. Install two 7/16 x 2-inch cap screws and tighten to 50 to 52 ft-lbs torque.



## Installing Transmission

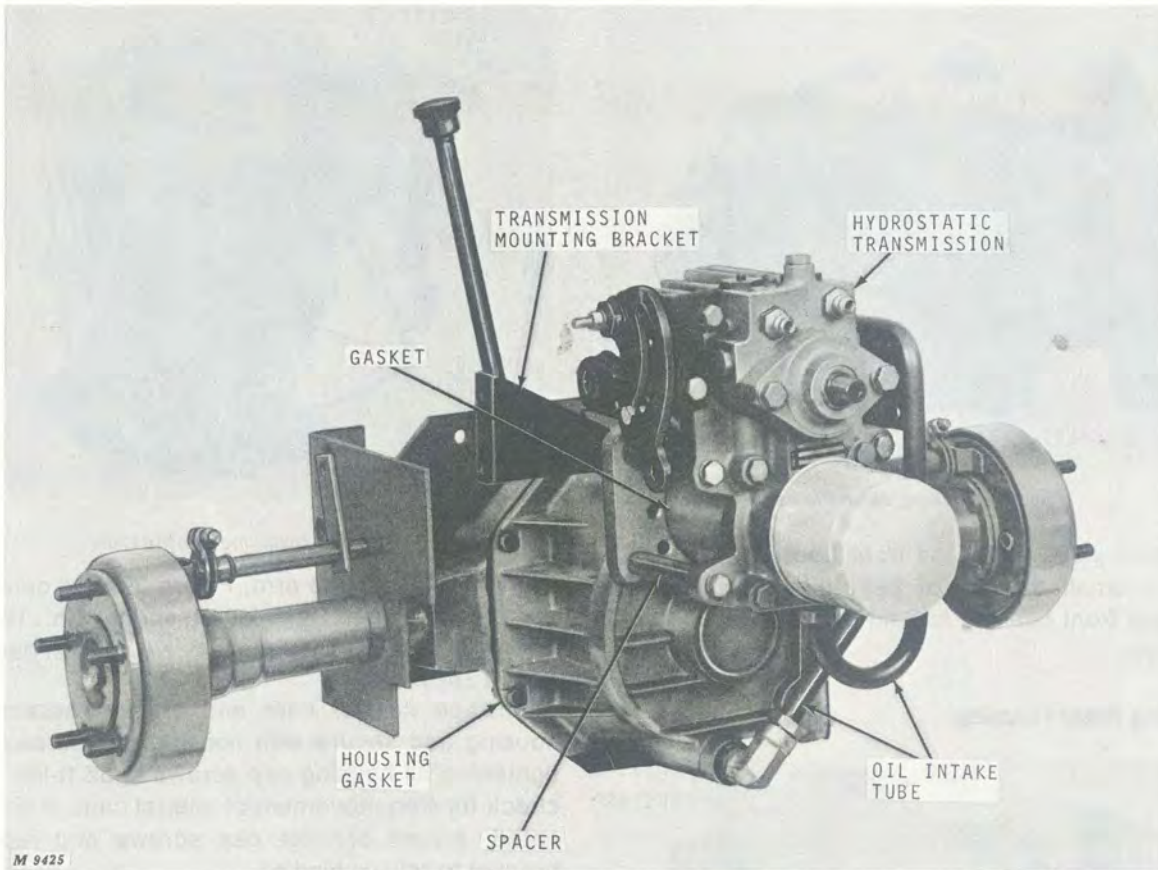

Fig. 41-Assembling Hydrostatic Transmission to Rear Axle

Apply a light coat of gasket sealer to axle mounting flange and position a new axle-to-hydrostatic unit gasket, Figure 41.

Place hydrostatic unit into position and install four cap screws and spacers. Tighten cap screws to 25 to 30 ft-lbs torque.

Install transmission mounting brackets, Figure 41, on top mounting cap screws and secure with lock washers and nuts.

Install oil intake tube, and oil filter (if filter had not been installed previously).

Refer to page 25-3 of this Section for proper procedure to install axle assemblies.

Move axle and transmission assembly into frame and install the following:

1. Drive shaft assembly
2. Wheels
3. Brake linkage
4. Hydraulic lines
5. Fender-deck
6. All control knobs
7. Lubricant in axle housing

Follow procedure on pages 20-3 and 20-4 of this Section to adjust control cam and hydrostatic control lever.

## SPECIFICATIONS

Component	Tolerance
Charge Pressure Test Reading .....	75 to 110 psi
Charge Pump Flow .....	3 gpm @ 100 psi
Implement Relief Valve Pressure .....	500 psi $\pm$ 50 psi
Implement Circuit Flow .....	1.5 gpm
Free-Wheeling Valve Plate-to-Valve Plungers .....	0.010 to 0.015 inch.

## TORQUE FOR HARDWARE

Location	Torque
Charge Pump .....	52 ft-lbs
Front-to-Rear Housing .....	35 ft-lbs
Motor Swashplate .....	65 in-lbs
Transmission-to-Axle .....	30 ft-lbs

## SPECIAL TOOLS

Name	Part No.	Use
0-1000 psi Gauge	Marsh Instrument Co. Skokie, Illinois	Measuring high pressure
Sliding Hammer Puller	Owatonna Tool Co. Snap-On Tool Co.	Pulling bearings





## Group 20 CONTROL CAM AND LINKAGE

### GENERAL INFORMATION

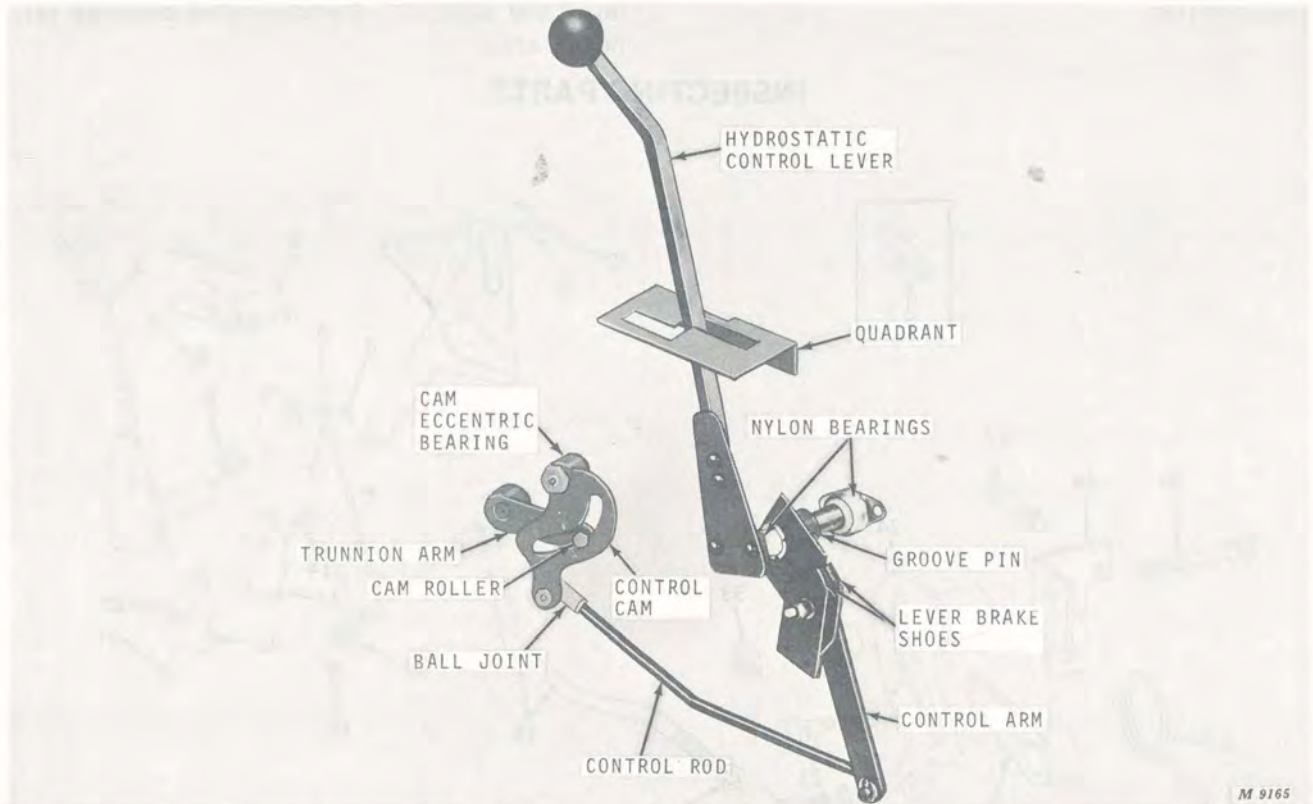

Fig. 1-Control Cam, Hydrostatic Lever and Linkage

The speed and direction of tractor travel is controlled by the position of the control cam on the hydrostatic transmission, Figure 1.

Moving the hydrostatic control lever either forward or rearward shifts the position of the control cam and in turn repositions the swashplate in the transmission.

This allows oil to enter the piston motor from one of two ports, thereby determining the direction of gear and axle rotation.

The further the control lever is moved in either direction, the greater the movement of the control cam, the greater the angle of the swashplate, and the greater the ground travel speed.

### DIAGNOSING MALFUNCTIONS

#### System Will Not Operate in Either Direction

Faulty control linkage.

Adjust linkage to pump trunnion shaft, not trunnion shaft to linkage.

#### Tractor Moves in Neutral

Control linkage or cam is adjusted improperly.

Adjust the cam eccentric bearing or control rod ball joint as described on page 20-3

#### Control Lever Seeks Neutral Position

Friction brake not properly adjusted.

Increase brake tension. See Figure 6.



## REMOVING CAM AND LINKAGE

### Cam Assembly

Remove shoulder bolt (21) and cam roller (20), Figure 2. Remove lock nut (33) and eccentric (23) from control cam (24). Remove jam nut (17) from ball joint (18).

### Linkage

Remove cotter pin (15) from control rod (16) and groove pin (8) from control arm (6). Remove bolts attaching quadrant (3). Slide out hydrostatic control lever and shaft (2). Remove nylon bearings (9), if necessary.

## INSPECTING PARTS

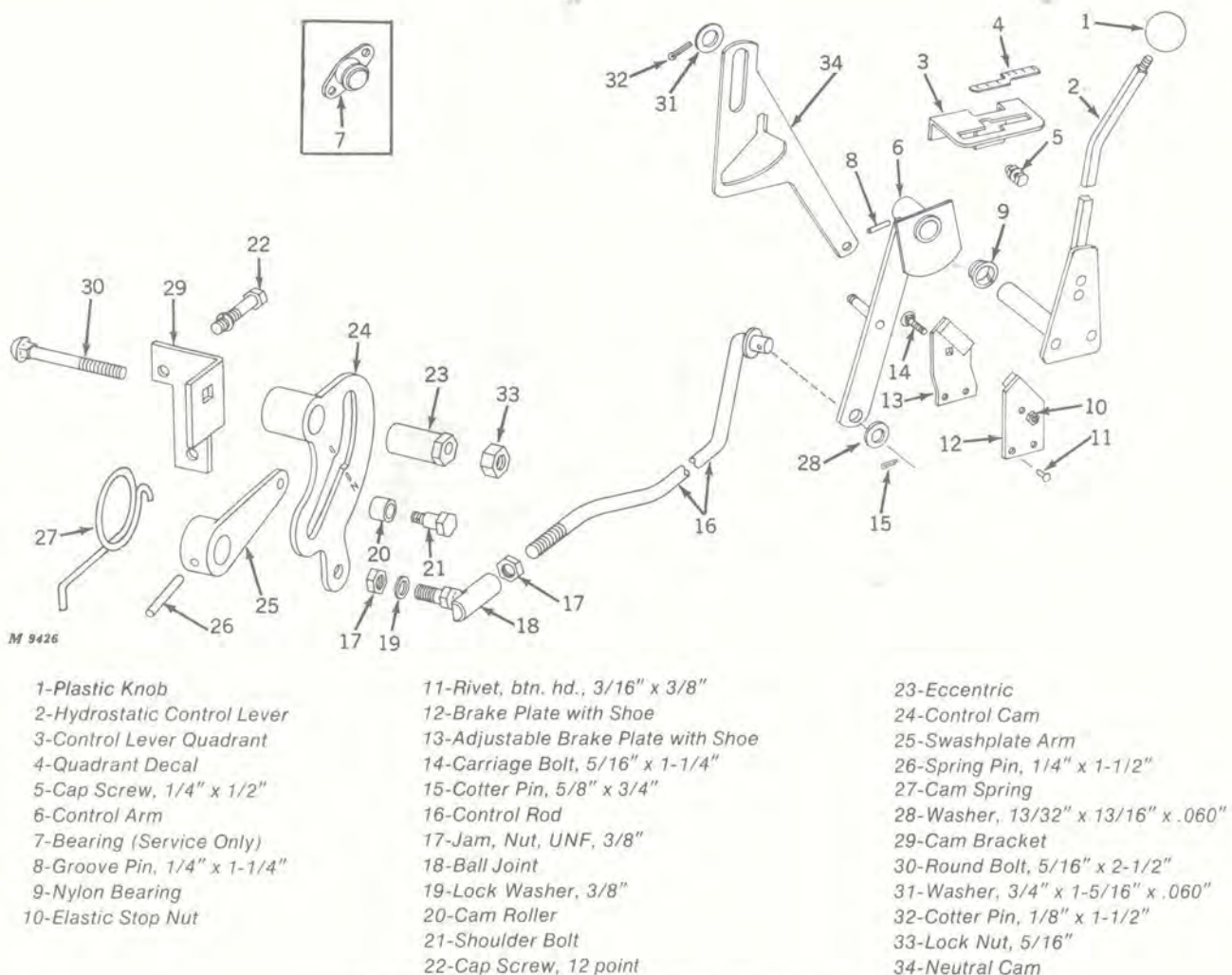

Fig. 2-Exploded View of Cam, Lever and Linkage

### Cam Assembly

Inspect slot in control cam (24) for excess wear. Check cam roller (20) for roundness. Measure eccentric for even wear using a micrometer.

### Linkage

Replace ball joint (18) at rear control rod (16) if neoprene dust cover is cracked or split, or if ball slips out of ball joint. Check control rod for damage.

### Hydrostatic Control Lever

Inspect nylon bearings (9) for roughness. Replace if damaged. Check control lever quadrant (3) and replace if lever notch is worn or lets lever slip out of neutral.

Check brake plates (12 and 13) for wear. Plates should permit lever to travel smoothly through full range, but apply enough tension to prohibit the lever from creeping back to neutral.

## ASSEMBLING CAM AND LINKAGE

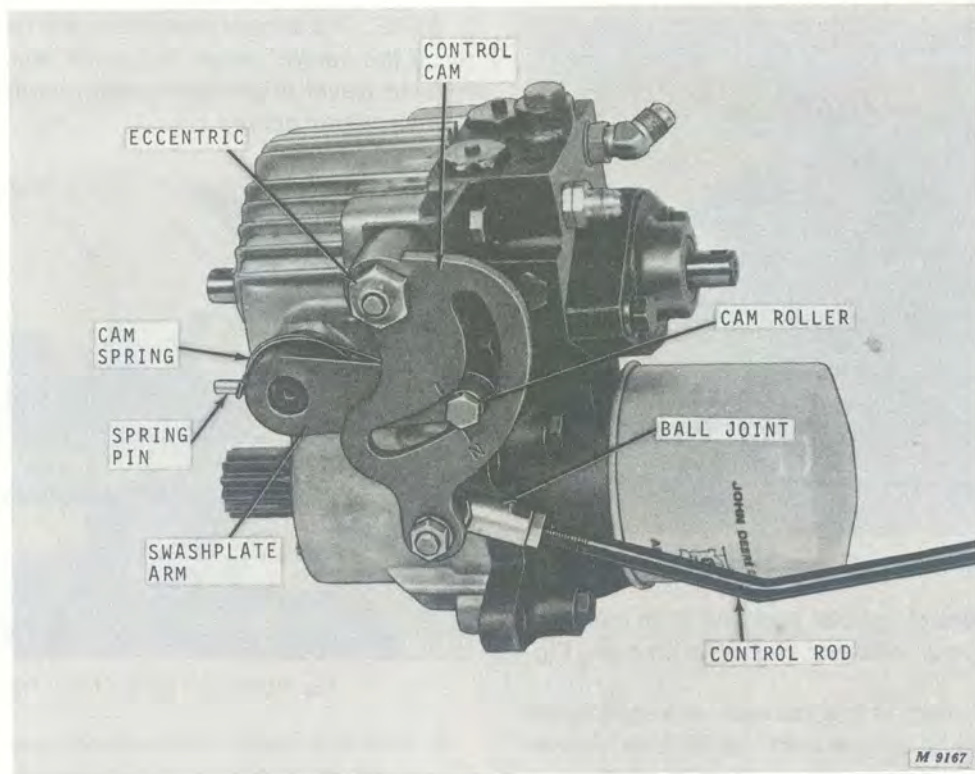

Fig. 3-Replacing Cam Assembly

### Cam Assembly

Install swashplate arm and cam spring Figure 3, on trunnion control shaft and fasten with spring pin. Insert eccentric into control cam and attach to cam bracket with a 2-1/2-inch round head bolt.

Place cam roller on shoulder bolt and insert through slot. Thread shoulder bolt into hole in swashplate arm. Tighten shoulder bolt to 90 to 100 in-lbs torque.

### Linkage

Fasten control rod ball joint to control cam. Fasten front of control rod to control arm, using washer and cotter pin.

### Hydrostatic Control Lever

Refer to Figure 2 and install new nylon bearings (9), if necessary. Slide shaft of control lever (2) through nylon bearings and control arm (6). Fasten control arm to lever shaft with groove pin (8).

Be sure plate on control arm is positioned between the two lever brake plate shoes (12 and 13). Insert carriage bolt (14) through brake plates and tighten elastic stop nut (10).

### ADJUSTING CAM AND LINKAGE

Whenever the control cam or linkage has been removed or disconnected, make the following adjustments to eliminate forward or reverse creep. With tractor on level surface, shut off engine.

1. Block one rear wheel off the ground. Block under the frame only, not under the transmission.
2. Close the free wheeling valve, release parking brake, and place hydrostatic control lever in neutral.



## ADJUSTING CAM AND LINKAGE—Continued

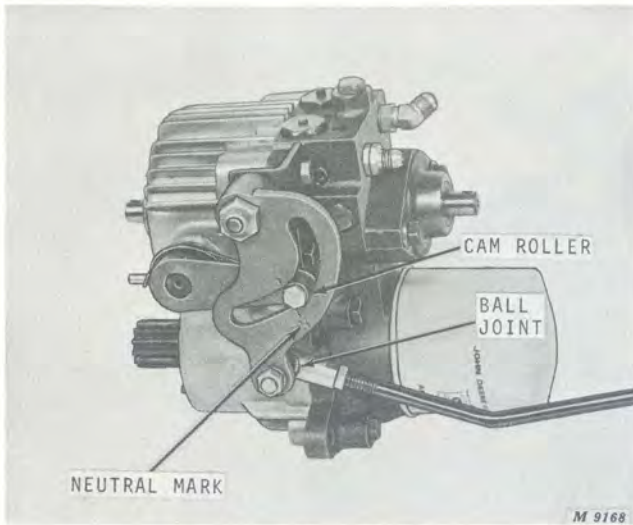

Fig. 4-Adjusting Control Rod Length

3. Remove control rod ball joint and align cam roller with neutral indicator mark (N) on cam, Figure 4.
4. Holding the cam in this position, adjust ball joint to drop into its hole in cam. Install lock washer and nut and tighten jam nut. Start the engine.

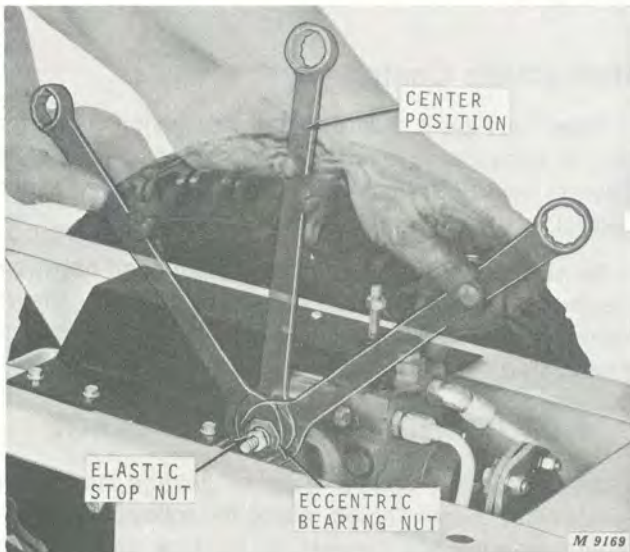

Fig. 5-Adjusting Eccentric Bearing Nut

**CAUTION:** Keep hands and tools away from transmission fan when operating tractor with fender-deck removed.

5. Run engine at idle. With 7/8-inch open end wrench, turn eccentric bearing nut forward until wheel creeps, then rearward until wheel creeps, Figure 5. Adjust for center position of wrench swing.

**NOTE:** This should place the cam roller in the center of the neutral range to provide equal forward and reverse travel of the hydrostatic control lever before wheel rotation occurs.

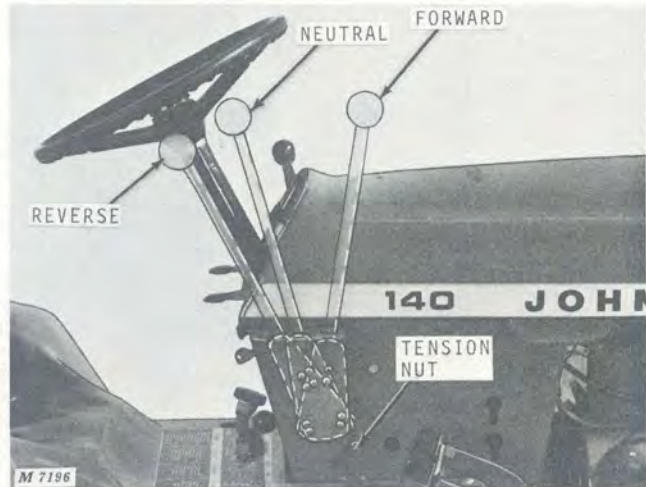

Fig. 6-Checking Control Lever Travel

6. With the tractor still blocked up and engine running, move control lever forward out of neutral. Check the distance that lever travels before wheel rotates, Figure 6. Follow the same procedure for reverse.
7. If lever travel (before wheel rotation occurs) is greater in a forward direction than in reverse, turn ball joint one or two turns to lengthen control rod. If lever travel is greater rearward than forward, turn ball joint onto control rod one or two turns.
8. Reconnect ball joint and tighten jam nut. Repeat step 5. Shut off engine and tighten nut on small bolt through eccentric bearing nut. Repeat steps 6 and 7, if necessary, until lever travel is equal.
9. Remove blocks and test tractor on a level surface for forward and reverse creep. Check at various engine operating speeds.

## Group 25 DIFFERENTIAL AND AXLE

### DESCRIPTION

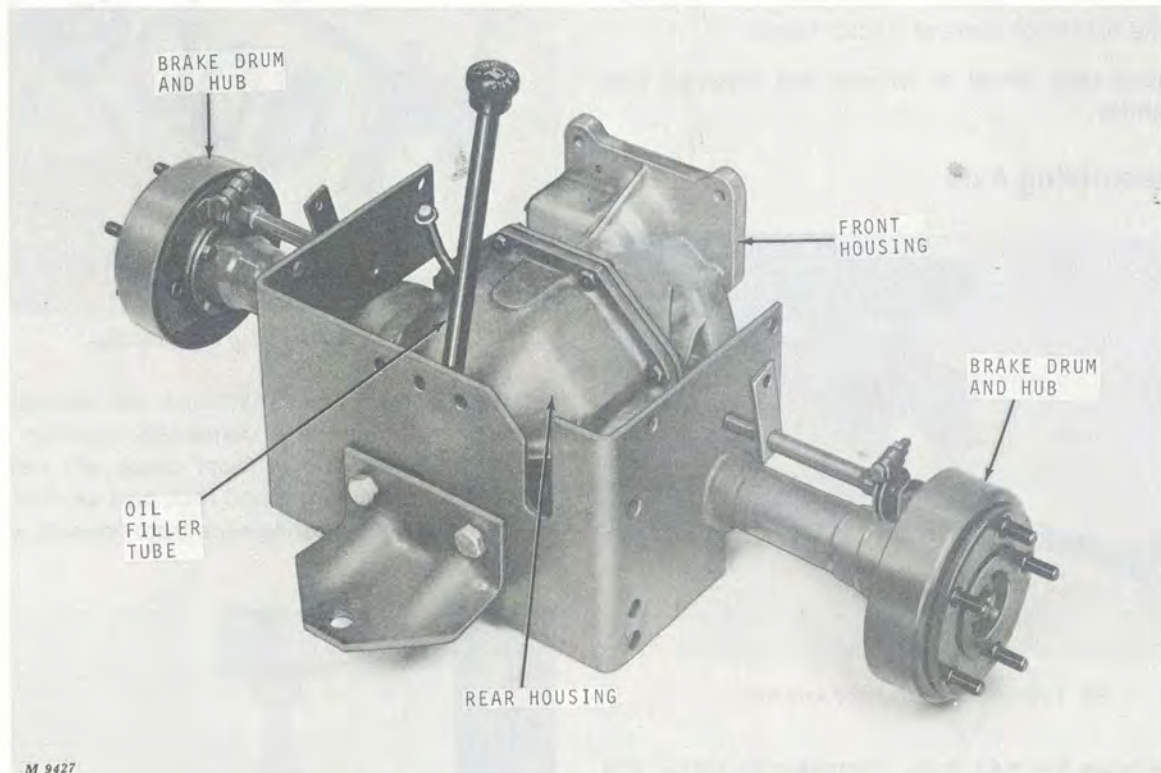

Fig. 1-Differential and Axle Assembly

The differential and axle, Figure 1, form the final drive of the power train. The differential features a heavy-duty case with automotive-type cut gears that rotate on tapered roller bearings.

Single-row, pre-set, tapered roller bearings are used on the outer ends of the axle shafts.

The entire drive line of the axle assembly is made from high-quality alloy steel and is encased in a die-cast aluminum housing. The use of steel affords high-strength and durability, while the aluminum housing aids lubricant cooling.

Double reduction gearing gives this unit the low axle ratio required for efficient use of engine torque, while keeping the overall size of the housing compact.

Power is transmitted from the transmission output gear to the pinion spur gear. The pinion spur gear transmits power directly to the differential drive gears, thus turning the axles and wheels.



## AXLE REPAIR

Oil seals, axle shafts, axle bearings and hubs can be serviced without removing the axle and differential housing from the tractor.

When servicing the axle in the tractor, place blocks under the rear hitch plate or tractor frame.

Remove rear wheel or wheels and proceed with disassembly.

### Disassembling Axle

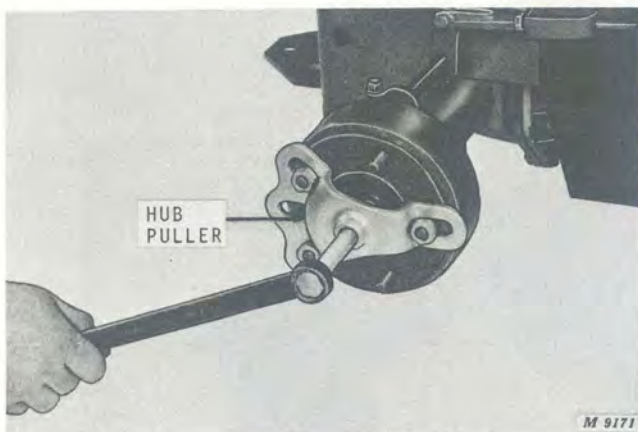

Fig. 2-Removing Right-Hand Axle Hub

To remove the axle hubs, remove cap screw and washer from center of hub. Install a universal hub and drum puller as shown in Figure 2, and pull hub from axle shaft.

Remove the four 5/16-inch nuts, lock washers and special cap screws shown in Figure 3. Remove back plate assembly, seal, gaskets, and bearing retainer.

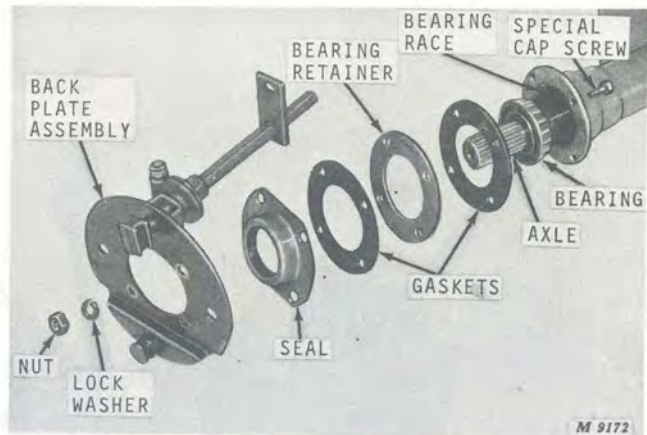

Fig. 3-Removing Axle and Seal

Grasp end of axle shaft and pull outward. Axle bearing and races are cemented together with an epoxy adhesive, and in most cases will remain together. In case bearing and race part as illustrated in Figure 3, remove bearing race from housing with your fingers.

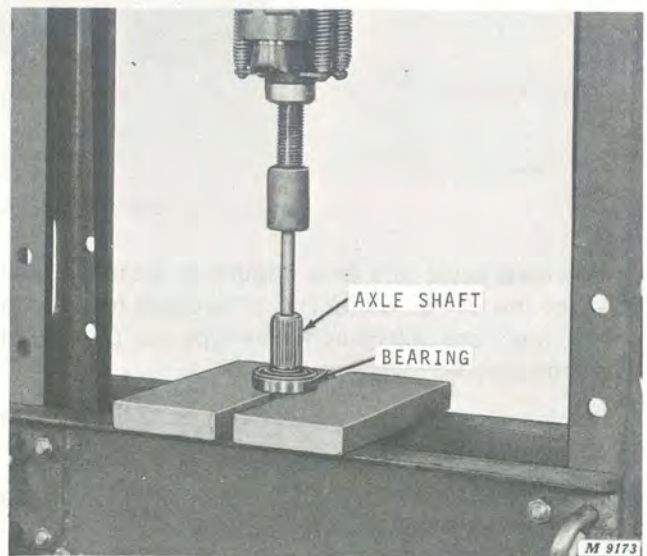

Fig. 4-Removing Axle Bearing

Press axle bearing from axle shaft by supporting inner bearing race on press bed and applying pressure to splined end of shaft, Figure 4.



## Inspecting Axle Parts

### Roller Bearings

Clean bearings in a safe solvent. The bearings should be free from rust and other foreign material. The bearings should rotate smoothly without excessive "play". Replace bearings if any defects are detected.

### Axles

Inspect splines for wear or breaks. Replace axle shaft if defects are evident.

### Oil Seals

Inspect oil seals for signs of leaking. Look for cuts or cracks. Be sure the spring on the inside of the seal lip is in place.

### Wheel Hubs

Inspect sealing surface of wheel hub. Replace hub if seal has grooved the hub surface more than 1/64-inch.

## Assembling Axle

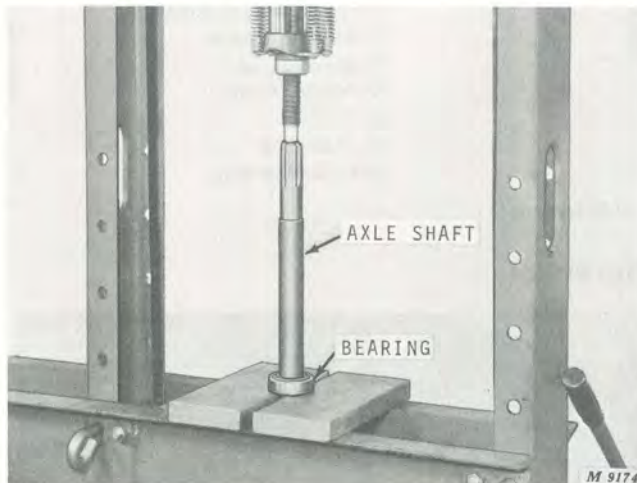

Fig. 5-Installing Axle Bearing

Place bearing on axle shaft with locking ring to the outside. Position bearing and axle shaft in press, Figure 5. Press bearing onto shaft until firmly seated against shaft shoulder.

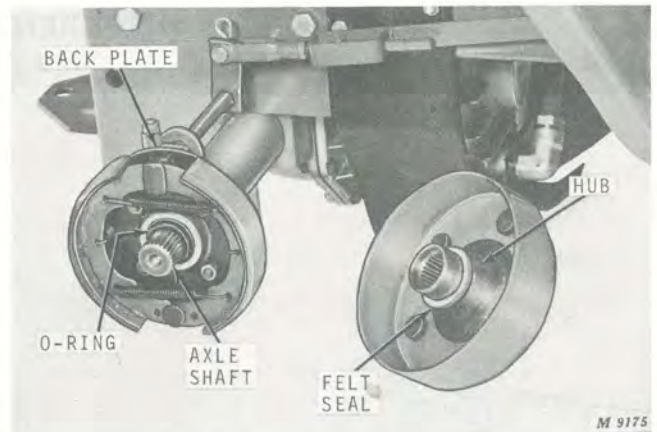

Fig. 6-Attaching Seal and Back Plate

Slide O-ring on axle shaft until it seats against axle bearing inner race.

**NOTE:** Some early models used a small O-ring in this position. Replace this with new 1/8 x 1-1/16 x 1-5/16 O-ring.

Assemble gaskets, bearing retainer, seal, and back plate as illustrated in Figures 3, 6, and 7.

**NOTE:** It may be necessary to install more than one gasket between end of axle tube and bearing retainer if wheel bearing protrudes slightly.

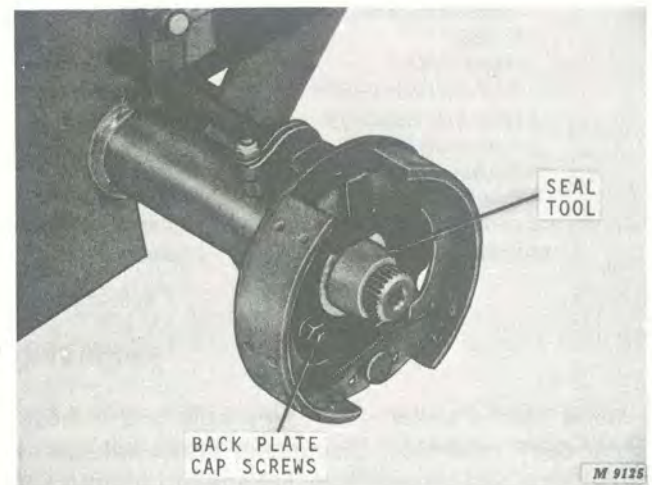

Fig. 7-Installing Back Plate

Assemble back plate to axle flange with four offset cap screws, lock washers and nuts.

Before tightening cap screws, align hub seal and back plate with JDST-9 seal tool, Figure 7.

**IMPORTANT:** The seal tool is required to prevent installing the seal off-center.

Tighten 5/16-inch back plate retaining nuts to 15 ft-lbs torque.

Install hub and drum as shown on page 50-10-10.



## DIFFERENTIAL REPAIR

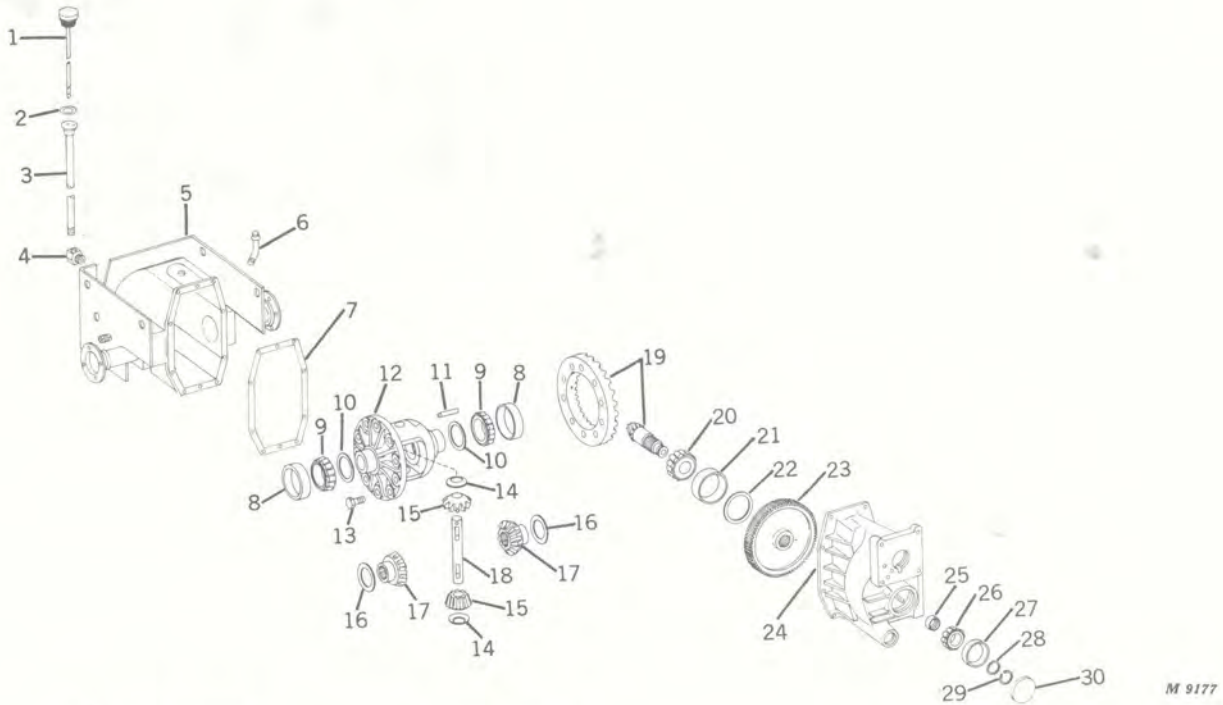

- 1-Dipstick Assembly
- 2-O-ring
- 3-Oil Fill Tube
- 4-Oil Tube Connector
- 5-Rear Axle Housing
- 6-Vent Assembly
- 7-Housing Gasket
- 8-Bearing Cup
- 9-Bearing Cone
- 10-Shim

- 11-Pinion Lock Pin
- 12-Differential Case
- 13-Cap Screw, UNF, 3/8" x 13/16"
- 14-Thrust Washer
- 15-Pinion Gear
- 16-Thrust Washer
- 17-Axle Gear
- 18-Pinion Shaft
- 19-Ring and Pinion Gear
- 20-Bearing Cone

- 21-Bearing Cup
- 22-Shims
- 23-Spur Gear
- 24-Front Housing Assembly
- 25-Bearing Spacer
- 26-Bearing Cup
- 27-Bearing Cone
- 28-Shim
- 29-Snap Ring
- 30-Expansion Plug

M 9177

Fig. 8-Exploded View of Differential

### Removing Differential

Place blocks under side frame rails and remove fender-deck assembly. Disconnect brake linkage at brake arms and transmission linkage at control cam ball joint.

Disconnect hydraulic oil lines at transmission, Figure 9.

Remove six self-tapping screws from top fan shield and remove shield. Drive spring pin from fan and remove fan and bottom fan shield.

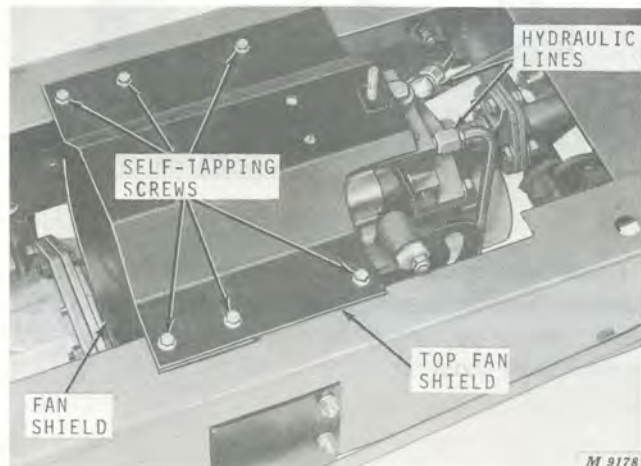

M 9178

Fig. 9-Removing Shields and Hydraulic Lines

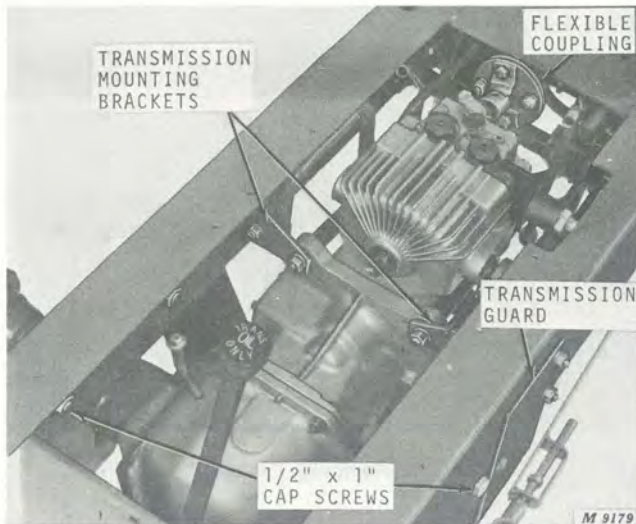

Fig. 10-Removing Brackets and Flexible Coupling

Remove transmission guard (if tractor is so equipped) and transmission mounting brackets, Figure 10. Drive both spring pins from rear flexible coupling hubs and slide coupling assembly forward.

Remove the four 1/2 x 1-inch cap screws securing rear axle and hitch plate assembly to frame side rails.

Tip transmission and axle assembly slightly forward to clear control cam attaching bolt. Slowly and carefully roll entire assembly rearward.

**IMPORTANT: Support axle adequately so that it doesn't fall forward from frame when bolts are removed.**

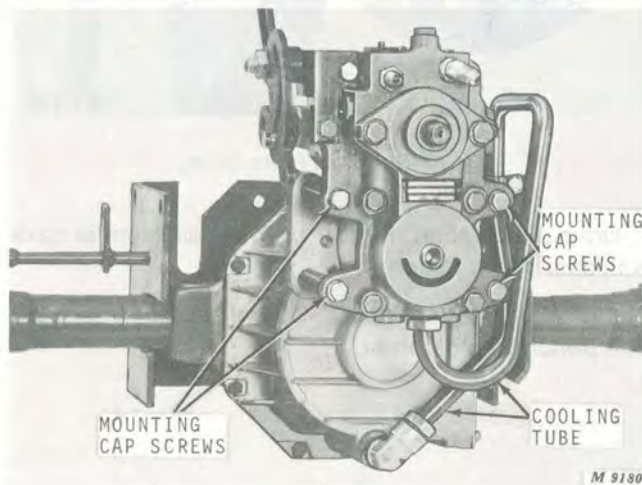

Fig. 11-Removing Hydrostatic Transmission

Drain oil from axle and transmission by removing oil cooling tube and oil filter, Figure 11.

After units are drained, remove four transmission mounting cap screws, Figure 11, and lift transmission from front axle housing.

**IMPORTANT: Protect transmission from contamination by re-installing oil filter. Cover oil outlet fittings.**

### Disassembling Differential

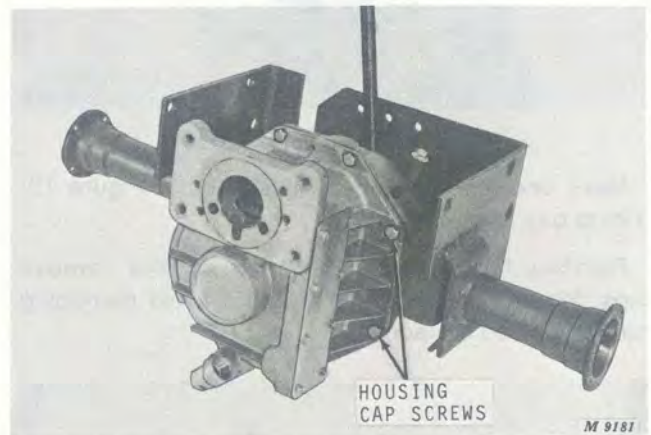

Fig. 12-Separating Front and Rear Housing

Remove right and left-hand axle assemblies as explained on page 25-2.

Remove eight 5/16 x 1-1/4-inch housing cap screws, Figure 12, and separate front and rear axle housings.



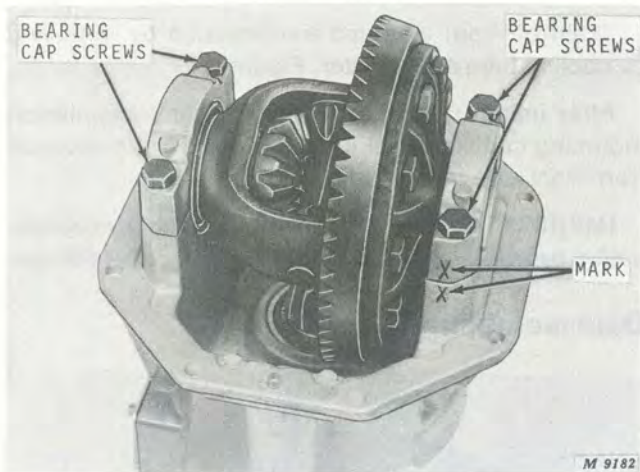

Fig. 13-Removing Bearing Caps

Mark one bearing cap as illustrated in Figure 13, prior to cap removal.

Remove four bearing cap screws and remove caps. Place caps in a safe place to avoid damaging their machined surfaces.

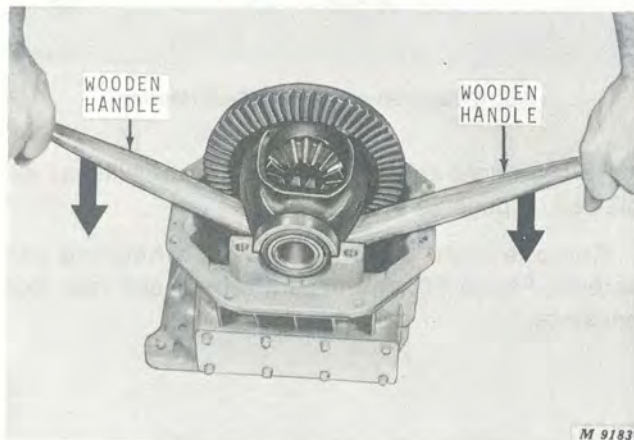

Fig. 14-Removing Differential Assembly

To remove differential assembly, Figure 14, place two wooden handles under differential case and pry sharply upward.

This is required because of the built-in bearing preload of housing.

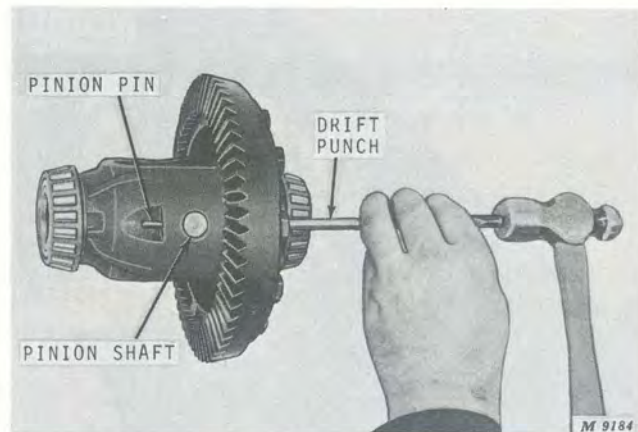

Fig. 15-Removing Pinion Pin

Using a long thin drift punch, drive pinion pin out of pinion shaft as shown in Figure 15.

Work on a clean surface and protect bearings from contamination.

Support differential properly to avoid bearing or ring gear damage during disassembly.

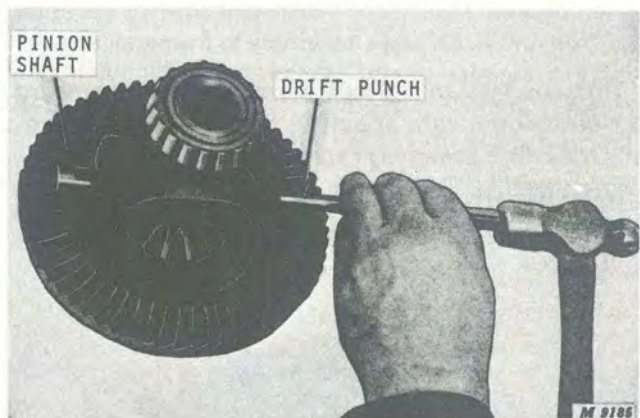

Fig. 16-Removing Pinion Shaft

Drive pinion shaft, Figure 16, from differential case with a long drift punch.

Avoid ring gear damage. Be careful not to slip off drift punch with hammer.



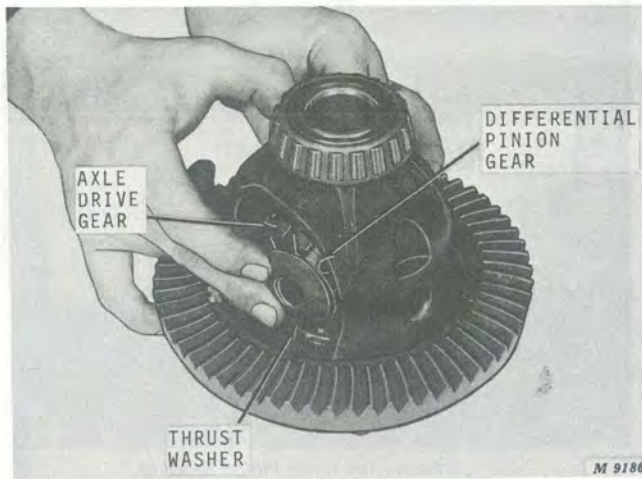

Fig. 17-Removing Differential Gears

Remove pinion gears and thrust washers, Figure 17, by rotating both gears 90 degrees to the openings in differential case.

Remove axle drive gears and thrust washers from case.

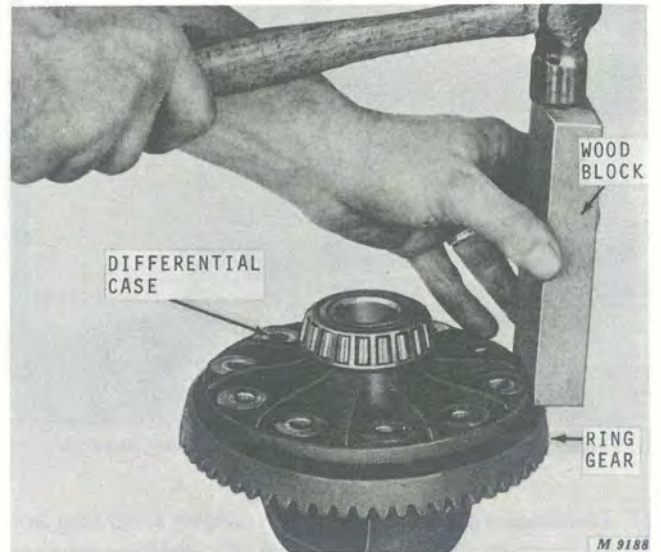

Fig. 19-Removing Ring Gear

Remove 10 ring gear retaining cap screws. Using a hardwood block and hammer, Figure 19, drive ring gear off differential case.

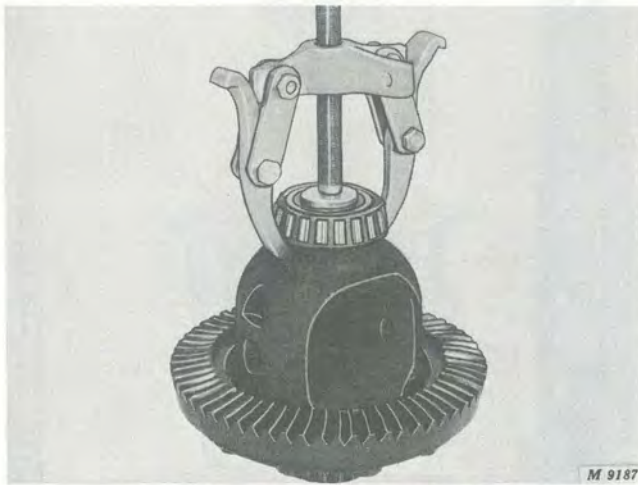

Fig. 18-Removing Differential Case Side Bearings

Do not remove bearings from differential case unless bearing failure is evident because bearings are easily damaged in removal.

Remove case side bearings with a narrow jaw puller, Figure 18. Be sure to insert jaws into indentations provided in the differential case.

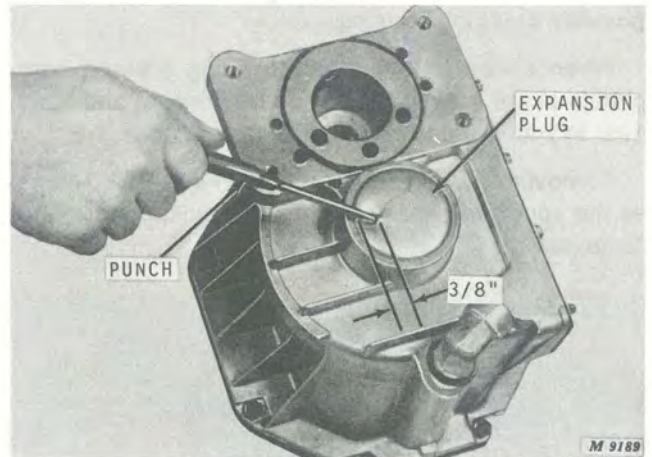

Fig. 20-Removing Pinion Expansion Plug

Remove pinion expansion plug, Figure 20, by driving a pointed punch through plug about 3/8-inch from outer edge. When hole is large enough, insert a large screwdriver and pry plug outward.



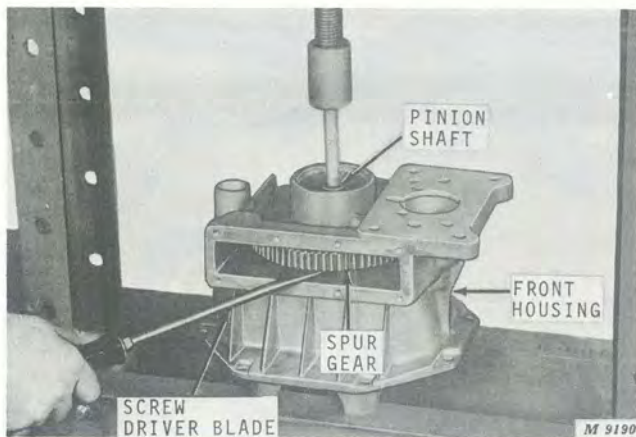

Fig. 21-Removing Differential Pinion Drive Gear Assembly

To remove pinion drive gear, remove snap ring and shim from end of pinion, Figure 22. Position housing and pinion drive gear assembly on hydraulic press bed.

Before starting to press gear, remove side cover and place a 1/8-inch piece of steel or a screwdriver blade under the edge of spur gear as shown in Figure 21. This will prevent spur gear from cocking and possibly cracking housing.

When pinion gear is close to being pressed completely out of bearing, reach under housing and catch gear in your hand to prevent damage to gear.

Removing the pinion drive gear, Figure 22, releases the spur gear, spacer, and outer pinion bearing for removal.

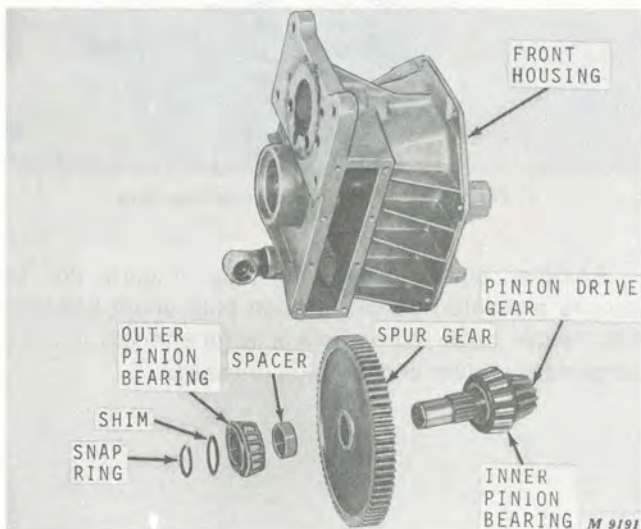

Fig. 22-Removing Spur Gear, Pinion Bearing and Spacer

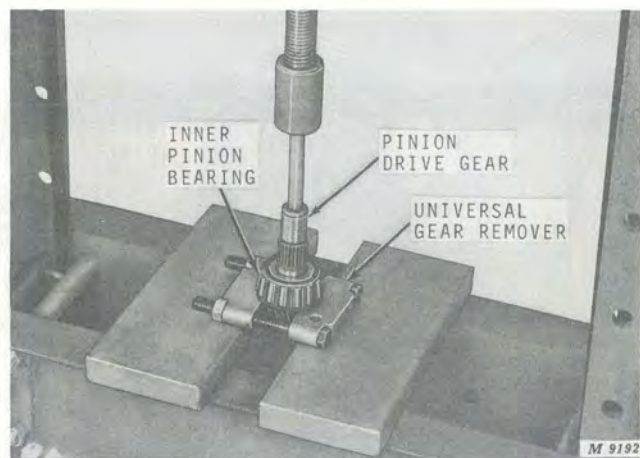

Fig. 23-Removing Inner Pinion Bearing

Clamp inner pinion bearing in a universal gear remover with a thin edge, Figure 23.

Position unit in press and carefully push pinion drive gear out of bearing. DO NOT allow pinion drive gear to drop on the floor. Damage will result.

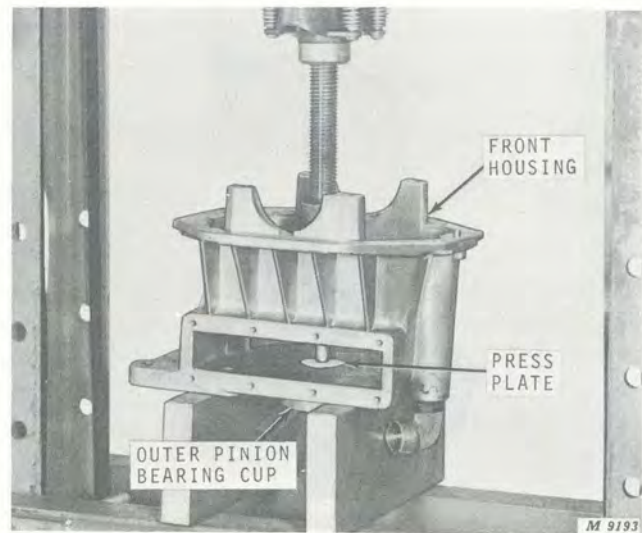

Fig. 24-Removing Outer Pinion Bearing Cup

To remove outer pinion bearing cup, Figure 24, position housing in press. Place a press plate of the proper size against cup. Press cup out of housing.



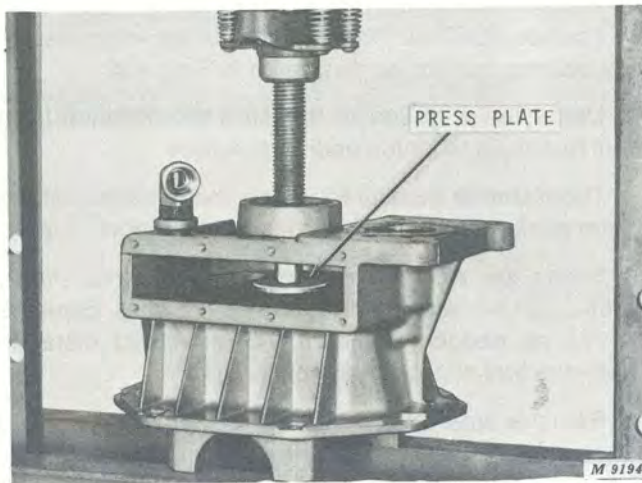

Fig. 25-Removing Inner Pinion Bearing Cup

Position front housing, Figure 25, on press bed with bearing saddles resting on press bed. Protect bearing saddles with a strip of wood if press bed is rough.

Insert a press plate of proper size and press bearing cup toward inside of housing. Retain shims located under bearing cup.

## Inspecting Differential Parts

### Bearings

Inspect all bearing rollers and cups for galling, rust or flaking.

Replace any bearing that is discolored or looks questionable.

### Gears

Check ring, pinion, and pinion drive gears for abnormal wear and damage. Replace if worn.

Inspect spur gear for spline wear and tooth wear. Replace if worn.

### Axle Housings

Inspect housings for cracks and external damage that could affect the operation of axle assembly.

## Differential Case

Inspect differential case for wear in the axle gear and pinion gear area. Replace case if machined areas are scored or if pinion shaft fits loosely in bore.

## Assembling Differential

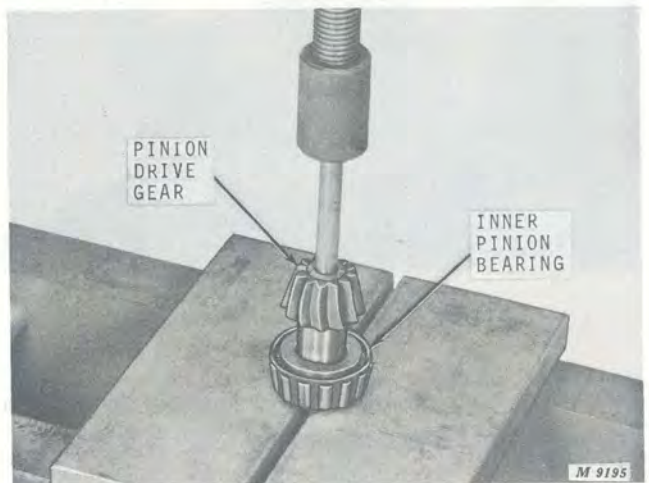

Fig. 26-Installing Inner Pinion Bearing

Press inner pinion bearing on pinion drive gear as shown in Figure 26. Support bearing on inner cup only when installing.

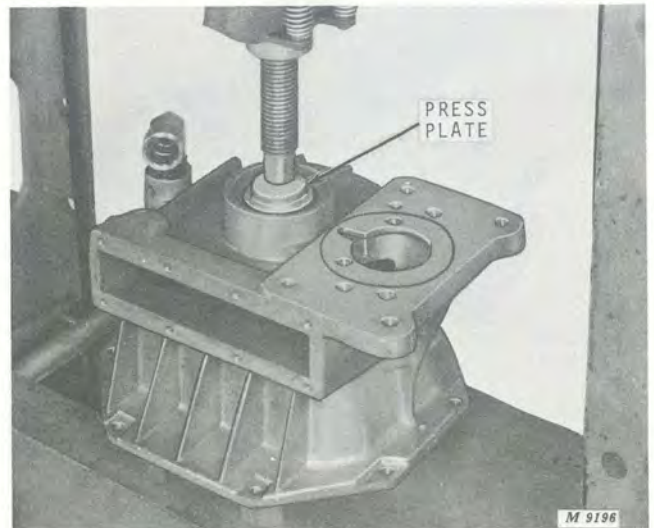

Fig. 27-Installing Outer Pinion Bearing Cup

Position front housing on press as shown in Figure 27, and using a press plate, push outer pinion bearing cup into housing until it bottoms in housing.



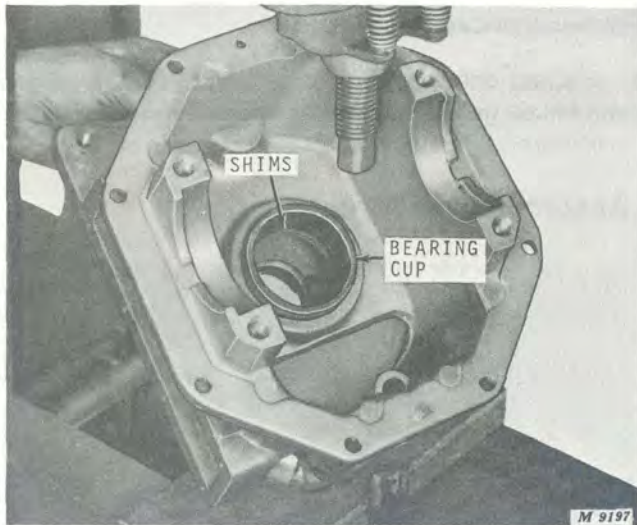

Fig. 28-Installing Inner Pinion Bearing Cup

When installing a new inner pinion bearing and cup in the original housing, reuse the original shim pack, Figure 28.

Use a press plate to push bearing cup into housing until it bottoms against housing flange.

*NOTE: If a new housing is installed, measure for proper shim pack thickness as explained below.*

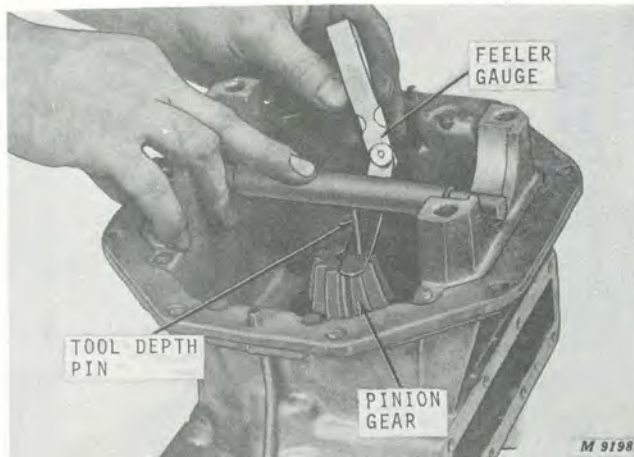

Fig. 29-Measuring Pinion Depth

When installing a NEW front housing, press inner pinion bearing cup, Figure 28, into housing WITHOUT shims. Place pinion drive gear (with bearing installed) into cup.

Position JDST-10 Pinion Depth Gauge into differential bearing cradles as illustrated in Figure 29.

Use a feeler gauge to measure the distance from tool depth pin to pinion gear button face.

The distance measured will be the thickness of the shim pack required under inner pinion bearing cup.

Shims are available in the following sizes: .003-, .005-, .010-, and .030-inch. Select and combine shims as needed to equal the measured distance between tool depth pin and pinion gear.

Remove inner pinion bearing cup. Install required shim pack and reinstall bearing cup into housing.

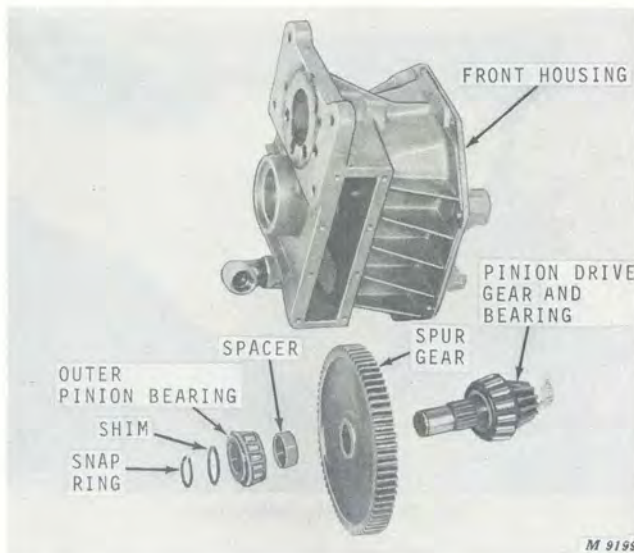

Fig. 30-Assembling Pinion Gear to Front Housing

Insert spur gear, Figure 30, into front housing with chamfered area of center spline toward pinion drive gear.

Insert pinion drive gear into spur gear. Place spacer over pinion drive gear shaft.

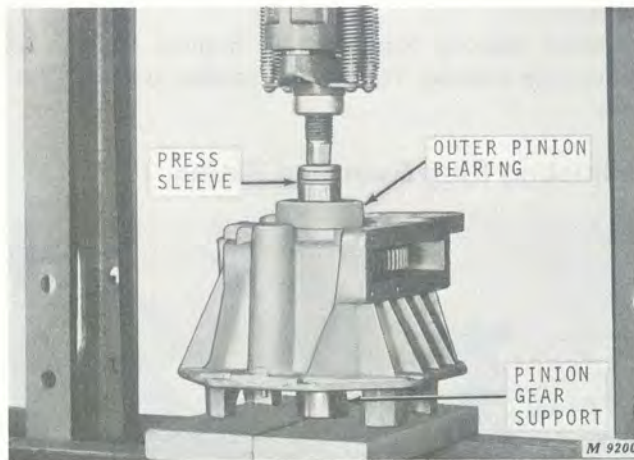

Fig. 31-Installing Outer Pinion Bearing

Position housing and pinion drive gear assembly into press. With pinion drive gear supported, place outer pinion bearing over shaft. With a press sleeve of proper diameter, push bearing onto pinion shaft until a slight drag is noticed when gear is turned by hand. If drag is too severe, tap pinion shaft with a soft metal hammer until drag is reduced.

Install a shim and snap ring, Figure 30, on end of pinion shaft. Use the thickest shim possible which will permit installation of the snap ring.

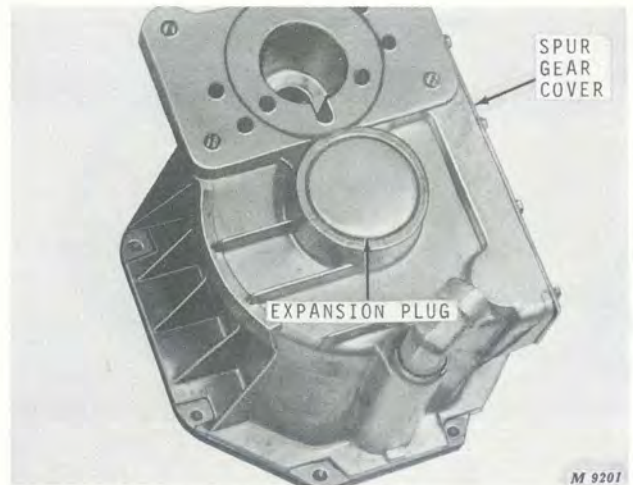

Fig. 32-Installing Expansion Plug and Spur Gear Cover

After pinion drive gear is positioned satisfactorily, install expansion plug and spur gear cover, Figure 32. Coat expansion plug with shellac before installing. Expand plug with a 1-inch diameter driver.

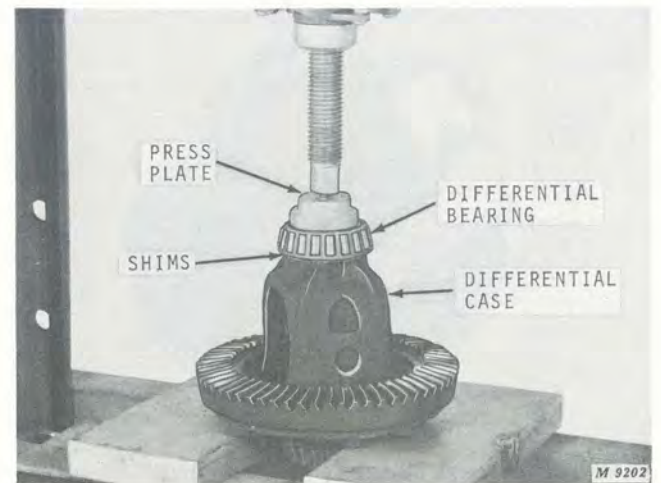

Fig. 33-Installing Differential Case Bearings

When installing new differential bearings, Figure 33, reuse original shims or use new shims of the same thickness. Press bearings onto case as shown.

If a new differential case is being installed, start with a .020-inch pack of shims under each differential bearing.

Shims are available in .003-, .005-, .010- and .030-inch sizes.



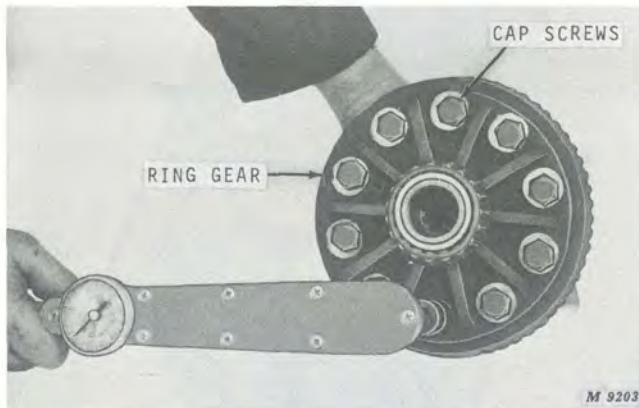

Fig. 34-Installing Ring Gear

Position ring gear, Figure 34, on differential case and start cap screws into gear with fingers. Proceed to tighten screws, alternating back and forth across gear to allow gear to be pulled evenly into place. Torque cap screws to 50 to 55 ft-lbs.

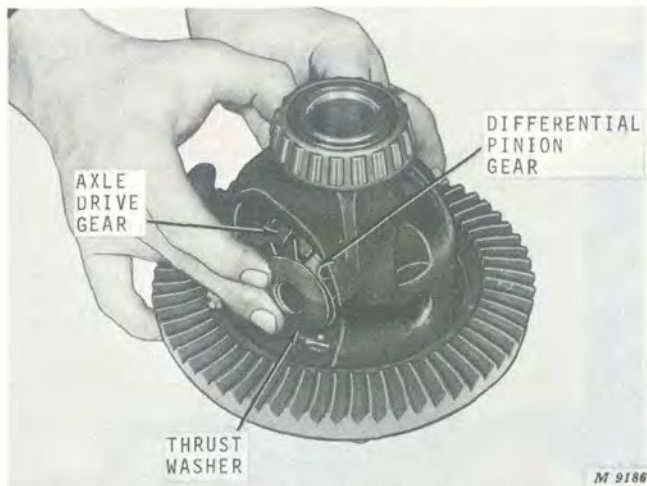

Fig. 35-Installing Differential Gears

Install thrust washers behind axle gears and place gears in differential case. Install differential pinion gears and thrust washers as shown in Figure 35. Rotate both pinion gears at the same time until pinion shaft can be inserted. Install pinion shaft and secure with pinion pin.

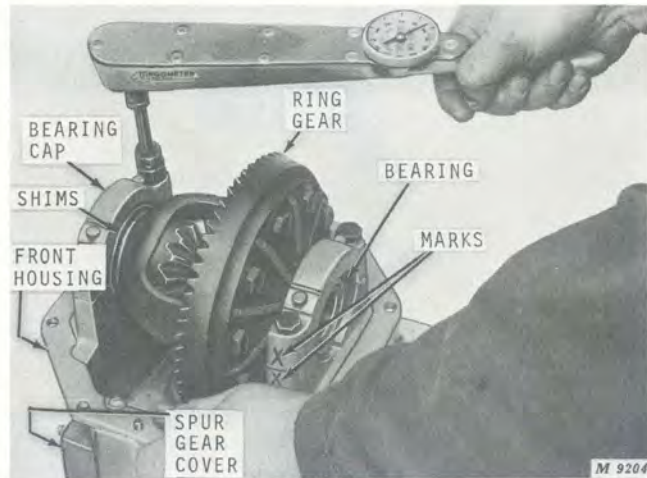

Fig. 36-Installing Differential

To assemble differential to front housing, Figure 36, position differential bearing caps on bearings and insert assembly into bearing cradles. Position assembly with ring gear facing same side as spur gear cover.

The bearing cradles are designed to apply a slight preload to bearings, therefore, it is important to push both bearing assemblies simultaneously into their cradles.

Install bearing caps in their original position as previously marked. Torque cap screws to 40 to 45 ft-lbs.

### Adjusting Ring Gear and Pinion

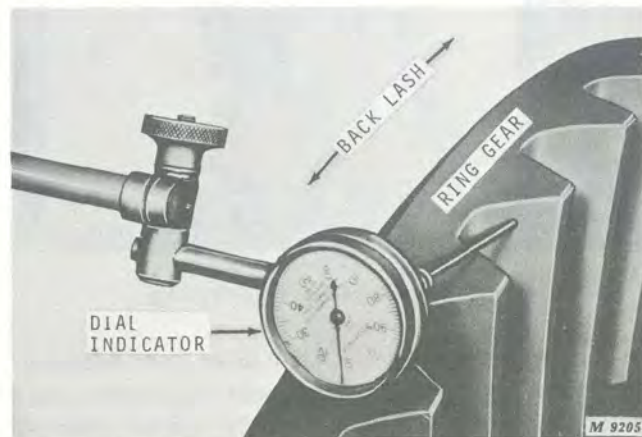

Fig. 37-Checking Ring Gear and Pinion Backlash

Using a dial indicator, check ring gear backlash. Ring gear backlash should be .003 to .007-inch.

If backlash is not in this range, move shims which are located beneath differential bearings, Figure 36, from one side to the other until correct backlash is attained.

Shims are available in .003-, .005-, .010-, and .030-inch sizes.

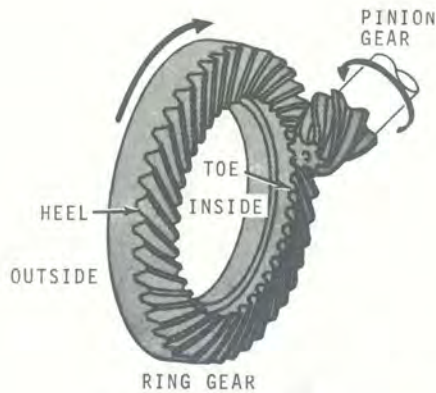

Fig. 38-Ring Gear and Pinion (Typical)

To check ring gear and pinion pattern, paint teeth of ring and pinion gear with gear pattern compound. Rotate pinion gear until ring gear has made one complete revolution.

Study the patterns illustrated and correct if necessary.

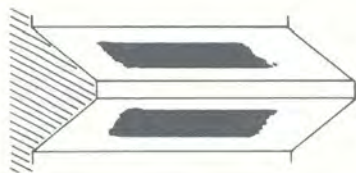

Fig. 39-Preferred Pattern

This is the preferred pattern on both sides of ring gear tooth.

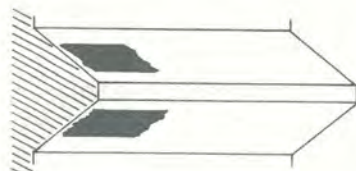

Fig. 40-Toe Pattern

To move toe pattern toward heel, increase backlash within .003 to .007-inch limits by shimming ring gear away from pinion gear.

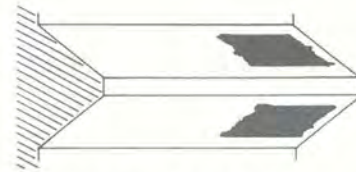

Fig. 41-Heel Pattern

To move heel pattern toward toe, decrease backlash within .003 to .007-inch limits by shimming ring gear toward pinion gear.

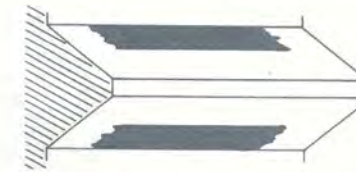

Fig. 42-Deep Pattern

To correct a deep pattern on the ring gear, reduce shim pack thickness under inner pinion bearing cup.

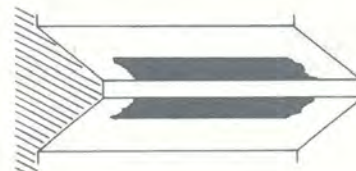

Fig. 43-Shallow Pattern

To correct a shallow pattern on the ring gear, increase shim pack thickness under inner pinion bearing cup.



## INSTALLING REAR AXLE

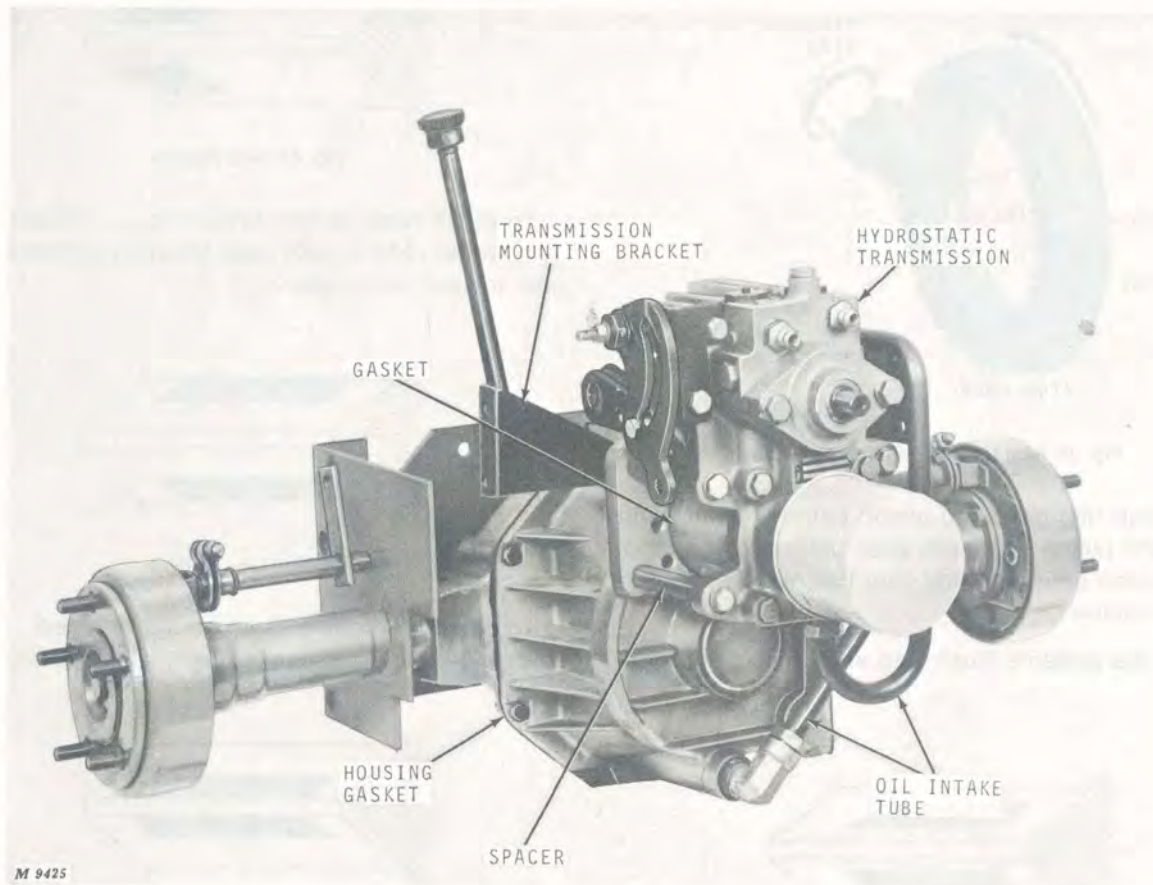

Fig. 44-Installing Rear Axle Assembly

Position a new housing gasket between front and rear axle housings and install eight housing cap screws. Tighten cap screws to 18 to 23 ft-lbs torque.

Install a new gasket between hydrostatic transmission and axle housing. Install four mounting cap screws and spacers. The 3/8 x 5-1/2-inch cap screws are used in the top mounting holes and the 3/8 x 4-3/4-inch cap screws in the bottom mounting holes. Tighten cap screws to 25 to 30 ft-lbs torque.

Place transmission mounting brackets on the top mounting cap screws. Secure brackets with lock washers and nuts.

Install oil intake tube.

Attach wheels to axle and roll assembly into tractor frame. Insert hitch plate cap screws and tighten securely. Position mounting brackets and attach to frame sides.

Install fan shields, fan, and drive shaft to transmission. Using a feeler gauge, check clearance between free-wheeling valve spring plate on top fan shield and plungers of check valves. Shim between spring plate and fan shield to provide clearance of 0.010 to 0.015 inch.

Attach control cam linkage and adjust if necessary. Refer to pages 20-3 and 20-4 of this Section for the correct procedure.

Fill transmission with Automatic Transmission Fluid-Type "F." With hydrostatic control lever in neutral and engine running, check fluid level. Fill to "full" mark on dipstick.

**CAUTION:** Keep hands and tools away from transmission fan when operating tractor with fender-deck removed.

After making necessary adjustments, install fender-deck and all control knobs.

## SPECIFICATIONS

Component	Tolerance
Ring Gear-to-Pinion Gear Backlash .....	.003 to .007 inch
Pinion Gear End Play .....	.000 to .005 inch

## TORQUE FOR HARDWARE

Location	Torque
Front-to-Rear Housing .....	18 to 23 ft-lbs.
Transmission-to-Rear Axle .....	25 to 30 ft-lbs.
Differential Bearing Caps .....	40 to 45 ft-lbs.
Ring Gear to Differential Case .....	50 to 55 ft-lbs.
Hub to Axle Shaft .....	35 to 40 ft-lbs.
Oil Seal .....	25 to 30 ft-lbs.

## SPECIAL TOOLS

Name	Part No.	Use
Telescopic Gauges .....	Starret S579H .....	Measure pinion depth.
Dial Indicator .....	Starret .....	Measure ring gear backlash.
0 to 4-inch Micrometers .....	Starret 230RL .....	Checking thickness of shims.
	Starret 2RL .....	
	Starret 436 XRL .....	
Sliding Hammer Puller .....	Owatonna Tool Co. ....	Pulling bearings from housing.
	Snap-On Tool Co. ....	
Retaining Ring Pliers .....	Tru-Arc #2 .....	Removing snap ring from pinion shaft.
JDST-9 Seal Aligning Sleeve .....	Service Tools Inc. ....	Centering axle seals.
	1901 Indiana Avenue	
	Chicago, Illinois 60616	
JDST-10 Pinion Depth Tool .....	Service Tools, Inc. ....	Measuring shim pack required for pinion drive gear.
	1901 Indiana Avenue	
	Chicago, Illinois 60616	
Hub and Drum Puller .....	OTC 967 .....	Pulling brake drum and hub.





# Section 60 HYDRAULIC LIFT SYSTEM

## Group 5 GENERAL INFORMATION

### TABLE OF CONTENTS

	Page		Page
<b>GROUP 5 - GENERAL INFORMATION</b>		<b>GROUP 20 - HYDRAULIC CYLINDERS</b>	
Principle of Operation .....	5-2	General Information .....	20-1
Analysis .....	5-3	Testing .....	20-2
Testing the Hydraulic System .....	5-3	Repair .....	20-2
Diagnosing Malfunctions .....	5-4	Installation .....	20-2
		Specifications .....	20-2
<b>GROUP 10 - HYDRAULIC CIRCUITS</b>			
General Information .....	10-1		
Hydraulic Couplers .....	10-3		
<b>GROUP 15 - HYDRAULIC CONTROL VALVES</b>			
General Information .....	15-1		
Removal .....	15-1		
Disassembly .....	15-2		
Repair .....	15-2		
Assembly .....	15-3		
Installation .....	15-3		



### PRINCIPLE OF OPERATION

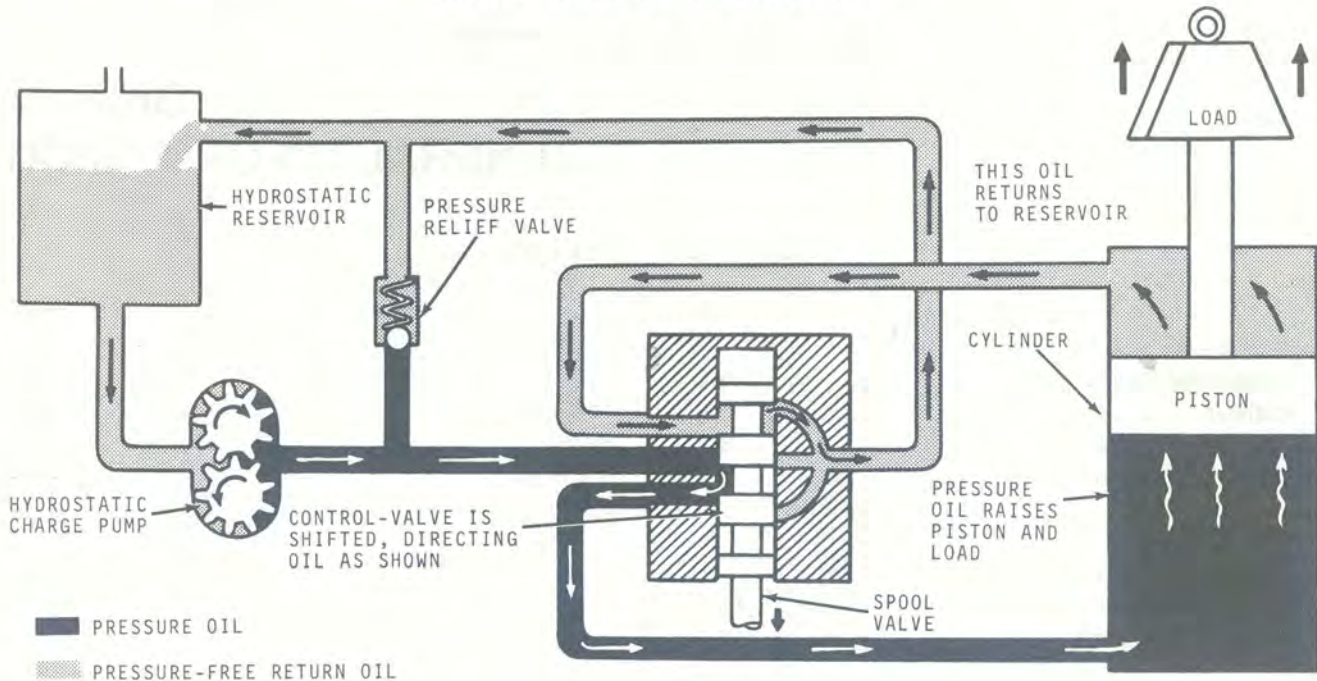

M 8935

Fig. 1-Components of Hydraulic Lift System

The 140 Hydrostatic Tractor has an open center hydraulic system, Figure 1, which uses the charge pressure of the hydrostatic transmission to lift and lower equipment.

An open center system is one in which the return and outlet ports of the valve are open in the neutral position, allowing a continuous flow of oil from the pump, Figure 2.

Operation of the hydrostatic unit is discussed in full in Section 50, Group 15.

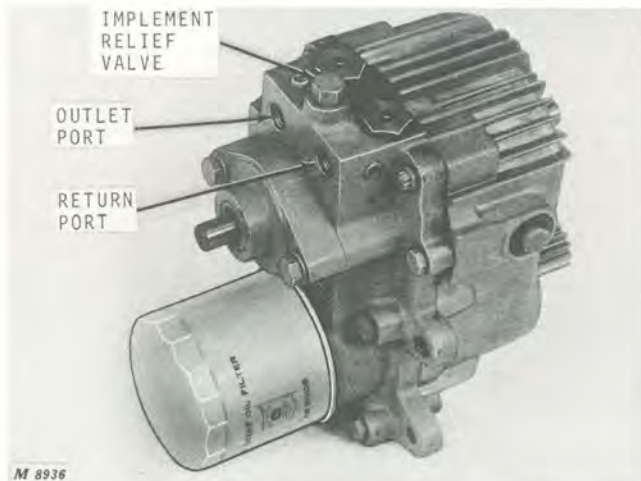

M 8936

Fig. 2-Implement Circuit Ports

The implement circuit furnishes a constant flow of oil at a pressure of 75 to 110 pounds per square inch. Oil under pressure from the fixed-displacement charge pump leaves the transmission through the charge relief valve and outlet port.

It travels continuously through the lines, hoses and valves and is returned to the transmission through the return port to the valve body. It is then dumped back into the reservoir.

When an implement control valve is actuated, this normal, unrestricted flow of oil is cut off and forced to the load. Pressure will build up to overcome the load or will be relieved at the implement relief valve.

The implement relief valve pressure is set at approximately 500 pounds per square inch. Any oil passing through the implement relief valve flows directly into the reservoir.



Fig. 3-Connecting Hose to Front Coupler

A 140 Tractor may be factory-equipped with either a single-spool valve and one hydraulic control lever (H-1 Tractor) or a 3-spool valve with three hydraulic control levers (H-3 Tractor).

The H-1 Tractor has a center-mounted, cylinder-operated rockshaft, and one set of front-mounted hydraulic couplers. Both of these systems operate on the same circuit.

The H-3 Tractor has a center-mounted, cylinder-operated rockshaft, and two sets of front-mounted hydraulic couplers. All three of these systems operate on separate circuits.

Both H-1 and H-3 Tractors can be equipped with optional rear-mounted hydraulic couplers, Figure 4.

A cylinder lock-out link is available and is used to lock the rockshaft cylinder in a retracted position. This is necessary to get instantaneous action of other implements, when using front or rear couplers, that are tied into the rockshaft circuit.

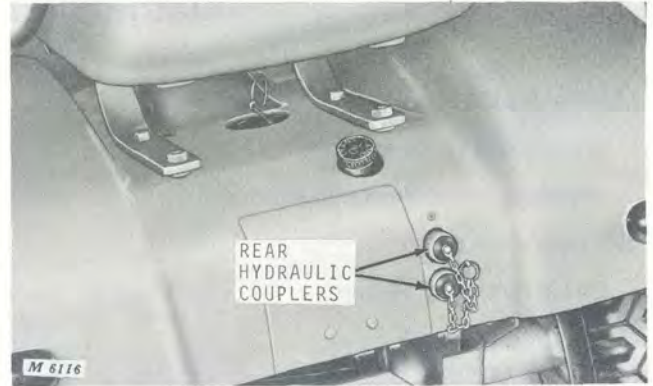

Fig. 4-Rear Hydraulic Couplers

## ANALYSIS

Analysis of failed parts affecting the operation of the hydraulic system can be found beginning on page 50-15-9 under "Inspecting Parts." Outside of the transmission most problems involving the hydraulic system will consist of failed O-rings, loose fittings or linkage problems.

## TESTING THE HYDRAULIC SYSTEM

Complete tests for checking the charge pressure and implement circuit pressure of the hydraulic system are found on page 15-5 of Section 50.



## DIAGNOSING MALFUNCTIONS

### Little or No Lift Power

- Insufficient engine speed.
- Improper transmission fluid used.
- System low on oil.
- Dirt in hydraulic system.
- Damaged linkage.
- Low charge pressure.
- Implement relief valve stuck open or leaking.
- Zero charge pressure.  
Check to be sure transmission drive shaft is engaged and turning.
- Broken implement line.
- Weak implement relief spring.

### Work Load Lowers with Spool in "Slow-Raise" Position

- Damaged lift check plunger.
- Damaged lift check seat.
- Damaged O-ring on lift check plug.

### Load Drops with Control Valve in "Neutral" Position

- Leaking or broken oil line or hose from control valve to cylinder.
- Oil leaking past cylinder packings or O-rings.
- Valve spool worn or damaged.

### Hydraulic Cylinder Lifts when Lever Is Pushed Forward; Lowers when Pulled Back

- Hoses installed in wrong coupler

### Leaking Valves

- Oil leaking at threads of fittings.
- O-rings defective.

### Overheating of Oil in System

- Dirt, grass and other contaminants in transmission cooling fins.
- Operator holding control valve in the power position too long, causing relief valve to open.
- Using incorrect oil in system.
- Low oil level in transmission.
- Dirty oil.
- Incorrect relief valve pressure.
- Dented, obstructed or undersized oil lines.

### Control Valve Not Centering when Released

- Check linkage for binding.
- Paint on exposed end of spool.
- Bent spool valve.

### Unable to Operate Rockshaft or Lift Cylinders

- Mechanical binding of equipment and tractor mount.
- Mower depth control locked in raised position.
- Cylinder lock-out strap in place.
- Cylinder defective.
- System overloaded.

### Couplers Leaking Oil

- Damaged O-rings or inefficient sealing around threads.

### Difficult to Attach or Detach Hoses to Couplers

- Hoses are pressurized.  
Move control levers back and forth after stopping the engine.

### Mower or Center Blade Raises and Lowers with Front Blade (H-1 Tractors)

- Cylinder lock-out link not installed.

# Group 10 HYDRAULIC CIRCUITS

## GENERAL INFORMATION

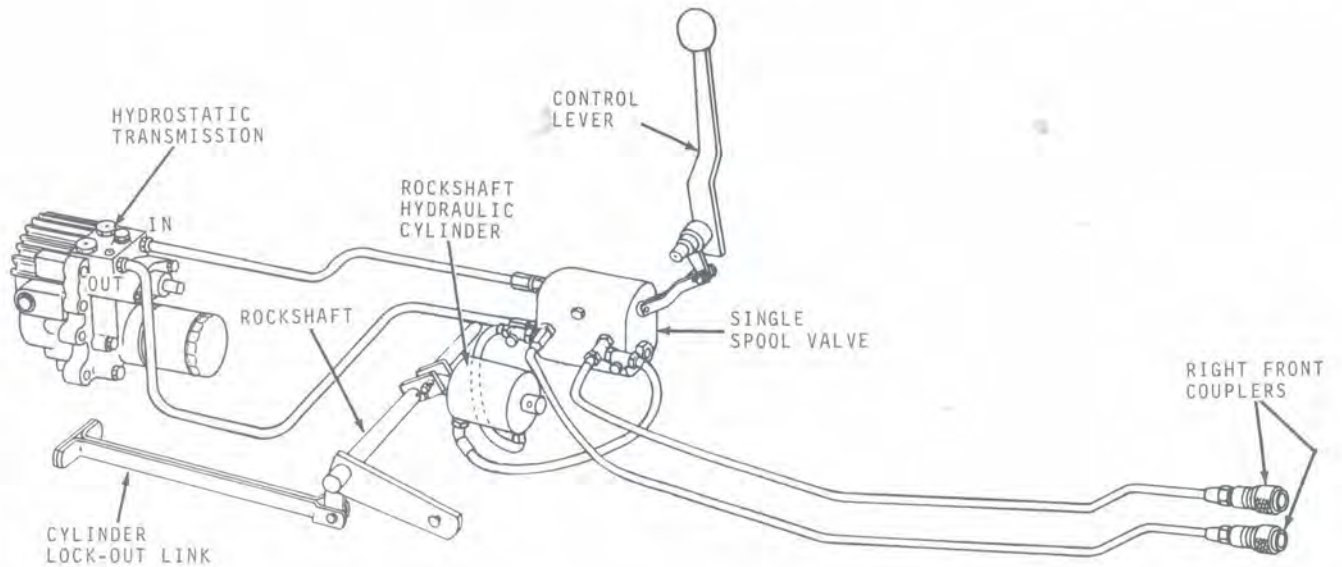

M 9428

Fig. 1-H-1 Hydraulic System Circuits

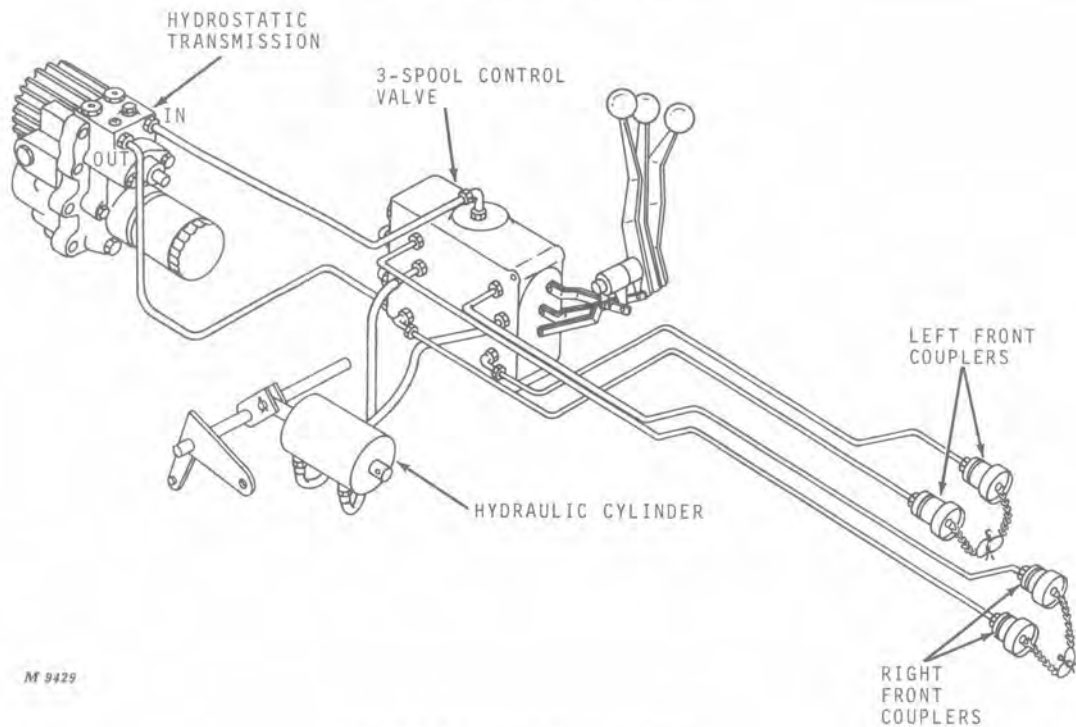

M 9429

Fig. 2-H-3 Hydraulic System Circuits



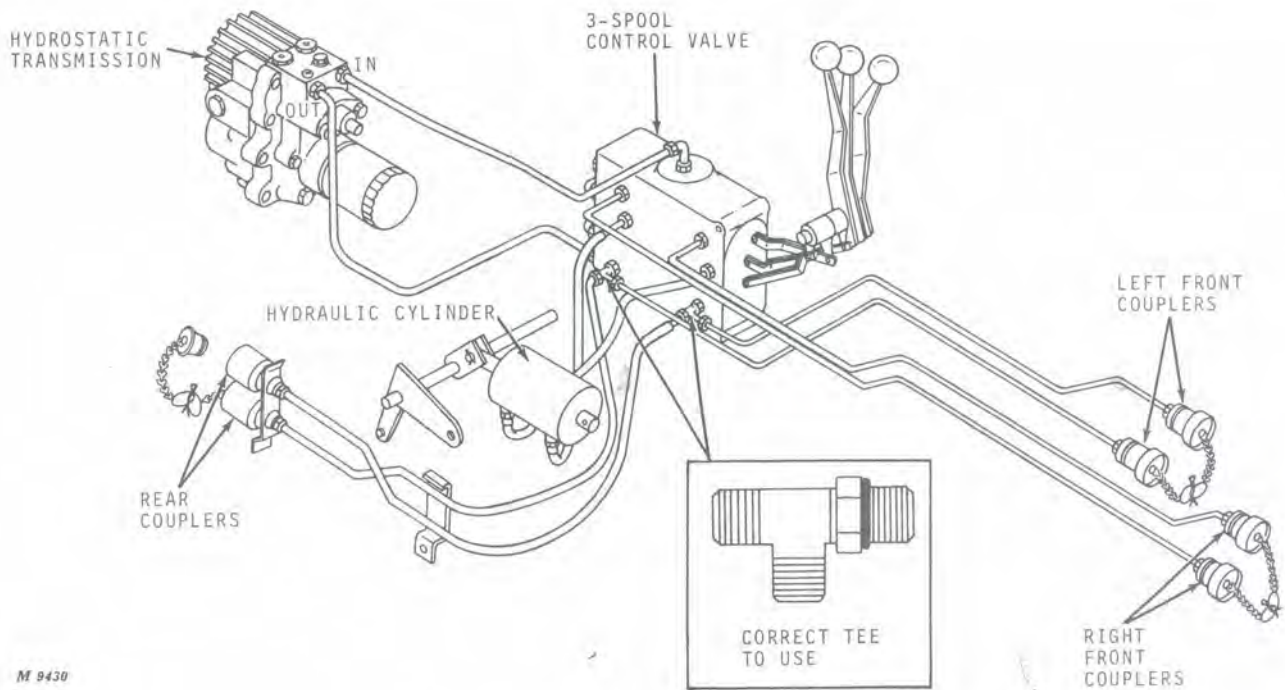

M 9430

Fig. 3-Assembly of Rear Hydraulic System on H-3 140 Tractors

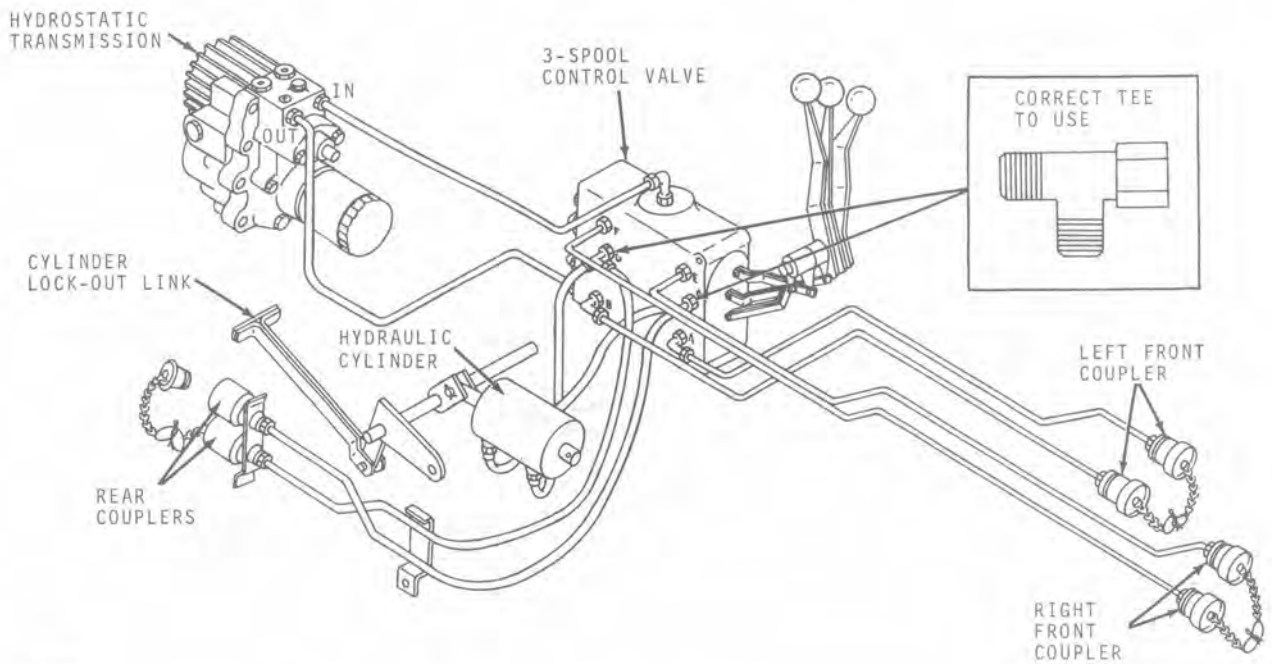

M 9431

Fig. 4-Optional Assembly of Rear Hydraulic System on H-3 140 Tractors

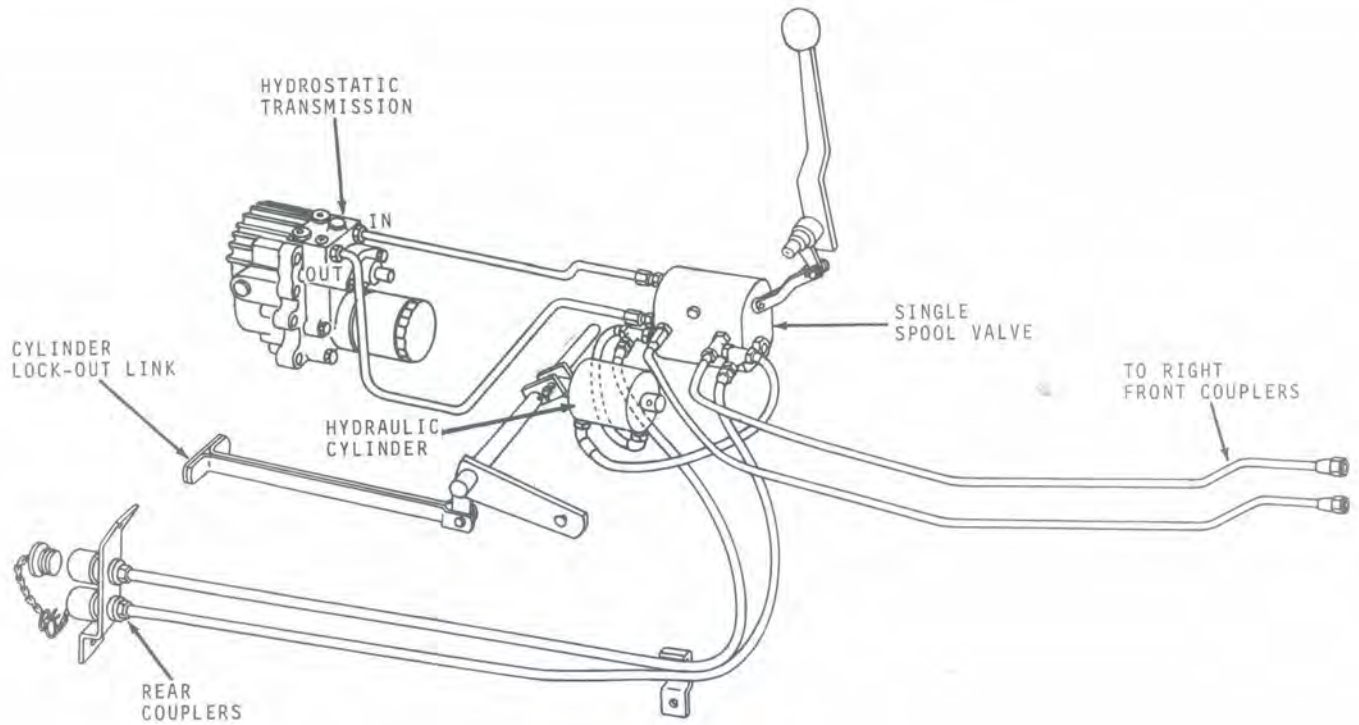

M 9432

Fig. 5-Assembly of Rear Hydraulic System on  
H-1 140 Tractors

## HYDRAULIC COUPLERS

If leakage occurs at the hydraulic couplers, remove coupler and inspect it for damaged O-rings, dirt or scoring.

Whenever couplers are removed from tractor, plug lines to prevent entrance of dirt. Also advise customers that they should always install dust plugs and dust caps when the coupler is uncoupled.

Do not attempt to repair coupler by removing inside ball checks and seats. These parts have been factory assembled to very close tolerances and should be repaired only at the factory.

Replace O-ring, Figure 6, and reinstall coupler using sealing compound on the male threads.

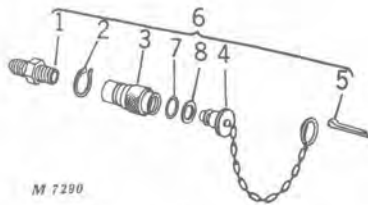

M 7290

- 1-Hose Union
- 2-Snap Ring
- 3-Hydraulic Coupler
- 4-Rubber Dust Plug
- 5-Cotter Pin
- 6-Hydraulic Kit
- 7-O-Ring
- 8-Backup Washer

Fig. 6-Hydraulic Coupler





## Group 15 HYDRAULIC CONTROL VALVES

### GENERAL INFORMATION

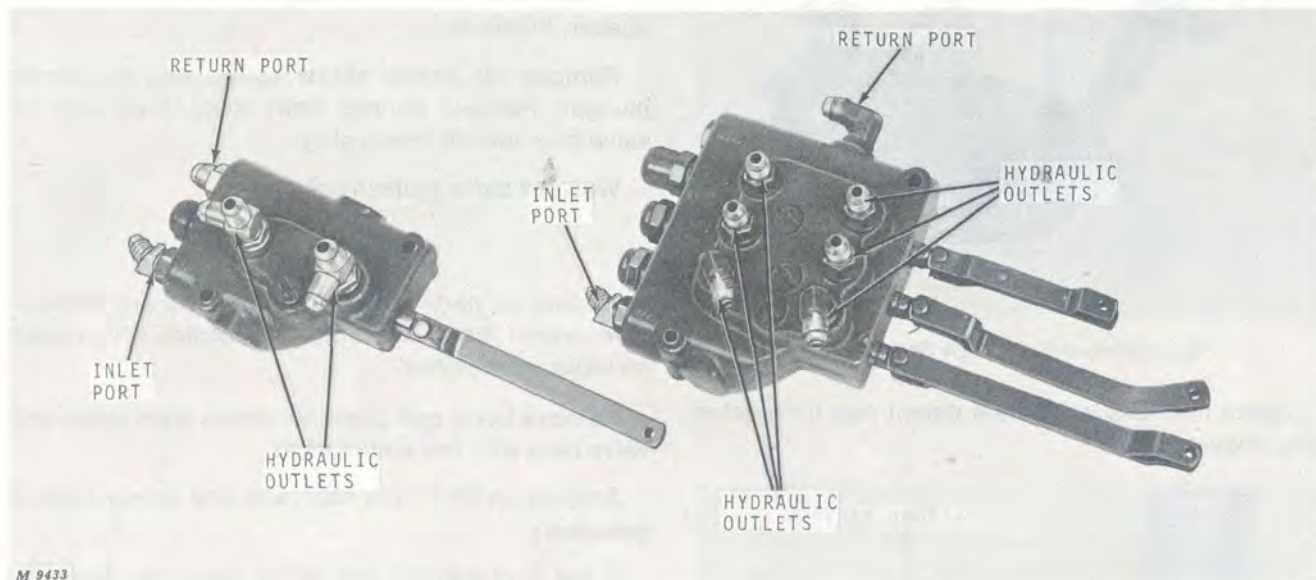

Fig. 1-Control Valves

The 140 Hydrostatic Tractor features open center control valves, Figure 1, providing a continuous flow of oil from the reservoir to the transmission charge pump, the valve and back to the reservoir.

The single spool valve is used on H-1 140 Tractors and the 3-spool valve is used on H-3 140 Tractors.

Oil flow is continuous as long as the control lever is in neutral. When lever is moved out of the neutral position, a restriction is created diverting oil under pressure to the work load.

### REMOVAL

Before removing control valve from tractor, be sure to check "Diagnosing Malfunctions", page 5-4 of this section, to determine all possible external causes of difficulty.

The control valve should be removed from the tractor and serviced if any of the following conditions exist.

1. Oil leakage is noticed.
2. Whenever system hesitates on the lift. (Indicates faulty check valve.)
3. Implement lowers when lever is in neutral. (Indicates check valve is either dirty or faulty.)

The control valve is removed from the underside of the tractor.

Clean around and disconnect all fittings from control valve. Cap or plug all lines, hoses and ports so dirt can't enter the system.

Disconnect linkage to hydraulic control levers by removing the small cotter pins. Remove two mounting bolts and remove valve.



## DISASSEMBLY

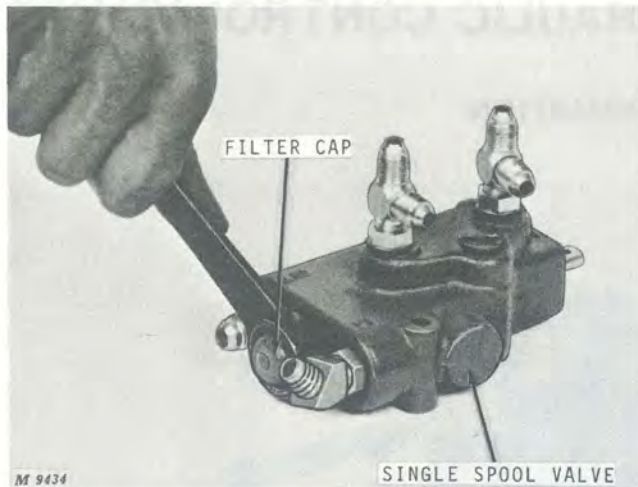

Fig. 2-Disassembly of Single Spool Valve

Loosen filter cap(s) or float detent cap from valve body, Figure 2.

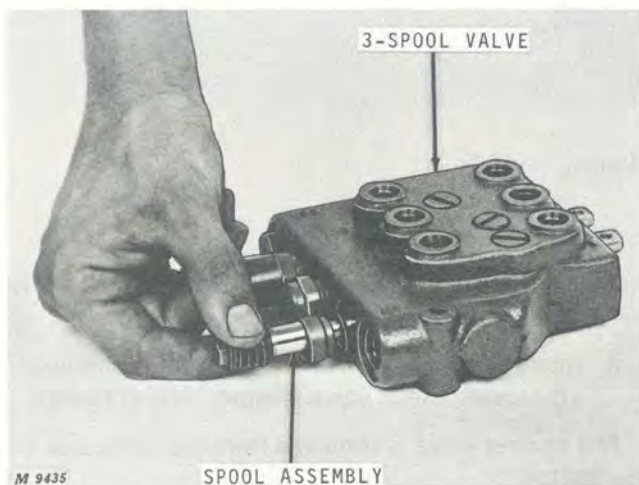

Fig. 3-Removing Spool From 3-Spool Valve

Remove spools by pushing them out filter cap end of valve body, Figure 3.

**NOTE:** When removing float detent cap, (longest cap) care must be taken to prevent losing spring-loaded steel balls. Place a cloth over assembly to catch balls as the cap is removed.

Be careful when disassembling valves so that spools are not mixed because they are select-fitted at the factory and should not be changed. If a spool or valve body is damaged, the entire valve must be replaced.

Remove screws from spools and remove springs and washers. Spools without detents have a steel spacer, Figure 4.

Remove lift check screw spring and lift check plunger. Remove O-rings from spool, lower end of valve bore and lift check plug.

Wash all parts in clean solvent.

## REPAIR

Inspect all parts thoroughly. All parts are serviceable except the spools and valve bodies which must be replaced together.

Remove burrs and slight scratches from spool and valve bore with fine emery cloth.

Smooth up lift check seat with fine emery cloth if necessary.

If the screw in the end of the spool has been removed, clean Loctite from threads. Thoroughly clean all parts and oil lightly prior to assembly.

## ASSEMBLY

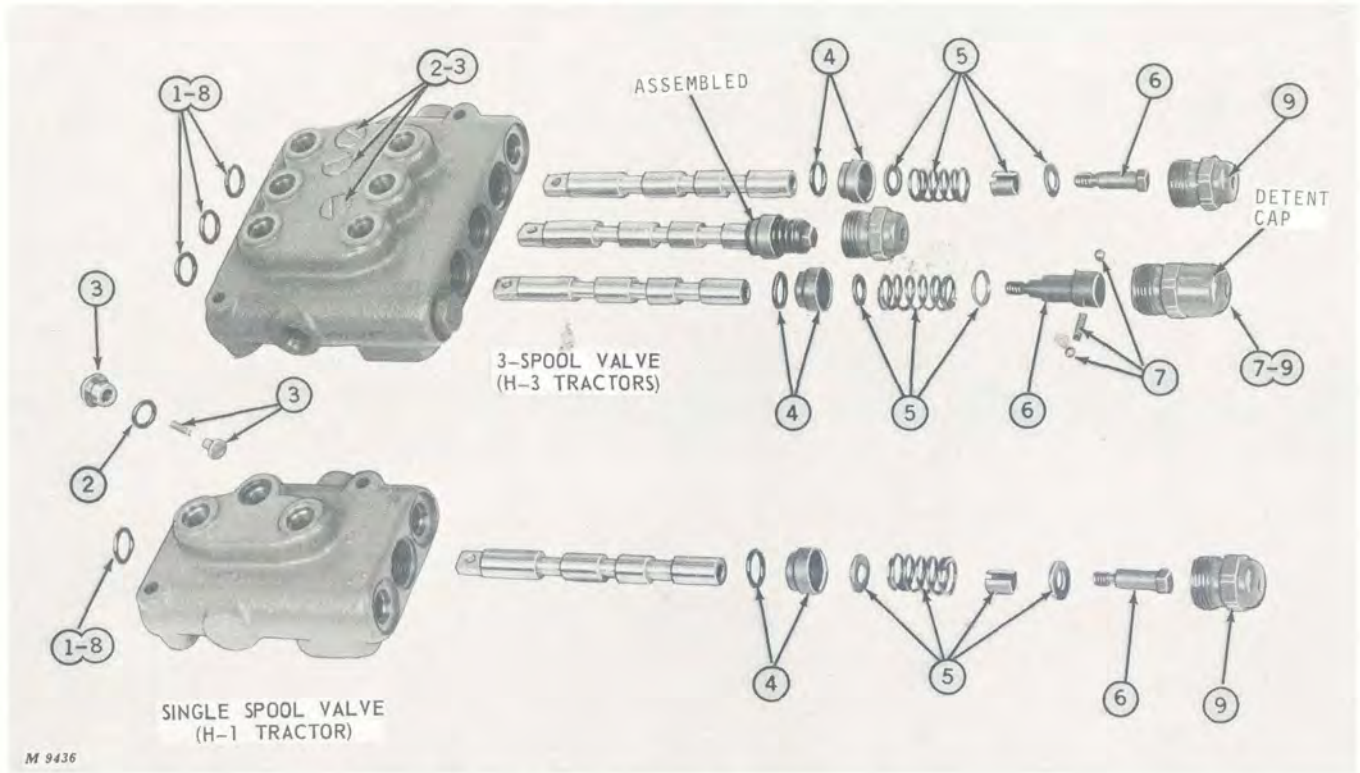

Fig. 4-Control Valve Components

Using Figure 4 for identification of parts, assemble control valves in the following sequence:

1. Install new O-ring in spool body.
2. Install new O-ring on lift check plug.
3. Install lift check plunger and lift check spring in valve body and secure with lift check plug. Tighten plug securely.
4. Place end of spool with flat side in vise and slide new O-ring on spool. Then slide bushing on spool.
5. Slip steel washer, spring and another steel washer on spool.  
*NOTE: On spools without detent, a spool spacer must be installed between the two steel washers. Springs are of different length.*
6. Apply Loctite to spool screw threads, and screw tightly into spool.
7. If installing detent spool, install spring into screw hole and push steel balls into hole while slipping cap over balls.

8. Grease lower O-ring in valve body and slowly insert spool into valve body.
9. Tighten cap slightly but not tight enough to bind the spool. This can be determined by turning the spool and checking the tightness.

## INSTALLATION

Attach valve to its proper mounting bracket using the two 1/4-inch bolts. Connect linkage from hydraulic control levers to valve spool. Remove caps and plugs from fittings and lines.

Install sealing compound on fittings. Attach hydraulic lines to proper fittings. See Group 10. Tighten securely.





## Group 20 HYDRAULIC CYLINDERS

### GENERAL INFORMATION

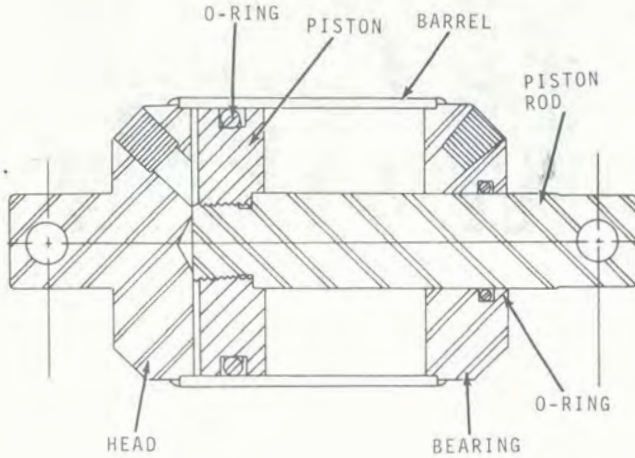

M5965N

Fig. 1-Cutaway of Rockshaft Cylinder

The rockshaft cylinder is connected to the cylinder arm of the lift shaft and the tractor frame. When the proper hydraulic control lever is moved forward or rearward, the cylinder is extended or retracted, actuating the lift linkage and raising or lowering mounted equipment.

The cylinder is double-acting and connected to the valve body by two high-pressure flexible hoses. Although the hydraulic cylinder is double-acting, slots in the linkage prevent the cylinder from exerting downward force on the tractor lift linkage for rockshaft mounted equipment. This prevents damage to the equipment and allows it to "float" with ground contours.

The rockshaft cylinder is a welded assembly and is not serviceable. A new cylinder must be installed if the old cylinder is defective. Check "Diagnosing Malfunctions," Group 5, for possible causes of cylinder failure.

Remove old cylinder and install new cylinder as instructed on the next page.

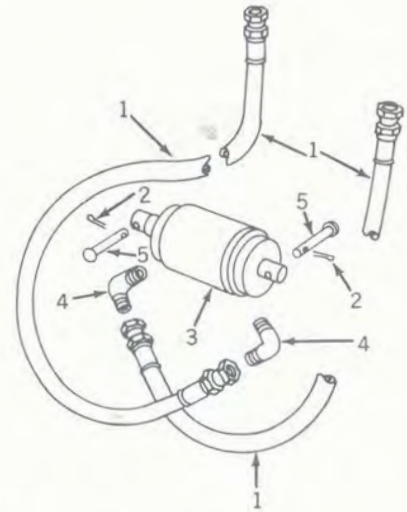

M9437N

- 1 - Hydraulic Hoses
- 2 - Cotter Pin
- 3 - Rockshaft Cylinder
- 4 - 90° Elbow
- 5 - Cylinder Pin

Fig. 2-Exploded View of Cylinder

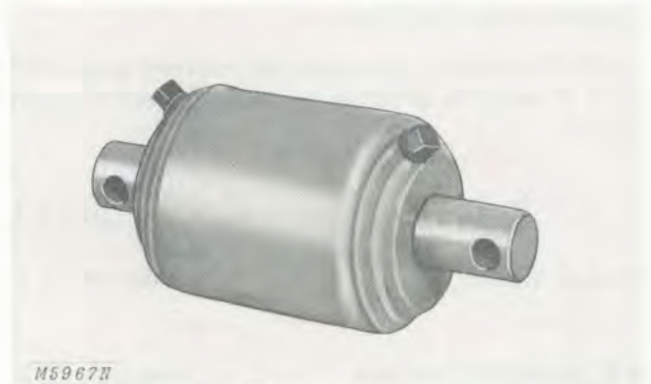

M5967N

Fig. 3-Rockshaft Cylinder



### TESTING

To test cylinder, Figure 1, retract cylinder. Disconnect hose from head end of cylinder at the control valve. Place end of hose in a clean can.

With engine running, move hydraulic control lever to retract cylinder. After initial oil flow stops there should be no oil flow into the can.

Continuous flow indicates oil leaking by piston O-ring. If such flow occurs, replace cylinder.

### REPAIR

Wipe all dirt from connections on valve body. Move hydraulic control lever back and forth to relieve all pressure in the system. Remove hoses and cylinder. Replace cylinder if defective.

### INSTALLATION

Lightly clamp cylinder in a vise with soft jaws.

Screw 90 degree connector into each end of cylinder and tighten firmly.

*NOTE: Apply sealing compound to threads prior to installation.*

Attach hoses to connectors and torque swivel nuts to 150 to 180 in-lbs.

Install hose from head end of cylinder to rear port in single-spool control valve. Attach hose from rear of cylinder to front port in valve.

*NOTE: Hydraulic lines may be reversed on control valve to reverse direction of lift lever control when desired.*

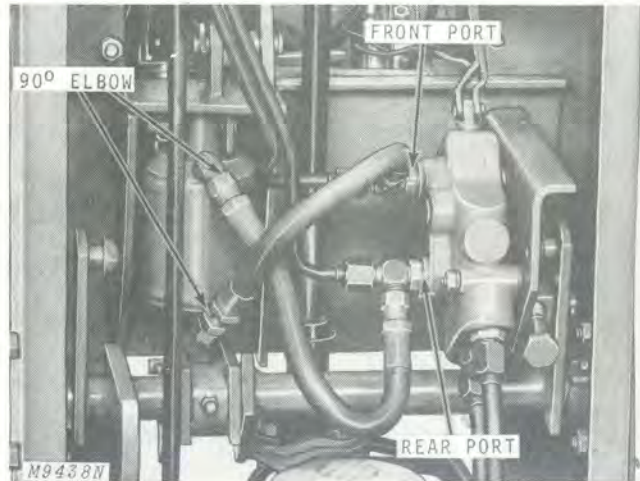

Fig. 4-Connecting Cylinder to Single Spool Valve

Insert pin through tractor frame, frame brackets and cylinder. Insert cotter pins and spread ends.

Insert pin through lower lift shaft arms and piston rod. Insert cotter pins and spread ends, Figure 3.

### SPECIFICATIONS

Item	New Part
Bore .....	2-1/2-inch diameter
Stroke .....	1-1/2-inch
Rod Size .....	0.875-inch diameter

### SPECIAL TOOLS

Torque Wrench	Snap-On QT-217	With Open End Crowfoot FCO-20 or AM8506-5
5/8" Open End Crowfoot	Snap-On FCO-20*	Torque swivel nuts on cylinder of H-1 Tractor
11/16" Open End Crowfoot	Snap-On AM8506-5*	Torque swivel nuts on cylinder of H-3 Tractor

\* Order from Snap-On Tool Corporation, 2115 South 162nd Street, New Berlin, Wisconsin 53159, or a local Snap-On representative.

# Section 70 MISCELLANEOUS

## Group 5 GENERAL INFORMATION

### TABLE OF CONTENTS

	Page		Page
<b>GROUP 5 - GENERAL INFORMATION</b>			
Steering .....	5-2	Removing Front Axle .....	15-2
Front Wheels and Axles .....	5-2	Inspecting Bearings .....	15-2
Fender-Deck and Seat .....	5-2	Inspecting Axle Bushings .....	15-2
Diagnosing Malfunctions .....	5-3	Removing Axle Bushings .....	15-3
<b>GROUP 10 - STEERING ASSEMBLY</b>			
General Information .....	10-1	Installation .....	15-3
Analysis .....	10-2	Installing Axle Bushings .....	15-3
Seal and Retainer .....	10-2	Installing Axle .....	15-3
Housing .....	10-2	Installing Spindles .....	15-4
Spindle .....	10-3	Installing Bearings and Wheels .....	15-4
Ball Joints .....	10-3	Adjustment .....	15-4
Repair .....	10-3	Front Wheel Bearing .....	15-4
Removing Steering Wheel and		Specifications .....	15-5
Steering Gear .....	10-4	Torque for Hardware .....	15-5
Disassembling Steering Gear .....	10-5	Special Tools .....	15-5
Inspecting Steering Gear .....	10-5	<b>GROUP 16 - FRONT WHEELS AND AXLE</b>	
Assembly .....	10-5	(Serial No. 38,001- )	
Assembling Steering Gear .....	10-5	Introduction .....	16-1
Installation .....	10-6	Repair .....	16-1
Installing Steering Gear .....	10-6	Removing Front Wheels .....	16-2
Installing Steering Linkage .....	10-7	Removing Spindle from Axle .....	16-2
Completing Installation .....	10-7	Removing Front Axle .....	16-2
Steering Adjustment .....	10-8	Installing Axle .....	16-3
Steering Cone Adjustment .....	10-8	Installing Spindles .....	16-3
Steering Gear Alignment .....	10-8	Installing Bearings and Wheels .....	16-3
Steering Gear Adjustment .....	10-9	Torque for Hardware .....	16-4
Front Wheel Toe-In Adjustment .....	10-10	Special Tools .....	16-4
Torque for Hardware .....	10-10	<b>GROUP 20 - FENDER-DECK AND SEAT</b>	
Special Tools .....	10-10	ASSEMBLY	
<b>GROUP 15 - FRONT WHEELS AND AXLE</b>			
(Serial No. 30,001-38,000)			
Introduction .....	15-1	General Information .....	20-1
Repair .....	15-1	Removal and Installation .....	20-1
Removing Front Wheels .....	15-2	Repair .....	20-2
Removing Spindles .....	15-2	Seat Adjustment .....	20-4



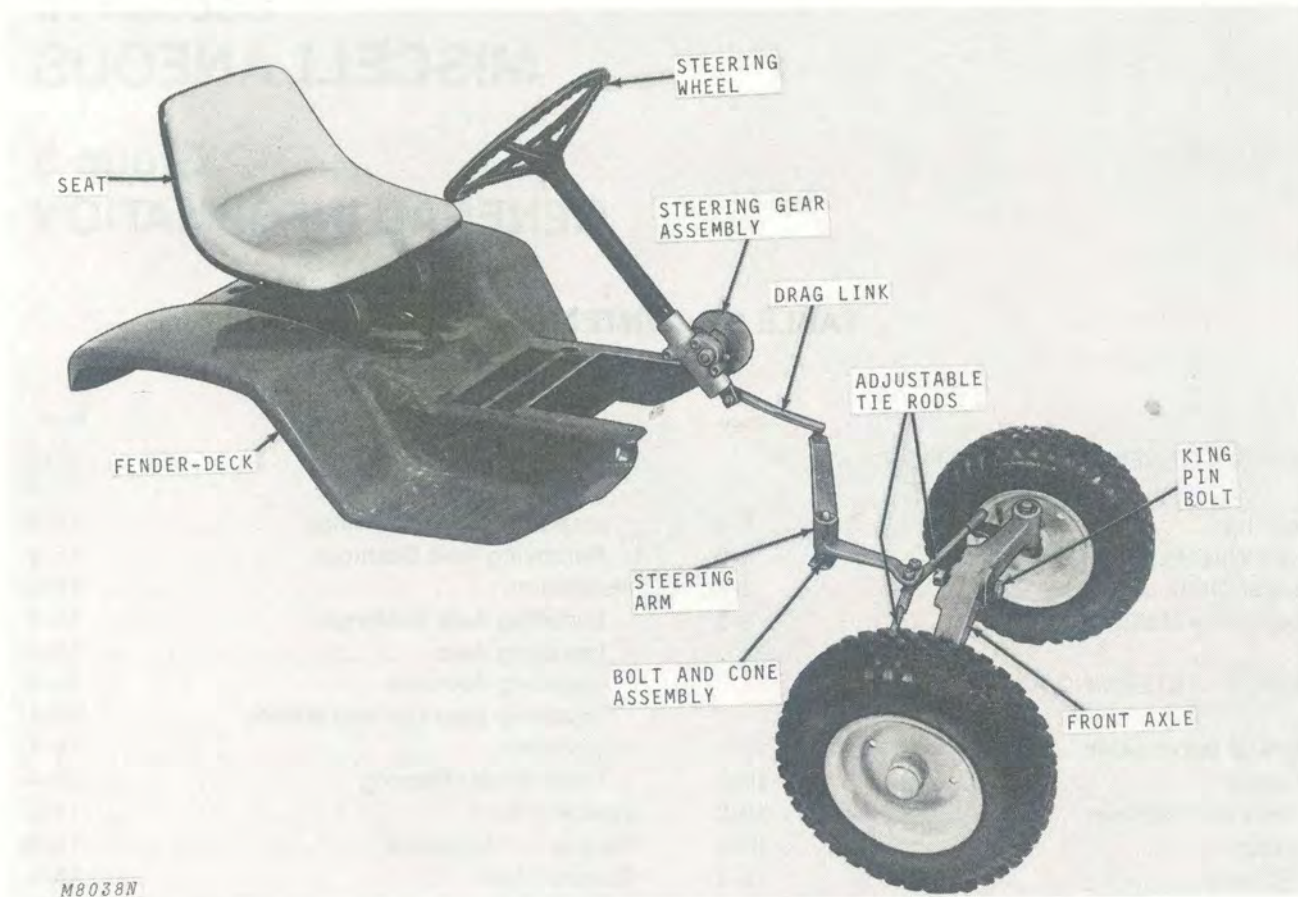

Fig. 1-Seat, Fender-Deck, Steering and Front Axle

## STEERING

Steering on the 140 Hydrostatic Tractor is accomplished through a steering wheel, steering column, steering gear assembly, drag link, steering arm, and adjustable tie rods.

Adjustments may be made to the gear assembly and tie rods to improve steering.

## FRONT WHEELS AND AXLE

Front wheels are mounted on spindles and turn on

roller bearings. The spindles are held in the front axle by snap rings, and are attached to the tie rods.

## FENDER-DECK AND SEAT

The one piece fender-deck adds to the attractiveness of the 140 Tractor and supplies an inclined mounting area for the seat. This permits the seat to be lowered automatically as it is moved forward; raised as it is moved backward. The deck is insulated from the frame by rubber pads and mounts for operator comfort.

## DIAGNOSING MALFUNCTIONS

### Steering

#### Loose Steering

- Steering gear out of adjustment.
- Loose steering arm.
- Cracked steering gear housing.
- Loose ball joint nuts.
- Worn ball joints.

#### Hard Steering

- Tires not properly inflated.
- Steering gear not properly adjusted (too tight).
- Tight spindles.
- Tight steering arm, not properly adjusted and/or lubricated.
- Drag link installed incorrectly.
- Bent spindle arm.
- Tight ball joint(s).
- Incorrect toe-in.

#### Tractor Turns Shorter in One Direction

- Drag link incorrectly installed.
- Bent spindle and/or spindle arm.
- Tie rods adjusted improperly.

#### Leaky Steering Gear Housing

- Damaged seal.
- Damaged retainer.
- Steering gear overlubricated.

#### Tire Strikes Tractor On Turns

- Steering linkage not properly adjusted.
- Bent spindle and/or spindle arm.

#### Tire Wear

- Wheels toed-out or toed-in excessively.
- Bent spindle and/or spindle arm.
- Tires not properly inflated.

#### Steering Column Squeaks When Steering Wheel Is Turned

- Loose steering column clamp.
- No insulating tape around steering column (clamp and bracket area in pedestal).
- Lack of lubrication.

#### Excessive End Play

- Loose adjusting plug.
- Bearings out of retainer in steering gear.

## Fender-Deck Assembly

#### Taillights Fail to Operate

- Metal ground strap not grounded to frame.

## Seat

#### Seat Is Not Easily Adjustable

- Check seat latch or pivot for bent or broken parts.

#### Seat Does Not Lock In Place

- Spring broken or loose.





## Group 10 STEERING ASSEMBLY

### GENERAL INFORMATION

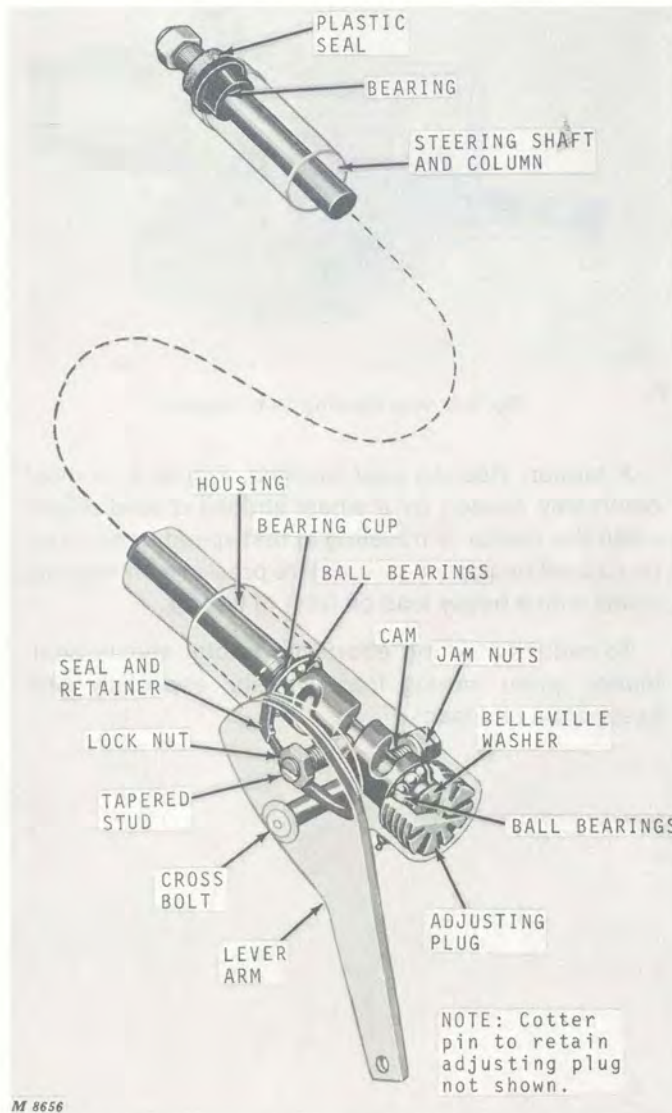

Fig. 1-Ross Steering Gear

The steering mechanism used on the 140 Hydrostatic Tractor consists of the steering wheel, steering gear assembly, drag link, steering arm, and tie rods.

The Ross steering gear, Figure 1, features a cam, actuated by the steering wheel and shaft. Cam movement causes the lever arm to move from front to rear. This, in turn, pulls or pushes the drag link, causing rotation of the steering arm on the bolt and cone assembly.

Movement of the steering arm causes the tie rods to move the spindles in the front axle, thereby changing wheel position.

The steering gear used on 140 Tractors has a 14:1 steering ratio coupled with one-piece drag link and adjustable tie rods, Figure 2.



Fig. 2-Adjustable Tie Rods



## ANALYSIS

Listed below is a preliminary analysis of difficulties that can occur with the steering system. Familiarize yourself with the information on this page and with "Diagnosing Malfunctions" on page 5-3 prior to repair.

### Seal and Retainer

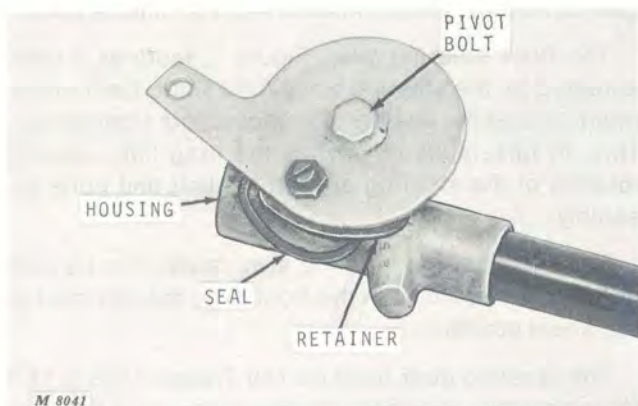

Fig. 3-Damaged Seal

A damaged seal, Figure 3, is caused by overgreasing the housing or an improperly adjusted pivot bolt in the lever arm.

### Housing

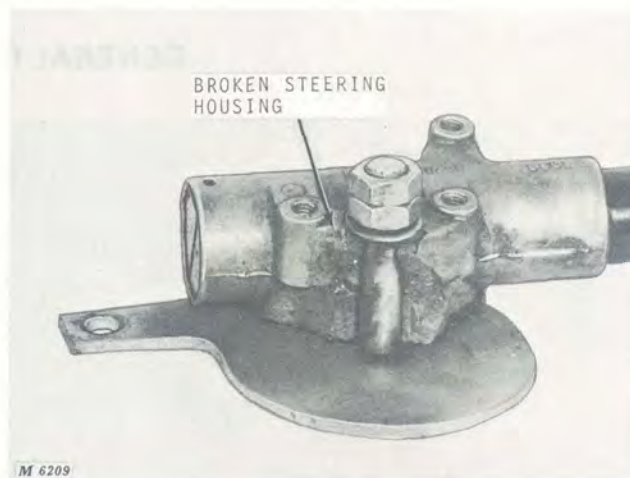

Fig. 4-Broken Steering Gear Housing

A broken steering gear housing, Figure 4, is most commonly caused by a wheel striking a solid object when the tractor is traveling at fast speed. It can also be caused by applying excessive pressure on steering wheel with a heavy load on front of tractor.

To reduce steering effort, the tractor should be in motion when turning front wheels, especially with heavy front end loads.

### Spindle

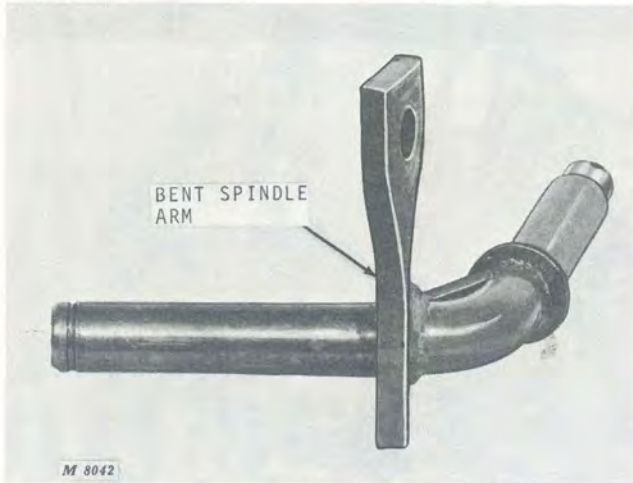

Fig. 5-Twisted Spindle Arm

A twisted or bent spindle arm as shown in Figure 5, is usually the result of the front wheel striking a solid object.

### Ball Joints



Fig. 6-Ball Joints

Replace ball joint assembly whenever excessive looseness or other damage is noticed, Figure 6.

## REPAIR

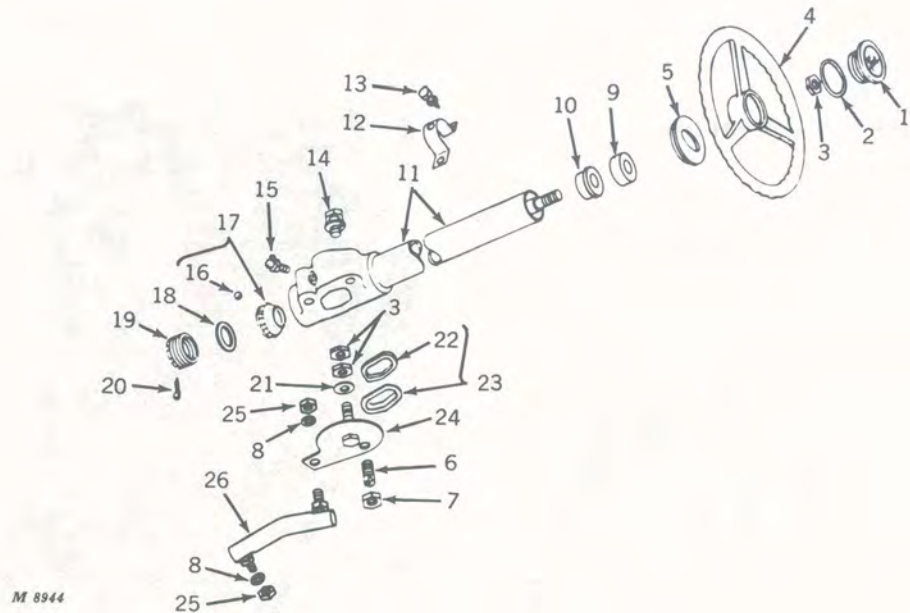

- |                          |                              |                              |
|--------------------------|------------------------------|------------------------------|
| 1-Steering Wheel Emblem  | 11-Steering Gear Assembly    | 20-Cotter Pin                |
| 2-O-ring                 | 12-Steering Column Clamp     | 21-Washer                    |
| 3-5/8" Hex. Nut (3 used) | 13-Screw                     | 22-Lever Arm Seal            |
| 4-Steering Wheel         | 14-Cap Screw and Lock Washer | 23-Retainer with Seal        |
| 5-Grommet                | 15-Grease Fitting            | 24-Lever Arm with Pivot Bolt |
| 6-Tapered Stud           | 16-Steel Ball                | 25-Jam Nut                   |
| 7-Jam Nut                | 17-Bearing Kit               | 26-Drag Link Assembly        |
| 8-Lock Washer            | 18-Belleville Washer         |                              |
| 9-Bearing Seal           | 19-Adjusting Plug            |                              |
| 10-Shaft Bearing         |                              |                              |

Fig. 7-Exploded View - Steering Linkage



**REPAIR—Continued**

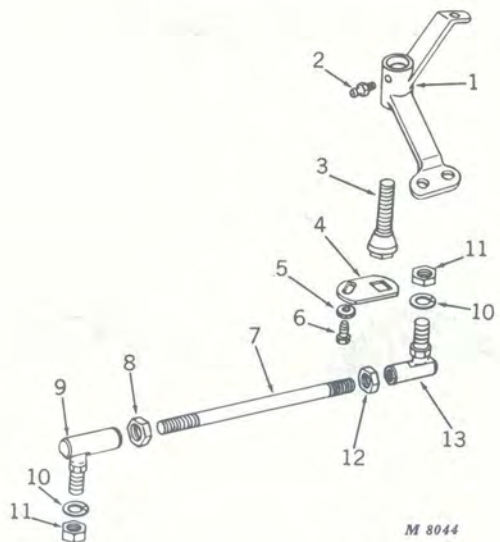

- |                      |                |
|----------------------|----------------|
| 1-Steering Arm       | 8-Jam Nut      |
| 2-Grease Fitting     | 9-Ball Joint   |
| 3-Bolt with Cone     | 10-Lock Washer |
| 4-Locking Strap      | 11-Nut         |
| 5-Washer             | 12-Jam Nut     |
| 6-Self-tapping Screw | 13-Ball Joint  |
| 7-Tie Rod            |                |

Fig. 8-Steering Arm and Tie-Rod Assembly

**Removing Steering Wheel and Steering Gear**

Remove steering wheel with puller, Figure 9. Remove battery, battery base and fuel tank.

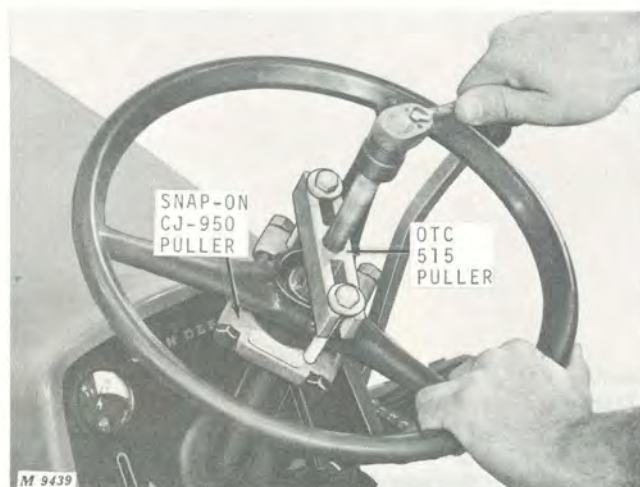

Fig. 9-Removing Steering Wheel

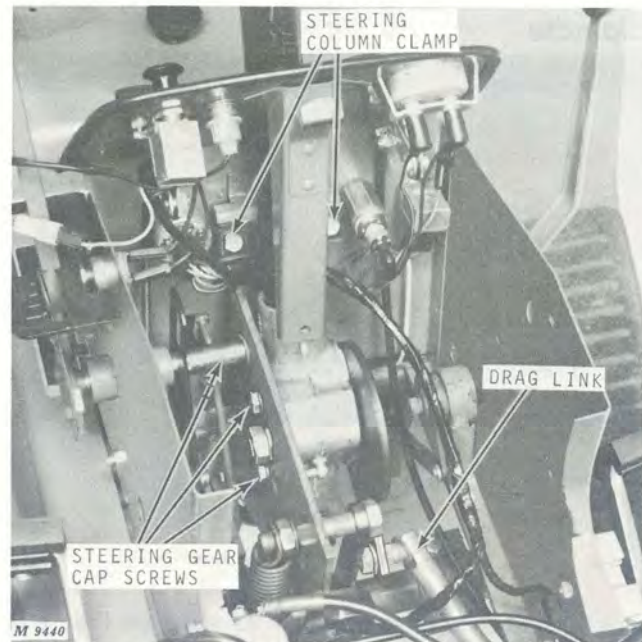

Fig. 10-Disconnecting Steering Gear

Disconnect drag link from steering gear lever arm, Figure 10. Remove the steering column clamp. Remove the three cap screws securing steering gear to tractor frame.

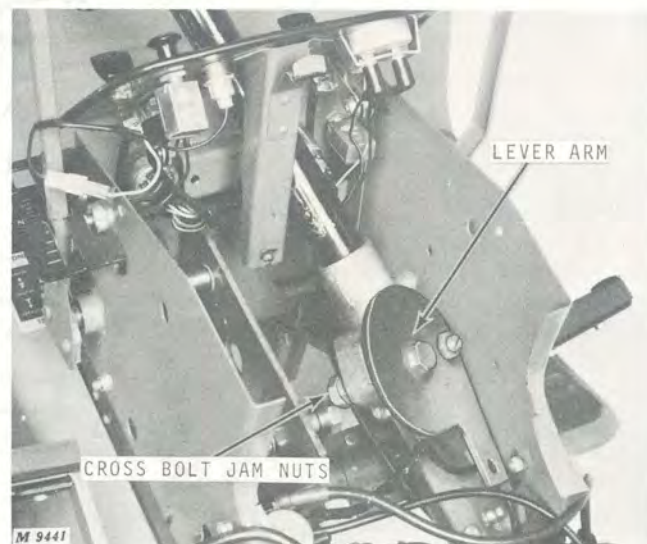

Fig. 11-Removing Lever Arm

Turn the steering gear on its side as shown in Figure 11. Remove the cross bolt jam nuts and then remove the lever arm and pivot bolt.

Lower steering gear and remove it from beneath tractor.

### Disassembling Steering Gear

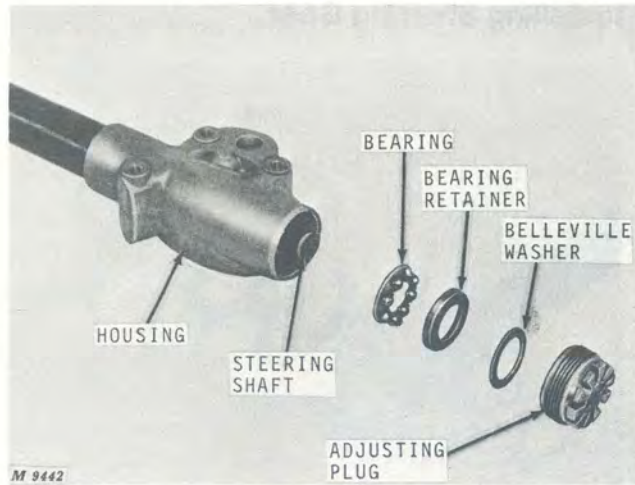

Fig. 12-Disassembling Gear

Remove adjusting plug, Belleville washer, bearing retainer, and bearing, Figure 12. Pull steering shaft out of gear housing.

### Inspecting Steering Gear Parts

Wash parts, Figure 13, in a clean, safe solvent and dry with compressed air and a clean cloth.

Check bearing condition. Inspect cam, housing and plug for cracks, scoring and other damage, especially in the bearing area. Replace parts showing excessive wear or damage.

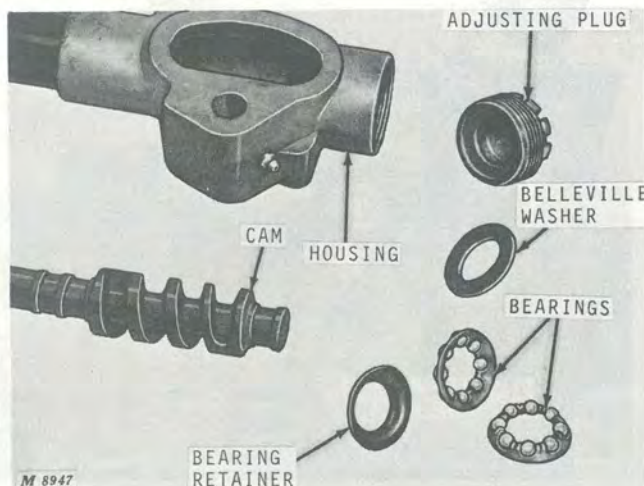

Fig. 13-Steering Gear Disassembled

### ASSEMBLY

### Assembling Steering Gear

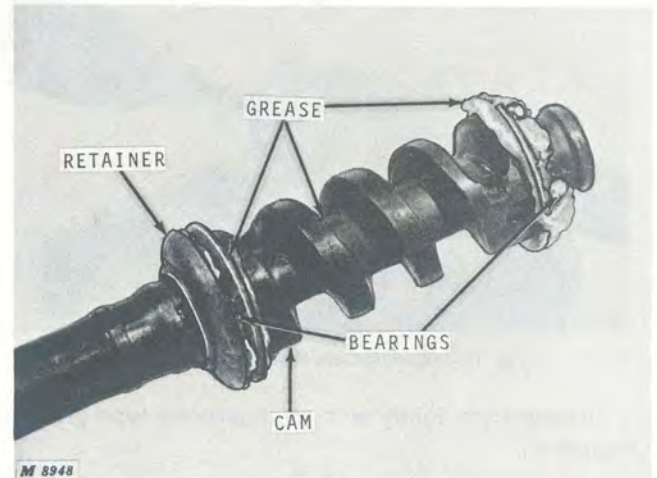

Fig. 14-Installing Bearings

Apply grease and place ball bearing, Figure 14, ball cups and retaining rings on both ends of cam.



## INSTALLATION

### Installing Steering Gear

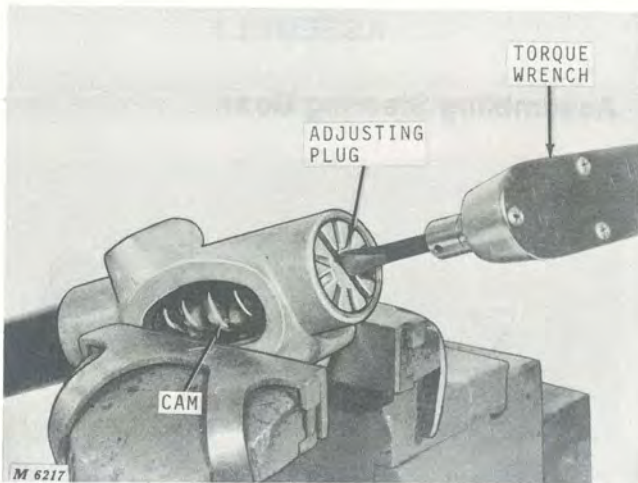

Fig. 15-Installing Cam Assembly in Housing

Grease cam lightly with multipurpose-type grease, Figure 15.

Slide cam and shaft assembly into housing and steering column. Install plug and tighten to 10 to 14 ft-lbs torque.

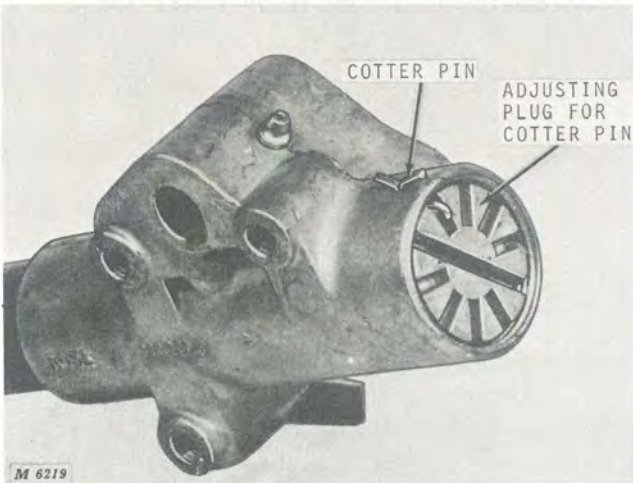

Fig. 16-Installing Cotter Pin Through Housing

After tightening, lock plug with cotter pin, Figure 16. Be sure steering shaft turns freely.

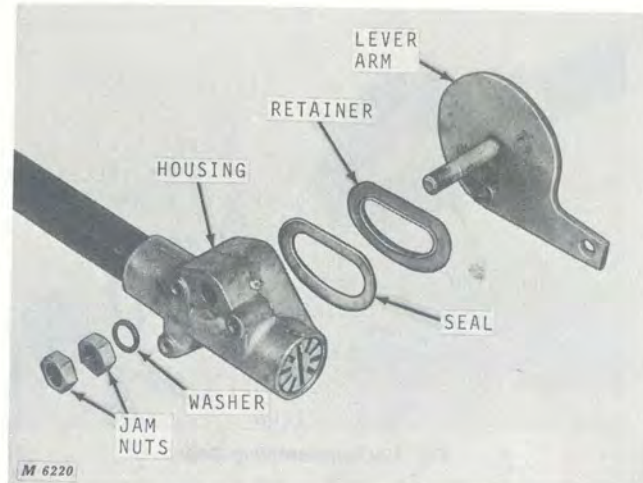

Fig. 17-Attaching Lever Arm to Steering Gear

Install steering gear by bringing it up from underneath tractor. Install new seal and retainer from repair kit, Figure 17. Attach lever arm to steering gear housing with washer and two jam nuts. See page 10-9 for proper adjustment.

Install three cap screws attaching steering gear to frame, Figure 18.

Lubricate steering gear according to instructions on page 10-20-4.

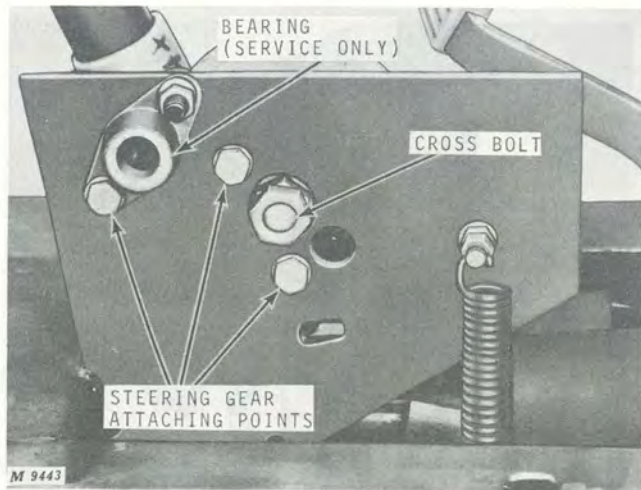

Fig. 18-Installing Steering Gear to Frame Mount  
(Pedestal Removed for Clarity)

## Installing Steering Linkage

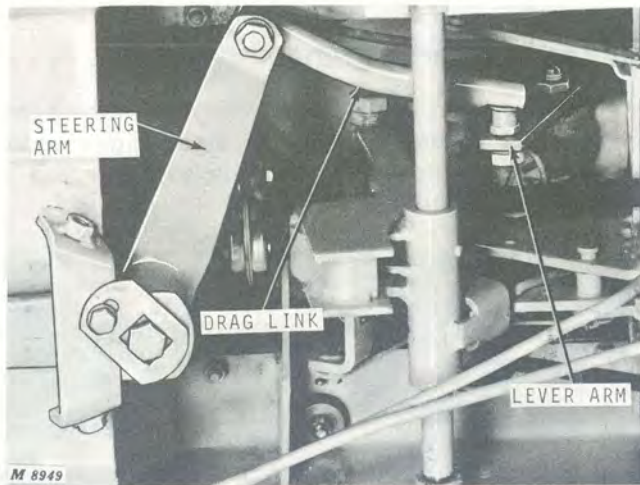

Fig. 19-Installing Drag Link

Attach drag link to steering arm and steering gear lever arm, Figure 19.

*NOTE: It is important that drag link is positioned with bend facing the center of the tractor before tightening nuts.*

Install clamp holding steering column to pedestal, Figure 10.

## Completing Installation

Adjust the steering gear mechanism according to the sequence explained on page 10-8 and 10-9.

Install battery base, battery and fuel tank. Install steering wheel and tighten nut to 10 to 12 foot-pounds torque. Replace O-ring and steering wheel emblem.



## STEERING ADJUSTMENT

Adjust steering mechanism in the sequence shown when excessive play (loose steering) is noticed, or if steering becomes difficult.

### Steering Cone Adjustment

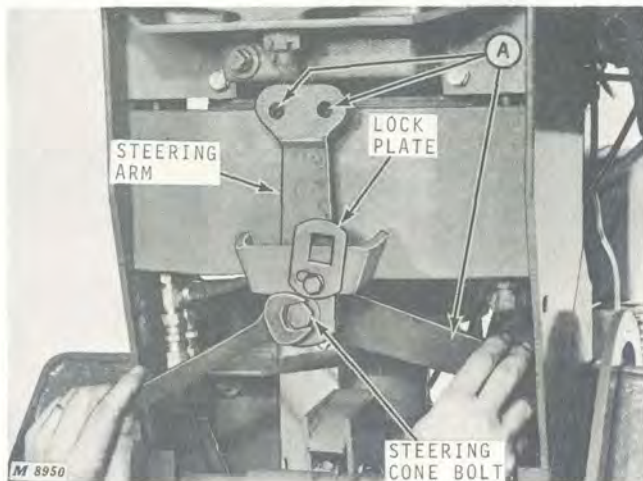

Fig. 20-Adjusting Steering Cone

1. Block up front end of tractor so that front tires are off the ground.
  2. Disconnect ball joints at points "A," Figure 20.
  3. Turn steering arm by hand and notice freedom of movement. When properly adjusted, the steering arm will pivot freely through the entire steering range with only a slight amount of drag.
  4. If steering arm turns hard or has worn and loosened so that you can feel end play in the steering arm bearing, remove lock plate, cone bearing and pivot bolt. Lubricate bearing cone and re-install pivot bolt.
  5. Tighten bolt only until a slight amount of drag can be felt when turning the steering arm and all end play has been removed.
  6. Position lock plate over bolt head and tighten lock plate cap screw. Be sure plain washer is used with lock plate cap screw.
- NOTE: If lock plate cannot be installed without turning bolt out of adjusted position, turn plate over.*
7. Connect ball joints at points "A."

### Steering Gear Alignment

Steering effort is minimized when the steering gear is properly aligned. Always align steering gear as detailed below before adjusting the steering gear as shown on page 10-9.

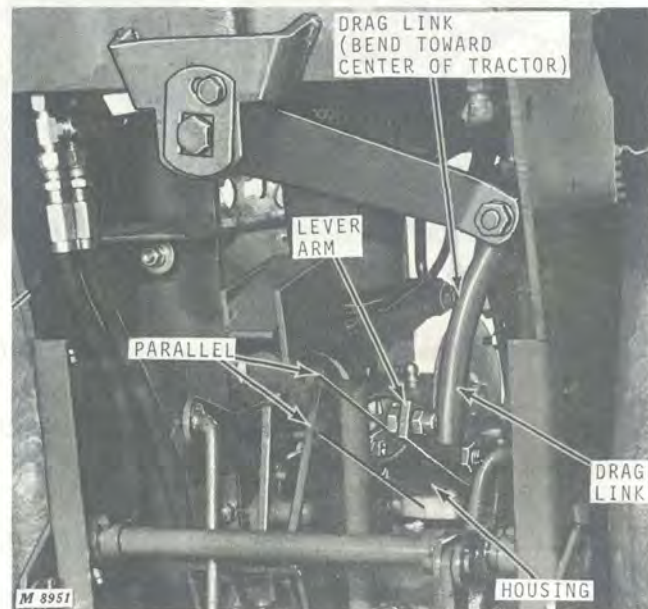

Fig. 21-Aligning Steering Gear

Visually check alignment of lever arm with steering gear housing, Figure 21. When properly aligned, lever arm will be parallel with the steering gear housing when the front wheels are pointed straight forward. Install drag link and tighten nuts securely.

**IMPORTANT: Be sure drag link is positioned as shown in Figure 21, with the bend pointing toward the center of the tractor, before tightening jam nuts.**

Steering effort is minimized when the steering gear is properly aligned. On 140 Tractors the drag link is a one-piece, non-adjustable rod. If no parts have been bent or damaged, the steering gear will remain properly aligned as long as tie-rods are adjusted to equal lengths. See "Front Wheel Toe-In Adjustment," page 10-10.



## Steering Gear Adjustment

Refer to Figures 22 and 23 and adjust steering gear as explained below to correct loose steering and steering wheel end play.

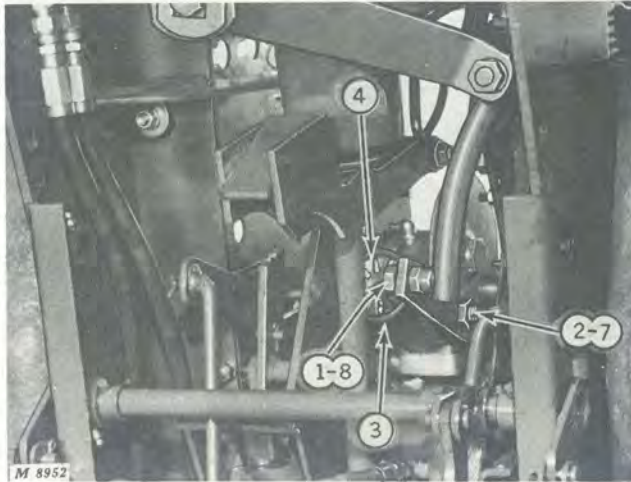

Fig. 22-Steering Gear (Viewed from Below Tractor)

Remove battery and battery base from tractor.

1. Disconnect ball joint from lever arm.
2. Loosen jam nut and stud two or three turns, Figure 22.
3. Remove cotter pin holding adjusting plug in steering gear housing. Use screwdriver socket and torque wrench to turn adjusting plug into steering gear housing until end play is removed. Torque adjusting plug 10 to 14 ft-lbs.
4. Turn plug only far enough after adjustment to insert cotter pin through housing and closest slot in plug. Spread cotter pin.

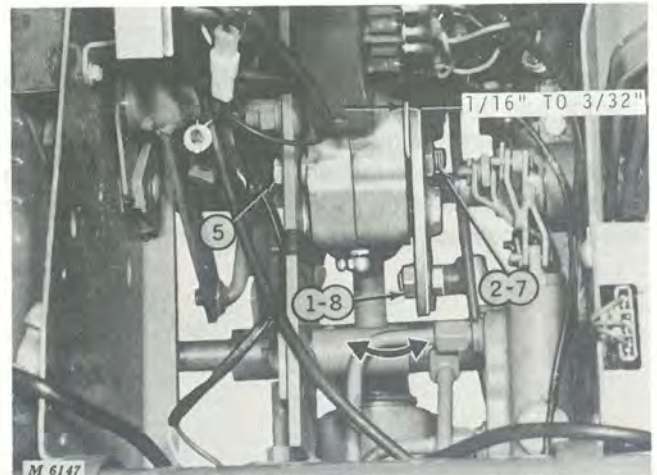

Fig. 23-Steering Gear (Viewed from Above Tractor)

5. Loosen jam nut on pivot bolt and tighten only the inside nut using a thin open end wrench, until all end play (see arrow) is removed or until the distance between the lever arm and steering gear housing is between 1/16 and 3/32-inch, Figure 23. Tighten jam nut.

*NOTE: It may be necessary to install extra washers under nuts to make it possible to get a wrench on the inside nut without getting interference from the frame.*

6. Turn steering wheel until the lever arm is parallel with steering gear housing. See page 10-8, Figure 21.

7. Turn stud in (clockwise) until snug to remove all looseness. Then move steering wheel through its full steering range in both directions (right to left). When properly adjusted, a slight drag can be detected in the midpoint of the range (when line between the pivot bolt and ball joint is vertical). Tighten jam nut firmly.

Make final test by turning steering arm through full range.

8. Connect ball joint to lever arm.



### Front Wheel Toe-In Adjustment

Measure distances "A" and "B," Figure 24. The tractor has proper toe-in or alignment when dimension "A" is 3/16 inch less than dimension "B." If adjustment is needed, loosen jam nuts and turn both right and left-hand tie rods "C" equally until proper toe-in is obtained. Tighten jam nuts firmly.

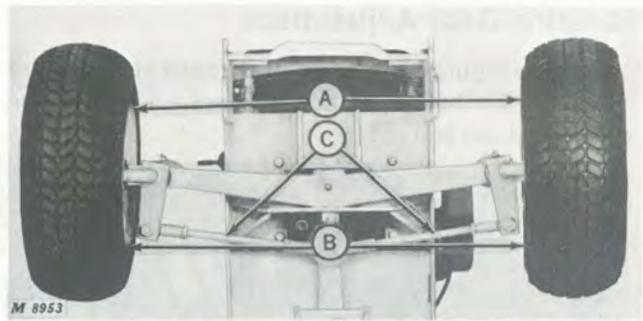

Fig. 24-Toe-in Adjustment

### TORQUE FOR HARDWARE

Location	Torque
Steering gear plug	10 to 14 ft-lbs
Lever arm pivot bolt	22 to 25 ft-lbs
Steering wheel retaining nut	10 to 12 ft-lbs

### SPECIAL TOOLS

Name	Part No.	Use
15/16" Open-End Tappet Wrench	See Figure 20	Locking lever arm pivot bolt
Puller	SNAP-ON CJ-950	To remove steering wheel
Puller	OTC 515	To remove steering wheel

# Group 15 FRONT WHEELS AND AXLE (SERIAL NO. 30,001-38,000)

## INTRODUCTION

Refer to Group 70-10, "Steering Assembly" for service and adjustment of all linkage related to the front wheels. Group 10 includes service of ball joints,

tie rods, toe-in, adjustment, etc. This group covers only front wheel spindles, bearings and axles on 140 Tractors (Serial No. 30,001-38,000).

## REPAIR

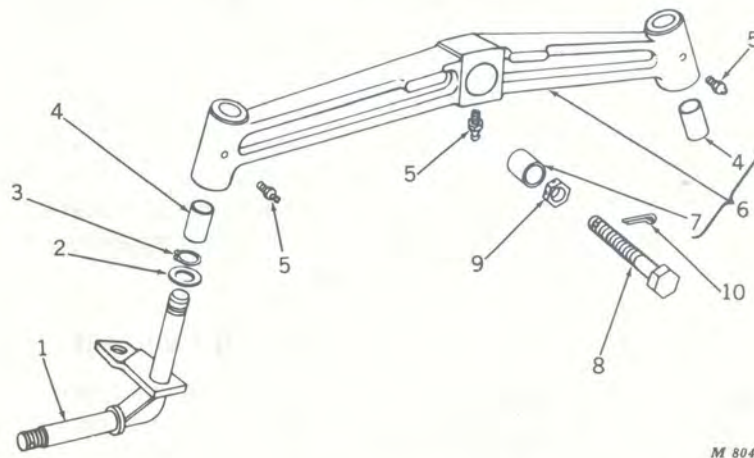

M 8046

- |                         |                      |                   |
|-------------------------|----------------------|-------------------|
| 1 - Front Wheel Spindle | 5 - Grease Fitting   | 8 - King Pin Bolt |
| 2 - Spindle Washer      | 6 - Front Axle       | 9 - Slotted Nut   |
| 3 - Snap Ring           | 7 - King Pin Bushing | 10 - Cotter Pin   |
| 4 - Spindle Bushing     |                      |                   |

Fig. 1-Exploded View of Front Axle Assembly

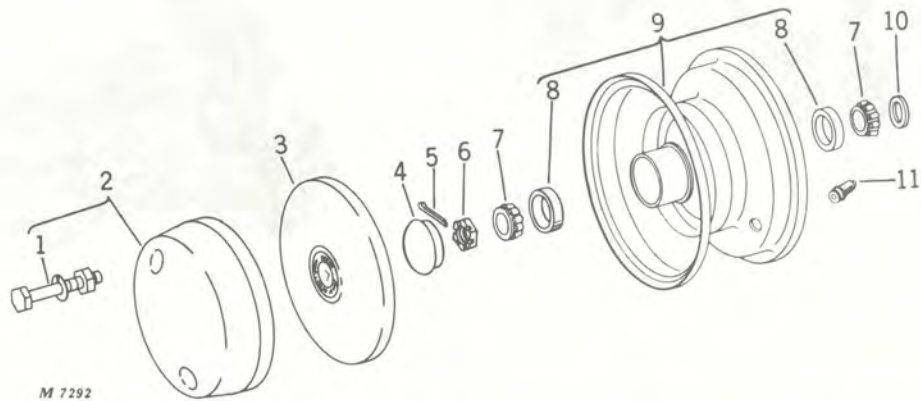

M 7292

- |                        |                 |                      |                 |
|------------------------|-----------------|----------------------|-----------------|
| 1 - Cap Screw          | 4 - Spindle Cap | 7 - Bearing Cone     | 10 - Cone Seal  |
| 2 - Front Wheel Weight | 5 - Cotter Pin  | 8 - Bearing Cup      | 11 - Tire Valve |
| 3 - Wheel Cover        | 6 - Slotted Nut | 9 - Front Disk Wheel |                 |

Fig. 2-Exploded View of Front Wheel Assembly



### Removing Front Wheels



M8047N GREASE CAP TOOL

Fig. 3-Removing Front Wheel Components from Axle

Block up or hoist front of tractor until wheel clears the ground. Remove cap from wheel, Figure 3. Remove cotter pin, slotted nut, wheel and bearings from spindle inside cap.

### Removing Spindles

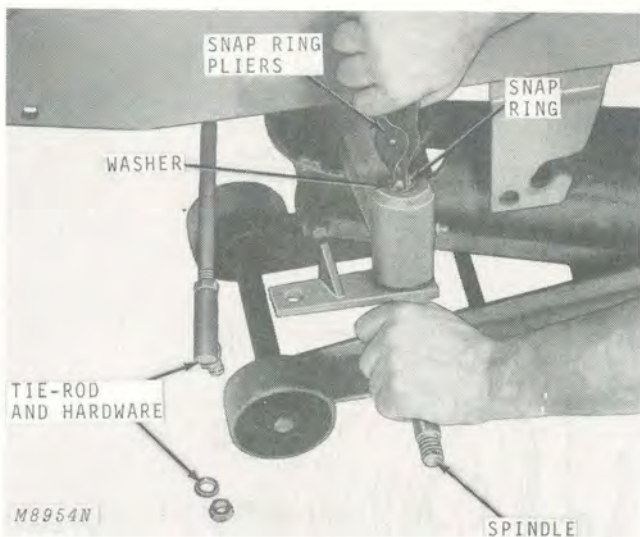

Fig. 4-Washer and Snap Ring

To remove spindle from axle disconnect tie rod. Use snap ring pliers and remove snap ring and washer, Figure 4. Slip spindle out of axle.

### Removing Front Axle

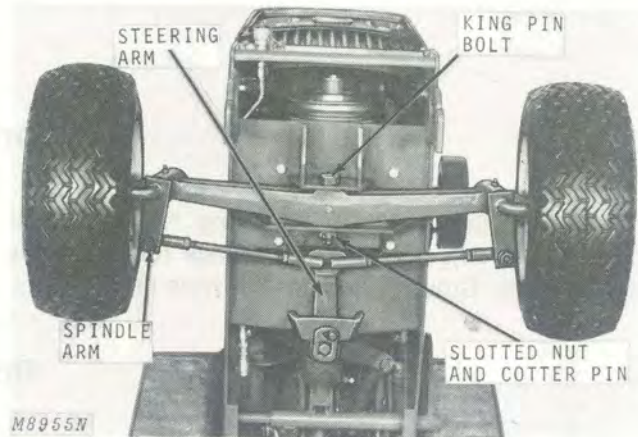

Fig. 5-Removing Axle from Tractor

To remove axle, Figure 5, block up or hoist front of tractor. Remove cotter pin from slotted nut. Remove nut and king pin bolt. Ease axle to floor. Remove tie rods from either steering arm or spindle arm, as desired.

### Inspecting Bearings

Refer to Section 20, Group 15, "Bearing Analysis," to determine wheel bearing condition. Service as necessary.

### Inspecting Axle Bushings

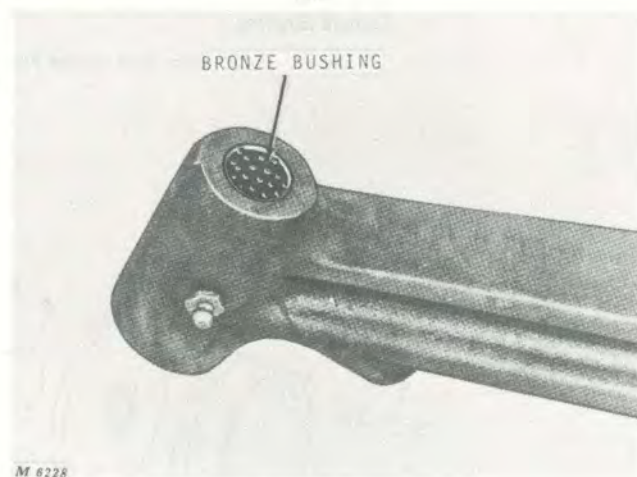

Fig. 6-Axle Spindle Bushing

Excessive wear of axle bushing, Figure 6, is caused by lack of lubrication. Replace bushing indicating excessive wear or out of round.



## Removing Axle Bushings

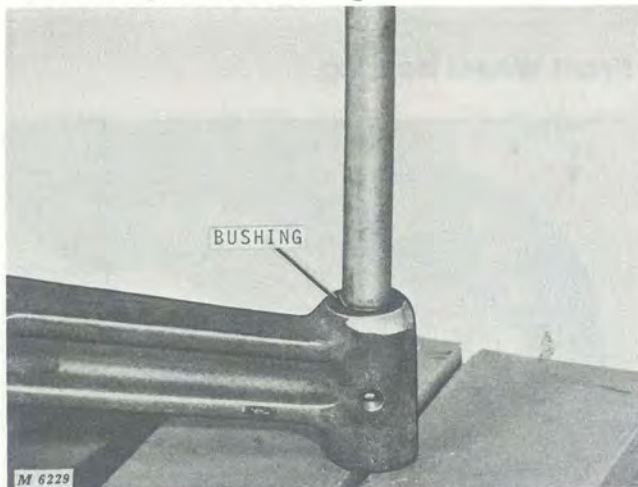

Fig. 7-Pressing Bushings Out of Axle

Place axle end on press bed and press bushings out of axle, Figure 7.

## INSTALLATION

### Installing Axle Bushings

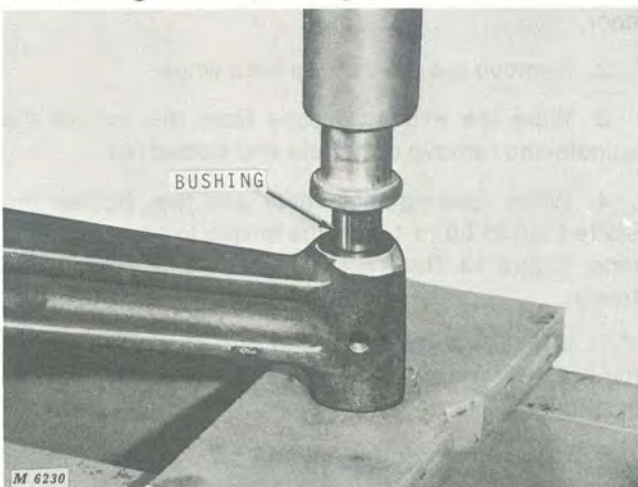

Fig. 8-Installing Axle Bushing

Wipe axle bushing bore clean. Coat bushing with oil. Place axle on press and press bushing in axle until bushing is flush with axle face, Figure 8.

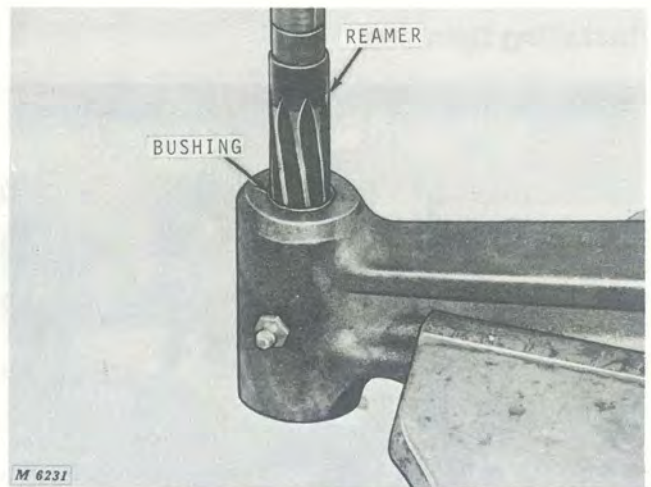

Fig. 9-Reaming Bushings

Place axle in a vise and turn reamer through axle bushings, Figure 9. Refer to "Specifications," page 15-5, for correct axle bushing dimension.

### Installing Axle

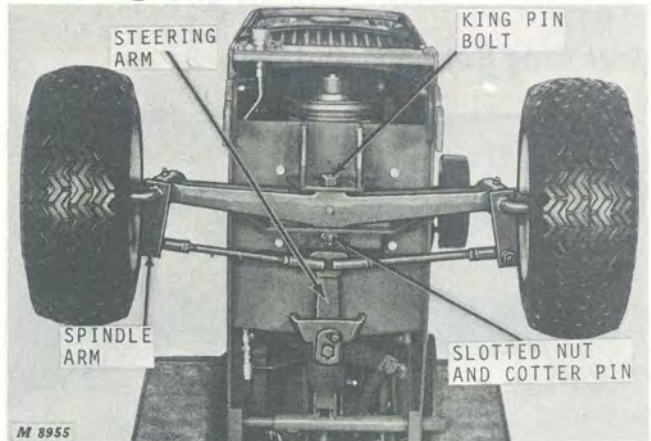

Fig. 10-Installing Axle on Tractor

Check king pin bushing and other king pin components for wear or other damage. Replace parts as necessary.

Grease king pin assembly and install axle on tractor frame, Figure 10. Secure king pin bolt with slotted nut and cotter pin.



## Installing Spindles

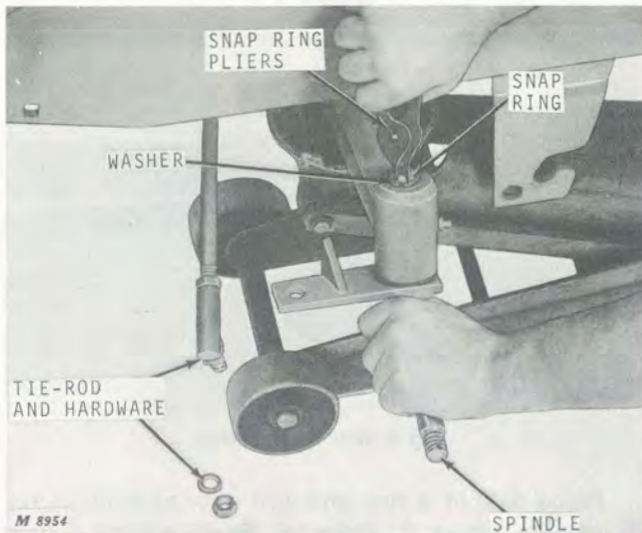

Fig. 11-Installing Front Axle, Spindles and Front Wheels

Apply light coat of grease on upper spindle shaft. Install spindles into axle bushing, Figure 11.

## Installing Bearings and Wheels

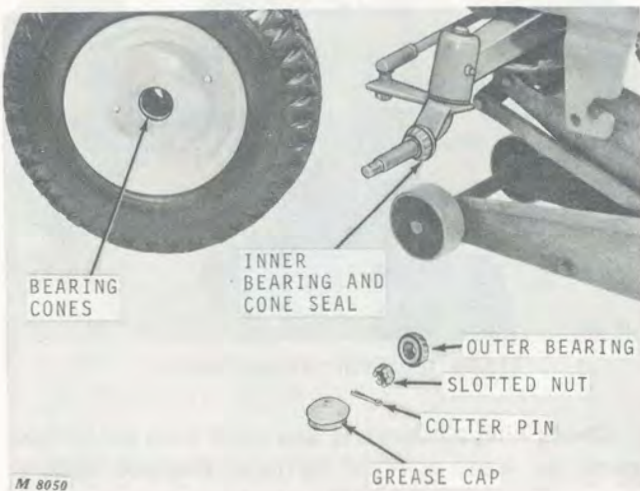

Fig. 12-Installing Bearings and Wheels

Pack wheels with SAE multipurpose-type grease. Install bearing with seal, wheel, outer bearing and slotted nut on axle, Figure 12. Adjust wheel bearings according to the following instructions. Place grease cap on wheel.

## ADJUSTMENT

### Front Wheel Bearing

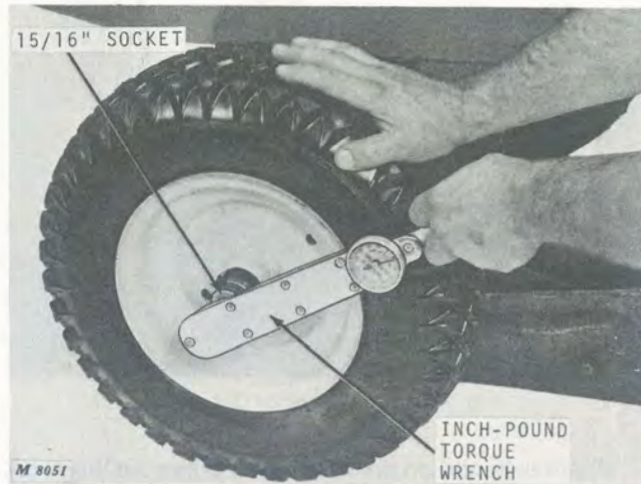

Fig. 13-Adjusting Wheel Bearing

Adjust the front wheel bearings if the wheel is loose on the spindle or if the wheel does not rotate freely.

1. Raise the tractor until the front tires clear the floor.
2. Remove the grease cap from wheel.
3. Wipe the excess grease from the end of the spindle and remove cotter pin and slotted nut.
4. While rotating the wheel and tire, tighten the slotted nut to 60 to 120 in-lbs torque to seat the bearings, Figure 13. Back off slotted nut until wheel turns freely.
5. Using a 15/16-inch open end wrench, back off the nut until the slot in nut aligns with cotter pin hole in spindle.
6. Install a new cotter pin and bend the long end of the cotter pin around the end of the axle.
7. Install cap.

### SPECIFICATIONS

Item	New Part	Wear Tolerance
Front Axle Spindle Bushings	0.751 to 0.755 in.	0.015 to 0.002 in.

### TORQUE FOR HARDWARE

Item	Torque
Wheel Bearing Slotted Nut	60 to 120 in-lbs. Back off nut. See Adjustments, page 70-15-4.

### SPECIAL TOOLS

Name	Part No.	Use
Retaining Ring Pliers	OTC No. 1340	To remove retaining ring from spindle.
Retaining Ring Pliers	OTC No. 614	To remove retaining ring from spindle.
Grease Cap Tool	SNAP-ON GCP-10	To remove grease cap from wheel.





# Group 16

## FRONT WHEELS AND AXLE

### (Serial No. 38,001- )

### INTRODUCTION

Refer to Group 70-10, "Steering Assembly" for service and adjustment of all linkage related to the front wheels. Group 10 includes service of ball joints,

tie rods, toe in, adjustment, etc. This group covers only front wheel spindles, bearings and axles on 140 Tractors (Serial No. 38,001- )

### REPAIR

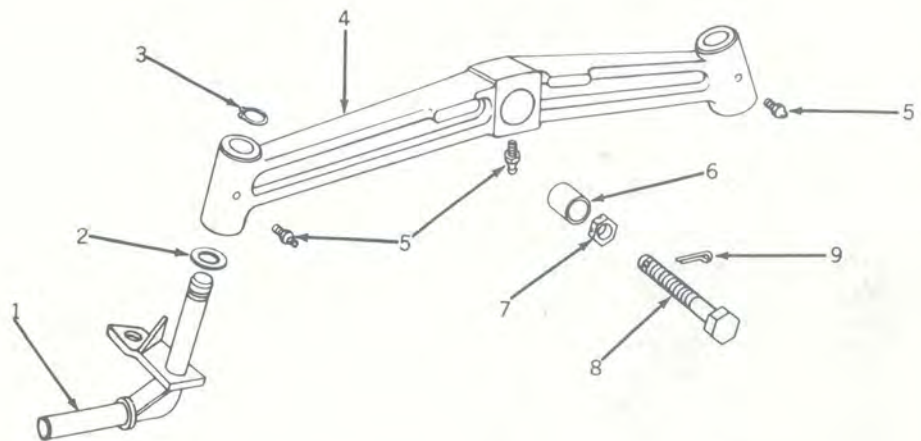

M13045N

- 1-Front Wheel Spindles
- 2-Spindle Washer
- 3-Snap Ring

- 4-Front Axle
- 5-Grease Fitting
- 6-King Pin Bushing

- 7-Slotted Nut
- 8-King Pin Bolt
- 9-Cotter Pin

Fig. 1-Exploded View of Front Axle Assembly

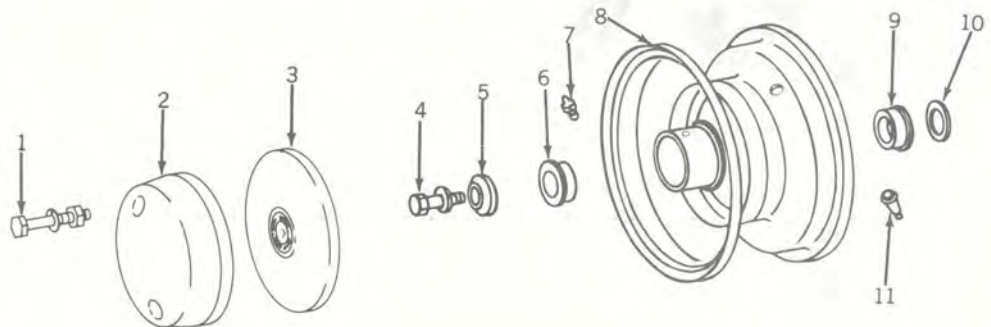

M13046N

- 1-Cap Screw, Washer and Nut
- 2-Front Wheel Weight
- 3-Wheel Cover

- 4-Cap Screw and Washer
- 5-Spindle Cup
- 6-Bearing

- 7-Grease Fitting
- 8-Front Wheel
- 9-Bearing

- 10-Spring Washer
- 11-Valve Stem

Fig. 2-Exploded View of Front Wheel Assembly



### Removing Front Wheels

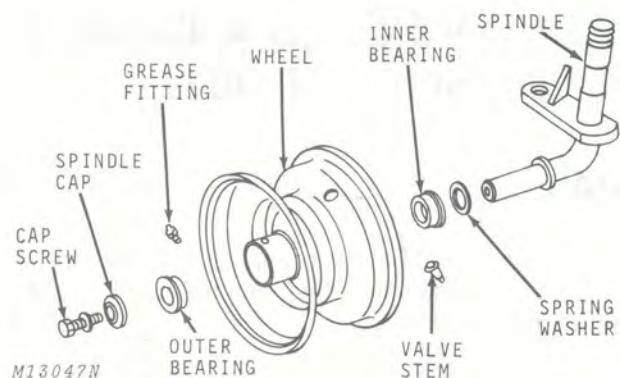

Fig. 3-Removing Front Wheel Components from Spindle

Jack up tractor until wheel clears the ground. Remove cap screw, Figure 3. Remove spindle cap, outer bearing, wheel, inner bearing, and spring washer.

### Removing Spindle from Axle

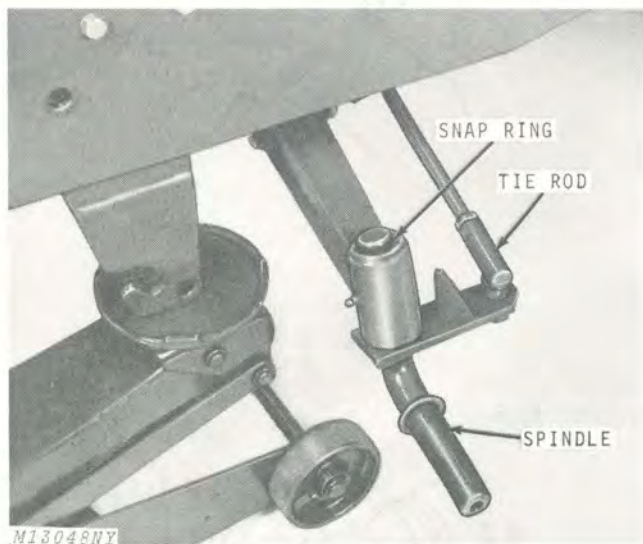

Fig. 4-Removing Spindle

To remove spindle, disconnect tie rod end, and using a snap ring pliers, remove snap ring, Figure 4. Slip spindle out of axle.

### Removing Front Axle

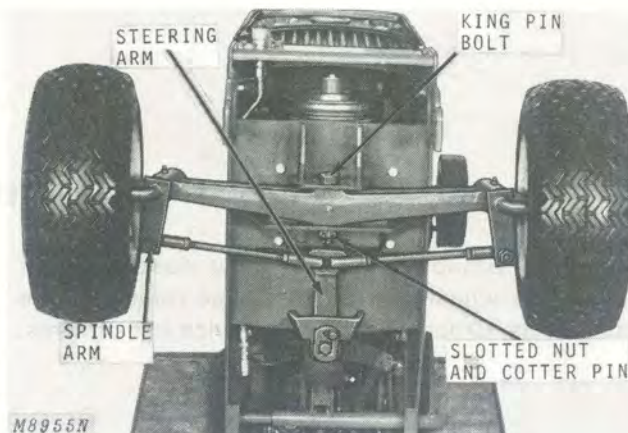

Fig. 5-Removing Axle from Tractor

To remove axle, Figure 5, block up or hoist front of tractor. Disconnect tie rods. Remove cotter pin from slotted nut. Remove nut and king pin bolt. Ease axle to floor.

### Installing Axle

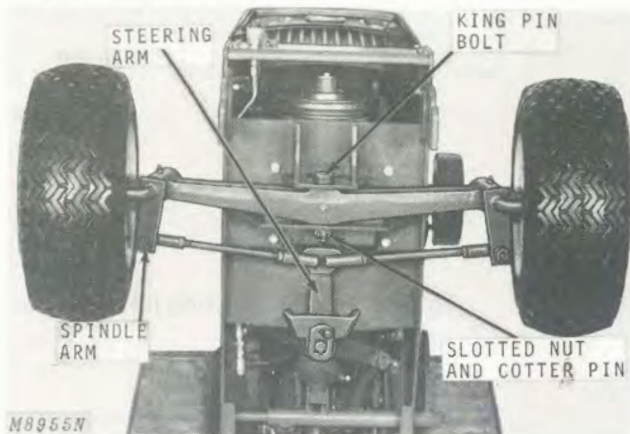

Fig. 6-Installing Front Axle on Tractor

Check king pin bushing and other king pin components for wear or other damage. Replace parts as necessary.

Grease king pin assembly and install axle on tractor frame, Figure 6. Secure king pin bolt with slotted nut and cotter pin.

### Installing Spindles

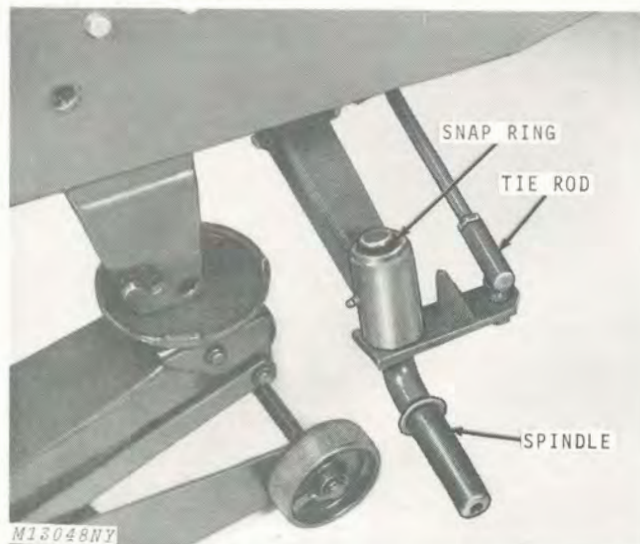

Fig. 7-Installing Spindles

Apply light coat of grease on upper spindle shaft. Install spindles into axle, Figure 7. Secure with a snap ring. Connect tie rod.

### Installing Bearings and Wheels

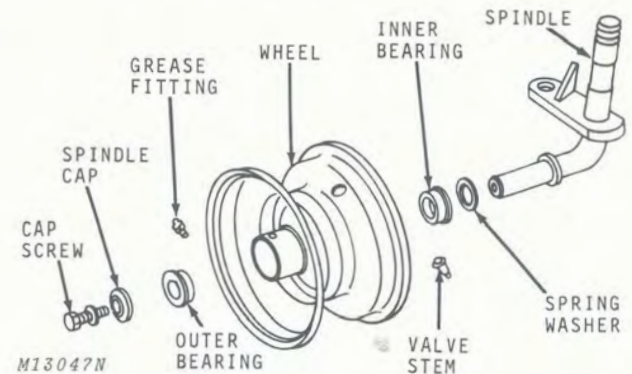

Fig. 8-Installing Bearings and Wheels

Pack wheel bearings with John Deere Multipurpose Lubricant or an equivalent SAE multipurpose-type grease. Install spring washer, inner bearing, wheel, outer bearing, spindle cap and cap screw, Figure 8. Tighten cap screw to 35 ft-lbs.

*NOTE: There is no adjustment necessary on the front wheel bearings.*



### TORQUE FOR HARDWARE

Item	Torque
Spindle Cap Screw .....	35 ft-lbs

### SPECIAL TOOLS

Name	Part No.	Use
Retaining Ring Pliers .....	OTC No. 1340 .....	To remove retaining ring from spindle

## Group 20 FENDER-DECK AND SEAT ASSEMBLY

### GENERAL INFORMATION

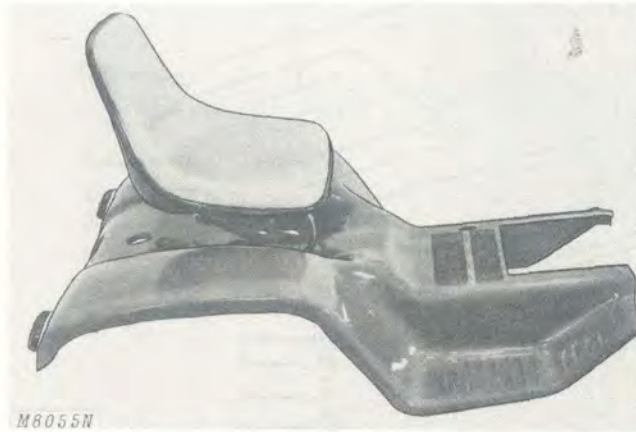

Fig. 1-Fender-Deck and Seat Assembly

The one-piece fender-deck assembly, Figure 1, is isolated from the tractor frame by two front and two rear mounts and two rubber pads, Figure 2.

In addition to adding to the attractiveness of the 140 Hydrostatic Tractor, the fender-deck provides an inclined mounting frame for the adjustable seat.

### REMOVAL AND INSTALLATION

To remove the fender-deck and seat assembly, remove knobs from mower depth control, free wheeling bolt, and parking brake. Remove the two front carriage bolts from front deck mounts and the nuts from rear deck mounts. Disconnect taillight wires at terminals. Lift fender-deck and seat from tractor. To install, reverse the procedure.

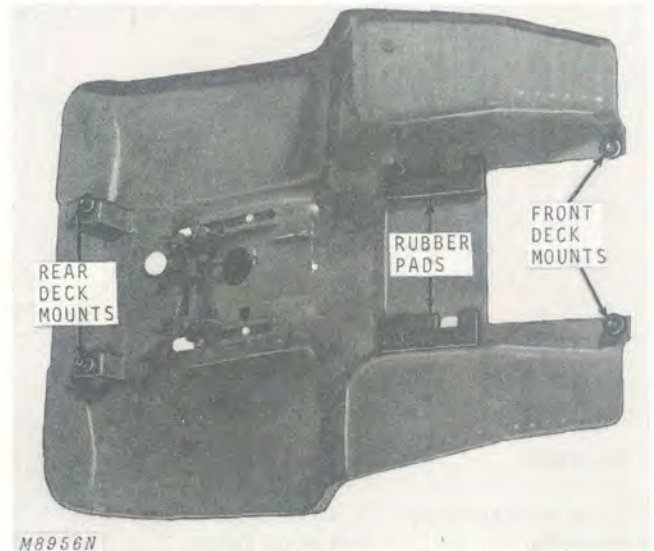
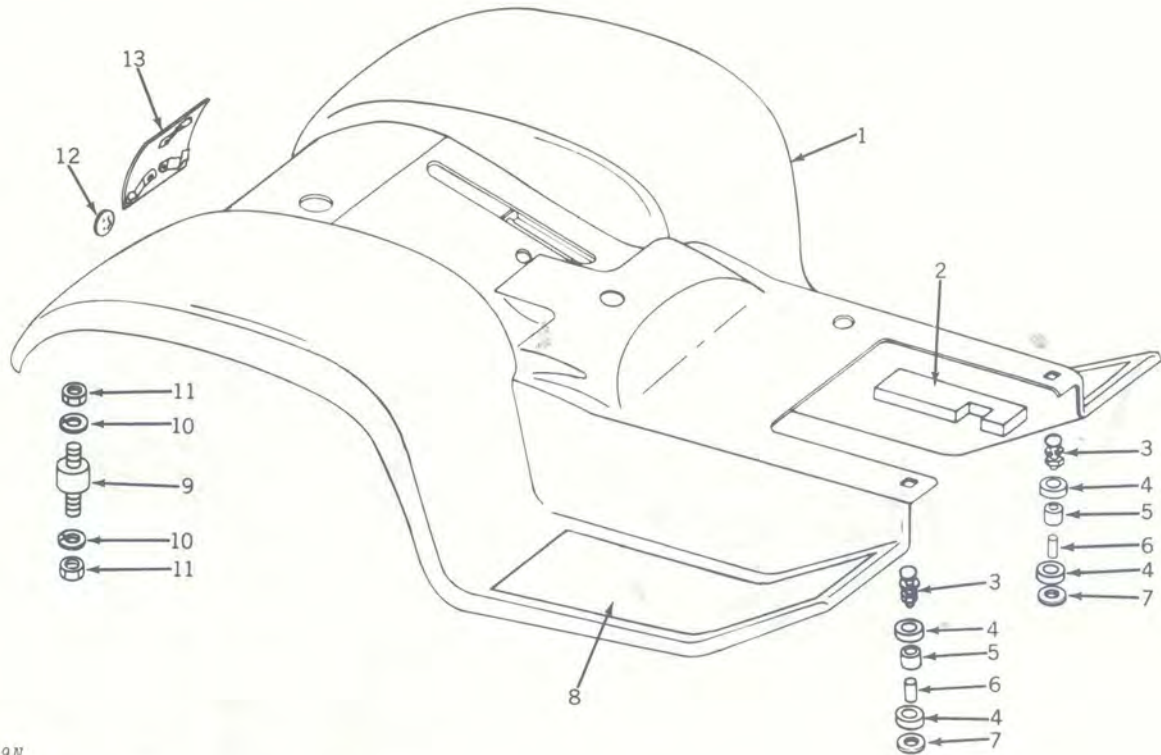

Fig. 2-Vibration-Dampening Deck Mounts



**REPAIR**



M13049N

1-Fender-Deck Assembly  
 2-Rubber Pad  
 3-Carriage Bolt

4-Front Deck Mount  
 5-Mount Guide  
 6-Guide Spacer

7-Flat Washer  
 8-Foot Tread  
 9-Rear Mount and Stud

10-Washer  
 11-Nut  
 12-Plug Button  
 13-Cover Plate

Fig. 3-Exploded View of Fender-Deck Components

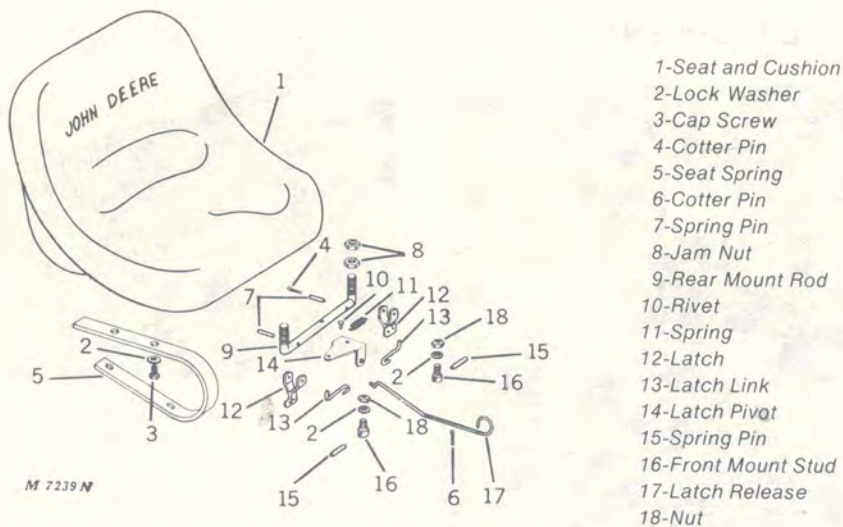

Fig. 4-Exploded View of Seat Components (Serial No. 30,001-38,000)

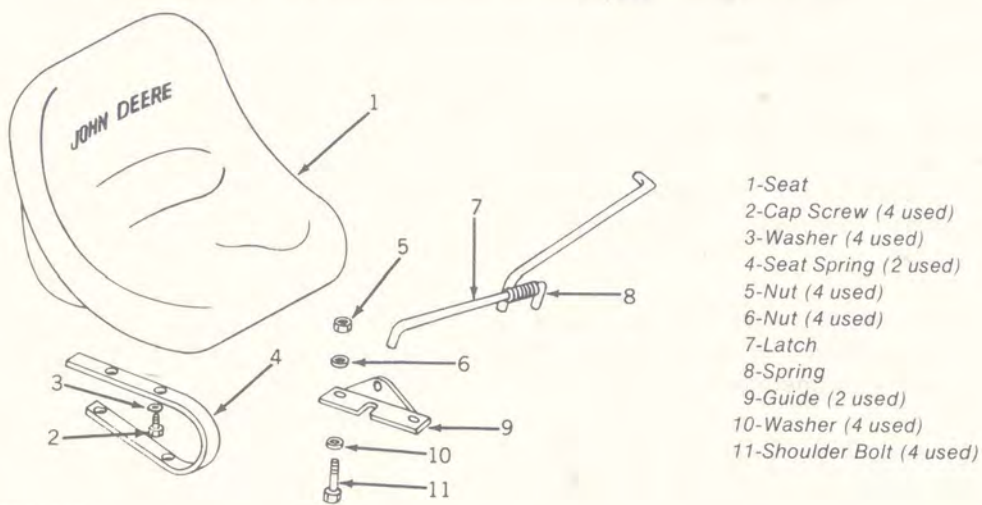

Fig. 5-Exploded View of Seat Components (Serial No. 38,001-46,500)

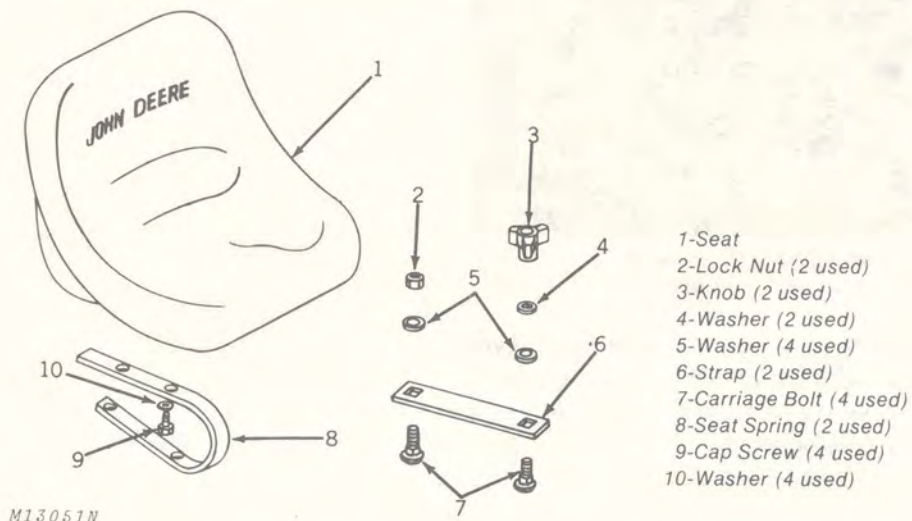

Fig. 6-Exploded View of Seat Components (Serial No. 46,501- )



### SEAT ADJUSTMENT

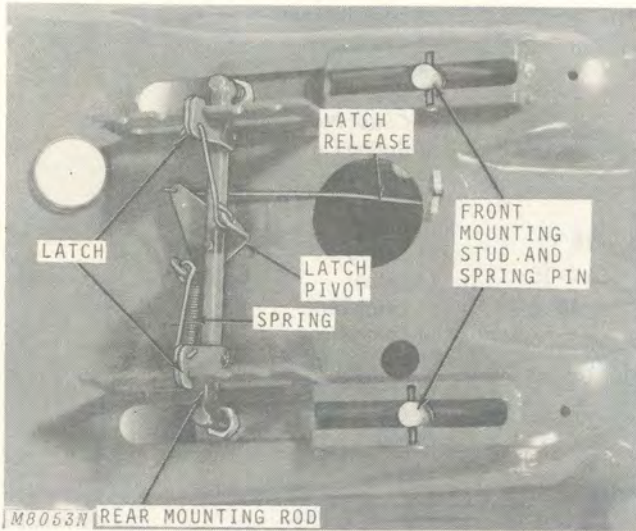

Fig. 7-Seat Adjusting Components  
(Serial No. 30,001-38,000)

To adjust the seat, Figure 7, pull out on latch release under the seat. This pulls the latch pivot forward, releasing the latch on the rear mounting rod from the notched areas in the rails on the underneath side of the fender-deck.

With the latch released, the seat may be moved forward and down or backward and up into any one of five positions to match the operator's individual requirements.



Fig. 8-Seat Adjusting Components  
(Serial No. 38,001-46,500)

To adjust seat, Figure 8, pull the seat latch lever outward. Slide seat forward or backward into one of six positions. Release the seat latch to lock the seat in the most comfortable position.

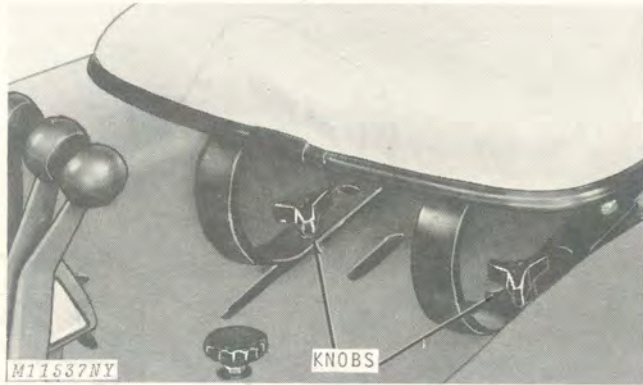

Fig. 9-Seat Adjusting Components  
(Serial No. 46,501- )

To adjust seat, Figure 9, loosen the two seat adjusting knobs. This allows the seat to be moved forward or backward into any position to match the operator's individual requirements.