



SANWA ELECTRONIC INSTRUMENT CO.,LTD.

1-2-50 YOSHIDA-HONMACHI
HIGASHIOSAKA, OSAKA, 578-0982 JAPAN

PHONE :81-729-62-1277
FACSIMILE :81-729-64-2831
E-MAIL :general@sanwa-denshi.co.jp

670A12978A

OPERATING MANUAL

SANWA



TABLE OF CONTENTS

Introduction.....	3
Usage Precautions	4
Features and Specifications	5
Features Familiarization	6-8
Driving Position Adjustments	9-10
Charging the Battery.....	11
LCD Menu Keys	12
Transmitter and Receiver Binding	13
Function Pages.....	14
Menu Flow Chart	15
Battery and Operating Timer	16
Steering Dual Rate	17
End Point Adjustment	18-20
Exponential.....	21-22
Adjustable Rate Control.....	23-24
Servo Speed.....	25-26
Anti-Lock Braking	27-28
Traction Control	28-30
Model Naming	31-32
Servo Sub-Trim	33
Track Timers.....	34-37
Servo Reversing.....	37
Starting Position	38
Throttle Hold.....	39
Brake Mixing.....	40-41
Compensation Mixing.....	42-44
Servo Monitor	45
Transmitter Set-Up	46-48
Audio Signal Sound.....	48-49
Key Assignments.....	50-53
User Naming.....	54
Fail Safe	55-56
Variable Rate Adjustment	57-58
Custom Menu Display	59
Troubleshooting Guide	60
Glossary of Terms.....	61-63
Index.....	64-66
Notes	67



This is a high-output full-range radio control system that should well exceed the range needed for any surface vehicle. For safety, the user should perform a range test at the area of operation to ensure that the radio control system has complete control of the vehicle at the farthest reaches of the operational area. Rather than operating the vehicle, we recommend that the user enlist the help of a fellow modeler to walk the vehicle to the farthest reaches of the track (or for boats, to walk the shore line well in excess of the operational distance of the boat), then test for proper operation.

INTRODUCTION

We appreciate your purchase of the new SANWA M11X FHSS-3 2.4GHz radio control system. This operating manual is intended to acquaint you with the many unique features of your state of the art M11X FHSS-3 2.4GHz radio control system. Please read this operating manual carefully so that you may obtain maximum success and enjoyment from the operation of your new M11X FHSS-3 2.4GHz radio control system.

The M11X FHSS-3 2.4GHz radio control system has been designed for the utmost in comfort and precise control of all types of model cars and boats. We wish you the best of success and fun with your new purchase.

 Additional 2.4GHz receivers can be purchased and paired with the M11X transmitter through the Binding operation. Please note that due to differences in the implementation of 2.4GHz technology among different manufacturers, only SANWA brand 2.4GHz FHSS-2 (TM-222FS and MX-3FG) and FHSS-3 (M11X) receivers are compatible with your radio control system. Please see your SANWA dealer for more information.

SAFETY

- Be certain to read this operating manual in its entirety.
- 'Safety First' for yourself, for others, and for your equipment.
- Observe all the rules of the field, track, or lake where you operate your radio control equipment.
- If at any time during the operation of your model, should you feel or observe erratic operation or abnormality, end your operation as quickly and safely as possible. DO NOT operate your model again until you are certain the problem has been corrected. TAKE NO CHANCES.
- Your model can cause serious damage or injury, so please use caution and courtesy at all times.
- Do not expose the radio control system to water or excessive moisture.
- Please waterproof the receiver and servos by placing them in a water-tight radio box when operating R/C model boats.
- If you have little to no experience operating R/C models, we strongly recommend you seek the assistance of experienced modelers or your local hobby shop for guidance.
- The low voltage alarm will sound when the transmitter battery voltage drops to 6.7 volts. If this occurs, stop using the transmitter as soon as possible, then recharge the transmitter battery.

 This radio control system operates on the 2.4GHz frequency band. The 2.4GHz connection is determined by the transmitter and receiver pair. Unlike ordinary crystal-based systems, your model can be used without frequency control.

THIS SPACE INTENTIONALLY LEFT BLANK

USAGE PRECAUTIONS

In addition to the Safety sections on the previous page, please observe the following precautions when installing and using your new SANWA M11X FHSS-3 2.4GHz radio control system.

2.4GHZ FREQUENCY BAND PRECAUTIONS

- The 2.4GHz frequency band may be used by other devices, or other devices in the immediate area may cause interference on the same frequency band. Always before use, conduct a bench test to ensure that the servos operate properly. Also, conduct checks with the transmitter as distant as possible from your model.
- The response speed of the receiver can be affected if used where multiple 2.4GHz radio controllers are being used, therefore, carefully check the area before use. Also, if response seems slow during use, stop your model immediately and discontinue use.
- If the 2.4GHz frequency band is saturated (too many radio controllers on at once), as a safety precaution, the radio control system may not bind. This ensures that your radio control system does not get hit by interference. Once the frequencies have been cleared, or the saturation level has dropped, your radio control system should be able to bind without any problems.

TRANSMITTER PRECAUTIONS

- Turn the transmitter ON first and then turn the receiver ON. After using your model, turn the receiver OFF first, then turn the transmitter OFF. It can be dangerous if you activate the components in reverse order as the servos may start up inadvertently.
- Before use, double-check that the transmitter and receiver batteries are sufficiently charged.
- Never touch the transmitter antenna during use. Doing so may cause loss of transmitter output, making it impossible to control your model.
- The transmitter's antenna is delicate. Handle it with care.
- Before use, the transmitter antenna should be moved in the fully upright position. After use, to prevent any chance of damaging the antenna, the antenna should be moved into the horizontal stowed position.
- Do not press the Bind key during use. The radio signal is interrupted while the Bind key is pressed. It may also require a short time to restore the signal after releasing the Bind key, which can be dangerous.

RECEIVER PRECAUTIONS

- The receiver antenna consists of a coaxial cable and a reception wire (the thin tip at the end of the coaxial cable). When you mount the receiver antenna, do not bend the reception wire. Reception performance decreases if the reception wire is bent.
- The antenna wire is delicate, therefore, handle with care. Do not pull on the antenna wire with force. Do not cut or extend the antenna wire.
- The coaxial cable (the thicker portion or the antenna) can be bent into gentle curves, however, do not bend the coaxial cable acutely, or repeatedly bend it, or the antenna core can be damaged.
- The antenna wire should be installed into a vertical plastic tube per your particular model's assembly instructions. Keep the receiver antenna as far away from the motor, battery, and ESC as possible.
- There is a danger of runaway operation if connectors shake loose during use. Make sure that the receiver, servo(s), and switch connectors are securely fitted.
- The receiver is susceptible to vibration, shock, and moisture. Take appropriate measures to protect against vibration and moisture. Failure to take appropriate measures could result in runaway operation or damage to the receiver.
- When installing the receiver, avoid contact with any carbon or metal chassis components.
- Contact between metal parts mounted on a model can result in electrical noise, which can adversely effect receiver performance and possibly result in runaway operation or damage to your model.
- With electric-powered models, be sure to fit the motor with a noise suppression capacitor. Without a noise suppression capacitor, excessive electrical noise generation can cause runaway operation and/or result in damage to your model.
- Use rubber anti-vibration absorbers with servos. Direct transmission of engine vibration to servos can cause servo failure and possibly result in runaway operation with damage to your model.
- The manufacturer disclaims all responsibility for damages resulting from use of components other than genuine SANWA components.

FEATURES AND SPECIFICATIONS

SYSTEM FEATURES

- 2.4GHz FHSS-3 Transmitter and Receiver
- New High-Power FHSS-3 Technology
- 2- or 4-Channel Mode Selectable
- 6 Cell Rechargeable NiMH Battery
- Large Backlit LCD Display
- Left or Right Hand Grip
- Digital Trim
- Key-Lock Switch
- Display Switch
- Adjustable Handle
- Adjustable Steering Wheel Tension
- Three-Page Programming
- Timer Vibration
- Battery Monitor
- User Naming
- White or Blue LCD Display Options
- Servo Monitor
- Exponential Tweak
- Two C-Mixes
- Brake Mixing
- Throttle Hold
- Starting Position
- Servo Reversing
- Lap, Interval and Down Timers
- Sub-Trim
- 30 Model Memory
- Model Copy
- Model Naming
- Model Select
- Assignable Digital Trims
- Assignable Switches
- Audio Sound Levels
- Anti-Lock Braking
- Adjustable Servo Speed
- ARC Steering and Throttle
- Expo Steering and Throttle
- End Point Adjustment
- Dual Rate Steering
- Rubber Stands
- LCD Protection Cover
- Programmable Dial Knob
- Grip Switch
- Variable Rate Adjustment
- Traction Control

SYSTEM SPECIFICATIONS

Transmitter

Model: M11X
 Output Power: 100mW
 Operating Voltage: 6.5v - 11.0v
 Power Supply: 7.2v 1500mAH
 Weight: 785g (with Battery)
 Frequency: 2.4GHz FHSS-3

Receiver

Model: RX-451
 Frequency: 2.4GHz FHSS-3
 Input Voltage: 4.8v - 6.0v
 Weight: 9g
 Dimensions: 36.5 x 24.0 x 15.0mm
 Fail Safe Limit: 3.8v Default / 3.5v - 5.0v Adjustable

Recommended Servos (Available From Your Local Dealer)

ERG-WZ Digital High-Speed Metal Gear Ball Bearing Servo



Torque: 5.9kg/cm @ 4.8v
 7.4kg/cm @ 6.0v
 Speed: 0.13 sec/60° @ 4.8v
 0.10 sec/60° @ 6.0v
 Dimensions: 39.1 x 20.1 x 37.3mm
 Weight: 56g

ERG-WG Digital High-Speed Precision Metal Gear Ball Bearing Servo



Torque: 4.8kg/cm @ 4.8v
 6.0kg/cm @ 6.0v
 Speed: 0.11 sec/60° @ 4.8v
 0.09 sec/60° @ 6.0v
 Dimensions: 39.1 x 20.1 x 37.3mm
 Weight: 56g

ERG-WX Digital High-Torque Metal Gear Ball Bearing Servo



Torque: 11.2kg/cm @ 4.8v
 14.0kg/cm @ 6.0v
 Speed: 0.15 sec/60° @ 4.8v
 0.12 sec/60° @ 6.0v
 Dimensions: 39.1 x 20.1 x 37.3mm
 Weight: 57g

SDX-901 MG Digital High-Torque Metal Gear Ball Bearing Servo



Torque: 23.0kg/cm @ 4.8v
 29.0kg/cm @ 6.0v
 Speed: 0.19 sec/60° @ 4.8v
 0.15 sec/60° @ 6.0v
 Dimensions: 40.6 x 21.1 x 38.1mm
 Weight: 66g

 Both analog and digital servos will work with your M11X FHSS-3 2.4GHz radio control system. To get the most out of your experience, we recommend the use of digital servos.

We recommend using SHR (Super High Response) Mode. SHR Mode will increase the digital servo's response time, even above the manufacturer's stated speed. See page 48 for more information.

FEATURES FAMILIARIZATION

FEATURES DIAGRAMS

Use the diagrams below and on the next page to familiarize yourself with the different system controls on your new M11X FHSS-3 2.4GHz transmitter and RX-451 receiver. Descriptions of these features can be found on page 8.

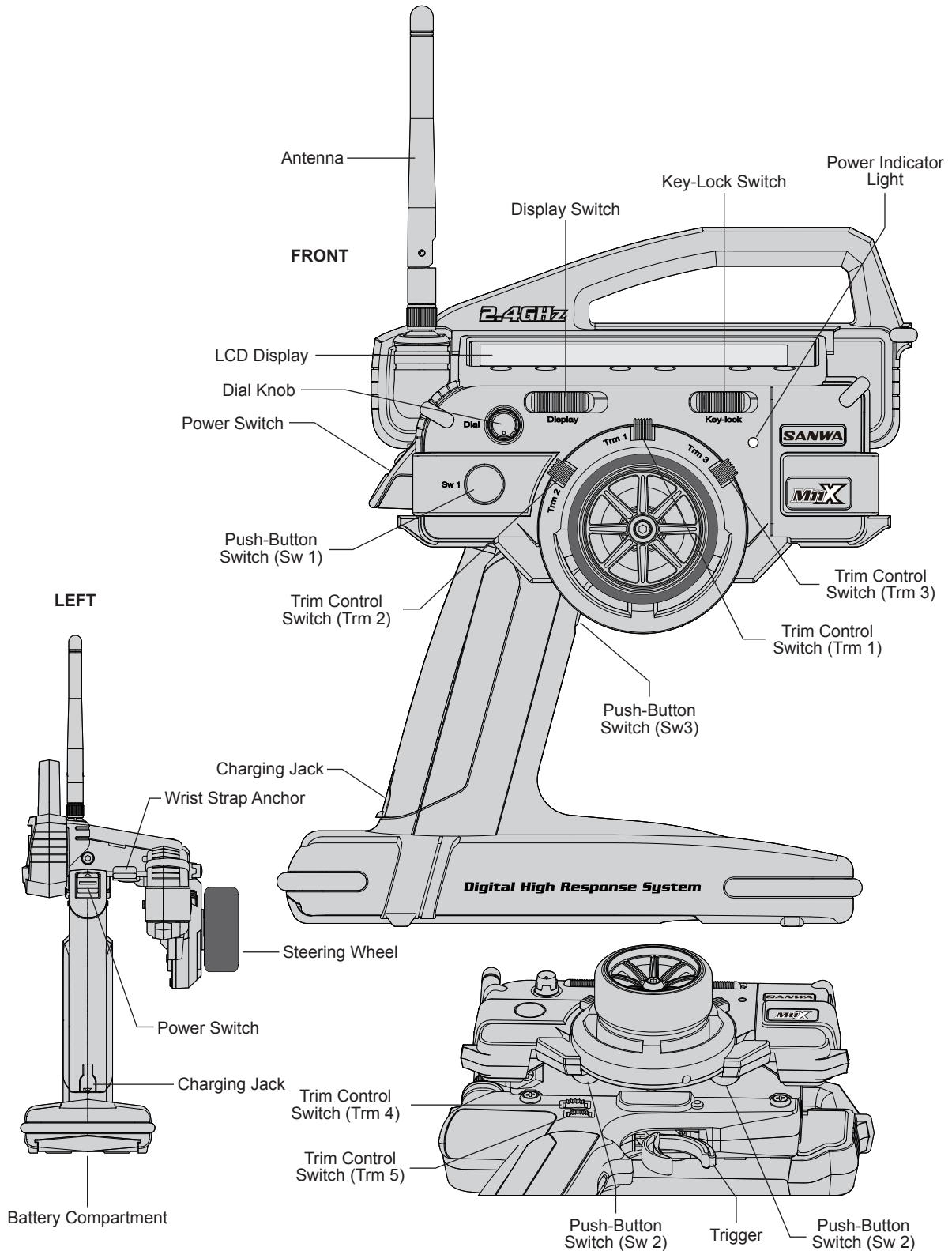

FEATURES FAMILIARIZATION

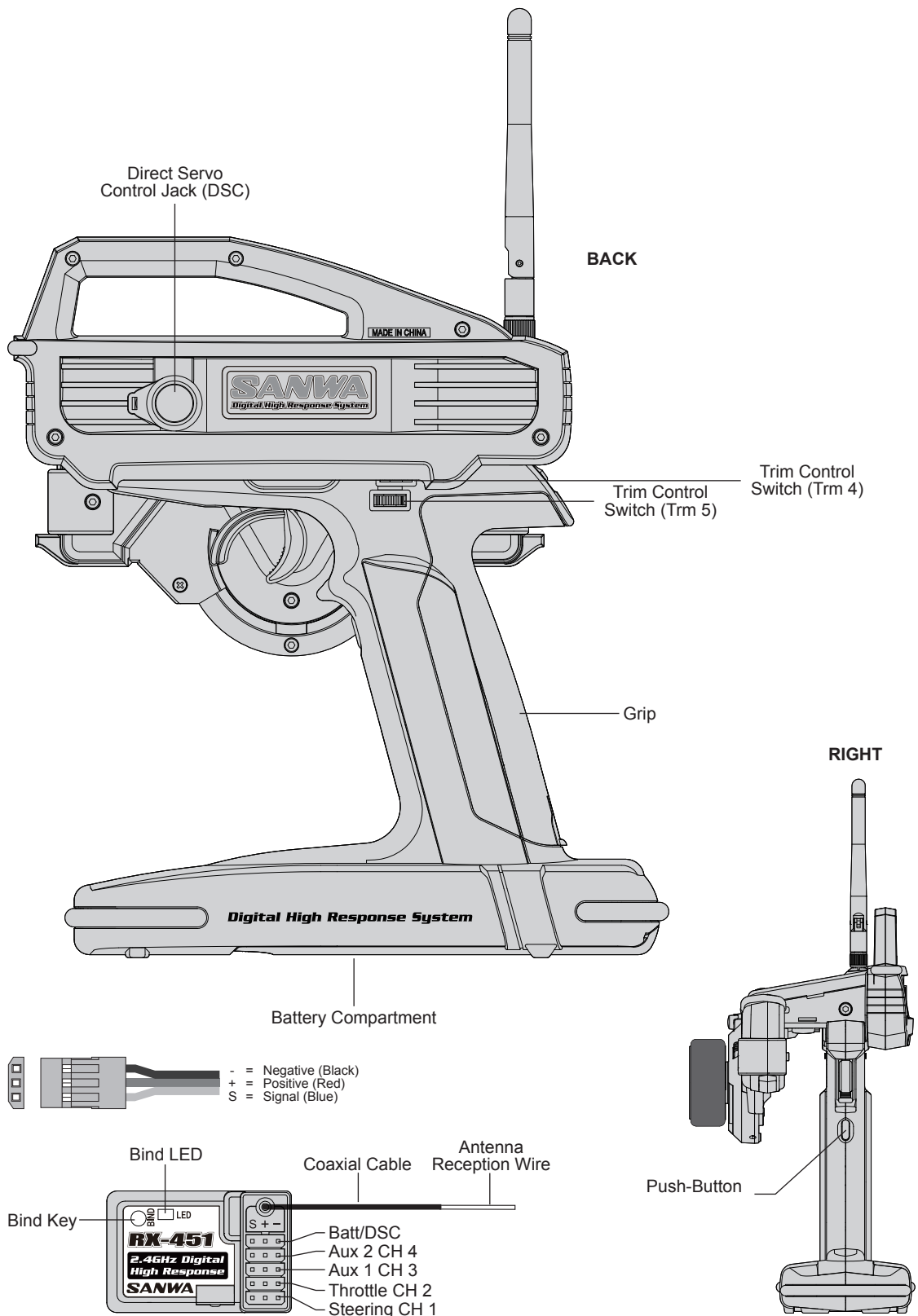

FEATURES FAMILIARIZATION

FEATURES DESCRIPTIONS

Antenna: Transmits the signal from the transmitter to the receiver in the model. The antenna should be extended in the vertical position during use. When not in use, the Antenna should be collapsed into the horizontal position to prevent damage.

Antenna Reception Wire: The portion of the antenna that actually receives the transmitter signal.



The Antenna Reception Wire should never be bent or it could be damaged and limit the range of your model.

Battery Compartment: Houses the 6 cell 1500mAH NiMH battery that powers the transmitter. The transmitter uses a 6 cell battery for lighter weight and better feel, while still maintaining a high power output.

Bind Key and Bind LED: Used in the process of Binding the transmitter and receiver.

Charging Jack: Used for onboard charging of the 6 cell 1500mAH NiMH battery.



Only use the charger included with your M11X FHSS-3 2.4GHz radio control system to charge the battery through the charging jack. Use of any other charger can damage the transmitter.

Coaxial Cable: The portion of the antenna that extends the Antenna Reception Wire. The Coaxial Cable can be bent into gentle curves, however, do not bend the Coaxial Cable acutely, or repeatedly bend it, or the antenna core can be damaged. The Coaxial Cable should be installed through a nylon tube (antenna tube) in the vertical position for the best reception.

Dial Knob: A rotary knob that can rotate 360°. The Dial Knob is programmable and will perform a different function depending on what function is assigned to it. For example, the Dial Knob can be used to scroll through programming menu selections or a trim function or even an auxiliary channel can be assigned to it.

Direct Servo Control Jack (DSC): Using the DSC cable (available separately), the Direct Servo Control Jack allows you to check your model's linkage and make necessary programming changes during a race or a situation when radio transmission is prohibited. When connected between the receiver and the transmitter, the receiver is turned ON and the Display Switch is utilized to complete programming. No signal is actually transmitted between the transmitter and receiver.

Display Switch: Activates the transmitter's LCD Display without actually turning the transmitter ON. This allows you to check and/or change programming settings without actually turning ON the transmitter. To turn the LCD Display ON using the Display Switch, push and hold the Display Switch forward for ~ 1 second. To turn the LCD Display OFF, push the Display Switch forward quickly.

Grip: Features a molded rubber pad for increased control and feel. The driving position height is adjustable to best suit your driving style.

Key-Lock Switch: Allows you to lock the LCD Display input keys so that no changes can inadvertently be made.

LCD Display: The heart of the programming and display features of the transmitter. All programming and transmitter display functions are shown on the LCD Display. Six keys below the LCD Display facilitate transmitter programming and user-selectable displays. Different aspects of the LCD Display can be customized by the user. For example, changing the LCD Display backlighting color, and automatic power-off time to conserve battery power.

Power Indicator Light: Illuminates when the transmitter is turned ON and transmitting a signal.

Power Switch: Turns the transmitter ON and OFF.

Push-Button Switch: The transmitter features three separate Push-Button Switches in different locations (Sw 1, Sw 2, and Sw 3). Each Push-Button Switch is programmable and will perform a different function depending on what function is assigned to it. For example, Sw 1 can be used to operate a reverse servo in a gas- or glow-powered model, and Sw 3 can be used to toggle Anti-Lock Braking ON and OFF.

Steering Wheel: Proportionally operates the model's right and left steering control. The Steering Wheel tension can be adjusted to best suit your driving style.

Trigger: Controls the speed of the model, both forward and backward, or the brake. The Trigger tension can be adjusted to best suit your driving style.

Trim Control Switch: The transmitter features five separate Trim Control Switches in different locations (Sw 1, Sw 2, Sw 3, Sw 4, and Sw 5). Each Trim Control Switch is programmable and will perform a different function depending on what function is assigned to it. For example, Trm 1 and Trm 2 are used to adjust the center-trim of the steering and throttle servos, and Trm 4 and Trm 5 are used to adjust dual rate and steering EPA.



Trm 4 and Trm 5 on the back of the transmitter are utilized with the steering wheel is set up for left-handed users.

DRIVING POSITION ADJUSTMENTS

Every effort has been made to provide the optimum transmitter weight and balance in the design of your M11X FHSS-3 2.4GHz radio control system. The steering wheel and trigger are placed on the same axis, permitting you to focus on steering and throttle control. The driving position and steering and throttle tension are adjustable to maximize driving precision and feel.

STEERING WHEEL TENSION

The steering wheel spring tension can be adjusted to suit your taste.

- 1) Adjust the steering wheel spring tension using a 1.5 mm hex wrench. To increase steering wheel spring tension tighten the hex screw (turn clockwise). To decrease steering wheel spring tension loosen the hex screw (turn counter-clockwise).

! Steering wheel spring tension is factory set to Medium tension.

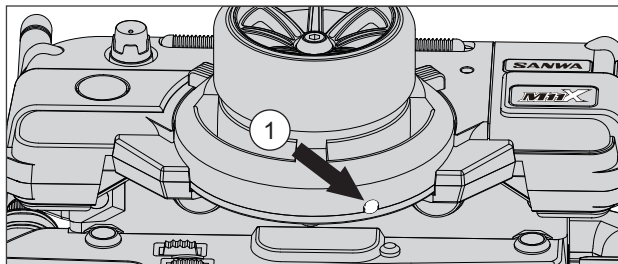

DRIVING POSITION HEIGHT

The driving position height can be adjusted to change the balance (feel) of the transmitter in your hand.

- 1) Remove the M4 socket-head cap screws on each side of the transmitter using a 3mm hex wrench.
- 2) Detach the grip downward from the upper transmitter unit. Be careful to avoid damaging the wires that are connected on both units.
- 3) There are four phillips head screws holding each side of the grip bracket. Remove the screws and reset the bracket screw hole at the lower screw hole. This sets the bracket to the higher height position.
- 4) After resetting the driving position, retighten the grip bracket screws, then align the upper transmitter unit and reinstall it using the two M4 socket-head cap screws.

! The transmitter ships with the grip bracket in the lower height position.

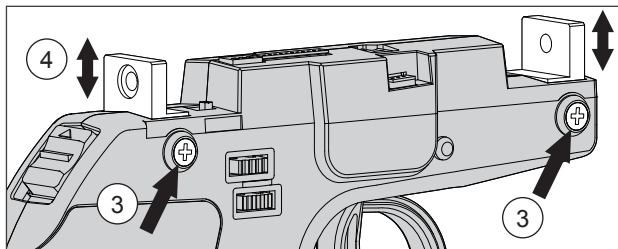
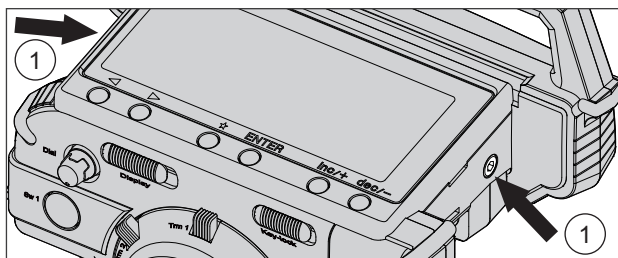

THROTTLE TRIGGER TENSION

The throttle trigger spring tension can be adjusted to suit your taste.

- 1) Remove the M4 socket-head cap screws on each side of the transmitter using a 3mm hex wrench.
- 2) Detach the grip downward from the upper transmitter unit. Be careful to avoid damaging the wires that are connected on both units.
- 3) Adjust the throttle trigger spring tension using a 1.5 mm hex wrench. To increase throttle trigger spring tension tighten the hex screw (turn clockwise). To decrease throttle trigger spring tension loosen the hex screw (turn counter-clockwise).
- 4) After resetting the throttle trigger spring tension, align the upper transmitter unit and reinstall it using the two M4 socket-head cap screws.

! Throttle trigger spring tension is factory set to Medium tension.

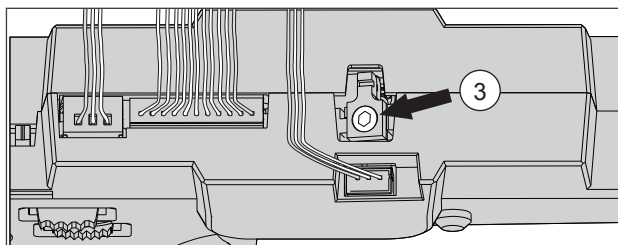
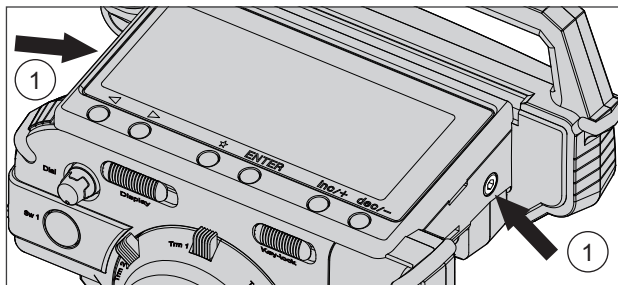

DRIVING POSITION ADJUSTMENTS

DIGITAL TRIM RING POSITION

The position of the digital trim ring can be repositioned to better suit your taste. Five different positions are available.

- 1) Remove the M4 socket-head cap screws on each side of the transmitter using a 3mm hex wrench.

⚠ Trm 1 is factory set at the top center position.

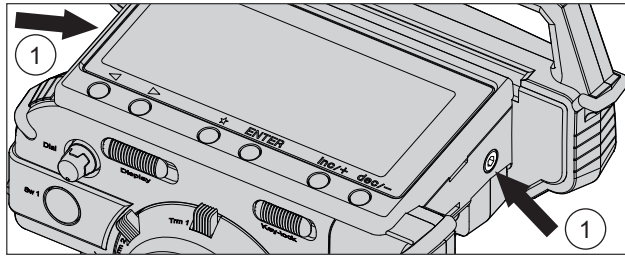

- 2) Detach the grip downward from the upper transmitter unit. Be careful to avoid damaging the wires that are connected on both units.

- 3) Remove the three M2.6 socket-head cap screws from the back of the digital trim ring (behind the steering wheel), using a 2mm hex wrench.

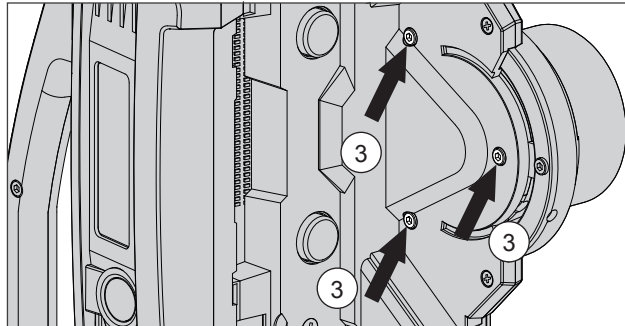

- 4) Rotate the digital trim ring to the desired position. The digital trim ring can be positioned in one of five different positions. Set the digital trim ring at the desired position, then retighten the three M2.6 socket-head cap screws.

- 5) After setting the digital trim ring position, align the upper transmitter unit and reinstall it using the two M4 socket-head cap screws.

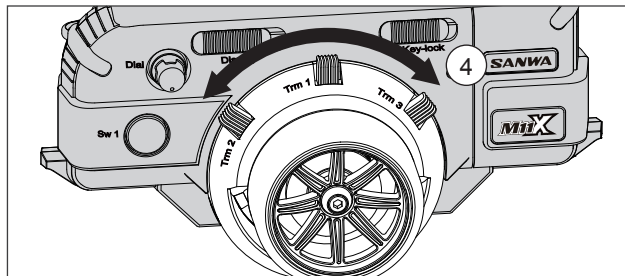

STEERING WHEEL POSITION

The steering wheel position can be changed from the right side to the left side to accommodate left-handed users.

- 1) Remove the M4 socket-head cap screws on each side of the transmitter using a 3mm hex wrench.

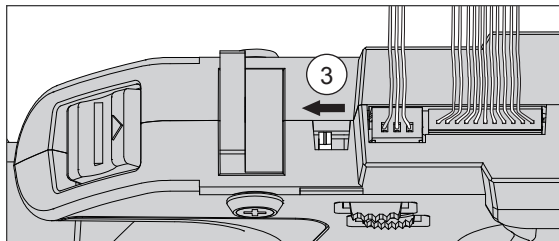

- 2) Detach the grip downward from the upper transmitter unit. Be careful to avoid damaging the wires that are connected on both units.

- 3) Set the Left/Right selector switch to 'L' located above the Trm 4 and Trm 5 switches.

- 4) Rotate the grip by 180 degrees, then align the upper transmitter unit and reinstall it using the two M4 socket-head cap screws.

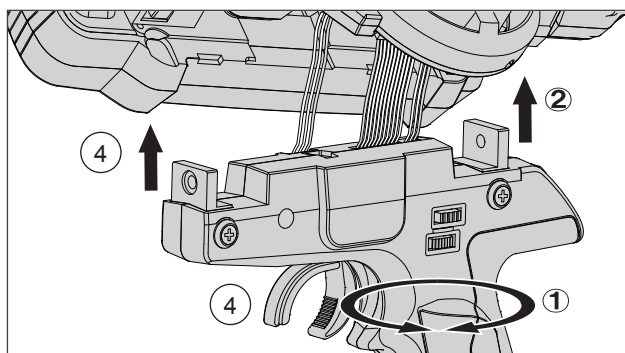
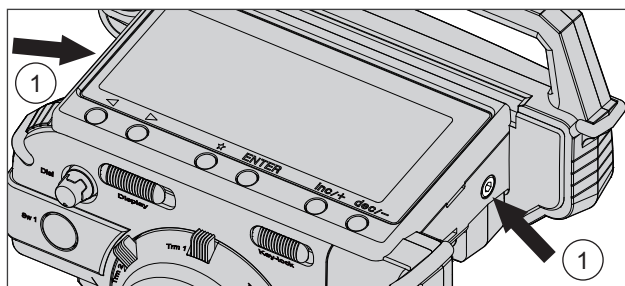

CHARGING THE BATTERY

The M11X FHSS-3 2.4GHz transmitter features a 6 cell 7.2v 1500mAH NiMH battery for lighter weight and longer battery life. The battery is charged directly through the transmitter, using the charging jack located at the base of the grip. Please observe the Safety Precautions and Charging Warnings below when charging the transmitter battery.

SAFETY PRECAUTIONS AND CHARGING WARNINGS

- Always follow the charging procedures described below to ensure safe and correct use of your NiMH battery.
- The NiMH battery is not charged when purchased. It is necessary to charge the NiMH battery before operation.
- Before charging the NiMH battery, double-check that the transmitter power switch is in the OFF position.
- Overcharging reduces the life of the battery and can result in electrolyte spills, overheating, and bursting. This may cause personal injury and/or property damage.
- Do not throw the NiMH battery or abuse it in any manner. Do not dispose of the NiMH battery in the fire or allow it to overheat.
- Do not short-circuit the NiMH battery terminals with wire or any other object.

CHARGING THE TRANSMITTER BATTERY

- 1) Plug the round connector from the charger into the charging jack in the grip of the transmitter.
- 2) Plug the supplied charger into a AC power wall socket. The charger LED will illuminate red indicating that the charger is plugged in and charging.
- 3) Transmitter charger output is 150mAH, therefore, it will take approximately 10 hours to recharge a fully-discharged battery. We suggest leaving the charger on overnight.

Charger Specifications

Model: OE-156CE

or

OE-156CU(UK)

Input Voltage: 100~240v

Tx Output Voltage: 8.5v@150mAH

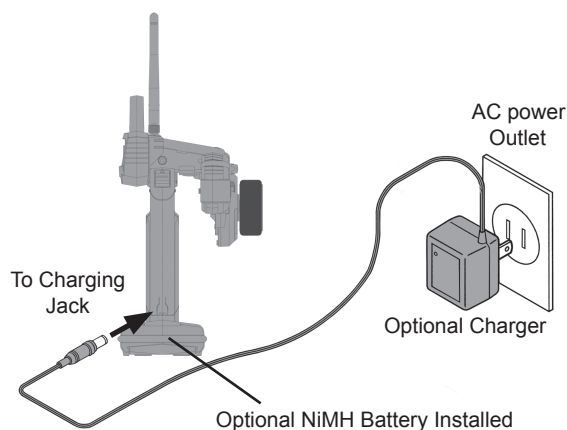

- ⚠ If the charger is plugged in to the wall socket, but not to the charging jack in the transmitter, the LED will illuminate green.
- ⚠ It's safe to charge a full-discharged battery from 10 to 15 hours. We do not suggest allowing the battery to charge for more than 15 hours.
- ⚠ An after-market peak-detection charger can be used to charge the NiMH transmitter battery, however, the battery must first be removed from the transmitter to be charged. The circuitry within the transmitter will interfere with the peak-detection charger's normal operation, resulting in over-charging and damaging the battery and possibly the transmitter itself.

USING A TRANSMITTER LIPO BATTERY

An after-market Li-Po battery can be used in place of the stock 6 Cell 7.2v 1500mAH NiMH transmitter battery. If you decide to replace the stock battery with a Li-Po battery, please observe the following:

- Use ONLY a 2 Cell 7.4v Li-Po battery of desired capacity. **DO NOT USE A 3 CELL 11.1V LI-PO BATTERY.**
- You MUST remove the battery from the transmitter to charge the battery.
- Do NOT use the charger included with the transmitter to charge a Li-Po battery. You MUST use a dedicated Li-Po battery charger.
- When you change the connector on your Li-Po battery, please observe correct polarity.

LCD MENU KEYS

The SANWA M11X FHSS-3 2.4GHz transmitter features six menu keys for menu operation. This section summarizes the functions of each of the 6 menu keys in addition to describing the main areas of the LCD Display.

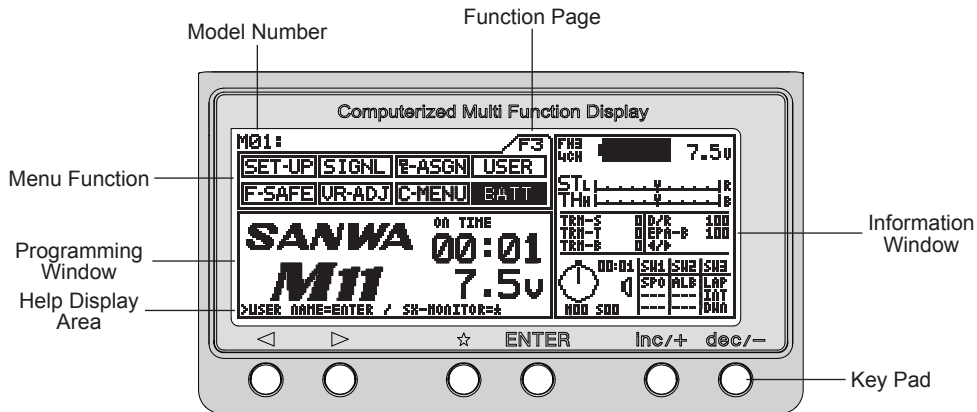

 A plastic cover is included that snaps over the LCD display and key pad to protect it during travel or storage.

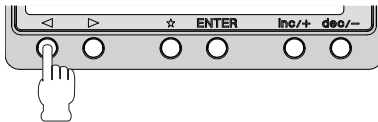
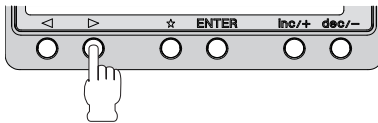
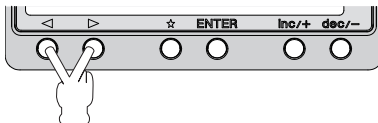
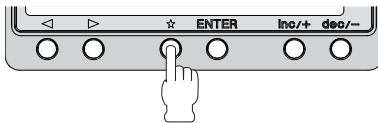
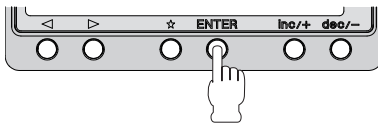
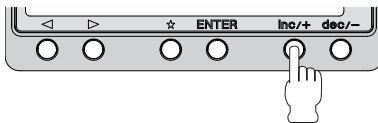
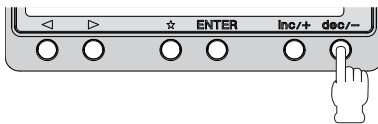
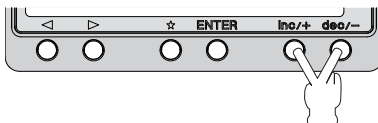
KEY	NAME	FUNCTION
	Function Key ◀	Moves the Menu Function cursor left (backward) to the previous menu function. Turning the Dial Knob counter-clockwise will move the Menu Function cursor left, too.
	Function Key ▶	Moves the Menu Function cursor right (forward) to the next menu function. Turning the Dial Knob clockwise will move the Menu Function cursor right, too.
	Function Page Select Key Sequence	Pressing both keys will scroll through the Function Pages in order - F1, F2, and F3. The first Menu Function will be highlighted on each page.
	★ Scroll Key	Moves the Cursor backward in the Programming Window. Also used in the Help Display Area and to display the Information Window.
	Enter Key	Moves the Cursor forward in the Programming Window. Also used in the Help Display Area.
	INC/+ Key (Increase)	Increases number values in the Programming Window. Also scrolls up a Selection List.
	DEC/- Key (Decrease)	Decreases number values in the Programming Window. Also scrolls down a Selection List.
	INC/+ and DEC/- Key Sequence (Reset)	Pressing both keys together will Reset the selection to the Factory Default Setting.

TRANSMITTER AND RECEIVER BINDING

When new, it is necessary to pair the transmitter and receiver to prevent interference from radio controllers operated by other users. This operation is referred to as 'binding'. Once the binding process is complete, the setting is remembered even when the transmitter and receiver are turned OFF, therefore, this procedure usually only needs to be done once. Under some circumstances, the receiver may not operate after turning the transmitter and receiver ON. If this occurs, perform the binding process again.

! Before beginning the binding process, plug your receiver battery into the switch, then plug the switch into the BATT/DSC slot in the receiver, making sure that the polarity is correct. Make sure that both the transmitter and receiver are turned OFF.

- 1) Turn on the transmitter, then press the two Function keys at the same time until Function Menu F3 is displayed. If the SET-UP menu is not automatically highlighted, continue to press the Function key until the SET-UP menu is highlighted.
- 2) With the SET-UP menu highlighted, press the Function key to select [BIND] in the Programming Window. SET BIND BUTTON will be displayed in the Programming Window.



- 3) Press the ★ key. SEND BIND COMMAND will be displayed in the Programming Window.

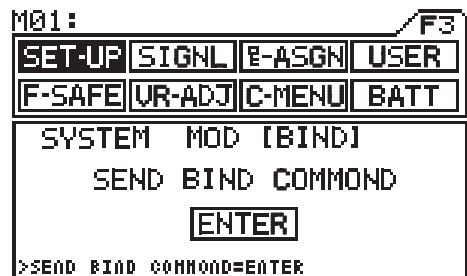

- 4) While holding down the Bind Button on the receiver, turn the receiver ON. The Bind LED on the receiver will blink slowly.

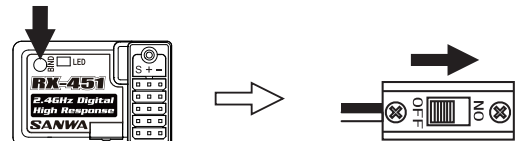

! Use the tip of a pencil or a 1.5mm hex wrench to reach the Bind Button on the receiver.

- 5) After ~ 2 seconds release the Bind Button. The Bind LED on the receiver will continue to blink slowly. Quickly press the ENTER key on the transmitter. SENDING will be displayed in the Programming Window, the Bind LED on the receiver will blink rapidly, then the Bind LED on the receiver will turn solid indicating the binding process is complete.

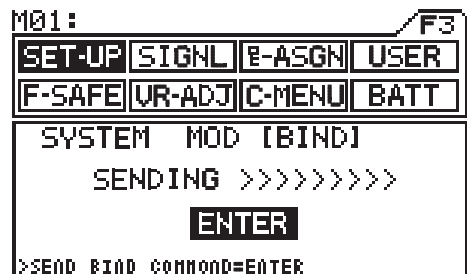

! After releasing the Bind Button, you must press the ENTER key quickly (within a couple of seconds). If you take too much time, you will need to restart the binding process.

! When the binding procedure is successful, the Bind LED on the receiver will stay solid blue when both the transmitter and receiver are turned ON. If the Bind LED on the receiver is blinking rapidly, the transmitter and receiver are not paired. In this case, turn both the transmitter and receiver OFF, then repeat the binding procedure.

! The M11X FHSS-3 2.4GHz radio control system uses FHSS-3 technology. The transmitter is compatible with FHSS-3 and FHSS-2 SANWA 2.4GHz receivers. To bind the transmitter to an FHSS-2 receiver (RX-442), the transmitter modulation must first be changed to FH2. For more information, please see page 47.

FUNCTION PAGES

The functions of the M11X FHSS-3 2.4GHz transmitter span three pages, F1 to F3. Pressing the ◀ and ▶ function keys at the same time displays each of the three function pages in succession - F1, F2, F3...F1, etc. Pressing either the ◀ or ▶ function keys separately scrolls through the individual functions assigned to the currently highlighted menu on the function page you're currently viewing. For example, press the Function Key Right to highlight the EPA menu in Function Page 1. The EPA menu will be highlighted and there will be brackets around [ST] in the Programming Window. Pressing the Function Key Right again will move the selection brackets to [TH] and so on until the EXP menu is highlighted.

⚠ The LCD Display backlighting will turn on when any menu key is pressed. If no menu key is pressed, the LCD display backlighting will turn off after 10 seconds to conserve battery power. This setting can be changed. See page 46 for more information.

Function Menu F1 consists of the following individual functions:

- Steering Dual Rate
- End Point Adjustment
- Exponential
- Adjustable Rate Control
- Steering / Brake Servo Speed
- Anti-Lock Braking
- Traction Control
- Model Naming / Model Select / Model Copy

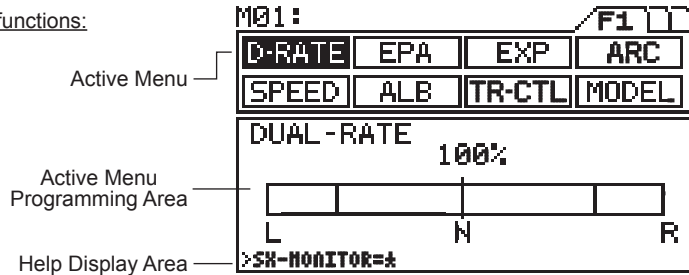

Function Menu F2 consists of the following individual functions:

- Servo Sub-Trim
- Track Timers
- Servo Reversing
- Start Position
- Throttle Hold
- Brake Mixing
- Compensation Mixing
- Servo Monitor

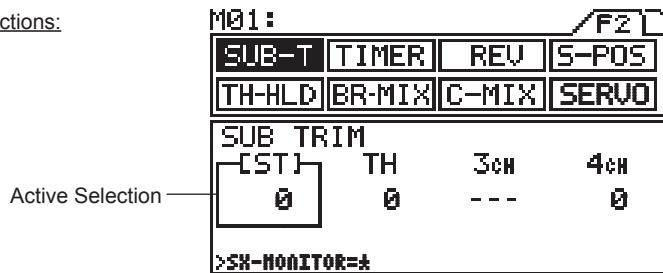

Function Menu F3 consists of the following individual functions:

- Transmitter Setup
- Audio Signal Sound
- Switch / Trim Assignment
- User Name
- Fail-Safe Setup
- VR-Adjustment
- Custom Menu Setup
- Battery Display

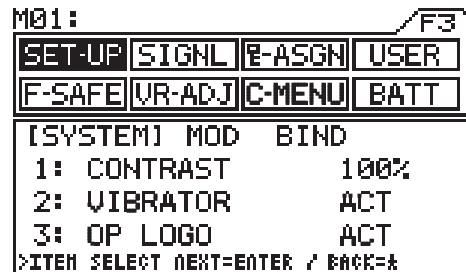

The Information Window described below is provided on the right side of the display. This makes it possible to determine, at a glance, the current setting status of various functions from any menu screen.

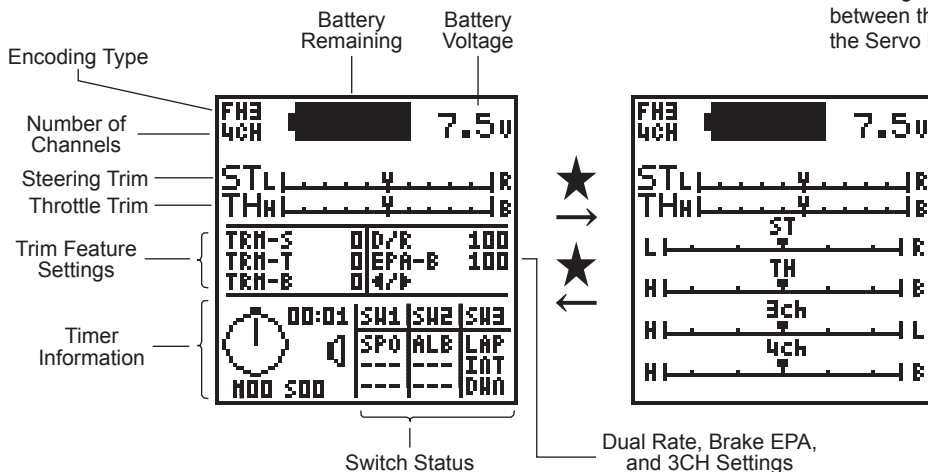

Pressing the ★ key switches quickly between the Information Screen and the Servo Monitor Screen.

MENU FLOW CHART

The Menu Flow Chart shows the different menus that are available for programming your M11X transmitter. The default setting when the transmitter is turned ON the very first time is the F3 Function Page BATT menu. When the transmitter is subsequently turned ON, the last screen displayed when the transmitter was turned OFF will be displayed.

! The following Menus are the result of pushing the Right Function key.

[F1] FUNCTION PAGE 1

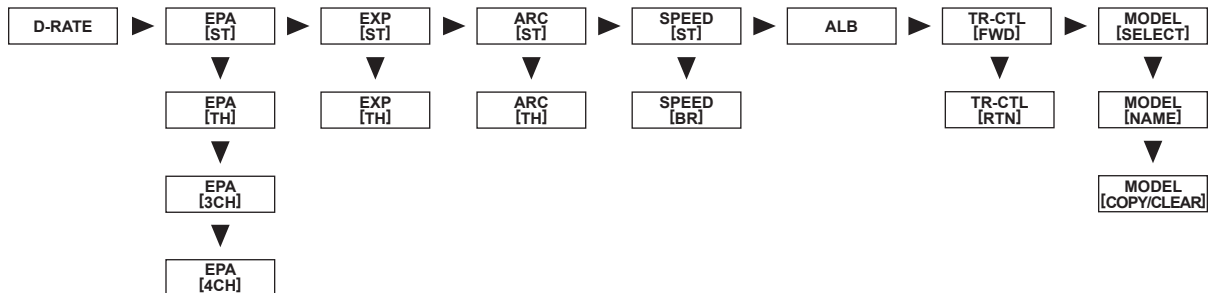

[F2] FUNCTION PAGE 2



[F3] FUNCTION PAGE 3

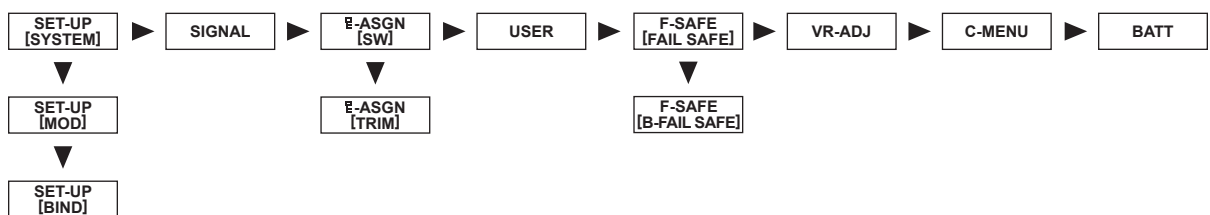

FUNCTION PAGES SPECIAL NOTES

- EPA 3CH Channel 3 or Auxiliary Channel 1
- EPA 4CH Channel 4 or Auxiliary Channel 2 (Note: Brake Side Only)
- BR..... Brake
- FWD..... Forward Servo Travel
- RTN..... Servo Return to Neutral Travel
- SUB-T 3CH Only Available in 4CH Mode
- SUB-T 4CH Only Available in 4CH Mode
- REV 3CH..... Channel 3 or Auxiliary Channel 1
- REV 4CH..... Channel 4 or Auxiliary Channel 2
- TH-HLD..... Intended for Gas- or Glow-Powered Models
- BR-MIX Only Available in 4CH Mode and Brake Mixing (BR-MIX) is Activated

BATTERY AND OPERATING TIMER

SET-UP	SIGNL	E-ASGN	USER
F-SAFE	VR-ADJ	C-MENU	BATT

Function Page 3 (BATT)

TRANSMITTER BATTERY VOLTAGE

When the transmitter is turned ON for the very first time, the BATT menu on Function Page 3 is displayed. When the transmitter is subsequently turned ON, the last menu and function page that was displayed when the transmitter was turned OFF is displayed.

The transmitter battery voltage is displayed on two different areas of the LCD display. Transmitter battery voltage is displayed in the information window and in the battery menu window. Transmitter battery voltage is displayed in decimal value increments of 0.1 volts. Operating voltage is 6.1 volts to 11.0 volts. Normal operating voltage is ~7.5 volts

Programming Window

Logo Screen

Battery Voltage*

Information Window

*Will start blinking if battery voltage reaches 6.7 volts.

When the transmitter battery voltage drops to 6.7 volts, the transmitter will start beeping and vibrating (if the vibration feature is enabled), and will continue every 30 seconds. When this happens, promptly stop operation and recharge the transmitter batteries. Continuing to use the transmitter after the low voltage alarm sounds can result in loss of control of your model.

User Screen

While in the BATT menu, press the ENTER key to switch between the Logo screen and the User screen.

To enter your Username so that it appears on the User Screen, see page 54.

OPERATING TIMER

The Operating Timer is a count-up timer that records the time the transmitter has been turned on in hours and minutes. This timer can be reset to 00:00 by pressing the INC/+ and DEC/- keys at the same time (only in the BATT menu). Resetting the Operating Timer after you have recharged the transmitter battery will give you the amount of time the battery has been in use.

Operation Timer

Operation Timer

END POINT ADJUSTMENT

- Test-run your model to set the brake adjustment using the Trm 5 switch. The Trm 5 switch can be used to change the EPA-B setting without accessing the Programming Menu. Push the trim switch forward to increase the Brake EPA and pull the trim switch backward to decrease the Brake EPA. This is convenient if you need to change the Brake EPA setting while driving.

! The EPA-B setting can be assigned to any desired trim switch using the Key Assign function. See page 51 for more information.

Trm 5 Switch (Lower)

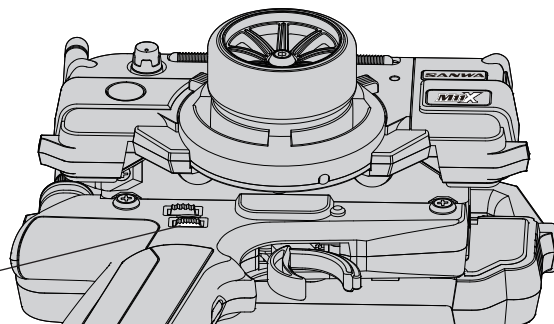

[3CH] AUXILIARY CHANNEL 3 END POINT ADJUSTMENT

With 3CH - BRAKE INH (Inhibited)

With the BRAKE function inhibited Auxiliary Channel 3 can be used for functions such as remote needle valve control, reversing transmissions, dig function in Crawlers, and more..

! In order to set any functions for Auxiliary Channel 3, you must first set the channel setting from 2CH to 4CH. In the default configuration (FH3 Modulation), the transmitter is set to 4CH Mode. If you are using FH2 Modulation with a legacy FHSS-2 receiver, the default configuration is 2CH Mode. To enable 4CH Mode, see page 47 for more information.

! Auxiliary Channel 3 must first be assigned to a Trim Switch or the Dial Knob. See page 51 for more information.

- Make sure that 4CH is selected in the SET-UP menu and that 3CH-BRAKE is set to INH in the BR-MIX menu. See pages 40 and 47 for more information.
- Press the Function key to move the cursor to [3CH] in the EPA Programming Window.
- To adjust the High side, turn the Dial knob to the right. The cursor will move next to 100%H. Press the INC/+ or DEC/- keys to increase or decrease the amount of servo travel. To adjust the Low side, turn the Dial Knob left. The cursor will move next to 100%L. Press the INC/+ or DEC/- keys to increase or decrease the amount of servo travel.

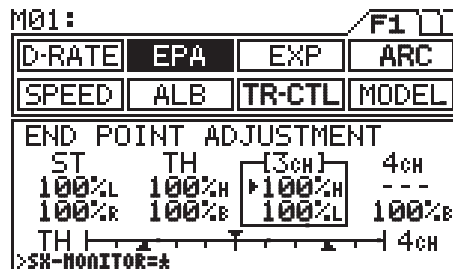

EPA 3CH setting range is between 0% and 150% in either direction. The default setting is 100%.

With 3CH - BRAKE ACT (Active)

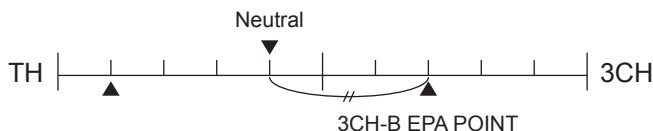

When using Auxiliary Channel 3 as an additional BRAKE channel, the End Point Adjustment can be set separately from the Auxiliary Channel 4 BRAKE channel. In this configuration, the 3CH BRAKE is activated using the throttle trigger brake function.

- Make sure that 4CH Mode is selected in the SET-UP menu and that 3CH-BRAKE is set to ACT in the BR-MIX menu. See pages 40 and 47 for more information.
- Press the Function key to move the cursor to [3CH] in the EPA Programming Window. The cursor will default next to 100%B. Press the INC/+ or DEC/- keys to increase or decrease the amount of servo travel.

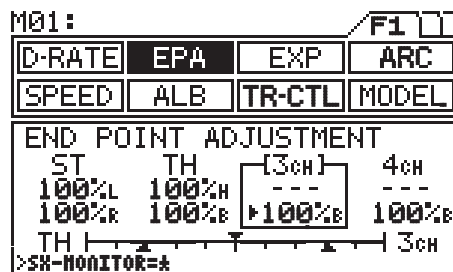

EPA 3CH-B setting range is between 0% and 160% in the Brake direction. The default setting is 100%.

EXPONENTIAL

M01:			F1
D-RATE	EPA	EXP	ARC
SPEED	ALB	TR-CTL	MODEL

Function Page 1 (EXP)

The Exponential function varies the amount of servo action with respect to manipulation of the steering wheel or throttle trigger near the neutral positions. Decreasing the Exponential value will 'soften' the control feel around neutral and increasing the Exponential value will 'quicken' the control feel around neutral. Using a lower negative value allows for smoother control. Using a higher positive value may result in more 'twitchy' control response.

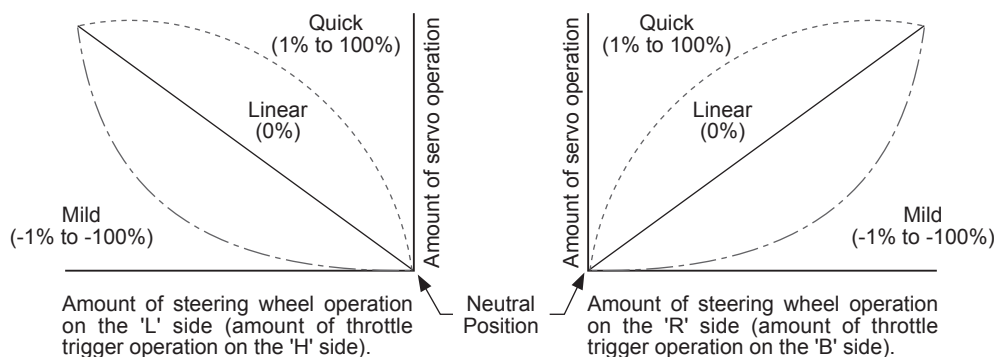

[ST] STEERING EXPONENTIAL

Steering Exponential can be variably adjusted from Mild through Linear to Quick to allow you to set the most effective steering response for your model. Generally, if your model over-steers, reduce the Exponential value, and if your model under-steers, increase the Exponential value.

1) Press the Function key to highlight the EXP menu. [ST] will be active in the Programming Window and the cursor will default above TWEAK.

2) Press the INC/+ or DEC/- keys to set the desired Exponential value.

⚠ Changes to the steering Exponential affects both right and left steering equally.

M01:			F1
D-RATE	EPA	EXP	ARC
SPEED	ALB	TR-CTL	MODEL

OUTPUT	[ST] TH	OUTPUT
▶	50%	
TWEAK		
0		0
L EXP	ACT R	

>ITEM SELECT=ENTER / SX-MONITOR=#

EXP-ST setting range is between -100% (Mild) to 100% (Quick). The default setting is 0% (Linear).

TWEAK Setting

Use the TWEAK setting when you want to fine-tune the left and right steering balance. This allows you to move and pinpoint the neutral position of the Exponential function independently anywhere between the Steering End Points, not just the center. This ensures that Exponential is balanced for both the right and left sides.

1) Press the ENTER key to move the cursor to the TWEAK setting.

2) To adjust left-hand steering, turn the steering wheel to the left. The cursor will point to the left. Press the INC/+ or DEC/- keys to adjust the parameters. To adjust the right-side steering, turn the steering wheel to the right. The cursor will point to the right and press the INC/+ or DEC/- keys to adjust the parameters.

EXP ST TWEAK setting range is between -20 to 20. The default setting is 0.

M01:			F1
D-RATE	EPA	EXP	ARC
SPEED	ALB	TR-CTL	MODEL

OUTPUT	[ST] TH	OUTPUT
▶	50%	
TWEAK		
0 4		0
L EXP	ACT R	

>ITEM SELECT=ENTER / SX-MONITOR=#

EXPONENTIAL

ACT/INH Setting

1) To use the Steering Exponential function, it must be Activated. Press the ENTER key to move the cursor to EXP, then press the INC/+ or DEC/- keys to either ACT (Activate) or INH (Inhibit) the Exponential function.

 The EXP ST ACT/INH setting can be assigned to any desired Push-Button switch using the Key Assign function. See page 50 for more information. By using this function, switching Exponential 'ON' or 'OFF' can be selected during model operation.

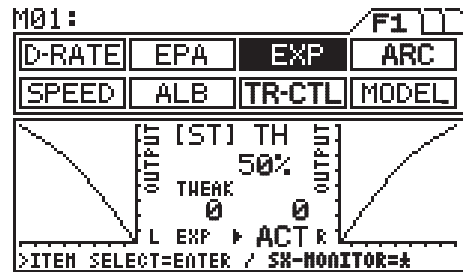

[TH] THROTTLE EXPONENTIAL

Throttle Exponential can be adjusted from Mild, Linear and Quick. In general, reduce the Exponential value on a slippery track or with a model that has a higher-torque motor or engine. Increase the Exponential value on a high-grip track or with a model that has a lower-torque motor or engine.

 The High throttle side and the Brake side can be set independently.

High Side Setting

- 1) Press the Function key to move the cursor to [TH] in the EXP Programming Window. The cursor will default next to H.
- 2) With the cursor at H (High throttle), press the INC/+ or DEC/- keys to set the desired amount of Exponential for the High throttle side.

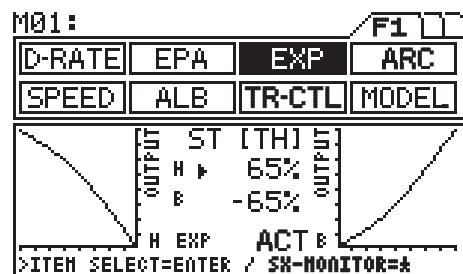

EXP TH-H setting range is between -100% (Mild) to 100% (Quick). The default setting is 0% (Linear).

Brake Side Setting

- 1) Press the ENTER key to move the cursor to B, then press the INC/+ or DEC/- keys to set the desired amount of Exponential for the Brake side.

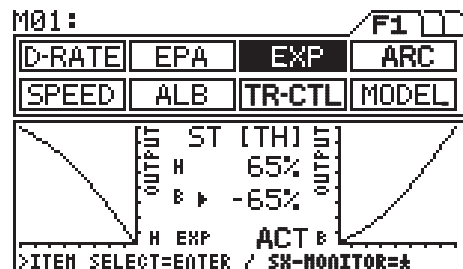

EXP TH-B setting range is between -100% (Mild) to 100% (Quick). The default setting is 0% (Linear).

ACT/INH Setting

- 1) To use the Throttle Exponential function, it must be Activated. Press the ENTER key to move the cursor to EXP, then press the INC/+ or DEC/- keys to either ACT (Activate) or INH (Inhibit) the Exponential function.

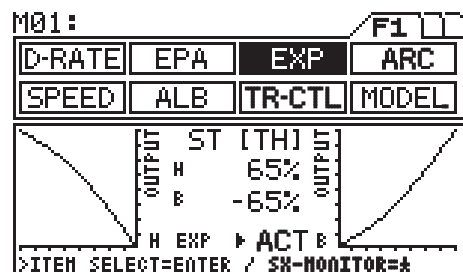

 The EXP TH ACT/INH setting can be assigned to any Push-Button switch using the Key Assign function. See page 50 for more information. By using this function, switching Exponential 'ON' or 'OFF' can be selected during model operation.

ADJUSTABLE RATE CONTROL

M01:			F1
D-RATE	EPA	EXP	ARC
SPEED	ALB	TR-CTL	MODEL

Function Page 1 (ARC)

The Adjustable Rate Control function varies the amount of servo action with respect to manipulation of the steering wheel or throttle trigger. Increasing the Adjustable Rate Control value will make the servo action quicker, while reducing the Adjustable Rate Control value will make the servo action milder.

⚠ Adjustable Rate Control is similar in function to Exponential, however, Adjustable Rate Control allows you to move and pinpoint the neutral position anywhere between the Steering or Throttle stops, not just the center.

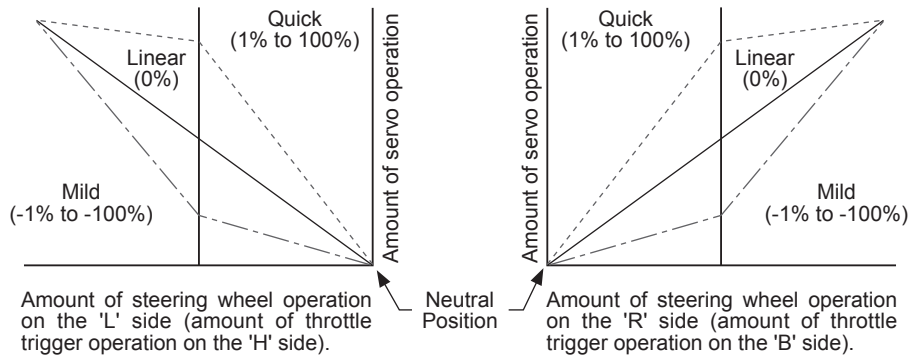

[ST] STEERING ADJUSTABLE RATE CONTROL

Steering Adjustable Rate Control can be adjusted from Mild through Linear to Quick. In general, if your model over-steers, reduce the Adjustable Rate Control value, and if your model under-steers, increase the Adjustable Rate Control value.

RATE Setting

- 1) Press the Function key to highlight the ARC menu. [ST] will be active in the Programming Window and the cursor will default below RATE.
- 2) Press the INC/+ or DEC/- keys to set the desired RATE value.

M01:			F1
D-RATE	EPA	EXP	ARC
SPEED	ALB	TR-CTL	MODEL
OUTPUT	[ST]	TH	OUTPUT
RATE	40		
POINT	50		
L ARC	ACT R		
>ITEM SELECT=ENTER / SW-MONITOR=#			

ARC ST RATE setting range is between -100% (Mild) to 100% (Quick). The default setting is 0% (Linear).

POINT Setting

- 1) Press the ENTER key to move the cursor to POINT.
- 2) Press the INC/+ or DEC/- keys to set the desired POINT value.

⚠ The POINT value pinpoints the center of the RATE value.

M01:			F1
D-RATE	EPA	EXP	ARC
SPEED	ALB	TR-CTL	MODEL
OUTPUT	[ST]	TH	OUTPUT
RATE	40		
POINT	50		
L ARC	ACT R		
>ITEM SELECT=ENTER / SW-MONITOR=#			

ARC ST POINT setting value is between 5 to 95. The default setting is 50.

⚠ Changes to the steering Adjustable Rate Control affects both right and left steering equally.

ADJUSTABLE RATE CONTROL

ACT/INH Setting

- 1) To use the Steering Adjustable Rate Control function, it must be Activated. Press the ENTER key to move the cursor to ARC then press the INC/+ or DEC/- keys to either ACT (Activate) or INH (Inhibit) the Adjustable Rate Control function.

 The ARC ST ACT/INH setting can be assigned to any Push-Button switch using the Key Assign function. See page 50 for more information. By using this function, switching Adjustable Rate Control 'ON' or 'OFF' can be selected during model operation.

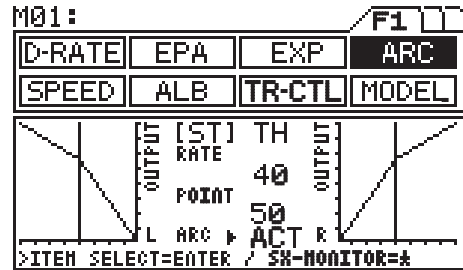

[TH] THROTTLE ADJUSTABLE RATE CONTROL

Throttle Adjustable Rate Control can be adjusted from Mild, Linear and Quick. In general, reduce the Adjustable Rate Control value on a slippery track or with a model that has a higher-torque motor or engine. Increase the Adjustable Rate Control value on a high-grip track or with a model that has a lower-torque motor or engine.

 The High throttle side and the Brake side can be set independently.

RATE Setting

- 1) Press the Function key and move the cursor to [TH] in the ARC Programming Window. The cursor will default to RATE.
- 2) To adjust the High throttle setting, pull the throttle trigger back. The cursor will point to the left. Press the INC/+ or DEC/- keys to set the desired RATE value.

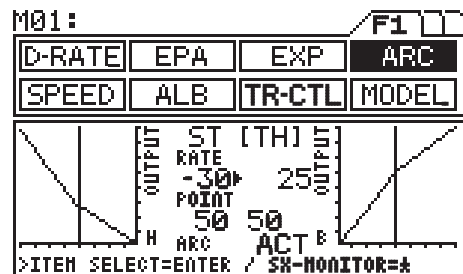

- 3) To adjust the Brake side setting, push the throttle trigger forward. The cursor will point to the right. Press the INC/+ or DEC/- keys to set the desired RATE value.

ARC TH RATE setting range is between -100% (Mild) to 100% (Quick). The default setting is 0% (Linear).

POINT Setting

- 1) Press the ENTER key to move the cursor to POINT.
- 2) To adjust the High throttle setting, pull the throttle trigger back. The cursor will point to the left. Press the INC/+ or DEC/- keys to set the desired POINT value.
- 3) To adjust the Brake side setting, push the throttle trigger forward. The cursor will point to the right. Press the INC/+ or DEC/- keys to set the desired POINT value.

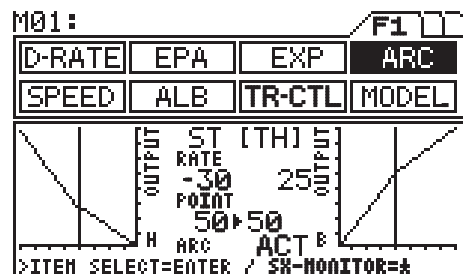

ARC TH POINT setting range is between 5 to 95. The default setting is 50.

ACT/INH Setting

- 1) To use the Adjustable Rate Control function, it must be Activated. Press the ENTER key to move the cursor to ARC, then press the INC/+ or DEC/- keys to either ACT (Activate) or INH (Inhibit) the Adjustable Rate Control function.

 The ARC TH ACT/INH setting can be assigned to any Push-Button switch, using the Key Assign function. See page 50 for more information. By using this function, switching Adjustable Rate Control 'ON' or 'OFF' can be selected during model operation.

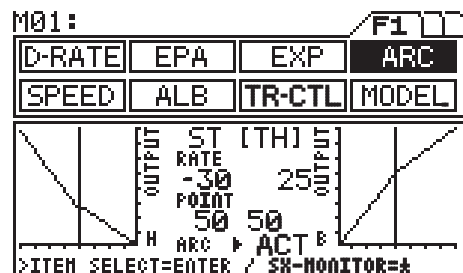

SERVO SPEED

M01:			F1
D-RATE	EPA	EXP	ARC
SPEED	ALB	TR-CTL	MODEL

Function Page 1 (SPEED)

The Speed function slows down the servo speed during use. When driving your model, proper steering and braking are vital. The steering Speed setting helps to limit excessive steering, which will enable you to achieve smoother cornering. The Speed function can also be set on the Brake side of the throttle to help ensure that the brakes don't react too quickly or become too 'touchy'.

[ST] STEERING SERVO SPEED

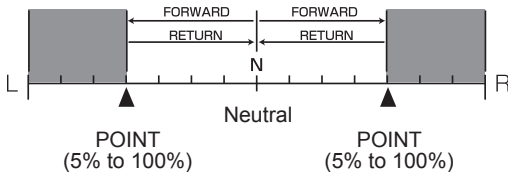

The Steering Servo Speed function affects left and right steering equally, and the Return to Neutral. The Steering Speed function will only be noticeable within this area. The Steering Speed function will not be noticeable within the outlying shaded areas.

Actual steering operation is slower than the actual speed of the steering servo.

FORWARD Setting

- 1) Press the Function key to highlight the SPEED menu. [ST] will be active in the Programming Window and the cursor will default to FORWARD.
- 2) Press the INC/+ or DEC/- keys to set the desired FORWARD value.

SPEED ST FORWARD setting range is 0 to -100. The default setting is 0. The FORWARD setting adjusts the SPEED of the servo from Neutral to the Right or the Left.

M01:			F1
D-RATE	EPA	EXP	ARC
SPEED	ALB	TR-CTL	MODEL
SPEED [ST] BR			
FORWARD	0	POINT	100%
RETURN	0	SPEED	ACT
L-----N-----R			
>ITEM SELECT=ENTER / X-MONITOR=#			

RETURN Setting

- 1) Press the ENTER key to move the cursor to RETURN, then press the INC/+ or DEC/- keys to set the desired RETURN value.

SPEED ST RETURN setting range is 0 to -100. The default setting is 0. The RETURN setting adjusts the SPEED of the servo back to Neutral.

M01:			F1
D-RATE	EPA	EXP	ARC
SPEED	ALB	TR-CTL	MODEL
SPEED [ST] BR			
FORWARD	0	POINT	100%
RETURN	0	SPEED	ACT
L-----N-----R			
>ITEM SELECT=ENTER / X-MONITOR=#			

POINT Setting

- 1) Press the ENTER key to move the cursor to POINT, then press the INC/+ or DEC/- keys to set the desired POINT value.

SPEED ST POINT setting range is 5% to 100%. The default setting is 100%. The POINT setting locates the actual point in the servo travel that you want to slow the servo's movement.

It is advisable to use both Steering Speed and Exponential functions together to achieve the best combination of steering operation.

M01:			F1
D-RATE	EPA	EXP	ARC
SPEED	ALB	TR-CTL	MODEL
SPEED [ST] BR			
FORWARD	0	POINT	100%
RETURN	0	SPEED	ACT
L-----N-----R			
>ITEM SELECT=ENTER / X-MONITOR=#			

ACT/INH Setting

- 1) To use the SPEED ST function, it must be Activated. Press the ENTER key to move the cursor to SPEED, then press the INC/+ or DEC/- keys to either ACT (Activate) or INH (Inhibit) the SPEED ST function.

The SPEED ST ACT/INH setting can be assigned to any Push-Button switch, using the Key Assign function. See page 50 for more information. By using this function, switching SPEED ST 'ON' or 'OFF' can be selected during model operation.

M01:			F1
D-RATE	EPA	EXP	ARC
SPEED	ALB	TR-CTL	MODEL
SPEED [ST] BR			
FORWARD	0	POINT	100%
RETURN	0	SPEED	ACT
L-----N-----R			
>ITEM SELECT=ENTER / X-MONITOR=#			

SERVO SPEED

[TH] THROTTLE SERVO SPEED

The Throttle Servo Speed function affects only the BRAKE side and the Return to Neutral. The SPEED setting does not affect throttle operation when the throttle trigger positioning is located within the shaded areas. The Throttle Servo Speed function will not be noticeable within the outlying shaded areas.

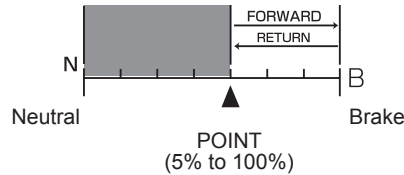

FORWARD Setting

- 1) Press the Function key to move the cursor to [BR] in the SPEED Programming Window. The cursor will default to FORWARD.
- 2) Press the INC/+ or DEC/- keys to set the desired FORWARD value.

SPEED BR FORWARD setting range is 0 to -100. The default setting is 0. The FORWARD setting adjusts the SPEED of the servo from Neutral to the Brake side.

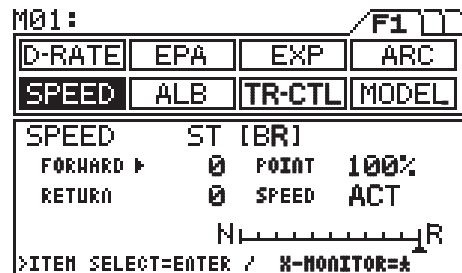

RETURN Setting

- 1) Press the ENTER key to move the cursor to RETURN, then set the RETURN value by pressing the INC/+ or DEC/- keys.

SPEED BR RETURN setting range is 0 to -100. The default setting is 0. The RETURN setting adjusts the SPEED of the servo back to Neutral.

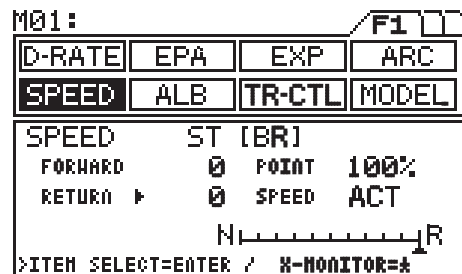

POINT Setting

- 1) Press the ENTER key to move the cursor to POINT, then press the INC/+ or DEC/- keys to set the desired POINT value.

SPEED BR POINT setting range is 5% to 100%. The default setting is 100%. The POINT setting locates the actual point in the servo travel that you want to slow the servo's movement.

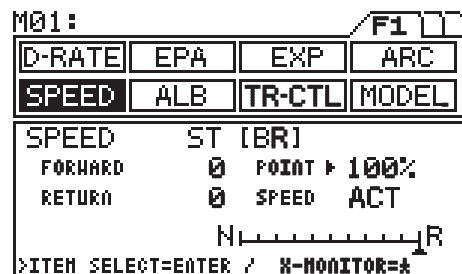

ACT/INH Setting

- 1) To use the SPEED BR function, it must be Activated. Press the ENTER key to move the cursor to SPEED, then press the INC/+ or DEC/- keys to either ACT (Activate) or INH (Inhibit) the SPEED BR function.

 The SPEED BR ACT/INH setting can be assigned to any Push-Button switch, using the Key Assign function. See page 50 for more information. By using this function, switching Speed 'ON' or 'OFF' can be selected during model operation.

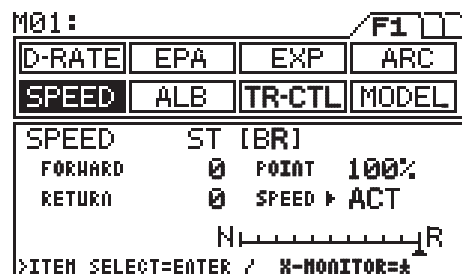

 It is advisable to use both Throttle Speed and Exponential functions together to achieve the best combination of braking operation.

ANTI-LOCK BRAKING

M01:			F1
D-RATE	EPA	EXP	ARC
SPEED	ALB	TR-CTL	MODEL

Function Page 1 (ALB)

Anti-Lock Braking makes it possible to achieve stable braking even on a slippery track. With stable braking, your model is better able to trace an exact line under braking. This function also enables you to set different braking characteristics depending on your particular model.

POINT 90% SPEED -2
 STROKE 50 SW → PUSH
 LAG 0.5 N |-----| B

STROKE
(0% to 100%)

POINT
(0% to 100%)

⚠ Set the hardest braking you can obtain from your model by carefully setting Anti-Lock Braking at the point right before the tires get fully locked but not slip and lose traction.

⚠ The Anti-Lock Brake function operates only when the throttle is moved from Neutral to the Brake direction.

POINT Setting

- 1) Press the Function key to highlight the ALB menu. The cursor will default to POINT in the Programming Window.
- 2) Press the INC/+ or DEC/- keys to set the desired POINT value.

ALB POINT setting range is 0% to 100%. The default setting is 90%. The POINT setting locates the actual point in the servo travel that you want the Anti-Lock Brake to activate.

STROKE Setting

- 1) Press the ENTER key to move the cursor to STROKE, then press the INC/+ or DEC/- keys to set the desired STROKE value.

ALB STROKE setting range is 0% to 100%. The default setting is 50%. The STROKE setting controls the amount of movement on the Brake side.

LAG Setting

- 1) Press the ENTER key to move the cursor to LAG, then press the INC/+ or DEC/- keys to set the desired LAG value.

ALB LAG setting range is 0.0 to 2.0. The default setting is 0.5. The LAG setting controls the amount of delay before the ALB activates after reaching the POINT.

SPEED Setting

- 1) Press the ENTER key to move the cursor to SPEED, then press the INC/+ or DEC/- keys to set the desired SPEED value.

ALB SPEED setting range is -1 to -30. The default setting is -2. The SPEED setting controls how quickly the Brake pulsates.

M01:			F1
D-RATE	EPA	EXP	ARC
SPEED	ALB	TR-CTL	MODEL
ANTI LOCK BRAKE			
POINT	▶ 90%	SPEED	-2
STROKE	50%	SW	PUSH
LAG	0.5	N ----- B	
>ITEM SELECT=ENTER / X-MONITOR=#			

M01:			F1
D-RATE	EPA	EXP	ARC
SPEED	ALB	TR-CTL	MODEL
ANTI LOCK BRAKE			
POINT	90%	SPEED	-2
STROKE	▶ 50%	SW	PUSH
LAG	0.5	N ----- B	
>ITEM SELECT=ENTER / X-MONITOR=#			

M01:			F1
D-RATE	EPA	EXP	ARC
SPEED	ALB	TR-CTL	MODEL
ANTI LOCK BRAKE			
POINT	90%	SPEED	-2
STROKE	50%	SW	PUSH
LAG	▶ 0.5	N ----- B	
>ITEM SELECT=ENTER / X-MONITOR=#			

M01:			F1
D-RATE	EPA	EXP	ARC
SPEED	ALB	TR-CTL	MODEL
ANTI LOCK BRAKE			
POINT	90%	SPEED	▶ -2
STROKE	50%	SW	PUSH
LAG	0.5	N ----- B	
>ITEM SELECT=ENTER / X-MONITOR=#			

ANTI-LOCK BRAKING

SW Setting

In the default configuration, Anti-Lock Braking is effective only as long as the Sw 2 switch is depressed. You can change the way the switch will operate the ALB function as follows:

- 1) Press the ENTER key to move the cursor to SW, then press the INC/+ or DEC/- keys to set the desired SW value.

The following SW value options are available:

PUSH - Depress and hold the switch for ALB to stay active.

TOGGLE - Depressing the switch once will activate ALB and depressing the switch again will deactivate ALB.

ACT - ALB will be active at all times. No switch is used. The ALB function will automatically activate when the throttle trigger reaches the POINT setting programmed previously.

M01:				F1	
D-RATE	EPA	EXP	ARC		
SPEED	ALB	TR-CTL	MODEL		
ANTI LOCK BRAKE					
POINT	90%	SPEED	-2		
STROKE	50%	SW	PUSH		
LAG	0.5	N ----- B			
>ITEM SELECT=ENTER / X-MONITOR=#					

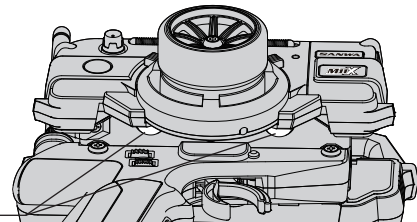

The ALB function can be assigned to another Push-Button switch, using the Key Assign function. See page 50 for more information.

TRACTION CONTROL

M01:				F1	
D-RATE	EPA	EXP	ARC		
SPEED	ALB	TR-CTL	MODEL		

Function Page 1 (TR-CTL)

The Traction Control function helps assure faster, smoother starts by reducing the chance of tire spin, even when the throttle trigger is applied abruptly. Traction Control also contributes to stability during acceleration, providing smoother running.

Ideal smoothness can be further refined by adjusting for intermittent locking in addition to normal servo speed delay adjustment. By making point settings and switch assignments (with the key assign function), Traction Control can be applied whenever necessary.

The Traction Control function operates only when the throttle is moved from Neutral to the High position. Traction Control can also be set separately when the throttle returns to Neutral from the High position.

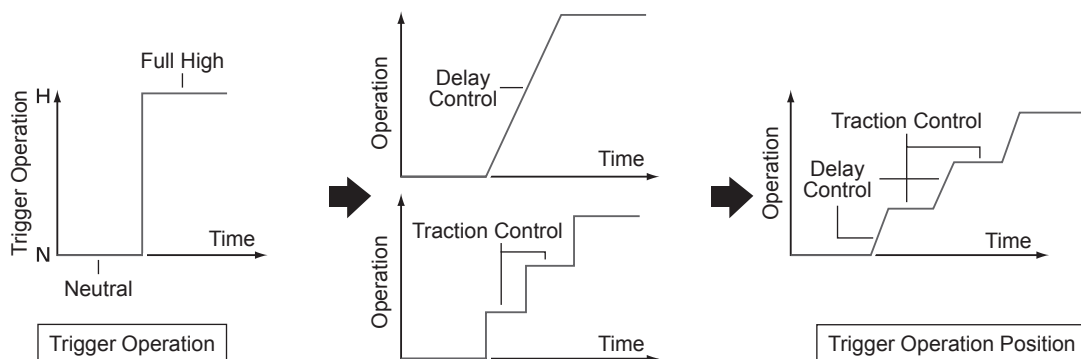

In the example above, the POINT value is 100%.

TRACTION CONTROL

[FWD] FORWARD TRACTION CONTROL

Forward Traction Control changes the Traction Control settings when the throttle is moving from Neutral to the High position. There is no traction control setting for the Brake side..

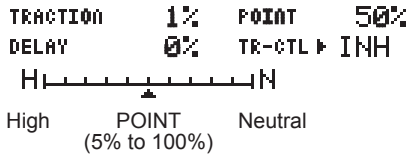

⚠ Increasing the TRACTION percentage, combined with the DELAY percentage creates a stepped acceleration through the servo's movement up to the POINT setting.

TRACTION Setting

- 1) Press the Function key to highlight the TR-CTL menu. [FWD] will be active in the Programming Window and the cursor will default to TRACTION.
- 2) Press the INC/+ or DEC/- keys to set the desired TRACTION value.

TR-CTL FWD TRACTION setting range is 1% to 100%. The default setting is 1%. The TRACTION setting adjusts the hold time before the servo moves.

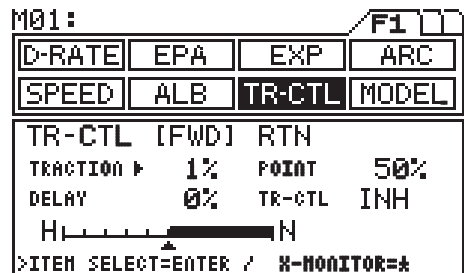

DELAY Setting

- 1) Press the ENTER key to move the cursor to DELAY, then press the INC/+ or DEC/- keys to set the desired DELAY value.

TR-CTL FWD DELAY setting range is 0% to 100%. The default setting is 0%. The DELAY setting controls when the servo performs its function.

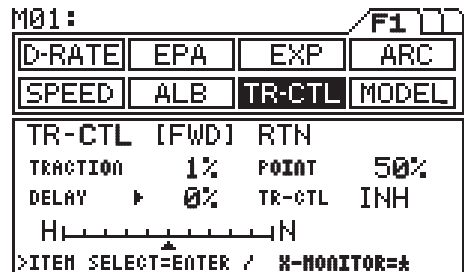

POINT Setting

- 1) Press the ENTER key to move the cursor to POINT, then press the INC/+ or DEC/- keys to set the desired POINT value.

TR-CTL FWD POINT setting range is 5% to 100%. The default setting is 50%. The POINT setting locates the actual point in the servo movement that you want the Traction Control to deactivate.

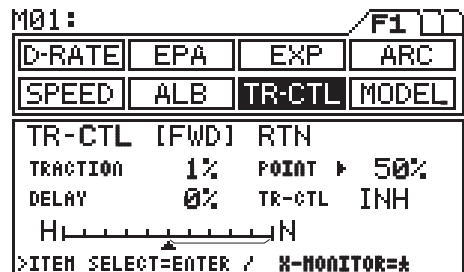

⚠ Traction Control applies only in the range from Neutral to the POINT setting position.

ACT/INH Setting

- 1) To use the TR-CTL FWD function, it must be Activated. Press the ENTER key to move the cursor to TR-CTL, then press the INC/+ or DEC/- keys to either ACT (Activate) or INH (Inhibit) the TR-CTL FWD function.

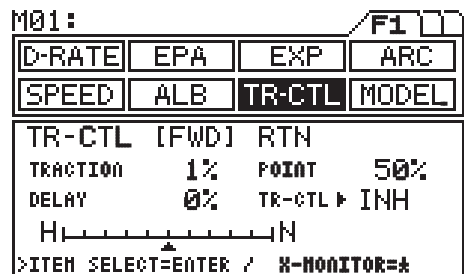

⚠ The TR-CTL FWD ACT/INH setting can be assigned to any Push-Button switch, using the Key Assign function. See page 50 for more information. By using this function, switching Traction Control 'ON' or 'OFF' can be selected during model operation.

TRACTION CONTROL

[RTN] RETURN TO NEUTRAL TRACTION CONTROL

Return to Neutral Traction Control changes the Traction Control settings when the throttle trigger is moving from High to the Neutral position.

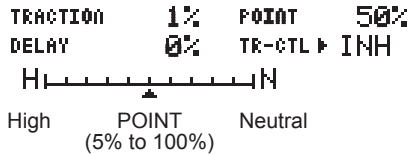

⚠ Increasing the TRACTION percentage, combined with the DELAY percentage creates a stepped acceleration through the servo's movement up to the POINT setting.

TRACTION Setting

- 1) Press the Function key to move the cursor to [RTN] in the TR-CTL Programming Window. The cursor will default to TRACTION.
- 2) Press the INC/+ or DEC/- keys to set the desired TRACTION value.

TR-CTL FWD TRACTION setting range is 1% to 100%. The default setting is 1%. The TRACTION setting adjusts the hold time before the servo moves.

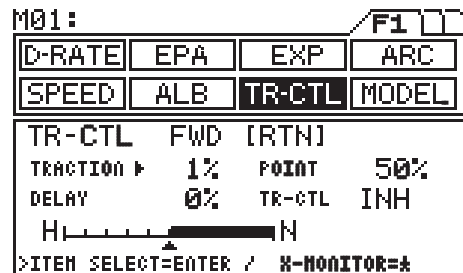

DELAY Setting

- 1) Press the ENTER key to move the cursor to DELAY, then press the INC/+ or DEC/- keys to set the desired DELAY value.

TR-CTL FWD DELAY setting range is 0% to 100%. The default setting is 0%. The DELAY setting controls when the servo performs its function.

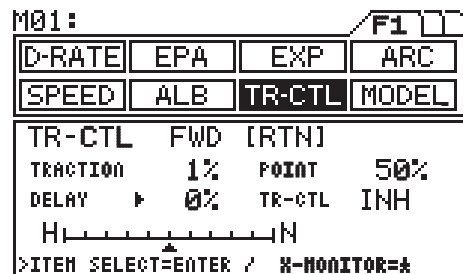

POINT Setting

- 1) Press the ENTER key to move the cursor to POINT, then press the INC/+ or DEC/- keys to set the desired POINT value.

TR-CTL FWD POINT setting range is 5% to 100%. The default setting is 50%. The POINT setting locates the actual point in the servo movement that you want the Traction Control to deactivate.

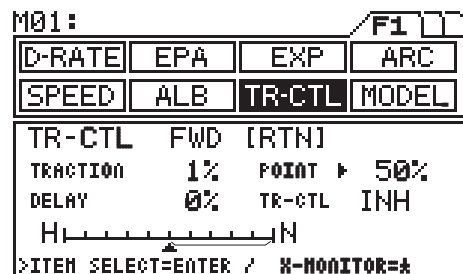

⚠ Traction Control applies only in the range from Neutral to the POINT setting position.

ACT/INH Setting

- 1) To use the TR-CTL RTN function, it must be Activated. Press the ENTER key to move the cursor to TR-CTL, then press the INC/+ or DEC/- keys to either ACT (Activate) or INH (Inhibit) the TR-CTL RTN function.

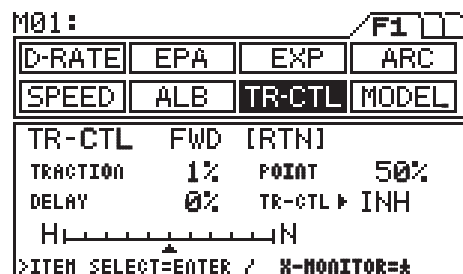

⚠ The TR-CTL RTN ACT/INH setting can be assigned to any Push-Button switch, using the Key Assign function. See page 50 for more information. By using this function, switching Traction Control 'ON' or 'OFF' can be selected during model operation.

MODEL NAMING



Function Page 1 (MODEL)

The Model function allows you to make settings related to Model Select (SELECT), Model Name (NAME), and Model Copy/Model Clear (COPY/CLEAR) functions. Data for up to 30 different models can be stored in the transmitter's built-in EEPROM memory. This allows you to use the transmitter with different models and quickly and easily select the programming for each of them.

[SELECT] MODEL SELECT

Data can be stored for any model M01 to M30. Since previous model memories are stored automatically, there is no risk for accidental erasing.

- 1) Press the Function key to highlight the MODEL menu. [SELECT] will be active in the Programming Window and the cursor will default to the currently active model.
- 2) Press the INC/+ or DEC/- keys to scroll the cursor to the model you would like to select. There are five separate model pages. The current page you are on is displayed in the lower right corner of the screen.

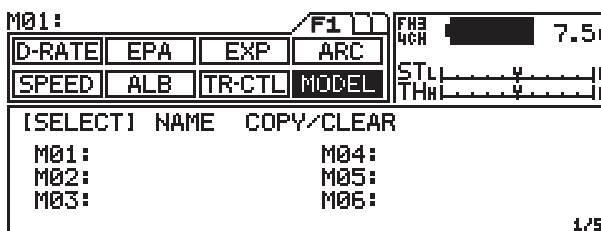

WARNING

Do not attempt to change the model when your model's receiver is turned on under actual operational conditions. Your model may run away or the servos may be damaged.

! The model changes immediately upon selection.

! Pages can be flipped through in sequence by pressing the INC/+ or DEC/- keys at the same time.

[NAME] MODEL NAME

Model names can consist of up to 12 letters, numerals, or symbols. Naming your different models makes it much easier to find and activate a particular model within the MODEL SELECT screen.

- 1) Press the Function key to move the cursor to [NAME] in the MODEL Programming Window. The cursor will blink next to the M01 selection.
- 2) The cursor will blink next to the M01: selection. Press the ENTER key to move the cursor to the right and press the ★ key to move the cursor to the left.
- 3) Press the INC/+ or DEC/- keys to select a character, then press the ENTER key to advance the cursor to the next space. Repeat to enter the rest of the characters.

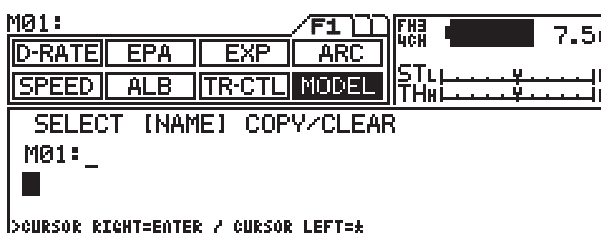

! To erase a character, move the cursor under the character you want to erase, then press the INC/+ and DEC/- keys at the same time until the single dark block (Erase Block) is selected. The underlined character will be erased.

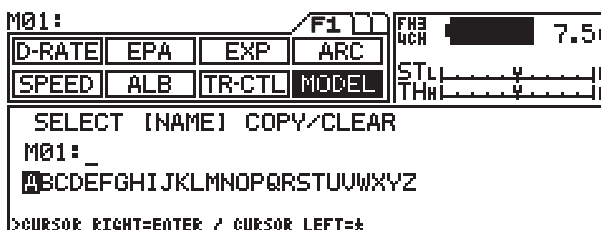

! A group of character styles can be selected by pressing the INC/+ and DEC/- keys at the same time. Choose from capital letters, lower case letters, symbols, higher case numerals, and lower case numerals.

! When entering a character in a position occupied by a space, a group can be selected from the preceding character by first pressing the DEC/- key. This is useful when entering several characters from the same group.

MODEL NAMING

[COPY / CLEAR] MODEL COPY / MODEL CLEAR

The Copy/Clear function enables you to copy data from the currently selected model to another model, or to copy another model's data into the currently selected model. Data can be cleared on the model that is currently selected.

Copy Model Data - Current Model to Another Model

- 1) Press the Function key to move the cursor to [COPY/ CLEAR] in the MODEL Programming Window.
- 2) To copy data from the currently selected model (<MASTER>) to another model (<SLAVE>), press the INC/+ or DEC/- keys to scroll the model numbers up or down to the model number you would like to copy the current model to (e.g. scroll M02: to the right of the cursor).
- 3) After you have selected the model number you wish to copy the currently selected model to, press the ENTER key. The Programming Window will display MODEL COPY! YES=<INC> and NO=<DEC>.
- 4) Press the INC/+ key to copy the data from the currently selected model to the new model. All of the data, including the name, will be copied.

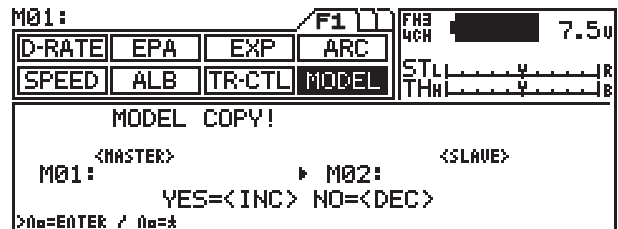
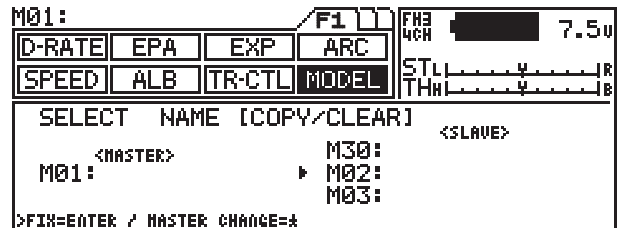

Copy Model Data - Another Model to Current Model

- 1) Press the Function key to move the cursor to [COPY/ CLEAR] in the MODEL Programming Window.
- 2) To copy data from another model (<SLAVE>) to the currently selected model (<MASTER>), press the ★ key to change the currently selected model to <Slave>. The cursor will point to the left and <MASTER> will be displayed above the model you would like to copy from.
- 3) Press the INC/+ or DEC/- keys to scroll the model numbers up or down to the model number you would like to copy from, then press the ENTER key. The Programming Window will display MODEL COPY! YES=<INC> and NO=<DEC>.
- 4) Press the INC/+ key to copy the data from the other model to the currently selected model. All of the programming data from the other model, including the name, will be copied to the currently selected model.

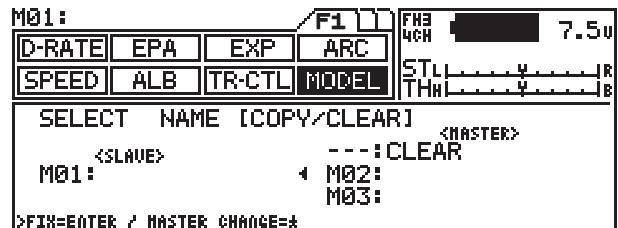

Clearing Model Data

- 1) Press the Function key to move the cursor to [COPY/ CLEAR] in the MODEL Programming Window.
- 2) Press the ★ key to change the currently selected model (<MASTER>) to <SLAVE>.
- 3) Press both the INC/+ and DEC/- keys at the same time to select (---:CLEAR), then press the ENTER key. The Programming Window will display MODEL COPY! YES=<INC> and NO=<DEC>.
- 4) Press the INC/+ key to clear all data from the currently selected model.

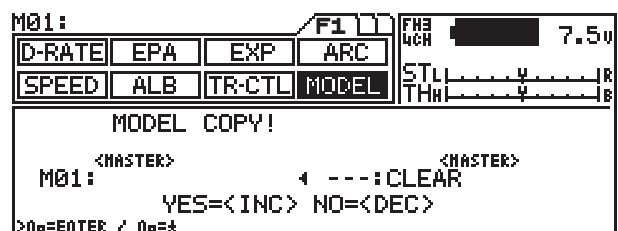
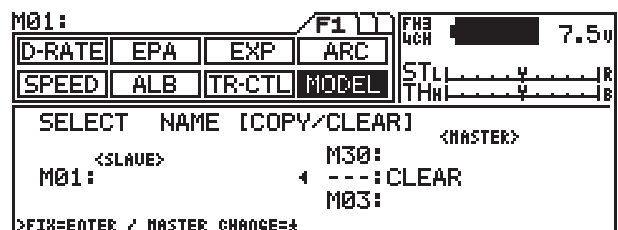

 The cursor in these screens are stationary and the model labels scroll up and down. The model that you're currently working with is displayed directly across from the cursor. The cursor always points toward the <SLAVE> model.

SERVO SUB-TRIM

M01:			F2
SUB-T	TIMER	REV	S-POS
TH-HLD	BR-MIX	C-MIX	SERVO

Function Page 2 (SUB-T)

The Sub-Trim function corrects the neutral trim setting for steering and throttle, making it possible to center the trim switches (Trm 1, Trm2, and Trm3) while ensuring the steering and throttle servo horns remain centered. When adjusting linkages, Sub-Trim allows you to fix an accurate center position. It's not unusual that when you center a servo and install the servo horn, the servo horn is not perfectly centered. Sub-trim allows you to center the servo horn perfectly, without altering the servo End-Point travel.

The Sub-Trim function can also be used for Brake Sub-Trim when using the transmitter in 4CH Mode. In this case, channels 3 and 4 can be set independently.

- 1) Before adjusting your model's linkages, be sure to set the three trim switches (Trm 1, Trm 2, and Trm 3) to the center positions (0) as displayed in the Information Window.

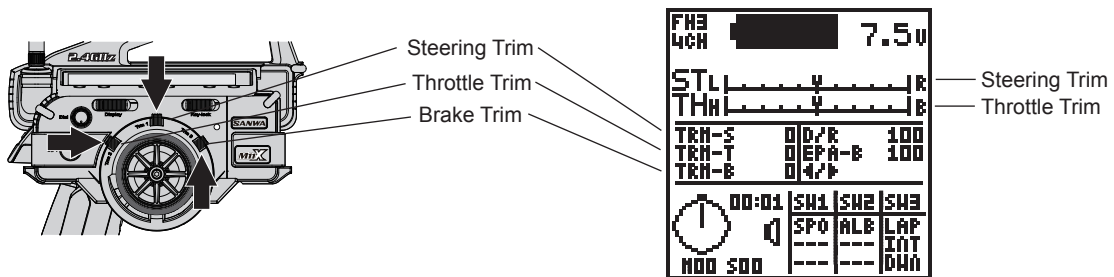

- 2) Attach your servo's servo horn (or servo saver horn) to your servo in the position that is closest to neutral (as close to centered as possible).

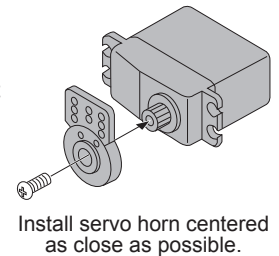

- 3) Press the Function key to highlight the SUB-T menu. The cursor will default to [ST] in the Programming Window.
- 4) Press the INC/+ and DEC/- keys to adjust the Sub-Trim value to center the Steering servo arm.

SUB-T ST setting range is 100L to 100R. The default setting is 0.

M01:			F2
SUB-T	TIMER	REV	S-POS
TH-HLD	BR-MIX	C-MIX	SERVO
SUB TRIM			
[ST]	TH	3ch	4ch
0	0	0	0
>SR-MONITOR=<			

- 5) Adjust the remaining Sub-Trim values using the same techniques.

! The Steering and Throttle Sub-Trim functions utilize Parallel Trim Technology. This allows you to adjust the Sub-Trim amount to center the servo horn and still maintain full servo travel (up to 150%) in each direction.

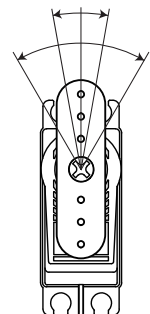

TRACK TIMERS



Function Page 2 (TIMER)

The Timer function features three different types of timers. Timers are provided for measuring Lap, Interval, and Countdown and Count-Up timers. These three timers can also be used simultaneously. In addition, a high degree of freedom and convenience is provided by the ability to assign each of the timers to a switch to perform simultaneous or independent operation. Separate tones can be assigned to each of the timers, making it easy to distinguish between them during simultaneous operation. The audible signal provided by the Tone is complemented by a Vibrator*, which can be set to operate either in concert with the tone, or simultaneously. The operational status of the timers is also displayed in the Information Window.

The timer status appears in the Information Window. The timers appear in the timer display area in the order FUNC1>FUNC2>FUNC3, as set using the Key Assign function. See page 50 for more information. In the example at right, LAP appears as assigned to FUNC1.

Pointer Revolves While Timer is Running

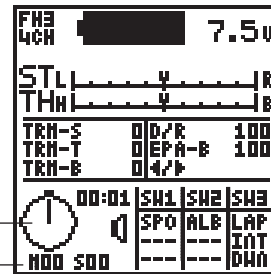

*See page 46 for more information.

[LAP] LAP TIMER

The Lap Timer function allows you to measure and record times for up to 99 laps. Featured are a Pre-Alarm (PRE-ALM), the ability to set a (GOAL) time, a real-time display of the best lap time (BEST), average lap time (AVE), and total (TOTAL) laps.

Turning On the Lap Timer (Count-Up Timer)

- 1) Press the Function key to highlight the TIMER menu. [LAP] will be active in the Programming Window and the cursor will default to OFF.
- 2) Press INC/+ or DEC/- keys to turn the Lap Timer ON.

! 00' (Minutes) 00" (Seconds) 00 (Milliseconds).

GOAL Time Setting

- 1) Press the ENTER key to move the cursor to GOAL in the Programming Window, then press INC/+ or DEC/- keys to set the desired GOAL value.

TIMER LAP GOAL setting range is 10 seconds to 60 minutes in 10 second increments. The default setting is 60 minutes.

Pre-Alarm Setting

- 1) Press the ENTER key to move the cursor to PRE-ALM in the Programming Window, then press INC/+ or DEC/- keys to set the desired PRE-ALM value.

TIMER LAP PRE-ALM setting range is OFF and 1 second to 20 seconds. The default setting is 5 seconds.

! The Pre-Alarm sounds the programmed number of seconds prior to the GOAL Time.

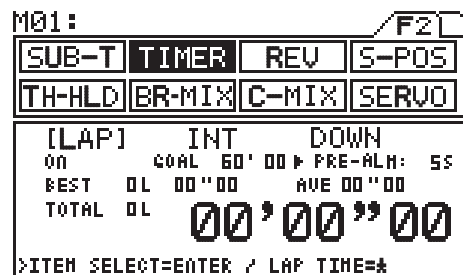
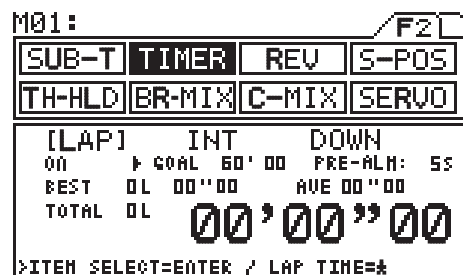
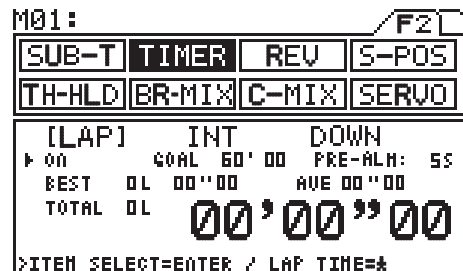

TRACK TIMERS

Starting the Lap Timer

1) In the default configuration, the Lap Timer Switch is assigned to Sw 3. To start the Lap Timer, press the Lap Timer Switch. The Lap Timer will start counting up. Pressing the Lap Timer switch a second time will store the first Lap Time, then begin counting a second Lap Time and display the Cumulative Time. Each time you press the Lap Timer Switch, the previous Lap Time is stored, a new Lap Time begins, and the Cumulative Time is displayed.

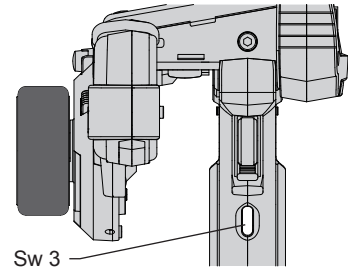

! Each time you press the Lap Timer Switch, the switch is deactivated for 3 seconds.

! The Lap Timer Switch can be assigned to another Push-Button switch, using the Key Assign function. See page 50 for more information.

! The Cumulative Time cannot be manually cleared. It will be automatically cleared when the Lap Timer is restarted.

Stopping the Lap Timer

1) The Lap Timer can be stopped using three different methods:

- A) By pressing the Lap Timer switch after the GOAL Time is reached.
- B) By pressing and holding the Lap Timer Switch for 3 seconds.
- C) By pressing the INC/+ and DEC/- keys at the same time.

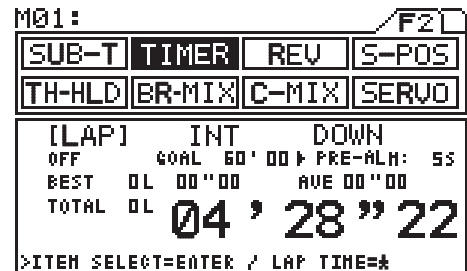

! When the Lap Timer is stopped, the Lap Timer function is automatically turned OFF. To turn the Lap Timer function back ON, see Turning On the Lap Timer on the previous page.

Verifying Lap Timer Results

1) Lap Timer results can be checked by pressing the ★ key in the TIMER LAP menu while the Lap Timer is stopped. The display shows lap times for 9 different laps on each page. Press the INC/+ or DEC/- keys to scroll through the different pages.

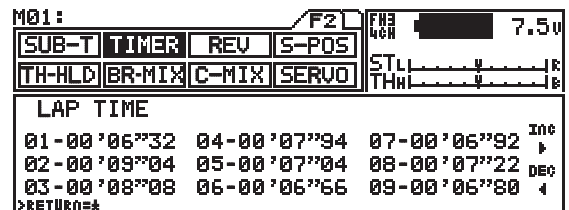

! Press the INC/+ and DEC/- keys at the same time to return the display to the first 9 laps.

! Press the ★ key to return to the TIMER LAP menu.

[INT] INTERVAL TIMER

The Interval Timer notifies you when a set interval elapses while you are driving, giving you an idea of how close you are to your target time. There are two separate Interval Timers. One Interval Timer for minutes and seconds, and one Interval Timer for seconds and milliseconds. Both Interval Timers can be used simultaneously and different Tones can be assigned to each.

Turning On the Interval Timers

- 1) Press the Function key to move the cursor to [INT] in the Programming Window. The cursor will default to OFF.
- 2) Press INC/+ or DEC/- keys to turn the Interval Timers ON.

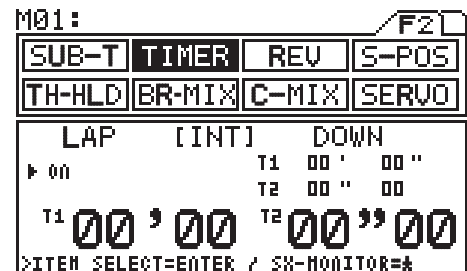

TRACK TIMERS

Setting Interval Timer One (T1)

- 1) Press the ENTER key to move the cursor to T1 00', then press INC/+ or DEC/- keys to set the desired Interval Time in Minutes.
- 2) Press the ENTER key to move the cursor to T1 00", then press INC/+ or DEC/- keys to set the desired Interval Time in Seconds.

TIIMER INT T1 setting range is 0 minutes to 99 minutes in 1 minute increments, and 0 seconds to 59 seconds in 1 second increments. The default setting is 00' minutes and 00" seconds.

Setting Interval Timer Two (T2)

- 1) Press the ENTER key to move the cursor to T2 00", then press INC/+ or DEC/- keys to set the desired Interval Time in Seconds.
- 2) Press the ENTER key to move the cursor to T2 00, then press INC/+ or DEC/- keys to set the desired Interval Time in Milliseconds.

TIIMER INT T2 setting range is 0 seconds to 59 seconds in 1 second increments, and 0 milliseconds to 90 milliseconds in 10 millisecond increments. The default setting is 00" seconds and 00 milliseconds.

Starting the Interval Timer(s)

- 1) In the default configuration, the Interval Timer Switch is assigned to Sw 3. To start the Interval Timer, press the Interval Timer Switch. Both Interval Timers will start counting up. When Interval Timer T2 reaches the preset time an alarm will sound and it will reset and begin counting up from zero. When Interval Timer T1 reaches the preset time, a different alarm will sound and it will reset and begin counting up from zero. Pressing the Interval Timer Switch a second time will reset the Interval Timers and they will begin counting up from zero again.

 The Interval Timer Switch can be assigned to another switch, using the Key Assign function. See page 50 for more information.

Stopping the Interval Timer(s)

- 1) The Interval Timer(s) can be stopped using two different methods:
 - A) By pressing and holding the Interval Timer Switch for 3 seconds.
 - B) By pressing the INC/+ and DEC/- keys at the same time.

 When the Interval Timer(s) are stopped, the Interval Timers function is automatically turned OFF. To turn the Interval Timers function back ON, see Turning On the Interval Timers on the previous page.

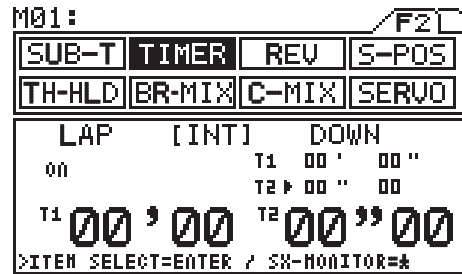
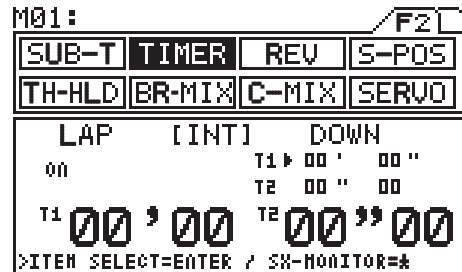

[DOWN] COUNTDOWN TIMER

The Countdown Timer function can notify you of your model's running time. For example, set the Countdown Timer to 7 minutes. When the Countdown Timer sounds, refuel. The Countdown Timer accepts settings of up to 99 minutes and 59 seconds. Once the count down timer has run out, the count up timer starts. This allows you to check the time elapsed since the timer ran out. (This timer has an alarm that sounds every minute).

Turning On the Countdown Timer

- 1) Press the Function key to move the cursor to [DOWN] in the Programming Window. The cursor will default to OFF.
- 2) Press INC/+ or DEC/- keys to turn the Countdown Timer ON.

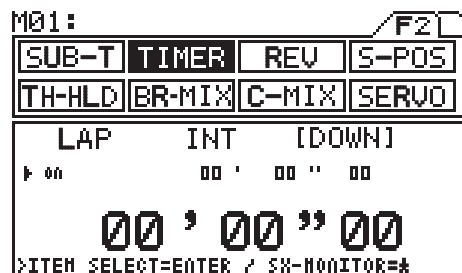

TRACK TIMERS

Setting the Countdown Timer

- 1) Press the ENTER key to move the cursor to 00', then press INC/+ or DEC/- keys to set the desired Countdown Time in Minutes.
- 2) Press the ENTER key to move the cursor to 00", then press INC/+ or DEC/- keys to set the desired Countdown Time in Seconds.
- 3) Press the ENTER key to move the cursor to 00, then press INC/+ or DEC/- keys to set the desired Countdown Time in Milliseconds.

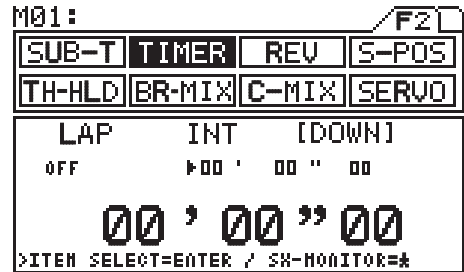

TIIMER DOWN setting range is 0 minutes to 99 minutes in 1 minute increments, 0 seconds to 59 seconds in 1 second increments, and 0 milliseconds to 90 milliseconds in 10 millisecond intervals. The default setting is 00' minutes, 00" seconds, and 00 milliseconds.

Starting the Countdown Timer

- 1) In the default configuration, the Countdown Timer Switch is assigned to Sw 3. To start the Countdown Timer, press the Countdown Timer Switch. The Countdown Timer will start counting down from the preset time. When the Countdown Timer is within 10 seconds of zero, an alarm will sound at 1 second intervals. Once zero is reached, a longer alarm will sound and the Countdown timer will begin counting up. An alarm will then sound at 1 minute intervals during the count up phase. Pressing the Countdown Timer Switch a second time will reset the Countdown Timer and it will begin counting down again.

! The Interval Timer Switch can be assigned to another switch, using the Key Assign function. See page 50 for more information.

Stopping the Countdown Timer

- 1) The Countdown Timer can be stopped using two different methods:
 - A) By pressing and holding the Countdown Timer Switch for 3 seconds.
 - B) By pressing the INC/+ and DEC/- keys at the same time.

! When the Countdown Timer stopped, the Countdown Timer function is automatically turned OFF. To turn the Countdown Timer function back ON, see Turning On the Countdown Timer on the previous page.

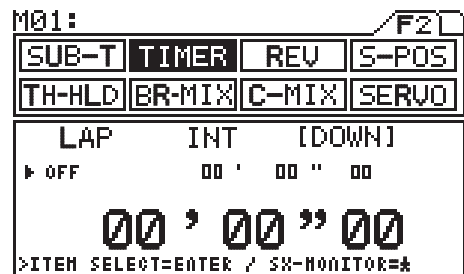

SERVO REVERSING



Function Page 2 (REV)

The Servo Reversing function electronically switches the direction of servo travel. For example, if you move the steering wheel to the right, and the steering servo moves to the left, you can use the Servo Reversing function to make the steering servo move to the left.

- 1) Press the Function key to highlight the REV menu. [ST] will be active in the Programming Window.
- 2) Press INC/+ or DEC/- keys to set the direction of servo travel.

REV setting range is NOR/REV. The default setting is NOR.

- 3) Adjust the remaining Servo Reversing settings using the same techniques. If the transmitter is set to 2CH Mode, only ST and TH will be shown in the Programming Window.

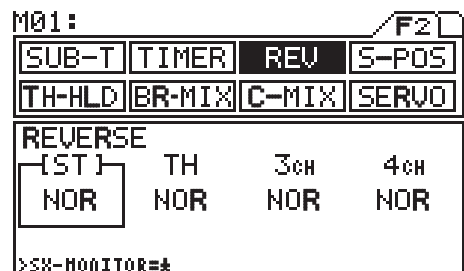

THROTTLE HOLD



Function Page 2 (TH-HLD)

The Throttle Hold function is used primarily with glow- or gas-powered models. It allows you to perform several different functions depending on how the Throttle Hold function is set up. For example, when set to a negative value, you can stop the engine with only the press of a button. This feature is often used with R/C boat models and is also known as 'Engine Cut'. When set to a positive value, the throttle can be held open a desired amount with only the press of a button. This feature is often used to hold the engine at a steady idle while refueling during a race. With the transmitter set to 4CH Mode, a desired amount of braking can be applied independently when set to a negative value.

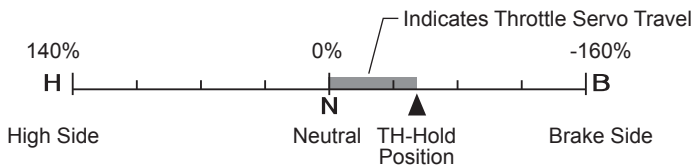

! The THROTTLE HOLD function must be assigned to a Push-Button switch, using the Key Assign function. See page 50 for more information. We suggest assigning it to its own switch, for example, Sw 2.

! When TH-HLD is active, the throttle servo is locked to the TH-HLD value, regardless of the current throttle trigger position.

Throttle Hold Setting

- 1) Press the Function key to highlight the TH-HLD menu. The cursor will default below THROTTLE HOLD in the Programming Window.
- 2) Press INC/+ or DEC/- keys to adjust the desired TH-HOLD value.

TH-HLD THROTTLE HOLD setting range is -160% to 140%. The default setting is 0%. The THROTTLE HOLD setting controls how far the throttle servo will travel with TH-HLD is activated.

INH/ACT Setting

- 1) Press the ENTER key to move the cursor to TH-HOLD in the Programming Window, then press INC/+ or DEC/- keys to set the desired value.

INH - Throttle Hold is not active. Depress and hold the Push-Button switch to activate Throttle Hold. When released, normal throttle operation returns.

ACT - Throttle Hold is active at all times. Press and hold the Push-Button switch to turn Throttle Hold OFF. When released, Throttle Hold will be active again.

4CH Hold Setting

- 1) Press the ENTER key to move the cursor to HOLD-4CH in the Programming Window, then press INC/+ or DEC/- keys to set the desired value.

TH-HLD HOLD-4CH setting range is ON or OFF. The default setting is ON. When set to ON the 4th channel brake will activate when TH-HLD is activated. When set to OFF the 4th channel brake servo will not activate when TH-HLD is activated.

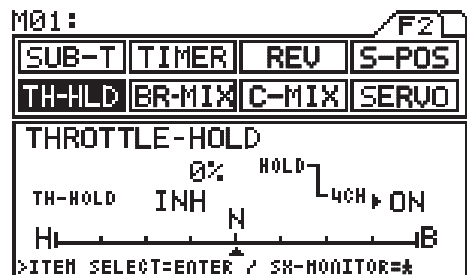
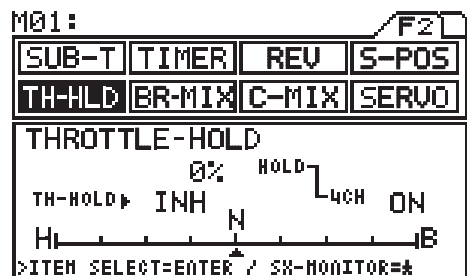
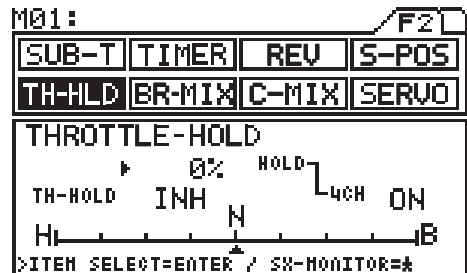

! The 4th channel brake servo will only activate when TH-HLD is set to a negative value. The 4th channel brake servo travel will be the same amount as the TH-HLD travel. For example, if your throttle servo moves 20 degrees, the 4th channel brake servo will also move 20 degrees.

BRAKE MIXING



Function Page 2 (BR-MIX)

The Brake Mixing function is used primarily with 1/5th scale gas-powered models or other types of models that use two separate brake servos. Brake servo Delay can be set for the 2nd channel brake, the 3rd channel brake, or the 4th channel brake either independently or at the same time. This allows you to adjust when each brake is engaged. For example, if your model features separate front and rear brakes, the rear brake can be adjusted to engage before the front brake engages or vice-versa.

Brake Mixing settings for various model types. E=Engine FB=Front Brake RB=Rear Brake				
	Receiver Type	3 or 4 Channel	4 Channel	4 Channel
3CH Brake	ACT	INH	ACT	ACT
TH-Brake Cut	INH	INH	ACT	ACT

- ⚠ Before making adjustments to the different Brake Mixing values, you must first make servo Reversing (REV), servo End Point Adjustments (EPA), and servo Sub-Trim adjustments (SUB-T) to your 3rd and/or 4th channel brake servos.
- ⚠ Making different adjustments to the DELAY value of the 2nd, 3rd, and 4th channel brake servos will result in a number of different combinations (mixing) of braking action to suit your particular setup.

With Transmitter Set to 4CH Mode

The transmitter should be set to 4CH Mode to ensure the greatest Brake Mixing functionality. See page 47 for more information.

2CH Delay Setting

- 1) Press the Function key to highlight the BR-MIX menu. The cursor will default to 2CH in the Programming Window.
- 2) Press INC/+ or DEC/- keys to adjust the desired 2CH DELAY value.

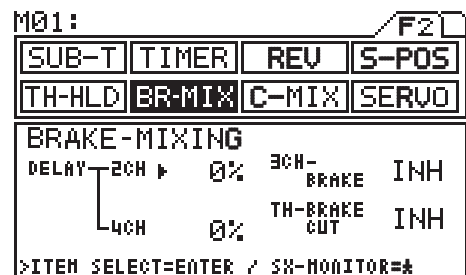

BR-MIX 2CH DELAY setting range is 0% to 100%. The default setting is 0%. The 2CH DELAY setting controls the speed of the Brake Side of the throttle servo. When the value is increased the speed of the Brake Side of the throttle servo is slowed while the speed of the 4th channel brake servo remains normal. This results in the 4th channel brake servo reaching its End Point before the Brake Side of the throttle servo reaches its End point.

4CH Delay Setting

- 1) Press the ENTER key to move the cursor to 4CH in the Programming Window, then press INC/+ or DEC/- keys to adjust the desired 4CH DELAY value.

BR-MIX 4CH DELAY setting range is 0% to 100%. The default setting is 0%. The 4CH DELAY setting controls the speed of the 4th channel brake servo. When the value is increased the speed of the 4th channel brake servo is slowed.

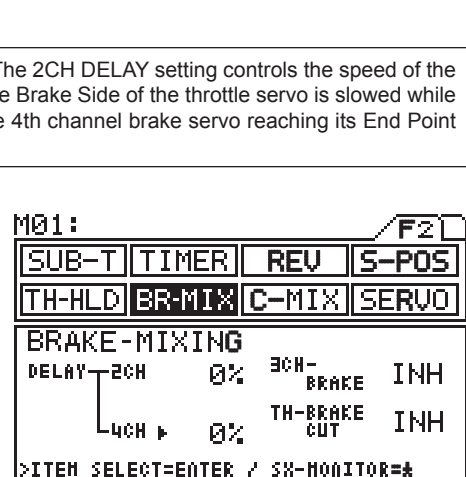

BRAKE MIXING

3CH-Brake Setting

- 1) Press the ENTER key to move the cursor to 3CH-BRAKE in the Programming Window, then press INC/+ or DEC/- keys to either Activate or Inhibit the 3rd Channel Brake.

! When you set 3CH-BRAKE to ACT, the 3CH DELAY option becomes available.

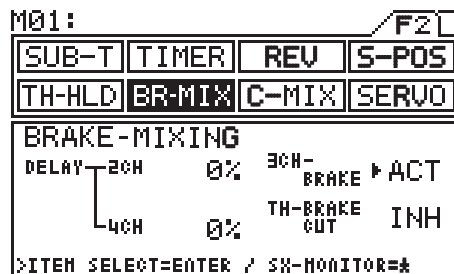

BR-MIX 3CH-BRAKE setting range is INH to ACT. The default setting is INH. When set to ACT, the 3rd channel brake servo is Activated and the 3CH DELAY value can be set. When set to INH, the 3rd channel brake servo will not function.

3CH Delay Setting

- 1) Press the ENTER key to move the cursor to 3CH in the Programming Window, then press INC/+ or DEC/- keys to adjust the desired 3CH DELAY value.

BR-MIX 3CH DELAY setting range is 0% to 100%. The default setting is 0%. The 3CH DELAY setting controls the speed of the 3rd channel brake servo. When the value is increased the speed of the 3rd channel brake servo is slowed.

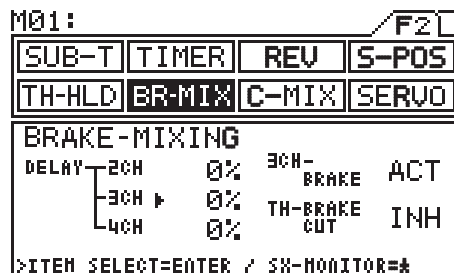

TH-Brake Cut Setting

- 1) Press the ENTER key to move the cursor to TH-BRAKE CUT in the Programming Window, then press INC/+ or DEC/- keys to either Activate or Inhibit the Throttle Brake Cut.

! BR-MIX TH-BRAKE CUT should ONLY be set to ACT if you are using one or two separate brake servos. If you set TH-BRAKE CUT to ACT while only using the 2nd channel brake (throttle/brake on the same servo), you will not have any brake function!

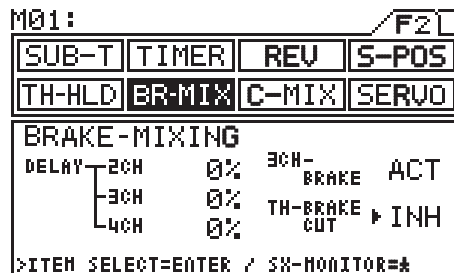

BR-MIX TH-BRAKE CUT setting range is INH to ACT. The default setting is INH. When set to ACT, the Brake Side of the throttle servo will not function, but the 4th channel brake servo (and the 3rd channel brake servo if set to ACT) will continue to function. When set to INH, both the Brake Side of the throttle servo and any separate Brake servos will function normally.

With Transmitter Set to 2CH Mode

The Brake Mixing function can also be used when the transmitter is set to 2CH Mode, although Brake Mixing functionality is highly reduced. The following Brake Mixing settings are available in 2CH Mode:

2CH Delay Setting

- 1) Press the Function key to highlight the BR-MIX menu. The cursor will default to DELAY-2CH in the Programming Window.
- 2) Press INC/+ or DEC/- keys to adjust the desired 2CH DELAY value. This setting operates the same as the 2CH DELAY setting described on the previous page.

TH-Brake Cut Setting

- 1) Press the ENTER key to move the cursor to TH-BRAKE CUT in the Programming Window, then press INC/+ or DEC/- keys to either Activate or Inhibit the Throttle Brake Cut. This setting operates the same as the TH-BRAKE CUT setting described above.

! Even when the transmitter is set to 2CH Mode, the 4th Channel Brake will function if you're using a 4 channel receiver.

COMPENSATION MIXING



Function Page 2 (C-MIX)

The Compensation Mixing function allows you to mix two channels together, then apply that mixing to the channels themselves. For example, you can use Compensation Mixing to activate an air-brake or a wing on your model when you apply the brakes, or when you reach full throttle. Or, you could use Compensation Mixing counter-act torque steer by applying a very slight amount of steering in one direction when you increase throttle. Two Compensation Mixers are available, and each can be Activated separately. Graphical indications make it easier to visualize the mixing settings.

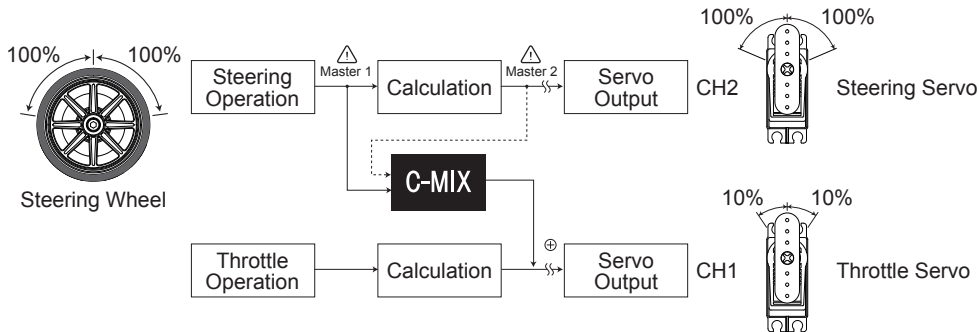

In the example above, C-MIX1 is set up as follows: MASTER ST1, L:10% / R:10%, SLAVE TH1, OFFSET: 0. In this example, when you move the steering wheel 100% in each direction, the steering servo will travel 100% in each direction and at the same time, the throttle servo will move 10% in each direction. In this example the steering servo is the MASTER and the throttle servo is the SLAVE.

⚠ There are two types of Compensation Mixing - Master 1 (ST1, TH1, and AUX1) and Master 2 (ST2, TH2, and AUX2). Master 1 Compensation Mixing outputs the raw operation data. Master 2 Compensation Mixing outputs the raw operation data, plus the calculated operation of certain programming options as described in the table at the bottom of the page.

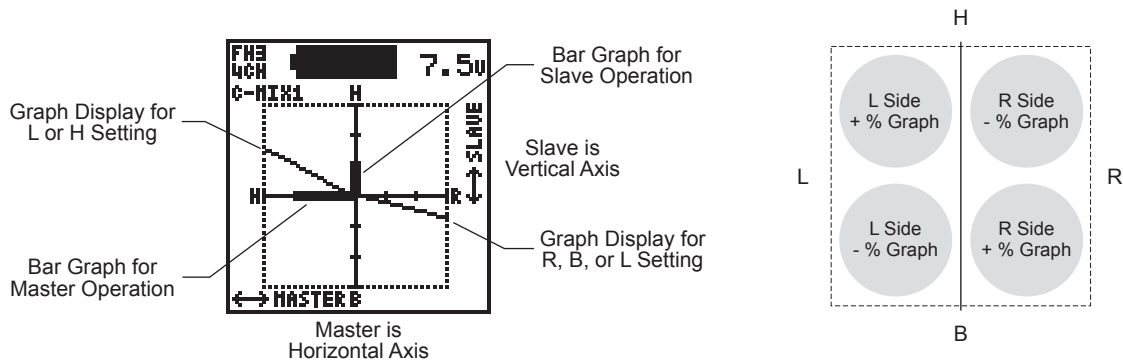

⚠ Press the ★ key to display the Compensation Mixing Graph in the Information Window.

SETTING	NAME	MASTER OUTPUT DATA
ST1	Steering Master 1	Raw Steering Output Only
ST2	Steering Master 2	Raw Steering Output Plus Calculated Amount of Operation for SPEED, EXP, ARC, D/R, EPA, and Trim (including Sub-Trim)
TH1	Throttle Master 1	Raw Throttle Output Only
TH2	Throttle Master 2	Raw Throttle Output Plus Calculated Amount of Operation for SPEED, TR-CTL, BR-MIX, EXP, ARC, S-POS, EPA, and Trim (including Sub-Trim)
AUX1	Auxiliary Master 1	Raw Auxiliary Output Only
AUX2	Auxiliary Master 2	Raw Auxiliary Output Plus Calculated Amount of Operation for EPA

COMPENSATION MIXING

[C-MIX1] COMPENSATION MIXING 1

Master L / R Mixing Setting

- 1) Press the Function key to highlight the C-MIX menu. [C-MIX1] will be active in the Programming Window and the cursor will default to ST1.
- 2) Press the INC/+ or DEC/- keys to choose which channel you want to be the MASTER. Choose from either ST1, ST2, TH1, TH2, AUX1, AUX2.
- 3) Press the ENTER key to move the cursor to L (H if MASTER is set to TH or AUX), then press the INC/+ or DEC/- keys to adjust the desired Mixing value.
- 4) Press the ENTER key to move the cursor to R (B if MASTER is set to TH or L if MASTER is set to AUX), then press the INC/+ or DEC/- keys to adjust the desired Mixing value.

C-MIX1 MASTER L / R setting range is -150% to 150%. The default setting is 0%. See below for description of use.

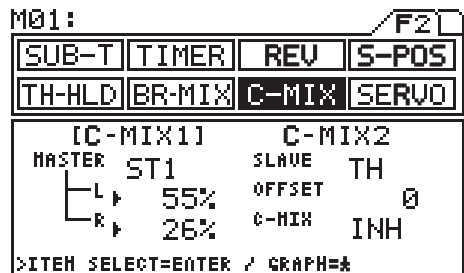
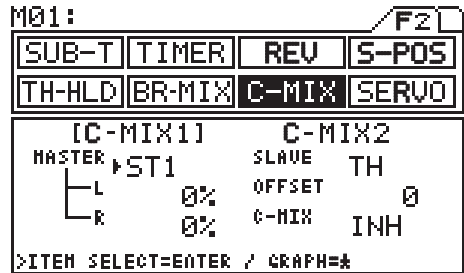

! The Mixing Percentage Value is the percentage that the SLAVE servo will travel in proportion to the MASTER servo. For example, if ST1 L is set to 55%, when the steering wheel is moved to the left, the TH (SLAVE) servo will travel 55% of the amount that the steering servo travels.

! The Mixing value cannot be set separately for different MASTER channels (ST1, TH1, etc) since only one MASTER channel can be mixed at any one time.

Slave Setting

- 1) Press the ENTER key to move the cursor to SLAVE, then press the INC/+ or DEC/- keys to choose which channel you want to be the SLAVE. Choose from either ST, TH, AUX, or BR.

! When the MASTER and SLAVE are set to the same channel, mixing takes place within the channel itself. This causes the servo travel to increase for positive percentage values and the servo travel to decrease for negative percentage values.

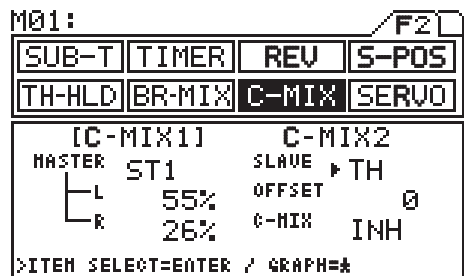

Offset Setting

! The OFFSET setting is primarily used to center the SLAVE servo and set the neutral position for the origin for Mixing when the Master 2 servo has Sub-Trim programmed. Secondly, the OFFSET setting can be used to set the neutral position for the origin for Mixing of the SLAVE servo separately from the Master 1 servo.

Correcting Master 2 Trim Deviation.

Master: ST2

Slave: TH

Amount of Deviation

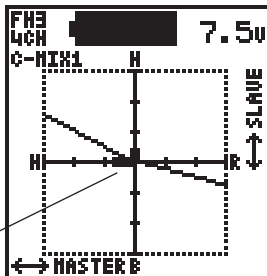

When trim deviation appears in the graph with the steering in the neutral position.....

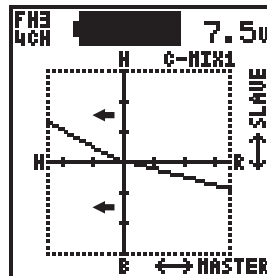

Adjust OFFSET value to move the vertical axis and erase the deviation bar graph.

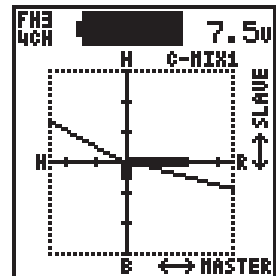

By adjusting to the point where the deviation disappears, the steering neutral position can become the origin for Mixing.

COMPENSATION MIXING

- 1) Press the ENTER key to move the cursor to OFFSET, then press the INC/+ or DEC/- keys to adjust the desired OFFSET value.

C-MIX C-MIX1 OFFSET setting range is -150 to 150. The default setting is 0.

M01:				F2
SUB-T	TIMER	REV	S-POS	
TH-HLD	BR-MIX	C-MIX	SERVO	
[C-MIX1]		C-MIX2		
MASTER	ST1	SLAVE	TH	
L	55%	OFFSET	-18	
R	26%	C-MIX	INH	
ITEM SELECT=ENTER / GRAPH=#				

! By setting the OFFSET value to 100, the Dial Knob (Auxiliary Channel 3) can be set so that no mixing occurs when the Dial Knob is turned all the way to the left, but full mixing will occur when the Dial Knob is turned all the way to the right. Set the H percentage value to 50% (or other desired value), set the L value to 0%, then set the OFFSET value to 100.

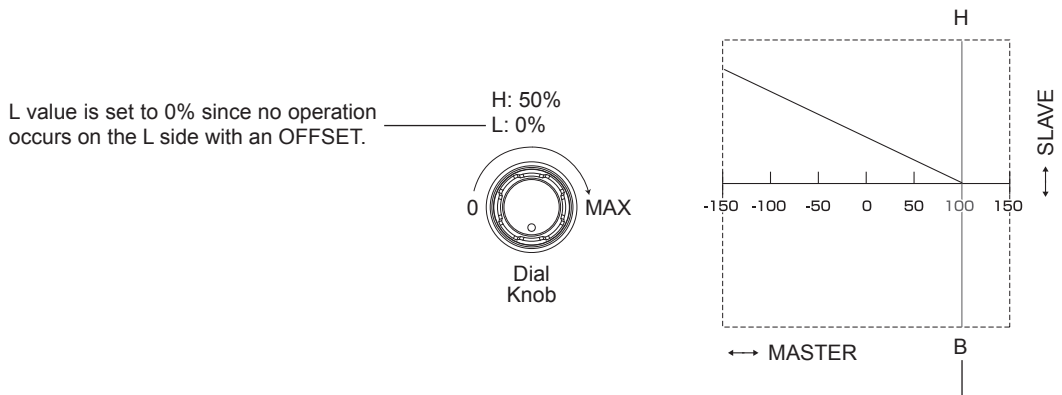

Since no operation occurs beyond 100 when the MASTER is set to AUX1, this can be set to 100.

ACT/INH Setting

- 1) To use the C-MIX1 function, it must be Activated. Press the ENTER key to move the cursor to C-MIX, then press the INC/+ or DEC/- keys to either ACT (Activate) or INH (Inhibit) the C-MIX1 function.

! The C-MIX1 ACT/INH setting can be assigned to any Push-Button switch using the Key Assign function. See page 50 for more information. By using this function, switching C-MIX1 'ON' or 'OFF' can be selected during model operation.

M01:				F2
SUB-T	TIMER	REV	S-POS	
TH-HLD	BR-MIX	C-MIX	SERVO	
[C-MIX1]		C-MIX2		
MASTER	ST1	SLAVE	TH	
L	55%	OFFSET	-18	
R	26%	C-MIX	ACT	
ITEM SELECT=ENTER / GRAPH=#				

[C-MIX2] COMPENSATION MIXING 2

- 1) Press the Function key to move the cursor to [C-MIX2] in the C-MIX Programming Window. The cursor will default to ST1.
- 2) Use the same techniques that you used to adjust the values for C-MIX1 to adjust the desired values for C-MIX2.

! Both C-MIX1 and C-MIX2 can be Active at the same time.

M01:				F2
SUB-T	TIMER	REV	S-POS	
TH-HLD	BR-MIX	C-MIX	SERVO	
C-MIX1		[C-MIX2]		
MASTER	ST1	SLAVE	TH	
L	0%	OFFSET	0	
R	0%	C-MIX	INH	
ITEM SELECT=ENTER / GRAPH=#				

! The C-MIX2 ACT/INH setting can be assigned to any Push-Button switch using the Key Assign function. See page 50 for more information. By using this function, switching C-MIX1 'ON' or 'OFF' can be selected during model operation.

SERVO MONITOR



Function Page 2 (SERVO)

The Servo Monitor function displays the output levels of the four different channels in bar graph form, allowing you to monitor servo operation in a virtual manner. This allows you to see servo movement and make setting changes without having the receiver turned on. When used in conjunction with the Display Switch, the Servo Monitor function allows you to see servo movement virtually and make setting changes without the transmitter actually transmitting a signal. Using the Servo Monitor function while making setting changes can also make it easier to understand the setting changes you're making.

- 1) Press the Function key to highlight the SERVO menu.
- 2) Moving the different transmitter controls will display the actual movement on the Servo Monitor in the Programming Window.

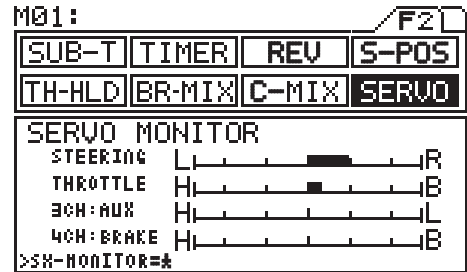

! Servo Reversing (REV) is not reflected in the Servo Monitor. The indications on the graph shows the direction of the transmitter input control (Steering Wheel, Throttle Trigger, Auxiliary Function, and 4th Channel Brake).

- 3) Press the ★ key to display the Servo Monitor function screen in the Information Window. This allows you to view the Servo Monitor function while making setting adjustments in many of the Programming Menus.

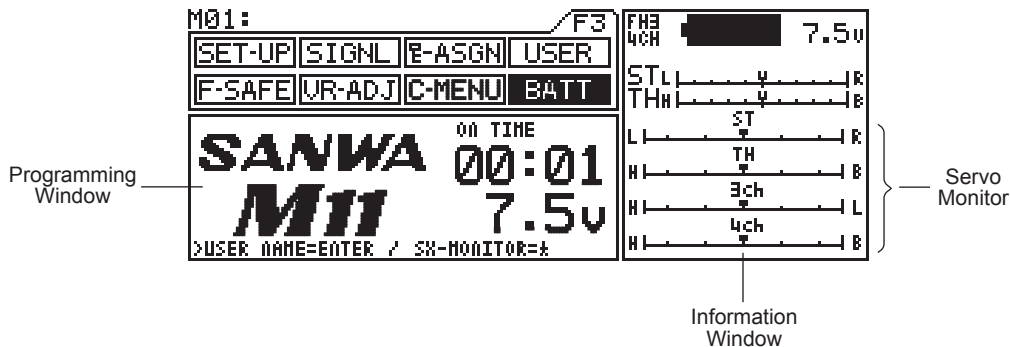

The Servo Monitor function screen can be displayed in the Information Window while in the following Programming Menus:

Function Page 1	Function Page 2	Function Page 3
D-RATE	SUB-T	VR-ADJ
EPA	TIMER*	BATT
EXP	REV	
ARC	S-POS	
SPEED	TH-HLD	
ALB	BR-MIX	
TR-CTL	SERVO	

! While in a Programming Menu that does not support the Servo Monitor being displayed in the Information Window, pressing the ★ key will move the cursor back instead.

*Cannot be displayed in the [LAP] sub-menu.

! If the bar graph always shows an amount of servo movement in one direction even though the servos are centered, the graph could be displaying the amount of servo Sub-Trim for that particular channel.

TRANSMITTER SET-UP

M01:				F3
SET-UP	SIGNL	E-ASGN	USER	
F-SAFE	VR-ADJ	C-MENU	BATT	

Function Page 3 (SET-UP)

The Set-Up function allows you to make a number of custom options related to transmitter function and display. Transmitter and receiver Binding is also accomplished through the Set-Up menu.

[SYSTEM] SYSTEM USER OPTIONS

LCD Display Contrast Setting

- 1) Press the Function key to highlight the SET-UP menu. [SYSTEM] will be active in the Programming Window and the cursor will default to CONTRAST.
- 2) Press the INC/+ or DEC/- keys to adjust the desired CONTRAST value.

M01:				F3
SET-UP	SIGNL	E-ASGN	USER	
F-SAFE	VR-ADJ	C-MENU	BATT	
[SYSTEM] MOD BIND				
1:	CONTRAST		▶ 80%	
2:	VIBRATOR		INH	
3:	OP LOGO		ACT	
▶ITEM SELECT NEXT=ENTER / BACK=#				

SET-UP SYSTEM CONTRAST setting range is 0% to 100%. The default setting is 80%. Increasing the CONTRAST setting will make the LCD Display easier to read in bright sunlight. Higher CONTRAST settings will increase battery usage.

Transmitter Vibrator Setting

- 1) Press the ENTER key to move the cursor to VIBRATOR, then press the INC/+ or DEC/- keys to select ACT or INH.

SET-UP SYSTEM VIBRATOR setting range is ACT and INH. The default setting is INH. When set to ACT, the transmitter will vibrate at the same time that the Timer alarms or the battery alarm activates. When set to INH, the transmitter will not vibrate.

M01:				F3
SET-UP	SIGNL	E-ASGN	USER	
F-SAFE	VR-ADJ	C-MENU	BATT	
[SYSTEM] MOD BIND				
1:	CONTRAST		80%	
2:	VIBRATOR		▶ INH	
3:	OP LOGO		ACT	
▶ITEM SELECT NEXT=ENTER / BACK=#				

 Activating the Vibrator feature is useful if you de-activate the Audible Alarms. See page 48 for more information.

ON Power Logo Setting

- 1) Press the ENTER key to move the cursor to OP LOGO, then press the INC/+ or DEC/- keys to select ACT or INH.

SET-UP SYSTEM OP LOGO setting range is ACT and INH. The default setting is ACT. When set to ACT, the M11 logo will be displayed in the Programming Window during the Power ON process. When set to INH, the M11 logo will not be displayed in the Programming Window during the Power ON process.

M01:				F3
SET-UP	SIGNL	E-ASGN	USER	
F-SAFE	VR-ADJ	C-MENU	BATT	
[SYSTEM] MOD BIND				
1:	CONTRAST		80%	
2:	VIBRATOR		INH	
3:	OP LOGO		▶ ACT	
▶ITEM SELECT NEXT=ENTER / BACK=#				

LCD Display Backlight Color Setting

- 1) Press the ENTER key to move the cursor to LIGHT-COLOR, then press the INC/+ or DEC/- keys to select WHITE or BLUE.

SET-UP SYSTEM LIGHT-COLOR setting range is WHITE and BLUE. The default setting is WHITE. When set to WHITE, the LCD Display backlight will be white. When set to BLUE, the LCD Display backlight will be blue.

M01:				F3
SET-UP	SIGNL	E-ASGN	USER	
F-SAFE	VR-ADJ	C-MENU	BATT	
[SYSTEM] MOD BIND				
4:	LIGHT-COLOR		▶ WHITE	
5:	LIGHT-MODE		KEY-ON	
6:	LIGHT-TIME		10sec	
▶ITEM SELECT NEXT=ENTER / BACK=#				

TRANSMITTER SET-UP

Servo Mode Setting

- 1) Press the ENTER key to move the cursor to ST, then press the INC/+ or DEC/- keys to set the desired Steering Servo Mode.

SET-UP MOD ST setting range is NOR and SHR. The default setting is NOR. NOR can be used with both Analog and Digital servos. SHR is used with Digital servos to give them a faster response time.

- 2) Adjust the remaining Servo Mode settings using the same techniques.

 Using the SHR setting with Digital servos will increase the servo's response time, even above the manufacturer's stated speed. This setting has no influence when used with Analog servos.

 Servo Mode settings are not available when using FH2 Modulation.

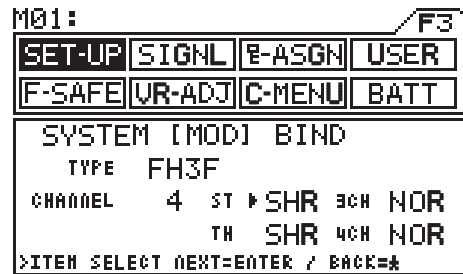

[BIND] TRANSMITTER AND RECEIVER BINDING

Please refer to page 13 for instructions regarding transmitter and receiver Binding.

AUDIO SIGNAL SOUND



Function Page 3 (SIGNL)

The Signal function allows you to set the audible key tones and alarm tones independently, and in different tonal scale. Tonal scale of each key press or alarm can be set differently for separate parts. For example, the tonal scale can be set separately for the first half and the second half of a tone, making it easier to differentiate between the two halves. Tones can be selected from among 10 different tones, providing a total of 100 pattern combinations for the first half and last half of signals.

Command Tone Setting

- 1) Press the Function key to highlight the SIGNL menu. The cursor will default to COMMAND in the Programming Window next to the left-side S10 setting.
- 2) Press the INC/+ or DEC/- keys to adjust the desired Tonal value for the first-half S10 setting, then press the ENTER key to move the cursor to the right-side S10 setting and press the INC/+ or DEC/- keys to adjust the desired Tonal value for the second half S10 setting.

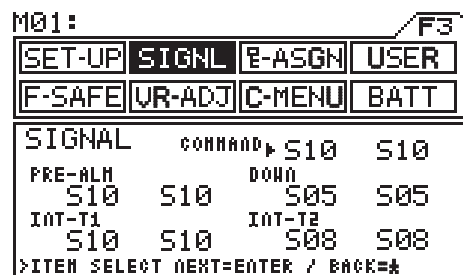

SIGNL COMMAND setting range is MUTE to S10. The default setting is S10. When changes are made to the Tonal settings, the currently selected Tone is sounded. The Command Tone setting affects the LCD Menu keys.

The Buzzer Icon  displayed in the Information Window will change to  if both halves of the Command Tone settings are Muted.

 If two Signal Tones overlap, they will sound as a single tone. The longer tone may not sound.

 If you do not want to hear a Signal Tone, select MUTE for both the first and the second half tones. If you mute only one half on the tone, the other half of the tone will sound.

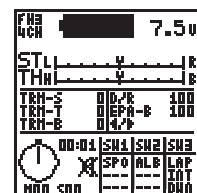

AUDIO SIGNAL SOUND

Pre-Alarm Tone Setting

- 1) Press the ENTER key to move the cursor to the left-side PRE-ALM S10 setting, then press the INC/+ or DEC/- keys to adjust the desired Tonal value for the first half S10 setting.
- 2) Press the ENTER key to move the cursor to the right-side PRE-ALM S10 setting, then press the INC/+ or DEC/- keys to adjust the desired Tonal value for the second half S10 setting.

M01: F3

SET-UP	SIGNAL	E-ASGN	USER
F-SAFE	UR-ADJ	C-MENU	BATT

SIGNAL	CONRAD	S10	S10
PRE-ALM		DOWN	
▶ S10	S10	▶ S05	S05
INT-T1		INT-T2	
S10	S10	S08	S08

>ITEN SELECT NEXT=ENTER / BACK=#

SIGNAL PRE-ALM setting range is MUTE to S10. The default setting is S10. When changes are made to the Tonal settings, the selected Tone is sounded. The Pre-Alarm Tone setting affects the Lap Timer.

Pre-Alarm Countdown Tone Setting

- 1) Press the ENTER key to move the cursor to the left-side DOWN S05 setting, then press the INC/+ or DEC/- keys to adjust the desired Tonal value for the first half S05 setting.
- 2) Press the ENTER key to move the cursor to the right-side DOWN S05 setting, then press the INC/+ or DEC/- keys to adjust the desired Tonal value for the second half S05 setting.

M01: F3

SET-UP	SIGNAL	E-ASGN	USER
F-SAFE	UR-ADJ	C-MENU	BATT

SIGNAL	CONRAD	S10	S10
PRE-ALM		DOWN	
S10	S10	▶ S05	S05
INT-T1		INT-T2	
S10	S10	S08	S08

>ITEN SELECT NEXT=ENTER / BACK=#

SIGNAL DOWN setting range is MUTE to S10. The default setting is S05. When changes are made to the Tonal settings, the selected Tone is sounded. The DOWN Tone setting affects the Countdown Timer.

Interval Timer Minutes Tone Setting

- 1) Press the ENTER key to move the cursor to the left-side INT-T1 S10 setting, then press the INC/+ or DEC/- keys to adjust the desired Tonal value for the first half S10 setting.
- 2) Press the ENTER key to move the cursor to the right-side INT-T1 S10 setting, then press the INC/+ or DEC/- keys to adjust the desired Tonal value for the second half S10 setting.

M01: F3

SET-UP	SIGNAL	E-ASGN	USER
F-SAFE	UR-ADJ	C-MENU	BATT

SIGNAL	CONRAD	S10	S10
PRE-ALM		DOWN	
S10	S10	S05	S05
INT-T1		INT-T2	
▶ S10	S10	S08	S08

>ITEN SELECT NEXT=ENTER / BACK=#

SIGNAL INT-T1 setting range is MUTE to S10. The default setting is S10. When changes are made to the Tonal settings, the selected Tone is sounded. The INT-T1 Tone setting affects the Minutes portion of the Interval Timer.

Interval Timer Seconds Tone Setting

- 1) Press the ENTER key to move the cursor to the left-side INT-T2 S08 setting, then press the INC/+ or DEC/- keys to adjust the desired Tonal value for the first half S08 setting.
- 2) Press the ENTER key to move the cursor to the right-side INT-T2 S08 setting, then press the INC/+ or DEC/- keys to adjust the desired Tonal value for the second half S08 setting.

M01: F3

SET-UP	SIGNAL	E-ASGN	USER
F-SAFE	UR-ADJ	C-MENU	BATT

SIGNAL	CONRAD	S10	S10
PRE-ALM		DOWN	
S10	S10	S05	S05
INT-T1		INT-T2	
S10	S10	▶ S08	S08

>ITEN SELECT NEXT=ENTER / BACK=#

SIGNAL INT-T2 setting range is MUTE to S10. The default setting is S08. When changes are made to the Tonal settings, the selected Tone is sounded. The INT-T2 Tone setting affects the Seconds portion of the Interval Timer.

KEY ASSIGNMENTS

M01:			F3
SET-UP	SIGNL	E-ASGN	USER
F-SAFE	UR-ADJ	C-MENU	BATT

Function Page 3 (E-ASGN)

The Key Assign function allows you to assign different functions to the Push-Button Switches (Sw 1, Sw 2, and Sw 3) and the Trim Switches (Trm 1, Trm 2, Trm 3, Trm 4, and Trm 5). When the transmitter is set to 4CH Mode, Auxiliary Channel 3 can be assigned to the Dial Knob or to any of the five Trim Switches. The Key Assign function also allows you to change the Trim Resolution of the five Trim Switches. This allows you to fine-tune the movement of the servos when the Trim Switches are pressed.

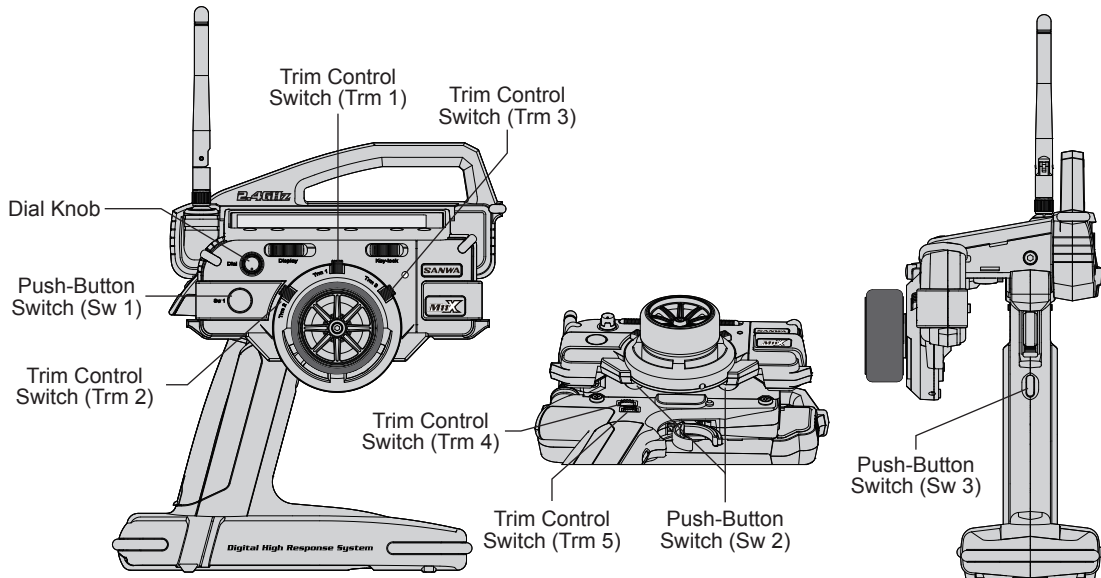

The following Switch and Trim Functions are the factory default settings:

- | | | |
|---|--|----------------------------------|
| Trm 1 - Steering Trim | Sw 1 - Starting Position ON/OFF | Dial Knob - Function Keys |
| Trm 2 - Throttle Trim | Sw 2 - Anti-Lock Brake ON/OFF | |
| Trm 3 - 4th Channel Brake Trim | Sw 3 - Timer ON/OFF | |
| Trm 4 - Dual Rate | | |
| Trm 5 - Brake End Point Adjustment | | |

[SW] SWITCH KEY ASSIGN

The Switch Key Assign function allows you to assign the ON/OFF control of various functions to Sw 1, Sw 2, and Sw 3. This allows you to use the Push-Button switches to turn functions ON (Active) and OFF (Inhibit) during use. Up to three different functions (FUNC1-FUNC3) can be assigned to a single Push-Button switch and turned ON and OFF simultaneously.

Highlighted functions in the Switch Function Display Screen in the Information Window are Active. If a function is not highlighted, it is not currently Active.

M01:			F3
SET-UP	SIGNL	E-ASGN	USER
F-SAFE	UR-ADJ	C-MENU	BATT
[SW] TRIM			
FUNC	SW1	SW2	SW3
1:	S-POS	ALB	LAP-T
2:	-----	-----	INT-T
3:	-----	-----	DWN-T
>SW SELECT NEXT=ENTER / BACK=* NOO 500			

F3	7.5V
STL	---
THL	---
TRM-S	00/100
TRM-T	00/100
TRM-E	04/100

SW1	SW2	SW3
S-POS	ALB	LAP
---	---	INT
---	---	DWN

Switch Function Display

Three different functions assigned to one switch.

KEY ASSIGNMENTS

- 1) Press the Function key to highlight the **E-ASG** menu. [SW] will be active in the Programming Window and the cursor will default to FUNC1.
- 2) Press the INC/+ or DEC/- keys to set the first desired Function for Sw 1.
- 3) Press the ENTER key to move the cursor to FUNC2, then press the INC/+ or DEC/- keys to set the second desired Function for Sw 1.
- 4) Follow the same procedures to assign and/or change the third desired Function for Sw1, and for Sw 2 and Sw 3.



! When more than one function is assigned to a Push-Button switch, all assigned functions will Activate when the Push-Button switch is pressed. Be careful that you do not assign functions to the same Push-Button switch that will not work well together. For example, you wouldn't want to assign negative EXPO and positive ARC to the same Push-Button switch. Timers must be Activated manually in the Timers Programming Window before they can be controlled by the Push-Button switch. We suggest Activating only one timer at any given time.

! Use the table below to help you assign the different Functions to the Push-Button Switches.

FUNCTION	MENU	INFORMATION WINDOW	DEFAULT SWITCH
Exponential - Steering	EXP-ST	EXS	
Exponential - Throttle	EXP-TH	EXT	
Adjustable Rate Control - Steering	ARC-ST	ARS	
Adjustable Rate Control - Throttle	ARC-TH	ART	
Speed - Steering	SPD-ST	SPS	
Speed - Brake	SPD-BR	SPB	
Anti-Lock Braking	ALB	ALB	Sw 2
Traction Control - Forward	TRC-F	TRF	
Traction Control - Return to Neutral	TRC-R	TRR	
Lap Timer	LAP-T	LAP	Sw 3
Interval Timer	INT-T	INT	Sw 3
Countdown Timer	DWN-T	DWN	Sw 3
Starting Position	S-POS	SPO	Sw 1
Starting Position - Brake Lock	BR-LCK	BRL	
Throttle Hold	TH-HLD	HLD	
Compensation Mixing 1	C-MIX1	CX1	
Compensation Mixing 2	C-MIX2	CX2	

[TRIM] TRIM KEY ASSIGN

The Trim Key Assign function allows you to assign different Trim functions to any one of the five Trim Switches Trm 1 to Trm 5, and to the Dial Knob. This allows you to choose the Trim function positions that are best suited to your situation. Trim Resolution, Trim Type (Center or Parallel) can also be chosen to fine-tune the Trim settings. You can adjust the Trim Switches to work in Normal or Reverse direction, too.

! Current trim assignments and trim values are shown in the Trim Switch Function Display Screen in the Information Window.

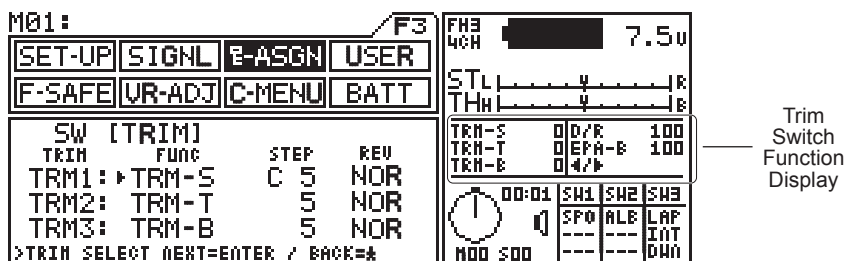

KEY ASSIGNMENTS

Function Selection Setting

- 1) Press the Function key to move the cursor to [TRIM] in the Programming Window. The cursor will default to TRM1.
- 2) Press the INC/+ or DEC/- keys to set the desired Function to be controlled by Trm 1.

```

M01: F3
┌───┬───┬───┬───┐
│SET-UP│SIGNAL│E-ASGN│USER│
├───┬───┬───┬───┤
│F-SAFE│VR-ADJ│C-MENU│BATT│
└───┬───┬───┬───┘
      SW [TRIM]
      TRIM  FUNC  STEP  REV
TRM1: ▶TRM-S  C 5  NOR
TRM2: TRM-T   5  NOR
TRM3: TRM-B   5  NOR
>TRIM SELECT NEXT=ENTER / BACK=#
    
```

Trim Step Setting

- 1) Press the ENTER key to move the cursor to STEP, then press the INC/+ or DEC/- keys to adjust the desired STEP value for Trm 1.

 Increasing the STEP value causes the servo to move less with each press of the Trim Switch (higher trim resolution). Decreasing the STEP value causes the servo to move more with each press of the Trim Switch (lower trim resolution).

```

M01: F3
┌───┬───┬───┬───┐
│SET-UP│SIGNAL│E-ASGN│USER│
├───┬───┬───┬───┤
│F-SAFE│VR-ADJ│C-MENU│BATT│
└───┬───┬───┬───┘
      SW [TRIM]
      TRIM  FUNC  STEP  REV
TRM1: TRM-S  ▶C 5  NOR
TRM2: TRM-T   5  NOR
TRM3: TRM-B   5  NOR
>TRIM SELECT NEXT=ENTER / BACK=#
    
```

 There are two different STEP values for the TRM-S function, 'C' (Center) and 'P' (Parallel). When 'P' is selected, End Point parameters will be adjusted so that servo travel will be equal both left and right regardless of the trim setting. When 'C' is selected, End Point parameters are not adjusted, therefore, servo travel will not be equal both right and left. This setting can be changed only for the Steering Trim. All other trims utilize Center trim.

Trim Direction Setting

- 1) Press the ENTER key to move the cursor to REV, then press the INC/+ or DEC/- keys to set the desired trim direction value.

E-ASGN TRIM REV setting range is NOR and REV. The default setting is NOR. When set to NOR, the trim switch will move the servo the same direction as the steering wheel. When set to REV, the trim switch will move the servo the opposite direction as the steering wheel.

```

M01: F3
┌───┬───┬───┬───┐
│SET-UP│SIGNAL│E-ASGN│USER│
├───┬───┬───┬───┤
│F-SAFE│VR-ADJ│C-MENU│BATT│
└───┬───┬───┬───┘
      SW [TRIM]
      TRIM  FUNC  STEP  REV
TRM1: TRM-S  C 5  ▶NOR
TRM2: TRM-T   5  NOR
TRM3: TRM-B   5  NOR
>TRIM SELECT NEXT=ENTER / BACK=#
    
```

- 2) Follow the same procedures to assign and/or change functions for Trm 2, Trm 3, Trm 4, Trm 5, and DIAL.

 Use the table below to help you assign the different Functions to the Trim Switches and the Dial Knob.

FUNCTION	MENU	DEFAULT STEP SETTING	DEFAULT SWITCH
Dual Rate	D/R	1 (1-10)	Trm 4
End Point Adjustment - Steering	EPA-S	1 (1-10)	
End Point Adjustment - Brake	EPA-B	1 (1-10)	Trm 5
Exponential - Steering	EX-S	1 (1-10)	
Exponential - Throttle High	EX-H	1 (1-10)	
Exponential - Brake	EX-B	1 (1-10)	
Adjustable Rate Control - Steering Rate	AR-S-R	1 (1-10)	
Adjustable Rate Control - Steering Point	AR-S-P	1 (1-10)	
Adjustable Rate Control - Throttle High Rate	AR-H-R	1 (1-10)	
Adjustable Rate Control - Brake Rate	AR-B-R	1 (1-10)	
Adjustable Rate Control - Throttle High Point	AR-H-P	1 (1-10)	
Adjustable Rate Control - Brake Point	AR-B-P	1 (1-10)	

KEY ASSIGNMENTS

FUNCTION	MENU	DEFAULT STEP SETTING	DEFAULT SWITCH
Speed - Steering - Forward	SP-S-F	1 (1-10)	
Speed - Steering - Return to Neutral	SP-S-R	1 (1-10)	
Speed - Steering - Point	SP-S-P	1 (1-10)	
Speed - Brake - Forward	SP-B-F	1 (1-10)	
Speed - Brake - Return to Neutral	SP-B-R	1 (1-10)	
Speed - Brake - Point	SP-B-P	1 (1-10)	
Anti-Lock Brake - Point	ALB-PT	0.1 (0.1-1)	
Anti-Lock Brake - Stroke	ALB-ST	1 (1-10)	
Anti-Lock Brake - Lag	ALB-LG	1 (1-10)	
Anti-Lock Brake - Speed	ALB-SP	1 (1-10)	
Traction Control - Forward	TR-T-F	1 (1-10)	
Traction Control - Return to Neutral	TR-T-R	1 (1-10)	
Traction Control - Delay - Forward	TR-D-F	1 (1-10)	
Traction Control - Delay - Return to Neutral	TR-D-R	1 (1-10)	
Traction Control - Point - Forward	TR-P-F	1 (1-10)	
Traction Control - Point - Return to Neutral	TR-P-R	1 (1-10)	
Starting Position	S-POS	1 (1-10)	
Throttle Hold	TH-HLD	1 (1-10)	
Brake Mixing Delay - 2CH	BM-2CH	1 (1-10)	
Brake Mixing Delay - 3CH	BM-3CH	1 (1-10)	
Brake Mixing Delay - 4CH	BM-4CH	1 (1-10)	
Compensation Mixing 1 - Offset	CX1-OF	1 (1-10)	
Compensation Mixing 1 - High	CX1-HI	1 (1-10)	
Compensation Mixing 1 - Low	CX1-LO	1 (1-10)	
Compensation Mixing 2 - Offset	CX2-OF	1 (1-10)	
Compensation Mixing 2 - High	CX2-HI	1 (1-10)	
Compensation Mixing 2 - Low	CX2-LO	1 (1-10)	
Trim - Steering	TRM-S	C5 (C1-C10 / P1-P10)	Trm 1
Trim - Throttle	TRM-T	5 (1-10)	Trm 2
Trim - Brake	TRM-B	5 (1-10)	Trm 3
Auxiliary Channel 3	3CH	10 (1-10, 20, 50, 100, 200)	
Function Keys	◀/▶	1 (1)	Dial Knob

THIS SPACE INTENTIONALLY LEFT BLANK

USER NAMING



Function Page 3 (USER)

The User Name function allows you to input a User Name to register the transmitter. The User Name can be displayed in the Programming Window when the Battery (BATT) menu is active. The User Name can consist of up to 12 letters, numerals, or symbols.

⚠ Press the ENTER key to move the cursor to the right and press the ★ key to move the cursor to the left.

- 1) Press the Function key to highlight the USER menu. The cursor will blink below USER NAME.



- 2) Press the INC/+ or DEC/- keys to select a character, then press the ENTER key to advance the cursor to the next space. Repeat to enter the rest of the characters.

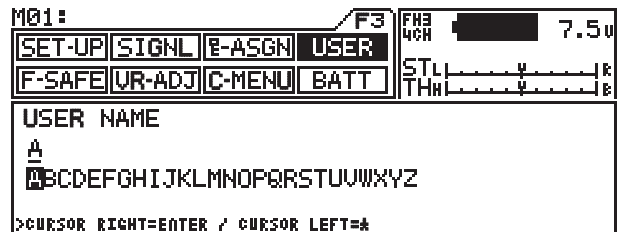

- ⚠ To erase a character, move the cursor under the character you want to erase, then press the INC/+ and DEC/- keys at the same time until the single dark block (Erase Block) is selected. The underlined character will be erased.
- ⚠ A group of character styles can be selected by pressing the INC/+ and DEC/- keys at the same time. Choose from capital letters, lower case letters, symbols, higher case numerals, and lower case numerals.
- ⚠ When entering a character in a position occupied by a space, a group can be selected from the preceding character by first pressing the DEC/- key. This is useful when entering several characters from the same group.

THIS SPACE INTENTIONALLY LEFT BLANK

FAIL SAFE



Function Page 3 (F-SAFE)

The Fail Safe function automatically sets the servos to a predetermined position in the event that the signal between the transmitter and the receiver is interrupted, whether due to signal degradation or to low battery. Several different setting options are available. The Fail Safe function can be set to Hold the servos in the last position they were in when the signal was lost, or each of the servos can be set to move to a custom position when the signal is lost. For example, the throttle servo moves to the Brake Side to engage the brakes and stop your model. If you're driving a gas- or glow-powered boat, the Fail Safe function could be set to lower the throttle to idle and turn the rudder slightly left or right so that the boat will continue in slow circles.

[FAIL SAFE] FAIL SAFE SETTING

- ! Fail Safe can be set on each of the four channels individually.
- ! The Fail Safe settings will be retained even if the transmitter loses power or if the transmitter and receiver must be paired again.

Fail Safe Setting

- 1) Press the Function key to highlight the F-SAFE menu. [FAIL SAFE] will be active in the Programming Window and the cursor will default to ST.
- 2) Press the ENTER key to move the cursor to TH, then press the INC/+ or DEC/- keys to set the desired value for TH. Choose from the values described below. We strongly suggest **FS**.

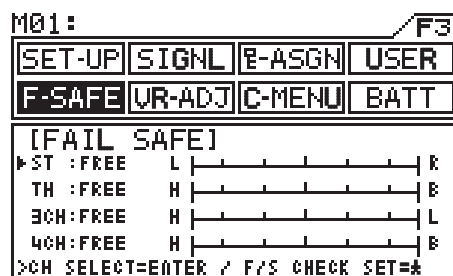

FREE - Fail Safe is disabled for this channel.

HOLD - When Fail Safe Activates, the servo will be held in the last position it was in when the signal was lost.

FS - When Fail Safe Activates, the servo will go to a predetermined position (see step 3 below) when the signal is lost.

- 3) With the cursor next to TH :FS 0% move the throttle trigger toward the Brake Side the amount you want the brake to engage when Fail Safe Activates.
- 4) Press the INC/+ and DEC/- keys at the same time to set the Brake Side Fail Safe setting as noted by the Point on the graph and the -% percentage value.

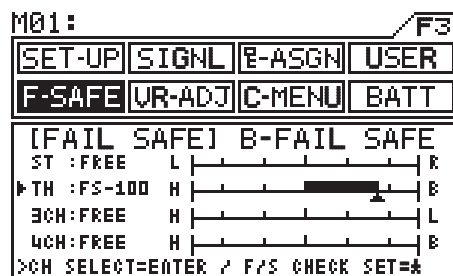

- 5) Repeat the previous procedures to set the Fail Safe settings for the desired remaining channels.

! The 4th Channel Brake Fail Safe setting can be set independently from the TH Brake Side Fail Safe setting.

Fail Safe Check

- 1) Press the ★ key, then press the ENTER key to check the Fail Safe settings. The servos will move to the predetermined positions as indicated on the bar graph. The information to the left of the bar graph will also blink, indicating that the Fail Safe is in Test Mode.
- 2) After verifying correct operation, press the ENTER key to return to the Fail Safe Programming Window.

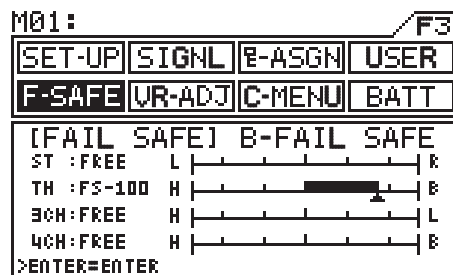

FAIL SAFE

Clearing Fail Safe Settings

- 1) Press the ENTER key to move the cursor next to the channel you would like to clear the Fail Safe setting from.
- 2) To reset the predetermined position to 0%, press the INC/+ and DEC/- keys at the same time.

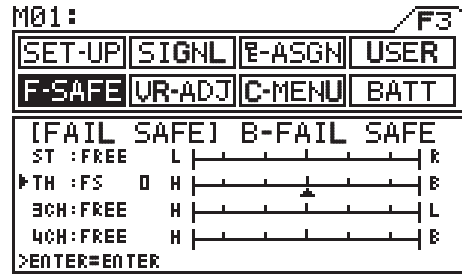

- 3) To change the Fail Safe setting to either HOLD or FREE, press the INC/+ or DEC/- keys to set the desired value.

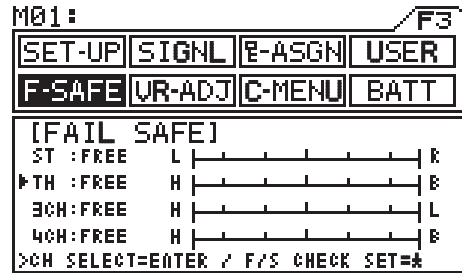

- 4) Repeat the previous procedures to clear the Fail Safe settings for the desired remaining channels.

[B-FAIL SAFE] BATTERY VOLTAGE FAIL SAFE SETTING

When TH:FS Percentage is set, [B-FAIL SAFE] menu activates. The Battery Fail Safe menu allows you to set a custom voltage that the Fail Safe function will Activate at. This useful if you're using servos with a higher than normal current draw that might run out of power before the receiver does.

 The receiver will operate down to 2.5 volts, however, the minimum operating voltage of most servos is higher than that.

B-F/S Setting

- 1) Press the Function key to move cursor to [B-FAIL SAFE] in the Programming Window. The cursor will default to B-F/S.
- 2) Press the INC/+ or DEC/- keys to set the desired value.

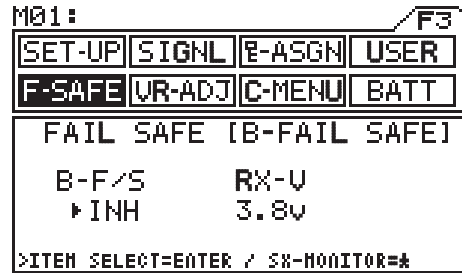

INH - Battery Fail Safe is not Active.

ACT - Battery Fail Safe is Active. Fail Safe will Activate when the receiver battery reaches the custom value in the RX-V setting.

RX-V Setting

- 1) Press the ENTER key to move cursor to RX-V, then press the INC/+ or DEC/- keys to adjust the desired receiver voltage value.

RX-V setting range is 3.5V to 5.0V. The default setting is 3.8V.

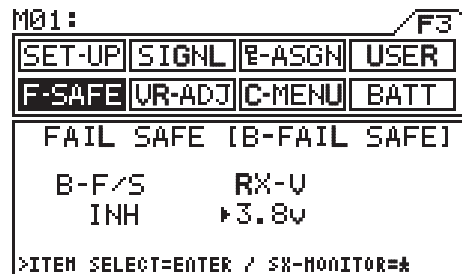

VARIABLE RATE ADJUSTMENT



Function Page 3 (VR-ADJ)

The Variable Rate Adjustment function allows you to periodically recalibrate your steering wheel and throttle trigger operation. The Variable Rate Adjustment function also allows you to adjust the servo to move 100% of its maximum travel if you choose to limit the movement of the steering wheel. For example, if you limit the steering wheel to move only 50% of its maximum deflection in each direction, the steering servo will move only 50% of its maximum travel. The Variable Rate Adjustment function would allow the servo to move 100% of its maximum travel.

Follow the Calibrating Servo Travel steps below as part of a periodic maintenance schedule. This will ensure that your steering and throttle controls are operating at the highest degree of accuracy as possible.

Calibrating Servo Travel

- 1) Press the Function key to highlight the VR-ADJ menu, then press the ENTER key to display the VR ADJUSTMENT YES / NO menu in the Programming Window.
- 2) Press the INC/+ to begin the VRADJUSTMENT process. To Cancel the VR ADJUSTMENT process, press the DEC/- key.
- 3) Turn the steering wheel completely to the left, then turn the steering wheel completely to the right. Release the steering wheel. The Maximum Travel will be indicated at the ends of the bar graph.

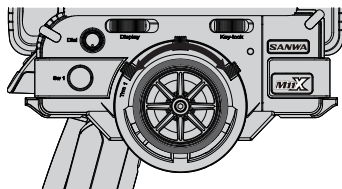

The numbers displayed at the ends of the bar graph may differ slightly. This is okay. If they differ greatly, the steering stops can be adjusted manually. See the next page for more information.

- 4) Pull the throttle trigger completely back, then push the throttle trigger completely forward. Release the throttle trigger. The Maximum Travel will be indicated at the ends of the bar graph.

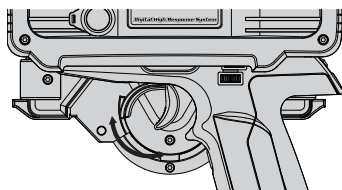

The numbers displayed at the ends of the bar graph will differ greatly. This is normal. The Brake Side of the throttle trigger only moves approximately one-half the distance of the High Side of the throttle trigger.

- 5) Press the ENTER key to display the VR ADJUSTMENT EXECUTE menu in the Programming Window.
- 6) Press the INC/+ key to Execute the VR ADJUSTMENT process. EXECUTING! will be displayed in the Programming Window. To Cancel the VR Adjustment process, press the DEC/- key.

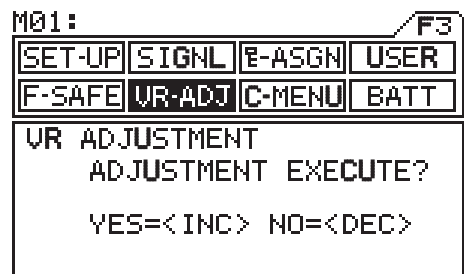
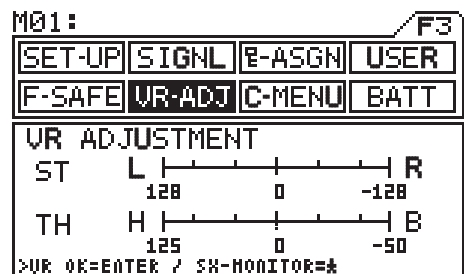
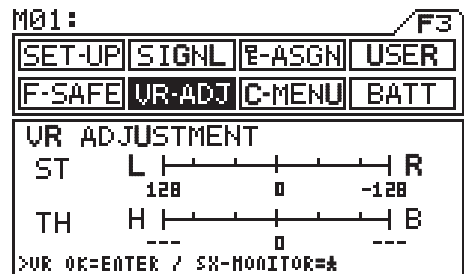
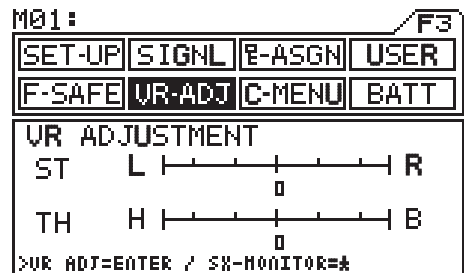

For the VR ADJUSTMENT Process to EXECUTE without an ERROR message, you MUST complete both steps 3 and 4. If you only complete step 3 or step 4, the VR ADJUSTMENT process will not EXECUTE.

CUSTOM MENU DISPLAY



Function Page 3 (C-MENU)

The Custom Menu function allows you to create up to three Custom Function Pages (C1, C2, and C3) that replace the Default Function Pages (F1, F2, and F3). This makes programming the transmitter more user-friendly, since you can place your most accessed menus onto one or more Custom Function Pages.

- 1) Press the Function key to highlight the C-MENU menu. The cursor will default to the upper left box in the C1 Custom Function Page in the Programming Window.

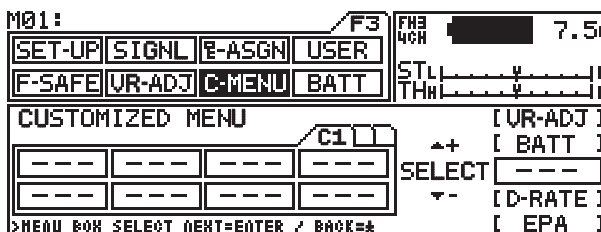

- 2) Press the INC/+ or DEC/- keys to scroll through the different Menu selections along the right side of the Programming Window. The selected Menu will display in the upper left box in the C1 Custom Function Page.

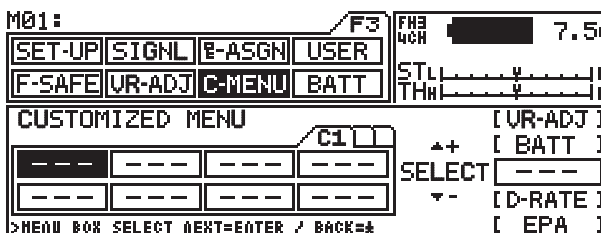

- 3) Press the ENTER key to move the cursor to the next box in the C1 Custom Function Page, then press the INC/+ or DEC/- keys to scroll through the different Menu selections to display the selected Menu.

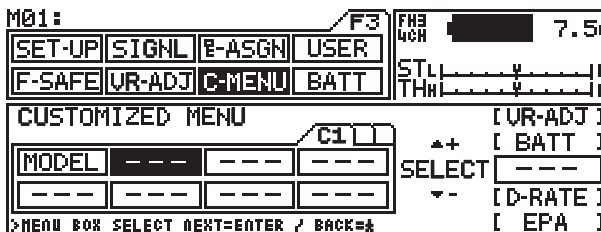

- 4) Repeat step 3 to add your most accessed menus into the remaining boxes in the C1 Custom Function Page.

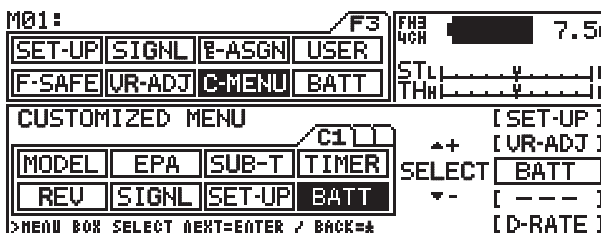

! Press the ENTER key after filling in the lower right box in the C1 Custom Function Page to cycle to the C2 Custom Function Page. If desired, continue adding your most accessed menus into the C2 and C3 Custom Function Pages.

- 5) After setting your Custom Function Pages, press and hold both Function keys down at the same time for ~ 2 seconds to swap between the default Function Pages and your Custom Function Pages.

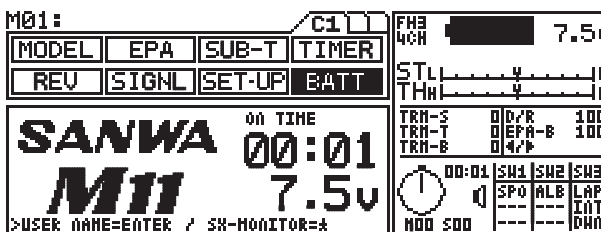

TROUBLESHOOTING GUIDE

This troubleshooting guide has been provided to help you diagnose and solve most problems that you may encounter with your M11X FHSS-3 2.4GHz radio control system. Most problems encountered can be solved by following the problem-cause-solution sections.

PROBLEM		CAUSE	SOLUTION
Does not transmit		Battery low or not fully charged	Charge battery
Power intermittently goes off		Loose battery connector	Unplug, then reinstall connector under battery
Alarm Does Not Stop	Alarm gives off a series of beeps	Battery voltage low	Charge battery
	Alarm gives off a continuous double beep	S-POS switch is in the ON position	Turn S-POS switch to the OFF position
	Alarm gives off a periodic double beep	The interval timer is ON	Turn the interval timer OFF
No key sound when keys are pressed		Command signals are disabled	Check command signal settings
No change in display when keys are pressed		Key lock switch is ON	Turn key lock switch OFF
Servo movement is slow	A negative value is set in the servo Speed menu		Check servo Speed settings
	Low battery		Recharge battery
	Linkage stiff or binding		Adjust linkage to operate freely
Left and right steering angles are different, even though settings are the same		Trim or Sub-Trim not centered	Align trim and Sub-Trim
Servo will not move to the end of its range		D-RATE and EPA settings are too large	Reset linkage on the servo for more travel from servo and reset settings
Servo does not move when using trim switch		Trim is outside of operational range	Reset trim to zero and center the servo horn and linkage on servo
Lap timer and interval timer do not function		Timers are set in the OFF position	Turn timers ON
Steering wheel does not center		Spring tension set too loose	Tighten spring tension
Transmitter will not bind to receiver	Too much time elapsed after pressing receiver Bind button		Quickly press the ENTER key in the Binding Menu after releasing the Bind button
	Attempting to Bind an incompatible receiver		Transmitter is compatible with FHSS-3 and FHSS-2 2.4GHz receivers. If using FHSS-2 receiver, transmitter modulation must be set to FH2
Servo Monitor bar graph always shows servo movement even though servos are centered		Servo Sub-Trim is programmed	The Servo Monitor will display servo Sub-Trim as movement. This is normal

GLOSSARY OF TERMS

Activate: To turn ON a particular function.

Adjustable Rate Control: Varies the amount of servo action with respect to manipulation of the steering wheel or throttle trigger. Increasing the Adjustable Rate Control value will make the servo action quicker, while reducing the Adjustable Rate Control value will make the servo action milder.

Antenna: Transmits the signal from the transmitter to the receiver in the model. The antenna should be extended in the vertical position during use. When not in use, the Antenna should be collapsed into the horizontal position to prevent damage.

Antenna Reception Wire: The portion of the receiver antenna that actually receives the transmitter signal. The Antenna Reception Wire should never be bent or it could be damaged and limit the range of your model.

Anti-Lock Braking: Makes it possible to achieve stable braking even on slippery surfaces. With stable braking, your model is better able to trace an exact line under braking.

Audible Signal: A tone that is emitted from the transmitter to alert you to various key-presses, alarms, and warnings. The tones of Audible Signals can be customized and even muted.

Battery Compartment: Houses the 6 cell 1500mAh NiMH battery that powers the transmitter. The transmitter uses a 6 cell battery for lighter weight and better feel, while still maintaining a high power output.

Binding: The act of pairing the transmitter and receiver to prevent interference from radio controllers operated by other users. The transmitter and receiver must be paired so that the two can 'talk' to each other. Once the Binding process is complete, the setting is remembered even when the transmitter and receiver are turned OFF.

Brake Mixing: Used primarily with 1/5th scale gas-powered models or other types of models that use two separate brake servos. Allows you to adjust when each brake is engaged. For example, if your model features separate front and rear brakes, the rear brake can be adjusted to engage before the front brake engages or vice-versa.

Brake Side: Refers to the throttle trigger stroke that engages the brakes on your model (pushing the throttle trigger).

Charging Jack: Used for onboard charging of the 6 cell 1500mAh NiMH battery. Only use the charger included with your M11X FHSS-3 2.4GHz radio control system to charge the battery through the charging jack. Use of any other charger can damage the transmitter.

Coaxial Cable: The portion of the receiver antenna that extends the Antenna Reception Wire. The Coaxial Cable can be bent into gentle curves, however, do not bend the Coaxial Cable acutely, or repeatedly bend it, or the antenna core can be damaged. The Coaxial Cable should be installed through a nylon tube (antenna tube) in the vertical position for the best reception.

Compensation Mixing: Allows you to mix two channels together, then apply that mixing to the channels themselves. For example, you can use Compensation Mixing to activate an air-brake or a wing on your model when you apply the brakes, or when you reach full throttle. Two Compensation Mixers are available, and each can be Activated separately. Graphical indications make it easier to visualize the mixing settings.

Countdown Timer: Used to notify you of your model's running time. For example, set the Countdown Timer to 7 minutes. When the Countdown Timer sounds, refuel. The Countdown Timer accepts settings of up to 99 minutes and 59 seconds. Once the count down timer has run out, the count up timer starts. This allows you to check the time elapsed since the timer ran out.

Custom Menu: Allows you to create up to three Custom Function Pages (C1, C2, and C3) that replace the Default Function Pages (F1, F2, and F3). This makes programming the transmitter more user-friendly, since you can place your most accessed menus onto one or more Custom Function Pages.

Dial Knob: A rotary knob that can rotate 360°. The Dial Knob is programmable and will perform a different function depending on what function is assigned to it. For example, the Dial Knob can be used to scroll through programming menu selections or a trim function or even an auxiliary channel can be assigned to it.

DEC/- Key: Decreases number values in the Programming Window. Also scrolls down a Selection List.

Direct Servo Control Jack (DSC): Using the DSC cable for M11X(available separately), the Direct Servo Control Jack allows you to check your model's linkage and make necessary programming changes during a race or a situation when radio transmission is prohibited. When connected between the receiver and the transmitter, the receiver is turned ON and the Display Switch is utilized to complete programming. No signal is actually transmitted between the transmitter and receiver.

Display Switch: Activates the transmitter's LCD Display without actually turning the transmitter ON. This allows you to check and/or change programming settings without actually turning ON the transmitter.

End Point Adjustment: Used to adjust the desired amount of servo travel in both the right and left directions independently. EPA can be set for the Steering channel, Throttle channel, Auxiliary channel, and Brake channel (4CH Mode).

Enter Key: Moves the Cursor forward in the Programming Window. Also used in the Help Display Area.

GLOSSARY OF TERMS

Exponential: Varies the amount of servo action with respect to manipulation of the steering wheel or throttle trigger near the neutral positions. Decreasing the Exponential value will 'soften' the control feel around neutral and increasing the Exponential value will 'quicken' the control feel around neutral.

Exponential Tweak: Allows you to move and pinpoint the neutral position of the Exponential function independently anywhere between the Steering End Points, not just the center. This ensures that Exponential is balanced for both the right and left sides.

Fail Safe: Automatically sets the servos to a predetermined position in the event that the signal between the transmitter and the receiver is interrupted, whether due to signal degradation or to low battery.

FH2 Modulation: Frequency Hopping 2nd generation FHSS technology. FH2 Modulation is used in legacy SANWA 2.4GHz FHSS-2 transmitters and receivers, such as the SANWA TM-222FS, and MX-3FG radio control systems.

FH3 Modulation: Frequency Hopping 3rd generation FHSS technology. FH3 Modulation is used in the SANWA M11X 2.4GHz FHSS-3 transmitter and receiver.

FH3F Modulation: Frequency Hopping 3rd generation FHSS technology used only in France. This is a special modulation type for the country of France only.

FHSS: Frequency Hopping Spread Spectrum. FHSS is a modulation type which transmits data across the entire frequency spectrum by transmitting data on different channels at an extremely fast interval.

Function Keys: Moves the Menu Function cursor left (backward) to the previous menu function or right (forward) to the next menu function.

Grip: Features a molded rubber pad for increased control and feel. The driving position height is adjustable to best suit your driving style.

Help Display Area: A space at the bottom of the Programming Window that displays various Help functions depending on the Programming Menu you are currently in.

High Side: Refers to the throttle trigger stroke that opens the throttle and powers your model (pulling the throttle trigger).

INC/+ Key: Increases number values in the Programming Window. Also scrolls up a Selection List.

Inhibit: To deactivate or turn OFF a particular function.

Information Window: An area on the right side of the LCD Display that displays a number of different informational items that relate to the current settings of the transmitter and its various functions. The Servo Monitor can also be displayed in this area by pressing the Scroll key.

Interval Timer: Notifies you when a set interval elapses while you are driving, giving you an idea of how close you are to your target time. There are two separate Interval Timers. One Interval Timer for minutes and seconds, and one Interval Timer for seconds and milliseconds. Both Interval Timers can be used simultaneously and different Tones can be assigned to each.

Key-Lock Switch: Allows you to lock the LCD Display input keys so that no changes can inadvertently be made.

Lag Setting: Controls the amount of delay before the ALB (Anti-Lock Brake) activates after reaching the POINT.

Lap Timer: Allows you to measure and record times for up to 99 laps. The Lap Timer features a pre-alarm, the ability to set a goal time, a real-time display of the best lap time, average lap time, and total laps.

LCD Display: Liquid Crystal Display. The LCD displays all of the transmitter programming and related information. The LCD contrast and display color can be customized.

Operating Voltage: The safe voltage that the transmitter or receiver can operate within. Exceeding the minimum operating voltage can result in loss of power to the device(s). Exceeding the maximum operating voltage can result in damage to the device(s).

Output Power: The power (in Milliwatts) that your transmitter transmits a signal. Output power is defined by government guidelines and differs by region.

Parallel Trim: A trim technology that maintains the maximum End Point parameters ensuring that servo travel will be equal on both the right and left sides regardless of the trim setting.

Point Setting: Locates the actual point in the servo travel that you want a specific programming setting to occur. This setting can vary depending on the actual programming setting the point setting is controlling.

Power Indicator Light: Illuminates when the transmitter is turned ON and transmitting a signal.

Power Switch: Turns the transmitter ON and OFF.

GLOSSARY OF TERMS

Programming Window: The area in the LCD Display that the actual programming of the different transmitter functions takes place.

Push-Button Switch: The transmitter features three separate Push-Button Switches in different locations (Sw 1, Sw 2, and Sw 3). Each Push-Button Switch is programmable and will perform a different function depending on what function is assigned to it.

Scroll Key: Moves the Cursor backward in the Programming Window. Also used in the Help Display Area and to display the Information Window.

Servo Monitor: The Servo Monitor function displays the output levels of the four different channels in bar graph form, allowing you to monitor servo operation in a virtual manner. This allows you to see servo movement and make setting changes without having the receiver turned on, and when used in conjunction with the Display Switch, allows you to see servo movement and make setting changes without the transmitter transmitting a signal. Using the Servo Monitor function while making setting changes can make it easier to understand the setting changes you're making.

Servo Speed: Slows down the steering servo speed during use. When driving your model, proper steering is vital, and excessive steering is to be avoided at all times. The steering Speed setting helps to limit excessive steering, which will enable you to achieve smoother cornering. The Speed function can also be set on the Brake side of the throttle.

Servo Reversing: Electronically switches the direction of servo travel. For example, if you move the steering wheel to the right, and the steering servo moves to the left, you can use the Servo Reversing function to make the steering servo move to the left.

SHR Mode: Super High Resolution mode. Using the SHR setting with Digital servos will increase the servo's response time, even above the manufacturer's stated speed. This setting has no influence when used with analog servos.

Starting Position: Used primarily with glow- or gas-powered models. It allows you to open the throttle a desired amount and hold it there with only the press of a button. This makes it easier to start the engine.

Steering Dual Rate: Used to change the amount of steering servo travel compared to the amount of movement of the steering wheel. For example, by increasing the Steering Dual Rate, you can make the steering servo travel more which might prevent your model from pushing during turns. If your model oversteers during turns, you can reduce the amount of Steering Dual Rate.

Steering Wheel: Proportionally operates the model's right and left steering control. The Steering Wheel tension can be adjusted to best suit your driving style.

Step Value: A preset amount that the servo will travel when the trim switch is pressed once. The step value can be adjusted so that the servo either moves more or moves less when the trim switch is pressed.

Sub-Trim: Corrects the neutral trim setting for steering and throttle, making it possible to center the trim switches while ensuring the steering and throttle servo horns remain centered. When adjusting linkages, Sub-Trim allows you to fix an accurate center position. It's not unusual that when you center a servo and install the servo horn, the servo horn is not perfectly centered. Sub-trim allows you to center the servo horn perfectly, without altering the servo End-Point travel.

Suppression Capacitor: Primarily used on electric motors, a suppression capacitor helps eliminate electrical noise that could interfere with the operation of your radio control system.

Throttle Hold: Used primarily with glow- or gas-powered models. It allows you to perform several different functions depending on how the Throttle Hold function is set up. For example, when set to a negative value, you can stop the engine with only the press of a button. This feature is often used with R/C boat models and is also known as 'Engine Cut'. When set to a positive value, the throttle can be held open a desired amount with only the press of a button. This feature is often used to hold the engine at a steady idle while refueling during a race.

Traction Control: Helps assure faster, smoother starts by reducing the chance of tire spin, even when the throttle trigger is applied abruptly. Traction Control also contributes to stability during acceleration, providing smoother running.

Trigger: Controls the speed of the model, both forward and backward, or the brake. The Trigger tension can be adjusted to best suit your driving style.

Trim Control Switch: The transmitter features five separate Trim Control Switches in different locations (Sw 1, Sw 2, Sw 3, Sw 4, and Sw 5). Each Trim Control Switch is programmable and will perform a different function depending on what function is assigned to it. For example, Trm 1 and Trm 2 are used to adjust the center-trim of the steering and throttle servos, and Trm 4 and Trm 5 are used to adjust dual rate and steering EPA.

Variable Rate Adjustment: Allows you to periodically recalibrate your steering wheel and throttle trigger operation. The Variable Rate Adjustment function also allows you to adjust the servo to move 100% of its maximum travel if you choose to limit the movement of the steering wheel.

Vibrator Setting: When activated, the transmitter will vibrate at the same time that the Timer alarms or the battery alarm activates. We recommend activating the vibrator setting if you choose to mute the audible signals.

INDEX

SYMBOLS

2CH Mode 18, 19, 20, 37, 41
4CH Mode 15, 18, 19, 20, 33, 38, 39, 40, 50, 61

A

ACT/INH Setting 22, 24, 25, 26, 29, 30, 44
Adjustable Rate Control 14, 23, 24, 51, 52, 61
Adjustable Servo Speed 5
Alarm Setting 34, 38
Antenna 6, 7, 8, 61
Antenna Reception Wire 8, 61
Anti-Lock Braking 5, 8, 14, 27, 28, 51, 61
Audible Signal 61

B

Battery Compartment 5, 6, 7, 8, 11, 14, 16, 54, 56, 60, 61
Battery Monitor 5
Bind Button 13
Binding 13
Bind Key 7, 8
Bind LED 7, 8, 13
Brake Mixing 5, 14, 15, 40, 41, 53, 61
Brake-Point Setting 38
Brake Side Setting 22

C

Charging 6, 8, 11, 61
Charging Jack 6, 8, 61
Coaxial Cable 7, 8, 61
Compensation Mixing 14, 42, 51, 53, 61
Countdown Timer 36, 37, 49, 51, 61
Custom Menu 14, 59, 61

D

DEC/- Key 12, 61
DELAY Setting 29, 30
Dial Knob 5, 6, 8, 12, 19, 44, 50, 51, 52, 53, 61
Digital Trim 5
Direct Servo Control Jack 8, 61
Display Switch 5, 6, 8, 45, 61, 63
Dual Rate Steering 5

E

End Point Adjustment 5, 14, 18, 19, 20, 50, 52, 61
Enter Key 12
Exponential 5, 14, 21, 22, 23, 25, 26, 51, 52, 58, 62
Exponential Tweak 5, 62

F

Fail Safe 5, 55, 56, 62
FH2 Modulation 18, 19, 20, 47, 48, 62
FH3F Modulation 47, 62
FH3 Modulation 18, 19, 20, 47, 62
FORWARD Setting 25, 26

INDEX

E

Function Keys 50, 53, 62
Function Pages 15

G

Grip 5, 7, 8, 62

H

Help Display Area 12, 14, 61, 62, 63
High Side 22, 38, 39, 57, 62
High Side Setting 22

I

INC/+ Key 12, 62
Information Window 12, 14, 63
Inhibit 22, 24, 25, 26, 29, 30, 41, 44, 50, 62
Interval Timer 35, 36, 49, 51, 62

K

Key-Lock Switch 5, 6, 8, 62

L

Lag Setting 62
Lap Timer 34, 35, 49, 51, 62
LCD Display 5, 6, 8, 12, 14, 46, 47, 61, 62, 63
Li-Po Battery Use 11

M

Menu Flow Chart 15
Model Copy 5, 14, 31
Model Naming 5, 14
Model Select 5, 14, 31

O

Offset Setting 38, 43
Operating Voltage 5, 62
Output Power 5, 62

P

Parallel Trim 33, 62
Point Setting 38, 62
Power Indicator Light 8
Power Switch 6, 8, 62
Programming Window 12, 63
Push-Button Switch 8, 63

R

RATE Setting 23, 24
RETURN Setting 25, 26
Return to Neutral 15, 25, 26, 30, 51, 53

INDEX

S

Safety 3, 4, 11
Scroll Key 12, 63
Servo 63
Servo Monitor 5, 14, 45, 60, 62, 63
Servo Reversing 5, 14, 37, 45, 63
Servo Speed 5, 14, 25, 26, 63
SHR Mode 5, 63
Specifications 5, 11
SPEED Setting 27
Spring tension 60
Starting Position 5, 38, 50, 51, 53, 63
Starting Position Setting 38
Steering Dual Rate 14, 17, 18, 63
Steering Wheel 5, 6, 8, 9, 10, 42, 45, 58, 63
Steering Wheel Tension 5, 9
Step Value 63
STROKE Setting 27
Sub-Trim 5, 14, 18, 33, 40, 42, 43, 45, 60, 63

T

Throttle Hold 5, 14, 39, 51, 53, 63
Traction Control 5, 14, 28, 29, 30, 51, 53, 63
TRACTION Setting 29, 30
Trigger 6, 8, 9, 28, 45, 63
Trim Control Switch 8, 63
Tweak 5, 62

U

User Naming 5

V

Variable Rate Adjustment 5, 57, 63
Vibrator Setting 46, 63

NOTES