

Haier

SERVICE MANUAL

LCD TV

Model No. HLC32K2

Service No. HLC32K2a

Chassis MTK5305



 **WARNING**

This service information is designed for experienced repair technicians only and is not designed for use by the general public. It does not contain warnings or cautions to advise non-technical individuals of potential dangers in attempting to service a product. Products powered by electricity should be serviced or repaired only by experienced professional technicians. Any attempt to service or repair the product or products dealt with in this service information by anyone else could result in serious injury or death.

©2010 Qingdao Haier Electronics Co., Ltd.

All rights reserved. Unauthorized copying and distribution is a violation of law.

Haier Group

CONTENTS

Chapter 1: General Information.....	3
1-1. Document Information.....	3
1-2. General Guidelines.....	3
1-3. Important Notice.....	3
1-3-1. Follow the regulations and warnings	3
1-3-2. Be careful to the electrical shock.....	3
1-3-3. Electro static discharge (ESD).....	3
1-3-4. About lead free solder (PbF).....	4
1-3-5. Use the genewing parts (specified parts)	4
1-3-6. Safety check after repairment.....	4
1-3-7. Ordering Spare Parts.....	6
1-3-8. Photo used in this manual	6
1-4. How to Read this Service Manual.....	6
1-4-1. Using icons:.....	6
 Chapter 2: Specification.....	 8
2-1. Specification List.....	8
2-2. External Pictures (four faces).....	9
 Chapter 3. Disassemble and Assemble.....	 11
3-1. Remove the Stand	11
3-2. Remove the Back Cover	11
3-2. Remove the Adhesive Tape	11
3-4. Remove the Power Supply Module.....	12
3-5. Remove the Mainboard.....	12
3-6. Remove the Keypad board	11
3-7. Remove the Speaker.....	12
3-8. Remove the Remote Control Board.....	12
 Chapter 4. Location of Controls&Components... 	 13
4-1. Board Location	13
4-2. Main Board & AV Board	13

4-2-1. Function Description:.....	14
4-2-2. Connector definition.....	14
4-3. Power Supply Board	16
4-3-1. Function description:.....	16
4-3-2. Connector definition:.....	16
4-4. LCD Panel	16
4-4-1. Function Description: Display the signal.....	17
4-4-2. Connector definition:.....	17
Chapter 5. Installation Instructions.....	18
5-1. External Equipment Connections.....	18
Chapter 6. Operation Instructions	23
6-1. Front Panel Controls.....	23
6-2. Back Panel Controls	24
6-3. Setting Up Your Remote Control	25
Chapter 7. Electrical Parts.....	26
7-1. Block Diagram	26
7-2. Circuit Diagram.....	27
7-3. Wiring Connection Diagram	44
Chapter 8. Measurements and Adjustments.....	45
8-1. Service Mode	45
8-1-1.How to enter into Service Mode.....	45
8-1-2.How to exit.....	45
8-2. Measurements and Adjustments	45
8-2-1. Version, S/N, Panel Resoution	45
8-2-2. Video.....	46
8-2-3. Audio.....	47
8-2-4. Channel	47
8-2-5. Gamma	48
8-2-6. Panel Index.....	48
8-2-7. Function.....	49
Chapter 9. Trouble shooting.....	52
9-1. Simple check	52
9-2. Power Supply Board Failure Check.....	53
9-3. Mainboard Failure Check	54

Chapter 1: General Information

1-1. Document Information

Document format: Adobe PDF

Author: Zhou Peng

Compiler: Bao Qinghong

1-2. General Guidelines

When servicing, observe the original lead dress. If a short circuit is found, replace all parts which have been overheated or damaged by the short circuit.

After servicing, see to it that all the protective devices such as insulation barriers, insulation papers shields are properly installed.

After servicing, make the following leakage current checks to prevent the customer from being exposed to shock hazards.

- 1) Leakage Current Cold Check
- 2) Leakage Current Hot Check
- 3) Prevention of Electro Static Discharge (ESD) to Electrostatically Sensitive

1-3. Important Notice

1-3-1. Follow the regulations and warnings

Most important thing is to list up the potential hazard or risk for the service personnel to open the units and disassemble the units. For example, we need to describe properly how to avoid the possibility to get electrical shock from the live power supply or charged electrical parts (even the power is off).



This symbol indicates that high voltage is present inside. It is dangerous to make any kind of contact with any inside part of this product.



This symbol indicates that there are important operating and maintenance instructions in the literature accompanying the appliance.

1-3-2. Be careful to the electrical shock

To prevent damage which might result in electric shock or fire, do not expose this TV set to rain or excessive moisture. This TV must not be exposed to dripping or splashing water, and objects filled with liquid, such as vases, must not be placed on top of or above the TV.

1-3-3. Electro static discharge (ESD)

Some semiconductor (solid state) devices can be damaged easily by static electricity. Such

components commonly are called Electrostatically Sensitive (ES) Devices. The following techniques should be used to help reduce the incidence of component damage caused by electrostatic discharge (ESD).

Electrostatically Sensitive (ES) Devices

Some semiconductor (solid-state) devices can be damaged easily by static electricity. Such components commonly are called Electrostatically Sensitive (ES) Devices. Examples of typical ES devices are integrated circuits and some field-effect transistors and semiconductor "chip" components. The following techniques should be used to help reduce the incidence of component damage caused by static by static electricity.

1. Immediately before handling any semiconductor component or semiconductor-equipped assembly, drain off any electrostatic charge on your body by touching a known earth ground. Alternatively, obtain and wear a commercially available discharging wrist strap device, which should be removed to prevent potential shock reasons prior to applying power to the unit under test.
2. After removing an electrical assembly equipped with ES devices, place the assembly on a conductive surface such as aluminum foil, to prevent electrostatic charge buildup or exposure of the assembly.

1-3-4. About lead free solder (PbF)

This product is manufactured using lead-free solder as a part of a movement within the consumer products industry at large to be environmentally responsible. Lead-free solder must be used in the servicing and repairing of this product.

1-3-5. Use the genuing parts (specified parts)

Special parts which have purposes of fire retardant (resistors), high-quality sound (capacitors), low noise (resistors), etc. are used.

When replacing any of components, be sure to use only manufacture's specified parts shown in the parts list.

Safety Component

- Components identified by mark have special characteristics important for safety.

1-3-6 Safety check after repairment

Confirm that the screws, parts and wiring which were removed in order to service are put in the original positions, or whether there are the positions which are deteriorated around the serviced places serviced or not. Check the insulation between the antenna terminal or external metal and the AC cord plug blades. And be sure the safety of that.

General Servicing Precautions

1. Always unplug the receiver AC power cord from the AC power source before:
 - a. Removing or reinstalling any component, circuit board module or any other receiver assembly.
 - b. Disconnecting or reconnecting any receiver electrical plug or other electrical connection.
 - c. Connecting a test substitute in parallel with an electrolytic capacitor in the receiver.

CAUTION: A wrong part substitution or incorrect polarity installation of electrolytic capacitors may result in an explosion hazard.

2. Test high voltage only by measuring it with an appropriate high voltage meter or other voltage measuring device (DVM, FETVOM, etc) equipped with a suitable high voltage probe.

Do not test high voltage by "drawing an arc".

3. Do not spray chemicals on or near this receiver or any of its assemblies.

4. Unless specified otherwise in this service manual, clean electrical contacts only by applying the following mixture to the contacts with a pipe cleaner, cotton-tipped stick or comparable non-abrasive applicator; 10% (by volume) Acetone and 90% (by volume) isopropyl alcohol (90%-99% strength).

CAUTION: This is a flammable mixture.

Unless specified otherwise in this service manual, lubrication of contacts is not required.

Capacitors may result in an explosion hazard.

5. Do not defeat any plug/socket B+ voltage interlocks with which receivers covered by this service manual might be equipped.

6. Do not apply AC power to this instrument and/or any of its electrical assemblies unless all solid-state device heat sinks are correctly installed.

7. Always connect the test receiver ground lead to the receiver chassis ground before connecting the test receiver positive lead.

Always remove the test receiver ground lead last. Capacitors may result in an explosion hazard.

8. Use with this receiver only the test fixtures specified in this service manual.

CAUTION: Do not connect the test fixture ground strap to any heat sink in this receiver.

9. Remove the antenna terminal on TV and turn on the TV.

10. Insulation resistance between the cord plug terminals and the external exposure metal should be more than Mohm by using the 500V insulation resistance meter.

11. If the insulation resistance is less than M ohm, the inspection repair should be required. If you have not the 500V insulation resistance meter, use a Tester. External exposure metal: Antenna terminal Headphone jack.

3. Use only a grounded-tip soldering iron to solder or unsolder ES devices.
4. Use only an anti-static type solder removal device. Some solder removal devices not classified as "anti-static" can generate electrical charges sufficient to damage ES devices.
5. Do not use freon-propelled chemicals. These can generate electrical charges sufficient to damage ES devices.
6. Do not remove a replacement ES device from its protective package until immediately before you are ready to install it.
(Most replacement ES devices are packaged with leads electrically shorted together by conductive foam, aluminum foil or comparable conductive material).
7. Immediately before removing the protective material from the leads of a replacement ES device, touch the protective material to the chassis or circuit assembly into which the device will be installed.

CAUTION: Be sure no power is applied to the chassis or circuit, and observe all other safety precautions.

8. Minimize bodily motions when handling unpackaged replacement ES devices. (Otherwise harmless motion such as the brushing together of your clothes fabric or the lifting of your foot from a carpeted floor can generate static electricity sufficient to damage an ES device.)

1-3-7. Ordering Spare Parts

Please include the following informations when you order parts. (Particularly the Version letter)

1. Model number, serial number and software version

The model number and serial number can be found on the back cover of each product. Software version can be found in the Spare Parts List.

2. Spare part No. and description

Spare part No. and description can be found in the Spare Parts List.

1-3-8. Photo used in this manual

The illustration and photos used in this Service Manual may not base on the final design of products, which may differ from your products in some way.

1-4. How to Read this Service Manual

1-4-1. Using icons:

Icons are used to attract the attention of the reader to specific information. The meaning of each icon is described in the table below:



Note:

A "note" provides information that is not indispensable, but may nevertheless be valuable to the reader, such as tips and tricks.

Caution:

A “caution” is used when there is danger that the reader, through incorrect manipulation, may damage equipment, lose data, get an unexpected result or has to restart (part of) a procedure.

**Warning:**

A “warning” is used when there is danger of personal injury.

Reference:

A “reference” guides the reader to other places in this binder or in this manual, where he/she will find additional information on a specific topic.

Chapter 2: Specification

2-1. Specification list

Model	HLC32K2		
Screen Size	32 inch		
Aspect Ratio	16:9		
Resolution	1366x768		
Response Time (ms)	8 (GRAY TO GRAY)		
Angel of View	176°		
Color Display	16777216		
No. of Preset Channels	181		
OSD Language	English/Franch/ Spanish		
Color System	NTSC		
Audio System	M, BG, I, L, L'		
Audio Output Power (Built-in) (W)	10W×2		
Audio Output Power (outer) (W)	No		
Total Power Input (W)	100W		
Voltage Range (V)	AC100V~240V		
Power Frequency (Hz)	50~60Hz		
Time of Sleep Timer (MINS)	240Min		
Net Weight (KG)	11.3		
Gross Weight (KG)	13.8		
Net Dimension (MM)	798*230*575		

2-2 External pictures (four faces)



Front Side



Left Side





Right Side



Back Side



Chapter 3. Disassemble and Assemble

3-1 Remove the Stand

1. Lay down the unit so that back cover faces upward



2. Remove the four screws from the back cover which are indicated with the circles in the picture above.

3. Remove the stand



3-2. Remove the Back Cover

1. Remove the twelve screws indicated (See picture right.)



2. Then remove the back cover from the unit.

3-3. Remove the Adhesive Tape

The location of the adhesive tape is shown below.

Remove the adhesive tape.

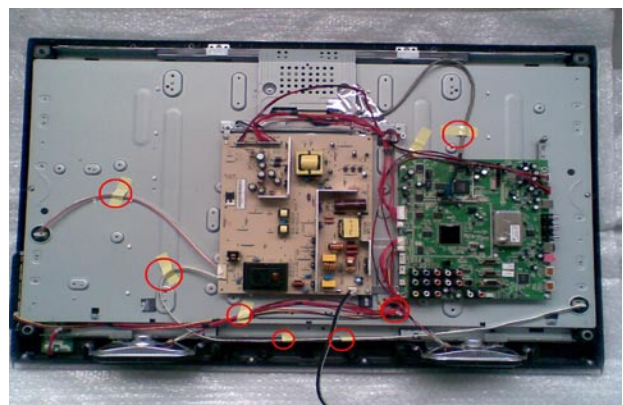

3-4. Remove the Power Supply Module

Remove the four screws indicated by the red circles in below picture.

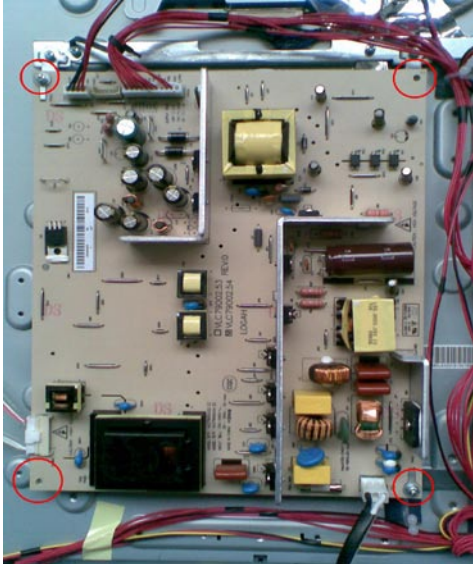

3-5. Remove the Mainboard

Remove the four screws indicated by the red circles in below picture.



Disconnected the coupler .
Remove the Mainboard.

3-6. Remove the Keypad Board

Remove the two screws indicated by the red circles in below picture.

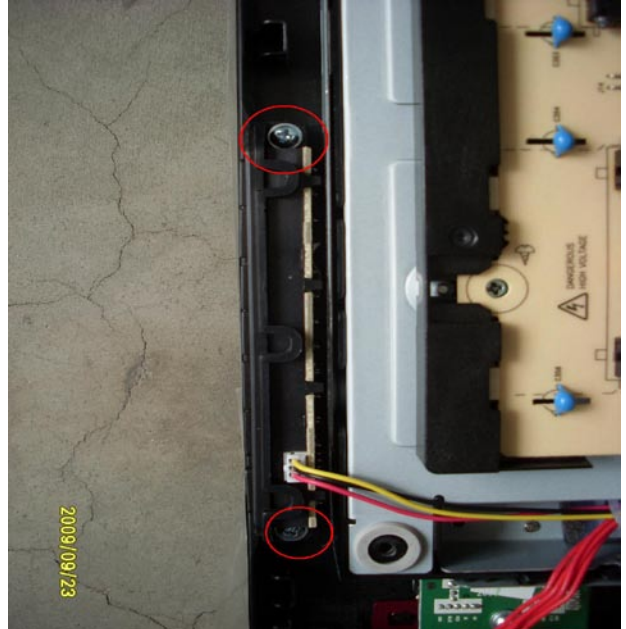

3-7. Remove the Speaker

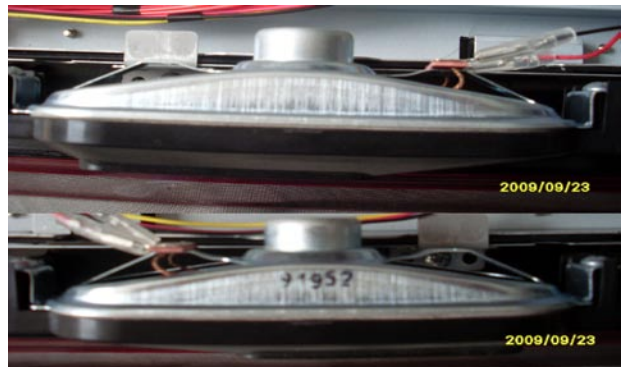

3-8. Remove the Remote Control

Remove the two screws indicated by the red circles in below picture.

Take out the remote control board.



Chapter 4. Location of Controls and Components

4-1. Board Location

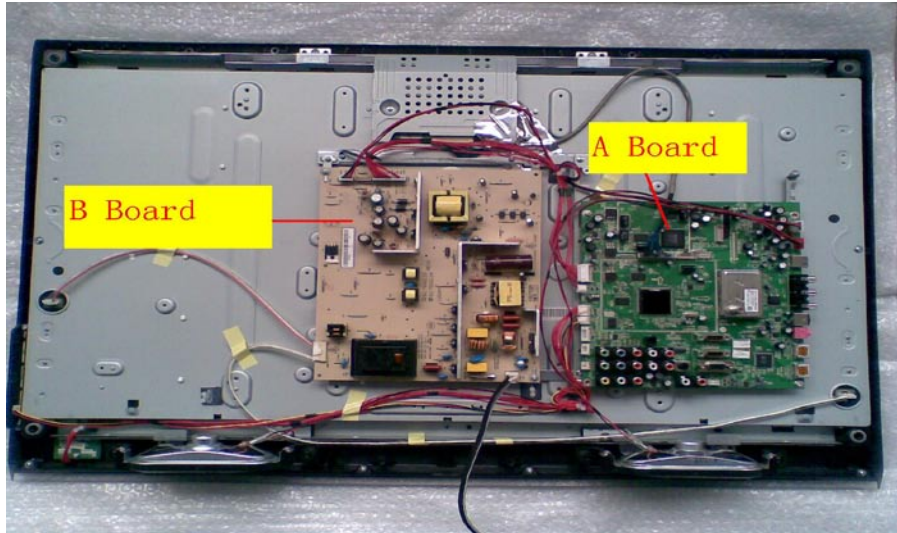

No.	Parts number	Description
A Board	Main Board	
B Board	Power Board	

4-2. Main Board & AV Board

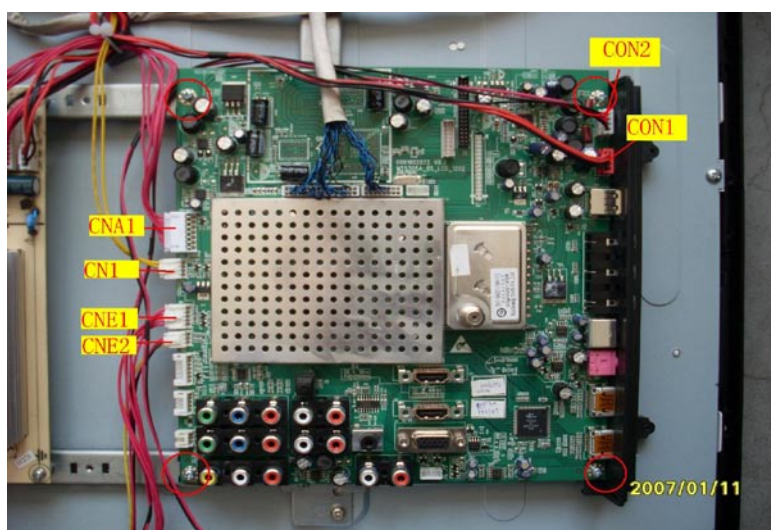

4-2-1 Function Description:

Main Board

Process signal which incept from exterior equipment then translate into signal that panel can display.

4-2-2 Connector definition

Main board connector

Power connectors (CNA1, CN1)

CNA1		CN1	
Pin number	Signal name	Pin number	Signal name
1	SW	1	DIMMING
2	GND	2	ON/OFF
3	+5VSB	3	GND
4	GND	4	SELECT
5	GND		
6	+12V		
7	+12V		

Notes:

CN1-Pin 2: Backlight on/off:

The system can turn on or turn off the backlight of TFT LCD Panel through the power supply unit path.

CNA1-Pin 1: System power on / standby

System board will use this pin to control system power.

CN1-Pin 1: Control the luminance of backlight

The system can generate the PWN signal to control the strength of TFT LCD Panel's backlight through this connector

Keypad and remote connector (CNE1,CNE2)

CNE1		CNE2	
Pin number	Signal name	Pin number	Signal name
1	SB5V	1	GND
2	IR	2	AD1
3	LED_R	3	AD2
4	LED_G		
5	GND		

Speaker power connector (CON1)

Pin number	Signal name	
1	24V	
2	24V	
3	GND	
4	GND	

Speaker Connector (CON2)

Pin number	Signal name	
1	L+	
2	L-	
3	R-	
4	R+	

Other connectors:

CNB2 to Upgrade the program of ZORAN785 (U1) AND FLASH (U7)

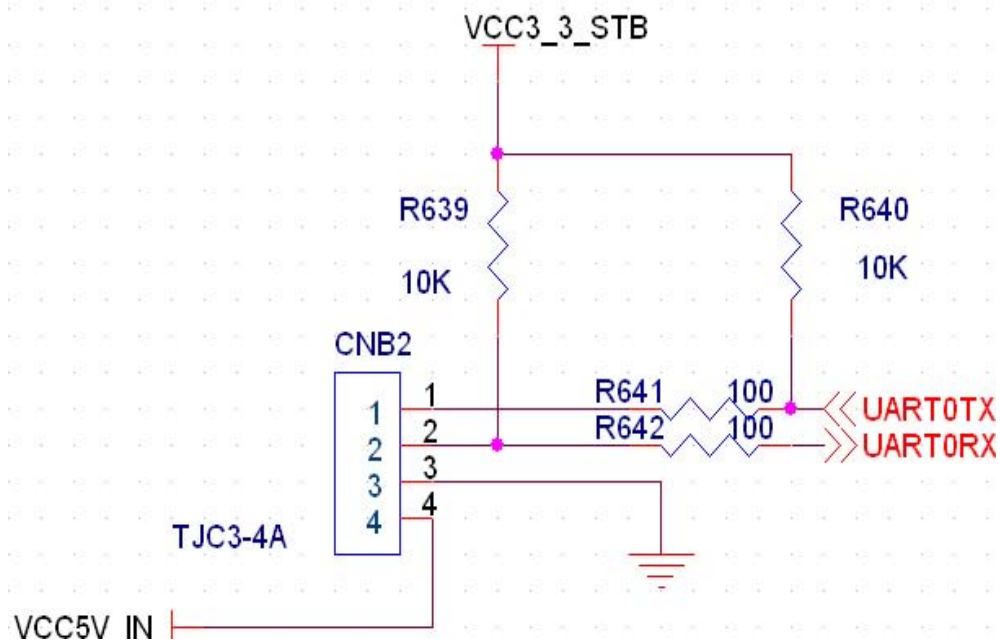

4-3. Power Supply Board



4-3-1. Function description:

To supply power for Mainboard, Panel.

4-3-2. Connector definition:

INPUT CONNECTOR

CN402	Signal name
1-2	+12V
3-4	GND
5	+5V
6	GND
7	Power ON/OFF
8	I_PWM/E_PWM

CN402	Signal name
9	I_PWM
10	BL_ON/OFF
11	E_PWM

CN401	Signal name
1	+24V
2	+24V
3	GND
4	GND

4-4. LCD Panel



4-4-1. Function Description: Display the signal.

4-4-2. Connector definition:

Pin No.	Symbol	Description
1	VLCD	Power Supply +12.0V
2	VLCD	Power Supply +12.0V
3	VLCD	Power Supply +12.0V
4	VLCD	Power Supply +12.0V
5	GND	Ground
6	GND	Ground
7	GND	Ground
8	GND	Ground
9	LVDS Select	'H' =JEIDA , 'L' or NC = VESA
10	NC	'No Connection'
11	GND	Ground
12	RA-	LVDS Receiver Signal(-)
13	RA+	LVDS Receiver Signal(+)
14	GND	Ground
15	RB-	LVDS Receiver Signal(-)
16	RB+	LVDS Receiver Signal(+)
17	GND	Ground
18	RC-	LVDS Receiver Signal(-)
19	RC+	LVDS Receiver Signal(+)
20	GND	Ground
21	RCLK-	LVDS Receiver Clock Signal(-)
22	RCLK+	LVDS Receiver Clock Signal(+)
23	GND	Ground
24	RD-	LVDS Receiver Signal(-)
25	RD+	LVDS Receiver Signal(+)
26	GND	Ground
27	NC	'No Connection'
28	NC	'No Connection'
29	GND	Ground
30	GND	Ground

Chapter 5. Installation Instructions

5-1 External Equipment Connections

Accessories

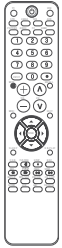

Remote control

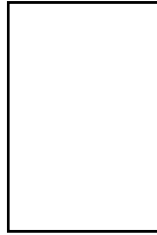

Owner's manual

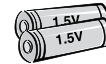

Alkaline battery (AAA) x2

Antenna Connection

Over-the-air TV reception quality will depend on your antenna type, antenna location and antenna positioning.

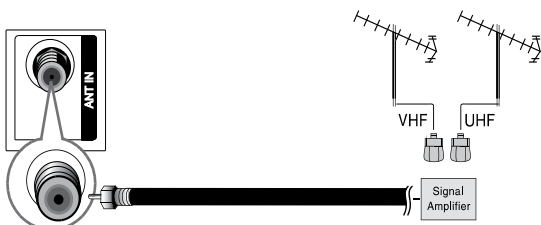
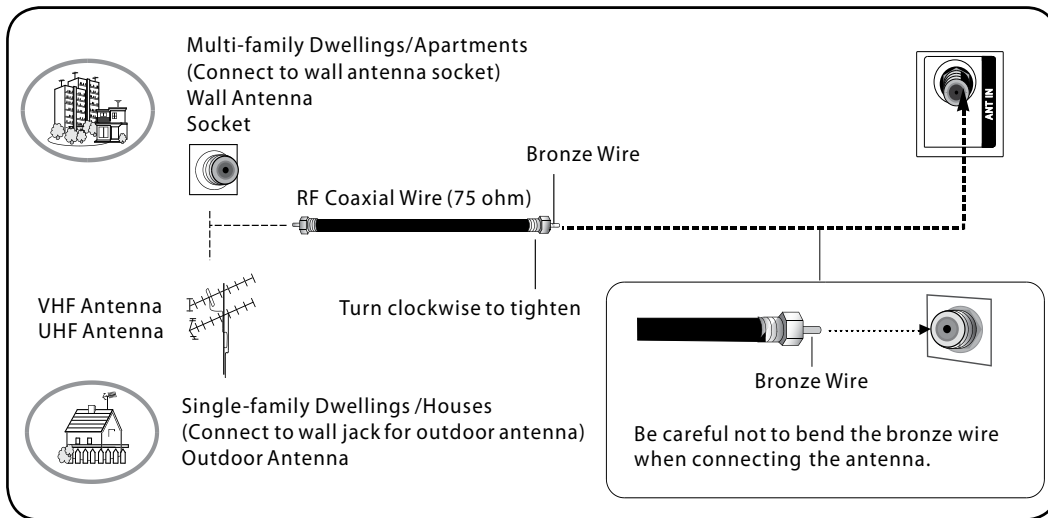

- To improve the picture quality in a poor signal area, please purchase a signal amplifier and install properly.
- If the antenna needs to be split for two TV's, install a "2-Way Signal Splitter" in the connections.
- To install the antenna properly please contact a professional in your area.

Choose Your Connection

There are several ways to connect your television, depending on the components you want to connect and the quality of the signal you want to achieve. The following are examples of some different ways to connect your TV with different input sources.

Connecting a VCR

To avoid picture noise (interference), leave an adequate distance between the VCR and TV.

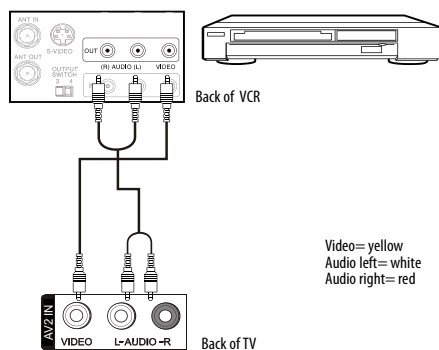

Connection Option 1

Set VCR output switch to channel 3 or 4 and then turn the TV to the same channel number.

Connection Option 2

- 1** Connect the audio and video cables from the VCR's output jacks to the TV input jacks, as shown in the figure. When connecting the TV to VCR, match the jack colors (Video = yellow, Audio Left = white, and Audio Right = red). If you connect a S-VIDEO output from VCR to the S-VIDEO input, the picture quality is improved; compared to connecting a regular VCR to the Video input.
- 2** Insert a video tape into the VCR and press **PLAY** on the VCR. (Refer to the VCR owner's manual.)
- 3** Select the input source with using the **INPUT** button on the remote control, and then press **▲ / ▼** button to select the source, press **ENTER** button to confirm.

External A V Source Setup

How to connect

- Connect the audio and video cables from the external equipment's output jacks to the TV input jacks, as shown in the figure.
- When connecting the TV to external equipment, match the jack colors (Video = yellow, Audio Left = white, and Audio Right = red).

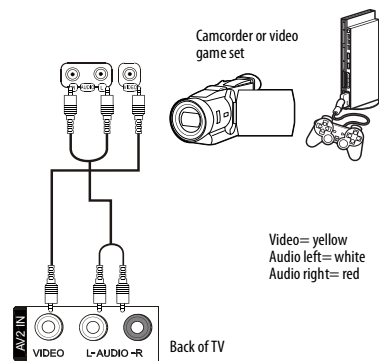

How to use

- 1** Select the input source with using the **INPUT** button on the remote control.
- 2** Press **▲ / ▼** button to select the desired source.
- 3** Press **ENTER** button to confirm.
- 4** Operate the corresponding external equipment.

Component Setup

How to connect

Connect the DVD video outputs (COMPONENT) to the Y Pb Pr jacks on the TV and connect the DVD audio outputs to the YPbPr Audio IN jacks on the TV, as shown in the figure.

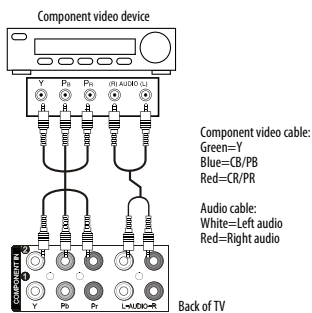

COMPONENT, VGA or HDMI source.

Signal	COMPONENT	HDMI
480 i	Yes	Yes
480 p	Yes	Yes
720 p	Yes	Yes
1080 i	Yes	Yes
1080 p	Yes	Yes

How to use

- 1 Turn on the DVD player, insert a DVD disc.
- 2 Use **INPUT** button on the remote control to select component mode.

Component Input ports

To get better picture quality, connect a DVD player to the component input ports as shown below.

Component ports on the TV	Y	Pb	Pr
Video output ports on DVD player	Y	Pb	Pr
	Y	B-Y	R-Y
	Y	Cb	Cr
	Y	Pb	Pr

Connecting a DTV (digital TV)

This TV can receive Digital Over-the-air/Cable signals without an external digital set-top box. However, if you do receive Digital signals from a digital set-top box or other digital external device, refer to the figure as shown below. This TV supports HDCP (High-bandwidth Digital Contents Protection) protocol for Digital Contents (480 p,720 p,1080 i).

How to connect

- Use the TV's COMPONENT, VGA or HDMI jack for video connections, depending on your set-top box connector. Then, make the corresponding audio connections.

How to use

- 1 Turn on the digital set-top box. (Refer to the owner's manual for the digital set-top box.)
- 2 Use **INPUT** on the remote control to select

Connecting a digital audio output

Send the TV's audio to external audio equipment (stereo system) via the Digital Audio Output (Optical) port.

How to connect

- 1 Connect one end of an optical cable to the TV Digital Audio (Optical) Output port.
- 2 Connect the other end of the optical cable to the digital audio (optical) input on the audio equipment. See the external audio equipment instruction manual for operation.

Note

- When connecting with external audio equipments, such as amplifiers or speakers, please turn the TV speakers off.

Caution:

- Do not look into the optical output port. Looking at the laser beam may damage your vision.

Connecting a computer

How to connect

- 1 To get the best picture quality, adjust the VGA graphics card to 1024×768.
- 2 Use the TV's VGA or DVI (Digital Visual Interface) Audio IN port for audio connections, depending on your computer connector.
 - If the graphic card on the computer does not output analog and digital RGB simultaneously,

connect only one of either VGA IN or HDMI IN to display the VGA on the TV.

- If the graphic card on the computer does output analog and digital RGB simultaneously, set the TV to either VGA or HDMI; (the other mode is set to Plug and Play automatically by the TV.)

- 3 Then, make the corresponding audio connection. If using a sound card, adjust the VGA sound as required.

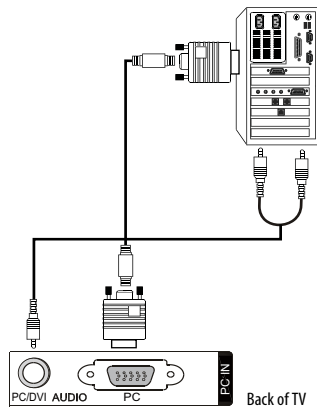

How to use

- 1 Turn on the computer and the TV.
- 2 Use INPUT on the remote control to select VGA or HDMI source.
- 3 Check the image on your TV. There may be noise associated with the resolution, vertical pattern, contrast or brightness in VGA mode. If noise is present, change the VGA mode to another resolution, change the refresh rate to another rate or adjust the brightness and contrast on the menu until the picture is clear. If the refresh rate of the VGA graphic card can not be changed, change the VGA graphic card or consult the manufacturer of the VGA graphic card.

Note

- ❑ Use a DVI cable.
- ❑ Avoid keeping a fixed image on the TV's screen for a long period of time. The fixed image may become permanently imprinted on the screen.
- ❑ The synchronization input form for Horizontal and Vertical frequencies is separate.

❖ Resolution

Mode	Resolution	Frame frequency (Hz)
VGA	640×480	60 Hz
SVGA	800×600	60 Hz
		75 Hz
XGA	1024×768	60 Hz
		75 Hz

HDMI and DVI input

When the source device (Blu-Ray player, DVD player or Set Top Box) supports HDMI

How To Connect

- 1 Connect the source device to HDMI port of this TV with an HDMI cable (not supplied with this product).
- 2 No separated audio connection is necessary.

How To Use

- Turn on the TV.
- Turn on the Blu-Ray player, DVD player or Set Top Box.
- Select HDMI input source on the TV using the INPUT button or HDMI button on the remote control.

When the source device (DVD player or Set Top Box) supports DVI

How To Connect

- 1 Connect the source device to HDMI port of this TV with a HDMI-to-DVI cable (not supplied with this product).
- 2 A separated audio connection is necessary.
- 3 If the source device has an analog audio output connector, connect the source device audio output to DVI Audio In port located on the left side of HDMI port.

How To Use

- If the source device supports Auto DVI function, the output resolution of the source device will be

automatically set to 1280×720 p.

- If the source device does not support Auto DVI, you need to set the output resolution appropriately. To get the best picture quality, adjust the output resolution of the source device to 1280×720 p.
- Press the **INPUT** button to select HDMI input source in input source option of Select Main source menu.

- ❑ If you cause a static discharge when touching the unit and the unit fails to function, simply unplug the unit from the AC outlet and plug it back in. The unit should return to normal operation.

Connecting Headphones

You can connect a set of headphones to your set if you wish to watch a TV programme without disturbing the other people in the room.

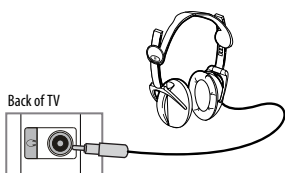

Plug a set of headphones into the 3.5 mm mini-jack socket on the side panel of the set.

Note

- ❑ Prolonged use of headphones at a high volume may damage your hearing.
- ❑ You will not receive sound from the speakers when you connect headphones to the system.

Power source

TO USE AC POWER SOURCE

- Use the AC polarized line cord provided for operation on AC. Insert the AC cord plug into a standard polarized AC outlet.

Note

- ❑ Never connect the AC line cord plug to other than the specified voltage. Use the attached power cord only.
- ❑ If the polarized AC cord does not fit into a non-polarized AC outlet, do not attempt to file or cut the blade. It is the user's responsibility to have an electrician replace the obsolete outlet.

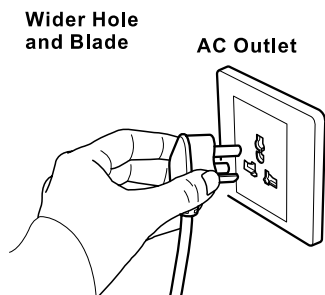

Polarized AC Cord Plug

Removing the table stand and installing a wall mount bracket

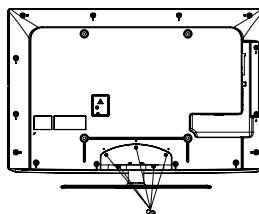

Remove 5 × M4 screws securing the stand to the TV, then remove the stand.

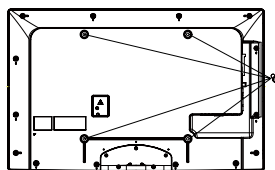

Use 4 × M8 screws to secure the wall bracket (not supplied) to the back of your TV.

Chapter 6. Operation Instructions

6-1. Front Panel Controls

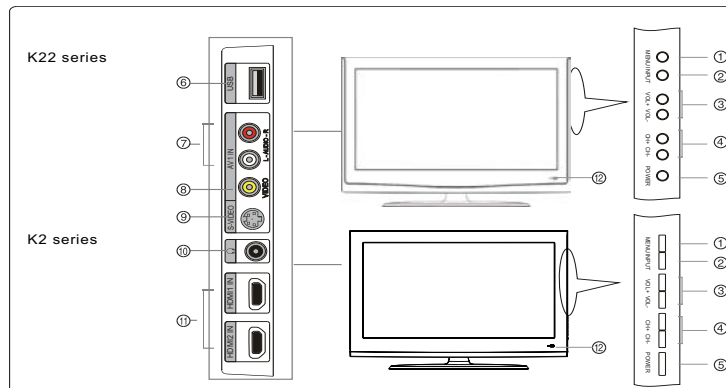

①	MENU	Menu display. Press to access the on-screen menu display.
②	INPUT	Press to access the input source mode. Press repeatedly to change the source to the one you want to watch. In the MENU screen, the INPUT button serves as the ENTER button.
③	VOL +/-	Press to adjust the volume. In the MENU screen, these buttons serve as left/right buttons.
④	CH +/-	Press to scan through channels. To scan quickly through channels, press and hold down either +/- . In the MENU screen, these buttons serve as up/down buttons.
⑤	POWER	Press to turn on and off the TV.
⑥	USB input	Connect a USB flash drive to view MPEG2 videos, JPEG images or listen to MP3 songs.

⑦	Av2 AUDIO IN	Connect the audio L/R cables from the video signal source to these jacks.
⑧	AV2 VIDEO IN	Connects the composite video cable from an external signal source to this jack.
⑨	S-VIDEO	Connects the S-VIDEO cables from an external signal source to this jack.
⑩	Headphone jack	Headphone audio output terminal.
⑪	HDMI In	Connect a HDMI device to receive digital audio and uncompressed digital video.
⑫	Remote Sensor	Receives IR signals from the remote control. Do not put anything near the sensor, which may block the remote control signal.

6-2. Back Panel Controls

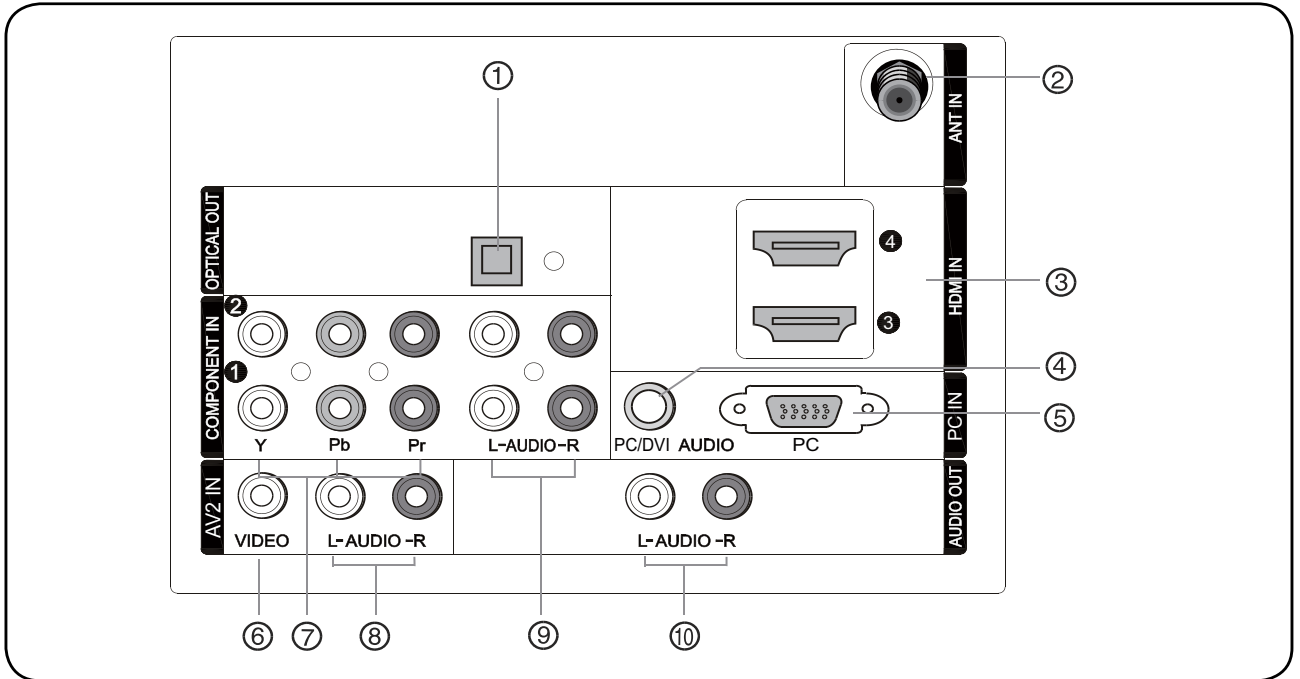

- | | | |
|---|-----------------------------|---|
| ① | Digital Audio Output | Connect various types of digital audio equipment.
Note
□ In standby mode, these ports will not work. |
| ② | Antenna Input | Connect cable or antenna signals to the TV, either directly or through your cable box. |
| ③ | HDMI In | Connect a HDMI device to receive digital audio and uncompressed digital video. |
| ④ | PC Audio In | Connect the audio L/R cables from a computer to this jack. |
| ⑤ | PC Video In | Connect a video cable from a computer to this jack. |

- | | | |
|---|---------------------------|---|
| ⑥ | VIDEO In | Connects the video signal from a video device. |
| ⑦ | Component Video In | Connect a component video device to these jacks. |
| ⑧ | AUDIO In | Connect the audio L/R cables from the video signal source to these jacks. |
| ⑨ | COMPONENT AUDIO In | Connect the audio L/R cables from the component video signal source to these jacks. |
| ⑩ | AUDIO Out | Connect the audio L/R cables to your audio equipment. |

6-3 Setting Up Your Remote Control

After being setting up properly, your remote control can operate in six different modes: TV, VCR, CABLE, DVD, SETBOX or AUDIO.

Pressing the corresponding button on the remote control allows you to switch between these modes, and control whichever piece of equipment you choose.

Note:

The remote control might not be compatible with all DVD Players, VCRs and Cable boxes.

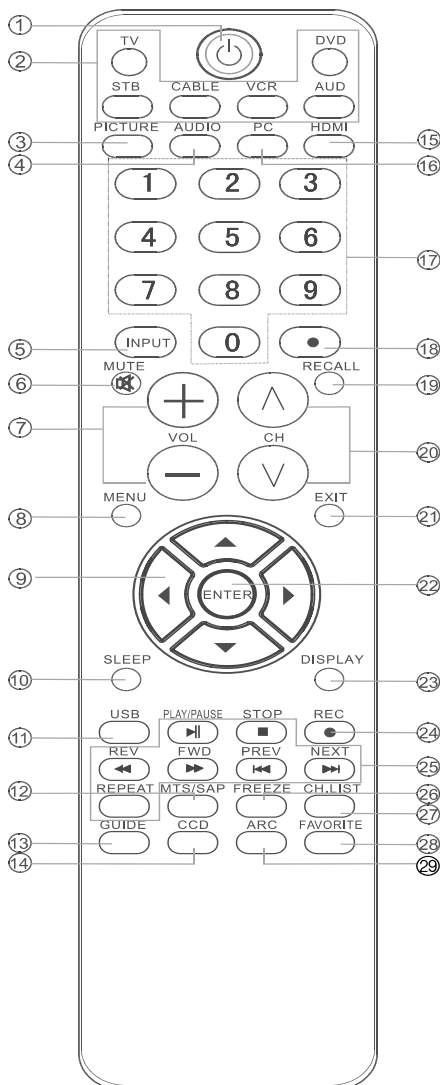

①	POWER	Press to turn on and off the TV.
②	TV DVD SETBOX CABLE VCR AUDIO	To select one of the system modes in which the remote control can be used.
③	PICTURE	Press repeatedly to cycle through the available picture modes.
④	AUDIO	Press to cycle through different sound settings.
⑤	INPUT	Show the input source.
⑥	MUTE	Switches the video sound on or off.
⑦	VOLUME UP/DOWN	Press to adjust the volume.
⑧	MENU	Press to open the on-screen menu.
⑨	THUMBSTICK (Up/Down/Left/Right)	Allows you to navigate the on-screen menus and adjust the system settings to your preference.
⑩	SLEEP button	Press to display the sleep timer option.
⑪	USB	Press to switch input source to USB in.
⑫	MTS/SAP	Selects MTS sound: Mono, Stereo, and SAP in Analog mode. Change the audio language in DTV mode.
⑬	GUIDE	Press to display the guide when you are watching analog or digital channels.
⑭	CCD(closed caption)	Select a closed caption.
⑮	HDMI	Press to select a device connected to the HDMI input
⑯	PC	Press to select the computer connected to the VGA input
⑰	Number buttons	Press to change a channel.
⑱	• button	Press to select digital channels. For example, to enter "54-3", press "54", "•" and "3".
⑲	● RECALL	Press to jump back and forth between two channels.
⑳	CHANNEL UP/DOWN	Press to scan through channels. To scan quickly between the last two channels, press and hold down either +/-.
㉑	EXIT	Clears all on-screen displays and returns to TV viewing from any menu.
㉒	ENTER	Accesses the highlighted item in the on-screen menu.
㉓	DISPLAY	Press to display the TV status information on the top of the TV screen.
㉔	REC	Press to start the recording process
㉕	USB Functions	Control the USB System. ◀◀/▶▶ Rewind / Fast Backward /Forward ■ Stop ▶▶ Play/Pause REPEAT
㉖	FREEZE	Press once to display a frozen image of the current program, but audio continues. Press again to return to the program.
㉗	CH.LIST	Open the channel list in TV.
㉘	FAV.LIST	Press to open the favorite channel list in TV.
㉙	ARC(Aspect Ratio Control)	Press to change the aspect ratio.

Chapter 7. Electrical Parts

7-1. Block Diagram

~

MTK5305

TA5708

Speaker

Peripheral components

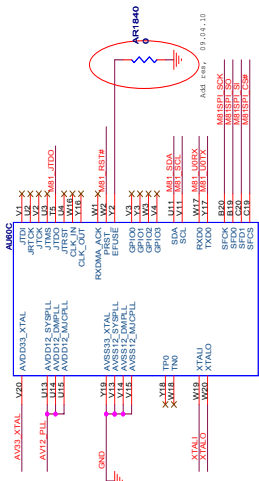

Core Power 1.0V
IO Power 3.3V

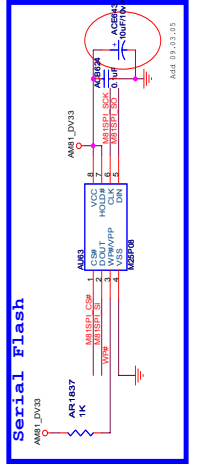
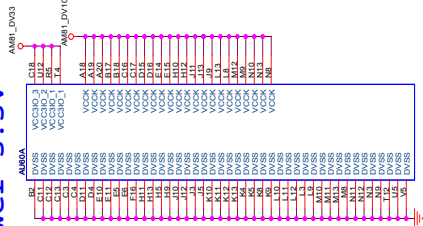

Trapping :
Default Low when no configuration external

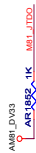

Pad_jtdo	Description
0	pad_jtdo tie 0 => dram boot
1	pad_jtdo tie 1 => flash boot

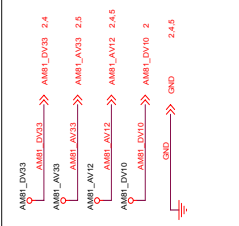
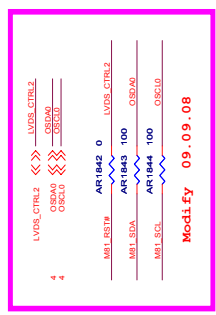
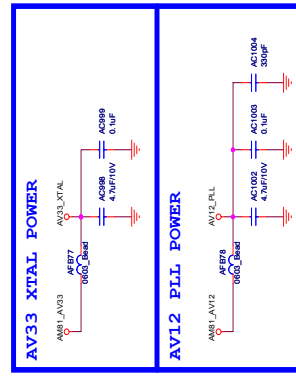
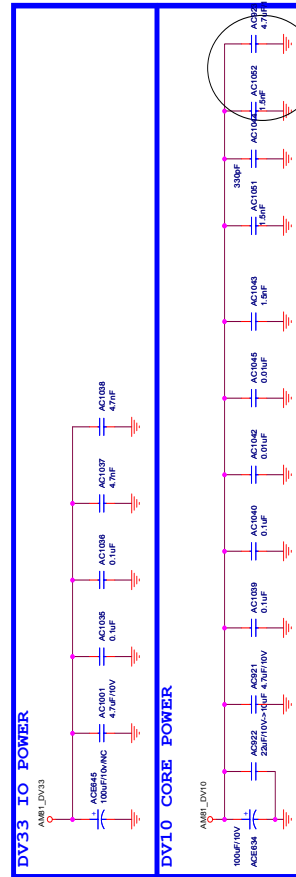
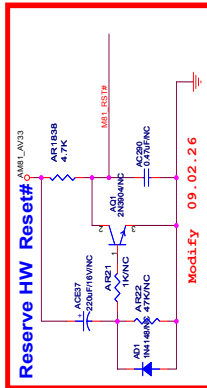
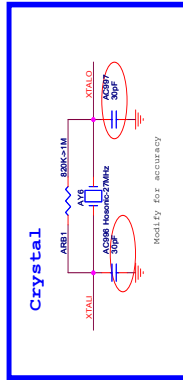
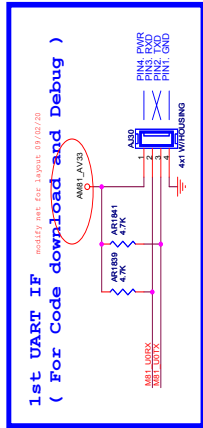

MediaTek Confidential

Rev	C	Docu	WTR281_DrvV1	Drawn	Mark
Date	05/07/2009	05/07/2009	05/07/2009	05/07/2009	05/07/2009

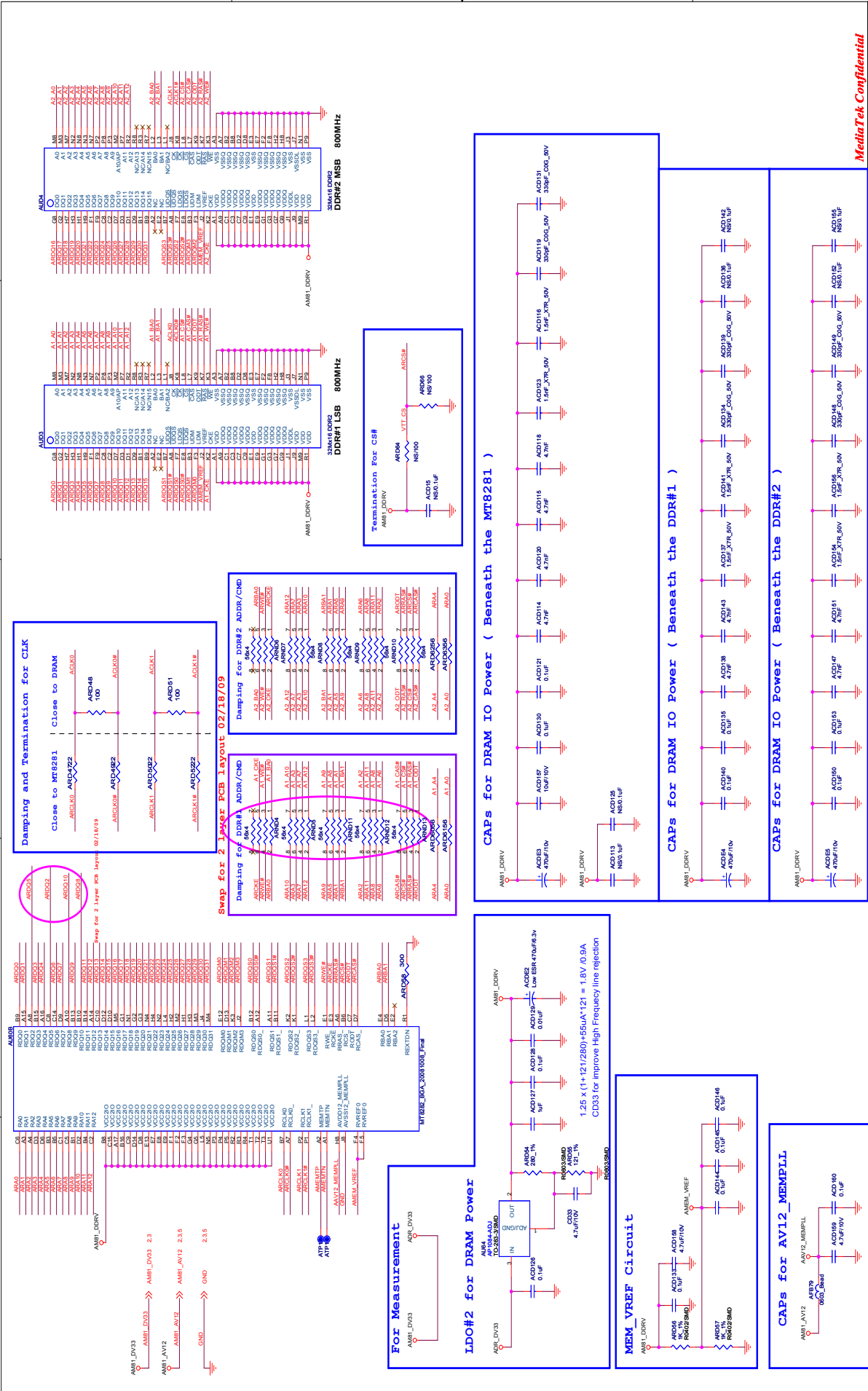

MediaTek Confidential



DPPE22 DRAM
WTRFEE_DrvV1

Rev: 1.0
Date: 05/01/2009

Rev: 1.0
Date: 05/01/2009

Rev: 1.0
Date: 05/01/2009

Rev: 1.0
Date: 05/01/2009

3,4,5,6,7,8,9,10,11,13,14	GND
1,17	11V
3,10,11,13,14	11ZV
1	LVDS0
1	LVDS1
1	LVDS2
3,4,5,6,7,8,9,10,11,13,14	AVS
1	AVS1
1	AVS2
3,4,5,6,7,8,9,10,11,13,14	LVDS_POWER_ON
4	LVDS_POWER_ON1
4	LVDS_POWER_ON2
4	LVDS_POWER_ON3
4	LVDS_POWER_ON4
4	LVDS_POWER_ON5
4	LVDS_POWER_ON6
4	LVDS_POWER_ON7
4	LVDS_POWER_ON8
4	LVDS_POWER_ON9
4	LVDS_POWER_ON10
4	LVDS_POWER_ON11
4	LVDS_POWER_ON12
4	LVDS_POWER_ON13
4	LVDS_POWER_ON14
4	LVDS_POWER_ON15
4	LVDS_POWER_ON16
4	LVDS_POWER_ON17
4	LVDS_POWER_ON18
4	LVDS_POWER_ON19
4	LVDS_POWER_ON20
4	LVDS_POWER_ON21
4	LVDS_POWER_ON22
4	LVDS_POWER_ON23
4	LVDS_POWER_ON24
4	LVDS_POWER_ON25
4	LVDS_POWER_ON26
4	LVDS_POWER_ON27
4	LVDS_POWER_ON28
4	LVDS_POWER_ON29
4	LVDS_POWER_ON30
4	LVDS_POWER_ON31
4	LVDS_POWER_ON32
4	LVDS_POWER_ON33
4	LVDS_POWER_ON34
4	LVDS_POWER_ON35
4	LVDS_POWER_ON36
4	LVDS_POWER_ON37
4	LVDS_POWER_ON38
4	LVDS_POWER_ON39
4	LVDS_POWER_ON40
4	LVDS_POWER_ON41
4	LVDS_POWER_ON42
4	LVDS_POWER_ON43
4	LVDS_POWER_ON44
4	LVDS_POWER_ON45
4	LVDS_POWER_ON46
4	LVDS_POWER_ON47
4	LVDS_POWER_ON48
4	LVDS_POWER_ON49
4	LVDS_POWER_ON50

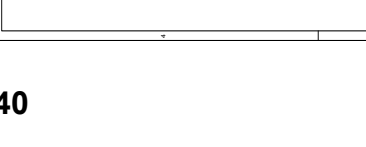
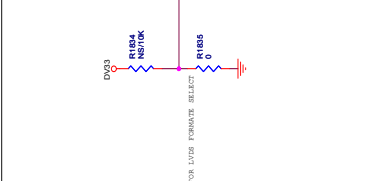
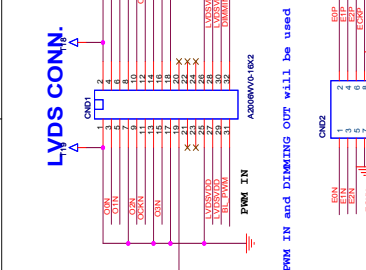
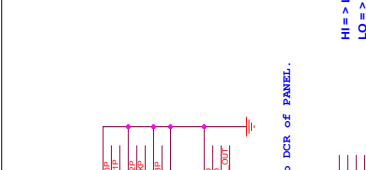
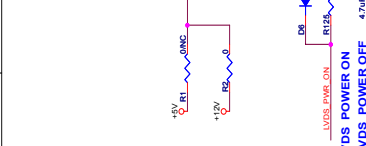
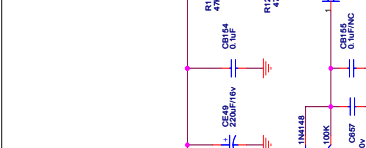
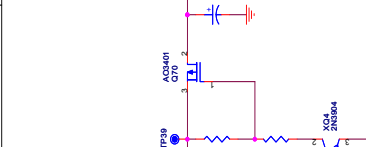
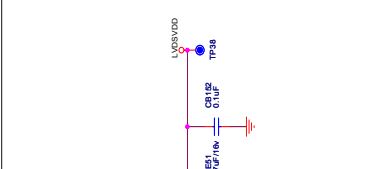
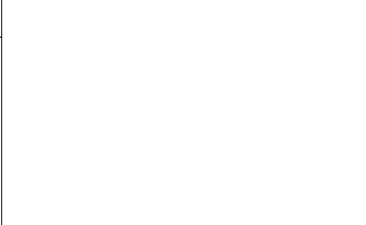

FRM IN and DIMMING OUT will be used to DCR of PANEL.

HI => LVDS POWER ON
LO => LVDS POWER OFF

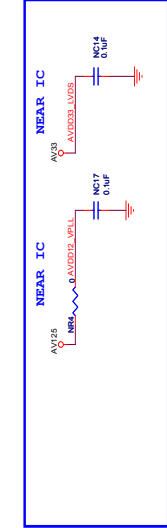
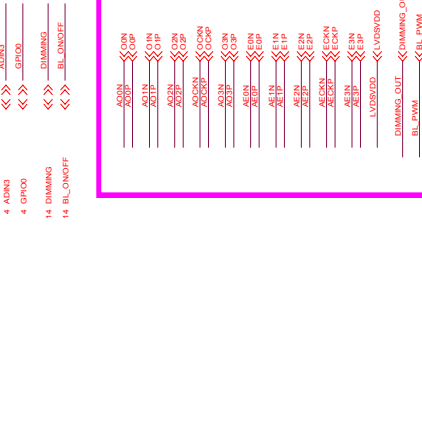
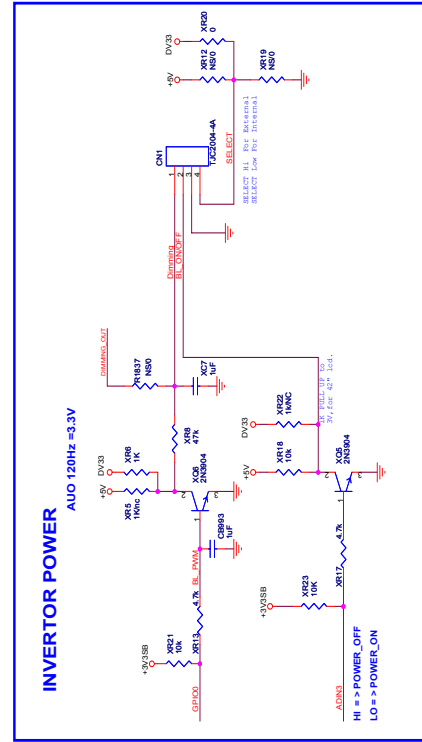

MediaTek Confidential

MediaTek Inc.
www.mediatek.com
LVDS/BACKLIGHT
Rev: 01
Date: 2009.12.03

- 344A7A801112.14 GND
- 310.1112.14 +12V
- 3488.9.12 AV33
- IF AGCT
- TUNER_CLK
- TUNER_DATA
- VP_ATV
- AVDD33_SF
- AVDD33_SFPA
- AVDD33_SFPA

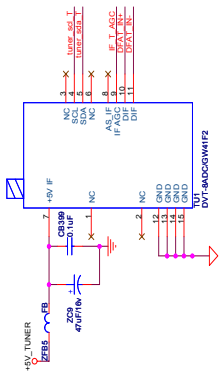
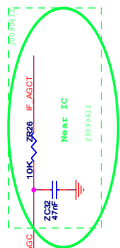
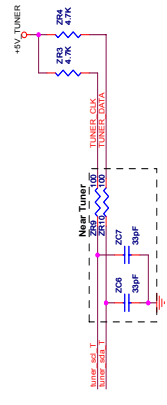
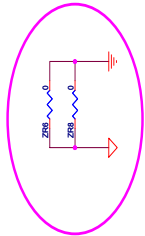

Near Tuner Near MT538X

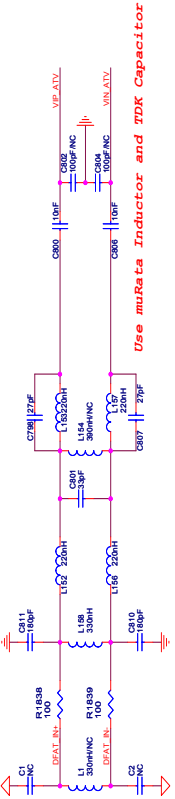

Use Murata Inductor and TDK Capacitor

muRa ta : IQM18NRR22K00 和 IQM18NRR39K00

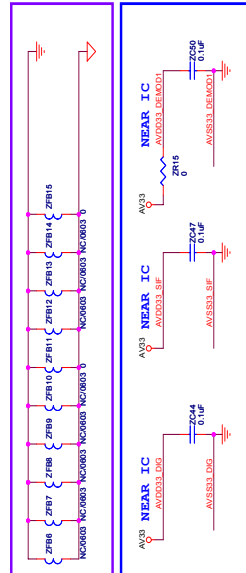
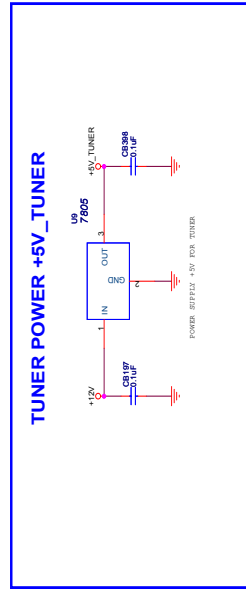

MediaTek Confidential
MediaTek Inc. 1000 W. W. Way, Sunnyvale, CA 94085, USA
www.mediatek.com

TUNER	
Doc ID: 01000000	MT5380A PIV1
DATE: 05/07, NOVEMBER 27, 2009	Version: 1.0
Drawn: [Blank]	Checked: [Blank]
15	16

3.4,4,7,8,9,10,11,12,13	GND	<<>	GND
3,5,9	+5VSB	<<>	+5VSB
3,5,9	+3VSB	<<>	+3VSB
3,5,9,11,12,13	+12V	<<>	+12V
3,5,9,11,12,13	+4V	<<>	+4V
4	OPWRSSB	<<>	OPWRSSB
4,6	OPCTRL2	<<>	OPCTRL2
3,4	VCC	<<>	VCC
4	ADN4	<<>	ADN4
12	DIMMING	<<>	DIMMING
12	BL_ONOFF	<<>	BL_ONOFF
12	OPVMS	<<>	OPVMS

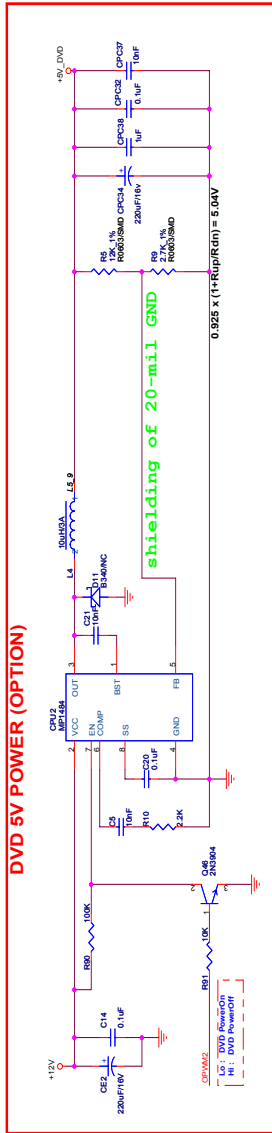
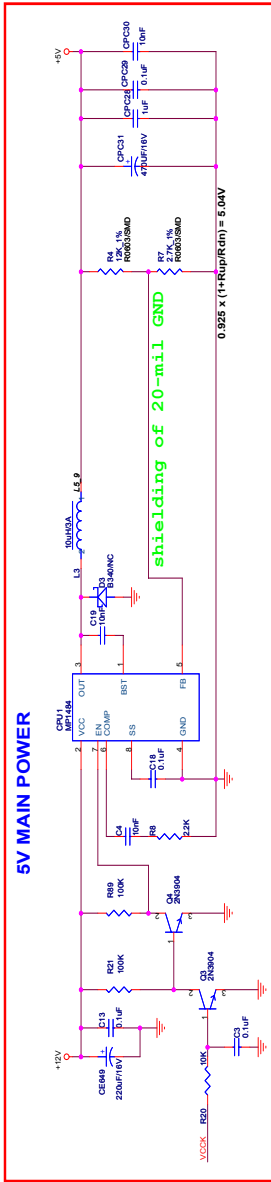
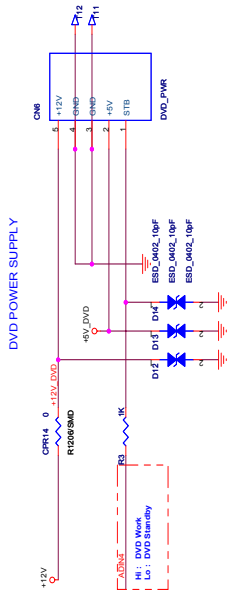
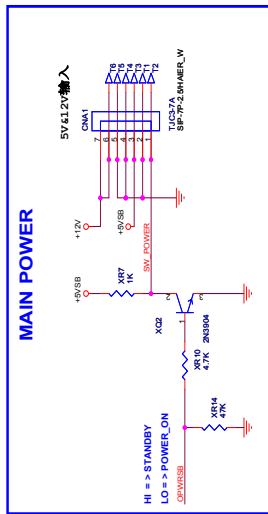

Mediatek Confidential

BACK LIGHT/MAIN POWER

WTR200A P.V1

DATE: 05/07/2009

DESIGN: 14

REV: VI

MediaTek Confidential
The DVDYPPr2's video input



without InnerDVD:
BR48/BR49 should be SMT ;74HC4052 will be NC.
with InnerDVD:
BR48/BR49 resistor will be NC; 74HC4052 will be SMT.

Inner DVD & I/R INPUT

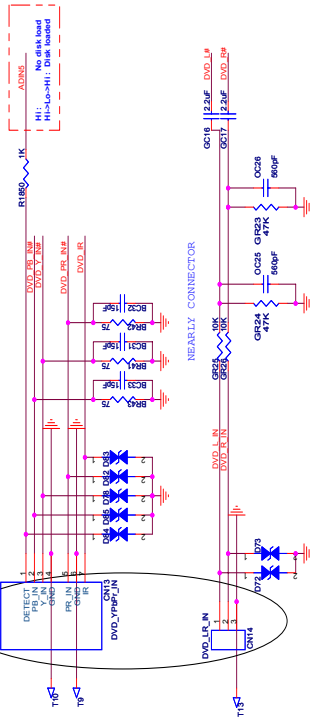

SV INPUT

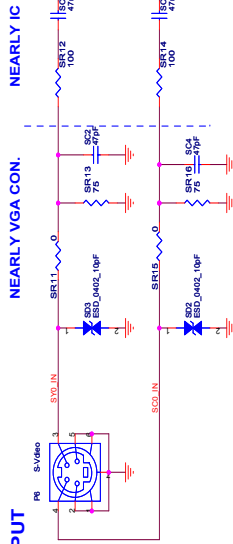

SV Audio Shares with AV2(Horizontal) which input to AIN0_L/R

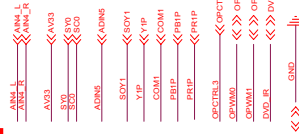

YPBR/RL#2 INPUT

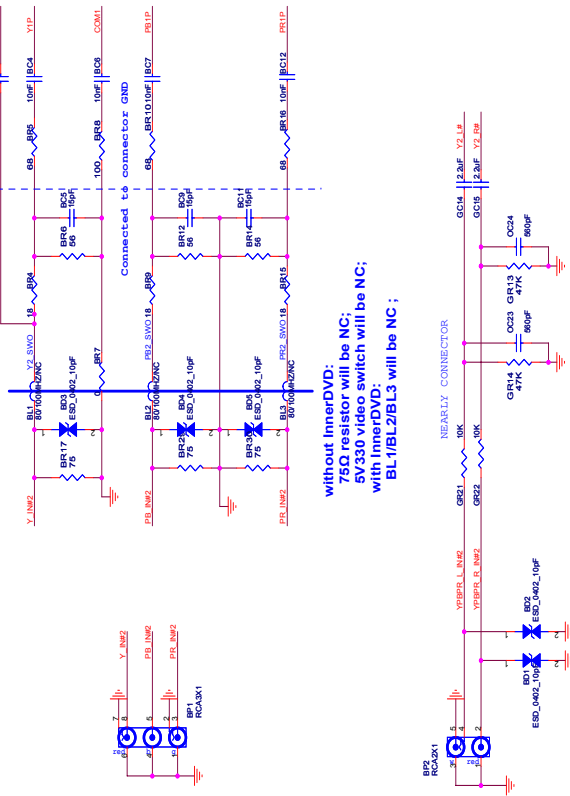

without InnerDVD:
75Ω resistor will be NC;
5V330 video switch will be NC;
with InnerDVD:
BL1/BL2/BL3 will be NC ;

YPBR2 & DVD VIDEO SWITCH

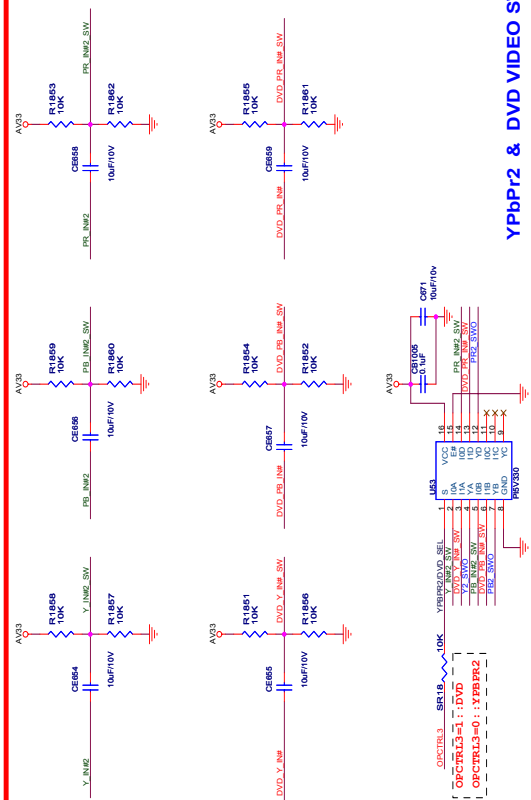

7-3 .Wiring Connection Diagram

Customer Model	HLC32K2
Service Model	HLC32K2a
Factory Model	LX32K3
Serial No.	DC1B80E0100
Job Order No.	HLC32K2091020
Country	America
Customer	HAC
Brand	Haier

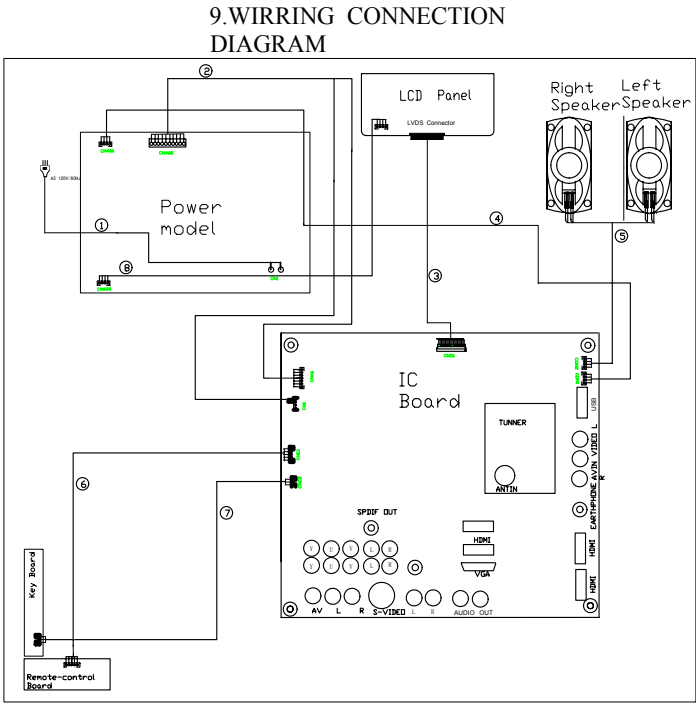

Connecting sketch

No.	serial No.	Name
①	0090403211	power cord
②	0090402341	Power supply wire
③	0090402070C	LVDS wire
④	0090403399E	Amplifier wire
⑤	0090400647	Speaker Wire
⑥	0090401643E	Remote control Wire
⑦	0090402750	keypad Wire
⑧	0090402340	Backlight Wire
Date	Sign	Approve

Arc (3)

Chapter 8. Measurements and Adjustments

8-1. Service Mode

8-1-1. How to enter into Service Mode

The way to the factory mode menu:

Step 1: Press Menu,

Step 2: Input 8893,

Step 3: Press "OK"

System will be into the factory mode menu when 3 steps above are done.

8-1-2. How to exit

If you want to exit this factory menu, please press the button "Exit" on the remote.

8-2. Measurements and Adjustments

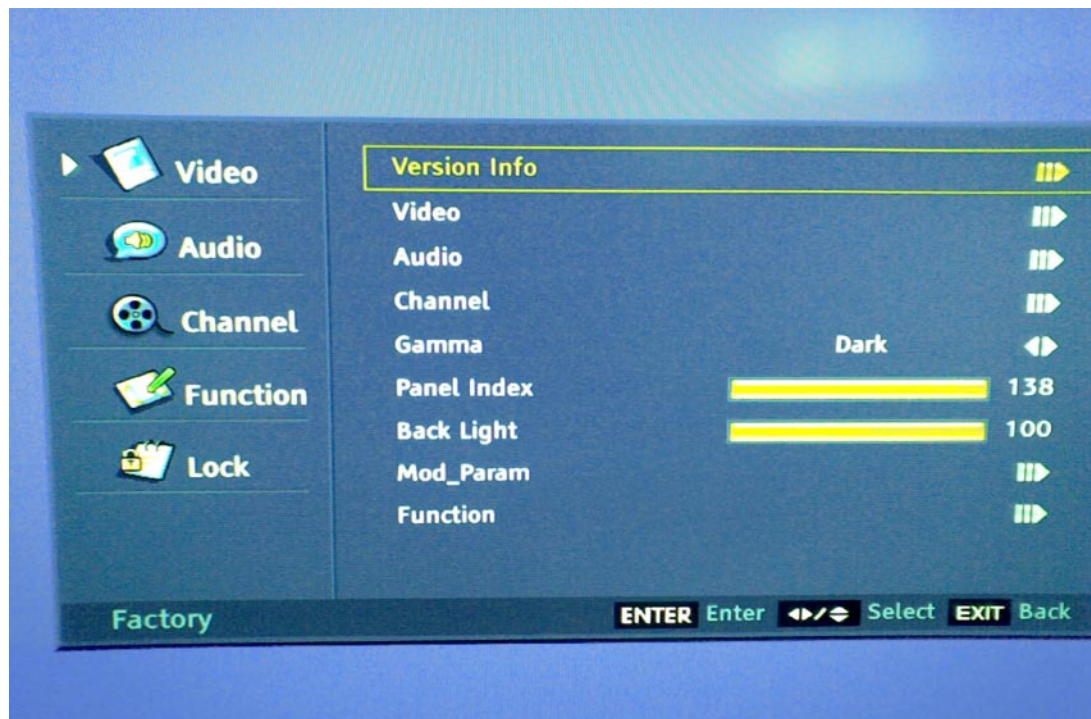

8-2-1. Version Info



8-2-2.Video



8-2-3. Audio

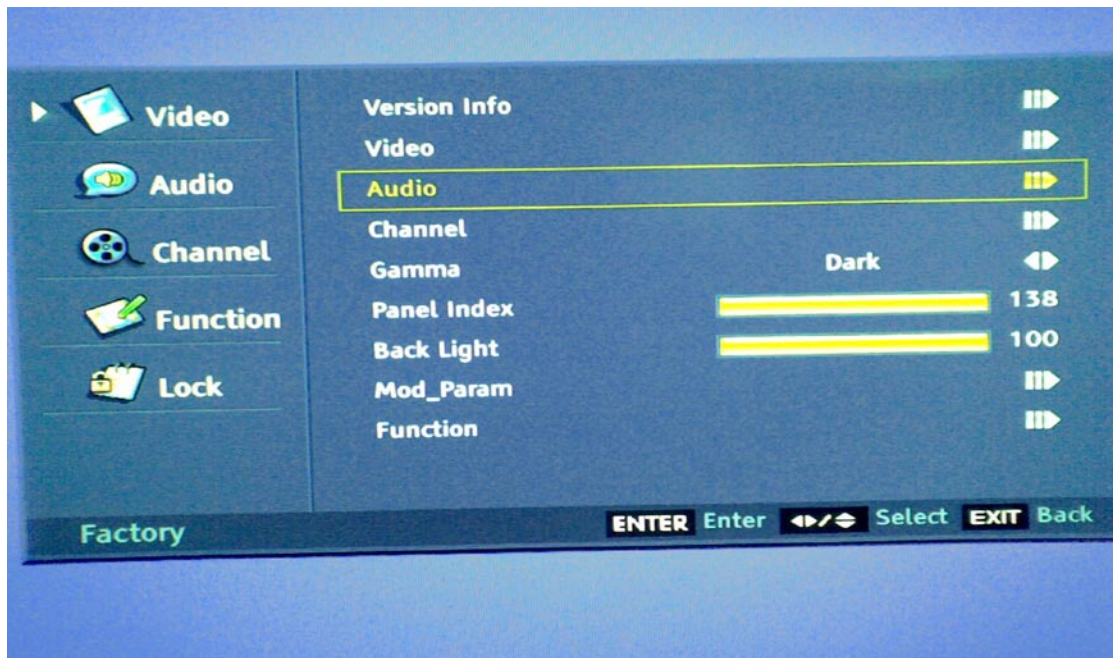

8-2-4. Picture Mode

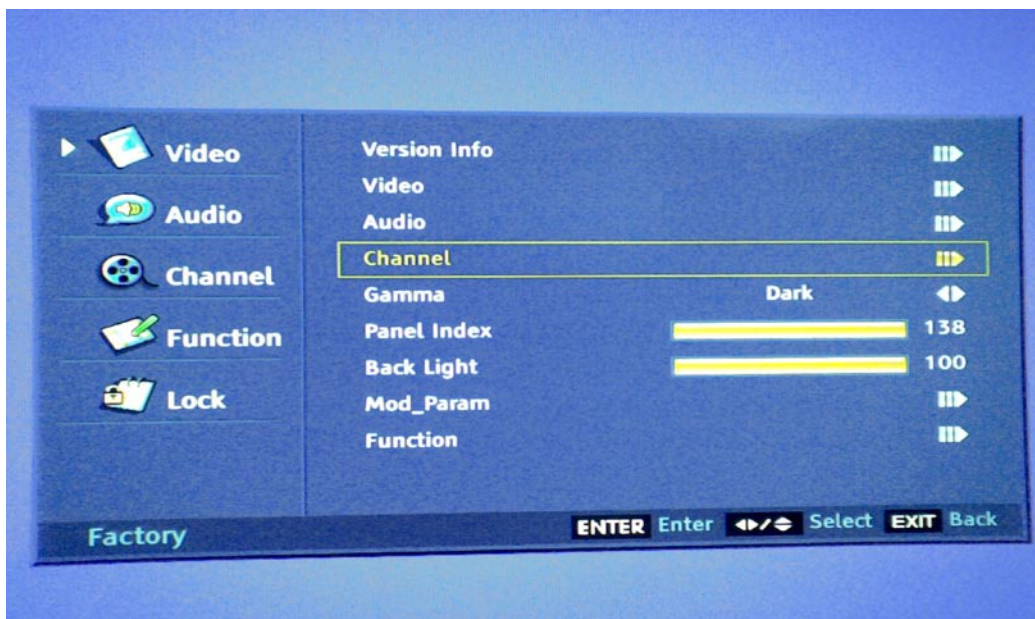

8-2-5. Gamma

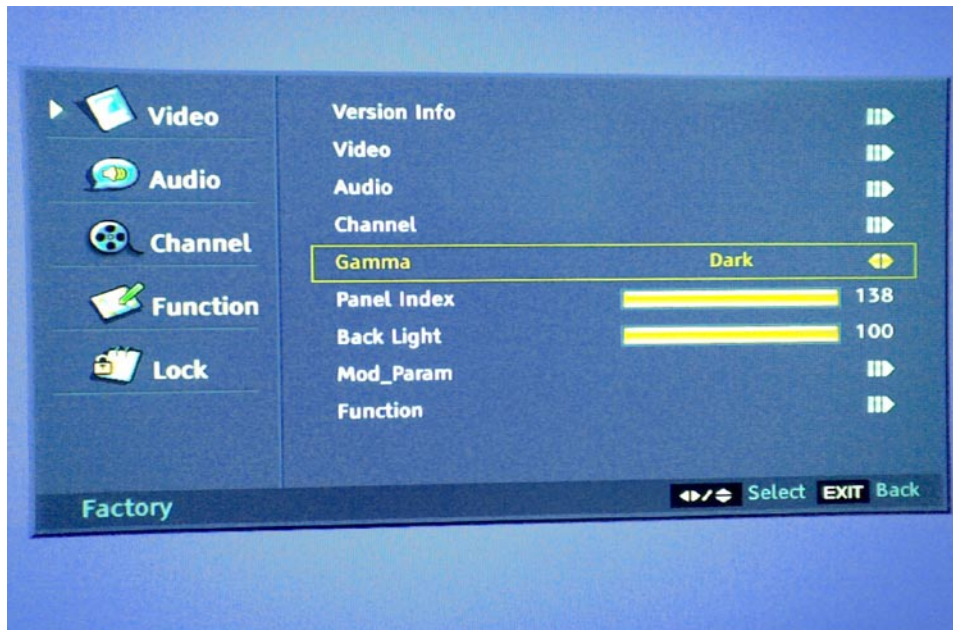

8-2-6. Panel Index

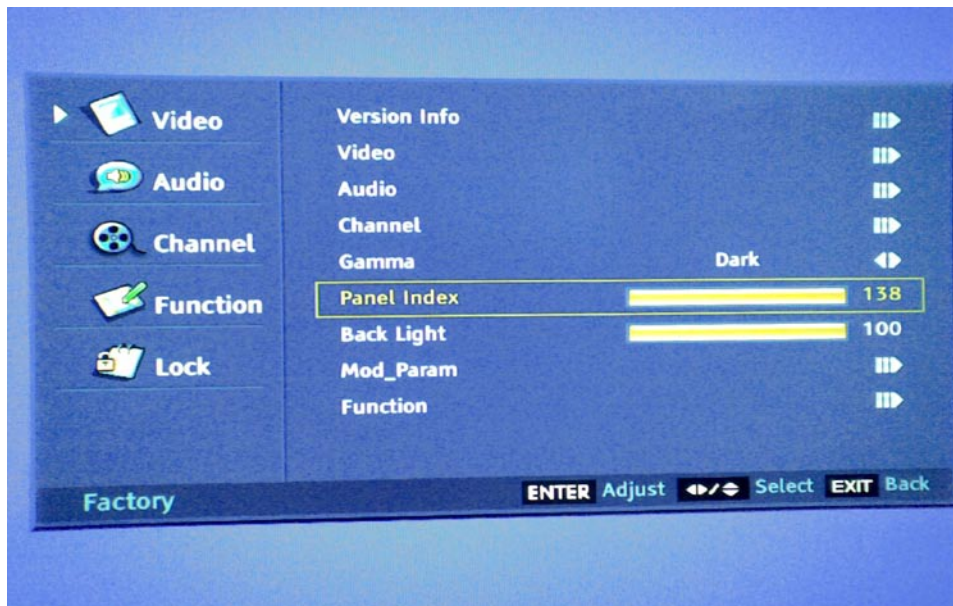

Tuner Diagnostic: Project debugging setting, used to inspect the audio function.

8-2-7. Back Light

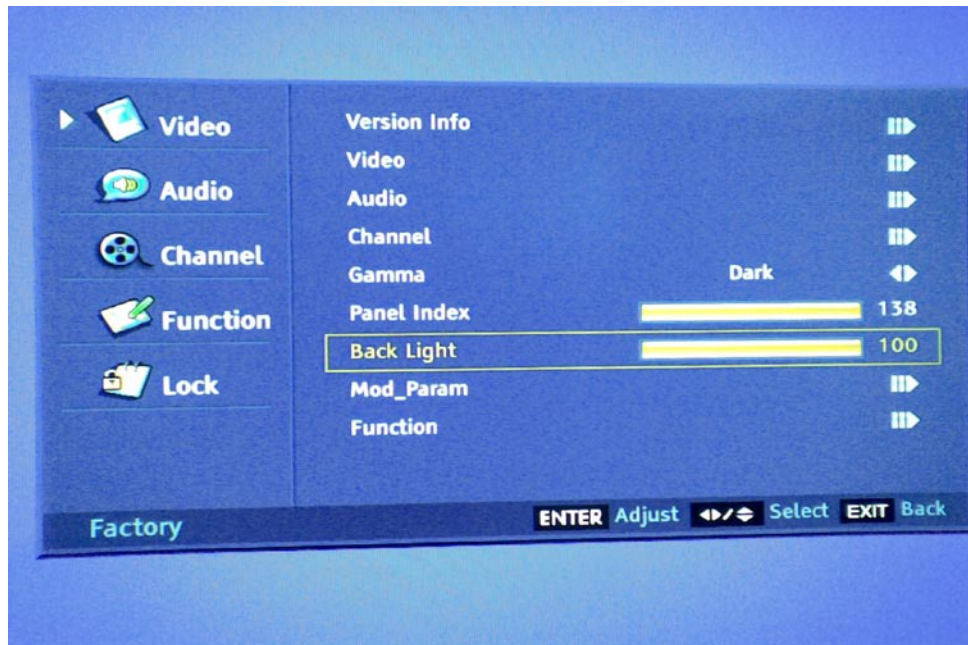

8-2-8. Mod_Param

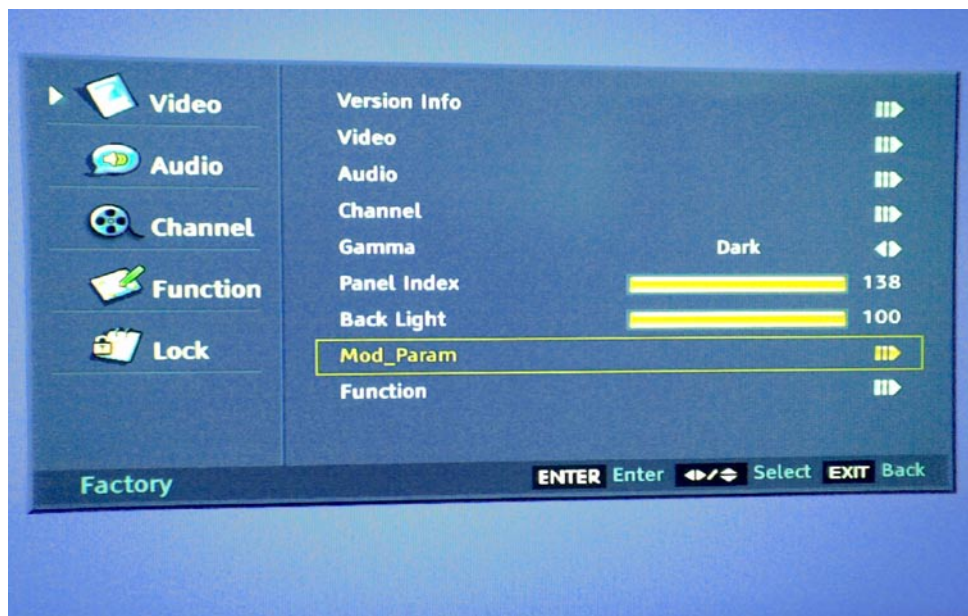

8-2-9. Function

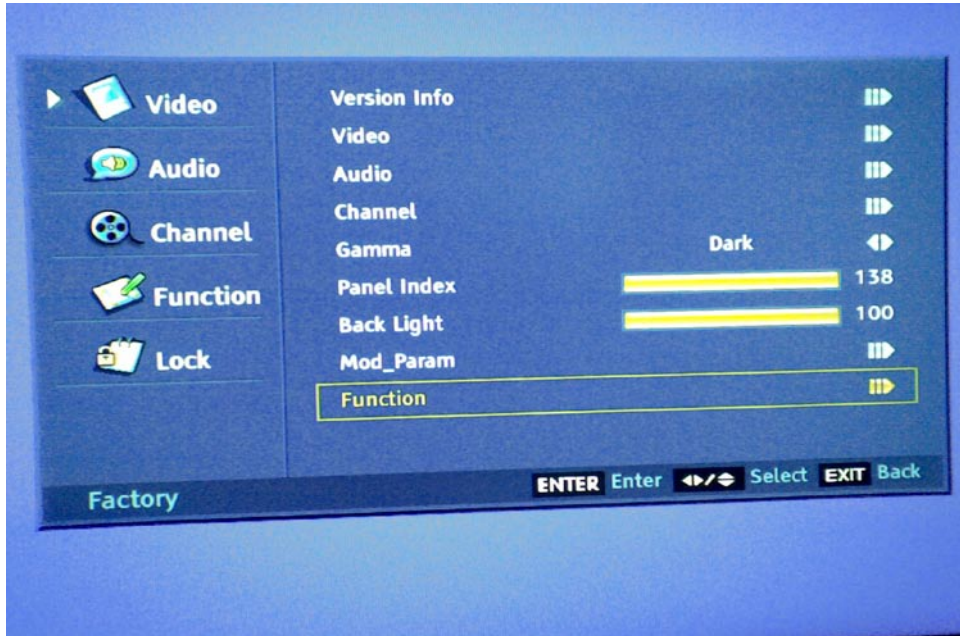

8-2-10. Reste to default

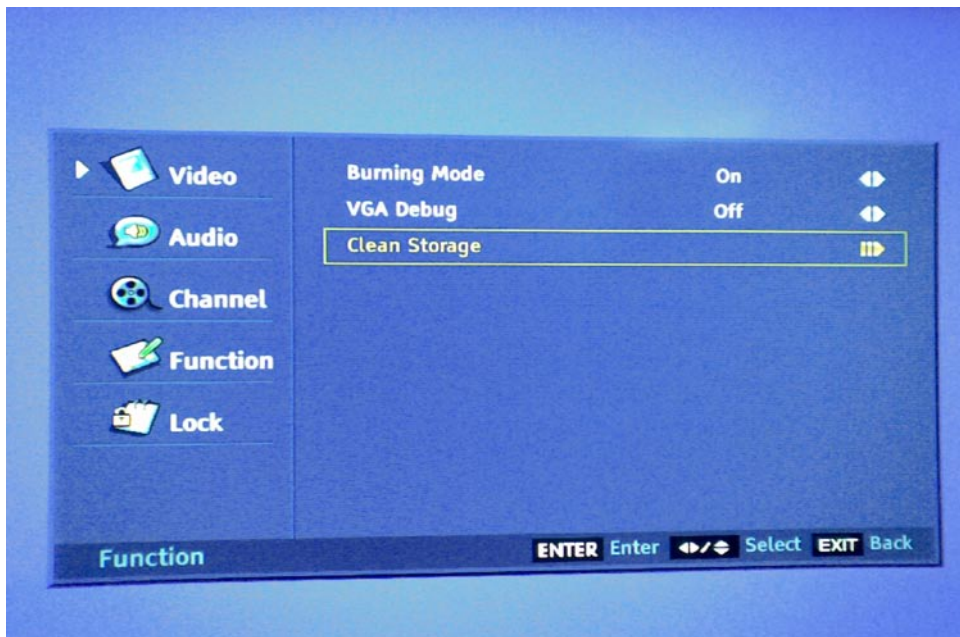



Chapter 9. Trouble shooting

9-1. Simple check

No picture/ No sound	Verify if the television is properly plugged Verify if the television is properly supplied power Verify if electricity is available.
Blank screen	Verify if correct signals are input Press INPUT button to change signal input to TV input Restart the television if power supply is interrupted
No sound	Press Mute button and verify if Mute mode is set. Switch to other channel and verify if the same problem happens. Press VOL+ button to see if the problem can be solved.
Poor sound	Verify if sound system is correct. Refer to some chapter for adjust.
No picture in some channel	Verify if correct channel is selected. Adjust the antenna. Make adjustments by Fine Tune and MANUAL Scan.
No color for some channel program (black and white)	Verify if the same problem exists in other channels. check out of picture and sound system. Refer to relative instructions in the Manual for color adjust.
Spots with some or all pictures	Verify if the antenna is correctly connected. Verify if the antenna is in good condition. Make fine adjustment of channel.
Horizontal/ vertical bars or picture shaking	Check for local interference such as an electrical appliance or power tool.
Television out of control	Disconnect the television from power supply and 10 seconds later, connect the television to the power supply. If the problem still exists, contact authorized after-sales service for technical assistance.

9-2. Power Supply Board Failure Check.

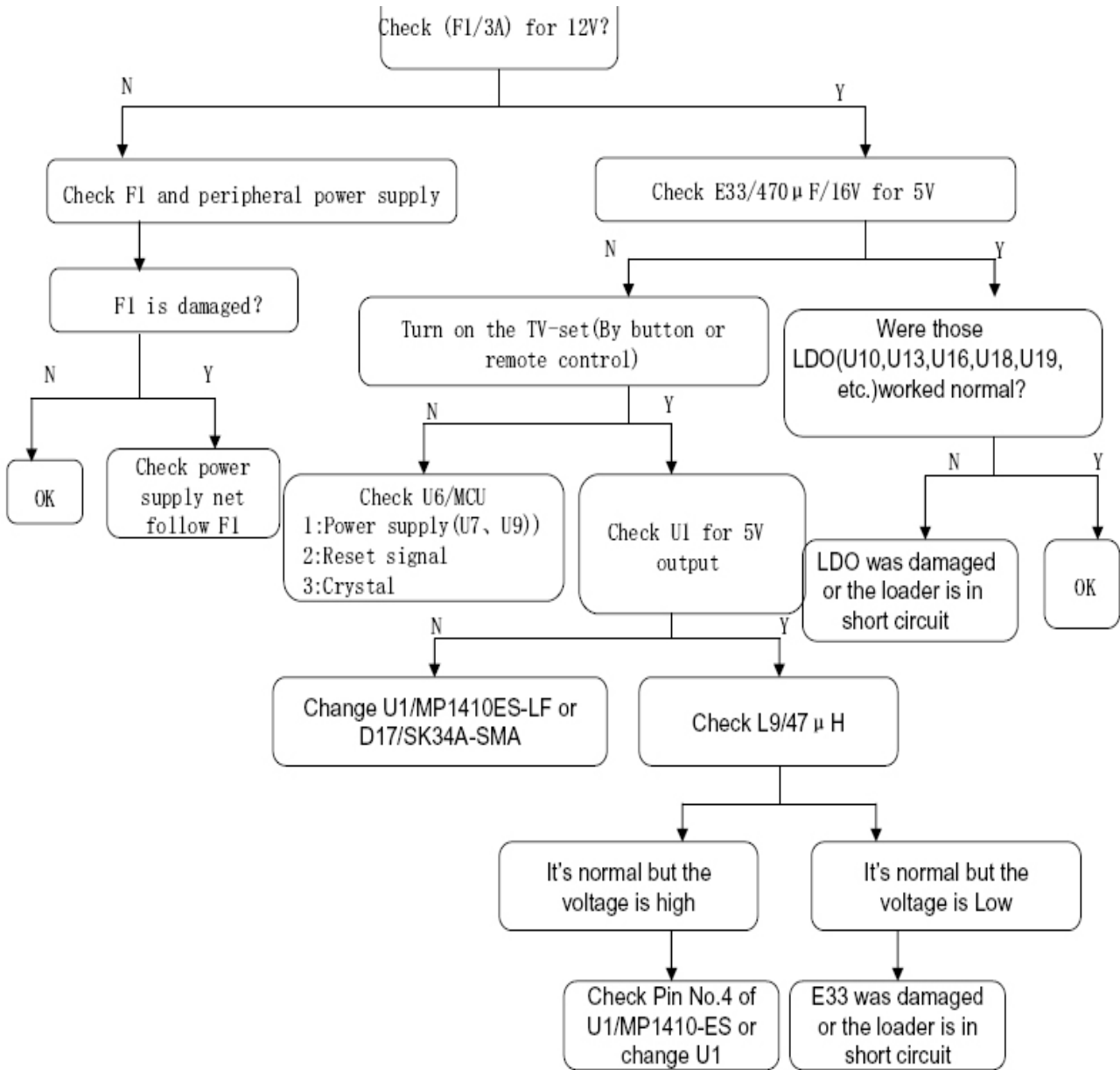



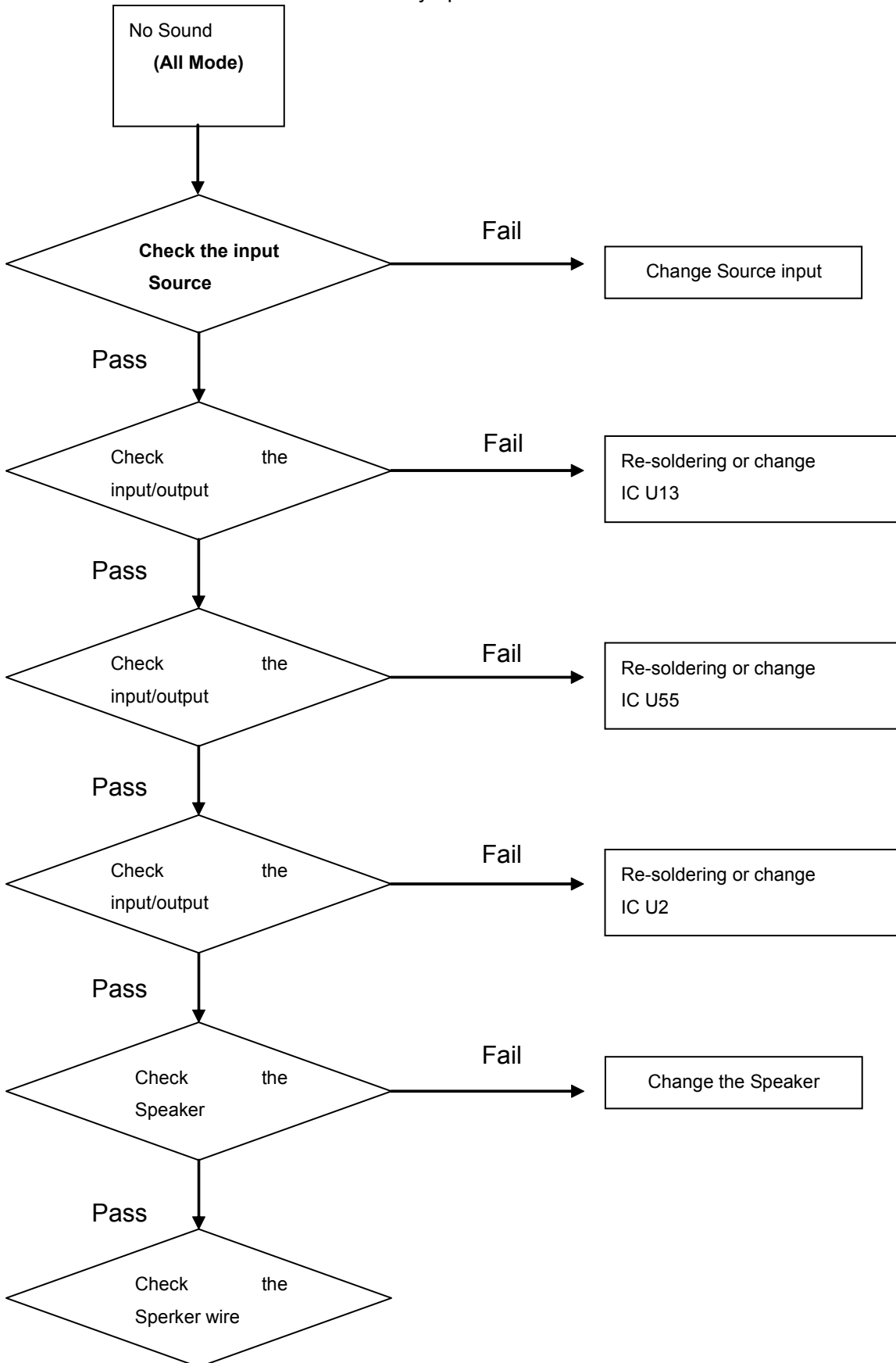

9-3. Mainboard Failure Check



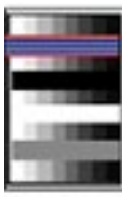

Symptom: No Sound

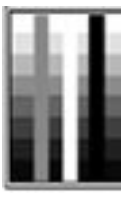

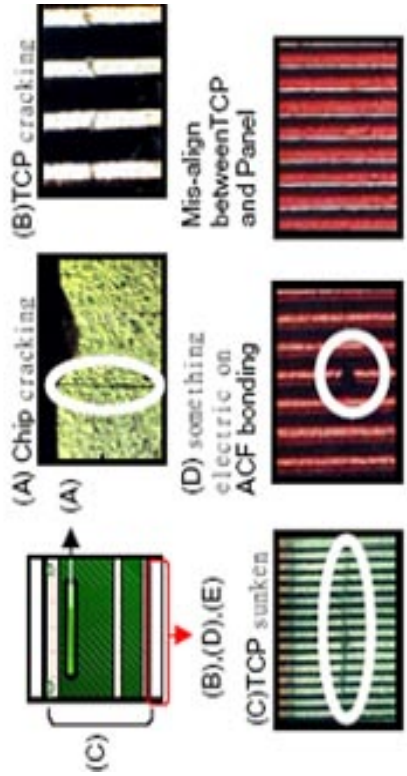





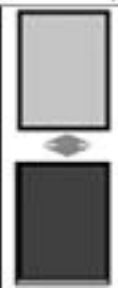

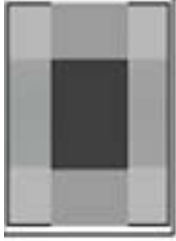

9-4. Pannel Failure



Failure Mode

Part	Name	Description	Phenomena	Failure cause	
TCP	V B/D	Vertical bar		Block Defect : TCP cracking or cracking Dim or L/D : TCP Sunken	
	V Dim	Vertal gray line		: TCP lead cracking : ACF bonding short : Awful environment and something electric enter into LCD	
	V L/D	Vertical color line(light or dark forever)		: Mis-align between TCP and Panel : Panel failure : TCP failure	
	H B/D	Horizontal bar			
	H Dim	Horizontal gary line			
	H L/D	Horizontal line(light or dark forever)			
					 <p>(A) Chip cracking (B) TCP cracking (C) TCP sunken (D) something electric on ACF bonding (E) Mis-align between TCP and Panel</p>

Part	Name	Description	Phenomena	Failure Cause
Panel or Polarizer	Dot Defect	Bright dot dark dot in pannel		Incoming Inspection Standard
	Polarizer Bubble	Bladder in Polarizer		Bladder between Polarizer and top glass
	Polarizer Scratch	Polarizer Scratch		Tine or rigidity arose
	F/inside Polarizer	Eyewinker inside Polarizer		Eyewinker inside Polarizer
Circuit	Abnormal Display	Abnormal Display		1. Chip lose action 2. IC ahort or jointiog bad 3. Pannel and vsc connect bad
	Flashing	Bright and dark display alternately		

Part	Name	Description	Phenomena	Failure Cause
Circuit	White Screen	B/L normal, only white screen display		Maybe caused by surge current and EDS
	Black Screen	B/L normal, only Black screen display		
	Flicker	Crosstalk		LCD Vcom imbalance
	Abnormal Color	Only color abnormal		Capacitance improper bring crosstalk inside LCD pannel
	Abnormal Color	Only color abnormal		1. Chip lose action 2. IC short or jointion bad 3. Pannel and vsc connect bad

Part	Name	Description	Phenomena	Failure cause
	Mechanical Noise	When turn panel, appear cacophony		Caused by Mechanical noise of backlight unit
	Ripple	Connectric circle		Caused by between mechanism and pannel
	B/L off	B/L lose action		*Connect badness between wire and electrode
	B/L dark	B/L brightness darker than normal		*Connect badnessShort between wire and electrode
	B/L wire damaged	B/L wire damaged		Operation abnormal or systemic noise
	B/L wire open	Without backlight		Operation abnormal or systemic noise
	B/L shut down	B/L shutdown in sometime		Short bitween lamp housing and wire, Because consume power too much
	F/M	F/M in B/L ,white, balck Rotundity or wirelike		F/M in B/L unit

Part	Name	Description	Phenomena	Failure Cause
Mechanical or B/L	Light leakage	Brightness at bottom of LCM brighter than normal		B/L unit badness
	Uniformity	B/L brightness asymmetric		Sheet in B/L unit is uneven
	Mount hole	Lack screw or screw damage		*Lack screw Screw damage