

SERVICE MANUAL



**Model TDI-1519ECMC Series Machine— 110 Volt
Economy Combination**



**Thompson Direct, Inc.
2397 Von Esch Road
Plainfield, IL. 60586
815-609-5164
www.thompsondirect.us**

INSTRUCTIONS FOR OPERATION AND REPAIR OF THE
MODEL TDI-1519ECMC SERIES SEALER
AND TUNNEL COMBINATION

Thompson Direct, Inc. Type text]

IMPORTANT - PLEASE READ THIS CAREFULLY

The development of a good safety program, that is rigidly enforced, is absolutely imperative when involved in the operation of industrial equipment. Our machinery is well designed and includes extremely important safety features. The part you the user play through proper installation and maintenance procedures is of far greater significance than our designs. Only properly trained individuals following rigidly enforced safety rules, as recommended by A.N.S.I. and O.S.H.A., should be allowed to operate these machines.

TABLE OF CONTENTS

Preface

Unpacking	4-8
Warranty Notice	9
Warranty	10-11
Warranty Exceptions	12
Warnings	13-15

Tunnel Section

Description and Specifications	16
Installation and Basic Set-Up	17-23
Film Threading Diagram	24
Front Panel Diagram	25
Temperature Control Adjustment	26
Sequence of Operation	27-31
Troubleshooting -- L'Sealer	32-46
Troubleshooting – Tunnel	47-55
Maintenance Tunnel	56-70
Maintenance – L'Sealer	71-79

Electrical Schematic – NOTICE! 80

Electrical Schematic Model TDI-1519ECMC 81

Electrical Panel Diagram Model TDI-1519ECMC 82

Electrical Schematic Model TDI-1519ECMC 83

Electrical Panel Diagram Model TDI-1519ECMC 84

Electrical Schematic Model TDI-1519ECMC 85-86

Electrical Panel Diagram Model TDI-1519ECMC 87

Parts Nomenclature 88-89

Replacement Parts List -- Sealer 90-91

Replacement Parts List – Tunnel 92-93

Spare Parts List 94

UNPACKING

THOROUGHLY INSPECT EQUIPMENT UPON ARRIVAL.

If goods are received short or in a damaged condition, it is important that you notify the carrier's driver **before he leaves your company** and **insist** on a notation of the loss or damage across the face of the freight bill. Unless this is done, no claim can be enforced against the transportation company.

If concealed loss or damage is discovered, notify the carrier at once and **insist** on an inspection. This is absolutely necessary! A concealed damage report must be made no later than ten (10) days from the date the shipment was delivered. Unless you do this, the carrier will not consider any claim for loss or damage. The carrier's agent will then make an inspection and grant a concealed damage notation. If you give the transportation company a clear receipt for the goods that have been damaged or lost in transit, you do so at your own risk and expense.

All claims must be filed within 10 days of delivery date or carrier will not accept them.

Thompson Direct, Inc. is willing to assist in every possible manner to collect claims for loss or damage; however, this does not hold Thompson Direct, Inc. responsible for collection on claims or replacement of material.

Do not throw away damaged pallets or box until freight inspection has occurred.

Thompson Direct, Inc. Type text]

Your new Model TDI-1519ECMC comes bolted to a pallet and has a tri-walled corrugated box strapped to the pallet to protect it.



1. If your machine does not arrive in this condition, **write on shipping paperwork that outside of box is damaged. Concealed damage may have occurred.**



2. Remove stretch film and Poly Bag covering machine.

Thompson Direct, Inc. Type text]

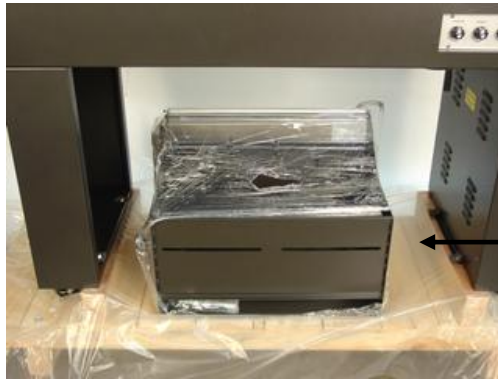

Film Rack

3. Remove film rack from under L'Sealer.



4. Check film rack. You should have
 - (a) (1) Film Rack
 - (b) (1) adjustable center knob
 - (c) (2) film roll guides

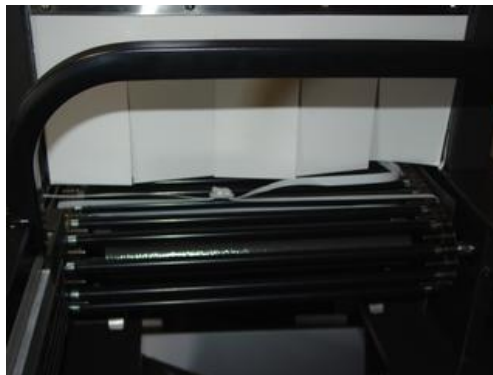

5. Cut plastic strap from **top and bottom** of conveyor rollers before attempting to operate conveyor.



6. Mount film rack on right side at end of machine (see page 18 for instructions).



7. Remove bolts holding L' Sealer to pallet using 13-mm wrench.
8. Place forks of forklift under center of frame of machine and lift off pallet.
9. Place in desired location and use locking casters to set in place.

IMPORTANT WARRANTY NOTICES

OPERATING AND MAINTENANCE MANUAL

The operating and maintenance manual has been carefully prepared to provide the user with all the information needed to properly install, operate, and maintain your Thompson Direct, Inc. equipment.

Please read this manual carefully and refer to it for information on the care and use of your Thompson Direct, Inc. equipment. It is recommended that additional copies be ordered for use by production, maintenance, and supervisory personnel. Although the design of this equipment incorporates safeguards to protect personnel, care should be used in operating, adjusting, and servicing.

Attention is directed to the warranty that accompanies all your Thompson Direct, Inc. equipment. The terms and conditions of this warranty apply only to unmodified units. **Any unauthorized modifications to the equipment automatically voids this warranty.**

Thompson Direct, Inc. provides a one-year warranty on parts, **excluding shipping or freight costs for replacement parts. All warranty parts are shipped F.O.B. Plainfield, Illinois.**

Thompson Direct, Inc.Type text]

THOMPSON DIRECT, INC.

WARRANTY

Thompson Direct, Inc. warrants each new product manufactured to be free from defects in material and workmanship for a period of (1) year from date of shipment by Thompson Direct, Inc.

This warranty is not transferable with any subsequent resale.

Defective parts under warranty must be returned to Thompson Direct, Inc. freight prepaid. Thompson Direct, Inc. sole obligation and purchaser's sole remedy in the event of a warranty dispute shall be, at Thompson Direct, Inc. option, to repair or replace the part in question. Labor incurred in removing or installing the defective part is not covered by this warranty. Prior to returning any parts for any reason, contact Thompson Direct, Inc. for a Return Authorization Number. This number must accompany all returns.

This warranty shall not apply if equipment has been tampered with, misused, improperly installed, altered, or has received damage due to abuse, carelessness, accident or failure to follow recommended regular maintenance procedures or has been serviced by someone other than a duly authorized factory representative without the express written consent of Thompson Direct, Inc.

This warranty is in lieu of all other warranties, expressed or implied, including but not limited to warranties of merchantability and fitness for a particular purpose, non-infringement or any other matter.

Thompson Direct, Inc. shall have no liability to any person for direct, indirect, incidental or consequential damages or delay

Thompson Direct, Inc.Type text]

resulting from any defect negligence, or tort and customer hereby waives for itself any and all claims for punitive damages and all claims of negligence of strict liability or both. In no event shall our liability exceed the purchase price of the product that was actually paid.

Thompson Direct, Inc. reserves the right to make changes, additions, or improvements to our products with no obligation to make such changes in any previously shipped product covered by this warranty.

Thompson Direct, Inc. shall not be held liable for any damages arising out of nor in connection with the operation of the equipment should customer or its agent fail to maintain equipment in safe operating condition. This warranty shall become unenforceable if and to the extent the customer or its agents remove, disconnect, or otherwise render useless any safety device and or parts designed or affixed by us or fails to maintain and service equipment in a manner as advised.

Thompson Direct, Inc. provides a one-year warranty on parts, excluding shipping or freight costs for replacement parts. All warranty parts are shipped F.O.B. Plainfield, Illinois. Service Labor to install part is not covered under warranty!

WARRANTY EXCEPTIONS

The following parts are an exception to the general warranty list on page 10. Each part listed below shall carry a 30-day warranty unless designated otherwise.

- TDI-1519ECMC Series Sealer Parts

1. Fuses
2. Conveyor Belt (Optional)

- Tunnel Parts

1. Silicone Tubing (Roller Covers)
2. Tunnel Curtains

The following sealer parts are considered to be consumable and not under warranty:

1. Silicone Sponge
2. Band Ribbon
3. Teflon Tapes

WARNINGS

Every effort has been taken to ensure your safety while operating this machine; however, there still remain certain risks. Do not allow this machine to be operated before informing all personnel of the following warnings.

WARNING.....

Do not tamper with the electrical wiring. Only use a licensed electrician for maintenance. Always disconnect the electrical power before attempting any maintenance to all electrical and/or moving parts.

WARNING.....

In order to prevent injury to personnel and/or machinery
DO NOT INCREASE SETTINGS OR RATINGS ON EITHER ELECTRICAL
OR MECHANICAL OVERLOAD SAFETY DEVICES.

WARNING.....

KEEP HANDS AWAY FROM MOVING CONVEYORS AND
ASSEMBLIES. Conveyor belts that have become worn or frayed are
capable of being hazardous. They should be replaced promptly.

WARNING.....

NEVER OPERATE THIS OR ANY MOVING EQUIPMENT
WITHOUT ALL COVERS AND GUARDS IN PLACE. The internal
mechanism of most packaging machinery contains numerous shear,
pinch, and inrunning nip points, many of which are capable of
causing severe injury and/or permanent disfigurement.

Thompson Direct, Inc.Type text]

WARNING.....

To minimize the potential for personnel injury, always be sure that machine operators and others working on the machinery are properly trained in the correct usage of the equipment and properly instructed regarding the safety procedures for operation.

WARNING.....

Heat sealing arms and jaws on packaging machinery can become very warm after a period of use. KEEP HANDS AWAY WHILE IN OPERATION AND USE CAUTION IF THE MACHINE HAS BEEN RUNNING RECENTLY.

WARNING.....

ANY MODIFICATIONS TO EITHER THE ELECTRICAL CIRCUITRY OR THE MECHANICAL ASSEMBLIES OF THE MACHINERY WILL VOID ANY WARRANTIES ASSOCIATED WITH THIS EQUIPMENT. Such modifications may introduce hazards that would not otherwise be associated with this machinery. Thompson Direct, Inc. will not be responsible for any consequences resulting from such unauthorized modifications.

WARNING.....

The use of certain types of plastic films in sealing and/or shrinking equipment may result in the release of HAZARDOUS FUMES due to the degradation of the film at high temperatures. Before using any plastic film in this equipment, the manufacturer or supplier of the film should be contacted for specific information concerning the potential release of hazardous fumes. ADEQUATE VENTILATION MUST BE PROVIDED AT ALL TIMES.

WARNING.....

It is important that the machine operator unplug the machine when he/she has finished operating the unit.

Thompson Direct, Inc. Type text]

WARNING.....

Turn off machine and disconnect power cord from power source before attempting to work on machine.

**DESCRIPTION AND SPECIFICATIONS OF
MODEL TDI-1519ECMC SERIES COMBINATION
SEALER TUNNEL**

DESCRIPTION

The purpose of a TDI-1519ECMC Series is for low to medium volume packaging requiring excellent seals and minimal maintenance. It features an impulse mode for sealing of films. This model incorporates an **optional** electromagnetic hold-down system, allowing the operator to load another package while the preceding package is being sealed. This system provides consistent seals. In addition, an **optional** package take-away conveyor increases production speed by automatically discharging product into the tunnel.

SPECIFICATIONS

Model:	TDI-1519ECMC Series
Seal Area:	Length: 19" Width: 15"
Machine Size:	Length: 74" Width: 24" Height: 53"
Volts:	110
Amperage:	20
Weight:	400 lbs.
Tunnel Chamber Size:	Length: 20" Width: 16" Height: 6"

INSTALLATION AND BASIC SET-UP OF L'SEALER PORTION OF MACHINE

IMPORTANT

Read this manual carefully, and make it available to everyone connected with the supervision, maintenance, or production of this machine. Additional copies are available at your request. (Contact your distributor for this information.) Be very careful when operating, adjusting, or servicing this equipment. If in doubt, stop and obtain qualified help before proceeding.

INSTALLATION OF PP-1519EC SERIES



Place the TDI-1519ECMC in the desired location with the required electrical power source available. (See power requirements.) Make certain that proper electrical wiring is provided to guard against low voltage. If the voltage is too low, the equipment will not function properly. **Machine comes complete with power cord and 110 volt plug.**

Finding the proper location is a most important function of the initial set-up. One must take several factors into consideration:

1. Adequate power source.
2. Relationship to source of product.
3. Relationship to L'Sealer.

Thompson Direct, Inc. Type text]

4. Relationship to any conveyors necessary to remove finished product.
5. Convenience of operator.

Make sure to connect machine to an Independent Power Source. **DO NOT run any other equipment on the same power line as your machine.**

Do not attempt to install, adjust, or operate this machine without first reading the contents of this manual. Although the design of the equipment incorporates safeguards to protect operating and maintenance personnel, care should be used in operating, adjusting, and servicing.

INSTALLING FILM RACK

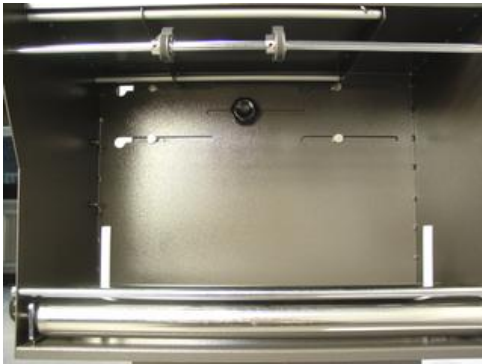

IMPORTANT: Remove film rack from under sealer and install at the end of the sealer on the right hand side with the four bolts and center knob provided. Mounting holes are slotted for adjustment, set film rack flush with backside of the machine frame.

MOUNTING FILM

Select the proper width of centerfold film for the item being packaged, allowing for width and height of package. With the package properly positioned within the film in the sealing area, allow sufficient film to overlap the sealing bars so that a seal may readily be made without any possibility of open areas due to insufficient film.

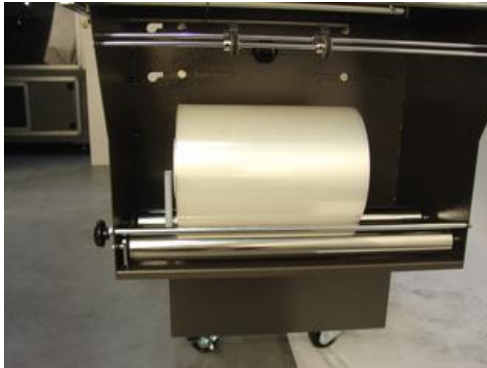

Place film roll on cradle mount film rack. The centerfold is to be placed away from the operator, toward the rear of the machine. Use core chucks to position film roll on rack and tighten film guide nuts to hold film roll in position.

PIN PERFORATOR



Located between the lower idler rollers, the pin perforator creates holes for air escape as the operator pulls on the film. This allows the air to escape as the package travels through the tunnel.

Thompson Direct, Inc. Type text]

The pin perforator is adjustable and must be properly placed in conjunction with the width of the desired package. The positioning should always be re-evaluated when setting the machine for different size product or different size film.

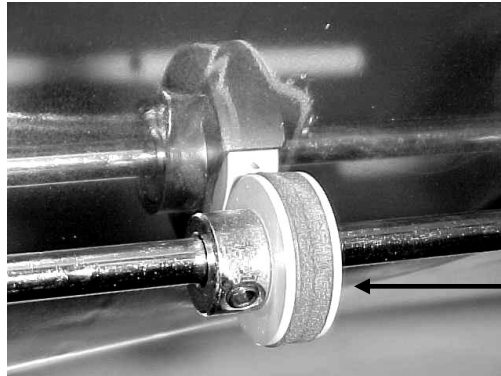

*CAM Design to
Adjust Depth*

Thread film through the Pin Perforator. Note that the perforator wheel turns freely and is not binding. You can adjust the depth of pin holes by Loosening the Allen screw on the sponge wheel and rotate the cam to allow the pin to push deeper or shallower into the film.

PRODUCT TRAY

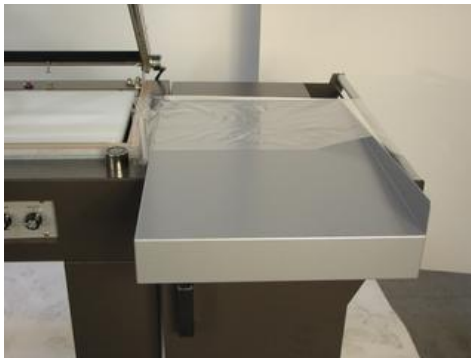

The product tray is an adjustable metal platform used to separate film and to insert product between top and bottom layers of film.

Once threaded, separate film top from bottom and insert product tray between. Make sure that the centerfold of film is placed at the rear of the product tray. This allows the operator to insert product between the layers of film on the product tray and to prepare to move product and film into the sealing area. When threading film, make sure to pull more than sufficient film through the rollers, across the product tray, and into the sealing area to ensure sufficient film to begin operation.

The tray is adjustable to achieve proper depth, equal to the depth of the package, allowing product to be placed exactly in the centerfold of the film each time. A locking wing screw allows you to set tray position.

Place product against rear of film separator tray. Then move product into seal area. Be sure to leave the bag loose around the product when making the seal. This helps eliminate the seals from blowing out in the shrink tunnel.

LOCKING WING SCREW



Once the product is placed in the desired location, tighten the wing screw under the loading tray to lock tray in position.

Optional Power Discharge Conveyor



Lower Power Discharge Conveyor using the crank wheel located underneath the Power Discharge Conveyor. The Conveyor should be set so the package height is centered to the seal pad. In essence, $\frac{1}{2}$ of the package is above the seal pad and the other $\frac{1}{2}$ of the package is below the seal pad. This will place the seal in the center of your package and help release any film tension that may occur.

FILM THREADING DIAGRAM

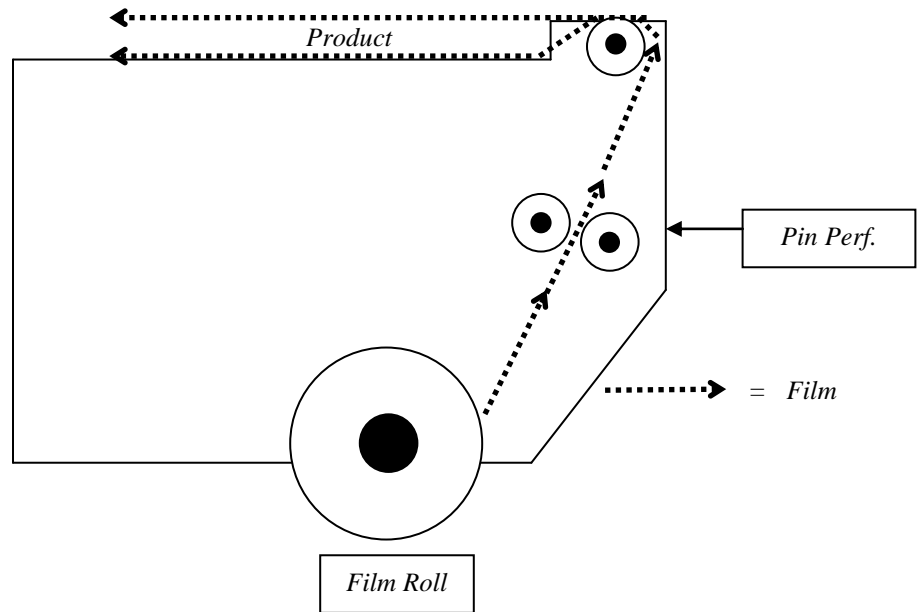

Thompson Direct, Inc. Type text]

Front Panel Diagram

TDI-1519ECMC



1. Start Switch -- Green
2. Heater Switch -- White
3. Temperature Control
4. Tunnel Conveyor Speed Control – Small Black Knob

Temperature Control Adjustment

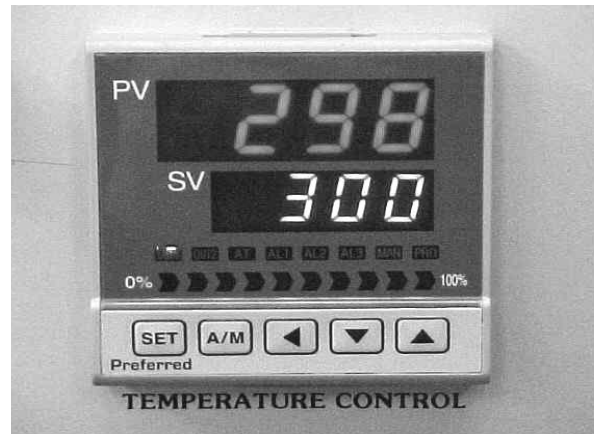

PV = Present Value
SV = Set Value

On the above temperature controller the set value is 300 degrees and its present temperature is at 298 degrees.

To Adjust Temperature Up or Down:

First you must press the arrow key that points left (←). When pressing this key the set value temperature will flash first in the ones column. While flashing, you may adjust temperature by now pressing the arrow keys either up or down (↑↓) to the desired temperature in the ones column. Repeat this procedure by pressing the left arrow (←) to move flashing light to the tens column or the hundreds column and adjust up or down to desired temperature. Once you have adjusted to desired temperature press the set key and the temperature will now become your new set value (SV).

SEQUENCE OF OPERATION



- A. **Turn the START switch** (1) to the on position to start the machine. (Temperature will be displayed on temperature control at this time. This will also start the cooling fan motor.)
- B. **Turn the HEATER switch** (2) to the on position, this will start the blower, conveyor motors and heater.
- C. **Set the Conveyor Speed Control** (3) between 1 and 3 until the exact desired conveyor speed is determined later (based on package size and sealer speed). Factory setting is 2.
- D. **Set the Temperature Controller** (4) at the temperature you believe will shrink your product. This temperature may need to be adjusted higher or lower until you have achieved the shrink you are happy with for that product. As long as you are running the same product, this temperature should not have to be adjusted again. Factory setting is 325 degrees. **Your 110 volts machine requires approximately 30 minutes to reach set temperature.**

TDI-1519ECMC —110 Volt Sealer/Tunnel Combination Service Manual



- E. **Set (Optional) Magnet Time** (5) to approximately $\frac{1}{2}$ to $\frac{3}{4}$ seconds. The sealing timer controls the length of time the magnets stay down in the sealing position.
- F. **Set Sealing Timer** (6) to approximately $\frac{1}{2}$ or .5 seconds. The Band Seal Technology seals very quickly with either PVC or Polyolefin shrink films. Use only enough Sealing Time to seal and cut film – no longer – otherwise overheating of Band Ribbon and Films will occur.
- G. **Set (Optional) Conveyor Time** (7) just enough to transfer product into shrink tunnel. If you are running a very small product, set conveyor time just long enough to move package out of immediate seal area and allow it to transfer into tunnel on the next cycle. This will allow you to speed up the operation of machine.

SEQUENCE OF OPERATION

- A. Product is placed on the film separator tray.
- B. The product tray functions as a means to separate the film, allowing placement of product between upper and lower portions of the film.
- C. Move product into seal head area by pushing the product to the left.
- D. Manually pull the seal head down. As the seal head meets the lower seal pad, the machine automatically activates the band ribbon. The **optional** magnet hold down timer is activated, automatically holding seal bar down during seal cycle. Timer is adjustable from one to six seconds.
- E. Take-away Conveyor Unit **Optional**. Once the seal is completed, the seal head automatically releases and the take-away conveyor begins to run. It is adjustable from one (1) to six (6) seconds. The timer is located on the front of the machine.

NOTE: If too much tension is on the film while the bag is being made, the seals will, more than likely, be weak or will “blow out” in the seal area while passing through the shrink tunnel. Make sure to relax the film tension prior to sealing.

SEQUENCE OF OPERATION

1. After completion of basic setup as described on pages 17-23 plug the sealer's cord into the power source.



- A. With film threaded, (see instructions for mounting film) place right hand on package and slide product into the upper left hand corner of the film (i.e. corner formed by folded rear edge of film and previously sealed left edge of film), pushing the package up against the ½" high package stop at rear of product loading tray.



- B. Place **right hand** under top sheet of film and on front right corner of product. Place **left hand** on tail of both sheets of film. Now push the package with right hand and pull the film with left hand moving package and film

TDI-1519ECMC —110 Volt Sealer/Tunnel Combination Service Manual

into lower right corner of seal area. Allow from ½" to 1" of extra film around package. This will allow some slack film between the package and the sealing bars, reducing film tension.



- C. Press sealing handle down. **Applying pressure to produce seal.** Hold the sealing head down for the duration of the time set on the seal timer, release seal bar when **Red Impulse Light** goes out. If film will not cut off, incrementally increase pulse timer until desired result is achieved.



- D. If you have the **OPTIONAL MAGNETIC Hold Down** operator should simply bring seal head down to contact magnets and immediately release pressure. Magnet timer will engage holding seal arm down for duration of seal

TDI-1519ECMC —110 Volt Sealer/Tunnel Combination Service Manual

time. Seal head will automatically release to up position. Magnet hold down time should be slightly longer than pulse time.



- E. The operator may then load the next package onto the product tray, thus speeding up the sealing operation.



- F. Product transfers manually via operator or automatically with **Optional Power Discharge Conveyor** through shrink tunnel. Refer to Tunnel Control setup on page 26 until desired package appearance is achieved.
- G. If you have the **optional Power Discharge Conveyor**, once the seal timer releases the magnets, the Power Conveyor will automatically transfer the product into the tunnel.

TROUBLESHOOTING – L'SEALER

The following guidelines are provided to aid in determining the source of any operation difficulties that may develop. In performing the tests and checks which follow, carefully inspect for any loose components, broken or loose wires, poor electrical connections, etc., while testing the various switches, controls, relays, transformers, etc. For checking electrical problems, use a voltage meter.

Note: While troubleshooting use caution to avoid danger of electrical shock. When power is not required for checking for the presence or value of voltages used, always have it disconnected.

DISCONNECT ALL POWER BEFORE MAKING ANY REPAIRS.

REFER TO ELECTRICAL BOARD LAYOUT AND ELECTRICAL SCHEMATIC FOR LOCATION OF ELECTRICAL COMPONENTS

NO HEAT TO BAND RIBBON

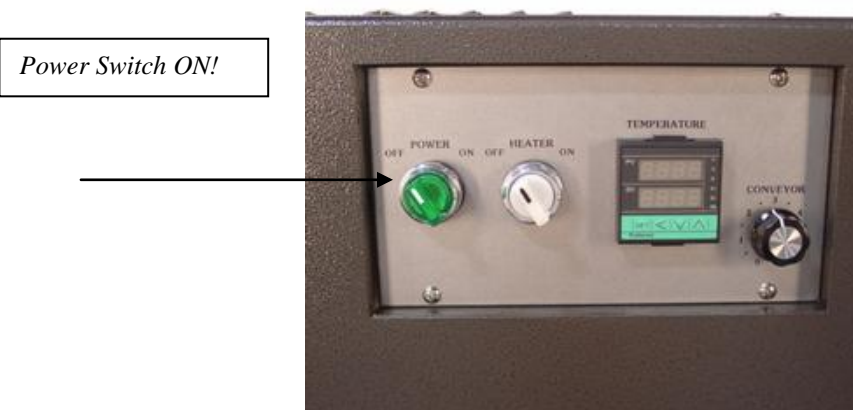

1. Check that the sealer is plugged in and that power is present at the socket. Make sure the power switch is in the **ON** position.

TDI-1519ECMC —110 Volt Sealer/Tunnel Combination Service Manual

Sealing



2. Make sure Sealing Timer is **not** set on zero (0).



3 screws on each side

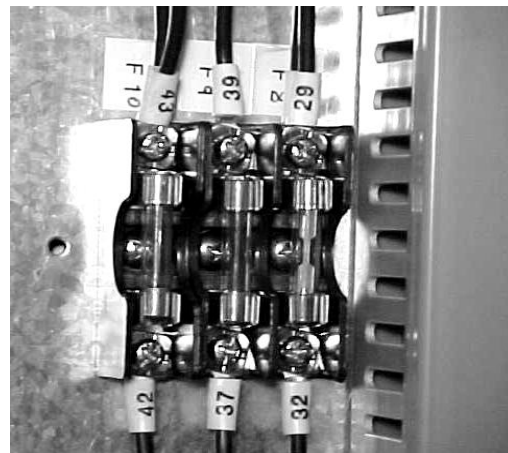

3. **Remove 6 screws to access L'Sealer Electronics. Make sure the fuse F8, 20 AMP wires #29 and 32, is not burned or that the band ribbon is not loose inside the compensators.**

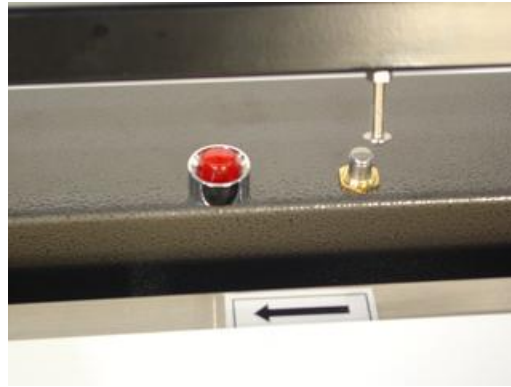

4. **Check Band pulse switch adjustment.**
 - (a) Make sure switch is being activated when the seal bar is within $\frac{1}{4}$ " of contact with band ribbon.
 - (b) Press switch by hand – if no click is heard, replace switch.

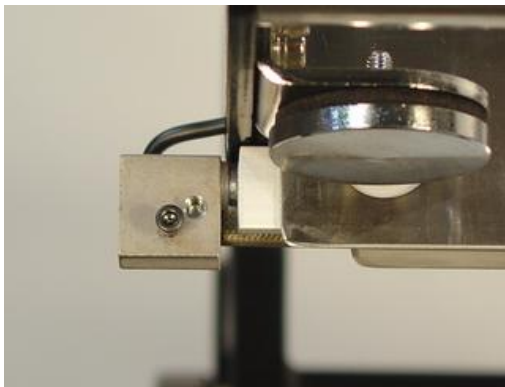

5. Check the connections at the end of each compensator of the band ribbon for loose or broken wires.
Make sure wires 7 and 25 are connected to each end of the band ribbon compensator.

TDI-1519ECMC —110 Volt Sealer/Tunnel Combination Service Manual

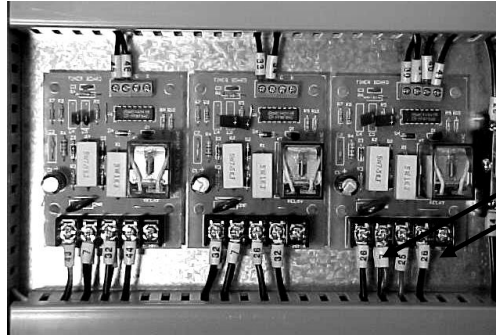

TR1. Wires 7 and 26.

- 6. Check Pulse Timer at TR1, wires 7 and 26.**

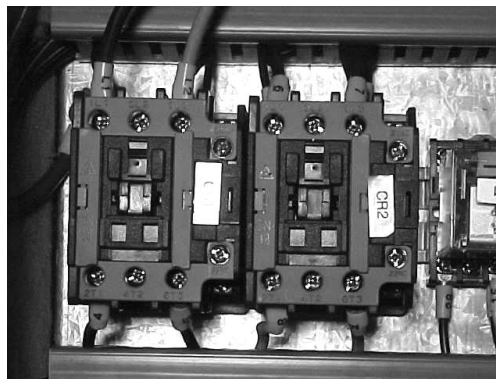

- 7. Check to see if CR1 is pulling in and voltage is present at coil.**

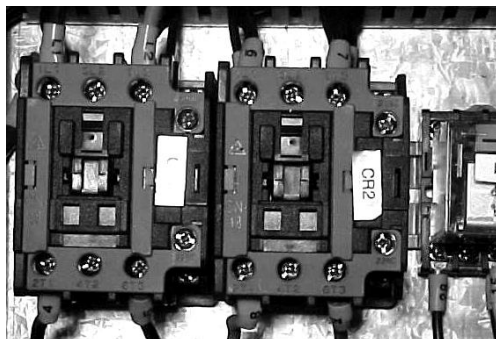

- 8. Check for operation of contactor CR2.**
 - Check circuit continuity through operated contacts of contactor CR2. If required, clean or replace contact points or replace contactor.

TDI-1519ECMC —110 Volt Sealer/Tunnel Combination Service Manual



9. Check for voltage present at primary and secondary of transformer T1 as per values shown in the voltage specifications.

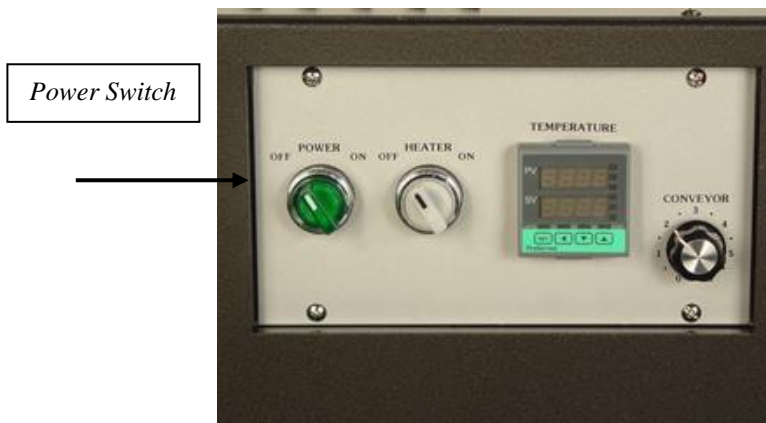

10. Check main power switch to determine if damaged or broken.

WEAK SEALS AND/OR POOR FILM CUT-OFF

1. Improper seal time – increase seal time.



Relax Film Before Sealing

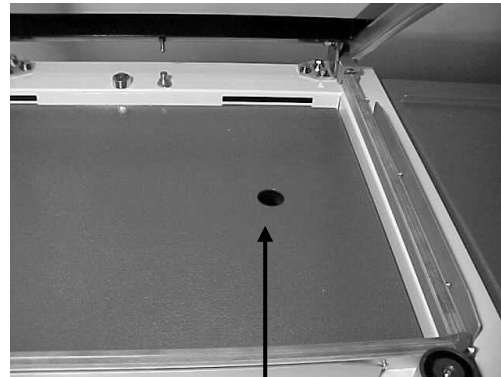

*Lower Product Tray to
Center Package in Seal*

2. Improper operating technique. Too much film tension-making sure film is relaxed prior to sealing. Make sure product tray is lowered so package is in center of seal bed.
3. Check Band Ribbon to see if cleaning or replacement is necessary.
4. Burned Teflon tapes 1/2" 10 mill or 2" 3 mill replace. If Teflon tapes become burned or worn, weak seal may occur. See page 75 for Replacement Instructions.

5. Wavy silicone rubber sealing pad. Replace. (See instructions on page 76.)
6. Hold down pressure uneven or incorrect on magnets. (See page 78 for instructions.)



- a. When seal bar is lowered, the gap between the lower magnet and the upper magnet clamp should be 1/8". (Refer to Maintenance Section, page 78, for proper adjustment.)

OPTIONAL CONVEYOR – WILL NOT RUN

F8 -- 20 AMP
F9 -- 2 AMP
F10 -- 1 AMP

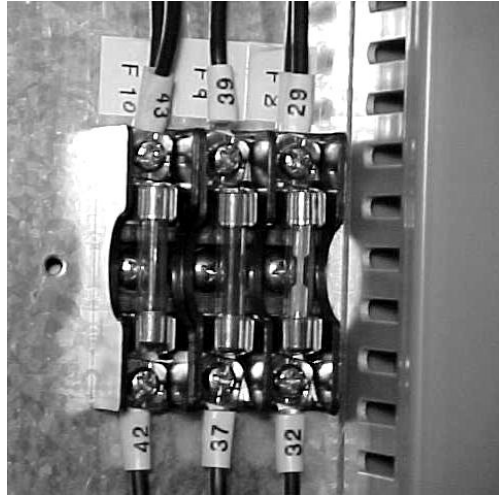

1. Check conveyor Fuse F10, 1 AMP, wires 42 and 43, replace if burned.
(a) Check main fuse F8, 20 AMP, wires 29 and 32.

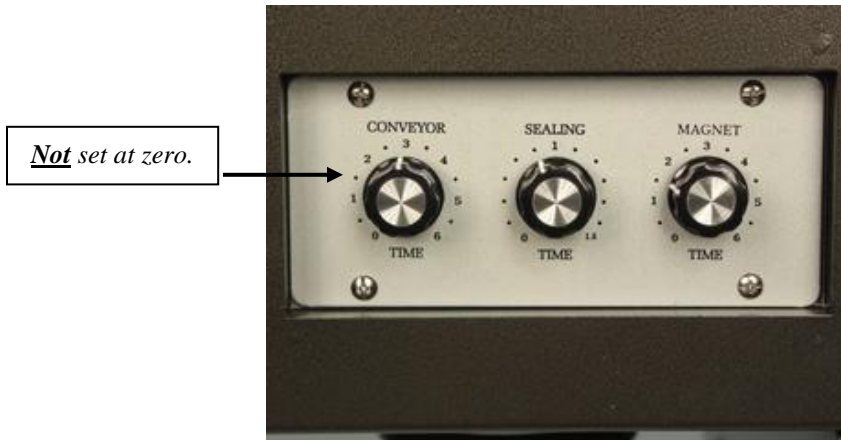

2. Check **optional** conveyor timer. Make sure it is not set at zero.

TDI-1519ECMC —110 Volt Sealer/Tunnel Combination Service Manual

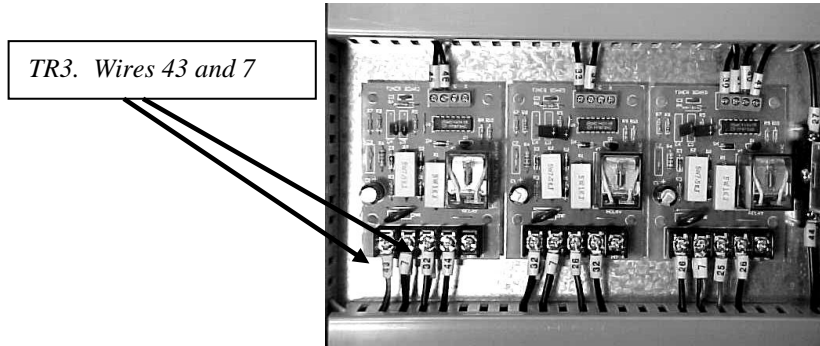

3. Check **optional** conveyor timer at TR3 wires 7 and 43.

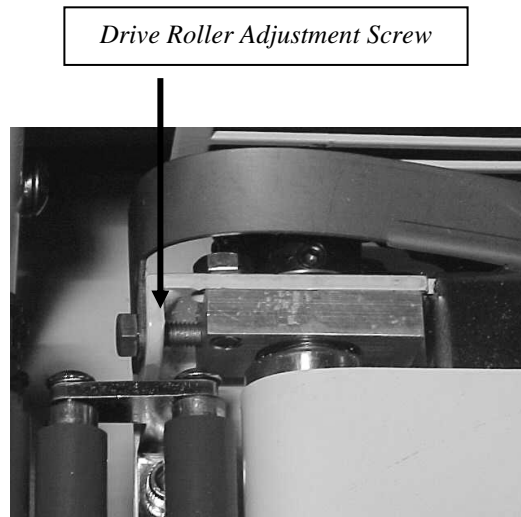

4. Check **optional** conveyor belt and make sure it is not adjusted too tightly. Adjust conveyor belt using Drive Roller Adjustment Screw.

TDI-1519ECMC —110 Volt Sealer/Tunnel Combination Service Manual



5. Check that conveyor motor sprocket set screws are not loose on shaft.
6. Check that conveyor chain is not jammed or broken.
7. Make sure wires 7, 7, and 43 are connected to the conveyor motor.

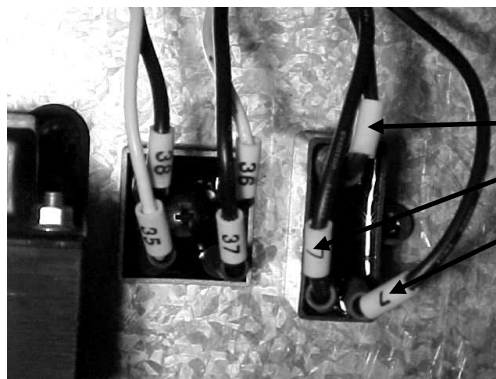

Wires 7, 7 and 43 at C2

8. Make sure wires number 7, 7 and 43 are connected to C2 capacitor.

TDI-1519ECMC —110 Volt Sealer/Tunnel Combination Service Manual

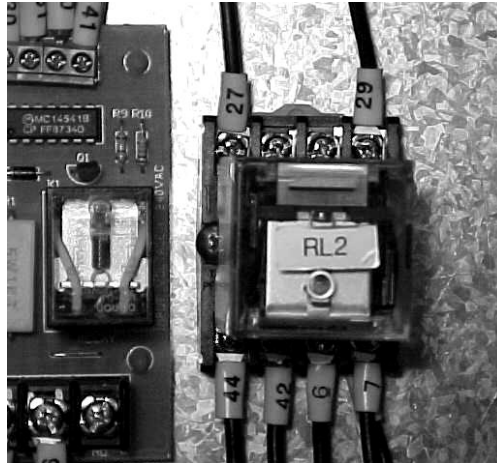

9. Make sure RL2, 110 V relay is secure in relay socket and points are not burnt.

OPTIONAL MAGNETIC HOLD DOWN



1. Seal head will not stay down – sealer operates normally otherwise.

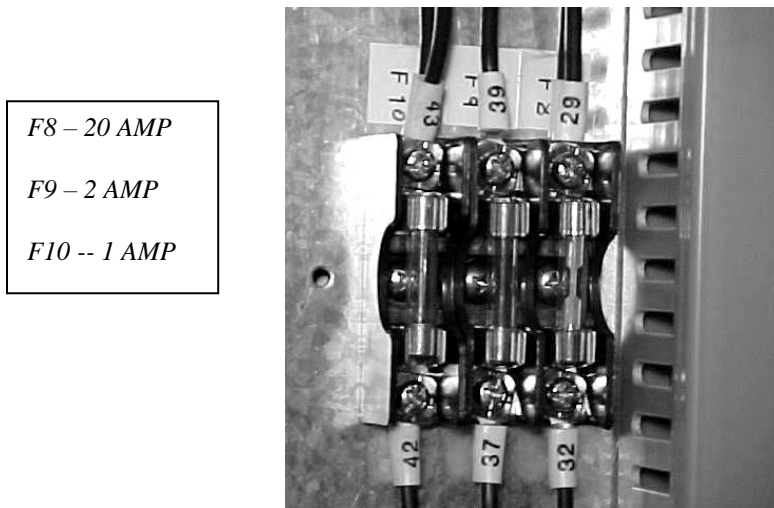

2. Check magnet Fuse F9, wire 37 and 39. Replace if burned.

TDI-1519ECMC —110 Volt Sealer/Tunnel Combination Service Manual



3. Hold-down pressure uneven or incorrect on magnets.
(Optional) See maintenance section, page 78, for proper adjustment.



*Sealing time
not at zero.*

4. Check seal timer (TR2) setting. Make sure it is **not** set at zero.

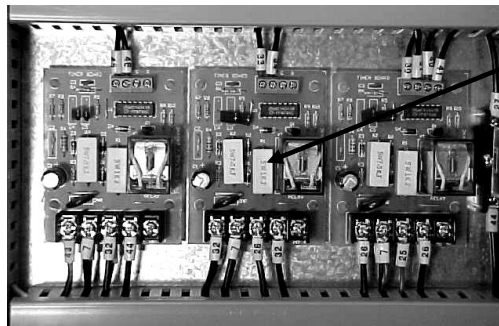

*Magnet Timer,
Center Timer*

5. Check **(optional)** Magnet Timer. Also, check to see if burned or damaged.

TDI-1519ECMC —110 Volt Sealer/Tunnel Combination Service Manual



6. Check for 110 Volts (nominal) to primary of transformer (T2) wires 7 and 26.
 - (a) If voltage is present to primary winding of transformer (T1), check for 24 (nominal) volts output from secondary of transformer. Wires 35 and 36.

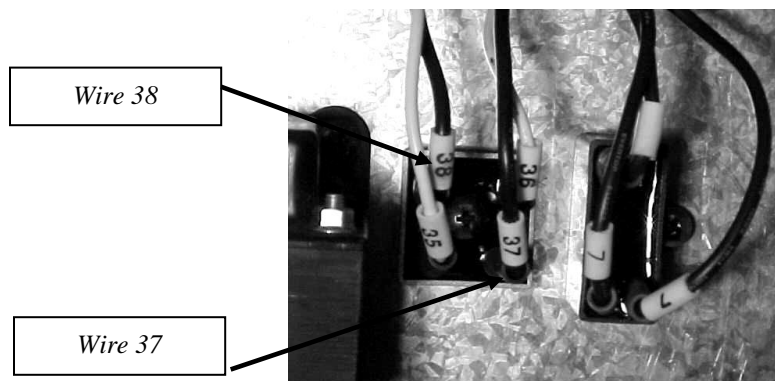

7. Check for 24 (nominal) volts DC output from + (positive) and – (negative) wires number 38 and 37 on terminals of rectifier. If no DC voltage, replace rectifier.

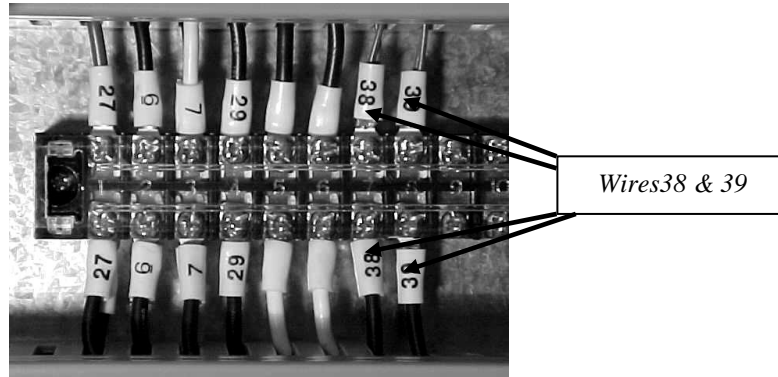

8. Check for circuit continuity through windings of hold-down magnets. **Check on terminal strip wires 38 and 39. Disconnect from terminal strip before testing.**

TROUBLESHOOTING – TUNNEL

Conveyor malfunction



1. Check main power at machine's main breaker.

F1 – 20 AMP
F2 – 20 AMP

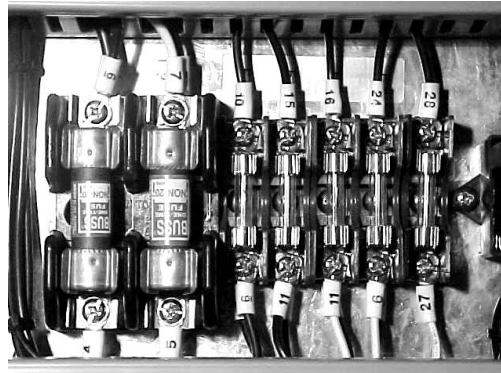

F3 – 1 AMP
F4 -- 3 AMP
F5 – 1 AMP
F6 -- .5 AMP
F7 -- .5 AMP

2. Open Tunnel Hood top panel, 12 screws. Check conveyor motor fuse (F5/1 AMP) wires No. 16 and 11. If bad, replace.

TDI-1519ECMC —110 Volt Sealer/Tunnel Combination Service Manual

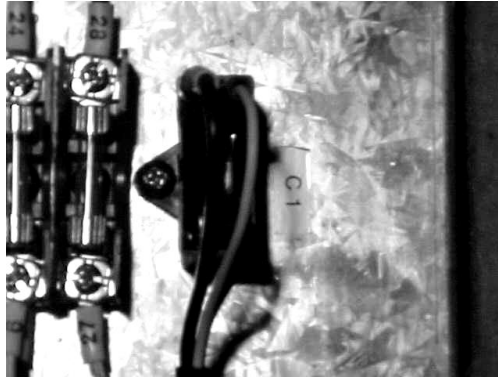

3. Check Motor Capacitor 1.5 mf. Make sure wires 7 and 23 and 22 are connected to Capacitor. Check to see if Capacitor is burned.

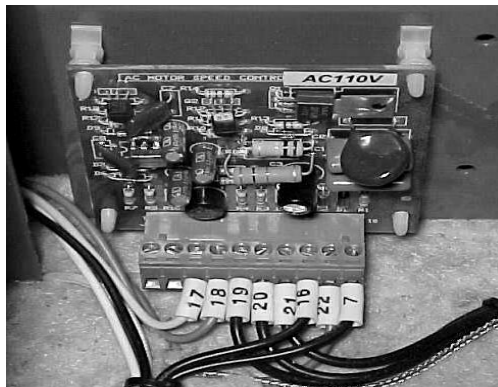

4. Check incoming power on AC Control Board 110 volt, wires 7 and 16 (Pins 8 and 10). If no power present replace AC board.
 - (a) Check to make sure AC Board is not burned or damaged.
 - (b) If power is present at both locations 7 and 16 and motor does not operate, replace conveyor motor.



5. Remove end cover.



6. Look for obstructed product or lodged rollers.
 - (a) Check lubrication of conveyor chains.



7. Make sure the connection wire on the motor and cable is not loose.
 - (a) Refer to electrical schematic on page 82-87 for proper wiring of the motor.
 - (b) Check wires 7 and 16 for power. If power present and motor does not operate, replace motor.



8. Check to make sure the chain is not loose and the sprockets are not touching the frame.
 - (a) Replace the motor if all the above checks properly. See Maintenance, page 80.

NO AIR FLOW

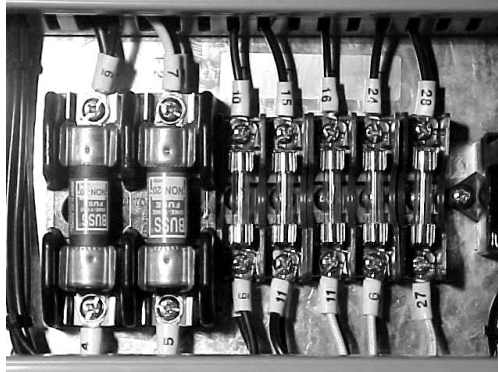

1. Open main electrical panel. Check power at fuse F1, 20 AMP and F2, 20 AMP.
2. Test fuses F1, F2, F3, F4, F5, F6 and F7.



3. Check to make sure no air holes are obstructed due to plastic build up covering air holes.

TDI-1519ECMC —110 Volt Sealer/Tunnel Combination Service Manual

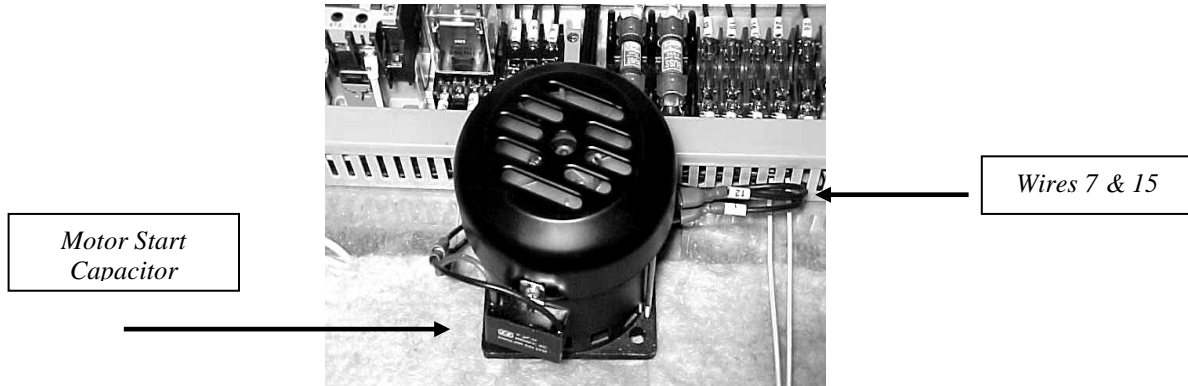

4. Check main blower motor and replace if necessary.
 - (a) Check motor start capacitor to see if burned.
 - (b) Check motor wires 7 and 15 for loose connection.
 - (c) Check for 110-volt power across wires 7 and 15 (motor wires). If voltage is present and the motor still does not operate, replace motor.

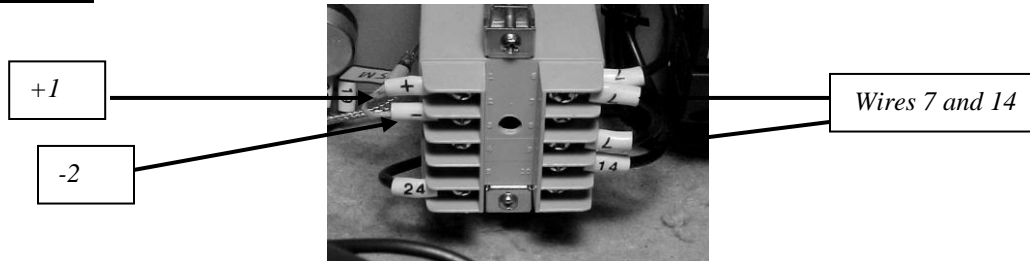

5. Check to make sure blower wheel is not loose on the blower motor shaft.

No Heat

1. Check thermocouple wires at temperature controller (Terminals +1 and -2). First, disconnect, then check with meter for continuity across the two thermocouple wires.



- (a) If no continuity is present across thermocouple wires, replace thermocouple.
 - (b) Check terminals at 6 and 9 (wires 7 and 14) for 110 volt under set temperature.
 - (c) Check for 110 volt present with heater switch in ON position. If no power is present, check Fuse F6, .5 AMP. If voltage present at wires 7 and 14 and Fuse F6 is good, replace Temperature Control.
2. **Please note before replacing the Temperature Control, check the TS1 (TS1 NO open; thermo overload for blower motor) and TS2 (TS2 NC closed, heat cool down sensor) for continuity with the lead wires disconnected from sensor.**

NOTE: When any of the sensors are not functioning properly, this causes the temperature controller to malfunction.

TDI-1519ECMC—110 Volt Sealer/Tunnel Combination Service Manual

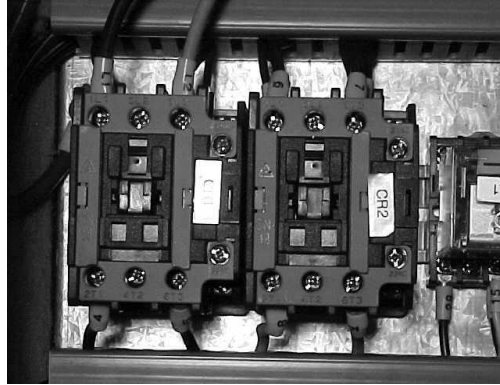

- (a) Check for 110 volts on wires 8 and 9 on CR2 with CR2 contactor pulled in under set temperature. If voltage is present on CR2, contactor on wires 8 and 9, check the Head Bank for broken lugs or wire inside the heater Bank. If leads and jumper wires on Heater Bank are not broken or burned, then replace the Heater Bank.

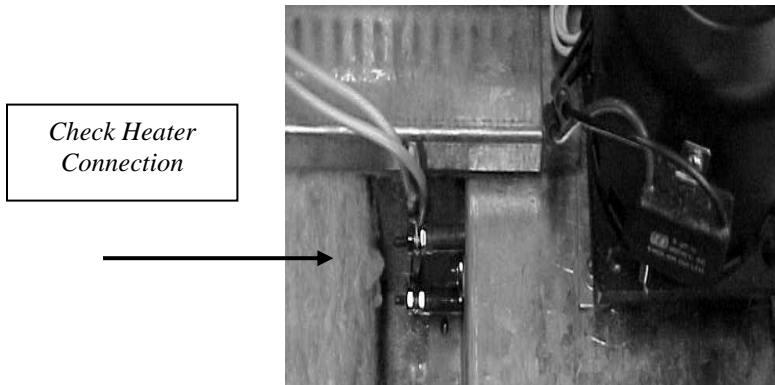

- (b) Check Heater Bank for replacement. Make sure no lugs on the Heater Bank have been broken.

TDI-1519ECMC—110 Volt Sealer/Tunnel Combination Service Manual

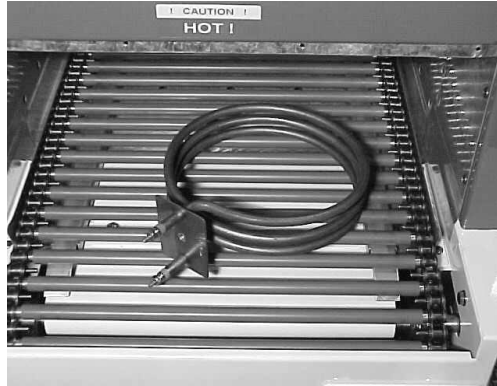

3. Check the heater bank to make sure the wires are not loose or broken on the heater bank. Pull the heater bank and make sure the heater bank has continuity across each leg. If not, replace it.

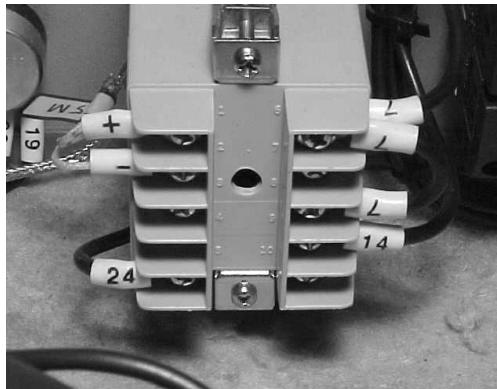

4. If no control over heat, interchange thermocouple wires at temperature controller. If still no control, check for replacement of CR2 or temperature control.

MAINTENANCE -- TUNNEL

To aid in maintaining the high reliability of this shrink tunnel, the following maintenance should be provided.

**DISCONNECT ALL POWER BEFORE MAKING ANY REPAIRS.
IF UNSURE OF ANYTHING, CONTACT A QUALIFIED
SERVICE TECHNICIAN**

- A. The conveyor chains should be lubricated once a month with a high temperature oil. The lubricant should be applied with a brush or sprayed while the conveyor is slowly running.
- B. The silicone covering on the tunnel rollers should be inspected regularly to assure that no scrap pieces of film are wrapped around the rollers to cause sticking of packages. To clean, run conveyor until the affected rollers are within the heated chamber, thus heating the film residue to soften the film, then advance the conveyor to stop the rollers outside the heat chamber for cleaning. Make sure the conveyor is stopped before putting your hands or anything else in the conveyor area. If necessary to remove the film residue, use a dull, blunt-edged tool. Do not use any sharp instruments, as nicking the silicone may result in having to replace the roller covering. To replace silicone covering on the roller:
- C. Disconnect power to machine.

TUNNEL CONVEYOR



- D. Remove loading tray to gain access to tunnel conveyor take-up bolts.

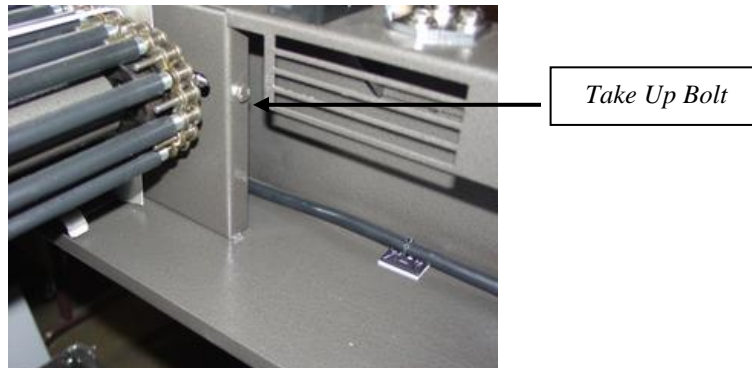

- E. Loosen the two take up bolts for the chain adjustment giving yourself enough slack to pull chain upward and spread chain apart to remove roller. See picture that follows.



Now you are ready to move the rollers.

- F. Remove old roller covering by very carefully slitting the covering and pulling off.
- G. Clean all rollers, using steel wool or a wire wheel. Make certain all rollers are smooth and free of residue or burrs.
- H. Fit the new silicone rubber tubing onto each roller and work on by hand at least 1/2". At the opposite end of the tubing, attach and secure an air supply hose of low pressure, maximum pressure 5 lbs. While the tubing is slightly expanded by the air pressure, push the tubing onto the roller. Be very careful to hold the roller at all times so it does not escape due to the air pressure.
- I. Replace rollers on conveyor by inserting roller end holes into the extended pins on the chain.
- J. Check conveyor chain tension as described below.

TDI-1519ECMC—110 Volt Sealer/Tunnel Combination Service Manual

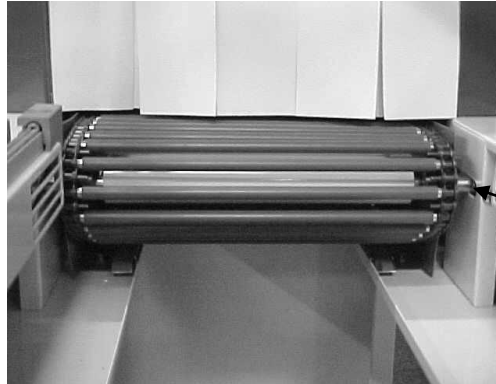

Roller at 3 o'clock position

- K. The adjustment of package conveyor chain tension should be checked occasionally to ensure that it is not excessive, as this would cause unnecessary wear of the sprockets. To check or adjust tension, shut off power to the tunnel. Remove idler end caps. Adjust conveyor to these specifications: On the idler end of the conveyor, bring a roller to the three o'clock position (the center of the end of the conveyor). From that point count seven rollers in; the seventh roller should be evenly touching the conveyor roller bottom rails.

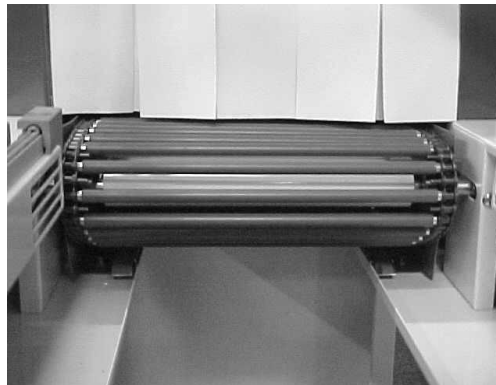

- L. **Replacement of idler roller shaft, bearings, or sprockets.** Disconnect the conveyor chains by removing the master links. Remove two bolts from the idler block holder and shaft assembly should pull right out. Remove two tension bolts

from idler block holder, then the shaft and sprockets will come right off. Replace and reassemble in the same manner as disassembled.



M. Drive shaft, bearings, or sprockets replacement.

- (1) Remove drive end guard instead of idler side.



- (2) Disconnect the conveyor chain by removing the master links.



- (3) Remove two bolts from the flange bearings and remove drive shaft assembly.
- (4) The drive shaft has one sprocket pinned to it and must be reinstalled the same way. The other sprocket and bearings will slide right off the drive shaft. Replace and reassemble.



N. Conveyor motor replacement.

- (1) Disconnect power to machine.

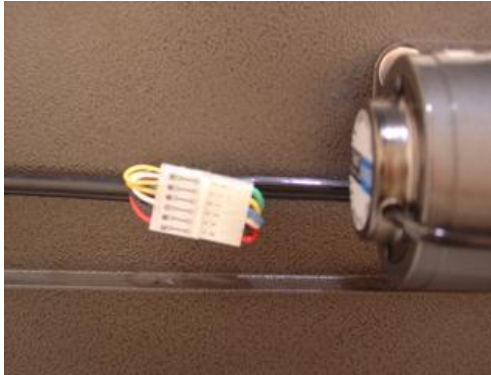

- (2) Disconnect electrical wires from drive motor, and remove four bolts that hold the drive motor.

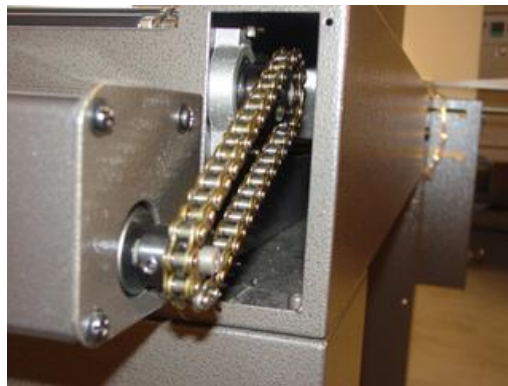

- (3) Remove sprocket from old motor and place on new drive motor. Reassemble in the same manner it was disassembled. For wire hook up refer to electrical schematic, page 82-87.

N. Heater bank replacement.

- (1) Shut off power to machine.



- (2) Remove left side tunnel curtains.

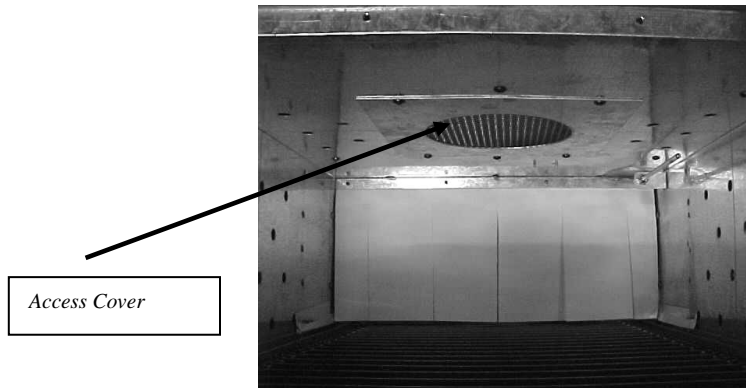

- (3) Remove four (4) access cover screws to Blower Wheel.

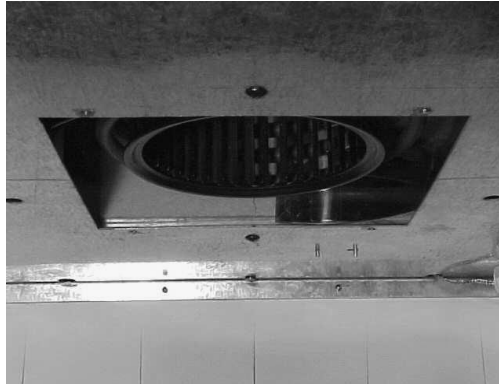

- (4) Remove Blower Wheel Squirrel cage.



- (5) Remove top cover of tunnel hood -- (12) Phillips screws.



- (6) Remove insulation from hood and disconnect two heater wires connected to heater coil.
 - (a) Remove screw holding heater coil in place and remove heater.

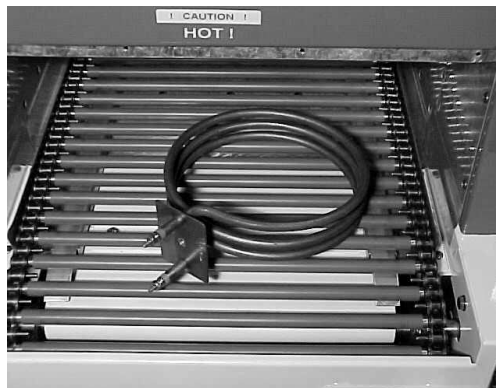

- (b) Then remove heater bank.
 - (c) Replace heater coil. Reassemble in the same manner it was disassembled.

P. Temperature controller replacement.

- (1) Shut off power to machine.
- (2) Remove top tunnel cover.

TDI-1519ECMC—110 Volt Sealer/Tunnel Combination Service Manual

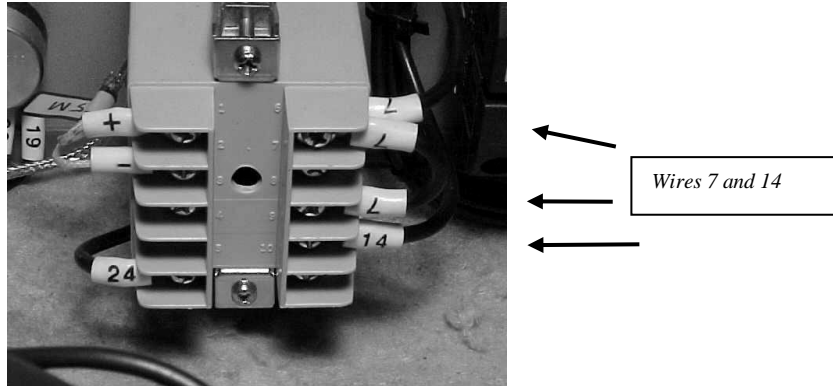

- (3) Disconnect four wires (Two Nos. 7 and 14) and thermocouple wires from temperature controller.
- (4) Loosen screws on side of controller itself and pull controller out of the front of the panel. Replace with new controller. Refer to electrical schematic for replacement of four wires (Two Nos. 7, 14 and 24) and thermocouple wires.

WARNING: IF NO CONTROL OVER HEAT, INTERCHANGE THERMOCOUPLE WIRES.

CAUTION! DO NOT EXCEED 500 DEGREES.

Q. Blower Motor Replacement.

- (1) Shut off power to machine.



- (2) Remove top panel and 12 screws holding the cover.

R. Remove insulation from hood exposing Blower Motor mounting bracket.



- (1) Disconnect wires on the Blower Motor.
- (2) Remove (4) bolts holding Blower Motor.

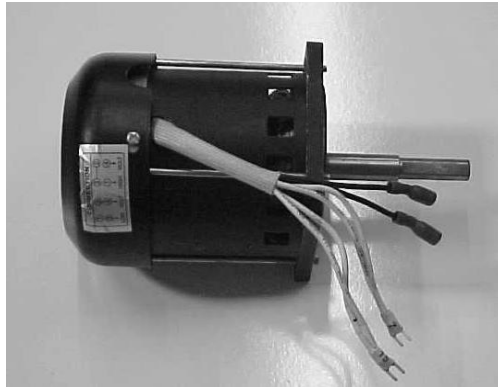

- (3) Replace Blower Motor.
- (4) Reinstall in same manner it was disassembled.

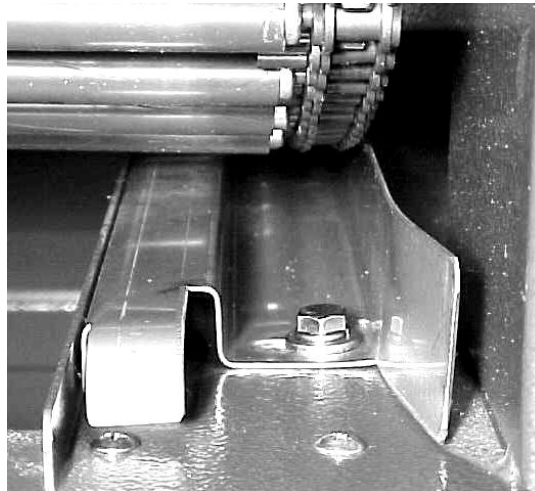

S. Wear rails lower adjustments.

- (1) Disconnect power to machine.
- (2) Remove idler and drive end caps. Loosen four bolts underneath conveyor, and slide rails over towards center. There should be 1/16" to a max. of 1/8" clearance between conveyor chain and roller. Retighten the four bolts and reassemble.

T. **Wear rails lower replacement.**

- (1) Disconnect power to machine.
- (2) Remove idler and drive end caps.
- (3) Remove two bolts underneath conveyor from each wear rail and slide rails out.
- (4) Slide new rails in; reassemble and readjust.

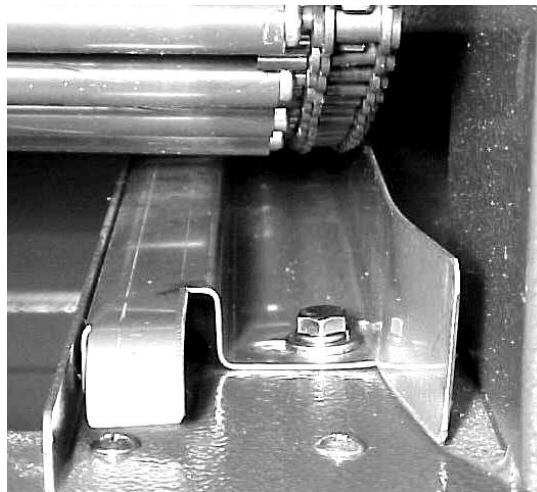

- (5) Wear rail should be 1/8" from edge of chain then tighten bolt to secure wear rails.

U. **Wear rails upper adjustments.**

- (1) Disconnect power to machine.
- (2) Remove drive and idler end caps, and refer to "L." and "M." of this section.

Note: Take out only ten rollers, then move the open space to one end. Loosen the one bolt that holds rail in place. With a screwdriver, pry rail over towards the center. Do the same on all four corners. Spin conveyor by hand and check clearance between chain and roller. The distance

should be about 1/16". Then tighten the four bolts on the rails.

V. Wear rail upper replacement.

- (1) Disconnect power to machine.
- (2) Remove drive and idler end caps, and refer to B-2 of this section.

Note: Take out only top half of rollers, then move the open space to expose upper wear rails. Remove the two bolts that hold rails in place. Pull out rails and replace with new rails; reassemble and readjust. Refer to Section K.

IF UNSURE OF ANYTHING, CONTACT A QUALIFIED SERVICE TECHNICIAN.

DOUBLE-CHECK ALL OF YOUR WORK BEFORE STARTING THE MACHINE.

MAINTENANCE -- L'SEALER

Replacing Band Ribbon

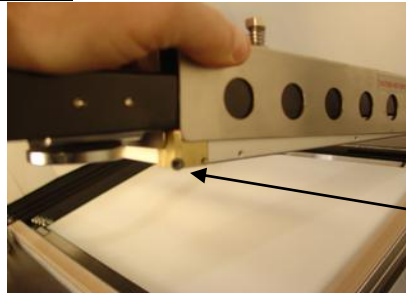

Loosen corner
screws

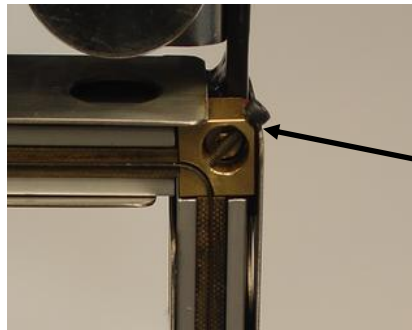

Band Ribbon Corner Screw

- A. Loosen screw holding Band Ribbon in corner.

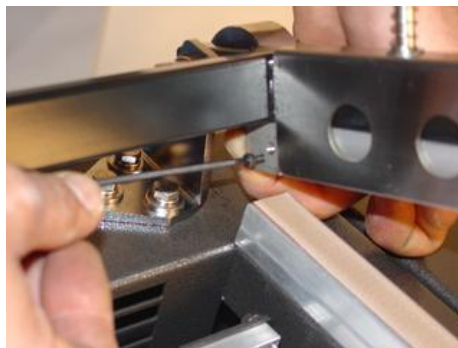

- B. Loosen screw holding Band Ribbon inside rear compensator assembly.



- C. Loosen screw holding Band Ribbon in front compensator assembly.



- D. Remove old Band Ribbon.
- E. Use pre-cut Band Ribbon and place piece of Teflon tape $\frac{1}{2}$ "L x $\frac{1}{4}$ "W x 3 mill around corner of new band ribbon. Install Band Ribbon on corner first then insert into each end of front and side compensator. Band Ribbon may be oversized slightly, if so cut to fit ends.



- F. Compensators are spring loaded. Use screwdriver to push in – flush to transite bars before fastening.

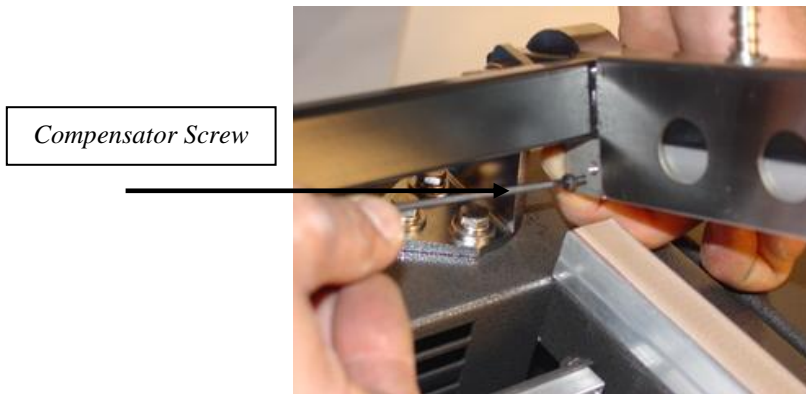

- G. Place other end of band ribbon in slot along front seal area. With band ribbon in slot, use screwdriver to move front compensator forward until band ribbon is inside compensator and compensator is resting against the front seal bar.
- H. Tighten the compensator screw to lock the band ribbon in position.

Replacing Transite Channels

1. Refer to steps on page 72-73 on removing and replacing band ribbon.
2. Remove band ribbon (see page 71-73)

3.

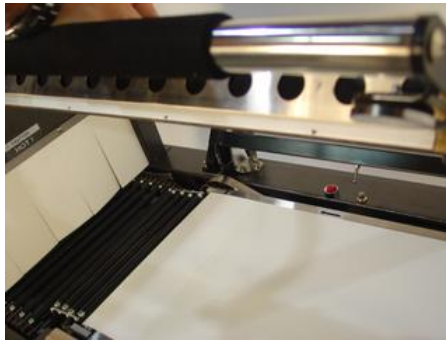

Remove the 4 each set screws holding the transite channels into place on the front and side seal bar.

4. Remove old transite channels and replace with new factory parts.

TAPE REPLACEMENT

The item most subject to wear on the sealer is the Teflon tape used to cover the silicone sponge rubber on the sealing bar. This $\frac{3}{4}$ " x 10 mill tape should never be permitted to burn through. To replace tape, proceed as follows:



1. Strip off old tape.
2. Cut off proper length of new Teflon, peel off backing, and press new tape into position.
3. Apply $\frac{1}{2}$ " x 10 mill Teflon tape over the top of the 2" 3 mill Teflon tape.

SILICONE RUBBER SEALING PAD REPLACEMENT

Occasionally it will be necessary to replace the silicone rubber sealing pads. This should be done if the following is noted:

- Gaps in the seal
- Weak seals
- Improper film cut-off
- Excessive sealing pressure required

To replace rubber, proceed as follows:

1. Seal pads are designed with a channel for easy replacement. Pull silicone rubber out of the channel.
2. Replace with new silicone rubber. Press rubber back into channel.
3. Install 3/4" - 10-mil Teflon tape on top of rubber.
4. Install 1/2" - 10 mil Teflon tape over the 3/4" tape.

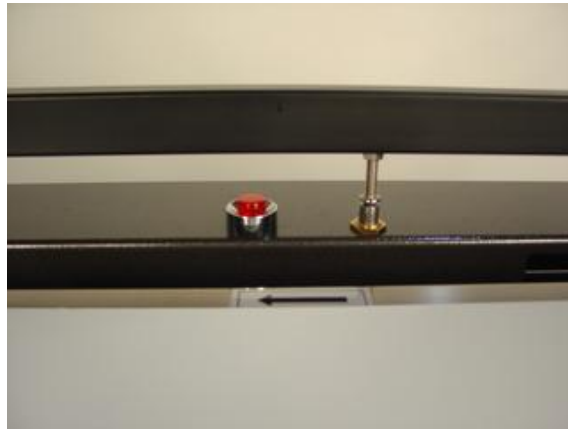
Element Pulse Switch Adjustment

The sealing cycle should not begin until the sealing head is within 1/4" or less of the film to be sealed. If the magnets energize before the head is within 1/4" of the film, loosen the lock-nut and turn the screw (located at the rear end of the side seal bar) up slightly (counterclockwise when viewed from above). The correct adjustment has been obtained when the magnets energize just as the seal bar comes into contact with lower pads.

Optional Adjustment of Magnets for Correct Sealing Pressure

All magnets have been factory adjusted for equal sealing pressure throughout the length of both the front and side seal bars. However, if an adjustment is required, proceed as follows:

1. Disconnect the sealer's power source.



2. Loosen the lower magnet bolts on all lower magnets so that the magnets set to their lowest position in the mounting slots.
3. Lower the sealer's operating handle fully and lift lower magnets to within 1/16" from the holders. Tighten the mounting bolts securely to retain the proper adjustment.

Optional Conveyor

From time to time, it will be necessary to disassemble the conveyor as it will need adjustments or replacement of worn parts and general maintenance. The following information is given to assist the operator in that general fashion. If a problem persists, discuss it with an authorized distributor of Thompson Direct, Inc. or with authorized service personnel.

TDI-1519ECMC—110 Volt Sealer/Tunnel Combination Service Manual

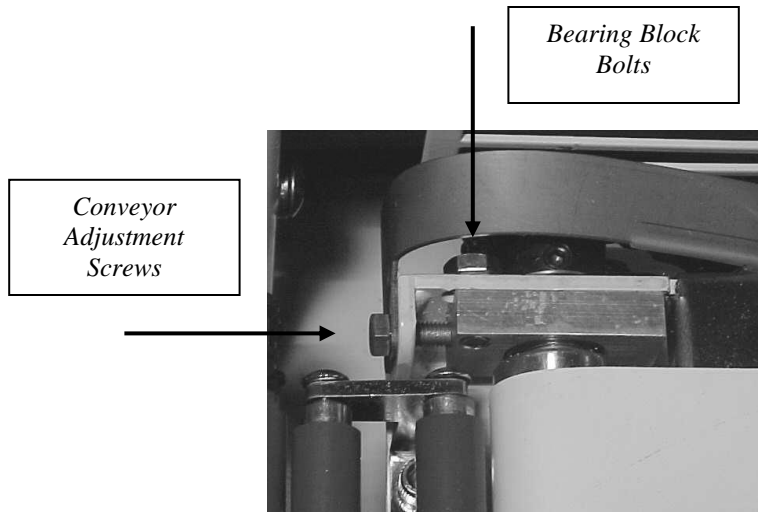

- A. Adjust Discharge Conveyor Belt by loosening the Bearing Block Mounting Bolts, then adjust the Conveyor Adjustment Screw in to loosen belt, or out to tighten belt.

Replacing Conveyor Motor

1. Disconnect power plug from source of power.



2. Disconnect the three power wires from the rear of the motor.
3. Loosen the four bolts that hold the motor mount bracket to the conveyor and slide motor mount forward.
4. Loosen set screws on sprocket that are attached to the motor and remove sprocket.
5. Remove four bolts. These bolts hold the motor in place. Hold motor while removing these bolts so the motor does not drop.

ELECTRICAL SCHEMATIC NOTICE!

This manual contains wiring schematics for the PP-1519EC series machines **(3 models)**. Please verify your model and use the appropriate wiring schematic and electrical drawing that pertains to your machine.

TDI-1519ECMC —110 Volt Sealer/Tunnel Combination Service Manual

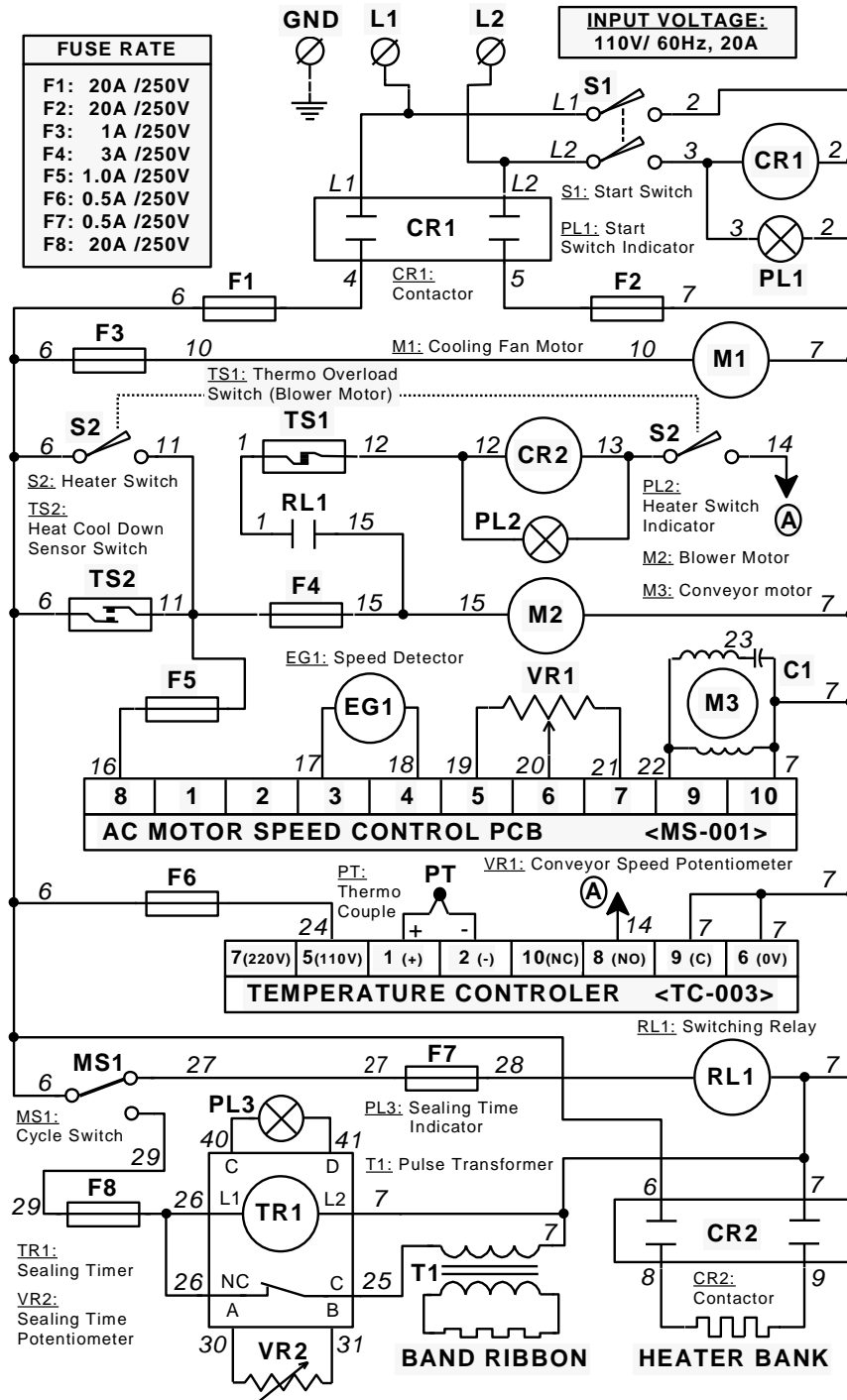

ECONOMY COMBO MODEL: PP1518EC (110V)

ELECTRICAL PANEL DIAGRAM
Controls for PP-1519EC—110 Volt
Tunnel

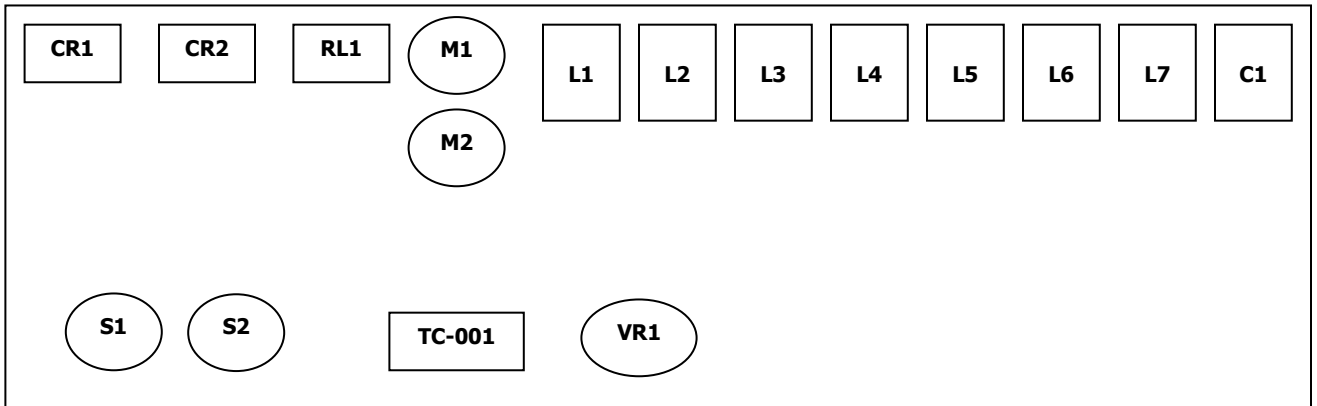

Controls for PP-1519EC—110 Volt
Sealer

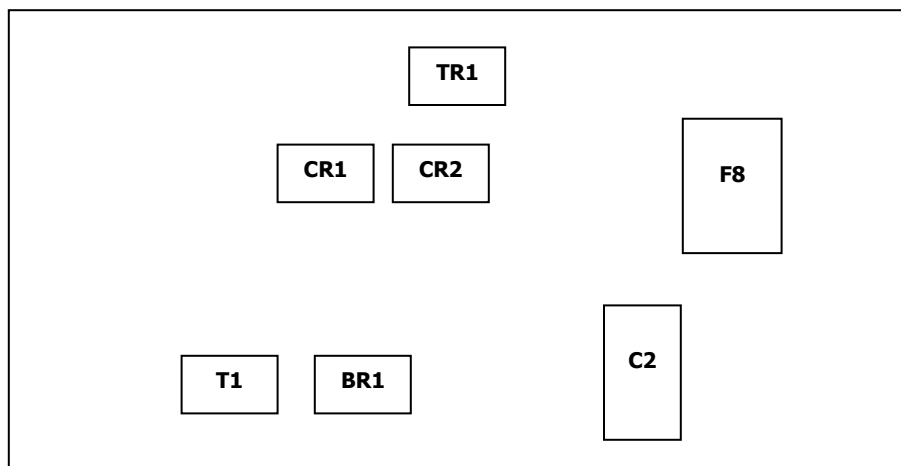

TDI-1519ECMC —110 Volt Sealer/Tunnel Combination Service Manual

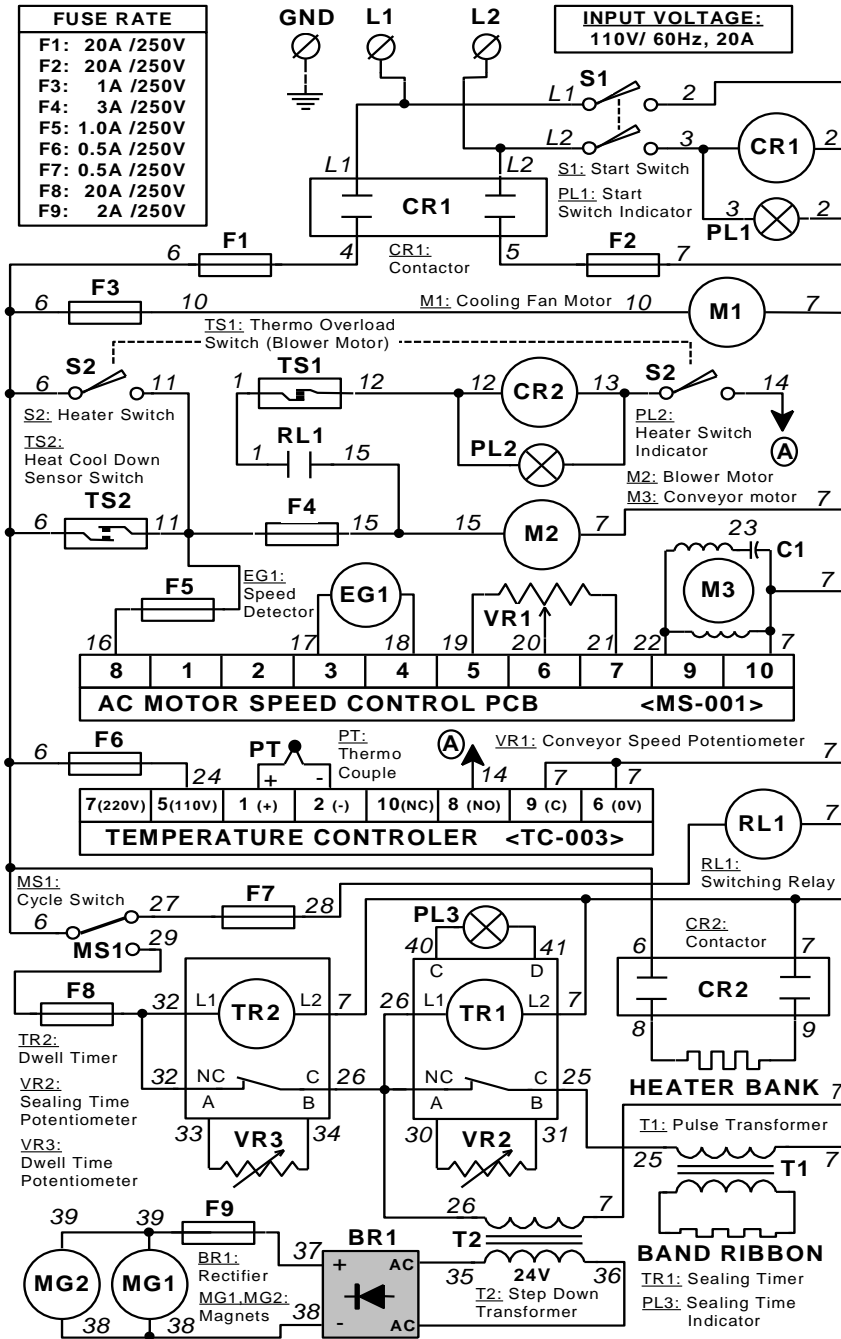

ECONOMY COMBO MODEL: PP1518ECM (110V)

ELECTRICAL PANEL DIAGRAM
Controls for PP-1519ECM—110 Volt
Tunnel

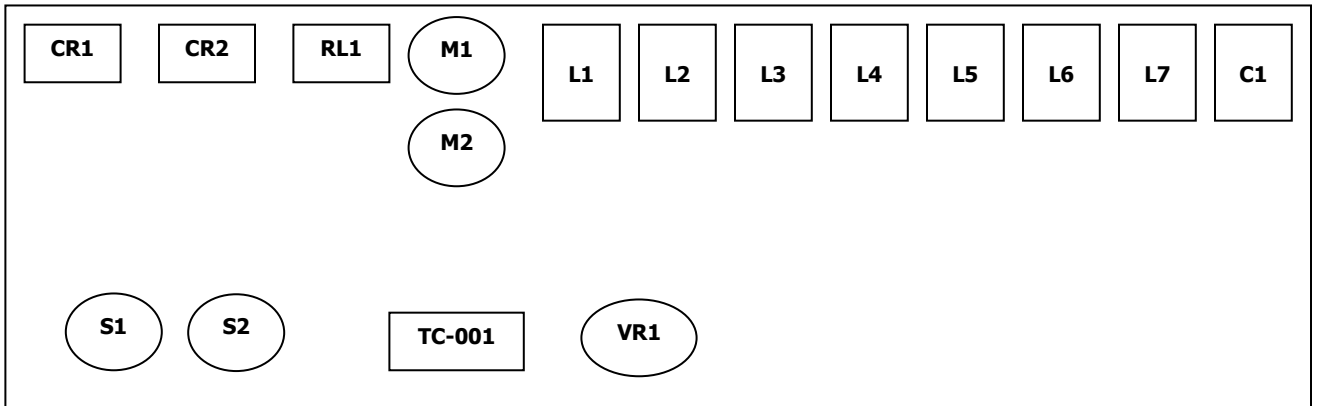

Controls for PP-1519ECM—110 Volt
Sealer

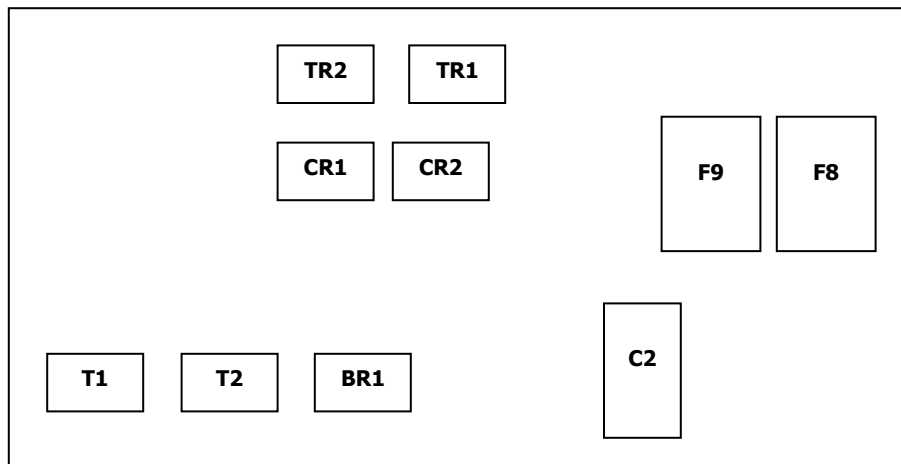

TDI-1519ECMC —110 Volt Sealer/Tunnel Combination Service Manual

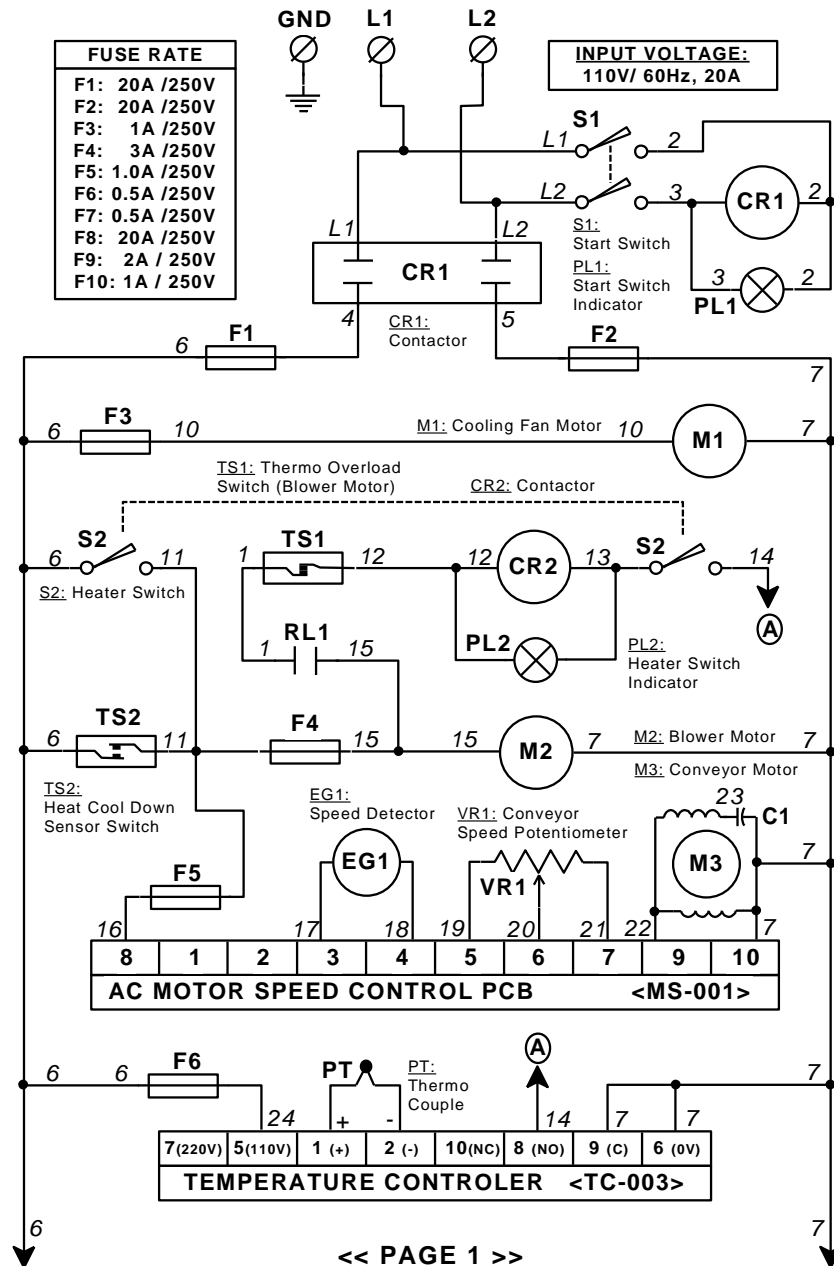

ECONOMY COMBO MODEL: PP1518ECMC (110V)

TDI-1519ECMC —110 Volt Sealer/Tunnel Combination Service Manual

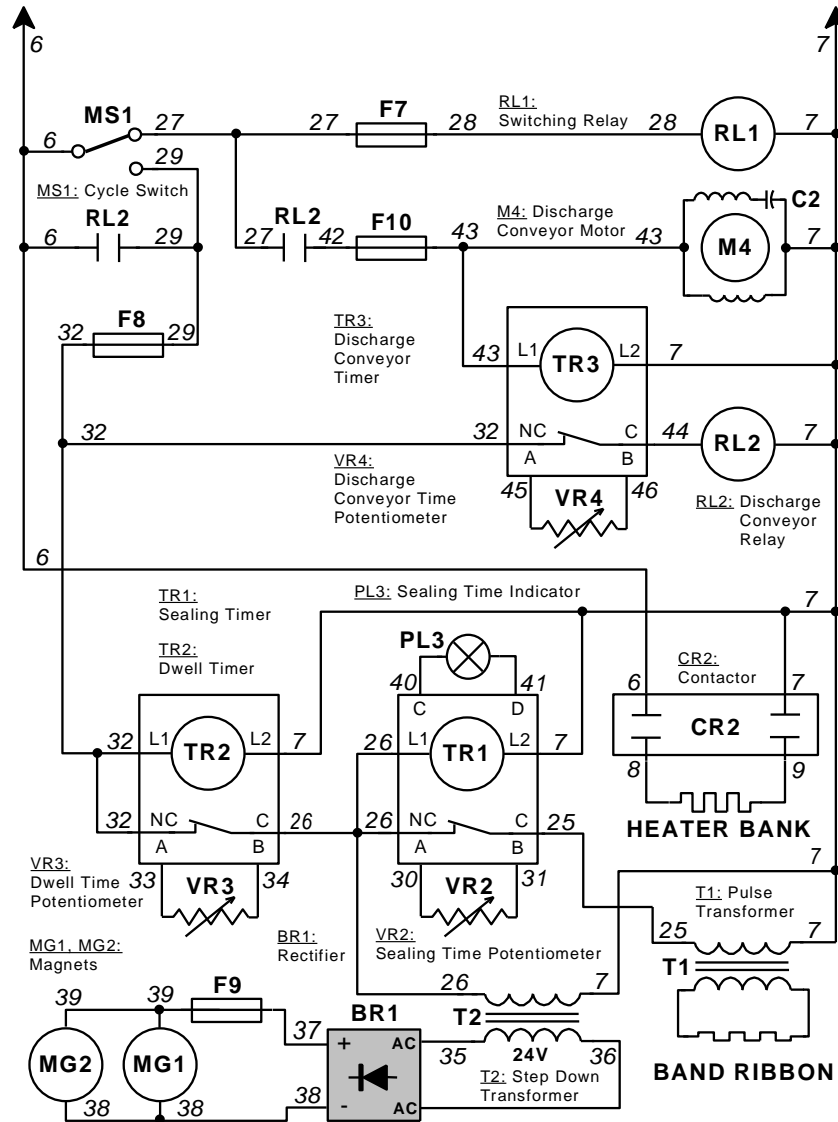

<< PAGE 2 >>

ECONOMY COMBO MODEL: PP1518ECMC (110V)

TDI-1519ECMC —110 Volt Sealer/Tunnel Combination Service Manual

ELECTRICAL PANEL DIAGRAM
Controls for TDI-1519ECMC —110 Volt
Tunnel

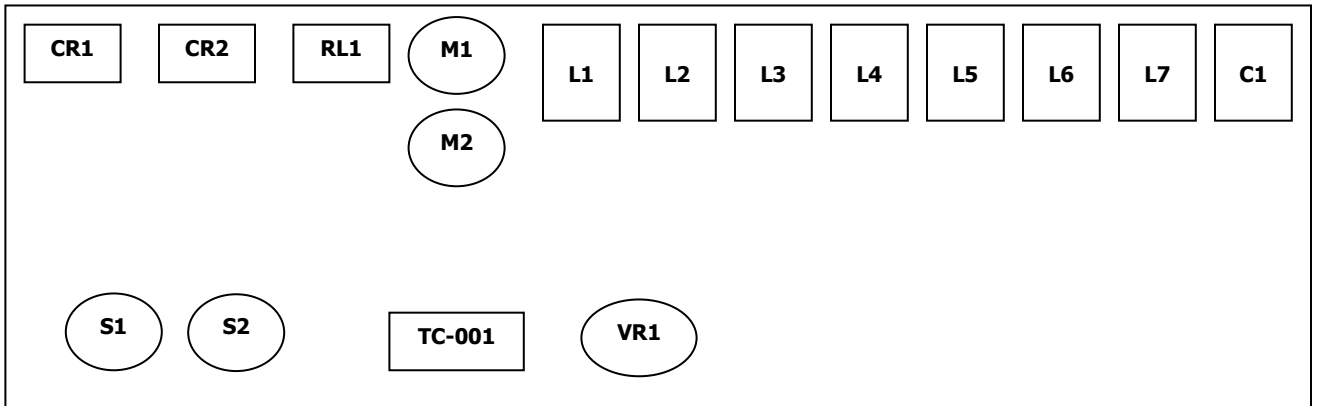

Controls for TDI-1519ECMC —110 Volt
Sealer

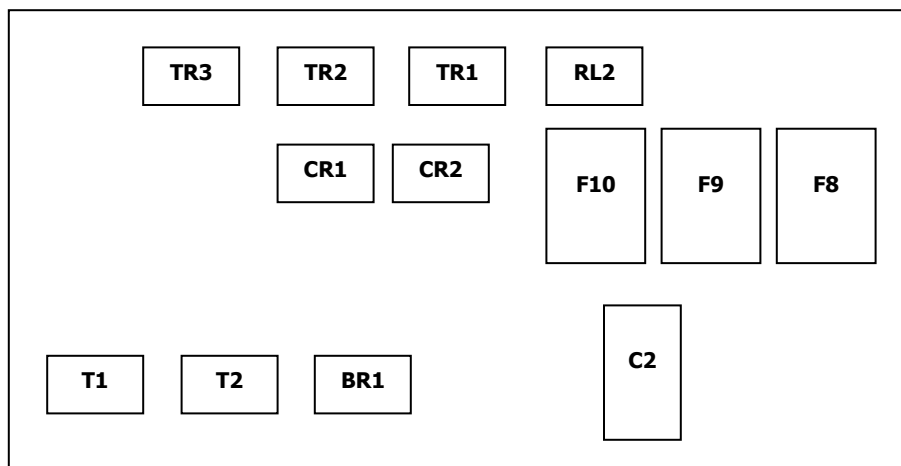

TDI-1519ECMC —110 Volt Sealer/Tunnel Combination Service Manual

MODEL TDI-1519ECMC SERIES

Item	Part #	Qty	Parts List Nomenclature
ACT	3600-30	1	AC Terminal
C1	3500-02	1	Capacitor – 3 MF 400 VAC
CR1	3400-13-110	1	Contactora – 2 Pole, 110V (Optional)
CR2	3400-12-110	1	Contactora Pulse – 110V
M1	1722-37-110	1	Cooling Fan Motor – 110 V
M4	1519-320-110	1	Discharge Conveyor Motor – 110V
F3 F6 F7	1519-335-110	1	Fuse -- .5 AMP
F1 F2 F8	1519-330-110	1	Fuse – 15 AMP, 110V
F4 & F9	1519-340-110	1	Fuse – 2 AMP, 110V
F5 & F10	1519-345-110	1	Fuse, 1 AMP
TS2	3500-46	1	Heat Cool Down Sensor (B-100)
Heater	1519-360-110	1	Heater Bank – 110V
MG1/MG2	1519-375	2	Magnets Hold Down (Optional)
M2	1519-350-110	1	Main Blower – 110V
PL-1 2 3	3600-10-110	3	Pilot Light, 110V
VR-1 2 3 4	3400-68	4	Potentiometer
LS	3400-47	1	Pulse Limit Switch
T1	1519-380		Pulse Transformer
BR1	1720-19	1	Rectifier (Optional)
RL1	1519-390	1	Relay Switching
RL2	1519-385	1	Relay – Discharge Conveyor
EG1	3500-25-110	1	Speed Control AC (PCB1) 110V
T2	1519-425	1	Stepdown Transformer – 110V/24V (Optional)
S1	3600-25	1	Switch-Start
S2	3600-20	1	Switch-Heater
TC-003	1519-355-110	1	Temperature Controller – 110V
TS1	3600-35	1	Thermo Overload Sensor (S-90)
PT	3600-15	1	Thermocouple
TR3	1519-430	1	Timer – Conveyor 110V—Optional
TR2	1519-435	1	Timer – Magnet 110V—Optional
TR1	1519-440	1	Timer – Sealing 110V

TDI-1519ECMC —110 Volt Sealer/Tunnel Combination Service Manual

Item	Part #	Qty	Parts List Nomenclature
M3	3500-08-110	1	Tunnel Conveyor Motor AC (25 W) 110V

TDI-1519ECMC —110 Volt Sealer/Tunnel Combination Service Manual

TDI-1519ECMC 110 VOLT SEALER REPLACEMENT PARTS

Part #	Qty	Description
1519U-701	1	Aluminum "C" Channel- Top-Front 5/8" x 5/8"
1519U-702	1	Aluminum "C" Channel- Top-Side 5/8" x 5/8"
1519U-703	1	Aluminum "C" Channel-Front- Bottom 7/8" x 1/2"
1519U-704	1	Aluminum "C" Channel-Side- Bottom 7/8" x 1/2"
1519U-705	1	Aluminum- Front Bar stock 1" x 3/8"
1519U-706	1	Aluminum-Side Bar stock 1" x 3/8"
1519-013	1	Band Ribbon- 37"
1519-395	1	Belt – Discharge Conveyor
1519-010	2	Blocks – Seal Head Mounting
1519U-028	1	Brass Corner Block
1519U-026	1	Brass Corner Block—Screw
1519-015	4	Casters
1519-400	1	Chain – Discharge Conveyor
1519U-710	2	Compensator Assembly – Complete-Stainless steel
1519U-711	1	Compensator – Screws
1519U-712	1	Compensators – Spring
1519-032	1	Contactors – 20 AMP, 110V
1519-713	2	Film Roll guides
1519-405	1	Discharge Conveyor Assembly-Complete
1519-714	1	Film Rack – Complete
3400-28	1	Fuse F1, F2, 15 AMP
3500-14	1	Fuse F3, F6, F7 .5 AMP,
3400-28	1	Fuse F8 15 AMP
3400-27	1	Fuse F9 2 AMP – (Optional) – Magnets F4
3400-99	1	Fuse F10 1 AMP (Optional) – Discharge Conveyor
3400-32	1	Handle – Crank for Discharge Conveyor
1519-045	1	Head Rear Shaft
1519-046	2	L'Brackets – Seal Bar Mounting Bracket
1519-055	2	Magnets – Upper – Optional
1519-042	2	Magnets coil lower(Optional)
1519-320-110	1	Motor – Discharge Conveyor

TDI-1519ECMC —110 Volt Sealer/Tunnel Combination Service Manual

Part #	Qty	Description
1519-720	2	Pin Perforator Assembly Complete with Shaft
1519-721	2	Pin Perforator Sponge Wheel
1519-070	2	Pin Perforator Wheels with Pins
1519-722	1	Roller – Film Rack Idler Roller
1519U-723	1	Seal Bar – Complete Assembly
3450-15	1	Seal Pad Sponge Rubber – Bottom
1519-130	1	Speed Potentiometer – Conveyor
3440-22	1	Sponge – Handle
1519-420	4	Sprockets – Conveyor Adjustment, Up and Down
1519-185	1	Sprocket – Conveyor Drive Shaft
1519-190	1	Sprocket – Conveyor Motor
3400-47	1	Switch – Impulse
100002	2	Teflon Tape—1/2" x 10 yards x 10 mill (Upper)
100003	1	3/4" 10 yd x 10 mil Teflon tape
1519-022	1	Teflon—Insert/Insulator
1519-150	1	Terminal Strip
3400-77-110	3	Timer – Seal, Magnet or Conveyor
1519-325-110	1	Transformer – Pulse, 110V
1524-27-110	1	Transformer – Stepdown 110V to 24V -- Optional
1519U-724	1	Transite channel –front top
1519U-725	1	Transite channel – side top
1519-165	1	Tray – Product Discharge
1519-075	1	Tray - Product Separator

TDI-1519ECMC —110 Volt Sealer/Tunnel Combination Service Manual

TDI-1519ECMC TUNNEL REPLACEMENT PARTS

Part #	Qty	Description
1519-170-110	1	AC Motor Speed Control – Complete 110V
1519-370	1	Belt – Teflon Mesh – 62 ½" L—Optional
1519-371	1	Belt – Teflon Mesh – Clamp Bar
1519-175-110	1	Blower Motor – 110 V
1519-180	1	Blower Wheel
3500-02	1	Capacitor, 3 MF, 400 VAC
3500-05	2	Chain – Master Link #40 Extended Pin
3600-06	2	Chain – Pinned #40
1519-190	1	Chain – Riveted #30
1519-190	1	Contactora – 2 Pole, 20 AMP 110V
1519-375	1	Contactora – 25 Amp
3500-08-110	1	Motor – Conveyor AC (25 W)
1519-205-110	1	Cooling Fan Motor
1519-215	2	Curtain Material Set
1519-220	1	Drive Shaft
1519-230	1	Fuse Block
3400-86	1	Fuse F4 3AMP
3500-14	1	Fuse F6 .5 AMP
1519-235	1	Fuse Holder
1519-330-110	2	Fuses F1 and F2 15 AMP
1519-260	2	Fuses F3 and F5 1 AMP
1519-240	2	Guide Rails
3500-46	1	Heat Cool Down Sensor (B-100)
1519-360-110	1	Heater Bank –110 V
1519-250	1	Idler Shaft
1519-255	59	Roller 12 ¾" – Covered 59
3500-26	2	Sprocket – Conveyor Drive
3500-27	2	Sprocket – Conveyor Idler with Bearing
3500-28	1	Sprocket – Conveyor Motor
3500-21	1	Switch – Heater Bank S2
3500-20	1	Switch – Start S1
1519-355-110	1	Temperature Controller – 110V

TDI-1519ECMC —110 Volt Sealer/Tunnel Combination Service Manual

Part #	Qty	Description
1519-310	1	Terminal Strip – Short – 3 Lug
3600-35	1	Thermo Overload Sensor (S-90)-Motor
3500-30	1	Thermocouple Probe
3500-29	1	Thermocouple Probe Holder
3500-70	1	Wire – High Temperature

TDI-1519ECMC —110 Volt Sealer/Tunnel Combination Service Manual

Spare Parts List

Item #	Part #	Description	Qty.	Price
1	1519-013	Band Ribbon	2	
2	1519-332-110	Fuse – 20 Amp	2	
3	1519-335-110	Fuse - .5 Amp	2	
4	1519-340-110	Fuse – 2 Amp	2	
5	1519-348-110	Fuse – 1 Amp	2	
6	1519-342-110	Fuse – 3 Amp	2	
7	1710-28	Lubrication Chain	1	
8	100002	1/2"x10 mill x 10yd Teflon Tape	1	
9	100003	3/4" X 10yd x 10mill	1	
10	3450-15	Seal Pad Rubber-Bottom	10ft	
11	1519U-724	Transite channel – Front	1	
12	1519U-725	Transite channel – Side	1	
Total Cost				\$call

TDI-1519ECMC —110 Volt Sealer/Tunnel Combination Service Manual

**Spare Parts Kit For
TDI-1519EC Series-110V, TDI-1519ECM, TDI-1519ECMC**

Item #	Part #	Description	Qty.	Price
1	1519-013	Band Ribbon	2	
2	1519U-724	Channel – Front transite	1	
3	1519U-725	Channel – Side transite	1	
4	1519-332-110	Fuse – 20 Amp	2	
5	1519-335-110	Fuse – .5 Amp	2	
6	1519-340-110	Fuse – 2 Amp	2	
7	1519-348-110	Fuse – 1 Amp	2	
8	1519-342-110	Fuse – 3 Amp	2	
9	1710-28	Lubrication Chain	1	
10	100002	1/2" x 10 mill x 10 yd. Teflon Tape	1	
11	100003	3/4" x 10 yd x 3 mil	1	
11	3450-15	Seal Pad Rubber – Bottom	1	
Total Cost				\$call