

# SHIMANO 105 Front Chainwheel

## FC-5703-S Silver Version

## FC-5703-L Black Version

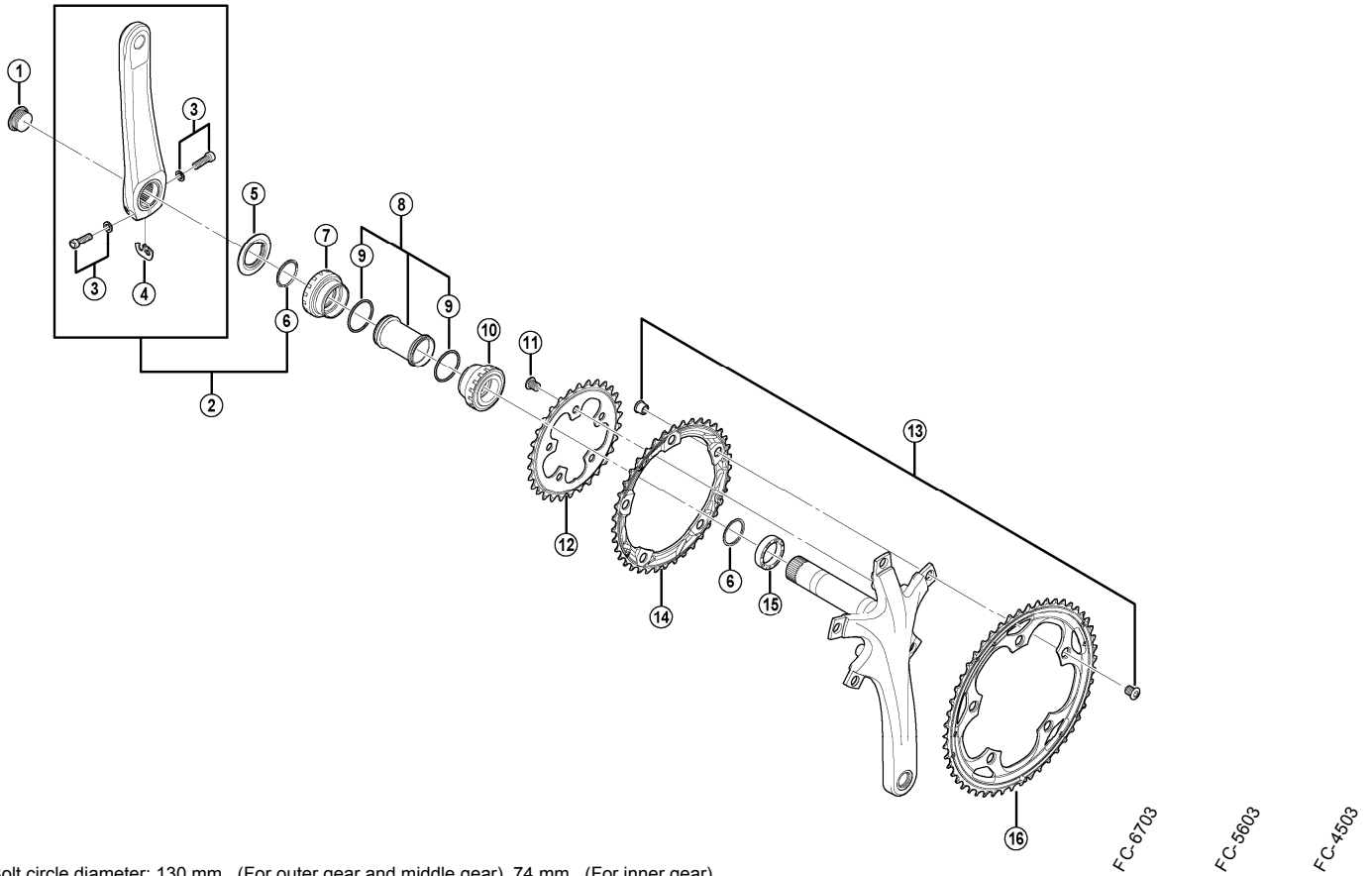

● Bolt circle diameter: 130 mm...(For outer gear and middle gear), 74 mm...(For inner gear)

ITEM NO.	SHIMANO CODE NO.	DESCRIPTION	INTERCHANGEABILITY		
1	Y1KS13000	Crank Arm Fixing Bolt	A		
	Y1M398010	Left Hand Crank Arm 165 mm (Silver) for FC-5703-S	B		
	Y1M398050	Left Hand Crank Arm 165 mm (Black) for FC-5703-L	B		
	Y1M398020	Left Hand Crank Arm 170 mm (Silver) for FC-5703-S	B		
2	Y1M398060	Left Hand Crank Arm 170 mm (Black) for FC-5703-L	B		
	Y1M398030	Left Hand Crank Arm 172.5 mm (Silver) for FC-5703-S	B		
	Y1M398070	Left Hand Crank Arm 172.5 mm (Black) for FC-5703-L	B		
	Y1M398040	Left Hand Crank Arm 175 mm (Silver) for FC-5703-S	B		
	Y1M398080	Left Hand Crank Arm 175 mm (Black) for FC-5703-L	B		
3	Y1KS98030	Clamp Bolt (M6 x 19) & Washer			A
4	Y1GE98050	Plate	A	A	A
5	Y1GF11000	Spacer (3 mm)	A	A	A
6	Y1F316000	Ring	A	A	A
7	Y1M398090	Left Hand Adapter (B.C.1.37" x 24T) English Thread	B	B	B
	Y1M398100	Left Hand Adapter (M36 x 24T) Italian Thread	B	B	B
8	Y1G398150	Inner Cover & O-Ring	A	A	B
9	Y1TF21000	O-Ring	A	A	A
10	Y1M398110	Right Hand Adapter (B.C.1.37" x 24T) English Thread	B	B	B
	Y1M398120	Right Hand Adapter (M36 x 24T) Italian Thread	B	B	B
11	Y1M498050	Gear Fixing Bolt (TORX <sup>®</sup> ** / M8 x 8.5 / 5pcs.)			B
* 12	Y1M430020	Chainring 30T (Silver) for FC-5703-S		B	
* 12	Y1M430030	Chainring 30T (Black) for FC-5703-L		B	
13	Y1M398170	Gear Fixing Bolt (TORX <sup>®</sup> ** / M8 x 8.5) & Nut (5 sets)		B	B
14	Y1M498010	Chainring 39T-D (Silver) for FC-5703-S			
	Y1M498020	Chainring 39T-D (Black) for FC-5703-L			
15	Y1F913000	Spacer (6.5 mm)	A	A	A
16	Y1M498030	Chainring 50T-D (Silver) for FC-5703-S			
	Y1M498040	Chainring 50T-D (Black) for FC-5703-L			

A: Same parts.

B: Parts are usable, but differ in materials, appearance, finish, size, etc.

Absence of mark indicates non-interchangeability.

Dec.-2010-3004B

© Shimano Inc. A

\*\* TORX is a registered trademark of Camcar LLC.

Specifications are subject to change without notice.

# SHIMANO

## General Safety Information

### ⚠ WARNING

- Be careful not to let the cuffs of your clothes get caught in the chain while riding, otherwise you may fall off the bicycle.
- Check that the tension of the chain is correct and that the chain is not damaged. If the tension is too weak or the chain is damaged, the chain should be replaced. If this is not done, the chain may break and you may fall off the bicycle.
- The two left crank arm mounting bolts should be tightened alternately in stages rather than each bolt being fully tightened all at once. Use a torque wrench to check that the final tightening torques are within the range of 12 - 14 N·m. Furthermore, after riding approximately 100 km (60 miles), use a torque wrench to re-check the tightening torques. It is also important to periodically check the tightening torques. If the tightening torques are too weak or if the mounting bolts are not tightened alternately in stages, the left crank arm may come off and the bicycle may fall over, and serious injury may occur as a result.
- Check that there are no cracks in the crank arms before riding the bicycle. If there are any cracks, the crank arm may break and you may fall off the bicycle.
- If the inner cover is not installed correctly, the axle may rust and become damaged, and the bicycle may fall over and serious injury may occur as a result.
- **Obtain and read the service instructions carefully prior to installing the parts.** Loose, worn or damaged parts may cause the bicycle to fall over and serious injury may occur as a result. We strongly recommend only using genuine Shimano replacement parts.
- **Obtain and read the service instructions carefully prior to installing the parts.** If adjustments are not carried out correctly, the chain may come off and this may cause you to fall off the bicycle which could result in serious injury.
- Read these Technical Service Instructions carefully, and keep them in a safe place for later reference.

### ⚠ CAUTION

- If the chain is on the smallest or intermediate chainring, there is the danger of injury from the tips of the teeth on the largest chainring.

### Note

- Make sure that the chainring combination matches the front chainwheel tooth configuration in the Product specifications table. If other combinations are used, the distance between the chainrings will be incorrect and the chain might slip off and get caught in between them.
- When the chain is in the position shown in the illustration, the chain may contact the front chainrings or front derailleur and generate noise. If the noise is a problem, shift the chain onto the next-larger rear sprocket or the one after.
- If the bottom bracket shell is not parallel, gear shifting performance will drop.
- Use the CN-7801/CN-6600/CN-5600 with the FC-5703.
- Before riding the bicycle, check that there is no play or looseness in the connection. Also, be sure to retighten the crank arms and pedals at periodic intervals.
- If a squeaking noise is heard coming from the bottom bracket axle and the left crank arm connector, apply grease to the connector and then tighten it to the specified torque.
- If you feel any looseness in the bearings, the bottom bracket should be replaced.
- In addition, if pedaling performance does not feel normal, check this once more.
- Do not wash the bottom bracket with high-pressure jets of water.
- When installing the left and right adapters, be sure to install the inner cover too, otherwise the waterproofing performance will drop.
- Apply grease to the left and right adapters before installing them.
- To ensure the best performance, be sure to use only the specified type of chain. The wide type of chain cannot be used.
- If the chain keeps coming off the chainrings during use, replace the chainrings and the chain.
- You should periodically wash the chainrings in a neutral detergent and then lubricate them again. In addition, cleaning the chain with neutral detergent and lubricating it can be an effective way of extending the useful life of the chainrings and the chain.
- The cuffs of your clothing may get dirty from the chain while riding.
- Parts are not guaranteed against natural wear or deterioration resulting from normal use.
- For maximum performance we highly recommend Shimano lubricants and maintenance products.
- For any questions regarding methods of installation, adjustment, maintenance or operation, please contact a professional bicycle dealer.

	Double	Triple
Front chainrings		
Rear sprockets		

## Technical Service Instructions

SI-1M30A-003

# FC-5700 / FC-5703 / FC-5750

## Front chainwheel

### Specifications

Model number	FC-5700	FC-5703	FC-5750
Chainwheel tooth combination	52B-39T 53B-39T	50D-39D-30T	50F-34T
Bolt circle diameter	130 mm	130 / 74 mm	110 mm
Crank arm length	165, 170, 172.5, 175 mm		
Pedal threads	B.C. 9/16" x 20T.P.I. (English thread)		
Applicable chain	CN-7901 CN-6701 CN-5701	CN-7801 CN-6600 CN-5600	CN-7901 CN-6701 CN-5701
Chain line	43.5 mm	45 mm	43.5 mm
Bottom bracket shell width (Thread dimensions)	68 mm (1.37 X 24 T.P.I.) 70 mm (M36 X 24 T.P.I.)		
Bottom bracket	SM-BB5700		

### Installation of the chainrings

- Smooth shifting will not be possible if the chainrings are incorrectly installed, so be sure to install the chainrings in the correct positions.

### Installation of the front chainwheel

Follow the procedure in the figure.

2. Use the TL-FC32/36 special tool to install the right adapter (counterclockwise thread), the inner cover and the left adapter (clockwise thread).  
Tightening torque: 35 - 50 N·m {305 - 435 in. lbs.}
3. Insert the right crank unit.
4. Set section A of the left crank into the axle of the right crank unit where the groove is wide. (Insert a spacer and a ring when installing the FC-5703 left crank unit.)
5. Use the TL-FC16/18 to tighten the cap.  
Tightening torque: 0.7 - 1.5 N·m {6 - 13 in. lbs.}
6. Push in the stopper plate and check that the plate pin is securely in place, and then tighten the bolt of the left crank arm. (5 mm Allen key)

**Note :** Each of the bolts should be evenly and equally tightened to 12 - 14 N·m {106 - 122 in. lbs.}.

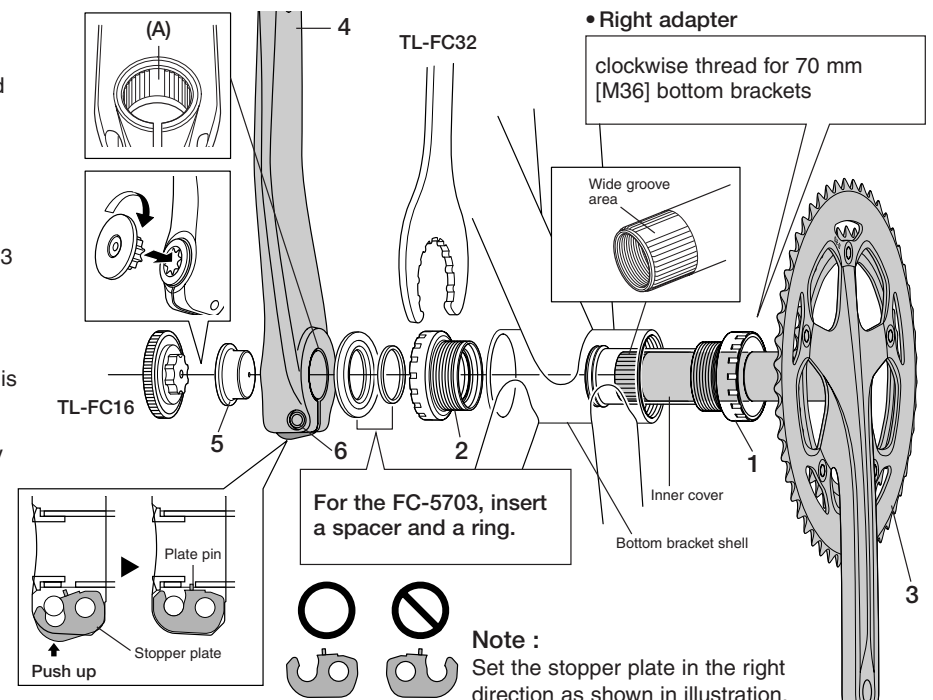

### < FC-5700 / 5750 >

With the marked surface of the larger chainring facing out, set the larger chainring so that the chain drop prevention pin is lined up with the crank arm position.

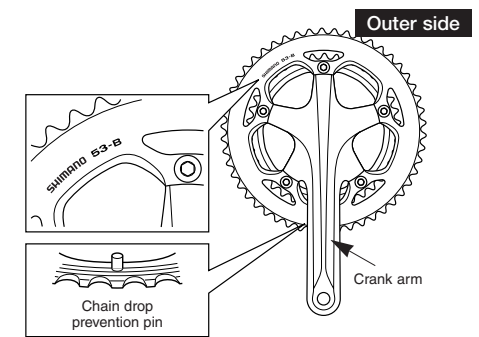

With the marked surface of the smaller chainring facing away from the crank arm, set the chainring so that the  $\Delta$  mark is lined up with the crank arm position.

**Tightening torque :**  
12 - 14 N·m  
{106 - 122 in. lbs.}

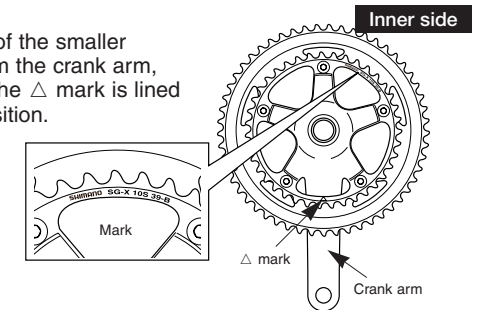

### < FC-5703 >

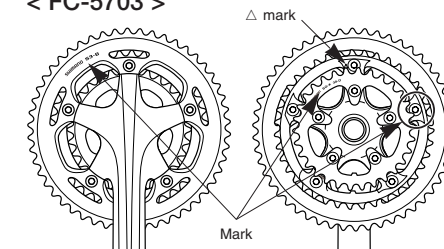

**Largest chainring / Intermediate chainring**  
Tightening torque :  
12 - 14 N·m {106 - 122 in. lbs.}

**Smallest chainring**  
Tightening torque :  
14 - 16 N·m {122 - 139 in. lbs.}

For the FC-5703, the tooth number marking on the largest chainring should face outward, and the markings on the intermediate and smallest chainrings should face inward.

# SHIMANO

SHIMANO AMERICAN CORPORATION  
One Holland, Irvine, California 92618, U.S.A. Phone: +1-949-951-5003

SHIMANO EUROPE B.V.  
Industrieweg 24, 8071 CT Nunspeet, The Netherlands Phone: +31-341-272222

SHIMANO INC.  
3-77 Oimatsu-cho, Sakai-ku, Sakai-shi, Osaka 590-8577, Japan

\* Service Instructions in further languages are available at :  
<http://techdocs.shimano.com>