

XTR Rear Derailleur (9-Speed)

RD-M970-GS Long Cage

RD-M970-SGS Super Long Cage

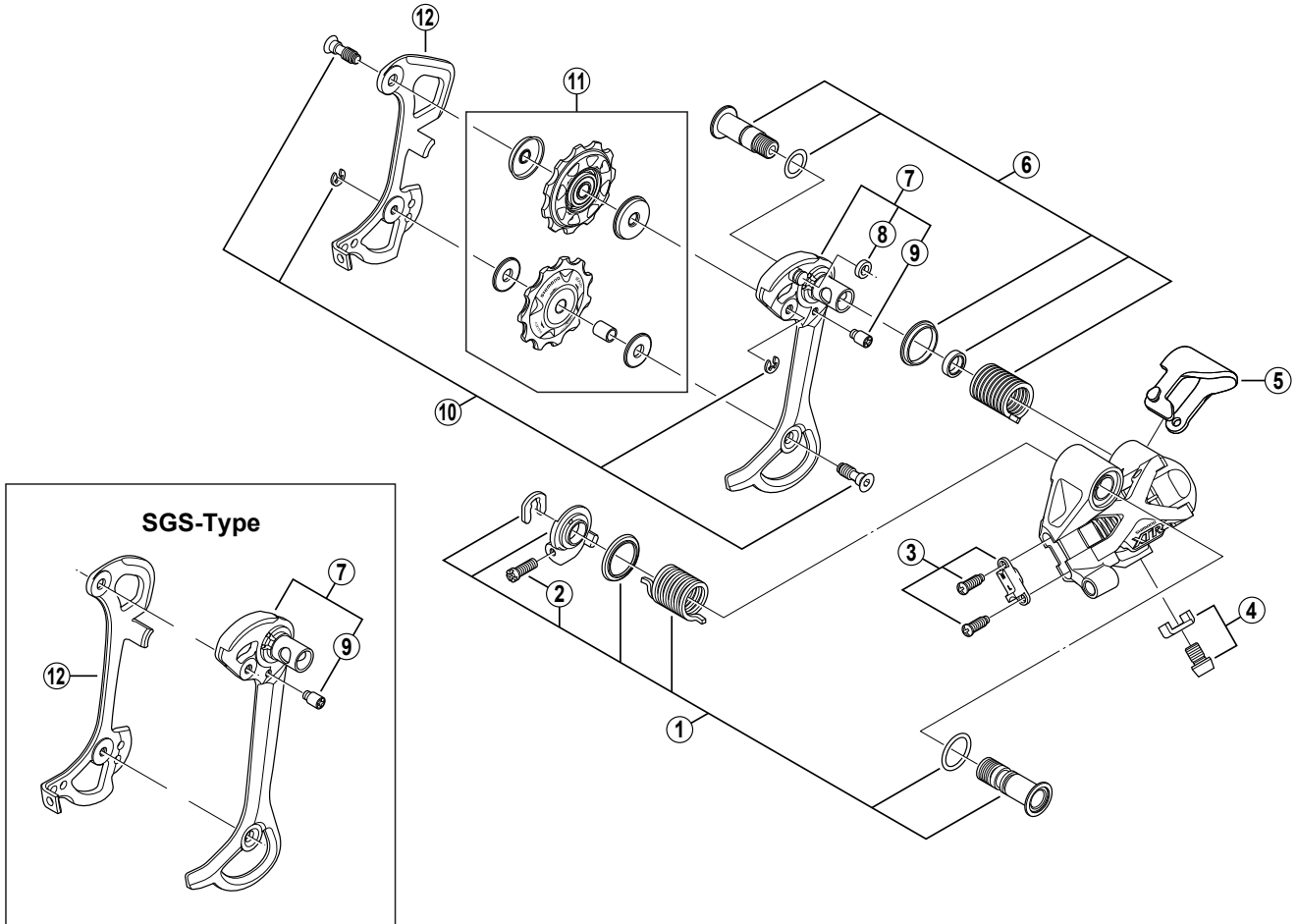

RD-M971
RD-M960
RD-M760

ITEM NO.	SHIMANO CODE NO.	DESCRIPTION	INTERCHANGEABILITY
1	Y-5VW98010	B-Axle Assembly	A B
2	Y-53M 21000	B-Tension Adjusting Screw (M4 x 12)	A A B
3	Y-5VW98020	Stroke Adjusting Screws (M4 x 11.5) & Plate	A
4	Y-5VW98030	Cable Fixing Bolt (M6 x 8) & Plate	A
5	Y-5U5 25100	Cover	A B
6	Y-5VW98040	Plate Axle Assembly	A B
7	Y-5VW98050	Outer Plate Assembly (GS-Type)	A B
	Y-5VW98060	Outer Plate Assembly (SGS-Type)	A B
8	Y-5U5 26000	Outer Plate Pin Cover	A A
9	Y-559 19200	Plate Stopper Pin	A B
10	Y-5VW98090	Pulley Bolt Unit	A B B
11	Y-5VW98100	Tension & Guide Pulley Set	A B B
12	Y-5U5 09100	Inner Plate (GS-Type)	A B B
	Y-5U5 10100	Inner Plate (SGS-Type)	A B

A: Same parts.

B: Parts are usable, but differ in materials, appearance, finish, size, etc.

Absence of mark indicates non-interchangeability.

0607-2606

Specifications are subject to change without notice.

SHIMANO

General Safety Information

WARNING

- Use neutral detergent to clean the chain. Do not use alkali-based or acid based detergent such as rust cleaners as it may result in damage and/or failure of the chain.
- Use the reinforced connecting pin only for connecting the narrow type of chain.
- There are two different types of reinforced connecting pins available. Be sure to check the table below before selecting which pin to use. If connecting pins other than reinforced connecting pins are used, or if a reinforced connecting pin or tool which is not suitable for the type of chain is used, sufficient connection force may not be obtained, which could cause the chain to break or fall off.

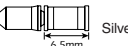
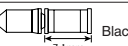
Chain	Reinforced connecting pin	Chain tool
9-speed super narrow chain such as CN-7701 / CN-HG93	 Silver	TL-CN32 / TL-CN23
8-/7-/6-speed narrow chain such as CN-HG50 / CN-IG51	 Black	TL-CN32 / TL-CN23

- If it is necessary to adjust the length of the chain due to a change in the number of sprocket teeth, make the cut at some other place than the place where the chain has been joined using a reinforced connecting pin or an end pin. The chain will be damaged if it is cut at a place where it has been joined with a reinforced connecting pin or an end pin.
- Check that the tension of the chain is correct and that the chain is not damaged. If the tension is too weak or the chain is damaged, the chain should be replaced. If this is not done, the chain may break and cause serious injury.
- Obtain and read the service instructions carefully prior to installing the parts. Loose, worn, or damaged parts may cause injury to the rider. We strongly recommend only using genuine Shimano replacement parts.
- Read these Technical Service Instructions carefully, and keep them in a safe place for later reference.

Note

- If gear shifting operations do not feel smooth, wash the derailleur and lubricate all moving parts.
- If the amount of looseness in the links is so great that adjustment is not possible, you should replace the derailleur.
- You should periodically clean the derailleur and lubricate all moving parts (mechanism and pulleys).
- If gear shifting adjustment cannot be carried out, check the degree of parallelism at the rear end of the bicycle. Also check if the cable is lubricated and if the outer casing is too long or too short.
- If you hear abnormal noise as a result of looseness in a pulley, you should replace the pulley.
- If the chain keeps coming off the sprockets during use, replace the sprockets and the chain.
- Adjust the RD-M970 reverse spring type rear derailleur from the low side.
- Use a frame with internal cable routing is strongly discouraged as it has tendencies to impair the SIS shifting function due to its high cable resistance.
- Always be sure to use the sprocket set bearing the same group marks.
- Never use in combination with a sprocket bearing a different group mark.
- Use an outer casing which still has some length to spare even when the handlebars are turned all the way to both sides. Furthermore, check that the shifting lever does not touch the bicycle frame when the handlebars are turned all the way.
- Make sure that the gear shifting cable and the brake cable do not obstruct each other during braking operations. If they do obstruct, it may interfere with braking.
- Install the cables so that they still have some slack in them even when the handlebars are turned fully in either direction.
- A special grease is used for the gear shifting cable (SIS-SP41). Do not use DURA-ACE grease or other types of grease, otherwise they may cause deterioration in gear shifting performance.
- Grease the inner cable and the inside of the outer casing before use to ensure that they slide properly.
- For smooth operation, use the specified outer casing and the bottom bracket cable guide.
- Operation of the levers related to gear shifting should be made only when the front chainwheel is turning.
- Parts are not guaranteed against natural wear or deterioration resulting from normal use.
- For maximum performance we highly recommend Shimano lubricants and maintenance products
- For any questions regarding methods of installation, adjustment, maintenance or operation, please contact a professional bicycle dealer.

Technical Service Instructions

SI-5VW0A

RD-M970

Rear derailleur

In order to realize the best performance, we recommend that the following combination be used.

Series	XTR
DUAL CONTROL lever	ST-M975
Outer casing	SIS-SP41
Rear derailleur	RD-M970
Type	SGS / GS
Freehub	FH-M975 / FH-M970
Gears	9
Cassette sprocket	CS-M970
Chain	CN-7701
Bottom bracket guide	SM-SP17 / SM-BT17

These Service Instructions describe the operation method when using the ST-M975 DUAL CONTROL lever in combination with the RD-M970 reverse spring-type rear derailleur. If using in combination with the RD-M971 top normal-type derailleur, the operations will be reversed.

Operating the levers

Operating the brake lever

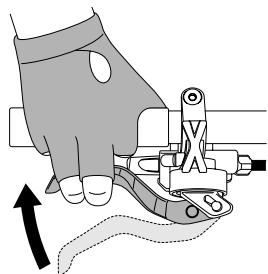

Gear shifting operation

The INSTANT RELEASE mechanism makes fast gear shifting possible because cable tension is released immediately when either the main lever or the secondary release lever is depressed. The levers are also equipped with a MULTI RELEASE mechanism so that you can now shift two gears with a single operation.

The lever always returns to the initial position when it is released after shifting. When operating the lever, always be sure to turn the crank arm at the same time.

To shift from a large sprocket to a smaller sprocket

You can vary the lever stroke to shift the desired number of gears, so that to shift by one gear only, move the lever to the (1) position, and to shift by two gears at one time, move the lever to the (2) position. A maximum two-gear shift can be made in this manner.

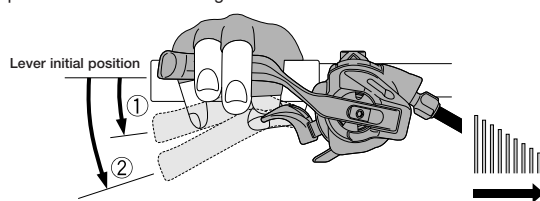

Adjusting the grip width

It is recommended that you adjust the grip widths of the levers to the most comfortable widths for gear shifting and braking.

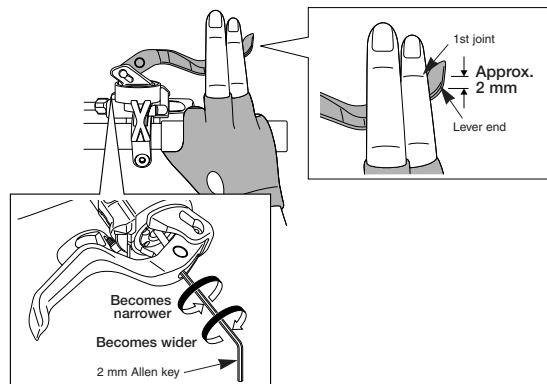

Installation of the rear derailleur

When installing, be careful not to let the B-tension adjustment screw come into contact with the dropout tab, otherwise deformation may result. Do not remove the Pro-Set alignment block at this time.

Bracket spindle Tightening torque :
8 - 10 N·m {70 - 86 in. lbs.}

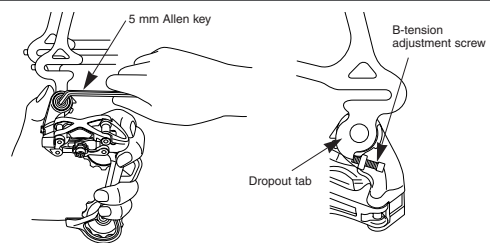

Chain length on bicycles with rear suspension

The length of A will vary depending on the movement of the rear suspension. Because of this, an excessive load may be placed on the drive system if the chain length is too short. Set the length of the chain by adding two links to the chain when the rear suspension is at a position where dimension "A" is longest and the chain is on the largest sprocket and the largest chainring. If the amount of movement of the rear suspension is large, the slack in the chain may not be taken up properly when the chain is on the smallest sprocket and smallest sprocket.

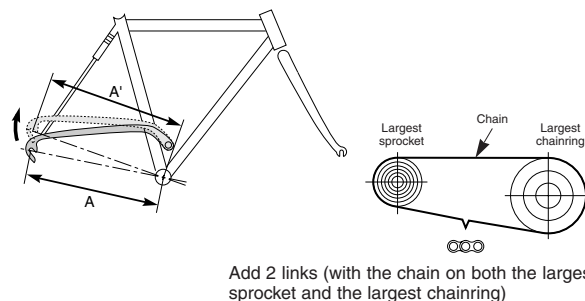

Tightening torque :
5 - 7 N·m {44 - 60 in. lbs.}

Connect the cable to the rear derailleur and, after taking up the initial slack in the cable, re-secure to the rear derailleur as shown in the illustration.

Pull

Tightening torque :
5 - 7 N·m {44 - 60 in. lbs.}

Connect the inner cable to the derailleur as shown in the illustration.

Note: Be sure that the cable is securely in the groove.

Install the inner hole cover by turning it as shown in the illustration until it stops. Do not turn it any further than this, otherwise it may damage the thread on the cover.

Tightening torque :
0.3 - 0.5 N·m {3 - 4 in. lbs.}

Turn the cable adjustment bolt clockwise to tighten it until the chain returns to the 2nd sprocket. * Turn the adjustment bolt together with the outer casing adjustment barrel cover.

Turn the cable adjustment bolt counterclockwise to loosen it until the chain touches a sprocket and generates noise. * Turn the adjustment bolt together with the outer casing adjustment barrel cover.

Best setting

The best setting is when the cable adjustment bolt is tightened (turned clockwise) until noise occurs without lever being operated, and then loosened (turned counterclockwise) 90 - 180 degrees from that point.

Operate lever to change gears, and check that no noise occurs in any of the gear positions.

For the best SIS performance, periodically lubricate all power-transmission parts.

This service instruction explains how to use and maintain the Shimano bicycle parts which have been used on your new bicycle. For any questions regarding your bicycle or other matters which are not related to Shimano parts, please contact the place of purchase or the bicycle manufacturer.

SHIMANO AMERICAN CORPORATION
One Holland, Irvine, California 92618, U.S.A. Phone: +1-949-951-5003

SHIMANO EUROPE B.V.
Industrieweg 24, 8071 CT Nunspeet, The Netherlands Phone: +31-341-272222

SHIMANO INC.
3-77 Oimatsu-cho Sakai-ku, Sakai, Osaka 590-8577, Japan

Please note: specifications are subject to change for improvement without notice. (English)
© Jul. 2006 by Shimano Inc. XBC SZK Printed in Japan.

SHIMANO

These service instructions are printed on recycled paper.

SHIMANO AMERICAN CORPORATION
One Holland, Irvine, California 92618, U.S.A. Phone: +1-949-951-5003

SHIMANO EUROPE B.V.
Industrieweg 24, 8071 CT Nunspeet, The Netherlands Phone: +31-341-272222

SHIMANO INC.
3-77 Oimatsu-cho Sakai-ku, Sakai, Osaka 590-8577, Japan

Please note: specifications are subject to change for improvement without notice. (English)
© Jul. 2006 by Shimano Inc. XBC SZK Printed in Japan.

SHIMANO

These service instructions are printed on recycled paper.

SHIMANO AMERICAN CORPORATION
One Holland, Irvine, California 92618, U.S.A. Phone: +1-949-951-5003

SHIMANO EUROPE B.V.
Industrieweg 24, 8071 CT Nunspeet, The Netherlands Phone: +31-341-272222

SHIMANO INC.
3-77 Oimatsu-cho Sakai-ku, Sakai, Osaka 590-8577, Japan

Please note: specifications are subject to change for improvement without notice. (English)
© Jul. 2006 by Shimano Inc. XBC SZK Printed in Japan.

SHIMANO

These service instructions are printed on recycled paper.

SHIMANO AMERICAN CORPORATION
One Holland, Irvine, California 92618, U.S.A. Phone: +1-949-951-5003

SHIMANO EUROPE B.V.
Industrieweg 24, 8071 CT Nunspeet, The Netherlands Phone: +31-341-272222

SHIMANO INC.
3-77 Oimatsu-cho Sakai-ku, Sakai, Osaka 590-8577, Japan

Please note: specifications are subject to change for improvement without notice. (English)
© Jul. 2006 by Shimano Inc. XBC SZK Printed in Japan.

SHIMANO

These service instructions are printed on recycled paper.

SHIMANO AMERICAN CORPORATION
One Holland, Irvine, California 92618, U.S.A. Phone: +1-949-951-5003

SHIMANO EUROPE B.V.
Industrieweg 24, 8071 CT Nunspeet, The Netherlands Phone: +31-341-272222

SHIMANO INC.
3-77 Oimatsu-cho Sakai-ku, Sakai, Osaka 590-8577, Japan

Please note: specifications are subject to change for improvement without notice. (English)
© Jul. 2006 by Shimano Inc. XBC SZK Printed in Japan.

SHIMANO

These service instructions are printed on recycled paper.

SHIMANO AMERICAN CORPORATION
One Holland, Irvine, California 92618, U.S.A. Phone: +1-949-951-5003

SHIMANO EUROPE B.V.
Industrieweg 24, 8071 CT Nunspeet, The Netherlands Phone: +31-341-272222

SHIMANO INC.
3-77 Oimatsu-cho Sakai-ku, Sakai, Osaka 590-8577, Japan

Please note: specifications are subject to change for improvement without notice. (English)
© Jul. 2006 by Shimano Inc. XBC SZK Printed in Japan.

SHIMANO

These service instructions are printed on recycled paper.

SHIMANO AMERICAN CORPORATION
One Holland, Irvine, California 92618, U.S.A. Phone: +1-949-951-5003

SHIMANO EUROPE B.V.
Industrieweg 24, 8071 CT Nunspeet, The Netherlands Phone: +31-341-272222

SHIMANO INC.
3-77 Oimatsu-cho Sakai-ku, Sakai, Osaka 590-8577, Japan

Please note: specifications are subject to change for improvement without notice. (English)
© Jul. 2006 by Shimano Inc. XBC SZK Printed in Japan.

SHIMANO

These service instructions are printed on recycled paper.

SHIMANO AMERICAN CORPORATION
One Holland, Irvine, California 92618, U.S.A. Phone: +1-949-951-5003

SHIMANO EUROPE B.V.
Industrieweg 24, 8071 CT Nunspeet, The Netherlands Phone: +31-341-272222

SHIMANO INC.
3-77 Oimatsu-cho Sakai-ku, Sakai, Osaka 590-8577, Japan

Please note: specifications are subject to change for improvement without notice. (English)
© Jul. 2006 by Shimano Inc. XBC SZK Printed in Japan.

SHIMANO

These service instructions are printed on recycled paper.

SHIMANO AMERICAN CORPORATION
One Holland, Irvine, California 92618, U.S.A. Phone: +1-949-951-5003

SHIMANO EUROPE B.V.
Industrieweg 24, 8071 CT Nunspeet, The Netherlands Phone: +31-341-272222

SHIMANO INC.
3-77 Oimatsu-cho Sakai-ku, Sakai, Osaka 590-8577, Japan

Please note: specifications are subject to change for improvement without notice. (English)
© Jul. 2006 by Shimano Inc. XBC SZK Printed in Japan.

SHIMANO

These service instructions are printed on recycled paper.

SHIMANO AMERICAN CORPORATION
One Holland, Irvine, California 92618, U.S.A. Phone: +1-949-951-5003

SHIMANO EUROPE B.V.
Industrieweg 24, 8071 CT Nunspeet, The Netherlands Phone: +31-341-272222

SHIMANO INC.
3-77 Oimatsu-cho Sakai-ku, Sakai, Osaka 590-8577, Japan

Please note: specifications are subject to change for improvement without notice. (English)
© Jul. 2006 by Shimano Inc. XBC SZK Printed in Japan.

SHIMANO

These service instructions are printed on recycled paper.

SHIMANO AMERICAN CORPORATION
One Holland, Irvine, California 92618, U.S.A. Phone: +1-949-951-5003

SHIMANO EUROPE B.V.
Industrieweg 24, 8071 CT Nunspeet, The Netherlands Phone: +31-341-272222

SHIMANO INC.
3-77 Oimatsu-cho Sakai-ku, Sakai, Osaka 590-8577, Japan

Please note: specifications are subject to change for improvement without notice. (English)
© Jul. 2006 by Shimano Inc. XBC SZK Printed in Japan.

SHIMANO

These service instructions are printed on recycled paper.

SHIMANO AMERICAN CORPORATION
One Holland, Irvine, California 92618, U.S.A. Phone: +1-949-951-5003

SHIMANO EUROPE B.V.
Industrieweg 24, 8071 CT Nunspeet, The Netherlands Phone: +31-341-272222

SHIMANO INC.
3-77 Oimatsu-cho Sakai-ku, Sakai, Osaka 590-8577, Japan

Please note: specifications are subject to change for improvement without notice. (English)
© Jul. 2006 by Shimano Inc. XBC SZK Printed in Japan.

SHIMANO

These service instructions are printed on recycled paper.

SHIMANO AMERICAN CORPORATION
One Holland, Irvine, California 92618, U.S.A. Phone: +1-949-951-5003

SHIMANO EUROPE B.V.
Industrieweg 24, 8071 CT Nunspeet, The Netherlands Phone: +31-341-272222

SHIMANO INC.
3-77 Oimatsu-cho Sakai-ku, Sakai, Osaka 590-8577, Japan

Please note: specifications are subject to change for improvement without notice. (English)
© Jul. 2006 by Shimano Inc. XBC SZK Printed in Japan.

SHIMANO

These service instructions are printed on recycled paper.

SHIMANO AMERICAN CORPORATION
One Holland, Irvine, California 92618, U.S.A. Phone: +1-949-951-5003

SHIMANO EUROPE B.V.
Industrieweg 24, 8071 CT Nunspeet, The Netherlands Phone: +31-341-272222

SHIMANO INC.
3-77 Oimatsu-cho Sakai-ku, Sakai, Osaka 590-8577, Japan

Please note: specifications are subject to change for improvement without notice. (English)
© Jul. 2006 by Shimano Inc. XBC SZK Printed in Japan.

SHIMANO

These service instructions are printed on recycled paper.

SHIMANO AMERICAN CORPORATION
One Holland, Irvine, California 92618, U.S.A. Phone: +1-949-951-5003

SHIMANO EUROPE B.V.
Industrieweg 24, 8071 CT Nunspeet, The Netherlands Phone: +31-341-272222

SHIMANO INC.
3-77 Oimatsu-cho Sakai-ku, Sakai, Osaka 590-8577, Japan

Please note: specifications are subject to change for improvement without notice. (English)
© Jul. 2006 by Shimano Inc. XBC SZK Printed in Japan.

SHIMANO

These service instructions are printed on recycled paper.

SHIMANO AMERICAN CORPORATION
One Holland, Irvine, California 92618, U.S.A. Phone: +1-949-951-5003

SHIMANO EUROPE B.V.
Industrieweg 24, 8071 CT Nunspeet, The Netherlands Phone: +31-341-272222

SHIMANO INC.
3-77 Oimatsu-cho Sakai-ku, Sakai, Osaka 590-8577, Japan

Please note: specifications are subject to change for improvement without notice. (English)
© Jul. 2006 by Shimano Inc. XBC SZK Printed in Japan.

SHIMANO

These service instructions are printed on recycled paper.

SHIMANO AMERICAN CORPORATION
One Holland, Irvine, California 92618, U.S.A. Phone: +1-949-951-5003

SHIMANO EUROPE B.V.
Industrieweg 24, 8071 CT Nunspeet, The Netherlands Phone: +31-341-272222

SHIMANO INC.
3-77 Oimatsu-cho Sakai-ku, Sakai, Osaka 590-8577, Japan

Please note: specifications are subject to change for improvement without notice. (English)
© Jul. 2006 by Shimano Inc. XBC SZK Printed in Japan.

SHIMANO

These service instructions are printed on recycled paper.

SHIMANO AMERICAN CORPORATION
One Holland, Irvine, California 92618, U.S.A. Phone: +1-949-951-5003

SHIMANO EUROPE B.V.
Industrieweg 24, 8071 CT Nunspeet, The Netherlands Phone: +31-341-272222

SHIMANO INC.
3-77 Oimatsu-cho Sakai-ku, Sakai, Osaka 590-8577, Japan

Please note: specifications are subject to change for improvement without notice. (English)
© Jul. 2006 by Shimano Inc. XBC SZK Printed in Japan.

SHIMANO

These service instructions are printed on recycled paper.

SHIMANO AMERICAN CORPORATION
One Holland, Irvine, California 92618, U.S.A. Phone: +1-949-951-5003

SHIMANO EUROPE B.V.
Industrieweg 24, 8071 CT Nunspeet, The Netherlands Phone: +31-341-272222

SHIMANO INC.
3-77 Oimatsu-cho Sakai-ku, Sakai, Osaka 590-8577, Japan

Please note: specifications are subject to change for improvement without notice. (English)
© Jul. 2006 by Shimano Inc. XBC SZK Printed in Japan.

SHIMANO

These service instructions are printed on recycled paper.

SHIMANO AMERICAN CORPORATION
One Holland, Irvine, California 92618, U.S.A. Phone: +1-949-951-5003

SHIMANO EUROPE B.V.
Industrieweg 24, 8071 CT Nunspeet, The Netherlands Phone: +31-341-272222

SHIMANO INC.
3-77 Oimatsu-cho Sakai-ku, Sakai, Osaka 590-8577, Japan

Please note: specifications are subject to change for improvement without notice. (English)
© Jul. 2006 by Shimano Inc. XBC SZK Printed in Japan.

SHIMANO

These service instructions are printed on recycled paper.

General Safety Information

WARNING

- The ST-M975 / ST-M970 DUAL CONTROL lever is used for both gear shifting and braking operations. Make sure that you fully understand and are accustomed to the gear shifting and braking operations for your bicycle. Refer to the illustration for the method of operation.
- If the internal unit of the DUAL CONTROL lever becomes damaged, the lever will move down from the normal lever position, and it may move to a position where braking is difficult to carry out. If this happens, you should stop riding the bicycle immediately.
- Check that the wheels are fastened securely before riding the bicycle. If the wheels are loose in any way, they may come off the bicycle and serious injury may result.
- Use neutral detergent to clean the chain. Do not use alkali-based or acid based detergent such as rust cleaners as it may result in damage and/or failure of the chain.
- Use the reinforced connecting pin only for connecting the narrow type of chain.
- There are two different types of reinforced connecting pins available. Be sure to check the table before selecting which pin to use. If connecting pins other than reinforced connecting pins are used, or if a reinforced connecting pin or tool which is not suitable for the type of chain is used, sufficient connection force may not be obtained, which could cause the chain to break or fall off.

Chain	Reinforced connecting pin	Chain tool
9-speed super narrow chain such as CN-7701 / CN-HG93	6.5mm Silver	TL-CN32 / TL-CN27
8-/7-/6-speed narrow chain such as CN-HG50 / CN-HG40	7.1mm Black	TL-CN32 / TL-CN27

- If it is necessary to adjust the length of the chain due to a change in the number of sprocket teeth, make the cut at some other place than the place where the chain has been joined using a reinforced connecting pin or an end pin. The chain will be damaged if it is cut at a place where it has been joined with a reinforced connecting pin or an end pin.
- Check that the tension of the chain is correct and that the chain is not damaged. If the tension is too weak or the chain is damaged, the chain should be replaced. If this is not done, the chain may break and cause serious injury.
- Use a front chainwheel which is compatible with 9-speed chains in conjunction with Shimano CN-7701, CN-HG93 and CN-HG73 chains. If a chainwheel for an 8-speed chain or less is used, front chainwheel gear shifting problems may occur, or the chain pins might fall out, causing the chain to break.
- Obtain and read the service instructions carefully prior to installing the parts. Loose, worn or damaged parts may cause the bicycle to fall over and serious injury may occur as a result. We strongly recommend only using genuine Shimano replacement parts.
- Obtain and read the service instructions carefully prior to installing the parts. If adjustments are not carried out correctly, the chain may come off and this may cause you to fall off the bicycle which could result in serious injury.
- Read these Technical Service Instructions carefully, and keep them in a safe place for later reference.

Note

- Do not use the fixing bolt (made from aluminum) for the auxiliary release lever cap to secure the auxiliary release lever.
- If gear shifting operations do not feel smooth, wash the derailleur and lubricate all moving parts.
- If the amount of looseness in the links is so great that adjustment is not possible, you should replace the derailleur.
- You should periodically clean the derailleur and lubricate all moving parts (mechanism and pulleys).
- If gear shifting adjustment cannot be carried out, check the degree of parallelism at the rear end of the bicycle. Also check if the cable is lubricated and if the outer casing is too long or too short.
- If you hear abnormal noise as a result of looseness in a pulley, you should replace the pulley.
- If the wheel becomes stiff and difficult to turn, you should lubricate it with grease.
- Do not apply any oil to the inside of the hub, otherwise the grease will come out.
- You should periodically wash the sprockets in a neutral detergent and then lubricate them again. In addition, cleaning the chain with neutral detergent and lubricating it can be an effective way of extending the useful life of the sprockets and the chain.
- If the chain keeps coming off the sprockets during use, replace the sprockets and the chain.
- Adjust the RD-M970 reverse spring type rear derailleur from the low side.
- Use a frame with internal cable routing is strongly discouraged as it has tendencies to impair the SIS shifting function due to its high cable resistance.
- Always be sure to use the sprocket set bearing the same group marks. Never use in combination with a sprocket bearing a different group mark.
- Use an outer casing which still has some length to spare even when the handlebars are turned all the way to both sides. Furthermore, check that the shifting lever does not touch the bicycle frame when the handlebars are turned all the way.
- Make sure that the gear shifting cable and the brake cable do not obstruct each other during braking operations. If they do obstruct, it may interfere with braking. Install the cables so that they still have some slack in them even when the handlebars are turned fully in either direction.
- A special grease is used for the gear shifting cable (SIS-SP41). Do not use DURA-ACE grease or other types of grease, otherwise they may cause deterioration in gear shifting performance.
- Grease the inner cable and the inside of the outer casing before use to ensure that they slide properly.
- For smooth operation, use the specified outer casing and the bottom bracket cable guide.
- Operation of the levers related to gear shifting should be made only when the front chainwheel is turning.
- If the brake fluid used in the oil disc brakes is of a type which tends to adhere to the plastic parts of the shifting lever, this may cause the plastic parts to crack or become discolored. Therefore, you should make sure that the brake fluid does not adhere to these plastic parts.
- The mineral oil which is used in SHIMANO disc brakes does not cause cracking or discoloration if it adheres to plastic parts, but such parts should be cleaned with alcohol beforehand to prevent foreign particles from adhering.
- Parts are not guaranteed against natural wear or deterioration resulting from normal use.
- For maximum performance we highly recommend Shimano lubricants and maintenance products
- For any questions regarding methods of installation, adjustment, maintenance or operation, please contact a professional bicycle dealer.

Technical Service Instructions

SI-6LN0B-002

Rear Drive System



00

In order to realize the best performance, we recommend that the following combination be used.

Series	XTR
DUAL CONTROL lever	ST-M975 / ST-M970
Outer casing	SIS-SP41
Rear derailleur	RD-M970
Type	SGS / GS
Freehub	FH-M975 / FH-M970
Gears	9
Cassette sprocket	CS-M970
Chain	CN-7701
Bottom bracket guide	SM-SP17 / SM-BT17

Specifications

Rear Derailleur

Model number	RD-M970	
Type	SGS	GS
Gears	9	9
Total capacity	43T	33T
Largest sprocket	34T	34T
Smallest sprocket	11T	11T
Front chainwheel tooth difference	22T	22T

Cassette sprocket tooth combination

Model number	Group name	Gears	Tooth combination
CS-M970	ba	9	11, 12, 14, 16, 18, 21, 24, 28, 32T
	bd	9	12, 14, 16, 18, 20, 23, 26, 30, 34T
	be	9	11, 13, 15, 17, 20, 23, 26, 30, 34T

Freehub

Model number	FH-M975 / FH-M970
Gears	9
No. of spoke holes	36 / 32

These Service Instructions describe the operation method when using the ST-M975 / ST-M970 DUAL CONTROL lever in combination with the RD-M970 reverse spring-type rear derailleur. If using in combination with the RD-M971 top normal-type derailleur, the operations will be reversed.

Operating the levers

■ Operating the brake lever

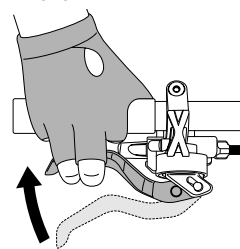

■ Gear shifting operation

The INSTANT RELEASE mechanism makes fast gear shifting possible because cable tension is released immediately when either the main lever or the secondary release lever is depressed. The levers are also equipped with a MULTI RELEASE mechanism so that you can now shift two gears with a single operation.

The lever always returns to the initial position when it is released after shifting. When operating the lever, always be sure to turn the crank arm at the same time.

To shift from a large sprocket to a smaller sprocket
You can vary the lever stroke to shift the desired number of gears, so that to shift by one gear only, move the lever to the (1) position, and to shift by two gears at one time, move the lever to the (2) position. A maximum two-gear shift can be made in this manner.

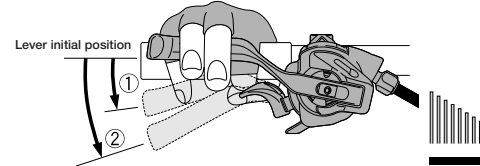

To shift from a small sprocket to a larger sprocket (MULTI RELEASE)
You can vary the lever stroke to shift the desired number of gears, so that to shift by one gear only, move the lever to the (1) position, and to shift by two gears at one time, move the lever to the (2) position. A maximum two-gear shift can be made in this manner.

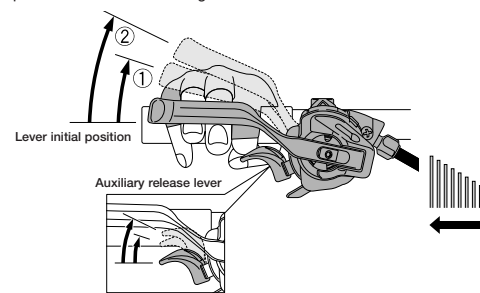

Adjusting the grip width

It is recommended that you adjust the grip widths of the levers to the most comfortable widths for gear shifting and braking.

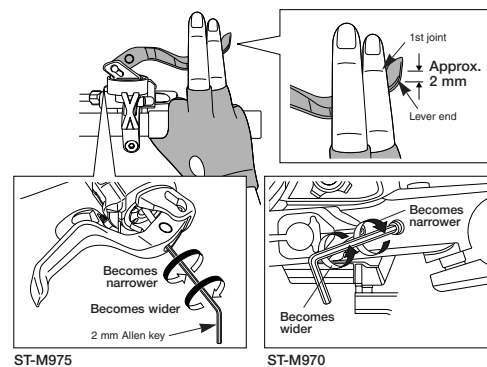

ST-M975

ST-M970

Installation of the rear derailleur

When installing, be careful not to let the B-tension adjustment screw come into contact with the dropout tab, otherwise deformation may result. Do not remove the Pro-Set alignment block at this time.

Bracket spindle Tightening torque : 8 - 10 N·m (70 - 86 in. lbs.)

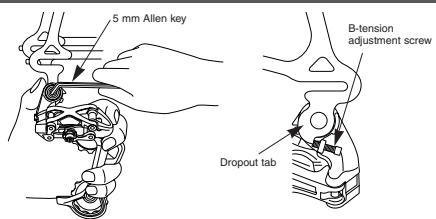

Installation of the sprockets

For each sprocket, the surface that has the group mark should face outward and be positioned so that the wider part of each sprocket and the A part (where the groove width is wide) of the freehub body are aligned.

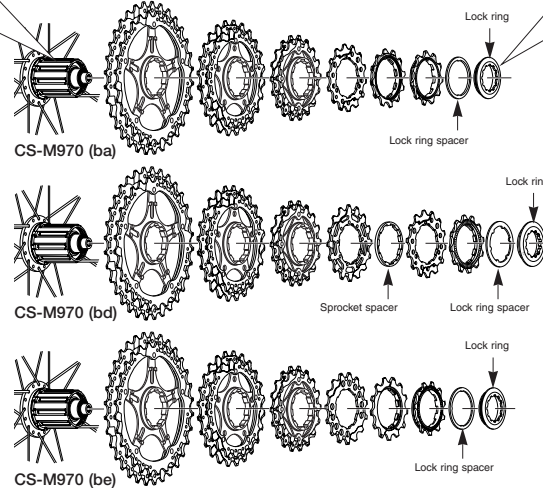
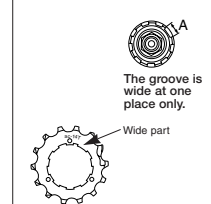

For installation of the HG sprockets, use the special tool (TL-LR15) to tighten the lock ring.

Tightening torque: 30 - 50 N·m (261 - 434 in. lbs.)

To replace the HG sprockets, use the special tool (TL-LR15) and TL-SR21 to remove the lock ring.

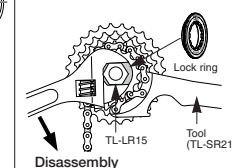

Chain length on bicycles with rear suspension

The length of A will vary depending on the movement of the rear suspension. Because of this, an excessive load may be placed on the drive system if the chain length is too short. Set the length of the chain by adding two links to the chain when the rear suspension is at a position where dimension "A" is longest and the chain is on the largest sprocket and the largest chaining. If the amount of movement of the rear suspension is large, the slack in the chain may not be taken up properly when the chain is on the smallest chaining and smallest sprocket.

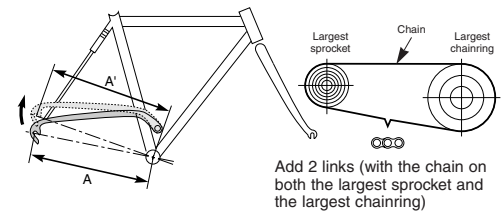

Add 2 links (with the chain on both the largest sprocket and the largest chaining)

Installation of the lever

Use a handlebar grip with a maximum outer diameter of 32 mm.

Tightening torque : 6 - 8 N·m (53 - 69 in. lbs.)

When installing the components to carbon frame/handle bar surfaces, verify with the manufacturer of the carbon frame/parts for their recommendation on tightening torque in order to prevent over tightening that can cause damage to the carbon material and/or under tightening that can cause lack of fixing strength for the components.

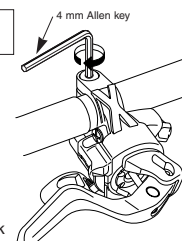

SIS Adjustment

Installation of the chain
Install the chain with the Pro-Set alignment block still attached. After installing, remove the Pro-Set alignment block.

Turn the crank arm to set the derailleur to the low position.

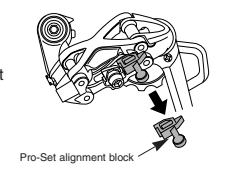

1. Low adjustment

Turn the low adjustment screw so that the guide pulley moves to a position directly in line with the largest sprocket.

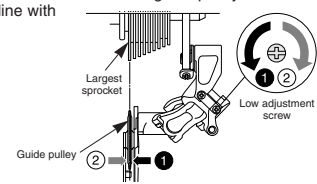

2. Top adjustment

Turn the crank arm while pulling the derailleur with your hand to move the derailleur to the top position, and then turn the top adjustment screw to adjust so that the guide pulley is in line with the outer line of the smallest sprocket when looking from the rear. Turn the crank arm to set the derailleur to the low position.

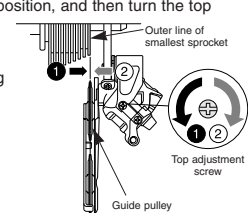

3. Connecting and securing the inner cable

Operate the lever eight times or more to set the lever to the lowest position. Then remove the inner hole cover and connect the inner cable.

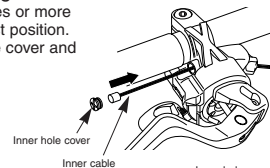

Install the inner hole cover by turning it as shown in the illustration until it stops. Do not turn it any further than this, otherwise it may damage the thread on the cover.

Tightening torque : 0.3 - 0.5 N·m (3 - 4 in. lbs.)

Connect the inner cable to the derailleur as shown in the illustration.

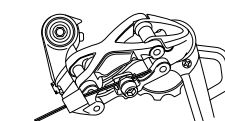

Note: Be sure that the cable is securely in the groove.

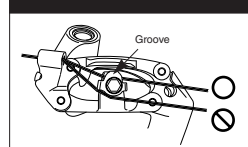

Connect the cable to the rear derailleur and, after taking up the initial slack in the cable, re-secure to the rear derailleur as shown in the illustration.

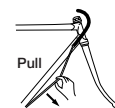

Tightening torque : 5 - 7 N·m (44 - 60 in. lbs.)

Cutting the outer casing

After cutting the outer casing, make the end round so that the inside of the hole has a uniform diameter.

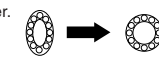

Attach the same outer end cap to the cut end of the outer casing.

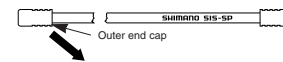

The sealed cap with tongue and the rubber shield should be installed to the outer casing stopper of the frame.

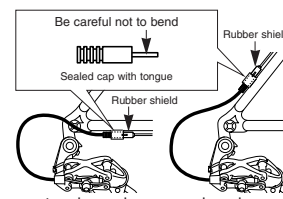

* If the rear derailleur moves to a large degree, such as in bicycles with rear suspension, it is recommended that you replace the cap with the accessory aluminum cap.

The end of the outer casing which has the aluminum cap should be at the derailleur side.

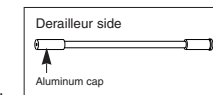

4. How to use the B-tension adjustment screw

Mount the chain on the smallest chaining and the largest sprocket, and turn the crank arm backward. Then turn the B-tension adjustment screw to adjust the guide pulley as close to the sprocket as possible but not so close that it touches. Next, set the chain to the smallest sprocket and repeat the above to make sure that the pulley does not touch the sprocket.

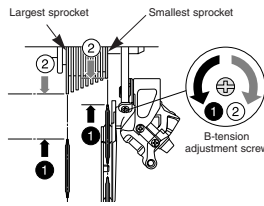

5. SIS Adjustment

Push lever while turning the crank arm to move the derailleur to the largest sprocket. Then operate lever once to move the derailleur to the 2nd-gear sprocket. After this, operate lever just as far as the extent of play, and then turn the crank arm.

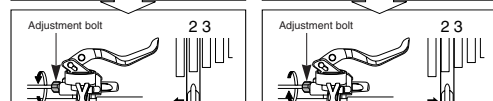
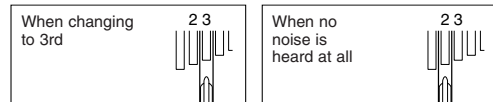

Turn the cable adjustment bolt clockwise to tighten it until the chain returns to the 2nd sprocket. * Turn the adjustment bolt together with the outer casing adjustment barrel cover.

Best setting

The best setting is when the cable adjustment bolt is tightened (turned clockwise) until noise occurs without lever being operated, and then loosened (turned counterclockwise) 90 - 180 degrees from that point.

Operate lever to change gears, and check that no noise occurs in any of the gear positions.

For the best SIS performance, periodically lubricate all power-transmission parts.

Read these Service Instructions in conjunction with the Service Instructions for the FH-M975/M970.

This service instruction explains how to use and maintain the Shimano bicycle parts which have been used on your new bicycle. For any questions regarding your bicycle or other matters which are not related to Shimano parts, please contact the place of purchase or the bicycle manufacturer.

SHIMANO

SHIMANO AMERICAN CORPORATION
One Holland, Irvine, California 92618, U.S.A. Phone: +1-949-951-5003

SHIMANO EUROPE B.V.
Industrieweg 24, 8071 CT Nurspeet, The Netherlands Phone: +31-341-272222

SHIMANO INC.
3-77 Oimatsu-cho, Sakai-ku, Sakai-shi, Osaka 590-8577, Japan

Please note: specifications are subject to change for improvement without notice. (English)
© Dec. 2006 by Shimano Inc. XBC SZK Printed in Japan.