

Operation, Maintenance and Service Manual

SUPERMAN™

THE PINBALL GAME

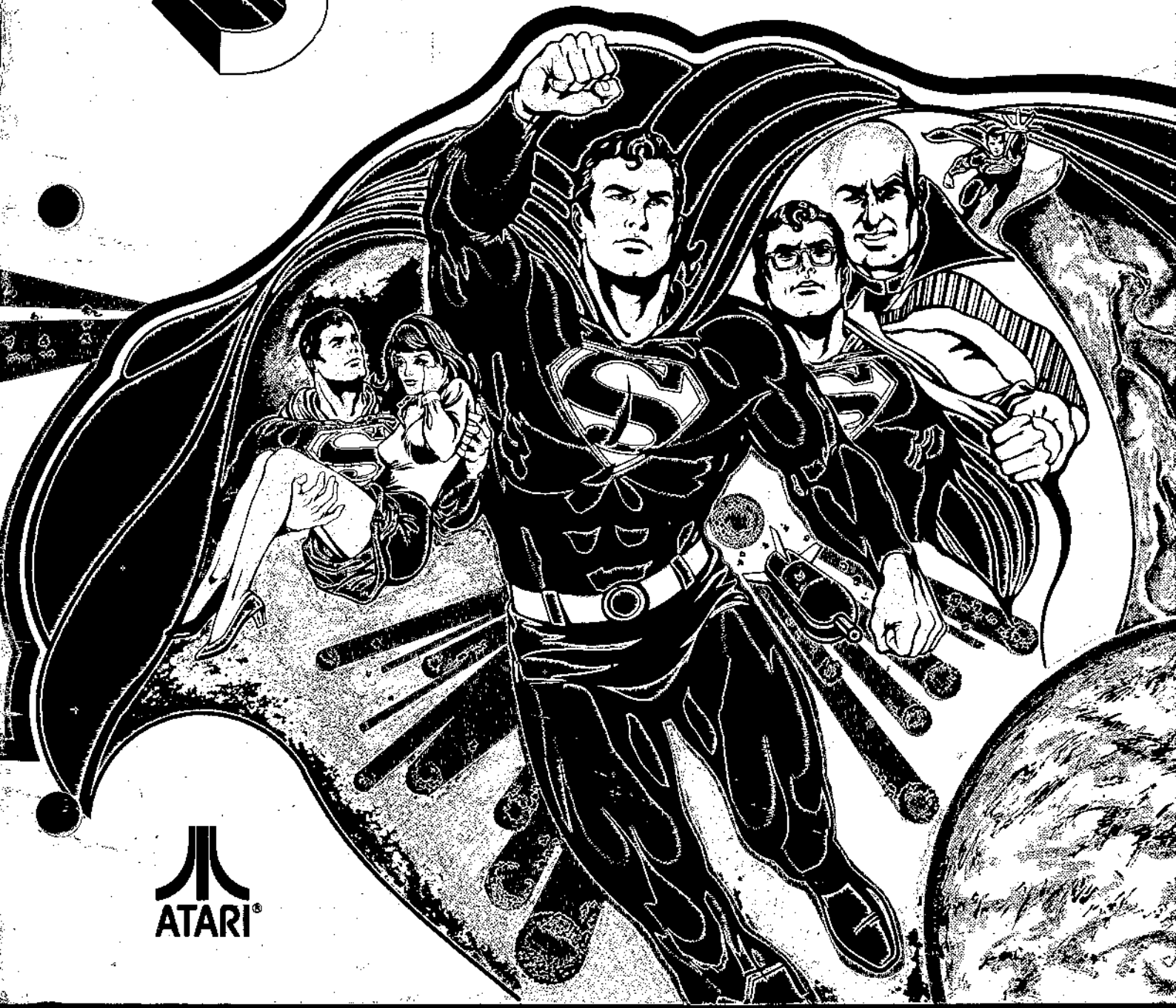

WARRANTY

Seller warrants that its printed circuit boards and parts thereon are free from defects in material and workmanship under normal use and service for a period of ninety (90) days from date of shipment. Seller warrants that its television monitors (in games supplied with monitors) are free from defects in material and workmanship under normal use and service for a period of thirty (30) days from date of shipment. None of the Seller's other products or parts thereof are warranted.

If the products described in this manual fail to conform to this warranty, Sellers' sole liability shall be, at its option, to repair, replace, or credit Buyer's account for such products which are returned to Seller during said warranty period, provided:

(a) Seller is promptly notified in writing upon discovery by Buyer that said products are defective;

(b) Such products are returned prepaid to Sellers' plant; and

(c) Seller's examination of said products discloses to Seller's satisfaction that such alleged defects existed and were not caused by accident, misuse, neglect, alteration, improper repair, installation or improper testing.

In no event shall Seller be liable for loss of profits, loss of use, incidental or consequential damages.

Except for any express warranty set forth in a written contract between Seller and Buyer which contract supersedes the terms of this order, this warranty is expressed in lieu of all other warranties expressed or implied, including the implied warranties of merchantability and fitness for a particular purpose, and of all other obligations or liabilities on the Seller's part, and it neither assumes nor authorizes any other person to assume for the Seller any other liabilities in connection with the sale of products under this order.

This document is and contains confidential trade secret information of Atari, Inc.

This document is loaned under confidential custody for the sole purpose of operation, maintenance or repair of Atari equipment and may not be used by or disclosed to any person for any other purpose whatever, and remains the property of Atari, Inc.

Neither it nor the information it contains may be reproduced, used, or disclosed to persons not having a need to know consistent with the purpose of the loan, without written consent of Atari, Inc.

SUPERMAN™

THE PINBALL GAME

Operation, Maintenance and Service Manual

ATARI INC
1265 BORREGAS AVENUE
P.O. BOX 9027
SUNNYVALE, CALIFORNIA 94086
408/745-2000 • TELEX 35-7488

TM indicates trademark of DC Comics Inc.
© DC Comics Inc. 1978



ATARI®

A Warner Communications Company 

Copyright © 1978 by Atari, Inc. All rights reserved

No part of this publication may be reproduced by any mechanical, photographic, or electronic process, or in the form of a phonographic recording, nor may it be stored in a retrieval system, transmitted, or otherwise copied for public or private use, without permission from the publisher.

For permissions request, write:

ATARI INC
1265 Borregas Avenue
P.O. Box 9027
Sunnyvale, California 94086

12G

Lithographed in the U.S.A.

TABLE OF CONTENTS

1 LOCATION SETUP

A. INVENTORY OF PARTS FROM SHIPPING CARTON	1-1
B. SHOP ASSEMBLY OF GAME	1-3
1. Attach Legs	1-3
2. Secure Back Box	1-3
3. Final Assembly of Game	1-4
C. GAME CHECKOUT	1-5
1. Check Back Box	1-5
2. Check Cabinet	1-5
3. Check Playfield	1-5
D. PERFORM SELF-TEST	1-6
E. SETTING THE OPTION SWITCHES	1-8
1. Definition of Game Option Switch Settings	1-8
2. Set the Options	1-9
F. FINAL CHECKOUT OF GAME	1-9
1. Check Power-Down Coin Rejection	1-9
2. Check Coin Acceptance	1-9
3. Check Operation of Mechanical Coin Counters	1-10
G. INSERT PLAYER INSTRUCTION CARDS	1-10
H. PERCENTAGING THE GAME	1-11
I. PREPARATION OF GAME FOR TRANSPORTING TO LOCATION	1-12
J. INSTALLING GAME AT LOCATION	1-12
1. Final Location Assembly and Inspection	1-12
2. Self-Test	1-12
K. CHECKLIST OF OPERATIONS COVERED BY THIS CHAPTER	1-12

2 GAME PLAY

A. ATTRACT MODE	2-2
1. Attract Mode After Power Up or Play Mode	2-2
2. Attract Mode After Self-Test Mode	2-2
B. PLAY MODE	2-2
C. GAME PLAY	2-2

3 MAINTENANCE AND ADJUSTMENTS

A. CLEANING	3-1
1. Cabinet and Back Box	3-1
2. Playfield	3-1
B. COIN MECHANISMS	3-2
1. Adjustment of Coin Switch Wires	3-2
2. Cleaning Coin Mechanism Coin Paths	3-3
3. Mechanical Adjustment of Coin Mechanism	3-3
4. Lubrication	3-5

TABLE OF CONTENTS

C. FUSE REPLACEMENT	3-5
D. LAMP REPLACEMENT	3-5
E. FLIPPER PADDLE REPLACEMENT	3-6
F. SWITCH MAINTENANCE	3-6
1. Switch Replacement	3-6
2. Switch Cleaning	3-6
G. LUBRICATION OF PLAYFIELD PARTS	3-6

4 DETAILS OF ELECTRONIC OPERATION

A. CIRCUIT FEATURES	4-1
1. RAM Batteries	4-1
2. LEDs on the Printed Circuit Boards	4-1
3. LED Displays	4-2
4. Microprocessor	4-2
5. ROM/PROM Memory	4-2
6. Flipper Enable and End-of-Throw Switch	4-2
7. Game Fusing	4-2
8. Processor PCB Low-Power Schottky TTL Circuitry	4-3
9. Solenoid Overcurrent Protection Circuit	4-3
10. Test Points on Printed Circuit Boards	4-3
B. GAME POWER DISTRIBUTION	4-3
C. PROCESSOR PCB'S MICROPROCESSOR CIRCUITRY	4-3
1. MPU (Microprocessor)	4-3
2. Clock and Watchdog Circuitry	4-5
3. Address Decoder	4-5
4. Program Memory	4-7
5. RAM (including Battery-Backed RAM Memory)	4-7
6. Power Input and Battery Circuit	4-7
7. Power Reset Circuit	4-7
D. SWITCH CIRCUITRY	4-7
1. Coin Door, START and Playfield Switches	4-10
2. Game Option Switches	4-10
3. TEST Test Point on Processor PCB	4-10
E. SOLENOID CIRCUITRY	4-11
1. Coin Door Lockout Coil and Flipper Enable Relays	4-11
2. Playfield Solenoids	4-11
F. LAMP CIRCUITRY	4-14
G. DISPLAY CIRCUITRY	4-17
H. AUDIO CIRCUITRY	4-18

LIST OF ILLUSTRATIONS

Figure 1-1	Inventory of Parts from Shipping Container	1-2
Figure 1-2	Game Assembly	1-3
Figure 1-3	Final Assembly of Game	1-4
Figure 1-4	Checking the Back Box	1-5
Figure 1-5	Folding and Displaying Player Instruction Cards	1-10
Figure 1-6	Percentaging the Game	1-11
Figure 1-7	Game Preparation for Transporting to Location	1-12
Figure 3-1	Coin Door Assembly	3-2
Figure 3-2	View of Coin Switch and Trip Wire	3-2
Figure 3-3	Surfaces to Clean Inside the Coin Mechanism	3-3
Figure 3-4	Removal of Plate Covering Rear of Coin Slot	3-3
Figure 3-5	Adjustments on Coin Mechanism	3-4
Figure 3-6	Lubrication Point	3-5
Figure 4-1	MPU Circuitry	4-4
Figure 4-2	Switch Circuitry	4-8
Figure 4-3	Solenoid Circuitry	4-12
Figure 4-4	Lamp Circuitry	4-14
Figure 4-5	Display Circuitry	4-18
Figure 4-6	Audio Circuitry	4-20

Support drawings, such as schematics, wiring diagrams, harness routing diagrams, etc., on four large sheets, are supplied with this manual.

LIST OF TABLES

Table 1-1	Self-Test Label	1-6
Table 1-2	Defining Self-Test	1-6
Table 1-3	Definition of Game Options	1-8
Table 1-4	Option Switch Label	1-9
Table 3-1	Fuse Functions and Values	3-5
Table 4-1	Processor PCB Memory Map	4-6

NOTE

If reading through this manual does not lead to solving a specific maintenance problem, you can call Tele-Help™ at the following two Atari Customer Service offices.

WEST and CENTRAL U.S.A.

Atari Coin-Op Customer Service
1344 Bordeaux Drive, Sunnyvale, CA 94086
Telex 17-1103
(Monday - Friday, 7:30 - 4:00 pm Pacific Time)

From California, Alaska or
Hawaii, dial (408) 745-2900

From anywhere else in this
area, dial toll-free
(800) 538-1611

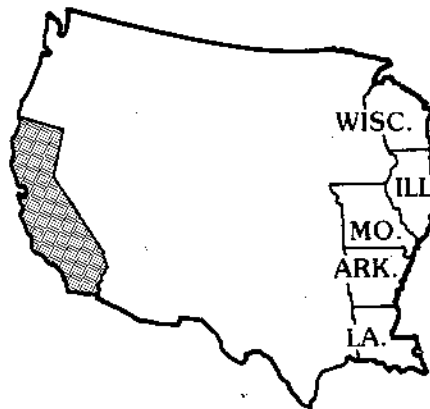

EAST U.S.A.

Atari Inc.
New Jersey Customer Service Office
44 Colonial Drive, Piscataway, NJ 08854
Telex 37-9347
(Monday - Friday, 8:30 - 5:00 pm Eastern time)

From New Jersey dial
(201) 981-0490

From anywhere else in this area,
dial toll-free (800) 631-5374

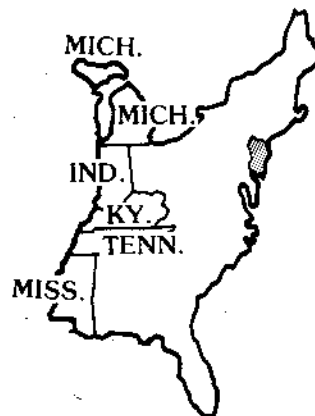

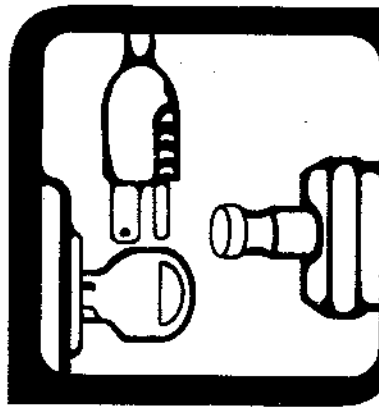

LOCATION SETUP

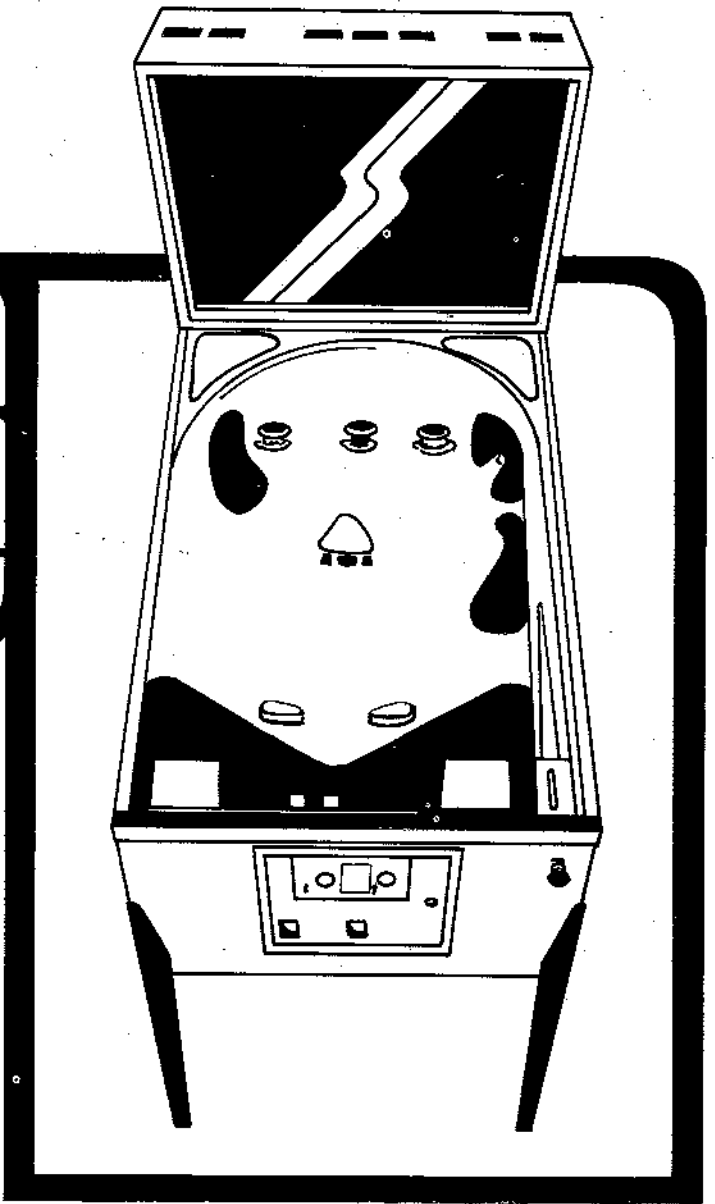

A. INVENTORY OF PARTS FROM SHIPPING CARTON

Figure 1-1 illustrates and lists all game pieces as they were unpacked from the shipping carton. Please note that if you intend to assemble the game in your shop and then deliver the game to an operator, save the cardboard Back Box sleeve and the reusable nylon strap. Section I of this Chapter explains how these items may be reused to prevent damage to the game.

SUPERMAN

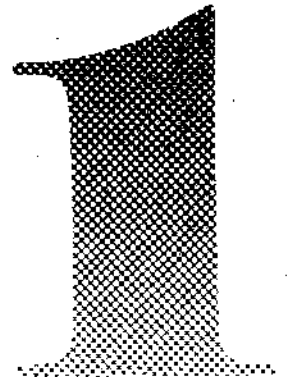

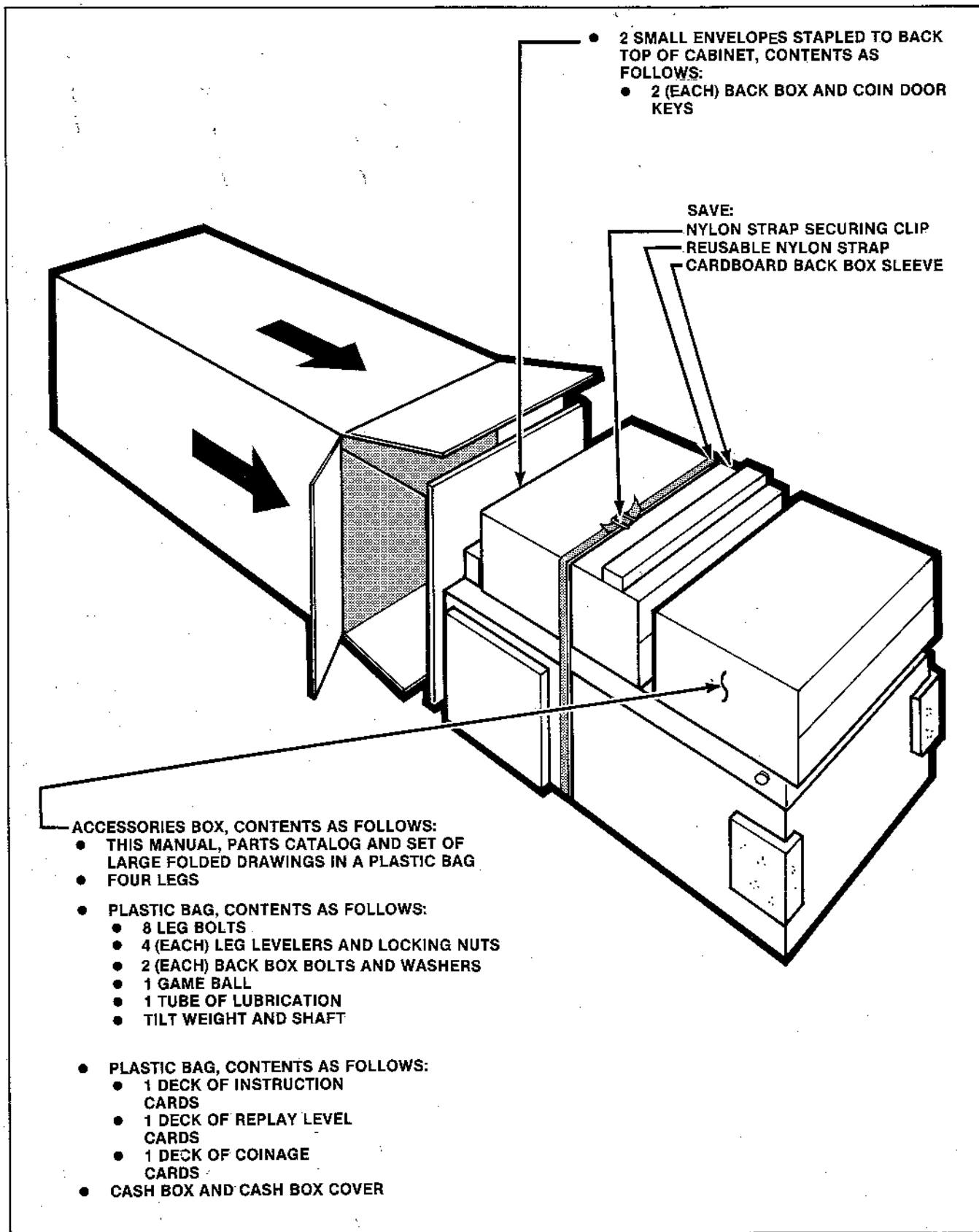

Figure 1-1 Inventory of Parts from Shipping Container

B. SHOP ASSEMBLY OF GAME

1. Attach Legs

See Figure 1-2, below, and attach the legs to the Cabinet.

2. Secure Back Box

See Figure 1-2, below, and secure the Back Box to the Cabinet.

WARNING

To prevent the Back Box from smashing into the playfield glass, it is *absolutely* necessary to lock the Back Box into place with the Locking Tab at the rear of the Back Box.

- 1 SCREW LEG LEVELERS INTO LEGS, THEN SCREW LOCKING NUT ONTO LEG LEVELERS

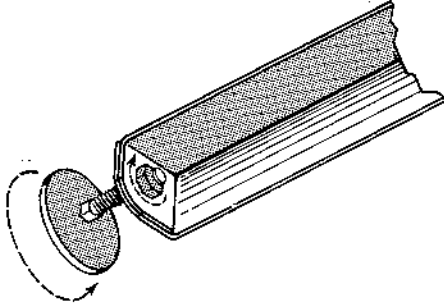

- 4 REMOVE AND SAVE NYLON STRAP SECURING CLIP, NYLON STRAP AND CARDBOARD BACK BOX SLEEVE

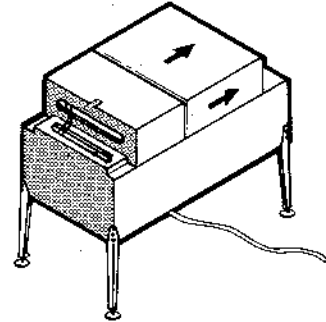

- 2 ATTACH FRONT LEGS TO CABINET WITH FOUR ACORN-HEAD BOLTS

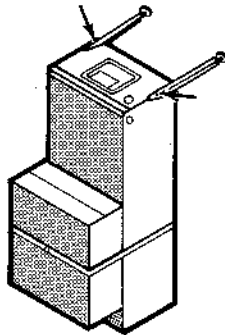

- 5 REACH INTO CABINET; PULL OUT POWER CORD AND PLACE CORD INTO SLOT

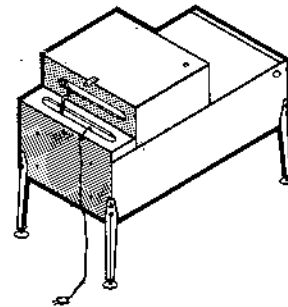

- 3 ATTACH REAR LEGS TO CABINET WITH FOUR ACORN-HEAD BOLTS

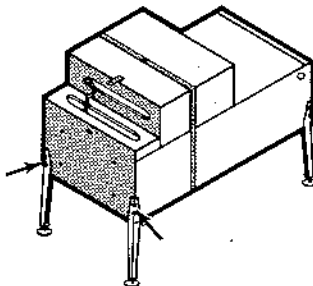

- 6 PIVOT BACK BOX INTO UPRIGHT POSITION AND SECURE WITH LOCKING TAB

BACK BOX
LOCKING-TAB

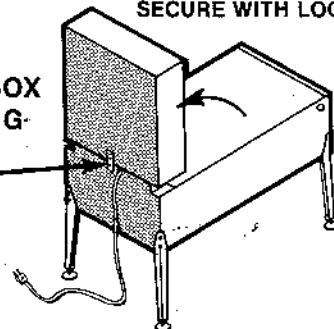

IF YOU ARE SETTING UP THE GAME IN ITS FINAL LOCATION, PERMANENTLY SECURE THE BACK BOX WITH THE TWO #3/8" - 16 x 2" BOLTS AND TWO 7/16" FLAT WASHERS

Figure 1-2 Game Assembly

3. Final Assembly of Game

See Figure 1-3, below, for the final assembly of the game.

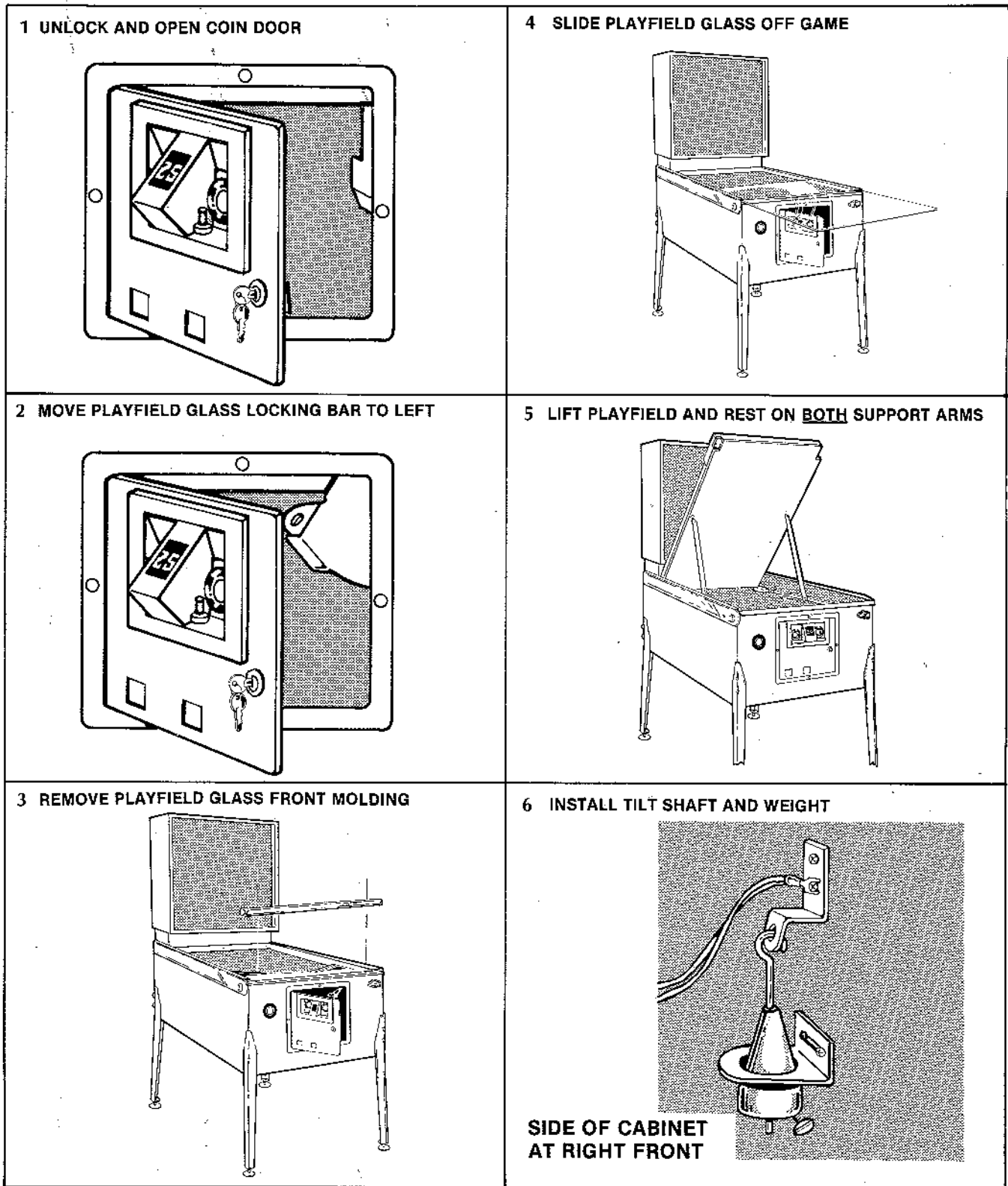

Figure 1-3 Final Assembly of Game

C. GAME CHECKOUT

We strongly advise you to thoroughly check the game before applying power. If you have never seen Atari's new generation pinball game, this is an excellent time to familiarize yourself with our new game.

1. Check Back Box

The Back Box contains all of the game's electronics; therefore this is a critical area for you to check. See Figure 1-4, below, for a list of items you should check in the Back Box.

2. Check Cabinet

Since Atari's new pinball games have all the electronics in the Back Box, there isn't much left in the bottom of the Cabinet. However, you should check that the transformer and harnesses were not damaged during the game's shipment to you.

3. Check Playfield

Raise the Playfield, rest it on both support arms, and give the Playfield a thorough visual check. Look for anything that may have come loose during the game's shipment to you.

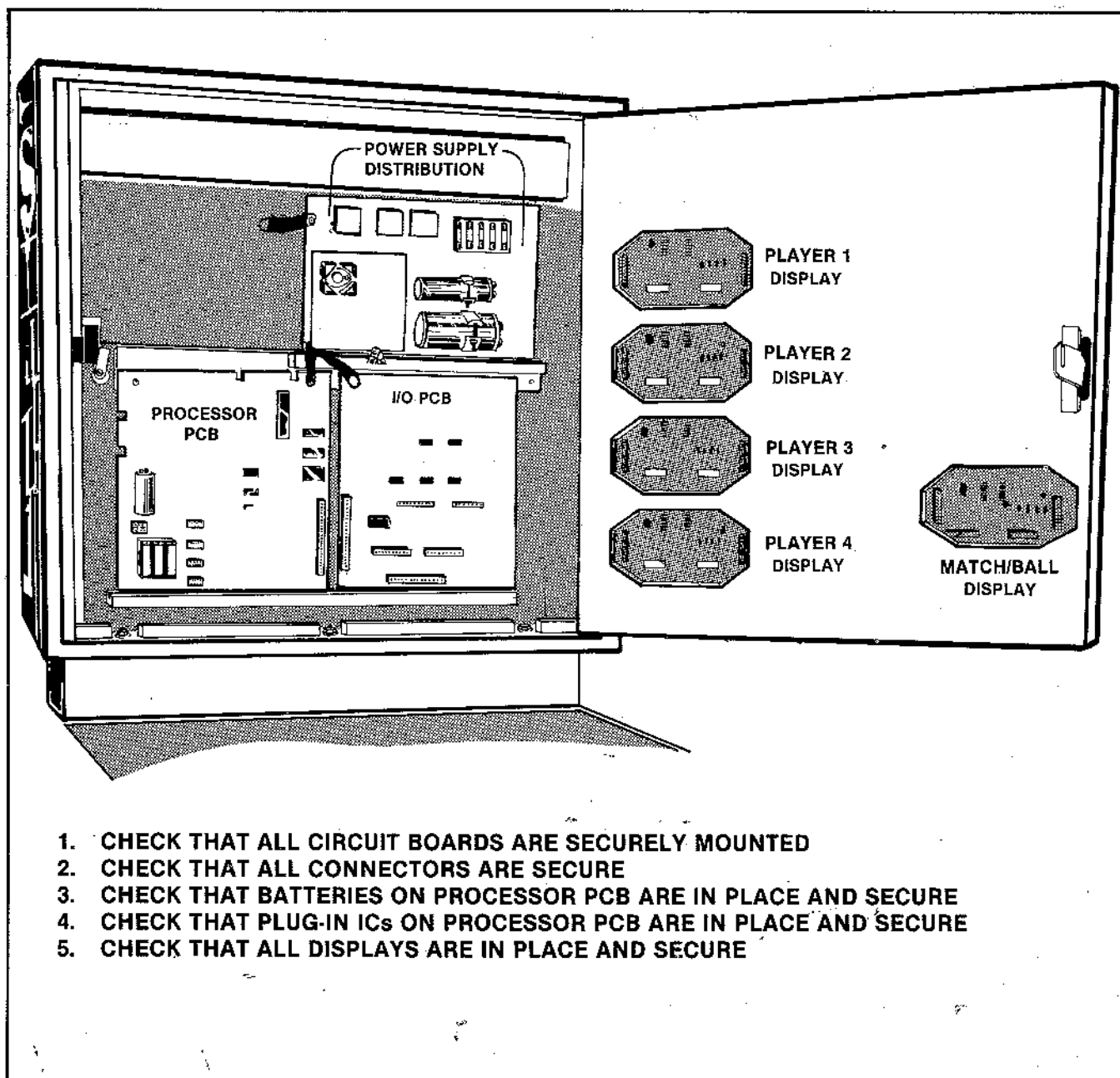

Figure 1-4 Checking the Back Box

D. PERFORM SELF-TEST

Table 1-1 is an exact duplicate of the Self-Test Label located inside the Coin Door on the Coin Box Cover. See Table 1-2 for an explanation of each Test step.

Table 1-1 Self-Test Label

TEST NO.	TEST NAME	TEST DESCRIPTION
		To advance from one test to the next, press Self-Test Switch on inside top of Coin Door.
	RAM/ROM Test	If test passes, Self-Test automatically advances to Test No. 1, Display Test. If test fails, Test does not advance to Test No. 1. If it fails, see instructions at top of Option Switch Settings label inside Back Box.
1	Display Test	All displays cycle through numerals 0 thru 9, blank for six beats, then cycle again. To stop cycling (and start again), press START.
2	Solenoid Test	Match/Ball display indicates Test No. 2. Solenoids activate one at a time while solenoid identification number is displayed in Credit display. To change to next solenoid, press START. See Solenoid Identification label on inside left front of cabinet.
3	Lamp and Switch Test	Match/Ball display indicates Test No. 3. All Playfield and Back Box Lamps are lighted. All microcomputer controlled lamps may be turned off (and on again) by pressing START. Any stuck or activated switches are identified by a switch identification number in the CREDIT display and a tone emitted from the game speaker. See Switch Identification label on inside left front of cabinet.
4	Sequential Lamp Test	One Lamp at a time is sequentially lighted for about 1 second each.
ACCOUNTING		
5	Credits	Present number of credits is displayed in player 1 Score display.
6	Left Coin Count	Left coin switch total count is displayed in player 1 Score display.
7	Right Coin Count	Right coin switch total count is displayed in player 1 Score display.
8	Total Coin Count	Total of Tests 6 and 7 is displayed in player 1 Score display.
9	Total Plays	Total number of plays is displayed in player 1 Score display.
10	Total Replays	Total number of Replays is displayed in player 1 Score display. (Add 10% of Total Plays for Match.)
11	Game Timer	Total time (minutes) of game play is displayed in player 1 Score display.
12	Specials Awarded	Total number of awarded Specials is displayed in player 1 Score display.
13	Extra Balls Awarded	Total number of awarded Extra Balls is displayed in player 1 Score display.
14	Tilts	Total number of Tilts is displayed in player 1 Score display.
15	Battery Backup Errors	Total number of Battery Backup Errors is displayed in player 1 Score display.
16	Replay Level	*Replay Level is displayed in player 1 Score display.
17	Replay Level	*Replay Level is displayed in player 1 Score display.
18	Replay Level	*Replay Level is displayed in player 1 Score display.
19	High Score to Date	*High Score to Date is displayed in player 1 Score display.

*To change, zero score number by activating right coin switch. Press START to increment Score by steps of 5000 as indicated in player 1 Score display.

Table 1-2 Defining Self-Test

TEST	TEST NAME	DEFINITION
	RAM/ROM Test	<p>If this test fails, the test will not advance to the Display Test. To determine the failing device, check the lighting of LEDs L1 thru L4 on the Processor PCB.</p> <p>If L1 is ON and L2 is ON—indicates failure of RAM H6 or L3 is ON—indicates failure of RAM K6 or L4 is ON—indicates failure of RAM J6</p> <p>If L1 is OFF and L2 is ON—indicates failure of ROM K/L7 or PROMs E5 and J5 or L3 is ON—indicates failure of ROM M7 or PROMs D5 and K5 or L4 is ON—indicates failure of ROM J7 or PROMs F5 and H5</p>
WARNING		
<p>A RAM/ROM test failure indicates a defective game. Continuing the test procedure may result in damaging the game. However, if you would like to continue to the next tests in such a situation, press TEST and START switches simultaneously and hold for at least a second.</p>		

Table 1-2 Defining Self-Test (continued)

TEST	TEST NAME	DEFINITION
1	Display Test	All displays cycle through numerals 0 thru 9, blank for six beats, then cycle again. While cycling, make sure the segments are lighting and blanking properly.
2	Solenoid Test	All solenoids and relays are actuated in this Test. The-Test begins by energizing the Outhole Kicker about once a second until you press START or press the SELF-TEST pushbutton. Each time you press START, the Test advances to energize the next solenoid. Each solenoid and relay is identified by a number in the Credit display. To identify displayed solenoid number, open the Coin Door and refer to the Switch and Solenoid Identification Label on the left front wall of the Cabinet.
3	Lamp and Switch Test	All microcomputer-controlled lamps are lighted for you to accurately check for burned-out bulbs. To turn the lights off and on, press START. Any stuck or activated switches are identified by a flashing number in the Credit display and an "oink" tone is emitted from the game speaker. To identify the displayed Switch number, open the Coin Door and refer to the Switch and Solenoid Identification Label on the left front wall of the Cabinet.
4	Sequential Lamp Test	This Test is specifically designed for Atari's Pinball Tester. See your Distributor for availability of this tester.
The following is an explanation of each Accounting step:		
5	Credits	Present number of credits accepted.
6	Left Coin Count	Total number of coins accepted by left coin chute.
7	Right Coin Count	Total number of coins accepted by right coin chute.
8	Total Coin Count	Total number of coins accepted.
9	Total Plays	Total number of games played.
10	Total Replays	Total number of replays awarded by game (to include MATCH, add 10% of Total Plays).
11	Game Timer	Total number of minutes game has been in play mode.
12	Specials Awarded	Total number of Specials awarded by game.
13	Extra Balls Awarded	Total number of Extra Balls awarded by game.
14	Tilts	Total number of tilts experienced by game.
15	Battery Backup Errors	This is a random number. If the number changes from previous reading, a battery backup error was experienced.
16	Replay Level	You may set three, two, one or no replay levels. To zero, activate right coin switch. Replay levels are set in increments of 5000 with the START button. Each zero setting eliminates that Replay level.
17	Replay Level	
18	Replay Level	
19	High Score to Date	This represents either the highest score achieved on this game or a score you set to challenge the players. To zero, activate right coin switch. Score is set in increments of 5000 by pressing the START button. Score can be completely eliminated by setting option switch SWC, toggle 8, to OFF. Suggested setting of High Score is about double the first replay level.

E. SETTING THE OPTION SWITCHES

1. Definition of Game Option Switch Settings

Atari's third generation pinball game has thirty-two option switches. By field testing the game, we feel the factory-set options maximize the profits of the game. If you wish to change some of these settings, see Table 1-3 for a definition of the options. The factory set options are as follows:

(NOTE: For 5-Ball Game Use Replay Card 021123-13)

AS SHIPPED

- 3 Ball Game
(Use Replay Card 021123-03)
- Free play Feature OFF
- Match Feature ON
- SPECIAL awards replay
- Extra ball awards EXTRA BALL
- Completing S-U-P-E-R-M-A-N awards 50,000
(Use "A" side of instruction card)
- Keep-Alive is OFF
- 1 Coin/1 Credit
- High Score to date million limit is ON
- High Score to Date Feature is ON
- Exceeding High Score to Date Awards 2 Replays
- 10 Maximum Credits

Table 1-3 Definition of Game Options

OPTION	DEFINITION
Balls Per Game	Number of balls (not including extra ball awards) per single game. Adjustable for 3 or 5-ball game.
Maximum Credits	Maximum number of credits that the Credit Accumulator will hold. Adjustable from 5 to 40 credits. Once Credit Accumulator reaches the maximum credit setting, coins are rejected from the coin mechanisms.
Free Play Feature	With Free Play Feature ON, game will always indicate 1 credit in Credit Accumulator. No coins are necessary to play the game. With Free Play Feature OFF, game can only be played if proper number of coins are inserted.
Match Feature	If the Match Feature is ON, when the last ball of the last player drops into the outhole, a random number is displayed on the Match/Ball display. If the number matches the last two digits of any player's score, one Replay is awarded for each matched score.
SPECIAL Feature	A SPECIAL is awarded if ball rolls over Right Drain rollover when its light is ON, or if ball drops into top ball ejector when its SPECIAL light is ON. The SPECIAL award may be set for replay, extra ball, 50,000 or 60,000 points.
Extra Ball	An Extra Ball is awarded if the ball rolls over the Left Drain rollover when its EXTRA BALL light is ON, or if the ball drops into the top ball ejector when its EXTRA BALL light is ON. The Extra Ball award may be set for 20,000 or 30,000 points instead of an extra ball.
SUPERMAN Spellout	When all letter-targets are actuated to spell out SUPERMAN, 30,000 or 50,000 points are awarded.
Keep-Alive	This should always be left in the OFF position.
Coin/Credit Settings	There are thirty-two settings for the number of coins required to play the game. The setting of the right coin mechanism is completely independent of the left coin mechanism.
HI SCORE TO DATE Display Feature	If set to ON, you may set and initial High Score to Date in increments of 5,000. If a player's score reaches the high score to date, 1, 2, or 3 credits (depending on the Replays for high score to date setting) is awarded. If set to OFF, HI SCORE TO DATE is not displayed.
Replays for HI SCORE TO DATE	This is the award setting for the HI SCORE TO DATE feature. May be set for 1, 2, or 3 credits.

2. Set the Options

Table 1-4 below duplicates the Option Setting Label located in the Back Box. Please note that the switch set-

tings descriptions are marked with the \$ symbol and the switch toggles are shaded to indicate how the game was shipped from Atari.

Table 1-4 Option Switch Label

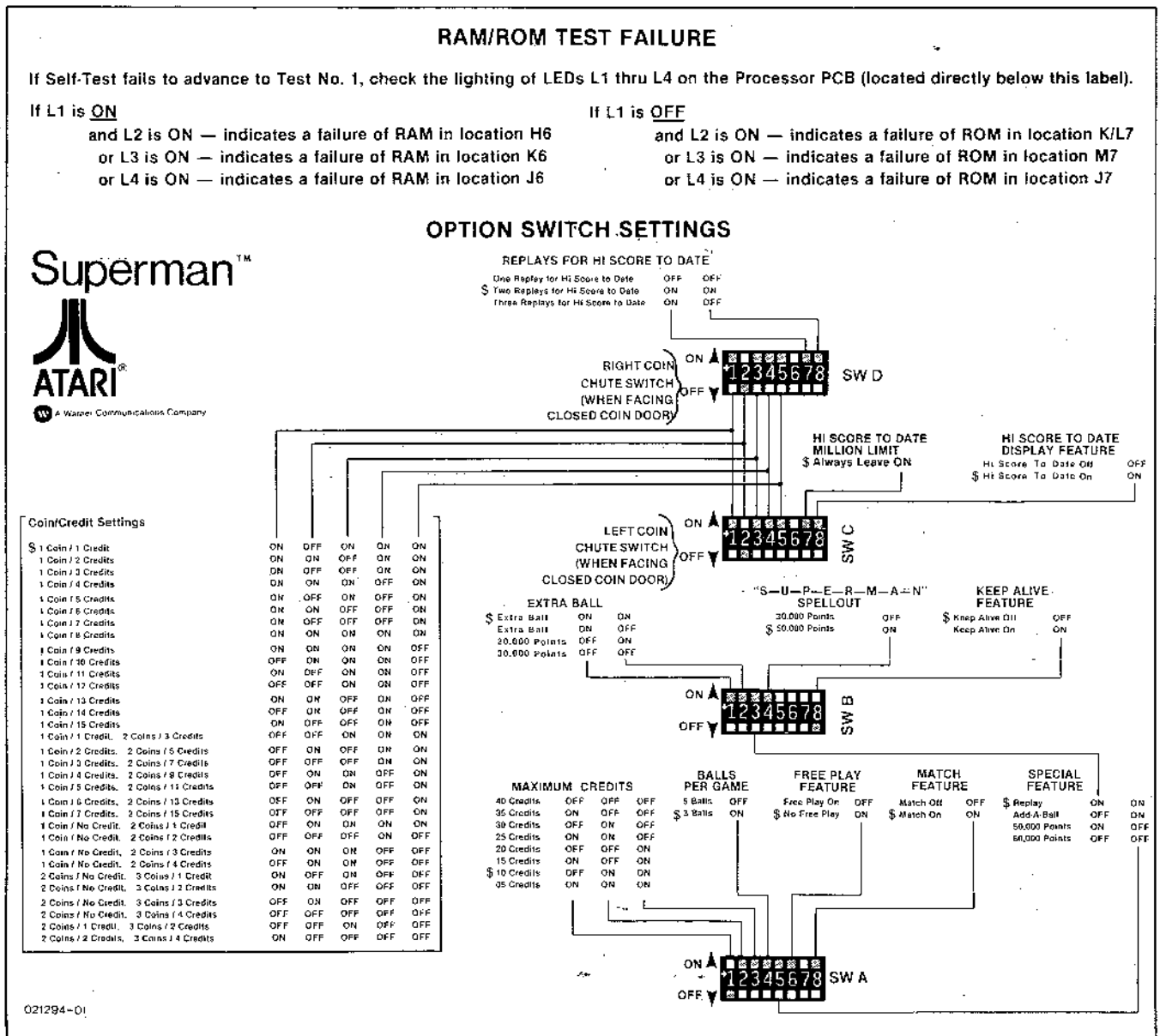

F. FINAL CHECKOUT OF GAME

1. Check Power-Down Coin Rejection

With the power to the game set to off, insert coins into

the game. The coins are rejected into the coin return of the Coin Door.

2. Check Coin Acceptance

With the power switch on and the Coin Door closed, insert coins into the game. The coins are accepted and enter the Cash Box.

3. Check Operation of Mechanical Coin Counters

Open Coin Door. Insert coins into game. The mechanical coin counters trip for each coin that is accepted.

G. INSERT PLAYER INSTRUCTION CARDS

The game was shipped with a plastic bag of Instruction, Coinage and Replay Level cards. The instruction card should be inserted in the right-hand side of the lower arch. The only difference between the front and back of this card is the value awarded for the S-U-P-E-R-M-A-N spellout: 30,000 or 50,000 points. Select the appropriate side according to the setting of Option switch SWB toggle 4.

There are fifteen Coinage cards, three of which you may use to write in the number of coins for the number of credits. Choose the proper card, according to the settings of option switches SWC and SWD, and insert at the bottom of the Instruction card.

There are ten Replay Level cards. The suggested card for 3-BALL is part number 021123-03, for 5-BALL part number 021123-13. These cards must be folded and inserted on the left of the lower arch. Five cards are for a 3-Ball game and the other five are for a 5-Ball game. On one side of the cards is Replay and on the other side Add-A-Ball. Fold the cards to display the number of replay levels for which the game is set—1, 2, or 3 replay levels. See Figure 1-5 below for the proper location to display the cards.

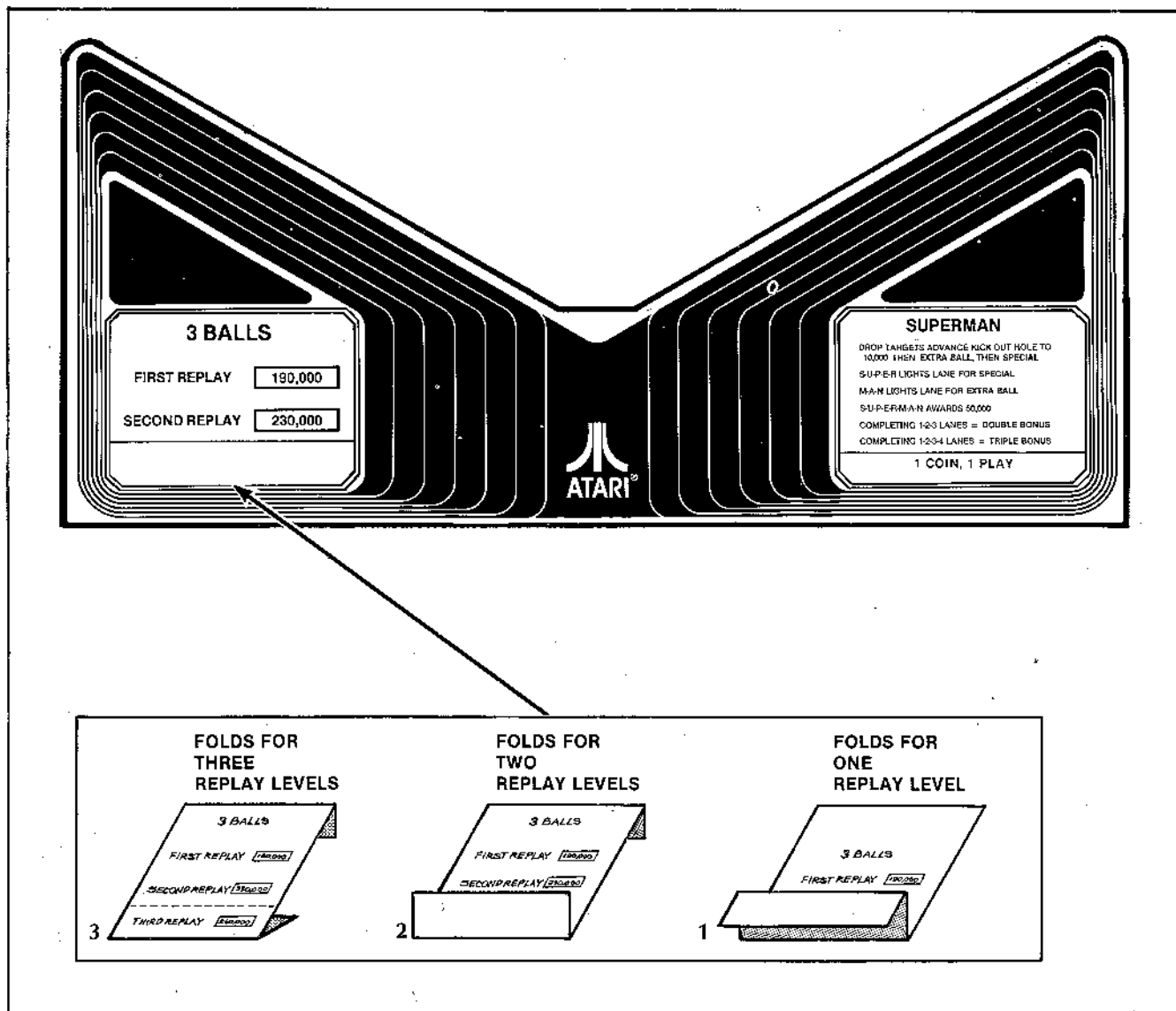

Figure 1-5 Folding and Displaying Player Instruction Cards

H. PERCENTAGING THE GAME

The left drain on the playfield may be adjusted to increase the percentage of the ball draining. To change

this, it is a matter of loosening the post from the bottom of the Playfield and moving the post to the right; then retighten (see Figure 1-6, below).

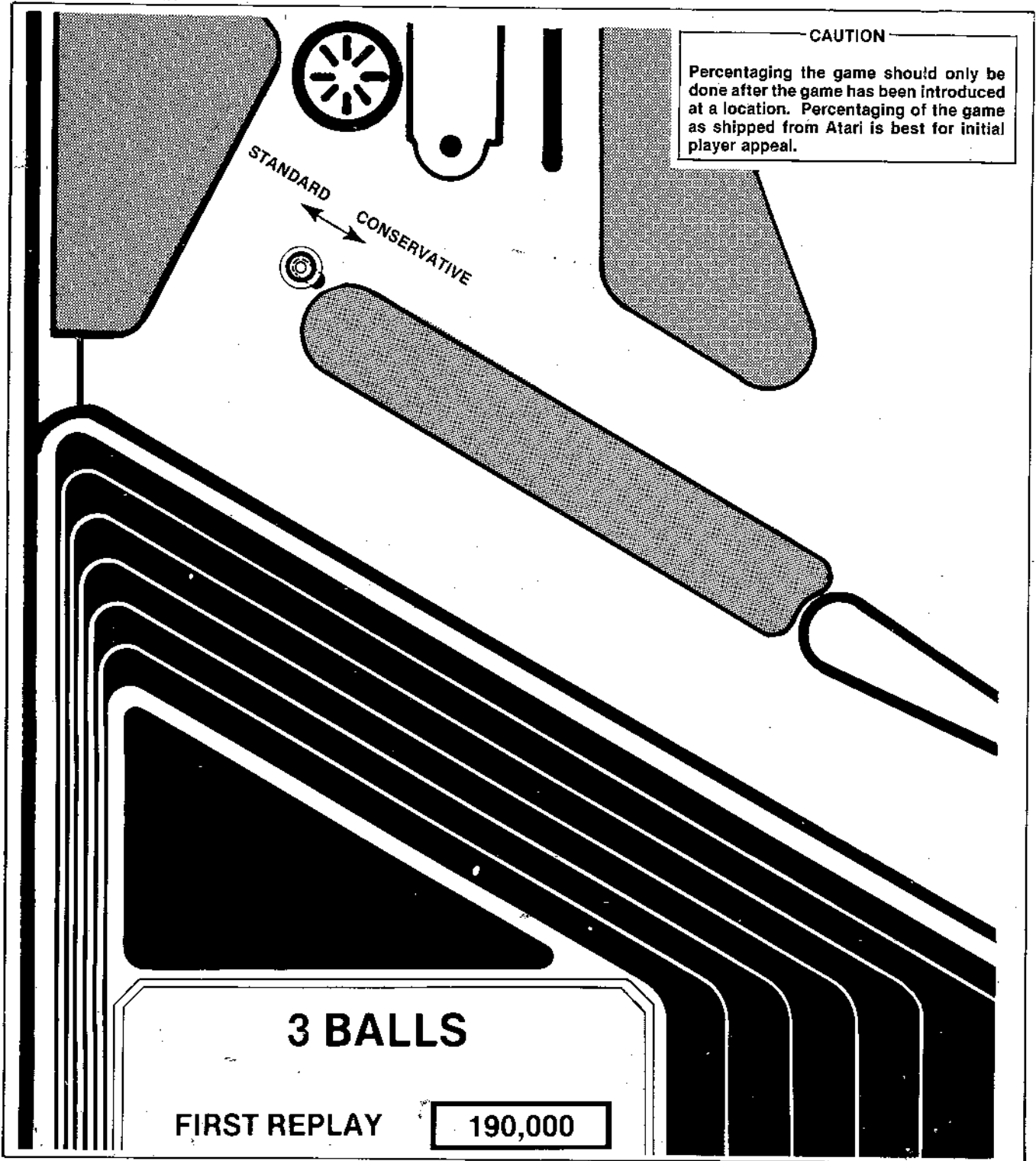

Figure 1-6 Percentaging the Game

I. PREPARATION OF GAME FOR TRANSPORTING TO LOCATION

See Figure 1-7 below and prepare the game for transporting to the location.

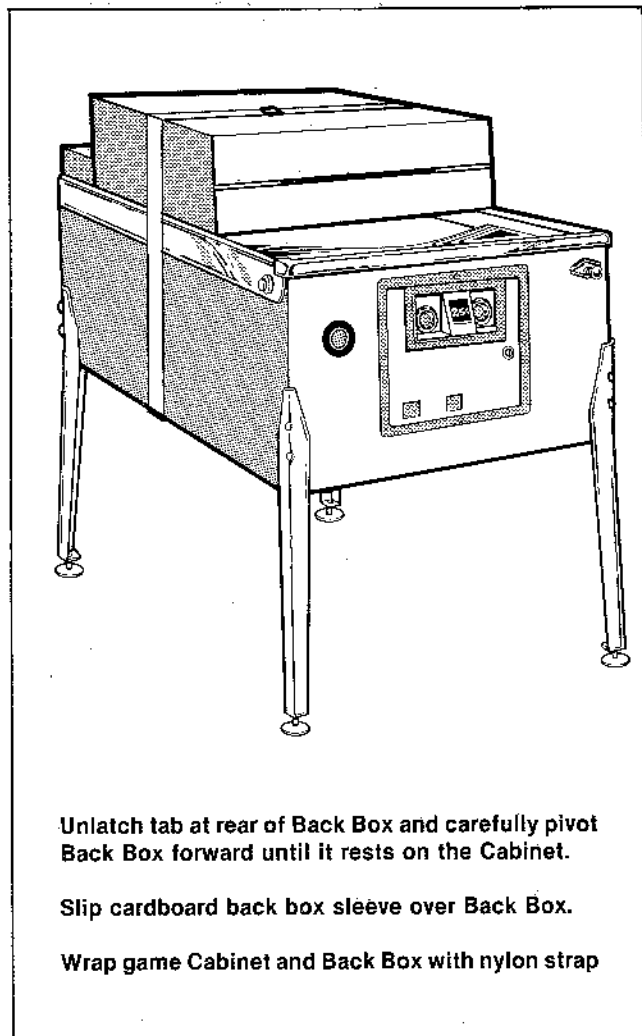

Figure 1-7 Game Preparation for Transporting to Location

J. INSTALLING GAME AT LOCATION

1. Final Location Assembly and Inspection

Before applying power to the game, thoroughly inspect the game to make sure that nothing came loose while transporting the game to its final location as follows:

- a) Remove nylon strap and Back Box cardboard sleeve.

- b) Lift Back Box into upright position and fasten Locking Tab at the rear of the Back Box.

WARNING

To prevent the Back Box from smashing into the playfield glass, it is *absolutely* necessary to lock the Back Box into place with the Locking Tab at the rear of the Back Box.

- c) Unlock and open Back Box; secure with two #3/8" - 16 x 2" Bolts and two 7/16" Flat Washers in each side of the Back Box bottom.
- d) Inspect the inside of the Back Box.
- e) Remove the Playfield Glass and raise the Playfield, then inspect the Playfield and Cabinet.
- f) Lower Playfield but leave Playfield Glass off.
- g) Remove protective plastic from metal side moldings on cabinet.

2. Self-Test

- a) Perform the Self-Test. During Test Step 3, activate each Playfield switch to make sure that the switches are properly adjusted.
- b) Adjust the Tilt Weight.
- c) Install Playfield Glass. This game is now ready to earn money.

K. CHECKLIST OF OPERATIONS COVERED BY THIS CHAPTER

The following is a checklist of things you should have done to the game by following this chapter.

1. Screwed leg levelers into legs.
2. Attached front and rear legs to Cabinet.
3. Installed tilt weight and wire.
4. Checked Back Box for shipping damage.
5. Checked Cabinet for shipping damage.
6. Checked Playfield for shipping damage.
7. Performed Self-Test.
8. Set Option Switches.
9. Checked for coin rejection and acceptance.
10. Checked for operation of mechanical coin counters.
11. Folded and displayed Instruction, Coinage, and Replay Level cards.
12. Percentaged game.
13. Prepared game for transporting to location.
14. Permanently secured Back Box.

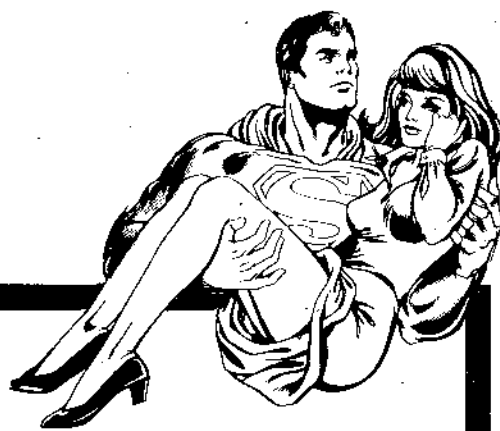
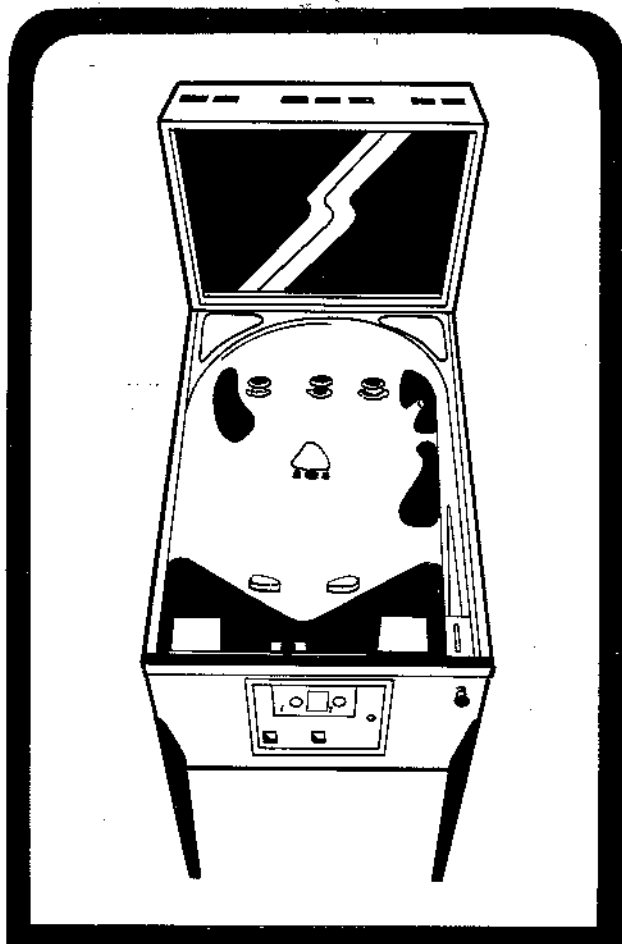

GAME PLAY

The game has three modes of operation: *Attract*, *Play*, and *Self-Test*. The attract mode is specifically programmed to attract potential players. The play mode begins when the START button is pressed. Self-Test serves to "freeze" several functions of the game so the operator can determine if everything is operating properly.

SUPERMAN

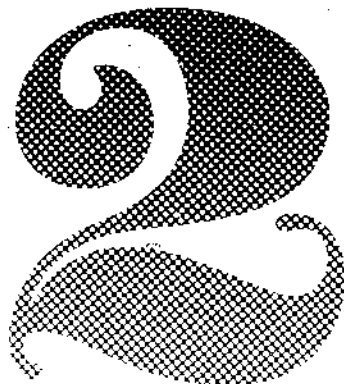

A. ATTRACT MODE

The attract mode begins after game power-up, exit from Self-Test, or after the end of a previous game.

1. Attract Mode After Power Up or Play Mode: In this mode, the Score display indicates the score(s) of the previous game, the Match/Ball display indicates the last ball (3 or 5) of the previous game, and the Credit display indicates the number of credits in the credit accumulator.

High Score to Date Option: If this option is selected, the Score display alternates between the score(s) of the previous game and the High Score to Date.

Match Option: If this option is selected, the match number of the previous game is displayed in the Match/Ball display.

2. Attract Mode After Self-Test Mode: In this mode, the Score display is blank, the Match/Ball display is blank, and the Credit display indicates the number of credits in the credit accumulator.

High Score to Date Option: If this option is selected, the Score display alternates between the score(s) of the previous game and the High Score to Date.

In the attract mode, the playfield lamps blink on and off in an exotic light show that attracts potential players. The game remains in this mode until a player presses the START button (if there are sufficient accumulated credits or the game is set for the Free Play option) or by the operator entering into the Self-Test mode by pressing the TEST button.

B. PLAY MODE

After the START button is pushed, the game responds as follows:

1. The PLAYER 1 Score display indicates two zeros.
2. The number in the Credit display decreases by one.
3. The Match/Ball display displays the number 1, representing the first ball in play.
4. The ball is ejected from the outhole and rolls over to the ball shooter.

5. All playfield lamps stop blinking, except the S-U-P-E-R-M-A-N Targets and Drop Target arrows. The 1,000-point bonus lamp is lighted. All other playfield lamps are unlighted.
6. The flipper controls are enabled.

Additional players may join the game any time before the last player's ball drops into the outhole. This is done by depositing the required number of coins (if necessary), then pressing the START button. Each time the game responds by adding another set of two zeros in the Score Displays and decreasing the accumulated credit in the Credit display by one.

C. GAME PLAY

1. All scoring is as shown on the playfield.
2. First completion of Drop Targets advances value of top Ball Ejector from 5,000 to 10,000 points. Second completion lights "EXTRA BALL". Third completion lights "SPECIAL".
3. Completing S-U-P-E-R lights right drain Star Rollover for "SPECIAL". Completing M-A-N lights left drain lane Star Rollover for "EXTRA BALL". Completing S-U-P-E-R-M-A-N awards 50,000 (standard) or 30,000 points (conservative). These targets are on memory from ball to ball until completion.
4. Completing 1, 2, 3 top rollthru lanes awards Double Bonus. Completing 1, 2, 3, 4 top rollthru lanes awards triple bonus. These lanes are stored in memory from ball to ball until completion.
5. Each slingshot contact alternates the lighting of the spinners.
6. The first contact with one of the top Thumper Bumpers randomly lights one of the top Thumper Bumpers. Thereafter, each contact with any of these Thumper Bumpers results in changing the lighting to the next Thumper Bumper in a clockwise direction.

MAINTENANCE AND ADJUSTMENTS

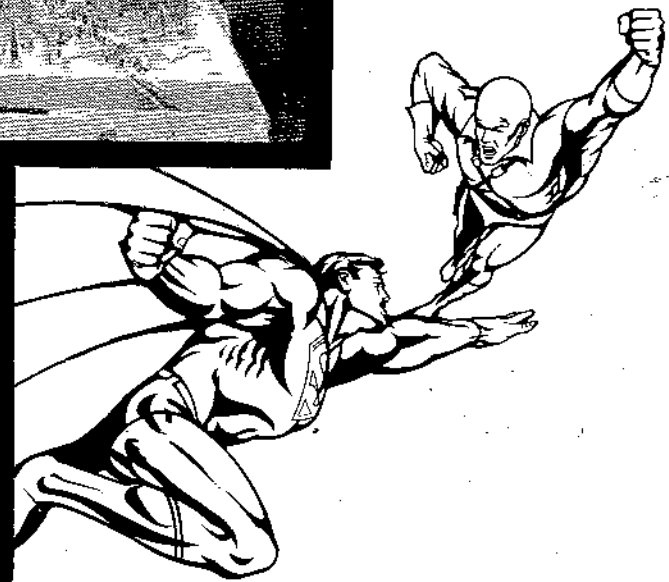

A. CLEANING

1. Cabinet and Back Box

Any non-abrasive household cleaner may be used to clean the Cabinet, Back Box and the Playfield Glass.

2. Playfield

Atari has greatly improved the Playfield for a longer-wearing surface. Much of the player appeal in a Pinball game depends on smooth ball travel over the entire surface. To keep the playfield and ball from prematurely wearing, use a non-abrasive cleaner.

SUPERMAN

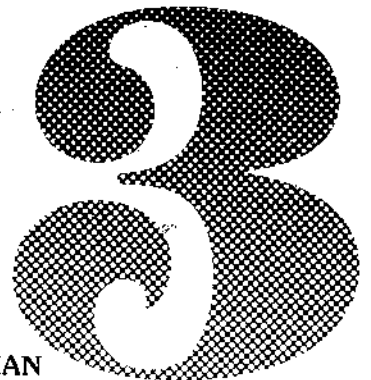

For even better care, wax the Playfield surface with a good Playfield wax, obtained from your distributor. Do not use products such as "Formula 409" or "Windex", kitchen cleansers, soapy cleaning pads or steel wool, waxes or polishes not specifically designed for Playfields, or great amounts of water. These products may remove the dirt, but they also remove the top surface of the Playfield graphics, and may cause the Playfield to collect even more buildup of residue.

While cleaning the Playfield, avoid getting foreign material into the bodies of Star Rollovers, onto the Lane Rollover Wire Actuators, or into the Lane Rollover Wire Actuator slots.

See the Superman game Illustrated Parts Catalog for Playfield replacement parts information.

B. COIN MECHANISMS

Figure 3-1 shows the back side of the Coin Door where the game's two Coin Mechanisms are mounted. Includ-

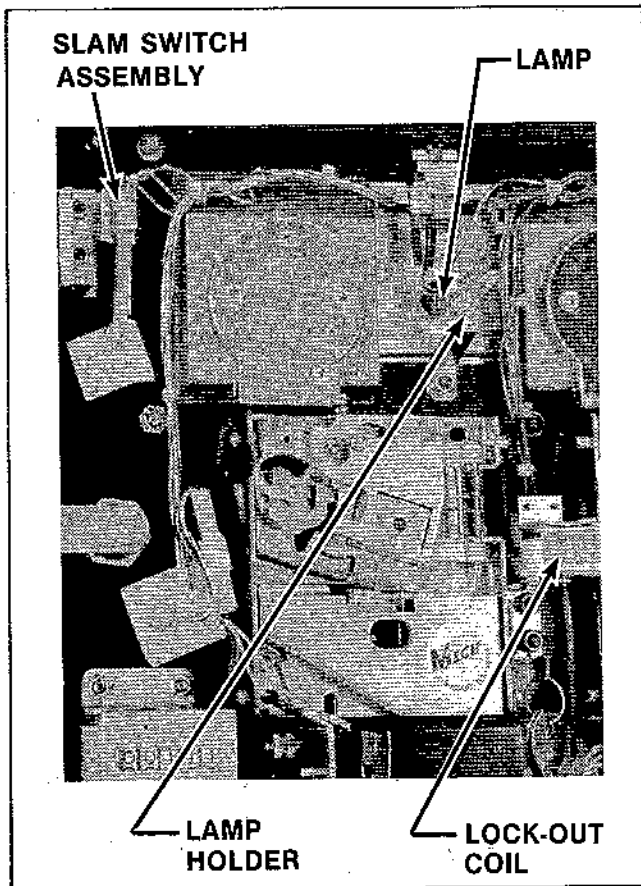

Figure 3-1 Coin Door Assembly

ed in this figure is the Lock-Out Coil Assembly; the lock-out wires are connected to this assembly but are hidden behind the two Coin Mechanisms. When the power is OFF, or if the credit accumulator is at its maximum, the lock-out wires protrude into the coin mechanisms to reject coins. When the power is ON and the credit accumulator is not at its maximum, the lock-out wires are retracted so coins may be accepted.

Directly below each Coin Mechanism is the secondary coin chute. A coin passing through the secondary coin chute trips the switch connected to the wire that extends across the coin chute.

1. Adjustment of Coin Switch Wires

In order for a coin switch to operate reliably when a coin travels down the secondary coin chute, the rest position of the switch's trip wire must be as shown in Figure 3-2. The trip wire must be long enough to just protrude past the "V" of the secondary chute. If longer, there is a possibility the wire will catch on the opening of the coin box cover.

If the wire is loose and falls off of its mounting stud, it will cause no credits to be given. Secure the wire by crim-

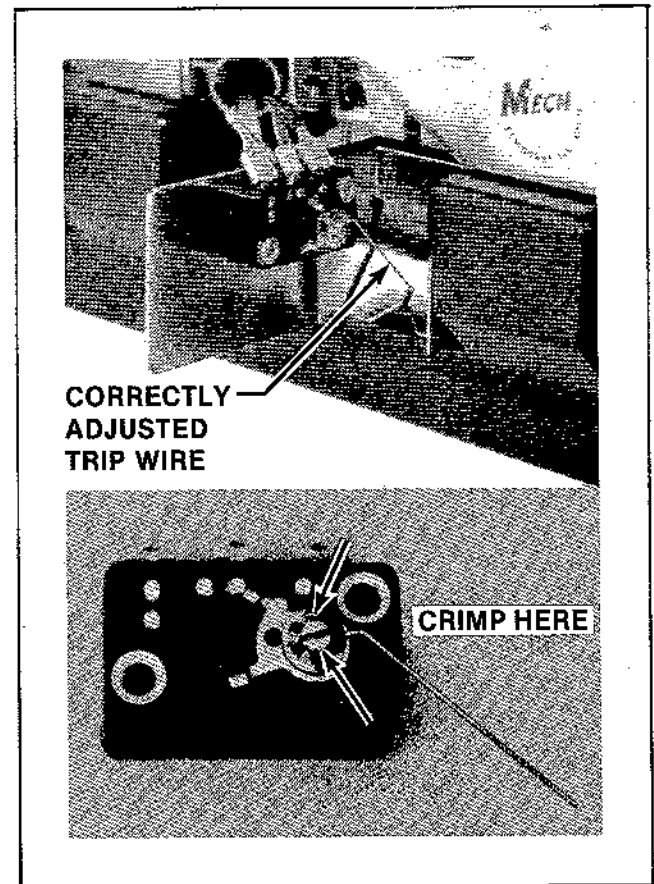

Figure 3-2 View of Coin Switch and Trip Wire

ping together both ends of the brass-colored mounting stud with a pair of pliers (see Figure 3-2). If you should ever need to remove the trip wire, the two halves of the mounting stud can be separated with a small screwdriver.

2. Cleaning Coin Mechanism Coin Paths

CAUTION

The use of an abrasive (such as steel wool or a wire brush) or applying a lubricant on a Coin Mechanism will result in a rapid buildup of residue.

By talking to many distributors and operators, we have learned the best method of cleaning a coin mechanism is by using hot or boiling water and a mild detergent. A toothbrush may be used for those stubborn buildups of residue. After cleaning, flush thoroughly with hot or boiling water, then blow out all water with compressed air.

Figure 3-3 shows the surfaces to clean inside the coin mechanism. These include the inside surface of the mainplate, and the corresponding surface of the gate assembly. There may also be metal particles clinging to the magnet itself. To remove these, you can guide the point of a screwdriver or similar tool along the edge of the magnet.

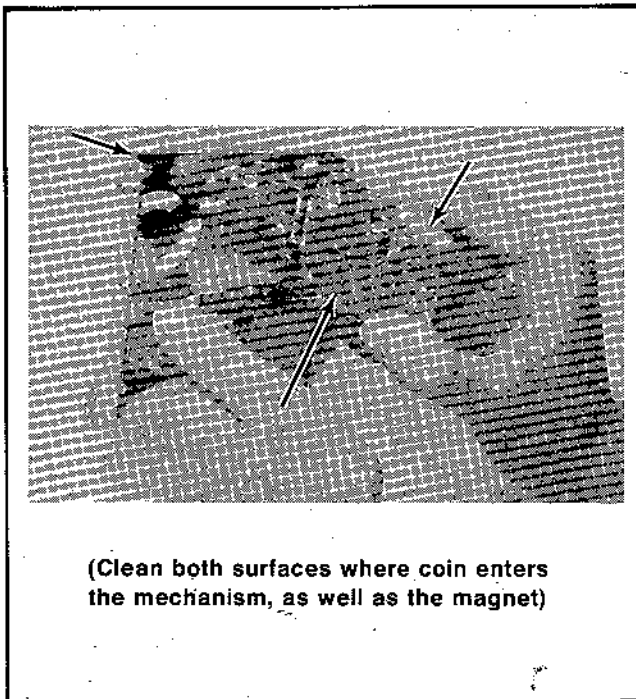

Figure 3-3 Surfaces to Clean Inside the Coin Mechanism

If coins are not traveling far enough to reach the coin mechanisms, you will need to clean the channel beneath the coin slot. To reach this channel use a Phillips-Head Screwdriver and remove the screws that secure the cover plate (See Figure 3-4). Removing the plate will provide access to the entire channel.

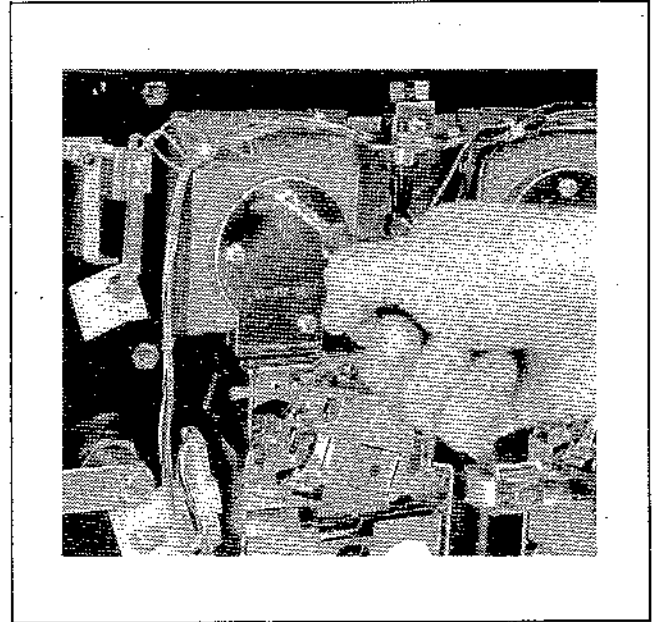
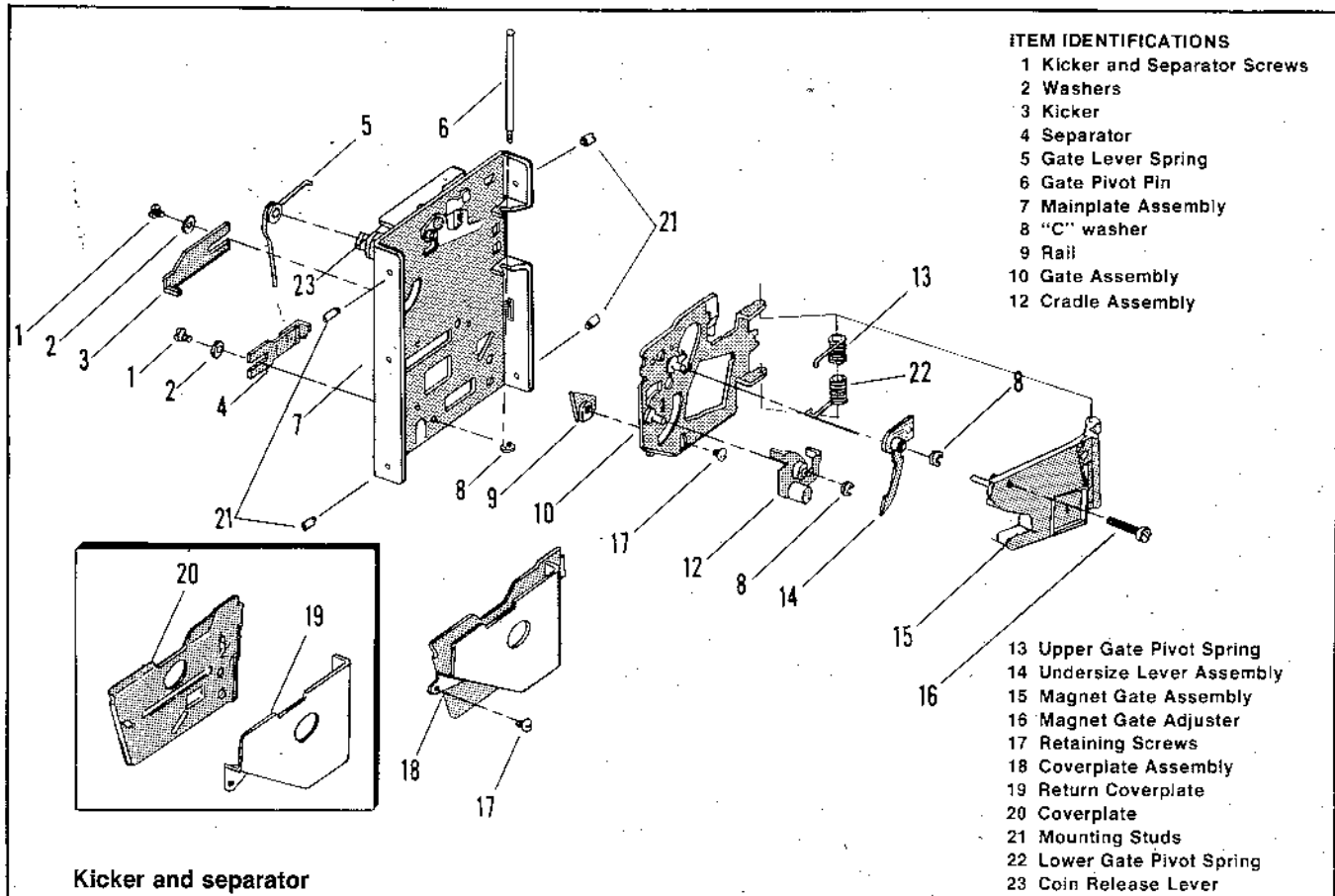

Figure 3-4 Removal of Plate Covering Rear of Coin Slot

3. Mechanical Adjustment of Coin Mechanism

Coin Mechanisms are adjusted prior to shipment from the factory and normally will retain these adjustments for many months. If, due to wear or other causes, it becomes necessary to make new adjustments, remove the coin mechanism from the coin door. Take the mechanism to a clean well-lighted area where it can be placed in a vertical position on a level surface (such as a bench top). Besides a screwdriver, you need a set of several coins, including both new and old. Figure 3-5 shows an exploded view of the mechanism and gives procedures for adjusting the kicker, separator, and the magnet gate. These adjustments should only be done by someone who has experience in servicing coin mechanisms and who understands their operation.



Kicker and separator

1. Set the acceptor with the back of the unit facing you in the vertical position.
2. Loosen the kicker and separator screws (1) and move the kicker (3) and the separator (4) as far to the right as they will go. Lightly tighten the screws.
3. Insert several test coins (both old and new) and note that some are returned by striking the separator.
4. Loosen the separator screw and move the separator a slight amount to the left. Lightly retighten the screw.
5. Insert the test coins again and, if some are still returned, repeat Step 4 until all the coins are accepted.
6. Loosen the kicker screw and move the kicker as far to the left as it will go. Lightly retighten the screw.
7. Insert the test coins and note that some are returned.
8. Loosen the kicker screw and move the kicker a slight amount to the right. Lightly retighten the screw.
9. Insert the test coins again and, if some are still returned, repeat Step 8 until all the coins are accepted.
10. Be sure that both screws are tight after the adjustments have been made.

Magnet gate

1. Set the acceptor with the front of the unit facing you in the test position.
2. Turn the magnet gate adjusting screw (16) out or counterclockwise until none of the coins will fit through.
3. With a coin resting in the acceptor entrance, turn the adjuster in or clockwise until the coin barely passes through the magnet gate.
4. Test this adjustment using several other coins (both old and new) and, if any fail to pass through the magnet gate, repeat Step 3 until all the coins are accepted.
5. Fix the magnet gate adjusting screw in this position with a drop of glue.

Additional Cleaning

1. Remove the transfer cradle (12) and the undersize lever (14).
2. Use a pipe cleaner or similar effective cleaning tool to clean the bushings and pivot pins.
3. Replace the transfer cradle and the undersize lever.
4. To be certain the coin mechanism is completely free of any residue, place the mechanism in boiling water for several minutes. Carefully remove it and blow out all water with compressed air before reinstalling in the door.

Figure 3-5 Adjustments on Coin Mechanism

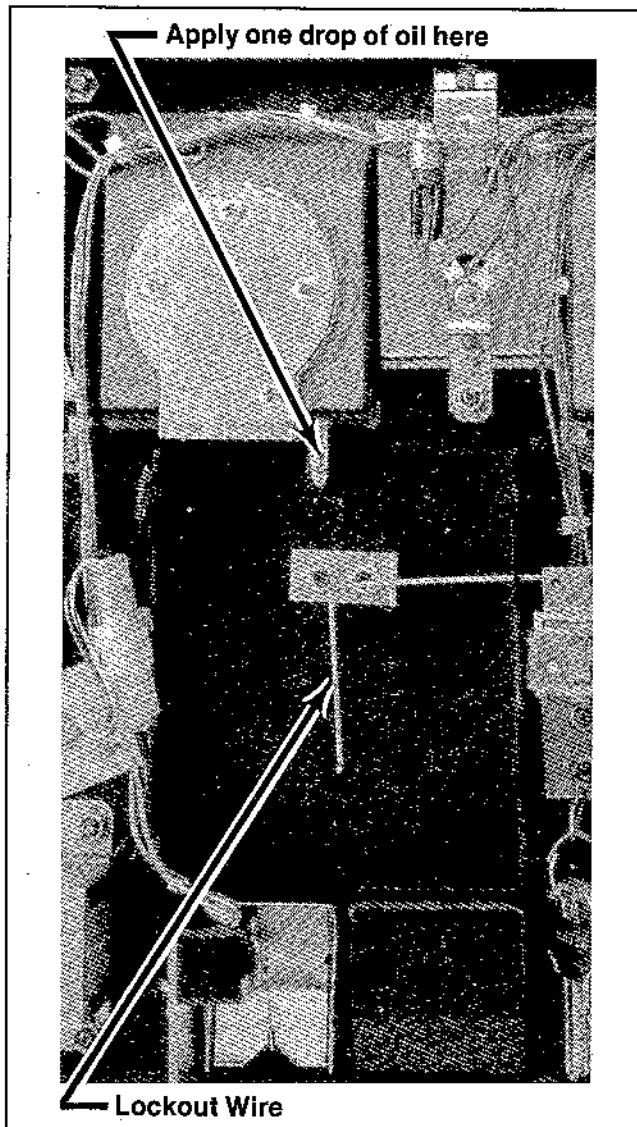

Figure 3-6 Lubrication Point

4. Lubrication

Do not apply lubrication to the coin mechanisms. The only points that may need lubrication (and only rarely) are the shafts of the scavenger buttons (coin rejection buttons) where they pass through the coin door. Apply only one drop of light machine oil, and be positive that no oil drops down onto a coin mechanism. Figure 3-6 shows this lubrication point.

C. FUSE REPLACEMENT

There are seven fuses in the game. Fuses F1 and F2 are located on the floor of the Cabinet. Fuses F3 thru F7 are located in the upper right corner of the Back Box. The function and value of each fuse is listed in Table 3-1.

D. LAMP REPLACEMENT

All Playfield and Back Box lamps are 6.3-volt, 150-milliampere, bayonet-based, general-purpose miniature lamps, type #47. In order to get optimum Playfield lighting, many of the lamps are mounted deep in the playfield. Due to this design, it may be difficult for you to change some of the lamps. Therefore, in many cases, you should remove the lamp socket to get good access to the lamps. In doing so, be careful not to break the harness wire connected to the lamp sockets.

To replace a Thumper Bumper lamp, remove the two Thumper Bumper cap (top) screws.

Table 3-1 Fuse Functions and Values

FUSE	VALUE	FUNCTION
F1	5 amp @ 250 V, Slow-Blow	Main Power
F2	2 amp @ 250 V, Slow-Blow	Service Outlet
F3	15 amp @ 250 V, Slow-Blow	Fluorescent Display high voltage and Solenoid power
F4	15 amp @ 250 V, Slow-Blow	LED Display power, Back Box controlled lamps power, and Playfield controlled lamps power
F5	7 amp @ 250 V, Slow-Blow	I/O PCB Audio Amplifier, Coin Door Lockout Coil, Coin Counter power, and unregulated logic supply
F6	10 amp @ 250 V, Slow-Blow	Fluorescent Display, uncontrolled Back Box lamps, uncontrolled Playfield lamps, and Coin Door lamp power
F7	1 amp @ 250 V, Slow-Blow	Fluorescent Display

E. FLIPPER PADDLE REPLACEMENT

When replacing flipper paddles, please note that we added punch marks to the playfield for aligning the flipper paddles. Align the center of the pointed ends of the flipper paddles with these marks and the game will maintain the designed response to the skill shots of the game.

F. SWITCH MAINTENANCE

1. Switch Replacement

Most of the game switches operate on 5 volts at a very low current. Therefore, pitting of these switches would be extremely rare. However, the "end-of-throw" switches on the Flipper solenoids and the Flipper Button switches handle 50 volts DC. These switches will have a tendency of wearing and will occasionally need to be replaced. If you replace any of the Flipper "end-of-throw" or Flipper Button switches, also *replace the shunt capacitor* that is wired to the switch. The shunt capacitor absorbs most of the arcing and sparking of the switches.

To get part numbers for "exact replacement" of a switch, refer to the Superman game Illustrated Parts Catalog.

2. Switch Cleaning

Don't burnish the switches. Burnishing switches removes the plating of the switches, thus increasing the corrosion of the contacts. *The best method of cleaning*

the switch contacts is to wipe them with a non-abrasive surface. A business card works great. In the case of the Flipper "end-of-throw" and Flipper Button switches, if these switches begin to badly pit, make a decision: either replace the switch or burnish the contacts. Replacing pitted switches solves the problem, burnishing switches prolongs the problem.

If the Flipper "end-of-throw" switch becomes dirty, it results in the Flippers not operating at all.

G. LUBRICATION OF PLAYFIELD PARTS

With this game you received a tube of lubricant. The lubricant is for you to use on the moving playfield parts such as Thumper Bumpers, Drop Targets, Ball Ejectors, and Ball Shooter. When lubricating a part, apply only a thin coat of lubricant with a cotton swab. When applying the lubricant to the Ball Shooter, make sure you don't get any lubricant on the Ball Shooter spring (it may come off on a player).

One cost advantage of lubricating solenoid plungers is that if a solenoid burns out, the plunger won't freeze to the plastic tube. Thus you would only have to replace the solenoid and tube, not the plunger.

Replace only with size AA Alkaline batteries. The following note applies:

NOTE

The RAM batteries should be replaced (**with game power on**) about once **every 9 months** to ensure no loss of data. Replace batteries **only with size AA Alkaline batteries**. Insert batteries with **polarities as marked** on the Processor PCB immediately above the battery clip.

2. LEDs on the Printed Circuit Boards

a. Processor PCB

There are five LEDs on the Processor PCB; they are identified as LED1 thru LED5.

When lit, LED1 is an indicator of the presence of the +5 VDC logic power. LED2 thru LED5 are used during the Self-Test procedure as an aid for troubleshooting a memory failure. Information at the top of the Option Switch label (located immediately above the Processor PCB in the Back Box) helps you determine if the memory failure is in the RAM or ROM and isolates the failure to the chip level.

b. I/O PCB

There are two LEDs on the I/O PCB. When lit, LED1 is an indicator of the presence of +5 VDC logic power. When lit, LED2 is an indicator of a failure in either one or more of the Playfield Driver Transistors or in a solenoid coil.

3. LED Displays

Atari's new generation Pinball games have LED Displays located in the Back Box. These displays along with their attached Driver PCB Assemblies are completely interchangeable. Therefore, if one fails, you may swap it with another.

4. Microprocessor

Atari pinball games are designed around the Motorola M6800 microprocessor. The microprocessor is at location N6 on the Processor PCB.

5. ROM/PROM Memory

ROM is the abbreviation for read-only memory. PROM is the abbreviation of programmable read-only memory.

When we begin the production of a pinball game, we generally program our own memory (PROMs). After the

first few weeks of production, we begin installing ROM memory in our games (it takes over two and one half months from the time of our order to have ROMs manufactured). Therefore, when you received this game, you may have either six PROMs or three ROMs for memory. In fact, it is even possible to have a combination of both ROMs and PROMs in your game. One ROM is equivalent to two PROMs. The following is a list of ROMs and their equivalent PROMs:

ROM1 in K/L7 = PROMs in E5 and J5
ROM2 in M7 = PROMs in D5 and K5
ROM3 in J7 = PROMs in F5 and H5

6. Flipper Enable and End-of-Throw Switch

This game has direct-driven flippers (not driven by the microprocessor). However, the microprocessor controls the Flipper Enable Relay that is located on the Power Distribution board (at the top right of the Back Box). When energized, the relay applies +50 VDC directly to the Flipper Solenoids.

An End-of-Throw switch is mounted on each flipper solenoid. When the solenoid is energized and completely engaged, the switch opens. The open switch results in adding turns to the flipper solenoid coil, thus decreasing the current through the coil. This feature provides a snappy flipper, yet when energized for extended periods of time there isn't enough current to burn up the flipper coil.

7. Game Fusing

There are seven fuses in the game. Chapter 3, Section C, discusses fuse replacement. Please be aware of the following note concerning Fluorescent Display fuse F7.

NOTE

If you have LED Displays in your game and you remove this fuse, the game will operate no differently than with the fuse installed. However, the fuse fuses the 6.3 VAC (riding on +12.5 VDC) that biases the Fluorescent Displays. Therefore, if you remove fuse F7 from the game and you have Fluorescent Displays, the displays will not light up.

8. Processor PCB Low-Power Schottky TTL Circuitry

The Processor PCB in the game uses mostly low-power Schottky TTL integrated circuitry. The advantages of this circuitry are high circuit density, high speed and low power; thus a smaller power supply is required

and less heat is generated by the PCB. However, there is one disadvantage in troubleshooting the PCB: grounding outputs or connecting them to +5 VDC may cause circuit damage. Therefore, the following caution applies to the Processor PCB.

CAUTION

The Processor PCB contains Lower Power Schottky (LS) integrated circuitry. Grounding the outputs of this circuitry or connecting them to +5 VDC may result in damaging the circuitry.

9. Solenoid Overcurrent Protection Circuit

All playfield solenoid drivers and coils are protected from potential fire hazard, in the event of a shorted driver or coil, by the overcurrent protection circuit of the Solenoid Circuitry. See section E of this chapter for a description of this circuit.

10. Test Points on Printed Circuit Boards

Test points have been provided on both the Processor and I/O PCB to aid you in troubleshooting the boards. Test points +5V and +12V are of the power inputs to both boards from the Power Supply Distribution. The Processor PCB has three conveniently located ground (GRD) points. The I/O PCB has two ground points.

On the Processor PCB, test points +9V, $\Phi 2$, TEST, and AUDIO are of signals generated on the Processor PCB. The WDOGKILL Test Point was added for use by Atari in developing future pinball games.

B. GAME POWER DISTRIBUTION

The game receives its power from the AC line via a Line Filter located in the rear of the cabinet. The AC voltage from the filter goes to the master ON/OFF switch located under the right front corner of the cabinet, then to the Primary Power Assembly located between the Coin Box and the Power Transformer T1. The Primary Power Assembly contains the primary power fuses (see Chapter 3, Section C, for fuse replacement information), the voltage selection plug for Transformer T1 primary winding, and the connectors for the line and Interlock switch. The Interlock switch, located on the hinge side of the Coin Door, turns the game power OFF when the Coin Door is opened. However, the Coin Door Interlock switch plunger may be pulled to the alternate ON position

for servicing the game with the Coin Door opened. The service outlet inside the cabinet is powered even when the Coin Door is opened and the Interlock switch is OFF, but not when the master ON/OFF switch is OFF.

Transformer T1's secondary connects to the Power Distribution Assembly located in the upper right corner of the Back Box. This assembly contains the rectifier bridges, fuses, filter capacitors, and Power Distribution PCB (see Chapter 3, Section C, for fuse replacement information). The Power Distribution PCB contains the +5 VDC regulator, the Flipper Enable Relay, and the various connectors for distributing power to the game.

With this game, you received this manual and four large drawings, marked Sheet 1 thru Sheet 4. Each sheet is marked Side A on one side and Side B on the reverse side. The wiring diagrams of Sheet 1, Side B and Sheet 3, sides A and B provide all the information for the distribution of power throughout the game. These diagrams contain cross references for you to locate the termination of connectors. As an aid in finding the right sheet for these terminations, see the Table of Contents of the four large sheets on the lower right of Sheet 1, Side A.

C. PROCESSOR PCB'S MICROPROCESSOR CIRCUITRY

The following paragraphs provide information about the circuitry of the printed circuit boards of the game. With this information we provide block diagrams of the circuits. In the block diagrams we have tried to use the same blocks in which we have divided the schematic diagrams of the Processor and I/O PCBs. We hope that this will aid you in directly identifying the actual functions of the circuitry.

The block diagram of Figure 4-1 illustrates how the circuitry is linked together on the Processor PCB for the MPU (microprocessor) Circuitry. The following is a discussion of the function of each block of figure 4-1.

1. MPU (Microprocessor)

The MPU, at location N6, controls the entire game circuitry. This device outputs addresses, reads data instructions, stores data in the RAM (random-access memory), reads previously stored data from the RAM, reads switches, and activates solenoids and lamps.

The MPU receives two clock signals $\Phi 1$ and $\Phi 2$ (Phase 1 and Phase 2) from the Clock Circuitry. These clock signals provide the basic synchronization that is critical to the operation of the MPU.

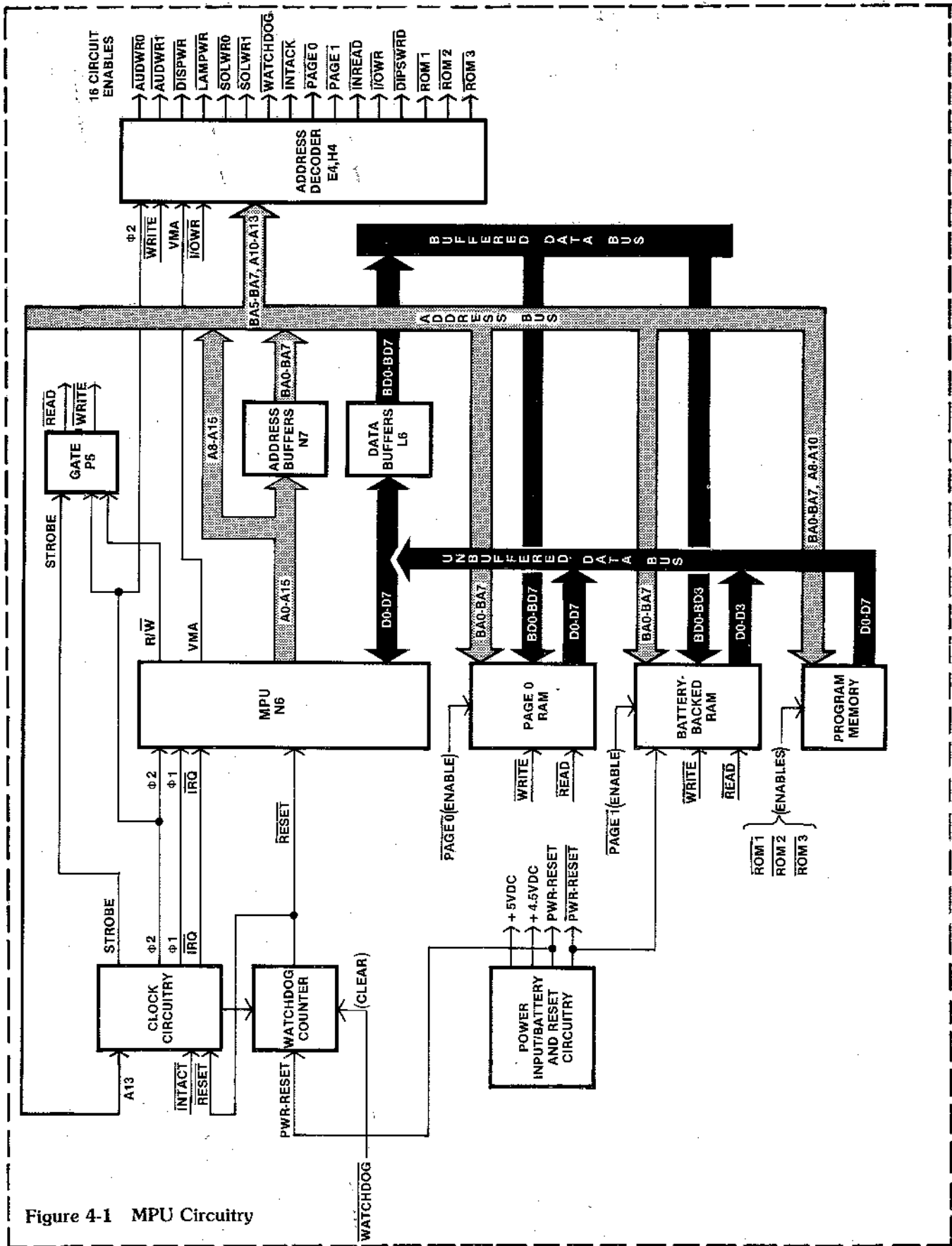

Figure 4-1 MPU Circuitry

The RESET input to the MPU forces the MPU to perform specific instructions when power is initially applied to the game or if a program error is detected by the Watchdog Circuitry.

The pulses of the IRQ (interrupt request) are counted by the MPU. These pulses are used as the basic timing of the game. For example, the information that you find in the accounting procedure of the Self-Test that gives the total play time of the game (in minutes) is a result of the MPU counting these pulses. The MPU also uses this timing to output lamp data, output data to the multiplexed displays, and to synchronously debounce switch inputs.

The R/W (read/write) output designates whether the MPU is in the read or write mode for a given clock cycle. R/W is gated by additional circuitry to provide READ and WRITE signals to the RAM (random-access memory) and Address Decoder.

The VMA (valid memory address) output of the MPU indicates to the Address Decoder that the MPU is performing a valid read or write operation, and that the address currently on the MPU address bus is stable, during the high duration of $\Phi 2$.

2. Clock and Watchdog Circuitry

The Clock Circuitry provides opposite phase, non-overlapping, $\Phi 1$ and $\Phi 2$ (Phase 1 and Phase 2) clock signals for the basic synchronization of the MPU. The circuitry also provides an IRQ (interrupt request) signal to the MPU every 2.048 milliseconds. The Watchdog Counter resets the MPU in the event of a program malfunction.

To allow for more access time for reading or writing the RAM, or reading or writing the I/O PCB, it was necessary to reduce the speed of the MPU clock from the normal 1 MHz rate to a rate of 0.667 MHz. However, since most of the MPU's time is spent reading Program Memory which does not require the lower frequency clock, it would be very inefficient to clock the MPU at a constant rate of 0.667 MHz. Therefore, it was necessary to have a two-speed clock. The signal CLOCKSWITCH controls the frequency of the MPU clock. Whenever the MPU is reading Program Memory, address line A13 goes high, causing the CLOCKSWITCH signal to pulse high. When the MPU is writing to or reading from RAM or the I/O PCB, A13 remains low, causing CLOCKSWITCH to be low. The CLOCKSWITCH signal is applied to Decade Counter R2. The results of CLOCKSWITCH at the preset B input of Counter R2 is that when low, the counter counts from four to nine: six counts. When the preset is high, the counter counts from six to nine: only four counts. This dynamically allocates the $\Phi 2$ high pulse duration as a function of the address range.

The $\Phi 1$ and $\Phi 2$ clock signals are derived from the 4 MHz crystal oscillator, Y1. The signal is divided down by counter R2 for a QB output of 1 MHz when CLOCKSWITCH input to R2 is high, and 0.667 MHz when CLOCKSWITCH is low. Therefore, $\Phi 1$ and $\Phi 2$ have two frequencies (frequency of $\Phi 1$ and $\Phi 2$ are always equal). The 1 MHz $\Phi 1$ and $\Phi 2$ waveform is two signals with a period of 1 microsecond (positive pulse and negative pulse each equal to 500 nanoseconds). The 0.667 MHz $\Phi 1$ and $\Phi 2$ waveform is two signals of opposite polarity with a period of 1.5 microseconds ($\Phi 1$ positive pulse equals 500 nanoseconds, negative pulse equals 1 microsecond— $\Phi 2$ positive pulse equals 1 microsecond, negative pulse equals 500 nanoseconds).

During normal operation, $\Phi 1$ and $\Phi 2$ clock signals are constantly changing from fast to slow. Therefore, if you look at the clock with an oscilloscope, the signals look unstable. However, to check the clock at the 1 MHz rate, check while depressing the RESET button on the Processor PCB. To check the clock at a continuous 0.667 MHz rate, clip pin 2 of Inverter N5. (When finished observing this speed of clock frequency, remember to resolder N5, pin 2.)

IRQ (Interrupt Request) countdown begins at the QA output of Counter R2. The division of the QA frequency continues through eight stages of Counter L2 and four stages of Counter M2 and is then fed to flip-flop M1. Since the QA output of Counter R2 is a constant 2 MHz, the IRQ output of flip-flop M1 is a constant pulse period of 2.048 milliseconds. When the MPU receives a low IRQ, it outputs the address 18E0 (HEX) that results in an INTACK (Interrupt Acknowledge) signal from the Address Decoder and then performs the function of the interrupt routine in the MPU. INTACK results in resetting flip-flop M1 for a high IRQ output. The flip-flop is also reset by a RESET signal that results from either a PWR-RESET (Power Reset) or an output from the Watchdog Counter.

The Watchdog Counter is a hardware circuit that guards against a software failure. The second half of Counter M2 receives an input clock from the QD output of the first half of Counter M2. The second portion of Counter M2 should never reach its maximum count. This is due to the MPU outputting the address 18C0 (HEX) that results in a low WATCHDOG signal from the Address Decoder. This signal clears the second half of Counter M2, thus preventing the output at QD of Counter M2 from going high. If the MPU should fail to output the necessary address, the counter will count to its maximum, resulting in a low RESET signal to the MPU input.

Table 4-1 Universal Processor PCB Memory Map

ADDRESS													R/W	DATA								FUNCTION	ADDRESS DECODER SIGNAL				
HEXDECIMAL	A15	A14	A13	A12	A11	A10	A9	A8	A7	A6	A5	A4		A3	A2	A1	A0	D7	D6	D5	D4			D3	D2	D1	D0
0000-00FF	X	X	0	0	0	X	X	X	A	A	A	A	A	A	A	A	R/W	D	D	D	D	D	D	D	D	Working RAM	PAGE 0
0800-08FF	X	X	0	0	1	X	X	X	A	A	A	A	A	A	A	A	R/W					D	D	D	D	Battery-Backed RAM (Half-Byte)	PAGE 1
1000	X	X	0	1	0	X	X	X	X	X	X	X	X	X	X	X	R	D								Self-Test Input	INREAD
1000	X	X	0	1	0	X	X	X	X	X	X	X	X	X	X	X	R		D							Disabled Solenoid Input	INREAD
1000-1007	X	X	0	1	0	X	X	X	X	X	X	X	A	A	A	A	R			D	D	D	D	D	D	External Switch Inputs	INREAD
1800	X	X	0	1	1	X	X	X	0	0	0	X	X	X	X	X	W	D								Audio Noise Enable	AUDWR0
1800	X	X	0	1	1	X	X	X	0	0	0	X	X	X	X	X	W		D							Audio Waveform Enable	AUDWR0
1800	X	X	0	1	1	X	X	X	0	0	0	X	X	X	X	X	W			D	D					Audio Octave Select	AUDWR0
1800	X	X	0	1	1	X	X	X	0	0	0	X	X	X	X	X	W					D	D	D	D	Audio Waveform Select	AUDWR0
1820	X	X	0	1	1	X	X	X	0	0	1	X	X	X	X	X	W	D	D	D	D					Audio Frequency Divisor	AUDWR1
1820	X	X	0	1	1	X	X	X	0	0	1	X	X	X	X	X	W					D	D	D	D	Audio Amplitude Control	AUDWR1
1840-1846	X	X	0	1	1	X	X	X	0	1	0	X	X	A	A	A	W				D	D	D	D		Display Data Output	DISPWR
1847	X	X	0	1	1	X	X	X	0	1	0	X	X	1	1	1	W						D	D	D	Display Digit Enable	DISPWR
1860-1867	X	X	0	1	1	X	X	X	0	1	1	X	X	A	A	A	W	D	D	D	D	D	D	D	D	Lamp Output	LAMPWR
1880	X	X	0	1	1	X	X	X	1	0	0	X	X	X	X	X	W					D	D	D	D	Solenoid Output	SOLWR0
18A0-18A5	X	X	0	1	1	X	X	X	1	0	1	X	X	A	A	A	W								D	Independent Control Output	SOLWR1
18A7	X	X	0	1	1	X	X	X	1	0	1	X	X	1	1	1	W								D	Solenoid Enable	SOLWR1
18C0	X	X	0	1	1	X	X	X	1	1	0	X	X	X	X	X	W									Watchdog Reset	WATCHDOG
18E0	X	X	0	1	1	X	X	X	1	1	1	X	X	X	X	X	W									Interrupt Acknowledge	INTACK
2000-2003	X	X	1	0	0	X	X	X	X	X	X	X	X	A	A	A	R	D	D	D	D	D	D	D	D	DIP Switch Input	DIPSWRD
A800-AFFF	X	X	1	0	1	A	A	A	A	A	A	A	A	A	A	A	R	D	D	D	D	D	D	D	D	ROM 1 Select	ROM 1
3000-37FF	X	X	1	1	0	A	A	A	A	A	A	A	A	A	A	A	R	D	D	D	D	D	D	D	D	ROM 2 Select	ROM 2
3800-3FFF	X	X	1	1	1	A	A	A	A	A	A	A	A	A	A	A	R	D	D	D	D	D	D	D	D	ROM 3 Select	ROM 3

3. Address Decoder

The Address Decoder performs the critical function of "turning on" or enabling the appropriate game circuitry (i.e., RAM, Program Memory, I/O PCB Solenoid latches, etc.) at the appropriate time. Once these circuits are enabled, information can be transferred back and forth between the MPU and the game circuitry.

Table 4-1 is the Memory Map for the MPU Circuitry Address Decoder. Note that the address is given in both hexadecimal and binary. In the binary column, an X indicates that it makes no difference whether that address line is high or low. The address necessary to select a given output of the Address Decoder is indicated with ones and zeros. The actual address lines that are used to address the selected game circuitry are indicated by As (plural of A). The R/W column shows that when WRITE (designated by W) is low, the MPU is writing to the selected circuitry. When READ is low, the MPU is reading the selected circuitry. The Data column shows the data lines used in the read or write operation. The

Function column defines the purpose of the read or write operation. The Address Decoder Signal column defines the selected output of the Address Decoder for the operation.

The Address Decoder consists of two Decoders at locations E4 and H4. Decoder E4 is driven by buffered address lines BA5 thru BA7 and I/O WR (I/O Write) gated with WRITE. Notice that only when I/O WR and WRITE are low, can the outputs of this decoder be active. Therefore, the control of this decoder is not only in address lines A5 thru A7, but also the decoder is enabled by the I/O WR output from Decoder H4. Additional control of Decoder E4 from the WRITE signal ensures that the selected game circuitry from this decoder is not enabled except for a write condition.

Decoder H4 is driven by Address lines A11 thru A13 and Φ2 gated with VMA. (Disregard address A15, as this is used only during game development.) Address lines A11 thru A13 determine the output of Decoder H4.

However, the outputs are all high until VMA is received from the MPU and the $\Phi 2$ clock is high. This ensures that the selected input or output is not enabled until the address lines are stabilized and valid.

4. Program Memory

Program Memory consists of three ROMs (read-only memory) or six PROMs (programmable read-only memory) with a total memory size of $6K \times 8$. See Section A of this chapter for information concerning the ROM/PROM equivalents. See the game Illustrated Parts Catalog for ROM or PROM part numbers.

The Program Memory has the function of instructing the MPU in the operation and rules of this specific pinball game. When addressed by the MPU, it supplies the data required for the game play. Each ROM or equivalent pair of PROMs are enabled by the Address Decoder.

5. RAM (including Battery-Backed RAM Memory)

The function of the RAM is to act as a scratch pad for the information that the MPU decides it wants to store. The RAM of locations K6 and L6 stores temporary information while the Battery-Backed RAM of H6 stores more permanent information, such as the accounting information of the Self-Test Procedure. The Battery-Backed RAM is automatically powered by a +4.5 VDC battery supply when the line power is turned off. At this time the CE2 input, pin 17, goes low so the RAM consumes less power in this standby mode.

In order to write information into a RAM, the WRITE input must be low, the READ input must be high, and the proper address decode must be active. To read information from the RAM, the WRITE input must be high, READ must be low, and it must be properly selected by the Address Decoder.

Note that the Battery-Backed RAM will lose data if the batteries are removed and the line power is off. Batteries should be changed with the power set to ON to retain data during the battery change. Batteries should be changed every nine months. Only size AA alkaline batteries should be used.

6. Power Input and Battery Circuit

The Power Input circuit receives +5 VDC, +7 VDC, and +12.5 VDC from the Power Distribution Board. The +5 VDC input is the logic supply voltage for all circuits on the Processor and I/O PCBs. To complement the +5 VDC input, resistor R9 supplies additional current to the logic supply from the +12.5 VDC input from

the Power Distribution Board. The +12.5 VDC input is also used as the supply voltage for the Audio Circuit on both the Processor PCB and I/O PCB. The +7 VDC input is used as the supply voltage for the Anode Drivers of the Display Interface Circuit.

With no power input, the battery supply BAT1 thru BAT3 provides +4.5 VDC to maintain data in the Battery-Backed RAM. When power is applied, +12.5 VDC (which is clamped to the +5 VDC supply by diode CR1) forward biases diode CR2, resulting in raising the Battery-Backed RAM voltage to +5 VDC. Therefore, the drain is removed from the batteries, as diode CR4 is reverse biased. The Battery-Backed RAM will retain data with a battery supply voltage greater than 3.0 VDC.

7. Power Reset Circuit

The Power Reset Circuit's function is to reset, and hold in the reset condition, the MPU and other game circuitry, until the power input voltages are stabilized. A delay is established by RC network C7 and R13. Because of this network, it takes a little less than half a second for a voltage to develop at the base of transistor Q1 that is sufficient for Q1 to conduct. When Q1 conducts, transistor Q2 turns off, resulting in a high PWR-RESET and a low PWR-RESET signal. Resistor R8 provides hysteretic feedback to the base of transistor Q1 to clamp Q1 into conduction. When power is removed from the game and as the +12.5 VDC supply drops below +10 VDC, the reverse of the preceding occurs and the MPU and other game circuitry are reset. The RC network of capacitor C29 and resistor R123 delays the reset input (PWR-RESET) to the Battery-Backed RAM. As the +5 VDC supply drops, diode CR7 becomes reverse biased, isolating the RC network from the bleeding +5 VDC supply. Therefore, the Battery-Backed RAM is permitted to complete its cycle during power down.

D. SWITCH CIRCUITRY

The following circuit description relates to the schematic diagram of the Processor PCB and I/O PCB. These schematics are located on Sheet 2, Sides A and B, of the large sheets included with this manual. See Figure 4-2 for a block diagram representation of this circuit.

The MPU addresses Option Switches SWA thru SWD with buffered address lines BA0 and BA1 and reads the switches thru data lines D0 thru D7. The Coin Door, START, and Playfield switches are addressed by buffered address lines BA0 thru BA2 and read thru data lines D0 thru D5.

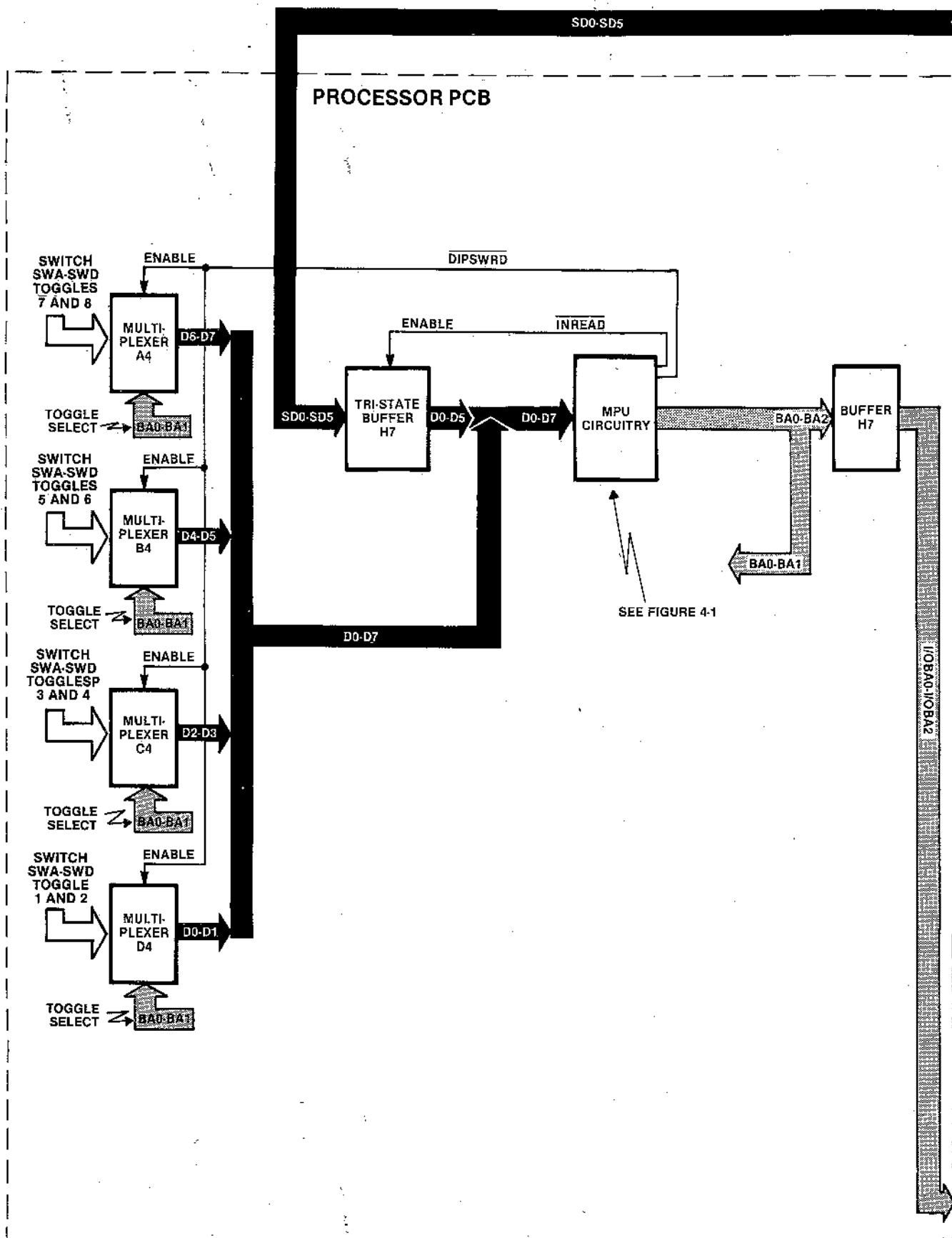
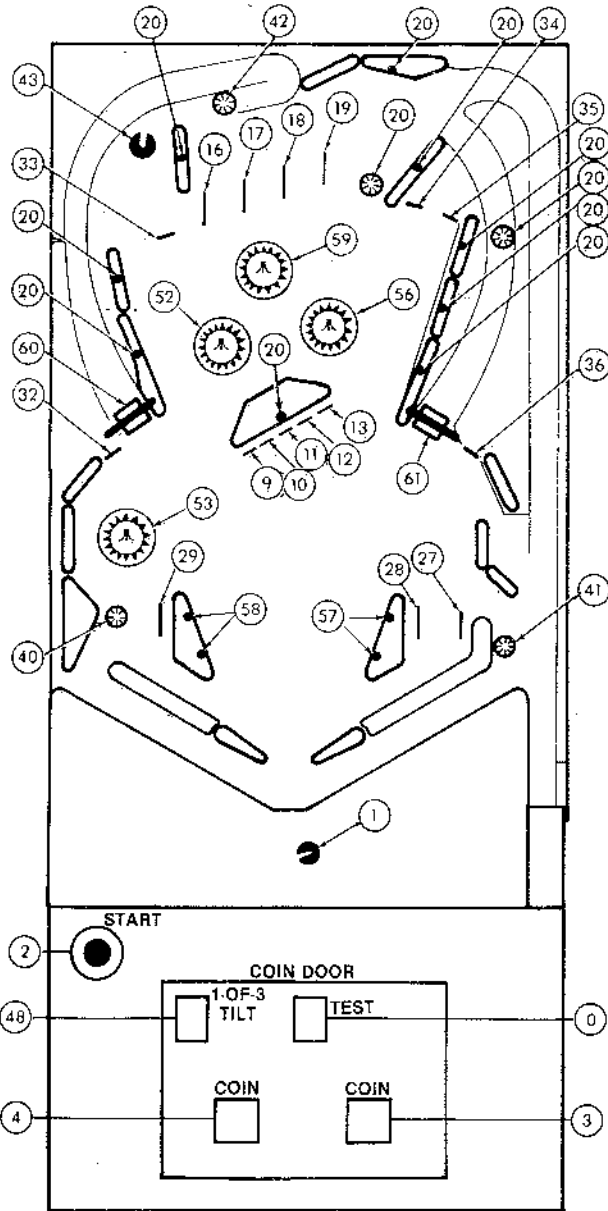
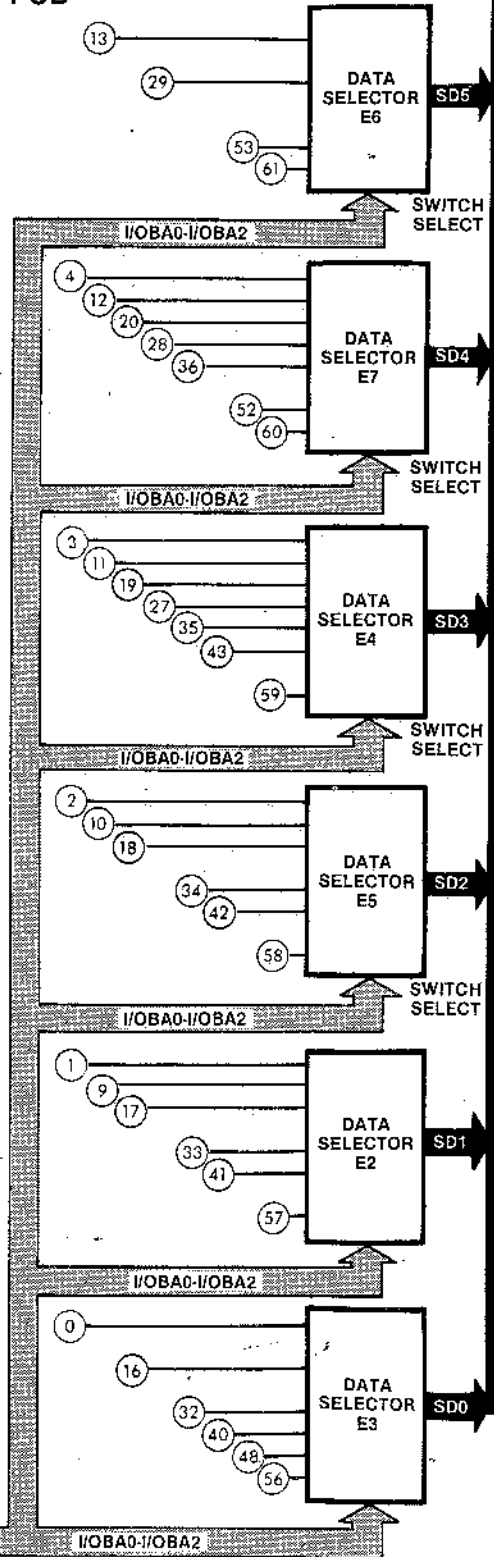

Figure 4-2 Switches Circuitry

PLAYFIELD ASSEMBLY



I/O PCB



1. Coin Door, START and Playfield Switches

The wipers (or "common" terminals) of all Coin Door, START, and Playfield switches are connected to the inputs of six Data Selectors E2 thru E7. The N.O. (normally open) contacts of each switch are connected directly to ground. Each switch input is connected to a pullup (470 ohm resistor tied to +5 VDC) on the I/O PCB. Therefore, when a switch is closed, the Data Selector input for that switch is pulled from +5 VDC to 0 VDC (ground) through a 100k ohm resistor (used to protect the Data Selector against static electricity).

Each Data Selector has the capability of handling eight switch inputs. Since there are six Data Selectors, this circuitry can handle up to forty-eight switches (although this game does not use all the possible switch inputs). The Address inputs (IOBA0 thru IOBA2) to the Data Selectors select the switches to be read by the MPU. Therefore, six switches at a time may be read by the MPU via data outputs SD0 thru SD5. Signals SD0 thru SD5 are buffered onto the MPU data bus by tristate buffer H7, which is enabled by the MPU Address Decoder signal INREAD.

2. Game Option Switches

One side of all the Option DIP (dual inline package)

switches on the Processor PCB is connected to ground. The opposite contact of all these switches is connected to the inputs of Multiplexers A4, B4, C4, D4. Each input of the Multiplexers is connected to a pullup (10k ohm resistor tied to +5 VDC). Therefore, a closed switch pulls the input from +5 VDC to 0 VDC (ground).

Each Multiplexer handles eight inputs from the DIP switches. The Address inputs (BA0 and BA1) to the Multiplexers select two toggles from each switch to be read by the MPU. Therefore, eight switch toggles at a time are read by the MPU via data outputs D0 thru D7. DIPSWRD (from the MPU Address Decoder) enables Multiplexers (A4, B4, C4, D4), which have tristate outputs, and gates Option Switch information onto the MPU data bus.

3. TEST Test Point on Processor PCB

Not only can the game's Self-Test be activated by the Coin Door Self-Test switch, but also by grounding the TEST test point on the Processor PCB. The MPU reads the test point, through tri-state buffer H7 on data line D7. Therefore, Self-Test may be easily activated while the Processor PCB is on the test bench.

E. SOLENOID CIRCUITRY

The following circuit description relates to the schematic diagram of the Processor PCB and I/O PCB. These schematics are located on Sheet 2, Sides A and B, of the large sheets included with this manual. See Figure 4-3 for a block diagram representation of this circuit.

All solenoids are energized by commands from the MPU Circuitry. There are two solenoid circuits on the I/O PCB. One is for long-term or low current relays, such as the Flipper Enable Relay and the Coin Door Lockout Coil. The other is for short-term high current solenoids, which are the Playfield solenoids.

1. Coin Door Lockout Coil and Flipper Enable Relays

The key to this circuitry is Addressable Latch A6/7, on the I/O PCB. From the MPU circuitry, the latch receives buffered address signals I/OBA0 thru I/OBA2, buffered data signal I/OBD0, and solenoid write command I/OSOLWR1. The address signals select the output of the latch to which the data is to be written. The solenoid write command signal I/OSOLWR1 (from the Address Decoder of the MPU Circuitry), when present, **allows** the data to be latched.

When power is initially applied to the game, the I/ORESET, generated by the MPU Circuitry, sets all the outputs of latch A6/7 to a low. The MPU eventually sends out the address and data for enabling the Coin Door Lockout Coil, when appropriate. When the latch receives the proper solenoid write command, a high is written to the Coin Door Lockout Coil output of the latch. The high biases Driver Transistor Q82 into conduction, thus applying a ground to the Lockout Coil. Since the other side of the Lockout is attached to +12.5 VDC, the coil energizes.

When the MPU Circuitry recognizes that there is credit for a game, the START button is pressed, and the game is not tilted, the Flipper Enable Relay is energized in the same manner as the Lockout Coil. When the Flipper Enable Relay energizes (by +50 VDC) the contacts of the relay apply +50 VDC directly to both the right and left Flipper Solenoids.

2. Playfield Solenoids

The Playfield solenoids, coin counters, and Total Plays Counter are enabled by the SOLENABLE signal from Latch A6/7 (see part 1 of this chapter for the operation of Latch A6/7). SOLENABLE sets the output of flip-flop

B4/5 for a high DISABLE and a low DISABLE output. The high DISABLE output provides the proper bias for the conduction of transistor Q81 and solenoid driver transistor Q103. The low DISABLE output of the flip-flop removes the inhibit from Decoder/Latch B2. The MPU writes to Decoder/Latch B2 with buffered data signals I/OBD0 thru I/OBD3 for the selected solenoid. When B2 receives the solenoid write command I/OSOLWR0, the selected output of B2 is latched high.

Let's say that the MPU writes to latch B2 with data to turn on output latch fifteen, the Outhole Kicker. The Outhole Kicker now has a ground path through resistor R109, solenoid enable transistor Q103, solenoid driver transistor Q90, and the Outhole Kicker coil to +50 VDC. Therefore, the Outhole Kicker energizes.

Under normal operation each playfield solenoid will conduct about 5 amps when energized. However, if a solenoid coil is shorted, the solenoid driver will initially attempt to supply the short circuit current. If one solenoid driver transistor is shorted and another solenoid is energized, the two energized solenoids will conduct about 10 amps of current. Transistors Q65, Q66, Q81, and Q103, together with current sense resistor R109, flip-flop B4/5 and associated resistors, capacitors and diodes, form an overcurrent protection circuit. Current in excess of approximately 7 Amps will cause a voltage of 0.7 volts across resistor R109 (the current sense resistor). The capacitor of RC network C12 and R108 charges to about 0.7 volts in approximately 5 microseconds (1 TC = 1 microsecond). The 0.7 volt charge on C12 biases transistor Q65 into conduction. This turns off transistor Q66. The reset input of flip-flop B4/5 becomes high, through diode CR2. This resets the flip-flop for a high DISABLE and a low DISABLE output. Transistor Q81 loses its bias, turning off transistor Q103, resulting in the loss of the ground path for the selected coil. Therefore, the coil deenergizes, or will not burn up if it was a shorted coil. The overcurrent protection circuit protects shorted coils or driver transistors from creating a fire hazard.

When power is initially applied to the game, Decoder/Latch B2 is reset for all low outputs by I/ORESET, generated by the MPU Circuitry. This prevents the floating address and data lines from energizing solenoids during power-up.

In the event of a shorted coil or driver transistor, the SENSE FAILURE LED will flash on for the duration of the time that the coil is on.

PROCESSOR PCB

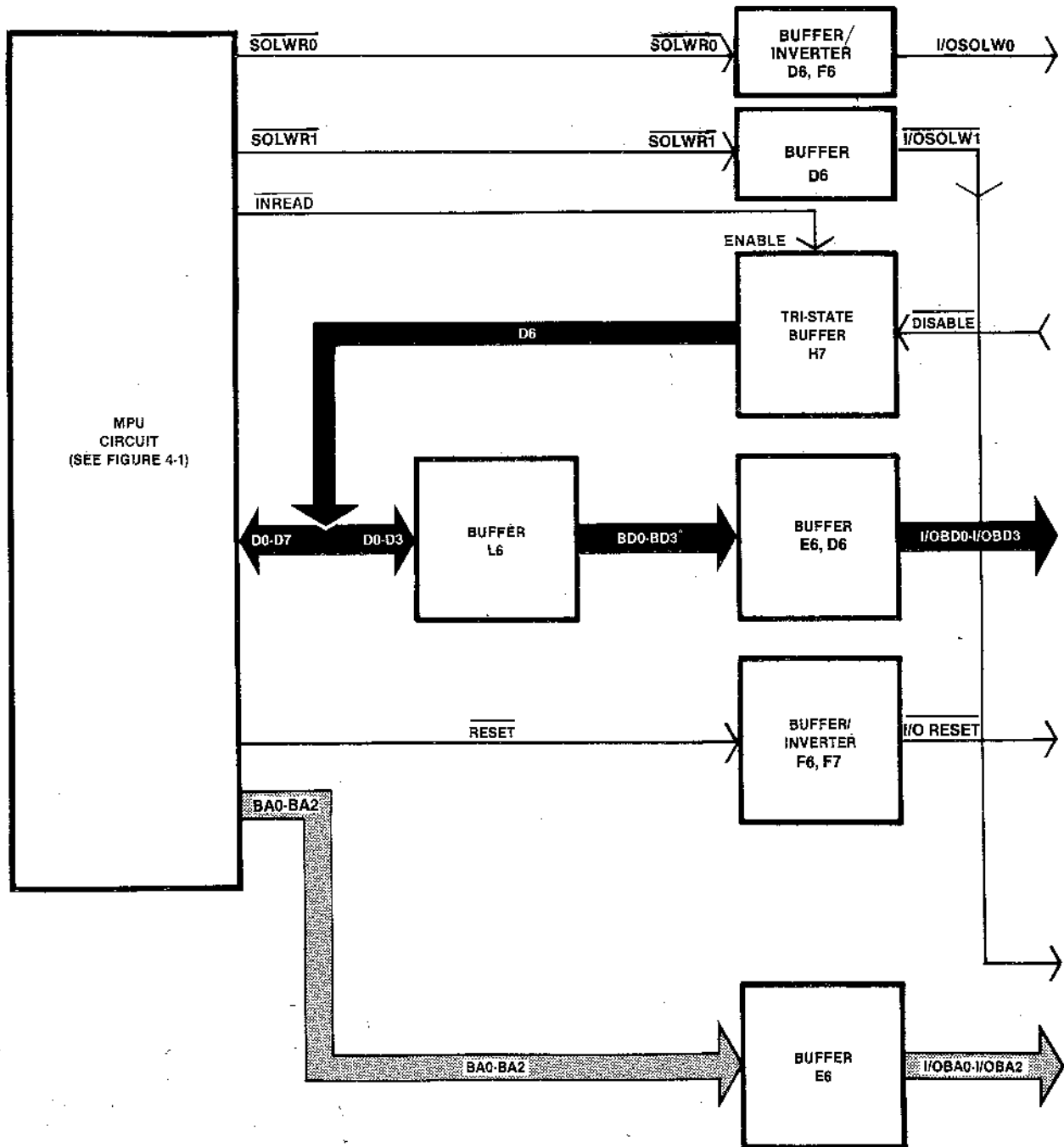

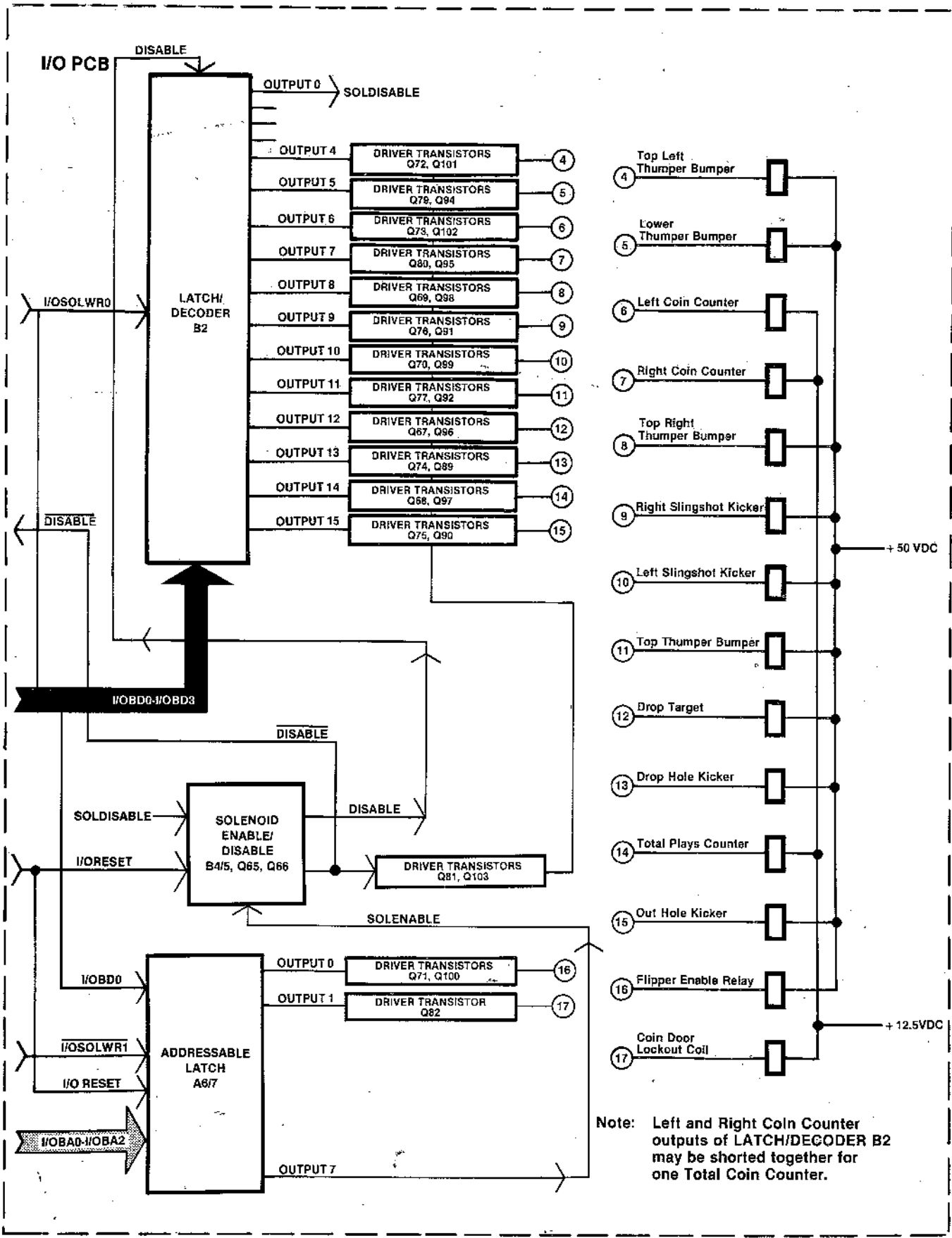

Note: Left and Right Coin Counter outputs of LATCH/DECODER B2 may be shorted together for one Total Coin Counter.

PROCESSOR PCB

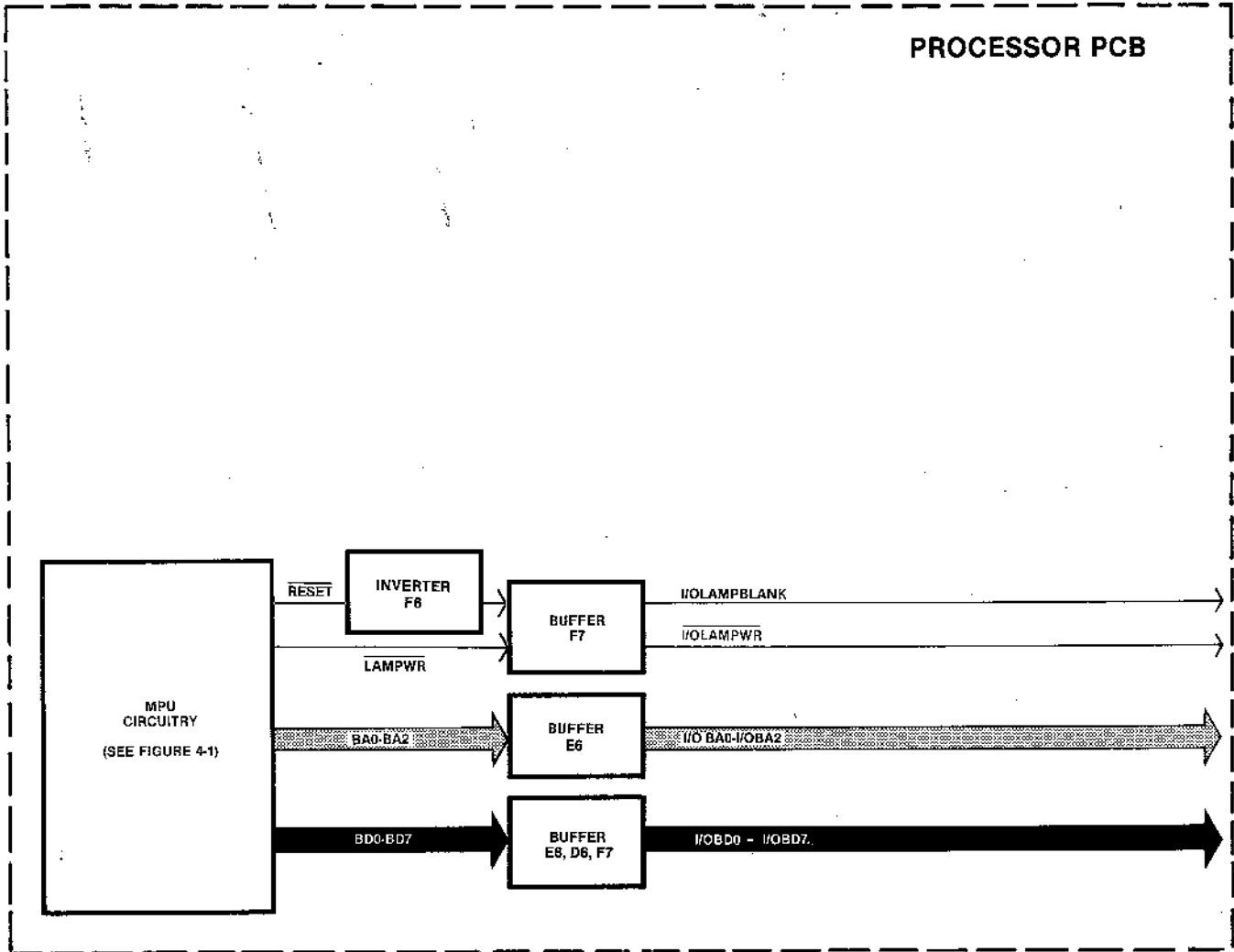

F. LAMP CIRCUITRY

The following circuit description relates to the schematic diagram of the Processor PCB and I/O PCB. These schematics are located on Sheet 2, Sides A and B, of the large sheets included with this manual. See Figure 4-4 for a block diagram representation of this circuit.

In the game, there are two different lamp circuits. The constantly lit general illumination lamps are powered by 6.3 VAC from the Power Supply. The second type of lamp is controlled by the microprocessor. The microprocessor-controlled lamps are the ones that turn on and off during the attract mode and during game play. Due to the simplicity of the general illumination lamps, the following information only relates to the microprocessor-controlled lamps.

The MPU addresses the sixty-four possible lamps (all sixty-four are not used in this game) through I/O PCB Latches C2/3, C4, C5/6, C6/7, D2/3, D4, D5/6, and D6/7 with buffered address lines BA0 thru BA2, then writes to the latches through buffered data lines D0 thru D7. When the latches receive the lamp write command I/OLAMPWR, the data is transferred to the selected output and latched. When the selected output goes high, the lamp driver transistor is biased into conduction. Since all of the MPU controlled lamps are connected to a common +7 VDC source, the lamp is lit through the ground path provided by the driver transistor and either diode CR7 or CR8.

When power is initially applied to the game, the latches are reset for all low outputs by I/OLAMPBLANK, generated by the MPU Circuitry. This prevents the floating address and data lines from lighting during game power-up.

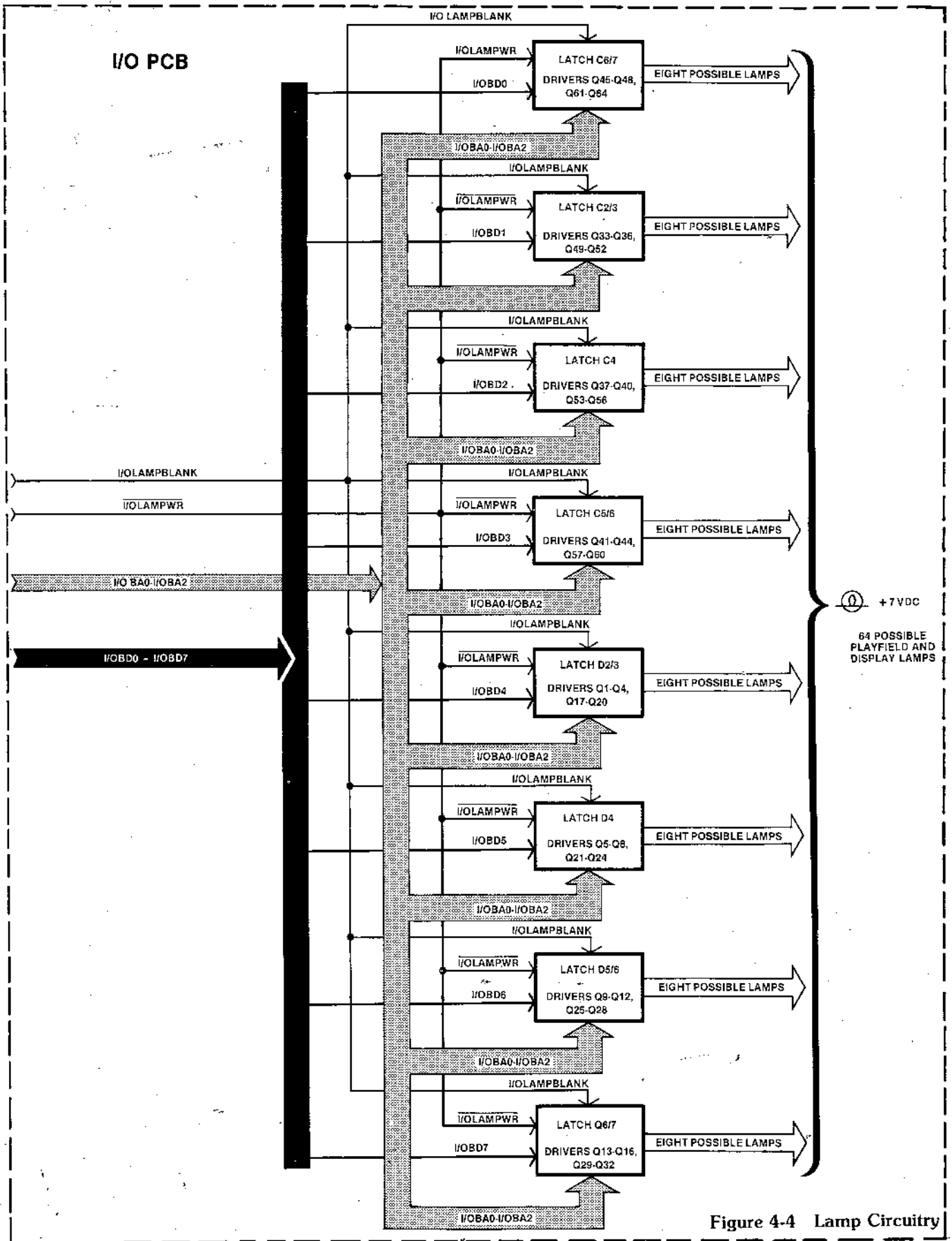
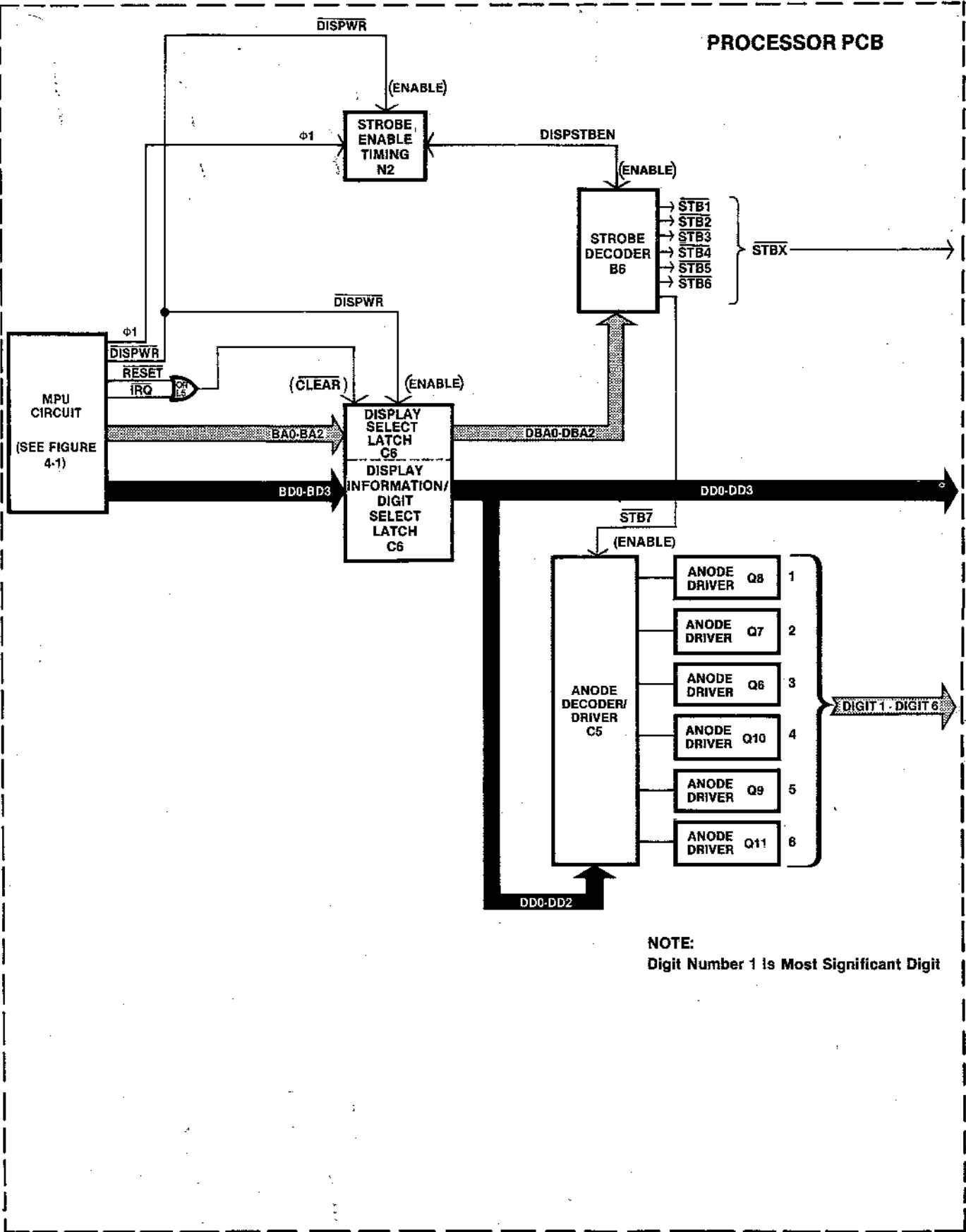

Figure 4-4 Lamp Circuitry

PROCESSOR PCB



NOTE:
Digit Number 1 is Most Significant Digit

Figure 4-5 Display Circuitry

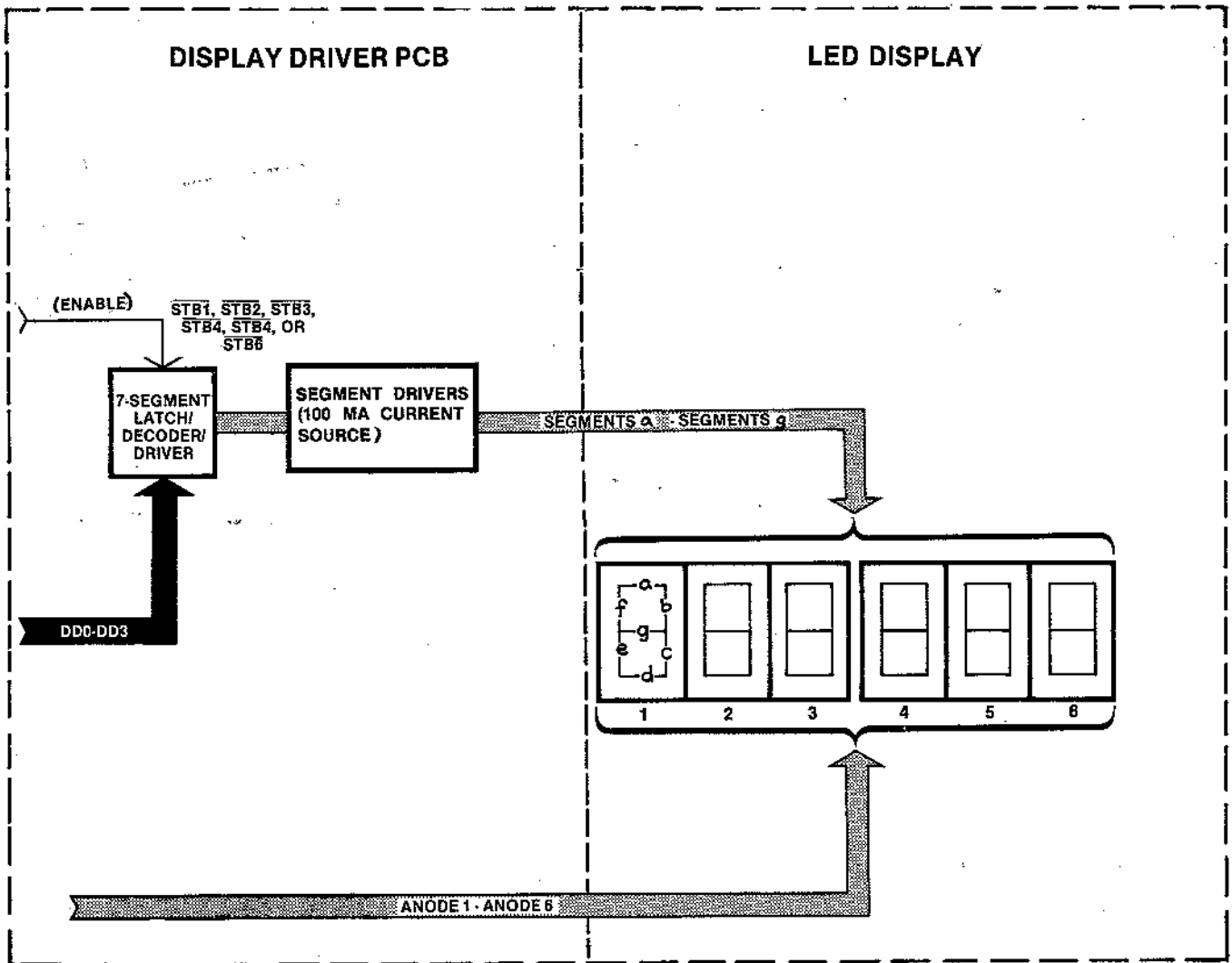

G. DISPLAY CIRCUITRY

The following circuit description relates to the schematic diagram of the Processor PCB and Display Driver PCBs. These schematics are located on Sheet 2, Side A and B, of the large sheets included with this manual. See Figure 4-5 for a block diagram representation of this circuit.

In the game, there are six possible displays; 1) Player 1, 2) Player 2, 3) Player 3, 4) Player 4, 5) BALL/CREDIT/MATCH, and 6) to be assigned on a future game. The MPU first writes display data to the individual Display Driver PCBs. Next it writes data that turns on a particular digit in all displays. This process is repeated for each of the six digits in each of the five separate displays.

When the Address Decoder of the MPU Circuitry outputs the display write command (DISPWR), the MPU address information at the input of Latch C6 is latched at its

output and transferred to the address input of Strobe Decoder B6. MPU data is also latched at the output of Latch C6. Both data and strobe information then go to the Display Driver PCBs. The Strobe Decoder decodes which Display Driver PCB is to be written to (via STB1-STB6). The Display data (DD0-DD3) determines what segment data is being written to that display.

The preceding process is done until all five (six) Displays have been addressed and data is latched into each of the 7-Segment Latch/Decoder/Drivers. The seventh address received by the Strobe Decoder causes input D of the Anode Decoder/Driver C5 to go low. This enables the Anode Decoder/Driver for an output as defined by the data input. The selected output of the Anode Decoder turns on the anode of the selected digit of all the Displays. This entire process is done until all six digits of the Displays are completed. This six digit cycle is continuously repeated, so that the displays appear to be continuously on.

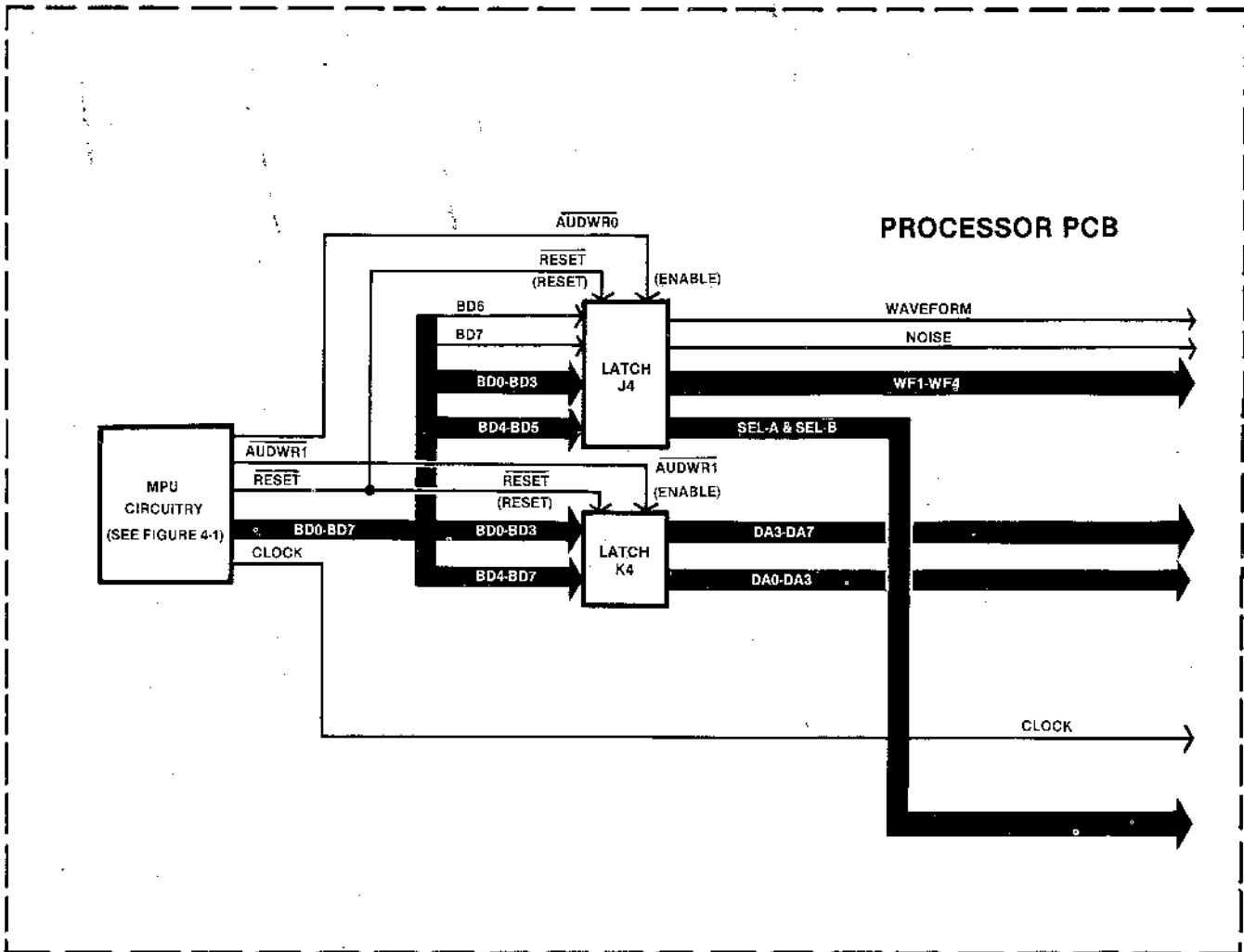

Figure 4-6 Audio Circuitry

H. AUDIO CIRCUITRY

The following circuit description relates to the schematic diagram of the Processor PCB and I/O PCB. These schematics are located on Sheet 2, Sides A and B, of the large sheets included with this manual. See Figure 4-6 for a block diagram representation of this circuit.

There are two audio generators in the Audio Circuitry: the noise generator, consisting of Shift Registers N4 and P4, and the waveform generator, consisting of Multiplexer K2, Programmable Counter K3, Binary Counter J2, and PROM J3. The two audio channels are summed at the input of Transistor Q5, then fed into the inputs of four Analog Gates L4. The outputs of the four gates are applied to a binary attenuator from which the outputs are summed and fed to the I/O PCB for amplification.

When power is initially applied to the game, RESET, generated by the MPU Circuitry, sets Latches J4 and K4 for all low outputs, disabling both audio channels. When the Address Decoder of the MPU Circuitry outputs its audio write command (AUDWR0), data is latched into Latch J4 which defines what generator is to be turned on. A high data bit BD6 turns on the waveform generator, and a high data bit BD7 turns on the noise generator. At the same time, the octave of the waveform is defined by data bits BD4 and BD5 and the shape of the waveform is defined by data bits BD0 thru BD3. The second audio write command (AUDWR1) latches data into Latch K4 which defines the frequency of the waveform and the amplitude of the summed audio signals.

The noise generator is a simple 15-bit pseudo-random sequence generator, clocked by the terminal count from the waveform generator to make the two frequencies harmoniously compatible. The summed output of the noise

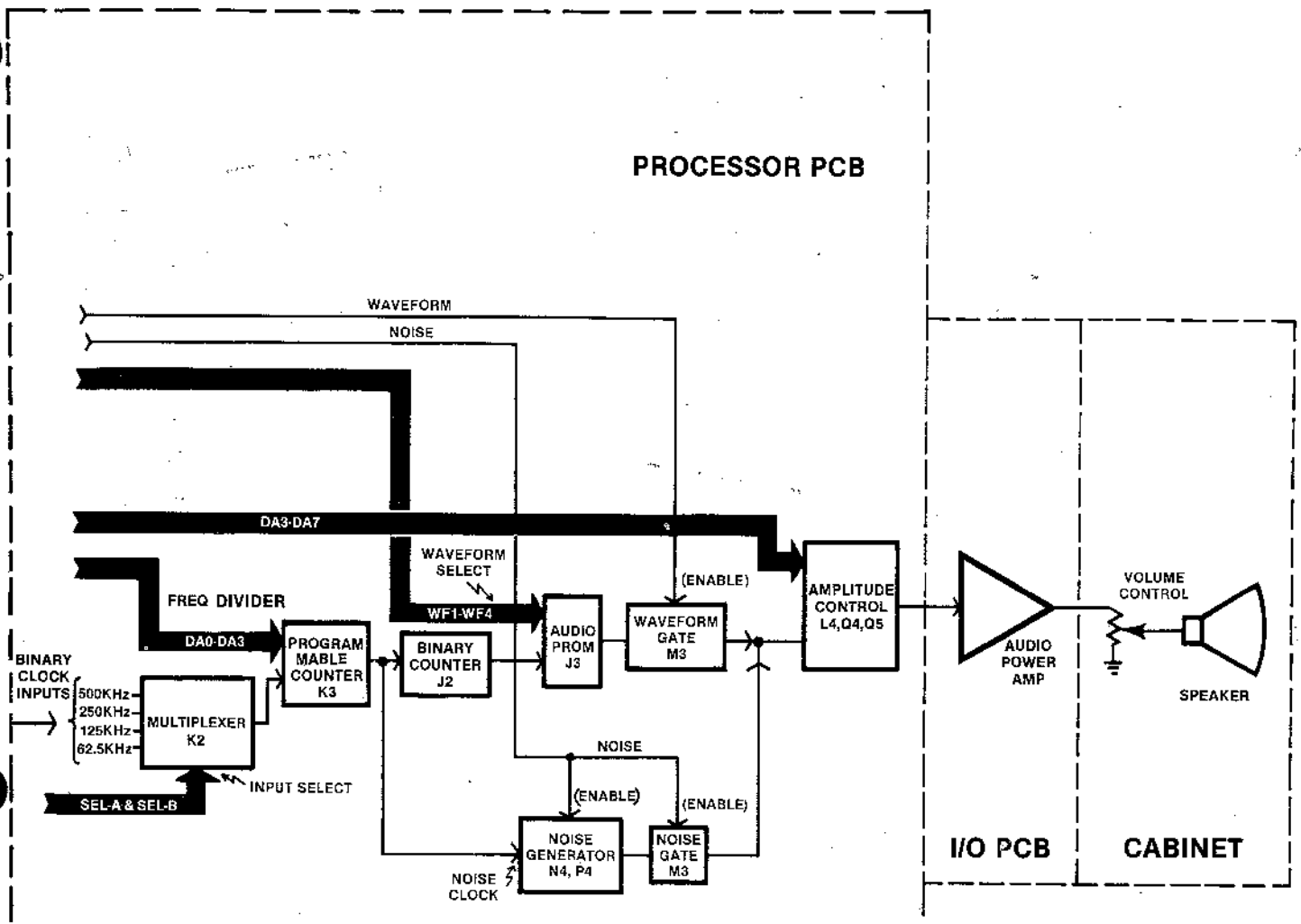

generator is AC coupled by Capacitor C10 and fed to voltage dividers R16 and R17 which provide a DC voltage reference. The output of Analog Gate M3 applies the noise frequency to the summing point of Transistor Q5.

The basic frequency of the waveform generator is selected from the input (AUD1-AUD4) of Multiplexer K2 (via SEL-A and SEL-B). Programmable Counter K3 receives the basic frequency and divides it by the two's complement of the digital number applied at the preset input of K3. In other words, if the selected frequency is 62.5k Hz and the preset input is 12 (DA3 thru DA0 are 1100), the output of counter K3 is 15.625k Hz (65.2k Hz divided by four). The divided frequency output of K3 is applied to the input of Binary Counter J2 and the clock inputs of the noise generator. The binary count output of J2 is used for the five, least significant bits of the address input of Audio PROM J3. The most significant bit inputs address the PROM for a given waveform (i.e. sine wave,

triangle wave, square wave, etc.), while the least significant bits address the time multiplexed amplitude components of the selected waveform. The data output bits from the PROM are fed to a digital weighted resistive network. PROM J3, together with Resistors R23 thru R27, forms a digital-to-analog waveform generator. The analog output, filtered by Capacitor C11, is AC coupled by Capacitor C12 and fed to voltage divider R21 and R22 which provide a DC voltage reference. The output of Analog Gate M3 applies the waveform to the summing point of Transistor Q5. Transistor Q5, configured as an emitter follower, buffers the summed signals. The signal is applied to the inputs of Analog Gates L4. The Analog Gates L4 are turned on or off by the control bits from Latch K4. Together with Resistors R65 thru R69, this circuit is a digitally controlled amplitude attenuator. When all gates of L4 are on, the maximum signal is delivered to the base of Transistor Q4. Transistor Q4 forms an emitter follower, which buffers the signal to Audio Amplifier D1 on the I/O PCB.

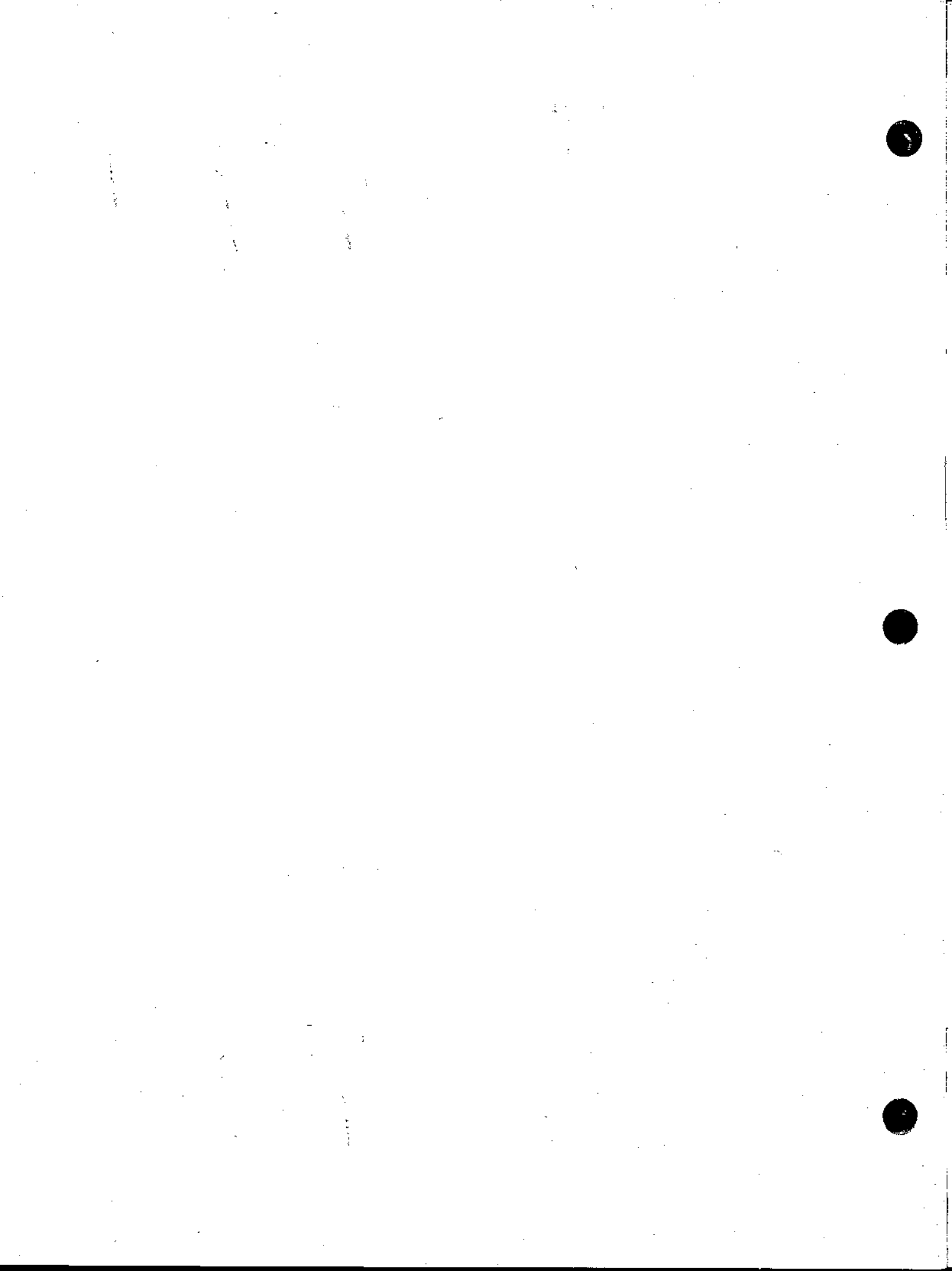

YOUR COMMENTS, PLEASE!

Your comments will assist Atari in improving the usefulness of our publications. They are an important part of preparing for revisions of manuals and parts catalogs. No postage stamp is necessary if mailed in the U.S.A.

If you have any technical questions about certain Atari or Kee Games products, or are requesting additional publications, we will immediately forward your note to the appropriate person.

Page:

Comments:

Cut along this line

Fill in if you wish a reply:

Name _____ Firm _____

- Distributor
- Operator
- Other _____

Address _____

City _____ State _____ Zip _____

First fold

FIRST CLASS
PERMIT NO. 1004
SUNNYVALE, CA

BUSINESS REPLY MAIL

No Postage Stamp Necessary if Mailed in The United States

POSTAGE WILL BE PAID BY

Atari, Inc.
P.O. Box 9027
Sunnyvale, California 94086

Attn: Publications Group, Coin-Op Engineering



Cut along this line

Second fold

ATARI, INC.
P.O. BOX 9027
SUNNYVALE, CA 94086

Tape this edge

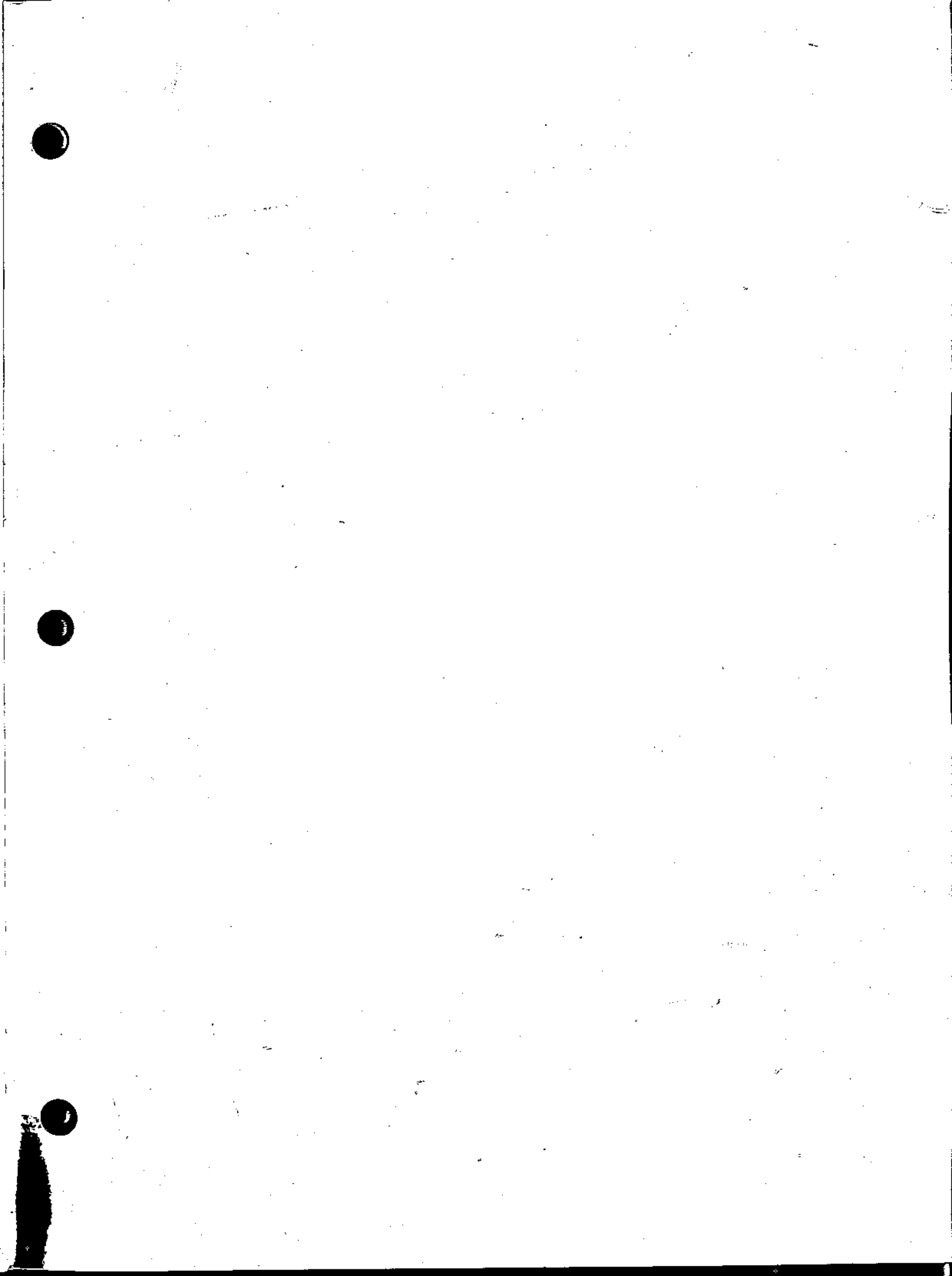

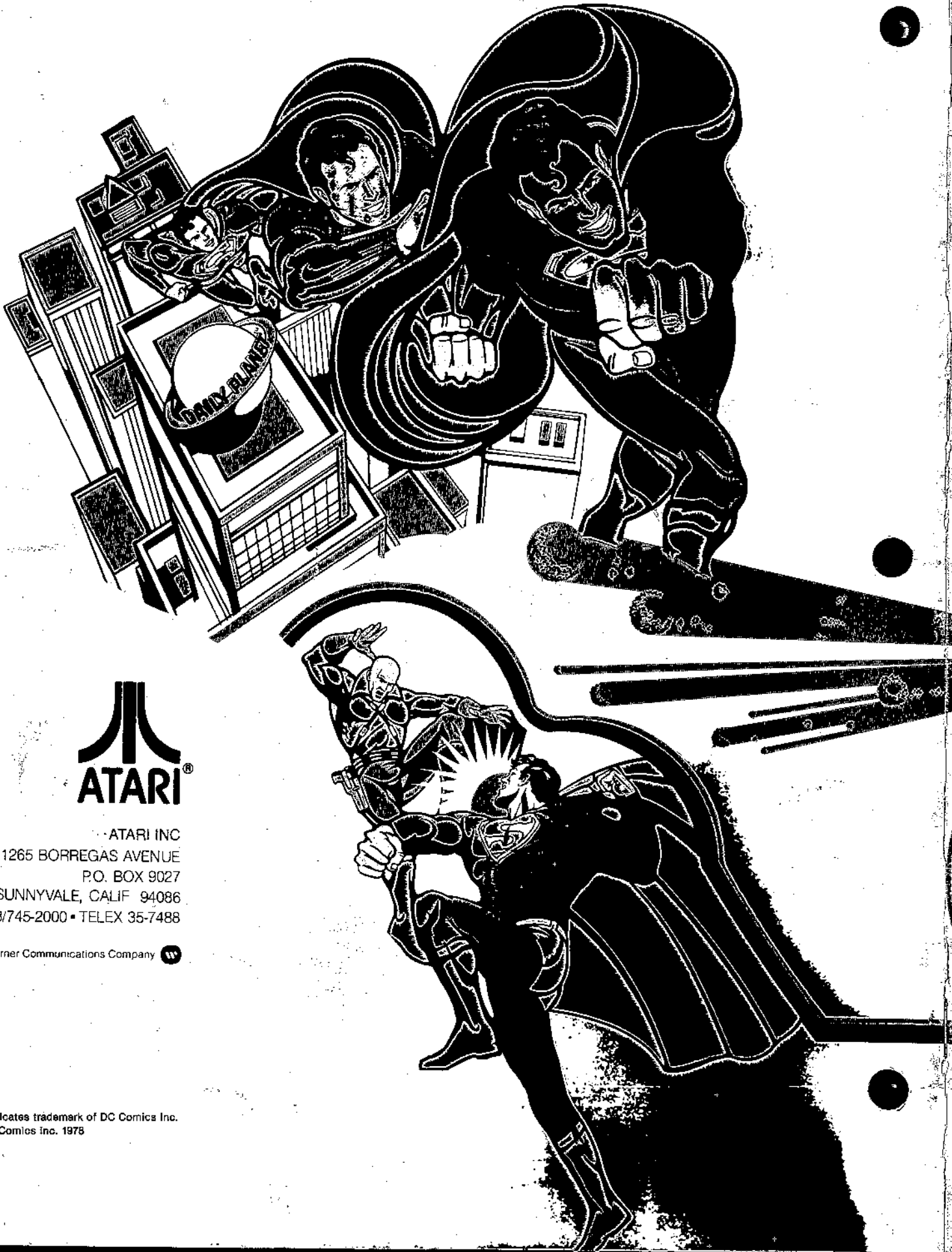

ATARI INC
1265 BORREGAS AVENUE
P.O. BOX 9027
SUNNYVALE, CALIF 94086
408/745-2000 • TELEX 35-7488

A Warner Communications Company 

TM Indicates trademark of DC Comics Inc.
© DC Comics Inc. 1978