

TunnelWatch
a product of DRB Systems, Inc.

Tunnel Control Station 2 Installation Instructions

Tunnel Control Station 2

Copyright © 2018 by DRB Systems. All rights reserved. All DRB Systems product names are trademarks or registered trademarks of DRB Systems. Other brand and product names are trademarks or registered trademarks of their respective holders.

For TunnelWatch versions 5.0 and higher.

Manual revision 013114

Table of Contents

1

INCLUDED EQUIPMENT 3

Prerequisites 3

Installation Overview: 5

Tunnel Control Station 2 Wiring Overview 6

STEPS FOR INSTALLING THE TCS2 BOX 7

 1ST) UNPACK THE TUNNEL CONTROL STATION 2 BOX 7

 2ND) MOUNT TCS2 BOX 7

 Mounting considerations: 7

 3RD) CONNECT CONDUIT TO THE TCS2 BOX 7

 Specifications and Precautions: 7

 4TH) CONNECT AC POWER 9

 Specifications and Precautions: 9

 5TH) WIRE RELAYS 9

 Specifications and Precautions: 9

 Guidelines for TCS2 Relay usage 10

 Wiring 12

 6TH) WIRE THE CONVEYOR ENABLE CIRCUIT 14

 Specifications and Precautions: 14

 7TH) WIRE INPUTS 17

 Specifications and Precautions: 17

 19

 8TH) WIRE THE TCS2 COMMUNICATIONS CABLE 20

 Specifications and Precautions: 20

 21

 9TH) INSTALL & WIRE THE TUNNEL ENTRANCE KEYPAD COMMUNICATIONS JACK 22

 Specifications and Precautions: 22

 RECHECK WIRING 25

 10TH) TURN ON THE AC POWER TO THE TCS2 BOX 25

 11TH) TEST TCS2 OPERATIONS 25

 Test Conveyor Control Circuit 25

 Conveyor Control Testing Procedure: 25

 Test for relay operation 28

 Test for input device detection 28

 12TH) LABEL ALL INPUTS, RELAY CARDS AND WIRE-WAYS 29

APPENDIX A: ALTERNATE METHODS FOR WIRING TCS2 COMPONENTS 30

Your Start/Stop Button Wiring is Different? 30

 How to Wire the Start/Stop Buttons Using 4 Separate Wire Runs 30

 How to Wire the Start/Stop Buttons Using 3 Separate Wire Runs 31

 How to Wire Using Only a Stop Button at Each Stop Station 32

 How to Daisy Chain Single Stop Buttons from Station to Station 33

Need a Different Source for Inputs? 34

 How to Replace the Provided 24VAC with a 24VDC Input Power Supply that You Provide 34

 How to Power Input Devices Using the Provided 24VAC and a 24VDC Power Supply 35

Need to Wire an Input Device that has more Than Two Wires? 36

 How to Wire Multi-Wire Input Devices 36

Have one primary TCS2 unit and one or more secondary TCS2 units? 37

 How to Connect one primary TCS2 unit to one or more secondary TCS2 units. 37

Have a Legacy TCS you want to interface to the TCS2? 38

 How to Connect a legacy TCS to a TCS2 38

Have a dual tunnel carwash that requires two primary TCS2 units? 41

 How to Connect two primary TCS2 units at a dual tunnel carwash. 41

Included Equipment

Tunnel Control Station 2 Tunnel Control Station 2 Box #1					
Qty	DSI Code	Item Description	Qty	DSI Code	Item Description
1	TW00200	Tunnel Control Station 2	1	TW00220	Logic Card, TCS2
1~12	TW00210	Relay Card, TCS2	1	TW00225	Conveyor Control Circuit Card, TCS2
			1	TW00230	Serial Interface Board
			1	TW00235	Motherboard
			1	TW00245	Power Supply Assembly
			1	TW00255	Ethernet Switch
			1	TW00265	Enclosure Cooling Fan
			1	PC37030	Touchscreen PC
1	TW00215	Input Card, TCS2			
1	N/A	TW TCS2 Installation Instructions			

Prerequisites

- The wiring on your site must accommodate your particular electrical requirements and conform to all local codes **including National Electrical Code and Canadian Electrical Code where applicable**. DRB Systems is not responsible for the installation, maintenance, or safety of your electrical wiring.
- Conduit hubs must be connected to the conduit before the hubs are connected to the enclosure.
- Metallic conduit must be used for all communication wire runs, including conduit for all Cat 5, Cat 6 and RS-422 cabling. This includes runs from the office computer to the Tunnel Control Station 2, and from the Tunnel Control Station 2 to a legacy Tunnel Control Station.
- The AC power supplying the TCS2 **must** be clean, “computer-grade” 120VAC, 15A, with its own isolated circuit.
- For new installations, DRB Systems highly recommends the following power wiring specifications to provide the most reliable equipment operation:
 - A dedicated 15A circuit breaker and dedicated 120VAC Hot, Neutral, and Ground conductors should be run to the TCS2 power input terminals. A metal conduit does not serve as a suitable ground conductor for this application.
 - All ground conductors connected to the TCS2 and to outlets that supply power to TunnelWatch and SiteWatch equipment (if applicable) must be properly bonded to each other, and to the system ground, in accordance with NEC. A metal conduit does not serve as a suitable ground conductor for this application.
 - If power to TunnelWatch and/or SiteWatch systems is provided from multiple services, as may be the case at sites with multiple buildings, two options exist to ensure reliable data communication:
 - Properly bond the system grounds together, in accordance with NEC.

Tunnel Control Station 2 Installation Instructions

- Add optical isolation to any communication link (RS232, RS485, Ethernet); fiber optic networking is the most robust method for accomplishing this. **Note:** DRB Systems does not provide, set up, or troubleshoot optical isolation and fiber optic networks. The customer is responsible for arranging local installation and support for this setup.

Installation Overview:

The following are the steps for installing the TunnelWatch Tunnel Control Station 2 unit:

- 1) Unpack the Tunnel Control Station 2.
- 2) Mount the TCS2 box.
 - Choose the correct placement for the unit.
- 3) Connect conduit to the TCS2 box.
 - Do NOT drill holes in the top of the TCS2 box. Use the provided conduit openings on the TCS2.
- 4) Connect AC power.
 - Wire the AC Power from a dedicated 110VAC circuit.
- 5) Wire the conveyor control circuit.
 - Wire the Stop/Start buttons to the TCS2.
 - Wire the conveyor control contactor to the TCS2.
 - Wire Conveyor Enable Interlock tunnel devices to the TCS2.
- 6) Wire relays.
 - Supply the source voltage and the control voltage to each relay to be used for controlling the tunnel devices. Wire source voltages through an interlock as recommended by the tunnel device manufacturer/distributor.
- 7) TCS2 Wire inputs.
 - Wire each Input device (Pulse, Enter and Tire switch devices, etc.)
- 8) Wire the TCS2 communications cable.
 - Connect the TCS2 Ethernet cable to the TCS2 network switch.
 - Connect the TCS2 Ethernet cable to the network switch connected to the site's Server computer. **Note:** This switch must connect to the X3 port on the site's router.
- 9) Install & wire the tunnel entrance terminal communications jack.
 - If using a keypad terminal (KPT) connected to TunnelWatch, wire the outdoor RJ14 phone jack with the 4 wires of the RS-422 cable from the TCS2 box.
 - If using an Outdoor Touch Terminal (OTT) connected to TunnelWatch, wire the outdoor RJ45 network jack with Cat 6 cable to the network switch in the TCS2 box.
- 10) Recheck wiring.
 - Make sure all wiring is correct and installed securely.
- 11) Turn on the AC power to the TCS2 box.
- 12) Test TCS2 operations.
 - Make sure all devices, relays, and the conveyor control circuit are operating correctly.
- 13) Label the Input card, Conveyor Control card, Relay cards, and wire-ways.
 - Label the name of each function in the area provided for the Relay and Input cards.
 - Label the location of the start and stop switches connected to the Conveyor Control card.
 - Label the voltage sources connected to the Interlock contacts of the Conveyor Control card.
 - Label the name of the devices wired to the source and output terminals on the provided wire-ways.

Tunnel Control Station 2 Wiring Overview

Tunnel Control Station 2 (TCS2)

You will be wiring each of the following:

1. 110VAC power
2. Each of your Stop and Start buttons, and interlocked relay source power to the Conveyor Control Circuit
3. Source power (as interlocked above) into and control voltages out of each relay for the tunnel devices
4. Connect the Conveyor Control Circuit CONVEYOR output to your conveyor motor contactor
5. The wires from each of your Input Devices (Pulse, Enter, Tire, etc.)
6. The Ethernet communication cable from the non-CDE (Cardholder Data Environment) network switch
7. Connect all conduit entry ways to the ground connections on the power supply assembly.

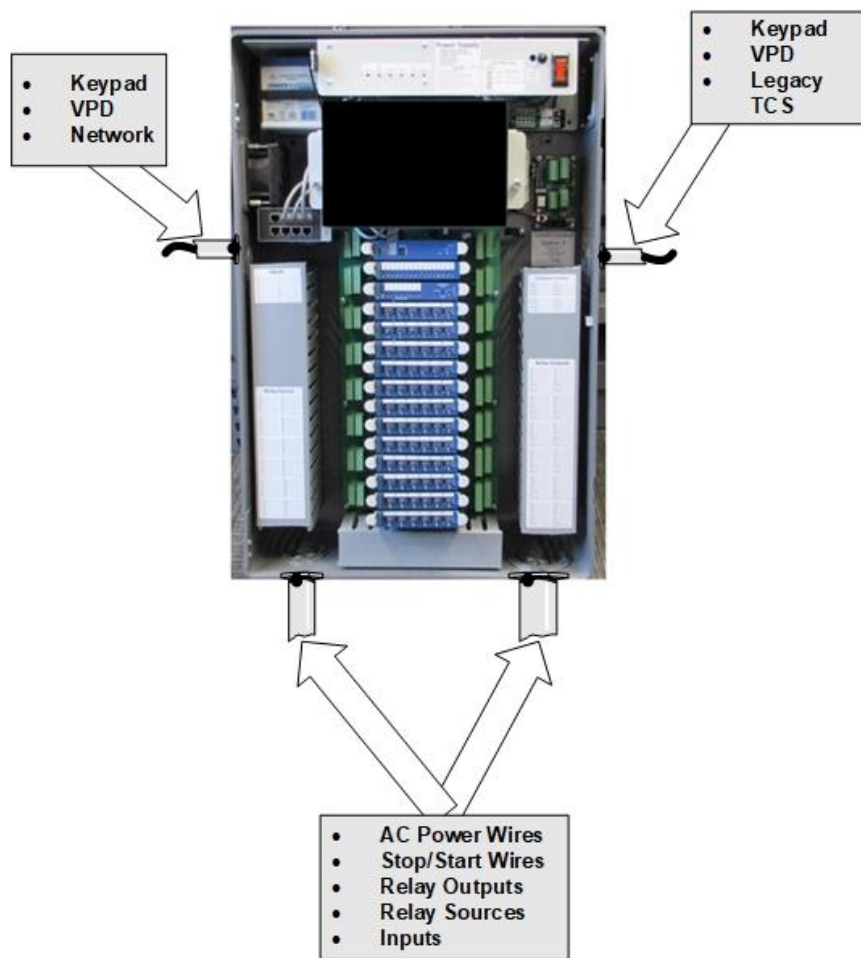

Tunnel Entrance Terminal

You will be wiring one of the following:

1. Cat 5/Cat 6 from an RJ45 jack to the TCS2 for Outdoor Touch Terminals
2. RS-422 from an RJ14 jack to the TCS2 for Keypad Terminals

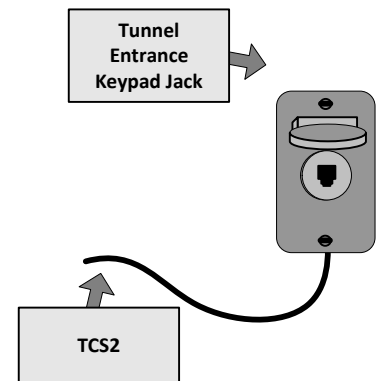

Tunnel Entrance Terminal

TCS2 Ethernet Connection

You will be wiring the following:

1. Cat 5/Cat 6 Ethernet cable from non-CDE network switch (connected to X3 on site's router) to TCS2 network switch.

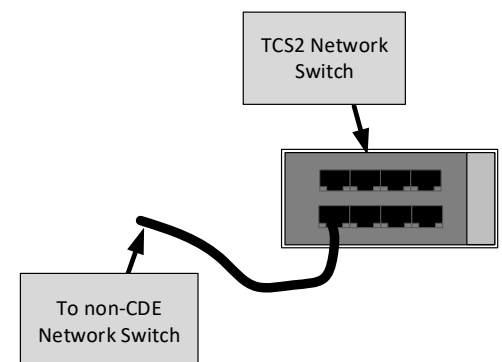

Steps for Installing the TCS2 Box

Note: If your wiring needs are different from the following recommended TCS2 wiring instructions, then see the appendix for approved alternate wiring instructions and diagrams.

1st) Unpack the Tunnel Control Station 2 box

- 1) Follow instructions on the TCS2 box for removing the equipment from the shipping carton.
- 2) Separate the equipment and place in its respective workstation:
 - TCS2 box will go where it will be wired (should be the equipment electrical room).
 - Outdoor phone jack at the tunnel entrance terminal if using a keypad.

Note: The key for the TCS2 box is taped to the outside of the TCS2 enclosure.

2nd) Mount TCS2 box

Mounting considerations:

- The TCS2 dimensions with door installed are 32.95"H x 22.14"W x 8.25"D.
- Easily accessible for height.
- Should have ample room surrounding for easy access, wiring, and adequate cooling fan space. Leave at least 6" of space around the exhaust openings on the top left and top right of the enclosure. Heat producing equipment should not be installed on the left side of the TCS2 where the intake cooling fan is located.
- Door should be able to extend beyond 90 degrees.
- Should be able to clearly see the TunnelWatch PC display, and Relay, Input, and Conveyor Control card LED indicators when main door is closed.

3rd) Connect conduit to the TCS2 box

Specifications and Precautions:

- Follow your **local codes** to run conduit for power and communications cables.
- Metallic conduit should be used for all communication wire runs, including conduit for all Cat 6 and RS-422 cabling. This includes runs from the office network switch to the TCS2s and from the TCS2 to all keypads and outdoor touch terminals.
- Conduit hubs must be connected to the conduit before the hubs are connected to the enclosure.
- Your conduit should be large enough to allow ample room for **current wiring needs** and **future expansion**.
- To reduce your communication cable's susceptibility to **lightning**, your conduit should be **metal** and should be well grounded to the site power ground point.
- Conduit hub locknuts with grounding posts should be used to properly ground the conduit to comply with NFPA 70.
- The conduit **MUST NOT** enter the TCS2 box from the **TOP**. The conduit can safely enter through the provided side or bottom conduit holes. Use of a top entry may cause electrical damage not covered by your warranty.
- **CAUTION: Take all precautions to protect the TCS2 electronic boards from metal chips/filings, condensation, etc.**

Four conduit entry points are recommended to reduce cross-talk interference.

- 1) Keypad, VPD, and legacy TCS wiring (right side conduit hole). **Note:** Use left side conduit hole for keypad and VPD wiring if needed. Do not run keypad, VPD, or legacy TCS communication wire through the same conduit or wireway as power wires or relay control wiring. Doing so will result in communication issues with the devices connected to the Serial Interface Board.
- 2) AC power wires, Stop/Start, Input devices wiring and Relay source/output wires (bottom left and bottom right conduit holes).
- 3) Cat 5/Cat 6 cable (left side conduit hole).

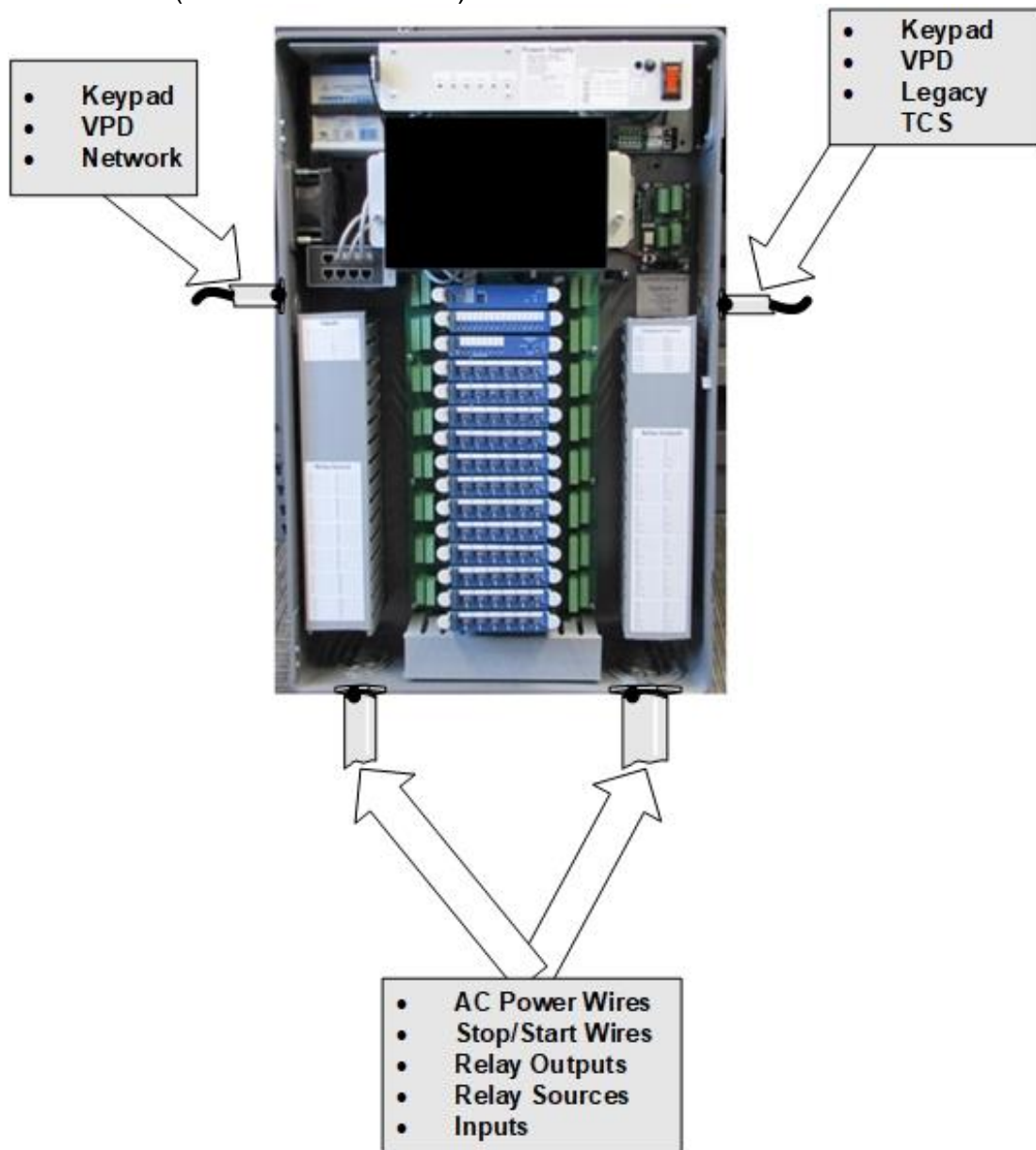

Figure 1: TCS2 Box with Conduits

4th) Connect AC Power

Specifications and Precautions:

- TCS2 power **must** be clean, “computer-grade” 120 V AC, 15 A, with its own isolated circuit.
- Make sure this circuit is connected to the site power ground.
- For new installations, DRB Systems highly recommends the following power wiring specifications to provide the most reliable equipment operation:
 - A dedicated 15A circuit breaker and dedicated 110VAC Hot, Neutral, and Ground conductors should be run to the TCS2 power input terminals. A metal conduit does not serve as a suitable ground conductor for this application.
 - All ground conductors connected to the TCS2 and to outlets that supply power to TunnelWatch and SiteWatch equipment (if applicable) must be properly bonded to each other, and to the system ground, in accordance with NEC. A metal conduit does not serve as a suitable ground conductor for this application.
 - If power provided to TunnelWatch and/or SiteWatch systems is provided from multiple services, as may be the case at sites with multiple buildings, two options exist to ensure reliable data communication:
 - Properly bond the system grounds together, in accordance with NEC.
 - Add optical isolation to any communication link (RS232, RS422, RS485, Ethernet); fiber optic networking is the most robust method for accomplishing this. **Note:** DRB Systems does not provide, set up, or troubleshoot optical isolation and fiber optic networks. The customer is responsible for arranging local installation and support for this setup.

- 1) Turn off the TCS2 main power switch before attempting to wire any part of the station.
- 2) Turn the breaker controlling the TCS2 box off.
- 3) Connect the AC power wires from your 110VAC power. See Figure 2: AC Wiring.

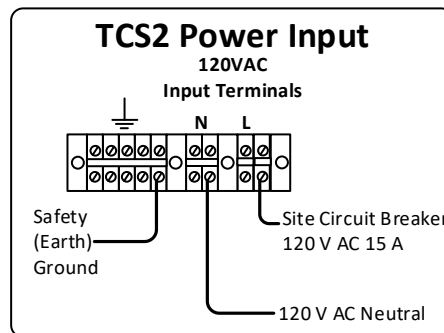

Figure 2: AC Wiring

5th) Wire Relays

Specifications and Precautions:

- Do not exceed the relay output ratings:
 - **Relay Output Load Capacity** -- 12V to 120V AC/DC, 2.5A continuous.
 - **Maximum Current** – 7A per relay, 13A total per relay card.

Note: 10A fuse is for protection only – 10A loads are not supported.

- Terminals can handle wires up to 12 AWG. 14 or 16 AWG recommended as allowed by NEC.
- Wires must be temperature rated to 60°C or higher.
- Aluminum or copper wires may be used.
- Each relay output card controls 6 relays.
 - They are lettered A through F.
 - Relays A, B, C, and D each surface a normally open contact.
 - Relays E & F each surface a normally open and normally closed contact.

Guidelines for TCS2 Relay usage

The TCS2 relays were selected for reliability and good performance. However, like all components, they have limitations and a finite lifespan. The following guidelines show the estimated lifespan relative to the load that is switched and the number of operations (wash volume per year). Since tunnel devices (motor starters, horns, solenoid valves, etc.) are usually turned on once per wash, the number of operations per year is about the same as the wash volume. This ignores a few test washes and those high-volume times when continuous operation occurs.

Note: Average estimated life is shown. Individual relays may last a longer or shorter time.

Flashing lights and/or signs, however, are special. If you set TW to use a TCS2 relay to flash a light/sign directly, that relay will flash from 10 to 30 times during each vehicle wash cycle. Thus, the number of TCS2 relay operations is 10 to 30 times the number of washes, and its life (calendar time) will be 1/10 to 1/30 of its normal (non-flashing) life.

For long TCS2 relay card life, **DRB Systems recommends that all light/sign flashing be done by a separate sign flasher module designed for that purpose.**

The flasher module is turned on by a TCS2 relay closure once per wash.

Two types of flasher modules exist: a module that installs in series with the TCS2 relay contacts to provide the make-break flashing function and a self-contained flasher that routes power to the light/sign through its internal flashing circuitry. The TCS2 relay provides an ON/OFF control signal (low current/voltage) to control the flasher.

Load – Device Type	Voltage VAC	Current Amps	Estimated Relay Life (by wash volume)		
			40K/yr	80K/yr	200K/yr
Motor Starter – Electronic	115	0.1A	10yr	10yr	5yr
Motor Starter – Contactor	115	1A	10yr	6yr	2yr
Warning Horn	115	0.2A	10yr	10yr	5yr
Solenoid Valves – 115V	115	0.5A	10yr	10yr	5yr
Solenoid Valves – 24V Lo Pwr	24	1A	10yr	10yr	5yr
Solenoid Valves – 24V Hi Pwr	24	3A	6yr	3yr	1yr
Non Flashing Signs Lo Pwr or Flasher Modules – Serial Contact	115	0.9A (100W)	10yr	6yr	2yr
Non Flashing Signs Hi Pwr or Flasher Modules – Serial Contact	115	1.7A (200W)	6yr	3yr	1yr

Tunnel Control Station 2 Installation Instructions

Non Flashing Signs 300W or Flasher Modules – Serial Contact	115	2.6A (300W)	NR 1yr	NR <1yr	NR 6mo
Flasher Modules – Self Contained	24/115	0.1A	10yr	10yr	5yr
Direct Flashing Signs – Lo Power	115	0.9A (100W)	NR 1yr	NR 6mo	NR 3mo
Direct Flashing Signs – Hi Power	115	1.7A (200W)	NR 6mo	NR 3mo	NR 2mo
Direct Flashing Signs – 300W	115	2.6A (300W)	NR <2mo	NR <2mo	NR <1mo

Note: **NR** = Not Recommended

Wiring

1) Wire each relay source voltage and output according to the specifications:

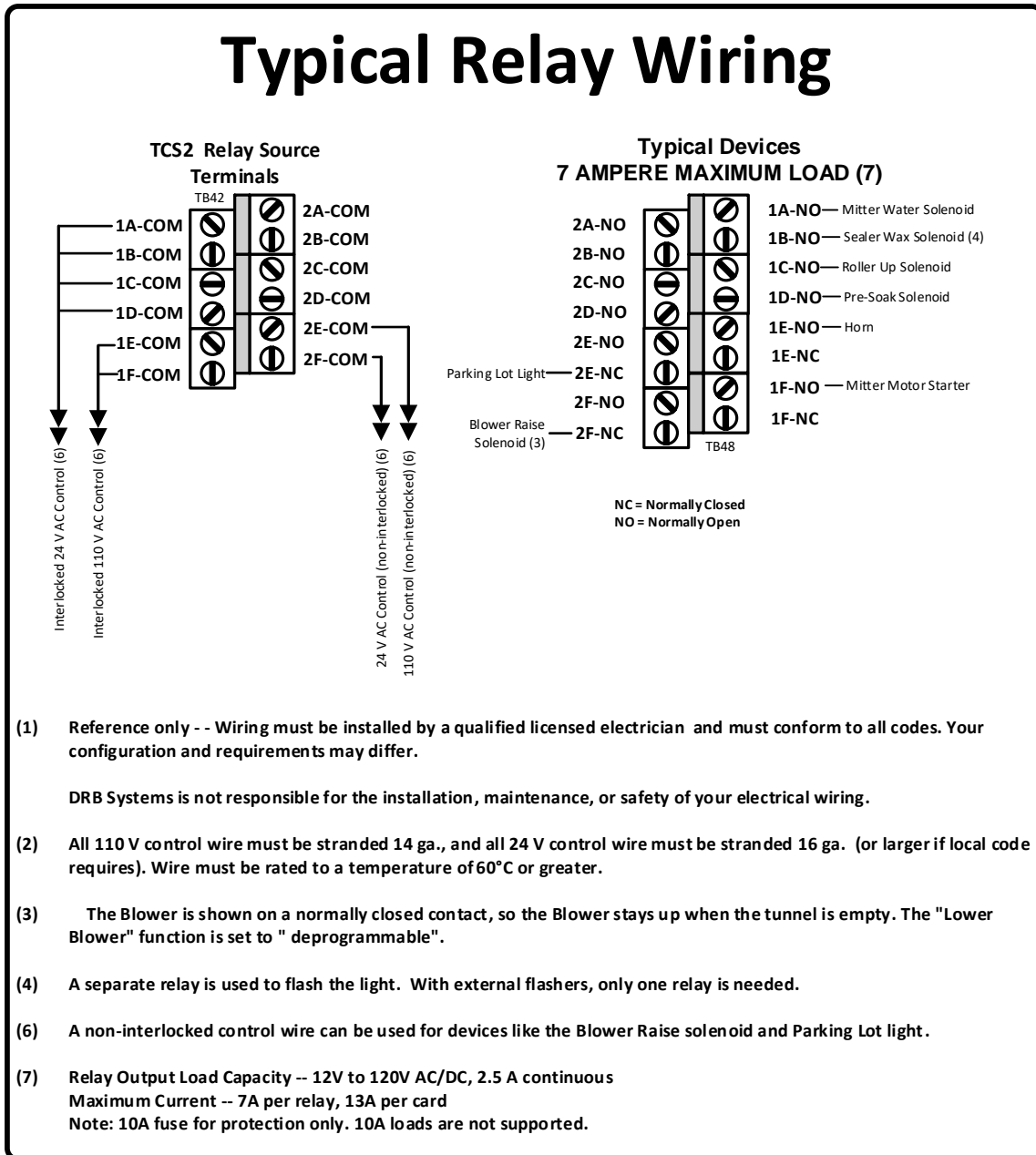

Figure 3: Relay Wiring

2) Bridge connectors are included with each TCS2 to eliminate the need for jumper wires on the relay common terminals, if a common power source is used for multiple devices.

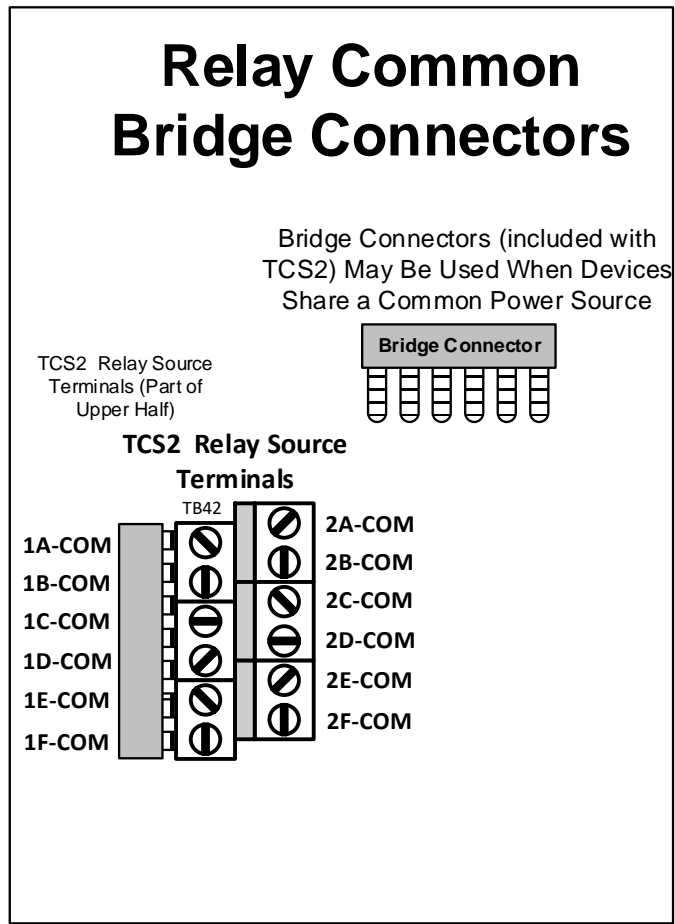

Figure 4: Relay Common Bridge Connectors

6th) Wire the Conveyor Enable Circuit

Specifications and Precautions:

- The TCS2 Conveyor Control logic is self-contained and uses the TCS2 24VAC power source.

The TCS2 surfaces one set of normally open Conveyor relay contacts signified by the **CONVEYOR** terminals on the TCS2 motherboard. **Caution:** Some car washes wire a conveyor override switch to the conveyor motor controller. Ensure that the voltage source connected through the Conveyor relay is the same as the voltage source connected through the conveyor override switch. If the two sources are different voltage or phase, damage to the equipment may result.

- Start and Stop switches should only be connected to the **START** and **STOP** connections on the TCS2 motherboard.
- An optional keylock security switch can be connected to any set of stop switch terminals. The keylock switch should be ON when the key is in and turned. The keylock switch should be OFF when the key is not in place. This, along with the lockable TCS2 door provides a way to ensure that the conveyor cannot be started unless authorized. The keylock switch should be located in a secure area such as the manager's office. Unused Stop terminals must be jumpered.
- An optional hydraulic fluid low switch can be connected to any set of stop switch terminals.

Conveyor Enable Circuit Defined:

The built-in Conveyor Enable Circuit of the Tunnel Control Station 2 is used to allow the TunnelWatch software to start and stop the conveyor based on workflow needs while still allowing the stop buttons to be used for emergencies. The conveyor Start and Stop buttons are wired directly into the Conveyor Enable Circuit.

The conveyor Stop buttons will only be used for emergencies.

The Start buttons will only be used to re-enable the Conveyor Enable Circuit after a Stop button has been pressed.

NOTE: The conveyor starter/motor driver is controlled by the conveyor relay normally open dry contacts. These contacts are labeled as **CONVEYOR** on the TCS2 motherboard.

- ◆ No other relay is needed to control the conveyor.

- 1) Wire the Stop and Start buttons from throughout the carwash into the Conveyor Enable Stop and Start Button terminals using the following wiring diagram.

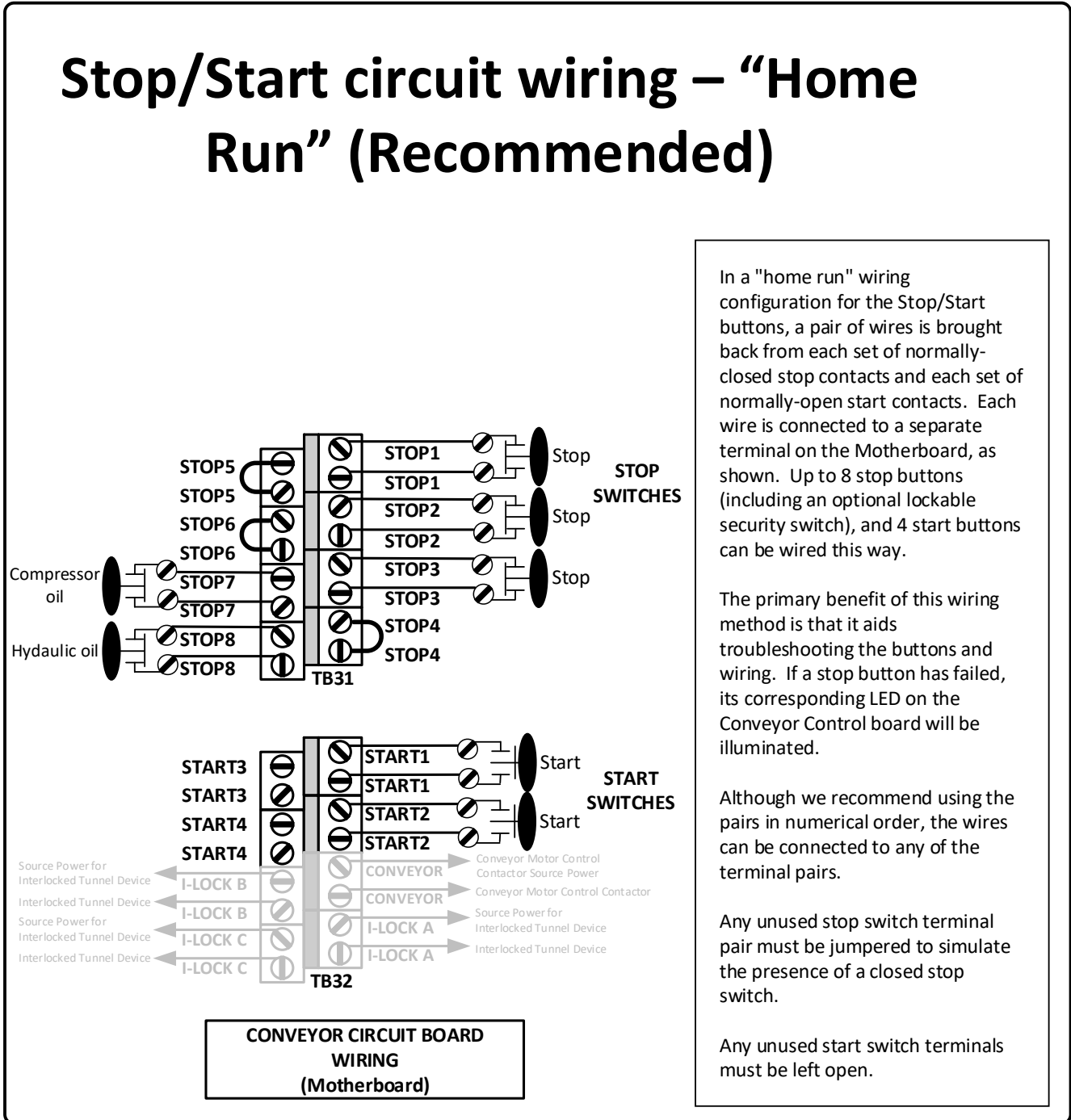

Figure 5: Start/Stop Circuit Wiring

- 2) Connect the Conveyor relay to the motor controller (starter coil/motor driver input).
Caution: Some car washes wire a conveyor override switch to the conveyor motor controller. Ensure that the voltage source connected through the Conveyor relay is the same as the voltage source connected through the conveyor override switch. If the two sources are different voltage or phase, damage to the equipment may result.
- Run a wire from the motor controller source voltage to one of the **CONVEYOR** terminals on the TCS2 Motherboard.
 - Run a wire from the other **CONVEYOR** terminal to the source power input of the motor controller.

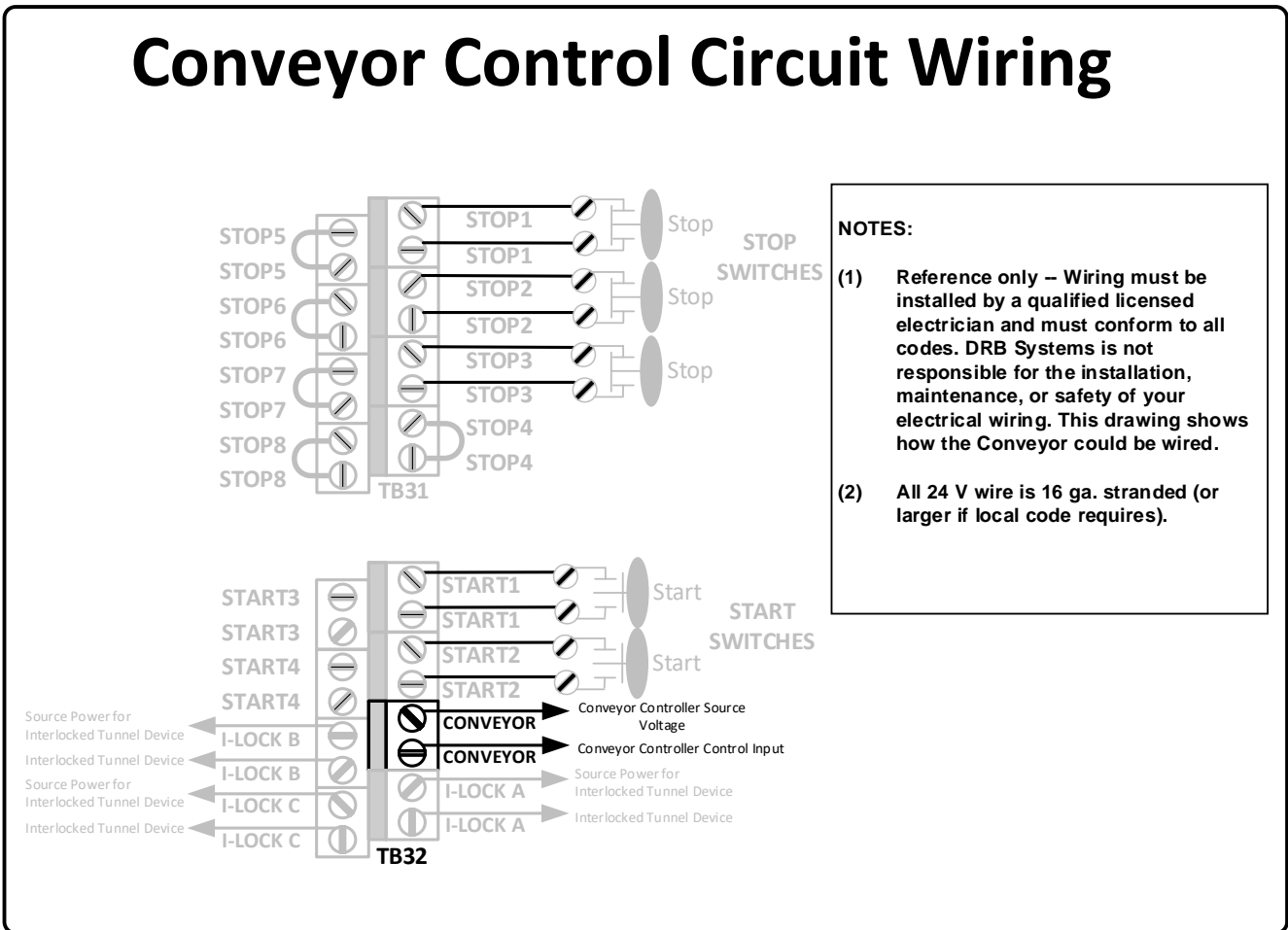

Figure 6: Conveyor Control Wiring

- 3) **(Recommended)** Use conveyor interlock relay contacts as a safety interlock for other tunnel devices. This provides a hard stop of tunnel devices in an emergency, rather than relying on computer control, which would present a possible safety issue.
- Three sets of normally open safety Interlock relay contacts are available on the TCS2 Motherboard. The relay contacts are closed when the conveyor enable is on. The relay contacts are open when the conveyor enable is off. They are labeled **I-LOCK A**,

I-LOCK B, and **I-LOCK C**. They are typically used to break the supply voltage that controls all the 24vAC devices, 110vAC devices, and 24vDC devices respectively that are under the control of the TCS2.

- Connect the source wire for the tunnel device to one Interlock terminal (e.g., **I-LOCK A**), then connect the tunnel device to the other interlock terminal (e.g., **I-LOCK A**).

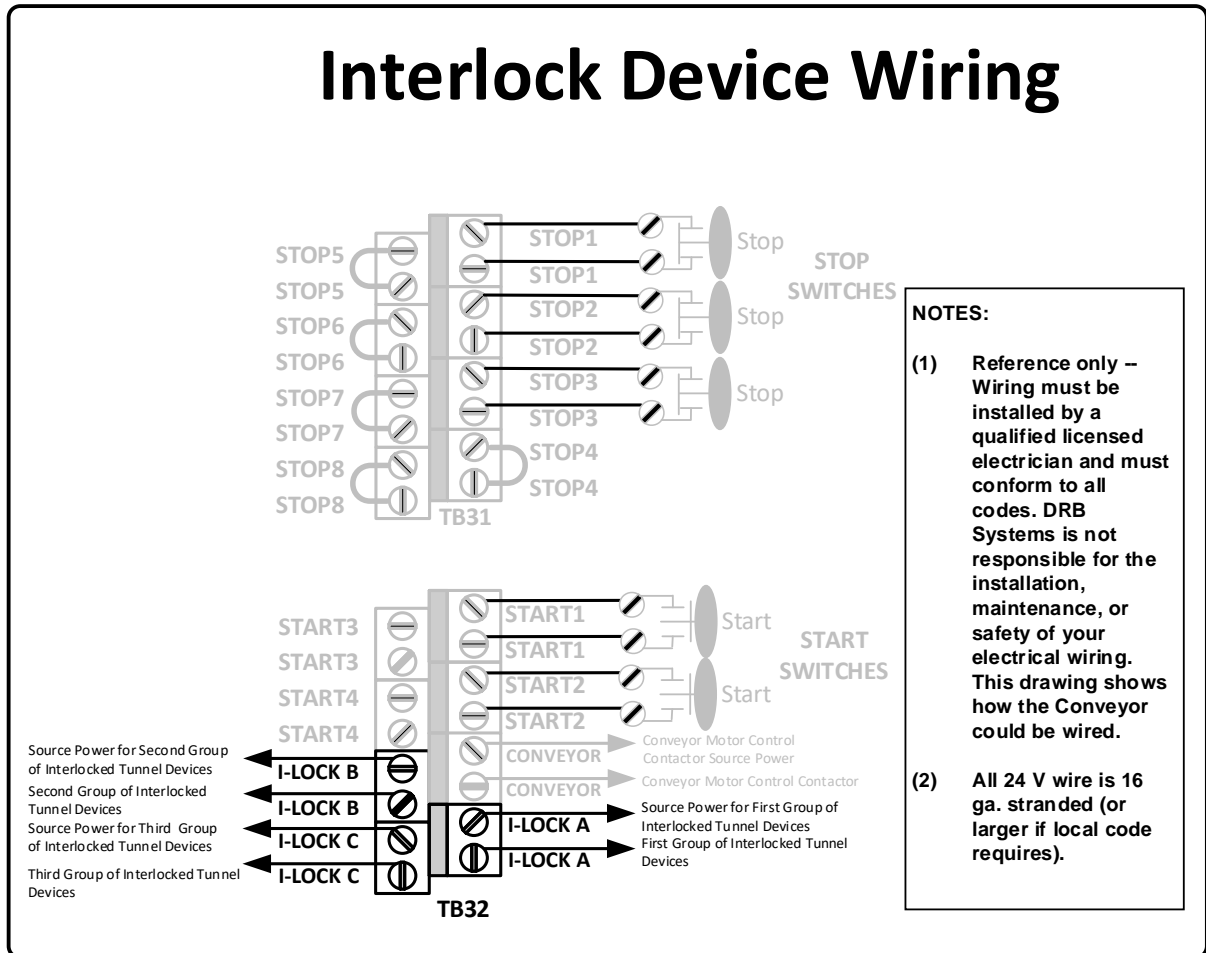

Figure 7: Interlocking Tunnel Devices

7th) Wire Inputs

Specifications and Precautions:

- The TCS2 24 VAC reference power for input sensing is internally supplied.
Caution: DO NOT connect the tunnel equipment (valving, actuators, etc.) to this 24VAC power. You **MUST** provide a separate 24VAC source for the tunnel equipment.
- If you need to wire in your own 24VAC power to the TB2 connector on the motherboard to power the input device, **DISCONNECT THE JUMPER** between **24V** and the **SRC** terminal on the motherboard **TB2** connector.
- If **DC** power is required to power input devices, **DISCONNECT THE JUMPER** between the **24V** and **SRC** terminals on the motherboard TB2 connector. A site-supplied 16v to 28v AC or DC power supply can be connected to the **SOURCE** and the **COM** terminals. Positive (+) of the DC power connects to the **SOURCE** terminal. Negative (-) of the DC

power connects to the **COM** terminal. **CAUTION:** If connecting a site supplied input power source to the TB2 terminal block on the mother board, the jumper between the **24V** and **SRC** terminals **MUST BE REMOVED**, or damage to the TCS2 will result.

- The **Inputs** may be used for optional input devices like a Tire Switch, Roller Cancel Switch, Auto-Roller Switch, or Send Car Switch/Button.
- DRB Systems strongly suggests that you wire the following input devices to these assigned terminals.
 - Pulse on Input 1A
 - Enter Switch on Input 1B
 - Tire Switch on Input 1C

- 1) Wire all input devices to the **COM** and an Input number/letter terminal (signal) as indicated in Figure 8: Input Wiring.

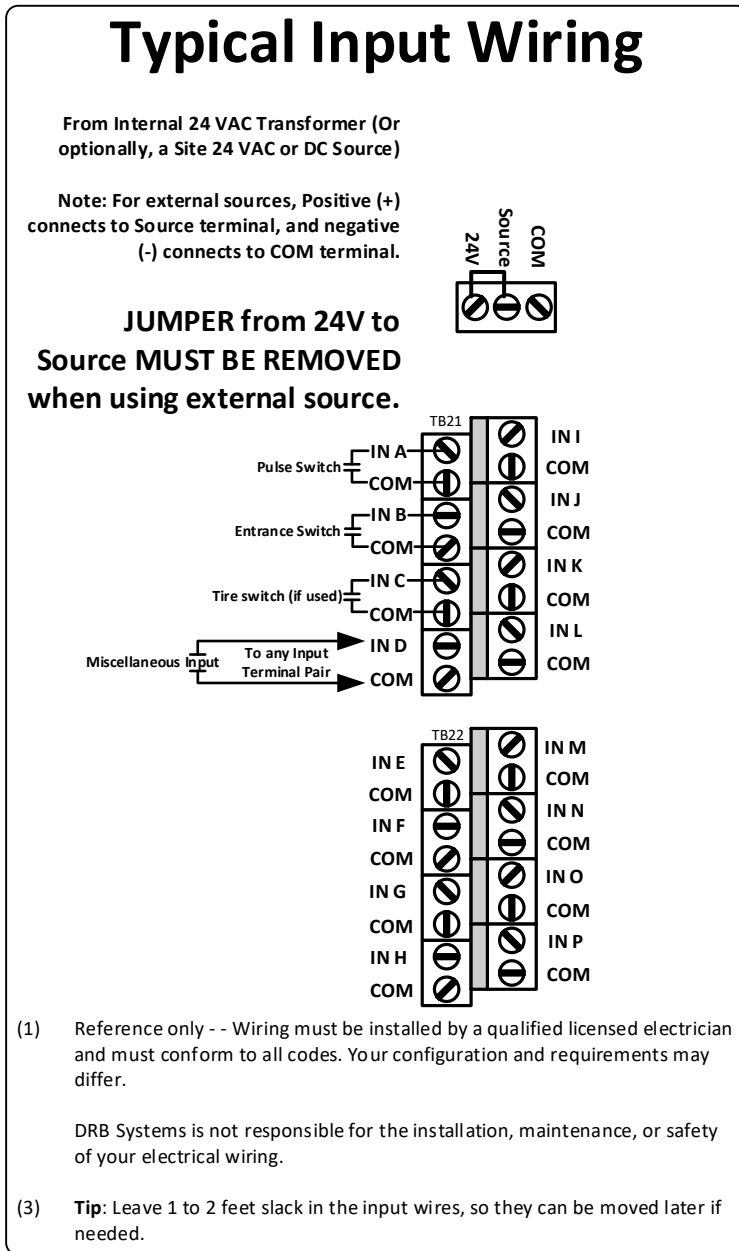

Figure 8: Input Wiring

8th) Wire the TCS2 Communications Cable

Specifications and Precautions:

- **All TCS2 communication cables should be Cat5 or Cat6 Ethernet cable.**
- 1) Run the Ethernet communications cable from the first TCS2 box to where the non-CDE (Cardholder Data Environment) network switch is located. This network switch is connected to the X3 port on the site router. **Note:** The first box would be the one with the panel PC installed.
 - 2) Connect one end of the Ethernet cable to the non-CDE network switch and the other to the TCS2 network switch.
 - 3) Run Ethernet communications cable between the first TCS2 box to each additional TCS2 box. Reference appendix for installations with more than one TCS2.

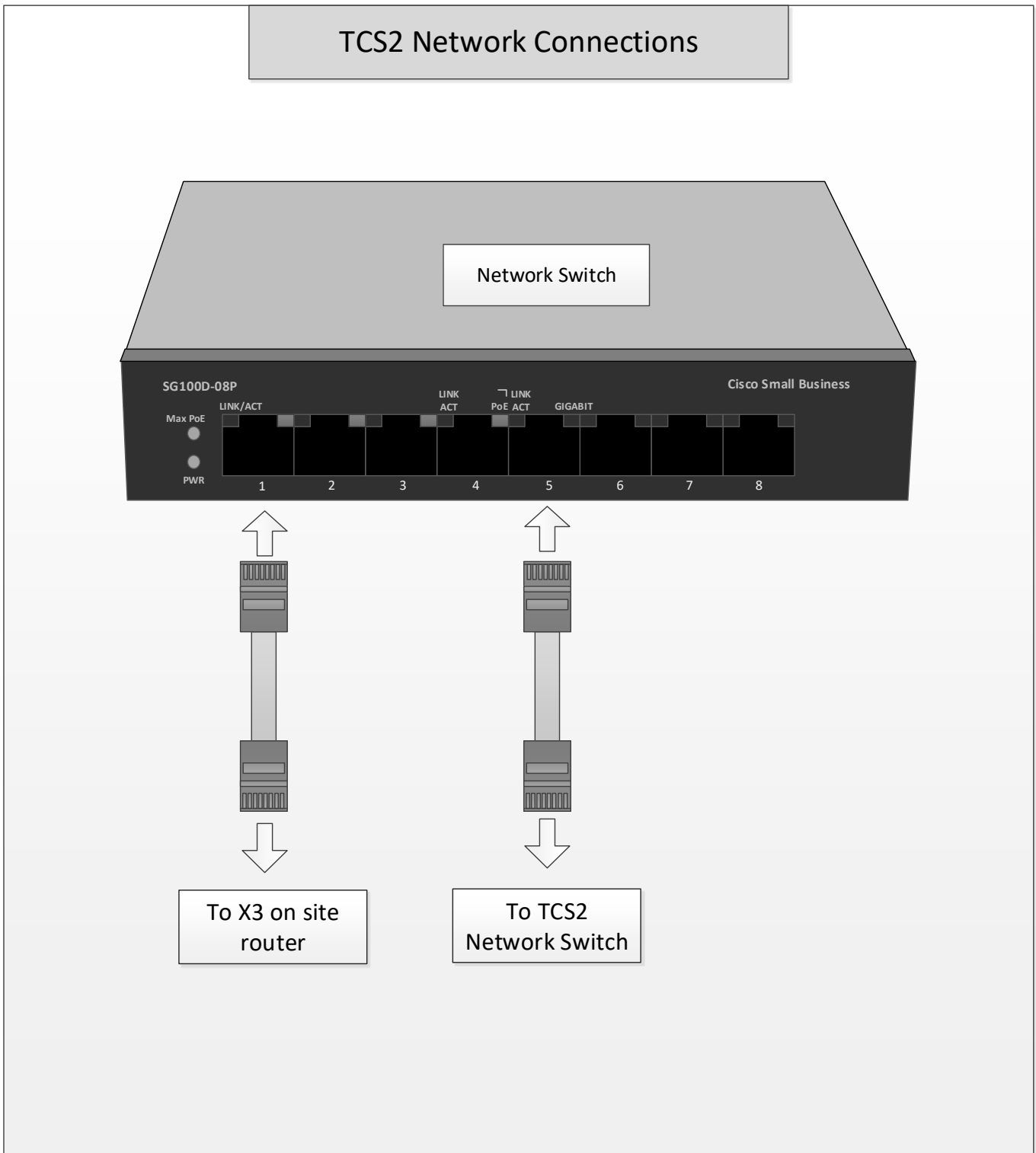
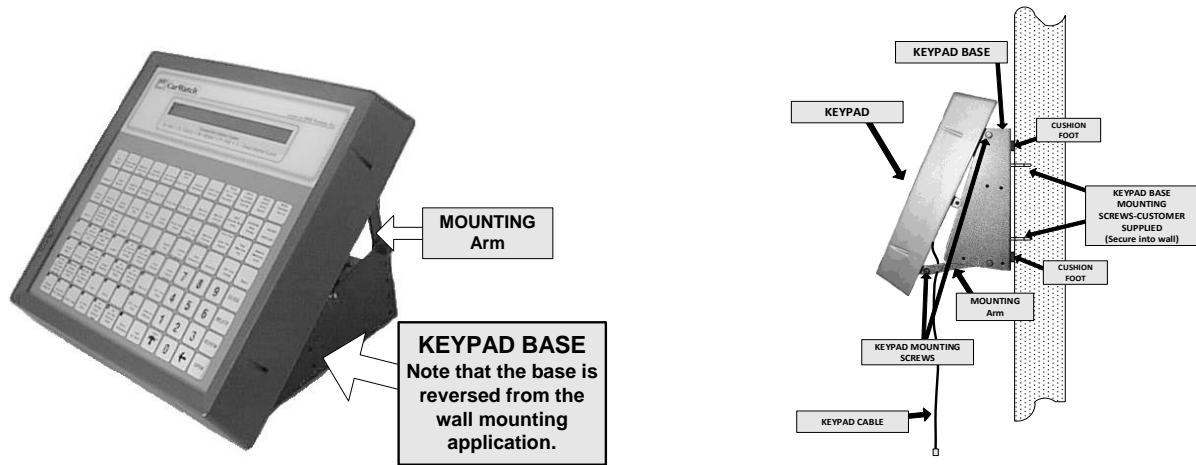

Figure 9: TCS2 Network Connection

9th) Install & Wire the Tunnel Entrance Keypad Communications Jack

Specifications and Precautions:

- All Serial communications cable must be RS-422 (shielded twisted pair). For wiring instructions, see Figure 10: Outdoor Phone Jack Installation and Wiring for details.
- RS-422 cable part numbers:
 - CA05422 (DRB Systems)
 - 1212C or 1292 or 2466C (Alpha)
 - 9502 or 1419A or 8723 (Belden)
 - C0890 or C0601 or C1352 (Carol)
 - 4A635 or 4A639 or 2W985 (Grainger)
- The shield wire should only be connected to the Serial Interface board located inside the TCS2 box.



Keypad Mounting Options

- 1) Run RS-422 communications cable from the TCS2 Serial Interface board to the tunnel entrance KPT station.
- 2) Wire RS-422 cable to the outdoor jack.
 - See Figure 10: Outdoor Phone Jack Installation and Wiring**Note:** The provided outdoor phone jack should be used if the KPT is to be used outdoors or in the carwash tunnel.

Tunnel Control Station 2 Installation Instructions

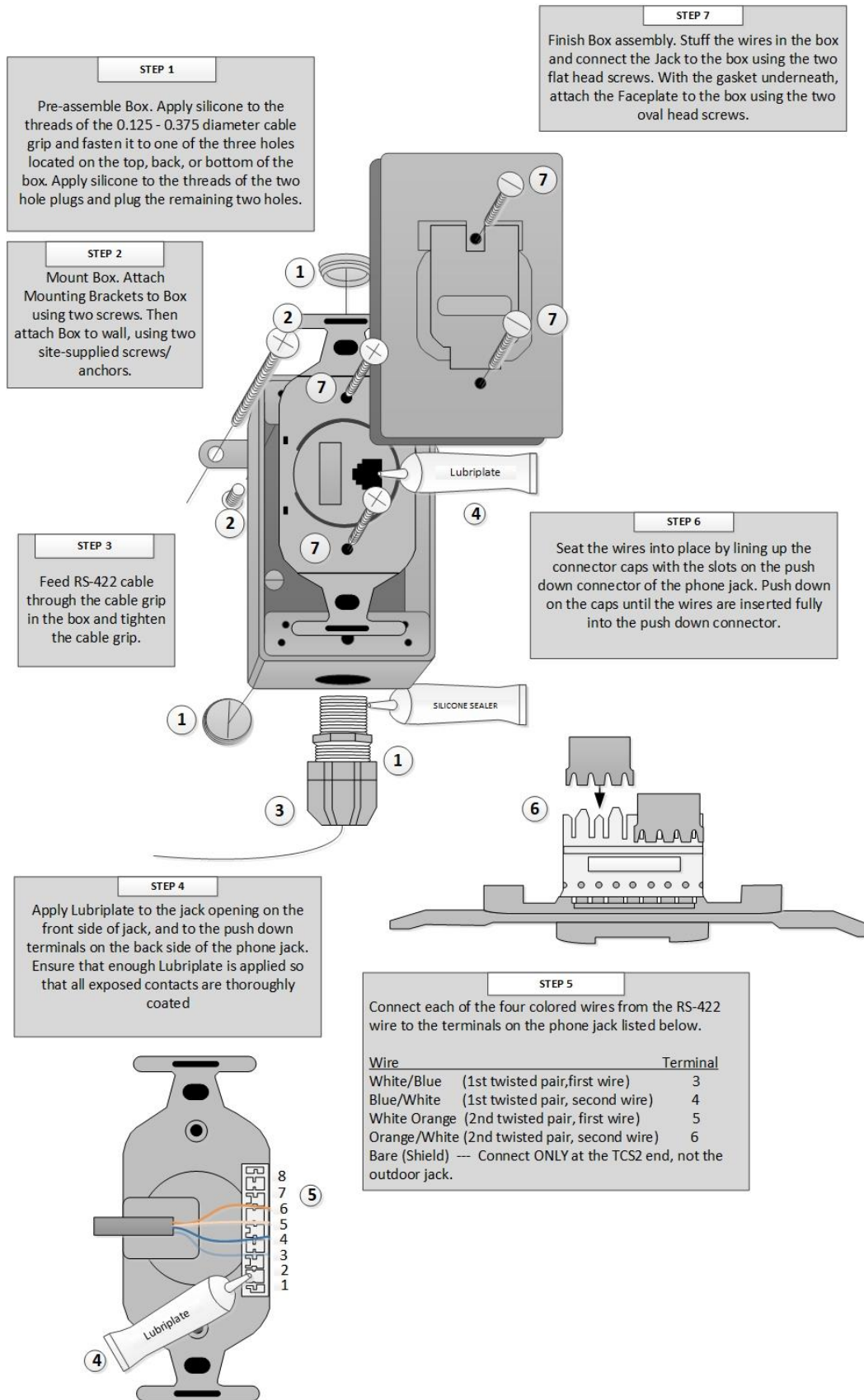

Figure 10: Outdoor Phone Jack Installation and Wiring

3) Wire the RS-422 cable to the Serial Interface board in the TCS2.

- Ensure that the wires connected to the colored terminals in the TCS2 connect to the same terminals in the outdoor phone jack as the like colored wires from the cover.
- Only connect the shield wire at the TCS2 Serial Interface Board end of the RS-422 cable.

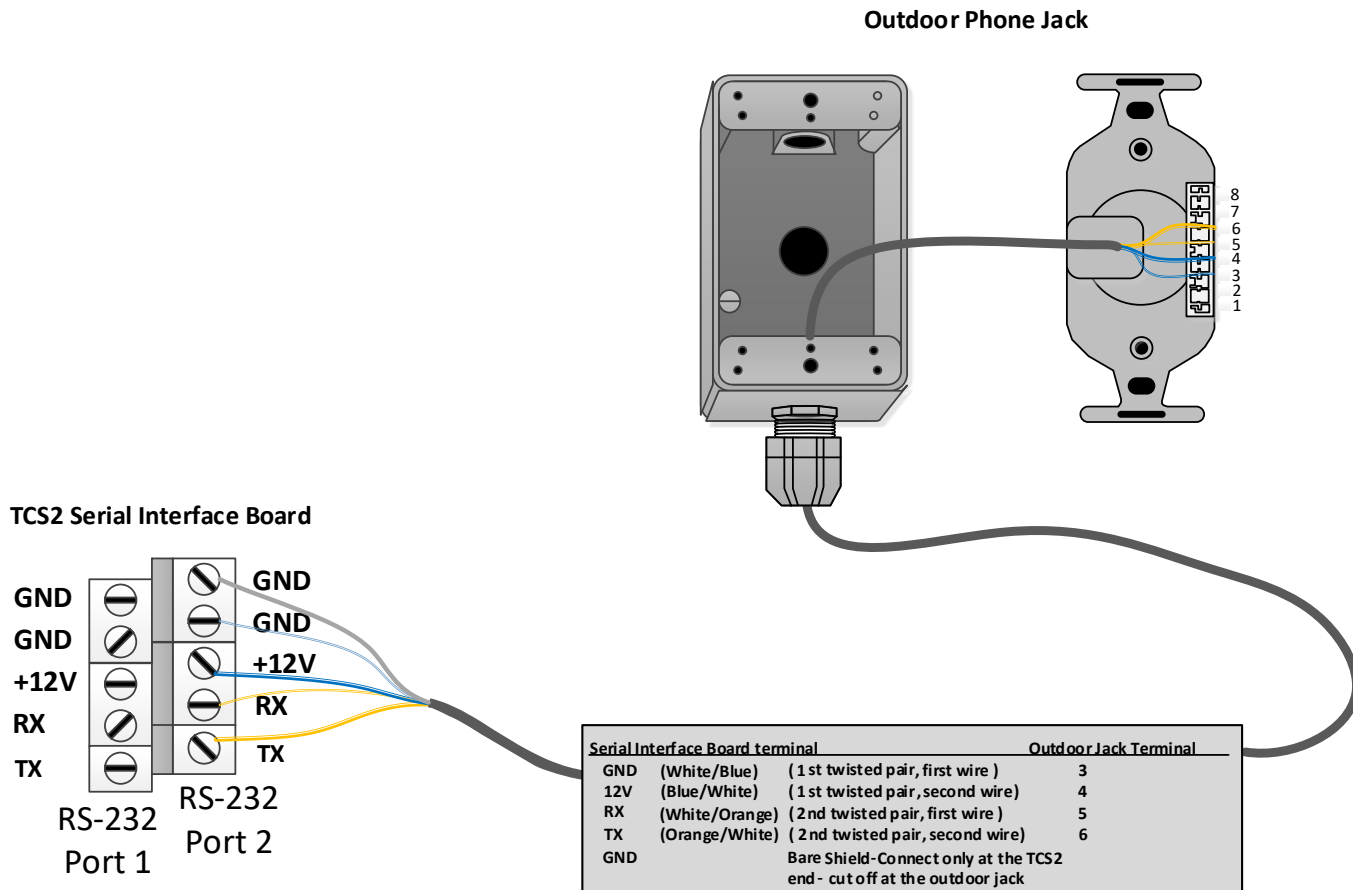

Figure 11: TCS2 Jack Wiring

Recheck wiring

- 4) Visually inspect the wiring connections from all previous steps.
 - Ensure that all connections are secure and safe for operation.

10th) Turn on the AC power to the TCS2 box

- 1) Switch on the circuit breaker that powers the TCS2 box.
- 2) Switch the TCS2 power switch to on.

11th) Test TCS2 Operations

Caution: These testing steps must be completed when the TunnelWatch computer is NOT connected to the TCS2.

Note: If any of these testing operations fail, consult the appropriate section of the **TunnelWatch TCS2 Installation Troubleshooting Guide** for help and then restart the testing step from the beginning.

Test Conveyor Control Circuit

- Repeat this test for each of the Start/Stop conveyor control button positions.
- An assistant would be helpful for completing this step.
- Be sure to have good communications between yourself and the assistant to ensure each operation is completed properly.
- Switch the Conveyor relay on the Conveyor Control board to the OFF position.

Conveyor Control Testing Procedure:

1. **Note:** All LEDs referred to in the procedure below are located on the Conveyor Control circuit board.
2. Override the Conveyor Relay to the OFF position.
 - This will keep the conveyor from operating while testing the Conveyor Control circuit.

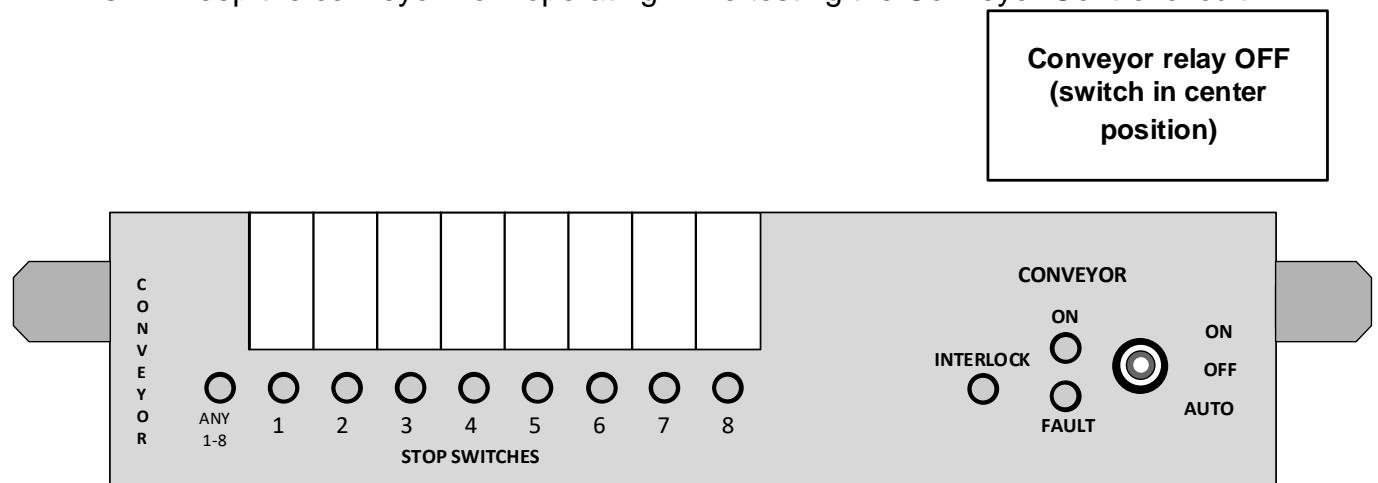

3. Are all red STOP LEDs off?
 - This indicates that 24VAC power is running through the STOP buttons and none of the STOP buttons are open.

Note: The STOP LEDs MUST be off before you complete the following steps.

4. Press and release a Start button.
 - The red STOP LEDs should stay off.
 - The green INTLK LED should turn on.

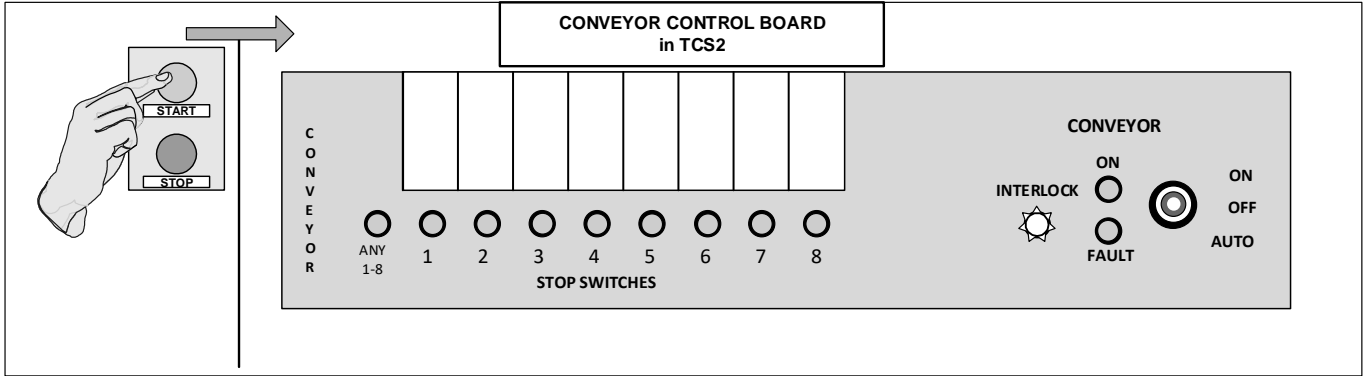

5. Press and hold a Stop button.
 - The red ANY stop LED should turn on.
 - The red STOP LED corresponding to the stop switch that was pressed should be on.
 - The green INTLK LED should turn off.

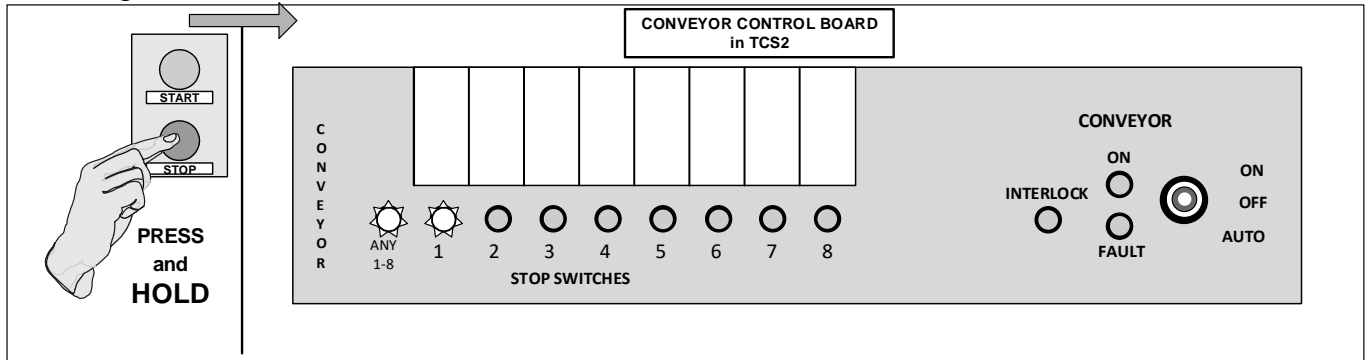

6. Release the Stop button
 - All red STOP LEDs should turn off.
7. Press and hold in a Stop button then press and hold in a Start button.
 - The red ANY stop LED should turn on.
 - The red STOP LED corresponding to the stop switch that was pressed should turn on.
 - The green INTLK LED should be off.
 - The green CONVEYOR ON LED should be off.

8. Press and release a Stop button.

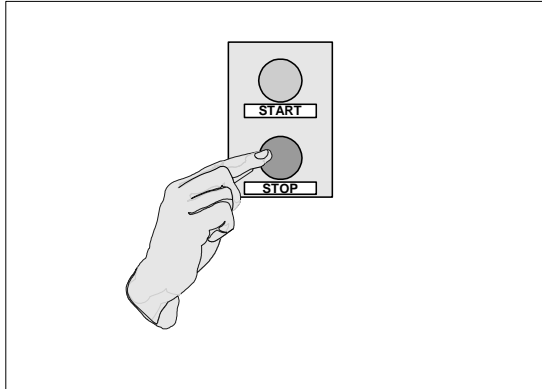

9. Turn the override switch for the Conveyor Relay to the **ON** position at the Tunnel Control Station 2.

- Conveyor should **NOT** turn on.
- The ERROR LED should blink repeatedly.

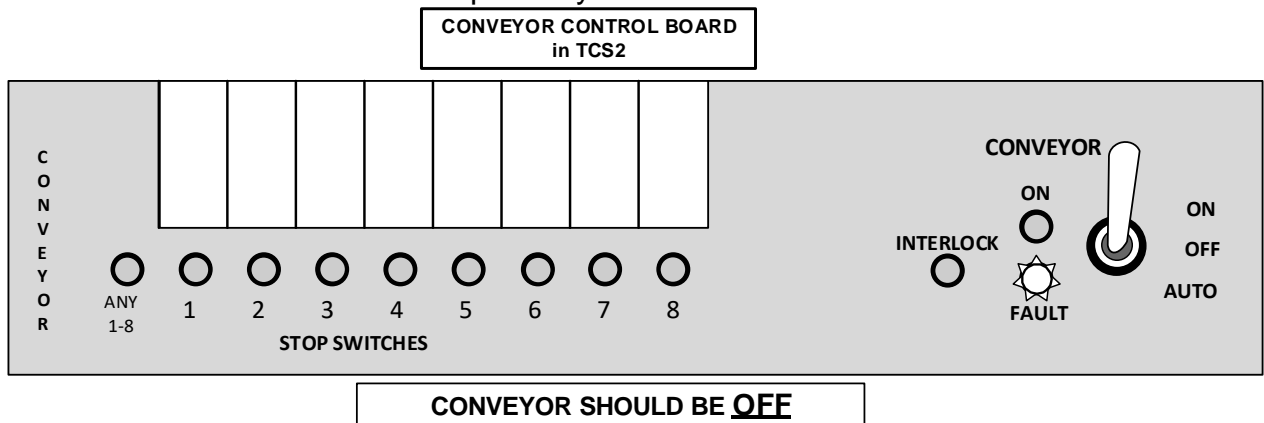

10. Press and release a Start button.

- The conveyor should start.

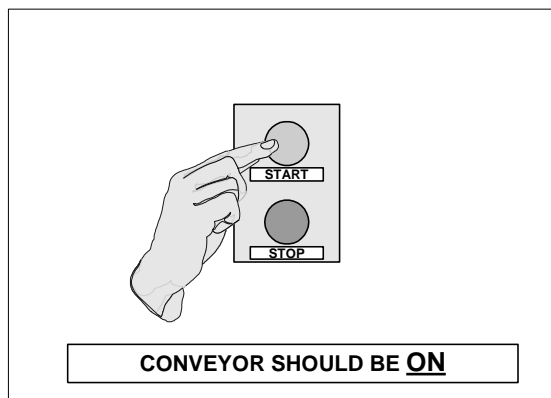

- The INTLK LED should be on.
- The CONVEYOR ON LED should be on.
- The CONVEYOR ERROR LED should be on steady, not blinking.

11. Press and release a Stop button.

Tunnel Control Station 2 Installation Instructions

- The conveyor **SHOULD** stop.
- The INTLK LED should be off.
- The CONVEYOR ON LED should be off.
- The CONVEYOR ERROR LED should blink repeatedly.

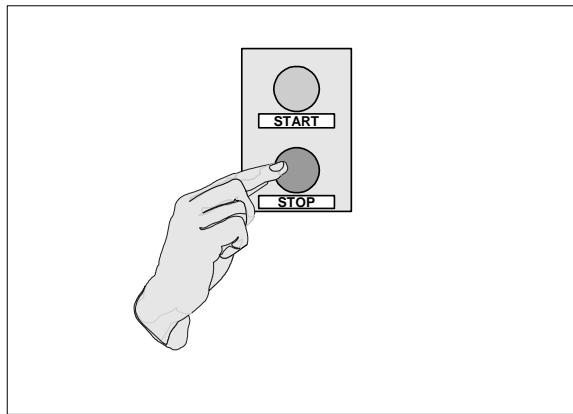

12. Return the Conveyor Relay override switch to the **Auto** position at the TCS2.

- All LEDs should be off.

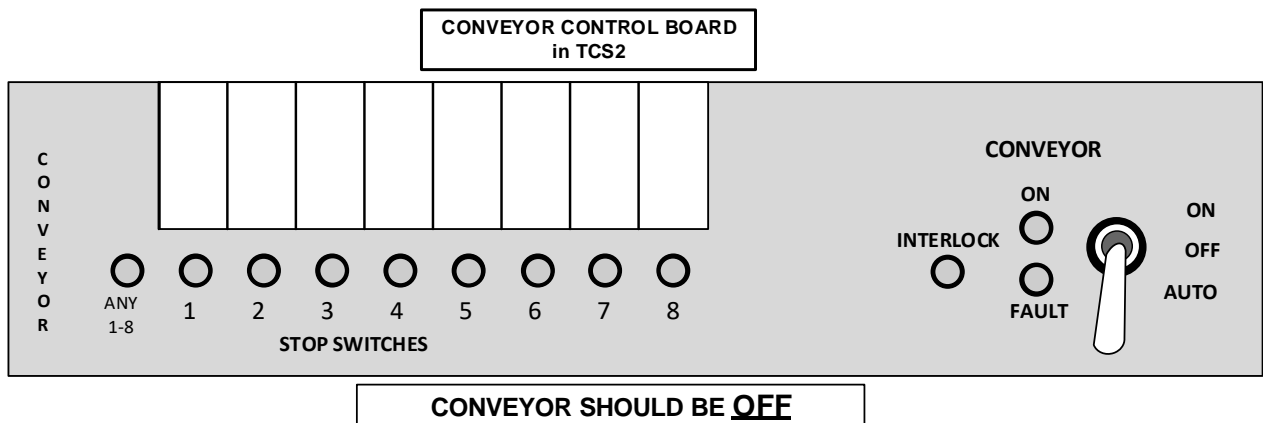

Test for relay operation

1) Override each relay in each TCS2 one at a time.

- Ensure that the device the relay is assumed to control is turning on.

Note: Any relays that are wired to conveyor interlocked power will need to be tested after the conveyor circuit is energized.

Test for input device detection

1) Simulate how a vehicle would activate each input device that is connected to the TCS2 input cards.

The following response should be seen for these critical input devices:

Tunnel Control Station 2 Installation Instructions

- Pulse Switch – The Pulse Switch input LED should blink on then off at a regular rate when the conveyor is running.
 - The time between activations should be AT LEAST 1/2 second.
- Enter Switch – The Enter Switch input LED should turn on and stay on as long as the switch is active.
- Tire Switch(es) – The Tire Switch input LEDs should turn on when each tire of a vehicle rolls over the switch. It should turn off immediately when the tires of the vehicle roll off the switch.
- Others - These switches can be connected to any input. Ensure that they activate the correct input LED for the appropriate length of time.

12th) Label all Inputs, Relay cards and wire-ways

- 1) Use a marker or label maker to label each relay and input used.
- 2) Label each wire-way space used for relays and inputs.

Appendix A: Alternate Methods for Wiring TCS2 Components

Your Start/Stop Button Wiring is Different?

Choose one of the following Alternate Wiring Diagrams to wire your Start/Stop buttons.

How to Wire the Start/Stop Buttons Using 4 Separate Wire Runs

Stop/Start circuit wiring – “4-Wire”

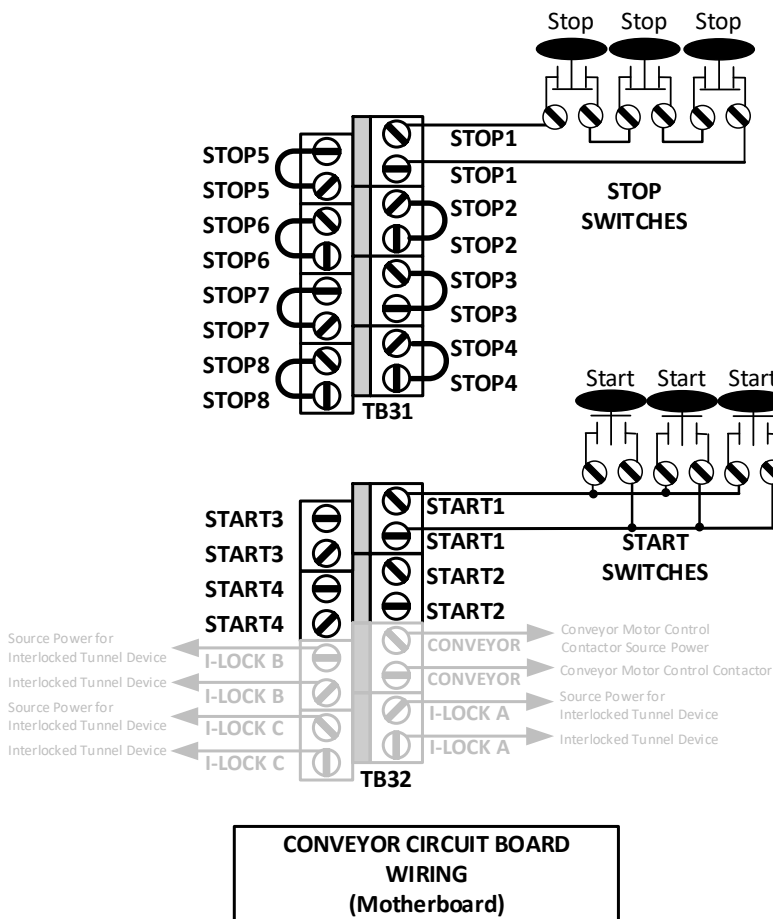

In a "4-Wire" wiring configuration for the Stop/Start buttons, one wire is connected to the first STOP1 terminal to provide a power source to the first Stop switch. Each additional Stop switch is added in series with the switched side of the button connecting to the source side of the next button in a daisy-chain, and the final switch side returns to second STOP1 terminal. A wire is run from the first START1 terminal to provide a power source for the source side of all Start switches. The switched side of all Start switches are connected together and run to the second START1 terminal.

This wiring method uses less wire than the "Home Run" method, but more wire than the "3-Wire" method. It is not a commonly used control wiring circuit.

The primary drawback to this method is that troubleshooting is more difficult than the "Home Run" method.

Note that the unused stop switch terminal pairs should be jumpered.

Any unused start switch terminals must be left open.

Figure 12: 4-Wire Start/Stop Wiring Method

How to Wire the Start/Stop Buttons Using 3 Separate Wire Runs

Stop/Start circuit wiring – “3-Wire”

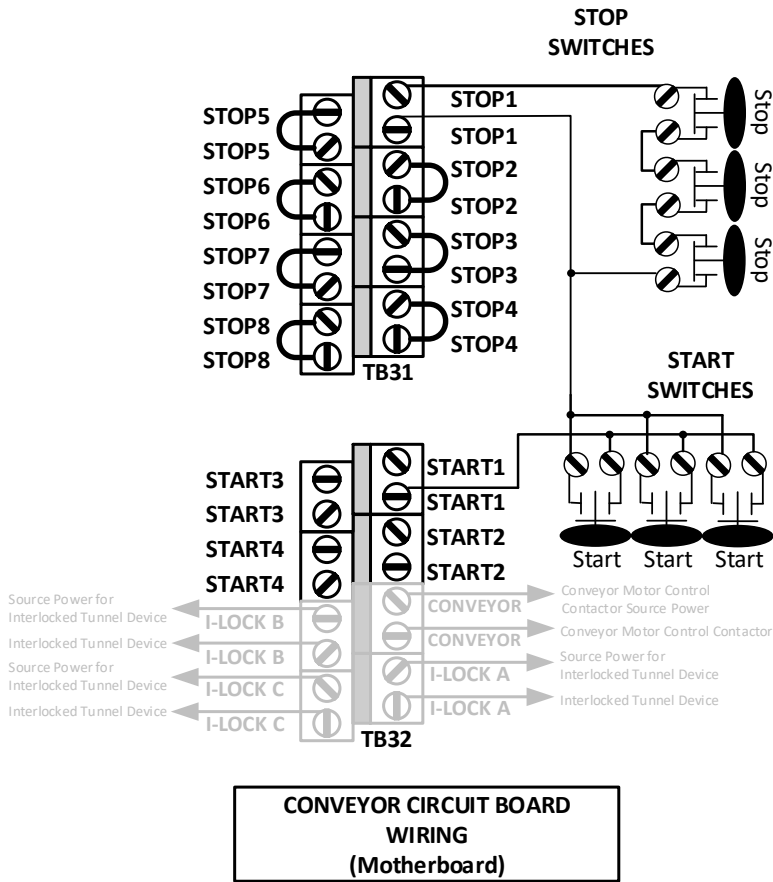

In a "3-Wire" wiring configuration for the Stop/Start buttons, one wire is connected to the first STOP1 terminal to provide a power source to the first Stop switch. Each additional Stop switch is added in series with the switched side of the button connecting to the source side of the next button in a daisy-chain, and the final switch side returns to the second STOP1 terminal. A wire is run from the switched side of the last Stop button to provide a power source for the source side of all Start switches. The switched side of all Start switches are connected together and run to the second START1 terminal.

This wiring method uses less wire than any other method, and is a commonly used control wiring circuit. It is often seen in existing washes where TunnelWatch is replacing a previous controller.

The primary drawback to this method is that troubleshooting is more difficult than the "Home Run" method.

Note that the unused stop switch terminal pairs should be jumpered.

Any unused start switch terminals must be left open.

Figure 13: 3-Wire Start/Stop Wiring Method

How to Wire Using Only a Stop Button at Each Stop Station

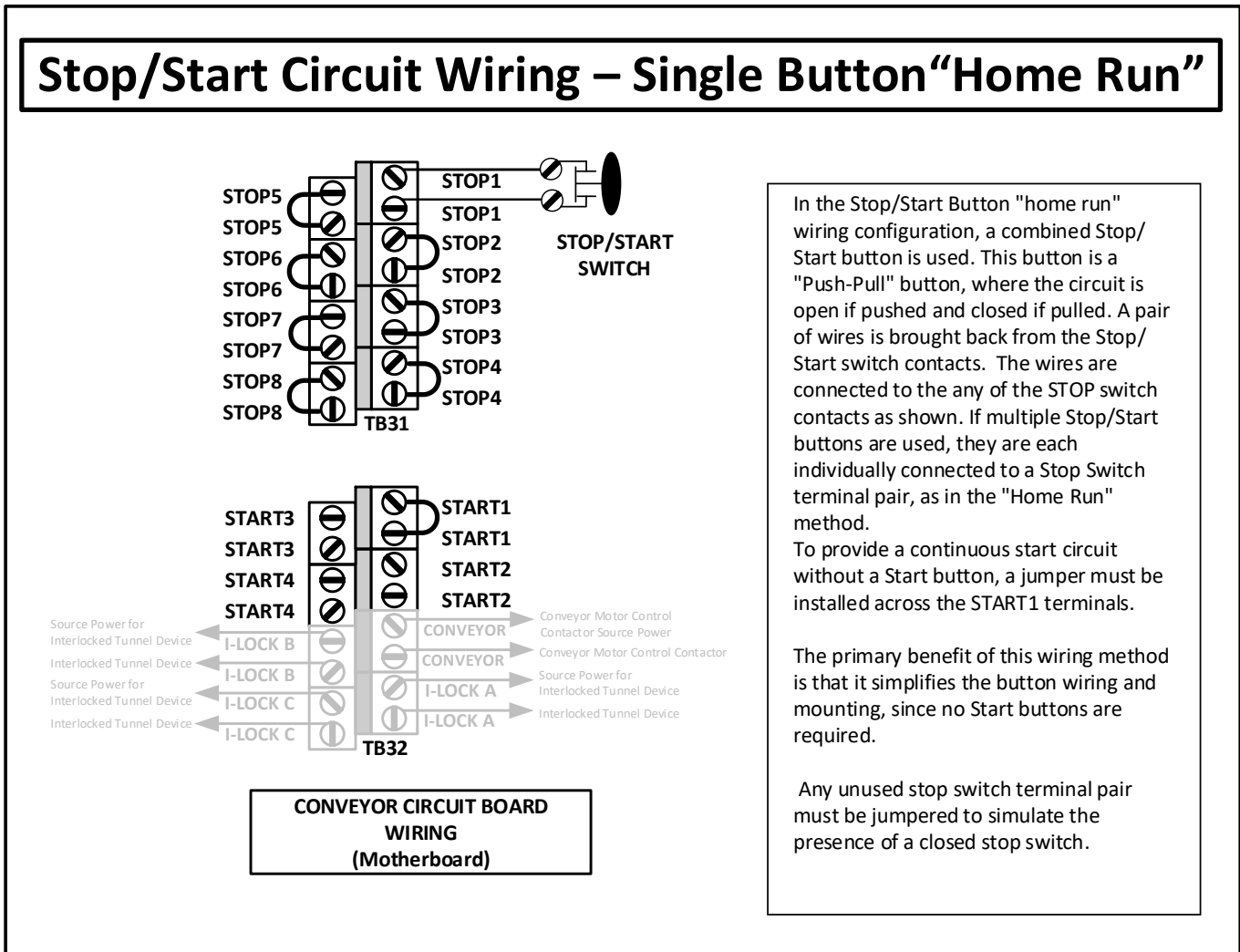
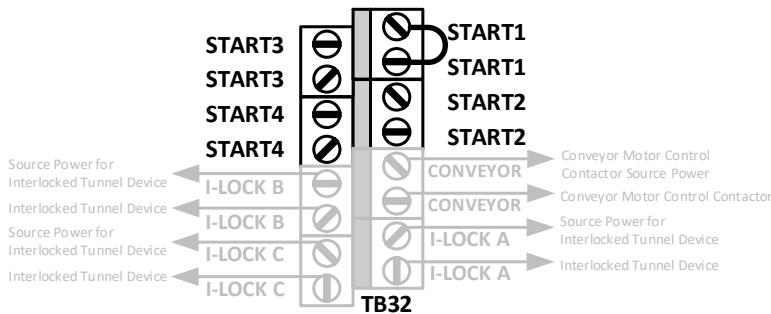
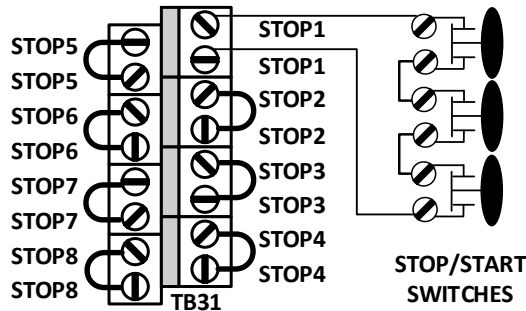

Figure 14: Single Button "Home Run" Wiring Method

How to Daisy Chain Single Stop Buttons from Station to Station

Stop/Start circuit wiring – Single Button “2-Wire Daisy Chain”



CONVEYOR CIRCUIT BOARD WIRING (Motherboard)

In the Stop/Start Button "2-wire Daisy Chain" wiring configuration, a combined Stop/Start button is used. This button is a "Push-Pull" button, where the circuit is open if pushed and closed if pulled. A wire is brought from the first STOP1 terminal on the TCS2 Motherboard to the source terminal of the first Stop/Start switch. If multiple Stop/Start buttons are used, the switched terminal of the first connects to the source terminal of the next until the last switch. The switched terminal of the last switch in the chain connects to the second STOP1 terminal on the TCS2 Motherboard. The remaining STOP inputs on the Motherboard should be jumpered.

To provide a continuous start circuit without a Start button, a jumper must be installed across one of the START connections.

The primary benefit of this wiring method is that it simplifies the button wiring and mounting, since no Start buttons are required, and only two wires are run to the TCS2.

Figure 15: Single Stop Button 2-Wire "Daisy Chain" Wiring Method

Need a Different Source for Inputs?

How to Replace the Provided 24VAC with a 24VDC Input Power Supply that You Provide

If your input devices require 24VDC power, you must supply an adequate power supply to power these devices.

To connect these devices, follow these instructions:

- 1) **REMOVE THE JUMPER** from the **24V** and **SOURCE** terminals on TB2 on the Motherboard. **CAUTION:** This jumper must be removed, or else damage to the TCS2 will result.
- 2) Connect the positive (+) wire from the power supply to the **SRC** terminal on TB2.
- 3) Connect the negative (-) wire to the **COM** terminal on TB2.

How to Power Input Devices Using the Provided 24VAC and a 24VDC Power Supply

- If some Input Devices require 24VAC and others require 24VDC, DRB Systems recommends you change all devices to 24VAC.
- If this is not an option, you can use Figure 16: 24VAC and 24VDC Input Device Wiring.

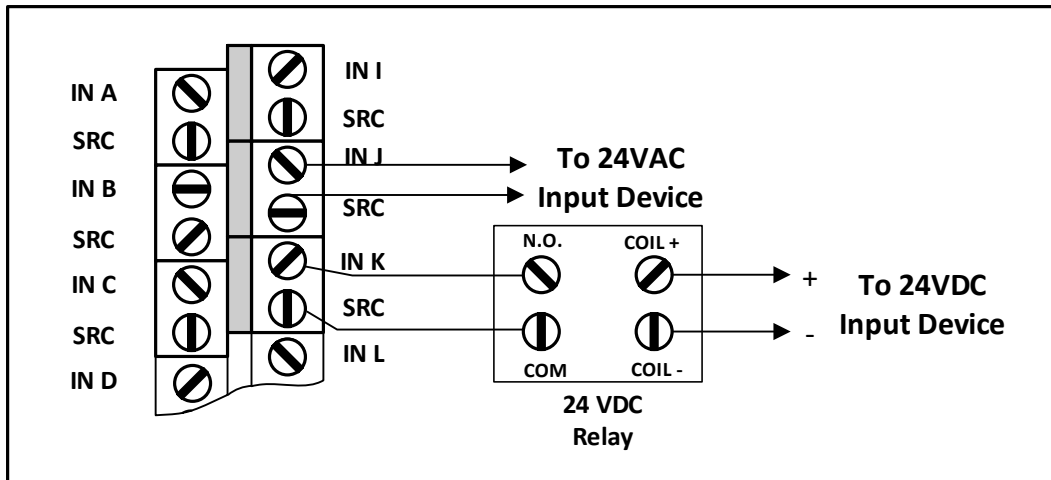

Figure 16: 24VAC and 24VDC Input Device Wiring

Need to Wire an Input Device that has more Than Two Wires?

How to Wire Multi-Wire Input Devices

If any of your input devices require multiple-wire (typically 3) connections, refer to

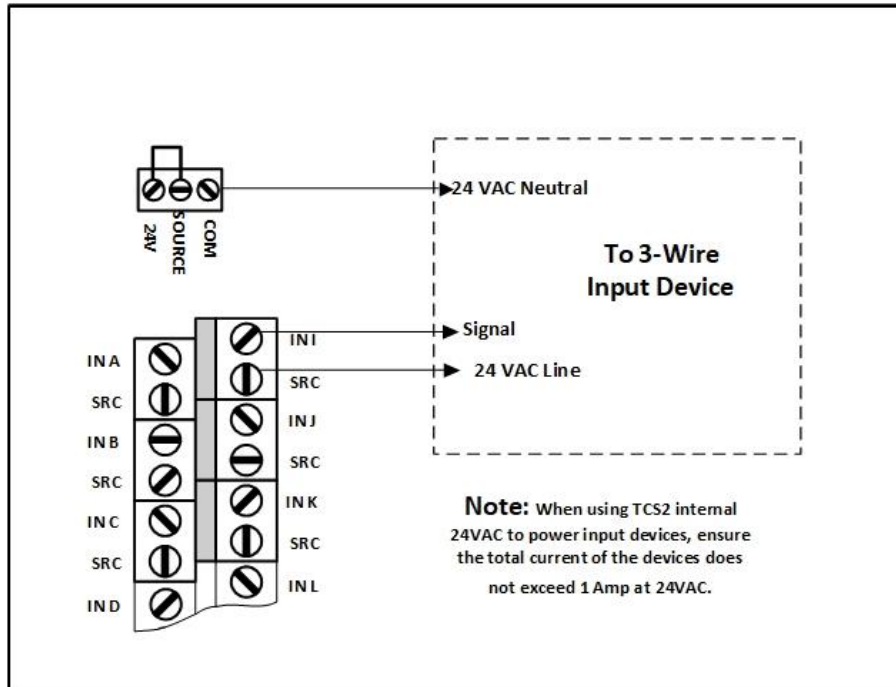

Figure 17: 3-Wire Input Device Wiring.

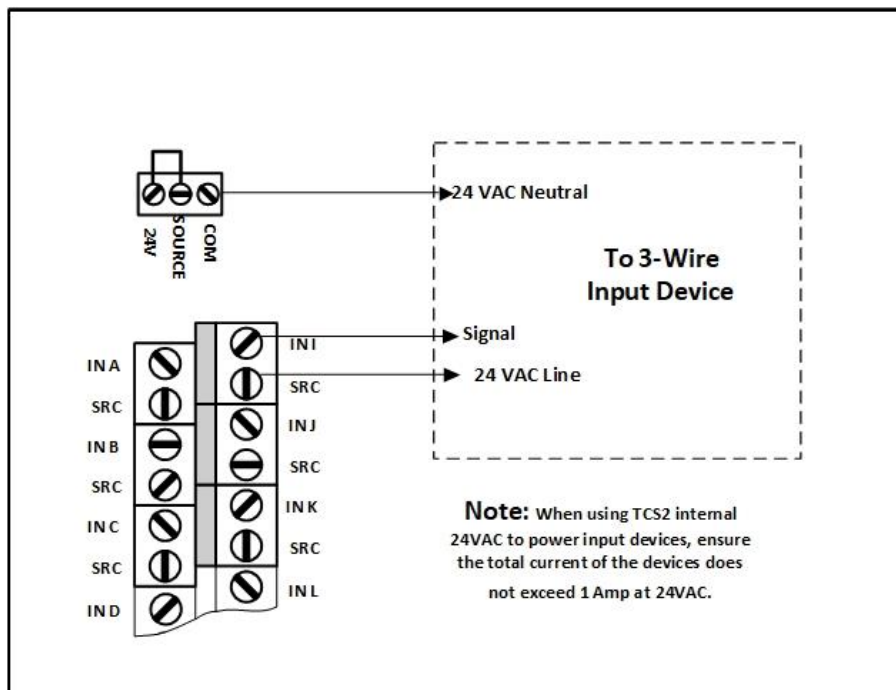

Figure 17: 3-Wire Input Device Wiring

Have one primary TCS2 unit and one or more secondary TCS2 units?

How to Connect one primary TCS2 unit to one or more secondary TCS2 units.

- 1st) Install Cat 5 or Cat 6 Ethernet cable from the primary TCS2 to each secondary TCS2.
 - 1) When installing one or more secondary TCS2 units to a primary TCS2, connect a Cat 5 or Cat 6 Ethernet cable from the primary TCS2 to each secondary TCS2.
 - 2) Connect the Ethernet cable to the network switch in the primary TCS2. This is the TCS2 with the panel PC in it.
 - See Figure 18: **One Primary TCS2/One or More Secondary TCS2 Units.**
 - 3) Connect the other end of the Ethernet cable from the network switch in the Primary TCS2 box to the motherboard in the first secondary TCS2 box.
 - See **Error! Reference source not found..**
 - 4) Repeat step #3 for each successive secondary TCS2 box.
 - See **Error! Reference source not found..**

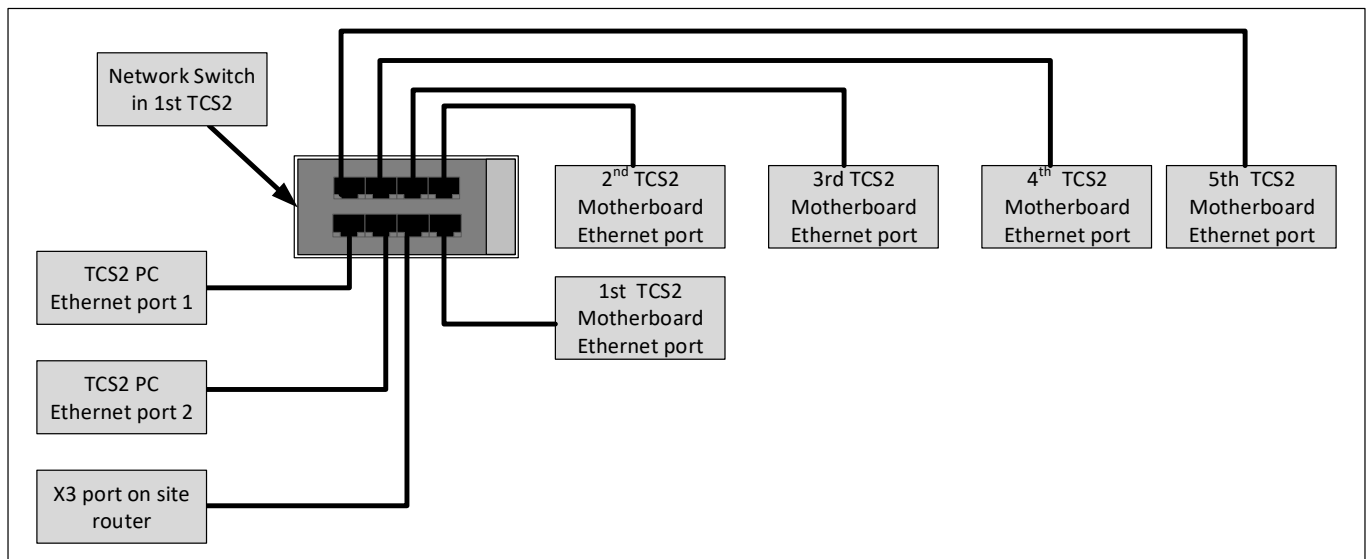

Figure 18: One Primary TCS2/One or More Secondary TCS2 Units

2nd) Configure the TCS2 Logic Cards

- 1) Set the address dial of the Primary TCS2 box logic card to 1.
- 2) Set the address dial of the first secondary TCS2 box logic card to 2.
- 3) Set the next secondary box to address 3, next box to address 4, etc.
- 4) Set the tenth box to address 0.

Have a Legacy TCS you want to interface to the TCS2?

How to Connect a legacy TCS to a TCS2.

1st) Install communication cable between the TCS2 and the Legacy TCS.

- 1) Connect an RS-422 cable between the TCS2 box and the legacy TCS box.
- 2) Connect one end of the RS-422 cable to RS-485 port 1 or RS-485 port 2 of the Serial Interface board in the TCS2.
 - See See Figure 19: **One Primary TCS2/One or More Secondary TCS2 Units.**
- 3) Connect the other end of the RS-422 cable to the communication terminals of the legacy TCS.
 - The shield wire will be connected to the SH terminals on the legacy TCS (Box 1) only.
 - See **Error! Reference source not found.** to Legacy TCS Communication Wiring.
- 4) Repeat step #3 for each successive Legacy TCS box.
 - See **Error! Reference source not found..**

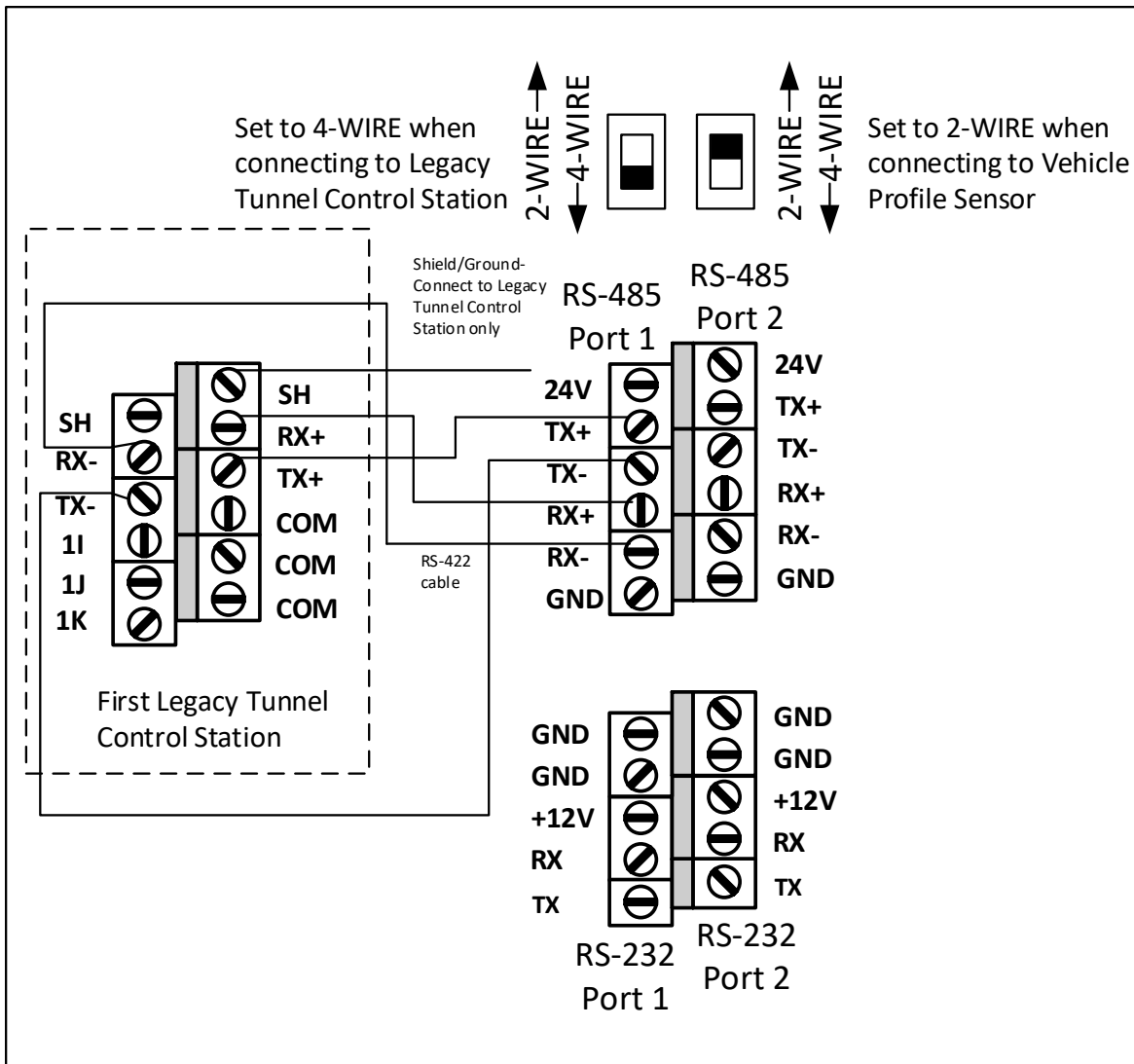

Figure 19: TCS2 to Legacy TCS Communication Wiring

Connecting a Vehicle Profile Sensor to the TCS2

Install communication cable between the TCS2 and the Vehicle Profile Sensor.

- 1) Connect an RS-422 cable between the TCS2 box and the Vehicle Profile Sensor.
- 2) Connect one end of the RS-422 cable to RS-485 port 1 or RS-485 port 2 of the Serial Interface board in the TCS2. **Note:** RS-485 port 1 is COM 5 in Windows. RS-485 port 2 is COM 6 in Windows.
 - See Figure 20: **TCS2 to Vehicle Profile Sensor Wiring.**
- 3) Connect the other end of the RS-422 cable to the M12 male connector, DRB Systems part number TW01540.
 - The shield wire will be connected to the SH terminals on TCS2 Box 1 only.
 - See Figure 20: TCS2 to Vehicle Profile Sensor Wiring.

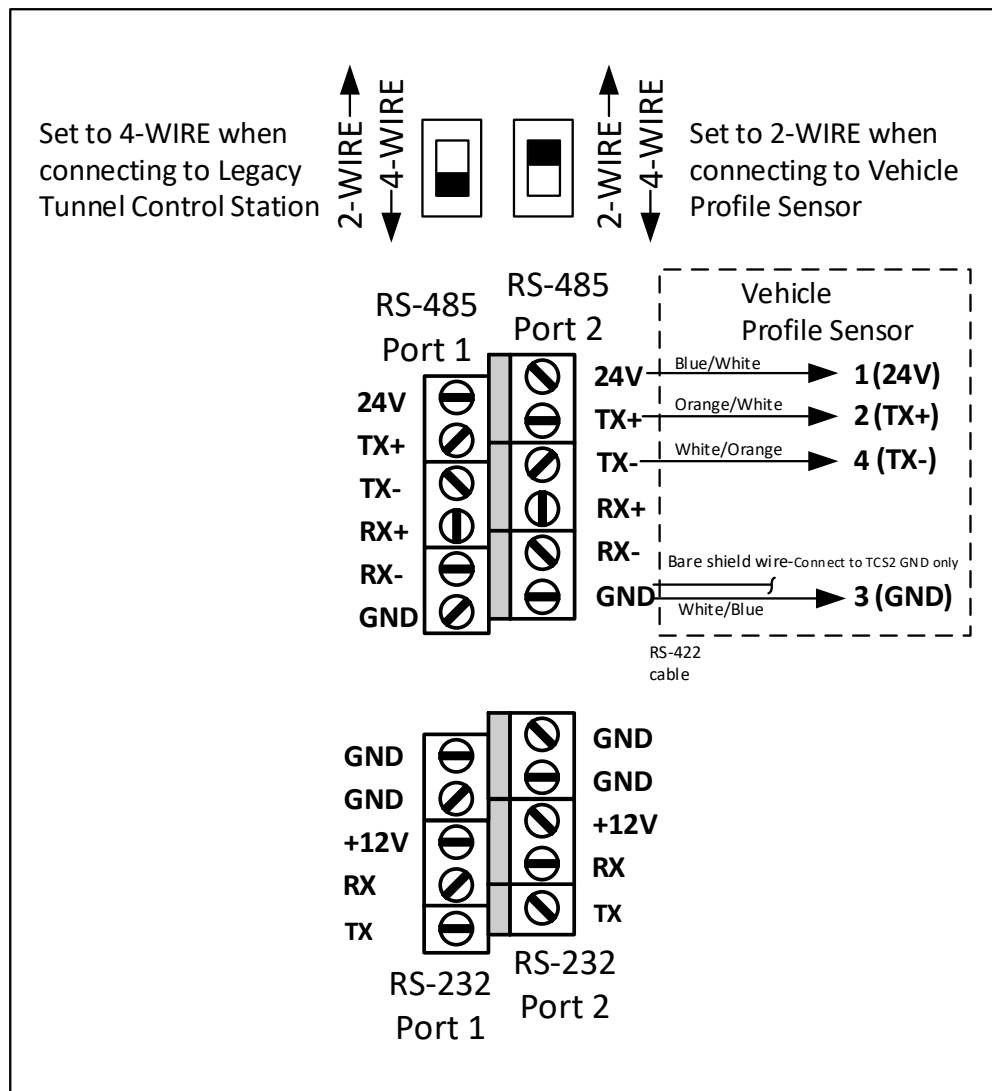

Figure 20: TCS2 to Vehicle Profile Sensor Wiring

Have a dual tunnel carwash that requires two primary TCS2 units?

How to Connect two primary TCS2 units at a dual tunnel carwash.

- 1st) On each TCS2 PC there are two network ports. On the first TCS2, locate the Ethernet patch cable that runs from the left-side Ethernet port (192.168.120.x subnet) to the TCS2 network switch and disconnect it. Set the Ethernet patch cable aside.
- 2nd) Repeat with second TCS2.
- 3rd) Connect a network cable from the site router X3 port to the unused network port (192.168.120.x subnet port) on the TCS2 panel PC.
- 4th) Repeat with the second TCS2.
- 5th) On the second TCS2 PC, change the IP address on the first LAN connection from 192.168.120.90 to 192.168.120.91.
- 6th) On the second TCS2 PC, change the IP address on the second LAN connection from 192.168.121.90 to 192.168.121.91.