

For Discount Tecumseh Engine Parts Call 606-678-9623 or 606-561-4983

F A C T O R Y T R A I N I N G



Technicians Update Seminar

1999

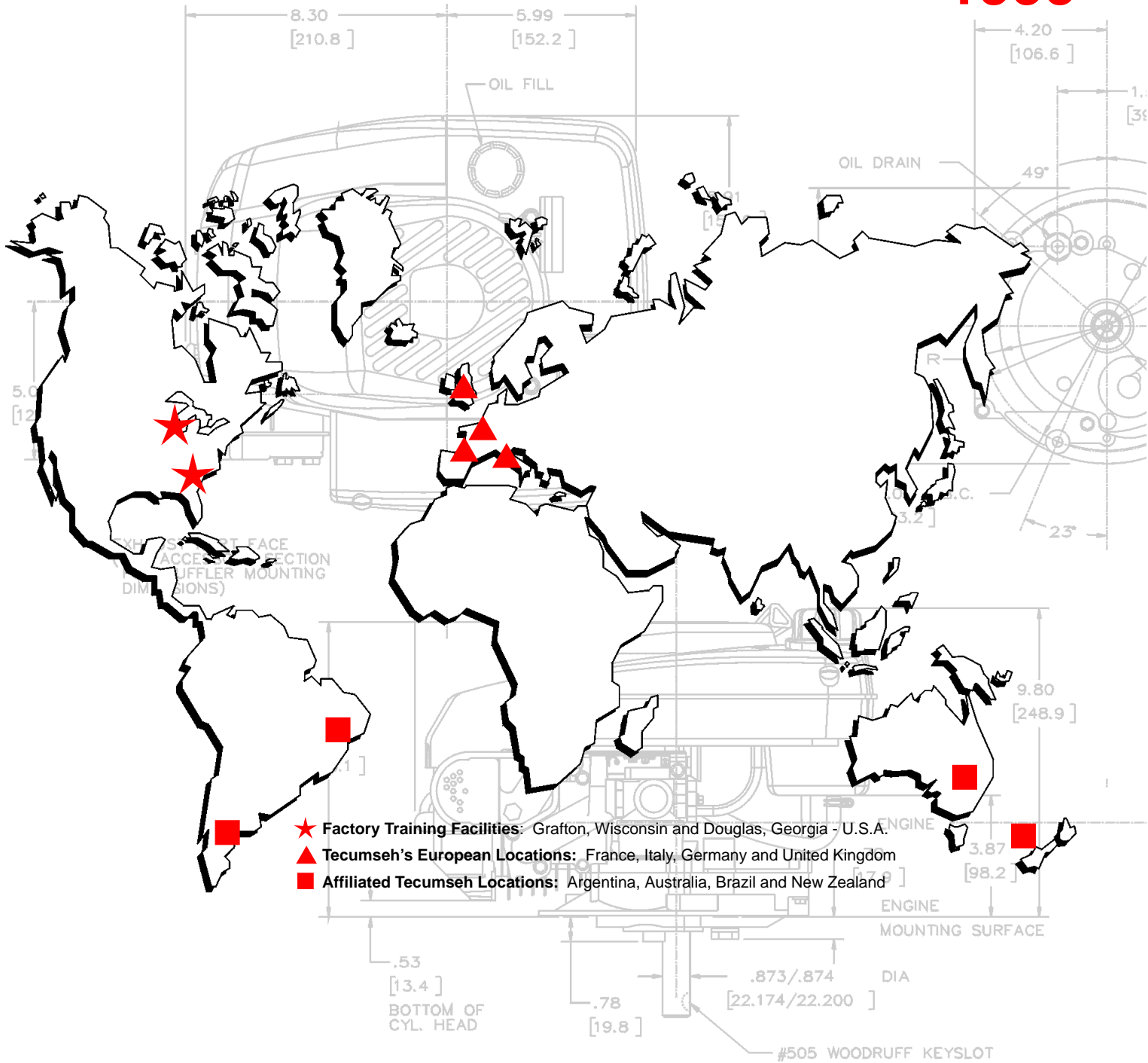

Technician's name: _____

Contents

REVIEW OF EMISSION STANDARD EFFECTIVE DATES	3
CALIFORNIA & U.S. EPA EMISSION CONTROL WARRANTY STATEMENT	3-5
FOUR CYCLE PRODUCTS NEWS	6
VENT TUBE EXTENSION	6
COLD START HANG TAG	6
HOW THE NEW EMISSIONS PRIMER WORKS	6
LEV/VLV VALVE STEM SEAL CHANGE	7
VLV AIR BAFFLE CHANGE	7
SERIES 11 CARBURETOR	7
VLV NO BOTTOM DRAIN FLANGE	8
HM CLIMATE GUARD™ KIT	8
LEV 80 NEW OFFERING	8
TORO FUEL TANK BAFFLE	8
OHH 7 AMP D.C. CHARGING SYSTEM	9
220 VOLT STARTERS	9
DIPSTICK COUNTER BORE OHH	9
ONE CONNECTING ROD FOR ALL	9
OHSK NEW HORSEPOWER	10
NEW RE-POWER PACKAGES	10
TWO CYCLE PRODUCTS NEWS	11
FLYMO REPLACEMENTS AVAILABLE	11
EMISSIONIZED AV520/600	11
PEERLESS® PRODUCTS NEWS	12
MST LEAKING AXLE SEALS	12
NEW MST SERVICE VIDEO 696250	12
820 SERIES SEALANT	12
NEW VST SERIES PULLER	12
1310 SERIES AXLES 1 1/8	13
NEW EXTERNAL SNUBBER FORCE ADJUSTMENT BULLETIN 308	13
SERVICE TIPS	14
LEV WIDER VALVE SEATS	14
CLIMATE GUARD™ OHH	14
EMISSIONS INTEGRITY	14
FUEL CAP TETHER	14
EMISSIONS SERVICE BULLETINS	15
BULLETIN 501	15
BULLETIN 502	15
HEAD GASKETS ARE BACK WITH SHORT BLOCKS	15
MODEL NUMBER STANDARDIZATION	16
TC SERIES CARBURETOR SPACER BLOCK	16
TC EMISSION CARBURETORS	16
PROPER TRANSAXLE WARRANTY INFORMATION BULLETIN 124	17
PROPER SHIFT COLLAR INSTALLATION	17
VST DIAGNOSTIC PROCEDURE	17
VLV WELCH PLUGS	18
LEV ENGINES MIS-FIRING FIXED LINE TRIMMERS	20
HH AND OH CAST IRON CRANKSHAFT AND CAM GEARS	20
TC AIR GAP REMINDER	20
MISCELLANEOUS PRODUCT NEWS	22
SNOW PRODUCTS STARTS	22
NEW SMART START PACKAGING	22
VST REPLACEMENT PROGRAM	23
BULLETIN 307	23
MICROFICHE UPDATES	23
ELECTRONIC PARTS LOOK-UP	24

ENGINE I.D. BULLETIN 123	24
QUICK FIX CARB KIT	24
NO METHANOL	25
STARTER CLIP BULLETIN 122	25
EUROPA NEWS	26
REVISED SOFT PULL STARTER	26
STARTER REPAIR KIT	26
VALVE CLEARANCE CHECK	26
REVISE CAMSHAFT	26
ELECTRIC START ENGINES	27
INLET VALVE OIL SEAL	27
FLYWHEEL ATTACHMENT MV100S ENGINES	27
3 AMP CHARGING SYSTEM	28
ENGINE IDENTIFICATION	28
CATALYTIC CONVERTERS	29
CONNECTING ROD	29
BULLETIN 108	30
BULLETIN 110	31
BULLETIN 122	32
BULLETIN 123	33
BULLETIN 124	34
BULLETIN 307	35
BULLETIN 308	36
BULLETIN 406	38
BULLETIN 501	39
BULLETIN 502	40
WARRANTY CLAIM FORM	41
ENGINE I.D. BULLETIN 123	42
STARTER 37102	43
OHH GOVERNED IDLE SYSTEMS AND COMMON HORIZONTAL SHAFT MEDIUM FRAME ENGINES	44
SPARK PLUG REPLACEMENT	45
TECUMSEH 4-CYCLE LUBRICATION REQUIREMENTS	46
TECUMSEH 2-CYCLE ENGINE OIL PART NO. 730227	47
SCHOOL COURSE SCHEDULE	48-50
SEND US YOUR TIPS	51
TECHNICIAN VIDEO UPDATE SEMINAR FORMAT	52
UPDATE SEMINAR TECHNICIAN VIDEO TEST	53-57
LABEL INFORMATION	58

REVIEW OF EMISSION STANDARD EFFECTIVE DATES

CARB: August 1, 1995

All Lawn and Garden/Utility Engines less than 25 HP produced for sale into California after August 1, 1995 (D.O.M. of 5213) must be CARB certified and labeled to indicate compliance. There are several applications which utilize engines typically thought to be in this category that are exempt from California regulations because they are considered Farm and/or Construction equipment.

U.S. EPA: (Phase 1) September 1, 1997

All Lawn and Garden/Utility Engines less than 19kw (25 HP) produced after September 1, 1997 (D.O.M. 7244) must be EPA certified and labeled to indicate compliance. All engines used on equipment considered Farm and/or Construction exempt in California must meet EPA requirements.

Our complete snow engine product line will be certified for both CARB and EPA beginning with the 1997 model year.

CALIFORNIA & US EPA EMISSION CONTROL WARRANTY STATEMENT

The U. S. Environmental Protection Agency ("EPA"), the California Air Resources Board ("CARB") and Tecumseh Products Co. are pleased to explain the Federal and California Emission Control Systems Warranty on your new utility or lawn and garden equipment engine. In California, new 1995 and later utility and lawn and garden equipment engines must be designed, built and equipped to meet the State's stringent anti-smog standards. In other states, new 1997 and later model year engines must be designed, built and equipped, at the time of sale, to meet the U.S. EPA regulations for small non-road engines. Tecumseh Products Co. will warrant the emission control system on your utility or lawn and garden equipment engine for the periods of time listed below, provided there has been no abuse, neglect, unapproved modification, or improper maintenance of your utility or lawn and garden equipment engine.

Your emission control system may include parts such as the carburetor, ignition system and exhaust system. Also included may be the compression release system and other emission-related assemblies.

Where a warrantable condition exists, Tecumseh Products Co. will repair your utility or lawn and garden equipment engine at no cost to you for diagnosis, parts and labor.

MANUFACTURER'S EMISSION CONTROL SYSTEM WARRANTY COVERAGE

Emission control systems on 1995 and later model year California utility and lawn and garden equipment engines are warranted for two years as hereinafter noted. In other states, 1997 and later model year engines are also warranted for two years. If, during such warranty period, any emission-related part on your engine is defective in materials or workmanship, the part will be repaired or replaced by Tecumseh Products Co.

OWNER'S WARRANTY RESPONSIBILITIES

As the utility or lawn and garden equipment engine owner, you are responsible for the performance of the required maintenance listed in your Owner's Manual, but Tecumseh Products Co. will not deny warranty solely due to the lack of receipts or for your failure to provide written evidence of the performance of all scheduled maintenance.

As the utility or lawn and garden equipment engine owner, you should, however, be aware that Tecumseh Products Co. may deny you warranty coverage if your utility or lawn and garden equipment or a part thereof has failed due to abuse, neglect, improper maintenance or unapproved modifications.

You are responsible for presenting your utility or lawn and garden equipment engine to a Tecumseh Authorized Service Outlet (any Tecumseh Registered Service Dealer, Tecumseh Authorized Service Distributor or Tecumseh Central Warehouse Distributor) as soon as a problem exists. The warranty repairs should be completed in a reasonable amount of time, not to exceed 30 days.

Warranty service can be arranged by contacting either a Tecumseh Authorized Service Outlet or by contacting Tecumseh Products Co., c/o Service Manager, Engine and Transmission Group Service Division, 900 North Street, Grafton, WI 53024-1499. Telephone 1-414-377-2700, or see your local telephone yellow pages under "Engines, Gasoline" for the name, address and telephone number of a Tecumseh Authorized Service Outlet near you.

IMPORTANT NOTE

This warranty statement explains your rights and obligations under the Emission Control System Warranty ("ECS Warranty") which is provided to you by Tecumseh Products Co. pursuant to California law. Tecumseh Products Co. also provides to original purchasers of new Tecumseh Products Co. engines. The Tecumseh Products Co. Limited Warranties for New Tecumseh Engine and Electronic Ignition Modules ("Tecumseh Products Co. Warranty") which is enclosed with all new Tecumseh Products Co. engines on a separate sheet. The ECS Warranty applies only to the emission control system of your new engine. To the extent that there is any conflict in terms between the ECS Warranty and the Tecumseh Products Co. Warranty, the ECS Warranty shall apply except in any circumstances in which the Tecumseh Products Co. Warranty may provide a longer warranty period. Both the ECS Warranty and the Tecumseh Products Co. Warranty describe important rights and obligations with respect to your new engine.

Warranty service can only be performed by a Tecumseh Products Co. Authorized Service Outlet, or by Tecumseh Products Co. at its factory in Grafton, WI. At the time of requesting warranty service, evidence must be presented of the date of sale to the original purchaser. The purchaser shall pay any charges for making service calls and/or for transporting the products to and from the place where the inspection and/or warranty work is performed. The purchaser shall be responsible for any damage or loss incurred in connection with the transportation of any engine or any part(s) thereof submitted for inspection and/or warranty work.

If you have any questions regarding your warranty rights and responsibilities, you should contact Tecumseh Products Co. at 1-414-377-2700.

EMISSION CONTROL SYSTEM WARRANTY

Emission Control System Warranty ("ECS Warranty") for 1995 and later model year California utility and lawn and garden equipment engines (for other states, 1997 and later model year engines):

- A. **APPLICABILITY:** This warranty shall apply to 1995 and later model year California utility and lawn and garden equipment engines (for other states, 1997 and later model year engines). The ECS Warranty Period shall begin on the date the new engine or equipment is delivered to its original, end-use purchaser, and shall continue for 24 consecutive months thereafter.
- B. **GENERAL EMISSIONS WARRANTY COVERAGE:** Tecumseh Products Co. warrants to the original, end-use purchaser of the new engine or equipment and to each subsequent purchaser that each of its utility and lawn and garden equipment engines is:
 - 1. Designed, built and equipped so as to conform with all applicable regulations adopted by the Air Resources Board pursuant to its authority in Chapters 1 and 2, Part 5, Division 26 of the Health and Safety Code, and

2. Free from defects in materials and workmanship which, at any time during the ECS Warranty Period, will cause a warranted emissions-related part to fail to be identical in all material respects to the part as described in the engine manufacturer's application for certification.
- C. The ECS Warranty only pertains to emissions-related parts on your engine, as follows:
 1. Any warranted, emissions-related parts which are not scheduled for replacement as required maintenance in the Owner's Manual shall be warranted for the ECS Warranty Period. If any such part fails during the ECS Warranty Period, it shall be repaired or replaced by Tecumseh Products Co. according to Subsection 4 below. Any such part repaired or replaced under the ECS Warranty shall be warranted for any remainder of the ECS Warranty Period.
 2. Any warranted, emissions-related part which is scheduled only for regular inspection as specified in the Owner's Manual shall be warranted for the ECS Warranty Period. A statement in such written instructions to the effect of "repair or replace as necessary", shall not reduce the ECS Warranty Period. Any such part repaired or replaced under the ECS Warranty shall be warranted for the remainder of the ECS Warranty Period.
 3. Any warranted, emissions-related part which is scheduled for replacement as required maintenance in the Owner's Manual, shall be warranted for the period of time prior to the first scheduled replacement point for that part. If the part fails prior to the first scheduled replacement, the part shall be repaired or replaced by Tecumseh Products Co. according to Subsection 4 below. Any such emissions-related part repaired or replaced under the ECS Warranty, shall be warranted for the remainder of the ECS Warranty Period prior to the first scheduled replacement point for such emissions-related part.
 4. Repair or replacement of any warranted, emissions-related part under this ECS Warranty shall be performed at no charge to the owner at a Tecumseh Authorized Service Outlet.
 5. The owner shall not be charged for diagnostic labor which leads to the determination that a part covered by the ECS Warranty is in fact defective, provided that such diagnostic work is performed at a Tecumseh Authorized Service Outlet.
 6. Tecumseh Products Co. shall be liable for damages to other original engine components or approved modifications proximately caused by a failure under warranty of an emission-related part covered by the ECS Warranty.
 7. Throughout the ECS Warranty Period, Tecumseh Products Co. shall maintain a supply of warranted emission-related parts sufficient to meet the expected demand for such emission-related parts.
 8. Any Tecumseh Products Co. authorized and approved emission-related replacement part may be used in the performance of any ECS Warranty maintenance or repair and will be provided without charge to the owner. Such use shall not reduce Tecumseh Products Co. ECS Warranty obligations.
 9. Unapproved add-on or modified parts may not be used to modify or repair a Tecumseh Products Co. engine. Such use voids this ECS Warranty and shall be sufficient grounds for disallowing an ECS Warranty claim. Tecumseh Products Co. shall not be liable hereunder for failures of any warranted parts of a Tecumseh Products Co. engine caused by the use of such an unapproved add-on or modified part.

EMISSION-RELATED PARTS INCLUDE THE FOLLOWING:

1. Carburetor Assembly and its Internal Components
 - a) Fuel filter
 - b) Carburetor gaskets
 - c) Intake pipe
2. Air Cleaner Assembly
 - a) Air filter element
3. Ignition System, including:
 - a) Spark plug
 - b) Ignition module
 - c) Flywheel assembly
4. Catalytic Muffler (if so equipped)
 - a) Muffler gasket (if so equipped)
 - b) Exhaust manifold (if so equipped)
5. Crankcase Breather Assembly and its Components
 - a) Breather connection tube

4 Cycle Product News

VENT TUBE EXTENSION

The Series "8" carburetor used on many LEV and OVRM series engines has a new extension tube added to the atmospheric vent passage. This tube part number **632766** was added to stabilize the atmospheric pressure in the bowl, improving the run quality. This was done in combination with carburetor calibration changes. This tube is serviceable and must be installed to a precise depth using tool part number **670343** to maintain emission standards and prevent blockage of the atmospheric vent passage. Do not use this tube on applications that it was not originally on. Always verify that the engine requires this tube by checking the parts list.

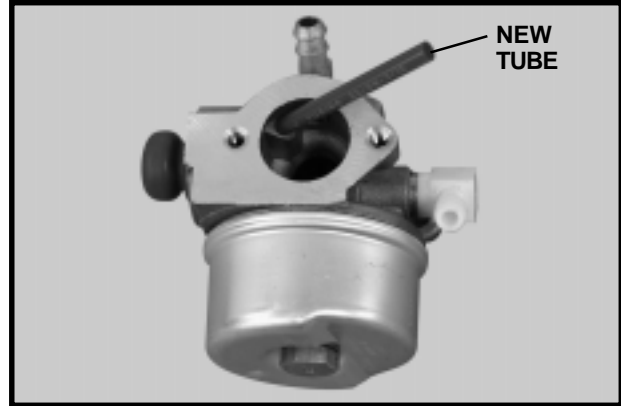

COLD START HANG TAG

Tecumseh has gone through extensive efforts to educate the customer in the proper procedures used to prime today's emissions engine. If a customer comments about an engine that is hard to start, it may be helpful to ask them to demonstrate the method they use when priming. In most cases there is not any engine problem and we have found improper priming is the cause. Most recently we have created a hang tag with instructions on the "Thumbs Up" five prime technique. This cold start procedure is outlined in the owners manuals and is illustrated by the use of a decal on the blower housing or fuel tank on some engines. It requires that the thumb be used to prime because the thumb's larger surface area covers the primer bulb better. **Remember always to wait two seconds between primes.**



HOW THE NEW EMISSIONS PRIMER WORKS

The primer used on emission grade carburetors has been designed to provide the precise amount of fuel being delivered with each compression. This style of primer must squarely make contact with the inside casting surface of the carburetor before any prime occurs. This will prevent air from being forced back into the air filter and send the prime charge into the carburetor. A brief delay of two seconds between each prime will assure that the primer has recovered ample air to provide an adequate prime charge.

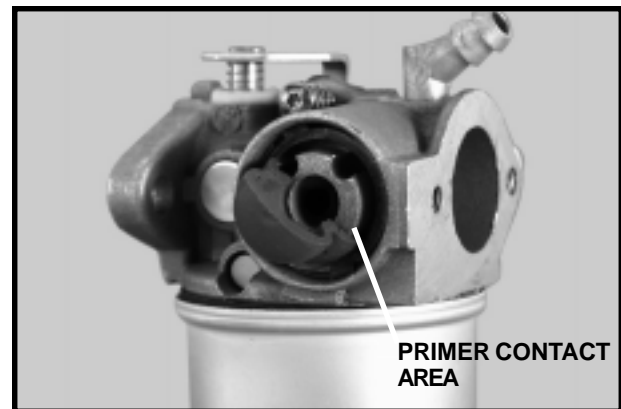

LEV/VLV VALVE STEM SEAL CHANGE

A design change has been made to the intake valve stem seal used on LEV and VLV engines. The seal area which makes contact with the casting surface in the valve box has been enlarged to improve sealing. A better seal on the valve stem will allow the elimination of an o-ring that had been used on engines prior to this. We have also reissued Service Bulletin "406" which references kit number **730617** to include the new seal. Removal of the intake valve may cause damage to the seal, always install a new seal when this type of repair work is done.



VLV AIR Baffle CHANGE

The fiber baffle/gasket used between the carburetor and cylinder block on the VLV engine has been changed to a metal baffle. A gasket is used on each side of the metal baffle which replaces the fiber gasket (an instruction sheet is included for installation). This baffle allows for cooler running carburetor bowl temperatures eliminating the occasional carburetor popping during high ambient temperature operation. We also created a bendable high speed adjustment tab as part of the baffle for fixed speed applications. Speed adjustments if necessary are done by bending the tab to the right to increase speed and to the left to decrease speed.

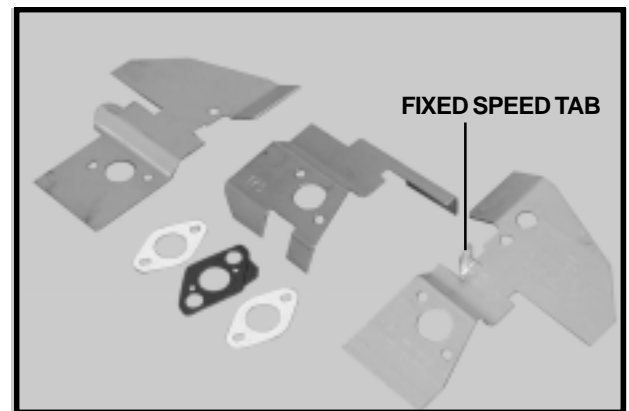

SERIES 11 CARBURETOR

This is possibly the most innovative and exciting primer type carburetor to be introduced since emissions standards were established. The series "11" carburetor is being released in limited quantities this year. Its design helps to eliminate the cold blooded nature of emissions engines by drawing fuel from a reservoir during the first minute of operation giving it smoother start up and warm up characteristics. This will give the engines using this carburetor the personality of one built prior to the emissions standards. The external physical package is identical to that of a series "8" carburetor. Removing the bowl will expose the welch plug used to cover the extended prime fuel chamber. There is also an **additional passage way** along side the center leg which feeds the fuel into this chamber when the carburetor is primed. During start up operation, the fuel is drawn from this chamber into the venturi until the chamber is empty, at which time normal operation is resumed. When cleaning an emissions carburetor remember the passages are extremely small. The best method for cleaning this carburetor is to remove all welch plugs and use carburetor cleaner and compressed air to clean the passages. It is not recommended to soak the carburetor in carburetor cleaner.

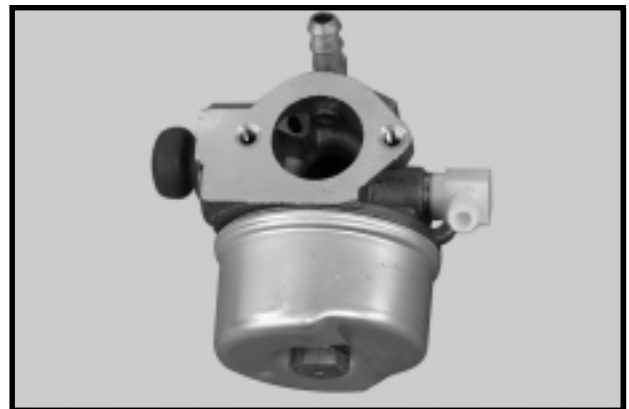

VLV NO BOTTOM DRAIN FLANGE

The VLV engine now has an option available to OEM's with no oil drain on the bottom of the mounting flange. This will be available for applications such as generators, pumps and pressure washers. In place of the bottom drain there is an optional side drain. If an OEM would choose to use this flange on a rotary lawnmower application, removing the oil may be accomplished by draining the oil out of the fill tube. This flange has been available since July 1998.

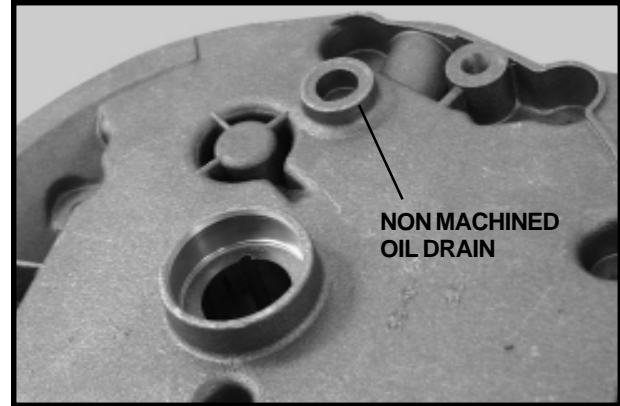

HM CLIMATE GUARD™ KIT

Climate Guard™ for HM engines is available on original equipment and will be used exclusively on Generac product for 1999. However, there is now a kit available for existing engines. If you have emissions or non-emissions engines that are used during both summer and winter seasons, you can now convert it to the Climate Guard™ system by using part number **730630**. Typical applications that could use this system are log splitters and generators.



LEV 80 NEW OFFERING

The LEV 80 is a new 3.5 hp engine being offered this year. It has been designed using the technology developed in the LEV engine with the straight valve train used in the TVS engines. This engine has the same cylinder fin design and flow through valve cooling system that allows the LEV to run at reduced cylinder block temperatures. It is being used on opening price point units and puts an offering in the market place that has the quality, and durability of the higher price units.



TORO FUEL TANK BAFFLE

The OHSK 120 used on Toro snow throwers has a foam baffle added to the fuel tank. This will prevent splashing and inconsistent fuel flow when there is less than an inch of fuel inside the tank. The foam baffle stabilizes the fuel supply to prevent the occasional fuel starvation situation. The material is similar to that used in race car fuel cells and is impervious to all of today's fuels within our standard fuel guidelines. The part number for the complete tank assembly is 37290.

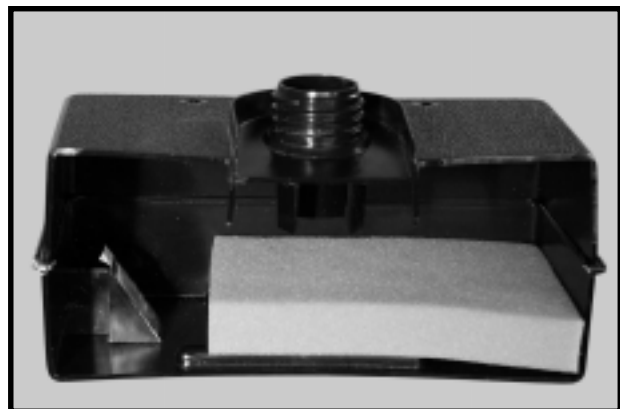

OHH 7 AMP D.C. CHARGING SYSTEM

This series of engines has quickly become one of the most popular engines in the industry. It is now poised to expand into markets that require a higher output charging system. A 7 Amp D.C. charging system is now available on OHH/OHSK 50-70 model engines. This reliable compact power plant can now be applied to those applications that require higher battery starting capabilities. The alternator part number is **611233**. Upgrading existing equipment will require that the flywheel be changed to accommodate the alternator which uses internal magnets.

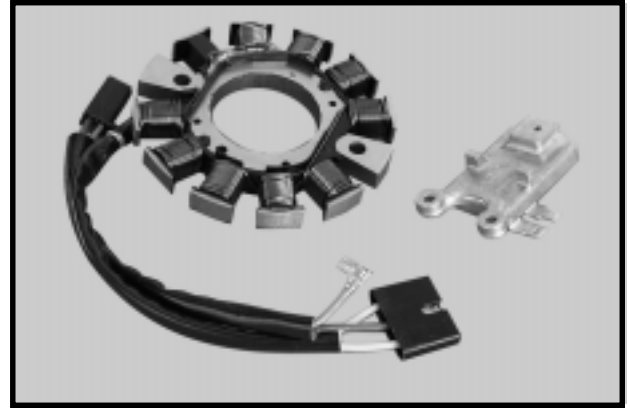

220 VOLT STARTERS

There is now a 220 volt 50 hertz starter available for countries outside the US and Canada. These starters, part number **37102** (H30-35, HS40-50, HSK34, HSSK40-50, OHSK50-70) and **37217** (HM70-100, HMSK70-100, OHSK80-120) have only a limited number of parts that are serviceable due to European Community regulation. None of the internal parts can be serviced. Only the parts from the engagement nut to the cap are serviceable externally. The starter does not include a power cord because of the multiple options used in different countries.



DIPSTICK COUNTER BORE OHH

On many applications the OHH engine uses a dipstick gauge that threads directly into the cylinder cover. Checking the oil has been a challenge at times because of difficulty reinstalling the oil gauge without cross threading. This situation has been corrected by machining a counter bore in the oil gauge hole and adding a 45° chamfer to the lead in thread making reinstallation easier. **Remember to instruct the customer to clean the area around the dipstick prior to removal.**

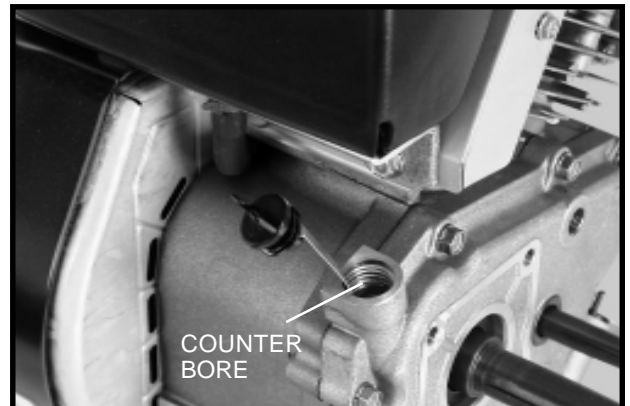

ONE CONNECTING ROD FOR ALL

In our continuing effort to reduce the inventory required to service our engines, a change has occurred to the small frame connecting rod. When you order connecting rod part number **32875A**, you will receive an instruction sheet explaining which oil dipper, if any, is used. An example is the H30-HS50 which uses dipper number **32654**. The same connecting rod is used on small frame overhead valve engines but uses the longer **36611** dipper. Please follow the instruction sheet carefully. Remember always assemble the rod and cap with the match marks facing out.



OHSK NEW HORSEPOWER

We are very pleased to expand our overhead valve engine line with three new models based on the HM series engine. There are three horsepower offerings being used in this seasons snow product. They are OHSK 80, 90 and 110.



NEW RE-POWER PACKAGES

With the change to emission product, several models of engine have been obsoleted. We have worked with our applications group to develop replacement for several application. The following kits are available from your engines source:

Troy Bilt Pony - Part Number **205128 OHH 50**, with features including 3/4" crankshaft, extended cam, mounting instructions and reverse belt.

Troy Bilt Pony - Part Number **205130 OHH 50**, with features including 3/4" crankshaft, extended cam, mounting instructions, reverse belt and electric start and harness.

Troy Bilt Horse - Part Number **208106 HM 80**, with features including 3/4" crankshaft and special rear tine tiller dipstick.

Ariens Rocket Tiller - Part Number **208120 HM 80**, with features 1" crankshaft, extended cam, special rear tine tiller dipstick and mounting template.

REPOWER PACKAGES

205128 - OHH50

205130 - OHH50

208106 - HM80

208120 - HM80

Two Cycle Products

FLYMO REPLACEMENTS AVAILABLE

There are now Service Replacement Engines available for the Flymo hover mower application. They are available in all states with the exception of California. These engines are able to meet the E.P.A. emissions standards for hand-held equipment through use of a fixed jet carburetor and cylinder port timing changes. The engines will be available in early 1999, under service part number's **800175 and 800176**. Please consult your parts lookup system or the service engine specification book to locate the correct one.



EMISSIONIZED AV520/600

The AV series engines used on post hole diggers and ice augers has been changed in several areas to meet the E.P.A. emissions regulations for hand-held product. These improvements include changes to cylinder port timing and the carburetor being made customer tamper-proof. The carburetor changes involve fixed jets in both the idle and high speed circuits. The idle restrictor jet can be removed for service but the idle restrictor cap (**640053**) must be re-installed to maintain compliance. All fixed jets that screw in seal against the taper, it is critical that you do not over tighten the jet when re-installing or damage to the metering hole will occur. Tighten to **5-8 inch lbs. (.5-1.0 NM)**



Peerless® Products News

MST LEAKING AXLE SEALS

Last year we advised you of the running change made to the axle seals used on all MST Series transaxles to improve sealing. We still hear about the occasional seal leakage on some MST's. Our evaluations have found that when the unit was serviced and then re-assembled the old seals were re-used with sealant placed around the perimeter of the seal. This sealant will get into the seal spring, harden and cause it to not function properly and leak. Always replace the seals if the transmission is serviced and **DO NOT** use sealant in the seal pockets. When re-assembly is complete we recommend a **low** pressure leak down testing of the unit. The test pressure must not exceed **15 PSI (1 Bar)** or seal damage will occur. We have developed a test kit part number **670345** as an add on for an existing leak down tester or our **complete kit 670340**. Both are available from your normal supplier.

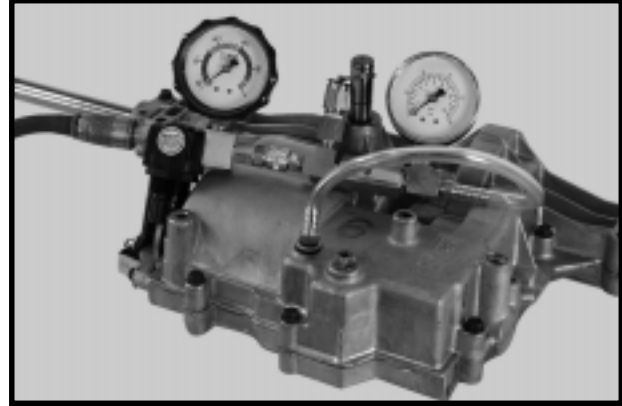

NEW MST SERVICE VIDEO 696250

We have released the latest video in our series to help technicians understand the new MST transaxles. This video covers complete disassembly and re-assembly with tips such as not blocking the oil galley to the axles and proper assembly of both "A" and "B" inputs. This video and others available at \$15.00 each (US price) are a great way to increase your knowledge or help a new technician you may have recently hired. Other videos available are:

- Ignition Systems - 695059
- 800 Series-Transaxle - 695285
- Carburetor Troubleshooting - 695015
- 900 Series-Transaxle - 695148
- Electrical Systems - 695185



820 SERIES SEALANT

The 820 series transaxle has been changed from Loctite 515 Gasket Eliminator to Loctite Ultra Gray RTV Silicone, Tecumseh Part Number **788093A**. This change improves the perimeter seal reducing the chance of water entering the case during cleaning by the operator. When service is needed on older models, please re-seal the case using the Loctite Ultra Gray RTV which is resistant to oil and grease.



NEW VST SERIES PULLER

The directional control arm on the VST205 hydrostatic series transaxle is attached using a tapered shaft or taper and key combination and then secured with a nut and lock washer. Should this arm need to be removed, a puller is required. Removal without using a puller can severely damage the internal parts of the transaxle, which is not repairable, causing replacement of the entire assembly. We have developed a special puller, Tecumseh Part Number **670342** to remove this arm. When the control arm is re-installed on the unit, it must be tightened in the neutral position, the nut is torqued to **25 to 30 ft. lbs. (33.9 - 40.7 Nm)**. Should you still have questions consult the 691218 Motion Drives Technician's Handbook.



1310 SERIES AXLES 1 1/8

At the request of the Toro Company, we have increased the axle diameter of their 1310 series unit to 1-1/8 inches. This diameter change increases the durability of this model for their application. Service replacements for this model have been upgraded to this new axle diameter as well.

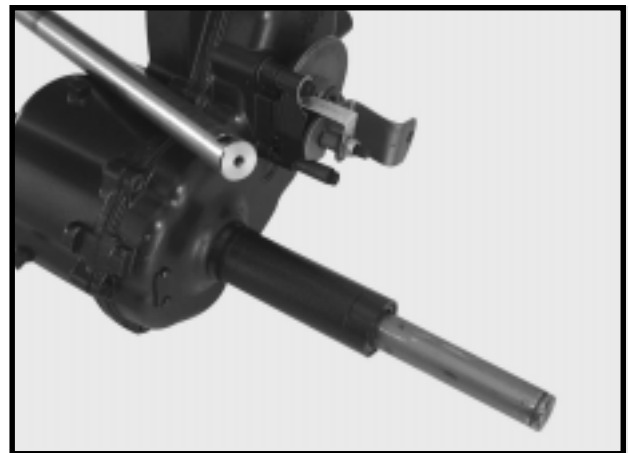

NEW EXTERNAL SNUBBER FORCE ADJUSTMENT BULLETIN 308

We have issued Service Bulletin 308 to review a change made to the "C" versions of the VST series transaxle (example VST205-024C) This bulletin outlines the adjustment of the shift force required to move the control lever. **Never** automatically assume the hydro is the problem, our evaluations of several units returned found no defect at all. In these situations we found a slipping belt (extremely glazed) from low tension to be the problem.

The bulletin outlines first cleaning the unit then the procedure for removing an access plug and adjusting the snubber screw which controls the shifting forces. You should **NEVER** need to turn the screw more than **one turn**. If you turn beyond this limit, the screw could come out of the case, this screw cannot be re-installed in the field and will require complete unit replacement. Please use extreme caution if performing this procedure and follow the bulletin exactly.

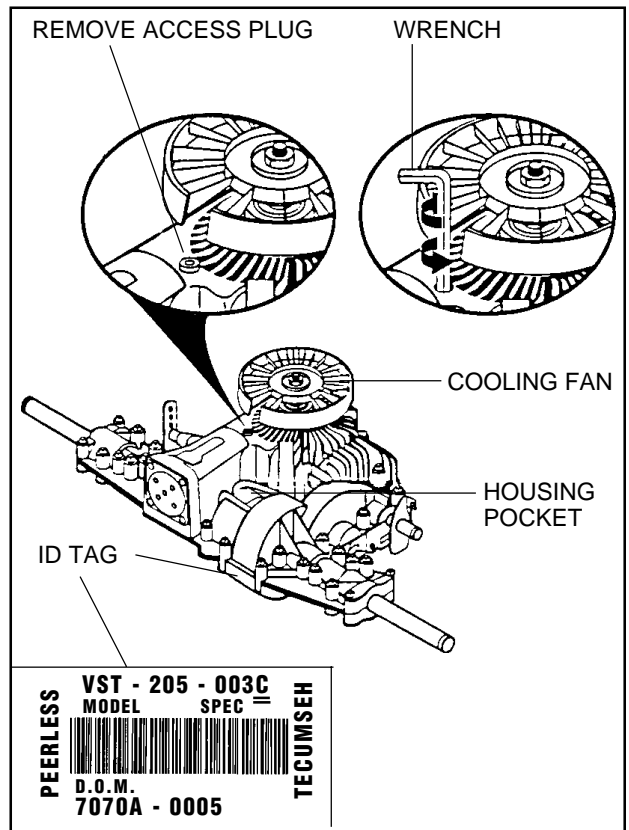

Service Tips

LEV WIDER VALVE SEATS

The valve seats on LEV engines (except the LEV 80) are being widened to help increase valve and seat durability. The width is being nearly doubled from **.040 (1 mm) to .078 (2 mm)**. This can be done on the LEV engine because of the unique design of the valve seats and cylinder block. This design helps remove heat from the valve seat area by distributing it into the cylinder block and then dissipating it in its flow through design. This is also being done in conjunction with the use of heavier valve springs. The combination of the two may also help eliminate the light to no load popping that sometimes occurs when engines are running at low speeds.

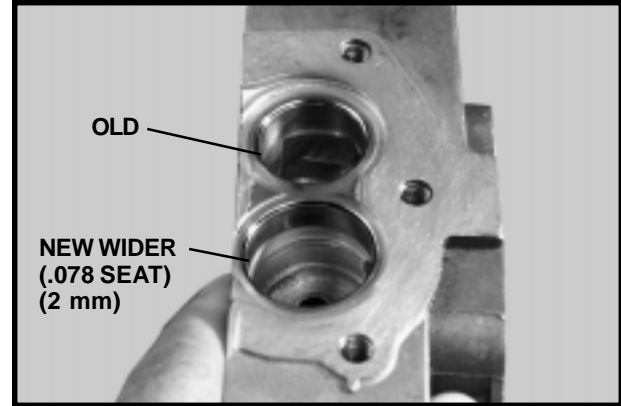

CLIMATE GUARD™ OHH

Although it was introduced last year, it now has a title, "Climate Guard™". The official name for the air filter system used on emissions engines that are run in both warm and cold weather environments. This system has a baffle, that when placed in the winter position blocks cold air from the blower housing. Warmer air is then drawn through the air filter backing plate, this warmer air prevents the possible icing of the breather tube inlet to the carburetor. The icing is caused by crankcase vapor/condensation from the breather system required on emissions engines. When placed in the summer position it allows the cooling air from the blower housing to function normally, maximizing air filter life through our Kleen Aire® system.

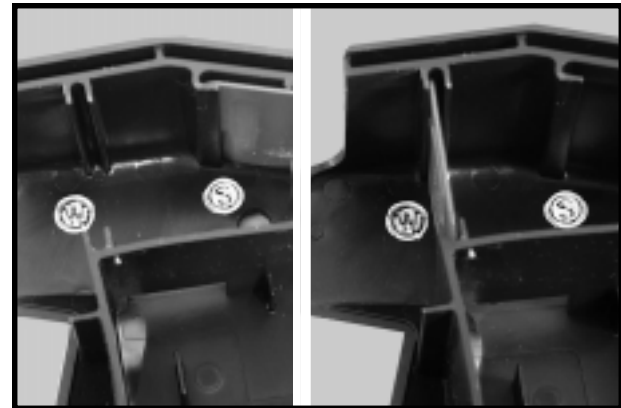

EMISSIONS INTEGRITY

Just a reminder to you and your customer that it is required to maintain EPA and CARB compliance to use "as built" factory original or approved parts. This means parts used in, fuel metering systems, air induction systems, ignition systems, exhaust systems and crankcase breather systems must be Genuine Original Tecumseh factory parts or their equivalent. Ask your distributor about the Real Ones Parts program to prevent any possibility of violating compliance regulations by using less than OEM quality after market parts.



FUEL CAP TETHER

The fuel cap tether has made a come back in recent years especially on recreational vehicles. This cap tether may come in handy for the customer that has lost their fuel cap while mowing or forgot to put it on. The part number is **35480** and can be retrofitted to most newer style fuel caps with the standard 1.750 (44.45 mm) opening.



EMISSIONS SERVICE BULLETINS

A new series of bulletins have been earmarked to deal specifically with emissions related concerns. These bulletins will be designated by the “**500**” series classification. The headings listed on these bulletins will include, Date Issued; Engine Model Concerned, Family; and D.O.M. (Date Of Manufacture) affected. The body of the bulletin will contain information concerning; Potential Emission Control System Problem; Affected Specifications Numbers; and Warranty Inspection and Repair Procedure.

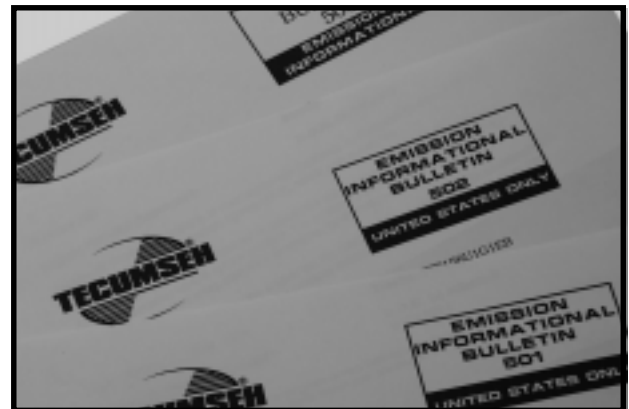

BULLETIN 501

Some LEV 115 engines built between date codes **8091** through **8166** have the incorrect bowl nut in the carburetor. The suspect units will have the bowl nut on the carburetor stamped with the number **174**. This jet should be replaced with part number **640087** which will have the number **169** stamped on it. There are 30 different specifications involved. Check the bulletin to determine if any units you may work on qualify.

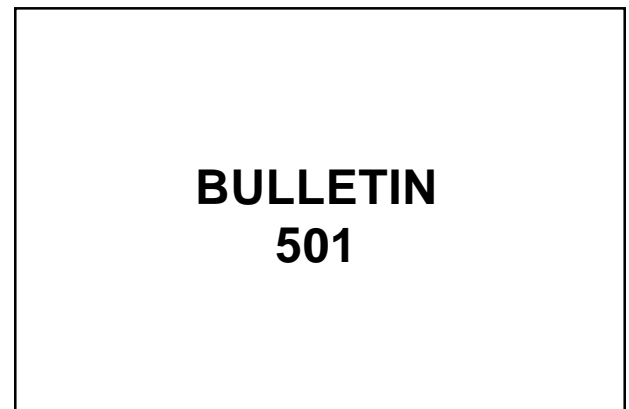

BULLETIN 502

The following three model and spec numbers H35-45690Z, H35-45726Z, and H40-55701A with D.O.M s of 8079 through 8201 have been built with the incorrect carburetor. You will need to locate and identify the manufacturing number on the carburetor mounting flange. If the number on the flange is stamped with the number **5161** the unit has already been changed and no repair is necessary. If the number is **5015** you need to replace it by ordering part number **640172**. This carburetor will have the manufacturing number **5161** stamped on the flange.

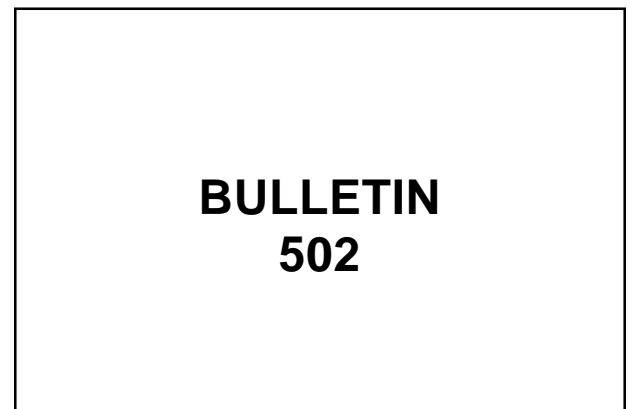

HEAD GASKETS ARE BACK WITH SHORT BLOCKS

Back in 1994 we removed the head gaskets from short blocks. This was done because of thickness differences between the gaskets used on older engines versus newer product. The decision has been made to standardize on the thicker gaskets on most short blocks. This will have very little effect on engine power and will make the short block procedure much simpler. The exceptions will be the medium frame (HM and TVM) 8 and 10 hp engines which will include both gaskets and allow you to select dependent on its original gasket. This will be a running change as inventories are upgraded.



MODEL NUMBER STANDARDIZATION

An effort is being made to standardize on the model number designations used on lightweight vertical shaft engines. In the past this designation has bounced back and forth from horse power to cubic inch displacement. Three more models have been brought into the cubic inch displacement group. The VLV and OVRM series engines are adding a VLV 126 (12.6 C.I./206.5cc) an OVRM 105 (10.5 C.I./172cc) and a OVRM120 (12 C.I./196.7cc). Previous designations used in these Models will not be affected.

VLV 126 (12.6 C.I./206.5cc)

OVRM 105 (10.5 C.I./172cc)

OVRM120 (12 C.I./196.7cc)

TC SERIES CARBURETOR SPACER BLOCK

We repeatedly receive calls from technicians regarding TC series engines not starting after servicing of the carburetor. During these evaluations we usually find one of two things have occurred. The first is an incorrectly installed insulator block causing the vacuum passage to not be aligned with the carburetor. The correct position is to have the impulse hole located in the spacer block facing toward the spark plug end. The transfer passage in the spacer block has to face toward the cylinder. The second is sealant or adhesive blocking the passage from previous improper service. Always check that these passages are open and use new gaskets during service, no sealant or adhesive is needed.

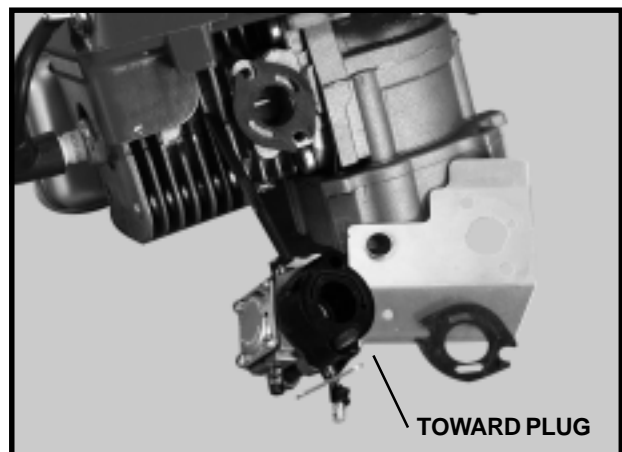

TC EMISSION CARBURETORS

The TC series carburetor has been changed to meet emission standards for E.P.A. hand-held equipment. This upgrade has been made to all service inventory for previously built product as well. When you order a new carburetor, you will receive instructions explaining how to optimize the carburetor settings and install tamper-proof caps.

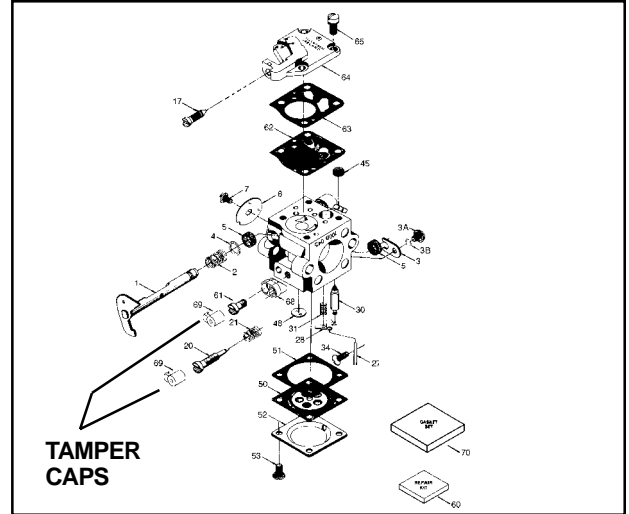

PROPER TRANSAXLE WARRANTY INFORMATION BULLETIN 124

We have been evaluating transaxle warranty claims which we have returned to service dealers for lack of proper information. This evaluation has shown some improvements could be made to our identification tag. We have published and sent all manual holders Bulletin 124 explaining how to locate and read this information. This information reviews both older models and the improvements made to newer I.D. Tags. Tecumseh wants to reimburse our dealers promptly, however, we cannot without proper filing of the **ESA-157R** Claim form. Please supply the needed information when sending in claims.

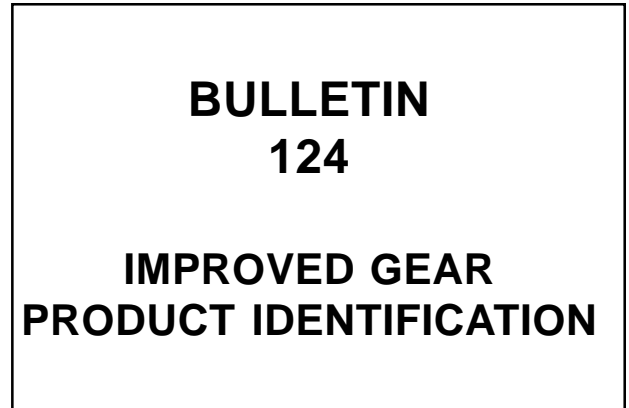

Beginning this March of 1999 Tecumseh is implementing a pilot warranty return program through selected CWD's. This new procedure will return warranty claims **not containing** the needed information through your distributor rather than directly to you. Your distributor will work with you to obtain the needed information and answer any questions, then re-submit the claim signed by the distributor representative for prompt payment.

PROPER SHIFT COLLAR INSTALLATION

We regularly receive calls from technicians regarding proper installation of the shifting key collar on transaxles. The following tips should help you during servicing: Shift collars will generally have one of several variations. If the collar has an offset on one side, the thicker side must face in toward the tips of the shift keys. If the collar has no offset, check to see if there is a recess on the inside diameter. If there is, the recess must face toward the inside. A combination of offset and recess always has both facing in.

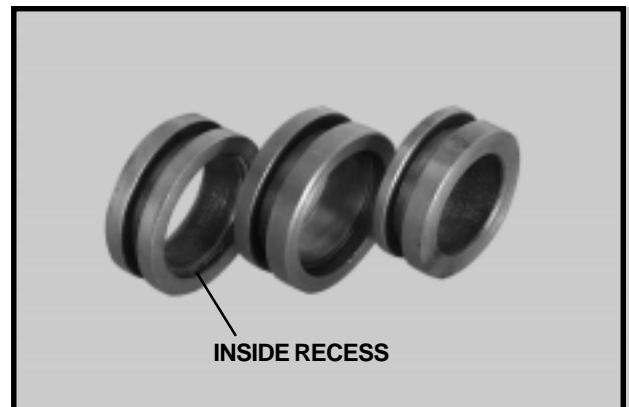

VST DIAGNOSTIC PROCEDURE

The information on the following pages has been provided to help understand the internal operation of the VST. Do not use this information to attempt any internal repairs. Tecumseh's current policy on hydrostatic transaxles that have internal failures is to replace the complete unit. This has not changed. However, Tecumseh would like to provide a failure checklist to assist in making an accurate evaluation of the complete tractor to eliminate any unnecessary replacements. Here is a list of items to check and corrective actions to take.

To properly test the unit for power loss.

1. Allow the unit to cool before trying the following steps.
2. Put the shift lever in a position that is 1/2 of the travel distance from neutral to forward.
3. Place the tractor on a 17 degree grade.
4. Drive the tractor up the grade (without the mower deck engaged). The loss of power experienced should be approximately 20%. This is considered normal. If the loss of power is approximately 50%, this would be considered excessive.
5. Bring the unit to neutral, shift into forward and note the response. Care should be taken to move the lever slowly to avoid an abrupt wheel lift.

To determine if the problem is with the hydro unit, all external problem possibilities must be eliminated. Here are some potential problem areas.

1. **Overheating:** Heat can cause a breakdown in the viscosity of the oil which reduces the pressure used to move the motor. Remove any grass, debris, or dirt buildup on the transaxle cover and / or between the cooling fins and fan. Buildup of material will reduce the cooling efficiency.
2. **Belt slippage:** A belt that is worn, stretched, or the wrong belt (too large or wide) can cause belt slippage. This condition may have the same loss of power symptom as overheating. Typically, the unit which has a slipping belt will exhibit a pulsating type motion of the mower. This can be verified visually by watching the belt and pulley relationship. If the belt is slipping, the belt will chatter or jump on the pulley. If the belt is good, a smooth rotation will be seen. Replace the belt and inspect the pulley for damage.
3. **Leakage:** The VST and 1800 Series have two oil reservoirs which can be checked for diagnostic purposes. The first is the pump and motor expansion bellows, With a small diameter blunt or round nose probe, check the bellows depth through the center vent hole. Proper depth from the edge of that hole is 3-1/4 - 3-1/2 inches (8.25 - 8.9 cm).

The second chamber is for the output gears including the differential. FIRST make sure the tractor is level, then remove the drain/fill plug. NOTE: Some units that do not have differential disconnect will have two plugs. We recommend using only the primary plug. With a small pocket rule insert until you touch bottom of case. You can then remove it and check for 1/4 - 3/8 inches (6.5 - 9.5 mm) contact this is full at its 8 oz. capacity.

4. **Low ground speed:** If the linkage is not synchronized to absolute neutral, or the shift lever is not properly fastened to the tapered control shaft, full forward travel may not be achieved. This may cause a false reading and be misdiagnosed as a low power condition. This also could be caused by the brake not releasing.

To determine absolute neutral, the hole in the tapered control shaft must face straight up and down, at this point make sure the OEM linkage is in neutral. To properly fasten the control lever to the shaft, torque the nut to 25-35 ft. lbs. (34 - 48.3 NM) of torque with the shaft and the lever in neutral.

When attaching the shifter arm to the shaft you must prevent any rotation during torquing. This can be done by placing a long 5/16 bolt in the hole as shown in Illustration. Hold the bolt until the tapers are locked and the nut torque is correct.

To make sure that the brake is not binding, drive the unit up a slight grade. Position the speed control lever into neutral. The unit should coast backwards. If the unit does not coast back slowly, the brake is not released from the brake disk. Adjust the brake linkage to release the brake completely when the foot pedal is released.

5. **Hard to shift:** Typically hard to shift symptoms are not caused by the hydrostatic unit. The shift arm should move with relative ease. Approximately 40-50 inch lbs. (4.48 - 5.6 NM) at the transaxle for foot pedal units or 150-200 inch lbs. (16.8 - 22.4 NM) for hand operated units. This varies depending on the type of linkage. Binding may occur in the linkage connections due to rust or moisture. Lubricating these connections and checking for bent or damaged parts should resolve hard shifting.

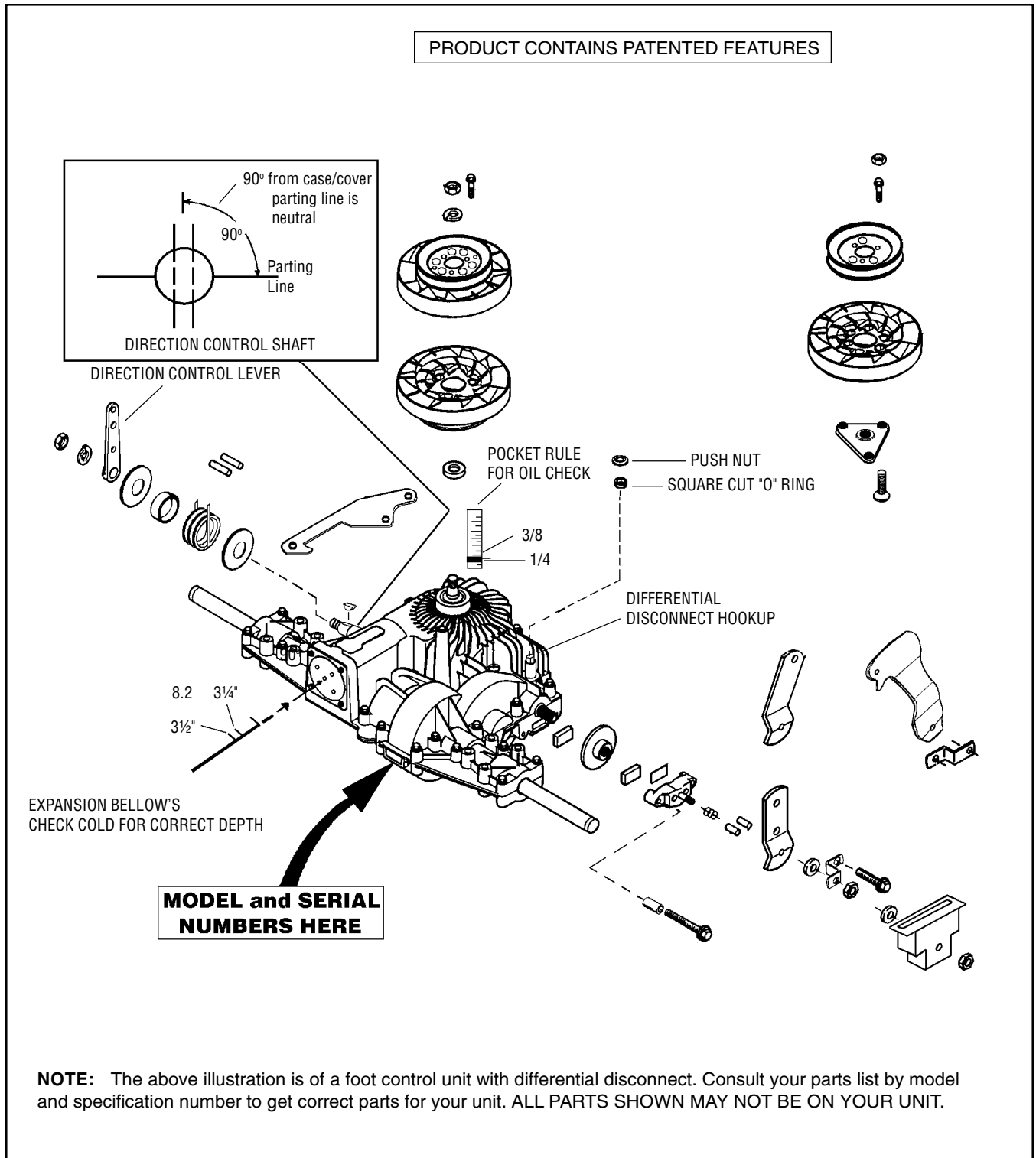

VLV WELCH PLUGS

We have received comments from technicians regarding VLV series engines hunting/surging, running erratic or popping at low speed. The evaluation of these units has revealed some poor sealing idle mixing chamber welch plugs. After first checking the fuel condition, air filter and spark plug, the engine still exhibits one of these conditions. We suggest that while the engine is running you spray the welch plug area with spray carburetor cleaner. If the run quality changes it would indicate a leak around the welch plug requiring repair. Completely clean the welch plug area, then re-seal the plug using fingernail polish which should eliminate the problem. If the run condition does not change when you spray the welch plug area, further inspection will be needed.

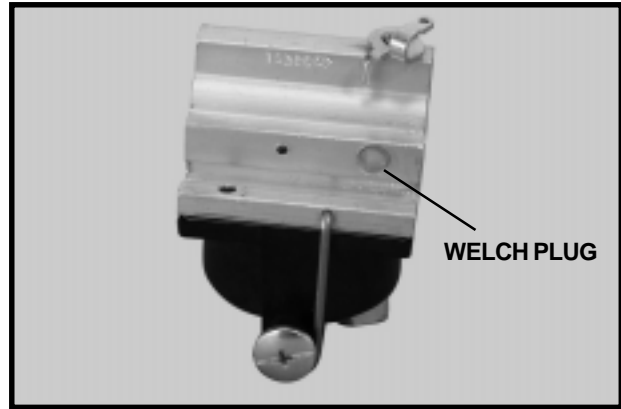

LEV ENGINES MIS-FIRING FIXED LINE TRIMMERS

We have been evaluating field comments regarding LEV engines popping or mis-firing out of the muffler. These particular models of LEV are used on the new fixed line trimmer applications equipped with a remote throttle stop in the control. We have found some production models where the ignition ground tab on the throttle control plate was positioned very close to the blower housing causing intermittent grounding. Should you encounter this condition remove the extra blade from the wire terminal as shown. This is done using a side cutter to trim the extra blade away. This procedure may require the removing of the blower housing to access the speed control.

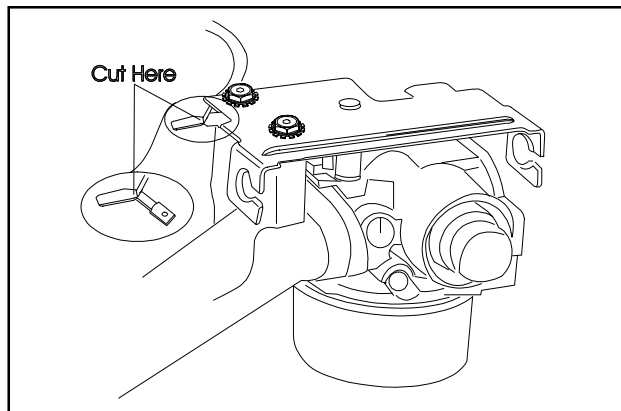

HH AND OH CAST IRON CRANKSHAFT AND CAM GEARS

In an effort to keep parts available for the OH and HH cast iron series engines, we have decided to obsolete the straight cut gears and will make available only crankshafts with helical cut gears. When using this crankshaft to repair older cast-iron units equipped with straight cut crankshaft, camshafts and governor gears, it will be necessary to order new helical cut camshaft and governor gears to match the crankshaft. When repairing the OH Cast Iron series engine you will need a 34751 helical governor gear and 34752 helical camshaft gear. If you are repairing a HH Series engine, order 34691 helical governor gear and 34692 helical camshaft gear.

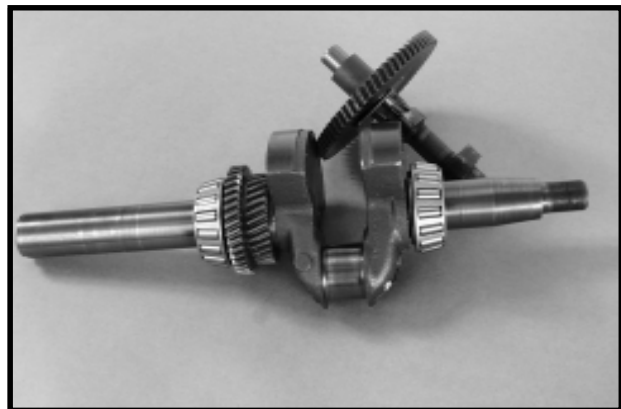

TC AIR GAP REMINDER

We occasionally hear complaints of poor or hard starting TC engines used on post hole diggers, ice augers and cultivator tillers. In addition to the normal checks for fresh fuel, good spark plug and a clean filter, check the CDI ignition module air gap. The TC series uses two different settings dependent on application and model which effect proper ignition timing. All TC200 and 300 rotary mowers applications use a .0125 gap (.317 mm), gap tool 670297. All other TC300 models use a gap of .030 (.762 mm), gap tool 670321.

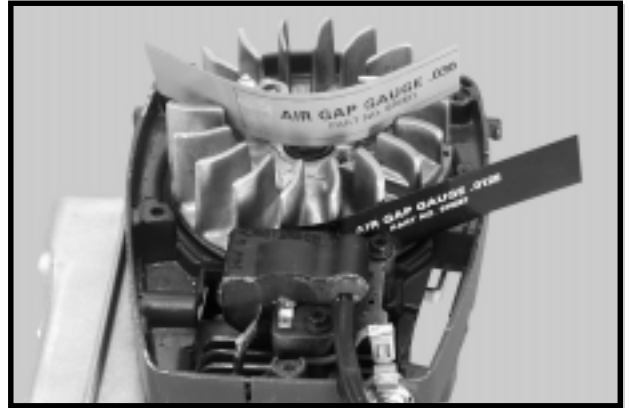

Miscellaneous Product News

SNOW PRODUCTS STARTS

There are times when dealers are confronted with customers who purchase snow equipment when the ambient temperature is above 50° F (10°C) The starting procedures at these temperatures should not require priming the engine. Therefore we have included the number of primes needed to start the engine at different temperature ranges in the operators manual. This will possibly prevent the over priming and flooding of engines at warmer temperatures, and eliminate this situation. The guidelines are as follows. With the choke on and temperatures below 15° F (-9°C) **three primes**, 15° F (-9°C) to 50° F (10°C) **one prime**, and above 50° F (10°C) **zero primes** choke only.

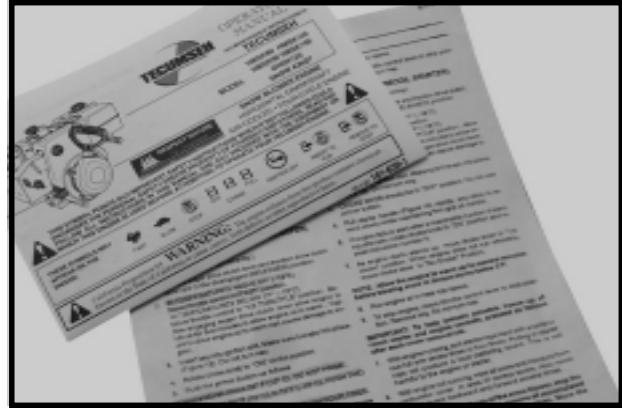

NEW SMART START PACKAGING

This product has been extremely popular in its inaugural year and has established itself firmly in the market place. This was done primarily through the counter display part number **730255**. This fuel stabilizer is now available in a three packet bubble pack display part number **740063**. This product has made fuel stabilization so easy that many consumers and shop owners use it year round, not just for off season storage. Just one packet stabilizes up to 21/2 gallons (10 Litres) of fresh fuel. This dry type stabilizer dissolves rapidly and does not create a mess or stain like many liquid varieties and requires no complicated mixing formulas.

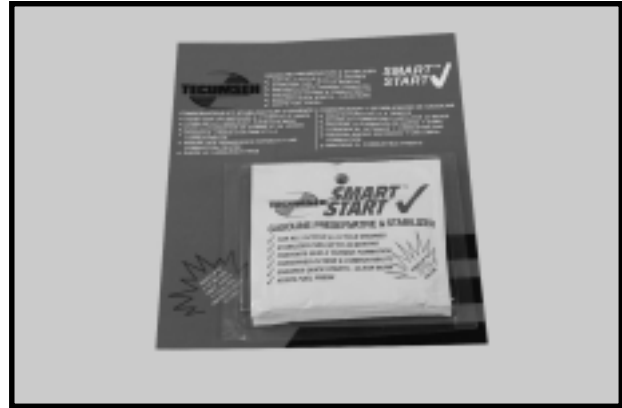

VST REPLACEMENT PROGRAM BULLETIN 307

We have again reviewed the issue of possible field service of the VST series transaxle. We have decided that Bulletin **307** must stay in effect for an indefinite period of time in the United States only. We would like to review some of the key issues that are driving this decision. The VST series transaxles used in this program are manufactured using the following stringent program:

1. Initial review of your warranty claim filed with the unit describing the condition.
2. Complete disassembly, cleaning and inspection of all components.
3. Replacement of any parts not meeting original manufacturing specifications.
4. Reassembly in a clean room environment (dust and dirt free) to original new specifications. Re-filling the pump and motor side with a special synthetic oil used in the aviation industry. All air is removed through a bleeding off process.
5. After re-assembly the unit is pressure tested insuring unit integrity.
6. We then load test the unit checking axle output torque and speed on a special test machine to assure the customer of trouble-free operation. This test bench alone would cost a service center \$20,000 US dollars to duplicate, adding to the complexity of field service.

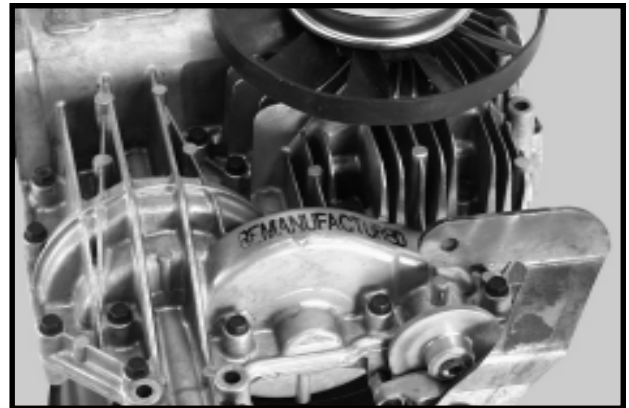
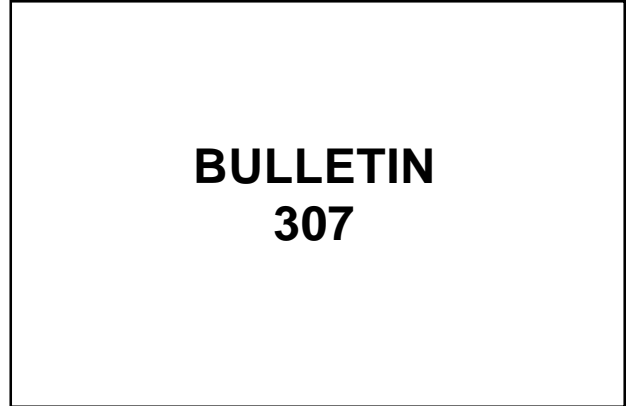

MICROFICHE UPDATES

During the past several months we have increased the number of Microfiche cards per mailing in an effort to keep your data as current as possible. During 1998 you should have received the following card numbers 1, 3A, 3B, 8A, 8F, 9B, 10C, 12A-1, 12B, 16B, 16C, 18B, 18B-1, 18B-2, 24, 24A, 27A, 30, 31, 33, 35, 35A and 35b. We have also sent out an up to date paper version of the index card dated **8/98** with the mechanic's mailing which began in December of 1998. Please use this card to verify that your microfiche is current, should you have any damaged or missing cards please send us a written request only for the needed replacements. If your registration is current we will send you up to two free cards. Should your deck need more than two we suggest you order a new set from your distributor.

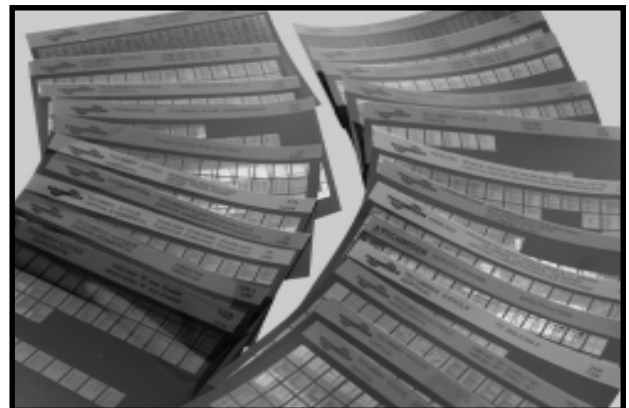

ELECTRONIC PARTS LOOK-UP

Many of you have probably heard that ARI Network Services, owners of Plus One Parts Look-up has purchased Power Com. The acquisition of this company should make available additional data that you may need. Tecumseh Products Company, believes very strongly in healthy competition in all aspects of our industry which helps you keep operating costs down. This acquisition will eliminate our previous concern regarding our competition owning a company we supply our data to. We will continue to supply data to both Parts Smart and Plus One. We suggest you contact both companies to determine which one fits your needs.

The phone numbers are:

Parts Smart **1-800-296-8771**

Plus One: **1-800-755-6040**



ENGINE I.D. BULLETIN 123

With the implementation of emissionized engines, we were required to change the engine identification system we used. This new system has caused many warranty claims to be rejected for a lack of proper information. We have published Bulletin **123** to help you understand the needed information. Please make sure you supply the information so we can reimburse you promptly.

Beginning this March of 1999 Tecumseh is implementing a pilot warranty return program through selected CWD's. This new procedure will return warranty claims **not containing** the needed information through your distributor rather than directly to you. Your distributor will work with you to obtain the needed information and answer any questions, then re-submit the claim signed by the distributor representative for prompt payment.

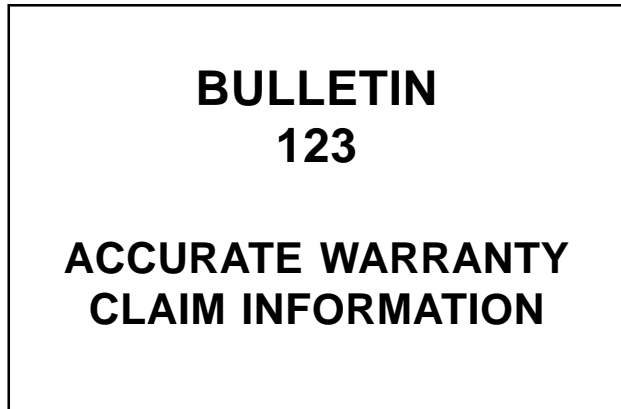

QUICK FIX CARB KIT

This kit was released late this year and we want to remind you of its availability. The part number is 632760 and can be ordered from your normal supplier. This one kit now replaces several previous kits and has been upgraded to include the idle restrictor cap. Please remember this kit does not service the series "7" or the Vector (VLV) non metallic bowl carburetors. When you service a carburetor, please order this kit and always remove and clean all Welch plug cavities before replacing them.

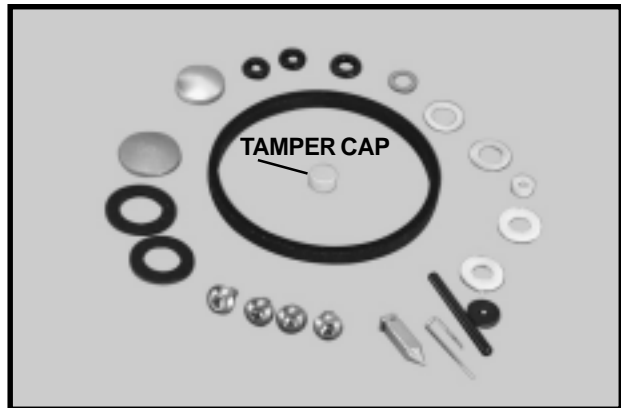

NO METHANOL

We have added a caution to our Owner's Manual regarding a zero tolerance level for any methanol blended fuel or additives. We have reviewed some carburetors returned from service and found the damage to have occurred from methanol based fuel and or fuel dryers. Should the customer feel they need a fuel dryer in their snow product use only isopropyl based dryers at the correct ratio to prevent freeze up. Remember if a little is good a lot is NOT better.

STARTER CLIP BULLETIN 122

In Spring of 1998 we issued this Bulletin **122** regarding starters not engaging principally on rotary mower product. We recently re-sent this to all manual holders. Should you encounter one of these situations, please order part number **590760**. This kit includes a replacement disc to prevent water migration into the starter. Then file an ESA-157R claims with us if warranty applies.

BULLETIN 108

FUEL ADDITIVES

Only fuel additives such as Tecumseh's fuel stabilizer Smart Start™ part number 730245 or liquid varieties can be used when mixed properly. **For winter applications, Isopropyl alcohol** fuel dryers may be used in the fuel system but must be mixed at the proper ratio recommended by the manufacturer.

NEVER USE METHANOL BASED DRYERS.

**BULLETIN
122**

**RECOIL STARTER WILL
NOT ENGAGE WHEN
PULLED**

Europa News

REVISED SOFT PULL STARTER

From production starting September 1998, a revised soft pull starter will be used. Although the design is very similar to existing product, improvements have been made to the housing, the pulley material, design, and the pawls. These improvements have been aimed at improving the durability of the unit, and to improve the way in which the rope is held on the pulley. Individual spare parts for this starter will be made available, and the repair procedures are identical to the existing product which uses the roll pin to secure the pulley to the housing.



STARTER REPAIR KIT

Utilizing the parts used in the new soft pull starter, a repair kit will be made available to service existing soft pull starters. This kit, which is available under part number **16630041**, will consist of pulley, recoil spring and retainer, pawls, pawl springs and retainer, together with new roll pin assembly.



VALVE CLEARANCE CHECK

Since July 1998 the valve clearance on Europa manufactured engines has been revised to the following:

4-cycle vertical shaft side valve (L'head)

0.15-0.25 mm (.006 - .010)

4-cycle horizontal shaft side valve (L'head)

0.10-0.20mm (.004 - .008)

4-cycle OHV engines(vertical & horizontal crankshaft)

0.050-0.15mm (.002 - .006)

Valve clearances are now as shown above irrespective of the decompression system used.

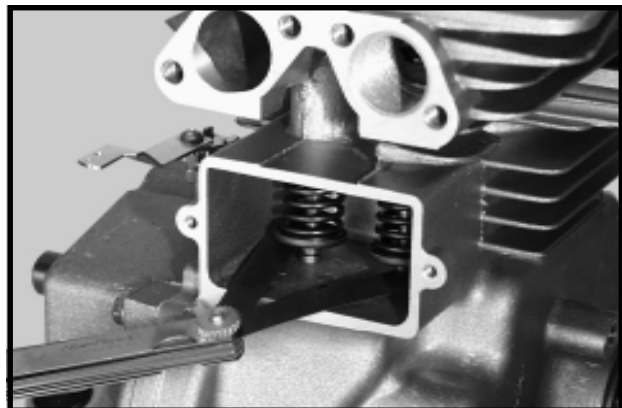

REVISE CAMSHAFT

Over the past 12 months some engines have been equipped with a camshaft manufactured with plastic lobes as well as the plastic timing gear. These camshafts are interchangeable with the standard camshaft. Valve clearances should be set as listed above.

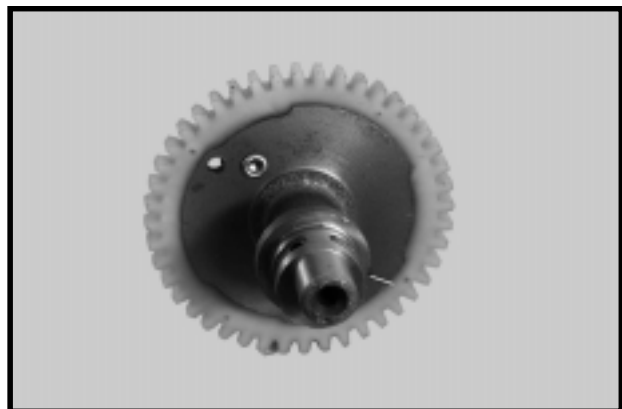

ELECTRIC START ENGINES

Electric start engines are now equipped with a flywheel that features a plastic ring gear in place of the aluminum ring gear that was cast as part of the flywheel. This is more robust than the original but also provides much quieter operation. It is however essential that the clearance between the flywheel ring gear and the starter pinion is set correctly. There should be a clearance of **1/16" (1.6 mm)** between the tip of one tooth and the root of another. This can easily be checked using a sized piece of wire. It is essential to check this clearance when replacing a flywheel that has broken teeth, as it is possible that when the failure occurred, the starter mounting has become distorted, increasing the clearance. Failure to check this clearance will result in premature ring gear failure.

**1/16" (1.6 mm)
Between Flywheel
and Starter**

INLET VALVE OIL SEAL

Most premium engines are now equipped with an inlet valve oil seal which acts as a top valve spring retainer. This seal, which is part number **19610001**, should be replaced whenever it has been removed from the valve stem. The correct installation is shown on the adjacent drawing.



FLYWHEEL ATTACHMENT MV100S ENGINES

Some MV100S engines utilize an adapter collar to locate them to the crankshaft as opposed to the standard flywheel key. The engine specification number will identify which system is used. When reinstalling the flywheel that utilizes this collar, it is necessary to press the collar into the flywheel taper flush to the inside hub before installing the flywheel to the crankshaft. The pressed ridge in the collar will align with the flywheel keyway.



3 AMP CHARGING SYSTEM

Some Futura 60 engines are now equipped with a 3 amp DC charging system to enable the use of an electric clutch. Should the charging be in doubt, it should be checked in the following way.

1. Start the engine and let it run at high speed.
2. Disconnect the engine from the machine's wiring loom by disconnecting the black multi connector.
3. Set the engine speed to 3000 rpm.
4. Check the DC voltage output by connecting a voltmeter between the red wire on the 4-way connector to earth. Minimum reading should be 9.5 volt DC. At this minimum reading the system is working correctly.
- 5: If this minimum reading is not achieved check the AC voltage output by pulling back the sheathing covering the diode and connecting the voltmeter (set on AC scale) between ground and output wire prior to the diode. The reading should be 22 volts AC at 3000 rpm. If this minimum reading is achieved the diode at fault must be replace.
6. If this minimum reading is not achieved than the alternator coils are at fault and require replacement.
7. Do not forget to reconnect the connector to the machine wiring harnes when repair has been completed. (If the machine still exhibits electrical problems and the charging system checks out OK, then the machine should be checked for a poor battery, poor connections, failed relays etc).

ENGINE IDENTIFICATION

Starting September 1997 all Tecumseh Europa engines were identified by an adhesive label affixed to the blower housing. The actual positioning of this label varies according to engine model. On vertical shaft engines it can usually be found on the oil filler side towards the spark plug. On horizontal shaft engines it can usually be found adjacent to the spark plug. A sample of this label is shown opposite. These labels are in addition to the existing information stamped on the crankcase.

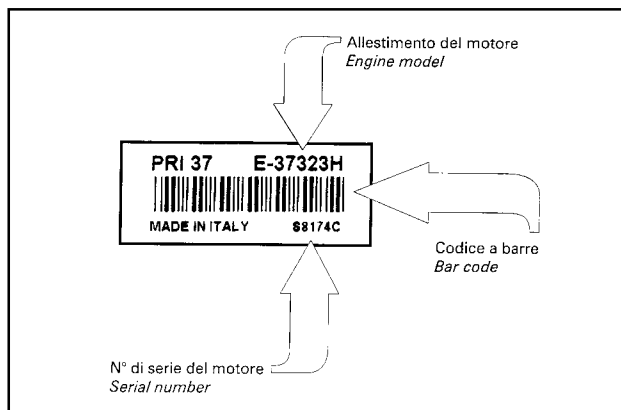
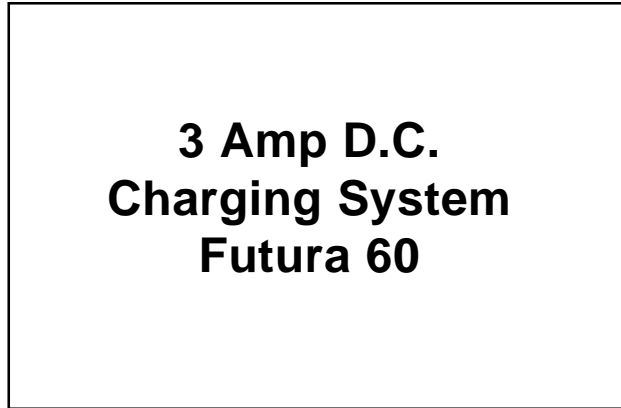

CATALYTIC CONVERTERS

Many of our engines can now be specified with catalytic converter which takes the form of a tablet or wire mesh which is installed within the muffler. These mufflers can be identified by the word "KAT" pressed into them. As with automotive catalytic converters, it is necessary to follow certain ruler if the catalytic converter is to remain effective for a reasonable period. Obviously the customer must be advised only to use unleaded fuel. In addition they should be made aware that the engine should not be over-filled with oil, or tipped in a way to allow oil to flood into the combustion chamber (spark plug down). Catalytic equipped engines are only supplied with primer carburetors, but the customer should also be made aware of the danger of unnecessary over-priming of the engine. With a little care the catalytic converters will be effective for many seasons.



CONNECTING ROD

The connecting rod used in our European manufactured engines ranging from 3.7 - 5.5 HP has been modified in the following areas.

1. Added oil feed channel to the beam of the connecting rod.
2. Added chamfer to the connecting rod/cap parting line.
3. Added oil groove to connecting rod cap.

This is a running change to service part numbers **16110010** and **16110011** and will occur as inventories change.

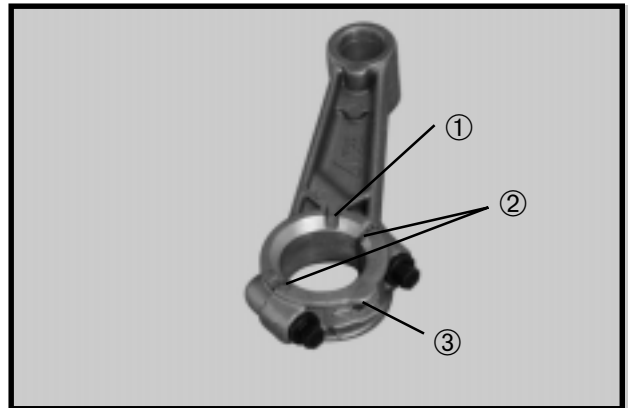

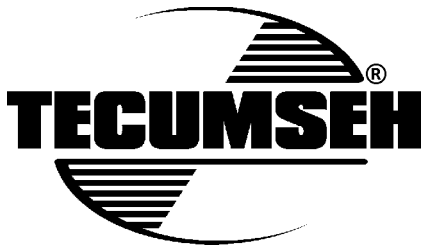

SERVICE
BULLETIN
108
INFORMATIONAL

ISSUED: May 1971

REVISED: October 1998

SUBJECT: Gasoline and Engine Oil Recommendations for 2 and 4-Cycle Engines

GASOLINE

Tecumseh Products Company strongly recommends the use of fresh, clean, unleaded regular gasoline in all Tecumseh engines. Unleaded gasoline burns cleaner, extends engine life, and promotes good starting by reducing the build-up of combustion chamber deposits. Leaded gasoline, gasohol containing no more than 10% ethanol, premium gasoline, or unleaded gasoline containing no more than 15% MTBE (Methyl Tertiary Butyl Ether), 15% ETBE (Ethyl Tertiary Butyl Ether) or 10% ethanol, can be used if unleaded regular gasoline is not available.

Reformulated gasoline that is now required in several areas of the United States is also acceptable.

NEVER USE gasoline, fuel conditioners, additives or stabilizers containing methanol, gasohol containing more than 10% ethanol, unleaded regular gasoline containing more than 15% MTBE (Methyl Tertiary Butyl Ether), 15% ETBE (Ethyl Tertiary Butyl Ether) or 10% ethanol, gasoline additives, or white gas because engine/fuel system damage could result.

See "STORAGE" instructions in Technician's Manual, Operator's Manual, or Bulletin 111.

For year round fuel stability in and out of season, use "Smart Start" part number 730245.

FUEL ADDITIVES

Only fuel additives such as Tecumseh's fuel stabilizer Smart Start™ part number 730245 or liquid varieties can be used when mixed properly. **For winter applications, Isopropyl alcohol** fuel dryers may be used in the fuel system but must be mixed at the proper ratio recommended by the manufacturer. **NEVER USE METHANOL BASED DRYERS.**

OILS

2-CYCLE

Tecumseh two cycle engines require the use of a NMMA TC-W3 or TC-WII certified oil.

TECUMSEH RECOMMENDS USING TWO CYCLE OIL PART #730227, which is a premium blend that ensures cylinder wall lubrication, mixes easy, does not separate and is specially formulated for use in air or water cooled two cycle engines.

The proper fuel mixture ratio of oil to gasoline for specific engines will be found in the owners operating instructions and on the decal attached to the blower housing or fuel tank of the engine.

FOR NEW ENGINES: USE TWICE THE NORMAL OIL QUANTITY FOR THE FIRST GALLON OF FUEL ACCEPT ON TC SERIES WHERE THE STANDARD MIX RATIO IS SUFFICIENT.

4-CYCLE

TECUMSEH FOUR CYCLE ENGINES REQUIRE THE USE OF A CLEAN, HIGH QUALITY DETERGENT OIL. Be sure original container is marked: A.P.I. service "SF" thru "SJ" or "CD".

TECUMSEH RECOMMENDS USING ONE OF THE FOLLOWING FOUR CYCLE OILS THAT ARE SPECIALLY FORMULATED TO TECUMSEH SPECIFICATIONS.

DO NOT USE SAE10W40 OIL.

FOR SUMMER (Above 32°F) USE SAE30 OIL. PART #730225

(SAE10W30 is an acceptable substitute.)

Use SAE30 oil in high temperature, high load applications. Using multigrade oil may increase oil consumption.

FOR WINTER (Below 32°F) USE SAE5W30 OIL. PART #730226

(SAE10W is an acceptable substitute.)

(BELOW 0°F ONLY): SAE0W30 is an acceptable substitute.

NOTE: For severe, prolonged winter operation of HH120 model, SAE10W oil is recommended.



**SERVICE
BULLETIN
110**

INFORMATIONAL

ISSUED: May 1985

REVISED: July 1997

SUBJECT: High Altitude Carburetor Kits for Fixed Main Carburetors

Engines built to O.E.M. specifications may experience starting and operating problems when used in areas of the country where the altitude is four thousand feet above sea level or higher. A leaner fuel/air mixture is more desirable at higher elevations to sustain good engine startability and operating characteristics. Engines built with adjustable idle and main circuit carburetors can be adjusted (or fine tuned by adjusting).

The following will assist you in selecting the correct high altitude/leaner jetted bowl nut for engines equipped with fixed main or dual system carburetors. Order your requirements from your source of supply.

4 CYCLE

ENGINE	STANDARD BOWL/NUT STAMPED	Over 4,000 Ft.
LEV115	Jet	*
TVS90-120/ECV90,100/TNT100	64, 65, 75, 79, 103,- 108, 126, 127, 137	632455
TVS90-120 / OHH50 / 55	158, 161, 164, 165, 166, 171, 172, 177	632737
TVS90 -120, OVRM40-60	124, 125,133, 135, 136	631026
OVM & OVXL120, OHV11-13 (Formula)	120, 141	632239
Dellorto	69	633017
VLV40, 50, 55, 60, 65, 66	Jet	632648
VLV40, 50, 55, 60, 65, 66	Nozzle	632638
TVM170-195	83, 132	632239
TVM220	109, 131	631973
OHV15 - Walbro LMK26	Jet	632688
OHV11 - 17 (Enduro)	Jet	*

2 CYCLE

AH/AV520 & 600, HSK600	101	632368
TVS/TVXL840	L118, L119	632463
HSK840, 845, 850/HXL840	124, 125	631026
TC200/TC300 Tillotson carburetor only.	Jet	632940
TC200/TC300 Tillotson HU112 and HU114	Jet	N/A

Do Not install leaner jetted bowl nuts on engines used below four thousand feet as starting and operating problems will occur. **WARRANTY DOES NOT APPLY.**

NOTE: Engines which are identified as compliant with CARB (California Air Resources Board) or EPA (US Environmental Protection Agency) regulations can NOT be changed from the factory unless specifically authorized.

* Altitude compensation not required due to use of emissions type carburetors.

**SERVICE
BULLETIN
122
INFORMATIONAL**



Issued: June 1998

Subject: RECOIL STARTER WILL NOT ENGAGE WHEN PULLED

Models Affected: Small Frame (3 thru 6 HP) Horizontal and Vertical Engines with DOM 7335 thru 8150

If you have experienced an occasion where the recoil starter will not engage when the rope is pulled, a simple repair may solve the problem. This repair will only affect starters that have the white plastic locking tab located in the top/center of the starter. The locking tab may be covered by a round protective decal or could be located in the recoil under a decorative cover. The decorative cover will have to be removed to allow for repair. However, it is not necessary to remove the recoil starter from the engine to make the repair.

To make the repair you need to remove the protective decal to expose the white plastic locking tab. Use a small flatblade screwdriver or needlenose pliers to pry up on the tab and remove it from the starter. Discard the old tab and replace it with a new metal locking tab part #590760, which also includes a new protective decal. Press the new metal locking tab down into the retainer until it snaps into place. Place the new protective decal over the tab hole to prevent any water or debris from entering the starter.

This procedure and paperwork should take approximately 15 minutes to complete. An ESA 157R warranty claim form should be filed through normal channels.

OLD

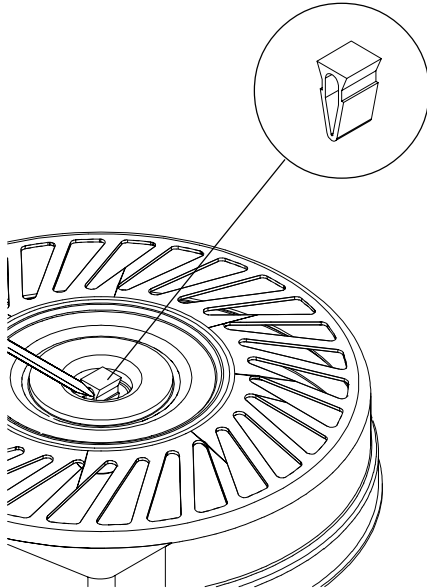

NEW

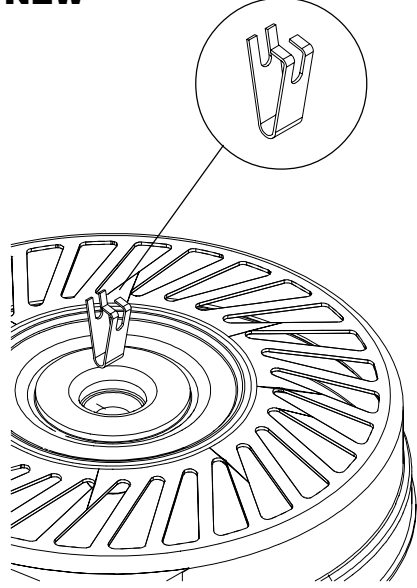

**SERVICE
BULLETIN
123**

INFORMATIONAL

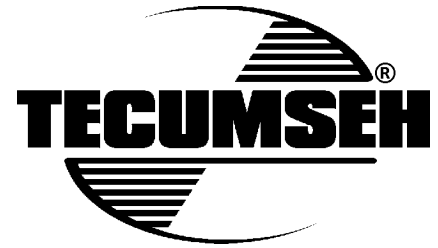

ISSUED: SEPTEMBER 1998

SUBJECT: ACCURATE WARRANTY CLAIM INFORMATION

Models Effected:All Models

In a recent audit of claims submitted from January through July of this year we have learned that almost 20% of the total claims have been returned to dealers due to lack of accurate information. Further research has identified that the majority of these returns are due to lack of or incorrect information being submitted in "Box 5", "D.O.M. or Serial No". Most often, the incorrect information furnished is the engine Family number sequence. The correct information to submit is the D.O.M. or date of manufacture or Engine serial number from the Engine I.D. label. See Example"

Example of "Box 5" ESA157R Claim Form

Model ENGINE:TVM195	Specification 150288G	Serial (DOM) 8150C
5) ENGINE/TRANSMISSION SPEC NO. D.O.M (SERIAL NO)		
TVM195	150288G	8150C

Typical Engine I.D. Label

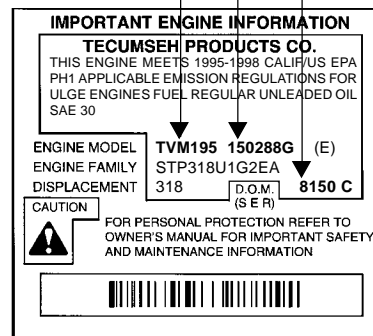

All claim information is extremely important for record keeping purposes. In fact, any missing or incorrect information results in the claim being returned. We ask that you help us by furnishing accurate and correct information in "Box 5" and all the other "Boxes" on the claim form.

Failure to help in this effort results in added expense and work for you and Tecumseh. It also results in delayed payments to you and that affects your receivables. Lastly, unless we can eliminate claims submitted with lack of accurate information we may consider having your Tecumseh source of supply receive your claims for editing prior to submitting claims to Tecumseh.

**SERVICE
BULLETIN
124**

INFORMATIONAL

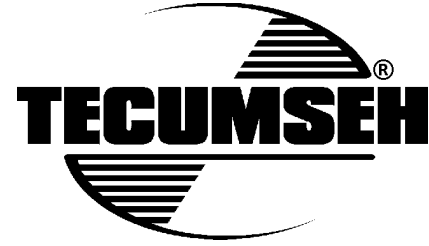

ISSUED: September 1998

SUBJECT: Improved Gear Product Identification

MODELS OR TYPES AFFECTED: All Models

The recent warranty audit referenced in bulletin number "123" suggested we review the way our new Tecumseh/Peerless® models are identified. That review found improvements where needed in the identification system to make them standard with the new emission regulation's requirements covering engine product and the "New ESA 157R Claim Form".

As a result of this review, we have changed the product ID tag to make it easier to read. Should this data be needed for service or warranty situations these improvements will make locating the needed model and specification information easier.

Example Numbers 1 and 2 below, show the present bar code labels currently being used. We have identified the important fields of information that is required for warranty claims.

In addition, a new easier to read bar code label (No. 3 below) is being introduced on all units provided after October 1, 1998. Again we have highlighted the information you are required to supply.

This information is critical for prompt warranty reimbursement to your shop, please pay close attention to this number.

MODEL NUMBER REQUIRED FOR WARRANTY

SPECIFICATION NUMBER REQUIRED FOR WARRANTY

PEERLESS 205 - 027C TECUMSEH

MODEL DATE SERIAL



205 - 027C8194A0048

D.O.M. (DATE OF MANUFACTURE)
ORIGINALLY SERIAL NUMBER

1

MODEL NUMBER REQUIRED FOR WARRANTY

SPECIFICATION NUMBER REQUIRED FOR WARRANTY

PEERLESS MST - 206 - 502A

DATE MFG. SERIAL NO.



6304A00013

D.O.M. (DATE OF MANUFACTURE)
ORIGINALLY SERIAL NUMBER

2

MODEL NUMBER REQUIRED FOR WARRANTY

SPECIFICATION NUMBER REQUIRED FOR WARRANTY

PEERLESS VST - 205 - 020C

MODEL SPEC

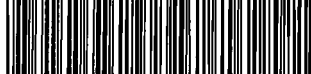

D.O.M.
7070A - 0005

D.O.M. (DATE OF MANUFACTURE)
ORIGINALLY SERIAL NUMBER

"NEW TYPE"

3



SERVICE
BULLETIN
307
PEERLESS

ISSUED: October 1997

SUBJECT: Peerless® Model VST 205 **WARRANTY** Replacement Program

The Service and Engineering groups of Tecumseh have reviewed extensively the servicing of the VST 205 Hydrostatic Transaxle. After review of the complex issues of servicing this unit, we have decided on a unique approach for Tecumseh to handle IN WARRANTY servicing by complete replacement, if needed, with factory furnished units. These units may be Tecumseh re-manufactured units or new units at our discretion.

Effective November 15, 1997, the following procedure is to be followed by all Authorized Tecumseh Service Centers if an Internal Failure occurs WITHIN THE WARRANTY PERIOD. We are enclosing the revised Warranty Policy reflecting this change.

1. Be sure you have reviewed the trouble shooting section of the Peerless® Technicians Handbook, No. 691218, to insure the problem is internal and not a linkage problem. All external components serviceable previously such as pulley, brakes, and levers are still serviceable as before.
2. If you have identified the trouble as internal, contact your distributor for replacement authorization under the normal warranty authorization procedure.
3. You will then need to look up the replacement transaxle using the attached list of replacements or the parts look up system you have chosen (i.e., microfiche, computer or paper). NOTE: Place an "R" on the end of the service replacement part number when ordering from your normal source. The unit will be shipped N/C with freight prepaid direct to your dealership. Example: Part #794667 (R). If your replacement model had an "A" suffix, change it to an "R" as referenced.
4. Ordering is done through your normal source of supply. DO NOT attempt to combine any "R" number with a regular order. Only the "R" will be shipped N/C Prepaid. Any added orders will be kicked out (not shipped).
5. You then file your **DISTRIBUTOR AUTHORIZED, COMPLETELY FILLED OUT** ESA157 warranty claim with us for the R&R of the transaxle. Upon receipt of the warranty claim in Grafton, Wisconsin, Tecumseh will issue a recall tag through UPS to pick up the unit for return to us.
6. When your claim is matched up with your returned transaxle, we will process it for prompt payment.
7. Before returning the defective transaxle, place a COPY of the ESA157 warranty claim in the original box, which should be used for return shipment of the transaxle.
8. This program will be in effect for the United States only.

We appreciate your assistance in this warranty replacement procedure.



SERVICE
BULLETIN
308
PEERLESS

ISSUED: December 1998

SUBJECT: Hydrostatic Transaxle Shift Force

MODELS AFFECTED: VST205

We have made a change to the VST series transaxle cover. This allows for external adjustment if necessary, of the shift force required to move the control lever. This adjustment can be accomplished on all "C" series and later model units. To determine if this adjustment can be made on the unit in for repair, locate the ID tag as shown in the illustration below.

When a "C" or newer unit is found, use the adjustment procedure as outlined below. **Remember to disconnect and check the equipment linkage first, before performing this adjustment or replacing the transaxle on early production units.**

TO ADJUST MOTION CONTROL LEVER (See Insert)

The motion control lever has been preset at the factory and adjustment should not be necessary. If for any reason the motion control lever will not hold its position while at a selected speed or is difficult to move, it may be adjusted as follows:

- Park tractor on a level surface. Stop tractor by turning key to the "OFF" position and engage parking brake.

NOTE: The transmission should not be warm when making this adjustment. Allow it to cool to room temperature before making this adjustment.

The plug may be accessible through the battery box area, however, each manufacturer may be different.

If access can be gained through the battery area, it will be necessary to remove the battery and the battery box from the tractor.

The most extreme case may require transaxle removal from the frame.

- Raise the seat and open battery box door. Disconnect BLACK battery cable first, then the RED cable.
- Remove battery and battery box from tractor.

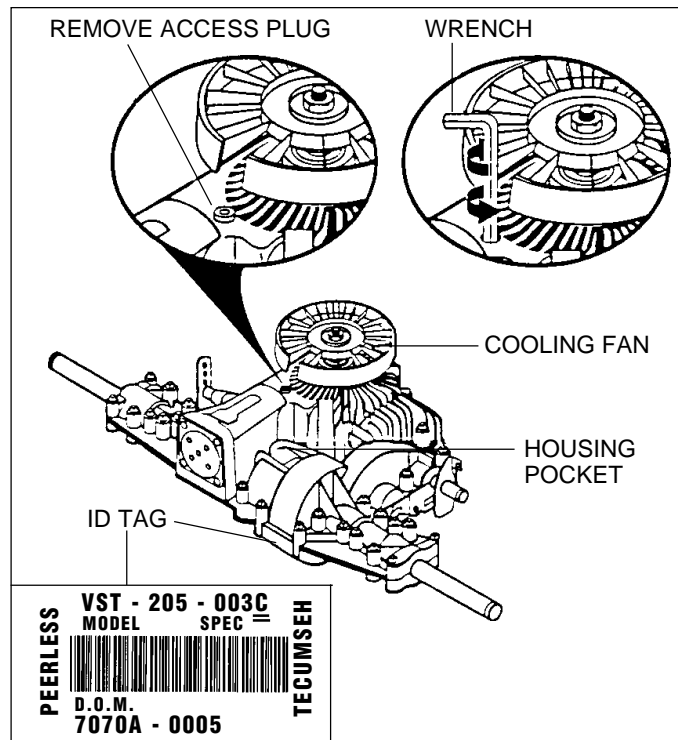

(continued on next page)

**SERVICE
BULLETIN
308 (Cont.)
PEERLESS**



NOTE: When reinstalling battery box, ensure that battery acid drain tube is routed toward the rear and is clear of the cooling fan.

- Locate the access plug under the cooling fan. This plug and surrounding area must be cleaned to prevent contamination of internal parts during this procedure. Before removing the plug, pack a cloth in the housing pocket to absorb excess oil.
- Clean the bellows cover plate.
- Place a piece of masking tape over the hole located in the center of cover plate. This will prevent air from entering the bellows area when access plug is removed, and prevent oil from coming out access hole when plug is removed.
- Using a needle nose pliers, remove the access plug described above. When the plug is removed, a small quantity of oil will flow out of the transaxle. This is normal and will not effect its function.
- Insert a #30 torx or 5/32 allen wrench into the access hole and locate the adjustment screw. Adjust the screw clockwise 1/4 turn at a time to increase motion control effort.

NOTE: If for any reason the effort to move the motion control lever becomes too excessive, reverse the above procedure by turning the adjustment screw counterclockwise 1/4 turn.

- Clean the access plug and insert it into position using the torx or allen wrench.
- Clean spilled oil from transaxle and reinstall battery box and battery into tractor. When connecting battery be sure to connect the RED battery cable first.
- An effort of 150-200 in-lbs. of torque to move the transaxle motion control lever is required for hand control units and an effort of 40-50 in-lbs. of torque to move the transaxle motion control lever on foot control units.
- An effort of 15 - 18 lbs. at the motion control lever knob is normal.

Road test tractor after adjustment and repeat procedure if necessary.

NOTE: The neutral spring must be removed to check the force on foot pedal control units.

**SERVICE
BULLETIN
406
4 CYCLE**

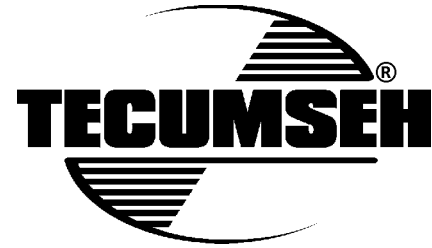

ISSUED: October 1998

SUBJECT: Smoking Out of Muffler on Initial Start Up

MODELS AFFECTED: VLV 50 through 66

SERIAL NO'S AFFECTED: 7002 through 7128

We have received comments from the service system regarding instances of NEW VLV model engines exhibiting smoke from the muffler during initial engine operation. These instances of smoke from the muffler in a new engine may be caused by storage or shipment with the spark plug pointing down.

BEFORE performing the procedure below please make sure the engine has been run for at least 30 minutes to burn out any oil residue inside the muffler. If the smoking continues after this time period proceed below.

After investigation we have determined the cause of the smoking. This is the result of an irregular casting surface in the valve spring box, which does not allow proper seating of the seal allowing oil to pass.

PROCEDURE:

1. Remove the muffler, cylinder head and valve box cover.
2. Remove the Intake valve spring, valve and seal.
3. Install the NEW valve stem seal part no. 40016A as shown (see illustration).
4. Replace the cylinder head gasket part no. 36061 and valve box cover gasket part no. 27234A.
5. Re-torque the cylinder head to 180-220 inch Lbs following the sequence below.
6. A kit containing all the above parts can be ordered under part no. **730617**.

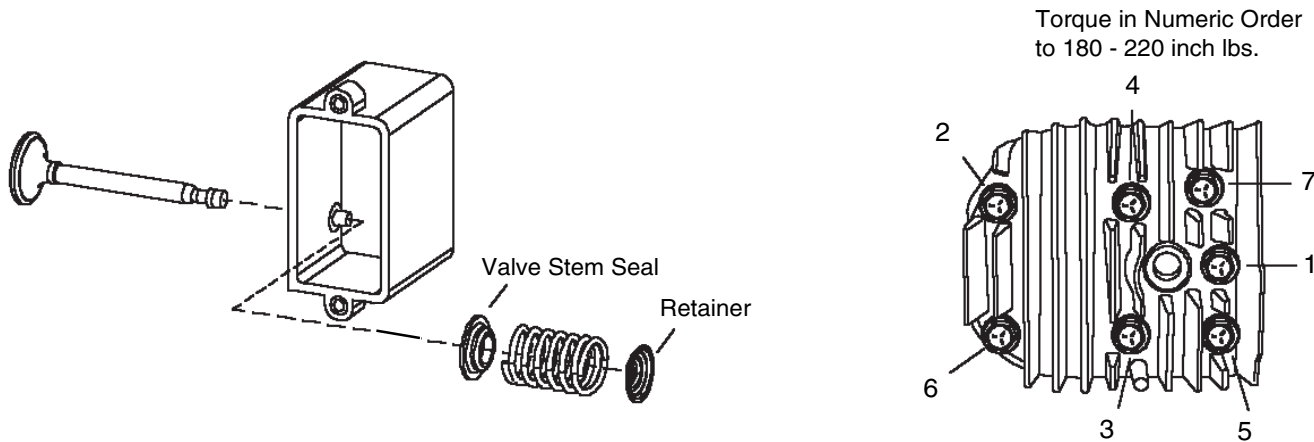

The time to perform this repair procedure is typically 45 minutes. We thank you in advance for correcting this problem and request you submit a claim to us for reimbursement.

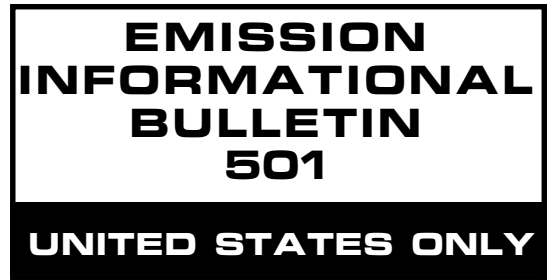

Date Issued: June, 1998

Family: STP185U1G1RA

Engine Model(s) Concerned: LEV115

D.O.M. (s) Affected: 8091-8166

Tecumseh Products Company, in cooperation with California Air Resource Board (CARB) and the US Environmental Protection Agency (EPA), needs your assistance.

Potential Emission Control System Problem:

The testing of engines manufactured in compliance with these regulations has identified a potential emission control system problem. The potential area of concern (outlined below) should be inspected when equipment is received for normal servicing.

Should the inspection reveal the engine has the concern outlined, repair the unit as instructed. After completion of the repair, file for warranty reimbursement, using the ESA 157R claim form.

Affected specifications numbers are:

350007A,B,C,	350010B,	350013B,	350041B,C,	350042C,	350063C,
350064C,	350075C,	350083C,	350086C,	350087C,	350089C,
350098C,	350099C,	350110C,	350112C,	355001A,	355003A,B,C,
355004B,	355010C,	355011C,	360002A,	360003A,	360004A,
360006A,	360009A,B,	360010B,	360011B,	360017B,	360018B

Warranty Inspection and Repair Procedure:

Inspect models in stock or that come in for service to determine high speed bowl nut number (stamped on bottom).

If stamped with #174, replace high speed bowl nut with #169 (part number 640087).

If stamped with #169, no change is required.

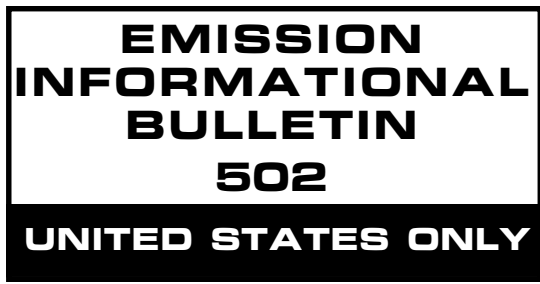
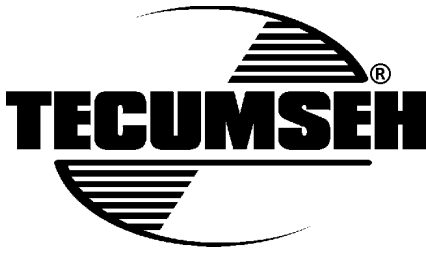

Date Issued: August, 1998

Family: TTP156U1G1EB

Engine Model(s) Concerned:
Compact H35 & H40

D.O.M. (s) Affected:
8079-8201

Tecumseh Products Company, in cooperation with California Air Resource Board (CARB) and the US Environmental Protection Agency (EPA), needs your assistance.

Potential Emission Control System Problem:

The testing of engines manufactured in compliance with these regulations has identified a potential emission control system problem. The area of concern (outlined below) should be inspected when equipment is received for normal servicing or if the customer complains of poor engine performance.

Should the inspection reveal the engine has the concern outlined, repair the unit as instructed. After completion of the repair, file for warranty reimbursement, using the ESA 157R claim form.

Affected specifications numbers are:
H35-45690Z, H35-45726Z, H40-55701A

Warranty Inspection and Repair Procedure:

Should you have one of the above mentioned units please check for previous repair. This is accomplished by locating the carburetor model number as shown (see illustration.) If the carburetor model number is **5015** it will be necessary to replace the carburetor.

If the engine has already been repaired the carburetor model number **5161** will be present in the same location, and this **bulletin does not apply**.

To complete the repair order replacement carburetor number **640172** from your usual source of supply. The usual time for this repair is 30-45 minutes which includes completely filling out the ESA 157R warranty claim.

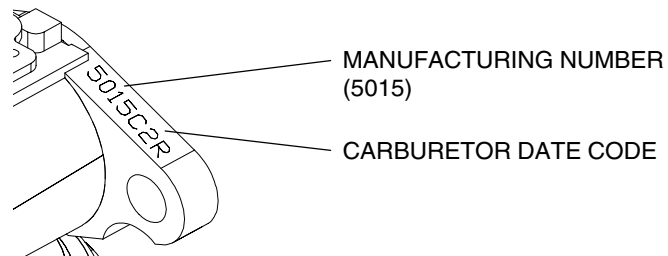
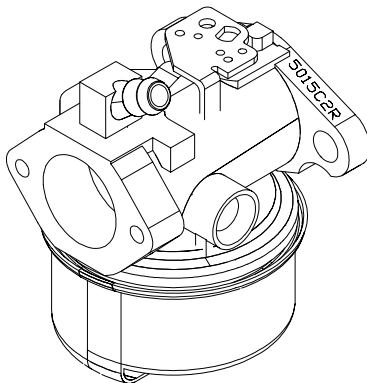



Engine Service Association, Inc. WARRANTY CLAIM

NO. SAMPLE

2 WARRANTY CODE NO.

PLEASE TYPE OR PRINT CLEARLY

1 TYPE OF CLAIM (CHECK ONLY ONE)

Warranty Repair New Defective Service Parts
 Policy Adjustment Questionable/Disputed

FOR

Kohler
 Tecumseh
 US Motor Power

3 OWNER'S LAST NAME _____ **COMMERCIAL USER**
 YES NO

FIRST _____ MI _____

ADDRESS _____

CITY _____ STATE _____

PHONE _____ ZIP _____

Customer Signature _____

5 Engine/Transmission Short/Block/Model No. _____	Spec. No. _____	D.O.M. or Serial No. _____
Equipment Manufacturer _____	Type of Equipment _____	Engine Received <input type="checkbox"/> Mounted <input type="checkbox"/> Detached

8 PARTS HAVE BEEN

Returned to Factory Returned to Central Retained & Tagged

9 DEFECTIVE PART NUMBER _____ **10 FAILURE SUFFIX** _____

4 WARRANTY PERFORMED BY CD SD DEALER

Firm Name _____

Address _____

City _____ State _____

Phone _____ Zip Code _____

Signed _____

Purchased Date			Failure Date			Repair Date		
Mo.	Day	Yr.	Mo.	Day	Yr.	Mo.	Day	Yr.

6 HOURS USED _____ **7 UNIT ORIGINALLY SOLD BY** _____

FAILURE SUFFIXES

AW- Assembled Wrong	FM- Foreign Material	SD- Shipping Damage
BC- Broken/Cracked	IF- Improper Fit	SG- Scored/Galled
BL- Blown	LK- Leaked	SS- Stuck/Seized
BT- Bent/Twisted	MI- Missing	ST- Stripped
CD- Porous/Casting Deficiency	ML- Magnet Loose	UO- Unknown/Other
CL- Came Loose/Off	NA- Not Seating	VC- Valve/Clearance
CP- Corroded/Pitted	NY- Noisy	WN- Worn
EF- Electric Failure	OA- Out of Adjustment	WP- Wrapped
	PM- Part Made/Machined Incorrectly	

11 Condition Found/Probable Cause of Failure (Word "Defective" Not Sufficient)

12 Job Number/Work Performed. If Necessary to Remove & Replace (R&R) Engine from Equipment, then Show R&R Separately.

13 Miscellaneous	Dollars	Cents
Freight/Postage Allowance Attach Freight Bill		

14 Labor	HRS.	MINS./TENTHS	JOB #
Repair 1			
Repair 2			
Repair 3			
Misc. Labor			
R & R			
TOTAL			

16 Part Number	Qty.	Description

15 FACTORY USE ONLY

OEM Code _____

Defect Code # _____

End Use Code # _____

Division _____

17 Engine/Short Block/Transmission (Authorized Signature)

Authorized By: _____

Firm Name: _____

ENGINE I.D. BULLETIN 123

With the implementation of emissionized engines, we were required to change the engine identification system we used. This new system has caused many warranty claims to be rejected for a lack of proper information. We have published Bulletin **123** to help you understand the needed information. Please make sure you supply the information so we can reimburse you promptly.

Beginning this March of 1999 Tecumseh is implementing a pilot warranty return program through selected CWD's. This new procedure will return warranty claims **not containing** the needed information through your distributor rather than directly to you. Your distributor will work with you to obtain the needed information and answer any questions, then re-submit the claim signed by the distributor representative for prompt payment.

BOX 5 ENGINE/TRANSMISSION INFORMATION:

Enter the entire model, specification, serial (DOM) number of the engine/transmission being repaired. When a repair is performed to a short block, enter the short block model and serial number. Check the appropriate box to indicate if the equipment was received mounted or detached from the OEM's equipment.

EXAMPLES:

	MODEL	SPECIFICATION	SERIAL (DOM)
ENGINE:	TVS115	61601	3240J
TRANSMISSION:	930	011	3071-7308
SHORT BLOCK:	SBV	2308	1198F

5 Engine/Transmission Short/Block/Model No.	Spec. No.	D.O.M. or Serial No.
	61601	3240J
Equipment Manufacturer	Type of Equipment	Engine Received
MTD	Rotary L.M.	<input checked="" type="checkbox"/> Mounted <input type="checkbox"/> Detached

Starter No. 37102

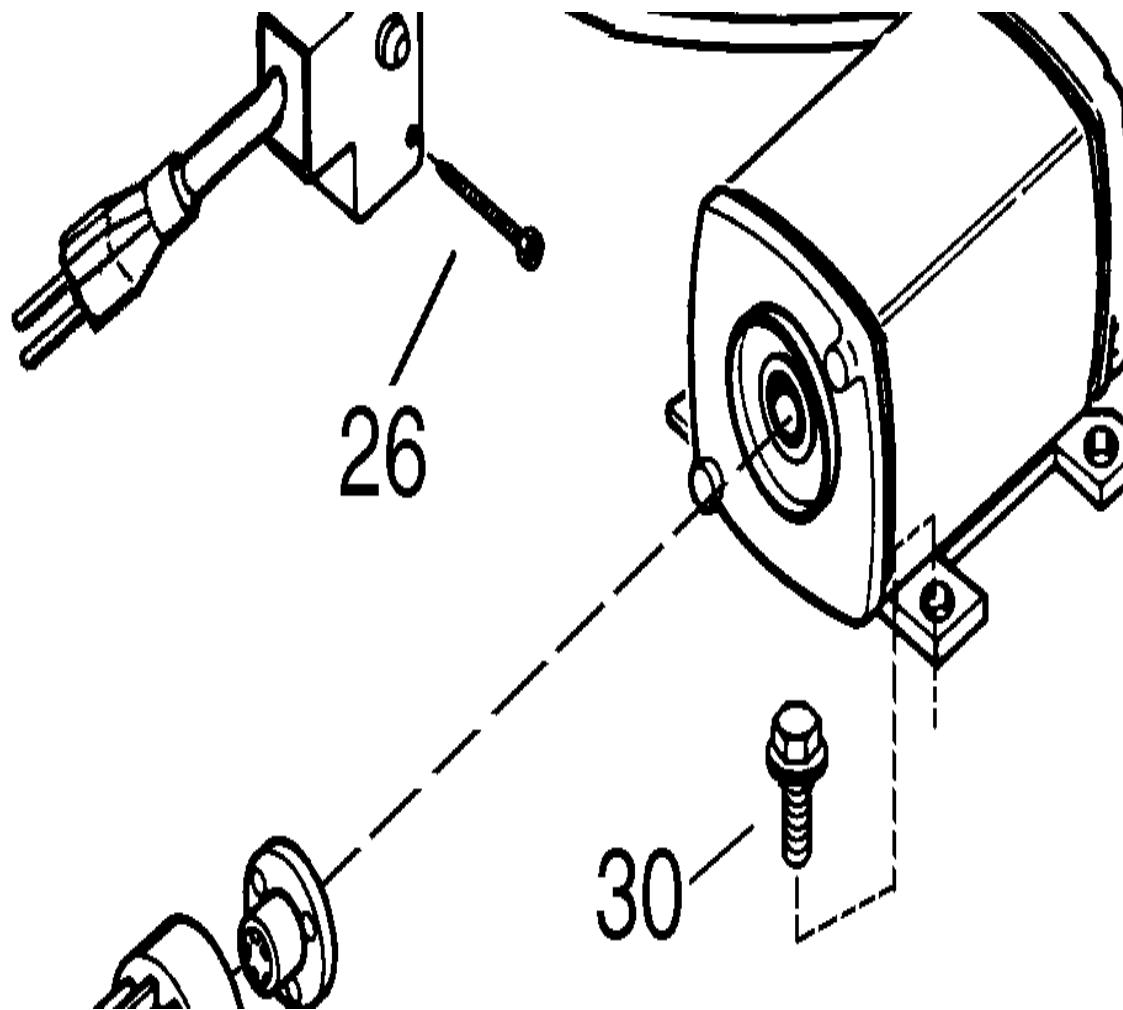

Note: Engines built with the 37000 electric starter motor are identified by the service part number located on the motor's label. Refer to Division 5, Section D, for service part information.

Ref.	Part No.	Description
1	33451	Dust Cover
2	33842	Retainer Ring
3	33430	Spring Retainer
4	33431	Anti-drift Spring
5A	37050	Gear & Nut (Incl. 2)
26	650819	Screw, 6-32 x 2-1/2"
30	30063	Screw, Torx T-30, 1/4-20 x 1/2"
31	650820	Screw, 1/4-20 x 1/2"

OHH GOVERNED IDLE SYSTEMS

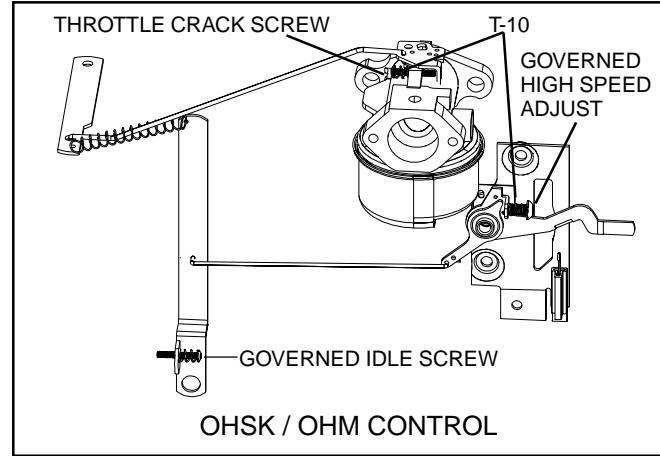
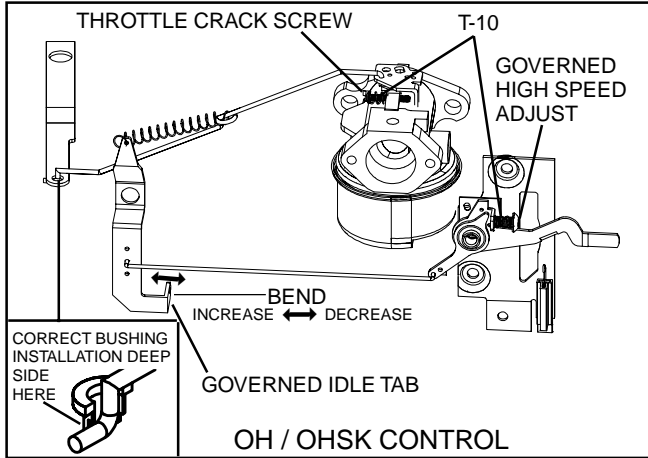

COMMON HORIZONTAL SHAFT MEDIUM FRAME ENGINES

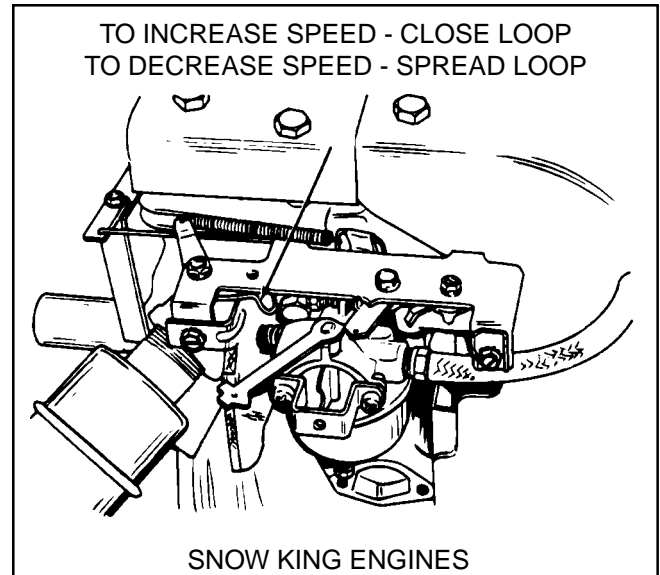
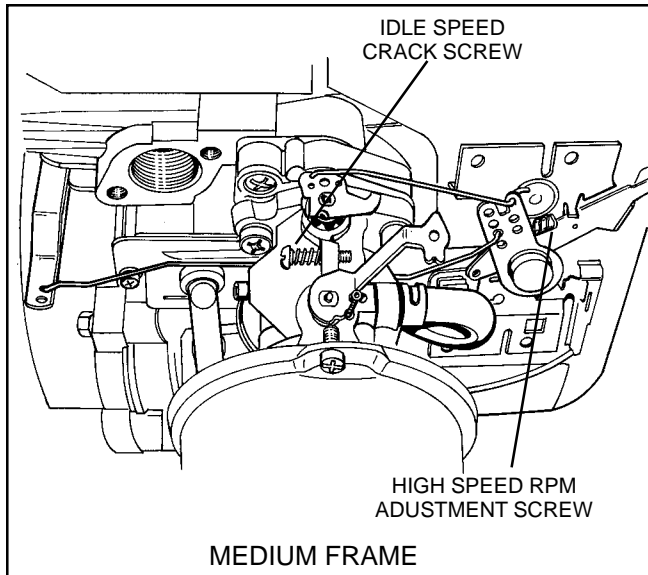
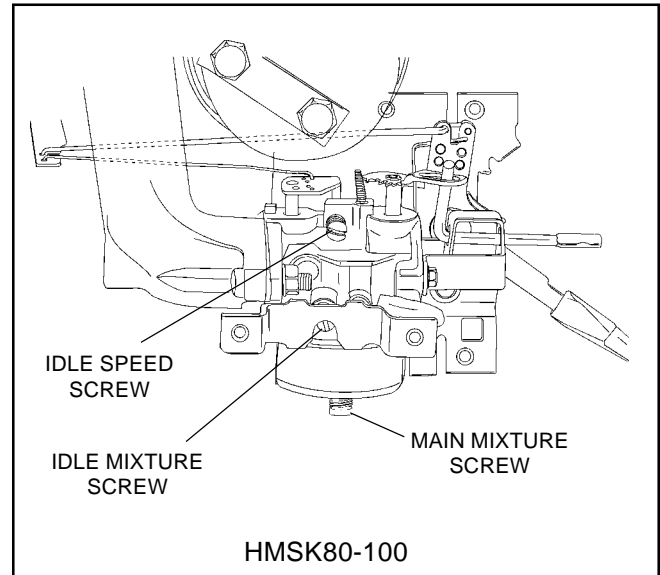
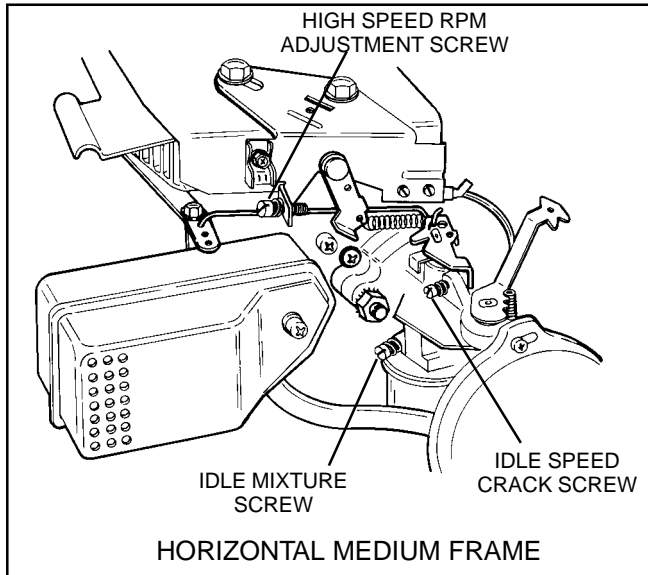



SPARK PLUG REPLACEMENT

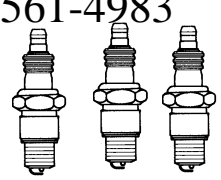

4-CYCLE SPARK PLUG

Service Number 34046
RL86C
 † OHM120 * OVXL120,
 ‡ OHSK110-130 * OVXL/C120
 OVM120 * OVXL125
Note:
 * OVXL models with specification nos. 202700, 203000 and up, use RN4C.
 † OHM 120 models with specification nos. 224000 and up, use RN4C.
 ‡ OHSK 110, 120, 130 models with specification nos. 223000 and up, use RN4C.

Service Number 33636
RJ17LM
 H30-80
 HM70-100
 HS40-50

Service Number 35552
RL82C
 HH140-160
 OH120-160

Service Number 34645
RN4C
 OH180 OHH/OHSK50-100 OHV110-17 OVRM40-all

Service Number 34277
RJ8C
 H22 HXL35
 H25 LAV25-50
 HH40-120 TVM125-220
 HHM80 TVXL170-220
 HMXL70 V40-80
 HT30 VH40-100
 HT35 VM70-100

Service Number 35395
RJ19LM
 ECV100-120 TNT120
 HMSK70-100 TVS75-120
 HSK30-70 TVXL105
 HSSK40-50 TVXL115
 LEV80-120 VLV-all
 TNT100

2-CYCLE SPARK PLUG

Service Number 611100
RCJ6Y
 TC300
 TCH300

Service Number 35395
RJ19LM
 TVS840
 TVXL840

Service Number 611049
RCJ8Y
 AH520 HSK850
 AH600 HXL840
 HSK600 TC200
 HSK840 TCH200
 HSK845 Type 1500

Service Number 33636
RJ17LM
 AV520
 AV600
 TVS600

EUROPA MODELS

4-CYCLE SPARK PLUG
Service Number 29010008
J17LM
 All Horizontal Models LAV
 BV Premier 153/173
 BVL Prisma
 BVS Spectra
 Futura Synergy
 HTL Vantage

Service Number 29010023
N4C
 Premier 45/55

2-CYCLE SPARK PLUG

Service Number 29010008
J17LM
 AV85/125
 AV520/600
 MV100

NOTE: THE SERVICE NUMBERS LISTED BELOW WILL GIVE CORRESPONDING CHAMPION AND AUTOLITE SUBSTITUTIONS.

	Champion	Autolite
35395 -	RJ-19LM	458
33657 -	RL-82C	
35552 -	L-82C *	2654
34046 -	RL-86C	425
34645 -	RN-4C	403
33636 -	J-17LM	245
34277 -	RJ-8C	304
611100 -	RCJ-6Y	

**NON CANADIAN APPLICATION*

SPARK PLUG AIR GAP ON ALL MODELS IS .030 (.762 mm)

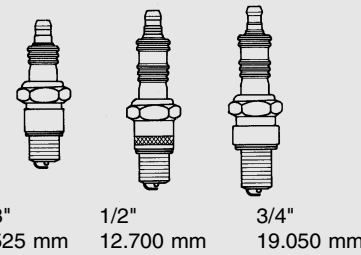

NOTE:
 Not all spark plugs have the same heat range or reach. Using an incorrect spark plug can cause severe engine damage or poor performance. Tecumseh uses all three of the reaches shown.

TECUMSEH 4-CYCLE LUBRICATION REQUIREMENTS

We often receive questions from both customers and dealers regarding the type and brand of oil we recommend.

Tecumseh recommends the use of a high quality, brand name petroleum based oil in our engines. Very few air cooled engines have any type of oil filtration system, making regular oil changes critical to remove impurities from the engine and maximize engine life. **Consult the operators or repair manual for the oil change interval and viscosity based on equipment operating temperature.**

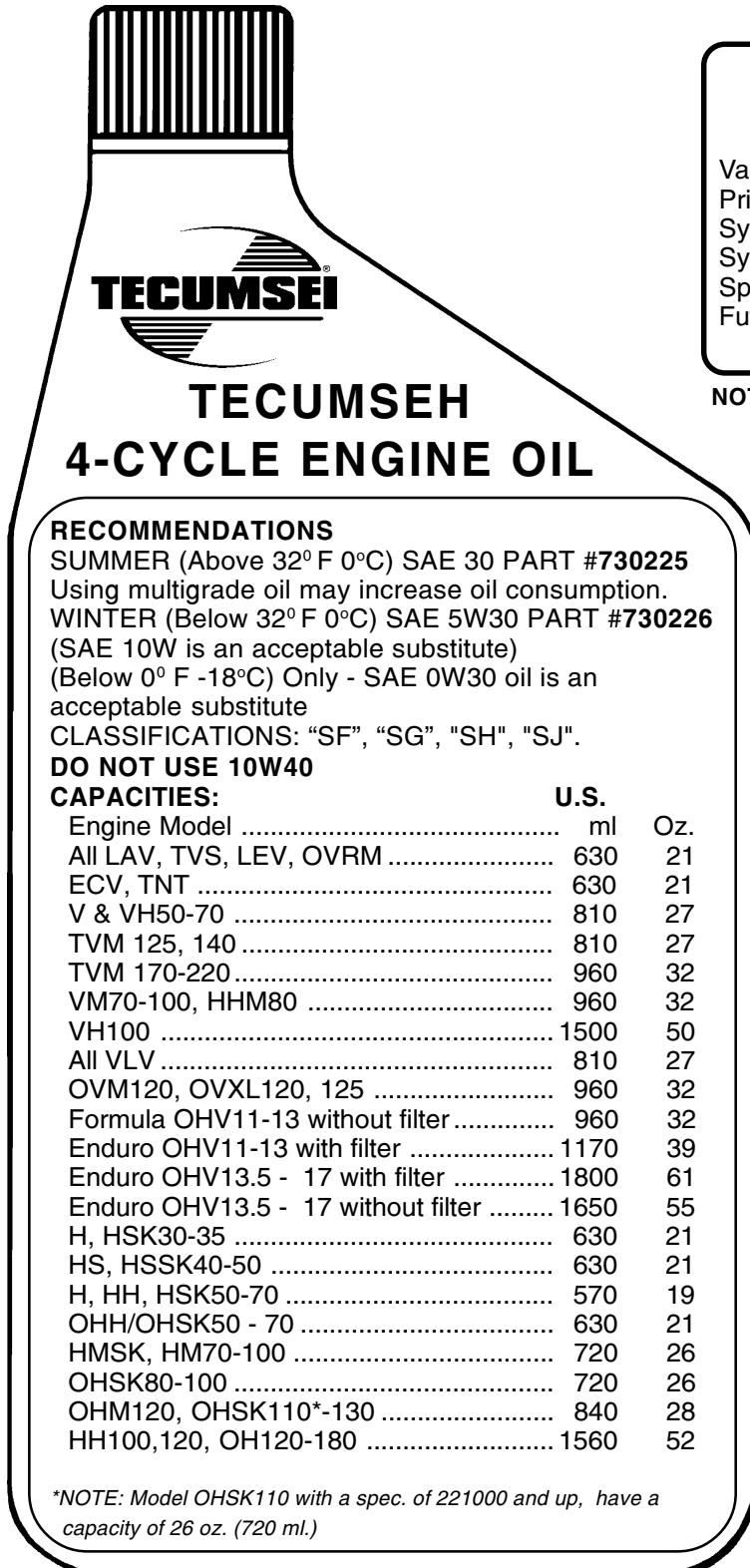

EUROPA MODELS *					
VERTICALS			VERTICALS (CONT.)		
	oz.	ml		oz.	ml
Vantage	21	630	Centura	21	630
Prisma	21	630	HTL	21	630
Synergy	21	630	BVS	21	630
Synergy "55"	27	810	HORIZONTALS		
Spectra	21	630	BH Series	21	630
Futura	21	630	Geo Tech	21	630
			Series 35 - 50		

NOTE: Vertical shaft engines with auxiliary PTO:
26 oz. / 720 ml

TECUMSEH 2-CYCLE ENGINE OIL PART NO. 730227

We also receive calls regarding what type or brand of two cycle oil to use in mini tillers and snow products. The proper type and ratio of two cycle oil is critical to long life and low maintenance of the engine. Tecumseh tests engines using NMMA (National Marine Manufacturers Association) certified oil such as Tecumseh part number 730227, but any NMMA certified two cycle oil will provide adequate lubrication for long life. The use of non certified oils and improper mix ratio's can cause severe engine problems and possibly void warranty consideration if the damage was the result of poor lubrication.

Our position regarding two cycle lubrication is simple, use only NMMA certified oil or Tecumseh two cycle oil mixed at our recommended ratio and your engine will be properly lubricated. Please do not recommend using anything else to your customer, this will avoid getting you caught in the middle, should problems occur.

TECUMSEH 2-CYCLE ENGINES REQUIRE THE USE OF BIA, NMMA, TC-WII OR TC-W3 CERTIFIED OIL, NON-BIODEGRADABLE.

NOTE: DOUBLE THE OIL QUANTITY FOR FIRST GALLON OF FUEL/OIL MIXTURE TO ASSIST BREAK-IN.

NOTE: FOR TC AND CRAFTSMAN ENGINES, DOUBLING OF THE MIX IS NOT REQUIRED.

SEARS CRAFTSMAN TWO CYCLE OIL HAS BEEN TESTED AND APPROVED. ALL MODELS USE A 40:1 MIX RATIO ON ALL 2-CYCLE ENGINES EXCEPT TC'S WHICH USE A 24:1

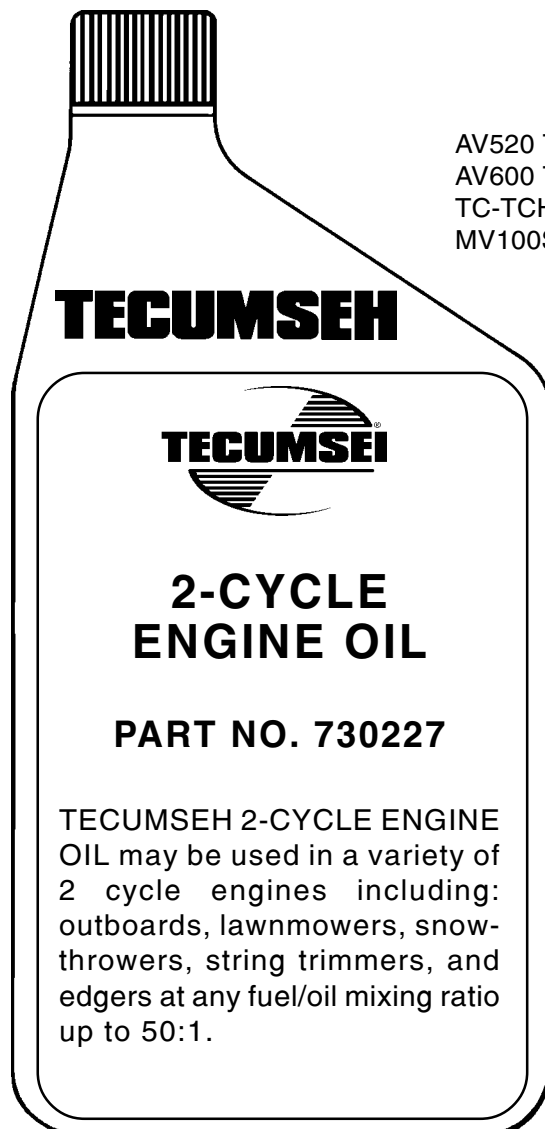

TWO-CYCLE FUEL/OIL MIX RATIOS

24:1
 AV520 Types 670 & 653
 AV600 Type 600-10 & Up
 TC-TCH 200/300
 MV100S

32:1
 TVS600 All Types
 AH600

50:1
 TVS / TVXL
 HSK840 - 850
 HSK600

MIXES EASY
 DOES NOT SEPARATE

PREMIUM BLEND FOR BOTH AIR AND WATER
 COOLED ENGINES ENSURES CYLINDER
 WALL LUBRICATION

	ENGINE FUEL MIX			
	U.S. Gasoline	U.S. Amount of Oil To Be Added	METRIC Petrol	METRIC Amount of Oil To Be Added
24:1	1 Gallon	5.3 oz.	4 Liters	167 ml
	2 Gallons	10.7 oz.	8 Liters	333 ml
32:1	1 Gallon	4 oz.	4 Liters	125 ml
	2 Gallons	8 oz.	8 Liters	250 ml
50:1	1 Gallon	2.5 oz.	4 Liters	80 ml
	2 Gallons	5.0 oz.	8 Liters	160 ml

(acceptable substitute, a high quality SAE30 or SAE40 two cycle oil, outboard type if applicable)

Tecumseh's Education Department welcomes the challenges facing our industry from emission controls to market changes. We believe that education is a vital part of meeting these challenges. This season, we will again be using the Parts Smart and Plus One computer parts look up system's as an interactive part of the class.

Friday mornings at the Douglas facility or Friday afternoons at the Grafton facility, will be reserved for the Master Technician Testing at no additional charge. **THE TESTING WILL BE AVAILABLE ONLY IF PRE REGISTERED ON THIS APPLICATION. NOTE: YOU MUST HAVE PASSED THE ESA / OPE TECHNICIAN 4 CYCLE TEST AS A PREREQUISITE. You can only be scheduled for the test by submitting proof of holding this certification.**

Both Course I and Advance Course utilize engine and transmission product for teardown and re-assembly extensively. The following are highlights and available school dates for your consideration.

We look forward to seeing you in Grafton, Wisconsin or our Douglas, Georgia school.

If you have any further questions, please call us.

COURSE SCHEDULE

November 15-20, 1998	WI	Course I	February 7-11, 1999	GA	Advance Course
December 6-11, 1998	GA	Course I	March 14-19, 1999	WI	Advance Course
January 10-15, 1998	WI	Course I			
February 1-6, 1999	GA	Course I			
February 21-26, 1999	WI	Course I	June 13-18, 1999	GA	Teachers School
March 7-12, 1999	WI	Course I	August 8-13, 1999	WI	Teachers School
March 21-25, 1999	GA	Course I			

COURSE I

Updating you on Tecumseh engines is complemented with a current mixture of our transmissions and transaxles.

Education is an ongoing process to ensure you and your customers of the best possible service repair.

Course I is not a "basic" course. It is designed to assist new technicians and those crafty veterans with current repair procedures.

Advance Course is available only after you have completed a Course I School.

COURSE I OVERVIEW

Computer Parts Look-up	2-Cycle Engine Teardown
Technician's Manual	4-Cycle Engine Teardown
Master Parts Manual	Overhead Valve Engine Teardown
Warranty	Tecumseh/Peerless Transmission/Transaxle Teardown
Ignition Timing	Service Bulletins
Electrical Systems	Running and Adjustment of a Reassembled Engine
Carburetion System	Failure Analysis
New Product Update	
Failure Analysis	Servicing Emission Product

ADVANCE COURSE

After having completed Course I you are eligible for Advance Course.

Advance Course attendance does not assure you of a diploma. Tests, homework and performance during the class earn you a diploma and a technical position above your competition.

More time is spent on the practices of troubleshooting and failure analysis. This "Hands On" approach allows you to sharpen skills and procedures.

ADVANCE COURSE OVERVIEW

Computer Parts Look-up	New Product Update
Micrometers	Troubleshooting and Failure Analysis of
Dial Calipers	<ul style="list-style-type: none"> • 2-Cycle Engines • 4-Cycle L-Head and OHV Engines • Tecumseh/Peerless Transmissions and Transaxles
Electrical Testers -	
Electrical Systems Diagnosis	
Carburetion Systems	
Valve Train	

TUITION COST AND HOTEL RESERVATIONS

	Program Only	Program and Double Occupancy Hotel	Program and Single Occupancy Hotel
Course I	\$200.00	\$325.00	\$450.00
Advance Course	\$200.00	\$325.00	\$450.00
Teachers School	\$200.00	\$325.00	\$450.00

All checks and money orders must be in U.S. Funds.

Make checks payable to Tecumseh Products Company and must be submitted with your application.

Master Charge, Visa or Discover Card is now being accepted. Please fill in the information required listed below.

The tuition costs covers the following items:

- Hotel fee (as indicated above) from Sunday night through Thursday night.
- Noon lunches Monday through Thursday.
- All class materials.
- Thursday night banquet.
- Daily bus service to and from class.
- Includes breakfast at the hotel (Monday thru Friday).

Classes in Grafton will run until 12 noon Fridays. Douglas classes are completed after the Thursday night banquet.

Tuition fee applies for all students. Cancellation must be received in writing at Tecumseh 10 days prior to week scheduled to obtain refund.

NOTE: INDIVIDUALS UNDER THE AGE OF 18 MUST BE ACCOMPANIED BY AN ADULT.

Mail this application along with the tuition fee to:

Tecumseh Products Company

900 North Street • Grafton, Wisconsin 53024-1499

ATTN: School Reservation

To check for availability call 1-414-377-2700

**To make payment using a credit card,
please fill out the following information:**

(Check One)

- Master Charge Visa Discover

Print Name (as it appears on card) _____

Account Number: _____

Signature of Card Holder _____

Exp. Date _____ Phone Number: _____

Please check all that apply.

- Single accommodations \$450.00 Smoker Non-smoker No Room Needed

Student's Signature _____

Employer's Signature _____

SEE OTHER SIDE FOR FACTORY TRAINING APPLICATION.

TECUMSEH FACTORY TRAINING APPLICATION

Please Print

Student Name _____

Address _____ City _____

State _____ Zip _____ Phone Number ____ / ____ - ____

Dealership Name _____

Address _____ City _____

State _____ Zip _____ Code No. _____ Phone Number ____ / ____ - ____

COURSE I Application to attend

ADVANCE COURSE Application to attend - please fill out ALL information on application

OPTIONAL

Master Technician Testing will only be offered for pre-registered applicants with proof of holding OPE 4-Cycle certification.

Master Technician Test I would like to take the Master Technician Test given on Friday

School Dates: 1st choice _____ 2nd choice _____

Applicants for Advance Course must fill out this part of application, or the application will be returned to you. **You MUST have attended a Course I school before being accepted into a Advance Course session.**

Course I was completed at Factory Central Warehouse Distributor

Other, please list _____

The dates of the school were _____ to _____ 19 ____.

The instructor was _____.

For registration information call: 414-377-2700.

The Central Warehouse Distributors in your area may hold in-house Dealer Schools. Please contact them for further information.

Dear Technician

Thank you for choosing the "**NEW**" technician video update seminar format for the 1999 service information. By completing this test and receiving a passing grade you have completed the agreement your dealership made with your distributor(s) and Tecumseh Products Company to regularly attend factory training schools. You or your dealership will be entitled to a credit or rebate based on the program that applies from your distributor dependent on territory or country. The amount will be approximately 50% of the purchase price per set of video's purchased, contact them for prices.

You must return a copy of the test and receive a passing grade of at least 75% from their education director to receive your attendance certificate and any rebate to be issued. **DO NOT** return the test to Tecumseh. All tests must be returned to your **central warehouse distributor by May 15, 1999** to qualify as having attended and be eligible to receive a rebate. If a passing test is not received by date, your refund is forfeited.

This test can be used for self-testing of technicians not taking the package. Dealers and or technicians not purchasing the complete package as outlined or attending a group update are not eligible for any rebate. Dealers and or technicians outside the United States, should contact your distributor regarding program availability.

DO NOT REMOVE THIS TEST FROM THE BOOK, SUBMIT ONLY A COPY TO YOUR DISTRIBUTOR. KEEP THE ORIGINAL FOR YOUR RECORDS AND REFERENCE.

Please Print

Technician Name _____ Dealership Name _____ Date _____

Dealership Location, Street Address _____ City _____

State, Country or Province _____ Phone Number _____

Update Seminar Technician Video Test

1. With the exception of the LEV80, what is the new valve seat width recommendation for all other LEV's?
A. .078" C. .040
B. .027" D. .012
2. What is the air gap setting on TC300 non-rotary mower applications?
A. .015" C. .030"
B. .0125" D. .025"
3. Correct priming is very critical to the start-up of an engine. How long of a delay should there be between each prime?
A. 1 second
B. 2 seconds
C. 3 seconds
D. Doesn't matter, rapid fire
4. What is one new method used to emissionize the two-cycle engine?
A. Fuel / oil mixture improvement
B. Cylinder port timing change
C. Fuel injection
D. Unrestricted air filter
5. What short blocks will come with two head gaskets?
A. LEV/TVS
B. OVRM/VLV
C. HM/TVM
D. OH/OHV
6. What series carburetor can not be serviced with kit number 632760?
A. Series 3
B. Dual System
C. Series 7
D. Series 11
7. What is stamped on catalytic mufflers to identify them?
A. "CAT"
B. "EMISSION"
C. "TECUMSEH"
D. "KAT"
8. When completing an ESA157R, which section can be left blank?
A. Purchased date
B. Failure Date
C. Repair Date
D. None of the above
9. How is the speed adjusted on a VLV with a fixed speed application?
A. Bendable tab
B. Assorted length spring kit
C. Screw
D. Non-adjustable
10. What is the diameter of the axle on 1300 series transaxle?
A. 1-1/8"
B. 1"
C. 15/16"
D. 1-1/4"
11. How many primes are recommended for snow engines below 15°F (-9°C)
A. 1 prime
B. 2 primes
C. 3 primes
D. Choke only, no primes
12. What year did the US EPA Phase 1 go into effect?
A. 1995
B. 1996
C. 1997
D. 1998
13. What special feature is incorporated on the Series 11 carburetor?
A. Leaner main jet
B. Larger venturi
C. Power valve
D. Fuel reservoir
14. What is the maximum psi for doing a leak down test on the MST?
A. 15 psi
B. 10 psi
C. 20 psi
D. 5 psi
15. What is the proper installation/orientation of the pulse hole on TC carburetor spacer block?
A. Towards the PTO
B. Towards the spark plug
C. Towards the flywheel
D. Doesn't matter
16. What is the part number for the soft-pull starter kit?
A. 590760
B. 730245
C. 16630041
D. 670297

17. Who can sign the authorization in box #17 of the ESA157R?
 - A. Dealer
 - B. Customer
 - C. Leave blank, for factory use only
 - D. Central Warehouse Distributor
18. How long can a Series 11 carburetor be soaked in carburetor cleaner?
 - A. 30 minutes
 - B. 15 minutes
 - C. 5 minutes
 - D. Not recommended
19. The fuel cap tether can be retrofitted to most standard 1.750" (44.45mm) caps.
 - A. True
 - B. False
20. What is the part number for a three pack of Smart Start™?
 - A. 730255
 - B. 740063
 - C. 730525
 - D. 740036
21. What does ECS stand for?
 - A. Emission Compliance Standards
 - B. Environmental Control Standards
 - C. Emission Control System
 - D. Effective Consumer Safety
22. VLV's will only be made without drain plugs.
 - A. True
 - B. False
23. What is the part number for the helical governor gear on OH cast iron series engine?
 - A. 34751
 - B. 34691
 - C. 34692
 - D. 34752
24. What is the clearance between the starter pinion gear and the flywheel ring gear?
 - A. 3/32" (.09 mm)
 - B. 5/64" (1.98 mm)
 - C. 1/16" (1.6 mm)
 - D. 1/32" (.79 mm)
25. Never use gasoline containing more than _ % ethanol.
 - A. 5
 - B. 10
 - C. 12
 - D. 15
26. What model year did Tecumseh's complete snow engine product line become certified for both CARB and EPA?
 - A. 1995
 - B. 1996
 - C. 1997
 - D. 1998
27. The HM Climate Guard™ kit can only be used on non-emission engines.
 - A. True
 - B. False
28. What is the correct fuel bowl nut number for LEV 115's with a DOM between 8091 and 8166
 - A. 174
 - B. 166
 - C. 169
 - D. 172
29. Up to 10% methanol can be used in a fuel dryer.
 - A. True
 - B. False
30. Which Service Bulletin was re-issued to cover valve stem seals?
 - A. 501
 - B. 123
 - C. 110
 - D. 406
31. What is the part number for the new 7 amp charging system on OHH model engines?
 - A. 611210
 - B. 622311
 - C. 611233
 - D. 621011
32. What is the new VST puller used for?
 - A. Pintle shaft
 - B. Pump retaining ring
 - C. Input shaft
 - D. Directional control arm
33. How much fuel will one packet of Tecumseh's fuel stabilizer treat?
 - A. 1 gallon
 - B. 1-1/2 gallons
 - C. 2 gallons
 - D. 2-1/2 gallons
34. What is the AC output voltage for the 3 amp charging system?
 - A. 21 volts
 - B. 22 volts
 - C. 13 volts
 - D. 14 volts

35. What weight oil is an acceptable substitute for below 0°F?
A. SAE 10W30
B. SAE 5
C. SAE 0W30
D. SAE 5W20
36. Emission control systems are warranted for ____ under Phase 1.
A. 1 year
B. 2 years
C. 3 years
D. life of the engine
37. Existing OHH model engines can be upgraded to a 7 amp DC charging system.
A. True
B. False
38. What engine model is designated by 126 (12.6 C.I.)?
A. LEV
B. TVS
C. OVRM
D. VLV
39. Some Europa engines utilize an adaptor collar to locate the flywheel to the crankshaft.
A. True
B. False
40. The fuel tank baffle is made from a material similar to what is used in a race car fuel cell.
A. True
B. False
41. What series number is used on Emission Service Bulletins?
A. 400 Series
B. 500 Series
C. 900 Series
D. 1000 Series
42. What tool is used to adjust the shift force on the VST?
A. #25 torx
B. #28 torx
C. 5/32" allen wrench
D. 1/4" allen wrench
43. Can the vent tube extension be installed into any existing carburetor?
A. True
B. False
44. What is the part number for the oil dipper on H30- HS50 model engines?
A. 32875A
B. 32654
C. 36611
D. 32645
45. What corrective action should be taken on fixed line trimmers that exhibit a mis-fire?
A. Replace ignition coil
B. Replace flywheel key
C. Replace carburetor
D. Cut off extra ignition ground tab
46. What fuel bowl nut can be used on a Dellorto carburetor above 4,000 ft. ?
A. 633017
B. 632239
C. 632648
D. 632368
47. Which specification may be effected by a potential emission control system problem?
A. H35-456912
B. H40-55107A
C. H35-457252
D. H40-55701A
48. An O-ring is still required with the new LEV/VLV valve stem seal.
A. True
B. False
49. What type of sealant is recommended for the 820 transaxle?
A. Loctite 515
B. Loctite 242 Blue
C. Loctite 404 Quick Set
D. Loctite Ultra Grey
50. When adjusting the shifting force on a VST205, the transmission must be at operating temperature.
A. True
B. False



Answer Sheet for Video Test

- | | | | | | | | | | |
|-----|-------------------------|-------------------------|-------------------------|-------------------------|-----|-------------------------|-------------------------|-------------------------|-------------------------|
| 1. | <input type="radio"/> A | <input type="radio"/> B | <input type="radio"/> C | <input type="radio"/> D | 26. | <input type="radio"/> A | <input type="radio"/> B | <input type="radio"/> C | <input type="radio"/> D |
| 2. | <input type="radio"/> A | <input type="radio"/> B | <input type="radio"/> C | <input type="radio"/> D | 27. | <input type="radio"/> A | <input type="radio"/> B | <input type="radio"/> C | <input type="radio"/> D |
| 3. | <input type="radio"/> A | <input type="radio"/> B | <input type="radio"/> C | <input type="radio"/> D | 28. | <input type="radio"/> A | <input type="radio"/> B | <input type="radio"/> C | <input type="radio"/> D |
| 4. | <input type="radio"/> A | <input type="radio"/> B | <input type="radio"/> C | <input type="radio"/> D | 29. | <input type="radio"/> A | <input type="radio"/> B | <input type="radio"/> C | <input type="radio"/> D |
| 5. | <input type="radio"/> A | <input type="radio"/> B | <input type="radio"/> C | <input type="radio"/> D | 30. | <input type="radio"/> A | <input type="radio"/> B | <input type="radio"/> C | <input type="radio"/> D |
| 6. | <input type="radio"/> A | <input type="radio"/> B | <input type="radio"/> C | <input type="radio"/> D | 31. | <input type="radio"/> A | <input type="radio"/> B | <input type="radio"/> C | <input type="radio"/> D |
| 7. | <input type="radio"/> A | <input type="radio"/> B | <input type="radio"/> C | <input type="radio"/> D | 32. | <input type="radio"/> A | <input type="radio"/> B | <input type="radio"/> C | <input type="radio"/> D |
| 8. | <input type="radio"/> A | <input type="radio"/> B | <input type="radio"/> C | <input type="radio"/> D | 33. | <input type="radio"/> A | <input type="radio"/> B | <input type="radio"/> C | <input type="radio"/> D |
| 9. | <input type="radio"/> A | <input type="radio"/> B | <input type="radio"/> C | <input type="radio"/> D | 34. | <input type="radio"/> A | <input type="radio"/> B | <input type="radio"/> C | <input type="radio"/> D |
| 10. | <input type="radio"/> A | <input type="radio"/> B | <input type="radio"/> C | <input type="radio"/> D | 35. | <input type="radio"/> A | <input type="radio"/> B | <input type="radio"/> C | <input type="radio"/> D |
| 11. | <input type="radio"/> A | <input type="radio"/> B | <input type="radio"/> C | <input type="radio"/> D | 36. | <input type="radio"/> A | <input type="radio"/> B | <input type="radio"/> C | <input type="radio"/> D |
| 12. | <input type="radio"/> A | <input type="radio"/> B | <input type="radio"/> C | <input type="radio"/> D | 37. | <input type="radio"/> A | <input type="radio"/> B | <input type="radio"/> C | <input type="radio"/> D |
| 13. | <input type="radio"/> A | <input type="radio"/> B | <input type="radio"/> C | <input type="radio"/> D | 38. | <input type="radio"/> A | <input type="radio"/> B | <input type="radio"/> C | <input type="radio"/> D |
| 14. | <input type="radio"/> A | <input type="radio"/> B | <input type="radio"/> C | <input type="radio"/> D | 39. | <input type="radio"/> A | <input type="radio"/> B | <input type="radio"/> C | <input type="radio"/> D |
| 15. | <input type="radio"/> A | <input type="radio"/> B | <input type="radio"/> C | <input type="radio"/> D | 40. | <input type="radio"/> A | <input type="radio"/> B | <input type="radio"/> C | <input type="radio"/> D |
| 16. | <input type="radio"/> A | <input type="radio"/> B | <input type="radio"/> C | <input type="radio"/> D | 41. | <input type="radio"/> A | <input type="radio"/> B | <input type="radio"/> C | <input type="radio"/> D |
| 17. | <input type="radio"/> A | <input type="radio"/> B | <input type="radio"/> C | <input type="radio"/> D | 42. | <input type="radio"/> A | <input type="radio"/> B | <input type="radio"/> C | <input type="radio"/> D |
| 18. | <input type="radio"/> A | <input type="radio"/> B | <input type="radio"/> C | <input type="radio"/> D | 43. | <input type="radio"/> A | <input type="radio"/> B | <input type="radio"/> C | <input type="radio"/> D |
| 19. | <input type="radio"/> A | <input type="radio"/> B | <input type="radio"/> C | <input type="radio"/> D | 44. | <input type="radio"/> A | <input type="radio"/> B | <input type="radio"/> C | <input type="radio"/> D |
| 20. | <input type="radio"/> A | <input type="radio"/> B | <input type="radio"/> C | <input type="radio"/> D | 45. | <input type="radio"/> A | <input type="radio"/> B | <input type="radio"/> C | <input type="radio"/> D |
| 21. | <input type="radio"/> A | <input type="radio"/> B | <input type="radio"/> C | <input type="radio"/> D | 46. | <input type="radio"/> A | <input type="radio"/> B | <input type="radio"/> C | <input type="radio"/> D |
| 22. | <input type="radio"/> A | <input type="radio"/> B | <input type="radio"/> C | <input type="radio"/> D | 47. | <input type="radio"/> A | <input type="radio"/> B | <input type="radio"/> C | <input type="radio"/> D |
| 23. | <input type="radio"/> A | <input type="radio"/> B | <input type="radio"/> C | <input type="radio"/> D | 48. | <input type="radio"/> A | <input type="radio"/> B | <input type="radio"/> C | <input type="radio"/> D |
| 24. | <input type="radio"/> A | <input type="radio"/> B | <input type="radio"/> C | <input type="radio"/> D | 49. | <input type="radio"/> A | <input type="radio"/> B | <input type="radio"/> C | <input type="radio"/> D |
| 25. | <input type="radio"/> A | <input type="radio"/> B | <input type="radio"/> C | <input type="radio"/> D | 50. | <input type="radio"/> A | <input type="radio"/> B | <input type="radio"/> C | <input type="radio"/> D |

Should you need a new label for any reason such as replacing a recoil housing, please fill out a copy and fax it to us. We will promptly mail you a new engine I.D. Tag.

When replacing the blower housing on an EPA/CARB certified engine with the serial number of 7213 or greater (6001 or greater if in California), use this form to fax an order for a replacement engine identification label. This label is supplied no-charge. Fill in the required information below and fax it in to the Tecumseh Customer Service Department at (414) 377-4485. If you have any questions, feel free to call a Service Representative at (414) 377-2700.

ENGINE INFORMATION REQUIRED:

Engine Model/Spec: _____

Family Number: _____

Displacement: _____

DOM (Date of Manufacture): _____

SHIP TO LABEL INFORMATION:

Send to: _____

Address: _____

City: _____ **State:** _____ **Zip:** _____

Phone No.: _____

Please allow 7-10 days for shipping & handling. Thank you.

FAX TO: (414)-377-4485