



by Weyerhaeuser

# TRUS JOIST®

## TJI® 110 ▪ TJI® 210

## TJI® 230 ▪ TJI® 360

## TJI® 560 JOISTS

### Featuring Silent Floor® Joists for Residential Applications

- Uniform and Predictable
- Lightweight for Fast Installation
- Resource Efficient
- Resists Bowing, Twisting, and Shrinking
- Significantly Reduces Callbacks
- Available in Long Lengths
- Limited Product Warranty



#TJ-4000 SPECIFIER'S GUIDE

[www.iLevel.com](http://www.iLevel.com)  
1.888.iLevel8 (1.888.453.8358)

 Weyerhaeuser

# WELCOME TO iLEVEL

iLevel is an exciting new brand and business within Weyerhaeuser. iLevel brings the most innovative and trusted products for residential construction together under one roof. Within iLevel, you'll still find all the reliable, brand-name building products that you've been using—Trus Joist® engineered wood products and design software, Structurwood® engineered panels, Performance Tested™ lumber, and more. But with iLevel, you'll work with only one service-oriented supplier to get all of these products and the support you need to build smarter.

iLevel. A family of brand-name building products...  
 a source for innovative ideas and solutions...  
 a supplier that's simpler to do business with.



## TJI® Joists Revolutionized the Way You Build Floors

Trus Joist® developed wooden I-joists nearly 40 years ago, and since then we've continually improved their quality and made them easier to work with. Engineered to provide strength and consistency, iLevel® Trus Joist® TJI® joists are a key part of our Silent Floor® System.

## Here's Why so Many Specifiers and Builders Choose Silent Floor® Joists:

Silent Floor® joists continue to set the standard for residential floor and roof joists. Their strength and long lengths give you the freedom to design the open, spacious floor plans that your customers want. Engineered for dimensional stability and predictable performance, Silent Floor® joists resist warping, twisting, and shrinking.

The precision engineering that makes Silent Floor® joists strong also makes them easier to install. Silent Floor® joists are designed for easy handling and fast installation. They are lightweight, easy to cut, and can be installed using standard construction tools. Silent Floor® joists come with pre-cut knockout holes, and additional holes for ductwork can be cut at the job site. These same features also make them a popular choice for roof joists.

### TABLE OF CONTENTS

Design Properties	3
Material Weights	3
Floor Span Tables	4
Floor Load Tables	5
PSF to PLF Conversion Table	5
Floor Performance	6
TJ-Pro™ Rated Floor System	7
Silent Floor® Joist Framing	8
Floor Details	9
Fastener Spacing and Diaphragm Design	9
Rim Board Selection and Installation	10
Allowable Holes	11
Cantilevers	12-13
Fire-Safe Construction	14
Understanding and Preventing Floor Noise	15
Roof Span Table	16-17
Roof Span Notes and Cut Length Calculation	17
Roof Framing	18
Roof Details	19-20
Roof Load Tables	21
Framing Connectors	22-23

## ABOUT THIS GUIDE

The applications provided in this guide are readily available through our nationwide network of distributors and dealers and are intended for use in single-family dwellings only.

For information on using these products in multi-family dwellings, contact your iLevel representative.

For commercial applications such as retail stores, office buildings, schools, restaurants, hotels, and nursing homes, please refer to the *iLevel Trus Joist® Commercial TJI® L65, L90, H90, HS90 Joists Specifier's Guide* (Reorder #COM-2000). Commercial products are typically designed, manufactured, and sold for each specific job.

For more information on any iLevel® product, please call **1-888-453-8358**.

## Design Properties (100% Load Duration)

Depth	TJI®	Basic Properties				Reaction Properties		
		Joist Weight (lbs/ft)	Maximum Resistive Moment <sup>(1)</sup> (ft-lbs)	Joist Only EI x 10 <sup>6</sup> (in. <sup>2</sup> -lbs)	Maximum Vertical Shear (lbs)	1¾" End Reaction (lbs)	3½" Intermediate Reaction (lbs)	
							No Web Stiffeners	With Web Stiffeners
9½"	110	2.3	2,380	140	1,220	885	1,935	N.A.
	210	2.6	2,860	167	1,330	980	2,145	N.A.
	230	2.7	3,175	183	1,330	1,035	2,410	N.A.
11¾"	110	2.5	3,015	238	1,560	885	1,935	2,295
	210	2.8	3,620	283	1,655	980	2,145	2,505
	230	3.0	4,015	310	1,655	1,035	2,410	2,765
	360	3.0	6,180	419	1,705	1,080	2,460	2,815
14"	560	4.0	9,500	636	2,050	1,265	3,000	3,475
	110	2.8	3,565	351	1,860	885	1,935	2,295
	210	3.1	4,280	415	1,945	980	2,145	2,505
	230	3.3	4,755	454	1,945	1,035	2,410	2,765
	360	3.3	7,335	612	1,955	1,080	2,460	2,815
16"	560	4.2	11,275	926	2,390	1,265	3,000	3,475
	210	3.3	4,895	566	2,190	980	2,145	2,505
	230	3.5	5,440	618	2,190	1,035	2,410	2,765
	360	3.5	8,405	830	2,190	1,080	2,460	2,815
	560	4.5	12,925	1,252	2,710	1,265	3,000	3,475

(1) **Caution:** Do not increase joist moment design properties by a repetitive member use factor.

*TJI® joists are intended for dry-use applications*

## General Notes

- Design reaction includes all loads on the joist. Design shear is computed at the inside face of supports and includes all loads on the span(s). Allowable shear may sometimes be increased at interior supports in accordance with ICC ES ESR-1153, and these increases are reflected in span tables.
- The following formulas approximate the uniform load deflection of Δ (inches):

For  
TJI® 110, 210, 230, and 360 Joists

$$\Delta = \frac{22.5 wL^4}{EI} + \frac{2.67 wL^2}{d \times 10^5}$$

For  
TJI® 560 Joists

$$\Delta = \frac{22.5 wL^4}{EI} + \frac{2.29 wL^2}{d \times 10^5}$$

w = uniform load in pounds per linear foot  
L = span in feet  
d = out-to-out depth of the joist in inches  
EI = value from table above

## Material Weights

(Include TJI® weights in dead load calculations—see **Design Properties** table at left for joist weights)

### Floor Panels

#### Southern Pine

½" plywood	1.7
⅝" plywood	2.0 psf
¾" plywood	2.5 psf
1½" plywood	3.8 psf
½" OSB	1.8 psf
⅝" OSB	2.2 psf
¾" OSB	2.7 psf
7⁄8" OSB	3.1 psf
1½" OSB	4.1 psf

Based on: Southern pine – 40 pcf for plywood, 44 pcf for OSB

### Roofing

Asphalt shingles	2.5 psf
Wood shingles	2.0 psf
Clay tile	9.0 to 14.0 psf
Slate (¾" thick)	15.0 psf

### Roll or Batt Insulation (1" thick):

Rock wool	0.2 psf
Glass wool	0.1 psf

### Floor Finishes

Hardwood (nominal 1")	4.0 psf
Sheet vinyl	0.5 psf
Carpet and pad	1.0 psf
¾" ceramic or quarry tile	10.0 psf

### Concrete:

Regular (1")	12.0 psf
Lightweight (1")	8.0 to 10.0 psf
Gypsum concrete (¾")	6.5 psf

### Ceilings

Acoustical fiber tile	1.0 psf
½" gypsum board	2.2 psf
⅝" gypsum board	2.8 psf
Plaster (1" thick)	8.0 psf

Code Evaluations: See ICC ES ESR-1153 and ICC ES ESR-1387

Not all products are available in all markets. Contact your iLevel representative for information.

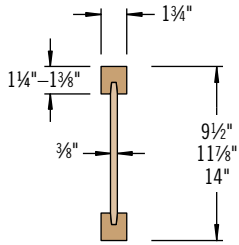

**TJI® 110 Joists**

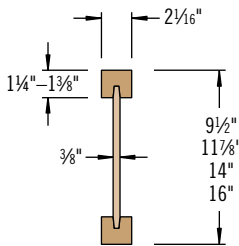

**TJI® 210 Joists**

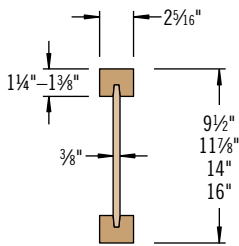

**TJI® 230 Joists**

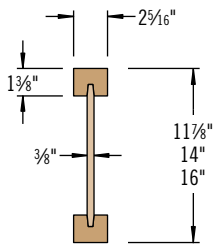

**TJI® 360 Joists**

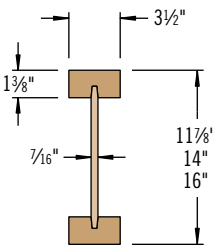

**TJI® 560 Joists**

## L/480 Live Load Deflection

Depth	TJI®	40 PSF Live Load / 10 PSF Dead Load				40 PSF Live Load / 20 PSF Dead Load			
		12" o.c.	16" o.c.	19.2" o.c.	24" o.c.	12" o.c.	16" o.c.	19.2" o.c.	24" o.c.
9 1/2"	110	16'-5"	15'-0"	14'-2"	13'-2"	16'-5"	15'-0"	13'-11"	12'-5"
	210	17'-3"	15'-9"	14'-10"	13'-10"	17'-3"	15'-9"	14'-10"	13'-8"
	230	17'-8"	16'-2"	15'-3"	14'-2"	17'-8"	16'-2"	15'-3"	14'-2"
11 7/8"	110	19'-6"	17'-10"	16'-10"	15'-5" <sup>(1)</sup>	19'-6"	17'-3"	15'-8"	14'-0" <sup>(1)</sup>
	210	20'-6"	18'-8"	17'-8"	16'-5"	20'-6"	18'-8"	17'-3"	15'-5" <sup>(1)</sup>
	230	21'-0"	19'-2"	18'-1"	16'-10"	21'-0"	19'-2"	18'-1"	16'-3" <sup>(1)</sup>
	360	22'-11"	20'-11"	19'-8"	18'-4"	22'-11"	20'-11"	19'-8"	17'-10" <sup>(1)</sup>
	560	26'-1"	23'-8"	22'-4"	20'-9"	26'-1"	23'-8"	22'-4"	20'-9" <sup>(1)</sup>
14"	110	22'-2"	20'-3"	18'-9"	16'-9" <sup>(1)</sup>	21'-8"	18'-9"	17'-1" <sup>(1)</sup>	14'-7" <sup>(1)</sup>
	210	23'-3"	21'-3"	20'-0"	18'-4" <sup>(1)</sup>	23'-3"	20'-7"	18'-9" <sup>(1)</sup>	16'-2" <sup>(1)</sup>
	230	23'-10"	21'-9"	20'-6"	19'-1"	23'-10"	21'-8"	19'-9"	17'-1" <sup>(1)</sup>
	360	26'-0"	23'-8"	22'-4"	20'-9" <sup>(1)</sup>	26'-0"	23'-8"	22'-4" <sup>(1)</sup>	17'-10" <sup>(1)</sup>
	560	29'-6"	26'-10"	25'-4"	23'-6"	<b>29'-6"</b>	<b>26'-10"</b>	25'-4" <sup>(1)</sup>	20'-11" <sup>(1)</sup>
16"	210	25'-9"	23'-6"	22'-0" <sup>(1)</sup>	19'-5" <sup>(1)</sup>	25'-5"	22'-0" <sup>(1)</sup>	20'-1" <sup>(1)</sup>	16'-2" <sup>(1)</sup>
	230	26'-5"	24'-1"	22'-9"	20'-7" <sup>(1)</sup>	<b>26'-5"</b>	23'-2"	21'-2" <sup>(1)</sup>	17'-1" <sup>(1)</sup>
	360	28'-9"	26'-3"	24'-8" <sup>(1)</sup>	21'-5" <sup>(1)</sup>	<b>28'-9"</b>	26'-3" <sup>(1)</sup>	22'-4" <sup>(1)</sup>	17'-10" <sup>(1)</sup>
	560	32'-8"	29'-8"	28'-0"	25'-2" <sup>(1)</sup>	<b>32'-8"</b>	<b>29'-8"</b>	26'-3" <sup>(1)</sup>	20'-11" <sup>(1)</sup>

## L/360 Live Load Deflection (Minimum Criteria per Code)

Depth	TJI®	40 PSF Live Load / 10 PSF Dead Load				40 PSF Live Load / 20 PSF Dead Load			
		12" o.c.	16" o.c.	19.2" o.c.	24" o.c.	12" o.c.	16" o.c.	19.2" o.c.	24" o.c.
9 1/2"	110	18'-2"	16'-7"	15'-3"	13'-8"	17'-8"	15'-3"	13'-11"	12'-5"
	210	19'-1"	17'-5"	16'-6"	15'-0"	19'-1"	16'-9"	15'-4"	13'-8"
	230	19'-7"	17'-11"	16'-11"	15'-9"	19'-7"	17'-8"	16'-1"	14'-5"
11 7/8"	110	21'-7"	18'-11"	17'-3"	15'-5" <sup>(1)</sup>	19'-11"	17'-3"	15'-8"	14'-0" <sup>(1)</sup>
	210	22'-8"	20'-8"	18'-11"	16'-10"	21'-10"	18'-11"	17'-3"	15'-5" <sup>(1)</sup>
	230	23'-3"	21'-3"	19'-11"	17'-9"	<b>23'-0"</b>	19'-11"	18'-2"	16'-3" <sup>(1)</sup>
	360	25'-4"	23'-2"	21'-10"	20'-4" <sup>(1)</sup>	<b>25'-4"</b>	<b>23'-2"</b>	<b>21'-10"<sup>(1)</sup></b>	17'-10" <sup>(1)</sup>
	560	28'-10"	26'-3"	24'-9"	23'-0"	<b>28'-10"</b>	<b>26'-3"</b>	<b>24'-9"</b>	20'-11" <sup>(1)</sup>
14"	110	23'-9"	20'-6"	18'-9"	16'-9" <sup>(1)</sup>	21'-8"	18'-9"	17'-1" <sup>(1)</sup>	14'-7" <sup>(1)</sup>
	210	25'-8"	22'-6"	20'-7"	18'-4" <sup>(1)</sup>	23'-9"	20'-7"	18'-9" <sup>(1)</sup>	16'-2" <sup>(1)</sup>
	230	26'-4"	23'-9"	21'-8"	19'-4" <sup>(1)</sup>	<b>25'-0"</b>	21'-8"	19'-9"	17'-1" <sup>(1)</sup>
	360	28'-9"	26'-3"	24'-9" <sup>(1)</sup>	21'-5" <sup>(1)</sup>	<b>28'-9"</b>	<b>26'-3"<sup>(1)</sup></b>	22'-4" <sup>(1)</sup>	17'-10" <sup>(1)</sup>
	560	32'-8"	29'-9"	28'-0"	25'-2" <sup>(1)</sup>	<b>32'-8"</b>	<b>29'-9"</b>	<b>26'-3"<sup>(1)</sup></b>	20'-11" <sup>(1)</sup>
16"	210	27'-10"	24'-1"	22'-0" <sup>(1)</sup>	19'-5" <sup>(1)</sup>	25'-5"	22'-0" <sup>(1)</sup>	20'-1" <sup>(1)</sup>	16'-2" <sup>(1)</sup>
	230	29'-2"	25'-5"	23'-2"	20'-7" <sup>(1)</sup>	<b>26'-9"</b>	23'-2"	21'-2" <sup>(1)</sup>	17'-1" <sup>(1)</sup>
	360	31'-10"	29'-0"	26'-10" <sup>(1)</sup>	21'-5" <sup>(1)</sup>	<b>31'-10"</b>	<b>26'-10"<sup>(1)</sup></b>	22'-4" <sup>(1)</sup>	17'-10" <sup>(1)</sup>
	560	36'-1"	32'-11"	31'-0" <sup>(1)</sup>	25'-2" <sup>(1)</sup>	<b>36'-1"</b>	<b>31'-6"<sup>(1)</sup></b>	26'-3" <sup>(1)</sup>	20'-11" <sup>(1)</sup>

(1) Web stiffeners are required at intermediate supports of continuous-span joists when the intermediate bearing length is *less* than 5/4" and the span on either side of the intermediate bearing is greater than the following spans:

TJI®	40 PSF Live Load / 10 PSF Dead Load				40 PSF Live Load / 20 PSF Dead Load			
	12" o.c.	16" o.c.	19.2" o.c.	24" o.c.	12" o.c.	16" o.c.	19.2" o.c.	24" o.c.
110	N.A.	N.A.	N.A.	15'-4"	N.A.	N.A.	16'-0"	12'-9"
210	N.A.	N.A.	21'-4"	17'-0"	N.A.	21'-4"	17'-9"	14'-2"
230	N.A.	N.A.	N.A.	19'-2"	N.A.	N.A.	19'-11"	15'-11"
360	N.A.	N.A.	24'-5"	19'-6"	N.A.	24'-5"	20'-4"	16'-3"
560	N.A.	N.A.	29'-10"	23'-10"	N.A.	29'-10"	24'-10"	19'-10"

• Long-term deflection under dead load, which includes the effect of creep, has not been considered. ***Bold italic*** spans reflect initial dead load deflection exceeding 0.33".

## How to Use These Tables

- Determine the appropriate live load deflection criteria.
- Identify the live and dead load condition.
- Select on-center spacing.
- Scan down the column until you meet or exceed the span of your application.
- Select TJI® joist and depth.

*Live load deflection is not the only factor that affects how a floor will perform. To more accurately predict floor performance, use our TJ-Pro™ Ratings.*

## General Notes

- Tables are based on:
  - Uniform loads.
  - More restrictive of simple or continuous span.
  - Clear distance between supports (1/4" minimum end bearing).
- Assumed composite action with a single layer of 24" on-center span-rated, glue-nailed floor panels for deflection only. **Spans shall be reduced 6" when floor panels are nailed only.**
- Spans generated from iLevel® software may exceed the spans shown in these tables because software reflects actual design conditions.
- For loading conditions not shown, refer to software or to the load table on page 5.

## Floor—100% (PLF)

Depth	TJI®	Joist Clear Span																	
		8'		10'		12'		14'		16'		18'		20'		22'		24'	
		Live Load L/480	Total Load	Live Load L/480	Total Load	Live Load L/480	Total Load	Live Load L/480	Total Load	Live Load L/480	Total Load	Live Load L/480	Total Load	Live Load L/480	Total Load	Live Load L/480	Total Load	Live Load L/480	Total Load
9½"	110	*	190	127	152	77	127	50	95										
	210	*	210	147	169	90	141	59	114	40	81								
	230	*	236	159	190	98	158	64	126	44	88								
11⅞"	110	*	190	*	152	*	127	83	109	57	92								
	210	*	210	*	169	*	141	97	121	67	106	48	87						
	230	*	236	*	190	*	158	105	136	73	119	52	97	39	78				
	360	*	241	*	193	*	162	136	139	95	121	69	108	51	97	39	78		
	560	*	294	*	236	*	197	*	169	138	148	101	132	76	119	58	108	45	91
14"	110	*	190	*	152	*	127	*	109	83	95	59	85						
	210	*	210	*	169	*	141	*	121	96	106	69	94	51	84				
	230	*	236	*	190	*	158	*	136	104	119	75	106	56	93	43	77		
	360	*	241	*	193	*	162	*	139	*	121	98	108	73	97	56	88	44	81
	560	*	294	*	236	*	197	*	169	*	148	*	132	107	119	83	108	65	99
16"	210	*	210	*	169	*	141	*	121	*	106	93	94	69	85	53	77		
	230	*	236	*	190	*	158	*	136	*	119	100	106	75	95	57	87		
	360	*	241	*	193	*	162	*	139	*	121	*	108	*	97	75	88	59	81
	560	*	294	*	236	*	197	*	169	*	148	*	132	*	119	*	108	86	99

\* Indicates that **Total Load** value controls.

## How to Use This Table

1. Calculate actual total and live load in pounds per linear foot (plf).
2. Select appropriate **Joist Clear Span**.
3. Scan down the column to find a TJI® joist that meets or exceeds actual total and live loads.

## General Notes

- Table is based on:
  - Uniform loads.
  - No composite action provided by sheathing.
  - More restrictive of simple or continuous span.
- **Total Load** limits joist deflection to L/240.
- **Live Load** is based on joist deflection of L/480.
- If a live load deflection limit of L/360 is desired, multiply value in **Live Load** column by 1.33. The resulting live load shall not exceed the **Total Load** shown.

## PSF to PLF Conversions

O.C. Spacing	Load in Pounds Per Square Foot (PSF)								
	20	25	30	35	40	45	50	55	60
	Load in Pounds Per Linear Foot (PLF)								
12"	20	25	30	35	40	45	50	55	60
16"	27	34	40	47	54	60	67	74	80
19.2"	32	40	48	56	64	72	80	88	96
24"	40	50	60	70	80	90	100	110	120



**DO NOT walk on joists until braced.**  
INJURY MAY RESULT.



**DO NOT stack building materials on unbraced joists.** Stack only over beams or walls.



**DO NOT walk on joists that are lying flat.**

## WARNING

**Joists are unstable until braced laterally**

**Bracing Includes:**

- Blocking
- Hangers
- Rim Board
- Sheathing
- Rim Joist
- Strut Lines

**WARNING NOTES:** Lack of proper bracing during construction can result in serious accidents. Observe the following guidelines:

1. All blocking, hangers, rim boards, and rim joists at the end supports of the TJI® joists must be completely installed and properly nailed.
2. Lateral strength, like a braced end wall or an existing deck, must be established at the ends of the bay. This can also be accomplished by a temporary or permanent deck (sheathing) fastened to the first 4 feet of joists at the end of the bay.
3. Safety bracing of 1x4 (minimum) must be nailed to a braced end wall or sheathed area (as in note 2) and to each joist. Without this bracing, buckling sideways or rollover is highly probable under light construction loads—such as a worker or one layer of unnailed sheathing.
4. Sheathing must be completely attached to each TJI® joist before additional loads can be placed on the system.
5. Ends of cantilevers require safety bracing on both the top and bottom flanges.
6. The flanges must remain straight within a tolerance of ½" from true alignment.



## It's About Choice—

iLevel® Trus Joist® TJ-Pro™ Ratings are generated by a sophisticated computer model designed to predict floor performance and evaluate the relationship between the cost and the “feel” of any given floor system. The methodology is based on extensive laboratory research, more than one million installations, and the combined expertise of some of the best engineers in the field. TJ-Pro™ Ratings go beyond deflection criteria to consider job-specific needs and expectations. In many cases, using TJ-Pro™ Ratings will offer a system that improves performance while actually reducing costs!

### TJ-Pro™ Rating Advantages

- Works as part of iLevel® Trus Joist® TJ-Beam® and TJ-Xpert® software
- Provides a new method for accurately predicting floor performance
- Takes perceptions of the homeowner into account
- Provides cost comparison

### Perceived Floor Performance



### Design Smarter—Don't Over-Specify

The traditional way to specify a floor system is to use live load deflection criteria, but deflection explains only part of how a floor performs. Depending on factors unique to the structure and its use, the code minimum of L/360 (or even the more restrictive limits of L/480) may disappoint many customers.

TJ-Pro™ Ratings are a much better predictor of floor performance because they consider the many factors that affect floor performance, even taking into account the perceptions of the homeowner. With so many variables, you can deliver an economical solution tailored to your customer's expectations.

### Factors That Affect Floor Performance

- TJI® joist series, depth, and spacing
- Deck thickness and quality
- Directly applied ceilings
- Location of partitions on floor
- Blocking
- Bearing conditions for the TJI® joists

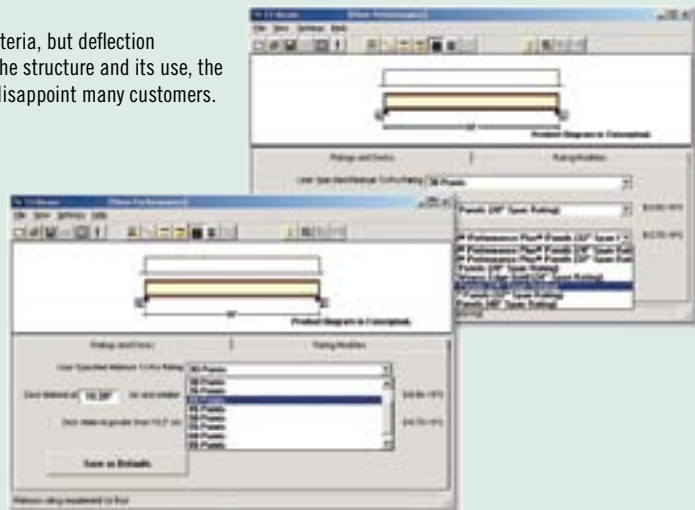

## Get the Support You Need—

We're here to help you make the most of TJ-Pro™ Ratings, whether it's help with setup, tips and tricks, or selecting the best rating for your project. Call your iLevel representative today.

# The iLevel® TJ-Pro™ Rated Floor System— The Premium Floor System From iLevel

## Design Your Floors to Suit Each Customer

With TJ-Pro™ Ratings and iLevel's proprietary materials, we can accurately predict what it will take to build a floor that satisfies even your most demanding customer. And you'll get the right balance of cost and performance in every system.

## Fewer Callbacks and More Referrals

Satisfied customers mean more referrals. And the iLevel® TJ-Pro™ Rated Floor System is the best way to make sure that there's less to complain about. It takes the guesswork out of how to build a floor that will make your customers happy.



**You'll Like the Way it Builds.  
Your Customers Will Love the Way it Feels.**

## Now You Can Build a Strong and Stable Floor—Without Overbuilding.



The performance of most commodity building products is unpredictable. But since we know the precise strength of every component in the iLevel® TJ-Pro™ Rated Floor System, we can comfortably build to your specifications while making sure that you don't use more material than you need.

Silent Floor® joists have very specific performance characteristics. Structurwood Edge Gold® panels are made with a proprietary formula, meet precise thickness tolerances, and have a top-quality edge seal—making them more stable and consistent than other structural panels. iLevel® Trus Joist®

TimberStrand® LSL rim board; TimberStrand® LSL, Parallam® PSL, and Microllam® LVL beams and columns; and our helpful installation guidelines give you more control, more strength, and more reliability than you could get with a package made up of typical framing materials.

So next time you're building someone's dream home, don't rely on guesswork. Bring your plans to any iLevel location and we'll show you how to make the most of both your framing material and the labor it takes to turn it into a home.

***For projects that demand quality, performance, and customer satisfaction, upgrade to the iLevel® TJ-Pro™ Rated Floor System. Contact your iLevel representative or call 1-888-453-8358 for more information.***

# SILENT FLOOR® JOIST FRAMING

*Silent Floor® joist framing does not require bridging or mid-span blocking*

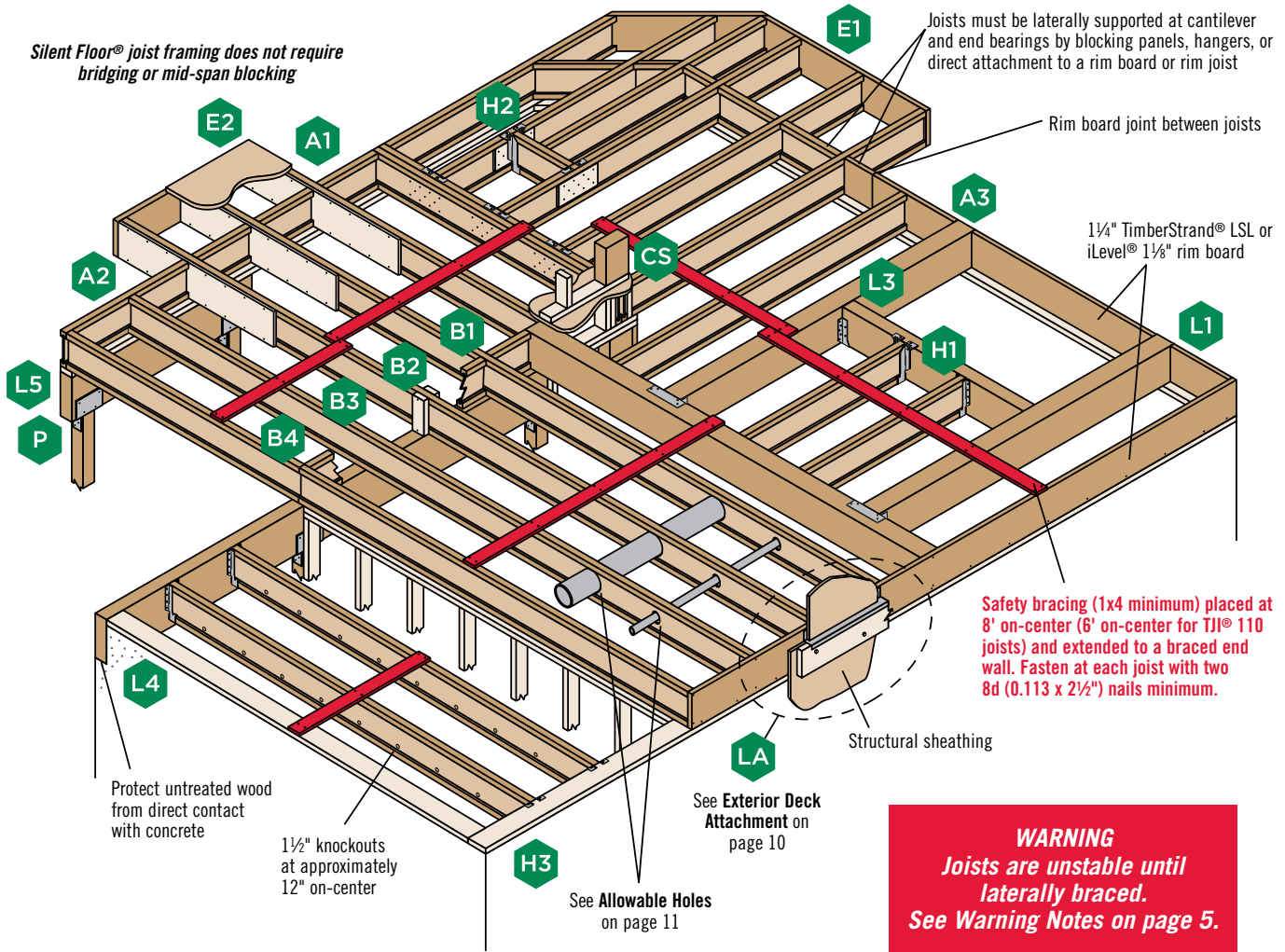

**WARNING**  
Joists are unstable until laterally braced.  
See Warning Notes on page 5.

## TJI® Joist Nailing Requirements at Bearing

### TJI® Joist to Bearing Plate

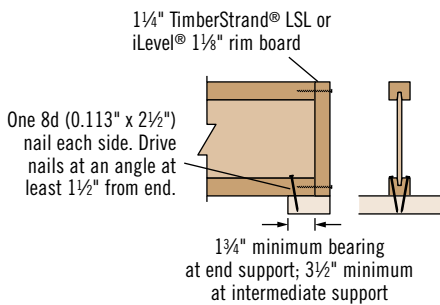

**Shear transfer: Connections equivalent to floor panel nailing schedule**

### Squash Blocks to TJI® Joist (Load bearing wall above)

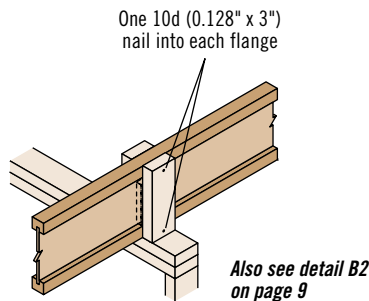

### Web Stiffener Attachment

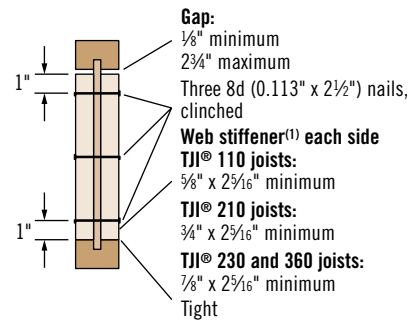

### TJI® 560 Joists Only

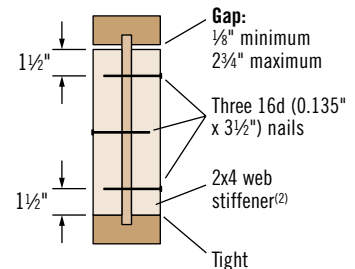

(1) PS1 or PS2 sheathing, face grain vertical

(2) Construction grade or better



### Rim to TJI® Joist

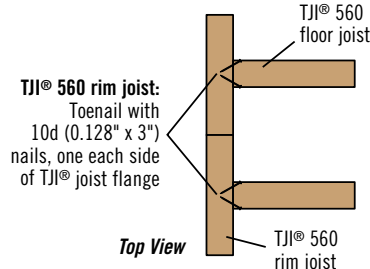
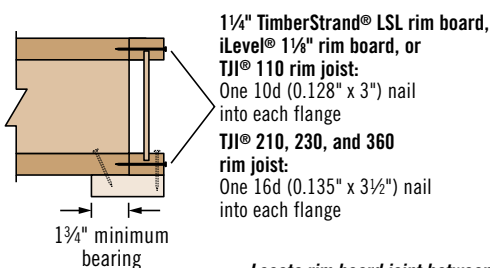



Load bearing or shear wall above  
(must stack over wall below)

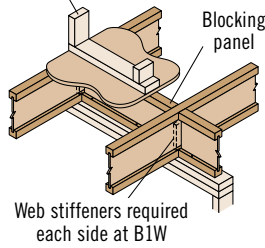

**IRC 502.7 requires lateral restraint (blocking) at all intermediate supports in Seismic Design Categories D<sub>o</sub>, D<sub>1</sub>, and D<sub>2</sub> to strengthen the floor diaphragm**

**B1 B1W**

Load bearing wall above  
(must stack over wall below)

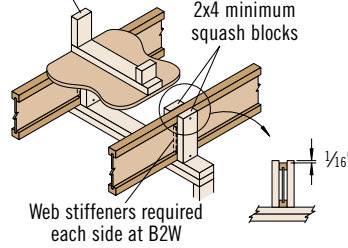

**Blocking panels may be required with shear walls above or below—see detail B1**

**B2 B2W**

## Intermediate Bearing – No Load Bearing Wall Above

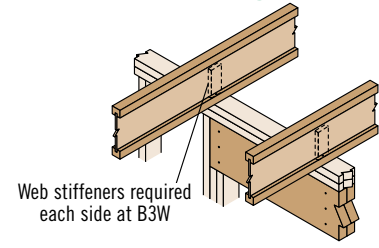

**Blocking panels may be required with shear walls above or below—see detail B1**

**B3 B3W**

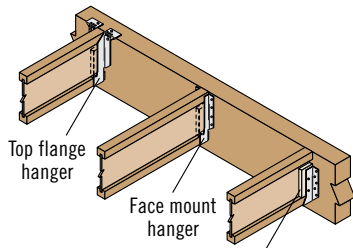

Web stiffeners required if sides of hanger do not laterally support at least 3/8" of TJI® joist top flange

**H1**

Flush bearing plate required. Maximum 1/4" overhang permitted at beam.

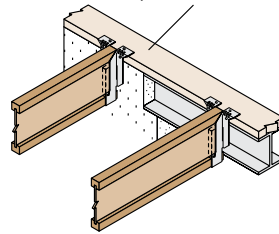

**H3**

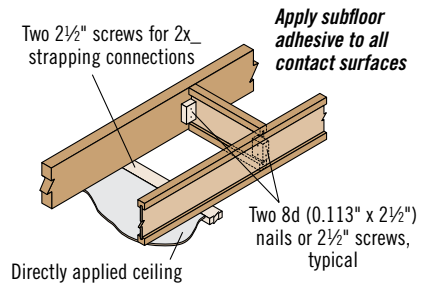

**When specified on the layout, one of the above bracing options is required**

**PB1**

**Backer block:** Install tight to top flange (tight to bottom flange with face mount hangers). Attach with ten 10d (0.128" x 3") nails, clinched when possible.

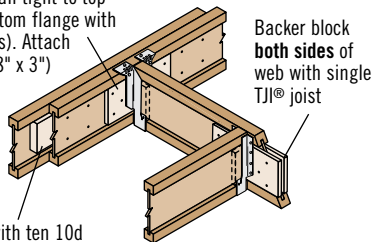

**Filler block:** Nail with ten 10d (0.128" x 3") nails, clinched. Use ten 16d (0.135" x 3 1/2") nails from each side with TJI® 560 joists.

**H2**

**With top flange hangers, backer block required only for downward loads exceeding 250 lbs or for uplift conditions**

## Filler and Backer Block Sizes

TJI®	110		210		230 or 360		560	
	9 1/2" or 11 7/8"	14"	9 1/2" or 11 7/8"	14" or 16"	9 1/2" or 11 7/8"	14" or 16"	11 7/8"	14" or 16"
<b>Filler Block<sup>(1)</sup> (Detail H2)</b>	2x6	2x8	2x6 + 3/8" sheathing	2x8 + 3/8" sheathing	2x6 + 1/2" sheathing	2x8 + 1/2" sheathing	Two 2x6	Two 2x8
<b>Cantilever Filler (Detail E4)</b>	2x6 4'-0" long	2x10 6'-0" long	2x6 + 3/8" sheathing 4'-0" long	2x10 + 3/8" sheathing 6'-0" long	2x6 + 1/2" sheathing 4'-0" long	2x10 + 1/2" sheathing 6'-0" long	Not applicable	
<b>Backer Block<sup>(1)</sup> (Detail F1 or H2)</b>	5/8" or 3/4"		3/4" or 7/8"		1" net		2x6	2x8

(1) If necessary, increase filler and backer block height for face mount hangers and maintain 1/8" gap at top of joist. See detail W. Filler and backer block dimensions should accommodate required nailing without splitting. The suggested minimum length is 24" for filler and 12" for backer blocks.

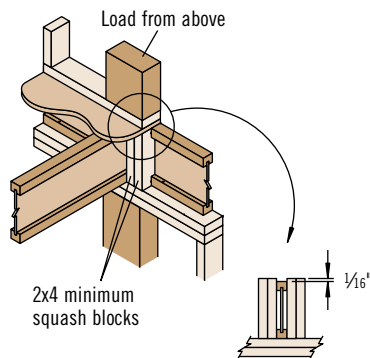

**CS**

**Use 2x4 minimum squash blocks to transfer load around TJI® joist**

## Fastener Spacing and Diaphragm Design Information for TJI® Joists

TJI®	Closest On-Center Spacing per Row <sup>(1)</sup>			Diaphragm Design Information <sup>(2)</sup>	
	8d (0.113" x 2 1/2"), 8d (0.131" x 2 1/2"), 10d (0.128" x 3"), 12d (0.128" x 3 1/4")	10d (0.148" x 3"), 12d (0.148" x 3 1/4"), 16d (0.135" x 3 1/2")	16d (0.162" x 3 1/2")	Equivalent Nominal Framing Width	Maximum Capacity (plf)
<b>110 and 210</b>	4"	4" <sup>(3)</sup>	6"	2"	425
<b>230</b>	4"	4" <sup>(3)</sup>	6"	3"	480
<b>360 and 560</b>	3"	4" <sup>(3)</sup>	6"	3"	720

- One row of fasteners permitted (two at abutting panel edges) for diaphragms. Stagger nails when using 4" on-center spacing and maintain 3/8" joist and panel edge distance. For other applications, multiple rows of fasteners are permitted if the rows are offset at least 1/2" and staggered.
- To achieve code-tabulated, unblocked diaphragm design values for TJI® 110, 210, and 230 joists, use fasteners in combination with an ASTM D3498 non-polyurethane sub-floor adhesive. For nailed-only conditions, use 85% of code-tabulated values.
- Can be reduced to 3" on-center for light gauge steel straps with 10d (0.148" x 1 1/2") nails.
  - Maximum spacing of nails is 18" on-center.
  - 14 ga. staples may be substituted for 8d (0.113" x 2 1/2") nails if minimum penetration of 1" is achieved.
  - Table also applies to the attachment of TJI® rim joists and blocking panels to the wall plate.

Also see nailing requirements on page 8

# RIM BOARD SELECTION AND INSTALLATION

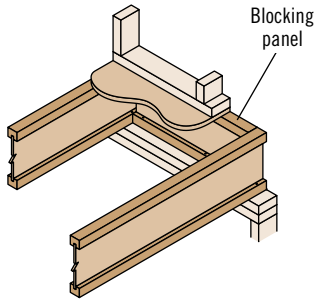

A1

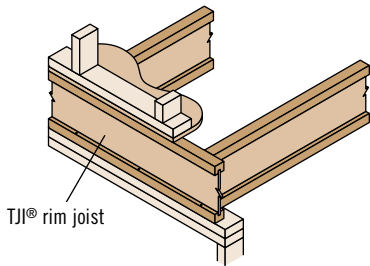

A2

Must have 1 1/4" minimum joist bearing at ends

## Exterior Deck Attachment

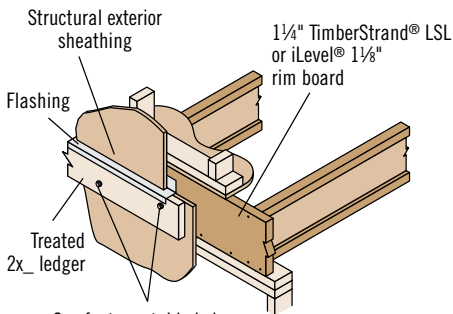

See fastener table below. Maintain 2" distance (minimum) from edge of ledger to fastener.

Fastener	Allowable Load <sup>(1)</sup> (lbs)	
	1/4" TimberStrand® LSL Rim Board	iLevel® 1 1/8" Rim Board
3/8" lag bolt	400	N.A.
1/2" lag bolt	475	400

(1) Allowable load determined in accordance with AC 124.

- Corrosion-resistant fasteners required for wet-service applications.

LA

Rim board is often an important structural link in the ability of a home to resist lateral wind loads. It also transfers vertical load around the TJI® joists.

Rim board detail A3 (shown below) satisfies conventional construction requirements. But if your project requires a designed solution, see our iLevel *Rim Board Specifier's Guide for Lateral Wind Loads*. This easy-to-use guide for specifiers and code officials goes beyond conventional construction guidelines—which were based on the smaller, simpler homes of the past—and provides design information that considers today's larger, more complex homes.

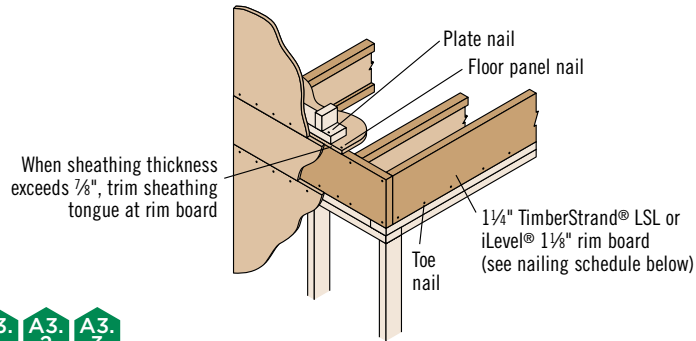

A3.1

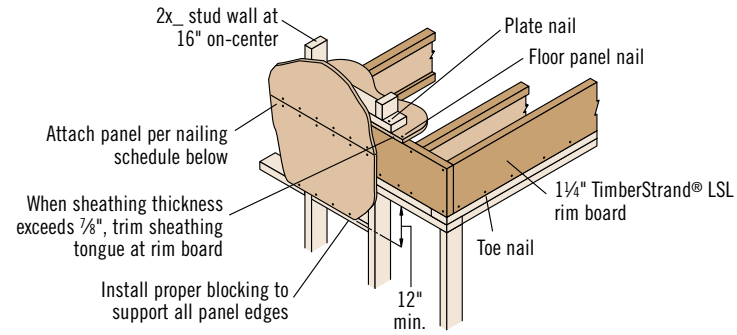

A3.2

## Fastening of Floor Panels to 1/4" TimberStrand® LSL or iLevel® 1 1/8" Rim Board

Nail Size	Closest On-Center Spacing per Row	
	Rim Board Thickness	
8d (0.113" or 0.131" x 2 1/2"), 10d (0.128" or 0.148" x 3"), 12d (0.128" or 0.148" x 3 1/4")	1 1/8"	1 1/4"
	6"	4"
16d (0.162" x 3 1/2")	16"	6" <sup>(1)</sup>

(1) Can be reduced to 4" on-center with maximum nail penetration of 1 3/8" into the narrow edge.

- If more than one row of nails is used, the rows must be offset at least 1/2" and staggered.
- 14 ga. staples may be substituted for 8d (0.113" x 2 1/2") nails if minimum penetration of 1" is achieved.

## Rim Board Installation

Specifications	A3 Conventional Construction, Code Minimum	A3.1, A3.2, A3.3, A3.4 Designed Solution
Rim Board Thickness	1 1/8" or 1 1/4"	See the iLevel <i>Rim Board Specifier's Guide for Lateral Wind Loads</i> (Reorder #TJ-8000)
Plate Nail—16d (0.135" x 3 1/2")	16" o.c.	
Floor Panel Nail—8d (0.131" x 2 1/2")	6" o.c.	
Toe Nail—10d (0.128" x 3")	6" o.c.	
Wall Sheathing	Per code	

## Vertical Load Transfer at Bearing

Allowable Uniform Vertical Loads (PLF)	
TJI® rim joist or blocking	2,100
1/4" TimberStrand® LSL rim board or blocking	4,250
iLevel® 1 1/8" rim board or blocking	4,000

- Loads may not be increased for duration of load.

Also see nailing requirements on page 8

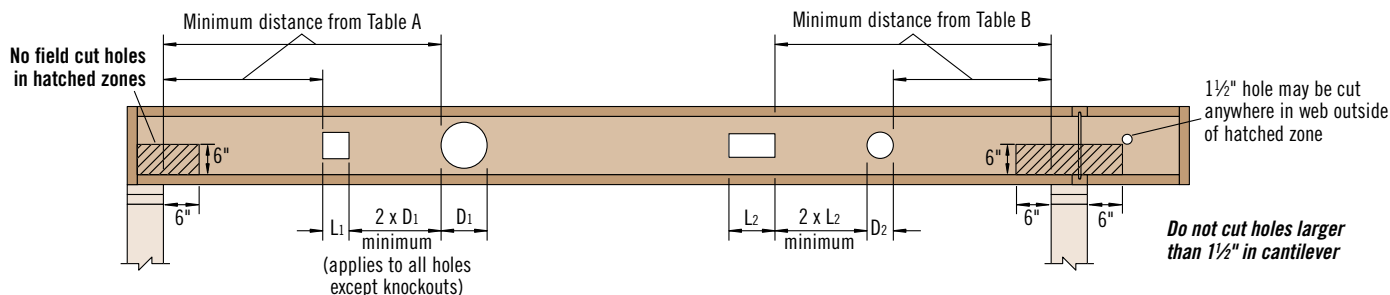

**Table A—End Support**  
Minimum distance from edge of hole to inside face of nearest end support

Depth	TJI®	● Round Hole Size									■ Square or Rectangular Hole Size								
		2"	3"	4"	5"	6½"	7"	8⅞"	11"	13"	2"	3"	4"	5"	6½"	7"	8⅞"	11"	13"
9½"	110	1'-0"	1'-6"	2'-0"	2'-6"	5'-0"					1'-0"	1'-6"	2'-6"	3'-6"	4'-6"				
	210	1'-0"	1'-6"	2'-0"	3'-0"	5'-0"					1'-0"	2'-0"	2'-6"	4'-0"	5'-0"				
	230	1'-0"	2'-0"	2'-6"	3'-6"	5'-6"					1'-0"	2'-0"	3'-0"	4'-6"	5'-0"				
11⅞"	110	1'-0"	1'-0"	1'-0"	1'-0"	2'-6"	2'-6"	5'-0"			1'-0"	1'-0"	1'-6"	2'-6"	4'-6"	4'-6"	6'-0"		
	210	1'-0"	1'-0"	1'-0"	1'-6"	2'-6"	3'-0"	5'-6"			1'-0"	1'-0"	2'-0"	3'-0"	5'-0"	5'-6"	6'-6"		
	230	1'-0"	1'-0"	1'-0"	2'-0"	3'-0"	3'-6"	6'-0"			1'-0"	1'-0"	2'-0"	3'-0"	5'-6"	5'-6"	7'-0"		
	360	1'-0"	1'-0"	1'-6"	2'-6"	4'-6"	5'-0"	7'-0"			1'-0"	1'-0"	2'-6"	4'-0"	6'-6"	6'-6"	7'-6"		
14"	110	1'-0"	1'-0"	1'-0"	1'-0"	1'-0"	1'-0"	2'-6"	5'-0"		1'-0"	1'-0"	1'-0"	1'-6"	3'-6"	4'-0"	6'-0"	8'-0"	
	210	1'-0"	1'-0"	1'-0"	1'-0"	1'-0"	1'-6"	3'-0"	6'-0"		1'-0"	1'-0"	1'-0"	2'-0"	4'-0"	4'-6"	6'-6"	8'-6"	
	230	1'-0"	1'-0"	1'-0"	1'-0"	1'-6"	2'-0"	3'-6"	6'-6"		1'-0"	1'-0"	1'-0"	2'-0"	4'-0"	5'-0"	7'-0"	9'-0"	
	360	1'-0"	1'-0"	1'-0"	1'-0"	2'-6"	3'-0"	5'-6"	8'-0"		1'-0"	1'-0"	1'-0"	2'-6"	5'-6"	6'-6"	8'-0"	9'-6"	
	560	1'-0"	1'-0"	1'-6"	3'-0"	5'-0"	5'-6"	8'-0"			1'-0"	2'-0"	3'-6"	5'-0"	7'-0"	7'-6"	8'-0"		
16"	210	1'-0"	1'-0"	1'-0"	1'-0"	1'-0"	1'-0"	1'-6"	3'-6"	6'-0"	1'-0"	1'-0"	1'-0"	1'-0"	2'-6"	3'-6"	6'-6"	8'-0"	10'-6"
	230	1'-0"	1'-0"	1'-0"	1'-0"	1'-0"	1'-0"	2'-0"	4'-0"	6'-6"	1'-0"	1'-0"	1'-0"	1'-0"	3'-0"	3'-6"	7'-0"	9'-0"	11'-0"
	360	1'-0"	1'-0"	1'-0"	1'-0"	1'-0"	1'-0"	3'-0"	6'-0"	9'-0"	1'-0"	1'-0"	1'-0"	1'-0"	4'-0"	5'-0"	9'-0"	10'-0"	11'-6"
	560	1'-0"	1'-0"	1'-0"	1'-0"	1'-0"	1'-0"	3'-0"	6'-6"	10'-0"	1'-0"	1'-0"	1'-0"	1'-6"	5'-0"	6'-0"	10'-0"	11'-0"	12'-0"

**Table B—Intermediate or Cantilever Support**  
Minimum distance from edge of hole to inside face of nearest intermediate or cantilever support

Depth	TJI®	● Round Hole Size									■ Square or Rectangular Hole Size								
		2"	3"	4"	5"	6½"	7"	8⅞"	11"	13"	2"	3"	4"	5"	6½"	7"	8⅞"	11"	13"
9½"	110	1'-6"	2'-6"	3'-0"	4'-0"	7'-6"					1'-6"	2'-6"	3'-6"	5'-6"	6'-6"				
	210	2'-0"	2'-6"	3'-6"	4'-6"	7'-6"					2'-0"	3'-0"	4'-0"	6'-0"	7'-0"				
	230	2'-6"	3'-0"	4'-0"	5'-0"	8'-0"					2'-6"	3'-0"	4'-6"	6'-6"	7'-6"				
11⅞"	110	1'-0"	1'-0"	1'-6"	2'-6"	4'-0"	4'-0"	8'-0"			1'-0"	1'-6"	2'-6"	4'-0"	6'-6"	7'-0"	9'-0"		
	210	1'-0"	1'-0"	2'-0"	3'-0"	4'-6"	5'-0"	9'-0"			1'-0"	2'-0"	3'-0"	4'-6"	7'-6"	8'-0"	10'-0"		
	230	1'-0"	2'-0"	2'-6"	3'-6"	5'-0"	5'-6"	9'-6"			1'-0"	2'-6"	3'-6"	5'-0"	8'-0"	8'-6"	10'-0"		
	360	2'-0"	3'-0"	4'-0"	5'-6"	7'-0"	7'-6"	11'-0"			2'-0"	3'-6"	5'-0"	7'-0"	9'-6"	9'-6"	11'-0"		
14"	110	1'-0"	1'-0"	1'-0"	1'-0"	2'-0"	2'-6"	4'-6"	8'-0"		1'-0"	1'-0"	1'-0"	2'-6"	5'-0"	6'-0"	9'-0"	12'-0"	
	210	1'-0"	1'-0"	1'-0"	1'-0"	2'-6"	3'-0"	5'-0"	9'-0"		1'-0"	1'-0"	2'-0"	3'-6"	6'-0"	7'-0"	10'-0"	12'-6"	
	230	1'-0"	1'-0"	1'-0"	2'-0"	3'-0"	3'-6"	5'-6"	10'-0"		1'-0"	1'-0"	2'-6"	4'-0"	6'-0"	7'-6"	10'-6"	13'-0"	
	360	1'-0"	1'-0"	2'-0"	3'-6"	5'-6"	6'-0"	8'-6"	12'-6"		1'-0"	2'-0"	4'-0"	5'-6"	9'-0"	10'-0"	12'-0"	14'-0"	
	560	1'-0"	1'-0"	1'-6"	3'-6"	5'-6"	6'-6"	9'-6"	13'-6"		1'-0"	3'-0"	5'-0"	7'-0"	10'-0"	11'-0"	13'-6"	15'-0"	
16"	210	1'-0"	1'-0"	1'-0"	1'-0"	1'-0"	1'-0"	3'-0"	5'-6"	9'-6"	1'-0"	1'-0"	1'-0"	2'-0"	4'-6"	5'-6"	9'-6"	12'-6"	15'-6"
	230	1'-0"	1'-0"	1'-0"	1'-0"	1'-6"	2'-0"	4'-0"	6'-6"	10'-6"	1'-0"	1'-0"	1'-0"	2'-6"	5'-0"	6'-0"	10'-6"	13'-0"	16'-0"
	360	1'-0"	1'-0"	1'-0"	1'-0"	3'-0"	4'-0"	6'-6"	10'-0"	13'-6"	1'-0"	1'-0"	2'-0"	4'-0"	7'-6"	8'-6"	13'-0"	14'-6"	17'-0"
	560	1'-0"	1'-0"	1'-0"	1'-0"	2'-6"	3'-6"	7'-0"	11'-0"	15'-0"	1'-0"	1'-0"	3'-6"	5'-6"	9'-0"	10'-0"	14'-6"	16'-0"	18'-0"

• Rectangular holes based on measurement of longest side.

## How to Use These Tables

- Using **Table A**, **Table B**, or both if required, determine the hole shape/size and select the TJI® joist and depth.
- Scan horizontally until you intersect the correct hole size column.
- Measurement shown is minimum distance from edge of hole to support.
- Maintain the required minimum distance from the end **and** the intermediate or cantilever support.

## General Notes

- Holes may be located vertically anywhere within the web. Leave ½" of web (minimum) at top and bottom of hole.
- Knockouts are located in web at approximately 12" on-center; they do not affect hole placement.
- For simple span (5' minimum) uniformly loaded joists meeting the requirements of this guide, one maximum size round hole may be located at the center of the joist span **provided that no other holes occur in the joist**.
- Distances are based on the maximum uniform loads shown in this guide. For other load conditions or hole configurations, use TJI-Beam® software or contact your iLevel representative.

**DO NOT**  
cut or notch flange.

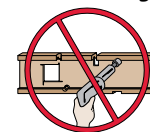

**DO NOT**  
cut holes in cantilever reinforcement.







Cantilever Reinforcement

Depth	TJI®	Roof Truss Span	Section A: Cantilevers less than 5" (Brick Ledge)									Section B: Cantilevers 5" to 24"									
			Roof Total Load									Roof Total Load									
			35 PSF			45 PSF			55 PSF			35 PSF			45 PSF			55 PSF			
			On-Center Joist Spacing									On-Center Joist Spacing									
16"	19.2"	24"	16"	19.2"	24"	16"	19.2"	24"	16"	19.2"	24"	16"	19.2"	24"	16"	19.2"	24"				
9½" 11⅞" 14"	110	20'			E5		E5	E5		E5	E5						X		X		
		22'			E5		E5	E5		E5	E5						X		X		
		24'			E5		E5	E5		E5	E5						X		X		
		26'		E5	E5	E5	E5	E5		E5	E5			X		E2	X	E2	X	X	
		28'		E5	X	E5	E5	X	E5	E5	X			E2	X	X	X	X	X	X	
		30'	E5	E5	X	E5	E5	X	E5	E5	X			E3	X	E3	X	X	X	X	
32'	E5	X	X	E5	X	X	E5	X	X	E2	X	X	X	X	X	X	X	X			
9½" 11⅞" 14" 16"	210	20'			E5		E5		E5	E5									X		
		22'			E5		E5	E5		E5	E5						E2			X	
		24'			E5		E5	E5	E5	E5	E5						E2			X	
		26'		E5	E5		E5	E5	E5	E5	E5						X		E2	X	
		28'		E5	E5	E5	E5	E5	E5	E5	E6			E2		E2	X	E2	X	X	
		30'		E5	E5	E5	E5	E5	E5	E5	E6			E3	E2	E3	X	E3	X	X	
32'	E5	E5	X	E5	E5	X	E5	E5	X			E2	X	E3	X	X	X	X			
9½" 11⅞" 14" 16"	230	24'			E5		E5	E5	E5	E5							E2			X	
		26'		E5	E5		E5	E5	E5	E5							E2		E2	X	
		28'		E5	E5	E5	E5	E5	E5	E5	E5				E2	E3	E2	E3	E3	X	
		30'		E5	E5	E5	E5	E5	E5	E5	E5			E2		E2	X	E2	X	X	
		32'	E5	E5	X	E5	E5	X	E5	E5	X			E2	E3	E2	E3	X	E3	X	X
		34'	E5	E5	X	E5	E5	X	E5	E5	X			E3	X	E3	X	X	X	X	X
11⅞" 14" 16"	360	28'			E5		E5	E5	E5	E5										E2	
		30'		E5	E5		E5	E5	E5	E5							E1W				E2
		32'		E5	E5	E5	E5	E5	E5	E5							E2				E2
		34'		E5	E5	E5	E5	E5	E5	E5	E6						E2		E1W		E3
		36'		E5	E5	E5	E5	E5	E5	E5	E6			E1W			E2		E2		E3
		38'	E5	E5	E5	E5	E5	E5	E5	E5	E6			E1W			E2		E2		E3
40'	E5	E5	E5	E5	E5	E5	E5	E5	E6			E1W		E1W	E2		E2		E3		
11⅞" 14" 16"	560	30'			E5		E5	E5		E5	E5										
		32'			E5		E5	E5		E5	E5										
		34'			E5		E5	E5		E5	E5										E2
		36'		E5	E5		E5	E5		E5	E5										E2
		38'		E5	E5	E5	E5	E5		E5	E5										E2
		40'		E5	E5	E5	E5	E5		E5	E5						E1W				E2

How to Use This Table

1. Identify TJI® joist and depth.
2. Locate the **Roof Truss Span** (horizontal) that meets or exceeds your condition.
3. Identify the cantilever condition (less than 5" or 5" to 24") and locate the **Roof Total Load** and **On-Center Joist Spacing** for your application.
4. Scan down to find the appropriate cantilever detail and refer to drawing on page 12:
  - Blank cells indicate that no reinforcement is required.
  - E4 may be used in place of E2 or E3 except when using TJI® 560 joists.
  - X indicates that cantilever will not work. Use TJ-Beam® or TJ-Xpert® software, or reduce spacing of joists and recheck table.

General Notes

- Table is based on:
  - 15 psf roof dead load on a horizontal projection.
  - 80 plf exterior wall load with 3'-0" maximum width window or door openings. For larger openings, or multiple 3'-0" width openings spaced less than 6'-0" on-center, additional joists beneath the opening's trimmers may be required.
  - More restrictive of simple or continuous span.
  - Roof truss with 24" soffits.
- ¾" reinforcement refers to ¾" Exposure 1 plywood or other ¾" Exposure 1, 48/24-rated sheathing that is cut to match the full depth of the TJI® joist. Install with face grain horizontal. Reinforcing member must bear fully on the wall plate.
- Designed for 2x4 and 2x6 plate widths.
- For conditions beyond the scope of this table, including cantilevers longer than 24", use our TJ-Beam® or TJ-Xpert® software.

Fire-safe construction and life safety are major concerns for everyone in the building materials and construction industry. The 2005 US Fire Administration (<http://www.usfa.dhs.gov/statistics/national/>) statistics on residential and commercial fires in the U.S. alone include 3,675 fire fatalities and an estimated \$10.7 billion in property damage. These numbers underscore the seriousness of the issue and the need for fire-safe construction.

Over the past 35 years, prefabricated wood I-joists and other iLevel building products have established a record of safe and reliable performance in millions of structures. Many of these structures, such as one- or two-family residential dwellings, do not require specific fire-resistance ratings per the building codes. The following information is intended to help you specify and install iLevel® Trus Joist® brand products with fire safety in mind.

## Active Fire Suppression

Automatic fire sprinkler systems are commonly required by building codes in schools, office buildings, factories, and other commercial buildings. Buildings designed with sprinkler systems are allowed larger heights and areas than buildings designed without sprinkler systems.

Fire service agencies, such as the US Fire Administration, promote the use of residential sprinkler systems. These agencies cite benefits such as lowering the total cost of construction to the homebuilder, ensuring a safer environment, and lowering insurance rates for the homeowner. Using automatic fire sprinkler systems provides the following benefits:

- Early and unsupervised suppression
- Reduced fire and smoke development
- Potentially enhanced life safety for the occupant(s)

## Smoke Detectors

Smoke detectors are universally recognized as the most cost-effective life-saving devices. While smoke detectors do not provide protection to the structure or to the contents in a home, they do alert occupants to potential fire hazards and allow them time to escape. Similarly, carbon monoxide detectors can also alert occupants to faulty heating appliances or air contamination in the early stages of a fire.

## Passive Fire Protection

Independent tests show that unprotected framing systems, whether combustible or non-combustible, suffer increased structural degradation when exposed to fire. All floor framing materials—sawn lumber, wood I-joists, trusses, and light-gauge

steel—succumb quickly to fire if not protected. If a protective membrane such as gypsum ceiling board is applied to all types of floor framing within the structure, it will provide additional and uniform protection to the structural framing members. Passive fire-protection can do the following:

- Delay fire growth involving structural elements
- Reduce the potential for significant property damage to structural elements
- Enhance the market value of the building

## Suggested Minimum Membrane Construction

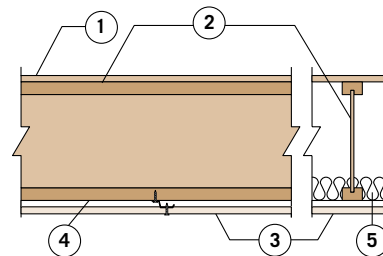

*iLevel supports the idea that all floor/ceiling and roof/ceiling assemblies in habitable areas be protected by a minimum membrane protection consisting of ½" gypsum board (or equivalent)*

1. 48/24 tongue-and-groove span-rated sheathing (Exposure 1)
2. TJI® joist
3. Single layer ½" thick gypsum board
4. Resilient channels at 16" on-center (optional)
5. Optional when used with resilient channels. Minimum 3½" thick glass fiber insulation or non-combustible insulation that is rated R-30 or less.

## One-Hour Assembly

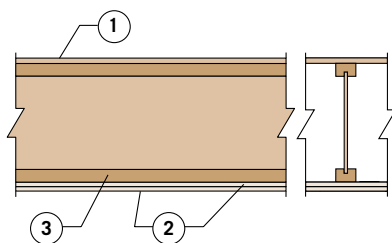

1. 48/24 tongue-and-groove, span-rated sheathing (Exposure 1)
2. Two layers ½" thick Type X gypsum board
3. TJI® joist

Optional when used with resilient channels (not shown): Minimum 3½" thick glass fiber insulation or non-combustible insulation that is rated R-30 or less

## Note

Resilient channels may be installed between the joists and gypsum board if improved STC and IIC sound ratings are desired.

Reference Assembly B per ICC ES ESR-1153

**For more information on fire assemblies and fire-safe construction, please refer to the iLevel Fire Facts Guide (Reorder #1500) or visit [www.iLevel.com](http://www.iLevel.com) and [www.i-joist.com](http://www.i-joist.com)**



Silent Floor® joists are structurally uniform and dimensionally stable, and they resist shrinking and twisting. This helps prevent gaps from forming around the nails between the joist and the floor panels—gaps that can potentially cause squeaks or other floor noise.

Using Silent Floor® joists can help you build a quieter floor, but only if the entire floor system is installed properly. This is because other components of the floor system, such as hangers, connectors, and nails can be a source of floor noise.

To get the best possible performance out of your Silent Floor® joists and minimize potential squeaks in your floor, we recommend the following installation tips:

## Properly Seat Each Joist in Hanger

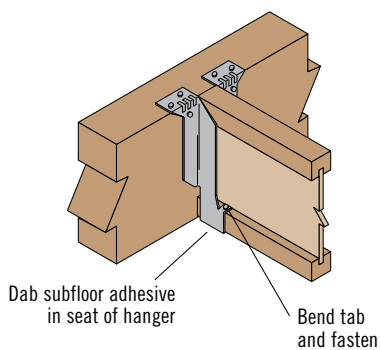

**Seat the joist tight to the bottom of the hanger. When using hangers with tabs, bend the flange tabs over and nail to the TJJ® joist bottom flange.**

**Placing a dab of subfloor adhesive in the seat of the hanger prior to installing the joist can reduce squeaks.**

## Use Adhesive and Special Nailing When Needed

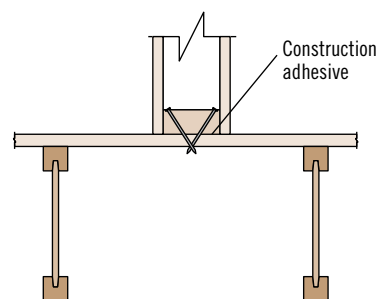

**Nail interior partitions to the joists when possible. If the wall can be nailed only to the floor panel, run a bead of adhesive under the wall and either cross nail, nail through and clinch tight, or screw tightly into the wall from below.**

## Prevent Shrinkage

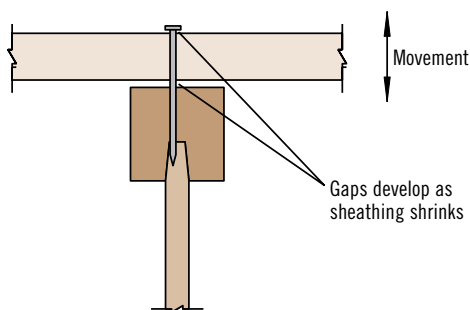

**Keep building materials dry, and properly glue floor panels to the joists. Panels that become excessively wet during construction shrink as they dry. This shrinkage may leave gaps that allow the panel to move when stepped on.**

## Avoid “Shiners”

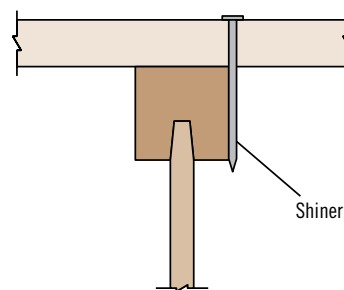

**Exercise care when nailing. Nails that barely hit the joists (shiners) do not hold the panel tight to the joist and should be removed. If left in, the nails will rub against the side of the joist when the panel deflects.**

**For more information and tips on how to prevent floor noise, refer to the *iLevel Prevention and Repair of Floor System Squeaks Technical Resource Sheet (Reorder #9009)* or contact your iLevel representative.**

# ROOF SPAN TABLE

## Maximum Horizontal Clear Spans—Roof

O.C. Spacing	Depth	TJI®	Design Live Load (LL) and Dead Load (DL) in PSF											
			Non-Snow (125%)						Snow Load Area (115%)					
			20LL + 15DL		20LL + 20DL		25LL + 15DL		30LL + 15DL		40LL + 15DL		50LL + 15DL	
			Low	High	Low	High	Low	High	Low	High	Low	High	Low	High
16"	9½"	110	19'-3"	17'-2"	18'-4"	16'-3"	18'-5"	16'-6"	17'-9"	15'-11"	16'-7"	15'-0"	15'-6"	14'-3"
		210	20'-5"	18'-2"	19'-5"	17'-3"	19'-6"	17'-6"	18'-9"	16'-11"	17'-7"	15'-11"	16'-7"	15'-1"
		230	21'-0"	18'-9"	20'-0"	17'-9"	20'-2"	18'-0"	19'-4"	17'-5"	18'-1"	16'-4"	17'-1"	15'-6"
	11⅞"	110	23'-0"	20'-6"	21'-11"	19'-5"	22'-0"	19'-9"	20'-11"	19'-1"	19'-0"	17'-11"	17'-6"	16'-11"
		210	24'-4"	21'-9"	23'-3"	20'-7"	23'-4"	20'-11"	22'-5"	20'-2"	20'-10"	19'-0"	19'-2"	18'-0"
		230	25'-1"	22'-5"	23'-11"	21'-3"	24'-1"	21'-7"	23'-1"	20'-10"	21'-7"	19'-7"	20'-3"	18'-7"
		360	27'-9"	24'-9"	26'-5"	23'-5"	26'-7"	23'-10"	25'-6"	23'-0"	23'-11"	21'-7"	22'-7"	20'-6"
		560	31'-11"	28'-6"	30'-5"	27'-0"	30'-7"	27'-5"	29'-5"	26'-5"	27'-6"	24'-10"	26'-0"	23'-7"
	14"	110	26'-3"	23'-5"	25'-0"	22'-2"	24'-1"	22'-6"	22'-9"	21'-9"	20'-8"	19'-11"	19'-1"	18'-5"
		210	27'-9"	24'-9"	26'-5"	23'-5"	26'-5"	23'-9"	25'-0"	22'-11"	22'-8"	21'-7"	20'-11"	20'-3"
		230	28'-7"	25'-6"	27'-2"	24'-2"	27'-4"	24'-6"	26'-4"	23'-8"	23'-11"	22'-3"	22'-0"	21'-1"
		360	31'-6"	28'-2"	30'-0"	26'-8"	30'-2"	27'-1"	29'-0"	26'-1"	27'-2"	24'-7"	25'-8"	23'-4"
560		36'-3"	32'-4"	34'-6"	30'-7"	34'-8"	31'-1"	33'-4"	30'-0"	31'-2"	28'-3"	29'-6"	26'-9"	
16"	210	30'-9"	27'-5"	29'-4"	26'-0"	28'-3"	26'-5"	26'-9"	25'-6"	24'-3"	23'-4"	22'-4"	21'-8"	
	230	31'-8"	28'-3"	30'-2"	26'-9"	29'-10"	27'-2"	28'-2"	26'-3"	25'-7"	24'-7"	23'-7"	22'-10"	
	360	34'-11"	31'-2"	33'-3"	29'-6"	33'-5"	30'-0"	32'-2"	28'-11"	30'-1"	27'-2"	26'-0"	25'-10"	
	560	40'-1"	35'-9"	38'-2"	33'-11"	38'-4"	34'-5"	36'-11"	33'-2"	34'-6"	31'-3"	31'-8"	29'-8"	
19.2"	9½"	110	18'-1"	16'-1"	17'-3"	15'-3"	17'-4"	15'-6"	16'-8"	15'-0"	15'-5"	14'-1"	14'-2"	13'-4"
		210	19'-2"	17'-1"	18'-3"	16'-2"	18'-4"	16'-5"	17'-8"	15'-10"	16'-6"	14'-11"	15'-7"	14'-2"
		230	19'-9"	17'-7"	18'-10"	16'-8"	18'-11"	16'-11"	18'-2"	16'-4"	17'-0"	15'-4"	16'-1"	14'-7"
	11⅞"	110	21'-7"	19'-3"	20'-7"	18'-3"	20'-3"	18'-6"	19'-1"	17'-11"	17'-4"	16'-8"	16'-0"	15'-5"
		210	22'-11"	20'-5"	21'-10"	19'-4"	21'-11"	19'-8"	20'-11"	18'-11"	19'-0"	17'-10"	17'-6"	16'-11"
		230	23'-7"	21'-1"	22'-6"	19'-11"	22'-7"	20'-3"	21'-8"	19'-6"	20'-0"	18'-4"	18'-5"	17'-5"
		360	26'-1"	23'-3"	24'-10"	22'-0"	24'-11"	22'-4"	24'-0"	21'-7"	22'-5"	20'-3"	21'-2"	19'-3"
		560	30'-0"	26'-9"	28'-7"	25'-4"	28'-8"	25'-9"	27'-7"	24'-10"	25'-9"	23'-4"	24'-4"	22'-2"
	14"	110	24'-6"	22'-0"	22'-9"	20'-10"	22'-0"	20'-11"	20'-9"	19'-10"	18'-10"	18'-2"	17'-0"	16'-10"
		210	26'-0"	23'-3"	24'-10"	22'-0"	24'-2"	22'-4"	22'-10"	21'-7"	20'-8"	19'-11"	18'-10"	18'-5"
		230	26'-10"	23'-11"	25'-7"	22'-8"	25'-5"	23'-0"	24'-0"	22'-3"	21'-10"	20'-11"	20'-1"	19'-5"
		360	29'-7"	26'-5"	28'-2"	25'-0"	28'-4"	25'-5"	27'-3"	24'-6"	25'-6"	23'-1"	21'-7"	21'-8"
560		34'-0"	30'-4"	32'-5"	28'-9"	32'-7"	29'-2"	31'-4"	28'-2"	29'-3"	26'-6"	26'-5"	25'-2"	
16"	210	28'-8"	25'-9"	26'-9"	24'-5"	25'-10"	24'-6"	24'-5"	23'-4"	22'-1"	21'-4"	18'-10"	19'-8"	
	230	29'-9"	26'-7"	28'-2"	25'-2"	27'-3"	25'-6"	25'-9"	24'-7"	23'-4"	22'-6"	21'-2"	20'-9"	
	360	32'-10"	29'-3"	31'-3"	27'-9"	31'-5"	28'-2"	30'-2"	27'-2"	25'-7"	25'-3"	21'-7"	21'-8"	
	560	37'-8"	33'-7"	35'-10"	31'-10"	36'-0"	32'-4"	34'-8"	31'-2"	31'-3"	29'-4"	26'-5"	25'-5"	
24"	9½"	110	16'-9"	14'-11"	15'-11"	14'-2"	16'-0"	14'-4"	15'-2"	13'-10"	13'-9"	13'-0"	12'-8"	12'-3"
		210	17'-9"	15'-10"	16'-11"	15'-0"	17'-0"	15'-3"	16'-4"	14'-8"	15'-1"	13'-10"	13'-11"	13'-1"
		230	18'-3"	16'-4"	17'-5"	15'-5"	17'-6"	15'-8"	16'-10"	15'-2"	15'-8"	14'-3"	14'-8"	13'-6"
	11⅞"	110	20'-0"	17'-10"	18'-9"	16'-11"	18'-1"	17'-2"	17'-1"	16'-4"	15'-6"	14'-11"	13'-7"	13'-10"
		210	21'-2"	18'-11"	20'-2"	17'-11"	19'-10"	18'-2"	18'-9"	17'-7"	17'-0"	16'-4"	15'-0"	15'-2"
		230	21'-10"	19'-6"	20'-10"	18'-5"	20'-11"	18'-9"	19'-9"	18'-1"	17'-11"	17'-0"	16'-6"	16'-0"
		360	24'-1"	21'-6"	23'-0"	20'-5"	23'-1"	20'-8"	22'-2"	20'-0"	20'-5"	18'-9"	17'-3"	17'-4"
		560	27'-9"	24'-9"	26'-5"	23'-6"	26'-7"	23'-10"	25'-6"	23'-0"	23'-10"	21'-7"	21'-1"	20'-3"
	14"	110	21'-10"	20'-4"	20'-4"	19'-1"	19'-8"	18'-8"	18'-7"	17'-9"	16'-0"	16'-3"	13'-7"	14'-2"
		210	24'-0"	21'-6"	22'-4"	20'-5"	21'-7"	20'-6"	20'-4"	19'-6"	17'-10"	17'-9"	15'-0"	15'-8"
		230	24'-10"	22'-2"	23'-7"	21'-0"	22'-9"	21'-4"	21'-6"	20'-6"	19'-6"	18'-9"	16'-11"	16'-7"
		360	27'-5"	24'-6"	26'-1"	23'-2"	26'-3"	23'-6"	25'-0"	22'-8"	20'-5"	20'-2"	17'-3"	17'-4"
560		31'-6"	28'-1"	30'-0"	26'-8"	30'-2"	27'-0"	29'-0"	26'-1"	24'-11"	23'-7"	21'-1"	20'-3"	
16"	210	25'-8"	23'-11"	23'-11"	22'-4"	23'-1"	21'-11"	21'-9"	20'-10"	17'-10"	18'-3"	15'-0"	15'-8"	
	230	27'-1"	24'-7"	25'-2"	23'-3"	24'-4"	23'-1"	23'-0"	22'-0"	20'-0"	19'-4"	16'-11"	16'-7"	
	360	30'-4"	27'-1"	28'-11"	25'-8"	28'-2"	26'-1"	25'-0"	24'-1"	20'-5"	20'-2"	17'-3"	17'-4"	
	560	34'-10"	31'-2"	33'-2"	29'-6"	33'-4"	29'-11"	30'-6"	28'-3"	24'-11"	23'-7"	21'-1"	20'-3"	

See page 17 for General Notes and information on how to use this table



## How to Use Roof Span Table on Page 16

1. Determine appropriate live and dead load, and the load duration factor.
2. If your slope is 6/12 or less, use the **Low** slope column. If it is between 6/12 and 12/12, use the **High** column.
3. Scan down the column until you find a span that meets or exceeds the span of your application.
4. Select TJI® joist and on-center spacing.

## General Notes

- Table is based on:
  - Uniform loads.
  - More restrictive of simple or continuous span.
  - Minimum roof surface slope of ¼" in 12".
  - 1¾" minimum end bearing and 3½" minimum intermediate bearing.
- Total load limits joist deflection to L/180.
- Live load is based on joist deflection of L/240.
- A support beam or wall at the high end is required. Ridge board applications do not provide adequate support.
- Spans shown assume no web stiffeners at intermediate bearings.

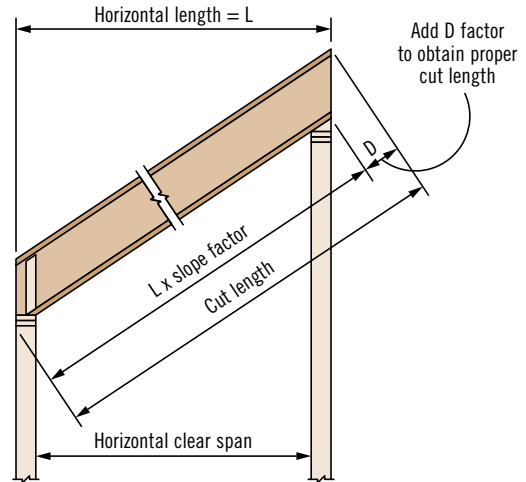

*Actual cut length can be approximated by multiplying the horizontal length by the slope factor and adding the D factor.*

## D Factors

Depth	Slope												
	2½ in 12	3 in 12	3½ in 12	4 in 12	4½ in 12	5 in 12	6 in 12	7 in 12	8 in 12	9 in 12	10 in 12	11 in 12	12 in 12
9½"	2"	2⅜"	2⅞"	3¼"	3⅝"	4"	4¾"	5⅝"	6⅜"	7⅞"	8"	8¾"	9½"
11⅞"	2½"	3"	3½"	4"	4½"	5"	6"	7"	8"	9"	10"	11"	11⅞"
14"	3"	3½"	4⅛"	4¾"	5¼"	5⅞"	7"	8¼"	9⅝"	10½"	11¾"	12⅞"	14"
16"	3⅝"	4"	4¾"	5⅝"	6"	6¾"	8"	9⅝"	10¾"	12"	13⅝"	14¾"	16"

## Slope Factors

Slope	2½ in 12	3 in 12	3½ in 12	4 in 12	4½ in 12	5 in 12	6 in 12	7 in 12	8 in 12	9 in 12	10 in 12	11 in 12	12 in 12
Factor	1.021	1.031	1.042	1.054	1.068	1.083	1.118	1.158	1.202	1.250	1.302	1.357	1.414



**WARNING**  
*Joists are unstable until laterally braced. See Warning Notes on page 5.*

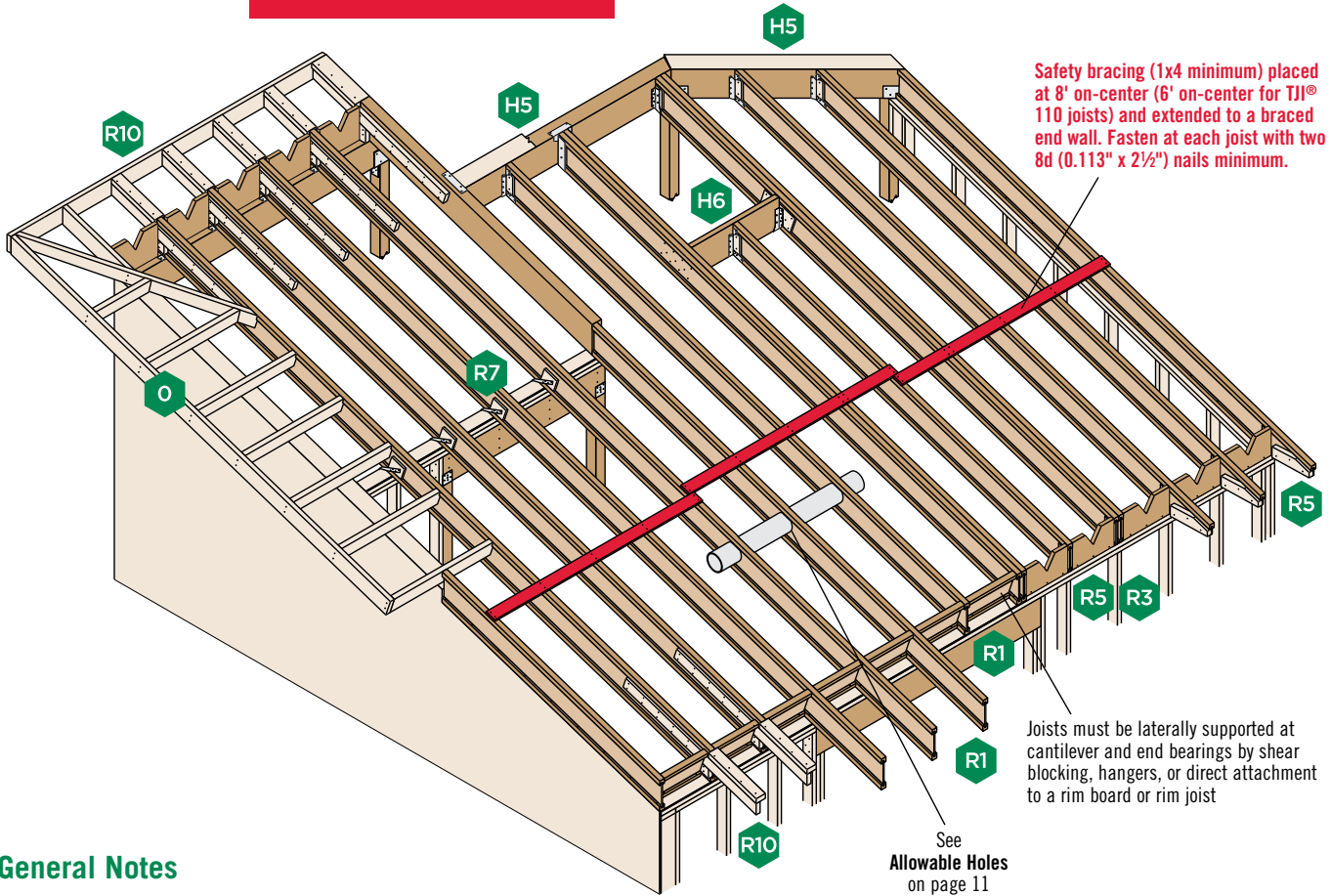

## General Notes

- Unless otherwise noted, all details are valid to a maximum slope of 12/12.
- Web stiffeners are required if the sides of the hanger do not laterally support at least  $\frac{3}{8}$ " of the TJI® joist top flange.

## TJI® Joist Nailing Requirements at Bearing

### TJI® Joist to Bearing Plate

**End Bearing**  
 (1 $\frac{3}{4}$ " minimum bearing required)

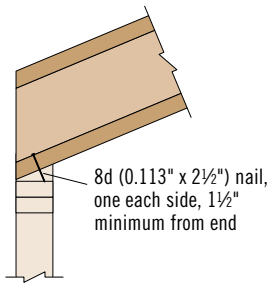

**Intermediate Bearing**  
 (3 $\frac{1}{2}$ " minimum bearing required)

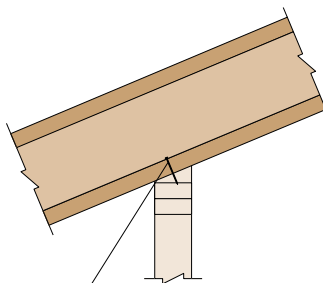

**Slopes 3/12 or less:**  
 One 8d (0.113" x 2 $\frac{1}{2}$ ") nail each side. See detail R7.  
**Slopes greater than 3/12:**  
 Two 8d (0.113" x 2 $\frac{1}{2}$ ") nails each side, plus a twist strap and backer block. See detail R7S.

### Blocking to Bearing Plate

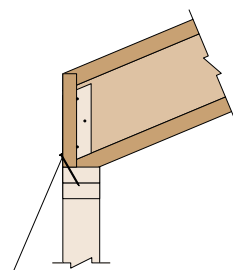

**1/4" TimberStrand® LSL or iLevel® 1 $\frac{1}{8}$ " rim board:**  
 Toenail with 10d (0.128" x 3") nails at 6" on-center or 16d (0.135" x 3 $\frac{1}{2}$ ") nails at 12" on-center  
**TJI® joist blocking:**  
 10d (0.128" x 3") nails at 6" on-center  
**Shear transfer nailing:**  
 Use connections equivalent to sheathing nail schedule

*When slope exceeds  $\frac{1}{4}$ " per foot, a beveled bearing plate, variable slope seat connector, or birdsmouth cut (at low end of joist only) is required*

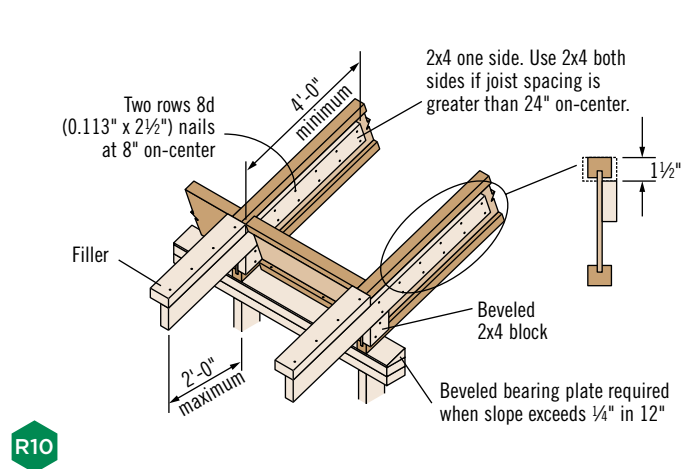
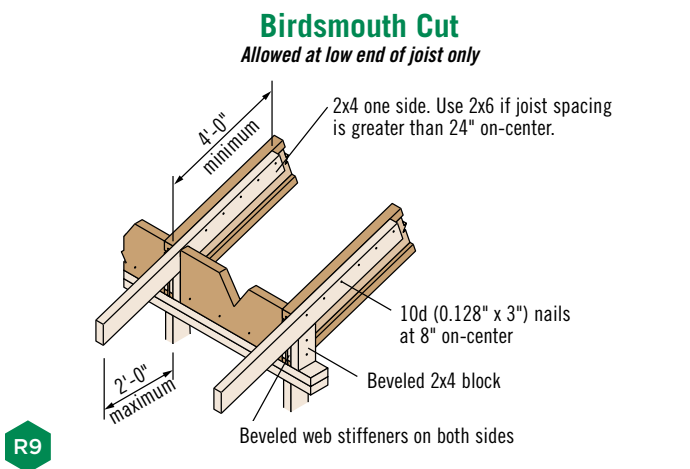
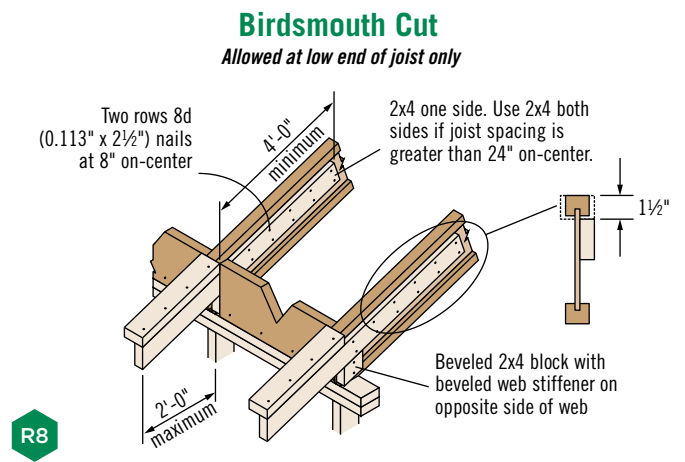
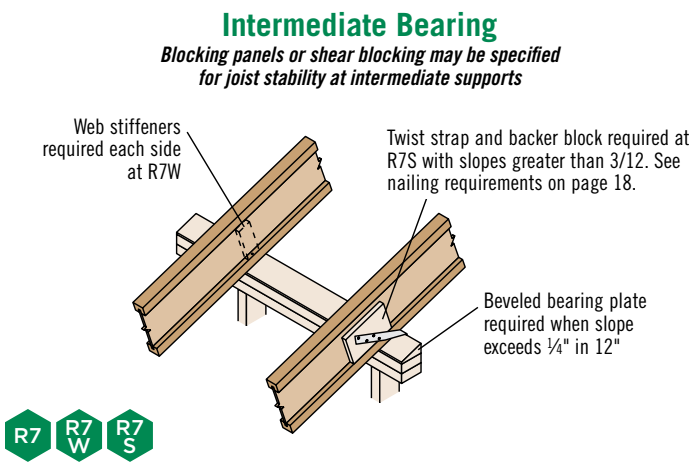
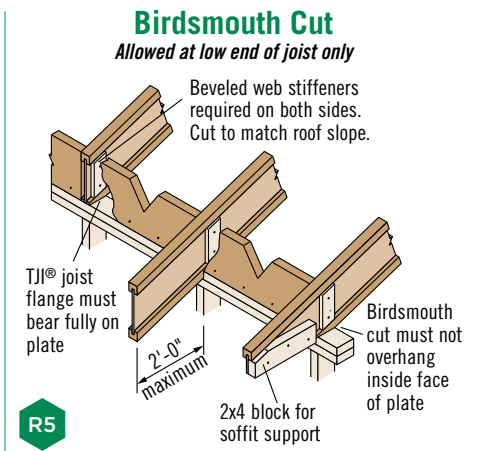
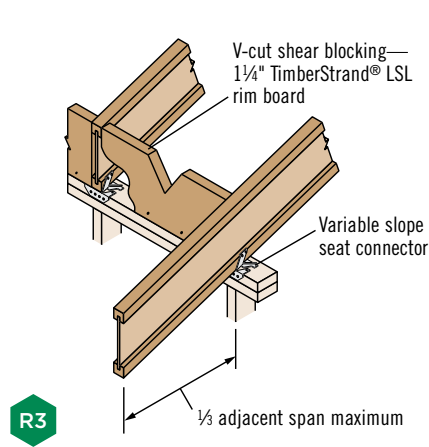
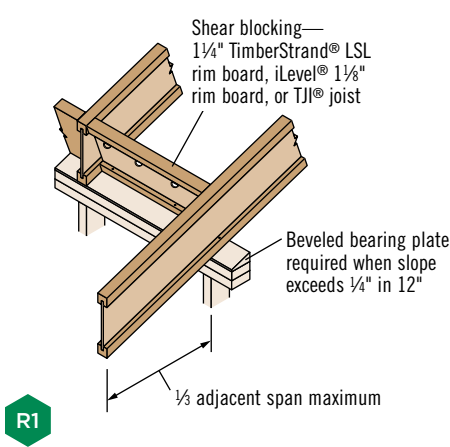

## These Conditions Are **NOT** Permitted

**DO NOT** cut holes  
too close to support.

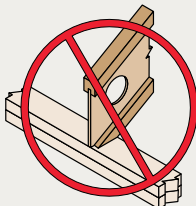

Refer to Allowable Holes on page 11  
for minimum distance from support.

**DO NOT** bevel cut joist  
beyond inside face of wall.

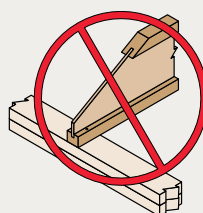

**DO NOT** overhang birdsmouth cut  
from inside face of plate.

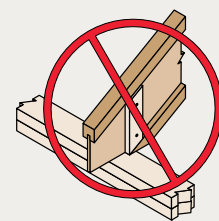

TJI® joist flange must bear fully on the plate.  
See detail BC on page 20.

# ROOF DETAILS

LSTA18 (Simpson or USP) strap with twelve 10d (0.148" x 1½") nails

**Additional blocking may be required for shear transfer**

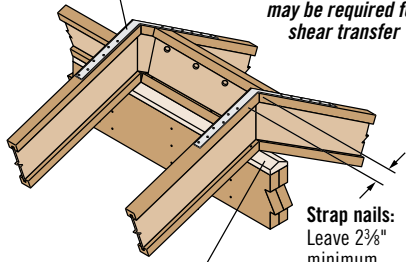

**Strap nails:** Leave 2¾" minimum end distance, typical

Double beveled bearing plate when slope exceeds ¼" in 12"

R14

Double joist may be required when L exceeds joist spacing

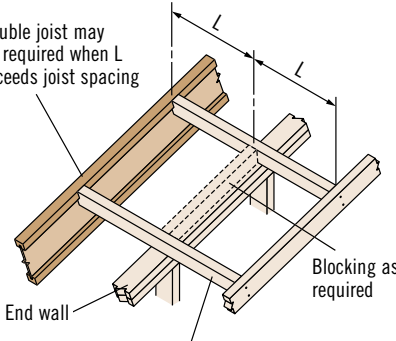

End wall

Blocking as required

2x overhang. Notch around TJI® joist top flange.

O

## Birdsmouth Cut

Allowed at low end of joist only

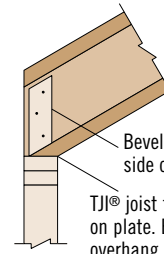

Beveled web stiffener each side of TJI® joist web

TJI® joist flange must bear fully on plate. Birdsmouth cut must not overhang inside face of plate.

BC

LSTA24 (Simpson or USP) strap with twelve 10d (0.148" x 1½") nails required at H5S with slopes greater than 3/12

**Additional blocking may be required for shear transfer**

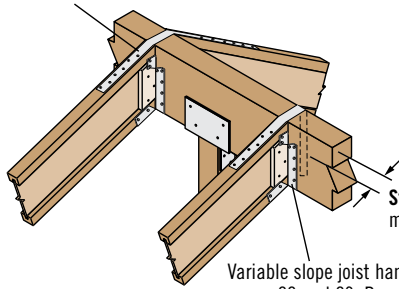

**Strap nails:** Leave 2¾" minimum end distance

Variable slope joist hanger. See pages 22 and 23. Beveled web stiffener required each side.

H5 H5S

**Filler block:** Attach with ten 10d (0.128" x 3") nails, clinched. Use ten 16d (0.135" x 3½") nails from each side with TJI® 560 joists.

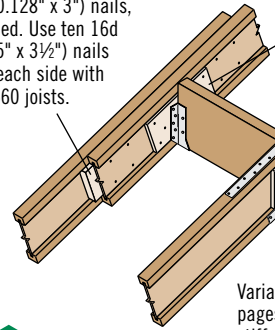

**Backer block:** Install tight to bottom flange (tight to top flange with top flange hangers). Attach with ten 10d (0.128" x 3") nails, clinched when possible.

LSTA18 strap nails at H6S with slopes greater than 3/12

**Strap nails:** Leave 2¾" minimum end distance, typical

Variable slope joist hanger. See pages 22 and 23. Beveled web stiffener required each side.

H6 H6S

## Shear Blocking and Ventilation Holes (Roof Only)

Field trim to match joist depth at outer edge of wall or locate on wall to match joist depth

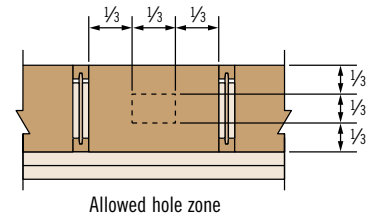
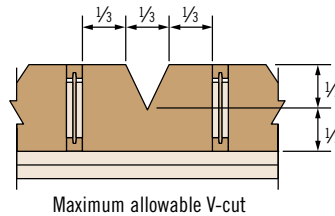
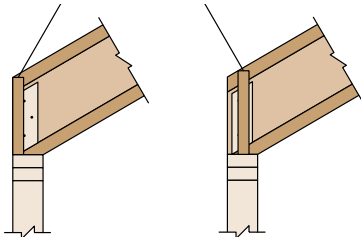

SB

For TJI® joists with slopes of 10/12 to 12/12, the vertical depth at bearing will require 1¼" TimberStrand® LSL or iLevel® 1½" rim board (for shear blocking) that is one size deeper than the TJI® joist

## Filler and Backer Block Sizes

TJI®	110		210		230 or 360		560	
Depth	9½" or 11⅞"	14"	9½" or 11⅞"	14" or 16"	9½" or 11⅞"	14" or 16"	11⅞"	14" or 16"
<b>Filler Block (Detail H6)</b>	2x6	2x8	2x6 + ⅜" sheathing	2x8 + ⅜" sheathing	2x6 + ½" sheathing	2x8 + ½" sheathing	Two 2x6	Two 2x8
<b>Backer Block (Detail H6)</b>	⅝" or ¾"		¾" or 7⁄8"		1" net		2x6	2x8

▪ If necessary, increase filler and backer block height for face mount hangers and maintain ⅛" gap at top of joist. See detail W. Filler and backer block dimensions should accommodate required nailing without splitting. The suggested minimum length is 24" for filler and 12" for backer blocks.

## Product Storage

Protect products from sun and water

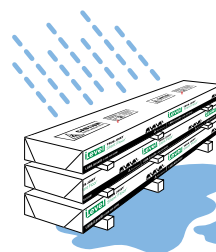

**CAUTION:** Wrap is slippery when wet or icy

Use support blocks at 10' on-center to keep products out of mud and water

See General Notes and nailing requirements on page 18



Roof—115% and 125% Load Duration (PLF) for 6'–16' Spans

Depth	TJI®	Roof Joist Horizontal Clear Span																	
		6'			8'			10'			12'			14'			16'		
		Total Load		Defl.	Total Load		Defl.	Total Load		Defl.	Total Load		Defl.	Total Load		Defl.	Total Load		Defl.
		Snow 115%	Non-Snow 125%	Live Load L/240	Snow 115%	Non-Snow 125%	Live Load L/240	Snow 115%	Non-Snow 125%	Live Load L/240	Snow 115%	Non-Snow 125%	Live Load L/240	Snow 115%	Non-Snow 125%	Live Load L/240	Snow 115%	Non-Snow 125%	Live Load L/240
9½"	110	289	314	*	218	237	*	175	190	*	146	159	155	109	118	101	83	91	69
	210	321	349	*	242	263	*	194	211	*	162	176	*	131	142	118	100	108	81
	230	360	392	*	272	295	*	218	237	*	182	198	196	145	158	128	112	118	88
11⅞"	110	289	314	*	218	237	*	175	190	*	146	159	*	125	136	*	106	115	*
	210	321	349	*	242	263	*	194	211	*	162	176	*	139	151	*	122	132	*
	230	360	392	*	272	295	*	218	237	*	182	198	*	156	170	*	137	149	146
	360	368	400	*	277	301	*	223	242	*	186	202	*	159	173	*	140	152	*
	560	449	488	*	338	368	*	272	295	*	227	246	*	195	212	*	170	185	*
14"	110	289	314	*	218	237	*	175	190	*	146	159	*	125	136	*	110	119	*
	210	321	349	*	242	263	*	194	211	*	162	176	*	139	151	*	122	132	*
	230	360	392	*	272	295	*	218	237	*	182	198	*	156	170	*	137	149	*
	360	368	400	*	277	301	*	223	242	*	186	202	*	159	173	*	140	152	*
	560	449	488	*	338	368	*	272	295	*	227	246	*	195	212	*	170	185	*
16"	210	321	349	*	242	263	*	194	211	*	162	176	*	139	151	*	122	132	*
	230	360	392	*	272	295	*	218	237	*	182	198	*	156	170	*	137	149	*
	360	368	400	*	277	301	*	223	242	*	186	202	*	159	173	*	140	152	*
	560	449	488	*	338	368	*	272	295	*	227	246	*	195	212	*	170	185	*

Roof—115% and 125% Load Duration (PLF) for 18'–28' Spans

Depth	TJI®	Roof Joist Horizontal Clear Span																	
		18'			20'			22'			24'			26'			28'		
		Total Load		Defl.	Total Load		Defl.	Total Load		Defl.	Total Load		Defl.	Total Load		Defl.	Total Load		Defl.
		Snow 115%	Non-Snow 125%	Live Load L/240	Snow 115%	Non-Snow 125%	Live Load L/240	Snow 115%	Non-Snow 125%	Live Load L/240	Snow 115%	Non-Snow 125%	Live Load L/240	Snow 115%	Non-Snow 125%	Live Load L/240	Snow 115%	Non-Snow 125%	Live Load L/240
9½"	110																		
	210	77	77	58															
	230	84	84	63															
11⅞"	110	84	91	82															
	210	101	109	96	82	89	71												
	230	112	121	105	91	98	78	75	79	59									
	360	124	135	*	112	122	103	102	105	78	82	82	61						
	560	152	165	*	137	148	*	124	135	117	114	122	91	97	97	73	79	79	59
14"	110	98	106	*	80	87	*												
	210	108	118	*	97	105	103	80	87	79									
	230	122	132	*	107	117	112	89	96	86	75	81	67						
	360	124	135	*	112	122	*	102	111	*	93	101	88	86	94	70	76	76	57
	560	152	165	*	137	148	*	124	135	*	114	124	*	105	114	104	98	106	85
16"	210	108	118	*	97	106	*	89	96	*	77	83	*						
	230	122	132	*	110	119	*	100	108	*	85	93	90		79	72			
	360	124	135	*	112	122	*	102	111	*	93	101	*	86	94	*	80	87	76
	560	152	165	*	137	148	*	124	135	*	114	124	*	105	114	*	98	106	*

\* Indicates that Total Load value controls.

Slope Factors

Slope	2½ in 12	3 in 12	3½ in 12	4 in 12	4½ in 12	5 in 12	6 in 12	7 in 12	8 in 12	9 in 12	10 in 12	11 in 12	12 in 12
Factor	1.021	1.031	1.042	1.054	1.068	1.083	1.118	1.158	1.202	1.250	1.302	1.357	1.414



How to Use These Tables



1. Calculate actual total load in pounds per linear foot (plf).
2. Select appropriate **Roof Joist Horizontal Clear Span**. For slopes greater than 2" in 12", approximate the increased dead load by multiplying the joist horizontal clear span by the **Slope Factor** above.
3. Scan down the column to find a TJI® joist that meets or exceeds actual total load. **Total Load** values are limited to deflection of L/180. For stiffer deflection criteria, use the **Live Load L/240** values.

General Notes

- Tables are based on:
  - Uniform loads.
  - No composite action provided by sheathing.
  - More restrictive of simple or continuous span.
  - Minimum roof surface slope of ¼" in 12".
- **Total Load** limits joist deflection to L/180.

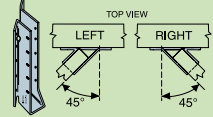
# FRAMING CONNECTORS (SIMPSON STRONG-TIE®)

Joist		Single Joist—Top Flange				Single Joist—Face Mount <sup>(1)</sup>				Face Mount Skewed 45° Joist Hanger <sup>(1)</sup>			
													
Depth	TJI®	Hanger	Capacity (lbs)	Nailing		Hanger	Capacity (lbs)	Nailing		Hanger	Capacity (lbs)	Nailing	
				Header	Joist			Header	Joist			Header	Joist
9½"	110	ITS1.81/9.5	1,365	10d	N.A.	IUS1.81/9.5	935	10d	N.A.	<b>SUR/L1.81/9</b>	1,595	16d	10d x 1½"
	210	ITS2.06/9.5	1,365	10d	N.A.	IUS2.06/9.5	935	10d	N.A.	<b>SUR/L2.1/9</b>	1,595	16d	10d x 1½"
	230	ITS2.37/9.5	1,365	10d	N.A.	IUS2.37/9.5	935	10d	N.A.	<b>SUR/L2.37/9</b>	2,015	16d	10d x 1½"
11⅞"	110	ITS1.81/11.88	1,365	10d	N.A.	IUS1.81/11.88	1,170	10d	N.A.	<b>SUR/L1.81/11</b>	2,130	16d	10d x 1½"
	210	ITS2.06/11.88	1,365	10d	N.A.	IUS2.06/11.88	1,170	10d	N.A.	<b>SUR/L2.1/11</b>	2,130	16d	10d x 1½"
	230	ITS2.37/11.88	1,365	10d	N.A.	IUS2.37/11.88	1,170	10d	N.A.	<b>SUR/L2.37/11</b>	2,305	16d	10d x 1½"
	360	ITS2.37/11.88	1,365	10d	N.A.	IUS2.37/11.88	1,170	10d	N.A.	<b>SUR/L2.37/11</b>	2,305	16d	10d x 1½"
	560	ITT411.88	1,300	10d	10d x 1½"	IUS3.56/11.88	1,405	10d	N.A.	<b>SUR/L410</b>	1,860	16d	16d
14"	110	ITS1.81/14	1,365	10d	N.A.	IUS1.81/14	1,405	10d	N.A.	<b>SUR/L1.81/14</b>	2,500	16d	10d x 1½"
	210	ITS2.06/14	1,365	10d	N.A.	IUS2.06/14	1,405	10d	N.A.	<b>SUR/L2.1/14</b>	2,130	16d	10d x 1½"
	230	ITS2.37/14	1,365	10d	N.A.	IUS2.37/14	1,405	10d	N.A.	<b>SUR/L2.37/14</b>	2,590	16d	10d x 1½"
	360	ITS2.37/14	1,365	10d	N.A.	IUS2.37/14	1,405	10d	N.A.	<b>SUR/L2.37/14</b>	2,590	16d	10d x 1½"
	560	ITT414	1,300	10d	10d x 1½"	IUS3.56/14	1,405	10d	N.A.	<b>SUR/L414</b>	2,395	16d	16d
16"	210	ITT2.1/16	1,300	10d	10d x 1½"	IUS2.06/16	1,640	10d	N.A.	<b>SUR/L2.1/16</b>	2,130	16d	10d x 1½"
	230	MIT3516	2,115	16d	10d x 1½"	IUS2.37/16	1,640	10d	N.A.	<b>SUR/L2.37/16</b>	2,590	16d	10d x 1½"
	360	MIT3516	2,115	16d	10d x 1½"	IUS2.37/16	1,640	10d	N.A.	<b>SUR/L2.37/16</b>	2,590	16d	10d x 1½"
	560	MIT416	2,115	16d	10d x 1½"	IUS3.56/16	1,640	10d	N.A.	<b>SUR/L416</b>	2,395	16d	16d

Joist		Double Joist—Top Flange				Double Joist—Face Mount <sup>(1)</sup>			
									
Depth	TJI®	Hanger	Capacity (lbs)	Nailing		Hanger	Capacity (lbs)	Nailing	
				Header	Joist			Header	Joist
9½"	110	MIT49.5	2,115	16d	10d x 1½"	MIU3.56/9	2,270	16d	10d x 1½"
	210	MIT4.28/9.5	2,115	16d	10d x 1½"	MIU4.28/9	2,270	16d	10d x 1½"
	230	MIT359.5-2	2,115	16d	10d x 1½"	MIU4.75/9	2,270	16d	10d x 1½"
11⅞"	110	MIT411.88	2,115	16d	10d x 1½"	MIU3.56/11	2,840	16d	10d x 1½"
	210	MIT4.28/11.88	2,115	16d	10d x 1½"	MIU4.28/11	2,840	16d	10d x 1½"
	230	MIT3511.88-2	2,115	16d	10d x 1½"	MIU4.75/11	2,840	16d	10d x 1½"
	360	MIT3511.88-2	2,115	16d	10d x 1½"	MIU4.75/11	2,840	16d	10d x 1½"
	560	<b>B7.12/11.88</b>	3,355	16d	16d	<b>HU412-2</b>	2,145	16d	16d
14"	110	MIT414	2,115	16d	10d x 1½"	MIU3.56/14	3,125	16d	10d x 1½"
	210	MIT4.28/14	2,115	16d	10d x 1½"	MIU4.28/14	3,125	16d	10d x 1½"
	230	MIT3514-2	2,115	16d	10d x 1½"	MIU4.75/14	3,125	16d	10d x 1½"
	360	MIT3514-2	2,115	16d	10d x 1½"	MIU4.75/14	3,125	16d	10d x 1½"
	560	<b>B7.12/14</b>	3,355	16d	16d	<b>HU414-2</b>	2,680	16d	16d
16"	210	LBV4.28/16	2,460	16d	10d x 1½"	MIU4.28/16	3,410	16d	10d x 1½"
	230	LBV4.75/16	2,460	16d	10d x 1½"	MIU4.75/16	3,410	16d	10d x 1½"
	360	LBV4.75/16	2,460	16d	10d x 1½"	MIU4.75/16	3,410	16d	10d x 1½"
	560	<b>B7.12/16</b>	3,355	16d	16d	<b>HU414-2</b>	2,680	16d	16d

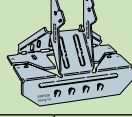
Joist		Variable Slope Seat Connector <sup>(2)</sup>			
					
TJI®	Hanger	Capacity (lbs)	Nailing		
			Header	Joist	
110	VPA25	1,050	10d	10d x 1½"	
210	VPA2.1	1,230	10d	10d x 1½"	
230	VPA35	1,230	10d	10d x 1½"	
360	VPA35	1,230	10d	10d x 1½"	
560	VPA4	1,230	10d	10d x 1½"	

Hanger information on these two pages was provided by either Simpson Strong-Tie® or USP Structural Connectors®. For additional information, please refer to their literature.

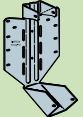
Joist		Variable Slope Seat Joist Hanger <sup>(1)(3)</sup>			
					
TJI®	Hanger	Capacity (lbs)		Nailing	
		Sloped Only	Sloped and Skewed	Header	Joist
110	<b>LSSU125</b>	1,110	995	10d	10d x 1½"
210	<b>LSSU2.1</b>	1,110	995	10d	10d x 1½"
230	<b>LSSU135</b>	1,110	995	10d	10d x 1½"
360	<b>LSSU135</b>	1,110	995	10d	10d x 1½"
560	<b>LSSU410</b>	2,430	1,625	16d	10d x 1½"

## General Notes

**Bold italic** hangers require web stiffeners.

Capacities will vary with different nailing criteria or other support conditions; contact your iLevel representative for assistance.

- Hanger capacities shown are either joist bearing capacity or hanger capacity—whichever is less. Joist end reaction must be checked to ensure it does not exceed the capacity shown in the tables.
- All capacities are for downward loads at 100% duration of load.
- Fill all round, dimple, and positive-angle nail holes.
- Use sloped seat hangers and beveled web stiffeners when TJI® joist slope exceeds ¼" per foot.
- Leave ¼" clearance (½" maximum) between the end of the supported joist and the header or hanger.

See additional notes on page 23

# FRAMING CONNECTORS (USP STRUCTURAL CONNECTORS®)

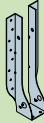
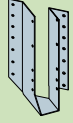
Joist		Single Joist—Top Flange				Single Joist—Face Mount <sup>(1)</sup>				Face Mount Skewed 45° Joist Hanger <sup>(1)(4)</sup>			
													
Depth	TJI®	Hanger	Capacity (lbs)	Nailing		Hanger	Capacity (lbs)	Nailing		Hanger	Capacity (lbs)	Nailing	
				Header	Joist			Header	Joist			Header	Joist
9½"	110	TH017950	950	10d	10d x 1½"	THF17925	910	10d	10d x 1½"	SKH1720L/R	915	10d	10d x 1½"
	210	TFL2095	1,045	10d	10d x 1½"	THF20925	910	10d	10d x 1½"	SKH2020L/R	1,015	10d	10d x 1½"
	230	TFL2395	1,095	10d	10d x 1½"	THF23925	1,220	10d	10d x 1½"	SKH2320L/R	1,065	10d	10d x 1½"
11⅞"	110	TH017118	950	10d	10d x 1½"	THF17112	910	10d	10d x 1½"	SKH1720L/R	915	10d	10d x 1½"
	210	TFL20118	1,045	10d	10d x 1½"	THF20112	910	10d	10d x 1½"	SKH2020L/R	1,015	10d	10d x 1½"
	230	TFL23118	1,095	10d	10d x 1½"	THF23118	1,220	10d	10d x 1½"	SKH2320L/R	1,065	10d	10d x 1½"
	360	TFL23118	1,145	10d	10d x 1½"	THF23118	1,265	10d	10d x 1½"	SKH2320L/R	1,110	10d	10d x 1½"
	560	TH035118	1,430	10d	10d x 1½"	THF35112	1,460	10d	10d x 1½"	SKH410L/R	1,460	16d	16d
14"	110	TH017140	1,215	10d	10d x 1½"	THF17140	950	10d	10d x 1½"	SKH1720L/R	915	10d	10d x 1½"
	210	TFL2014	1,045	10d	10d x 1½"	THF20140	1,045	10d	10d x 1½"	SKH2020L/R	1,015	10d	10d x 1½"
	230	TFL2314	1,095	10d	10d x 1½"	THF23140	1,220	10d	10d x 1½"	SKH2324L/R	1,065	10d	10d x 1½"
	360	TFL2314	1,145	10d	10d x 1½"	THF23140	1,265	10d	10d x 1½"	SKH2324L/R	1,110	10d	10d x 1½"
	560	TH035140	1,430	10d	10d x 1½"	THF35140	1,460	10d	10d x 1½"	SKH414L/R	1,460	16d	16d
16"	210	TFL2016	1,045	10d	10d x 1½"	THF20157	1,400	10d	10d x 1½"	SKH2024L/R	1,015	10d	10d x 1½"
	230	TFL2316	1,095	10d	10d x 1½"	THF23160	1,220	10d	10d x 1½"	SKH2324L/R	1,065	10d	10d x 1½"
	360	TFL2316	1,145	10d	10d x 1½"	THF23160	1,265	10d	10d x 1½"	SKH2324L/R	1,110	10d	10d x 1½"
	560	TH035160	1,430	10d	10d x 1½"	THF35157	1,460	10d	10d x 1½"	SKH414L/R	1,460	16d	16d

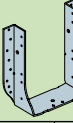
Joist		Double Joist—Top Flange				Double Joist—Face Mount <sup>(1)</sup>			
									
Depth	TJI®	Hanger	Capacity (lbs)	Nailing		Hanger	Capacity (lbs)	Nailing	
				Header	Joist			Header	Joist
9½"	110	TH035950	2,050	10d	10d x 1½"	THF35925	1,370	10d	10d x 1½"
	210	TH020950-2	2,330	16d	10d	THF20925-2	1,390	10d	10d
	230	TH023950-2	2,680	16d	10d	THF23925-2	1,625	10d	10d
11⅞"	110	TH035118	2,050	10d	10d x 1½"	THF35112	1,825	10d	10d x 1½"
	210	TH020118-2	2,330	16d	10d	THF20112-2	1,855	10d	10d
	230	TH023118-2	2,680	16d	10d	THF23118-2	1,855	10d	10d
	360	TH023118-2	2,770	16d	10d	THF23118-2	1,855	10d	10d
	560	BPH71118	3,185	16d	10d	HD7120	2,240	16d	10d
14"	110	TH035140	2,100	10d	10d x 1½"	THF35140	2,165	10d	10d x 1½"
	210	TH020140-2	2,330	16d	10d	THF20140-2	2,320	10d	10d
	230	TH023140-2	2,680	16d	10d	THF23140-2	2,435	10d	10d
	360	TH023140-2	2,770	16d	10d	THF23140-2	2,500	10d	10d
	560	BPH7114	3,185	16d	10d	HD7140	2,800	16d	10d
16"	210	TH020160-2	2,330	16d	10d	THF20140-2	2,320	10d	10d
	230	TH023160-2	2,680	16d	10d	THF23160-2	2,435	10d	10d
	360	TH023160-2	2,770	16d	10d	THF23160-2	2,530	10d	10d
	560	BPH7116	3,185	16d	10d	HD7160	2,920	16d	10d

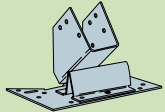
Joist		Variable Slope Seat Connector <sup>(5)</sup>			
					
TJI®	Hanger	Capacity (lbs)	Nailing		
			Header	Joist	
110	TMP175	1,150	10d	10d x 1½"	
	TMPH175	1,485	10d	10d x 1½"	
210	TMP21	1,290	10d	10d x 1½"	
	TMPH21	1,565	10d	10d x 1½"	
230	TMP23	1,460	10d	10d x 1½"	
	TMPH23	1,580	10d	10d x 1½"	
360	TMP23	1,505	10d	10d x 1½"	
	TMPH23	1,630	10d	10d x 1½"	
560	TMP4	1,725	10d	10d x 1½"	
	TMPH4	1,855	10d	10d x 1½"	

### Support Requirements

- Support material assumed to be iLevel® engineered lumber or sawn lumber (Douglas fir or southern pine species).
- Minimum support width for single- and double-joist top mount hangers is 3" (1½" for ITT hangers).
- Minimum support width for face mount hangers with 10d and 16d nails is 1¾" and 2", respectively.

### Footnotes:

- Face mount hanger capacities may be increased up to 15% for snow roofs or 25% for non-snow roofs. Maximum increase for LSSU, LSSUI, and LSSH hangers is 15%.
- VPA connectors are allowed on slopes of 3/12 through 12/12 only.
- LSSU, LSSUI and LSSH hangers can be field adjusted for slopes and skews of up to 45 degrees. Additional lateral restraints are required for 16" deep TJI® joists.
- Miter cut is required at end of joist.
- TMP connectors are allowed on slopes of 1/12 through 6/12 only, and TMPH connectors are allowed on slopes of 6/12 through 12/12 only.

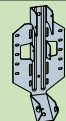
Joist		Variable Slope Seat Joist Hanger <sup>(1)(3)</sup>			
					
TJI®	Hanger	Capacity (lbs)		Nailing	
		Sloped Only	Sloped and Skewed	Header	Joist
110	LSSH179	1,140	1,140	10d	10d x 1½"
210	LSSH20	1,140	1,140	10d	10d x 1½"
230	LSSH23	1,140	1,140	10d	10d x 1½"
360	LSSH23	1,140	1,140	10d	10d x 1½"
560	LSSH35	1,590	1,590	16d	10d x 1½"

See General Notes on page 22



# WE CAN HELP YOU BUILD SMARTER.

At iLevel, our goal is to help you build solid and durable homes by providing high-quality residential building products and unparalleled technical and field support.

**Floors and Roofs:** Start with the best framing components in the industry: our iLevel® Trus Joist® Silent Floor® joists; TimberStrand® LSL rim board; and TimberStrand® LSL, Microllam® LVL, and Parallam® PSL headers and beams. Pull them all together with our durable iLevel® Strukturwood® roof sheathing and self-gapping Strukturwood Edge® or Strukturwood Edge Gold® floor panels.

**Walls:** Get the best value out of your framing package—use TimberStrand® LSL studs for tall walls, kitchens, and bathrooms, and our traditional, solid-sawn lumber everywhere else. Cut down installation time by using TimberStrand® LSL headers for doors and windows, and our Strukturwood® wall sheathing with its handy two-way nail lines.

**Software Solutions:** If you are a design professional or lumber dealer, iLevel offers a full array of software packages to help you specify individual framing members, create cut lists, manage inventories—even help you design whole-house framing solutions. Contact your iLevel representative to find out how to get the software you need.

**Technical Support:** Need technical help? iLevel has one of the largest networks of engineers and sales representatives in the business. Call us for help, and a skilled member from our team of experts will contact you within one business day to evaluate and help solve your structural frame problems—GUARANTEED.

## CONTACT US

1.888.iLevel8 (1.888.453.8358)

[www.iLevel.com](http://www.iLevel.com)

[iLevel@weyerhaeuser.com](mailto:iLevel@weyerhaeuser.com)

2910 East Amity Road

Boise, ID 83716

208.364.3600

P.O. Box 8449

Boise, ID 83707-2449

## OUR GUARANTEE

**iLevel** TRUE JOIST  
Silent Floor Joist  
**HOMEBUYER'S GUARANTEE**

We guarantee that the iLevel® True Joist® products used in your home have been manufactured to exact tolerances and are free from defects in materials and workmanship. In the unlikely event that your iLevel® True Joist® Silent Floor® joist develops a defect or any other condition caused by us, we will, at our option, repair or replace the joist, or provide you with a replacement joist, at no cost to you.

In addition, if you call us with a problem that you believe may be covered by our product's performance guarantee, we will contact you within one business day to evaluate the problem and help resolve it.

This guarantee is effective for the life of your home.

**1-888-453-8358**

Weyerhaeuser

February 2008  
Reorder TJ-4000

This document supersedes all previous versions. If this is more than one year old, contact your dealer or iLevel rep.  
NW

Weyerhaeuser, iLevel®, Microllam®, Parallam®, Silent Floor®, Strukturwood®, Strukturwood Edge®, Strukturwood Edge Gold®, TimberStrand®, TJ®, TJ-Beam®, TJI®, TJ-Xpert®, and Trus Joist® are registered trademarks, and All in One™, Performance Tested™, and TJ-Pro™ are trademarks of Weyerhaeuser.  
© 2008 Weyerhaeuser Company. All rights reserved. Printed in the USA.