

## CONTENTS

GENERAL .....	2	TERMINAL FUNCTION .....	64
SYSTEM SET-UP .....	2	ADJUSTMENT .....	69
INSTALLATION .....	3	PC BOARD	
OPERATING FEATURES .....	4	CONTROL UNIT (X53-3882-71) .....	81
REALIGNMENT .....	13	TX UNIT (X56-3072-70) .....	91
APPLICATION NOTE .....	15	RX UNIT (X55-3050-11) .....	103
DISASSEMBLY FOR REPAIR .....	24	SCHEMATIC DIAGRAM .....	109
CIRCUIT DESCRIPTION .....	26	BLOCK DIAGRAM .....	121
SEMICONDUCTOR DATA .....	43	LEVEL DIAGRAM .....	123
COMPONENTS DESCRIPTION .....	46	INTERCONNECTION DIAGRAM .....	125
PARTS LIST .....	48	KES-4 (EXTERNAL SPEAKER) .....	127
EXPLODED VIEW .....	61	KPG-46 (PROGRAMMING INTERFACE CABLE) .....	128
PACKING .....	63	SPECIFICATIONS .....	BACK COVER

# TKR-740

## GENERAL / SYSTEM SET-UP

### INTRODUCTION

#### SCOPE OF THIS MANUAL

This manual is intended for use by experienced technicians familiar with similar types of commercial grade communications equipment. It contains all required service information for the equipment and is current as of the publication date. Changes which may occur after publication are covered by either Service Bulletins or Manual Revisions. These are issued as required.

#### ORDERING REPLACEMENT PARTS

When ordering replacement parts or equipment information, the full part identification number should be included. This applies to all parts, components, kits, or chassis. If the part number is not known, include the chassis or kit number of which it is a part, and a sufficient description of the required component for proper identification.

#### PERSONNEL SAFETY

The following precautions are recommended for personnel safety:

- DO NOT transmit until you verify that all RF connectors are secure and any open connectors are properly terminated.
- SHUT OFF and DO NOT operate this equipment near electrical blasting caps or in an explosive atmosphere.
- This equipment should be serviced by a qualified technician only.

#### SERVICE

This radio is designed for easy servicing. Refer to the schematic diagrams, printed circuit board views, and alignment procedures contained within.

### SYSTEM SET-UP

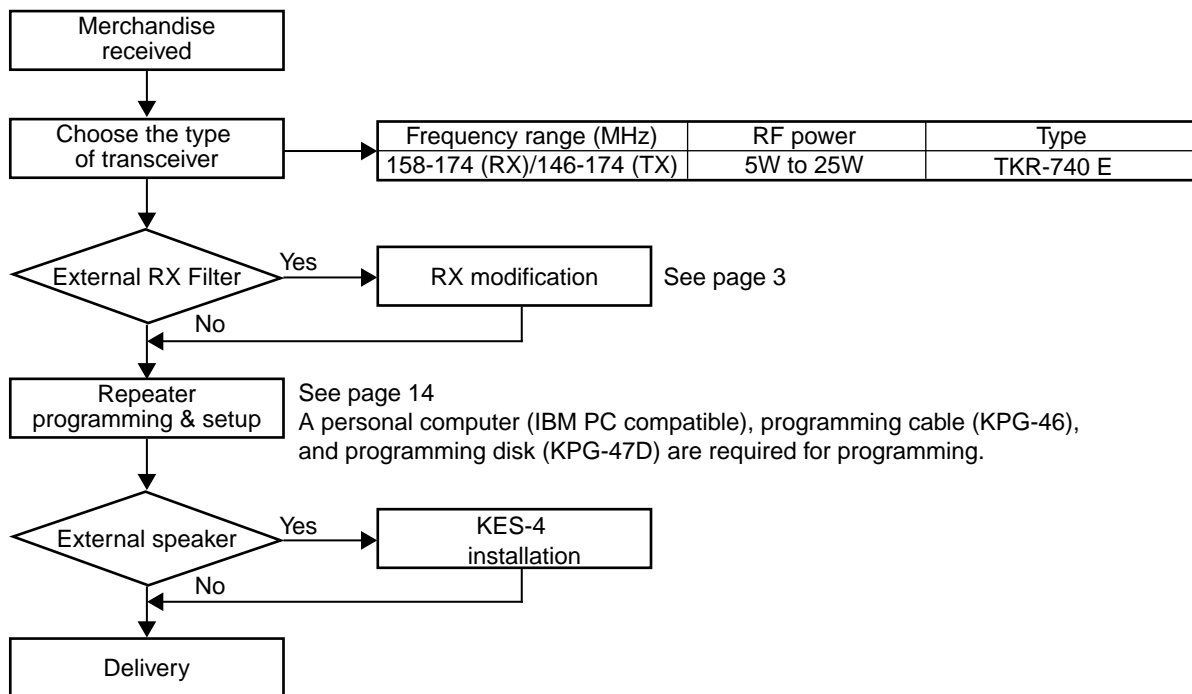

# INSTALLATION

## RX MODIFICATION FOR EXTERNAL PRESELECTOR FILTER

This model may be modified to use an external pre-selector filter.

- ① Remove the RX cover panel.
- ② Remove the flat clip spring from IC4 and L16
- ③ Remove the 11 screws from the RX unit and the 10 screws from the shield case.
- ④ Remove the jumper (R179) from the reverse side of the RX unit.
- ⑤ Insert an SMB receptacle (E04-0409-05) at CN10. Solder the 5 leads in place.
- ⑥ Replace the screws on the RX unit and shield case, and the flat clip spring on IC4 and L16.
- ⑦ Move the RX IN signal cable (from the back panel) from CN1 to CN10.
- ⑧ Connect a tracking generator signal to RX IN, then use a spectrum analyzer to read the output at CN2 while adjusting L16 for the proper response.
- ⑨ Next, adjust IF , squelch , and RSSI.
- ⑩ Replace the RX cover panel.

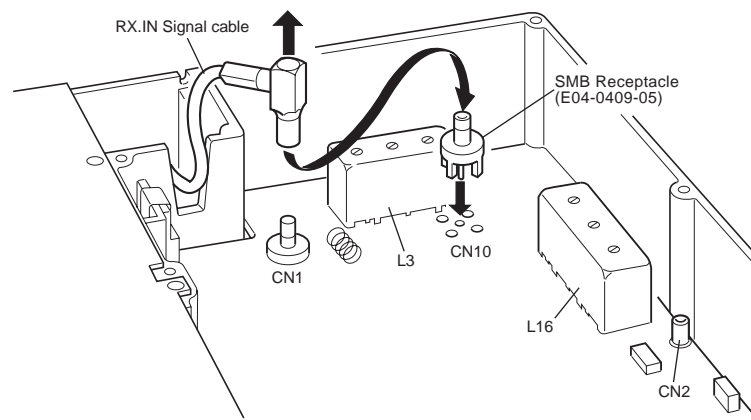
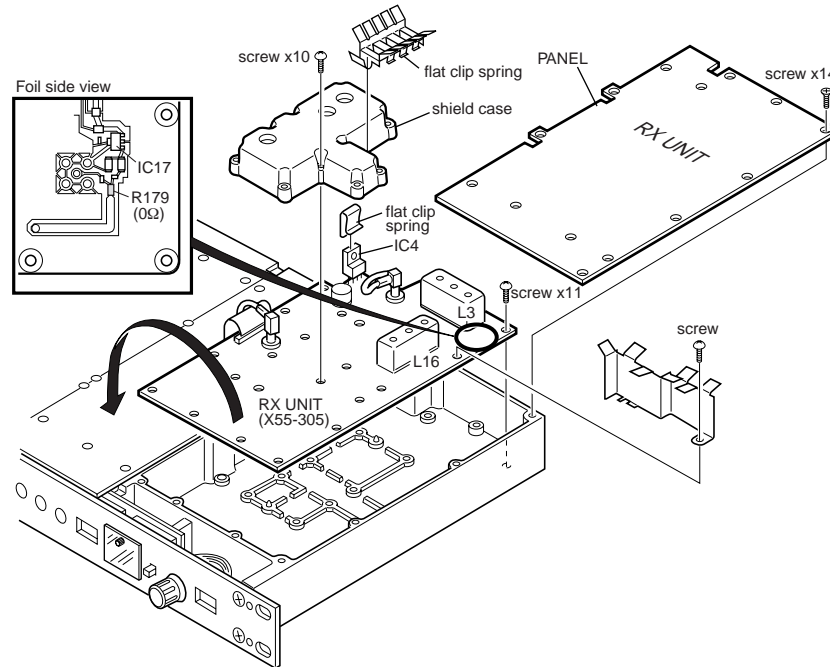

# TKR-740

## OPERATING FEATURES

### 1. Front Panel

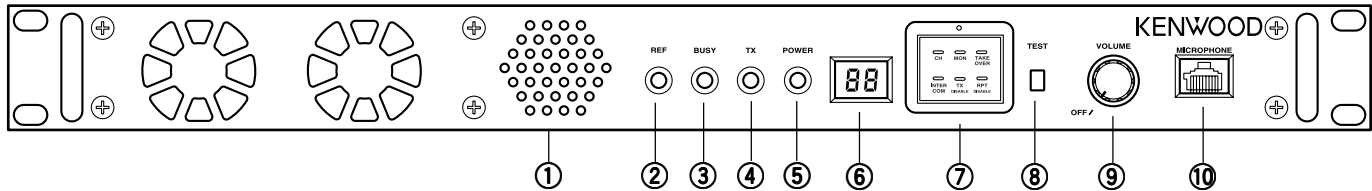

**① Speaker**

**② REF (reference) indicator**

Lights red when using an external reference oscillator. Lights green when using the internal oscillator.

**③ BUSY indicator**

Lights green when receiving. Flashes when receiving data from the KPG-47D or when the receiver PLL is unlocked.

**④ TX (transmit) indicator**

Lights red when transmitting. Flashes when transmitting data to the KPG-47D (during programming) or when the transmit PLL is unlocked.

**⑤ POWER indicator**

Lights green when DC power is applied to the TKR-740.

**⑥ Display**

Two 7-segment digits display the channel number or status.

**⑦ Programmable Function keys**

Press these keys to activate their programmable functions.

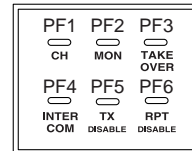

PF 1 Key	Default: CH (CH UP)
PF 2 Key	Default: MON (MONITOR ON/OFF)
PF 3 Key	Default: TAKE OVER (TAKE OVER ON/OFF)
PF 4 Key	Default: INTERCOM (INTERCOM ON/OFF)
PF 5 Key	Default: TX DISABLE (TX Disable/Enable)
PF 6 Key	Default: RPT DISABLE (Repeat Disable/Enable)

**⑧ TEST switch**

Press to transmit an unmodulated signal with no local microphone connected. If an external modulation signal source is connected to the **CONTROL I/O** jack, the RF signal is modulated with this signal source.

**⑨ VOLUME control**

Turn clockwise until a click sounds, to unmute the volume. Rotate to adjust the volume. Turn counterclockwise fully to mute the volume.

**⑩ MICROPHONE jack**

Connect a microphone to 8-pin modular jack.

### 2. Rear Panel

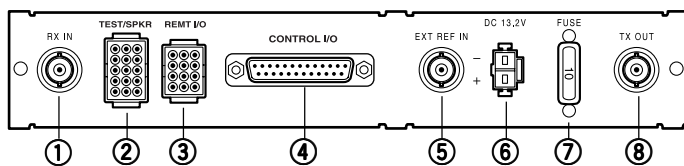

**① RX IN jack**

Connect an RX antenna or a duplexer to this BNC receptacle.

**② TEST/SPKR jack**

Test input/output jack. Connect an external speaker to this jack.

**③ REMT I/O jack**

Connect an external remote controller to this jack.

**④ CONTROL I/O jack**

Connect an external programming device or an external repeater controller to this DB-25 interface port.

**⑤ EXT REF IN jack**

Connect a high-stability external frequency reference oscillator (10MHz, -10dBm or higher) to this BNC receptacle (optional).

**⑥ DC 13.2V jack**

Connect a 13.2 V DC power supply to this jack.

**⑦ FUSE**

Insert a 10 A blade fuse into this fuse holder.

**⑧ TX OUT jack**

Connect a TX antenna or a duplexer to this BNC receptacle.

## OPERATING FEATURES

## 3. Two 7-segment LED Displays

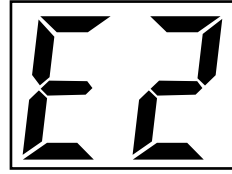
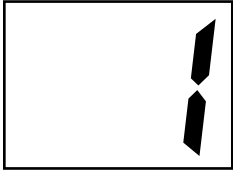

- Channel display (1-32): while operating normally in User Mode

- "E2" displayed when the channel data is not written.

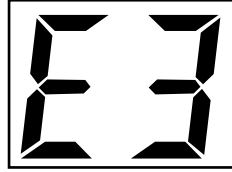

- "PC" displayed while in PC Mode.

- "E3" displayed when PLL is unlocked .  
Receiver PLL unlocked = flashing BUSY LED.  
Transmitter PLL unlocked = flashing TX LED.  
Internal 19.2MHz reference unlocked = flashing decimal point



- "PG" displayed while in Firmware Programming Mode  
2 decimal points displayed = 115,200 bps  
1 decimal point displayed = 57,600 bps  
No decimal = 38,400 bps

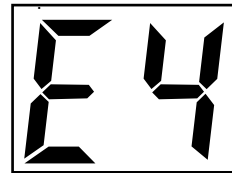

- "E4" displayed when PTT is attempted on a channel number that has no frequency data programmed.

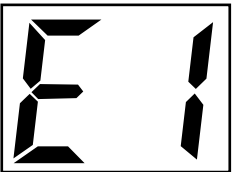

- "E1" displayed when FPU data is not written.

- "SC" displayed while in scan mode  
when the displayed channel is contained in scan sequence,  
the right side decimal point is displayed.  
When the displayed channel is the priority channel, the left  
side decimal point is displayed.

## OPERATING FEATURES

## 4. Programmable Functions

TKR-740 contains many Programmable Functions tabled below.

Programmable Function	Description
Channel 1-32	Directly select Channel 1 to 32, respectively.
Channel Down	The channel decrements by one.
Channel Up	The channel increments by one.
AUX Out 1-6 Off	AUX Out 1 to 6 ports become deactivated, respectively.
AUX I/O 1-7 Off	AUX I/O 1 to 7 ports become deactivated, respectively.
AUX Out 1-6 On	AUX Out 1 to 6 ports become activated, respectively.
AUX I/O 1-7 On	AUX I/O 1 to 7 ports become activated, respectively.
AUX Out 1-6 On/Off	AUX Out 1 to 6 ports are toggled between its active and inactive states, respectively.
AUX I/O 1-7 On/Off	AUX I/O 1 to 7 ports are toggled between its active and inactive states, respectively.
Repeat Enable	Enables repeater operation.
Repeat Disable	Disables repeater operation.
Repeat Disable/Enable	Toggles between disabling and enabling repeater operation.
TX Enable	The transmitter is enabled (normal).
TX Disable	The transmitter is inhibited.
TX Disable/Enable	Toggles between transmitter enabled (normal) and transmitter inhibited.
Remote TX Enable	The Remote PTT is enabled.
Remote TX Disable	The Remote PTT is disabled.
Remote TX Disable/Enable	The Remote PTT is toggled between disabled and enabled.
Local TX Enable	The local mic's PTT is enabled.
Local TX Disable	The local mic's PTT is disabled.
Local TX Disable/Enable	The local mic's PTT is toggled between disabled and enabled.
Scan Off	Inhibits scanning.
Scan On	Starts scanning.
Scan On/Off	Scanning is toggled between being enabled or inhibited.
Intercom On	The Intercom feature is enabled.
Intercom Off	The Intercom feature is disabled.
Intercom On/Off	The Intercom feature is toggled between enabled and disabled.
Voting Tone Off	Inhibits the Voting Pilot Tone.
Voting Tone On	Enables the Voting Pilot Tone.
Voting Tone On/Off	Toggles between enabling and inhibiting the Voting Pilot Tone.
Take Over	Toggles between enabling and disabling remote wireline control.
QT/DQT Encode Enable	Enables the QT/DQT encode operation.
QT/DQT Encode Disable	Disables the QT/DQT encode operation.
QT/DQT Encode Disable/Enable	Toggles between disabling and enabling the QT/DQT decode operation.
QT/DQT Decode Enable	Enables the QT/DQT decode operation.
QT/DQT Decode Disable	Disables the QT/DQT decode operation.
QT/DQT Decode Disable/Enable	Toggles between disabling and enabling the QT/DQT decode operation.
Test Tone Off	The Test Tone is inhibited.
Test Tone On	The Test Tone is enabled.
Test Tone On/Off	Toggles between enabling and inhibiting the Test Tone.
Squelch Off	The Squelch unmutes.
Squelch On	The Squelch mutes.
Squelch On/Off	The receiver's squelch toggles between muted and unmuted.
Squelch Momentary	The squelch momentarily unmutes.
Monitor Off	The QT/DQT decoder is enabled.
Monitor On	The QT/DQT decoder is disabled.
Monitor On/Off	The QT/DQT decoder is toggled between enable and disable.

## OPERATING FEATURES

Programmable Function	Description
Monitor Momentary	The QT/DQT decoder is momentarily disabled.
CW ID On	The CW ID is transmitted.
CW Message 1-8 On	The CW Message 1 to 8 is transmitted, respectively.
TOT Enable	The Time Out Timer is enabled.
TOT Disable	The Time Out Timer is disabled.
TOT Disable/Enable	The Time Out Time is toggled between enabled and disabled.
Hold Time Enable	The parameter of Repeat Hold Time is enabled.
Hold Time Disable	The parameter of Repeat Hold Time is disabled.
Hold Time Disable/Enable	The parameter of Repeat Hold Time is toggled between disabled and enabled.
Scrambler Off	Disables an installed optional voice scrambler board.
Scrambler On	Enables an installed optional voice scrambler board.
Scrambler On/Off	Toggles between enabling and disabling an installed optional voice scrambler board.
Digital Pager PTT	Accepts the external paging encoder's PTT on AUX Input 2.
Digital Pager Data	Accepts the external paging encoder's digital signal on AUX Input 3.
Reset	Resets to default condition set up by FPU.
None	No function.

- The following Programmable Functions are output functions used to tell the condition of the TKR-740 to an external device.
- The output functions can be assigned to only AUX Outputs as follows.

Programmable Function	Description
COR(Carrier Operate Relay)	This function becomes valid if an RF carrier is present.
TOR(Tone Operate Relay)	This function becomes valid if an RF carrier and specified QT/DQT are present.
TXS(TX Sense)	This function becomes valid when the transmitter is keyed.
RX Unlock	This alarm function becomes valid if the RX PLL circuitry becomes unlocked.
TX Unlock	This alarm function becomes valid if the TX PLL circuitry become unlocked.
Exciter Temperature	This alarm function becomes valid if the temperature of transmitter's exciter exceeds approximately 203°F (95°C) while transmitting.
Power Supply Upper Limit	This alarm function becomes valid if the DC power supply voltage exceeds the preset point. The preset point is selected in the range of 13.9V to 15.9V.
Power Supply Lower Limit	This alarm function becomes valid if the DC power supply voltage becomes less than the preset point. The preset point is selected in the range of 11.7V to 13.8V.
Exciter Power Upper Limit	This alarm function becomes valid if the transmitter's RF Power output exceeds the preset point in High power range.
Exciter Power Lower Limit	This alarm function becomes valid if the transmitter's RF Power output becomes less than the preset point in High power range.
RX Signal Detect (Above)	This function becomes valid if the receive signal strength exceeds the preset point. The preset point is selected in the range of -120dBm to -80dBm.
RX Signal Detect (Below)	This function becomes valid if the receive signal strength becomes less than the preset point. The preset point is selected in the range of -120dBm to -80dBm.
Selectable	AUX Outputs which are set up as Selectable appear in the available Function List for the AUX Input Functions and Key Assignment. This allows AUX Inputs and PF Keys to be used to control AUX Outputs.

## OPERATING FEATURES

### 5. Trigger Assignment

The Programmable Functions described above can be assigned to PF Keys, AUX Input, and Start Up according to following table. In the last column of the table, when the Programmable Functions is assigned to any PF Keys, it expresses that the

LED in the PF Key turns on either conditions. 'O' expresses that the trigger is available the Programmable Function. 'X' expresses that the trigger is not available the Programmable Function.

Function	Trigger			Condition of LED on
	PF Keys	AUX Input	Start Up	
Channel 1-32, Up/Down	O	O	O	Do not turn on
AUX Out 1-6(I/O 1-7) Off	X	O	O	-
AUX Out 1-6(I/O 1-7) On	X	O	O	-
AUX Out 1-6(I/O 1-7) On/Off	O	O	X	Turns on in ON status
Repeat Enable	X	O	O	-
Repeat Disable	X	O	O	-
Repeat Disable/Enable	O	O	X	Turns on in Disable status
TX Enable	X	O	O	-
TX Disable	X	O	O	-
TX Disable/Enable	O	O	X	Turns on in Disable status
Remote TX Enable	X	O	O	-
Remote TX Disable	X	O	O	-
Remote TX Disable/Enable	O	O	X	Turns on in Disable status
Local TX Enable	X	O	O	-
Local TX Disable	X	O	O	-
Local TX Disable/Enable	O	O	X	Turns on in Disable status
Scan Off	X	O	O	-
Scan On	X	O	O	-
Scan On/Off	O	O	X	Turns on in ON status
Intercom On	X	O	O	-
Intercom Off	X	O	O	-
Intercom On/Off	O	O	X	Turns on in ON status
Voting Off	X	O	O	-
Voting On	X	O	O	-
Voting On/Off	O	O	X	Turns on in ON status
Take Over	O	X	X	Turns on in ON status
QT/DQT Encode Enable	X	O	O	-
QT/DQT Encode Disable	X	O	O	-
QT/DQT Encode Disable/Enable	O	O	X	Turns on in Disable status
QT/DQT Decode Enable	X	O	O	-
QT/DQT Decode Disable	X	O	O	-
QT/DQT Decode Disable/Enable	O	O	X	Turns on in Disable status
Test Tone Off	X	O	O	-
Test Tone On	X	O	O	-
Test Tone On/Off	O	O	X	Turns on in ON status
Squelch Off	X	O	O	-
Squelch On	X	O	O	-
Squelch On/Off	O	O	X	Turns on in OFF status
Squelch Momentary	O	X	X	Turns on in OFF status
Monitor Off	X	O	O	-



## OPERATING FEATURES

Function	Trigger	PF Keys	AUX Input	Start Up	Condition of LED on
Monitor On		X	O	O	-
Monitor On/Off		O	O	X	Turns on in ON status
Monitor Momentary		O	X	X	Turns on in ON status
CW ID On		O	O	O	Turns on while transmitting
CW Message 1-8 On		O	O	O	Turns on while transmitting
TOT Enable		X	O	O	-
TOT Disable		X	O	O	-
TOT Disable/Enable		O	O	X	Turns on in Disable status
Hold Time Enable		X	O	O	-
Hold Time Disable		X	O	O	-
Hold Time Disable/Enable		O	O	X	Turns on in Disable status
Scrambler Off		X	O	O	-
Scrambler On		X	O	O	-
Scrambler On/Off		O	O	X	Turns on in ON status
Reset		O	O	X	Do not turn on
None		O	O	O	Do not turn on

## OPERATING FEATURES

### 6. Simplex/Duplex Operation

The Simplex/Duplex function is used to specify whether the channel is used as simplex (receiver muted during transmit) or duplex (receiver unmuted during transmit). The channel has same TX/RX frequency and can operate only in Simplex mode.

### 7. Repeater/Base Station Operation

The Repeat function is used to specify whether the channel is used as a repeater or as a base station. A repeater simultaneously and automatically re-transmits its received audio; a duplex base station has independent simultaneous transmit and receive paths; a simplex base station are mutually exclusive transmit and receive paths.

### 8. Signalling Feature

#### 8.1 Multiple QT/DQT

The TKR-740 can function as a multiple-QT/DQT decode/encode unit for operation as a community repeater or multiple-QT/DQT base station. 16 Multi Tables can be created, each Multi Table consisting of 16 decode / encode combinations and can be assigned on a per-channel basis.

The Multi Table function enables the TKR-740 to decode any one of the 16 QT/DQTs pre-programmed into the selected Multi Table. When receiving a signal (repeater operation), the repeater uses the QT/DQT encode which corresponds to the decoded QT/DQT as set in the Multi Table. In the Multi Table, signalling pair of "No.1" (first column) is defined as "Primary". A receiving signalling (if it is contained within No.1 to No.16) is defined as "Current".

#### 8.2 Encode Tone in Multiple

When Local mic PTT, Remote PTT or Ext. PTT is active while the repeater is in use or the duplex-base station is receiving, the encode signalling is determined according to Encode Tone in Multiple function. The simplex-base station always transmits the "Primary" encode QT/DQT.

Current : When any PTT as described above is active while the repeater is in use or the duplex-base station is receiving, the "paired" encode QT/DQT associated with receiving QT/DQT is transmitted. When any PTT is active while the repeater or the duplex-base station is in idle period, the "Primary" encode QT/DQT is transmitted.

Primary : When any PTT (provided that the Priority of any PTT is higher than the Priority of Repeat PTT) is active while the repeater is in use, the encode QT/DQT changes "paired" encode QT/DQT to "Primary" while continuing to transmit. When any PTT is active while the repeater is in idle period, the "Primary" encode QT/DQT is transmitted. In the base station, the "Primary" encode QT/DQT is always transmitted regardless of the receiver status.

#### 8.3 QT Reverse Burst Time

During repeat with QT tones, the repeater re-transmits a phase-shifted burst of the QT tone ("reverse burst") when it detects the radio using the repeater has un-keyed and also

sent a reverse QT burst (squelch-tail elimination). This mutes a receiving radio's speaker audio before its receiver circuit shuts off causes squelch tail noise in the speaker audio. The TKR-740 can select the time between 140 to 200 ms that the QT reverse burst is sent. Typically this time should not have to be adjusted from the default value. The transmission of the QT reverse burst can be also inhibited if the QT Reverse Burst function is set to "No".

#### 8.4 DQT Turn Off Code Time

During repeat with DQT codes, the repeater re-transmits a specific turn-off code when it detects the radio using the repeater has un-keyed and also sent the turn-off code (squelch-tail elimination). This mutes a receiving radio's speaker audio before its receiver circuit shuts off and causes squelch tail noise in the speaker audio. The TKR-740 can select the time between 140 to 200 ms that the DQT turn-off code is sent. Typically this time should not have to be adjusted from the default value.

#### 8.5 Off Hook Decode

The TKR-740 is able to decode QT/DQT regardless whether the local microphone is in the on- or off-hook condition. When the Off Hook Decode function is enabled, the TKR-740 is capable of QT/DQT decode even though the microphone is in the off-hook condition (or a local microphone is not installed).

### 9. Scan Feature

#### 9.1 Scan Operation

Providing that the TKR-740 contains two or more non-priority ADD channel or one or more non-priority ADD channel and Priority channel, it starts scanning once the Scan On function is executed and displays "SC" on the 7-seg LED. Scanning stops temporarily if any following conditions become valid.

- 1) if a RF carrier and a valid QT/DQT is present. The receiving channel number is displayed and the received audio is heard from a speaker.
- 2) if a RF carrier is present, providing that the Monitor On function is executed.
- 3) if the Squelch Off function is executed. Scanning stops on the channel being scanned when Squelch Off is executed, the channel number is displayed and the received audio is heard from a speaker.
- 4) if a local microphone's hook is in off hook status, providing that the Off Hook Scan function is set to Disable. Scanning stops on the Revert channel, but the audio is not heard until a valid signal is received.

When the received call is ended, scanning automatically resumes after the period set in Dropout Delay Time function has expired. When the Scan Off function is executed, the TKR-740 inhibits scanning and displays the selected channel.

#### 9.2 Scan Sequence

- 1) Normal Scan : When no Priority channel is set, scanning of ADD channels is done in ascending order.
- 2) Single Priority Scan : The Priority channel is set as either a

## OPERATING FEATURES

fixed channel or a selected channel. When Priority channel is set, Priority channel and non Priority channel is scanned by turns. When scanning stops on the non Priority channel, calls from the Priority channel is still checked at set intervals while scanning is stopped. This operation is called Look Back and the interval period is selected by the Look Back Time function.

### 9.3 Revert Channel

The Revert channel is a channel that used to transmit during scanning. The time from the end of transmission on Revert channel to the time scanning automatically resumes is set in Dwell Time function. The Revert channel types are Last Called, Last Used, Selected + Talkback, Priority, Priority plus Talkback, and Selected.

- 1) Last Called : The TKR-740 reverts to the channel upon which a call was last received even if scanning has resumed (power on default = selected channel).
- 2) Last Used (with Talkback) : The TKR-740 reverts to the channel that was last transmitted on (power on default = selected channel). However, if a call is received on a channel other than the last transmit channel and PTT is pressed before scanning resumes, the transceiver "talks back" on the current receive channel.
- 3) Selected+Talkback : The TKR-740 reverts to the channel set by the Channel 'X' functions or Channel Select function prior to scan initiation. However, if a call is received on a channel other than the selected channel and PTT is pressed before scanning resumes, the transceiver "talks back" on the current receive channel.
- 4) Priority : The TKR-740 always reverts to the Priority channel.
- 5) Priority+Talkback : The TKR-740 always reverts to the Priority channel. However, if a call is received on a channel other than the Priority channel and PTT is pressed before scanning resumes, the transceiver "talks back" on the current receive channel.
- 6) Selected : The transceiver reverts to the channel set by the function prior to scan initiation.

### 10. CW ID and Message

The TKR-740 contains internal automatic station identifiers. The CW ID (Morse code) is set and transmitted on a per-channel basis. The CW ID is transmitted when the interval period is reached (TX Interval Time function), the channel is changed (CW ID on Channel Change function) or CW ID On function is executed. When CW ID is activated by any functions described above, it is actually sent after the total time of TX Delay Time (not applied to CW ID On function) and CW Modulation Delay Time has expired. TX Delay Time is a period from CW ID is activated to the transmitter is keyed. CW Modulation Delay is a period from the transmitter is keyed to the CW ID tone is sent. The CW ID tone is routed to the Remote Receive Audio (Remote RA) port if the Send CW ID to Remote RA function is set to Yes, consequently the console can monitor the CW ID tone.

The TKR-740 contains 8 message banks for CW Message. CW Message 1 to 8 is transmitted on the current channel when the CW Message 1 to 8 On function is activated, respectively.

### 11. PTT Priority

A number of keying sources can be used to cause the TKR-740 to transmit. The transmit audio path is switched according to their keying sources and when PTTs is simultaneously activated, the transmit audio path related to the PTT with higher priority is given priority. These are Local Mic PTT, External PTT, Remote PTT, Repeat PTT and Digital Pager PTT. However, since Digital Pager PTT is considered lowest of priority, it is not selected in the order of priority.

### 12. Intercom Operation

The repeater has an Intercom feature which allows wireline communication between the dispatcher at the remote site and the servicing technician at the repeater. To use this feature, Intercom On/Off (mandatory), TX Disable/Enable, Local TX Disable/Enable and Remote TX Disable/Enable functions must be optionally assigned to a PF Key or an Aux Input.

When Intercom On function is executed and a PTT is activated, a intercom operation becomes valid and a transmitter is also keyed. To use the Intercom without keying the transmitter, enable the TX Disable function (PF Key or Aux Input). To use the Intercom with a local mic's PTT without keying the transmitter, enable the Local TX Disable function. To use the Intercom with the wireline remote site's PTT without keying the transmitter, enable the Remote TX Disable function.

The audio routing during Intercom operation is determined by the Intercom Remote/Local function.

- 1) Remote : Audio from the Remote TA port will be heard on the local speaker while a Remote PTT is pressed, regardless of whether receiver audio is present.
- 2) Local : Audio from the local Mic will be routed to the Remote RA port on the rear panel regardless of whether receiver audio is present. This local Mic audio will be heard at the remote.
- 3) Remote/Local : Audio from the remote and the local Mic audio will be heard from the local speaker and from the remote respectively, regardless of whether receiver audio is present.

### 13. Voting Pilot Tone

The TKR-740 contains an internal Voting Pilot Tone Generator to be used with a voting comparator shelf. The Voting Pilot Tone is sent from a remote receiver to a voting comparator during idle periods. This continuous tone is used to confirm that the phone line is intact as well as establish a reference amplitude for the audio which will be present once the remote receiver is unscelched by a received signal. The Voting Pilot Tone is a single-frequency sine wave and is turned On and Off by toggling Voting Tone On/Off functions. When any Voting Pilot Tone is selected, the selected Voting Pilot Tone is automatically output to RA and Remote RA ports.

## OPERATING FEATURES

### 14. Digital Pager

The TKR-740 can be used as a digital paging transmitter by using the Digital Pager inputs on the rear panel. These inputs accept the logical 0 or 1 (0 V or 5 V) from the external paging encoder, producing a +4.0 kHz carrier shift in response to a 0 and a -4.0 kHz in response to a 1. If Digital Paging Input function is enabled, the TKR-740 accepts the external encoder's digital signal on AUX In 3 and its PTT on AUX In 2 (active low).

### 15. Time Out Timer

The Time Out Timer function determines the period of time users can continuously transmit. When the selected period expires, the transmission is inhibited.

### 16. Repeat Hold Time

The Repeat Hold Timer (hang timer) function is used to prevent the repeater from being repeatedly keyed and unkeyed in response to short message traffic. When a mobile transceiver unkeys, the repeater's Hold Timer allows the repeater to continue transmitting for a brief period while waiting for a responding end user. If no valid QT/DQT is detected within the Hold Timer period, the transmitter is allowed to unkey. This function determines the period of time that the transmitter is allowed to remain keyed after the loss of a valid QT/DQT received signal.

### 17. Take Over

Take Over function is used to disable the remote wireline control of the repeater. When Take Over function is enable, the AUX Inputs and outputs, remote audio inputs and outputs, External PTT, External Monitor, Remote PTT and TXD2/RXD2 serial data lines are disabled. All AUX Input functions assigned to any AUX Input remain in current state. However Remote PTT, External PTT and External Monitor become a "Off" state.

### 18. Test Tone

The Test Tone is a single-frequency audio sine wave and is turned On and Off by toggling Test Tone On/Off functions. The transmitter can be modulated without a local mic by using the test tone. When Test Tone On function is executed and any PTT is activated, the TKR-740 transmits the test tone with mic mute and also routes the test tone to Remote RA port.

### 19. AUX Input and Output

There are 7 programmable AUX I/O Ports 1-7(pins 6-12) on the rear 12 pin REMT I/O connector and 3 programmable AUX Input Ports 1-3 (pins 4-6) and 6 programmable AUX Output ports (pins 20-25) on the rear 25 pin D-Sub connector. The 7 programmable AUX I/O pins are primarily intended for remote control interfaces. Each AUX I/O Port can be set for AUX Input, AUX Output or remote Channel Select types.

The AUX Input port can be set execute a single input function or a set of up to three functions when the port is activated. If the port type for an AUX I/O Ports 1-7 is set for "AUX Input", it will also appear AUX Input window for function programming. The input logic is fixed as active low.

The AUX Output port can be set execute a single output function. If the port type for an AUX I/O Ports 1-7 is set for "AUX Output" it will also appear AUX Output window for function programming. The Output logic of AUX Output can be set as either active High or active Low by the Logic Type function. Active High outputs a High (5V) when the programmed condition becomes valid; active Low outputs a Low (0V) when the condition becomes valid.

### 20. Channel Select

AUX I/O Ports 1-5 (1 or all 5) can each be set for "Channel Select" providing up to 32 channel selection capability. These are 1 to 5 bit Binary Coded Decimal (BCD) inputs. AUX I/O 1 is a least significant bit. When all of AUX I/O ports 1-5 is set to Channel Select, "11111" input (LSB on the right side) signifies the Channel 1 and "11110" input signifies the Channel 2. When the Channel Select function is set to any AUX I/O Ports, The Channel 'X' function (Channel Up, Channel Down, Channel 1, etc.) can not be set to the AUX Input ports, but can be set to the PF Keys. Normally the channel control is controlled by the Channel Select function. If the Take Over function is executed, the channel control is disabled to be controlled by the Channel Select and enabled to be controlled by the PF Keys.

### 21. Start Up

When the TKR-740 is first turned on or is reset, up to 3 functions pre-programmed into the Start Up function are executed in sequence.

### 22. Optional Board

The TKR-740 can be installed as a optional scrambler board. Scrambler codes between 1 and 16 are available per channel. If the scrambler board is not to be used (although it is installed), set the parameter to "Off". When any Scrambler code is set up and Scrambler On function is executed, the scrambler board is activated.

# REALIGNMENT

## 1. Modes

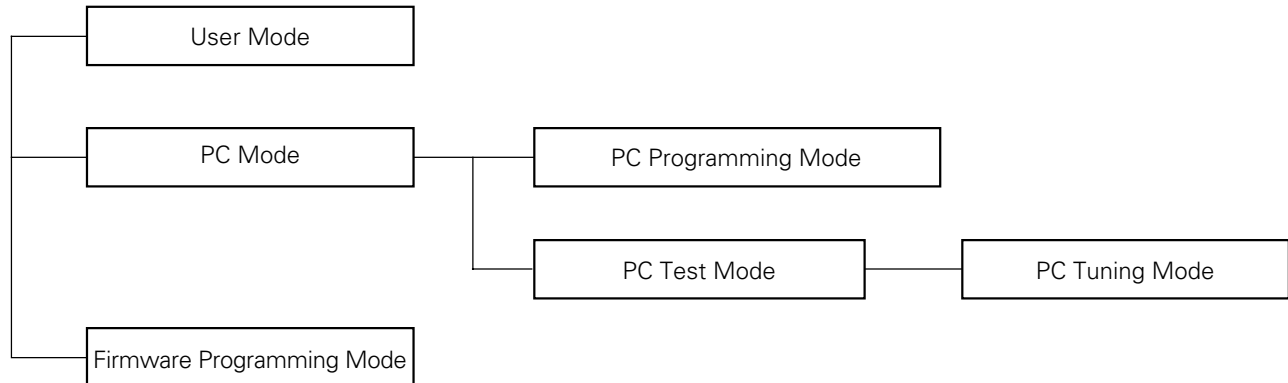

Mode	Function
User Mode	Use this mode for normal operation.
PC Mode	Use this mode to make various settings by means of the FPU through the RS-232C port.
PC Programming Mode	Use to read and write frequency data and other features to and from the Repeater.
PC Test Mode	Use to check the Repeater using the PC. This feature is included in the FPU.
PC Tuning Mode	Use to tune the Repeater using the PC. This feature is included in the FPU.
Firmware Programming Mode	Use when changing the Firmware program of the flash memory.

## 2. How to Enter Each Mode

Mode	Operation
User Mode	Power ON.
PC Mode	Received commands from PC.
Firmware Programming Mode	[PF1] key + Power ON (one second).

# TKR-740

## REALIGNMENT

### 3. PC Mode

#### 3-1. Preface

The TKR-740 repeater is programmed by using a personal computer, programming interface and KPG-47D software. (Version 2.00 or later)

#### 3-2. Connection procedure

1. Connect the TKR-740 to the personal computer with the interface cable.
2. When power is applied, the user mode is entered immediately. When the PC sends a command, the repeater enters the PC mode and displays "PC" on the 7-segment LED. When data is being transmitted to the PC from the repeater, the TX LED flashes. The BUSY LED flashes when data from the PC is being received by the repeater.

#### Notes:

- The data stored in the personal computer must match the model type, when it is written into the flash memory.
- Change the TKR-740 to PC mode, then attach the interface cable.

#### 3-3. KPG-46 description (PC programming interface cable : Option)

The KPG-46 is required to interface the TKR-740 to the computer. It has a circuit in its D-subconnector (25-pin) case that converts the RS-232C logic level to the TTL level. The KPG-46 connects the MICROPHONE connector of the TKR-740 to the computer's RS-232C serial port.

#### 3-4. Programming software description

The KPG-47D programming disk is supplied in 3-1/2" disk format. The software on the disk allows a user to program TKR-740 repeater via the programming interface cable (KPG-46).

#### 3-5. Programming with IBM PC

Data can be programmed into the flash memory in RS-232C format via the MICROPHONE connector.

#### Note:

Select a frequency band [2.158-174MHz] in the band select menu of FPU.

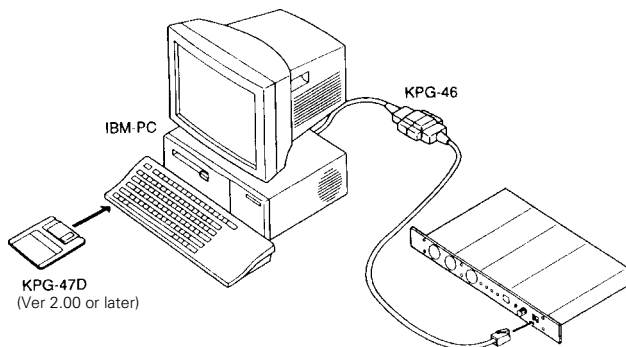

Fig.1

### 4. Firmware Programming Mode

#### 4-1. Preface

The TKR-740 uses flash memory to allow it to be easily upgraded when new features are released in the future.

#### 4-2. Connection procedure

Connect the TKR-740 to the personal computer (IBM PC or compatible) with the interface cable (KPG-46). (Connection is the same as in the PC Mode.)

#### Note:

You can only program firmware from the 8-pin microphone connector on the front panel. Using the 25-pin logic interface on the rear panel will not work.

#### 4-3. Programming

1. Start up the programming software (KPG-47D), select "firmware program" in the "Program" item, and press the Return key on the personal computer. This starts up the firmware programmer.
2. The top screen is displayed. Press any key to advance to the next screen.
3. Set the communications speed (normally, 115200 bps) and communications port in the Setup item.
4. Set the firmware to be updated by File select (=F1).
5. Turn the TKR-740 power ON with the [PF 1] key held down. Hold the key down for one second until the 7-segment display changes to "P.G.". When "P.G." appears, release your finger from the key.
6. Check the connection between the TKR-740 and the personal computer, and make sure that the TKR-740 is in the Program Mode.
7. Press F10 on the personal computer. A window opens on the display to indicate progress of writing.
8. If writing ends successfully, the TX LED on the TKR-740 lights.
9. If you want to continue programming other TKR-740s, repeat steps 3 to 6.

#### Notes:

- To start the Firmware Programmer from KPG-47D, the Fpro path must be set up by KPG-47D Setup.
- This mode cannot be entered if the Firmware Program mode is set to Disable in the Programming software (KPG-47D).

#### 4-4. Function

If you press the [PF 1] key (front panel), both decimal point on the 7-segment display will disappear. The writing speed is 38400 bps (low-speed mode). If you press the [PF 1] key again, the right hand decimal points will light. The writing speed is 57600 bps (middle-speed mode).

#### Note:

Normally, write in the high-speed mode (115200 bps).

## APPLICATION NOTE

### 1. External I/O Connector Description

#### 1.1. MICROPHONE jack

Connector	No.	Terminal Name	Description
MICROPHONE	1	NC	No Connection
	2	+B	Power Source; 13.2V / 0.75A maximum
	3	GND	GND *1
	4	PTT (PC serial data from radio)	PC Read/Write, PC Tuning, Firmware programming
	5	MIG	MIC Ground *1
	6	MIC	MIC input (600Ω) *1
	7	HOOK (PC serial data to radio)	PC Read/Write, PC Tuning, Firmware programming
	8	NC	No Connection

**Notes:**

\*1 Pin 5 (MIG) is used for MIC audio ground only. Electrical grounds such as PTT current return must use Pin 3 (GND).

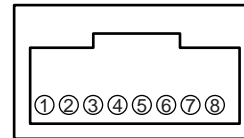

**MICROPHONE jack (Viewed from Front Panel)**

#### 1.2. TEST/SPKR jack

Connector	No.	Terminal Name	Description	I/O	Level	
TEST / SPKR	1	B+(AUX)	Un-switched B+ 1A maximum	*1	O	13.2V
	2	B+(AUX)	Un-switched B+ 1A maximum	*1	O	13.2V
	3	NC	No Connection			
	4	GND	GND			
	5	GND	GND			
	6	SPG (Speaker Ground)	GND	*2		
	7	RD (RX Data output)	RX Detector audio output (non-squelched) (Receive @1kHz Modulation, 60% Deviation)		O	80mV
	8	RSSI	RSSI voltage check (See Reference Table)		O	0 to 5V
	9	SPI (Internal Speaker Input)	Internal Speaker Input	*2	I	
	10	TXCV	TX VCO lock voltage check (See Reference Table)		O	1.0 to 4.5V
	11	RXCV	RX VCO lock voltage check (See Reference Table)		O	1.0 to 4.5V
	12	SPO	External Speaker Output (4W/4Ω)	*2	O	
	13	VC	Voltage check of Power Source (Impedance: 10kΩ)		O	13.2V
	14	FWD	Voltage check of Forward power (See Reference Table)		O	0 to 5V
	15	EXT REF	External reference check (INT; 5V EXT; 0V)		O	0 or 5V

**Notes:**

\*1 This source can be used to power external equipment to a maximum 1A on each line (max 2A total).  
Use is prohibited with the fuse beyond 6A strictly.

\*2 Connect SPI and SPO by using the 15pin I/O plug when using the internal speaker. (INT-SP: 0.25W/32Ω)  
When using an external speaker, remove the jumper lead from the connector and attach the speaker cable to SPO (pin 12) and SPG (pin 6).

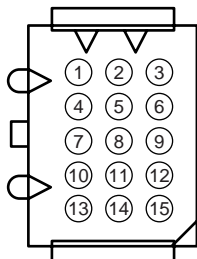

**TEST / SPKR jack (Viewed from Back Panel)**

**VOLTAGE REFERENCE TABLE (approximate +VDC)**

	TKR-740E
RSSI (@ -100dBm)	2.5V
FWD	2.7V @ 25W 0.6V @ 5W
TXCV	1.4V @ 136.0MHz
	4.5V @ 154.9MHz
	1.8V @ 155.0MHz
RXCV	4.5V @ 174.0MHz
	1.8V @ 147.0MHz
	4.5V @ 153.9MHz
	1.8V @ 154.0MHz
	4.5V @ 162.0MHz

## APPLICATION NOTE

### 1.3. CONTROL I/O jack

Connector	No.	Terminal Name	Description	I/O	Level
CONTROL I/O	1	NC	No Connection		
	2	RXD2 (PC serial data to radio)	PC Read/Write, PC Tuning, Remote *1	I	RS-232C Level
	3	TXD2 (PC serial data from radio)	PC Read/Write, PC Tuning, Remote *1	O	RS-232C Level
	4	AUXI 1	Programmable Function input 1 *2	I	0 or 5V
	5	AUXI 2	Programmable Function input 2 *2	I	0 or 5V
	6	AUXI 3	Programmable Function input 3 *2	I	0 or 5V
	7	DG (Digital Ground)	GND (for Digital ground only)		
	8	TD (TX Data input)	TX Signalling data input *3	I	0.5Vpp
	9	TA (TX Audio input)	TX Audio input *3	I	140mVrms
	10	RD (RX Data output)	RX Signalling data output *3	O	80mVrms
	11	RA (RX Audio output)	RX Audio output *3	O	400mVrms
	12	RXG (RX Ground)	GND (for RA, RD ground only)		
	13	SPM (Speaker Mute)	Mute input; "Mute: Low"	I	0 or 5V
	14	NC	No Connection		
	15	EXT MON (Monitor SW)	External Monitor input; "Active: Low"*5	I	0 or 5V
	16	EXT PTT (Same as Test SW)	External PTT input "ON: 0V OFF: 5V" *3	I	0 or 5V
	17	SC (Squelch Control)	Squelch status output; "Busy: Low"	O	0 or 5V
	18	NC	No Connection		
	19	TXG (TX Ground)	GND (for TA,TD ground only) *3		
	20	AUXO 1	Programmable Function output 1 *4	O	0 or 5V
	21	AUXO 2	Programmable Function output 2 *4	O	0 or 5V
	22	AUXO 3	Programmable Function output 3 *4	O	0 or 5V
	23	AUXO 4	Programmable Function output 4 *4	O	0 or 5V
	24	AUXO 5	Programmable Function output 5 *4	O	0 or 5V
	25	AUXO 6	Programmable Function output 6 *4	O	0 or 5V

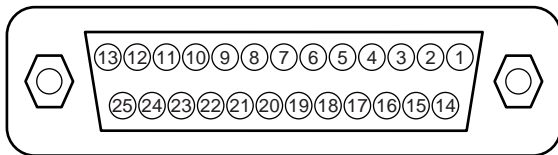

**CONTROL I/O (25pin D-SUB) jack  
(Viewed from Back Panel)**

**Notes:**

\*1 Serial data communications with a PC can be done through either front panel 8-pin modular microphone jack or the rear panel 25-pin D-SUB interface connector. Firmware can only be written through the 8-pin modular microphone jack.

Mode	8pin Modular	25pin D-sub
FPU Read/Write	Yes	Yes
FPU Tuning mode	Yes	Yes
Firmware programming	Yes	No
Serial Remote	No	Yes
Real time Monitor	No	Yes

**Serial Data transmission method**

- Full duplex communication
- Asynchronous system (start-stop asynchronous)
- Non-parity check
- Start bit: 1bit, Stop bit: 2bit
- Data: 8bit, LSB output
- Baud rate: 9600bps
- Hardware flow control line not used

\*2 All AUX I terminals (Section 1.3, 1.4), including any AUX I/O programmed as "AUX Input" with the KGP-47D are Active-Low logic.



## APPLICATION NOTE

- \*3 TD ; TX Data input-transmit signalling (QT / DQT / LTR) input. (Impedance 600Ω)
- TA ; TX Audio input-transmit audio input. (Impedance 600Ω)
- RD ; Receiver detector output non-squelched, non-de-emphasized detector audio output ( 80mVrms/4.7kΩ)
- RA ; Receiver Audio output-with de-emphasis, filtering and squelched, line level only (not for driving a speaker). ( 400mVrms/ 4.7 kΩ)
- PTT ; Press-to-Talk-external transmit key line.
- TXG ; TX Ground-common ground.

- \*4 The output logic level of all AUX O terminals (Section 1.3, 1.4), including any AUX I/O programmed as "AUX Output" with the KGP-47D may be selected as either Active-High or Active-Low. Note: If Active-Low is selected in KGP-47D, the AUX Output port will be driven temporarily High for about 500ms immediately after a forced reset or when power is first applied. External equipment must have appropriate de-bounce.

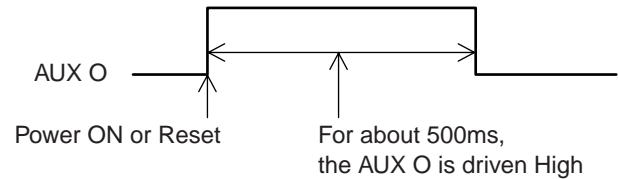

- \*5 EXT MON is the same as EXT MON on the REMT I/O (Section 1.4).

### 1.4. REMT I/O jack

Connector	No.	Terminal Name	Description	I/O	Level	
REMT I/O	1	Remote RA (RX Audio output)	Audio output, line level	*1	O	400mVrms
	2	Remote TA (TX Audio input)	Audio input, line level	*1	I	140mVrms
	3	Remote PTT	Remote PTT input (Active-Low)	*1	I	0 or 5V
	4	EXT MON	External Monitor input (Active-Low)		I	0 or 5V
	5	GND	Ground			
	6	AUX I/O 1	External Ch 1 or programmable Function	*2 *3	I/O	0 or 5V
	7	AUX I/O 2	External Ch 2 or programmable Function	*2 *3	I/O	0 or 5V
	8	AUX I/O 3	External Ch 3 or programmable Function	*2 *3	I/O	0 or 5V
	9	AUX I/O 4	External Ch 4 or programmable Function	*2 *3	I/O	0 or 5V
	10	AUX I/O 5	External Ch 5 or programmable Function	*2 *3	I/O	0 or 5V
	11	AUX I/O 6	Programmable Function	*2 *4	I/O	0 or 5V
	12	AUX I/O 7	Programmable Function	*2 *4	I/O	0 or 5V

#### Notes:

- \*1 Remote RA ; Receiver Audio output with de-emphasis to Remote Terminal.( 400mVrms/ 4.7 kΩ Load)
- Remote TA ; Transmit audio signal input from Remote terminal.(Impedance 600Ω)
- Remote PTT ; Press-to-Talk for Remote Terminal transmit key.
- \*2 AUX I/O 1-5 can be programmed for AUX Input, AUX Output or (BCD) Channel Select.
- AUX I/O 6-7 can be programmed for either AUX Input or AUX Output.
- \*3 AUX I/O 1-5: Provides 1 of 32 channel selection via 5 bit Binary Coded Decimal (BCD) on REMT I/O connector.

Select channel	No.	10	9	8	7	6	pin
1		1	1	1	1	1	
2		1	1	1	1	0	
3		1	1	1	0	1	
4		1	1	1	0	0	
...		...					
29		0	0	0	1	1	
30		0	0	0	1	0	
31		0	0	0	0	1	
32		0	0	0	0	0	

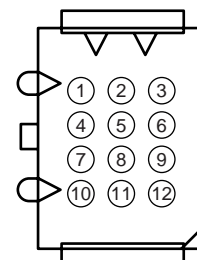

REMT I/O jack (Viewed from Back Panel)

## APPLICATION NOTE

\*4 AUX I/O 6 and 7 can each be modified to sink up to 600mA of open collector current. The following modification should be installed when AUX I/O 6 or 7 is used to control external equipment.

1. Program AUX I/O 6 [7] for "AUX Output" in the KGP-47D.
2. Remove D32, R84 and R88 for AUX I/O 6 [ D36, R83 and R87 for AUX I/O 7] on the component side of control unit PCB (see diagram below).
3. Install \$Q14, \$Q15 and \$R154 for AUX I/O 6 [\$Q12, \$Q13 and \$R153 for AUX I/O 7] on foil side of control unit PCB (see diagram below).

\$Q12,13,14,15    DTD114EKA  
 \$R153,154        3.9kΩ (RK73GB1J392J) chip resistor

4. Change R320 for AUX I/O 6 [R319 for AUX I/O 7] from 1kΩ (RK73GB1J102J) to 0Ω (R92-1252-05).  
 By making this modification, AUX I/O 6 and 7 can now sink up to 600mA each.

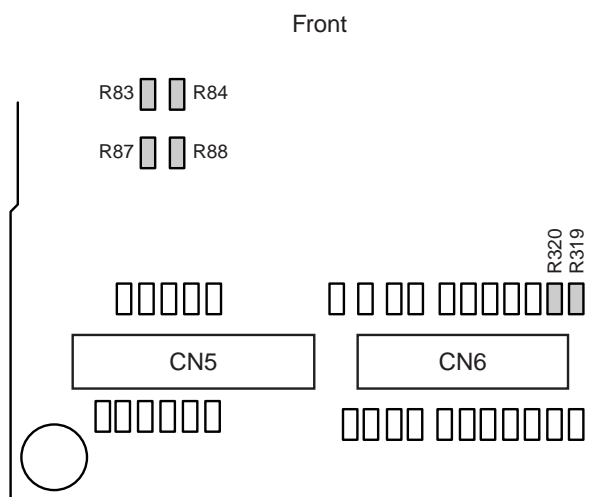
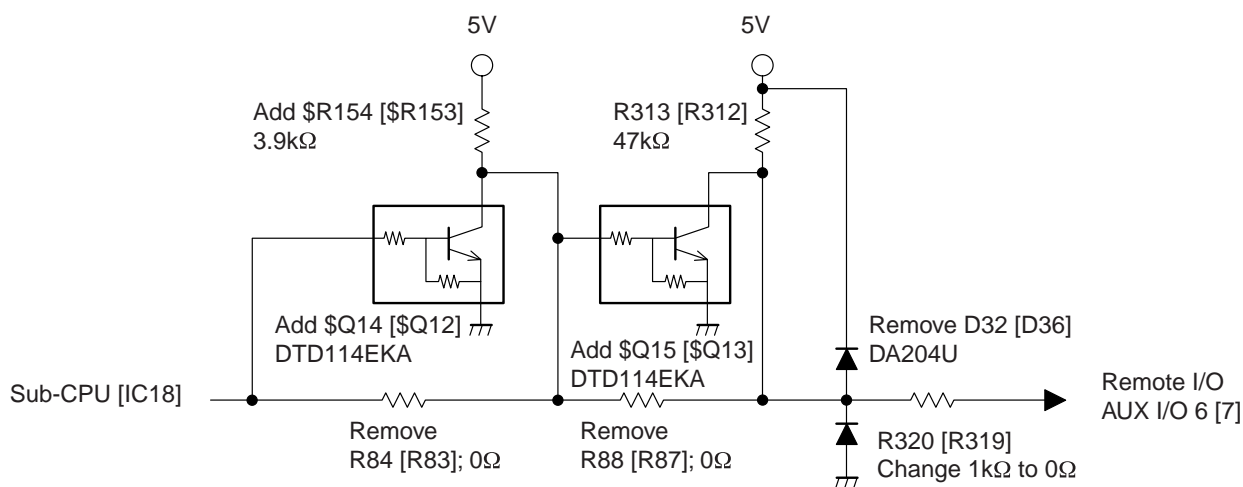

Rear

Component Side

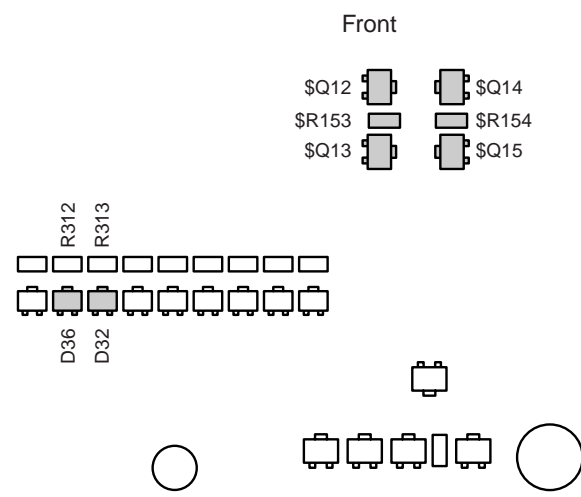

Rear

Foil Side

Components having those reference numbers marked as "\$" are not used in this transceiver, although they are described in this service manual for other application purpose.

## APPLICATION NOTE

## 1.5 Connection to External Equipment

	No	Terminal	Remote Termination(VEGA)	Model 38-MAX (ZETRON)	Raider (TRIDENT)
CONTROL I/O	1	NC			
	2	RXD2			
	3	TXD2			
	4	AUXI 1	(F1 to F8 optionally)		
	5	AUXI 2	(F1 to F8 optionally)		
	6	AUXI 3	(F1 to F8 optionally)		
	7	DG		PTT Common	
	8	TD		CTCSS/DCS Encode	TX Data Output
	9	TA		TX Audio	TX Audio Output
	10	RD		Discriminator	RX Discriminator Input
	11	RA			
	12	RXG		RX Ground	
	13	SPM			
	14	NC			
	15	EXT MON			
	16	EXT PTT		PTT No	TX PTT Output
	17	SC		COR	
	18	NC			
	19	TXG		TX Ground	
	20	AUXO 1			
	21	AUXO 2			
	22	AUXO 3			
	23	AUXO 4			
	24	AUXO 5			
	25	AUXO 6			
REMT I/O	1	Remote RA	RX Audio output		
	2	Remote TA	TX Audio input		
	3	Remote PTT	PTT		
	4	EXT MON	MON		
	5	GND	(TX return)		
	6	AUX I/O 1	(F1 to F8 optionally)		
	7	AUX I/O 2	(F1 to F8 optionally)		
	8	AUX I/O 3	(F1 to F8 optionally)		
	9	AUX I/O 4	(F1 to F8 optionally)		
	10	AUX I/O 5	(F1 to F8 optionally)		
	11	AUX I/O 6	(F1 to F8 optionally)		
	12	AUX I/O 7	(F1 to F8 optionally)		
TEST/SPKR	1	B+(AUX)		B+	Power
	2	B+(AUX)	B+		
	3	NC			
	4	GND		GND	Ground
	5	GND	GND		
	6	SPG			
	7	RD			
	8	RSSI			
	9	SPI			
	10	TXCV			
	11	RXCV			
	12	SPO			
	13	VC			
	14	FWD			
	15	EXT REF			

# TKR-740

## APPLICATION NOTE

### 1.6 Controller and Remote Termination Panel Interconnection Diagram

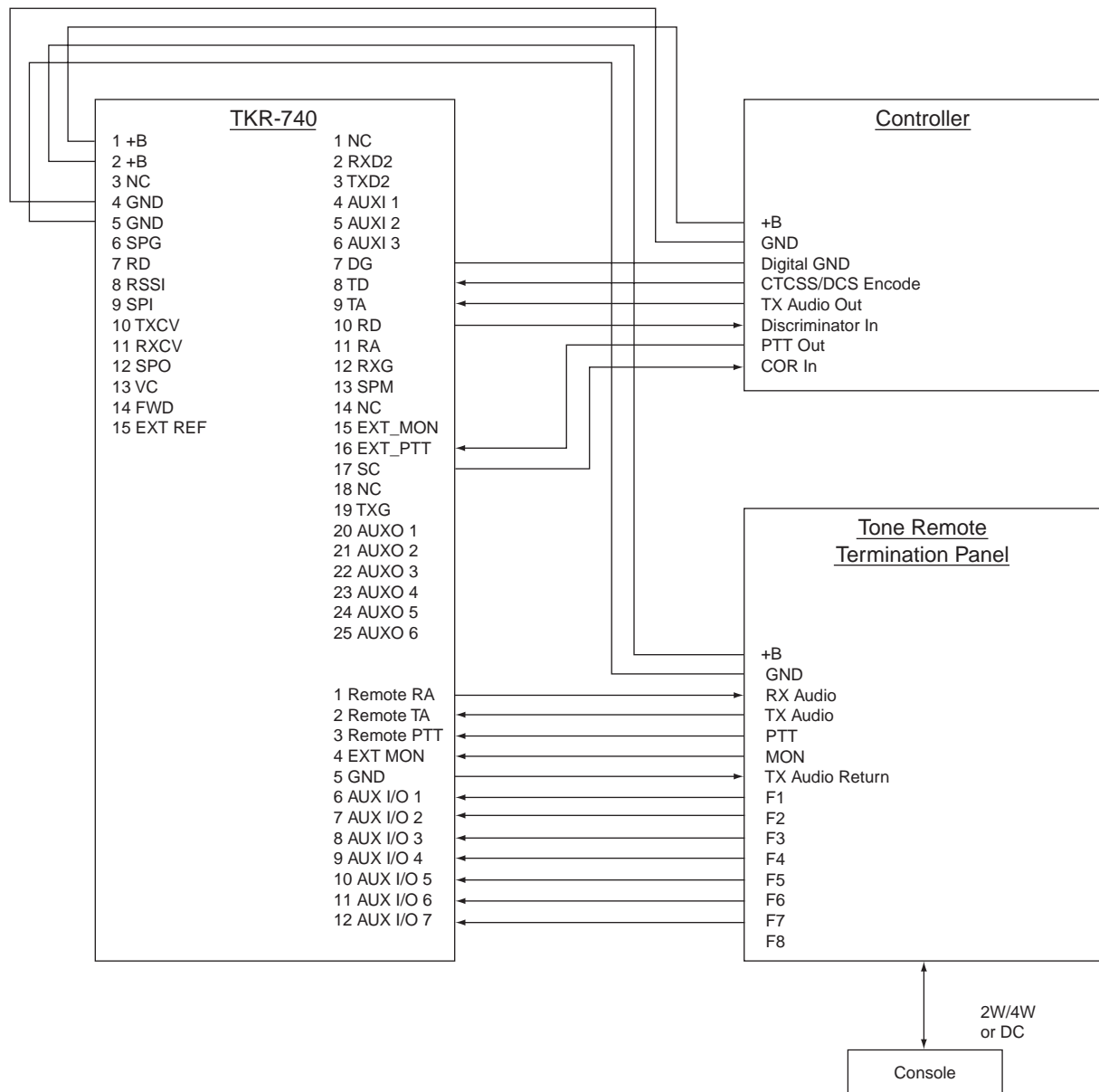

## 2. TKR-740 Programming Settings with External Equipment

### 2.1. LTR Logic Controllers

- 1) Program the RX/TX channel frequency but do not set QT/DQT tone/codes..
- 2) Edit the channel data by pressing [F10].  
Set: Simplex = "No"; Repeat = "No"; this will override the TKR-740 internal conventional repeater controller function.
- 3) Select Time Out Timer = OFF.  
<Edit>→<Optional features>→Time Out Timer "OFF".
- 4) Connect the 25-pin D-sub on TKR-740 to the interface port on LTR controller with a cable.  
Layout of 25-pin D-Sub connector is compatible with TKR-740 and TKR-830.  
The cable for TKR-830 can be use for TKR-740.
- 5) Adjust a LTR controller (RX data, RPT audio, TX data, etc) according its installation manual.

## APPLICATION NOTE

### 2.2. Intercom Function

The Intercom function allows two communications between a dispatcher at a remote console and the TKR-740 unit at a site via the remote termination unit-to-console audio link. This function operates in repeater or base station mode.

- 1) Connect the 12-pin Remote I/O Connector on TKR-740 to the interface port on Remote Termination unit with a cable.
- 2) Select PTT Priority if desired: Local Mic PTT, Ext. PTT (ext. controller), Remote PTT (remote termination unit), Repeat PTT (TKR-740 internal controller repeat PTT). This allows for example the Remote PTT can take precedent over the Ext. PTT and front panel Local Mic PTT.

<Edit>→<Optional features>→<PTT Priority...>

- 3) Select the audio routing during Intercom operation (Remote, Local or Remote/Local)

<Edit>→<Optional features>→"Intercom Remote/Local"

Remote: Remote TA, transmit audio out from the remote term. unit will be heard in the front panel speaker when the Remote PTT is active even if receiver audio is present. Audio from the Remote TA port will also be transmitted over the air (see 5; TX Disable).

Local: Front panel Local Mic audio will be routed to the Remote RA port (audio input to the remote term. unit) even if receiver audio is present. Audio from the Local Mic will be transmitted over the air (see 5; TX Disable).

Remote/Local:

Remote TA, transmit audio out from the termination unit will be heard in the front panel speaker. Front panel mic audio will be routed to the Remote RA audio input to the remote termination unit, even if receiver audio is present. All audio will be transmitted over the air (see 5 TX Disable). Transmit Audio priority is dependent on the PTT Priority setting.

- 4) Program a front panel PF key or AUX Input to set Intercom ON/OFF.

<Edit>→<Key assignment>→"Intercom ON/OFF"

<Edit>→<Optional features>→<AUX I/O Ports...>→

<AUX Input Functions (12-pin & 25-pin)...>→"Intercom On/Off"

- 5) To inhibit Intercom audio from being transmitted over the air, program a front PF key and/or AUX Input to disable transmit during Intercom.

To use the Intercom with Local Mic PTT without keying the transmitter, enable the Local TX Disable function at PF key or AUX Input. This must be manually activated by the Local Mic user.

<Edit>→<Key assignment>→"TX Disable/Enable"

To use the Intercom with Remote PTT without keying the transmitter, enable the Remote TX Disable function at PF key or AUX Input. If a PF key is programmed the Local Mic user must activate this during Intercom operation. If an AUX Input is programmed, a "function" or "auxiliary" function switch on the remote console must be used to activate the

AUX Input (prog. for Remote TX Disable) during Intercom operation.

<Edit>→<Optional features>→<AUX I/O Ports...>→

<AUX Input Functions (12-pin & 25-pin)...>→"TX Disable/Enable"

### 2.3. Setting for Voting system

- 1) The Voting Tone is output from the RA port of the 25-pin D-sub and interfaced with the audio link of the systems voting Comparator unit. This link may be a dedicated telco line or an RF link such as a point-to-point microwave or conventional analog FM link. (Note: The voting tone will also be output through the Remote RA audio port. If Intercom operation is activated then Local Mic audio will be outputted. Do not use the Remote RA port for the voting output when Intercom operate).

- 2) Program the voting tone frequency by pressing PF2 or space bar.

<Edit>→<Optional features>→<Voting tone>→"1950"

Note: Set to "Disable" for non-voter system use.

- 3) A front panel key can be programmed for a Voting Tone On/Off function for service and test purposes.

<Edit>→<Key assignment>→<PF key>→"Voting Tone ON/OFF"

### 2.4. Digital Paging systems

The TKR-740 can be used as a continuous-duty paging transmitter. It has a direct carrier frequency shift input for bi-level type paging protocols such as POCSAG (note this is not for quad-level formats such as Motorola Flex).

1. Program the Digital Paging Input as "Enable":

<Edit>→<Optional features>→<Digital Paging Input>→"Enable"

When this function is set to "Enable", AUX Input 2 is automatically assigned as the "Digital Pager PTT" and AUX Input 3 is automatically assigned "Digital Pager Data".

Digital Pager Data Input level (AUX Input 3):

+5.30V > High > +4.0V

-0.30V < Low < +1.00V

Digital Pager PTT Input (AUX Input 2): Active Low

Baud Rate: Less than 2400 bps

Frequency Shift Polarity:

High: -4.0 kHz ±0.5 kHz shift

Low: +4.0 kHz ±0.5 kHz shift

Adjust the Digital Pager Deviation at 102 digit in FPU for 4.0kHz shift.(0 digit; 0 kHz 255 digit; 8.4kHz)

Caution ;Pin5(AUX Input 2) on the 25-pin D-Sub connector corresponds to a RS-232C CTS. when Digital Paging Input is "Enable" and the 25-pin D-Sub on TKR-740 is connected to the serial port on PC with a 25-pin D-Sub straight cable, note that TKR-740 is likely to transmit.

### 3. Internal I/O Terminal Description

The TKR-740 has internal connection terminals for adding internal option boards such as voice encryption /scramblers boards, ANI encoders and tone encoders (two-tone, burst, 5-6 tone, etc.).

## APPLICATION NOTE

### 3.1. Internal I/O Terminal Description

Terminal Name	Description	I/O	Level
B	Power Source	O	13.2V
GND	GND		
TXI	TX audio output to optional board	O	35mVrms @ 2.4kHz Deviation
TXO	TX audio input from optional board	I	
RXI	RX audio output to optional board	O	200mVrms @ 1kHz Mod 60% Dev
RXO	RX audio input from optional board	I	
DETI	Discriminator output to optional board	O	170mVrms @ 1kHz Mod 60% Dev
DETO	Discriminator input from optional board	I	
ANI	TX ANI input	I	15mVrms input
PTTI	PTT output to optional board	O	Mic PTT ON ; 0V OFF ; 5V
PTTO	PTT input from optional board	I	
TESTI	Ext.PTT output to optional board	O	Ex PTT or TEST SW ON ; 0V OFF ; 5V
TESTO	Ext.PTT input from optional board	I	
RPTTI	Remote PTT output to optional board	O	Remote PTT ON ; 0V OFF ; 5V
RPTTO	Remote PTT input from optional board	I	
OPTION	Enable/Disable scrambler board	O	Scrambler ON ; 5V Scrambler OFF(normally) ; 0V
CODE1	Scrambler code setting	O	0V or 5V
CODE2	Scrambler code setting	O	0V or 5V
CODE3	Scrambler code setting	O	0V or 5V
CODE4	Scrambler code setting	O	0V or 5V

### 3.2. Connection to Optional Boards

Terminal Name	SC20-460(Transcrypt)	CDEU-1(Cimarron)	ID-12(CSC)
B	+V	+B	Power Supply
GND	GND	GND	GND
TXI	TXIN *1		
TXO	TXOUT *1		
RAI	RXOUT *2	SIDE TONE *4	
RAO	RXIN *2		
DETI	(RXOUT) *3		
DETO	(RXIN) *3	DATA IN	
ANI		DATA OUT	AUDIO OUT
PTTI		PTT *5	PTTIN *5
PTTO	PTT	KEY *5	PTTOUT *5
TESTI		(PTT) *6	(PTTIN) *6
TESTO	(PTT) *6	(KEY) *6	(PTTOUT) *6
RPTTI		(PTT) *7	(PTTIN) *7
RPTTO	(PTT) *7	(KEY) *7	(PTTOUT) *7
OPTION	SCRAMBLE		
CODE1	Binary 1		
CODE2	Binary 2		
CODE3	Binary 4		
CODE4	Binary 8		
AUX I/O		EMER *8	
AUX I/O		CH BUSY *9	
SPM		MUTE *10	

## APPLICATION NOTE

**Notes:**

- \*1 Remove R117.
- \*2 Remove R118.  
Note: RAI and RAO (de-emphasized squelch controlled audio) should be used for the receive audio in/out for an encryption or scrambler board.
- \*3 Remove R120  
Note: When DETI and DETO are used, (bypasses de-emphasized squelch controlled audio) the TKR-740 can not decode QT/DQT because the scrambler board will not pass sub-audible tones. If the scrambler board modification is need due to use of RAI and RAO, refer to Its manufacturer's Installation manual.
- \*4 If ANI side tone is to be output from an external speaker, connect the ANI board side tone output line to terminal RAI. If side tone output is to output from the front panel local speaker, connect the board side tone output line to IC45, pin 2 (IC45 device: LA4422).
- \*5 Remove R115.
- \*6 When using an EXT PTT, connect the PTT wires of option board to TESTI/TESTO terminal.  
Remove R116.
- \*7 When using a Remote PTT, connect PTT wires of option board to RPTTI/RPTTO terminal..  
Remove R114.
- \*8 An external switch may be connected to an AUX I (I/O) if an emergency function is required.
- \*9 Some ANI boards have a "channel busy" input line. Use an AUX (I/O) programmed as Carrier Operated Relay or Tone Operated Relay (COR or TOR) output may be used (alternative: use the Squelch Control (SC) line on the 25 Pin D-sub).
- \*10 Some ANI boards have a "speaker mute" output line. Use the SPM line on the 25 Pin D-sub.

**4. FPU Setting For Optional Board****Voice scrambler**

- 1) Select each item to enable for scrambler unit.  
<model>→<TKR-740>→<158-174>→<Voice Scrambler>  
→"OK"
- 2) Select the channel(s) which will use scramble mode and then press [ F10].  
Select a voice scrambler code address (1-of-16, 4 bit BCD) if necessary.
- 3) Assign the "Scrambler On/Off" function to front panel any PF key or AUX Input.  
<Edit>→<Key Assignment>→[PF 2]→"Scrambler On/Off"  
<Edit>→<Optional features>→<AUX I/O ports...>→<AUX Input Functions(12-pin & 25-pin...)>→<AUX In>

The scrambler function is primarily designed for TKR-740 base station operation. However if used in repeater operation, be aware that the repeated audio operation differ between the RAI/RAO and DETI/DETO terminals. When RAI/RAO are used, de-scrambled (clear) audio will be heard from the local speaker and scrambled audio will be transmitted over the air; RAI/RAO are the preferred scrambler receiver audio connection terminals. When DETI/DETO are used, de-scrambled (clear) audio will be heard from both the local speaker and transmitted over the air. Since the repeated audio should leave the repeater scrambled (in most applications), it is recommended to use the RAI and RAO.

# TKR-740

## DISASSEMBLY FOR REPAIR

### Cooling Fan installation for the TKR-740(E)

#### 1. Cooling Fan (Front side)

(1) Secure the fan to the fan enclosure with the 2 supplied screws.

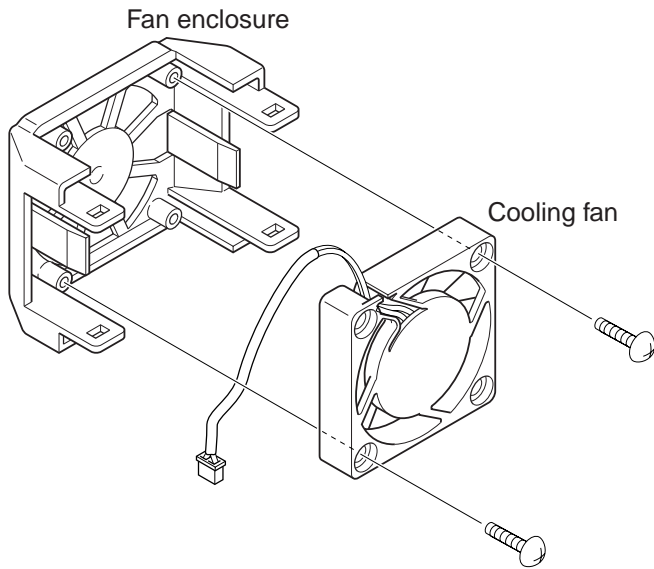

(2) Attach the fan enclosure to the front of the TKR-740(E) heatsink so that the enclosure tabs are securely mounted to the heatsink chassis.

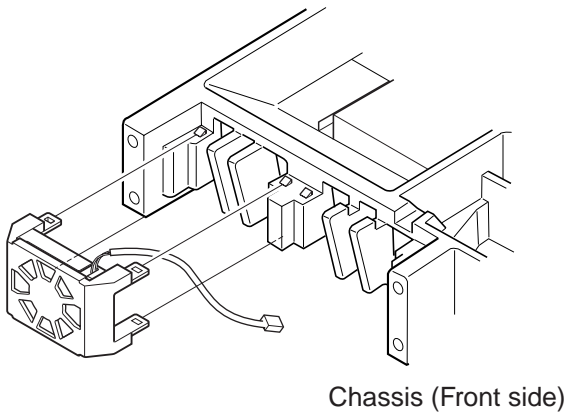

(3) Guide the fan cable along with the front of the chassis and through the cable slot.

(4) Hook the fan cable around the cable holder, then plug the connector into the CN104 on the TX unit (A/3).

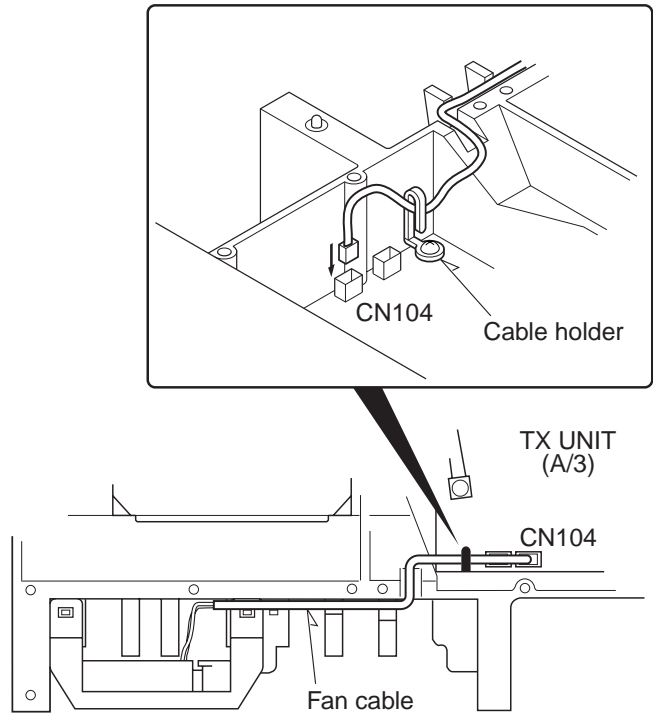



## DISASSEMBLY FOR REPAIR

### 2. Cooling Fan (Rear side)

(1) Attach the fan to the front of the chassis with the 2 supplied screws.

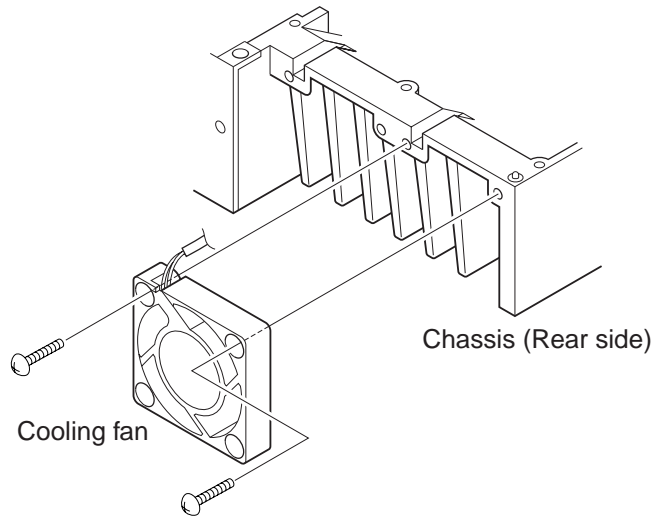

### How to install a coaxial cable between CN301 and CN1 (TX unit)

When you connect CN1 (TX unit A/3) and CN301 (TX unit B/3) with a coaxial cable, you must guide and align the coaxial cable with the shielded case as shown in the figure below. Ensure that the coaxial cable makes contact with the metal shielded case.

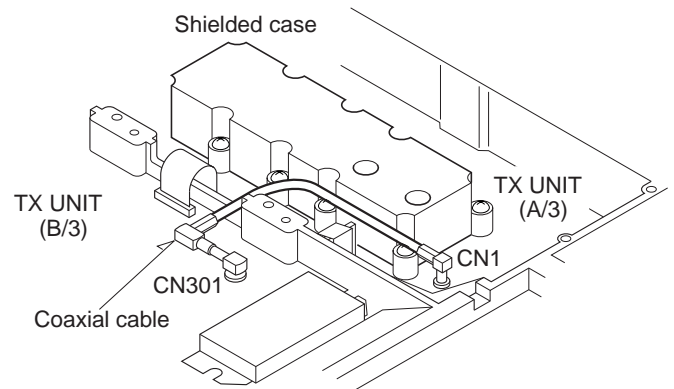

(2) Slide the fan cable through the cable slot in the chassis, then push the cable underneath the corner of the PCB (TX unit (B/3)).

Guide the fan cable along to the chassis, then plug the connector into the CN305 on the TX unit (B/3).

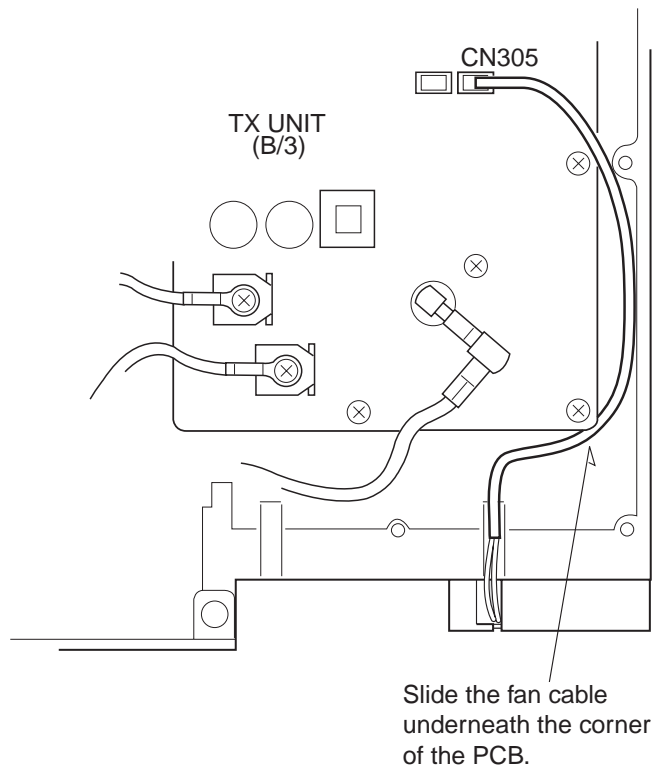

## CIRCUIT DESCRIPTION

### 1.Outline

The TKR-740 is a VHF repeater operating in the 158-174MHz (RX), 146-174MHz (TX) frequency range. It has the following features:

- High-performance model with enhanced features.
- 32 channel radio with 16 QT / DQT.
- Remote functions for use by base stations.
- Fine frequency steps using Direct Digital Synthesizer (DDS).
- Signalling decoding and AF processing using Digital Signal Processor (DSP).

### 2.Transmitter Unit

The transmitter unit (X56-307 A/3) consists of the following circuits: (1) internal/external reference circuit, (2) transmitter reference PLL circuit, (3) transmitter DDS circuit, (4) transmitter main PLL circuit, (5) driver circuit, (6) modulation level adjustment circuit, and (7) other circuits.

#### 2.1 Internal/external reference circuit

The internal/external reference circuit switches between the internal +/-1.0ppm/20MHz TCXO (X101) and the 10MHz external reference automatically. If there is no external reference signal applied to the unit, the internal TCXO is used as the reference frequency. When an external reference (10MHz/-10dBm or higher) is applied, the external reference is automatically used as the reference frequency. The circuit consists of Q102, Q106, XF210, Q109, D101, D103, Q15, X101, Q205, D205, Q206, IC204, Q110, Q114, Q112, Q113, Q108, XF211, and Q115.

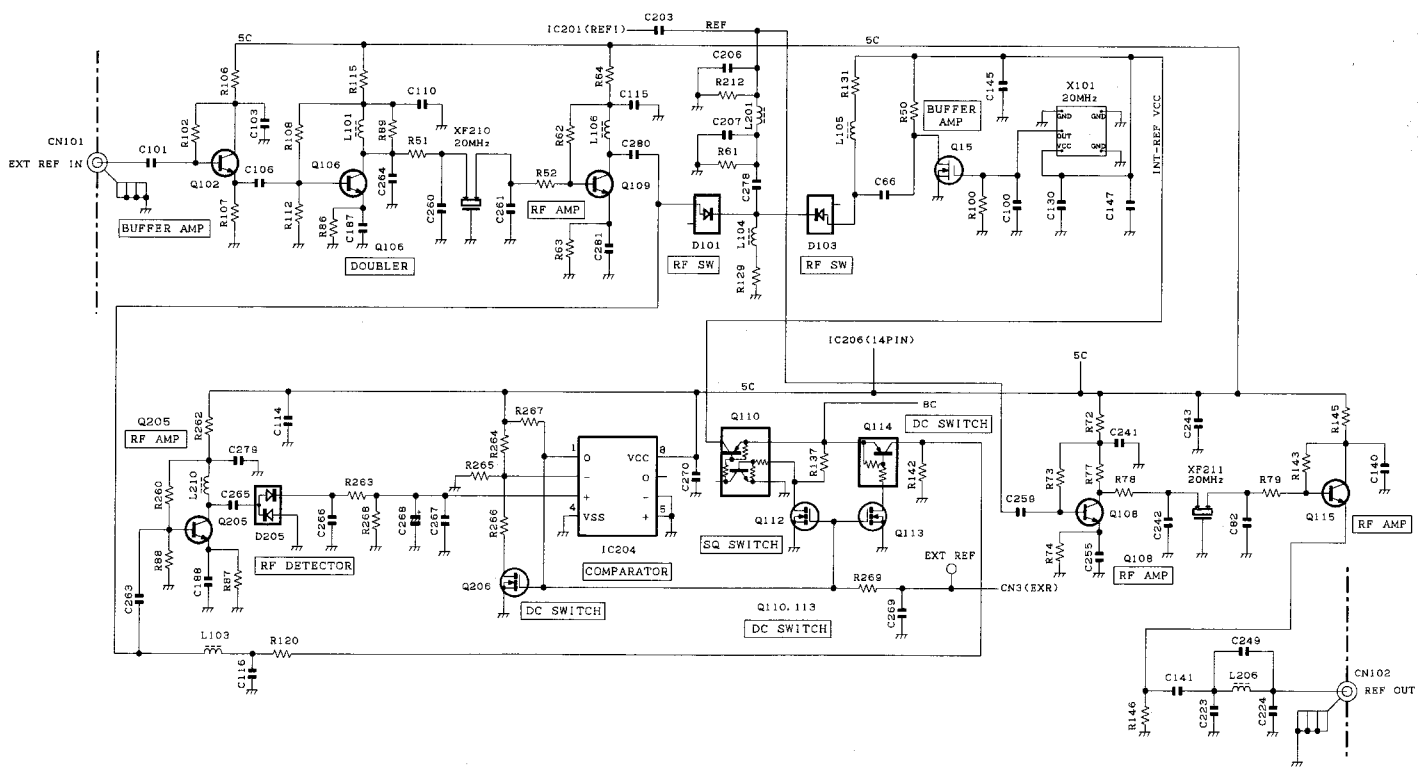

Fig.1 Internal/external reference circuit

### 2.2 Transmitter reference PLL circuit

The transmitter reference PLL circuit generates the reference frequency signal (19.2MHz) for the transmitter DDS and modulates the low-frequency components of QT and DQT. This circuit consists of IC201, X201, Q201, and Q202. The VCO consists of Q201, X201, D203, D201, and D202.

The signal generated by the VCO is fed to buffer amplifier Q202 and unwanted harmonics are removed with an LPF. The resulting signal goes to the PLL IC (IC201), and its phase is

compared with that of the reference frequency using the comparison frequency of 200 kHz. The phase difference signal is converted to a DC voltage by a lag-lead type loop filter. The capacitance of D201 and D204 are varied by the DC voltage to keep the VCO oscillator frequency at 19.2MHz. The 19.2MHz oscillator signal is fed to Q241 and used as the reference frequency signal for the transmitter DDS.

## CIRCUIT DESCRIPTION

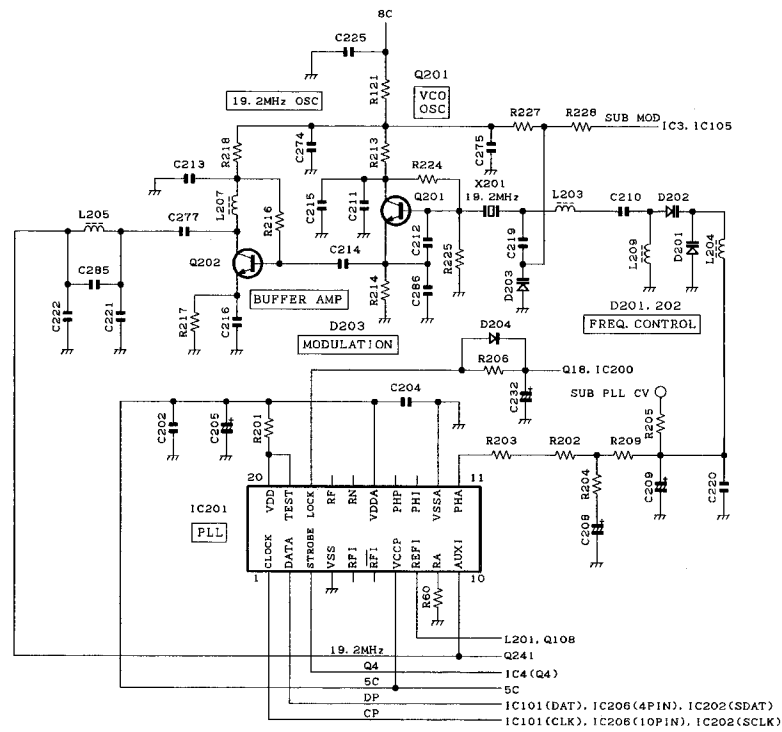

Fig.2 Transmitter reference PLL circuit

### 2.3 Transmitter DDS circuit

The transmitter DDS circuit produces the reference frequency signal (4.5 MHz) for the transmitter main PLL and modulates the low-frequency components of digital pager modulation. This circuit consists of Q241, IC202, IC107, Q207, Q240, and Q242. The 19.2MHz signal coming from the transmitter sub PLL is amplified by Q241 and fed to IC202. IC202 produces the 4.5MHz reference frequency signal for the transmitter main PLL based on the 19.2MHz signal. Since the comparison frequency of the transmitter main PLL is 100 kHz, the PLL frequency step is 100 kHz. However, fine

frequency steps, such as 2.5kHz and 1.25kHz, can be used because the DDS output frequency is variable. IC202 performs binary FSK modulation. Digital pager modulation is implemented by applying low-range modulation to DDS and high-range modulation to the transmitter main PLL. There is a two-stage Butterworth filter (cutoff frequency: 1.9kHz) consisting of IC102 in the high-range modulation line. The IC102 shift input is delayed by IC107 and IC207 to maintain phase balance between the low and high ranges. (See the level adjustment circuit description.)

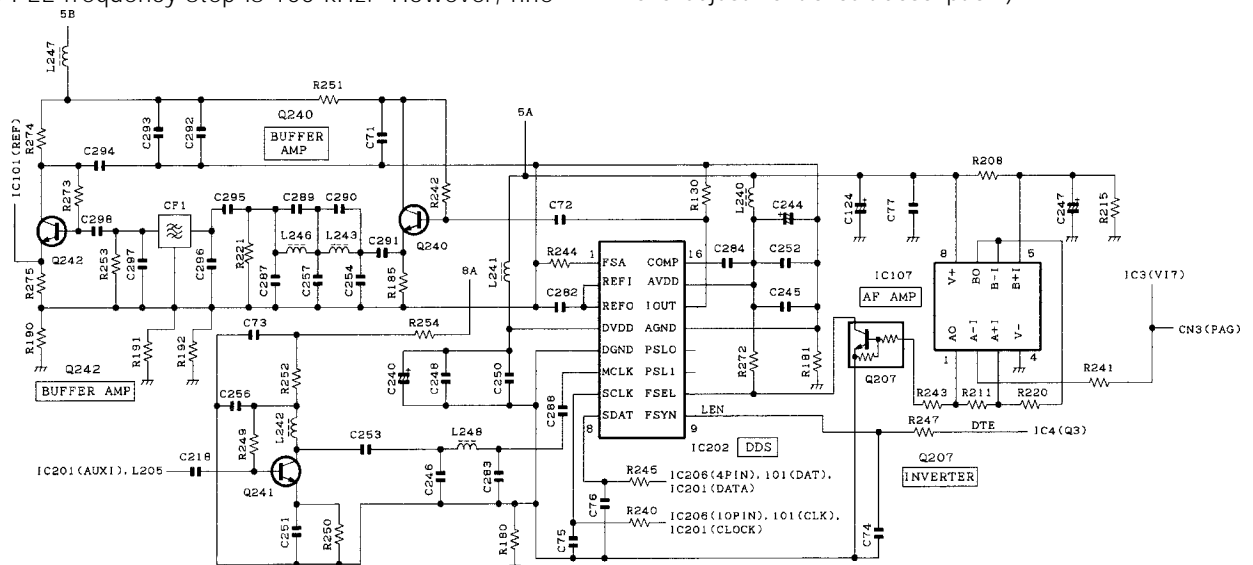

Fig.3 Transmitter DDS circuit

## CIRCUIT DESCRIPTION

### 2.4 Transmitter main PLL circuit

The transmitter main PLL circuit produces the transmitter frequency signal and consists of VCO (Q1 and Q2) and a single-chip PLL IC (IC101). Transmit frequencies from 146.000 MHz to 154.995 MHz are derived from VCO Q1. Transmit frequencies from 155.000 MHz to 174.000 MHz are derived from VCO Q2.

IC101 divides the VCO oscillator signal and the transmitter PLL reference signal (4.5 MHz) and its phase is compared with

the 100kHz comparison frequency. The phase difference signal is converted to a DC signal with a lag-lead type loop filter. The DC signal is applied to varicap D1, D3, D2, D4 to lock the VCO oscillator frequency with the desired oscillator frequency. At the same time, the DC signal passes through the IC109 operational amplifier and buffer amplifier, and is output as a voltage signal (CVT) for monitoring the transmitter main PLL lock voltage.

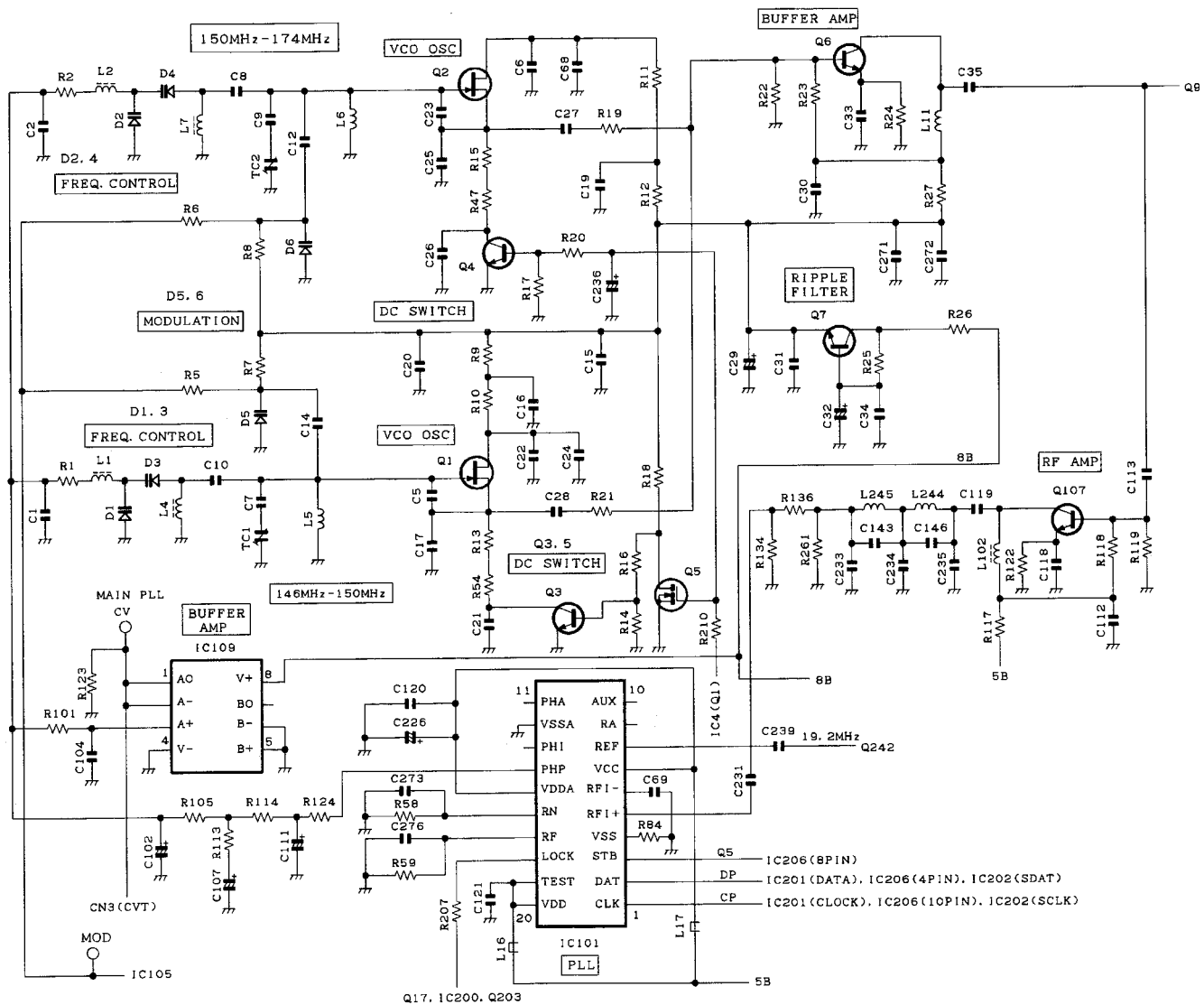

Fig.4 Transmitter main PLL circuit

### 2.5 Driver circuit

The Driver circuit amplifies the transmitter frequency signal to the level required for input to the final unit (X56-307 B/3). This circuit consists of RF amplifier Q9, RF switch D7, RF amplifier Q13, RF amplifier Q14, and switches Q203, Q8, Q12, and Q11.

The transmitter signal level input to Q13 is about 0 dBm (1 milliwatt). Since it is amplified by about 15 dB by Q13, and also amplified by about 13 dB by Q14, the output from Q14 becomes about 630 milliwatts. After being attenuated by attenuators R257, R258, and R259, the net output is +22 dBm (160 milliwatts) at drive output connector CN1.

## CIRCUIT DESCRIPTION

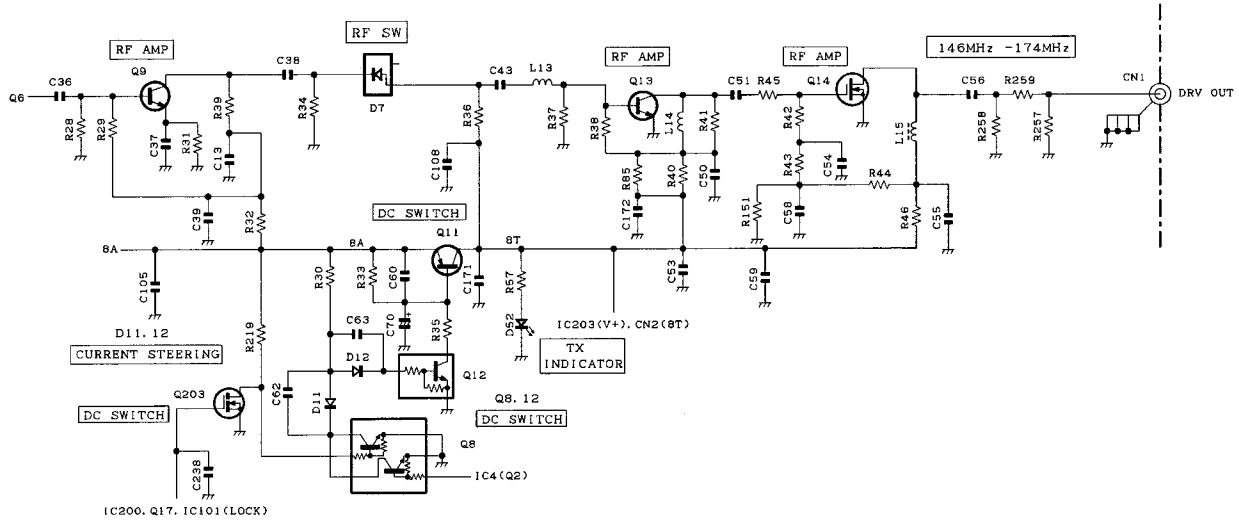

Fig.5 Driver circuit

### 2.6 Modulation level adjustment circuit

The level adjustment circuit adjusts the modulation signal level to provide the required level of modulation and adjusts the transmitter output power. This circuit consists of IC105, IC3, IC100, IC102, IC203, Q208, and Q21. IC3 is an electronic volume control IC. The signalling frequency change adjustment, signalling modulation balance adjustment, digital pager modulation waveform balance adjustment, maximum AF Dev. change, and the reference voltage setting for transmitter power adjustment are performed according to data

from the CPU using the FPU. IC105 is a modulation signal summing amplifier (A/2) and a signalling signal amplitude fine-adjustment amplifier (B/2). IC102 is a splatter filter for digital pager modulation and has a two-stage Butterworth filter with a cutoff frequency of 1.9kHz. IC203 is a DC amplifier that amplifies the transmitter power reference voltage generated by IC3. Q21 outputs 5 V to the final unit as an H/L signal when the transmitter power mode is " LOW " and outputs 0 V when the transmitter power mode is " HIGH " .

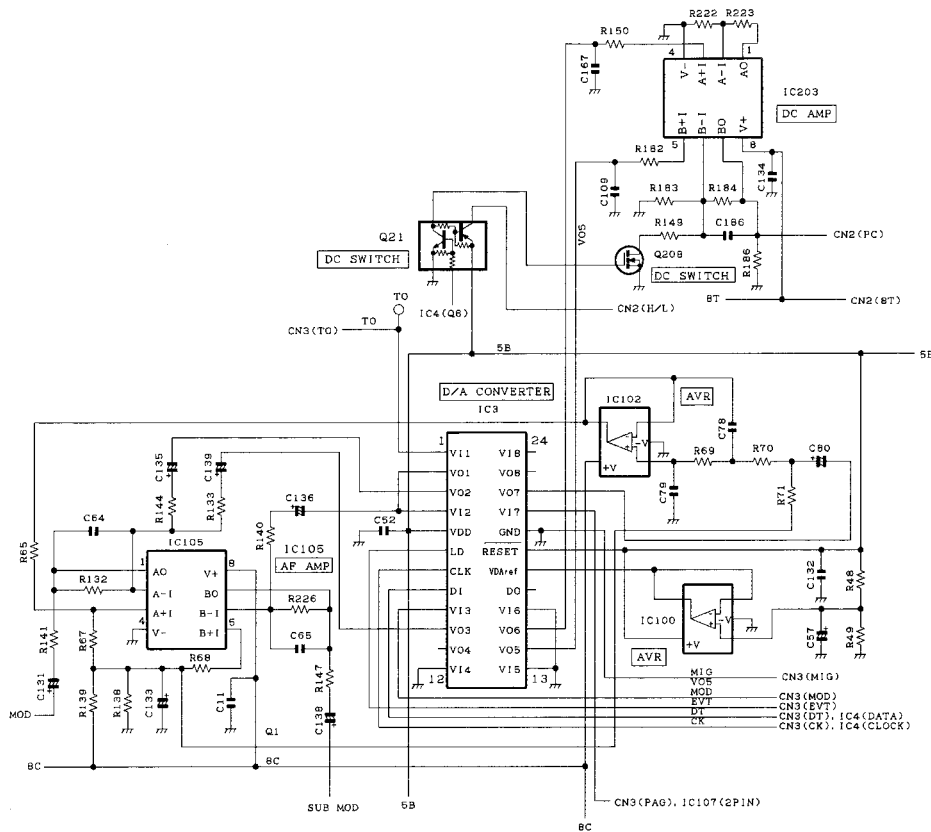

Fig.6 Modulation level adjustment circuit

## CIRCUIT DESCRIPTION

### 2.7 Other circuits

In addition, IC106 is an EEPROM. The transmitter adjustment data adjusted for each unit is written into the EEPROM. If the unit is installed in another set, it is not necessary to adjust it again from the beginning, but only fine-adjustment is necessary for each unit.

IC1, IC2, IC103, IC108, IC205, and IC110 are three-pin AVR ICs. Each circuit contains its own power regulator IC to maintain isolation between circuits.

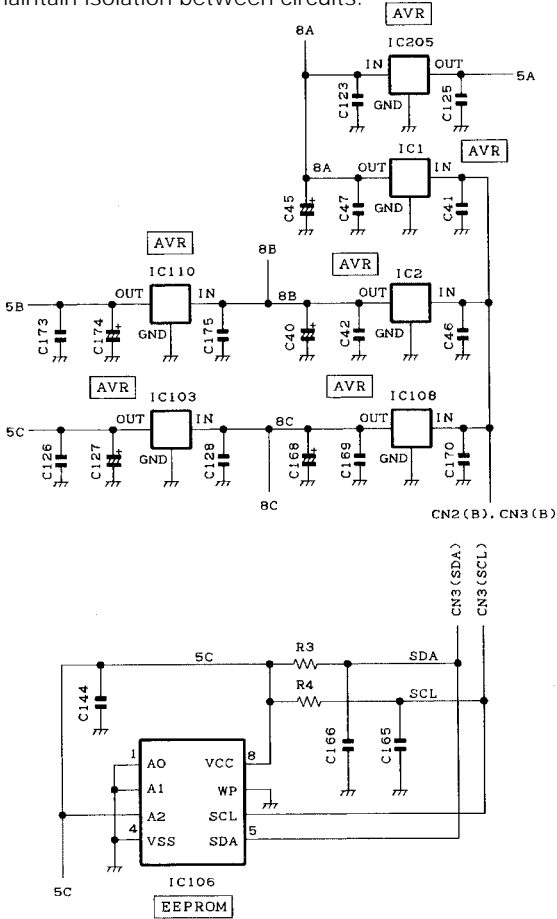

Fig.7 Other circuits

### 3. Final Unit

The RF final amplifier unit (X56-307 B/3) amplifies transmitter power to a specified level. This unit consists of the following circuits: (1) Transmitter power module, (2) harmonic filter circuit, (3) forward/reflected power detector circuit, (4) APC circuit, (5) high temperature detector circuit, (6) common mode spurious filter circuit.

### 3.1 Transmitter power module

The power module IC301 uses a power module RA30H1317M to improve its efficiency. The driver output of the transmitter unit passes through an attenuator and enters power module IC301 on its pin 1. Power module IC301 amplifies the RF power according to the voltage at the amplification control pin 2 (VGG) and outputs it on pin (RFO).

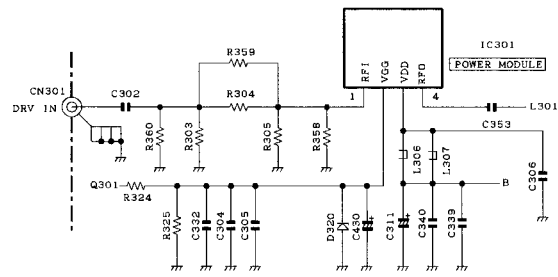

Fig.8 Transmitter power module

### 3.2 Harmonic filter circuit

The harmonic filter circuit uses a three-stage “pi” type Chebyshev type LPF consisting of L301, L302, L303, C307, C312, C315, C316, C336, C337, and C338. This circuit removes harmonics from the transmitter output and sends the filtered signal to the forward/reflected power detector circuit.

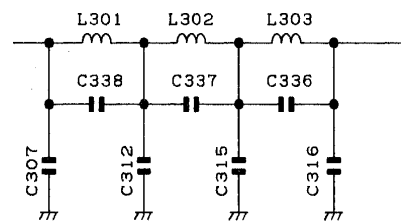

Fig.9 Harmonic filter circuit

### 3.3 Forward/reflected power detector circuit

The forward/reflected power detector circuit consists of a CM coupling type detection circuit formed by a strip line and a DC amplifier IC303 (A/2, B/2). The transmitter power which passes through the strip line is output from CN308.

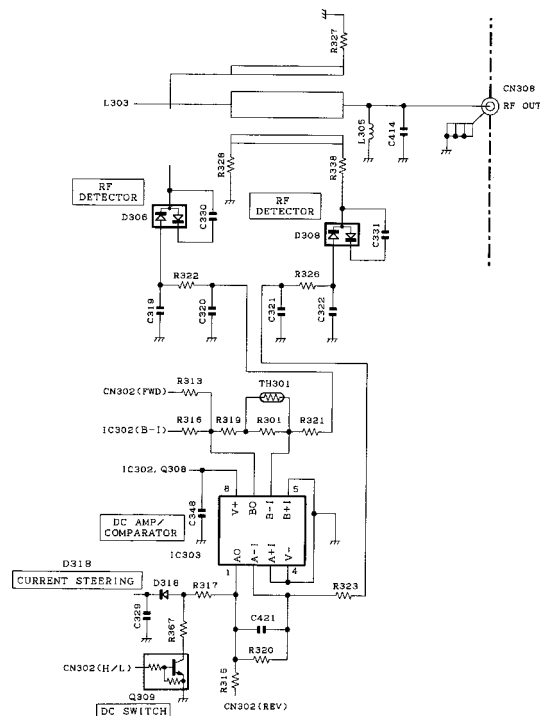

Fig.10 Forward/reflected power detector circuit

## CIRCUIT DESCRIPTION

### 3.4 APC circuit

The APC circuit consists of differential amplifier IC302 (B/2), DC amplifier Q301, and switching transistors Q304. The power setting range in the high-power mode is 25 W; the power setting range in the low-power mode is 5 W.

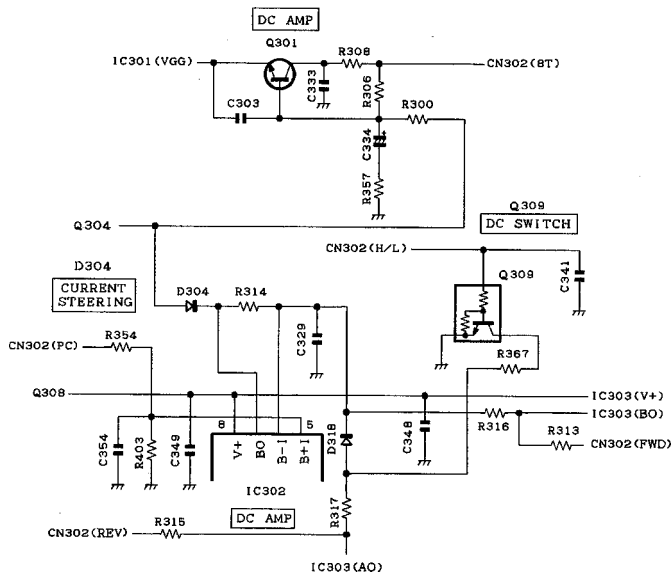

Fig.11 APC circuit

### 3.5 High temperature detector circuit

The high temperature detector circuit consists of thermal switch TS301 and switching transistor Q302. This circuit disables the transmitter power amplifier to protect the circuits when the final unit temperature is too high (95 °C or higher) and the circuit cannot be operated safely.

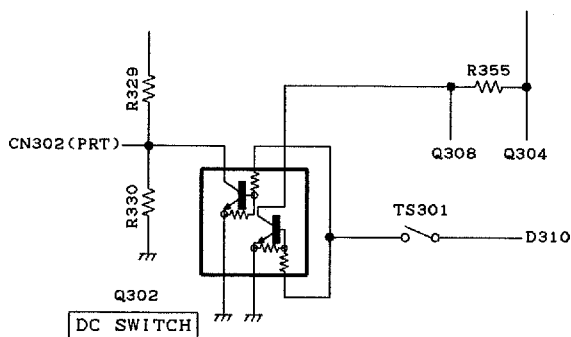

Fig.12 High temperature detector circuit

### 3.6 Common mode spurious filter circuit

The TKR-740 has a filter L304 at the DC power line inlet in the final unit to reduce common mode radiation from the power cable.

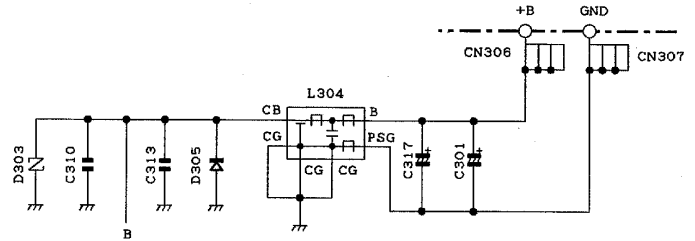

Fig.13 Common mode spurious filter circuit

## CIRCUIT DESCRIPTION

### 4.Receiver Unit

The receiver unit (X55-305) consists of the following circuits: (1) front-end circuit, (2) narrow IF circuit, (3) wide IF circuit, (4) receiver main PLL circuit, (5) receiver DDS circuit, (6) baseband circuit, and (7) other circuits.

#### 4.1 Front-end circuit

The front-end circuit consists of BPF L3, RF amplifier IC17, BPF L16, mixer DBM A1, and IF switch D10. The helical BPF covers frequency ranges 158.000 to 174.000 MHz, with a passband of 3.0 MHz.

BPF L16 attenuates the unwanted out-of-band RF components produced by RF amplifier IC17 and sends only the desired signal to mixer DBM A1. Mixer DBM A1 mixes

the first local oscillator signal generated by the first local crystal oscillator with the receive signal coming from the helical BPF L16 to produce the first IF signal (44.85MHz). The first IF signal is fed to the narrow IF or wide IF circuit (depending on programming) by switch D10.

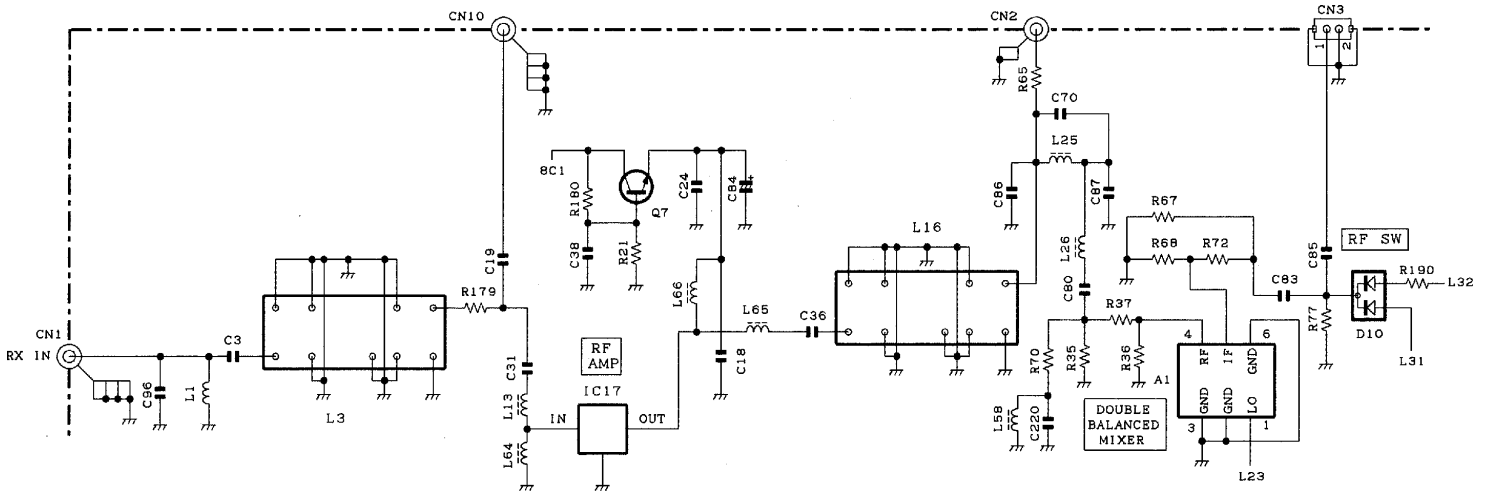

Fig.14 Front-end circuit



## CIRCUIT DESCRIPTION

### 4.2 Narrow IF circuit

The narrow IF circuit consists of two-pole MCF XF2, four-pole MCF XF4, IF amplifier Q25, IF amplifier Q32, FM detector IC7, crystal oscillator X1 and ceramic filters CF1, CF3. The unwanted components of the signal are removed by two-pole MCF XF2 and four-pole MCF XF4, and the resulting signal is amplified by IF amplifiers Q32. The FM IC IC7 produces the second IF signal (450 kHz), ceramic filters CF1 and CF3 remove unwanted components and an IF amplifier amplifies the signal, and the quadrature detector circuit FM-detects the signal to produce a baseband signal and outputting it to pin 15.

The baseband signal passes through analog switch IC18, inversion amplifier IC15 (B/2), AF amplifier IC11 (A/2 and B/2), and goes to the Y0 input of multiplexer IC9 and the V2 input of electronic volume control IC9. The level of the signal that

enters V2 of the electronic volume control IC is adjusted, the signal passes through the hysteresis circuit AF switch Q34, goes to IC7 noise filter input (pin 17), and high-frequency components are selected by an HPF consisting of an external RC network. The signal is noise-detected and compared, and the noise squelch signal (N-DET) is fed to DC switch Q36. The signal strength analog voltage (RSSI) from the two second IF amplifiers in IC7 is compared with the reference voltage set by electronic volume control V4 by the internal RSSI comparator, and the RSSI squelch signal (C-DET) is output from pin 20 of IC7. C-DET enters DC switch Q37 and is ANDed with the N-DET by DC switch Q38. A squelch signal (SQ) is output from connector CN6.

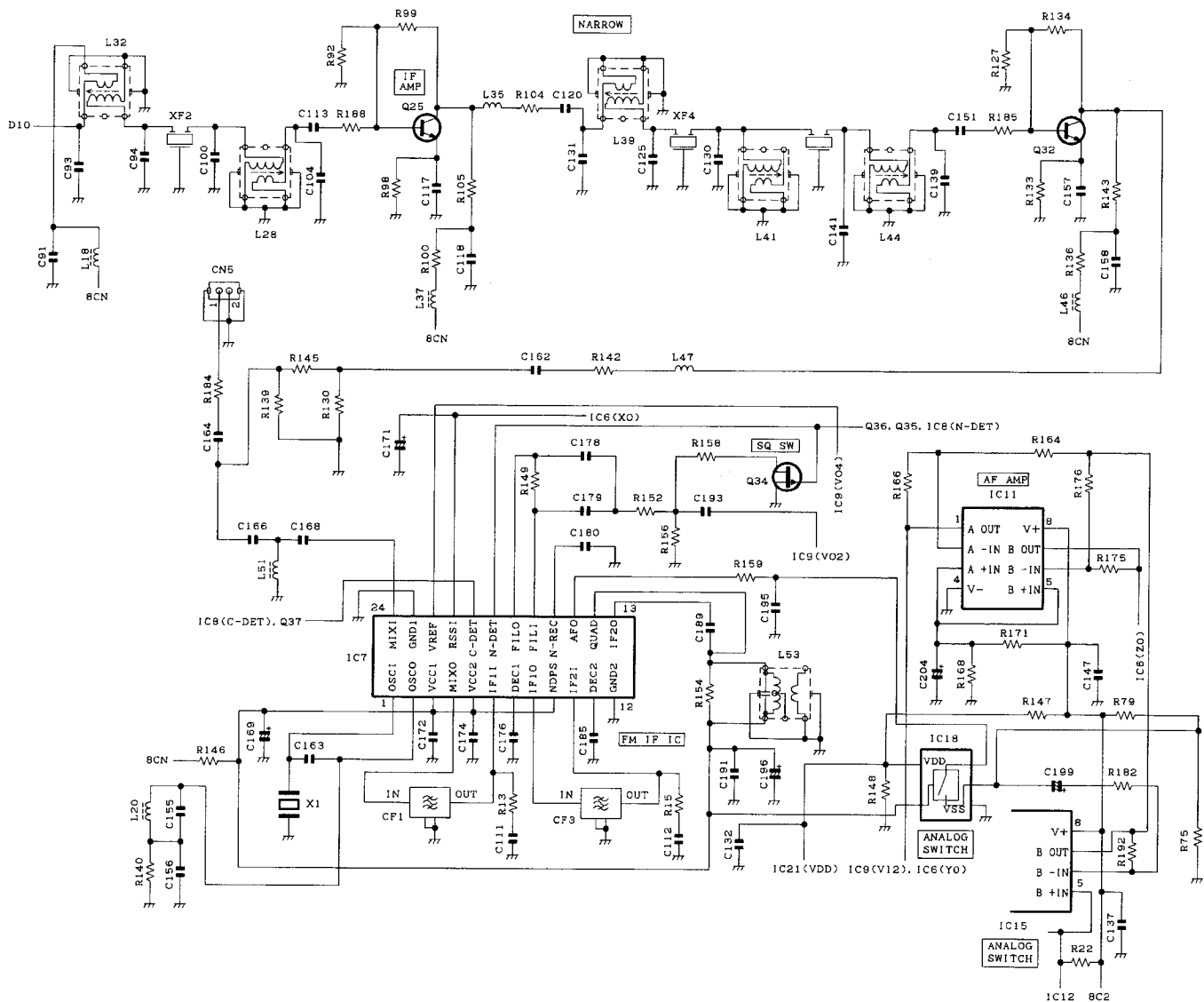

Fig.15 Narrow IF circuit

## CIRCUIT DESCRIPTION

### 4.3 Wide IF circuit

The wide IF circuit consists of two-pole MCF XF1, four-pole MCF XF3, IF amplifier Q24, IF amplifier Q31, FM detector IC8, crystal oscillator X2, ceramic filter CF2, CF4. The unwanted components of the signal are removed by two-pole MCF XF1 and four-pole MCF XF3 and the resulting signal is amplified by IF amplifiers Q24 and Q31. The second IF signal (450 kHz) is produced by FM detector IC8. Unwanted components of the second IF signal are removed by ceramic filter CF2, CF4, and the resulting signal is amplified by the built-in IF amplifier and FM-detected by the quadrature detection circuit to generate a baseband signal. This signal is output from pin 15. It then passes through analog switch IC21, invert amplifier IC15 (A/2) and AF amplifier IC12 (A/2) and goes to the Y1 input of multiplexer IC and the V1 input of electronic volume control IC9.

The level of the signal that enters V1 of the electronic volume control IC is adjusted, the signal passes through AF switch Q35, goes to IC8 noise filter input (pin 17), and high-frequency components are selected by an HPF consisting of an external RC network. The signal is noise-detected and the compared noise squelch signal (N-DET) is fed to DC switch Q36. The signal strength analog voltage (RSSI) from the two second IF amplifiers in IC8 is compared with the reference voltage set by electronic volume control V3 by the internal RSSI comparator, and the RSSI squelch signal (C-DET) is output from pin 20 of IC8. C-DET enters DC switch Q37 and is ANDed with the N-DET by DC switch Q38 and output as a squelch signal (SC).

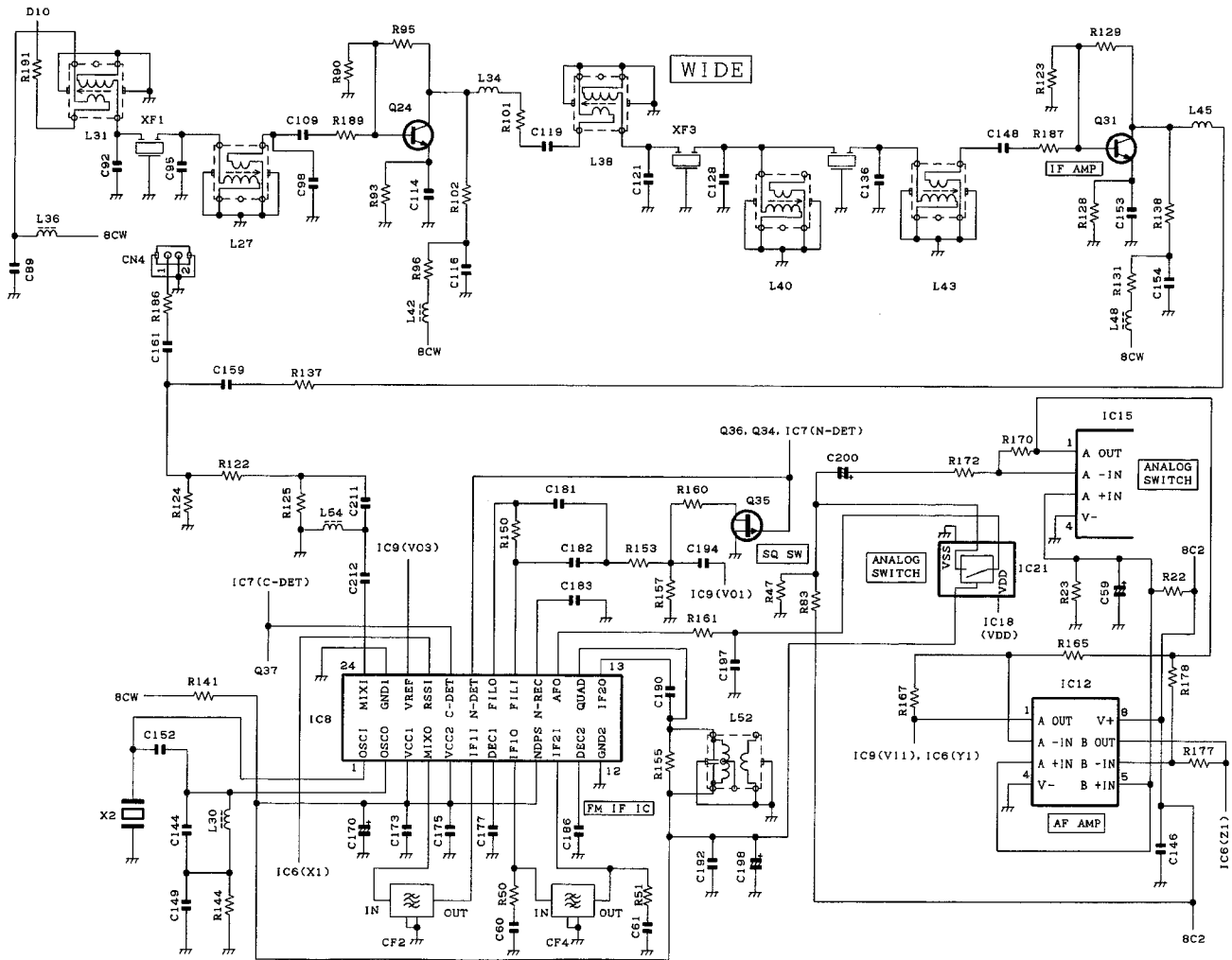

Fig.16 Wide IF circuit

## CIRCUIT DESCRIPTION

### 4.4 Receiver main PLL circuit

The receiver main PLL circuit consists of VCO (Q8, Q9) and a single-chip PLL IC IC1, buffer amplifier Q14, RF amplifier Q3, Q1, Q5, and Q6. The first local oscillator is an upper heterodyne local oscillator, and the VCO oscillator frequency is 202.850 to 218.850 MHz. In addition, the two VCOs cover

two bands: the Q8 VCO covers the lower band and the Q9 VCO covers the upper band. PLL IC1 compares the 4.5MHz signal from the receiver DDS circuit and the VCO signal with the 100kHz comparison frequency.

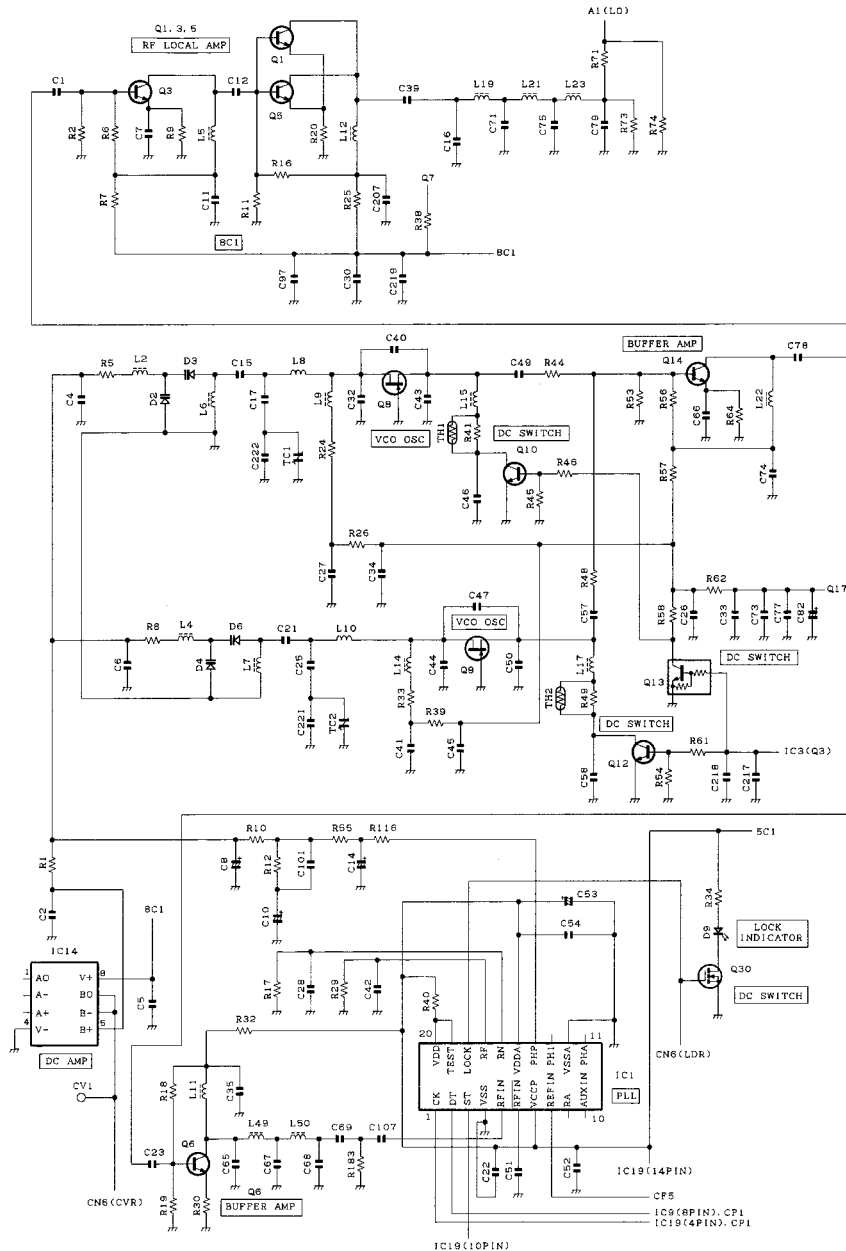

Fig.17 Receiver main PLL circuit

## CIRCUIT DESCRIPTION

### 4.5 Receiver DDS circuit

The receiver DDS circuit varies the reference frequency of the receiver main PLL to implement fine frequency steps which cannot be achieved by a single-loop PLL. This circuit comprises IC20, Q33, Q39, and CF5. The output frequency is used as the reference frequency for the receiver main PLL.

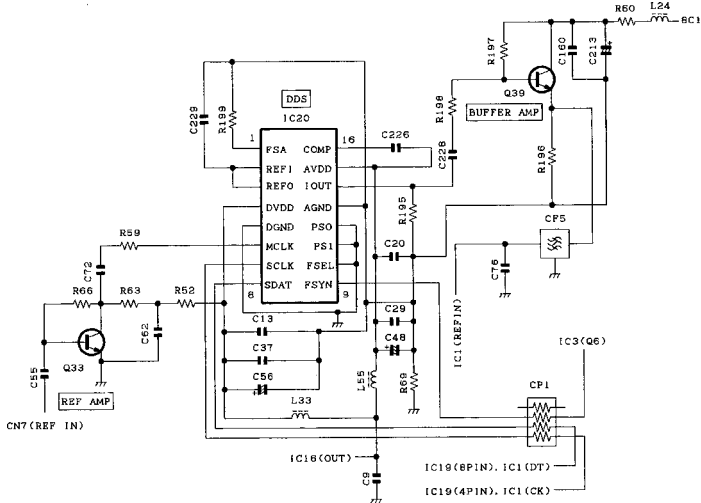

Fig.18 Receiver DDS circuit

### 4.6 Baseband circuit

The baseband signal circuit consists of HPF Q26, LPF Q28, D11, and Q29. The baseband signals detected by the narrow FM and wide FM detector circuits are de-emphasized by LPF Q28. The sub-audible components of the signal are removed by HPF Q26, and the resulting signal is switched with a squelch signal by D11 and Q29, and output as an RA signal from CN6.

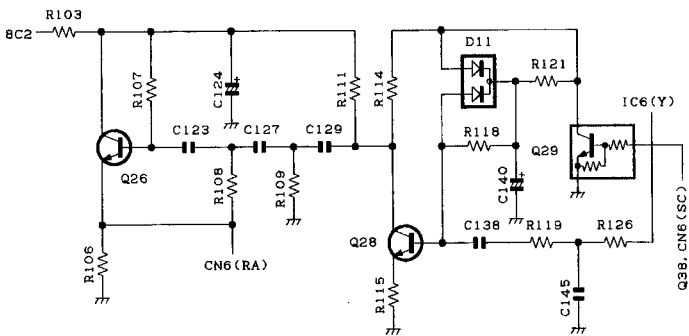

Fig.19 Baseband circuit

### 4.7 Other circuits

In addition, the receiver circuit contains an EEPROM (IC10) as in the transmitter circuit. Adjustment data for each unit and the last channel data are written into the EEPROM. IC2, IC4, IC13, and IC16 are three-pin AVR ICs. Q17 is a ripple filter for the power supplied to the first local oscillator VCO. IC3 is a shift register. Q16, Q18, Q19, Q20, and Q22 are switching transistors.

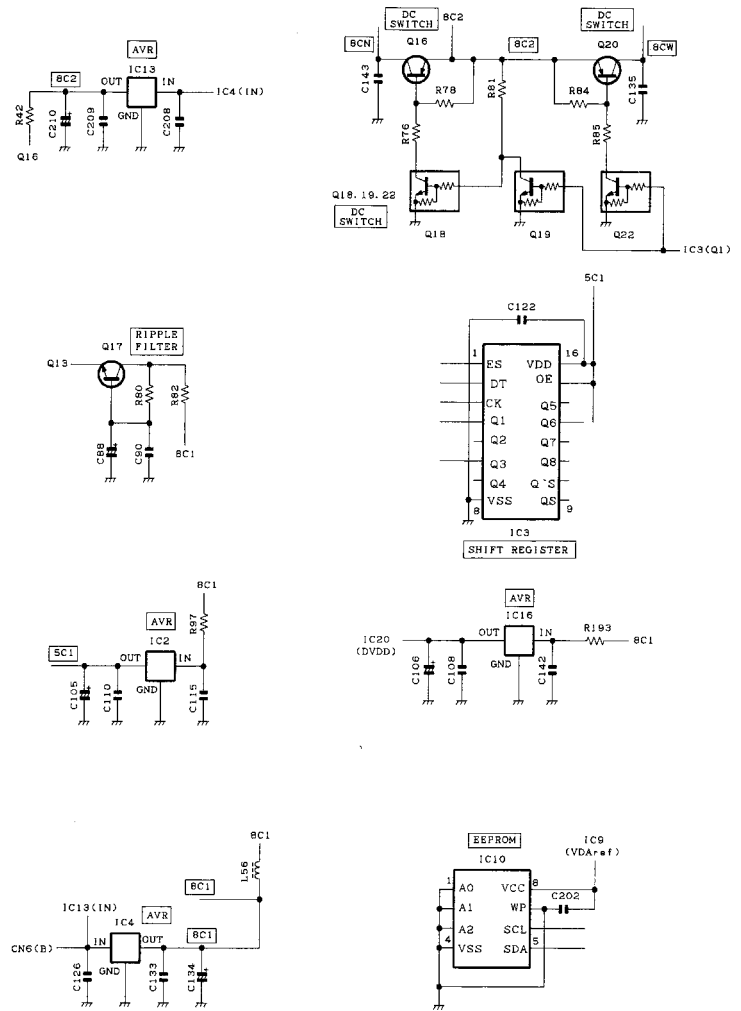

Fig.20 Other circuits

## CIRCUIT DESCRIPTION

### 5. Control Circuit

The control unit (X53-388) consists of the following circuits: (1) main CPU, (2) sub CPU, (3) DSP circuit, (4) AF PA circuit, (5) display circuit, (6) baseband circuit, (7) Microphone AGC circuit, (8) RS-232C circuit, and (9) power supply circuit.

### 5.1 Main CPU

The main CPU (IC17) is a 16-bit single-chip microcomputer containing a 128k ROM and a 5k RAM. This CPU controls the sub CPU, the flash ROM, and the DSP, encodes high-speed and low-speed data, controls the transmitter unit, the receiver unit, the control unit, and the display circuit and sends data to or from an external device.

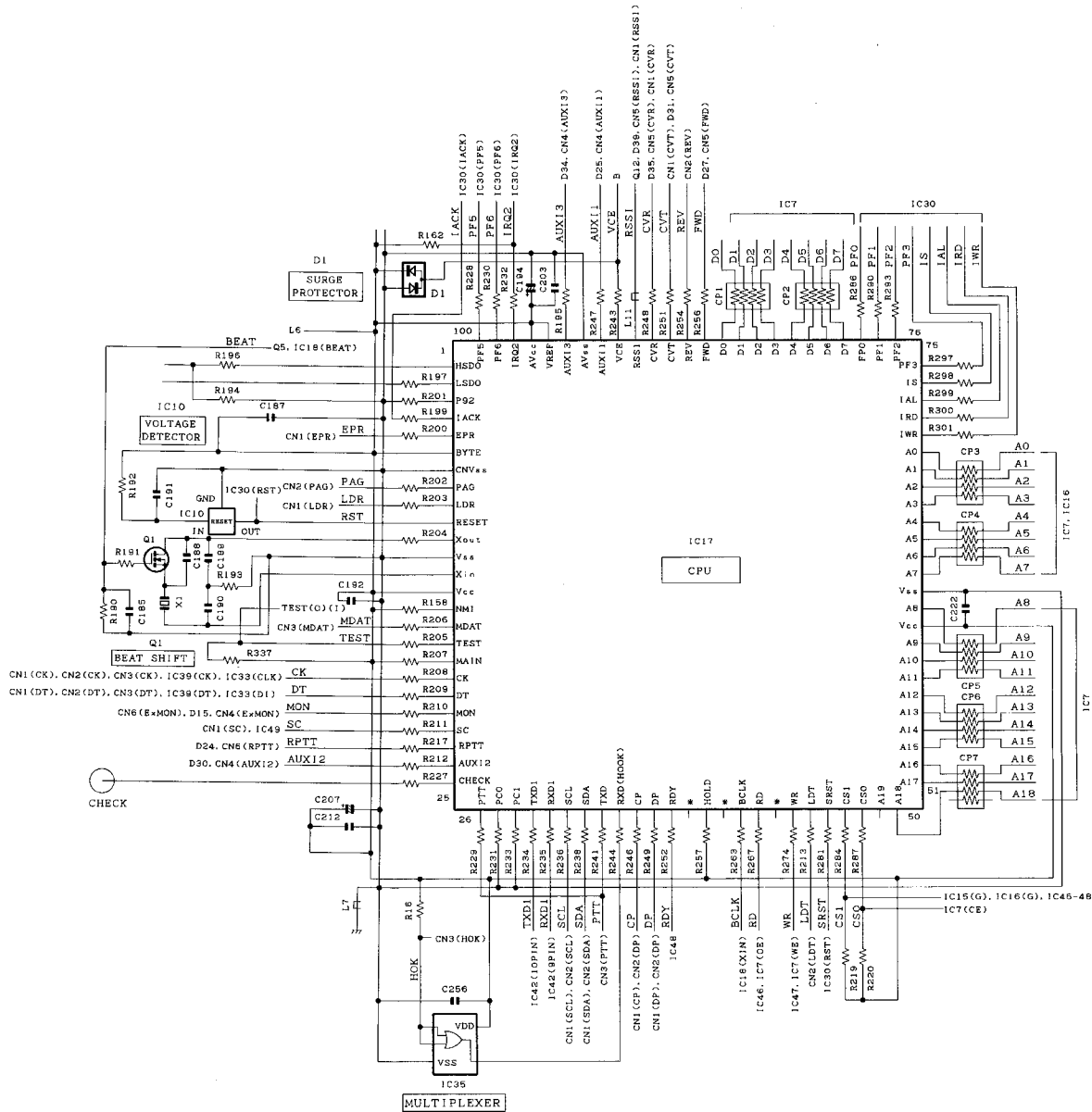

Fig.21 Main CPU

# TKR-740

## CIRCUIT DESCRIPTION

### 5.2 Sub CPU

The sub CPU (IC18) is of the same type as the main CPU, but is programmed so that it operates as the sub CPU by connecting its pin 18 to GND (pin 18 of the main CPU is connected to Vdd.). The sub CPU functions as an I/O expander, and controls the flash ROM, DSP, and extended I/O. IC15 and IC16 are data bus buffer ICs.

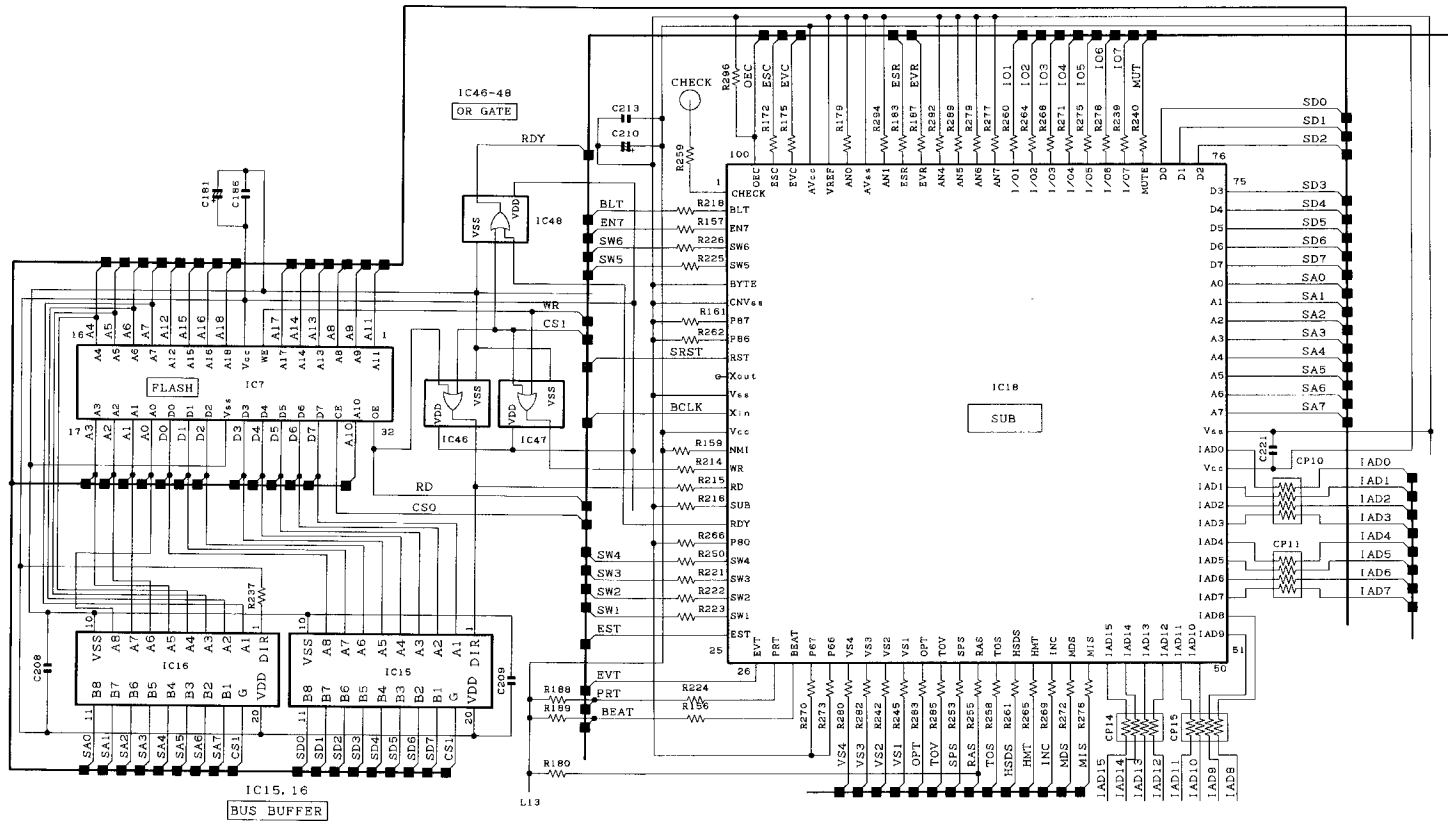

Fig.22 Sub CPU

## CIRCUIT DESCRIPTION

### 5.3 DSP circuit

The DSP circuit filters transmitter/receiver audio signals and decodes signalling (QT, DQT). This circuit consists of IC30, IC24, IC27, IC22, IC31, IC34, and IC25. The receiver signal DET is converted from analog to digital by codec IC27 with a sampling frequency of 16.128 kHz. The digitized audio signal is sent to DSP IC30 to process the signalling signal and audio signal. The processed digital audio signal is fed to codec IC27, converted from digital to analog, and the analog signal is output from pin 12 (Vout R). Then, the audio signal is amplified by IC34 (B/2), passes through the IC34 (A/2) low-pass filter, and goes to multiplexer IC37.

The transmitter audio signal coming from pin 13 of IC29 is

amplified by IC22 (B/2), fed to pin 6 (Vin R) of codec IC27, and converted from analog to digital at a sampling frequency of 16.128 kHz. The digitized transmitter audio signal is AGC-processed, pre-emphasized and filtered at 300 Hz to 3 kHz by DSP IC30, and the resulting signal is fed back to codec IC27, converted from digital to analog, and the analog signal is output from pin 15 (Vout L). The transmit signal from Vout L is amplified by IC34 (B/2), passes through the IC34 (A/2) low-pass filter, and goes to the IC12 (A/2) summing amplifier. IC24 is a counter IC and the clock required for the codec and DSP is generated by dividing the 16.515MHz clock signal produced by DSP IC30.

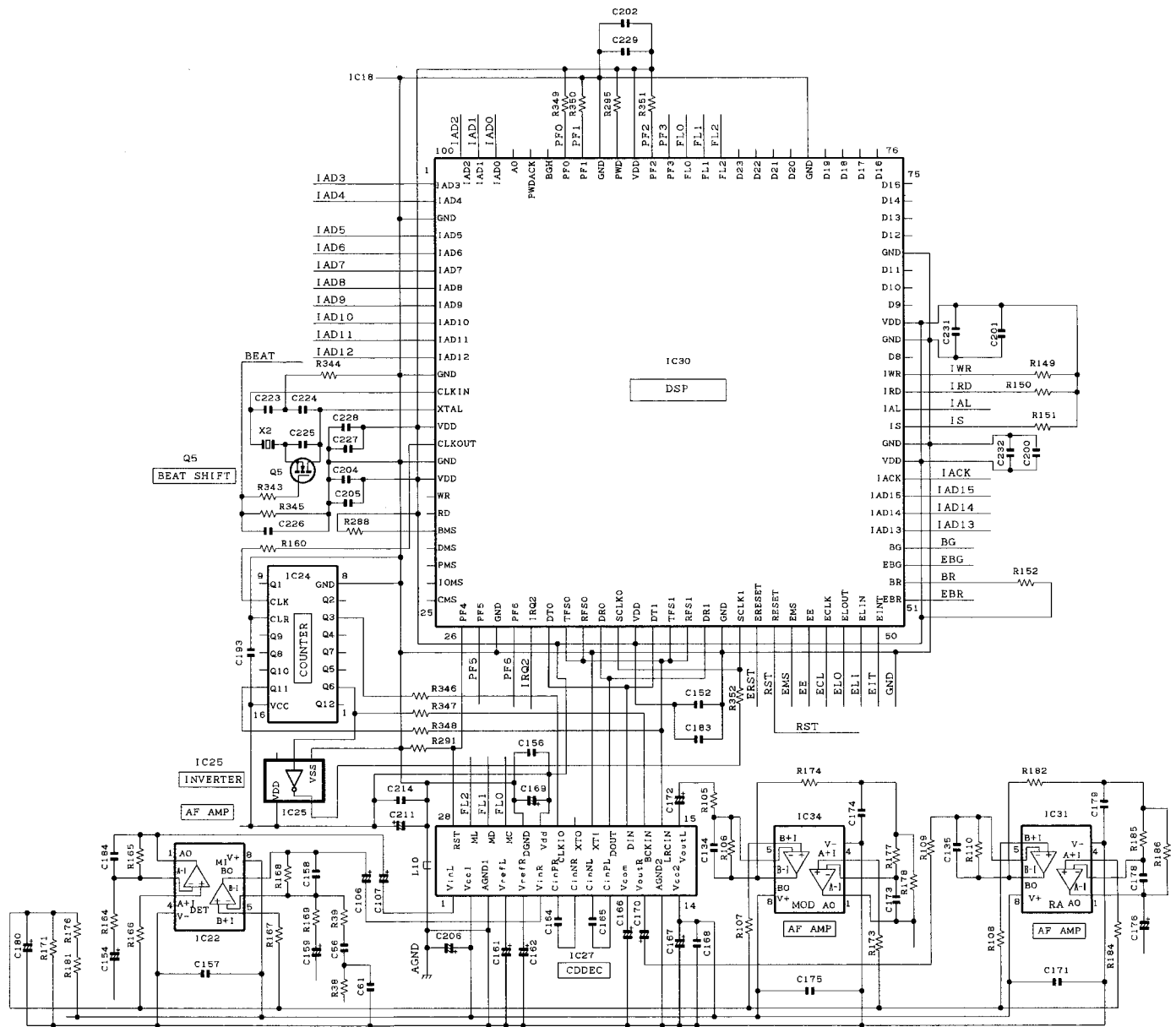

Fig.23 DSP circuit

## CIRCUIT DESCRIPTION

### 5.4 AF PA circuit

The AF PA circuit is an AF amplifier for driving speakers to monitor received audio signals. This circuit consists of IC45. The 4W audio output can be provided to an external 4 ohm speaker by supplying power supply voltage through the 15-

pin test connector "SPO, SPG" on the rear panel. The impedance of the internal speaker is adjusted to provide an audio output of about 0.2 W when the internal speaker installed on this model front panel is used.

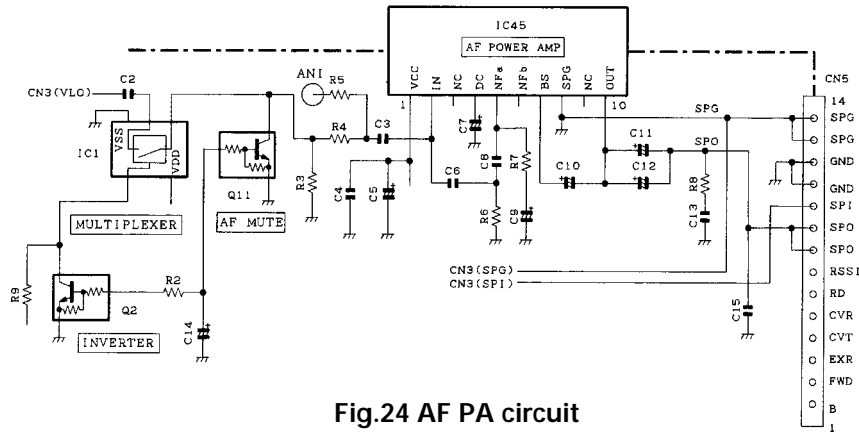

Fig.24 AF PA circuit

### 5.5 Display circuit

The display circuit contains 7-segment LED D700, D701 (orange: see the operation manual for details of display), D703 (green: circuit power supply), D704 (red: transmit), D705 (green: busy), two-color LED D702 (green: internal; red: external reference state), LEDs in switches S700 to S705, IC700, IC701, IC702 and IC703 to display this model channels

and states. IC700 to IC703 are shift registers which convert serial data from the CPU to parallel data and light LEDs. Q706, Q707, Q708, Q709, and Q710 are switching transistors which control two-color LED D702. IC704, IC705, and IC706 are three-pin AVR ICs which produce power used for the display circuit.

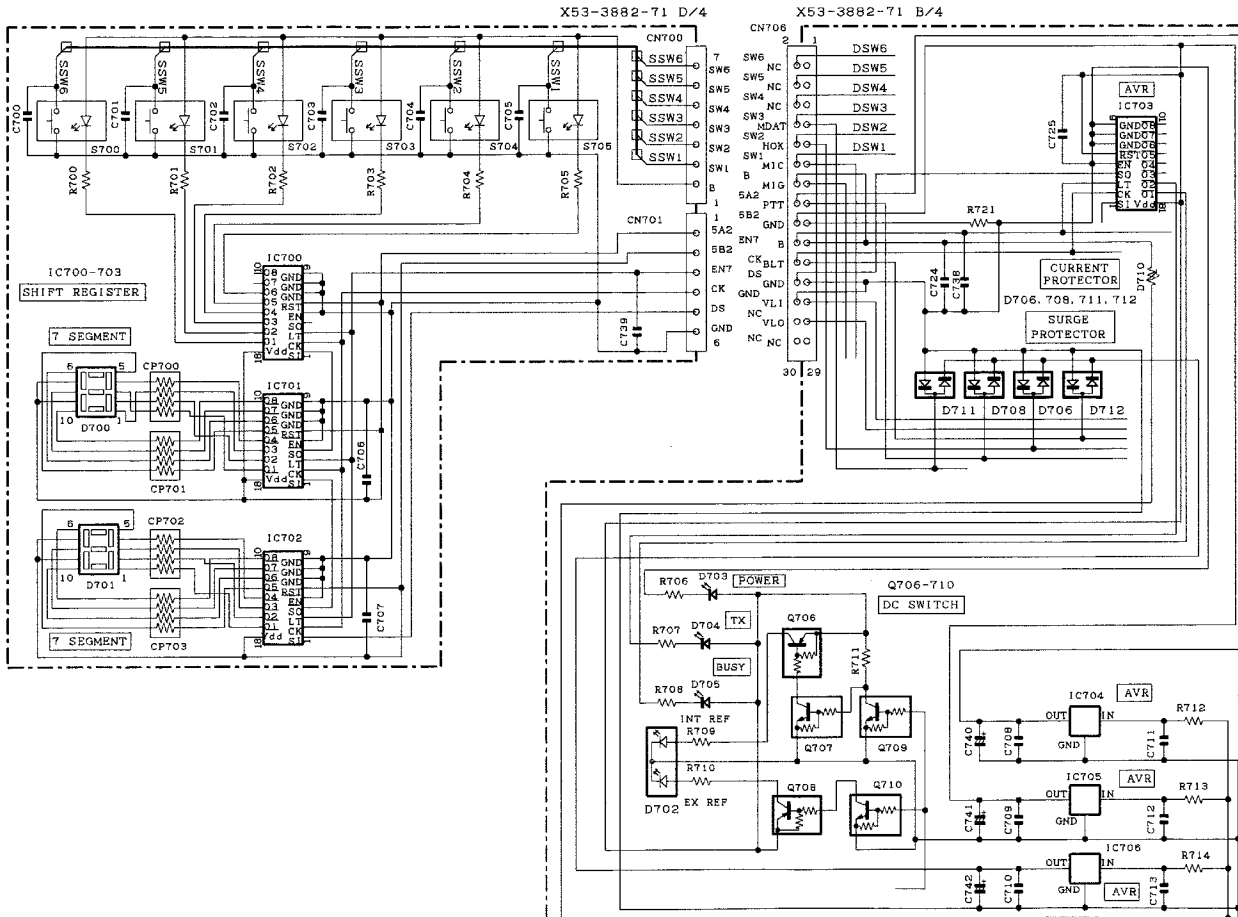

Fig.25 Display circuit



## CIRCUIT DESCRIPTION

### 5.6 Baseband circuit

The baseband circuit switches between the modulation signal to the transmitter unit, demodulation signal from the receiver unit, and remote audio signal and adjusts their levels. This circuit consists of IC12, IC13, IC14, IC29, IC32, IC33, IC36, IC37 and IC40. Modulation inputs include local microphone input, low-speed data (LSD), high-speed data (HSD), external audio input (TA), external data input (TD), and remote

modulation input (RTA), and demodulation outputs include receive audio output (RA), receive data output (RD), and remote receive audio (RRA). The multiplexer (IC14, IC29, IC37) changes signals, the electronic volume control (IC33) adjusts the level, and the operational amplifier (IC12, IC13, IC32, IC36, IC42) amplifies and sums signals.

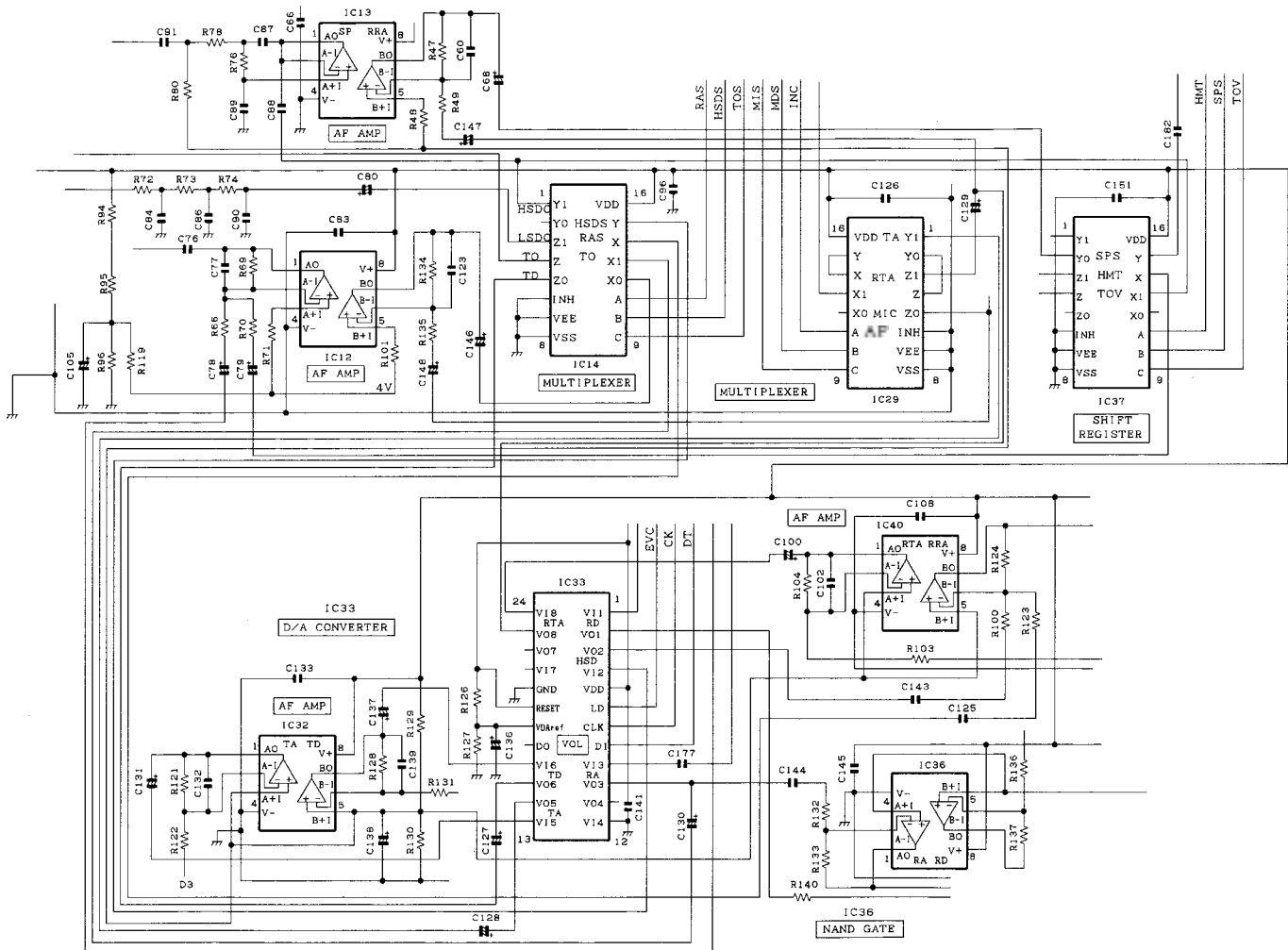

Fig.26 Baseband circuit

## CIRCUIT DESCRIPTION

### 5.7 Microphone AGC circuit

The microphone AGC circuit AGC-amplifies an audio signal coming from a local microphone so that it does not overdrive the modulator. This circuit consists of IC23, D707, D709, Q700, and Q701. The AGC is operated by controlling the + and - levels of amplitude using the current obtained by positive and negative detection of the amplified audio signal.

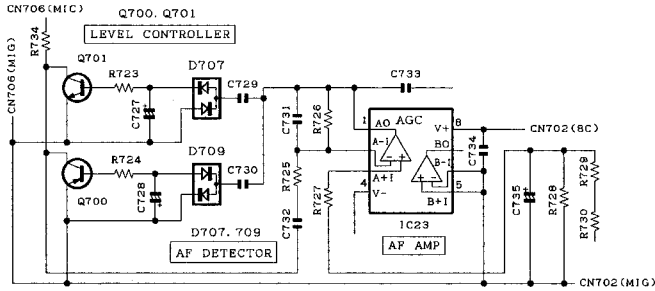

Fig.27 Microphone AGC circuit

### 5.8 RS-232C circuit

The RS-232C circuit connects the RS-232C serial port of a personal computer directly to this model to perform FPU operation. The FPU operation can also be performed by connecting a programming cable (KPG-46) to the local microphone on the front panel. If the D-sub connector on the rear panel is used, the programming cable is not required. The 232C driver IC (IC42) changes the TTL-232C level. The FPU (KPG-47D) has a new transmitter/receiver circuit monitor function (transmitter: forward power, reflected power display, transmitter main PLL lock voltage; receiver: RSSI display, receive main PLL lock voltage). Data required for this function is also transferred through the RS-232C serial port. The firmware can only be rewritten using the local microphone connector on the front panel.

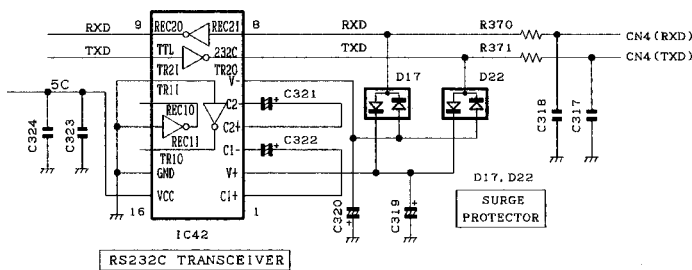

Fig.28 RS-232C circuit

### 5.9 Power supply circuit

The power supply circuit generates power to operate the CPU, DSP, flash ROM, bi-directional buffer, and baseband circuit. This circuit consists of IC3, IC4, IC5 and IC6.

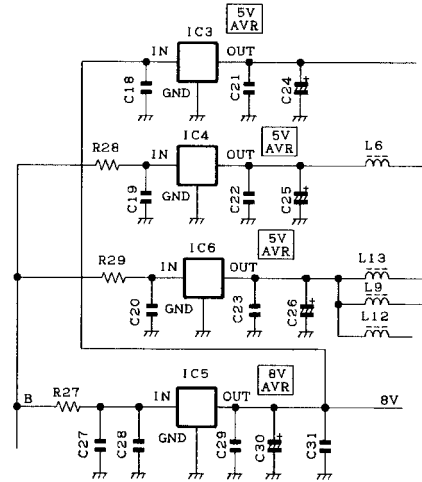

Fig.29 Power supply circuit

## SEMICONDUCTOR DATA

## MAIN CPU : 30622M4-103GP (CONTROL UNIT IC17)

## ■ Pin function

Pin No.	Port name	I/O	Function
1	HSDO	O	High speed data output
2	LSDO	O	Low speed data output
3	P92	-	Not used
4	IACK	I	DSP IDMA Acknowledge input
5	EPR	O	RX PLL data strobe output
6	BYTE	I	+5V
7	CNVss	I	GND
8	PAG	O	Digital pager signal output
9	LDR	I	RX PLL lock detect input
10	RESET	I	Microcomputer reset input
11	Xout	-	14.745MHz (system clock)
12	Vss	-	GND
13	Xin	-	14.745MHz (system clock)
14	Vcc	-	+5V
15	NMI	-	Not used
16	MDAT	I	Not used
17	TEST	I	Test switch input
18	MAIN	I	Main/Sub CPU select input (H:Sub,L:Main)
19	CK	O	Common data output
20	DT	O	Common clock output
21	MON	I	Monitor switch input
22	SC	I	Squelch control input
23	RPTT	I	Remote PTT input
24	AUXI2	I	Auxiliary input 2
25	CHECK	-	Check port
26	PTT	I	PTT switch input
27,28	PC0,1	-	Not used
29	TXD1	O	Serial interface output 1 (ex. PC)
30	RXD1	I	Serial interface input 1 (ex. PC)
31	SCL	O	Serial EEPROM clock output
32	SDA	I/O	Serial EEPROM data input/output
33	TXD	O	Serial interface output 0 (ex. PC)
34	RXD	I	Serial interface input 0 (ex. PC)
35	CP	O	PLL clock output
36	DP	O	PLL data output
37	RDY	I	CPU ready input
38	ALE	-	Not used
39	HOLD	-	Not used
40	HLDA	-	Not used
41	BCLK	O	Sub CPU clock output
42	RD	O	Flash memory/Sub CPU RD bus
43	BHE	-	Not used
44	WR	O	Flash memory/Sub CPU WR bus
45	LDT	I	TX PLL lock detect input
46	SRST	O	Sub CPU reset output
47	CS1	O	Sub CPU chip select
48	CS0	O	Flash memory chip select
49	A19	O	Not used
50-59	A18-9	O	Flash memory address bus
60	Vcc	-	+5V
61	A8	O	Flash memory address bus
62	Vss	-	GND

Pin No.	Port name	I/O	Function
63-70	A7-0	O	Flash memory/Sub CPU address bus
71	IWR	O	DSP IDMA write output
72	IRD	O	DSP IDMA read output
73	IAL	O	DSP IDMA address latch output
74	IS	O	DSP IDMA select output
75	PF3	O	DSP RX mute control output
76	PF2	-	Not used
77	PF1	O	DSP modulation control output
78	PF0	-	Not used
79-86	D7-0	I/O	Flash memory/Sub CPU data bus
87	AN7	I	Forward power voltage input
88	AN6	I	Reverse power voltage input
89	AN5	I	TX VCO voltage input
90	AN4	I	RX VCO voltage input
91	AN3	I	RSSI level input
92	AN2	I	Power supply voltage input
93	AUXI1	I	Auxiliary input 1
94	Avss	-	GND
95	AUXI3	I	Auxiliary input 3
96	Vref	I	+5V
97	Avcc	I	GND
98	IRQ2	O	DSP interrupt request output
99	PF6	O	DSP Mic mute control output
100	PF5	O	DSP TX/RX control output

## SUB CPU : 30622M4-103GP (CONTROL UNIT IC18)

## ■ Pin function

Pin No.	Port name	I/O	Function
1	P94	-	Check port
2	BLT	-	Not used
3	EN7	O	LED data strobe output
4,5	SW6,5	I	PF6,5 key input
6	BYTE	I	GND
7	CNVss	I	GND
8,9	P87,86	-	Not used
10	RST	I	Microcomputer reset input
11	Xout	-	14.745MHz (system clock)
12	Vss	-	GND
13	Xin	-	14.745MHz (system clock)
14	Vcc	-	+5V
15	NMI	-	Not used
16	WR	I	Write enable input
17	RD	I	Read enable input
18	SUB	I	Main/Sub CPU select input (H:Sub,L:Main)
19	RDY	O	Main CPU ready control output
20	P80	-	Not used
21-24	SW4-1	I	PF4-1key input
25	EST	O	TX shift register data strobe output
26	EVT	O	TX D/A converter IC data strobe output
27	PRT	I	Exciter Temperature detect input
28	BEAT	O	Beat shift control (H:ON,L:OFF)
29,30	P67,P66	-	Not used
31-34	VS4-1	O	Voice scrambler data output 4-1
35	OPT	O	Option board control output (H:OFF,L:ON)

## SEMICONDUCTOR DATA

Pin No.	Port name	I/O	Function
36	TOV	O	Take over control output
37	SPS	O	Local speaker output select
38	RAS	O	RA output select
39	TOS	O	TO output select
40	HSDS	O	High speed data output control
41	HMT	O	High speed data mute control
42	INC	-	Not used
43	MDS	O	Modulation select
44	MIS	O	Mic select
45~50	IAD15~10	I/O	DSP IDMA address/data bus
51~59	IAD9~1	I/O	DSP IDMA address/data bus
60	Vcc	-	+5V
61	IAD0	I/O	DSP IDMA address/data bus
62	Vss	-	GND
63~70	A7~0	I	Address bus
71	D7	I/O	Data bus
72~78	D6~0	I/O	Data bus
79	MUTE	O	Local speaker mute control output
80~86	I/O7~1	I/O	Auxiliary input/output 7~1
87~90	AN7~4	-	Not used
91	EVR	O	RX D/A converter IC data strobe output
92	ESR	O	RX shift register data strobe output
93	AN1	-	Not used
94	Avss	-	Not used
95	AN0	-	Not used
96	Vref	-	Not used
97	Avcc	-	Not used
98	EVC	O	Control D/A converter IC data strobe output
99	ESC	O	Control shift register data strobe output
100	OEC	O	Control shift register data output enable

## DSP : ADSP2185BST133 (CONTROL UNIT IC30)

## ■ Pin function

Pin No.	Port name	I/O	Function
1,2	IAD3,4	I/O	Internal DMA port / Sub CPU
3	GND	-	GND
4~11	IAD5~12	I/O	Internal DMA port / Sub CPU
12	GND	-	GND
13	CLKIN	I	Clock input / 16.515072MHz
14	XTAL	I	Clock input / 16.515072MHz
15	Vdd	-	Vdd
16	CLKOUT	O	DSP clock output / 33.030144MHz
17	GND	-	GND
18	Vdd	-	Vdd
19	WR	O	Memory Write Enable / NC
20	RD	O	Memory Write Enable / NC
21	BMS	O	Byte memory select / pull up
22	DMS	O	Data memory select / NC
23	PMS	O	Program memory select/NC
24	IOMS	O	Memory select/NC
25	CMS	O	Combined memory select / NC
26	PF4	O	Prog. I/O / CODEC reset
27	PF5	I	Prog. I/O / Main CPU / Mic mute,0:OFF / 1:ON
28	GND	-	GND

Pin No.	Port name	I/O	Function
29	PF6	I	Prog. I/O / Main CPU / TX / Rxcontrol,0:TX / 1:RX
30	IRQ2	I	Interrupt Req./pull up
31	DTO	I/O	SPORT0 / CODEC / CODEC Data
32	TFS0	I/O	SPORT0 / CODEC,Devider / CODEC Data
33	RFS0	I/O	SPORT0 / CODEC,Devider / CODEC Data
34	DRO	I/O	SPORT0 / CODEC / CODEC Data
35	SCLKO	I/O	SPORT0 / CODEC,Devider / CODEC Data
36	Vdd	-	Vdd
37	DT1	I/O	SPORT1 / CODEC
38	TFS1	I/O	SPORT1 / CODEC,Devider
39	RSF1	I/O	SPORT1 / CODEC,Devider
40	DR1	I/O	SPORT1 / CODEC
41	GND	-	GND
42	SCLK1	I/O	SPORT1 / CODEC,Devider
43	ERESET	-	Emulation / ICE conector
44	RESET	I	Reset IN/Reset IC,ICE conector/DSP reset
45	EMS	-	Emulation / ICE conector
46	EE	-	Emulation / ICE conector
47	ECLK	-	Emulation / ICE conector
48	ELOUT	-	Emulation / ICE conector
49	ELIN	-	Emulation / ICE conector
50	EINT	-	Emulation / ICE conector
51	EBR	-	Emulation / ICE conector
52	BR	I	Bus request / pull up,ICE conector
53	EBG	-	Emulation / ICE conector
54	BG	O	Bus request / ICE conector
55~57	IAD13~15	I/O	Internal DMA port / Sub CPU
58	IACK	O	IDMA Acknowledge / Main CPU
59	Vdd	-	Vdd
60	GND	-	GND
61	IS	I	IDMA Select / pull up, Main CPU
62	IAL	I	IDMA Address Latch / pull up, Main CPU
63	IRD	I	IDMA Read Enable / pull up, Main CPU
64	IWR	I	IDMA Write Enable / pull up, Main CPU
65	D8	I/O	Data I/O / NC
66	GND	-	GND
67	Vdd	-	Vdd
68~70	D9~11	I/O	Data I/O / NC
71	GND	-	GND
72~79	D12~19	I/O	Data I/O / NC
80	GND	-	GND
81~84	D20~23	I/O	Data I/O / NC
85	FL2	O	Output Frag / CODEC MC terminal
86	FL1	O	Output Frag / CODEC MD terminal
87	FL0	O	Output Frag / CODEC ML terminal
88	PF3	I	Prog. I/O / Main CPU / RX mute 0:OFF / 1:ON
89	PF2	I	Mode Select / pull up / HOST mode select
90	Vdd	-	Vdd
91	PWD	I	Power Control/VDD
92	GND	-	GND
93	PF1	I	Mode Select / pull down / HOST mode select
94	PF0	I	Mode Select / pull up / HOST mode select
95	BGH	O	Bus Grant Hung / NC
96	PWDACK	O	Power Control / NC
97	A0	O	Address / NC
98~100	IAD0~2	I/O	Internal DMA port / Sub CPU

## SEMICONDUCTOR DATA

## POWER MODULE : RA30H1317M (TX UNIT IC301)

## ■ MAXIMUM RATINGS (Tc=25°C, Zg=Zl=50Ω)

Symbol	Parameter	Conditions	Ratings	Unit
Vdd	SUPPLY VOLTAGE	Vgg ≤ 5.0V, Zg=Zl=50Ω	17	V
Vgg	GATE BIAS VOLTAGE	Vdd ≤ 12.5V, Pin=50mW, Zg=Zl=50Ω	6	V
Idd	DRAIN CURRENT		10	A
Pin	INPUT POWER	f=135-175MHz, Vgg ≤ 5.0V	100	mW
Po	OUTPUT POWER	f=135-175MHz, Vgg ≤ 5.0V	45	W
Tc(op)	OPERATION CASE TEMPERATURE	f=135-175MHz, Vgg ≤ 5.0V	-30 to +110	°C
Tstg	STORAGE TEMPERATURE		-40 to +110	°C

## ■ ELECTRICAL CHARACTERISTICS (Tc=25°C, Zg=Zl=50Ω)

Symbol	Parameter	Conditions	LIMIT		Unit
			MIN	MAX	
Po	OUTPUT POWER	f=135-175MHz,	30		W
ηt	TOTAL EFFICIENCY	Vdd=12.5V, Vgg=5V, Pin=50mW	40		W
2fo	2nd HARMONIC			-25	dBc
3fo	3rd HARMONIC			-30	dBc
VSWRin	INPUT VSWR			3:1	-
Idd	LEAKAGE CURRENT	Vdd=17V, Vgg=0V, Pin=0mW		1	mA
-	LOAD VSWR TOLERANCE	f=135-175MHz, Po=30W(Vgg control), Vdd=15.2V, Pin=50mW, LOAD VSWR=20:1	No degradation or destroy		-
-	STABILITY	f=135/155/175MHz, Vdd=10/12.5/15.2V, Vgg=0-5V, Pin=25/50/70mW, Po ≤ 30W, LOAD VSWR=3:1	No over -60 dBc Parasitic oscillation		-

# TKR-740

## COMPONENTS DESCRIPTION

### CONTROL UNIT (X53-3882-71)

REF.No	Parts name	DESCRIPTION
IC1	IC	MULTIPLEXER
IC3~6	IC	AVR
IC7	IC	FLASH ROM
IC10	IC	VOLTAGE DETECTOR
IC12,13	IC	AF AMP
IC14	IC	MULTIPLEXER
IC15,16	IC	BUS BUFFER
IC17,18	IC	CPU
IC22,23	IC	AF AMP
IC24	IC	COUNTER
IC25	IC	INVERTER
IC27	IC	CODEC
IC29	IC	MULTIPLEXER
IC30	IC	DSP
IC31,32	IC	AF AMP
IC33	IC	D/A CONVERTER
IC34	IC	AF AMP
IC35	IC	MULTIPLEXER
IC36	IC	NAND GATE
IC37	IC	SHIFT REGISTER
IC38	IC	NAND GATE
IC39	IC	SHIFT REGISTER
IC40	IC	AF AMP
IC42	IC	RS232C TRANSCEIVER
IC45	IC	AF POWER AMP
IC46~49	IC	OR GATE
IC700~703	IC	SHIFT REGISTER
IC704~706	IC	AVR
Q1,5	FET	BEAT SHIFT
Q2,8~10	TRANSISTOR	INVERTER
Q11	TRANSISTOR	AF MUTE
Q12	TRANSISTOR	RSSI MUTE
Q700,701	TRANSISTOR	LEVEL CONTROLLER
Q706~710	TRANSISTOR	DC SWITCH
D1,3~22 D24~28 D30~32 D34~39	DIODE	SURGE PROTECTOR
D700,701	LED ASS'Y	7 SEGMENT
D702	LED	REFERENCE
D703	LED	POWER
D704	LED	TX
D705	LED	BUSY
D706	DIODE	SURGE PROTECTOR
D707	DIODE	AF DETECT
D708	VARISTOR	SURGE PROTECTOR
D709	DIODE	AF DETECTOR
D710	VARISTOR	CURRENT PROTECTOR
D711, 712	DIODE	SURGE PROTECTOR

### RX UNIT (X55-3050-11)

PIN. No	Parts name	DESCRIPTION
A1	DBM	DOUBLE BALANCED MIXER
IC1	IC	PLL
IC2	IC	AVR
IC3	IC	SHIFT REGISTER
IC4	IC	AVR
IC5	IC	DC AMP
IC6	IC	MULTIPLEXER
IC7,8	IC	FM IF IC
IC9	IC	D/A CONVERTER
IC10	IC	EEPROM
IC11,12	IC	AF AMP
IC13	IC	AVR
IC14	IC	DC AMP
IC15	IC	PLL
IC16	IC	AVR
IC17	IC	RF AMP
IC18	IC	ANALOG SWITCH
IC19	IC	INVERTER
IC20	MOS IC	DDS
IC21	IC	ANALOG SWITCH
Q1,3,5	TRANSISTOR	RF LOCAL AMP
Q6	TRANSISTOR	BUFFER AMP
Q7	TRANSISTOR	AVR
Q8,9	FET	VCO OSC
Q10,12,13	TRANSISTOR	DC SWITCH
Q14	TRANSISTOR	BUFFER AMP
Q16	TRANSISTOR	DC SWITCH
Q17	TRANSISTOR	RIPPLE FILTER
Q18~20	TRANSISTOR	DC SWITCH
Q22	TRANSISTOR	DC SWITCH
Q24,25	TRANSISTOR	IF AMP
Q26	TRANSISTOR	ACTIVE FILTER
Q28	TRANSISTOR	SQ AMP
Q29	TRANSISTOR	SQ SWITCH
Q30	FET	DC SWITCH
Q31,32	TRANSISTOR	IF AMP
Q33	TRANSISTOR	REF AMP
Q34,35	FET	SQ SWITCH
Q36~38	TRANSISTOR	SQ SWITCH
Q39	TRANSISTOR	BUFFER AMP
D2~4,6	VARICAP	FREQ. CONTROL
D9	LED	INDICATOR
D10	DIODE	RF SW
D11	DIODE	SQ SW

## COMPONENTS DESCRIPTION

## TX UNIT (X56-3072-70)

PIN. No	Parts name	DESCRIPTION
IC1,2	IC	AVR
IC3	IC	D/A CONVERTER
IC4	IC	SHIFT REGISTER
IC100	IC	AVR
IC101	IC	PLL
IC102,103	IC	AVR
IC105	IC	AF AMP
IC106	IC	EEPROM
IC107	IC	AF AMP
IC108	IC	AVR
IC109	IC	BUFFER AMP
IC110	IC	AVR
IC200	IC	AND GATE
IC201	IC	PLL
IC202	MOS IC	DDS
IC203	IC	DC AMP
IC204	IC	COMPARATOR
IC205	IC	AVR
IC206	IC	INVERTER
IC301	IC	POWER MODULE
IC302	IC	COMPARATOR
IC303	IC	DC AMP
Q1,2	FET	VCO OSC
Q3,4	TRANSISTOR	DC SWITCH
Q5	FET	DC SWITCH
Q6	TRANSISTOR	BUFFER AMP
Q7	TRANSISTOR	RIPPLE FILTER
Q8	TRANSISTOR	DC SWITCH
Q9	TRANSISTOR	RF AMP
Q11,12	TRANSISTOR	DC SWITCH
Q13	TRANSISTOR	RF AMP
Q14	FET	RF AMP
Q15	FET	BUFFER AMP
Q17,18	FET	DC SWITCH
Q21	TRANSISTOR	DC SWITCH
Q102	TRANSISTOR	BUFFER AMP
Q106	TRANSISTOR	DOUBLER
Q107~109	TRANSISTOR	RF AMP
Q110	TRANSISTOR	DC SWITCH
Q112	FET	SQ SWITCH
Q113	FET	DC SWITCH
Q114	TRANSISTOR	DC SWITCH
Q115	TRANSISTOR	RF AMP
Q201	TRANSISTOR	VCO OSC
Q202	TRANSISTOR	BUFFER AMP
Q203	FET	DC SWITCH
Q205	TRANSISTOR	RF AMP
Q206	FET	DC SWITCH
Q207	TRANSISTOR	INVERTER
Q208	FET	DC SWITCH
Q240	TRANSISTOR	BUFFER AMP
Q241	TRANSISTOR	RF AMP
Q242	TRANSISTOR	BUFFER AMP

PIN. No	Parts name	DESCRIPTION
Q301	TRANSISTOR	DC AMP
Q302,304	TRANSISTOR	DC SWITCH
Q308	TRANSISTOR	DC SWITCH
Q309	TRANSISTOR	DC SWITCH
D1-4	VARICAP	FREQ. CONTROL
D5,6	VARICAP	MODULATION
D7	DIODE	RF SWITCH
D11,12	DIODE	CURRENT STEERING
D50,51	LED	LOCK INDICATOR
D52	LED	TX INDICATOR
D101,103	DIODE	RF SWITCH
D201	VARICAP	FREQ. CONTROL
D202	VARICAP	FREQ. CONTROL
D203	VARICAP	MODULATION
D204	DIODE	CURRENT STEERING
D205	DIODE	RF DETECTOR
D206	VARISTOR	CURRENT PROTECTOR
D303	SURGE ABSORBER	SURGE PROTECTOR
D304	DIODE	CURRENT STEERING
D305	DIODE	REVERSE VOLTAGE PROTECTOR
D306,308	DIODE	RF DETECTOR
D310	VARISTOR	CURRENT PROTECTOR
D318	DIODE	CURRENT STEERING
D320	ZENER DIODE	HIGH VOLTAGE PROTECTOR
D500	VARISTOR	CURRENT PROTECTOR

# TKR-740

## PARTS LIST

\* New Parts.  $\Delta$  indicates safety critical components.  
 Parts without **Parts No.** are not supplied.  
 Les articles non mentionnés dans le **Parts No.** ne sont pas fournis.  
 Teile ohne **Parts No.** werden nicht geliefert.

L: Scandinavia      K: USA      P: Canada  
 Y: PX (Far East, Hawaii)      T: England      E: Europe  
 Y: AAFES (Europe)      X: Australia      M: Other Areas

### TKR-740 (Y54-3142-71) CONTROL UNIT (X53-3882-71)

Ref. No.	Address	New parts	Parts No.	Description	Destination
<b>TKR-740</b>					
1	3A		A62-0726-03	PANEL (FRONT)	
2	3A,1E		B10-2590-04	FRONT GLASS	
3	3B		B11-1223-04	FILTER (PF KEYS)	
4	3A		B11-1225-04	FILTER (FRONT PANEL-LED)	
5	3B		B11-1231-04	FILTER (FRONT PANEL-7SEG)	
6	1F	*	B62-1700-00	INSTRUCTION MANUAL	
7	2C		E30-3343-15	DC CORD	
8	2E		E30-3344-15	DC CORD      ACCESSORY	
9	1E		E31-3228-05	LEAD WIRE WITH CONNECTOR (15P) ACC	
10	2B		E37-0712-05	FLAT CABLE (CONTROL-TX,RX UNIT)	
11	1B		E37-0713-05	FLAT CABLE (TX-FINAL)	
12	2D		E37-0715-05	LEAD WIRE WITH CONNECTOR (D-SUB)	
13	3B		E37-0717-05	LEAD WIRE WITH CONNECTOR (SP)	
14	2C,2D		E37-0718-05	LEAD WIRE WITH CONNECTOR (BNC)	
15	1B		E37-0719-05	LEAD WIRE WITH CONNECTOR (TX-RX)	
16	1B		E37-0720-05	LEAD WIRE WITH CONNECTOR (TX-FINAL)	
17	2D		E37-0721-15	LEAD WIRE WITH CONNECTOR (15P)	
18	1B		E37-0791-15	LEAD WIRE WITH TERMINAL (DC+)	
19	3B		E37-0813-05	LEAD WIRE WITH CONNECTOR (7SEG)	
20	2D		E37-0814-05	LEAD WIRE WITH CONNECTOR (12P)	
21	1E		E59-0410-05	SQUARE PLUG (12P)      ACCESSORY	
22	1D,1E		F06-1032-05	FUSE (BLADE) (10A/32V)	
23	2A		F07-1429-03	COVER (FAN-FRONT)	
24	2A,2B	*	F09-0477-05	FANMOTOR (FRONT,REAR)	
25	2A		F10-2200-04	SHIELDING PLATE (POWER MODULE)	
26	2D		F10-2297-04	SHIELDING PLATE (RX UNIT)	
27	2C		F10-2312-04	SHIELDING PLATE (RX UNIT)	
28	1A		F10-2355-04	SHIELDING COVER (POWER MODULE)	
29	1B,2C		G02-0576-14	FLAT SPRING (RX:IC4, TX:IC1)	
30	2C		G02-0839-04	FLAT SPRING (RX:L16)	
31	3B		G13-1653-14	CUSHION (SP)	
32	3B		G13-1669-04	CUSHION (MIC)	
33	3B		G13-1703-14	CUSHION (FRONT PANEL)	
34	3B		G13-1728-04	CUSHION (LED)	
35	3B		G13-1729-04	CUSHION (PF KEYS)	
36	3B		G13-1730-04	CUSHION (FRONT PANEL-PF KEYS)	
37	3B		G13-1754-04	CUSHION (VOL,TEST)	
38	3A		G13-1861-04	CUSHION (FRONT PANEL-SP)	
39	2E,2F		H10-6612-02	POLYSTYRENE FOAMED FIXTURE	
40	2F		H20-1437-03	PROTECTION COVER	
41	1E		H25-0029-04	PROTECTION BAG (60/110/0,07)	
42	1E		H25-0720-04	PROTECTION BAG (200X350)	
43	3F	*	H52-1966-02	ITEM CARTON CASE	
44	2B	*	J19-5452-05	HOLDER (TX-FAN CABLE)	
45	1A		J21-8375-04	HARDWARE FIXTURE (FINAL:TS301)	
46	1E		K01-0421-05	HANDLE      ACCESSORY	
47	3A		K29-3002-14	PUSHKNOB (TEST)	
48	3A		K29-4539-04	KNOB (VOL)	
49	3A,1E		N08-0543-04	DRESSED SCREW (FRONT GLASS)	
50	1D		N09-2292-05	HEXAGON HEAD SCREW (D-SUB)	
A	1C,2D		N32-3005-45	FLAT HEAD MACHINE SCREW	
B	3A,3B		N32-4008-45	FLAT HEAD MACHINE SCREW	

Ref. No.	Address	New parts	Parts No.	Description	Destination
C	2B		N35-3006-46	BINDING HEAD MACHINE SCREW	
D	1A,2B		N67-3006-46	PAN HEAD SEMS SCREW W	
E	1A,1B		N87-2606-46	BRAZIER HEAD TAPTITE SCREW	
F	2A,2B		N87-2610-46	BRAZIER HEAD TAPTITE SCREW	
G	2B		N87-2612-46	BRAZIER HEAD TAPTITE SCREW	
H	1B		N87-2616-46	BRAZIER HEAD TAPTITE SCREW	
51	3B		T07-0347-05	SPEAKER	
<b>CONTROL UNIT (X53-3882-71)</b>					
D700,701			LA301DB	LED ASSY	
D702			B30-0864-05	LED (RED/GREEN)	
D703			B30-2198-05	LED (GREEN)	
D704			B30-2197-05	LED (RED)	
D705			B30-2198-05	LED (GREEN)	
C1			CK73GB1E103K	CHIP C      0.010UF      K	
C2,3			CK73EB1C105K	CHIP C      1.0UF      K	
C4			CK73GB1H102K	CHIP C      1000PF      K	
C5			C92-0729-05	CHIP-ELE      330UF      25WV	
C6			CK73GB1H102K	CHIP C      1000PF      K	
C7			C92-0726-05	CHIP-ELE      47UF      25WV	
C8			CK73GB1H102K	CHIP C      1000PF      K	
C9,10			C92-0726-05	CHIP-ELE      47UF      25WV	
C11,12			C92-0728-05	CHIP-ELE      470UF      16WV	
C13			CK73FB1E104K	CHIP C      0.10UF      K	
C14			C92-0519-05	CHIP-TAN      1.0UF      25WV	
C15			CC73GCH1H101J	CHIP C      100PF      J	
C18			CK73FB1E104K	CHIP C      0.10UF      K	
C19,20			CK73EB1C105K	CHIP C      1.0UF      K	
C21-23			CK73GB1E103K	CHIP C      0.010UF      K	
C24-26			C92-0628-05	CHIP-TAN      10UF      10WV	
C27			CK73GB1H102K	CHIP C      1000PF      K	
C28			CK73FB1E104K	CHIP C      0.10UF      K	
C29			CK73GB1E103K	CHIP C      0.010UF      K	
C30			C92-0628-05	CHIP-TAN      10UF      10WV	
C31			CK73GB1H102K	CHIP C      1000PF      K	
C32-46			CC73GCH1H101J	CHIP C      100PF      J	
C49-53			CC73GCH1H101J	CHIP C      100PF      J	
C54			CK73GB1E103K	CHIP C      0.010UF      K	
C55			CC73GCH1H101J	CHIP C      100PF      J	
C56			CK73EB1C105K	CHIP C      1.0UF      K	
C57,58			CC73GCH1H101J	CHIP C      100PF      J	
C59			CK73GB1H562J	CHIP C      5600PF      J	
C60			CC73GCH1H101J	CHIP C      100PF      J	
C61			CK73FB1E223K	CHIP C      0.022UF      K	
C66			CK73GB1E103K	CHIP C      0.010UF      K	
C68			C92-0519-05	CHIP-TAN      1.0UF      25WV	
C76			CK73EB1C105K	CHIP C      1.0UF      K	
C77			CC73GCH1H101J	CHIP C      100PF      J	
C78-80			C92-0628-05	CHIP-TAN      10UF      10WV	
C83			CK73GB1E103K	CHIP C      0.010UF      K	
C84			CK73GB1H472K	CHIP C      4700PF      K	
C86			CK73GB1H472K	CHIP C      4700PF      K	
C87			CK73GB1H152K	CHIP C      1500PF      K	
C88			CK73EB1C105K	CHIP C      1.0UF      K	
C89			CC73FCH1H751J	CHIP C      750PF      J	



## PARTS LIST

CONTROL UNIT (X53-3882-71)

Ref. No.	Address	New parts	Parts No.	Description	Destination	Ref. No.	Address	New parts	Parts No.	Description	Destination
C90			CK73GB1E103K	CHIP C 0.010UF K		C203			CK73GB1E103K	CHIP C 0.010UF K	
C91			CK73EB1C105K	CHIP C 1.0UF K		C204			CK73GB1H471K	CHIP C 470PF K	
C96			CK73GB1E103K	CHIP C 0.010UF K		C205			CK73GB1E103K	CHIP C 0.010UF K	
C100,101			C92-0628-05	CHIP-TAN 10UF 10WV		C206			C92-0628-05	CHIP-TAN 10UF 10WV	
C102			CC73GCH1H101J	CHIP C 100PF J		C207			C92-0771-05	CHIP-ELE 220UF 6.3WV	
C105-107			C92-0628-05	CHIP-TAN 10UF 10WV		C208,209			CK73GB1E103K	CHIP C 0.010UF K	
C108			CK73GB1E103K	CHIP C 0.010UF K		C210,211			C92-0771-05	CHIP-ELE 220UF 6.3WV	
C123			CC73GCH1H101J	CHIP C 100PF J		C212-214			CK73EB1C105K	CHIP C 1.0UF K	
C125			CK73EB1C105K	CHIP C 1.0UF K		C221,222			CK73GB1E103K	CHIP C 0.010UF K	
C126			CK73FB1E103K	CHIP C 0.010UF K		C223,224			CC73GCH1H270J	CHIP C 27PF J	
C127			C92-0628-05	CHIP-TAN 10UF 10WV		C225			CC73GCH1H150J	CHIP C 15PF J	
C128-131			C92-0519-05	CHIP-TAN 1.0UF 25WV		C226,227			CK73GB1E103K	CHIP C 0.010UF K	
C132			CC73GCH1H101J	CHIP C 100PF J		C228			CK73GB1H471K	CHIP C 470PF K	
C133			CK73GB1E103K	CHIP C 0.010UF K		C229			CK73GB1E103K	CHIP C 0.010UF K	
C134,135			CC73GCH1H101J	CHIP C 100PF J		C231,232			CK73GB1E103K	CHIP C 0.010UF K	
C136			C92-0546-05	CHIP-TAN 68UF 6.3WV		C256			CK73FB1E103K	CHIP C 0.010UF K	
C137,138			C92-0628-05	CHIP-TAN 10UF 10WV		C300-303			CC73GCH1H101J	CHIP C 100PF J	
C139			CC73GCH1H330J	CHIP C 33PF J		C304-312			CK73GB1H102K	CHIP C 1000PF K	
C140-142			CK73GB1H102K	CHIP C 1000PF K		C313			CC73GCH1H101J	CHIP C 100PF J	
C143,144			CK73EB1C105K	CHIP C 1.0UF K		C315,316			CK73FB1E103K	CHIP C 0.010UF K	
C145			CK73GB1E103K	CHIP C 0.010UF K		C317,318			CC73GCH1H101J	CHIP C 100PF J	
C146-148			C92-0519-05	CHIP-TAN 1.0UF 25WV		C319-322			C92-0519-05	CHIP-TAN 1.0UF 25WV	
C149			C92-0628-05	CHIP-TAN 10UF 10WV		C323			CK73GB1H102K	CHIP C 1000PF K	
C150			C92-0519-05	CHIP-TAN 1.0UF 25WV		C324			CK73FB1E104K	CHIP C 0.10UF K	
C151			CK73GB1E103K	CHIP C 0.010UF K		C325-327			CK73GB1H102K	CHIP C 1000PF K	
C152			CK73GB1H471K	CHIP C 470PF K		C328-330			CC73GCH1H101J	CHIP C 100PF J	
C153			CK73EB1C105K	CHIP C 1.0UF K		C331-337			CK73GB1H102K	CHIP C 1000PF K	
C154			C92-0628-05	CHIP-TAN 10UF 10WV		C700-705			CC73GCH1H101J	CHIP C 100PF J	
C155			CK73EB1C105K	CHIP C 1.0UF K		C706,707			CK73GB1E103K	CHIP C 0.010UF K	
C156,157			CK73GB1E103K	CHIP C 0.010UF K		C708-710			CK73FB1E104K	CHIP C 0.10UF K	
C158			CK73GB1H102K	CHIP C 1000PF K		C711-713			CK73FF1E334Z	CHIP C 0.33UF Z	
C159			C92-0628-05	CHIP-TAN 10UF 10WV		C714,715			CK73GB1H102K	CHIP C 1000PF K	
C160			CK73EB1C105K	CHIP C 1.0UF K		C716			C92-0628-05	CHIP-TAN 10UF 10WV	
C161,162			C92-0606-05	CHIP-TAN 4.7UF 10WV		C717,718			CC73GCH1H101J	CHIP C 100PF J	
C164,165			CK73GB1H102K	CHIP C 1000PF K		C719			CK73GB1H471K	CHIP C 470PF K	
C166			C92-0606-05	CHIP-TAN 4.7UF 10WV		C720-722			CC73GCH1H101J	CHIP C 100PF J	
C167			C92-0628-05	CHIP-TAN 10UF 10WV		C723			CK73GB1H471K	CHIP C 470PF K	
C168			CK73FB1E104K	CHIP C 0.10UF K		C724			CC73GCH1H101J	CHIP C 100PF J	
C169,170			C92-0628-05	CHIP-TAN 10UF 10WV		C725			CK73FB1E104K	CHIP C 0.10UF K	
C171			CK73GB1E103K	CHIP C 0.010UF K		C727,728			C92-0501-05	CHIP-TAN 1.5UF 10WV	
C172			C92-0628-05	CHIP-TAN 10UF 10WV		C729,730			CK73FB1E104K	CHIP C 0.10UF K	
C173			CC73GCH1H181J	CHIP C 180PF J		C731			CC73GCH1H470J	CHIP C 47PF J	
C174			CK73GB1H182K	CHIP C 1800PF K		C732,733			CK73FB1E104K	CHIP C 0.10UF K	
C175			CK73GB1E103K	CHIP C 0.010UF K		C734			CK73FB1E103K	CHIP C 0.010UF K	
C176			C92-0628-05	CHIP-TAN 10UF 10WV		C735			C92-0628-05	CHIP-TAN 10UF 10WV	
C177			CK73EB1C105K	CHIP C 1.0UF K		C736,737			CC73GCH1H101J	CHIP C 100PF J	
C178			CC73GCH1H271J	CHIP C 270PF J		C738,739			CK73GB1H102K	CHIP C 1000PF K	
C179			CK73GB1H272K	CHIP C 2700PF K		C740-742			C92-0628-05	CHIP-TAN 10UF 10WV	
C180,181			C92-0628-05	CHIP-TAN 10UF 10WV		C750			CK73FB1E104K	CHIP C 0.10UF K	
C182			CK73EB1C105K	CHIP C 1.0UF K		CN1-3			E40-5736-05	FLAT CABLE CONNECTOR	
C183			CK73GB1E103K	CHIP C 0.010UF K		CN4			E40-5960-05	PIN ASSY	
C184			CC73GCH1H101J	CHIP C 100PF J		CN5			E40-5701-05	PIN ASSY	
C185-187			CK73GB1E103K	CHIP C 0.010UF K		CN6			E40-5702-05	PIN ASSY	
C188			CC73GCH1H101J	CHIP C 100PF J		CN700			E40-4676-05	PIN ASSY	
C189,190			CC73GCH1H220J	CHIP C 22PF J		CN701			E40-5986-05	PIN ASSY	
C191			CK73FB1C105K	CHIP C 1.0UF K		CN702			E40-5761-05	FLAT CABLE CONNECTOR	
C192			CK73GB1E103K	CHIP C 0.010UF K		CN703			E40-5538-05	PIN ASSY	
C193			CK73FB1E104K	CHIP C 0.10UF K		CN705			E40-5701-05	PIN ASSY	
C194			C92-0628-05	CHIP-TAN 10UF 10WV		CN706			E40-5960-05	PIN ASSY	
C200-202			CK73GB1H471K	CHIP C 470PF K							

# TKR-740

## PARTS LIST

### CONTROL UNIT (X53-3882-71)

Ref. No.	Address	New parts	Parts No.	Description	Destination	Ref. No.	Address	New parts	Parts No.	Description	Destination
J700			E08-0876-05	MODULAR JACK		R107,108			RK73GB1J223J	CHIP R 22K J	1/16W
L1-5			L92-0140-05	FERRITE CHIP		R109			RK73GB1J473J	CHIP R 47K J	1/16W
L6			L40-1005-48	SMALL FIXED INDUCTOR (10UH)		R110			RK73GB1J334J	CHIP R 330K J	1/16W
L7			L92-0140-05	FERRITE CHIP		R114-120			R92-0670-05	CHIP R 0 OHM	
L9			L40-1005-48	SMALL FIXED INDUCTOR (10UH)		R121			RK73GB1J333J	CHIP R 33K J	1/16W
L10,11			L92-0140-05	FERRITE CHIP		R122			RK73GB1J104J	CHIP R 100K J	1/16W
L12,13			L40-1005-48	SMALL FIXED INDUCTOR (10UH)		R123			RK73GB1J103J	CHIP R 10K J	1/16W
X1			L78-0431-05	RESONATOR (14.7456MHZ)		R124			RK73GB1J273J	CHIP R 27K J	1/16W
X2			L77-1799-05	CRYSTAL RESONATOR (16.515MHZ)		R125			RK73GB1J102J	CHIP R 1.0K J	1/16W
						R126			RK73GB1J103J	CHIP R 10K J	1/16W
CP1-7			R90-0724-05	MULTI-COMP 1K X4		R127			RK73GB1J123J	CHIP R 12K J	1/16W
CP10,11			R90-1016-05	MULTI-COMP 470 X4		R128			RK73GB1J224J	CHIP R 220K J	1/16W
CP14,15			R90-1016-05	MULTI-COMP 470 X4		R129			RK73GB1J104J	CHIP R 100K J	1/16W
CP700-703			R90-1016-05	MULTI-COMP 470 X4		R130			RK73GB1J124J	CHIP R 120K J	1/16W
R1			RK73GB1J101J	CHIP R 100 J	1/16W	R131			RK73GB1J223J	CHIP R 22K J	1/16W
R2			RK73GB1J103J	CHIP R 10K J	1/16W	R132			RK73GB1J103J	CHIP R 10K J	1/16W
R3			RK73GB1J473J	CHIP R 47K J	1/16W	R133			RK73GB1J273J	CHIP R 27K J	1/16W
R4,5			RK73GB1J103J	CHIP R 10K J	1/16W	R134			RK73GB1J104J	CHIP R 100K J	1/16W
R6			RK73GB1J105J	CHIP R 1.0M J	1/16W	R135			RK73GB1J273J	CHIP R 27K J	1/16W
R7			RK73GB1J471J	CHIP R 470 J	1/16W	R136,137			RK73GB1J103J	CHIP R 10K J	1/16W
R8			RK73FB2A2R2J	CHIP R 2.2 J	1/10W	R138			RK73GB1J104J	CHIP R 100K J	1/16W
R9			RK73GB1J473J	CHIP R 47K J	1/16W	R139			RK73GB1J124J	CHIP R 120K J	1/16W
R14			R92-1252-05	CHIP R 0 OHM J	1/16W	R140			R92-0670-05	CHIP R 0 OHM	
R16			RK73GB1J473J	CHIP R 47K J	1/16W	R141,142			RK73GB1J101J	CHIP R 100 J	1/16W
R27-29			R92-0685-05	CHIP R 22 J	1/2W	R143,144			RK73GB1J102J	CHIP R 1.0K J	1/16W
R30,31			RK73GB1J102J	CHIP R 1.0K J	1/16W	R145-148			RK73GB1J122J	CHIP R 1.2K J	1/16W
R32			RK73GB1J104J	CHIP R 100K J	1/16W	R149-152			RK73GB1J473J	CHIP R 47K J	1/16W
R33,34			RK73GB1J102J	CHIP R 1.0K J	1/16W	R153,154			RK73GB1J122J	CHIP R 1.2K J	1/16W
R35			RK73GB1J333J	CHIP R 3.3K J	1/16W	R155-157			RK73GB1J102J	CHIP R 1.0K J	1/16W
R36,37			RK73GB1J102J	CHIP R 1.0K J	1/16W	R158,159			RK73GB1J473J	CHIP R 47K J	1/16W
R38			RK73GB1J183J	CHIP R 18K J	1/16W	R160			RK73GB1J101J	CHIP R 100 J	1/16W
R39			RK73GB1J472J	CHIP R 4.7K J	1/16W	R161,162			RK73GB1J473J	CHIP R 47K J	1/16W
R40-43			RK73GB1J102J	CHIP R 1.0K J	1/16W	R164			RK73GB1J104J	CHIP R 100K J	1/16W
R44			RK73GB1J333J	CHIP R 3.3K J	1/16W	R165			RK73GB1J124J	CHIP R 120K J	1/16W
R45			RK73GB1J333J	CHIP R 33K J	1/16W	R166-168			RK73GB1J223J	CHIP R 22K J	1/16W
R46			RK73GB1J683J	CHIP R 68K J	1/16W	R169			RK73GB1J103J	CHIP R 10K J	1/16W
R47			RK73GB1J104J	CHIP R 100K J	1/16W	R171			RK73GB1J154J	CHIP R 150K J	1/16W
R48			RK73GB1J473J	CHIP R 47K J	1/16W	R172			RK73GB1J102J	CHIP R 1.0K J	1/16W
R49			RK73GB1J183J	CHIP R 18K J	1/16W	R173			RK73GB1J223J	CHIP R 22K J	1/16W
R66			RK73GB1J104J	CHIP R 100K J	1/16W	R174			RK73GB1J473J	CHIP R 47K J	1/16W
R69			RK73GB1J104J	CHIP R 100K J	1/16W	R175			RK73GB1J102J	CHIP R 1.0K J	1/16W
R70			RK73GB1J563J	CHIP R 56K J	1/16W	R176			RK73GB1J104J	CHIP R 100K J	1/16W
R71			RK73GB1J474J	CHIP R 470K J	1/16W	R177-180			RK73GB1J473J	CHIP R 47K J	1/16W
R72-74			RK73GB1J222J	CHIP R 2.2K J	1/16W	R181			RK73GB1J103J	CHIP R 10K J	1/16W
R76			RK73GB1J473J	CHIP R 47K J	1/16W	R182			RK73GB1J473J	CHIP R 47K J	1/16W
R78			RK73GB1J473J	CHIP R 47K J	1/16W	R183			RK73GB1J102J	CHIP R 1.0K J	1/16W
R80			RK73GB1J474J	CHIP R 470K J	1/16W	R184			RK73GB1J223J	CHIP R 22K J	1/16W
R83,84			R92-1252-05	CHIP R 0 OHM J	1/16W	R185,186			RK73GB1J473J	CHIP R 47K J	1/16W
R86			R92-0670-05	CHIP R 0 OHM		R187			RK73GB1J102J	CHIP R 1.0K J	1/16W
R87,88			R92-1252-05	CHIP R 0 OHM J	1/16W	R188			RK73GB1J473J	CHIP R 47K J	1/16W
R90-93			R92-0670-05	CHIP R 0 OHM		R189			RK73GB1J472J	CHIP R 4.7K J	1/16W
R94			R92-1252-05	CHIP R 0 OHM J	1/16W	R190			RK73GB1J473J	CHIP R 47K J	1/16W
R95			RK73GB1J104J	CHIP R 100K J	1/16W	R191			RK73GB1J472J	CHIP R 4.7K J	1/16W
R96			RK73GB1J124J	CHIP R 120K J	1/16W	R192			RK73GB1J103J	CHIP R 10K J	1/16W
R100			RK73GB1J273J	CHIP R 27K J	1/16W	R193			R92-0670-05	CHIP R 0 OHM	
R101			RK73GB1J473J	CHIP R 47K J	1/16W	R194			RK73GB1J183J	CHIP R 18K J	1/16W
R103			RK73GB1J104J	CHIP R 100K J	1/16W	R195			RK73GB1J102J	CHIP R 1.0K J	1/16W
R104			RK73GB1J333J	CHIP R 33K J	1/16W	R196			RK73GB1J473J	CHIP R 47K J	1/16W
R105			RK73GB1J223J	CHIP R 22K J	1/16W	R197			R92-1252-05	CHIP R 0 OHM J	1/16W
R106			RK73GB1J224J	CHIP R 220K J	1/16W	R199			RK73GB1J101J	CHIP R 100 J	1/16W

## PARTS LIST

CONTROL UNIT (X53-3882-71)

Ref. No.	Address	New parts	Parts No.	Description	Destination	Ref. No.	Address	New parts	Parts No.	Description	Destination
R200			RK73GB1J471J	CHIP R 470 J 1/16W		R307			RK73GB1J473J	CHIP R 47K J 1/16W	
R201			RK73GB1J473J	CHIP R 47K J 1/16W		R312-318			RK73GB1J473J	CHIP R 47K J 1/16W	
R202,203			RK73GB1J102J	CHIP R 1.0K J 1/16W		R319-328			RK73GB1J102J	CHIP R 1.0K J 1/16W	
R204			R92-1252-05	CHIP R 0 OHM J 1/16W		R329			RK73GB1J101J	CHIP R 100 J 1/16W	
R205,206			RK73GB1J102J	CHIP R 1.0K J 1/16W		R331			RK73GB1J473J	CHIP R 47K J 1/16W	
R207			RK73GB1J473J	CHIP R 47K J 1/16W		R334			RK73GB1J392J	CHIP R 3.9K J 1/16W	
R208,209			R92-1252-05	CHIP R 0 OHM J 1/16W		R335-342			RK73GB1J473J	CHIP R 47K J 1/16W	
R210-215			RK73GB1J102J	CHIP R 1.0K J 1/16W		R343			RK73GB1J472J	CHIP R 4.7K J 1/16W	
R216			RK73GB1J473J	CHIP R 47K J 1/16W		R344			R92-0670-05	CHIP R 0 OHM	
R217,218			RK73GB1J102J	CHIP R 1.0K J 1/16W		R345			RK73GB1J473J	CHIP R 47K J 1/16W	
R219,220			RK73GB1J473J	CHIP R 47K J 1/16W		R346-348			RK73GB1J101J	CHIP R 100 J 1/16W	
R221-227			RK73GB1J102J	CHIP R 1.0K J 1/16W		R349-351			RK73GB1J473J	CHIP R 47K J 1/16W	
R228			RK73GB1J101J	CHIP R 100 J 1/16W		R352			RK73GB1J101J	CHIP R 100 J 1/16W	
R229			R92-1252-05	CHIP R 0 OHM J 1/16W		R353-357			RK73GB1J473J	CHIP R 47K J 1/16W	
R230			RK73GB1J101J	CHIP R 100 J 1/16W		R358-372			RK73GB1J102J	CHIP R 1.0K J 1/16W	
R231			RK73GB1J102J	CHIP R 1.0K J 1/16W		R700-705			RK73FB2A472J	CHIP R 4.7K J 1/10W	
R232			RK73GB1J101J	CHIP R 100 J 1/16W		R706			RK73FB2A221J	CHIP R 220 J 1/10W	
R233-236			RK73GB1J102J	CHIP R 1.0K J 1/16W		R707			RK73FB2A331J	CHIP R 330 J 1/10W	
R237			RK73GB1J473J	CHIP R 47K J 1/16W		R708,709			RK73FB2A221J	CHIP R 220 J 1/10W	
R238-240			RK73GB1J102J	CHIP R 1.0K J 1/16W		R710			RK73FB2A331J	CHIP R 330 J 1/10W	
R241			RK73GB1J472J	CHIP R 4.7K J 1/16W		R711			RK73FB2A472J	CHIP R 4.7K J 1/10W	
R242-252			RK73GB1J102J	CHIP R 1.0K J 1/16W		R712			R92-1213-05	CHIP R 100 J 1/2W	
R253			RK73GB1J101J	CHIP R 100 J 1/16W		R713			R92-0686-05	CHIP R 33 J 1/2W	
R254			RK73GB1J102J	CHIP R 1.0K J 1/16W		R714			R92-1213-05	CHIP R 100 J 1/2W	
R255			RK73GB1J101J	CHIP R 100 J 1/16W		R715			R92-1279-05	CHIP R 33 J 1W	
R256			RK73GB1J102J	CHIP R 1.0K J 1/16W		R716			RK73GB1J683J	CHIP R 68K J 1/16W	
R257			RK73GB1J473J	CHIP R 47K J 1/16W		R717,718			RK73GB1J102J	CHIP R 1.0K J 1/16W	
R258			RK73GB1J101J	CHIP R 100 J 1/16W		R719			RK73GB1J681J	CHIP R 680 J 1/16W	
R259,260			RK73GB1J102J	CHIP R 1.0K J 1/16W		R720			RK73GB1J102J	CHIP R 1.0K J 1/16W	
R261			RK73GB1J101J	CHIP R 100 J 1/16W		R721			R92-0670-05	CHIP R 0 OHM	
R262			RK73GB1J473J	CHIP R 47K J 1/16W		R722,723			RK73GB1J102J	CHIP R 1.0K J 1/16W	
R263,264			RK73GB1J102J	CHIP R 1.0K J 1/16W		R724			RK73GB1J682J	CHIP R 6.8K J 1/16W	
R265			RK73GB1J101J	CHIP R 100 J 1/16W		R725			RK73GB1J103J	CHIP R 10K J 1/16W	
R266			RK73GB1J473J	CHIP R 47K J 1/16W		R726			RK73GB1J224J	CHIP R 220K J 1/16W	
R267,268			RK73GB1J102J	CHIP R 1.0K J 1/16W		R727			RK73GB1J103J	CHIP R 10K J 1/16W	
R269			RK73GB1J101J	CHIP R 100 J 1/16W		R728			RK73GB1J154J	CHIP R 150K J 1/16W	
R270			RK73GB1J473J	CHIP R 47K J 1/16W		R729			RK73GB1J104J	CHIP R 100K J 1/16W	
R271			RK73GB1J102J	CHIP R 1.0K J 1/16W		R730			RK73GB1J103J	CHIP R 10K J 1/16W	
R272			RK73GB1J101J	CHIP R 100 J 1/16W		R731,732			RK73GB1J102J	CHIP R 1.0K J 1/16W	
R273			RK73GB1J473J	CHIP R 47K J 1/16W		R733			RK73GB1J682J	CHIP R 6.8K J 1/16W	
R274,275			RK73GB1J102J	CHIP R 1.0K J 1/16W		R734			RK73GB1J103J	CHIP R 10K J 1/16W	
R276			RK73GB1J101J	CHIP R 100 J 1/16W		VR700			R12-6423-05	TRIMMING POT. (10K)	
R277			RK73GB1J473J	CHIP R 47K J 1/16W		VR701			R05-3442-05	POTENTIOMETER (10K)	
R278			RK73GB1J102J	CHIP R 1.0K J 1/16W		S700-705			S70-0410-15	TACT SWITCH	
R279			RK73GB1J473J	CHIP R 47K J 1/16W		S706			S40-2441-15	PUSH SWITCH	
R280			RK73GB1J102J	CHIP R 1.0K J 1/16W		D1			DA204U	DIODE	
R281			RK73GB1J101J	CHIP R 100 J 1/16W		D3-22			DA204U	DIODE	
R282,283			RK73GB1J102J	CHIP R 1.0K J 1/16W		D24-28			DA204U	DIODE	
R284			RK73GB1J101J	CHIP R 100 J 1/16W		D30-32			DA204U	DIODE	
R285			RK73GB1J102J	CHIP R 1.0K J 1/16W		D34-39			DA204U	DIODE	
R286,287			RK73GB1J101J	CHIP R 100 J 1/16W		D706			DA204U	DIODE	
R288,289			RK73GB1J473J	CHIP R 47K J 1/16W		D707			HSM88AS	DIODE	
R290			RK73GB1J101J	CHIP R 100 J 1/16W		D708			DA204U	DIODE	
R291			RK73GB1J472J	CHIP R 4.7K J 1/16W		D709			HSM88AS	DIODE	
R292			RK73GB1J473J	CHIP R 47K J 1/16W		D710			MINISMD075-02	VARISTOR	
R293			RK73GB1J101J	CHIP R 100 J 1/16W		D711,712			DA204U	DIODE	
R294-296			RK73GB1J473J	CHIP R 47K J 1/16W		IC1			TC7S66FU	MOS IC	
R297-301			RK73GB1J101J	CHIP R 100 J 1/16W		IC3			NJM78L05UA	BI-POLAR IC	
R302-305			RK73GB1J102J	CHIP R 1.0K J 1/16W		IC4			TA7805F	MOS IC	
R306			RK73GB1J103J	CHIP R 10K J 1/16W							

# TKR-740

## PARTS LIST

CONTROL UNIT (X53-3882-71)

RX UNIT (X55-3050-11)

Ref. No.	Address	New parts	Parts No.	Description	Destination	Ref. No.	Address	New parts	Parts No.	Description	Destination
IC5			NJM78L08UA	BI-POLAR IC		C16			CC73GCH1H150J	CHIP C 15PF J	
IC6			TA7805F	MOS IC		C17			CC73FCH1H470J	CHIP C 47PF J	
IC7			AT29C020-90TI	ROM IC		C18-20			CK73GB1H102K	CHIP C 1000PF K	
IC10			RH5VL42C	MOS IC		C21			CC73FCH1H120G	CHIP C 12PF G	
IC12,13			NJM4558E	MOS IC		C22			CK73GB1H102K	CHIP C 1000PF K	
IC14			BU4053BCF	MOS IC		C23			CC73GCH1H040C	CHIP C 4.0PF C	
IC15,16			TC74VHC245FT	MOS IC		C24			CK73GB1H103K	CHIP C 0.010UF K	
IC17,18			30622M4-103GP	MPU		C25			CC73FCH1H470J	CHIP C 47PF J	
IC22,23			NJM4558E	MOS IC		C26			CK73GB1H102K	CHIP C 1000PF K	
IC24			TC74HC4040AF	MOS IC		C27			CK73GB1H103K	CHIP C 0.010UF K	
IC25			TC7S04F	MOS IC		C28			CK73FB1E104K	CHIP C 0.10UF K	
IC27			PCM3000E	MOS IC		C29			CK73GB1H103K	CHIP C 0.010UF K	
IC29			BU4053BCF	MOS IC		C30,31			CK73GB1H102K	CHIP C 1000PF K	
IC30			ADSP2185BST133	MPU		C32			CC73FCH1H150G	CHIP C 15PF G	
IC31,32			NJM4558E	MOS IC		C33			CC73GCH1H220J	CHIP C 22PF J	
IC33			M62364FP	MOS IC		C34-36			CK73GB1H102K	CHIP C 1000PF K	
IC34			NJM4558E	MOS IC		C37			CK73GB1H103K	CHIP C 0.010UF K	
IC35			TC7S32FU	MOS IC		C38			CK73FB1C105K	CHIP C 1.0UF K	
IC36			NJM4558E	MOS IC		C39			CC73GCH1H390J	CHIP C 39PF J	
IC37			BU4053BCF	MOS IC		C40			CC73FCH1H150G	CHIP C 15PF G	
IC38			TC7S00FU	MOS IC		C41			CK73GB1H103K	CHIP C 0.010UF K	
IC39			BU4094BCFV	MOS IC		C42			CK73FB1E104K	CHIP C 0.10UF K	
IC40			NJM4558E	MOS IC		C43,44			CC73FCH1H150G	CHIP C 15PF G	
IC42		*	ADM202EARW	MOS IC		C45,46			CK73GB1H102K	CHIP C 1000PF K	
IC42			ADM232LAR	MOS IC		C47			CC73FCH1H150G	CHIP C 15PF G	
IC45			LA4422	BI-POLAR IC		C48			C92-0628-05	CHIP-TAN 10UF 10WV	
IC46-49			TC7S32FU	MOS IC		C49			CC73GCH1H0R5B	CHIP C 0.5PF B	
IC700-703			BU2114F	MOS IC		C50			CC73FCH1H150G	CHIP C 15PF G	
IC704			NJM78L05UA	BI-POLAR IC		C51,52			CK73GB1H102K	CHIP C 1000PF K	
IC705			TA78L05F	MOS IC		C53			C92-0628-05	CHIP-TAN 10UF 10WV	
IC706			NJM78L05UA	BI-POLAR IC		C54			CK73GB1H102K	CHIP C 1000PF K	
Q1			2SK1824	FET		C55			CK73GB1H103K	CHIP C 0.010UF K	
Q2			DTC114EUA	DIGITAL TRANSISTOR		C56			C92-0628-05	CHIP-TAN 10UF 10WV	
Q5			2SK1824	FET		C57			CC73GCH1H0R5B	CHIP C 0.5PF B	
Q8			DTC144EUA	DIGITAL TRANSISTOR		C58			CK73GB1H102K	CHIP C 1000PF K	
Q9			DTC114EUA	DIGITAL TRANSISTOR		C59			C92-0628-05	CHIP-TAN 10UF 10WV	
Q10			DTC144EUA	DIGITAL TRANSISTOR		C60,61			CK73FB1E104K	CHIP C 0.10UF K	
Q11			DTC363EK	DIGITAL TRANSISTOR		C62			CK73GB1H103K	CHIP C 0.010UF K	
Q12			DTC114EUA	DIGITAL TRANSISTOR		C65			CC73GCH1H150J	CHIP C 15PF J	
Q700			2SA1586(Y,GR)	TRANSISTOR		C66			CK73GB1H102K	CHIP C 1000PF K	
Q701			2SC4116(Y)	TRANSISTOR		C67			CC73GCH1H270J	CHIP C 27PF J	
Q706			DTA114EUA	DIGITAL TRANSISTOR		C68			CC73GCH1H150J	CHIP C 15PF J	
Q707			DTC144EUA	DIGITAL TRANSISTOR		C69,70			CK73GB1H102K	CHIP C 1000PF K	
Q708			DTA114EUA	DIGITAL TRANSISTOR		C71			CC73GCH1H270J	CHIP C 27PF J	
Q709,710			DTC144EUA	DIGITAL TRANSISTOR		C72			CK73GB1H103K	CHIP C 0.010UF K	
<b>RX UNIT (X55-3050-11)</b>						C73,74			CK73GB1H102K	CHIP C 1000PF K	
D9			B30-2130-05	LED (YG)		C75			CC73GCH1H270J	CHIP C 27PF J	
C1			CC73GCH1H050C	CHIP C 5.0PF C		C76			CC73GCH1H100D	CHIP C 10PF D	
C2,3			CK73GB1H102K	CHIP C 1000PF K		C77			CK73FB1E104K	CHIP C 0.10UF K	
C4-6			CK73GB1H103K	CHIP C 0.010UF K		C78			CC73GCH1H090D	CHIP C 9.0PF D	
C7			CK73GB1H102K	CHIP C 1000PF K		C79			CC73GCH1H150J	CHIP C 15PF J	
C8			C92-0002-05	CHIP-TAN 0.22UF 35WV		C80			CC73GCH1H180J	CHIP C 18PF J	
C9			CK73FB1C105K	CHIP C 1.0UF K		C82			C92-0728-05	CHIP-ELE 470UF 16WV	
C10			C92-0545-05	CHIP-TAN 2.2UF 6.3WV		C83			CK73GB1H103K	CHIP C 0.010UF K	
C11			CK73GB1H102K	CHIP C 1000PF K		C84			C92-0589-05	CHIP-TAN 47UF 6.3WV	
C12			CC73GCH1H470J	CHIP C 47PF J		C85			CK73GB1H103K	CHIP C 0.010UF K	
C13			CK73GB1H102K	CHIP C 1000PF K		C88			C92-0633-05	CHIP-TAN 22UF 10WV	
C14			C92-0001-05	CHIP-C 0.1UF 35WV		C89-91			CK73GB1H103K	CHIP C 0.010UF K	
C15			CC73FCH1H150G	CHIP C 15PF G		C92			CC73GCH1H040C	CHIP C 4.0PF C	
						C93			CC73GCH1H680J	CHIP C 68PF J	

## PARTS LIST

RX UNIT (X55-3050-11)

Ref. No.	Address	New parts	Parts No.	Description	Destination	Ref. No.	Address	New parts	Parts No.	Description	Destination
C94,95			CC73GCH1H040C	CHIP C 4.0PF C		C169,170			C92-0628-05	CHIP-TAN 10UF 10WV	
C96			CM73F2H120J	CHIP C 12PF J		C171			C92-0003-05	CHIP-TAN 0.47UF 25WV	
C98			CC73GCH1H180J	CHIP C 18PF J		C172,173			CK73FB1E104K	CHIP C 0.10UF K	
C100			CC73GCH1H040C	CHIP C 4.0PF C		C174,175			CK73GB1H102K	CHIP C 1000PF K	
C101			CK73FB1E223K	CHIP C 0.022UF K		C176,177			CK73FB1E104K	CHIP C 0.10UF K	
C104			CC73GCH1H680J	CHIP C 68PF J		C178,179			CK73GB1H221K	CHIP C 220PF K	
C105,106			C92-0589-05	CHIP-TAN 47UF 6.3WV		C180			CK73FB1E104K	CHIP C 0.10UF K	
C107			CK73GB1H102K	CHIP C 1000PF K		C181,182			CK73GB1H221K	CHIP C 220PF K	
C108-110			CK73GB1H103K	CHIP C 0.010UF K		C183-186			CK73FB1E104K	CHIP C 0.10UF K	
C111,112			CK73FB1E104K	CHIP C 0.10UF K		C187,188			CK73GB1H102K	CHIP C 1000PF K	
C113			CK73GB1H103K	CHIP C 0.010UF K		C189,190			CC73GCH1H270J	CHIP C 27PF J	
C114			CK73GB1H102K	CHIP C 1000PF K		C191,192			CK73FB1E104K	CHIP C 0.10UF K	
C115			CK73FB1E104K	CHIP C 0.10UF K		C193			CC73GCH1H680J	CHIP C 68PF J	
C116			CK73GB1H103K	CHIP C 0.010UF K		C194			CC73GCH1H220J	CHIP C 22PF J	
C117			CK73GB1H102K	CHIP C 1000PF K		C195			CK73GB1H102K	CHIP C 1000PF K	
C118-120			CK73GB1H103K	CHIP C 0.010UF K		C196			C92-0628-05	CHIP-TAN 10UF 10WV	
C121			CC73GCH1H030C	CHIP C 3.0PF C		C197			CK73GB1H102K	CHIP C 1000PF K	
C122			CK73FB1E104K	CHIP C 0.10UF K		C198-200			C92-0628-05	CHIP-TAN 10UF 10WV	
C123			CK73GB1H562K	CHIP C 5600PF K		C201,202			CK73FB1E104K	CHIP C 0.10UF K	
C124			C92-0633-05	CHIP-TAN 22UF 10WV		C203			C92-0775-05	CHIP-TAN 47UF 4WV	
C125			CC73GCH1H030C	CHIP C 3.0PF C		C204			C92-0628-05	CHIP-TAN 10UF 10WV	
C126			CK73FB1E104K	CHIP C 0.10UF K		C207			CK73GB1H102K	CHIP C 1000PF K	
C127			CK73GB1H562K	CHIP C 5600PF K		C208			CK73FB1E104K	CHIP C 0.10UF K	
C128			CC73GCH1H2R5C	CHIP C 2.5PF C		C209			CK73GB1H103K	CHIP C 0.010UF K	
C129			CK73GB1C393K	CHIP C 0.039UF K		C210			C92-0633-05	CHIP-TAN 22UF 10WV	
C130			CC73GCH1H040C	CHIP C 4.0PF C		C211			CC73GCH1H080D	CHIP C 8.0PF D	
C131			CC73GCH1H680J	CHIP C 68PF J		C212			CK73GB1H103K	CHIP C 0.010UF K	
C132			CK73FB1E104K	CHIP C 0.10UF K		C213			C92-0514-05	CHIP-TAN 2.2UF 10WV	
C133			CK73GB1H103K	CHIP C 0.010UF K		C217			CK73GB1H102K	CHIP C 1000PF K	
C134			C92-0633-05	CHIP-TAN 22UF 10WV		C218			CC73GCH1H220J	CHIP C 22PF J	
C135			CK73GB1H103K	CHIP C 0.010UF K		C219			CC73GCH1H101J	CHIP C 100PF J	
C136			CC73GCH1H030C	CHIP C 3.0PF C		C220			CC73GCH1H180J	CHIP C 18PF J	
C137			CK73GB1H103K	CHIP C 0.010UF K		C221,222			CC73FCH1H040B	CHIP C 4.0PF B	
C138			CK73GB1C333K	CHIP C 0.033UF K		C226			CK73GB1H103K	CHIP C 0.010UF K	
C139			CC73GCH1H680J	CHIP C 68PF J		C228,229			CK73FB1E104K	CHIP C 0.10UF K	
C140			C92-0001-05	CHIP-C 0.1UF 35WV		TC1,2			C05-0393-05	CERAMIC TRIMMER CAP (8PF)	
C141			CC73GCH1H030C	CHIP C 3.0PF C		CN1			E04-0409-05	RF COAXIAL RECEPTACLE (SMB)	
C142			CK73FB1E104K	CHIP C 0.10UF K		CN2			E04-0154-05	PIN SOCKET	
C143			CK73GB1H103K	CHIP C 0.010UF K		CN3-5			E40-5538-05	PIN ASSY	
C144			CC73GCH1H220J	CHIP C 22PF J		CN6			E40-5736-05	FLAT CABLE CONNECTOR	
C145			CK73GB1E223K	CHIP C 0.022UF K		CN7			E04-0409-05	RF COAXIAL RECEPTACLE (SMB)	
C146-148			CK73GB1H103K	CHIP C 0.010UF K		CF1			L72-0956-05	CERAMIC FILTER	
C149			CK73GB1H102K	CHIP C 1000PF K		CF2			L72-0953-05	CERAMIC FILTER	
C150			C92-0628-05	CHIP-TAN 10UF 10WV		CF3			L72-0956-05	CERAMIC FILTER	
C151			CK73GB1H103K	CHIP C 0.010UF K		CF4			L72-0953-05	CERAMIC FILTER	
C152			CC73GCH1H090D	CHIP C 9.0PF D		CF5			L72-0976-05	CERAMIC FILTER	
C153			CK73GB1H102K	CHIP C 1000PF K		L1			L34-4523-05	AIR-CORE COIL	
C154			CK73GB1H103K	CHIP C 0.010UF K		L2			L40-1005-34	SMALL FIXED INDUCTOR (10UH)	
C155			CC73GCH1H220J	CHIP C 22PF J		L3			L79-1738-05	HELICAL BLOCK	
C156,157			CK73GB1H102K	CHIP C 1000PF K		L4			L40-1005-34	SMALL FIXED INDUCTOR (10UH)	
C158,159			CK73GB1H103K	CHIP C 0.010UF K		L5			L40-4775-34	SMALL FIXED INDUCTOR (47NH)	
C160			CK73FB1E104K	CHIP C 0.10UF K		L6,7			L40-1005-34	SMALL FIXED INDUCTOR (10UH)	
C161			CK73GB1H102K	CHIP C 1000PF K		L8			L34-4598-05	AIR-CORE COIL	
C162			CK73GB1H103K	CHIP C 0.010UF K		L9			L40-1005-34	SMALL FIXED INDUCTOR (10UH)	
C163			CC73GCH1H090D	CHIP C 9.0PF D		L10			L34-4598-05	AIR-CORE COIL	
C164			CK73GB1H102K	CHIP C 1000PF K		L11			L40-1095-34	SMALL FIXED INDUCTOR (1UH)	
C165			C92-0003-05	CHIP-TAN 0.47UF 25WV		L12			L40-1085-34	SMALL FIXED INDUCTOR (100NH)	
C166			CC73GCH1H080D	CHIP C 8.0PF D		L13			L40-8271-34	SMALL FIXED INDUCTOR (82NH)	
C167			CK73FB1E104K	CHIP C 0.10UF K		L14,15			L40-1005-34	SMALL FIXED INDUCTOR (10UH)	
C168			CK73GB1H103K	CHIP C 0.010UF K							

# TKR-740

## PARTS LIST

### RX UNIT (X55-3050-11)

Ref. No.	Address	New parts	Parts No.	Description	Destination	Ref. No.	Address	New parts	Parts No.	Description	Destination
L16			L79-1734-05	HELICAL BLOCK		R25			RK73FB2A100J	CHIP R	10 J 1/10W
L17,18			L40-1005-34	SMALL FIXED INDUCTOR (10UH)		R26			RK73GB1J101J	CHIP R	100 J 1/16W
L19			L40-4775-34	SMALL FIXED INDUCTOR (47NH)		R28			R92-1252-05	CHIP R	0 OHM J 1/16W
L20			L40-1095-34	SMALL FIXED INDUCTOR (1UH)		R29			RK73GB1J473J	CHIP R	47K J 1/16W
L21			L40-4775-34	SMALL FIXED INDUCTOR (47NH)		R30			RK73GB1J101J	CHIP R	100 J 1/16W
L22			L40-6875-34	SMALL FIXED INDUCTOR (68NH)		R32			RK73GB1J101J	CHIP R	100 J 1/16W
L23			L40-4775-34	SMALL FIXED INDUCTOR (47NH)		R33			R92-1252-05	CHIP R	0 OHM J 1/16W
L24			L40-1015-34	SMALL FIXED INDUCTOR (100UH)		R34			RK73GB1J102J	CHIP R	1.0K J 1/16W
L26			L40-4775-34	SMALL FIXED INDUCTOR (47NH)		R35,36			RK73GB1J181J	CHIP R	180 J 1/16W
L27,28			L34-4527-05	COIL		R37			RK73GB1J270J	CHIP R	27 J 1/16W
L30			L40-1095-34	SMALL FIXED INDUCTOR (1UH)		R38			R92-0670-05	CHIP R	0 OHM
L31,32			L34-4527-05	COIL		R39			RK73GB1J101J	CHIP R	100 J 1/16W
L33			L40-1015-34	SMALL FIXED INDUCTOR (100UH)		R40			R92-1252-05	CHIP R	0 OHM J 1/16W
L34,35			L40-1281-37	SMALL FIXED INDUCTOR (0.120UH)		R41			RK73GB1J271J	CHIP R	270 J 1/16W
L36,37			L40-1005-34	SMALL FIXED INDUCTOR (10UH)		R42,43			R92-1252-05	CHIP R	0 OHM J 1/16W
L38-41			L34-4527-05	COIL		R44			RK73GB1J470J	CHIP R	47 J 1/16W
L42			L40-1005-34	SMALL FIXED INDUCTOR (10UH)		R45			RK73GB1J103J	CHIP R	10K J 1/16W
L43,44			L34-4527-05	COIL		R46			RK73GB1J472J	CHIP R	4.7K J 1/16W
L45			L40-1281-37	SMALL FIXED INDUCTOR (0.120UH)		R47			RK73GB1J104J	CHIP R	100K J 1/16W
L46			L40-1005-34	SMALL FIXED INDUCTOR (10UH)		R48			RK73GB1J470J	CHIP R	47 J 1/16W
L47			L40-1281-37	SMALL FIXED INDUCTOR (0.120UH)		R49			RK73GB1J271J	CHIP R	270 J 1/16W
L48			L40-1005-34	SMALL FIXED INDUCTOR (10UH)		R50,51			RK73GB1J222J	CHIP R	2.2K J 1/16W
L49,50			L40-4775-34	SMALL FIXED INDUCTOR (47NH)		R52			RK73GB1J101J	CHIP R	100 J 1/16W
L51			L40-1095-34	SMALL FIXED INDUCTOR (1UH)		R53,54			RK73GB1J103J	CHIP R	10K J 1/16W
L52,53			L34-4725-05	COIL		R55			RK73GB1J222J	CHIP R	2.2K J 1/16W
L54			L40-1095-34	SMALL FIXED INDUCTOR (1UH)		R56			RK73GB1J223J	CHIP R	22K J 1/16W
L55			L40-1015-34	SMALL FIXED INDUCTOR (100UH)		R57			RK73GB1J101J	CHIP R	100 J 1/16W
L56			L40-1075-34	SMALL FIXED INDUCTOR (10NH)		R58			RK73GB1J472J	CHIP R	4.7K J 1/16W
L58			L40-4775-34	SMALL FIXED INDUCTOR (47NH)		R59			R92-1252-05	CHIP R	0 OHM J 1/16W
L64			L40-1005-34	SMALL FIXED INDUCTOR (10UH)		R60			RK73GB1J101J	CHIP R	100 J 1/16W
L65			L40-3375-34	SMALL FIXED INDUCTOR (33NH)		R61			RK73GB1J472J	CHIP R	4.7K J 1/16W
L66			L40-1885-34	SMALL FIXED INDUCTOR (180NH)		R62			R92-1252-05	CHIP R	0 OHM J 1/16W
X1,2			L77-1788-05	CRYSTAL RESONATOR (44.4MHZ)		R63			RK73GB1J471J	CHIP R	470 J 1/16W
XF1			L71-0542-05	MCF (44.85MHZ WIDE)		R64			RK73GB1J101J	CHIP R	100 J 1/16W
XF2			L71-0543-05	MCF (44.85MHZ NARROW)		R65			RK73GB1J102J	CHIP R	1.0K J 1/16W
XF3			L71-0544-05	MCF (44.85MHZ WIDE)		R66			RK73GB1J104J	CHIP R	100K J 1/16W
XF4			L71-0545-05	MCF (44.85MHZ NARROW)		R67,68			RK73GB1J821J	CHIP R	820 J 1/16W
CP1			R90-0724-05	MULTI-COMP 1K X4		R69			R92-1252-05	CHIP R	0 OHM J 1/16W
R1			RK73GB1J105J	CHIP R 1.0M J 1/16W		R70			RK73GB1J470J	CHIP R	47 J 1/16W
R2			RK73GB1J183J	CHIP R 18K J 1/16W		R71			RK73FB2A120J	CHIP R	12 J 1/10W
R3,4			RK73GB1J473J	CHIP R 47K J 1/16W		R72			RK73GB1J100J	CHIP R	10 J 1/16W
R5			R92-1252-05	CHIP R 0 OHM J 1/16W		R73,74			RK73GB1J471J	CHIP R	470 J 1/16W
R6			RK73GB1J223J	CHIP R 22K J 1/16W		R75			RK73GB1J104J	CHIP R	100K J 1/16W
R7			RK73GB1J470J	CHIP R 47 J 1/16W		R76			RK73GB1J182J	CHIP R	1.8K J 1/16W
R8			R92-1252-05	CHIP R 0 OHM J 1/16W		R77			RK73GB1J102J	CHIP R	1.0K J 1/16W
R9			RK73GB1J560J	CHIP R 56 J 1/16W		R78			RK73GB1J103J	CHIP R	10K J 1/16W
R10,11			RK73GB1J102J	CHIP R 1.0K J 1/16W		R79			RK73GB1J684J	CHIP R	680K J 1/16W
R12			RK73GB1J152J	CHIP R 1.5K J 1/16W		R80			RK73GB1J122J	CHIP R	1.2K J 1/16W
R13			RK73GB1J182J	CHIP R 1.8K J 1/16W		R81			RK73GB1J103J	CHIP R	10K J 1/16W
R14			RK73GB1J560J	CHIP R 56 J 1/16W		R82			RK73FB2A220J	CHIP R	22 J 1/10W
R15			RK73GB1J182J	CHIP R 1.8K J 1/16W		R83			RK73GB1J684J	CHIP R	680K J 1/16W
R16			RK73GB1J222J	CHIP R 2.2K J 1/16W		R84			RK73GB1J103J	CHIP R	10K J 1/16W
R17			RK73GB1J102J	CHIP R 1.0K J 1/16W		R85			RK73GB1J182J	CHIP R	1.8K J 1/16W
R18,19			RK73GB1J103J	CHIP R 10K J 1/16W		R90			RK73GB1J681J	CHIP R	680 J 1/16W
R20			RK73FB2A100J	CHIP R 10 J 1/10W		R92			RK73GB1J681J	CHIP R	680 J 1/16W
R21			RK73GB1J561J	CHIP R 560 J 1/16W		R93			RK73GB1J680J	CHIP R	68 J 1/16W
R22			RK73GB1J102J	CHIP R 1.0K J 1/16W		R95			RK73GB1J152J	CHIP R	1.5K J 1/16W
R23			RK73GB1J122J	CHIP R 1.2K J 1/16W		R96			RK73GB1J470J	CHIP R	47 J 1/16W
R24			R92-1252-05	CHIP R 0 OHM J 1/16W		R97			RK73FB2A220J	CHIP R	22 J 1/10W
						R98			RK73GB1J680J	CHIP R	68 J 1/16W

## PARTS LIST

RX UNIT (X55-3050-11)

Ref. No.	Address	New parts	Parts No.	Description	Destination	Ref. No.	Address	New parts	Parts No.	Description	Destination
R99			RK73GB1J152J	CHIP R 1.5K J 1/16W		R170			RK73GB1J104J	CHIP R 100K J 1/16W	
R100			RK73GB1J470J	CHIP R 47 J 1/16W		R171			RK73GB1J102J	CHIP R 1.0K J 1/16W	
R101			RK73GB1J220J	CHIP R 22 J 1/16W		R172			RK73GB1J104J	CHIP R 100K J 1/16W	
R102			RK73GB1J680J	CHIP R 68 J 1/16W		R173,174			RK73GB1J103J	CHIP R 10K J 1/16W	
R103			RK73GB1J101J	CHIP R 100 J 1/16W		R175			RK73GB1J224J	CHIP R 220K J 1/16W	
R104			RK73GB1J220J	CHIP R 22 J 1/16W		R176-178			RK73GB1J104J	CHIP R 100K J 1/16W	
R105			RK73GB1J680J	CHIP R 68 J 1/16W		R179			R92-0670-05	CHIP R 0 OHM	
R106			RK73GB1J222J	CHIP R 2.2K J 1/16W		R180			RK73GB1J331J	CHIP R 330 J 1/16W	
R107			RK73GB1J564J	CHIP R 560K J 1/16W		R181			RK73GB1J102J	CHIP R 1.0K J 1/16W	
R108			RK73GB1J473J	CHIP R 47K J 1/16W		R182			RK73GB1J104J	CHIP R 100K J 1/16W	
R109			RK73GB1J223J	CHIP R 22K J 1/16W		R183			RK73GB1J560J	CHIP R 56 J 1/16W	
R111			RK73GB1J222J	CHIP R 2.2K J 1/16W		R184			RK73GB1J102J	CHIP R 1.0K J 1/16W	
R114			RK73GB1J394J	CHIP R 390K J 1/16W		R185			R92-1252-05	CHIP R 0 OHM J 1/16W	
R115,116			RK73GB1J222J	CHIP R 2.2K J 1/16W		R186			RK73GB1J102J	CHIP R 1.0K J 1/16W	
R118			RK73GB1J104J	CHIP R 100K J 1/16W		R187-191			R92-1252-05	CHIP R 0 OHM J 1/16W	
R119			RK73GB1J393J	CHIP R 39K J 1/16W		R192			RK73GB1J104J	CHIP R 100K J 1/16W	
R120			R92-0679-05	CHIP R 0 OHM		R193			RK73FB2A220J	CHIP R 22 J 1/10W	
R121			RK73GB1J104J	CHIP R 100K J 1/16W		R195			RK73GB1J331J	CHIP R 330 J 1/16W	
R122			RK73GB1J680J	CHIP R 68 J 1/16W		R196			RK73GB1J221J	CHIP R 220 J 1/16W	
R123			RK73GB1J681J	CHIP R 680 J 1/16W		R197			RK73GB1J153J	CHIP R 15K J 1/16W	
R124,125			RK73GB1J101J	CHIP R 100 J 1/16W		R198			RK73GB1J102J	CHIP R 1.0K J 1/16W	
R126			RK73GB1J183J	CHIP R 18K J 1/16W		R199			RK73GB1J392J	CHIP R 3.9K J 1/16W	
R127			RK73GB1J681J	CHIP R 680 J 1/16W		D2-4			1SV283	VARIABLE CAPACITANCE DIODE	
R128			RK73GB1J680J	CHIP R 68 J 1/16W		D6			1SV283	VARIABLE CAPACITANCE DIODE	
R129			RK73GB1J152J	CHIP R 1.5K J 1/16W		D10			DAN235K	DIODE	
R130			RK73GB1J101J	CHIP R 100 J 1/16W		D11			DAN202U	DIODE	
R131			RK73GB1J470J	CHIP R 47 J 1/16W		IC1			CD8468	MOS IC	
R132			RK73GB1J103J	CHIP R 10K J 1/16W		IC1			SA7025DK	MOS IC	
R133			RK73GB1J680J	CHIP R 68 J 1/16W		IC2			NJM78L05UA	BI-POLAR IC	
R134			RK73GB1J152J	CHIP R 1.5K J 1/16W		IC3			BU4094BCFV	MOS IC	
R135			RK73GB1J103J	CHIP R 10K J 1/16W		IC4			TA7808S	MOS IC	
R136			RK73GB1J470J	CHIP R 47 J 1/16W		IC5			NJM2904E	MOS IC	
R137			RK73GB1J220J	CHIP R 22 J 1/16W		IC6			BU4053BCF	MOS IC	
R138			RK73GB1J680J	CHIP R 68 J 1/16W		IC7,8			TA31137FN	MOS IC	
R139			RK73GB1J101J	CHIP R 100 J 1/16W		IC9			M62364FP	MOS IC	
R140			RK73GB1J104J	CHIP R 100K J 1/16W		IC10			AT24C08N10SI18	ROM IC	
R141			RK73FB2A681J	CHIP R 680 J 1/10W		IC11,12			NJM4558E	MOS IC	
R142			RK73GB1J220J	CHIP R 22 J 1/16W		IC13			NJM78L08UA	BI-POLAR IC	
R143			RK73GB1J680J	CHIP R 68 J 1/16W		IC14			NJM2904E	MOS IC	
R144			RK73GB1J104J	CHIP R 100K J 1/16W		IC15			NJM4558E	MOS IC	
R145			RK73GB1J680J	CHIP R 68 J 1/16W		IC16			NJM78L05UA	BI-POLAR IC	
R146			RK73FB2A681J	CHIP R 680 J 1/10W		IC17			AM1	ANALOG IC	
R147			RK73GB1J222J	CHIP R 2.2K J 1/16W		IC18			TC7S66FU	MOS IC	
R148			RK73GB1J562J	CHIP R 5.6K J 1/16W		IC19			TC74HC14AF	MOS IC	
R149,150			RK73GB1J154J	CHIP R 150K J 1/16W		IC20			AD9835BRU	MOS IC	
R151			RK73GB1J222J	CHIP R 2.2K J 1/16W		IC21			TC7S66FU	MOS IC	
R152,153			RK73GB1J103J	CHIP R 10K J 1/16W		Q1			2SC3357	TRANSISTOR	
R154,155			RK73GB1J223J	CHIP R 22K J 1/16W		Q3			2SC3120	TRANSISTOR	
R156,157			RK73GB1J332J	CHIP R 3.3K J 1/16W		Q5			2SC3357	TRANSISTOR	
R158			RK73GB1J472J	CHIP R 4.7K J 1/16W		Q6			2SC4215(Y)	TRANSISTOR	
R159			RK73GB1J272J	CHIP R 2.7K J 1/16W		Q7			2SC2873(Y)	TRANSISTOR	
R160			RK73GB1J472J	CHIP R 4.7K J 1/16W		Q8,9			2SK508NV(K53)	FET	
R161			RK73GB1J272J	CHIP R 2.7K J 1/16W		Q10			2SC3722K(S)	TRANSISTOR	
R162			RK73GB1J152J	CHIP R 1.5K J 1/16W		Q12			2SC3722K(S)	TRANSISTOR	
R163			RK73GB1J102J	CHIP R 1.0K J 1/16W		Q13			DTC114EUA	DIGITAL TRANSISTOR	
R164,165			RK73GB1J473J	CHIP R 47K J 1/16W		Q14			2SC4215(Y)	TRANSISTOR	
R166			RK73GB1J474J	CHIP R 470K J 1/16W		Q16			2SB1386(R)	TRANSISTOR	
R167			RK73GB1J224J	CHIP R 220K J 1/16W		Q17			2SC3722K(S)	TRANSISTOR	
R168			RK73GB1J122J	CHIP R 1.2K J 1/16W		Q18,19			DTC114EUA	DIGITAL TRANSISTOR	
R169			RK73GB1J103J	CHIP R 10K J 1/16W							

# TKR-740

## PARTS LIST

RX UNIT (X55-3050-11)

TX UNIT (X56-3072-70)

Ref. No.	Address	New parts	Parts No.	Description	Destination
Q20			2SB1386(R)	TRANSISTOR	
Q22			DTC114EUA	DIGITAL TRANSISTOR	
Q24,25			2SC3357	TRANSISTOR	
Q26			2SC4081(R)	TRANSISTOR	
Q28			2SC4081(R)	TRANSISTOR	
Q29			DTC114EUA	DIGITAL TRANSISTOR	
Q30			2SK1824	FET	
Q31,32			2SC3357	TRANSISTOR	
Q33			2SC4081(R)	TRANSISTOR	
Q34,35			2SJ106(GR)	FET	
Q36-38			DTC114EUA	DIGITAL TRANSISTOR	
Q39			2SC4081(R)	TRANSISTOR	
TH1,2			157-153-65001	THERMISTOR	
A1			W02-1968-05	DBM	
A1			W02-1982-05	DBM	

### TX UNIT (X56-3072-70)

Ref. No.	Address	New parts	Parts No.	Description	Destination
D50,51			B30-2130-05	LED (YG)	
D52			B30-2048-05	LED	
C1,2			CK73GB1H102K	CHIP C 1000PF K	
C3,4			CC73GCH1H471J	CHIP C 470PF J	
C5			CC73FCH1H080B	CHIP C 8.0PF B	
C6			CK73GB1H102K	CHIP C 1000PF K	
C7			CC73FCH1H120G	CHIP C 12PF G	
C8			CC73FCH1H470J	CHIP C 47PF J	
C9			CC73FCH1H120G	CHIP C 12PF G	
C10			CC73FCH1H560J	CHIP C 56PF J	
C11			CK73GB1H103K	CHIP C 0.010UF K	
C12			CC73GCH1H010B	CHIP C 1.0PF B	
C13			CK73GB1H102K	CHIP C 1000PF K	
C14			CC73GCH1H010B	CHIP C 1.0PF B	
C15,16			CK73GB1H102K	CHIP C 1000PF K	
C17			CC73FCH1H100B	CHIP C 10PF B	
C19-22			CK73GB1H102K	CHIP C 1000PF K	
C23			CC73FCH1H080B	CHIP C 8.0PF B	
C24			CK73GB1H103K	CHIP C 0.010UF K	
C25			CC73FCH1H080B	CHIP C 8.0PF B	
C26			CK73GB1H102K	CHIP C 1000PF K	
C27,28			CC73GCH1H010B	CHIP C 1.0PF B	
C29			C92-0728-05	CHIP-ELE 470UF 16WV	
C30			CK73GB1H102K	CHIP C 1000PF K	
C31			CK73GB1H103K	CHIP C 0.010UF K	
C32			C92-0633-05	CHIP-TAN 22UF 10WV	
C33			CK73GB1H102K	CHIP C 1000PF K	
C34			CK73GB1H103K	CHIP C 0.010UF K	
C35,36			CC73GCH1H100D	CHIP C 10PF D	
C37			CK73GB1H102K	CHIP C 1000PF K	
C38			CC73GCH1H470J	CHIP C 47PF J	
C39			CK73GB1H471K	CHIP C 470PF K	
C40			C92-0633-05	CHIP-TAN 22UF 10WV	
C41			CK73FB1E104K	CHIP C 0.10UF K	
C42			CK73GB1H103K	CHIP C 0.010UF K	
C43			CK73GB1H471K	CHIP C 470PF K	
C45			C92-0633-05	CHIP-TAN 22UF 10WV	
C46			CK73FB1E104K	CHIP C 0.10UF K	
C47			CK73GB1H103K	CHIP C 0.010UF K	
C50			CK73GB1H471K	CHIP C 470PF K	
C51			CC73GCH1H101J	CHIP C 100PF J	
C52			CK73GB1H102K	CHIP C 1000PF K	
C53-55			CK73GB1H471K	CHIP C 470PF K	

Ref. No.	Address	New parts	Parts No.	Description	Destination
C56			CC73GCH1H471J	CHIP C 470PF J	
C57			C92-0560-05	CHIP-TAN 10UF 6.3WV	
C58,59			CK73GB1H102K	CHIP C 1000PF K	
C60			CK73GB1H471K	CHIP C 470PF K	
C61			CK73GB1H102K	CHIP C 1000PF K	
C62,63			CK73GB1H471K	CHIP C 470PF K	
C64,65			CC73GCH1H101J	CHIP C 100PF J	
C66			CK73GB1H102K	CHIP C 1000PF K	
C68			CK73GB1H103K	CHIP C 0.010UF K	
C69			CK73GB1H102K	CHIP C 1000PF K	
C70			C92-0606-05	CHIP-TAN 4.7UF 10WV	
C71-73			CK73GB1H103K	CHIP C 0.010UF K	
C74-76			CC73GCH1H470J	CHIP C 47PF J	
C77			CK73GB1H103K	CHIP C 0.010UF K	
C78			CK73GB1H222K	CHIP C 2200PF K	
C79			CK73GB1H102K	CHIP C 1000PF K	
C80			C92-0628-05	CHIP-TAN 10UF 10WV	
C82			CC73GCH1H100D	CHIP C 10PF D	
C100			CC73GCH1H070D	CHIP C 7.0PF D	
C101			CK73GB1H103K	CHIP C 0.010UF K	
C102			C92-0001-05	CHIP-C 0.1UF 35WV	
C103,104			CK73GB1H103K	CHIP C 0.010UF K	
C105			CK73GB1H102K	CHIP C 1000PF K	
C106			CK73GB1H471K	CHIP C 470PF K	
C107			C92-0606-05	CHIP-TAN 4.7UF 10WV	
C108,109			CK73GB1H102K	CHIP C 1000PF K	
C110			CK73GB1H103K	CHIP C 0.010UF K	
C111			C92-0003-05	CHIP-TAN 0.47UF 25WV	
C112			CK73GB1H102K	CHIP C 1000PF K	
C113			CC73GCH1H100D	CHIP C 10PF D	
C114-116			CK73GB1H103K	CHIP C 0.010UF K	
C118			CK73GB1H102K	CHIP C 1000PF K	
C119			CC73GCH1H101J	CHIP C 100PF J	
C120			CK73GB1H102K	CHIP C 1000PF K	
C121			CK73FB1E104K	CHIP C 0.10UF K	
C123			CK73FB1E104K	CHIP C 0.10UF K	
C124			C92-0589-05	CHIP-TAN 47UF 6.3WV	
C125,126			CK73GB1H103K	CHIP C 0.010UF K	
C127			C92-0589-05	CHIP-TAN 47UF 6.3WV	
C128			CK73FB1E104K	CHIP C 0.10UF K	
C130			CK73GB1H103K	CHIP C 0.010UF K	
C131			C92-0628-05	CHIP-TAN 10UF 10WV	
C132			CK73GB1H102K	CHIP C 1000PF K	
C133			C92-0628-05	CHIP-TAN 10UF 10WV	
C134			CK73GB1H102K	CHIP C 1000PF K	
C135,136			C92-0628-05	CHIP-TAN 10UF 10WV	
C138			C92-0628-05	CHIP-TAN 10UF 10WV	
C139			C92-0004-05	CHIP-TAN 1.0UF 16WV	
C140			CK73GB1H103K	CHIP C 0.010UF K	
C141			CK73GB1H102K	CHIP C 1000PF K	
C143			CC73GCH1H050C	CHIP C 5.0PF C	
C144			CK73GB1H102K	CHIP C 1000PF K	
C145			CK73GB1H103K	CHIP C 0.010UF K	
C146			CC73GCH1H050C	CHIP C 5.0PF C	
C147			CK73FB1E104K	CHIP C 0.10UF K	
C165,166			CC73GCH1H101J	CHIP C 100PF J	
C167			CK73GB1H102K	CHIP C 1000PF K	
C168			C92-0633-05	CHIP-TAN 22UF 10WV	
C169			CK73GB1H103K	CHIP C 0.010UF K	
C170			CK73FB1E104K	CHIP C 0.10UF K	



## PARTS LIST

TX UNIT (X56-3072-70)

Ref. No.	Address	New parts	Parts No.	Description	Destination	Ref. No.	Address	New parts	Parts No.	Description	Destination
C171,172			CK73GB1H102K	CHIP C 1000PF K		C278-281			CK73GB1H102K	CHIP C 1000PF K	
C173			CK73GB1H103K	CHIP C 0.010UF K		C282			CK73GB1H103K	CHIP C 0.010UF K	
C174			C92-0589-05	CHIP-TAN 47UF 6.3WV		C283			CC73GCH1H271J	CHIP C 270PF J	
C175			CK73FB1E104K	CHIP C 0.10UF K		C284			CK73GB1H103K	CHIP C 0.010UF K	
C186			CK73GB1C104K	CHIP C 0.10UF K		C285			CC73GCH1H330J	CHIP C 33PF J	
C187,188			CK73GB1H102K	CHIP C 1000PF K		C286			CC73GCH1H151J	CHIP C 150PF J	
C202-204			CK73GB1H103K	CHIP C 0.010UF K		C287			CC73GCH1H101J	CHIP C 100PF J	
C205			C92-0633-05	CHIP-TAN 22UF 10WV		C288			CK73GB1H102K	CHIP C 1000PF K	
C206,207			CC73GCH1H271J	CHIP C 270PF J		C289			CC73GCH1H220J	CHIP C 22PF J	
C208			C92-0628-05	CHIP-TAN 10UF 10WV		C290			CC73GCH1H100D	CHIP C 10PF D	
C209			C92-0519-05	CHIP-TAN 1.0UF 25WV		C291			CK73GB1H102K	CHIP C 1000PF K	
C210			CC73GCH1H820J	CHIP C 82PF J		C292			CK73GB1H103K	CHIP C 0.010UF K	
C211			CK73GB1H102K	CHIP C 1000PF K		C293			CK73GB1H102K	CHIP C 1000PF K	
C212			CC73GCH1H151J	CHIP C 150PF J		C294			CK73GB1H103K	CHIP C 0.010UF K	
C213			CK73GB1H103K	CHIP C 0.010UF K		C295			CC73GCH1H221J	CHIP C 220PF J	
C214			CC73GCH1H100D	CHIP C 10PF D		C296,297			CC73GCH1H100D	CHIP C 10PF D	
C215,216			CK73GB1H103K	CHIP C 0.010UF K		C298			CK73GB1H102K	CHIP C 1000PF K	
C218,219			CC73GCH1H101J	CHIP C 100PF J		C301			C92-0729-05	CHIP-ELE 330UF 25WV	
C220			CK73GB1H103K	CHIP C 0.010UF K		C302,303			CK73GB1H102K	CHIP C 1000PF K	
C221-224			CC73GCH1H271J	CHIP C 270PF J		C304			CK73GB1H471K	CHIP C 470PF K	
C225			CK73GB1H102K	CHIP C 1000PF K		C305			CK73GB1H103K	CHIP C 0.010UF K	
C226			C92-0628-05	CHIP-TAN 10UF 10WV		C306			CC73GCH1H330J	CHIP C 33PF J	
C228		*	C90-4115-05	ELECTRO C 100UF 20WV		C307			C93-0563-05	CHIP C 18PF J	
C231			CK73GB1H471K	CHIP C 470PF K		C310			CK73FB1E104K	CHIP C 0.10UF K	
C232			C92-0004-05	CHIP-TAN 1.0UF 16WV		C311			C92-0719-05	CHIP-ELE 47UF 25WV	
C233			CC73GCH1H180J	CHIP C 18PF J		C312			C93-0567-05	CHIP C 39PF J	
C234			CC73GCH1H390J	CHIP C 39PF J		C313			CK73GB1H102K	CHIP C 1000PF K	
C235			CC73GCH1H180J	CHIP C 18PF J		C315			C93-0566-05	CHIP C 33PF J	
C236			C92-0512-05	CHIP-TAN 1.0UF 16WV		C316			C93-0561-05	CHIP C 12PF J	
C237-239			CK73GB1H102K	CHIP C 1000PF K		C317			C92-0729-05	CHIP-ELE 330UF 25WV	
C240			C92-0628-05	CHIP-TAN 10UF 10WV		C319-322			CK73GB1H471K	CHIP C 470PF K	
C241			CK73GB1H102K	CHIP C 1000PF K		C324-328			CK73GB1H102K	CHIP C 1000PF K	
C242			CC73GCH1H100D	CHIP C 10PF D		C329			CK73GB1H103K	CHIP C 0.010UF K	
C243			CK73GB1H102K	CHIP C 1000PF K		C330,331			CK73GB1H102K	CHIP C 1000PF K	
C244			C92-0628-05	CHIP-TAN 10UF 10WV		C332,333			CK73FB1E104K	CHIP C 0.10UF K	
C245			CK73GB1H103K	CHIP C 0.010UF K		C334			C92-0003-05	CHIP-TAN 0.47UF 25WV	
C246			CC73GCH1H271J	CHIP C 270PF J		C335			CK73GB1H102K	CHIP C 1000PF K	
C247			C92-0004-05	CHIP-TAN 1.0UF 16WV		C336,337			C93-0550-05	CHIP C 1.0PF C	
C248			CK73GB1H102K	CHIP C 1000PF K		C338			C93-0552-05	CHIP C 2.0PF C	
C249			CC73GCH1H330J	CHIP C 33PF J		C339			CK73GB1H102K	CHIP C 1000PF K	
C250			CK73GB1H103K	CHIP C 0.010UF K		C340			CK73FB1E104K	CHIP C 0.10UF K	
C251-253			CK73GB1H102K	CHIP C 1000PF K		C341			CK73GB1H102K	CHIP C 1000PF K	
C254			CC73GCH1H101J	CHIP C 100PF J		C348,349			CK73GB1H102K	CHIP C 1000PF K	
C255,256			CK73GB1H102K	CHIP C 1000PF K		C353			C93-0603-05	CHIP C 1000PF K	
C257			CC73GCH1H221J	CHIP C 220PF J		C354			CK73GB1H102K	CHIP C 1000PF K	
C258,259			CK73GB1H103K	CHIP C 0.010UF K		C410			C93-0552-05	CHIP C 2.0PF C	
C260,261			CC73GCH1H100D	CHIP C 10PF D		C411,412			C93-0556-05	CHIP C 6.0PF D	
C262			CK73GB1H103K	CHIP C 0.010UF K		C413			C93-0553-05	CHIP C 3.0PF C	
C263			CC73GCH1H220J	CHIP C 22PF J		C414			C93-0561-05	CHIP C 12PF J	
C264			CC73GCH1H560J	CHIP C 56PF J		C420			C92-0040-05	CHIP-ELE 47UF 16WV	
C265			CK73GB1C104K	CHIP C 0.10UF K		C425		*	C90-4115-05	ELECTRO C 100UF 20WV	
C266,267			CK73GB1E223K	CHIP C 0.022UF K		C430			C92-0514-05	CHIP-TAN 2.2UF 10WV	
C268			C92-0628-05	CHIP-TAN 10UF 10WV		C431,432			C92-0729-05	CHIP-ELE 330UF 25WV	
C269,270			CK73GB1H103K	CHIP C 0.010UF K		TC1,2			C05-0393-05	CERAMIC TRIMMER CAP (8PF)	
C271			CK73GB1H471K	CHIP C 470PF K		CN1			E04-0409-05	RF COAXIAL RECEPTACLE (SMB)	
C272			CC73GCH1H470J	CHIP C 47PF J		CN2			E40-5758-05	FLAT CABLE CONNECTOR	
C273,274			CK73FB1E104K	CHIP C 0.10UF K		CN3			E40-5736-05	FLAT CABLE CONNECTOR	
C275			CK73GB1H102K	CHIP C 1000PF K		CN101,102			E04-0409-05	RF COAXIAL RECEPTACLE (SMB)	
C276			CK73FB1E104K	CHIP C 0.10UF K		CN103,104			E40-5538-05	PIN ASSY	
C277			CC73GCH1H560J	CHIP C 56PF J							

# TKR-740

## PARTS LIST

### TX UNIT (X56-3072-70)

Ref. No.	Address	New parts	Parts No.	Description	Destination	Ref. No.	Address	New parts	Parts No.	Description	Destination
CN301			E04-0408-05	RF COAXIAL RECEPTACLE (SMB)		R19			RK73GB1J470J	CHIP R	47 J 1/16W
CN302			E40-5758-05	FLAT CABLE CONNECTOR		R20			RK73GB1J103J	CHIP R	10K J 1/16W
CN304,305			E40-5538-05	PIN ASSY		R21			RK73GB1J471J	CHIP R	470 J 1/16W
CN306,307			E23-0902-05	TERMINAL		R22			RK73GB1J103J	CHIP R	10K J 1/16W
CN308			E04-0408-05	RF COAXIAL RECEPTACLE (SMB)		R23			RK73GB1J183J	CHIP R	18K J 1/16W
CN502			E40-5783-05	PIN ASSY		R24			RK73GB1J101J	CHIP R	100 J 1/16W
J402			J13-0071-05	FUSE HOLDER		R25			RK73GB1J472J	CHIP R	4.7K J 1/16W
CF1			L72-0976-05	CERAMIC FILTER		R26			RK73GB1J220J	CHIP R	22 J 1/16W
L1,2			L40-1005-34	SMALL FIXED INDUCTOR (10UH)		R27			RK73GB1J101J	CHIP R	100 J 1/16W
L4			L40-1005-34	SMALL FIXED INDUCTOR (10UH)		R28			RK73GB1J103J	CHIP R	10K J 1/16W
L5			L34-4601-05	AIR-CORE COIL		R29			RK73GB1J183J	CHIP R	18K J 1/16W
L6			L34-4600-05	AIR-CORE COIL		R30			RK73GB1J103J	CHIP R	10K J 1/16W
L7			L40-1005-34	SMALL FIXED INDUCTOR (10UH)		R31			RK73GB1J101J	CHIP R	100 J 1/16W
L11			L40-1081-36	SMALL FIXED INDUCTOR (100NH)		R32			RK73GB1J221J	CHIP R	220 J 1/16W
L13			L40-1071-36	SMALL FIXED INDUCTOR (10NH)		R33			RK73GB1J103J	CHIP R	10K J 1/16W
L14			L40-4771-36	SMALL FIXED INDUCTOR (47NH)		R34			RK73GB1J222J	CHIP R	2.2K J 1/16W
L15			L40-1085-54	SMALL FIXED INDUCTOR (100NH)		R35			RK73GB1J182J	CHIP R	1.8K J 1/16W
L16			L92-0140-05	FERRITE CHIP		R36			RK73GB1J472J	CHIP R	4.7K J 1/16W
L17			L92-0138-05	FERRITE CHIP		R37			RK73GB1J153J	CHIP R	15K J 1/16W
L101			L40-1095-34	SMALL FIXED INDUCTOR (1UH)		R38			RK73GB1J183J	CHIP R	18K J 1/16W
L102			L40-4785-34	SMALL FIXED INDUCTOR (470NH)		R39			RK73GB1J331J	CHIP R	330 J 1/16W
L103-105			L40-1015-34	SMALL FIXED INDUCTOR (100UH)		R40			RK73GB1J101J	CHIP R	100 J 1/16W
L106			L40-1095-34	SMALL FIXED INDUCTOR (1UH)		R41			RK73GB1J152J	CHIP R	1.5K J 1/16W
L201			L40-4785-34	SMALL FIXED INDUCTOR (470NH)		R42			RK73GB1J470J	CHIP R	47 J 1/16W
L202			L92-0179-05	FERRITE CHIP		R43			RK73GB1J102J	CHIP R	1.0K J 1/16W
L203			L40-1595-34	SMALL FIXED INDUCTOR (1.5UH)		R44			RK73GB1J393J	CHIP R	39K J 1/16W
L204			L40-1015-34	SMALL FIXED INDUCTOR (100UH)		R45			R92-1252-05	CHIP R	0 OHM J 1/16W
L205,206			L40-4785-34	SMALL FIXED INDUCTOR (470NH)		R46			R92-0699-05	CHIP R	10 J 1/2W
L207			L40-1095-34	SMALL FIXED INDUCTOR (1UH)		R47			R92-1252-05	CHIP R	0 OHM J 1/16W
L208			L92-0179-05	FERRITE CHIP		R48			RK73GB1J103J	CHIP R	10K J 1/16W
L209,210			L40-1015-34	SMALL FIXED INDUCTOR (100UH)		R49			RK73GB1J123J	CHIP R	12K J 1/16W
L240,241			L40-1015-34	SMALL FIXED INDUCTOR (100UH)		R50			RK73GB1J471J	CHIP R	470 J 1/16W
L242,243			L40-1005-34	SMALL FIXED INDUCTOR (10UH)		R51,52			RK73GB1J331J	CHIP R	330 J 1/16W
L244,245			L40-4771-36	SMALL FIXED INDUCTOR (47NH)		R54			R92-1252-05	CHIP R	0 OHM J 1/16W
L246			L40-1005-34	SMALL FIXED INDUCTOR (10UH)		R55,56			RK73GB1J102J	CHIP R	1.0K J 1/16W
L247			L40-1015-34	SMALL FIXED INDUCTOR (100UH)		R57			RK73GB1J471J	CHIP R	470 J 1/16W
L248			L40-4785-34	SMALL FIXED INDUCTOR (470NH)		R58,59			RK73GB1J683J	CHIP R	68K J 1/16W
L301-303			L34-4520-05	AIR-CORE COIL		R60			RK73GB1J224J	CHIP R	220K J 1/16W
L304			L79-0558-05	FILTER		R61			RK73GB1J471J	CHIP R	470 J 1/16W
L305			L34-4523-05	AIR-CORE COIL		R62			RK73GB1J104J	CHIP R	100K J 1/16W
L306-308			L92-0179-05	FERRITE CHIP		R63			RK73GB1J101J	CHIP R	100 J 1/16W
X101			L77-1735-15	TCXO (20MHZ)		R64			RK73GB1J471J	CHIP R	470 J 1/16W
X201			L77-1748-05	CRYSTAL RESONATOR		R65			RK73GB1J474J	CHIP R	470K J 1/16W
XF210,211			L71-0529-05	MCF (20MHZ)		R66			RK73GB1J124J	CHIP R	120K J 1/16W
R1,2			RK73GB1J221J	CHIP R	220 J 1/16W	R67			RK73GB1J224J	CHIP R	220K J 1/16W
R3,4			RK73GB1J473J	CHIP R	47K J 1/16W	R68			RK73GB1J563J	CHIP R	56K J 1/16W
R5,6			RK73GB1J104J	CHIP R	100K J 1/16W	R69,70			RK73GB1J474J	CHIP R	470K J 1/16W
R7			RK73GB1J333J	CHIP R	33K J 1/16W	R71			RK73GB1J101J	CHIP R	100 J 1/16W
R8			RK73GB1J273J	CHIP R	27K J 1/16W	R72			RK73GB1J104J	CHIP R	100K J 1/16W
R9			RK73GB1J101J	CHIP R	100 J 1/16W	R73			RK73GB1J221J	CHIP R	220 J 1/16W
R10,11			R92-1252-05	CHIP R	0 OHM J 1/16W	R74			RK73GB1J471J	CHIP R	470 J 1/16W
R12			RK73GB1J101J	CHIP R	100 J 1/16W	R77			RK73GB1J331J	CHIP R	330 J 1/16W
R13			RK73GB1J471J	CHIP R	470 J 1/16W	R78,79			R92-1252-05	CHIP R	0 OHM J 1/16W
R14			RK73GB1J103J	CHIP R	10K J 1/16W	R84			RK73GB1J101J	CHIP R	100 J 1/16W
R15			RK73GB1J471J	CHIP R	470 J 1/16W	R85-87			RK73GB1J183J	CHIP R	18K J 1/16W
R16			RK73GB1J103J	CHIP R	10K J 1/16W	R88			RK73GB1J222J	CHIP R	2.2K J 1/16W
R17			RK73GB1J473J	CHIP R	47K J 1/16W	R89			RK73GB1J103J	CHIP R	10K J 1/16W
R18			RK73GB1J103J	CHIP R	10K J 1/16W	R100			RK73GB1J105J	CHIP R	1.0M J 1/16W
						R101			RK73GB1J473J	CHIP R	47K J 1/16W
						R102			RK73GB1J101J	CHIP R	100 J 1/16W
						R105,106					

## PARTS LIST

TX UNIT (X56-3072-70)

Ref. No.	Address	New parts	Parts No.	Description	Destination	Ref. No.	Address	New parts	Parts No.	Description	Destination
R107			RK73GB1J471J	CHIP R 470 J 1/16W		R222			RK73GB1J103J	CHIP R 10K J 1/16W	
R108			RK73GB1J183J	CHIP R 18K J 1/16W		R223			RK73GB1J153J	CHIP R 15K J 1/16W	
R109			R92-0670-05	CHIP R 0 OHM		R224			RK73GB1J223J	CHIP R 22K J 1/16W	
R112			RK73GB1J183J	CHIP R 18K J 1/16W		R225			RK73GB1J103J	CHIP R 10K J 1/16W	
R113			RK73GB1J102J	CHIP R 1.0K J 1/16W		R226			RK73GB1J124J	CHIP R 120K J 1/16W	
R114			RK73GB1J222J	CHIP R 2.2K J 1/16W		R227			RK73GB1J473J	CHIP R 47K J 1/16W	
R115			RK73GB1J101J	CHIP R 100 J 1/16W		R228			RK73GB1J104J	CHIP R 100K J 1/16W	
R117			RK73GB1J101J	CHIP R 100 J 1/16W		R240			RK73GB1J101J	CHIP R 100 J 1/16W	
R118			RK73GB1J183J	CHIP R 18K J 1/16W		R241,242			RK73GB1J473J	CHIP R 47K J 1/16W	
R119			RK73GB1J103J	CHIP R 10K J 1/16W		R243			RK73GB1J103J	CHIP R 10K J 1/16W	
R120			RK73GB1J102J	CHIP R 1.0K J 1/16W		R244			RK73GB1J392J	CHIP R 3.9K J 1/16W	
R121			R92-1252-05	CHIP R 0 OHM J 1/16W		R245			RK73GB1J101J	CHIP R 100 J 1/16W	
R122			RK73GB1J101J	CHIP R 100 J 1/16W		R247			RK73GB1J101J	CHIP R 100 J 1/16W	
R123			RK73GB1J103J	CHIP R 10K J 1/16W		R249			RK73GB1J473J	CHIP R 47K J 1/16W	
R124			RK73GB1J222J	CHIP R 2.2K J 1/16W		R250			RK73GB1J221J	CHIP R 220 J 1/16W	
R129			RK73GB1J102J	CHIP R 1.0K J 1/16W		R251,252			RK73GB1J101J	CHIP R 100 J 1/16W	
R130			RK73GB1J331J	CHIP R 330 J 1/16W		R253			RK73GB1J102J	CHIP R 1.0K J 1/16W	
R131			RK73GB1J102J	CHIP R 1.0K J 1/16W		R254			R92-1252-05	CHIP R 0 OHM J 1/16W	
R132			RK73GB1J124J	CHIP R 120K J 1/16W		R255,258			R92-1261-05	CHIP R 150 J 1/2W	
R133			RK73GB1J104J	CHIP R 100K J 1/16W		R259			R92-1273-05	CHIP C 39 J 1/2W	
R134			RK73GB1J101J	CHIP R 100 J 1/16W		R260			RK73GB1J183J	CHIP R 18K J 1/16W	
R136			RK73GB1J680J	CHIP R 68 J 1/16W		R261,262			RK73GB1J101J	CHIP R 100 J 1/16W	
R137			RK73GB1J103J	CHIP R 10K J 1/16W		R263			RK73GB1J473J	CHIP R 47K J 1/16W	
R138			RK73GB1J124J	CHIP R 120K J 1/16W		R264-266			RK73GB1J273J	CHIP R 27K J 1/16W	
R139			RK73GB1J104J	CHIP R 100K J 1/16W		R267			RK73GB1J103J	CHIP R 10K J 1/16W	
R140			RK73GB1J393J	CHIP R 39K J 1/16W		R268			RK73GB1J153J	CHIP R 15K J 1/16W	
R141			RK73GB1J102J	CHIP R 1.0K J 1/16W		R269			RK73GB1J102J	CHIP R 1.0K J 1/16W	
R142			RK73GB1J104J	CHIP R 100K J 1/16W		R270,271			R92-0685-05	CHIP R 22 J 1/2W	
R143			RK73GB1J473J	CHIP R 47K J 1/16W		R272			RK73GB1J103J	CHIP R 10K J 1/16W	
R144			RK73GB1J334J	CHIP R 330K J 1/16W		R273			RK73GB1J473J	CHIP R 47K J 1/16W	
R145,146			RK73GB1J101J	CHIP R 100 J 1/16W		R274			RK73GB1J101J	CHIP R 100 J 1/16W	
R147			RK73GB1J102J	CHIP R 1.0K J 1/16W		R275			RK73GB1J560J	CHIP R 56 J 1/16W	
R149			RK73GB1J103J	CHIP R 10K J 1/16W		R300			RK73GB1J182J	CHIP R 1.8K J 1/16W	
R150			RK73GB1J472J	CHIP R 4.7K J 1/16W		R301			R92-1252-05	CHIP R 0 OHM J 1/16W	
R151			RK73GB1J682J	CHIP R 6.8K J 1/16W		R303			RK73FB2A182J	CHIP R 1.8K J 1/10W	
R180,181			R92-1252-05	CHIP R 0 OHM J 1/16W		R304			RK73FB2A120J	CHIP R 12 J 1/10W	
R182			RK73GB1J472J	CHIP R 4.7K J 1/16W		R305			RK73FB2A182J	CHIP R 1.8K J 1/10W	
R183			RK73GB1J473J	CHIP R 47K J 1/16W		R306			RK73GB1J103J	CHIP R 10K J 1/16W	
R184			RK73GB1J153J	CHIP R 15K J 1/16W		R308			RK73GB1J102J	CHIP R 1.0K J 1/16W	
R185			RK73GB1J101J	CHIP R 100 J 1/16W		R310			R92-0685-05	CHIP R 22 J 1/2W	
R186			RK73GB1J472J	CHIP R 4.7K J 1/16W		R311			RK73GB1J473J	CHIP R 47K J 1/16W	
R190-192			R92-1252-05	CHIP R 0 OHM J 1/16W		R312			R92-0685-05	CHIP R 22 J 1/2W	
R201,202			R92-1252-05	CHIP R 0 OHM J 1/16W		R313			RK73GB1J102J	CHIP R 1.0K J 1/16W	
R203			RK73GB1J223J	CHIP R 22K J 1/16W		R314			RK73GB1J104J	CHIP R 100K J 1/16W	
R204			RK73GB1J822J	CHIP R 8.2K J 1/16W		R315			RK73GB1J102J	CHIP R 1.0K J 1/16W	
R205			RK73GB1J473J	CHIP R 47K J 1/16W		R316			RK73GB1J473J	CHIP R 47K J 1/16W	
R206,207			RK73GB1J474J	CHIP R 470K J 1/16W		R317			RK73GB1J393J	CHIP R 39K J 1/16W	
R208			RK73GB1J104J	CHIP R 100K J 1/16W		R319			RK73GB1J154J	CHIP R 150K J 1/16W	
R209			RK73GB1J103J	CHIP R 10K J 1/16W		R320			RK73GB1J124J	CHIP R 120K J 1/16W	
R210			R92-1252-05	CHIP R 0 OHM J 1/16W		R321,322			RK73GB1J103J	CHIP R 10K J 1/16W	
R211			RK73GB1J474J	CHIP R 470K J 1/16W		R323			RK73GB1J102J	CHIP R 1.0K J 1/16W	
R212			RK73GB1J471J	CHIP R 470 J 1/16W		R324			RK73GB1J222J	CHIP R 2.2K J 1/16W	
R213			RK73GB1J101J	CHIP R 100 J 1/16W		R325			RK73GB1J562J	CHIP R 5.6K J 1/16W	
R214			RK73GB1J821J	CHIP R 820 J 1/16W		R326			RK73GB1J103J	CHIP R 10K J 1/16W	
R215			RK73GB1J124J	CHIP R 120K J 1/16W		R327			RK73FB2A681J	CHIP R 680 J 1/10W	
R216			RK73GB1J104J	CHIP R 100K J 1/16W		R328			RK73FB2A271J	CHIP R 270 J 1/10W	
R217,218			RK73GB1J471J	CHIP R 470 J 1/16W		R329			RK73GB1J103J	CHIP R 10K J 1/16W	
R219			RK73GB1J103J	CHIP R 10K J 1/16W		R330			RK73GB1J123J	CHIP R 12K J 1/16W	
R220			RK73GB1J473J	CHIP R 47K J 1/16W		R338,339			R92-1252-05	CHIP R 0 OHM J 1/16W	
R221			RK73GB1J560J	CHIP R 56 J 1/16W		R354			RK73GB1J103J	CHIP R 10K J 1/16W	

# TKR-740

## PARTS LIST

### TX UNIT (X56-3072-70)

Ref. No.	Address	New parts	Parts No.	Description	Destination	Ref. No.	Address	New parts	Parts No.	Description	Destination
R355			RK73GB1J473J	CHIP R 47K J 1/16W		Q13			2SC3356	TRANSISTOR	
R357			RK73GB1J102J	CHIP R 1.0K J 1/16W		Q14			2SK2596	FET	
R358			RK73FB2A182J	CHIP R 1.8K J 1/10W		Q15			2SK302(Y)	FET	
R359			RK73FB2A120J	CHIP R 12 J 1/10W		Q17,18			2SK1824	FET	
R360			RK73FB2A182J	CHIP R 1.8K J 1/10W		Q21			UMC5	TRANSISTOR	
R367			RK73GB1J102J	CHIP R 1.0K J 1/16W		Q102			2SC4215(Y)	TRANSISTOR	
R403			RK73GB1J104J	CHIP R 100K J 1/16W		Q106			2SC4215(Y)	TRANSISTOR	
TS301			S79-0401-05	THERMAL SWITCH		Q107			2SC3120	TRANSISTOR	
D1-6			1SV283	VARIABLE CAPACITANCE DIODE		Q108,109			2SC4215(Y)	TRANSISTOR	
D7			1SV128	DIODE		Q110			UMC5	TRANSISTOR	
D11,12			1SS355	DIODE		Q112,113			2SK1824	FET	
D101			1SV128	DIODE		Q114			DTA114EUA	DIGITAL TRANSISTOR	
D103			1SV128	DIODE		Q115			2SC4215(Y)	TRANSISTOR	
D201-203			1SV283	VARIABLE CAPACITANCE DIODE		Q201,202			2SC4215(Y)	TRANSISTOR	
D204			1SS355	DIODE		Q203			2SK1824	FET	
D205			HSM88AS	DIODE		Q205			2SC4215(Y)	TRANSISTOR	
D206			MINISMDC075-02	VARISTOR		Q206			2SK1824	FET	
D303			ERZ-M14DK220M	SURGE ABSORBER		Q207			DTC114EUA	DIGITAL TRANSISTOR	
D304			1SS355	DIODE		Q208			2SK1824	FET	
D305			DSM3MA1	DIODE		Q240-242			2SC4215(Y)	TRANSISTOR	
D306			HSM88AS	DIODE		Q301			2SC4081(R)	TRANSISTOR	
D308			HSM88AS	DIODE		Q302			IMH5A	TRANSISTOR	
D310			MINISMDC075-02	VARISTOR		Q304			IMH5A	TRANSISTOR	
D318			1SS355	DIODE		Q308			UMC5	TRANSISTOR	
D320			02DZ5.6(X,Y)	ZENER DIODE		Q309			DTC114EUA	DIGITAL TRANSISTOR	
D500			MINISMDE190	VARISTOR							
IC1			TA7808S	MOS IC							
IC2			NJM78L08UA	BI-POLAR IC							
IC3			M62364FP	MOS IC							
IC4			BU4094BCFV	MOS IC							
IC100			TA75S01F	MOS IC							
IC101			CD8468	MOS IC							
IC102			TA75S01F	MOS IC							
IC103			NJM78L05UA	BI-POLAR IC							
IC105			NJM4558E	MOS IC							
IC106			AT24C08N10SI18	ROM IC							
IC107			NJM4558E	MOS IC							
IC108			NJM78L08UA	BI-POLAR IC							
IC109			NJM2904E	MOS IC							
IC110			NJM78L05UA	BI-POLAR IC							
IC200			TC4S81F	MOS IC							
IC201			CD8468	MOS IC							
IC202			AD9835BRU	MOS IC							
IC203			NJM2904E	MOS IC							
IC204			NJM2903M	MOS IC							
IC205			NJM78L05UA	BI-POLAR IC							
IC206			TC74HC14AF	MOS IC							
IC301		*	RA30H1317M	MOS IC							
IC302,303			OP291GS	BI-POLAR IC							
Q1,2			2SK508NV(K52)	FET							
Q3,4			2SC3722K(S)	TRANSISTOR							
Q5			2SK1824	FET							
Q6			2SC3120	TRANSISTOR							
Q7			2SC3722K(S)	TRANSISTOR							
Q8			IMH5A	TRANSISTOR							
Q9			2SC3120	TRANSISTOR							
Q11			2SB1386(R)	TRANSISTOR							
Q12			DTC114EUA	DIGITAL TRANSISTOR							

# TKR-740 TKR-740

## EXPLODED VIEW

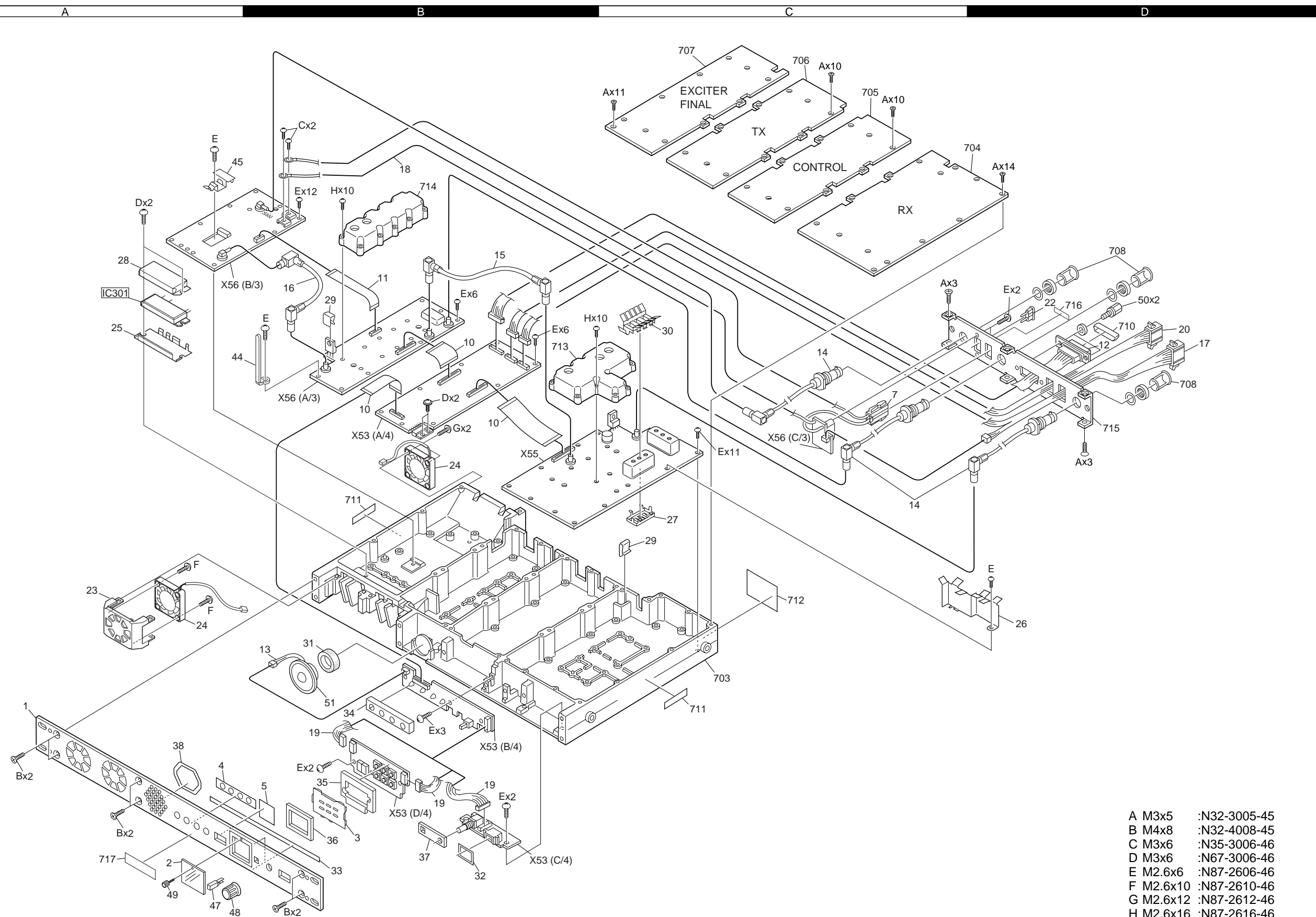

A	M3x5	:N32-3005-45
B	M4x8	:N32-4008-45
C	M3x6	:N35-3006-46
D	M3x6	:N67-3006-46
E	M2.6x6	:N87-2606-46
F	M2.6x10	:N87-2610-46
G	M2.6x12	:N87-2612-46
H	M2.6x16	:N87-2616-46

## PACKING

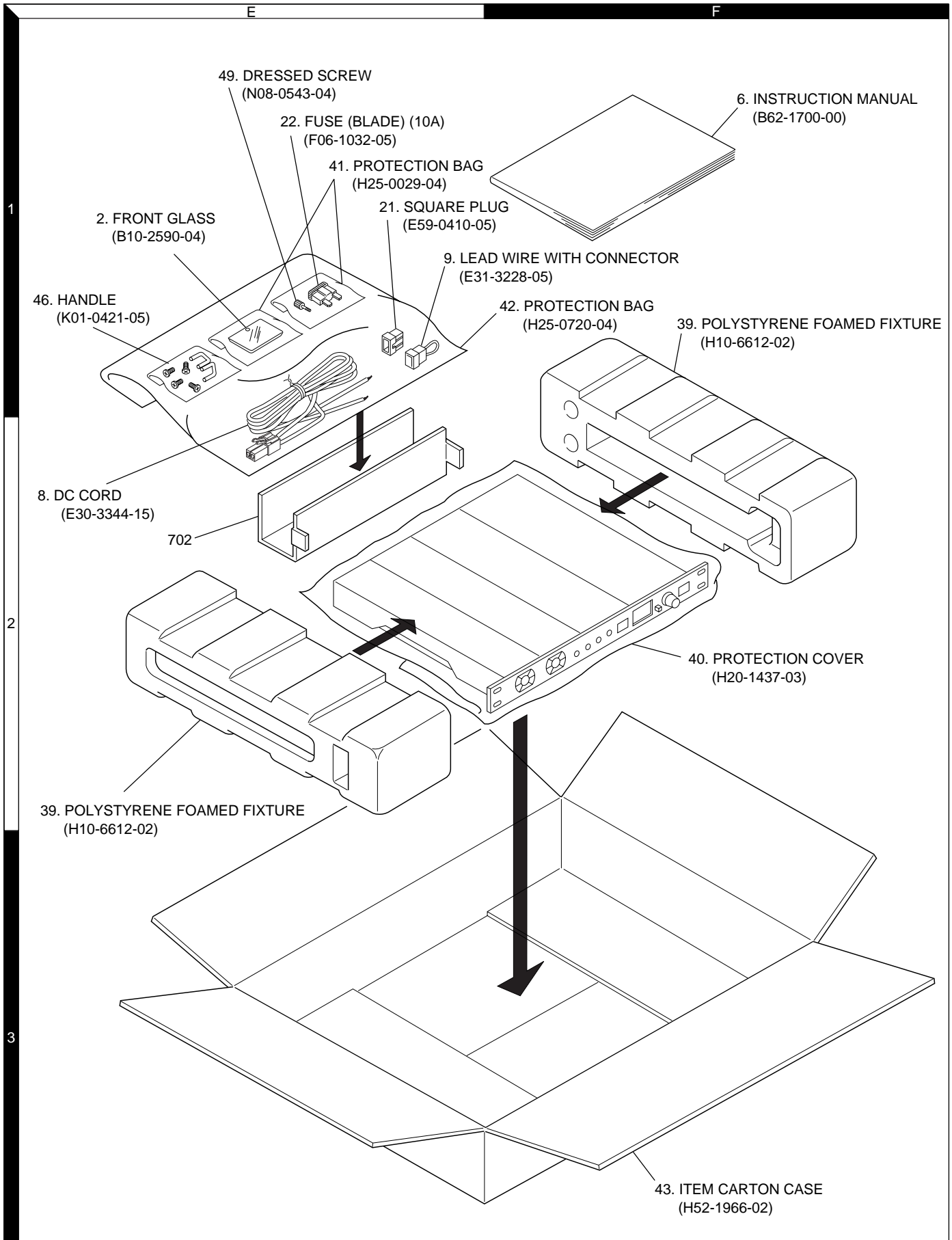

# TKR-740

## TERMINAL FUNCTION

### CONTROL UNIT (X53-3882-71)

CN1

Terminal No.	Terminal name	Terminal function	I/O
1	RA	RX Audio (filtered signal)	I
2	RXG	RX Audio ground	-
3	DET	Detector audio	I
4	DEG	Detector audio ground	-
5	SC	Noise squelch control	I
6	RSSI	RX signal strength indicator	I
7	CK	Common clock	O
8	DT	Common data	O
9	ESR	Shift register strobe	O
10	EVR	Electronic volume strobe	O
11	SCL	RX EEPROM serial clock	O
12	SDA	RX EEPROM serial data	I/O
13	DP	PLL data signal	O
14	CP	PLL clock signal	O
15	EPR	RX main PLL strobe signal	O
16	LDR	RX PLL lock detector	I
17	GND	Ground	-
18	CVR	RX main PLL lock voltage	I
19	NC	No connection	-
20	NC	No connection	-
21	B	Power supply (Vcc)	O
22	B	Power supply (Vcc)	O
23	B	Power supply (Vcc)	O
24	NC	No connection	-
25	NC	No connection	-
26	NC	No connection	-

CN3

Terminal No.	Terminal name	Terminal function	I/O
1	SPI	Local speaker input	O
2	SPG	Local speaker ground	-
3	VLO	AF volume control output	I
4	VLI	AF volume control input	O
5	GND	Ground	-
6	BLT	Mic connector J700 (1pin)	I
7	8C	8V constant voltage	O
8	HOK	Hook-switch	I
9	PTT	Press-to-talk-switch	I
10	EXR	Exit reference indicator	O
11	SW1	Programable switch S705	I
12	SW2	Programable switch S704	I
13	B	Power supply (Vcc)	O
14	B	Power supply (Vcc)	O
15	SW3	Programable switch S703	I
16	SW4	Programable switch S702	I
17	TEST	Test switch	I
18	SW5	Programable switch S701	I
19	SW6	Programable switch S700	I
0	EN7	Shift register enable signal	O
21	MDAT	Mic connector J700 (8pin)	I
22	DT	Serial data for IC703	O
23	CK	Common serial clock	O
24	GND	Ground	-
25	MI	Microphone signal	I
26	MIG	Microphone ground	-

CN2

Terminal No.	Terminal name	Terminal function	I/O
1	MOD	Modulation signal	O
2	TO	Signalling signal	O
3	MIG	Microphone ground	-
4	EVT	TX electronic volume enable signal	O
5	EST	TX shift register enable signal	O
6	DT	Data signal for IC3 & IC4	O
7	CK	Clock signal for IC3 & IC4	O
8	NC	No connection	-
9	NC	No connection	-
10	SDA	RX EEPROM serial data	O
11	SCL	RX EEPROM serial clock	I/O
12	LDT	TX main PLL lock detector	I
13	PRT	High temperature detect	I
14	CP	TX both PLL clock signal	O
15	NC	No connection	-
16	DP	TX both PLL data signal	O
17	EXR	Exit reference detector	I
18	CVT	TX main PLL lock voltage	I
19	REV	Reverse TX power detector	I
20	FWD	Forward TX power detector	I
21	GND	Ground	-
22	PAG	Digital pager signal	O
23	B	Power supply (Vcc)	I
24	B	Power supply (Vcc)	I
25	B	Power supply (Vcc)	I
26	PAB	Power supply for AF PA IC	I

## TERMINAL FUNCTION

### CONTROL UNIT (X53-3882-71)

CN4

Terminal No.	Terminal name	Terminal function	I/O
1	SPM	Speaker mute signal	I
2	AUX06	Auxiliary output 6	O
3	RXG	RX signal ground	-
4	AUX05	Auxiliary output 5	O
5	RA	RX audio (voice)	O
6	AUX04	Auxiliary output 4	O
7	RD	RX data (voice & data)	O
8	AUX03	Auxiliary output 3	O
9	TA	TX audio (voice)	I
10	AUX02	Auxiliary output 2	O
11	TD	TX data (data or signalling)	I
12	AUX01	Auxiliary output 1	O
13	DG	Control line ground	-
14	TXG	TX signal ground	-
15	AUXI3	Auxiliary input 3	I
16	NC	No connection	-
17	AUXI2	Auxiliary input 2	I
18	SC	SQ control	O
19	AUXI1	Auxiliary input 1	I
20	ExPTT	External press-to-talk switch	I
21	TXD	RS-232C output signal (for FPU)	O
22	ExMON	External monitor switch	I
23	RXD	RS-232C input signal (for FPU)	I
24	NC	No connection	-
25	NC	No connection	-
26	NC	No connection	-
27	NC	No connection	-
28	NC	No connection	-
29	NC	No connection	-
30	NC	No connection	-

CN5

Terminal No.	Terminal name	Terminal function	I/O
1	B	Power supply (Vcc)	O
2	FWD	TX forward power detect signal	O
3	EXR	External reference detect signal	O
4	CVT	TX main PLL lock voltage signal	O
5	CVR	RX main PLL lock voltage signal	O
6	RD	RX data (data & voice)	O
7	RSSI	RX signal strength indicator signal	O
8	SPO	External Speaker AF	O
9	SPO	External Speaker AF	O
10	SPI	Internal Speaker AF input	I
11	GND	Ground	-
12	GND	Ground	-
13	SPG	External Speaker ground	-
14	SPG	External Speaker ground	-

CN6

Terminal No.	Terminal name	Terminal function	I/O
1	RRA	Remote RX signal (voice)	O
2	RTA	Remote TX signal (voice)	I
3	RPTT	Remote Press-to-talk switch	I
4	ExMON	External monitor switch	I
5	GND	Ground	-
6	I/O1	Programable I/O 1	I/O
7	I/O2	Programable I/O 2	I/O
8	I/O3	Programable I/O 3	I/O
9	I/O4	Programable I/O 4	I/O
10	I/O5	Programable I/O 5	I/O
11	I/O6	Programable I/O 6	I/O
12	I/O7	Programable I/O 7	I/O

CN700

Terminal No.	Terminal name	Terminal function	I/O
1	B	Power supply (Vcc)	I
2	SW1	S705 output	O
3	SW2	S704 output	O
4	SW3	S703 output	O
5	SW4	S702 output	O
6	SW5	S701 output	O
7	SW6	S700 output	O

CN701

Terminal No.	Terminal name	Terminal function	I/O
1	5A2	5V constant voltage A	I
2	5B2	5V constant voltage B	I
3	EN7	Enable signal for IC700, 701, 702	I
4	CK	Common Clock for IC700, 701, 702	I
5	DS	Serial data for IC702	I
6	GND	Ground	-



# TKR-740

## TERMINAL FUNCTION

### CONTROL UNIT (X53-3882-71)

CN702

Terminal No.	Terminal name	Terminal function	I/O
1	SPI	Local speaker input	I
2	SPG	Local speaker ground	-
3	VLO	AF volume control output	O
4	VLI	AF volume control input	I
5	GND	Ground	-
6	BLT	Mic connector J700 (1pin)	O
7	8C	8V constant voltage	I
8	HOK	Hook-switch	O
9	PTT	Press-to-talk-switch	O
10	EXR	External reference indicator	I
11	SW1	Programable switch S705	O
12	SW2	Programable switch S704	O
13	B	Power supply (Vcc)	I
14	B	Power supply (Vcc)	I
15	SW3	Programable switch S703	O
16	SW4	Programable switch S702	O
17	TEST	Test switch	O
18	SW5	Programable switch S701	O
19	SW6	Programable switch S700	O
20	EN7	Shift register enable signal	I
21	MDAT	Mic connector J700 (8pin)	O
22	DT	Serial data for IC703	I
23	CK	Common serial clock	I
24	GND	Ground	-
25	MI	Microphone signal	O
26	MIG	Microphone ground	-

CN703

Terminal No.	Terminal name	Terminal function	I/O
1	SPG	Internal Speaker ground	-
2	SP	Internal Speaker AF output	O

CN705

Terminal No.	Terminal name	Terminal function	I/O
1	VLO	AF signal for VR701	I
2	VLI	AF signal from VR701	O
3	GND	Ground	-
4	BLT	Mic connector J700 (pin1)	-
5	B	Power supply (Vcc)	I
6	GND	Ground	-
7	PTT	Press-to-talk switch	O
8	MIG	Microphone ground	-
9	MIC	Microphone signal	O
10	HOK	Hook signal	O
11	MDAT	Mic connector J700 (pin8)	-
12	NC	No connection	-
13	NC	No connection	-
14	NC	No connection	-

CN706

Terminal No.	Terminal name	Terminal function	I/O
1	NC	No connection	-
2	SW6	Switch S700 signal	I
3	NC	No connection	-
4	SW5	Switch S701 signal	I
5	NC	No connection	-
6	SW4	Switch S702 signal	I
7	MDAT	Mic connector J700 (pin8)	-
8	SW3	Switch S703 signal	I
9	HOK	Hook signal	I
10	SW2	Switch S704 signal	I
11	MIC	Local mic signal	I
12	SW1	Switch S705 signal	I
13	MIG	Local mic ground	-
14	B	Power supply (Vcc)	O
15	PTT	Press to talk switch	I
16	5A2	5V constant voltage A	O
17	GND	Ground	-
18	5B2	5V constant voltage B	O
19	B	Power supply (Vcc)	O
20	EN7	Shift register enable	O
21	BLT	Mic connector J700 (pin1)	-
22	CK	Common clock	O
23	GND	Ground	-
24	DS	Serial data from IC703	O
25	VLI	AF signal for VR701	I
26	GND	Ground	-
27	VLO	AF signal from VR701	O
28	NC	No connection	-
29	NC	No connection	-
30	NC	No connection	-

## TERMINAL FUNCTION

## TX UNIT (X56-3072-70)

## CN1

Terminal No.	Terminal name	Terminal function	I/O
-	DRIV OUT	Drive signal output (coaxial)	O

## CN2

Terminal No.	Terminal name	Terminal function	I/O
1	PAB	AFPA power supply (Vcc)	I
2	B	Power supply (Vcc)	I
3	B	Power supply (Vcc)	I
4	B	Power supply (Vcc)	I
5	H/L	High power/Low power control	O
6	FWD	Forward power detect voltage	I
7	REV	Reflected power detect voltage	I
8	PC	TX power control signal	O
9	PRT	High temperature detector signal	I
10	GND	Ground	-
11	8T	TX 8V constant voltage	O
12	AUX	Auxiliary	-

## CN3

Terminal No.	Terminal name	Terminal function	I/O
1	MOD	Modulation signal	I
2	TO	Signalling signal	I
3	MIG	Microphone ground	-
4	EVT	TX electronic volume enable signal	I
5	EST	TX shift register enable signal	I
6	DT	Data signal for IC3 & IC4	I
7	CK	Clock signal for IC3 & IC4	I
8	NC	No connection	-
9	NC	No connection	-
10	SDA	RX EEPROM serial data	I
11	SCL	RX EEPROM serial clock	I/O
12	LDT	TX main PLL lock detector	O
13	PRT	High temperature detect	O
14	CP	TX both PLL clock signal	I
15	NC	No connection	-
16	DP	TX both PLL data signal	I
17	EXR	External reference detector	O
18	CVT	TX main PLL lock voltage	O
19	REV	Reverse TX power detector	O
20	FWD	Forward TX power detector	O
21	GND	Ground	-
22	PAG	Digital pager signal	I
23	B	Power supply (Vcc)	O
24	B	Power supply (Vcc)	O
25	B	Power supply (Vcc)	O
26	PAB	Power supply for AF PA IC	O

## CN101

Terminal No.	Terminal name	Terminal function	I/O
-	EXT REF	External reference signal input (coaxial)	I

## CN102

Terminal No.	Terminal name	Terminal function	I/O
-	REF OUT	RX reference signal output (coaxial)	O

## CN103

Terminal No.	Terminal name	Terminal function	I/O
1	GND	Ground	-
2	FB	Fused +B (for cooling FAN)	O

## CN104

Terminal No.	Terminal name	Terminal function	I/O
1	GND	Ground	-
2	FB	Fused +B (for cooling FAN)	O

## CN301

Terminal No.	Terminal name	Terminal function	I/O
-	DRIV IN	Drive signal input (coaxial)	I

## CN302

Terminal No.	Terminal name	Terminal function	I/O
1	PAB	AFPA power supply (Vcc)	O
2	B	Power supply (Vcc)	O
3	B	Power supply (Vcc)	O
4	B	Power supply (Vcc)	O
5	H/L	High power/Low power control	I
6	FWD	Forward power detect voltage	O
7	REV	Reflected power detect voltage	O
8	PC	TX power control signal	I
9	PRT	High temperature detector signal	O
10	GND	Ground	-
11	8T	TX 8V constant voltage	I
12	AUX	Auxiliary	-

## CN304

Terminal No.	Terminal name	Terminal function	I/O
1	GND	Ground	-
2	FB	Fused +B (for cooling FAN)	O

## CN305

Terminal No.	Terminal name	Terminal function	I/O
1	GND	Ground	-
2	FB	Fused +B (for cooling FAN)	O

## CN306

Terminal No.	Terminal name	Terminal function	I/O
-	+B	Power supply input (Vcc)	I

# TKR-740

## TERMINAL FUNCTION

### TX UNIT (X56-3072-70)

#### CN307

Terminal No.	Terminal name	Terminal function	I/O
-	GND	Power supply ground	-

#### CN308

Terminal No.	Terminal name	Terminal function	I/O
-	RF OUT	TX power output (coaxial)	I

#### CN502

Terminal No.	Terminal name	Terminal function	I/O
1	B	Fused +B (for external equipment)	O
2	B	Fused +B (for external equipment)	O
3	NC	No connection	-

### RX UNIT (X55-3050-11)

#### CN1

Terminal No.	Terminal name	Terminal function	I/O
-	RX IN	Receive signal input (coaxial)	I

#### CN2

Terminal No.	Terminal name	Terminal function	I/O
-	-	Use for RX helical BPF tuning	O

#### CN3

Terminal No.	Terminal name	Terminal function	I/O
1	IN	Use for RX MCF tuning	I
2	GND	Use for RX MCF tuning	-

#### CN4

Terminal No.	Terminal name	Terminal function	I/O
1	OUT	Use for wide band MCF tuning	O
2	GND	Use for wide band MCF tuning	-

#### CN5

Terminal No.	Terminal name	Terminal function	I/O
1	OUT	Use for narrow band MCF tuning	O
2	GND	Use for narrow band MCF tuning	-

#### CN6

Terminal No.	Terminal name	Terminal function	I/O
1	RA	RX Audio (filtered signal)	O
2	RXG	RX Audio ground	-
3	DET	Detector audio	O
4	DEG	Detector audio ground	-
5	SC	Noise squelch control	O
6	RSSI	RX signal strength indicator	O
7	CK	Common clock	I
8	DT	Common data	I
9	ESR	Shift register strobe	I
10	EVR	Electronic volume strobe	I
11	SCL	RX EEPROM serial clock	I
12	SDA	RX EEPROM serial data	I/O
13	DP	PLL data signal	I
14	CP	PLL clock signal	I
15	EPR	RX main PLL strobe signal	I
16	LDR	RX PLL lock detector	O
17	GND	Ground	-
18	CVR	RX main PLL lock voltage	O
19	NC	No connection	-
20	NC	No connection	-
21	B	Power supply (Vcc)	I
22	B	Power supply (Vcc)	I
23	B	Power supply (Vcc)	I
24	NC	No connection	-
25	NC	No connection	-
26	NC	No connection	-

#### CN7

Terminal No.	Terminal name	Terminal function	I/O
-	REF IN	Reference signal input (coaxial)	I

## ADJUSTMENT

### Test Equipment Required for Alignment

No. Test Equipment	Major Specifications	
1. Standard Signal Generator (SSG)	Frequency Range Modulation Output	136 to 174MHz. Frequency modulation and external modulation. 0.1μV to greater than 1mV.
2. Power Meter	Input Impedance Operation Frequency Measurement Capability	50Ω. 136 to 174MHz or more. Vicinity of 50W.
3. Deviation Meter	Frequency Range	136 to 174MHz.
4. Digital Volt Meter	Measuring Range Accuracy	1 to 20V DC. High input impedance for minimum circuit loading.
5. Oscilloscope		DC through 30MHz.
6. High Sensitivity Frequency Counter	Frequency Range Frequency Stability	10Hz to 600MHz. 0.2ppm or less.
7. Ammeter		10A or more.
8. AF Volt Meter (AF VTVM)	Frequency Range Voltage Range	50Hz to 10kHz. 3mV to 3V.
9. Audio Generator(AG)	Frequency Range Output	50Hz to 5kHz. 0 to 1V.
10. Distortion Meter	Capability Input Level	3% or less at 1kHz. 50mV to 10Vrms.
11. Voltmeter	Measuring Range Input Impedance	10 to 1.5V DC or less. 50kΩ/V or greater.
12. 4Ω Dummy Load		Approx. 4Ω, 5W

### The Following Parts are Required for Adjustment

- Test cable for local microphone

MIC connector  
front PANEL view

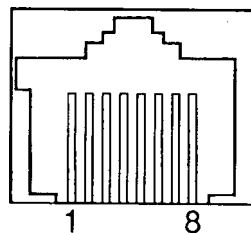

No.	Terminal name & Description
1	NC
2	+B
3	GND
4	PTT/TXD1(PC serial data from radio)
5	MIC G
6	MIC
7	HOOK/RXD1(PC serial data to radio)
8	NC

- The following test cables are recommended

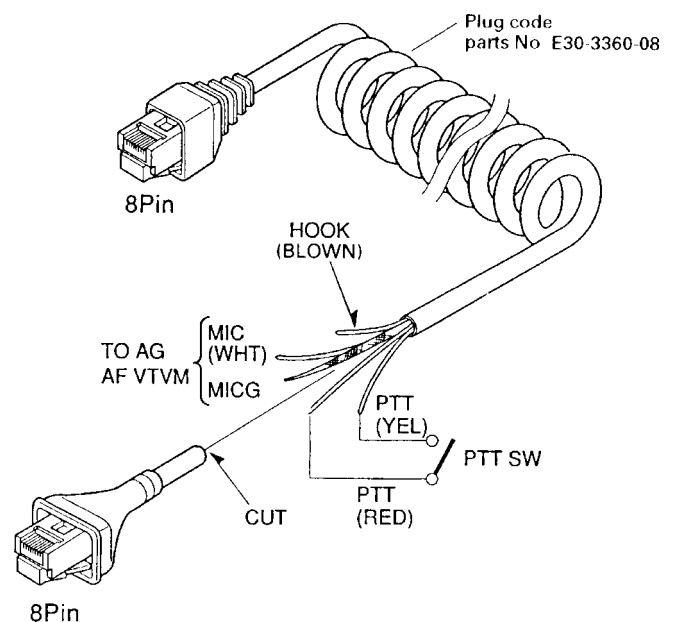

Test cable for Microphone input.

# TKR-740

## ADJUSTMENT

### Adjustment Location

• Top view

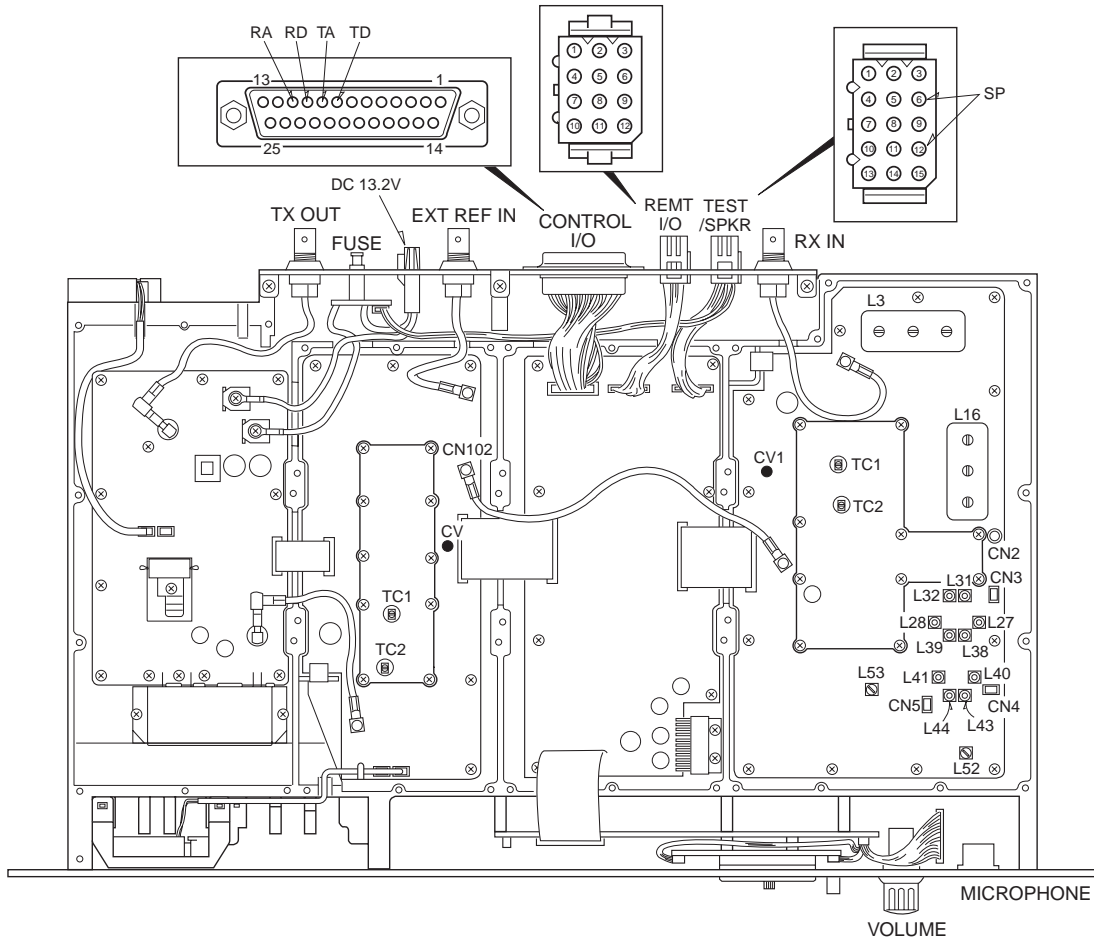

### Section Arrangement (Top view)

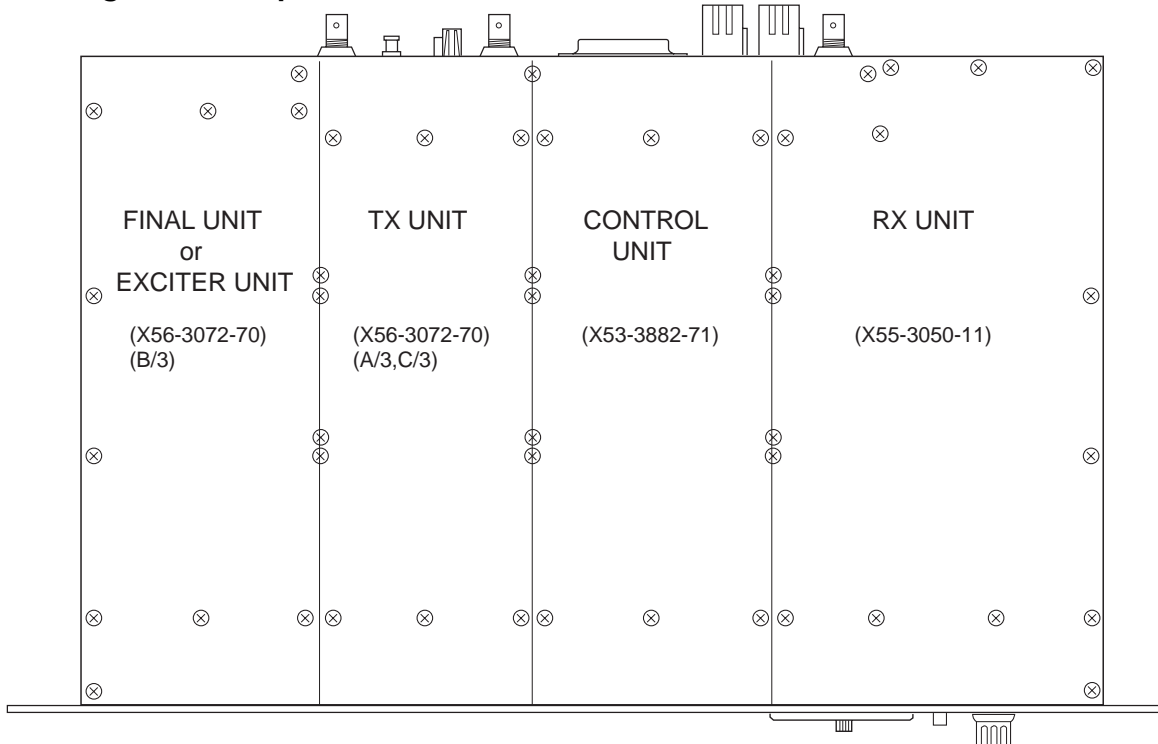

## ADJUSTMENT

★ Factory use CH1 to CH16

CH	RX Frequency	TX Frequency	Beat Shift	W/N	Power H/L	VCO	NOTE
1	158.1000	136.0000	No	Wide	H	A Low	VCO A Low
2	162.1000	145.5000	No	Wide	H	A Center	VCO A Center
3	165.9000	154.9500	No	Wide	H	A High	VCO A High
4	166.1000	155.0000	No	Wide	H	B Low	VCO B Low
5	170.1000	164.5000	No	Wide	H	B Center	VCO B Center
6	173.9000	174.0000	No	Wide	H	B High	VCO B High
7	158.1000	136.0000	No	Narrow	L	A Low	VCO A Low
8	162.1000	145.5000	No	Narrow	L	A Center	VCO A Center
9	165.9000	154.9500	No	Narrow	L	A High	VCO A High
10	166.1000	155.0000	No	Narrow	L	B Low	VCO B Low
11	170.1000	164.5000	No	Narrow	L	B Center	VCO B Center
12	173.9000	174.0000	No	Narrow	L	B High	VCO B High
13	162.1000	145.5000	Yes	Wide	H	A Center	For production Beat VCO A Center
14	170.1000	164.5000	Yes	Wide	H	B Center	For production Beat VCO B Center
15	164.5000	167.5000	No	Wide	H	A(Hi)/B(Low)	For production Center TX/RX
16	167.5000	164.5000	No	Wide	H	B(Low)/A(Hi)	For production Center TX/RX
17	164.4000	152.4000	No	Wide	H	A High	Helical (Center) Low edge
18	167.6000	155.6000	No	Wide	H	B Low	Helical (Center) High edge
19	164.4000	152.4000	No	Narrow	L	A High	Helical (Center) Low edge
20	167.6000	155.6000	No	Narrow	L	B Low	Helical (Center) High edge
21	159.6000	159.6000	No	Wide	H	A Low	Helical (Low) High edge
22	159.6000	159.6000	No	Narrow	L	A Low	Helical (Low) High edge
23	172.4000	172.4000	No	Wide	H	B High	Helical (Hi) Low edge
24	172.4000	172.4000	No	Narrow	L	B High	Helical (Hi) Low edge
25	158.1000	136.0000	No	Wide	H	A Low	In band Low edge
26	166.1000	155.0000	No	Wide	H	B Low	In band Center
27	173.9000	174.0000	No	Wide	H	B High	In band High edge
28	165.9750	165.3750	No	Wide	H	B(Low)/A(Hi)	Center LTR+KSI Repeater
29	165.9750	165.3750	No	Narrow	L	B(Low)/A(Hi)	Center LTR+KSI Repeater
30	166.5500	166.5500	No	Wide	H	B Low	For reserve and TX/RX
31	162.1000	170.1000	No	Narrow	L	A(Center)/B(Center)	For reserve and TX/RX
32	170.1000	162.1000	No	Narrow	L	B(Center)/A(Center)	For reserve and TX/RX

# TKR-740

## ADJUSTMENT

### RX UNIT

Item	Condition	Measurement			Adjustment			Specifications/ Remarks
		Test equipment	Unit	Terminal	Unit	Parts	Method	
1. Setting	1) VOL : OFF 2) 13.2V External power supply 3) POWER : ON							
2. RX Lock Voltage	1) CH6 (RX B Hi) 2) CH4 (RX B Lo)	DVM	RX	CV1	RX	TC2	4.5V ADJ Check	±0.1V 1V or more
	3) CH3 (RX A Hi) 4) CH1 (RX A Lo)						TC1	4.5V ADJ Check
3. BPF Adjust	Connect the TG to RX IN, then connect CN2 to the spectrum analyzer input.	TG Spectrum Analyzer		RX IN CN2		L3 L16	Center the frequency you are using, then adjust it to look like the wave on page 80.	Refer to page 80
4. MCF Adjust (Wide)	Connect the TG to CN3, then connect CN4 to the spectrum analyzer input. 1) CH4				CN3 CN4		L31 L27 L38 L40 L43	Adjust it to look like the wave on page 80.
(Narrow)	Connect the TG to CN3, then connect CN5 to the spectrum analyzer input. 1) CH10			CN3 CN5		L32 L28 L39 L41 L44	Adjust it to look like the wave on page 80.	Refer to page 80
5. Discriminator Adjust (Wide)	Connect the SSG to RX IN 1) CH4 MOD: 1kHz DEV : 2.4kHz SSG : 501 $\mu$ V (-53dBm) AF : 0.45V/4 $\Omega$	SSG AFVM		TEST/SPKR SPO Terminal (pin 12)		L52	Adjust for maximum	
	(Narrow)		1) CH10 MOD: 1kHz DEV : 1.5kHz SSG : 501 $\mu$ V (-53dBm) AF : 0.45V/4 $\Omega$			L53		
6. Sensitivity Check (Wide)	1) Connect the SSG to RX IN, then select the channel that the user will use (Wide) MOD: 1kHz DEV : 2.4kHz SSG : 0.707 $\mu$ V (-110dBm) AF : 0.45V/4 $\Omega$ filter : CCITT	SSG Audio, Analyzer		RX IN TEST/SPKR SPO Terminal (pin 12)			Check	20dB SINAD or more
	(Narrow)		1) Connect the SSG to RX IN, then select the channel that the user will use (Narrow) MOD: 1kHz DEV : 1.5kHz SSG : 0.707 $\mu$ V (-110dBm) AF : 0.45V/4 $\Omega$ filter : CCITT					

## ADJUSTMENT

## RX UNIT

Item	Condition	Measurement			Adjustment			Specifications/ Remarks
		Test equipment	Unit	Terminal	Unit	Parts	Method	
7. Analog Squelch Adjust (Wide)	1) Connect the SSG to RX IN, then select the channel that the user will use (Wide) MOD: 1kHz DEV : 2.4kHz SSG : 3dB below to 12dB SINAD level AF : 0.45V/4Ω	SSG Audio, Analyzer VTVM oscilloscope	RX	RX IN TEST/SPKR SPO Terminal (pin 12) 4Ω Load			PC ADJ Adjust to point of opening squelch	
	(Narrow)							
8. RSSI Squelch Adjust (Wide)	1) Connect the SSG to RX IN, then select the channel that the user will use (Wide) MOD: 1kHz DEV : 2.4kHz SSG : 3dB below to 12dB SINAD level AF : 0.45V/4Ω							
	(Narrow)							
9. RX S/N Check (Wide)	1) Connect the SSG to RX IN, then select the channel that the user will use (Wide) MOD: 1kHz DEV : 2.4kHz SSG : 501μV (-53dBm) AF : 2.84V/4Ω						Check	-56dB or less
	(Narrow)							1) Connect the SSG to RX IN, then select the channel that the user will use (Narrow) MOD: 1kHz DEV : 1.5kHz SSG : 501μV (-53dBm) AF : 2.84V/4Ω
10. RD Output Level Adjust (Wide)	1) Connect the SSG to RX IN, then select the channel that the user will use (Wide) MOD: 1kHz DEV : 2.4kHz SSG : 501μV (-53dBm)	SSG DVM		RX IN CONTROL I/O RD Terminal (pin 10) 600Ω Load			PC ADJ 80mV	±5mV
	(Narrow)							



# TKR-740

## ADJUSTMENT

### RX UNIT

Item	Condition	Measurement			Adjustment			Specifications/ Remarks
		Test equipment	Unit	Terminal	Unit	Parts	Method	
11.RA Output Level Adjust (Wide)	1) Connect the SSG to RX IN, then select the channel that the user will use (Wide) MOD: 1kHz DEV : 2.4kHz SSG : 501 $\mu$ V (-53dBm)	SSG AFVM		RX IN			PC ADJ 400mV	$\pm$ 20mV
	CONTROL I/O RA Terminal (pin 11)							
(Narrow)	2) connect the SSG to RX IN, then select the channel that the user will use (Narrow) MOD: 1kHz DEV : 1.5kHz SSG : 501 $\mu$ V (-53dBm)			600 $\Omega$ Load				
12.RRA Output Level Adjust (Wide)	1) Connect the SSG to RX IN, then select the channel that the user will use (Wide) MOD: 1kHz DEV : 2.4kHz SSG : 501 $\mu$ V (-53dBm)	SSG AFVM		RX IN			PC ADJ 400mV	$\pm$ 20mV
	REMT I/O Remote RA Terminal (pin 1)							
(Narrow)	2) connect the SSG to RX IN, then select the channel that the user will use (Narrow) MOD: 1kHz DEV : 1.5kHz SSG : 501 $\mu$ V (-53dBm)			600 $\Omega$ Load				
13.Voting Pilot Tone Adjust (Wide)	1) CH4 (Center Frequency) Voting Pilot Tone : 1950Hz SSG : OFF	AFVM		CONTROL I/O RA Terminal (pin 11)			PC ADJ 400mV	$\pm$ 20mV
	(Narrow)			1) CH10 (Center Frequency) Voting Pilot Tone : 1950Hz SSG : OFF				

### TX UNIT

Item	Condition	Measurement			Adjustment			Specifications/ Remarks
		Test equipment	Unit	Terminal	Unit	Parts	Method	
14.TX Lock Voltage	1) CH3 (TX A Hi) 2) CH1 (TX A Lo) 3) CH6 (TX B Hi) 4) CH4 (TX B Lo)	DVM	TX A/3	CV	TX A/3	TC1 TC2	4.5V ADJ Check	$\pm$ 0.1V 1V or more
				4.5V ADJ Check			$\pm$ 0.1V 1V or more	
15.RX Ref Check	Connect a frequency counter to CN102, then measure the frequency. 1) CH2	f.counter		CN102			Check	20MHz $\pm$ 1ppm
16.EXT Ref check	•Connect a frequency counter to CN102, then measure the frequency. •Connect a SSG to EXT REF IN. 1) CH2 SSG :10MHz 70.7mV (-10dBm) MOD : OFF	f.counter SSG					Check	20MHz
	2) frequency=10MHz $\pm$ 10ppm							20MHz $\pm$ 10ppm



# TKR-740

## ADJUSTMENT

### TX UNIT

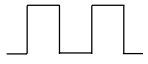
Item	Condition	Measurement			Adjustment			Specifications/ Remarks
		Test equipment	Unit	Terminal	Unit	Parts	Method	
21.DQT Balance Adjust (Wide)	1) CH2 (VCO-A Center) 2) CH5 (VCO-B Center) AG.f : 50Hz (square wave) LEVEL : Insert 0.5Vp-p into the CONTROL I/O TD terminal (pin 8) LPF : 3kHz HPF : OFF Transmission	MOD ANA Oscilloscope	TX A/3	TX OUT CONTROL I/O TD Terminal (pin 8)			PC ADJ Make the demodulated waves into square waves.	 Oscilloscope DC range
	(Narrow)							
22.TD Dev Adjust (Wide)	1) CH2 (VCO-A Center) 2) CH5 (VCO-B Center) AG.f : 100Hz (Sine wave) LEVEL : Insert 0.5Vp-p into the CONTROL I/O TD terminal (pin 8) LPF : 3kHz HPF : OFF Transmission						PC ADJ 0.75kHz	±0.05kHz
	(Narrow)							
23.TA Dev Adjust (Wide)	1) CH4 (Center Frequency) AG.f : 1kHz (Sine wave) LEVEL : Insert 280mV into the CONTROL I/O TA terminal (pin 9) LPF : 15kHz HPF : OFF Transmission			TX OUT CONTROL I/O TA Terminal (pin 9)			PC ADJ 2.4kHz	±0.1kHz
	(Narrow)							

## ADJUSTMENT

## TX UNIT

Item	Condition	Measurement			Adjustment			Specifications/ Remarks
		Test equipment	Unit	Terminal	Unit	Parts	Method	
24.TA Dev Check (Wide)	1) CH2 (VCO-A Center) 2) CH5 (VCO-B Center) AG.f : 1kHz LEVEL : 280mV LPF : 15kHz HPF : OFF Transmission	MOD ANA Oscilloscope	TX A/3	TX OUT CONTROL I/O TA Terminal (pin 9)			Check	2.4kHz±0.1kHz
	(Narrow)							
25.RTA Dev Adjust (Wide)	1) CH4 (Center Frequency) AG.f : 1kHz (Sine wave) LEVEL : Insert 280mV into the REMT I/O Remote TA terminal (pin 2) LPF : 15kHz HPF : OFF Transmission			TX OUT REMT I/O Remote TA Terminal (pin 2)			PC ADJ 2.4kHz	±0.1kHz
	(Narrow)							
26.RTA Dev Check (Wide)	1) CH2 (VCO-A Center) 2) CH5 (VCO-B Center) AG.f : 1kHz (Sine wave) LEVEL : 280mV LPF : 15kHz HPF : OFF Transmission						Check	2.4kHz±0.1kHz
	(Narrow)							
27.OT Dev Adjust (Wide)	1) CH4 (Center Frequency) QT : 151.4Hz LPF : 3kHz HPF : OFF Detector : p-p/2 Transmission			TX OUT			PC ADJ 0.60kHz	±0.05kHz
	(Narrow)							

# TKR-740

## ADJUSTMENT

### TX UNIT

Item	Condition	Measurement			Adjustment			Specifications/ Remarks
		Test equipment	Unit	Terminal	Unit	Parts	Method	
28.QT Dev Check (Wide)	1) CH2 (VCO-A Center) 2) CH5 (VCO-B Center) QT : 151.4Hz LPF : 3kHz HPF : OFF Detector : p-p/2 Transmission	MOD ANA Oscilloscope	TX A/3	TX OUT			Check	0.60kHz±0.05kHz
	(Narrow)							
29.DQT Dev Adjust (Wide)	1) CH4 (Center Frequency) DQT : 023N LPF : 3kHz HPF : OFF Detector : Peak Hold Transmission						PC ADJ 0.60kHz	±0.05kHz
	(Narrow)							
30.DQT Dev Check (Wide)	1) CH2 (VCO-A Center) 2) CH5 (VCO-B Center) DQT : 023N LPF : 3kHz HPF : OFF Detector : Peak Hold Transmission						Check	0.60kHz±0.1kHz
	(Narrow)							
31.Test Tone Dev Adjust (Wide)	1) CH4 (Center Frequency) TEST TONE : 1kHz LPF : 15kHz HPF : OFF Transmission						PC ADJ 2.4kHz	±0.1kHz
	(Narrow)							
32.CW ID Dev Adjust (Wide)	1) CH4 (Center Frequency) LPF : 15kHz HPF : OFF Transmission						PC ADJ 1.6kHz	±0.1kHz
	(Narrow)							

## ADJUSTMENT

## TX UNIT

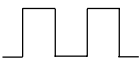
Item	Condition	Measurement			Adjustment			Specifications/ Remarks
		Test equipment	Unit	Terminal	Unit	Parts	Method	
33.Repeat Gain Level Adjust (Wide)	1) CH4 (Center Frequency) MOD : 1kHz DEV : 1kHz LEVEL : 501 $\mu$ V (-53dBm) LPF : 15kHz HPF : OFF Transmission	MOD ANA Oscilloscope	TX A/3	TX OUT			PC ADJ 1kHz	$\pm 0.2$ kHz
	(Narrow)						1) CH10 (Center Frequency) MOD : 1kHz DEV : 1kHz LEVEL : 501 $\mu$ V (-53dBm) Transmission	PC ADJ 1kHz
34.Pager Shift Level Writing	1) CH2 (VCO-A Center)						PC ADJ writing	102
35.Pager Waveform Balance Adjust	1) CH2 (VCO-A Center) 2) CH5 (VCO-B Center) LPF : 3kHz HPF : OFF Transmission						Make the demodulated wave square	 Oscilloscope DC range
	36.TX S/N Check (Wide)	1) CH2 (VCO-A Center) 2) CH5 (VCO-B Center) No modulation LPF : 3kHz HPF : 300Hz De-emphasis : 750 $\mu$ S Transmission			CONTROL I/O TA Terminal (pin 9)		Check	-54dB or less
(Narrow)	3) CH8 (VCO-A Center) 4) CH11 (VCO-B Center) Transmission							-53dB or less

# TKR-740

## ADJUSTMENT

### BPF-wave

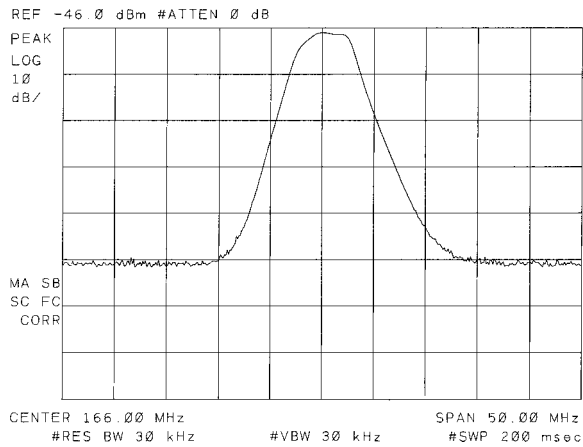

Example : The wave will look like this when using a frequency of 166.000 MHz.  
(Factory default setting: 166.000MHz)

### MCF-wave

(Wide)

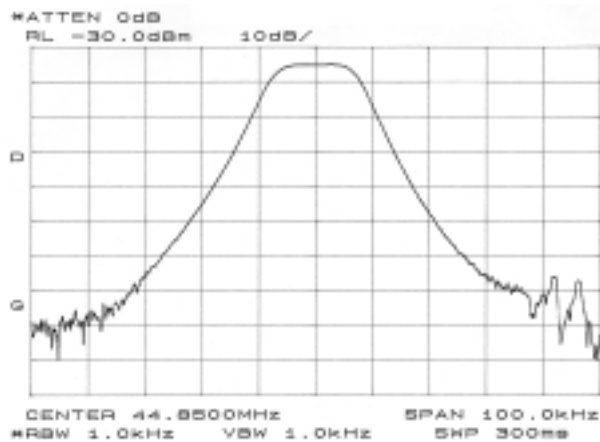

(Narrow)

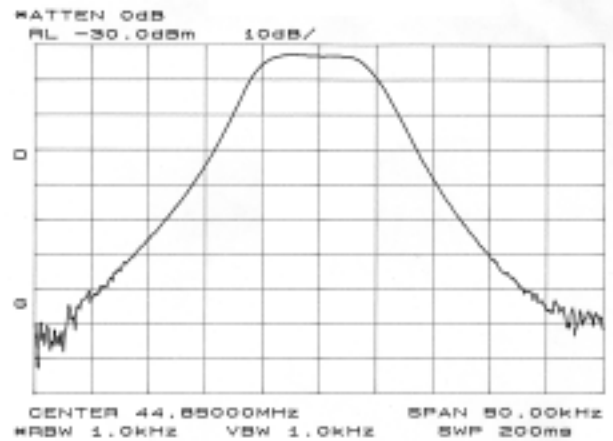

# PC BOARD TKR-740

CONTROL UNIT (X53-3882-71) (A/4) Component Side View (J72-0668-11)

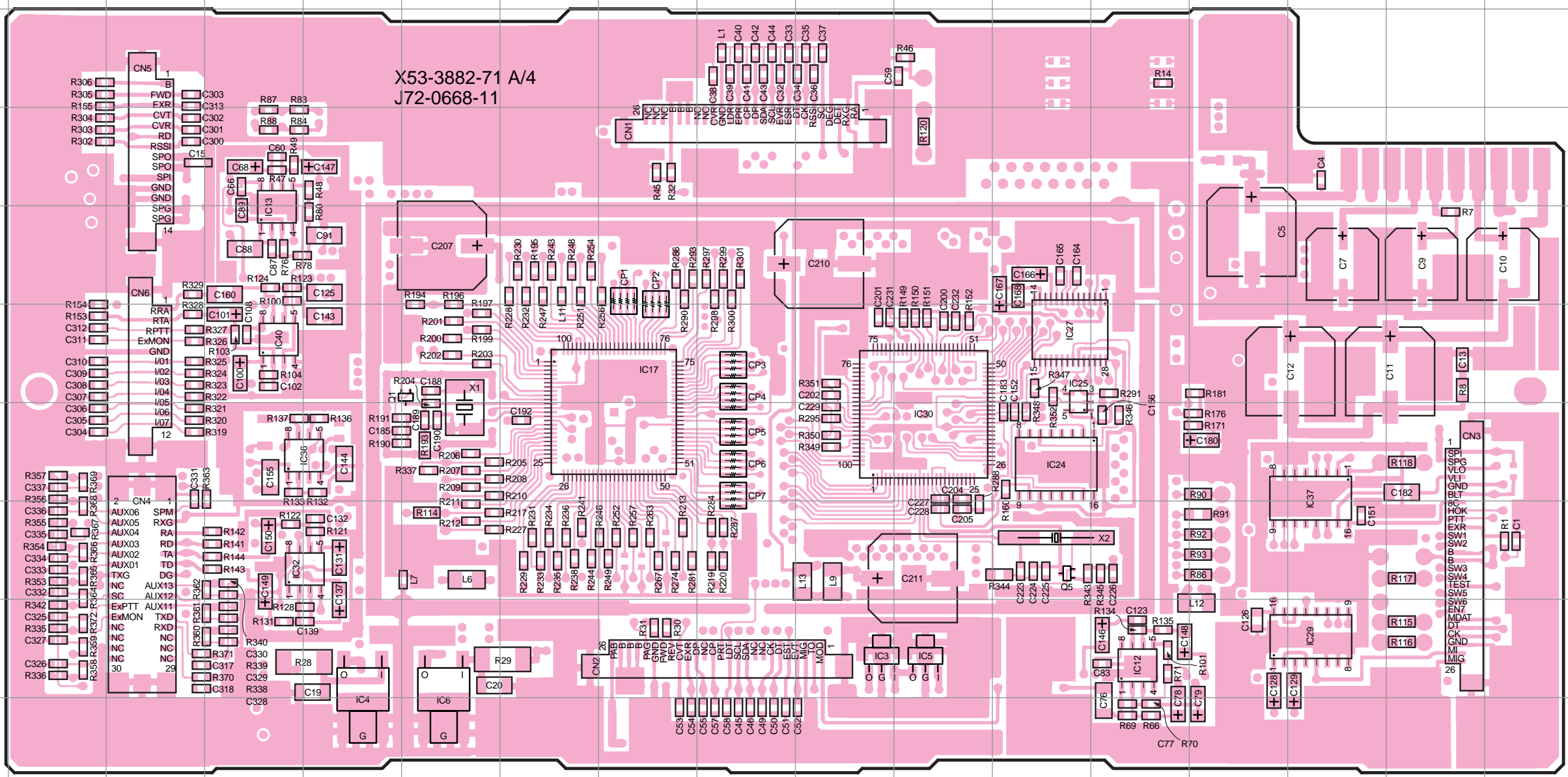

CONTROL UNIT (X53-3882-71) (A/4)

Ref. NO.	Address
IC3	9J
IC4	9E
IC5	9K
IC6	9F
IC12	9M
IC13	4D
IC17	6H
IC24	7L
IC25	6L
IC27	6L
IC29	9O
IC30	7K
IC32	8D
IC36	7E
IC37	7O
Q1	6F
Q5	8L

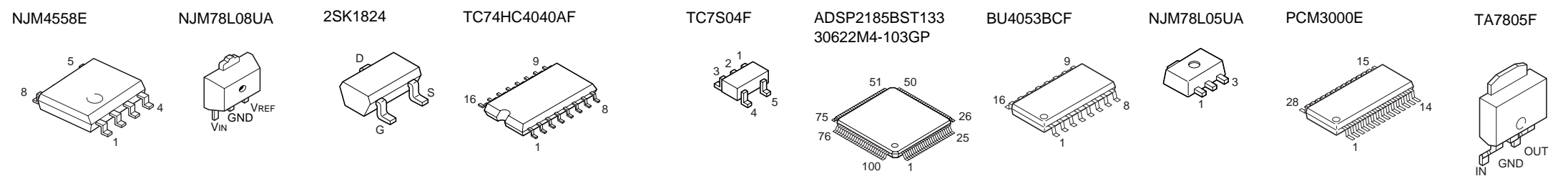
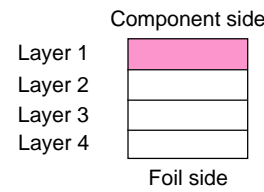



# TKR-740 PC BOARD

## CONTROL UNIT (X53-3882-71) (A/4) Foil Side View (J72-0668-11)

X53-3882-71 A/4  
J72-0668-11

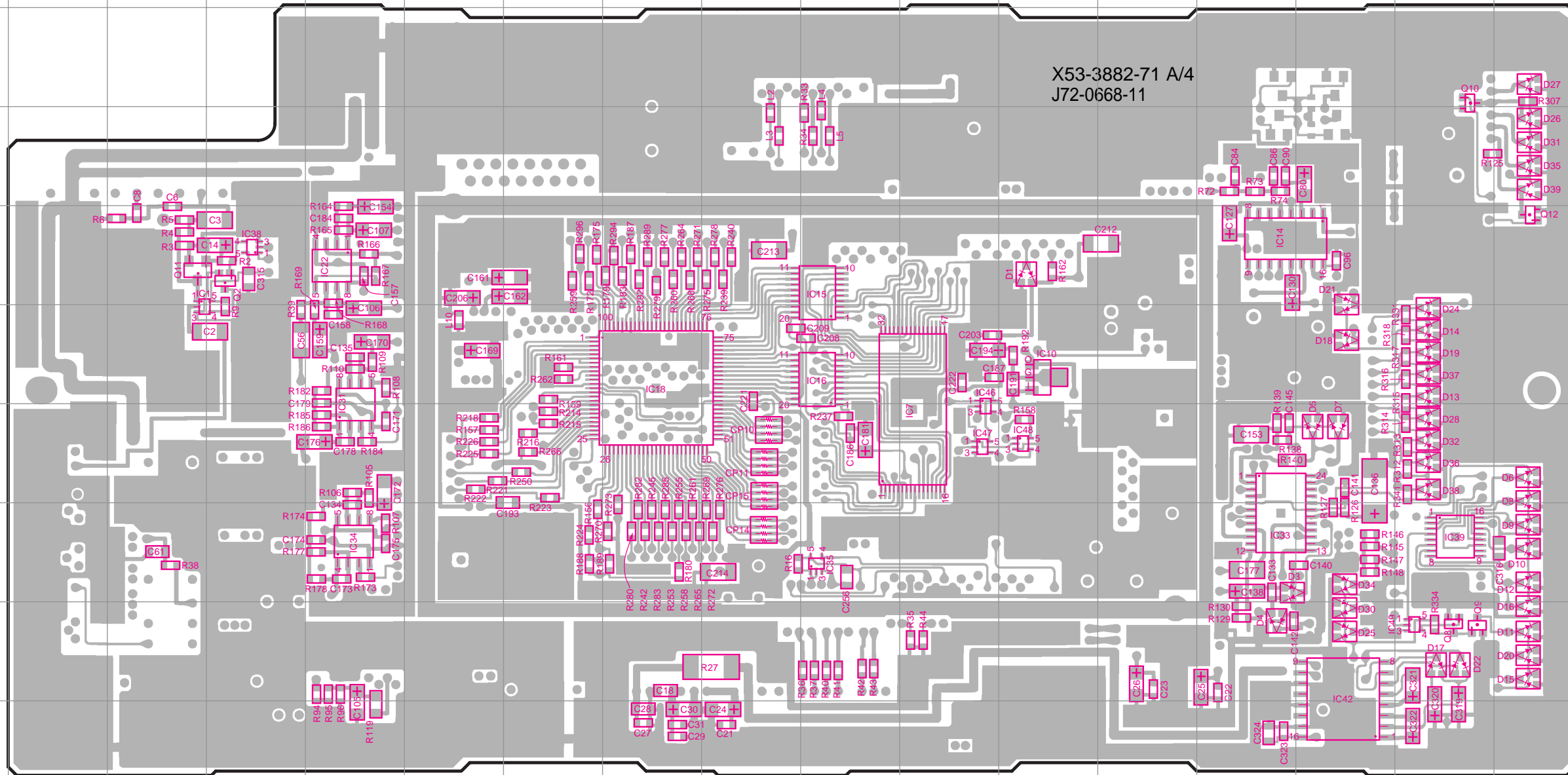

### CONTROL UNIT (X53-3882-71) (A/4)

Ref. NO.	Address
IC1	6C
IC7	7K
IC10	6L
IC14	5N
IC15	5J
IC16	6J
IC18	6H
IC22	5E
IC31	7E
IC33	8N
IC34	8E
IC35	8J
IC38	5D
IC39	8P
IC42	9O
IC46	7K
IC47	7K
IC48	7L
IC49	9P
Q2	5D
Q8	9P
Q9	9P
Q10	3P
Q11	5C
Q12	5Q
D1	5L
D3	8N
D4	9N
D5	7O
D6	7Q
D7	7O
D8	7Q
D9	8Q
D10	8Q
D11	9Q
D12	8Q
D13	6P
D14	6P
D15	9Q
D16	9Q
D17	9P
D18	6O
D19	6P
D20	9Q
D21	5O
D22	9P
D24	6P
D25	9O
D26	4Q
D27	3Q
D28	7P
D30	9O
D31	4Q
D32	7P
D34	8O
D35	4Q
D36	7P
D37	6P
D38	7P
D39	4Q

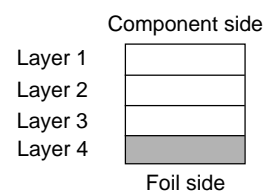

DTC363EK

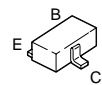

DTC114EUA  
DTC144EUA

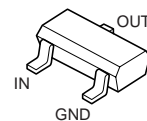

NJM4558E

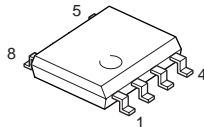

ADM232LAR

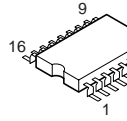

DA204U



TC7S00FU  
TC7S32FU  
TC7S66FU

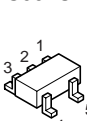

30622M4-103GP

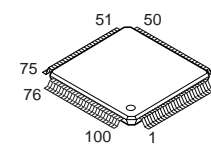

AT29C020-90TI

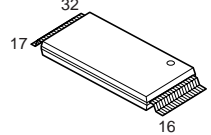

BU4053BCF

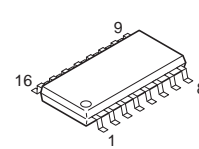

RH5VL42C

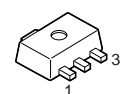

BU4094BCFV

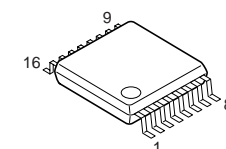

M62364FP

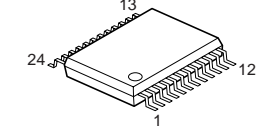

ADM202EARW

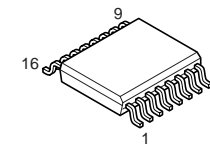

TC74VHC245FT

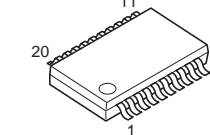

# PC BOARD TKR-740

## CONTROL UNIT (X53-3882-71) (A/4) Component Side + Foil Side View (J72-0668-11)

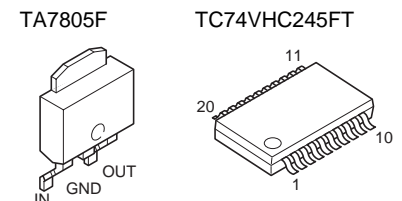
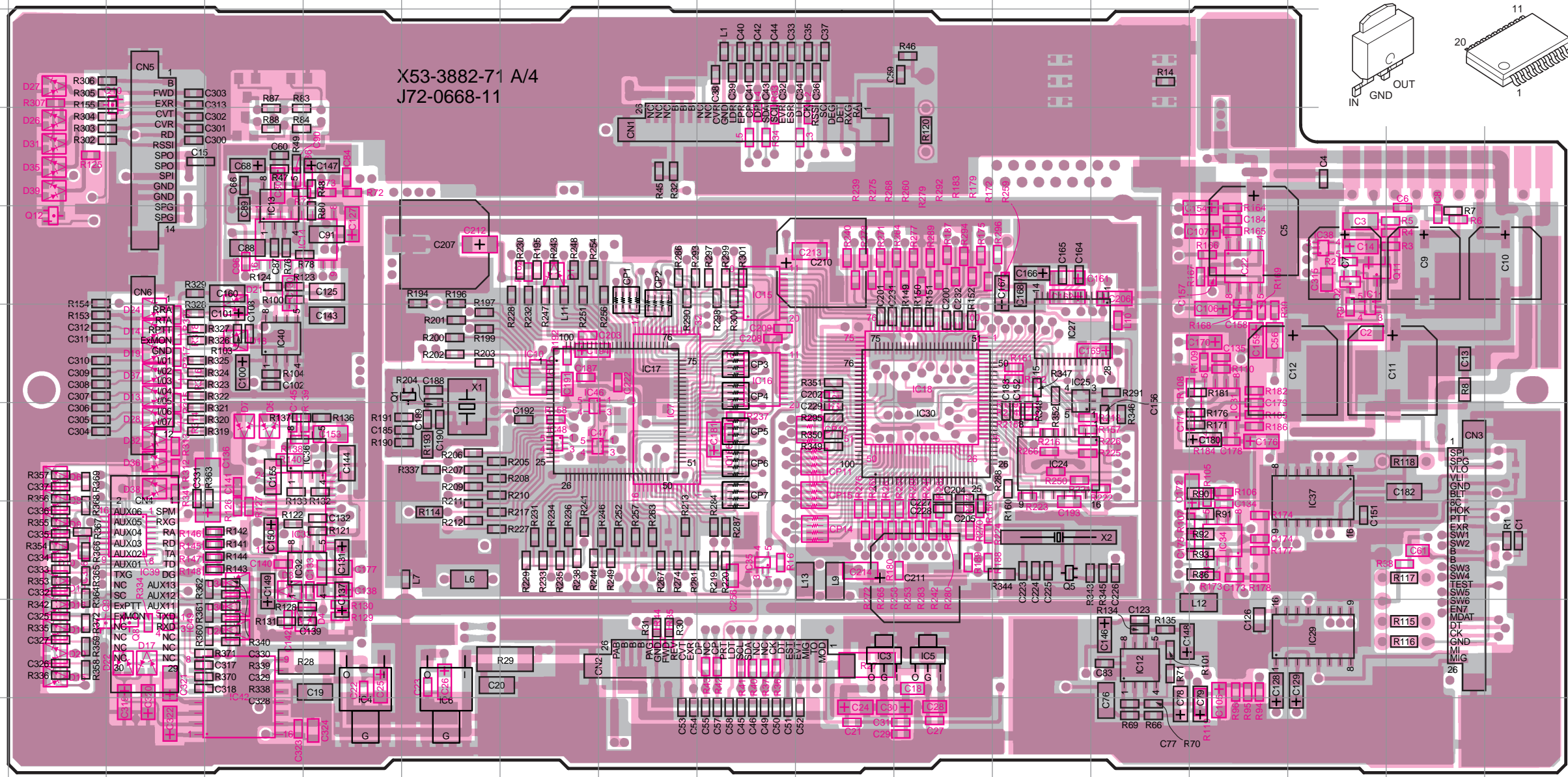

### CONTROL UNIT (X53-3882-71) (A/4)

Ref. NO.	Address
IC1	6O
IC3	9J
IC4	9E
IC5	9K
IC6	9F
IC7	7H
IC10	6G
IC12	9M
IC13	4D
IC14	5E
IC15	5I
IC16	6I
IC17	6H
IC18	6K
IC22	5N
IC24	7L
IC27	6L
IC29	9O
IC30	7K
IC31	7N
IC32	8D
IC33	8E
IC34	8N
IC35	8I
IC36	7E
IC37	7O
IC38	5O
IC39	8C
IC40	6D
IC42	9D
IC46	7H
IC47	7H
IC48	7G
IC49	9C
Q1	6F
Q2	5O
Q5	8L
Q8	9C
Q9	9C
Q10	3C
Q11	5G
D1	5G
D3	8E
D4	9E
D5	7D
D6	7B
D7	7D
D8	7B
D9	8B
D10	8B
D11	9B
D12	8B
D13	6C
D14	6C
D15	9B
D16	9B
D17	9C
D18	6D
D19	6C
D20	9B
D21	5D
D22	9C
D24	6C
D25	9D
D26	4B
D27	3B
D28	7C
D30	9D
D31	4B
D32	7C
D34	8D
D35	4B
D36	7C
D37	6C
D38	7C
D39	4B

Component side

Layer 1  
Layer 2  
Layer 3  
Layer 4

Foil side

DTC114EUA  
DTC144EUA

ADM232LAR

DA204U

TC74HC4040AF

ADSP2185BST133  
30622M4-103GP

BU4053BCF

BU4094BCFV

M62364FP

DTC363EK

NJM4558E

NJM78L08UA

2SK1824

TC7S00FU  
TC7S04F  
TC7S32FU  
TC7S66FU

AT29C020-90TI

NJM78L05UA  
RH5VL42C

PCM3000E

ADM202EARW





# PC BOARD TKR-740

CONTROL UNIT (X53-3882-71) (C/4) Component Side View (J72-0668-11)

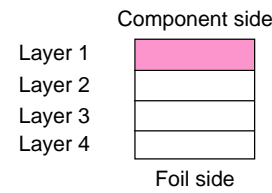
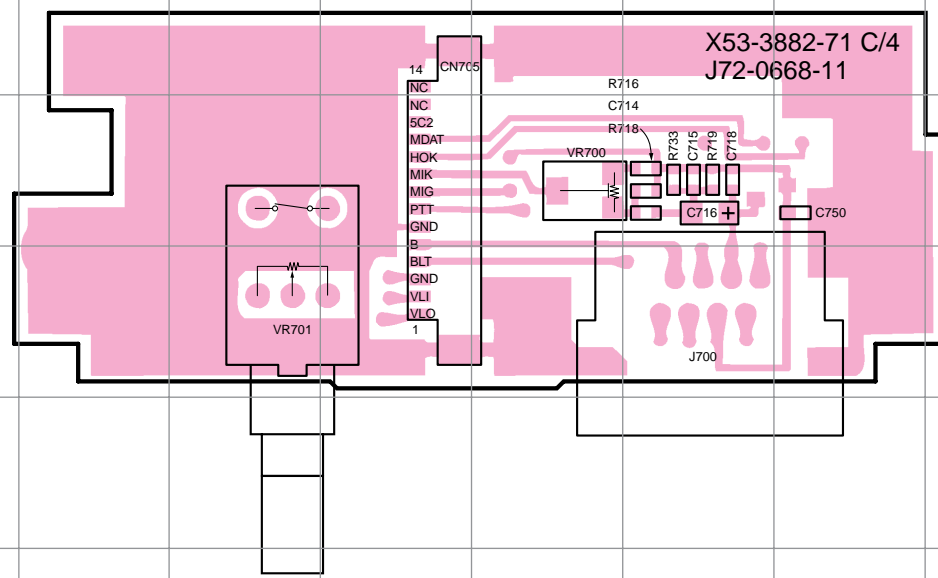

CONTROL UNIT (X53-3882-71) (D/4) Component Side View (J72-0668-11)

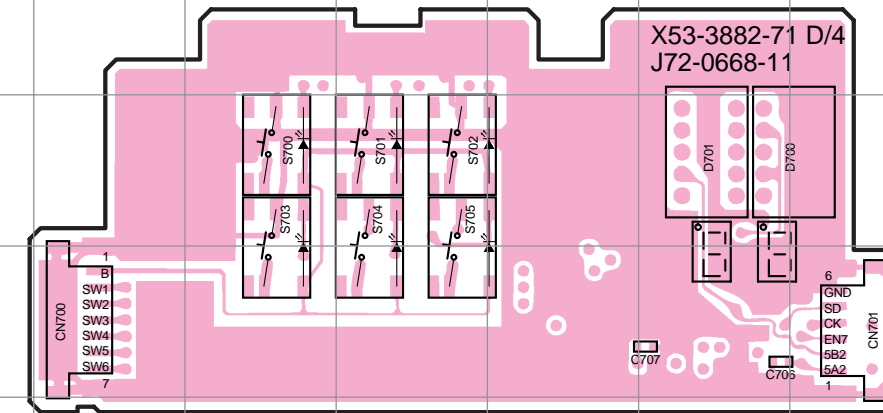

CONTROL UNIT (X53-3882-71) (D/4)

Ref. NO.	Address
D700	3P
D701	3O

CONTROL UNIT (X53-3882-71) (C/4) Foil Side View (J72-0668-11)

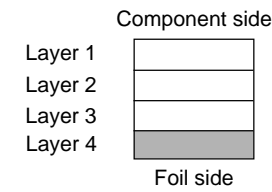
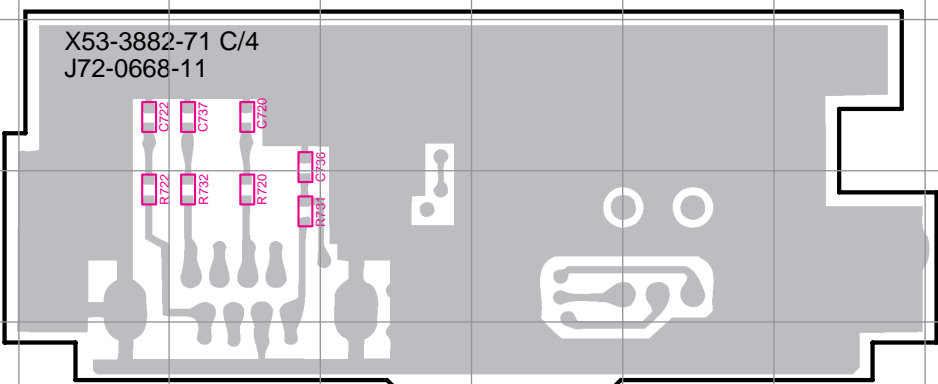

CONTROL UNIT (X53-3882-71) (D/4) Foil Side View (J72-0668-11)

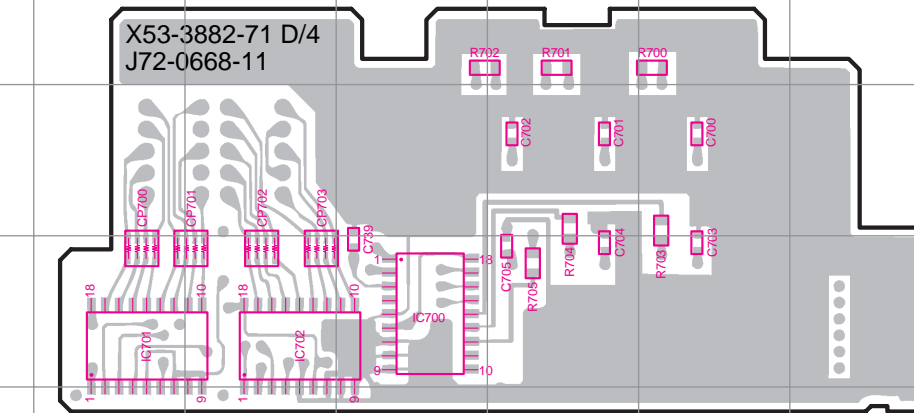

CONTROL UNIT (X53-3882-71) (D/4)

Ref. NO.	Address
IC700	8M
IC701	8K
IC702	8L

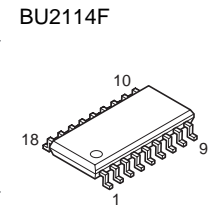

CONTROL UNIT (X53-3882-71) (C/4) Component Side + Foil Side View (J72-0668-11)

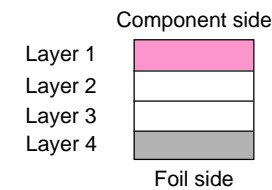
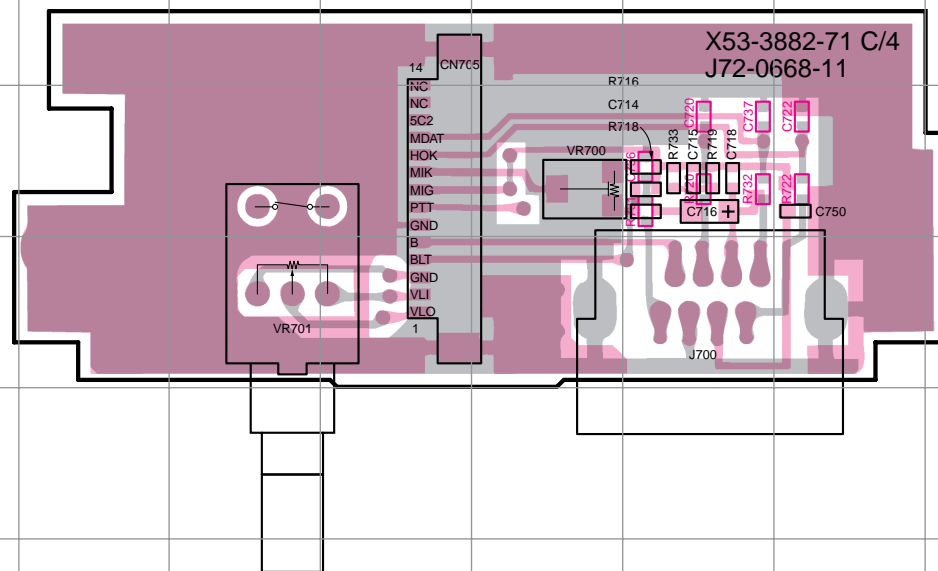

CONTROL UNIT (X53-3882-71) (D/4) Component Side + Foil Side View (J72-0668-11)

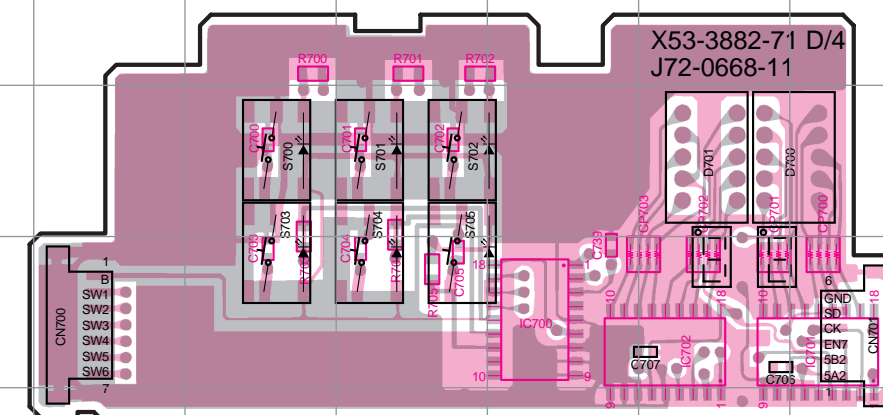

CONTROL UNIT (X53-3882-71) (D/4)

Ref. NO.	Address
IC700	12N
IC701	12P
IC702	12O
D700	11P
D701	11O

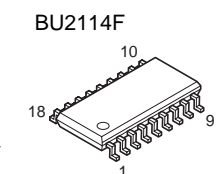

# TKR-740 PC BOARD

TX UNIT (X56-3072-70) (A/3) Component Side View (J72-0879-09)

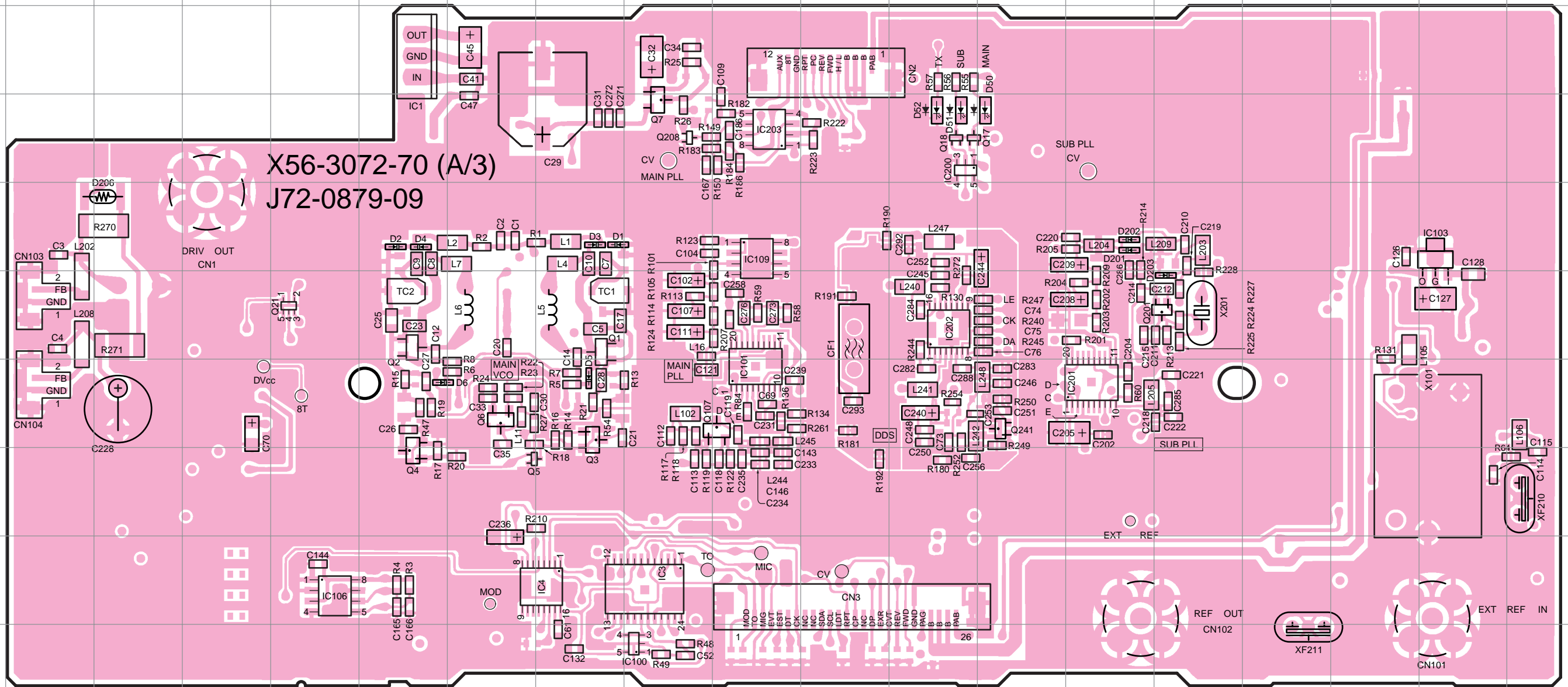

2SC3120  
2SC3722K(S)  
2SC4215(Y)

NJM2904E

2SK1824

NJM78L05UA

TA7808S

AT24C08N10SI18

TA75S01F

CD8468

TX UNIT  
(X56-3072-70) (A/3)

Component side

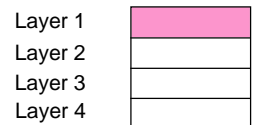

Foil side

UMC5

2SK508NV(K52)

TC4S81F

BU4094BCFV

M62364FP

AD9835BRU

Ref. NO.	Address
IC1	3F
IC3	9I
IC4	9H
IC100	10I
IC101	7J
IC103	5R
IC106	9E
IC109	5J
IC200	4L
IC201	7N
IC202	6L
IC203	4J
Q1	6H
Q2	6F
Q3	7H

Ref. NO.	Address
Q4	8F
Q5	8C
Q6	7G
Q7	4I
Q17	4L
Q18	4L
Q21	6E
Q201	6O
Q208	4I
Q241	7M
D1	5H
D2	5F
D3	5H
D4	5F

Ref. NO.	Address
D5	7H
D6	7F
D50	4M
D51	4L
D52	4L
D201	5N
D202	5N
D203	6O
D206	5C

TX UNIT (X56-3072-70) (A/3) Foil Side View (J72-0879-09)

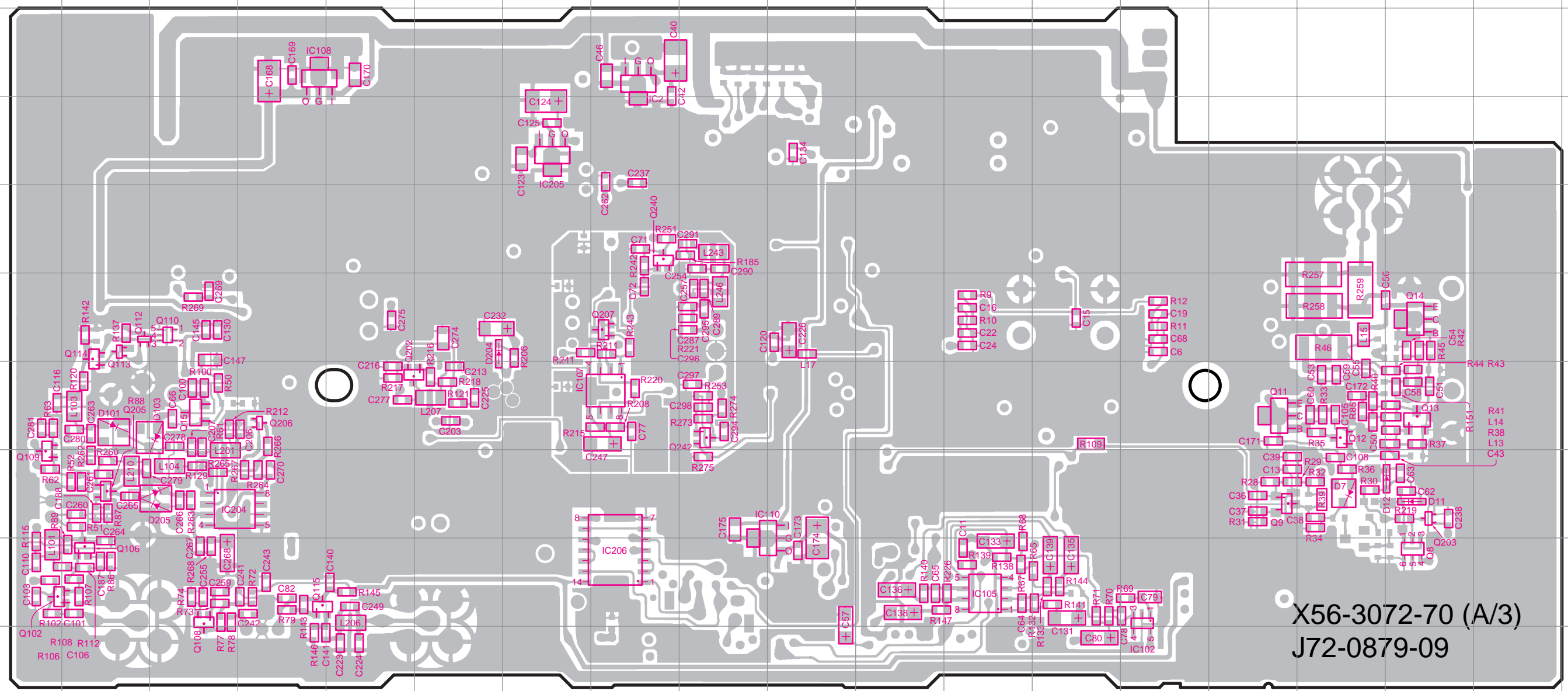

X56-3072-70 (A/3)  
J72-0879-09

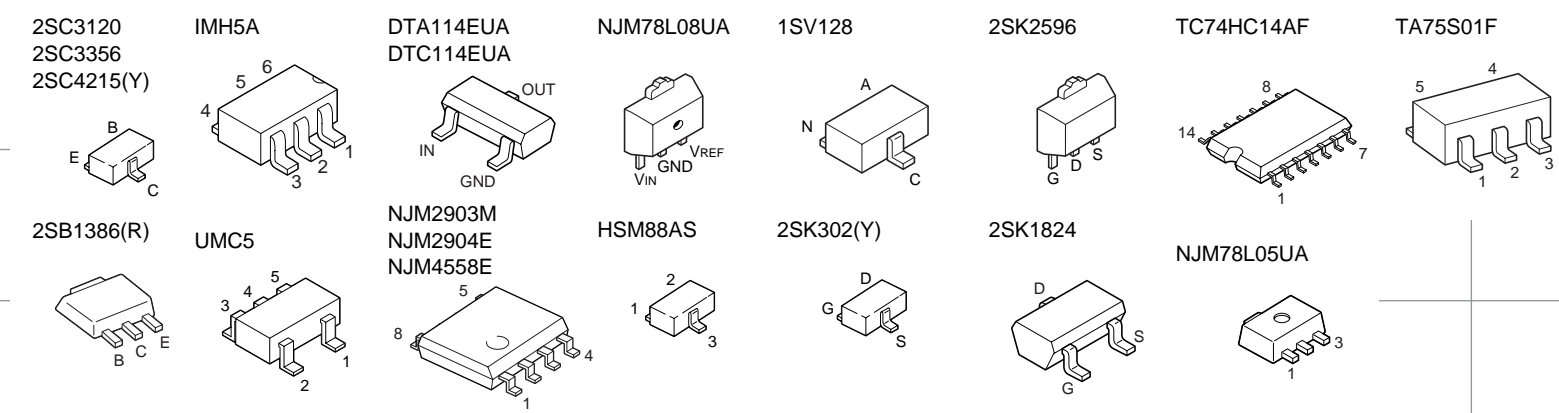
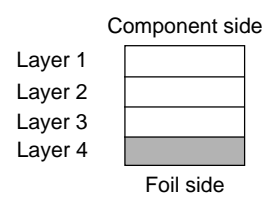

TX UNIT  
(X56-3072-70) (A/3)

Ref. NO.	Address	Ref. NO.	Address	Ref. NO.	Address
IC2	3H	Q106	9B	D12	8P
IC102	10N	Q108	9C	D101	7B
IC105	9L	Q109	8A	D103	7B
IC107	7H	Q110	6C	D204	6F
IC108	3D	Q112	6B	D205	8C
IC110	9I	Q113	6B		
IC204	8D	Q114	7B		
IC205	4G	Q115	9D		
IC206	9H	Q202	7E		
Q8	9Q	Q203	8Q		
Q9	8O	Q205	8B		
Q11	7O	Q206	7D		
Q12	7P	Q207	6H		
Q13	7Q	Q240	5H		
Q14	6Q	Q242	7I		
Q15	7C	D7	8P		
Q102	9A	D11	8Q		



# TKR-740 PC BOARD

TX UNIT (X56-3072-70) (A/3)  
Component Side + Foil Side View (J72-0879-09)

BU4094BCFV

TA7808S

AT24C08N10S118

M62364FP

TA75S01F

AD9835BRU

CD8468

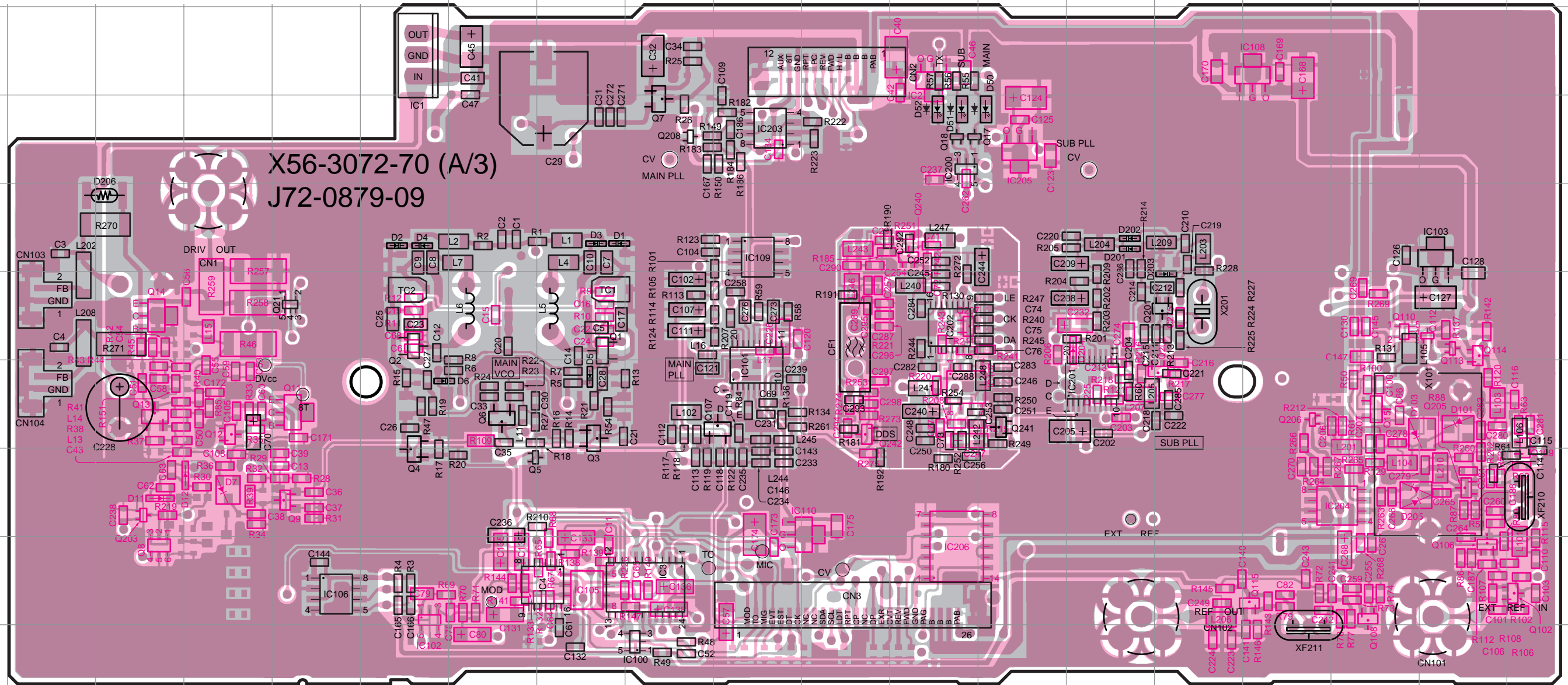
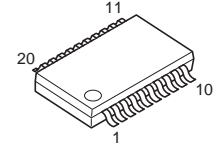
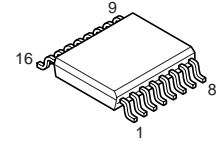
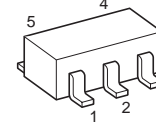
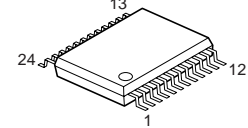
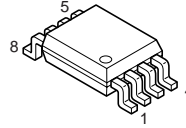
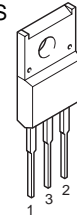
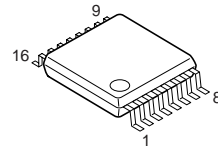

X56-3072-70 (A/3)  
J72-0879-09

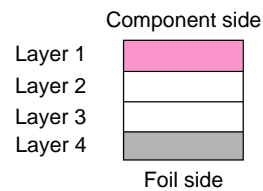

2SB1386(R)

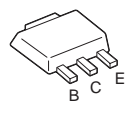

UMC5

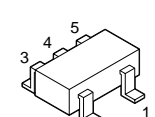

NJM2903M  
NJM2904E  
NJM4558E

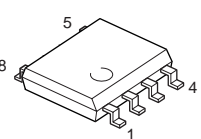

HSM88AS

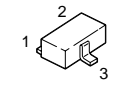

2SK508NV(K52)

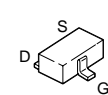

2SK1824

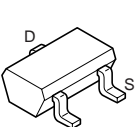

TC4S81F

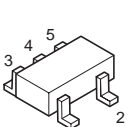

TX UNIT  
(X56-3072-70) (A/3)

Ref. NO.	Address
IC1	3F
IC2	3L
IC3	9I
IC4	9H
IC100	10I
IC101	7J
IC102	10F
IC103	5R
IC106	9H
IC107	7L
IC108	3P
IC109	5J
IC110	9K
IC200	4L
IC201	7N
IC202	6L
IC203	4J

Ref. NO.	Address
IC204	8P
IC205	4M
IC206	9L
Q1	6H
Q2	6F
Q3	7H
Q4	8F
Q5	8G
Q6	7G
Q7	4I
Q8	9C
Q9	8E
Q11	7E
Q12	7D
Q13	7C
Q14	6C
Q15	7Q

Ref. NO.	Address
Q17	4L
Q18	4L
Q21	6E
Q102	9S
Q106	9R
Q107	7J
Q108	9Q
Q109	8S
Q110	6Q
Q112	6R
Q113	6R
Q114	7R
Q115	9P
Q201	6O
Q202	7O
Q203	8C
Q205	8R

Ref. NO.	Address
Q206	7P
Q207	6L
Q208	4I
Q240	5L
Q241	7M
Q242	7K
D1	5H
D2	5F
D3	5H
D4	5F
D5	7H
D6	7F
D7	8D
D11	8C
D12	8D
D50	4M
D51	4L

Ref. NO.	Address
D52	4L
D101	7R
D103	7R
D201	5N
D202	5N
D203	6O
D204	6N
D205	8Q
D206	5C

2SC3120  
2SC3356  
2SC3722K(S)  
2SC4215(Y)

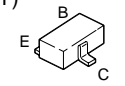

IMH5A

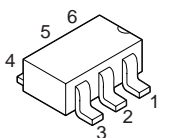

DTA114EUA  
DTC114EUA

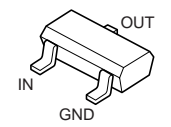

NJM78L08UA

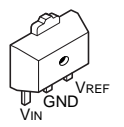

2SK302(Y)

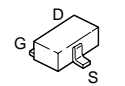

2SK2596

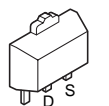

TC74HC14AF

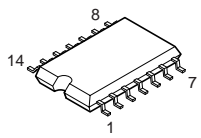

NJM78L05UA

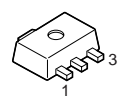

TX UNIT (X56-3072-70) (B/3) (C/3) Component Side View (J72-0879-09)

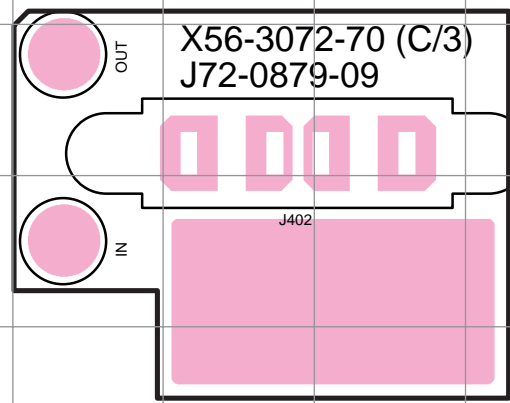
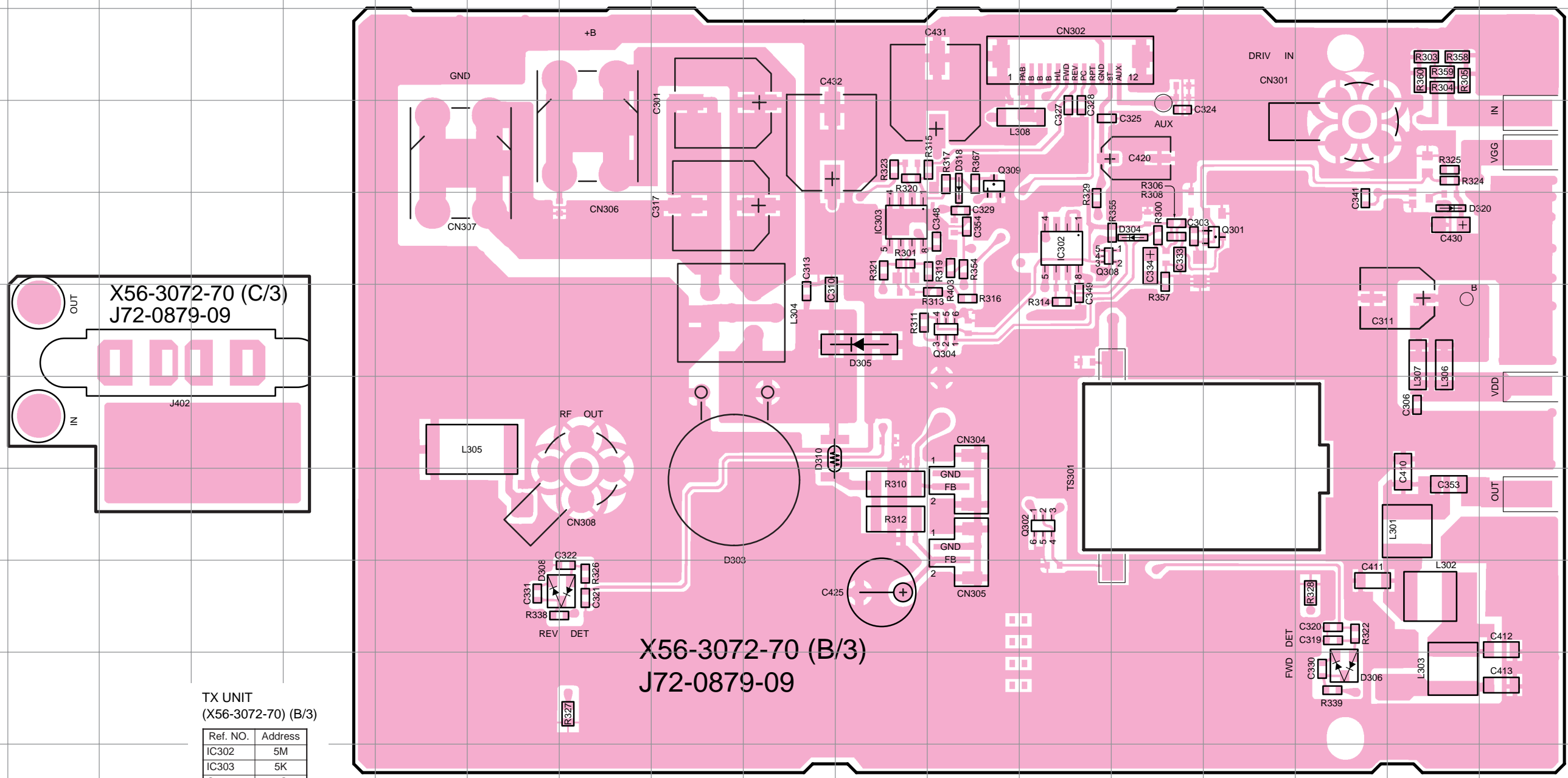

TX UNIT (X56-3072-70) (B/3)

Ref. NO.	Address
IC302	5M
IC303	5K
Q301	5O
Q302	8M
Q304	6L
Q308	5M
Q309	4L
D303	8I
D304	5N
D305	6K
D306	10Q
D308	9H
D310	7K
D318	4L
D320	5Q

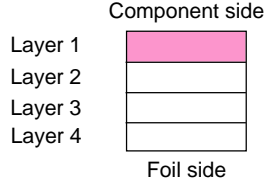
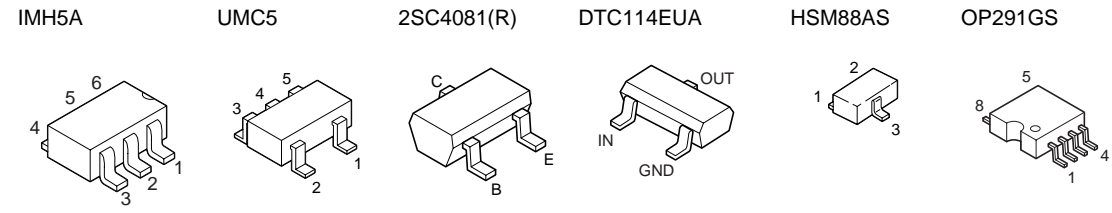



# TKR-740 PC BOARD

TX UNIT (X56-3072-70) (B/3) (C/3) Foil Side View (J72-0879-09)

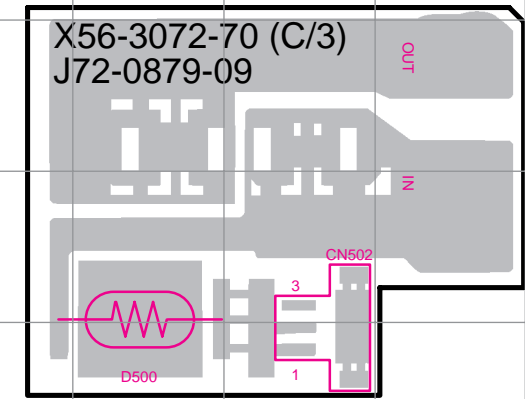
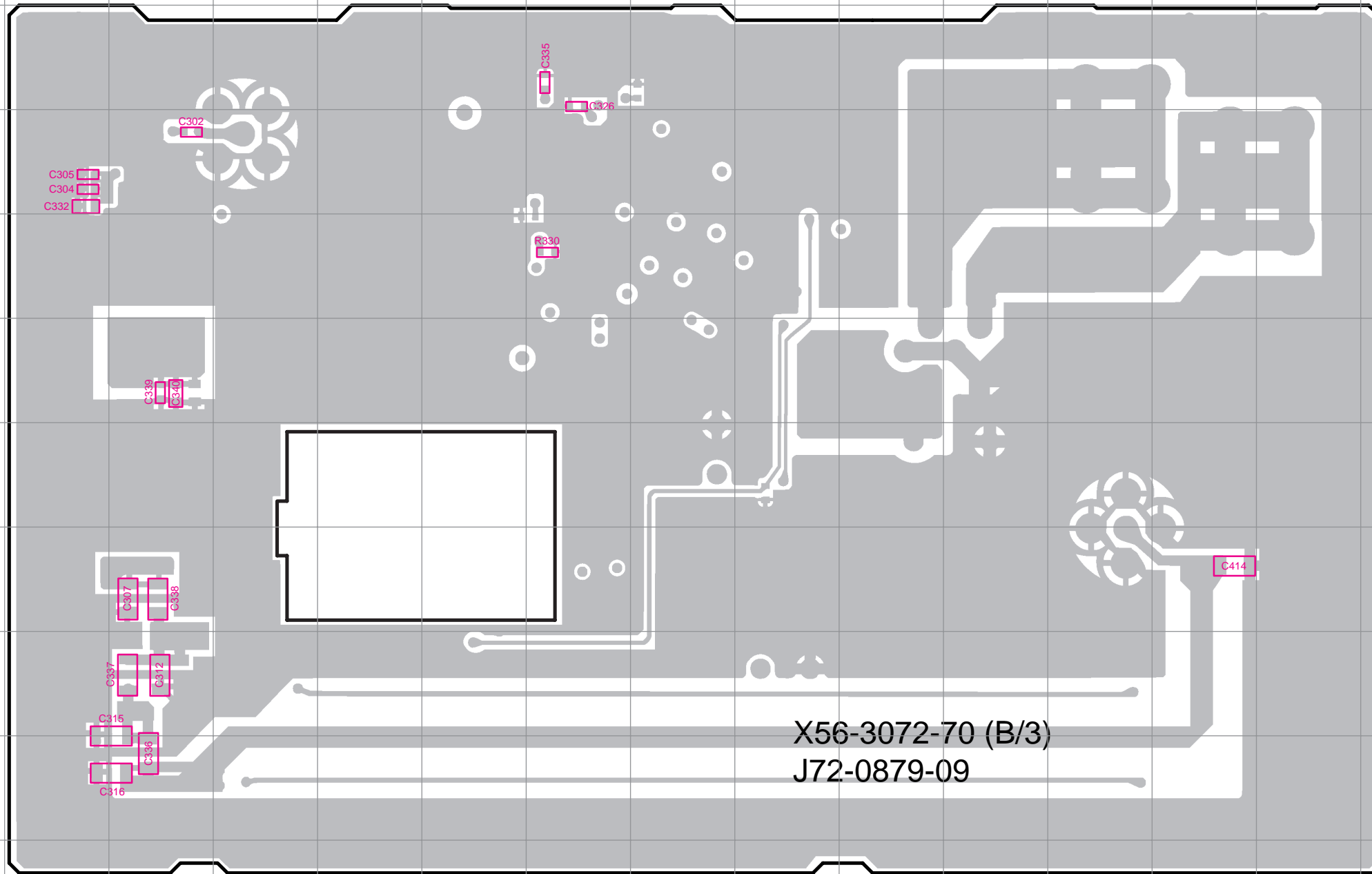

TX UNIT  
(X56-3072-70) (C/3)

Ref. NO.	Address
D500	8P

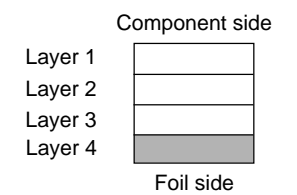

## TX UNIT (X56-3072-70) (B/3) (C/3) Component Side + Foil Side View (J72-0879-09)

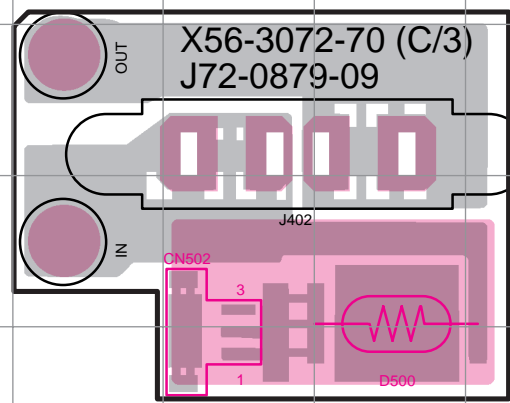
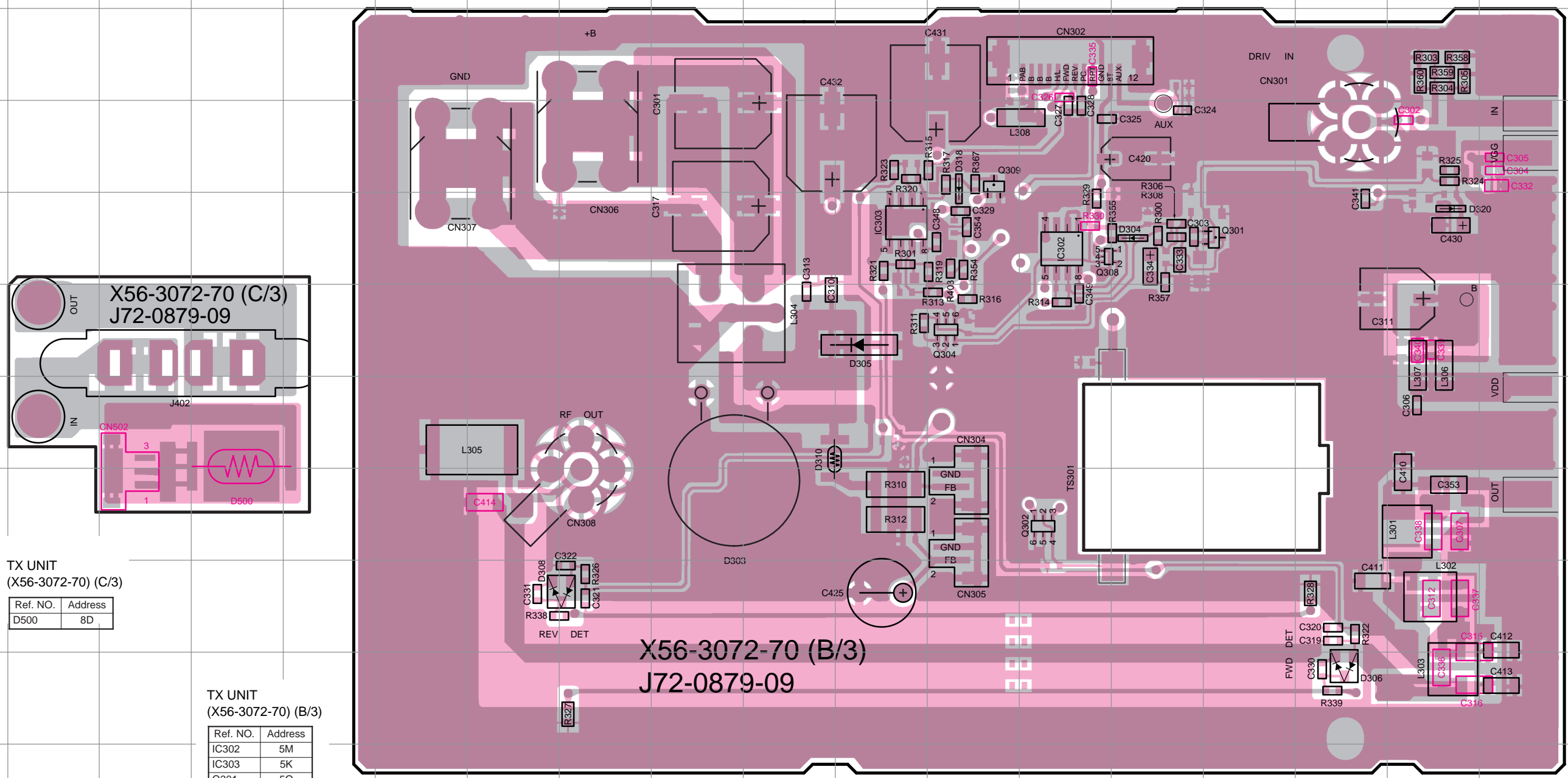

TX UNIT (X56-3072-70) (C/3)

Ref. NO.	Address
D500	8D

TX UNIT (X56-3072-70) (B/3)

Ref. NO.	Address
IC302	5M
IC303	5K
Q301	5O
Q302	8M
Q304	6L
Q308	5M
Q309	4L
D303	8I
D304	5N
D305	6K
D306	10Q
D308	9H
D310	7K
D318	4L
D320	5Q

- IMH5A
- UMC5
- 2SC4081(R)
- DTC114EUA
- HSM88AS
- OP291GS

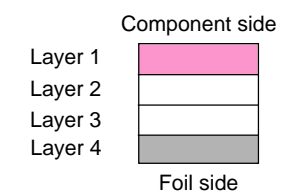
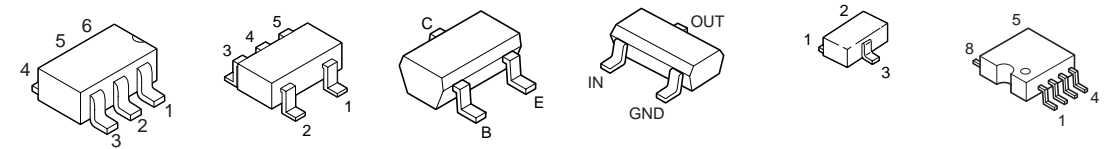

# TKR-740 PC BOARD

## RX UNIT (X55-3050-11) Component Side View (J72-0666-01)

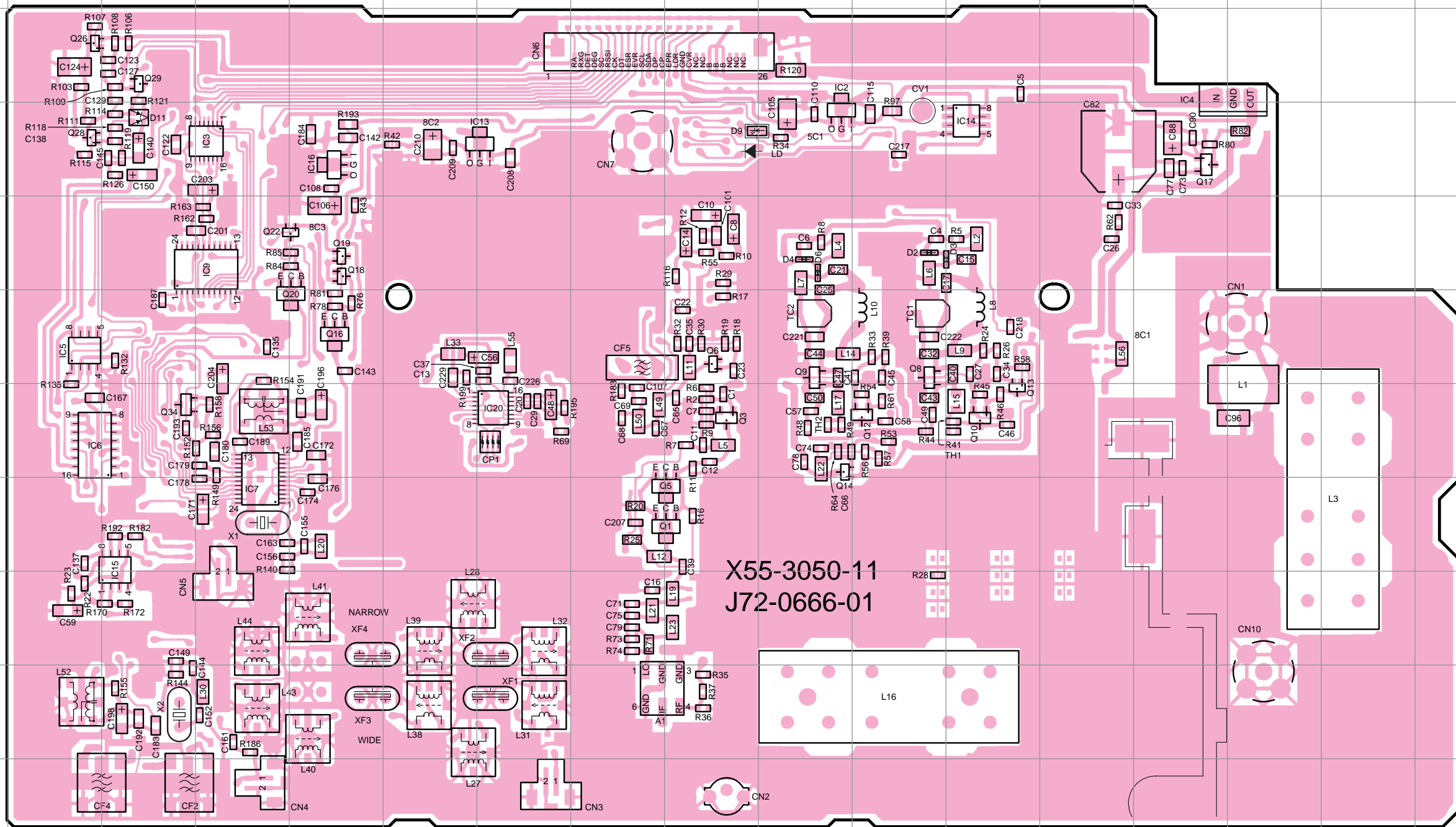

### RX UNIT (X55-3050-11)

Ref. NO.	Address
IC2	4J
IC3	4D
IC4	3N
IC5	6B
IC6	7B
IC7	8D
IC9	5D
IC13	4G
IC14	4L
IC15	8C
IC16	4E
IC20	7G
Q1	8H
Q3	7I
Q5	8H
Q6	6I
Q8	6K
Q9	6J
Q10	7L
Q12	7K
Q13	7L
Q14	7J
Q16	6E
Q17	4N
Q18	5E
Q19	5E
Q20	6E
Q22	5E
Q26	3B
Q28	4B
Q29	3C
Q34	7C
D2	5K
D3	5L
D4	5J
D6	5J
D9	4I
D11	4C

Component Side   
 Foil Side

2SC3120  
2SC3722K(S)  
2SC4215(Y)

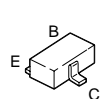

2SB1386(R)  
2SC3357

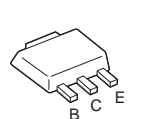

2SC4081(R)

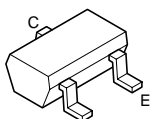

DTC114EUA

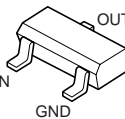

NJM2904E  
NJM4558E

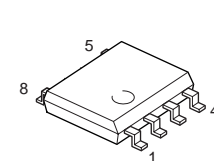

DAN202U



NJM78L08UA

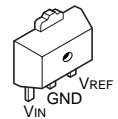

2SJ106(GR)  
2SK508NV(K53)

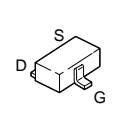

BU4053BCF

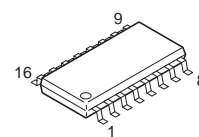

NJM78L05UA

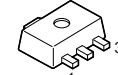

BU4094BCFV

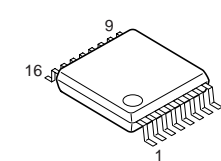

TA7808S

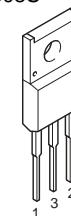

M62364FP  
TA31137FN

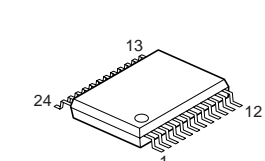

AD9835BRU

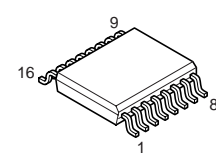

**RX UNIT (X55-3050-11) Foil Side View (J72-0666-01)**

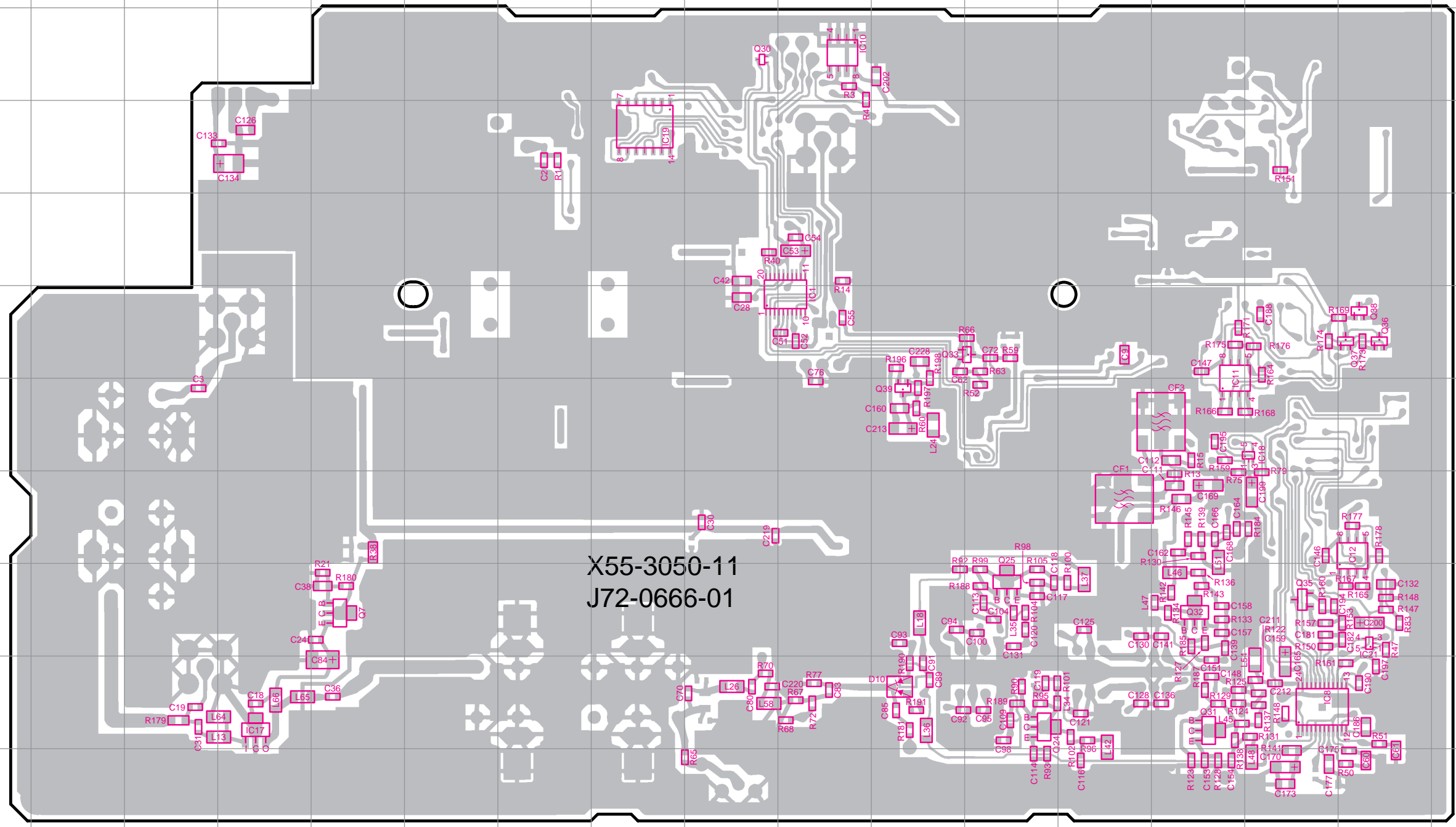
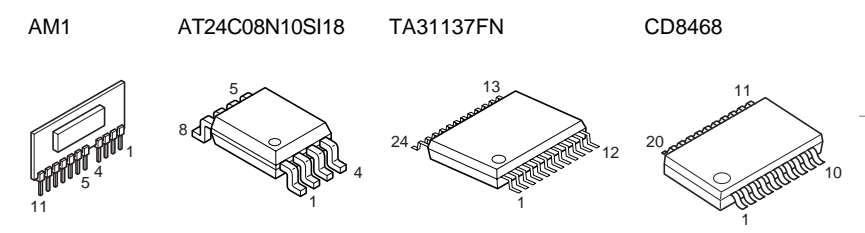

**RX UNIT (X55-3050-11)**

Ref. NO.	Address
IC1	6J
IC8	10O
IC10	3J
IC11	6N
IC12	8P
IC17	10D
IC18	7O
IC19	4H
IC21	9P
Q7	9E
Q24	10L
Q25	9L
Q30	3I
Q31	10N
Q32	9N
Q33	6L
Q35	9O
Q36	6P
Q37	6P
Q38	6P
Q39	7K
D10	10K

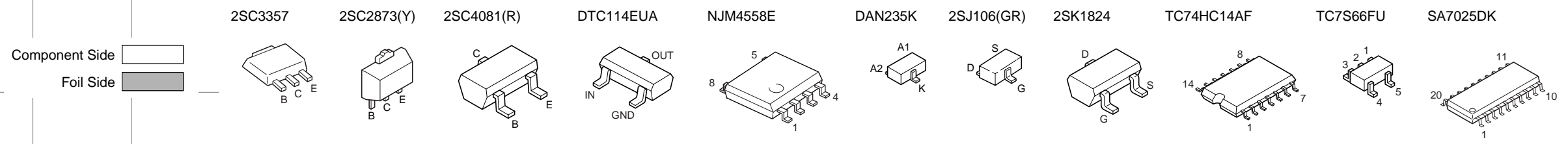



# PC BOARD TKR-740

## RX UNIT (X55-3050-11) Component Side + Foil Side View (J72-0666-01)

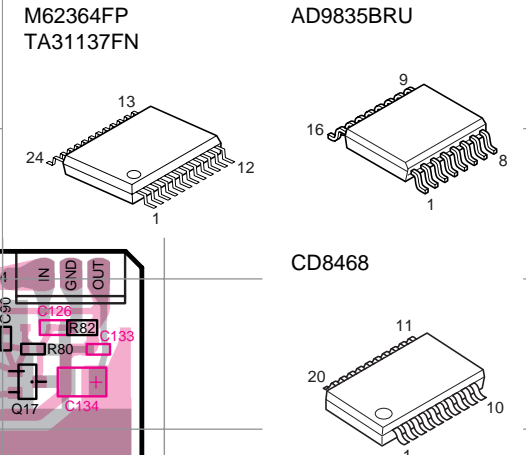
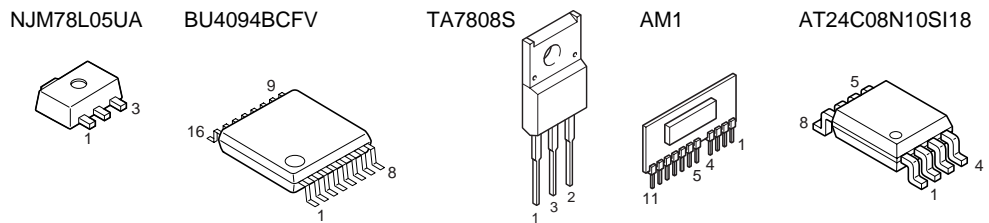
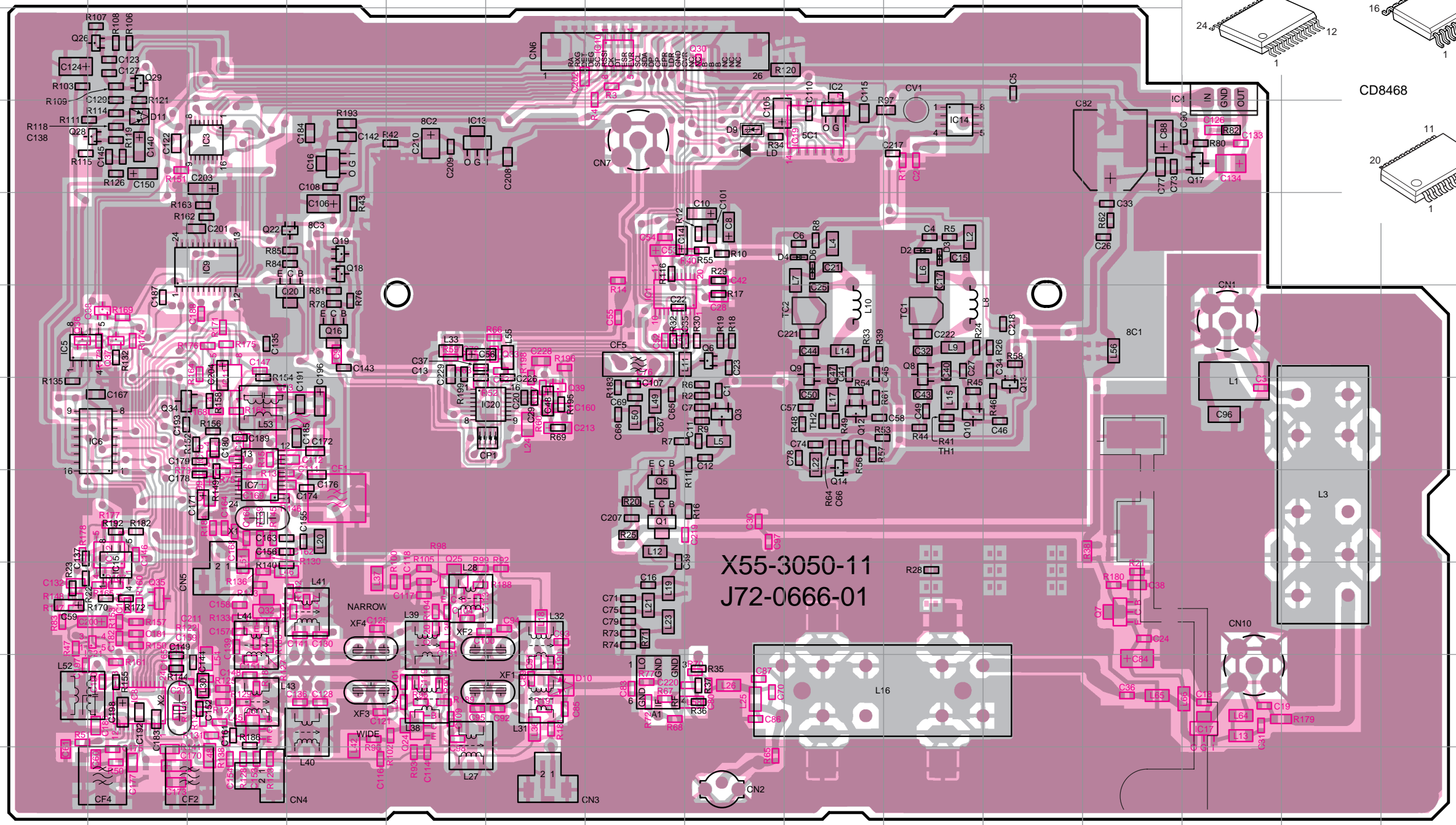

### RX UNIT (X55-3050-11)

Ref. NO.	Address
IC1	6AB
IC2	3AC
IC3	4W
IC4	3AG
IC5	6U
IC6	7U
IC7	8W
IC8	10V
IC9	5W
IC10	3AA
IC11	6W
IC12	8V
IC13	4Z
IC14	4AE
IC15	8V
IC16	4X
IC17	10AG
IC18	7W
IC19	4AC
IC20	7Z
IC21	9U
Q1	8AA
Q3	7AB
Q5	8AA
Q6	6AB
Q7	9AF
Q8	6AD
Q9	6AC
Q10	7AE
Q12	7AD
Q13	7AE
Q14	7AC
Q16	6X
Q17	4AG
Q18	5X
Q19	5X
Q22	5X
Q24	10Y
Q25	9Y
Q26	3U
Q28	4U
Q29	3V
Q30	3AB
Q31	10W
Q32	9W
Q33	6Z
Q34	7V
Q35	9V
Q36	6U
Q37	6V
Q38	6V
Q39	7Z
D2	5AD
D3	5AE
D4	5AC
D6	5AC
D9	4AB
D10	10Z
D11	4V

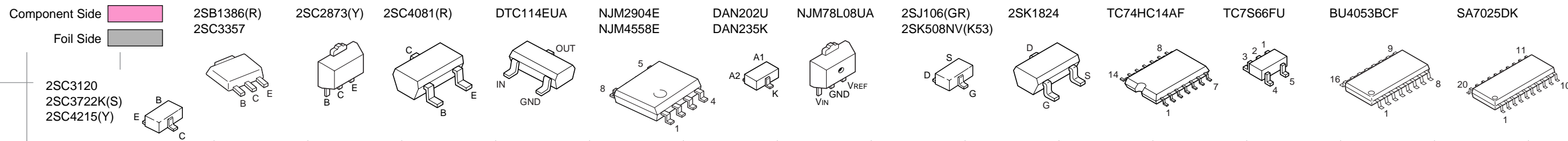



# TKR-740 SCHEMATIC DIAGRAM

X53-3882-71 A/4 CONTROL UNIT

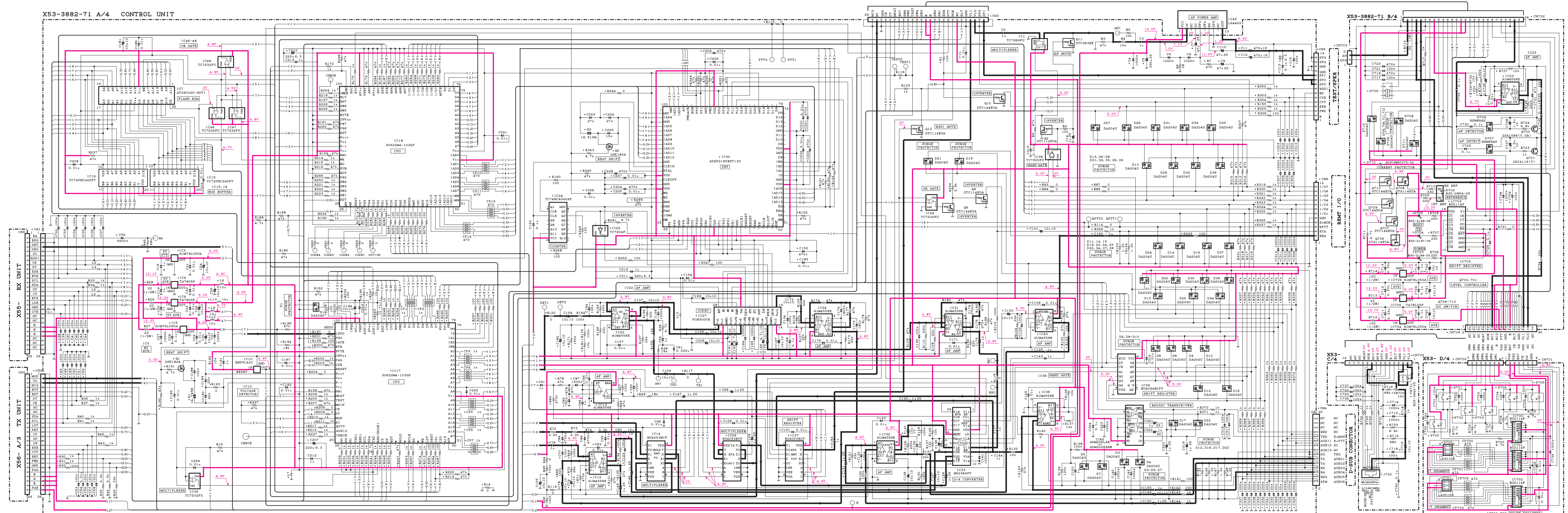

D1, 3-22, 24-28, 30-32, 34-39, 706, 711, 712	DA204U	D703, 705	B30-2198-05	D710	MINIMC0075-02	Q1, 5	28K1824	Q11	DTC363EK	IC1	TC766FU	IC5	NJM76L05UA	IC12, 13, 22, 29, 31, 32, 34, 36, 40	NJM4558E	IC17, 18	30622M4-103GP	IC27	PM3000E	IC35, 46-49	TC7832PU	IC42	ADM232LAR or ADM202EARW
D700, 701	LA301DB	D704	B30-2197-05	D707, 709	H5M89A2	Q2, 9, 12	DTC1448UA	Q700	28A1596(T, GR)	IC2	AT28C020-90T1	IC14, 29, 37	B4053BCF	IC24	TC74HC4040AF	IC30	ADSP1858ST133	IC38	TC7800PU	IC700-703	B2114F	IC705	TAT8L05F
D702	B30-0864-05	D707, 709	H5M89A2	D707, 709	H5M89A2	Q3, 10, 707, 709, 710	DTC1448UA	Q701	28C4116(V7)	IC4	TC74HC4040AF	IC6	R5V142C	IC15, 16	TC74VHC49PT	IC25	TC7804P	IC39	B4094BCFV	IC705	TAT8L05F		

Note : The components marked with a dot (●) are parts of layer1.



# SCHEMATIC DIAGRAM TKR-740

X56-3072-70 A/3 TX UNIT

X56-3072-70 B/3

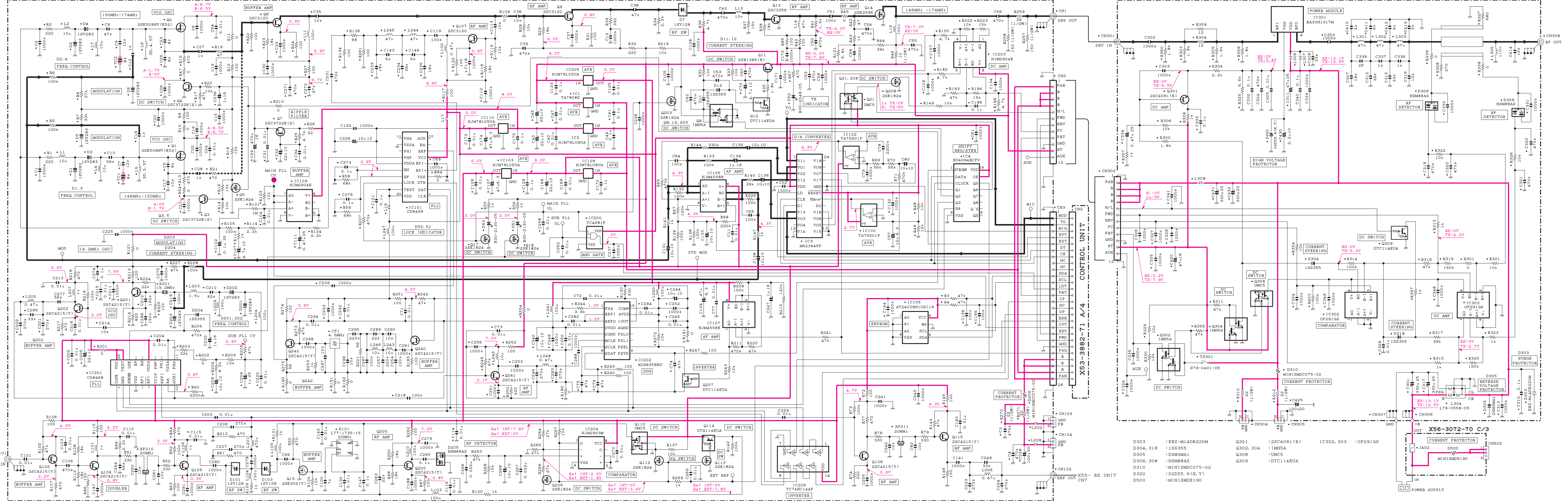

D1-6, 201-203	: 1SV283	D50, 51	: B30-2130-05	D206	: MINISMD075-02	Q3, 4, 7		: 2SC3722K(S)	Q8	: 1MHS5A	Q13	: 2SC3356	Q101, 110		: UMC5	IC1	: TA7808S	IC4	: BU4094BCFV	IC103, 110, 205	: NJM78L05UA	IC109, 203	: NJM2904E	IC204	: NJM2903M
D7, 101, 103	: 1SV128	D52	: B30-2048-05	Q1, 2	: 2SK508NV(K52)	Q5, 17, 18, 112, 113, 203, 206, 208	: 2SK1824	Q8	: 1MHS5A	Q13	: 2SK2596	Q102, 106, 108, 109, 115, 201, 202, 205, 240-242	: 2SC4215(Y)	IC1	: TA7808S	IC4	: BU4094BCFV	IC103, 110, 205	: NJM78L05UA	IC109, 203	: NJM2904E	IC204	: NJM2903M		
D11, 12, 204	: 1SS355	D205	: HSM88AS	Q1, 2	: 2SK508NV(K52)	Q6, 9, 107		: 2SC3120	Q12, 207	: DTC114EUA	Q15	: 2SK302(Y)	Q114		: DTA114EUA	IC3	: M62364FP	IC101, 201	: CD8468	IC106	: AT24C08N10S118	IC202	: AD9835BRU		

Note : The components marked with a dot (●) are parts of layer1.



# TKR-740 SCHEMATIC DIAGRAM

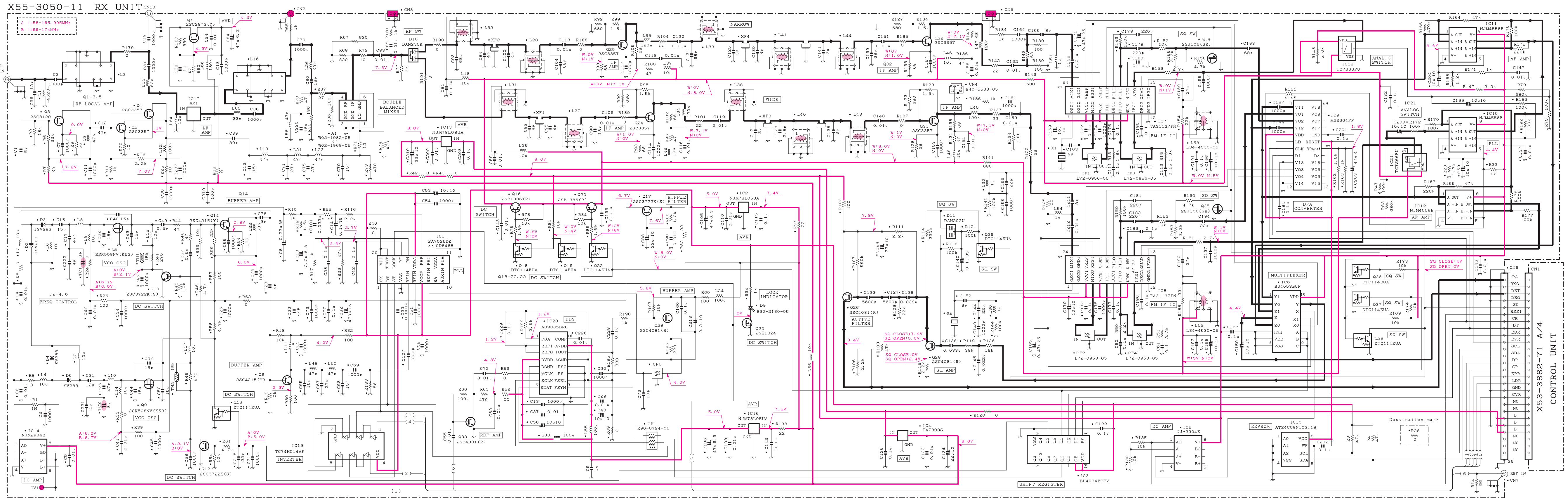

D2, 3, 4, 6	:1SV283	IC1	:SA7025DK or CD8468	IC5, 14	:NJM2904E	IC10	:AT24CO8N10S118	IC18, 21	:TC7S66FU	Q1, 5, 24, 25, 31, 32	:2SC3357	Q8, 9	:2SK508NV(K53)	Q26, 28, 33, 39	:2SC4081(R)
D9	:B30-2130-05	IC2, 16	:NJM78L05UA	IC6	:BU4053BCF	IC11, 12, 15	:NJM4558E	IC19	:TC74HC14AF	Q3	:2SC3120	Q10, 12, 17	:2SC3722K(S)	Q30	:2SK1824
D10	:DAN235K	IC3	:BU4094BCFV	IC7, 8	:TA31137FN	IC13	:NJM78L05UA	IC20	:AD9835BRU	Q6, 14	:2SC4215(Y)	Q13, 18, 19, 22, 29, 36-38	:DTC114EUA	Q34, 35	:2SJ106(GR)
D11	:DAN202U	IC4	:TA7808S	IC9	:M62364FP	IC17	:AM1	Q7	:2SC2873(Y)	Q16, 20	:2SC2873(Y)	Q16, 20	:2SB1386(R)		

Note : The components marked with a dot (●) are parts of layer 1.



# TKR-740 TKR-740

## BLOCK DIAGRAM

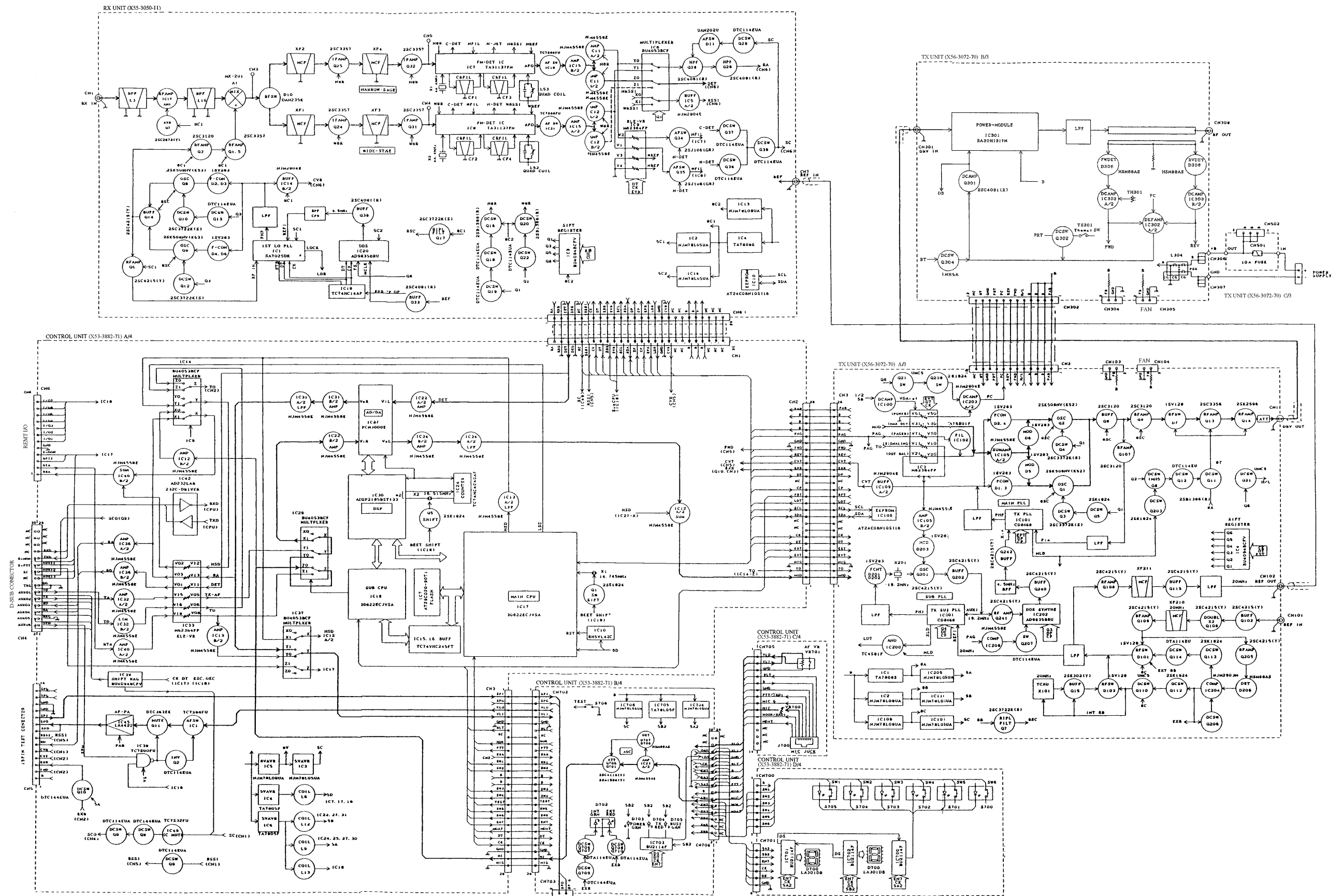

# TKR-740 TKR-740

## LEVEL DIAGRAM

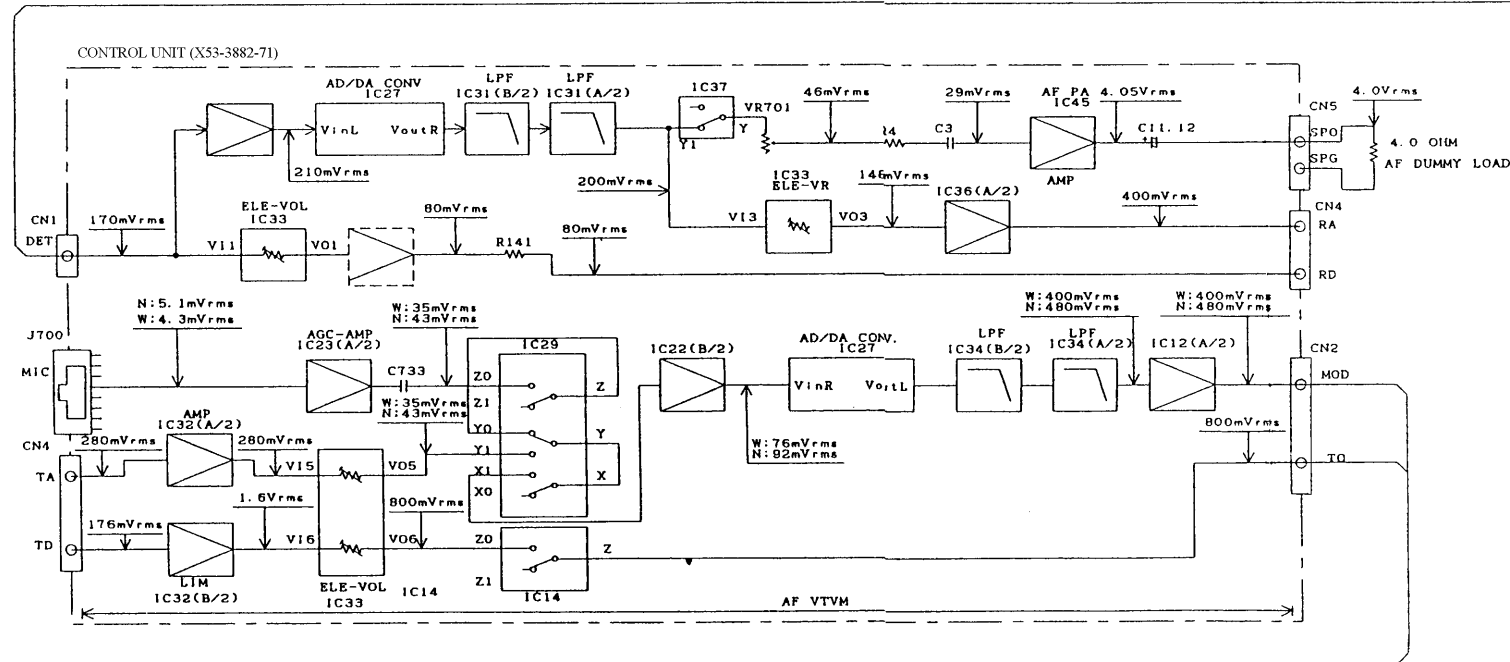
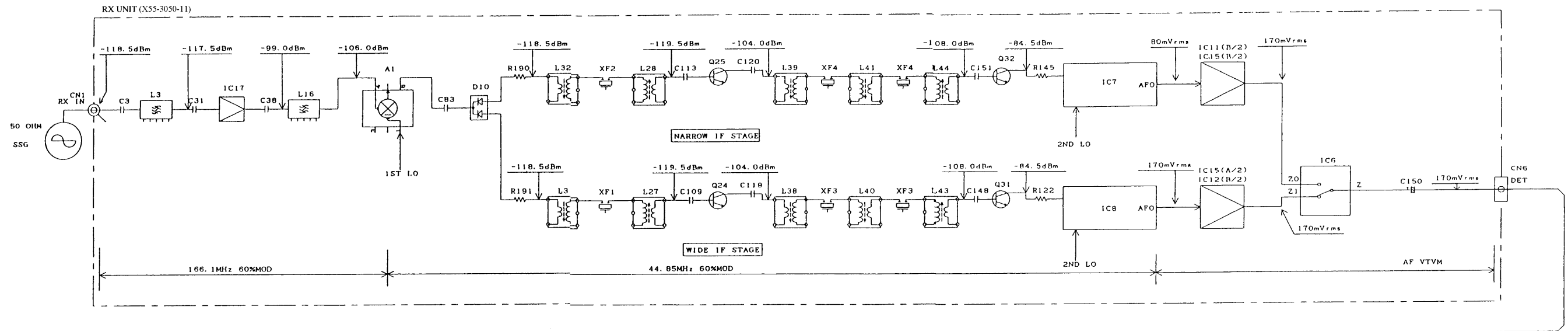

- Note**
- Because the speech output terminal reaches 12dB SINAD when receiving high frequencies, you need an antenna input level (60% modulation)
  - Even though the speech output terminal reaches 4W when receiving low frequencies, you need a 1kHz AF signal level.
  - Even though the modulation reaches 60% when transmitting low frequencies, you need a 1kHz MIC input level.
  - Measure the level of transmitted high frequencies directly from a special quality 50Ω impedance spec trum analyzer.

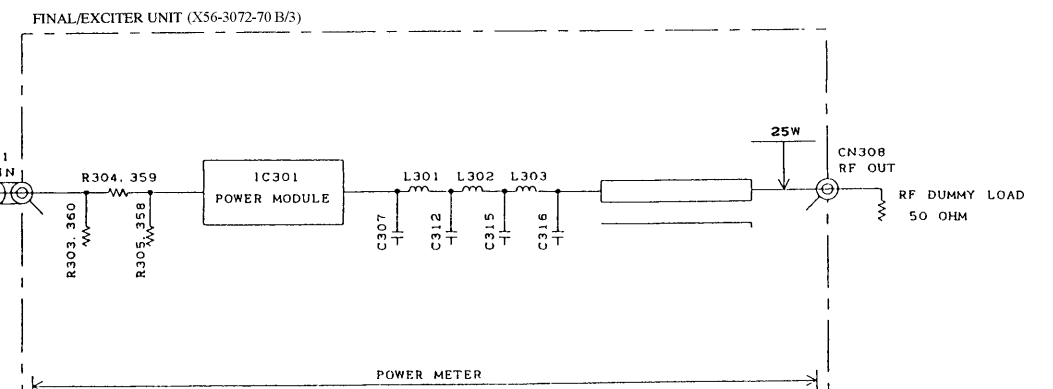
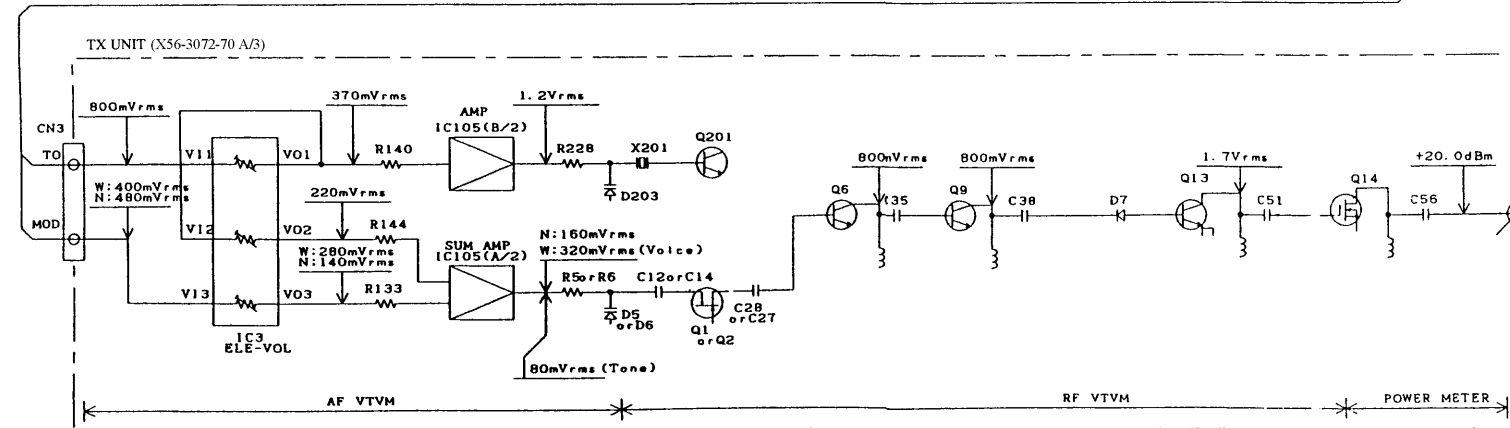

# TKR-740 TKR-740

## INTERCONNECTION DIAGRAM

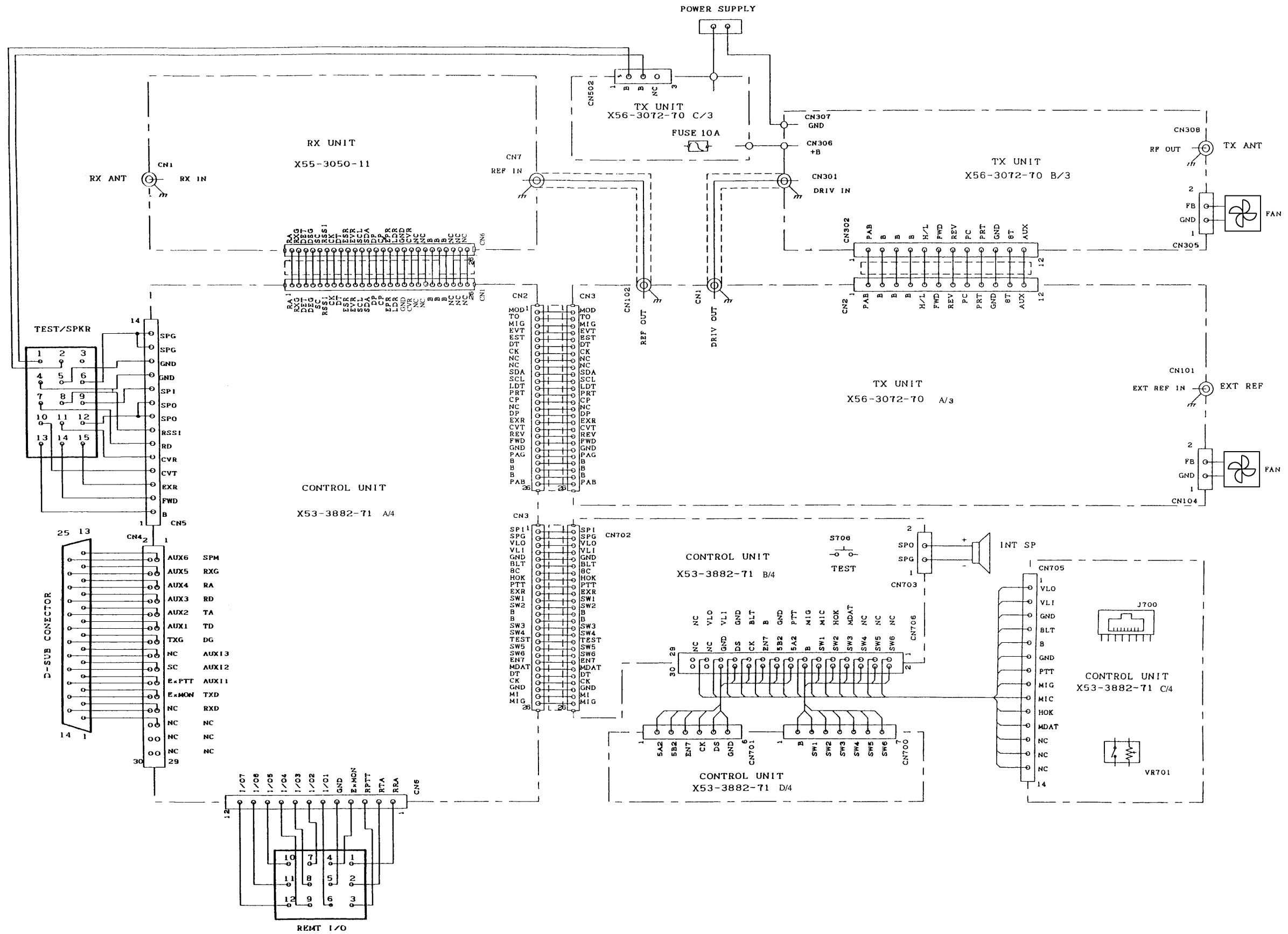

## KES-4 (EXTERNAL SPEAKER)

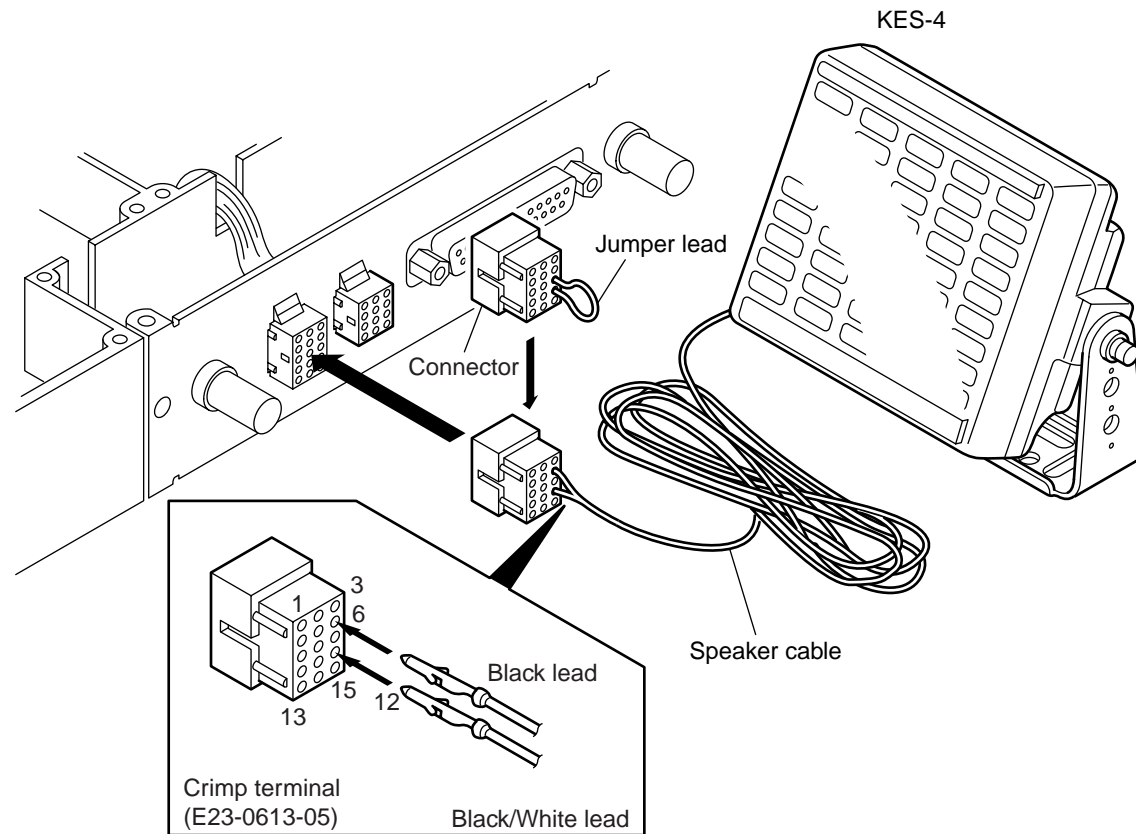

## KPG-46 (PROGRAMMING INTERFACE CABLE)

KPG-46 External view



■ When using an external speaker :

1. Make sure the unit's power is turned OFF.
2. When using the external speaker, remove the jumper lead from the connector, and attach the speaker cable.
3. When not using the external speaker, replace the jumper lead and insert the connector into the speaker jack. (pins 9 and 12)

■ SPECIFICATIONS

Specifications	KES-4
Speaker size	120mm
Maximum input power	20W
Impedance	4 ohms
Frequency response	100 to 5000 Hz
Dimensions (W × H × D) projection not inclrded	127 × 127 × 65mm 5" × 5" × 2-9/16"
Weight	780g (1.72lbs)

# MEMO

A series of horizontal dotted lines for writing.

# TKR-740

## SPECIFICATIONS

### GENERAL

Frequency Range .....	RX : 158 to 174MHz, TX : 146 to 174MHz
Number of Channels .....	32
Channel Spacing .....	Wide : 20kHz, Narrow : 12.5kHz
PLL Channel Stepping .....	2.5kHz, 5kHz, 6.25kHz
Antenna Impedance .....	50Ω
Operating Voltage .....	13.2V DC (10.8 ~ 15.6V)
Current Drain .....	Standby : Less than 1.2A Receive : Less than 1.7A Transmit/Receive : Less than 8.0A
Duty Cycle .....	Receive : 100%, Transmit : 100%
Frequency Stability .....	±0.00015% (-22°F to +140°F)
Operating Temperature Range .....	-30°C to +60°C (-22°F to +140°F)
Dimensions (Including protrusions) .....	483 (19) W X 44 (1-3/4) H X 305 (12) D mm (inches)
Weight .....	4kg (8.8 lbs.)

### RECEIVER (Measurements made per TIA/EIA-603, EN-086)

Sensitivity (EN 20dB SINAD) .....	0.50μV
Selectivity .....	Wide : 88dB (±20kHz), Narrow : 85dB (±12.5kHz)
Spurious Response Rejection .....	95dB
Intermodulation .....	80dB
FM Hum and Noise (EIA) .....	Wide : 58dB, Narrow : 55dB
Audio Output (Ext. Speaker) .....	4W at 4Ω less than 5% distortion
Audio Distortion (Ext. Speaker) .....	Less than 2% at 1000Hz
Band Spread .....	3MHz

### TRANSMITTER (Measurements made per TIA/EIA-603, EN-086)

RF Power Output .....	25W adjustable to 5W
Spurious Emission .....	-36dBm ≤ 1GHz, -30dBm > 1GHz
Type of Emission .....	Wide : 14K0F3E, 12K0F2D, 12K0F1D Narrow : 8K50F3E, 7K50F2D
FM Hum and Noise (EIA) .....	Wide : 55dB, Narrow : 50dB
Audio Distortion (EIA) .....	Less than 0.5% at 1000Hz
Microphone Impedance .....	600Ω
Band Spread .....	28MHz
EXT Reference Sensitivity (10MHz, 50Ω) .....	-10dBm

KENWOOD follows a policy of continuous advancement in development. For this reason specifications may be changed without notice.

## KENWOOD CORPORATION

2967-3, Ishikawa-machi, Hachioji-shi, Tokyo 192-8525, Japan

### KENWOOD U.S.A. CORPORATION

P.O. BOX 22745, 2201 East Dominguez Street, Long Beach, CA 90801-5745, U.S.A.

### KENWOOD ELECTRONICS CANADA INC.

6070 Kestrel Road, Mississauga, Ontario, Canada L5T 1S8

### KENWOOD ELECTRONICS DEUTSCHLAND GMBH

Rembrücker Str. 15, 63150 Heusenstamm, Germany

### KENWOOD ELECTRONICS BELGIUM N.V.

Leuvensesteenweg 248 J, 1800 Vilvoorde, Belgium

### KENWOOD ELECTRONICS FRANCE S.A.

13, Boulevard Ney, 75018 Paris, France

### KENWOOD ELECTRONICS U.K. LIMITED

KENWOOD House, Dwigth Road, Watford, Herts., WD18 9EB, United Kingdom

### KENWOOD ELECTRONICS EUROPE B.V.

Amsterdamseweg 37, 1422 AC Uithoorn, The Netherlands

### KENWOOD ELECTRONICS ITALIA S.p.A.

Via G. Sirtori, 7/9 20129 Milano, Italy

### KENWOOD IBERICA S.A.

Bolivia, 239-08020 Barcelona, Spain

### KENWOOD ELECTRONICS AUSTRALIA PTY. LTD.

(A.C.N. 001 499 074)

16 Giffnock Avenue, Centrecourt Estate, North Ryde, N.S.W. 2113, Australia

### KENWOOD ELECTRONICS (HONG KONG) LTD.

Unit 3712-3724, Level 37, Tower one Metroplaza, 223 Hing Fong Road, Kwai Fong, N.T., Hong Kong

### KENWOOD ELECTRONICS TECHNOLOGIES(S) PTE LTD.

Sales Marketing Division

1 Ang Mo Kio Street 63, Singapore 569110

