

2004 TL Online Reference Owner's Manual

Use these links (and links throughout this manual) to navigate through this reference.
For a printed owner's manual, click on authorized manuals or go to www.helminc.com.

Contents

Owner's Identification Form

Introduction	i
A Few Words About Safety	ii
Your Vehicle at a Glance	2
Driver and Passenger Safety	5
Proper use and care of your vehicle's seat belts, and Supplemental Restraint System.	
Instruments and Controls	49
Instrument panel indicator and gauge, and how to use dashboard and steering column controls.	
Comfort and Convenience Features	109
How to operate the climate control system, the audio system, and other convenience features.	
Before Driving	163
What gasoline to use, how to break-in your new vehicle, and how to load luggage and other cargo.	
Driving	175
The proper way to start the engine, shift the transmission, and park, plus towing a trailer.	
Maintenance	193
The Maintenance Schedule shows you when you need to take your vehicle to the dealer.	
Taking Care of the Unexpected	229
This section covers several problems motorists sometimes experience, and how to handle them.	
Technical Information	253
ID numbers, dimensions, capacities, and technical information.	
Warranty and Customer Relations (U.S. and Canada)	265
A summary of the warranties covering your new Honda, and how to contact us.	
Authorized Manuals (U.S. only)	269
How to order manuals and other technical literature.	
Index	I

Service Information Summary

A summary of information you need when you pull up to the fuel pump.

Owner's Identification

OWNER _____

ADDRESS _____
STREET

_____ CITY

STATE/PROVINCE

ZIP CODE/
POSTAL CODE

V. I. N. _____

DELIVERY DATE _____
(Date sold to original retail purchaser)

DEALER NAME _____ DEALER NO. _____

ADDRESS _____
STREET

_____ CITY

STATE/PROVINCE

ZIP CODE/
POSTAL CODE

OWNER'S SIGNATURE _____

DEALER'S SIGNATURE _____

This Owner's Manual should be considered a permanent part of the vehicle, and should remain with the vehicle when it is sold.

This Owner's Manual covers all models of the Acura TL. You may find descriptions of equipment and features that are not on your particular model.

The information and specifications included in this publication were in effect at the time of approval for printing. Honda Motor Co., Ltd. reserves the right, however, to discontinue or change specifications or design at any time without notice and without incurring any obligation whatsoever.

POUR CLIENTS CANADIEN
AVIS IMPORTANT: Si vous avez
besoin d'un Manuel du Conducteur
en français, veuillez demander à
votre concessionnaire de
commander le numéro de pièce
33SEPC00.

Congratulations! Your selection of a 2004 Acura TL was a wise investment. It will give you years of driving pleasure.

One of the best ways to enhance the enjoyment of your new Acura is to read this manual. In it, you will learn how to operate its driving controls and convenience items. Afterwards, keep this owner's manual in your vehicle so you can refer to it at any time.

Several warranties protect your new Acura. Read the warranty booklet thoroughly so you understand the coverages and are aware of your rights and responsibilities.

Maintaining your vehicle according to the schedules given in this manual helps to keep your driving trouble-free while it preserves your investment. When your vehicle needs maintenance, keep in mind that your Acura dealer's staff is specially trained in servicing the many systems unique to your Acura. Your Acura dealer is dedicated to your satisfaction and will be pleased to answer any questions and concerns.

California Proposition 65 Warning

WARNING: This product contains or emits chemicals known to the State of California to cause cancer and birth defects or other reproductive harm.

As you read this manual, you will find information that is preceded by a **NOTICE** symbol. This information is intended to help you avoid damage to your Acura, other property, or the environment.

A Few Words About Safety

Your safety, and the safety of others, is very important. And operating this vehicle safely is an important responsibility.

To help you make informed decisions about safety, we have provided operating procedures and other information on labels and in this manual. This information alerts you to potential hazards that could hurt you or others.

Of course, it is not practical or possible to warn you about all the hazards associated with operating or maintaining your vehicle. You must use your own good judgement.

You will find this important safety information in a variety of forms, including:

- **Safety Labels** — on the vehicle.
- **Safety Messages** — preceded by a safety alert symbol  and one of three signal words: **DANGER**, **WARNING**, or **CAUTION**.
These signal words mean:

 **DANGER**

You **WILL** be **KILLED** or **SERIOUSLY HURT** if you don't follow instructions.

 **WARNING**

You **CAN** be **KILLED** or **SERIOUSLY HURT** if you don't follow instructions.

 **CAUTION**

You **CAN** be **HURT** if you don't follow instructions.

- **Safety Headings** — such as Important Safety Reminders or Important Safety Precautions.
- **Safety Section** — such as Driver and Passenger Safety.
- **Instructions** — how to use this vehicle correctly and safely.

This entire book is filled with important safety information — please read it carefully.

Your Vehicle at a Glance

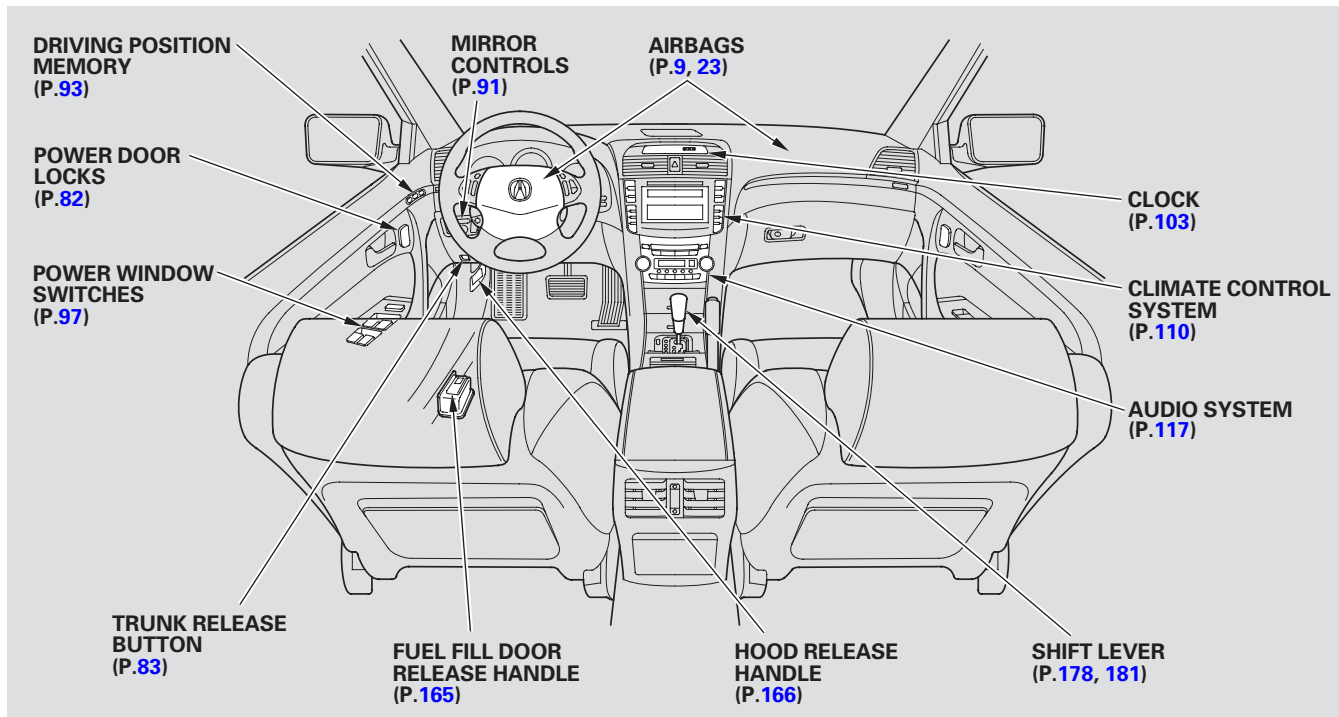

Your Vehicle at a Glance

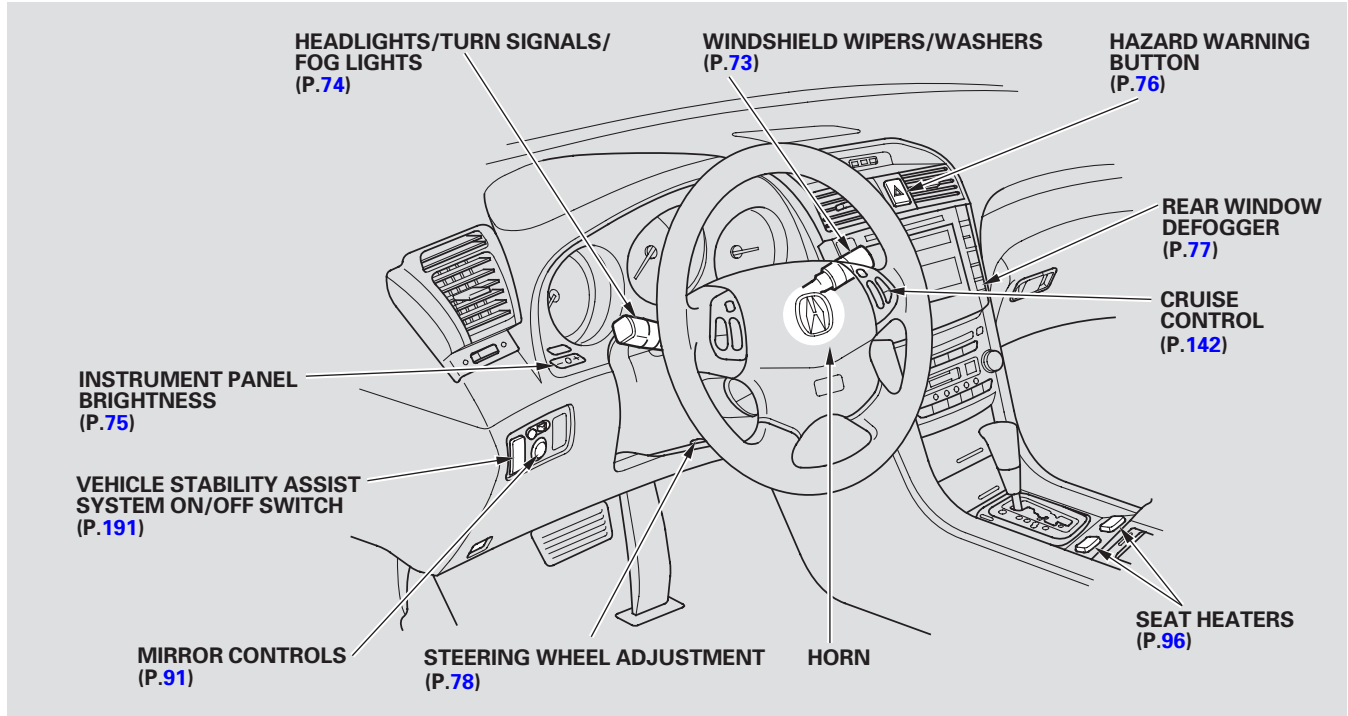

This section gives you important information about how to protect yourself and your passengers. It shows you how to use seat belts properly. It explains how your airbags work. And it tells you how to properly restrain infants and children in your vehicle.

Important Safety Precautions	6
Your Vehicle's Safety Features.....	7
Seat Belts	8
Airbags	9
Protecting Adults and Teens.....	11
1. Close and Lock the Doors	11
2. Adjust the Front Seats	11
3. Adjust the Seat-Backs	12
4. Adjust the Head Restraints	13
5. Fasten and Position the Lap/Shoulder Seat Belts	14
6. Adjust the Steering Wheel	16
7. Maintain a Proper Sitting Position	16

Advice for Pregnant Women.....	17
Additional Safety Precautions....	18
Additional Information About Your	
Seat Belts	19
Seat Belt System Components... ..	19
Lap/Shoulder Belt	19
Automatic Seat Belt Tensioners.....	20
Seat Belt Maintenance	21
Additional Information About Your	
Airbags.....	22
Airbag System Components.....	22
How Your Front Airbags Work.....	23
How Your Side Airbags Work....	25
How Your Side Curtain Airbags Work.....	26
How the SRS Indicator Works... ..	26
How The Side Airbag Cutoff Indicator Works	27
Airbag Service.....	28
Additional Safety Precautions....	28
Protecting Children – General	
Guidelines.....	29
All Children Must Be Restrained	29

All Children Should Sit in the Back Seat	30
The Passenger's Front Airbag Poses Serious Risks.....	30
If You Must Drive with Several Children	32
If a Child Requires Close Attention	32
Additional Safety Precautions....	33
Protecting Infants	34
Protecting Small Children	35
Selecting a Child Seat.....	36
Installing a Child Seat	37
Installing a Child Seat Using LATCH.....	38
Installing a Child Seat with a Lap/Shoulder Belt.....	40
Installing a Child Seat with a Tether	41
Protecting Larger Children	42
Checking Seat Belt Fit	43
Using a Booster Seat.....	43
Additional Safety Precautions....	45
Carbon Monoxide Hazard	46
Safety Labels	47

Important Safety Precautions

You'll find many safety recommendations throughout this section, and throughout this manual. The recommendations on this page are the ones we consider to be the most important.

Always Wear Your Seat Belt

A seat belt is your best protection in all types of collisions. Airbags supplement seat belts, but airbags are designed to inflate only in a moderate to severe frontal collision. So even though your vehicle is equipped with airbags, make sure you and your passengers always wear your seat belts, and wear them properly (see page 14).

Restrain All Children

Children age 12 and under should ride properly restrained in a back seat. Infants and small children should be restrained in a child seat. Larger children should use a booster and a lap/shoulder belt until they

can use the belt properly without a booster (see page 43).

Be Aware of Airbag Hazards

While airbags can save lives, they can cause serious or fatal injuries to occupants who sit too close to them, or are not properly restrained. Infants, young children, and short adults are at the greatest risk. Be sure to follow all instructions and warnings in this manual.

Don't Drink and Drive

Alcohol and driving don't mix. Even one drink can reduce your ability to respond to changing conditions, and your reaction time gets worse with every additional drink. So don't drink and drive, and don't let your friends drink and drive, either.

Control Your Speed

Excessive speed is a major factor in crash injuries and deaths. Generally, the higher the speed, the greater the risk, but serious injuries can also occur at lower speeds. Never drive faster than is safe for current conditions, regardless of the maximum speed posted.

Keep Your Vehicle in Safe Condition

Having a tire blowout or a mechanical failure can be extremely hazardous. To reduce the possibility of such problems, check your tire pressures and condition frequently, and perform all regularly scheduled maintenance (see page 194).

Your Vehicle's Safety Features

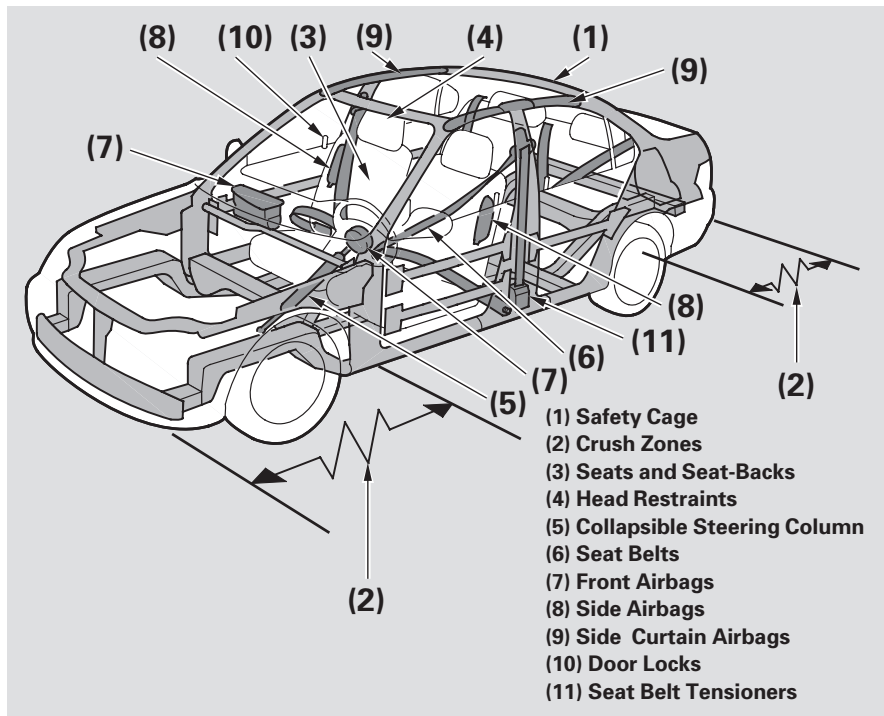

Your vehicle is equipped with many features that work together to protect you and your passengers during a crash.

Some safety features do not require any action on your part. These include a strong steel framework that forms a safety cage around the passenger compartment; front and rear crush zones, a collapsible steering column, and seat belt tensioners that tighten the front seat belts in the event of a crash.

CONTINUED

Your Vehicle's Safety Features

However, you and your passengers can't take full advantage of these safety features unless you remain sitting in a proper position and always wear your seat belts properly. In fact, some safety features can contribute to injuries if they are not used properly.

The following pages explain how you can take an active role in protecting yourself and your passengers.

Seat Belts

Your vehicle is equipped with seat belts in all seating positions.

Your seat belt system also includes an indicator on the instrument panel to remind you and your passengers to fasten your seat belts.

Why Wear Seat Belts

Seat belts have proven to be the single most effective safety device.

Not wearing a seat belt properly increases the chance of serious injury or death in a crash, even though your vehicle has airbags.

In addition, most states and all Canadian provinces require you to wear seat belts.

▲ WARNING

Not wearing a seat belt properly increases the chance of serious injury or death in a crash, even if you have airbags.

Be sure you and your passengers always wear seat belts and wear them properly.

When properly worn, seat belts:

- Keep you connected to the vehicle so you can take advantage of the vehicle's built-in safety features.
- Help protect you in almost every type of crash, including frontal, side, and rear impacts and rollovers.

- Help keep you from being thrown against the inside of the vehicle and against other occupants.
- Keep you from being thrown out of the vehicle.
- Help keep you in a good position should the airbags ever deploy. A good position reduces the risk of injury from an inflating airbag, and allows you to get the best advantage from the airbag.

Of course, seat belts cannot completely protect you in every crash. But in most cases, seat belts can reduce your risk of serious injury.

What You Should Do:

Always wear your seat belt, and make sure you wear it properly.

Airbags

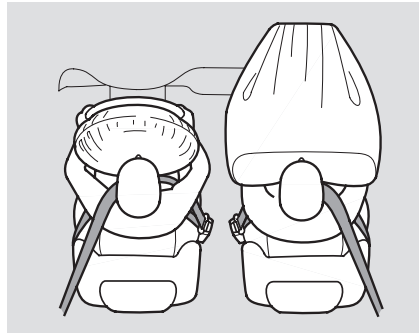

Your vehicle has a Supplemental Restraint System (SRS) with front airbags to help protect the heads and chests of the driver and a front seat passenger during a moderate to severe frontal collision (see page [23](#) for more information on how your front airbags work).

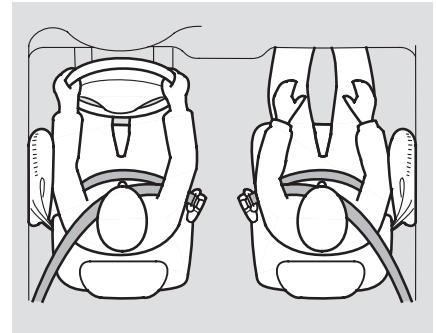

Your vehicle also has side airbags to help protect the upper torso of the driver or a front seat passenger during a moderate to severe side impact. (See page [25](#) for more information on how your side airbags work.)

CONTINUED

Your Vehicle's Safety Features

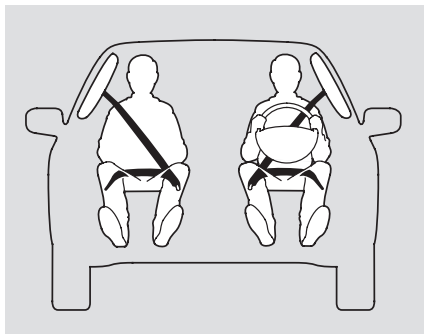

Your vehicle also has side curtain airbags to help protect the heads of the driver, front passenger, and passengers in the outer rear seating positions. (See page 26 for more information on how your side curtain airbags work.)

The most important things you need to know about your airbags are:

- ***Airbags do not replace seat belts.*** They are designed to supplement the seat belts.
- ***Airbags offer no protection in rear impacts, rollovers, or minor collisions.***
- ***Airbags can pose serious hazards.*** To do their job, airbags must inflate with tremendous force. So while airbags help save lives, they can cause minor injuries or more serious or even fatal injuries if occupants are not properly restrained or sitting properly.

What you should do: Always wear your seat belt properly, and sit upright, and as far back from the steering wheel while allowing full control of the vehicle. A front passenger should move their seat as far back from the dashboard as possible.

The rest of this section gives more detailed information about how you can maximize your safety.

Remember however, that no safety system can prevent all injuries or deaths that can occur in severe crashes, even where seat belts are properly worn and the airbags deploy.

The following pages provide instructions on how to properly protect the driver, adult passengers and teenage children who are large enough and mature enough to ride in the front seat.

See page [29](#) for important guidelines on how to properly protect infants, small children, and larger children who ride in your vehicle.

1. Close and Lock the Doors

After everyone has entered the vehicle, be sure the doors are closed and locked.

Locking the doors reduces the chance of someone being thrown out of the vehicle during a crash, and it helps prevent passengers from accidentally opening a door and falling out.

Locking the doors also helps prevent an outsider from unexpectedly opening a door when you come to a stop.

See page [82](#) for how to lock the doors.

2. Adjust the Front Seats

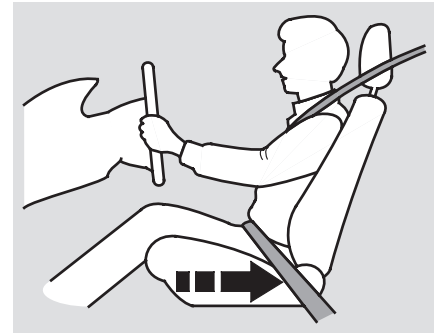

Adjust the driver's seat as far to the rear as possible while allowing you to maintain control of the vehicle. Have your front passenger adjust their seat as far to the rear as possible.

If you sit too close to the steering wheel or dashboard, you can be seriously injured by an inflating front airbag, or by striking the steering wheel or dashboard.

CONTINUED

Protecting Adults and Teens

The National Highway Traffic Safety Administration and Transport Canada recommend that drivers allow at least 10 inches (25 cm) between the center of the steering wheel and the chest.

If you cannot get far enough away from the steering wheel and still reach the controls, we recommend that you investigate whether some type of adaptive equipment may help.

Once your seat is adjusted correctly, rock it back and forth to make sure it is locked into position. See page [88](#) for how to adjust the front seats.

⚠ WARNING

Sitting too close to an airbag can result in serious injury or death if the airbags inflate.

Always sit as far back from the airbags as possible while allowing full control of the vehicle.

3. Adjust the Seat-Backs

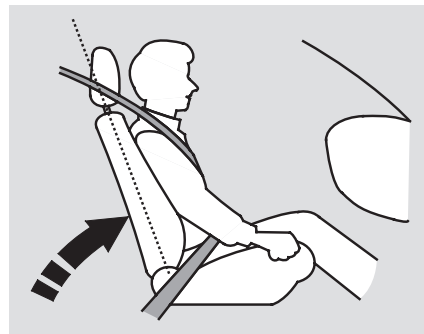

Adjust the driver's seat-back to a comfortable, upright position, leaving ample space between your chest and the airbag cover in the center of the steering wheel.

Passengers with adjustable seat-backs should also adjust their seat-back to a comfortable, upright position.

Reclining a seat-back so that the shoulder part of the belt no longer rests against the occupant's chest reduces the protective capability of the belt. It also increases the chance of sliding under the belt in a crash and being seriously injured. The farther a seat-back is reclined, the greater the risk of injury.

⚠ WARNING

Reclining the seat-back too far can result in serious injury or death in a crash.

Adjust the seat-back to an upright position, and sit well back in the seat.

See page [88](#) for how to adjust seat-backs.

4. Adjust the Head Restraints

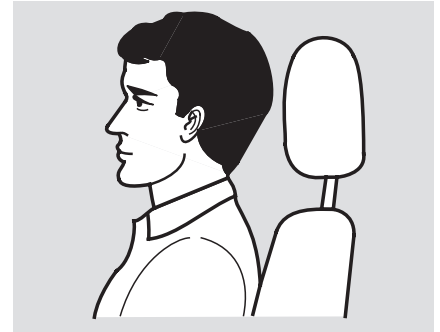

Adjust the driver's head restraint so the back of your head rests against the center of the restraint.

Have passengers with adjustable restraints adjust their restraints properly as well. A taller person should adjust their restraint as high as possible.

CONTINUED

Protecting Adults and Teens

⚠ WARNING

Improperly positioning head restraints reduces their effectiveness, and you can be seriously injured in a crash.

Make sure head restraints are in place and positioned properly before driving.

Properly adjusted head restraints will help protect occupants from whiplash and other crash injuries.

See page [89](#) for how to adjust the head restraints.

5. Fasten and Position the Seat Belts

Insert the latch plate into the buckle, then tug on the belt to make sure the belt is securely latched. Also check that the belt is not twisted, because a twisted belt can cause serious injuries in a crash.



Position the lap part of the belt as low as possible across your hips, then pull up on the shoulder part of the belt so the lap part fits snugly. This lets your strong pelvic bones take the force of a crash and reduces the chance of internal injuries.

If necessary, pull up on the belt again to remove any slack, then check that the belt rests across the center of your chest and over your shoulder. This spreads the forces of a crash over the strongest bones in your upper body.

If the seat belt touches or crosses your neck, or if it crosses your arm instead of your shoulder, you need to adjust the seat belt anchor height.

Never place the shoulder portion of a lap/shoulder belt under your arm or behind your back. This could cause very serious injuries in a crash.

⚠ WARNING

Improperly positioning the seat belts can cause serious injury or death in a crash.

Make sure all seat belts are properly positioned before driving.

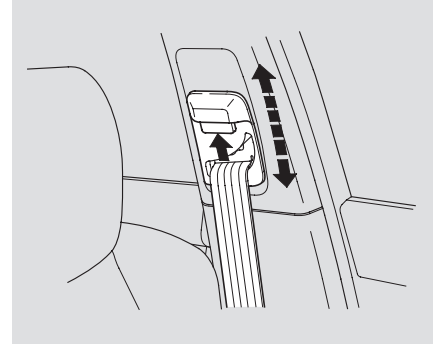

To adjust the height of a front seat belt anchor, press and hold the release buttons, and slide the anchor up or down as needed (it has four positions).

CONTINUED

Protecting Adults and Teens

If a seat belt does not seem to work as it should, it may not protect the occupant in a crash.

No one should sit in a seat with an inoperative seat belt. Using a seat belt that is not working properly can result in serious injury or death. Have your Acura dealer check the belt as soon as possible.

See page [19](#) for additional information about your seat belts and how to take care of them.

6. Adjust the Steering Wheel

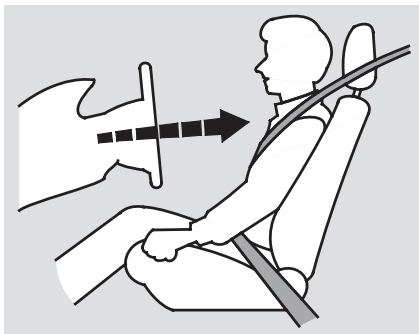

Adjust the steering wheel, if needed, so that the wheel points toward your chest, not toward your face. This provides optimal protection from the front airbag.

See page [78](#) for how to adjust the steering wheel.

7. Maintain a Proper Sitting Position

After all occupants have adjusted their seats and put on seat belts, it is very important that they continue to sit upright, well back in their seats, with their feet on the floor, until the vehicle is parked and the engine is off.

Sitting improperly can increase the chance of injury during a crash. For example, if an occupant slouches, lies down, turns sideways, sits forward, leans forward or sideways, or puts one or both feet up, the chance of injury during a crash is greatly increased.

In addition, an occupant who is out of position in the front seat can be seriously or fatally injured in a crash by striking interior parts of the vehicle or being struck by an inflating airbag.

⚠ WARNING

Sitting improperly or out of position can result in serious injury or death.

Always sit upright, well back in the seat, with your feet on the floor.

Advice for Pregnant Women



If you are pregnant, the best way to protect yourself and your unborn child when driving or riding in a vehicle is to always wear a seat belt, and keep the lap part of the belt as low as possible across the hips.

When driving, remember to sit upright and adjust the seat as far back as possible while allowing full control of the vehicle. When riding as a front passenger, adjust the seat as far back as possible.

This will reduce the risk of injuries to both you and your unborn child that can be caused by a crash or an inflating airbag.

Each time you have a check-up, ask your doctor if it's okay for you to drive.

Protecting Adults and Teens

Additional Safety Precautions

- **Two people should never use the same seat belt.** If they do, they could be very seriously injured in a crash.
- **Do not put any accessories on seat belts.** Devices intended to improve occupant comfort or reposition the shoulder part of a seat belt can reduce the protective capability of the seat belt and increase the chance of serious injury in a crash.
- **Do not place hard or sharp objects between yourself and a front airbag.** Carrying hard or sharp objects on your lap, or driving with a pipe or other sharp object in your mouth, can result in injuries if your airbags inflate.
- **Do not attach or place objects on the airbag covers.** Objects on the covers marked “SRS AIRBAG” could interfere with the proper operation of the airbags or be propelled inside the vehicle and hurt someone if the airbags inflate.
- **Do not attach hard objects on or near a front door.** If a side airbag or a side curtain airbag inflates, a cup holder or other hard object attached on or near the door could be propelled inside the vehicle and hurt someone.
- **Keep your hands and arms away from the airbag covers.** If your hands or arms are close to an airbag cover, they could be injured if the airbags inflate.

Additional Information About Your Seat Belts

Seat Belt System Components

Your seat belt system includes lap/shoulder belts in all five seating positions. The front seat belts are also equipped with automatic seat belt tensioners.



The seat belt system includes an indicator on the instrument panel to remind you and your passengers to fasten your belts. If you turn the ignition switch to ON (II) without fastening your belt, a beeper will sound and the indicator will blink. The beeper will stop after a few seconds, but the indicator will stay on until the driver's seat belt is fastened.

If you do not fasten your seat belt before the beeper stops, the indicator will stop blinking but remain on. If you continue driving without fastening your seat belt, the indicator will start blinking again and the beeper will sound at regular intervals.

Lap/Shoulder Belt

The lap and shoulder belt goes over your shoulder, across your chest, and across your hips.

To fasten the belt, insert the latch plate into the buckle, then tug on the belt to make sure the buckle is latched (see page 14 for how to properly position the belt).

To unlock the belt, push the red PRESS button on the buckle. Guide the belt across your body so that it retracts completely. After exiting the vehicle, be sure the belt is out of the way and will not get closed in the door.

All seat belts have an emergency locking retractor. In normal driving, the retractor lets you move freely in your seat while it keeps some tension on the belt. During a collision or sudden stop, the retractor automatically locks the belt to help restrain your body.

The seat belts in all positions except the driver's have an additional locking mechanism that must be activated to secure a child seat (see page 40).

If the shoulder part of the belt is pulled all the way out, the locking mechanism will activate. The belt will retract, but it will not allow the passenger to move freely.

CONTINUED

Additional Information About Your Seat Belts

To deactivate the locking mechanism, unlatch the buckle, and let the seat belt fully retract. To refasten the belt, pull it out only as far as needed.

Automatic Seat Belt Tensioners



For added protection, the front seat belts are equipped with automatic seat belt tensioners. When activated, the tensioners immediately tighten the belts to help hold the driver and a front passenger in place.

The tensioners are designed to activate primarily in frontal collisions, and they should activate in any collision severe enough to cause airbag inflation.

However, the tensioners can be activated during a collision in which the airbags do not deploy. In this case, the airbags would not be needed, but the additional restraint could be helpful.

When the tensioners are activated, the seat belts will remain tight until they are unbuckled in the normal manner.

Additional Information About Your Seat Belts

Seat Belt Maintenance

For safety, you should check the condition of your seat belts regularly.

Pull each belt out fully, and look for frays, cuts, burns, and wear. Check that the latches work smoothly and the belts retract easily. Any belt that is not in good condition or not working properly will not provide good protection and should be replaced as soon as possible.

Acura provides a lifetime warranty on seat belts for U.S. models. See your *Acura Warranty Information* booklet for details.

If a seat belt is worn during a crash, it must be replaced by the dealer. A belt that has been worn during a crash may not provide the same level of protection in a subsequent crash. The dealer should also inspect the anchors for damage and replace them if needed. If the automatic seat belt tensioners activate during a crash, they must be replaced.

For information on how to clean your seat belts, see page [218](#).

WARNING

Not checking or maintaining seat belts can result in serious injury or death if the seat belts do not work properly when needed.

Check your seat belts regularly, and have any problem corrected as soon as possible.

Additional Information About Your Airbags

Airbag System Components

Your Airbag System includes:

- Two SRS (Supplemental Restraint System) front airbags. The driver's airbag is stored in the center of the steering wheel; the front passenger's airbag is stored in the dashboard. Both are marked "SRS AIRBAG."
- Two side airbags, one for the driver and one for a front passenger. The airbags are stored in the outer edges of the seat-backs. Both are marked "Side Airbag" (see page 25).
- Two side curtain airbags, one for each side of the vehicle. The airbags are stored in the front, center, and rear pillars. The front and center pillars on both sides are marked "SIDE CURTAIN AIRBAG" (see page 26).
- Automatic front seat belt tensioners (see page 20).
- Sensors that can detect a moderate to severe front impact or side impact.
- A sophisticated electronic system that continually monitors and records information about the sensors, the control unit, the airbag activators, and driver and front passenger seat belt use when the ignition is in the ON (II) position.
- An indicator on the instrument panel that alerts you to a possible problem with your airbags (see page 26).
- Emergency backup power in case your vehicle's electrical system is disconnected in a crash.

Additional Information About Your Airbags

How Your Front Airbags Work

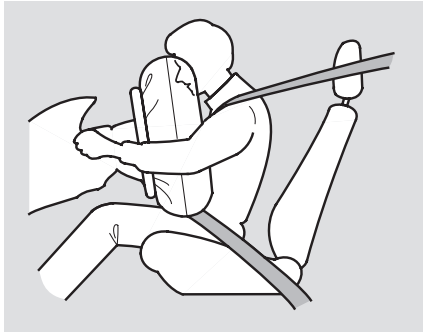

If you ever have a moderate to severe frontal collision, sensors will detect the vehicle's rapid deceleration. If the rate of deceleration is high enough, the control unit will instantly inflate driver's and front passenger's front airbags.

During a frontal crash, your seat belt restrains your lower body and torso, and the front airbag helps protect your head and chest.

Although both airbags normally inflate within split second of each other, it is possible for only one airbag to deploy.

This can happen if the severity of a collision is at the margin, or threshold, that determines whether or not the airbags will deploy. In such cases, the seat belt will provide sufficient protection, and the supplemental protection offered by the airbag would be minimal.

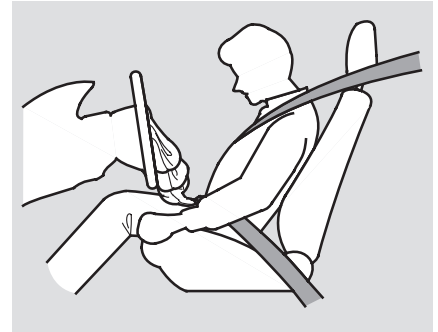

After inflating, the front airbags immediately deflate, so they won't interfere with the driver's visibility, or the ability to steer or operate other controls.

CONTINUED

Additional Information About Your Airbags

The total time for inflation and deflation is one-tenth of a second, so fast that most occupants are not aware that the airbags deployed until they see them lying in their laps.

After a crash, you may see what looks like smoke. This is actually powder from the airbag's surface. Although the powder is not harmful, people with respiratory problems may experience some temporary discomfort. If this occurs, get out of the vehicle as soon as it is safe to do so.

Dual-Stage Airbags

Your front airbags are dual-stage airbags. This means they have two inflation stages that can be ignited sequentially or simultaneously, depending on crash severity.

In a **more severe** crash, both stages will ignite simultaneously to provide the quickest and greatest protection.

In a **less severe** crash, one stage will ignite first, then the second stage will ignite a split second later. This provides longer airbag inflation time with a little less force.

Dual-Threshold Airbags

Your front airbags are also dual-threshold airbags. Airbags with this feature have two deployment thresholds that depend on whether or not the occupant is wearing a seat belt.

If the occupant's belt is **not latched**, the airbag will deploy at the same threshold as a conventional airbag, because the occupant would need extra protection.

If the occupant's belt **is latched**, the airbag will inflate at a slightly higher threshold, when the airbag would be needed to supplement the protection provided by the seat belt.

Additional Information About Your Airbags

How Your Side Airbags Work

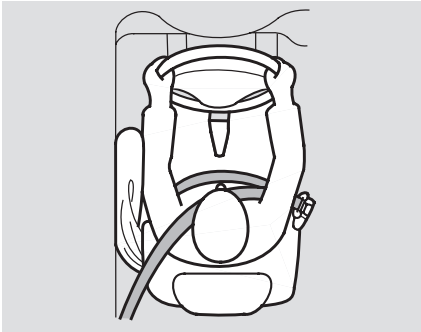

If you ever have a moderate to severe side impact, the sensors will detect rapid deceleration and signal the control unit to instantly inflate either the driver's or the passenger's side airbag.

Only one airbag will deploy during a side impact. If the impact is on the passenger's side, the passenger's side airbag will deploy even if there is no passenger.

To get the best protection from the side airbags, front seat occupants should wear their seat belts and sit upright and well back in their seats.

The passenger's side airbag has a cutoff system designed to turn off the passenger's side airbag if a child's head is in the airbag's deployment path (see page 27).

If the side airbag off indicator comes on, have the passenger sit upright. Once the passenger is out of the deployment path of the side airbag, the system will turn the airbag back on, and the indicator will go out.

A front seat passenger should not use a cushion or other object as a backrest. It may prevent the cutoff system from working properly.

If a short adult leans sideways, or a larger adult slouches and leans sideways into the side airbag deployment path, the system may also shut off the side airbag.

Additional Information About Your Airbags

How Your Side Curtain Airbags Work

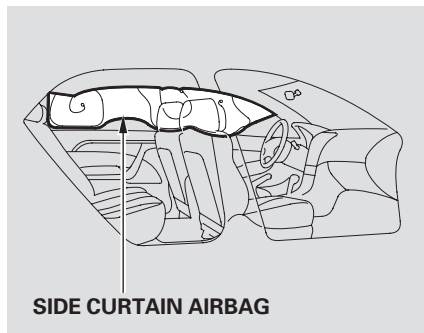

Your vehicle is equipped with side curtain airbags. These airbags are stored in the front, center, and rear pillars on both sides. The front and rear pillars on both sides are marked "SIDE CURTAIN AIRBAG."

In a moderate to severe side impact, sensors will detect rapid deceleration and signal the control unit to instantly inflate the side curtain airbag on the driver's or the passenger's side of the vehicle. If the impact is on the passenger's side, the passenger's side curtain airbag will inflate even if there are no occupants on that side of the vehicle.

To get the best protection from the side curtain airbags, occupants should wear their seat belts and sit upright and well back in their seats.

How the SRS Indicator Works



The SRS indicator alerts you to a potential problem with your airbags or seat belt tensioners.

When you turn the ignition switch to ON (II), this indicator will come on briefly then go out. This tells you that the system is working properly.

If the indicator comes on at any other time, or does not come on at all, you should have the system checked by your dealer. For example:

- If the SRS indicator does not come on after you turn the ignition to ON (II).
- If the indicator stays on after the engine starts.

Additional Information About Your Airbags

- If the indicator comes on or flashes on and off while you drive.

If you see any of these indications, the airbags and the seat belt tensioners may not work properly when you need them.

WARNING

Ignoring the SRS indicator can result in serious injury or death if the airbag systems or tensioners do not work properly.

Have your vehicle checked by a dealer as soon as possible if the SRS indicator alerts you to a possible problem.

How the Side Airbag Off Indicator Works



This indicator alerts you that the passenger's side airbag has been automatically shut off. It does **not** mean there is a problem with your side airbags.

To reduce the risk of injury from an inflating side airbag, your vehicle has an automatic cutoff system for the passenger's side airbag.

Although Acura does not encourage children to ride in front, this system is designed to shut off the side airbag if a child leans sideways and the child's head is in the side airbag deployment path.

A front seat passenger should not use a cushion or other object as a backrest. It may prevent the cutoff system from working properly.

When you turn the ignition to ON (II), the indicator should come on briefly and go out. If it doesn't come on, stays on, or comes on while driving without a passenger in the front seat, have the system checked.

Additional Information About Your Airbags

Airbag Service

Your airbag systems are virtually maintenance-free, and there are no parts you can safely service. However, you must have your vehicle serviced if:

- **An airbag ever inflates.** Any airbag that has deployed must be replaced along with the control unit and other related parts. If a front airbag inflates, the seat belt tensioners must also be replaced. Do not try to remove or replace any airbag by yourself. This must be done by an Acura dealer or a knowledgeable body shop.
- **The SRS indicator alerts you to a problem.** Take your vehicle to an authorized Acura dealer as soon as possible. If you ignore this indication, your airbags may not operate properly.

Additional Safety Precautions

- **Do not attempt to deactivate your airbags.** Together, airbags and seat belts provide the best protection.
 - **Do not tamper with airbag components or wiring for any reason.** Tampering could cause the airbags to deploy, possibly causing very serious injury.
 - **Do not expose the front seat-backs to liquid.** If water or another liquid soaks into a seat-back, it can prevent the side airbag cutoff system from working properly.
- **Do not cover or replace front seat-back covers without consulting an Acura dealer.** Improperly replacing or covering front seat-back covers can prevent your side airbags from inflating during a side impact.

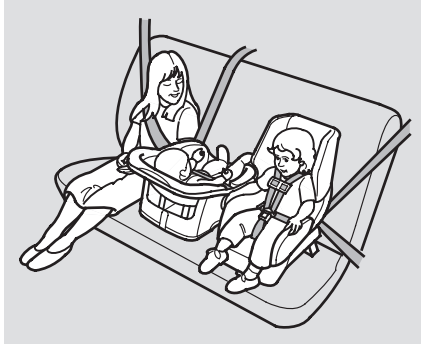

Children depend on adults to protect them. However, despite their best intentions many adults do not know how to properly protect child passengers.

⚠ WARNING

Children who are unrestrained or improperly restrained can be seriously injured or killed in a crash.

Any child too small for a seat belt should be properly restrained in a child seat. A larger child should be properly restrained with a seat belt and use a booster if necessary.

If you have children, or if you ever need to drive with a child in your vehicle, be sure to read this section. It begins with important general guidelines, then presents special information for infants, small children, and larger children.

All Children Must Be Restrained
Each year, many children are injured or killed in vehicle crashes because they are either unrestrained or not properly restrained. In fact, vehicle accidents are the number one cause of death of children ages 12 and under.

To reduce the number of child deaths and injuries, every state and Canadian province requires that infants and children be properly restrained when they ride in a vehicle.

CONTINUED

Protecting Children – General Guidelines

Infants and small children must be restrained in an approved child seat that is properly secured to the vehicle (see pages 34 – 35).

Larger children must be restrained with a lap/shoulder belt and ride on a booster until the seat belt fits them properly (see pages 42 – 45).

All Children Should Sit in the Back Seat

According to accident statistics, children of all ages and sizes are safer when they are restrained in the back seat. The National Highway Traffic Safety Administration and Transport Canada recommend that all children age 12 and under be properly restrained in the back seat.

Children who ride in back are less likely to be injured by striking interior vehicle parts during a collision or hard braking.

The Passenger's Front Airbag Can Pose Serious Risks

Front airbags have been designed to help protect adults in a moderate to severe frontal collision. To do this the passenger's front airbag is quite large and it can inflate with enough force to cause very serious injuries.

Infants

Never put a rear-facing child seat in the front seat of a vehicle equipped with a passenger's front airbag. If the airbag inflates, it can hit the back of the child seat with enough force to kill or very seriously injure an infant.

Small Children

Placing a forward-facing child seat in the front seat of a vehicle equipped with passenger's front airbag can be hazardous. If the vehicle seat is too far forward, or the child's head is thrown forward during a collision, an inflating front airbag can strike the child with enough force to kill or very seriously injure a small child.

Larger Children

Children who have outgrown child seats are also at risk of being injured or killed by an inflating passenger's front airbag. Whenever possible, larger children should sit in the back seat, in a booster seat if needed, and be properly restrained with a seat belt (see page 42 for important information about protecting larger children).

U.S. Models

To remind you of the passenger's front airbag hazards, and that children must be properly restrained in the back seat, your vehicle has warning labels on the dashboard and on the driver's and front passenger's visors. Please read and follow the instructions on these labels.

⚠ WARNING	
	DEATH or SERIOUS INJURY can occur <ul style="list-style-type: none">• Children 12 and under can be killed by the air bag• The BACK SEAT is the SAFEST place for children• NEVER put a rear-facing child seat in the front• Sit as far back as possible from the air bag• ALWAYS use SEAT BELTS and CHILD RESTRAINTS

⚠ WARNING
Children Can Be KILLED or INJURED by Passenger Air Bag
<ul style="list-style-type: none">• The back seat is the safest place for children 12 and under.• Make sure all children use seat belts or child seats.
To be removed by owner only.

Canadian Models

To remind you of the front airbag hazards, your vehicle has warning labels on the driver's and front passenger's visors. Please read and follow the instructions on these labels.

CAUTION TO AVOID SERIOUS INJURY: <ul style="list-style-type: none">• FOR MAXIMUM SAFETY PROTECTION IN ALL TYPES OF CRASHES, YOU MUST ALWAYS WEAR YOUR SAFETY BELT.• DO NOT INSTALL REARWARD-FACING CHILD SEATS IN ANY FRONT PASSENGER SEAT POSITION.• DO NOT SIT OR LEAN UNNECESSARILY CLOSE TO THE AIR BAG.• DO NOT PLACE ANY OBJECTS OVER THE AIR BAG OR BETWEEN THE AIR BAG AND YOURSELF.• SEE THE OWNER'S MANUAL FOR FURTHER INFORMATION AND EXPLANATIONS.	PRÉCAUTION: POUR ÉVITER DES BLESSURES GRAVES: <ul style="list-style-type: none">• POUR PROFITER D'UNE PROTECTION MAXIMALE LORS D'UNE COLLISION BOUCLEZ TOUJOURS VOTRE CEINTURE DE SÉCURITÉ.• N'INSTALLEZ JAMAIS UN SIÈGE POUR ENFANTS FAISANT FACE À L'ARRIÈRE SUR LE SIÈGE DU PASSAGER AVANT.• NE VOUS APPUYEZ PAS ET NE VOUS ASSEYEZ PAS PRES DU COUSSIN GONFLABLE.• NE DEPOSEZ AUCUN OBJET SUR LE COUSSIN GONFLABLE OU ENTRE LE COUSSIN GONFLABLE ET VOUS.• LISEZ LE GUIDE UTILISATEUR POUR DE PLUS AMPLES RENSEIGNEMENTS.
--	---

Protecting Children – General Guidelines

If You Must Drive with Several Children

Your vehicle has three seating positions in the back seat where children can be properly restrained. If you ever have to carry four children, and a child must ride in front:

- Place the largest child in the front seat, provided the child is large enough to wear the lap/shoulder belt properly (see page 43).
- Move the vehicle seat as far to the rear as possible (see page 11).
- Have the child sit upright and well back in the seat (see page 16).
- Make sure the seat belt is properly positioned and secured (see page 14).

If a Child Requires Close Attention

Many parents say they prefer to put an infant or small child in the front passenger seat so they can watch the child, or because the child requires attention.

Placing a child in the front seat exposes the child to hazards in a frontal collision, and paying close attention to a child distracts the driver from the important tasks of driving, placing both of you at risk.

If a child requires physical attention or frequent visual contact, we strongly recommend that another adult ride with the child in the back seat. The back seat is far safer for a child than the front.

Additional Safety Precautions

- Never hold an infant or child on your lap. If you are not wearing a seat belt in crash, you could be thrown forward and crush the child against the dashboard or a seat-back. If you are wearing a seat belt the child can be torn from your arms and be seriously hurt or killed.
 - Never put a seat belt over yourself or a child. During a crash, the belt could press deep into the child and cause serious or fatal injuries.
 - Never let two children use the same seat belt. If they do, they could be very seriously injured in a crash.
 - Use childproof door locks to prevent children from opening the doors. This can prevent children from accidentally falling out.
- Do not leave children alone in a vehicle. Leaving children without adult supervision is illegal in most states and Canadian provinces, and can be very hazardous. For example, infants and small children left in a vehicle on a hot day can die from heatstroke. A child left alone with the key in the ignition can accidentally set the vehicle in motion, possibly injuring themselves or others.
 - Lock all doors and the trunk when your vehicle is not in use. Children who play in vehicles can accidentally get trapped inside the trunk. Teach your children not to play in or around vehicles. Know how to operate the emergency trunk opener and decide if your children should be shown how to use this feature (see page 84).
- Keep vehicle keys and remote transmitters out of the reach of children. Even very young children learn how to unlock vehicle doors, turn on the ignition, and open the trunk, which can lead to accidental injury or death.

Protecting Infants and Small Children

Protecting Infants

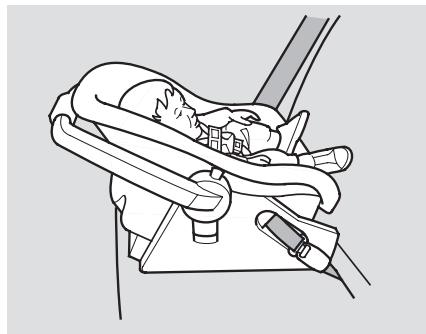

Child Seat Type

Only a rear-facing child seat provides proper support for a baby's head, neck, and back.

An infant must be properly restrained in a rear-facing, reclining child seat until the child reaches the seat maker's weight or height limit for the seat, and the child is at least one year old.

⚠ WARNING

Placing a rear-facing child seat in the front seat can result in serious injury or death if the passenger's front airbag inflates.

Always place a rear-facing child seat in the back seat, not the front.

Two types of seats may be used: a seat designed exclusively for infants, or a convertible seat used in the rear-facing, reclining mode.

Do not put a rear-facing child seat in a forward-facing position. If placed facing forward, an infant could be very seriously injured during a frontal collision.

Child Seat Placement

In this vehicle, a rear-facing child seat can be placed in any seating position in the back seat, but not in the front.

Never put a rear-facing child seat in the front seat. If the passenger's front airbag inflates, it can hit the back of the child seat with enough force to kill or seriously injure an infant.

When properly installed, a rear-facing child seat may prevent the driver or a front passenger from moving the seat as far back as recommended, or from locking the seat-back in the desired position. In either of these situations, we strongly recommend that you install the child seat in a different back seating position or get a smaller rear-facing child seat.

Protecting Small Children

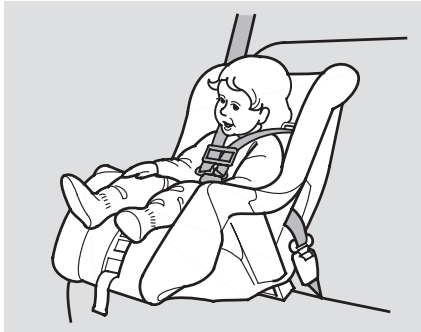

Child Seat Type

A child who is at least one year old, and who fits within the child seat maker's weight and height limits, should be restrained in a forward-facing, upright child seat.

Of the different seats available, we recommend those that have a five-point harness system as shown.

We also recommend that a small child stay in the child seat as long as possible, until the child reaches the weight or height limit for the seat.

Child Seat Placement

We strongly recommend placing a forward-facing child seat in a back seat, not the front.

Placing a forward-facing child seat in the front seat of a vehicle equipped with a passenger's airbag can be hazardous. If the vehicle seat is too far forward, or the child's head is thrown forward during a collision, an inflating airbag can strike the child with enough force to cause very serious or fatal injuries.

If it is necessary to put a forward-facing child seat in the front, move the vehicle seat as far to the rear as possible, be sure the child seat is firmly secured to the vehicle, and the child is properly strapped in the seat.

⚠ WARNING

Placing a forward-facing child seat in the front seat can result in serious injury or death if the front airbag inflates.

If you must place a forward-facing child seat in front, move the vehicle seat as far back as possible, and properly restrain the child.

Selecting a Child Seat

When buying a child seat, you need to choose between a conventional child seat, or one designed for use with the Lower Anchors and Tethers for Children (LATCH) system.

Conventional child seats must be secured to a car with a seat belt, whereas LATCH-compatible seats are secured by attaching the seat to hardware built into the two outer rear seats.

Since LATCH-compatible child seats are easier to install and reduce the possibility of improper installation, we recommend selecting this style.

We also recommend selecting a LATCH-compatible seat with a rigid, rather than a flexible, anchor (see page 39).

In seating positions and vehicles not equipped with LATCH, a LATCH-compatible child seat can be installed using a seat belt.

Whatever type of seat you choose, to provide proper protection, a child seat should meet three requirements:

- 1. The child seat should meet U.S. or Canadian Motor Vehicle Safety Standard 213.*** Look for FMVSS 213 or CMVSS 213 on the box.
- 2. The child seat should be of the proper type and size to fit the child.*** Rear-facing for infants, forward-facing for small children.
- 3. The child seat should fit the vehicle seating position (or positions) where it will be used.***

Before purchasing a conventional child seat, or using a previously purchased one, we recommend that you test the seat in the specific vehicle seating position, or positions, where the seat will be used.

After selecting a proper child seat, and a good place to install the seat, there are three main steps in installing the seat:

- 1. Properly secure the child seat to the vehicle.** All child seats must be secured to the vehicle with the lap part of a lap/shoulder belt or with the LATCH (Lower Anchors and Tethers for Children) system. A child whose seat is not properly secured to the vehicle can be endangered in a crash.
- 2. Make sure the child seat is firmly secured.** After installing a child seat, push and pull the seat forward and from side to side to verify that it is secure.

A child seat secured with a seat belt should be installed as firmly as possible. However, it does not need to be “rock solid”. Some side-to-side movement can be expected and should not reduce the child seat’s effectiveness.

If the child seat is not secure, try installing it in a different seating position, or use a different style of child seat that can be firmly secured.

- 3. Secure the child in the child seat.** Make sure the child is properly strapped in the child seat according to the child seat maker’s instructions. A child who is not properly secured in a child seat can be seriously injured in a crash.

The following pages provide guidelines on how to properly install a child seat. A forward-facing child seat is used in all examples, but the instructions are the same for a rear-facing child seat.

Installing a Child Seat

Installing a Child Seat Using LATCH

Your vehicle is equipped with LATCH (Lower Anchors and Tethers for Children) at the outer rear seats. The lower anchors are located between the seat-back and seat bottom, and are to be used only with a child seat designed for use with LATCH.

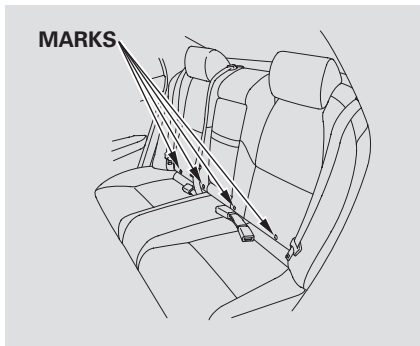

The location of each lower anchor is marked with a small button above the point.

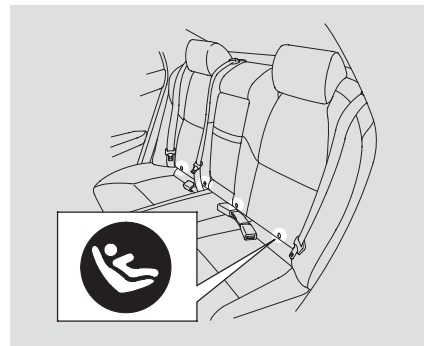

Each button has the symbol shown above. To install a LATCH-compatible child seat:

1. Move the seat belt buckle or tongue away from the lower anchors.
2. Make sure there are no objects near the anchors that could prevent a secure connection between the child seat and anchors.

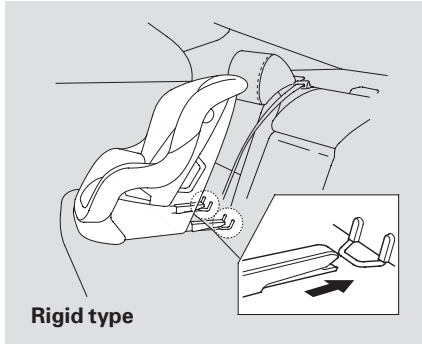

3. Place the child seat on the vehicle seat, and attach the seat to the lower anchors according to the child seat maker's instructions.

Some LATCH-compatible seats have a rigid-type connection as shown above.

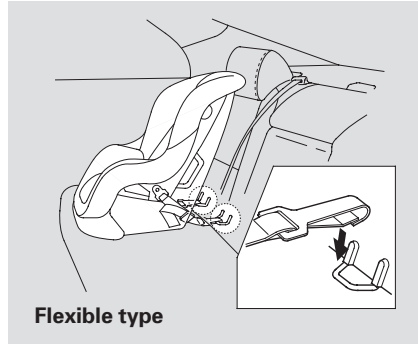

4. Whatever type you have, follow the child seat maker's instructions for adjusting or tightening the fit.

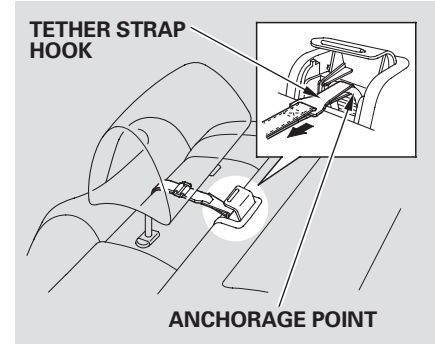

5. Attach the tether strap hook to the anchor (see page 42), then tighten the strap as instructed by the child seat maker.
6. Push and pull the child seat forward and from side-to-side to verify that it is secure.

Installing a Child Seat

Installing a Child Seat with a Lap/Shoulder Belt

When not using the LATCH system, all child seats must be secured to the vehicle with the lap part of a lap/shoulder belt.

In addition, the lap/shoulder belts in the back seating positions, and in the front passenger seat, have a locking mechanism that must be activated to secure a child seat.

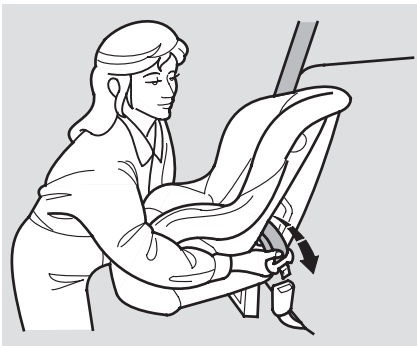

1. With the child seat in the desired seating position, route the belt through the child seat according to the seat maker's instructions, then insert the latch plate into the buckle.

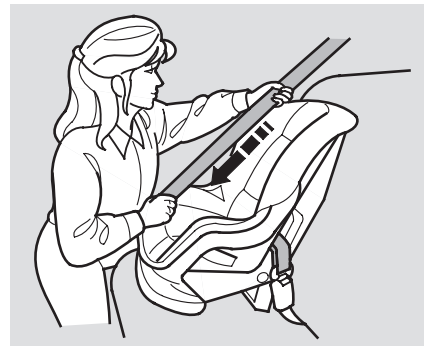

2. To activate the lockable retractor, slowly pull the shoulder part of the belt all the way out until it stops, then let the belt feed back into the retractor.
3. After the belt has retracted, tug on it. If the belt is locked, you will not be able to pull it out. If you can pull the belt out, it is not locked, and you will need to repeat these steps.



4. After confirming that the belt is locked, grab the shoulder part of the belt near the buckle, and pull up to remove any slack from the lap part of the belt. Remember, if the lap part of the belt is not tight, the child seat will not be secure.

To remove slack, it may help to put weight on the child seat, or push on the back of the seat while pulling up on the belt.

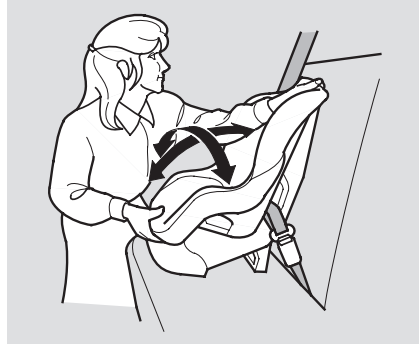

5. Push and pull the child seat forward and from side to side to verify that it is firmly secured. If the child seat is not secure, unlatch the belt, allow it to retract fully, then repeat these steps.

To deactivate the locking mechanism and remove a child seat, unlatch the buckle, unrout the seat belt, and let the belt fully retract.

Installing a Child Seat with a Tether

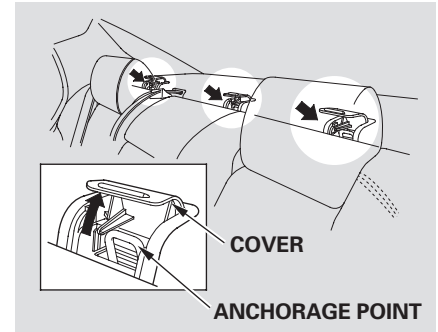

A child seat with a tether can be installed in any seating position in the back seat, using one of the anchorage points shown above.

Since a tether can provide additional security to the lap/shoulder belt installation, we recommend using a tether whenever one is required or available. (Tethers are required in Canada.)

Installing a Child Seat, Protecting Larger Children

Using an Outer Anchorage Point

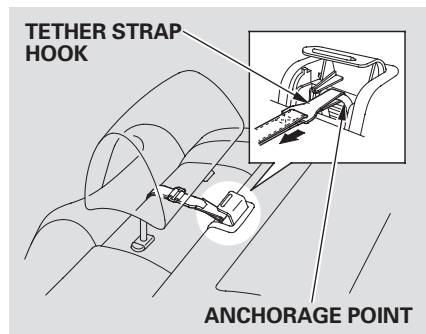

1. After properly securing the child seat with the lap/shoulder belt (see page 40), route the tether strap over the top of the seat-back and through the legs of the head restraint.
2. Lift the anchor point lid, then attach the tether strap hook to the anchor, making sure the strap is not twisted.
3. Tighten the strap according to the seat maker's instructions.

Using the Center Anchorage Point

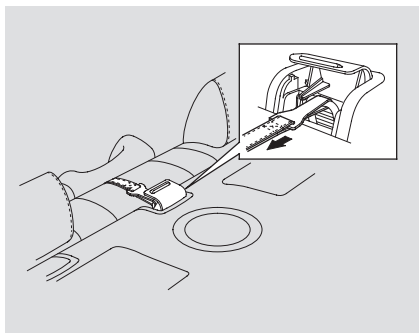

1. After properly securing the child seat with the lap/shoulder belt (see page 40), route the tether strap over the top of the seat-back.
2. Attach the tether strap hook to the anchor, making sure the strap is not twisted, then tighten the strap according to the seat-maker's instructions.

Protecting Larger Children

When a child reaches the recommended weight or height limit for a forward-facing child seat, the child should sit in a back seat on a booster and wear a lap/shoulder belt. The following pages provide guidelines to help you decide when a given child may ride in front, and how to properly protect the child.

⚠ WARNING

Allowing a larger child age **12** or under to sit in front can result in injury or death if the passenger's front airbag inflates.

If a larger child must ride in front, move the vehicle seat as far back as possible, use a booster seat if needed, and have the child sit up properly and wear the seat belt properly.

Checking Seat Belt Fit



To determine if a lap/shoulder belt properly fits a child, have the child put on the seat belt, then ask yourself:

1. Does the child sit all the way back against the seat?
2. Do the child's knees bend comfortably over the edge of the seat?

3. Does the shoulder belt cross between the child's neck and arm?
4. Is the lap part of the belt as low as possible, touching the child's thighs?
5. Will the child be able to stay seated like this for the whole trip?

If you answer yes to all these questions, the child is ready to wear the lap/shoulder belt correctly. If you answer no to any question, the child needs to ride on a booster seat.

Using a Booster Seat



A child who has outgrown a forward-facing child seat should ride in a back seat and use a booster seat until the lap/shoulder belt fits them properly without the booster.

CONTINUED

Protecting Larger Children

Some states also require children to use a booster until they reach a given age or weight (e.g., 6 years or 60 lbs). Be sure to check current laws in the state or states where you intend to drive.

Booster seats can be high-back or low-back. Whichever style you select, make sure the booster meets federal safety standards and that you follow the booster seat maker's instructions.

If a child who uses a booster must ride in front, move the vehicle seat as far back as possible, and be sure the child is wearing the seat belt properly.

A child may continue using a booster seat until the tops of their ears are even with the top of the vehicle's or booster's seat-back. A child of this height should be tall enough to use the lap/shoulder belt without a booster.

When Can a Larger Child Sit in Front
The National Highway Traffic Safety Administration and Transport Canada recommend that all children ages 12 and under be properly restrained in the back seat.

If the passenger's front airbag inflates in a moderate to severe frontal collision, the airbag can cause serious injuries to a child who is unrestrained, improperly restrained, sitting too close to the airbag, or out of position.

The side airbag also poses risks. If any part of a larger child's body is in the path of a deploying side airbag, the child could receive possibly serious injuries.

Of course, children vary widely. And while age may be one indicator of when a child can safely ride in the front. There are other important factors you should consider.

Maturity

To safely ride in front, a child must be able to follow the rules, including sitting properly, and wearing the seat belt properly throughout the ride.

Physical Size

Physically, a child must be large enough for the lap/shoulder belt to properly fit (see page 43). If the seat belt does not fit properly, with or without the child sitting on a booster, the child should not sit in the front.

If you decide that a child can safely ride up front, be sure to:

- Carefully read the owner's manual, and make sure you understand all seat belt instructions and all safety information.
- Move the vehicle seat to the rear-most position.
- Have the child sit up straight, back against the seat, and feet on or near the floor.
- Check that the child's seat belt is properly and securely positioned.
- Supervise the child. Even mature children sometimes need to be reminded to fasten the seat belts or sit properly.

Additional Safety Precautions

Do not let a child wear a seat belt across the neck. This could result in serious neck injuries during a crash.

Do not let a child put the shoulder part of a seat belt behind the back or under the arm. This could cause very serious injuries during a crash. It also increases the chance that the child will slide under the belt in a crash and be injured.

Two children should never use the same seat belt. If they do, they could be very seriously injured in a crash.

Do not put any accessories on a seat belt. Devices intended to improve a child's comfort or reposition the shoulder part of a seat belt can make the belt less effective, and increase the chance of serious injury in a crash.

Carbon Monoxide Hazard

Your vehicle's exhaust contains carbon monoxide gas. You should have no problem with carbon monoxide entering the vehicle in normal driving if you maintain your vehicle properly.

Have the exhaust system inspected for leaks whenever:

- The vehicle is raised for an oil change.
- You notice a change in the sound of the exhaust.
- The vehicle was in an accident that may have damaged the underside.

WARNING

Carbon monoxide gas is toxic. Breathing it can cause unconsciousness and even kill you.

Avoid any enclosed areas or activities that expose you to carbon monoxide.

High levels of carbon monoxide can collect rapidly in enclosed areas, such as a garage. Do not run the engine with the garage door closed. Even with the door open, run the engine only long enough to move the vehicle out of the garage.

With the trunk lid open, air flow can pull exhaust gas into your vehicle's interior and create a hazardous condition. If you must drive with the trunk lid open, open all the windows, and set the climate control system as shown below.

If you must sit in your parked vehicle, even in an unconfined area, with the engine running, adjust the climate control system as follows:

1. Select the Fresh Air mode.
2. Select the  mode.
3. Set the fan speed to high.
4. Set the temperature control to a comfortable setting.

These labels are in the locations shown. They warn you of potential hazards that could cause serious injury. Read these labels carefully.

If a label comes off or becomes hard to read, contact your Acura dealer for a replacement.

RADIATOR CAP



DASHBOARD

U.S. models only



HOOD

U.S. models

SUPPLEMENTAL RESTRAINT SYSTEM (SRS)

This vehicle is equipped with front airbags, side airbags in the front seats, front seatbelt trimmers, and side curtain airbags.

All SRS electrical wiring and connectors are colored yellow.

Tampering with, disconnecting or using test equipment on the SRS wiring can make the system inoperative or cause accidental deployment.

WARNING

Accidental deployment can seriously hurt or kill you.
Follow Service Manual instructions carefully.

Canadian models

SUPPLEMENTAL RESTRAINT SYSTEM (SRS)

This vehicle is equipped with front airbags, side airbags in the front seats, front seatbelt trimmers, and side curtain airbags.

All SRS electrical wiring and connectors are colored yellow. Tampering with, disconnecting or using test equipment on the SRS wiring can make the system inoperative or cause accidental deployment.

WARNING

Accidental deployment can seriously hurt or kill you.
Follow Service Manual instructions carefully.

SYSTEME DE RETENUE SUPPLEMENTAIRE (SRS)

Cette véhicule est équipée de coussins gonflables frontaux, coussins gonflables latéraux et de coussins gonflables latéraux de type rideau ainsi que de garnitures de ceinture de sécurité avant.

Tous les fils électriques et connecteurs du système SRS sont jaunes. La situation où le débranchement des fils du système SRS ou encore l'utilisation d'appareils d'essai sur les circuits pourrait rendre le système inopérant ou déclencher un déploiement accidentel.

ATTENTION

Un déploiement accidentel risque de causer graves blessures, voire la mort.
Suivre attentivement les instructions du manuel de réparation.

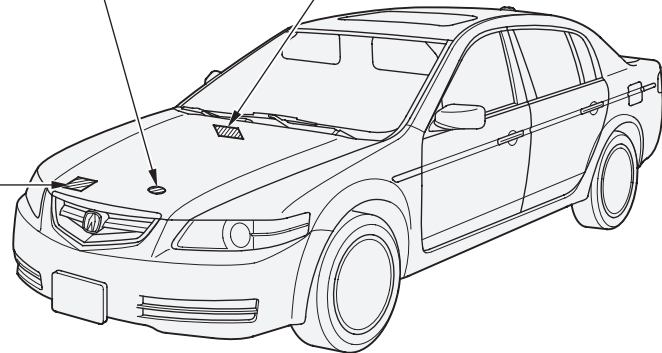

CONTINUED

Safety Labels

SUN VISOR

U.S. models

⚠ WARNING

DEATH or SERIOUS INJURY can occur

- Children 12 and under can be killed by the air bag
- The BACK SEAT is the SAFEST place for children
- NEVER put a rear-facing child seat in the front
- Sit as far back as possible from the air bag
- ALWAYS use SEAT BELTS and CHILD RESTRAINTS

Canadian models

<p>CAUTION</p> <p>TO AVOID SERIOUS INJURY:</p> <ul style="list-style-type: none">• FOR MAXIMUM SAFETY PROTECTION IN ALL TYPES OF CRASHES, YOU MUST ALWAYS WEAR YOUR SAFETY BELT.• DO NOT INSTALL REARWARD-FACING CHILD SEATS IN ANY FRONT PASSENGER SEAT POSITION.• DO NOT SIT OR LEAN UNNECESSARILY CLOSE TO THE AIR BAG.• DO NOT PLACE ANY OBJECTS OVER THE AIR BAG OR BETWEEN THE AIR BAG AND YOURSELF.• SEE THE OWNER'S MANUAL FOR FURTHER INFORMATION AND EXPLANATIONS.	<p>PRÉCAUTION:</p> <p>POUR ÉVITER DES BLESSURES GRAVES:</p> <ul style="list-style-type: none">• POUR PROFITER D'UNE PROTECTION MAXIMALE LORS D'UNE COLLISION BOUCLEZ TOUJOURS VOTRE CEINTURE DE SÉCURITÉ.• N'INSTALLEZ JAMAIS UN SIÈGE POUR ENFANTS FAISANT FACE À L'ARRIÈRE SUR LE SIÈGE DU PASSAGER AVANT.• NE VOUS APPUYEZ PAS ET NE VOUS ASSEYEZ PAS PRÈS DU COUSSIN GONFLABLE.• NE DÉPOSEZ AUCUN OBJET SUR LE COUSSIN GONFLABLE OU ENTRE LE COUSSIN GONFLABLE ET VOUS.• LISEZ LE GUIDE UTILISATEUR POUR DE PLUS AMPLES RENSEIGNEMENTS.
---	--

DOORJAMB

U.S. models

SIDE AIRBAG

- This car is equipped with side airbags in the front seats and side curtain airbags.
- Do not lean against the door.
- See owner's manual for more information.

Canadian models

SIDE AIRBAG

- This car is equipped with side airbags in the front seats and side curtain airbags.
- Do not lean against the door.
- See owner's manual for more information.

COUSSIN GONFLABLE LATÉRAL

- Cette automobile est équipée de coussins gonflables latéraux dans les sièges avant ainsi que de coussins gonflables latéraux de type rideau.
- Ne vous appuyez pas sur la porte.
- Consultez le Manuel du propriétaire pour en savoir plus.

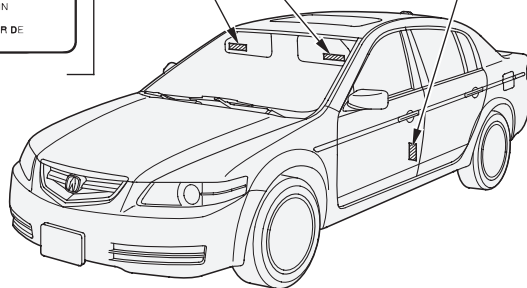

This section gives information about the controls and displays that contribute to the daily operation of your Acura. All the essential controls are within easy reach.

Control Locations	50	Mirrors	91
Instrument Panel	51	Driving Position Memory System.....	93
Instrument Panel Indicators.....	52	Seat Heaters	96
Gauges	57	Power Windows	97
Temperature Gauge.....	57	Moonroof	100
Fuel Gauge	57	Clock	103
Multi-Information Display	58	Parking Brake	103
Controls Near Steering Wheel.....	72	Interior Lights	104
Windshield Wipers and Washers ..	73	Interior Convenience Items.....	105
Turn Signal and Headlights.....	74	Beverage Holder.....	106
Fog Lights.....	75	Accessory Power Socket	106
Instrument Panel Brightness	75	Glove Box	107
Automatic Lighting Off.....	76	Console Compartment	107
Hazard Warning Button.....	76	Front Door Pocket.....	108
Rear Window Defogger	77		
Steering Wheel Adjustment	78		
Keys.....	79		
Ignition Switch	80		
Immobilizer System.....	81		
Door Locks	82		
Trunk.....	83		
Emergency Trunk Opener	84		
Childproof Door Locks	84		
Remote Transmitter	85		
Seats	90		
Trunk Pass-through Cover.....	90		

Control Locations

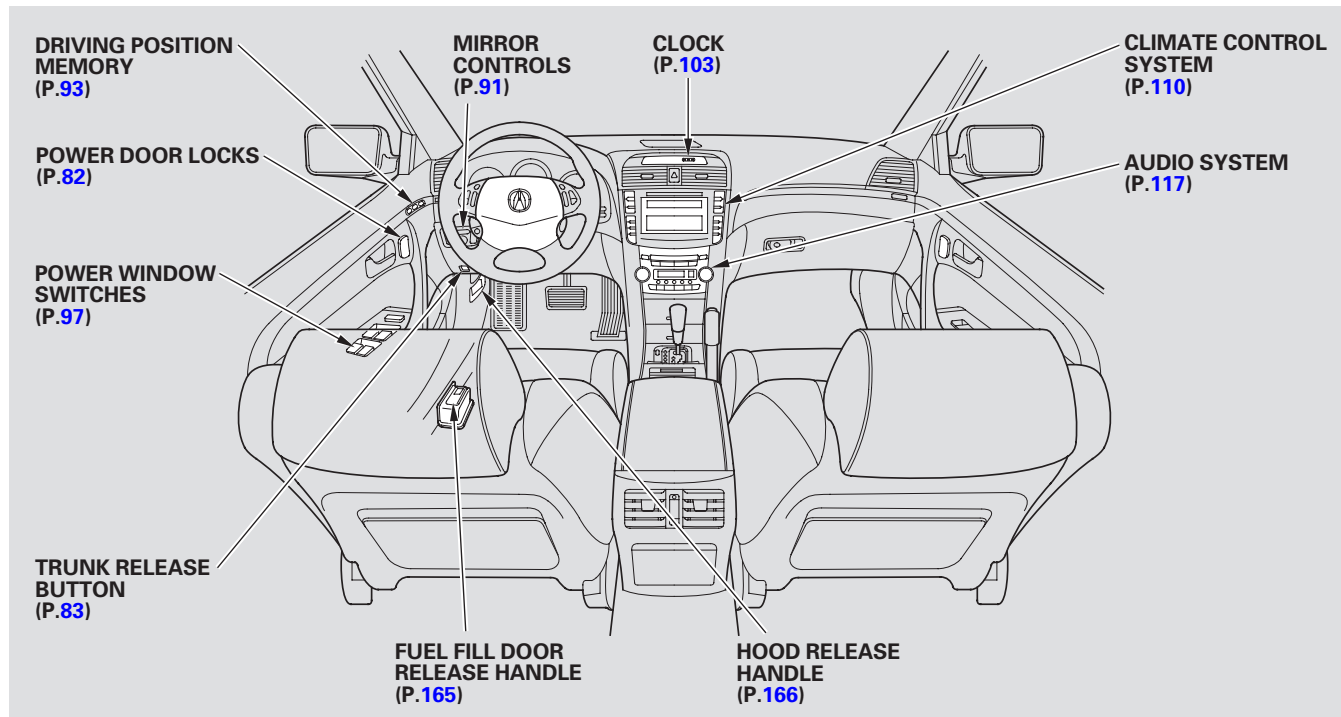

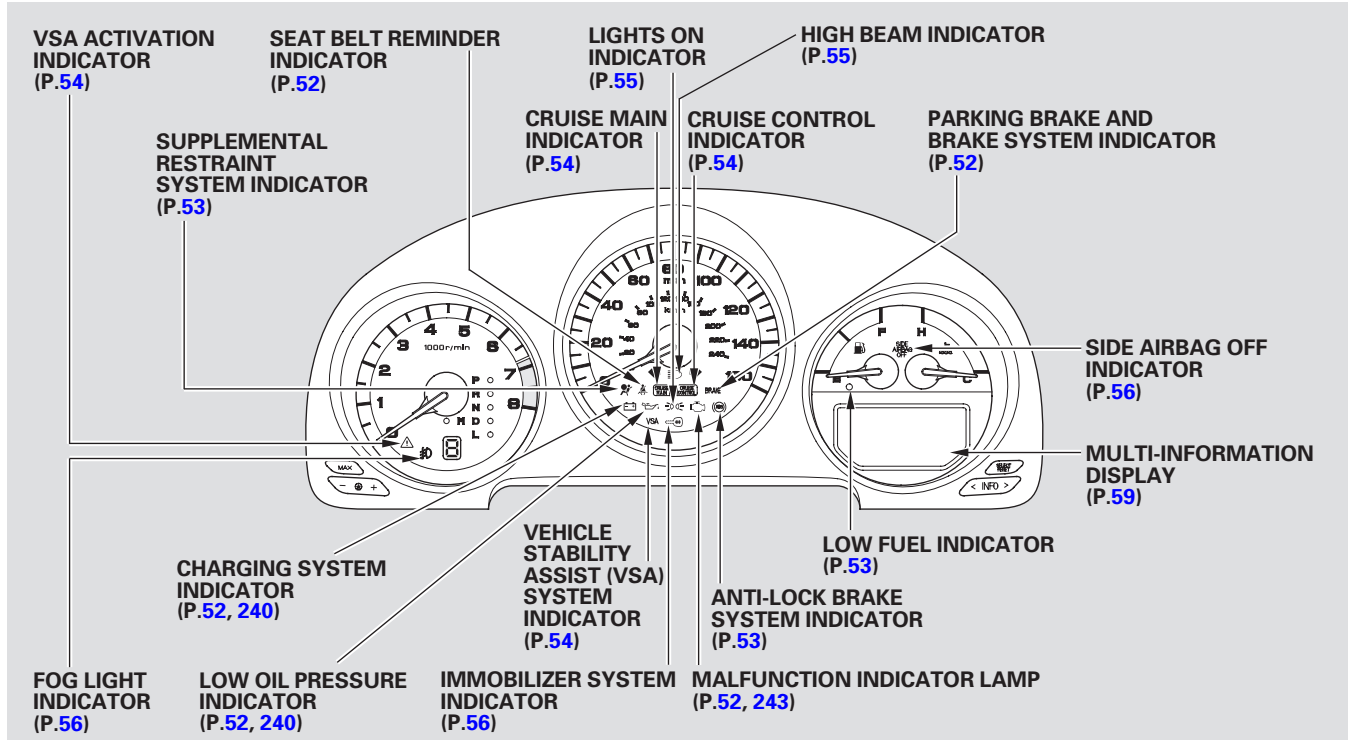

Instrument Panel Indicators

The instrument panel has many indicators to give you important information about your vehicle.



Seat Belt Reminder Indicator

If you turn the ignition switch to ON (II) before fastening your belt, the beeper sounds and the indicator flashes. If you do not fasten your seat belt before the beeper stops, the indicator stops flashing but remains on.

If you continue driving without fastening your seat belt, the beeper sounds and the indicator flashes again at regular intervals, and you will see “FASTEN SEAT BELT” in the multi-information display.



Low Oil Pressure Indicator

The engine can be severely damaged if this indicator flashes or stays on when the engine is running. For more information, see page [242](#).



Charging System Indicator

If this indicator comes on when the engine is running, the battery is not being charged. For more information, see page [242](#).



Malfunction Indicator Lamp

See page [243](#).

U.S. Canada Parking Brake and Brake System Indicator

U.S.
BRAKE

Canada
(!)

Parking Brake and
Brake System
Indicator

This indicator has two functions:

1. It comes on when you turn the ignition switch to ON (II). It is a reminder to check the parking brake. Driving with the parking brake not fully released can damage the brakes and tires.
2. If it stays on after you have fully released the parking brake while the engine is running, or if it comes on while driving, it can indicate a problem in the brake system. For more information, see page [244](#).

If you drive without releasing the parking brake, a chime will sound, and you will see a “RELEASE PARKING BRAKE” message in the Multi-Information Display.



Anti-lock Brake System (ABS) Indicator

This indicator normally comes on for a few seconds when you turn the ignition switch to ON (II), and when the ignition switch is turned to START (III). If this indicator comes on at any other time, there is a problem in the ABS. If this happens, take the vehicle to your dealer to have it checked. With the indicator on, your vehicle still has normal braking ability but no anti-lock. For more information, see page [189](#).



Supplemental Restraint System Indicator

This indicator comes on briefly when you turn the ignition switch to ON (II). If it comes on at any other time, it indicates a potential problem with your front airbags. This light will also alert you to a potential problem with your side airbags, passenger's side airbag automatic cutoff system, automatic seat belt tensioners, or side curtain airbags. For more information, see page [26](#).



Side Airbag Cutoff Indicator

This indicator comes on when you turn the ignition switch to ON (II). If it comes on at any other time, it indicates that the passenger's side airbag has automatically shut off. For more information, see page [27](#).

Instrument Panel Indicators

Vehicle Stability Assist (VSA) System Indicator

This indicator normally comes on for a few seconds when you turn the ignition switch to ON (II).

If it comes on and stays on at any other time, or it does not come on when you turn the ignition switch to ON (II), there is a problem with the VSA system. Take your vehicle to a dealer to have it checked. Without VSA, your vehicle still has normal driving ability, but will not have VSA traction and stability enhancement. See page [190](#) for more information on the VSA system.

VSA Activation Indicator

This indicator has three functions.

1. It comes on as a reminder that you have turned off the Vehicle Stability Assist (VSA) system.
2. It flashes when VSA is active (see page [190](#)).
3. It comes on along with the VSA system indicator if there is a problem with the VSA system.

This indicator normally comes on for a few seconds when you turn the ignition switch to ON (II). See page [190](#) for more information on the VSA system.

Cruise Main Indicator

This indicator comes on when you turn on the Cruise Control System by pressing the Master Button (see page [142](#)).

Cruise Control Indicator

This indicator comes on when you set the cruise control. See page [142](#) for information on operating the cruise control.



Turn Signal and Hazard Warning Indicators

The left or right turn signal light blinks when you signal a lane change or turn. If the indicators do not blink or blinks rapidly, it usually means one of the turn signal bulbs is burned out (see page 214). Replace the bulb as soon as possible, since other drivers cannot see that you are signaling.

When you press the Hazard Warning button, both turn signals blink. All turn signals on the outside of the vehicle should flash.



“Daytime Running Lights” Indicator

Canadian models only

This indicator comes on when you turn the ignition switch to ON (II) with the headlight switch off and the parking brake set. It should go off if you turn on the headlights or release the parking brake. If it comes on at any other time, it means there is a problem with the DRL.





High Beam Indicator

This indicator comes on with the high beam headlights. See page 74 for information on the headlight controls.



Lights On Indicator

This indicator reminds you that the exterior lights are on. It comes on when the light switch is in either the  or  position. If you turn the ignition switch to ACCESSORY (I) or LOCK (0) without turning off the light switch, this indicator will remain on. A reminder chime will also sound when you open the driver's door.

Instrument Panel Indicators



Immobilizer System Indicator

This indicator comes on for a few seconds when you turn the ignition switch to ON (II). It then will go off if you have inserted a properly-coded ignition key. If it is not a properly-coded key, the indicator will blink and the engine will not start (see page 81).

This indicator also blinks several times when you turn the ignition switch from ON (II) to ACCESSORY (I) or LOCK (0).

Low Fuel Indicator

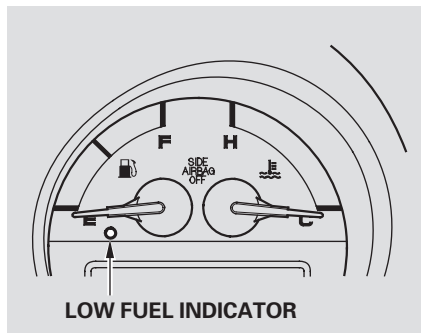

This indicator is in the fuel gauge. It comes on as a reminder that you must refuel soon.



Fog Light Indicator

U.S. models only

This indicator comes on when you turn on the fog lights. See page 75 for information on fog light operation.

Temperature Gauge

This shows the temperature of the engine's coolant. During normal operation, the pointer should rise to about the middle of the gauge. In severe driving conditions, the pointer may rise to the upper zone. If it reaches the red (Hot) mark, pull safely to the side of the road. Turn to page [240](#) for instructions and precautions on checking the engine's cooling system.

Fuel Gauge

This shows how much fuel you have. It may show slightly more or less than the actual amount. The needle returns to the bottom after you turn off the ignition.

NOTICE

Avoid driving with an extremely low fuel level. Running out of fuel could cause the engine to misfire, damaging the catalytic converter.

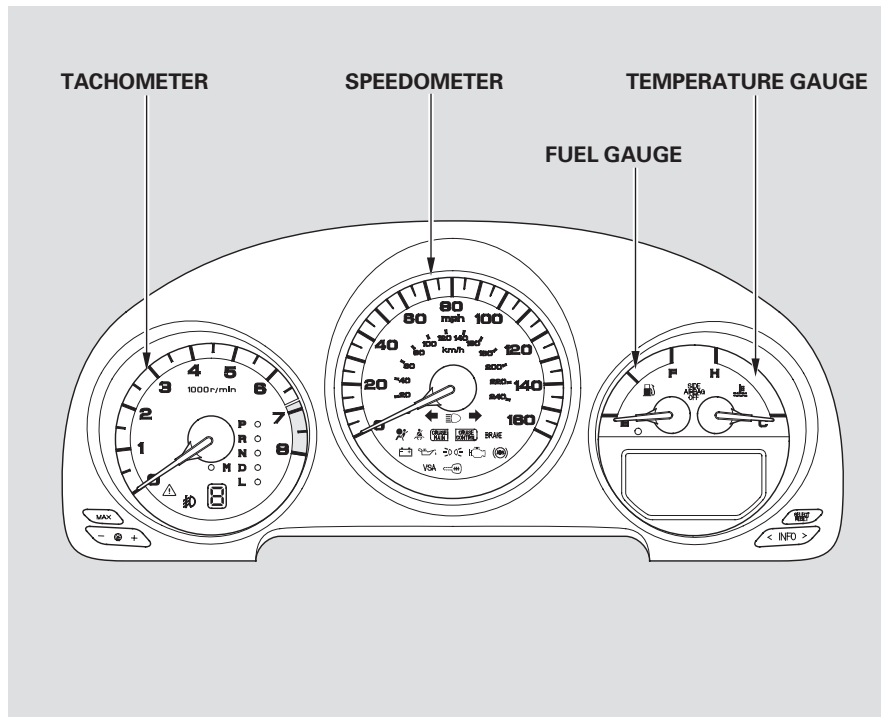

Multi-Information Display

The multi-information display in the instrument panel displays various information and messages. Some of the messages help you operate your vehicle more comfortably. Others help to keep you aware of the periodic maintenance your vehicle needs for continued trouble-free driving.

Here is a list of the messages you can see. The following pages give you more information on these messages.

- Driver 1 or 2 Detected
- Door and Trunk Open
- Fasten Seat Belt
- Release Parking Brake
- Check Fuel Cap
- Low Windshield Washer Fluid Level (Canada only)
- Odometer
- Trip Meter
- Outside Temperature
- Engine Oil Life

- Maintenance Messages
- Trip Computer
- Keyless Memory Settings™
- HandsFree Link™
- Language Selection (Canada only)

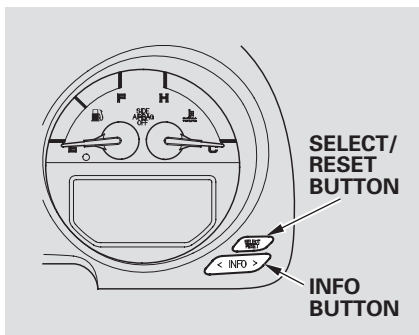

With the multi-information display and the two buttons next to it, you can also customize these vehicle control settings to your liking.

- Auto door lock conditions
- Auto door unlock conditions
- Whenever unlocking (driver's door, or all doors)
- Keyless lock acknowledgment conditions
- Security relock timer
- Headlight auto off timer
- Interior light dimming time

To customize these control settings, see page [66](#).

With the ignition switch in the ON (II) position, the basic display changes, as shown in the illustration, each time you press the > side of the INFO button. If you press the < side of the INFO button, the display returns to the previous message.

On Canadian models, the language in the multi information display can be set to English or French. To change the language see page 71.

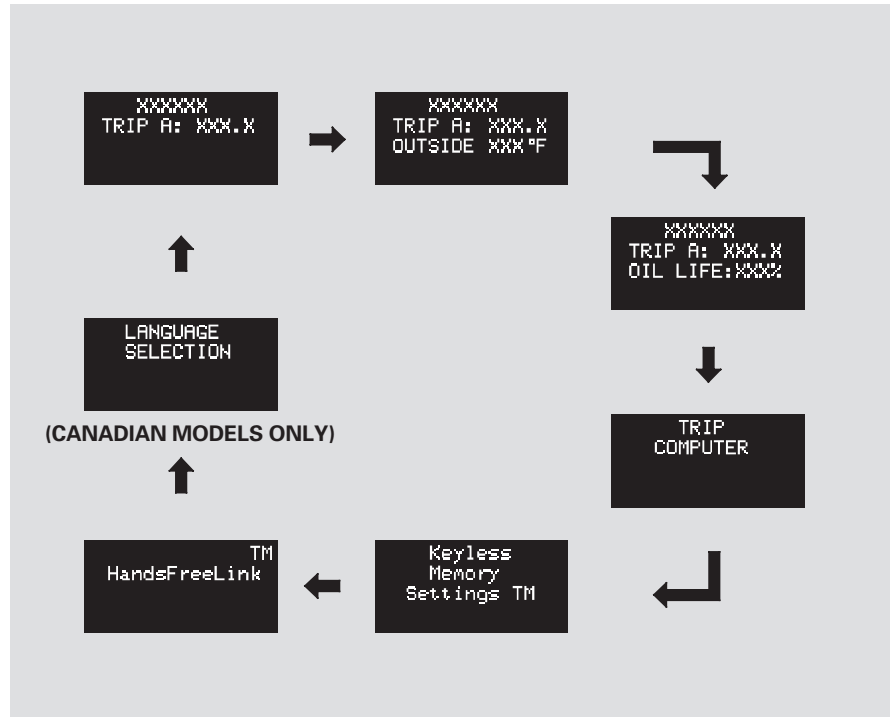

Multi-Information Display

Driver 1 or 2 Detected



When you unlock and open the driver's door with the key, the display shows "DRIVER 1 DETECTED" or "DRIVER 2 DETECTED", depending on which remote transmitter was used last. (The driver's "ID" is determined by the transmitter.)

If you use the remote transmitter to unlock the driver's door, the display shows "DRIVER 1 DETECTED" or "DRIVER 2 DETECTED" depending on which transmitter you use, and the driver's seat and outside mirrors move to the positions stored in that transmitter (see page [93](#)).

Door and Trunk Open

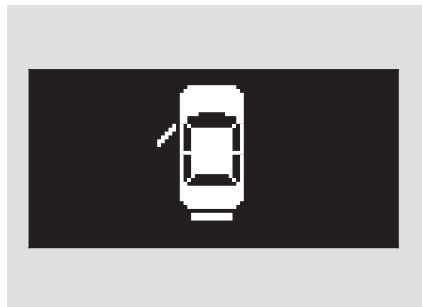

If the trunk or any door is not closed tightly, the display reminds you to close the open trunk or the door(s) before you start driving.

Fasten Seat Belt



In addition to the Seat Belt Reminder in the instrument panel, the multi-information display interrupts the current display and shows "FASTEN SEAT BELT" for about 6 seconds if you do not fasten your seat belt while driving. This message repeats if you ignore it and do not wear your seat belt while the vehicle is moving.

Release Parking Brake



If you start driving without releasing the parking brake, the multi-information display interrupts the current display and shows "RELEASE PARKING BRAKE!". This message continues, and a chime sounds, until you release the parking brake or the vehicle speed slows down to less than 0.5 mph (0.8 km/h).

Check Fuel Cap



If the fuel fill cap is missing or not tightened properly, you will see "CHECK FUEL CAP". Make sure the fuel cap is installed and tightened properly to at least 3 clicks.

The CHECK FUEL CAP message should go off after tightening the fuel cap, turning the ignition switch off and on, then driving over 30 mph for at least 45 seconds. Due to different driving conditions, it may take a few drive trips to make the message go off.

If a loose or missing fuel cap was not the cause of the CHECK FUEL CAP message coming on, the message will turn off and the Malfunction Indicator Lamp will come on. If this happens, have your vehicle checked by an Acura dealer as soon as possible.

Multi-Information Display

Low Windshield Washer Fluid Level



On Canadian models
If the fluid level in the windshield washer reservoir gets low, the multi-information display shows the above message.

Odometer



The odometer shows the total distance your vehicle has been driven. It measures miles in U.S. models and kilometers in Canadian models. It is illegal under U.S. federal law and Canadian provincial regulations to disconnect, reset, or alter the odometer with the intent to change the number of miles or kilometers indicated.

Trip Meter

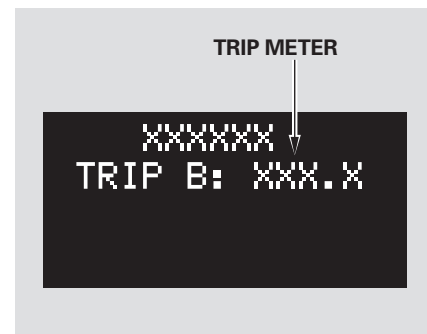

This meter shows the number of miles (U.S.) or kilometers (Canada) driven since you last reset it. There are two trip meters: Trip A and Trip B. When you first turn the ignition switch to ON (II), Trip A is displayed. Switch between Trip A and Trip B by pressing the Select/Reset button repeatedly. Each trip meter works independently, so you can keep track of two different distances.

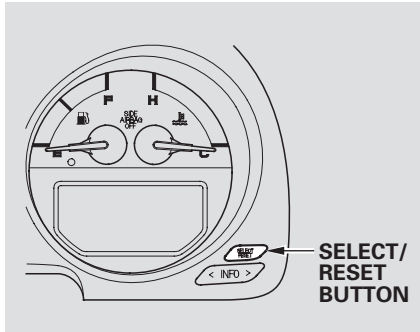

To reset a trip meter, display it, then press and hold the Select/Reset button until the number resets to "0.0".

Both trip meters will reset if the vehicle's battery goes dead or is disconnected.

Outside Temperature



This shows the outside Fahrenheit temperature in U.S. models, and Centigrade temperature in Canadian models.

The temperature sensor is in the front bumper. The temperature reading can be affected by heat reflection from the road surface, engine heat, and the exhaust from surrounding traffic. This can cause an incorrect temperature reading when your speed is under 19 mph (30 km/h). When you start your trip, the sensor is not fully acclimatized, therefore it may take several minutes until the proper temperature is displayed.

In certain weather conditions, temperature readings near freezing (32°F, 0°C) could mean that ice is forming on the road surface.

Multi-Information Display

Engine Oil Life



This shows the remaining life of the engine oil. It shows 100% after the engine oil is replaced and the display is reset. The engine oil life is calculated based on engine operating conditions and accumulated engine revolutions.

Maintenance Messages



When the engine oil life reaches 15 percent, the display shows “SERVICE DUE SOON” and the code for the maintenance items to be performed.

When the engine oil life reaches 5 percent, the display shows “SERVICE DUE NOW” along with the same maintenance items.

Have your dealer do the indicated maintenance as soon as you see this message, and have them reset the display after completing the service.

If you do not perform the indicated maintenance or do not reset the display, the message changes to “SERVICE PAST DUE” when the engine oil life becomes 0 percent.

These messages appear on the multi-information display each time you turn the ignition switch to ON (II).

For details on engine oil life and maintenance messages, refer to page [195](#).

Also refer to page [194](#) for important maintenance safety precautions.

Trip Computer



When the multi-information display is in the trip computer mode, press the Select/Reset button. The display changes as shown above.

The messages in this display indicate:

- AVG MPG: Average vehicle speed
- AVG MPH: Average fuel economy
- DIST: Distance traveled
- TIME: Time traveled

To reset the values in the trip computer, press Select/Reset button, and hold it for about 1 second.



When the display shows the initial screen of the trip computer, press the > side of the INFO button to display “MILES TO EMPTY”. This is the estimated distance you can travel on the fuel remaining in the tank. This distance is estimated from the fuel economy you received over the last several miles, so it will vary with changes in speed, traffic, etc.

Multi-Information Display

Keyless Memory Settings™



You can customize some of the vehicle control settings to your preference. Here are the settings you can customize:

- Auto door lock conditions
- Auto door unlock conditions
- Keyless lock acknowledgment conditions
- Security relock timer
- Headlight auto off timer
- Interior light dimming time



While “Keyless Memory Settings” is displayed, press the Select/Reset button. The display will change to the screen shown above.

Select the menu item you want (“CHG SETTINGS”, “DEFAULT ALL” or “EXIT”) by moving the pointer “>” with the INFO button. After selecting a menu item, enter your selection by pressing the Select/Reset button.

To exit this mode without changing the current settings, select “EXIT” and press the Select/Reset button. The display will move to the next mode.

If you want to change the settings, select “CHG SETTINGS”, and press the Select/Reset button. The display will change to the screen shown in the middle column of this page.



If you want the settings as they were when the vehicle left the factory, select “DEFAULT ALL” and press the Select/Reset button. The display will change to the screen shown above. Press the Select/Reset button to select “OK” or press the < or > side of the INFO button to cancel.



The first Keyless Memory Setting is Auto Door Lock conditions. Select the desired condition by moving the pointer with the > side of the INFO button. On the display > will be next to the current setting.

Here are the three possible settings:

OFF: The auto door lock is deactivated all the time.

SHIFT FROM P: The doors will lock whenever you move the shift lever out of P. (Models with automatic transmission.)

10 MPH: The doors will lock when the vehicle speed reaches 10 mph.

CONTINUED

Multi-Information Display



The next setting menu is Auto Door Unlocking conditions.

1. OFF: The auto door unlock is deactivated all the time.
2. SHIFT TO P: The driver's door or all doors depending on your selection in the next step, will unlock whenever you move the shift lever to P.

3. IGN OFF: The driver's door or all doors will unlock when you turn the ignition switch to OFF (0).

Enter your selection by moving the pointer with the > side of the INFO button.



4. To designate the door(s) that unlock under the previous step, select "DRIVER'S DOOR" or "ALL DOORS" by moving the pointer with the INFO button. Then enter your selection by moving the pointer with the > side of the INFO button.

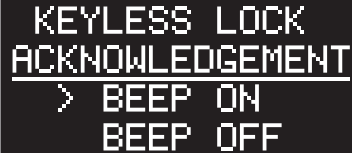

```
KEYLESS LOCK
ACKNOWLEDGEMENT
-----
> BEEP ON
  BEEP OFF
```

The next setting menu is “KEYLESS LOCK ACKNOWLEDGMENT”. When you push the LOCK button a second time within 5 seconds after you lock the doors with the remote transmitter, a beep will sound to verify that doors are locked and the security system has set. If you do not want the beeper to sound, select “BEEP OFF” and enter your selection by moving the pointer with the > side of the INFO button.



```
SECURITY
RELOCK TIMER
-----
> 30S  60S
      90S
```

The next setting menu is “SECURITY RELOCK TIMER”. If you unlock the doors with the remote transmitter, but do not open any of the doors within 30 seconds, the doors automatically relock and the security system sets. You can change this relock time from 30 seconds to 60 or 90 seconds. Select the desired relock time by moving the pointer with the > side of the INFO button.



```
HEADLIGHT AUTO
OFF TIMER
-----
> 0S  15S  30S
      60S
```

The last two setting menus are “HEADLIGHT AUTO OFF TIMER” and “INTERIOR LIGHT DIMMING TIME”. Select the time (“0S, 15S, 30S or 60 S”) and enter your selection by pressing the Select/Reset button. The headlights, parking lights, taillights and licence plate light turn off after the selected time when you remove the key from the ignition switch and close the driver’s door.

Multi-Information Display



The interior lights fade out when you close all doors (see page 104). Select how long it takes for the interior lights to fade out (in seconds) from 5S, 15S, or 30S, and enter your selection by moving the pointer with the > side of the INFO button.

HandsFreeLink™



You can receive or make phone-calls from your cell phone through your Acura's HandsFreeLink (HFL) system without touching your cell phone.

To use the system, your cell phone and the HFL system must be linked. Not all cell phones are compatible with this system. Refer to page 154 for instructions on how to link your cell phone to the HFL and how to receive or make phone calls.

Language Selection



On Canadian models only

You can switch the language of the multi-information display between French and English.

When the multi-information display is in the “LANGUAGE SELECTION” mode (screen shown above), press the Select/Reset button. The display will change to the selection screen.



Select the desired language, French or English, by pressing the > side of the INFO button, and enter your selection by pressing the Select/Reset button.

Controls Near the Steering Wheel

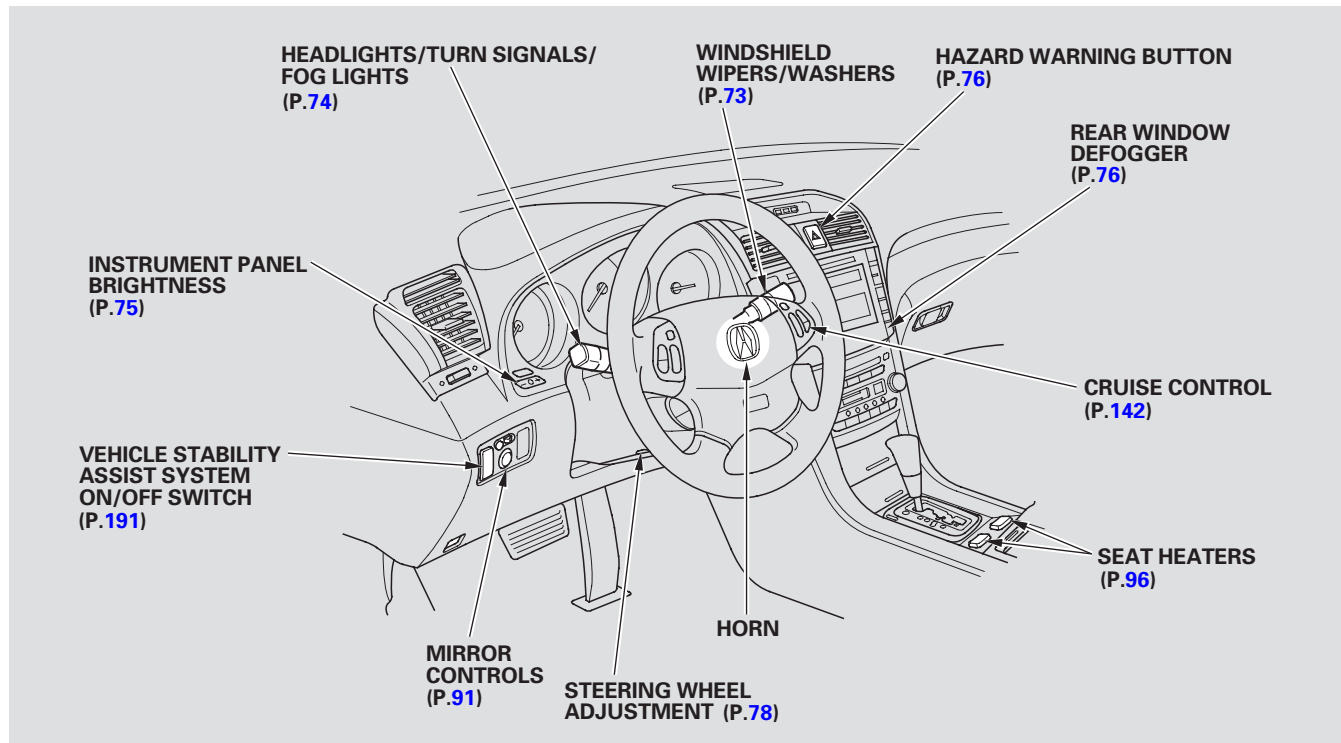

Windshield Wipers and Washers

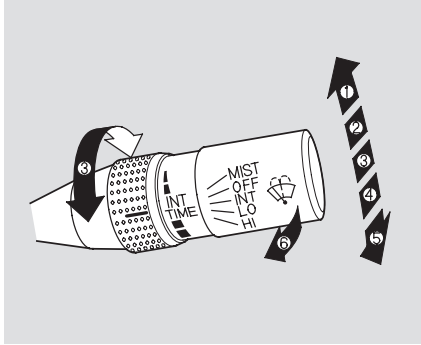

1. MIST
2. OFF
3. INT – Intermittent
4. LO – Low
5. HI – High
6. Windshield Washers

Push the right lever up or down to select a position.

MIST – The wipers run at high speed until you release the lever.

OFF – The wipers are not activated.

INT – The length of the wiper interval is varied automatically according to the vehicle's speed.

Vary the delay by turning the INT TIME ring. If you turn it to the shortest delay, the wipers will change to low speed operation when the vehicle speed exceeds 12 mph (20 km/h).

LO – The wipers run at low speed.

HI – The wipers run at high speed.

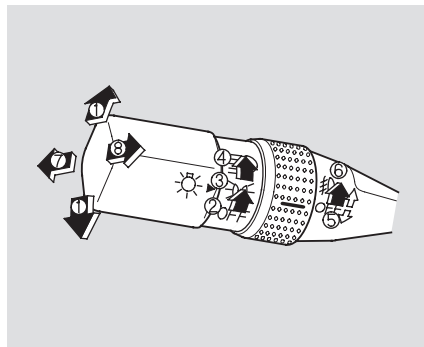

Windshield Washer – Pull back and hold the wiper control lever. The washers spray until you release the lever. The wipers run at low speed, then complete one more sweep after you release the lever.

Turn Signal and Headlights



1. Turn Signal
2. Off
3. Parking and instrument panel
4. Headlights on
5. Fog lights off (U.S. models)
6. Fog lights on (U.S. models)
7. High beams
8. Flash high beams

Turn Signal — Push down on the left lever to signal a left turn and up to signal a right turn. To signal a lane change, push lightly on the lever and hold it. The lever will return to center when you release it or complete a turn.

Headlights — The rotating switch on the left lever controls the lights. Turning this switch to the “ ” position turns on the parking lights, taillights, instrument panel lights, side-marker lights, and rear license plate lights. Turning the switch to the “ ” position turns on the headlights. If you leave the lights on with the key removed from the ignition switch, you will hear a reminder tone when you open the driver’s door.

High Beams — To switch from low beams to high beams, push the left lever forward until you hear a click. The blue high beam indicator will come on (see page 55). Pull it back to return to low beams. To flash the high beams, pull the lever back lightly, then release it. The high beams will stay on as long as you hold the lever back.

Daytime Running Lights (Canadian Models)

With the headlight switch off, the daytime running lights come on when you turn the ignition switch to ON (II) and release the parking brake. They remain on until you turn the ignition off, even if you set the parking brake.

Fog Lights (U.S. models only)

Turn the fog lights on and off by turning the switch next to the headlight switch.

You can use the fog lights only when the headlights are on low beam.

Instrument Panel Brightness

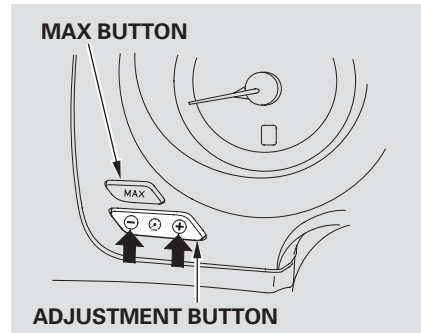

Adjust the brightness of the instrument panel by pressing the - or + side of the adjustment button. Press + to increase the brightness and - to decrease it. You can adjust the brightness with the headlight switch on or off.

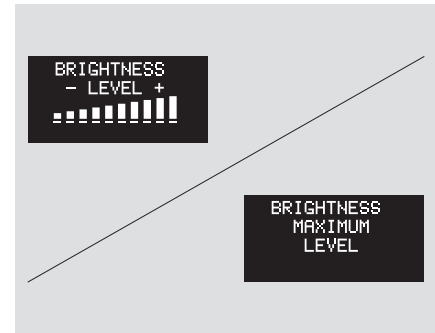

The level of brightness is shown on the multi-information display while you adjust it. It goes out 5 seconds after you finish adjusting.



To reduce glare at night, the instrument panel illumination dims when you turn the light switch to or . Pressing the MAX button will bring it to the maximum level.

Automatic Lighting Off, Hazard Warning Button

Automatic Lighting Off Feature

The automatic lighting off feature turns off the headlights, all other exterior lights, and the instrument panel lights within 15 seconds of removing the key from the ignition switch and closing the driver's door.

You can change this 15 second timer to 0, 30, or 60 seconds (see page 69).

The automatic lighting off feature activates if you leave the headlight switch in the “ ” or “ ” position, remove the key, open, then close the driver's door.

If you remove the key from the ignition switch with the headlight switch on, but do not open the door and get out, the lights will turn off after 10 minutes.

The lights will turn on again when you unlock or open the driver's door. If you unlock the door, but do not open it within 15 seconds, the lights will go off. With the driver's door open, you will hear a lights-on reminder chime.

Hazard Warning Button

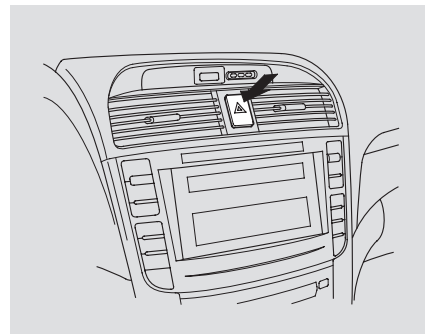

Push the button between the center vents to turn on the hazard warning lights (four-way flashers). This causes all four outside turn signals and both indicators in the instrument panel to flash. Use the hazard warning lights if you need to park in a dangerous area near heavy traffic, or if your vehicle is disabled.

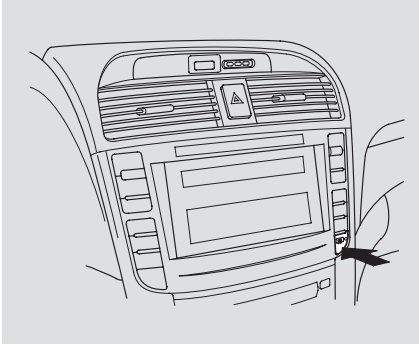

The rear window defogger clears fog, frost, and thin ice from the window. Push the defogger button to turn it on and off. The indicators in the button comes on to show the defogger is on. If you do not turn it off, the defogger will shut itself off after about 15 minutes. It also shuts off when you turn off the ignition. You have to turn it on again when you restart the vehicle.

Make sure the rear window is clear and you have good visibility before starting to drive.

The defogger and antenna wires on the inside of the rear window can be accidentally damaged. When cleaning the glass, always wipe side to side.

Steering Wheel Adjustment

See page 16 for important safety information about how to properly position the steering wheel.

Make any steering wheel adjustment before you start driving.

⚠ WARNING

Adjusting the steering wheel position while driving may cause you to lose control of the vehicle and be seriously injured in a crash.

Adjust the steering wheel only when the vehicle is stopped.

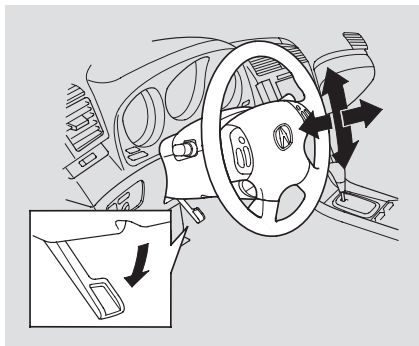

To adjust the steering wheel:

1. Push the lever under the steering column all the way down.
2. Move the steering wheel up or down, and in or out to the desired position, making sure the wheel points toward your chest, not toward your face. Make sure you can see the instrument panel gauges and the indicators.
3. Push the lever up to lock the steering wheel in that position.
4. Make sure you have securely locked the steering wheel in place by trying to move it up, down, in, and out.

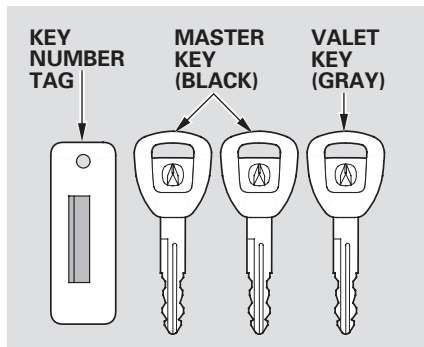

The master key fits all the locks on your vehicle.

The valet key works only in the ignition and the driver's door lock. You can keep the trunk pass-through cover and the glove box locked when you leave your vehicle and the valet key at a parking facility.

You should have received a key number tag with your key. You will need this key number if you ever have to get a lost key replaced. Use only an Acura-approved key blank.

These keys contain electronic circuits that are activated by the Immobilizer System. They will not work to start the engine if the circuits are damaged.

- Protect the key from direct sunlight, high temperature, and high humidity.
- Do not drop the keys or set heavy objects on them.
- Keep the keys away from liquids. If they get wet, dry them immediately with a soft cloth.

The keys do not contain batteries. Do not try to take them apart.

Ignition Switch

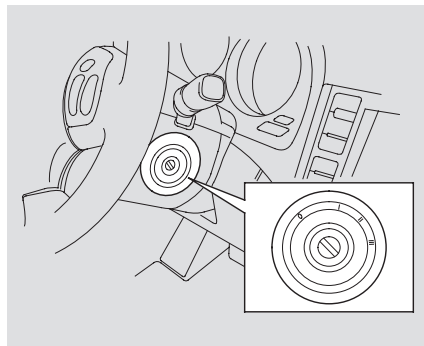

The ignition switch has four positions: LOCK (0), ACCESSORY (I), ON (II), and START (III).

LOCK (0) – You can insert or remove the key only in this position. To turn the key, you must push the key in slightly. If your vehicle has an automatic transmission, the shift lever must also be in park.

If the front wheels are turned, the anti-theft lock may make it difficult to turn the key. Firmly turn the steering wheel to the left or right as you turn the key.

ACCESSORY (I) – You can operate the audio system and the accessory power sockets in this position.

ON (II) – This is the normal key position when driving. Several of the indicators on the instrument panel come on as a test when you turn the ignition switch from ACCESSORY (I) to ON (II).

START (III) – Use this position only to start the engine. The switch returns to ON (II) when you let go of the key.

You will hear a reminder beeper if you leave the key in the ignition switch in the LOCK (0) or ACCESSORY (I) position and open the driver's door. Remove the key to turn off the beeper.

If your vehicle has an automatic transmission, the shift lever must be in Park before you can remove the key from the ignition switch.

⚠ WARNING

Removing the key from the ignition switch while driving locks the steering. This can cause you to lose control.

Remove the key from the ignition switch only when parked.

The Immobilizer System protects your vehicle from theft. If an improperly-coded key (or other device) is used, the engine's fuel system is disabled.

When you turn the ignition switch to ON (II), the Immobilizer System indicator should come on for a few seconds, then go out. If the indicator starts to blink, it means the system does not recognize the coding of the key. Turn the ignition switch to LOCK (0), remove the key, reinsert it, and turn the switch to ON (II) again.

The system may not recognize your key's coding if another immobilizer key or other metal object (i.e. key fob) is near the ignition switch when you insert the key.

If the system repeatedly does not recognize the coding of your key, contact your Acura dealer.

Do not attempt to alter this system or add other devices to it. Electrical problems could result that may make your vehicle undriveable.

If you have lost your key and cannot start the engine, contact an Acura dealer.

As required by the FCC:

This device complies with Part 15 of the FCC rules. Operation is subject to the following two conditions: (1) This device may not cause harmful interference, and (2) this device must accept any interference received, including interference that may cause undesired operation.

Changes or modifications not expressly approved by the party responsible for compliance could void the user's authority to operate the equipment.

This device complies with Industry Canada Standard RSS-210.

Operation is subject to the following two conditions: (1) this device may not cause interference, and (2) this device must accept any interference that may cause undesired operation of the device.

Door Locks

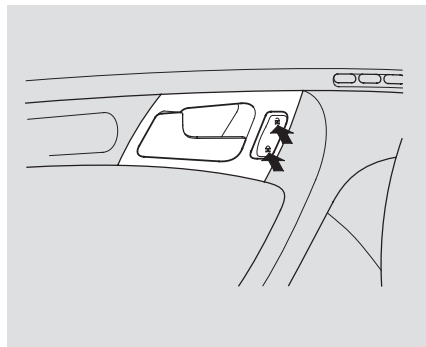

Each front door has a master door lock switch. Either switch locks and unlocks all doors. Push the bottom of the switch to lock the doors and the top to unlock them.

Each door has a lock tab on the top. Push the tab down to lock the door and pull it up to unlock. When you push down the lock tab on the driver's door, all the doors lock.

To lock any door when getting out of the vehicle, push the lock tab in and close the door.

All doors can be locked from the outside by using the key in the driver's door. To unlock only the driver's door, insert the key, turn the key, and release it. The remaining doors unlock when you turn the key a second time within a few seconds.

Lockout Prevention

With the driver's door open and the key in the ignition, both master door lock switches are disabled. If you try to lock an open driver's door by pushing in the lock tab, the tabs on all doors pop up.

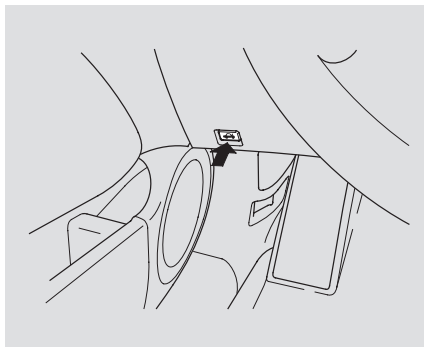

To open the trunk, press the trunk release button on the left corner of the dashboard. To open the trunk from the outside, press the trunk release button on the remote transmitter.

To close the trunk, press down on the trunk lid.

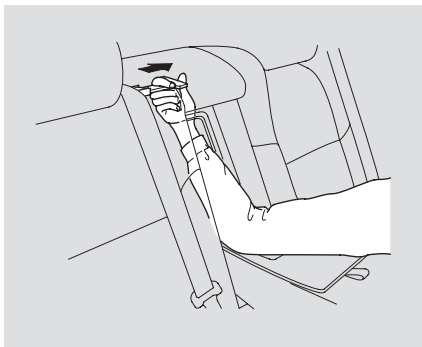

If your vehicle's battery goes dead or is disconnected, you can open the trunk from the rear seat by pulling the trunk release handle. Reach the handle through the trunk pass-through.

Keep the trunk lid closed at all times while driving to avoid damaging it and to prevent exhaust gas from getting into the interior. See Carbon Monoxide Hazard, page [46](#).

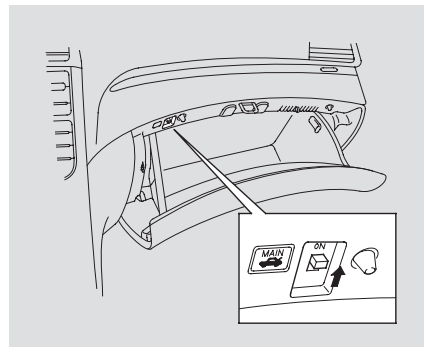

To protect items in the trunk, you can disable the trunk-release button on the dashboard by turning off the trunk main switch in the glove box, locking the glove box, and locking the trunk pass-through cover with the master key.

If you need to give the key to someone else, give them the valet key.

Trunk, Childproof Door Locks

Emergency Trunk Opener

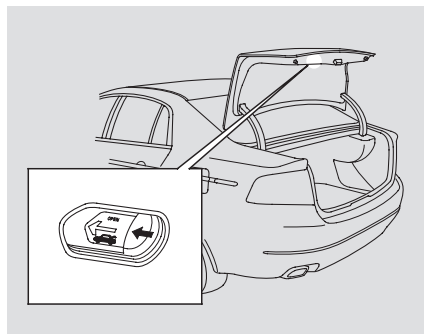

As a safety feature, your vehicle has a release lever on the trunk latch so the trunk can be opened from inside. To open the trunk, push the release lever to the left.

Parents should decide if their children should be shown how to use this feature.

Childproof Door Locks

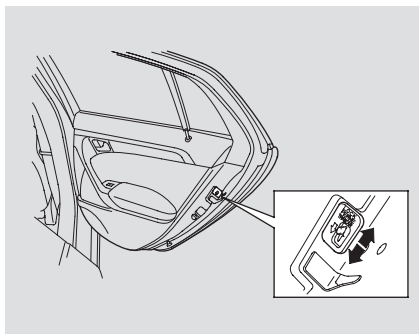

The childproof door locks are designed to prevent children seated in the rear from accidentally opening the rear doors. Each rear door has a lock lever near the edge. With the lever in the LOCK position, the door cannot be opened from the inside regardless of the position of the lock tab. To open the door, pull the lock tab up and use the outside door handle.

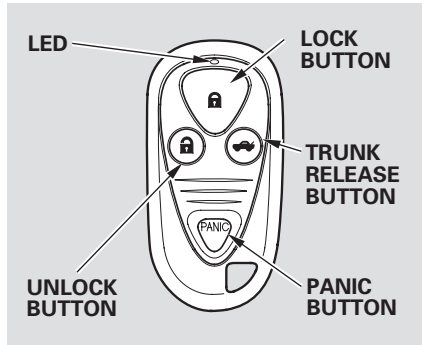

LOCK – Press this button once to lock all doors. Some exterior lights will flash. When you push LOCK twice within 5 seconds, you will hear a beep to verify that the doors are locked and the security system has set. You cannot lock the doors if any door is not fully closed or if the key is in the ignition switch.

UNLOCK – Press this button once to unlock the driver’s door or all the doors (depending on the Keyless Memory Setting). Press it twice to unlock the other doors. Some exterior lights will flash twice each time you press the button.

The ceiling light (if the ceiling light switch is in the center position) will come on when you press the UNLOCK button. If you do not open any doors within 30 seconds (or whatever setting the relock timer is set to), the light fades out. If you relock the doors with the remote transmitter before 30 seconds have elapsed, the light will go off immediately.

If you unlock the doors with the remote transmitter, but do not open any doors within 30 seconds, the doors automatically relock and the security system sets. To change this setting, refer to Keyless Memory Settings on page [66](#).

TRUNK – Press this button for about 1 second to open the trunk. You cannot open the trunk with the remote transmitter if the trunk main button is turned off.

PANIC – Press this button for about 2 seconds to attract attention: the horn will sound and the exterior lights will flash for about 30 seconds. To cancel panic mode, press any other button on the remote transmitter or turn the ignition switch to ON (II).

Remote Transmitter

Recalling a Memorized Driving Position

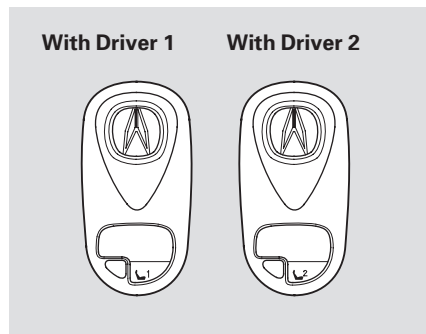

Each remote transmitter also activates the Driving Position Memory System and changes the keyless memory settings related to that remote (see page 93). When you open the driver's door after unlocking it with the remote transmitter, you will hear a beep. The driver's seat and outside mirrors move to the positions stored in that memory location. You will hear two

beeps when the movement is completed.

The driving position memory activated (Driver 1, Driver 2) is shown on the back of each transmitter. Make sure you store your desired driving position in the memory that is activated by the transmitter you normally carry.

You can turn off this driving position memory activation. Press and hold the LOCK and UNLOCK buttons at the same time. The LED in the remote transmitter will blink twice. Then release the buttons. Doing this also cancels the keyless memory settings for that remote and restores the default settings.

To turn it back on, repeat this procedure. The LED will come on for 1 second to indicate the feature has been turned on.

Remote Transmitter Care

- Avoid dropping or throwing the transmitter.
- Protect the transmitter from extreme temperature.
- Do not immerse the transmitter in any liquid.
- If you lose a transmitter, the replacement needs to be reprogrammed by your Acura dealer.

Replacing the Transmitter Battery

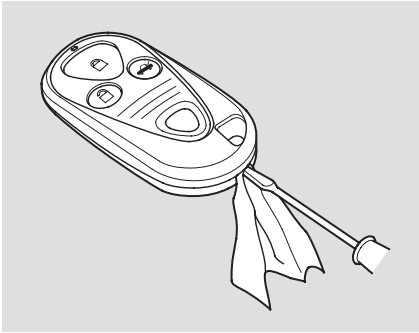

If it takes several pushes on the button to lock or unlock the doors, replace the battery as soon as possible.
Battery type: CR2025

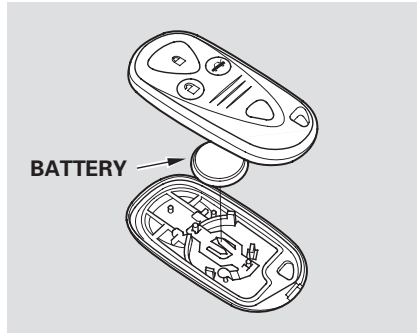

To replace the battery, place a cloth on the edge of the transmitter and remove the upper half by carefully prying on the edge with a small flat-tip screwdriver. Remove the old battery and insert a new battery with the $-$ side facing up. Snap the two halves of the transmitter case back together.

As required by the FCC:

This device complies with Part 15 of the FCC rules. Operation is subject to the following two conditions: (1) This device may not cause harmful interference, and (2) this device must accept any interference received, including interference that may cause undesired operation.

Changes or modifications not expressly approved by the party responsible for compliance could void the user's authority to operate the equipment.

This device complies with Industry Canada Standard RSS-210. Operation is subject to the following two conditions: (1) this device may not cause interference, and (2) this device must accept any interference that may cause undesired operation of the device.

Seats

Front Seat Power Adjustments

See pages 11 – 12 for important safety information and warnings about how to properly position seats and seat-backs.

The controls for the power adjustable front seats are on the outside edge of each seat bottom. You can adjust the seats with the ignition switch in any position. Make all seat adjustments before you start driving.

Moving the long horizontal switch on the driver's seat adjusts the seat bottom in several directions. On the passenger's seat, the long horizontal switch moves the seat only back and forth. The short vertical switch adjusts the seat back angle.

The short horizontal switch on the driver's seat adjusts the degree of lumbar support.

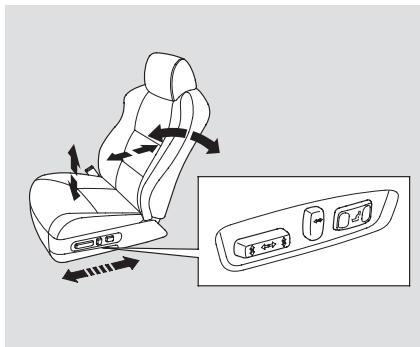

Moves the seat forward and backward.



Moves the seat up or down and the rear of the seat up or down. (Driver's seat only)



Raises or lowers the seat. (Driver's seat only)

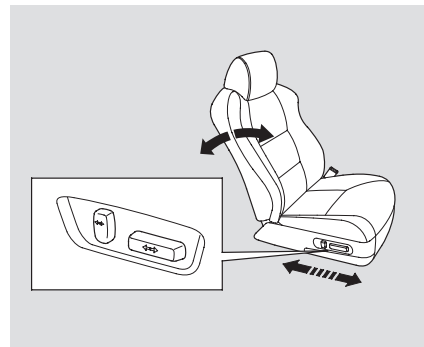

Adjusts the seat-back angle forward or backward.



Increases or decreases the lumbar support. (Driver's seat only)

Head Restraints

See page 13 for important safety information and a warning about how to properly position the head restraints.

The head restraints help protect you and your passengers from whiplash and other injuries. They are most effective when you adjust them so the back of the occupant's head rests against the center of the restraint. A taller person should adjust the restraint as high as possible.

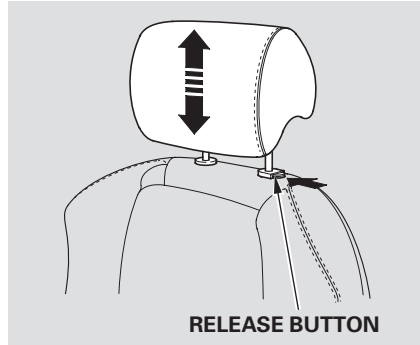

All head restraints adjust for height. The tilt of the front head restraints is also adjustable. You need both hands to adjust the restraint. Do not attempt to adjust it while driving. To raise it, pull upward. To lower the restraint, push the release button sideways, and push the restraint down. To adjust the tilt, pivot the front head restraint to the desired position.

Armrest

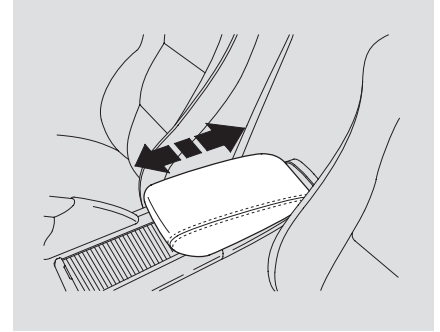

The lid of the console compartment can be used as an armrest by moving it forward and backward. Make sure the armrest is securely latched.

Make sure the passenger's hands or fingers are away from the armrest before moving it.

Seats, Trunk Pass-through Cover

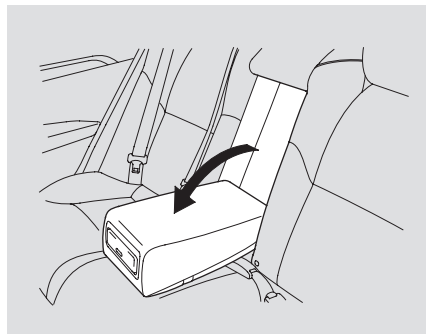

The rear seat armrest is in the center of the rear seat. Pivot it down to use it.

Trunk Pass-through Cover

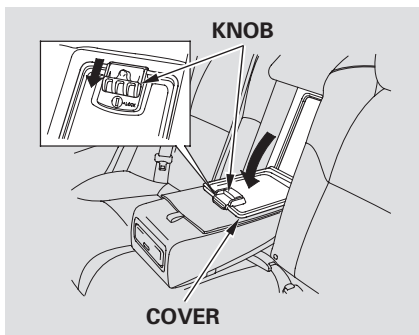

The trunk pass-through cover can be opened from either side; it folds forward onto the center armrest. Open the cover by sliding the knob downward and pushing or pulling on the cover. To close the cover, swing it up and push firmly on the top. Make sure it latches properly.

Make sure all items in the trunk and those extending through the pass-through are secured.

For security, this cover can be locked and unlocked only with the master key. To lock the cover, insert the key and turn it clockwise.

Never drive with this cover open and the trunk lid open.

See **Carbon Monoxide Hazard** on page [46](#).

Keep the inside and outside mirrors clean and adjusted for best visibility. Be sure to adjust the mirrors before you start driving.

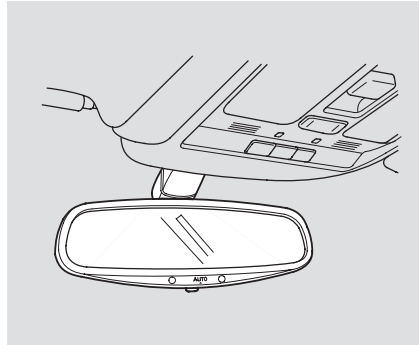

The inside mirror can automatically darken to reduce glare. To turn on this feature, press the button on the bottom of the mirror. The AUTO indicator comes on as a reminder. When it is on, the mirror darkens when it senses the headlights of a vehicle behind you, then returns to normal visibility when the lights are gone. Press the button again to turn off this sensing.

Adjusting the Power Mirrors

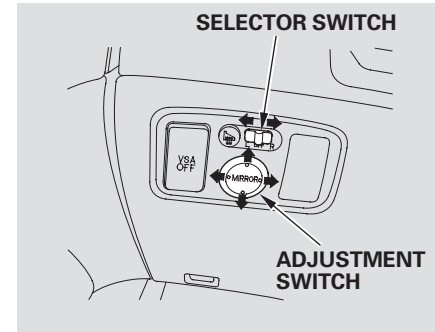

1. Move the selector switch to L (driver's side) or R (passenger's side).
2. Push the appropriate edge of the adjustment switch to move the mirror right, left, up, or down.

Mirrors

- When you finish, move the selector switch to the center (off) position. This turns off the adjustment switch so you can't move a mirror out of position by accidentally bumping the switch.

Depending on the position of the selector switch, the left or right side mirror will pivot downward slightly when you shift the transmission into reverse. In the Left position, the left mirror pivots. In the Right position, the right mirror pivots. This gives you a better view of that side of the vehicle while parallel parking. The mirror returns to its original position when you take the transmission out of reverse. To turn this feature off, leave the switch in the center position.

Outside mirror positions can be stored in the driving position memory system (see page [93](#)).

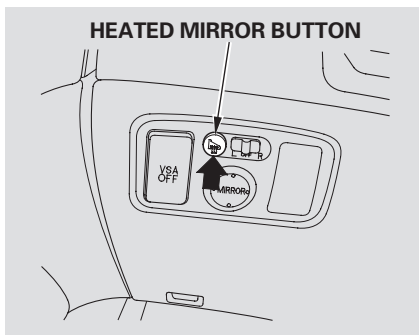

The outside mirrors are heated to remove fog and frost. With the ignition switch in the ON (II) position, turn on the heaters by pressing the button. The indicator in the button comes on as a reminder. Press the button again to turn the heaters off.

Your Acura has a memory feature for the driver's seat and outside mirror positions.

Two seat and outside mirror positions, can be stored in separate memories. You select a memorized position by pushing the appropriate button or using the appropriate remote transmitter (Driver 1 or Driver 2).

Storing a Driving Position in Memory

Store a driving position only when the vehicle is parked.

1. Turn the ignition switch to ON (II). You cannot add a new driving position in the memory unless the ignition switch is in the ON (II) position. You can recall a memorized position with the ignition switch in any position.
2. Adjust the seat to a comfortable position (see page 88). Adjust the outside mirrors for best visibility (see page 91).
3. Press and release the MEMO button on the control panel. You will hear a beep. Immediately press and hold one of the memory buttons (1 or 2) until you hear two beeps. The indicator in the memory button will come on. The current positions of the driver's seat and outside mirrors are now stored.

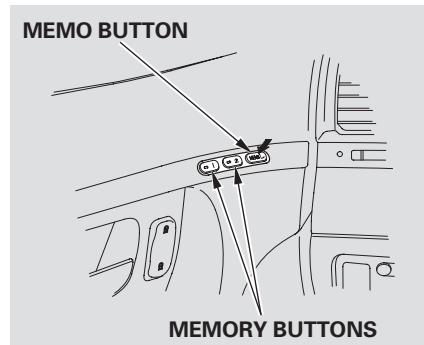

CONTINUED

Driving Position Memory System

Doing any of the following after pressing the MEMO button will cancel the storing procedure.

- Not pressing a memory button within 5 seconds.
- Readjusting the seat position.
- Readjusting the outside mirror position.

Each memory button stores only one driving position. Storing a new position erases the previous setting stored in that button's memory. If you want to add a new position while retaining the current one, use the other memory button.

Selecting a Memorized Position

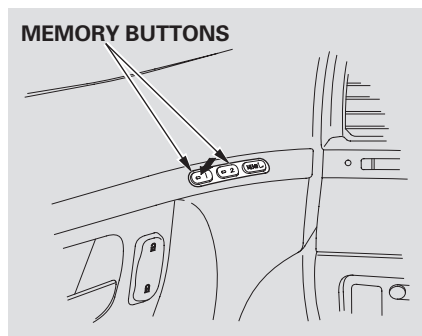

To select a memorized position, do this:

1. Make sure the parking brake is set (M/T) or the shift lever is in Park (A/T).
2. Press the desired memory button (1 or 2) until you hear a beep, then release the button.

The system will move the seat and outside mirrors to the memorized positions. The indicator in the selected memory button will flash during movement. When the adjustments are complete, you will hear two beeps, and the indicator will remain on.

Notes for vehicles with M/T

- You cannot select a memorized position if the transmission is in Reverse. Shift to another gear, then select.
- If the parking brake is not set, you must press and hold the memory button until the adjustment is complete.

To stop the system's automatic adjustment, do any of these actions:

- Press any button on the control panel: MEMO, 1, or 2.
- Push any of the adjustment switches for the seat.
- Shift out of Park.
- Adjust the outside mirrors.

If desired, you can use the adjustment switches to change the positions of the seat or outside mirrors after they are in their memorized position. If you change the memorized position, the indicator in the memory button will go out. To keep this driving position for later use, you must store it in the driving position memory.

Seat Heaters

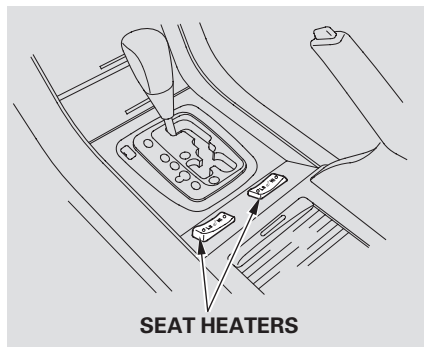

Both front seats are equipped with seat heaters. The ignition switch must be in the ON (II) position to use them. Push the HI side of the switch to rapidly heat up the seat. After the seat reaches a comfortable temperature, push the LO side of the switch. This will keep the seat warm.

The HI or LO indicator stays on until you turn it off by pushing the opposite side of the switch lightly.

In HI, the heater turns off when the seat gets warm, and turns back on after the seat's temperature drops. It continues to cycle as long as you leave it set on HI. The HI indicator stays on as a reminder that you have the heater on.

In LO, the heater runs continuously. It does not cycle with temperature changes.

Follow these precautions whenever you use the seat heaters:

- Use the HI setting only to heat the seats quickly. Select the LO setting when the seats feel warm. The HI setting draws large amounts of current from the battery.
- Do not use the seat heaters, even on the LO setting, if the engine is left idling for an extended period. This can weaken the battery, causing hard starting.

Because of the sensors for the side airbag system, there is no heater in the passenger's seat-back.

Your vehicle's windows are electrically-powered. Turn the ignition switch to ON (II) to raise or lower any window.

Each door has a switch that controls its window. To open the window, push the switch down and hold it. Release the switch when you want the window to stop. Close the window by pulling back on the switch and holding it.

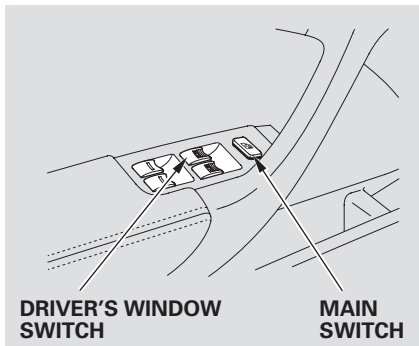

The driver's door armrest has a master power window control panel. To open any window, push down on the appropriate switch and hold it until the window reaches the desired position. To close the window, pull back on the window switch. Release the switch when the window gets to the position you want.

⚠ WARNING

Closing a power window on someone's hands or fingers can cause serious injury.

Make sure your passengers are away from the windows before closing them.

Power Windows

The master control panel also has these features:

AUTO — To open either front window fully, push the window switch firmly down to the second detent, then release it. The window automatically goes down all the way. To stop the window from going all the way down, pull back on the window switch briefly.

To close either front window fully, pull back the window switch firmly to the second detent, then release it. The window automatically goes all the way up. To stop the window from going all the way up, push down on the window switch briefly.

To open or close either front window partially, push down or pull back on the window switch lightly to the first detent and hold it. The window will stop when you release the switch.

The front passenger's window switch also has the AUTO feature.

Auto Reverse

If either front window runs into any obstacle while it is closing automatically, it will reverse direction, and then stop. To close the window, remove the obstacle, then use the window switch again.

Auto reverse stops sensing when the window is almost closed. You should always check that all passengers and objects are away from the window before closing it.

The MAIN switch controls power to the passenger's windows. With this switch off, the passenger's windows cannot be raised or lowered. The MAIN switch does not affect the driver's window. To cancel this feature, push on the switch again to get it to pop up. Keep the MAIN switch off when you have children in the vehicle so they do not injure themselves by operating the windows unintentionally.

The indicators inside the switches come on when you turn the ignition switch to ON (II).

If your vehicle's battery is disconnected or goes dead, or a front window fuse is removed, the AUTO function could be disabled. If the AUTO function is disabled, do the following:

1. Start the engine. Push down on the front window switch until the window is fully open.
2. Pull back on the front window switch to close the window completely, then hold the switch for a second or two more.

If the power windows do not operate properly after resetting, have your vehicle checked by an Acura dealer.

The power window system has a key-off delay function. The windows will still operate for up to 10 minutes after you turn off the ignition. Opening either front door cancels the delay function. You must turn the ignition switch to ON (II) again before you can operate the windows.

Power Windows, Moonroof

Opening the Windows and Moonroof with the Remote Transmitter

You can open all of the windows and the moonroof from outside with the remote transmitter.

1. Press the UNLOCK button once to unlock the driver's door.
2. Press the UNLOCK button a second time, and hold it. The passenger's doors unlock, and all four windows and moonroof start to open. To stop the windows and moonroof, release the button.
3. To open the windows and moonroof further, press the button again and hold it. If the windows and the moonroof stop before the desired position, repeat steps 1 and 2.

You cannot close the windows or the moonroof with the remote transmitter.

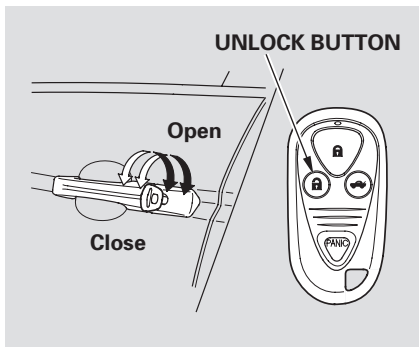

Opening/Closing the Windows and Moonroof with the Key

You can open and close the windows and moonroof with the key in the driver's door lock.

To open:

1. Insert the key in the driver's door lock.
2. Turn the key clockwise, then release it.

3. Turn the key clockwise again, and hold it. All four windows and moonroof start to open. To stop the windows and the moonroof, release the key.
4. To open the windows and moonroof further, turn and hold the key again (within 15 seconds).

To close:

1. Insert the key in the driver's door lock.
2. Turn the key counterclockwise, then release it.
3. Turn the key counterclockwise again, and hold it. All four windows and moonroof start to close. To stop the windows and moonroof, release the key.
4. To close the windows and moonroof further, turn and hold the key again (within 15 seconds).

NOTE: If the windows and moonroof stop before the desired position, repeat steps 2 and 3.

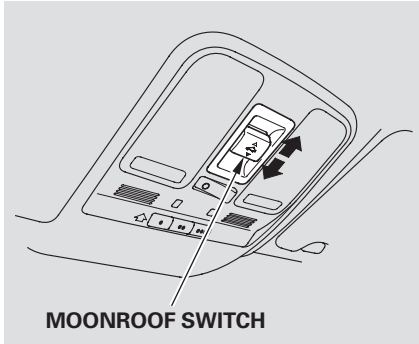

To slide the moonroof open, pull back the moonroof switch firmly. The moonroof automatically opens all the way. To stop the moonroof from opening fully, push the switch forward briefly.

To tilt the moonroof, press straight up on the center of the switch. To stop the moonroof from tilting fully open, press the switch a second time.

To close the moonroof fully, push the switch firmly forward. The moonroof automatically close all the way. To stop the moonroof from closing fully, pull back the switch briefly.

To open or close the moonroof partially, pull back or push forward the moonroof switch lightly and hold it. The moonroof will stop when you release the switch.

Make sure everyone's hands are away from the moonroof before opening or closing it.

⚠ WARNING

Opening or closing the moonroof on someone's hands or fingers can cause serious injury.

Make sure all hands and fingers are clear of the moonroof before opening or closing it.

Auto Reverse

If the moonroof runs into any obstacle while it is closing automatically, it will reverse direction, and then stop. To close the moonroof, remove the obstacle, then use the moonroof switch again.

Auto reverse stops sensing when the moonroof is almost closed. You should always check that all passengers and objects are away from the moonroof before closing it.

Moonroof

The moonroof has a key-off delay. You can still open and close the moonroof for up to 10 minutes after you turn off the ignition. The key-off delay cancels as soon as you open either front door. You must then turn the ignition to ON (II) for the moonroof to operate.

NOTICE

If you try to open the moonroof in below-freezing temperatures, or when it is covered with snow or ice, you can damage the moonroof panel or its motor.

Operating the Moonroof with the Remote Transmitter or the Key

You can use the remote transmitter or the key to operate the moonroof from the outside. Refer to page 100 for details.

Clock

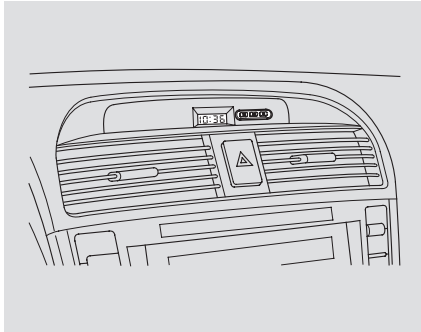

On models without Navigation System
The clock displays the time with the ignition switch in the ON (II) position. If your vehicle's battery is disconnected or goes dead, you will need to reset the clock.

Change the hour by pressing and holding the H button until the numbers advance to the desired time. Change the minutes by pressing and holding the M button until the numbers advance to the desired time.

You can quickly set the time to the nearest hour. If the displayed time is before the half hour, press the R button to set the clock back to the previous hour. If the displayed time is after the half hour, the clock sets forward to the beginning of the next hour.

For example: 1:06 will reset to 1:00
1:52 will reset to 2:00

On models with Navigation System
The clock is set automatically.

Parking Brake

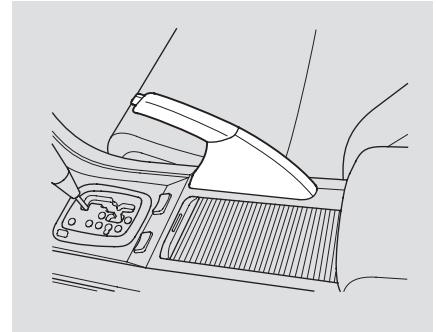

To apply the parking brake, pull the lever up fully. To release it, pull up slightly, push the button, and lower the lever. The parking brake indicator on the instrument panel should go out when the parking brake is fully released (see page 52).

NOTICE

Driving the vehicle with the parking brake applied can damage the rear brakes and axles.

Interior Lights

Ceiling Light

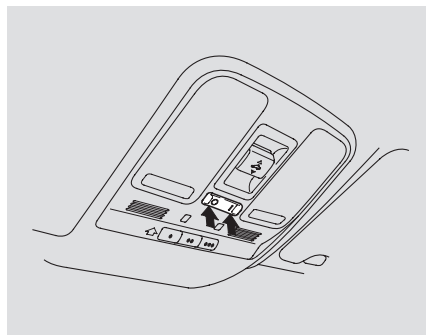

The front ceiling light has a three-position switch; ON, Door Activated, and OFF.

When the “ | ” side of the switch is pushed in, both front and rear ceiling lights are ON all the time.

When the “ ○ ” side is pushed in, the lights are off all the time.

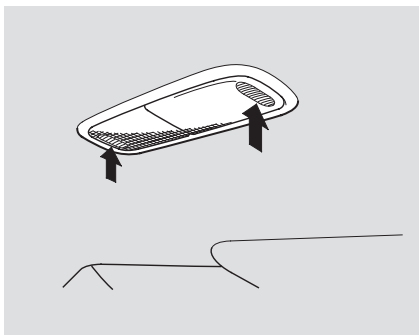

When neither side is pushed in (Door Activated), the lights come on when you:

- Open any door.
- Unlock the doors with the key or remote transmitter.

After all doors are closed tightly, both front and rear ceiling lights fade out in 5, 15, or 30 seconds depending on your custom setting (see page 70).

Both front and rear ceiling lights work as individual map lights. To turn a map light on or off, press its lens. You can use the front map lights regardless of the position of the front ceiling light switch.

With the front ceiling light switch in the OFF position, the rear map lights do not work, and the interior lights do not come on when you open a door.

Interior Convenience Item

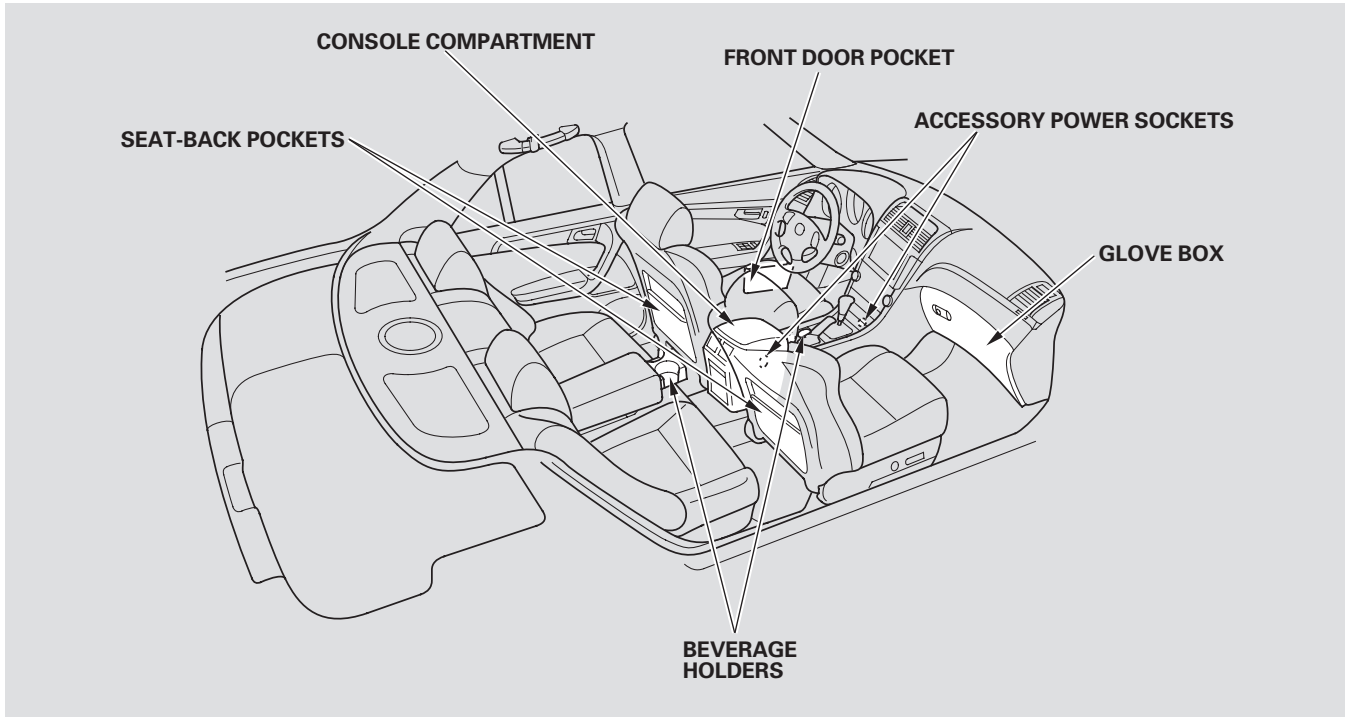

Interior Convenience Items

Beverage Holders

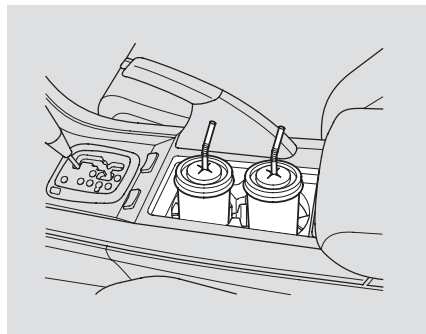

Be careful when you are using the beverage holders. A spilled liquid that is very hot can scald you or your passengers. Spilled liquids can also damage the upholstery, carpeting, and electrical components in the interior.

Open the front beverage holder by sliding its cover backward.

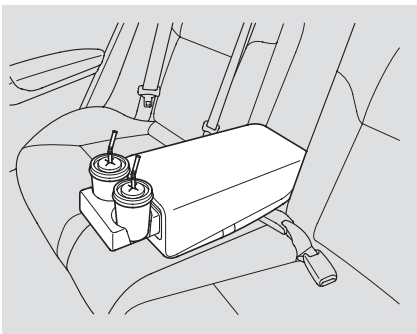

The rear beverage holder is in the rear seat armrest. Open the beverage holder by pushing the front of it, and pulling the holder all the way out.

Accessory Power Sockets

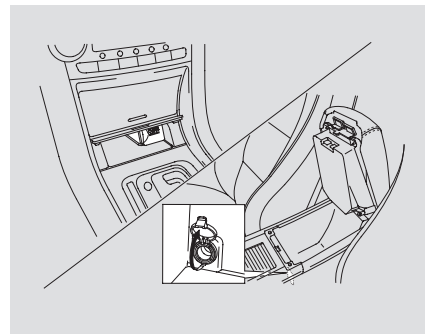

There are two accessory power sockets. One is in the front of the center console under the utility pocket lid. The other is under the armrest in the console compartment storage area.

These sockets are intended to supply power for 12 volt DC accessories that are rated 120 watts or less (10 amps).

Glove Box

Open the glove box by squeezing the handle. Close it with a firm push. Lock or unlock the glove box with the master key.

⚠ WARNING

An open glove box can cause serious injury to your passenger in a crash, even if the passenger is wearing the seat belt.

Always keep the glove box closed while driving.

Console Compartment

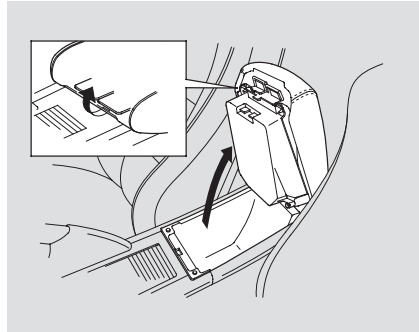

To open the console compartment, pull up on the right lever, and lift the armrest. To open the console compartment storage area, pull up on the left lever, and lift the armrest. To close, lower the armrest, and push it down until it latches.

You can put small items in the tray located in the console compartment lid. To use the tray, pull up on the left lever and lift up the armrest.

The coin holder inside the console compartment is removable. To remove it, pull it up. The coin holder can also be stored in either front door pocket.

Interior Convenience Item

Front Door Pocket

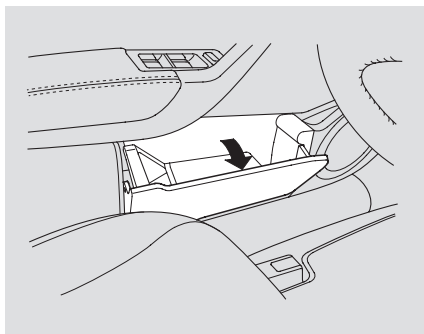

The interior of each front door has an extendable pocket for maps and other small, light weight items. Each pocket also has a sunglasses holder. You can remove the sunglasses holder to make more room in the pocket.

Comfort and Convenience Features

The climate control systems in your Acura provide a comfortable driving environment in all weather conditions.

The standard audio system has many features. This section describes those features and how to use them.

Vents, Heating, and A/C	110
Air Flow Buttons.....	112
Climate Control.....	115
Playing the Radio.....	117
Radio Reception	122
Playing the XM Satellite Radio (U.S. models)	124
Playing Discs.....	129
Protecting Your Discs.....	134
Disc Change Error Messages.....	135
Playing a Tape.....	136
Audio System	139
Radio Theft Protection.....	140
Security System	141
Cruise Control.....	142
HomeLink Universal Transceiver.....	145
HandsFreeLink.....	149

Vents, Heating, and A/C

Vehicles without Navigation System

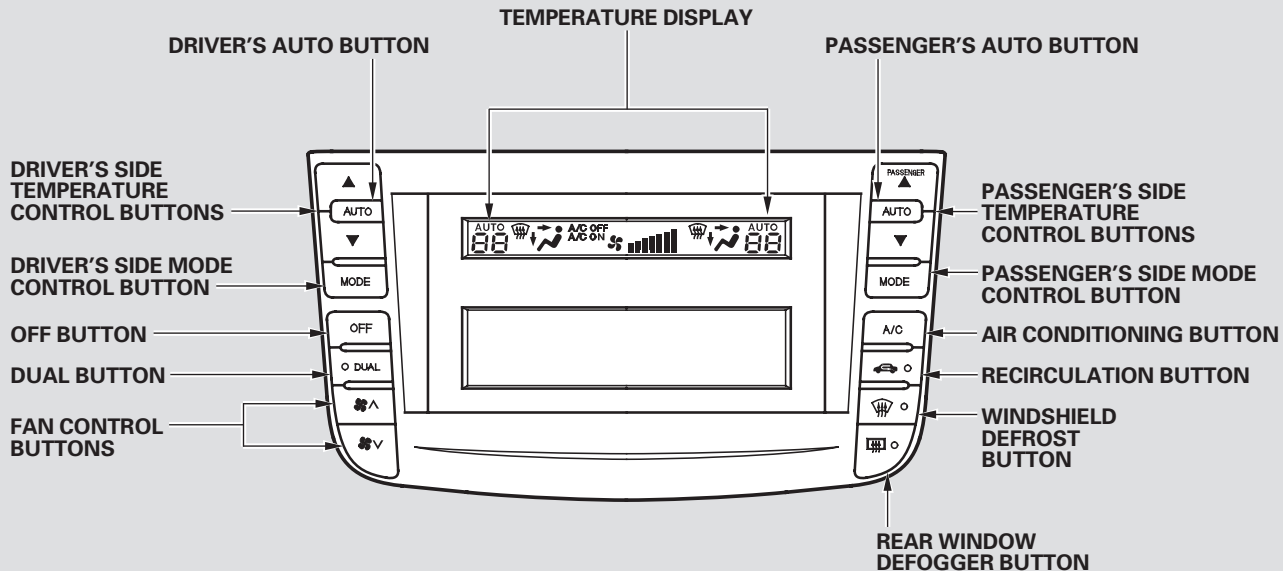



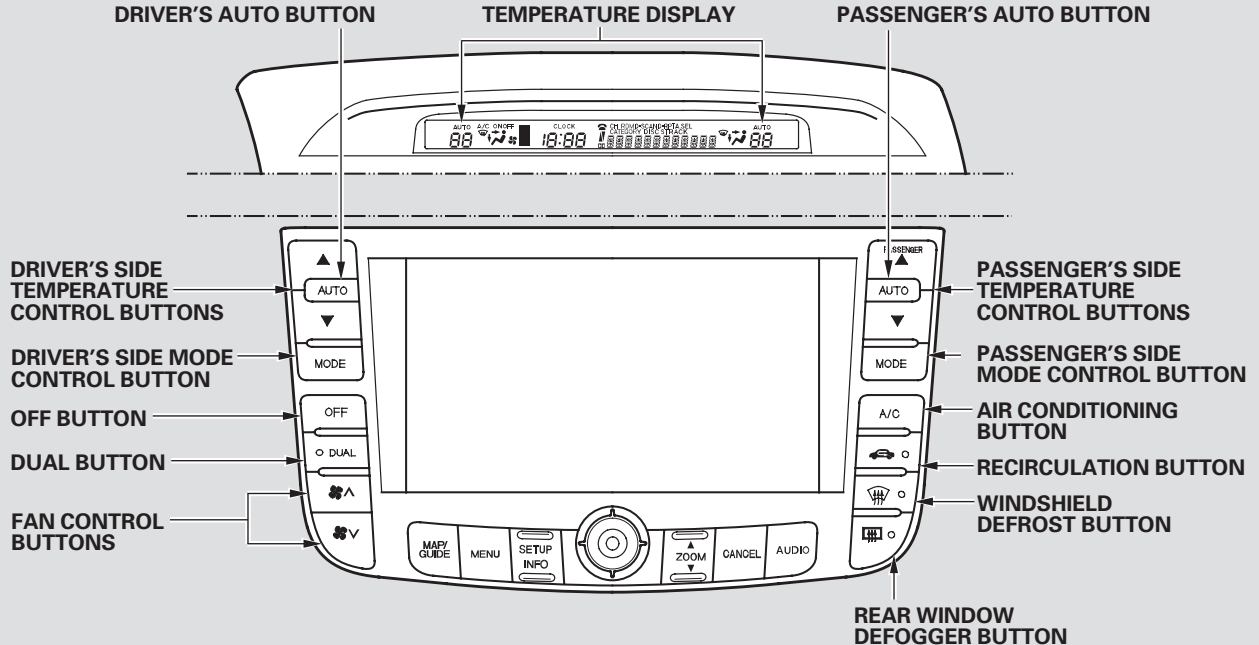

Vehicles with Navigation System





Airflow Buttons

Fan Control Buttons

Press the   button to increase the fan speed and air flow. Press the   button to decrease them.

Temperature Control Buttons

The driver's side temperature and passenger's side temperature can be set separately. Press either side's  button to increase the temperature of air flow. Press either side's  button to decrease it. When you set the temperature to its lower limit or its upper limit, it will be displayed as "Lo" or "Hi".

Air Conditioning (A/C) Button

This button turns the air conditioning on and off. The A/C ON indicator comes on in the display when the A/C is on.

Recirculation Button

When the indicator in the button is on, air from the vehicle's interior is recirculated throughout the system.

When the indicator is off, air is brought in from the outside of the vehicle (Fresh Air mode).

The outside air intakes for the heating and cooling system are at the base of the windshield. Keep this area clear of leaves and other debris.

The system should be left in Fresh Air mode under almost all conditions. Keeping the system in Recirculation mode, particularly with the A/C off, can cause the windows to fog up.

Switch to Recirculation mode when driving through dusty or smoky conditions, then return to Fresh Air mode.

Rear Window Defogger Button

This button turns the rear window defogger off and on (see page 77).



Mode Control Button

Use the mode control button to

select the vents the air flows from. Some air will flow from the dashboard vents in all modes.



 Air flows from the center and corner vents in the dashboard.

 Airflow is divided between the vents in the dashboard and the floor vents.

 Air flows from the floor vents. When you select , the system automatically switches to Fresh Air mode.

 Airflow is divided between the floor vents and the defroster vents at the base of the windshield.

 Air flows from the defroster vents at the base of the windshield.

When you select , the system automatically switches to Fresh Air mode and turns on the A/C. The driver's side mode and passenger's side mode can be selected separately when the dual button is pressed. However, when  is selected on the driver's side, mode selection on the passenger's side is not possible.

When  is selected, the passenger's temperature cannot be set separately from the driver's.

Dual Button

You can set the temperatures and modes for the driver's side and the passenger's side separately when this button is pressed (indicator on). When the indicator in the DUAL button is off, you can adjust both sides to the same temperature and mode with the driver's side temperature control buttons and mode control button.

Ventilation

The flow-through ventilation system draws in outside air, circulates it through the interior, then exhausts it through vents near the rear window.

1. Set the temperature to maximum.
2. Make sure the A/C is off.
3. Select  and Fresh Air mode.
4. Set the fan to the desired speed.

Using the Heater

The heater uses engine coolant to warm the air. If the engine is cold, it will be several minutes before you feel warm air coming from the system.

1. Select  and Fresh Air mode.
2. Set the fan to the desired speed.
3. Adjust the warmth of the air with the temperature control buttons.

Using the A/C

Air conditioning places an extra load on the engine. Watch the engine coolant temperature gauge (see page 57). If it moves near the red zone, turn off the A/C until the gauge reads normally.

1. Turn on the A/C by pressing the button. The indicator in the button comes on when a fan speed is selected.
2. Make sure the temperature is set to maximum heat.
3. Select .
4. If the outside air is humid, select Recirculation mode. If the outside air is dry, select Fresh Air mode.
5. Set the fan to the desired speed.

If the interior is very warm, you can cool it down more rapidly by partially opening the windows, turning on the A/C, and setting the fan to maximum speed in Fresh Air mode.

Vents, Heating, and A/C

Dehumidify the Interior



Air conditioning, as it cools, removes moisture from the air. When used in combination with the heater, it makes the interior warm and dry.

1. Switch the fan on.
2. Turn on the air conditioning.
3. Select  and Fresh Air mode.
4. Adjust the temperature to your preference.

This setting is suitable for all driving conditions whenever the outside temperature is above 32°F (0°C).



To Defog and Defrost

To remove fog from inside the windows:

1. Select . When you select , the system automatically switches to Fresh Air mode and turns on the A/C. (The A/C ON indicator will not come on in U.S. vehicles.)
2. Adjust the temperature so the airflow feels warm.
3. Select  to help clear the rear window.

When you switch to another mode from , the A/C stays on. Press the A/C button to turn it off.

To Remove Exterior Frost or Ice From the Windows

1. Select . The system automatically switches to Fresh Air mode and turns on the A/C. (The A/C indicator will not come on in U.S. vehicles.)
2. Select .
3. Set the fan and temperature controls to maximum level.

To clear the windshield faster, you can close the dashboard corner vents by rotating the wheel below each vent. This sends more warm air to the windshield defroster vents. Once the windshield is clear, select Fresh Air mode to avoid fogging the windows.

For your safety, make sure you have a clear view through all the windows before driving.

To Cool or Heat Automatically

The automatic climate control system adjusts the fan speed and airflow levels to maintain the interior temperature you select.

On models with Navigation System

In the AUTO mode, the vehicle's interior temperature is independently regulated for the driver and passenger. If the driver's side of the vehicle is getting too much sun, the system will adjust to a lower temperature.

Using Automatic Climate Control

1. Press the AUTO button.
2. Set the desired temperature with the temperature control buttons. You will see AUTO in the system's display.

When the AUTO button on the driver's side is pressed, the temperature control buttons on the passenger's side are disabled, and the interior temperature is regulated to the temperature set on the driver's side. When the AUTO button on the passenger's side is pressed, temperature can be set on the driver's side and passenger's side separately.

The system automatically selects the proper mix of conditioned and/or heated air that will, as quickly as possible, raise or lower the interior temperature to your preference.

When you set the temperature to its lower or its upper limit, the system runs at full cooling or heating only. It does not regulate the interior temperature.

When you press a fan control button, the fan is taken out of AUTO mode and starts to run at its lowest speed. Press the   button to make the fan run faster.

Semi-automatic Operation

You can manually select various functions of the climate control system when it is in fully automatic mode. All other features remain automatically controlled. Making any manual selection causes the word AUTO in the display to go out.

To Turn Everything Off

Press the OFF button. However, a lack of air flow can cause the windows to fog up. It is recommended that you keep the fan on at all times so stale air and moisture do not build up in the interior and cause fogging.

Climate Control

Sunlight and Temperature Sensors

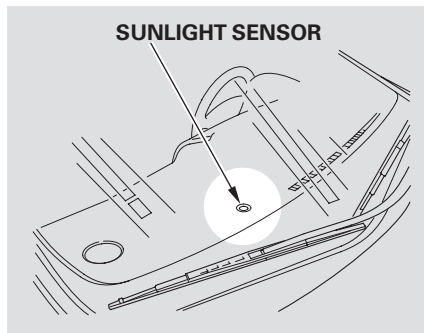

The climate control system has two sensors. A sunlight sensor is in the top of the dashboard, and a temperature sensor is next to the steering column. Do not cover the sensors or spill any liquid on them.

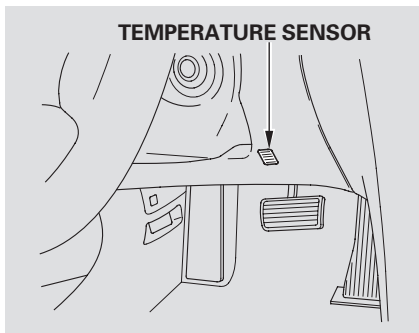

U.S. Models (With navigation system)

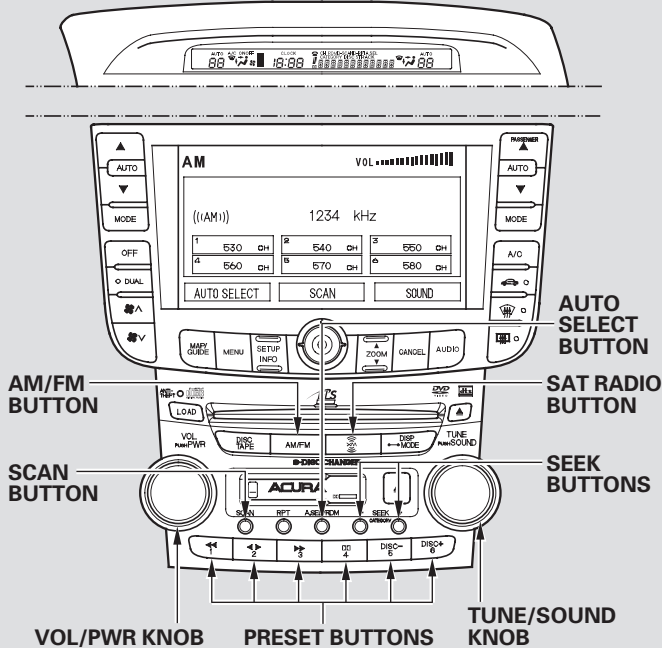

Canadian Models (Without navigation system)

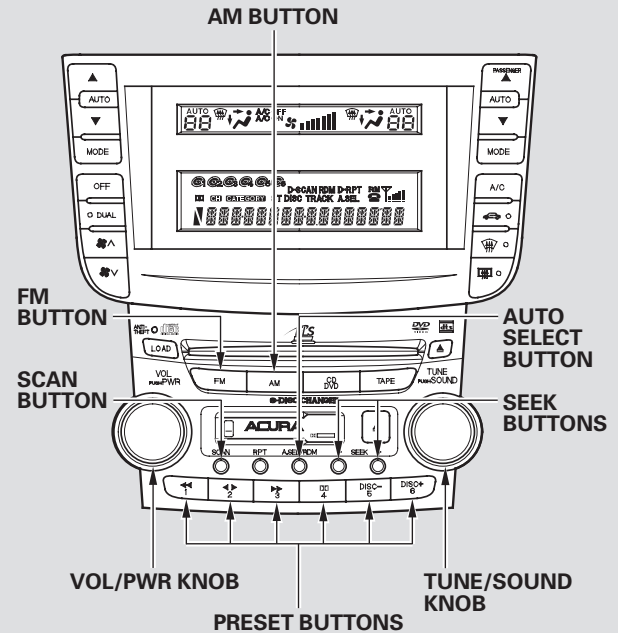

Playing the Radio

To Play the Radio

The ignition switch must be in the ACCESSORY (I) or ON (II) position. Turn the system on by pushing the VOL/PWR knob or the AM/FM button (AM or FM button on Canadian model). Adjust the volume by turning the same knob.

The band and frequency that the radio was last tuned to is displayed. To change bands, press the AM/FM button (AM or FM button on Canadian model). On the FM band, ST will be displayed if the station is broadcasting in stereo. Stereo reproduction on AM is not available.

To Select a Station

You can use any of five methods to find radio stations on the selected band: **TUNE**, **SEEK**, **SCAN**, the preset buttons, and **AUTO SELECT**.

TUNE — Use the TUNE knob to tune the radio to a desired frequency. Turn the knob right to tune to a higher frequency, or left to tune to a lower frequency.

SEEK — The SEEK function searches up and down from the current frequency to find a station with a strong signal. To activate it, press the + or – SEEK button, then release it.

SCAN — The SCAN function samples all stations with strong signals on the selected band. To activate it, press the SCAN button, or touch the SCAN icon (models with navigation system), then release it. You will see SCAN in the display. The system will scan for a station with a strong signal. When it finds one, it will stop and play that station for about 5 seconds.

If you do nothing, the system will scan for the next strong station and play it for 5 seconds. When it plays a station you want to listen to, press the SCAN button again.

Preset — Each preset button or preset icon (models with navigation system) can store one frequency on AM and two frequencies on FM.

1. Select the desired band, AM or FM. FM1 and FM2 let you store two frequencies with each preset button (icon).
2. Use the TUNE, SEEK, or SCAN function to tune the radio to a desired station.
3. Pick a preset button (icon), and hold it until you hear a beep.
4. Repeat steps 1 to 3 to store a total of six stations on AM and twelve stations on FM.

AUTO SELECT — If you are traveling far from home and can no longer receive your preset stations, you can use the Auto Select feature to find stations in the local area.

Press the A. SEL button or the AUTO SELECT icon (models with navigation system). “A.SEL” (AUTO SEL) flashes in the display, and the system goes into scan mode for several seconds. It stores the frequencies of six AM, and twelve FM stations in the preset buttons.

You will see a “0” displayed or see no station number on the preset icons after pressing a preset button (icon) if Auto Select cannot find a strong station for every preset button.

If you do not like the stations Auto Select has stored, you can store other frequencies on the preset buttons (icons). Use the TUNE, SEEK, or SCAN functions to find stations, then store them in the preset buttons (icons) as previously described.

To turn off Auto Select, press the A.SEL button (AUTO SELECT icon). This restores the presets you originally set.

CONTINUED

Playing the Radio

Adjusting the Sound

On models without Navigation System Bass, Treble, Balance, and Fader are each adjustable. In addition, you can adjust the strength of the sound coming from the center and the subwoofer speakers.

Press the TUNE/SOUND knob repeatedly to display the Bass (BASS), Treble (TREB), Balance (BAL), Fader (FADE), Center (CNTR) and Subwoofer (SUBW) setting.

Each mode is shown in the display as it changes. Turn the TUNE/SOUND knob to adjust the setting to your liking. When the level reaches the center, you will see “C” in the display. The system will automatically return the display to the selected audio mode about 5 seconds after you stop adjusting a mode.

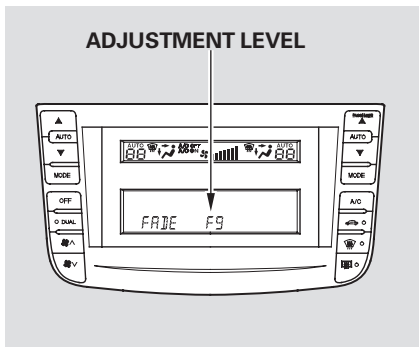

Treble/Bass — Use the TREB/BASS modes to adjust the tone to your liking.

Balance/Fader — These two modes adjust the strength of the sound coming from each speaker. BAL adjust the side-to-side strength, and FADE adjusts the front-to-back strength.

Center/Subwoofer — These two modes adjust the strength of the sound coming from the center speaker and the subwoofer speaker.

If you turn the TUNE/SOUND knob all the way to the left, you will see “OFF” in the display, and the center speaker and/or subwoofer speaker will be off.

On models with Navigation System Bass, Treble, Left/Right Balance, and Front/Rear Fader are each adjustable. In addition, you can adjust the strength of the sound coming from the center and the subwoofer speakers.

To adjust them, enter the sound grid by touching the SOUND icon on the display or pressing the TUNE/SOUND knob.

Treble/Bass — To adjust the treble and bass, touch ◀ or ▶ on each side of the Treble or Bass adjustment bar. Then continue pressing ◀ or ▶, or turn the TUNE/SOUND knob. The adjustment bar shows you the current setting.

Subwoofer/Center — To adjust the sound from the subwoofer or center speaker, touch ◀ or ▶ icon on each side of the Subwoofer or Center adjustment bar. Then continue pressing ◀ or ▶, or

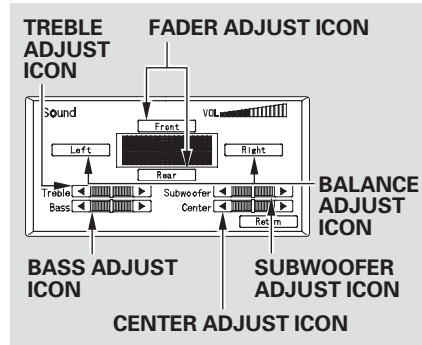

turn the TUNE/SOUND knob. The adjustment bar shows you the current setting.

Left/Right Balance, and Front/Rear Fader — These modes adjust the strength of the sound coming from each speaker. Left/Right balance adjust the side-to-side strength, while Front/Rear fader adjust the front-to-back strength. To adjust the left/right balance, touch the left or right icon on the sound

grid. When you touch an icon, the yellow bars on the grid turn orange and move toward the icon, changing the balance left or right. At this point, you can also use the TUNE/SOUND knob to adjust the balance. To equalize the balance, touch the left or right icon until each side has an orange bar at the center of the sound grid.

To adjust the Front/Rear fader, touch the front or rear icon on the sound grid. When you touch an icon, the yellow bars on the grid turn orange and move toward the icon, changing the fader to the front or rear. At this point, you can also use the TUNE/SOUND knob to adjust the balance. To equalize the fader, touch the front or rear icon until each side has an orange bar at the center of the sound grid.

To see the audio screen when you are finished adjusting the sound, touch the RETURN icon, or wait 5 seconds.

Radio Reception

Radio Frequencies

Your Acura's radio can receive the complete AM and FM bands. Those bands cover these frequencies:

AM band:

530 to 1,710 kilohertz

FM band:

87.7 to 107.9 megahertz

Radio stations on the AM band are assigned frequencies at least ten kilohertz apart (530, 540, 550). Stations on the FM band are assigned frequencies at least 0.2 megahertz apart (87.9, 88.1, 88.3).

Stations must use these exact frequencies. It is fairly common for stations to round-off the frequency in their advertising, so your radio could display a frequency of 100.9 even though the announcer may identify the station as "FM101."

Radio Reception

How well your Acura's radio receives stations is dependent on many factors, such as the distance from the station's transmitter, nearby large objects, and atmospheric conditions.

A radio station's signal gets weaker as you get farther away from its transmitter. If you are listening to an AM station, you will notice the sound volume becoming weaker, and the station drifting in and out. If you are listening to an FM station, you will see the stereo indicator flickering off and on as the signal weakens. Eventually, the stereo indicator will go off and the sound will fade completely as you get out of range of the station's signal.

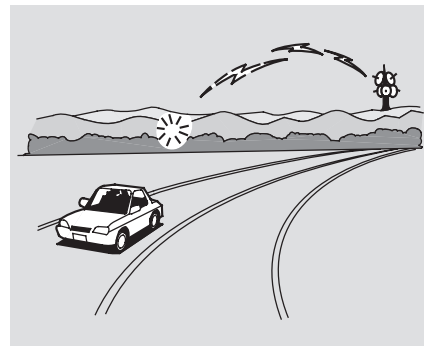

Driving very near the transmitter of a station that is broadcasting on a frequency close to the frequency of the station you are listening to can also affect your radio's reception. You may temporarily hear both stations, or hear only the station you are close to.

Radio Reception

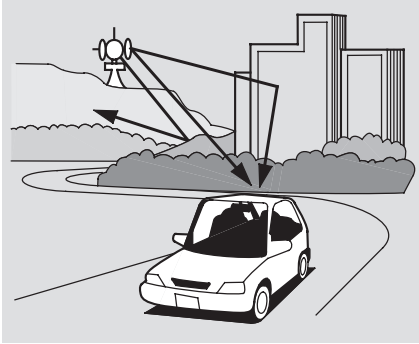

Radio signals, especially on the FM band, are deflected by large objects such as buildings and hills. Your radio then receives both the direct signal from the station's transmitter, and the deflected signal. This causes the sound to distort or flutter. This is a main cause of poor radio reception in city driving.



Radio reception can be affected by atmospheric conditions such as thunderstorms, high humidity, and even sunspots. You may be able to receive a distant radio station one day and not receive it the next day because of a change in conditions.

Electrical interference from passing vehicles and stationary sources can cause temporary reception problems.

*As required by the FCC:
Changes or modifications not expressly approved by the party responsible for compliance could void the user's authority to operate the equipment.*

Playing the XM® Satellite Radio (U.S. Models)

Without navigation system

With navigation system

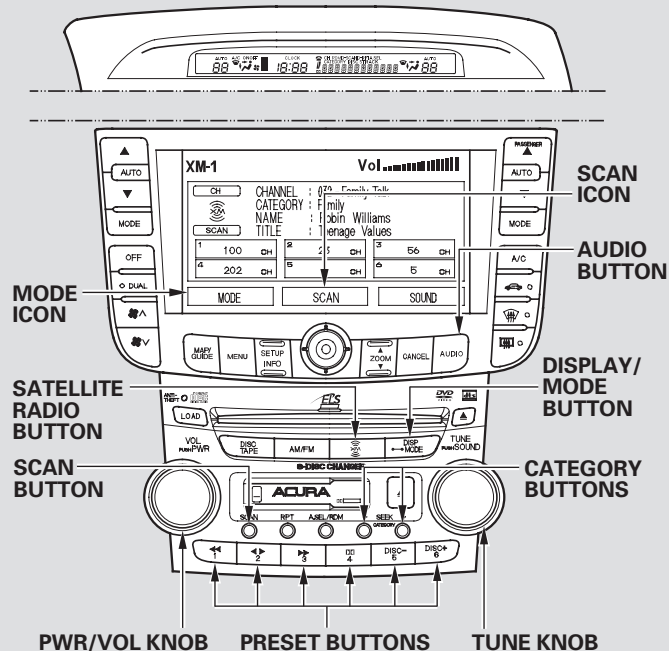
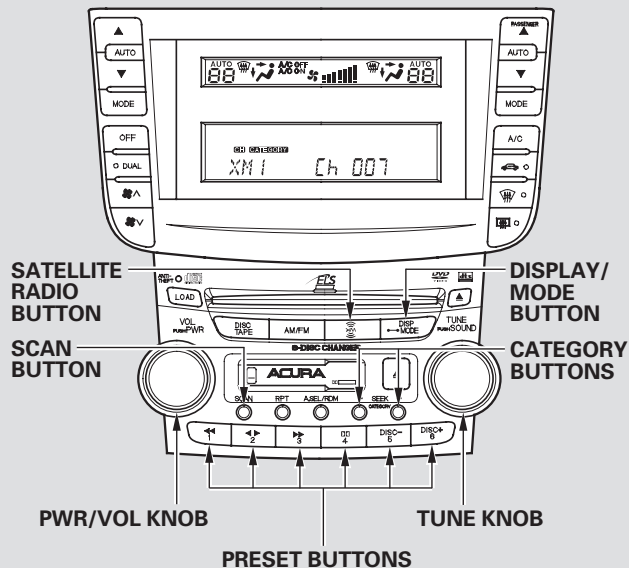

Playing the XM® Satellite Radio (U.S. Models)

Your Acura is capable of receiving XM® Satellite Radio anywhere in the United States, except Hawaii and Alaska.

XM® is registered trade mark of XM Satellite Radio Inc.

Satellite radio receives signals from two satellites to produce clear, high-quality digital reception. It offers many channels in several categories. Along with a large selection of different types of music, satellite radio also allows you to view channel and category selections in the audio display.

Operating Satellite Radio

To listen to satellite radio, turn the ignition switch to ACCESSORY (I) or ON (II). Push the PWR/VOL knob to turn on the audio system, and press the  button. Adjust the volume by turning the PWR/VOL knob. The last channel you listened to will show in the display.

MODE – To switch between the channel mode and the category mode, press and hold the DISP/MODE button until the mode changes. On models with navigation system, touch the MODE icon on the audio display.

In the channel mode, you can select all of the available channels. In the category mode, such as Jazz, Rock, Classical, etc., you can select all of the channels within that category.

Each time you press and release the DISP/MODE button, the display changes in the following sequence: channel name, channel number, category, artist name, and music title.

You may experience periods when XM Radio does not transmit the artist's name and the song title information. If this happens, there is nothing wrong with your system.

On models with navigation system, push the AUDIO button to display XM information on the screen.

TUNE – Turn the TUNE knob left or right to select channels. In the category mode, you can only select channels within that category.

CATEGORY (⊖ or ⊕) – In the category mode, press either button to select another category.

Playing the XM® Satellite Radio (U.S. Models)

SCAN — The SCAN function gives you a sampling of all channels while in the channel mode. In the category mode, only the stations within that category are scanned. To activate SCAN, press the SCAN button or touch the SCAN icon on the audio display (models with navigation system). The system plays each channel in numerical order for a few seconds, then selects the next channel. When you hear a channel you want to continue listening to, press the button or touch the icon again.

To store a channel:

Preset — You can store up to 12 preset channel using the six preset buttons or preset icons (models with navigation system). Each button stores one channel from the XM1 band and one channel from the XM2 band.

To store a channel:

1. Press the  button. Either XM1 or XM2 will show in the display.
2. Use the TUNE knob, or the CATEGORY or SCAN buttons to tune to a desired channel.

In the category mode, only channels within that category can be selected. In the channel mode, all channels can be selected.

3. Pick the preset button (icon) you want for that channel. Press and hold the button (icon) until you hear a beep.
4. Repeat steps 2 and 3 to store the first six channels.
5. Press the  button again. The other XM band will show. Store the next six channels using steps 2 and 3.

Once a channel is stored, simply press and release the proper preset button (icon) to tune to it.

The presets will be lost if your vehicle's battery goes dead, is disconnected, or the radio fuse is removed.

Playing the XM® Satellite Radio (U.S. Models)

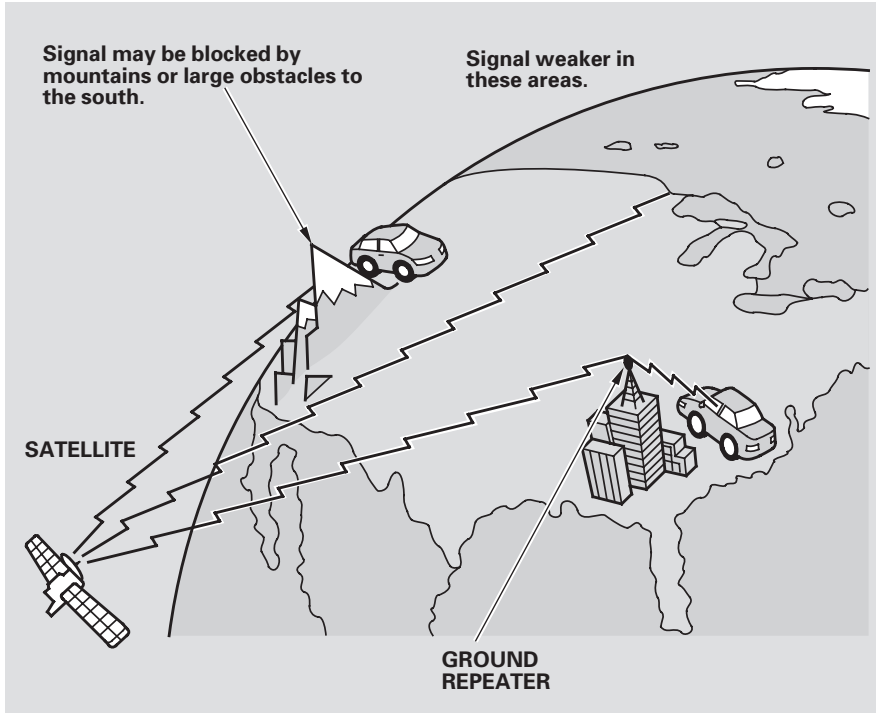

The XM satellites are in orbit over the equator; therefore, objects south of the vehicle may cause satellite reception interruptions. To help compensate for this, ground-based repeaters are placed in major metropolitan areas. Satellite signals are more likely to be blocked by tall buildings and mountains the farther north you travel from the equator.

CONTINUED

Playing the XM® Satellite Radio (U.S. Models)

Depending on where you drive, you may experience reception problems. Interference can be caused by any of these conditions:

- Driving on the south side of an east/west mountain road
- Driving on the north side of a large commercial truck on an east/west road
- Driving in the tunnels
- Driving on a road beside a vertical wall, steep cliff or hill to the south of you
- Driving on the lower level of a multi-tiered road
- Driving on a single lane road alongside dense trees taller than 50 ft. (15 m) to the south of you

There may be other geographic situations that could affect satellite radio reception.

*As required by the FCC:
Changes or modifications not expressly approved by the party responsible for compliance could void the user's authority to operate the equipment.*

Receiving Satellite Radio Service

If your XM Radio service has expired or you purchased your vehicle from a previous owner, you can listen to a sampling of the broadcasts available on XM Satellite Radio. With the ignition switch in the ACCESSORY (I) or ON (II) position, push the PWR/VOL knob to turn on the audio system and press the  button. A variety of music types and styles will play.

If you decide to purchase XM Satellite Radio service, contact XM Radio at www.xmradio.com, or at 1-800-852-9696. You will need to give them your radio I.D. number and your credit card number. To get your radio I.D. number, turn the TUNE

knob until “0” appears in the display. Your I.D. will appear in the display.

After you've registered with XM Radio, keep your audio system in the Satellite Radio mode while you wait for activation. This should take about 30 minutes.

While awaiting activation, make sure your vehicle remains in an open area with good reception. Once your audio system is activated, “category” or “CH” will appear in the display and you'll be able to listen to XM Radio broadcasts. XM Radio will continue to send an activation signal to your vehicle for at least 12 hours from activation request. If the service has not been activated after 36 hours, contact XM Radio.

U.S. Models (with Navigation system)

Canadian Models (without Navigation system)

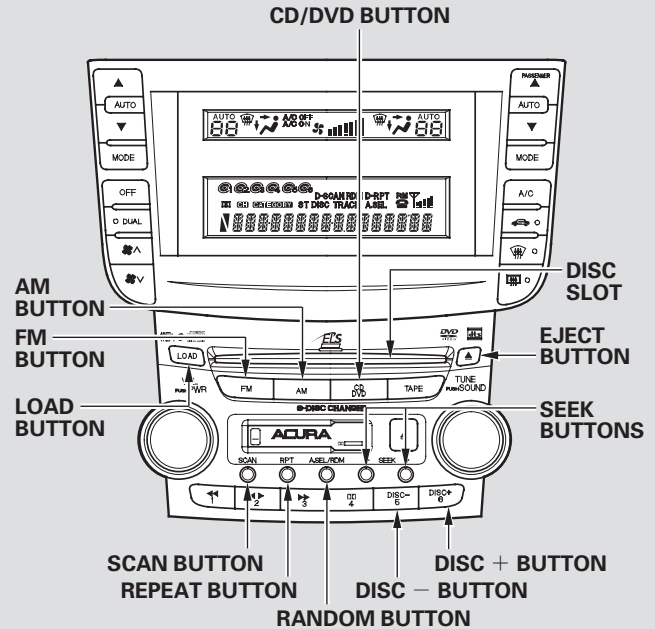
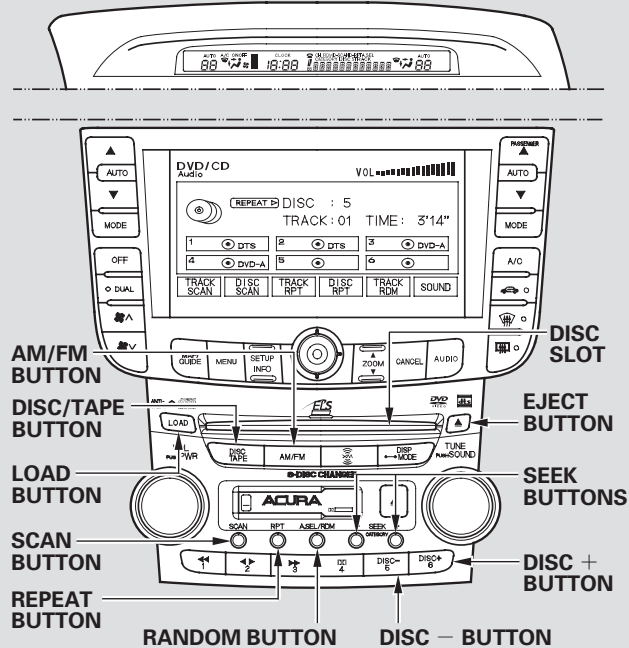

Playing Discs

Your Acura's audio system has an in-dash disc changer that holds up to six discs. You operate this disc changer with the same controls used for the radio. To operate the disc changer, the ignition switch must be in the ACCESSORY (I) or ON (II) position.

The disc changer can play these disc formats:

- CD
- CD-R
- DVD-A
- DTS™

DVD-A discs not meeting DVD verification standards may not be playable.

The changer cannot play DVD-V, DVD-R/RW, MP3, or WMA formats. Some CD-DA and CD-ROM mixed discs are not playable.

DTS™ is registered trademark of Digital Theater System, Inc.

Loading Discs in the Changer

To load multiple discs in one operation:

1. With the ignition in ACCESSORY (I) or ON (II), press and hold the LOAD button until you hear a beep and see "LOAD" in the display, then release the button.
2. Insert the disc into the slot. Insert it only about halfway; the drive will pull it in the rest of the way.
3. When the "DISC LOAD" appears in the display, insert the next disc into the slot.
4. Repeat this until all six positions are loaded. The system will then begin playing the last disc loaded.

If you stop loading discs before all six positions are filled, the system will wait for 15 seconds, stop the load operation, and begin playing the last disc loaded.

To load a single disc:

1. Press and release the LOAD button.
2. The disc number for an empty position is highlighted and the green load indicator comes on. When you see "LOAD" in the display, insert the disc into the slot. Insert it only about halfway; the drive will pull it in the rest of the way.

If you press the LOAD button while a disc is playing, the system will stop playing that disc and start the loading sequence. It will then play the disc just loaded.

To Play a Disc

Select the disc changer by pressing the DISC/TAPE button (U.S. models) or CD/DVD button (Canadian models). The system will begin playing the last selected disc in the disc changer. You will see the disc and track numbers displayed.

To select a different disc when all six positions are loaded, use the preset 5 (DISC -) or preset 6 (DISC +) button. Otherwise, press the corresponding number on the preset buttons or icons. On models with navigation system, you can also touch the appropriate disc icon (1-6) to select a different disc.

To Change Tracks

Each time you press and release the SEEK + button, the player skips forward to the beginning of the next track. Press and release the SEEK - button to skip backward to the beginning of the current track.

Track Scan

When you press the SCAN button or touch the TRACK SCAN icon on the audio display (models with navigation system), the first track of the current disc plays for about 10 seconds. You will see SCAN (TRACK SCAN) highlighted in the display. To hear the rest of the track, press the SCAN button or touch TRACK SCAN again within 10 seconds. If you don't, the system advances to the next track, plays about 10 seconds of it, and continues through the rest of the tracks the same way.

Disc Scan

When you press and hold the SCAN button until you see D-Scan in the display, or when you touch the DISC SCAN icon on the audio display (models with navigation system), the first track of the current disc plays for about 10 seconds. You will see D-Scan (DISC SCAN) in the display. To hear the rest of the disc, press the SCAN button or touch DISC SCAN again, within 10 seconds. If you don't, the system advances to the next disc, plays about 10 seconds of it, and continues throughout the rest of the discs the same way. When the system reaches the last disc, DISC SCAN is cancelled, and the disc you originally had on plays normally.

CONTINUED

Playing Discs

Track Repeat

When you press the RPT button or touch the TRACK RPT icon on the audio display (models with navigation system), the system continuously replays the current track. As a reminder, you will see REPEAT (TRACK REPEAT) in the display. To turn this feature off, press the RPT button, or touch TRACK REPEAT again.

Disc Repeat

When you press and hold the RPT button until REPEAT is in the display, or when you touch the DISC RPT icon on the audio display (models with navigation system), the system continuously replays the current disc. As a reminder, D-RPT (DISC RPT) is highlighted in the display. To turn this feature off, press the RPT button or touch DISC RPT again.

Random Play

When you press the RDM button or touch the TRACK RDM icon (models with navigation system), the system plays the tracks of the current disc in random order. You will see RANDOM (TRACK RANDOM) in the display. To turn this feature off, press the RDM button (touch the TRACK RDM icon) again.

Playing a DVD

You can also play DVD-As in your audio system the same way as playing discs.

To Stop Playing a Disc

To take the system out of disc mode, press the AM/FM button (AM or FM button on Canadian models), press the  button (U.S. models), or insert a tape in the tape player. To return to disc mode, press the DISC/TAPE button (CD/DVD button on Canadian models).

If you turn the system off while a disc is playing, either with the PWR/VOL knob or the ignition switch, play will continue at the same point when you turn it back on.

Removing Discs from the Changer

To remove the disc that is currently playing, press the eject button. You will see “EJECT” in the display. When you remove the disc from the slot, the system automatically begins the load sequence so you can load another disc in that position. If you do not load another disc, within 15 seconds, the system selects the previous mode [AM, FM1, FM2, tape, or Satellite Radio (U.S. models)].

If you do not remove the disc from the slot, the system will reload the disc after 15 seconds and put the disc changer in pause mode. To begin playing the disc, press the disc button.

To remove a different disc from the changer, first select it by pressing the corresponding number on the preset button (touching the appropriate disc icon on models with navigation system). When that disc begins playing, press the eject button.

When you press the eject button while listening to the radio, or with the audio system turned off, the disc that was last selected is ejected. After that disc is ejected, pressing the eject button again will eject the next disc in numerical order. By doing this six times, you can remove all the discs from the changer.

You can also eject discs when the ignition switch is off:

To eject one disc, press and release the eject button.

To eject all discs, press and hold the eject button until the system beeps.

Protecting Your Discs

General Information

- When using CD-R discs, use only high quality discs labeled for audio use.
- When recording a CD-R, the recording must be closed for it to be used by the disc changer.
- Play only standard round discs. Odd-shaped discs may jam in the drive or cause other problems.
- Handle your discs properly to prevent damage and skipping.

Protecting Discs

When a disc is not being played, store it in its case to protect it from dust and other contamination. To prevent warpage, keep discs out of direct sunlight and extreme heat.

To clean a disc, use a clean soft cloth. Wipe across the CD from the center to the outside edge.

A new disc may be rough on the inner and outer edges. The small plastic pieces causing this roughness can flake off and fall on the recording surface of the disc, causing skipping or other problems. Remove these pieces by rubbing the inner and outer edges with the side of a pencil or pen.

Never try to insert foreign objects in the disc changer.

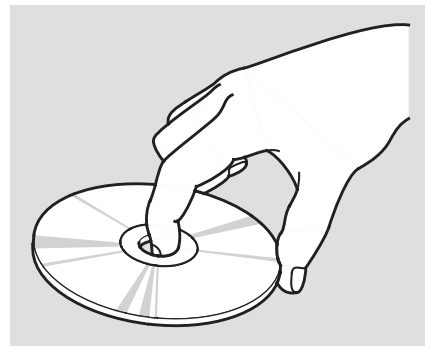

Handle a disc by its edges; never touch either surface. Do not place stabilizer rings or labels on the disc. These, along with contamination from finger prints, liquids, and felt-tip pens, can cause the disc to not play properly, or possibly jam in the drive.

Disc Changer Error Messages

If you see an error message in the display while playing a disc, find the cause in the chart to the right. If you cannot clear the error message, take your vehicle to an Acura dealer.

Message	Cause	Solution
CODE DISC	FOCUS Error.	Press the disc eject button and remove the disc(s). Check for an error indication. Insert the disc(s) again. If the code does not disappear or the disc(s) cannot be removed, consult your Acura dealer.
CODE NODISC	No CD in the changer.	Insert CD.
CODE ERR	Mechanical Error.	Press the disc eject button and remove the disc(s). Check for an error indication. Insert the disc(s) again. If code does not disappear or the disc(s) cannot be remove, consult your Acura dealer.
CODE ---H	High temperature.	Will disappear when the temperature returns to normal.

Playing a Tape

U.S. Models (with Navigation system)

Canadian Models (without Navigation system)

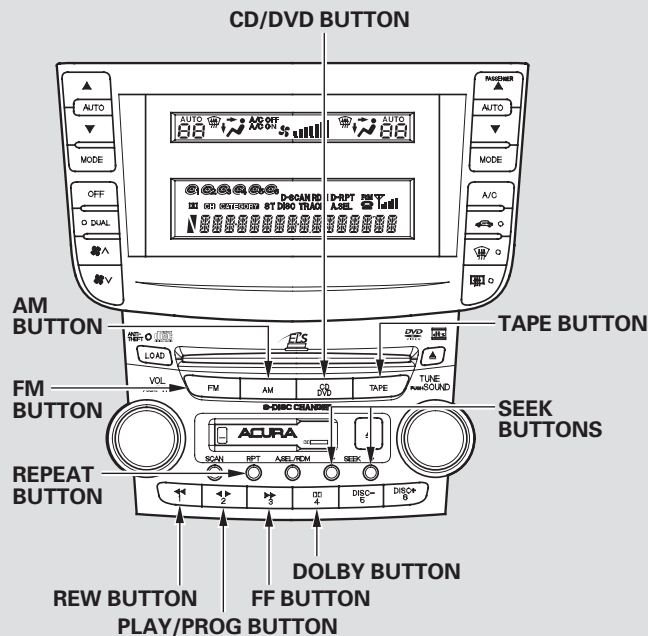
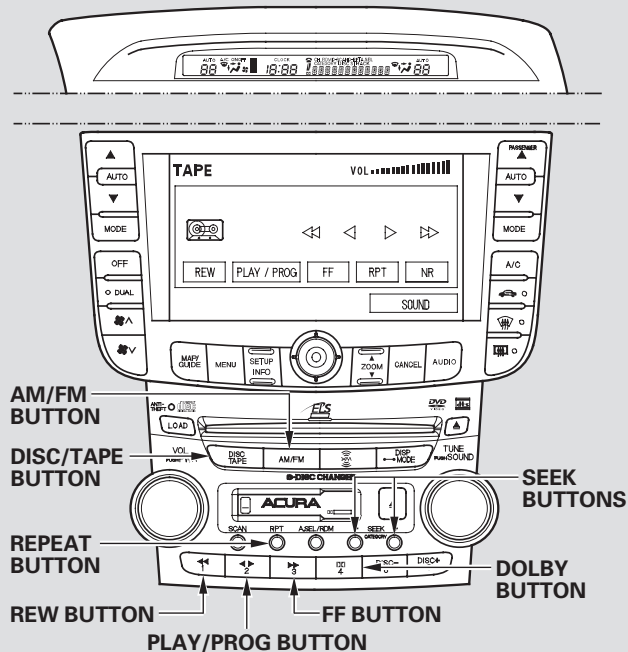

To Play a Tape

The ignition switch must be in the ACCESSORY (I) or ON (II) position. Make sure the open side of the tape is facing right, then insert the tape most of the way into the slot. The system will pull the tape in the rest of the way, and begin to play it.

The tape direction indicator in the display comes on to show you which side of the tape is playing. The ▲ indicates the side you inserted upward is now playing. If you want to play the other side, press the PLAY/PROG (preset2) button or touch the PLAY/PROG icon on the audio display (models with navigation system). When the player reaches the end of the tape, it will automatically reverse direction and play the other side.

Dolby* noise reduction turns on when you insert a tape. The □□ indicator and NR icon (models

with navigation system) will come on in the display. If the tape was not recorded in Dolby, turn it off by pressing the □□ (preset 4) button or touching the NR icon on the audio display. Dolby remains off until you press the button (touch the icon) again.

* Dolby noise reduction manufactured under license from Dolby Laboratories Licensing Corporation. "DOLBY" and the double-D symbol □□ are trademarks of Dolby Laboratories Licensing Corporation.

To Stop Playing a Tape

To remove the tape, press the EJECT button. If you want to turn the player off, press the VOL/PWR knob or turn off the ignition. The tape will remain in the drive. When you turn the system back on, the tape will begin playing where it left off.

To switch to the radio, Satellite

Radio (U.S. models) or disc changer while a tape is playing, press the AM/FM button (AM or FM button on Canadian models),  button or DISC/TAPE button (CD/DVD button on Canadian models). To change back to the tape player, press the DISC/TAPE button (TAPE/AUX button on Canadian models).

Tape Search Function

FF/REW – To rewind the tape, push the ◀◀ (preset 1) button or touch the REW icon on the audio display (models with navigation system). You will see REW in the display (TAPE REW on models with navigation system). To fast forward the tape, push the ▶▶ (preset 3) button or touch the FF icon. You will see FF displayed (TAPE FF on models with navigation system). Press the ▶▶, ◀◀, or PLAY/PROG button (icon) to take the system out of rewind or fast forward.

CONTINUED

Playing a Tape

SKIP — Press the SEEK — button to find the beginning of the current song or passage. Press the SEEK + button to find the beginning of the next song or passage. When the system reaches the beginning of a song or passage, it begins to play it.

REPEAT — Press the RPT button or touch the RPT icon on the audio display (models with navigation system) to continuously play a song or passage. You will see RPT displayed. The track will repeat until you press the RPT button or icon again.

NOTE: The SKIP and REPEAT functions use silent periods on the tape to find the end of a song or passage. These features may not work if there is almost no gap between selections, a high noise level, or a silent period in the middle of a selection.

Caring for the Player and Tapes

The tape player picks up dirt and oxides from the tape. This contamination build up over time and causes the sound quality to degrade. To prevent this, you should clean the player after every 30 hours of use.

If you do not clean the tape player regularly, it may eventually become impossible to remove the contamination with a normal cleaning kit. Your Acura dealer has a cleaning kit available.

Use 100-minute or shorter tapes. Tapes longer than that may break or jam the drive.

If the tape is loose, tighten it by turning the hub with a pencil or your finger. If the label is peeling off, remove it or it could cause the tape to jam in the player. Never try to insert a warped or damaged tape in the player.

Store tapes in their cases to protect them from dust and moisture. Never place tapes where they will be exposed to direct sunlight, high heat, or high humidity. If a tape is exposed to extreme heat or cold, let it reach a moderate temperature before inserting it into the player.

Never try to insert foreign objects into the tape player.

Remote Audio Controls

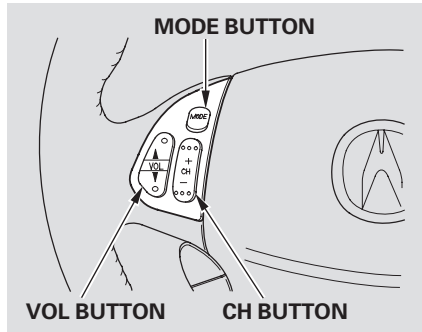

Three controls for the audio system are mounted in the steering wheel hub. These let you control basic functions without removing your hand from the wheel.

The VOL button adjusts the volume up (▲) or down (▼). Press the top or bottom of the button and hold it until the desired volume is reached, then release it.

The MODE button changes the mode. Pressing the button repeatedly selects FM1, FM2, AM, XM Satellite Radio (U.S. models), CD (if a CD is loaded), or a tape (if a tape is loaded).

If you are listening to the radio, use the CH button to change stations. Each time you press the top (+) of the button, the system goes to the next preset station on the band you are listening to. Press the bottom (-) to go back to the previous station.

If you are playing a CD, the system skips to the beginning of the next track each time you press the top (+) of the CH button. Press the bottom (-) to return to the beginning of the current track. Press it again to return to the previous track. You will see the disc and track numbers in the display.

If you are playing a tape, press the top (+) of the CH button to advance to the next selection. Press the bottom (-) to go back to the previous selection. The system senses a silent period, then goes back to Play mode.

Radio Theft Protection

Radio Theft Protection

Your vehicle's audio system will disable itself if it is disconnected from electrical power for any reason. To make it work again, you must enter a specific five-digit code in the preset buttons. Because there are hundreds of number combinations possible from five digits, making the system work without knowing the exact code is nearly impossible.

You should have received a card that lists your audio system code number and serial number. It is best to store this card in a safe place at home. In addition, you should write the audio system's serial number in this Owner's Manual.

If you should happen to lose the card, you must obtain the code number from an Acura dealer. To do this, you will need the system's serial number.

If your vehicle's battery is disconnected or goes dead, the audio system will disable itself. If this happens, you will see "CODE" in the frequency display the next time you turn on the system. Use the preset buttons to enter the five-digit code. The code is located on the radio code card included in your Owner's Manual kit. When it is entered correctly, the radio will start playing.

If you make a mistake entering the code, do not start over; complete the five-digit sequence, then enter the correct code. You have ten tries to enter the correct code. If you are unsuccessful in ten attempts, you must then leave the system on for 1 hour before trying again.

If the code card is lost, an Acura dealer can access your code with your radio's serial number. To access the serial number, turn the radio on. It must display "CODE",

then turn the radio off. Push the preset 1, preset 6, and power buttons at the same time, then quickly release. The serial number will appear in two sets of four digits.

You will have to store your favorite XM stations in the preset buttons after the system begins working. Your original setting were lost when the power was disconnected.

The security system helps to protect your vehicle and valuables from theft. The horn sounds and a combination of headlights, parking lights, side marker lights and taillights flash if someone attempts to break into your vehicle or remove the radio. This alarm continues for 2 minutes, then the system resets. To reset an alarming system before the 2 minutes have elapsed, unlock the driver's door with the key or use the remote transmitter.

The security system sets automatically 15 seconds after you lock the doors, hood, and trunk. For the system to activate, you must lock the doors from the outside with the key, lock tab, door lock switch, or remote transmitter. The security system indicator next to the driver's door lock starts blinking immediately to show you the system is setting itself.

SECURITY SYSTEM LIGHT

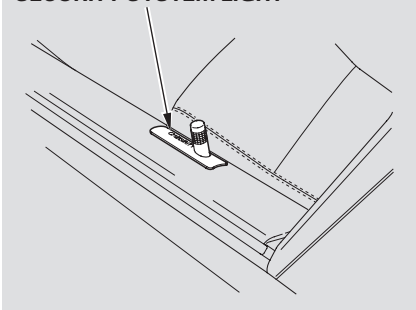

Once the security system is set, opening any door or the hood without using the key or the remote transmitter will cause the system to alarm. It also alarms if the radio is removed from the dashboard or the wiring is cut.

With the system set, you can still open the trunk with the remote transmitter without triggering the alarm. The alarm will sound if the trunk is opened with the trunk release button on the driver's door, the trunk release handle behind the trunk pass-through cover, or the emergency trunk opener.

The security system will not set if the hood, trunk, or any door is not fully closed. If the system will not set, check the Door and Trunk Open Monitor on the multi-information display (see page 60) to see if the doors and trunk are fully closed. Since it is not part of the monitor display, manually check the hood.

Do not attempt to alter this system or add other devices to it.

Cruise Control

Cruise control allows you to maintain a set speed above 25 mph (40 km/h) without keeping your foot on the accelerator pedal. It should be used for cruising on straight, open highways. It is not recommended for city driving, winding roads, slippery roads, heavy rain, or bad weather.

⚠ WARNING

Improper use of the cruise control can lead to a crash.

Use the cruise control only when traveling on open highways in good weather.

Using the Cruise Control

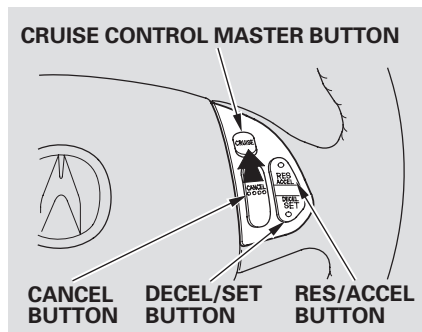

1. Push in the Cruise Control Master Button on the steering wheel. The CRUISE MAIN indicator on the instrument panel will come on.
2. Accelerate to the desired cruising speed above 25 mph (40 km/h).

3. Press and release the DECEL/SET button on the steering wheel. The CRUISE CONTROL indicator on the instrument panel comes on to show the system is now activated.

The cruise control may not hold the set speed when you are going up and down hills. If your speed increases going down a hill, use the brakes to slow down to the desired speed. This will cancel the cruise control. To resume the set speed, press the RES/ACCEL button. The CRUISE CONTROL indicator on the instrument panel comes on.

When climbing a steep hill, the automatic transmission may downshift to hold the set speed.

Changing the Set Speed

You can increase the set cruising speed in any of these ways:

- Press and hold the RES/ACCEL button. When you reach the desired cruising speed, release the button.
- Push on the accelerator pedal. Accelerate to the desired cruising speed and press the DECEL/SET button.
- To increase your speed in very small amounts, tap the RES/ACCEL button. Each time you do this, your vehicle will speed up about 1 mph (1.6 km/h).

You can decrease the set cruising speed in any of these ways:

- Press and hold the DECEL/SET button. Release the button when you reach the desired speed.
- To slow down in very small amounts, tap the DECEL/SET button. Each time you do this, your vehicle will slow down about 1 mph (1.6 km/h).
- Tap the brake or clutch pedal lightly with your foot. The CRUISE CONTROL indicator on the instrument panel will go out. When the vehicle slows to the desired speed, press the DECEL/SET button.

Even with the cruise control turned on, you can still use the accelerator pedal to speed up for passing. After completing the pass, take your foot off the accelerator pedal. The vehicle will return to the set cruising speed.

Resting your foot on the brake or clutch pedal will cause the cruise control to cancel.

Cruise Control

Canceling the Cruise Control

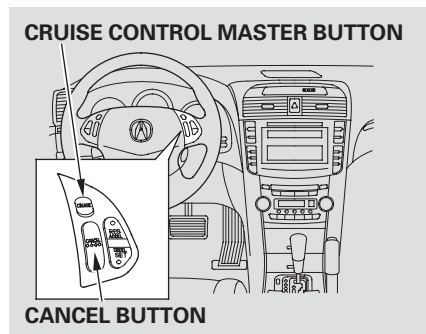

You can cancel the cruise control in any of these ways:

- Tap the brake or clutch pedal.
- Press the CANCEL button on the steering wheel.
- Press the Cruise Control Master button on the steering wheel.

When you push the CANCEL button, or tap the brake or clutch pedal, the system remembers the previously set cruising speed. To return to that speed, accelerate to above 25 mph (40 km/h), then press and release the RES/ACCEL button. The CRUISE CONTROL indicator comes on, the vehicle will accelerate to the same cruising speed as before.

Pressing the Cruise Control Master button turns the system completely off and erases the previous cruising speed.

The HomeLink® Universal Transceiver built into your vehicle can be programmed to operate up to three remote controlled devices around your home, such as garage doors, lighting, or home security systems.

General Information

If you are training HomeLink to operate a garage door or gate, you should unplug the motor for that device during training. Repeatedly pressing the remote control button could burn out the motor.

The HomeLink Transceiver stores the code in a permanent memory. There should be no need to retrain HomeLink if your vehicle's battery goes dead or is disconnected.

If your garage door opener was manufactured before April 1982, you may not be able to program HomeLink to operate it. They do not have the safety feature that causes

the motor to stop and reverse if an obstacle is detected during closing, increasing the risk of injury.

Important Safety Precautions

Always refer to the opening instructions and safety information that came with your garage door opener or other equipment you intend to operate with the HomeLink Universal Transceiver. If you do not have this information, contact the manufacturer of the equipment.

Training HomeLink

Before you begin — If you just received your vehicle and have not trained any of the buttons in HomeLink before, you should erase any previously learned codes before training the first button.

To do this, press and hold the two outside buttons on the HomeLink transceiver for about 20 seconds, until the red light flashes. Release the buttons, then proceed to Step 1.

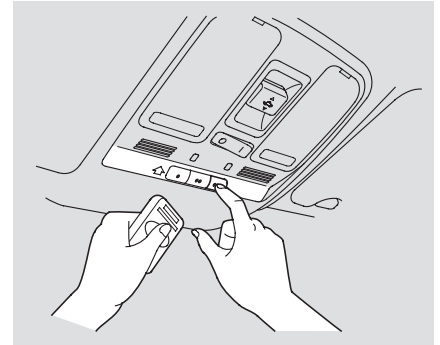

If you are training the second or third buttons, go directly to Step 1.

1. Unplug the garage door opener motor from the house current.
2. Hold the end of the garage door opener remote control 2 to 5 inches from HomeLink. Make sure you are not blocking your view of the red light in HomeLink.

HomeLink Universal Transceiver

3. Press and hold the remote control button and one of the HomeLink buttons at the same time.

Canadian Owners: The remote control you are training from may stop transmitting after 2 seconds. This is not long enough for HomeLink to learn the code. Release and press the button on the remote control every 2 seconds until HomeLink has learned the code.

4. The red light in HomeLink should begin flashing. It will flash slowly at first, then rapidly.
5. When the red light flashes rapidly, release both buttons. HomeLink should have learned the code from the remote control.
6. Plug in the garage door opener motor, then test the HomeLink Transceiver button by pushing it.

If the button does not work, repeat this procedure to train it again. If it still does not work, you may have a variable or rolling code garage door opener. See if you do by pressing and holding the HomeLink transceiver button you just trained. If the red light blinks for 2 seconds, then stays on, you have a rolling code garage door opener. Go to “Training With a Rolling Code System”.

7. Repeat these steps to train the other two HomeLink buttons to operate any other remotely-controlled devices around your home (lighting, automatic gate, security system, etc.).

Training With a Rolling Code System

For security purposes, newer garage door opening systems use a “rolling” or variable code. Information from the remote control and the garage door opener are needed before HomeLink can operate the garage door opener.

The “Training HomeLink” procedure trains HomeLink to the proper garage door opener code. The following procedure synchronizes HomeLink to the garage door opener so they send and receive the correct codes.

1. Make sure you have properly completed the “Training HomeLink” procedure.
2. Find the “Training” button on your garage door opener unit. The location will vary, depending on the manufacturer.

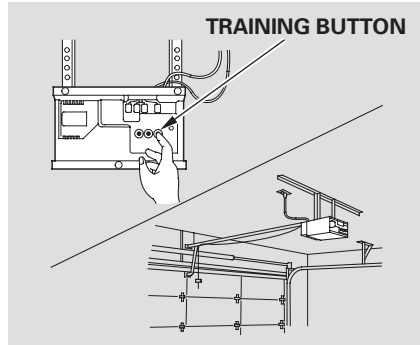

3. Press the Training button on the garage door opener unit until the light next to the button comes on, then release it. The light may blink, or come on and stay on. You then have approximately 30 seconds to complete the following steps.

4. Press and hold the button on HomeLink for 3 – 4 seconds.
5. Press and hold the HomeLink button again for 3 – 4 seconds. This should turn off the training light on the garage door opener unit. (Some systems may require you to press the button up to three times.)
6. Press the HomeLink button again. It should operate the garage door.

HomeLink Universal Transceiver

Erasing Codes

To erase the codes stored in all three buttons, press and hold the two outside buttons until the red light begins to flash, then release the buttons.

You should erase all three codes before selling the vehicle.

Retraining a Button

To train an already programmed transceiver button with a new device, you do not have to erase all the memory. Train the selected button over the existing memory code following the steps under **Training HomeLink**.

Customer Assistance

If you have problems with training the HomeLink Universal Transceiver, or would like information on home products that can be operated by the transmitter, call (800) 355-3515. On the Internet, go to www.homelink.com.

As required by the FCC:

This device complies with Part 15 of the FCC rules. Operation is subject to the following two conditions: (1) This device may not cause harmful interference, and (2) this device must accept any interference received, including interference that may cause undesired operation.

Changes or modifications not expressly approved by the party responsible for compliance could void the user's authority to operate the equipment.

This device complies with Industry Canada Standard RSS-210.

Operation is subject to the following two conditions: (1) this device may not cause interference, and (2) this device must accept any interference that may cause undesired operation of the device.

Your vehicle is equipped with the HandsFreeLink (HFL). HFL uses Bluetooth technology as a wireless link between it and your Bluetooth compatible cell phone. When you are in your vehicle and your phone is linked to the HFL, you'll enjoy safe, hands-free phone use. The HFL is available only in English.

Here are the main features of the HFL. Instructions for using the HFL begin on page [152](#).

Voice Control

HFL recognizes simple voice commands, such as phone numbers and names. It uses these commands to automatically dial, receive, and store numbers. For more information on voice control, see Using Voice Control on page [152](#).

Bluetooth® Wireless Technology

Bluetooth® is a registered trademark of Bluetooth SIG, Inc.

Bluetooth is the wireless technology that links your phone to the HFL. The HFL uses a Class 3 Bluetooth, which means the maximum range between your phone and vehicle is 30 feet (10 meters) or less.

To use the HFL, your phone must have Bluetooth capability along with the Hands Free Profile. This type of phone is available through many phone makers and cellular carriers. You can also find a phone by visiting www.acura.com. In Canada, visit www.acura.ca.

Incoming/Outgoing Calls

With a linked phone, the HFL allows you to send and receive calls in your vehicle without holding the phone.

Phonebook

The HFL can store up to 50 names and phone numbers in its phonebook. With a linked phone, you can then automatically dial any name or number in the phonebook.

Here are the main components of the HFL system:

Microphone

The HFL microphone is on the ceiling, between the front seat spotlights. On models with navigation system, the microphone is shared with the navigation system.

Audio System

When the HFL is in use, the sound comes through the vehicle's front audio system speakers. If the audio system is in use while making a call, the HFL over-rides the audio system. To change the volume level, use the audio system volume knob.

CONTINUED

HFL Buttons

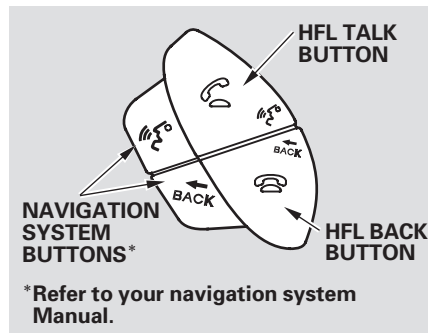

To operate the HFL, use the HFL Talk and Back buttons on the left side of the steering wheel. On navigation-equipped vehicles, there are two sets of buttons: one for the navigation, climate control, and audio systems, and the other for the HFL.

Here is the function of each HFL button:

HFL Talk: This button is used before you give a command, to answer incoming calls, and to confirm system information.

HFL Back: This button is used to end a call, go back to the previous voice control command, and to cancel an operation.

Multi-Information Display

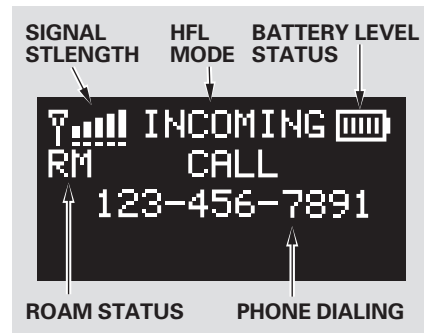

When you are operating the HFL, or when you manually scroll through the Multi-Information Display and select HFL, you will see this information on the screen:

- **Signal Strength*** – Indicates the network signal strength of the current phone call. Five bars equals full strength.

- **ROAM Status*** — Indicates your phone is roaming.
 - **Battery Level status*** — Indicates the power remaining in your phone's current battery charge. Five bars equals full battery strength.
 - **HFL Mode** — Indicates when you are dialing and receiving calls.
 - **Phone Dialing** — Indicates the number you entered or the number of the incoming call.
- * : Some phones will not send this information to the HFL.

Center Console Display

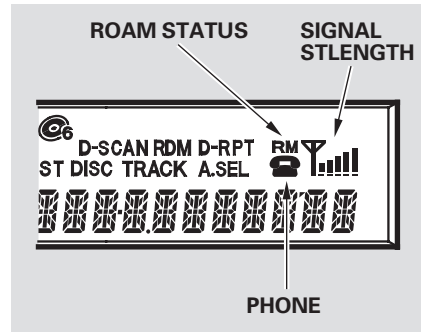

This information is displayed whether or not the phone is being used:

- **Phone** — Indicates a phone is currently linked to the HFL.
- **Signal Strength*** (models without navigation system) — Indicates the network signal strength of the current phone call. Five bars equals full signal strength.

- **ROAM Status*** (models without navigation system) — Indicates your phone is roaming.

* : Some phones will not send this information to the HFL.

CONTINUED

How to Use the HFL

The HFL is operated by the HFL Talk and Back buttons on the left side of the steering wheel. The next few pages provide easy-to-use instructions for all basic features of the HFL.

Note: All phones may not operate identically, and some may cause inconsistent operation of the HFL.

Using Voice Control

Here are some guidelines for using voice control:

- To enter a command, press the Talk button. Then, after the beep, say your command in a clear, natural tone.
- For best system operation, set the climate control fan speed to low, and direct the center vents away from the microphone in the ceiling.
- If the HFL does not recognize a command, its response is,

“Pardon”. If it doesn’t recognize the command a second time, its response is, “Please repeat.” If it doesn’t recognize the command a third time, it plays the Help prompt.

- To hear a list of available options at any time, press the Talk button, wait for the beep, and say, “Hands free link help.”
- Many commands can be spoken together. For example, you can say, “Dial 123-456-7891”.
- To enter a string of numbers in a Call or Dial command, you can say them all at once, or you can separate them in blocks of 3, 4, 7, 10, and 11.
- To skip a voice prompt, press the Talk button while the HFL is speaking. The HFL will then begin listening for your next command.

- To go back one step in a command process, say, “Go back,” or press the Back button.

If nothing is said while the HFL is listening for a command, the HFL will time out and stop its voice recognition. The next time you press the Talk button, the HFL begins listening from the point at which it timed out.

- To end a command sequence at any time, press and hold the Back button, or press the Talk button, wait for the beep, and say, “Cancel.” The next time you press the Talk button, the HFL begins from its main menu.
- When you finish a command sequence, the HFL goes back to its main menu. For example, when you store the name, “Eric,” the HFL response is, “Eric has been stored.” The next time you press the Talk button, you will be at the main menu.

Setting Your Passcode

The HFL will accept a numeric, four-digit passcode that you can use for security purposes.

To set your passcode, do this:

1. With the ignition in the ON (II) position, press and release the Talk button on the steering wheel. After the beep, say “Security.” The HFL response is “Security options are lock, unlock, and set passcode.”
2. Press and release the Talk button. After the beep, say “Set passcode.”
3. The HFL response is “What is the new four-digit passcode?” (If you are changing the passcode, you will first be asked for the current passcode.)

4. Press and release the Talk button. After the beep, say the four-digit passcode you want to use. For example, say “1, 2, 3, 4.” The HFL response is “1, 2, 3, 4. Is this correct?”
5. Press and release the Talk button. After the beep, say “Yes.” The HFL response is “The new passcode has been stored. Returning to the main menu.”

Locking or Unlocking the HFL

Once a passcode is set, you can lock the HFL so it only operates after the passcode is entered, or you can unlock it so anyone using your vehicle can also use the HFL.

To lock or unlock the HFL, do this:

1. Press and release the Talk button. After the beep, say “Security.” The HFL response is “Security options are lock, unlock, and set passcode.”

2. Press and release the Talk button. After the beep, say “Lock” or “Unlock.” **Lock** means the HFL will prompt you for your passcode each time the ignition switch is turned to ON (II) and you press the Talk button. You will only be asked for the passcode once per ignition cycle. If the HFL is locked, its response is “System is locked. Each time the vehicle is turned on, the passcode will be required to use the system.” If the HFL is unlocked, its response is “The system is unlocked. Returning to the main menu.”

Setting Up the System

The voice of the HFL can be set to male or female (U.S. models only). Also, the incoming notification can be set to a ring tone, a prompt, or no notification.

To set up the system, do this:

1. Press and release the Talk button. After the beep, say "System." The HFL response is, "System options are setup and clear."
2. Press and release the Talk button. After the beep, say "Setup." The HFL response is "Would you like male or female prompts?"
3. Press and release the Talk button. After the beep, say "Male" or "Female," depending on the system voice you want. The HFL response is, "Male (Female) prompts have been selected. Would you like an audible notification of an incoming call?"

4. Press and release the Talk button. If you say "Yes" after the beep, the HFL response is, "Would you like a ring tone or a prompt?" If you say "No" after the beep, the HFL returns to its main menu. Saying "No" will result in no ring tone or prompt playback during an incoming call. The audio system will still mute, and a message will be displayed.
5. Press and release the Talk button. After the beep, say "Ring tone" or "Prompt." If you choose "Ring tone" you will hear a ring tone through the audio speakers to announce an incoming call. If you choose "Prompt," you will hear this message to announce an incoming call: "You have an incoming call."

Pairing Your Phone

Your Bluetooth compatible phone with HandsFree Profile must be paired to the HFL before you can make and receive hands-free call.

NOTE:

- HFL does not allow you to pair your phone if the vehicle is moving.
- For pairing, your phone must be in its Discovery mode.
- Up to six phones can be paired to the HFL.
- The following procedure works for most phones. If you cannot pair your phone to the HFL with this procedure, refer to your phone's operating manual, or talk to your phone retailer.
- During the pairing process, turn off any previously paired phones before pairing a new phone.

1. With your phone on and the ignition in the ACCESSORY (I) or ON (II) position, press and release the Talk button. After the beep, say "Phone set up." The HFL response is "Phone set up options are status, pair, edit, delete, and list."
 2. Press and release the Talk button. After the beep, say "Pair." The HFL response is "The pairing process requires operation of your mobile phone. For safety, only perform this function while the vehicle is stopped. State a four-digit code for pairing. Note this code. It will be requested by the phone."
 3. Press and release the Talk button. After the beep, say the four-digit code you want to use. For example, say "1, 2, 3, 4." The HFL response is, "1, 2, 3, 4. Is this correct?"
 4. Press and release the Talk button. After the beep, say "Enter". The HFL response is "Searching for a Bluetooth phone."
- NOTE:** Steps 5 and 6 show a common way to get your phone into its Discovery mode. If these steps do not work on your phone, refer to the phone's operating manual.
5. Follow the prompts on your phone to get it into its Search mode. The phone will search for the HFL. When it comes up, select HandsFreeLink from the list of options displayed on your phone.
 6. When asked by the phone, enter the four-digit code from step 3 into your phone. The HFL response is "A new phone has been found. What would you like to name this phone?"
 7. Press and release the Talk button. After the beep, say the name you want to use. For example, say "Eric's phone." The HFL response is "Eric's phone has been successfully paired. Returning to the main menu."
 8. If you want to pair another phone, repeat steps 1 through 7.

CONTINUED

To rename a paired phone do this:

1. Press and release the Talk button.
After the beep, say “Phone setup.”
The HFL response is “Phone setup options are status, pair, edit, delete, and list.”
2. Press and release the Talk button.
After the beep, say “Edit.” The HFL response is “Which phone would you like to edit?”
3. Press and release the Talk button.
After the beep, say the name of the phone you want to rename.
For example, say “Eric’s phone.”
The HFL response is “What is the new name for Eric’s phone?”
4. Press and release the Talk button.
After the beep, say the new name of the phone. For example, say “Lisa’s phone.” The HFL response is, “The name has been changed. Returning to the main menu.”

To delete a paired phone, do this:

1. Press and release the Talk button.
After the beep, say “Phone setup.”
The HFL response is, “Phone setup options are status, pair, edit, delete, and list.”
2. Press and release the Talk button.
After the beep, say “Delete.” The HFL response is, “Which phone would you like to delete?”
3. Press and release the Talk button.
After the beep, say the name of the phone you want to delete. For example say “Eric’s phone.” The HFL response is “Would you like to delete Eric’s phone?”

4. Press and release the Talk button.
After the beep, say “Yes.” The HFL response is “Preparing to delete Eric’s phone.” Say “OK” to continue. Otherwise, say “Go back,” or “Cancel.”
5. Press and release the Talk button.
If you say “OK” after the beep, the HFL response is “The phone has been deleted. Returning to the main menu”. If you say “Go back,” or “Cancel,” the phone will not be deleted.

To list all paired phones, do this:

1. Press and release the Talk button. After the beep, say “Phone setup.” The HFL response is “Phone setup options are status, pair, edit, delete, and list.”
2. Press and release the Talk button. After the beep, say “List.” The HFL responds by listing the name of each paired phone. When all phones paired to the system have been read, the HFL response is “The entire list has been read. Returning to the main menu.”

To find out the status of the phone being used, do this:

1. Press and release the Talk button. After the beep, say “Phone setup.” The HFL response is “Phone setup options are status, pair, edit, delete, and list.”
2. Press and release the Talk button. After the beep, say “Status.” An example of the HFL response is, “Eric’s phone is linked. Battery strength is three bars. Signal strength is five bars, and the phone is roaming. Returning to the main menu.”

To change from the currently linked phone to another paired phone, do this:

1. Press and release the Talk button. After the beep, say “Next phone.” The HFL response is “Searching for the next phone.” The HFL then disconnects the linked phone and searches for another paired phone. If no other phones are found, the first phone remains linked.

Making a Call

You can make calls using any phone number, or by using a name in the HFL phonebook. You can also redial the last number called. During a call, the HFL allows you to talk up to 30 minutes after you remove the key from the ignition switch.

To make a call using a phone number, do this:

1. With your phone on and the ignition in the ACCESSORY (I) or ON (II) position, press and release the Talk button. After the beep, say “Call” or “Dial.” The HFL response is, “What name or number would you like to call/dial?”
2. Press and release the Talk button. After the beep, say the number you want to call. For example, say “123 456 7891.” The HFL response is “123 456 7891. Say call, dial, or continue to add numbers.”

3. Press and release the Talk button. After the beep, say “Call” or “Dial.” The HFL response is “Calling” or “Dialing.” Once connected, you will hear the person you called through the audio speakers. To change the volume, use the audio system volume knob.
4. To end the call, press the Back button.

To make a call using a name in the HFL phonebook, do this:

1. With your phone on and the ignition in the ACCESSORY (I) or ON (II) position, press and release the Talk button. After the beep, say “Call” or “Dial.” The HFL response is “What name or number would you like to call/dial?”
2. Press and release the Talk button. After the beep, say the name you want to call. For example, say

“Eric.” The HFL response is “Would you like to call Eric?”

3. Press and release the Talk button. After the beep, say “Yes.” The HFL response is “Calling” or “Dialing.” Once connected, you will hear the person you called through the audio speakers. To change the volume, use the audio system volume knob.
4. To end the call, press the Back button.

To redial the last number called by the phone, press and release the Talk button. After the beep, say “Redial.” The HFL response is, “Redialing.” Once connected, you will hear the person you called through the audio speakers. To change the volume, use the audio system volume knob.

Sending Numbers or Names During a Call

The HFL allow you to send numbers or names during a call. This is useful when you call a menu-driven phone system. You can also program account numbers into the HFL phonebook for easy retrieval during menu-driven calls.

To send a number during a call, do this:

1. Press and release the Talk button. After the beep, say “Send.” The HFL response is, “What name or number would you like to send?”
2. Press and release the Talk button. After the beep, say the number you want to send. For example, say “1, 2, 3.” The HFL response is “1, 2, 3. Say send, or continue to add numbers.”

3. Press and release the Talk button. After the beep, say “Send.” The dial tones will be sent, and the call will continue.

To send a name during a call, do this:

1. Press and release the Talk button. After the beep, say “Send.” The HFL response is “What name or number would you like to send?”
2. Press and release the Talk button. After the beep, say the name you want to send. For example, say “Account number.” The HFL response is “Would you like to send account number?”
3. Press and release the Talk button. After the beep, say “Send.” The dial tones will be sent, and the call will continue.

Receiving a Call

If you receive a call when you are not on the phone, the HFL interrupts the audio system (if it is on), and plays the incoming call notification, if activated. To answer the call, press the Talk button and begin speaking. If you don’t want to answer the call, press the Back button.

If your phone has Call Waiting, and you receive a call when you are on the phone, press the Talk button to answer it. When you do this, the original call is placed on hold. To return to the original call, press the Talk button again. If you don’t want to answer the new call, disregard it, and continue with your original call. If you want to hang up the original call and answer the new call, press the Back button.

Transferring a Call

During a call, you can transfer it from the HFL to your phone, or from your phone to the HFL.

To transfer a call from the HFL to your phone, do this:

1. Press and release the Talk button. After the beep, say “Transfer”. The audio switches from the HFL to the phone.

To transfer a call from your phone to the HFL, do this:

2. Press and release the Talk button. After the beep, say “Transfer.” The audio switches from your phone to the HFL.

Muting a Call

During a call, you can mute or unmute your voice to the person you’re talking to.

To mute your voice, do this:

1. Press and release the Talk button. After the beep, say “Mute.” The HFL response is, “Mute is active.”

To unmute your voice, do this:

2. Press and release the Talk button. After the beep, say “Mute.” The HFL response is, “Mute is cancelled.”

Setting up the Phonebook

The HFL phonebook can store up to 50 names with their associated numbers. These can be any types of numbers. For example, you can store a phone number and use it to make a call, or you can store an account number and use it during a call to a menu-driven phone system.

To add a name, do this:

1. Press and release the Talk button. After the beep, say “Phonebook.” The HFL response is “Phonebook options are store, edit, delete, and list.”
2. Press and release the Talk button. After the beep, say “Store.” The HFL response is, “What name would you like to store?”
3. Press and release the Talk button. After the beep, say the name you would like to store. For example, say “Eric” or say “account number.” The HFL response is “What is the number for Eric,” or “What is the number for account number?”
4. Press and release the Talk button. After the beep, say the number. For example, say “123 456 7891.” The HFL response is “123 456 7891.”

5. Press and release the Talk button. After the beep, say “Enter.” The HFL response is “Eric (or account number) has been stored. Returning to the main menu.”

To edit the number of a name, do this:

1. Press and release the Talk button. After the beep, say “Phonebook.” The HFL response is “Phonebook options are store, edit, delete, and list.”
2. Press and release the Talk button. After the beep, say “Edit.” The HFL response is, “What name would you like to edit?”
3. Press and release the Talk button. After the beep, say the name you would like to edit. For example, say “Eric.” The HFL response is “What is the new number for Eric?”

4. Press and release the Talk button. After the beep, say the new number for Eric. For example, say “987 654 3219.” The HFL response is, “987 654 3219.”

5. Press and release the Talk button. After the beep, say “Enter.” The HFL response is “The number has been changed. Returning to the main menu.”

To delete a name, do this:

1. Press and release the Talk button. After the beep, say “Phonebook.” The HFL response is, “Phonebook options are store, edit, delete, and list.”
2. Press and release the Talk button. After the beep, say “Delete.” The HFL response is, “What name would you like to delete?”

3. Press and release the Talk button. After the beep, say the name you would like to delete. For example, say “Eric.” The HFL response is “Do you want to delete Eric?”

4. Press and release the Talk button. After the beep, say “Yes.” The HFL response is, “The name has been deleted. Returning to the main menu.”

To list all names in the phonebook, do this:

1. Press and release the Talk button. After the beep, say “Phonebook.” The HFL response is, “The Phonebook options are store, edit, delete, and list.”

CONTINUED

2. Press and release the Talk button. After the beep, say “List.” The HFL responds by listing the names in the phonebook. When the end of the list is reached, the HFL response is, “The entire list has been read. Returning to the main menu.”

To call a name from the phonebook list, do this:

1. Press and release the Talk button. After the beep, say “Phonebook.” The HFL response is “Phonebook options are store, edit, delete, and list.”
2. Press and release the Talk button. After the beep, say “List.” The HFL responds by listing the names in the phonebook. When it says the name you want to call, for example, Eric, press the Talk button, and then say “Call.” The HFL response is, “Would you like to call Eric?”

3. Press and release the Talk button. After the beep, say “Yes.” The HFL response is “Calling.” Once connected, you will hear the person you called through the audio speakers. To change the volume, use the audio system volume knob.

Clearing the System

This operation clears the HFL of your passcode, your paired phones, and all names in the HFL phonebook. Clearing is recommended before you sell your vehicle.

To clear the system, do this:

1. Press and release the Talk button. After the beep, say “System.” The HFL response is, “System options are setup and clear.”

2. Press and release the Talk button. After the beep, say “Clear.” The HFL response is, “This process will clear all paired phones, clear all entries in the phonebook, and clear the passcode. Is this what you would like to do?”
3. Press and release the Talk button. After the beep, say “Yes.” The HFL response is “Preparing to clear all paired phones, all phonebook entries, and the passcode. This may take up to 2 minutes to complete.” Press and release the Talk button. After the beep, say “OK.” to proceed, or say “Go back” or “Cancel.”
4. If you said “OK,” after a short period of time, the HFL response is, “System has been cleared. Returning to the main menu.”

Before you begin driving your Acura, you should know what gasoline to use, and how to check the levels of important fluids. You also need to know how to properly store luggage or packages. The information in this section will help you. If you plan to add any accessories to your vehicle, please read the information in this section first.

Break-in Period	164
Gasoline Type	164
Service Station Procedures	165
Fuel Economy	168
Accessories and Modifications	169
Carrying Cargo	171

Break-in Period, Gasoline Type

Break-in Period

Help assure your vehicle's future reliability and performance by paying extra attention to how you drive during the first 600 miles (1,000 km). During this period:

- Avoid full-throttle starts and rapid acceleration.
- Avoid hard braking for the first 200 miles (300 km).
- Do not change the oil until the multi-information display indicates it is needed.

You should follow these same recommendations with an overhauled or exchanged engine, or when the brakes are relined.

Gasoline Type

Your Acura is designed to operate on unleaded gasoline with a pump octane number of 91 or higher. Use of a lower octane gasoline can cause occasional metallic knocking noises in the engine and will result in

decreased engine performance.

On TL with manual transmission

You may hear a knocking noise from the engine if you drive the vehicle at low engine speed (below about 1,000 rpm) in a higher gear. To stop this, raise engine speed by shifting to a lower gear.

We recommend gasolines containing detergent additives that help prevent fuel system and engine deposits. In addition, in order to maintain good performance, fuel economy, and emissions control, we strongly recommend, in areas where it is available, the use of gasoline that does NOT contain manganese-based fuel additives such as MMT.

Use of gasoline with these additives may adversely affect performance, and cause the Malfunction Indicator Lamp on your instrument panel to come on. If this happens, contact

your authorized Acura dealer for service.

For further important fuel-related information, please refer to your Quick Start Guide.

Some gasoline today is blended with oxygenates such as ethanol or MTBE. Your vehicle is designed to operate on oxygenated gasoline containing up to 10 percent ethanol by volume and up to 15 percent MTBE by volume. Do not use gasoline containing methanol.

If you notice any undesirable operating symptoms, try another service station or switch to another brand of gasoline.

Fueling

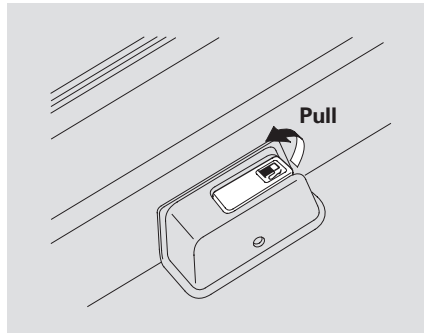

1. Park with the driver's side closest to the service station pump.
2. Open the fuel fill door by pulling on the handle to the left of the driver's seat.

⚠ WARNING

Gasoline is highly flammable and explosive. You can be burned or seriously injured when handling fuel.

- Stop the engine, and keep heat, sparks, and flames away.
 - Handle fuel only outdoors.
 - Wipe up spills immediately.
3. Remove the fuel fill cap slowly. You may hear a hissing sound as pressure inside the tank escapes. Place the knob on the cap in the notch on the fuel fill door.
 4. Stop filling the tank after the fuel nozzle automatically clicks off. Do not try to "top off" the tank. Leave some room for the fuel to expand with temperature changes.

If the fuel nozzle keeps clicking off even though the tank is not full, there may be a problem with your vehicle's fuel vapor recovery system. The system helps keep fuel vapors from going into the atmosphere. Consult your dealer.

5. Screw the fuel fill cap back on until it clicks at least three times. If you do not properly tighten the cap, the Malfunction Indicator Lamp may come on (see page 243).
6. Push the fuel fill door closed until it latches.

Service Station Procedures

Opening the Hood



1. Park the vehicle, and set the parking brake. Pull the hood release handle located under the lower left corner of the dashboard. The hood will pop up slightly.
2. Put your fingers between the front edge of the hood and the front grille to locate the hood latch handle. Push this handle up until it releases the hood. Lift the hood.

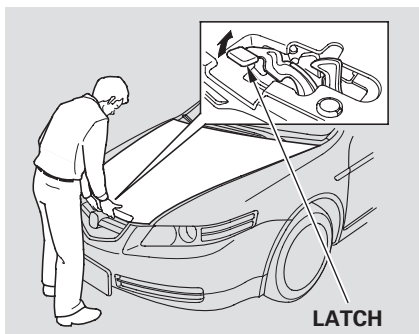

- If the hood latch handle moves stiffly, or if you can open the hood without lifting the handle, the mechanism should be cleaned and lubricated (see page [212](#)).
3. Lift the hood up most of the way. The hydraulic supports will lift it up the rest of the way and hold it up.

To Close the Hood

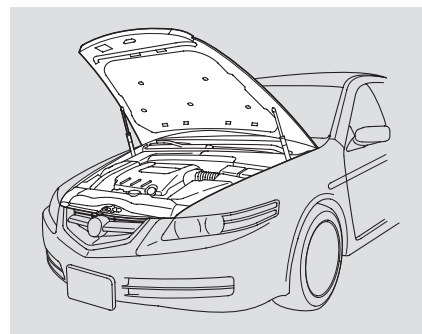

Lower the hood to about a foot (30 cm) above the fender, then press down firmly with your hands. Make sure it is securely latched.

Oil Check

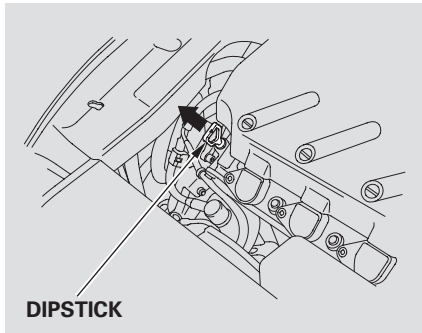

Wait a few minutes after turning the engine off before you check the oil.

1. Remove the dipstick (orange loop).
2. Wipe off the dipstick with a clean cloth or paper towel.
3. Insert it all the way back in its tube.

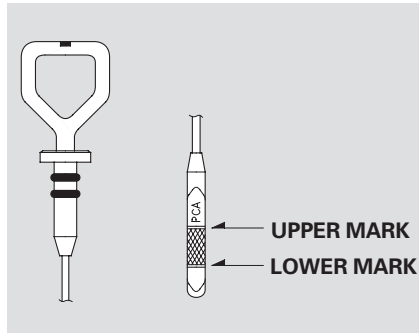

4. Remove the dipstick again and check the level. It should be between the upper and lower marks.

If it is near or below the lower mark, see **Adding Oil** on page 204 .

Engine Coolant Check

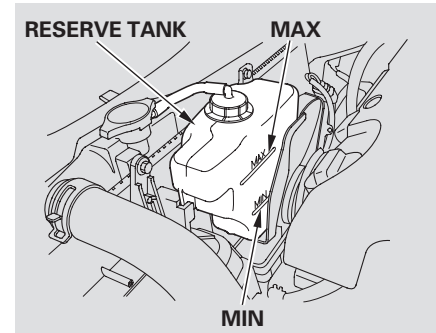

Look at the coolant level in the radiator reserve tank. Make sure it is between the MAX and MIN lines. If it is below the MIN line, see **Adding Engine Coolant** on page 207 for information on adding the proper coolant.

Refer to **Owner's Maintenance Checks** on page 198 for information about checking other items on your Acura.

Fuel Economy

Improving Fuel Economy

- Always maintain your vehicle according to the maintenance messages given by the multi-information display. See **Owner's Maintenance Checks** on page [198](#).

For example, an underinflated tire causes more “rolling resistance,” which uses fuel.

The build-up of snow or mud on your vehicle's underside adds weight and rolling resistance. Frequent cleaning helps your fuel mileage and reduces the chance of corrosion.

- Drive moderately. Rapid acceleration, abrupt cornering, and hard braking use more fuel.
- Always drive in the highest gear possible.

- Try to maintain a constant speed. Every time you slow down and speed up, your vehicle uses extra fuel. Use the cruise control when appropriate.
- Combine several short trips into one.
- The air conditioning puts an extra load on the engine which makes it use more fuel. Use the fresh-air ventilation when possible.

Modifying your vehicle, or installing some non-Acura accessories, can make it unsafe. Before you make any modifications or add any accessories, be sure to read the following information.

Accessories

Your dealer has Acura accessories that allow you to personalize your vehicle. These accessories have been designed and approved for your vehicle, and are covered by warranty.

Although aftermarket accessories may fit on your vehicle, they may not meet factory specifications, and could adversely affect your vehicle's handling and stability (see page [170](#)).

WARNING

Improper accessories or modifications can affect your vehicle's handling, stability, and performance, and cause a crash in which you can be hurt or killed.

Follow all instructions in this owner's manual regarding accessories and modifications.

When properly installed, cellular phones, alarms, two-way radios, and low-powered audio systems should not interfere with your vehicle's computer controlled systems, such as the SRS and the anti-lock brake system.

Before installing any accessory:

- Make sure the accessory does not obscure any lights, or interfere with proper vehicle operation or performance.
- Be sure electronic accessories do not overload electrical circuits (see page [245](#)) or interfere with proper operation.
- Have the installer contact your Acura dealer for assistance before installing any electronic accessory.

Accessories and Modifications

Modifying Your Vehicle

Removing parts from your vehicle, or replacing components with non-Acura (aftermarket) components could seriously affect your vehicle's handling, stability, and reliability.

Some examples are:

- Lowering your vehicle with an aftermarket suspension kit that significantly reduces ground clearance can allow the undercarriage to hit speed bumps or other raised objects, which could cause the airbags to deploy.
- Raising your vehicle with an aftermarket suspension kit can affect the handling and stability.
- Aftermarket wheels, because they are a universal design, can cause excessive stress on suspension components.

- Larger or smaller wheels and tires can interfere with the operation of your vehicle's anti-lock brakes and other systems.

Do not modify your steering wheel or any other part of your Supplemental Restraint System. Modifications could make the system ineffective. See the safety precautions on page [28](#).

If you plan to modify your vehicle, consult your Acura dealer.

Carrying Cargo

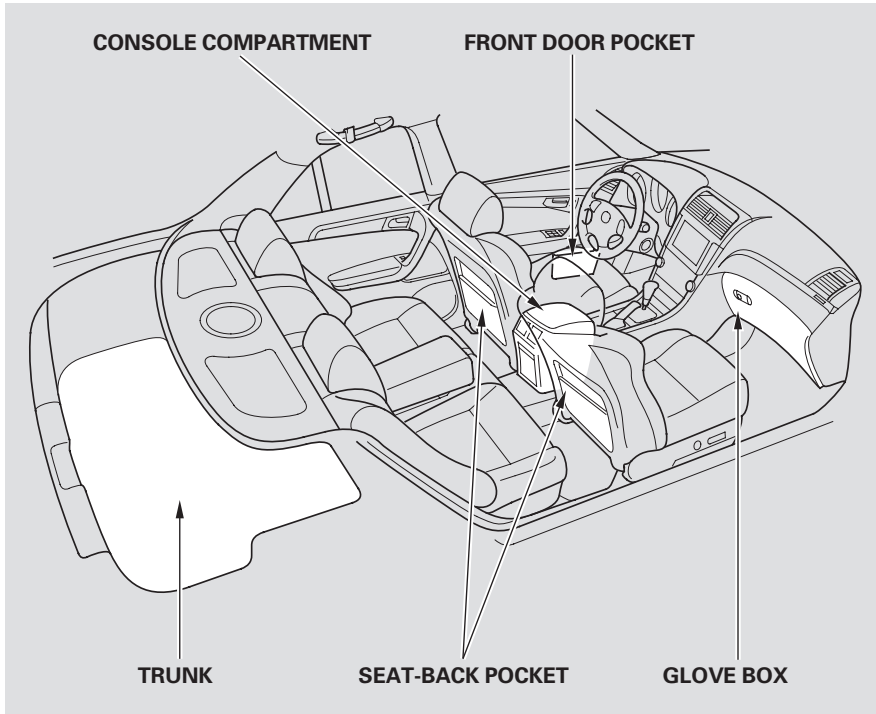

Your vehicle has several convenient storage areas:

- Glove box
- Front door and seat-back pockets
- Console compartment
- Trunk
- Roof-rack (if installed)

In addition, the trunk pass-through allows you to carry longer items. However, carrying too much cargo, or improperly storing it, can affect your vehicle's handling, stability, stopping distance, and tires, and make it unsafe. Before carrying any type of cargo, be sure to read the following pages.

Carrying Cargo

The maximum load for your vehicle is 850 lbs (395 kg). This figure includes total weight of all occupants, cargo, and accessories.

To determine the correct cargo and luggage load limit:

1. Locate the statement, “the combined weight of occupants and cargo should never exceed 850 lbs (395 kg)” on your vehicle’s placard (on the driver’s doorjamb).
2. Determine the combined weight of the driver and passengers that will be riding in the vehicle. (Five is seating capacity of your vehicle.)
3. Subtract the combined weight of the driver and passengers from 850 lbs (395 kg).
4. The resulting figure equals the available load capacity.

For example, if there will be four 150 lbs (70 kg) occupants in your vehicle, the amount of available cargo and luggage load capacity is 250 lbs (115 kg).

$4 \times 150 \text{ lbs (70 kg)} = 600 \text{ lbs (280 kg)}$

$850 \text{ lbs (395 kg)} - 600 \text{ lbs (280 kg)} = 250 \text{ lbs (115 kg)}$

5. Determine the combined weight of accessories, luggage, and cargo being loaded in the vehicle. The weight may not safely exceed the available cargo and luggage load capacity calculated in step 4.

WARNING

Overloading or improper loading can affect handling and stability and cause a crash in which you can be hurt or killed.

Follow all load limits and other loading guidelines in this manual.

Carrying Items in the Passenger Compartment

- Store or secure all items that could be thrown around and hurt someone during a crash.
- Do not put any items on top of the trunk panel. They can block your view and be thrown around the vehicle during a crash.
- Be sure items placed on the floor behind the front seats cannot roll under the seats and interfere with the pedals or seat operation.
- Keep the glove box closed while driving. If it is open, a passenger could injure their knees during a crash or sudden stop.

Carrying Cargo in the Trunk or on a Roof Rack

- Distribute cargo evenly on the floor of the trunk, placing the heaviest items on the bottom and as far forward as possible.
- If you carry large items that prevent you from closing the trunk lid, exhaust gas can enter the passenger area. To avoid the possibility of **carbon monoxide poisoning**, follow the instructions on page 46 .
- If you carry any items on a roof rack, be sure the total weight of the rack and the items does not exceed the maximum allowable weight. Please contact your Acura dealer for further information.

Cargo Nets

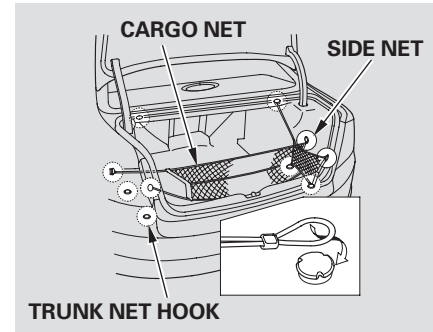

The cargo net can be used to help hold down items stored in the trunk. To use the cargo net, hook it to the buttons on the floor and sides of the trunk. You can use the cargo net in several configurations by hooking it to different buttons. There is also a side net that can be used on either side of the trunk. When you are not using the cargo net, store it in the pocket in the spare tire tool case.

This section gives you tips on starting the engine under various conditions, and how to operate the 6-speed manual and the automatic transmission. It also includes important information on parking your vehicle, the braking system and the Vehicle Stability Assist System.

Preparing to Drive	176
Starting the Engine.....	177
6-Speed Manual Transmission....	178
Automatic Transmission.....	181
Parking	187
Braking System.....	188
Anti-lock Brakes (ABS)	189
Vehicle Stability Assist System....	190
Towing a Trailer	192

Preparing to Drive

You should do the following checks and adjustments every day before you drive your vehicle.

1. Make sure all windows, mirrors, and outside lights are clean and unobstructed. Remove frost, snow, or ice.
2. Check that the hood and trunk are fully closed.
3. Visually check the tires. If a tire looks low, use a gauge to check its pressure.
4. Check that any items you may be carrying with you inside are stored properly or fastened down securely.
5. Check the seat adjustment (see page 88).
6. Check the adjustment of the inside and outside mirrors (see page 91).
7. Check the steering wheel adjustment (see page 78).
8. Make sure the doors are securely closed and locked.
9. Fasten your seat belt. Check that your passengers have fastened their seat belts (see page 14).

When you start the engine, check the gauges and indicator lights in the instrument panel (see page 51).

1. Apply the parking brake.
2. In cold weather, turn off all electrical accessories to reduce the drain on the battery.
3. *Manual Transmission:*
Push the clutch pedal down all the way.

Automatic Transmission:
Make sure the shift lever is in Park. Press on the brake pedal.
4. Without touching the accelerator pedal, turn the ignition key to the START (III) position. Do not hold the key in START for more than 15 seconds at a time. If the engine does not start right away, pause for at least 10 seconds before trying again.

5. If the engine does not start within 15 seconds, or starts but stalls right away, repeat step 4 with the accelerator pedal pressed halfway down. If the engine starts, release pressure on the accelerator pedal so the engine does not race.
6. If the engine fails to start, press the accelerator pedal all the way down and hold it there while starting to clear flooding. If the engine still does not start, return to step 5.

NOTICE: *The engine is harder to start in cold weather. Also, the thinner air found at altitudes above 8,000 feet (2,400 meters) adds to this problem.*

6-speed Manual Transmission

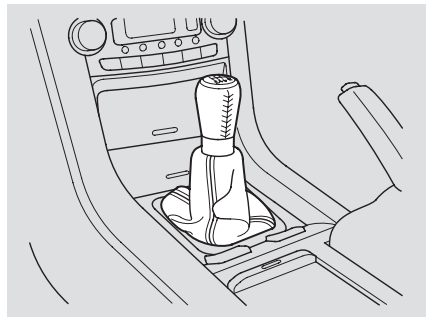

The manual transmission is synchronized in all forward gears for smooth operation. It has a lockout so you cannot accidentally shift from fifth to Reverse instead of sixth (see page 180) while the vehicle is moving. When shifting up or down, make sure you push the clutch pedal down all the way, shift to the next gear, and let the pedal up gradually. When you are not shifting, do not rest your foot on the clutch pedal. This can cause your clutch to wear out faster.

Note: *The engine can be damaged if you inadvertently downshift into the wrong gear (for example, going from third gear at high rpms to second gear instead of upshifting to fourth gear; the rev limiter will not work in this situation).*

Come to a full stop before you shift into Reverse. You can damage the transmission by trying to shift into Reverse with the vehicle moving. Push down the clutch pedal, and pause for a few seconds before shifting into Reverse, or shift into one of the forward gears for a moment. This stops the gears so they won't "grind."

When slowing down, you can get extra braking from the engine by shifting to a lower gear. This extra braking can help you maintain a safe speed and prevent your brakes from overheating while going down a steep hill. Before downshifting, make sure engine speed will not go into the tachometer's red zone in the lower gear.

WARNING

Rapid slowing or speeding-up can cause loss of control on slippery surfaces. If you crash, you can be injured.

Use extra care when driving on slippery surfaces.

Recommended Shift Points

Drive in the highest gear that lets the engine run and accelerate smoothly. This will give you the best fuel economy and effective emissions control. The following shift points are recommended:

Shift up	Normal acceleration
1st to 2nd	17 mph (27 km/h)
2nd to 3rd	27 mph (43 km/h)
3rd to 4th	36 mph (58 km/h)
4th to 5th	41 mph (66 km/h)
5th to 6th	44 mph (71 km/h)

Engine Speed Limiter

If you exceed the maximum speed for the gear you are in, the engine speed will enter into the tachometer's red zone. If this occurs, you may feel the engine cut in and out. This is caused by a limiter in the engine's computer controls. The engine will run normally when you reduce the RPM below the red zone.

Before downshifting, make sure the engine will not go into the tachometer's red zone.

6-speed Manual Transmission

Reverse Lockout

The 6-speed manual transmission has an electric lockout so you cannot accidentally shift from Fifth to Reverse instead of Sixth. If you cannot shift to Reverse when the vehicle is stopped:

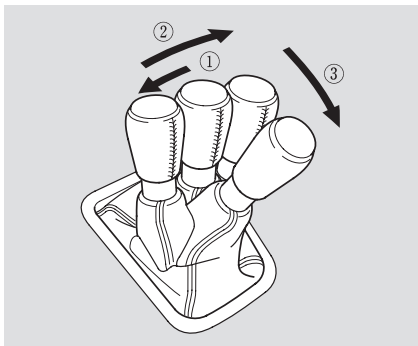

1. With the clutch pedal pressed, move the shift lever to the first/second gear side of the Neutral gate, then shift to Reverse.

2. If you are still unable to shift to Reverse, apply the parking brake and turn the ignition key to ACCESSORY (I) or LOCK (0).
3. Press the clutch pedal, and shift to Reverse.
4. With the clutch pedal still pressed, start the engine.

If you need to use this procedure to shift to Reverse, your vehicle may be developing a problem. Have the vehicle checked by your Acura dealer.

Shift Lever Position Indicators

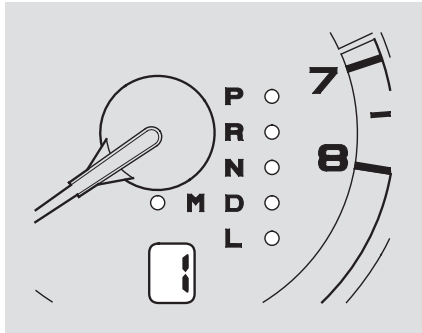

These indicators on the instrument panel show which position the shift lever is in. The illuminated number next to the “L” indicator shows you the gear you have selected in the Sequential SportShift mode.

The “D” indicator comes on for a few seconds when you turn the ignition switch to ON (II). If it flashes while driving (in any shift position), it indicates a possible problem in the transmission. Avoid rapid acceleration and have the transmission checked by an Acura dealer as soon as possible.

Shifting

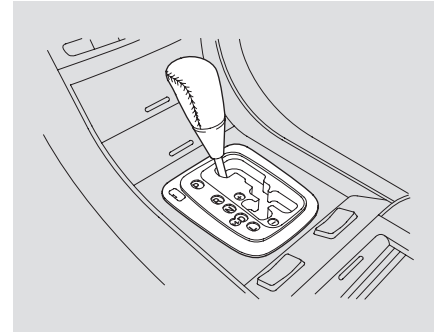

To shift from any position, press firmly on the brake pedal. You cannot shift out of Park when the ignition switch is in the LOCK (0) or ACCESSORY (I) position.

CONTINUED

Automatic Transmission

To shift from:	Do this:
P to R	Press the brake pedal, then move the shift lever.
R to N N to D D to L L to D D to N N to R R to P	Move the lever.

Park (P) — This position mechanically locks the transmission. Use Park whenever you are turning off or starting the engine. To shift out of Park, you must press on the brake pedal and have your foot off the accelerator pedal.

If you have done all of the above and still cannot move the lever out of Park, see **Shift Lock Release** on page [185](#).

To avoid transmission damage, come to a complete stop before shifting into Park. The shift lever must be in Park before you can remove the key from the ignition switch.

Reverse (R) — Press the brake pedal to shift from Park to Reverse. To shift from Neutral to Reverse, come to a complete stop and then shift.

Your vehicle has a reverse lockout so you cannot accidentally shift to Reverse from Neutral or any other driving position when the vehicle speed exceeds 5–6 mph (8–10 km/h).

If you cannot shift to Reverse when the vehicle is stopped, press the brake pedal and slowly shift to Neutral, and then to Reverse.

If there is a problem in the reverse lockout system, or your vehicle's

battery is disconnected or goes dead, you cannot shift to Reverse. (Refer to Shift Lock Release on page [185](#)).

Neutral (N) — Use Neutral if you need to restart a stalled engine, or if it is necessary to stop briefly with the engine idling. Shift to the Park position if you need to leave your vehicle for any reason. Press on the brake pedal when you are moving the shift lever from Neutral to another gear.

Drive (D) — Use this position for your normal driving. The transmission automatically selects a suitable gear for your speed and acceleration.

For faster acceleration when in D, you can get the transmission to automatically downshift by pushing the accelerator pedal to the floor. The transmission will shift down one, two or three gears, depending on your speed.

Low (L) – When you move the shift lever to this position, the transmission shifts to the lowest gear that can be selected without exceeding the engine redline. At normal speeds, it selects third gear. As the vehicle slows, it selects second gear at about 53 mph (85 km/h), and first gear at about 28 mph (45 km/h). Accelerating in first gear, the transmission upshifts to second gear at about 37 mph (59 km/h). You must move the shift lever to D for the transmission to upshift to third gear.

Sequential SportShift Mode – With the shift lever in “D” position, you can select the Sequential SportShift Mode to shift gears much like a manual transmission, but without a clutch pedal. To enter the Sequential SportShift Mode, move the shift lever further to the driver’s side. To return to “D”, move the shift lever to the



passenger’s side. When you move the shift lever from “D” to the Sequential SportShift mode, the display shows the selected gear.

In Sequential SportShift mode, each time you push forward on the shift lever, the transmission shifts to a higher gear. Pull back on the lever to downshift. The number of the gear selected is displayed on the instrument panel.

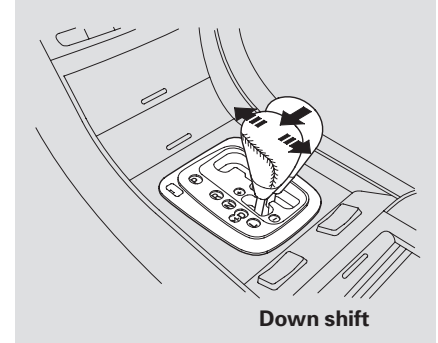

When you accelerate away from a stop, the transmission will start in first gear and then automatically upshift to second gear. You have to manually upshift between second and fifth gears. Make sure you upshift before the engine speed reaches the tachometer’s red zone. The transmission remains in the selected gear (5, 4, 3). There is no automatic downshift when you push the accelerator pedal to the floor.

CONTINUED

Automatic Transmission

The transmission may automatically downshift from the higher gear to the lower gear under these conditions:

Driving on level roads and downhill

To shift from	Speed range
4 → 3	under 18 mph (29 km/h)
5 → 4	under 38 mph (60 km/h)

Driving uphill

To shift from	Speed range
4 → 3	under 41 mph (65 km/h)
5 → 4	under 47 mph (75 km/h)

Downshifting gives you more power when climbing, and provides engine braking when going down a steep hill.

The transmission will also shift automatically as the vehicle comes to a complete stop. It will downshift to first gear when the vehicle speed is under 9 mph (15 km/h).

If you try to manually downshift at a speed that would cause the engine to exceed the redline in a lower gear, the transmission will not downshift. The gear indicator will flash the number of the lower gear several times, then return to the higher gear.

If the vehicle speed slows to below the redline of the selected lower gear position while the indicator is flashing, the transmission will downshift and the display will show the selected lower gear.

The table shows the speed ranges for upshifting and downshifting.

To shift from	Speed range
1 → 2	over 0 mph (0 km/h)
2 → 3	over 9 mph (15 km/h)
3 → 4	over 18 mph (29 km/h)
4 → 5	over 37 mph (60 km/h)

To shift from	Speed range
3 → 2	under 63 mph (102 km/h)
4 → 3	under 97 mph (156 km/h)
5 → 4	under 149 mph (240 km/h)

Starting in Second Gear

When you are in Sequential Sportshift mode, and the vehicle is stopped, push forward on the shift lever to shift to second gear. You will see “2” in the display. Starting out in second gear will help to reduce wheelspin in deep snow or on a slippery surface.

Engine Speed Limiter

If you exceed the maximum speed for the gear you are in, the engine speed will enter into the tachometer’s red zone. If this occurs, you may feel the engine cut in and out. This is caused by a limiter in the engine’s computer controls. The engine will run normally when you reduce the RPM below the red zone.

Shift Lock Release

This allows you to move the shift lever out of Park if the normal method of pushing on the brake pedal does not work. This procedure is also used to release the Reverse Lockout.

1. Set the Parking brake.
2. Make sure the ignition switch is in the LOCK (0) position.

To release the Reverse Lockout, make sure the ignition switch is in the ACCESSORY (I) position.

CONTINUED

Automatic Transmission

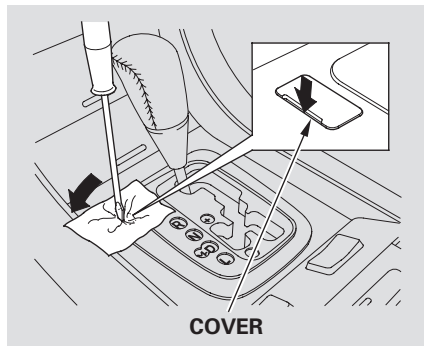

3. Put a cloth on the edge of the Shift Lock Release slot cover next to the shift lever. Use a small flat-tipped screwdriver or a metal fingernail file to remove the cover. Carefully pry on the edge of the cover.

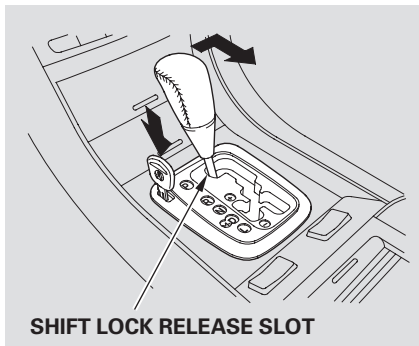

4. Insert a key into the Shift Lock Release slot.
5. Push down on the key and move the shift lever out of Park to Neutral.

To release the Reverse Lockout, move the shift lever from Neutral to Reverse, then to Park.

6. Remove the key from the Shift Lock Release slot, then reinstall the cover. Make sure the notch on the cover is on the right side. Press the brake pedal, and restart the engine.

If you need to use the Shift Lock Release, it means your vehicle is developing a problem. Have the vehicle checked by an Acura dealer.

Always use the parking brake when you park your vehicle. Make sure the parking brake is set firmly or your vehicle may roll if it is parked on an incline.

If your vehicle has an automatic transmission, set the parking brake before you put the transmission in Park. This keeps the vehicle from moving and putting pressure on the parking mechanism in the transmission.

Parking Tips

- Make sure the moonroof and the windows are closed.
- Turn off the lights.
- Place any packages, valuables, etc., in the trunk or take them with you.
- Lock the doors.

- Never park over dry leaves, tall grass, or other flammable materials. The hot three way catalytic converter could cause these materials to catch on fire.
- If the vehicle is facing uphill, turn the front wheels away from the curb. If you have a manual transmission, put it in first gear.
- If the vehicle is facing downhill, turn the front wheels toward the curb. If you have a manual transmission, put it in reverse gear.
- Make sure the parking brake is fully released before driving away. Driving with the parking brake partially set can overheat or damage the rear brakes.

Braking System

Your Acura is equipped with disc brakes at all four wheels. A power assist helps reduce the effort needed on the brake pedal. The ABS helps you retain steering control when braking very hard.

Resting your foot on the pedal keeps the brakes applied lightly, builds up heat, and reduces their effectiveness. It also keeps your brake lights on all the time, confusing drivers behind you.

Constant application of the brakes when going down a long hill builds up heat and reduces their effectiveness. Use the engine to assist the brakes by taking your foot off the accelerator and downshifting to a lower gear.

Check the brakes after driving through deep water. Apply the brakes moderately to see if they feel normal. If not, apply them gently and frequently until they do. Be extra cautious in your driving.

Braking System Design

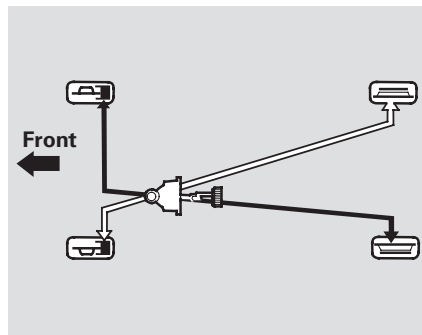

The hydraulic system that operates the brakes has two separate circuits. Each circuit works diagonally across the vehicle (the left-front brake is connected with the right-rear brake,

etc.). If one circuit should develop a problem, you will still have braking at two wheels.

Brake Wear Indicators

If the brake pads need replacing, you will hear a distinctive, metallic screeching sound when you apply the brake pedal. If you do not have the brake pads replaced, they will screech all the time. It is normal for the brakes to occasionally squeal or squeak when you apply them.

The Anti-lock Brake System (ABS) helps prevent the brakes from locking up and helps you retain steering control by pumping the brakes rapidly, much faster than a person can do it.

You should never pump the brake pedal. Let the ABS work for you by always keeping firm, steady pressure on the brake pedal. This is sometimes referred to as “stomp and steer.”

You will feel a pulsation in the brake pedal when the ABS activates, and may hear some noise. This is normal: it is the ABS rapidly pumping the brakes. On dry pavement, you will need to press on the brake pedal very hard before the ABS activates. However, you may feel the ABS activate immediately if you are trying to stop on snow or ice.

ABS Indicator

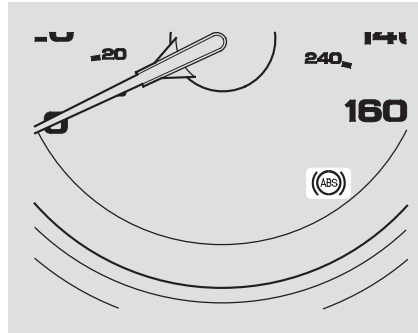

If the ABS indicator comes on, the anti-lock function of the braking system has shut down. The brakes still work like a conventional system, but without anti-lock. You should have the dealer inspect your vehicle as soon as possible.

Important Safety Reminders
ABS does not reduce the time or distance it takes to stop the vehicle; it only helps with steering control during braking.

ABS will not prevent a skid that results from changing direction abruptly, such as trying to take a corner too fast or making a sudden lane change.

ABS cannot prevent a loss of stability. Always steer moderately when you are braking hard. Severe or sharp steering wheel movement can still cause your vehicle to veer into oncoming traffic or off the road.

A vehicle with ABS may require a longer distance to stop on loose or uneven surfaces, such as gravel or snow, than a vehicle without anti-lock.

Vehicle Stability Assist (VSA) System

The Vehicle Stability Assist system helps to stabilize the vehicle during cornering if the vehicle turns more or less than desired. It also assists you in maintaining traction while accelerating on loose or slippery road surfaces. It does this by regulating the engine's output, and by selectively applying the brakes.

When VSA activates, you may notice that the engine does not respond to the accelerator in the same way it does at other times.

In manual transmission models, if the VSA system is off and you accelerate from a stop, the vehicle may pull, and it may take extra effort to return the steering wheel to center.

VSA Activation Indicator

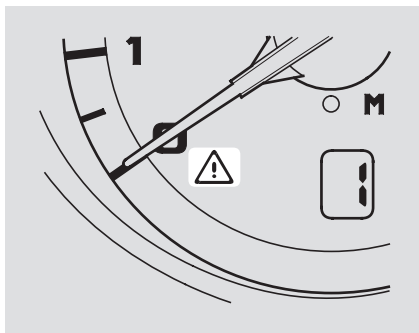

The VSA system cannot enhance the vehicle's driving stability in all situations and does not control your vehicle's entire braking system. It is still your responsibility to drive and corner at reasonable speeds and to leave a sufficient margin of safety.

When VSA activates, you will see the VSA Activation indicator blink.

VSA System Indicator

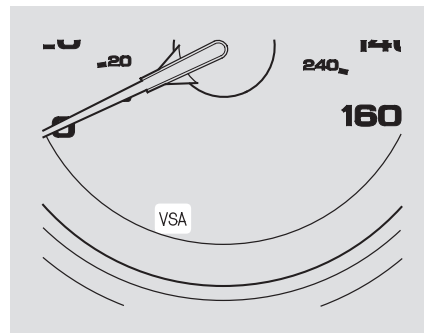

If the VSA system indicator comes on while driving, pull to the side of the road when it is safe, and turn off the engine. Reset the system by restarting the engine. If the VSA system indicator stays on, or comes back on while driving, have the VSA system inspected by an Acura dealer.

Vehicle Stability Assist (VSA) System

If the indicator does not come on when the ignition switch is turned to ON (II), there may be a problem with the VSA system. Have an Acura dealer inspect your vehicle as soon as possible.

Without VSA, your vehicle will have normal braking and cornering ability, but it will not have VSA traction and stability enhancement.

VSA Off Switch

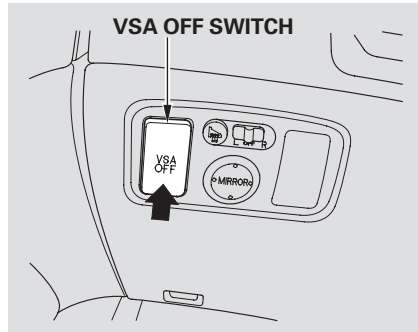

This switch is under the left vent. Press it to turn the Vehicle Stability Assist system on and off.

When VSA is off, the VSA Activation Indicator comes on as a reminder. Pressing the switch again turns the system back on.

VSA is turned on every time you start the engine, even if you turned it off the last time you drove the vehicle.

VSA and Tire Sizes

Driving with varying tire or wheel sizes may cause the VSA to malfunction. When replacing tires, make sure they are the same size and type as your original tires (see page [224](#)).

Deactivate the VSA system if you need to drive with the compact spare tire installed (see page [230](#)).

If you install winter tires, make sure they are the same size as those that were originally supplied with your vehicle. Exercise the same caution during winter driving as you would if your vehicle was not equipped with VSA.

Towing a Trailer

Your vehicle is not designed to tow a trailer. Attempting to do so can void your warranties.

This section explains why it is important to keep your vehicle well maintained and how to follow basic maintenance safety precautions.

This section also includes instructions on how to read the maintenance messages in the Multi-Information Display, a Maintenance Record, and instructions for simple maintenance tasks you may want to take care of yourself.

If you have the skills and tools to perform more complex maintenance tasks on your Acura, you may want to purchase the Service Manual. See page 269 for information on how to obtain a copy, or see your Acura dealer.

Maintenance Safety.....	194
Maintenance Minder.....	195
Maintenance Record.....	200
Fluid Locations.....	202
Engine Compartment Covers.....	203
Adding Engine Oil.....	204
Changing the Oil and Filter.....	205
Engine Coolant.....	207
Windshield Washers.....	208
Automatic Transmission Fluid.....	209
Manual Transmission Fluid.....	210
Brake and Clutch Fluid.....	211
Power Steering Fluid.....	212
Hood Latch.....	212
Lights.....	213
Seat Belts.....	218
Floor Mats.....	218
Wiper Blades.....	219
Tires.....	220
Checking the Battery.....	226
Vehicle Storage.....	227

Maintenance Safety

All service items not detailed in this section should be performed by an Acura technician or other qualified mechanic.

Important Safety Precautions

To eliminate potential hazards, read the instructions before you begin, and make sure you have the tools and skills required.

- Make sure your vehicle is parked on level ground, the parking brake is set, and the engine is off.
- To clean parts, use a commercially available degreaser or parts cleaner, not gasoline.
- To reduce the possibility of fire or explosion, keep cigarettes, sparks, and flames away from the battery and all fuel-related parts.

- Wear eye protection and protective clothing when working with the battery or compressed air.

WARNING

Improperly maintaining this vehicle or failing to correct a problem before driving can cause a crash in which you can be seriously hurt or killed.

Always follow the inspection and maintenance recommendations in this owner's manual.

Potential Vehicle Hazards

- **Carbon Monoxide poison from engine exhaust.** Be sure there is adequate ventilation whenever you operate the engine.
- **Burns from hot parts.** Let the engine and exhaust system cool before touching any parts.

- **Injury from moving parts.** Do not run the engine unless instructed to do so.

WARNING

Failure to properly follow maintenance instructions and precautions can cause you to be seriously hurt or killed.

Always follow the procedures and precautions in this owner's manual.

Some of the most important safety precautions are given here. However, we cannot warn you of every conceivable hazard that can arise in performing maintenance. Only you can decide whether or not you should perform a given task.

One of the most convenient and important features of the Multi-Information Display on your Acura is the Maintenance Minder.

Based on engine operating conditions and accumulated engine revolutions, the onboard computer in your Acura calculates the remaining engine oil life.

The system also displays the code for other scheduled maintenance items needing service.

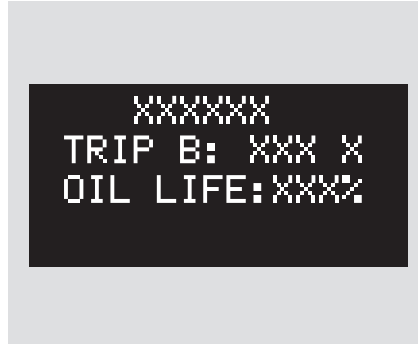

The remaining engine oil life is displayed on the Multi-Information Display as a percentage when you turn the ignition switch to ON (II).

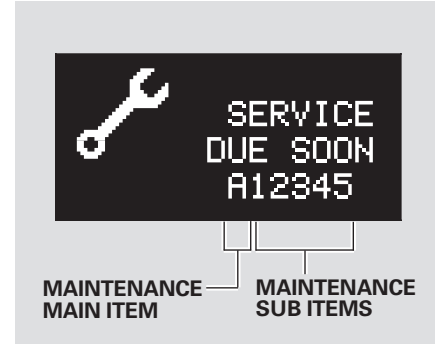

When the remaining engine oil life is 15 percent, you will see the message “SERVICE DUE SOON” along with all maintenance items that are needed at oil change time. Refer to page [199](#) for a complete list of the maintenance main items and sub items.

CONTINUED

Maintenance Minder



When the remaining oil life is less than 5 percent, you will see the message “SERVICE DUE NOW” with the same maintenance items you saw when “SERVICE DUE SOON” was displayed. When you see this message, have the indicated maintenance performed as soon as possible.

Your Acura dealer will reset the display after completing the required maintenance service. You will see “OIL LIFE 100%” on the display the next time you turn the ignition switch to ON (II).

If maintenance service is done by someone other than your Acura dealer, reset the display as follows:

1. Turn the ignition switch to ON (II).
2. Press the < or > button repeatedly until the oil life is displayed.
3. Press and hold the Select/Reset button for 10 seconds. The Multi-Information Display will ask for a confirmation.
 - If you are sure you want to reset the display, press the Select/Reset button to select “OK”.
 - If you do not want to reset the display, press the < or > button to select “Cancel”.

If you have the required service performed but do not reset the display, or reset the display without performing the service, the system will not show the proper maintenance intervals. This can lead to serious mechanical problems because you will no longer have an accurate record of when maintenance is needed.



If the indicated maintenance service is not done and the remaining engine oil life gets less than 0 percent, you will see the message “SERVICE PAST DUE” on the display. Immediately have the service performed, and make sure to reset the display as previously described.

Your authorized Acura dealer knows your vehicle best and can provide competent, efficient service. However, service at a dealer is not mandatory to keep your warranties in effect. Maintenance may be done by any qualified service facility or person who is skilled in this type of automotive service. Keep all receipts as proof of completion, and have the person who does the work fill out the Maintenance Record. Check your warranty booklet for more information.

We recommend the use of Acura parts and fluids whenever you have maintenance done. These are manufactured to the same high-quality standards as the original components, so you can be confident of their performance and durability.

CONTINUED

Maintenance Minder

U.S. Vehicles:

Maintenance, replacement, or repair of emissions control devices and systems may be done by any automotive repair establishment or individual using parts that are “certified” to EPA standards.

According to state and federal regulations, failure to perform maintenance on the items marked with # will not void your emissions warranties. However, Acura recommends that all maintenance services be performed in accordance with the intervals indicated by the Multi-Information Display.

Owner’s Maintenance Checks

You should check the following items at the specified intervals. If you are unsure of how to perform any check, turn to the appropriate page listed.

- Engine oil level – Check every time you fill the fuel tank. See page [167](#) .
 - Engine coolant level – Check the radiator reserve tank every time you fill the fuel tank. See page [167](#) .
 - Automatic transmission – Check the fluid level monthly. See page [209](#) .
 - Brakes – Check the fluid level monthly. See page [211](#) .
 - Tires – Check the tire pressure monthly. Examine the tread for wear and foreign objects. See page [222](#) .
- Lights – Check the operation of the headlights, parking lights, taillights, high-mount brake light, and license plate lights monthly. See page [213](#) .

Symbol	Maintenance Main Items
A	<ul style="list-style-type: none"> • Replace engine oil*¹
B	<ul style="list-style-type: none"> • Replace engine oil and oil filter • Rotate tires • Inspect front and rear brakes • Check parking brake adjustment • Visually inspect these items: <ul style="list-style-type: none"> • Tie rod ends, steering gear box, and boots • Suspension components • Driveshaft boots • Brake hoses and line (including ABS) • All fluid levels and condition of fluids • Exhaust system[#] • Fuel lines and connections[#]

* 1 : If the message "SERVICE DUE NOW" does not appear more than 12 months after the display is reset, change the engine oil every year.

: See information on maintenance and emissions warranty, the first column, page 198 .

NOTE: • Independent of the maintenance messages in the Multi-Information Display, replace the brake fluid every 3 years.
 • Inspect idle speed every 160,000 miles (256,000 km).
 • Adjust the valves during services A, B, 1, 2, or 3 if they are noisy.

Symbol	Maintenance Sub Items
1	<ul style="list-style-type: none"> • Rotate tires
2	<ul style="list-style-type: none"> • Replace air cleaner element If you drive primarily in dusty conditions, replace every 15,000 miles (24,000 km). • Replace dust and pollen filter If you drive primarily in urban areas that have high concentrations of soot in the air from industry and from diesel-powered vehicles, replace every 15,000 miles (24,000 km). • Inspect drive belt
3	<ul style="list-style-type: none"> • Replace transmission fluid Driving in mountainous areas at very low vehicle speeds results in higher transmission temperatures. This requires transmission fluid changes more frequently than recommended by the Maintenance Minder. If you regularly drive your vehicle under these conditions, have the transmission fluid changed at 60,000 miles (100,000 km), then every 30,000 miles (48,000 km).
4	<ul style="list-style-type: none"> • Replace spark plugs • Replace timing belt and inspect water pump If you drive regularly in very high temperatures (over 110°F, 43°C), or in very low temperatures (under -20°F, 29°C), replace every 60,000 mile[#] (U.S.)/100,000 km (Canada) • Inspect valve clearance
5	<ul style="list-style-type: none"> • Replace engine coolant

Maintenance Record

You or the servicing dealer can record all completed maintenance here. When maintenance is performed, record the mileage, circle the coded item(s) completed, and write in any other non-coded items (such as brake fluid replacement) below the codes. Keep the receipts for all work done on your vehicle.

Mileage	Maintenance Performed	Signature
		Date
mi km	A B 1 2 3 4 5	
mi km	A B 1 2 3 4 5	
mi km	A B 1 2 3 4 5	
mi km	A B 1 2 3 4 5	
mi km	A B 1 2 3 4 5	
mi km	A B 1 2 3 4 5	
mi km	A B 1 2 3 4 5	

Mileage	Maintenance Performed	Signature
		Date
mi km	A B 1 2 3 4 5	
mi km	A B 1 2 3 4 5	
mi km	A B 1 2 3 4 5	
mi km	A B 1 2 3 4 5	
mi km	A B 1 2 3 4 5	
mi km	A B 1 2 3 4 5	
mi km	A B 1 2 3 4 5	

Maintenance Record

Mileage	Maintenance Performed					Signature		
						Date		
mi km	A	B	1	2	3	4	5	
mi km	A	B	1	2	3	4	5	
mi km	A	B	1	2	3	4	5	
mi km	A	B	1	2	3	4	5	
mi km	A	B	1	2	3	4	5	
mi km	A	B	1	2	3	4	5	
mi km	A	B	1	2	3	4	5	

Mileage	Maintenance Performed					Signature		
						Date		
mi km	A	B	1	2	3	4	5	
mi km	A	B	1	2	3	4	5	
mi km	A	B	1	2	3	4	5	
mi km	A	B	1	2	3	4	5	
mi km	A	B	1	2	3	4	5	
mi km	A	B	1	2	3	4	5	
mi km	A	B	1	2	3	4	5	

Fluid Locations

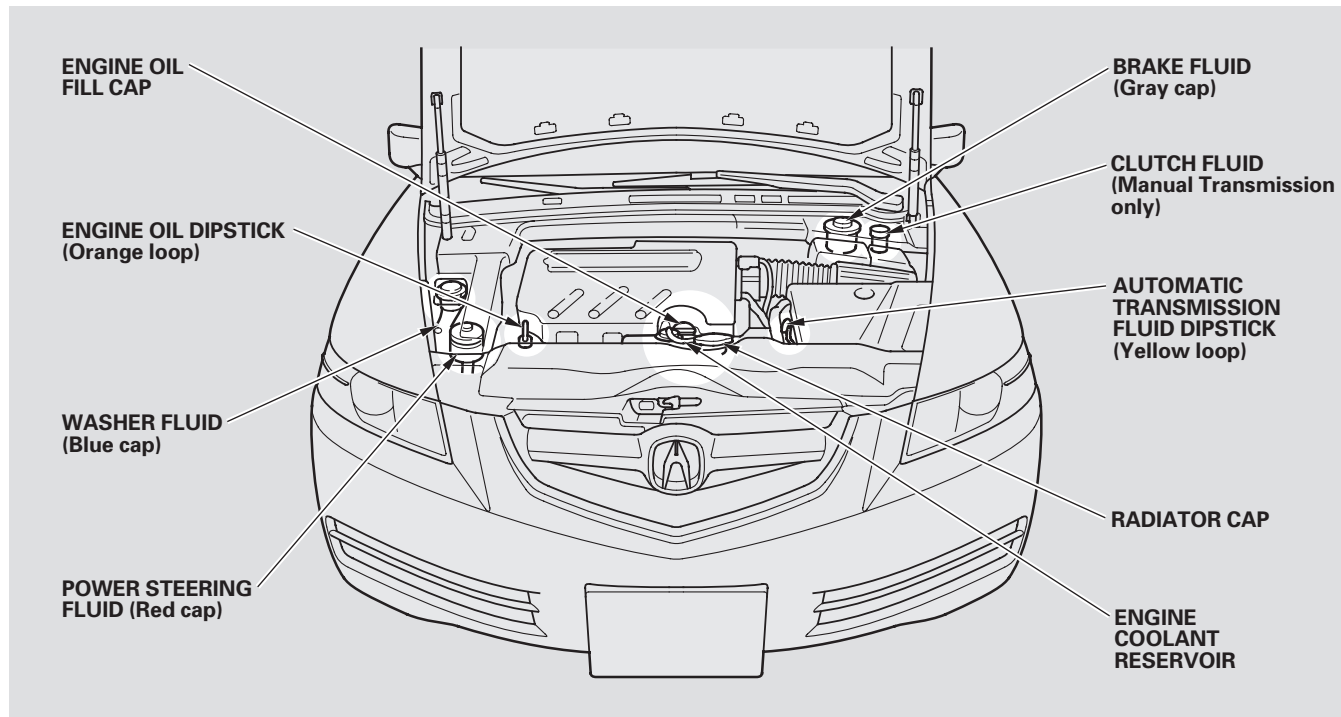

Engine Compartment Covers

The component parts in the engine compartment are protected by several covers. You may need to remove the covers when you perform some simple maintenance work.

Most of the covers can be removed simply by pulling them straight up.

To remove the left or right cowl cover, push the tabs inward and pull the cover straight up.

To remove the front bulkhead cover, first remove the four holding clips using a flat-tipped screwdriver.

When reinstalling the covers, make sure the pins and tabs are in their proper positions.

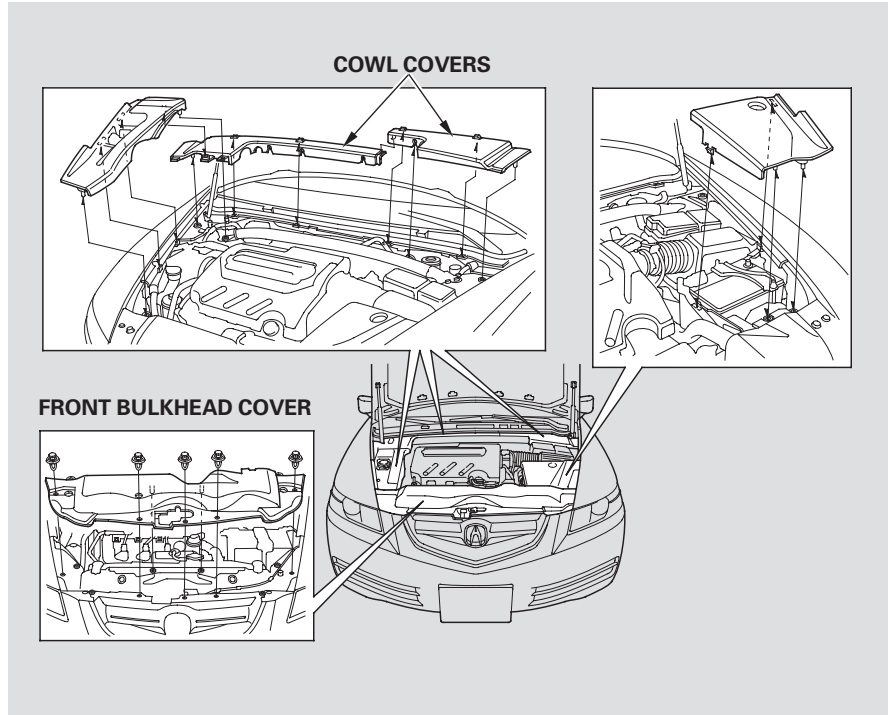

Adding Engine Oil

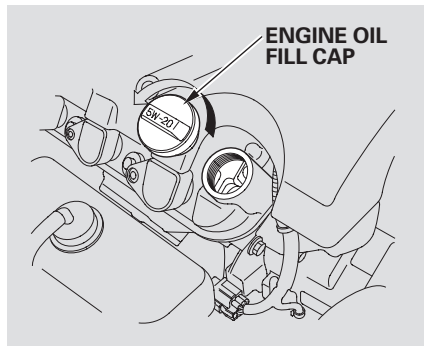

Unscrew and remove the engine oil fill cap on top of the valve cover. Pour in the oil slowly and carefully so you do not spill. Clean up any spills immediately. Spilled oil could damage components in the engine compartment. Install the engine oil fill cap and tighten it securely. Wait a few minutes and recheck the oil level (see page 167). Do not fill above the upper mark on the dipstick; you could damage the engine.

Recommended Engine Oil

Oil is a major contributor to your engine's performance and longevity. Always use a premium-grade 5W-20 detergent oil displaying the API Certification Seal. This seal indicates the oil is energy conserving, and that it meets the American Petroleum Institute's latest requirements.



Honda Motor Oil is the preferred 5W-20 lubricant for your vehicle. It is highly recommended that you use Honda Motor Oil in your vehicle for optimum engine protection. Make sure the API Certification Seal says "For Gasoline Engines".

The oil viscosity or weight is provided on the container's label. 5W-20 oil is formulated for year-round protection of your Acura to improve cold weather starting and fuel economy.

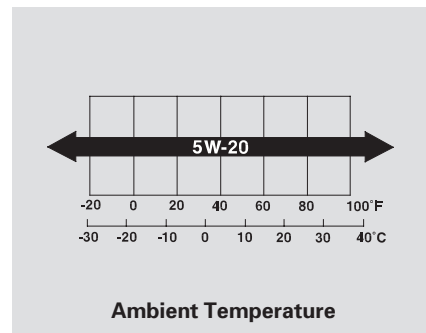

Adding Engine Oil, Changing the Oil and Filter

Synthetic Oil

You may use a synthetic motor oil if it meets the same requirements given for a conventional motor oil: it displays the API Certification Seal and it is the proper weight. You must follow the oil and filter change intervals shown on the Multi-Information Display.

Engine Oil Additives

Your Acura does not require any oil additives. Additives may adversely affect your engine's or transmission's performance and durability.

Changing the Oil and Filter

Always change the oil and filter according to the maintenance messages shown on the Multi-Information Display. The oil and filter collect contaminants that can damage your engine if they are not removed regularly.

Changing the oil and filter requires special tools and access from underneath the vehicle. The vehicle should be raised on a service station-type hydraulic lift for this service. Unless you have the knowledge and proper equipment, you should have this maintenance done by a skilled mechanic.

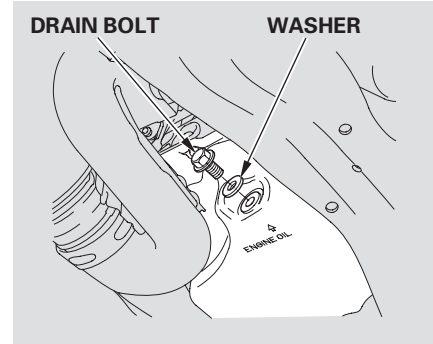

1. Run the engine until it reaches normal operating temperature, then shut it off.
2. Open the hood, and remove the engine oil fill cap. Remove the oil drain bolt and washer from the bottom of the engine. Drain the oil into an appropriate container.

Changing the Oil and Filter

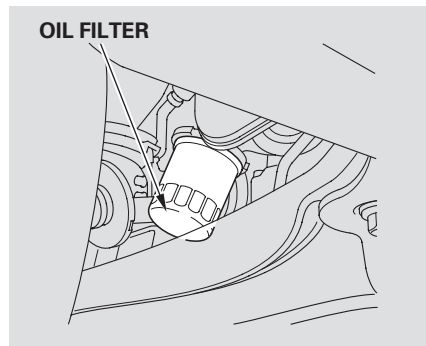

3. Remove the oil filter, and let the remaining oil drain. A special wrench (available from your Acura dealer) is required.
4. Install a new oil filter according to the instructions that come with it.

5. Put a new washer on the drain bolt, then reinstall the drain bolt. Tighten it to:

29 lbf-ft (39 N·m , 4.0 kgf·m)

6. Refill the engine with the recommended oil.

Engine oil change capacity
(including filter):

4.5 US qt (4.3 ℓ)

7. Replace the engine oil fill cap. Start the engine. The oil pressure indicator should go out within 5 seconds. If it does not, turn off the engine and check your work.
8. Let the engine run for several minutes, then check the drain bolt and oil filter for leaks.
9. Turn off the engine, let it sit for several minutes, then check the oil level on the dipstick. If necessary, add more oil.

NOTICE: *Improper disposal of engine oil can be harmful to the environment. If you change your own oil, please dispose of the used oil properly. Put it in a sealed container, and take it to a recycling center. Do not discard used oil in a trash bin or dump it on the ground.*

Adding Engine Coolant

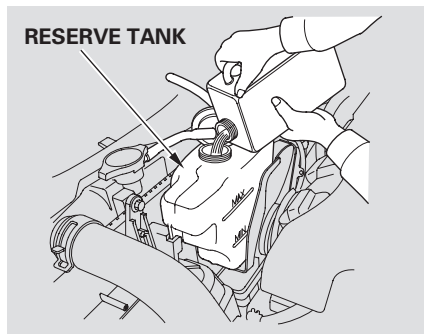

If the coolant level in the reserve tank is at or below the MIN line, add coolant to bring it up to the MAX line. Inspect the cooling system for leaks. Always use Honda All Season Antifreeze/Coolant Type 2. This coolant is pre-mixed with 50 percent antifreeze and 50 percent water. Never add straight antifreeze or plain water.

If Honda antifreeze/coolant is not available, you may use another major-brand non-silicate coolant as a temporary replacement. Make sure it is a high-quality coolant recommended for aluminum engines. Continued use of any non-Honda coolant can result in corrosion, causing the cooling system to malfunction or fail. Have the cooling system flushed and refilled with Honda antifreeze/coolant as soon as possible.

If the reserve tank is completely empty, you should also check the coolant level in the radiator.

⚠ WARNING

Removing the radiator cap while the engine is hot can cause the coolant to spray out, seriously scalding you.

Always let the engine and radiator cool down before removing the radiator cap.

Engine Coolant, Windshield Washers

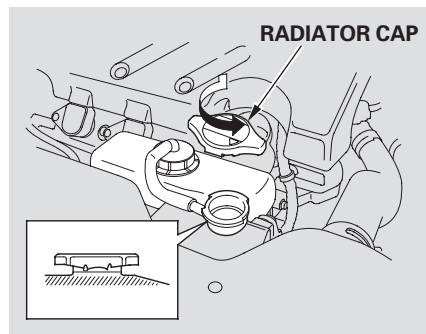

1. When the radiator and engine are cool, relieve any pressure in the cooling system by turning the radiator cap counterclockwise, without pressing down.
2. Remove the radiator cap by pushing down and turning counterclockwise.

3. The coolant level should be up to the base of the filler neck. Add coolant if it is low. Pour the coolant slowly and carefully so you do not spill. Clean up any spill immediately; it could damage components in the engine compartment.

4. Put the radiator cap back on and tighten it.
5. Pour coolant into the reserve tank. Fill it to halfway between the MAX and MIN marks. Put the cap back on the reserve tank.

Do not add any rust inhibitors or other additives to your vehicle's cooling system. They may not be compatible with the coolant or engine components.

Windshield Washers

Check the fluid level in the windshield washer reservoir at least monthly during normal use.

On Canadian models: If the fluid level is low, a message will be shown on the Multi-Information Display.

Fill the reservoir with a good-quality windshield washer fluid. This increases the cleaning capability and prevents freezing in cold weather. When you refill the reservoir, clean the edges of the windshield wiper blades with windshield washer fluid on a clean cloth. This will help to condition them.

NOTICE: Do not use engine antifreeze or a vinegar/water solution in the windshield washer reservoir. Antifreeze can damage your vehicle's paint, while a vinegar/water solution can damage the windshield washer pump. Use only commercially-available windshield washer fluid.

Automatic Transmission Fluid

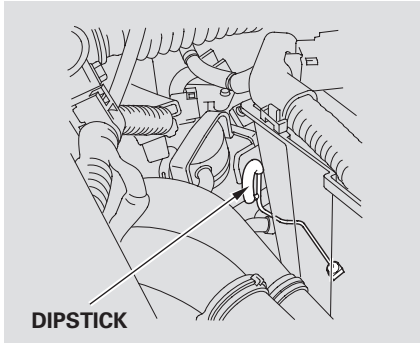

Check the fluid level with the engine at normal operating temperature.

1. Park the vehicle on level ground. Shut off the engine.
2. Within 60 to 90 seconds, remove the dipstick (yellow loop) from the transmission, and wipe it with a clean cloth.
3. Insert the dipstick all the way into the transmission securely.

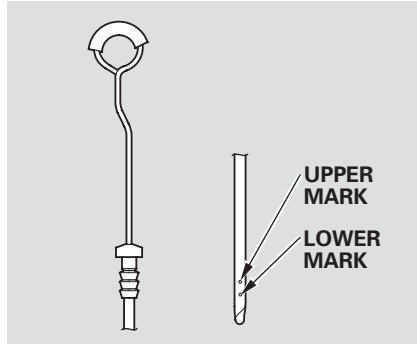

4. Remove the dipstick, and check the fluid level. It should be between the upper and lower marks.
5. If the level is below the lower mark, add fluid into the filler hole to bring it to the upper mark.

Always use Honda ATF-Z1 (Automatic Transmission Fluid). If it's not available, you may use a DEXRON® III automatic transmission fluid as a temporary replacement. However, continued use can affect the shift quality. Have the transmission flushed and refilled with Honda ATF-Z1 as soon as it is convenient. To thoroughly flush the transmission, the technician should drain and refill it with Honda ATF-Z1, then drive the vehicle for a short distance. Do this three times. Then drain and refill the transmission a final time.

6. Insert the dipstick all the way back in the transmission.

The transmission should be drained and refilled with new fluid when this service is shown on a maintenance message in the Multi-Information Display.

Manual Transmission Fluid

Manual Transmission Fluid

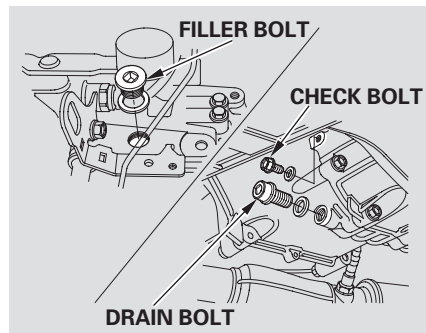

Check the fluid level with the transmission at normal operating temperature and the vehicle sitting on level ground. Remove the check bolt, and look for transmission fluid coming out of the bolt hole. If a small amount of fluid drips out of the bolt hole, reinstall the check bolt.

If no fluid comes out, remove the filler bolt. Slowly add Honda Manual Transmission Fluid (MTF) until it starts to run out of the check bolt hole. Let the fluid run out until it stops, then reinstall the check bolt and the filler bolt.

If Honda MTF is not available, you may use an SAE 10W-30 or 10W-40 viscosity motor oil with the API Certification seal that says “FOR GASOLINE ENGINES” as a temporary replacement. However, motor oil does not contain the proper additives, and continued use can cause stiffer shifting. Replace as soon as it is convenient.

The transmission should be drained and refilled with new fluid when this service is shown on a maintenance message in the Multi-Information Display.

Check the brake fluid level in the reservoirs monthly after removing the engine compartment rear cover (see page 203).

Replace it every 3 years, independent of mileage.

Always use Honda Heavy Duty Brake Fluid DOT 3. If it is not available, you should use only DOT 3 or DOT 4 fluid, from a sealed container, as a temporary replacement.

Using any non-Honda brake fluid can cause corrosion and decrease the life of the system. Have the brake system flushed and refilled with Honda Heavy Duty Brake Fluid DOT 3 as soon as possible.

Brake fluid marked DOT 5 is not compatible with your vehicle's braking system and can cause extensive damage.

Brake System

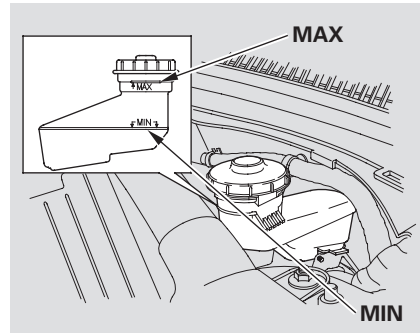

The fluid level should be between the MIN and MAX marks on the side of the reservoir. If the level is at or below the MIN mark, your brake system needs attention. Have the brake system inspected for leaks or worn brake pads.

Clutch System

Manual Transmission only

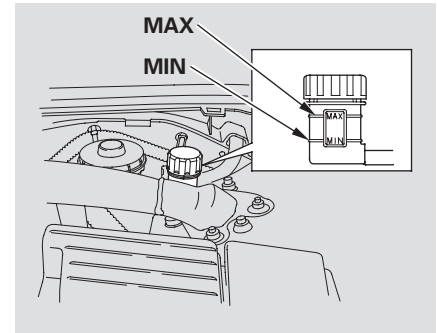

The fluid level should be between the MIN and MAX marks on the side of the reservoir. If it is not, add brake fluid to bring it up to that level. Use the same fluid specified for the brake system.

A low fluid level can indicate a leak in the clutch system. Have this system inspected as soon as possible.

Power Steering Fluid, Hood Latch

Power Steering Fluid

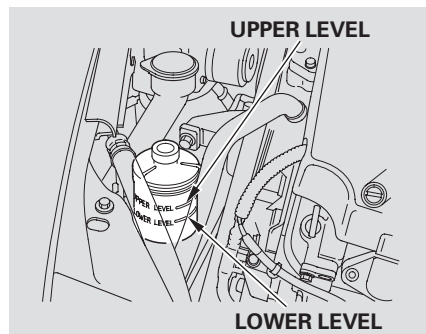

Check the level on the side of the reservoir when the engine is cold, and the engine compartment right-side cover is off (see page 203). The fluid should be between the UPPER LEVEL and LOWER LEVEL. If not, add power steering fluid to the UPPER LEVEL mark.

Always use Honda Power Steering Fluid. You may use another power steering fluid as an emergency

replacement, but have the power steering system flushed and refilled with Honda PSF as soon as possible.

A low power steering fluid level can indicate a leak in the system. Check the fluid level frequently, and have the system inspected as soon as possible.

NOTICE: *Turning the steering wheel to full left or right lock and holding it there can damage the power steering pump.*

Hood Latch

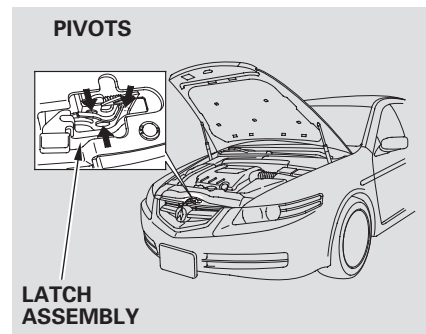

Periodically clean the hood latch assembly with a mild cleaner, then lubricate it with a multipurpose grease. Lubricate all the moving parts (as shown), including the pivot. If you are not sure how to do this, contact your Acura dealer.

Headlight Aiming

The headlights were properly aimed when your vehicle was new. If you regularly carry heavy items in the trunk, readjustment may be required. Adjustment should be performed by an Acura dealer or other qualified mechanic.

Headlights

The headlight bulbs are a type of high voltage discharge tube. High voltage can remain in the circuit even with the light switch off and the key removed. Because of this, you should not attempt to examine or change a headlight bulb yourself. If a headlight bulb fails, take your vehicle to a dealer to have it replaced.

Replacing a Front Fog Light or Daytime Running Light Bulb

1. Remove the left or right side engine compartment cover from the side you are working on by carefully pulling the cover out.

If you are replacing the bulb on the driver's side, remove the air intake cover by removing the two fastener pins and pulling the cover out. Then remove the upper part of the air intake duct by pulling it straight up.

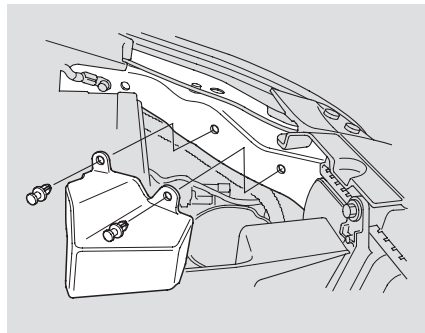

CONTINUED

Lights

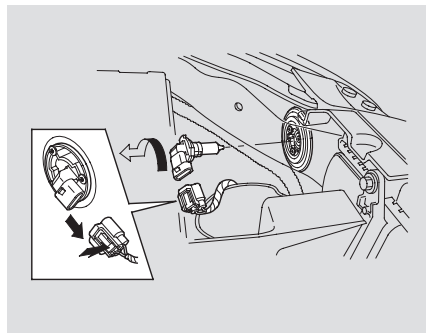

2. Remove the electrical connector from the bulb by pushing on the tab and pulling the connector down.
3. Remove the bulb by turning it one-quarter turn counterclockwise.

4. Insert the new bulb into the hole and turn it one-quarter turn clockwise to lock it in place.
5. Push the electrical connector back onto the bulb. Make sure it is on all the way.
6. Turn on the fog lights to test the new bulb.
7. (Driver's side)
Install the upper part of the air intake duct.
8. (Driver's side)
Install the engine compartment corner cover, and secure it with two fastener pins.
9. Install the engine compartment side cover.

Replacing the Front Turn Signal/ Parking Light Bulb

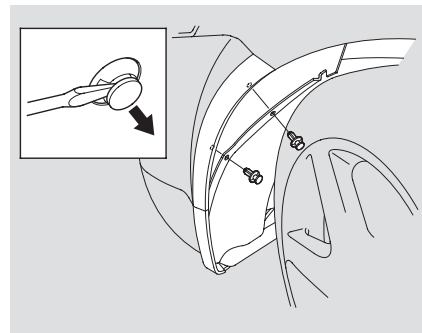

1. Start the engine. If you are replacing a driver's side bulb, turn the steering wheel all the way to the right. If you are replacing a passenger's side bulb, turn the steering wheel to the left. Turn off the engine.

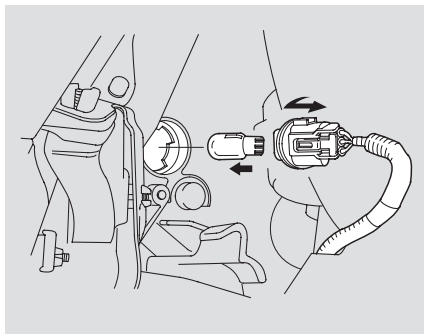

2. Use a flat-tipped screwdriver to remove the holding clip from the middle edge of the inner fender cover, and pull the inner fender cover back.
3. Remove the socket from the headlight assembly by turning it one-quarter turn counterclockwise.

4. Remove the bulb from the socket by pushing it in and turning it counterclockwise until it unlocks.
5. Install the new bulb in the socket. Turn it clockwise to lock it in place.
6. Insert the socket into the headlight assembly. Turn it clockwise to lock it in place.
7. Test the lights to make sure the new bulb is working.
8. Push the inner fender cover in place. Install the holding clip, and lock it in place by pushing on its center.

Replacing the Rear Turn Signal Bulb (in Fenders)

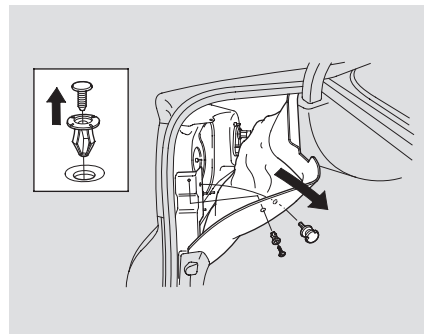

1. Open the trunk. Using a small screwdriver, pop up the pin in the center of the fastener, then remove the fastener. Unscrew and remove the cargo net hook from the fender. Pull back the trunk lining.
2. Remove the socket by turning it one-quarter turn counterclockwise.

CONTINUED

Lights

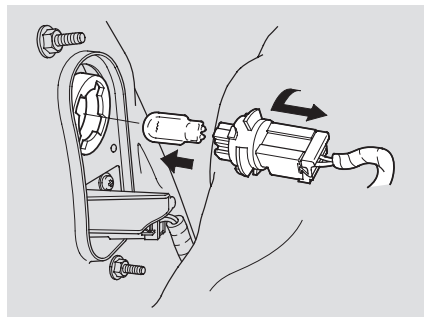

3. Pull the bulb straight out of its socket. Push the new bulb straight into the socket until it bottoms.
4. Reinstall the socket into the light assembly by turning it clockwise until it locks.
5. Test the lights to make sure the new bulb is working.
6. Reinstall the trunk lining. Make sure it is installed under the edge of the trunk seal.

7. Insert the fastener into the hole on the side of the trunk lining, and push in the head of the fastener. Screw the cargo net hook into the fender.

Replacing the Back-up Light Bulb (in Trunk Lid)

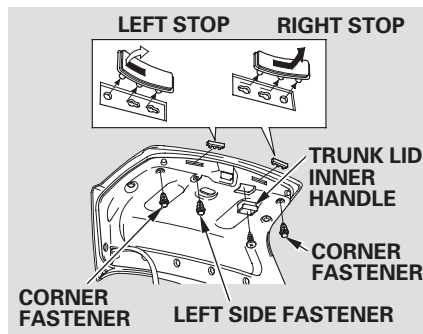

- 1 a. Determine which back-up light is out (left or right), then open the trunk.

- b. Pop up the pin in the center of the left or right corner fastener with a small screwdriver, and remove the fastener. *Left side only:* Remove the left side fastener the same way.
- c. Pull out the outside edge of the rubber stop, then push the stop outward, and pull it to remove it.
- d. *Right side only:* Remove the screw from the trunk lid inner handle, and remove the handle trim.
- e. Pull back the corner of the trunk lid lining.

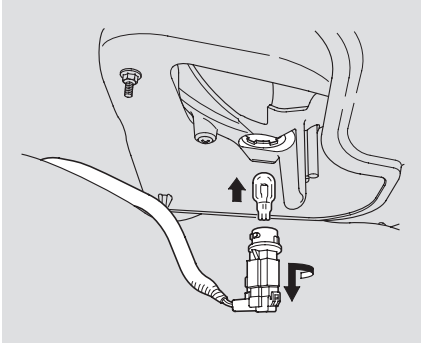

2. Remove the socket by turning it one-quarter turn counterclockwise.
3. Pull the bulb straight out of its socket. Push the new bulb straight into the socket until it bottoms.

4. Insert the socket into the light assembly. Turn it clockwise to lock it in place.
5. Test the lights to make sure the new bulb is working.
6. Reinstall the trunk lid lining. Make sure it is installed under the edge of the trunk seal.
7. Install all removed parts.

Seat Belts, Floor Mats

Seat Belts

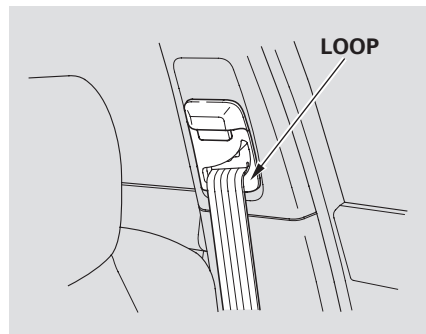

If your seat belts get dirty, use a soft brush with a mixture of mild soap and warm water to clean them. Do not use bleach, dye, or cleaning solvents. Let the belts air-dry before you use the vehicle.

Dirt build-up in the loops of the seat belt anchors can cause the belts to retract slowly. Wipe the insides of the loops with a clean cloth dampened in mild soap and warm water, or isopropyl alcohol.

Floor Mats

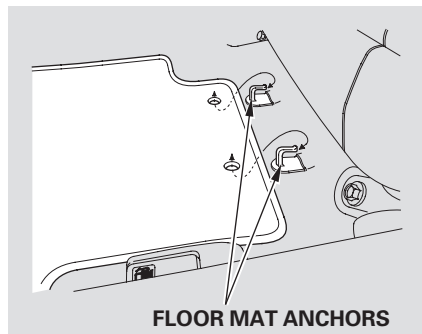

The driver's floor mat that came with your vehicle hooks over the floor mat anchors. This keeps the floor mat from sliding forward and possibly interfering with the pedals.

If you remove the driver's floor mat, make sure to re-anchor it when you put it back in your vehicle.

If you use a non-Acura floor mats, make sure they fit properly and that they can be used with the floor mat anchors. Do not put additional floor mats on top of the anchored mats.

Check the condition of the wiper blades at least every 6 months. Replace them if you find signs of cracking in the rubber, areas that are getting hard, or if they leave streaks and unwiped areas when used.

1. Raise the wiper arm off the windshield.

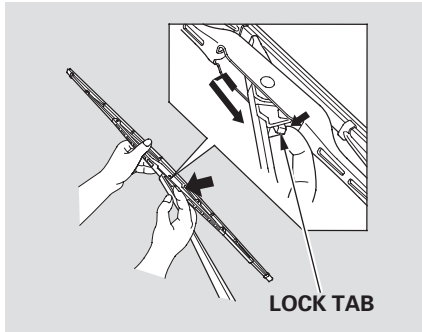

2. Disconnect the blade assembly from the wiper arm by pushing in the lock tab. Hold the lock tab in while you push the blade assembly toward the base of the arm.

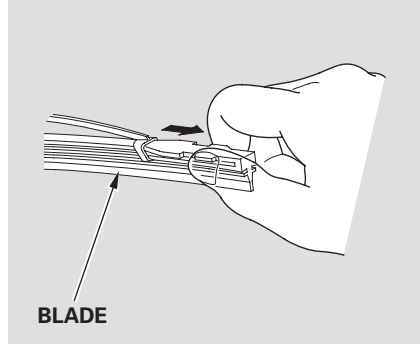

3. Remove the blade from its holder by grasping the tabbed end of the blade. Pull firmly until the tabs come out of the holder.

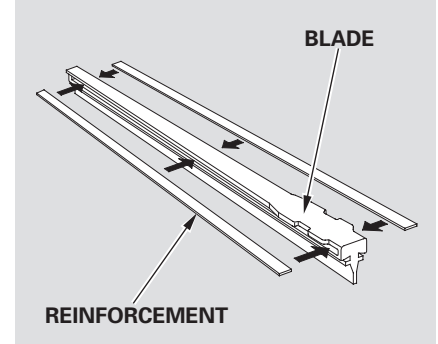

4. Examine the new wiper blades. If they have no plastic or metal reinforcement along the back edge, remove the metal reinforcement strips from the old wiper blade, and install them in the slots along the edge of the new blade.
5. Slide the new wiper blade into the holder until the tabs lock.

Wiper Blades, Tires

- Slide the wiper blade assembly onto the wiper arm. Make sure it locks in place.
- Lower the wiper arm down against the windshield.

Tires

To safely operate your vehicle, your tires must be the proper type and size, in good condition with adequate tread, and correctly inflated.

The following pages give more detailed information about your tires, how and when to inspect your tires for damage and wear, and what to do when your tires need to be replaced.

Tyre Types

All Models Except 6-Speed with Summer Tires

Your vehicle is equipped with high performance all-season tires (marked All Season or M + S on the sidewalls). These tires provide excellent handling and braking performance in most driving situations.

6-Speed with Summer Tires

Your vehicle is equipped with high performance summer tires. These tires have a high-traction compound and tread pattern to provide superior acceleration, cornering, and stopping under most driving conditions.

However, these tires are not suitable for driving on snow or ice, so all-season or winter tires must be installed for winter driving conditions.

See page [224](#) for winter driving conditions.

Inflation

Keeping the tires properly inflated provides the best combination of handling, tread life, and riding comfort.

- Underinflated tires wear unevenly, adversely affect handling and fuel economy, and are more likely to fail from being overheated.
- Overinflated tires can make your vehicle ride more harshly, are more prone to damage from road hazards, and wear unevenly.

Because your tires have a low profile, do not rely on a visual inspection to determine whether the tires have the proper air pressure.

Instead, we recommend that you use a gauge to measure the air pressures **at least once a month**. Even tires that are in good condition may lose one to two psi (10 to 20 kPa, 0.1 to 0.2 kgf/cm²) per month.

⚠ WARNING

Using tires that are excessively worn or improperly inflated can cause a crash in which you can be seriously hurt or killed.

Follow all instructions in this owner's manual regarding tire inflation and maintenance.

Remember to check the spare tire at the same time you check all the other tires.

Recommended Tire Pressures for Normal Driving

The following chart shows the recommended cold tire pressures for most normal driving conditions and speed.

Automatic Transmission Models

Tire Size	Cold Tire Pressure for Normal Driving
P235/45R17 93W	Front: 32 psi (220 kPa , 2.2 kgf/cm ²) Rear: 32 psi (220 kPa , 2.2 kgf/cm ²)

Manual Transmission Models

Tire Size	Cold Tire Pressure for Normal Driving
P235/45R17 93W 235/45R17 93W	Front: 35 psi (240 kPa , 2.4 kgf/cm ²) Rear: 32 psi (220 kPa , 2.2 kgf/cm ²)

The compact spare tire pressure is: 60 psi (420 kPa , 4.2 kgf/cm²)

Recommended Tire Pressures for High Speed Driving

Acura strongly recommends that you not drive faster than posted speed limits and conditions allow. If you decide it is safe to drive at high speeds (over 118 mph or 190 kph), be sure to adjust the cold tire pressures as shown below. If you do not adjust the tire pressure, excessive heat can build up and cause sudden tire failure.

All Models

Tire Size	Cold Tire Pressure for High Speed Driving
P235/45R17 93W 235/45R17 93W	Front: 39 psi (270 kPa , 2.7 kgf/cm ²) Rear: 35 psi (240 kPa , 2.4 kgf/cm ²)

CONTINUED

Tires

When you return to normal speed driving, be sure to readjust the tire pressure for normal driving. You should wait until the tires are cold before adjusting the tire pressure.

For convenience, the recommended tire sizes and cold air pressures are on a label on the driver's doorjamb.

For additional technical information, see page [258](#).

Check the pressure in the tires when the tires are cold. This means the vehicle has been parked for at least three hours. If you have to drive the vehicle before checking pressures, the tires can still be considered "cold" if you drive less than 1 mile (1.6 km).

If you check the pressures when the tires are hot (the vehicle has been driven several miles), you will see readings 4 to 6 psi (30 to 40 kPa, 0.3 to 0.4 kgf/cm²) higher than the cold readings.

Add or release air, if needed, to match the recommended cold tire pressures on page [221](#).

Tubeless tires have some ability to self-seal if they are punctured. You should look closely for punctures if a tire starts losing pressure.

You should get your own tire pressure gauge and use it whenever you check your tire pressures. This will make it easier for you to tell if a pressure loss is due to a tire problem and not due to a variation between gauges.

Tire Inspection

Every time you check inflation, you should also examine the tires for damage, foreign objects, and wear.

You should look for:

- Bumps or bulges in the tread or side of the tire. Replace the tire if you find either or these conditions.
- Cuts, splits, or cracks in the side of the tire. Replace the tire if you can see fabric or cord.
- Excessive tread wear.

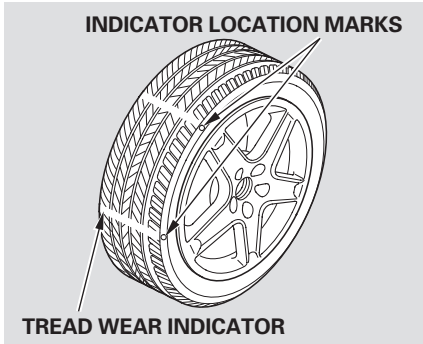

Your vehicle's tires have wear indicators molded into the tread. When the tread wears down to that point, you will see a 1/2 inch (12.7 mm) wide band running across the tread. This shows there is less than 1/16 inch (1.6 mm) of tread left on the tire. A tire that is this worn gives very little traction on wet roads. You should replace the tire if you can see the tread wear indicator in three or more places around the tire.

Tire Maintenance

In addition to proper inflation, correct wheel alignment helps to decrease tire wear. If you find a tire is worn unevenly, have your dealer check the wheel alignment.

Have your dealer check the tires if you feel a consistent vibration while driving. A tire should always be rebalanced if it is removed from the wheel. When you have new tires installed, make sure they are balanced. This increases riding comfort and tire life. For best results, have the installer perform a dynamic balance.

Tire Rotation

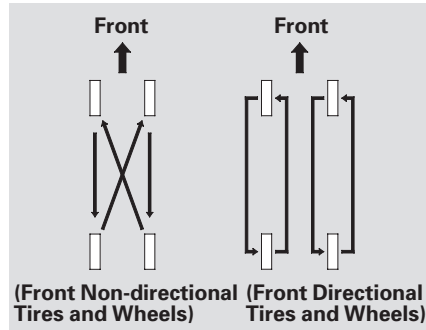

Move the tires to the positions shown in the illustration each time they are rotated. If you purchase directional tires, rotate only front-to-back.

Tires

Replacing Tires

Replace your tires with radial tires of the same size, load range, speed rating and maximum cold tire pressure rating (as shown on the tire's side wall).

Mixing radial and bias-ply tires on your vehicle can reduce braking ability, traction, and steering accuracy. Using tires of a different size or construction can cause the anti-lock brake and the vehicle stability assist systems to work inconsistently.

It is best to replace all four tires at the same time. If that is not possible or necessary, replace the two front tires or two rear tires as a pair. Replacing just one tire can seriously affect your vehicle's handling.

If you ever replace a wheel, make sure that the wheel's specifications match those of the original wheels.

⚠ WARNING

Installing improper tires on your vehicle can affect handling and stability. This can cause a crash in which you can be seriously hurt or killed.

Always use the size and type of tires recommended in this owner's manual.

Wheel and Tire Specifications

Wheels:

17 x 8.0 JJ

Tires:

P235/45R17 93W
(All season tire)

235/45R17 93W
(Summer tire)

See page [258](#) for DOT tire quality grading information, and page [259](#) for tire size information.

Winter Driving

Tires marked “M + S” or “All Season” on the sidewall have an all-weather tread design suitable for most winter driving conditions.

For the best performance in snowy or icy conditions, you should install snow tires or tire chains. They may be required by local laws under certain conditions.

Summer Tires

If your vehicle is equipped with summer tires, be aware that these tires are not designed for winter driving conditions. For more information, consult your Acura dealer.

Snow Tires

If you mount snow tires on your Acura, make sure they are radial tires of the same size and load range as original tires. Mount snow tires on all four wheels. The traction provided by snow tires on dry roads may be lower than your original tires. Check with the tire dealer for maximum speed recommendations.

Tire Chains

Because your Acura has limited tire clearance, mount only SAE Class “S” cable-type traction devices, with rubber chain tensioners on the front tires. Use traction devices only when required by driving conditions or local laws. Make sure they are the correct size for your tires. Metal link-type “chains” should not be used.

When installing cables, follow the manufacturer’s instructions, and mount them as tight as you can. Make sure they are not contacting the brake lines or suspension. Drive slowly with them installed. If you hear them coming into contact with the body or chassis, stop and investigate. Remove them as soon as you begin driving on cleared roads.

NOTICE: *Traction devices that are the wrong size or improperly installed can damage your vehicle’s brake lines, suspension, body, and wheels. Stop driving if they are hitting any part of the vehicle.*

Checking the Battery

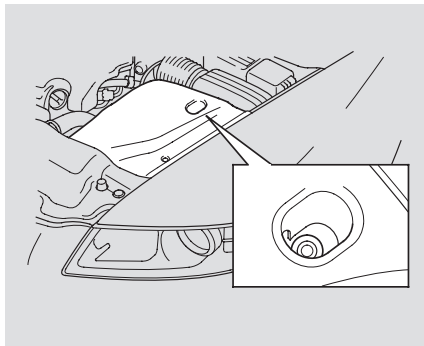

Check the condition of the battery monthly by looking at the test indicator window. The label on the battery explains the test indicator's colors.

Check the terminals for corrosion (a white or yellowish powder). To remove it, cover the terminals with a solution of baking soda and water. It will bubble up and turn brown. When this stops, wash it off with plain water. Dry off the battery with a cloth or paper towel. Coat the terminals with grease to help prevent further corrosion.

If additional battery maintenance is needed, see your Acura dealer or a qualified technician.

WARNING: Battery posts, terminals, and related accessories contain lead and lead compounds. **Wash your hands after handling.**

If you need to connect the battery to a charger, disconnect both cables to prevent damaging your vehicle's electrical system. Always disconnect the negative (–) cable first, and reconnect it last.

⚠ WARNING

The battery gives off explosive hydrogen gas during normal operation.

A spark or flame can cause the battery to explode with enough force to kill or seriously hurt you.

Wear protective clothing and a face shield, or have a skilled mechanic do the battery maintenance.

If you need to park your vehicle for an extended period (more than one month), there are several things you should do to prepare it for storage. Proper preparation helps prevent deterioration and makes it easier to get your vehicle back on the road. If possible, store your vehicle indoors.

- Fill the fuel tank.
- Change the engine oil and filter.
- Wash and dry the exterior completely.
- Clean the interior. Make sure the carpeting, floor mats, etc., are completely dry.
- Leave the parking brake off. Put the transmission in Reverse (6-speed manual) or Park (automatic).

- Block the rear wheels.
- If the vehicle is to be stored for a longer period, it should be supported on jackstands so the tires are off the ground.
- Leave one window open slightly (if the vehicle is being stored indoors).
- Disconnect the battery.
- Support the front wiper blade arms with a folded towel or rag so they do not touch the windshield.
- To minimize sticking, apply a silicone spray lubricant to all door and trunk seals. Also, apply a vehicle body wax to the painted surfaces that mate with the door and trunk seals.
- Cover the vehicle with a “breathable” cover, one made from a porous material such as cotton. Non-porous materials, such as plastic sheeting, trap moisture, which can damage the paint.
- If possible, periodically run the engine until it reaches full operating temperature (the cooling fan cycles twice). Preferably do this once a month.

This section covers the more common problems that motorists experience with their vehicles. It gives you information about how to safely evaluate the problem and what to do to correct it. If the problem has stranded you on the side of the road, you may be able to get going again. If not, you will also find instructions on getting your vehicle towed.

Compact Spare Tire.....	230
Changing a Flat Tire	231
If the Engine Won't Start.....	236
Jump Starting	238
If the Engine Overheats	240
Low Oil Pressure Indicator	242
Charging System Indicator.....	242
Malfunction Indicator Lamp	243
Brake System Indicator	244
Fuses	245
Fuse Locations.....	247
Emergency Towing	249
If Your Vehicle Gets Stuck.....	251

Compact Spare Tire

Use the compact spare tire as a temporary replacement only. Get your regular tire repaired or replaced and put it back on your vehicle as soon as you can.

Check the inflation pressure of the compact spare tire every time you check the other tires. It should be inflated to:
60 psi (420 kPa , 4.2 kgf/cm²)

Follow these precautions:

- Never exceed 50 mph (80 km/h).
- This tire gives a harsher ride and less traction on some road surfaces. Use greater caution while driving.
- Do not mount snow chains on it.
- Do not use your compact spare tire on another vehicle unless it is the same make and model.
- Turn off the VSA system (see page 191).
Driving with the compact spare tire may activate the VSA system.
- On models with manual transmission, do not drive for a long period with the compact spare tire mounted on a front wheel; it will damage the limited slip differential.

INDICATOR LOCATION MARK

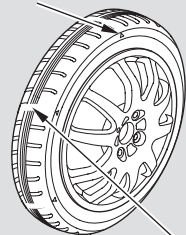

TREAD WEAR INDICATOR BAR
(The M/T compact spare is shown.)

Replace the tire when you can see the tread wear indicator bars. The replacement should be the same size and design tire, mounted on the same wheel. The spare tire is not designed to be mounted on a regular wheel, and the spare wheel is not designed for mounting a regular tire.

If you have a flat tire while driving, stop in a safe place to change it. Drive slowly along the shoulder until you get to an exit or an area to stop that is far away from the traffic lanes.

⚠ WARNING

The vehicle can easily roll off the jack, seriously injuring anyone underneath.

Follow the directions for changing a tire exactly, and never get under the vehicle when it is supported only by the jack.

1. Park the vehicle on firm, level, and non-slippery ground. Put the transmission in Park (automatic) or Reverse (manual). Apply the parking brake.
2. Turn on the hazard warning lights, and turn the ignition switch to LOCK (0). Have all the passengers get out of the vehicle while you change the tire.
3. Open the trunk. Raise the trunk floor by lifting up on the back edge.
4. Take the tool case out of the spare tire.
5. Unscrew the wing bolt and take the spare tire out of its well.

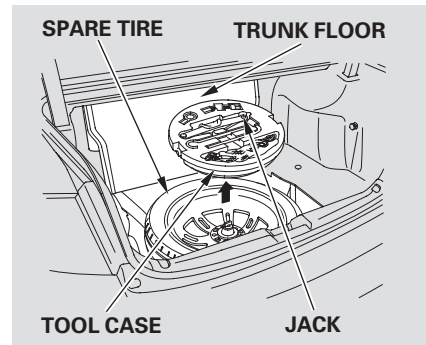

CONTINUED

Changing a Flat Tire

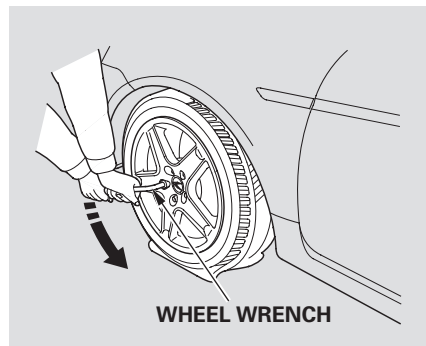

6. Loosen each wheel nut 1/2 turn with the wheel wrench.

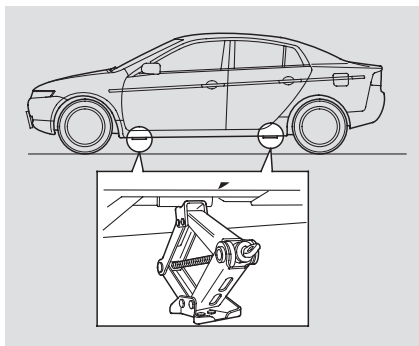

7. Locate the jacking point nearest the tire you need to change. It is pointed to by an arrow molded into the underside of the body. Place the jack under the jacking point. Turn the end bracket clockwise until the top of the jack contacts the jacking point. Make sure the jacking point tab is resting in the jack notch.

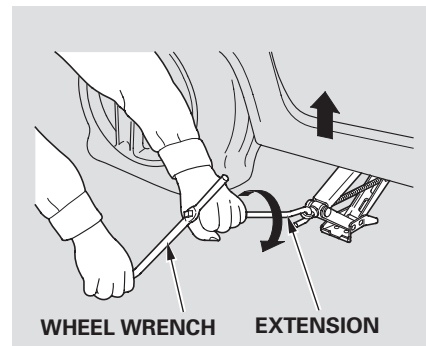

8. Use the extension and wheel wrench as shown to raise the vehicle until the flat tire is off the ground.

Changing a Flat Tire

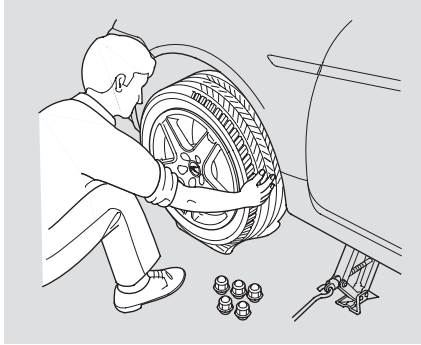

9. Remove the wheel nuts, then remove the flat tire. Temporarily place the flat tire on the ground with the outside surface of the wheel facing up. You could scratch the wheel if you put it face down.

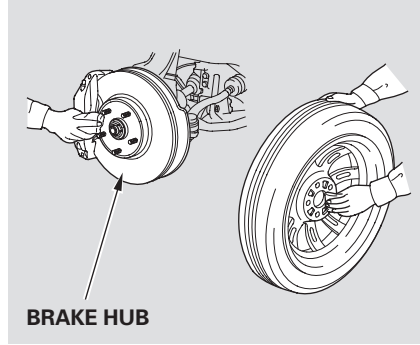

10. Before mounting the spare tire, wipe any dirt off the mounting surface of the wheel and hub with a clean cloth. Wipe the hub carefully; it may be hot from driving.

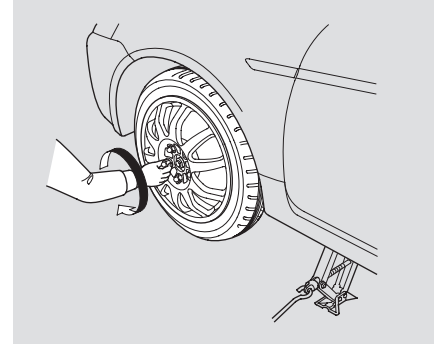

11. Put on the spare tire. Put the wheel nuts back on finger-tight, then tighten them in a crisscross pattern with the wheel wrench until the wheel is firmly against the hub. Do not try to tighten them fully.

CONTINUED

Changing a Flat Tire

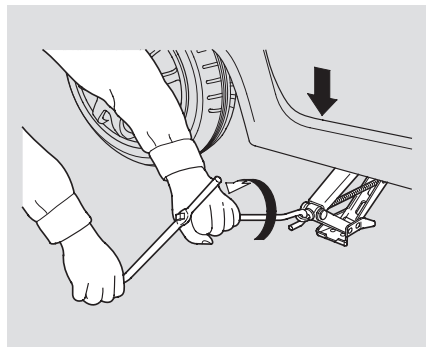

12. Lower the vehicle to the ground, and remove the jack.

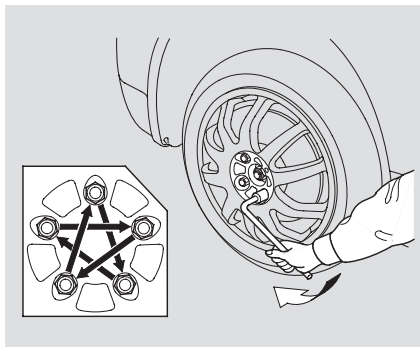

13. Tighten the wheel nuts securely in the same crisscross pattern. Have the wheel nut torque checked at the nearest automotive service facility.

Tighten the wheel nuts to:
80 lbf-ft (108 N·m , 11 kgf·m)

14. Remove the center cap before storing the flat tire in the trunk well.

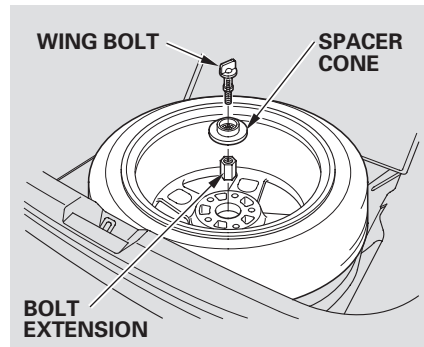

15. Place the flat tire face down in the spare tire well.

16. Remove the spacer cone from the wing bolt, turn it over, and put it back on the bolt. Attach the wing bolt to the bolt extension over the spacer cone.

17. Secure the flat tire by screwing the wing bolt back into its hole.

18. Store the jack and tools in the tool case. Place the tool case in the flat tire.

WARNING

Loose items can fly around the interior in a crash and could seriously injure the occupants.

Store the wheel, jack, and tools securely before driving.

19. Store the center cap in the trunk.
20. Lower the trunk floor, and close the trunk lid.

If the Engine Won't Start

Diagnosing why the engine won't start falls into two areas, depending on what you hear when you turn the key to START (III):

- You hear nothing, or almost nothing. The engine's starter motor does not operate at all, or operates very slowly.
- You can hear the starter motor operating normally, or the starter motor sounds like it is spinning faster than normal, but the engine does not start up and run.

Nothing Happens or the Starter Motor Operates Very Slowly

When you turn the ignition switch to START (III), you do not hear the normal noise of the engine trying to start. You may hear a clicking sound or series of clicks, or nothing at all. Check these things:

- Check the transmission interlock. If you have a manual transmission, the clutch pedal must be pushed all the way to the floor or the starter will not operate. With an automatic transmission, the shift lever must be in Park or Neutral.
- Turn the ignition switch to ON (II). Turn on the headlights, and check their brightness. If the headlights are very dim or don't light at all, the battery is discharged. See **Jump Starting** on page [238](#).

- Turn the ignition switch to START (III). If the headlights do not dim, check the condition of the fuses. If the fuses are OK, there is probably something wrong with the electrical circuit for the ignition switch or starter motor. You will need a qualified technician to determine the problem (see **Emergency Towing** on page [249](#)).

If the headlights dim noticeably or go out when you try to start the engine, either the battery is discharged or the connections are corroded. Check the condition of the battery and terminal connections (see page [226](#)). You can then try jump starting the vehicle from a booster battery (see page [238](#)).

The Starter Operates Normally

In this case, the starter motor's speed sounds normal, or even faster than normal, when you turn the ignition switch to START (III), but the engine does not run.

- Are you using a properly coded key? An improperly coded key will cause the immobilizer system indicator in the instrument panel to blink rapidly (see page [56](#)).
- Are you using the proper starting procedure? Refer to **Starting the Engine** on page [177](#).

- Do you have fuel? Check the fuel gauge; the warning indicator may not be working.
- There may be an electrical problem, such as no power to the fuel pump. Check all the fuses (see page [245](#)).

If you find nothing wrong, you will need a qualified technician to find the problem. See **Emergency Towing** on page [249](#).

Jump Starting

Although this seems like a simple procedure, you should take several precautions.

⚠ WARNING

A battery can explode if you do not follow the correct procedure, seriously injuring anyone nearby.

Keep all sparks, open flames, and smoking materials away from the battery.

You cannot start an Acura with an automatic transmission by pushing or pulling it.

To Jump Start Your Vehicle:

1. Open the hood, and check the physical condition of the battery. In very cold weather, check the condition of the electrolyte. If it seems slushy or like ice, do not try jump starting until it thaws.

NOTICE: *If a battery sits in extreme cold, the electrolyte inside can freeze. Attempting to jump start with a frozen battery can cause it to rupture.*

2. Turn off all the electrical accessories: heater, A/C, stereo system, lights, etc. Put the transmission in Neutral or Park, and set the parking brake.
3. Connect one jumper cable to the positive (+) terminal on your battery. Connect the other end to the positive (+) terminal on the booster battery.

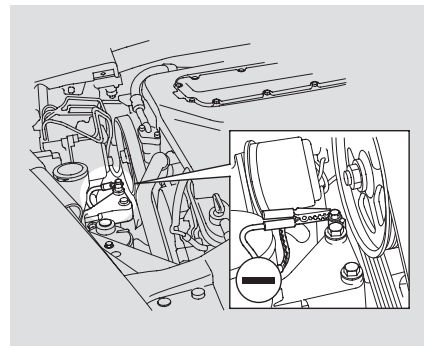

4. Connect the second jumper cable to the negative (-) terminal on the booster battery. Connect the other end to the grounding strap as shown. Do not connect this jumper cable to any other part of the engine.

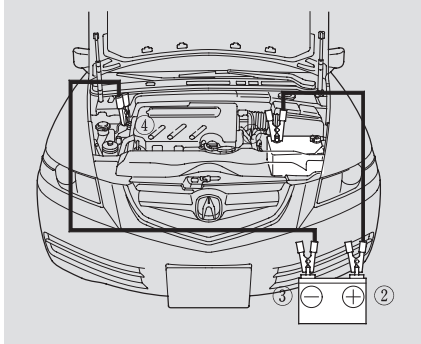

The numbers in the illustration show you the order to connect the jumper cables.

5. If the booster battery is in another vehicle, have an assistant start that vehicle and run it at a fast idle.

6. Start the vehicle. If the starter motor still operates slowly, check that the jumper cables have good metal-to-metal contact.
7. Once the vehicle is running, disconnect the negative cable from the vehicle, then from the booster battery. Disconnect the positive cable from the vehicle, and then from the booster battery.

Keep the ends of the jumper cables away from each other and any metal on the vehicle until everything is disconnected. Otherwise, you may cause an electrical short.

If the Engine Overheats

The pointer of the vehicle's temperature gauge should stay in the midrange. If it climbs to the red mark, you should determine the reason (hot day, driving up a steep hill, etc.).

If the vehicle overheats, you should take immediate action. The only indication may be the temperature gauge climbing to or above the red mark. Or you may see steam or spray coming from under the hood.

NOTICE: *Driving with the temperature gauge pointer at the red mark can cause serious damage to your engine.*

WARNING

Steam and spray from an overheated engine can seriously scald you.

Do not open the hood if steam is coming out.

1. Safely pull to the side of the road. Put the transmission in Neutral or Park, and set the parking brake. Turn off all accessories, and turn on the hazard warning indicators.
2. If you see steam and/or spray coming from under the hood, turn off the engine. Wait until you see no more signs of steam or spray, then open the hood.
3. If you do not see steam or spray, leave the engine running, and watch the temperature gauge. If the high heat is due to overloading, the engine should start to cool down almost immediately. If it does, wait until the temperature gauge comes down to the midpoint, then continue driving.
4. If the temperature gauge stays at the red mark, turn off the engine.
5. Look for any obvious coolant leaks, such as a split radiator hose. Everything is still extremely hot, so use caution. If you find a leak, it must be repaired before you continue driving (see **Emergency Towing** on page 249).

- If you don't find an obvious leak, check the coolant level in the radiator reserve tank. Add coolant if the level is below the MIN mark (see **Adding Engine Coolant** on page 207).
- If there was no coolant in the reserve tank, you may need to add coolant to the radiator. Let the engine cool down until the pointer reaches the middle of the temperature gauge, or lower, before checking the radiator.

WARNING

Removing the radiator cap while the engine is hot can cause the coolant to spray out, seriously scalding you.

Always let the engine and radiator cool down before removing the radiator cap.

- Using gloves or large heavy cloth, turn the radiator cap counterclockwise, without pushing down, to the first stop. After the pressure releases, push down on the cap, and turn it until it comes off.
- Start the engine and set the interior temperature to maximum. Add coolant to the radiator up to the base of the filler neck. If you do not have the proper coolant mixture available, you can add plain water. Remember to have the cooling system drained and refilled with the proper mixture as soon as you can.
- Put the radiator cap back on tightly. Run the engine, and watch the temperature gauge. If it goes back to the red mark, the engine needs repair (see **Emergency Towing** on page 249).
- If the temperature stays normal, check the coolant level in the radiator reserve tank. If it has gone down, add coolant to the MAX mark. Put the cap back on tightly.

Low Oil Pressure Indicator, Charging System Indicator

Low Oil Pressure Indicator



This indicator should never come on when the engine is running. If it starts flashing or stays on, the oil pressure has dropped very low or lost pressure. Serious engine damage is possible and you should take immediate action.

NOTICE: *Running the engine with low oil pressure can cause serious mechanical damage almost immediately. Turn off the engine as soon as you can safely get the vehicle stopped.*

1. Safely pull off the road, and shut off the engine. Turn on the hazard warning indicators.
2. Let the vehicle sit for a minute. Open the hood, and check the oil level (see page 167). An engine very low on oil can lose pressure during cornering and other driving maneuvers.
3. If necessary, add oil to bring the level back to the full mark on the dipstick (see page 204).
4. Start the engine, and watch the oil pressure indicator. If it does not go out within 10 seconds, turn off the engine. There is a mechanical problem that needs to be repaired before you can continue driving (see **Emergency Towing** on page 249).

Charging System Indicator



If the charging system indicator comes on brightly when the engine is running, the battery is not being charged.

Immediately turn off all electrical accessories. Try not to use other electrically operated controls such as the power windows. Keep the engine running; starting the engine will discharge the battery rapidly.

Go to a service station or garage where you can get technical assistance.



If the indicator comes on while driving, it means one of the engine's emissions control systems may have a problem. Even though you may feel no difference in your vehicle's performance, it can reduce your fuel economy and cause increased emissions. Continued operation may cause serious damage.

If you have recently refueled your vehicle, the indicator coming on could be a loose or missing fuel fill cap. Tighten the cap until it clicks at least three times. Tightening the cap will not turn the indicator off immediately; it takes at least three days of normal driving.

If the indicator comes on repeatedly, even though it may go off as you continue driving, have the vehicle checked by the dealer as soon as possible.

NOTICE: *If you keep driving with the Malfunction Indicator Lamp on, you can damage your vehicle's emission controls and the engine. Those repairs may not be covered by your vehicle's warranties.*

Readiness Code

Your vehicle has certain "readiness codes" that are part of the on-board diagnostics for the emissions systems. In some states, part of the emissions testing is to make sure these codes are set. If they are not set, the test cannot be completed.

If your vehicle battery has been disconnected or gone dead, these codes are erased. It takes at least three days of normal driving to set the codes again.

To check if they are set, turn the ignition to ON (II), without starting the engine. The Malfunction Indicator Lamp will come on for 20 seconds. If it then goes off, the readiness codes are set. If it blinks 5 times, the readiness codes are not set. If possible, do not take your vehicle for a state emissions test until the readiness codes are set. Refer to State Emissions Testing for more information (see page 263).

Brake System Indicator

U.S.

BRAKE

The brake system indicator normally comes on when you turn the ignition switch to ON (II) and as a reminder to check the parking brake. It will stay on if you do not fully release the parking brake.

Canada



It will stay on if you do not fully release the parking brake.

If the brake system indicator comes on while driving, the brake fluid level is probably low. Press lightly on the brake pedal to see if it feels normal. If it does, check the brake fluid level the next time you stop at a service station (see page 211).

If the fluid level is low, take your vehicle to a dealer and have the brake system inspected for leaks or worn brake pads.

However, if the brake pedal does not feel normal, you should take immediate action. A problem in one part of the system's dual circuit design will still give you braking at two wheels. You will feel the brake pedal go down much farther before the vehicle begins to slow down, and you will have to press harder on the pedal.

Slow down by shifting to a lower gear, and pull to the side of the road when it is safe. Because of the long distance needed to stop, it is hazardous to drive the vehicle. You should have it towed and repaired as soon as possible (see **Emergency Towing** on page 249).

If you must drive the vehicle a short distance in this condition, drive slowly and carefully.

If the ABS indicator and the VSA system indicator come on with the brake system indicator, have your vehicle inspected by an Acura dealer immediately.

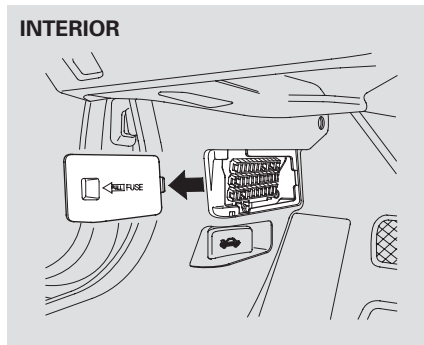

The vehicle's fuses are in two fuse boxes. The interior fuse box is on the driver's lower left side. To remove the fuse box lid, put your finger in the notch on the lid, pull it toward you, and take it out of its hinges.

The under-hood fuse box is on the driver's side next to the air cleaner housing.

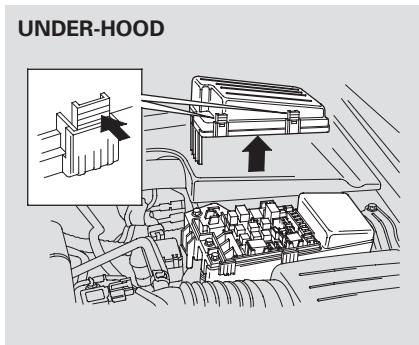

Checking and Replacing Fuses

If something electrical in your vehicle stops working, the first thing you should check for is a blown fuse. Determine from the chart on pages [247](#) and [248](#) or the diagram on the fuse box lid, which fuses control that device. Check those fuses first, but check all the fuses before deciding that a blown fuse is the cause. Replace any blown fuses, and check if the device works.

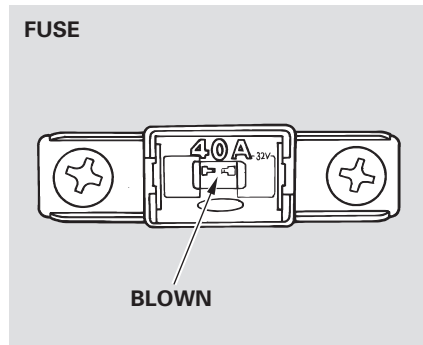

1. Turn the ignition switch to LOCK (0). Make sure the headlights and all other accessories are off.
2. Remove the cover from the fuse box.
3. Check each of the large fuses in the under-hood fuse box by looking through the top at the wire inside. Remove the screws with a phillips-head screwdriver.

CONTINUED

Fuses

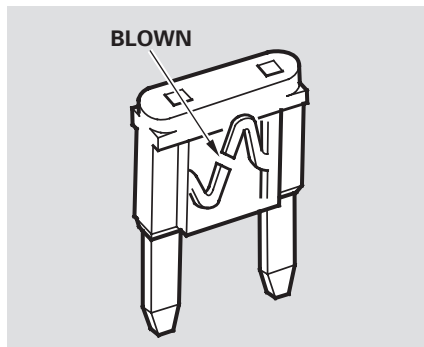

4. Check the smaller fuses in the under-hood fuse box and all the fuses in the interior fuse box by pulling out each fuse with the fuse puller provided in the under-hood fuse box.
5. Look for a burned wire inside the fuse. If it is burned, replace it with one of the spare fuses of the same rating or lower.

If you cannot drive the vehicle without fixing the problem, and you do not have a spare fuse, take a fuse of the same rating or a lower rating from one of the other circuits. Make sure you can do without that circuit temporarily (such as the accessory power socket or radio).

If you replace the blown fuse with a spare fuse that has a lower rating, it might blow out again. This does not indicate anything wrong. Replace the fuse with one of the correct rating as soon as you can.

NOTICE: *Replacing a fuse with one that has a higher rating greatly increases the chances of damaging the electrical system. If you do not have a replacement fuse with the proper rating for the circuit, install one with a lower rating.*

6. If the replacement fuse of the same rating blows in a short time, there is probably a serious electrical problem in your vehicle. Leave the blown fuse in that circuit, and have your vehicle checked by a qualified mechanic.

If the radio fuse is removed, the audio system will disable itself. The next time you turn on the radio you will see “CODE” in the frequency display. Use the preset buttons to enter the five-digit code (see page [140](#)).

UNDER-HOOD FUSE BOX

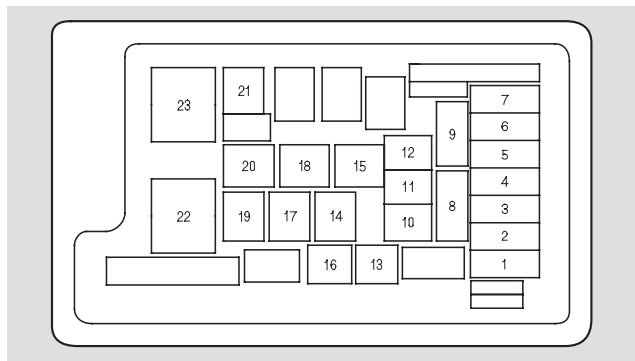

No.	Amps.	Circuits Protected
1	15 A	Left Headlight Low Beam
2	30 A	Rear Defroster Coil
3	7.5 A	Left Headlight High Beam
4	10 A	Small Light
5	7.5 A	Right Headlight High Beam

No.	Amps.	Circuits Protected
6	15 A	Right Headlight Low Beam
7	7.5 A	Back Up
8	15 A	IGP
9	30 A	Condenser Fan
10	20 A	Front Fog Light* ¹
	15 A	Daytime Running Light* ²
11	30 A	Radiator Fan Motor
12	7.5 A	MG Clutch Relay
13	20 A	Horn, Stop
14	40 A	Rear Defroster
15	40 A	Back UP, ACC
16	15 A	Hazard Warning
17	30 A	VSA Pump Motor Relay
18	40 A	VSA Fail Safe Relay
19	40 A	FI ECU
20	40 A	Power Seat
21	40 A	Heater Motor
22	100 A	Battery
23	50 A	IGI Main

*1 : U.S. models *2 : Canadian models

Fuse Locations

INTERIOR FUSE BOX

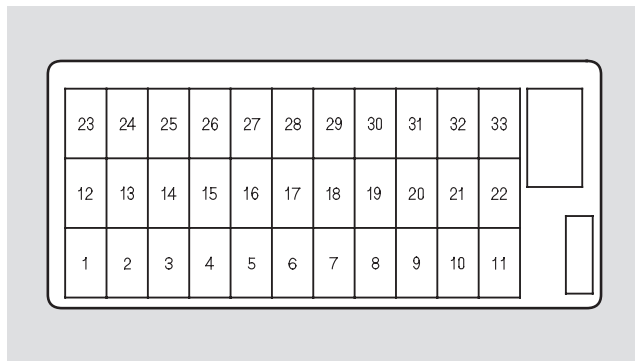

No.	Amps.	Circuits Protected
1	15 A	DBW
2	15 A	IGI Coil
3	—	Not Used
4	15 A	LAF
5	20 A	Radio
6	7.5 A	Interior Lights
7	7.5 A	Back Up
8	20 A	Door Lock
9	15 A	Front Accessory Socket

No.	Amps.	Circuits Protected
10	7.5 A	IGI OPDS
11	30 A	IGI Wiper
12	—	Not Used
13	20 A	Passenger's Power Seat (Recline)
14	20 A	Driver's Power Seat (Slide)
15	20 A	Seat Heater
16	20 A	Driver's Power Seat (Recline)
17	20 A	Passenger's Power Seat (Slide)
18	15 A	IGI ACG
19	15 A	IGI Fuel Pump
20	7.5 A	Washer
21	7.5 A	Meter
22	10 A	SRS
23	7.5 A	IGP
24	20 A	Rear Left Power Window
25	20 A	Rear Right Power Window
26	20 A	Front Right Power Window
27	20 A	Front Left Power Window
28	20 A	Moonroof
29	7.5 A	OP1
30	7.5 A	HAC
31	7.5 A	OP2
32	7.5 A	ACC
33	7.5 A	HAC OP

If your vehicle needs to be towed, call a professional towing service or organization. Never tow your vehicle behind another vehicle with just a rope or chain. It is very dangerous.

There are three popular types of professional towing equipment.

Flat-bed Equipment — The operator loads your vehicle on the back of a truck. **This is the best way to transport your Acura.**

Wheel-lift Equipment — The tow truck uses two pivoting arms that go under the tires (front or rear) and lift them off the ground. The other two tires remain on the ground. **This is an acceptable way to tow your Acura.**

Sling-type Equipment — The tow truck uses metal cables with hooks on the ends. These hooks go around parts of the frame or suspension and the cables lift that end of the vehicle off the ground. Your vehicle's suspension and body can be seriously damaged. **This method of towing is unacceptable.**

If your Acura cannot be transported by flat-bed, it should be towed by wheel-lift equipment with the front wheels off the ground. If, due to damage, your vehicle must be towed with the front wheels on the ground, do the following:

6-speed Manual Transmission:

- Release the parking brake.
- Shift the transmission to Neutral.

Automatic Transmission:

- Release the parking brake.
- Start the engine.
- Shift to D, then to N.
- Turn off the engine.

NOTICE: *Improper towing preparation will damage the transmission. Follow the above procedure exactly. If you cannot shift the transmission or start the engine (automatic transmission), your vehicle must be transported with the front wheels off the ground.*

Emergency Towing

With the front wheels on the ground, it is best to tow the vehicle no farther than 50 miles (80 km), and keep the speed below 35 mph (55 km/h).

If your vehicle is equipped with a front spoiler, remove it before towing so it is not damaged.

If you decide to tow your vehicle with all four wheels on the ground, make sure you use a properly-designed and attached tow bar. Prepare the vehicle for towing as described previously, and leave the ignition switch in the ACCESSORY (I) position so the steering wheel does not lock. Make sure the radio and any items plugged into the accessory power socket are turned off so they do not run down the battery.

NOTICE: *The steering system can be damaged if the steering wheel is locked. Leave the ignition switch in the ACCESSORY (I) position, and make sure the steering wheel turns freely before you begin towing.*

NOTICE: *Trying to lift or tow your vehicle by the bumpers will cause serious damage. The bumpers are not designed to support the vehicle's weight.*

If Your Vehicle Gets Stuck

If your vehicle gets stuck in sand, mud, or snow, call a towing service to pull it out (see page 249).

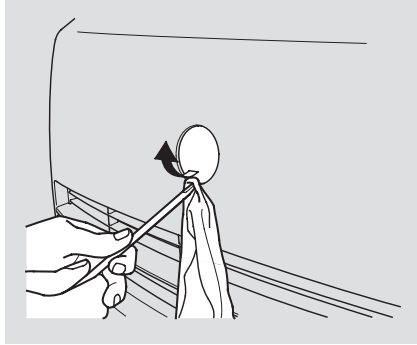

For very short distances, such as freeing the vehicle, you can use the detachable towing hook that mounts on the anchor in the front bumper.

To use the towing hook:

1. Remove the cover from the bumper.

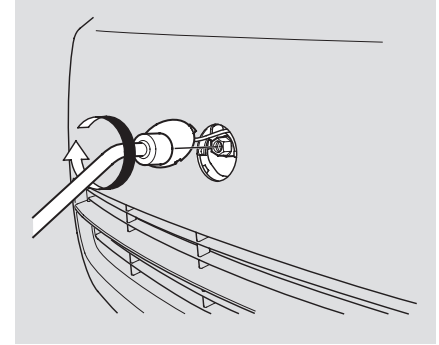

2. Remove the towing hook, hook extension, and wheel wrench from the tool case in the spare tire.
3. Using the wheel wrench, fasten the extension into the bolt hole in the anchor.

CONTINUED

If Your Vehicle Gets Stuck

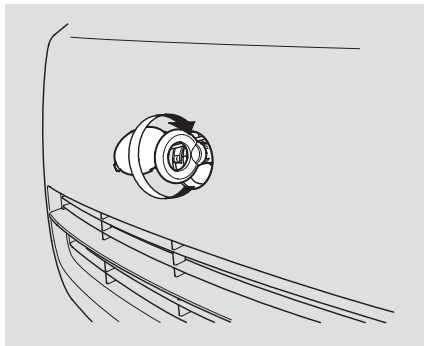

4. Screw the towing hook into the extension and tighten it securely by hand.

NOTICE: *To avoid damage to your vehicle, use the towing hook for straight, flat ground towing only. Do not tow at an angle. The tow hook should not be used to tow the vehicle onto a flat bed. Do not use it as a tie down.*

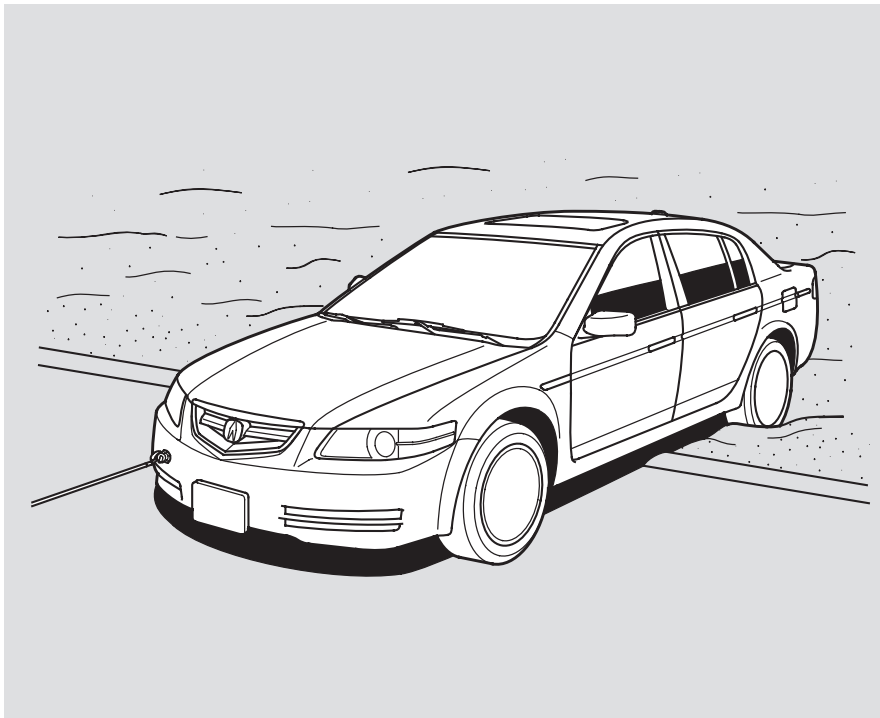

The diagrams in this section give you the dimensions and capacities of your Acura, and the locations of the identification numbers. It also includes information you should know about your vehicle's tires and emissions control systems.

Identification Numbers.....	254	Emissions Controls.....	260
Specifications	256	The Clean Air Act.....	260
DOT Tire Quality Grading		Crankcase Emissions Control	
(U.S. Vehicles)	258	System.....	260
Treadwear	258	Evaporative Emissions Control	
Traction.....	258	System.....	260
Temperature	259	Onboard Refueling Vapor	
Tire Labeling.....	259	Recovery	260
		Exhaust Emissions Controls ...	261
		PGM-FI System	261
		Ignition Timing Control	
		System.....	261
		Exhaust Gas Recirculation	
		(EGR) System.....	261
		Three Way Catalytic	
		Converter.....	261
		Replacement Parts.....	261
		Three Way Catalytic Converter...	262
		State Emissions Testing	263

Identification Numbers

Your vehicle has several identifying numbers located in various places.

The Vehicle Identification Number (VIN) is the 17-digit number your Acura dealer uses to register your vehicle for warranty purposes. It is also necessary for licensing and insuring your vehicle. The easiest place to find the VIN is on a plate fastened to the top of the dashboard. You can see it by looking through the windshield on the driver's side. It is also on the Certification label attached to the driver's doorjamb, and is stamped on the engine compartment bulkhead. The VIN is also provided in bar code on the Certification label.

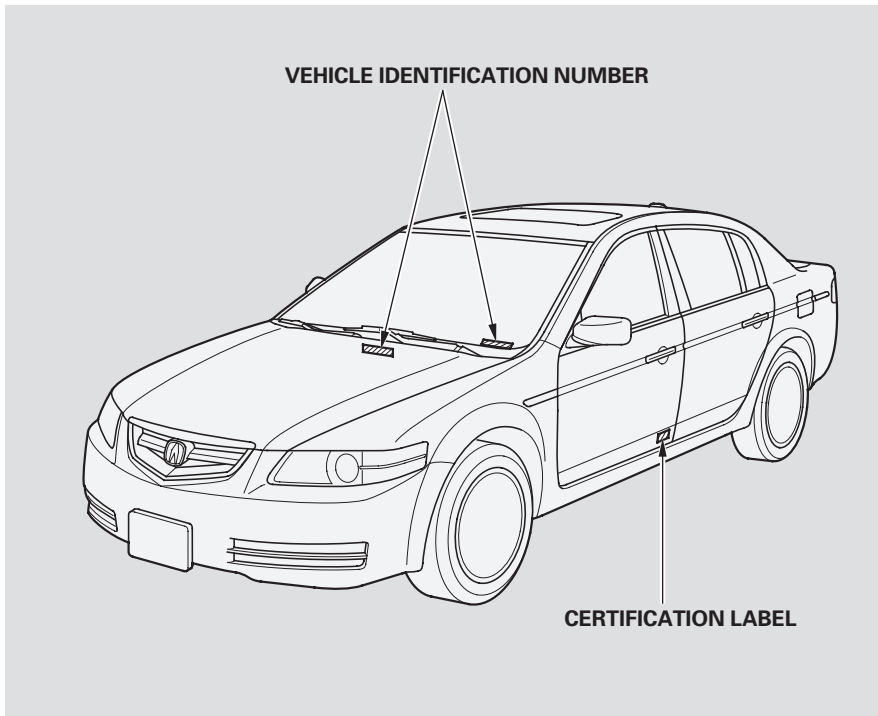

Identification Numbers

The Engine Number is stamped into the engine block.

The Transmission Number is on a label on top of the transmission.

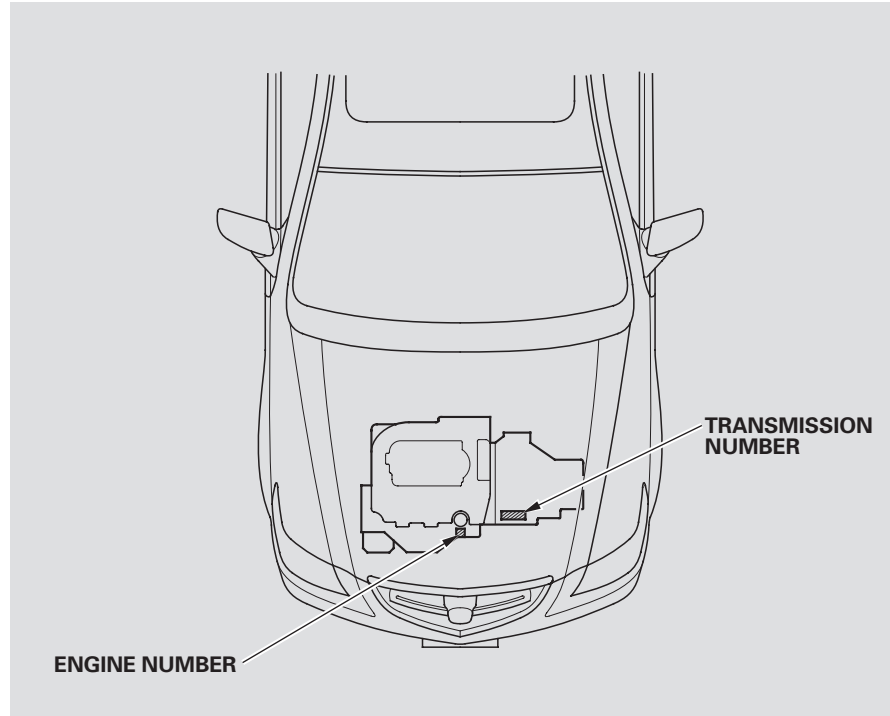

Specifications

Dimensions

Length	186.2 in (4,730 mm)
Width	72.2 in (1,835 mm)
Height	56.7 in (1,441 mm)
Wheelbase	107.9 in (2,740 mm)
Track	Front 62.1 in (1,577 mm)
	Rear 62.0 in (1,576 mm)

Weights

Gross vehicle weight rating	See the certification label attached to the driver's doorjamb.
-----------------------------	--

Air Conditioning

Refrigerant type	HFC-134a (R-134a)
Charge quantity	17.6–19.4 oz (500–550 g)
Lubricant type	ND-OIL8

Capacities

Fuel tank	Approx. 17.09 US gal (64.7 ℓ)
-----------	----------------------------------

Capacities

Engine coolant	Change* ¹	
	Manual	1.66 US gal (6.3 ℓ)
	Automatic	1.69 US gal (6.4 ℓ)
	Total	
	Manual	2.09 US gal (7.9 ℓ)
	Automatic	2.14 US gal (8.1 ℓ)
Engine oil	Change* ²	
	Including filter	4.5 US qt (4.3 ℓ)
	Without filter	4.2 US qt (4.0 ℓ)
	Total	5.3 US qt (5.0 ℓ)
Automatic transmission fluid	Change	3.1 US qt (2.9 ℓ)
	Total	7.6 US qt (7.2 ℓ)
Manual transmission fluid	Change	2.3 US qt (2.2 ℓ)
	Total	2.6 US qt (2.5 ℓ)
Windshield washer reservoir	U.S. Vehicle	2.6 US qt (2.5 ℓ)
	Canada Vehicle	4.8 US qt (4.5 ℓ)

* 1 : Including the coolant in the reserve tank and that remaining in the engine.

Reserve tank capacity: 0.16 US gal (0.6 ℓ)

* 2 : Excluding the oil remaining in the engine.

Specifications

Lights

DRL (Canadian models)	12 V – 51 W (HB3)
Front turn signal/Side marker/ Parking lights	12 V – 21/5 W
Fog Lights	12 V – 51 W (HB4)
Rear turn signal lights	12 V – 21 W
Back-up lights	12 V – 21 CP
License plate light	12 V – 3 CP
Ceiling light	12 V – 5 W
Trunk light	12 V – 5 W
Door courtesy lights	12 V – 2 CP
Vanity mirror lights	12 V – 5 W
Spotlights	12 V – 4 CP

Battery

Capacity	12 V – 65 AH/20 HR
----------	--------------------

Fuses

Interior	See page 248 or the fuse label attached to the inside of the fuse box door on each side of the dashboard.
Under-hood	See page 247 or the fuse box cover.

Engine

Type	Water cooled 4-stroke SOHC VTEC 6-cylinder (V6), gasoline engine
Bore x Stroke	3.50 x 3.39 in (89.0 x 86.0 mm)
Displacement	195.8 cu-in (3,210 cm ³)
Compression ratio	11 : 1
Spark plugs	NGK: IZFR6K-11 DENSO: SKJ20DR-M11

Alignment

Toe-in	Front	0.00 in (0.0 mm)
	Rear	0.08 in (2.0 mm)
Camber	Front	– 0°30'
	Rear	– 1°00'
Caster	Front	3°17'

Tires

Size	Front/Rear	P235/45R17 93W *1 235/45R17 93W *2
	Spare	A/T Vehicles: T135/80R16 101M M/T Vehicles: T145/70R17 96M
Pressure	Front	35 psi (240 kPa, 2.4 kgf/cm ²)*3 32 psi (220 kPa, 2.2 kgf/cm ²)*4
	Rear	32 psi (220 kPa, 2.2 kgf/cm ²)
	Spare	60 psi (420 kPa, 4.2 kgf/cm ²)

* 1 : All season tire

* 2 : Summer tire

* 3 : Vehicles with manual transmission

* 4 : Vehicles with automatic transmission

DOT Tire Quality Grading (U.S. Cars)

The tires on your vehicle meet all U.S. Federal Safety Requirements. All tires are also graded for treadwear, traction, and temperature performance according to Department of Transportation (DOT) standards. The following explains these gradings.

Uniform Tire Quality Grading

Quality grades can be found where applicable on the tire sidewall between the tread shoulder and the maximum section width. For example:

Treadwear 200

Traction AA

Temperature A

All passenger car tires must conform to Federal Safety Requirements in addition to these grades.

Treadwear

The treadwear grade is a comparative rating based on the wear rate of the tire when tested under controlled conditions on a specified government test course. For example, a tire graded 150 would wear one and one-half (1 1/2) times as well on the government course as a tire graded 100. The relative performance of tires depends upon the actual conditions of their use, however, and may depart significantly from the norm due to variations in driving habits, service practices, and differences in road characteristics and climate.

Traction — AA, A, B, C

The traction grades, from highest to lowest, are AA, A, B, and C. Those grades represent the tire's ability to stop on wet pavement as measured under controlled conditions on specified government test surfaces of asphalt and concrete. A tire marked C may have poor traction performance.

Warning: The traction grade assigned to this tire is based on straight-ahead braking traction tests, and does not include acceleration, cornering, hydroplaning, or peak traction characteristics.

DOT Tire Quality Grading (U.S. Vehicles), Tire Labeling

Temperature – A, B, C

The temperature grades are A (the highest), B, and C, representing the tire's resistance to the generation of heat and its ability to dissipate heat when tested under controlled conditions on a specified indoor laboratory test wheel. Sustained high temperature can cause the material of the tire to degenerate and reduce tire life, and excessive temperature can lead to sudden tire failure. The grade C corresponds to a level of performance, which all passenger vehicle tires must meet under the Federal Motor Vehicle Safety Standard No. 109 and No. 139. Grades B and A represent higher levels of performance on the laboratory test wheel than the minimum required by law. Warning: The temperature grade for this tire is established for a tire that is properly inflated and not overloaded. Excessive speed, underinflation, or excessive loading, either

separately or in combination, can cause heat buildup and possible tire failure.

Tire Labeling

The tires that came on your vehicle have a number of markings. Those you should be aware of are described below.

Tire Size

Whenever tires are replaced, they should be replaced with tires of the same size. Following is an example of tire size with an explanation of what each component means.

P235/45R17 93W

- P – Vehicle type (P indicates passenger vehicle).
- 235 – Tire width in millimeters.
- 45 – Aspect ratio (the tire's section height as a percentage of its width).

- R – Tire construction code (R indicates radial).
- 17 – Rim diameter in inches.
- 93 – Load index (a numerical code associated with the maximum load the tire can carry).
- W – Speed symbol (an alphabetical code indicating the maximum speed rating).

Tire Identification Number

Tire Identification Number (TIN) is a group of numbers and letters that look like the following example TIN.

DOT OBGN PVC 2202

- DOT – This indicates that the tire meets all requirements of the U.S. Department of Transportation.
- OBGN – Manufacturer's identification mark.
- PVC – Tire type code.
- 2202 – Date of manufacture.

Emissions Controls

The burning of gasoline in your vehicle's engine produces several by-products. Some of these are carbon monoxide (CO), oxides of nitrogen (NOx) and hydrocarbons (HC). Gasoline evaporating from the tank also produces hydrocarbons. Controlling the production of NOx, CO, and HC is important to the environment. Under certain conditions of sunlight and climate, NOx and HC react to form photochemical "smog." Carbon monoxide does not contribute to smog creation, but it is a poisonous gas.

The Clean Air Act

The United States Clean Air Act* sets standards for automobile emissions. It also requires that automobile manufacturers explain to owners how their emissions controls work and what to do to maintain them. This section summarizes how the emissions controls work.

* In Canada, Acura vehicles comply with the Canadian Motor Vehicle Safety Standards (CMVSS) for Emissions valid at the time they are manufactured.

Crankcase Emissions Control System

Your vehicle has a Positive Crankcase Ventilation System. This keeps gasses that build up in the engine's crankcase from going into the atmosphere. The Positive Crankcase Ventilation valve routes them from the crankcase back to the intake manifold. They are then

drawn into the engine and burned.

Evaporative Emissions Control System

As gasoline evaporates in the fuel tank, an evaporative emissions control canister filled with charcoal adsorbs the vapor. It is stored in this canister while the engine is off. After the engine is started and warmed up, the vapor is drawn into the engine and burned during driving.

Onboard Refueling Vapor Recovery

The Onboard Refueling Vapor Recovery (ORVR) system captures the fuel vapors during refueling. The vapors are adsorbed in a canister filled with activated carbon. While driving, the fuel vapors are drawn into the engine and burned off.

Exhaust Emissions Controls

The exhaust emissions controls include four systems: PGM-FI, Ignition Timing Control, Exhaust Gas Recirculation and Three Way Catalytic Converter. These four systems work together to control the engine's combustion and minimize the amount of HC, CO, and NO_x that comes out the tailpipe. The exhaust emissions control systems are separate from the crankcase and evaporative emissions control systems.

PGM-FI System

The PGM-FI System uses sequential multiport fuel injection. It has three subsystems: Air Intake, Engine Control, and Fuel Control. The Powertrain Control Module (PCM) uses various sensors to determine how much air is going into the engine. It then controls how much fuel to inject under all operating conditions.

Ignition Timing Control System

This system constantly adjusts the ignition timing, reducing the amount of HC, CO, and NO_x produced.

Exhaust Gas Recirculation (EGR) System

The Exhaust Gas Recirculation (EGR) system takes some of the exhaust gas and routes it back into the intake manifold. Adding exhaust gas to the air/fuel mixture reduces the amount of NO_x produced when the fuel is burned.

Three Way Catalytic Converter

The three way catalytic converter is in the exhaust system. Through chemical reactions, it converts HC, CO, and NO_x in the engine's exhaust to carbon dioxide (CO₂), nitrogen (N₂), and water vapor.

Replacement Parts

The emissions control systems are designed and certified to work together in reducing emissions to levels that comply with the Clean Air Act. To make sure the emissions remain low, you should use only new Acura replacement parts or their equivalent for repairs. Using lower quality parts may increase the emissions from your vehicle.

The emissions control systems are covered by warranties separate from the rest of your vehicle. Read your warranty manual for more information.

Three Way Catalytic Converter

The three way catalytic converter contains platinum, palladium, and rhodium. These metals serve as catalysts, promoting chemical reactions to convert the exhaust gasses without affecting the metals. The catalytic converter is referred to as a three-way catalyst, since it acts on HC, CO, and NOx. A replacement unit must be an original Acura part or its equivalent.

The three way catalytic converter must operate at a high temperature for the chemical reactions to take place. It can set on fire any combustible materials that come near it. Park your vehicle away from high grass, dry leaves, or other flammables.

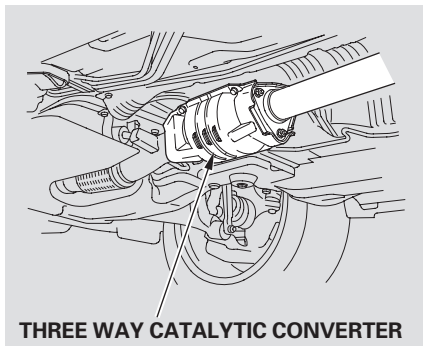

THREE WAY CATALYTIC CONVERTER

A defective three way catalytic converter contributes to air pollution, and can impair your engine's performance. Follow these guidelines to protect your vehicle's three way catalytic converter.

- Always use unleaded gasoline. Even a small amount of leaded gasoline can contaminate the catalyst metals, making the three way catalytic converter ineffective.

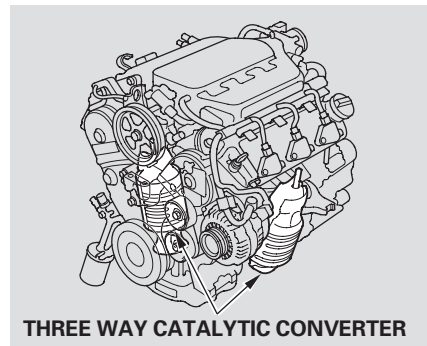

THREE WAY CATALYTIC CONVERTER

- Keep the engine tuned-up.
- Have your vehicle diagnosed and repaired if it is misfiring, backfiring, stalling, or otherwise not running properly.

Testing of Readiness Codes

If you take your vehicle for a state emissions test shortly after the battery has been disconnected or gone dead, it may not pass the test. This is because of certain “readiness codes” that must be set in the on-board diagnostics for the emissions systems. These codes are erased when the battery is disconnected, and set again only after several days of driving under a variety of conditions.

If the testing facility determines that the readiness codes are not set, you will be requested to return at a later date to complete the test. If you must get the vehicle re-tested within the next two or three days, you can condition the vehicle for re-testing by doing the following.

- Make sure the gas tank is nearly, but not completely, full (around 3/4).
- Make sure the vehicle has been parked with the engine off for 8 hours or more.
- Make sure the ambient temperature is between 20° and 95° F.

- Without touching the accelerator pedal, start the engine, and let it idle for 20 seconds.
- Keep the vehicle in Park (automatic transmission) or Neutral (manual transmission). Increase the engine speed to 2,000 rpm and hold it there until the temperature gauge rises to at least 1/4 of the scale (approximately 3 minutes).

CONTINUED

State Emissions Testing

- Select a nearby lightly traveled major highway where you can maintain a speed of 50 to 60 mph (80 to 97 km/h) for at least 20 minutes. Drive on the highway in D (A/T) or 6th (M/T). Do not use the cruise control. When traffic allows, drive for 90 seconds without moving the accelerator pedal. (Vehicle speed may vary slightly; this is okay.) If you cannot do this for a continuous 90 seconds because of traffic conditions, drive for at least 30 seconds, then repeat it two more times (for a total of 90 seconds).

- Then drive in city/suburban traffic for at least 10 minutes. When traffic conditions allow, let the vehicle coast for several seconds without using the accelerator pedal or the brake pedal.

If the testing facility determines the readiness codes are still not set, see your Acura dealer.

Warranty and Customer Relations

Customer Service Information.....	266
Warranty Coverages	267
Reporting Safety Defects (U.S. Vehicles)	268
Authorized Manuals.....	269

Customer Service Information

Acura dealership personnel are trained professionals. They should be able to answer all your questions. If you encounter a problem that your dealership does not solve to your satisfaction, please discuss it with the dealership's management. The Service Manager or General Manager can help. Almost all problems are solved in this way.

If you are dissatisfied with the decision made by the dealership's management, contact the Acura Customer Relations Office.

U.S. Owners:

American Honda Motor Co., Inc.
Acura Client Services
Mail Stop 500-2N-7E
1919 Torrance Blvd.
Torrance, CA 90501-2746

Tel: (800) 382-2238

Canadian Owners: **CUSTOMER RELATIONS RELATIONS AVEC LA CLIENTÈLE**

Honda Canada Inc.
715 Milner Avenue
Toronto, ON
M1B 2K8

Tel: 1-888-9-ACURA-9

Fax: Toll-free 1-877-939-0909
Toronto (416) 287-4776

In Puerto Rico and the U.S. Virgin Islands:

Bella International Corp.
C-1 Bechara St. Segarra Corner
Puerto Nuevo, Puerto Rico 00920

Tel: (787) 620-7020

When you call or write, please give us this information:

- Vehicle Identification Number (see page [254](#))
- Name and address of the dealer who services your vehicle
- Date of purchase
- Mileage on your vehicle
- Your name, address, and telephone number
- A detailed description of the problem
- Name of the dealer who sold the vehicle to you

U.S. Owners

Your new Acura is covered by these warranties:

New Vehicle Limited Warranty – covers your new vehicle, except for the battery, emissions control systems, and accessories, against defects in materials and workmanship.

Emissions Control Systems Defects Warranty and Emissions Performance Warranty – these two warranties cover your vehicle's emissions control systems. Time, mileage, and coverage are conditional. Please read the warranty manual for exact information.

Original Equipment Battery Limited Warranty – this warranty gives up to 100 percent credit toward a replacement battery.

Seat Belt Limited Warranty – a seat belt that fails to function properly is covered for the useful life of the vehicle.

Rust Perforation Limited Warranty – all exterior body panels are covered for rust-through from the inside for the specified time period with no mileage limit.

Accessory Limited Warranty – Acura accessories are covered under this warranty. Time and mileage limits depend on the type of accessory and other factors. Please read your warranty manual for details.

Replacement Parts Limited Warranty – covers all Acura replacement parts against defects in materials and workmanship.

Replacement Battery Limited Warranty – provides prorated coverage for a replacement battery purchased from an Acura dealer.

Replacement Muffler Lifetime Limited Warranty – provides coverage for as long as the purchaser of the muffler owns the vehicle.

Restrictions and exclusions apply to all these warranties. Please read the 2004 Acura Warranty Information booklet that came with your vehicle for precise information on warranty coverages. Your Acura's original tires are covered by their manufacturer. Tire warranty information is in a separate booklet.

Canadian Owners

Please refer to the 2004 Warranty Manual that came with your vehicle.

Reporting Safety Defects (U.S. Vehicles)

If you believe that your vehicle has a defect which could cause a crash or could cause injury or death, you should immediately inform the National Highway Traffic Safety Administration (NHTSA) in addition to notifying Acura Automobile Division, American Honda Motor Co., Inc.

If NHTSA receives similar complaints, it may open an investigation, and if it finds that a safety defect exists in a group of vehicles, it may order a recall and remedy campaign. However, NHTSA cannot become involved in individual problems between you, your dealer, or Acura Automobile Division, American Honda Motor Co., Inc.

To contact NHTSA, you may either call the Auto Safety Hotline toll-free at 1-800-424-9393 (or 366-0123 in Washington D.C. area) or write to: NHTSA, U.S. Department of Transportation, Washington, D.C. 20590. You can also obtain other information about motor vehicle safety from the Hotline.

Purchasing Factory Authorized Manuals (U.S. only)

The publications shown below can be purchased from Helm Incorporated. You can order in any of three ways:

- Detach and mail the order form on the right half of this page
- Call Helm Inc. at 1-800-782-4356 (credit card orders only)
- Go online at www.helminc.com

If you are interested in other years or models, contact Helm Inc. at 1-800-782-4356

Publication Form Number	Form Description	Price Each*
61SEP00	2004 Acura TL Service Manual	\$69.00
61SEP00EL	2004 Acura TL Electrical Troubleshooting Manual	\$47.00
61SEP30	2004 Acura TL Body Repair Manual	\$44.00
31SEP600	2004 Acura TL Owner's Manual	\$37.00
31SEP700	2004 Acura TL Navigation Manual	\$29.00
31SEP700	2004 Acura TL Maintenance Journal	\$12.00
31SEPP000	2004 Acura TL Quick Start Guide	\$12.00
ACU-R	Order Form for Previous Years- Indicate Year and Model Desired	FREE
* Prices are subject to change without notice and without incurring obligation.		

Valid only for sales within the U.S. Canadian owners should contact their authorized Acura dealer.

ORDER TOLL FREE: 1-800-782-4356

(NOTE: For Credit Card Holder Orders Only)

Monday-Friday 8:00 A.M. — 6:00 P.M. EST

MINIMUM CREDIT CARD PURCHASE \$10.00

OR

By completing this form you can order the materials desired. You can pay by check or money order, or charge to your credit card. Mail to Helm Incorporated at the address shown on the back of the order form.

2004 ACU	PUBLICATION NUMBER	VEHICLE MODEL		Qty	Price Each*	Total Price
		Name	Year			
* Prices are subject to change without notice and without incurring obligation.					TOTAL MATERIAL	
					Mich. Purchases Add 6% Sales Tax	
Orders are mailed within 10 days. Please allow adequate time for delivery.					HANDLING CHARGE	\$6.95
					GRAND TOTAL	

Authorized Manuals

S H I P T O	NOTE: Dealers and Companies please provide dealer or company name, and also the name of the person to whose attention the shipment should be sent. For purchases outside U.S.A. please write to the address shown below for a quotation.	
	_____	_____
	Customer Name	Attention
	_____	_____
	Street Address -- No P.O. Box Number	Apartment Number
_____	_____	
City	State & Zip Code	
Daytime Telephone Number () _____		

P A Y M E N T	<input type="checkbox"/> Check or money order enclosed payable to Helm Inc -- U.S. funds only. Do not send cash	
	<input type="checkbox"/> Master Card	<input type="checkbox"/> VISA <input type="checkbox"/> Check here if your billing address is different from the shipping address shown above.
	Account Number	Expiration: Mo. Yr.
	<input type="text"/> <input type="text"/> <input type="text"/> <input type="text"/> <input type="text"/> <input type="text"/> <input type="text"/> <input type="text"/> <input type="text"/> <input type="text"/> <input type="text"/> <input type="text"/> <input type="text"/> <input type="text"/> <input type="text"/> <input type="text"/> <input type="text"/> <input type="text"/>	<input type="text"/> <input type="text"/> <input type="text"/> <input type="text"/> <input type="text"/> <input type="text"/> <input type="text"/> <input type="text"/> <input type="text"/> <input type="text"/> <input type="text"/> <input type="text"/> <input type="text"/> <input type="text"/> <input type="text"/> <input type="text"/>
	_____	_____
CUSTOMER SIGNATURE	DATE	

These Publications cannot be returned for credit without receiving advance authorization within 14 days of delivery. On returns, a restocking fee may be applied against the original order.

HELM P.O. BOX 07280-DETROIT, MICHIGAN 48207-1-800-782-4356

Service Manual:

This manual covers maintenance and recommended procedures for repair to engine and chassis components. It is written for the journeyman mechanic, but is simple enough for most mechanically-inclined owners to understand.

Electrical Troubleshooting Manual:

This manual complements the Service Manual by providing in-depth troubleshooting information for each electrical circuit in your vehicle.

Body Repair Manual:

This manual describes the procedures involved in the replacement of damaged body parts.

A

Accessories and Modifications	168
Accessories.....	169
Modifications	170
ACCESSORY (Ignition Key Position)	80
Accessory Power Sockets.....	106
Adding Engine Coolant.....	207
Adding Engine Oil	204
Additives, Engine Oil.....	205
Airbag (SRS)	9, 22
Additional Information.....	22
Servicing	28
System Components.....	22
Air Conditioning System.....	110
Air Pressure, Tires	221
Antifreeze	207
Anti-lock Brakes (ABS) Indicator.....	53, 189
Operation.....	189
Anti-theft, Audio System.....	140
Anti-theft Steering Column Lock ..	80
Audio System	117
Automatic Lighting Off Feature....	76
Automatic Seat Belt Tensioners	20

Automatic Speed Control.....	142
Automatic Transmission.....	181
Capacity, Fluid	256
Checking Fluid Level.....	209
Shifting.....	181
Shift Lever Position Indicator ..	181
Shifting.....	181
Shift Lock Release.....	185

B

Battery	
Charging System	
Indicator.....	52, 242
Jump Starting	238
Maintenance.....	226
Specifications	257
Before Driving	163
Belts, Seat	8, 19
Beverage Holder.....	106
Brakes	
Anti-lock System (ABS)	189
Break-in, New Linings	164
Fluid	211
Parking.....	103
System Indicator.....	52, 244

Wear Indicators	188
Braking System.....	188
Break-in, New Car	164
Brightness Control, Instruments...	75
Brights, Headlights	74
Bulb Replacement	
Back-up Lights	216
Fog Lights	213
Specifications	257
Turn Signal Lights.....	214, 215
Bulbs, Halogen.....	213

C

Capacities Chart.....	256
Carbon Monoxide Hazard	46
Carrying, Cargo	171
Cassette Player	
Care	138
Operation.....	136
CAUTION, Explanation of	ii
Ceiling Light.....	104
Certification Label.....	254
Chains, <i>tires</i>	225

CONTINUED

Index

Changing Oil	
How to.....	205
When to.....	195
Changing a Flat Tire	231
Charging System Indicator	52, 242
Checklist, Before Driving.....	176
Childproof Door Locks	84
Child Safety	29
Booster Seats	43
Child Seats.....	36
Infants	34
Large Children.....	42
LATCH.....	38
Risks with Airbags.....	30
Small Children.....	35
Tethers.....	41
Where Should a Child Sit?	30
Cleaning	
Floor Mats	218
Seat Belts.....	218
Climate Control System.....	115
Clock	103
CO in the Exhaust	46
Compact Spare <i>tire</i>	230
Console Compartment	107
Consumer Information *	265

Controls, Instruments and.....	49
Coolant	
Adding.....	207
Checking.....	167
Proper Solution	207
Temperature Gauge.....	57
Crankcase Emissions Control	
System.....	260
Cruise Control Indicator	54
Cruise Control Operation	142
Cup Holders.....	106
Customer Relations Office	266

D

DANGER, Explanation of	ii
Dashboard	2, 50
Daytime Running Lights **	74
Daytime Running Light	
Indicator**	55
Defects, Reporting Safety.....	268
Defogger, Rear Window	77
Defrosting the Windows.....	114
Dimensions.....	256
Dimming the Headlights	74

Dipstick	
Automatic Transmission.....	209
Engine Oil.....	167
Directional Signals.....	74
Disc Brake Wear Indicators.....	188
Disc Changer.....	129
Disc Changer Error Messages	135
Disposal of Used Oil.....	206
Doors	
Monitor Light.....	60
Power Door Locks.....	82
DOT Tire Quality Grading	258
Driver and Passenger Safety.....	5
Driving	175
Economy	168
Driving Position Memory	
System.....	93

E

Economy, Fuel	168
Emergencies on the Road.....	229
Battery, Jump Starting	238
Brake System Indicator	244
Changing a Flat Tire	231
Charging System Indicator	242

Checking the Fuses.....	245
Hazard Warning Flashers	76
If Your Vehicle Gets Stuck.....	249
Jump Starting	238
Low Oil Pressure Indicator	242
Malfunction Indicator Lamp	243
Overheated Engine	240
Towing	249
Emergency Brake.....	103
Emergency Flashers	76
Emergency Towing	249
Emergency Trunk Opener	84
Emissions Controls.....	260
Emissions Testing, State	263
Engine	
Coolant Temperature Gauge	57
Malfunction Indicator	
Lamp	52, 243
Oil Life	64
Oil Pressure Indicator	52, 242
Oil, What Kind to Use	204
Overheating.....	240
Specifications	257
Speed Limiter.....	179, 185
Starting.....	177
Engine, <i>if it won't start</i>	236

Ethanol in Gasoline	164
Evaporative Emissions Controls..	260
Exhaust Fumes	46
Expectant Mothers, Use of Seat	
Belts by	17

F

Fan, Interior.....	122
Features, Comfort and	
Convenience	109
Filling the Fuel Tank.....	165
Filter, Oil.....	205
Flashers, Hazard Warning.....	76
Flat Tire, Changing a	231
Floor Mats	218
Fluids	
Automatic Transmission.....	209
Brake.....	211
Clutch.....	211
Manual Transmission	210
Power Steering.....	212
Windshield Washers	208
FM Stereo Radio	
Reception	122
Fog Lights*	75

Four-way Flashers	76
Front Airbags	9, 22
Front Seats	90
Adjusting.....	90
Heaters.....	96
Airbags.....	9, 22
Fuel.....	164
Fill Door and Cap.....	165
Gauge	57
Octane Requirement	164
Reserve Indicator.....	56
Tank, Filling the.....	165
Fuses, Checking the.....	245

G

Gas Mileage, Improving.....	168
Gasoline	164
Fuel Reserve Indicator.....	56
Gauge	57
Octane Requirement	164
Tank, Filling the.....	165
Gas Station Procedures.....	165

CONTINUED

Index

Gauges	
Engine Coolant Temperature	57
Fuel.....	57
Speedometer	57
Tachometer	57
Gearshift Lever Positions	
Automatic Transmission.....	181
6-speed Manual	
Transmission.....	178
Glove Box	107

H

Halogen Fog Bulbs.....	213
HandsFree Link (HFL).....	70, 149
Hazard Warning Flashers.....	76
Headlights.....	74
Aiming.....	213
Automatic Lighting Off	
Feature.....	76
Daytime Running Lights**	74
High Beam Indicator.....	55
Reminder Chime.....	74
Turning on.....	74
Head Restraints	89
High-Low Beam Switch	74

HomeLink Universal	
Transceiver.....	145
Hood Latch.....	212
Hood, Opening the	166

I

Identification Number, Vehicle....	254
Ignition	
Keys.....	79
Switch.....	80
Timing Control System.....	261
Immobilizer System.....	81
Important Safety Precautions	6
Indicators.....	52
ABS (Anti-Lock Brake).....	53, 189
Brake (Parking and Brake	
System)	52, 244
Charging System	52, 242
Cruise Control.....	54
DRL (Daytime Running	
Lights)**	55
Fog Light*	56
High Beam.....	55
Key (Immobilizer System)	56
Low Fuel	56

Low Oil Pressure	54, 242
Side Airbag Off	53
SRS	26, 53
Turn Signal and Hazard	
Warning	55
VSA Activation	54
VSA System.....	54
Infant Restraint	34
Infant Seats.....	34
Tether Anchorage Points	41
Inflation, Proper Tire	221
Inside Mirror	91
Inspection, Tire	222
Instrument Panel	51
Instrument Panel Indicators.....	52
Instrument Panel Brightness	75
Interior Lights	104
Introduction.....	i

J

Jacking up the Vehicle	232
Jack, Tire	231
Jump Starting	238

K

Keys..... 79
 Keyless Memory Setting 66

L

Label, Certification..... 254
 Lane Change, Signaling 74
 Lap/Shoulder Belts 19
 Lights
 Bulb Replacement 213
 Indicator 52
 Parking..... 74
 Turn Signal 74
 Load Limit 172
 LOCK (Ignition Key Position) 80
 Lockout Prevention 82
 Locks
 Anti-theft Steering Column 80
 Glove Box 107
 Power Door 82
 Trunk 83
 Low Coolant Level..... 167
 Low Oil Pressure Indicator 52, 242
 Lubricant Specifications Chart 256

Luggage, *Storing (Cargo)*..... 171

M

Maintenance..... 193
 Messages 64
 Minder..... 195
 Owner Maintenance Checks.... 198
 Record 200
 Safety..... 194
 Malfunction Indicator
 Lamp 52, 243
 Manual Transmission..... 178
 Manual Transmission Fluid 210
 Memory, Driving Position 93
 Meters, Gauges..... 57
 Mirrors, Adjusting 91
 Modifying Your Vehicle..... 170
 Moonroof 100
 Multi-Information Display 59
 Engine Oil Life 64
 HandsFree Link..... 70
 Keyless Memory Settings 66
 Maintenance Messages 64
 Odometer..... 62
 Outside Temperature..... 63

Trip Computer 65
 Trip Meter 62

N

Neutral Gear Position..... 182
 New Vehicle Break-in 164
 NOTICE, Explanation of..... i
 Numbers, Identification 254

O

Octane Requirement, Gasoline 164
 Odometer 62
 Odometer, Trip 62
 Oil
 Change, How to 205
 Change, When to 195
 Checking Engine 167
 Pressure Indicator 52, 242
 Selecting Proper Viscosity
 Chart 204
 ON (Ignition Key Position) 80

CONTINUED

Index

Onboard Refueling Vapor Recovery	260
Outside Mirrors	91
Outside Temperature.....	63
Overheating, Engine	240
Owner's Maintenance Checks	198

P

Panel Brightness Control	75
Park Gear Position.....	182
Parking	187
Parking Brake	103
Parking Brake and Brake System Indicator.....	52, 244
Parking Lights.....	74
Parking Over Things that Burn... ..	187
PGM-FI System.....	261
Power Socket Locations.....	106
Pregnancy, Using Seat Belts	17
Protecting Adults and Teens.....	11
Additional Safety Precautions....	18
Advice for Pregnant Women.....	17
Protecting Children	29
Installing a Child Seat Using Latch	38

Installing a Child Seat with a Lap/Shoulder Belt.....	40
Installing a Child Seat with a Tether	41
Selecting a Child Seat.....	36
Protecting Infants	34
Protecting Larger Children.....	42
Protecting Small Children	35
Protecting Your Discs	134

R

Radiator Overheating.....	240
Radio/Cassette/Disc Sound System.....	117
Readiness Codes.....	243, 263
Rear Lights, Bulb Replacement... ..	215
Rear Seat Armrest	89
Rear View Mirror.....	91
Rear Window Defogger	77
Reclining the Seat Backs	88
Reminder Lights	52
Remote Audio Controls.....	139
Remote Transmitter	85
Replacement Information	
Engine Oil and Filter	205

Fuses	245
Light Bulbs	213
Tires	224
Wiper Blades.....	219
Replacing Seat Belts After a Crash	21
Reserve Tank, Engine Coolant	167
Restraint, Child	34, 35
Reverse Gear Position.....	182
Rotation, Tire	223

S

Safety Belts.....	8, 19
Safety Defects, Reporting*	268
Safety Features	7
Airbags.....	9
Door Locks	11
Head Restraints	13
Seat Belts	8
Seats & Seat-Backs.....	12
Safety Labels, Location of	47
Safety Messages	ii
Satellite Radio.....	124
Seat Belts	8, 19
Additional Information.....	19

Cleaning.....	218	Spare Tire		Storing Your Vehicle.....	227
Lap/Shoulder Belt.....	14, 19	Inflating.....	230	Sunglasses Holder.....	108
Maintenance.....	21	Specifications.....	257	Supplemental Restraint System....	22
Reminder Light and		Specifications Charts.....	256	Servicing.....	28
Beeper.....	19, 52	Speed Control.....	142	SRS Indicator.....	26
System Components.....	19	SRS, Additional Information.....	33	System Components.....	22
Use During Pregnancy.....	17	Additional Safety Precautions....	28		
Seat Heaters.....	96	Airbag Components.....	22	T	
Seats, Adjusting the.....	90	Airbag Service.....	28	Tachometer.....	57
Security System.....	141	How the SRS Indicator		Taking Care of the Unexpected ..	229
Sequential SportShift Mode.....	183	Works.....	26	Tape Player.....	136
Serial Number.....	254	How Your Front Airbags		Technical Descriptions	
Service Intervals.....	195	Work.....	23	DOT Tire Quality Grading.....	258
Service Manual*.....	269	How Your Side Airbags Work....	25	Emissions Control Systems.....	260
Service Station Procedures.....	165	How Your Side Curtain Airbags		Three Way Catalytic	
Setting the Clock.....	103	Work.....	26	Converter.....	262
Shift Lever Position Indicator.....	181	SRS Indicator.....	26, 53	Temperature Gauge.....	57
Shift Lock Release.....	185	START (Ignition Key Position).....	80	Temperature, Outside.....	63
Shifting.....	181	Starting the Engine.....	177	Temperature, Inside Sensor.....	116
Side Airbags.....	9, 25	With a Dead Battery.....	238	Tether Anchorage Points.....	41
Side Airbag Off Indicator.....	27, 53	State Emissions Testing.....	263	Three Way Catalytic Converter...	262
Side Curtain Airbags.....	26	Steam Coming from Engine.....	236	Tilt the Steering Wheel.....	78
Signaling Turns.....	74	Steering Wheel		Time, Setting the.....	103
Snow Tires.....	225	Adjustment.....	78		
Sound System.....	117	Anti-theft Column Lock.....	80		
		Stereo Sound System.....	117		

CONTINUED

Index

Tire Chains	225
Tire, How to Change a Flat	231
Tires	220
Air Pressure	221
Checking Wear	222
Compact Spare	230
DOT Tire Quality Grading	258
Inflation	221
Inspection	222
Replacing	224
Rotating	223
Snow	225
Specifications	257
Summer Tire	224
Traction Devices	225
Winter Driving	224
Tools, Tire Changing	231
Towing	
A Trailer	192
Emergency Wrecker	249
Traction Devices	225
Transmission	
Checking Fluid Level, Automatic	209
Checking Fluid Level Manual..	210
Fluid Selection	209, 210

Identification Number	254
Shifting the Automatic	190
Shifting the Manual	178
Treadwear	223, 258
Trip Computer	65
Trip Meter	62
Trunk	80
Emergency Trunk Release	84
Opening the	83
Open Monitor Light	60
Turn Signals	74

U

Unexpected, Taking Care of the	229
Uniform Tire Quality Grading	258
Unleaded Gasoline	164
Used Oil, How to Dispose of	206

V

Vehicle Capacity Load	172
Vehicle Dimensions	256
Vehicle Identification Number	254

Vehicle Stability Assist (VSA) System	190
VSA System Indicator	54, 190
VSA Activation Indicator	54, 190
VSA Off Switch	191
Vehicle Storage	227
VIN	254
Viscosity, Oil	204

W

WARNING, Explanation of	ii
Warning Labels, Location of	47
Warranty Coverages*	267
Washer, Windshield	
Checking the Fluid Level	208
Indicator	62
Operation	73
Wheels	
Adjusting the Steering	78
Alignment and Balance	223
Compact Spare	230
Windows	
Operating the Power	97
Rear, Defogger	77

Windshield	
Cleaning	73
Defroster	114
Washers	208
Wipers, Windshield	
Changing Blades.....	219
Operation	73
Worn Tires	223
Wrecker, Emergency Towing.....	249

X

XM Satellite Radio*	124
---------------------------	-----

*: U.S. and Canada only

** : Canada only

Service Information Summary

Gasoline:

Premium unleaded gasoline, pump octane number of 91 or higher.

Fuel Tank Capacity:

17.09 US gal (64.7 ℓ)

Recommended Engine Oil:

API Service SJ "Energy Conserving" oil, SAE 5W-20 viscosity (see page [204](#)).

Oil change capacity (including filter):

4.5 US qt (4.3 ℓ)

Automatic Transmission Fluid:

Honda ATF-Z1 (Automatic Transmission Fluid) preferred, or a DEXRON® III ATF as a temporary replacement (see page [209](#)).

Manual Transmission

Honda Manual Transmission Fluid preferred, or an SAE 10W-30 or 10W-40 motor oil as a temporary replacement (see page [210](#)).

Capacity:

2.6 US qt (2.5 ℓ)

Power Steering Fluid:

Honda Power Steering Fluid preferred, or another brand of power steering fluid as a temporary replacement. Do not use ATF (see page [212](#)).

Brake Fluid:

Honda Heavy Duty Brake Fluid DOT 3 preferred, or a DOT 3 or DOT 4 brake fluid as a temporary replacement (see page [211](#)).

Tire Pressure (measured cold):

Manual Transmission Models

Front:

35 psi (240 kPa , 2.4 kgf/cm²)

Rear:

32 psi (220 kPa , 2.2 kgf/cm²)

Automatic Transmission Models

Front:

32 psi (220 kPa , 2.2 kgf/cm²)

Rear:

32 psi (220 kPa , 2.2 kgf/cm²)

Spare Tire Pressure:

60 psi (420 kPa , 4.2 kgf/cm²)