

# **322, 330, 332 and 430 Lawn and Garden Tractors**

For complete service information also see:

Yanmar Gasoline Engines . . . . . CTM12  
John Deere Series 220 Diesel Engines . . . CTM3

**John Deere Horicon Works  
TM1591 (15JUL95)**

LITHO IN U.S.A.  
ENGLISH

# Introduction

## FOREWORD

This manual is written for an experienced technician. Essential tools required in performing certain service work are identified in this manual and are recommended for use.

Live with safety: Read the safety messages in the introduction of this manual and the cautions presented throughout the text of the manual.

**N** This is the safety-alert symbol. When you see this symbol on the machine or in this manual, be alert to the potential for personal injury.

Technical manuals are divided in two parts: repair and diagnostics. Repair sections tell how to repair the components. Diagnostic sections help you identify the majority of routine failures quickly.

Information is organized in groups for the various components requiring service instruction. At the beginning of each group are summary listings of all applicable essential tools, other materials needed to do the job and service parts kits.

Section 10, Group 15—Repair Specifications, consist of all applicable specifications, near tolerances and specific torque values for various components on each individual machine.

Section 10, Group 20—Test and Adjustment Specifications, consist of all applicable test and adjustment specifications for various systems for each individual machine.

Binders, binder labels, and tab sets can be ordered by John Deere dealers direct from the John Deere Distribution Service Center.

This manual is part of a total product support program.

FOS MANUALS—REFERENCE

TECHNICAL MANUALS—MACHINE SERVICE

COMPONENT MANUALS—COMPONENT SERVICE

Fundamentals of Service (FOS) Manuals cover basic theory of operation, fundamentals of troubleshooting, general maintenance, and basic type of failures and their causes. FOS Manuals are for training new personnel and for reference by experienced technicians.

Technical Manuals are concise guides for specific machines. Technical manuals are on-the-job guides containing only the vital information needed for diagnosis, analysis, testing, and repair.

Component Technical Manuals are concise service guides for specific components. Component technical manuals are written as stand-alone manuals covering multiple machine applications.

# Contents

## SECTION 10—GENERAL INFORMATION

- Group 05—Safety
- Group 10—General Specifications
- Group 15—Repair Specifications
- Group 20—Test and Adjustment Specifications
- Group 25—Fuels and Lubricants
- Group 30—Serial Number Locations

## SECTION 20—ENGINE REPAIR

- Group 05—Engine—322
- Group 06—Engine—330, 332 and 430

## SECTION 40—ELECTRICAL REPAIR

- Group 05—Front PTO Clutch

## SECTION 50—POWER TRAIN REPAIR

- Group 05—Transmission
- Group 10—Transmission Control Linkage
- Group 15—Differential
- Group 20—Rear Axles
- Group 25—Drive Shaft—322, 330 and 332
- Group 26—Drive Shaft—430

## SECTION 60—STEERING AND BRAKE REPAIR

- Group 05—Steering—330
- Group 06—Steering—322, 332 and 430
- Group 10—Brakes

## SECTION 70—HYDRAULIC REPAIR

- Group 05—Hydraulic Control Valve

## SECTION 80—MISCELLANEOUS REPAIR

- Group 05—Front Axle
- Group 10—Mower Spindle and Jack Sheave Repair
- Group 15—Mower Gear Case Repair

## SECTION 220—ENGINE, FUEL AND AIR SYSTEM CHECKOUT AND DIAGNOSIS

- Group 05—Engine, Fuel and Air System Checkout

- Group 10—Diagnosis, Tests and Adjustments—322
- Group 11—Diagnosis, Tests and Adjustments—330, 332 and 430

## SECTION 240—ELECTRICAL SYSTEM CHECKOUT, OPERATION AND DIAGNOSIS

- Group 05—Electrical System Checkout
- Group 10—Electrical Schematics
- Group 15—Component Location and Operation
- Group 20—Electrical System Diagnosis
- Group 25—Electrical System Component Tests and Adjustments

## SECTION 250—POWER TRAIN CHECKOUT, OPERATION AND DIAGNOSIS

- Group 05—Power Train Checkout
- Group 10—Theory of Operation
- Group 15—Diagnosis, Tests and Adjustments

## SECTION 260—STEERING AND BRAKES CHECKOUT, OPERATION AND DIAGNOSIS

- Group 05—Steering And Brakes System Checkout
- Group 10—Theory of Operation
- Group 15—Diagnosis, Tests and Adjustments

## SECTION 270—HYDRAULIC SYSTEM CHECKOUT, OPERATION AND DIAGNOSIS

- Group 05—Hydraulic System Checkout
- Group 10—Hydraulic Schematics
- Group 15—Theory of Operation
- Group 20—Diagnosis, Tests and Adjustments

## SECTION 299—DEALER FABRICATED TOOLS

- Group 00—Dealer Fabricated Tools

## Index

*All information, illustrations and specifications in this manual are based on the latest information available at the time of publication. The right is reserved to make changes at any time without notice.*

TM1591-19-15JUL95

COPYRIGHT© 1995  
DEERE & COMPANY  
Moline, Illinois  
All rights reserved  
A John Deere ILLUSTRATION™ Manual

*Contents*

10

20

40

50

60

70

80

220

240

250

260

270

299

INDX

*Contents*

260

270

299

INDX

# Dealer Presentation Sheet

## JOHN DEERE DEALERS

**IMPORTANT: Please remove this page and route through your service department.**

This is a complete revision for models 322, 330, 332 and 430 found in TM1277, TM1309 and TM1345. The complete revision of remaining machines (316, 318 and 420) can be found in TM1590. AFTER receiving both TM1590 and TM1591, please discard old TM1277 dated December 1987, TM1309 dated July 1985 and TM1345 dated June 1986.

*NOTE: There are several "versions" of each model tractor. All versions were not available at time of latest printing. Some versions may not be covered.*

*Dealer Presentation Sheet*



# Section 10

# GENERAL INFORMATION

## Contents

Page

**Group 05—Safety** . . . . . 10-05-1

**Group 10—General Specifications**

Machine Specifications

322 and 330 . . . . . 10-10-1

332 and 430 . . . . . 10-10-4

**Group 15—Repair Specifications**

Repair Specifications . . . . . 10-15-1

Metric Series Torque Chart . . . . . 10-15-4

Inch Series Torque Chart . . . . . 10-15-5

Metric Torque Values—Grade 7 . . . . . 10-15-6

Set Screw Torque Chart . . . . . 10-15-6

Service Recommendations

Flat Face O-Ring Seal Fittings . . . . . 10-15-8

Tube and Hose Fitting, 37° Flare and  
30° Cone Seat Connectors . . . . . 10-15-9

**Group 20—Test and Adjustment  
Specifications** . . . . . 10-20-1

**Group 25—Fuels and Lubricants**

Fuel—322 . . . . . 10-25-1

Diesel Fuel—330, 332 and 430 . . . . . 10-25-2

Storing Fuel . . . . . 10-25-3

Do Not Use Galvanized Containers . . . . . 10-25-3

Engine Oil—322 . . . . . 10-25-4

Diesel Engine Oil—330, 332 and 430 . . . . . 10-25-5

Engine Coolant . . . . . 10-25-6

Liquid Coolant Conditioner . . . . . 10-25-6

Transmission and Hydraulic Oil . . . . . 10-25-7

Grease . . . . . 10-25-8

Mower Deck Gear Case Oil . . . . . 10-25-8

Alternative and Synthetic Lubricants . . . . . 10-25-9

Lubricant Storage . . . . . 10-25-9

Mixing of Lubricants . . . . . 10-25-9

**Group 30—Serial Number Locations**

Serial Numbers

Product Identification . . . . . 10-30-1

Engine . . . . . 10-30-1

Transmission . . . . . 10-30-1

Differential . . . . . 10-30-2

Control Valve . . . . . 10-30-2



## RECOGNIZE SAFETY INFORMATION

This is the safety-alert symbol. When you see this symbol on your machine or in this manual, be alert to the potential for personal injury.

Follow recommended precautions and safe operating practices.

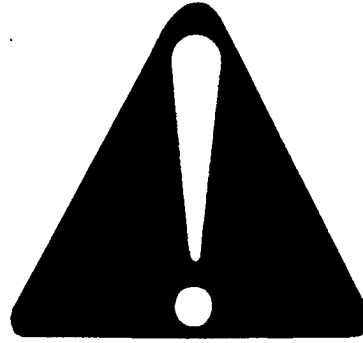

DX,ALERT -19-03MAR93

10  
05  
1  
-UN-07DEC88  
T81389

## UNDERSTAND SIGNAL WORDS

A signal word—DANGER, WARNING, or CAUTION—is used with the safety-alert symbol. DANGER identifies the most serious hazards.

DANGER or WARNING safety signs are located near specific hazards. General precautions are listed on CAUTION safety signs. CAUTION also calls attention to safety messages in this manual.



DX,SIGNAL -19-03MAR93

-19-30SEP88  
TS187

## FOLLOW SAFETY INSTRUCTIONS

Carefully read all safety messages in this manual and on your machine safety signs. Keep safety signs in good condition. Replace missing or damaged safety signs. Be sure new equipment components and repair parts include the current safety signs. Replacement safety signs are available from your John Deere dealer.

Learn how to operate the machine and how to use controls properly. Do not let anyone operate without instruction.

Keep your machine in proper working condition. Unauthorized modifications to the machine may impair the function and/or safety and affect machine life.

If you do not understand any part of this manual and need assistance, contact your John Deere dealer.



DX,READ -19-03MAR93

-UN-23AUG88  
TS201

10  
05  
2

## HANDLE FLUIDS SAFELY—AVOID FIRES

When you work around fuel, do not smoke or work near heaters or other fire hazards.

Store flammable fluids away from fire hazards. Do not incinerate or puncture pressurized containers.

Make sure machine is clean of trash, grease, and debris.

Do not store oily rags; they can ignite and burn spontaneously.



DX,FLAME -19-04JUN90

-UN-23AUG88  
TS227

## PREVENT BATTERY EXPLOSIONS

Keep sparks, lighted matches, and open flame away from the top of battery. Battery gas can explode.

Never check battery charge by placing a metal object across the posts. Use a volt-meter or hydrometer.

Do not charge a frozen battery; it may explode. Warm battery to 16°C (60°F).



DX,SPARKS -19-03MAR93

-UN-23AUG88  
TS204

## PREPARE FOR EMERGENCIES

Be prepared if a fire starts.

Keep a first aid kit and fire extinguisher handy.

Keep emergency numbers for doctors, ambulance service, hospital, and fire department near your telephone.

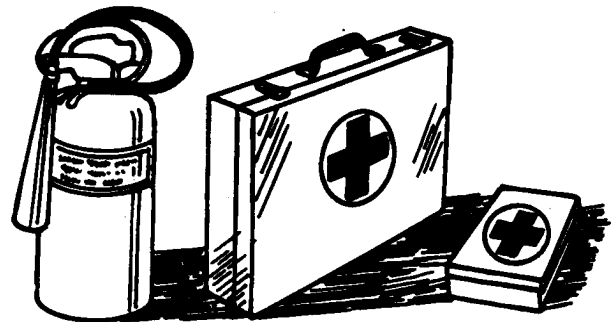

DX,FIRE2 -19-03MAR93

-UN-23AUG88  
TS291

## PREVENT ACID BURNS

Sulfuric acid in battery electrolyte is poisonous. It is strong enough to burn skin, eat holes in clothing, and cause blindness if splashed into eyes.

Avoid the hazard by:

1. Filling batteries in a well-ventilated area.
2. Wearing eye protection and rubber gloves.
3. Avoiding breathing fumes when electrolyte is added.
4. Avoiding spilling or dripping electrolyte.
5. Use proper jump start procedure.

If you spill acid on yourself:

1. Flush your skin with water.
2. Apply baking soda or lime to help neutralize the acid.
3. Flush your eyes with water for 15—30 minutes. Get medical attention immediately.

If acid is swallowed:

1. Do not induce vomiting.
2. Drink large amounts of water or milk, but do not exceed 2 L (2 quarts).
3. Get medical attention immediately.

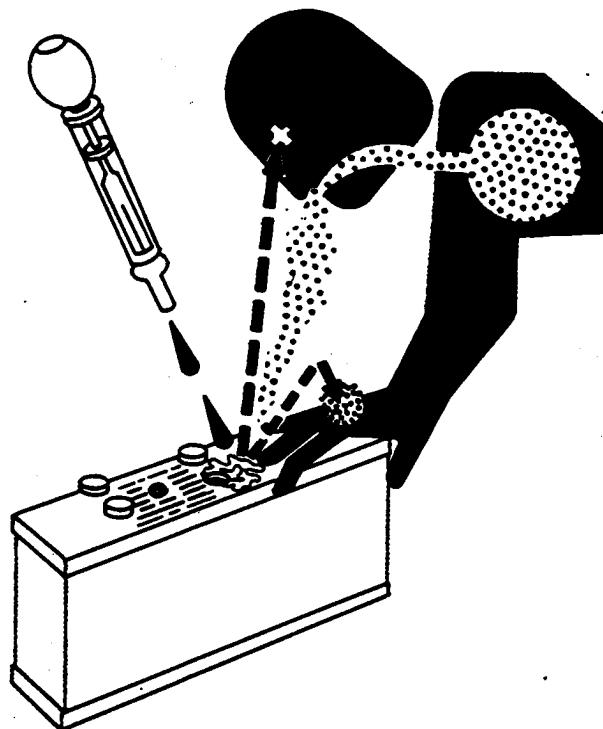

DX,POISON -19-21APR93

TSS203 -UN-23AUG88

## SERVICE COOLING SYSTEM SAFELY

Explosive release of fluids from pressurized cooling system can cause serious burns.

Shut off engine. Only remove filler cap when cool enough to touch with bare hands. Slowly loosen cap to first stop to relieve pressure before removing completely.

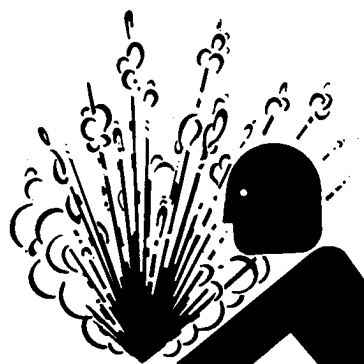

DX,RCAP -19-04JUN90

TSS281 -UN-23AUG88

## HANDLE CHEMICAL PRODUCTS SAFELY

Direct exposure to hazardous chemicals can cause serious injury. Potentially hazardous chemicals used with John Deere equipment include such items as lubricants, coolants, paints, and adhesives.

A Material Safety Data Sheet (MSDS) provides specific details on chemical products: physical and health hazards, safety procedures, and emergency response techniques.

Check the MSDS before you start any job using a hazardous chemical. That way you will know exactly what the risks are and how to do the job safely. Then follow procedures and recommended equipment.

(See your John Deere dealer for MSDS's on chemical products used with John Deere equipment.)

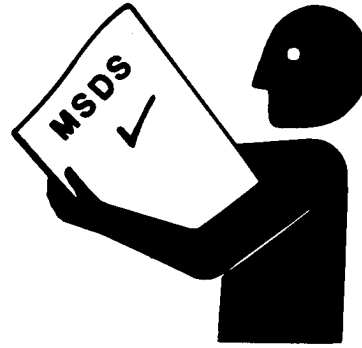

DX,MSDS,NA -19-03MAR93

TS1132 -UN-26NOV90

## AVOID HIGH-PRESSURE FLUIDS

Escaping fluid under pressure can penetrate the skin causing serious injury.

Avoid the hazard by relieving pressure before disconnecting hydraulic or other lines. Tighten all connections before applying pressure.

Search for leaks with a piece of cardboard. Protect hands and body from high pressure fluids.

If an accident occurs, see a doctor immediately. Any fluid injected into the skin must be surgically removed within a few hours or gangrene may result. Doctors unfamiliar with this type of injury should reference a knowledgeable medical source. Such information is available from Deere & Company Medical Department in Moline, Illinois, U.S.A.

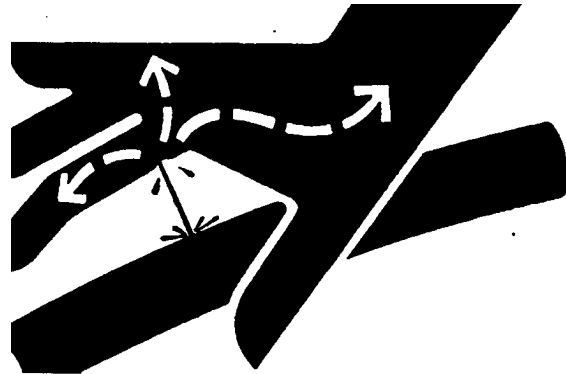

DX,FLUID -19-03MAR93

X9811 -UN-23AUG88

## PREPARE MACHINE FOR REPAIR

1. Move hydrostatic control lever to STOP position.
2. Disengage PTO's
3. Lower all equipment to the ground.
4. Engage park brake.
5. Stop the engine and remove the key.
6. Operate all hydraulic control levers to release hydraulic pressure in the system.

Before you leave the operator's seat, wait for engine and attachment parts to stop moving.

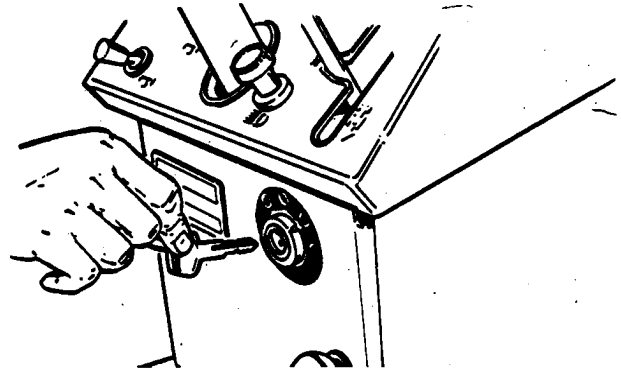

MX,1005R,8 -19-01APR86

M34228 -UN-24APR89

## SUPPORT MACHINE PROPERLY

Always lower the attachment or implement to the ground before you work on the machine. If you must work on a lifted machine or attachment, securely support the machine or attachment.

Do not support the machine on cinder blocks, hollow tiles, or props that may crumble under continuous load. Do not work under a machine that is supported solely by a jack. Follow recommended procedures in this manual.

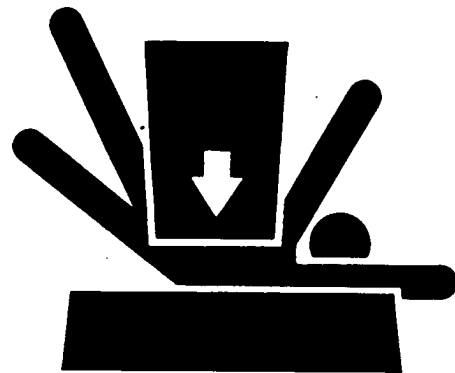

DX,LOWER -19-04JUN90

TS229 -UN-23AUG88

### WEAR PROTECTIVE CLOTHING

Wear close fitting clothing and safety equipment appropriate to the job.

Prolonged exposure to loud noise can cause impairment or loss of hearing.

Wear a suitable hearing protective device such as earmuffs or earplugs to protect against objectionable or uncomfortable loud noises.

Operating equipment safely requires the full attention of the operator. Do not wear radio or music headphones while operating machine.

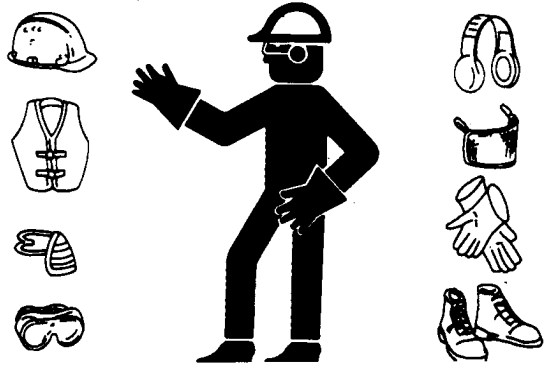

DX,WEAR -19-10SEP90

TS206 -UN-23AUG88

### WORK IN CLEAN AREA

Before starting a job:

- Clean work area and machine.
- Make sure you have all necessary tools to do your job.
- Have the right parts on hand.
- Read all instructions thoroughly; do not attempt shortcuts.

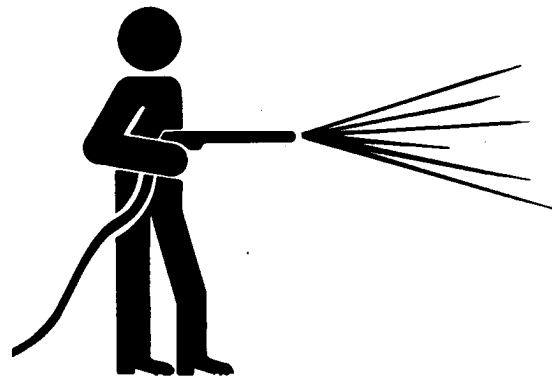

DX,CLEAN -19-04JUN90

T6642EJ -UN-18OCT88

### SERVICE MACHINES SAFELY

Tie long hair behind your head. Do not wear a necktie, scarf, loose clothing, or necklace when you work near machine tools or moving parts. If these items were to get caught, severe injury could result.

Remove rings and other jewelry to prevent electrical shorts and entanglement in moving parts.

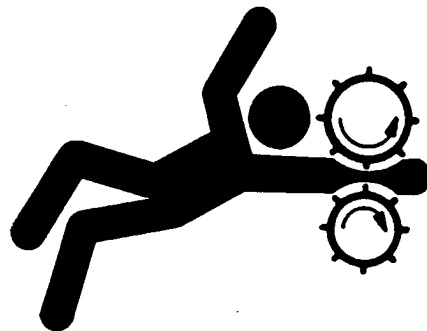

DX,LOOSE -19-04JUN90

TS228 -UN-23AUG88



### WORK IN VENTILATED AREA

Engine exhaust fumes can cause sickness or death. If it is necessary to run an engine in an enclosed area, remove the exhaust fumes from the area with an exhaust pipe extension.

If you do not have an exhaust pipe extension, open the doors and get outside air into the area.

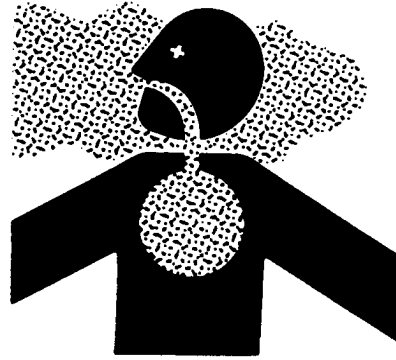

DX,AIR -19-04JUN90

TS220 -UN-23AUG88

### ILLUMINATE WORK AREA SAFELY

Illuminate your work area adequately but safely. Use a portable safety light for working inside or under the machine. Make sure the bulb is enclosed by a wire cage. The hot filament of an accidentally broken bulb can ignite spilled fuel or oil.

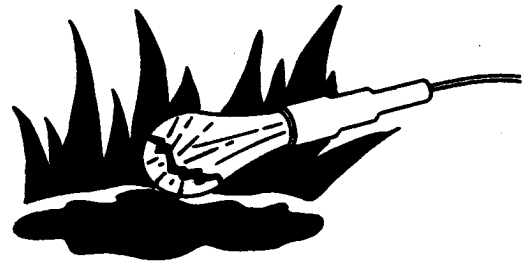

DX,LIGHT -19-04JUN90

TS223 -UN-23AUG88

### REPLACE SAFETY SIGNS

Replace missing or damaged safety signs. See the machine operator's manual for correct safety sign placement.



DX,SIGNS1 -19-04JUN90

TS201 -UN-23AUG88

### USE PROPER LIFTING EQUIPMENT

Lifting heavy components incorrectly can cause severe injury or machine damage.

Follow recommended procedure for removal and installation of components in the manual.

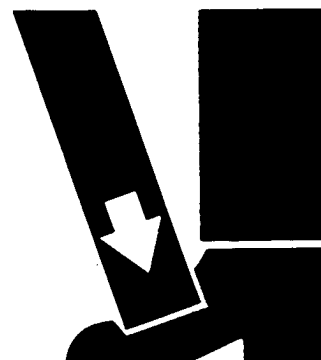

DX,LIFT -19-04JUN90

TS226 -UN-23AUG88

10  
05  
8

## REMOVE PAINT BEFORE WELDING OR HEATING

Avoid potentially toxic fumes and dust.

Hazardous fumes can be generated when paint is heated by welding, soldering, or using a torch.

Do all work outside or in a well ventilated area. Dispose of paint and solvent properly.

Remove paint before welding or heating:

- If you sand or grind paint, avoid breathing the dust. Wear an approved respirator.
- If you use solvent or paint stripper, remove stripper with soap and water before welding. Remove solvent or paint stripper containers and other flammable material from area. Allow fumes to disperse at least 15 minutes before welding or heating.

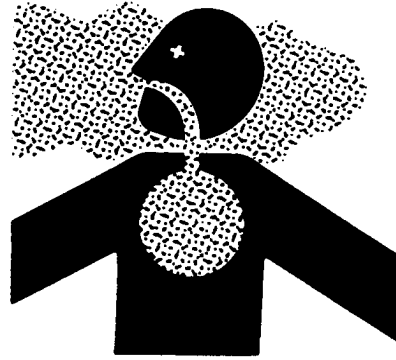

TS220 -UN-23AUG88

DX,PAINT -19-03MAR93

## AVOID HEATING NEAR PRESSURIZED FLUID LINES

Flammable spray can be generated by heating near pressurized fluid lines, resulting in severe burns to yourself and bystanders. Do not heat by welding, soldering, or using a torch near pressurized fluid lines or other flammable materials. Pressurized lines can be accidentally cut when heat goes beyond the immediate flame area.



TS953 -UN-15MAY90

DX,TORCH -19-03MAR93

## SERVICE TIRES SAFELY

Explosive separation of a tire and rim parts can cause serious injury or death.

Do not attempt to mount a tire unless you have the proper equipment and experience to perform the job.

Always maintain the correct tire pressure. Do not inflate the tires above the recommended pressure. Never weld or heat a wheel and tire assembly. The heat can cause an increase in air pressure resulting in a tire explosion. Welding can structurally weaken or deform the wheel.

When inflating tires, use a clip-on chuck and extension hose long enough to allow you to stand to one side and NOT in front of or over the tire assembly. Use a safety cage if available.

Check wheels for low pressure, cuts, bubbles, damaged rims or missing lug bolts and nuts.



DX,TIRECP -19-24AUG90

9510  
-UN-12APR90  
TS952

## AVOID HARMFUL ASBESTOS DUST

Avoid breathing dust that may be generated when handling components containing asbestos fibers. Inhaled asbestos fibers may cause lung cancer.

Components in products that may contain asbestos fibers are brake pads, brake band and lining assemblies, clutch plates, and some gaskets. The asbestos used in these components is usually found in a resin or sealed in some way. Normal handling is not hazardous as long as airborne dust containing asbestos is not generated.

Avoid creating dust. Never use compressed air for cleaning. Avoid brushing or grinding material containing asbestos. When servicing, wear an approved respirator. A special vacuum cleaner is recommended to clean asbestos. If not available, apply a mist of oil or water on the material containing asbestos.

Keep bystanders away from the area.

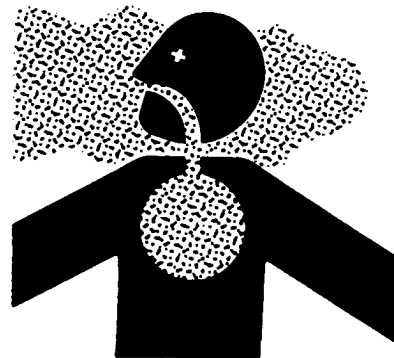

DX,DUST -19-15MAR91

-UN-23AUG88  
TS220

10  
05  
10

### PRACTICE SAFE MAINTENANCE

Understand service procedure before doing work. Keep area clean and dry.

Never lubricate, service, or adjust machine while it is moving. Keep hands, feet, and clothing from power-driven parts. Disengage all power and operate controls to relieve pressure. Lower equipment to the ground. Stop the engine. Remove the key. Allow machine to cool.

Securely support any machine elements that must be raised for service work.

Keep all parts in good condition and properly installed. Fix damage immediately. Replace worn or broken parts. Remove any buildup of grease, oil, or debris.

Disconnect battery ground cable (-) before making adjustments on electrical systems or welding on machine.



DX,SERV -19-03MAR93

TS218 -UN-23AUG88

### USE PROPER TOOLS

Use tools appropriate to the work. Makeshift tools and procedures can create safety hazards.

Use power tools only to loosen threaded parts and fasteners.

For loosening and tightening hardware, use the correct size tools. DO NOT use U.S. measurement tools on metric fasteners. Avoid bodily injury caused by slipping wrenches.

Use only service parts meeting John Deere specifications.



DX,REPAIR -19-04JUN90

TS779 -UN-08NOV89

## DISPOSE OF WASTE PROPERLY

Improperly disposing of waste can threaten the environment and ecology. Potentially harmful waste used with John Deere equipment include such items as oil, fuel, coolant, brake fluid, filters, and batteries.

Use leakproof containers when draining fluids. Do not use food or beverage containers that may mislead someone into drinking from them.

Do not pour waste onto the ground, down a drain, or into any water source.

Air conditioning refrigerants escaping into the air can damage the Earth's atmosphere. Government regulations may require a certified air conditioning service center to recover and recycle used air conditioning refrigerants.

Inquire on the proper way to recycle or dispose of waste from your local environmental or recycling center, or from your John Deere dealer.

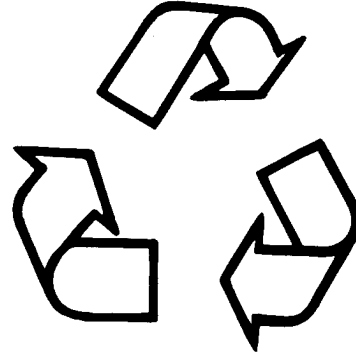

DX,DRAIN -19-03MAR93

10-05-11  
-JUN-26NOV90  
TS1133

## LIVE WITH SAFETY

Before returning machine to customer, make sure machine is functioning properly, especially the safety systems. Install all guards and shields.



DX,LIVE -19-25SEP92

-19-07OCT88  
TS231

10  
05  
12

**MACHINE SPECIFICATIONS—322 AND 330**

	322	330
<b>ENGINE</b>		
Manufacturer	Yanmar	Yanmar
Model Number	3TG66UJ	3TN66UJ
Horsepower (SAEJ1349)	13.4 kW (18 hp)	12 kW (16 hp)
Torque	4.2 kg m (30.3 ft lbs)	4.2 kg m (30.3 ft lbs)
<b>Engine Rated Speeds</b>		
Fast Idle (No Load)	3500 rpm	3450 rpm
Low Idle (No Load)	1300 rpm	1300 rpm
Number of Cylinders	3	3
Crankshaft Alignment	Horizontal	Horizontal
Stroke/Cycle	4 Cycle	4 Cycle
Bore	66 mm (2.6 in.)	66 mm (2.6 in.)
Stroke	64.2 mm (2.5 in.)	64.2 mm (2.5 in.)
Displacement	658 cm <sup>3</sup> (40.1 cu in.)	658 cm <sup>3</sup> (40.1 cu in.)
Compression Ratio	8.7:1	22.4:1
Cooling	Liquid	Liquid
Coolant Capacity	2.8 L (3 U.S. qt)	2.8 L (3 U.S. qt)
Air Filter Type	Dry with Primary and Secondary Elements	Dry with Primary and Secondary Elements
Lubrication System	Full Pressure w/Filter	Full Pressure w/Filter
Crankcase Capacity (w/o Filter)	2.5 L (2.6 U.S. qt)	2.5 L (2.6 U.S. qt)
Oil Filter	Replaceable	Replaceable
Spark Plugs	NGK BPR4BS Champion RN11YC	N/A
<b>FUEL SYSTEM</b>		
Fuel Tank Location	Rear	Rear
Fuel Gauge	Standard	Standard
Fuel Tank Capacity	17 L (4.5 U.S. gal)	17 L (4.5 U.S. gal)
Fuel	85 Octane Unleaded	No.1 or No.2 Diesel
Fuel Pump Location	Frame	Frame
Fuel Pump Type	Electric	Electric
Fuel Delivery	Fixed Jet Carburetor	Indirect Injection
Injection Pump Type	N/A	In-Line Multi-Plunger
Fuel Shutoff	Electric Solenoid	Manual
<b>ELECTRICAL SYSTEM</b>		
Ignition	Electronic	N/A
Type of Starter	12 Volts, Solenoid	12 Volts, Solenoid
Charging System	Remote Alt. 20 amp	Remote Alt. 20 amp
Battery Type	BCI Group, U1	BCI Group, U1
Battery Voltage	12V	12V
Battery Reserve Capacity @25 amp	44 minutes	44 minutes
<b>Battery</b>		
Cold Cranking amp @0°F	342 amp	342 amp
Headlights	Standard	Standard
Reflector/Tail Lights	Standard	Standard
Dash Indicator Lights	Standard	Standard
Operator Presence System	Standard	Standard
Hourmeter	Standard	Standard

*Continued on next page.*

MX,15911010,1 -19-13JUL95

General Specifications/Machine Specifications

10  
10  
2

	322	330
<b>POWER TRAIN</b>		
Transmission Type	Hydrostatic	Hydrostatic
Number of Speeds	Infinite	Infinite
<b>Travel Speeds</b>		
Forward	0—12.38 km/h (0—7.69 mph)	0—12.38 km/h (0—7.69 mph)
Reverse	0—6.19 km/h (0—3.85 mph)	0—6.19 km/h (0—3.85 mph)
Transmission Capacity (w/Filter)	6.1 L (13 U.S. pt)	6.1 L (13 U.S. pt)
Trans. Oil Cooler	Optional	N/A
Trans. Oil Filter	Standard	Standard
Differential Lock	N/A	N/A
<b>STEERING</b>		
Type	Power, Hydrostatic	Manual
<b>BRAKES</b>		
Location	Rear Wheels	Rear Wheels
Individual Control	Standard	N/A
Type	Shoe and Drum	Shoe and Drum
Return-to-Neutral Braking	Standard	Standard
Parking	Yes	Yes
<b>HYRAULIC SYSTEM</b>		
Type	Two-Function (One w/Float)	Single-Function
Hydraulic Couplers	Two Sets	One Set
<b>PTO</b>		
Front	Standard	Standard
Rear	Optional	Optional
Type	Electric Clutch	Electric Clutch
Control	Elec. Switch on Dash	Elec. Switch on Dash
<b>PTO rpm (No Load)</b>		
Front	3500	3450
Rear	2000	2000
<b>MOWER ATTACHMENT</b>		
Compatibility	38, 46 and 50 Inch	38, 46 and 50 Inch
Lift System	Hydraulic	Hydraulic
<b>WHEEL TREAD</b>		
Front	813 mm (32 in.)	813 mm (32 in.)
<b>Rear</b>		
Narrow	775 mm (30.5 in.)	775 mm (30.5 in.)
Wide	834 mm (32.8 in.)	834 mm (32.8 in.)

Continued on next page.

MX,15911010,2 -19-13JUL95



*General Specifications/Machine Specifications*

10  
10  
3

	322	330
<b>TIRES</b>		
Standard Tires		
Front Turf . . . . .	16 x 6.50-8, 2 PR . . . . .	16 x 6.50-8, 2 PR
Rear Turf or Bar . . . . .	23 x 10.50-12, 2 PR . . . . .	23 x 10.50-12, 2 PR
Optional Tires		
Front (Turf) . . . . .	16 x 6.50-8, 4 PR . . . . .	16 x 6.50-8, 4 PR
Rear (Turf or Bar) . . . . .	23 x 8.50-12, 2 PR . . . . .	23 x 8.50-12, 2 PR
Inflation Pressure		
Front . . . . .	41—110 kPa (6—16 psi) . . . . .	41—110 kPa (6—16 psi)
Rear . . . . .	34—69 kPa (5—10 psi) . . . . .	34—69 kPa (5—10 psi)
<b>SEAT</b>		
Style . . . . .	High-Back . . . . .	High-Back
Suspension . . . . .	2 Spring . . . . .	2 Spring
Adjustment . . . . .	Slide Rail . . . . .	Slide Rail
<b>DIMENSIONS</b>		
Wheel Base . . . . .	1.2 m (46 in.) . . . . .	1.2 m (46 in.)
Overall Length . . . . .	1.8 m (69.5 in.) . . . . .	1.8 m (69.5 in.)
Overall Height . . . . .	1.1 m (44.5 in.) . . . . .	1.1 m (44.5 in.)
Overall Width (max.) . . . . .	1.1 m (43.3 in.) . . . . .	1.1 m (43.3 in.)
Overall Width (min.) . . . . .	1.04 m (41 in.) . . . . .	1.04 m (41 in.)
Turning Radius		
Inside Rear Wheel . . . . .	0.66 m (26 in.) . . . . .	0.66 m (26 in.)
Outside Front Wheel . . . . .	2.0 m (80 in.) . . . . .	2.0 m (80 in.)
NET WEIGHT (No Fuel) . . . . .	408 kg (900 lbs) . . . . .	408 kg (900 lbs)
SHIPPING WEIGHT . . . . .	445 kg (980 lbs) . . . . .	445 kg (980 lbs)

*(Specifications and design subject to change without notice.)*

MX,15911010,3 -19-13JUL95

## MACHINE SPECIFICATIONS—332 AND 430

	332	430
<b>ENGINE</b>		
Manufacturer	Yanmar	Yanmar
Model Number	3TN66UJ	3TNA72UJ
Horsepower (SAEJ1349)	12 kW (16 hp)	15 kW (20 hp)
Torque	4.2 kg m (30.3 ft lbs)	5.1 kg m (36.8 ft lbs)
<b>Engine Rated Speeds</b>		
Fast Idle (No Load)	3425 rpm	3400 rpm
Low Idle (No Load)	1400 rpm	1300 rpm
Number of Cylinders	3	3
Crankshaft Alignment	Horizontal	Horizontal
Stroke/Cycle	4 Cycle	4 Cycle
Bore	66 mm (2.6 in.)	72 mm (2.84 in.)
Stroke	64.2 mm (2.5 in.)	72 mm (2.84 in.)
Displacement	658 cm <sup>3</sup> (40.1 cu in.)	879 cm <sup>3</sup> (53.6 cu in.)
Compression Ratio	22.4:1	21.6:1
Cooling	Liquid	Liquid
Coolant Capacity	2.8 L (3 U.S. qt)	3.8 L (1 U.S. gal)
Air Filter Type	Dry with Primary and Secondary Elements	Dry with Primary and Secondary Elements
Lubrication System	Full Pressure w/Filter	Full Pressure w/Filter
Crankcase Capacity (w/o Filter)	2.5 L (2.6 U.S. qt)	2.9 L (3.1 U.S. qt)
Oil Filter	Replaceable	Replaceable
<b>FUEL SYSTEM</b>		
Fuel Tank Location	Rear	Rear
Fuel Gauge	Standard	Standard
Fuel Tank Capacity	17 L (4.5 U.S. gal)	24.6 L (6.5 U.S. gal)
Fuel	No.1 or No.2 Diesel	No.1 or No.2 Diesel
Fuel Pump Location	Frame	Frame
Fuel Pump Type	Electric	Electric
Fuel Delivery	Indirect Injection	Indirect Injection
Injection Pump Type	In-Line Multi-Plunger	In-Line Multi-Plunger
Fuel Shutoff	Electric Solenoid	Electric Solenoid
<b>ELECTRICAL SYSTEM</b>		
Ignition	N/A	N/A
Type of Starter	12 Volts, Solenoid	12 Volts, Solenoid
<b>Charging System</b>		
Early Machines	Remote Alt. 20 amp	Remote Alt. 35 amp
Later Machines	Remote Alt. 20 amp	Remote Alt. 40 amp
Battery Type	BCI Group, U1	BCI Group, 22F
Battery Voltage	12V	12V
Battery Reserve Capacity @25 amp	44 minutes	102 minutes
<b>Battery</b>		
Cold Cranking amp @0°F	342 amp	491 amp
Headlights	Standard	Standard
Reflector/Tail Lights	Standard	Standard
Dash Indicator Lights	Standard	Standard
Operator Presence System	Standard	Standard
Hourmeter	Standard	Standard

Continued on next page.

MX,15911010,4 -19-13JUL95

General Specifications/Machine Specifications

	332	430
<b>POWER TRAIN</b>		
Transmission Type	Hydrostatic	Hydrostatic, 2 Ranges
Number of Speeds	Infinite	Infinite
<b>Travel Speeds</b>		
Forward	0—12.38 km/h (0—7.69 mph)	N/A
Reverse	0—6.19 km/h (0—3.85 mph)	N/A
Forward, High	N/A	0—16.09 km/h (0—10 mph)
Forward, Low	N/A	0—9.35 km/h (0—5.80 mph)
Reverse, High	N/A	0—6.44 km/h (0—4 mph)
Reverse, Low	N/A	0—4.66 km/h (0—2.90 mph)
Transmission Capacity (w/Filter)	6.1 L (13 U.S. pt)	7.1 L (15 U.S. pt)
Trans. Oil Cooler	Optional	Standard
Trans. Oil Filter	Standard	Standard
Differential Lock	N/A	Standard
<b>STEERING</b>		
Type	Power, Hydrostatic	Power, Hydrostatic
<b>BRAKES</b>		
Location	Rear Wheels	Rear Wheels
Individual Control	Standard	Standard
Type	Shoe and Drum	Shoe and Drum
Return-to-Neutral Braking	Standard	Standard
Parking	Yes	Yes
<b>HYDRAULIC SYSTEM</b>		
Type	Two-Function (One w/Float)	Three-Function (One w/Float)
Hydraulic Couplers	Two Sets	Two Sets
<b>PTO</b>		
Front	Standard	Standard
Rear	Optional	Optional
Type	Electric Clutch	Electric Clutch
Control	Elec. Switch on Dash	Elec. Switch on Dash
<b>PTO rpm (No Load)</b>		
Front	3425	3400
Rear	2000	2000
<b>MOWER ATTACHMENT</b>		
Compatibility	38, 46 and 50 Inch	50 and 60 Inch, 260 Rotary
Lift System	Hydraulic	Hydraulic

Continued on next page.

MX,15911010,5 -19-13JUL95

10  
10  
5

General Specifications/Machine Specifications

10-10-6

332

430

**WHEEL TREAD**

Front	813 mm (32 in.)	914 mm (36 in.)
Rear		
Narrow	775 mm (30.5 in.)	818 mm (32 in.)
Wide	834 mm (32.8 in.)	980 mm (38.6 in.)

**TIRES**

**Standard Tires**

Front Turf	16 x 6.50-8, 2 PR	18 x 8.50-8, 4 PR
Rear Turf or Bar	23 x 10.50-12, 2 PR	26 x 12.00-12, 2 PR

**Optional Tires**

Front (Turf)	16 x 6.50-8, 4 PR	N/A
Rear (Turf or Bar)	23 x 8.50-12, 2 PR	N/A

**Inflation Pressure**

Front	41—110 kPa (6—16 psi)	41—152 kPa (6—22 psi)
Rear	34—69 kPa (5—10 psi)	34—69 kPa (5—10 psi)

**SEAT**

Style	High-Back/Tilt	High-Back/Tilt
Suspension	2 Spring	Deluxe Seat Suspension
Adjustment	Slide Rail	Slide Rail

**DIMENSIONS**

Wheel Base	1.2 m (46 in.)	1.3 m (52 in.)
Overall Length	1.8 m (69.5 in.)	2.13 m (84 in.)
Overall Height	1.1 m (44.5 in.)	1.22 m (48.5 in.)
Overall Width (max.)	1.1 m (43.3 in.)	1.31 m (51.5 in.)
Overall Width (min.)	1.04 m (41 in.)	1.14 m (45 in.)
Turning Radius		
Inside Rear Wheel	0.66 m (26 in.)	0.66 m (26 in.)
Outside Front Wheel	2.0 m (80 in.)	2.2 m (86 in.)

**NET WEIGHT (No Fuel)** . . . . . 408 kg (900 lbs) . . . . . 533 kg (1116 lbs)

**SHIPPING WEIGHT** . . . . . 445 kg (980 lbs) . . . . . 567 kg (1219 lbs)

*(Specifications and design subject to change without notice.)*

MX,15911010,6 -19-13JUL95

**REPAIR SPECIFICATIONS**

Item	Specifications
<b>ENGINE</b>	
For all repair specifications—Use CTM12 (322) and CTM3 (330, 332 and 430)	
Engine Mounting Cap Screw/Nut Torque . . . . .	49 N·m (36 lb-ft)
Drive Shaft to Engine Cap Screw Torque	
330 and 430 . . . . .	27 N·m (20 lb-ft)
322 and 332 . . . . .	37 N·m (27 lb-ft)
Drive Shaft Universal Joint Cap Screw Torque . . . . .	60 N·m (45 lb-ft)
PTO Belt Tension Spring Length (430) . . . . .	35 mm (1.38 in.)
Fuel/Water Separator Cap Screw Torque (430) . . . . .	20 N·m (180 lb-in.)
<b>ELECTRICAL</b>	
Front PTO Clutch-to-Crankshaft Cap Screw Torque . . . . .	47 N·m (35 lb-ft)
PTO Clutch Armature to Rotor Clearance . . . . .	0.46 mm (0.018 in.)
PTO Belt Tension Spring Length (430) . . . . .	35 mm (1.380 in.)
<b>POWER TRAIN</b>	
<b>Transmission</b>	
Charge Pump-to-Transmission Cap Screw Torque . . . . .	70 N·m (52 lb-ft)
Transmission Cover Bearing Installation Height . . . . .	3 mm (0.118 in.) above housing surface
Center Section-to-Housing Cap Screw Torque . . . . .	35 N·m (26 lb-ft)
Transmission-to-Differential Cap Screw Torque . . . . .	45 N·m (33 lb-ft)
Axle Housing-to-Frame Cap Screw Torque . . . . .	100 N·m (75 lb-ft)
Brake Rod Spring Length . . . . .	42 mm (1.650 in.)
Differential-to-Frame Support Cap Screw Torque . . . . .	61 N·m (45 lb-ft)
Swashplate Control Arm-to-Control Shaft Nut Torque . . . . .	60 N·m (44 lb-ft)
Drive Shaft Clamping Yoke-to-Transmission Pump Shaft Cap Screw Torque . . . . .	60 N·m (44 lb-ft)
<b>Differential</b>	
Case and Cover Oil Groove Depth (Minimum) . . . . .	0.25 mm (0.010 in.)
Carrier Cap Screw Torque . . . . .	53 N·m (39 lb-ft)
Cover-to-Case Cap Screw Torque . . . . .	23 N·m (204 lb-in.)
<b>Axle Housing</b>	
Differential Seal Depth . . . . .	3 mm (0.118 in.) below differential surface
Axle Housing-to-Differential Cap Screw Torque . . . . .	81 N·m (60 lb-ft)
Brake Plate-to-Axle Housing Cap Screw Torque . . . . .	68 N·m (50 lb-ft)
Axle Housing-to-Frame Cap Screw Torque . . . . .	100 N·m (75 lb-ft)
Brake Rod Spring Length . . . . .	42 mm (1.650 in.)
Brake Drum Nut Torque . . . . .	88 N·m (65 lb-ft)
Rear Wheel Cap Screw Torque . . . . .	70 N·m (52 lb-ft)
<b>Drive Shaft—322 and 332</b>	
Isolator-to-Engine Cap Screw Torque . . . . .	37 N·m (27 lb-ft)
<b>Drive Shaft Cap Screws and Lock Nut Torque</b>	
Flange-to-Isolator . . . . .	27 N·m (20 lb-ft)
Clamping Yoke-to-Transmission Pump Shaft . . . . .	60 N·m (44 lb-ft)
<b>Drive Shaft—330</b>	
Isolator-to-Engine Cap Screw Torque . . . . .	27 N·m (20 lb-ft)
<b>Drive Shaft Cap Screws and Lock Nut Torque</b>	
Flange-to-Isolator . . . . .	27 N·m (20 lb-ft)
Clamping Yoke-to-Transmission Pump Shaft . . . . .	60 N·m (44 lb-ft)

Continued on next page.

MX,15911015,1 -19-13JUL95

10  
15  
2

Item	Specifications
<b>POWER TRAIN, continued</b>	
<b>Drive Shaft—430</b>	
Flange-to-Engine Cap Screw Torque . . . . .	27 N·m (20 lb-ft)
Clamping Yoke-to-Transmission Pump Shaft Cap Screw Torque . . . . .	60 N·m (44 lb-ft)
Tube Yoke Shaft-to-Bushing Yoke Tube Lock Nut Torque . . . . .	3 N·m (25 lb-in.)
<b>STEERING AND BRAKES</b>	
<b>Steering—330</b>	
Gearbox Mounting Cap Screw Torque . . . . .	95 N·m (70 lb-ft)
Steering Wheel-to-Shaft Nut Torque . . . . .	15 N·m (133 lb-in.)
Pitman Arm Nut Torque . . . . .	224 N·m (165 lb-ft)
Preload Adjuster Maximum End Clearance . . . . .	0.05 mm (0.002 in.)
Side Cover-to-Gearbox Housing Cap Screw Torque . . . . .	40 N·m (30 lb-ft)
Worm Bearing Preload Rolling Torque . . . . .	0.60—1.0 N·m (5—8 lb-in.)
Over-Center Preload Rolling Torque . . . . .	0.50—1.20 N·m (4—10 lb-in.)
Preload Adjuster Lock Nut Torque . . . . .	34 N·m (25 lb-ft)
Steering Shaft Universal Joint-to-Worm Shaft Cap Screw Torque . . . . .	24 N·m (212 lb-in.)
<b>Steering—322, 332 and 430</b>	
Steering Wheel-to-Shaft Nut Torque . . . . .	15 N·m (133 lb-in.)
Rotor-to-Stator Maximum Allowable Clearance . . . . .	0.08 mm (0.003 in.)
Steering Tube Bushing Depth . . . . .	2.5 mm (0.100 in.) below top of tube
Commutator Cover-to-Commutator Screw Torque . . . . .	1.4 N·m (12 lb-in.)
Port Cover Nut Torque . . . . .	30 N·m (22 lb-ft)
Check Ball Plug Torque (Early Version) . . . . .	14 N·m (124 lb-in.)
Steering Cylinder Mounting Nut Torque . . . . .	163 N·m (120 lb-ft)
<b>Brakes</b>	
Brake Plate-to-Axle Housing Cap Screw Torque . . . . .	68 N·m (50 lb-ft)
Axle Housing-to-Frame Cap Screw Torque . . . . .	100 N·m (75 lb-ft)
Brake Rod Spring Length . . . . .	42 mm (1.650 in.)
Brake Drum-to-Axle Nut Torque . . . . .	88 N·m (65 lb-ft)
Rear Wheel Cap Screw Torque . . . . .	70 N·m (52 lb-ft)
<b>HYDRAULICS</b>	
<b>Single-Spool Valve</b>	
Spool Screw Torque . . . . .	4 N·m (35 lb-in.)
Spool Cap-to-Body Screw Torque . . . . .	4 N·m (35 lb-in.)
Check Valve Plug Torque . . . . .	31 N·m (23 lb-ft)
<b>Two-Spool Valve</b>	
<b>Versions One and Two</b>	
Spool Cap-to-Body Screw Torque . . . . .	31 N·m (23 lb-ft)
<b>Versions Three and Four</b>	
Spool Screw and Detent Torque . . . . .	4 N·m (35 lb-in.)
Spool Cap-to-Body Screw Torque . . . . .	4 N·m (35 lb-in.)
Check Valve Plug Torque . . . . .	31 N·m (23 lb-ft)
<b>Three-Spool Valve</b>	
Spool Screws and Detent Torque . . . . .	4 N·m (35 lb-in.)
Spool Cap-to-Body Screw Torque . . . . .	4 N·m (35 lb-in.)
Check Valve Plug Torque . . . . .	31 N·m (23 lb-ft)

Continued on next page.

MX,15911015,2 -19-13JUL95

Item	Specifications
<b>MISCELLANEOUS</b>	
<b>Front Axle</b>	
PTO Belt Tension Spring Length (430) .....	35 mm (1.380 in.)
Toe-In .....	4.8 mm (3/16 in.)
<b>Mower Blade Spindles</b>	
Driven Sheave-to-Spindle Lock Nut Torque .....	140 N·m (103 lb-ft)
Blade-to-Spindle Cap Screw Torque .....	73 N·m (54 lb-ft)
<b>Mower Blade Jack Sheave</b>	
Jack Sheave-to-Spindle Lock Nut Torque .....	140 N·m (103 lb-ft)
Blade-to-Spindle Cap Screw Torque .....	73 N·m (54 lb-ft)
<b>50-Inch Mower Gear Case</b>	
Plug Installation Depth .....	1.59 mm (0.062 in.) below gear case surface
Retainer Seal Installation Depth .....	2.54 mm (0.100 in.) below retainer surface
Retainer-to-Gear Case Cap Screw Torque .....	30 N·m (22 lb-ft)
Pillow Block Seal Installation Depth .....	2.54 mm (0.100 in.) below block surface
Pillow Block-to-Gear Case Cap Screw Torque .....	30 N·m (22 lb-ft)
<b>Early 60-Inch Mower Gear Case</b>	
Cap-to-Gear Case Cap Screw Torque .....	30 N·m (22 lb-ft)
Output Shaft Endplay .....	0.025—0.076 mm (0.001—0.003 in.)
Input Shaft Backlash .....	0.076—0.130 mm (0.003—0.005 in.)
<b>Later 60-Inch Mower Gear Case</b>	
Gear Case Seal Installation Depth .....	2.54 mm (0.100 in.) below gear case surface
Retainer-to-Gear Case Cap Screw Torque .....	30 N·m (22 lb-ft)
Pillow Block Seal Installation Depth .....	2.54 mm (0.100 in.) below block surface
Pillow Block-to-Gear Case Cap Screw Torque .....	30 N·m (22 lb-ft)
<b>260 Rotary Mower Gear Case</b>	
End Cap-to-Gear Case Cap Screw Torque .....	30 N·m (22 lb-ft)
Input Shaft Endplay .....	0.025—0.076 mm (0.001—0.003 in.)
Output Shaft Backlash .....	0.076—0.130 mm (0.003—0.005 in.)
Housing-to-Gear Case Cap Screw Torque .....	30 N·m (22 lb-ft)

MX,15911015,3 -19-13JUL95

**METRIC BOLT AND CAP SCREW TORQUE VALUES**

10  
15  
4

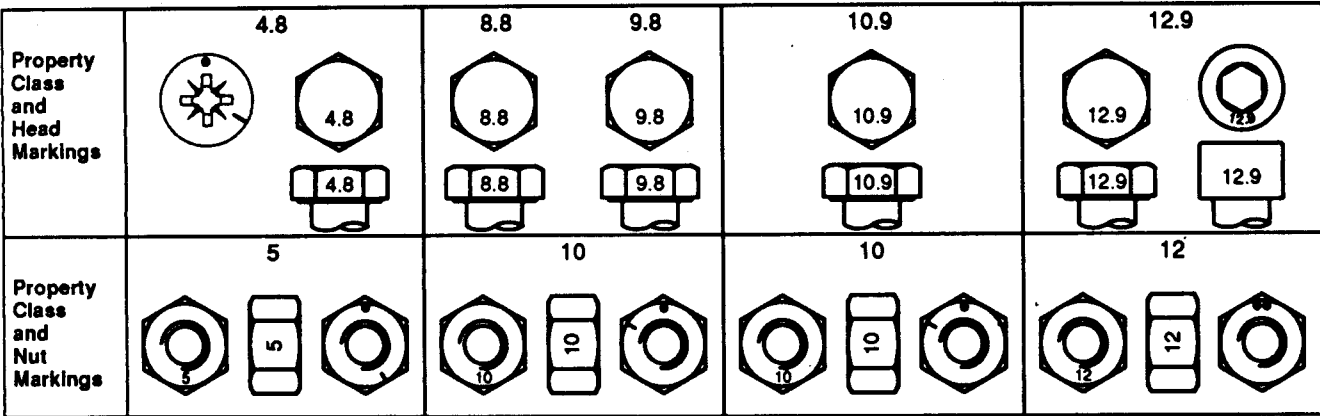

TS1163 -19-04/MAR91

Size	Class 4.8				Class 8.8 or 9.8				Class 10.9				Class 12.9			
	Lubricated <sup>a</sup>		Dry <sup>a</sup>		Lubricated <sup>a</sup>		Dry <sup>a</sup>		Lubricated <sup>a</sup>		Dry <sup>a</sup>		Lubricated <sup>a</sup>		Dry <sup>a</sup>	
	N-m	lb-ft	N-m	lb-ft	N-m	lb-ft	N-m	lb-ft	N-m	lb-ft	N-m	lb-ft	N-m	lb-ft	N-m	lb-ft
M6	4.8	3.5	6	4.5	9	6.5	11	8.5	13	9.5	17	12	15	11.5	19	14.5
M8	12	8.5	15	11	22	16	28	20	32	24	40	30	37	28	47	35
M10	23	17	29	21	43	32	55	40	63	47	80	60	75	55	95	70
M12	40	29	50	37	75	55	95	70	110	80	140	105	130	95	165	120
M14	63	47	80	60	120	88	150	110	175	130	225	165	205	150	260	190
M16	100	73	125	92	190	140	240	175	275	200	350	255	320	240	400	300
M18	135	100	175	125	260	195	330	250	375	275	475	350	440	325	560	410
M20	190	140	240	180	375	275	475	350	530	400	675	500	625	460	800	580
M22	260	190	330	250	510	375	650	475	725	540	925	675	850	625	1075	800
M24	330	250	425	310	650	475	825	600	925	675	1150	850	1075	800	1350	1000
M27	490	360	625	450	950	700	1200	875	1350	1000	1700	1250	1600	1150	2000	1500
M30	675	490	850	625	1300	950	1650	1200	1850	1350	2300	1700	2150	1600	2700	2000
M33	900	675	1150	850	1750	1300	2200	1650	2500	1850	3150	2350	2900	2150	3700	2750
M36	1150	850	1450	1075	2250	1650	2850	2100	3200	2350	4050	3000	3750	2750	4750	3500

DO NOT use these values if a different torque value or tightening procedure is given for a specific application. Torque values listed are for general use only. Check tightness of fasteners periodically.

Shear bolts are designed to fail under predetermined loads. Always replace shear bolts with identical property class.

Fasteners should be replaced with the same or higher property class. If higher property class fasteners are used, these should only be tightened to the strength of the original.

<sup>a</sup> "Lubricated" means coated with a lubricant such as engine oil, or fasteners with phosphate and oil coatings. "Dry" means plain or zinc plated without any lubrication.

Make sure fasteners threads are clean and that you properly start thread engagement. This will prevent them from failing when tightening.

Tighten plastic insert or crimped steel-type lock nuts to approximately 50 percent of the dry torque shown in the chart, applied to the nut, not to the bolt head. Tighten toothed or serrated-type lock nuts to the full torque value.



**UNIFIED INCH BOLT AND CAP SCREW TORQUE VALUES**

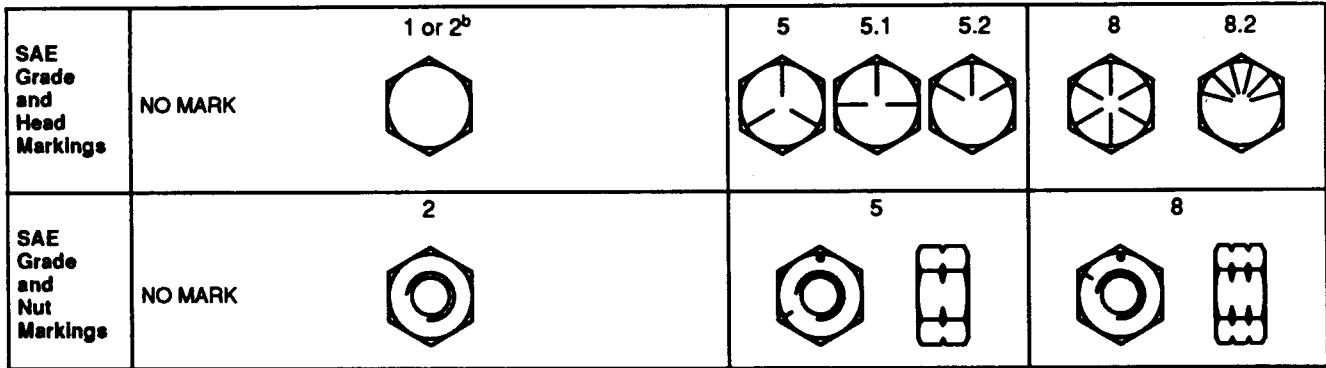

Size	Grade 1				Grade 2 <sup>b</sup>				Grade 5, 5.1, or 5.2				Grade 8 or 8.2			
	Lubricated <sup>a</sup>		Dry <sup>a</sup>		Lubricated <sup>a</sup>		Dry <sup>a</sup>		Lubricated <sup>a</sup>		Dry <sup>a</sup>		Lubricated <sup>a</sup>		Dry <sup>a</sup>	
	N-m	lb-ft	N-m	lb-ft	N-m	lb-ft	N-m	lb-ft	N-m	lb-ft	N-m	lb-ft	N-m	lb-ft	N-m	lb-ft
1/4	3.7	2.8	4.7	3.5	6	4.5	7.5	5.5	9.5	7	12	9	13.5	10	17	12.5
5/16	7.7	5.5	10	7	12	9	15	11	20	15	25	18	28	21	35	26
3/8	14	10	17	13	22	16	27	20	35	26	44	33	50	36	63	46
7/16	22	16	28	20	35	26	44	32	55	41	70	52	80	58	100	75
1/2	33	25	42	31	53	39	67	50	85	63	110	80	120	90	150	115
9/16	48	36	60	45	75	56	95	70	125	90	155	115	175	130	225	160
5/8	67	50	85	62	105	78	135	100	170	125	215	160	240	175	300	225
3/4	120	87	150	110	190	140	240	175	300	225	375	280	425	310	550	400
7/8	190	140	240	175	190	140	240	175	490	360	625	450	700	500	875	650
1	290	210	360	270	290	210	360	270	725	540	925	675	1050	750	1300	975
1-1/8	400	300	510	375	400	300	510	375	900	675	1150	850	1450	1075	1850	1350
1-1/4	570	425	725	530	570	425	725	530	1300	950	1650	1200	2050	1500	2600	1950
1-3/8	750	550	950	700	750	550	950	700	1700	1250	2150	1550	2700	2000	3400	2550
1-1/2	1000	725	1250	925	990	725	1250	930	2250	1650	2850	2100	3600	2650	4550	3350

DO NOT use these values if a different torque value or tightening procedure is given for a specific application. Torque values listed are for general use only. Check tightness of fasteners periodically.

Fasteners should be replaced with the same or higher grade. If higher grade fasteners are used, these should only be tightened to the strength of the original.

Shear bolts are designed to fail under predetermined loads. Always replace shear bolts with identical grade.

Make sure fasteners threads are clean and that you properly start thread engagement. This will prevent them from failing when tightening.

Tighten plastic insert or crimped steel-type lock nuts to approximately 50 percent of the dry torque shown in the chart, applied to the nut, not to the bolt head. Tighten toothed or serrated-type lock nuts to the full torque value.

<sup>a</sup> "Lubricated" means coated with a lubricant such as engine oil, or fasteners with phosphate and oil coatings. "Dry" means plain or zinc plated without any lubrication.

<sup>b</sup> Grade 2 applies for hex cap screws (not hex bolts) up to 152 mm (6-in.) long. Grade 1 applies for hex cap screws over 152 mm (6-in.) long, and for all other types of bolts and screws of any length.

10 5 15 19-04/MAR91 TS1162

**METRIC CAP SCREW TORQUE  
VALUES—GRADE 7**

*NOTE: When bolting aluminum parts, tighten to 80% of torque specified in table.*

Size	N-m	(lb-ft)
M6	9.5 - 12.2	(7-9)
M8	20.3 - 27.1	(15-20)
M10	47.5 - 54.2	(35-40)
M12	81.4 - 94.9	(60-70)
M14	128.8 - 146.4	(95-108)
M16	210.2 - 240	(155-177)

MX,15901015,3 -19-01MAR95

**SET SCREW SEATING TORQUE CHART**

Screw Size	Cup Point	Square Head
Torque in Inch Pounds		
#5	(1.02 N-m) 9	—
#6	(1.02 N-m) 9	—
#8	(2.26 N-m) 20	—
#10	(3.73 N-m) 33	—
1/4	(9.83 N-m) 87	(23.96 N-m) 212
5/16	(18.65 N-m) 165	(47.46 N-m) 420
3/8	(32.77 N-m) 290	(93.79 N-m) 830
7/16	(48.59 N-m) 430	—
1/2	(70.06 N-m) 620	(237.30 N-m) 2100
9/16	(70.06 N-m) 620	—
5/8	(138.43 N-m) 1225	(480.25 N-m) 4250
3/4	(240.13 N-m) 2125	(870.10 N-m) 7700

*NOTE: Allow a tolerance of plus or minus 10 per cent on all torques given in this chart.*

*Divide readings by 12 for foot-pound values.*

MX,TORQ,SET -19-09DEC94

M77900 -19-15DEC94

## SERVICE RECOMMENDATIONS FOR O-RING BOSS FITTINGS

### STRAIGHT FITTING

1. Inspect O-ring boss seat for dirt or defects.
2. Lubricate O-ring with petroleum jelly. Place electrical tape over threads to protect O-ring. Slide O-ring over tape and into O-ring groove of fitting. Remove tape.
3. Tighten fitting to torque value shown on chart.

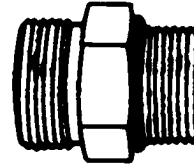

### ANGLE FITTING

1. Back-off lock nut (A) and back-up washer (B) completely to head-end (C) of fitting.
2. Turn fitting into threaded boss until back-up washer contacts face of boss.
3. Turn fitting head-end counterclockwise to proper index (maximum of one turn).
4. Hold fitting head-end with a wrench and tighten locknut and back-up washer to proper torque value.

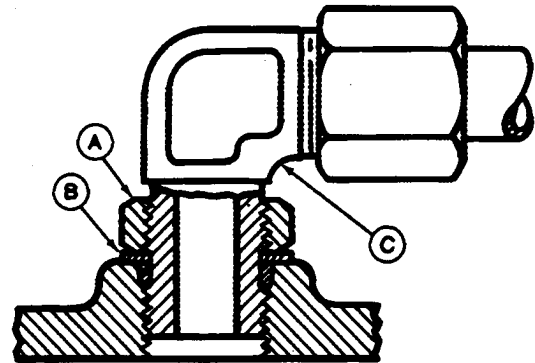

*NOTE: Do not allow hoses to twist when tightening fittings.*

### TORQUE VALUE

Thread Size	N-m	lb-ft
3/8-24 UNF	8	6
7/16-20 UNF	12	9
1/2-20 UNF	16	12
9/16-18 UNF	24	18
3/4-16 UNF	46	34
7/8-14 UNF	62	46
1-1/16-12 UN	102	75
1-3/16-12 UN	122	90
1-5/16-12 UN	142	105
1-5/8-12 UN	190	140
1-7/8-12 UN	217	160

*NOTE: Torque tolerance is  $\pm 10\%$ .*

MX,159110153,A -19-13JUL95

10  
15  
7  
-UN-18OCT88  
T6249AE  
-UN-18OCT88  
T6520AB

## SERVICE RECOMMENDATIONS FOR FLAT FACE O-RING SEAL FITTINGS

1. Inspect the fitting sealing surfaces. They must be free of dirt or defects.
2. Inspect the O-ring. It must be free of damage or defects.
3. Lubricate O-rings and install into groove using petroleum jelly to hold in place.
4. Push O-ring into the groove with plenty of petroleum jelly so O-ring is not displaced during assembly.
5. Index angle fittings and tighten by hand pressing joint together to insure O-ring remains in place.
6. Tighten fitting or nut to torque valve shown on the chart per dash size stamped on the fitting. Do not allow hoses to twist when tightening fittings.

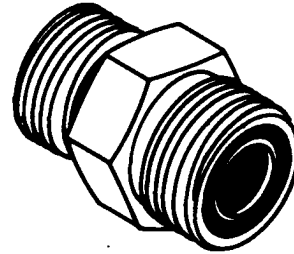

T6249AD -JUN-18OCT88

FLAT FACE O-RING SEAL FITTING TORQUE

Nominal Tube mm	O.D. (in.)	Dash Size	Thread Size In.	Swivel Nut Torque		Bulkhead Nut Torque	
				N-m	(lb-ft)	N-m	(lb-ft)
6.35	0.250	-4	9/16-18	16	12	5.0	3.5
9.52	0.375	-6	11/16-16	24	18	9.0	6.5
12.70	0.500	-8	13/16-16	50	37	17.0	12.5
15.88	0.625	-10	1-14	69	51	17.0	12.5
19.05	0.750	-12	1 3/16-12	102	75	17.0	12.5
22.22	0.875	-14	1 3/16-12	102	75	17.0	12.5
25.40	1.000	-16	1 7/16-12	142	105	17.0	12.5
31.75	1.250	-20	1 11/16-12	190	140	17.0	12.5
38.10	1.500	-24	2-12	217	160	17.0	12.5

NOTE: Torque tolerance is +15 -20%.

OR,SEAL,FIT -19-03MAR89

## **TUBE AND HOSE FITTING, 37° FLARE AND 30° CONE SEAT CONNECTOR SERVICE RECOMMENDATIONS**

1. Inspect the flare and the flare seat. They must be free of dirt and defects. If repeated leaks occur, inspect for defects with a magnifying glass. If burrs and raised nicks on the connector body cannot be removed with a slip stone, replace the connector.
2. Defects in the tube flare cannot be repaired. Replace the tube. Overtightening a defective flared fitting will not stop leaks.
3. As a field repair, a ductile truncated cone shaped washer can be used between the tube flare and connector body. These washers are soft enough to fill defects in the seat and flare. They will also seal the connection. Ductile washers are available from industrial supply houses.
4. Align the tube with the fitting before attempting to start the nut. Failure to do so can cause a deformed flare and subsequent leaks. Install hoses without twists. A twisted hose attempts to straighten out when pressure is applied. This exerts a torque on the connection, eventually causing failure.
5. Lubricate the connection with hydraulic fluid, petroleum jelly or soap. Tighten the swivel nut by hand until it is snug.
6. Mark a line across the nut and connector body. This line will serve as a visual indicator as to whether the nut has been tightened and by how much.
7. Using two wrenches, one on the connector body and a torque wrench on the nut, tighten the nut to the torque value as shown in the chart. In the case of a hose, it may be necessary to use three wrenches to prevent twisting.

MX,15901015,4 -19-17JAN95

10  
15  
9

TUBE AND HOSE FITTING, 37° FLARE AND 30° CONE SEAT CONNECTOR TORQUE

Thread Size	N·m	Torque <sup>1</sup> (lb-ft)	New <sup>2</sup> Number of Flats	Used <sup>3</sup> Number of Flats
3/8-24 UNF	8	(6)	2-1/2	1
7/16-20 UNF	12	(9)	2-1/2	1
1/2-20 UNF	16	(12)	2-1/2	1
9/16-18 UNF	24	(18)	2	1
3/4-16 UNF	46	(34)	2	1
7/8-14 UNF	62	(46)	1-1/2	1
1-1/16-12 UN	102	(75)	1	3/4
1-3/16-12 UN	122	(90)	1	3/4
1-5/16-12 UN	142	(105)	3/4	3/4
1-5/8-12 UN	190	(140)	3/4	3/4
1-7/8-12 UN	217	(160)	1/2	1/2

1. Tolerance of ± 10 percent.

2. To be used if a torque wrench cannot be used. After tightening fitting by hand, put a mark across the fittings, then tighten fitting the number of flats shown.

3. Flare connection seal by deforming or squeezing the tube between the nut and the connector. More deformation is possible with new parts than with old. Therefore, if a torque wrench is not used for re-assembly, the values in this column must be used to prevent damage.

MX,15901015,5 -19-17JAN95

**TEST AND ADJUSTMENT SPECIFICATIONS**

Item	Specifications
<b>ENGINE—322</b>	
Slow Idle Speed	
3TG66UJ .....	1350 ± 50 rpm
Fast Idle Speed	
3TG66UJ .....	3450 ± 50 rpm
Fuel Pump	
Minimum Fuel Flow	
3TG66UJ .....	200 mL (7 oz.)/30 seconds
Minimum Fuel Pressure	
3TG66UJ .....	14 kPa (2 psi)
Choke Plate Clearance (Later models) .....	2 mm (0.78 in.)
Oil Pressure	
3TG66UJ .....	294—440 kPa (43—64 psi)
Spark Plug Gap	
3TG66UJ .....	0.80 mm (0.032 in.)
Cooling System Pressure Test	
3TG66UJ .....	117 kPa (17 psi)
Minimum Pressure After After 15 Seconds	
3TG66UJ .....	90 kPa (13 psi)
Radiator Cap	
Opening Pressure	
3TG66UJ .....	97—104 kPa (14—15 psi)
Compression	
Minimum	
3TG66UJ .....	779 kPa (113 psi)
Maximum Difference Between Cylinders	
3TG66UJ .....	97 kPa (14 psi)
Engine Cranking Speed	
3TG66UJ .....	300 rpm

MX,15911020,1 -19-13JUL95

10  
20  
1

Test and Adjustment Specifications

10  
20  
2

Item	Specifications
ENGINE—330, 332, and 430	
Fuel Pump	
Minimum Fuel Flow	
3TN66UJ . . . . .	200 mL (7 oz.)/30 seconds
3TNA72UJ . . . . .	600 mL (20 oz.)/30 seconds
Minimum Fuel Pressure	
3TN66UJ . . . . .	21 kPa (3 psi)
3TNA72UJ . . . . .	21 kPa (3 psi)
Compression	
Minimum	
3TN66UJ . . . . .	2448 kPa (355 psi)
3TNA72UJ . . . . .	2448 kPa (355 psi)
Maximum Difference Between Cylinders	
3TN66UJ . . . . .	490 kPa (71 psi)
3TNA72UJ . . . . .	490 kPa (71 psi)
Minimum Engine Cranking Speed . . . . .	250 rpm
Oil Pressure	
3TN66UJ . . . . .	365 ±69 kPa (53 ±10 psi)
3TNA72UJ . . . . .	365 ±69 kPa (53 ±10 psi)
Slow Idle Speed	
3TN66UJ and Later 3TNA72UJ . . . . .	1350 ± 50 rpm
Early 3TNA72UJ . . . . .	1300 ± 50 rpm
Fast Idle Speed	
3TN66UJ and Later 3TNA72UJ . . . . .	3450 ± 50 rpm
Early 3TNA72UJ . . . . .	3400 ± 50 rpm
Cooling System Pressure Test	
3TN66UJ . . . . .	117 kPa (17 psi)
3TNA72UJ . . . . .	117 kPa (17 psi)
Minimum Pressure After After 15 Seconds	
3TN66UJ . . . . .	90 kPa (13 psi)
3TNA72UJ . . . . .	90 kPa (13 psi)
Radiator Cap	
Opening Pressure	
3TN66UJ . . . . .	97—104 kPa (14—15 psi)
3TNA72UJ . . . . .	97—104 kPa (14—15 psi)
Fuel Injection Pump Cover Nut Torque	
3TN66UJ and Later 3TNA72UJ . . . . .	9 N·m (78 lb-in.)
Fuel Injection Pump Cover Cap Screw Torque	
Early 3TNA72UJ . . . . .	9 N·m (78 lb-in.)

MX,15911020,3 -19-13JUL95



*Test and Adjustment Specifications*

10  
20  
3

Item	Specifications
<b>ELECTRICAL SYSTEM</b>	
Pulser Coils—322	
Minimum Voltage Output . . . . .	0.05 VAC
Resistance . . . . .	15.5—23.3 ohms
Ignition Coils—322	
Primary Coil Resistance . . . . .	3.8—5.2 ohms
Secondary Coil Resistance . . . . .	10.8—16.2 K-ohms
Glow Plugs—330, 332 and 430	
Minimum Resistance . . . . .	1.00 ohms
PTO Clutch Armature-to-Rotor Clearance . . . . .	
	0.46 mm (0.018 in.)
Starter—322, 330 and 332	
Current Draw (Maximum) . . . . .	230 amps
No-Load rpm (Minimum) . . . . .	7000 rpm
No-Load Amp Draw (Maximum) . . . . .	60 amps
Starter—430	
Current Draw (Maximum) . . . . .	230 amps
No-Load rpm (Minimum) . . . . .	3000 rpm
No-Load Amp Draw (Maximum) . . . . .	90 amps
Fuel Shutoff Solenoid (430 S.N. —420468)	
Lever-to-Stop Clearance . . . . .	2 mm (0.080 in.)
Alternator—322, 330 and 332	
Regulated Voltage Output . . . . .	13.5—15 volts
Unregulated Voltage Output (Minimum) . . . . .	30 volts
Regulated Current Output (Minimum) . . . . .	18 amps
Alternator—430	
Regulated Voltage Output . . . . .	13.8—14.7 volts
Unregulated Current Output (Minimum)	
(S.N. —420468) . . . . .	35 amps
(S.N. 420469— ) . . . . .	40 amps
<b>POWER TRAIN</b>	
Oil Temperature for Hydraulic Tests . . . . .	43°C (110°F)
Charge Pump Pressure . . . . .	620—1240 kPa (90—180 psi)
Implement Relief Valve Pressure . . . . .	5861—6722 kPa (850—975 psi)
Minimum Charge Pump Flow at 3450 kPa (500 psi) . . . . .	11 L/min (3 gpm)
322, 332 and 430; Steering Valve Pressure in Neutral Position . . . . .	620—1240 kPa (90—180 psi)
Hydrostatic Lever Tension . . . . .	31—44.5 N (7—10 lb force)
Turnbuckle Lock Nut Torque	
(Transmission Control Lever Linkage, 330 and Version One—322, 332 and 430) . . . . .	33 N·m (24 lb-ft)
Detent Spring Length (Transmission Control Lever Linkage, Later Versions—322, 332 and 430) . . . . .	
	50 mm (1.970 in.)

MX,15911020,2 -19-13JUL95

Test and Adjustment Specifications

10  
20  
4

Item	Specifications
<b>STEERING AND BRAKES</b>	
Oil Temperature for Hydraulic Tests . . . . .	43°C (110°F)
Steering System Leakage Test at Slow Idle	
Torque Applied to Steering Wheel Nut . . . . .	6.8 N·m (60 lb-in.)
Maximum Left and Right Turn rpm . . . . .	6 rpm
<b>HYDRAULIC SYSTEM</b>	
Oil Temperature for Hydraulic Tests . . . . .	43°C (110°F)
Control Valve Leakage Test	
Control Valve Pressure . . . . .	5860—6550 kPa (850—950 psi)
Control Valve Leakage . . . . .	15 mL/min (1/2 fl oz/min)

MX,15911020,4 -19-13JUL95

FUEL—322

**N** CAUTION: Handle fuel carefully. If the engine is hot or running, do not fill the fuel tank. Do not smoke while you fill the fuel tank or service the fuel system. Fill fuel tank only to bottom of filler neck.

**IMPORTANT: DO NOT mix oil with gasoline.**

1. Unleaded fuel is recommended. Regular leaded gasoline with an anti-knock index of 87 or higher may be used. Avoid switching from unleaded to regular gasoline to prevent engine damage.

Use of gasohol is acceptable as long as the ethyl alcohol blend does not exceed 10 percent. Unleaded gasohol is preferred over leaded gasohol.

2. Fill fuel tank at end of each day's operation. Fill fuel tank only to bottom of filler neck.



10  
25  
1  
-JUN-25AUG88  
M33122

MX,15911025,1 -19-13JUL95

## DIESEL FUEL—330, 332 AND 430

Consult your local fuel distributor for properties of the diesel fuel available in your area.

In general, diesel fuels are blended to satisfy the low temperature requirements of the geographical area in which they are marketed. Recommended standard grades are shown on the temperature charts.

Diesel fuels meeting Military Specification VV-F-800E are preferred. If diesel fuel specified to ASTM D975 is used, the fuel must meet the following properties:

- Cetane Number 40 minimum.  
Cetane number greater than 50 is preferred, especially for temperatures below  $-20^{\circ}\text{C}$  ( $-4^{\circ}\text{F}$ ) or elevations above 1500 m (5000 ft).
- Cold Filter Plugging Point (CFPP) below the expected low temperature OR Cloud Point at least  $5^{\circ}\text{C}$  ( $9^{\circ}\text{F}$ ) below the expected low temperature
- Sulfur content:
  - Sulfur content should not exceed 0.5% Sulfur content less than 0.05% is preferred.
  - If diesel fuel with sulfur content greater than 0.5% sulfur content is used, reduce the service interval for engine oil and filter by 50%
  - DO NOT use diesel fuel with sulfur content greater than 1.0%
- Lubricity
  - Fuel lubricity must pass the BOCLE scuffing test at 3300 gram minimum load level.
  - If fuel of low or unknown lubricity is used, add John Deere All-Season Diesel Fuel Conditioner at specified concentration.

Bio-diesel fuels with these properties and meeting an appropriate specification may be used as an alternative to petroleum-based diesel fuel.

Arctic fuels (such as Military Specification VV-F-800E, Grade DF-A) may be used at temperatures below  $-30^{\circ}\text{C}$  ( $-22^{\circ}\text{F}$ ).

**N** **CAUTION: Handle fuel carefully. Do not fill the fuel tank when engine is running. DO NOT smoke while you fill the fuel tank or service the fuel system.**

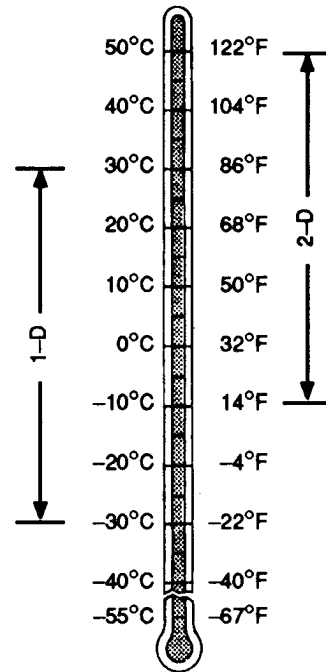

North America ASTM D975

## STORING FUEL

If there is a very slow turnover of fuel in the fuel tank or supply tank, it may be necessary to add a fuel conditioner to prevent water condensation. Contact your John Deere dealer for proper service or maintenance recommendations.

DX,FUEL -19-03MAR93

## DO NOT USE GALVANIZED CONTAINERS

**IMPORTANT: Diesel fuel stored in galvanized containers reacts with zinc coating on the container to form zinc flakes. If fuel contains water, a zinc gel will also form. The gel and flakes will quickly plug fuel filters and damage fuel injectors and fuel pumps.**

DO NOT USE a galvanized container to store diesel fuel.

Store fuel in:

- plastic containers.
- aluminum containers.
- specially coated steel containers made for diesel fuel.

DO NOT USE brass-coated containers: brass is an alloy of copper and zinc.

M21,FLQ,B1 -19-02AUG85

## ENGINE OIL—322

Use oil viscosity based on the expected air temperature range during the period between oil changes.

The following oils are preferred:

- John Deere TURF-GARD™
- John Deere PLUS-4®

Other oils may be used if they meet one or more of the following:

- API Service Classification SH
- API Service Classification SG
- CCMC Specification G5

Arctic oils (such as Military Specification MIL-L-46167B) may be used at temperature below -30°C (-22°F).

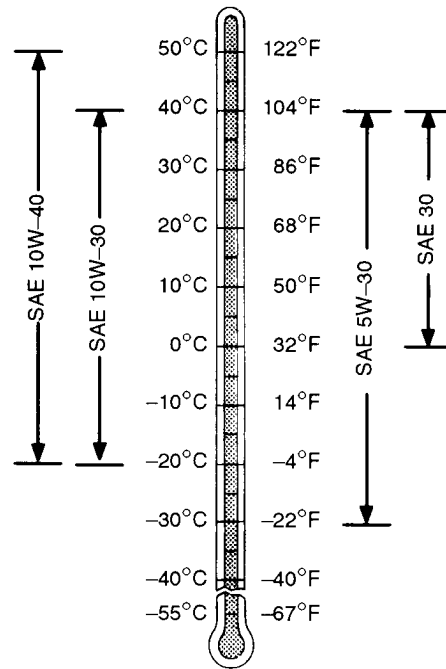

TS1624 -JUN-07NOV/94

MX,15911025,3 -19-13JUL95

## DIESEL ENGINE OIL—330, 332 AND 430

Use oil viscosity based on the expected air temperature range during the period between oil changes.

Viscosity grade SAE 15W-40 is preferred.

If other viscosity grades are used, reduce the service interval for oil and filter changes by 50%

The following oil is preferred:

- John Deere TORQ-GARD SUPREME<sup>®</sup> PLUS-50™

If John Deere TORQ-GARD SUPREME PLUS-50 engine oil and a John Deere oil filter are used, the service interval for oil and filter changes may be extended by 50 hours.

The following oil is also recommended:

- John Deere TORQ-GARD SUPREME<sup>®</sup>

Other oils may be used if they meet one or more of the following:

- API Service Classification CG4
- API Service Classification CF4
- API Service Classification CE

Oils meeting one of the following may be used, but reduce the service interval for engine oil and filter changes by 50%:

- John Deere UNI-GARD™
- CCMC Specification D5
- CCMC Specification D4

If diesel fuel with sulfur content greater than 0.5% is used, reduce the service interval for engine oil and filter by 50%

Arctic oils (such as Military Specification MIL-L-46167B) may be used at temperatures below -30°C (-22°F). Reduce the service interval for oil and filter changes by 50%

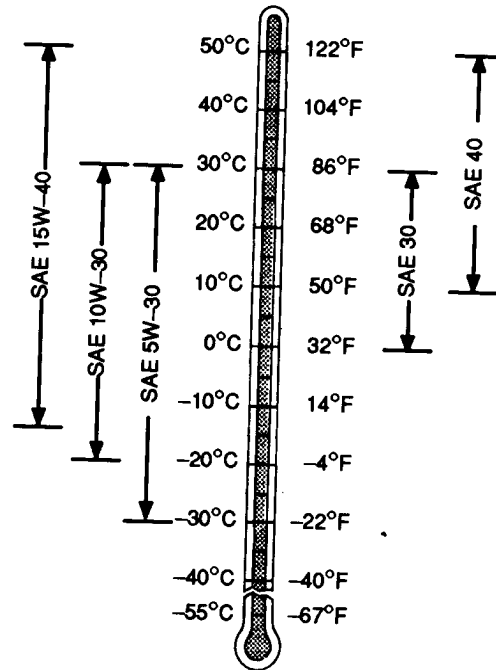

10  
25

-UN-22JUL94

TS1618

MX,15911025,4 -19-13JUL95

## ENGINE COOLANT

John Deere Low Silicate Antifreeze is recommended.

Also recommended is low silicate antifreeze formulated to GM6038M or equivalent.

Other antifreezes that may be used:

- Ethylene-glycol type.
- Those containing not more than 0.1 percent anhydrous metasilicate.
- Those meeting General Motors Performance Specification GM1899M

**IMPORTANT: Some types of ethylene-glycol antifreeze are intended for automotive use. These products are often labeled for use in aluminum engines and usually contain more than 0.1 percent of anhydrous metasilicate.**

Check container label or consult with antifreeze supplier before using.

Mix 50-67 percent low silicate antifreeze with 33-50 percent distilled or deionized water.

Low silicate antifreeze provides:

- Adequate heat transfer.
- Corrosion-resistant environment within the cooling system.
- Compatibility with cooling system hose and seal material.
- Protection during cold and hot weather operations.

Certain geographical areas may require special antifreeze or coolant practices. If you have any questions, consult your authorized servicing dealer to obtain the latest information and recommendations.

DX,COOL -19-04JUN90

## LIQUID COOLANT CONDITIONER

John Deere Liquid Coolant Conditioner is recommended for wet-sleeve diesel engines not having a coolant filter option. Other conditioners may be used if it contains non-chromate inhibitors.

**IMPORTANT: If engine is equipped with a John Deere Coolant Filter Conditioner, the correct inhibitors are contained in the filter. If both are used, a gel-type deposit is created which could inhibit heat transfer and block coolant flow. John Deere Liquid Coolant Conditioner does not protect against freezing.**

Various sizes of coolant conditioners are available from your John Deere dealer.



RG4690 -UN-14DEC88

DX,COOL1 -19-04JUN90



## TRANSMISSION AND HYDRAULIC OIL

Use oil viscosity based on the expected air temperature range during the period between oil changes.

The following oils are preferred:

- John Deere HY-GARD®
- John Deere Low Viscosity HY-GARD®

The following oils are also recommended:

- John Deere UNI-GARD™
- John Deere BIO-HY-GARD™<sup>1</sup>

Other oils may be used if they meet one of the following:

- John Deere Standard JDM J20C
- John Deere Standard JDM J20D
- John Deere Standard JDM J27A

**IMPORTANT: Do not use engine oil for this application.**

Arctic oils (such as Military Specification MIL-L-46167B) may be used at temperatures below -30°C (-22°F).

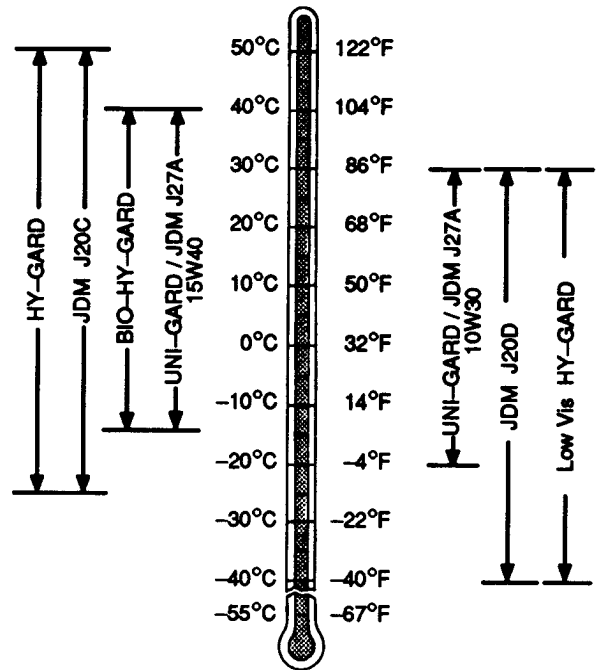

<sup>1</sup>BIO-HY-GARD meets or exceeds the minimum biodegradability of 80% within 21 days according to CEC-L-33-T-82 test method. BIO-HY-GARD should not be mixed with mineral oils because this reduces the biodegradability and makes proper oil recycling impossible.

10  
25  
8

## GREASE

Use grease based on the expected air temperature range during the service interval.

The following greases are preferred:

- John Deere MOLY HIGH TEMPERATURE EP GREASE
- John Deere HIGH TEMPERATURE EP GREASE
- John Deere GREASE-GARD™

Other greases may be used if they meet one of the following:

- SAE Multipurpose EP Grease with a maximum of 5% molybdenum disulfide
- SAE Multipurpose EP Grease

Greases meeting Military Specification MIL-G-10924F may be used as arctic grease.

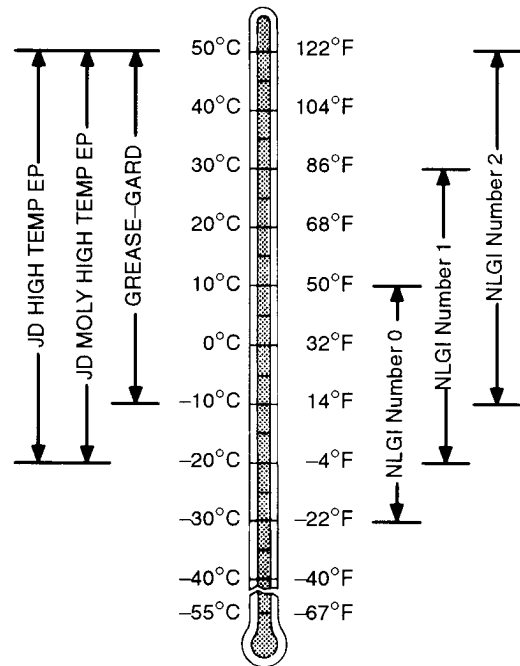

DX.GREA1 -19-02NOV94

TS1622 -UN-02NOV94

## MOWER DECK GEAR CASE OIL

Depending upon the expected air temperature range during the drain interval, use oil viscosity shown on the adjoining temperature chart.

John Deere API GL-5 Gear Oil is recommended. If other oils are used, they must meet performance requirements of:

- API Service Classification GL-5
- Military Specifaciton MIL-L-2105C

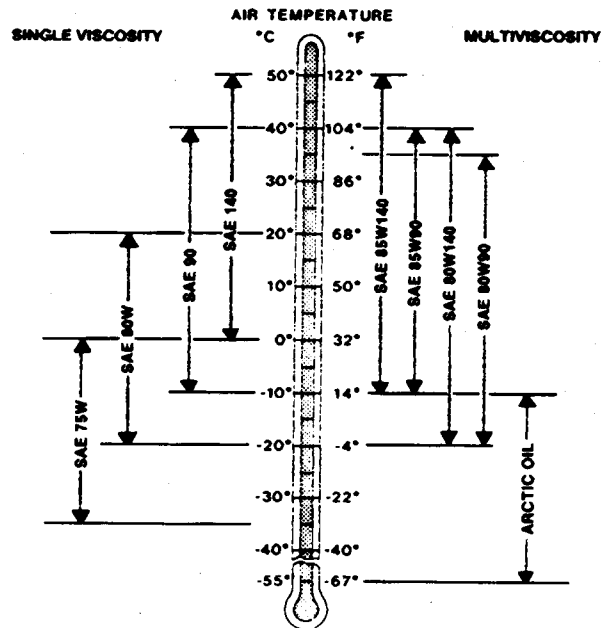

MX,15901025,3 -19-14FEB95

X9322 -19-30SEP88

## ALTERNATIVE AND SYNTHETIC LUBRICANTS

Conditions in certain geographical areas may require lubricant recommendations different from those printed in this manual. Some John Deere lubricants may not be available in your location. Consult your John Deere dealer to obtain information and recommendations.

Synthetic lubricants may be used if they meet the performance requirements listed in this manual.

DX,ALTER -19-01FEB94

## LUBRICANT STORAGE

Your equipment can operate at top efficiency only if clean lubricants are used.

Use clean containers to handle all lubricants.

Whenever possible, store lubricants and containers in an area protected from dust, moisture, and other contamination. Store containers on their side to avoid water and dirt accumulation.

DX,LUBST -19-01FEB94

## MIXING OF LUBRICANTS

In general, avoid mixing different brands or types of oil. Oil manufacturers blend additives in their oils to meet certain specifications and performance requirements. Mixing different oils can interfere with the proper functioning of these additives and degrade lubricant performance.

DX,LUBMIX -19-01FEB94

10  
25  
10

## SERIAL NUMBERS

When working on machines or components that are covered by warranty, it is **IMPORTANT** that you include the tractor Product Identification Number and the component serial number on the warranty claim form.

The location of component serial number plates are shown below.

MX,M21,1030R,1 -19-22APR85

## PRODUCT IDENTIFICATION NUMBER

*NOTE: All identification number plates are located on the pedestal. On some models, the plate is on the right-hand side. On others, front top left corner.*



M34494  
-UN-08NOV89

MX,15901030,1 -19-12MAY95

## ENGINE SERIAL NUMBER



M34495  
-UN-08NOV89

MX,15911030,1 -19-13JUL95

## TRANSMISSION SERIAL NUMBER

Serial number plate (A) location.

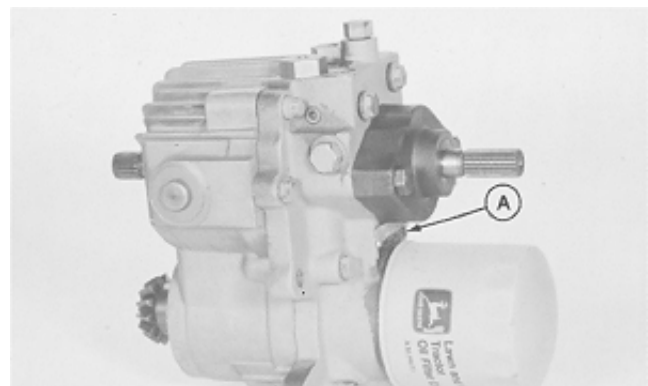

M38478  
-UN-29AUG88

MX,15901030,3 -19-12MAY95

10  
30  
2

### DIFFERENTIAL SERIAL NUMBER

Serial number plate (A) location.

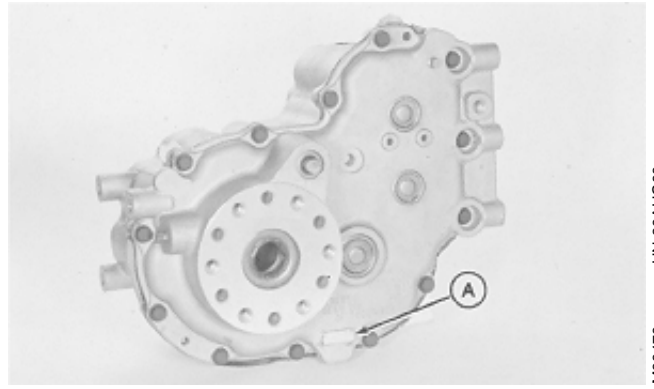

M38479 -UN-29AUG88

MX,15901030,4 -19-12MAY95

### CONTROL VALVE SERIAL NUMBER

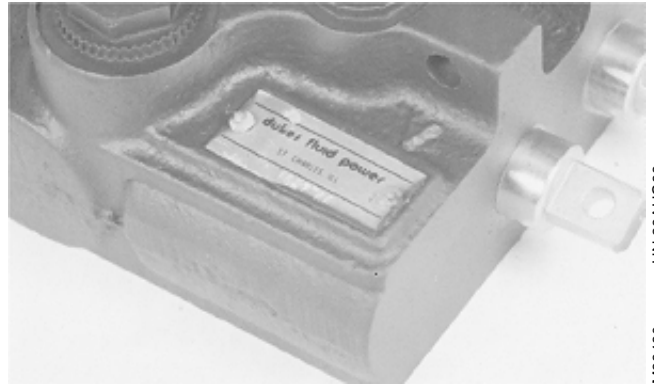

M38480 -UN-29AUG88

MX,15901030,5 -19-12MAY95

# Section 20 ENGINE REPAIR

## Contents

### Page

#### **Group 05—Engine—322**

Repair—Use CTM12 . . . . .	20-05-1
Remove and Install . . . . .	20-05-1

#### **Group 06—Engine—330, 332 and 430**

Repair—Use CTM3 . . . . .	20-06-1
Remove and Install—330 and 332 . . . . .	20-06-1
Remove—430 . . . . .	20-06-4
Install—430 . . . . .	20-06-8

20





## YANMAR GASOLINE ENGINE REPAIR—USE CTM12

For complete repair information, the component technical manual (CTM) is also required. Use the component technical manual in conjunction with this machine manual.



MX,15912005,1 -19-13JUL95

TS225

-UN-17JAN89

20-05-1

## REMOVE AND INSTALL ENGINE—322

1. Remove grille, side panels, battery, battery base and belly screen.
2. Disconnect headlight and hour meter leads.
3. Remove hood, hood support and battery base support.

**N CAUTION:** Explosive release of fluids from pressurized cooling system can cause serious burns.

**Shut off engine. Only remove filler cap when cool enough to touch with bare hands. Slowly loosen cap to first stop to relieve pressure before removing completely.**

4. Drain radiator. Approximate capacity is 2.8 L (3 U.S. qt).
5. Disconnect items (A—D).

- A—Starter Cable and Leads
- B—Alternator Lead
- C—Voltage Regulator Lead
- D—Temperature Coolant Lead

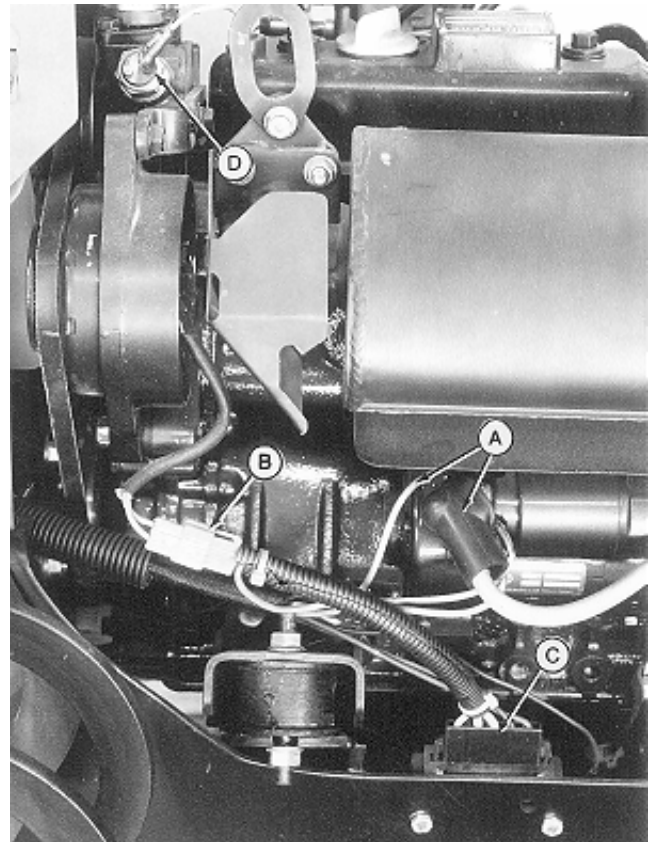

-UN-23AUG88

TS281

-UN-15DEC94

M77901

MX,15912005,2 -19-13JUL95

6. Disconnect items (A—I).

- A—Radiator Hoses
- B—Throttle Cable
- C—Choke Cable
- D—Ignition Coil Lead
- E—Ignition Trigger Lead
- F—Oil Pressure Sensor Lead
- G—PTO Clutch Lead
- H—Wire Harness Ground and Frame to Engine Ground
- I—Fuel Line at Filter

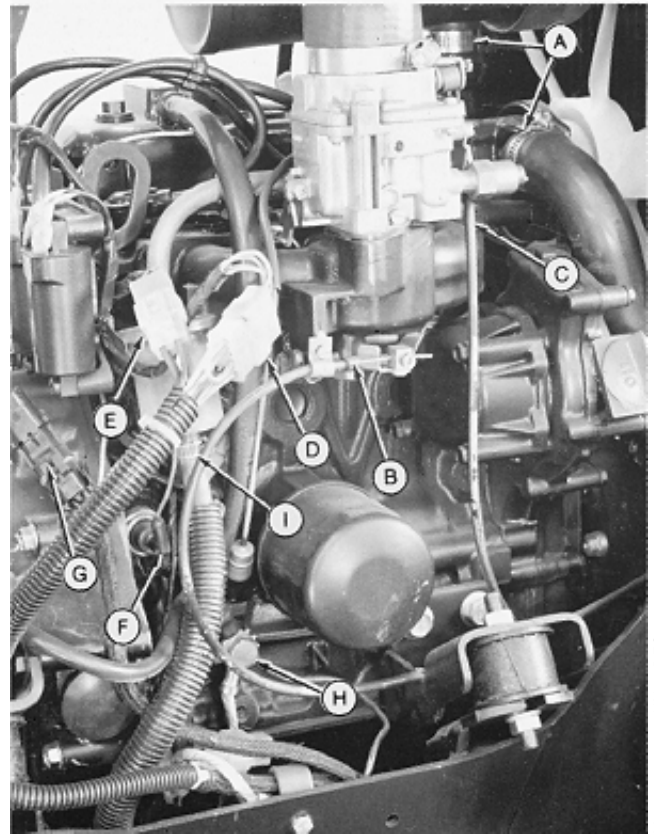

M49504 -JUN-20DEC89

MX,5M3,2005K,H -19-18DEC87

20  
05  
2

7. Remove cap screws (A) holding rubber drive shaft isolator to engine.
8. Loosen cap screws at universal joint at transmission input shaft and slide drive shaft toward transmission. This will eliminate any preload on the drive shaft when reassembling.
9. Remove engine mounting nuts.
10. Attach load positioning sling to lift eyes and remove engine.
11. Make repairs as necessary. (See CTM12.)
12. Installation is done in the reverse order of removal.

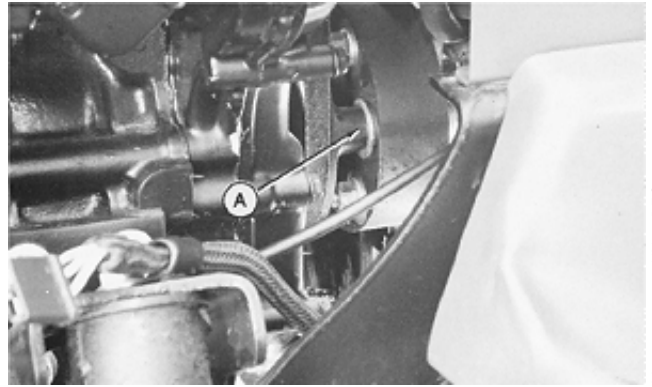

M49505 -UN-20DEC89

20  
05  
3

- Tighten engine mounting nuts to specifications.
- When connecting drive shaft, tighten cap screws to specifications.
- Close drain valve and fill radiator with proper coolant until coolant is 13—25 mm (0.500—1 in.) below bottom of filler neck. (See Engine Coolant in Section 10, Group 25.)

*NOTE: On Early models, the choke is activated manually by a cable. On Later models, the choke operates automatically.*

- Early models; Adjust choke cable. (See Section 220, Group 10.)
- Adjust slow and fast idle. (See Section 220, Group 10.)

**TORQUE SPECIFICATIONS**

Engine Mounting Nuts . . . . .	49 N·m (36 lb-ft)
Drive Shaft	
Engine Mounting Cap Screws . . . . .	37 N·m (27 lb-ft)
Universal Joint Cap Screws . . . . .	60 N·m (45 lb-ft)

MX,15912005,3 -19-13JUL95



## YANMAR DIESEL ENGINE REPAIR—USE CTM3

For complete repair information, the component technical manual (CTM) is also required. Use the component technical manual in conjunction with this machine manual.



MX,15912006,1 -19-13JUL95

TS225

2006

## REMOVE AND INSTALL ENGINE—330 AND 332

1. Remove grille, side panels, battery, battery base and belly screen.
2. Disconnect headlight and hour meter leads.
3. Remove hood, hood support and battery base support.

**N CAUTION:** Explosive release of fluids from pressurized cooling system can cause serious burns.

**Shut off engine. Only remove filler cap when cool enough to touch with bare hands. Slowly loosen cap to first stop to relieve pressure before removing completely.**

4. Drain radiator. Approximate capacity is 2.8 L (3 U.S. qt).

*NOTE: On 330, wiring harness ground and engine-to-frame ground (D) are connected to rear engine mount.*

5. Disconnect items (A—E).

- A—Battery Positive (+) Cable and Starter Leads
- B—Alternator Lead
- C—PTO Clutch Lead
- D—Wiring Harness Ground and Engine to Frame Ground
- E—Coolant Temperature Lead

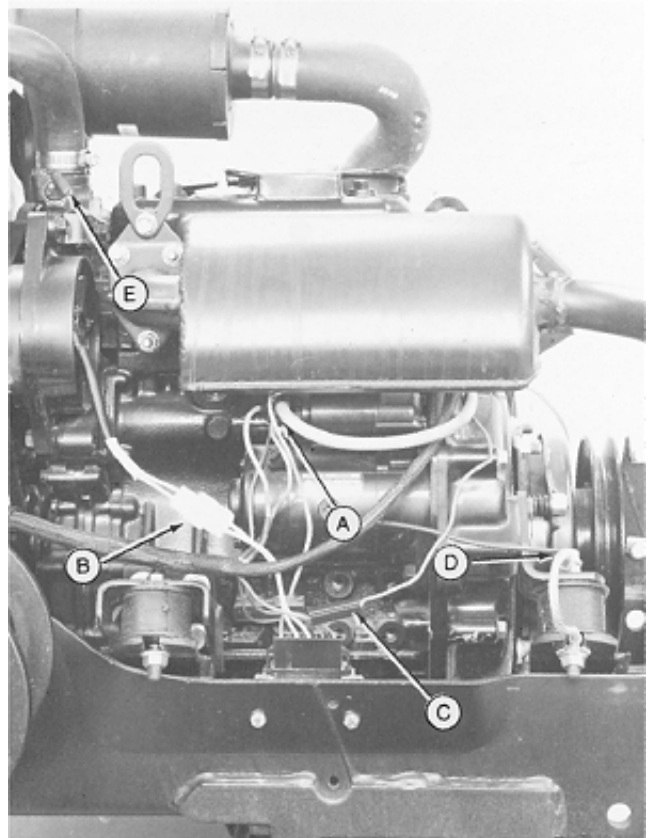

MX,15912006,2 -19-13JUL95

TS281

2006

TS281

M49506

*NOTE: On Early 330, fuel shutoff solenoid is activated manually by a cable. On 332 and Later 330, fuel shutoff solenoid is activated electronically.*

6. Disconnect items (A—G).

- A—Radiator Hoses
- B—Return Fuel Line
- C—Throttle Cable
- D—Fuel Pump Hose
- E—Fuel Shutoff Solenoid Connector (332, Later 330)  
—Fuel Shutoff Solenoid Cable (Early 330)
- F—Glow Plug Lead
- G—Oil Pressure Sensor Lead

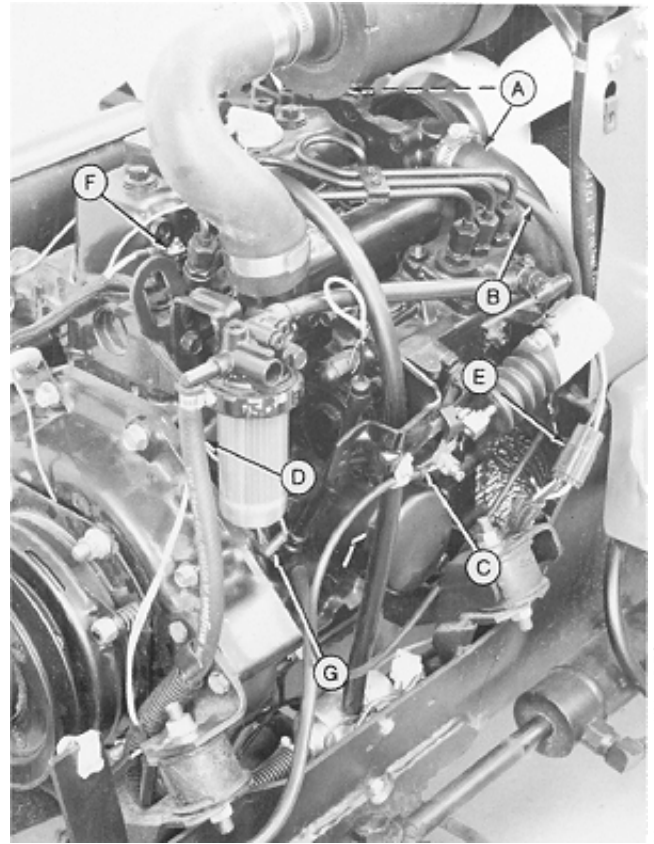

M49507 -JUN-20DEC89

MX,15912006,3 -19-13JUL95

20  
06  
2

7. Remove cap screws (A) holding rubber drive shaft isolator to engine.
  8. Loosen cap screws at universal joint at transmission input shaft and slide drive shaft toward transmission. This will eliminate any preload on the drive shaft when reassembling.
  9. Remove engine mounting nuts.
  10. Attach load positioning sling to lift eyes and remove engine.
  11. Make repairs as necessary. (See CTM3.)
  12. Installation is done in the reverse order of removal.
- Tighten engine mounting nuts to specifications.
  - When connecting drive shaft, tighten cap screws to specifications.
  - Close drain valve and fill radiator with proper coolant until coolant is 13—25 mm (0.500—1 in.) below bottom of filler neck. (See Engine Coolant in Section 10, Group 25.)
  - Bleed the fuel system. (See Section 220, Group 10.)
  - Adjust slow and fast idle. (See Section 220, Group 10.)

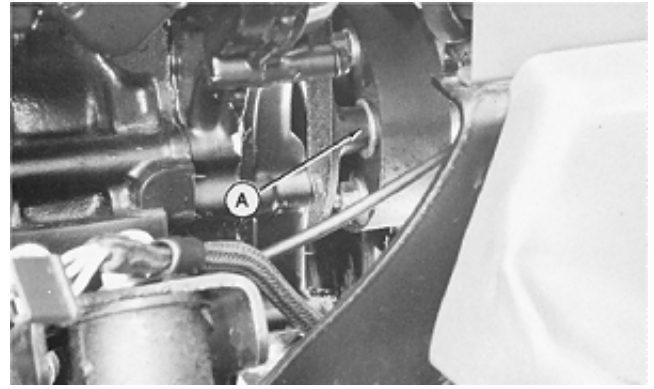

M49505 -UN-20DEC89

20063

**TORQUE SPECIFICATIONS**

Engine Mounting Nuts . . . . .	49 N·m (36 lb-ft)
Drive Shaft	
Engine Mounting Cap Screws	
330 . . . . .	27 N·m (20 lb-ft)
332 . . . . .	37 N·m (27 lb-ft)
Universal Joint Cap Screws . . . . .	60 N·m (45 lb-ft)

MX,15912006,4 -19-13JUL95

## REMOVE ENGINE—430

1. Remove grille, side panels, battery and battery base.

**N** **CAUTION:** Explosive release of fluids from pressurized cooling system can cause serious burns.

Shut off engine. Only remove filler cap when cool enough to touch with bare hands. Slowly loosen cap to first stop to relieve pressure before removing completely.

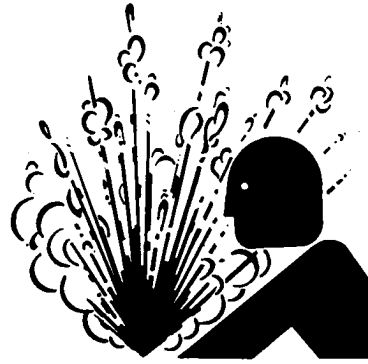

2. Drain radiator. Approximate capacity is 3.8 L (4 U.S. qt).
3. Turn air vent on fuel/water separator counterclockwise to open air vent.
4. Turn drain plug (C) counterclockwise to drain fuel from separator.
5. Disconnect fuel injection pump inlet hose (B) and leak-off hose (A).
6. Remove three cap screws and fuel/water separator.

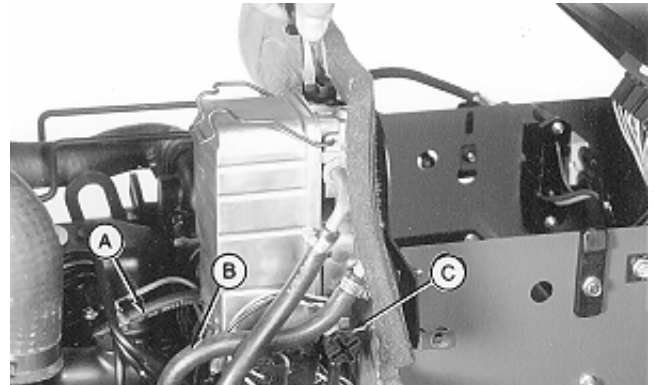

MX,15912006,5 -19-13JUL95

7. Disconnect hoses (A—C).
8. Remove cap screw (D) and clamp (E).

A—Air Cleaner Hose  
 B—Water Pump Inlet Hose  
 C—Water Pump Outlet Hose  
 D—Cap Screw  
 E—Clamp

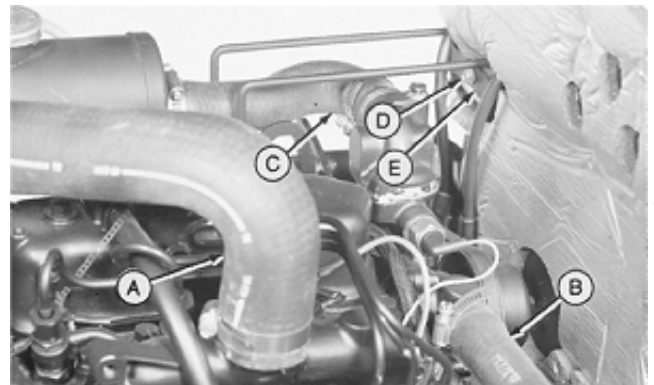

MX,15912006,6 -19-13JUL95



9. Disconnect hoses (A and B).

10. Remove cap screw (C), ground wire (D)(Early Models), clamp (E) and coolant recovery tank (F).

- A—Upper Radiator Hose
- B—Radiator Inlet Hose
- C—Cap Screw
- D—Headlight Ground Wire (Early Models)
- E—Clamp
- F—Coolant Recovery Tank

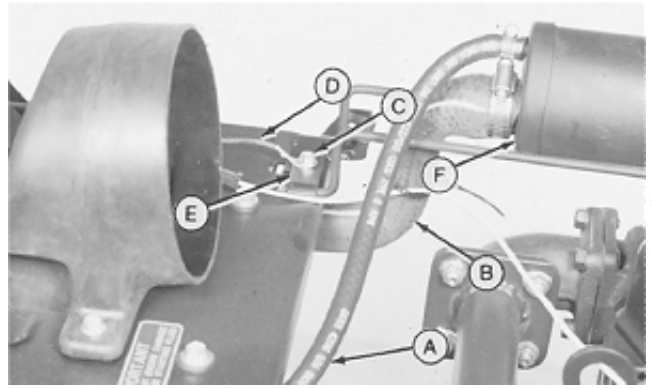

MX,15912006,7 -19-13JUL95

M35462 -JUN-16NOV89

5106

11. Loosen hose clamp (A) to remove water pump inlet hose (B).

12. Remove two cap screws and washers to disconnect fan shroud.

13. Disconnect headlight wiring lead.

14. Remove four cap screws and hood assembly.

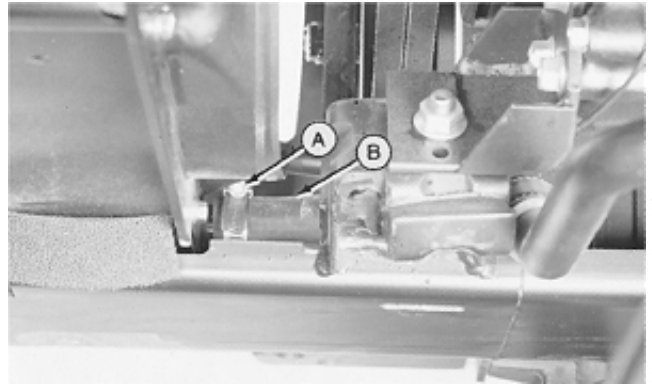

MX,15912006,8 -19-13JUL95

M35463 -JUN-16NOV89

15. Disconnect wiring leads (A—G).
16. Disconnect battery negative (—) cable from right rear engine mount.
17. Remove battery cables.

- A—Alternator-to-Starting Motor (Output)
- B—Alternator-to-Key Switch (Field)
- C—Alternator-to-Control Module
- D—Starting Motor Solenoid-to-Safe-Start Relay
- E—Battery Positive (+) Cable
- F—Starting Motor-to-Key Switch
- G—Starting Motor-to-Glow Plug Controller

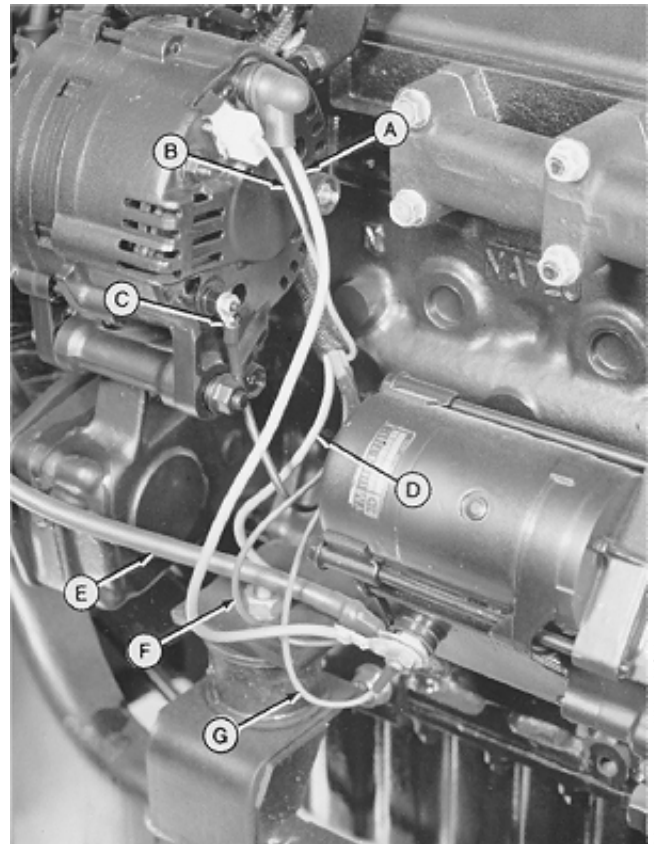

Right-Hand Side

M35466  
-JUN-16/NOV-89

MX,15912006,9 -19-13JUL95

20  
06  
6

18. Disconnect wiring leads (A—F).
19. Remove cap screw (G) and clamp (H).
20. Disconnect throttle cable (I).
21. Turn steering wheel to full left turn position to aid in muffler removal.
22. Remove muffler.
23. Remove PTO belt guard.
24. Loosen PTO belt tension and remove belts from engine.
25. Disconnect drive shaft at engine.
26. Remove fan shroud.

*NOTE: Rear engine mounts have a nut and two washers.*

27. Remove engine mounting nuts and washers, if equipped.
28. Attach load positioning sling to lift eyes and remove engine.
29. Make repairs as necessary. (See CTM3.)

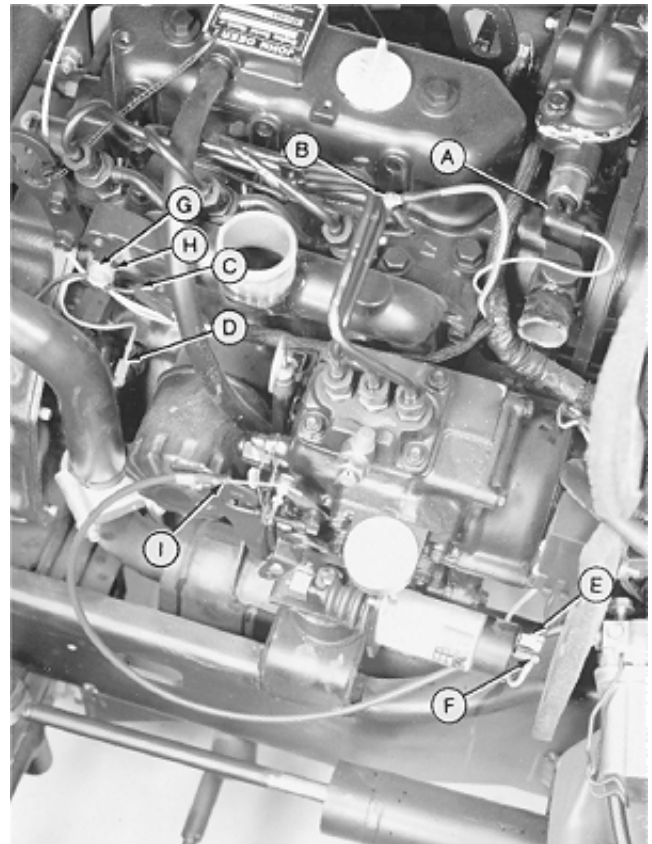

Left-Hand Side

- A—Coolant Temperature Sender
- B—Glow Plug
- C—Front PTO Clutch
- D—Oil Pressure Sender
- E—Fuel Shutoff Solenoid-to-Circuit Breaker (Early Models)
- F—Fuel Shutoff Solenoid-to-Control Module
- G—Cap Screw
- H—Clamp
- I—Throttle Cable

MX,15912006,10 -19-13JUL95

2006  
-JUN-16/NOV/89  
M35469

## INSTALL ENGINE—430

1. If necessary, loosen one front engine mount nut. Align engine mount stud with hole in front engine mounting bracket. Install the engine. Align front engine mount dowel pin with hole in frame mounting bracket. Tighten nut.

*NOTE: Rear engine mounts have a nut and two washers.*

2. Install two washers, if equipped, and engine mounting nuts. Tighten nuts to specifications.

3. Install fan shroud.

4. Connect drive shaft to engine. Tighten cap screws to specifications.

5. Install two belts on PTO pulley. Tighten adjuster nut until spring is 35 mm (1.380 in.) long.

6. Install PTO belt guard.

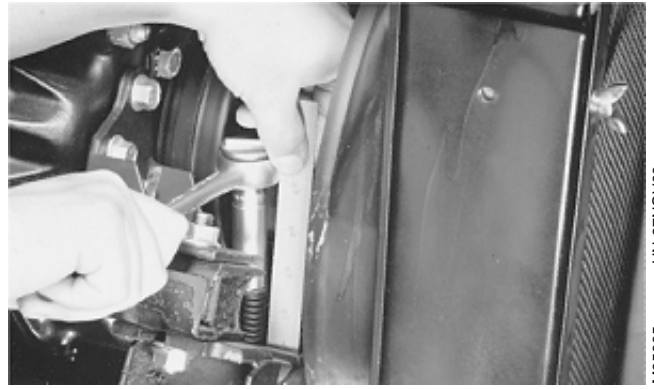

M35665 -UN-27NOV89

### TORQUE SPECIFICATIONS

Engine Mounting Nuts . . . . .	49 N-m (36 lb-ft)
Drive Shaft Mounting Cap Screws . . . . .	27 N-m (20 lb-ft)

MX,15912006,11 -19-13JUL95

20  
06  
8

7. Loosen four cap screws (C).
8. Install muffler. Tighten mounting hardware finger-tight.

**IMPORTANT: Tighten exhaust mounting hardware in sequence described. Failure to do so, may create binding around exhaust system resulting in muffler breaking off.**

9. Tighten exhaust mounting hardware in the following sequence:

- A—Muffler-to-Engine Mount Cap Screw (2 used)
- B—Muffler-to-Gear Case Cover Cap Screw (2 used)
- C—Exhaust Pipe-to-Manifold Cap Screw (4 used)
- D—Muffler Clamp Nut (2 used)

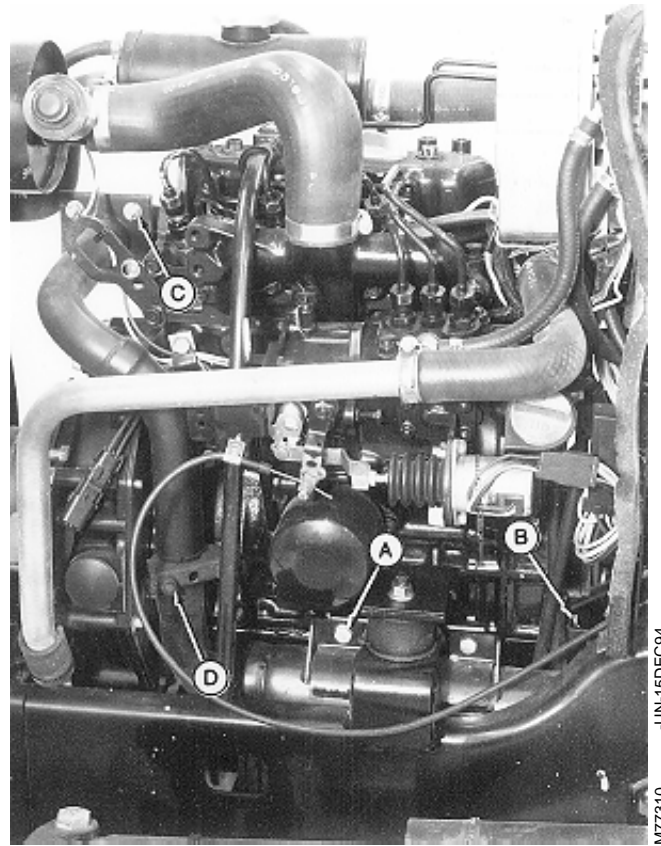

20  
06-9

M77310 -JUN-15DEC94

MX,15912006,12 -19-13JUL95

10. Connect throttle cable (I).
11. Install clamp (H) and cap screw (G).
12. Connect wiring leads (A—F).

- A—Coolant Temperature Sender
- B—Glow Plug
- C—Front PTO Clutch
- D—Oil Pressure Sender
- E—Fuel Shutoff Solenoid-to-Circuit Breaker (Early Models)
- F—Fuel Shutoff Solenoid-to-Control Module
- G—Cap Screw
- H—Clamp
- I—Throttle Cable

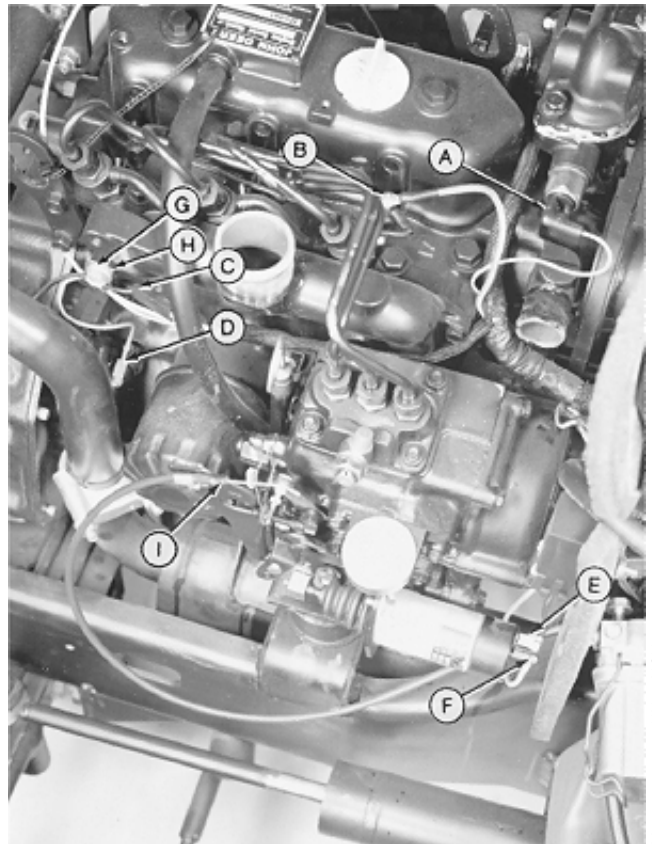

Left-Hand Side

M35469 -JUN-16/NOV-89

MX,15912006,13 -19-13JUL95

20  
06  
10

13. Install battery cables.

14. Connect battery negative (—) cable to right rear engine mount. Tighten cap screw to 49 N-m (36 lb-ft).

15. Connect wiring leads (A—G).

- A—Alternator-to-Starting Motor (Output)
- B—Alternator-to-Key Switch (Field)
- C—Alternator-to-Control Module
- D—Starting Motor Solenoid-to-Safe-Start Relay
- E—Battery Positive (+) Cable
- F—Starting Motor-to-Key Switch
- G—Starting Motor-to-Glow Plug Controller

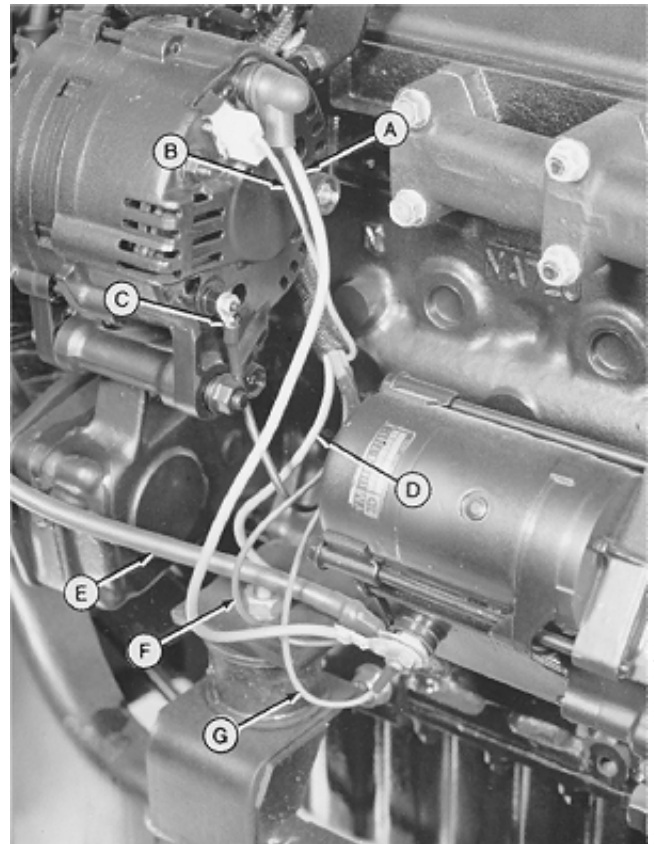

Right-Hand Side

MX,15912006,14 -19-13JUL95

16. Install hood assembly.

17. Install two washers and cap screws connect fan shroud to hood assembly.

18. Connect headlight wiring lead.

19. Install water pump inlet hose (B). Tighten hose clamp (A).

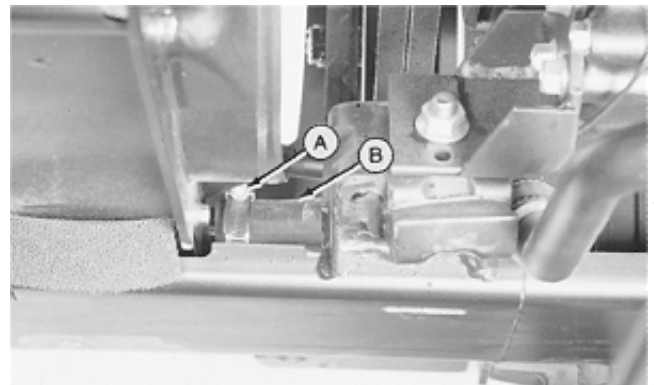

MX,15912006,15 -19-13JUL95

20. Install coolant recovery tank (F), clamp (E), ground wire (D)(Early Models) and cap screw (C).

21. Connect hoses (A and B).

- A—Upper Radiator Hose
- B—Radiator Inlet Hose
- C—Cap Screw
- D—Headlight Ground Wire (Early Models)
- E—Clamp
- F—Coolant Recovery Tank

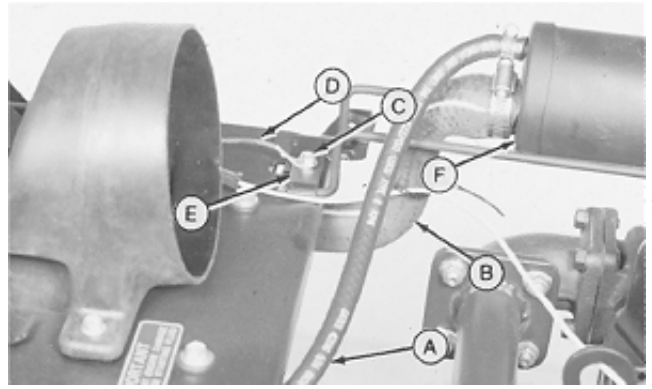

MX,15912006,16 -19-13JUL95

M35462 -JUN-16NOV89

22. Install clamp (E) and cap screw (D).

23. Connect hoses (A—C).

- A—Air Cleaner Hose
- B—Water Pump Inlet Hose
- C—Water Pump Outlet Hose
- D—Cap Screw
- E—Clamp

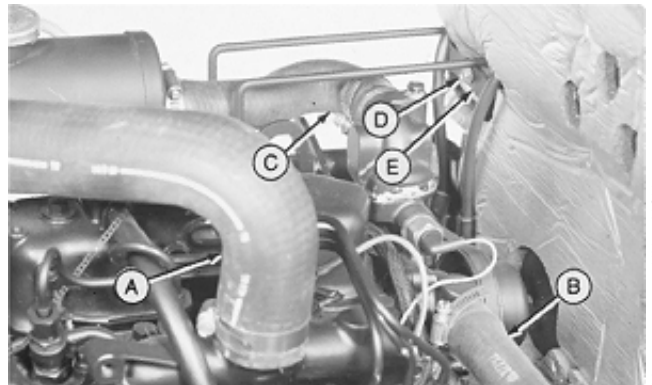

MX,15912006,17 -19-13JUL95

M35461 -JUN-16NOV89

24. Install fuel/water separator. Tighten cap screws to 20 N·m (180 lb-in.).

25. Connect fuel injection pump inlet hose (B) and leak-off hose (A).

26. Turn drain plug (C) and air vent plug clockwise to close.

27. Install battery base and battery.

28. Close drain valve and fill radiator with proper coolant until coolant is 13—25 mm (0.500—1 in.) below bottom of filler neck. (See Engine Coolant in Section 10, Group 25.)

29. Bleed the fuel system. (See Section 220, Group 11.)

30. Adjust slow and fast idle. (See Section 220, Group 11.)

31. Install side panels and grille.

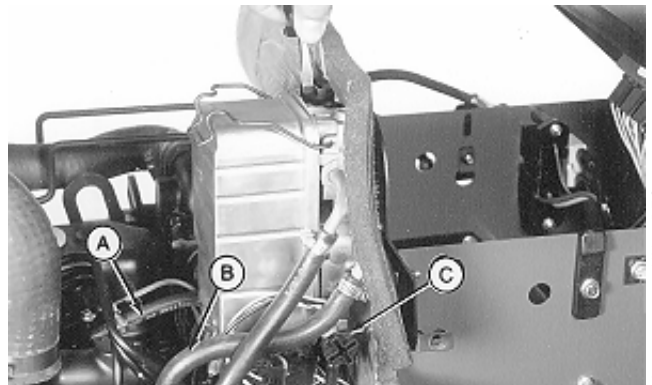

MX,15912006,18 -19-13JUL95

M77902 -JUN-15DEC94



# Section 40 ELECTRICAL REPAIR

## Contents

### Page

#### Group 05—Front PTO Clutch

Other Materials . . . . .	40-05-1
Remove—322, 330 and 332 . . . . .	40-05-1
Remove—430 . . . . .	40-05-2
Disassemble, Inspect and Assemble . . . . .	40-05-4
Install—322, 330 and 332 . . . . .	40-05-6
Install—430 . . . . .	40-05-7

40



## OTHER MATERIAL

Number	Name	Use
LOCTITE® PRODUCTS U.S./Canadian/LOCTITE No.		
T43512/TY9473/242	Thread Lock and Sealer (Medium Strength)	Apply to threads of front PTO clutch-to-crankshaft cap screw.

®LOCTITE is a registered trademark of the Loctite Corp.

MX,15914005,20 -19-13JUL95

## REMOVE FRONT PTO CLUTCH—322, 330 AND 332

1. Remove grille and left-hand side panel.
2. Loosen PTO belt tension and remove belt from PTO clutch sheave.
3. Disconnect PTO clutch wire lead.
4. Remove cap screw and washer holding clutch to crankshaft.
5. Remove three lock nuts (A).

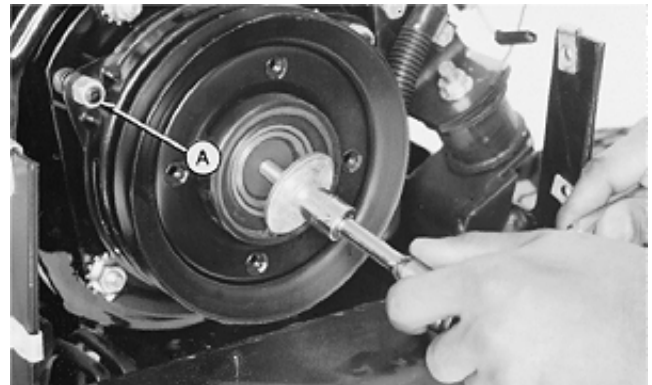

40-05-1  
-JUN-09DEC89  
M55045

MX,15914005,1 -19-13JUL95

6. Remove armature, pulley and brake assembly from field coil.
7. Remove three springs.

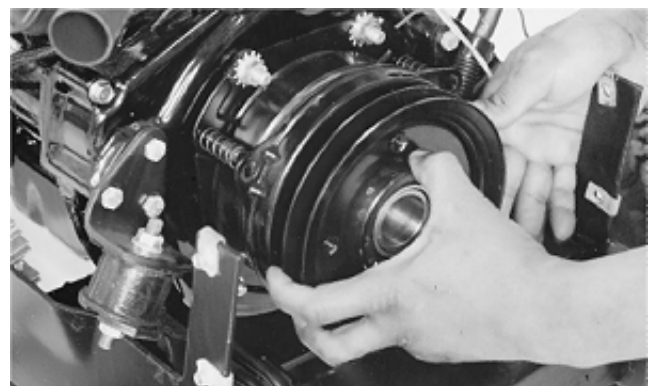

-JUN-09DEC89  
M55046

MX,15914005,2 -19-13JUL95

8. Remove rotor from field coil.
9. Remove key from shaft.

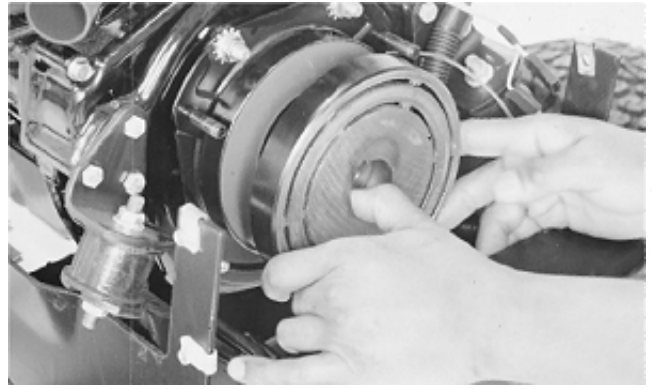

M55048  
-UN-09DEC89

MX,15914005,3 -19-13JUL95

*NOTE: Note position of clutch wire lead to aid in installation.*

10. Remove field coil.

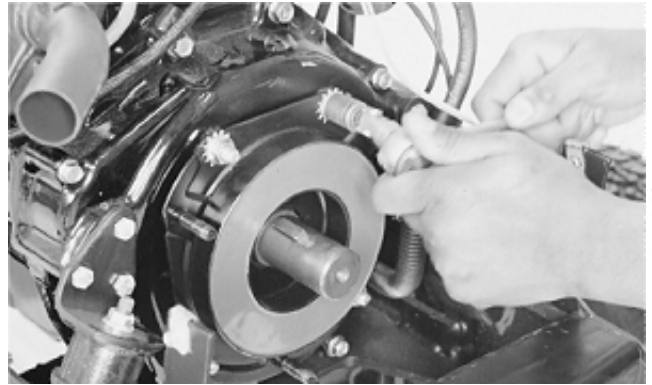

M55049  
-UN-09DEC89

MX,15914005,4 -19-13JUL95

## REMOVE FRONT PTO CLUTCH—430

**N** **CAUTION:** Explosive release of fluids from pressurized cooling system can cause serious burns.

Shut off engine. Only remove filler cap when cool enough to touch with bare hands. Slowly loosen cap to first stop to relieve pressure before removing completely.

1. Drain and remove radiator. Approximate capacity is 3.8 L (4 U.S. qt).
2. Remove fan and fan spacer.



TS281  
-UN-23AUG88

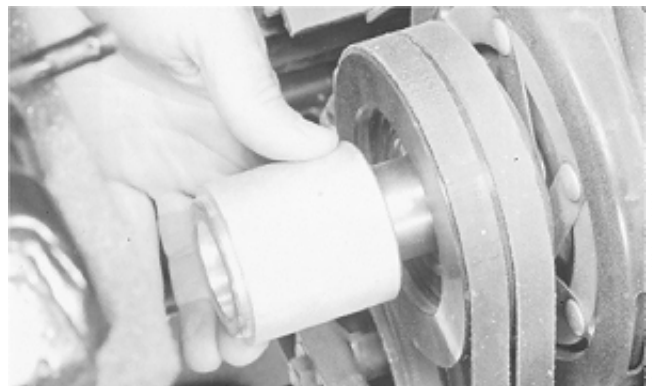

M36821  
-UN-25JAN90

MX,15914005,5 -19-13JUL95

3. Loosen PTO belt tension and remove adjusting assembly.
4. Remove belts from PTO clutch sheaves.
5. Remove three lock nuts holding brake plate to field coil.
6. Push idler (A) back and remove brake plate.
7. Remove three springs (B).

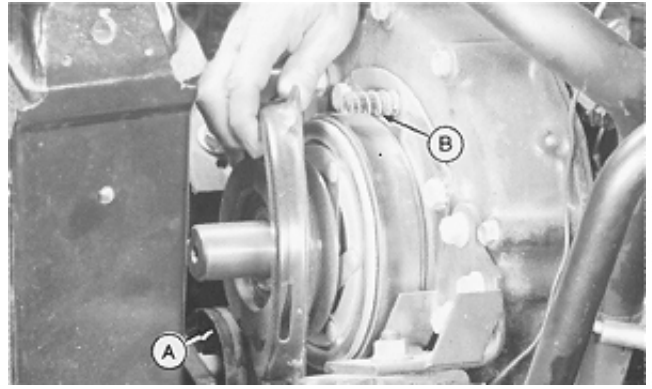

MX,15914005,6 -19-13JUL95

M36624 -UN-25JAN90

8. Remove armature assembly from field coil.

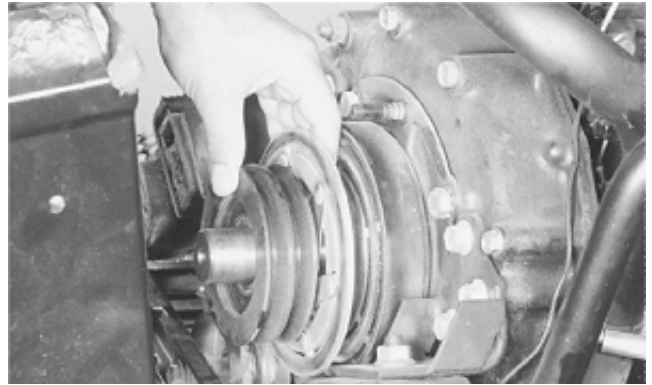

MX,15914005,7 -19-13JUL95

M36625 -UN-25JAN90

9. Remove rotor from field coil.
10. Remove key from shaft.

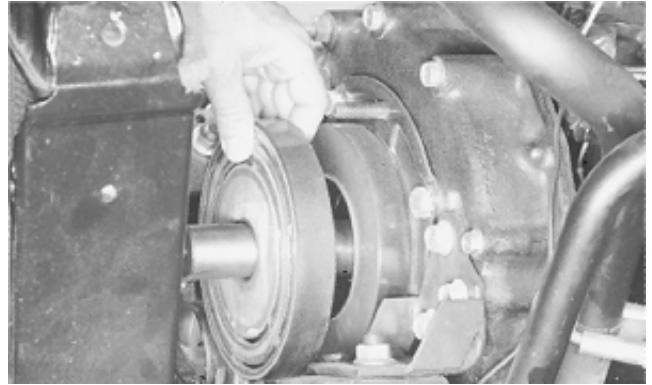

MX,15914005,8 -19-13JUL95

M36626 -UN-25JAN90

*NOTE: Note position of clutch wire lead to aid in installation.*

11. Disconnect PTO clutch wire lead (A).
12. Loosen cap screw (B) to disconnect lead from clip.
13. Remove four cap screws and lock washers (C) and field coil.

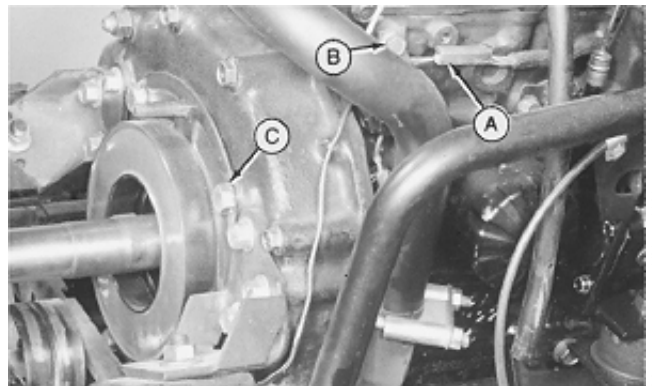

MX,15914005,9 -19-13JUL95

M36627 -UN-25JAN90

## DISASSEMBLE, INSPECT AND ASSEMBLE FRONT PTO CLUTCH

1. Inspect armature for bent, weak or broken contact springs. Replace armature if damaged.
2. Inspect rotor and armature face contacts for wear. Replace if worn or grooved. Clean face contacts of dirt or foreign material.

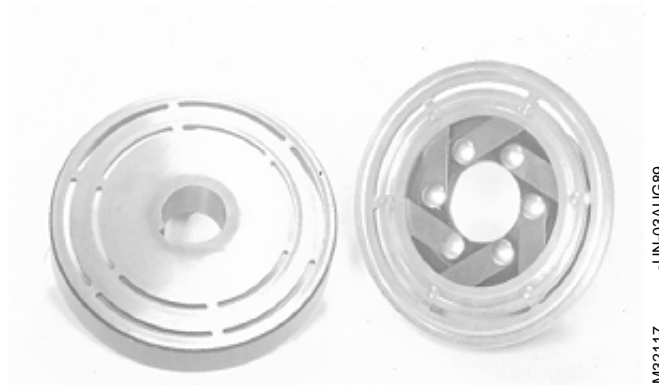

MX,15904005.3 -19-12MAY95

M32117 -UN-03AUG89

*NOTE: Bearing is press-fit in armature. Remove only if replacement is necessary.*

3. Inspect armature bearing for wear or damage. Replace if necessary.
4. To replace armature bearing; remove snap ring.



MX,15904005.4 -19-14DEC94

M32113 -UN-03AUG89

5. Remove hub and bearing from armature using a press and a 1-11/16 in. driver disk. Make sure assembly is supported on pulley, NOT on armature plate.
6. Remove shim washer from inside pulley hub.
7. Remove hub from bearing using a press and a 1-3/4 in. driver disk.
8. Install hub into new bearing using a press and driver disk.
9. Install shim washer in bottom of pulley hub.

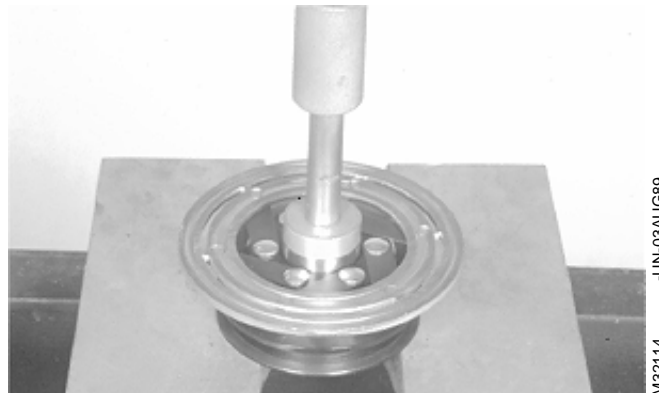

MX,15904005.5 -19-14DEC94

M32114 -UN-03AUG89

**IMPORTANT:** Support the armature assembly on the spring rivets when installing bearing/hub assembly into armature assembly, or damage to armature and springs will occur.

10. Support armature on spring rivets and install bearing/hub assembly into pulley hub with a press and a 2-15/16 in. driver disk.

11. Install snap ring.



UN-03AUG89  
M32120

MX,15904005,6 -19-14DEC94

12. Inspect field coil for wear or damage. Replace if necessary.

13. Test field coil for electrical continuity.

Early version:

- Attach field coil lead to positive (+) terminal of a charged storage battery.
- Set coil base on negative (—) battery terminal.
- Put a steel bolt across coil. Electromagnetic action will hold bolt to coil if coil is good. If bolt does not stick to coil, replace the coil.

Later version:

- Attach a jumper wire from one terminal of two-pin connector to negative (—) battery terminal.
- Attach another jumper wire from the remaining terminal of two-pin connector to positive (+) battery terminal.
- Put a steel bolt across coil. Electromagnetic action will hold bolt to coil if coil is good. If bolt does not stick to coil, replace the coil.

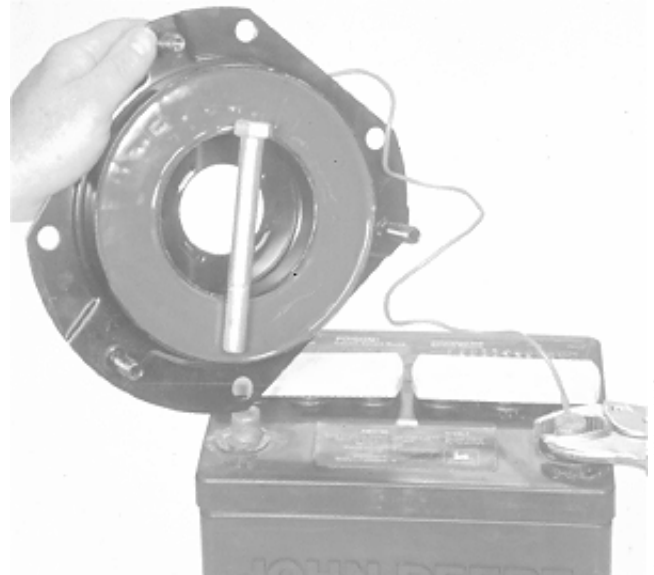

UN-03AUG89  
M32118

Early Version

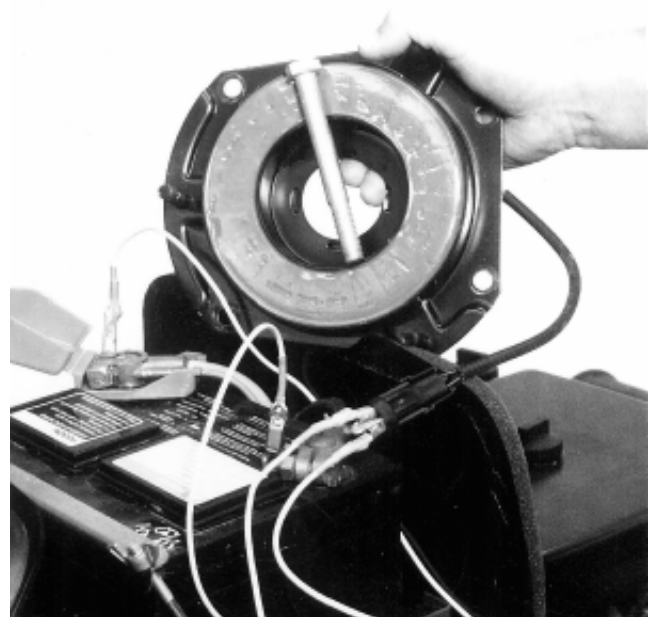

UN-25JAN95  
M77321

Later Version

MX,15904005,7 -19-19JAN95

## INSTALL FRONT PTO CLUTCH—322, 330 AND 332

**IMPORTANT:** Make sure clutch wire lead is in same position as when removed, to prevent shorting of wires.

1. Install field coil and fasten with four cap screws and star washers. Be sure centering lugs on backside of coil are properly seated in engine face. Tighten cap screws.
2. Install rotor and key.

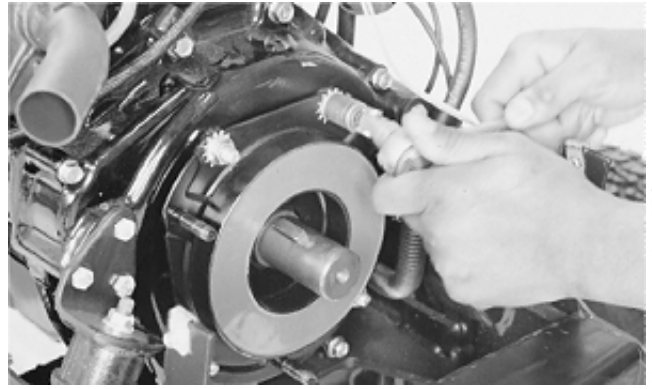

M55049 -UN-09DEC89

MX,15914005,10 -19-13JUL95

3. Install three springs on mounting studs.
4. Install armature, pulley and brake plate assembly.

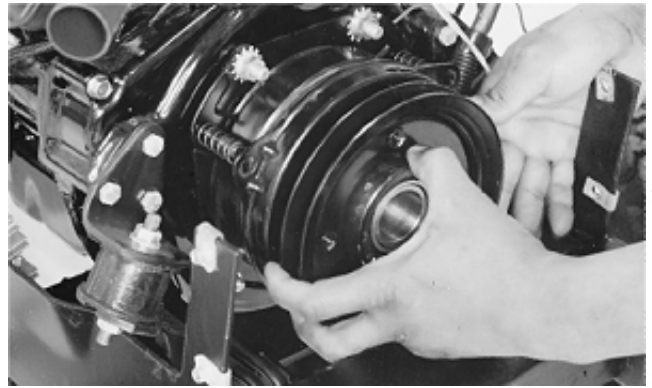

M55046 -UN-09DEC89

MX,15914005,11 -19-13JUL95

5. Install three lock nuts (A). DO NOT tighten nuts.
6. Install washer and cap screw on end of crankshaft. Tighten cap screw to 47 N·m (35 lb-ft).
7. Connect PTO clutch wire lead.

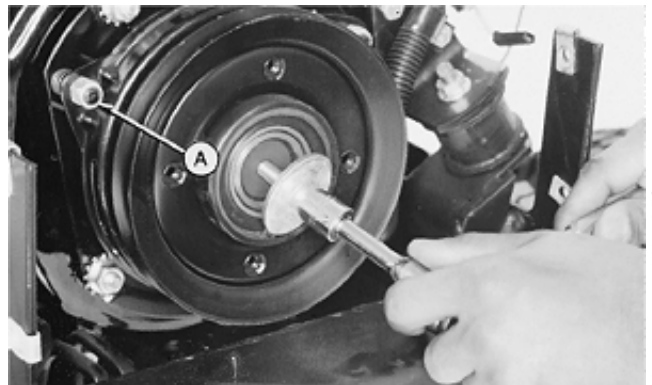

M55045 -UN-09DEC89

MX,15914005,12 -19-13JUL95



8. Put a 0.46 mm (0.018 in.) flat feeler gauge through slots in brake plate between rotor and armature. Turn lock nuts until space between rotor and armature is 0.46 mm (0.018 in.). Be sure all three nuts are adjusted so space between armature and rotor is adjusted to specification at each of three slots in brake plate.

9. After adjusting, turn ignition switch ON. Move PTO switch ON and OFF several times to seat parts. Turn ignition switch OFF. Recheck clearance and adjust as necessary.

10. Install PTO clutch belt.

11. Install side panel and grille.

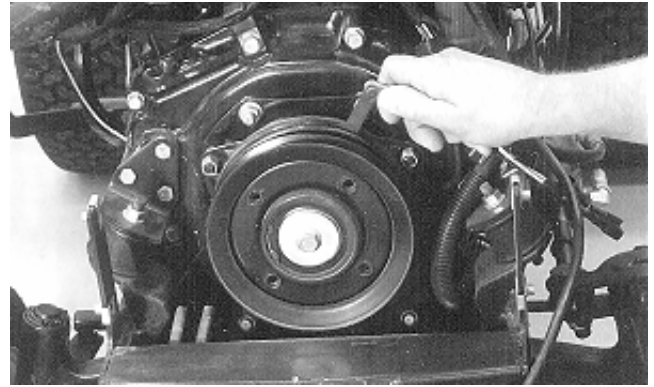

M77322 -UN-13FEB95

MX,15914005,13 -19-13JUL95

## INSTALL FRONT PTO CLUTCH—430

**IMPORTANT:** Make sure clutch wire lead is in same position as when removed, to prevent shorting of wires.

1. Install field coil and fasten with four cap screws and lock washers (C). Be sure centering lugs on backside of coil are properly seated in engine face. Tighten cap screws.

2. Install PTO clutch wire lead in clip (B) and tighten cap screw.

3. Connect PTO wire lead (A).

4. Install rotor and key.

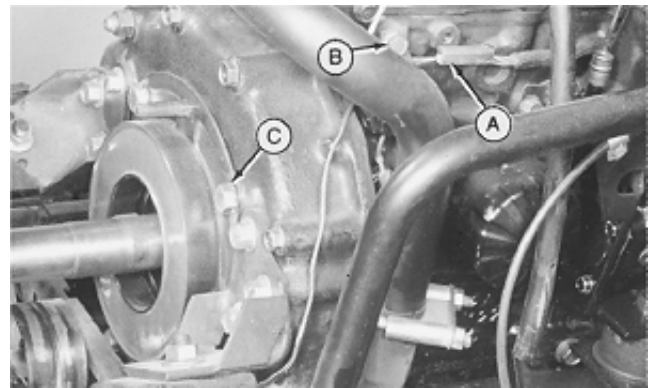

M36627 -UN-25JAN90

MX,15914005,14 -19-13JUL95

5. Install armature assembly. Make sure slot in hub aligns with shaft key.

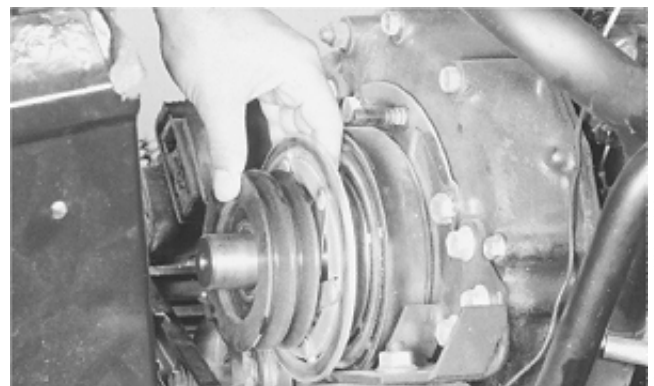

M36625 -UN-25JAN90

MX,15914005,15 -19-13JUL95

6. Install three springs (B).
7. Push idler (A) back and install brake plate.
8. Install three lock nuts (A). DO NOT tighten nuts.

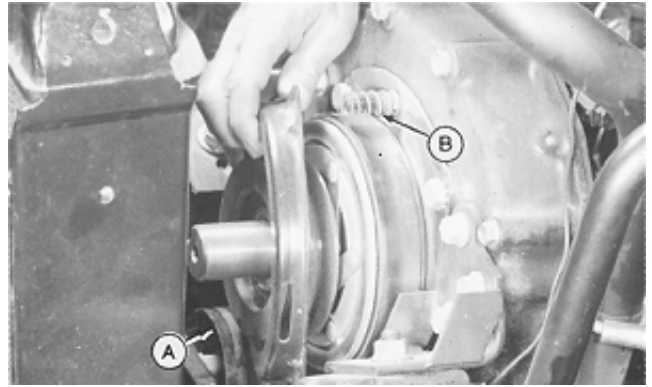

M36624  
-JUN-25/JAN90

MX,15914005,16 -19-13JUL95

9. Put a 0.46 mm (0.018 in.) flat feeler gauge through slots in brake plate between rotor and armature. Turn lock nuts until space between rotor and armature is 0.46 mm (0.018 in.). Be sure all three nuts are adjusted so space between armature and rotor is adjusted to specification at each of three slots in brake plate.
10. After adjusting, turn ignition switch ON. Move PTO switch ON and OFF several times to seat parts. Turn ignition switch OFF. Recheck clearance and adjust as necessary.

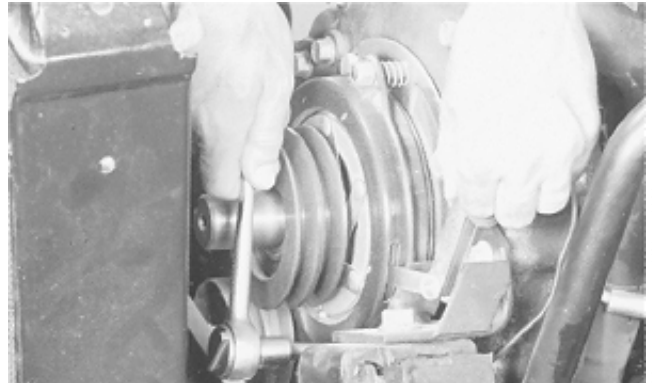

M36629  
-JUN-25/JAN90

MX,15914005,17 -19-13JUL95

11. Install PTO clutch belts.
12. Install idler adjustment assembly.
13. Lubricate idler shaft with multipurpose grease.
14. Adjust PTO belt tension; tighten nut until spring measures 35 mm (1.380 in.).

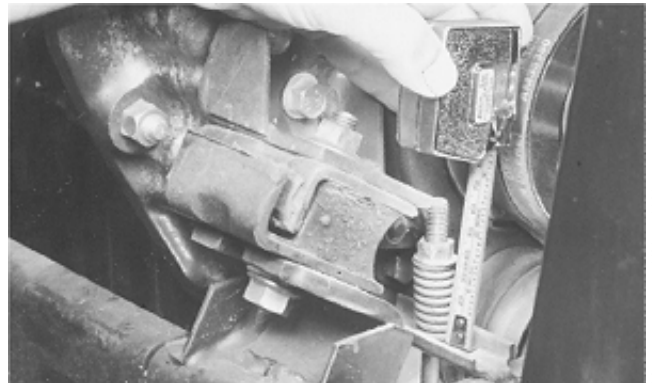

M36630  
-JUN-25/JAN90

MX,15914005,18 -19-13JUL95

15. Install fan spacer with grooved end of spacer facing away from engine.

16. Install fan.

17. Apply thread lock and sealer (medium strength) to threads of cap screw. Install cap screw and tighten to 47 N·m (35 lb-ft).

18. Install radiator.

19. Close drain valve and fill radiator with proper coolant until coolant is 13—25 mm (0.500—1 in.) below bottom of filler neck. (See Engine Coolant in Section 10, Group 25.)

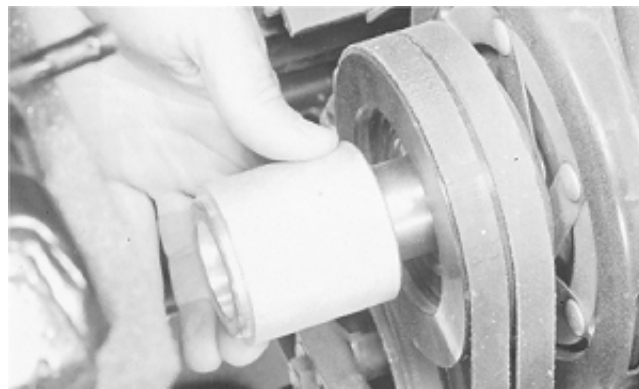

M/36621 -UN-25JAN90

40-05-9

MX,15914005,19 -19-13JUL95

40  
05  
10

# Section 50

# POWER TRAIN REPAIR

## Contents

	Page	Page
<b>Group 05—Transmission</b>		
Other Materials . . . . .	50-05-1	
Service Parts Kits . . . . .	50-05-1	
Charge Pump		
Remove and Install . . . . .	50-05-2	
Disassemble and Inspect . . . . .	50-05-3	
Assemble . . . . .	50-05-4	
Remove and Install		
Charge Relief Valve . . . . .	50-05-5	
Implement Relief Valve . . . . .	50-05-6	
Remove Transmission . . . . .	50-05-6	
Disassemble		
Transmission Cover . . . . .	50-05-11	
Pump and Motor . . . . .	50-05-14	
Pump and Motor Housing . . . . .	50-05-16	
Assemble		
Pump and Motor Housing . . . . .	50-05-19	
Pump and Motor . . . . .	50-05-21	
Transmission Cover . . . . .	50-05-22	
Install Transmission . . . . .	50-05-25	
 <b>Group 10—Transmission Control Linkage</b>		
Inspect and Repair Control Linkage—330 . . . . .	50-10-1	
Inspect and Repair Control Linkage—322, 332 and 430		
Version One—322 and 332 . . . . .	50-10-2	
Version One—430 . . . . .	50-10-3	
Version Two . . . . .	50-10-4	
Version Three . . . . .	50-10-5	
Inspect and Repair Differential Lock and Two-Speed Linkage (430) . . . . .	50-10-6	
 <b>Group 15—Differential</b>		
Other Materials . . . . .	50-15-1	
Service Parts Kits . . . . .	50-15-1	
Remove and Install . . . . .	50-15-2	
Disassemble and Inspect . . . . .	50-15-2	
Assemble . . . . .	50-15-12	
 <b>Group 20—Rear Axles</b>		
Other Materials . . . . .	50-20-1	
Remove . . . . .	50-20-1	
Install . . . . .	50-20-4	
 <b>Group 25—Drive Shaft—322, 330 and 332</b>		
Other Materials . . . . .	50-25-1	
Remove and Install—322 and 332 . . . . .	50-25-2	
Remove and Install—330 . . . . .	50-25-3	
Disassemble and Inspect . . . . .	50-25-4	
Assemble . . . . .	50-25-5	
 <b>Group 26—Drive Shaft—430</b>		
Other Materials . . . . .	50-26-1	
Remove and Install		
Early Models . . . . .	50-26-1	
Later Models . . . . .	50-26-4	
Disassemble and Inspect . . . . .	50-26-5	
Assemble . . . . .	50-26-7	



**OTHER MATERIAL**

<b>Number</b>	<b>Name</b>	<b>Use</b>
M79292	MPG-2® Multi-Purpose Polymer Grease	Prevents parts from seizing. Apply to splines of transmission input shaft.

*®MPG-2 is a registered trademark of DuBois USA.*

MX,15905005,OTH-19-07MAR95

**SERVICE PARTS KITS**

The following kits are available through your parts catalog:

Charge Relief Valve Shim Pack Kit

Implement Relief Valve Shim Pack Kit

Differential Frame Support Bracket Replacement Kit for Early Models

Motor Valve Plate Replacement Part for Early Models

MX,15905005,KIT-19-23FEB95

50  
05  
1

## REMOVE AND INSTALL CHARGE PUMP

1. Remove fender deck and fuel tank.
2. Remove drive shaft. (See procedure in Group 25.)

**N** **CAUTION:** To avoid injury from escaping fluid under pressure, stop engine and relieve the pressure in the system before disconnecting or connecting hydraulic or other lines. Tighten all connections before applying pressure.

3. Remove two cap screws and charge pump.

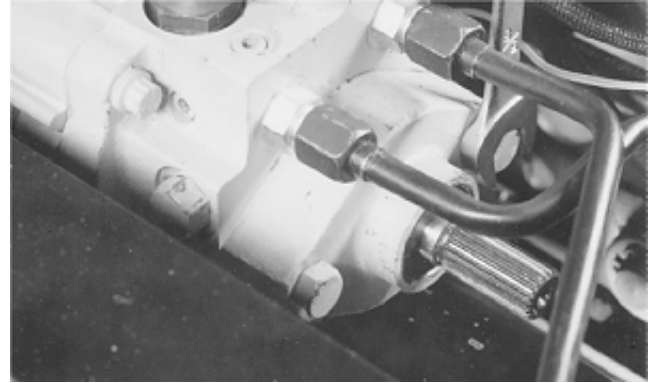
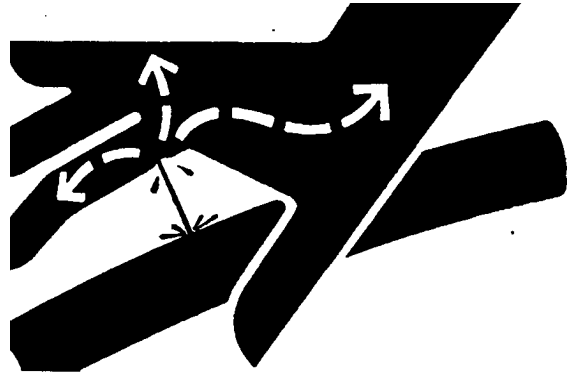

430 Shown

MX,15915005,2 -19-13JUL95

-UN-23AUG88

X9811

M36534 -UN-25JAN90



*NOTE: Transmission is removed for photographic purpose only.*

4. Remove pin (A). Inspect pin for straightness and rounded ends. Replace if necessary.
5. Inspect machined surface (B) of transmission for severe scoring. If scoring is noted replace transmission.
6. Make repairs as necessary. (See Disassemble, Inspect and Assemble Charge Pump.)
7. Installation is done in the reverse order of removal.

- Apply clean John Deere Low Viscosity HY-GARD® oil on all internal components.

- Apply petroleum jelly to pin (A) (to hold in place) and lip of oil seal.

**IMPORTANT: Tape end of transmission input shaft to prevent seal damage during charge pump installation.**

- Apply tape around end of transmission input shaft.
- Install charge pump onto shaft. Turn pump until flat side of casting is on relief valve side.
- Install mounting cap screws and tighten to 70 N-m (52 lb-ft).
- Remove tape from shaft and apply MPG-2® Multi-Purpose Polymer Grease on splines.

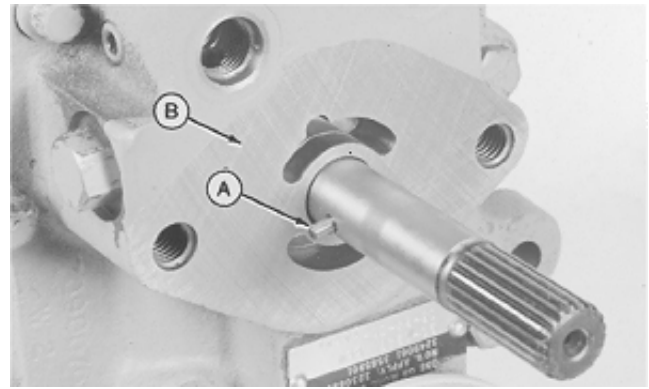

M36084 -UN-29AUG88

MX,15905005,3 -19-07MAR95

## DISASSEMBLE AND INSPECT CHARGE PUMP

1. Remove inner ring and rotor ring (A).
2. Remove O-ring (B).

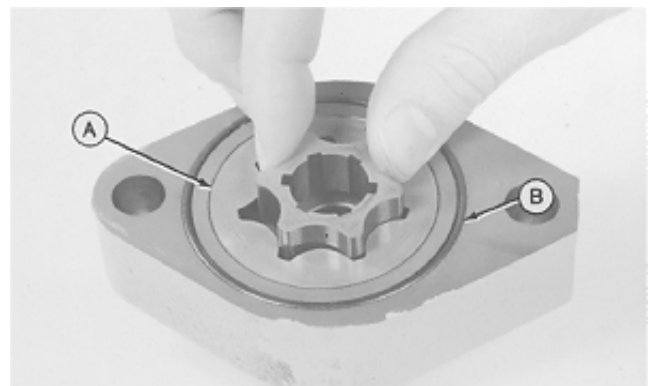

M36085 -UN-29AUG88

MX,15905005,4 -19-23FEB95

## Transmission/Charge Pump

3. Inspect inner ring key way for damage or shear pin debris.
4. Inspect rotor ring (A) for cracks or signs of scoring on the outer edge.
5. Inspect gerotor set for wear or damage. If any component is worn or damaged, replace gerotor set as an assembly.

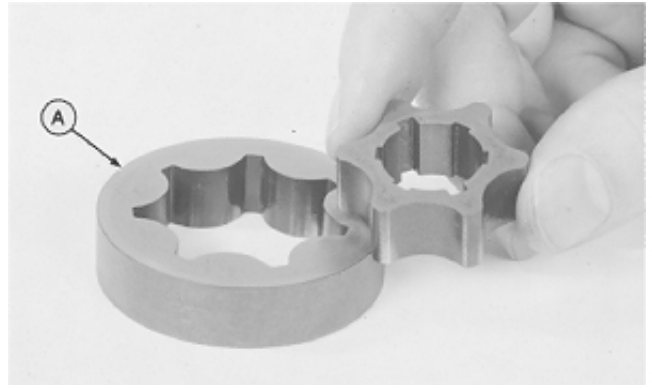

MX,15905005,5 -19-23FEB95

M36086 -UN-29JAN90

6. Pry out seal using a screwdriver.

*NOTE: Bearing is press-fit in housing. Remove bearing only if replacement is necessary.*

7. Inspect bearing for wear or damage. Remove bearing using a driver set.
8. Inspect housing for wear or damage. Replace entire charge pump if necessary.

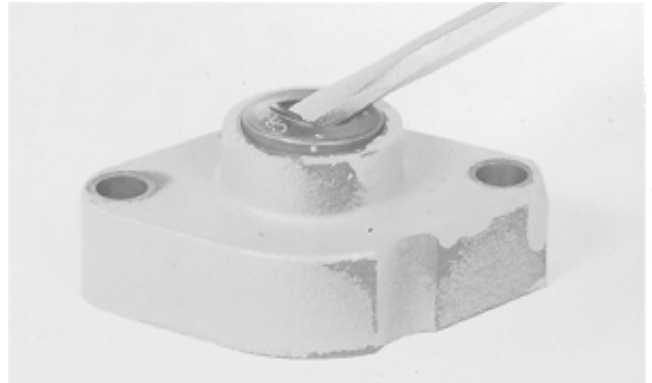

MX,15905005,6 -19-23FEB95

M36087 -UN-29AUG88

## ASSEMBLE CHARGE PUMP

**IMPORTANT: Always use new seals and O-rings. Damaged or used parts will leak.**

*NOTE: Lubricate all seals and O-rings with petroleum jelly during assembly.*

1. Apply clean John Deere Low Viscosity HY-GARD® oil on all internal parts.
2. If removed, press bearing into housing using a 1-1/8 in. driver disk. Install bearing until flush with housing surface.
3. Install new seal using a 1-5/8 in. driver disk. Install seal with lip (spring side) toward inside of housing.



MX,15905005,7 -19-23FEB95

M36089 -UN-29AUG88

4. Install new O-ring (B). Apply petroleum jelly to seal and housing to hold O-ring in its groove.

5. Install rotor ring (A) and inner ring. The gerotor set must spin freely in housing.

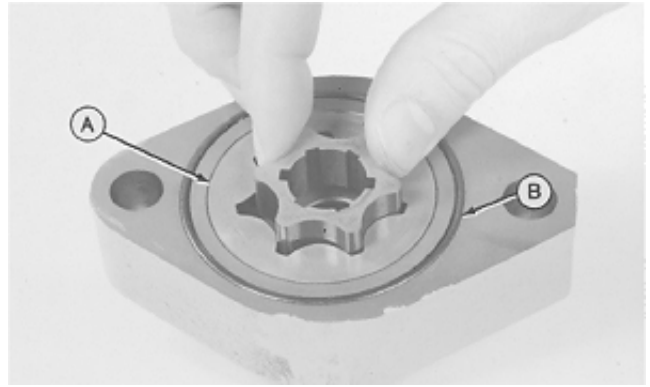

MX,15905005,8 -19-23FEB95

M36085 -UN-29AUG88

### REMOVE AND INSTALL CHARGE RELIEF VALVE

1. Remove fender deck and fuel tank.
2. Remove charge relief valve plug from right side of transmission housing.

**IMPORTANT:** If relief valve is being disassembled to be cleaned, the same number and thicknesses of shims must be installed when assembled.

3. Remove shims (A) if equipped, spring and valve.
  4. Inspect valve and housing for wear or damage. Valve must slide freely in bore. Replace parts if required.
  5. Installation is done in the reverse order of removal.
- Apply clean John Deere Low Viscosity HY-GARD® oil on valve and spring.

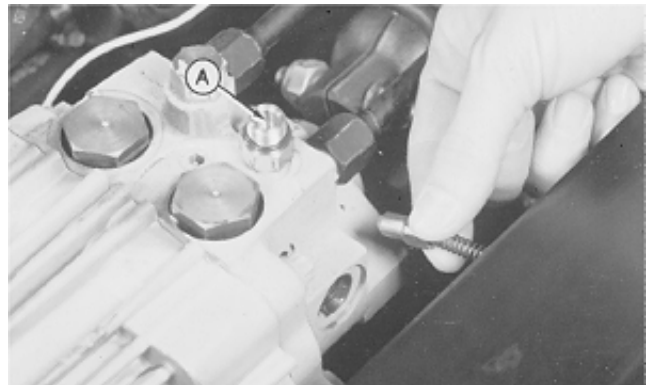

430 Shown

MX,15915005,3 -19-13JUL95

M36537 -UN-25JAN90

5050

## REMOVE AND INSTALL IMPLEMENT RELIEF VALVE

1. Remove fender deck and fuel tank.
2. Remove implement relief valve plug from top of transmission housing.

**IMPORTANT: If relief valve is being disassembled to be cleaned, the same number and thicknesses of shims must be installed when assembled.**

3. Remove shims (A) if equipped, spring and valve.
4. Inspect valve and housing for wear or damage. Valve must slide freely in bore. Replace parts as necessary.
5. Installation is done in the reverse order of removal.
  - Apply clean John Deere Low Viscosity HY-GARD® oil on valve and spring.

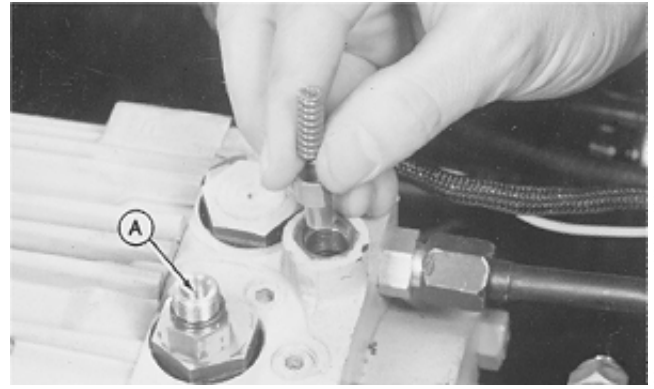

430 Shown

M36539 -UN-25JAN90

MX,15915005,4 -19-13JUL95

## REMOVE TRANSMISSION

1. Remove drain plug (A) to drain transmission oil. Approximate capacity is 4.7 L (5 U.S. qt).
2. Remove fender deck and fuel tank.
3. Remove belly screen/pan.

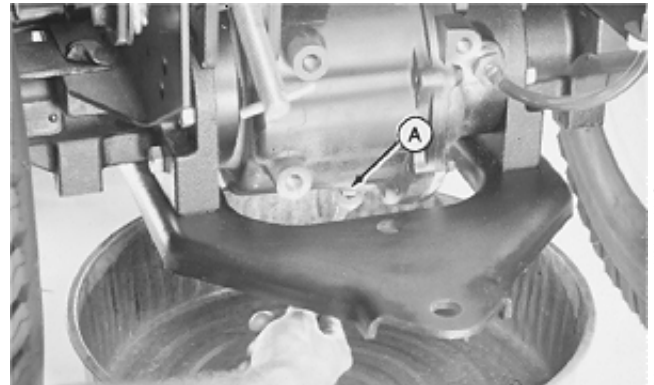

MX,15905005,11 -19-23FEB95

M33430 -UN-25AUG88

4. Loosen two lock nuts and cap screws, if equipped.
5. On 330; Remove deflector shields with foam at rear of transmission.
6. Remove hydraulic pressure line (A) and return line (B). Close all openings with caps and plugs.

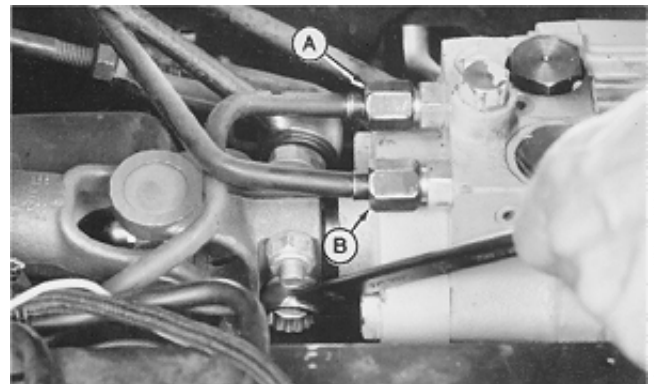

430 Shown

MX,15915005,5 -19-13JUL95

M36540 -UN-25JAN90

## Transmission/Remove Transmission

**NOTE:** There are different versions of the swashplate control arm. Also, attaching swashplate control arm to the control shaft on transmission is different. Some machines use a safety wire and roll pin, others use a nut and cap screw.

7. Remove safety wire and roll pin (A) or nut and cap screw to disconnect transmission control linkage.

Early Model Shown

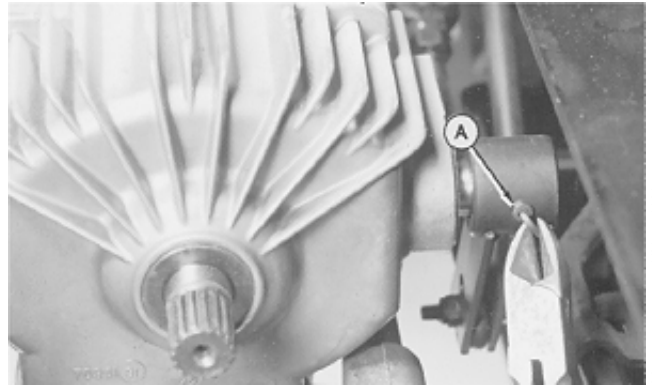

M36541  
-UN-25JAN90

MX,15915005,6 -19-13JUL95

8. Disconnect two hoses (A and B).

9. Disconnect oil fill tube hose (C).

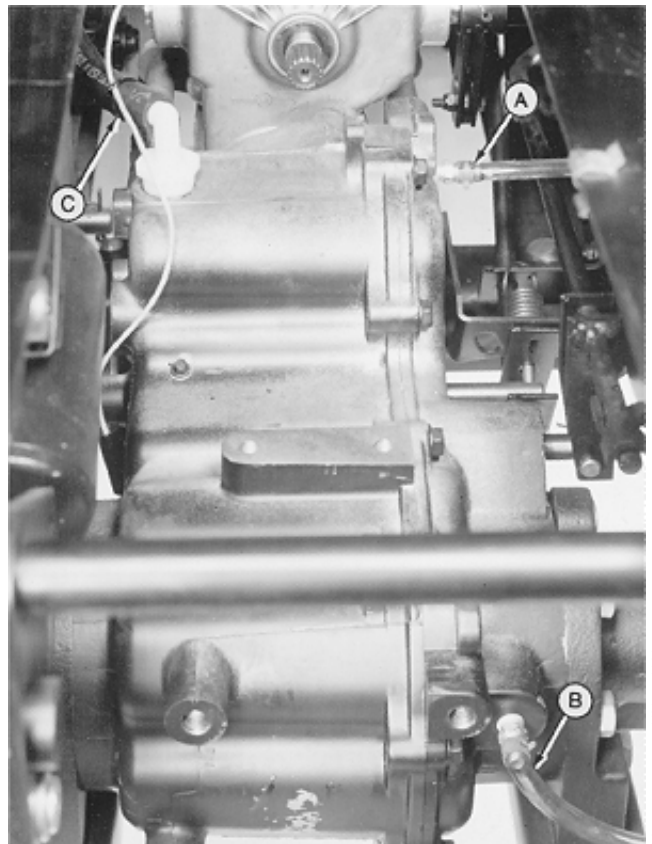

M36542  
-UN-25JAN90

MX,15915005,7 -19-13JUL95

*NOTE: Steps 10 through 12 are for 430 only. Go to Step 13 to continue removal procedures for all machines.*

10. Move 2-speed axle shift lever to fast (rabbit) position to aid in removal of linkage.

11. Remove cotter pin (A), washer (B) and pin (G) to disconnect two-speed differential linkage (C).

12. Remove cotter pin (F) and pin (E) to disconnect differential lock linkage (D).

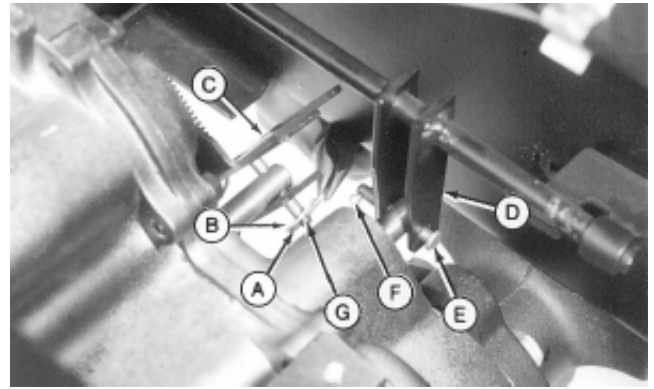

M36543 -UN-19JAN95

- A—Cotter Pin
- B—Washer
- C—Two-Speed Differential Linkage
- D—Differential Lock Linkage
- E—Pin
- F—Cotter Pin
- G—Pin

MX,15915005,8 -19-13JUL95

13. Use a floor jack to support transmission and place jack stands under tractor frame.

*NOTE: Early models had two bolts (A) attaching differential to frame support bracket (C). Later models have one shoulder bolt (A) or one bolt with a washer and spacer.*

14. Remove two bolts or shoulder bolt (A) or bolt, washer and spacer.

15. Disconnect suction hose (B) from transmission. Close all openings using caps and plugs.

16. Disconnect all other mounting bolts, hoses and clamps needed to remove the transmission and differential.

**IMPORTANT: It is recommended to replace the early model differential frame support bracket (C) with the later configuration (D). The early models attached the differential to the frame support bracket with two bolts (A). One in the differential case and the other in the differential cover. When the machine went over rough terrain, the flexing of the cover and case caused the differential gasket to leak. With the later model frame support bracket installed, the slotted hole and single shoulder bolt (A) (attached to the case only) will allow for flexing, eliminating any possible leaks.**

17. Early models; Remove differential frame support bracket (C).

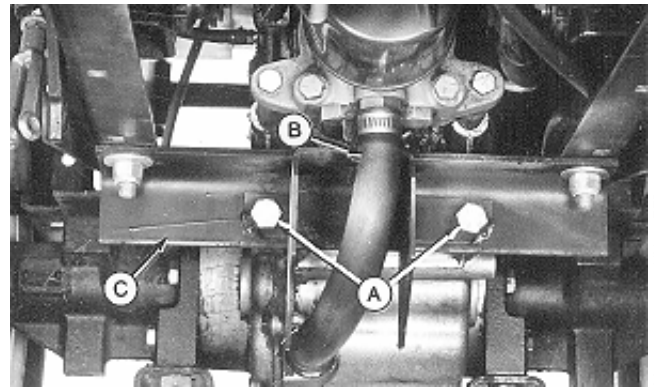

Early Models

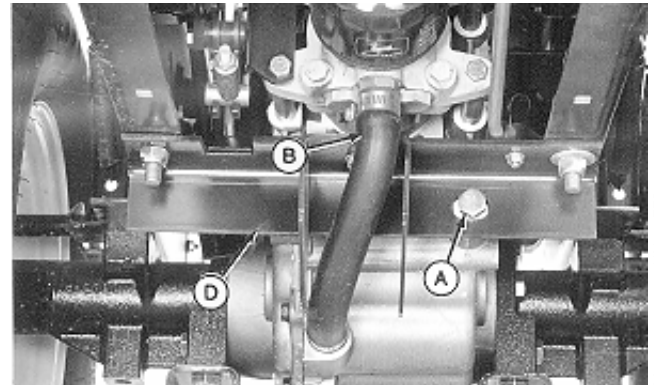

Later Models

- A—Bolt(s)
- B—Suction Hose
- C—Differential Frame Support Bracket (Early Models)
- D—Differential Frame Support Bracket (Later Models)

MX,15915005,9 -19-13JUL95

*NOTE: Disconnect brakes on both sides of machine.*

18. Disconnect spring (A).
19. Remove nut (B), plate or washer (D) and spring (C).
20. Bend tabs (F) flat. Remove two cap screws (E) from each side of machine.
21. Lower differential and transmission assembly and roll away from frame.

- A—Return Spring
- B—Nut
- C—Spring
- D—Plate (Early 430)  
—Washer (All and Later 430)
- E—Mounting Cap Screw (2 used)
- F—Lock Plate Tab

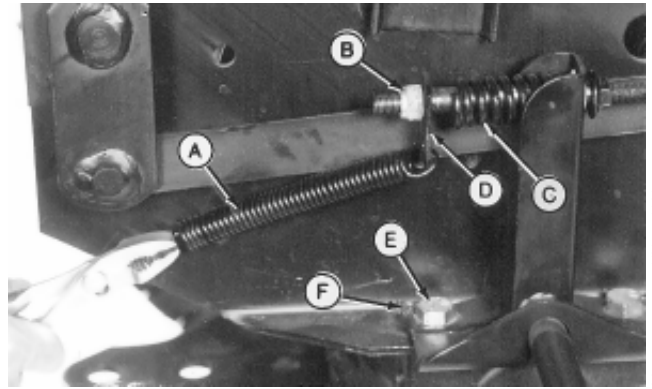

Early 430

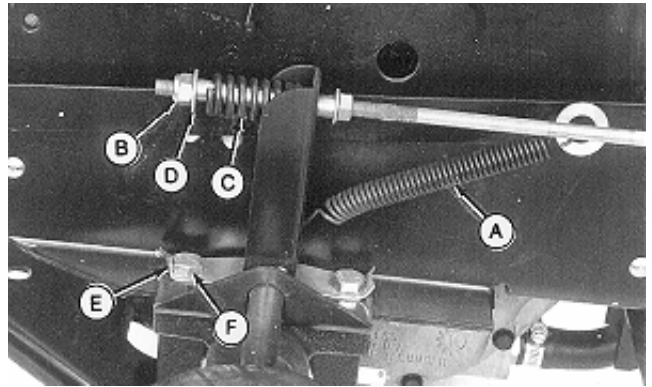

All and Later 430

MX,15915005,10 -19-13JUL95

22. Thoroughly clean outside surface of differential assembly with steam cleaner or cleaning solvent.

**IMPORTANT: Mark spacers and cap screws before disassembly. Each spacer must be installed in its original location.**

23. Remove four cap screws and spacers (A) to remove transmission.
24. Make repairs as necessary. (See procedures in this group.)

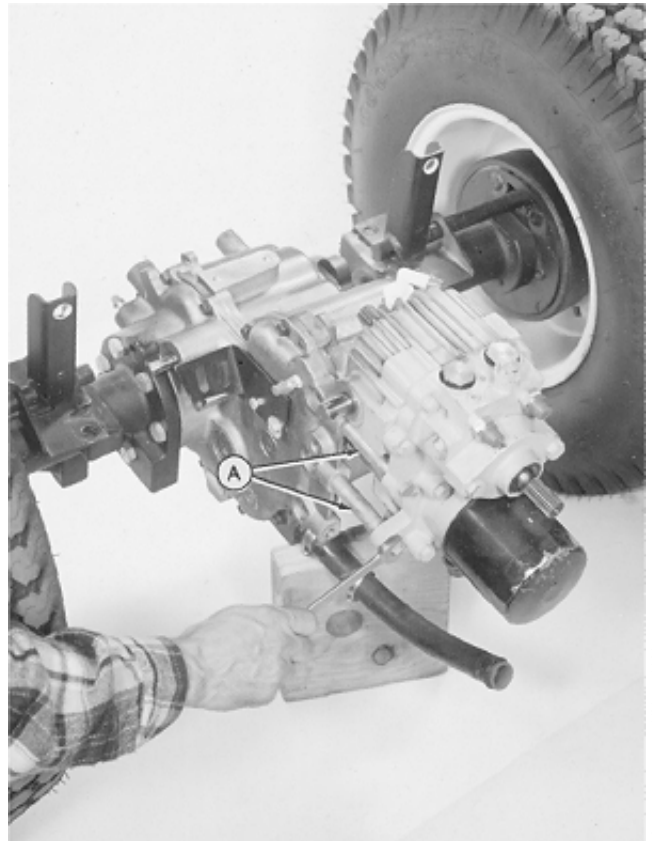

MX,15915005,11 -19-13JUL95



## DISASSEMBLE TRANSMISSION COVER

1. Thoroughly clean outside surface of transmission using a steam cleaner or cleaning solvent.
2. Install transmission on a bench fixture.
3. Remove charge pump (B). (See procedure in this group.)
4. Remove implement relief valve (D). (See procedure in this group.)
5. Remove charge relief valve (C). (See procedure in this group.)
6. Remove filter (A).

A—Oil Filter  
 B—Charge Pump  
 C—Charge Relief Valve  
 D—Implement Relief Valve

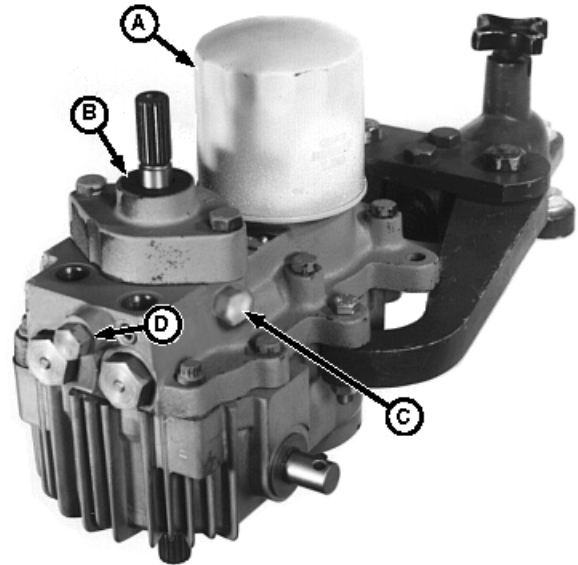

-JUN-21FEB95

M77333

50-05-11

MX,15905005,19 -19-14MAR95

7. Remove hose connector.
8. Remove two plugs and O-rings (A).

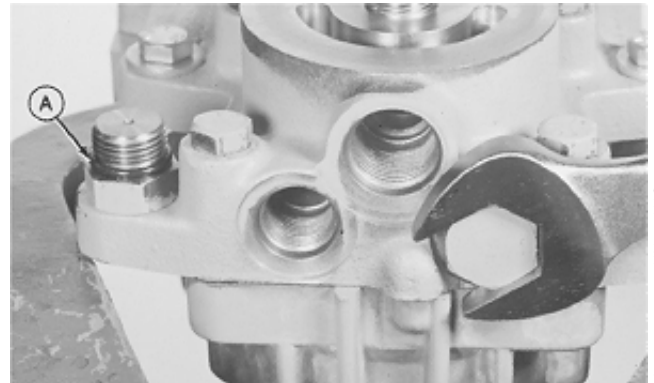

-JUN-29AUG88

M36100

5M3,5005K,O -19-18DEC87

9. Remove two check valves.

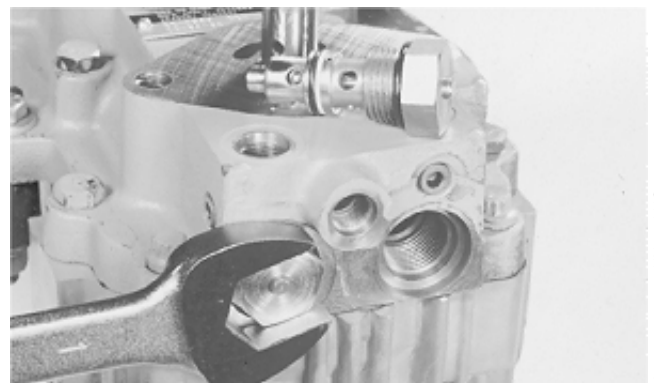

-JUN-29AUG88

M36101

5M3,5005K,P -19-18DEC87

10. Remove O-ring, backup ring (B) and O-ring (A).

*NOTE: Originally equipped 430 transmissions do not have manually operated check valves. If check valves have been replaced; service replacements will have manually operated check valves.*

11. Internal valve (C) must move freely inside check valve.

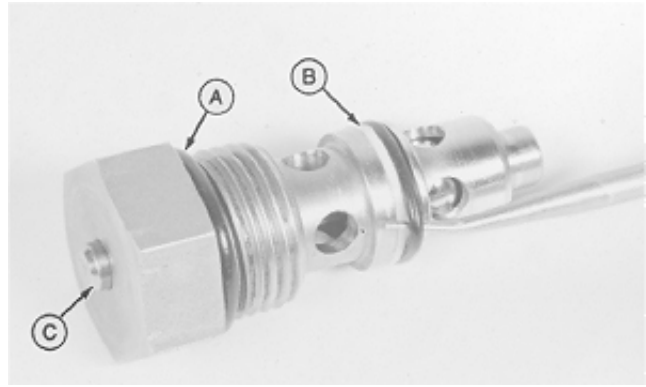

M36102  
-UN-29AUG88

MX,15915005,17 -19-13JUL95

12. Remove four pipe plugs.

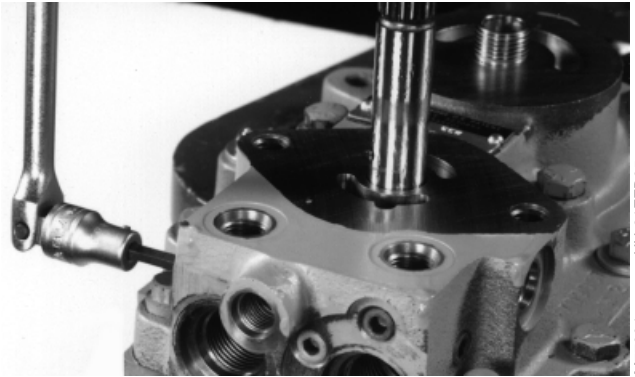

M77534  
-UN-21FEB95

MX,15905005,41 -19-14MAR95

13. Remove snap ring to remove output shaft drive gear.

14. Remove O-ring.

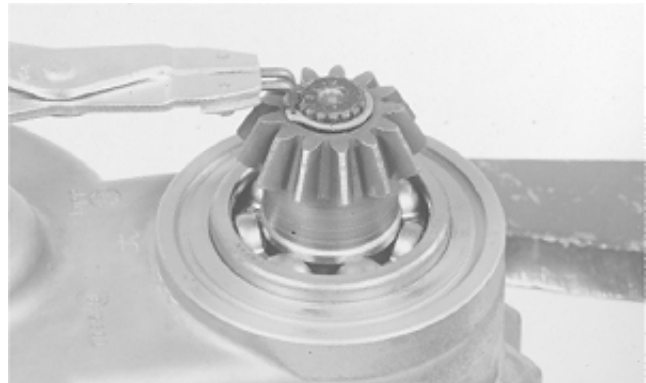

M36104  
-UN-29AUG88

5M3,5005K,S -19-18DEC87

**IMPORTANT: Do not disassemble the transmission any further while in the bench fixture.**

15. LOOSEN eight cap screws (do not remove). Remove transmission from bench fixture.

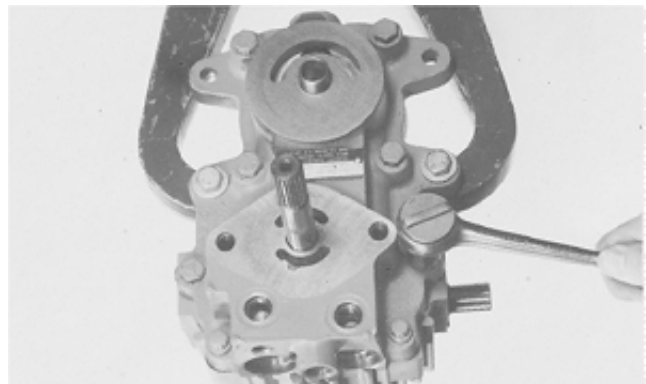

M36522  
-UN-25JAN90

5M3,5005K,T -19-18DEC87

**IMPORTANT: Do not allow internal parts to fall when removing center section.**

16. Put transmission on work bench and remove cap screws, center section and gasket (A).

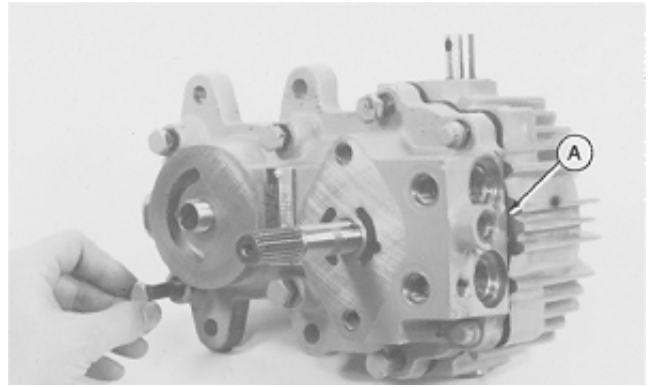

M36523 -UN-25JAN90

5M3,5005K,U -19-18DEC87

**IMPORTANT: Do not nick or scratch lapped or machined surfaces of the center section, valve plates or cylinder blocks.**

**Keep pump and motor components separate, they are not interchangeable.**

17. Remove valve plates (A and B). If it is necessary to pry valve plates loose from center section, use a wooden dowel and pry only at dowel pin grooves.

If valve plates do not come off with center section, remove valve plates from cylinder block assemblies.

It may be necessary to apply diesel fuel between valve plate and cylinder block to cut oil film.

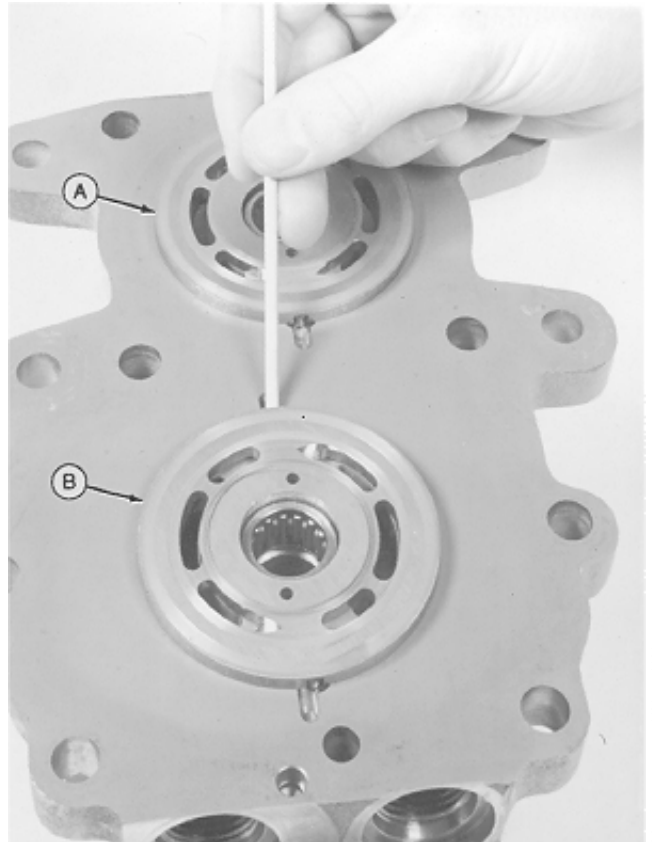

M36107 -UN-31JAN90

5M3,5005K,V -19-19DEC87

18. Inspect bearing plates. Bearing plates should be flat, free of all nicks, burrs, scratches and erosion around the ports. The bronze metal should show no scoring, smearing or be discolored.

*NOTE: Scoring is indicated by fine scratches or grooves cut into the plate.*

*When these scratches can be detected by feel, finger nail or lead pencil, the plate should be replaced.*

*Some models may have a narrow slot (A) rather than a wide slot (B). While others may NOT have slots at all.*

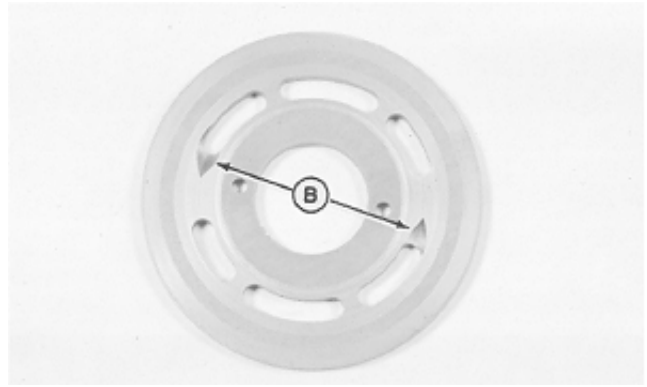

M49510 -UN-20DEC89

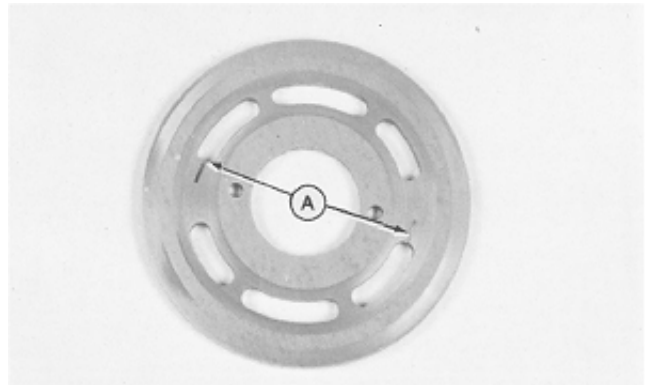

M49511 -UN-20DEC89

MX,15905005,20 -19-23FEB95

19. Inspect both bearings in center section, replace if necessary.

20. Install center section in bench fixture and remove bearing using a 2-jaw puller and a slide hammer.

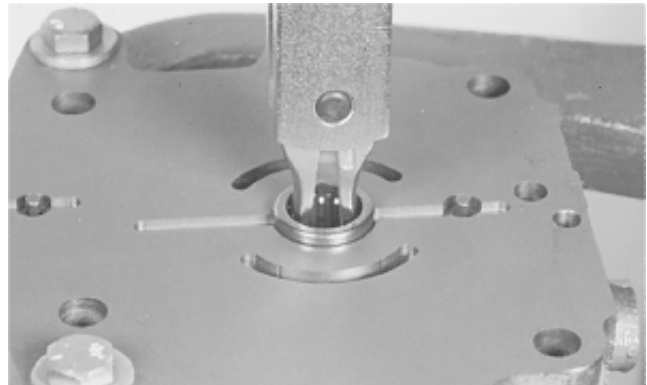

M36109 -UN-29AUG88

5M3,5005K,X -19-18DEC87

## DISASSEMBLE PUMP AND MOTOR

**IMPORTANT:** Do not nick or scratch lapped surface of cylinder blocks.

**Piston-to-Bore relationship need not be maintained; keep pump and motor components separate, they are not interchangeable.**

1. Remove motor and pump cylinder blocks.

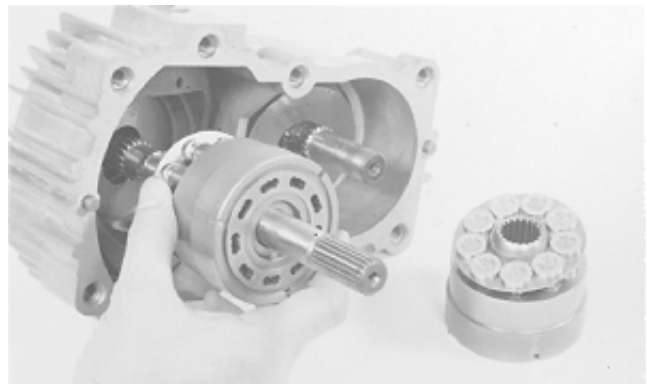

M36110 -UN-29AUG88

MX,15905005,21 -19-23FEB95

2. Inspect cylinder block assemblies.

**IMPORTANT: Do not interchange pistons between motor and pump cylinder blocks. Pistons and cylinder blocks are matched.**

Lift piston retainer and pistons from cylinder block.  
Check for free movement of pistons in cylinder bores.



M45,5005A,51 -19-11JAN85

M36111 -UN-29AUG88

3. Remove and inspect all pistons.

Check barrel (B) for scoring, discoloration, or any signs of separation of slippers.

Check slipper (A) for scoring, smearing, rolled edges and a full 360° free rotation on barrel.

Check lubrication hole (C) for blockage. Clean with compressed air.

If any component of the piston is damaged, the cylinder block assembly must be replaced.



M45,5005A,52 -19-11JAN85

M36112 -UN-29AUG88

4. Remove and inspect both piston retainers.

Check retainer for flatness, nicks, burrs and discoloration.

Check area around piston slippers (A) for scoring.

If any part of the piston retainer is damaged, the cylinder block assembly must be replaced.

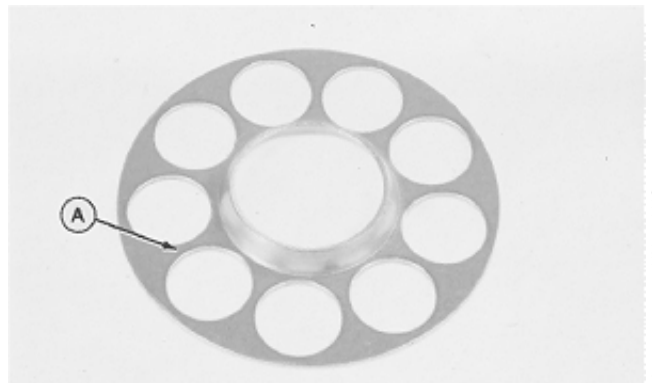

M45,5005A,53 -19-11JAN85

M36113 -UN-29AUG88

5. Inspect both cylinder blocks.

Check ball guide area (A) for scoring, wear and damage.

Check nine cylinder bores (B) for burrs and scoring.

Check lapped surface (C) for wear and damage.

Check spring assembly (D) for damage and free movement.

If any part of the cylinder block is damaged, the cylinder block assembly must be replaced.

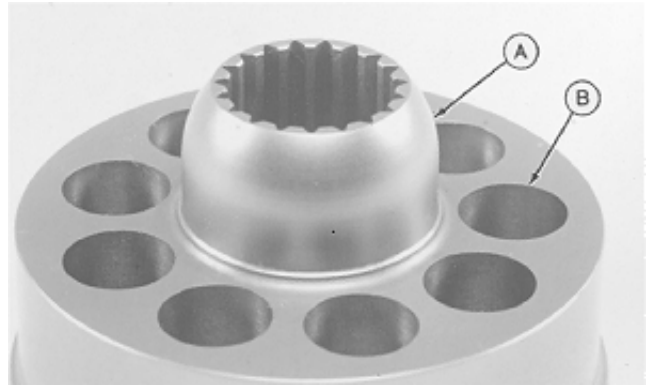

M36114 -UN-29AUG88

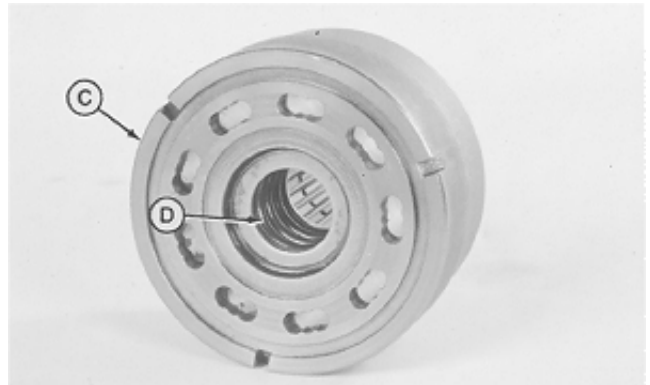

M36115 -UN-29AUG88

M45,5005A,54 -19-11JAN85

**IMPORTANT: Do not scratch machined surfaces of thrust plates or swashplates.**

6. Remove pump and motor thrust plates using a brass O-ring pick.

7. Inspect thrust plates. Check plates for scoring and smeared bronze material.

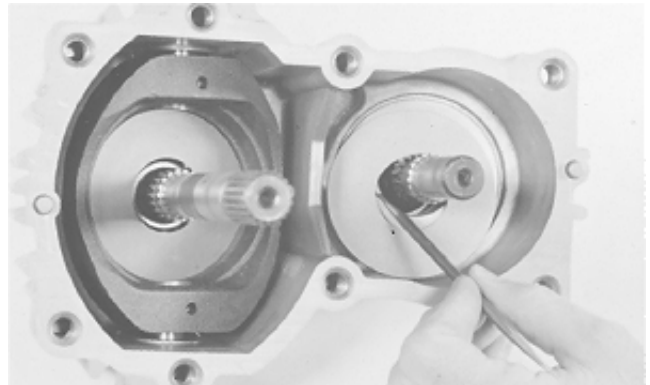

M36116 -UN-29AUG88

M45,5005A,55 -19-11JAN85

### DISASSEMBLE PUMP AND MOTOR HOUSING

1. Remove snap ring and washer (A) from both trunnion and control shafts.

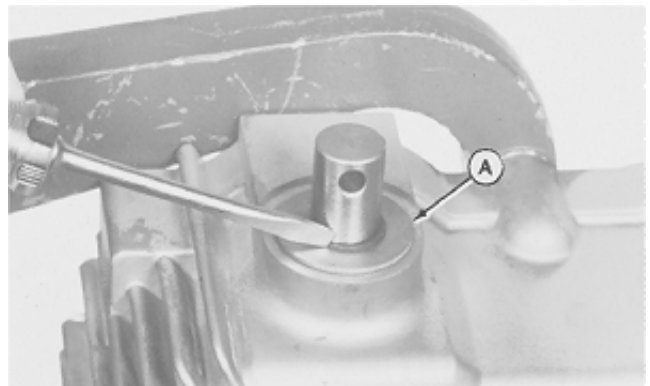

M36524 -UN-25JAN90

MX,15905005,22 -19-23FEB95

50  
05  
16

**IMPORTANT:** Pump shaft and bearing assembly could restrict movement of swashplate. Full swashplate movement is approximately 25 mm (1 in.) in each direction. If necessary tap shaft with a soft faced hammer.

2. Push top of swashplate (C) down until it contacts the stops in the housing.

**IMPORTANT: DO NOT** drive pins after they bottom. Housing damage will result.

3. Drive pin (B) until it bottoms in housing.

4. Drive two pins (D) until the lower one bottoms in housing.

5. Turn swashplate to the neutral position. Pins should fall into housing.

6. Repeat the above steps to remove second pin (D).

7. Remove control shaft (E) and trunnion shaft (A) to remove swashplate.

8. Inspect swashplate and motor housing (F).

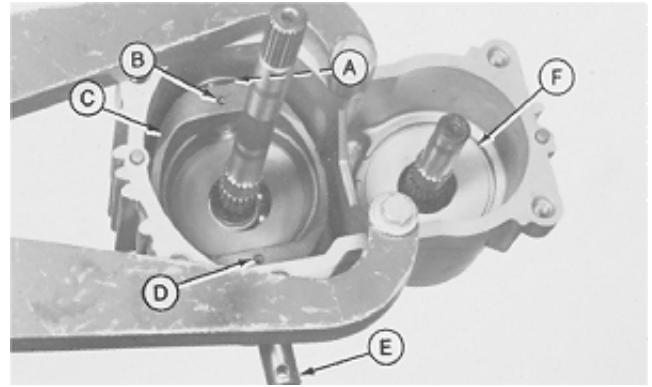

A—Trunnion Shaft  
 B—Spring Pin  
 C—Pump Swashplate  
 D—Spring Pin (2 used)  
 E—Control Shaft  
 F—Motor Housing

M36525 -UN-25JAN90

50  
05  
17

5M3,5005K,Z -19-18DEC87

9. Remove pump shaft.

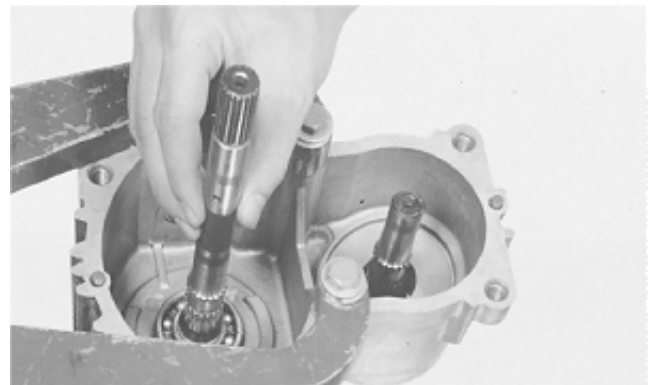

M45,5005A,58 -19-11JAN85

M36119 -UN-29AUG88

10. Inspect bearing, replace if necessary.

**IMPORTANT: Be sure to hold shaft while removing bearing.**

11. Remove bearing using a 1 in. driver disk (A), bearing puller attachment and a press.

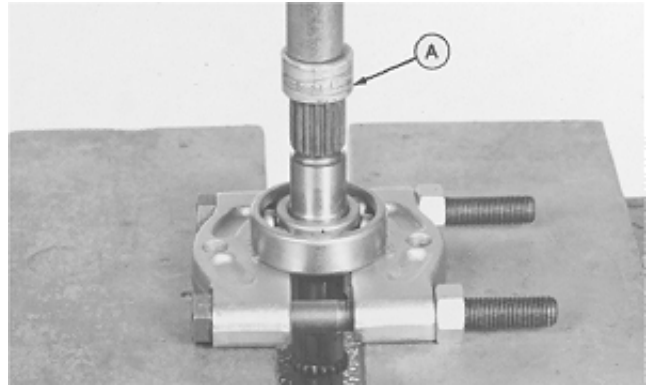

M45,5005A,59 -19-13MAR85

M36120 -UN-29AUG88

12. Remove three seals from housing.

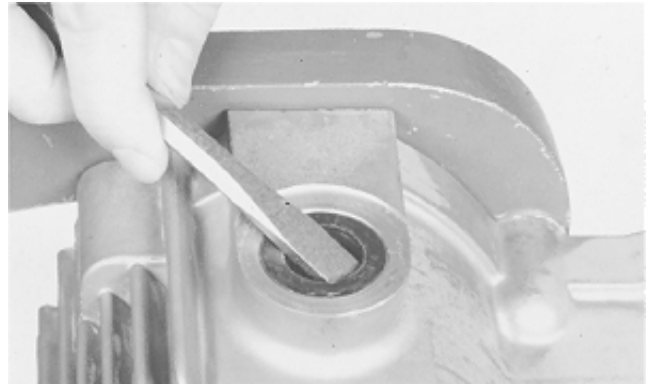

M45,5005A,60 -19-11JAN85

M36121 -UN-29AUG88

*NOTE: Some transmissions will have bearings, while others will have bushings.*

13. Inspect trunnion bearing and control shaft bearing. Replace if necessary.

14. Drive bearings or bushings through housing using a 13/16 in. driver disk (A) for bearings and a 7/8 in. driver disk for bushings.

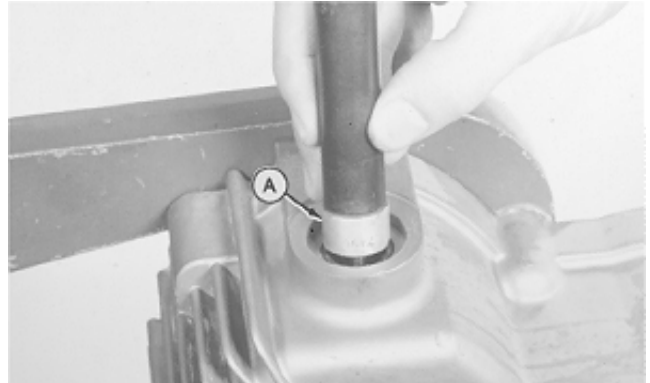

5M3,5005K,AA -19-18DEC87

M36122 -UN-29AUG88

**IMPORTANT: Be sure to hold shaft and bearing when removing from housing.**

15. Remove motor shaft and bearing. Using a 1-in. driver disk (A), and a press.

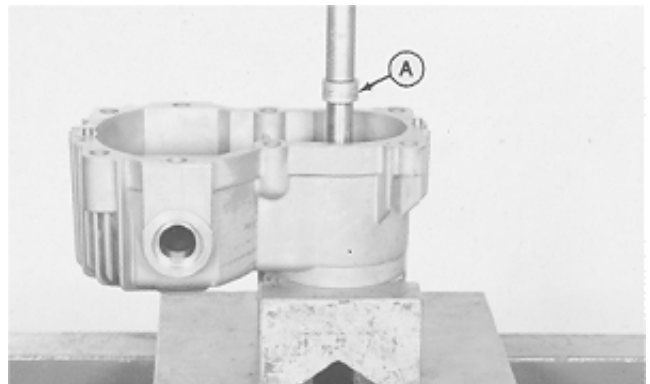

M45,5005A,62 -19-13MAR85

M36123 -UN-29AUG88

50  
05  
18



16. Inspect bearing, replace if necessary.

**IMPORTANT: Be sure to hold shaft while removing bearing.**

17. Remove bearing using a 1 in. driver disk (A), bearing puller attachment and a press.

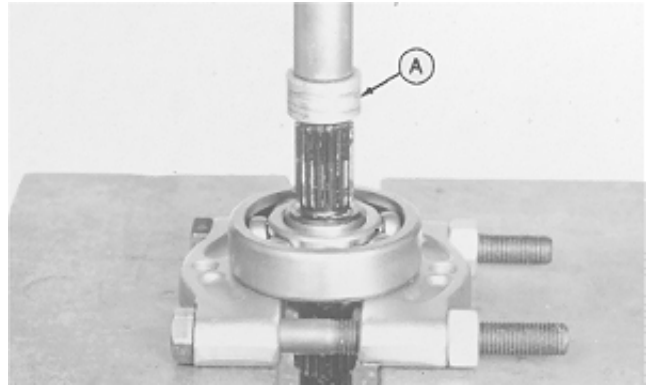

M45,5005A,63 -19-26APR85

M36124 -UN-29AUG88

### ASSEMBLE PUMP AND MOTOR HOUSING

**IMPORTANT: Always use new seals and O-rings. Damaged or used parts will leak.**

*NOTE: Lubricate all seals and O-rings with petroleum jelly during assembly.*

1. Push motor shaft into bearing until it is on the shaft shoulder using 1 in. driver disk (A), bearing puller attachment, and a press.

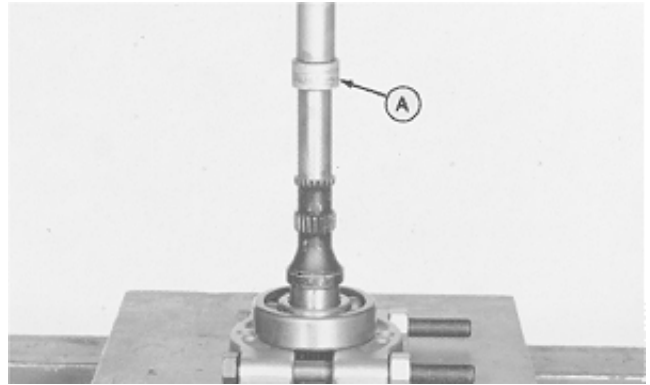

MX,15905005,24 -19-23FEB95

M36126 -UN-29AUG88

**IMPORTANT: To prevent bearing damage, press only on outer race of bearing when installing motor shaft assembly.**

2. Push motor shaft assembly into housing until bearing is at the bottom of bore using a 1-7/16 in. driver disk (A), socket (B) and a donut type disk (C) and a press.

*NOTE: There will be approximately 5 mm (3/16 in.) of the bearing race above the mounting surface.*

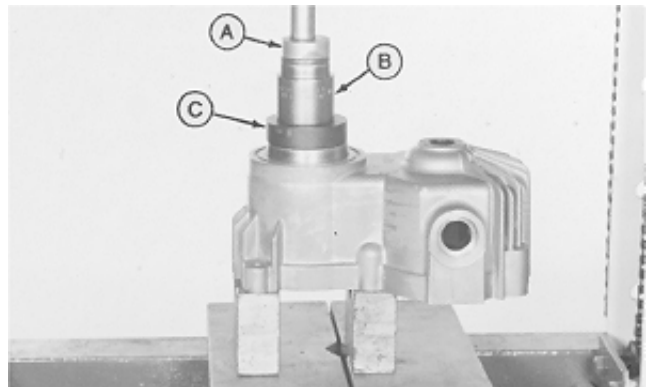

M45,5005A,66 -19-13MAR85

M36127 -UN-29AUG88

3. Install housing on bench fixture.

4. Drive bearings or bushings into housing until they are flush with surface using a 1-1/8 in. driver disk (A).

5. Install three oil seals. Install seal with lip of seal (spring side) toward inside of housing using a 1-7/16 in. driver disk.



MX,15905005,25 -19-23FEB95

M36128 -UN-29AUG88

6. Push pump shaft into bearing until it is on the shaft shoulder using a 1-in. driver disk (A) bearing puller attachment and a press.

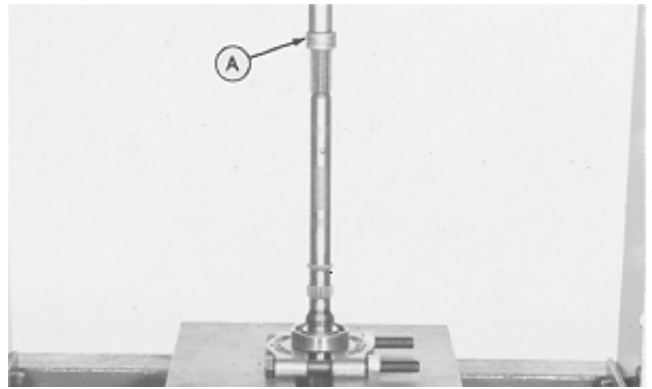

M45,5005A,69 -19-13MAR85

M36130 -UN-29AUG88

*NOTE: Tape over splines to protect seals from possible damage when installing shafts, remove tape after installation.*

7. Install pump shaft.

8. Install swashplate (C), control shaft (E), and shaft (A).

**IMPORTANT: Pump shaft and bearing assembly could restrict movement of swashplate. Full swashplate movement is approximately 25 mm (1 in.) each direction. If necessary tap shaft with a soft faced hammer to seat bearing.**

9. Drive pin (B) into swashplate and shaft until pin is about 6 mm (1/4 in.) below swashplate surface.

10. Drive two pins (D) into swashplate and control shaft until top pin is about 6 mm (1/4 in.) below swashplate surface.

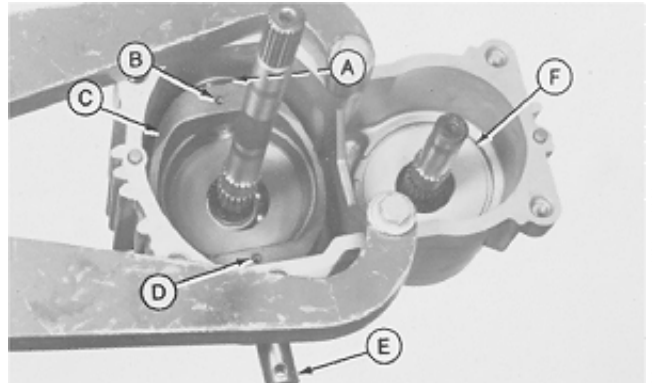

A—Trunnion Shaft  
B—Spring Pin  
C—Pump Swashplate  
D—Spring Pin (2 used)  
E—Control Shaft  
F—Motor Housing

M36525 -UN-25JAN90

MX,15905005,26 -19-23FEB95

11. Install washer (A) and snap ring on trunnion and control shaft.

12. Remove housing from bench fixture.

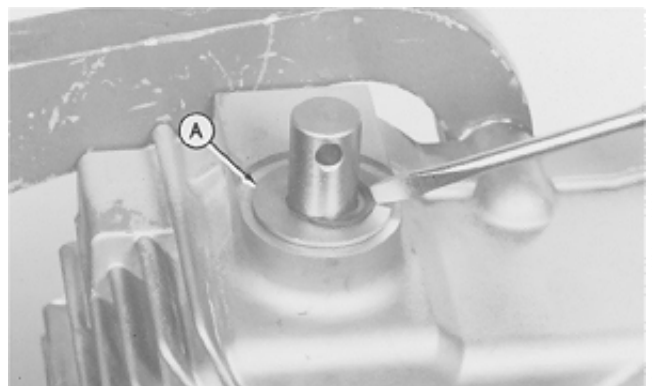

5M3,5005K,AF -19-18DEC87

M36526 -UN-25JAN90

50  
05  
20

## ASSEMBLE PUMP AND MOTOR

**IMPORTANT:** Do not nick or scratch lapped surface of cylinder blocks.

**Piston-to-Bore relationship need not be maintained; keep pump and motor components separate, they are not interchangeable.**

1. Put clean John Deere Low Viscosity HY-GARD® oil or an equivalent on all internal parts.
2. Install pump and motor thrust plates.

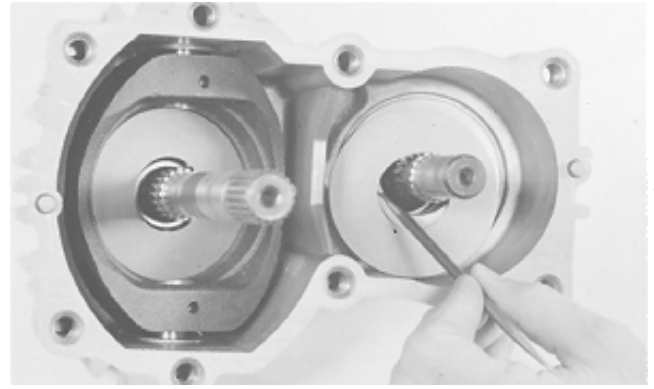

M36116 -UN-29AUG88

MX,15905005,27 -19-23FEB95

3. Install pistons and piston retainer.

Lift piston retainer and piston from cylinder block. Check for free movement of pistons in cylinder block before installing in housing.



M36111 -UN-29AUG88

M45,5005A,74 -19-14JAN85

4. Install pump and motor cylinder blocks.

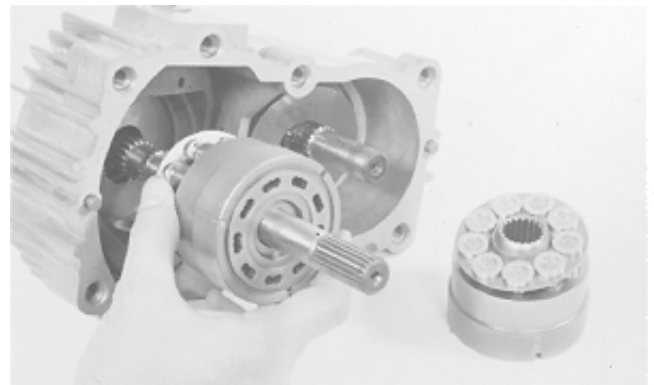

M36110 -UN-29AUG88

M45,5005A,75 -19-14JAN85

## ASSEMBLE TRANSMISSION COVER

**IMPORTANT:** Do not nick or scratch lapped or machined surfaces of the center section, valve plates or cylinder block.

Keep pump and motor components separate. They are not interchangeable.

Always use new seals and O-rings. Damaged or used parts will leak.

*NOTE:* Lubricate all seals and O-rings with petroleum jelly during assembly.

1. Install two needle bearings. Drive bearings into housing until they are approximately 3 mm (0.118 in.) above the surface of the housing using a 5/8 in. driver disk (A).

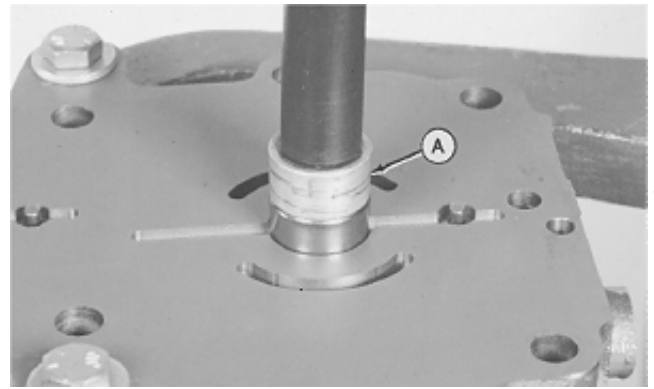

M36132 -UN-29AUG88

MX,15905005,28 -19-23FEB95

2. Put clean John Deere Low Viscosity HY-GARD® oil on valve plates and housing surface.

**IMPORTANT:** Pump valve plate (B) has TWO slotted ports (D).

Motor valve plate (A) may, or may not have slotted ports. Early models have FOUR slotted ports (C). Quiet hydro's (later models) have no slotted ports. All service or replacement plates will not have slotted ports.

*NOTE:* The motor valve plates are interchangeable between quiet hydros and early models.

3. Install pump valve plate (B) and motor valve plate (A) over the protruding bearings and align slots in plates with pins in housing.

- A—Motor Valve Plate
- B—Pump Valve Plate
- C—Slotted Ports (4) (Early Models)
- D—Slotted Ports (2)

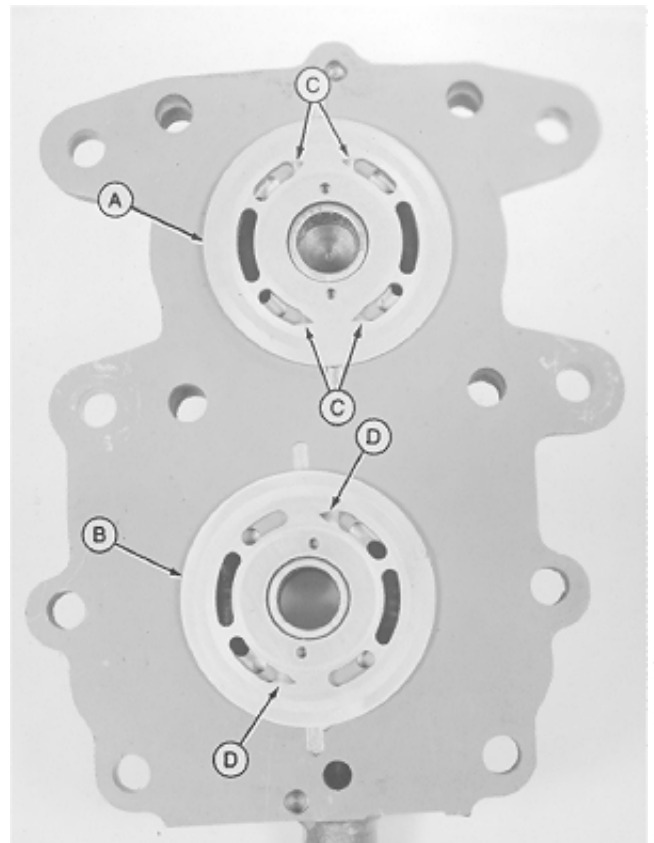

M36133 -UN-22NOV89

MX,15905005,29 -19-23FEB95

**IMPORTANT:** Use extreme care when assembling the center section, valve plates and cylinder block to avoid dropping, nicking or scratching lapped surfaces.

4. Install center section and gasket (A) on housing and install eight cap screws. Tighten cap screws evenly.

*NOTE:* Center section will seem springy, this is because the springs inside the cylinder blocks are being compressed.

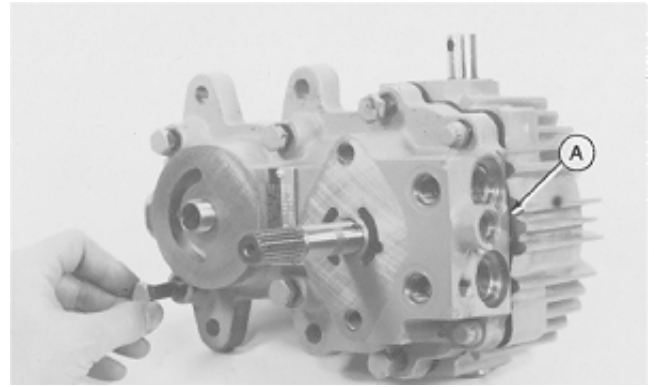

M36523 -UN-25JAN90

5M3,5005K,AG -19-18DEC87

5. Install transmission in bench fixture.

**IMPORTANT:** Check for proper internal assembly by slowly rotating pump, motor and control shaft while tightening cap screws.

6. Tighten cap screws to 35 N·m (26 lb-ft).

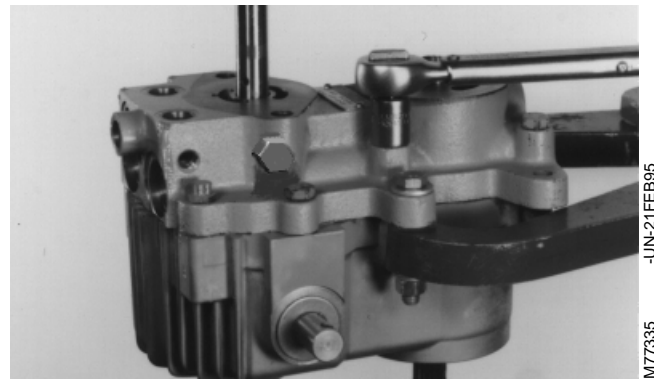

M77335 -UN-21FEB95

MX,15905005,30 -19-14MAR95

7. Install gear on motor shaft (output shaft). Install snap ring.



M36104 -UN-29AUG88

M45,5005A,80 -19-14JAN85

8. Install and tighten four pipe plugs.

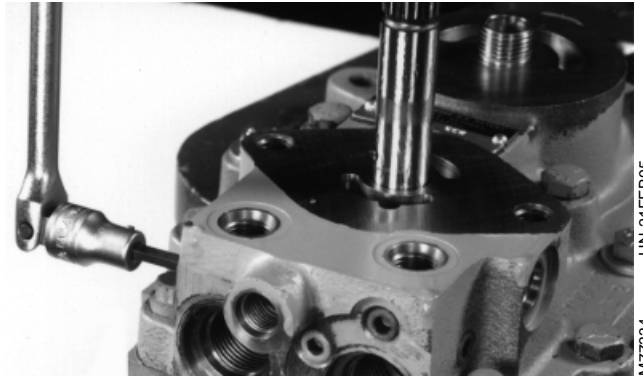

-UN-21FEB95  
M77334

MX,15905005,42 -19-14MAR95

9. Install O-ring (A), backup ring (B) and O-ring. Internal valve (C) must move freely.

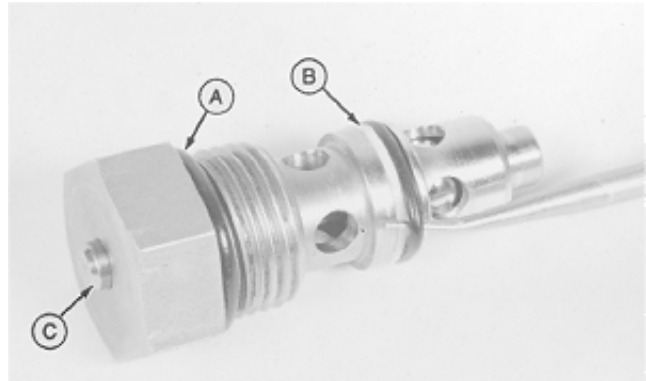

-UN-29AUG88  
M36102

M45,5005A,82 -19-13MAR85

10. Install and tighten two check valves.

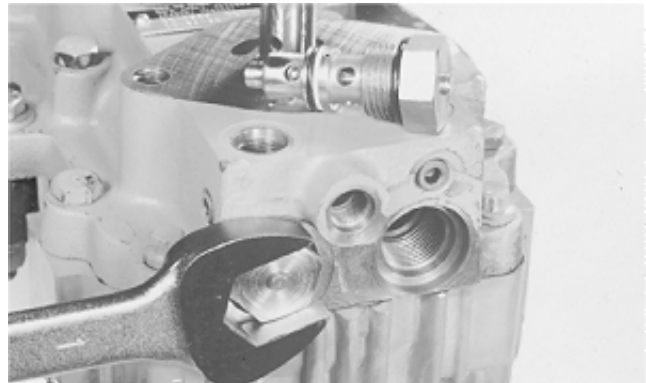

-UN-29AUG88  
M36101

M45,5005A,83 -19-14JAN85

11. Install plugs and O-rings (A).

12. Install suction line fitting.

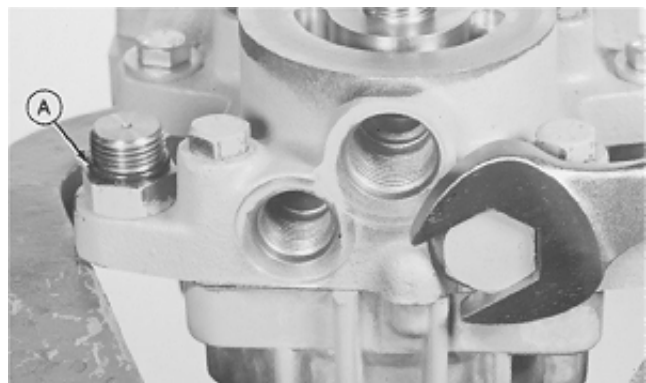

-UN-29AUG88  
M36100

5M3,5005K,AI -19-18DEC87

13. Install new filter (A).

14. Install charge relief valve (C), implement relief valve (D) and charge pump (B). (See procedures in this group.)

- A—Oil Filter
- B—Charge Pump
- C—Charge Relief Valve
- D—Implement Relief Valve

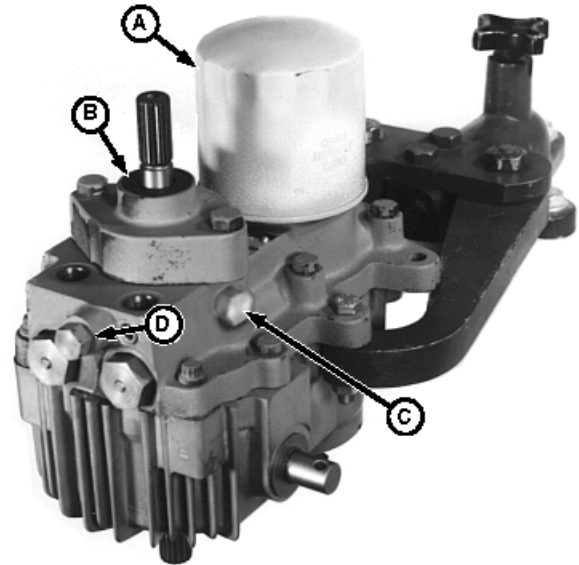

MX,15905005.31 -19-14MAR95

-JUN-21FEB95

M77333

50-05-25

## INSTALL TRANSMISSION

**IMPORTANT:** Always use new seals and O-rings. Damaged or used parts will leak.

*NOTE: Lubricate all seals and O-rings with petroleum jelly during assembly.*

1. Install new O-ring (B).
2. Install transmission; engage transmission output gear with differential gear.
3. Install four spacers and cap screws (A) in their original locations as marked during removal. Tighten cap screws to 45 N-m (33 lb-ft).

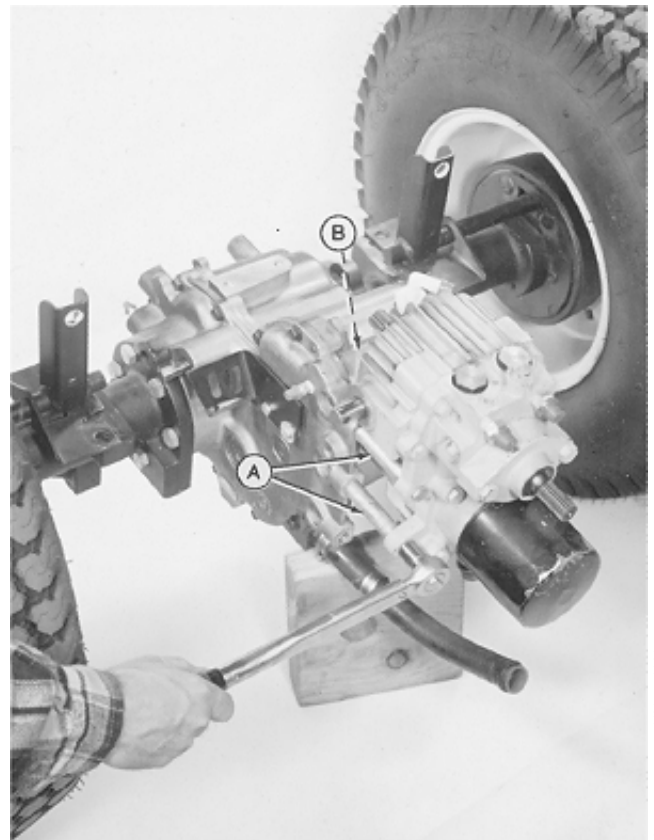

MX,15905005.32 -19-23FEB95

-JUN-25JAN90

M36651

4. Position differential assembly under tractor.
5. On 430; Hold differential lock linkage away from differential using wire, tape, etc.
6. Lift and position differential assembly. Put driveshaft on transmission input shaft. Turn pump shaft to align splines.

430 Shown

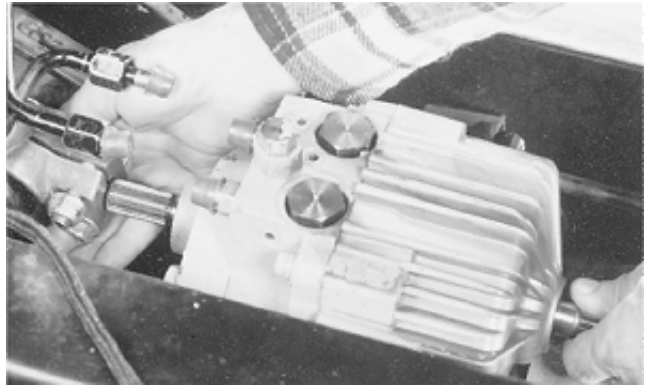

M36578 -UN-25JAN90

MX,15915005,12 -19-13JUL95

7. Position brake linkage and install install cap screws (E) on each side of machine. Tighten cap screws to 100 N-m (75 lb-ft). Bend tabs (F) over flat of cap screws.

*NOTE: Connect brakes on both sides of machine.*

8. Install spring (C), plate or washer (D) and nut (B).
9. Connect spring (A).

- A—Return Spring
- B—Nut
- C—Spring
- D—Plate (Early 430)
- Washer (All and Later 430)
- E—Mounting Cap Screw (2 used)
- F—Lock Plate Tab

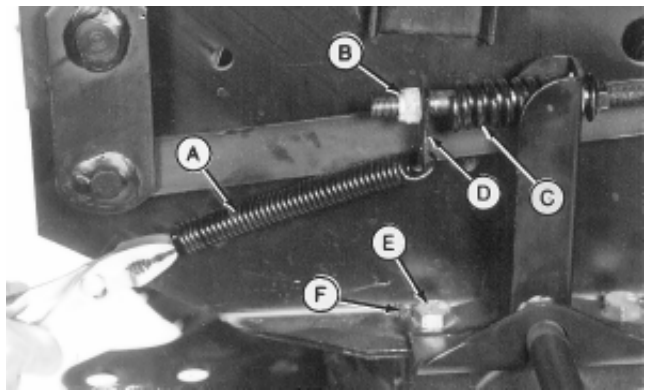

Early 430

M77903 -UN-19JAN95

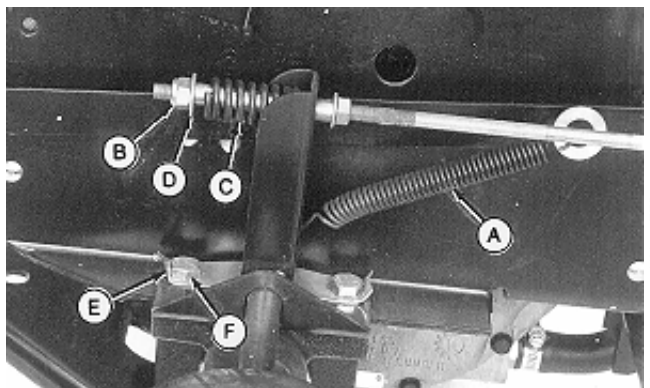

All and Later 430

M77332 -UN-13FEB95

MX,15915005,18 -19-13JUL95



10. Lock brake pedals together (322, 332, 430) and apply park brake.

11. Loosen lock nut (A).

12. Turn nut until spring is 42 mm (1.650 in.) long. Tighten lock nut.

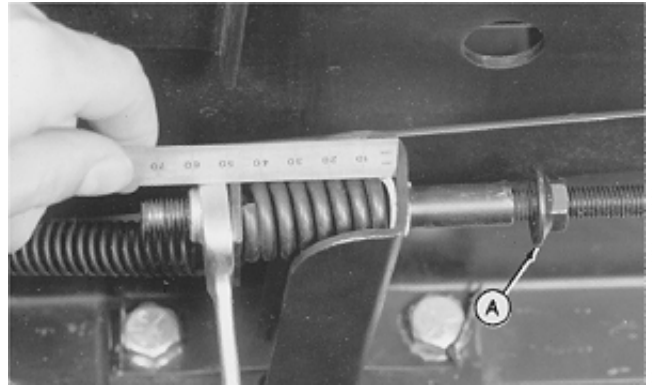

MX,15915005,13 -19-13JUL95

M36554 -UN-25JAN90

**NOTE:** Early models have two bolts (A) attaching differential to frame support bracket (C). Later models have one shoulder bolt (A) or one bolt with a washer and spacer.

**IMPORTANT:** It is recommended to replace the early model differential frame support bracket (C) with the later configuration (D). The early models attached the differential to the frame support bracket with two bolts (A). One in the differential case and the other in the differential cover. When the machine went over rough terrain, the flexing of the cover and case caused the differential gasket to leak. With the later model frame support bracket installed, the slotted hole and single shoulder bolt (A) (attached to the case only) will allow for flexing, eliminating any possible leaks.

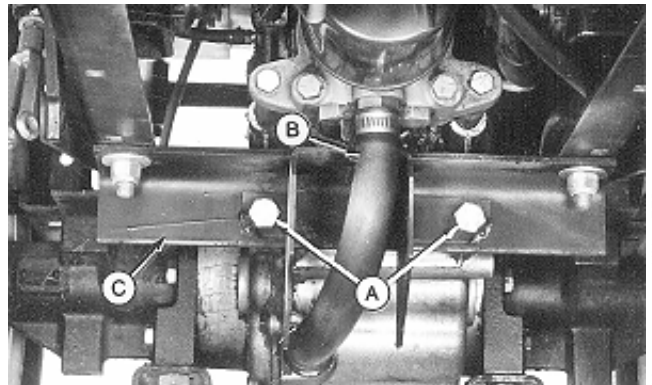

Early Models

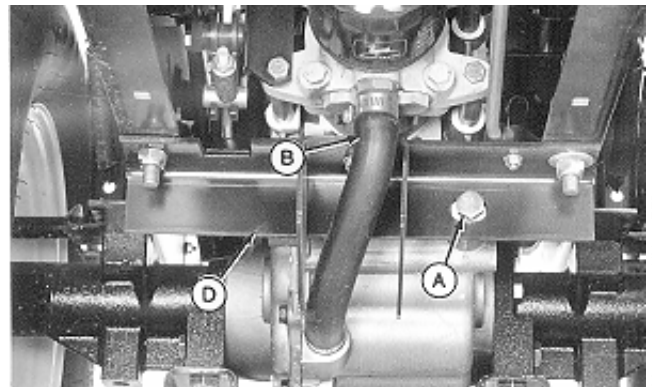

Later Models

13. Early models; Install new differential frame support bracket (D).

14. Install shoulder bolt (A) or bolt, washer and spacer. Tighten to 61 N·m (45 lb-ft).

15. Attach all mounting bolts, hoses and clamps.

16. Connect suction hose (B).

17. Remove jack stands and lower tractor.

- A—Bolt(s)
- B—Suction Hose
- C—Differential Frame Support Bracket (Early Models)
- D—Differential Frame Support Bracket (Later Models)

MX,15905005,36 -19-23FEB95

50  
05  
27

M77300 -UN-24FEB95

M77301 -UN-24FEB95

*NOTE: Steps 18 and 19 are for 430 only. Go to Step 20 to continue installation procedures for all machines.*

18. Connect differential lock linkage (D). Install pin (E) and cotter pin (F).

19. Connect two-speed differential linkage (C). Install pin (G), washer (B) and cotter pin (A).

- A—Cotter Pin
- B—Washer
- C—Two-Speed Differential Linkage
- D—Differential Lock Linkage
- E—Pin
- F—Cotter Pin
- G—Pin

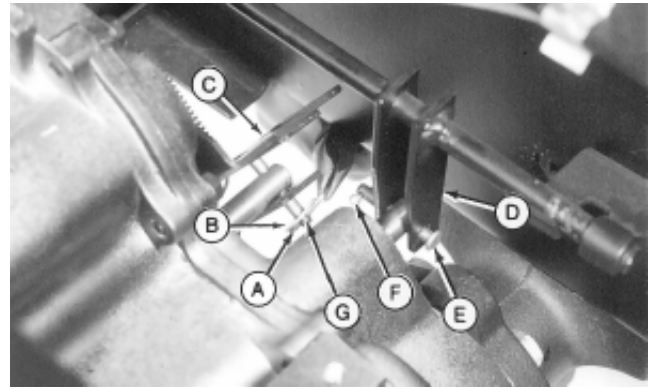

M36543 -UN-19JAN95

MX,15915005,14 -19-13JUL95

20. Connect oil fill tube hose (C).

21. Connect two hoses (A and B).

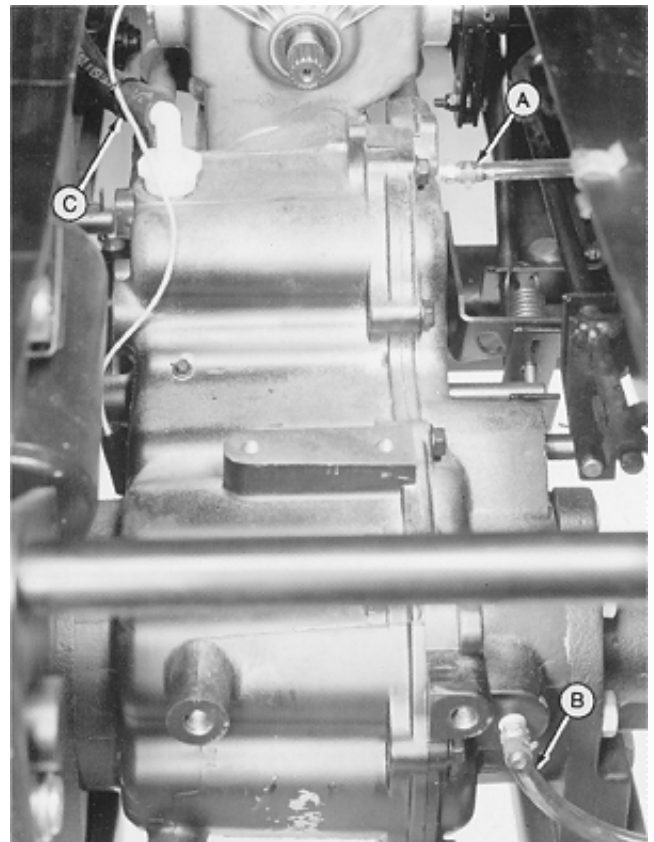

M36542 -UN-25JAN90

MX,15905005,38 -19-23FEB95

50  
05  
28

**NOTE:** There are different versions of the swashplate control arm. Also, attaching swashplate control arm to the control shaft on transmission is different. Some machines use a safety wire and roll pin, others use a nut and cap screw.

22. Attach swashplate control arm to control shaft with roll pin and safety wire or cap screw and nut. Tighten nut to 60 N·m (44 lb-ft).

23. On 330; Install deflector shields with foam at rear of transmission.

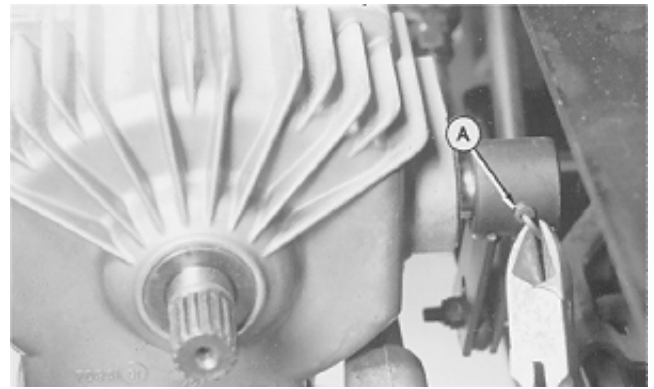

Early Models Shown

MX,15915005,15 -19-13JUL95

24. Connect hydraulic pressure line (A) and return line (B).

25. Tighten two nuts and cap screws, if equipped, on drive shaft to 60 N·m (44 lb-ft) or install drive shaft, if necessary. (See procedure in Group 25.)

26. Install drain plug.

27. Install belly screen/pan.

28. Install fuel tank and fender deck.

29. Fill transmission with the recommended amount of John Deere Low Viscosity HY-GARD® oil.

30. Bleed the hydraulic system. (See procedure in Section 270, Group 20.)

31. If tractor creeps forward or reverse while in neutral, adjust neutral and neutral return linkage. (See procedures in Section 250, Group 15.)

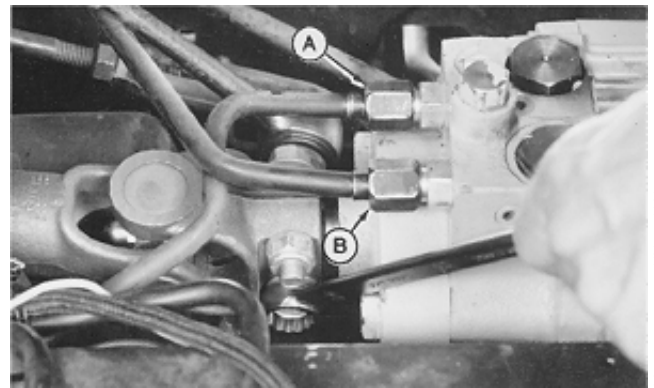

430 Shown

MX,15915005,16 -19-13JUL95

50  
05  
30

INSPECT AND REPAIR TRANSMISSION CONTROL LINKAGE—330

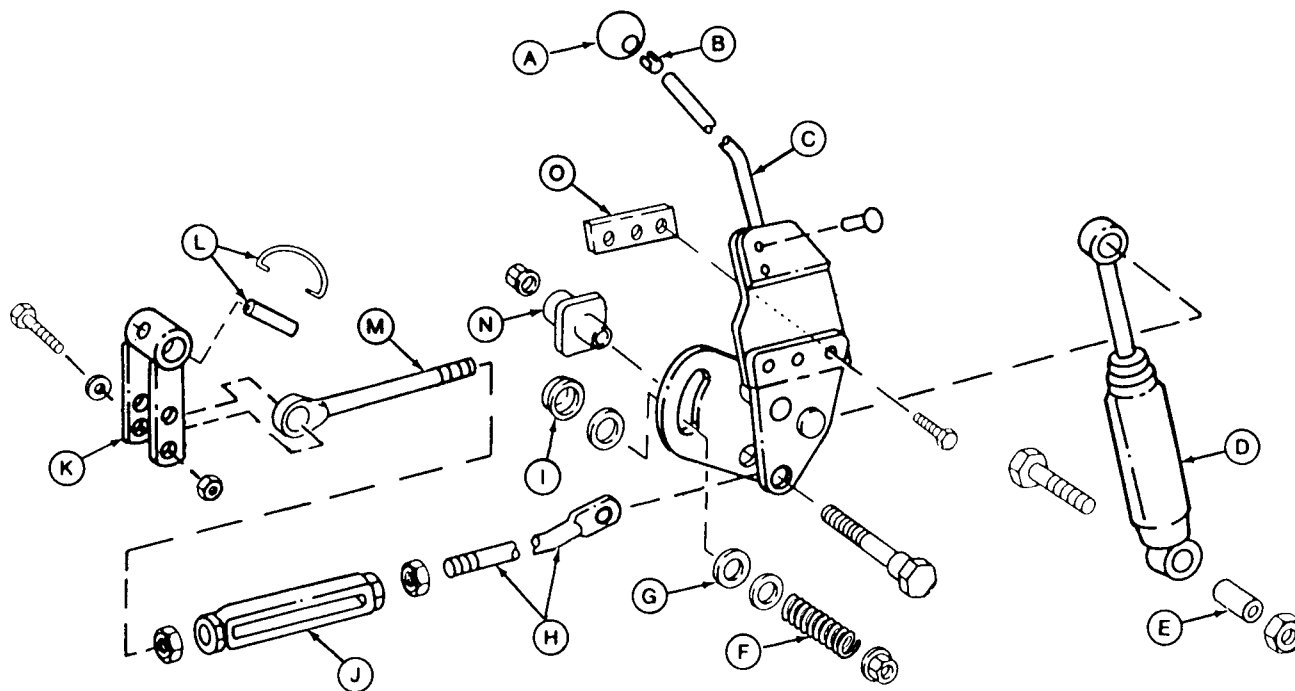

- |                       |                          |                            |            |
|-----------------------|--------------------------|----------------------------|------------|
| A—Knob                | E—Spacer                 | I—Spacer                   | M—Eyebolt  |
| B—Clip                | F—Compression Spring     | J—Turnbuckle               | N—Guide    |
| C—Speed Control Lever | G—Friction Disc (2 used) | K—Swashplate Arm           | O—Weld Nut |
| D—Shock Absorber      | H—Speed Control Rod      | L—Spring Pin and Lock Wire |            |

1. Remove belly screen, fender deck and fuel tank.
2. Remove engine side panels.
3. Remove right-hand pedestal side panel.
4. Inspect linkage for wear or damage. Replace parts as necessary.
5. Adjust hydrostatic lever friction and neutral return linkage. (See procedures in Section 250, Group 15.)

MX,15915010,1 -19-13JUL95

50  
10  
-JUN-13/MAR95  
MT8044

## INSPECT AND REPAIR TRANSMISSION CONTROL LINKAGE—VERSION ONE (322 AND 332)

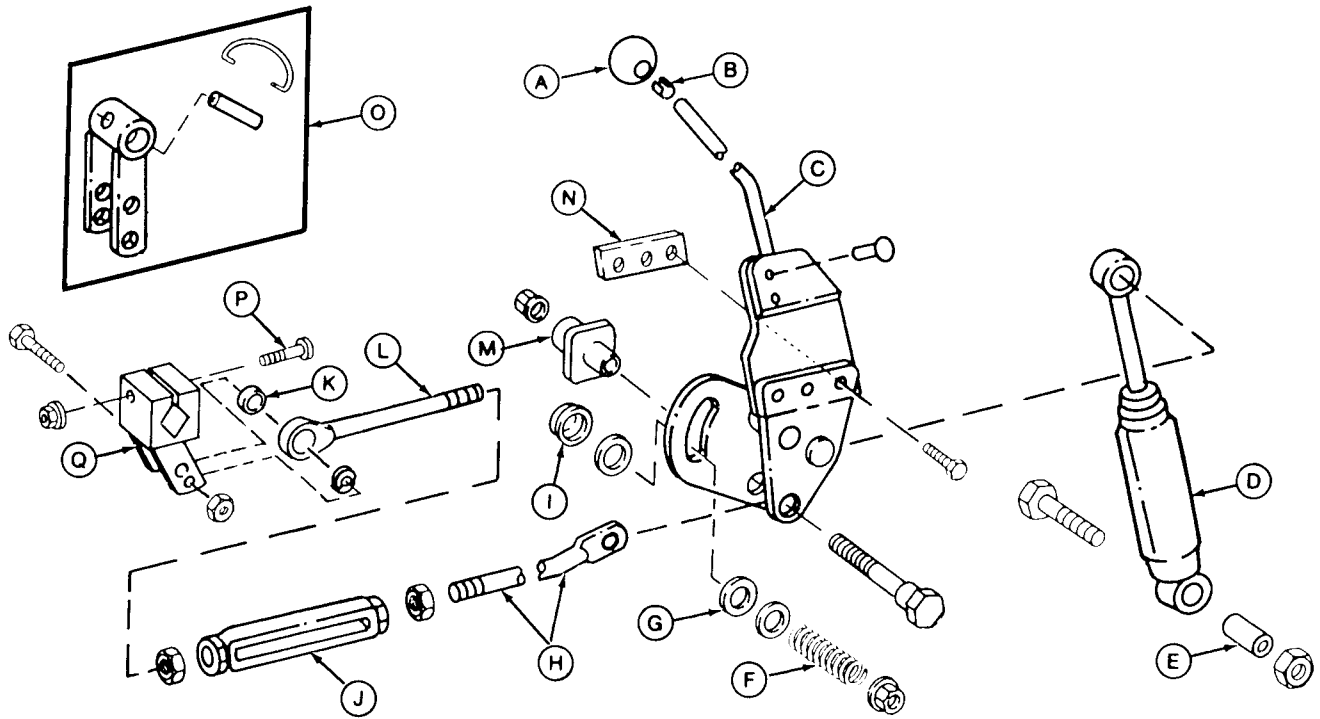

A—Knob  
 B—Clip  
 C—Speed Control Lever  
 D—Shock Absorber  
 E—Spacer  
 F—Compression Spring

G—Friction Disc (2 used)  
 H—Speed Control Rod  
 I—Spacer  
 J—Turnbuckle  
 K—Spacer

L—Eyebolt  
 M—Guide  
 N—Weld Nut  
 O—Swashplate Arm Assembly (Early Models—332)

P—Cap Screw (Later Models—322 and 332)  
 Q—Swashplate Arm (Later Models—322 and 332)

1. Remove belly screen, fender deck and fuel tank.
2. Remove engine side panels.
3. Remove right-hand pedestal side panel.
4. Inspect linkage for wear or damage. Replace parts as necessary.
5. Adjust hydrostatic lever friction. (See procedure in Section 250, Group 15.)
6. After connecting swashplate arm (Q) to transmission control shaft, tighten cap screw (P) to 60 N·m (44 lb-ft).
7. Adjust neutral return linkage. (See procedure in Section 250, Group 15.)

MX,15915010,2 -19-13JUL95

50  
10  
2

M77908 -JUN-13/MAR95

## INSPECT AND REPAIR TRANSMISSION CONTROL LINKAGE—VERSION ONE (430)

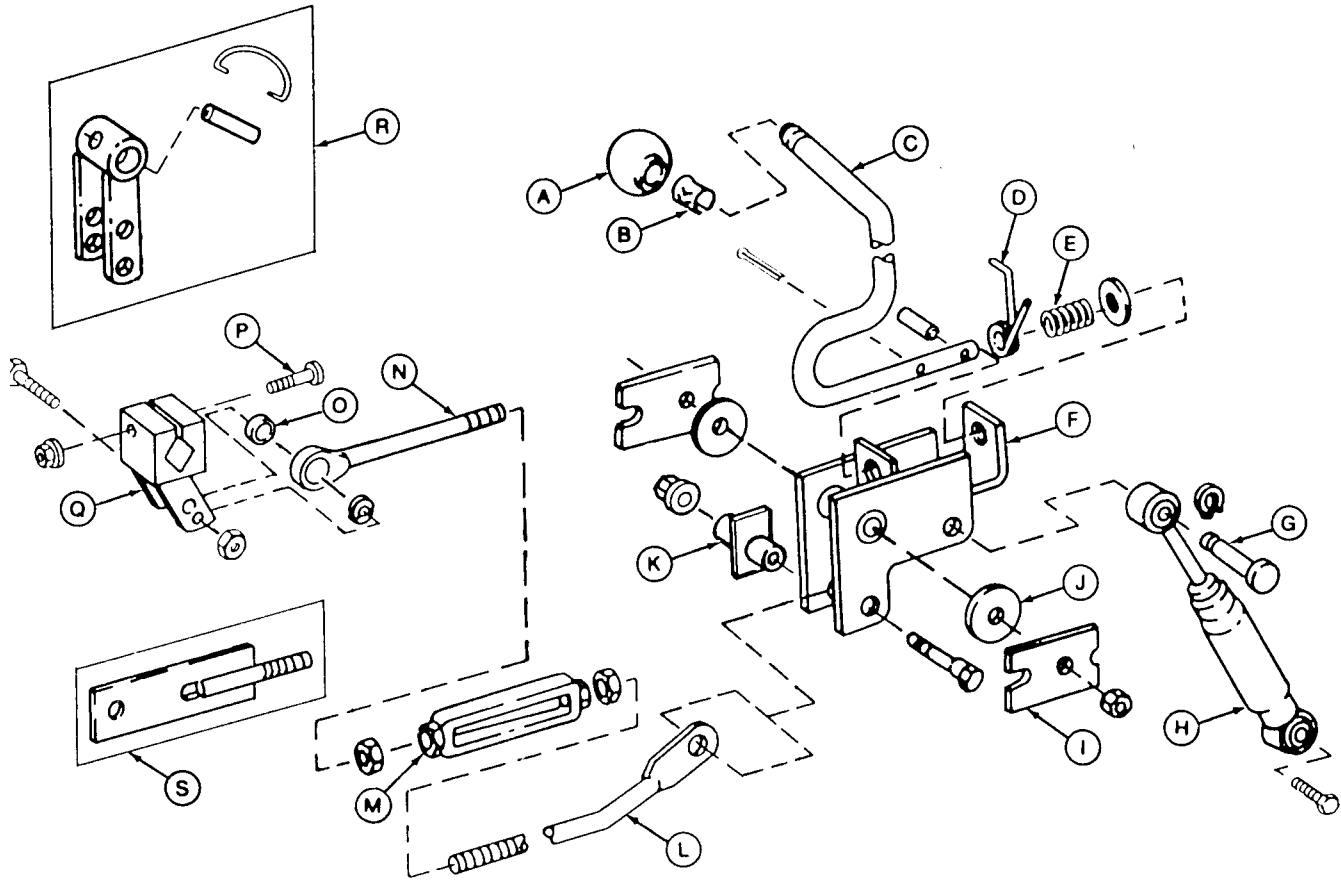

A—Knob  
 B—Clip  
 C—Speed Control Lever  
 D—Torsion Spring  
 E—Compression Spring  
 F—Bracket

G—Pin  
 H—Shock Absorber  
 I—Brake Plate (2 used)  
 J—Friction Disc (2 used)  
 K—Guide

L—Speed Control Rod  
 M—Turnbuckle  
 N—Eyebolt (Later Models)  
 O—Spacer  
 P—Cap Screw (Later Models)

Q—Swashplate Arm (Later Models)  
 R—Swashplate Arm Assembly (Early Models)  
 S—Stud (Early Models)

1. Remove belly pan, fender deck and fuel tank.
2. Remove front grille and engine side panels.
3. Remove battery and battery base.
4. Remove right-hand pedestal side panel.
5. Inspect linkage for wear or damage. Replace parts as necessary.

6. Adjust hydrostatic lever friction. (See procedure in Section 250, Group 15.)
7. After connecting swashplate arm (Q) to transmission control shaft, tighten cap screw (P) to 60 N·m (44 lb-ft).
8. Adjust neutral return linkage. (See procedure in Section 250, Group 15.)

50  
10  
3  
M78045 -UN-17FEB95

## INSPECT AND REPAIR TRANSMISSION CONTROL LINKAGE—VERSION TWO (ALL)

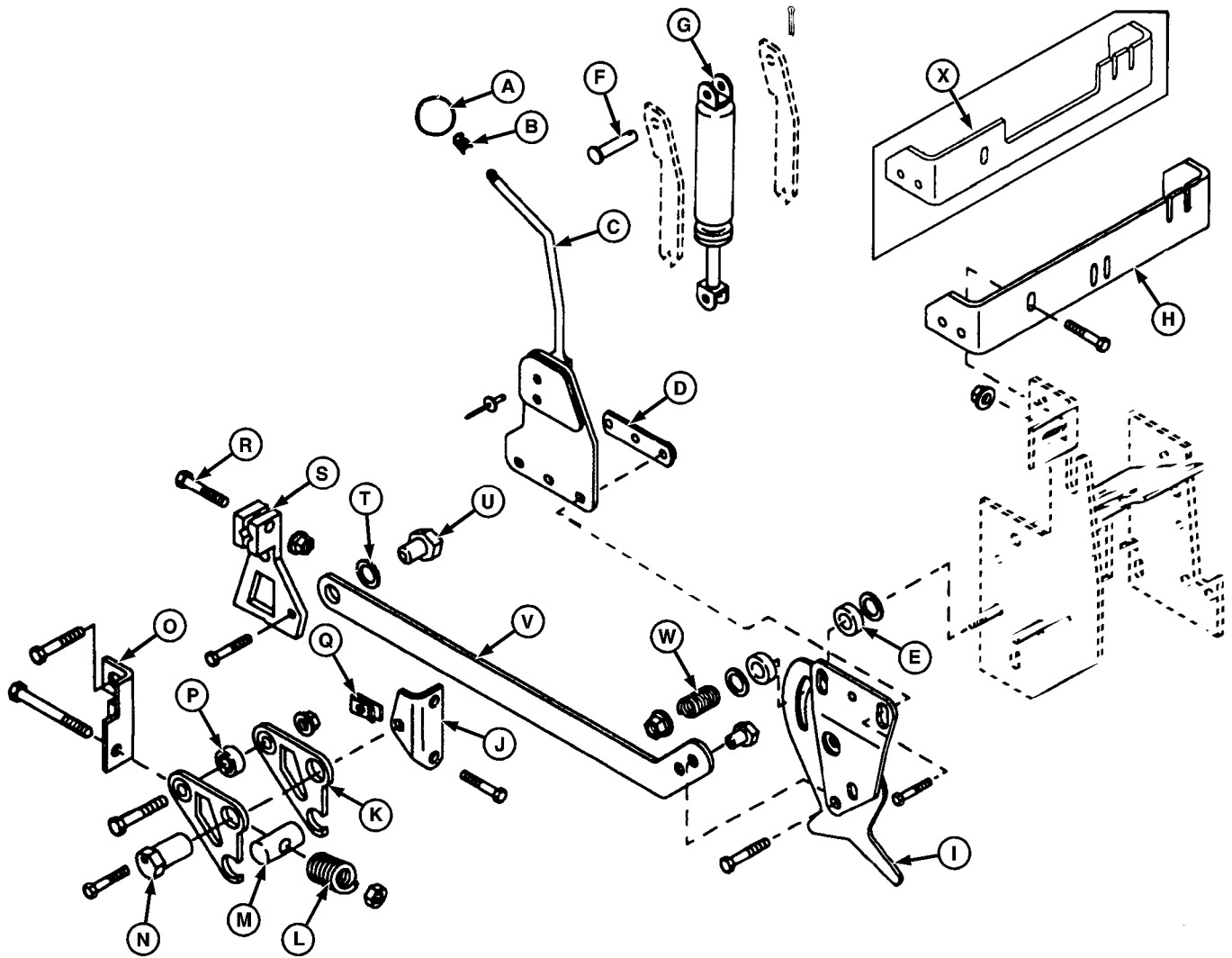

- |                          |                       |                                |                      |
|--------------------------|-----------------------|--------------------------------|----------------------|
| A—Knob                   | H—Bracket (322, 332)  | N—Adjustable Eccentric Bearing | S—Swashplate Arm     |
| B—Clip                   | I—Control Plate       | O—Bracket                      | T—Spring Washer      |
| C—Speed Control Lever    | J—Angle Bracket       | P—Ball Bearing                 | U—Nut (2 used)       |
| D—Weld Nut               | K—Detent Arm (2 used) | Q—Clamp-On Nut                 | V—Speed Control Link |
| E—Friction Disc (2 used) | L—Compression Spring  | R—Cap Screw                    | W—Compression Spring |
| F—Pin                    | M—Pivot Pin           |                                | X—Bracket (430)      |
| G—Torsional Dampener     |                       |                                |                      |

1. Remove belly screen/pan, fender deck and fuel tank.
2. Remove front grille and engine side panels.
3. On 430; Remove battery and battery base.
4. Remove right-hand pedestal side panel.
5. Inspect linkage for wear or damage. Replace parts as necessary.
6. After connecting swashplate arm (S) to transmission control shaft, tighten cap screw (R) to 60 N·m (44 lb-ft).
7. Adjust neutral and neutral return linkage. (See procedure in Section 250, Group 15.)
8. Adjust hydrostatic lever friction. (See procedure in Section 250, Group 15.)

MX,15915010,4 -19-13JUL95



## INSPECT AND REPAIR TRANSMISSION CONTROL LINKAGE—VERSION THREE (ALL)

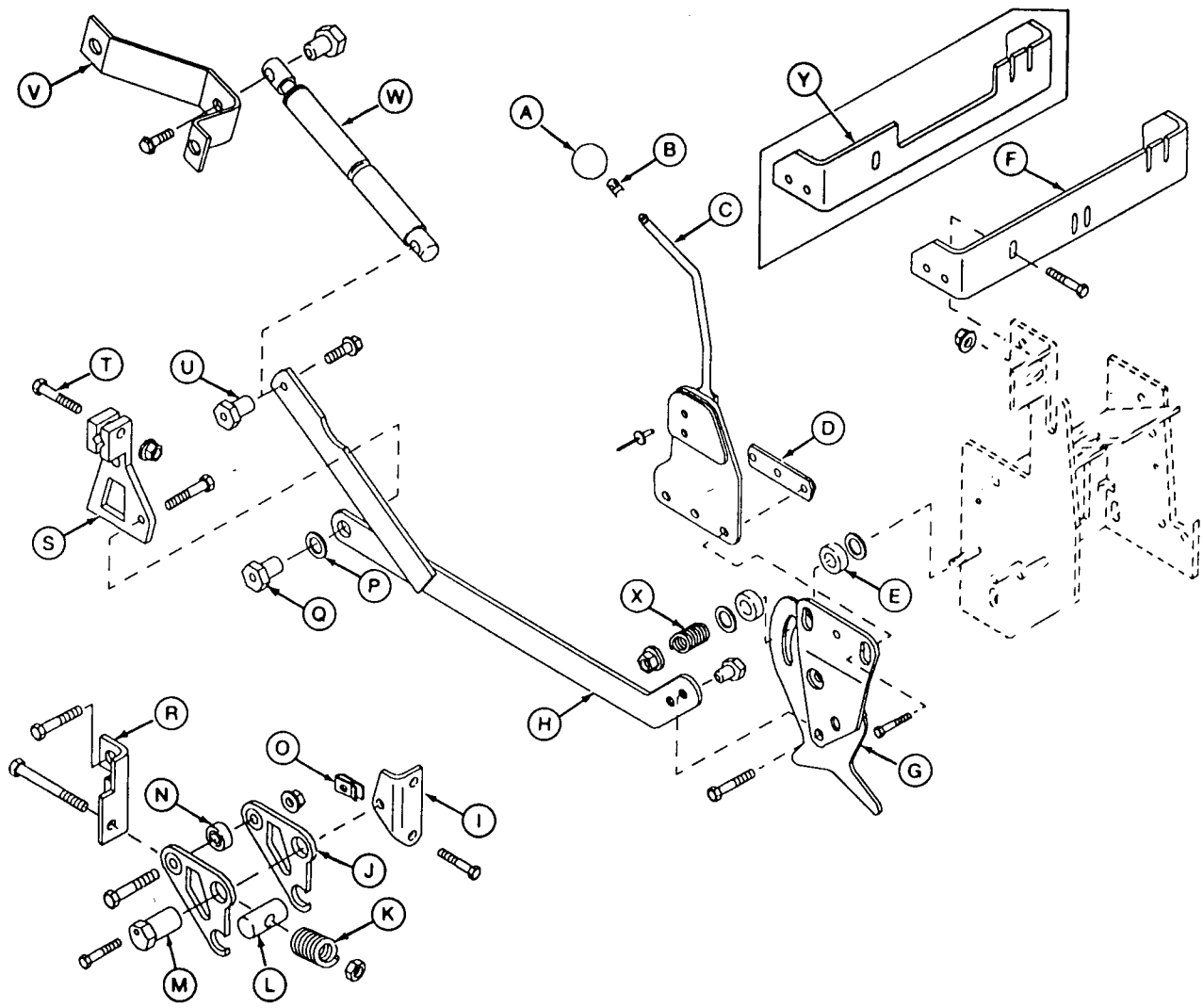

- |                          |                                |                  |                       |
|--------------------------|--------------------------------|------------------|-----------------------|
| A—Knob                   | H—Speed Control Link           | N—Ball Bearing   | T—Cap Screw           |
| B—Clip                   | I—Angle Bracket                | O—Clamp-On Nut   | U—Spacer Nut (2 used) |
| C—Speed Control Lever    | J—Detent Arm (2 used)          | P—Spring Washer  | V—Bracket             |
| D—Weld Nut               | K—Compression Spring           | Q—Nut (2 used)   | W—Torsional Dampener  |
| E—Friction Disc (2 used) | L—Pivot Pin                    | R—Bracket        | X—Compression Spring  |
| F—Bracket (322, 332)     | M—Adjustable Eccentric Bearing | S—Swashplate Arm | Y—Bracket (430)       |
| G—Control Plate          |                                |                  |                       |

1. Remove belly screen/pan, fender deck and fuel tank.
2. Remove front grille and engine side panels.
3. On 430; Remove battery and battery base.
4. Remove right-hand pedestal side panel.
5. Inspect linkage for wear or damage. Replace parts as necessary.
6. After connecting swashplate arm (S) to transmission control shaft, tighten cap screw (T) to 60 N·m (44 lb-ft).
7. Adjust neutral and neutral return linkage. (See procedure in Section 250, Group 15.)
8. Adjust hydrostatic lever friction. (See procedure in Section 250, Group 15.)

MX,15915010,5 -19-13JUL95

## INSPECT AND REPAIR DIFFERENTIAL LOCK AND TWO-SPEED CONTROL LINKAGE (430)

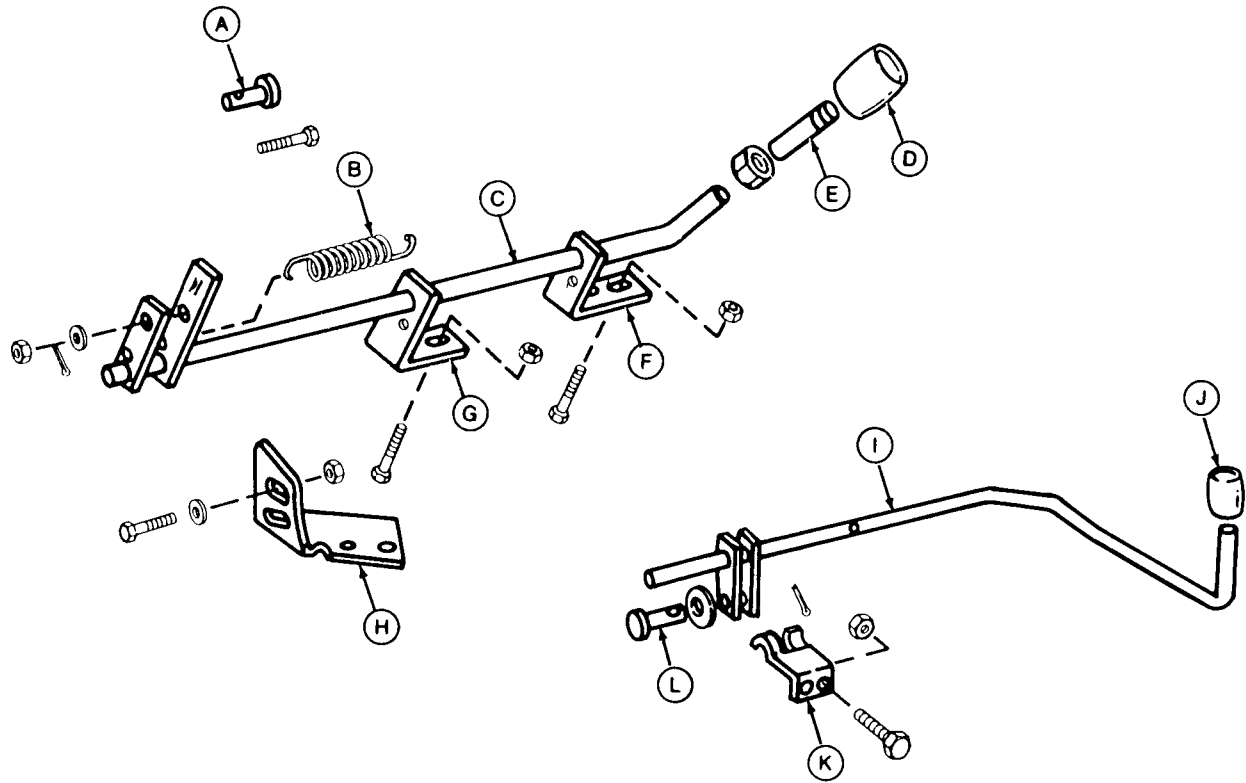

- |                         |                       |
|-------------------------|-----------------------|
| A—Pin                   | D—Knob                |
| B—Spring                | E—Stud Extension      |
| C—Two-Speed Control Rod | F—Front Angle Bracket |

- |                         |                 |
|-------------------------|-----------------|
| G—Rear Angle Bracket    | J—Knob          |
| H—Two-Speed Bracket     | K—Clip (2 used) |
| I—Differential Lock Rod | L—Pin           |

1. Remove belly pan.
2. Inspect linkage for wear or damage. Replace parts as necessary.

3. Adjust two-speed axle lever detent, if necessary. (See procedure in Section 250, Group 15.)

MX,15915010,6 -19-13JUL95

**OTHER MATERIAL**

<b>Number</b>	<b>Name</b>	<b>Use</b>
LOCTITE® PRODUCTS U.S./Canadian/LOCTITE No.		
TY6305/TY9485/764	Clean and Cure Primer	Cleans parts and speeds cure of sealant.
T43512/TY9473/242	Thread Lock and Sealer (Medium Strength)	Apply to threads of carrier cap screws.
TY6304/TY9484/518	Flexible Sealant	Apply to mating surfaces of differential cover and case halves.

*®LOCTITE is a registered trademark of the Loctite Corp.*

MX,15905015,OTH-19-23FEB95

**SERVICE PARTS KITS**

The following kits are available through your parts catalog:

Differential Tabbed Thrust Washer Kit for Early Models

MX,15905015,KIT-19-23FEB95

50  
15  
1

## REMOVE AND INSTALL DIFFERENTIAL

1. Remove transmission (D). (See procedure in Group 05.)
2. Remove both axles (B). (See procedure in Group 20.)
3. Remove bracket (C) and fittings (A).
4. Installation is done in the reverse order of removal.

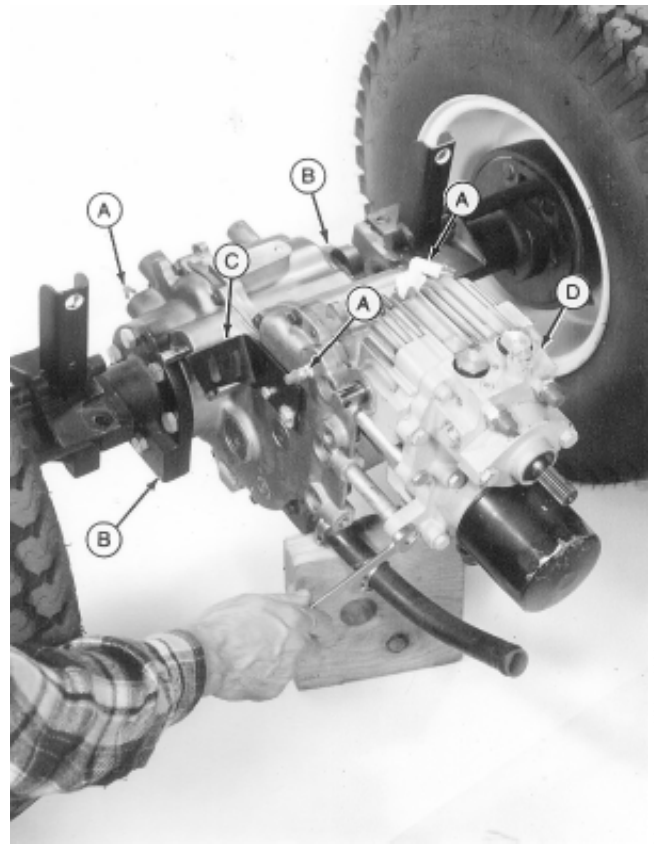

M36657 -JUN-19/JAN95

MX,15905015,1 -19-23FEB95

## DISASSEMBLE AND INSPECT DIFFERENTIAL

*NOTE: This disassembly procedure is for the One-Speed Differential (322, 330 and 332) and the Two-Speed Differential with Differential Lock (430). The differences are noted.*

1. Drive two dowel pins (A) into differential case just far enough to clear the cover.
2. Remove cap screws to remove cover and gasket.

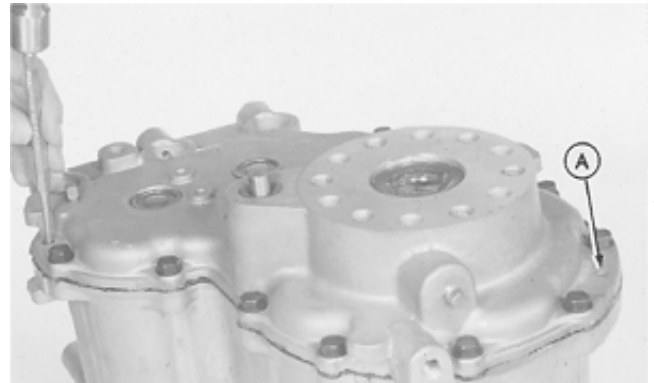

M36226 -JUN-22/NOV89

MX,15915015,1 -19-13JUL95

*NOTE: Early models have FLAT thrust washers. Later models have TABBED thrust washers. All service or replacement thrust washers will have the tabs.*

**IMPORTANT:** It is recommended to replace the early model (flat) thrust washers with the later model (tabbed) thrust washers. The early model washers may spin with their respective shafts, causing wear to the cover bearing surfaces.

3. Remove three thrust washers (A).

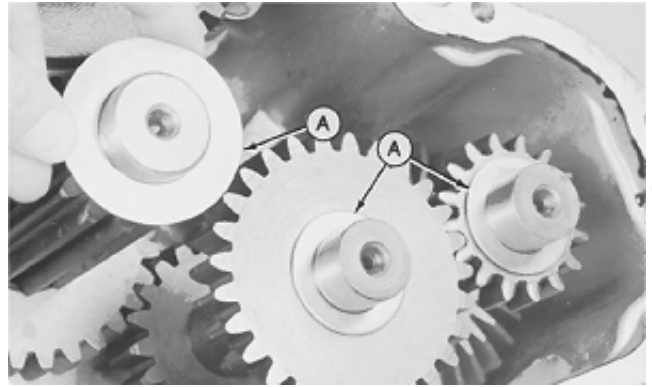

One-Speed Differential

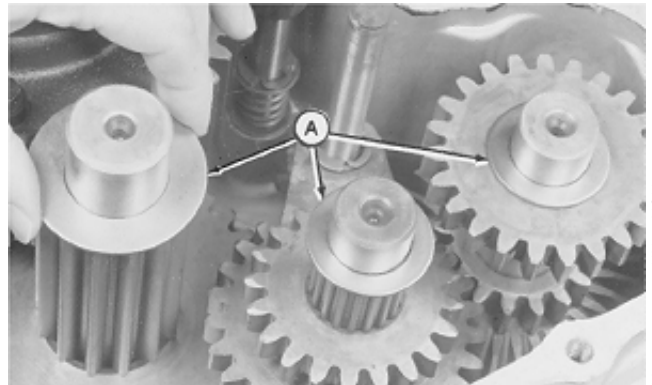

Two-Speed Differential

MX,15905015,3 -19-23FEB95

4. Remove differential; if equipped with differential lock, remove shift rod assembly with differential.

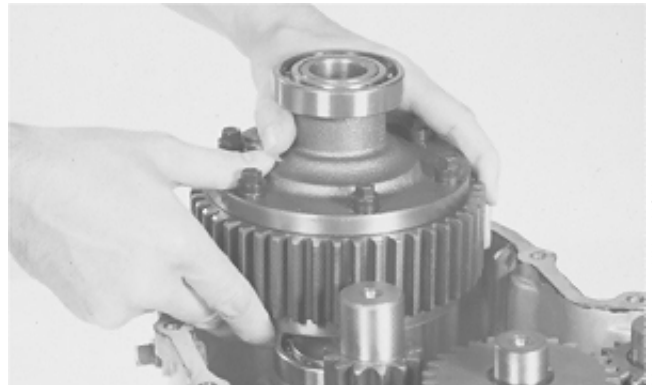

Without Differential Lock

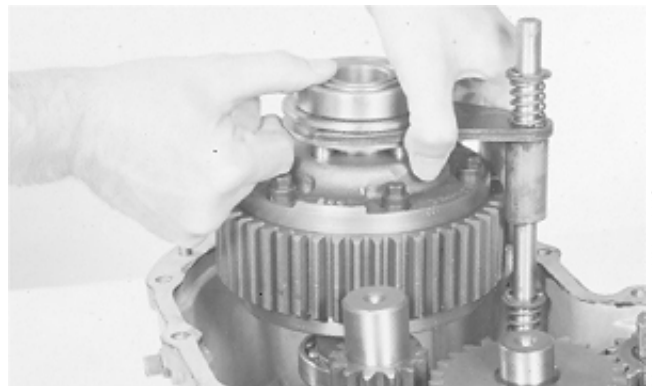

With Differential Lock

MX,15905015,4 -19-23FEB95

5. If equipped with differential lock; disassemble shift rod assembly by removing three E-Rings (A) washers (B), springs (C), fork (D), and snap ring (E).

Inspect shaft for straightness or damage. Replace if necessary.

- A—E-Ring (3 used)
- B—Washer (3 used)
- C—Spring (2 used)
- D—Fork
- E—Snap Ring

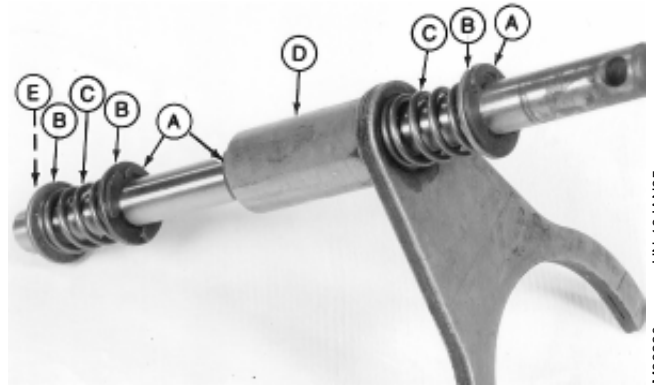

MX,15905015,5 -19-23FEB95

M36230 -UN-19JAN95

*NOTE: Early model with differential lock shown.*

6. Remove cap screws to separate carriers (F) from ring gear (E).

7. Disassemble and inspect pinion assembly.

Inspect pinion gears (A), bevel gears (C), ring gear (E), pinion blocks (B), and cross shaft (D) for wear or damage. Replace if necessary.

If equipped with differential lock, inspect bevel gear with holes (G) for wear or damage. Replace if necessary.

- A—Pinion Gear (2 used)
- B—Pinion Block (2 used)
- C—Bevel Gear (2 used)
- D—Cross Shaft
- E—Ring Gear
- F—Carrier (2 used)
- G—Bevel Gear with Holes

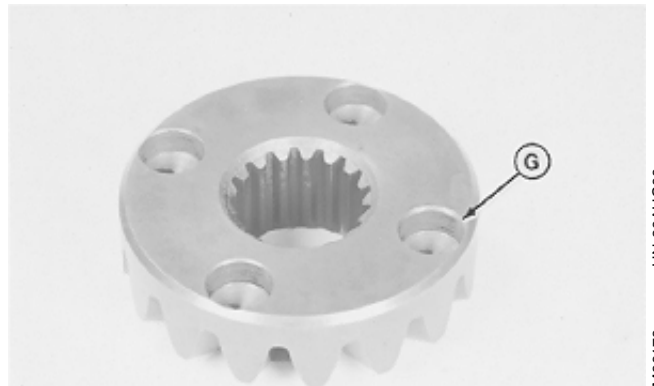
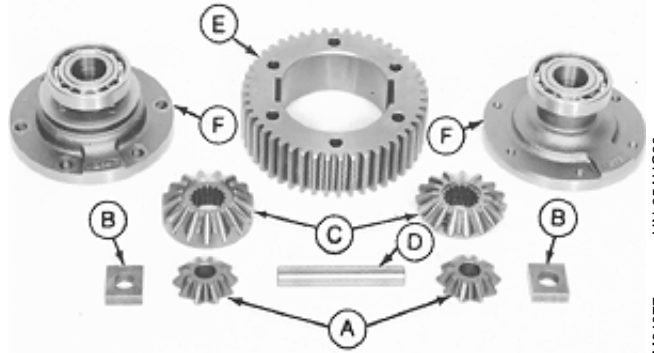

MX,15905015,6 -19-20MAR95

M31977 -UN-25AUG88

M36173 -UN-29AUG88

50  
15  
4

**NOTE:** Later models have oil grooves (E), an oil hole (D) and a thrust washer (F) in carriers.

Machines without differential lock have one thrust washer in each carrier. Machines with differential lock have one thrust washer and one new style carrier on the non-differential lock side only.

All service or replacement carriers will have these features.

Bearings (C) are press-fit on carriers. Remove bearings only if replacement is necessary.

8. Inspect bearings (C) for wear or damage. Replace if necessary.

9. Remove bearings using a knife-edge puller set.

10. Inspect carriers and thrust washers (F), if equipped, for wear or damage. Replace if necessary.

11. With differential lock; inspect locking pins (A) and collar (B). Replace collar if necessary.

- A—Locking Pins
- B—Collar
- C—Bearing
- D—Oil Hole
- E—Oil Grooves
- F—Thrust Washer

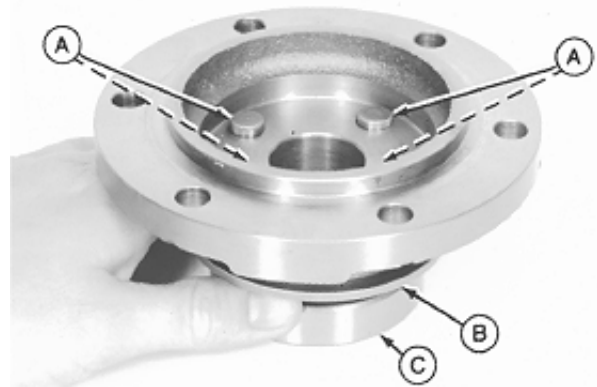

With Differential Lock

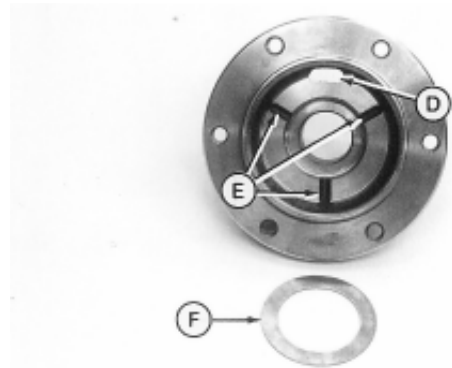

-UN-03AUG89

M31971

-UN-19JAN95

M77309

50  
15

MX,15905015,7 -19-23FEB95

12. Remove and inspect countershaft assembly.

Inspect spur gear (A) and bevel gear (B) for worn or damaged teeth.

Inspect countershaft (C) for worn or damaged splines or bearing surfaces.

13. Remove spacer (D), thrust washers (E) and thrust bearing (F).

Inspect parts for wear or damage. Replace if necessary.

- A—Spur Gear
- B—Bevel Gear
- C—Countershaft
- D—Spacer
- E—Thrust Washer (2 used)
- F—Thrust Bearing

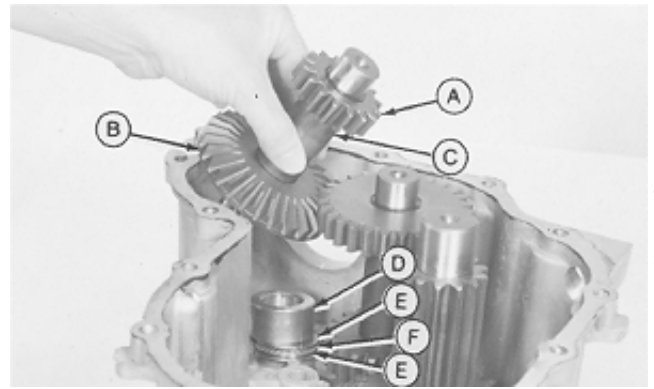

One-Speed Differential

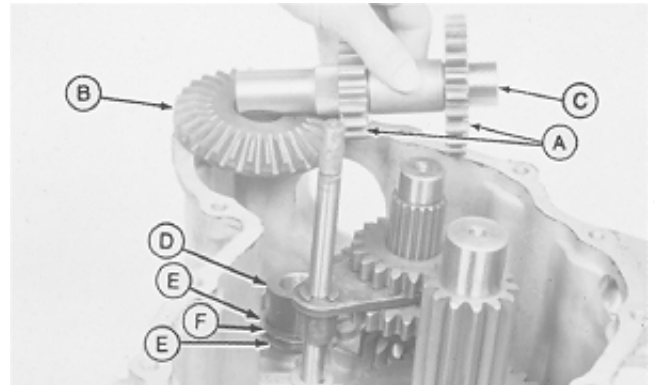

Two-Speed Differential

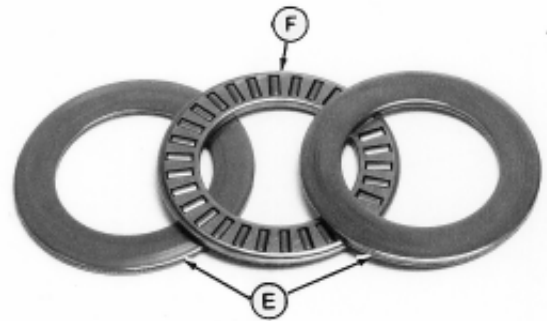

50  
15  
6

M36175 -UN-29AUG88

M36232 -UN-22NOV89

M77905 -UN-19JAN95

MX,15905015,8 -19-23FEB95



14. Two-speed differential; remove set screw, spring, and detent ball.



M36233 -UN-22NOV89



M36234 -UN-22NOV89

MX,15905015,9 -19-23FEB95

50  
15

15. Remove and inspect intermediate shaft assembly; if equipped with two-speed differential, remove shift rod assembly with intermediate shaft.

Inspect intermediate gears (B and C) for worn or damaged teeth.

Inspect intermediate shaft (D) for worn or damaged splines or bearing surfaces.

*NOTE: Early models have a FLAT thrust washer. Later models have a TABBED thrust washer. All service or replacement thrust washers will have the tabs.*

**IMPORTANT: It is recommended to replace the early model (flat) thrust washers with the later model (tabbed) thrust washers. The early model washers may spin with their respective shafts, causing wear to the case bearing surface.**

16. Remove and inspect thrust washer (A) for wear or damage.

- A—Thrust Washers
- B—Intermediate Gear
- C—Intermediate Gear
- D—Intermediate Shaft

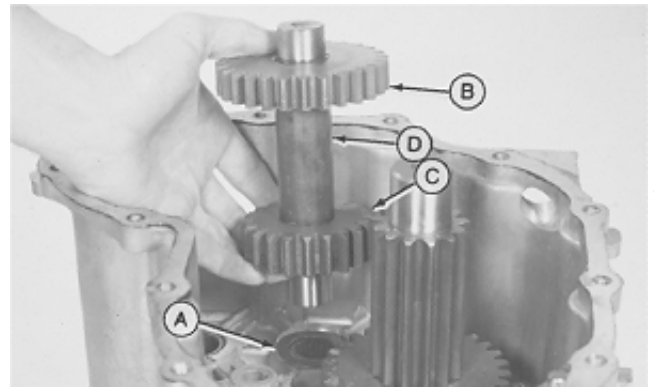

One-Speed Differential

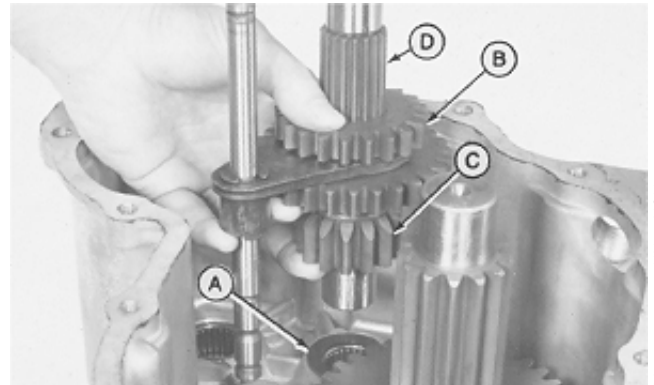

Two-Speed Differential

MX,15905015,10 -19-23FEB95

17. Two-speed differential; disassemble shift rod by removing two E-rings (A) and fork (B).

Inspect shaft for straightness, burrs, and damaged detent lands. Replace if necessary.

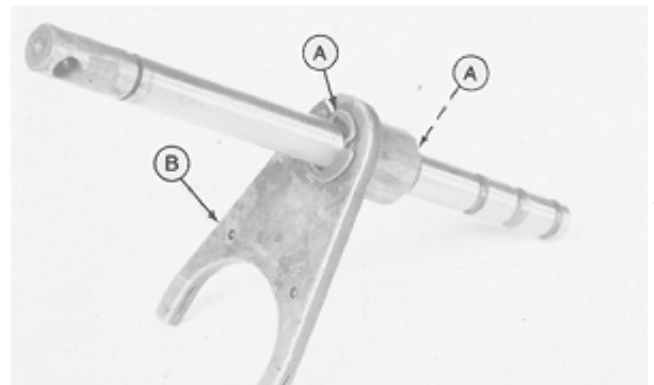

MX,15905015,11 -19-23FEB95

50  
15  
8

M36176 -UN-29AUG88

M36235 -UN-22NOV89

M36236

M36236 -UN-22NOV89

M36236

18. Remove and inspect output shaft assembly.

Inspect output gear (C) for worn or damaged teeth.

Inspect output shaft (B) for wear on splined surfaces.

*NOTE: Early models have a FLAT thrust washer. Later models have a TABBED thrust washer. All service or replacement thrust washers will have the tabs.*

**IMPORTANT: It is recommended to replace the early model (flat) thrust washers with the later model (tabbed) thrust washers. The early model washers may spin with their respective shafts, causing wear to the case bearing surface.**

19. Remove and inspect thrust washer (A) for wear or damage.

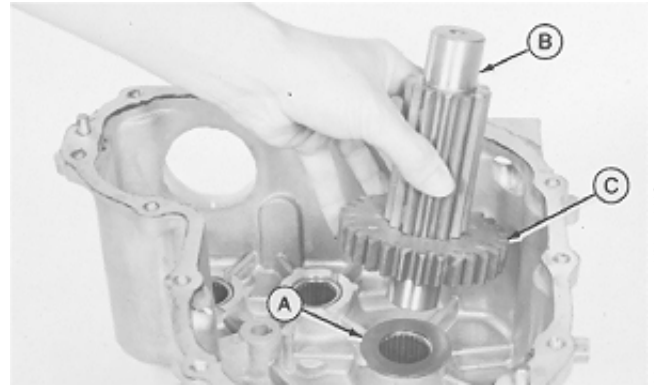

One-Speed Differential

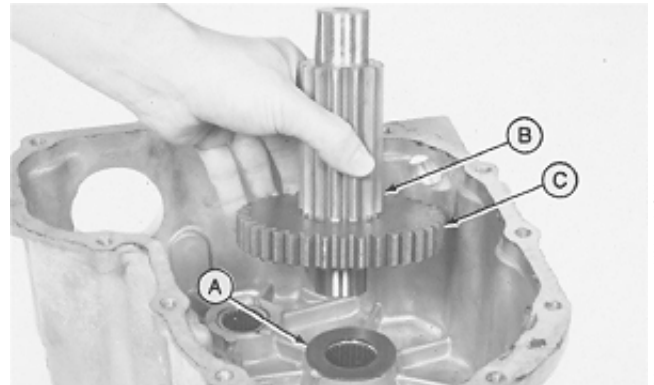

Two-Speed Differential

MX,15905015,12 -19-23FEB95

M36177 -UN-29AUG88

M36237 -UN-22NOV89

50-15-9

20. Inspect differential case and cover for wear, cracks or damage. Replace case and/or cover if necessary.

Inspect case and cover bearing surfaces of output shaft (A), intermediate shaft (B) and countershaft (C) for wear, cracks or damage.

Inspect depth of oil grooves (D) in case and cover. If depth of grooves are less than 0.25 mm (0.010 in.), replace case and/or cover.

Inspect reinforcement ribs (E). If ribs protrude above wear surface, file or grind flush.

Inspect bearing races (F) for wear. If bearing race is worn away, replace bearings.

- A—Output Shaft Bearing Surface
- B—Intermediate Shaft Bearing Surface
- C—Countershaft Bearing Surface
- D—Oil Grooves
- E—Reinforcement Ribs
- F—Bearing Races

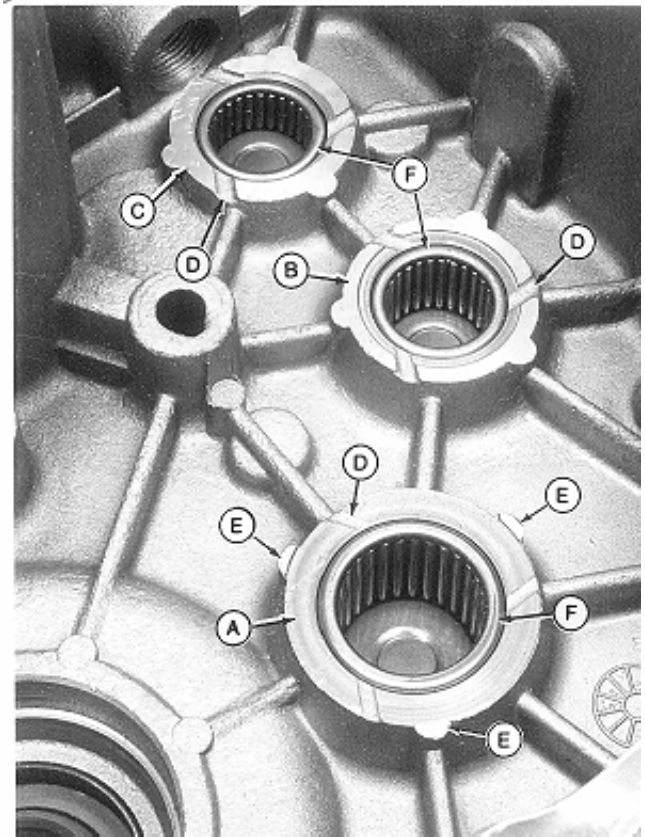

Differential Case Shown

MX,15905015,13 -19-23FEB95

21. Inspect output shaft bearings (A), intermediate shaft bearings (B) and countershaft bearings (C) in case (D) and cover (E) for wear, damage or corrosion.

Check that bearings turn freely.

Inspect case and cover for cracks.

Inspect axle shaft seals (F) in case and cover.

Two-Speed with differential lock; inspect shift rod seals for wear or damage.

- A—Output Shaft Bearings
- B—Intermediate Shaft Bearings
- C—Countershaft Bearings
- D—Differential Case
- E—Differential Cover
- F—Axle Shaft Seals

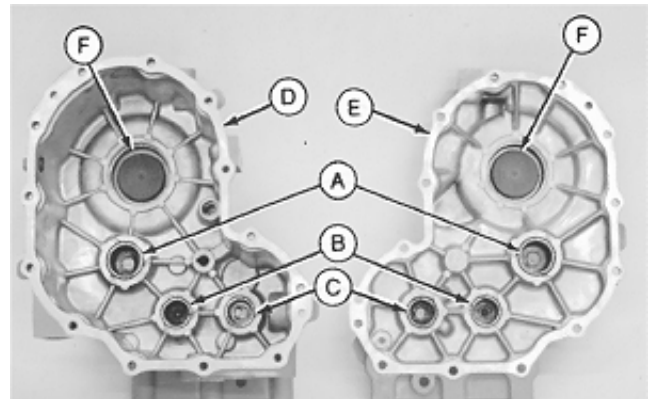

MX,15905015,14 -19-23FEB95

22. Replace bearings if necessary.

<b>Bearing</b>	<b>Removal or Installation</b>	<b>Side Driven From</b>	<b>Pilot Size</b>	<b>Driver Size</b>
Output Pinion Bearing	Remove	Outside	1-1/4 in.	1-9/16 in.
	Install	Inside	1-1/4 in.	1-9/16 in.
Shifter Shaft Bearing	Remove	Outside		1-1/4 in.
	Install	Inside	1 in.	1-1/4 in.
Countershaft Bearing	Remove	Outside		1-1/4 in.
	Install	Inside	1 in.	1-1/4 in.

MX,15905015,15 -19-23FEB95

50  
15  
11

## ASSEMBLE DIFFERENTIAL

**NOTE:** This assembly procedure is for the One-Speed Differential (322, 330 and 332) and the Two-Speed Differential with Differential Lock (430). The differences are noted.

Lubricate all seals with petroleum jelly during assembly.

Early models have **FLAT** thrust washers. Later models have **TABBED** thrust washers. All service or replacement thrust washers will have the tabs.

**IMPORTANT:** It is recommended to replace the early model (flat) thrust washers with the later model (tabbed) thrust washers. The early model washers may spin with their respective shafts, causing wear to case bearing surfaces.

**Always use new seals. Damaged or used parts will leak.**

1. Put clean John Deere Low Viscosity HY-GARD® oil or an equivalent on all internal parts during assembly.
2. Put needle bearing (A) between two flat thrust washers (B). Put assembly on case countershaft bearing surface (C).
3. Put small tabbed thrust washer on intermediate shaft bearing surface with tab (D) pointing down between reinforcement ribs (E).
4. Put large tabbed thrust washer on output shaft bearing surface with tab (F) pointing down between reinforcement ribs (G).

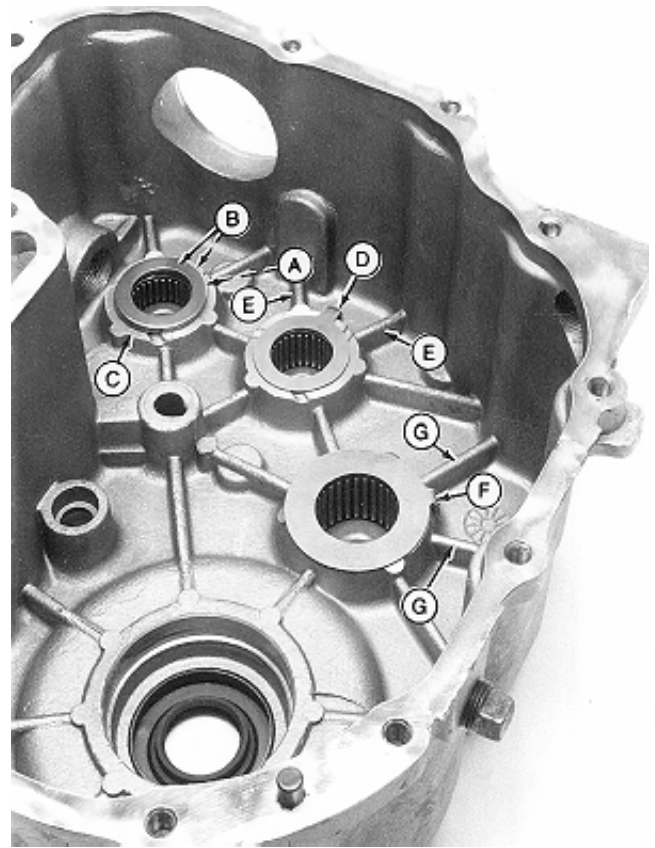

M74075 -JUN-24FEB95

MX,15915015,2 -19-13JUL95

5. Assemble gear (C) and shaft (B).

6. Install output shaft assembly through tabbed thrust washer (A).

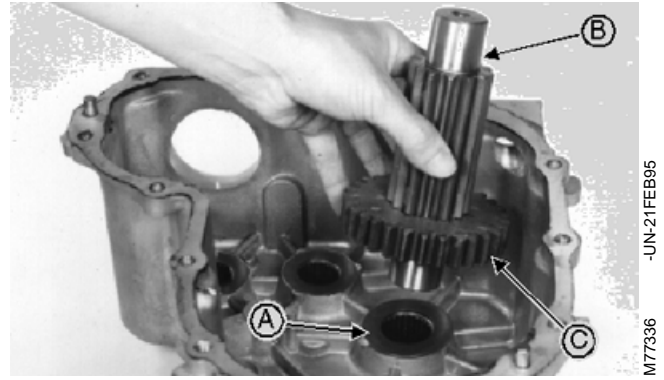

One-Speed Differential

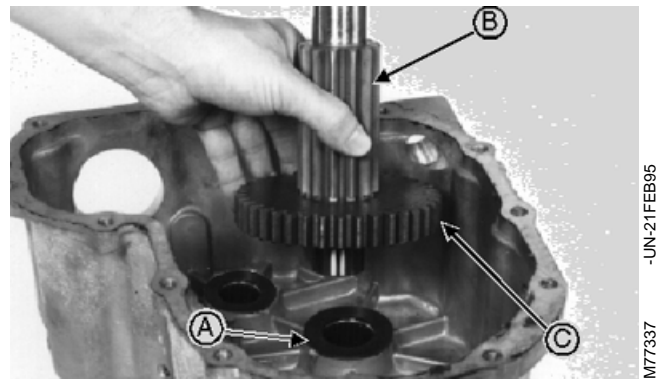

Two-Speed Differential

MX,15905015,19 -19-14MAR95

7. Two-speed differential; assemble shift rod by installing fork (B) and two E-rings (A).

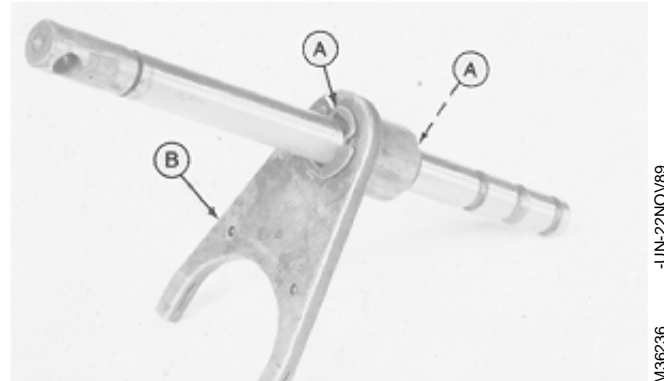

MX,15905015,20 -19-23FEB95

8. Assemble gears (B and C) and shaft (D).

9. Install intermediate shaft assembly through tabbed thrust washer (A); if equipped with two-speed, install shift rod assembly with intermediate shaft assembly.

- A—Thrust Washer
- B—Intermediate Gear
- C—Intermediate Gear
- D—Intermediate Shaft

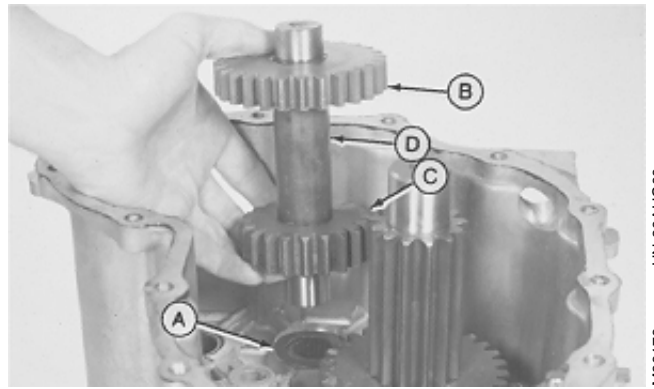

One-Speed Differential

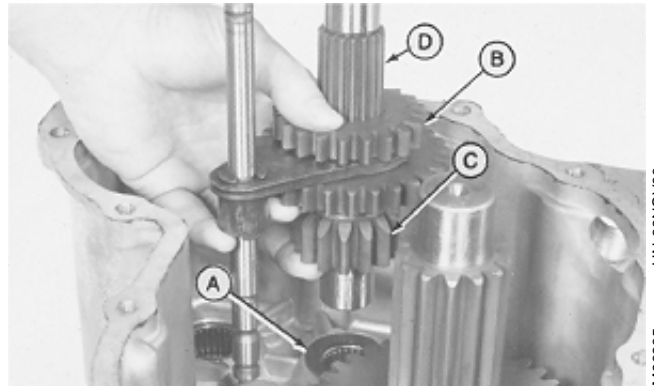

Two-Speed Differential

MX,15905015,21 -19-23FEB95

M36176 -UN-29AUG88

M36235 -UN-22NOV89

10. Two-speed differential; install detent ball, spring and set screw.



M36234 -UN-22NOV89

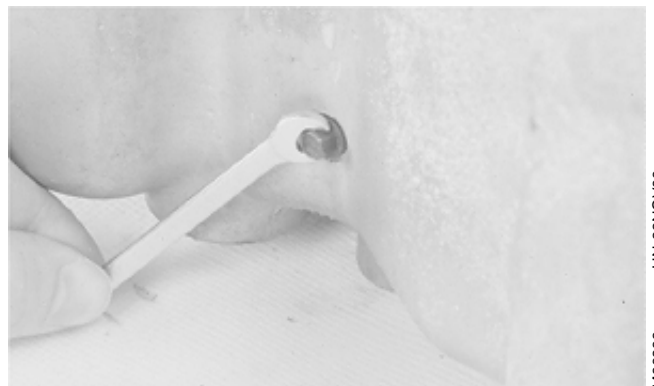

M36233 -UN-22NOV89

MX,15905015,22 -19-23FEB95

50  
15  
14



11. Assemble gears (A and B) and shaft (C).

12. Install countershaft assembly through spacer (D), thrust bearing (F) and thrust washers (E).

- A—Spur Gear
- B—Bevel Gear
- C—Countershaft
- D—Spacer
- E—Thrust Washer (2 used)
- F—Thrust Bearing

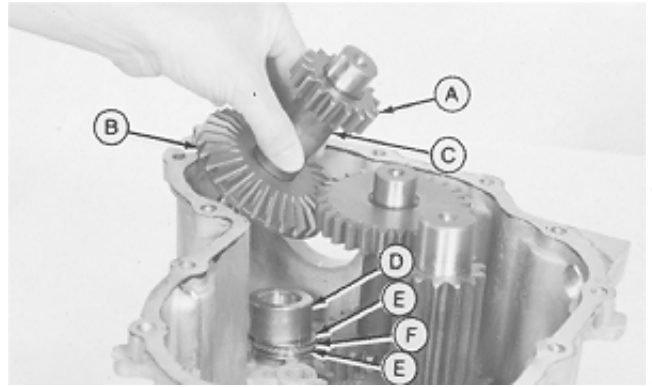

M36175 -UN-29AUG88

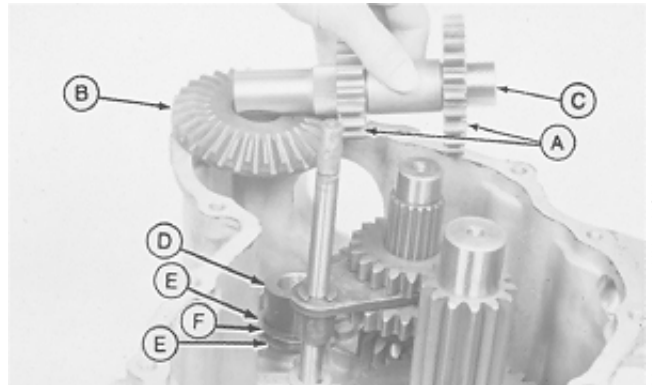

M36232 -UN-22NOV89

Two-Speed Differential

MX,15905015,23 -19-23FEB95

NOTE: Early model with differential lock shown.

13. If removed, install collar (with differential lock) and bearings on carriers (F) using a driver set and a press. Install bearings flush with shaft surfaces.

NOTE: Carriers on later models have oil grooves, an oil hole and a thrust washer in carriers.

Machines without differential lock have one thrust washer in each carrier. Machines with differential lock have one thrust washer and one new style carrier on the non-differential lock side only.

All service or replacement carriers will have these features.

14. Install thrust washers, if equipped, in carriers (F).

15. Assemble carriers (F), ring gear (E), pinion gears (A), bevel gears (C), cross shaft (D), and pinion blocks (B).

If equipped with differential lock, install bevel gear with holes (G) toward carrier with lock pins and collar.

16. Clean the threads of all six cap screws and threaded carrier, using Clean and Cure Primer. Apply thread lock and sealer (medium strength) to the threads of cap screws.

17. Install cap screws and tighten to 53 N·m (39 lb-ft).

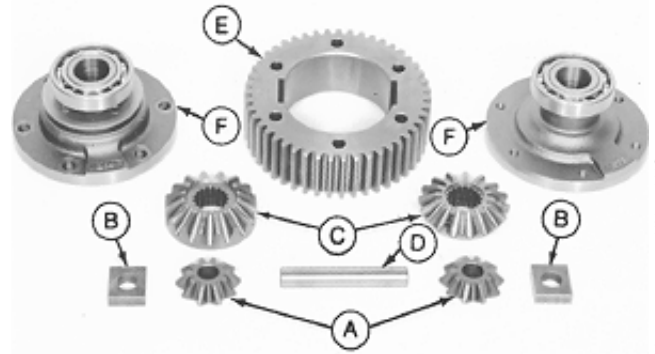

M31977 -UN-25AUG88

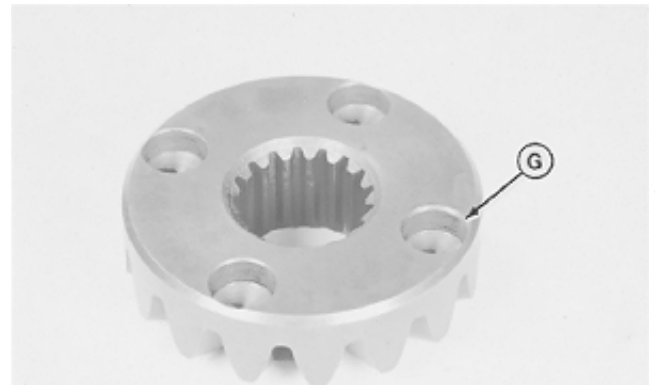

M36173 -UN-29AUG88

- A—Pinion Gear (2 used)
- B—Pinion Block (2 used)
- C—Bevel Gear (2 used)
- D—Cross Shaft
- E—Ring Gear
- F—Carrier (2 used)
- G—Bevel Gear with Holes

MX,15905015,24 -19-20MAR95

18. If equipped with differential lock, assemble shift rod, snap ring (E), washers (B), springs (C), fork (D), and E-rings (A).

- A—E-Ring (3 used)
- B—Washer (3 used)
- C—Spring (2 used)
- D—Fork
- E—Snap Ring

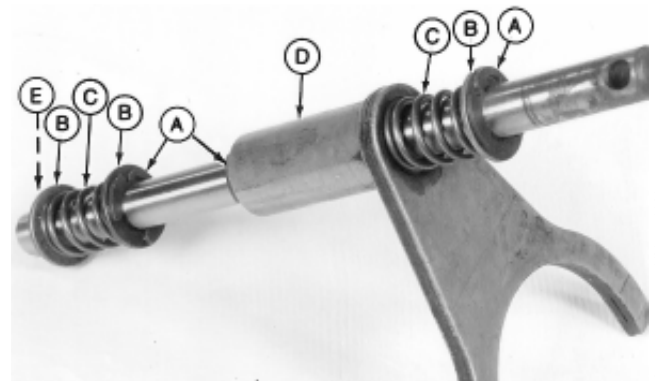

M36230 -UN-19JAN95

MX,15905015,25 -19-23FEB95

19. Install differential; if equipped with differential lock, install shift rod assembly with differential.

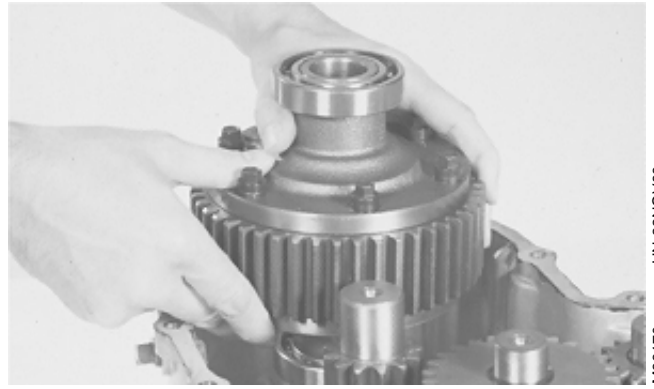

*Without Differential Lock*

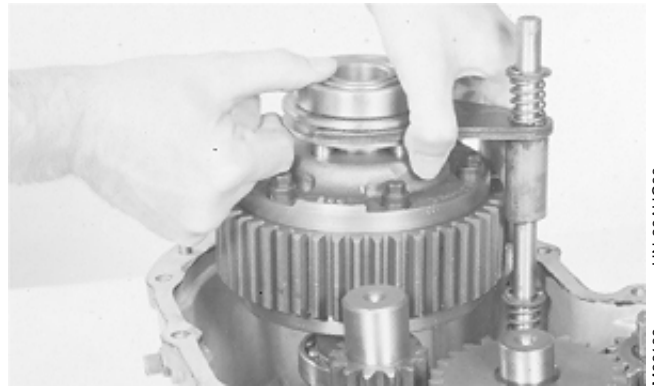

*With Differential Lock*

MX,15905015,26 -19-23FEB95

M36170 -UN-22NOV89

M36169 -UN-29AUG88

50  
15  
17

*NOTE: Early models have FLAT thrust washers. Later models have TABBED thrust washers. All service or replacement thrust washers will have the tabs.*

**IMPORTANT: It is recommended to replace the early model (flat) thrust washers with the later model (tabbed) thrust washers. The early model washers may spin with their respective shafts, causing wear to the cover bearing surfaces.**

20. Put a small tabbed thrust washer on countershaft gear with tab (A) pointing up so it will be between the two cover reinforcement ribs that correspond to the same case reinforcement ribs.

21. Put other small tabbed thrust washer on intermediate shaft gear with tab (B) pointing up so it will be between the two cover reinforcement ribs that correspond to the same case reinforcement ribs.

22. Put large tabbed thrust washer on output shaft with tab (C) pointing up so it will be between the two cover reinforcement ribs that correspond to the same case reinforcement ribs.

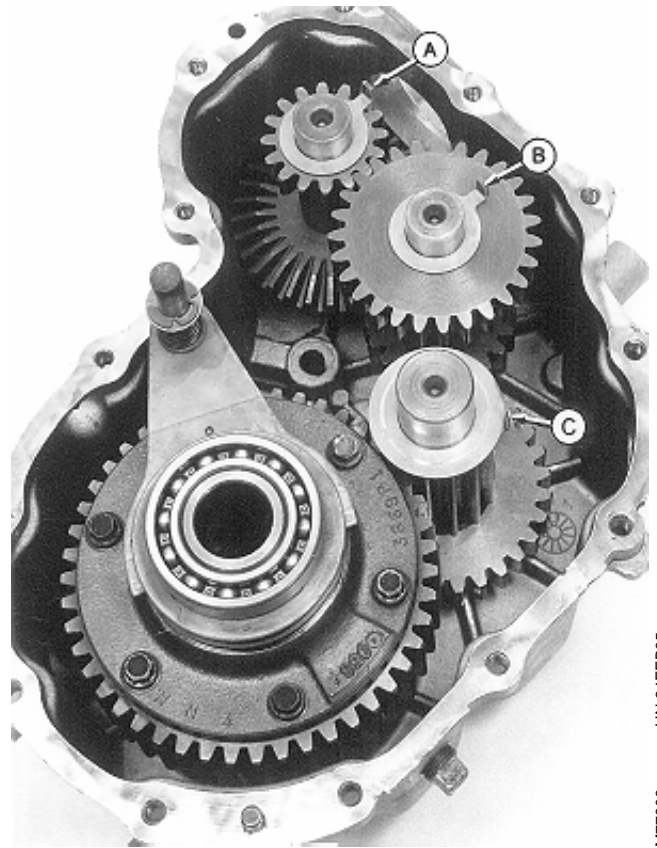

*Two-Speed Differential Shown*

M77906 -JUN-24FEB95

MX,15905015,27 -19-23FEB95

**IMPORTANT:** If replacement gasket is made of rubber coated laminated metal, clean mating surfaces of differential case and cover and install gasket. Do not apply sealant. It will cause oil to leak.

If replacement gasket is made of paper, clean mating surfaces of differential case and cover, apply recommended sealant, then install gasket.

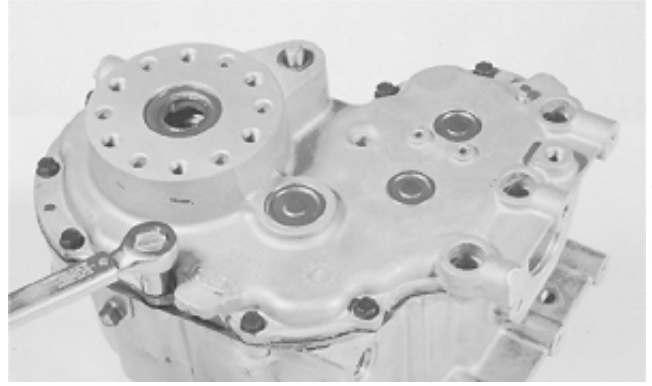

M36181 -UN-29AUG88

23. Clean the mating surfaces of differential case and cover using Clean and Cure Primer. Apply a coat of Flexible Sealant or an equivalent to differential cover and case when using paper gasket only.

24. Install gasket, cover, and 13 cap screws. Install cap screws finger-tight.

25. Drive two dowel pins into differential cover.

26. Tighten cap screws to 23 N·m (204 lb-in.).

MX,15905015,28 -19-23FEB95

50  
15  
20

## OTHER MATERIAL

Number	Name	Use
M79292	MPG-2® Multi-Purpose Polymer Grease	Prevents parts from seizing. Apply to axle shafts.
LOCTITE® PRODUCTS U.S./Canadian/LOCTITE No.		
TY6305/TY9485/764	Clean and Cure Primer	Cleans parts and speeds cure of sealant.
T43512/TY9473/242	Thread Lock and Sealer (Medium Strength)	Apply to threads of brake plate-to-axle cap screws.

®MPG-2 is a registered trademark of DuBois USA.

®LOCTITE is a registered trademark of the Loctite Corp.

MX,15905020,OTH-19-07MAR95

## REMOVE AXLE

1. Disconnect battery negative (—) cable.
2. Remove drain plug (A) to drain transmission oil. Approximate capacity is 4.7 L (5 U.S. qt). After oil is completely drained, install and tighten drain plug.
3. Raise rear of tractor and install support stands.
4. Remove rear wheel.

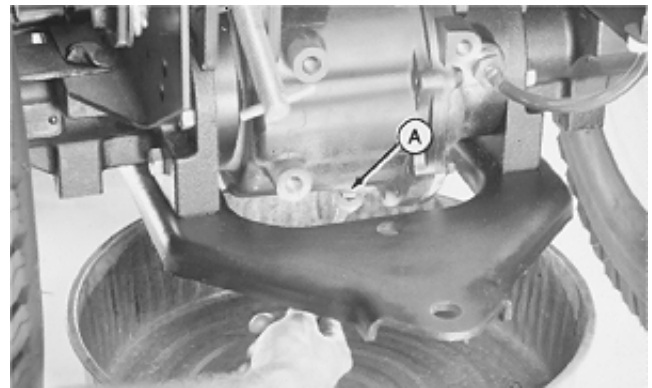

MX,15905020,1 -19-23FEB95

5. Bend edge of washer (A) flat against drum.
6. Remove nut and washer.
7. Pull drum off axle.

If drum hits shoes, turn the adjuster to reduce the drag on the drum from shoes.

If drum is tight on shaft from corrosion, remove drum using a three-leg wheel puller. Do not use impact puller.

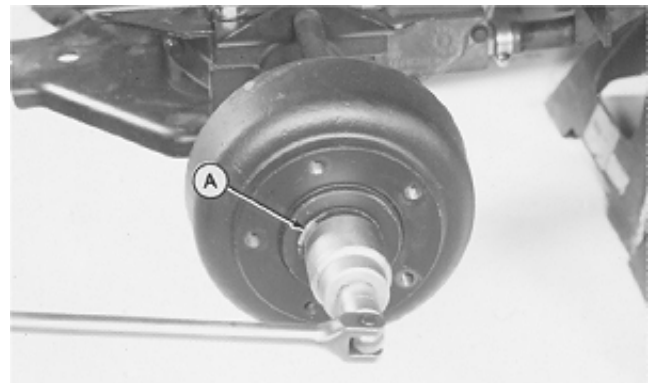

5M3,5020K,C -19-18DEC87

8. Disconnect spring (A).

9. Remove nut (B), plate or washer (D) and spring (C).

- A—Return Spring
- B—Nut
- C—Spring
- D—Plate (Early 430)
- Washer (All and Later 430)

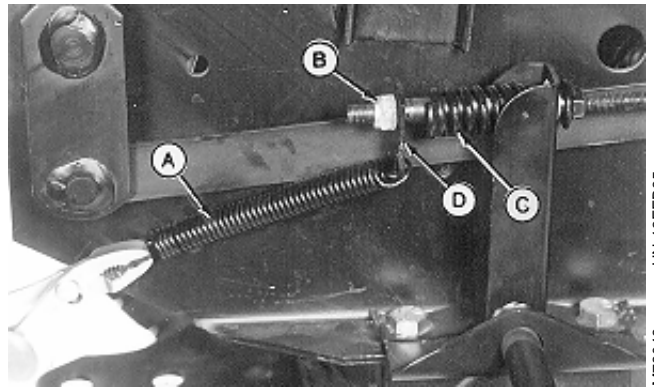

Early 430

M78048 -UN-13FEB95

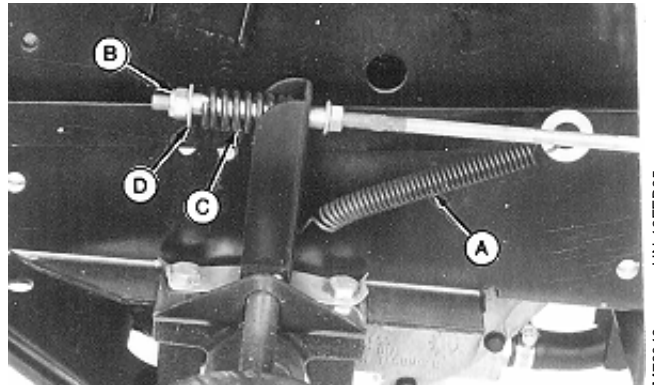

All and Later 430

M78049 -UN-13FEB95

MX,15915020,2 -19-13JUL95

10. Bend tabs (A) flat and remove two cap screws.

11. Remove four cap screws and washers (B) to remove brake plate assembly (C).

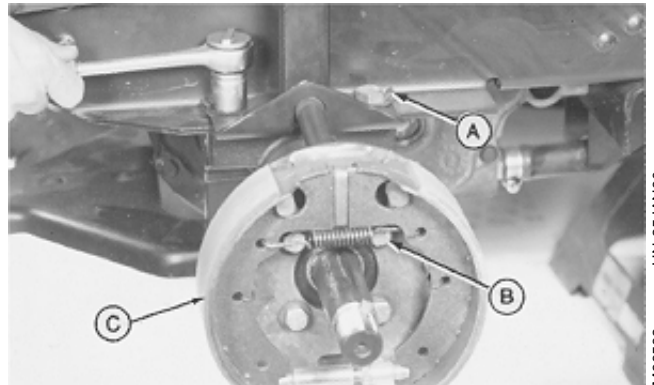

5M3,5020K,E -19-18DEC87

M36562 -UN-25JAN90

12. Remove axle shaft assembly using a bearing puller (A), H-Bar (B), and slide hammer (C).

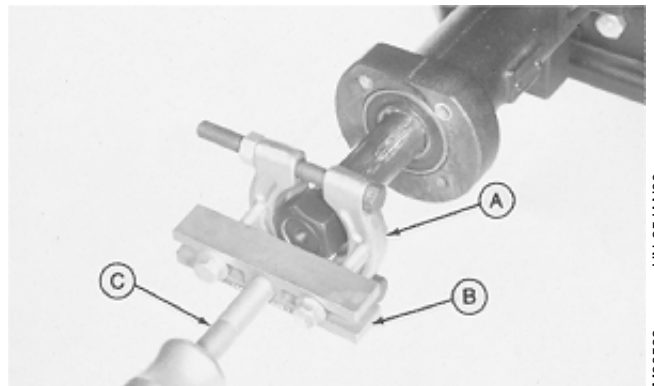

MX,15905020,2 -19-23FEB95

M36563 -UN-25JAN90

50  
20  
2



## Rear Axles/Remove

13. Inspect bearing (A), replace if necessary.

**IMPORTANT: Be sure to hold shaft while removing bearing.**

14. Remove bearing using a bearing puller (B) and a press.

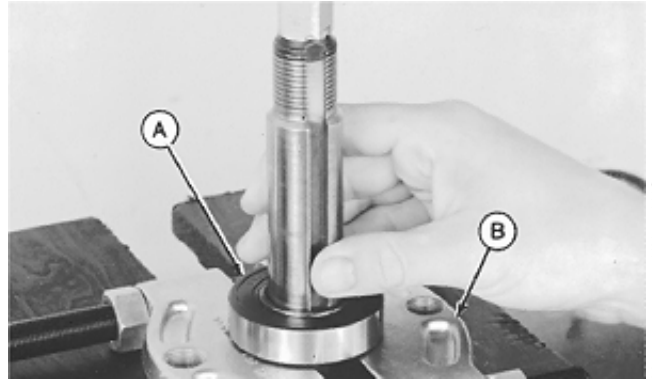

5M3,5020K,G -19-18DEC87

M31951 -JUN-25AUG88

15. Remove two cap screws (A) to disconnect axle from hitch plate (B).

16. Remove six cap screws to remove axle housing.

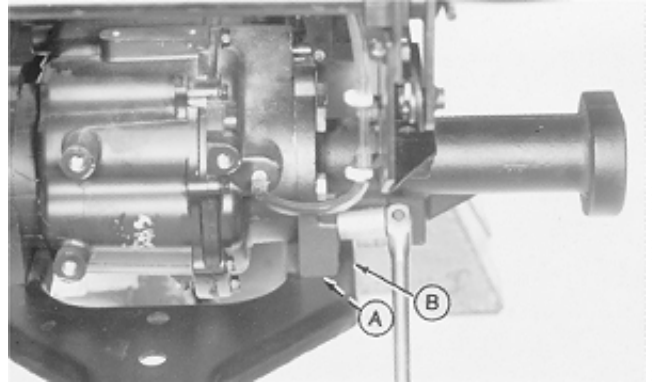

5M3,5020K,H -19-18DEC87

M36564 -JUN-25JAN90

17. Remove spacer.

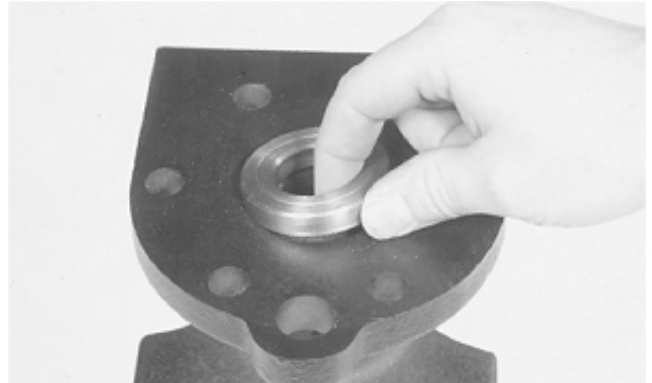

5M3,5020K,I -19-18DEC87

M36565 -JUN-25JAN90

18. Remove seal from differential using a 2-jaw puller and a slide hammer.

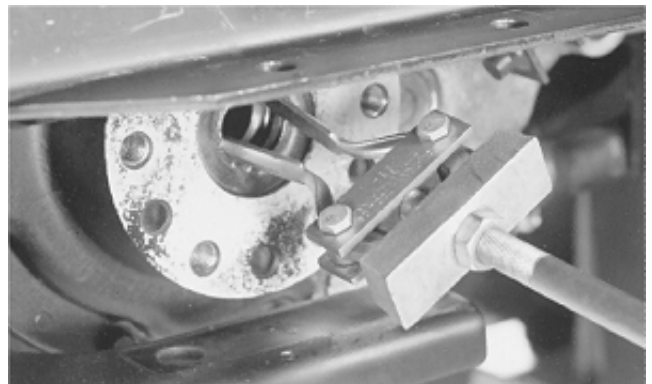

5M3,5020K,J -19-18DEC87

M36566 -JUN-25JAN90

## INSTALL AXLE

**IMPORTANT:** Always use new seals. Damaged or used parts will leak.

*NOTE:* Lubricate all seals with petroleum jelly during assembly.

1. Install new seal 3 mm (0.118 in.) below machined surface of differential using a 2-1/16 in. driver disk.

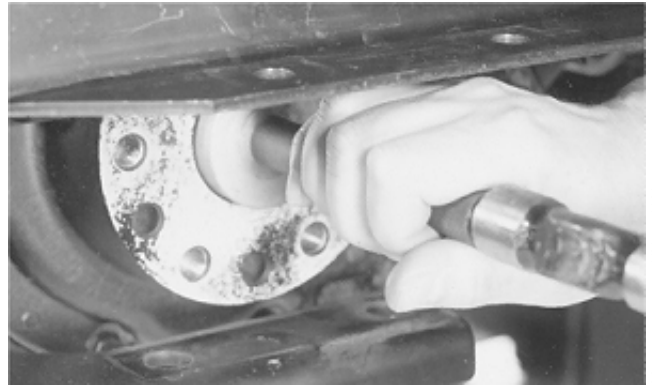

M36567  
-UN-25JAN90

MX,15905020,3 -19-23FEB95

2. Install spacer.

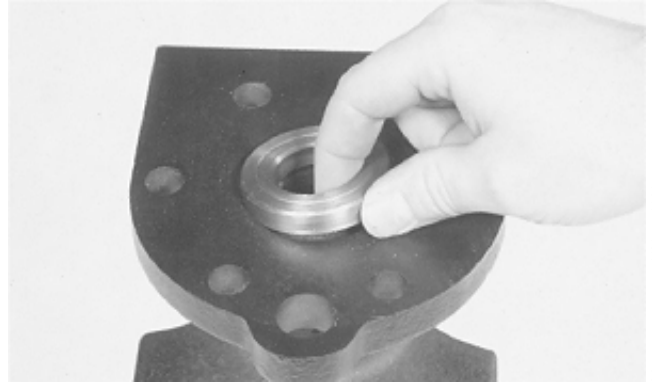

M36565  
-UN-25JAN90

M21,5020R,15 -19-14MAY85

3. Install axle housing and fasten with six cap screws. Tighten cap screws to 81 N-m (60 lb-ft).

4. Install and tighten two hitch plate cap screws (A).

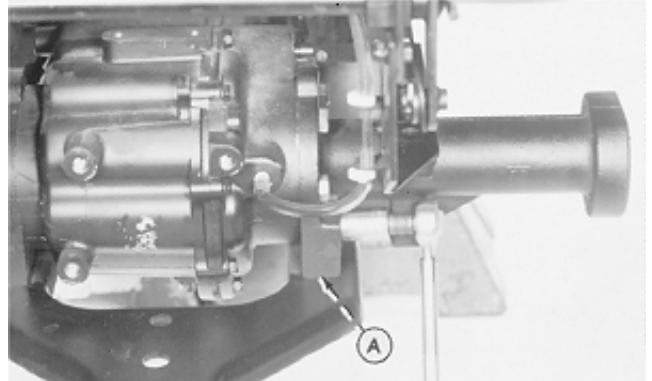

M36568  
-UN-25JAN90

MX,15905020,8 -19-23FEB95

5. Install bearing (A) on axle shaft using a bearing puller (B) and a press. Push bearing tight against axle shaft shoulder.

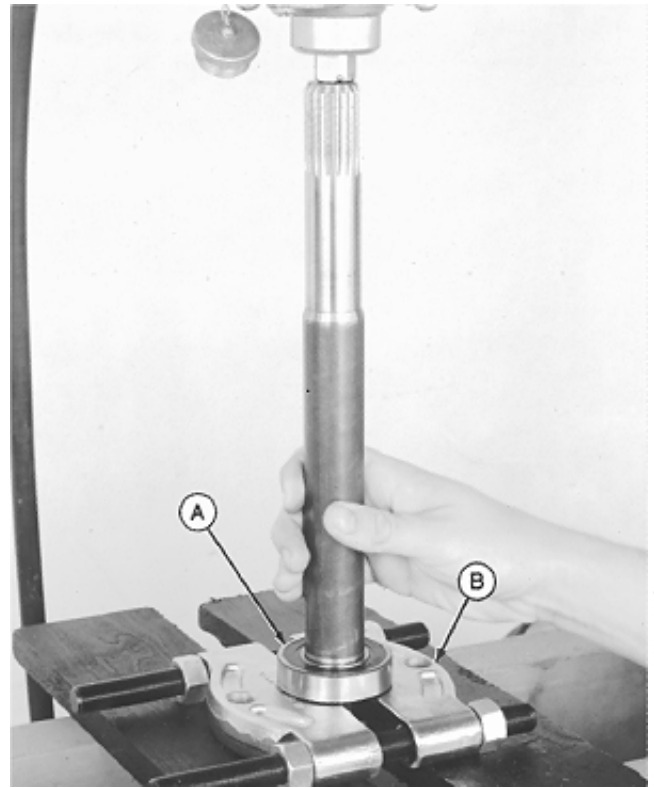

M31952  
-UN-25AUG88  
5120

M21,5020R,17 -19-14MAY85

6. Apply clean transmission fluid to the splined end of the axle shaft.

7. Carefully install axle shaft into housing and through seal in differential. Align splines on shaft with splined gear inside differential.

8. Tap shaft assembly into axle housing until bearing is flush with housing.

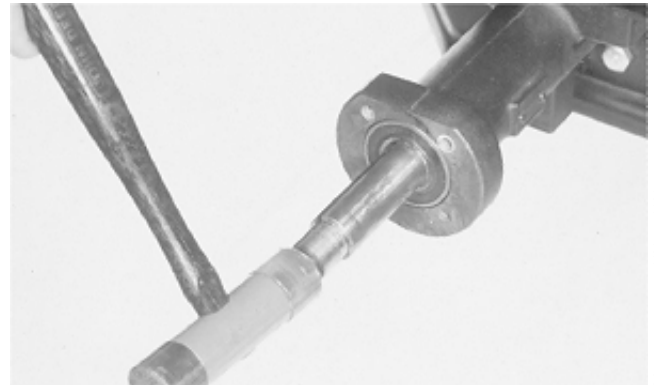

M36569  
-UN-25JAN90

M21,5020R,18 -19-14MAY85

9. Clean the threads of all four brake plate cap screws and threaded axle housing using Clean and Cure Primer.
10. Apply thread lock and sealer (medium strength) on threads of brake plate cap screws (A).
11. Install brake rod in brake arm hole.
12. Install brake plate assembly (B) on axle. Install and tighten four cap screws (A) to specifications.
13. Install brake support (C), lock plate (D) and two cap screws. Tighten cap screws to specifications. Bend lock plate tabs over flat of cap screws.

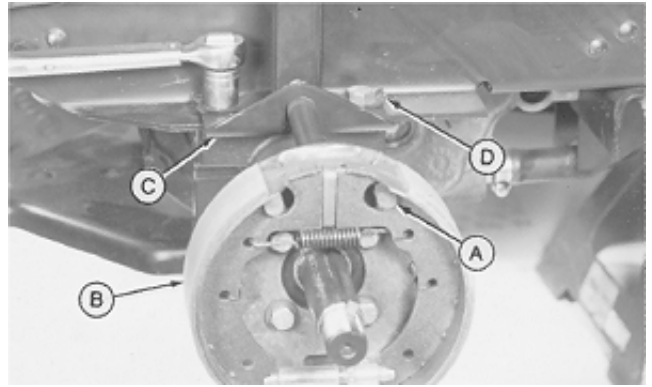

M36570 -UN-25JAN90

**TORQUE SPECIFICATIONS**

Brake Plate-to-Axle Housing	
Cap Screws	68 N-m (50 lb-ft)
Axle Housing-to-Frame Cap Screws	100 N-m (75 lb-ft)

- A—Cap Screw (4 used)
- B—Brake Plate Assembly
- C—Brake Support
- D—Lock Plate

50  
20  
6

MX,15905020,4 -19-08MAY95

14. Install spring (C), plate or washer (D) and nut (B).
15. Connect spring (A).

- A—Return Spring
- B—Nut
- C—Spring
- D—Plate (Early 430)
- Washer (All and Later 430)

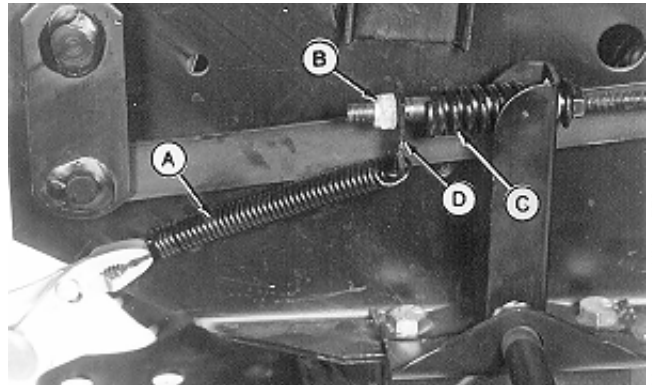

Early 430

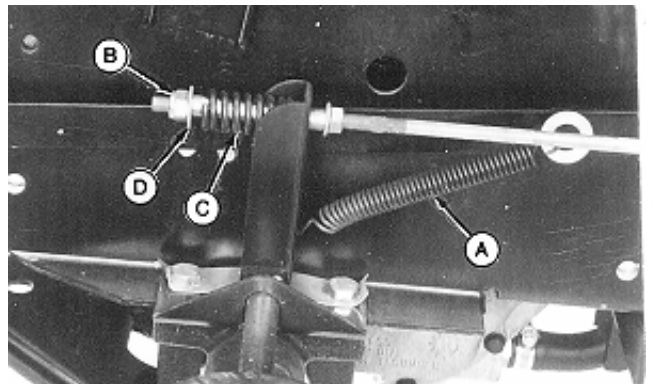

All and Later 430

M78048 -UN-13FEB95

M78049 -UN-13FEB95

MX,15915020,3 -19-13JUL95

Rear Axles/Install

16. Lock brake pedals together (322, 332 and 430) and apply park brake.

17. Loosen lock nut (A).

18. Turn nut until spring is 42 mm (1.650 in.) long. Tighten lock nut.

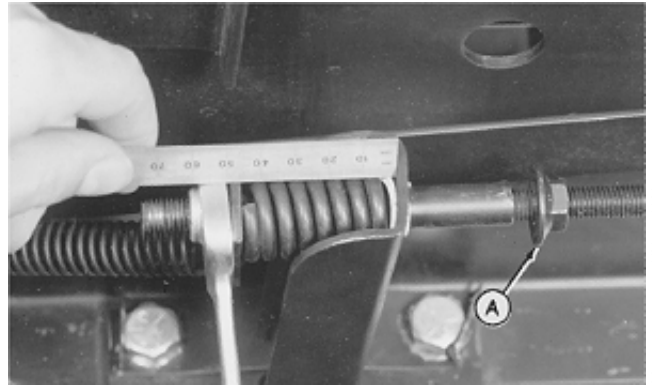

M36554 -UN-25JAN90

MX,15915020,1 -19-13JUL95

19. Apply MPG-2® Multi-Purpose Polymer Grease on axle shaft.

20. Install key and brake drum.

21. Install washer and nut. Tighten nut to specifications.

22. Bend one side of washer over nut to lock nut in place.

23. Install wheel. Tighten cap screws to specifications.

24. Remove support stands.

25. Fill differential with the recommended amount of John Deere Low Viscosity HY-GARD® oil.

26. Connect battery negative (—) cable.

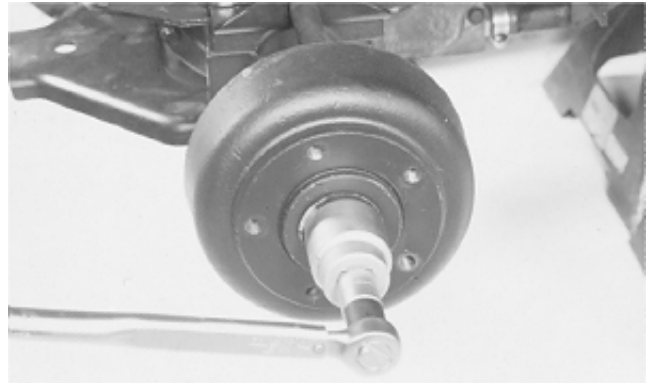

M36571 -UN-25JAN90

**TORQUE SPECIFICATIONS**

Brake Drum-to-Axle Nut . . . . .	88 N-m (65 lb-ft)
Rear Wheel Cap Screws . . . . .	70 N-m (52 lb-ft)

MX,15905020,6 -19-07MAR95



**OTHER MATERIAL**

<b>Number</b>	<b>Name</b>	<b>Use</b>
M79292	MPG-2® Multi-Purpose Polymer Grease	Prevents parts from seizing. Apply to splines of transmission input shaft.

®MPG-2 is a registered trademark of DuBois USA.

MX,15905005,OTH-19-07MAR95

50  
25  
1

## REMOVE AND INSTALL DRIVE SHAFT—322 AND 332

1. Disconnect battery negative (—) cable.
2. Remove belly screen and left-hand engine side panel.
3. Remove three cap screws and lock nuts (A) holding drive shaft to rubber isolator.
4. Remove three cap screws and washers holding rubber isolator to engine. Remove isolator.
5. Loosen two lock nuts and cap screws on drive shaft at transmission pump shaft end.

**N CAUTION:** To avoid injury from escaping fluid under pressure, stop engine and relieve the pressure in the system before disconnecting or connecting hydraulic or other lines. Tighten all connections before applying pressure.

6. Disconnect hydraulic line directly under drive shaft. (Control valve-to-left front inside coupler.)
  7. Remove drive shaft by sliding forward to remove from transmission, then rearward and drop out.
  8. Installation is done in the reverse order of removal.
- Before installing drive shaft, apply MPG-2® Multi-Purpose Polymer Grease on splines of transmission input shaft.
  - Apply multipurpose grease to lubrication fittings.
  - Bleed hydraulic system. (See procedure in Section 270, Group 20.)

### TORQUE SPECIFICATIONS

Isolator-to-Engine Cap Screws . . . . .	37 N·m (27 lb-ft)
Drive Shaft Cap Screws and Lock Nuts	
Flange-to-Isolator . . . . .	27 N·m (20 lb-ft)
Clamping Yoke-to-Transmission	
Pump Shaft . . . . .	60 N·m (44 lb-ft)

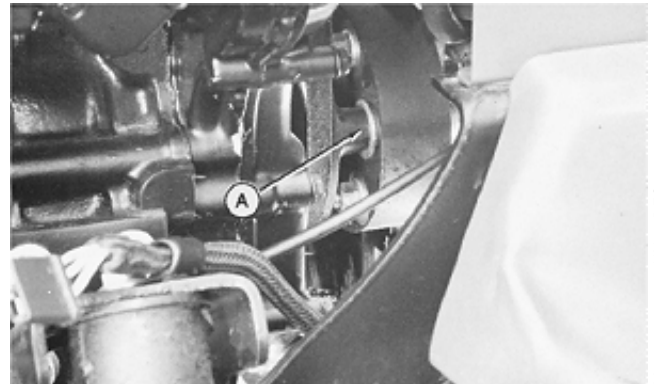
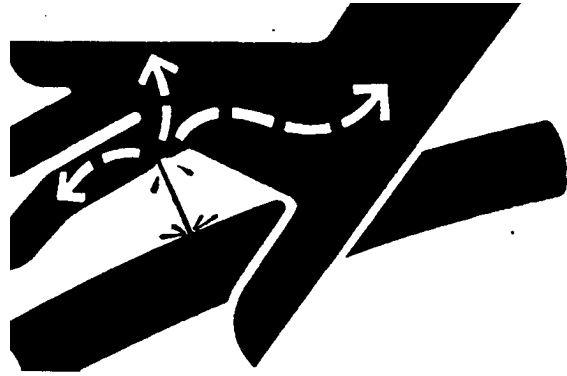

50  
25  
2

-UN-23AUG88

X9811

-UN-20DEC89

M49505



## REMOVE AND INSTALL DRIVE SHAFT—330

1. Disconnect battery negative (—) cable.
2. Remove fender deck.
3. Lift hood and remove engine side panels.
4. Remove right and left pedestal side panels.

**N** **CAUTION:** Explosive release of fluids from pressurized cooling system can cause serious burns.

**Shut off engine. Only remove filler cap when cool enough to touch with bare hands. Slowly loosen cap to first stop to relieve pressure before removing completely.**

5. Drain radiator. Approximate capacity is 2.8 L (3 U.S. qt).
6. Loosen block drain valve. Drain engine coolant from engine block. Tighten drain valve.
7. Remove radiator.



MX,15915025,2 -19-13JUL95

8. Loosen two lock nuts and cap screws on drive shaft at transmission pump shaft end.
9. Remove three cap screws and lock nuts holding drive shaft to rubber isolator. Push drive shaft rearward.

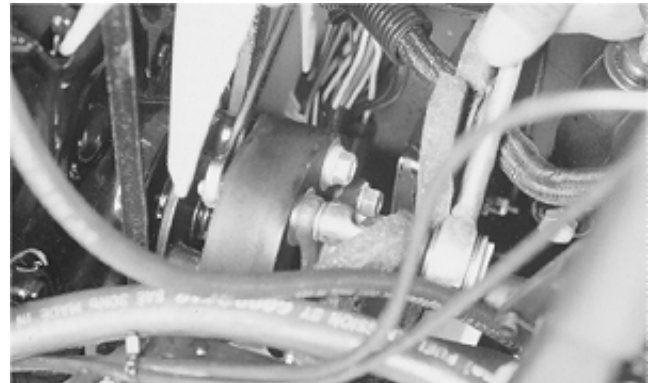

MX,15915025,3 -19-13JUL95

TS281 -UN-23AUG88

-UN-09DEC89

M55053

-UN-09DEC89

M55058

10. Remove three cap screws and washers holding rubber isolator to engine. Remove isolator.

11. Pull drive shaft forward to remove from transmission pump shaft. Remove drive shaft from machine.

12. Installation is done in the reverse order of removal.

- Before installing drive shaft, apply MPG-2® Multi-Purpose Polymer Grease on splines of transmission input shaft.

- Apply multipurpose grease to lubrication fittings.

- Close drain valve and fill radiator with proper coolant until coolant is 13—25 mm (0.500—1 in.) below bottom of filler neck. (See Engine Coolant in Section 10, Group 25.)

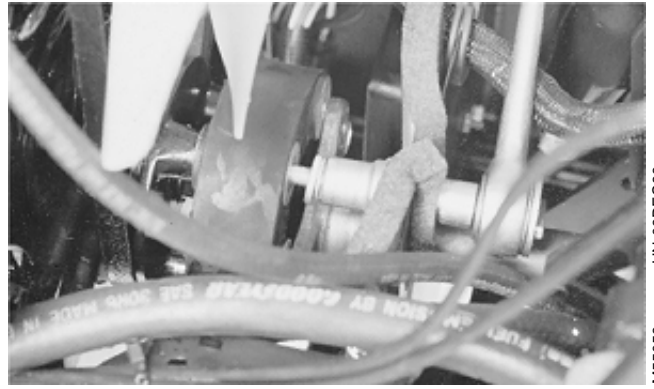

M55059 -UN-09DEC89

**TORQUE SPECIFICATIONS**

Isolator-to-Engine Cap Screws . . . . .	27 N-m (20 lb-ft)
Drive Shaft Cap Screws and Lock Nuts	
Flange-to-Isolator . . . . .	27 N-m (20 lb-ft)
Clamping Yoke-to-Transmission	
Pump Shaft . . . . .	60 N-m (44 lb-ft)

MX,15915025,4 -19-13JUL95

50  
25  
4

**DISASSEMBLE AND INSPECT DRIVE SHAFT**

1. Inspect splined yoke (A), cross and bearing assembly (B) and front tube yoke (C) for cracks, wear or damage.

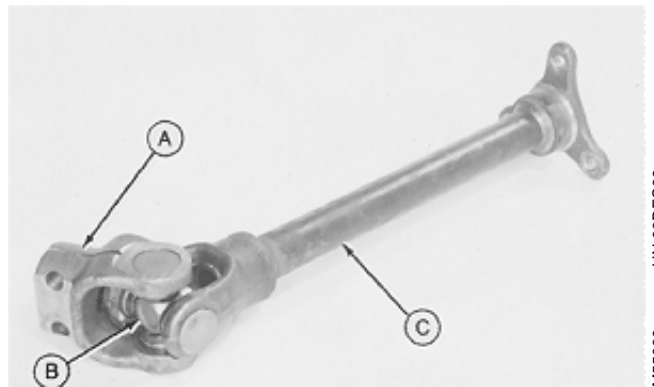

M55060 -UN-09DEC89

MX,15915025,5 -19-13JUL95

**NOTE:** Note position of grease zerk (B) so after reassembly and installation, drive shaft can be lubricated.

2. Remove four snap rings (A).

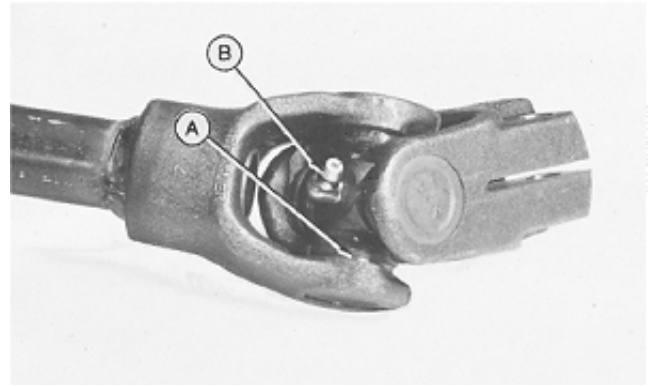

MX,15915025,6 -19-13JUL95

M49512  
-UN-20DEC89

3. Remove bearings (A) and cross (B) using a brass drift. Push a bearing down into a donut type press plate (C) until it can be removed from the bottom.

4. Turn cross and bearing assembly over and repeat procedure.

5. Separate end yoke from front tube yoke.

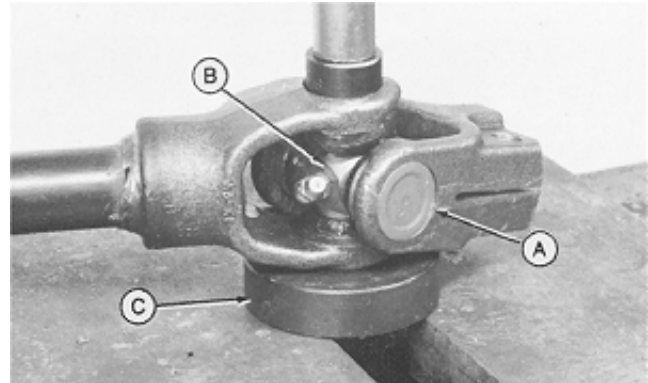

MX,15915025,7 -19-13JUL95

M49513  
-UN-20DEC89

6. Remove cross and bearing assembly using a brass drift. Push bearing down until bottom bearing can be removed.

7. Remove cross and top bearing.

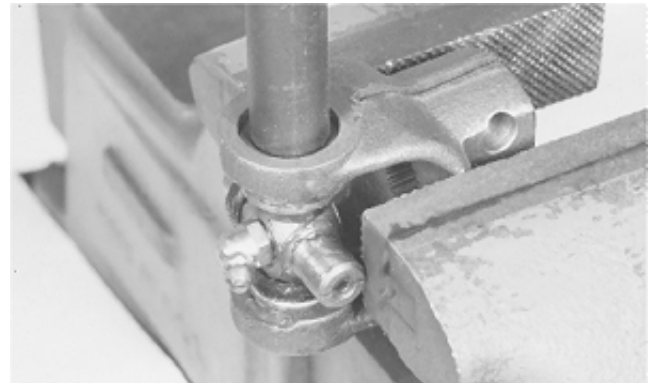

MX,15915025,8 -19-13JUL95

M36591  
-UN-25JAN90

## ASSEMBLE DRIVE SHAFT

**IMPORTANT:** Be careful not to damage needle rollers and seal while installing cross and bearing assembly.

1. Press bearings onto cross only until snap rings can be installed.

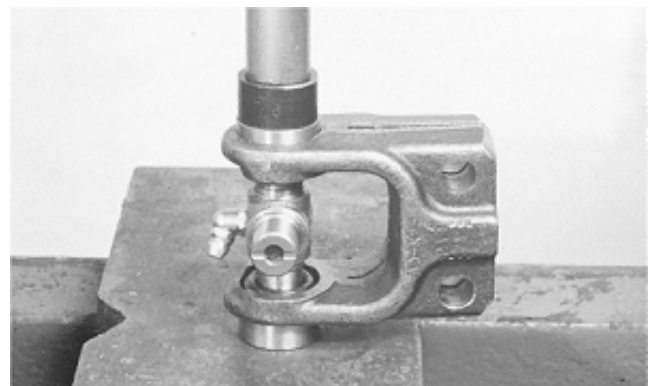

MX,15915025,9 -19-13JUL95

M49514  
-UN-20DEC89

2. Install cross (B) in front tube yoke (C) with grease fitting toward tube yoke.
3. Press bearing down until snap ring groove is inside front tube yoke.
4. Turn cross and bearing assembly, and end yoke (A) over and install other bearing.
5. Install four snap rings.

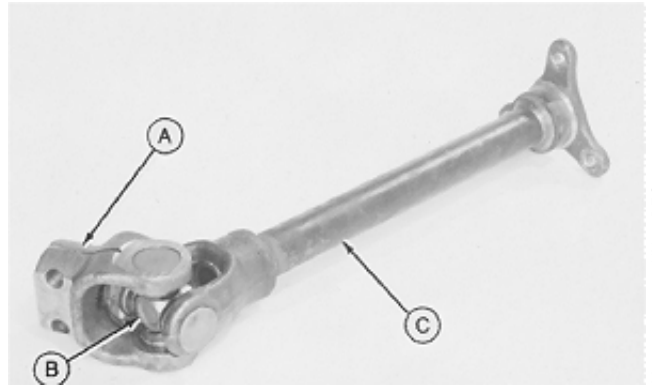

M55060 -UN-09DEC89

MX,15915025,10 -19-13JUL95

## OTHER MATERIAL

Number	Name	Use
M79292	MPG-2® Multi-Purpose Polymer Grease	Prevents parts from seizing. Apply to splines of transmission input shaft.

®MPG-2 is a registered trademark of DuBois USA.

MX,15905005,OTH-19-07MAR95

## REMOVE AND INSTALL DRIVE SHAFT—EARLY MODELS

1. Lift hood and remove front grille and engine side panels.
2. Remove battery and battery base.
3. Remove fender deck.
4. Remove belly pan.
5. Remove right pedestal side.

**NOTE:** There are three versions of the transmission control linkage. Version one is shown. See Group 10, in this section, to confirm which version your machine is equipped with. It may not be necessary to perform some steps if equipped with later versions of linkage on later models.

6. Remove snap ring and pin to remove shock absorber.

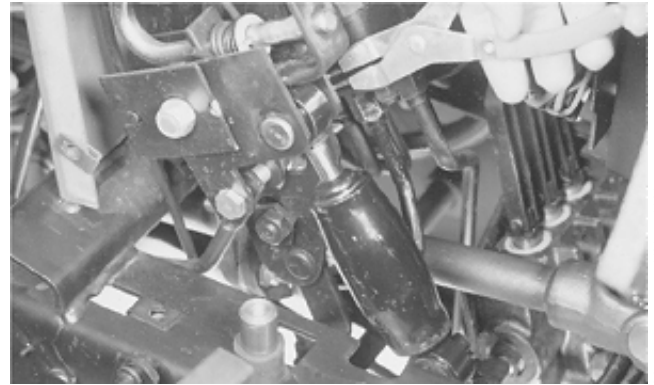

50  
26  
1  
-JUN-29JAN90  
M36501

MX,15915026,1 -19-13JUL95

**NOTE:** On some models the cylinder mounting pin (A) may be longer than 30 mm (1.181 in.). Any extra length will need to be cut off, to provide clearance to remove drive shaft.

7. Measure length of cylinder mounting pin (A). If more than 30 mm (1.181 in.) long, cut off extra length.

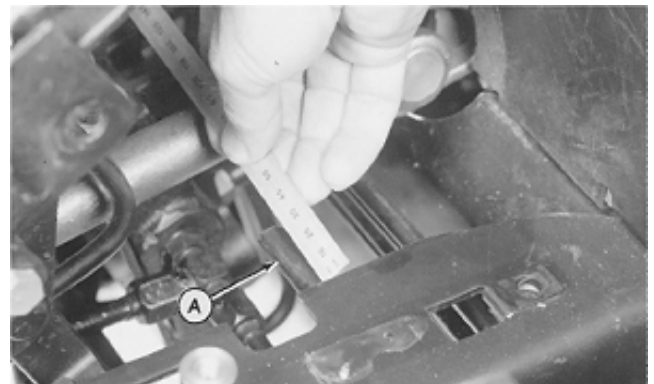

-JUN-25JAN90  
M36581

MX,15915026,2 -19-13JUL95

**N** **CAUTION:** To avoid injury from escaping fluid under pressure, stop engine and relieve the pressure in the system before disconnecting or connecting hydraulic or other lines. Tighten all connections before applying pressure.

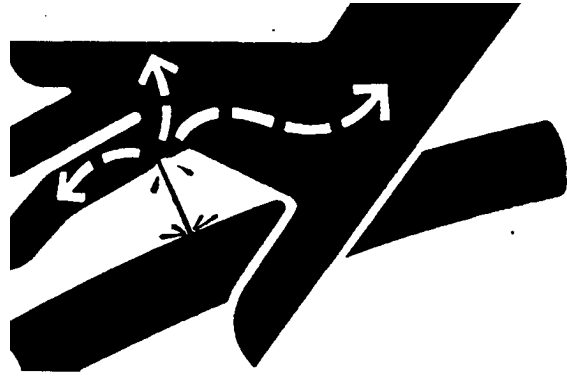

-UN-23AUG88

X9811

8. Remove hydraulic line (A).

9. Loosen two lock nuts and cap screws, if equipped, on drive shaft at transmission pump shaft end.

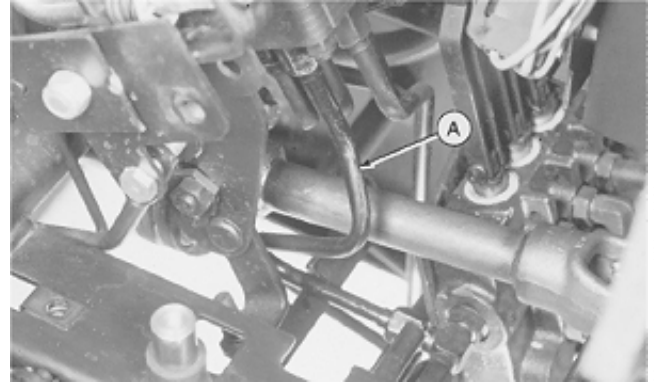

-UN-25JAN90

M36582

MX,15915026,3 -19-13JUL95

10. Remove four cap screws to disconnect partition (A) from pedestal.

11. Lift partition to access drive shaft-to-engine cap screws.

12. Hold drive shaft using a screwdriver. Remove four cap screws to disconnect drive shaft from engine.

13. Pull drive shaft all the way back onto transmission pump shaft. Turn front flanged yoke to clear crankshaft pulley.

14. Push drive shaft forward to disconnect from transmission pump shaft.

15. Remove drive shaft.

16. Installation is done in the reverse order of removal.

• Before installing drive shaft, apply MPG-2® Multi-Purpose Polymer Grease on splines of transmission input shaft.

• Apply multipurpose grease to lubrication fittings.

• Bleed hydraulic system. (See procedure in Section 270, Group 20.)

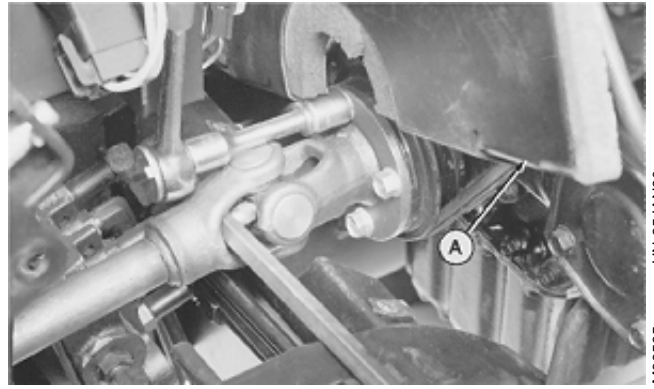

M36585 -UN-25JAN90

50  
26  
3

**TORQUE SPECIFICATIONS**

Drive Shaft Cap Screws and/or Lock Nuts

Flange-to-Engine . . . . .	27 N-m (20 lb-ft)
Clamping Yoke-to-Transmission	
Pump Shaft . . . . .	60 N-m (44 lb-ft)

MX,15915026,4 -19-13JUL95

## REMOVE AND INSTALL DRIVE SHAFT—LATER MODELS

1. Lift hood and remove front grille and engine side panels.
2. Remove battery and battery base.
3. Remove belly pan.
4. Loosen two lock nuts and cap screws, if equipped, on drive shaft at transmission pump shaft end.
5. Remove four cap screws to disconnect partition (A) from pedestal.
6. Lift partition to access drive shaft-to-engine cap screws.
7. Hold drive shaft using a screwdriver. Remove four cap screws to disconnect drive shaft from engine.
8. Pull drive shaft all the way back onto transmission pump shaft. Turn front flanged yoke to clear crankshaft pulley.

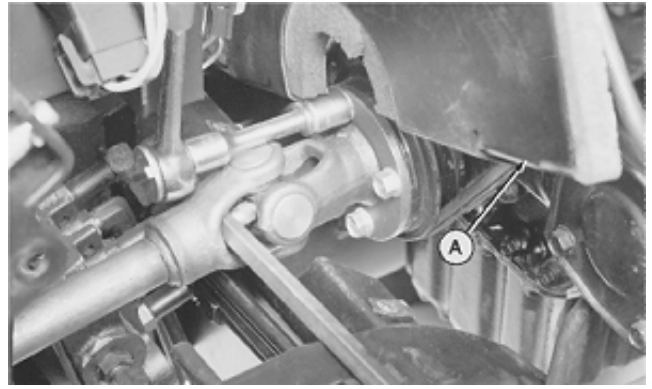

M36585  
-UN-25JAN90

50  
26  
4

MX,15915026,13 -19-13JUL95



**NOTE:** There are three versions of the transmission control and brake pedal and neutral control linkages. Version two is shown. See Group 10, in this section, and/or Section 60, Group 10 to confirm which version your machine is equipped with. It may not be necessary to perform some steps if equipped with later versions of linkage on later models.

9. To provide clearance to remove drive shaft; remove nut (A), strap (B), spacer (C) and arm (D) from cap screw (E).

10. Depress either brake pedal for arm (D) to drop out of the way. Put nut (A) back onto cap screw (E) to hold remaining assembly together. Push assembly toward brake pedals to move out of the way.

11. Push drive shaft up and forward to disconnect from transmission pump shaft.

12. Remove drive shaft.

13. Installation is done in the reverse order of removal.

- Before installing drive shaft, apply MPG-2® Multi-Purpose Polymer Grease on splines of transmission input shaft.

- Apply multipurpose grease to lubrication fittings.

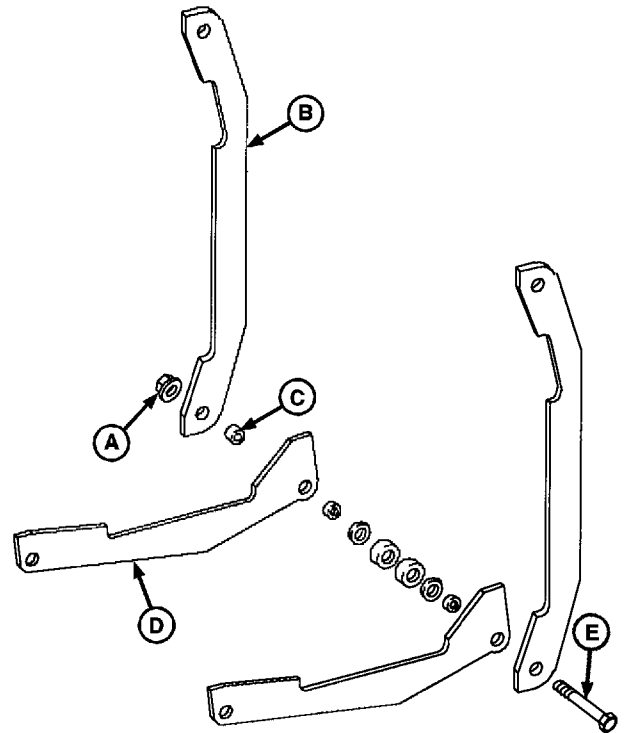

A—Nut  
B—Strap  
C—Spacer  
D—Arm  
E—Cap Screw

**TORQUE SPECIFICATIONS**

Drive Shaft Cap Screws and/or Lock Nuts	
Flange-to-Engine . . . . .	27 N-m (20 lb-ft)
Clamping Yoke-to-Transmission	
Pump Shaft . . . . .	60 N-m (44 lb-ft)

MX,15915026,14 -19-13JUL95

50  
26  
-UN-14MAR95  
M78702

**DISASSEMBLE AND INSPECT DRIVE SHAFT**

1. Inspect coupling assembly for cracked disks (A), wear or damage.
2. Remove cap screws and washers to disconnect coupling assembly.
3. Pull drive shaft apart to remove disks.

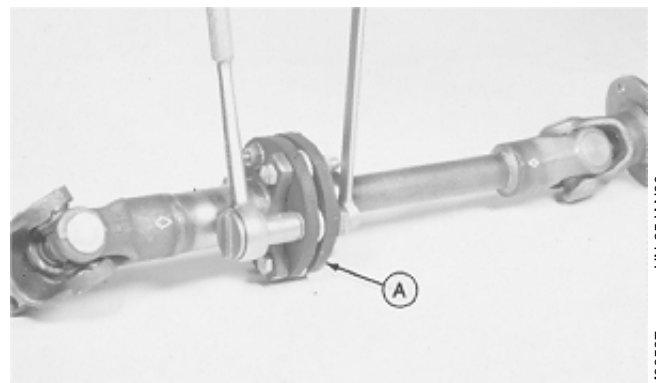

MX,15915026,5 -19-13JUL95

-UN-25JAN90  
M36587

4. Inspect yokes (A—D) and cross and bearing assemblies (E) for cracks, wear or damage.

- A—Flanged Yoke
- B—Tube Yoke
- C—End Yoke
- D—Bushing Yoke
- E—Cross and Bearing Assembly (2 used)

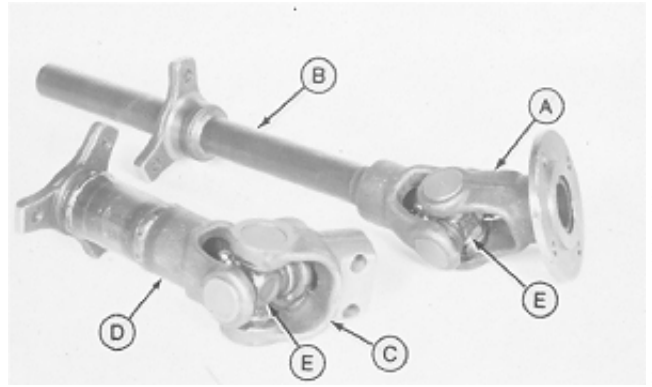

MX,15915026,6 -19-13JUL95

M36588  
-UN-25JAN90

*NOTE: Cross and bearing disassembly procedures are the same for both drive shaft yoke assemblies. Drive shaft bushing yoke with end yoke is shown.*

5. Remove four snap rings.

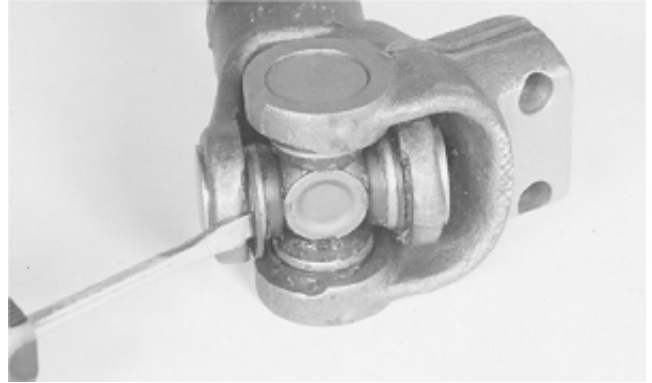

MX,15915026,7 -19-13JUL95

M36589  
-UN-25JAN90

6. Remove cross and bearing assembly using a brass drift. Push bearing down until it can be removed from the bottom.

7. Turn cross and bearing assembly over and repeat procedure.

8. Separate end yoke from drive shaft bushing yoke.

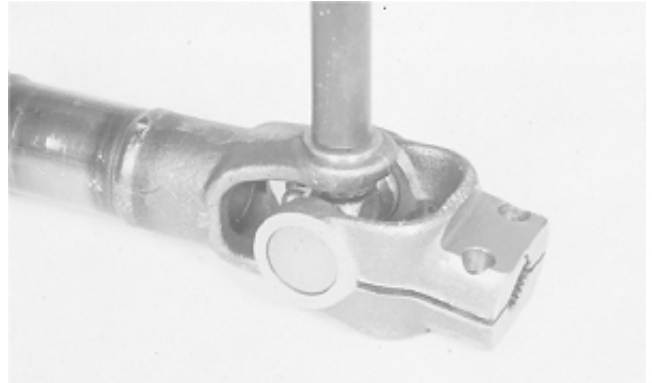

MX,15915026,8 -19-13JUL95

M36590  
-UN-25JAN90

9. Remove cross and bearing assembly using a brass drift. Push bearing down until bottom bearing can be removed.

10. Remove cross and top bearing.

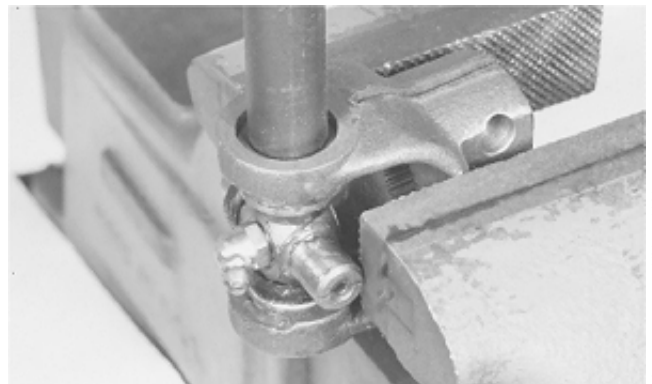

MX,15915026,9 -19-13JUL95

M36591  
-UN-25JAN90

## ASSEMBLE DRIVE SHAFT

**IMPORTANT:** Be careful not to damage needle rollers and seal while installing cross and bearing assembly.

1. Press bearings onto cross only until snap rings can be installed.

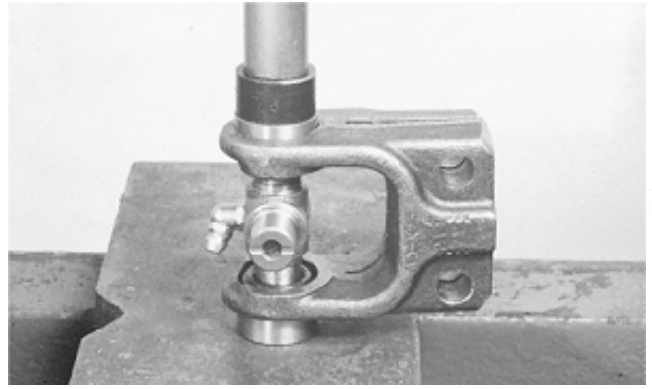

M49514  
-UN-20DEC89

MX,15915026,10 -19-13JUL95

*NOTE: Cross and bearing disassembly procedures are the same for both drive shaft yoke assemblies. Drive shaft bushing yoke with end yoke is shown.*

*Be sure to connect end yoke (A) to bushing yoke (B) and flanged yoke to tube yoke.*

2. Install cross in bushing yoke with grease fitting toward bushing yoke.
3. Install bearing using a soft-faced hammer. Push bearing down until snap ring groove is inside bushing yoke.
4. Turn cross and bearing assembly over and install other bearing.
5. Install four snap rings.

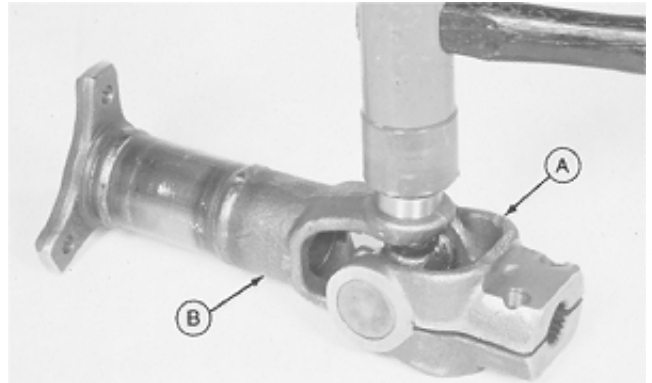

M36593  
-JUN-25JAN90

MX,15915026,11 -19-13JUL95

6. Install disks (A) on tube yoke shaft (B). Insert tube yoke shaft into bushing yoke tube (C).

**IMPORTANT: Align arrows (D) on tube yoke shaft and bushing yoke tube to prevent drive shaft imbalance.**

7. Install cap screws (E), beaded washers (F), special washers (G) and lock nuts (H). Tighten lock nuts to 3 N·m (25 lb-in.).

- A—Disk (2 used)
- B—Tube Yoke Shaft
- C—Bushing Yoke Tube
- D—Arrows
- E—Cap Screw (6 used)
- F—Beaded Washer (24 used)
- G—Special Washer (6 used)
- H—Lock Nut (6 used)

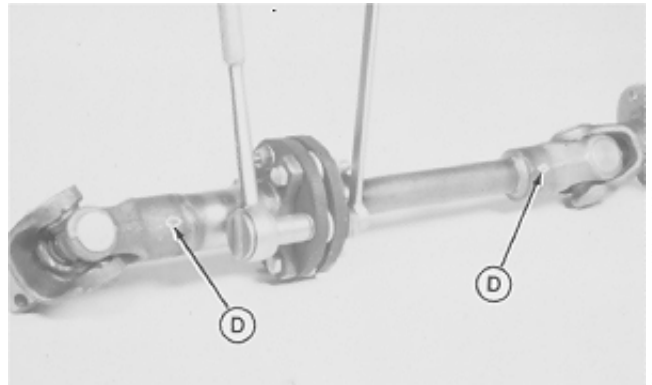
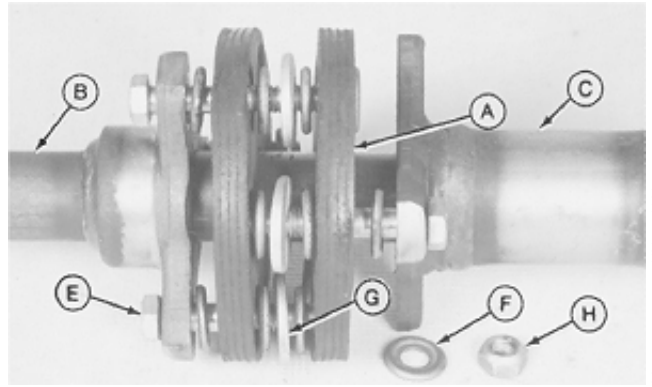

M/36596 -UN-25JAN90

M/36596 -UN-25JAN90

MX,15915026,12 -19-13JUL95

50  
26  
8

# Section 60

# STEERING AND BRAKE REPAIR

## Contents

### Page

#### Group 05—Steering—330

Special or Essential Tools . . . . .	60-05-1
Service Parts Kits . . . . .	60-05-1
Gearbox and Shaft	
Remove and Install . . . . .	60-05-1
Disassemble and Inspect . . . . .	60-05-5
Assemble . . . . .	60-05-12

#### Group 06—Steering—322, 332 and 430

Other Materials . . . . .	60-06-1
Service Parts Kits . . . . .	60-06-1
Steering Valve and Column	
Remove and Install—322 and 332 . . . . .	60-06-2
Remove and Install—430 . . . . .	60-06-4
Disassemble and Inspect . . . . .	60-06-6
Assemble . . . . .	60-06-15
Steering Cylinder	
Remove and Install . . . . .	60-06-25

#### Group 10—Brakes

Other Materials . . . . .	60-10-1
Brakes	
Remove . . . . .	60-10-2
Install . . . . .	60-10-5
Adjust . . . . .	60-10-7
Brake Pedal(s) and Neutral Return	
Linkage	
Inspect and Repair—330 . . . . .	60-10-8
Inspect and Repair—322 and 332 . . . . .	60-10-10
Inspect and Repair—430 . . . . .	60-10-14
Inspect and Repair Park Brake Lever . . . . .	60-10-19



## SPECIAL OR ESSENTIAL TOOLS

*NOTE: Order tools according to information given in the U.S. SERVICE-GARD™ Catalog or in the European Microfiche Tool Catalog (MTC).*

DX,TOOLS -19-05JUN91

Steering Gear Service Set.....JDG457

Used to service steering gearbox.

MX,JDG457 -19-01MAR95

## SERVICE PARTS KITS

The following kits are available through your parts catalog:

Return Guide Clamp Kit

Side Cover Kit

MX,15906005,KIT-19-01MAR95

## REMOVE AND INSTALL STEERING GEARBOX AND SHAFT

1. Remove drive shaft. (See procedure in Section 50, Group 25.)

**IMPORTANT: Do not pound on end of steering shaft or damage to steering shaft will occur.**

2. Remove steering wheel.

3. Remove belly screen.

**CAUTION:** To avoid injury from escaping fluid under pressure, stop engine and relieve the pressure in the system before disconnecting or connecting hydraulic or other lines. Tighten all connections before applying pressure.

4. Disconnect lines (A, B and C) from hydraulic control valve.

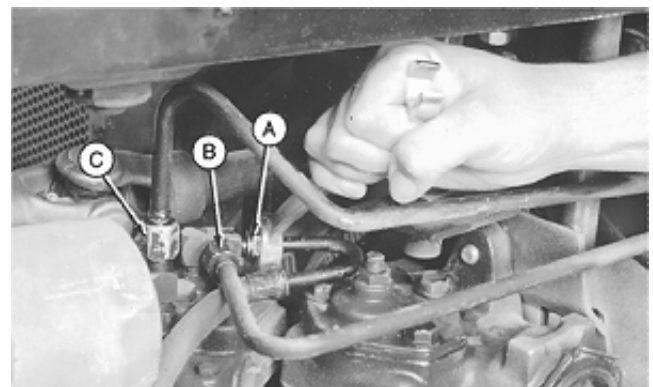
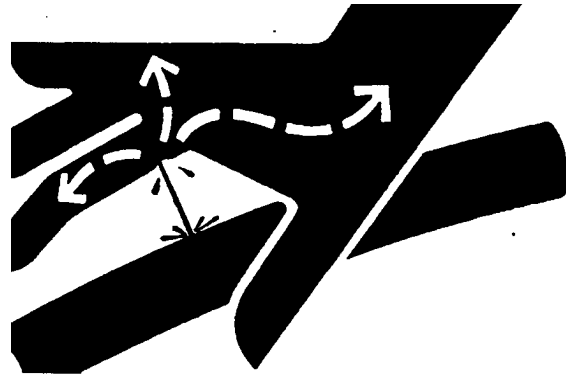

-UN-23AUG88

X9811

-UN-03OCT89

M33937

MX,15916005,1 -19-13JUL95

5. Remove nut and line clamp.

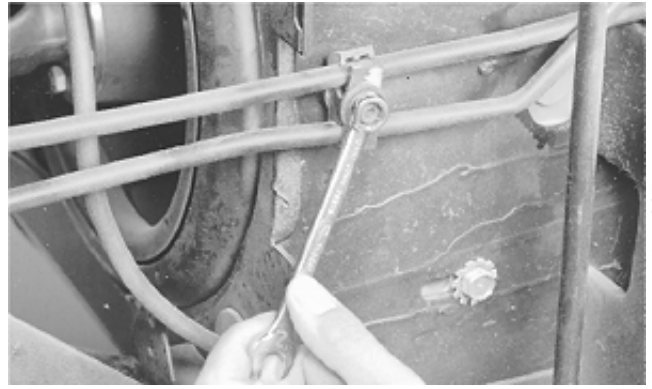

MX,15916005,2 -19-13JUL95

M33938 -UN-03OCT89

6. Remove bracket mounting cap screw.

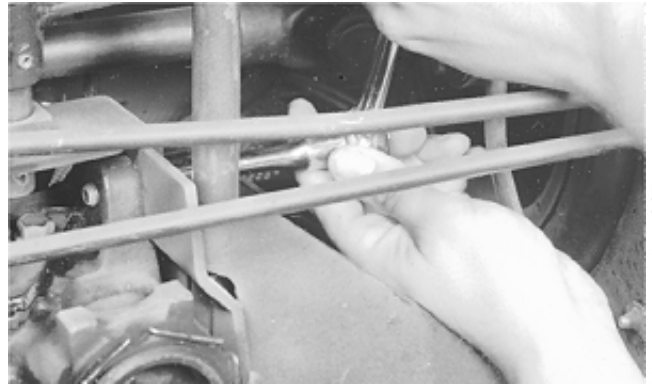

MX,15916005,3 -19-13JUL95

M33939 -UN-03OCT89

7. Remove clip and disconnect brake neutral return linkage.

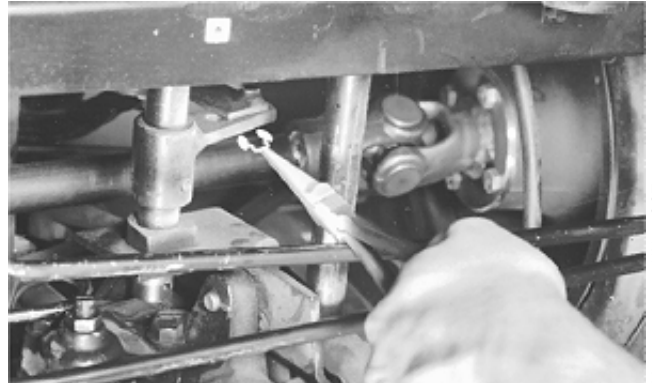

MX,15916005,4 -19-13JUL95

M33940 -UN-03OCT89

8. Remove pitman arm nut and washer. Remove pitman arm using a two-jaw puller.

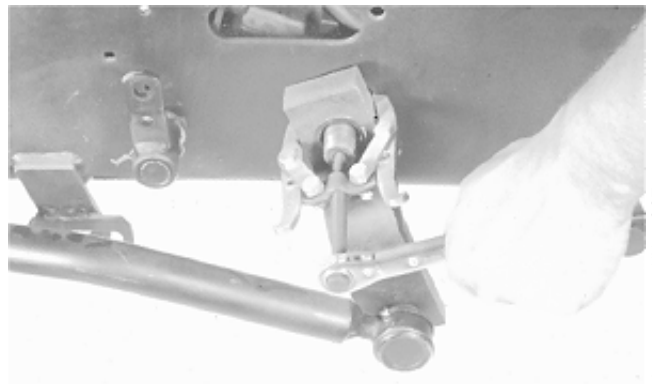

MX,15916005,5 -19-13JUL95

M33942 -UN-03OCT89



9. Remove cotter pin (A) and washer (B) to disconnect brake linkage on left side of machine frame.

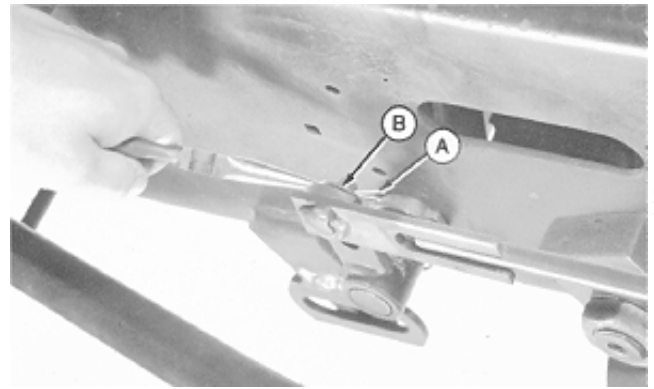

MX,15916005,6 -19-13JUL95

M33943 -UN-03OCT89

10. Remove safety wire and spring pin to remove brake arm (A), washer (B) and bushing (C).

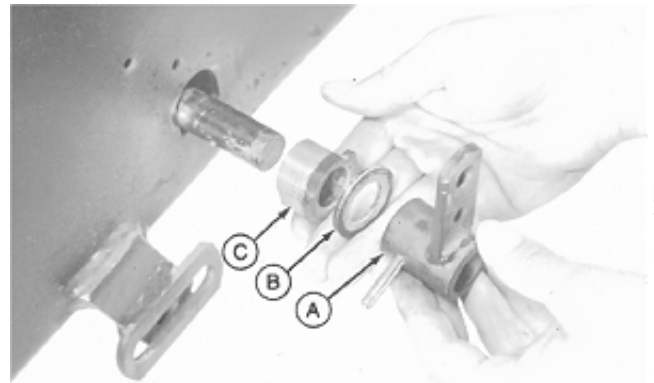

MX,15916005,7 -19-13JUL95

M33958 -UN-03OCT89

11. Remove left side of pedestal.

12. Remove cotter pin (A) and draft pin (B). Turn rockshaft control valve linkage (C) to gain access for steering shaft removal.

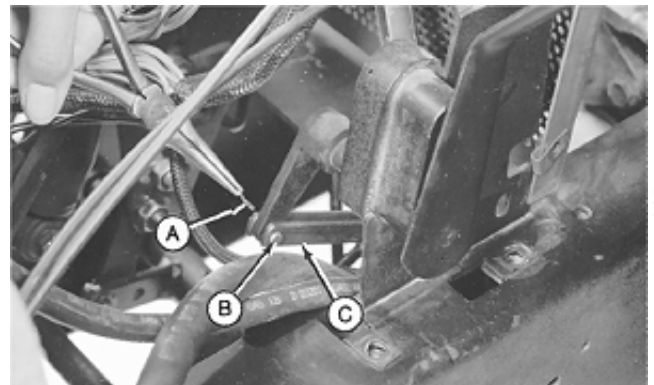

MX,15916005,8 -19-13JUL95

M33961 -UN-03OCT89

13. Remove cotter pins (A) and washers (B) to disconnect brake linkage on right side of machine frame.

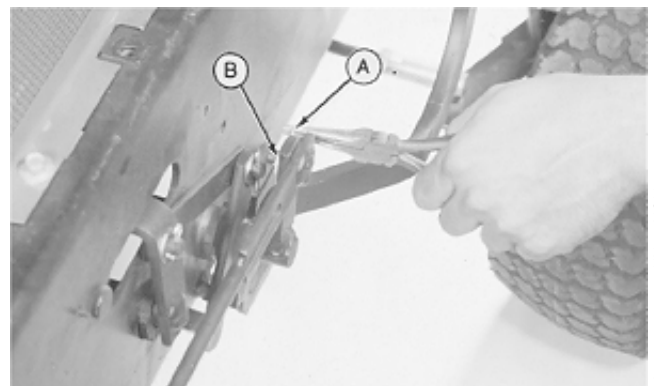

MX,15916005,9 -19-13JUL95

M34170 -UN-08NOV89

14. Remove cotter pin and washer to disconnect link from brake linkage.

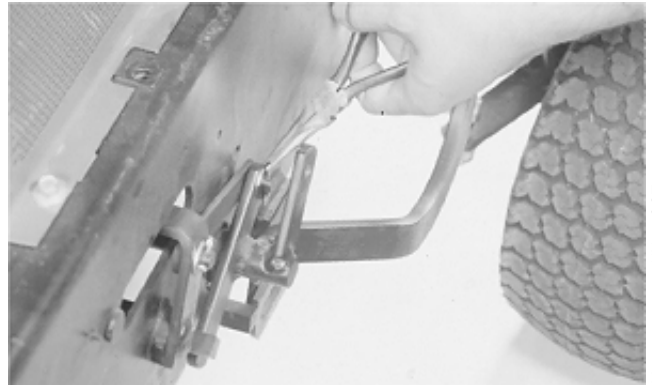

M33962  
-UN-03OCT89

MX,15916005,10 -19-13JUL95

15. Remove brake arm (A), washer (B) and bushing (C).

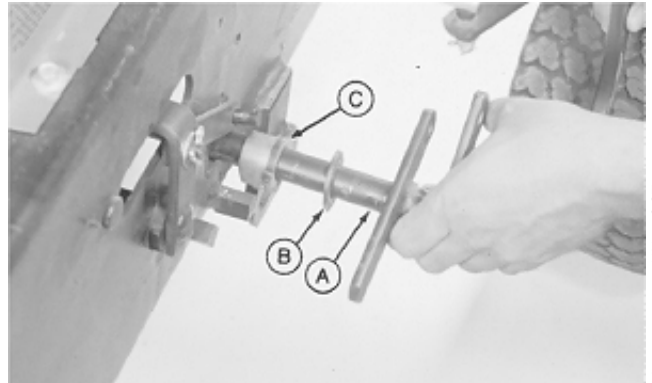

M33963  
-UN-03OCT89

MX,15916005,11 -19-13JUL95

16. Remove three cap screws (A) from gearbox mounting plate.

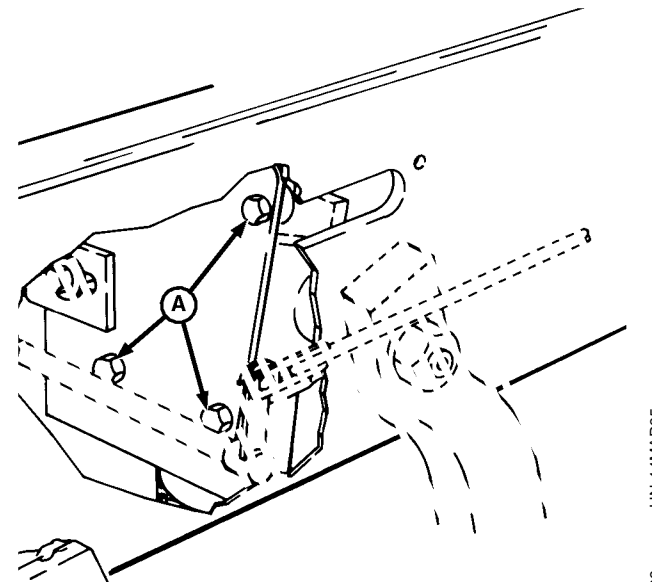

M77339  
-UN-14MAR95

MX,15916005,12 -19-13JUL95

60  
05  
4

17. Remove steering gearbox and shaft as an assembly, from bottom of machine.

18. Make repairs as necessary. (See procedure in this group.)

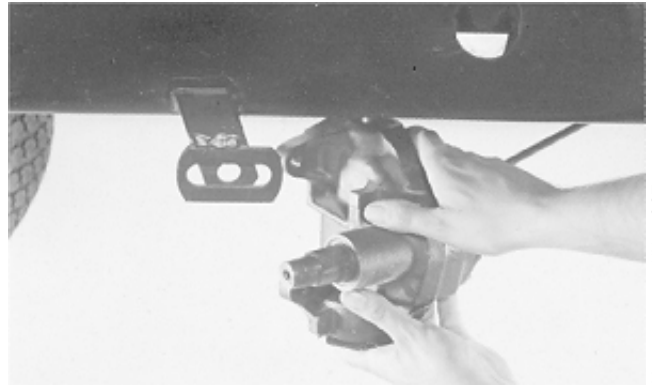

M33965 -UN-03OCT89

MX,15916005,13 -19-13JUL95

19. Inspect steering shaft bushings for wear or damage. Replace if necessary.

20. Remove bushings using a pilot bearing puller.

21. Installation is done in the reverse order of removal.

- If removed, install steering shaft bushings using a driver set.
- Apply multipurpose grease to I.D. of steering shaft bushings.



M34018 -UN-03OCT89

**TORQUE SPECIFICATIONS**

Gearbox Mounting Cap Screws . . . . .	95 N-m (70 lb-ft)
Steering Wheel-to-Shaft Nut . . . . .	15 N-m (133 lb-in.)
Pitman Arm Nut . . . . .	224 N-m (165 lb-ft)

MX,15916005,14 -19-13JUL95

**DISASSEMBLE AND INSPECT STEERING GEARBOX AND SHAFT**

1. Put an open-end wrench between both steering shaft universal joints.
2. Turn steering shaft using locking pliers to determine amount of play at universal joints. Replace steering shaft if play exists.

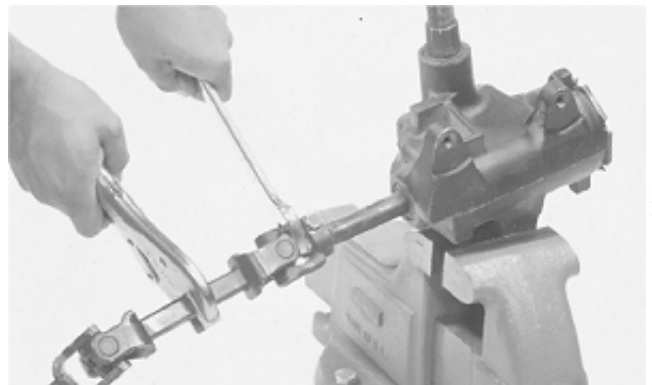

M33966 -UN-03OCT89

MX,15916005,15 -19-13JUL95

3. Remove cap screw and washer from universal joint.
4. Remove steering shaft from gearbox.
5. Inspect steering shaft spline for wear or damage. Replace if necessary.

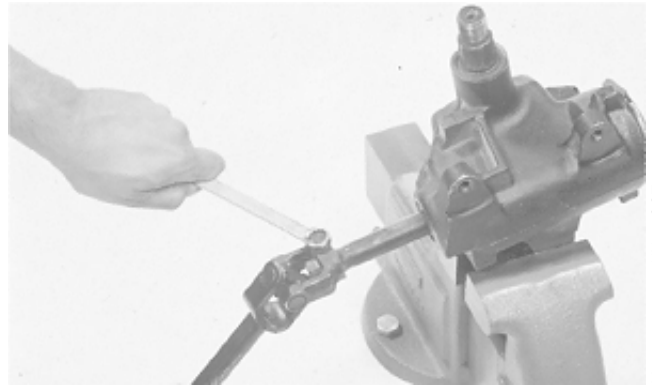

M33967  
-UN-03OCT89

MX,15906005,16 -19-01MAR95

6. Put gearbox in a vise.
7. Remove three side cover cap screws.

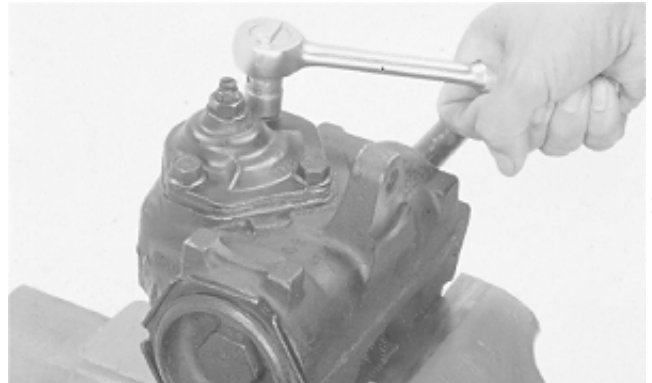

M33969  
-UN-03OCT89

MX,15906005,17 -19-01MAR95

*NOTE: If replacing side cover gasket only, it is not necessary to remove preload adjuster nut.*

8. Hold preload adjuster screw and remove adjuster nut.



M33970  
-UN-03OCT89

MX,15906005,18 -19-01MAR95

9. Remove pitman shaft, gasket and side cover as an assembly.

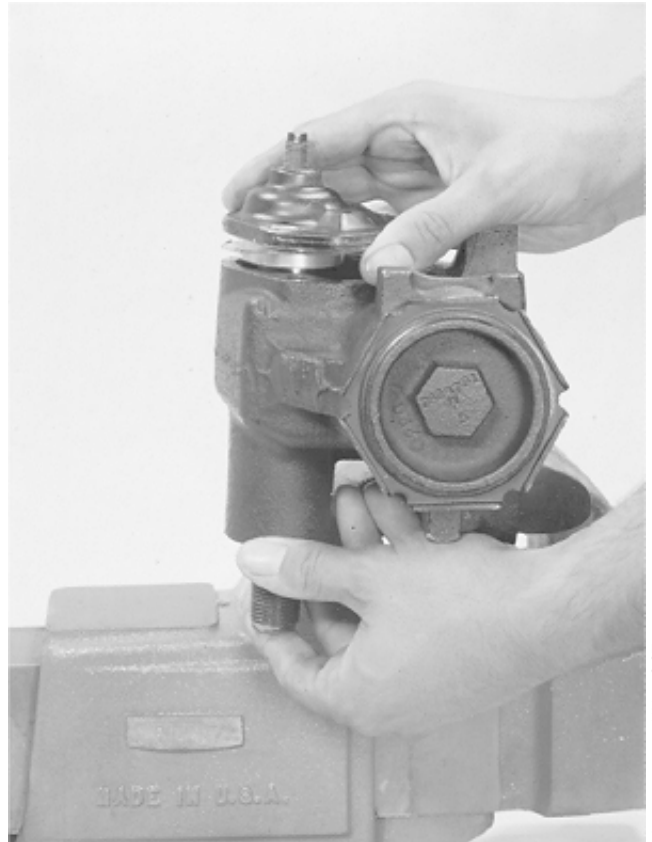

MX,15906005,19 -19-01MAR95

M33971 -UN-03OCT89

7950

10. Remove preload adjuster and shim, if equipped, from side cover.

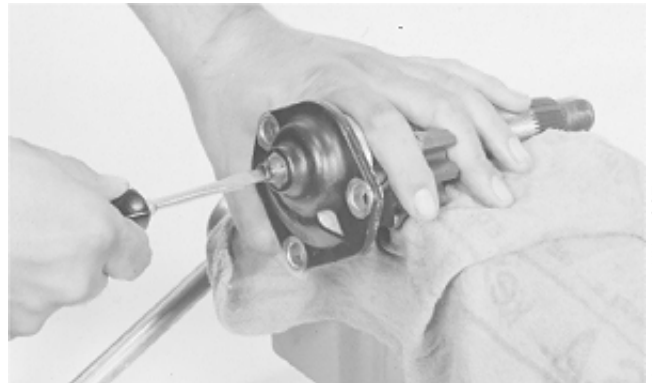

MX,15906005,20 -19-01MAR95

M33972 -UN-03OCT89

11. Remove worm bearing adjuster lock nut using a punch and hammer.

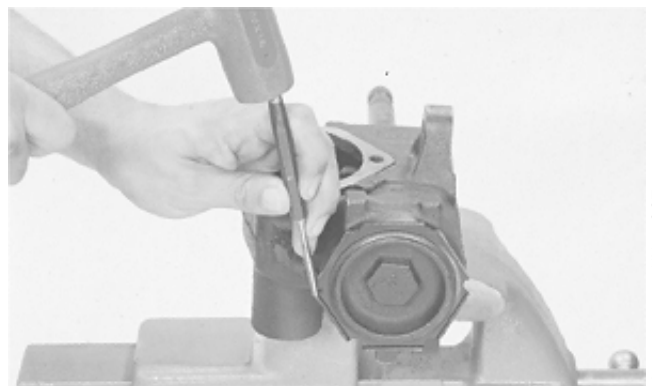

MX,15906005,21 -19-01MAR95

M33973 -UN-03OCT89

12. Remove worm bearing adjuster.

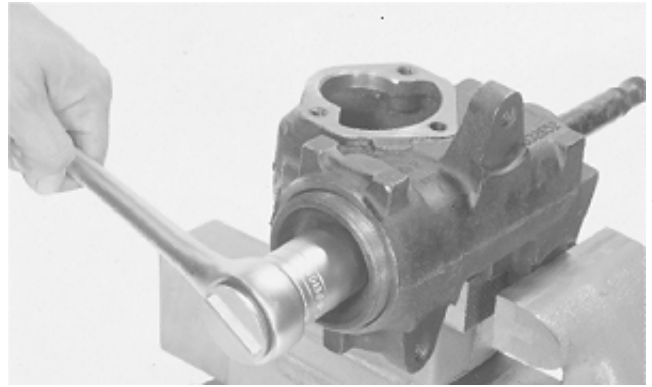

M33974 -UN-08NOV89

MX,15906005,22 -19-01MAR95

**IMPORTANT:** Do not allow worm shaft to turn to the end of its travel or damage can occur to the ends of the ball guides.

13. Remove ball nut (A) and worm shaft (B).

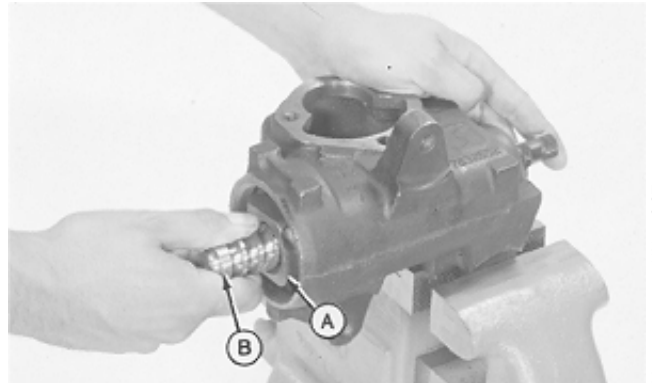

M33978 -UN-03OCT89

MX,15906005,23 -19-01MAR95

14. Pry out lower bearing retainer using a screwdriver.

15. Remove lower worm bearing cone.



M33976 -UN-03OCT89

MX,15906005,24 -19-01MAR95

80510

**NOTE:** Bearing cup is press-fit in bearing adjuster.  
Remove bearing cup only if replacement is necessary.

*Bearing cups and cones are matched and must be replaced as complete assemblies.*

16. Inspect bearing cup in bearing adjuster for wear or damage. Replace if necessary.

17. Screw bearing adjuster (A) into gearbox housing.  
Remove bearing cup using a slide hammer and puller from JDG457 Steering Gear Service Set.

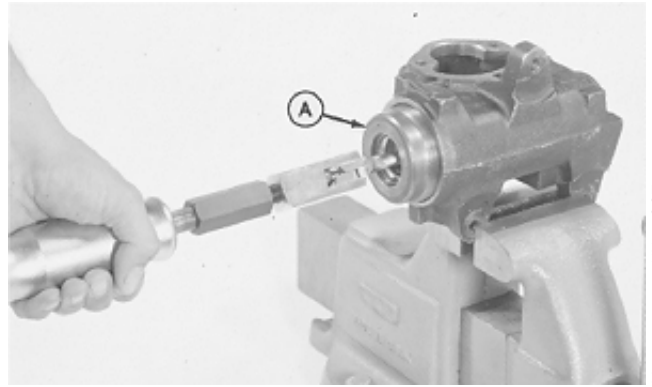

M33977 -UN-03OCT89

MX,15906005,25 -19-01MAR95

18. Remove upper worm bearing cone from shaft or gearbox housing.

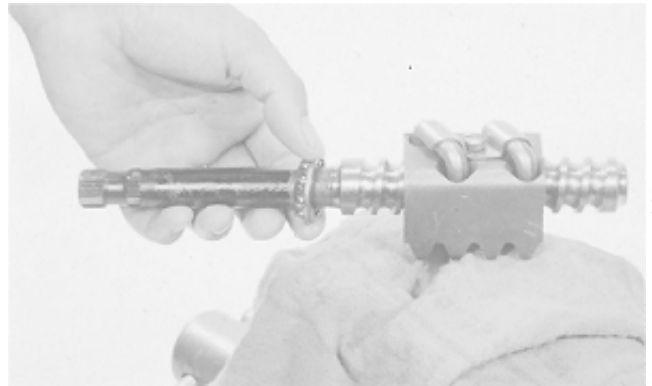

M33979 -UN-03OCT89

MX,15906005,26 -19-01MAR95

19. Remove ball guide screw and clamp.

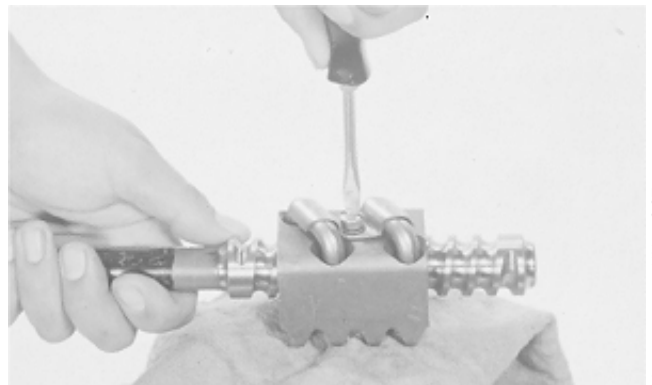

M33980 -UN-03OCT89

MX,15906005,27 -19-01MAR95

20. Remove ball guides (A), balls (B) and ball nut (D) from worm shaft (C).

*NOTE: Ball nut and worm shaft are matched and must be replaced as a complete assembly.*

*If any ball becomes lost or damaged, install new balls as a complete set.*

21. Inspect all parts for wear or damage. Replace as necessary.

- A—Ball Guides
- B—Balls (50 used)
- C—Worm Shaft
- D—Ball Nut

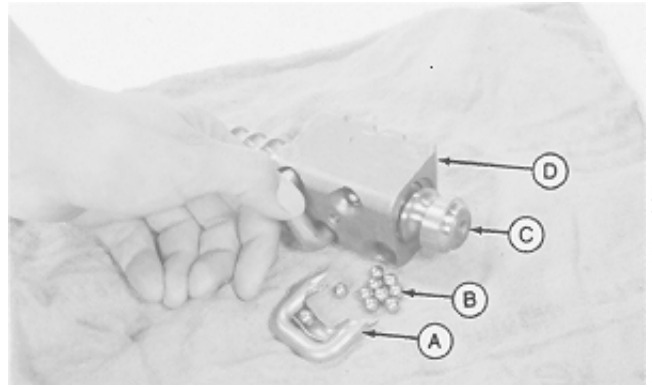

M33981 -UN-03OCT89

MX,15906005,28 -19-01MAR95

22. Remove pitman shaft and worm shaft seals from gearbox housing.



Pitman Shaft Seal

M34019 -UN-03OCT89

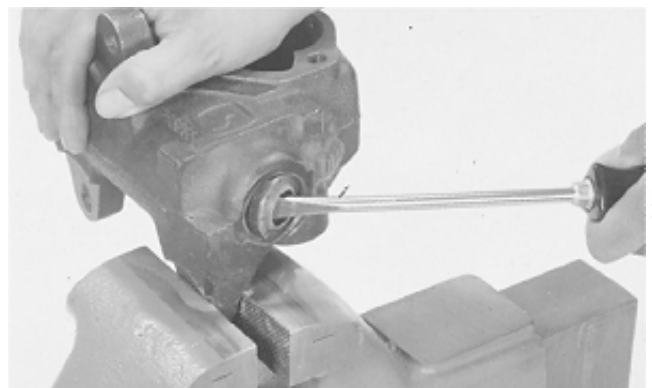

Worm Shaft Seal

M34020 -UN-03OCT89

MX,15906005,29 -19-01MAR95

60  
05  
10



**NOTE:** Pitman shaft needle bearing and worm shaft bearing cup are press-fit in gearbox housing. Remove bearing or cup only if replacement is necessary.

Lip (B) is part of gearbox housing, not part of bearing race.

23. Inspect needle bearing and bearing cup (A) in gearbox housing for wear or damage. Replace if necessary.

24. Remove needle bearing using a driver from JDG457 Steering Gear Service Set.

25. Remove bearing cup using a driver set.

26. Inspect pitman shaft for roller wear or other damage. Replace if necessary.

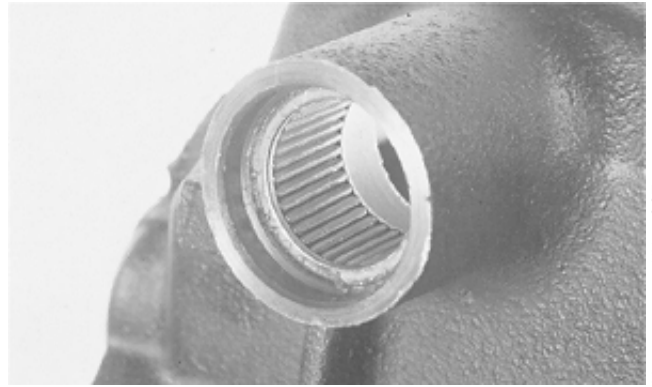

Needle Bearing

M33987 -UN-03OCT89

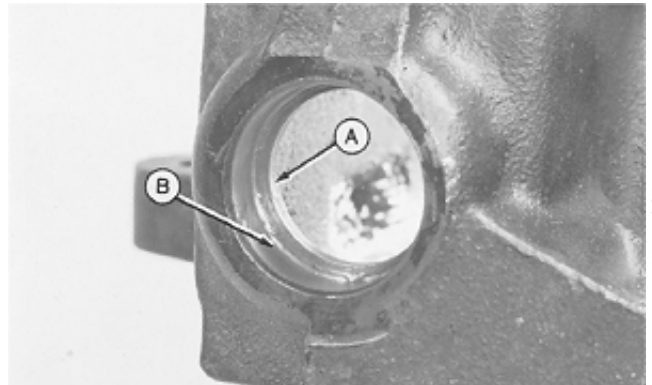

Bearing Cup

M34021 -UN-03OCT89

MX,15906005,30 -19-10MAR95

**NOTE:** A steering gearlash adjustment shim is available through the parts catalog.

27. Check preload adjuster (A) end clearance with a feeler gauge as shown. If clearance is greater than 0.05 mm (0.002 in.), order and install shim (B).

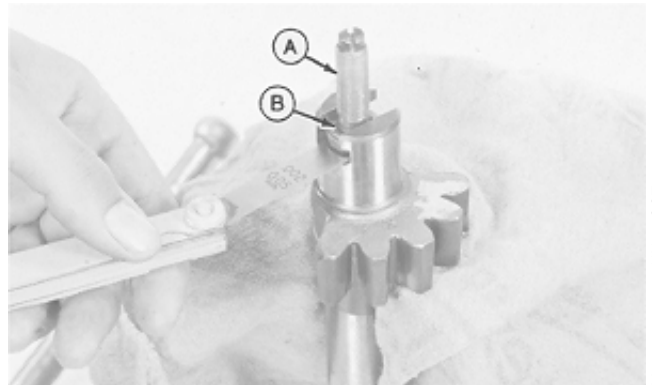

M33989 -UN-03OCT89

MX,15906005,31 -19-10MAR95

## ASSEMBLE STEERING GEARBOX AND SHAFT

**IMPORTANT:** Always use new seals and gasket.  
Damaged or used parts will leak.

*NOTE:* Apply clean multipurpose grease on all internal parts during assembly.

1. Install new worm shaft bearing cup in gearbox housing, if removed, using a driver set.
2. Install new needle bearing in gearbox housing, if removed, using a driver from JDG457 Steering Gear Service Set.

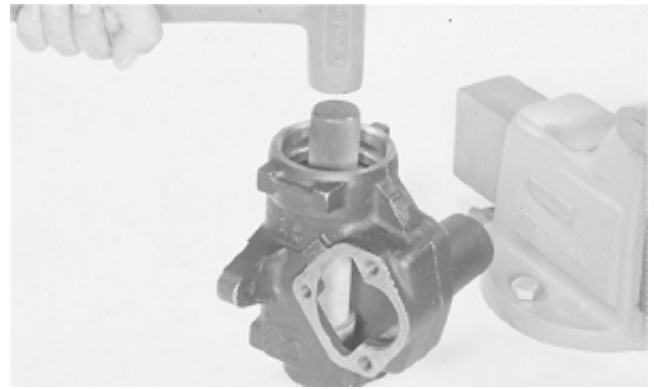

Bearing Cup

M34159 -UN-08NOV89

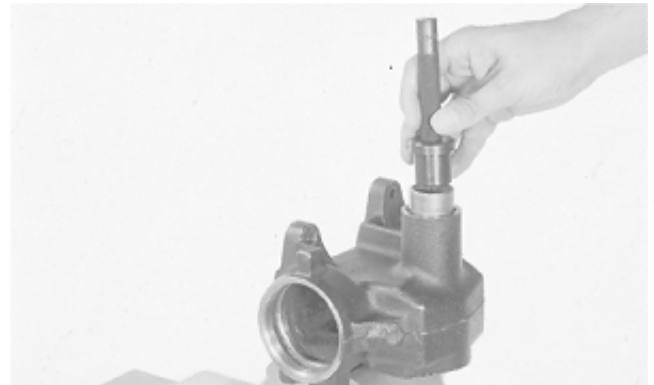

Needle Bearing

M34160 -UN-08NOV89

MX,15916005,16 -19-13JUL95

3. Install new pitman shaft and worm shaft seals into gearbox housing using drivers from JDG457 Steering Gear Service Set.

4. Apply multipurpose grease to lip of seals.



Pitman Shaft Seal

M34161 -UN-08NOV89

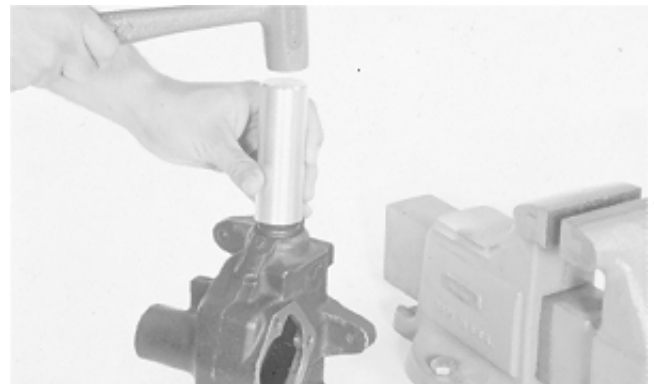

Worm Shaft Seal

M34158 -UN-08NOV89

MX,15906005,33 -19-01MAR95

**IMPORTANT:** Install ball nut onto worm shaft as shown. An improperly installed ball nut could cause gear damage or steering lockup.

5. Assemble ball nut and worm shaft (B) with narrow end of ball nut teeth up (A) and worm shaft at the left.

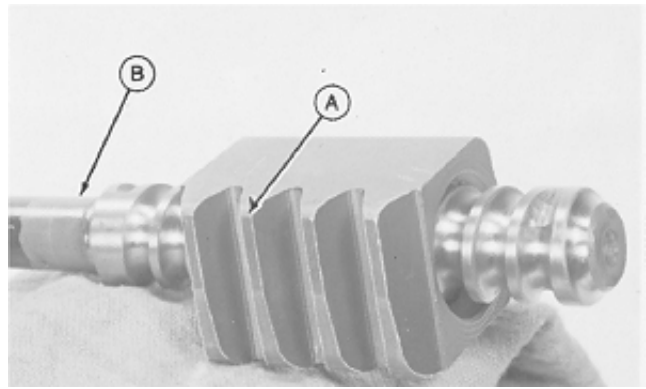

M33988  
-UN-03OCT89

MX,15906005,34 -19-01MAR95

6. Insert ball guide half into ball nut (C) as shown.

7. Fill circuit with 27 balls (A) and install other half of ball guide (B).

8. Repeat procedures on other circuit with remaining balls and guides.

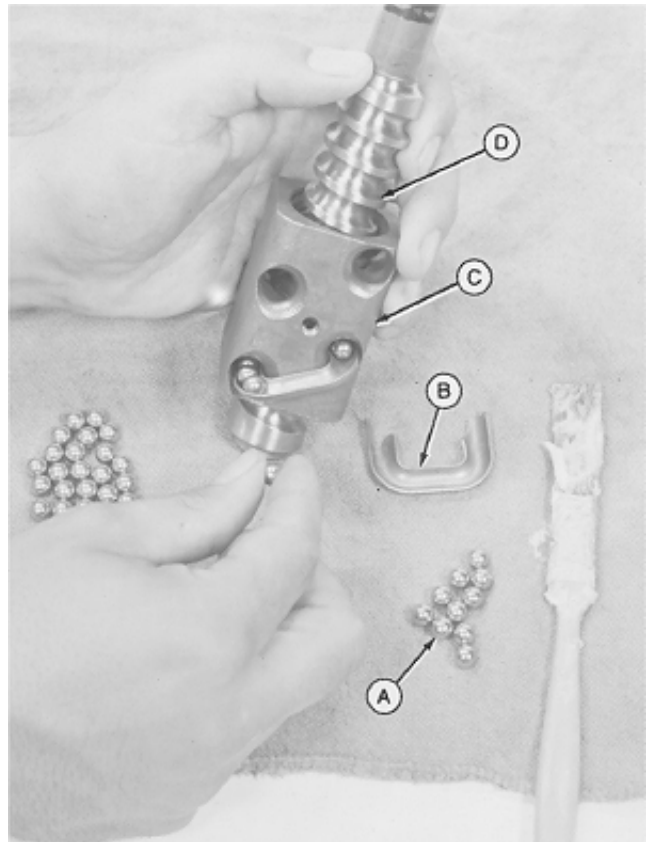

M33992  
-UN-03OCT89

MX,15906005,35 -19-01MAR95

9. Install ball guide clamp with screws and tighten securely.

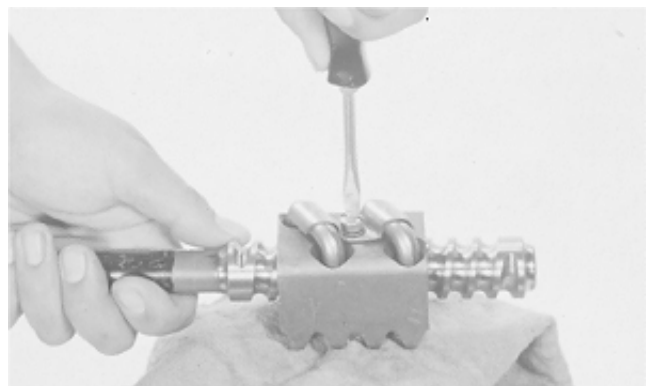

M33980  
-UN-03OCT89

MX,15906005,36 -19-01MAR95

10. Pack upper worm bearing cone with multipurpose grease.

11. Install upper worm bearing on shaft with small O.D. facing away from ball nut.

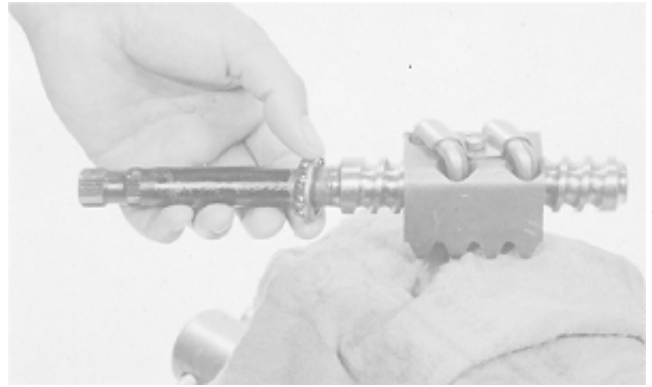

MX,15906005,37 -19-01MAR95

M33979 -UN-03OCT89

**IMPORTANT: Tape splined end of worm shaft to prevent seal damage during shaft installation.**

12. Apply tape around splined end of worm shaft.

13. Install ball nut (A) and worm shaft (B) with bearing cone, into gearbox housing. Remove tape.

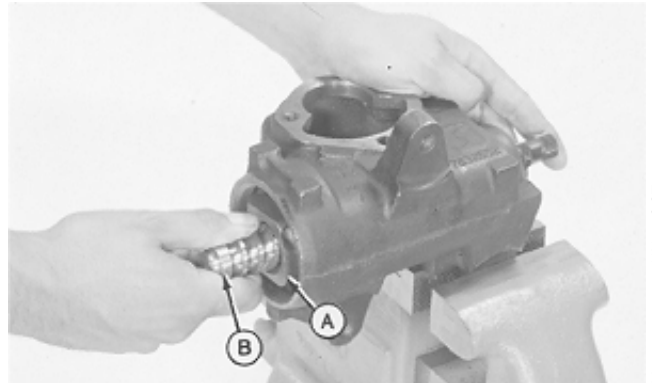

MX,15906005,38 -19-01MAR95

M33978 -UN-03OCT89

14. Install new bearing cup in worm bearing adjuster, if removed, using a driver set.

15. Pack lower worm bearing cone with multipurpose grease.

16. Install lower worm bearing cone into worm bearing adjuster with large O.D. facing away from threaded end of adjuster.

17. Install retainer until flush with outside surface of adjuster, using a plastic hammer.

18. Apply a coat of a lithium base grease to threads of worm bearing adjuster.



MX,15906005,39 -19-01MAR95

M33996 -UN-03OCT89

19. Install worm bearing adjuster (A).

**IMPORTANT: Ball nut must be centered during assembly. If not, the steering will only turn fully in one direction and damage can be done by bottoming the worm drive against the ball nut.**

20. Center ball nut (B) in gearbox housing as shown.

21. Fill gearbox with approximately 312 g (11 oz) of multipurpose grease.

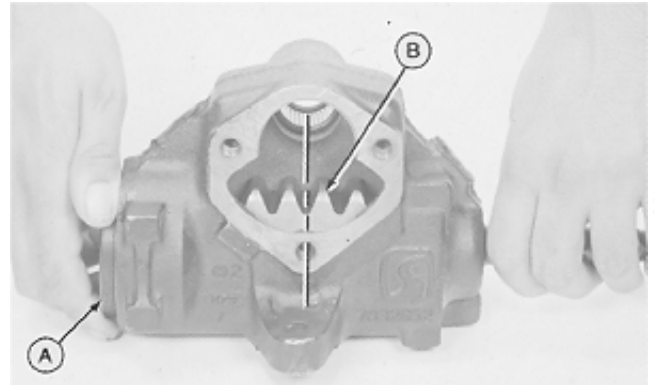

M/33997 -UN-03OCT89

MX,15906005,40 -19-01MAR95

22. Assemble pitman shaft (A) with preload adjuster (B) and shim (C), if equipped.

23. Install side cover (D) onto shaft with preload adjuster.

24. Turn preload adjuster screw counterclockwise until it bottoms. Then, back screw off one-half turn.

- A—Pitman Shaft
- B—Preload Adjuster
- C—Shim (if equipped)
- D—Side Cover

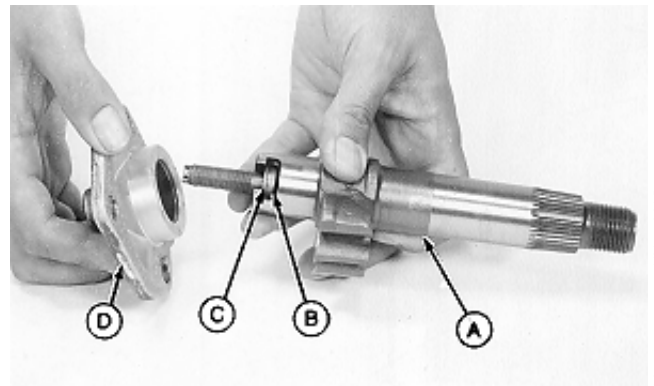

M/33999 -UN-06MAR95

MX,15906005,41 -19-01MAR95

60  
05  
15

25. Install new gasket on side cover.

**IMPORTANT: Tape end of pitman shaft to prevent seal damage during shaft installation.**

26. Apply tape around end of pitman shaft.

27. Center teeth of pitman shaft with teeth on ball nut.

28. Install pitman shaft into gearbox housing. Remove tape.

29. Install three side cover cap screws. Tighten cap screws to 40 N-m (30 lb-ft).

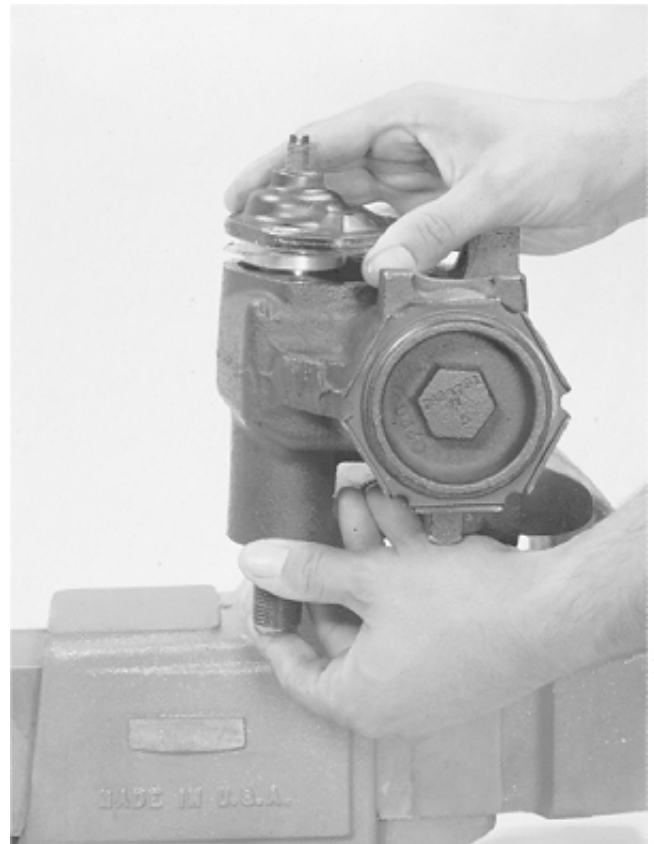

M33971 -UN-03OCT89

MX,15906005,42 -19-01MAR95

30. Adjust worm bearing preload:

- Tighten worm bearing adjuster until it bottoms, then loosen one-quarter turn.

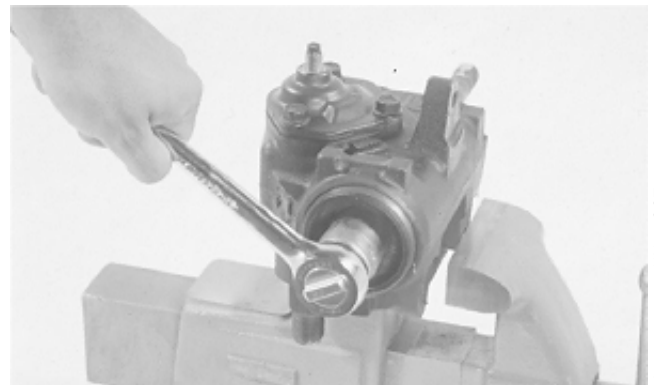

M34006 -UN-03OCT89

MX,15906005,43 -19-01MAR95

- Carefully turn worm shaft all the way to end of travel, then turn back one-half turn.

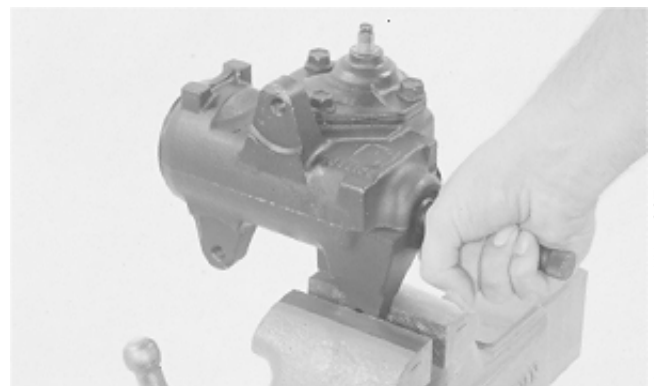

M34003 -UN-03OCT89

MX,15906005,44 -19-01MAR95

*NOTE: Due to tolerances, some 11/16 in. sockets require a wrapping of card stock around the serrations on end of worm shaft.*

- Install 1-1/8 in. socket with ratchet on worm bearing adjuster and an 11/16 in. 12-point socket with torque wrench on end of worm shaft.

*NOTE: If worm shaft begins to bottom while reading the torque wrench, back worm shaft out and start torque reading again.*

- Tighten worm bearing adjuster until torque wrench reads 0.60—1.0 N·m (5—8 lb-in.) rolling torque.

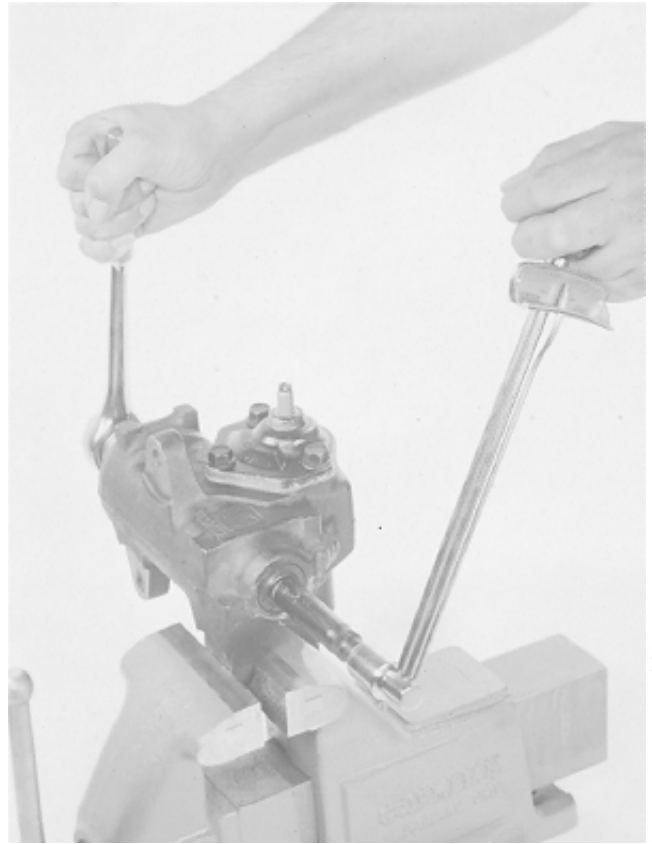

MX,15906005,45 -19-01MAR95

M34004 -JUN-03OCT89

60  
05  
17

- Install lock nut on worm bearing adjuster and tighten using a punch and hammer.

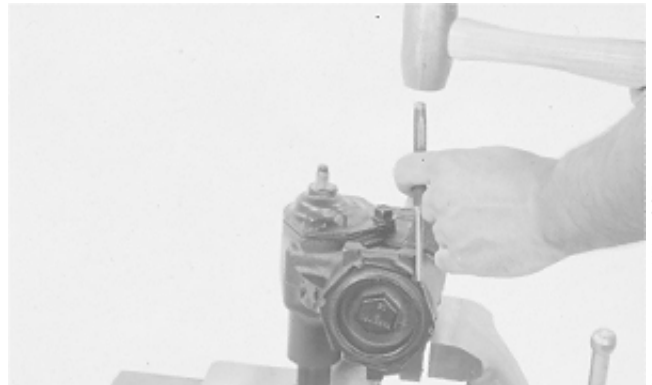

MX,15906005,46 -19-01MAR95

M34005 -JUN-03OCT89

### 31. Adjust over center preload:

- Back off preload adjuster until it stops, then turn it in one full turn.
- Center gear travel by rotating shaft.
- Check torque required to turn worm shaft. Record reading.



MX,15906005,47 -19-01MAR95

M34002 -JUN-03OCT89

- Turn preload adjuster in, until rolling torque required to turn worm shaft is 0.50—1.20 N·m (4—10 lb-in.) more than first reading.
- Install lock nut. Hold preload adjuster screw and tighten lock nut to 34 N·m (25 lb-ft).

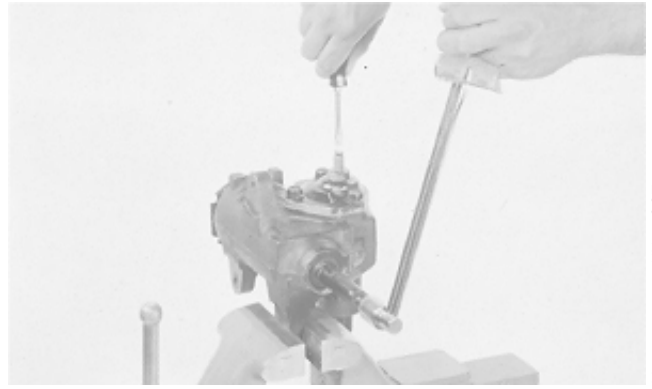

MX,15906005,48 -19-01MAR95

M34008 -UN-03OCT89

32. Install steering shaft onto worm shaft as shown. Tighten cap screws to 24 N·m (212 lb-in.).

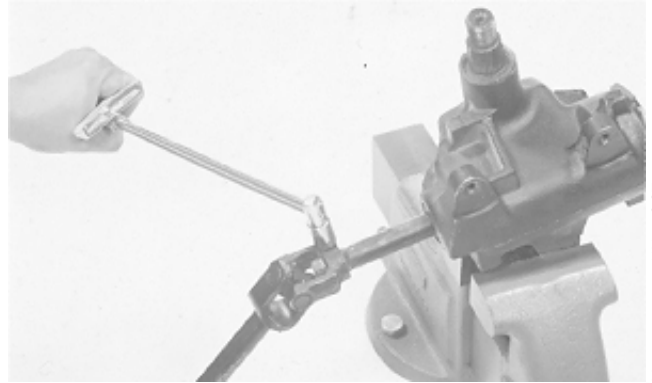

MX,15906005,49 -19-01MAR95

M34010 -UN-03OCT89



**OTHER MATERIAL**

Number	Name	Use
LOCTITE® PRODUCTS U.S./Canadian/LOCTITE No.		
TY6305/TY9485/764	Clean and Cure Primer	Cleans parts and speeds cure of sealant.
TY9369/NA/222	Thread Lock and Sealer (Low Strength)	Apply to threads of metering assembly screws.

®LOCTITE is a registered trademark of the Loctite Corp.

MX,15906006,OTH-19-01MAR95

**SERVICE PARTS KITS**

The following kits are available through your parts catalog:

- Steering Column (Tube) Bushing Kit
  
- Steering Valve
  - Seal Kit
  - Needle Roller Kit
  - Metering Kit
  - Spring Kit
  - Port Cover and Check Valve Kit

MX,15916006,KIT-19-13JUL95

60  
06  
1

## REMOVE AND INSTALL STEERING VALVE AND COLUMN—322 AND 332

*NOTE: Removal and installation procedures for later models may vary slightly.*

1. Remove fender deck.
2. Remove engine side panels.
3. Remove right and left-hand pedestal sides.

**N** **CAUTION: Explosive release of fluids from pressurized cooling system can cause serious burns.**

**Shut off engine. Only remove filler cap when cool enough to touch with bare hands. Slowly loosen cap to first stop to relieve pressure before removing completely.**

4. Drain radiator. Approximate capacity is 2.8 L (3 U.S. qt).
5. Loosen block drain valve. Drain engine coolant from engine block. Tighten drain valve.
6. Remove radiator and air cleaner shroud.



TS281 -UN-23AUG88

60  
06  
2

MX,15916006,1 -19-13JUL95

**IMPORTANT:** Do not pound on end of steering shaft or damage to steering shaft will occur.

7. Remove steering wheel.

**N CAUTION:** To avoid injury from escaping fluid under pressure, stop engine and relieve the pressure in the system before disconnecting or connecting hydraulic or other lines. Tighten all connections before applying pressure.

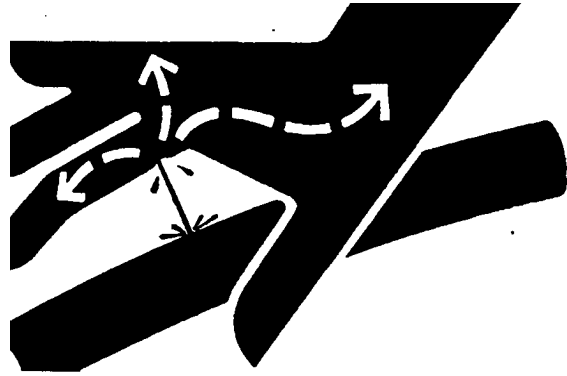

8. Disconnect five hydraulic lines (A) from bottom of steering valve.

9. Hold top of steering column and remove mounting nuts (C).

10. Remove steering column-to-dash panel mounting bracket (D).

11. Remove steering unit out the right side of the machine.

12. Make repairs as necessary. (See procedure in this group.)

13. Installation is done in the reverse order of removal.

- Install steering unit with alignment grooves (B) in port manifold and cover, facing engine.
- Tighten steering wheel-to-shaft nut to 15 N·m (133 lb-in.).
- Close drain valve and fill radiator with proper coolant until coolant is 13—25 mm (0.500—1 in.) below bottom of filler neck. (See Engine Coolant in Section 10, Group 25.)
- Bleed hydraulic system. (See procedure in Section 270, Group 20.)

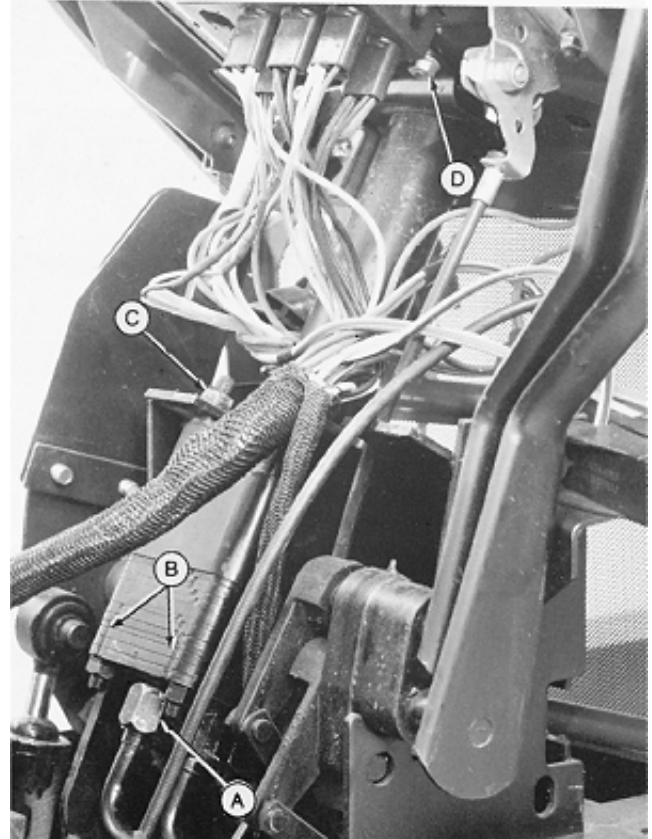

A—Hydraulic Lines (5)  
 B—Alignment Grooves  
 C—Mounting Nuts  
 D—Mounting Bracket

MX,15916006,2 -19-13JUL95

-UN-23AUG88

X9811

60-06-3

-UN-20DEC89

M49509

## REMOVE AND INSTALL STEERING VALVE AND COLUMN—430

*NOTE: Removal and installation procedures for later models may vary slightly.*

1. Remove fender deck.
2. Remove belly pan.
3. Lift hood and remove front grille and engine side panels.
4. Remove battery and battery base.
5. Remove cap screw and clamp.
6. Remove cap screw (A) and clamps (B).
7. Remove right-hand pedestal side.

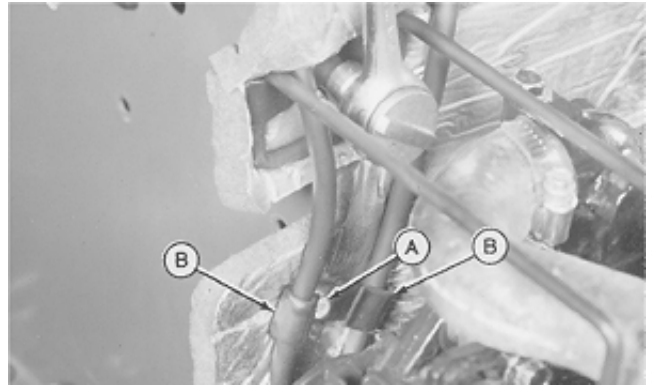

M36498  
-UN-29JAN90

60  
06  
4

MX,15916006,3 -19-13JUL95

*NOTE: There are three versions of the transmission control linkage. Version one on early models is shown. See Group 10, in this section, to confirm which version your machine is equipped with. It may not be necessary to perform some Steps if equipped with later versions of linkage on later models.*

8. Early Models; Remove snap ring and pin to remove shock absorber.



*Early Models Shown*

M36501  
-UN-29JAN90

MX,15916006,4 -19-13JUL95

**N CAUTION:** To avoid injury from escaping fluid under pressure, stop engine and relieve the pressure in the system before disconnecting or connecting hydraulic or other lines. Tighten all connections before applying pressure.

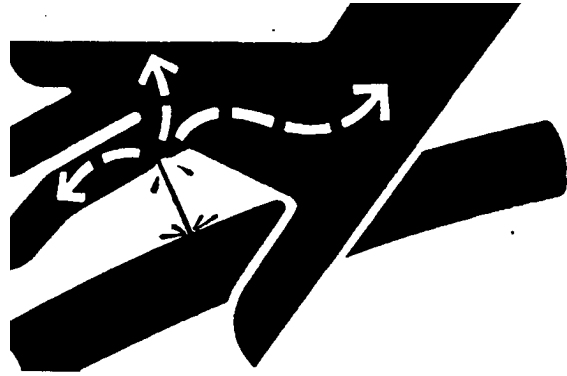

9. Remove hydraulic lines (A and B).

10. Disconnect three remaining hydraulic lines from bottom of steering valve.

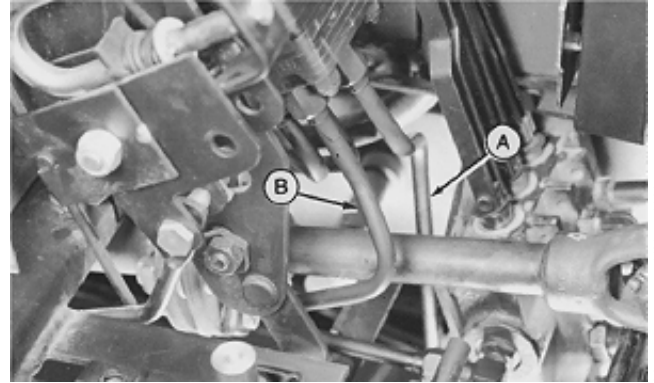

MX,15916006,5 -19-13JUL95

-UN-23AUG88

X9811

-UN-25JAN90

M36817

606

**IMPORTANT:** Do not pound on end of steering shaft or damage to steering shaft will occur.

11. Remove steering wheel.

12. Hold top of steering column and remove four mounting nuts. Remove steering unit from machine.

13. Make repairs as necessary. (See procedure in this group.)

14. Installation is done in the reverse order of removal.

- Install steering unit with alignment grooves (A) in port manifold and cover, facing engine.
- Tighten steering wheel-to-shaft nut to 15 N·m (133 lb-in.).
- Bleed hydraulic system. (See procedure in Section 270, Group 20.)



MX,15916006,6 -19-13JUL95

-UN-25JAN90

M36620

## DISASSEMBLE AND INSPECT STEERING VALVE AND COLUMN

*NOTE: There are early and later versions of steering valve. The early version had a plug, O-ring and check ball in the side of the port cover. The later version has a check ball in the center of the port cover (internal) and no external plug or O-ring.*

**IMPORTANT: Use DFMX1 Steering Valve Fixture when servicing control valve. Holding control valve in a vise can damage valve.**

1. Install DFMX1 Steering Valve Fixture (A) in a vise. (See Section 299 for instructions to make fixture.)
2. Install steering valve, with steering column down, in fixture. Fasten valve to fixture using four 5/16-24 UNF nuts.
3. Check position of alignment grooves (B) to aid in assembly.

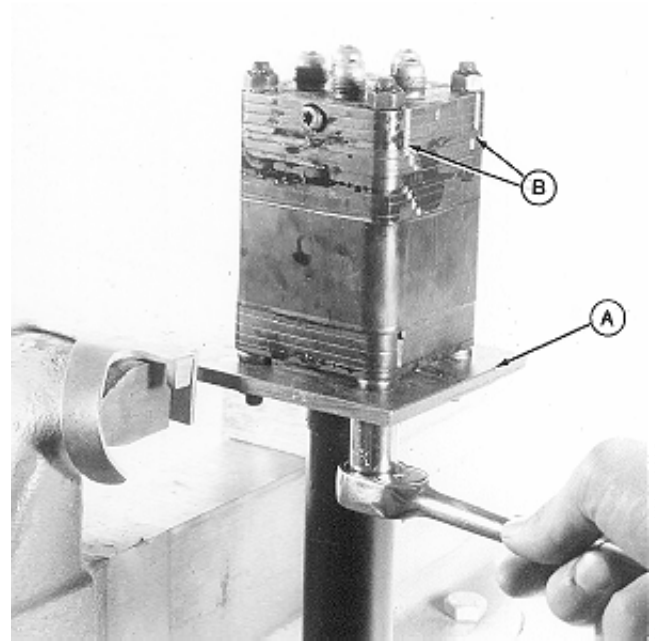

Early Version—322 and 332

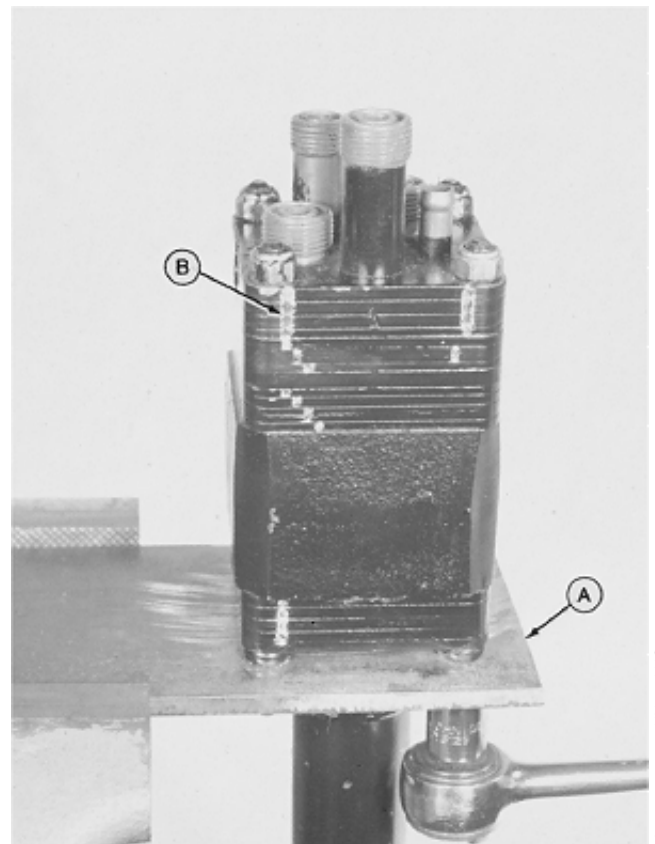

Early Version—430

M43639 -UN-06MAR95

M36631 -UN-29AUG88

60-06-6

4. Early version; Loosen plug one turn.



M77338  
-JUN-21FEB95

MX,15916006,16 -19-13JUL95

**IMPORTANT:** Do not damage fittings during nut removal. Do not nick or scratch the machined surfaces of the steering valve.

5. Remove nuts to remove port cover assembly (four plates bonded together).



M43841  
-JUN-08JAN90

Early Version—322 and 332

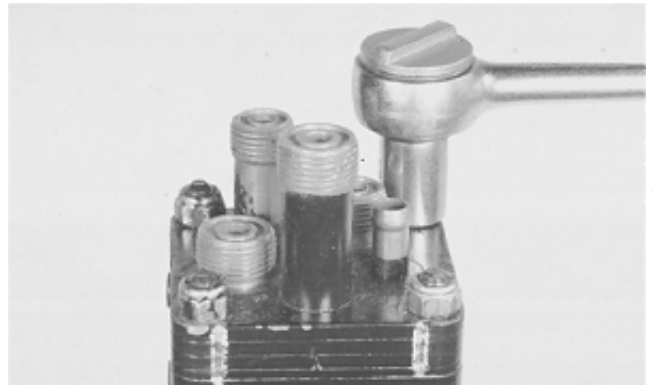

M36633  
-UN-29AUG88

Early Version—430

MX,15916006,8 -19-13JUL95

6. Later version; Remove port cover and check ball (A).

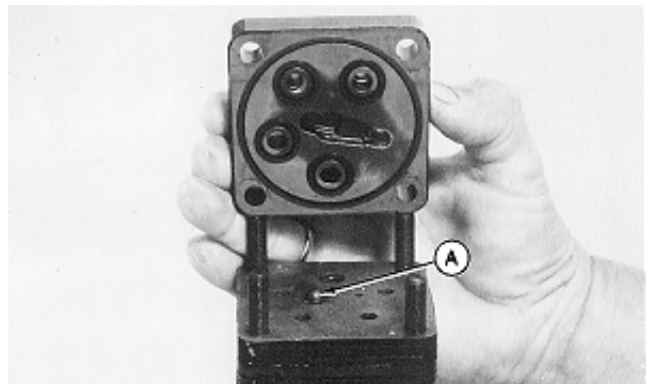

M77303  
-UN-06MAR95

MX,15916006,17 -19-13JUL95

7. Remove seal ring and O-rings (A).

8. Inspect port cover for scratches on machined surfaces or damage to fittings. Replace cover if damaged.

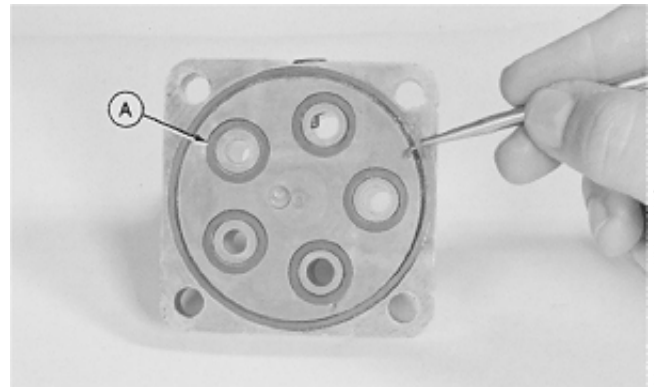

Early Version

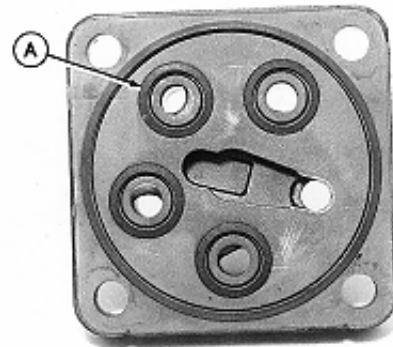

Later Version

MX,15916006,18 -19-13JUL95

M36634 -UN-29AUG88

-UN-06MAR95

M78056

8060

9. Early version; Remove plug (A), O-ring (B) and check ball (C).

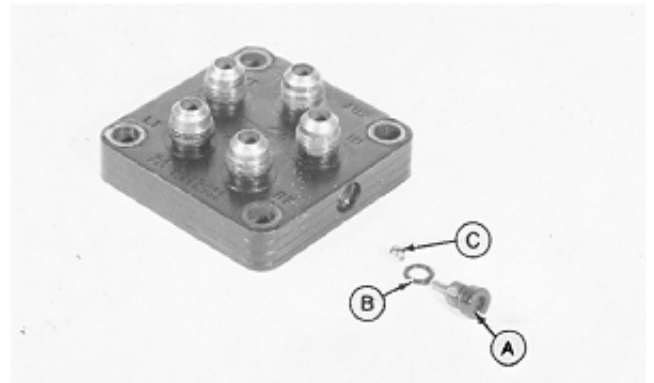

322 and 332

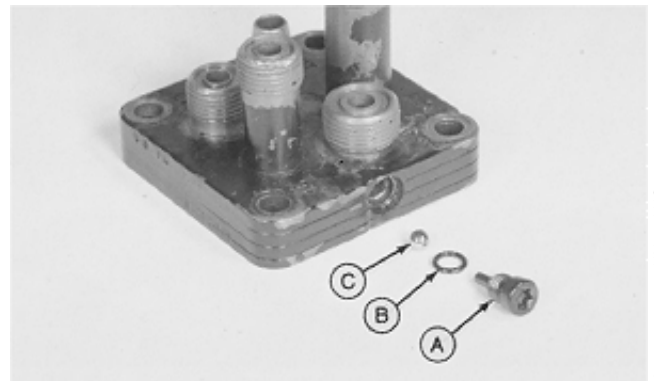

430

MX,15916006,9 -19-13JUL95

-UN-08JAN90

M43832

-UN-29AUG88

M36635



*NOTE: Port manifold has three springs which may come loose during disassembly.*

10. Carefully remove port manifold (three plates bonded together).

**IMPORTANT: Do not interchange springs. The steering valve has two sets of springs. Keep springs with respective manifold.**

11. Remove three springs (A).

*NOTE: If one or more springs are damaged, all six springs in valve must be replaced.*

12. Inspect springs and pins (B) for distortion, wear, or damage.

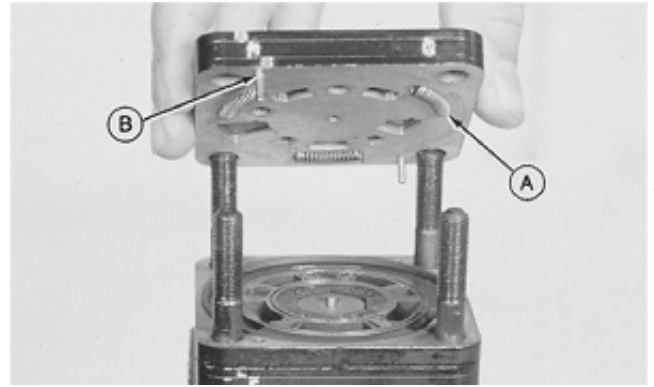

M36636 -UN-29AUG88

MX,15906006,10 -19-10MAR95

13. Inspect port manifold machined surfaces (A) for scratches or scoring. A polished pattern from the rotation of the valve plate and hex drive assembly is normal. All edges (B) must be sharp, free of nicks and burrs.

*NOTE: Scoring is indicated by fine scratches or grooves cut into the manifold. When these scratches can be detected by feel finger nail or lead pencil, the manifold should be replaced.*

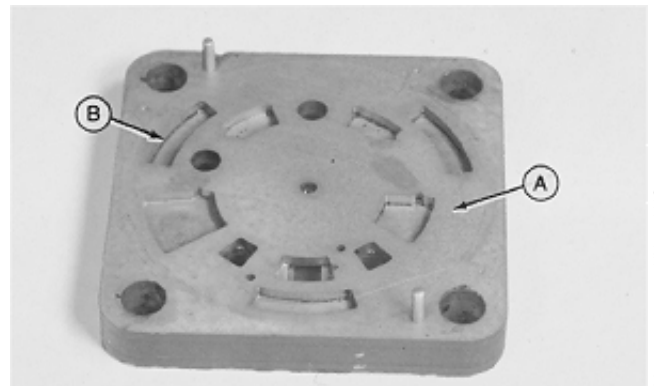

M36637 -UN-29AUG88

MX,15906006,11 -19-01MAR95

14. Remove the valve ring and two seal rings (A). Check valve ring for nicks and scoring. If the valve ring is damaged, it must be replaced.

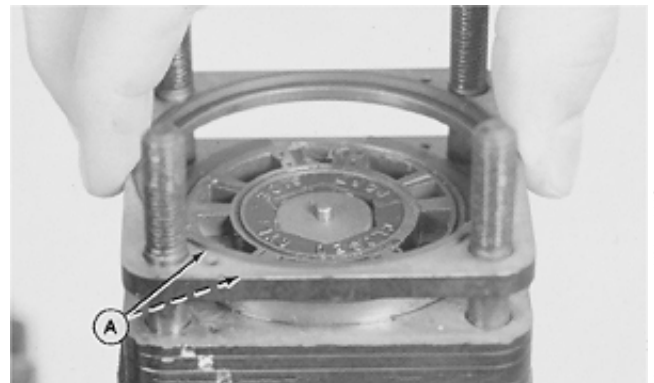

M36638 -UN-29AUG88

MX,15906006,12 -19-01MAR95

15. Remove valve plate. Inspect the slots and ground surfaces for nicks or wear. If the valve plate is scored or the edges are not sharp, the valve plate and valve ring both must be replaced.

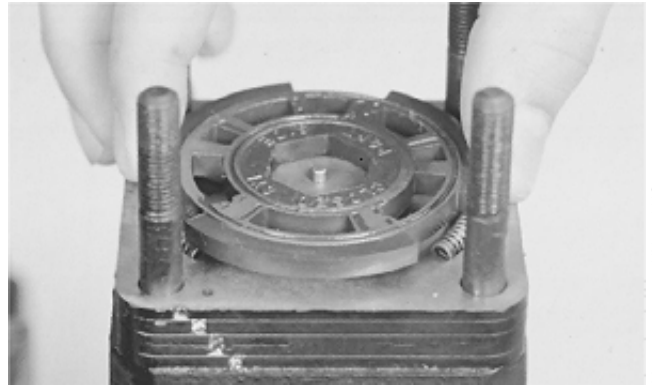

M36639  
-UN-29AUG88

MX,15906006,13 -19-01MAR95

16. Remove and inspect hex drive assembly. Check sides and slot for wear, grooves, or scoring. Pin (A) should be tight and show no wear or damage.

17. Remove three springs (B).

18. Inspect springs for broken coils, wear, or damage.

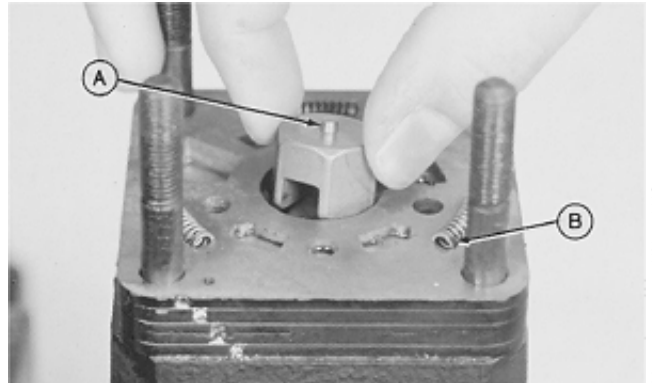

M36840  
-UN-29AUG88

MX,15906006,14 -19-01MAR95

19. Remove the isolation manifold (four plates bonded together). Check manifold surface, holes and edges for nicks, or unusual wear. A polished pattern from the rotation of the valve plate and commutator cover is normal.

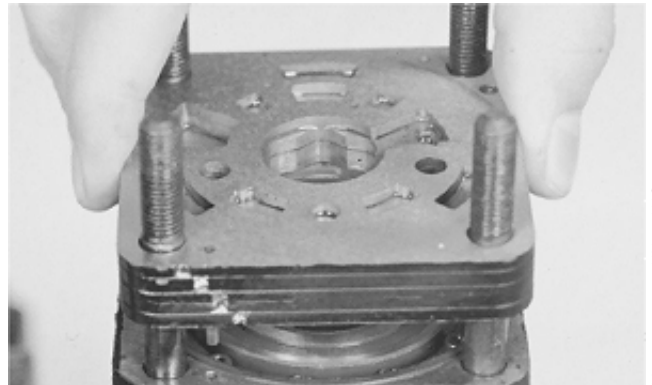

M36841  
-UN-29AUG88

MX,15906006,15 -19-01MAR95

20. Remove drive link. Check the four crowned surfaces (A) for wear or scoring.

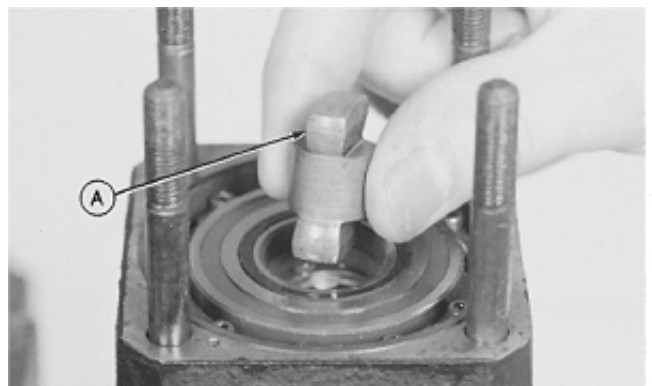

M36642  
-UN-29AUG88

MX,15906006,16 -19-01MAR95

60  
06  
10

21. Remove metering ring and upper and lower seals (A). If the bore (B) is scored, the metering ring must be replaced.

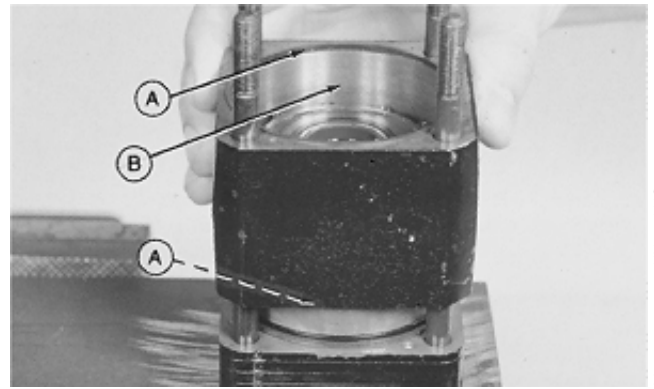

MX,15906006,17 -19-01MAR95

M36643 -UN-29AUG88

**IMPORTANT: Do not clamp metering assembly in a vise.**

22. Remove metering assembly. Put assembly on a clean surface.

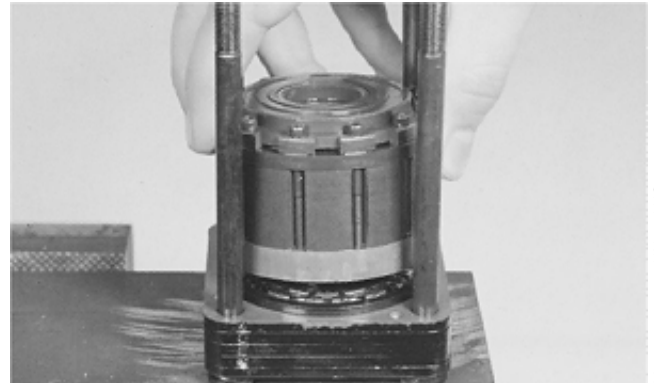

MX,15906006,18 -19-01MAR95

M36644 -UN-29AUG88

23. Remove commutator seal (A).

24. Remove 11 screws to remove commutator cover. Inspect screws for damage and replace if necessary.

25. Check commutator cover machined surface for nicks, burrs, scoring, or unusual wear. A polished pattern due to rotation of the commutator is normal.



MX,15906006,19 -19-01MAR95

M36645 -UN-29AUG88

**IMPORTANT: Handle commutator ring with care; it is easily broken.**

26. Remove commutator ring and inspect for wear, burrs, cracks, or scoring.

*NOTE: The commutator ring and commutator are a matched set. If either is worn or damaged, both must be replaced.*



MX,15906006,20 -19-01MAR95

M36647 -UN-29AUG88

**IMPORTANT: DO NOT use a screwdriver to remove commutator. Commutator can be damaged.**

27. Remove commutator and five pins (A) using a wood dowel or equivalent.

*NOTE: The commutator is made up of two plates bonded together. It is a permanent assembly and cannot be disassembled.*

28. Check commutator machined surface, holes and edges for nicks. Edges must be sharp.

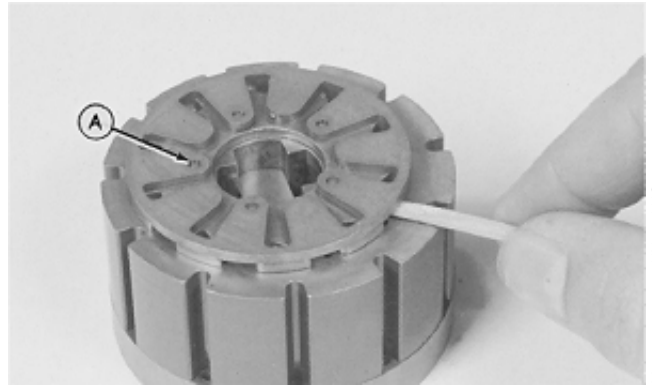

M36648 -UN-29AUG88

MX,15906006,21 -19-01MAR95

29. Remove drive link spacer. Check spacer for grooves, wear, or damage.

30. The rotor should rotate and orbit freely within the stator. Check commutator side of stator face for grooves or scoring.

*NOTE: Stator and rotor are a matched set. If either are worn or damaged, both must be replaced.*

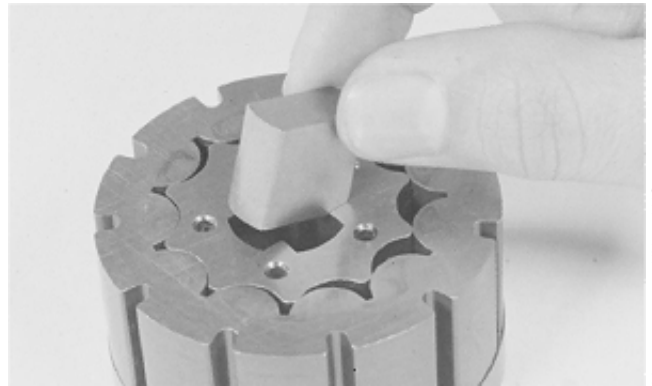

M36649 -UN-29AUG88

MX,15906006,22 -19-01MAR95

31. Measure rotor-to-stator clearance. Center rotor lobe (A) between stator lobes and check clearance directly opposite lobe (A).

If rotor-to-stator clearance is more than 0.08 mm (0.003 in.), replace rotor and stator.

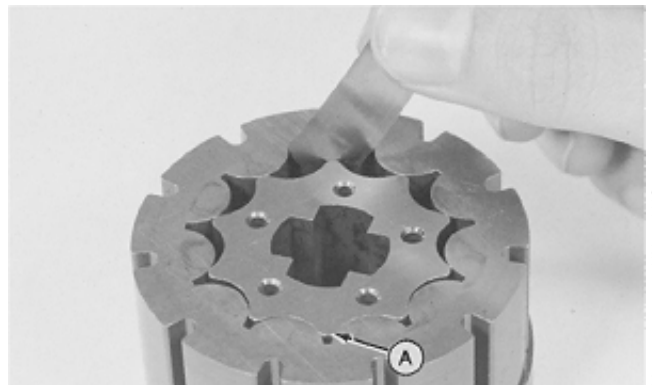

M36850 -UN-29AUG88

MX,15906006,23 -19-01MAR95

32. Lift the rotor and stator from the drive plate.

33. Check the drive plate side of the rotor assembly for nicks, grooves, or scoring. A spiral pattern due to rotor movement is normal.

The thrust bearing side of the plate should also show a normal wear pattern without grooves, flaking, or dents.

The flat sides of the input shaft hole should not be grooved or worn.

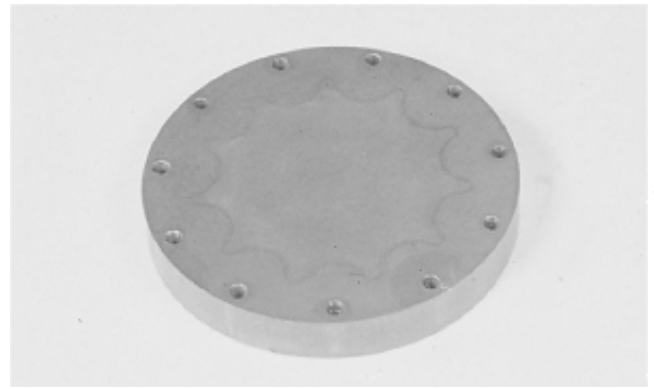

Drive Plate Side

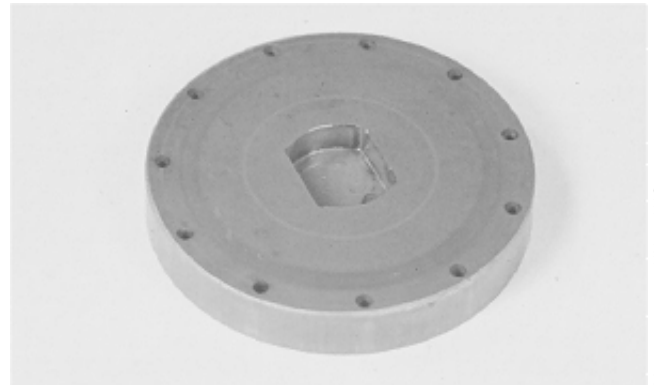

Thrust Bearing Side

MX,15906006,24 -19-01MAR95

M36651 -UN-29AUG88

M36852 -UN-29AUG88

60  
06  
13

*NOTE: Early versions had a seal spacer and backup ring. Later versions have a seal spacer only.*

34. Remove parts (A—E).

35. Inspect parts for wear or damage. Replace if necessary.

- A—Thrust Bearing Spacer
- B—Thrust Bearing
- C—Face Seal
- D—Backup-Ring (Early Version)
- E—Seal Spacer

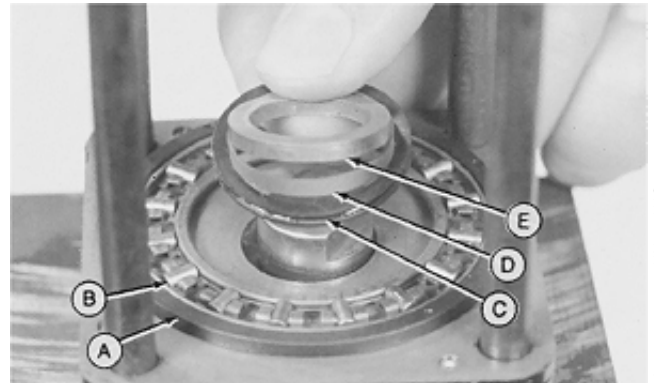

Early Version

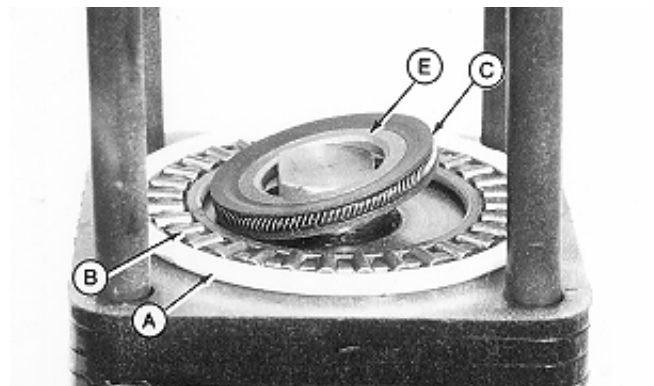

Later Version

MX,15916006,19 -19-13JUL95

M36853 -UN-29AUG88

M77305 -UN-06MAR95

36. Remove upper cover plate (four plates bonded together).

37. Check plate surface for grooves, dents, or metal flakes. A polished pattern due to the action of the seal is normal.

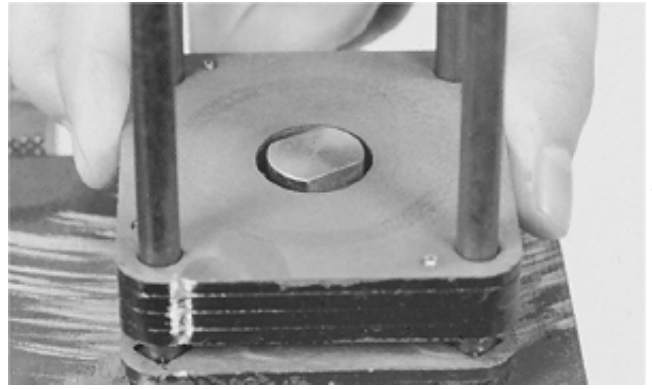

M36654  
-UN-29AUG88

MX,15906006,26 -19-01MAR95

38. Remove steering shaft and snap ring (A).

39. Inspect steering shaft serrations, threads, and flats for grooves, wear, or damage.

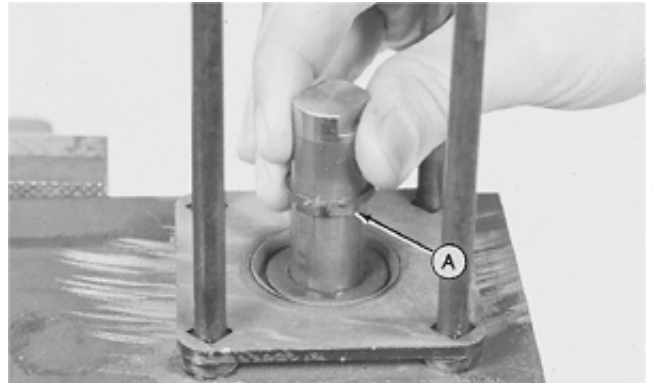

M36655  
-UN-29AUG88

MX,15906006,27 -19-01MAR95

40. Remove washer and steering tube (A).

*NOTE: Steering tube and retaining plate (B) are a matched set. If either part is worn or damaged, both must be replaced.*

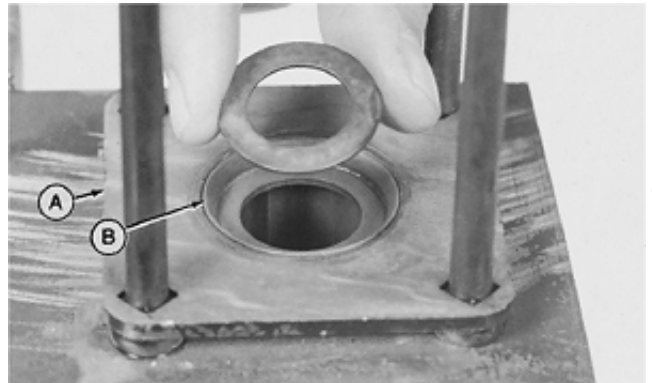

M36656  
-UN-29AUG88

MX,15906006,28 -19-01MAR95

**IMPORTANT: Hold steering tube in a soft-jaw vice.  
Be careful not to crush steering tube.**

41. Inspect bushing (A) for wear or damage. If bushing replacement is necessary, straighten crimped area of steering tube using a punch.

42. Remove bushing using a 2-jaw puller and slide hammer.

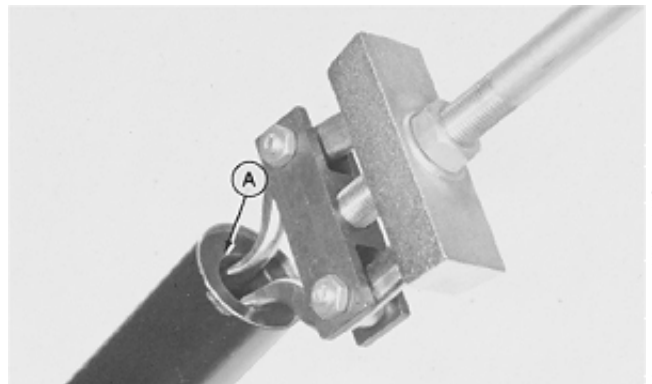

M36657  
-UN-29AUG88

MX,15906006,29 -19-01MAR95

43. Remove nuts holding the four bolts to the fixture, and remove the bolts.

44. Inspect bolts for wear or damage. Replace if necessary.

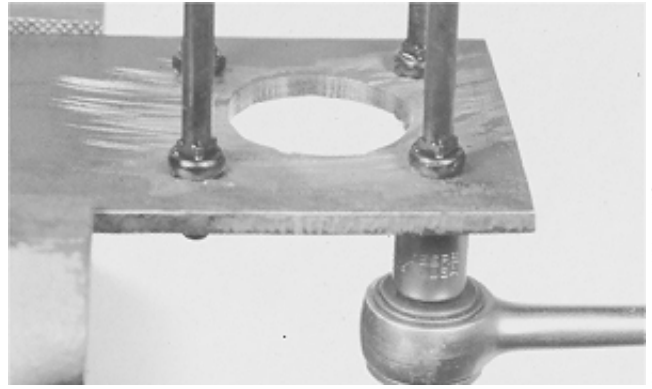

MX,15906006,30 -19-01MAR95

M36658  
-JUN-29AUG88

## ASSEMBLE STEERING VALVE AND COLUMN

**IMPORTANT:** Always use new seals and O-rings. Damaged or used parts will leak.

*NOTE:* Lubricate all seals and O-rings with petroleum jelly during assembly.

1. Apply clean John Deere Low Viscosity HY-GARD® oil on all internal parts.
2. Install four bolts, with short threaded end down, in fixture. Install nuts and tighten finger tight.

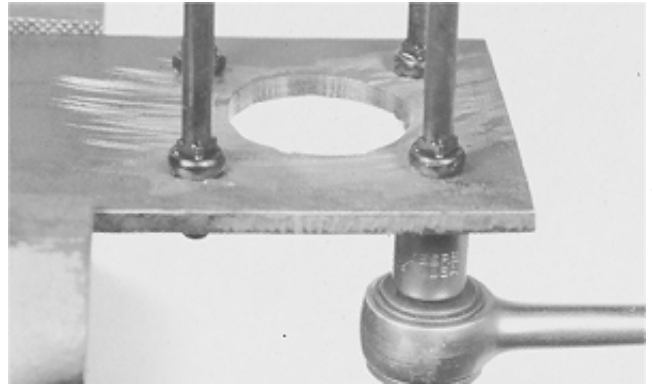

MX,15916006,10 -19-13JUL95

M36658  
-JUN-29AUG88

3. Install bushing into steering tube with recess facing into tube, using a driver set. Install bushing 2.5 mm (0.100 in.) below top of steering tube.

4. Slightly bend edges of steering tube over bushing using a punch.

5. Apply multipurpose grease to inside of bushing.

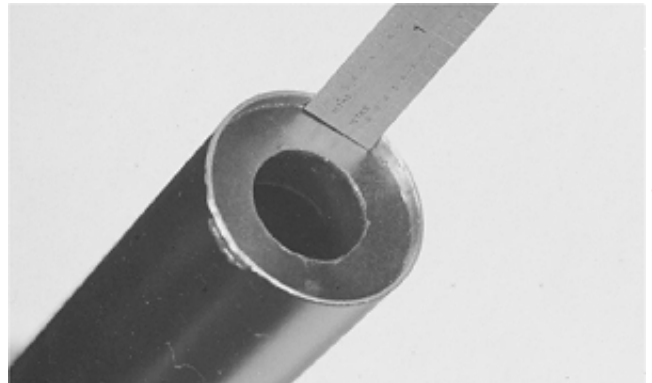

MX,15906006,32 -19-01MAR95

M36660  
-JUN-29AUG88

6. Install steering tube (A) on bolts. Be sure the square holes in the steering tube are seated on the square shoulders of the bolts.

7. Apply multipurpose grease on retainer plate (B) and washer.

8. Install washer.

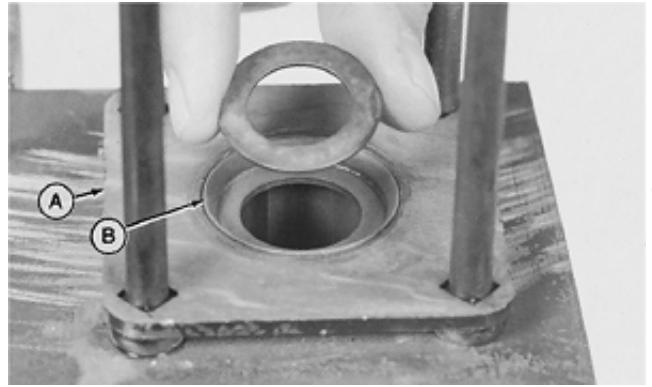

MX,15906006,33 -19-01MAR95

M36656  
-UN-29AUG88

9. Install snap ring (A) on steering shaft.

10. Install steering shaft with threaded end down into steering tube.

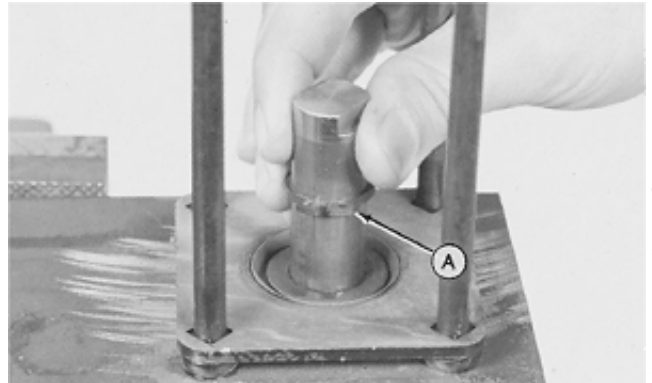

MX,15906006,34 -19-01MAR95

M36855  
-UN-29AUG88

**IMPORTANT:** Alignment grooves must be on only one side of steering valve for proper valve operation.

11. Install upper cover plate over four bolts with the highly polished surface up.

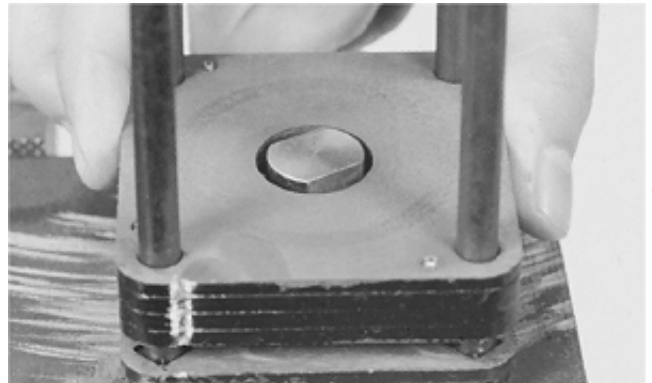

MX,15906006,35 -19-01MAR95

M36854  
-UN-29AUG88



12. Apply multipurpose grease on the face of the upper cover plate, steering shaft end and thrust bearing (B).

*NOTE: Wide shoulder of spacer (A) faces up, away from upper cover plate.*

13. Install parts (A—E).

- A—Thrust Bearing Spacer
- B—Thrust Bearing
- C—Face Seal
- D—Backup-Ring (Early Version)
- E—Seal Spacer

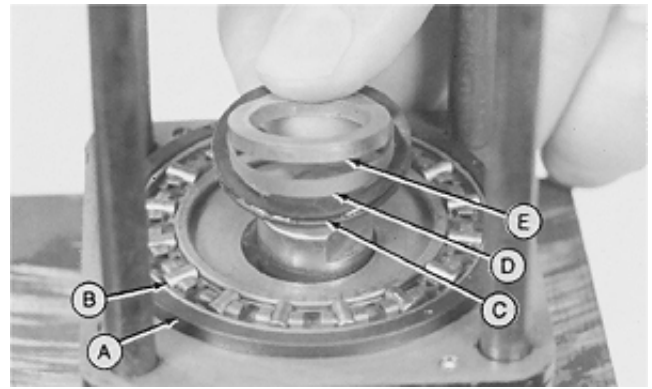

Early Version

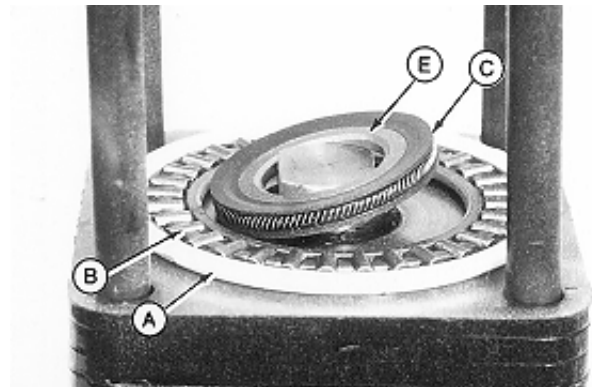

Later Version

MX,15916006.20 -19-13JUL95

M36653 -UN-29AUG88

-UN-06MAR95

M77305

60  
06  
17

14. Put drive plate (A) on a clean surface with slot downward.

15. Install and turn stator (B) until the stator slots (C) are aligned with drive plate holes (D).

16. Install rotor (E) with five pin holes (F) up.

- A—Drive Plate
- B—Stator
- C—Stator Slot (11)
- D—Drive Plate Hole (11)
- E—Rotor
- F—Pin Hole (5)

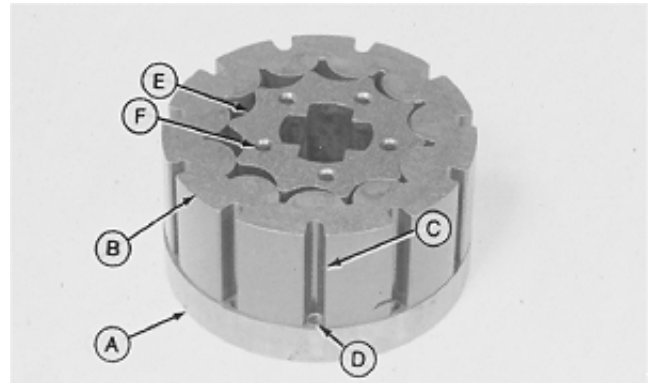

MX,15906006.37 -19-01MAR95

-UN-29AUG88

M36861

17. Apply multipurpose grease on spacer.

18. Install spacer in rotor drive slot.

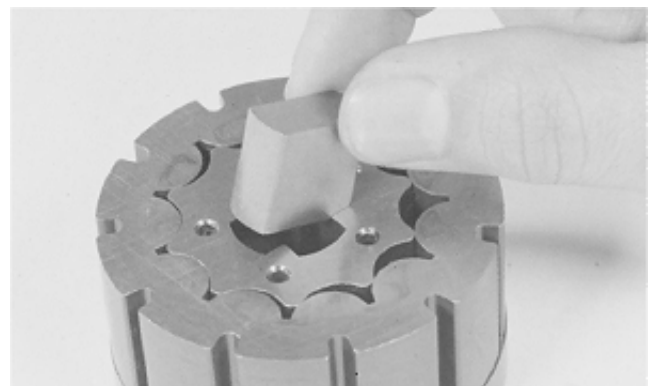

MX,15906006.38 -19-01MAR95

-UN-29AUG88

M36649

19. Install commutator (A) on rotor, with long grooves (B) upward.

**IMPORTANT: Pins must be installed below the surface of the commutator to prevent commutator cover damage.**

20. Align commutator holes with rotor holes and install five pins.

21. Put a few drops of clean John Deere Low Viscosity HY-GARD® oil into each groove of the commutator.

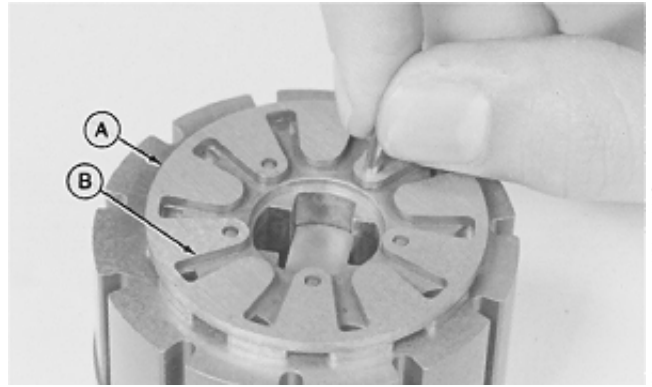

M/36662 -UN-29AUG88

MX,15906006,39 -19-01MAR95

22. Align commutator ring slots (A) with stator slots (B) and install commutator ring.

23. Align commutator cover holes (C) with commutator ring slots. Install commutator cover with flat surface toward commutator.

24. Clean screw threads using Clean and Cure Primer. Apply Thread Lock and Sealer (low strength) to threads of commutator cover-to-commutator screws.

25. Install 11 screws into metering assembly. DO NOT tighten screws at this time.

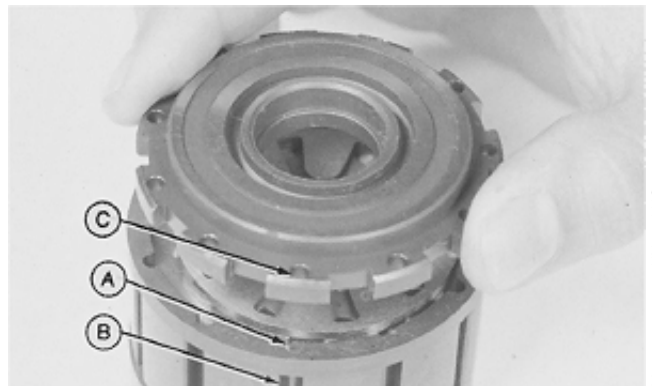

M/36663 -UN-29AUG88

MX,15906006,40 -19-01MAR95

60  
06  
18

**IMPORTANT:** The following procedure must be used to minimize an out-of-round condition between commutator ring and drive plate. The commutator ring is self-centering when the drive plate is shimmed. Use DFMX2 Alignment Shims.

26. Install metering assembly, with drive plate (A) up into metering ring (B).

27. Install two DFMX2 Alignment Shims (C) each between drive plate and metering ring 120° apart. (See Section 299 for instructions to make shims.)

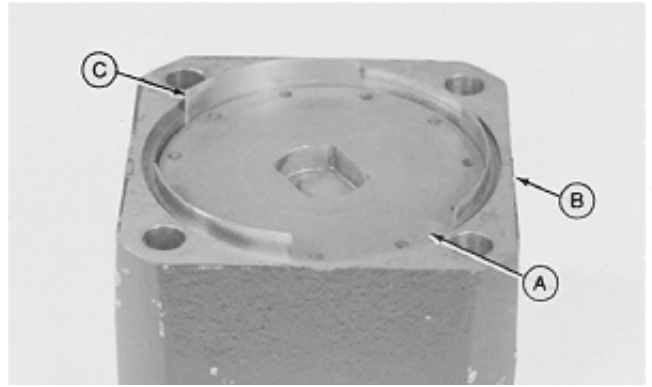

MX,15916006,11 -19-13JUL95

28. Turn metering ring over on a flat surface and push metering assembly down. Tighten 11 screws in several steps and in the sequence shown to 1.4 N-m (12 lb-in.).

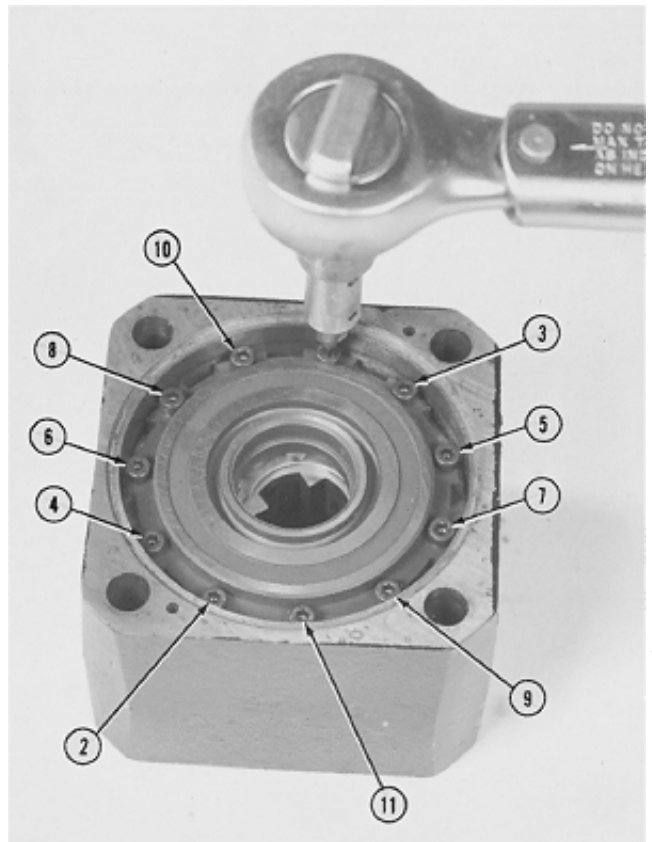

MX,15906006,42 -19-01MAR95

29. Remove Shims and metering assembly from metering ring.

30. Install THICK end of drive link into the slot in the rotor. Hold the drive link and rotate the metering assembly by hand. The rotor should turn freely inside the stator.

If the rotor binds or does not move, disassemble and inspect to find the cause.

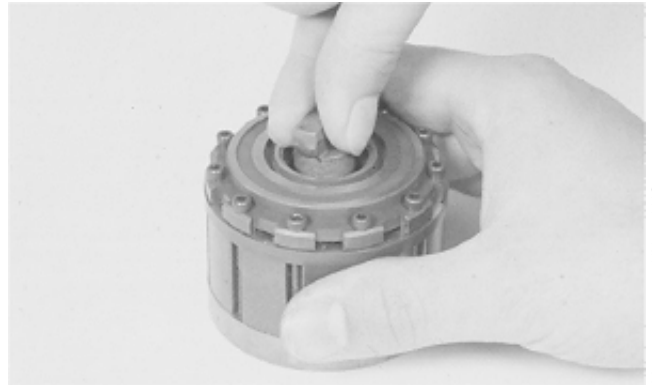

MX,15906006,43 -19-29MAR95

M36666 -UN-29AUG88

31. Apply petroleum jelly on seal ring. Install seal ring on metering ring end without pin holes.

**IMPORTANT: Align pin hole (A) in metering ring with groove (B) on upper cover plate so that remaining parts can be aligned correctly.**

32. Install metering ring over bolts with pin holes up.

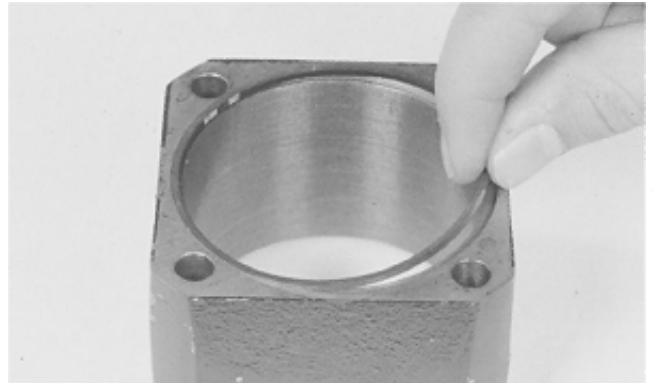

M36667 -UN-29AUG88

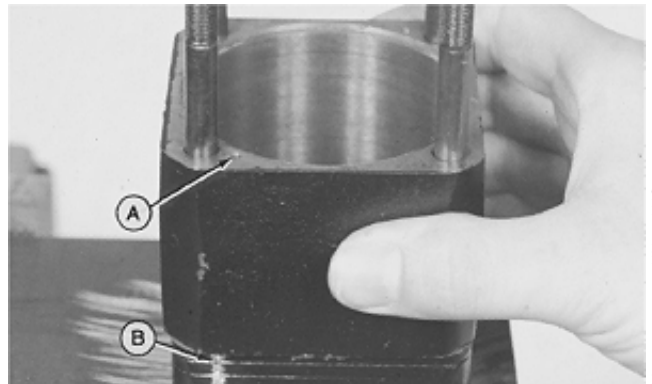

M36679 -UN-29AUG88

MX,15906006,44 -19-01MAR95

33. Apply multipurpose grease on drive plate surface.

34. Install metering assembly, with drive plate down, into metering ring. Turn metering assembly until the steering shaft engages the drive plate hole. When properly seated, the metering assembly is below the surface of the metering ring.

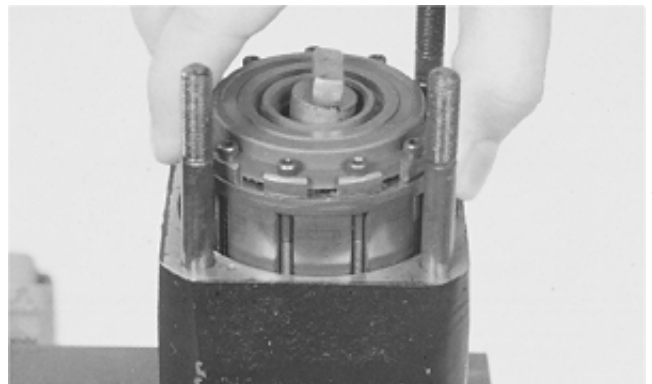

MX,15906006,45 -19-01MAR95

M36668 -UN-29AUG88

60  
06  
20

35. Apply petroleum jelly on new commutator seal (A) and seal ring (B).

36. Install new commutator seal with yellow mark (C) or narrow edge, down into commutator cover.

37. Install seal ring (B) and pins (D).

- A—Commutator Seal
- B—Seal Ring
- C—Yellow Mark or Narrow Edge
- D—Pin (2 used)

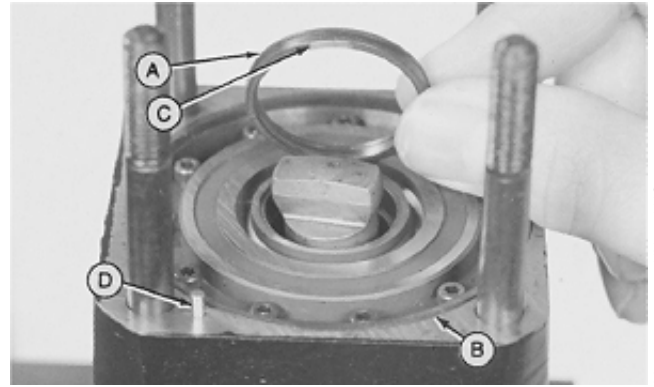

MX,15906006,46 -19-01MAR95

M36669 -UN-29AUG88

**IMPORTANT: Align grooves (A) in isolation manifold with groove (B) in upper cover plate.**

38. Install isolation manifold, with recessed slots up, on metering ring.

39. Install pins (C).

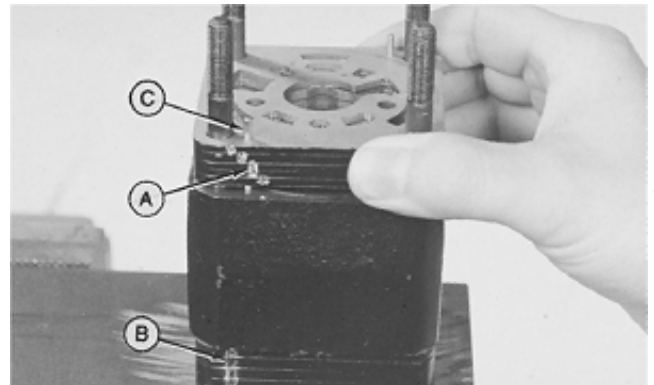

MX,15906006,47 -19-01MAR95

M36870 -UN-29AUG88

40. Install three 13 mm (1/2 in.) springs (B) in recessed slots of the isolation manifold.

41. Install hex drive assembly, with pin (A) up, on drive link.

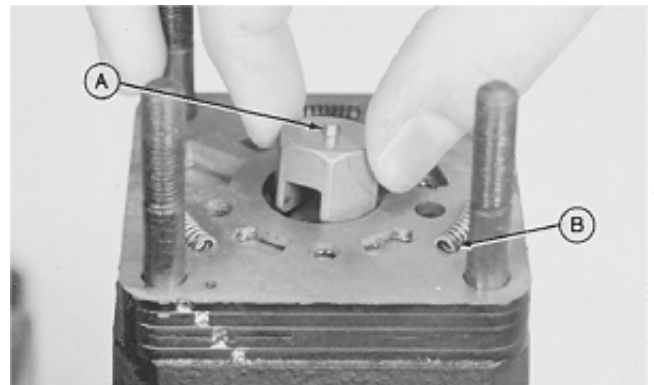

MX,15906006,48 -19-01MAR95

M36840 -UN-29AUG88

42. Apply petroleum jelly on new seal rings (A). Install seal rings on valve ring.

43. Align valve ring holes (B) with pins (C) to install valve ring.

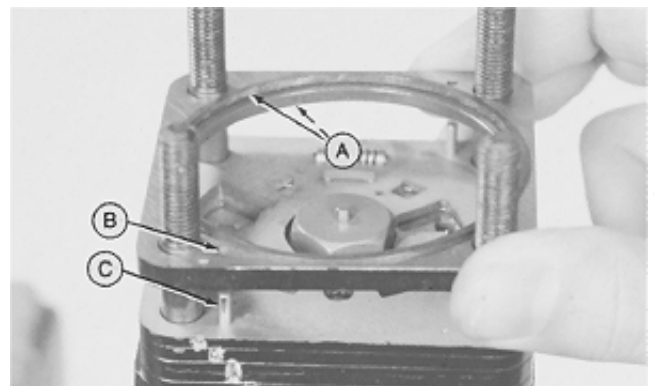

MX,15906006,49 -19-01MAR95

M36671 -UN-29AUG88

**IMPORTANT:** Valve plate must be installed with “PORT SIDE” (A) directly opposite (12 o’clock position) from alignment grooves (B) for proper operation. Valve plate spring slots and springs must be aligned to prevent spring damage when installing port manifold.

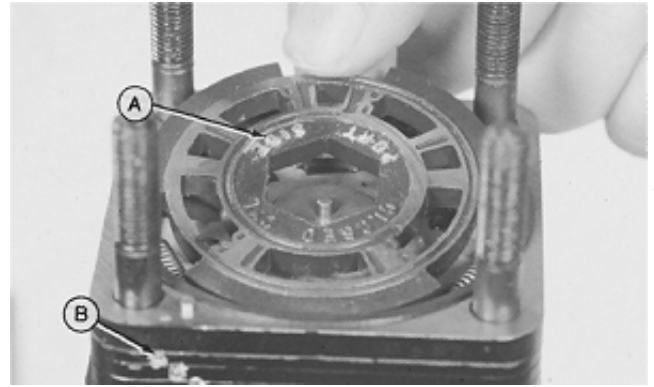

M36672 -UN-29AUG88

44. Install valve plate, with “PORT SIDE” up, on isolation manifold. Turn valve plate to make sure springs are centered in valve plate spring slots.

45. Apply clean John Deere Low Viscosity HY-GARD® oil on valve plate.

MX,15906006,50 -19-01MAR95

46. Install three 25 mm (1 in.) springs (F) in recessed slots (A) of the port manifold.

**IMPORTANT:** Align grooves (H) in port manifold with grooves (C) in isolation manifold. Be careful not to damage springs while installing port manifold.

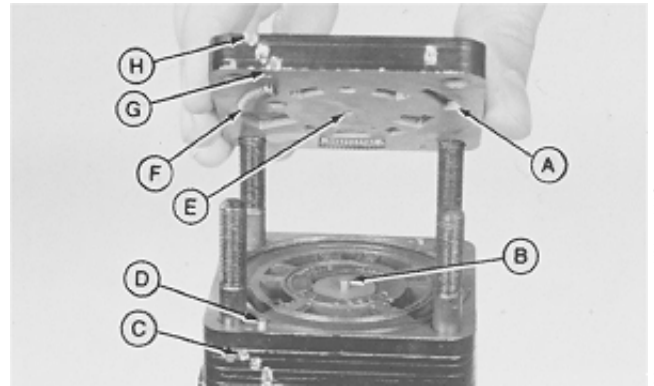

M36673 -UN-29AUG88

47. Install port manifold with springs toward valve plate. Be sure pins (D) engage alignment holes (G) in port manifold. Be sure hex drive assembly pin (B) engages center hole (E) in port manifold.

- A—Recessed Slots
- B—Hex Drive Assembly Pin
- C—Isolation Manifold Grooves
- D—Pin (2 used)
- E—Port Manifold Center Hole
- F—25 mm (1 in.) Spring (3 used)
- G—Port Manifold Alignment Hole (2 used)
- H—Port Manifold Grooves

MX,15906006,51 -19-12MAY95

60  
06  
22

48. Early version; Install new O-ring (B) on plug (A). Install check ball (C). Be sure check ball is seated in bottom of hole. Install plug. Do not tighten.

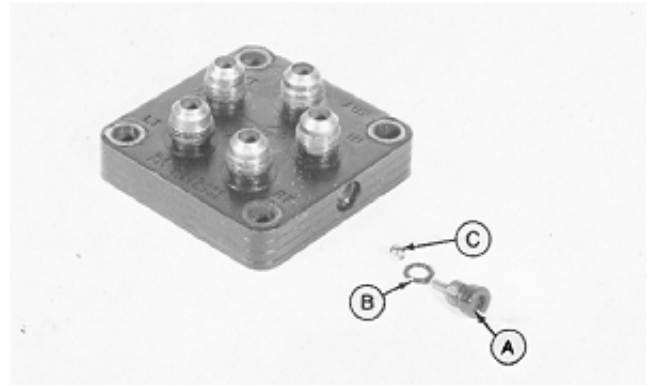

322 and 332

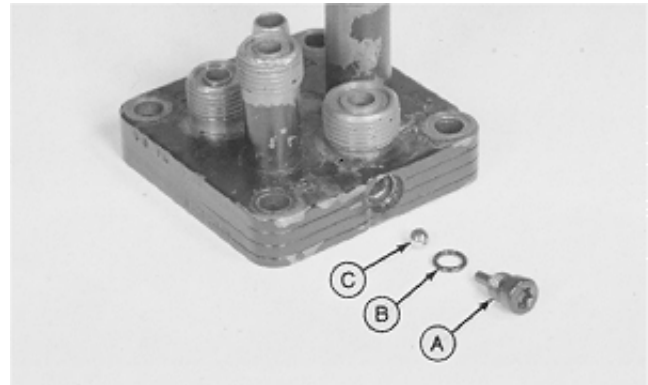

430

MX,15916006.12 -19-13JUL95

M43632 -UN-08JAN90

M36835 -UN-29AUG88

60  
06  
23

49. Later version; Install check ball (E) in countersunk hole (hole closest to the center of the port manifold).

50. Apply petroleum jelly on new O-rings (A) and new seal ring (B). Install O-rings and seal ring in port cover.

**IMPORTANT: Align grooves (C) in port cover with grooves (D) in manifold.**

51. Install port cover with seals toward port manifold.

- A—O-Ring (5 on Early Version  
O-Ring (4 on Later Version)
- B—Seal Ring
- C—Port Cover Alignment Grooves
- D—Port Manifold Alignment Grooves
- E—Check Ball (Later Version)

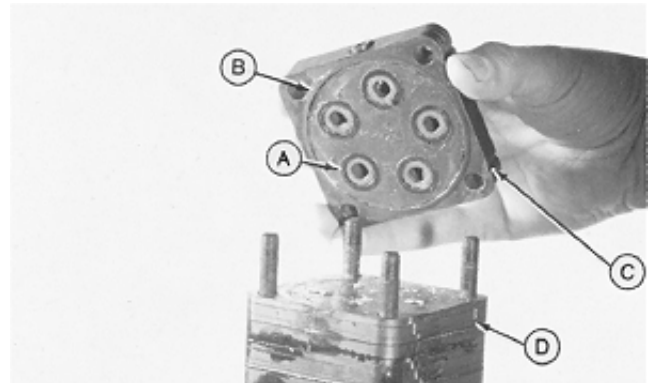

Early Version

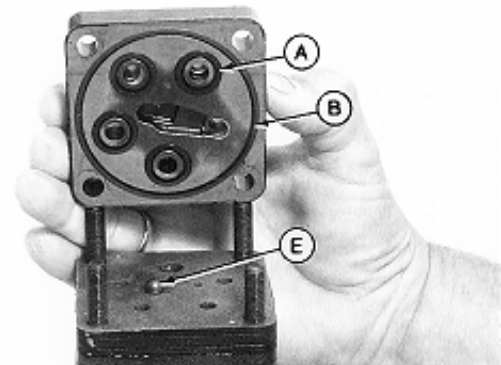

Later Version

MX,15916006.21 -19-13JUL95

M43843 -UN-08JAN90

M78055 -UN-06MAR95

52. Install and tighten four nuts in the sequence shown. Tighten in several steps to 30 N-m (22 lb-ft).

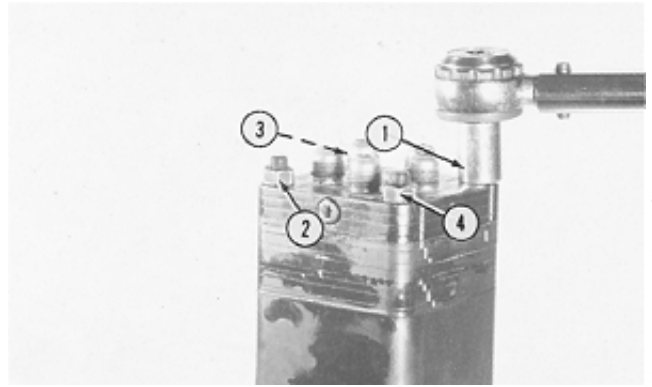

Early Version—322 and 332

M43845  
-UN-11NOV89

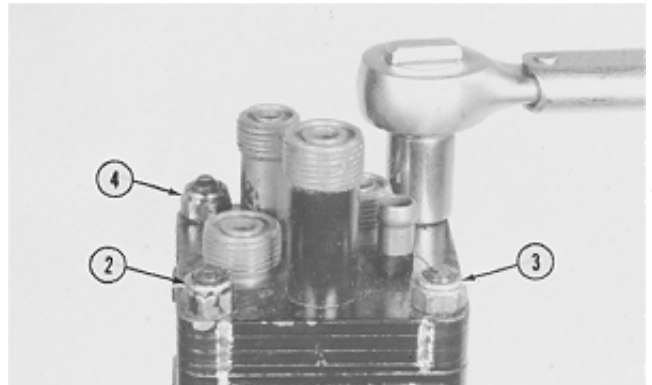

Early Version—430

M36875  
-UN-29AUG88

MX,15916006,13 -19-13JUL95

53. Early version; Tighten plug (A) to 14 N-m (124 lb-in.).

54. Remove steering valve from fixture.

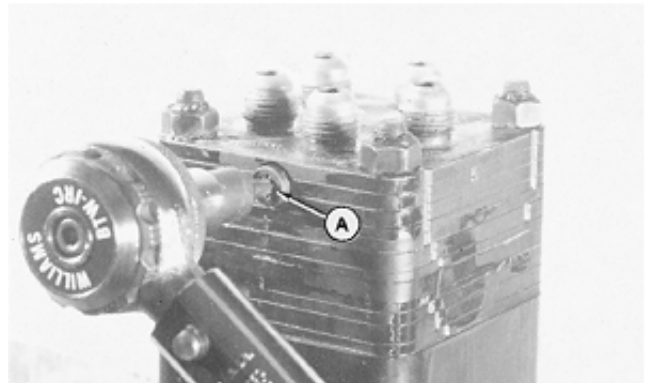

322 and 332

M43844  
-UN-08JAN90

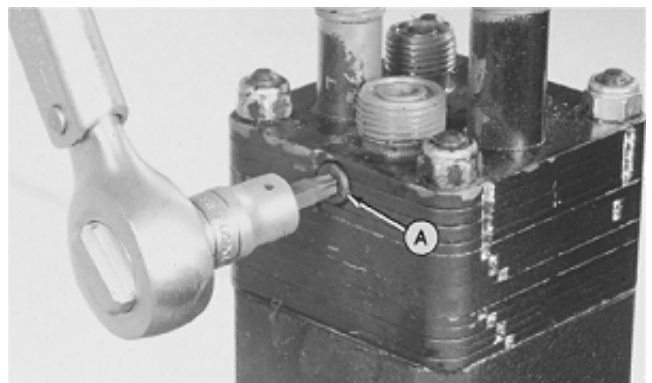

430

M36876  
-UN-29AUG88

MX,15916006,14 -19-13JUL95

60  
06  
24



## REMOVE AND INSTALL STEERING CYLINDER

**N** **CAUTION:** Escaping fluid under pressure can penetrate the skin causing serious injury. Avoid the hazard by relieving pressure before disconnecting hydraulic or other lines. Tighten all connections before applying pressure. Search for leaks with a piece of cardboard. Protect hands and body from high pressure fluids.

If an accident occurs, see a doctor immediately. Any fluid injected into the skin must be surgically removed within a few hours or gangrene may result. Doctors unfamiliar with this type of injury should reference a knowledgeable medical source. Such information is available from Deere & Company Medical Department in Moline, Illinois, U.S.A.

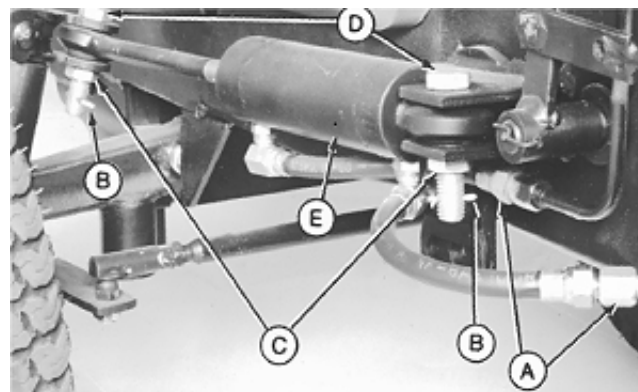
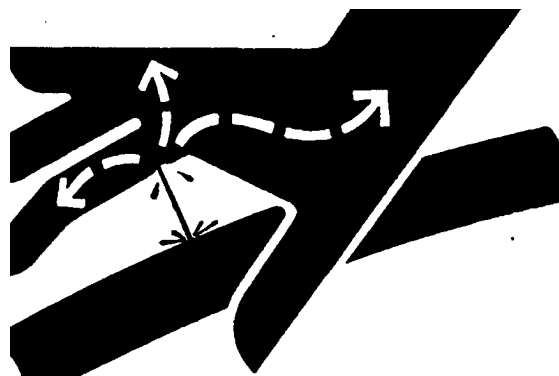

Early Model Shown

A—Hydraulic Lines  
 B—Cotter Pins (if equipped)  
 C—Nuts (Early Models)  
 —Lock Nuts (Later Models)  
 D—Bolts  
 E—Steering Cylinder

1. Disconnect hydraulic hoses at lines (A).
  2. Support cylinder and remove cotter pins (B), if equipped, nuts (C) and bolts (D).
  3. Remove steering cylinder (E).
- NOTE: Cylinder is not repairable. If defective, replace complete assembly.*
4. Installation is done in the reverse order of removal.
- Tighten nuts (C) to 163 N·m (120 lb-ft).
  - Bleed the hydraulic system. (See procedure in Section 270, Group 20.)

MX,15916006,15 -19-13JUL95

-UN-23AUG88

X9811

-UN-28JUL89

M31822

60  
06  
25

60  
06  
26

**OTHER MATERIAL**

<b>Number</b>	<b>Name</b>	<b>Use</b>
M79292	MPG-2® Multi-Purpose Polymer Grease	Prevents parts from seizing. Apply to axle shafts.
LOCTITE® PRODUCTS U.S./Canadian/LOCTITE No.		
TY6305/TY9485/764	Clean and Cure Primer	Cleans parts and speeds cure of sealant.
T43512/TY9473/242	Thread Lock and Sealer (Medium Strength)	Apply to threads of brake plate-to-axle cap screws.

®MPG-2 is a registered trademark of DuBois USA.

®LOCTITE is a registered trademark of the Loctite Corp.

MX,15905020,OTH-19-07MAR95

## REMOVE BRAKES

**N** **CAUTION:** Avoid breathing dust that may be generated when handling components containing asbestos fibers. Inhaled asbestos fibers may cause lung cancer. Normal handling is not hazardous as long as airborne dust containing asbestos is not generated.

Avoid creating dust. Never use compressed air for cleaning. Avoid brushing or grinding material containing asbestos. When servicing, wear an approved respirator. A special vacuum cleaner is recommended to clean asbestos. If not available, apply a mist of oil or water on the material containing asbestos.

Keep bystanders away from the area.

1. Disconnect battery negative (—) cable.
2. Raise rear of machine and install support stands under frame.
3. Remove rear wheel.
4. Bend edge of washer (A) flat against drum.
5. Remove nut and washer.
6. Pull drum off axle.

If drum hits shoes, turn the adjuster to reduce the drag on drum.

If drum is tight on shaft from corrosion, remove drum using a three-leg wheel puller. DO NOT use an impact puller.

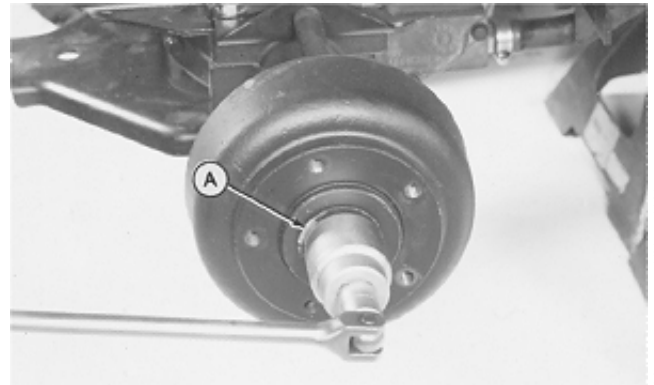

TS220 -UN-23AUG88

M36560 -UN-25JAN90

MX,15905010,19 -19-14FEB95

7. Inspect lining on brake shoes (A) for wear or oil contamination. Replace shoes if worn. Inspect axle oil seal if shoes are oily.

8. Inspect return spring (B) and hold-down springs (C) for wear or stretching.

9. Check adjuster assembly (D) for ease of movement.

10. Remove brake return spring (B), hold-down springs (C), adjuster (D), and shoes (A).

- A—Brake Shoes
- B—Return Spring
- C—Hold-Down Springs
- D—Adjuster Assembly

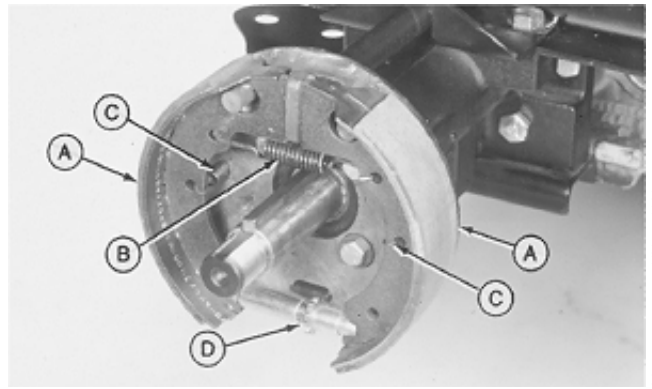

M36673 -UN-25JAN90

MX,15905010,20 -19-14FEB95

11. Disconnect return spring (A).

12. Remove nut (B), plate or washer (D) and spring (C).

- A—Return Spring
- B—Nut
- C—Spring
- D—Plate (Early 430)
- Washer (All and Later 430)

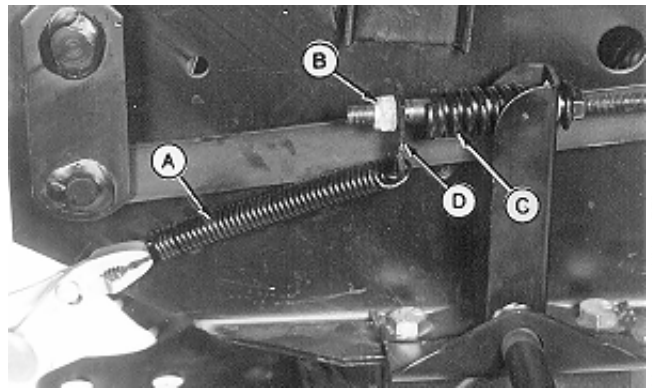

Early 430

M78048 -UN-13FEB95

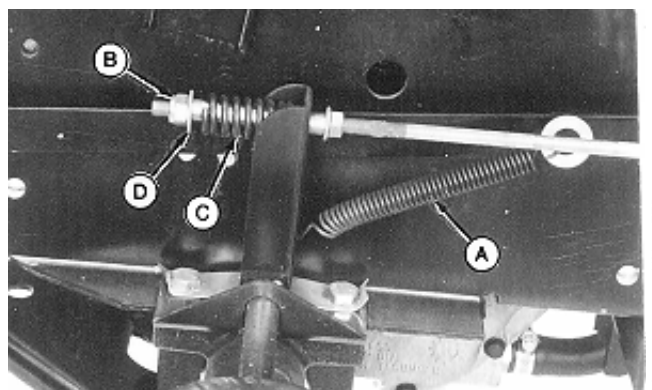

All and Later 430

M78049 -UN-13FEB95

MX,15915010,13 -19-13JUL95

13. Bend lock plate tabs (A) flat. Remove two cap screws (B).
14. Remove four cap screws and washers to remove brake plate assembly.
15. Remove brake arm (C) and brake support (D).

- A—Lock Plate Tab (2)
- B—Cap Screw (2 used)
- C—Brake Arm
- D—Brake Support

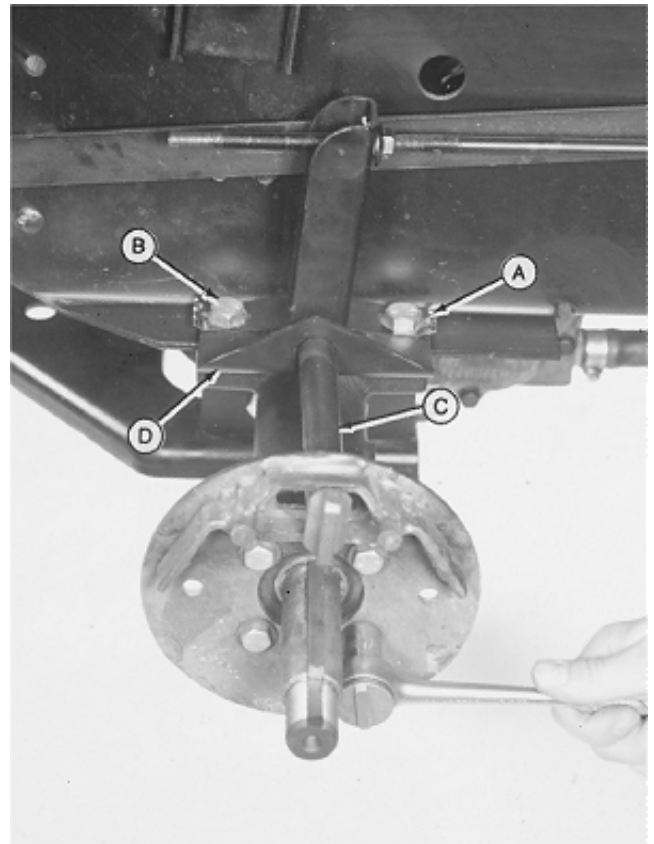

MX,15905010,22 -19-07MAR95

## INSTALL BRAKES

1. Install brake support (A) on brake arm (B).
2. Install brake arm in brake plate (C).
- 3 Clean the threads of all four brake plate cap screws and threaded axle housing using Clean and Cure Primer.
- 4 Apply thread lock and sealer (medium strength) on threads of brake plate cap screws.
5. Install brake rod (D) in brake arm hole.
6. Install brake plate assembly on axle. Install and tighten four cap screws to specifications.
7. Install brake support (A), lock plate (E) and two cap screws (F). Tighten cap screws to specifications. Bend lock plate tabs over flat of cap screws.

### TORQUE SPECIFICATIONS

Brake Plate-to-Axle Housing	
Cap Screws	68 N-m (50 lb-ft)
Axle Housing-to-Frame Cap Screws	100 N-m (75 lb-ft)

- A—Brake Support
- B—Brake Arm
- C—Brake Plate
- D—Brake Rod
- E—Lock Plate
- F—Cap Screw (2 used)

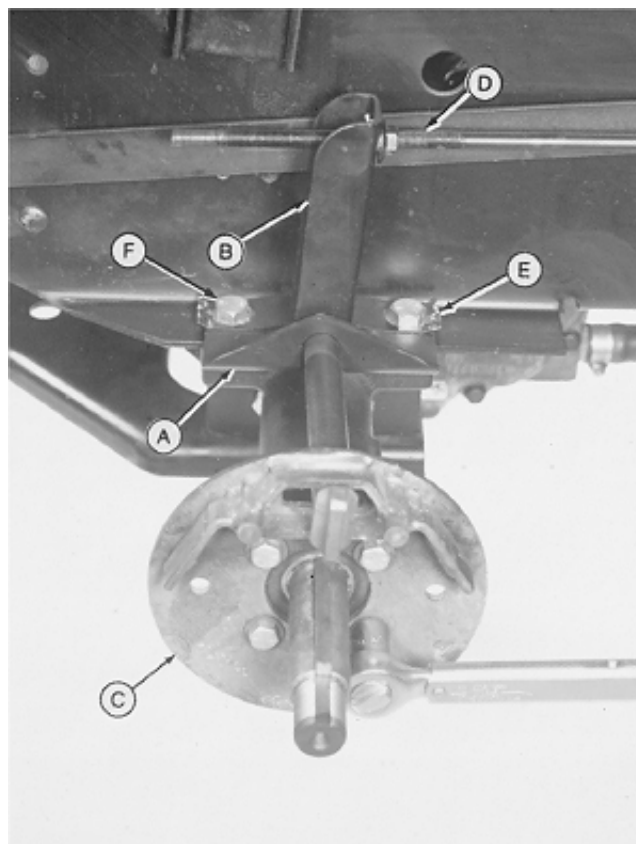

M36577 -JUN-25/JAN90

60  
5-10

MX,15905010,23 -19-08MAY95

8. Install spring (C), plate or washer (D) and nut (B).
9. Connect return spring (A).

- A—Return Spring
- B—Nut
- C—Spring
- D—Plate (Early 430)
- Washer (All and Later 430)

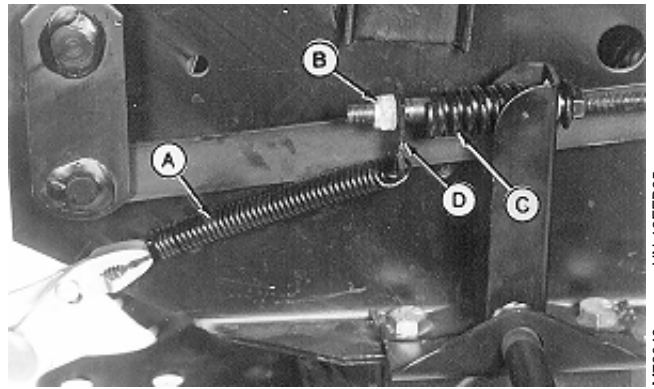

Early 430

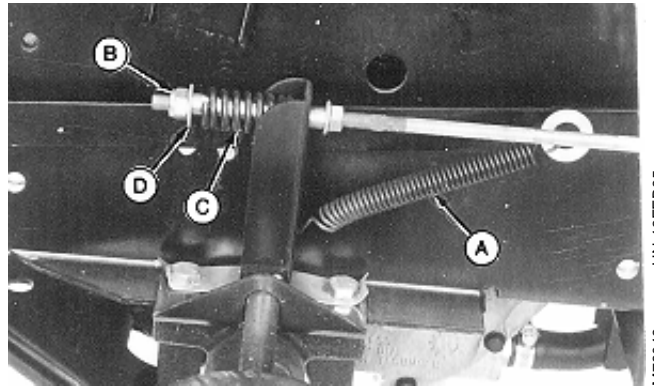

All and Later 430

MX,15915010,14 -19-13JUL95

10. Lock brake pedals together (322, 332 and 430) and apply park brake.
11. Loosen lock nut (A).
12. Turn nut until spring is 42 mm (1.650 in.) long. Tighten lock nut.

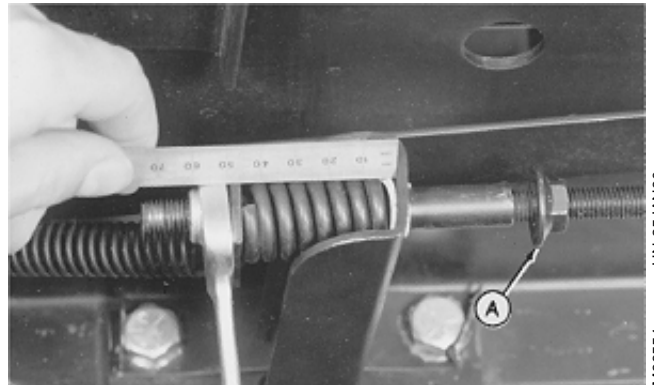

MX,15915010,15 -19-13JUL95

13. Install shoes (D), adjuster (C), hold-down springs (B), and brake return spring (A).

- A—Brake Return Spring
- B—Hold-Down Springs
- C—Adjuster
- D—Shoes

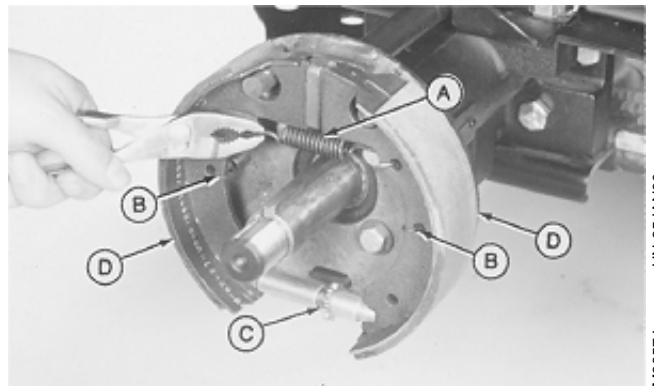

MX,M21,6010R,12-19-24JUN85



14. Apply MPG-2® Multi-Purpose Polymer Grease to axle shaft.
15. Install key and brake drum.
16. Install washer and nut. Tighten nut to specifications.
17. Bend one side of washer over nut to lock nut in place.
18. Install wheel. Tighten cap screws to specifications.
19. Remove support stands.
20. Connect battery negative (—) cable.
21. Adjust brakes. (See procedure in this group.)

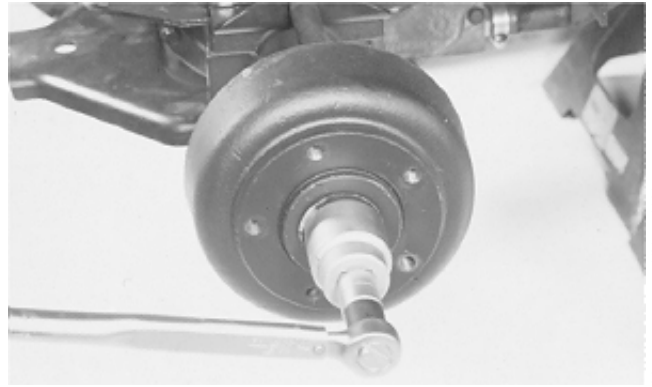

M36571 -UN-25JAN90

**TORQUE SPECIFICATIONS**

Brake Drum-to-Axle Nut . . . . .	88 N-m (65 lb-ft)
Rear Wheel Cap Screws . . . . .	70 N-m (52 lb-ft)

MX,15905020,26 -19-07MAR95

**ADJUST BRAKES**

1. Disconnect battery negative (—) cable.
2. Raise rear of machine and install support stands under frame.

*NOTE: Wheel and brake drum are removed for photographic purpose only.*

3. Reach through slot in back plate (A) with screwdriver for access to star adjuster (B).
4. Turn wheel by hand. Turn adjusting star until brake shoes begin to drag on drum.
5. Push brake pedal(s) down firmly to seat brake shoes and check adjustment. Adjust brakes so brake shoes just clear drums and do not drag when pedal(s) are released.

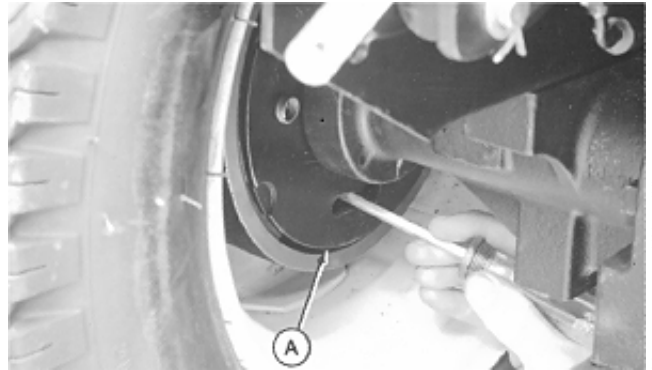

M31941 -UN-28JUL89

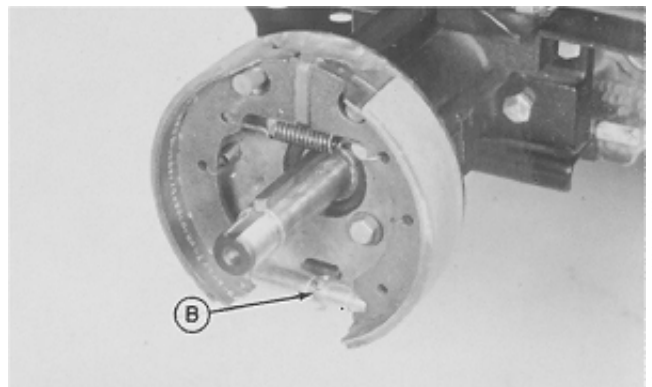

M36881 -UN-25JAN90

MX,15905010,27 -19-14FEB95

6. Lock brake pedals together (322, 332 and 430) and apply parking brake.
7. Check length of spring on both sides of machine. Spring should be approximately 42 mm (1.650 in.).
8. If necessary, adjust length of spring.
9. Loosen lock nut (A).
10. Turn nut until spring is 42 mm (1.650 in.) long. Tighten lock nut.
11. Remove support stands.
12. Connect battery negative (—) cable.

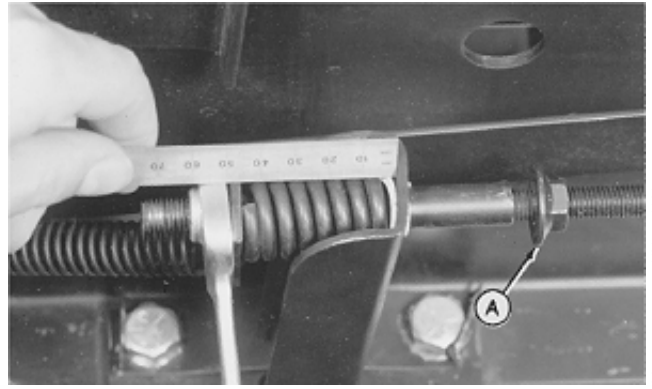

MX,15915010,16 -19-13JUL95

### INSPECT AND REPAIR BRAKE PEDAL AND NEUTRAL RETURN LINKAGE—330

1. Remove belly screen and fender deck.

*NOTE: Disconnect brake rods from both sides of machine.*

2. Disconnect return spring (A).
3. Remove nut (B), washer (D) and spring (C). Inspect springs for weak coils.
4. Disconnect brake rods from brake pedal.

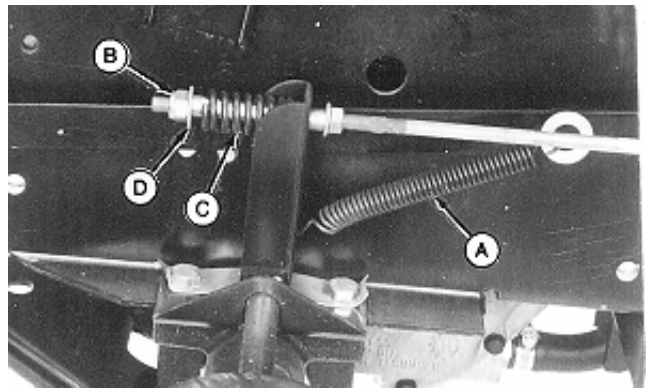

- A—Return Spring
- B—Nut
- C—Spring
- D—Washer

MX,15916010,1 -19-13JUL95

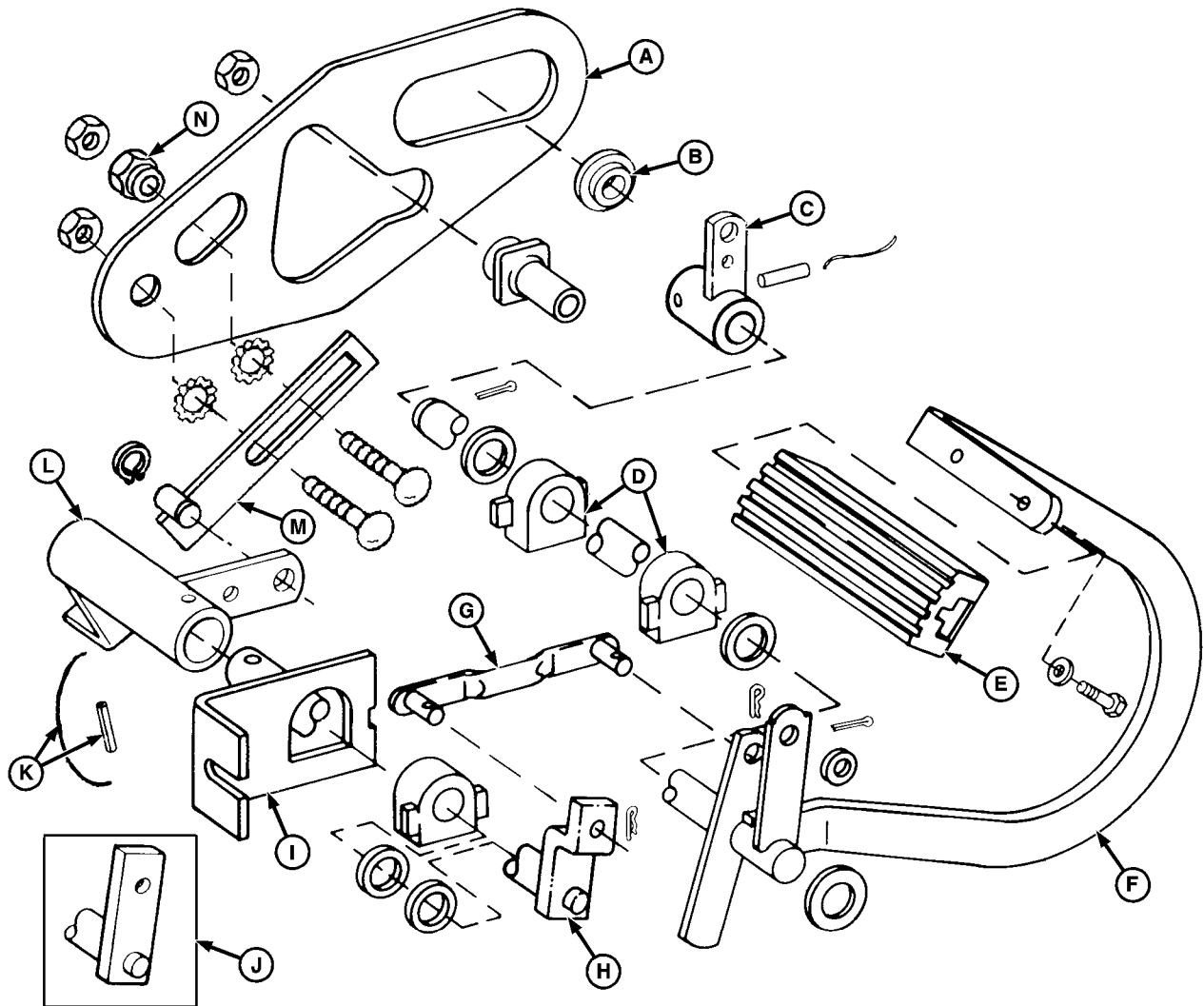

- |                            |  |  |                                   |
|----------------------------|--|--|-----------------------------------|
| A—Neutral Return Cam Plate | F—Brake Pedal                            | I—Bracket                                | L—Neutral Return Arm              |
| B—Spacer                   | G—Neutral Return Link                    | J—Neutral Return Shaft<br>(Early Models) | M—Neutral Return Sliding<br>Lever |
| C—Left-Hand Brake Arm      | H—Neutral Return Shaft<br>(Later Models) | K—Lock Wire and Spring Pin               | N—Eccentric Adjustment Nut        |
| D—Bearing (4 used)         |  |  |                                   |
| E—Pedal Pad                |  |  |                                   |

5. Inspect linkage for wear or damage. Replace parts as necessary.

6. If necessary to replace neutral return cam plate (A), remove transmission control lever assembly. (See Inspect and Repair Transmission Control Linkage—330 in Section 50, Group 10.)

7. Install all parts.
8. Connect brake rods to brake pedal.
9. Install spring (C), washer (D) and nut (B).
10. Connect return spring (A).

A—Return Spring  
B—Nut  
C—Spring  
D—Washer

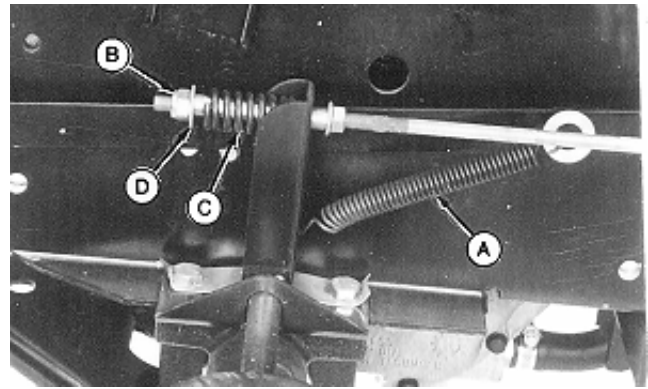

MX,15916010,3 -19-13JUL95

M78049 -UN-13FEB95

11. Apply parking brake.
12. Loosen lock nut (A).
13. Turn nut until spring is 42 mm (1.650 in.) long. Tighten lock nut.
14. Install fender deck and belly screen.

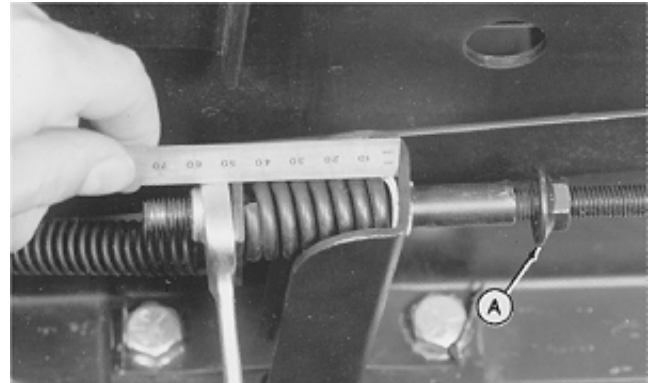

MX,15906010,6 -19-14FEB95

M36654 -UN-25JAN90

60  
10  
10

### INSPECT AND REPAIR BRAKE PEDALS AND NEUTRAL RETURN LINKAGE—322 AND 332

1. Remove belly screen and fender deck.
- NOTE: Disconnect brake rods from both sides of machine.*
2. Disconnect spring (A).
  3. Remove nut (B), washer (D) and spring (C). Inspect springs for weak coils.
  4. Disconnect brake rods from brake pedal.

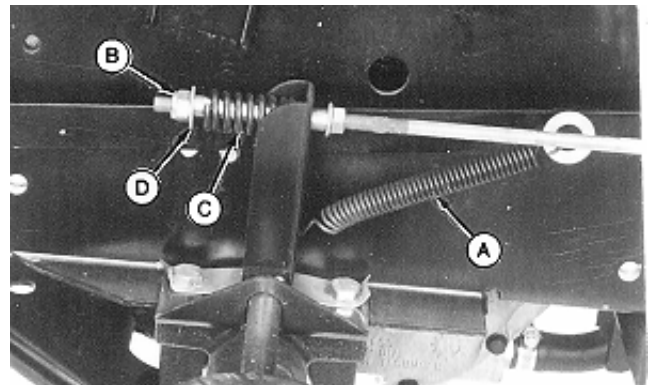

A—Return Spring  
B—Nut  
C—Spring  
D—Washer

MX,15916010,4 -19-13JUL95

M78049 -UN-13FEB95

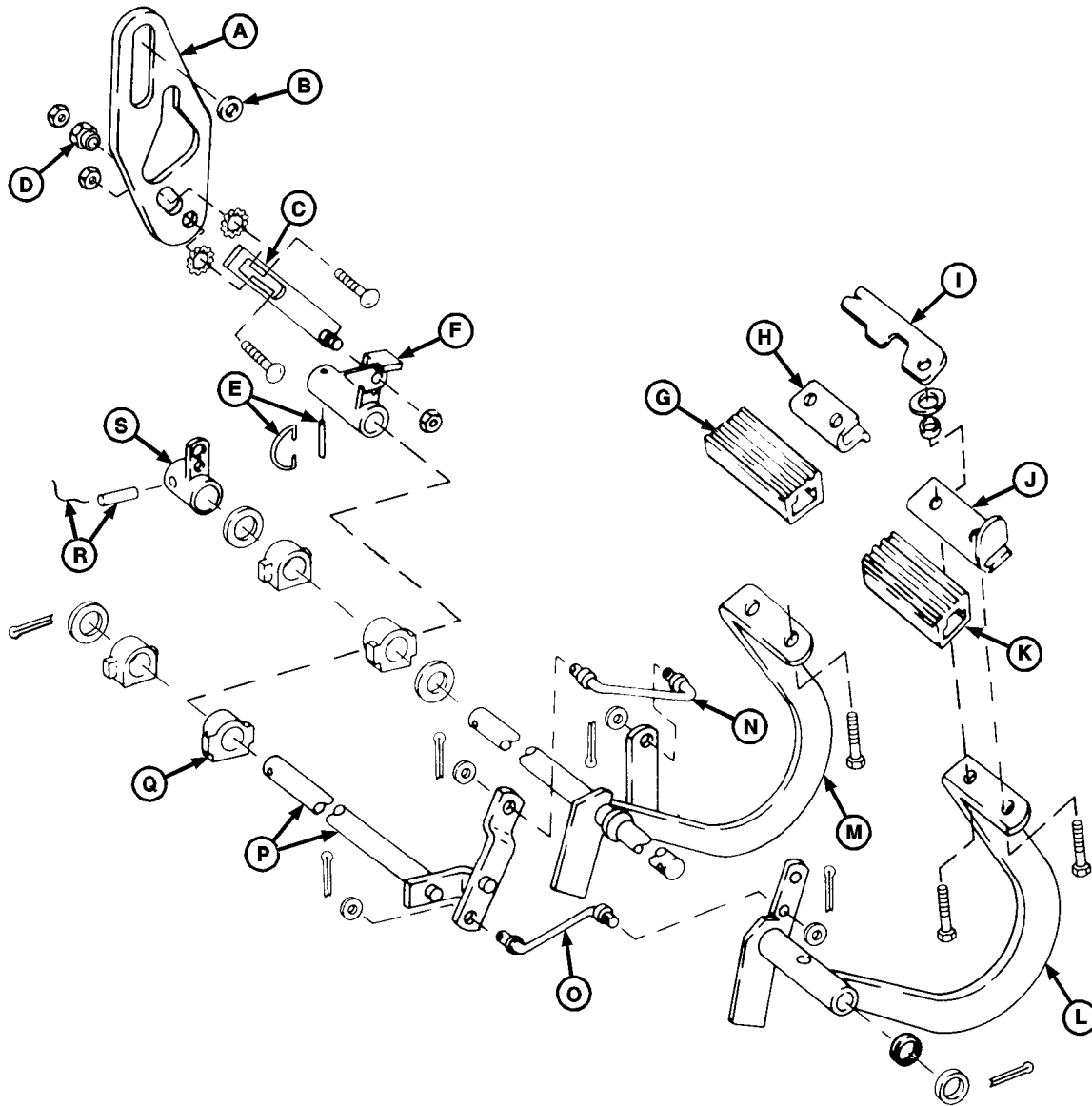

- |                                   |                            |                       |                            |
|-----------------------------------|----------------------------|-----------------------|----------------------------|
| A—Neutral Return Cam Plate        | E—Lock Wire and Spring Pin | J—Support             | O—Neutral Return Link      |
| B—Spacer                          | F—Neutral Return Arm       | K—Right Pedal Pad     | P—Neutral Return Shaft     |
| C—Neutral Return Sliding<br>Lever | G—Left Pedal Pad           | L—Right Brake Pedal   | Q—Bearing (4 used)         |
| D—Eccentric Adjustment Nut        | H—Plate                    | M—Left Brake Pedal    | R—Lock Wire and Spring Pin |
|                                   | I—Strap                    | N—Neutral Return Link | S—Left-Hand Brake Arm      |

Version One (322 and 332)

**NOTE:** Brake pedal and neutral return linkage—Version One, is used on machines equipped with transmission control linkage—Version One for 322 and 332 only.

5. Inspect linkage for wear or damage. Replace parts as necessary.

6. If necessary to replace neutral return cam plate (A), remove transmission control lever assembly. (See Inspect and Repair Transmission Control Linkage—Version One for 322 and 332 only in Section 50, Group 10.)

Brakes/Brake Pedal(s) and Neutral Return Linkage

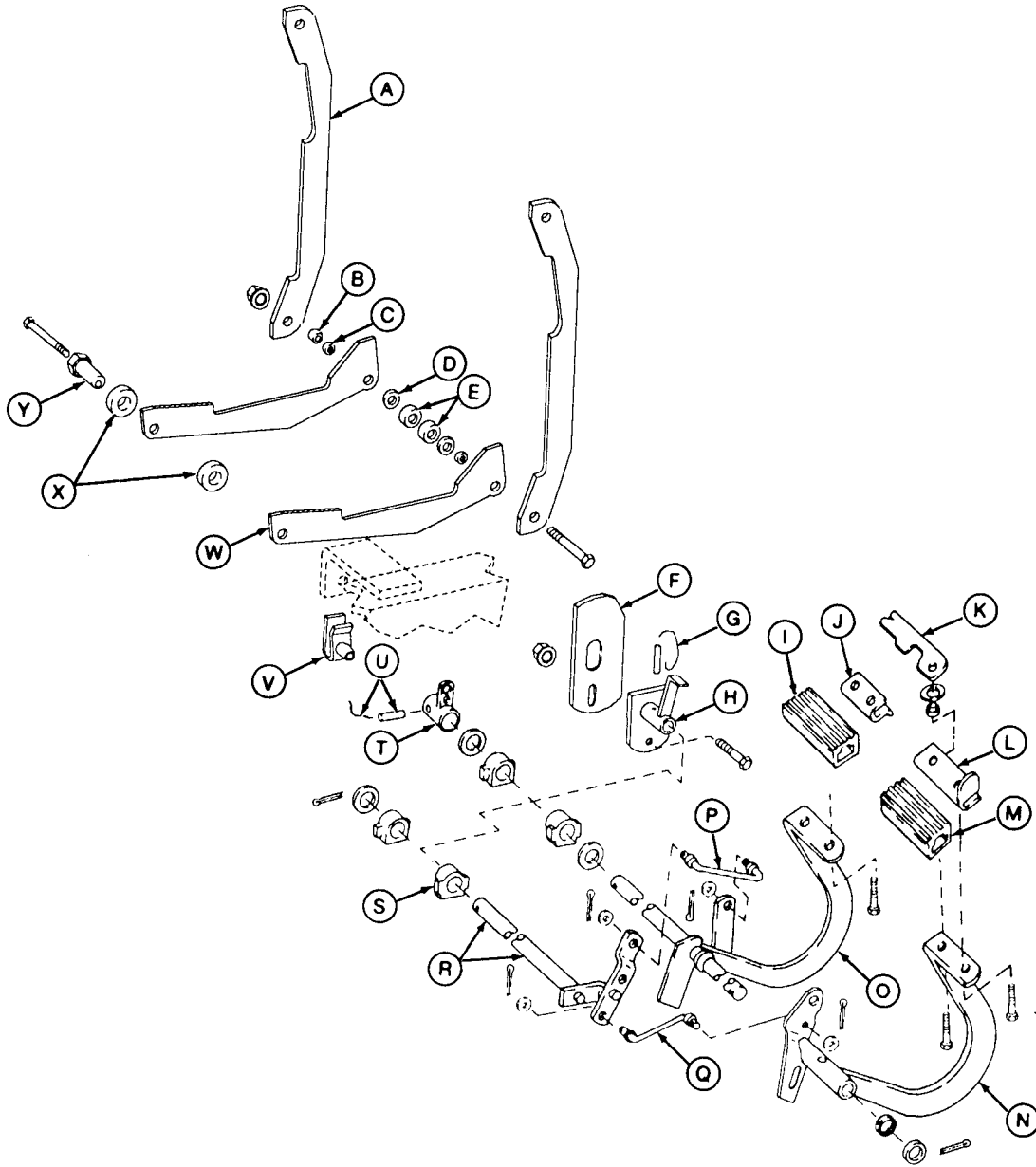

- |                              |                      |                        |                              |
|------------------------------|----------------------|------------------------|------------------------------|
| A—Strap (2 used)             | H—Neutral Return Arm | O—Left Brake Pedal     | U—Lock Wire and Spring Pin   |
| B—Spacer                     | I—Left Pedal Pad     | P—Neutral Return Link  | V—Clamp-On Nut               |
| C—Bushing (2 used)           | J—Plate              | Q—Neutral Return Link  | W—Speed Control Arm (2 used) |
| D—Washer (2 used)            | K—Strap              | R—Neutral Return Shaft | X—Bushings                   |
| E—Ball Bearings              | L—Support            | S—Bearing (4 used)     | Y—Eccentric Adjustment Nut   |
| F—Neutral Return Cam         | M—Right Pedal Pad    | T—Left-Hand Brake Arm  |                              |
| G—Safety Wire and Spring Pin | N—Right Brake Pedal  |                        |                              |

Version Two (322 and 332)

NOTE: Brake pedal and neutral return linkage—Version Two, is used on machines equipped with transmission control linkage—Version Two only.

MX,15916010,6 -19-13JUL95

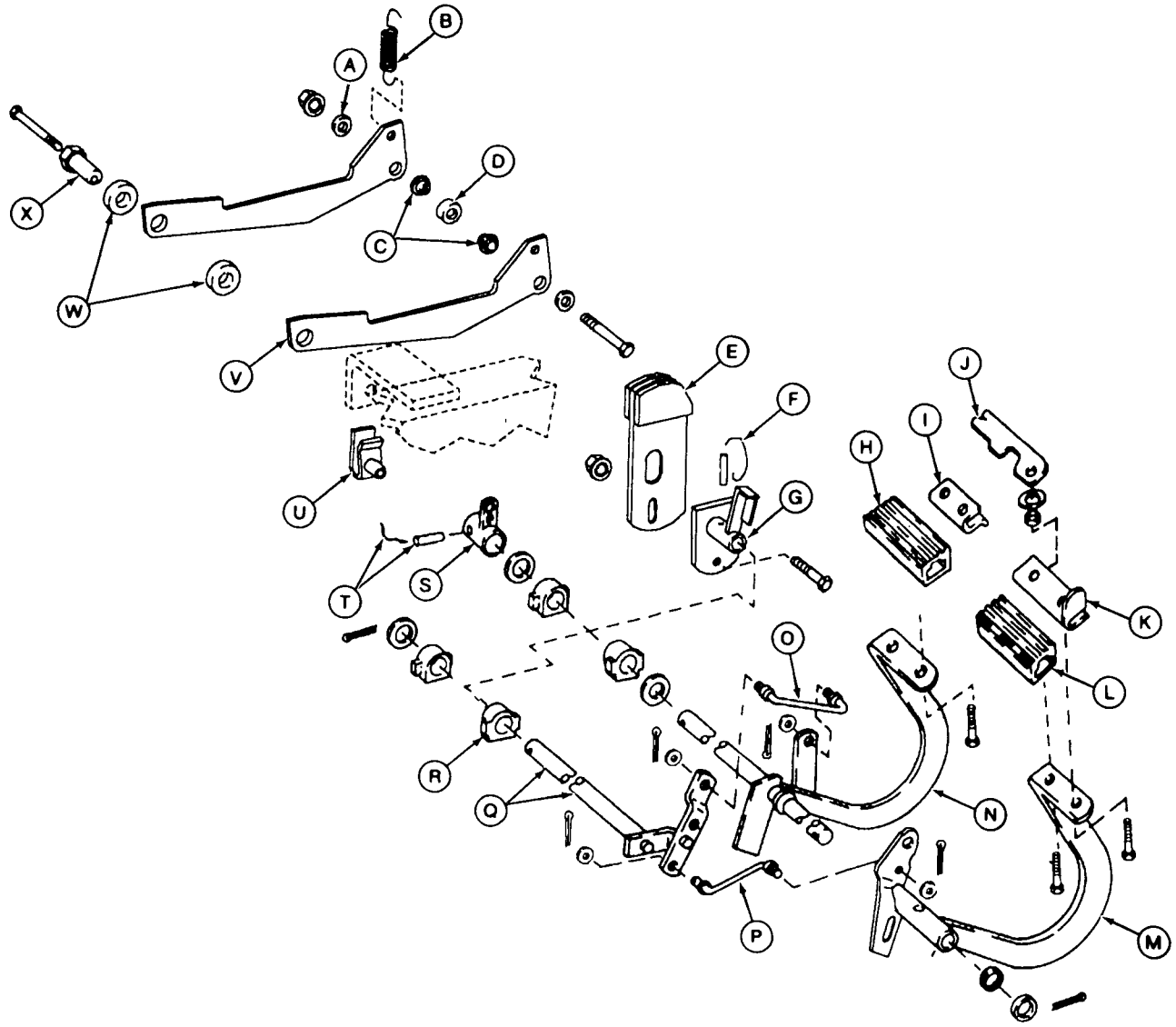

- |                              |                      |                        |                              |
|------------------------------|----------------------|------------------------|------------------------------|
| A—Washer (2 used)            | G—Neutral Return Arm | N—Left Brake Pedal     | T—Lock Wire and Spring Pin   |
| B—Spring                     | H—Left Pedal Pad     | O—Neutral Return Link  | U—Clamp-On Nut               |
| C—Bushings                   | I—Plate              | P—Neutral Return Link  | V—Speed Control Arm (2 used) |
| D—Ball Bearing               | J—Strap              | Q—Neutral Return Shaft | W—Bushings                   |
| E—Neutral Return Cam         | K—Support            | R—Bearing (4 used)     | X—Eccentric Adjustment Nut   |
| F—Safety Wire and Spring Pin | L—Right Pedal Pad    | S—Left-Hand Brake Arm  |                              |
|                              | M—Right Brake Pedal  |                        |                              |

Version Three (322 and 332)

**NOTE:** Brake pedal and neutral return linkage—Version Three, is used on machines equipped with transmission control linkage—Version Three only.

60  
10  
13

M78040 -UN-13JAN95

## Brakes/Brake Pedal(s) and Neutral Return Linkage

7. Install all parts.
8. Connect brake rods to brake pedal.
9. Install spring (C), washer (D) and nut (B).
10. Connect return spring (A).

A—Return Spring  
 B—Nut  
 C—Spring  
 D—Washer

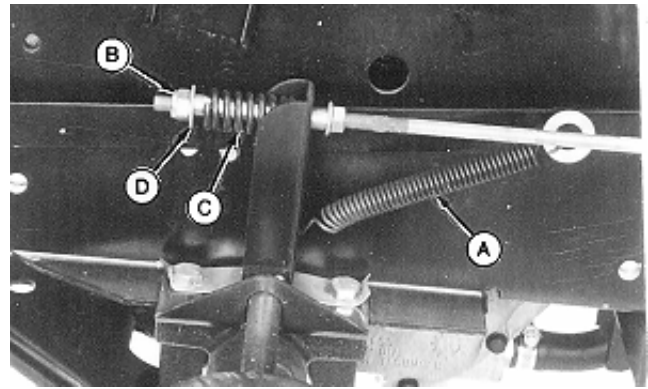

MX,15916010,3 -19-13JUL95

M78049 -UN-13FEB95

11. Lock brake pedals together and apply parking brake.
12. Loosen lock nut (A).
13. Turn nut until spring is 42 mm (1.650 in.) long. Tighten lock nut.
14. Install fender deck and belly screen.

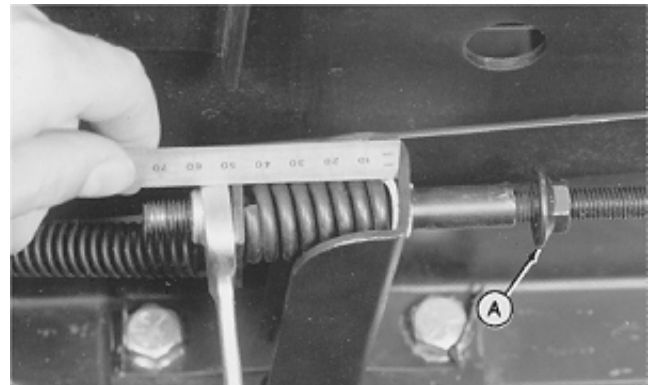

MX,15906010,12 -19-14FEB95

M36654 -UN-25JAN90

60  
10  
14

### INSPECT AND REPAIR BRAKE PEDALS AND NEUTRAL RETURN LINKAGE—430

1. Remove belly pan and fender deck.
- NOTE: Disconnect brake rods from both sides of machine.*
2. Disconnect return spring (A).
  3. Remove nut (B), plate or washer (D) and spring (C). Inspect springs for weak coils.
  4. Disconnect brake rods from brake pedal.

A—Return Spring  
 B—Nut  
 C—Spring  
 D—Plate (Early Models)  
 —Washer (Later Models)

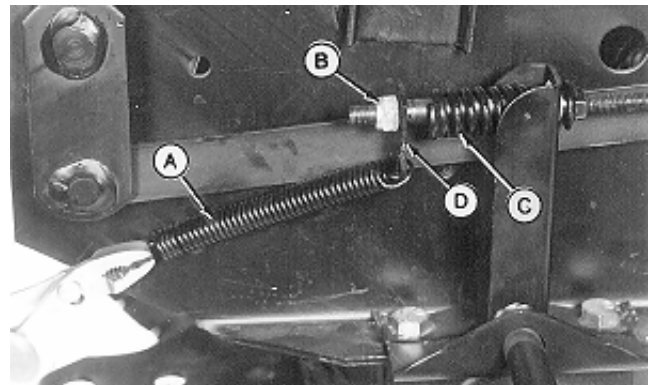

Early Models

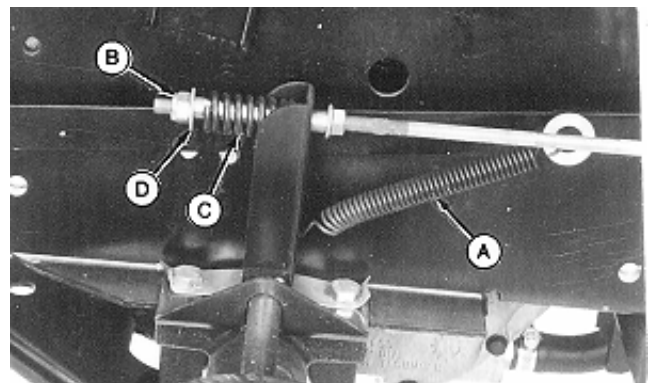

Later Models

MX,15916010,8 -19-13JUL95

M79048 -UN-13FEB95

M78049 -UN-13FEB95



Brakes/Brake Pedal(s) and Neutral Return Linkage

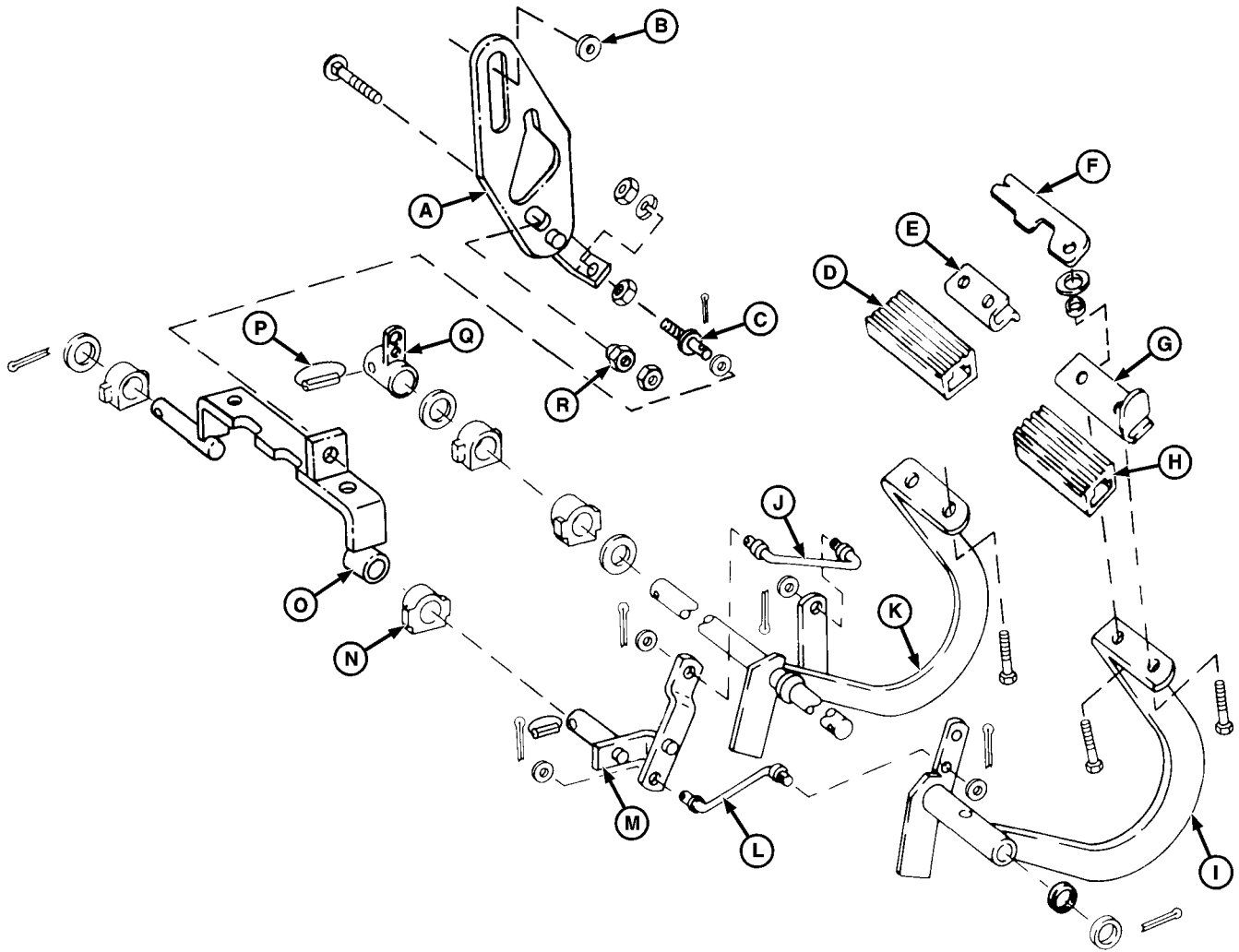

- |                            |                       |                               |                            |
|----------------------------|-----------------------|-------------------------------|----------------------------|
| A—Neutral Return Cam Plate | F—Strap               | K—Left Brake Pedal            | P—Lock Wire and Spring Pin |
| B—Spacer                   | G—Support             | L—Neutral Return Link         | Q—Left-Hand Brake Arm      |
| C—J-Bolt                   | H—Right Pedal Pad     | M—Neutral Return Shaft        | R—Eccentric Adjustment Nut |
| D—Left Pedal Pad           | I—Right Brake Pedal   | N—Bearing (4 used)            |                            |
| E—Plate                    | J—Neutral Return Link | O—Neutral Return Welded Shaft |                            |

Version One (430)

**NOTE:** Brake pedal and neutral return linkage—Version One, is used on machines equipped with transmission control linkage—Version One for 430 only.

5. Inspect linkage for wear or damage. Replace parts as necessary.

6. If necessary to replace neutral return cam plate (A), remove transmission control lever assembly. (See Inspect and Repair Transmission Control Linkage—Version One for 430 only in Section 50, Group 10.)

60  
10  
15

MT8041 -JUN-14/MAR95

Brakes/Brake Pedal(s) and Neutral Return Linkage

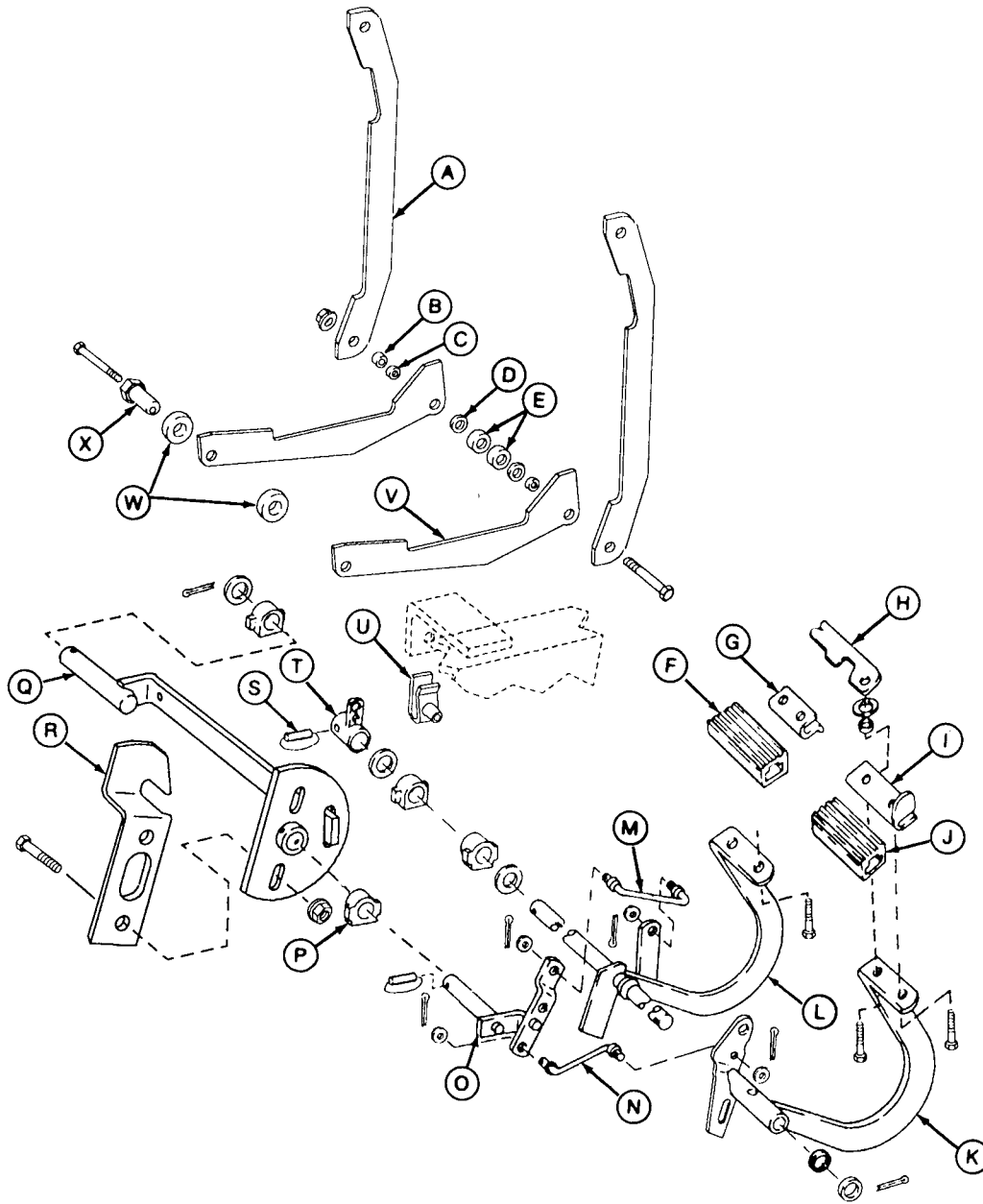

- |                    |                       |                                |                              |
|--------------------|-----------------------|--------------------------------|------------------------------|
| A—Strap (2 used)   | H—Strap               | O—Neutral Return Shaft (Short) | T—Left-Hand Brake Arm        |
| B—Spacer           | I—Support             | P—Bearing (4 used)             | U—Clamp-On Nut               |
| C—Bushing (2 used) | J—Right Pedal Pad     | Q—Neutral Return Shaft (Long)  | V—Speed Control Arm (2 used) |
| D—Washer (2 used)  | K—Right Brake Pedal   | R—Neutral Return Cam           | W—Bushings                   |
| E—Ball Bearings    | L—Left Brake Pedal    | S—Lock Wire and Spring Pin     | X—Eccentric Adjustment Nut   |
| F—Left Pedal Pad   | M—Neutral Return Link |                                |                              |
| G—Plate            | N—Neutral Return Link |                                |                              |

Version Two (430)

**NOTE:** Brake pedal and neutral return linkage—Version Two, is used on machines equipped with transmission control linkage—Version Two only.

60  
10  
16

M78042 -UN-13MAR95

Brakes/Brake Pedal(s) and Neutral Return Linkage

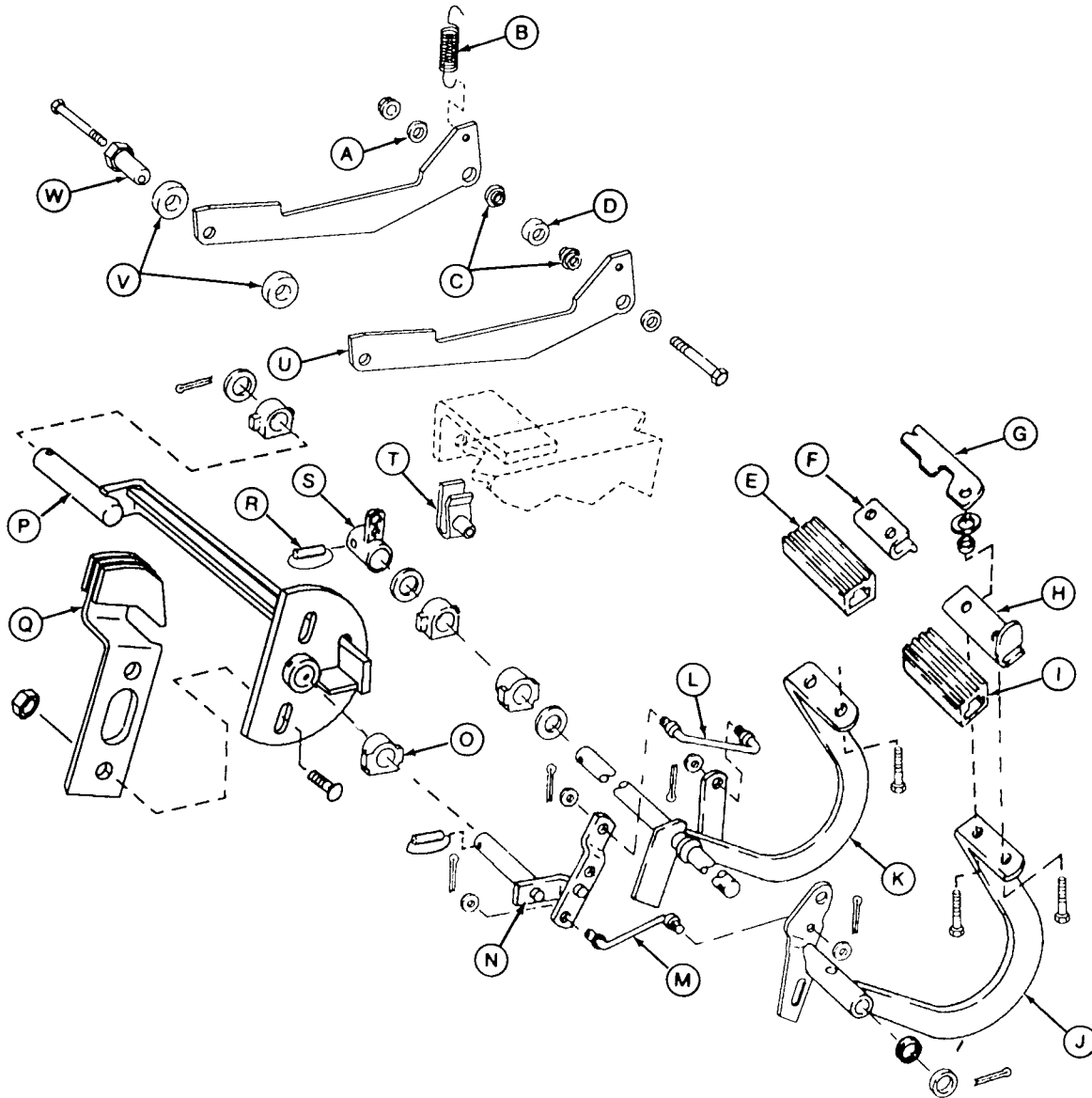

- |                   |                                |                               |                              |
|-------------------|--------------------------------|-------------------------------|------------------------------|
| A—Washer (2 used) | H—Support                      | O—Bearing (4 used)            | T—Clamp-On Nut               |
| B—Spring          | I—Right Pedal Pad              | P—Neutral Return Shaft (Long) | U—Speed Control Arm (2 used) |
| C—Bushings        | J—Right Brake Pedal            | Q—Neutral Return Cam          | V—Bushings                   |
| D—Ball Bearing    | K—Left Brake Pedal             | R—Lock Wire and Spring Pin    | W—Eccentric Adjustment Nut   |
| E—Left Pedal Pad  | L—Neutral Return Link          | S—Left-Hand Brake Arm         |                              |
| F—Plate           | M—Neutral Return Link          |                               |                              |
| G—Strap           | N—Neutral Return Shaft (Short) |                               |                              |

Version Three (430)

**NOTE:** Brake pedal and neutral return linkage—Version Three, is used on machines equipped with transmission control linkage—Version Three only.

Brakes/Brake Pedal(s) and Neutral Return Linkage

7. Install all parts.
8. Connect brake rods to brake pedal.
9. Install spring (C), plate or washer (D) and nut (B).
10. Connect return spring (A).

A—Return Spring  
B—Nut  
C—Spring  
D—Plate (Early Models)  
—Washer (Later Models)

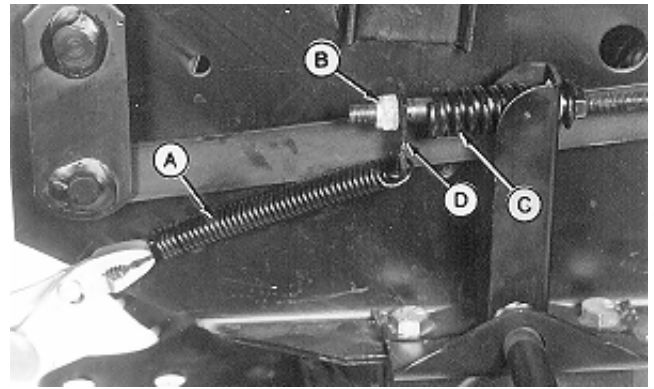

Early Models

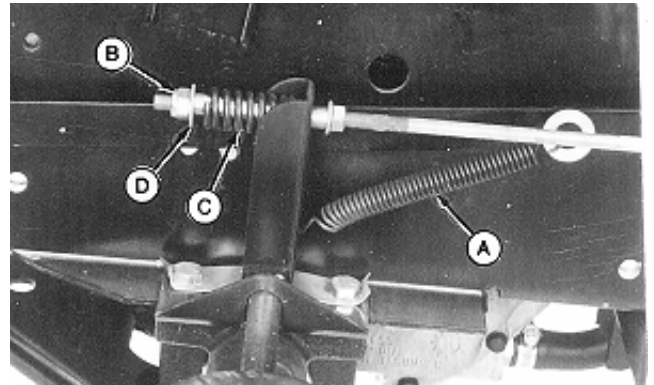

Later Models

MX,15916010,12 -19-13JUL95

11. Lock brake pedals together and apply parking brake.
12. Loosen lock nut (A).
13. Turn nut until spring is 42 mm (1.650 in.) long. Tighten lock nut.
14. Install fender deck and belly pan.

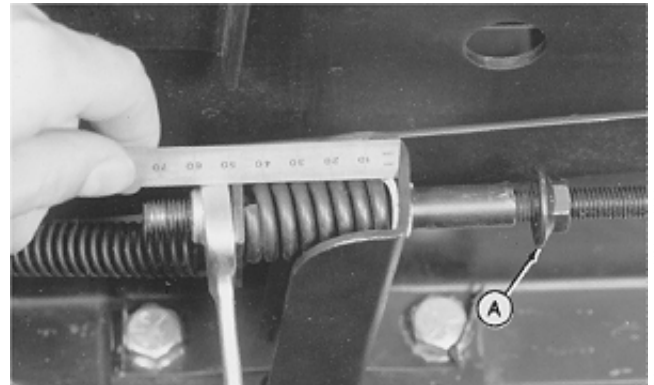

MX,15906010,17 -19-14FEB95

## INSPECT AND REPAIR PARK BRAKE LEVER

1. Remove belly screen/pan.
2. Inspect all parts for wear or damage. Replace as necessary.

A—Knob  
B—Lock Washer  
C—Washer  
D—Weld Nut  
E—Park Brake Rod  
F—Lock Plate  
G—Pin  
H—Torsion Spring

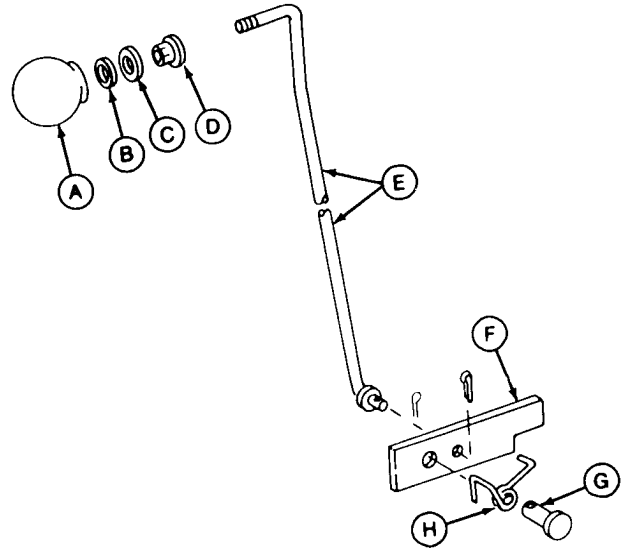

M77913 -UN-13FEB95

60  
10  
19

MX.15906010,18 -19-12MAY95

60  
10  
20

# Section 70 HYDRAULIC REPAIR

## Contents

### Page

#### Group 05—Hydraulic Control Valve

Other Materials . . . . .	70-05-1
Service Parts Kits . . . . .	70-05-1
Remove and Install	
322 and 332 . . . . .	70-05-2
330 . . . . .	70-05-3
430 . . . . .	70-05-6
Disassemble, Inspect and Assemble	
Single-Spool . . . . .	70-05-9
Two-Spool . . . . .	70-05-10
Three-Spool . . . . .	70-05-12





**OTHER MATERIAL**

Number	Name	Use
M79292	MPG-2® Multi-Purpose Polymer Grease	Prevents parts from seizing. Apply to spool springs and end cap cavities.
LOCTITE® PRODUCTS U.S./Canadian/LOCTITE No.		
TY6305/TY9485/764	Clean and Cure Primer	Cleans parts and speeds cure of sealant.
T43512/TY9473/242	Thread Lock and Sealer (Medium Strength)	Apply to threads spool screws.

*®MPG-2 is a registered trademark of DuBois USA.*

*®LOCTITE is a registered trademark of the Loctite Corp.*

MX,15907005,OTH-19-20APR95

**SERVICE PARTS KITS**

The following kits are available through your parts catalog:

Single-Spool Valve  
 Spring Center Kit  
 Load Check Kit  
 Seal Kit

Two-Spool Valve  
 Versions One and Two  
 Seal Kit  
 Detent Replacement Kit  
 Versions Three and Four  
 Seal Kit  
 Load Check Kit  
 Spring Center Kit  
 Float Detent Kit  
 Valve Detent Kit

Three-Spool Valve  
 Seal Kit  
 Load Check Kit  
 Spring Center Kit  
 Float Detent Kit

MX,15917005,KIT-19-13JUL95

70  
05  
1

## REMOVE AND INSTALL HYDRAULIC CONTROL VALVE—322 AND 332

**N** **CAUTION:** Escaping fluid under pressure can penetrate the skin causing serious injury. Avoid the hazard by relieving pressure before disconnecting hydraulic or other lines. Tighten all connections before applying pressure. Search for leaks with a piece of cardboard. Protect hands and body from high pressure fluids.

If an accident occurs, see a doctor immediately. Any fluid injected into the skin must be surgically removed within a few hours or gangrene may result. Doctors unfamiliar with this type of injury should reference a knowledgeable medical source. Such information is available from Deere & Company Medical Department in Moline, Illinois, U.S.A.

*NOTE: Removal and installation procedures for later models may vary slightly.*

1. Remove ten cap screws (C) and belly screen (B).
2. Disconnect suction hose (A) to drain transmission oil. Approximate capacity is 4.7 L (5 U.S. qt).
3. Remove hydraulic filter.

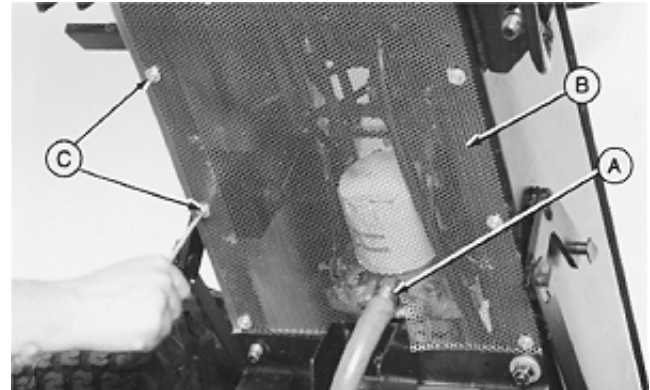
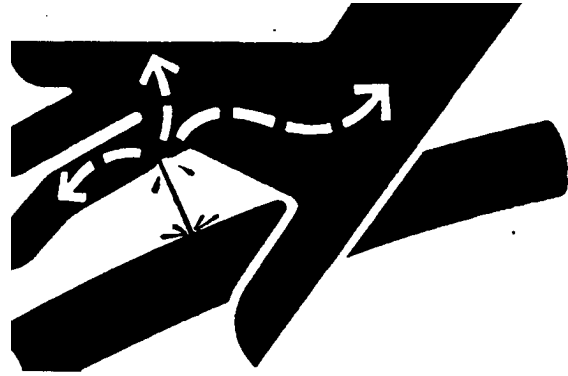

-UN-23AUG88

X9811

-UN-28JUL89

M31751

MX,15917005,1 -19-13JUL95

4. Remove fender deck.
5. Disconnect hydraulic lines from control valve.
6. Disconnect control linkage.

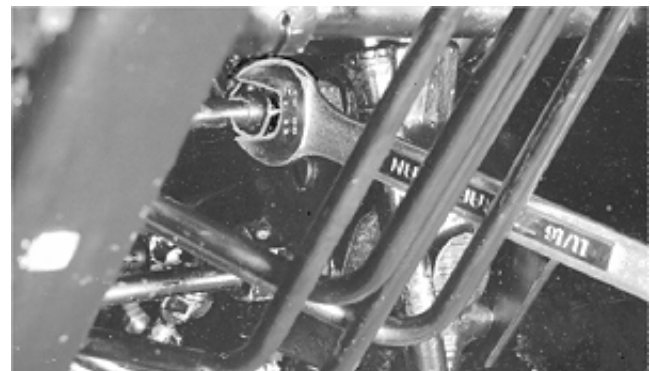

-UN-03AUG89

M32026

MX,15917005,2 -19-13JUL95

7. Remove two mounting bolts (B) and control valve (A).
8. Installation is done in the reverse order of removal.

- Fill transmission with the recommended amount of John Deere Low Viscosity HY-GARD® oil.
- Bleed the hydraulic system. (See procedure in Section 270, Group 20.)

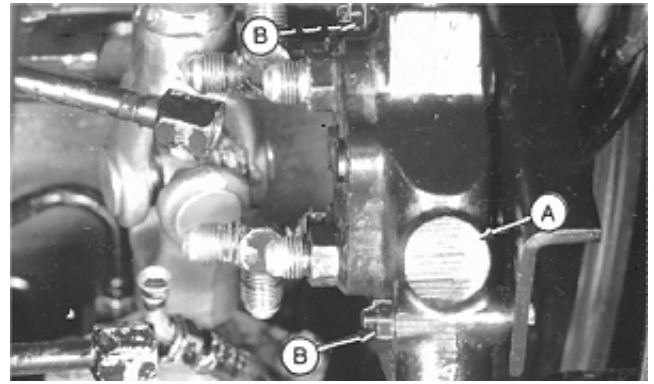

MX,15917005,3 -19-13JUL95

M32046 -UN-03AUG89

### REMOVE AND INSTALL HYDRAULIC CONTROL VALVE—330

**N** **CAUTION:** Escaping fluid under pressure can penetrate the skin causing serious injury. Avoid the hazard by relieving pressure before disconnecting hydraulic or other lines. Tighten all connections before applying pressure. Search for leaks with a piece of cardboard. Protect hands and body from high pressure fluids.

If an accident occurs, see a doctor immediately. Any fluid injected into the skin must be surgically removed within a few hours or gangrene may result. Doctors unfamiliar with this type of injury should reference a knowledgeable medical source. Such information is available from Deere & Company Medical Department in Moline, Illinois, U.S.A.

1. Remove ten cap screws (C) and belly screen (B).
2. Disconnect suction hose (A) to drain transmission oil. Approximate capacity is 4.7 L (5 U.S. qt).
3. Remove hydraulic filter.

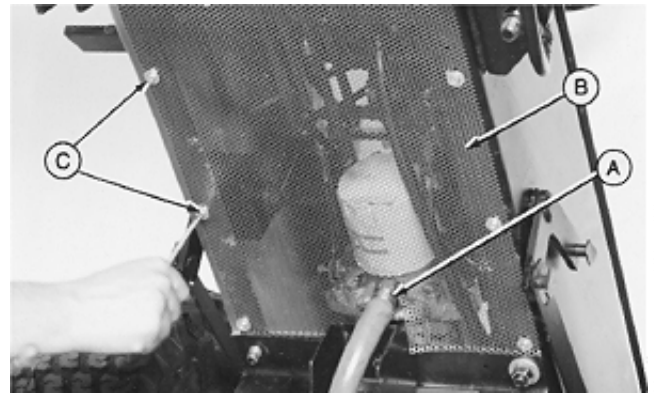
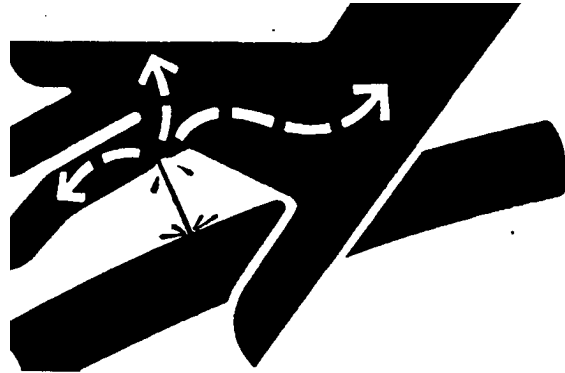

MX,15917005,4 -19-13JUL95

X9811 -UN-23AUG88

M31751 -UN-28JUL89

70-05-3

4. Lift hood and remove engine side panels.
5. Remove fender deck.
6. Remove right and left pedestal side panels.

**N CAUTION:** Explosive release of fluids from pressurized cooling system can cause serious burns.

**Shut off engine. Only remove filler cap when cool enough to touch with bare hands. Slowly loosen cap to first stop to relieve pressure before removing completely.**

7. Drain radiator. Approximate capacity is 2.8 L (3 U.S. qt).
8. Loosen block drain valve. Drain engine coolant from engine block. Tighten drain valve.
9. Remove radiator.



MX,15917005,5 -19-13JUL95

-UN-23AUG88  
TS281

M55053  
-UN-09DEC89

70  
05  
4

10. Remove cotter pin (A) from draft pin (B). Disconnect control linkage.

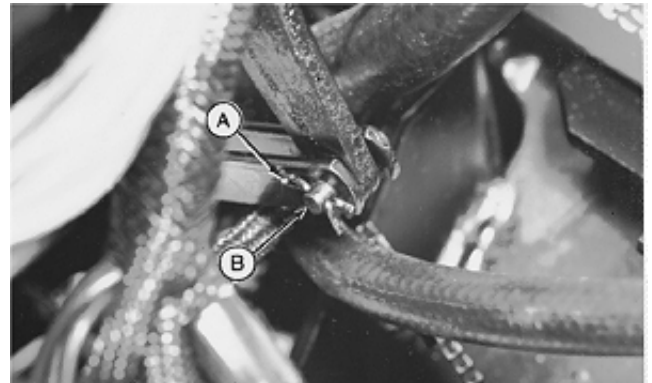

MX,15917005,6 -19-13JUL95

M55071  
-UN-09DEC89

11. Disconnect hydraulic lines from control valve.

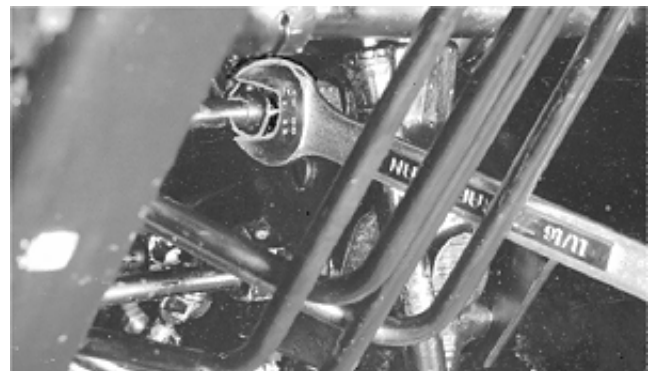

MX,15917005,7 -19-13JUL95

M32026  
-UN-03AUG89

## Hydraulic Control Valve/Remove and Install

12. Remove two mounting bolts (B) and control valve (A).

13. Installation is done in the reverse order of removal.

- Close drain valve and fill radiator with proper coolant until coolant is 13—25 mm (0.500—1 in.) below bottom of filler neck. (See Engine Coolant in Section 10, Group 25.)

- Fill transmission with the recommended amount of John Deere Low Viscosity HY-GARD® oil.

- Bleed the hydraulic system. (See procedure in Section 270, Group 20.)

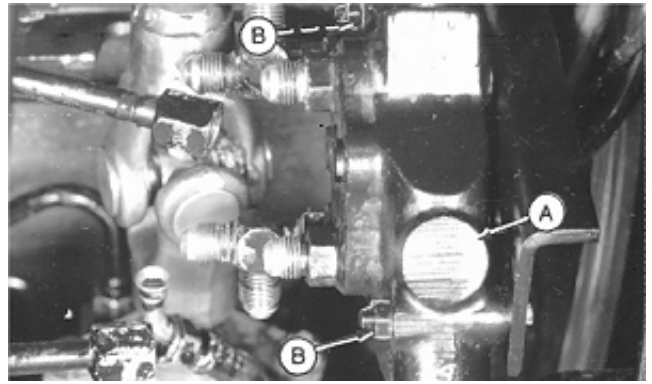

M32046 -JUN-03AUG89

MX,15917005,8 -19-13JUL95

## REMOVE AND INSTALL HYDRAULIC CONTROL VALVE—430

**N** **CAUTION:** Escaping fluid under pressure can penetrate the skin causing serious injury. Avoid the hazard by relieving pressure before disconnecting hydraulic or other lines. Tighten all connections before applying pressure. Search for leaks with a piece of cardboard. Protect hands and body from high pressure fluids.

If an accident occurs, see a doctor immediately. Any fluid injected into the skin must be surgically removed within a few hours or gangrene may result. Doctors unfamiliar with this type of injury should reference a knowledgeable medical source. Such information is available from Deere & Company Medical Department in Moline, Illinois, U.S.A.

*NOTE: Removal and installation procedures for later models may vary slightly.*

1. Remove battery and battery tray.
2. Remove TDC module (A) and neutral start relay (B).

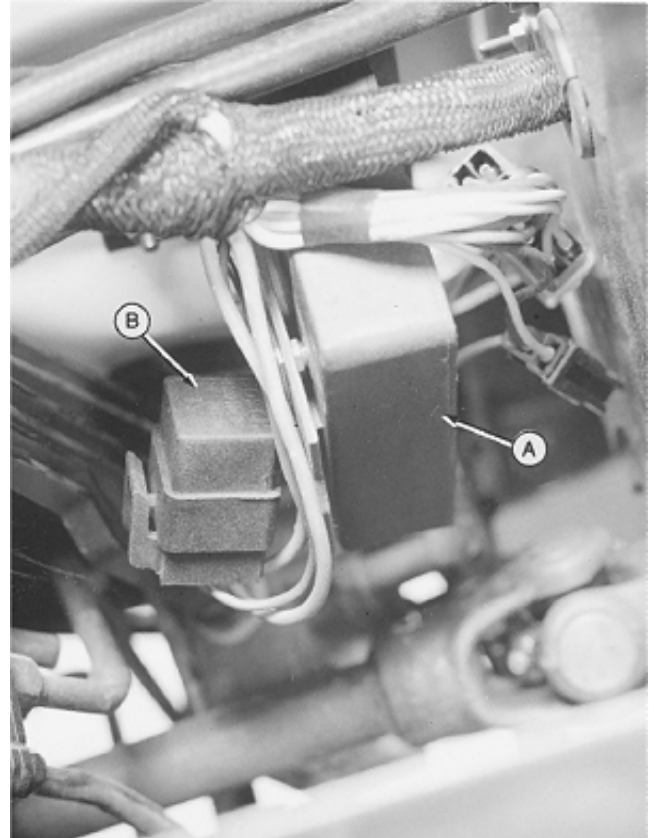
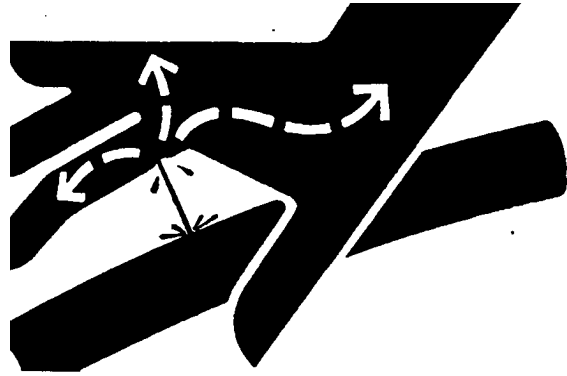

-UN-23AUG88

X9811

-UN-25JAN90

M36784

MX,15917005,9 -19-13JUL95

3. Remove three cotter pins (A) (one from each linkage) and pins (B).

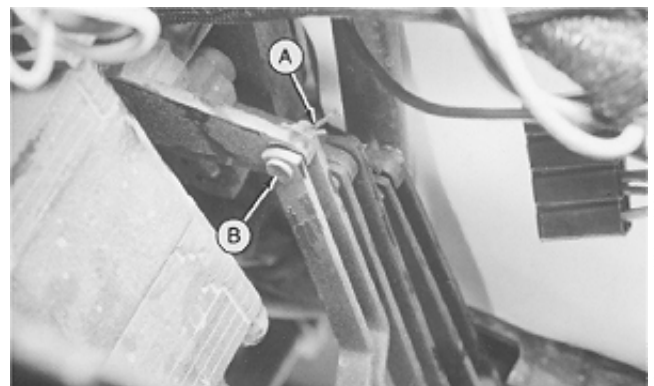

-UN-25JAN90

M36785

MX,15917005,10 -19-13JUL95

70  
05  
6

## Hydraulic Control Valve/Remove and Install

4. Disconnect two hydraulic lines (A) from top side of control valve.

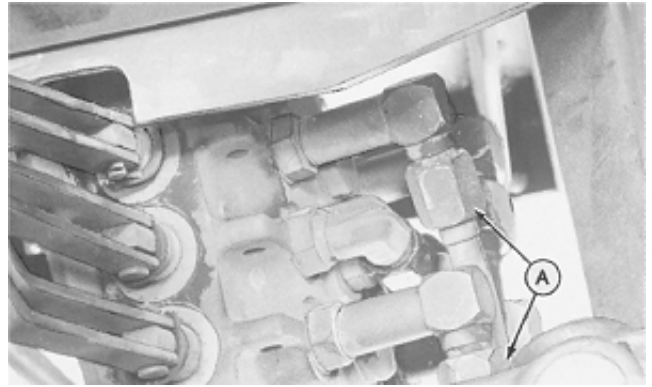

M36786  
MX,15917005,11 -19-13JUL95

-UN-25JAN90

5. Remove both engine side panels.

6. Loosen muffler clamp (A) and remove two cap screws (B).

7. Remove belly pan.

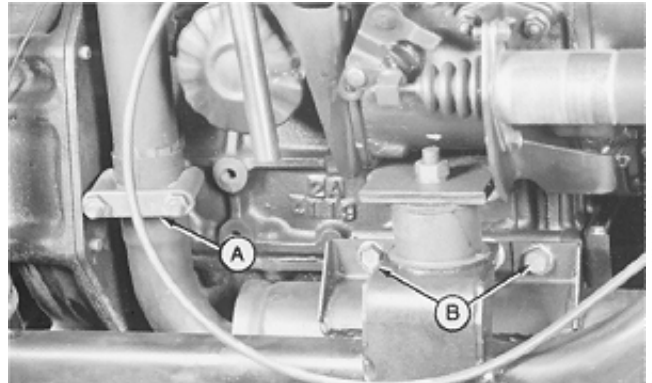

M36787  
MX,15917005,12 -19-13JUL95

-UN-25JAN90

8. Remove two cap screws (A) (one on each side of firewall) that fasten lower shield plate.

9. Remove two small cap screws fastening muffler to engine block. Remove muffler.

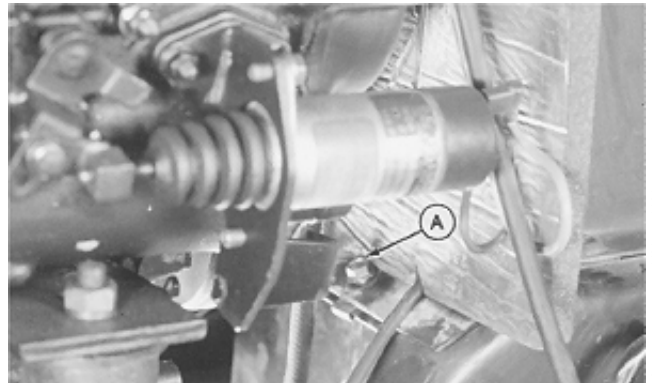

M36788  
MX,15917005,13 -19-13JUL95

-UN-25JAN90

10. Remove shield plate from under machine.

11. Disconnect remaining hydraulic lines (A, B and C) from bottom side of control valve.

12. Remove two mounting bolts and control valve.

13. Make repairs as necessary. (See procedures in this group.)

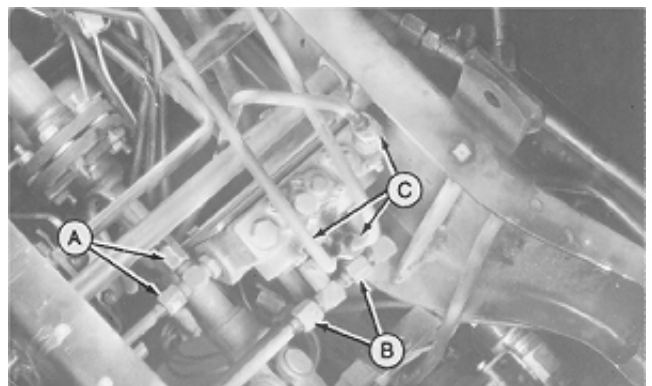

M36790  
MX,15917005,14 -19-13JUL95

-UN-25JAN90

14. Installation is done in the reverse order of removal.

**IMPORTANT:** Tighten exhaust mounting hardware in sequence described. Failure to do so, may create binding around exhaust system resulting in muffler breaking off.

• Install muffler as follows:

—Loosen four cap screws (C).

—Install muffler. Tighten mounting hardware finger-tight.

—Tighten exhaust mounting hardware in the following sequence:

A—Muffler-to-Engine Mount Cap Screw (2 used)

B—Muffler-to-Gear Case Cover Cap Screw (2 used)

C—Exhaust Pipe-to-Manifold Cap Screw (4 used)

D—Muffler Clamp Nut (2 used)

• Bleed the hydraulic system. (See procedure in Section 270, Group 20.)

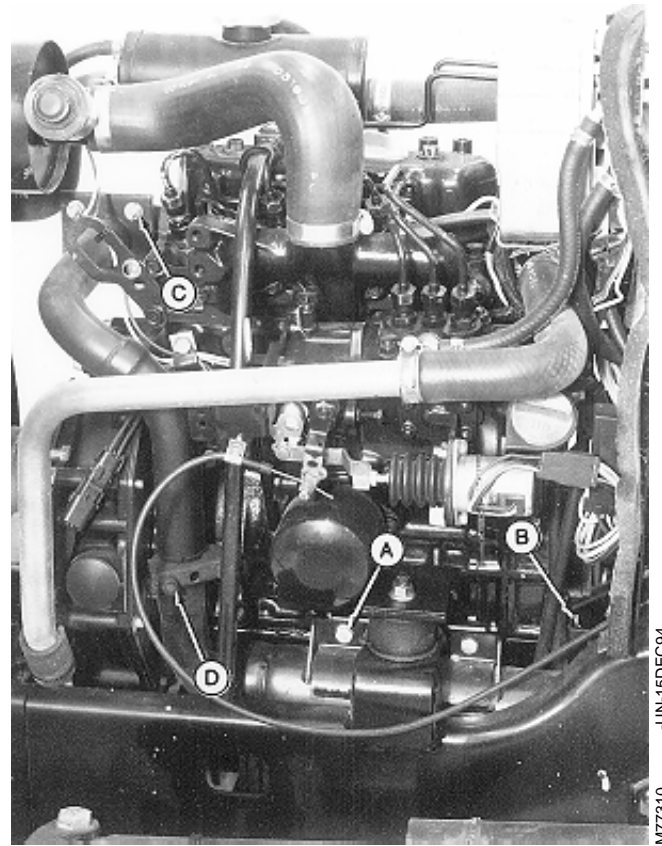

MX,15917005,15 -19-13JUL95



## DISASSEMBLE, INSPECT AND ASSEMBLE HYDRAULIC CONTROL VALVE—SINGLE-SPOOL

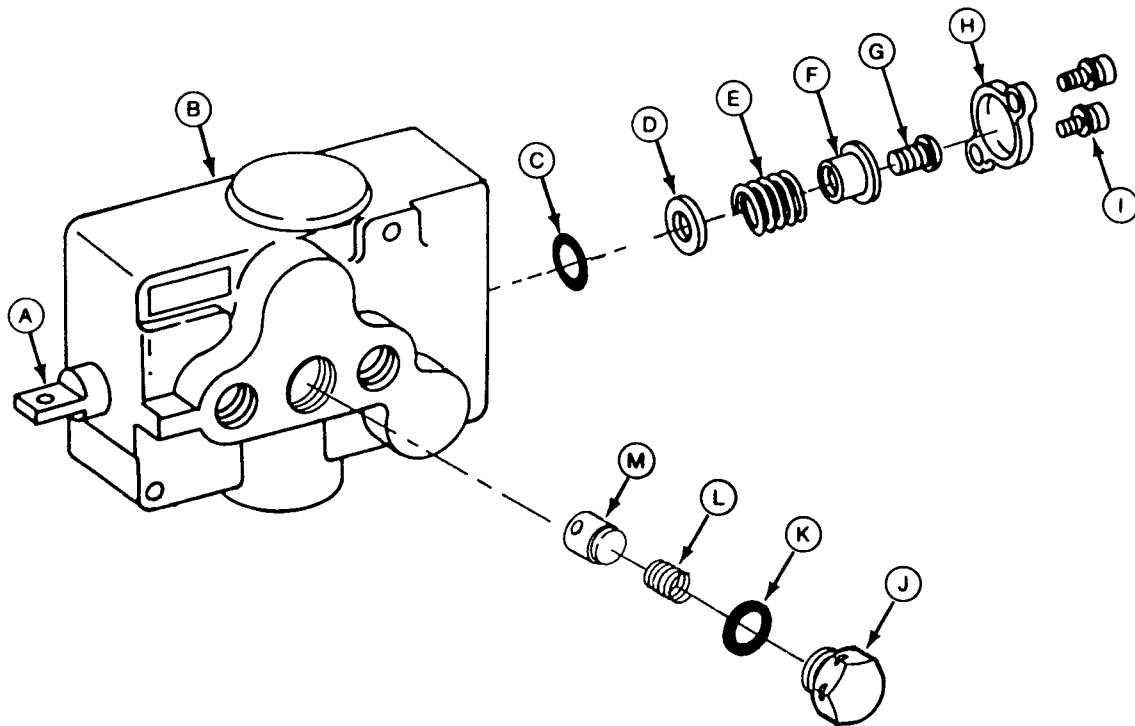

A—Spool  
B—Body  
C—O-Ring  
D—Washer

E—Spring  
F—Spring Retainer  
G—Screw

H—Cap  
I—Screw (2 used)  
J—Plug

K—O-Ring  
L—Spring  
M—Poppet

**IMPORTANT:** Spool and body are matched and must be replaced as a unit.

**Always use new O-rings. Damaged or used parts will leak.**

*NOTE:* Note location and position of fittings and linkage to aid in assembly.

*Lubricate all O-rings with petroleum jelly during assembly.*

Inspect all parts for wear or damage. Replace as necessary.

- Apply clean John Deere Low Viscosity HY-GARD® oil on all internal parts during assembly.

- Clean threads in end of spool (A) and on screw (G) using Clean and Cure Primer. Apply thread lock and sealer (medium strength) on threads of screw (G).

- Apply MPG-2® Multi-Purpose Polymer Grease on spring (E) and inside of cap (H).

- Tighten screws (G and I) and plug (J) to specifications.

### TORQUE SPECIFICATIONS

Screws (G and I) . . . . . 4 N-m (35 lb-in.)  
Plug (J) . . . . . 31 N-m (23 lb-ft)

**DISASSEMBLE, INSPECT AND ASSEMBLE HYDRAULIC CONTROL VALVE—TWO-SPOOL**

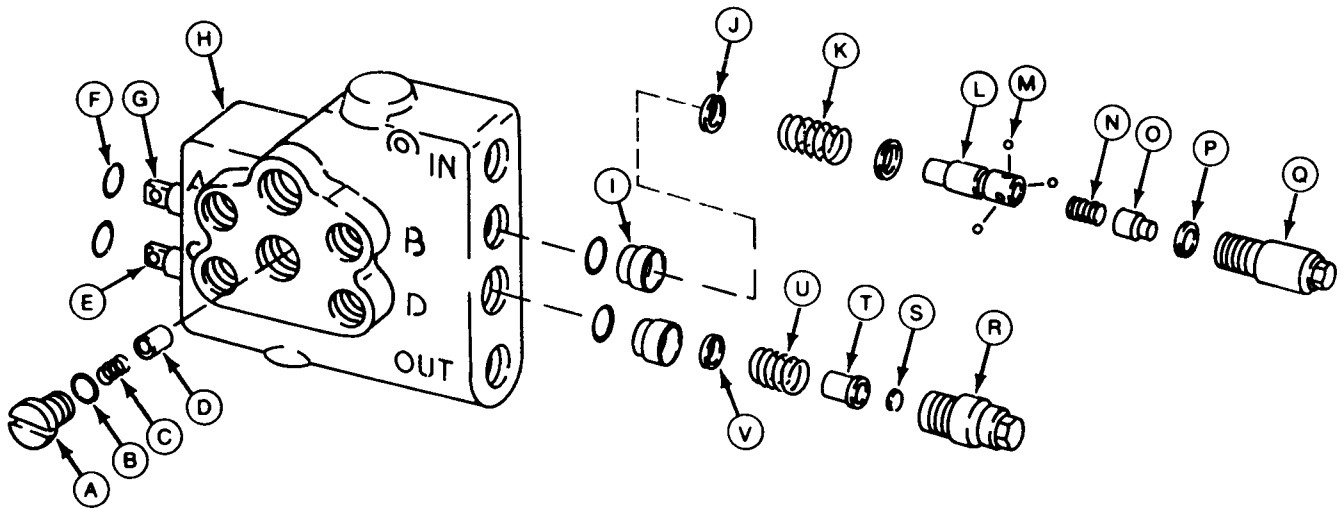

A—Check Valve Plug (2 used)  
 B—O-Ring (2 used)  
 C—Spring (2 used)  
 D—Poppet (2 used)  
 E—Spool

F—O-Ring (4 used)  
 G—Float Detent Spool  
 H—Body  
 I—Bushing (2 used)  
 J—Washer (2 used)  
 K—Spring

L—Detent  
 M—Ball (3 used)  
 N—Spring  
 O—Cap  
 P—Washer  
 Q—Cap

R—Cap  
 S—Snap Ring  
 T—Spacer  
 U—Spring  
 V—Washer

Versions One and Two

**NOTE:** There are four versions of this valve. Disassembly and assembly procedures may vary slightly.

**IMPORTANT:** Spools and body are matched and must be replaced as a unit. Spools must be installed into the same bores from which they were removed for proper operation of each function.

**Always use new O-rings. Damaged or used parts will leak.**

**NOTE:** Note location and position of fittings and linkages to aid in assembly.

Lubricate all O-rings with petroleum jelly during assembly.

Inspect all parts for wear or damage. Replace as necessary.

- Apply clean John Deere Low Viscosity HY-GARD® oil on all internal parts during assembly.
- Apply MPG-2® Multi-Purpose Polymer Grease on springs (K, N and U) and inside of caps (Q and R).
- Tighten caps (Q and R) to 31 N·m (23 lb-ft).

70  
05  
10

M78840 -JUN-14APR95

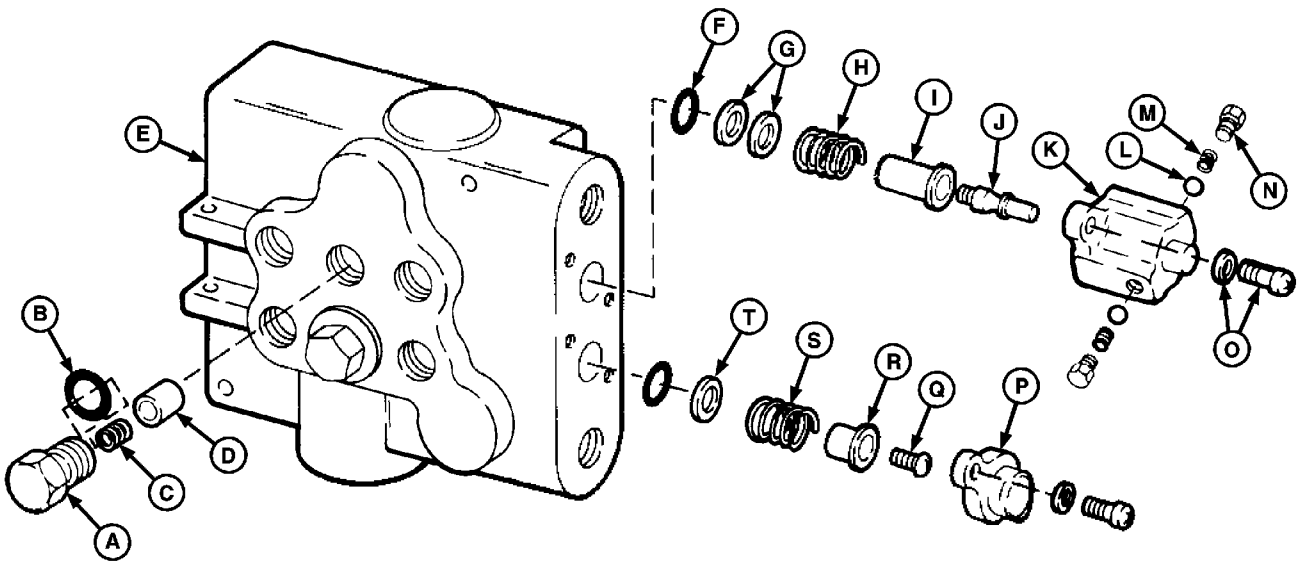

A—Check Valve Plug (2 used)  
 B—O-Ring (2 used)  
 C—Spring (2 used)  
 D—Poppet (2 used)  
 E—Spools and Body

F—O-Ring (4 used)  
 G—Washers  
 H—Spring  
 I—Spacer  
 J—Detent  
 K—Cap

L—Ball (2 used)  
 M—Spring (2 used)  
 N—Plug (2 used)  
 O—Screw and Washer (4 used)

P—Cap  
 Q—Screw  
 R—Spacer  
 S—Spring  
 T—Washer

Versions Three and Four

**IMPORTANT:** Spools and body are matched and must be replaced as a unit. Spools must be installed into the same bores from which they were removed for proper operation of each function.

**Always use new O-rings. Damaged or used parts will leak.**

*NOTE:* Note location and position of fittings and linkages to aid in assembly.

*Lubricate all O-rings with petroleum jelly during assembly.*

Inspect all parts for wear or damage. Replace as necessary.

- Apply clean John Deere Low Viscosity HY-GARD® oil on all internal parts during assembly.
- Clean threads in end of spools, detent (J) and screw (Q) using Clean and Cure Primer. Apply thread lock and sealer (medium strength) on threads of detent (J) and screw (Q).
- Apply MPG-2® Multi-Purpose Polymer Grease on springs (H and S) and inside of caps (K and P).
- Tighten detent (J), screw (Q), screw and washers (O) and plugs (A) to specifications.

**TORQUE SPECIFICATIONS**

Detent (J), Screw (Q) and Screw and Washers (O) . . . . .	4 N·m (35 lb-in.)
Plugs (A) . . . . .	31 N·m (23 lb-ft)

## DISASSEMBLE, INSPECT AND ASSEMBLE HYDRAULIC CONTROL VALVE—THREE-SPOOL

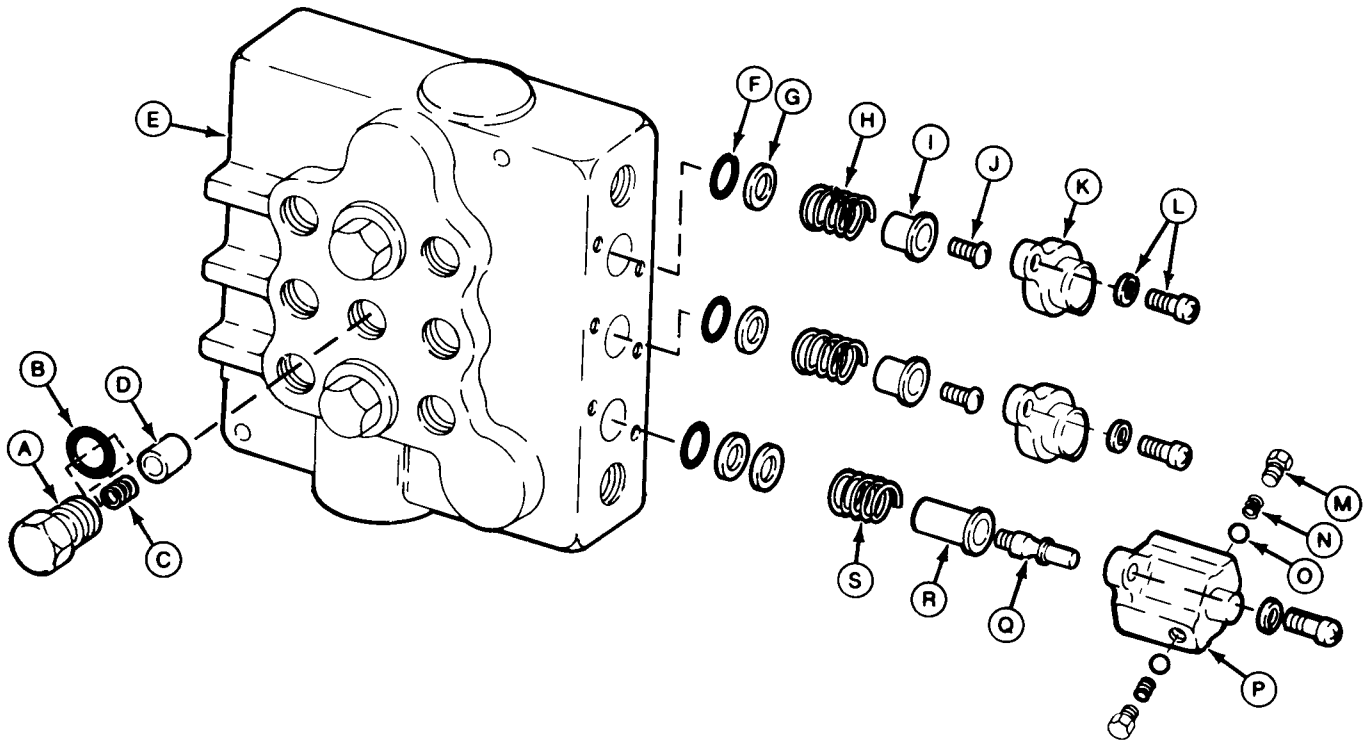

A—Check Valve Plug (3 used)  
 B—O-Ring (3 used)  
 C—Spring (3 used)  
 D—Poppet (3 used)  
 E—Spools and Body

F—O-Ring (6 used)  
 G—Washer (4 used)  
 H—Spring (2 used)  
 I—Spacer (2 used)  
 J—Screw (2 used)

K—Cap (2 used)  
 L—Screw and Washer (6 used)  
 M—Plug (2 used)  
 N—Spring (2 used)

O—Ball (2 used)  
 P—Cap  
 Q—Detent  
 R—Spacer  
 S—Spring

**IMPORTANT:** Spools and body are matched and must be replaced as a unit. Spools must be installed into the same bores from which they were removed for proper operation of each function.

**Always use new O-rings. Damaged or used parts will leak.**

*NOTE:* Note location and position of fittings and linkages to aid in assembly.

*Lubricate all O-rings with petroleum jelly during assembly.*

Inspect all parts for wear or damage. Replace as necessary.

- Apply clean John Deere Low Viscosity HY-GARD® oil on all internal parts during assembly.
- Clean threads in end of spools, detent (Q) and screws (J) using Clean and Cure Primer. Apply thread lock and sealer (medium strength) on threads of detent (Q) and screws (J).
- Apply MPG-2® Multi-Purpose Polymer Grease on springs (H and S) and inside of caps (K and P).
- Tighten detent (Q), screws (J), screw and washers (L) and plugs (A) to specifications.

### TORQUE SPECIFICATIONS

Detent (Q), Screws (J) and	
Screw and Washers (L)	4 N-m (35 lb-in.)
Plugs (A)	31 N-m (23 lb-ft)

MX,15917005,18 -19-13JUL95

70  
05  
12

M75843 -JUN-14APR95

# Section 80

# MISCELLANEOUS REPAIR

## Contents

Page

### Group 05—Front Axle

Special or Essential Tools . . . . .	80-05-1
Front Axle—322, 330 and 332	
Remove and Install . . . . .	80-05-1
Inspect and Replace Pivot Bushings . . .	80-05-2
Front Axle—430	
Remove . . . . .	80-05-3
Disassemble and Inspect Pivot Pin . . .	80-05-5
Assemble Pivot Pin . . . . .	80-05-6
Install . . . . .	80-05-7
Spindles	
Remove and Install . . . . .	80-05-9
Inspect and Replace Bushings . . . . .	80-05-11
Inspect and Replace Wheel Bearings . . .	80-05-12
Adjust Toe-in . . . . .	80-05-12

### Group 10—Mower Spindle and Jack Sheave Repair

Mower Blade Spindles	
38 (Early), 46 and 50-Inch Mower . . . .	80-10-1
38-Inch Mower (Later) . . . . .	80-10-1
Early 60-Inch and 260 Rotary Mower . .	80-10-2
Later 60-Inch and 260 Rotary Mower . .	80-10-3
Mower Blade Jack Sheaves	
46 and 50-Inch Mower . . . . .	80-10-4

### Group 15—Mower Gear Case Repair

Other Materials . . . . .	80-15-1
50-Inch Mower	
Disassemble and Inspect . . . . .	80-15-1
Assemble . . . . .	80-15-6
Early 60-Inch Mower (Curtis)	
Disassemble and Inspect . . . . .	80-15-10
Assemble . . . . .	80-15-14
Later 60-Inch Mower (Peerless)	
Disassemble and Inspect . . . . .	80-15-19
Assemble . . . . .	80-15-23
260 Rotary Mower	
Disassemble and Inspect . . . . .	80-15-27
Assemble . . . . .	80-15-32

80



**SPECIAL OR ESSENTIAL TOOLS**

*NOTE: Order tools according to information given in the U.S. SERVICE-GARD™ Catalog or in the European Microfiche Tool Catalog (MTC).*

DX,TOOLS -19-05JUN91

Installer Sleeve.....JDM8-3

For 430 tractor; Used to install PTO shaft assembly into pivot pin.

MX,15918005,A -19-08MAR95

**REMOVE AND INSTALL FRONT AXLE—322, 330 AND 332**

*NOTE: The 330 has manual steering and is connected to the steering arm by a drag link. The 322 and 332 have power steering and are connected to the steering arm by a cylinder.*

1. Raise front of machine and block securely with jack stands.
2. Remove cotter pin, if equipped, from steering link/cylinder at steering arm on spindle.
3. Remove nut and bolt (322 and 332) from arm.
4. Disconnect steering link/cylinder from spindle.



322 and 332 Shown

M31963 -UN-28JUL89

MX,15918005,1 -19-13JUL95

5. Loosen axle deflector adjustment bolts and turn in to allow maximum clearance.



MX,15908005,2 -19-15FEB95

M32000 -UN-03AUG89

6. Place a floor jack under center of axle.
7. Remove cotter pin from pivot bolt.
8. Remove pivot bolt nut and remove bolt through axle (towards rear). Remove axle.
9. Inspect axle and pivot bushings for damage or wear. (See procedure in this group.)
10. Installation is done in the reverse order of removal.

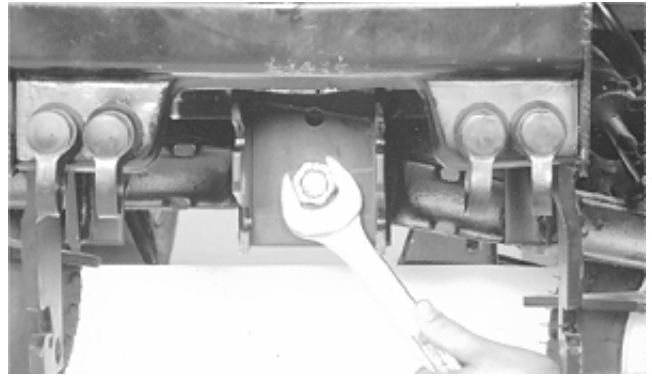

-UN-03AUG89  
M32002

- Apply multipurpose grease to pivot bolt before installing.
- Tighten pivot bolt nut until axle is snug, but still free to pivot.
- Adjust axle deflector adjustment bolts for smooth up and down operation of axle. Axle should move freely without sticking in one spot.

MX,15908005,3 -19-08MAR95

### INSPECT AND REPLACE PIVOT BUSHINGS—322, 330 AND 332

1. Inspect pivot bushings (A) and pivot bolt for wear or damage. The pivot bolt should not be bent or have stripped threads.
2. Replace bushings if necessary, using a driver set.
3. Inspect the axle for bends, cracks, or damage. Replace any damaged components.



-UN-17FEB95  
M31582

MX,15918005,2 -19-13JUL95

80-05-2



## REMOVE FRONT AXLE—430

1. Raise front of machine and block securely with jack stands.
2. Remove front PTO extension, if equipped.
3. Remove cotter pin, if equipped, from steering cylinder at steering arm on spindle.
4. Remove nut and bolt from steering arm. Disconnect steering cylinder from steering arm.

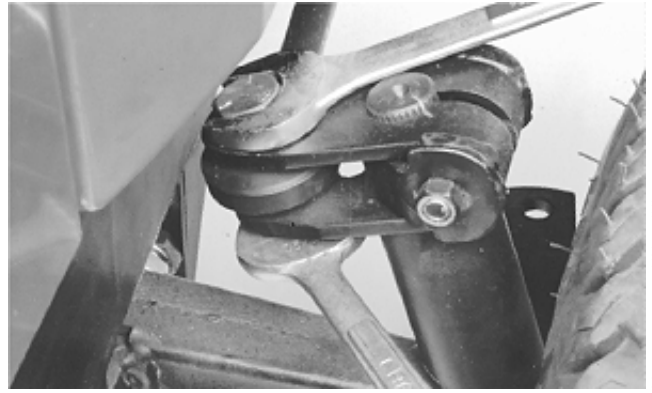

M31963 -UN-28JUL89

MX,15918005,3 -19-13JUL95

5. Loosen axle deflector adjustment bolts and turn in to allow maximum clearance.

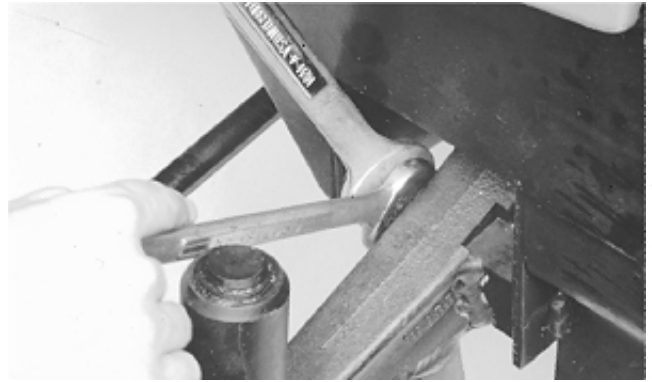

M31970 -JUN-03AUG89

MX,15908005,6 -19-15FEB95

6. Remove engine side panels and front grille.
7. Remove two nuts to remove belt guard.



M35471 -JUN-16NOV89

MX,15918005,4 -19-13JUL95

8. Loosen belt tensioning nut as far as possible.

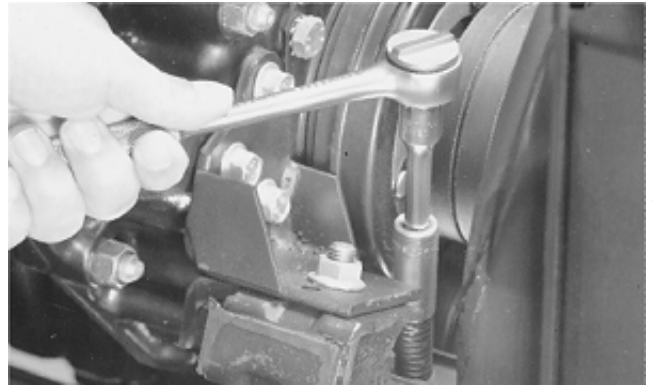

MX,15918005,5 -19-13JUL95

M35472 -UN-16NOV89

9. Remove snap ring (A) from PTO shaft.

10. Remove belts from drive pulley.

*NOTE: It may be necessary to remove the four radiator shroud-to-radiator screws. This allows shroud to move to allow clearance for removing PTO pulley.*

11. Remove drive pulley from PTO shaft.

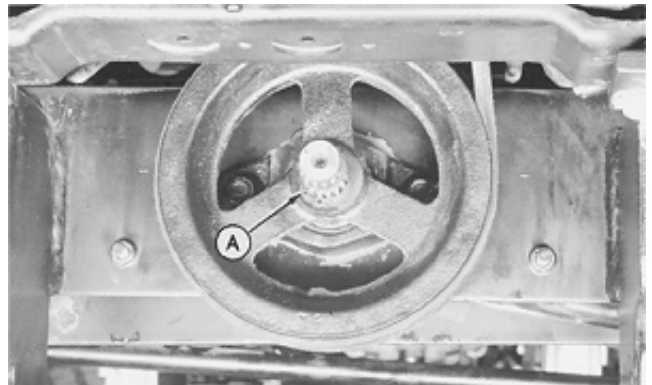

MX,15918005,6 -19-13JUL95

M36800 -UN-25JAN90

12. Remove two pivot pin retaining nuts (A).

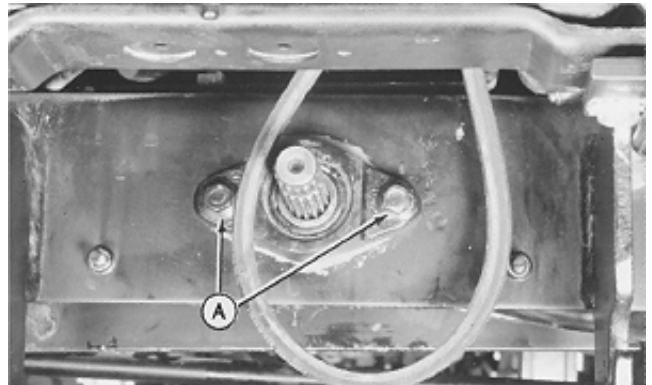

MX,15918005,7 -19-13JUL95

M36801 -UN-29JAN90

13. Place a floor jack under center of axle.

14. Slide pivot pin (A) out towards front of tractor. Remove axle.

15. Inspect pivot pin bore (B) and axle (C) for damage or excessive wear. Replace axle if necessary.

16. Inspect pivot pin for damage or wear. (See procedure in this group.)

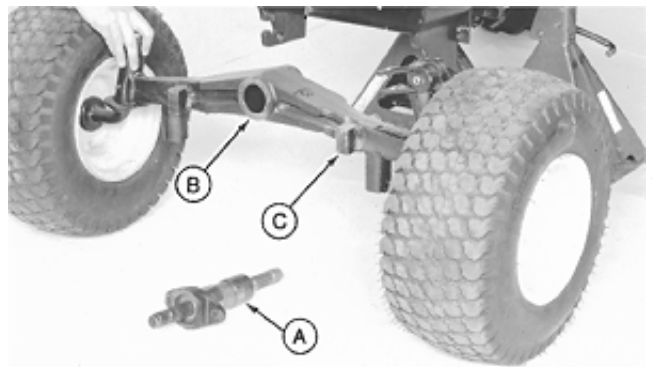

MX,15918005,8 -19-13JUL95

M31998 -UN-03AUG89

80  
05-4

### DISASSEMBLE AND INSPECT PIVOT PIN—430

1. Remove snap ring (A).



M36602 -UN-29JAN90

MX,15918005,9 -19-13JUL95

2. Push PTO shaft (A) and bearing (B) from pivot pin using a press.

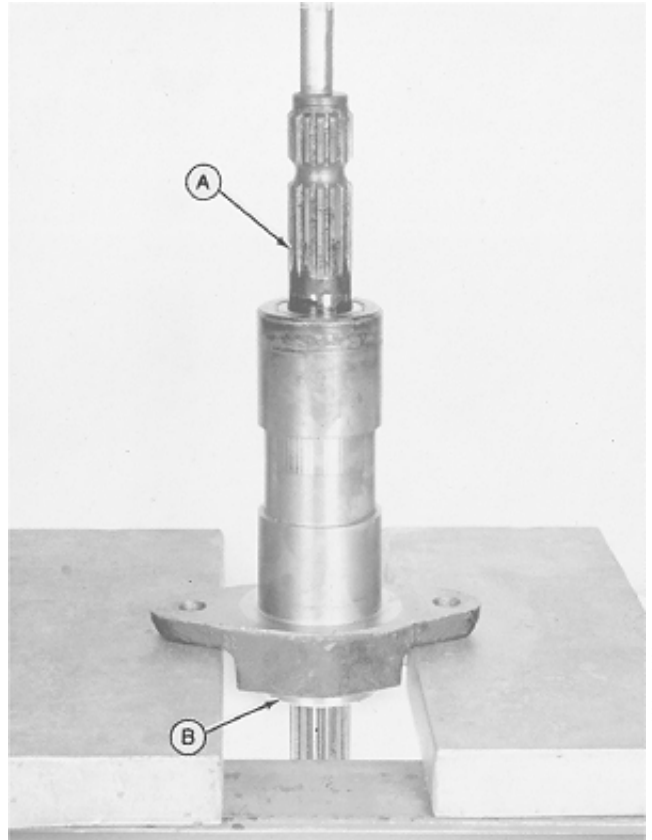

M36803 -UN-25JAN90

MX,15908005,13 -19-15FEB95

3. Inspect PTO shaft bearing (A) for wear or damage. Replace if necessary.

4. If replacing bearing, remove snap ring (B).

5. Push PTO shaft from bearing using a press and a knife-edge puller.

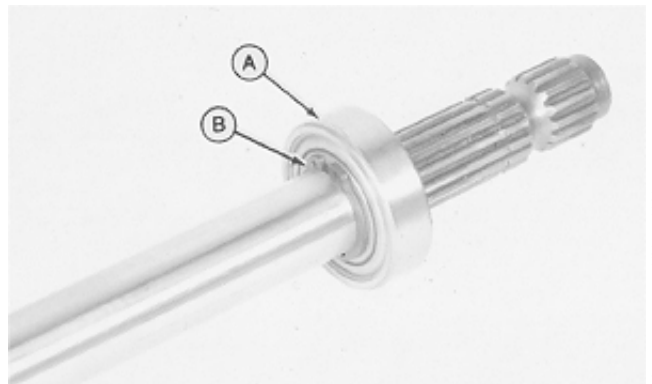

M36604 -UN-29JAN90

MX,15908005,14 -19-15FEB95

6. Inspect caged needle bearing (A) for wear or damage. Replace if necessary.

7. Remove needle bearing using a blind hole puller set and a slide hammer.



M36606  
-UN-25JAN90

MX,15908005,15 -19-15FEB95

### ASSEMBLE PIVOT PIN—430

1. Support pivot pin on a press. Put a driver disk (A) on bearing (B). Install bearing using a press until disk bottoms on pivot pin.

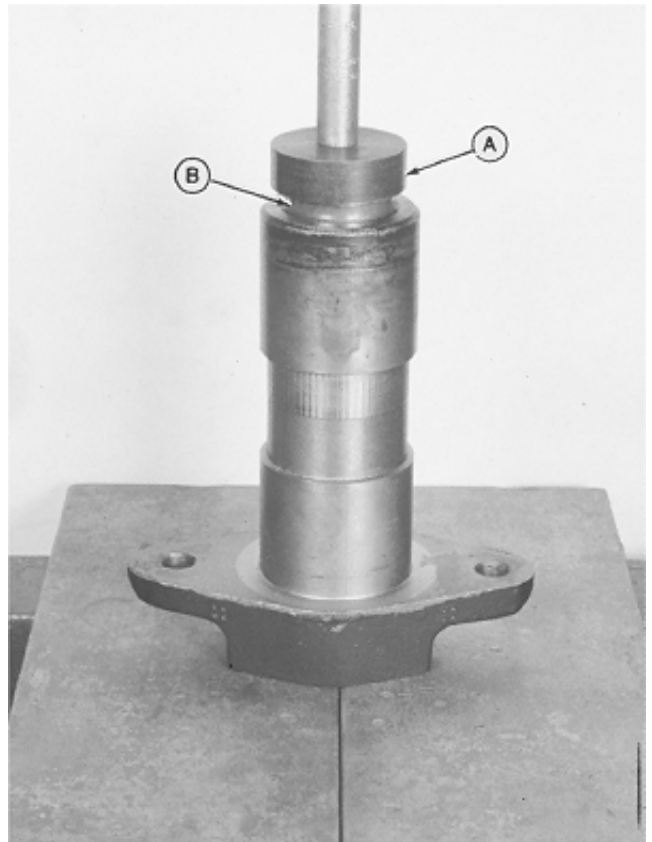

M36808  
-UN-25JAN90

MX,15918005,10 -19-13JUL95

2. Install snap ring (A) on PTO shaft.

3. Support bearing on a knife-edge puller. Press PTO shaft (B) into bearing until it bottoms on snap ring.

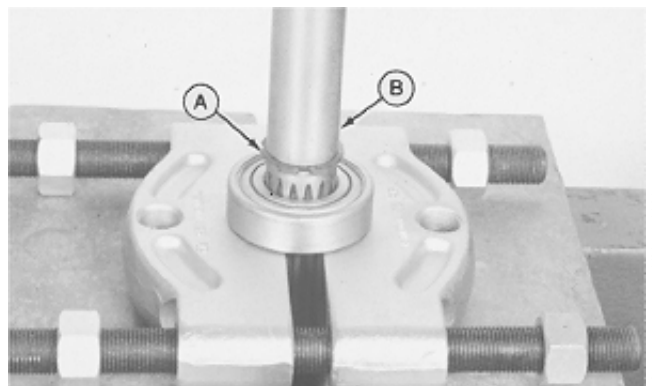

M36609  
-UN-25JAN90

MX,15908005,17 -19-07MAR95

- Support pivot pin on a press. Install PTO shaft assembly into pivot pin.
- Put JDM8-3 Installation Sleeve (A) or a piece of pipe over PTO shaft. Put a suitable size driver disk (B) on Sleeve or pipe.
- Press shaft assembly into pivot pin until bearing bottoms in bore.

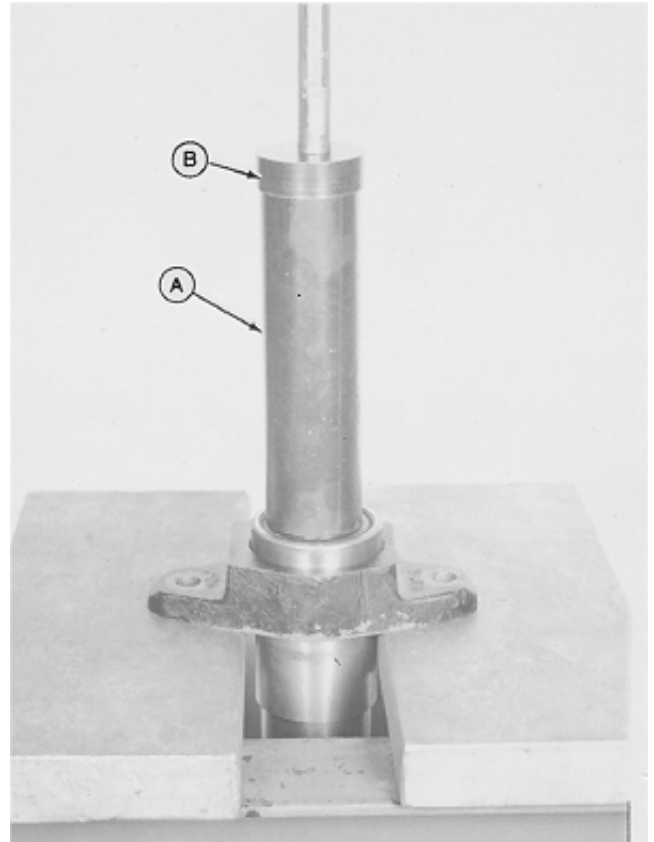

M36810 -JUN-25/JAN90

MX,15908005,18 -19-07MAR95

- Install snap ring (A).



M36802 -JUN-29/JAN90

MX,15908005,19 -19-15FEB95

## INSTALL FRONT AXLE—430

- Install two pivot pin bolts (A) through machine frame.
- Fasten cap screws with tape to back of frame to keep them from falling out when installing axle.

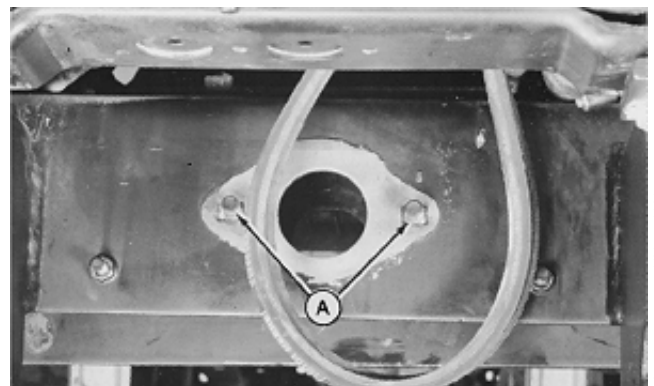

M36611 -JUN-25/JAN90

MX,15918005,11 -19-13JUL95

3. Install axle under front of machine.
4. Raise left wheel off ground enough to connect steering cylinder end (A) to steering arm. Then put blocks under left front wheel.
5. Lift right side of axle to align pivot hole with hole in frame.
6. Slide pivot pin through frame and axle.
7. Secure pivot pin to frame with retaining nuts.

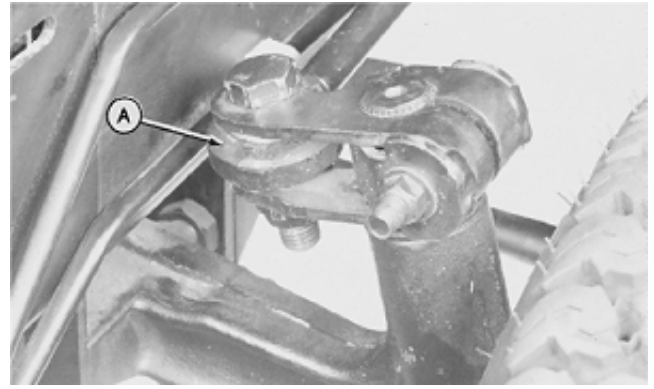

M36612 -UN-25JAN90

MX,15918005,12 -19-13JUL95

8. Slide drive pulley onto PTO shaft.
9. Install snap ring (A) in PTO shaft groove.
10. Install belts on pulley.
11. Install PTO pulley guard.
12. Install radiator shroud-to-radiator screws, if removed.

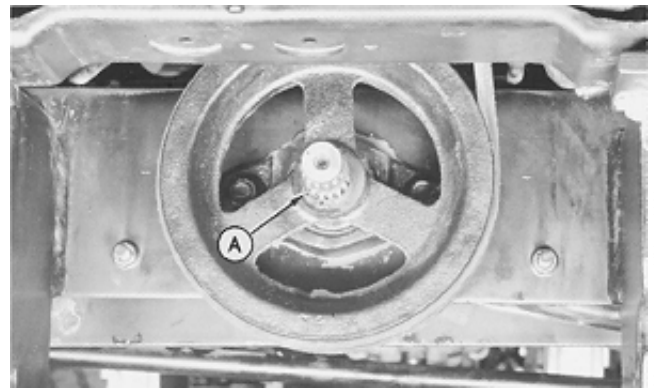

M36600 -UN-25JAN90

MX,15918005,13 -19-13JUL95

13. Tighten belt tensioning nut until spring measures 35 mm (1.380 in.).
14. Install front grille and engine side panels.
15. Install front PTO extension, if equipped.

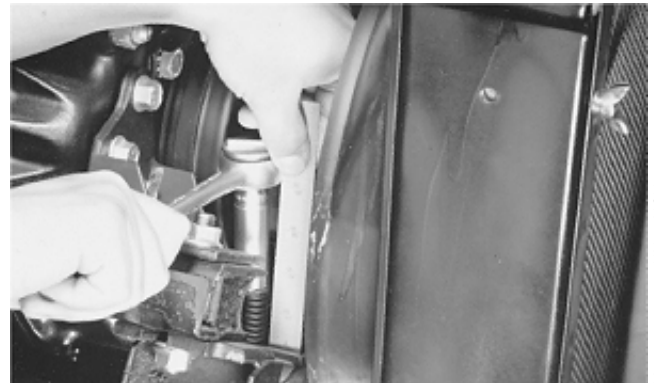

M35665 -JUN-27NOV89

MX,15918005,14 -19-13JUL95

80-05-8

## Front Axle/Spindles

16. Adjust axle deflector bolts for smooth up and down operation of axle.

17. Test for proper axle deflector adjustment, by pushing down on a wheel. The axle should move freely without sticking in one spot. Readjust if necessary.

18. Lower tractor from jack stands.

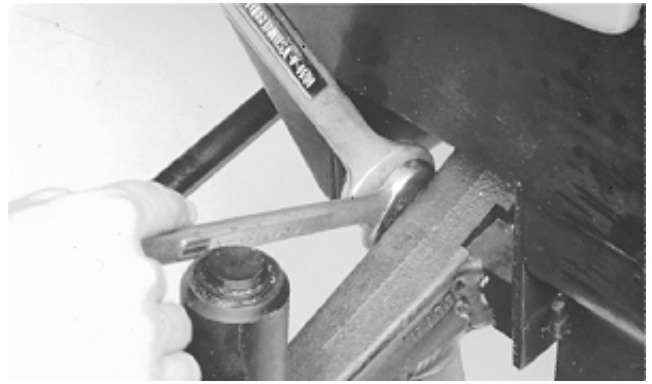

MX,15918005,16 -19-13JUL95

M31970  
-UN-03AUG89

## REMOVE AND INSTALL SPINDLES

*NOTE: The 330 has manual steering and is connected to the steering arm by a drag link. The 322, 332 and 430 have power steering and are connected to the steering arm by a cylinder.*

1. Raise front of machine and block securely with jack stands.
2. Remove front wheels.
3. Remove cotter pin, if equipped, from steering link/cylinder at steering arm on left spindle.
4. Remove nut and bolt (322, 332 and 430) from arm.
5. Disconnect steering link/cylinder from steering arm.

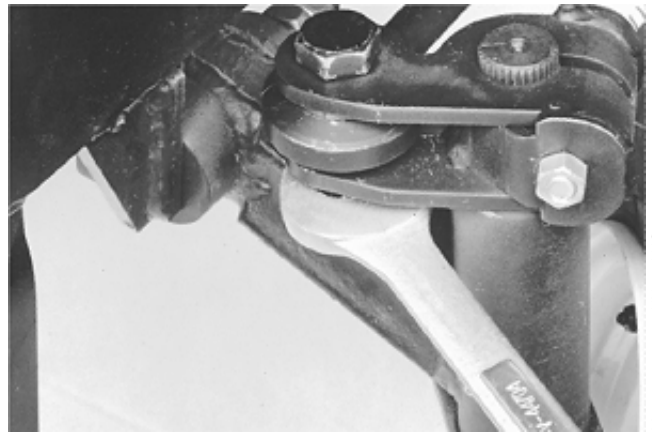

322 and 332 Shown

MX,15918005,15 -19-13JUL95

M32067  
-UN-03AUG89

6. Disconnect both tie rod ends and remove tie rod.



MX,15908005,27 -19-15FEB95

M32068  
-UN-03AUG89

Front Axle/Spindles

7. Put an alignment mark across top of steering arm and left spindle to aid in installation.

8. Remove nut, washer (if equipped), bolt and steering arm from left spindle.

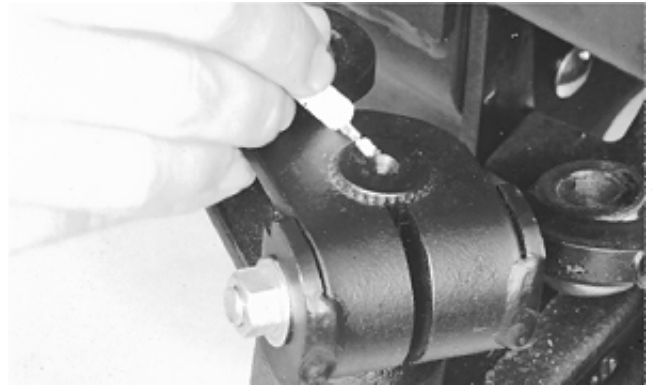

M32069  
-UN-03AUG89

MX,15908005,28 -19-15FEB95

9. Slide left spindle down out of axle to remove.



-UN-14MAR95

M78701

MX,15908005,29 -19-14MAR95

80  
05  
10



## Front Axle/Spindles

10. Remove snap ring from top of right spindle.
  11. Slide right spindle down out of axle to remove.
  12. Inspect spindles for wear or damage. Replace if necessary.
  13. Inspect bushings for wear or damage. Replace if necessary. (See procedure in this group.)
  14. Installation is done in the reverse order of removal.
- On left-hand side; align marks made on steering arm and spindle shaft.
  - Apply multipurpose grease to lubrication fittings.
  - Adjust toe-in. (See procedure in this group.)

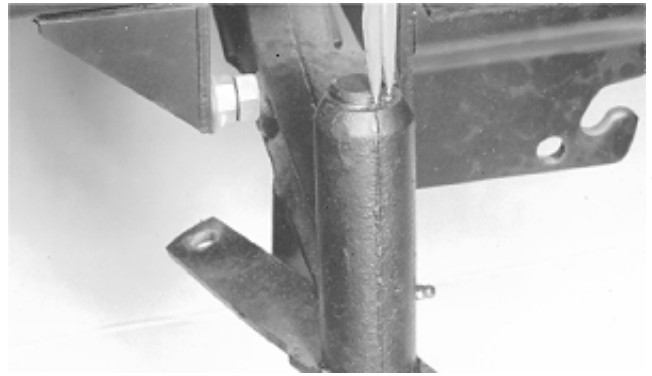

M32072 -UN-03AUG89

MX,15908005,30 -19-07MAR95

### INSPECT AND REPLACE SPINDLE BUSHINGS

1. Remove spindles. (See procedure in this group.)
2. Remove bushings (A) from axle using a long brass drift and a plastic headed hammer.
3. Install new bushings using a plastic headed hammer. Install bushings until they bottom against axle.

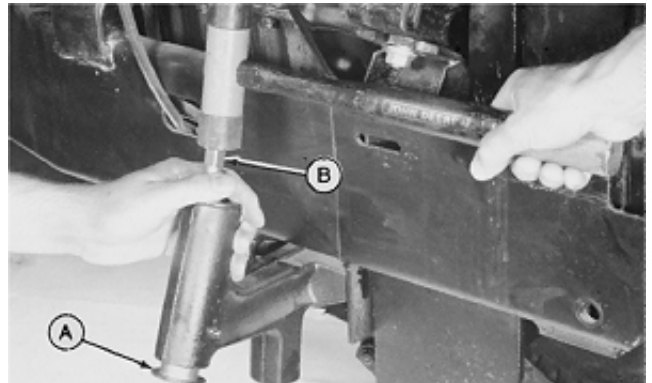

M36815 -UN-25JAN90  
80-05-11

MX,15908005,31 -19-15FEB95

## INSPECT AND REPLACE WHEEL BEARINGS

1. Remove front wheels.
2. The front wheels are equipped with sealed roller bearings in both the front and rear of hub. Check the bearings for damage by spinning the inner race by hand. If the bearing binds or shows excessive wear, it must be replaced.
3. Tap the bearings out from the back side with a long drift and a hammer.
4. Install new bearings using a driver set.



M32007 -UN-03AUG89

MX,15908005,32 -19-12MAY95

## ADJUST TOE-IN

1. Position wheels so they are pointing straight ahead.
2. Measure distance between the inner edges of the tires at the rear.

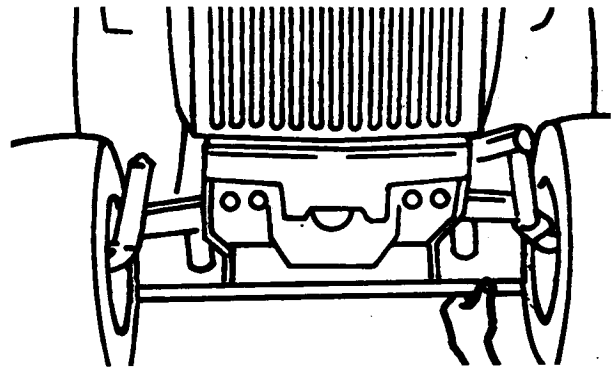

M32064 -UN-28APR89

MX,15908005,33 -19-12MAY95

3. Measure front distance between tires. When properly adjusted, front distance should be 4.8 mm (3/16 in.) shorter than rear distance (a slight toe-in).

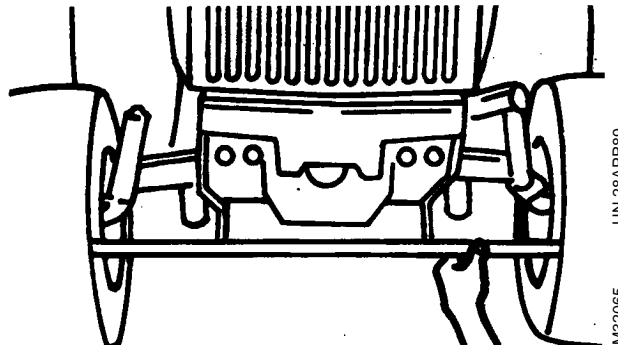

M32065 -UN-28APR89

MX,15908005,34 -19-15FEB95

80-05-12

## Front Axle/Adjust Toe-in

4. Loosen jam nuts and adjust tie rod to lengthen or shorten distance.

**IMPORTANT: Make sure there is free movement of ball joints after tightening jam nuts.**

5. Make certain to securely tighten jam nuts after adjusting tie rod.



M32066 -JUN-03AUG89

MX,M21.7005K,X -19-04NOV82

80  
05  
13

*Front Axle/Adjust Toe-in*

80  
05  
14

**SERVICE MOWER BLADE SPINDLES—38 (EARLY), 46 AND 50-INCH MOWER**

*NOTE: On 50-Inch, Three-Point Hitch Mowers; some spindles may have a grease zerk in the top end of the spindle shaft.*

If, for any reason the spindle must be disassembled, be sure to lubricate and torque parts as required.

When assembling bearings and spacer, fill cavities (J and M) 75 percent full of multipurpose grease.

**TORQUE SPECIFICATIONS**

Lock Nut (A) . . . . . 140 N·m (103 lb-ft)  
Cap Screw (H) . . . . . 73 N·m (54 lb-ft)

- |                 |                 |
|-----------------|-----------------|
| A—Lock Nut      | H—Cap Screw     |
| B—Key           | I—Spindle       |
| C—Driven Sheave | J—Grease Cavity |
| D—Hub           | K—Bearing       |
| E—Snap Rings    | L—Spacer        |
| F—Mower Blade   | M—Grease Cavity |
| G—Washer        | N—Bearing       |

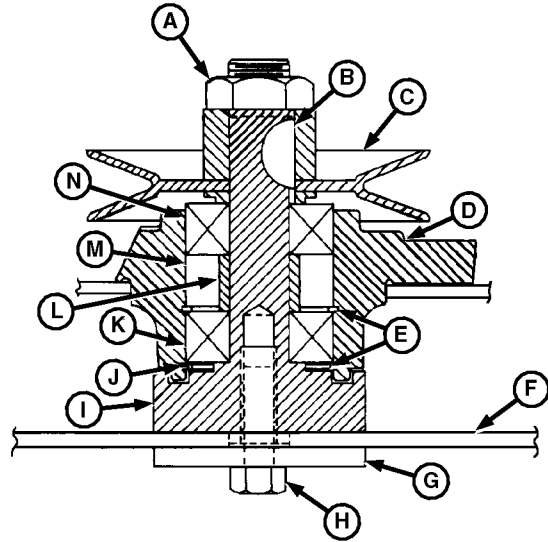

M78050 -UN-21FEB95

MX,15908010,1 -19-13MAR95

**SERVICE MOWER BLADE SPINDLES—38-INCH MOWER (LATER)**

*NOTE: Some spindles may not have fan (C).*

If, for any reason the spindle must be disassembled, be sure to lubricate and torque parts as required.

After assembly, fill grease cavity (M) by applying multipurpose grease to grease zerk (E).

**TORQUE SPECIFICATIONS**

Lock Nut (A) . . . . . 140 N·m (103 lb-ft)  
Cap Screw (I) . . . . . 73 N·m (54 lb-ft)

- |                 |                 |
|-----------------|-----------------|
| A—Lock Nut      | I—Cap Screw     |
| B—Driven Sheave | J—Spindle       |
| C—Fan           | K—Bearing       |
| D—Washer        | L—Spacer        |
| E—Grease Zerk   | M—Grease Cavity |
| F—Hub           | N—Bearing       |
| G—Mower Blade   | O—Key           |
| H—Washer        |                 |

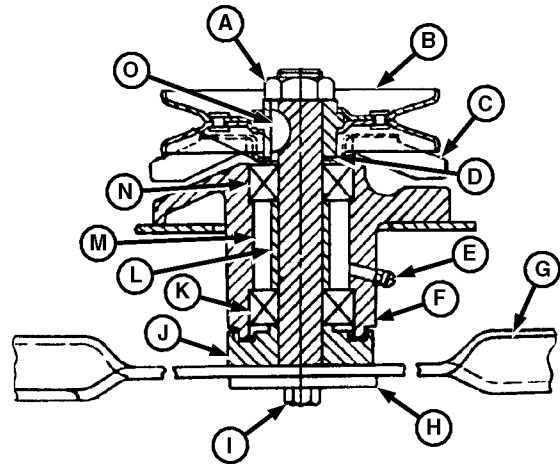

M78051 -UN-21FEB95

MX,15908010,2 -19-15FEB95

### SERVICE MOWER BLADE SPINDLES—EARLY 60-INCH AND 260 ROTARY MOWER

If, for any reason the spindle must be disassembled, be sure to lubricate and torque parts as required.

When assembling bearings and spacer, fill cavities (E and H) 75 percent full of multipurpose grease.

#### TORQUE SPECIFICATIONS

Lock Nut (A) . . . . . 140 N·m (103 lb-ft)  
 Cap Screw (I) . . . . . 73 N·m (54 lb-ft)

- |                 |                 |
|-----------------|-----------------|
| A—Lock Nut      | I—Cap Screw     |
| B—Bearing       | J—Washer        |
| C—Snap Ring     | K—Mower Blade   |
| D—Spacer        | L—Spindle       |
| E—Grease Cavity | M—Hub           |
| F—Snap Ring     | N—Driven Sheave |
| G—Bearing       | O—Key           |
| H—Grease Cavity |                 |

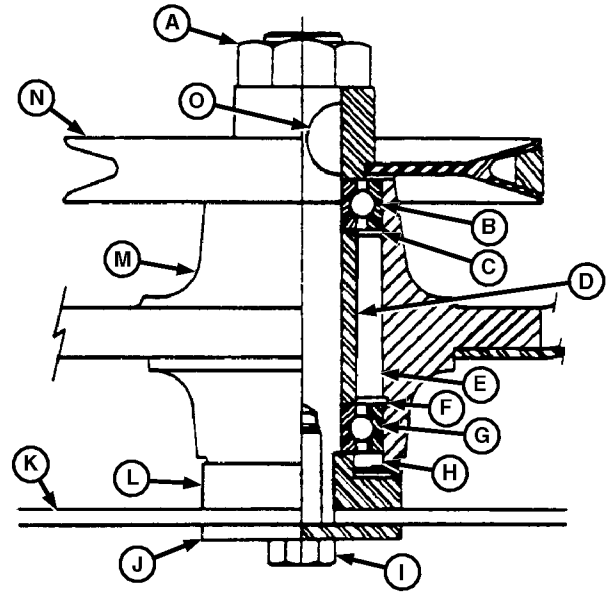

M78052 -UN-21FEB95

MX,15908010,3 -19-13MAR95

80  
10  
2

## SERVICE MOWER BLADE SPINDLES—LATER 60-INCH AND 260 ROTARY MOWER

If, for any reason the spindle must be disassembled, be sure to lubricate and torque parts as required.

**IMPORTANT:** Bushing (F) must be installed with grease grooves on end of bushing facing bearing (R) or bearings won't get any grease.

**Bearing (M) must be install with sealed surface side facing away from snap ring (N) to keep grease within grease cavity (P) and bearing.**

During assembly, install bushing (F) with grease grooves on end of bushing facing toward bearing (R). Also, install bearing (M) with sealed surface side facing away from snap ring (N).

After assembly, fill grease cavity (P) by applying multipurpose grease to grease zerk (B).

### TORQUE SPECIFICATIONS

Lock Nut (A) . . . . . 140 N-m (103 lb-ft)  
 Cap Screw (L) . . . . . 73 N-m (54 lb-ft)

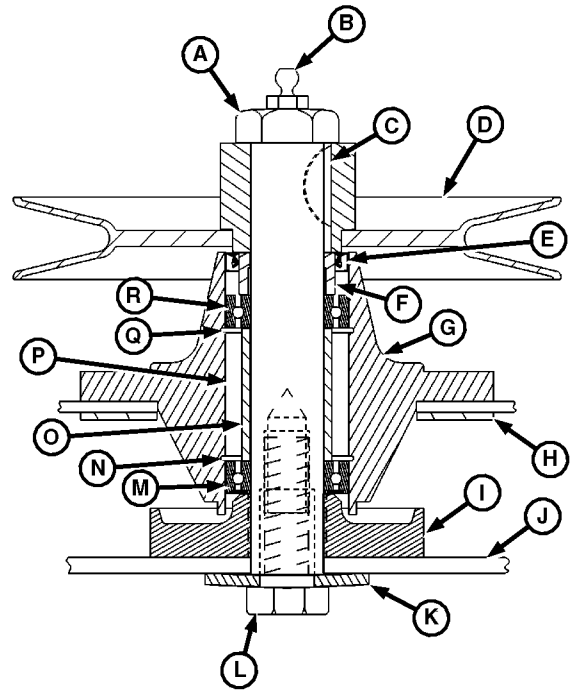

- A—Lock Nut
- B—Grease Zerk
- C—Key
- D—Driven Sheave
- E—Seal
- F—Bushing
- G—Hub
- H—Washer
- I—Spindle
- J—Mower Blade
- K—Washer
- L—Cap Screw
- M—Bearing
- N—Snap Ring
- O—Spacer
- P—Grease Cavity
- Q—Snap Ring
- R—Bearing

MX.15908010.4 -19-15FEB95

M78053 -UN-21FEB95

80  
10  
3

## SERVICE MOWER BLADE JACK SHEAVES—46 AND 50-INCH MOWER

Mower blade jack sheaves normally require no lubrication or service. If, for any reason the jack sheave must be disassembled, be sure to lubricate and torque parts as required.

When assembling bearings and spacer, fill cavities (K and N) 75 percent full of multipurpose grease.

### TORQUE SPECIFICATIONS

Lock Nut (A) ..... 140 N·m (103 lb-ft)  
 Cap Screw (I) ..... 73 N·m (54 lb-ft)

- |               |                 |
|---------------|-----------------|
| A—Lock Nut    | I—Cap Screw     |
| B—Key         | J—Spindle       |
| C—Jack Sheave | K—Grease Cavity |
| D—Washer      | L—Bearing       |
| E—Hub         | M—Spacer        |
| F—Snap Rings  | N—Grease Cavity |
| G—Mower Blade | O—Bearing       |
| H—Washer      |                 |

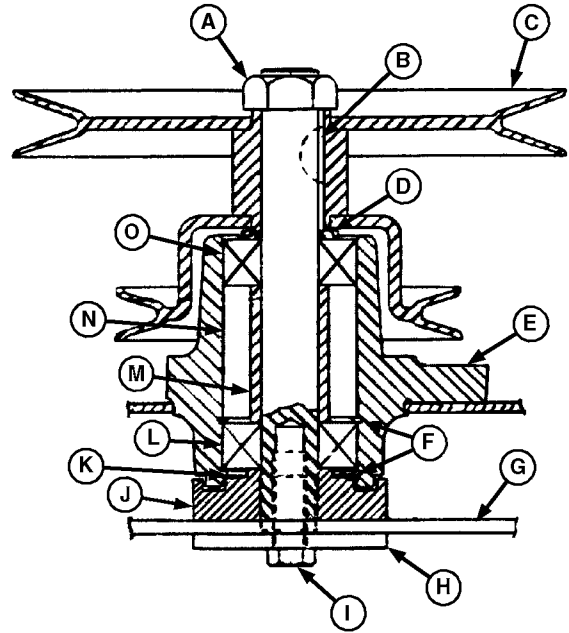

M78054 -UN-21FEB95

MX,15908010,5 -19-15FEB95



**OTHER MATERIAL**

Number	Name	Use
LOCTITE® PRODUCTS U.S./Canadian/LOCTITE No.		
TY6305/TY9485/764	Clean and Cure Primer	Cleans parts and speeds cure of sealant.
TY15130/NA/395	Form-In-Place Gasket Sealant	Early 60-Inch Mower and 260 Rotary Mower; Apply to mating surfaces of gear case and caps.

®LOCTITE is a registered trademark of the Loctite Corp.

MX,15908015,OTH-19-22FEB95

**DISASSEMBLE AND INSPECT MOWER GEAR CASE—50-INCH MOWER**

1. Remove drain plugs (A and B) and drain oil from gear case.



MX,15908015,1 -19-22FEB95

M77316 -UN-24FEB95

**80-15-1**

2. Remove four cap screws (A) and input shaft assembly.
3. Remove lock nut (B), washer (C) and bevel gear (E) and bearing from shaft.

*NOTE: Bearing cone is press-fit on bevel gear. Remove bearing only if replacement is necessary.*

*Bearing cone, cup in pillow block and shim(s) are matched and must be replaced as complete assemblies.*

4. Inspect bearing cone (D) for wear or damage. Replace if necessary.
5. Remove bearing cone from bevel gear using a knife-edge puller and a press.
6. Remove shim(s) (F) and key (G).

- A—Cap Screw (4 used)
- B—Lock Nut
- C—Washer
- D—Bearing Cone
- E—Bevel Gear
- F—Shims (as required)
- G—Key

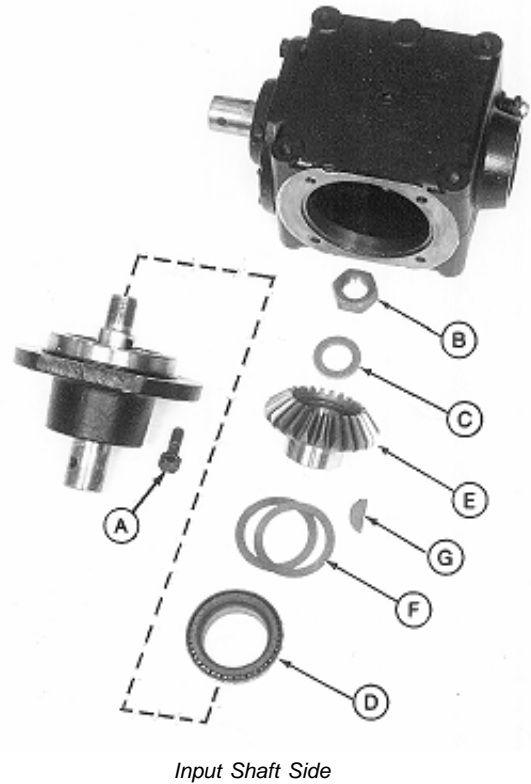

Input Shaft Side

MX,15908015,2 -19-22FEB95

M77317 -JUN-24FEB95

7. Press on threaded end of input shaft (C) to remove seal (A) and input shaft assembly from pillow block (I).

*NOTE: Bearing cone is press-fit on input shaft. Remove bearing only if replacement is necessary.*

*Bearing cups are press-fit in pillow block. Remove cups only if replacement is necessary.*

*Bearing cones and cups are matched and must be replaced as complete assemblies.*

8. Inspect bearing cone (D) and cups (G and H) for wear or damage. Replace as necessary.

9. Remove snap ring (B) and press input shaft (C) from bearing (D).

10. Remove O-ring (E) and snap ring (F).

**IMPORTANT: Remove bearing cups using a press and driver disk, if possible. Using a punch and hammer can damage pillow block. Use only if necessary.**

11. Remove bearing cups (G and H) using a press and driver set or punch and hammer.

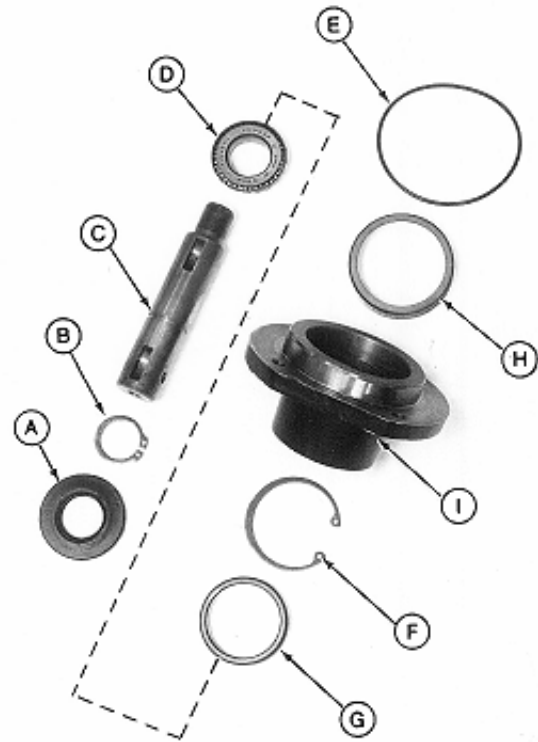

Input Shaft Assembly

- A—Seal
- B—Snap Ring
- C—Input Shaft
- D—Bearing Cone
- E—O-Ring
- F—Snap Ring
- G—Bearing Cup
- H—Bearing Cup
- I—Pillow Block

M77318 -JUN-24FEB95

80  
15  
3

12. Remove vent plug (A) and adapter (B) from gear case (C).

13. Remove four cap screws (D). Remove retainer (L) and output shaft assembly (M).

14. Remove output shaft assembly (M) from retainer (L).

**IMPORTANT: Remove and discard crush ring (I). A new crush ring must be installed during assembly to achieve proper output shaft end play.**

15. Remove O-ring (G), shim (J), bearing cup (H) and crush ring (I). Discard crush ring.

16. Press out seal (K) from retainer (L).

*NOTE: Bearing cup (F) and plug (E) are press-fit in gear case. Remove bearing cup (F) only if replacement is necessary.*

*Bearing cones and cups are matched and must be replaced as complete assemblies.*

17. Inspect bearing cups (F and H) for wear or damage. Replace as necessary.

18. Press out plug (E) and bearing cup (F).

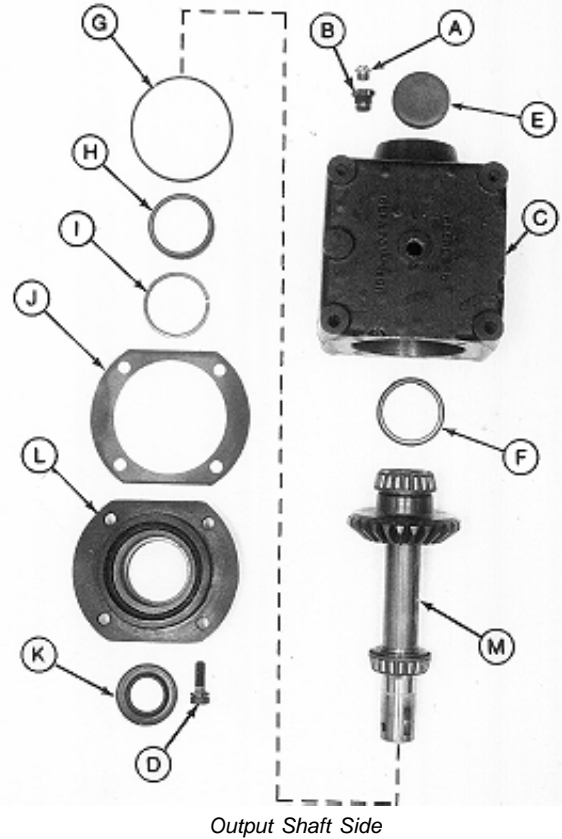

- A—Vent Plug
- B—Adapter
- C—Gear Case
- D—Cap Screw (4 used)
- E—Plug
- F—Bearing Cup
- G—O-Ring
- H—Bearing Cup
- I—Crush Ring
- J—Shim (as required)
- K—Seal
- L—Retainer
- M—Output Shaft Assembly

MX,15908015,4 -19-29MAR95

M77319 -JUN-24FEB95

**NOTE:** Bearing cones are press-fit on output shaft.  
Remove bearings only if replacement is necessary.

*Bearing cones and cups are matched and must be replaced as complete assemblies.*

20. Inspect bearing cones (A and D) for wear or damage. Replace if necessary.
21. Press output shaft (B) from bearing cone (A). Remove snap ring (C).
22. Remove bearing cone (D) from output shaft (B) using a knife-edge puller and a press.
23. Remove bevel gear (E), snap ring (F) and key (G).
24. Inspect all parts for wear or damage. Replace as necessary.

- A—Bearing Cone
- B—Output Shaft
- C—Snap Ring
- D—Bearing Cone
- E—Bevel Gear
- F—Snap Ring
- G—Key

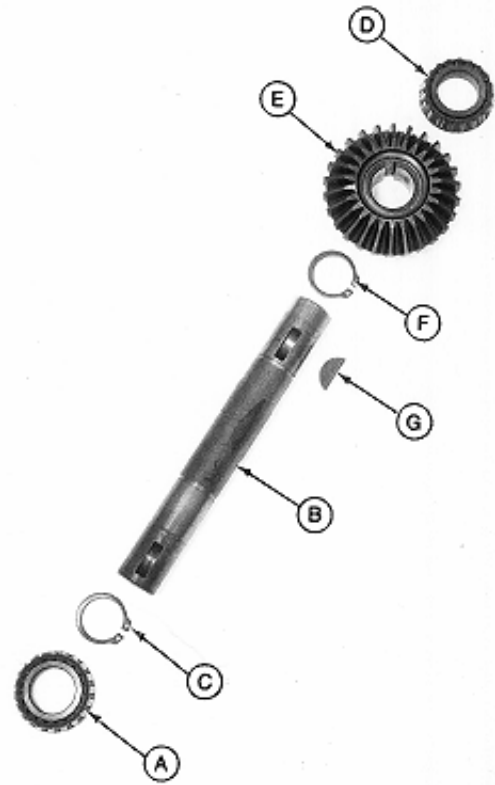

Output Shaft Assembly

M77320 -JUN-24FEB95

MX,15908015,5 -19-29MAR95

80  
15  
5

## ASSEMBLE MOWER GEAR CASE—50-INCH MOWER

**IMPORTANT:** Always use new seals and O-rings.  
Damaged or used parts will leak.

*NOTE:* Lubricate all O-rings with petroleum jelly during assembly.

*Apply clean gear case oil on all internal parts during assembly.*

1. Install snap ring (F), key (G) and bevel gear (E).  
Install bevel gear on output shaft, small O.D. first.
2. Press bearing cone (D) on output shaft (B) with small O.D. facing away from bevel gear (E). Install bearing until it bottoms against bevel gear.
3. Install snap ring (C).
4. Press bearing cone (A) on output shaft with small O.D. facing away from bevel gear (E). Install bearing until it bottoms against snap ring.

**A—Bearing Cone**  
**B—Output Shaft**  
**C—Snap Ring**  
**D—Bearing Cone**  
**E—Bevel Gear**  
**F—Snap Ring**  
**G—Key**

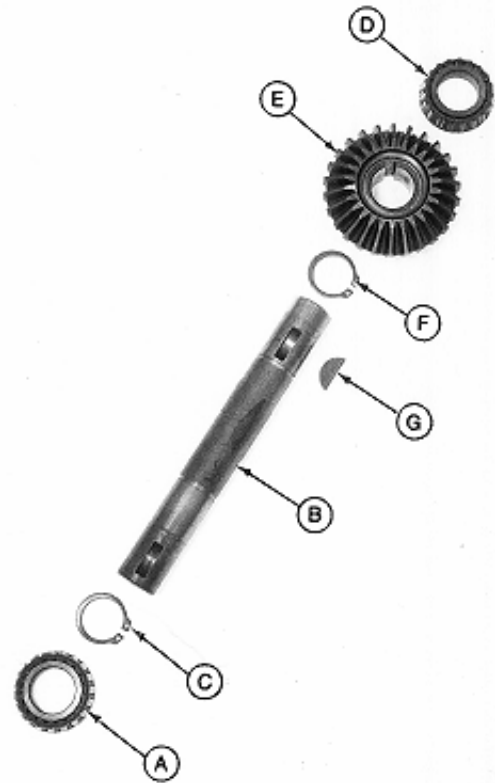

Output Shaft Assembly

MX,15908015,6 -19-13MAR95

M77320 -JUN-24FEB95

5. Install new bearing cup (F), if removed, using a driver set.

6. Press plug (E) into gear case (C) with lip facing away from gear case. Install plug until recessed 1.59 mm (0.062 in.) below gear case surface.

7. Install adapter (B) and vent plug (A).

8. Press new seal (K) into retainer (L) until top of seal is recessed 2.54 mm (0.100 in.) below retainer surface.

9. Apply multipurpose grease to lip of seal.

**IMPORTANT: A new crush ring must be installed during assembly. The ring collapses when retainer is tightened to gear case to achieve proper output shaft end play.**

10. Install new crush ring (I) and bearing cup (H).

11. Install shim (J) and new O-ring (G).

**IMPORTANT: Tape end of output shaft to prevent seal damage during shaft installation.**

12. Apply tape around end of output shaft.

13. Assemble output shaft assembly (M) and retainer (L). Remove tape.

14. Install retainer and output shaft assembly into gear case (C).

15. Install four cap screws (D) and tighten to 30 N·m (22 lb-ft).

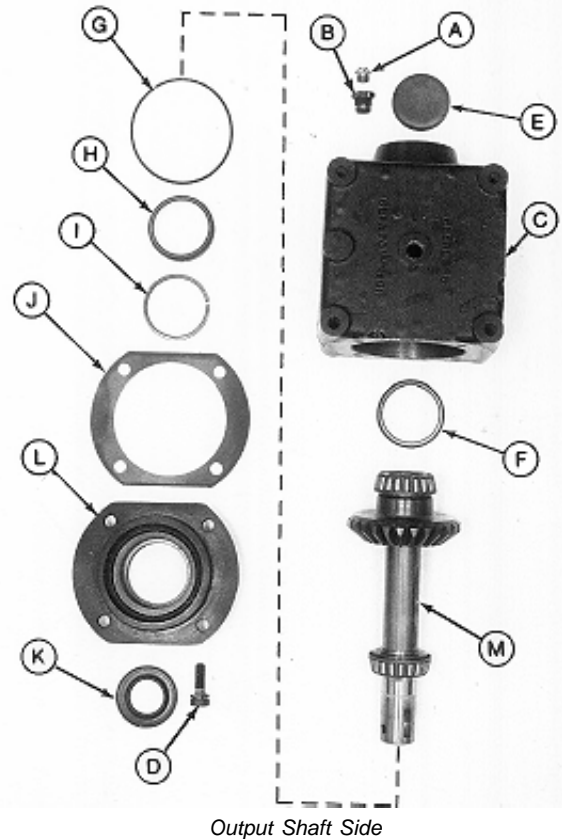

- A—Vent Plug
- B—Adapter
- C—Gear Case
- D—Cap Screw (4 used)
- E—Plug
- F—Bearing Cup
- G—O-Ring
- H—Bearing Cup
- I—Crush Ring
- J—Shim (as required)
- K—Seal
- L—Retainer
- M—Output Shaft Assembly

MX,15908015,7 -19-13MAR95

M77319 -JUN-24FEB95

80  
15  
7

16. Install snap ring (F).

17. Install new bearing cups (G and H), if removed, using a driver set. Press into pillow block (I) until seated against snap ring and housing.

18. Install snap ring (B) on input shaft (C).

19. Press bearing cone (D) on input shaft with small O.D. facing away from snap ring (B). Install bearing until it bottoms against snap ring.

**IMPORTANT: Tape end of input shaft to prevent seal damage during seal installation.**

20. Apply tape around large end of input shaft.

21. Install input shaft assembly into pillow block (I).

22. Apply multipurpose grease to lip of new seal (A).

23. Press new seal (A) into pillow block (I) until top of seal is recessed 2.54 mm (0.100 in.) below block surface. Remove tape from end of shaft.

24. Install new O-ring (E).

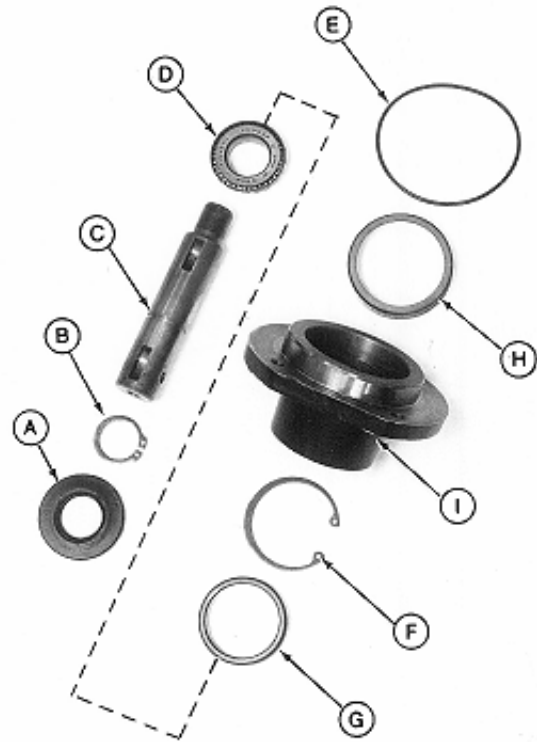

Input Shaft Assembly

- A—Seal
- B—Snap Ring
- C—Input Shaft
- D—Bearing Cone
- E—O-Ring
- F—Snap Ring
- G—Bearing Cup
- H—Bearing Cup
- I—Pillow Block

80  
15  
8

M77318 -JUN-24FEB95



25. Install shims (F) on bevel gear (E).

26. Press bearing cone (D) on bevel gear (E) with small O.D. facing away from bevel gear. Install bearing until it bottoms against shims.

27. Install key (G) into input shaft.

28. Install bevel gear assembly onto input shaft.

**IMPORTANT: DO NOT overtighten lock nut (B). Overtightening can damage bearing cone (D).**

29. Install washer (C) and lock nut (B). Tighten lock nut until there is zero endplay in input shaft.

30. Install input shaft assembly into gear case.

31. Install four cap screws (A) and tighten to 30 N-m (22 lb-ft).

- A—Cap Screw (4 used)
- B—Lock Nut
- C—Washer
- D—Bearing Cone
- E—Bevel Gear
- F—Shims (as required)
- G—Key

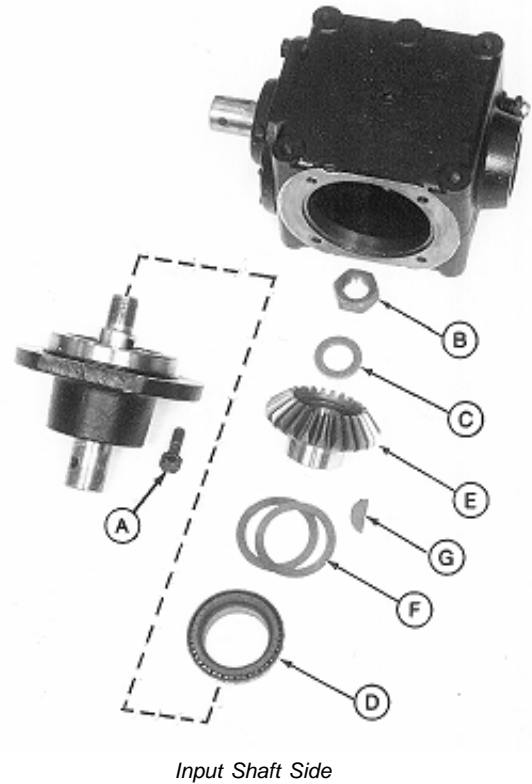

MX,15908015,9 -19-22FEB95

32. AFTER installing gear case on mower deck, fill gear case to proper level with John Deere API GL-5 Gear Oil.

33. Install plugs (A and B).

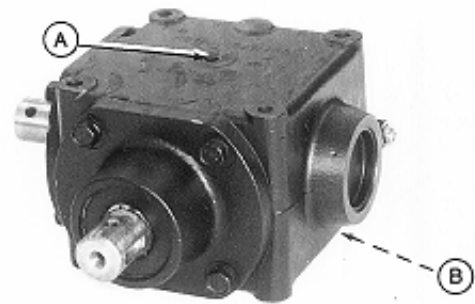

MX,15908015,10 -19-22FEB95

M77317 -JUN-24FEB95

M77316 -JUN-24FEB95

## DISASSEMBLE AND INSPECT MOWER GEAR CASE—EARLY 60-INCH MOWER (CURTIS)

1. Remove drain plugs (A and B) and drain oil from gear case.
2. Scribe an alignment mark across caps and gear case. Mark both caps in relation to the case side they are removed from to aid in assembly.



MX,15908015,11 -19-13MAR95

M77328 -UN-24FEB95

3. Remove four cap screws and lock plates (A).
4. Remove cap (B) and input shaft assembly from gear case (C).
5. Remove shims (D) and input shaft assembly from cap (B).
6. Pry out seal (E).

*NOTE: Bearing cup is press-fit in cap. Remove bearing cup only if replacement is necessary.*

*Bearing cone (K) is press-fit on input shaft.*

*Bearing cones and cups (one in gear case housing) are matched and must be replaced as complete assemblies.*

7. Inspect bearing cup (F) for wear or damage. Replace if necessary.

**IMPORTANT: Remove bearing cups using a press and driver disk, if possible. Using a punch and hammer can damage cap. Use only if necessary.**

8. Remove bearing cup (F) using a press and driver set or punch and hammer.
9. Slide bearing cone (G) off of input shaft (H).
10. Remove spring pin (I) using a punch and hammer.
11. Press shaft (H) from bevel gear (J) and bearing cone (K).
12. Remove key (L).

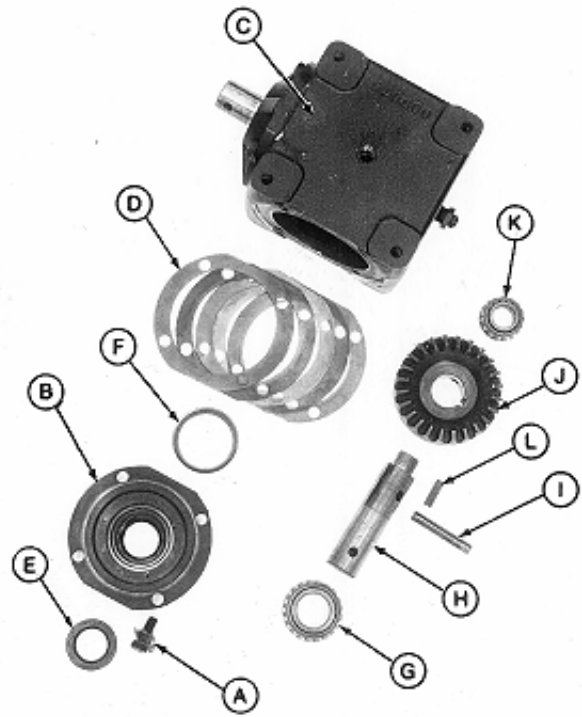

Input Shaft Side

- A—Cap Screw and Lock Plate (4 used)
- B—Cap
- C—Gear Case
- D—Shims (as required)
- E—Seal
- F—Bearing Cup
- G—Bearing Cone
- H—Input Shaft
- I—Spring Pin
- J—Bevel Gear
- K—Bearing Cone
- L—Key

M77329 -JUN-24FEB95

80  
15  
11

MX,15908015,12 -19-13MAR95

13. Remove four cap screws and lock plates (A).

14. Remove cap (B) and output shaft assembly from gear case (C).

15. Remove shims (D) and output shaft assembly from cap (B).

16. Pry out seal (E).

*NOTE: Bearing cup is press-fit in cap. Remove bearing cup only if replacement is necessary.*

*Bearing cone (K) is press-fit on input shaft.*

*Bearing cones and cups (one in gear case housing) are matched and must be replaced as complete assemblies.*

17. Inspect bearing cup (F) for wear or damage. Replace if necessary.

**IMPORTANT: Remove bearing cups using a press and driver disk, if possible. Using a punch and hammer can damage cap. Use only if necessary.**

18. Remove bearing cup (F) using a press and driver set or punch and hammer.

19. Slide bearing cone (G) off of output shaft (H).

20. Remove spring pin (I) using a punch and hammer.

21. Press shaft (H) from bevel gear (J) and bearing cone (K).

22. Remove key (L).

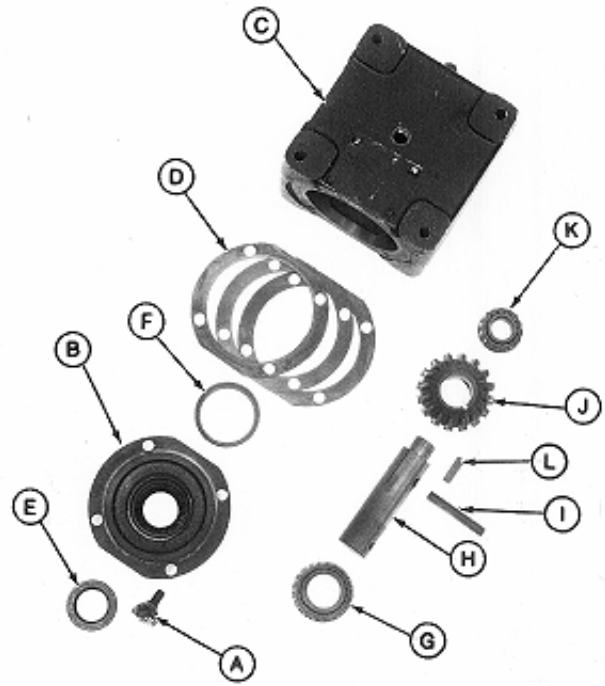

Output Shaft Side

- A—Cap Screw and Lock Plate (4 used)
- B—Cap
- C—Gear Case
- D—Shims (as required)
- E—Seal
- F—Bearing Cup
- G—Bearing Cone
- H—Output Shaft
- I—Spring Pin
- J—Bevel Gear
- K—Bearing Cone
- L—Key

M77330 -JUN-24FEB95

MX,15908015,13 -19-13MAR95

80-15-12

23. Remove vent plug (A) and adapter (B).

*NOTE: Bearing cups are press-fit in gear case. Remove bearing cups only if replacement is necessary.*

*Bearing cups and cones are matched and must be replaced as complete assemblies.*

24. Inspect bearing cups (D and E) for wear or damage. Replace if necessary.

**IMPORTANT: Remove bearing cups using a slide hammer and inside puller, if possible. Using a punch and hammer can damage gear case. Use only if necessary.**

25. Remove bearing cups from gear case (C) using a slide hammer and inside puller or punch and hammer.

26. Remove shims (F), if equipped.

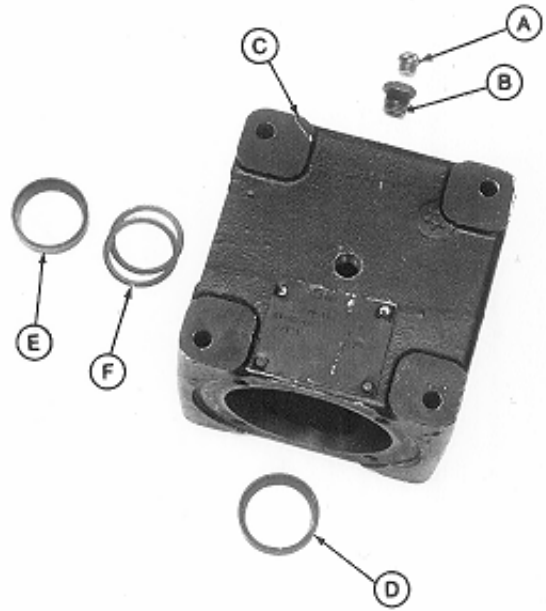

- A—Vent Plug
- B—Adapter
- C—Gear Case
- D—Bearing Cup
- E—Bearing Cup
- F—Shims (as required)

MX,15908015,14 -19-13MAR95

M77331 -UN-24FEB95

## ASSEMBLE MOWER GEAR CASE—EARLY 60-INCH MOWER (CURTIS)

**IMPORTANT:** Always use new seals. Damaged or used seals will leak.

*NOTE:* Apply clean gear case oil on all internal parts during assembly.

1. Install shims (F), if equipped, into gear case (C).
2. Install new bearing cups (E and D), if removed, using a driver set.
3. Install adapter (B) and vent plug (A).

A—Vent Plug  
B—Adapter  
C—Gear Case  
D—Bearing Cup  
E—Bearing Cup  
F—Shims (as required)

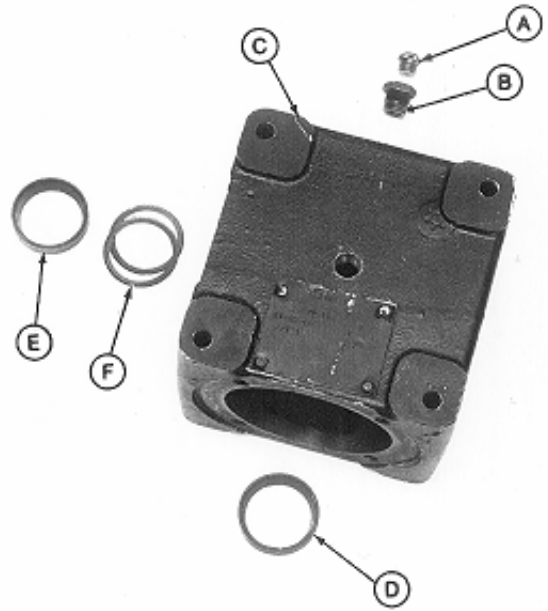

M77331 -UN-24FEB95

MX,15908015,15 -19-13MAR95

4. Install key (L) and bevel gear (J), shoulder end first, onto shaft (H).
5. Align holes in bevel gear and shaft and install spring pin (I).
6. Press bearing cone (K) on shaft with small O.D. facing away from bevel gear (J). Install bearing cone until seated.
7. Slide bearing cone (G) onto other end of output shaft (H).

**IMPORTANT: Do not press seal in until seated or bottomed out. Seal will become damaged and will leak.**

8. Press new seal (E) into cap (B) until seal is flush with first recess in bottom of cap.
9. Install new bearing cup (F), if removed, using a driver set.
10. Apply multipurpose grease to lip of seal.

- |                                     |                |
|-------------------------------------|----------------|
| A—Cap Screw and Lock Plate (4 used) | G—Bearing Cone |
| B—Cap                               | H—Output Shaft |
| C—Gear Case                         | I—Spring Pin   |
| D—Shims (as required)               | J—Bevel Gear   |
| E—Seal                              | K—Bearing Cone |
| F—Bearing Cup                       | L—Key          |

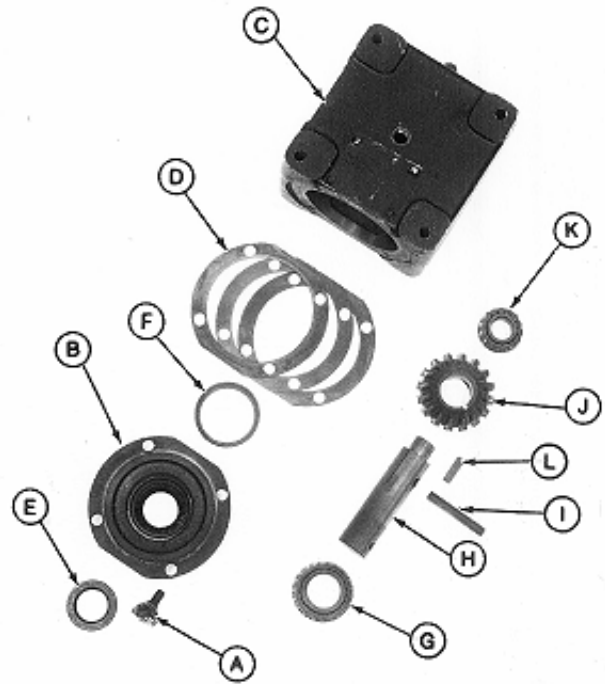

Output Shaft Side

MX,15908015,16 -19-13MAR95

M77330 -JUN-24FEB95

**IMPORTANT: Tape end of output shaft to prevent seal damage during shaft installation.**

11. Apply tape around end of output shaft.
12. Assemble output shaft assembly and cap (B).  
Remove tape.

*NOTE: Flat sides of cap must align with flat sides of gear case. Gear case mounting surface must be flat to install gear case on mower deck.*

13. Install shims (D). Align marks made during disassembly and install output shaft assembly into gear case (C).
14. Install four cap screws and lock plates (A) and tighten to 30 N·m (22 lb-ft).
15. Check output shaft endplay. Endplay should be within 0.025—0.076 mm (0.001—0.003 in.). If necessary, remove cap and output shaft assembly and add or remove shims (D) as needed.
16. Again, remove four cap screws and lock plates (A) and cap and output shaft assembly.
17. Clean mating surfaces of cap, shims and gear case using Clean and Cure Primer. Apply a bead of Form-In-Place Gasket, or an equivalent, between inside edge of top shim and lip on cap (B).
18. Align and install cap and output shaft assembly into gear case. Install four cap screws and lock plates (A) and tighten to 30 N·m (22 lb-ft). Bend lock plates up around cap screws.

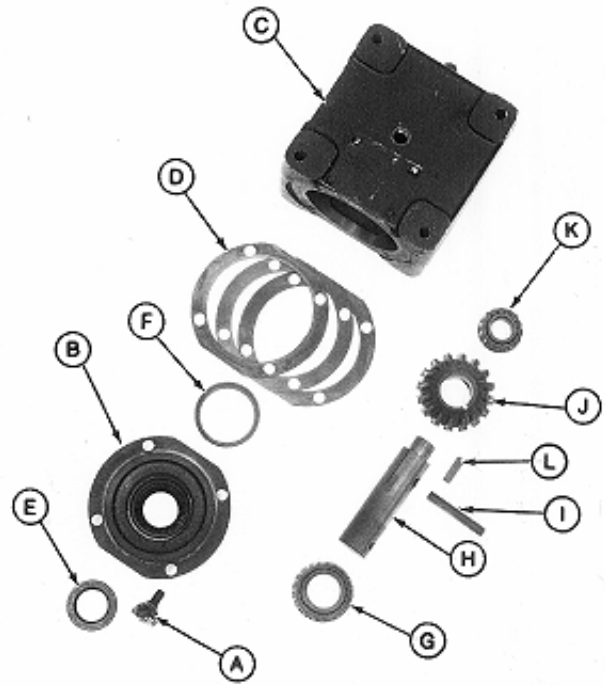

Output Shaft Side

- A—Cap Screw and Lock Plate (4 used)
- B—Cap
- C—Gear Case
- D—Shims (as required)
- E—Seal
- F—Bearing Cup
- G—Bearing Cone
- H—Output Shaft
- I—Spring Pin
- J—Bevel Gear
- K—Bearing Cone
- L—Key

MX,15908015,39 -19-13MAR95

M77330 -JUN-24FEB95



19. Install key (L) and bevel gear (J), shoulder end first, onto shaft (H).
20. Align holes in bevel gear and shaft and install spring pin (I).
21. Press bearing cone (K) on shaft with small O.D. facing away from bevel gear (J). Install bearing until seated.
22. Slide bearing cone (G) onto other end of input shaft (H).

**IMPORTANT: Do not press seal in until seated or bottomed out. Seal will become damaged and will leak.**

23. Press new seal (E) into cap (B) until seal is flush with first recess in bottom of cap.
24. Install new bearing cup (F), if removed, using a driver set.
25. Apply multipurpose grease to lip of seal.

- |                                     |                |
|-------------------------------------|----------------|
| A—Cap Screw and Lock Plate (4 used) | G—Bearing Cone |
| B—Cap                               | H—Input Shaft  |
| C—Gear Case                         | I—Spring Pin   |
| D—Shims (as required)               | J—Bevel Gear   |
| E—Seal                              | K—Bearing Cone |
| F—Bearing Cup                       | L—Key          |

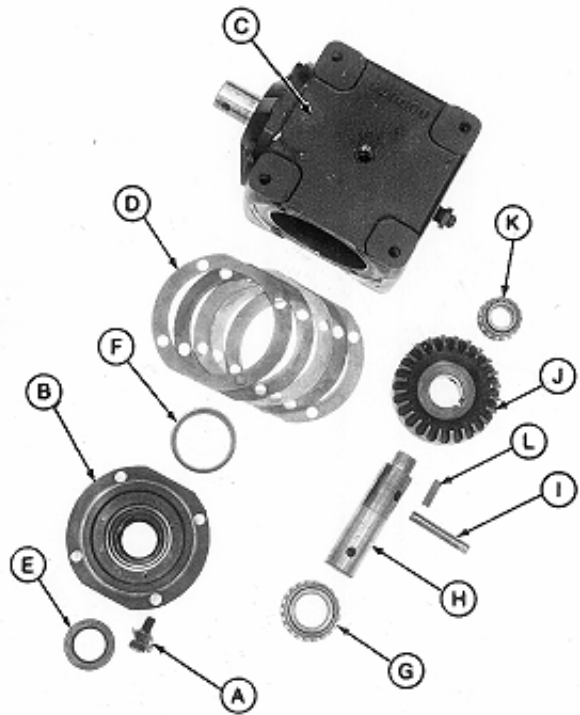

Input Shaft Side

MX,15908015,17 -19-29MAR95

M77329 -JUN-24FEB95

**IMPORTANT: Tape end of input shaft to prevent seal damage during shaft installation.**

26. Apply tape around end of input shaft.

27. Assemble input shaft assembly and cap (B). Remove tape.

*NOTE: Flat sides of cap must align with flat sides of gear case. Gear case mounting surface must be flat to install gear case on mower deck.*

28. Install shims (D). Align marks made during disassembly and install input shaft assembly into gear case (C).

29. Install four cap screws and lock plates (A) and tighten to 30 N·m (22 lb-ft).

30. Hold output shaft securely and check input shaft backlash. Backlash should be within 0.076—0.130 mm (0.003—0.005 in.). If necessary, remove cap and input shaft assembly and add or remove shims (D) as needed.

31. Again, remove four cap screws and lock plates (A) and cap and input shaft assembly.

32. Clean mating surfaces of cap, shims and gear case using Clean and Cure Primer. Apply a bead of Form-In-Place Gasket, or an equivalent, between inside edge of top shim and lip on cap (B).

33. Align and install cap and input shaft assembly into gear case. Install four cap screws and lock plates (A) and tighten to 30 N·m (22 lb-ft). Bend lock plates up around cap screws.

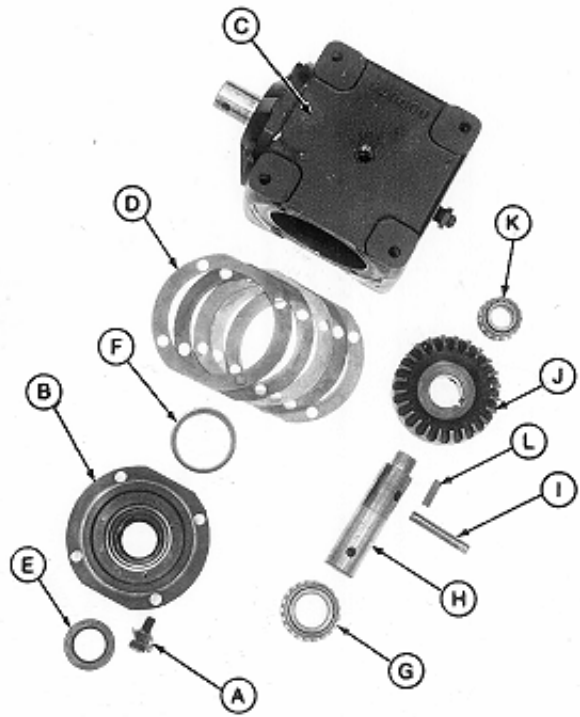

Input Shaft Side

- A—Cap Screw and Lock Plate (4 used)
- B—Cap
- C—Gear Case
- D—Shims (as required)
- E—Seal
- F—Bearing Cup
- G—Bearing Cone
- H—Input Shaft
- I—Spring Pin
- J—Bevel Gear
- K—Bearing Cone
- L—Key

MX,15908015,40 -19-13MAR95

M77329 -UN-24FEB95

80  
15  
18

34. AFTER installing gear case on mower deck, fill gear case to proper level with John Deere API GL-5 Gear Oil.

35. Install plugs (A and B).

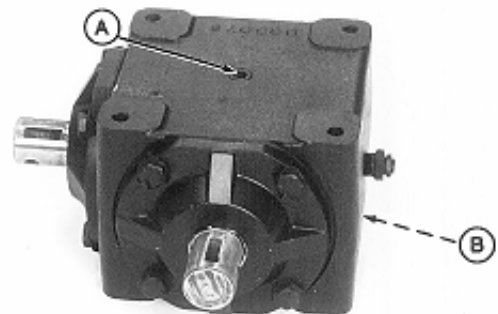

MX,15908015,18 -19-22FEB95

M77328 -UN-24FEB95

## DISASSEMBLE AND INSPECT MOWER GEAR CASE—LATER 60-INCH MOWER (PEERLESS)

1. Remove drain plugs (A and B) and drain oil from gear case.



M77311 -UN-24FEB95

MX,15908015,19 -19-22FEB95

2. Remove four cap screws (A) and input shaft assembly.

3. Remove lock nut (B), washer (C) and bevel gear (E) and bearing from shaft.

*NOTE: Bearing cone is press-fit on bevel gear. Remove bearing cone only if replacement is necessary.*

*Bearing cone, cup in pillow block and shim(s) are matched and must be replaced as complete assemblies.*

4. Inspect bearing cone (D) for wear or damage. Replace if necessary.

5. Remove bearing cone from bevel gear using a knife-edge puller and a press.

6. Remove shim(s) (F) and key (G).

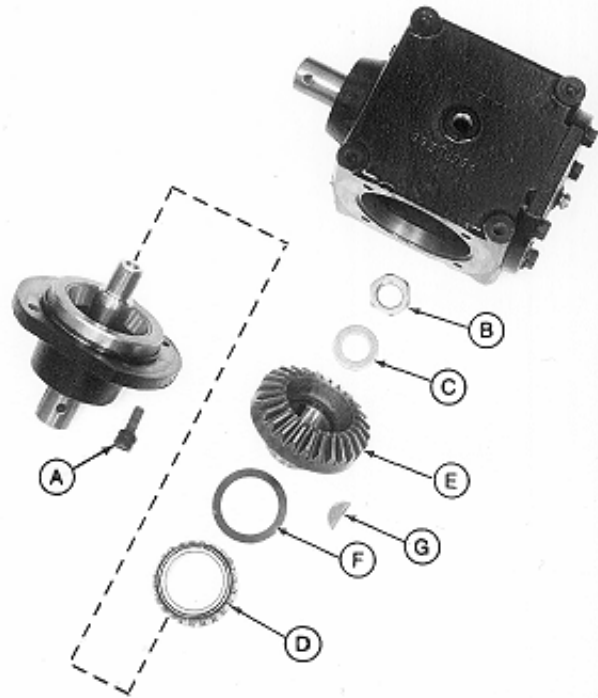

Input Shaft Side

- A—Cap Screw (4 used)
- B—Lock Nut
- C—Washer
- D—Bearing Cone
- E—Bevel Gear
- F—Shim (as required)
- G—Key

M77312 -UN-24FEB95

MX,15908015,20 -19-13MAR95

7. Press on threaded end of input shaft (C) to remove seal (A) and input shaft assembly from pillow block (H).

*NOTE: Bearing cone is press-fit on input shaft. Remove bearing only if replacement is necessary.*

*Bearing cups are press-fit in pillow block. Remove cups only if replacement is necessary.*

*Bearing cones and cups are matched and must be replaced as complete assemblies.*

8. Inspect bearing cone (D) and cups (F and G) for wear or damage. Replace as necessary.

9. Remove snap ring (B) and press shaft (C) from bearing (D).

10. Remove bearing cups (F and G) using a brass drift or punch and hammer.

11. Remove O-ring (E).

- A—Seal
- B—Snap Ring
- C—Input Shaft
- D—Bearing Cone
- E—O-Ring
- F—Bearing Cup
- G—Bearing Cup
- H—Pillow Block

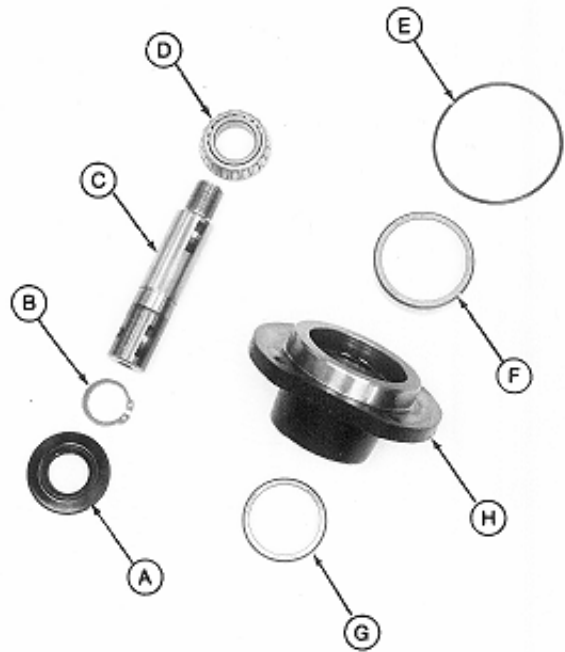

Input Shaft Assembly

MX,15908015,21 -19-13MAR95

M77313 -JUN-24FEB95

12. Remove vent plug (A) from retainer (G).
13. Remove four cap screws (B). Remove retainer (G) and output shaft assembly (K) by tapping on end of shaft with a rubber mallet.
14. Remove output shaft assembly (K) from retainer (G).
15. Remove O-ring (F) and shim (C) from retainer (G).

**IMPORTANT: Remove and discard crush ring (E). A new crush ring must be installed during assembly to achieve proper output shaft end play.**

16. Remove bearing cup (D) and crush ring (E). Discard crush ring.

17. Pry out seal (H).

*NOTE: Bearing cup is press-fit in gear case. Remove bearing cup only if replacement is necessary.*

*Bearing cones and cups are matched and must be replaced as complete assemblies.*

18. Inspect bearing cups (D and I) for wear or damage. Replace as necessary.

19. Remove bearing cup (I) using a brass drift or punch and hammer.

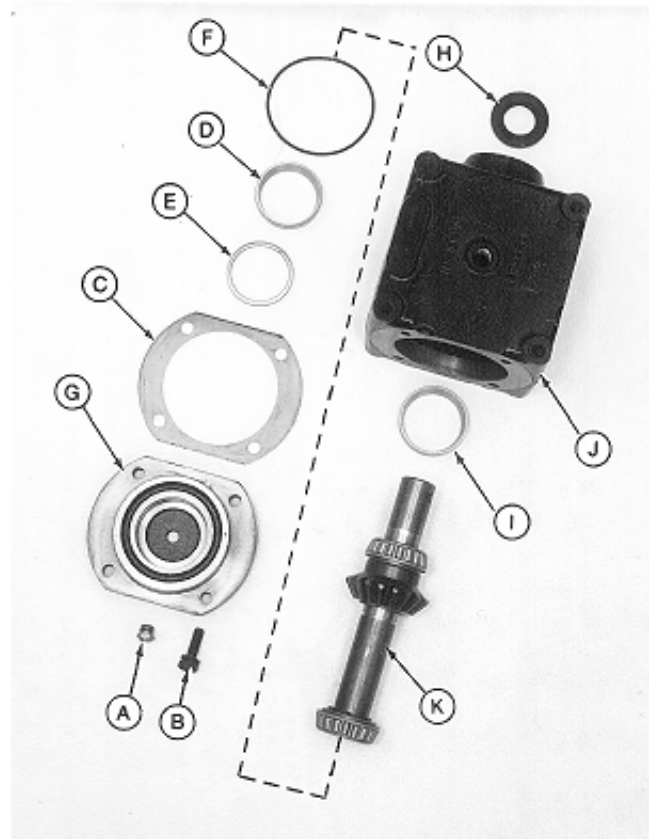

Output Shaft Side

- A—Vent Plug
- B—Cap Screw (4 used)
- C—Shim (as required)
- D—Bearing Cup
- E—Crush Ring
- F—O-Ring
- G—Retainer
- H—Seal
- I—Bearing Cup
- J—Gear Case
- K—Output Shaft Assembly

MX,15908015,22 -19-13MAR95

M77314 -JUN-24FEB95

80  
15  
21

**NOTE:** Bearing cones are press-fit on output shaft.  
Remove bearings only if replacement is necessary.

*Bearing cones and cups are matched and must be replaced as complete assemblies.*

20. Inspect bearing cones (A and D) for wear or damage. Replace if necessary.
21. Press shaft (C) from bearing cone (A). Remove snap ring (B).
22. Remove bearing cone (D) from shaft (C) using a knife-edge puller and a press.
23. Remove shims (E), bevel gear (F), snap ring (G) and key (H).
24. Inspect all parts for wear or damage. Replace as necessary.

- A—Bearing Cone
- B—Snap Ring
- C—Output Shaft
- D—Bearing Cone
- E—Shims (as required)
- F—Bevel Gear
- G—Snap Ring
- H—Key

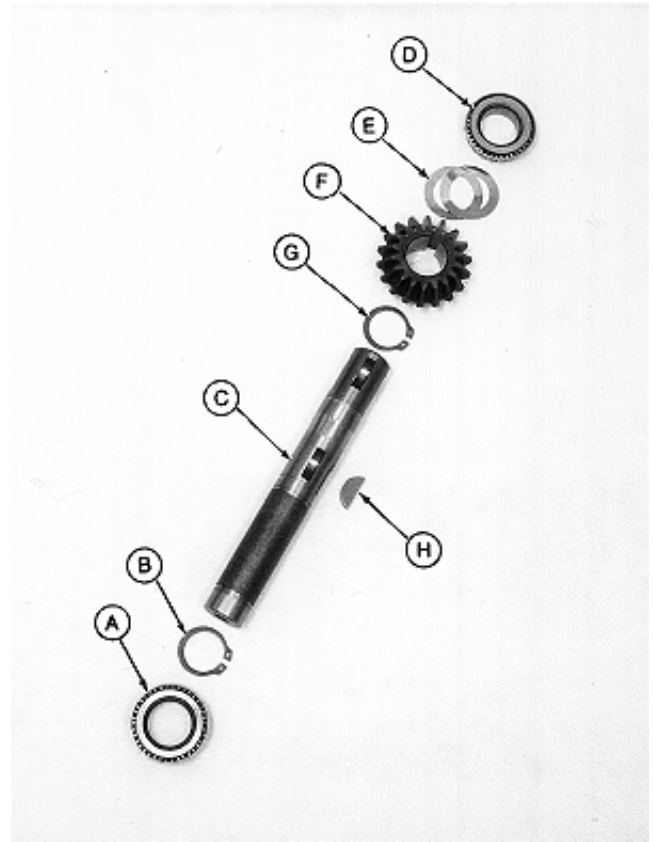

Output Shaft Assembly

M77315 -JUN-24FEB95

MX,15908015,23 -19-13MAR95

## ASSEMBLE MOWER GEAR CASE—LATER 60-INCH MOWER (PEERLESS)

**IMPORTANT:** Always use new seals and O-rings.  
Damaged or used parts will leak.

*NOTE:* Lubricate all O-rings with petroleum jelly during assembly.

*Apply clean gear case oil on all internal parts during assembly.*

1. Install snap ring (G) in first groove under keyway for key (H).
2. Install key (H), bevel gear (F) and shims (E). Install bevel gear on shaft with shoulder facing away from snap ring (G).
3. Press bearing cone (D) on output shaft (C) with small O.D. facing away from shims (E). Install bearing cone until it bottoms against shims.
4. Install snap ring (B).
5. Press bearing cone (A) on output shaft with small O.D. facing away from bevel gear (F). Install bearing cone until it bottoms against snap ring.

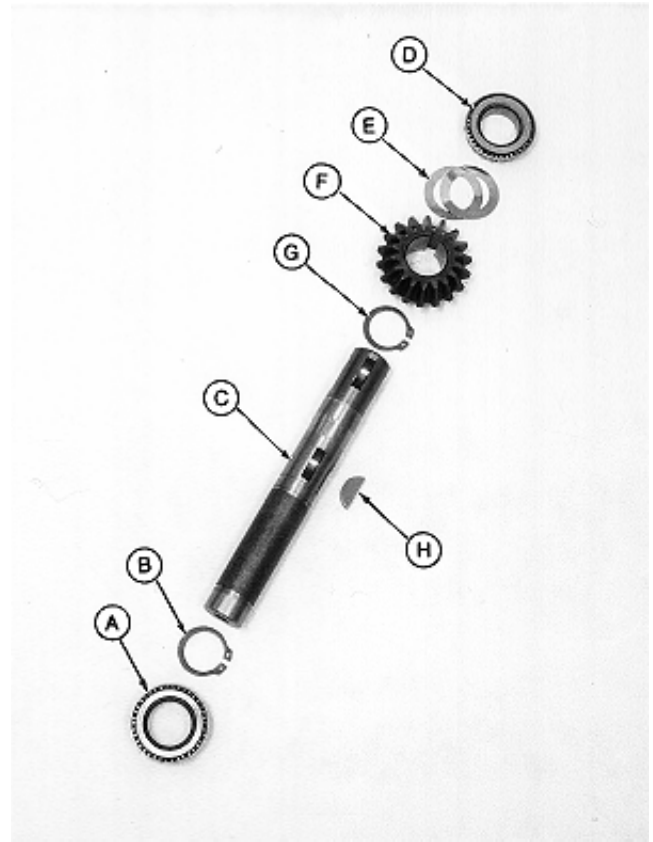

Output Shaft Assembly

- A—Bearing Cone
- B—Snap Ring
- C—Output Shaft
- D—Bearing Cone
- E—Shims (as required)
- F—Bevel Gear
- G—Snap Ring
- H—Key

MX,15908015,24 -19-13MAR95

M77315 -JUN-24FEB95

80  
15  
23

6. Install new bearing cup (I), if removed, into gear case (J) using a driver set.
7. Press new seal (H) into gear case (J) until top of seal is recessed 2.54 mm (0.100 in.) below gear case surface.
8. Apply multipurpose grease to lip of seal.
9. Install vent plug (A).

**IMPORTANT: A new crush ring must be installed during assembly. The ring collapses when retainer is tightened to gear case to achieve proper output shaft end play.**

10. Install new crush ring (E) and bearing cup (D).
11. Install shim (C) and new O-ring (F).

**IMPORTANT: Tape end of output shaft to prevent seal damage during shaft installation.**

12. Apply tape around end of output shaft.
13. Install output shaft assembly (K) into gear case (J). Remove tape.
14. Install retainer assembly and four cap screws (B). Tighten cap screws to 30 N·m (22 lb-ft).

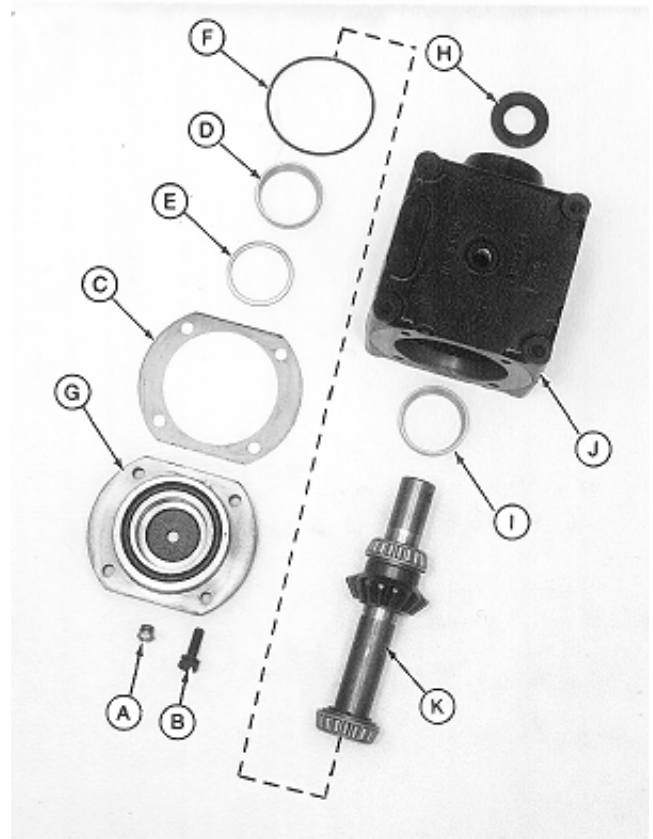

Output Shaft Side

- A—Vent Plug
- B—Cap Screw (4 used)
- C—Shim (as required)
- D—Bearing Cup
- E—Crush Ring
- F—O-Ring
- G—Retainer
- H—Seal
- I—Bearing Cup
- J—Gear Case
- K—Output Shaft Assembly

MX,15908015,25 -19-13MAR95



15. Install new bearing cups (F and G), if removed, using a driver set. Press into pillow block (H) until seated against housing.

16. Install snap ring (B) onto input shaft (C).

17. Press bearing cone (D) on input shaft with small O.D. facing away from snap ring (B). Install bearing until it bottoms against snap ring.

**IMPORTANT: Tape end of input shaft to prevent seal damage during seal installation.**

18. Apply tape around large end of input shaft.

19. Install input shaft assembly into pillow block (H).

20. Apply multipurpose grease to lip of new seal (A).

21. Press new seal (A) into pillow block (H) until top of seal is recessed 2.54 mm (0.100 in.) below pillow block surface. Remove tape from end of shaft.

22. Install new O-ring (E).

- A—Seal
- B—Snap Ring
- C—Input Shaft
- D—Bearing Cone
- E—O-Ring
- F—Bearing Cup
- G—Bearing Cup
- H—Pillow Block

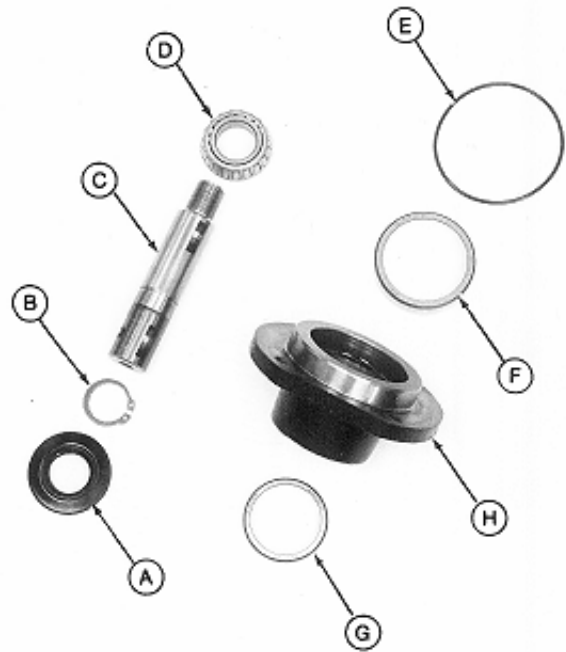

Input Shaft Assembly

MX,15908015,26 -19-13MAR95

M77313 -JUN-24FEB95

23. Install shim (F) on bevel gear (E).

24. Press bearing cone (D) on bevel gear (E) with small O.D. facing away from bevel gear. Install bearing until it bottoms against shim.

25. Install key (G) into input shaft.

26. Install bevel gear assembly onto input shaft.

**IMPORTANT: DO NOT overtighten lock nut (B). Overtightening can damage bearing cone (D).**

27. Install washer (C) and lock nut (B). Tighten lock nut until there is zero endplay in input shaft.

28. Install input shaft assembly into gear case.

29. Install four cap screws (A) and tighten to 30 N-m (22 lb-ft).

- A—Cap Screw (4 used)
- B—Lock Nut
- C—Washer
- D—Bearing Cone
- E—Bevel Gear
- F—Shim (as required)
- G—Key

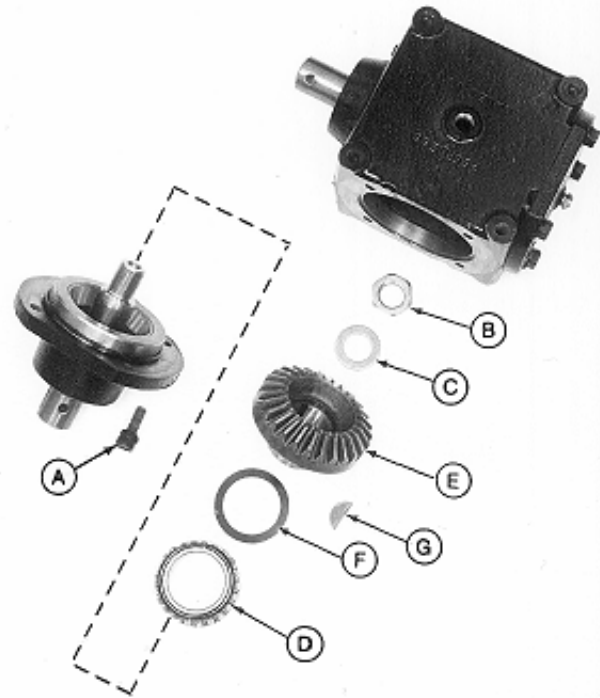

Input Shaft Side

MX,15908015,27 -19-13MAR95

M77312 -JUN-24FEB95

30. AFTER installing gear case on mower deck, fill gear case to proper level with John Deere API GL-5 Gear Oil.

31. Install plugs (A and B).

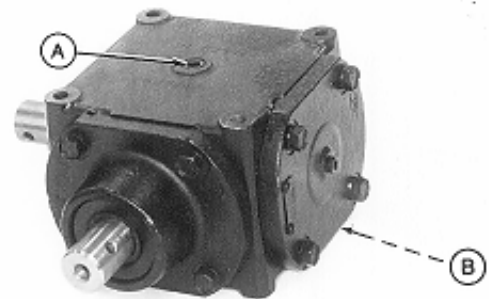

MX,15908015,28 -19-13MAR95

M77311 -JUN-24FEB95

## DISASSEMBLE AND INSPECT MOWER GEAR CASE—260 ROTARY MOWER

1. Remove drain plugs (A and B) and drain oil from gear case.

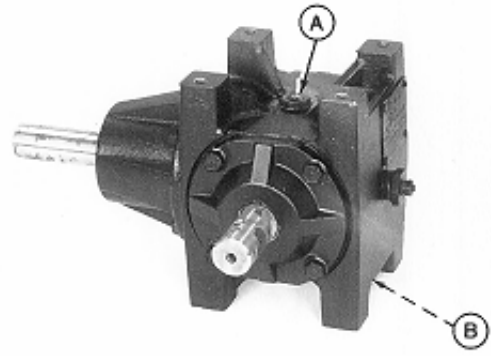

MX,15908015,29 -19-22FEB95

M77323 -UN-24FEB95

2. Remove four cap screws (A).
3. Remove output shaft assembly and housing from gear case (B).
4. Remove shims (C).
5. Punch a hole in seal (D) and pry out of housing (L).
6. Bend out exterior locking tab on toothed washer (E) from lock nut (F).
7. Turn lock nut (F) counterclockwise using a hammer and punch. Remove lock nut.
8. Bend interior locking tab on toothed washer (E) away from groove in shaft (I). Remove toothed washer.
9. Remove tabbed washer (G) and bearing cone (H).
10. Remove output shaft assembly (I) from housing (L).

*NOTE: Bearing cups are press-fit in housing. Remove bearing cups only if replacement is necessary.*

*Bearing cones and cups are matched and must be replaced as complete assemblies.*

11. Inspect bearing cups (K and J) for wear or damage. Replace if necessary.
12. Remove bearing cups using a brass drift or punch and hammer.

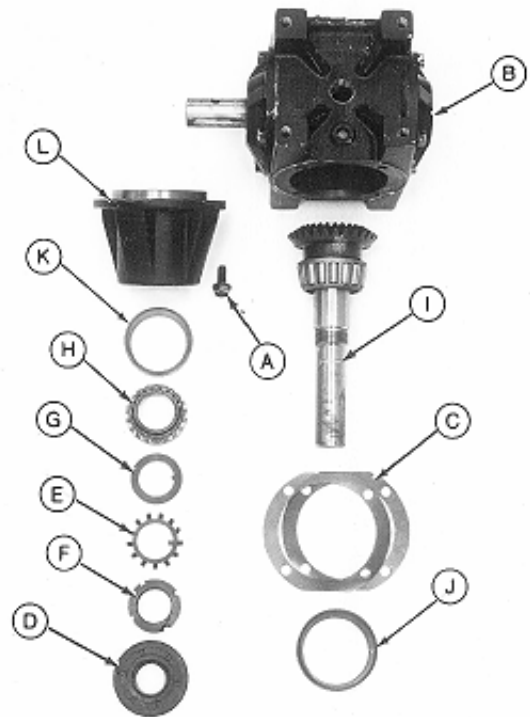

Output Shaft Side



- A—Cap Screw (4 used)
- B—Gear Case
- C—Shims (as required)
- D—Seal
- E—Toothed Washer
- F—Lock Nut
- G—Tabbed Washer
- H—Bearing Cone
- I—Output Shaft Assembly
- J—Bearing Cup
- K—Bearing Cup
- L—Housing

MX,15908015,30 -19-22FEB95

13. Remove bearing cone (A) from shaft (B) using a knife-edge puller and a press.

14. Remove c-ring (C), locking collar (D), bevel gear (E) and key (F).

15. Inspect all parts for wear or damage. Replace as necessary.

- A—Bearing Cone
- B—Output Shaft
- C—C-Ring
- D—Locking Collar
- E—Bevel Gear
- F—Key

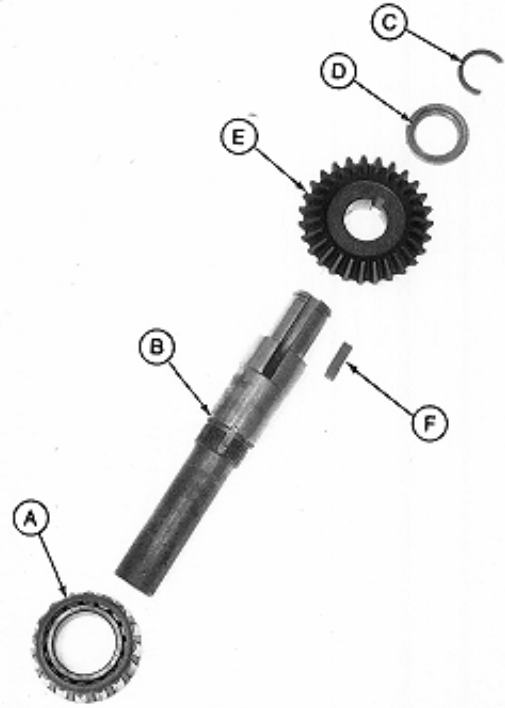

Output Shaft Assembly

MX,15908015,31 -19-22FEB95

M77325 -JUN-24FEB95

16. Remove four cap screws (A).
17. Remove input shaft assembly (B) from gear case (C).
18. Remove four cap screws (D), end cap (E) and shims (F).
19. Remove vent plug (H) and adapter (I).

*NOTE: Bearing cup is press-fit in end cap. Remove bearing cup only if replacement is necessary.*

*Bearing cones and cups are matched and must be replaced as complete assemblies.*

20. Inspect bearing cup (G) for wear or damage. Replace if necessary.

21. Remove bearing cup (G) using a slide hammer and a three-jaw puller.

- A—Cap Screw (4 used)
- B—Input Shaft Assembly
- C—Gear Case
- D—Cap Screw (4 used)
- E—End Cap
- F—Shims (as required)
- G—Bearing Cup
- H—Vent Plug
- I—Adapter

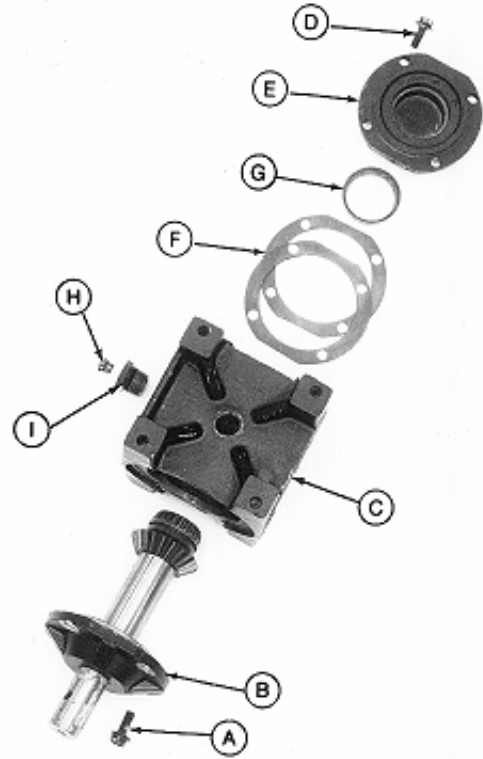

Input Shaft Side

M77326 -JUN-24FEB95

MX,15908015,32 -19-22FEB95

22. Remove input shaft assembly from cap (A).

23. Remove shims (B).

24. Remove seal (C) using a punch and hammer.

*NOTE: Bearing cup is press-fit in cap. Remove bearing cup only if replacement is necessary.*

*Bearing cups and cones are matched and must be replaced as complete assemblies.*

25. Inspect bearing cup (D) for wear or damage. Replace if necessary.

26. Remove bearing cup using a brass drift or punch and hammer.

27. Press shaft (E) from bearing cone (F).

28. Press shaft (E) from bevel gear (G) and bearing cone (H).

29. Remove key (I).

30. Inspect all parts for wear or damage. Replace as necessary.

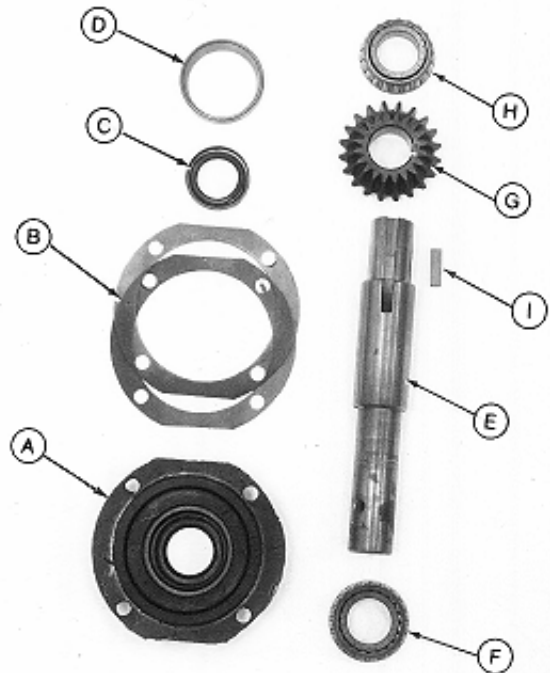

Input Shaft Assembly

- A—Cap
- B—Shims (as required)
- C—Seal
- D—Bearing Cup
- E—Input Shaft
- F—Bearing Cone
- G—Bevel Gear
- H—Bearing Cone
- I—Key

M77327 -JUN-24FEB95

80  
15  
31

## ASSEMBLE MOWER GEAR CASE—260 ROTARY MOWER

**IMPORTANT:** Always use new seals. Damaged or used seals will leak.

*NOTE:* Apply clean gear case oil on all internal parts during assembly.

1. Install key (I) into input shaft (E).
2. Press bevel gear (G), tapered end first, onto shaft (E) until started.
3. Press bearing cone (H) on shaft with small O.D. facing away from bevel gear (G). Install both bearing cone and bevel gear until bearing bottoms against shaft.
4. Press bearing cone (F) onto other end of input shaft (E) with small O.D. facing away from bevel gear.

**IMPORTANT:** Do not press seal in until seated or bottomed out. Seal will become damaged and will leak.

5. Press new seal (C) into cap (A) until top of seal is flush with first recess inside cap.
  6. Apply multipurpose grease to lip of seal.
  7. Install new bearing cup (D), if removed, using a driver set.
- IMPORTANT:** Tape end of input shaft to prevent seal damage during shaft installation.

8. Apply tape around end of input shaft.
9. Assemble input shaft assembly and cap (A). Remove tape.
10. Install shims (B) on cap (A).

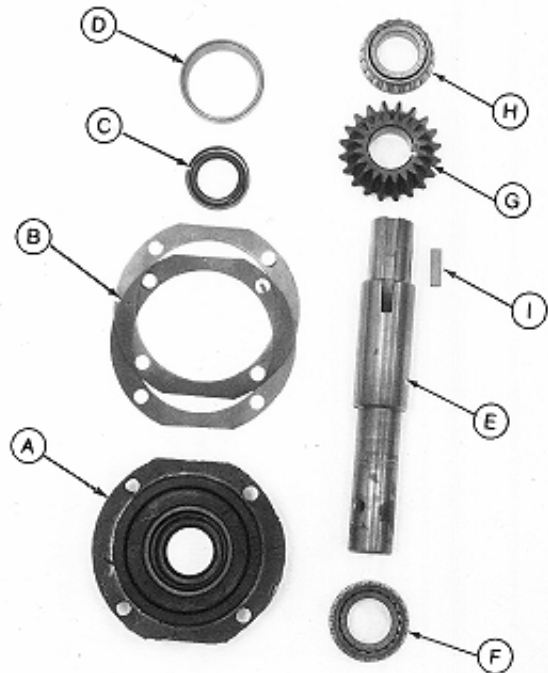

Input Shaft Assembly

- A—Cap
- B—Shims (as required)
- C—Seal
- D—Bearing Cup
- E—Input Shaft
- F—Bearing Cone
- G—Bevel Gear
- H—Bearing Cone
- I—Key

MT7327 -JUN-24FEB95

MX,15908015,34 -19-29MAR95



11. Install new bearing cup (G), if removed, into end cap (E) using a driver set.
12. Install shims (F) onto end cap (E).
13. Clean mating surfaces of cap, shims and gear case using Clean and Cure Primer. Apply a bead of Form-In-Place Gasket, or an equivalent, between inside edge of top shim and flange on end cap (E).
14. Install end cap and four cap screws (D) onto gear case (C). Tighten cap screws to 30 N·m (22 lb-ft).
15. Install input shaft assembly (B) into gear case (C).
16. Install four cap screws (A) and tighten to 30 N·m (22 lb-ft).
17. Check input shaft endplay. Endplay should be within 0.025—0.076 mm (0.001—0.003 in.). If necessary, remove four cap screws (D) and end cap (E) and add or remove shims (F) as needed.
18. Remove input shaft assembly (B).
19. Clean mating surfaces of cap, shims and gear case using Clean and Cure Primer. Apply a bead of Form-In-Place Gasket, or an equivalent, between inside edge of top shim and flange on cap.
20. Install input shaft assembly and four cap screws (D). Tighten cap screws to 30 N·m (22 lb-ft).
21. Install adapter (I) and vent plug (H).

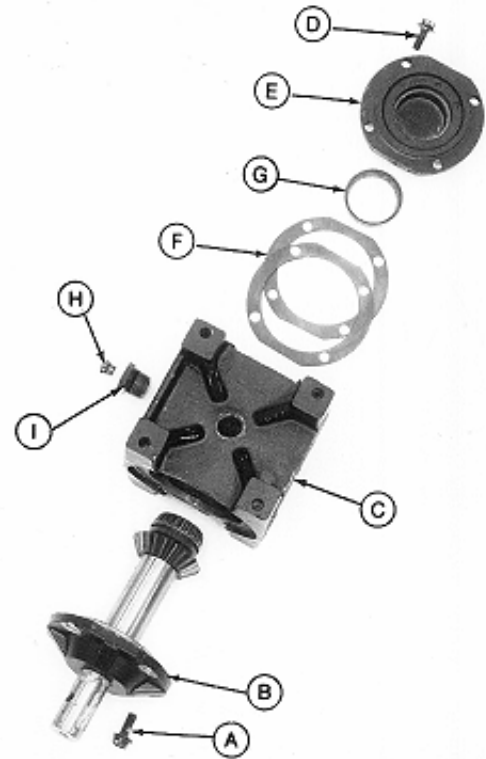

Input Shaft Side

- A—Cap Screw (4 used)
- B—Input Shaft Assembly
- C—Gear Case
- D—Cap Screw (4 used)
- E—End Cap
- F—Shims (as required)
- G—Bearing Cup
- H—Vent Plug
- I—Adapter

M77326 -JUN-24FEB95

80  
15  
33

MX,15908015,35 -19-29MAR95

22. Install key (F) and bevel gear (E) on shaft (B). Install bevel gear with shoulder end toward threaded end of shaft.

23. Install locking collar (D) with groove facing away from bevel gear. Install c-ring (C).

24. Press bearing cone (A) on shaft with small O.D. facing away from bevel gear (E). Install bearing until it bottoms locking collar (D) against c-ring (C).

- A—Bearing Cone
- B—Output Shaft
- C—C-Ring
- D—Locking Collar
- E—Bevel Gear
- F—Key

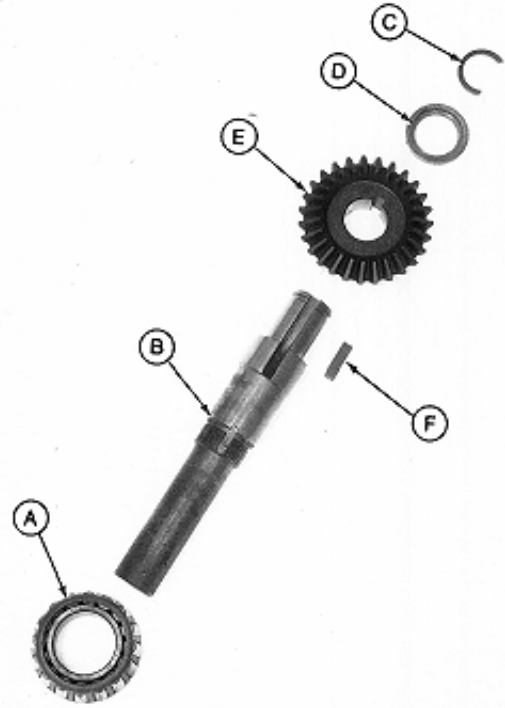

Output Shaft Assembly

MX,15908015,36 -19-13MAR95

M77325 -JUN-24FEB95

25. Install new bearing cups (K and J), if removed, into housing (L) using a driver set.

26. Install output shaft assembly (I) into housing (L).

27. Slide bearing cone (H) on shaft with small O.D. facing toward housing (L).

28. Install tabbed washer (G) and toothed washer (E). Press internal tab on toothed washer (E) into slot on shaft using a screwdriver.

29. Install lock nut (F). Tighten lock nut, using a punch and hammer, until there is zero endplay in output shaft. Bend up one tab from toothed washer (E), that is in alignment with a slot in lock nut (F), to secure nut in place.

**IMPORTANT: Tape end of output shaft to prevent seal damage during shaft installation.**

30. Apply tape around end of output shaft.

31. Apply multipurpose grease to lip of seal.

32. Press new seal (D) into housing (L) until seal is flush with top of housing. Remove tape.

33. Install shims (C) on housing (L).

34. Install output shaft assembly and housing into gear case (B).

35. Install four cap screws (A) and tighten to 30 N-m (22 lb-ft).

36. Hold input shaft securely and check output shaft backlash. Backlash should be within 0.076—0.130 mm (0.003—0.005 in.). If necessary, remove four cap screws (A) and housing and output shaft assembly and add or remove shims (C) as needed.

37. Again, remove four cap screws (A) and housing and output shaft assembly.

38. Clean mating surfaces of housing, shims and gear case using Clean and Cure Primer. Apply a bead of Form-In-Place Gasket, or an equivalent, between inside edge of top shim and flange on housing (L).

39. Install housing and output shaft assembly into gear case. Install four cap screws (A) and tighten to 30 N-m (22 lb-ft).

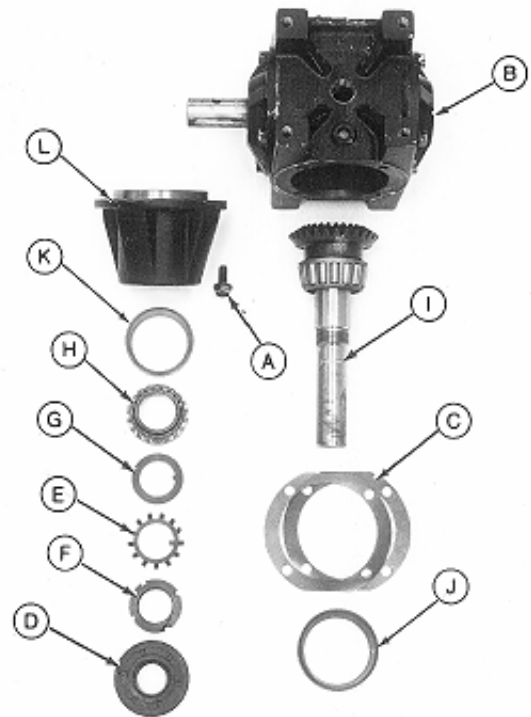

Output Shaft Side

- A—Cap Screw (4 used)
- B—Gear Case
- C—Shims (as required)
- D—Seal
- E—Toothed Washer
- F—Lock Nut
- G—Tabbed Washer
- H—Bearing Cone
- I—Output Shaft Assembly
- J—Bearing Cup
- K—Bearing Cup
- L—Housing

-JUN-24/FEB95  
MT7324

80  
15  
35

40. AFTER installing gear case on mower deck, fill gear case to proper level with John Deere API GL-5 Gear Oil.

41. Install plugs (A and B).

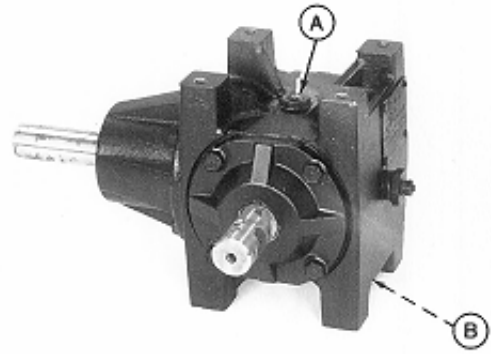

MX,15908015,38 -19-13MAR95

M77323 -UN-24FEB95

# Section 220

# ENGINE, FUEL AND AIR SYSTEM CHECKOUT AND DIAGNOSIS

## Contents

	Page	Page
<b>Group 05—Engine, Fuel and Air System Checkout</b>		
Before You Start . . . . .	220-05-1	
Engine Oil Leak Check . . . . .	220-05-1	
Engine Cooling System Leak Check . . . . .	220-05-2	
Air Cleaner and Radiator Screen Check . . . . .	220-05-2	
Fan and Belt Check . . . . .	220-05-3	
Throttle Lever Check . . . . .	220-05-3	
Governor Linkage Check . . . . .	220-05-4	
Fuel System Check . . . . .	220-05-5	
Engine Start Check . . . . .	220-05-6	
Choke Lever Check (Early 322) . . . . .	220-05-6	
Fuel Shutoff Lever Check (330) . . . . .	220-05-7	
Engine Oil Pressure Check . . . . .	220-05-7	
Engine Performance Check . . . . .	220-05-7	
Operator Complaint Not Identified . . . . .	220-05-8	
<b>Group 10—Diagnosis, Tests and Adjustments—322</b>		
About This Group . . . . .	220-10-1	
Troubleshooting Guide . . . . .	220-10-1	
Radiator Bubble Test . . . . .	220-10-5	
Throttle Lever Adjustment . . . . .	220-10-5	
Carburetor Idle Mixture Screw Adjustment . . . . .	220-10-6	
Governor Linkage and Idle Speed Adjustments . . . . .	220-10-6	
Throttle Cable Adjustment . . . . .	220-10-7	
Fuel Transfer Pump Test . . . . .	220-10-8	
Choke Adjustment . . . . .	220-10-8	
Engine Oil Pressure Test . . . . .	220-10-11	
Ignition Spark Test . . . . .	220-10-11	
Cooling System Pressure Test . . . . .	220-10-12	
Compression Pressure Test . . . . .	220-10-12	
<b>Group 11—Diagnosis, Tests and Adjustments—330, 332 and 430</b>		
About This Group . . . . .	220-11-1	
Troubleshooting Guide . . . . .	220-11-2	
Radiator Bubble Test . . . . .	220-11-6	
Throttle Lever Adjustment . . . . .	220-11-6	
Throttle Cable Adjustment . . . . .	220-11-6	
Fuel Transfer Pump Test . . . . .	220-11-7	
Bleed Fuel Injection System . . . . .	220-11-8	
Compression Pressure Test . . . . .	220-11-10	
Engine Oil Pressure Test . . . . .	220-11-11	
Idle Speed Adjustment . . . . .	220-11-12	
Cooling System Pressure Test . . . . .	220-11-14	
Fuel Controller Adjustment . . . . .	220-11-15	



# Group 05 Engine, Fuel and Air System Checkout

## BEFORE YOU START

Always begin with this group to identify a failure in the engine, fuel or air system. The step-by-step procedures will provide you with a quick check of the system. No special tools are required to perform these checks. If a failure is indicated, you will be referred to a more detailed check, adjustment, or test.

Always start with the first step and follow the sequence from left to right. Read each step completely before performing the check.

This procedure is designed as a quick check of the system. While performing the check, concentrate only on the check you are performing and disregard signals from unrelated components.

**NOTE:** 322 (S.N. —010713); Manual choke.  
322 (S.N. 010714— ); Automatic choke.

**NOTE:** When instructed to “turn the key switch ON”:

322 and 430; Turn the key switch to the “RUN” position.

330 and 332; Turn the key switch to the “ON” position.

For clarity in this section, machines including and before serial numbers listed below will be referred to as “Early Models”. Machines including and after serial number listed below will be referred to as “Later Models”.

Later model machines have a brake switch added to the neutral start circuit, which is activated by depressing the brake pedals.

MODEL	EARLY	LATER
322	(S.N. —596005)	(S.N. 596006— )
330	(S.N. —420000)	N/A
332	(S.N. —475000)	(S.N. 475001— )
430	(S.N. —596047)	(S.N. 596048— )

MX,159122005,1A-19-13JUL95

<p><b>ENGINE OIL LEAK CHECK</b></p>	<p>Check engine oil level, condition and viscosity.</p>	 <p>M44146 -UN-08JAN90</p> <p><b>LOOK:</b> Oil level must be between add and full marks.</p> <p><b>LOOK:</b> Oil must not look “milky”.</p> <p><b>SMELL:</b> Oil must not smell burned.</p> <p>If oil level is low, add oil. Inspect for external oil leakage from oil pan gasket, drain plug, valve cover gasket, seals, dipstick and oil filter. Repair as necessary.</p>	<p><b>OK:</b> GO TO ' 11</p> <p><b>NOT OK:</b> OIL LOOKS “MILKY” (Indicates water in oil): 322; GO TO ' 11, Group 10 330, 332 and 430; GO TO ' 11, Group 11</p> <p><b>OIL SMELLS BURNED:</b> (Indicates cooling system malfunction) GO TO ' 11</p> <p>MX,159122005,1 -19-13JUL95</p>
-------------------------------------	---	--	--

Engine, Fuel and Air System Checkout/Air Cleaner and Radiator Screen Check

<p><b>' ENGINE COOLING SYSTEM LEAK CHECK</b></p>	<p><b>N CAUTION: DO NOT REMOVE RADIATOR CAP UNLESS ENGINE IS COOL. THEN TURN CAP SLOWLY TO THE STOP. RELEASE ALL PRESSURE BEFORE YOU REMOVE CAP.</b></p>	
--	--	--

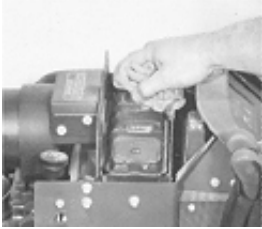
 <p>M49179 -UN-20DEC89</p>	<p>Remove radiator cap and check coolant level and condition.</p> <p><i>LISTEN: If radiator is warmer than air temperature a "whoosh" must be heard when radiator cap is opened to first stop position.</i></p> <p><i>LOOK: The radiator cap must have a good seal and gasket. The seal must move freely and the spring must not be corroded.</i></p> <p><i>LOOK: The coolant must not be oily, foamy, or rusty.</i></p> <p><i>LOOK: Inspect for external leakage from radiator, water pump, thermostat cover and radiator hoses.</i></p> <p><i>LOOK: Inspect radiator for bent or clogged fins.</i></p>	<p><b>OK: GO TO Æ</b></p> <p><b>NOT OK:</b>  <b>RADIATOR CAP DEFECTIVE:</b> Replace cap.</p> <p><b>COOLANT OILY OR FOAMY:</b>          322; GO TO ', Group 10          330, 332 and 430; GO TO ', Group 11</p> <p><b>COOLANT RUSTY:</b> Drain, flush, and put in new coolant.</p> <p><b>COOLING SYSTEM LEAKS OR RADIATOR FINS BENT OR CLOGGED:</b> Repair, replace or clean as necessary, then GO TO Æ.</p> <p style="text-align: right;">MX,159122005,2 -19-13JUL95</p>
---	--	--

<p><b>Æ AIR CLEANER AND RADIATOR SCREEN CHECK</b></p>	 <p>M49176 -UN-20DEC89</p>	<p>Remove air cleaner cover.</p> <p>Inspect air cleaner, grill and radiator screen for debris or plugged condition.</p>	<p>Clean or replace as required, then GO TO Æ</p> <p style="text-align: right;">MX,159122005,3 -19-13JUL95</p>
---	---	---	--

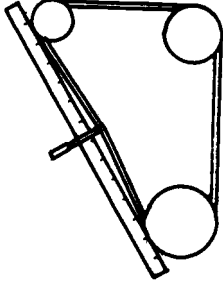
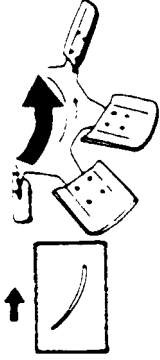

Engine, Fuel and Air System Checkout/Throttle Lever Check

<p><b>Ä FAN AND BELT CHECK</b></p>	<p>Inspect fan blade, belts, and sheaves for damage.</p> <p>Check fan for loose mounting cap screws.</p> <p>Check crankshaft sheave to be sure it is not slipping on the crankshaft.</p>	 <p>T6171CA -UN-25MAY89</p>  <p>T6171CB -UN-25MAY89</p>	<p><i>LOOK: Fan belt deflection should be approximately 13 mm (0.500 in.) when a 10—11 kg (22—24 lb) force is applied midway between alternator and crankshaft sheave.</i></p> <p><i>LOOK: Fan belt must not have any cracks or contact bottom of sheave grooves.</i></p> <p><i>LOOK: Make sure there is no oil on belt.</i></p> <p><i>LOOK: Cupped side of fan blades must be away from radiator and mounting cap screws must be tight.</i></p> <p><i>NOTE: If the fan blade has been installed backwards about 50% of its capacity is lost.</i></p>	<p><b>OK:</b> GO TO Ö</p> <p><b>NOT OK:</b> Adjust fan belt as necessary.</p> <p>FAN BELT WORN, OILY, OR DAMAGED; Clean or replace as necessary.</p> <p>FAN ON BACKWARDS; Remove and install fan correctly.</p> <p>After making necessary repairs or adjustments, then GO TO Ö</p>
------------------------------------	--	--	---	--

MX,159122005,4 -19-13JUL95

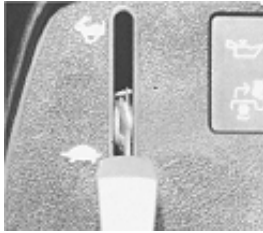
<p><b>Ö THROTTLE LEVER CHECK</b></p>	 <p>M49006 -UN-08JAN90</p>	<p>Move throttle lever from slow idle position to fast idle position.</p> <p><i>FEEL: Throttle lever must move smoothly with a slight drag.</i></p>	<p><b>OK:</b> 322; GO TO 6a 330, 332 and 430; GO TO 6b</p> <p><b>NOT OK:</b> 322; GO TO Ä, Group 10 330, 332 and 430; GO TO Ä, Group 11</p>	<p>MX,159122005,5 -19-13JUL95</p>
--------------------------------------	---	---	---	-----------------------------------

220  
05  
3

Engine, Fuel and Air System Checkout/Governor Linkage Check

0 GOVERNOR LINKAGE CHECK

MX,159122005,6 -19-13JUL95

6a 322

Remove left engine side panel.



M49006 -UN-08JAN90

Move throttle lever to slow idle position.

LOOK: Carburetor governor linkage must be against stop (A).



M44150 -UN-08JAN90

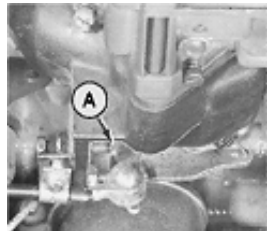

M44151 -UN-08JAN90

Move throttle lever to fast idle position.

LOOK: Carburetor governor linkage must be against stop (A).



M44152 -UN-08JAN90

LOOK: If bracket is equipped with more than one hole, spring (A) must be in outer hole.

OK: GO TO 7a  
NOT OK: GO TO 0, Group 10.

MX,159122005,7 -19-13JUL95

6b 330, 332 and 430

Remove left engine side panel.

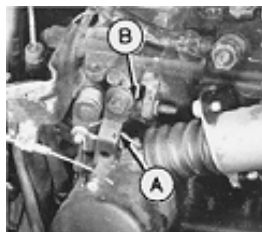

M49180 -UN-20DEC89

Move throttle lever on instrument panel to slow idle.

LOOK: Injection pump lever (A) must strike slow idle stop screw (B).

Move throttle lever on instrument panel to fast idle.

FEEL: Injection pump lever (A) must strike fast idle stop screw. (Located inside governor housing).

OK: GO TO 7b  
NOT OK: GO TO Å, Group 11.

MX,159122005,8 -19-13JUL95

220  
05  
4

Engine, Fuel and Air System Checkout/Fuel System Check

0 FUEL SYSTEM CHECK

MX,159122005,9 -19-13JUL95

7a 322

Turn key switch to RUN position.

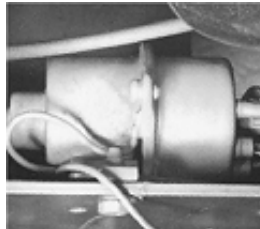

M49009 -UN-08JAN90

*LISTEN: Fuel pump must run making a "ticking" sound.*



M44154 -UN-08JAN90

*LOOK: Fuel level in filter must rise when fuel transfer pump is turned on.*

**OK:** GO TO 8a

**NOT OK:** Fuel pump not OK; GO TO Section 240.

No fuel in filter; GO TO 0, GROUP 10.

MX,159122005,10-19-13JUL95

7b 330, 332 and 430

Be sure fuel tank has the correct grade of diesel fuel in it.

Turn key switch to ON/RUN position.

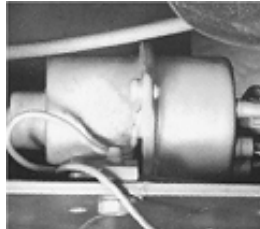

M49009 -UN-08JAN90

*LISTEN: Fuel pump must run making a "ticking" sound.*

*LOOK: 332 and 430; Fuel shutoff solenoid must pull in and hold.*



**OK:** GO TO 8b

**NOT OK:** Go to Section 240.

MX,159122005,11-19-13JUL95

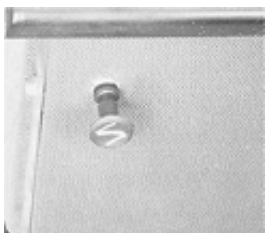

220  
05  
5

Engine, Fuel and Air System Checkout/Choke Lever Check (Early 322)

<p>Ü <b>ENGINE START CHECK</b></p>				<p>MX,159122005,12-19-13JUL95</p>
<p>8a 322</p>	<p>Operator on seat.</p> <p>Put hydrostatic control lever in N/STOP position.</p> <p>PTO switch OFF.</p> <p>Later Models; Depress brake pedals.</p>	 <p>M49177 -UN-20DEC89</p>	<p>Turn key to START position.</p> <p><i>LISTEN: Starter must crank. Engine must start.</i></p>	<p><b>OK:</b> Early Models with choke lever, GO TO Ü Later Models without choke lever, GO TO 1!</p> <p><b>NOT OK:</b> STARTER DOES NOT CRANK; GO TO Section 240.</p> <p>STARTER CRANKS BUT ENGINE WILL NOT START; GO TO A, Group 10.</p> <p>MX,159122005,13-19-13JUL95</p>
<p>8b 330, 332 and 430</p>	<p>Operator on seat.</p> <p>Put hydrostatic control lever in N/STOP position.</p> <p>PTO switch OFF.</p> <p>Later Models; Depress brake pedal(s).</p>	 <p>M49177 -UN-20DEC89</p>	<p>Turn key to ON/RUN position. After glow plug lamp goes off, turn key to START.</p> <p><i>LISTEN: Starter must crank. Engine must start.</i></p>	<p><b>OK:</b> 332 and 430; GO TO 1! 330; GO TO 10</p> <p><b>NOT OK:</b> STARTER DOES NOT CRANK; GO TO Section 240.</p> <p>STARTER CRANKS BUT ENGINE WILL NOT START; GO TO A, Group 11.</p> <p>MX,159122005,14-19-13JUL95</p>
<p>Ü <b>CHOKE LEVER CHECK (EARLY 322)</b></p>	 <p>M49178 -UN-20DEC89</p>	<p>Start and run engine at half throttle.</p> <p>Quickly pull choke knob fully out, then push in.</p>	<p><i>LISTEN: Engine must falter, then resume speed.</i></p>	<p><b>OK:</b> GO TO 1!</p> <p><b>NOT OK:</b> GO TO Ü, Group 10.</p> <p>MX,159122005,15-19-13JUL95</p>

220  
05  
6

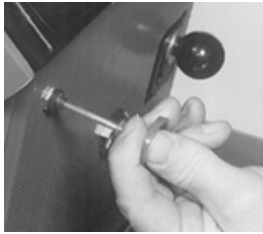
*Engine, Fuel and Air System Checkout/Engine Performance Check*

<p><b>10 FUEL SHUTOFF LEVER CHECK (330)</b></p>		<p>Start and run engine at half throttle.</p> <p>Quickly pull fuel shutoff knob fully out, then push in.</p>	<p><i>LISTEN: Engine must falter, then resume speed.</i></p>	<p><b>OK: GO TO 1!</b></p> <p><b>NOT OK:</b> Inspect linkage for binding. Replace if necessary.</p>
<p><b>1! ENGINE OIL PRESSURE CHECK</b></p>		<p>Start and run engine at half throttle.</p> <p><i>LOOK: Immediately after engine starts oil pressure lamp (A) must go off.</i></p>	<p><b>OK: GO TO 1@</b></p> <p><b>NOT OK:</b> OIL PRESSURE LAMP STAYS ON; Test oil pressure switch. See Section 240.</p> <p>If switch is OK and lamp is still on: 322; GO TO U, Group 10 330, 332 and 430; GO TO U, Group 11</p>	<p align="right">MX,159122005,16-19-13JUL95</p>
<p><b>1@ ENGINE PERFORMANCE CHECK</b></p>	<p><b>CAUTION: ENGINE EXHAUST FUMES CAN CAUSE SICKNESS OR DEATH. IF RUNNING AN ENGINE IN AN ENCLOSED AREA, REMOVE THE EXHAUST FUMES FROM THE AREA WITH AN EXHAUST PIPE EXTENSION. IF YOU DO NOT HAVE AN EXHAUST PIPE EXTENSION, OPEN THE DOORS AND GET OUTSIDE AIR INTO THE AREA.</b></p>			<p align="right">MX,159122005,17-19-13JUL95</p>
<p><b>1&lt;a Engine Under No-Load</b></p>		<p>Operator on seat.</p> <p>PTO switch OFF.</p> <p>Start engine.</p> <p>Move throttle lever from slow idle to fast idle.</p> <p><i>LISTEN: Engine must accelerate smoothly, without hesitation.</i></p> <p><i>LOOK: Exhaust must be clear.</i></p> <p><i>LISTEN: Governor must hold engine at a constant rpm and not surge.</i></p> <p><i>LISTEN: Engine must not make any abnormal sounds or backfire.</i></p>	<p><b>OK: GO TO 1&lt;b</b></p> <p><b>NOT OK:</b> 322; GO TO ; , Group 10 330, 332 and 430; GO TO ; , Group 11</p>	

220  
05  
7

*Engine, Fuel and Air System Checkout/Operator Complaint Not Identified*

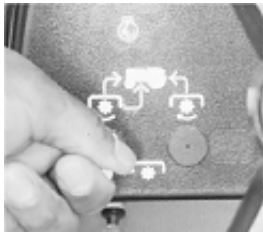
<p><b>1 &lt; b</b> Engine Under Load</p>	 <p>M55019 -UN-09DEC89</p> <p>Start engine and run at half throttle.</p> <p>Engage PTO lever with implement attached.</p> <p>Move throttle lever to fast idle position.</p> <p>Cycle attached implement, if possible, to load engine.</p> <p><i>LISTEN: Governor must increase and decrease engine rpm to match load condition.</i></p> <p><i>LOOK: Exhaust must be clear.</i></p> <p><i>LISTEN: Engine must not make any abnormal sounds or backfire.</i></p> <p><i>LISTEN: Engine must not hesitate or stumble.</i></p>	<p><b>OK:</b> System Normal.</p> <p><b>NOT OK:</b> 322; GO TO ; , Group 10 330, 332 and 430; GO TO ; , Group 11</p> <p align="right">MX,159122005,20-19-13JUL95</p>
<p><b>1 # OPERATOR COMPLAINT NOT IDENTIFIED</b></p>	<p>If you completed the checkout procedure and did not isolate a malfunction, the problem may be intermittent.</p> <p>Try to duplicate the conditions of the malfunction identified by the operator.</p> <p>Repeat system checkout in this group.</p>	<p>IF A MALFUNCTION IS NOT IDENTIFIED AFTER REPEATING SYSTEM CHECKOUT PROCEDURE, FACTORY ASSISTANCE IS AVAILABLE THROUGH THE DEALER TECHNICAL ASSISTANCE CENTER (DTAC).</p> <p align="right">MX,159122005,18-19-13JUL95</p>

220  
05  
8

## ABOUT THIS GROUP

Always perform the system checkout procedures in Group 05 BEFORE making any tests or adjustments in this group. The step-by-step procedures in this group provide you with the detailed diagnostic information you will need to isolate a malfunction. Basic diagnostic equipment is used.

It is assumed that you are familiar with the machine and its engine, fuel and air system components.

Engine rpm and temperature are critical in most engine tests. Be sure to follow test specifications carefully.

Always start with the first step and follow the sequence from left to right. Read each step completely before performing the test.

Upon completing a test or adjustment, check to see whether the problem is corrected by performing the checkout procedures in Group 05.

*NOTE: For clarity in this section, machines (S.N. —596005) will be referred to as “Early Models”. Machines (S.N. 596006— ) will be referred to as “Later Models”.*

*Later model machines have a brake switch added to the neutral start circuit, which is activated by depressing the brake pedals.*

MX,159122010,1A-19-13JUL95

## ; TROUBLESHOOTING GUIDE

If engine does not operate properly, select the appropriate symptom from the list below. (If engine does not crank, see Section 240.)

- ENGINE WILL NOT START OR STARTS HARD: GO TO A
- ENGINE BACKFIRES: GO TO B
- ENGINE MISSES: GO TO C
- ENGINE SURGES OR STALLS FREQUENTLY: GO TO D
- ENGINE DOES NOT DEVELOP FULL POWER: GO TO E
- ENGINE RUNS ERRATICALLY: GO TO F
- ENGINE OVERHEATS OR RUNS COLD: GO TO G
- ABNORMAL ENGINE NOISE: GO TO H
- LOW OIL PRESSURE: GO TO I
- ENGINE USES TOO MUCH OIL: GO TO J
- ENGINE USES TOO MUCH FUEL: GO TO K

MX,159122010,1 -19-13JUL95

## A ENGINE WILL NOT START OR STARTS HARD

- Test ignition spark and spark plugs: GO TO 10
- Test fuel shutoff solenoid: See Section 240.
- Test fuel transfer pump: GO TO 0
- Inspect and adjust choke: GO TO U
- Adjust idle mixture screw: GO TO A
- Check carburetor float adjustment: See Engine CTM12.

MX,159122010,2 -19-13JUL95

## B ENGINE BACKFIRES

- Check ignition system: See Section 240.
- Adjust idle mixture screw: GO TO A
- Check for sticking valves: See Engine CTM12.
- Check and adjust valve clearance: See Engine CTM12.

MX,159122010,3 -19-13JUL95

## C ENGINE MISSES

- Test ignition spark and spark plugs: GO TO 10
- Adjust idle mixture screw: GO TO A
- Check for wet or deteriorated spark plug wires.
- Check ignition system: See Section 240.
- Check carburetor float adjustment: See Engine CTM12.
- Check and adjust valve clearance: See Engine CTM12.

MX,159122010,4 -19-13JUL95



## **D ENGINE SURGES OR STALLS FREQUENTLY**

- Test fuel transfer pump: GO TO 0
- Adjust idle mixture screw: GO TO A
- Inspect and adjust choke: GO TO U
- Check carburetor gasket and intake manifold gasket for air leaks.
- Check carburetor float adjustment: See Engine CTM12.
- Test cooling system: GO TO 1!
- Test thermostat: See Engine CTM12.
- Test compression pressure: GO TO 1@
- Check and adjust valve clearance: See Engine CTM12.

MX,159122010,5 -19-13JUL95

## **E ENGINE DOES NOT DEVELOP FULL POWER**

- Adjust idle mixture screw: GO TO A
- Check and adjust idle speeds: GO TO 0
- Test ignition spark and spark plugs: GO TO 10
- Test fuel transfer pump: GO TO 0
- Check muffler for restriction or plugged condition.
- Test compression pressure: GO TO 1@
- Check and adjust valve clearance: See Engine CTM12.

MX,159122010,6 -19-13JUL95

## **F ENGINE RUNS ERRATICALLY**

- Adjust idle mixture screw: GO TO A
- Check carburetor for plugged passages and float level adjustment: See Engine CTM12.
- Check for loose electrical connections: See Section 240.
- Test ignition spark and spark plugs: GO TO 10
- Check ignition system: See Section 240.
- Test fuel transfer pump: GO TO 0
- Test compression pressure: GO TO 1@
- Check and adjust valve clearance: See Engine CTM12.

MX,159122010,7 -19-13JUL95

## **G ENGINE OVERHEATS OR RUNS COLD**

- Test coolant temperature lamp and switch: See Section 240.
- Test thermostat: See Engine CTM12.
- Test cooling system: GO TO 1!
- Check muffler for restriction or plugged condition.
- Adjust idle mixture screw: GO TO Å
- Check engine oil pressure: GO TO Ü
- Check for defective water pump: See Engine CTM12.
- Check for carbon build-up in combustion chamber: See Engine CTM12.

MX,159122010,8 -19-13JUL95

## **H ABNORMAL ENGINE NOISE**

- Check for loose flywheel: See Engine CTM12.
- Check and adjust valve clearance: See Engine CTM12.
- Check for carbon build-up in combustion chamber: See Engine CTM12.
- Inspect engine for worn cylinder walls, loose or worn connecting rods, excessive main bearing end play, and excessive crankshaft or camshaft end play: See Engine CTM12.

MX,159122010,9 -19-13JUL95

## **I LOW OIL PRESSURE**

- Test oil pressure lamp and switch: See Section 240.
- Check engine oil pressure: GO TO Ü
- Check for excessive main bearing clearance and connecting rod bearing clearance: See Engine CTM12.

MX,159122010,10-19-13JUL95

**J ENGINE USES TOO MUCH OIL**

- Test compression pressure: GO TO 1@
- Check valve stem seals: See Engine CTM12.

MX,159122010,11-19-13JUL95

**K ENGINE USES TOO MUCH FUEL**

- Test spark plugs: GO TO 10
- Adjust idle mixture screw: GO TO A
- Inspect and adjust choke: GO TO U
- Check carburetor float adjustment: See Engine CTM12.

MX,159122010,12-19-13JUL95

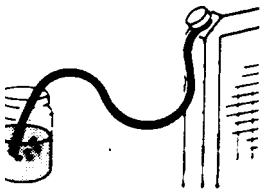
<p><b>RADIATOR BUBBLE TEST</b></p>	<p>Coolant at proper level. Radiator cap tightened. Start and run engine to bring it to operating temperature.</p>	 <p>Put end of radiator overflow hose in a container of water. <i>LOOK: While engine is running, check for bubbles coming from hose.</i></p> <p>T6171AR -UN-25MAY89</p>	<p><b>NO BUBBLES:</b> Continue with test. <b>BUBBLES PRESENT:</b> Replace head gasket, See engine CTM12.</p> <p>MX,159122010,13-19-13JUL95</p>
------------------------------------	--	--	--

<p>Change engine oil. Check old oil for water contamination.</p>	<p>Drain and flush cooling system. Refill cooling system with new coolant.</p>	<p>Operate machine normally. Periodically monitor the engine oil and coolant for signs of contamination. If oil and coolant are OK after several hours of operation, the original problem was caused by condensation or the use of contaminated oil.</p>	<p><b>COOLANT IN OIL OR OIL IN COOLANT:</b> Check for blown head gasket, cracked block or cracked cylinder head. See engine CTM12.</p> <p>MX,15912201013A-19-13JUL95</p>
--	--	--	--

<p><b>THROTTLE LEVER ADJUSTMENT</b></p>	 <p>M49159 -UN-20DEC89</p>	<p>Tighten or loosen nut (A) until throttle lever moves from slow to fast idle with a slight drag. Replace friction washers (B) if necessary. Throttle lever must hold in all positions.</p> <p>MX,159122010,14-19-13JUL95</p>
---	---	--

220  
10  
5

**Ä CARBURETOR IDLE MIXTURE SCREW ADJUSTMENT**

Raise hood.  
Remove left engine side panel.

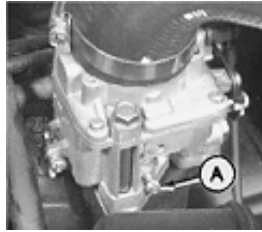

M44139 -UN-08JAN90

**IMPORTANT: Forcing the idle mixture screw tight will damage the needle and seat.**

Turn idle mixture screw (A) clockwise until lightly seated then counterclockwise 1-1/2 turns.

Start and run engine to bring it to normal operating temperature.

Move throttle lever to slow idle position.



M44140 -UN-07SEP88

**N CAUTION: ENGINE WILL BE HOT. BE CAREFUL NOT TO BURN HANDS.**

Hold throttle lever against low speed stop.

Turn idle mixture screw (A) in until engine speed drops, then out until engine speed increases and begins to drop again.

Adjust idle mixture screw for highest engine speed between drops, then turn screw out an additional 1/8 turn.

MX,159122010,15-19-13JUL95

220  
10  
6

**Ö GOVERNOR LINKAGE AND IDLE SPEED ADJUSTMENTS**

*NOTE: Carburetor idle mixture must be adjusted before making idle speed adjustments. GO TO Ä*

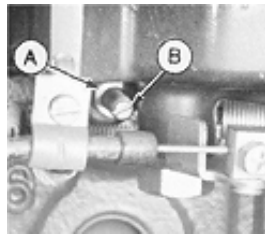

M45278 -UN-12JAN90

Engine OFF.

Move throttle control lever to fast idle position.

Loosen jam nut (A). Turn start adjust screw (B) to align throttle plate indicator (C) with index mark (D).

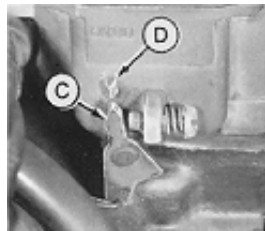

M44156 -UN-08JAN90

Tighten jam nut (A).

**Continued on next page**

MX,159122010,16-19-15JUL95

**OK:** Connect throttle cable, then GO TO 0

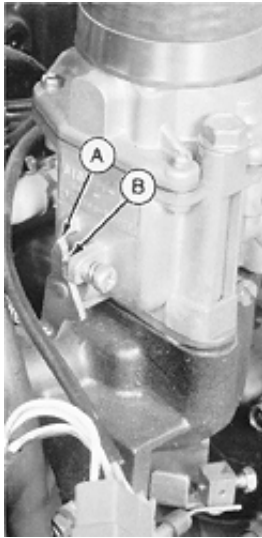

M45279 -UN-12JAN90

Start and run engine to bring it to normal operating temperature.

Disconnect throttle cable.

*NOTE: Check engine speeds using JT05719 Hand-Held Digital Tachometer. Read rpm at front universal joint of drive shaft or flywheel.*

Remove rubber plug from flywheel viewing hole.

Hold throttle plate indicator (A) against stop screw (B). Turn screw (B) until slow idle is  $1350 \pm 50$  rpm.

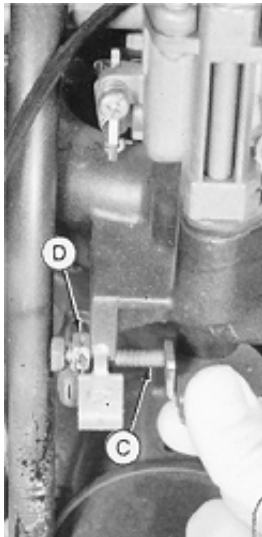

M45280 -UN-08JAN90

Hold governor lever against fast idle stop bolt (C). Fast idle should be  $3450 \pm 50$  rpm.

If fast idle rpm is not correct, loosen nut (D) and turn bolt (C) until fast idle speed is correct. Tighten nut (D).

MX,15912201016A-19-13JUL95

**0 THROTTLE CABLE ADJUSTMENT**

Remove left engine side panel.

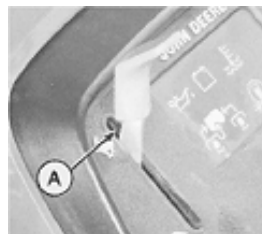

M45281 -UN-08JAN90

Move throttle lever (A) to fast idle position on instrument panel.

Loosen throttle cable clamp (B).

Pull cable and hold governor lever against fast idle stop bolt (C) and tighten clamp (B).

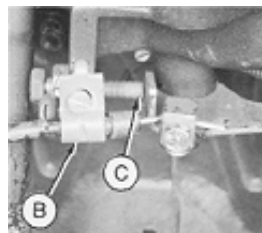

M45282 -UN-08JAN90

MX,159122010,17-19-13JUL95

Diagnosis, Tests and Adjustments—322/Choke Adjustment

**0 FUEL TRANSFER PUMP TEST**



M49171 -UN-20DEC89

Disconnect fuel hose from carburetor. Put end of hose in a graduated container.

Turn key switch to RUN position for 30 seconds and record amount of fuel in container. DO NOT start engine.

Minimum fuel flow is 200 mL/30 seconds (7 oz/30 seconds).



M49172 -UN-20DEC89

Connect JDG356 Pressure Test Kit to outlet side of fuel filter.

Turn key switch to RUN position, then record pressure reading. DO NOT start engine.

Minimum pressure is 14 kPa (2 psi).

**OK:** Connect fuel hose.

**NOT OK:** Check fuel filter, fuel lines and fuel tank suction screen for plugged condition.

Repeat test. If pump output still low, replace fuel transfer pump.

MX,159122010,18-19-13JUL95

**U CHOKE ADJUSTMENT**

Remove air intake hose from carburetor.

MX,159122010,19-19-13JUL95

**8a Early Models (Choke Cable)**

Inspect choke linkage for loose screws, wear or damage.

Pull choke knob out, then push knob in.

*LOOK: Choke plate must be completely closed, then completely open.*

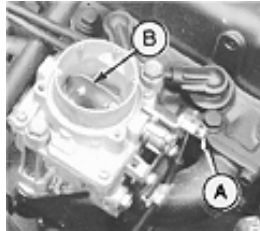

M44143 -UN-07SEP88

If necessary, loosen screw (A) and push choke control knob in. Hold choke plate (B) straight up in carburetor and tighten screw (A).

Check for completely open and completely closed positions.

Install air intake hose on carburetor.

MX,159122010,20-19-13JUL95

8b Later Models  
(Automatic Choke)

**IMPORTANT:** Engine must be cold for this adjustment. Choke plate must be closed.

MX,159122010,21-19-13JUL95



M78977 -UN-21JUN95

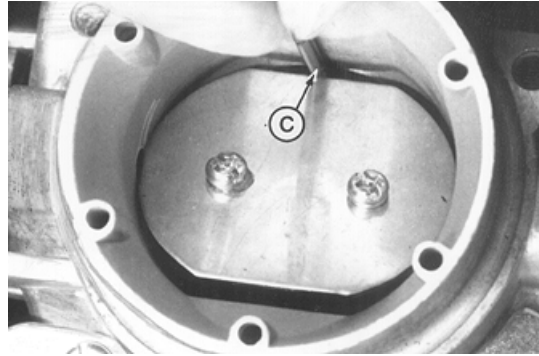

M78978 -UN-21JUN95

*NOTE: DO NOT touch linkage rod (B) when pushing in on vacuum diaphragm lever (A) or it will affect opening position of the choke plate.*

Push in on vacuum diaphragm lever (A) until it bottoms out. Be careful not to touch linkage rod (B).

Put a 2 mm (5/64 in.) drill bit (C) between bottom of choke plate and carburetor venturi.

If clearance is not 2 mm (5/64 in.), bend rod (B) to adjust gap.

Start engine and check clearance. Stop engine and readjust as necessary.

*NOTE: This check must be done quickly, while engine is still cold. Once engine starts to warm up, the automatic choke coil will start to open the choke plate.*

**Continued on next page**

MX,15912201021B-19-15JUL95

220  
10  
10

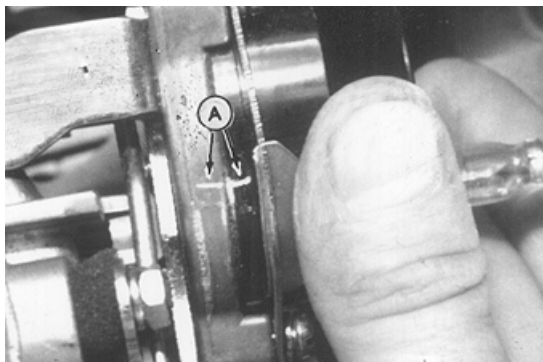

M78979 -UN-21JUN95

**IMPORTANT: Engine must be cold for this adjustment. Choke plate must be closed.**

Put a mark (A) across plastic and metal housings for starting point reference.

Loosen three screws securing coil housing.

**IMPORTANT: DO NOT turn coil too far or spring and adjustment tang will disengage and choke will not work.**

Start engine.

Rotate housing 1/8 turn or less in either direction to obtain desired engine performance; clockwise for less choke (leaner) or counterclockwise for more choke (richer).

Tighten screws.

Install air intake hose on carburetor.



Adjust governor linkage and idle speed; GO TO 0

MX,15912201021A-19-13JUL95

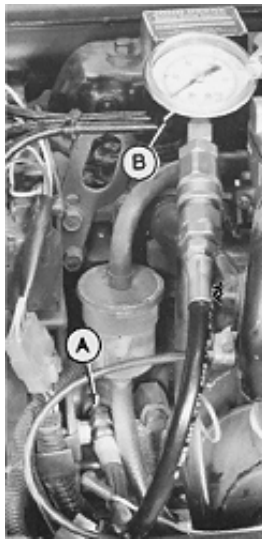

<p><b>Ü ENGINE OIL PRESSURE TEST</b></p>	<p><b>IMPORTANT: If oil pump has failed completely, running engine will cause extensive damage to engine.</b></p> <p>Remove left engine side panel.</p>	 <p>M44164 -UN-08JAN90</p>	<p>Disconnect wiring lead and remove oil pressure switch.</p> <p>Install JT03349 Adapter (A) in oil pressure switch port.</p> <p>Connect JT03017 Hose Assembly and JT05577 0—700 kPa (0—100 psi) Gauge (B).</p> <p>Start and run engine for five minutes at fast idle, to warm oil to normal operating temperature. Record pressure reading.</p> <p>Engine oil pressure should be 294—440 kPa (43—64 psi).</p>	<p><b>OK:</b> Install oil pressure switch and connect wiring lead.</p> <p><b>NOT OK:</b> If pressure reading is low, check oil pressure regulating valve for a broken spring or a stuck or damaged valve. See Engine CTM12.</p> <p>If pressure does not increase, check for a worn or damaged oil pump. See Engine CTM12.</p>
--	---	---	--	---

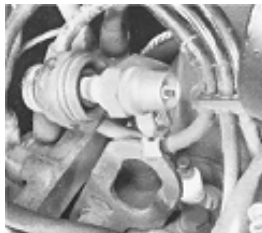
MX,159122010,22-19-13JUL95

<p><b>10 IGNITION SPARK TEST</b></p>	<p>Perform this test on all three spark plugs.</p>	 <p>M49173 -UN-20DEC89</p>  <p>M49174 -UN-20DEC89</p>	<p>Connect spark plug wire to JDM-74-5 Ignition Test Plug or D-05351ST Spark Tester.</p> <p>Disconnect positive (+) wires (A) from coils of cylinders not being tested.</p> <p>Crank engine and watch for spark.</p> <p><b>LOOK:</b> Ignition Test Plug or Tester must spark.</p>	<p><b>OK:</b> SPARK "BLUE" HOT; Continue with test.</p> <p><b>NOT OK:</b> NO SPARK OR "YELLOW" WEAK SPARK; Go to Section 240.</p>
--------------------------------------	--	---	---	---

MX,159122010,23-19-13JUL95

 <p>M44166 -UN-08JAN90</p>	<p>Remove spark plugs.</p> <p>Inspect spark plugs for wet or fouled condition or damage. Replace plugs if worn or damaged.</p> <p>Check spark plug gap. Spark plug gap should be 0.80 mm (0.032 in.).</p> <p>Repeat spark test with original plugs.</p>	<p><b>NOT OK:</b> NO SPARK; Replace plugs.</p>
---	---	--

MX,15912201023A-19-13JUL95

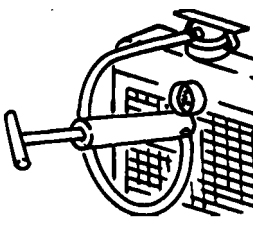
<p><b>1!</b> COOLING SYSTEM PRESSURE TEST</p>	<p><b>CAUTION: DO NOT REMOVE RADIATOR CAP UNTIL RADIATOR HOSE IS COOL TO THE TOUCH.</b></p>	 <p>Remove radiator cap and attach D05104ST Cooling System Pressure Pump to radiator.</p> <p>Pressurize cooling system to 117 kPa (17 psi). Minimum pressure after 15 seconds should be 90 kPa (13 psi).</p> <p>M44123 -UN-26APR89</p>	<p><b>OK:</b> Continue with test.</p> <p><b>NOT OK:</b> If pressure does not meet specification, check radiator, hoses, and connections for leakage. Repair leaks or replace parts as necessary.</p> <p>If pressure test still indicates leakage and all external leaks have been stopped, a blown head gasket or cracked block may be the cause.</p> <p>MX,159122010,24-19-13JUL95</p>
---	---	---	---

 <p>M44093 -UN-08JAN90</p>	<p>Wet sealing surfaces of radiator cap and install on D05104ST Cooling System Pressure Pump.</p> <p>Pressurize radiator cap until it opens. Pressure valve in cap should open at 97—104 kPa (14—15 psi).</p>	<p><b>NOT OK:</b> If cap leaks, retighten then test again. Replace cap if it does not meet specifications.</p> <p>MX,15912201024A-19-13JUL95</p>
---	---	--

<p><b>1@</b> COMPRESSION PRESSURE TEST</p>	<p>Start and run engine approximately five minutes at fast idle, to bring it to normal operating temperature.</p> <p>Stop engine.</p> <p>MX,159122010,25-19-13JUL95</p>
--	---

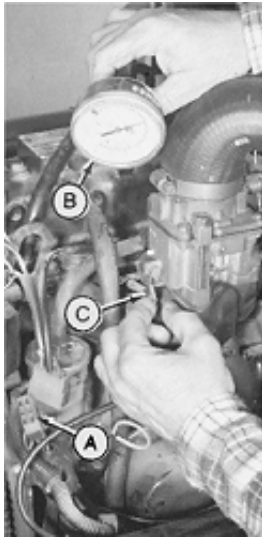

M44167 -UN-08JAN90

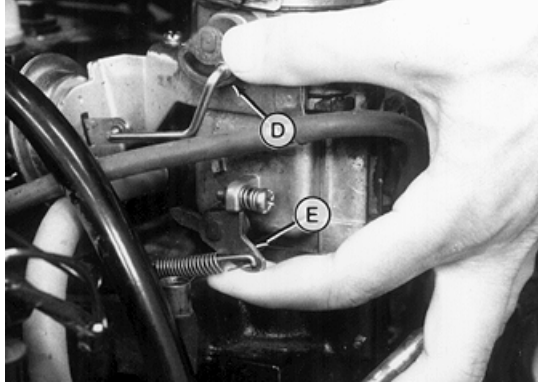

M79122 -UN-23JUN95

**NOTE:** Far left photo: Early models (choke cable).  
Right photo: Later models (automatic choke).

Disconnect positive (+) coil lead connectors (A) from all three coils.

Remove spark plugs.

Connect JDM59 Compression Gauge (B) to spark plug port.

**Early Models:**  
Make sure choke plate is in wide open position (choke knob pushed in).

Move throttle lever to fast idle position. Pull throttle plate lever (C) to wide open position.

**Later Models:**  
Move throttle lever to fast idle position. Push choke plate lever (D) down toward engine. Pull throttle plate lever (E) up to fully open position.

**IMPORTANT: DO NOT overheat starting motor during test.**

Crank engine for a few seconds with starting motor. Record pressure reading for each cylinder.

**TEST SPECIFICATIONS**

Minimum Pressure . . . . . 779 kPa (113 psi)  
Maximum Difference Between  
Cylinders . . . . . 97 kPa (14 psi)  
Engine Cranking Speed . . . . . 300 rpm

**OK:** If compression pressure is to specifications, install spark plugs. Connect coil lead connectors.

**NOT OK:**  
If pressure reading is not to specification, put clean engine oil on piston rings through spark plug ports. Repeat compression pressure test.

If compression pressure increases significantly, check rings, piston, and cylinder bore for broken rings, scoring, wear, or damage. See Engine CTM12.

If compression pressure does not increase significantly after retest, check for leaking valves, valve seats, or cylinder head gasket. See Engine CTM12.

220  
10  
13



**ABOUT THIS GROUP**

Always perform the system checkout procedures in Group 05 BEFORE making any tests or adjustments in this group. The step-by-step procedures in this group provide you with the detailed diagnostic information you will need to isolate a malfunction. Basic diagnostic equipment is used.

It is assumed that you are familiar with the machine and its engine, fuel and air system components.

Engine rpm and temperature are critical in most engine tests. Be sure to follow test specifications carefully.

Always start with the first step and follow the sequence from left to right. Read each step completely before performing the test.

Upon completing a test or adjustment, check to see whether the problem is corrected by performing the checkout procedures in Group 05.

*NOTE: When instructed to “turn the key switch ON”:*

*330 and 332; Turn the key switch to the “ON” position.*

*430; Turn the key switch to the “RUN” position.*

*For clarity in this section, machines including and before serial numbers listed below will be referred to as “Early Models”. Machines including and after serial number listed below will be referred to as “Later Models”.*

*Later model machines have a brake switch added to the neutral start circuit, which is activated by depressing the brake pedals.*

MODEL	EARLY	LATER
330	(S.N. —420000)	N/A
332	(S.N. —475000)	(S.N. 475001— )
430	(S.N. —596047)	(S.N. 596048— )

MX,159122011,1A-19-13JUL95

## ; TROUBLESHOOTING GUIDE

If engine does not operate properly, select the appropriate symptom from the list below. (If engine does not crank, see Section 240.)

- ENGINE WILL NOT START OR STARTS HARD: GO TO A
- ENGINE SURGES OR STALLS FREQUENTLY: GO TO B
- ENGINE MISSES: GO TO C
- ENGINE DOES NOT DEVELOP FULL POWER: GO TO D
- EXCESSIVE BLACK OR GRAY EXHAUST SMOKE: GO TO E
- WHITE EXHAUST SMOKE: GO TO F
- SLOW ACCELERATION: GO TO G
- ABNORMAL ENGINE NOISE: GO TO H
- LOW OIL PRESSURE: GO TO I
- OIL IN COOLANT OR COOLANT IN OIL: GO TO J
- ENGINE OVERHEATS: GO TO K

MX,159122011,1 -19-13JUL95

## A ENGINE WILL NOT START OR STARTS HARD

- 330; Inspect fuel shutoff linkage for binding.
- 332 and 430; Test fuel shutoff solenoid: See Section 240.
- Test fuel transfer pump: GO TO 0
- Bleed fuel injection system: GO TO 0
- Test glow plug controller: See Section 240.
- Test compression pressure: GO TO 0
- Test injection nozzles: See Engine CTM3.
- Check injection pump timing: See Engine CTM3 (AUG93 or later).
- Check and adjust valve clearance: See Engine CTM3.
- Remove fuel injection pump and have it tested: See Engine CTM3.

MX,159122011,2 -19-13JUL95

## **B ENGINE SURGES OR STALLS FREQUENTLY**

- Test fuel transfer pump: GO TO 0
- Bleed fuel injection system: GO TO 0
- Test injection nozzles: See Engine CTM3.
- Check injection pump timing: See Engine CTM3 (AUG93 or later).
- Test cooling system: GO TO 10
- Check thermostat: See Engine CTM3.
- Remove fuel injection pump and have it tested: See Engine CTM3.
- Test compression pressure: GO TO 0
- Check and adjust valve clearance: See Engine CTM3.

MX,159122011,3 -19-13JUL95

## **C ENGINE MISSES**

- Test fuel transfer pump: GO TO 0
- Bleed fuel injection system: GO TO 0
- Test injection nozzles: See Engine CTM3.
- Check injection pump timing: See Engine CTM3 (AUG93 or later).
- Remove fuel injection pump and have tested: See Engine CTM3.
- Check and adjust valve clearance: See Engine CTM3.

MX,159122011,4 -19-13JUL95

## **D ENGINE DOES NOT DEVELOP FULL POWER**

- Check and adjust idle speeds: GO TO 0
- Test fuel transfer pump: GO TO 0
- Bleed fuel injection system: GO TO 0
- Test injection nozzles: See Engine CTM3.
- Check injection pump timing: See Engine CTM3 (AUG93 or later).
- Remove fuel injection pump and have tested: See Engine CTM3.
- Test compression pressure: GO TO 0
- Check and adjust valve clearance: See Engine CTM3.

MX,159122011,5 -19-13JUL95

## **E EXCESSIVE BLACK OR GRAY EXHAUST SMOKE**

- Test injection nozzles: See Engine CTM3.
- Check injection pump timing: See Engine CTM3 (AUG93 or later).
- Adjust fuel controller: GO TO 1!

MX,159122011,6 -19-13JUL95

## **F WHITE EXHAUST SMOKE**

- Test injection nozzles: See Engine CTM3.
- Check injection pump timing: See Engine CTM3 (AUG93 or later).
- Test compression pressure: GO TO 0

MX,159122011,7 -19-13JUL95

## **G SLOW ACCELERATION**

- Test fuel transfer pump: GO TO 0
- Test injection nozzles: See Engine CTM3.
- Check injection pump timing: See Engine CTM3 (AUG93 or later).
- Remove fuel injection pump and have it tested: See Engine CTM3.

MX,159122011,8 -19-13JUL95

## **H ABNORMAL ENGINE NOISE**

- Test injection nozzles: See Engine CTM3.
- Check injection pump timing: See Engine CTM3 (AUG93 or later).
- Check and adjust valve clearance: See Engine CTM3.
- Inspect pistons, piston pins, pin bushings, connecting rod bearings, and rod caps: See Engine CTM3.
- Inspect main bearings and bearing caps: See Engine CTM3.

MX,159122011,9 -19-13JUL95



## I LOW OIL PRESSURE

- Test oil pressure lamp and switch: See Section 240.
- Check engine oil pressure: GO TO Ú
- Inspect for excessive main bearing clearance and connecting rod bearing clearance: See Engine CTM3.
- Inspect for cracked cylinder block.

MX,159122011,10-19-13JUL95

## J OIL IN COOLANT OR COOLANT IN OIL

- Test compression pressure for leaking cylinder head gasket: GO TO Õ
- Inspect for cracked cylinder block.

MX,159122011,11-19-13JUL95

## K ENGINE OVERHEATS

- Test coolant temperature lamp and switch: See Section 240.
- Check thermostat: See Engine CTM3.
- Test cooling system: GO TO 10
- Check for excessive hydraulic system temperature: See Section 270.
- Test injection nozzles: See Engine CTM3.
- Check injection pump timing: See Engine CTM3 (AUG93 or later).
- Adjust fuel controller: GO TO 1!
- Inspect for scored piston: See Engine CTM3.

MX,159122011,12-19-13JUL95

220  
11  
5

Diagnosis, Tests and Adjustments—330, 332 and 430/Throttle Cable Adjustment

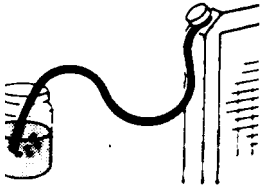
<p><b>RADIATOR BUBBLE TEST</b></p>	<p>Coolant at proper level. Radiator cap tightened. Start and run engine to bring it to operating temperature.</p>	 <p>Put end of radiator overflow hose in a container of water. <i>LOOK: While engine is running, check for bubbles coming from hose.</i></p> <p>T6171AR -UN-25MAY89</p>	<p><b>NO BUBBLES:</b> Continue with test. <b>BUBBLES PRESENT:</b> Replace head gasket, See engine CTM3.</p> <p>MX,159122011,13-19-13JUL95</p>
------------------------------------	--	--	---

<p>Change engine oil. Check old oil for water contamination.</p>	<p>Drain and flush cooling system. Refill cooling system with new coolant.</p>	<p>Operate machine normally. Periodically monitor the engine oil and coolant for signs of contamination. If oil and coolant are OK after several hours of operation, the original problem was caused by condensation or the use of contaminated oil.</p>	<p><b>COOLANT IN OIL OR OIL IN COOLANT:</b> Check for blown head gasket, cracked block or cracked cylinder head. See engine CTM3.</p> <p>MX,15912201113A-19-13JUL95</p>
--	--	--	---

<p><b>THROTTLE LEVER ADJUSTMENT</b></p>	 <p>M49159 -UN-20DEC89</p>	<p>Tighten or loosen nut (A) until throttle lever moves from slow to fast idle with a slight drag. Replace friction washers (B) if necessary. Throttle lever must hold in all positions.</p> <p>MX,159122011,14-19-13JUL95</p>
---	--	--

<p><b>THROTTLE CABLE ADJUSTMENT</b></p>	<p>Remove left engine side panel.</p> <p>MX,159122011,15-19-13JUL95</p>
---	---

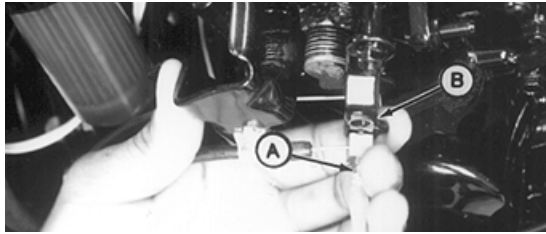
<p>4a 330 and 430</p>	 <p>M79123 -UN-21JUN95</p>	<p>Move throttle lever on instrument panel to fast idle position. Loosen throttle cable set screw (A). Hold injection pump throttle lever (B) forward against fast idle stop, then tighten throttle cable set screw (A). Install left engine side panel.</p> <p>MX,15912201115A-19-13JUL95</p>
-----------------------	---	--

4b 332

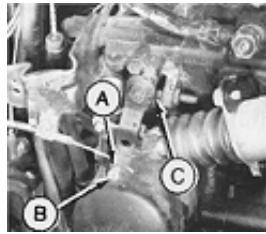

M49170 -UN-20DEC89

Move throttle lever on instrument panel to slow idle position.

Loosen throttle cable nut (A) and set screw (B). Governor throttle arm must strike slow idle stop screw (C).

Be sure throttle lever is striking bottom of slot on instrument panel, then tighten throttle cable set screw (B) and nut (A).

Install left engine side panel.

MX,15912201115B-19-13JUL95

**Ö FUEL TRANSFER PUMP TEST**



M49160 -UN-20DEC89

*NOTE: 330/332 Shown.*

*Perform test at room temperature.*

Disconnect fuel transfer pump outlet hose from fuel filter (330, 332) or fuel/water separator (430). Put end of hose in a graduated container.

Turn key switch to ON/RUN position for 30 seconds and record amount of fuel in container. **DO NOT** start engine.

**MINIMUM FUEL FLOW**

330 and 332	.....	200 mL/30 seconds (7 oz/30 seconds)
430	.....	600 mL/30 seconds (20 oz/30 seconds)

MX,159122011,16-19-13JUL95



M49161 -UN-20DEC89

Connect JDG356 Pressure Test Kit to outlet hose.

Turn key switch to ON/RUN position, then record pressure reading. **DO NOT** start engine.

Minimum pressure is 21 kPa (3 psi).

**OK:** GO TO Ö

**NOT OK:** Check fuel filter (330, 332) or fuel/water separator (430), fuel lines and fuel tank suction screen for plugged condition.

Repeat test. If pump output still low, replace fuel transfer pump. Then GO TO Ö

MX,15912201116A-19-13JUL95

0 BLEED FUEL INJECTION SYSTEM

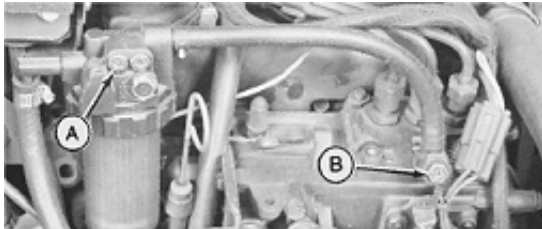

M43915 -UN-31AUG88

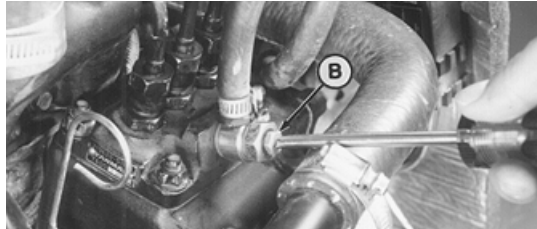

M79124 -UN-21JUN95



M78720 -UN-21JUN95

*NOTE: Top left photo shows 330/332.*

*Other photos show 430.*

Loosen bleed screw/plug (A) on fuel filter (330, 332) or fuel/water separator (430). Turn key switch to ON/RUN position. Fuel transfer pump will run. Tighten bleed screw/plug (A) when fuel appears.

Loosen bleed screw (B). Turn key switch to ON/RUN position. Fuel transfer pump will run. When fuel appears at line and no air bubbles are visible, close bleed screw (B).

Continued on next page



M43916 -UN-31AUG88

Start engine.

**IMPORTANT: When loosening or tightening fuel injection lines, DO NOT turn pump delivery valve fittings. Turning pump fittings can damage pump internally.**

*NOTE: 330/332 shown.*

If engine does not start or if it runs rough, loosen fuel injection line fitting (A) at injection nozzle.

If engine is not running, use starter to turn engine over.

When fuel appears at nozzle and no air bubbles are visible, tighten fuel line.

Repeat procedure for remaining injection nozzles, if necessary.

Start engine.

If engine does not start, repeat bleed procedure.

MX,159122011,17-19-13JUL95

**0 COMPRESSION PRESSURE TEST**

Start and run engine approximately five minutes at fast idle, to bring it to normal operating temperature.

Stop engine.

Remove left engine side panel.

**CAUTION: ESCAPING FLUID UNDER PRESSURE CAN PENETRATE THE SKIN CAUSING SERIOUS INJURY. RELIEVE PRESSURE BEFORE DISCONNECTING HYDRAULIC OR OTHER LINES. TIGHTEN ALL CONNECTIONS BEFORE APPLYING PRESSURE. KEEP HANDS AND BODY AWAY FROM PIN-HOLES AND NOZZLES WHICH EJECT FLUIDS UNDER HIGH PRESSURE. USE A PIECE OF CARDBOARD OR PAPER TO SEARCH FOR LEAKS.**

IF ANY FLUID IS INJECTED INTO THE SKIN, IT MUST BE SURGICALLY REMOVED WITHIN A FEW HOURS BY A DOCTOR FAMILIAR WITH THIS TYPE OF INJURY OR GANGRENE MAY RESULT.

MX,159122011,21-19-13JUL95



M43993 -UN-07SEP88

*NOTE: 332 Shown.*

*Motorite Compression Tester can be used using JT01681 and JDG472 Adapter or use Compression Test Kit JT01674.*

330; Pull fuel shutoff knob on dash all the way out.

332 and 430; Disconnect fuel shutoff solenoid wiring connector/leads (A).

Remove fuel injection nozzles. See engine CTM3. Remove heat protectors from injection nozzle ports.

Connect JT01682 Pressure Gauge and Hose (B) to fuel injection nozzle port using JDG472 Adapter (C).

**IMPORTANT: DO NOT overheat starting motor during test.**

Crank engine for a few seconds with starting motor.

Record pressure reading for each cylinder.

**TEST SPECIFICATIONS**

Minimum Pressure . . . . .	2448 kPa (355 psi)
Maximum Difference Between	
Cylinders . . . . .	490 kPa (71 psi)
Minimum Engine Cranking Speed . . . . .	250 rpm

	<p><b>OK:</b> If compression pressure is to specifications; —Install heat protectors and injection nozzles.</p> <p>—330; Push fuel shutoff knob all the way in.</p> <p>—332 and 430; Connect fuel shutoff solenoid wiring connector/leads.</p> <p>—Bleed fuel injection system: GO TO 0</p> <p><b>NOT OK:</b> If pressure reading is not to specification, put clean engine oil on piston rings through injection nozzle ports. Repeat compression pressure test.</p> <p>If compression pressure increases</p>	<p>significantly, check rings, piston, and cylinder bore for broken rings, scoring, wear, or damage. See engine CTM3.</p> <p>If compression pressure does not increase significantly after retest, check for leaking valves, valve seats, or cylinder head gasket. See engine CTM3.</p>
--	--	---

MX,15912201121A-19-13JUL95

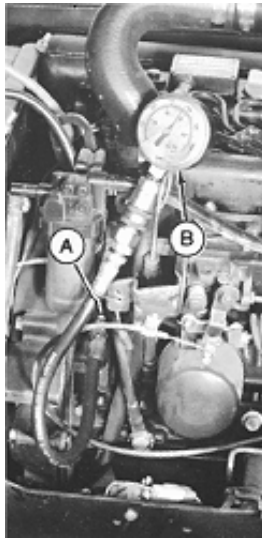
<p><b>U ENGINE OIL PRESSURE TEST</b></p>	<p><b>IMPORTANT: If oil pump has failed completely, running engine will cause extensive damage to engine.</b></p> <p>Remove left engine side panel.</p>		<p><i>NOTE: 332 shown.</i></p> <p>Disconnect wiring lead and remove oil pressure switch.</p> <p>330 and 332; Install JT03349 Adapter (A) in oil pressure switch port.</p> <p>430; Install JT03338 Adapter in oil pressure switch port.</p> <p>Connect JT03017 Hose Assembly and JT05577 0—700 kPa (0—100 psi) Gauge (B).</p> <p>Start and run engine for five minutes at fast idle, to warm oil to normal operating temperature. Record pressure reading.</p> <p>Engine oil pressure should be 365 ±69 kPa (53 ±10 psi).</p>	<p><b>OK:</b> Install oil pressure switch and connect wiring lead.</p> <p><b>NOT OK:</b> If pressure reading is low, check oil pressure regulating valve for a broken spring or a stuck or damaged valve. If oil pressure regulating valve is not damaged, add shims to inside of cap. See engine CTM3.</p> <p>Check connecting rod and main bearing journals for excessive wear. See engine CTM3.</p> <p>If pressure does not increase, check for a worn or damaged oil pump. See engine CTM3.</p>
--	---	--	--	---

M49167 -UN-20DEC89

MX,159122011,22-19-13JUL95

220  
11  
11

**Ü IDLE SPEED ADJUSTMENT**

Start and run engine approximately five minutes at fast idle to bring it to normal operating temperature.

Disconnect throttle cable.

MX,159122011,23-19-13JUL95

**9a 330, 332 and Later 430**



M49168 -UN-20DEC89

*NOTE: Check engine speeds using JT05719 Hand-Held Digital Tachometer. Read rpm at front universal joint of drive shaft or flywheel.*

Remove rubber plug from flywheel viewing hole.

Slow idle speed:  
Hold injection pump throttle lever rearward, away from flywheel, and read Tachometer. Slow idle speed should be 1350 ±50 rpm.

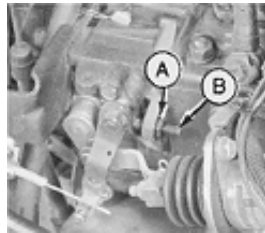

M43995 -UN-07SEP88

If slow idle rpm is not correct, loosen nut (A) and turn screw (B) to adjust slow idle. After adjustment, tighten nut (A).



M49169 -UN-20DEC89

Fast idle speed:  
Hold injection pump throttle lever forward, toward flywheel, and read Tachometer. Fast idle speed should be 3450 ±50 rpm.

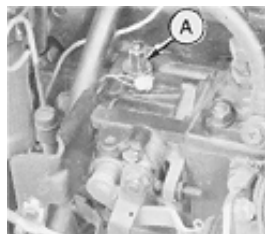

M43998 -UN-07SEP88

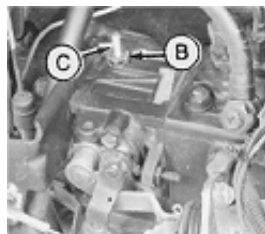

M43999 -UN-07SEP88

If fast idle rpm is not correct, remove wire and cap (A). Loosen nut (B). Turn screw (C) until fast idle speed is to specification. After adjustment, tighten nut (B). Install cap (A).

**OK:** Install new sealing wire. Fasten and identify lead seal using JDF10 Sealing Wire Pliers, then GO TO A

**NOT OK:** If engine will not meet fast idle specification, replace regulator spring. See engine CTM3.

MX,15912201123B-19-13JUL95

220  
11  
12



9b Early 430

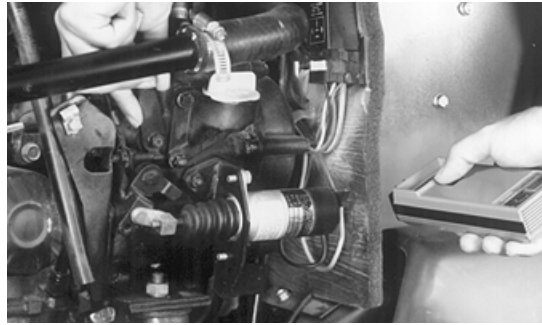

M78729 -UN-21JUN95

*NOTE: Check engine speeds using JT05719 Hand-Held Digital Tachometer. Read rpm at front universal joint of drive shaft or flywheel.*

Remove rubber plug from flywheel viewing hole.

Slow idle speed:  
Hold injection pump throttle lever rearward, away from flywheel, and read Tachometer. Slow idle speed should be  $1300 \pm 50$  rpm.

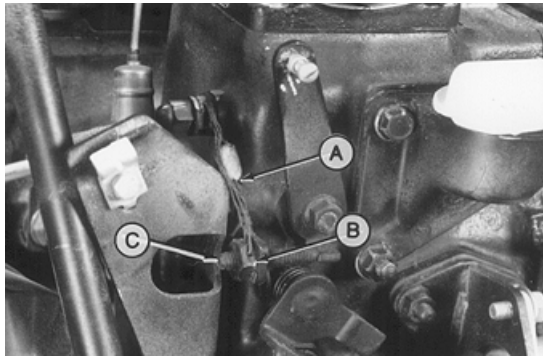

M78726 -UN-21JUN95

If slow idle rpm is not correct, remove sealing wire (A).

Loosen lock nut (B) and turn screw (C) to adjust slow idle. After adjustment, tighten lock nut (B).

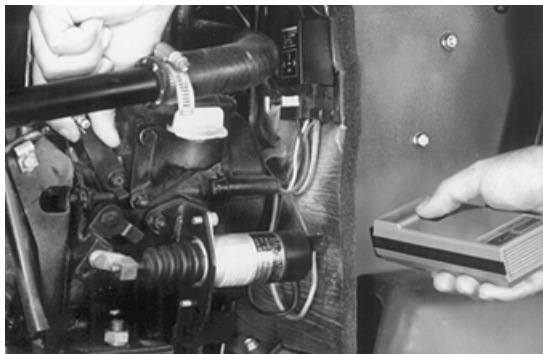

M78730 -UN-21JUN95

Fast idle speed:  
Hold injection pump throttle lever forward, toward flywheel, and read Tachometer. Fast idle speed should be  $3400 \pm 50$  rpm.

220  
11  
13

Continued on next page

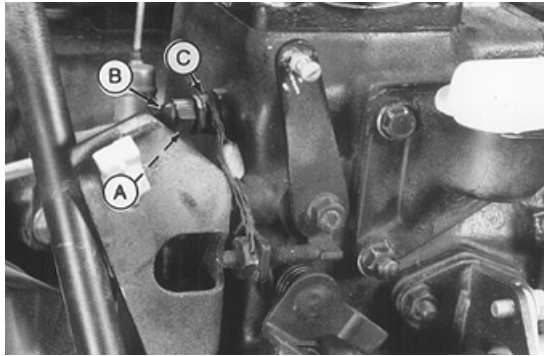

M78727 -UN-21JUN95

If fast idle rpm is not correct, remove cap (B). Loosen lock nut (C). Turn screw (A) until fast idle speed is to specification. After adjustment, tighten lock nut (C). Install cap (B).

**OK:** Install new sealing wire. Fasten and identify lead seal using JDF10 Sealing Wire Pliers, then GO TO Å

**NOT OK:** If engine will not meet fast idle specification, replace regulator spring. See engine CTM3.

MX,15912201123C-19-13JUL95

**10 COOLING SYSTEM PRESSURE TEST**

**CAUTION: DO NOT REMOVE RADIATOR CAP UNTIL RADIATOR HOSE IS COOL TO THE TOUCH.**

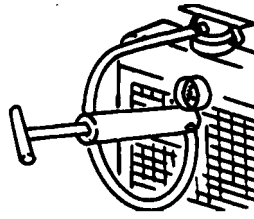

M44123 -UN-26APR89

Remove radiator cap and attach D05104ST Cooling System Pressure Pump to radiator.

Pressurize cooling system to 117 kPa (17 psi). Minimum pressure after 15 seconds should be 90 kPa (13 psi).

**OK:** Continue with test.

**NOT OK:** If pressure does not meet specification, check radiator, hoses, and connections for leakage. Repair leaks or replace parts as necessary.

If pressure test still indicates leakage and all external leaks have been stopped, a blown head gasket or cracked block may be the cause.

MX,159122011,24-19-13JUL95

220  
11  
14



M44093 -UN-08JAN90

Wet sealing surfaces of radiator cap and install on D05104ST Cooling System Pressure Pump.

Pressurize radiator cap until it opens. Pressure valve in cap should open at 97—104 kPa (14—15 psi).

**NOT OK:** If cap leaks, retighten then test again. Replace cap if it does not meet specifications.

MX,15912201024A-19-13JUL95

**1! FUEL CONTROLLER ADJUSTMENT**

MX,159122011,25-19-13JUL95

**1: a 330, 332 and Later 430**

*NOTE: The fuel controller may be referred to in other manuals as the "Torque Spring Capsule".*

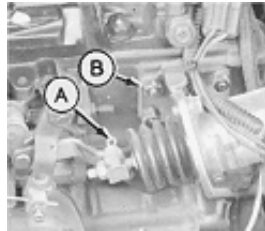

M44001 -UN-09JAN90

*NOTE: 332 shown.*

Remove left engine side panel.

Remove spring pin (A) and washer.

Remove four nuts (B) to remove injection pump cover and fuel shutoff solenoid.

Move solenoid aside.

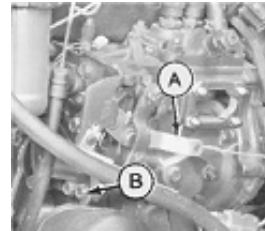

M44002 -UN-09JAN90

Move fuel shutoff lever (A) to full fuel position (toward fuel shutoff solenoid) and use a wire to hold it.

Remove cap screw (B) to remove oil dipstick tube.

MX,15912201125F-19-13JUL95

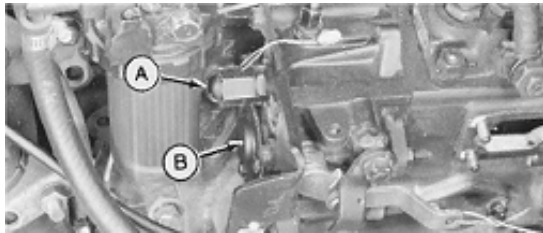

M44003 -UN-09JAN90

Remove sealing wire and cap (A).

Remove three cap screws to remove governor housing cover (B).

**Continued on next page**

MX,15912201125A-19-15JUL95

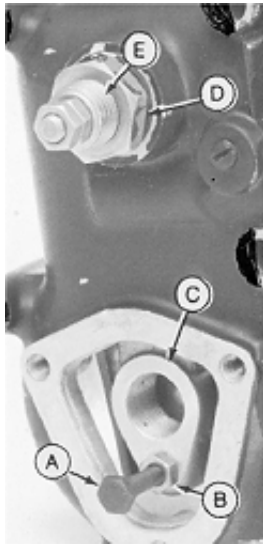

A—4 mm Fine Thread Screw  
 B—Nut  
 C—Fuel Control Lever  
 D—Jam Nut  
 E—Torque Spring Assembly

M44004 -UN-09JAN90

Install a 4 mm fine thread bolt (A) and nut (B) through bottom hole of fuel control lever (C) and into hole of governor lever. Turn bolt two turns only.

Pull bolt outward until governor spring is completely compressed, then tighten nut (B).

**IMPORTANT: If governor spring is not completely compressed or if bolt (A) extends through the governor lever and hits governor flyweights, the torque spring capsule adjustment will be incorrect.**

Loosen nut (D).

Turn torque spring assembly (E) counterclockwise to obtain clearance between assembly and fuel control lever.

**IMPORTANT: DO NOT disassemble torque spring assembly. The inner spring assembly is factory adjusted and is only serviced as a complete assembly.**

MX,15912201125B-19-13JUL95

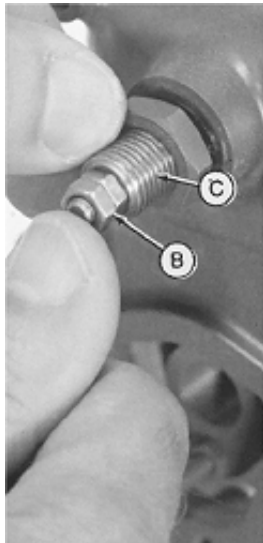

A—Injection Pump Rack  
 B—Small Nuts (2 used)  
 C—Torque Spring Assembly  
 D—Alignment Mark  
 E—Plate

M44008 -UN-09JAN90

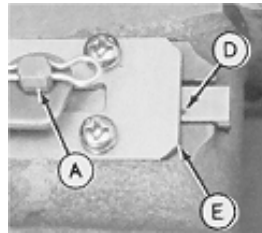

M44009 -UN-09JAN90

**IMPORTANT: DO NOT compress inner torque spring during adjustment. If the small nuts on the torque spring assembly are moving outward (toward flywheel), the torque spring is being compressed.**

Push injection pump rack (A) toward torque spring assembly. Push and hold small nuts (B) tight against threaded body (C) during adjustment. Turn torque spring assembly clockwise until mark (D) on the injection pump rack aligns with the right edge of plate (E).

Continued on next page

MX,15912201125C-19-15JUL95

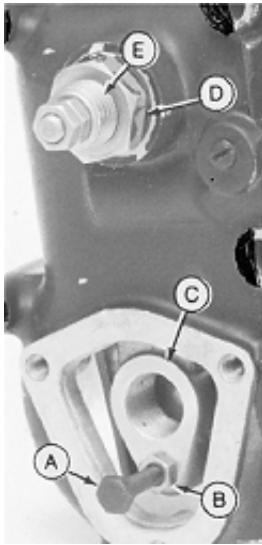

A—4 mm Fine Thread Screw  
 B—Nut  
 C—Fuel Control Lever  
 D—Jam Nut  
 E—Torque Spring Assembly

M44004 -UN-09JAN90

Hold torque spring assembly (E) and tighten nut (D).

Check alignment of mark and plate to be sure the torque spring assembly has not moved.

Remove screw (A) and nut (B).

MX,15912201125D-19-13JUL95

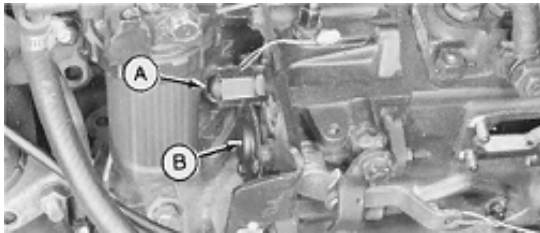

M44003 -UN-09JAN90

Install governor housing cover (B). Fasten it with three cap screws.

Install and tighten cap (A).

Install a new sealing wire. Fasten and identify lead seal using JDF10 Sealing Wire Pliers.

Install oil dipstick tube.

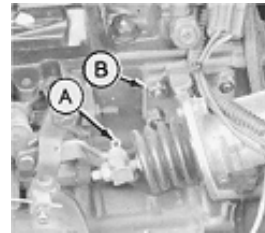

M44001 -UN-09JAN90

Install fuel shutoff solenoid and fuel injection pump cover. Install and tighten four nuts (B) to 9 N·m (78 lb-in.).

Connect fuel shutoff lever. Fasten it with a washer and spring pin (A).

MX,15912201125E-19-13JUL95

1: b Early 430

Remove front grille and left engine side panel.

Remove two cap screws and nut to remove oil fill/cover and gasket from injection pump.

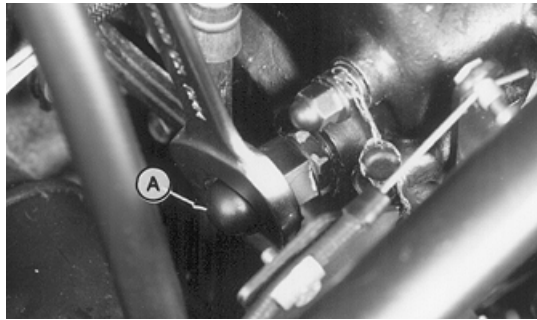

M78732 -UN-21JUN95

Remove cap (A).

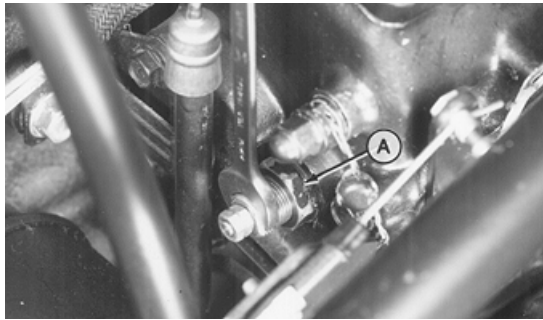

M78733 -UN-21JUN95

Loosen lock nut (A).

Turn fuel controller counterclockwise to obtain clearance between fuel controller and fuel control lever. Push injection pump rack forward.

**IMPORTANT: DO NOT disassemble fuel controller spring assembly. The spring assembly is factory adjusted and is only serviced as a complete assembly.**



M78734 -UN-21JUN95

220  
11  
18

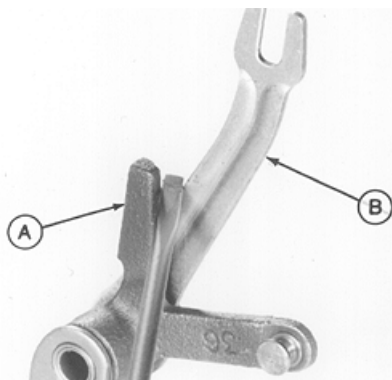

M78735 -UN-21JUN95

Turn key to RUN position. DO NOT start engine.

Install a screwdriver between the fuel control lever (A) and governor shaft lever (B). Push down and twist screwdriver slightly to separate levers and to compress governor spring. The governor spring must be completely compressed for this adjustment.

**IMPORTANT: Keep slight downward pressure on screwdriver between levers. DO NOT push fuel control lever forward against fuel controller during adjustment. If the governor spring is not compressed or fuel control lever is pushed forward, the fuel controller adjustment will be incorrect.**

Continued on next page

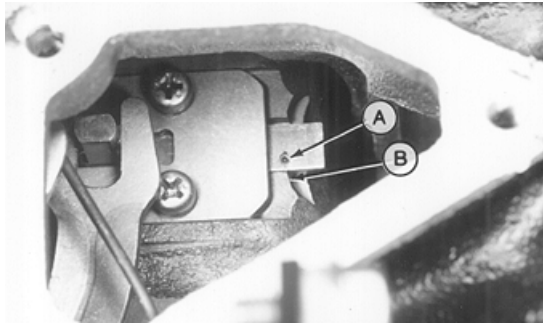

M78736 -UN-21JUN95

Turn fuel controller clockwise until the mark (A) on the injection pump rack is in alignment with the reference face (B) on the injection pump body.

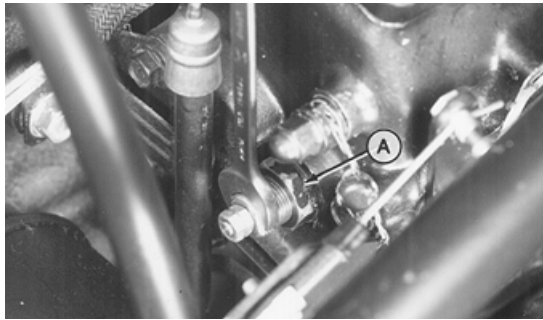

M78733 -UN-21JUN95

Hold fuel controller and tighten lock nut (A).

Check alignment of mark and reference face to be sure the fuel controller has not moved.

Install and tighten cap.

Install new gasket.

Install oil fill/cover to side of injection pump and fasten with two cap screws and nut. Tighten cap screws and nut to 9 N·m (78 lb-in.).

Install left engine side panel and front grille.

MX,15912201125G-19-13JUL95





# Section 240

# ELECTRICAL SYSTEM CHECKOUT, OPERATION AND DIAGNOSIS

## Contents

	Page	Page
<b>Group 05—Electrical System Checkout</b>		
Before You Start . . . . .	240-05-1	
Dash Lamp Circuit Check . . . . .	240-05-2	
PTO Clutch and Lamp Check . . . . .	240-05-2	
Starting Circuit Check . . . . .	240-05-3	
Fuel Shutoff Solenoid Check (322, 332 and 430) . . . . .	240-05-4	
Fuel Transfer Pump Check . . . . .	240-05-5	
Glow Plug Controller Check (330, 332 and 430) . . . . .	240-05-5	
Ignition Circuit Check (322) . . . . .	240-05-5	
Hour Meter Check . . . . .	240-05-6	
Lighting Check . . . . .	240-05-6	
Operator Complaint Not Identified . . . . .	240-05-7	
<b>Group 10—Electrical Schematics</b>		
Electrical Schematic Information . . . . .	240-10-1	
Main Electrical Schematics		
322 . . . . .	240-10-3	
330 . . . . .	240-10-4	
332 (S.N. —475000) . . . . .	240-10-7	
332 (S.N. 475001— ) . . . . .	240-10-8	
430 (S.N. —420468) . . . . .	240-10-11	
430 (S.N. 420469— ) . . . . .	240-10-12	
Light Circuit Schematic—All Machines . . . . .	240-10-14	
<b>Group 15—Component Location and Operation</b>		
About This Group . . . . .	240-15-1	
Electrical Component Location		
Glow Plug Control Module—330 and 332 . . . . .	240-15-1	
Glow Plug Control Module—430 . . . . .	240-15-1	
TDC Module and Neutral Start Relay—322, 330 and 332 . . . . .	240-15-1	
TDC Module and Neutral Start Relay—430 . . . . .	240-15-2	
TDC 8-Pin and 2-Pin Connectors—322 and 330 . . . . .	240-15-2	
TDC 8-Pin and 2-Pin Connectors—430 (S.N. —420468) . . . . .	240-15-2	
Electrical Component Location—Continued		
TDC 6-Pin and 3-Pin Connectors—332 . . . . .	240-15-3	
TDC 6-Pin and 3-Pin Connectors—430 (S.N. 420469— ) . . . . .	240-15-3	
Engine Oil Pressure Switch . . . . .	240-15-3	
Engine Coolant Temperature Switch . . . . .	240-15-4	
Transmission Neutral Start Switch . . . . .	240-15-4	
Fuel Transfer Pump—322, 330, 332 . . . . .	240-15-5	
Fuel Transfer Pump—430 . . . . .	240-15-5	
Fuel Shutoff Solenoid—322 . . . . .	240-15-5	
Fuel Shutoff Solenoid—332 and 430 . . . . .	240-15-5	
Water-In-Fuel Sensor (430) . . . . .	240-15-6	
Voltage Regulator/Rectifier (322, 330 and 332) . . . . .	240-15-6	
Transistor Module (322) . . . . .	240-15-6	
Ignition and Pulsar Coils (322) . . . . .	240-15-7	
Theory of Operation		
Starting Circuit . . . . .	240-15-8	
Ignition and Fuel Shutoff Solenoid Circuit (322) . . . . .	240-15-10	
PTO Circuit—322, 330 and 430 (S.N. —420468) . . . . .	240-15-14	
PTO Circuit—332 and 430 (S.N. 420469— ) . . . . .	240-15-18	
Charging Circuit—322, 330 and 332 . . . . .	240-15-22	
Charging Circuit—430 . . . . .	240-15-24	
Fuel Shutoff Solenoid Circuit—430 (S.N. —420468) . . . . .	240-15-26	
Fuel Shutoff Solenoid Circuit—332 and 430 (S.N. 420469— ) . . . . .	240-15-28	
Engine Preheat Circuit (330, 332 and 430) . . . . .	240-15-30	
Water-In-Fuel Circuit (430) . . . . .	240-15-32	
Low Fuel Level Circuit (322, 332 and 430) . . . . .	240-15-34	
<b>Group 20—Electrical System Diagnosis</b>		
About This Group . . . . .	240-20-1	

Continued on next page

Page

Verify System Grounds  
 322 and 332 . . . . . 240-20-1  
 330 . . . . . 240-20-3  
 430 . . . . . 240-20-3  
 Battery Tests . . . . . 240-20-4  
 Dash Lamp Circuit Tests . . . . . 240-20-7  
 PTO Clutch and Lamp Circuit Tests . . . 240-20-18  
 Starting Circuit Tests . . . . . 240-20-24  
 Fuel Shutoff Solenoid Circuit Tests . . . . 240-20-30  
 Fuel Transfer Pump Circuit Tests . . . . . 240-20-35  
 Glow Plug Controller Circuit Tests (330,  
 332 and 430) . . . . . 240-20-37  
 Ignition Circuit Tests (322) . . . . . 240-20-38  
 Hour Meter Circuit Test . . . . . 240-20-47  
 Head and Tail Light Circuit Tests . . . . . 240-20-48

**Group 25—Electrical System Component Tests  
 and Adjustments**

Before You Start . . . . . 240-25-1  
 Dash Lamps Sensor Tests . . . . . 240-25-1  
 PTO Clutch Adjustment Check . . . . . 240-25-3  
 Starting System Component Tests . . . . . 240-25-4  
 Fuel Shutoff Solenoid Adjustment . . . . . 240-25-9  
 Charging System Tests . . . . . 240-25-10  
 System Short Circuit Tests  
 10-Amp Fuse . . . . . 240-25-16  
 25-Amp Fuse . . . . . 240-25-17

## BEFORE YOU START

Always begin with this group to identify a failure in the electrical system. The step-by-step procedures will provide you with a quick check of the system. No special tools are required to perform these checks. If a failure is indicated, you will be referred to a more detailed check, adjustment, or test located in Groups 20 and 25.

Always start with the first step and follow the sequence from left to right. Read each step completely before performing the check.

This procedure is designed as a quick check of the system. Concentrate only on the check being performed and disregard signals from unrelated components. If unfamiliar with the operation or location of system components, refer to Group 15 in this section.

*NOTE: When instructed to "turn the key switch ON":*

*322 and 430; Turn the key switch to the "RUN" position.*

*330 and 332; Turn the key switch to the "ON" position.*

*For clarity in this section, machines including and before serial numbers listed below will be referred to as "Early Models". Machines including and after serial number listed below will be referred to as "Later Models".*



*Later model machines have a brake switch added to the neutral start circuit, which is activated by depressing the brake pedals.*

MODEL	EARLY	LATER
322	(S.N. —596005)	(S.N. 596006— )
330	(S.N. —420000)	N/A
332	(S.N. —475000)	(S.N. 475001— )
430	(S.N. —596047)	(S.N. 596048— )



MX,159124005,1 -19-13JUL95

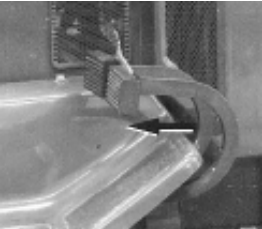

*Electrical System Checkout/Starting Circuit Check*

<p><b>2a Seat Switch Check For PTO</b></p>	<p>Sit on seat. PTO switch OFF. Hydrostatic lever in N/STOP position. Later Models; Engage park brake.</p>	
 <p>M55019 -UN-09DEC89</p>	<p>Turn key switch to ON/RUN position. Move PTO switch to ON position. Raise off seat for 2—3 seconds. <i>LOOK/LISTEN: PTO lamp must turn off and PTO clutch "click" off.</i> Sit back down on seat. Lamp and clutch must stay off. Turn key switch to START position. <i>LISTEN: Engine must NOT crank.</i> Turn PTO switch OFF, then ON. Raise off seat and quickly sit back down before one second elapses.</p>	<p><i>LOOK/LISTEN: PTO lamp and clutch must stay ON.</i></p> <p><b>OK:</b> GO TO Æ</p> <p><b>NOT OK:</b> GO TO ' , Group 20.</p> <p align="right">MX,159124005,14-19-13JUL95</p>
<p><b>Æ STARTING CIRCUIT CHECK</b></p>	<p>Sit on seat. PTO switch OFF. Hydrostatic lever in N/STOP position. Later Models; Depress brake pedal(s).</p>	 <p>M36488 -UN-29JAN90</p>  <p>M55026 -UN-09DEC89</p> <p>Turn key switch to START position. <i>LISTEN: Starter must crank engine.</i></p> <p><b>OK:</b> For machines: 322 (S.N. 596006— ) 332 (S.N. 475001— ) 430 (S.N. 596048— ), GO TO 3a For all other machines, GO TO 3b <b>NOT OK:</b> Check 25-amp fuse, then GO TO Æ, Group 20.</p> <p align="right">MX,159124005,7 -19-13JUL95</p>
<p><b>3a Brake Switch Neutral Start Check</b> 322 (SN 596006— ) 332 (SN 475001— ) 430 (SN 596048— )</p>	<p>PTO switch OFF. Hydrostatic lever in N/STOP position.</p>	 <p>M77933 -UN-17JAN95</p> <p>Brake pedal(s) completely released. Turn key switch to START position. <i>LISTEN: Engine must NOT crank.</i></p> <p><b>OK:</b> GO TO 3b <b>NOT OK:</b> GO TO 3f, Group 20.</p> <p align="right">MX,159124005,8 -19-13JUL95</p>

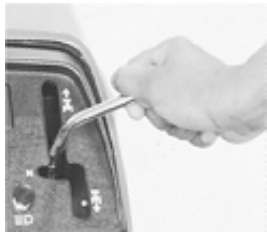

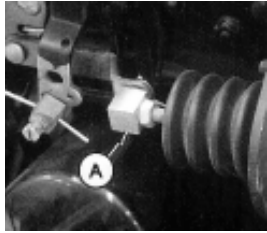
*Electrical System Checkout/Fuel Shutoff Solenoid Check (322, 332 and 430)*

<p><b>3b Transmission Switch Neutral Start Check</b></p>	<p>PTO switch OFF.</p> <p>Later Models; Engage park brake.</p>	 <p>Move hydrostatic lever to the right away from N/STOP switch.</p> <p>Turn key switch to START position.</p> <p><i>LISTEN: Engine must NOT crank.</i></p> <p><small>M55018 -UN-09DEC89</small></p>	<p><b>OK:</b> GO TO 3c</p> <p><b>NOT OK:</b> GO TO 3i , Group 20.</p> <p align="right"><small>MX,159124005,9 -19-13JUL95</small></p>
<p><b>3c PTO Switch Neutral Start Check</b></p>	<p>Hydrostatic lever in N/STOP position.</p> <p>Later Models; Depress brake pedal(s).</p>	 <p>Move PTO switch to ON position.</p> <p>Turn key switch to START position.</p> <p><i>LISTEN: Engine must NOT crank.</i></p> <p><small>M55019 -UN-09DEC89</small></p>	<p><b>OK:</b> GO TO Å</p> <p><b>NOT OK:</b> GO TO 3m, Group 20.</p> <p align="right"><small>MX,159124005,10-19-13JUL95</small></p>
<p><b>Å FUEL SHUTOFF SOLENOID CHECK (322, 332 and 430)</b></p>	<p>PTO switch OFF.</p> <p>Hydrostatic lever in N/STOP position.</p> <p>Later Models; Engage park brake.</p> <p>Open hood.</p> <p>332 and 430; Remove left engine side panel.</p>	 <p><i>NOTE: 322; Hold a screwdriver against the fuel shutoff solenoid. Screwdriver will amplify sound.</i></p> <p><i>Do not confuse the "click" from the neutral start relay with "click" from the fuel shutoff solenoid.</i></p> <p>Turn key switch ON, then OFF a few times.</p> <p><i>LISTEN: Fuel shutoff solenoid must "click" when key is turned ON.</i></p> <p><i>LOOK: 332 and 430; Solenoid armature must move fuel shutoff linkage to ON position.</i></p>  <p><small>M44161 -UN-08JAN90</small></p> <p><small>M78964 -UN-27APR95</small></p>	<p><b>OK:</b> GO TO 4a</p> <p><b>NOT OK:</b> GO TO Å, Group 20.</p> <p align="right"><small>MX,159124005,4 -19-13JUL95</small></p>
<p><b>4a Seat Switch Check For Fuel Shutoff (322, 332 and 430)</b></p>	<p>Sit on seat.</p> <p>PTO switch OFF.</p> <p>Hydrostatic lever in N/STOP position.</p> <p>Later Models; Engage park brake.</p>	<p>Start engine and operate at slow idle.</p> <p>Move hydrostatic lever fully to right while keeping lever in the N/STOP slot.</p> <p>Raise off seat for 2—3 seconds.</p> <p><i>LISTEN: Engine must stop.</i></p>	<p align="right"><b>Continued on next page</b></p>

240  
05  
4

*Electrical System Checkout/Ignition Circuit Check (322)*

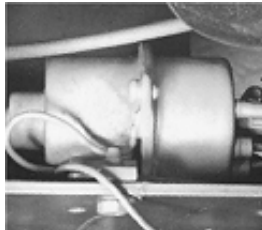

<p>Restart engine.</p> <p>Again, move hydrostatic lever to the right while keeping lever in the N/STOP slot.</p> <p>Raise off seat and quickly sit back down before one second elapses.</p> <p><i>LISTEN: Engine may falter, but</i></p>	<p align="center"><i>must stay running.</i></p>	<p><b>OK:</b> GO TO 0</p> <p><b>NOT OK:</b> GO TO 4p, Group 20.</p> <p align="right">MX,159124005,5 -19-13JUL95</p>
--	---	---

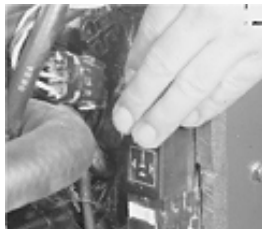
<p><b>0 FUEL TRANSFER PUMP CHECK</b></p>	<p>Turn key switch to ON/RUN position.</p>	<div style="display: flex; flex-direction: column;">  <p align="center"><small>M49009 -UN-08JAN90</small></p>  <p align="center"><small>M36486 -UN-12APR95</small></p> </div> <p><i>LISTEN: Fuel transfer pump must "click" continuously.</i></p> <p><i>NOTE: 322, 330 and 332; The fuel transfer pump is located behind left engine panel, mounted to machine frame. (Upper photo.)</i></p> <p><i>430; The fuel transfer pump is located inside the left side of machine frame behind the left footrest. (Lower photo.)</i></p>	<p><b>OK:</b> 322; GO TO 0</p> <p>330, 332 and 430; GO TO 0</p> <p><b>NOT OK:</b> Check 10-amp fuse (322, 330 and 332) or 25-amp fuse (430), then GO TO 0, Group 20.</p> <p align="right">MX,159124005,3 -19-13JUL95</p>
--	--	--	--

<p><b>0 GLOW PLUG CONTROLLER CHECK (330, 332 and 430)</b></p>	<p>Open hood.</p> <p>Remove left engine side panel.</p>	<div style="display: flex; flex-direction: column;">  <p align="center"><small>M36487 -UN-29JAN90</small></p> </div> <p>Put hand on glow plug controller.</p> <p>Turn key switch to ON/RUN position.</p> <p><i>FEEL: Glow plug controller must disengage in 30 seconds or less.</i></p> <p><i>NOTE: If you listen near the controller, you can also hear it "click".</i></p>	<p><b>OK:</b> GO TO U</p> <p><b>NOT OK:</b> OR CAN'T TELL; Check 10-amp fuse, then GO TO 0, Group 20.</p> <p align="right">MX,159124005,6 -19-13JUL95</p>
---	---	---	---

<p><b>0 IGNITION CIRCUIT CHECK (322)</b></p>	<p>PTO switch OFF.</p> <p>Hydrostatic lever in N/STOP position.</p> <p>Later Models; Engage park brake.</p>	<div style="display: flex; flex-direction: column;">  <p align="center"><small>M45176 -UN-08JAN90</small></p> </div> <p>Turn key switch to START position.</p> <p><i>LISTEN: Engine must start and run.</i></p> <p>Stop engine after check.</p>	<p><b>OK:</b> GO TO 7a</p> <p><b>NOT OK:</b> Engine does not run or engine misfires; GO TO 0, Group 20.</p> <p align="right">MX,159124005,11-19-13JUL95</p>
--	---	--	---

*Electrical System Checkout/Lighting Check*

<p><b>7a Seat Switch Check For Ignition</b></p>	<p>Sit on seat. PTO switch OFF. Hydrostatic lever in N/STOP position. Later Models; Engage park brake.</p>	 <p>M55018 -UN-09DEC89</p>	<p>Start engine and operate at slow idle. Move hydrostatic lever to the right away from the N/STOP switch. Raise off seat for 2—3 seconds. <i>LISTEN: Engine must stop.</i> Restart engine. Again, move hydrostatic lever to the right away from the N/STOP slot. Raise off seat and quickly sit back down before one second elapses. <i>LISTEN: Engine must stay running.</i></p>	<p><b>OK:</b> GO TO Ü <b>NOT OK:</b> GO TO 7n, Group 20.</p> <p align="right">MX,159124005,12-19-13JUL95</p>
<p><b>Ü HOUR METER CHECK</b></p>	<p>Turn key switch to ON/RUN position.</p>	 <p>M55017 -UN-11DEC89</p>	<p><i>LOOK: Hour meter must operate.</i></p>	<p><b>OK:</b> GO TO Ü <b>NOT OK:</b> GO TO Ü, Group 20.</p> <p align="right">MX,159124005,15-19-13JUL95</p>
<p><b>Ü LIGHTING CHECK</b></p>	<p>Turn key switch to ON/RUN position.</p>	 <p>M55080 -UN-09DEC89</p>	<p>Pull light switch ON. <i>LOOK: All headlights and tail lights (if equipped) must be on.</i></p>	<p><b>OK:</b> System normal. <b>NOT OK:</b> GO TO Ü, Group 20.</p> <p align="right">MX,159124005,16-19-13JUL95</p>

240  
05  
6



*Electrical System Checkout/Operator Complaint Not Identified*

<p><b>10 OPERATOR COMPLAINT NOT IDENTIFIED</b></p>	<p>If you completed the checkout procedure and did not isolate a malfunction, the problem may be intermittent.</p> <p>Try to duplicate the conditions of the malfunction identified by the operator.</p> <p>Perform battery tests and ground tests as instructed in Group 20.</p> <p>Verify system grounds and battery condition. (See steps A and B in Group 20).</p>	<p>PERFORM BATTERY TESTS AND GROUND TESTS AS INSTRUCTED IN GROUP 20 AND REPEAT THE CHECKOUT PROCEDURE IN THIS GROUP.</p> <p>IF A MALFUNCTION IS NOT IDENTIFIED AFTER REPEATING SYSTEM CHECKOUT PROCEDURE, FACTORY ASSISTANCE IS AVAILABLE THROUGH THE DEALER TECHNICAL ASSISTANCE CENTER (DTAC).</p> <p>MX,159124005,17-19-13JUL95</p>
--	--	--

240  
05  
7

*Electrical System Checkout/Operator Complaint Not Identified*

240  
05  
8

## ELECTRICAL SCHEMATIC INFORMATION

The electrical schematics are made up of sections (SE) which are laid out from left-to-right in logical sequence (e.g. SE-1 Starting Circuit, SE-2 PTO Circuit, etc.).

Each section contains subsystems which are made up of groups of related components. The sections are named to reflect the function of the group of components.

The electrical schematics are drawn showing the power in (battery positive) circuit across the top and the ground (battery negative) circuit across the bottom. The flow is (if possible) from top to bottom through each circuit and component. All components are shown in the off position.

*NOTE: 332 and 430; Two schematics for each model are provided to show component, component wiring and ground circuit changes for different versions of machines.*

MX,159124010,1A-19-13JUL95

## MAIN ELECTRICAL SCHEMATIC LEGEND—322

A1—Time Delay Control (TDC) Module	P6—Engine Oil Pressure Lamp	X4—Front PTO Switch 3-Pin Connector	X18—Engine Harness 2-Pin Connector
A3—Transistor Module	P7—Hour Meter	X5—Rear PTO Harness 3-Pin Connector	X19—Fuel Pump 2-Pin Connector
B1—No.1 Pulser Coil	R2—Electric Choke (S.N. 010714— )	X6—Rear PTO Switch 2-Pin Connector (Optional)	X20—No.1 Pulser Coil 2-Pin Connector
B2—No.2 Pulser Coil	S1—Key Switch	X7—Rear PTO Switch 3-Pin Connector (Optional)	X21—No.2 Pulser Coil 2-Pin Connector
B3—No.3 Pulser Coil	S2—Front PTO Switch	X8—Transmission Neutral Switch 1-Pin Connector	X22—No.3 Pulser Coil 2-Pin Connector
B4—Low Fuel Level Sensor	S3—Rear PTO Switch (Optional)	X9—Transmission Neutral Switch 1-Pin Connector	X23—Low Fuel Level Sensor 2-Pin Connector
B5—Engine Coolant Temperature Switch	S4—Brake Switch (S.N. 596006— )	X10—Front PTO Clutch 2-Pin Connector	X24—Pulsar Coil Harness 4-Pin Connector
B6—Engine Oil Pressure Switch	S5—Transmission Neutral Switch	X11—Rear PTO Lamp 1-Pin Connector (Ground)	X25—Transistor Module 4-Pin Connector
E1—Spark Plug	S6—Seat Switch	X12—Rear PTO Clutch 1-Pin Connector (Optional)	X26—Transistor Module 6-Pin Connector
E2—Spark Plug	T1—No.1 Ignition Coil	X13—TDC Module 8-Pin Connector	X27—Ignition Coil Harness 6-Pin Connector
E3—Spark Plug	T2—No.2 Ignition Coil	X14—TDC Module 2-Pin Connector	X28—Fuel Shutoff Solenoid and Electric Choke 2-Pin Connector (S.N. 010714— )
F1—25-Amp Fuse	T3—No.3 Ignition Coil	X15—Seat Switch 2-Pin Connector	Y1—Front PTO Clutch
F2—10-Amp Fuse	V1—Diode	X16—Voltage Regulator/Rectifier 5-Pin Connector	Y2—Rear PTO Clutch (Optional)
F4—Fusible Link	V2—Diode	X17—Alternator 2-Pin Connector	Y3—Fuel Shutoff Solenoid
G1—Battery	W1—Engine Ground		
G2—Alternator	W3—Frame Ground		
K1—Neutral Start Relay	W4—Frame Ground at Voltage Regulator/Rectifier		
M1—Starter Motor	X1—Neutral Start Relay 4-Pin Connector		
M2—Fuel Pump	X2—Brake Switch 2-Pin Connector (S.N. 596006— )		
N1—Voltage Regulator/Rectifier	X3—Front PTO Switch 2-Pin Connector		
P1—Front PTO Lamp			
P2—Rear PTO Lamp (Optional)			
P3—Battery Discharge Lamp			
P4—Low Fuel Level Lamp			
P5—Engine Coolant Temperature Lamp			

NOTE: 1. For machines not equipped with optional rear PTO, a jumper wire is used at connector (X5) in place of rear PTO switch (S3). The jumper wire connects purple wire "750" to wires "770" (purple) and "771" (purple/white).

The blue wire "780" deadends at connector (X5).

NOTE: 2. Machines (S.N. —596005); Brake switch (S4) is not used. Purple wire "811" connects transmission neutral switch (S5) directly to neutral start relay (K1).

NOTE: 3. Machines (S.N. 010714— ); Electric choke (R2) is used. 2-Pin connector (X28) distributes current to fuel shutoff solenoid (Y3) and the electric choke.

MAIN ELECTRICAL SCHEMATIC—322

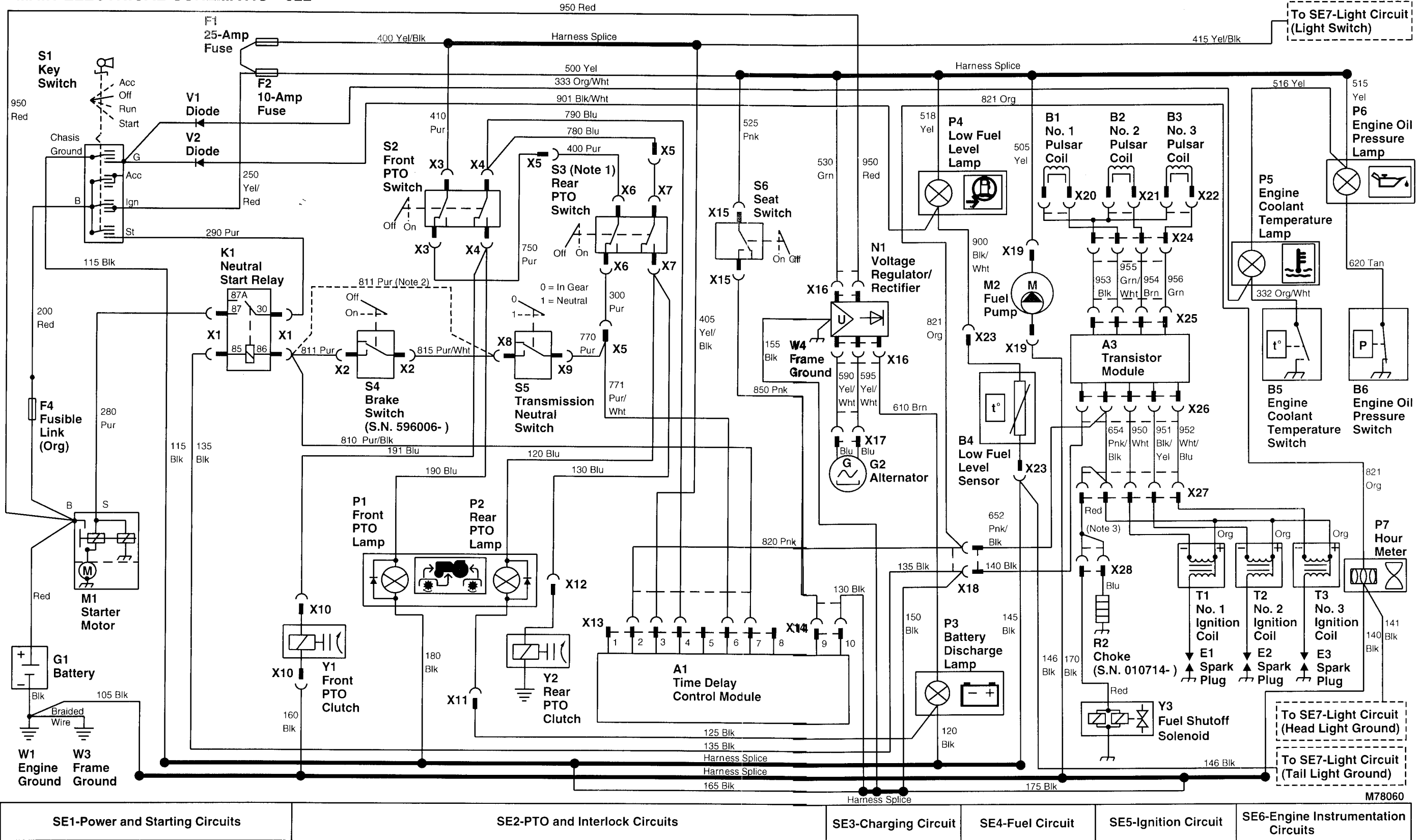

M78060

1060 X 640

MX.159124010.2 -19-13JUL95

TM1591 (15JUL95)

240-10-3

322,330,332 & 430 Lawn & Garden Tractors

170795

MAIN ELECTRICAL SCHEMATIC—322

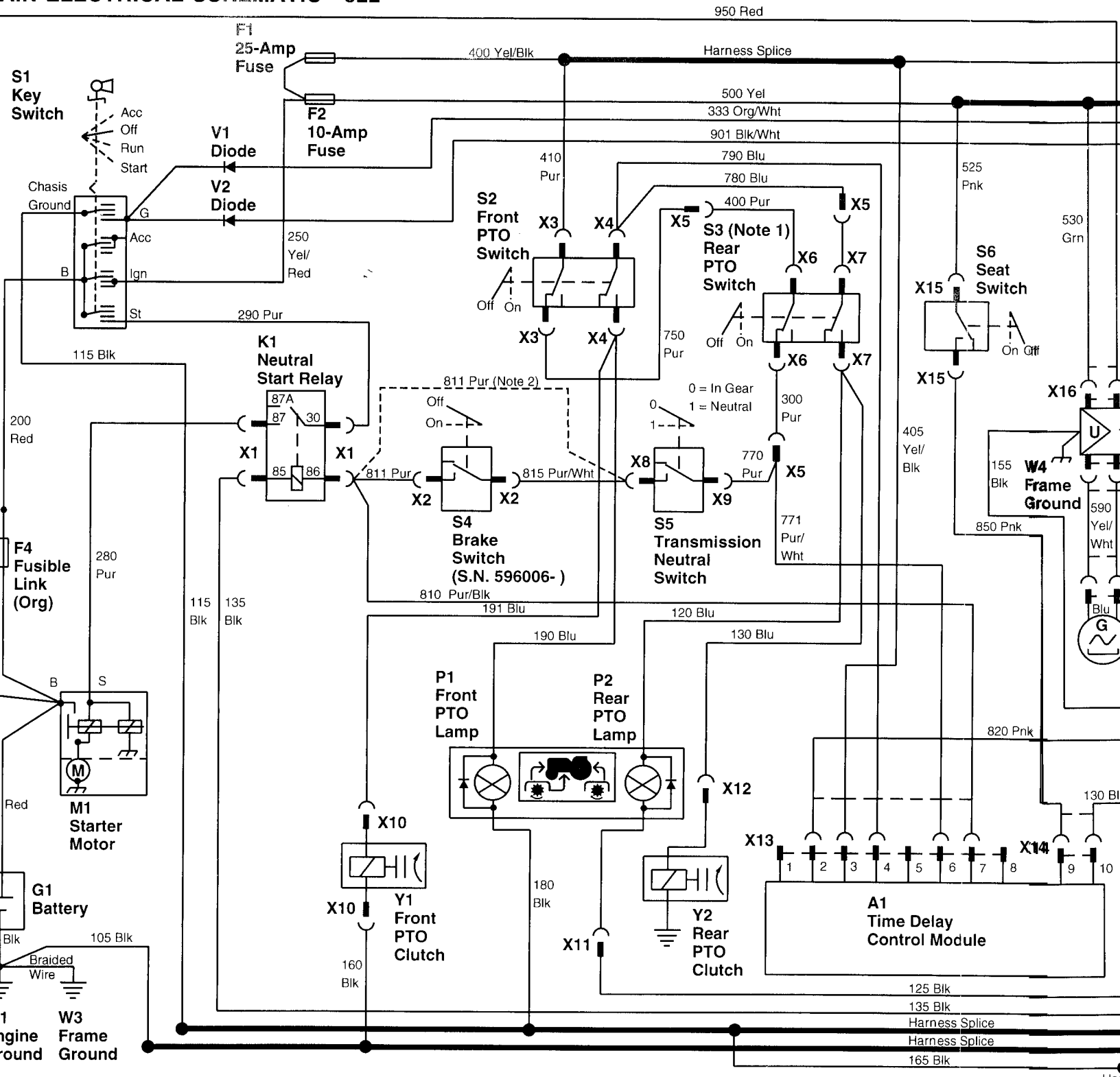

SE1-Power and Starting Circuits

SE2-PTO and Interlock Circuits

SE3-

8060

1060 X 640

MX.159124010.2 -19-13JUL95

591 (15JUL95)

240-10-3

322,330,332 & 430 Lawn & Garden Tractors

170795

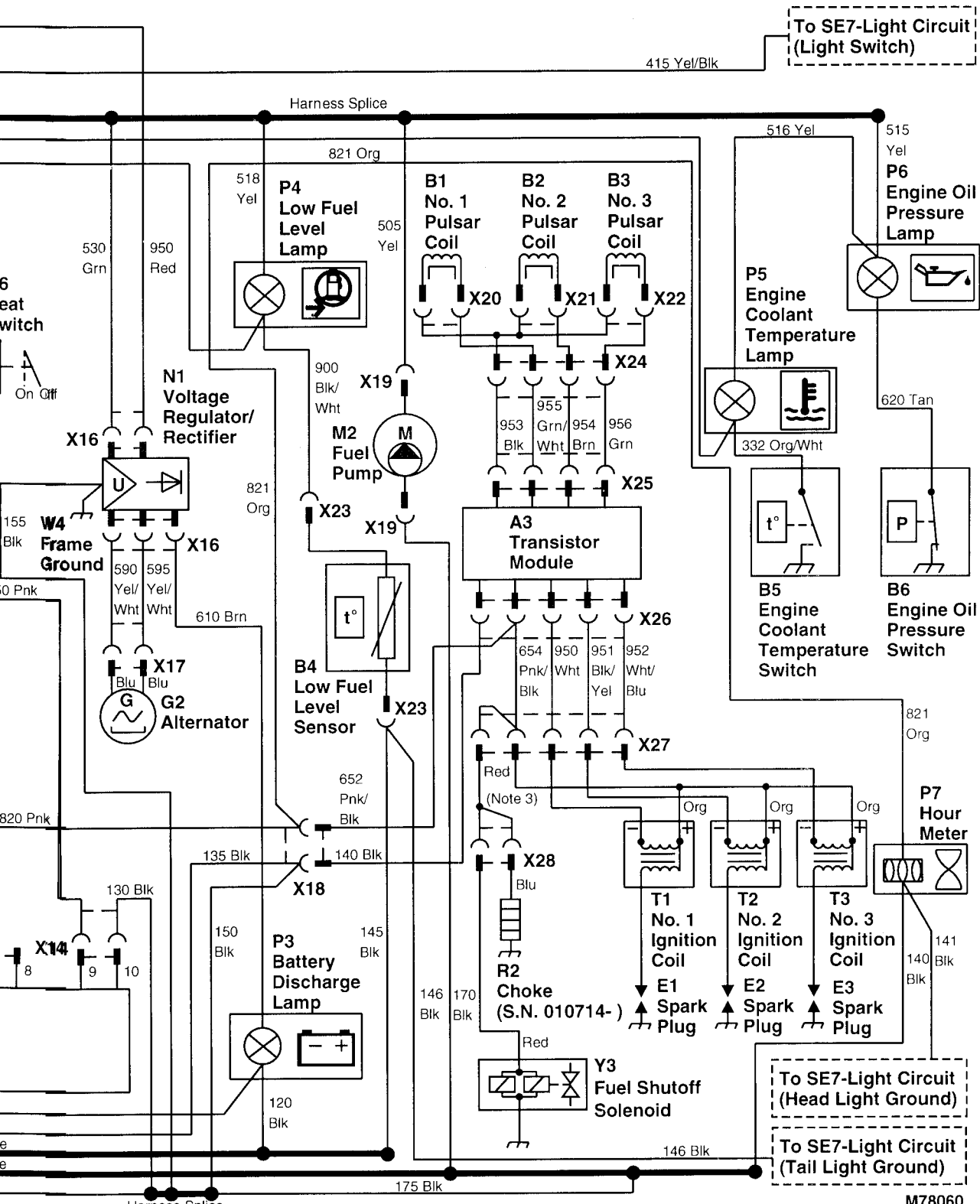

SE3-Charging Circuit	SE4-Fuel Circuit	SE5-Ignition Circuit	SE6-Engine Instrumentation Circuits
----------------------	------------------	----------------------	-------------------------------------

M78060

MAIN ELECTRICAL SCHEMATIC—330

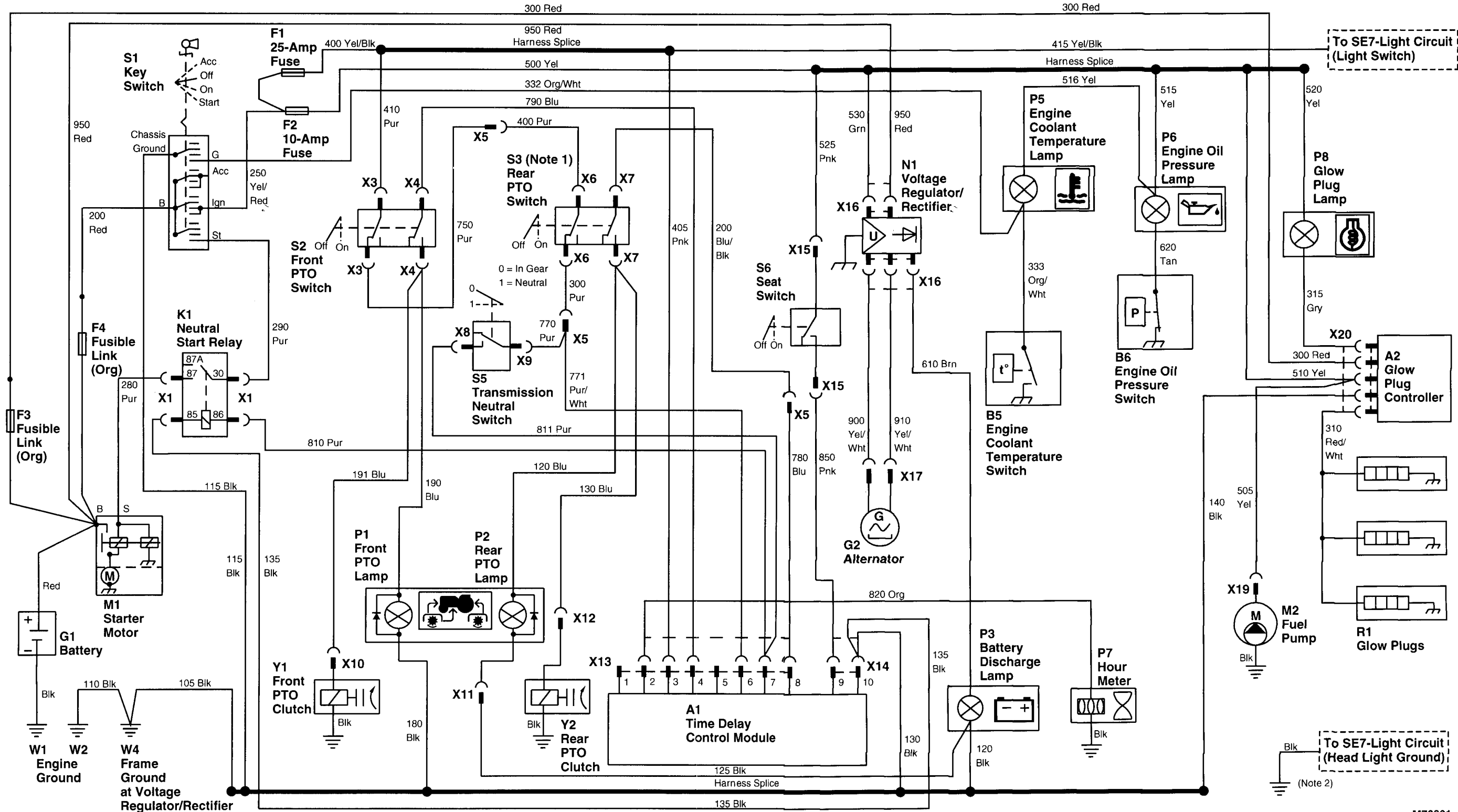

M78061

SE1-Power and Starting Circuits	SE2-PTO and Interlock Circuits	SE3-Charging Circuit	SE4-Engine Instrumentation Circuits	SE5-Fuel System and Glow Plug Circuits
---------------------------------	--------------------------------	----------------------	-------------------------------------	--

M78061

1060 X 640

MX 159124010.3 -19-13JUL95

TM1591 (15JUL95)

240-10-4

322,330,332 & 430 Lawn & Garden Tractors

170795



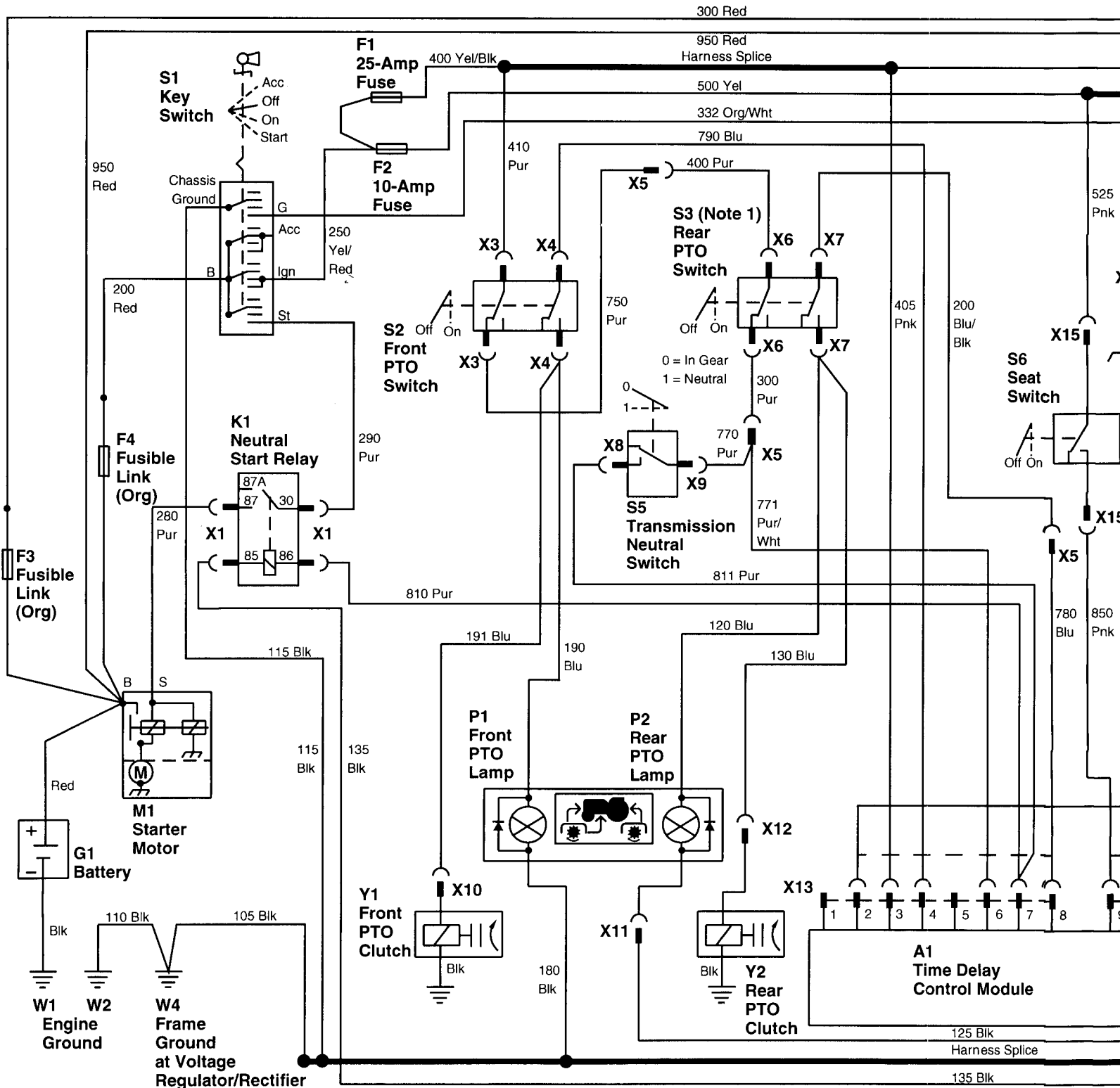

SE1-Power and Starting Circuits

SE2-PTO and Interlock Circuits

MAIN ELECTRICAL SCHEMATIC—330

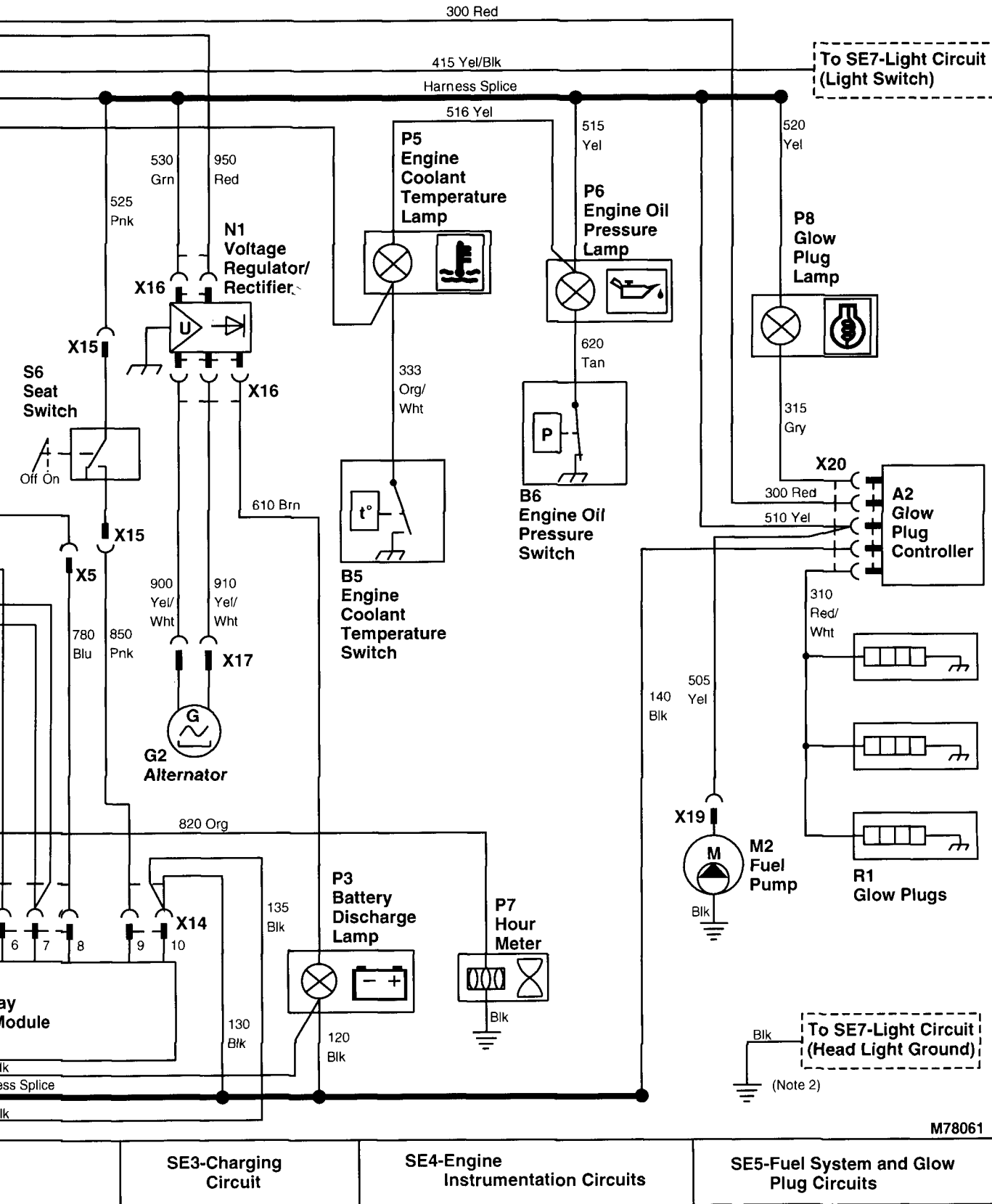

M78061

SE3-Charging Circuit

SE4-Engine Instrumentation Circuits

SE5-Fuel System and Glow Plug Circuits

MX,159124010.3 -19-13JUL95

## MAIN ELECTRICAL SCHEMATIC LEGEND—330

A1—Time Delay Control (TDC) Module	P3—Battery Discharge Lamp	X1—Neutral Start Relay 4-Pin Connector	X12—Rear PTO Clutch 1-Pin Connector (Optional)
A2—Glow Plug Controller	P5—Engine Coolant Temperature Lamp	X3—Front PTO Switch 2-Pin Connector	X13—TDC Module 8-Pin Connector
B5—Engine Coolant Temperature Switch	P6—Engine Oil Pressure Lamp	X4—Front PTO Switch 3-Pin Connector	X14—TDC Module 2-Pin Connector
B6—Engine Oil Pressure Switch	P7—Hour Meter	X5—Rear PTO Harness 3-Pin Connector	X15—Seat Switch 2-Pin Connector
F1—25-Amp Fuse	P8—Glow Plug Lamp	X6—Rear PTO Switch 2-Pin Connector (Optional)	X16—Voltage Regulator/Rectifier 5-Pin Connector
F2—10-Amp Fuse	R1—Glow Plugs (3 used)	X7—Rear PTO Switch 3-Pin Connector (Optional)	X17—Alternator 2-Pin Connector
F3—Fusible Link	S1—Key Switch	X8—Transmission Neutral Switch 1-Pin Connector	X19—Fuel Pump 1-Pin Connector
F4—Fusible Link	S2—Front PTO Switch	X9—Transmission Neutral Switch 1-Pin Connector	X20—Glow Plug Controller 5-Pin Connector
G1—Battery	S3—Rear PTO Switch (Optional)	X10—Front PTO Clutch 1-Pin Connector	Y1—Front PTO Clutch
G2—Alternator	S5—Transmission Neutral Switch	X11—Rear PTO Lamp 1-Pin Connector (Ground)	Y2—Rear PTO Clutch (Optional)
K1—Neutral Start Relay	S6—Seat Switch		
M1—Starter Motor	W1—Engine Ground		
M2—Fuel Pump	W2—Engine Ground		
N1—Voltage Regulator/Rectifier	W4—Frame Ground at Voltage Regulator/Rectifier		
P1—Front PTO Lamp			
P2—Rear PTO Lamp (Optional)			

*NOTE: 1. For machines not equipped with optional rear PTO, a jumper wire is used at connector (X5) in place of rear PTO switch (S3). The jumper wire connects purple wire "750" to wires "770" (purple) and "771" (purple/white).*

*The blue wire "780" deadends at connector (X5).*

*NOTE: 2. Model 330 does not come equipped with rear tail lights. Red reflectors are used instead.*

MX,159124010,4 -19-13JUL95

**MAIN ELECTRICAL SCHEMATIC LEGEND—332 (S.N. —475000)**

A1—Time Delay Control (TDC) Module	P4—Low Fuel Level Lamp	X1—Neutral Start Relay 4-Pin Connector	X14—TDC Module 3-Pin Connector
A2—Glow Plug Controller	P5—Engine Coolant Temperature Lamp	X3—Front PTO Switch 2-Pin Connector	X15—Seat Switch 2-Pin Connector
B4—Low Fuel Level Sensor	P6—Engine Oil Pressure Lamp	X4—Front PTO Switch 3-Pin Connector	X16—Voltage Regulator/Rectifier 5-Pin Connector
B5—Engine Coolant Temperature Switch	P7—Hour Meter	X5—Rear PTO Harness 3-Pin Connector	X17—Alternator 2-Pin Connector
B6—Engine Oil Pressure Switch	P8—Glow Plug Lamp	X6—Rear PTO Switch 2-Pin Connector (Optional)	X19—Fuel Pump 1-Pin Connector
F1—25-Amp Fuse	R1—Glow Plugs (3 used)	X7—Rear PTO Switch 3-Pin Connector (Optional)	X20—Glow Plug Controller 5-Pin Connector
F2—10-Amp Fuse	S1—Key Switch	X8—Transmission Neutral Switch 1-Pin Connector	X21—Fuel Shutoff Solenoid 3-Pin Connector
F3—Fusible Link	S2—Front PTO Switch	X9—Transmission Neutral Switch 1-Pin Connector	X23—Low Fuel Level Sensor 2-Pin Connector
F4—Fusible Link	S3—Rear PTO Switch (Optional)	X10—Front PTO Clutch 1-Pin Connector	Y1—Front PTO Clutch
G1—Battery	S5—Transmission Neutral Switch	X11—Rear PTO Lamp 1-Pin Connector (Ground)	Y2—Rear PTO Clutch (Optional)
G2—Alternator	S6—Seat Switch	X12—Rear PTO Clutch 1-Pin Connector (Optional)	Y3—Fuel Shutoff Solenoid
K1—Neutral Start Relay	V1—Diode	X13—TDC Module 6-Pin Connector	
M1—Starter Motor	V2—Diode		
M2—Fuel Pump	W1—Engine Ground		
N1—Voltage Regulator/Rectifier	W2—Engine Ground		
P1—Front PTO Lamp	W3—Frame Ground		
P2—Rear PTO Lamp (Optional)	W4—Frame Ground at Voltage Regulator/Rectifier		
P3—Battery Discharge Lamp			

*NOTE: 1. For machines not equipped with optional rear PTO, a jumper wire is used at connector (X5) in place of rear PTO switch (S3). The jumper wire connects purple wire "750" to wires "770" (purple) and "771" (purple/white).*

*The blue wire "780" deadends at connector (X5).*

MX,159124010,5 -19-13JUL95

MAIN ELECTRICAL SCHEMATIC—332 (S.N. —475000)

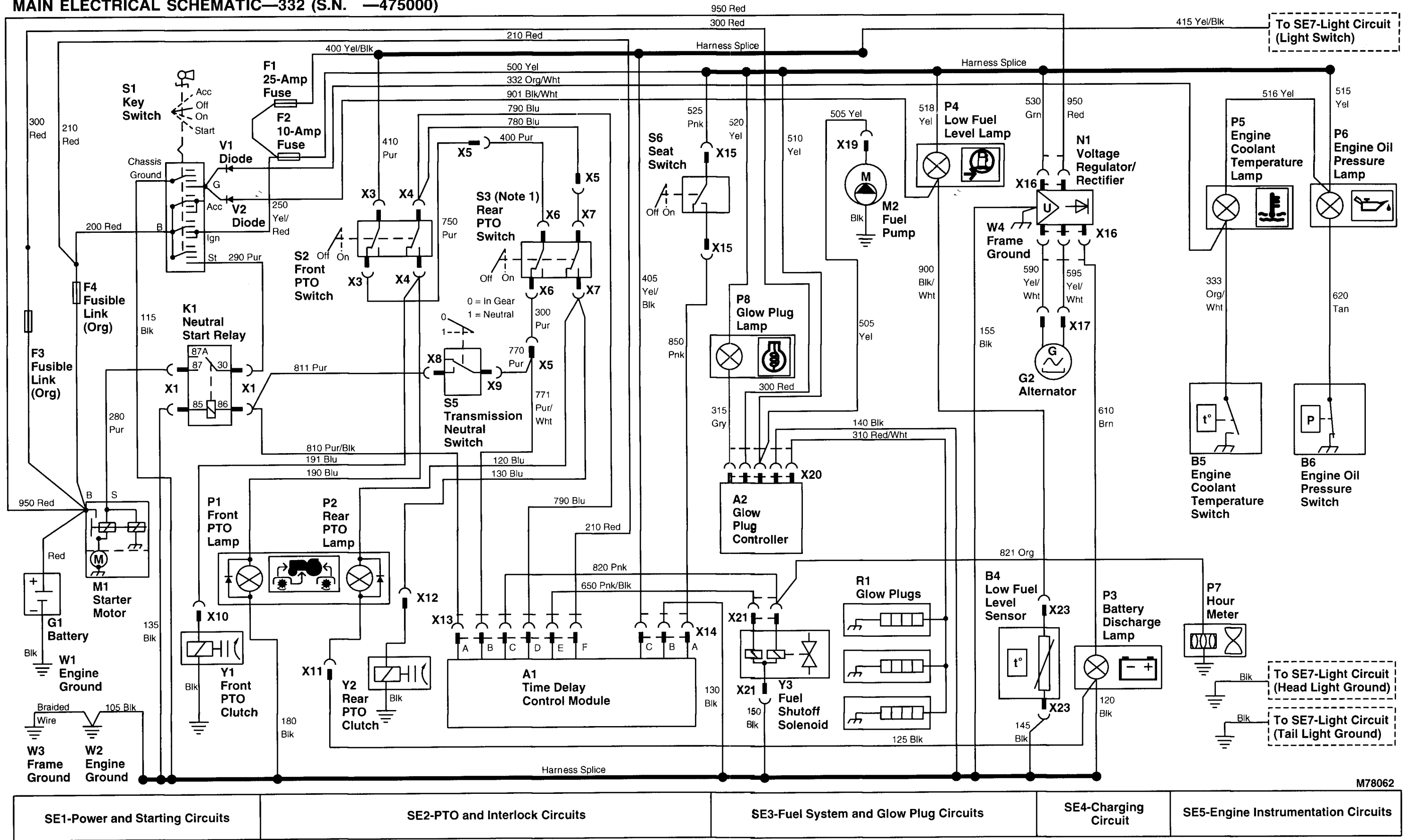

M78062

M78062

TM1591 (15JUL95)

240-10-7

322,330,332 & 430 Lawn & Garden Tractors

1060 X 640

MX.159124010.6 -19-13JUL95

170795

MAIN ELECTRICAL SCHEMATIC—332 (S.N. —475000)

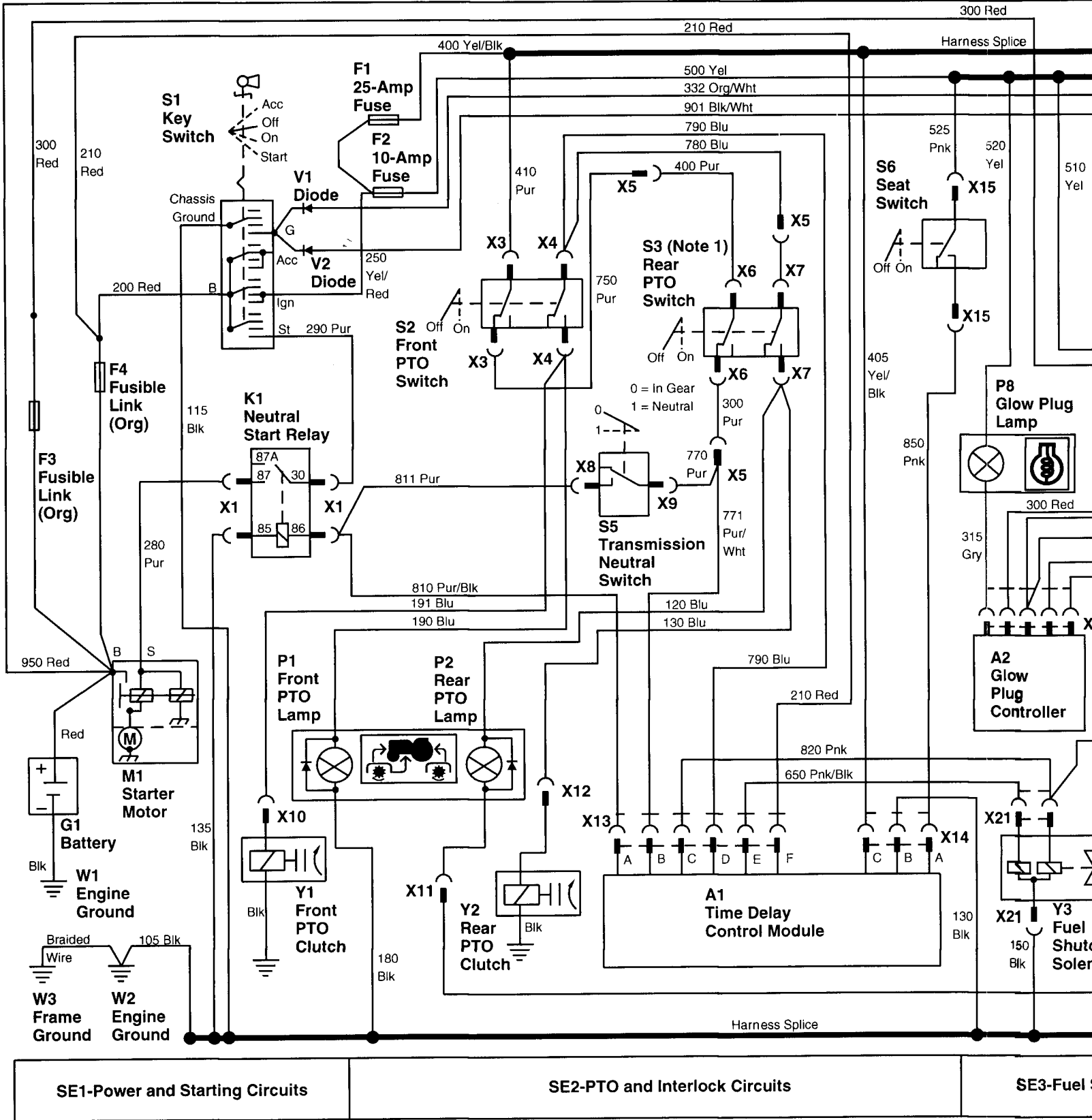

M78062

TM1591 (15JUL95)

240-10-7

322,330,332 & 430 Lawn & Garden Tractors

170795

1060 X 640

MX.159124010.6 -19-13JUL95

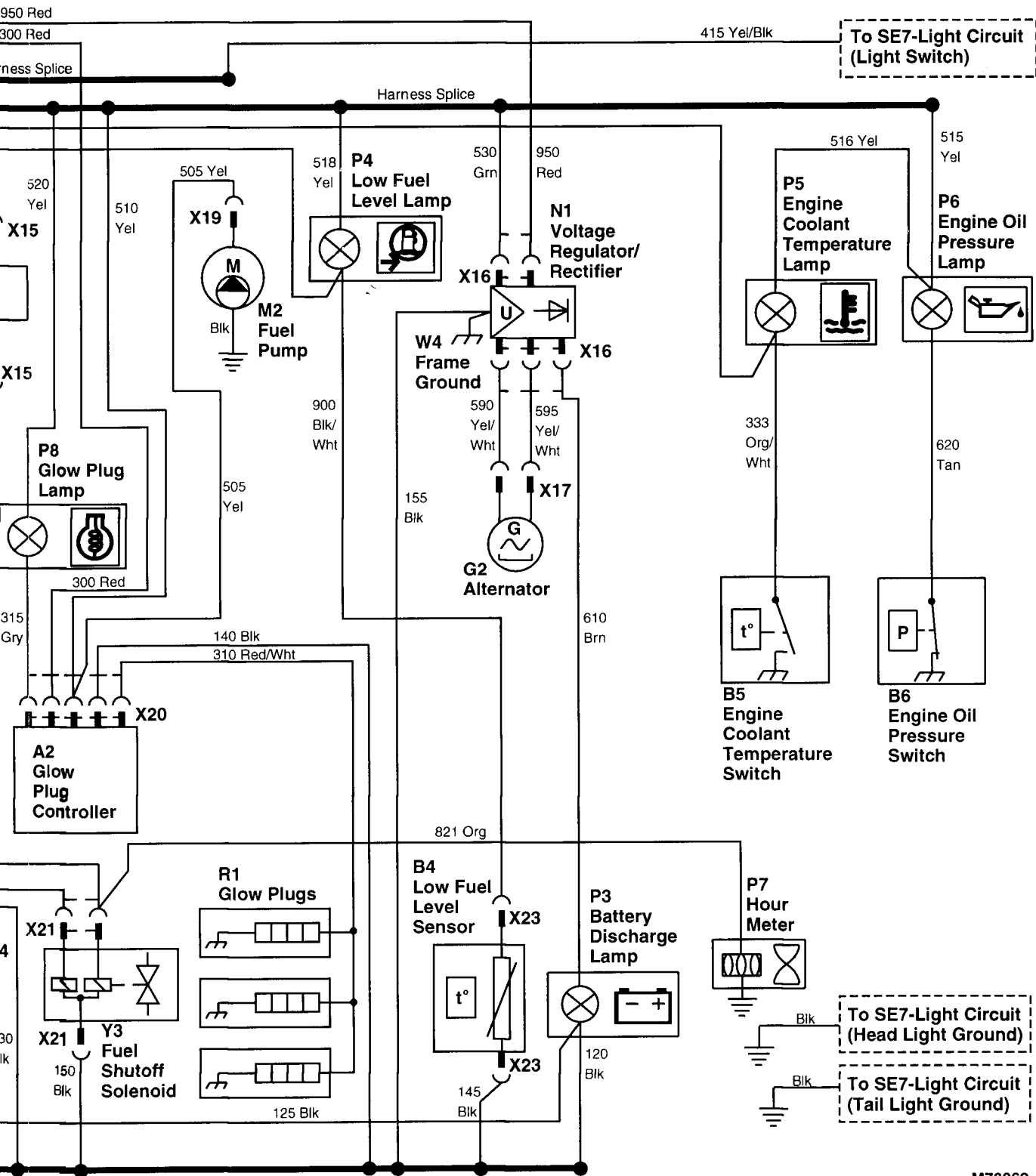

M78062

SE3-Fuel System and Glow Plug Circuits

SE4-Charging Circuit

SE5-Engine Instrumentation Circuits

MAIN ELECTRICAL SCHEMATIC—332 (S.N. 475001— )

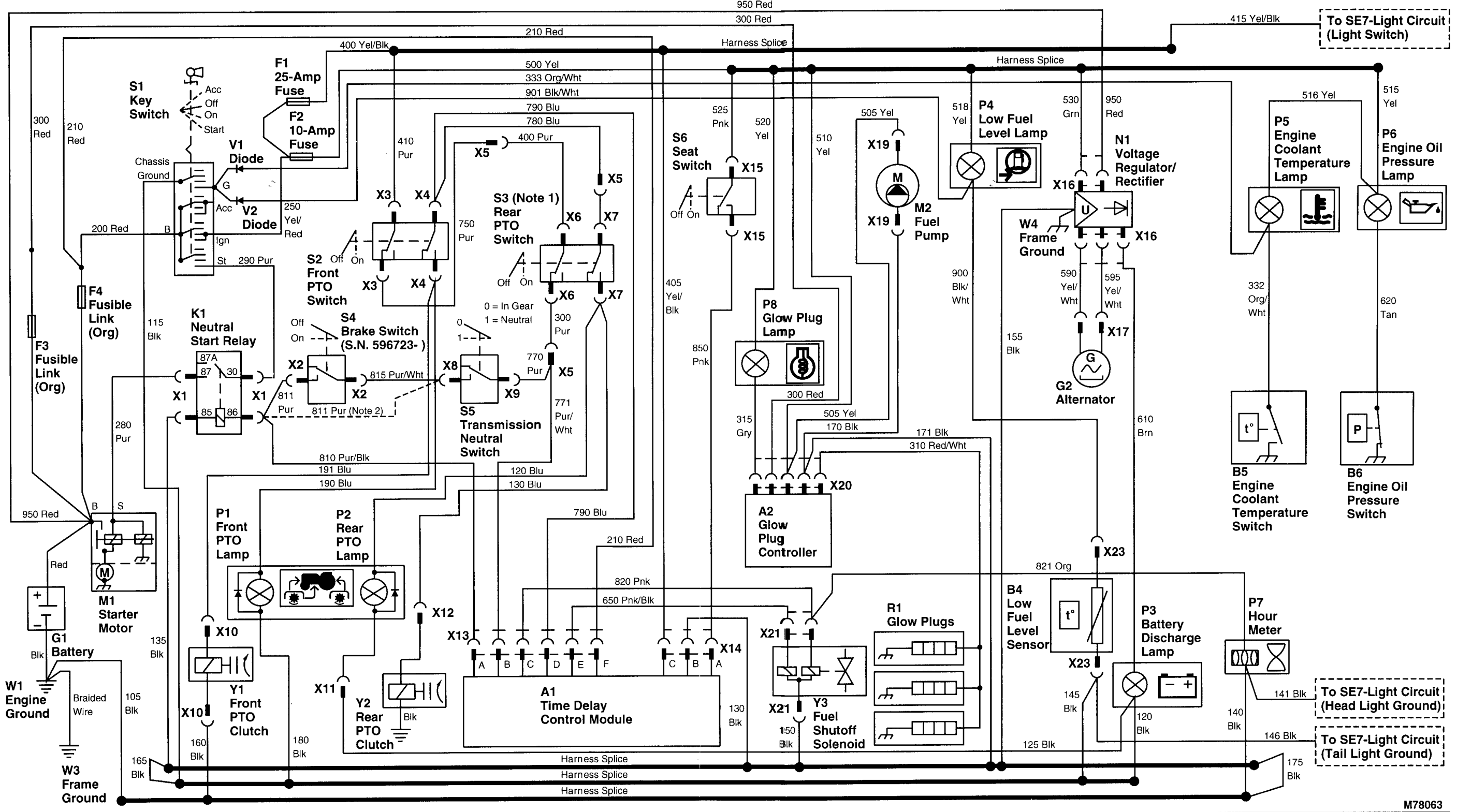

SE1-Power and Starting Circuits	SE2-PTO and Interlock Circuits	SE3-Fuel System and Glow Plug Circuits	SE4-Charging Circuit	SE5-Engine Instrumentation Circuits
---------------------------------	--------------------------------	--	----------------------	-------------------------------------



# MAIN ELECTRICAL

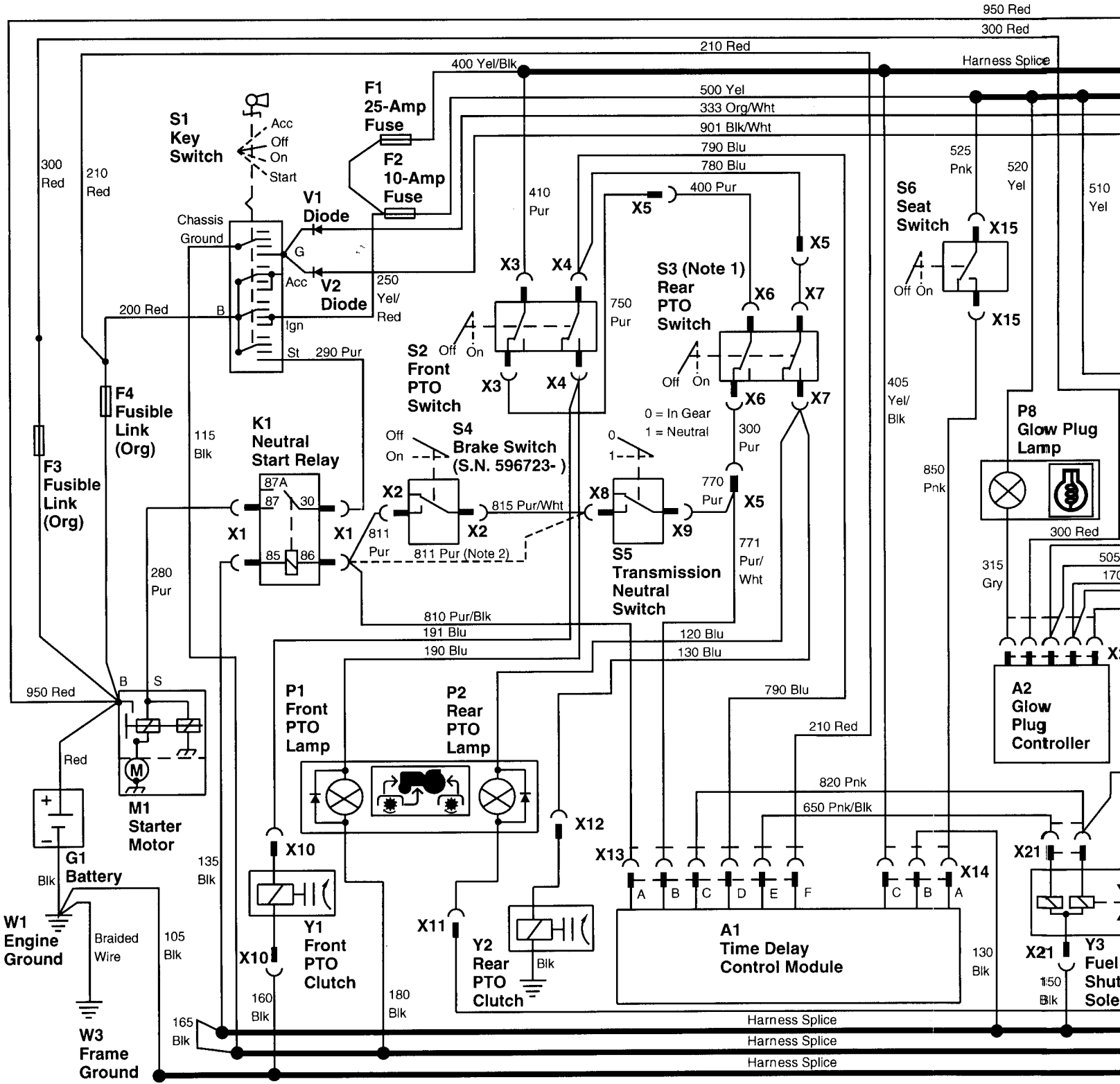

SE1-Power and Starting Circuits

SE2-PTO and Interlock Circuits

SE3-Fuel S

**MAIN ELECTRICAL SCHEMATIC—332 (S.N. 475001— )**

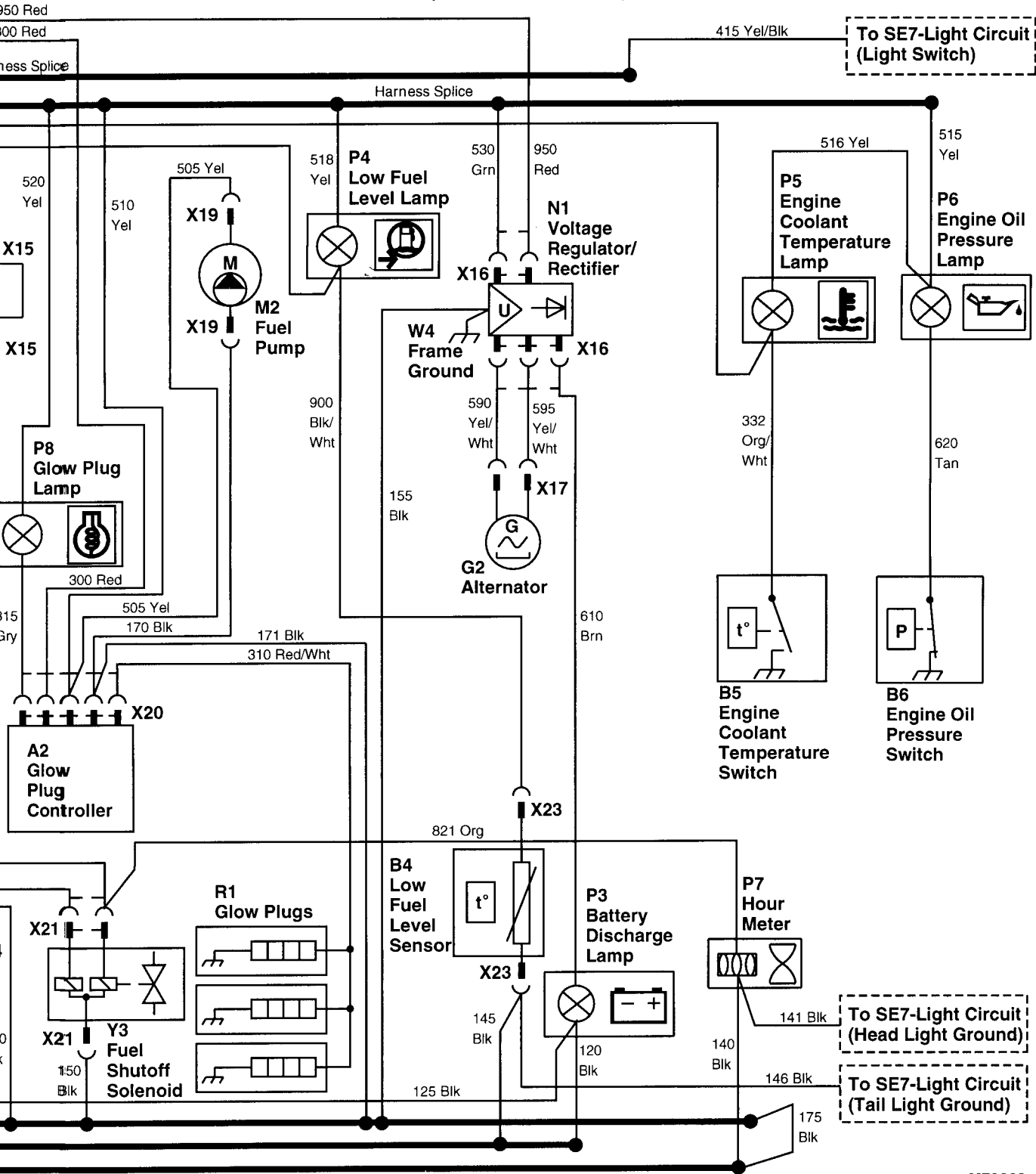

M78063

SE3-Fuel System and Glow Plug Circuits	SE4-Charging Circuit	SE5-Engine Instrumentation Circuits
--	----------------------	-------------------------------------

**MAIN ELECTRICAL SCHEMATIC LEGEND—332 (S.N. 475001— )**

A1—Time Delay Control (TDC) Module	P5—Engine Coolant Temperature Lamp	X2—Brake Switch 2-Pin Connector (S.N. 596723— )	X13—TDC Module 6-Pin Connector
A2—Glow Plug Controller	P6—Engine Oil Pressure Lamp	X3—Front PTO Switch 2-Pin Connector	X14—TDC Module 3-Pin Connector
B4—Low Fuel Level Sensor	P7—Hour Meter	X4—Front PTO Switch 3-Pin Connector	X15—Seat Switch 2-Pin Connector
B5—Engine Coolant Temperature Switch	P8—Glow Plug Lamp	X5—Rear PTO Harness 3-Pin Connector	X16—Voltage Regulator/Rectifier 5-Pin Connector
B6—Engine Oil Pressure Switch	R1—Glow Plugs (3 used)	X6—Rear PTO Switch 2-Pin Connector (Optional)	X17—Alternator 2-Pin Connector
F1—25-Amp Fuse	S1—Key Switch	X7—Rear PTO Switch 3-Pin Connector (Optional)	X19—Fuel Pump 2-Pin Connector
F2—10-Amp Fuse	S2—Front PTO Switch	X8—Transmission Neutral Switch 1-Pin Connector	X20—Glow Plug Controller 5-Pin Connector
F3—Fusible Link	S3—Rear PTO Switch (Optional)	X9—Transmission Neutral Switch 1-Pin Connector	X21—Fuel Shutoff Solenoid 3-Pin Connector
F4—Fusible Link	S4—Brake Switch (S.N. 596723— )	X10—Front PTO Clutch 2-Pin Connector	X23—Low Fuel Level Sensor 2-Pin Connector
G1—Battery	S5—Transmission Neutral Switch	X11—Rear PTO Lamp 1-Pin Connector (Ground)	Y1—Front PTO Clutch
G2—Alternator	S6—Seat Switch	X12—Rear PTO Clutch 1-Pin Connector (Optional)	Y2—Rear PTO Clutch (Optional)
K1—Neutral Start Relay	V1—Diode		Y3—Fuel Shutoff Solenoid
M1—Starter Motor	V2—Diode		
M2—Fuel Pump	W1—Engine Ground		
N1—Voltage Regulator/Rectifier	W3—Frame Ground		
P1—Front PTO Lamp	W4—Frame Ground at Voltage Regulator/Rectifier		
P2—Rear PTO Lamp (Optional)	X1—Neutral Start Relay 4-Pin Connector		
P3—Battery Discharge Lamp			
P4—Low Fuel Level Lamp			

*NOTE: 1. For machines not equipped with optional rear PTO, a jumper wire is used at connector (X5) in place of rear PTO switch (S3). The jumper wire connects purple wire "750" to wires "770" (purple) and "771" (purple/white).*

*The blue wire "780" deadends at connector (X5).*

*NOTE: 2. Machines (S.N. —596722); Brake switch (S4) is not used. Purple wire "811" connects transmission neutral switch (S5) directly to neutral start relay (K1).*

MX,159124010,8 -19-13JUL95

**MAIN ELECTRICAL SCHEMATIC LEGEND—430 (S.N. —420468)**

A1—Time Delay Control (TDC) Module	P3—Battery Discharge Lamp	X1—Neutral Start Relay 4-Pin Connector	X13—TDC Module 8-Pin Connector
A2—Glow Plug Controller	P4—Low Fuel Level Lamp	X3—Front PTO Switch 2-Pin Connector	X14—TDC Module 2-Pin Connector
B4—Low Fuel Level Sensor	P5—Engine Coolant Temperature Lamp	X4—Front PTO Switch 3-Pin Connector	X15—Seat Switch 2-Pin Connector
B5—Engine Coolant Temperature Switch	P6—Engine Oil Pressure Lamp	X5—Rear PTO Harness 3-Pin Connector	X19—Fuel Pump 1-Pin Connector
B6—Engine Oil Pressure Switch	P7—Hour Meter	X6—Rear PTO Switch 2-Pin Connector (Optional)	X20—Glow Plug Controller 5-Pin Connector
B7—Water-In-Fuel Sensor	P8—Glow Plug Lamp	X7—Rear PTO Switch 3-Pin Connector (Optional)	X21—Fuel Shutoff Solenoid 1-Pin Connector
F1—25-Amp Fuse	P9—Water-In-Fuel Lamp	X8—Transmission Neutral Switch 1-Pin Connector	X22—Water-In-Fuel 3-Pin Connector
F2—10-Amp Fuse	R1—Glow Plugs (3 used)	X9—Transmission Neutral Switch 1-Pin Connector	X23—Low Fuel Level Lamp 1-Pin Connector
F3—Fusible Link	S1—Key Switch	X10—Front PTO Clutch 1-Pin Connector	Y1—Front PTO Clutch
F4—Fusible Link	S2—Front PTO Switch	X11—Rear PTO Lamp 1-Pin Connector (Ground)	Y2—Rear PTO Clutch (Optional)
F5—8-Amp Circuit Breaker	S3—Rear PTO Switch (Optional)	X12—Rear PTO Clutch 1-Pin Connector (Optional)	Y3—Fuel Shutoff Solenoid
G1—Battery	S5—Transmission Neutral Switch		
G2—Alternator	S6—Seat Switch		
K1—Neutral Start Relay	V1—Diode		
M1—Starter Motor	V2—Diode		
M2—Fuel Pump	V3—Diode		
P1—Front PTO Lamp	W1—Engine Ground		
P2—Rear PTO Lamp (Optional)	W5—Frame (Pedestal) Ground		

*NOTE: 1. For machines not equipped with optional rear PTO, a jumper wire is used at connector (X5) in place of rear PTO switch (S3). The jumper wire connects purple wire "750" to wires "770" (purple) and "771" (purple/white).*

*The blue wire "780" deadends at connector (X5).*

MX,159124010,9 -19-13JUL95

MAIN ELECTRICAL SCHEMATIC—430 (S.N. —420468)

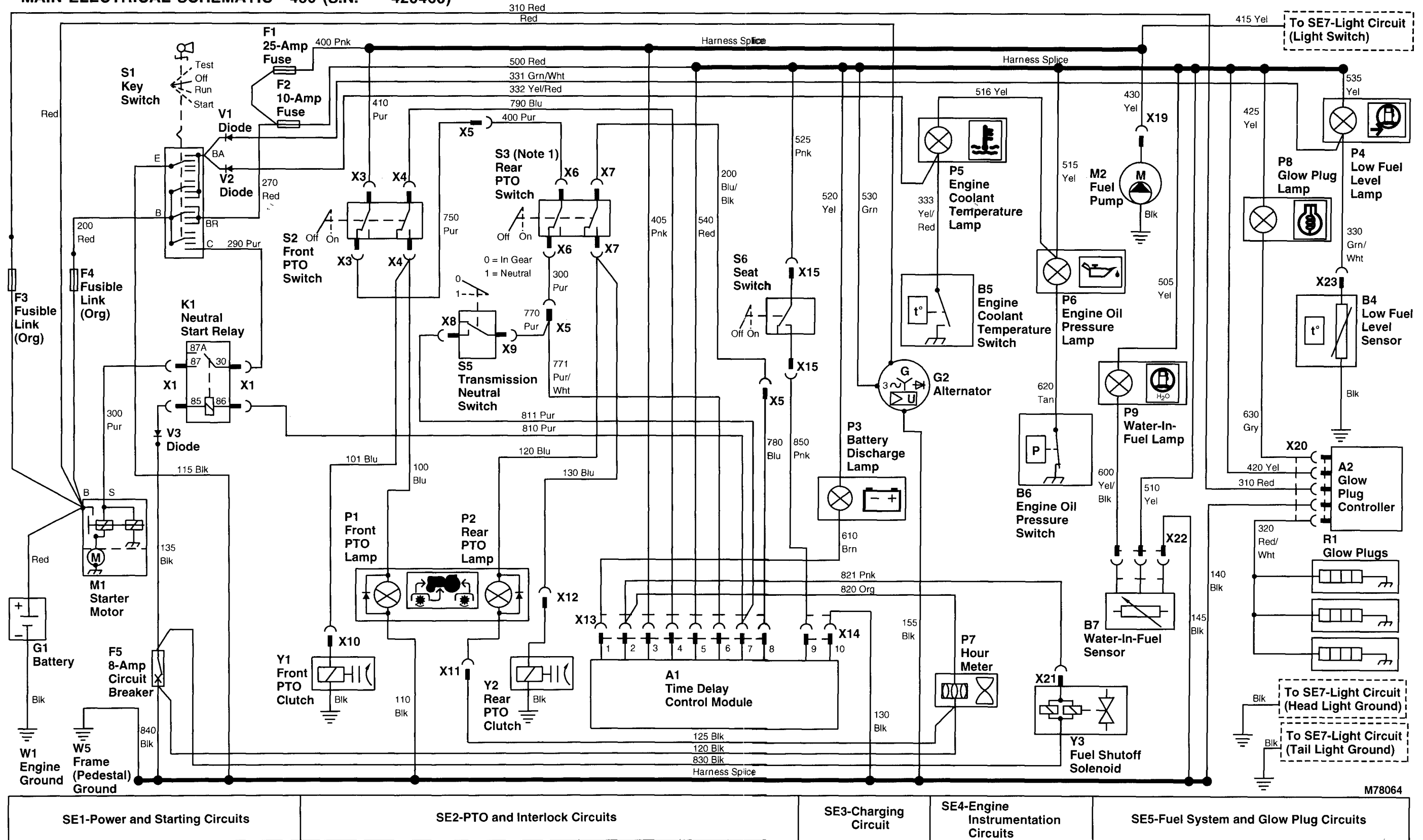

M78064

M78064

TM1591 (15JUL95)

240-10-11

322,330,332 & 430 Lawn & Garden Tractors

170795

1060 X 640

MX.159124010.10-19-13JUL95

MAIN ELECTRICAL SCHEMATIC—430 (S.N. —420468)

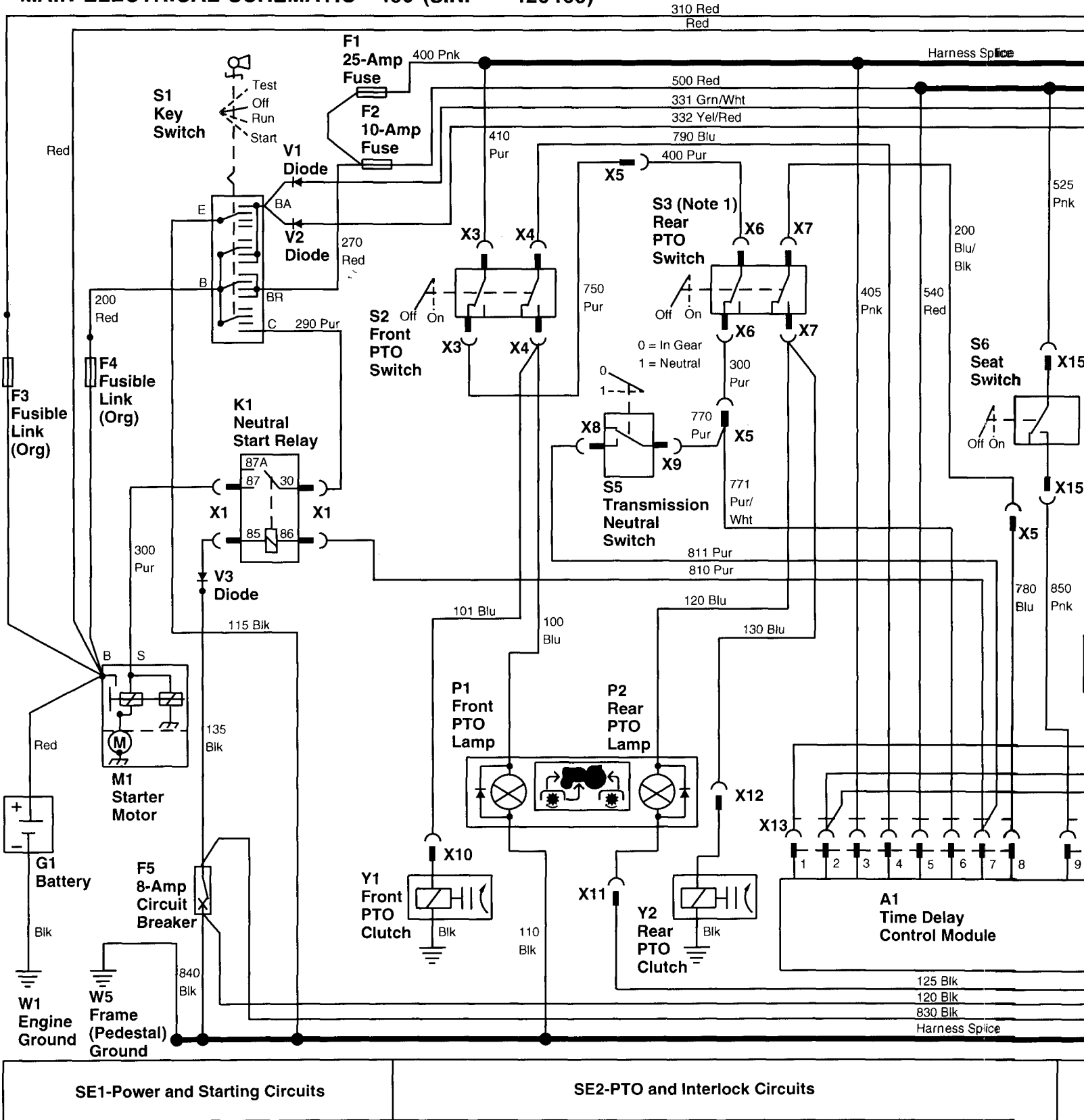

M78064

1060 X 640

MX.159124010.10-19-13JUL95

TM1591 (15JUL95)

240-10-11

322,330,332 & 430 Lawn & Garden Tractors

170795

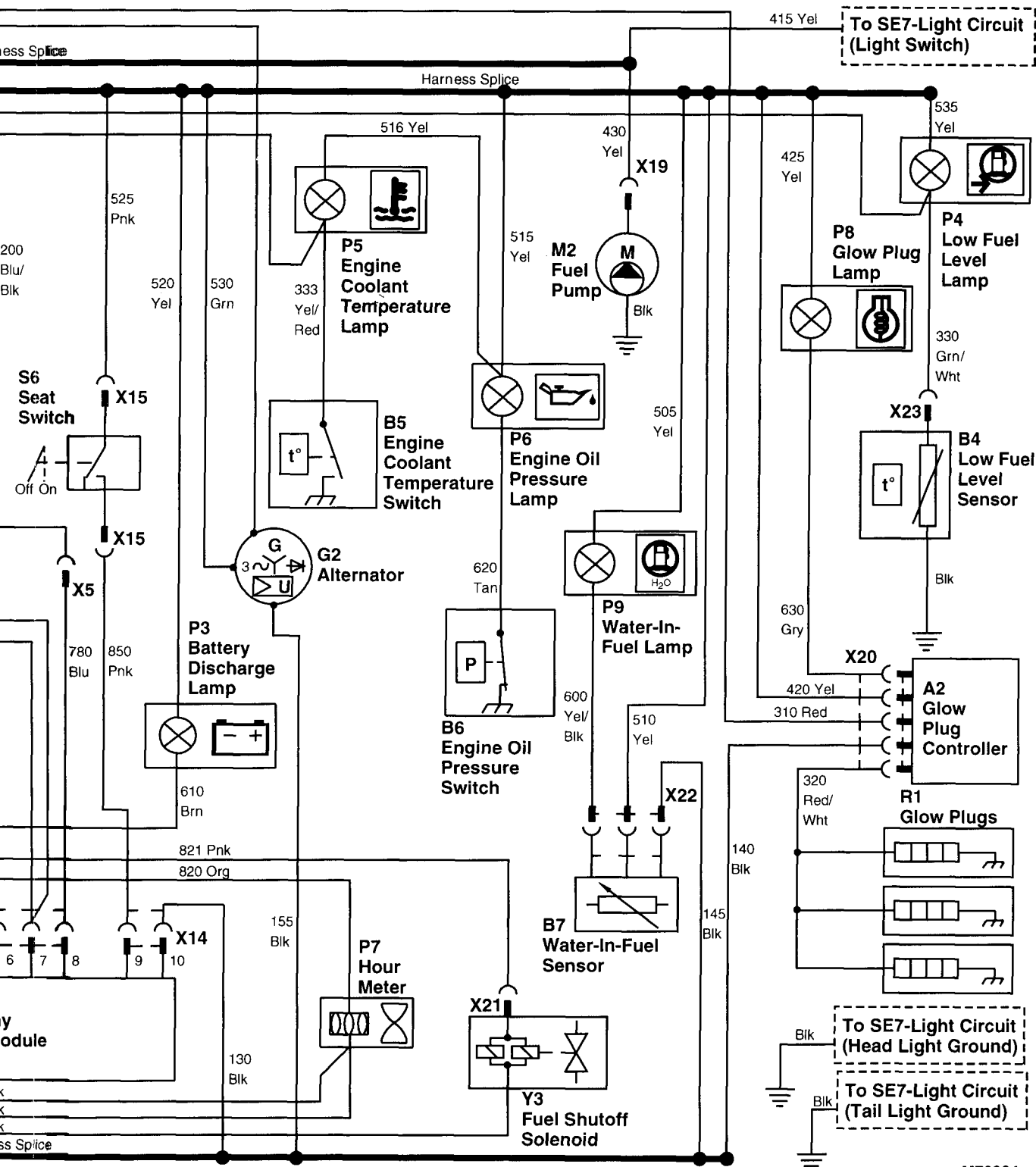

M78064

SE3-Charging Circuit

SE4-Engine Instrumentation Circuits

SE5-Fuel System and Glow Plug Circuits

MAIN ELECTRICAL SCHEMATIC—430 (S.N. 420469— )

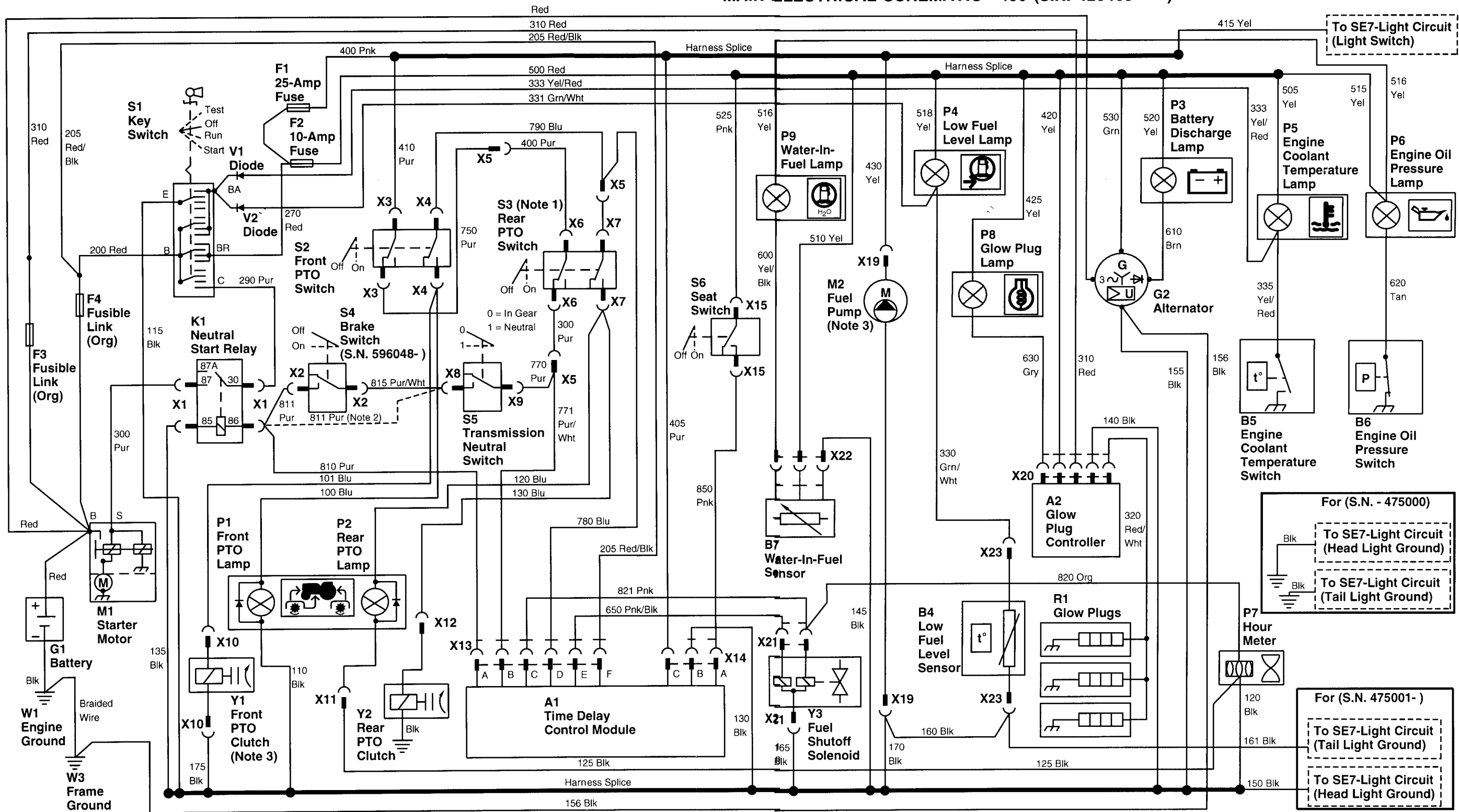

SE1-Power and Starting Circuits	SE2-PTO and Interlock Circuits	SE3-Fuel System and Glow Plug Circuits	SE4-Charging Circuit	SE5-Engine Instrumentation Circuits
---------------------------------	--------------------------------	--	----------------------	-------------------------------------

M78065



# MAIN ELECTRICAL

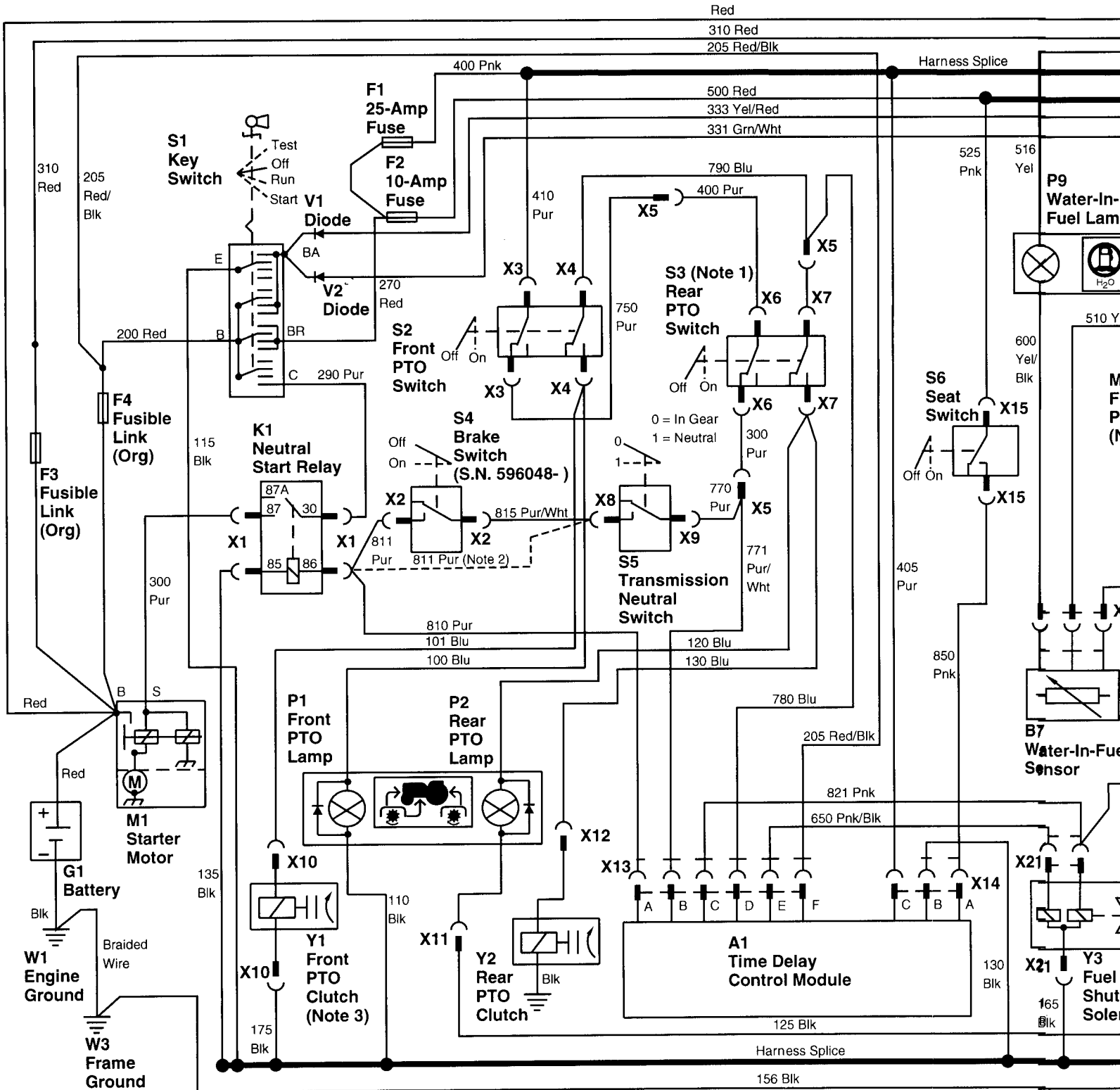

SE1-Power and Starting Circuits

SE2-PTO and Interlock Circuits

SE3-Fuel

MAIN ELECTRICAL SCHEMATIC—430 (S.N. 420469— )

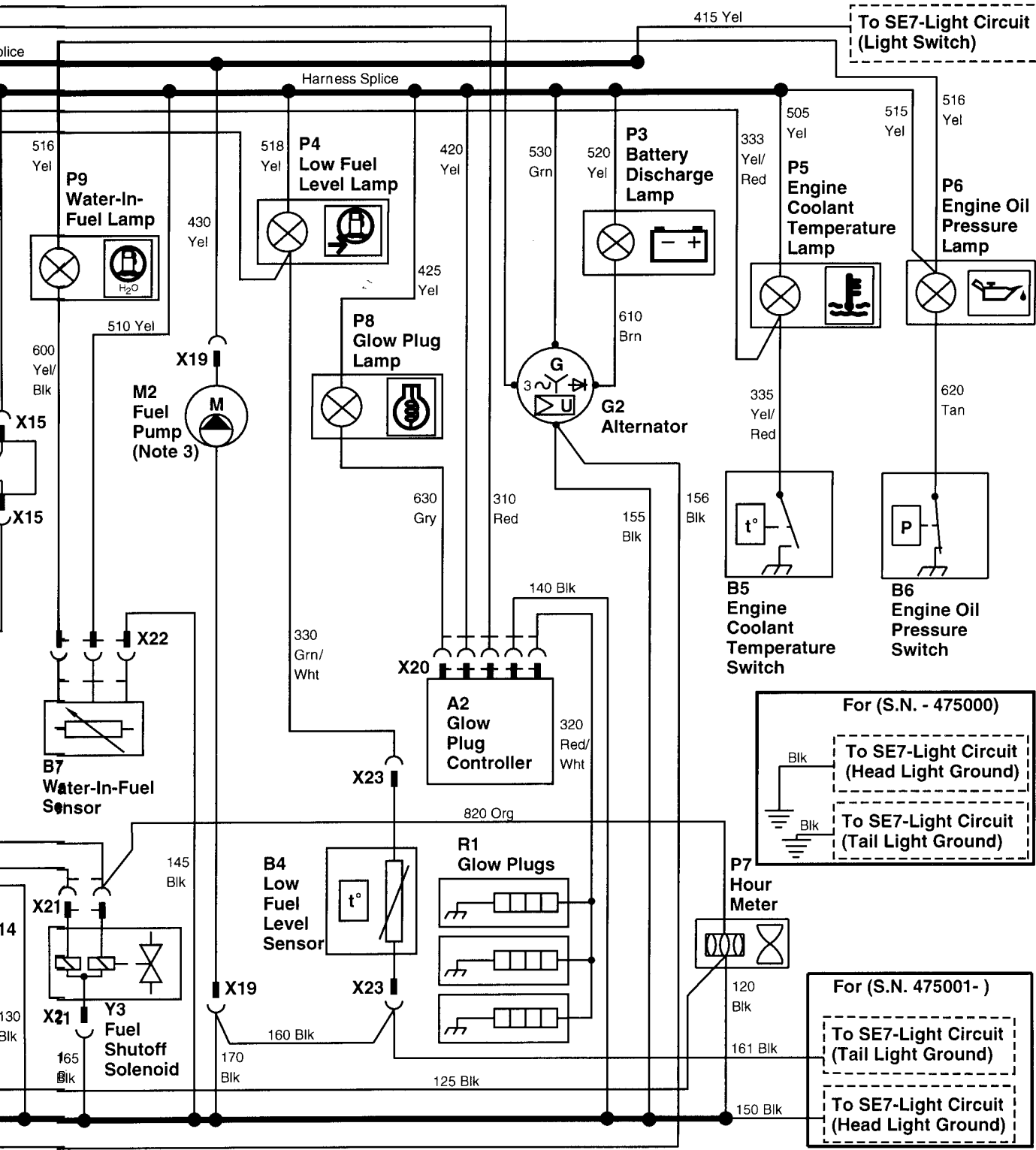

M78065

SE3-Fuel System and Glow Plug Circuits	SE4-Charging Circuit	SE5-Engine Instrumentation Circuits
--	----------------------	-------------------------------------

**MAIN ELECTRICAL SCHEMATIC LEGEND—430 (S.N. 420469— )**

A1—Time Delay Control (TDC) Module	P6—Engine Oil Pressure Lamp	X3—Front PTO Switch 2-Pin Connector	X13—TDC Module 6-Pin Connector
A2—Glow Plug Controller	P7—Hour Meter	X4—Front PTO Switch 3-Pin Connector	X14—TDC Module 3-Pin Connector
B4—Low Fuel Level Sensor	P8—Glow Plug Lamp	X5—Rear PTO Harness 3-Pin Connector	X15—Seat Switch 2-Pin Connector
B5—Engine Coolant Temperature Switch	P9—Water-In-Fuel Lamp	X6—Rear PTO Switch 2-Pin Connector (Optional)	X19—Fuel Pump: (S.N. —475000) 1-Pin Connector
B6—Engine Oil Pressure Switch	R1—Glow Plugs (3 used)	X7—Rear PTO Switch 3-Pin Connector (Optional)	(S.N. 475001— ) 2-Pin Connector
B7—Water-In-Fuel Sensor	S1—Key Switch	X8—Transmission Neutral Switch 1-Pin Connector	X20—Glow Plug Controller 5-Pin Connector
F1—25-Amp Fuse	S2—Front PTO Switch	X9—Transmission Neutral Switch 1-Pin Connector	X21—Fuel Shutoff Solenoid 3-Pin Connector
F2—10-Amp Fuse	S3—Rear PTO Switch (Optional)	X10—Front PTO Clutch: (S.N. —475000) 1-Pin Connector	X22—Water-In-Fuel 3-Pin Connector
F3—Fusible Link	S4—Brake Switch (S.N. 596048— )	(S.N. 475001— ) 2-Pin Connector	X23—Low Fuel Level Sensor 2-Pin Connector
F4—Fusible Link	S5—Transmission Neutral Switch	X11—Rear PTO Lamp 1-Pin Connector (Ground)	Y1—Front PTO Clutch
G1—Battery	S6—Seat Switch	X12—Rear PTO Clutch 1-Pin Connector (Optional)	Y2—Rear PTO Clutch (Optional)
G2—Alternator	V1—Diode		Y3—Fuel Shutoff Solenoid
K1—Neutral Start Relay	V2—Diode		
M1—Starter Motor	W1—Engine Ground		
M2—Fuel Pump	W3—Frame Ground		
P1—Front PTO Lamp	X1—Neutral Start Relay 4-Pin Connector		
P2—Rear PTO Lamp (Optional)	X2—Brake Switch 2-Pin Connector (S.N. 596048— )		
P3—Battery Discharge Lamp			
P4—Low Fuel Level Lamp			
P5—Engine Coolant Temperature Lamp			

*NOTE: 1. For machines not equipped with optional rear PTO, a jumper wire is used at connector (X5) in place of rear PTO switch (S3). The jumper wire connects purple wire “750” to wires “770” (purple) and “771” (purple/white).*

*The blue wire “780” deadends at connector (X5).*

*NOTE: 2. Machines (S.N. —596047); Brake switch (S4) is not used. Purple wire “811” connects transmission neutral switch (S5) directly to neutral start relay (K1).*

*NOTE: 3. Machines (S.N. —475000); Component ground wire connects directly to machine frame.*

MX,159124010,12-19-13JUL95

**LIGHT CIRCUIT SCHEMATIC—ALL MACHINES**

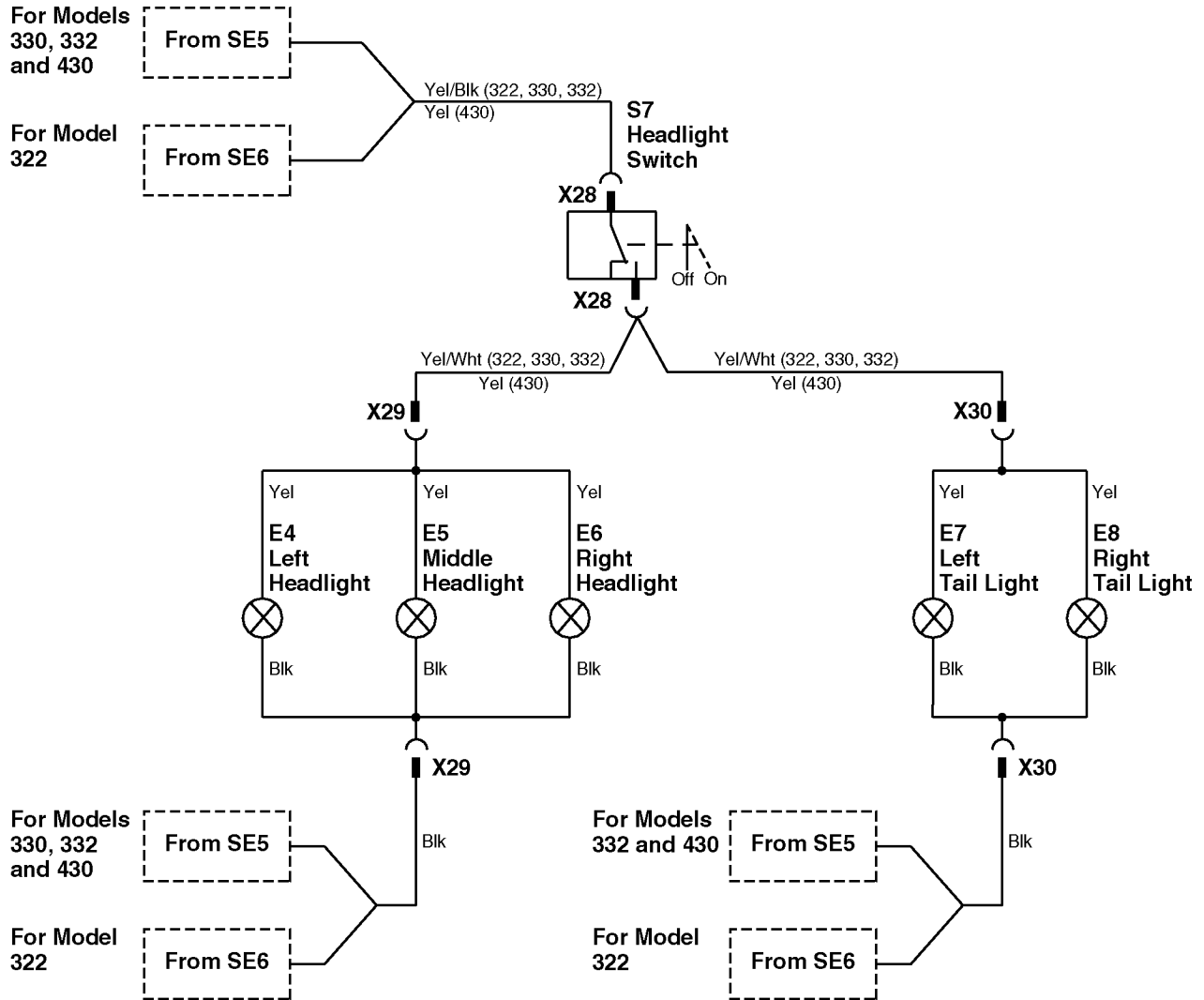

SE7-Light Circuit

E4—Left Headlight  
 E5—Middle Headlight  
 E6—Right Headlight  
 E7—Left Tail Light

E8—Right Tail Light  
 S7—Light Switch  
 X28—Light Switch 2-Pin Connector

X29—Headlight 2-Pin Connector (S.N. 475001— )

X30—Tail Light 2-Pin Connector (S.N. 475001— )

NOTE: 330; Headlight connector (X29) is a 1-pin connector. The headlight ground wires connect directly to machine frame.

NOTE: "SE" boxes with dashed lines indicate wire comes from circuit number (shown in "SE" box) located on main electrical schematics.

332/430 (S.N. —475000); Head and tail light connectors (X29 and X30) are 1-pin connectors. The head and tail light ground wires connect directly to machine frame.

240  
10  
14

M78066 -19-23JUN95

## ABOUT THIS GROUP

The information that follows will help you locate and access many of the electrical components on the machines. Obvious components such as the starter, alternator, key switch, etc. will not be shown. See CTM3 or CTM12 for more specific information on removal and installation of electrical components.

Theory of operation and diagrams for specific circuits follow the component location information.

*NOTE: The operation of the fuel pump, engine coolant temperature, and engine oil pressure circuits are not discussed or shown in detail because of the simplicity of these circuits.*

MX,159124015,1 -19-13JUL95

## GLOW PLUG CONTROL MODULE—330 AND 332

The glow plug control module (A) is located on the lower left side of the engine firewall.

Open hood and remove left engine side panel to access the control module.



M55119  
-JUN-09DEC89

MX,159124015,2 -19-13JUL95

## GLOW PLUG CONTROL MODULE—430

The glow plug control module (A) is located on the upper left side of the engine firewall.

Open hood and remove left engine side panel to access the control module.

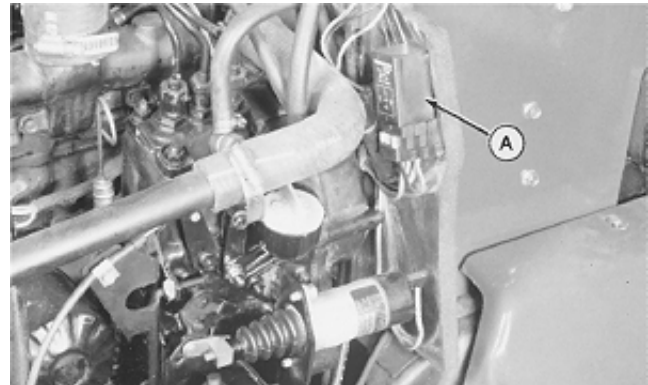

M36704  
-JUN-25JAN90

MX,159124015,3 -19-13JUL95

## TIME DELAY CONTROL (TDC) MODULE AND NEUTRAL START RELAY—322, 330 AND 332

The TDC module (A) and neutral start relay (B) are located on the lower right side of the engine firewall.

Remove right engine side panel to access the TDC module relay.



M55120  
-UN-09DEC89

MX,159124015,4 -19-13JUL95

### TIME DELAY CONTROL (TDC) MODULE AND NEUTRAL START RELAY—430

The TDC module (A) is located in the compartment directly under the battery tray. The module is mounted to the left side of the pedestal.

The neutral start relay (B) is mounted onto the TDC module.

Remove battery and battery tray to access TDC module and relay.

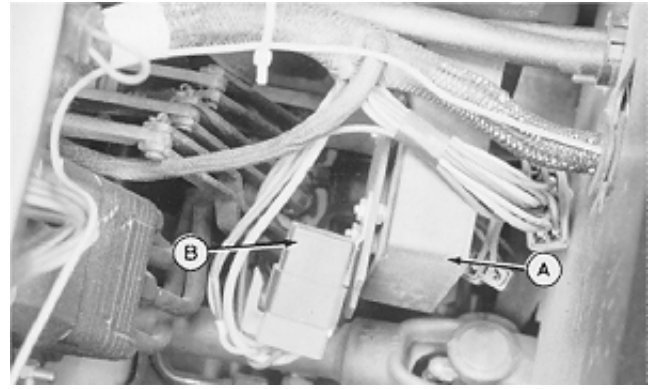

M36705 -UN-25JAN90

MX,159124015.5 -19-13JUL95

### TDC EIGHT-PIN AND TWO-PIN CONNECTORS—322 AND 330

The 8-pin (A) and 2-pin (B) TDC connectors are located in the engine compartment directly ahead of lower right side of engine firewall.

Open hood and remove right engine side panel to access connectors.

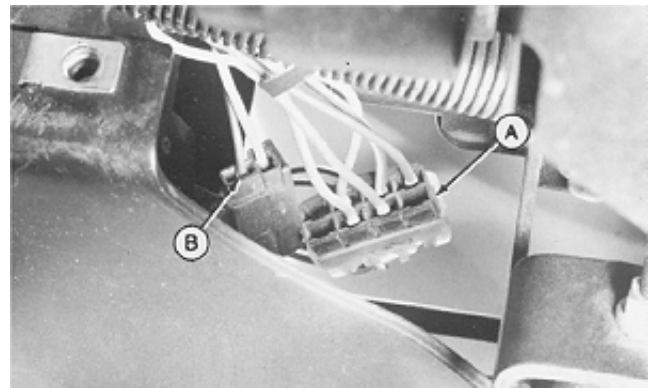

M45237 -UN-12JAN90

MX,159124015.6 -19-13JUL95

### TDC EIGHT-PIN AND TWO-PIN CONNECTORS—430 (S.N. —420468)

The 8-pin (A) and 2-pin (B) TDC connectors are located in the compartment directly under the battery tray.

Connectors can be accessed through the opening in the pedestal just behind the firewall.

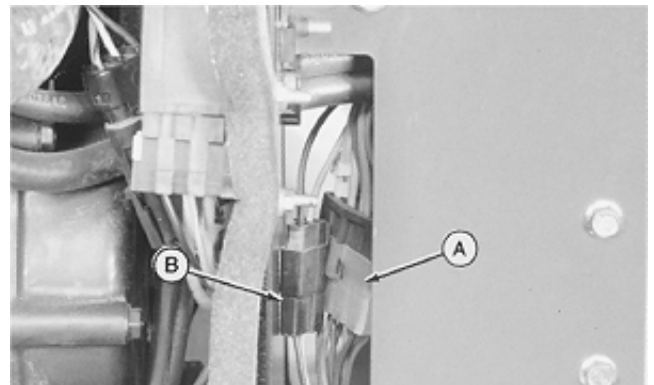

M36706 -UN-25JAN90

MX,159124015.7 -19-13JUL95

### TDC SIX-PIN AND THREE-PIN CONNECTORS—332

The 6-pin (A) and 3-pin (B) TDC connectors are located in the engine compartment directly ahead of lower right side of engine firewall.

Open hood and remove right engine side panel to access connectors.

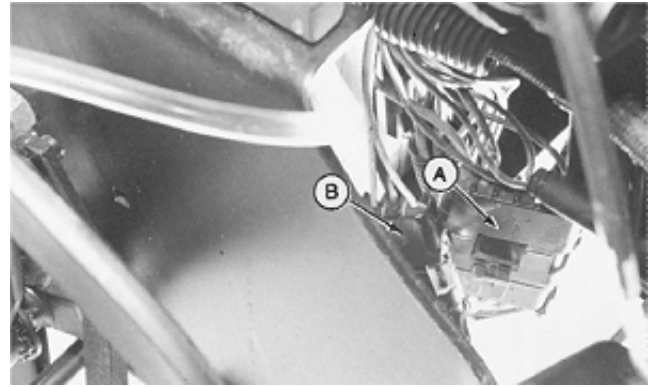

M49024  
-UN-08JAN90

MX,159124015,8 -19-13JUL95

### TDC SIX-PIN AND THREE-PIN CONNECTORS—430 (S.N. 420469— )

The 6-pin (A) and 3-pin (B) TDC connectors are located in the compartment directly under the battery tray.

Connectors can be accessed through the opening in the pedestal just behind the firewall.

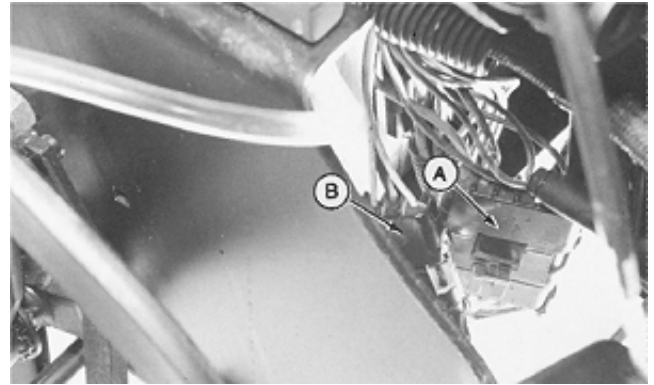

M49024  
-UN-08JAN90

MX,159124015,9 -19-13JUL95

### ENGINE OIL PRESSURE SWITCH

The engine oil pressure switch (A) is located on the left side of engine toward the front.

Remove left engine side panel to access switch.

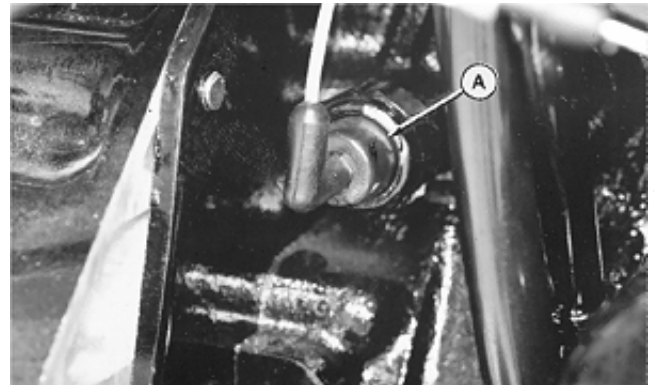

322, 330 and 332

M55122  
-UN-09DEC89

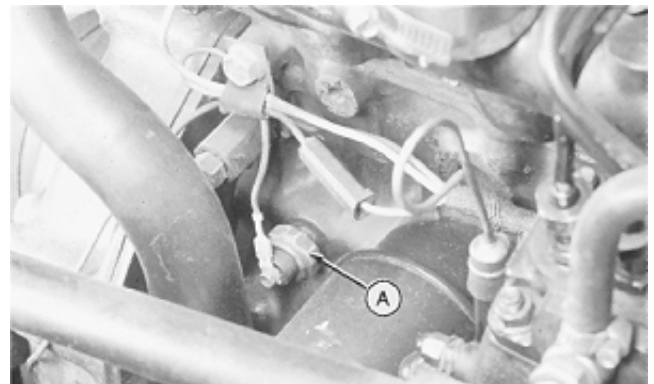

430

M36709  
-UN-25JAN90

MX,159124015,10-19-13JUL95

## ENGINE COOLANT TEMPERATURE SWITCH

The engine coolant temperature switch (A) is mounted in the thermostat housing.

Open hood to access the switch.

*NOTE: 430 (S.N. 420469— ); Coolant temperature switch is located on opposite side of thermostat housing.*

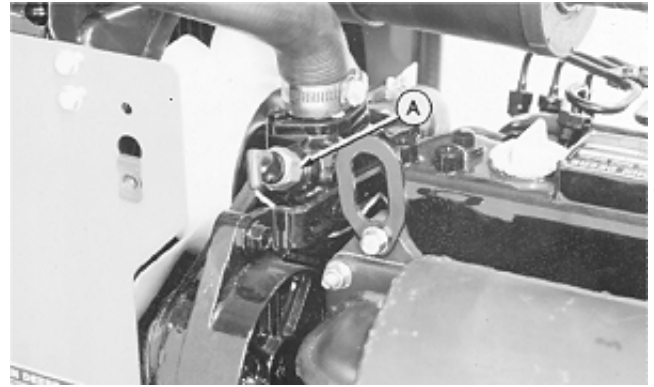

322, 330 and 332

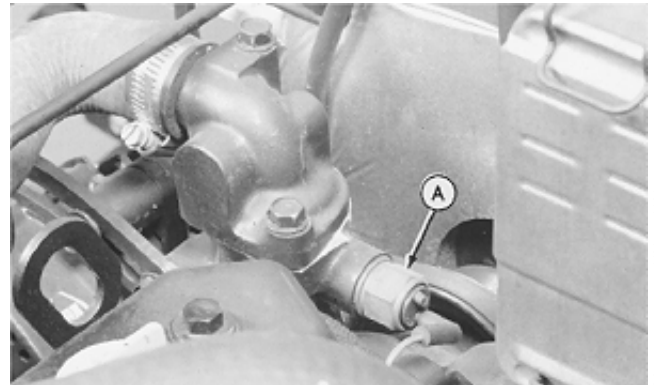

430 (S.N. —420468)

MX,159124015,11-19-13JUL95

M55123 -UN-09DEC89

M36710 -UN-25JAN90

## TRANSMISSION NEUTRAL START SWITCH

The transmission neutral start switch (A) is located under the dash panel, next to the hydrostatic control lever.

Open hood to access switch.



322, 330 and 332

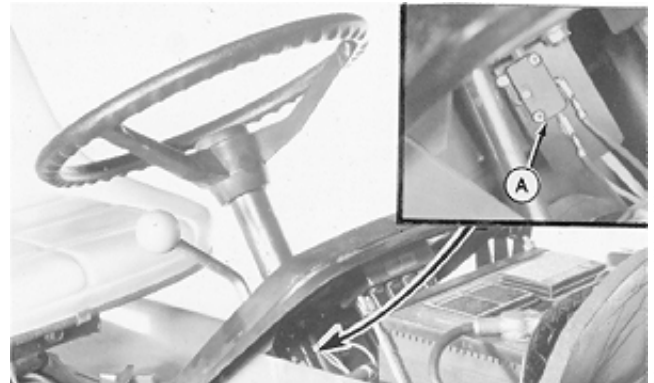

430

MX,159124015,12-19-13JUL95

M55124 -UN-09DEC89

M36711 -UN-25JAN90

240  
15  
4



### FUEL TRANSFER PUMP—322, 330 AND 332

The electric fuel transfer pump (A) is located inside the left side frame directly above the front axle.

Open hood and remove left side engine panel to access the pump.

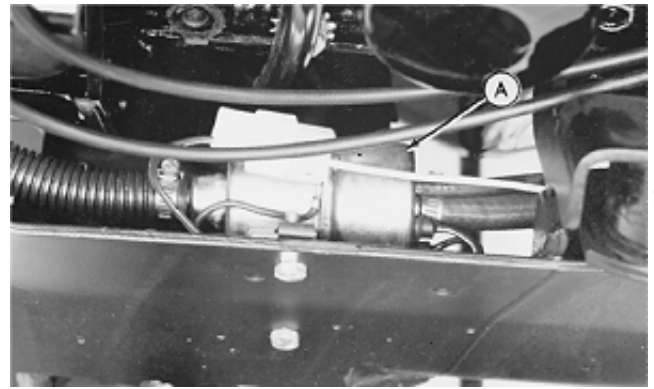

M55125  
-UN-09DEC89

MX,159124015,13-19-13JUL95

### FUEL TRANSFER PUMP—430

The electric fuel transfer pump (A) is located inside the left side frame behind the left foot rest.

Remove fender deck or bottom guard plate from tractor frame to access pump.

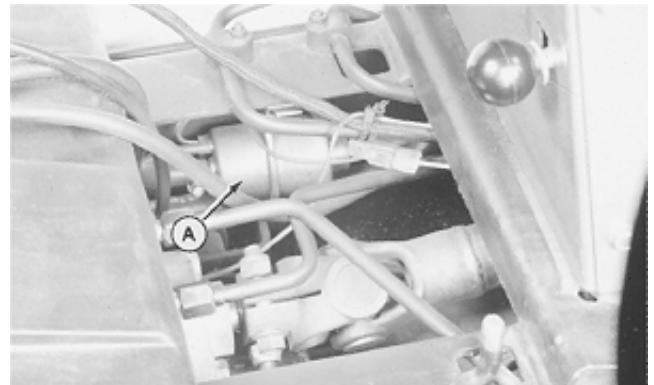

M36712  
-UN-25JAN90

MX,159124015,14-19-13JUL95

### FUEL SHUTOFF SOLENOID—322

The fuel shutoff solenoid (A) is mounted on the rear of the carburetor.

Open hood and remove left engine side panel to access the solenoid.

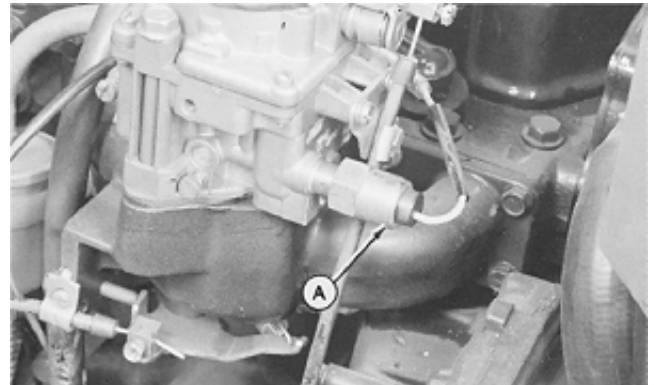

M45242  
-UN-12JAN90

MX,159124015,15-19-13JUL95

### FUEL SHUTOFF SOLENOID—332 AND 430

The fuel shutoff solenoid (A) is located on the left side of the engine.

Open hood and remove left engine side panel to access the solenoid.

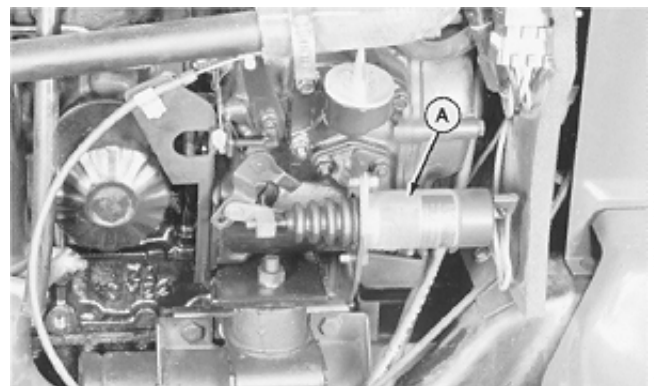

M36707  
-UN-25JAN90

MX,159124015,16-19-13JUL95

430 (S.N. —420468) Shown

### WATER-IN-FUEL SENSOR (430)

The water-in-fuel sensor is located inside the fuel filter base (A).

Remove filter and filter base as an assembly to access the sensor.

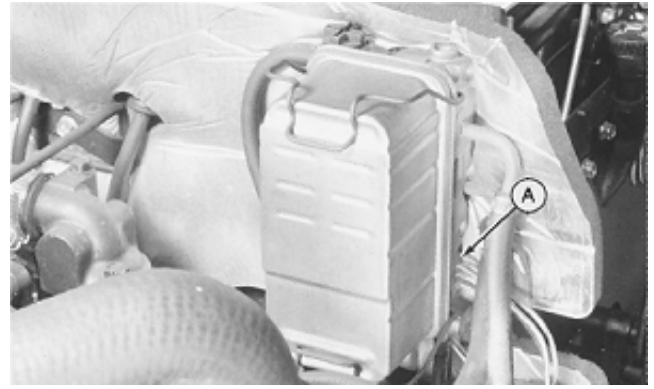

M36708  
-UN-25JAN90

MX,159124015,17-19-13JUL95

### VOLTAGE REGULATOR/RECTIFIER (322, 330 AND 332)

322; Voltage regulator/rectifier is located at right side of engine compartment and is attached inside the machine frame near pedestal.

330 and 332; Voltage regulator/rectifier (A) is located at right side of engine compartment and is attached inside the machine frame.

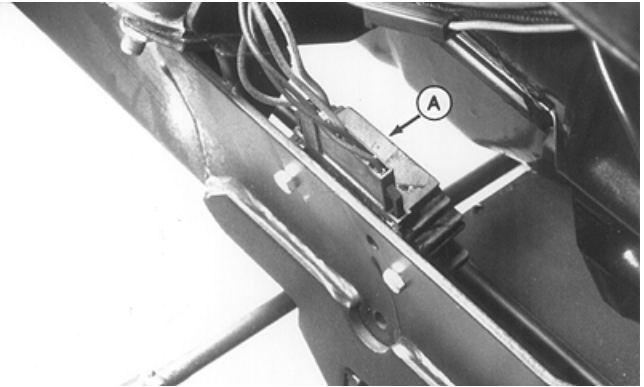

M49023  
-JUN-13JUL95

332 Shown

MX,159124015,18-19-13JUL95

### TRANSISTOR MODULE (322)

The transistor module (A) is located on the lower left side of the engine firewall.

Open hood and remove left engine side panel to access the module.

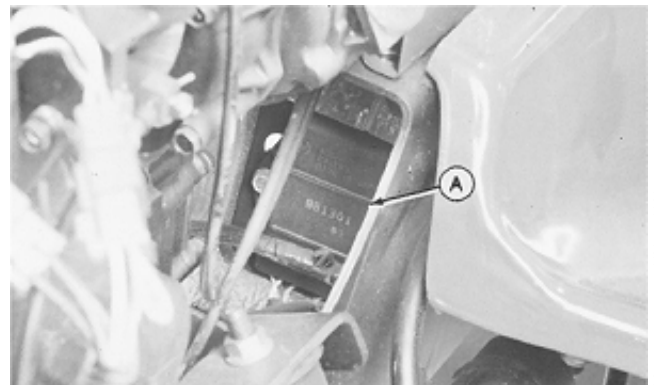

M45238  
-JUN-12JAN90

MX,159124015,19-19-13JUL95

## IGNITION AND PULSAR COILS (322)

The ignition coils (A) are located above the flywheel. The pulsar coils (B) are mounted to the flywheel housing plate.

Open hood and remove both engine side panels to access coils.

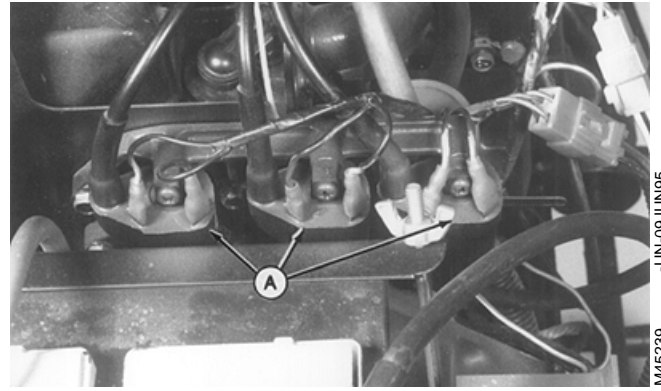

M45239  
-UN-09JUN95

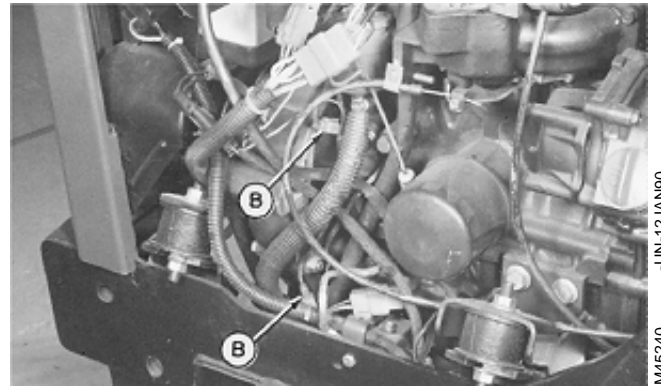

M45240  
-UN-12JAN90

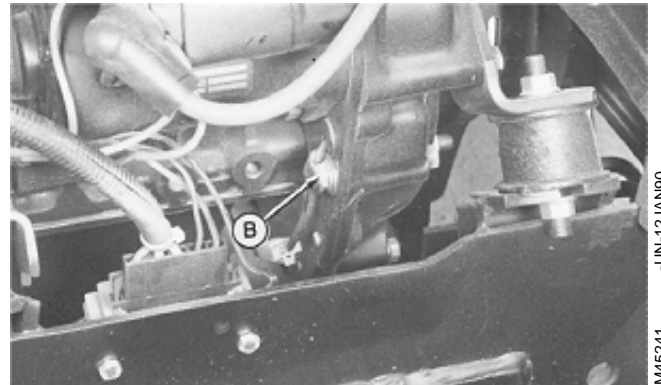

M45241  
-UN-12JAN90

MX,159124015,20-19-13JUL95

## STARTING CIRCUIT OPERATION

The function of the starting circuit is to crank the engine by energizing starter motor (M1). PTO switches (S2 and S3), transmission neutral switch (S5), and brake switch (S4) are used as interlock switches within the starter circuit.

For the starter motor to energize, the following conditions must be met:

- Front and rear PTO switches in "OFF" position.
- Hydrostatic Control Lever in N/STOP position.
- Brake pedal depressed.
  - 322 (S.N. 596006— )
  - 332 (S.N. 596723— )
  - 430 (S.N. 596048— )
- Key Switch in "START" position.

PTO switches (S2 and S3) are used in the starting circuit to prevent the engine from cranking while the PTO is engaged. Each PTO switch contains two sets of contacts; one for the PTO circuit and the other as a safety interlock for the starting circuit. When the PTO switch is in the ON position (PTO engaged), the PTO switch "interlock" contacts are open, preventing starter operation. When the PTO switch is in the OFF position (PTO disengaged), the "interlock" contacts are closed, allowing current to flow to transmission neutral switch (S5).

The transmission neutral switch is used in the starting circuit to prevent the engine from cranking when the transmission is in gear. When the hydrostatic control lever is in the forward or reverse position, the transmission neutral switch contacts are open, preventing starter operation. Moving the hydrostatic control lever to the N/STOP position closes the contacts, allowing current to flow to brake switch (S4).

*NOTE: Brake switch equipped on 322 (S.N. 596006— ), 332 (S.N. 596723— ) and 430 (S.N. 596048— ) only. For all other machines, current flows from the transmission switch, directly to neutral start relay (K1).*

The brake switch will prevent the engine from cranking unless the brake pedal is depressed. Depressing the brake pedal closes the brake switch contacts, allowing current to flow to neutral start relay (K1).

Key switch (S1) initiates current flow through the starting circuit. When the key switch is turned to the START position, the ignition contacts (A) and start contacts (B) close. If all the interlock switch contacts in the start circuit are closed, current from the battery positive (+) terminal flows through fusible link (F4) to terminal "B" on the key switch. Current flows across contacts (A) and out terminal "IGN" (322, 330 and 332) or terminal "BR" (430) to the 25 amp fuse (F1). From fuse (F1), current flows through the PTO, transmission, and brake (if equipped) switches to terminal "86" of the neutral start relay. The current flows through the relay coil windings and out terminal "85" to ground, thus energizing the relay and closing the normally open relay contacts (D).

The closed relay contacts complete the starter circuit which allows current to flow from key switch start contacts (B) to terminal "30" on the neutral start relay. Current flows across the relay contacts and out terminal "87". From terminal "87", current flows to starter solenoid (K2), through the solenoid coil windings, then to ground.

Starter solenoid (K2) contains two coils; one called the pull-in and the other called the hold-in. Current flowing through these coils produces a strong magnetic field, which pulls a plunger inward and closes solenoid main contacts (C). Because the starter is a shift type (solenoid is mounted on starter), the plunger also moves the starter drive gear outward to mesh with the flywheel ring gear.

When the solenoid contacts close, high current from the battery flows across the solenoid contacts to starter motor (M1), causing it to turn. Because the pull-in coil is grounded through the starter, current will flow through the pull-in coil only as long as the solenoid main contacts are open.

When the solenoid contacts close, both ends of the pull-in coil have the same voltage. This causes the current to stop flowing through the pull-in coil. Current continues to flow through the hold-in coil, which is grounded directly to the chassis. This keeps the solenoid energized (main contacts closed; starter drive engaged) until the key switch is released to the ON/RUN position or turned to the OFF position.

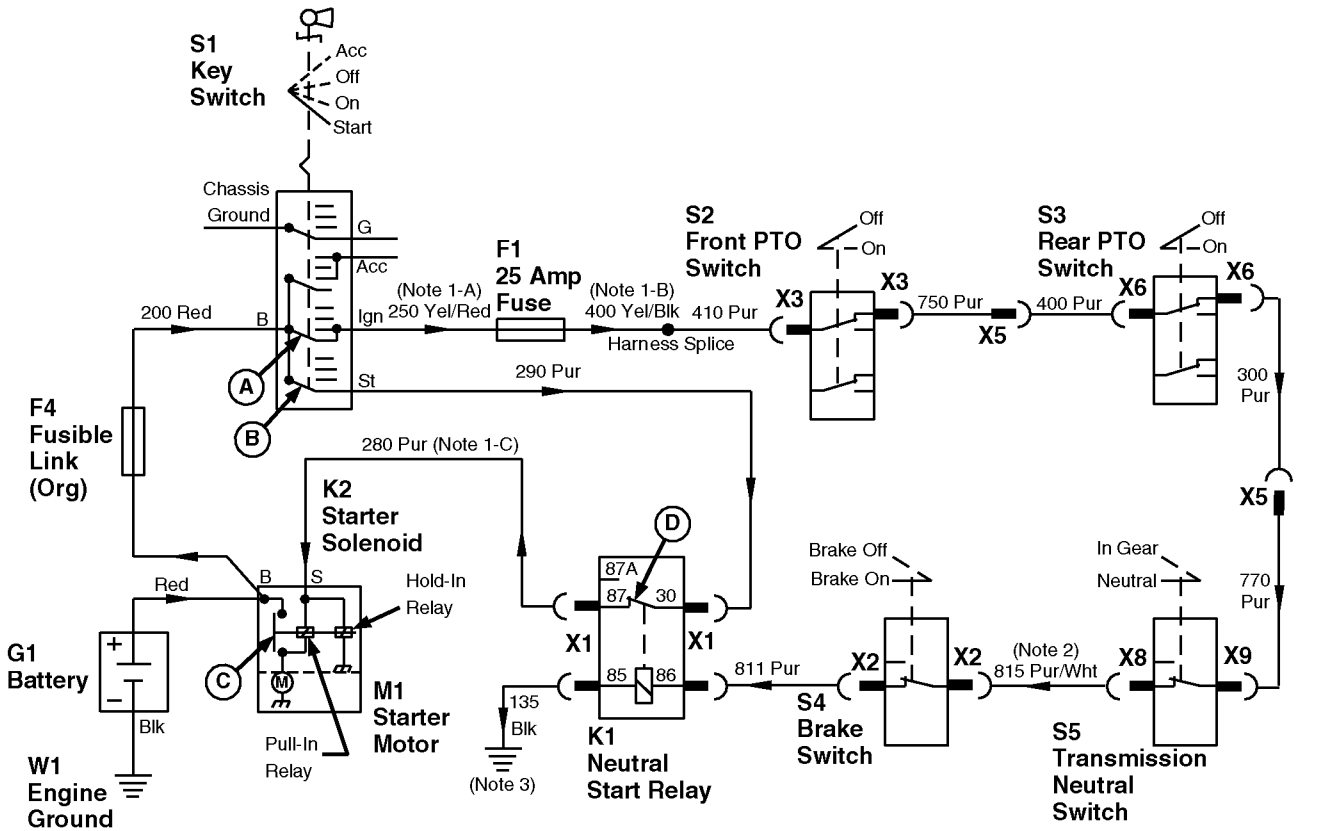

A—Key Switch ON or RUN Contact  
 B—Key Switch START Contact  
 C—Starter Solenoid Main Contact  
 D—Neutral Start Relay Contact  
 F1—25 Amp Fuse  
 F4—Fusible Link

G1—Battery  
 K1—Neutral Start Relay  
 K2—Starter Solenoid  
 M1—Starter Motor  
 S1—Key Switch  
 S2—Front PTO Switch  
 S3—Rear PTO Switch (Optional)  
 S4—Brake Switch:  
 322 (S.N. 596006— )  
 332 (S.N. 596723— )  
 430 (S.N. 596048— )

S5—Transmission Neutral Switch  
 W1—Engine Ground  
 X1—Neutral Start Relay 4-Pin Connector  
 X2—Brake Switch 2-Pin Connector  
 X3—Front PTO Switch 2-Pin Connector

X5—Rear PTO Harness 3-Pin Connector  
 X6—Rear PTO Switch 2-Pin Connector  
 X8—Transmission Neutral Switch 1-Pin Connector  
 X9—Transmission Neutral Switch 1-Pin Connector

NOTE: Illustration shows key switch configuration for 322, 330 and 332. For 430, terminal designation "BR" is used instead of "IGN".

NOTE: 1. 430; The following wire numbers/color apply where noted on drawing:  
 -A) 270 Red  
 -B) 400 Pink  
 -C) 290 Purple  
 -D) 210 Red

NOTE: 2. 322 (S.N. —496005) and 332 (S.N. —596722); Purple wire "811" connects the transmission neutral switch to the neutral start relay.

330 and 430 (S.N. —420468); Purple wire "811" connects the transmission neutral switch to the TDC module 8-pin connector. Another purple wire (wire "810") connects the neutral start relay to the same 8-pin connector terminal used by the "811" wire.

NOTE: 3. Because ground circuits differ between models and versions, refer to the Main Electrical Schematics in Group 10 for more detail on ground circuit.

M75067 -19-14JUN95

240  
15  
9

## IGNITION AND FUEL SHUTOFF SOLENOID CIRCUIT OPERATION (322)

*NOTE: Power is supplied to the fuel shutoff solenoid, whenever the ignition circuit is energized. When energized, the solenoid opens a valve in the fuel line to allow fuel to flow into the carburetor. When de-energized, the solenoid closes the valve and stops fuel flow.*

*Because the ignition and fuel shutoff solenoid circuits share the same control circuitry from the TDC module, only the ignition circuit will be discussed in detail. Control of power to the fuel shutoff solenoid is the same as for the ignition circuit.*

The function of the ignition circuit is to produce spark across the gap of spark plugs (E1—E3) at the correct time. The circuit is a “distributorless”, battery ignition type. The circuit uses pulsars (B1—B3) to make and break (trigger) the primary circuit and provide the proper timing to fire the spark plugs. The timing is fixed and cannot be adjusted.

The ignition circuit is made up of three separate circuits, one for each cylinder. Each spark plug has its own separate pulsar, transistor switch [located inside transistor module (A2)] and ignition coil. This system eliminates the need for a distributor.

The ignition circuit uses seat switch (S6) and time delay control module (A1) to automatically stop the engine anytime the operator rises from the seat for more than one second when the tractor is IN GEAR or if PTO is ENGAGED.

### **OPERATOR ON SEAT—MACHINE IN GEAR AND/OR PTO ENGAGED:**

When the key switch (S1) is turned to the RUN or START position, current flows from the positive (+) terminal of battery (G1), through fusible link (F4), to key switch terminal “B”. From terminal “B”, current flows across the key switch contacts to terminal “IGN”, then to 25-amp fuse (F1) and 10-amp fuse (F2). From fuse (F2), current flows across the closed contacts of the seat switch to pin “9” of TDC module connector (X14). Inside the TDC module, current flows through time delay integrated circuit (IC) (E), then to switch transistor (D).

As long as current from IC (E) flows to transistor (D), the transistor is “switched on”. In this state, the transistor completes the path to ground for TDC ignition relay coil (B). The ground path allows current to flow from fuse (F1) to pin “3” of the TDC module 8-pin connector (X13). Inside the TDC module, current flows through the ignition relay coil and transistor (D) to ground. This energizes the relay coil which closes ignition relay contacts (A). Current from fuse (F1) then flows across the relay contacts and out pin “2” of connector (X13). From pin “2”, current flows to transistor module (A2), and to the positive (+) terminal of ignition coils (T1—T3). The transistor module provides a path to ground for the primary circuit of each coil. This allows current to flow through the primary windings to induce a magnetic field in the ignition coil windings.

Pulsars (B1—B3) are mounted at fixed locations around the flywheel. These positions provide the correct ignition timing for each cylinder.

When the flywheel is turning, a notch in the flywheel travels past the pulsars and induces a voltage (pulse) in each pulsar. The voltage flows from the pulsars to transistors located inside the transistor module. The transistors provide a path to ground for the ignition coil primary windings.

The pulse from each pulsar causes its respective transistor, in the transistor module, to momentarily “switch off”. This “switching off” breaks the respective ignition coils primary windings path to ground, thus interrupting current flowing through the primary windings. When the primary current stops flowing, the magnetic field in the primary windings collapses across the ignition coil secondary windings. The collapsing field induces a high voltage into the secondary winding, which travels to ground by jumping the spark plug gap.

Continued

Component Location and Operation/Theory of Operation

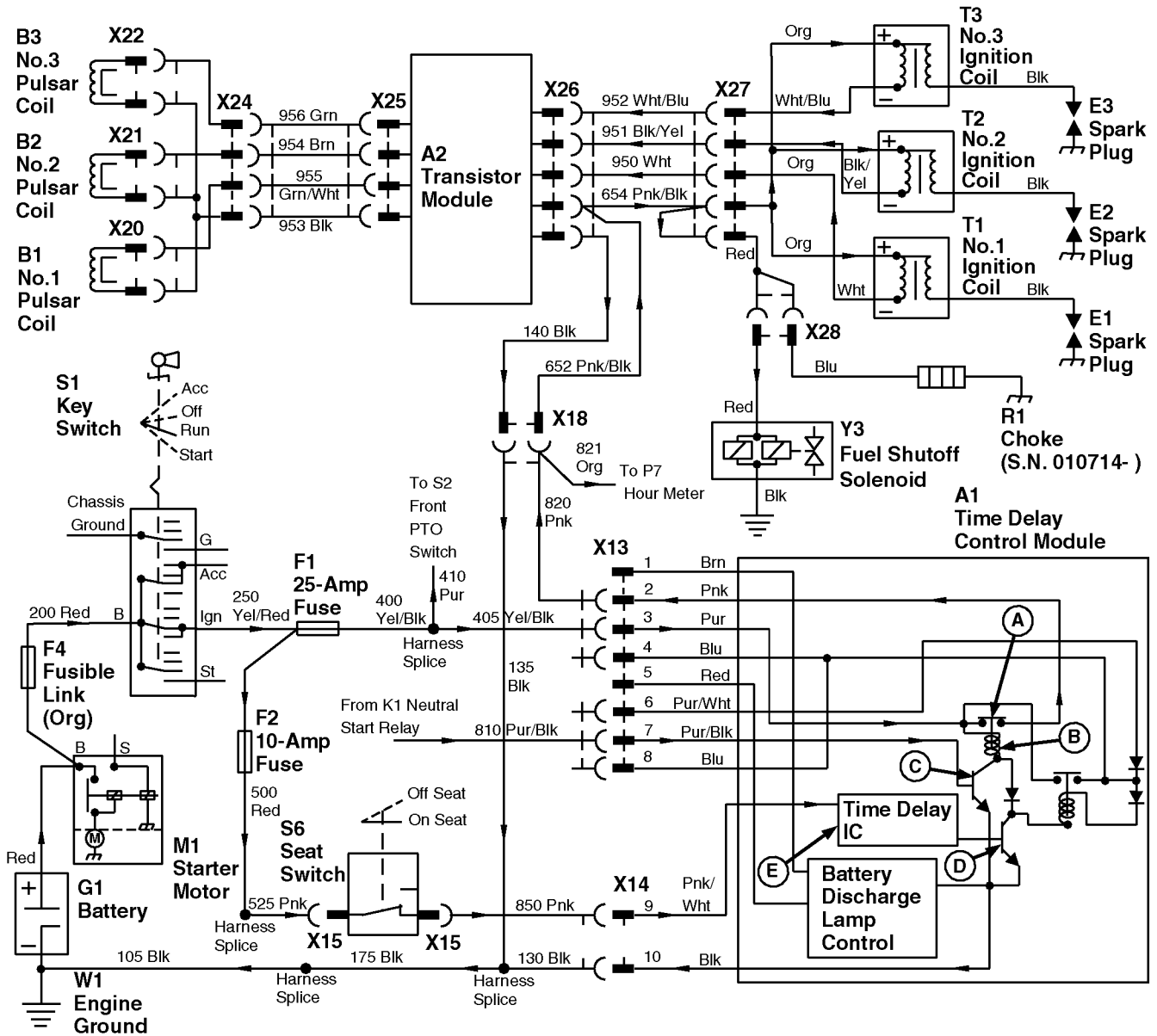

- |                                      |                                   |  |  |
|--------------------------------------|-----------------------------------|--|--|
| A—TDC Ignition Relay Contacts        | E3—Spark Plug                     | X14—TDC Module 2-Pin Connector                     | X25—Transistor Module 4-Pin Connector                |
| B—TDC Ignition Relay Coil            | F1—25 Amp Fuse                    | X15—Seat Switch 2-Pin Connector                    | X26—Transistor Module 6-Pin Connector                |
| C—Transistor                         | F2—10 Amp Fuse                    | X18—Main Harness-to-Engine Harness 2-Pin Connector | X27—Engine Harness-to-Ignition Coils 6-Pin Connector |
| D—Time Delay Transistor              | F4—Fusible Link                   | X20—No.1 Pulsar Coil 2-Pin Connector               | X28—Electric Choke 2-Pin Connector (S.N. 010714— )   |
| E—Time Delay Integrated Circuit (IC) | G1—Battery                        | X21—No.2 Pulsar Coil 2-Pin Connector               | Y3—Fuel Shutoff Solenoid                             |
| A1—Time Delay Control (TDC) Module   | M1—Starter Motor                  | X22—No.3 Pulsar Coil 2-Pin Connector               |  |
| A2—Transistor Module                 | R2—Electric Choke (S.N. 010714— ) | X24—Engine Harness-to-Pulsar Coils 4-Pin Connector |  |
| B1—No.1 Pulsar Coil                  | S1—Key Switch                     |  |  |
| B2—No.2 Pulsar Coil                  | S6—Seat Switch                    |  |  |
| B3—No.3 Pulsar Coil                  | T1—No.1 Ignition Coil             |  |  |
| E1—Spark Plug                        | T2—No.2 Ignition Coil             |  |  |
| E2—Spark Plug                        | T3—No.3 Ignition Coil             |  |  |
|                                      | W1—Engine Ground                  |  |  |
|                                      | X13—TDC Module 8-Pin Connector    |  |  |

-19-14JUN95  
MT78068

240  
15  
11

MX,159124015,24-19-13JUL95

## IGNITION AND FUEL SHUTOFF SOLENOID CIRCUIT OPERATION (322)—CONTINUED

When the operator rises from the seat, the seat switch contacts open, causing current to stop flowing to time delay IC (E). If the operator does not return to the seat within approximately one second, the time delay IC stops current flow to transistor (D). The transistor will “switch off”, causing current through relay coil (B) to stop flowing and de-energize the coil. With the coil no longer energized, relay contacts (A) will open. Current stops flowing to transistor module (A2), ignition coils (T1—T3) and fuel shutoff solenoid (Y3), thus stopping the engine.

*NOTE: (S.N. 010714— ); An electric choke (R2) is used. The choke receives power from the same source as the fuel shutoff does.*

*Driving the machine over rough terrain can cause the seat switch contacts to momentarily open and close. If this happens, the time delay IC allows the engine to operate without interruption.*

If the operator returns to the seat within approximately one second, current flow is re-established to the time delay IC before it has a chance to “time out” and stop current flow to the transistor. Current flow is NOT interrupted to the transistor module, ignition coils, and fuel shutoff solenoid, allowing the engine to continue operating.

### OPERATOR OFF SEAT—MACHINE IN NEUTRAL AND PTO DISENGAGED:

*NOTE: (S.N. 596006— ); The park brake must be engaged.*

When operator is off the seat, current to the ignition components can still be maintained through the interlock circuit. For current to flow through the interlock circuit, key switch (S1) must be turned to the RUN or START position, the hydrostatic control lever in the N/STOP position, the PTO switches in the OFF position (PTO disengaged) and park brake engaged (S.N. 596006— ).

With these conditions met, current flows from terminal (IGN) of the key switch to 25-amp fuse (F1). From fuse (F1), current flows through the PTO switch interlock contacts, transmission neutral switch, brake switch (if equipped) and neutral start relay to pin “7” of the TDC module connector (X13). Inside the TDC module, current flows from pin “7” to transistor (C). As long as current from the interlock circuit flows to transistor (C), the transistor is “switched on”. In this state, the transistor provides an alternate path to ground for relay coil (B). The energized relay closes the ignition relay contacts, allowing current to flow to the transistor module, ignition coils and fuel shutoff solenoid.

The 25 amp fuse (F1) and 10 amp fuse (F2) protect the ignition circuit from excessive current.

MX,159124015,25-19-13JUL95



Component Location and Operation/Theory of Operation

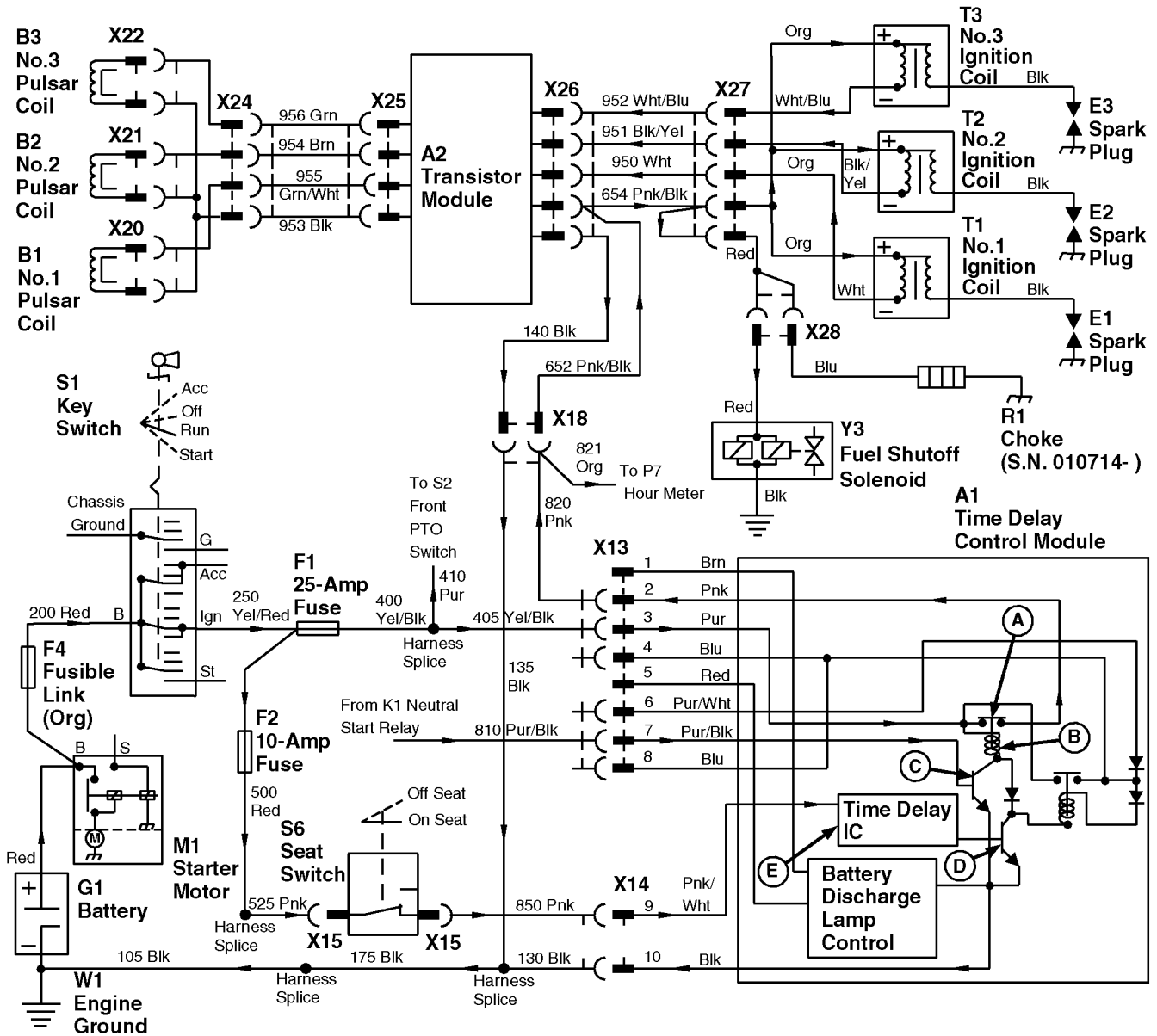

- |                                      |                                   |  |  |
|--------------------------------------|-----------------------------------|--|--|
| A—TDC Ignition Relay Contacts        | E3—Spark Plug                     | X14—TDC Module 2-Pin Connector                     | X25—Transistor Module 4-Pin Connector                |
| B—TDC Ignition Relay Coil            | F1—25 Amp Fuse                    | X15—Seat Switch 2-Pin Connector                    | X26—Transistor Module 6-Pin Connector                |
| C—Transistor                         | F2—10 Amp Fuse                    | X18—Main Harness-to-Engine Harness 2-Pin Connector | X27—Engine Harness-to-Ignition Coils 6-Pin Connector |
| D—Time Delay Transistor              | F4—Fusible Link                   | X20—No.1 Pulsar Coil 2-Pin Connector               | X28—Electric Choke 2-Pin Connector (S.N. 010714— )   |
| E—Time Delay Integrated Circuit (IC) | G1—Battery                        | X21—No.2 Pulsar Coil 2-Pin Connector               | Y3—Fuel Shutoff Solenoid                             |
| A1—Time Delay Control (TDC) Module   | M1—Starter Motor                  | X22—No.3 Pulsar Coil 2-Pin Connector               |  |
| A2—Transistor Module                 | R2—Electric Choke (S.N. 010714— ) | X24—Engine Harness-to-Pulsar Coils 4-Pin Connector |  |
| B1—No.1 Pulsar Coil                  | S1—Key Switch                     |  |  |
| B2—No.2 Pulsar Coil                  | S6—Seat Switch                    |  |  |
| B3—No.3 Pulsar Coil                  | T1—No.1 Ignition Coil             |  |  |
| E1—Spark Plug                        | T2—No.2 Ignition Coil             |  |  |
| E2—Spark Plug                        | T3—No.3 Ignition Coil             |  |  |
|                                      | W1—Engine Ground                  |  |  |
|                                      | X13—TDC Module 8-Pin Connector    |  |  |

-19-14JUN95

MT8068

240  
15  
13

MX,159124015,24-19-13JUL95

## PTO CIRCUIT OPERATION—322, 330 AND 430 (S.N. —420468)

A—Time Delay Integrated Circuit (IC)	F4—Fusible Link	X4—Front PTO Switch 3-Pin Connector	X12—Rear PTO Clutch 1-Pin Connector
B—Time Delay Switch Transistor	G1—Battery	X5—Rear PTO Harness 3-Pin Connector	X13—TDC Module 8-Pin Connector
C—Isolation Diode	M1—Starter Motor	X6—Rear PTO Switch 2-Pin Connector	X14—TDC Module 2-Pin Connector
D—TDC PTO Relay Contacts	P1—Front PTO Lamp	X7—Rear PTO Switch 3-Pin Connector	X15—Seat Switch 2-Pin Connector
E—Isolation Diode	P2—Rear PTO Lamp (Optional)	X10—Front PTO Clutch 2-Pin Connector	Y1—Front PTO Clutch
F—Isolation Diode	S1—Key Switch	X11—Rear PTO Lamp 1-Pin Connector (Ground)	Y2—Rear PTO Clutch (Optional)
G—TDC PTO Relay Coil	S2—Front PTO Switch		
A1—Time Delay Control (TDC) Module	S3—Rear PTO Switch (Optional)		
F1—25-Amp Fuse	S6—Seat Switch		
F2—10-Amp Fuse	W1—Engine Ground		
	X3—Front PTO Switch 2-Pin Connector		

### Legend For PTO Circuit

The function of the PTO circuit is to energize the front PTO clutch and/or optional rear PTO clutch and turn on the PTO indicator lamp(s). Also, the PTO circuit uses a time delay controller and a seat switch to automatically disengage the PTO clutch(es) anytime the operator rises off the seat for more than one second.

To engage the PTO clutch(es), the following conditions must be met:

- Operator on seat.
- PTO switch(es) initially at OFF position.
- Key switch turned to ON position (330) or RUN position (322 and 430).
- PTO switch moved to ON position.

The normally open contacts of seat switch (S6) close when the operator sits on the seat. When the key switch (S1) is turned to the ON position (330) or RUN position (322 and 430), current flows from the positive terminal of battery (G1), through fusible link (F4), across key switch contacts, to 25-amp fuse (F1) and 10-amp fuse (F2). From fuse (F2), current flows across the closed contacts of seat switch (S6) to pin "9" of TDC module 2-pin connector (X14).

Inside the TDC module, current flows through time delay integrated circuit (IC) (A), to transistor (B). As long as current from IC (A) flows to transistor (B), the transistor is "switched on". In this state, the transistor completes the path to ground for PTO relay coil (G).

*NOTE: If machine is not equipped with optional rear PTO, a jumper wire at connector (X5) is used in place of the rear PTO switch.*

*Front PTO switch (S2) and optional rear PTO switches (S3) have two sets of contacts each. One set is used to actuate the clutch(es) and the other set is used in the interlock circuit (See Starting Circuit Operation in this group).*

*The interlock current enables the PTO circuit by causing PTO relay contacts (D) to close.*

When the ground path is completed by transistor (B) and PTO switch(es) are in the OFF position, current will flow from fuse (F1) to connector (X3) on the front PTO switch. Current flows across the PTO switch interlock contacts, then to 3-pin connector (X5). If equipped with optional rear PTO, current will flow from connector (X5) to connector (X6) on the rear PTO switch. Current flows across the rear PTO switch interlock contacts and back out to connector (X5). From connector (X5), the interlock current flows to the TDC module across pin "6" of 8-pin connector (X13).

Inside the TDC module, the interlock current flows through diodes (E and F), to PTO relay coil (G), then through transistor (B) to ground. The interlock current causes PTO relay contacts (D) to close.

When PTO relay contacts (D) close, current from 25-amp fuse (F1), flows across pin "3" of 8-pin connector (X13) and PTO relay contacts (D). From the PTO relay contacts, current flows through PTO relay coil (G) then through transistor (B) to ground.

Continued

MX,159124015,26-19-13JUL95

Component Location and Operation/Theory of Operation

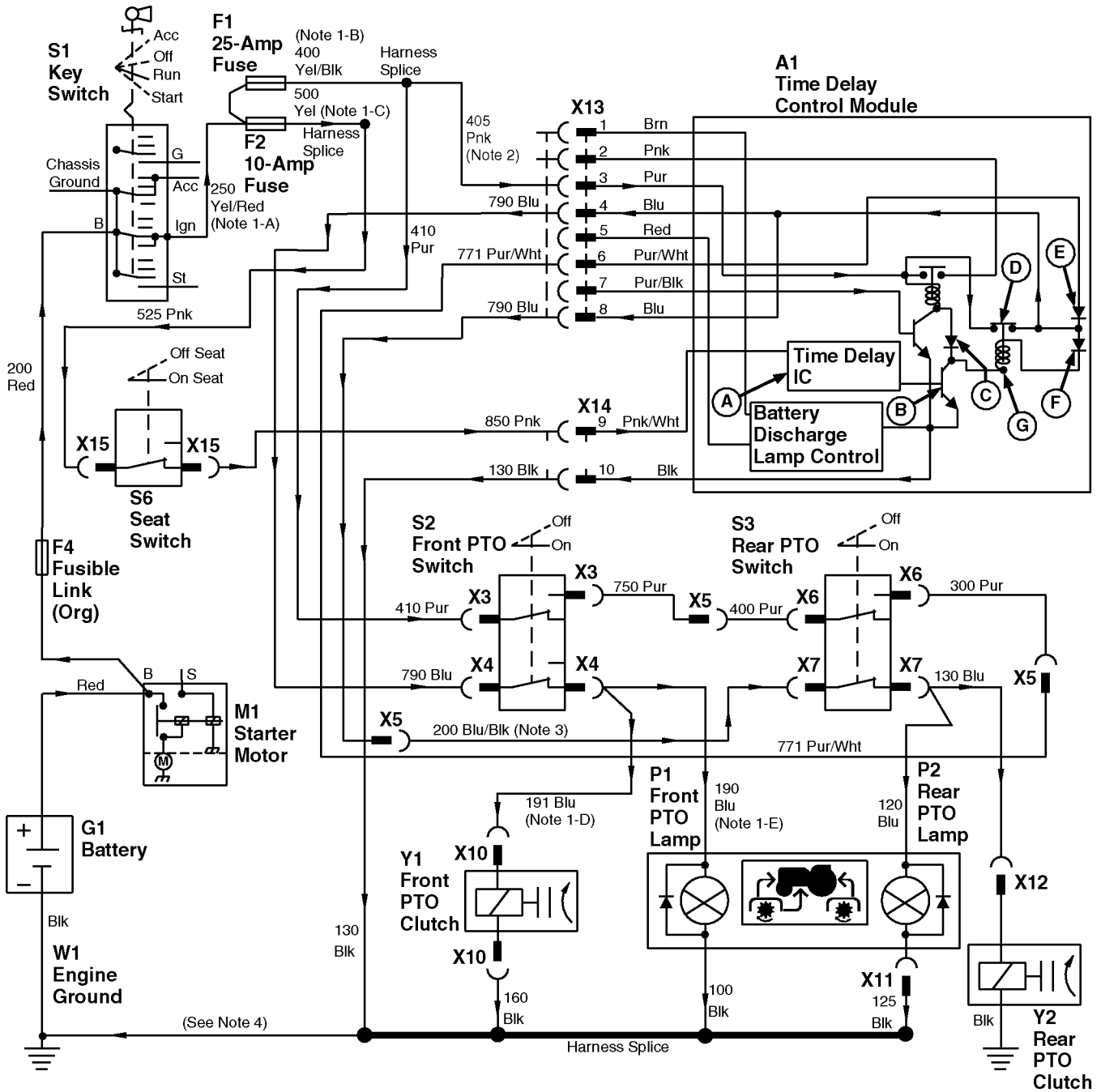

NOTE: 1. 430; The following wire numbers/color apply where noted on drawing:

- A) 270 Red
- B) 400 Pink
- C) 500 Red
- D) 101 Blue
- E) 100 Blue

NOTE: 2. 322; The color of "405" wire is yellow/black.

NOTE: 3. 322; Pin "8" of connector (X13) is not used. Blue wire "780" connects to blue wire "790" at connector (X4) and to connector (X7) at the rear PTO switch.

NOTE: 4. Because ground circuits differ between models and versions, refer to the Main Electrical Schematics in Group 10 for more detail on ground circuit.

M78072 -19-14JUN95

240  
15  
15

**PTO CIRCUIT OPERATION—322, 330 AND 430 (S.N. —420468) (CONTINUED)**

A—Time Delay Integrated Circuit (IC)	F4—Fusible Link	X4—Front PTO Switch 3-Pin Connector	X12—Rear PTO Clutch 1-Pin Connector
B—Time Delay Switch Transistor	G1—Battery	X5—Rear PTO Harness 3-Pin Connector	X13—TDC Module 8-Pin Connector
C—Isolation Diode	M1—Starter Motor	X6—Rear PTO Switch 2-Pin Connector	X14—TDC Module 2-Pin Connector
D—TDC PTO Relay Contacts	P1—Front PTO Lamp	X7—Rear PTO Switch 3-Pin Connector	X15—Seat Switch 2-Pin Connector
E—Isolation Diode	P2—Rear PTO Lamp (Optional)	X10—Front PTO Clutch 2-Pin Connector	Y1—Front PTO Clutch
F—Isolation Diode	S1—Key Switch	X11—Rear PTO Lamp 1-Pin Connector (Ground)	Y2—Rear PTO Clutch (Optional)
G—TDC PTO Relay Coil	S2—Front PTO Switch		
A1—Time Delay Control (TDC) Module	S3—Rear PTO Switch (Optional)		
F1—25-Amp Fuse	S6—Seat Switch		
F2—10-Amp Fuse	W1—Engine Ground		
	X3—Front PTO Switch 2-Pin Connector		

*Legend For PTO Circuit*

The current flowing across PTO relay contacts (D) keeps the PTO relay coil energized (latched) as long as transistor (B) provides a path to ground. When the PTO relay is latched, current from the interlock circuit is no longer required. At this point, the PTO switch(es) can be moved to the ON position to energize the PTO clutch(es).

When front PTO switch (S2) is moved to the ON position, current flowing across the PTO relay contacts (D) will also flow out pin “4” of 8-pin connector (X13) to connector (X4) on the front PTO switch. Current flows across the PTO switch contacts to front PTO clutch (Y1), engaging the clutch. Current also flows to front PTO lamp (P1), turning the lamp on.

*NOTE: Operation of optional rear PTO is same as front PTO except power comes from pin “8” of connector (X13) (330 and 430 only).*

*322; Pin “8” is not used. Power comes from pin “4”, same as front PTO.*

When the operator rises from the seat, the seat switch (S6) contacts open, causing current to stop flowing to the time delay integrated circuit (IC) (A). If

the operator does not return to the seat within approximately one second, the time delay IC stops current flow to transistor (B). The transistor will “switch off”, stopping current flow through PTO relay coil (G), which de-energizes the coil. At this point PTO relay contacts (D) will open and stop current flow to the PTO clutch(es) and lamp(s), thus disengaging the PTO clutch(es) and turning the lamp(s) off.

*NOTE: Driving the machine over rough terrain can cause the seat switch contacts to momentarily open and close. If this happens, the time delay IC delays the opening of PTO relay contacts (D), which allows the PTO(s) to operate without interruption.*

If the operator returns to the seat within approximately one second, current flow is re-established to the time delay IC before it has a chance to “time out” and stop current flow to the transistor. Current flow is NOT interrupted, allowing the PTO(s) to continue operating.

The 25 amp fuse (F1) and 10 amp fuse (F2) protect the PTO circuit from excessive current.

Component Location and Operation/Theory of Operation

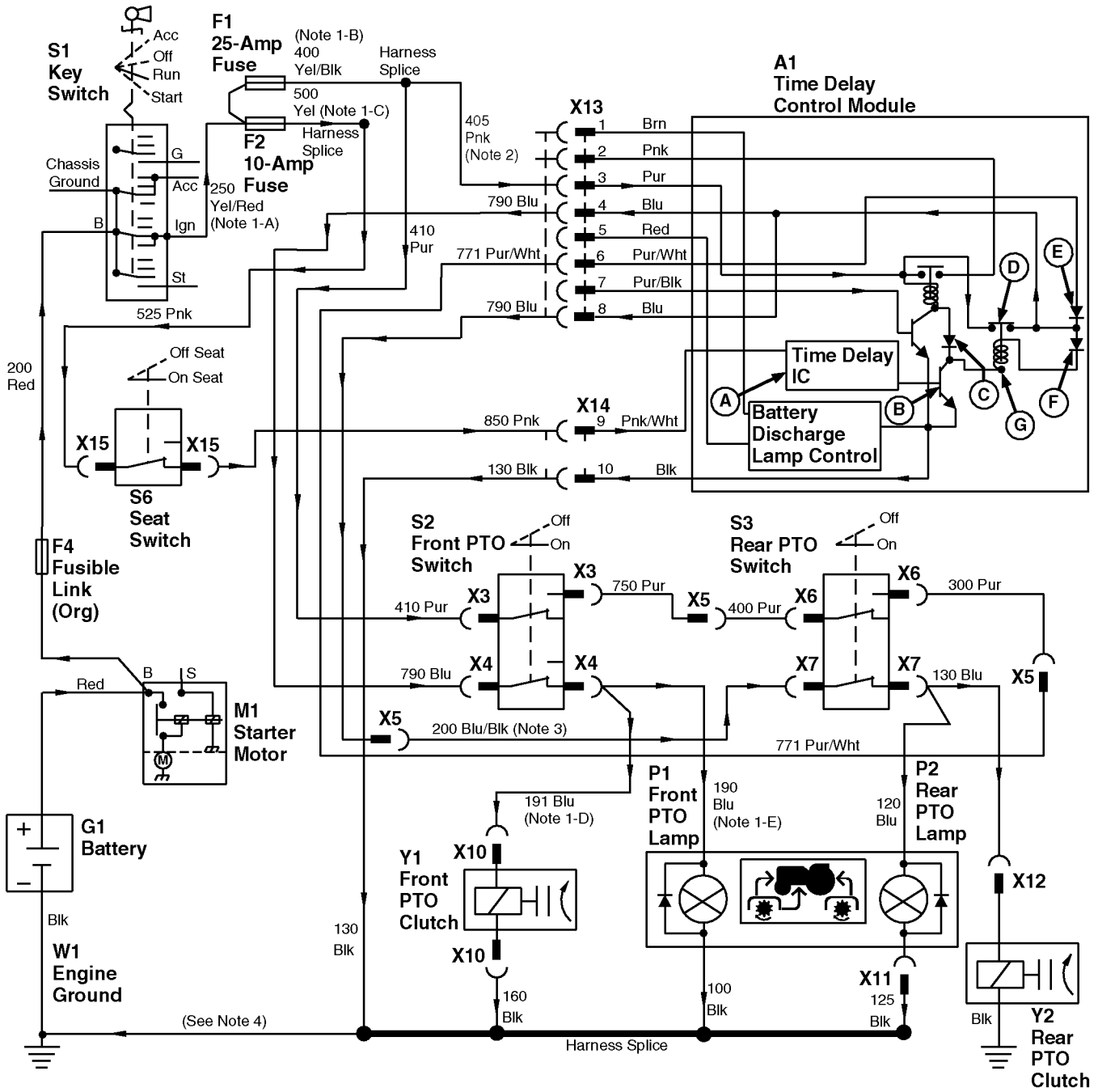

NOTE: 1. 430; The following wire numbers/color apply where noted on drawing:

- A) 270 Red
- B) 400 Pink
- C) 500 Red
- D) 101 Blue
- E) 100 Blue

NOTE: 2. 322; The color of "405" wire is yellow/black.

NOTE: 3. 322; Pin "8" of connector (X13) is not used. Blue wire "780" connects to blue wire "790" at connector (X4) and to connector (X7) at the rear PTO switch.

NOTE: 4. Because ground circuits differ between models and versions, refer to the Main Electrical Schematics in Group 10 for more detail on ground circuit.

MX,159124015,27-19-13JUL95

## PTO CIRCUIT OPERATION—332 AND 430 (S.N. 420469— )

A—Seat Switch Time Delay Integrated Circuit (IC)	G1—Battery	X4—Front PTO Switch 3-Pin Connector	X11—Rear PTO Lamp 1-Pin Connector (Ground)
B—Time Delay Switch Transistor	M1—Starter Motor	X5—Rear PTO Harness 3-Pin Connector	X12—Rear PTO Clutch 1-Pin Connector
C—Isolation Diode	P1—Front PTO Lamp	X6—Rear PTO Switch 2-Pin Connector	X13—TDC Module 6-Pin Connector
D—TDC PTO Relay Contacts	P2—Rear PTO Lamp (Optional)	X7—Rear PTO Switch 3-Pin Connector	X14—TDC Module 3-Pin Connector
E—Isolation Diode	S1—Key Switch	X10—Front PTO Clutch 1-Pin Connector (Early)	X15—Seat Switch 2-Pin Connector
F—Isolation Diode	S2—Front PTO Switch	W1—Engine Ground 2-Pin Connector (Later)	Y1—Front PTO Clutch (Optional)
G—TDC PTO Relay Coil	S3—Rear PTO Switch (Optional)		Y2—Rear PTO Clutch (Optional)
A1—Time Delay Control (TDC) Module	S6—Seat Switch		
F1—25-Amp Fuse	W1—Engine Ground		
F2—10-Amp Fuse	X3—Front PTO Switch 2-Pin Connector		
F4—Fusible Link			

### Legend For PTO Circuit

The function of the PTO circuit is to energize the front PTO clutch and/or optional rear PTO clutch and turn on the PTO indicator lamp(s). Also, the PTO circuit uses a time delay controller and a seat switch to automatically disengage the PTO clutch(es) anytime the operator rises off the seat for more than one second.

To engage the PTO clutch(es), the following conditions must be met:

- Operator on seat.
- PTO switch(es) initially at OFF position.
- Key switch turned to ON position (332) or RUN position (430).
- PTO switch moved to ON position.

The normally open contacts of seat switch (S6) close when the operator sits on the seat. When the key switch (S1) is turned to the ON position (332) or RUN position (430), current flows from the positive terminal of battery (G1), through fusible link (F4), across key switch contacts, to 25-amp fuse (F1) and 10-amp fuse (F2). From fuse (F2), current flows across the closed contacts of seat switch (S6) to pin "A" of 3-pin connector (X14). Inside the TDC module, current flows through seat switch time delay integrated circuit (IC) (A), to transistor (B).

As long as current from IC (A) flows to transistor (B), the transistor is "switched on". In this state, the transistor completes the path to ground for PTO relay coil (G).

*NOTE: Front PTO switch (S2) and optional rear PTO switch (S3) have two sets of contacts each.*

*One set is used to actuate the clutch(es) and the other set is used in the interlock circuit (See Starting Circuit Operation in this group).*

*The interlock current enables the PTO circuit by causing PTO relay contacts (D) to close.*

*If machine is not equipped with optional rear PTO, a jumper wire at connector (X5) is used in place of the rear PTO switch.*

When the ground path is completed by transistor (B) and PTO switch(es) are in the OFF position, current will flow from fuse (F1) to connector (X3) on the front PTO switch. Current flows across the switch interlock contacts, then to 3-pin connector (X5). If equipped with optional rear PTO, current will flow from connector (X5) to connector (X6) on the rear PTO switch. Current flows across the PTO switch interlock contacts and back out to connector (X5). From connector (X5), current flows to pin "B" of the TDC module 6-pin connector (X13).

Inside the TDC module, the interlock current flows through diode (E), to PTO relay coil (G), then through transistor (B) to ground. The interlock current causes the PTO relay contacts (D) to close.

When PTO relay contacts (D) close, current from 25-amp fuse (F1) flows across pin "C" of 3-pin connector (X14) and PTO relay contacts (D). From the PTO relay contacts current flows through diode (F) and PTO relay coil (G), then through transistor (B) to ground.

Continued

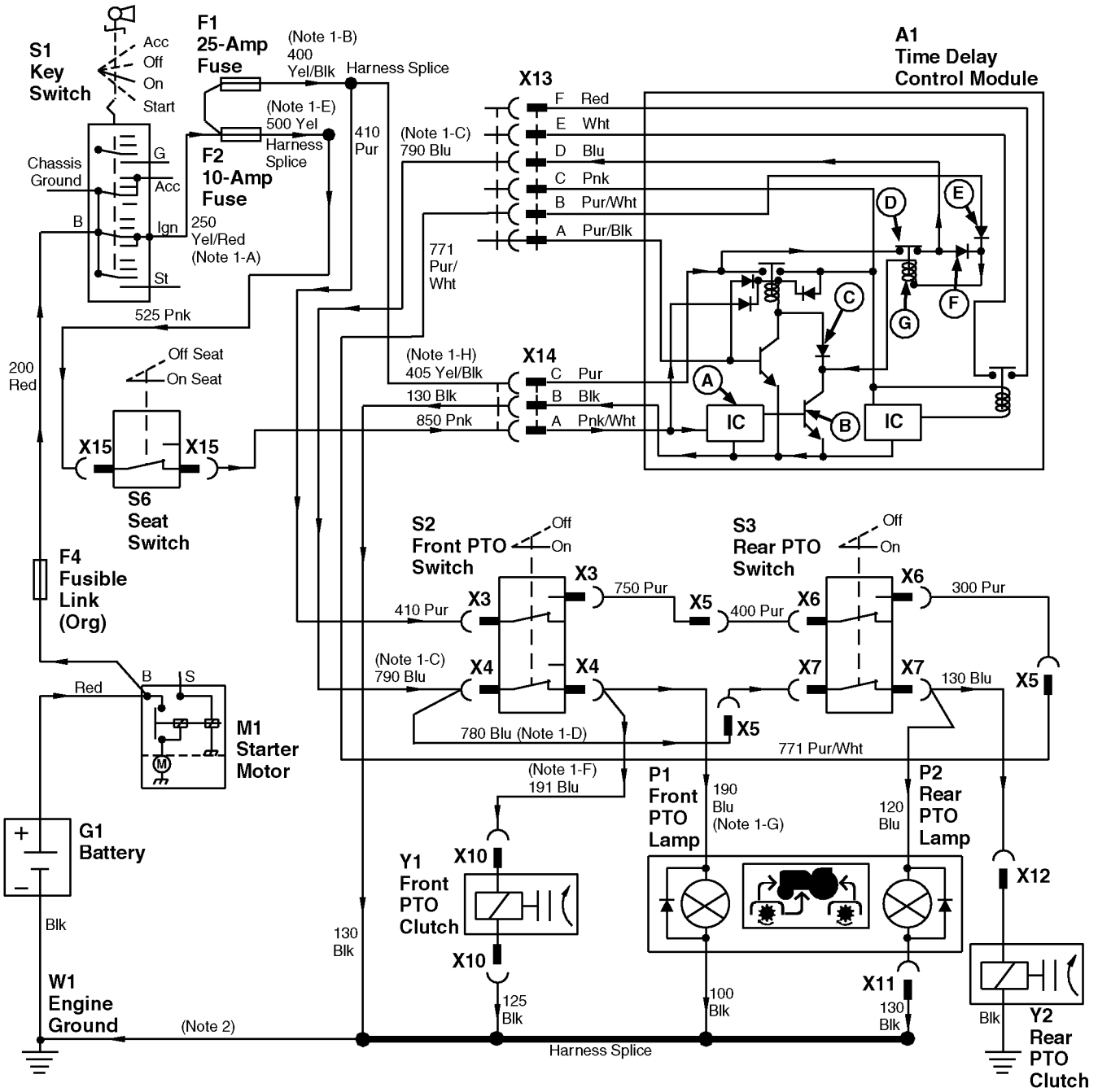

NOTE: 1. 430; The following wire numbers/color apply where noted on drawing:

- A) 270 Red
- B) 400 Pink
- C) 780 Blue
- D) 790 Blue
- E) 500 Red
- F) 101 Blue
- G) 100 Blue
- H) 405 Purple

NOTE 1. 430; Blue wires "780" and "790" terminate together at connector (X5) not at connector (X4) as shown in drawing.

NOTE: 2. Because ground circuits differ between models and versions, refer to the Main Electrical Schematics in Group 10 for more detail on ground circuit.

MX.159124015.30-19-13JUL95

**PTO CIRCUIT OPERATION—332 AND 430 (S.N. 420469— ) (CONTINUED)**

A—Seat Switch Time Delay Integrated Circuit (IC)	G1—Battery	X4—Front PTO Switch 3-Pin Connector	X11—Rear PTO Lamp 1-Pin Connector (Ground)
B—Time Delay Switch Transistor	M1—Starter Motor	X5—Rear PTO Harness 3-Pin Connector	X12—Rear PTO Clutch 1-Pin Connector
C—Isolation Diode	P1—Front PTO Lamp	X6—Rear PTO Switch 2-Pin Connector	X13—TDC Module 6-Pin Connector
D—TDC PTO Relay Contacts	P2—Rear PTO Lamp (Optional)	X7—Rear PTO Switch 3-Pin Connector	X14—TDC Module 3-Pin Connector
E—Isolation Diode	S1—Key Switch	X10—Front PTO Clutch 1-Pin Connector (Early)	X15—Seat Switch 2-Pin Connector
F—Isolation Diode	S2—Front PTO Switch	W1—Engine Ground 2-Pin Connector (Later)	Y1—Front PTO Clutch
G—TDC PTO Relay Coil	S3—Rear PTO Switch (Optional)		Y2—Rear PTO Clutch (Optional)
A1—Time Delay Control (TDC) Module	S6—Seat Switch		
F1—25-Amp Fuse	W1—Engine Ground		
F2—10-Amp Fuse	X3—Front PTO Switch 2-Pin Connector		
F4—Fusible Link			

*Legend For PTO Circuit*

The current flowing across PTO relay contacts (D) keeps the PTO relay coil energized (latched) as long as transistor (B) provides a path to ground. When the PTO relay is latched, current from the interlock circuit is no longer required. At this point, the PTO switch(es) can be moved to the ON position to energize the PTO clutch(es).

When the front PTO switch is moved to the ON position, current flowing across the relay contacts will also flow out pin “D” of 6-pin connector (X13) to connector (X4) on the front PTO switch. Current flows across the PTO switch contacts to front PTO clutch (Y1), engaging the clutch. Current also flows to front PTO lamp (P1), turning the lamp on.

*NOTE: Operation of optional rear PTO is same as front PTO.*

When the operator rises from the seat, the seat switch contacts open, causing current to stop flowing to seat switch time delay IC (A). If the operator does not return to the seat within approximately one second, the time delay IC stops current flow to transistor (B). The transistor will “switch off”, stopping current flow through PTO relay coil (G), which de-energizes the coil. At this point PTO relay contacts (D) will open and stop current flow to the PTO clutch(es) and lamp(s), thus disengaging the PTO clutch(es) and turning the lamp(s) off.

*NOTE: Driving the machine over rough terrain can cause the seat switch contacts to momentarily open and close. If this happens, the seat switch time delay IC delays the opening of PTO relay contacts (D), which allows the PTO(s) to operate without interruption.*

If the operator returns to the seat within approximately one second, current flow is re-established to the time delay IC before it has a chance to “time out” and stop current flow to the transistor. Current flow is NOT interrupted, allowing the PTO(s) to continue operating.

The 25 amp fuse (F1) and 10 amp fuse (F2) protect the PTO circuit from excessive current.

240  
15  
20



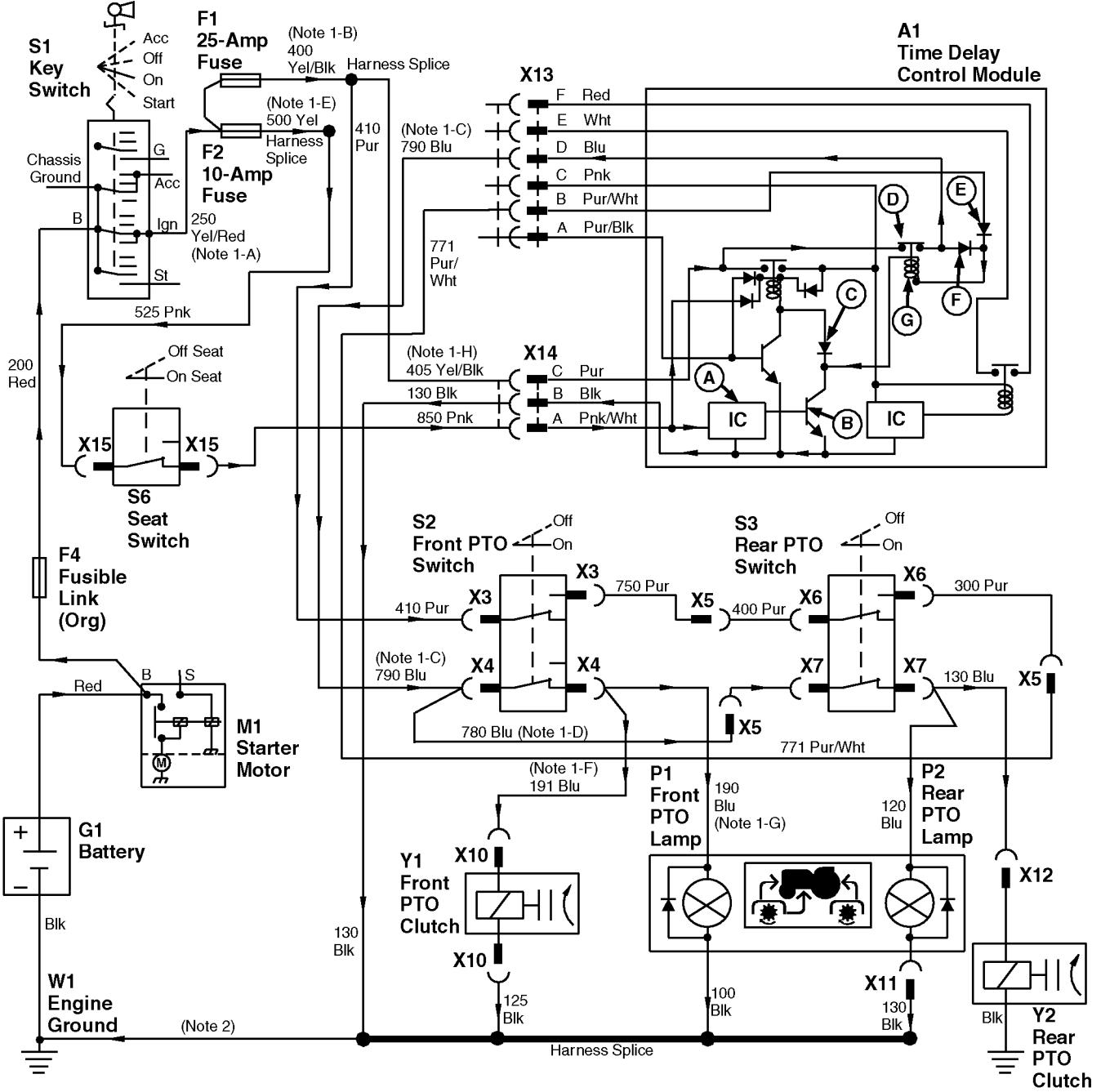

NOTE: 1. 430; The following wire numbers/color apply where noted on drawing:

- A) 270 Red
- B) 400 Pink
- C) 780 Blue
- D) 790 Blue
- E) 500 Red
- F) 101 Blue
- G) 100 Blue
- H) 405 Purple

NOTE 1. 430; Blue wires "780" and "790" terminate together at connector (X5) not at connector (X4) as shown in drawing.

NOTE: 2. Because ground circuits differ between models and versions, refer to the Main Electrical Schematics in Group 10 for more detail on ground circuit.

MX.159124015.30-19-13JUL95

M78078 -19-14JUN95

## CHARGING CIRCUIT OPERATION—322, 330 AND 332

The function of the charging circuit is to keep the battery properly charged by supplying approximately 13.5—15.0 VDC to the battery while the engine is operating.

The alternator (G2) produces a high (AC) output current at high engine rpm. This output current is controlled by voltage regulator/rectifier (N1), which is mounted separately from alternator. Battery discharge lamp (P3) warns the operator when alternator output is low. The battery discharge lamp DOES NOT monitor battery state of charge.

When the engine is operating, alternating current (AC) from the alternator flows to the voltage regulator/rectifier. The rectifier portion of the voltage regulator/rectifier converts the alternating current to direct current (DC). The regulator portion stabilizes the direct current and increases or decreases current flow as required by the battery. It does this by comparing battery voltage at fuse (F2) with voltage output from the alternator.

When battery voltage is low (voltage difference not within specifications), the regulator/rectifier allows current produced by the alternator to flow directly to the battery through wire (A). When the battery is fully charged, the regulator/rectifier stops current flow to the battery.

When the engine is not operating and the key switch is in the ON position (330 and 332) or RUN position (322), the regulator/rectifier senses no current output from the alternator. In this state the regulator/rectifier allows current to flow to the discharge lamp, turning the lamp on. During engine operation, the regulator will also allow current to the battery discharge lamp when alternator output is below specification.

When the engine is operating and the alternator produces current output that's over the minimum specification, the regulator/rectifier senses the current output and stops current flowing to the discharge lamp, turning the lamp off.

The 10-amp fuse (F2) protects the battery discharge lamp circuit from excessive current.

MX,159124015,32-19-13JUL95

Component Location and Operation/Theory of Operation

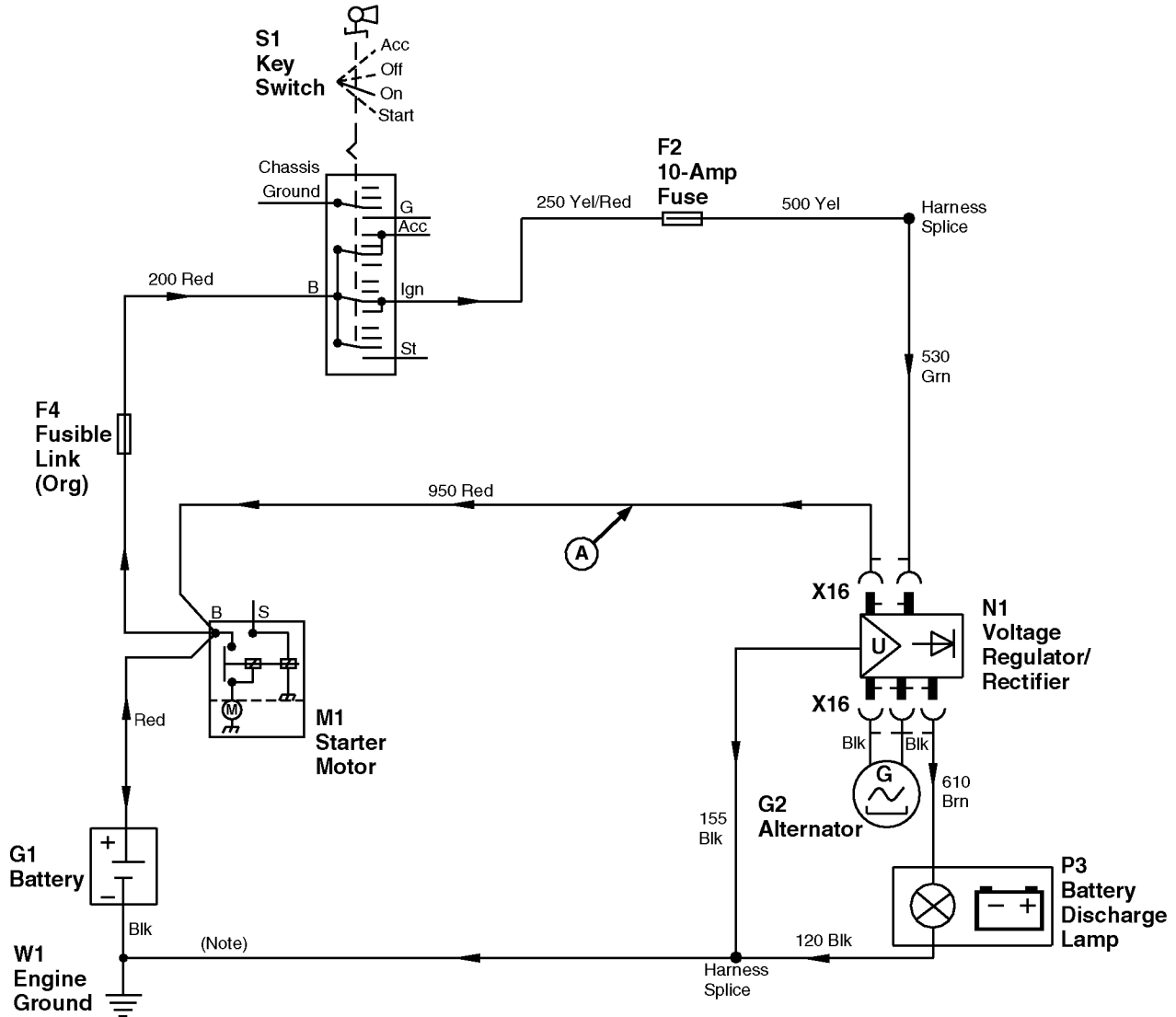

A—Voltage Regulator/Rectifier-to-Battery Wire  
F2—10 Amp Fuse

F4—Fusible Link  
G1—Battery  
G2—Alternator  
M1—Starter Motor

N1—Voltage Regulator/Rectifier  
P3—Battery Discharge Lamp  
S1—Key Switch

W1—Engine Ground  
X16—Voltage Regulator/Rectifier 5-Pin Connector

NOTE: Because ground circuits differ between models and versions, refer to the Main Electrical Schematics in Group 10 for more detail on ground circuit.

MX,159124015,33-19-13JUL95

MT78069 -19-14JUN95

240  
15  
23

## CHARGING CIRCUIT OPERATION—430

A—Alternator-to-Battery Wire	F4—Fusible Link	P3—Battery Discharge Lamp	X13—TDC Module 8-Pin Connector
B—Battery Discharge Lamp Controller	G1—Battery	S1—Key Switch	X14—TDC Module 2-Pin Connector
A1—TDC Module	G2—Alternator	W1—Engine Ground	
F2—10 Amp Fuse	M1—Starter Motor	W3—Frame Ground	

*Legend For Charging Circuit*

The function of the charging circuit is to keep the battery properly charged by supplying approximately 13.5—15.0 VDC to the battery while the engine is operating.

Alternator (G2) is made up of a rotor (rotating electromagnet), stator, rectifier, and regulator. The rotor is belt driven by the engine crankshaft.

When key switch (S1) is turned to the RUN position, current from battery (G1) flows through fusible link (F4) to terminal "B" on the key switch. Current flows across the key switch contacts to terminal "BR". From terminal "BR", current flows to 10 amp fuse (F2) and then to the regulator located inside the alternator.

From the regulator, current flows to the rotor field windings, which induces a magnetic field around the rotor and stator windings. As the rotor turns, the magnetic field cuts across the stator windings. This produces an alternating current (AC) in the stator windings.

The rectifier converts the (AC) current from the stator windings to direct current (DC). The regulator stabilizes the direct current and then compares battery voltage at 10-amp fuse (F2) with the alternator output voltage to battery. The regulator then varies the strength of the magnetic field accordingly, by varying the current flow to the rotor field windings. The strength of the magnetic field increases and decreases proportionally with the amount of current to the rotor. The stronger the magnetic field, the higher the alternator output.

Output current from the alternator flows directly to the battery through wire (A).

**For (S.N. —420468):**

Battery discharge lamp (P3) warns the operator when battery voltage is low (battery voltage below specification). The battery discharge lamp DOES NOT monitor current output from the alternator.

Battery discharge lamp controller (B) senses battery voltage present at fuse (F2). If the lamp controller senses low voltage (less than 12.3 volts), the lamp controller provides a path to ground for the battery discharge lamp. Since battery voltage is always available at the discharge lamp when the key switch is at the RUN position, the ground path provided by the lamp controller will allow battery current from fuse (F2) to flow through the battery discharge lamp and lamp controller, causing the discharge lamp to turn on. The discharge lamp will stay on until battery voltage increases to approximately 12.7 volts. At this point, the lamp controller will break the path to ground, turning the discharge lamp off.

**For (S.N. 420469— ):**

Battery discharge lamp (P3) warns the operator when alternator output is low. It DOES NOT monitor battery state of charge.

When the engine is not operating and the key switch is in the RUN position, the regulator senses no current output from the alternator. In this state, the regulator provides a path to ground for the battery discharge lamp, turning the lamp on. During engine operation, the regulator will also provide a path to ground for the battery discharge lamp when current output is below specification (less than 12.3 volts).

When the engine is operating and the alternator produces current output that's over the minimum specification (approximately 12.7 volts), the regulator senses the current output and breaks the ground path to the discharge lamp, turning the lamp off.

Component Location and Operation/Theory of Operation

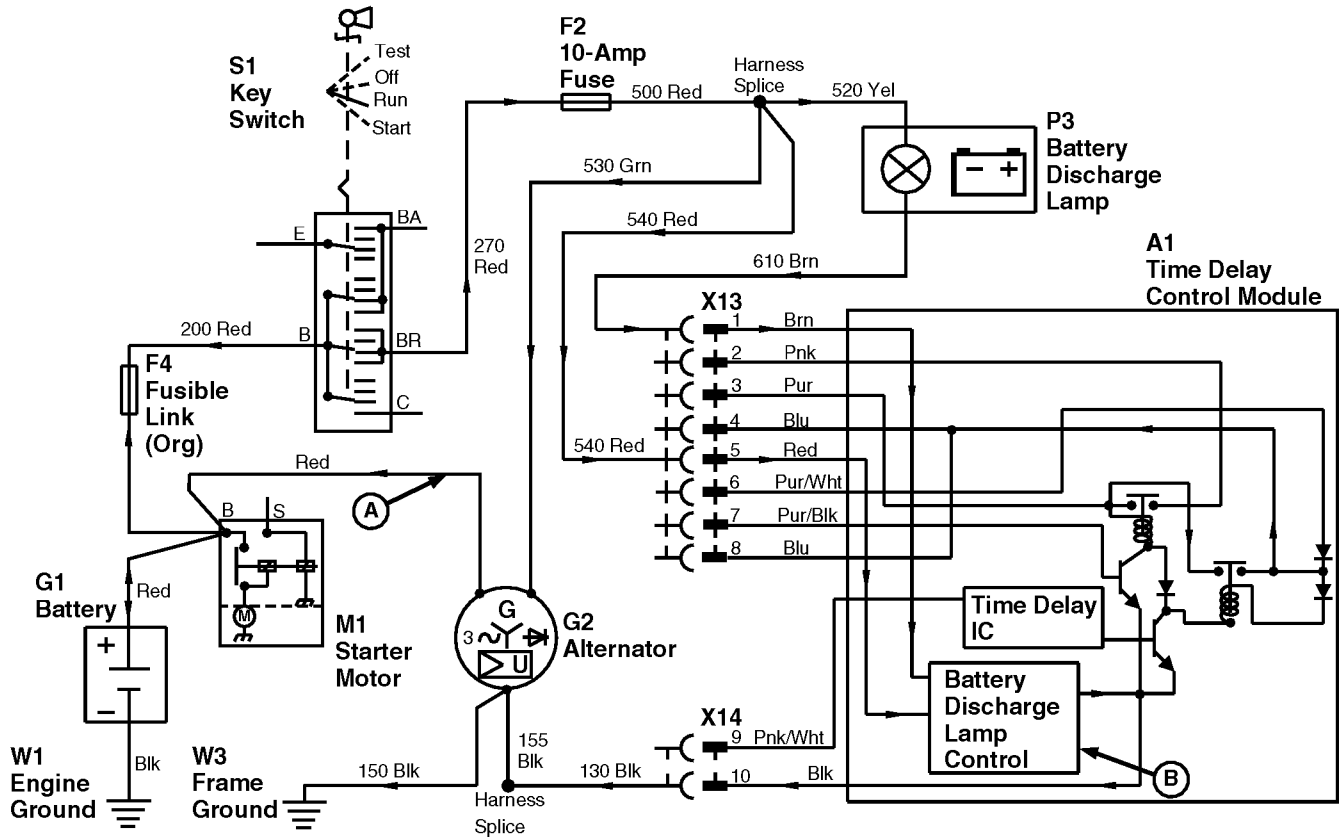

430 (S.N. —420468)

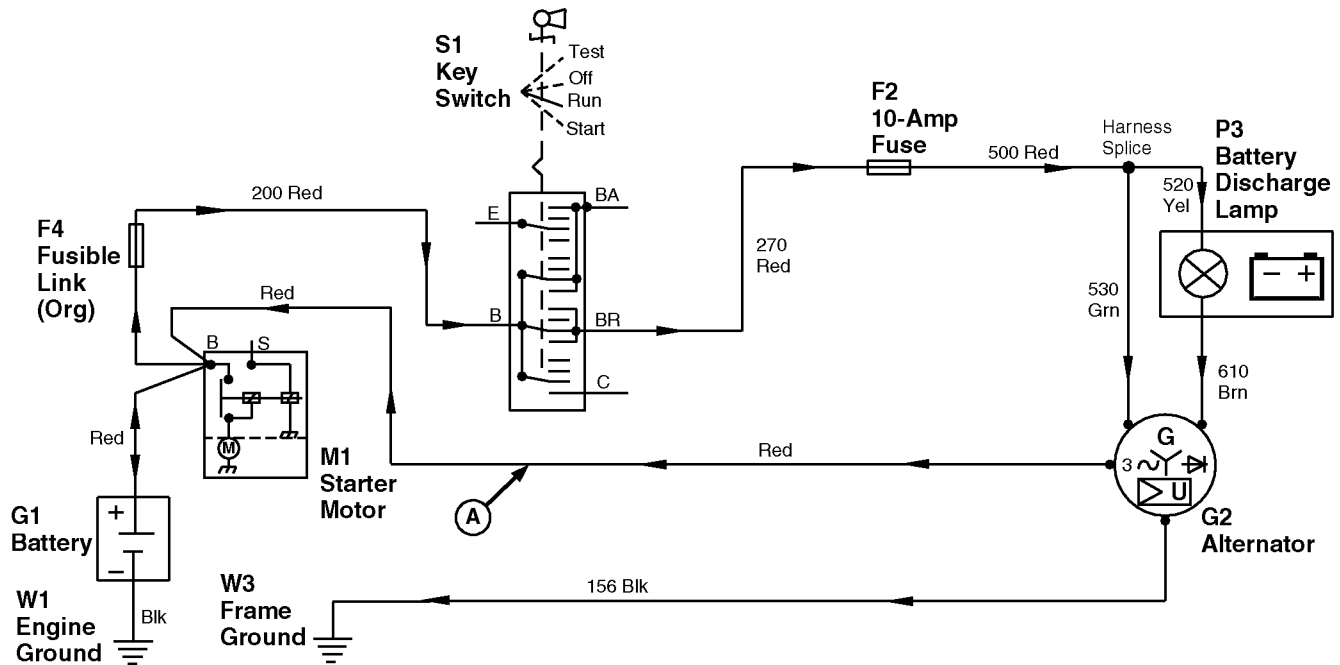

430 (S.N. 420469— )

M78070 -19-14JUN95

M78071 -19-14JUN95

240  
15  
25

MX,159124015,35-19-13JUL95

**FUEL SHUTOFF SOLENOID CIRCUIT OPERATION—430 (S.N. —420468)**

The function of the fuel shutoff solenoid circuit is to stop engine operation by shutting off fuel flow to the fuel injector pump. This is accomplished either manually using the key switch or automatically when the operator rises from the seat for more than one second with machine in gear or PTO engaged.

**OPERATOR ON SEAT—MACHINE IN GEAR AND/OR PTO ENGAGED:**

The normally open contacts of seat switch (S6) close when the operator sits on the seat. When the key switch (S1) is turned to the RUN or START position, current flows from the positive (+) terminal of battery (G1), through fusible link (F4) to terminal "B" of the key switch. Current flows across the key switch contacts to terminal "BR". From terminal "BR", current flows to 25-amp fuse (F1) and 10-amp fuse (F2). From fuse (F2), current flows across the closed contacts of the seat switch to pin "9" of TDC module 2-pin connector (X14).

Inside the TDC module, current flows through seat time delay integrated circuit (IC) (E), then to seat time delay transistor (D). As long as current from the time delay IC flows to the transistor, the transistor is "switched on". In this state, the transistor completes the path to ground for fuel shut-off relay coil (B). The ground path allows current to flow from fuse (F1) to pin "3" of the TDC module 8-pin connector (X13). Inside the TDC module, current flows through the fuel shut-off relay coil to ground. This energizes the relay coil which closes fuel shut-off relay contacts (A). Current from fuse (F1) then flows across the relay contacts and out pin "2" of 8-pin connector (X13). From pin "2", current flows to fuel shutoff solenoid (Y3). From solenoid (Y3), current flows through 8-amp circuit breaker (F5) to ground, energizing the solenoid. The energized solenoid moves the fuel shutoff linkage to the ON position. This opens a valve and allows fuel to flow into the fuel injector pump.

When the operator rises from the seat, the seat switch contacts open, causing current to stop flowing to the seat time delay IC. If the operator does not return to the seat within approximately one second, the time delay IC stops current flow to transistor (D). The transistor will "switch off", causing current through the fuel shut-off relay coil to stop flowing, which opens the fuel shutoff relay contacts. The open relay

contacts stops current flow to the fuel shutoff solenoid, de-energizing the solenoid. The de-energized solenoid moves the fuel shutoff linkage to the OFF position. This shuts off the fuel flow, thus stopping the engine.

*NOTE: Driving the machine over rough terrain can cause the seat switch contacts to momentarily open and close. If this happens, the seat time delay IC delays the opening of fuel shutoff relay contacts (A), which allows the engine to operate without interruption.*

If the operator returns to the seat within approximately one second, current flow is re-established to the time delay IC before it has a chance to "time out" and stop current flow to the transistor. Current flow is NOT interrupted to the fuel shutoff solenoid, allowing the engine to continue operating.

**OPERATOR OFF SEAT—MACHINE IN NEUTRAL AND PTO DISENGAGED:**

When operator is off the seat, current to the fuel shutoff solenoid can still be maintained through the interlock circuit. For current to flow through the interlock circuit, the key switch must be turned to the RUN or START position, the hydrostatic control lever in the N/STOP position, and PTO switch(es) in the OFF position (PTO disengaged).

With these conditions met, current flows from fuse (F1) through the interlock contacts of the PTO switches, transmission neutral switch, to pin "7" of TDC module 8-pin connector (X13). Inside the TDC module, current flows from pin "7" to fuel shut-off transistor (C). As long as current from the interlock circuit flows to transistor (C), the transistor is "switched on". In this state, the transistor provides an alternate path to ground for the fuel shut-off relay coil. The fuel shutoff relay contacts close, allowing current to flow to the fuel shutoff solenoid.

The 25-amp fuse (F1) and 10-amp fuse (F2) protect the fuel shutoff circuit from excessive current.

The 8-amp circuit breaker (F5) disables the start circuit and fuel shutoff solenoid (solenoid will not energize) if breaker is tripped.

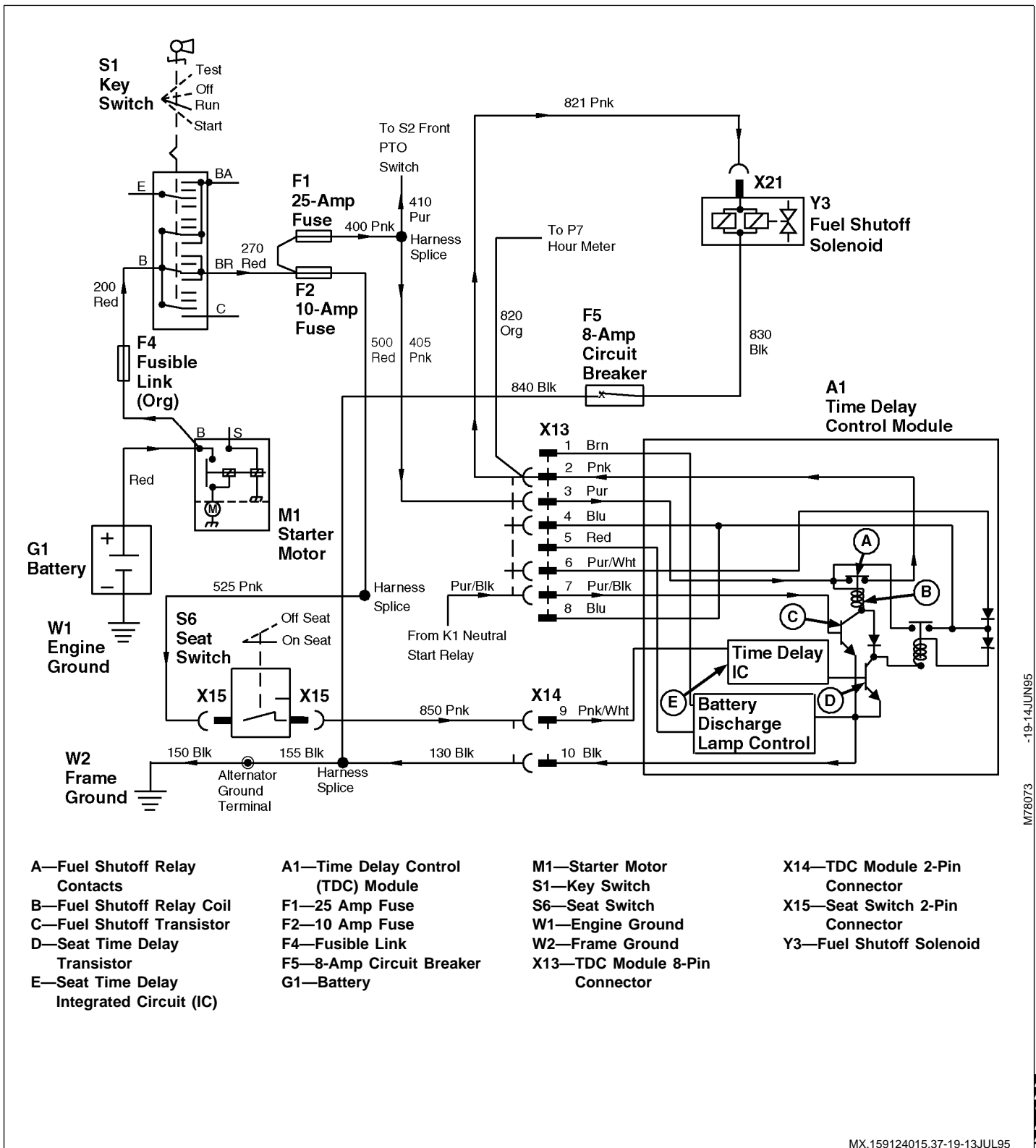

M78073 -19-14JUN95

240  
15  
27

MX,159124015,37-19-13JUL95

**FUEL SHUTOFF SOLENOID CIRCUIT OPERATION—332 AND 430 (S.N. 420469— )**

The function of the fuel shutoff solenoid circuit is to stop engine operation by shutting off fuel flow to the fuel injector pump. This is accomplished either manually using the key switch or automatically when the operator rises from the seat for more than one second with machine in gear or PTO engaged.

**OPERATOR ON SEAT—MACHINE IN GEAR AND/OR PTO ENGAGED:**

When the key switch (S1) is turned to the ON position, current flows from the positive (+) terminal of battery (G1), through fusible link (F4) to the key switch. Current flows across key switch contacts to 25-amp fuse (F1) and 10-amp fuse (F2). From fuse (F2), current flows across the closed contacts of seat switch (S6) to pin “A” of TDC module 3-pin connector (X14).

Inside the TDC module, current flows to seat time delay IC (J), then to time delay transistor (H). As long as current from IC (J) flows to transistor (H), the transistor is “switched on”. In this state, the transistor completes the path to ground, allowing current from the seat switch to flow through relay coil (D), energizing the relay. This closes contacts (C), which allows current from fuse (F1), to flow to solenoid (Y3) hold-in windings (B). The magnetic field produced in the hold-in windings is not strong enough to move the armature of fuel shutoff solenoid by itself.

From relay contacts (C), current also flows to pull-in time delay IC (G) and pull-in relay coil (F). IC (G) provides a path to ground for relay coil (F), causing the relay to energize and close relay contacts (E). This allows high current from the battery to flow through fusible link (F4), across relay contacts (E), to solenoid pull-in windings (A). This energizes the pull-in coil, which pulls the fuel shutoff solenoid armature in and moves the injection pump linkage to the ON position.

After approximately one second, IC (G) breaks the pull-in relay’s path to ground, thus stopping current flow through the relay coil. The relay contacts (E) open, causing current to stop flowing to the solenoid pull-in windings.

Current continues to flow to the solenoid hold-in windings. The magnetic field produced by this current is strong enough to hold the solenoid armature in, thus keeping the injector pump linkage at the ON position.

When the operator rises from the seat, the seat switch contacts open, causing current to stop flowing to seat time delay IC (J). If the operator does not return to the seat within approximately one second, IC (J) stops current flow to transistor (H). The transistor will “switch off”, stopping current flowing through relay coil (D), causing relay contacts (C) to open. Current stops flowing to the solenoid hold-in windings, de-energizing the fuel shutoff solenoid. With the solenoid no longer energized, a return spring moves the injector pump linkage back to the OFF position, thus stopping fuel flow to the injection pump.

*NOTE: Driving the machine over rough terrain can cause the seat switch contacts to momentarily open and close. If this happens, the seat time delay IC allows the engine to operate without interruption.*

If the operator returns to the seat within approximately one second, current flow is re-established to IC (J) before it has a chance to “time out” and stop current flow to transistor (H). Current flow is NOT interrupted to the fuel shutoff solenoid, allowing the engine to continue operating.

**OPERATOR OFF SEAT—MACHINE IN NEUTRAL AND PTO DISENGAGED:**

*NOTE: 332 (S.N. 596723— ) and 430 (S.N. 596048— ); Park brake must be engaged.*

When operator is off the seat, current to the fuel shutoff solenoid can still be maintained through the interlock circuit. For current to flow through the interlock circuit, the key switch must be turned to the ON or START position, the hydrostatic control lever in the N/STOP position, the PTO switches in the OFF position (PTO disengaged) and park brake engaged (332 (S.N. 596723— ) and 430 (S.N. 596048— ) only).

With these conditions met, current flows from fuse (F1), through the interlock contacts of the PTO switches, transmission neutral switch, and brake switch (if equipped) to pin “A” of TDC module 6-pin connector (X13). Inside the TDC module, the interlock current flows to transistor (I), causing the transistor to “switch on”. In this state, the transistor provides an alternate path to ground for relay coil (D). The relay coil energizes, closing relay contacts (C), thus allowing current to flow to the fuel shutoff solenoid hold-in windings (B).

MX,159124015,38-19-13JUL95



Component Location and Operation/Theory of Operation

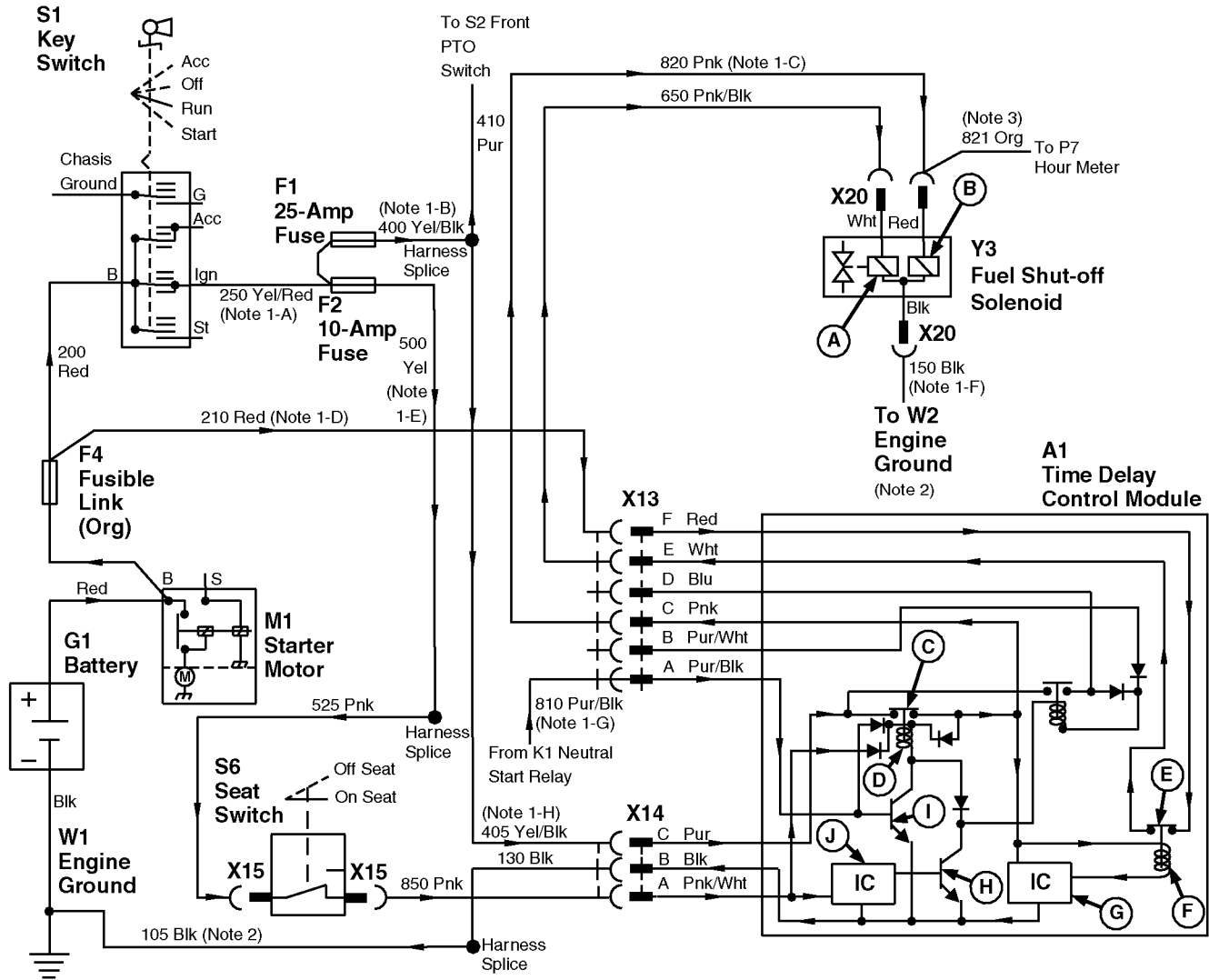

A—Solenoid Pull-In Windings  
 B—Solenoid Hold-In Windings  
 C—Hold-In Relay Contacts  
 D—Hold-In Relay Coil  
 E—Pull-In Relay Contacts  
 F—Pull-In Relay Coil  
 G—Pull-In Time Delay Integrated Circuit (IC)

H—Seat Time Delay Transistor  
 I—Hold-In Transistor  
 J—Seat Time Delay IC  
 A1—Time Delay Control (TDC) Module  
 F1—25 Amp Fuse  
 F2—10 Amp Fuse

F4—Fusible Link  
 G1—Battery  
 M1—Starter Motor  
 S1—Key Switch  
 S6—Seat Switch  
 W1—Engine Ground  
 X13—TDC Module 6-Pin Connector

X14—TDC Module 3-Pin Connector  
 X15—Seat Switch 2-Pin Connector  
 X20—Fuel Shutoff 3-Pin Connector  
 Y3—Fuel Shutoff Solenoid

NOTE: Illustration shows key switch configuration for 332.

NOTE: 2. 430; Harness ground wire number is "156" and connects to frame ground.

NOTE: 1. 430; The following wire numbers/color apply where noted on drawing:

- A) 270 Red
- B) 400 Pink
- C) 821 Pink
- D) 205 Red/Black
- E) 500 Red
- F) 165 Black
- G) 810 Purple
- H) 405 Purple

NOTE: 3. 430; Orange wire number is "820".

M78074 -19-14JUN95

240  
15  
29

## ENGINE PREHEAT CIRCUIT OPERATION (330, 332 AND 430)

The function of the engine preheat circuit is to supply current to the glow plugs for easier starting of the engine in cold weather. The circuit also informs the operator when the engine is ready to start. The system is fully automatic and does not require any operator interaction. The system functions only when the key switch is in the ON position (330 and 332) or RUN position (430) or START position and engine compartment temperature is approximately 20°C (68°F) or lower.

When the engine compartment temperature is less than 20°C (68°F), turning key switch (S1) to the ON position (330 and 332) or RUN position (430) or START position allows current from the positive (+) terminal of battery (G1) to flow to fusible link (F4). From the fusible link, current flows across key switch contacts, through 10 amp fuse (F2), to pin "3" on 5-pin connector (X20) of glow plug controller (A2). Inside the glow plug controller, current flows to the integrated circuits (ICs) (D—F) and to thermistor (G).

Temperature changes causes the thermistor's resistance to change in value, which increases or decreases current flow to IC (F). The current from thermistor (G) controls IC (F). IC (F) controls ICs (D and E).

Current from IC (E) causes transistor (C) to "switch on", completing a path to ground for glow plug lamp (P8). Current flows from fuse (F2), through the glow plug lamp, then through transistor (C) to ground, causing the lamp to turn on.

After approximately 8 seconds has elapsed, a timer in IC (E) will stop current flowing to transistor (C). This causes the transistor to "switch off", turning the glow plug lamp off.

Current from IC (D) causes transistor (B) to "switch on", completing a path to ground for glow plug relay (A). The ground path allows current from fuse (F2) to flow through the glow plug relay coil, which energizes the relay and closes the relay contacts. The closed relay contacts allow current to flow directly from the battery, through fusible link (F3), across the relay contacts, then out to glow plugs (R1).

After approximately 30 seconds has elapsed, a timer in IC (D) will stop current flow to transistor (B), causing the transistor to "switch off". This stops current flow to the relay coil, which causes the relay contacts to open, thus stopping current flow to the glow plugs.

MX,159124015,40-19-13JUL95

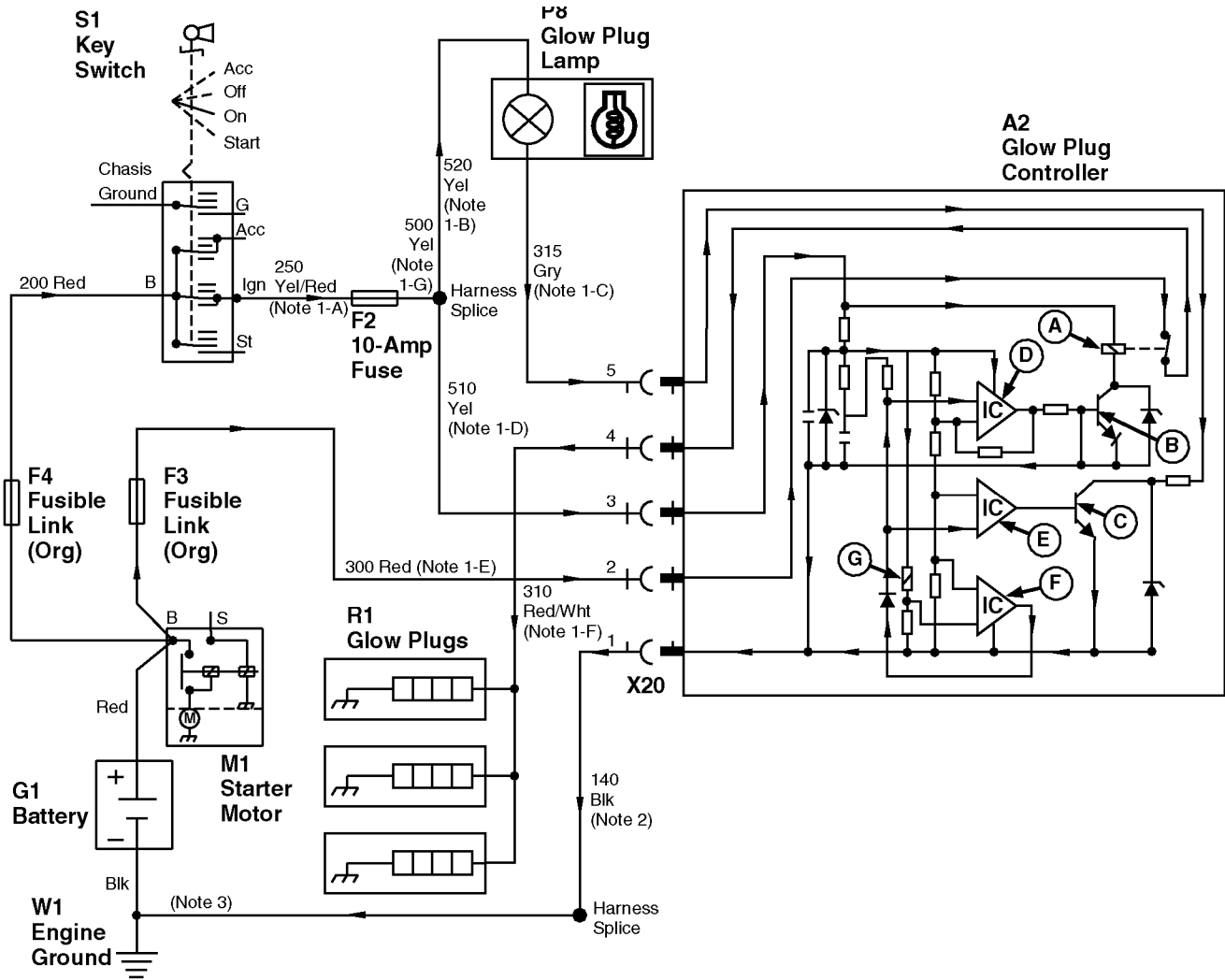

- |                                     |                             |                   |                          |
|-------------------------------------|-----------------------------|-------------------|--------------------------|
| A—Glow Plug Relay                   | E—Glow Plug Lamp IC         | F3—Fusible Link   | R1—Glow Plugs            |
| B—Relay Transistor                  | F—Temperature Controlled IC | F4—Fusible Link   | S1—Key Switch            |
| C—Glow Plug Lamp Transistor         | G—Thermistor                | G1—Battery        | W1—Engine Ground         |
| D—Glow Plug Integrated Circuit (IC) | A2—Glow Plug Controller     | M1—Starter Motor  | X20—Glow Plug Controller |
|                                     | F2—10-Amp Fuse              | P8—Glow Plug Lamp | 5-Pin Connector          |

NOTE: Illustration shows key switch configuration for 330 and 332.

NOTE: 2. 332 (S.N. 475001— ); Wire number "171" is used instead of "140".

NOTE: 1. 430; The following wire numbers/color apply where noted on drawing:

- |                |                   |
|----------------|-------------------|
| -A) 270 Red    | -E) 310 Red       |
| -B) 425 Yellow | -F) 320 Red/White |
| -C) 630 Gray   | -G) 500 Red       |
| -D) 420 Yellow |                   |

NOTE: 3. Because ground circuits may differ between models and versions, refer to the Main Electrical Schematics in Group 10 for more detail on ground circuit connections.

M78075 -19-14JUN95

240  
15  
31

## **WATER-IN-FUEL CIRCUIT OPERATION (430)**

The function of the water-in-fuel circuit is to warn the operator when water is present in the fuel system.

This is done by a sensor that's located in the fuel filter base that senses the resistance of the fuel. Since diesel fuel has a higher resistance than water, fuel contaminated with water will have a lower resistance.

Turning key switch (S1) to the RUN position allows current to flow from the positive (+) terminal of battery (G1), through fusible link (F4), to key switch terminal "B". Current flow across the key switch contacts to terminal "BR". From terminal "BR", current flows through 10-amp fuse (F2), to water-in-fuel sensor (B7), energizing the sensor. When the sensor is initially energized, it completes a path to ground for water-in-fuel lamp (P9), turning the lamp on. The lamp will stay on for a few seconds then, if there is no water present in the fuel, the sensor will break the path to ground, turning the lamp off.

Inside the sensor, current flows to a probe that is submersed in the fuel. From the probe, current flows through the fuel to ground. When water is present in the fuel, the resistance through the fuel to ground is lowered, causing increased current flow. Current flow will continue to increase until a transistor in the sensor "switches on", completing the path to ground for the water-in-fuel lamp. As long as there is water in the filter base, the lamp will stay on when the key switch is in the RUN position.

MX,159124015,42-19-13JUL95

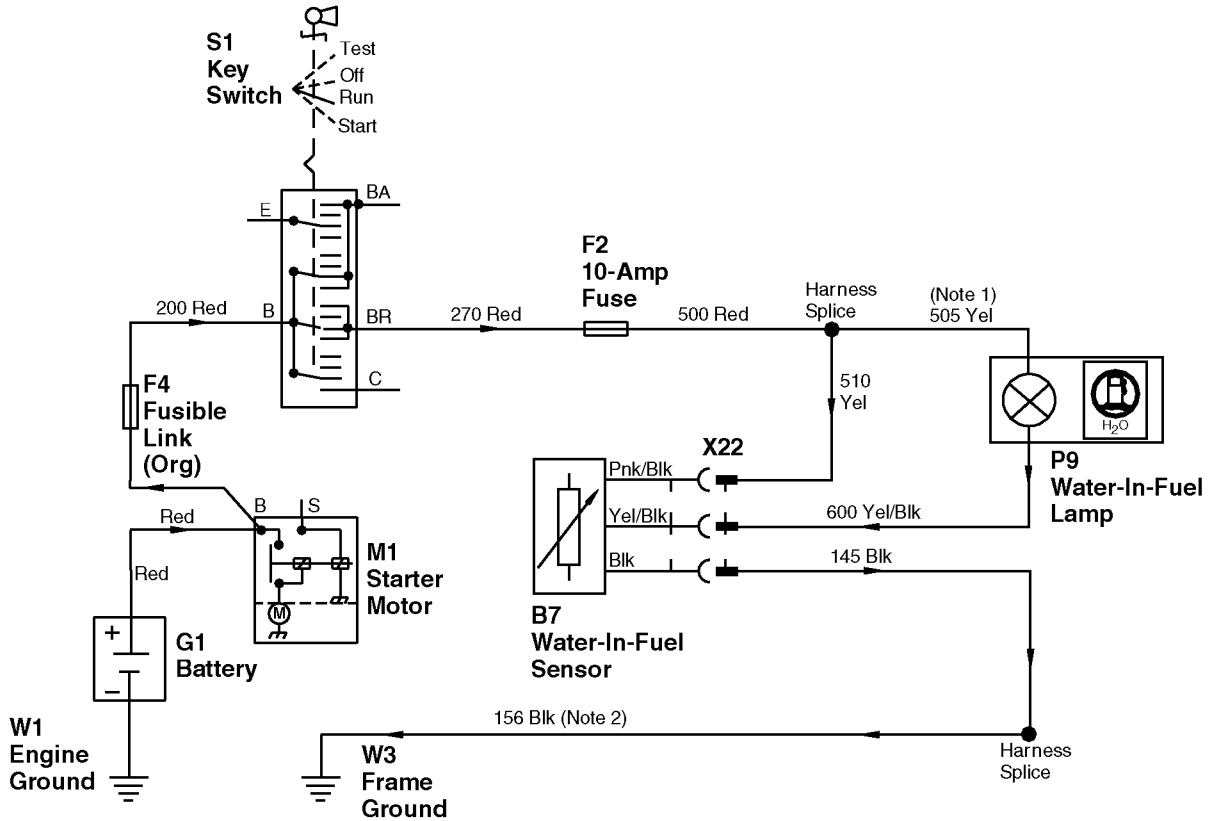

B7—Water-In-Fuel Sensor  
 F2—10-Amp Fuse  
 F4—Fusible Link

G1—Battery  
 M1—Starter Motor  
 P9—Water-In-Fuel Lamp

S1—Key Switch  
 W1—Engine Ground  
 W3—Frame Ground

X22—Water-In-Fuel Sensor  
 3-Pin Connector

NOTE: 1. 430 (S.N. 420469— ); Wire number "516" is used instead of "505".

NOTE: 2. 430 (S.N. —420468); Harness ground wire connects to frame ground at pedestal.

The "516" yellow wire connects to "515" yellow wire at the engine oil pressure lamp. The "515" wire connects the oil pressure lamp to the fuse (F2) harness splice.

MX,159124015,43-19-13JUL95

M75076 -19-14JUN95

## LOW FUEL LEVEL CIRCUIT OPERATION (322, 332 AND 430)

The function of the low fuel level circuit is to warn the operator when the fuel level in the fuel tank is low. Also, a "lamp test" function is provided to check the warning lamp circuit.

The low fuel level sensor (B4) is actually a temperature sensor that increases or decreases current flow through low fuel level lamp (P4) as sensor temperature increases or decreases.

When the sensor is submersed in fuel, the fuel cools the sensor. The cooled sensor prevents current flow to ground. When the sensor is dry (fuel level is below sensor), the sensor heats up, allowing current to flow. The amount of current flow is directly proportional to the temperature of the sensor. Because of this, a partially exposed sensor will allow a small amount of current flow, causing the low fuel level lamp to glow dimly. When the sensor is completely exposed, full current flows through the lamp, turning the lamp on fully.

When key switch (S1) is turned to the ON position (330 and 332) or RUN position (322 and 430) and the fuel level sensor is exposed, current from the positive (+) terminal of battery (G1) flows through fusible link (F4) to key switch terminal "B". Current flows across the key switch contacts to terminal "IGN" (322 and 332) or terminal "BR" (430). From the key switch, current flows to 10-amp fuse (F2). From the fuse, current flows through the low fuel level lamp, through the sensor, then to ground.

Diodes (V1 and V2) block engine coolant temperature lamp access to the ground provided by the low fuel level sensor. This prevents the coolant temperature lamp from turning on when the low fuel level lamp turns on.

322 and 332; When the key switch is turned to the START position, a separate set of contacts in the key switch connects the low fuel level lamp directly to ground to provide the lamp test function.

430; When the key switch is turned to the TEST position (key switch turned fully counterclockwise), a separate set of contacts in the key switch connects the low fuel level lamp directly to ground to provide the lamp test function.

MX,159124015,44-19-13JUL95

Component Location and Operation/Theory of Operation

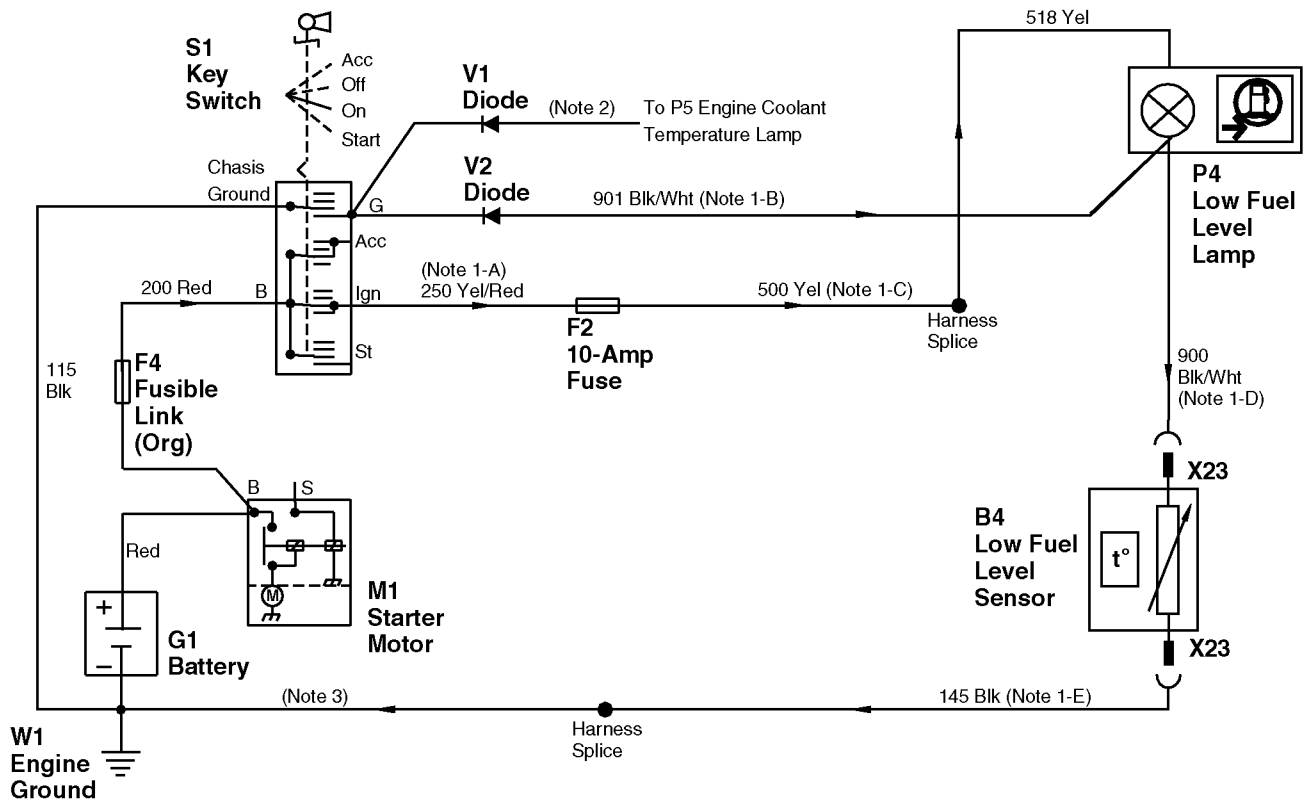

B4—Low Fuel Level Sensor  
 F2—10-Amp Fuse  
 F4—Fusible Link

G1—Battery  
 M1—Starter Motor  
 P4—Low Fuel Level Lamp

S1—Key Switch  
 V1—Isolation Diode  
 V2—Isolation Diode

W1—Engine Ground  
 X23—Low Fuel Level Sensor  
 2-Pin Connector

NOTE: Illustration shows key switch configuration for 322 and 332.

NOTE: 1. 430; The following wire number/color apply where noted on drawing:

- A) 270 Red
- B) 331 Green/White
- C) 500 Red
- D) 330 Green/White

NOTE: 2. Refer to the following chart for wire number/color of coolant temperature lamp ground "test" wire.

MACHINE MODEL

WIRE NUMBER/COLOR

322	.....	333 Orange/White
332 (S.N. 475001— )	.....	333 Orange/White
332 (S.N. —475000)	.....	332 Orange/White
430 ( —420468)	.....	332 Yellow/Red
430 (S.N. 420469— )	.....	333 Yellow/Red

NOTE: 3. Because ground circuits differ between models and versions, refer to the Main Electrical Schematics in Group 10 for more detail on ground circuit connections and wire numbers.

M75077 -19-14JUN95

MX,159124015,45-19-13JUL95

240  
15  
35





## ABOUT THIS GROUP

Always perform the system checkout procedures in Group 05 BEFORE doing any tests in this group. The step-by-step procedures in this group provide you with the detailed diagnostic information you will need to isolate a malfunction. Always start with the first step and follow the sequence from left to right. Read each step completely before performing the test.

Basic diagnostic equipment is used. It is assumed that you are familiar with the machine and its electrical components.

**IMPORTANT: Before doing any testing, verify the system ground circuits and test the battery. All ground connections must be clean and tight and the battery fully charged.**

With any component failure, it is usually best to trace current flow from the component back to the battery. If there is voltage at the component, verify its ground connection, then repair or replace the component.

Use the electrical schematics in Group 10 to trace current flow.

Upon completing a test or adjustment, check to see whether the problem is corrected by performing the checkout procedure for that step in Group 05.

*NOTE: For clarity in this section, machines including and before serial numbers listed below will be referred to as "Early Models". Machines including and after serial number listed below will be referred to as "Later Models".*

*Later model machines have a brake switch added to the neutral start circuit, which is activated by depressing the brake pedals.*

MODEL	EARLY	LATER
322	(S.N. —596005)	(S.N. 596006— )
330	(S.N. —420000)	N/A
332	(S.N. —475000)	(S.N. 475001— )
430	(S.N. —596047)	(S.N. 596048— )

MX,159124020,1 -19-13JUL95

### A VERIFY SYSTEM GROUNDS—322 AND 332

*NOTE: 332 (S.N. —475000); The PTO clutch, fuel pump and head and tail lights are individually grounded to the machine frame. All other electrical components are grounded through the harness. Inside the harness, the ground circuits are spliced together with one wire connecting the ground circuits to engine ground, then to frame ground.*

*332 (S.N. 475001— ) and 322 (All); All electrical system components are grounded through the harness. Inside the harness, the ground circuits are spliced together with two wires connecting the ground circuits to the machine frame. One goes to frame at regulator/rectifier and the other, first to engine then to frame.*

Continued on next page

240  
20  
1

Electrical System Diagnosis/Verify System Grounds

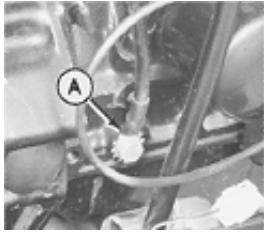

M45227 -UN-12JAN90

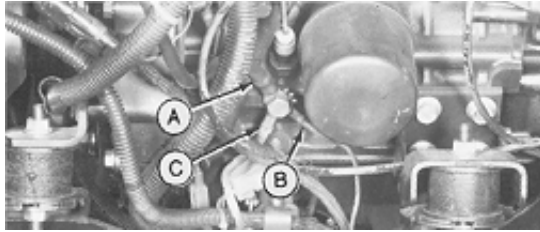

M45177 -UN-08JAN90

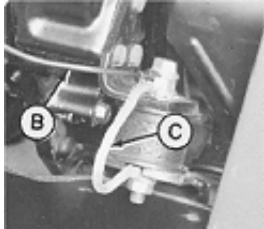

M45228 -UN-12JAN90

*NOTE: Upper and lower left photos show battery, harness and frame ground connections for Early 332.*

*Right photo shows 322 (All) and Later 332. Harness, battery and frame ground are connected to the left front side of engine block. Later 332; A second harness ground is connected to regulator/rectifier to frame on right side of engine compartment. 322 (All); A second harness ground is connected to regulator/rectifier to frame on right side of engine compartment near pedestal.*

Key switch OFF.

Verify the system grounds using a continuity tester or ohmmeter.

Check for good continuity between battery negative (—) terminal and the following ground connections located on engine block, frame and regulator/rectifier to frame:

- A—Battery Ground
- B—Harness Ground
- C—Frame Ground

**NOT OK:** Clean and tighten ground connections as necessary.

**OK:** GO TO B

Electrical System Diagnosis/Verify System Grounds

—! VERIFY SYSTEM GROUNDS—330

*NOTE: The PTO clutch, fuel pump, head light and hour meter are individually grounded to the machine frame. All other electrical components are grounded through the harness. Inside the harness, the ground circuits are spliced together with one wire connecting the ground circuits to the engine mounting bracket, then to frame.*

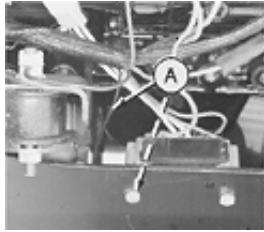

M55097 -UN-09DEC89

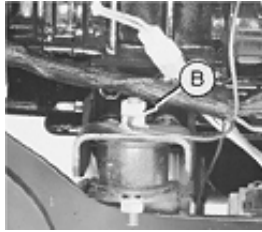

M55098 -UN-09DEC89



M55099 -UN-28APR95

Key switch OFF.

Verify the system grounds using a continuity tester or ohmmeter.

Check for good continuity between battery negative (—) terminal and the following:

- A—Alternator/Regulator Ground Connection to Frame
- B—Wiring Harness Ground Connection to Engine Mounting Bracket then to Frame
- C—Battery Ground Connection at Engine Block

**NOT OK:** Clean and tighten ground connections as necessary.

**OK:** GO TO B

MX,159124020,3 -19-13JUL95

—@ VERIFY SYSTEM GROUNDS—430

*NOTE: 430 (S.N. —475000); The PTO clutch, fuel pump, low fuel sensor and head and tail lights are individually grounded to the machine frame. All other electrical components are grounded through the harness. Inside the harness, the ground circuits are spliced together with one wire connecting the ground circuits to the machine frame.*

*430 (S.N. 475001— ); All electrical system components are grounded through the harness. Inside the harness, the ground circuits are spliced together with one wire connecting the ground circuits to the machine frame.*

Continued on next page

240  
20  
3

Electrical System Diagnosis/Battery Tests

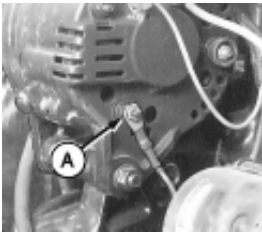
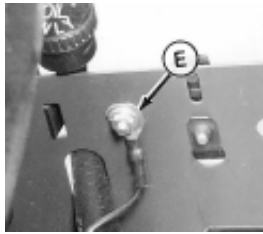
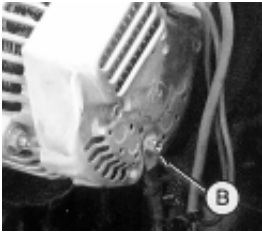
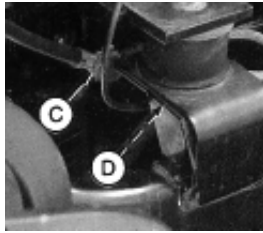
 <p>M36662 -UN-27APR95</p>	 <p>M36663 -UN-27APR95</p>	<p>Key switch OFF.</p> <p>Verify the system grounds using a continuity tester or ohmmeter.</p> <p>Check for good continuity between battery negative (—) terminal and the following:</p> <p>(S.N. —475000):</p> <ul style="list-style-type: none"> <li>• Alternator ground connection (A)</li> <li>• Wiring harness-to-frame ground connection (E) at pedestal</li> <li>• Battery ground connection (C) at engine block</li> </ul> <p>(S.N. 475001— ):</p> <ul style="list-style-type: none"> <li>• Battery ground connection (C) at engine block</li> <li>• Engine block-to-frame ground connection at engine mount (D)</li> <li>• Alternator ground connection (B) to engine mount</li> </ul>	<p><b>NOT OK:</b> Clean and tighten ground connections as necessary.</p> <p><b>OK:</b> GO TO B</p> <p>MX,159124020,4 -19-13JUL95</p>
 <p>M78968 -UN-27APR95</p>	 <p>M78969 -UN-27APR95</p>		

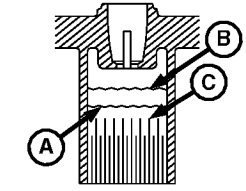
<p><b>B BATTERY TESTS</b></p> <p><i>NOTE: If problem is with starting circuit, perform all battery tests. If problem is with other components, perform battery tests only if starter does not crank engine satisfactorily.</i></p>	 <p>M78970 -UN-09MAY95</p> <p>A—Minimum electrolyte level—No less than 6 mm (0.250 in.) above plate separators</p> <p>B—Maximum electrolyte level—No more than 13 mm (0.500 in.) above plate separators</p> <p>C—Plate Separators</p>	<p>Check electrolyte level in each cell of battery. If low, add the proper amount of electrolyte or DISTILLED water.</p> <p>MX,159124020,4A-19-13JUL95</p>
--	--	--

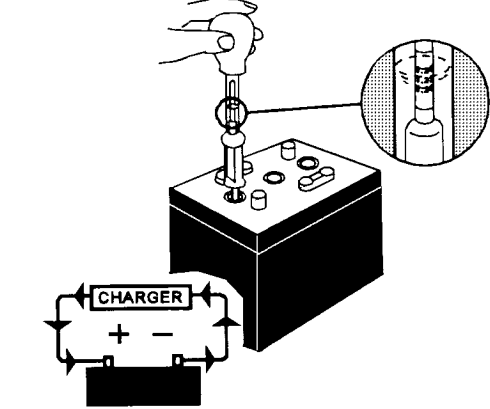
 <p>M78971 -UN-09MAY95</p> <p>Check specific gravity of each cell with a hydrometer.</p>	<p><b>SPECIFIC GRAVITY</b></p> <p>ALL CELLS LESS THAN 1.175: GO TO —@</p> <p>ALL CELLS MORE THAN 1.225 WITH LESS THAN 50 (0.050) GRAVITY POINT VARIATION: GO TO —#</p> <p>ALL CELLS LESS THAN 1.225 WITH LESS THAN 50 (0.050) GRAVITY POINT VARIATION: GO TO —!</p> <p>CELLS VARY MORE THAN 50 POINTS: Replace Battery.</p> <p>MX,159124020,4B-19-13JUL95</p>
---	---

240  
20  
4

*Electrical System Diagnosis/Battery Tests*

<p><b>—! Test Battery Voltage</b></p>	<p><i>NOTE: Battery need not be disconnected from machine.</i></p>	<p><b>IMPORTANT: Before connecting JT05685 Tester to battery, make sure load knob is turned fully counterclockwise.</b></p> <p>Check battery voltage with voltmeter or JT05685 Battery Tester.</p>	<p>12.4 VOLTS OR MORE: GO TO —%  LESS THAN 12.4 VOLTS: GO TO —@</p> <p style="text-align: right;"><small>MX,159124020,6 -19-13JUL95</small></p>
<p><b>—@ Charge Battery</b></p>	<p>Connect a variable-rate type charger to battery. Start charger at a slow rate. Increase charge rate one setting at a time. Check ammeter (on charger) after 1 minute at each setting. Try to maintain a 10 amp charge rate. Use boost setting as necessary.</p> <p>The maximum charging time at boost setting is 10 minutes. Allow an additional 5 minutes for each 10°F below 70°F.</p>	<p>BATTERY DID NOT REQUIRE WATER AT STEP B AND IS ACCEPTING A 10-AMP CHARGE: GO TO —\$</p> <p>BATTERY REQUIRED WATER AT STEP B OR ALL CELLS WERE BELOW 1.175, BUT BATTERY IS ACCEPTING A 10-AMP CHARGE: GO TO —#</p> <p>BATTERY DOES NOT ACCEPT A 10-AMP CHARGE AFTER 10 MINUTES AT BOOST SETTING: Replace Battery.</p> <p style="text-align: right;"><small>MX,159024025,5 -19-16MAY95</small></p>	
<p><b>—# Increase Charge Rate</b></p>	<p>Set charger at 15—25 amps.</p>	<p><b>IMPORTANT: Decrease charge rate if battery gases or bubbles excessively or becomes too warm to hold.</b></p>	<p>Check specific gravity after 30 minutes.</p> <p>VARIATION BETWEEN CELLS IS MORE THAN 50 SPECIFIC GRAVITY POINTS (0.050): Replace Battery.</p> <p>VARIATION BETWEEN CELLS IS LESS THAN 50 SPECIFIC GRAVITY POINTS (0.050): GO TO —\$</p> <p style="text-align: right;"><small>MX,159024025,7 -19-16MAY95</small></p>

240  
20  
5

Electrical System Diagnosis/Battery Tests

<p>—\$ Continue Charging Battery</p>	<p><b>IMPORTANT:</b> Decrease charge rate if battery gases or bubbles too much or if battery gets too warm to hold.</p> <p>Continue charging battery until specific gravity is 1.230—1.265 points.</p>	<p>BATTERY WAS DISCHARGED AT A SLOW RATE OR DISCHARGE RATE IS UNKNOWN: Charge battery at 10—15 amps for 6—12 hours. (Maintenance free battery may require 12—24 hours.)</p> <p>THEN GO TO —%</p> <p>BATTERY WAS DISCHARGED AT A FAST RATE: Charge battery at 20—25 amps. Battery may require 2—4 hours charging time. (Maintenance free battery may need 4—8 hours.)</p> <p>THEN GO TO —%</p>
--------------------------------------	--	---

MX,159024025,8 -19-16MAY95

<p>—% Load Test Battery</p>	 <p>M36665 -UN-29AUG88</p>	<p>Connect JT05685 Tester to battery.</p> <p>Follow instructions on back of meter for testing battery.</p>	<p>REPLACE BATTERY AS NEEDED.</p>
-----------------------------	--	--	-----------------------------------

MX,159024025,9 -19-16MAY95

240  
20  
6

Electrical System Diagnosis/Dash Lamp Circuit Tests

<p><b>DASH LAMP CIRCUIT TESTS</b></p> <p>Listed at right are symptoms that may occur in a malfunctioning dash lamp circuit. Locate the symptom that applies, then proceed to the appropriate test.</p>	<p><b>LAMP CIRCUIT SYMPTOMS:</b></p> <p>—Fuses Blow When Any Of The Lamp Circuits Are Energized. Check For Shorts In The Power Circuit: GO TO 0, Group 25.</p> <p>—No Lamps Come ON: GO TO 1a</p> <p>—Oil Pressure Lamp Does Not Come On: GO TO 1c</p> <p>—Oil Pressure Lamp On All The Time: GO TO 1e</p> <p>—Coolant Temperature Lamp Does Not Come On: GO TO 1f</p> <p>—Coolant Temperature Lamp On All The Time: GO TO 1h</p> <p>—Coolant Temperature Lamp Comes On When Low Fuel Lamp Comes On: GO TO 1i .</p> <p>—Low Fuel Lamp Does Not Come On—322/332 (All) and 430 (S.N. 475001— ): GO TO 1k</p> <p>—Low Fuel Lamp Does Not Come</p>	<p>On—430 (S.N. —475000): GO TO 1l</p> <p>—Low Fuel Lamp On All The Time: GO TO 1n</p> <p>—Battery Discharge Lamp Does Not Come On—322, 330 and 332: GO TO 1o</p> <p>—Battery Discharge Lamp Does Not Come On—430: GO TO 1p</p> <p>—Battery Discharge Lamp On All The Time—430: GO TO 1s</p> <p>—Engine Preheat Lamp Does Not Come On: GO TO 1t</p> <p>—Engine Preheat Lamp On All The Time: GO TO 1v</p> <p>—Water-In-Fuel Lamp Does Not Come On—430: GO TO 1w</p> <p>—Water-In-Fuel Lamp On All The Time—430: GO TO 1x a</p>
--	--	--

MX,159124020,11-19-13JUL95

**1a No Lamps Work**

*NOTE: The dash lamps receive power from the 10-amp fuse. When no lamps work, check for a problem in the power circuit.*

Check 10-amp fuse.



M49010 -UN-08JAN90

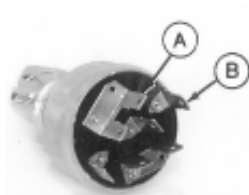

M55135 -UN-28APR95



M36599 -UN-27APR95

*NOTE: Top photos show key switch for 322, 330 and 332.*

*Lower photo shows key switch for 430.*

322, 330 and 332; Check for voltage at "BAT" terminal (B).

430; Check for voltage at "B" terminal (D).

**NO VOLTAGE: GO TO 1b**

**VOLTAGE:** Turn key switch to ON/RUN position.

322, 330 and 332; Check for voltage at "IGN" terminal (A).

430; Check for voltage at "BR" terminal (C).



**VOLTAGE:** Power circuit and key switch OK. Check for voltage at 10-amp fuse. If no voltage at fuse, wire between key switch and fuse is open. Repair or replace wire as necessary, then GO TO ; , Group 05.

**NO VOLTAGE: GO TO 1e, Group 25.**

MX,159124020,12-19-13JUL95

240  
20  
7

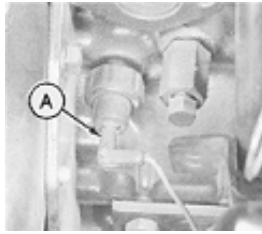

Electrical System Diagnosis/Dash Lamp Circuit Tests

<p><b>1b Key Switch Fusible Link Test</b></p>	<p>Key switch OFF.</p>		<p><i>NOTE: Top photo—322, 330 and 332.</i></p> <p><i>Bottom photo—430.</i></p> <p>Check for voltage at starter common terminal (A).</p>	<p>VOLTAGE: Replace fusible link.</p> <p>NO VOLTAGE: Check battery terminals and cables. Repair or replace as needed.</p>
<p><b>1c Engine Oil Pressure Lamp Test</b></p> <p>Check 10-amp fuse.</p> <p><i>NOTE: If lamp stays on at all times: GO TO 1e</i></p>	<p>Remove left engine side panel.</p> <p>Key switch ON/RUN position.</p>		<p>Remove wire (A) from oil pressure switch.</p> <p>Touch wire (A) to ground.</p> <p><i>LOOK: Lamp should be ON.</i></p>	<p><b>OK:</b> Replace switch, then GO TO ; , Group 05.</p> <p><b>NOT OK:</b> GO TO 1d</p>
<p><b>1d Engine Oil Pressure Lamp Voltage Test</b></p>	<p>Remove bulb socket from dash.</p> <p>Remove bulb.</p>		<p>Check for voltage at terminal with two yellow wires (A).</p>	<p>VOLTAGE: Tan wire to oil pressure switch is open. Repair or replace wire, then GO TO ; , Group 05.</p> <p>NO VOLTAGE: Wire between 10-amp fuse and lamp socket is open. Repair or replace wire, then GO TO ; , Group 05.</p>

240  
20  
8

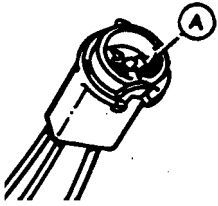

*Electrical System Diagnosis/Dash Lamp Circuit Tests*

<p><b>1e Engine Oil Pressure Lamp Short Circuit Test</b></p>	<p>Key switch OFF.</p> <p>Remove left engine side panel.</p> <p>Disconnect tan lead from oil pressure switch.</p> <p>Remove bulb socket from dash.</p> <p>Remove bulb.</p>	 <p>M36633 -UN-24APR89</p> <p>Check for continuity between terminal with tan wire (A) and ground.</p>	<p>CONTINUITY: The tan wire is shorted to ground. Repair or replace, then GO TO ; , Group 05.</p> <p>NO CONTINUITY: Circuit is OK. Check engine oil pressure. (See Section 220.)</p> <p style="text-align: right;">MX,159124020,16-19-13JUL95</p>
<p><b>1f Engine Coolant Temperature Lamp Test</b></p>	<p>Check 10-amp fuse.</p> <p>If lamp stays on at all times: GO TO 1h</p>	 <p>M36603 -UN-25JAN90</p> <p>Turn key switch to ON/RUN position.</p> <p>Disconnect wire from temperature switch.</p> <p>Touch temperature switch wire to ground.</p> <p><i>LOOK: Lamp should be ON.</i></p>	<p><b>OK:</b> Replace switch, then GO TO ; , Group 05.</p> <p><b>NOT OK:</b> GO TO 1g</p> <p style="text-align: right;">MX,159124020,17-19-13JUL95</p>

Electrical System Diagnosis/Dash Lamp Circuit Tests

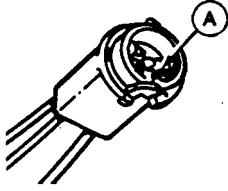
<p><b>1g Engine Coolant Temperature Lamp Voltage Test</b></p>	<p>Remove bulb socket from dash.</p> <p>Remove bulb.</p> <p>Turn key switch to ON/RUN position.</p>	 <p>M36636 -UN-08SEP88</p> <p>Check for voltage at terminal with single yellow wire (A).</p>	<p><b>VOLTAGE:</b> Wire between temperature switch and bulb socket is open. Repair or replace wire, then GO TO ; , Group 05.</p> <p><b>NO VOLTAGE:</b> Check for voltage at terminal with two yellow wires on oil pressure lamp socket.</p> <p><b>VOLTAGE:</b> Yellow wire between oil pressure lamp and coolant temperature lamp is open. Repair or replace wire, then GO TO ; , Group 05.</p> <p><b>NO VOLTAGE:</b> Wire between oil pressure lamp and 10-amp fuse is open. Repair or replace wire, then GO TO ; , Group 05.</p> <p style="text-align: right;">MX,159124020,18-19-13JUL95</p>
---	---	---	---

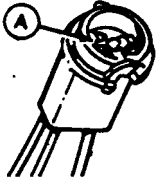
<p><b>1h Engine Coolant Temperature Lamp Short Circuit Test</b></p>	<p>Key switch OFF.</p> <p>Remove lamp socket from dash.</p> <p>Remove bulb.</p>	 <p>M36603 -UN-25JAN90</p>  <p>M36632 -UN-26AUG88</p> <p>Disconnect wire from coolant temperature switch.</p> <p>Check continuity between contact with two wires (A) at lamp socket and ground.</p> <p><i>NOTE: Because this circuit contains a diode, there may be continuity to ground in one direction only.</i></p> <p>Reverse meter leads, then check continuity again.</p>	<p><b>CONTINUITY:</b> Wire between temperature switch and lamp socket or wire between lamp socket and key switch is shorted to ground. Repair or replace wire, then GO TO ; , Group 05.</p> <p><b>NO CONTINUITY:</b> Circuit is OK. Check engine oil pressure. (See Section 220.)</p> <p style="text-align: right;">MX,159124020,19-19-13JUL95</p>
---	---	--	--

Electrical System Diagnosis/Dash Lamp Circuit Tests

**1i Diode and Lamp Ground Circuit Test**

*NOTE: Diodes are designed to allow current flow in only one direction.*

*The 330 does not use diodes in the lamp test circuit.*

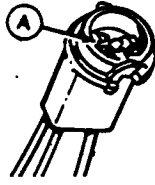

M36632 -UN-26AUG88

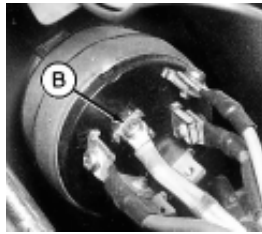

M36604 -UN-27APR95



M45185 -UN-08JAN90

*NOTE: Upper right photo shows key switch used in 430.*

*Lower left photo shows key switch used in 322, 330 and 332.*

Key switch OFF.

Remove either defective low fuel or coolant temperature bulb socket from dash.

Remove bulb.

Check continuity between the two wire contact (A) on the bulb socket and terminal (B) of key switch.

Reverse meter leads and check continuity again.

CONTINUITY ONE DIRECTION: Diode OK, GO TO 1j

CONTINUITY IN BOTH DIRECTIONS: Diode shorted. Replace diode, then GO TO ; , Group 05.

NO CONTINUITY: Diode or wire between diode and lamp socket is open. Replace diode and/or repair wire, then GO TO ; , Group 05.

MX,159124020,20-19-13JUL95

**1j Key Switch Ground Circuit Test**

*NOTE: Upper photo shows key switch used in 322, 330 and 332.*

*Lower photo shows key switch used in 430.*



M45184 -UN-08JAN90

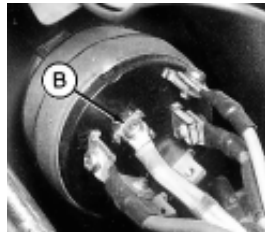

M36604 -UN-27APR95

322, 330 and 332:  
 —Disconnect key switch connector.  
 —Turn key switch to START position.  
 —Check continuity between key switch "G" terminal (A) and ground.

430:  
 —Disconnect battery negative (—) cable.  
 —Disconnect lead with yellow/red and green/white wires from "BA" terminal (B).  
 —Turn key switch fully counterclockwise to the lamp test position.  
 —Check continuity between terminal (B) and ground.

CONTINUITY: Ground circuit OK.

NO CONTINUITY: 322, 330 and 332; Check continuity between key switch chassis and ground.



430; Check continuity between terminal "E" on key switch and ground.

CONTINUITY: Replace key switch, then GO TO ; , Group 05.

NO CONTINUITY: Black wire between key switch and ground is open or ground wire has poor connection. Repair or replace as necessary, then GO TO ; , Group 05.

MX,159124020,21-19-13JUL95

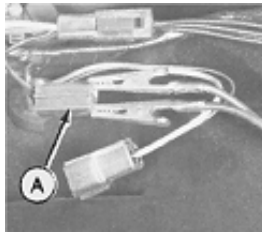
Electrical System Diagnosis/Dash Lamp Circuit Tests

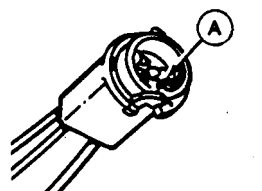
<p><b>1k Low Fuel Circuit Test—322, 332 and 430 (SN 475001— )</b></p> <p><i>NOTE: The problem maybe a blown fuse or burned out bulb. Check the 10-amp fuse and low fuel lamp bulb before preceding with circuit test.</i></p>	<p>Remove fender deck to access low fuel sensor.</p>	 <p>M45182 -UN-08JAN90</p>	<p>Disconnect low fuel sensor 2-pin connector.</p> <p>Connect a jumper wire across terminals of harness side of connector (A).</p> <p>Turn key switch to ON/RUN position.</p> <p><i>LOOK: Low fuel lamp must come ON.</i></p>	<p><b>OK:</b> GO TO ; , Group 25.</p> <p><b>NOT OK:</b> Connect jumper wire from black/white wire at connector to ground.</p> <p><b>LAMP ON:</b> Black wire between sensor and ground is open. Repair or replace wire, then GO TO ; , Group 05.</p> <p><b>LAMP NOT ON:</b> GO TO 1m</p> <p>MX,159124020,22-19-13JUL95</p>
<p><b>1l Low Fuel Circuit Test—430 (SN —475000)</b></p> <p><i>NOTE: The problem maybe a blown fuse or burned out bulb. Check the 10-amp fuse and low fuel lamp bulb before preceding with circuit test.</i></p>	<p>Remove fender deck to access low fuel sensor.</p>	 <p>M36610 -UN-27APR95</p>	<p>Disconnect green/white wire (A) from sensor terminal.</p> <p>Connect jumper wire from the green/white wire to ground.</p> <p>Turn key switch to ON/RUN position.</p> <p><i>LOOK: Low fuel lamp must come ON.</i></p>	<p><b>OK:</b> GO TO ; , Group 25.</p> <p><b>NOT OK:</b> GO TO 1m</p> <p>MX,159124020,23-19-13JUL95</p>
<p><b>1m Low Fuel Lamp Voltage Test</b></p>	<p>Remove bulb socket from dash.</p> <p>Remove bulb.</p>	 <p>M36636 -UN-08SEP88</p>	<p>Turn key switch to ON/RUN position.</p> <p>Check for voltage at yellow wire contact (A).</p>	<p><b>VOLTAGE:</b> Replace wire between sensor and bulb socket.</p> <p><b>NO VOLTAGE:</b> Replace wire between 10-amp fuse and bulb socket.</p> <p>MX,159124020,24-19-13JUL95</p>

240  
20  
12

**1n Low Fuel Lamp Short Circuit Test**

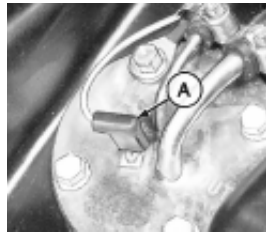

M36610 -UN-27APR95

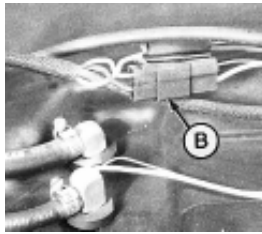

M49016 -UN-28APR95

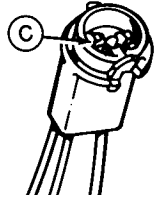

M78963 -UN-27APR95

Key switch OFF.

Remove fender deck to access low fuel sensor.

430 (S.N. —475000); Disconnect green/white wire (A) from low fuel sensor.

322/332 (All) and 430 (S.N. 475001— ); Disconnect low fuel sensor 2-pin connector (B).

Remove low fuel bulb socket from dash and remove bulb.

Check continuity between bulb socket contact with two wires (C) and ground.

*NOTE: Because this circuit contains a diode, there may be continuity to ground in one direction only.*

Reverse meter leads, then check continuity again.

**CONTINUITY:** Wire between sensor and lamp socket or wire between lamp socket and key switch is shorted to ground. Repair or replace wire, then GO TO ; , Group 05.

**NO CONTINUITY:** Circuit is OK.

MX,159124020,25-19-13JUL95

Electrical System Diagnosis/Dash Lamp Circuit Tests

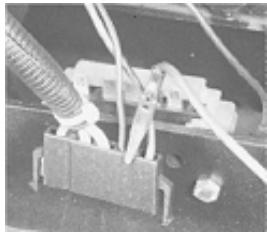
<p><b>1o Battery Discharge Lamp Test—322, 330 and 332</b></p>	<p>Check 10 amp fuse.</p> <p><i>NOTE: If discharge stays on at all times, test voltage output of charging system. GO TO 0, Group 25.</i></p>	 <p>M45179 -UN-08JAN90</p> <p>Disconnect regulator/rectifier connector.</p> <p>Connect jumper wire from brown lead in connector to positive (+) battery terminal.</p> <p><i>LOOK: Discharge lamp must come ON.</i></p>	<p><b>OK:</b> Verify good ground at black wire terminal of regulator/rectifier. Turn key switch ON/RUN to check for voltage at green wire terminal of regulator/rectifier connector. If voltage and ground OK, replace regulator/rectifier.</p> <p><b>NOT OK:</b> Brown wire between regulator/rectifier and lamp socket is open or black wire between discharge lamp socket and ground is open or has bad ground connection. Repair or replace as necessary, then GO TO ; , Group 05.</p>
---	--	---	--

MX,159124020,26-19-13JUL95

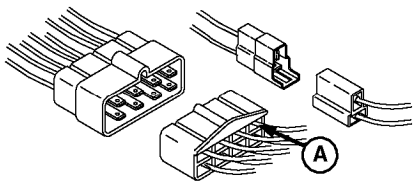
<p><b>1p Battery Discharge Lamp Test—430</b></p> <p>Check 10 amp fuse.</p> <p><i>NOTE: If discharge lamp stays on at all times, GO TO 1s</i></p>	 <p>M36634 -UN-09JUN95</p>	<p>Connect a jumper wire from brown wire (A) to ground.</p> <p>Turn key switch to ON/RUN position.</p> <p><i>LOOK: Discharge lamp must come ON.</i></p>	<p><b>OK:</b> GO TO 1q</p> <p><b>NOT OK:</b> GO TO 1r</p>
--	---	---	---

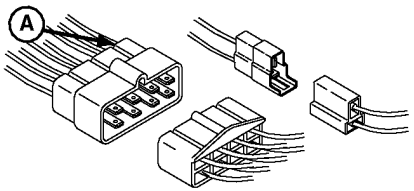

MX,159124020,27-19-13JUL95

<p><b>1q Battery Discharge Lamp Ground Circuit Test—430</b></p>	 <p>M78975 -UN-09JUN95</p>	<p>Key switch OFF.</p> <p>Check continuity between terminal with brown wire (A) (TDC side of 8-pin connector) and ground.</p>	<p><b>CONTINUITY:</b> Circuit OK.</p> <p><b>NO CONTINUITY:</b> Disconnect 2-pin connector and check continuity between terminal with black wire (harness side of connector) and ground.</p> <p><b>CONTINUITY:</b> Replace TDC module, then GO TO ; , Group 05.</p> <p><b>NO CONTINUITY:</b> Repair or replace black wire, then GO TO ; , Group 05.</p>
---	---	---	--

MX,159124020,28-19-13JUL95

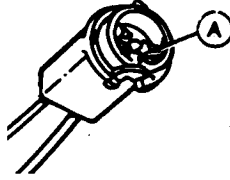
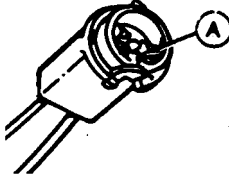

240  
20  
14

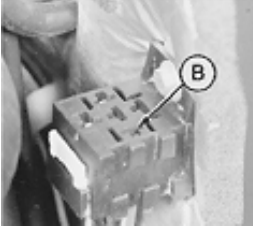
Electrical System Diagnosis/Dash Lamp Circuit Tests

<p><b>1r Battery Discharge Lamp Voltage Test—430</b></p>	 <p>M36635 -UN-24APR89</p>	<p>Remove battery discharge bulb socket from dash.</p> <p>Remove bulb.</p> <p>Turn key switch to ON/RUN position.</p> <p>Check for voltage at terminal with single yellow wire (A).</p>	<p>VOLTAGE: Circuit OK. Replace bulb.</p> <p>NO VOLTAGE: Yellow wire between 10-amp fuse and lamp socket is open. Repair or replace wire, then GO TO ; , Group 05.</p> <p>MX,159124020,29-19-13JUL95</p>
<p><b>1S Battery Discharge Lamp Short Circuit Test—430</b></p>	<p>Key switch OFF.</p>	 <p>M36635 -UN-24APR89</p> <p>Remove battery discharge bulb socket from dash.</p> <p>Remove bulb.</p> <p>(S.N. —420468); Disconnect TDC module 8-pin connector.</p> <p>(S.N. 420469— ); Disconnect 2-pin connector from alternator.</p> <p>Check continuity between terminal with brown wire (A) and ground.</p>	<p>CONTINUITY: Brown wire is shorted to ground. Repair or replace wire, then GO TO ; , Group 05.</p> <p>NO CONTINUITY: Circuit OK. Test voltage output of charging circuit; GO TO 5d, Group 25.</p> <p>MX,159124020,30-19-13JUL95</p>
<p><b>1t Engine Preheat Lamp Test (330, 332, 430)</b></p> <p>NOTE: If lamp stays on at all times, GO TO 1v</p>	<p>Check 10-amp fuse.</p> <p>Remove left engine side panel.</p>	 <p>M55103 -UN-09DEC89</p>  <p>M36609 -UN-25JAN90</p> <p>Remove glow plug controller (A).</p> <p>Connect jumper wire from grey lead wire terminal (B) of connector to ground.</p> <p>LOOK: Engine preheat lamp must come ON.</p>	<p>OK: GO TO Å</p> <p>NOT OK: Check bulb, then GO TO 1u</p> <p>MX,159124020,31-19-13JUL95</p>

240  
20  
15

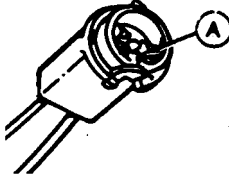

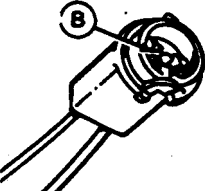
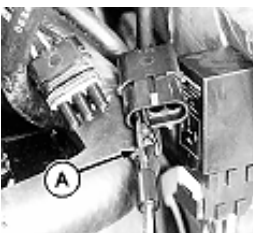
*Electrical System Diagnosis/Dash Lamp Circuit Tests*

<p><b>1U Engine Preheat Lamp Circuit Test (330, 332, 430)</b></p>	<p>Remove bulb socket from dash.</p> <p>Remove bulb.</p> <p>Turn key switch to ON/RUN position.</p>	 <p>M36635 -UN-24APR89</p>	<p>Check for voltage at terminal with yellow lead (A).</p>	<p><b>VOLTAGE:</b> Repair or replace grey wire to glow plug controller socket, then GO TO ; , Group 05.</p> <p><b>NO VOLTAGE:</b> Repair or replace wire between 10-amp fuse and bulb socket, then GO TO ; , Group 05.</p>
<p><b>1V Engine Preheat Lamp Short Circuit Test (330, 332, 430)</b></p>	<p>Key switch OFF.</p>	 <p>M55103 -UN-09DEC89</p>  <p>M36637 -UN-24APR89</p>	<p>Remove glow plug controller (A).</p> <p>Remove bulb socket from dash. Remove bulb.</p> <p>Check for continuity between terminal with grey lead (B) and ground.</p>	<p><b>CONTINUITY:</b> Grey lead to controller is shorted. Repair or replace as necessary, then GO TO ; Group 05.</p> <p><b>NO CONTINUITY:</b> Install controller and lamp socket, then GO TO A</p>
<p><b>1W Water-In-Fuel Lamp Test (430)</b></p> <p>If lamp stays on at all times, GO TO 1x a</p>	<p>Remove left engine side panel.</p> <p>Turn key switch to RUN position.</p>	 <p>M36605 -UN-12APR95</p>	<p>Disconnect 3-pin connector at fuel filter base.</p> <p>Connect a jumper wire (A) from yellow/black wire to ground.</p> <p><i>LOOK: Water-in-fuel lamp must come ON.</i></p>	<p><b>OK:</b> GO TO 1z</p> <p><b>NOT OK:</b> Check bulb, then GO TO 1x</p>

240  
20  
16

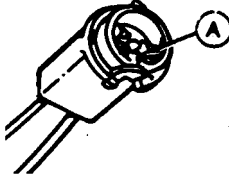
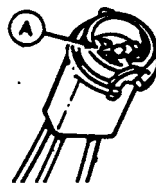

*Electrical System Diagnosis/Dash Lamp Circuit Tests*

<p><b>1X Water-In-Fuel Lamp Circuit Test (430)</b></p>	<p>Remove water-in-fuel bulb socket from dash.</p> <p>Remove bulb.</p> <p>Turn key switch to RUN position.</p>	 <p>M36635 -UN-24APR89</p>	<p>Check for voltage at terminal with yellow wire (A).</p>	<p><b>VOLTAGE:</b> Repair or replace yellow/black wire between bulb socket and sensor connector, then GO TO ; , Group 05.</p> <p><b>NO VOLTAGE:</b> For (S.N. —420468); Repair or replace wire between 10-amp fuse and bulb socket, then GO TO ; , Group 05.</p> <p>For (S.N. 420469— ); GO TO 1y</p> <p align="right">MX,159124020,35-19-13JUL95</p>
<p><b>1y Water-In-Fuel Lamp Circuit Test—Continued (430)</b></p>	<p>Remove engine oil pressure bulb socket from dash.</p> <p>Remove bulb.</p> <p>Turn key switch to RUN position.</p>	 <p>M36632 -UN-26AUG88</p>	<p>Check for voltage at oil pressure socket terminal with two yellow wires (A).</p>	<p><b>VOLTAGE:</b> Repair or replace yellow wire between water-in-fuel bulb socket and oil pressure bulb socket, then GO TO ; , Group 05.</p> <p><b>NO VOLTAGE:</b> Repair or replace wire between 10-amp fuse and oil pressure bulb socket, then GO TO ; , Group 05.</p> <p align="right">MX,15912402035A-19-13JUL95</p>
<p><b>1Z Water-In-Fuel Sensor Circuit Test (430)</b></p>	<p>Remove left engine side panel.</p> <p>Turn key switch to RUN position.</p>	 <p>M36606 -UN-12APR95</p>	<p>Check for voltage at yellow wire of 3-pin sensor connector.</p>	<p><b>VOLTAGE:</b> Test water-in-fuel sensor, GO TO ; , Group 25.</p> <p><b>NO VOLTAGE:</b> Repair or replace wire between 10-amp fuse and 3-pin connector, then GO TO ; , Group 05.</p> <p align="right">MX,159124020,36-19-13JUL95</p>

Electrical System Diagnosis/PTO Clutch and Lamp Circuit Tests

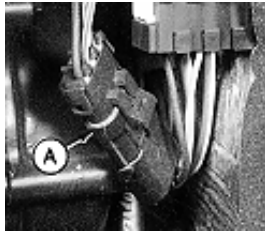
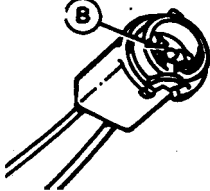
<p>1x a <b>Water-In-Fuel Lamp Short Circuit Test (430)</b></p>	<p>Key switch OFF.</p>	 <p>M36607 -UN-12APR95</p>  <p>M36637 -UN-24APR89</p>	<p>Disconnect 3-pin connector (A) at fuel filter base.</p> <p>Remove bulb socket from dash.</p> <p>Remove bulb.</p> <p>Check for continuity between terminal with yellow/black wire (B) and ground.</p>	<p>CONTINUITY; Yellow/black wire is shorted to ground. Repair or replace as needed, then GO TO ; , Group 05.</p> <p>NO CONTINUITY: Circuit OK. Test sensor, GO TO ; , Group 25.</p>
--	------------------------	---	---	---

MX,159124020,37-19-13JUL95

<p><b>' PTO CLUTCH AND LAMP CIRCUIT TESTS</b></p> <p>Check 10-amp and 25-amp fuses.</p>	<p>Listed at right are symptoms that may occur if the PTO clutch circuit malfunctions. Locate the symptom that applies, then proceed to the appropriate test.</p>	<p><b>IMPORTANT: Test battery and verify system ground connections before testing PTO circuit. (See A and B at the beginning of this group.)</b></p>	<p>PTO CLUTCH CIRCUIT SYMPTOMS:</p> <ul style="list-style-type: none"> <li>—PTO Lamp Does Not Come On, But Clutch Engages: GO TO 2a</li> <li>—PTO Lamp Burns Out Frequently: GO TO 2b</li> <li>—PTO Lamp Comes On, But Clutch Doesn't Engage: GO TO 2c</li> <li>—PTO Lamp Does Not Come On And Clutch Doesn't Engage: GO TO 2d</li> <li>—PTO Doesn't Disengage When Operator Raises From Seat For One Second Or Longer: GO TO 2k</li> <li>—PTO Clutch Slips: GO TO ' , Group 25.</li> </ul>
---	---	--	---

MX,159124020,93-19-13JUL95

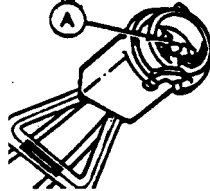
<p>2a <b>PTO Lamp Test</b></p>	<p>Remove PTO lamp socket from dash.</p> <p>Remove and check bulb. Replace as necessary.</p>	 <p>M36643 -UN-29AUG88</p>	<p>If bulb is OK, check for continuity between terminal with black lead (A) and ground.</p>	<p>NO CONTINUITY: Repair or replace ground wire as needed.</p> <p>CONTINUITY: Repair or replace blue wire between PTO switch and bulb socket.</p>
--------------------------------	--	---	---	---

MX,159124020,94-19-13JUL95

*Electrical System Diagnosis/PTO Clutch and Lamp Circuit Tests*

<p><b>2b PTO Lamp Diode Test</b></p> <p><i>NOTE: Diodes are designed to allow current flow in one direction only.</i></p>	<p>Remove dash lamp socket. Remove bulb.</p>	<p>Check diode with ohmmeter or continuity tester. If using a digital meter, use the DIODE CHECK position on meter.</p>	<p>Check for continuity across terminals of bulb socket. Reverse leads and check again.</p> <p><i>LOOK: There should be continuity in one direction only.</i></p>	<p>CONTINUITY ONE DIRECTION ONLY: Circuit probably has an intermittent short. Check all connections and grounds.</p> <p>CONTINUITY BOTH DIRECTIONS OR NO CONTINUITY: Replace diode, then GO TO ' , Group 05.</p> <p align="right">MX,159124020,95-19-13JUL95</p>
---	--	---	---	--

<p><b>2C PTO Clutch Test</b></p>	<p><i>NOTE: To test the optional rear PTO clutch, remove fender deck and raise fuel tank off frame. Disconnect the rear PTO clutch wire connector located along left side of rear machine frame, then follow same test procedure used for front PTO clutch.</i></p>	
----------------------------------	---	--

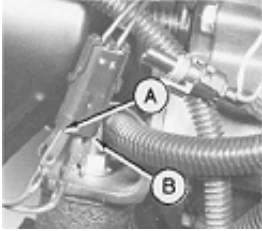
 <p>M45186 -UN-08JAN90</p>	<p><i>NOTE: 322 (All) and 332/430 (S.N. 475001— ) use a 2-pin connector for the PTO clutch.</i></p> <p><i>330 and 332/430 (S.N. —475000); A 1-pin connector is used. The clutch ground wire connects directly to the machine frame.</i></p> <p>Disconnect PTO clutch wire connector.</p> <p>322 (All) and 332/430 (S.N. 475001— ); Connect one end of a jumper wire to terminal (B) (black wire) at clutch connector and the other end to ground.</p> <p>All machines; Connect one end of a jumper wire to battery positive (+) terminal and the other end to terminal (A) (blue wire) at clutch connector.</p>	<p><b>CLUTCH ENGAGES:</b>          330 and 332/430 (S.N. —475000); Blue wire between PTO switch and PTO clutch is open. Repair or replace wire, then GO TO ' , Group 05.</p> <p>322 (All) and 332/430 (S.N. 475001— ); Verify ground at black wire (harness side) of 2-pin connector. If ground OK, blue wire between PTO switch and PTO clutch is open. Repair or replace wire, then GO TO ' , Group 05.</p> <p><b>CLUTCH DOES NOT ENGAGE:</b>          322 (All) and 332/430 (S.N. 475001— ); Repair clutch. GO TO Section 40.</p> <p>330 and 332/430 (S.N. —475000); Check for good ground. If ground OK, repair clutch. GO TO Section 40.</p> <p align="right">MX,159124020,96-19-13JUL95</p>
---	---	---

Electrical System Diagnosis/PTO Clutch and Lamp Circuit Tests

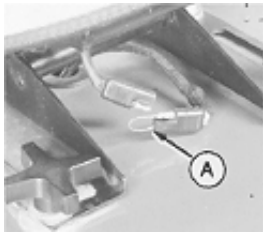
<p><b>2d PTO Clutch Circuit Test</b></p>	 <p>M36627 -UN-25JAN90</p>	<p>Install jumper wire (A) across seat switch connector (harness side of connector).</p> <p><i>NOTE: Seat switch for 330 and 332/430 (S.N. —475000) shown.</i></p>	<p>Turn key switch to ON/RUN position.</p> <p>Move PTO switch to ON position.</p> <p><i>LOOK/LISTEN: PTO lamp must come ON. Clutch must “click” to engage.</i></p>	<p><b>OK:</b> Replace seat switch, then GO TO ' , Group 05.</p> <p><b>NOT OK:</b> GO TO 2e</p>
--	---	--	--	--

MX,159124020,97-19-13JUL95

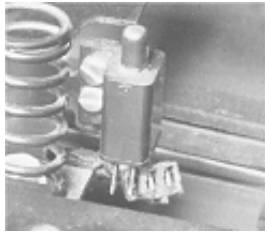
<p><b>2e Voltage Test At Seat Connector</b></p>	<p>Turn key switch to ON/RUN position.</p>	 <p>M45187 -UN-08JAN90</p>	<p><i>NOTE: Seat switch for 322 (All) and 332/430 (S.N. 475001— ) shown.</i></p> <p>Check for voltage at seat connector.</p>	<p><b>VOLTAGE:</b> 322, 330 and 430 (S.N. —420468), GO TO 2f</p> <p>332 (All) and 430 (S.N. 420469— ), GO TO 2g</p> <p><b>NO VOLTAGE:</b> Pink wire between seat switch connector and 10-amp fuse is open. Repair or replace wire as necessary, then GO TO ' , Group 05.</p>
---	--	--	--	--

MX,159124020,98-19-13JUL95

<p><b>2f PTO Circuit Voltage Test At TDC Module—322, 330 and 430 (SN —420468)</b></p> <p><i>NOTE: Perform all continuity and voltage tests before going to the result column.</i></p>	<p><i>Check both sides of connector when testing for voltage and continuity. If test OK at only one side of connector, repair or replace connector as needed.</i></p>	<p><b>Continued on next page</b></p>
---	---	--------------------------------------

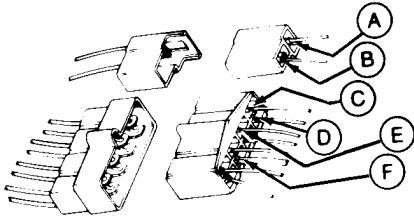

M36645 -UN-28APR95

PTO switch OFF.

Key switch OFF.

Install jumper wire across harness side of seat switch connector.

At TDC Module 2-pin connector:

- Check for continuity between terminal with black wire (B) and ground.
- Turn key switch to ON/RUN position.
- Check for voltage at terminal with pink wire (A).

At TDC Module 8-pin connector:

- Check for voltage at terminal with purple/white wire (F).
- Check for voltage at terminal with pink wire (E) (yellow/black wire, 322).
- Check for voltage at terminal with blue wire (C).

*NOTE: For machines equipped with optional rear PTO (except 322), Check for voltage at terminal with blue wire (D).*

CONTINUITY AND VOLTAGE OK: GO TO 2j

NO CONTINUITY BETWEEN TERMINAL (B) AND GROUND: Black wire between TDC 2-pin connector and ground is open. Repair or replace wire as necessary, then GO TO ' , Group 05.

NO VOLTAGE AT TERMINAL (A): Pink wire between TDC 2-pin connector and seat switch connector is open. Repair or replace wire as necessary, then GO TO ' , Group 05.

NO VOLTAGE AT TERMINAL (F): GO TO 2h

NO VOLTAGE AT TERMINAL (E): Wire between 8-pin connector and 25-amp fuse is open. Repair or replace wire, then GO TO ' , Group 05.

NO VOLTAGE AT TERMINALS (C) OR (D) WHEN ALL OTHER TERMINALS TEST OK: Replace TDC module.

MX,159124020,99-19-13JUL95

**2g** PTO Circuit  
Voltage Test At  
TDC Module—332  
(All) and  
430 (SN 420469— )

*Check both sides of connector when testing for voltage and continuity. If test OK at only one side of connector, repair or replace connector as needed.*

*NOTE: Perform all voltage and continuity tests before going to the result column.*

Continued on next page

240  
20  
21



M49012 -UN-08JAN90

PTO switch OFF.  
 Key switch OFF.  
 Install jumper wire across harness side of seat switch connector.  
 At TDC Module 3-pin connector:  
 —Check for continuity of black wire between terminal “B” of connector and ground.  
 —Turn key switch to ON/RUN position.  
 —Check for voltage at pink wire at terminal “A” of connector.  
 At TDC Module 6-pin connector (A):  
 —Check for voltage at purple/white wire at terminal “B” of connector.  
 —Check for voltage at blue wire at terminal “D” of connector.

CONTINUITY AND VOLTAGE OK: GO TO 2j  
 NO CONTINUITY BETWEEN TERMINAL “B” OF 3-PIN CONNECTOR AND GROUND: Black wire between connector and ground is open. Repair or replace wire as necessary, then GO TO ‘ , Group 05.  
 NO VOLTAGE AT TERMINAL “A” OF 3-PIN CONNECTOR: Pink wire between connector and seat switch connector is open. Repair or replace wire as necessary, then GO TO ‘ , Group 05.  
 NO VOLTAGE AT TERMINAL “B” OF 6-PIN CONNECTOR: GO TO 2h  
 NO VOLTAGE AT TERMINAL “D” OF 6-PIN CONNECTOR WHEN ALL OTHER TERMINALS TEST OK: Replace TDC module.

MX,159124020100-19-13JUL95

**2h Neutral Start Circuit Voltage Test At Rear PTO Switch**

*NOTE: This test is for machines equipped with the optional rear PTO. If machine is equipped with front PTO only, GO TO 2i .*

PTO switches OFF.  
 Turn key switch to ON/RUN position.

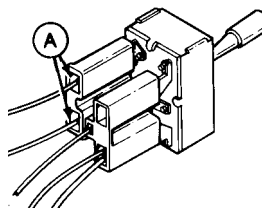

M36642 -UN-28APR95

Check for voltage at terminals with purple wires (A) on rear PTO switch.

VOLTAGE AT BOTH TERMINALS:  
 Purple/white wire between TDC 8-pin connector and rear PTO harness 3-pin connector or purple wire between rear PTO harness 3-pin connector rear PTO switch is open. Repair or replace as necessary, then GO TO ‘ , Group 05.  
 VOLTAGE AT ONE TERMINAL: Replace switch, then GO TO ‘ , Group 05.  
 NO VOLTAGE AT BOTH TERMINALS: GO TO 2i

MX,159124020101-19-13JUL95

240  
20  
22

Electrical System Diagnosis/PTO Clutch and Lamp Circuit Tests

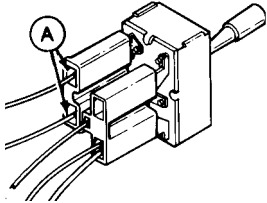
<p><b>2i Neutral Start Circuit Voltage Test At Front PTO Switch</b></p>	<p>PTO switch OFF. Turn key switch to ON/RUN position.</p>	<p>Check for voltage at terminals with purple wires (A) on front PTO switch.</p>  <p>M36642 -UN-28APR95</p> <p style="text-align: right;">MX,159124020102-19-13JUL95</p>
---	--	---

 <p>M36624 -UN-25JAN90</p>	<p><i>NOTE: For machines not equipped with the optional rear PTO, a jumper wire located at rear PTO harness connector (A) is used to complete the circuit to the transmission neutral start switch.</i></p>	<p><b>VOLTAGE AT BOTH TERMINALS:</b> For machines equipped with optional rear PTO, purple wire or rear PTO harness 3-pin connector between rear PTO switch and front PTO switch is open. Repair or replace as necessary, then GO TO ' , Group 05.</p> <p>For machines equipped with front PTO only, purple/white wire, or purple wire, or 3-pin connector with jumper wire (A) between TDC 8-pin connector and front PTO switch is open. Repair or replace as necessary, then GO TO ' , Group 05.</p> <p><b>VOLTAGE AT ONLY ONE TERMINAL:</b> Replace switch, then</p> <p>GO TO ' , Group 05.</p> <p><b>NO VOLTAGE AT EITHER TERMINAL:</b> Wire between front PTO switch and 25-amp fuse is open. Repair or replace wire as necessary, then GO TO ' , Group 05.</p> <p style="text-align: right;">MX,159124020108-19-13JUL95</p>
---	---	--

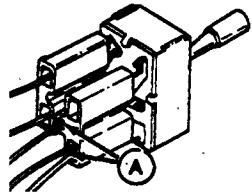
<p><b>2j PTO Circuit Voltage Test At PTO Switch</b></p>	 <p>M36646 -UN-24APR89</p>	<p>Install jumper wire across harness side of seat switch connector.</p> <p>Turn key switch to ON/RUN position.</p> <p>Move PTO switch to ON position.</p> <p>Check for voltage at both terminals with blue wires (A) on PTO switch.</p> <p><b>VOLTAGE AT ONE TERMINAL:</b> Replace PTO switch.</p> <p><b>VOLTAGE AT BOTH TERMINALS:</b> Repair or replace wires between PTO switch and clutch and/or PTO switch and lamp.</p> <p style="text-align: right;">MX,159124020103-19-13JUL95</p>
---	---	---

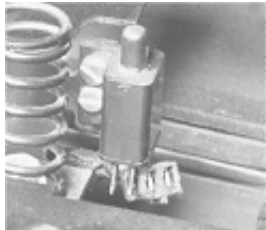
<p><b>2k Seat Switch Test</b></p>	 <p>M45187 -UN-08JAN90</p>	<p><i>NOTE: Seat switch for 322 and 332/430 (S.N. 475001— ) shown.</i></p> <p>There should NOT be continuity.</p> <p>Key switch OFF.</p> <p>Disconnect seat switch connector.</p> <p>Connect ohmmeter or continuity tester across switch terminals.</p> <p style="text-align: right;"><b>Continued on next page</b></p>
-----------------------------------	---	---

Electrical System Diagnosis/Starting Circuit Tests

Press down on seat switch button.

There should be continuity.

**OK:** Connect seat switch connector.

**NOT OK:** Replace switch, then GO TO 2a, Group 05.

MX,159124020104-19-13JUL95

**A STARTING CIRCUIT TESTS**

Listed at right are symptoms that may occur in a malfunctioning starting circuit. Locate the symptom that applies, then proceed to the appropriate test.

**IMPORTANT: Test battery and verify grounds before testing starting circuit. (See steps A and B at the beginning of this group.)**

**STARTING CIRCUIT SYMPTOMS:**

- Starter Operates, But Doesn't Crank Engine: Repair starter. (See CTM3 or CTM12.)
- Solenoid Doesn't Click, Starter Doesn't Operate:  
322, 330 and 332, GO TO 3a  
430, GO TO 3b
- Solenoid Clicks, Starter Doesn't Operate: GO TO 3c
- Starter Cranks Engine Slowly Or Erratically: GO TO 3d, Group 25.

MX,159124020,61-19-13JUL95

**3a Starter Test—322, 330 and 332**



M45190 -UN-08JAN90



M55022 -UN-09DEC89

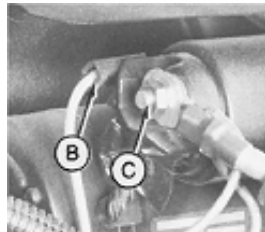

M45191 -UN-08JAN90

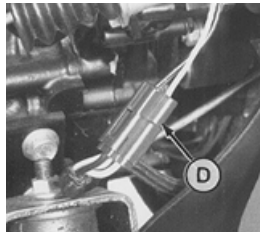

M45234 -UN-10JUL95

Key switch OFF.

PTO switch OFF.

Hydrostatic lever in N/STOP position.

Engage park brake.

322; Disconnect ignition coil 6-pin connector (A).

330; Pull fuel stop knob all the way out.

332; Disconnect fuel shutoff solenoid connector (D).

Disconnect purple wire (B) from starter solenoid. Connect jumper wire to terminal.

Briefly jump across to large starter terminal (C).

*LISTEN: Starter must run.*

**OK:** GO TO 3d

**NOT OK:** GO TO 3c



Connect wires after testing.

MX,159124020,62-19-13JUL95

240  
20  
24

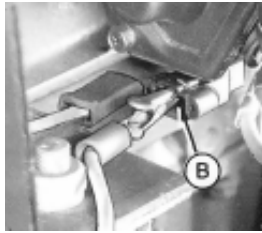

Electrical System Diagnosis/Starting Circuit Tests

<p><b>3b Starter Test—430</b></p>	<p>Key switch OFF. PTO switch OFF. Hydrostatic lever in N/STOP position. Park brake engaged.</p>	 <p>M36602 -UN-12APR95</p>  <p>M36630 -UN-27APR95</p>	<p><i>NOTE: 430 (S.N. —420468) shown.</i></p> <p>430 (S.N. 420469— ); <i>The fuel shutoff solenoid uses a 3-pin connector.</i></p> <p>Disconnect red wire (A) or 3-Pin connector from fuel shutoff solenoid.</p> <p>Disconnect purple wire from starter solenoid. Connect jumper wire (B) to terminal.</p> <p>Briefly jump across to large starter terminal.</p> <p><i>LISTEN: Starter must run.</i></p>	<p><b>OK:</b> GO TO 3d</p> <p><b>NOT OK:</b> GO TO 3c</p> <p>Connect wires after testing.</p> <p style="text-align: right;">MX,159124020,63-19-13JUL95</p>
<p><b>3c Starter Solenoid Test</b></p>	<p>Key switch OFF. PTO switch OFF. Hydrostatic lever in N/STOP position. Park brake engaged.</p>	 <p>M45192 -UN-08JAN90</p>	<p>322; Ignition coil 6-pin connector disconnected.</p> <p>330; Fuel stop knob all the way out.</p> <p>332 and 430; Fuel shutoff solenoid connector disconnected.</p> <p>Briefly jump between two large starter terminals (A).</p> <p><i>LISTEN: Starter must run.</i></p>	<p><b>OK:</b> Replace solenoid.</p> <p><b>NOT OK:</b> Check battery and starter wiring connections. If OK, repair starter. (See CTM3 or CTM12.)</p> <p style="text-align: right;">MX,159124020,64-19-13JUL95</p>

240  
20  
25

Electrical System Diagnosis/Starting Circuit Tests

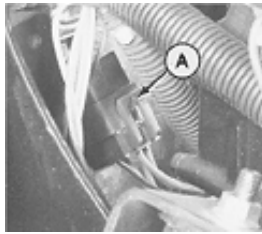
<p><b>3d Neutral Start Circuit Test at Neutral Start Relay</b></p>	<p>PTO switch OFF.</p> <p>Hydrostatic lever in N/STOP position.</p> <p>Later Models; Engage park brake.</p> <p>332 and 430; Disconnect the fuel shutoff solenoid connector.</p>	 <p>M45196 -UN-08JAN90</p>	<p>Put hand on neutral start relay (A).</p> <p>Turn key switch to ON/RUN position.</p> <p><i>LISTEN/FEEL: Neutral start relay must "click".</i></p>	<p><b>OK:</b> GO TO 3n</p> <p><b>NOT OK:</b> For machines: 322 (S.N. 596006— ) 332 (S.N. 475001— ) 430 (S.N. 596048— ), GO TO 3e</p> <p>For machines: 330 430 (S.N. —420468), GO TO 3g</p> <p>For machines: 322 (S.N. —596005) 332 (S.N. —475000) 430 (S.N. 420469— 596047), GO TO 3h</p> <p>Connect shutoff solenoid connector after test.</p> <p style="text-align: right;">MX,159124020,65-19-13JUL95</p>
--	---	---	---	--

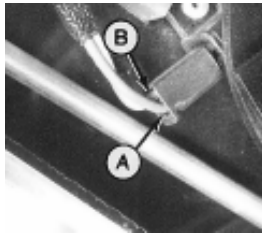
<p><b>3e Neutral Start Circuit Test at Brake Switch</b> 322 (SN 596006— ) 332 (SN 475001— ) 430 (SN 596048— )</p>	<p>PTO switch OFF.</p> <p>Hydrostatic lever in N/STOP position.</p> <p>Park brake engaged.</p>	 <p>M77931 -UN-17JAN95</p>	<p>Turn key switch to ON/RUN position.</p> <p>Check for voltage at terminal with purple wire (A).</p>	<p><b>VOLTAGE:</b> Purple wire between brake switch and neutral start relay is open. Repair or replace wire as necessary, then GO TO Æ, Group 05.</p> <p><b>NO VOLTAGE AT (A):</b> Check for voltage at terminal (B).</p> <p><b>VOLTAGE:</b> GO TO 3f</p> <p><b>NO VOLTAGE:</b> GO TO 3h</p> <p style="text-align: right;">MX,159124020,66-19-13JUL95</p>
---	--	---	---	---

Electrical System Diagnosis/Starting Circuit Tests

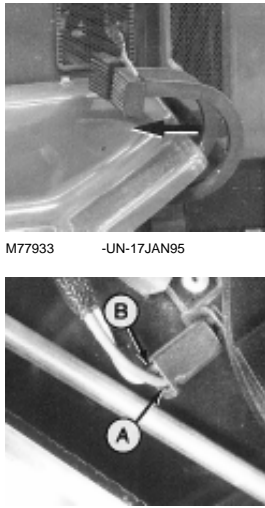
<p><b>3f Brake Switch Test</b>                  322 (SN 596006— )                  332 (SN 475001— )                  430 (SN 596048— )</p>	<p>PTO switch OFF.                  Hydrostatic lever in N/STOP position.</p>	 <p>M77933 -UN-17JAN95                  M77931 -UN-17JAN95</p>	<p>Release brake pedal completely.                  Turn key switch to ON/RUN position.                  Check for voltage at purple lead (A).</p>	<p><b>VOLTAGE:</b> Check for proper switch engagement. If OK; replace switch, then GO TO <math>\bar{E}</math>, Group 05.</p> <p><i>NOTE: Brake switch engagement can be adjusted by slightly bending the engagement pad that's welded on the brake linkage shaft. Check for proper brake adjustment before bending the tab. (See Section 60, Group 10.)</i></p> <p>MX,159124020,67-19-13JUL95</p>
---	---	---	--	---

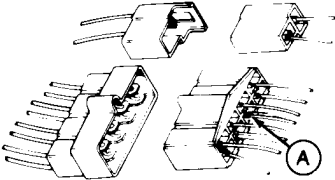
<p><b>3g Neutral Start Circuit Test at TDC 8-Pin Connector</b>                  330 and                  430 (SN —420468)</p>	 <p>M36641 -UN-13APR95</p>	<p>PTO switch OFF.                  Hydrostatic lever in N/STOP position.                  Turn key switch to ON/RUN position.</p> <p><i>NOTE: It is not necessary to disconnect the TDC module 8-pin connector for this test.</i></p> <p><i>Make sure both purple wires are attached securely to connector terminal.</i></p> <p>Check for voltage at the TDC 8-pin connector at terminal with two purple wires (A).</p>	<p><b>VOLTAGE:</b> Purple wire between TDC module 8-pin connector and neutral start relay is open. Repair or replace wire as necessary, then GO TO <math>\bar{E}</math>, Group 05.</p> <p><b>NO VOLTAGE:</b> GO TO 3h</p> <p>MX,159124020,68-19-13JUL95</p>
---	---	--	---

<p><b>3h Neutral Start Circuit Test at Transmission Switch</b></p>	<p>PTO switch OFF.                  Hydrostatic lever in N/STOP position.                  Turn key switch to ON/RUN position.</p>	<p>Continued on next page</p>
--	--	-------------------------------

Electrical System Diagnosis/Starting Circuit Tests

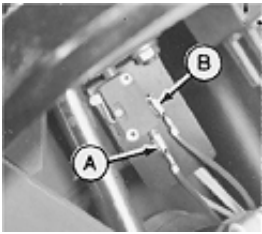
 <p>M36623 -UN-25JAN90</p>	<p>Check voltage at terminal (A).</p> <p><b>VOLTAGE:</b> 322 (S.N. —596005), 332 (S.N. —475000), and 430 (S.N. 420469—596047) ; Voltage at (A) indicates either a faulty neutral start relay, poor relay ground, or the wire between the transmission neutral start switch and neutral start relay is open. Repair or replace as necessary, then GO TO <math>\bar{E}</math>, Group 05.</p> <p>330 and 430 (S.N. —420468); Voltage at (A) indicates purple wire between TDC module 8-pin connector and transmission neutral start switch is open. Repair or replace wire as necessary, then GO TO <math>\bar{E}</math>, Group 05.</p>	<p>322 (S.N. 596006— ), 332 (S.N. 475001— ), and 430 (S.N. 596048— ); Voltage at (A) indicates purple/white wire between brake switch and transmission neutral start switch is open. Repair or replace wire as necessary, then GO TO <math>\bar{E}</math>, Group 05.</p> <p><b>NO VOLTAGE:</b> Check for voltage at (B).</p>	<p><b>VOLTAGE AT (B):</b> GO TO 3i</p> <p><b>NO VOLTAGE:</b> GO TO 3j</p> <p><i>NOTE: To test the neutral start relay; GO TO <math>\bar{E}</math>, Group 25.</i></p> <p>MX,159124020,69-19-13JUL95</p>
---	--	--	--

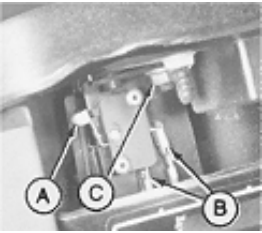
<p><b>3i Transmission Switch Test</b></p>	<p>Key switch OFF.</p> <p>Put hydrostatic lever in REVERSE position.</p>	 <p>M45195 -UN-08JAN90</p> <p>With arm (A) fully released, check for continuity across terminals (B).</p>	<p><b>CONTINUITY:</b> Replace switch.</p> <p><b>NO CONTINUITY:</b> Push switch arm (A) fully in. Check for continuity across terminals (B) again.</p> <p><b>NO CONTINUITY:</b> Replace switch.</p> <p><b>CONTINUITY:</b> Adjust switch. GO TO 3j</p> <p>MX,159124020,70-19-13JUL95</p>
---	--	---	--

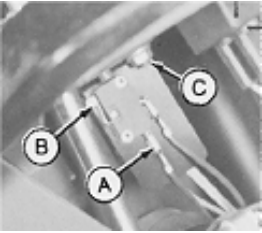
<p><b>3j Transmission Switch Adjustment</b></p>	<p>Key switch OFF.</p> <p>Put hydrostatic lever in N/STOP position.</p>	 <p>M36647 -UN-25JAN90</p> <p><b>IMPORTANT: After tightening nut (C), make sure hydrostatic lever does not push switch arm (B) against switch body, otherwise, damage to switch may result.</b></p> <p>Loosen adjusting nut (C) and slide switch toward hydrostatic lever until switch closes. Tighten nut.</p>	<p>After replacing or adjusting switch; GO TO 3b, Group 05.</p> <p>MX,15912402070A-19-13JUL95</p>
---	---	--	---

240  
20  
28

Electrical System Diagnosis/Starting Circuit Tests

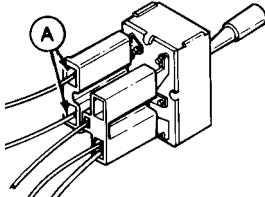
<p><b>3k Neutral Start Circuit Test At Rear PTO Switch</b></p> <p><i>NOTE: This test is for machines equipped with the optional rear PTO. If machine is equipped with front PTO only, GO TO 3l .</i></p>	<p>PTO switches OFF.</p> <p>Turn key switch to ON/RUN position.</p>	 <p>M36642 -UN-28APR95</p>	<p>Check for voltage at terminals with purple wires (A) on rear PTO switch.</p>	<p><b>VOLTAGE AT BOTH TERMINALS:</b> Purple wire between rear PTO switch and transmission neutral start switch or rear PTO harness 3-pin connector is open. Repair or replace as necessary, then GO TO Æ Group 05.</p> <p><b>VOLTAGE AT ONE TERMINAL:</b> Replace switch, then GO TO Æ Group 05.</p> <p><b>NO VOLTAGE AT BOTH TERMINALS:</b> GO TO 3l</p> <p>MX,159124020,71-19-13JUL95</p>
--	---	---	---	---

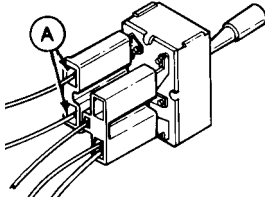
<p><b>3l Neutral Start Circuit Test At Front PTO Switch</b></p>	<p>PTO switch OFF.</p>	 <p>M36642 -UN-28APR95</p>	<p>Turn key switch to ON/RUN position.</p> <p>Check for voltage at terminals with purple wires (A) on front PTO switch.</p>	<p>MX,159124020,72-19-13JUL95</p>
---	------------------------	---	---	-----------------------------------

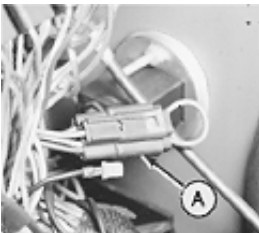
 <p>M36624 -UN-25JAN90</p>	<p><i>NOTE: For machines not equipped with the optional rear PTO, a jumper wire located at rear PTO harness connector (A) is used to complete the circuit to the transmission neutral start switch.</i></p>	<p><b>VOLTAGE AT BOTH TERMINALS:</b> For machines equipped with optional rear PTO, purple wire between rear PTO switch and front PTO switch is open. Repair or replace wire as necessary, then GO TO Æ Group 05.</p> <p>For machines equipped with front PTO only, purple wire between transmission neutral start switch and front PTO switch or connector with jumper wire (A) is open. Repair or replace wire as necessary, then GO TO Æ Group 05.</p> <p><b>VOLTAGE AT ONLY ONE TERMINAL:</b> Replace switch, then GO TO Æ Group 05.</p> <p><b>NO VOLTAGE AT EITHER TERMINAL:</b> Wire between front PTO switch and 25-amp fuse is open. Repair or replace as necessary, then GO TO Æ Group 05.</p> <p>MX,159124020109-19-13JUL95</p>
---	---	--

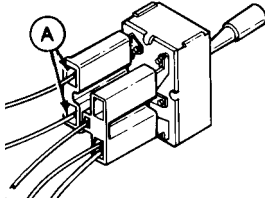
<p><b>3m PTO Switch Test</b></p>	<p>Turn key switch ON.</p> <p>Move PTO switch to ON position.</p>	 <p>M36642 -UN-28APR95</p>	<p>Check for voltage at terminals with purple wires (A).</p>	<p><b>VOLTAGE AT BOTH TERMINALS:</b> Replace switch, then GO TO 3c, Group 05.</p> <p><b>VOLTAGE AT ONE TERMINAL:</b> Switch OK.</p> <p>MX,159124020,73-19-13JUL95</p>
----------------------------------	---	---	--	---

Electrical System Diagnosis/Fuel Shutoff Solenoid Circuit Tests

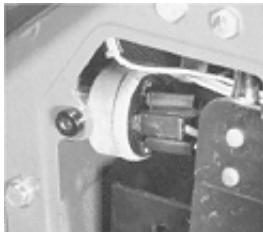
<p>3n Neutral Start Circuit Test At Key Switch</p>	 <p><i>NOTE: 332 shown in photo.</i></p> <p>Turn key switch to START position.</p> <p>322, 330 and 332; Check for voltage at key switch terminal "ST".</p> <p>430; Check voltage at key switch terminal "C".</p> <p>M49010 -UN-08JAN90</p>	<p>VOLTAGE: Purple wire between key switch and neutral start relay is open.</p> <p>NO VOLTAGE: Check key switch and fusible link.</p> <p>MX,159124020,74-19-13JUL95</p>
--	---	---

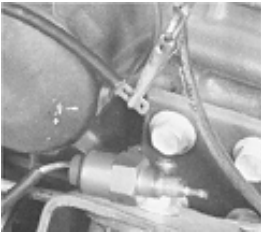

<p>Å FUEL SHUTOFF SOLENOID CIRCUIT TESTS</p>	<p>322; GO TO 4a</p> <p>332 (All) and 430 (S.N. 420469— ):          —If fuel shutoff solenoid doesn't "pull in";          GO TO 4c          —If fuel shutoff solenoid doesn't "hold in";          GO TO 4d</p> <p>430 (S.N. —420468); GO TO 4I</p> <p>MX,159124020,42-19-13JUL95</p>
--	--

<p>4a Fuel Shutoff Solenoid Test—322</p>	 <p>Key switch OFF.</p> <p>Disconnect ignition coil harness 6-pin connector.</p> <p>Connect one end of a jumper wire to terminal with red wire (A) on solenoid side of connector. Connect other end to positive (+) battery terminal.</p> <p><i>LISTEN: Solenoid (B) should "click".</i></p> <p>M45202 -UN-08JAN90</p> <p>M45203 -UN-08JAN90</p>	<p>OK: Solenoid OK, GO TO 7c</p> <p>NOT OK: GO TO 4b</p> <p>MX,159124020,43-19-13JUL95</p>
--	--	--



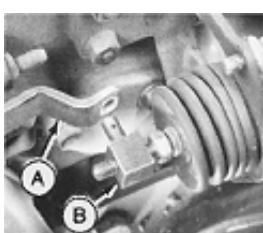

<p>4b Fuel Shutoff Solenoid Bench Test—322</p>	<p><b>CAUTION:</b>  <b>GASOLINE WILL DRAIN FROM CARBURETOR WHEN SOLENOID IS REMOVED. KEEP GAS AWAY FROM SPARKS, FLAME OR HOT ENGINE PARTS.</b></p>	 <p>Remove solenoid from carburetor.</p> <p>Connect one jumper wire from red wire on solenoid to battery positive (+) terminal and connect a second jumper wire from solenoid body to negative (—) terminal.</p> <p><i>LOOK: Solenoid should retract when connected to battery and extend when disconnected from battery.</i></p> <p>M45204 -UN-08JAN90</p>	<p>OK: Install solenoid, then GO TO 7c</p> <p>NOT OK: Replace solenoid, then GO TO Å, Group 05.</p> <p>MX,159124020,44-19-13JUL95</p>
--	--	--	---

240  
20  
30

Electrical System Diagnosis/Fuel Shutoff Solenoid Circuit Tests



<p><b>4c Fuel Shutoff Solenoid Pull-In Test</b> 332 (All) and 430 (SN 420469— )</p> <p><i>NOTE: If linkage is bent, binding or solenoid is being replaced GO TO <math>\hat{A}</math>, Group 25.</i></p>	 <p>M49008 -UN-08JAN90</p>	<p>Disconnect fuel shutoff solenoid connector.</p> <p>Connect one end of a jumper wire to black wire on solenoid side of the 3-pin connector. Connect other end to machine frame.</p> <p>Connect one end of a jumper wire to white lead on solenoid side of the 3-pin connector. Connect other end to positive (+) battery terminal.</p> <p><i>LOOK: Solenoid must retract.</i></p>	<p><b>OK:</b> Connect solenoid connector, then GO TO 4f</p> <p><b>NOT OK:</b> Replace solenoid.</p> <p>MX,159124020,45-19-13JUL95</p>
<p><b>4d Fuel Shutoff Solenoid Hold-In Test</b> 332 (All) and 430 (SN 420469— )</p> <p><i>NOTE: If linkage is bent, binding or solenoid is being replaced GO TO <math>\hat{A}</math>, Group 25.</i></p>	 <p>M49008 -UN-08JAN90</p>	<p>Disconnect fuel shutoff solenoid connector.</p> <p>Connect one end of a jumper wire to black wire on solenoid side of the 3-pin connector. Connect other end to machine frame.</p> <p>Connect one end of a jumper wire to red wire on solenoid side of the 3-pin connector. Connect other end to positive (+) battery terminal.</p> <p>Push solenoid arm in.</p> <p><i>LOOK: Solenoid must stay in.</i></p>	<p><b>OK:</b> GO TO 4f</p> <p><b>NOT OK:</b> GO TO 4e</p> <p>MX,159124020,46-19-13JUL95</p>
<p><b>4e Fuel Shutoff Solenoid Hold-In Test (Linkage Removed)</b> 332 (All) and 430 (SN 420469— )</p>	 <p>M43343 -UN-15JAN90</p>	<p>Disconnect fuel shutoff arm (A) from solenoid arm (B).</p> <p>Connect one end of a jumper wire to black wire on solenoid side of the 3-pin connector. Connect other end to machine frame.</p> <p>Connect one end of a jumper wire to red wire on solenoid side of the 3-pin connector. Connect other end to positive (+) battery terminal.</p> <p>Push solenoid arm in.</p> <p><i>LOOK: Solenoid must stay in.</i></p>	<p><b>OK:</b> Adjust solenoid linkage. GO TO <math>\hat{A}</math>, Group 25.</p> <p><b>NOT OK:</b> Replace solenoid.</p> <p>MX,159124020,47-19-13JUL95</p>

Electrical System Diagnosis/Fuel Shutoff Solenoid Circuit Tests

<p>4f Fuel Shutoff Solenoid Ground Test 332 (All) and 430 (SN 420469— )</p>	<p>Key switch OFF.</p>	 <p>M49008 -UN-08JAN90</p>	<p>Disconnect solenoid 3-pin connector.</p> <p>Check continuity between black wire on harness side of connector and ground.</p>	<p>CONTINUITY: —If testing “pull-in” circuit; GO TO 4g —If testing “hold-in” circuit; GO TO 4h</p> <p>NO CONTINUITY: Repair or replace black ground wire.</p> <p>MX,159124020,48-19-13JUL95</p>
<p>4g Fuel Shutoff Solenoid Pull-In Voltage Test at TDC Module 332 (All) and 430 (SN 420469— )</p>	<p>Key switch OFF.</p> <p>Install jumper wire across harness side of seat switch connector.</p>	 <p>M49012 -UN-08JAN90</p>	<p>Connect a voltmeter or test light to terminal “E” of TDC module 6-pin connector (A).</p> <p><i>NOTE: “E” is terminal with white wire on TDC side of connector.</i></p> <p>Turn key switch to ON/RUN position.</p> <p><i>LOOK: Voltage, then after 1 second, no voltage.</i></p>	<p>VOLTAGE (FOR 1 SECOND): Wire is open between TDC module and solenoid.</p> <p>NO VOLTAGE: GO TO 4h</p> <p>VOLTAGE FOR LESS THAN 1/2 SECOND OR MORE THAN 1 SECOND: Replace TDC module.</p> <p>MX,159124020,49-19-13JUL95</p>
<p>4h Fuel Shutoff Solenoid Hold-In Voltage Test at TDC Module 332 (All) and 430 (SN 420469— )</p>	<p>Install a jumper wire across harness side of seat switch connector.</p> <p>Turn key switch to ON/RUN position.</p>	 <p>M49012 -UN-08JAN90</p>	<p>Check for voltage at terminal “C” of TDC module 6-pin connector (A).</p> <p><i>NOTE: “C” is terminal with large pink wire on TDC side of connector.</i></p>	<p>VOLTAGE: Pink wire to solenoid connector is open.</p> <p>NO VOLTAGE: GO TO 4i</p> <p>MX,159124020,50-19-13JUL95</p>
<p>4i TDC Module Input (Pull-In) Voltage Test 332 (All) and 430 (SN 420469— )</p>	<p>Key switch OFF.</p>	 <p>M49012 -UN-08JAN90</p>	<p>Check for voltage at terminal “F” of TDC module 6-pin connector (A).</p> <p><i>NOTE: “F” is terminal with red wire on TDC side of connector.</i></p>	<p>NO VOLTAGE: Check fusible link at starter terminal.</p> <p>VOLTAGE: GO TO 4j</p> <p>MX,159124020,51-19-13JUL95</p>

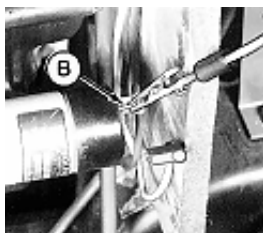

Electrical System Diagnosis/Fuel Shutoff Solenoid Circuit Tests

<p>4j <b>TDC Input (Interlock) Voltage Test</b> 332 (All) and 430 (SN 420469— )</p>	<p>PTO switch OFF.</p> <p>Hydrostatic lever in N/STOP position.</p> <p>Later Models; Engage park brake.</p> <p>Turn key switch to ON/RUN position.</p>	 <p>M49012 -UN-08JAN90</p>	<p>Check for voltage at terminal "A" of TDC module 6-pin connector (A).</p> <p><i>NOTE: "A" is terminal with purple/black wire on TDC side of connector.</i></p>	<p>VOLTAGE: GO TO 4k</p> <p>NO VOLTAGE: GO TO 3d</p>
<p>4k <b>TDC Input (Hold-In) Voltage Test</b> 332 (All) and 430 (SN 420469— )</p>	<p>Turn key switch to ON/RUN position.</p>	 <p>M49017 -UN-08JAN90</p>	<p>Check for voltage at terminal "C" of TDC module 3-pin connector (A).</p> <p><i>NOTE: "C" is terminal with purple wire on TDC side of connector.</i></p>	<p>VOLTAGE: Verify ground at terminal "B" (black wire) of TDC module 3-pin connector. If ground OK, replace TDC module.</p> <p>NO VOLTAGE: Wire between terminal "C" of 3-pin connector and 25-amp fuse is open. Repair or replace wire.</p>
<p>4l <b>Fuel Shutoff Solenoid Circuit Test</b> 430 (SN —420468)</p>	 <p>M36602 -UN-12APR95</p>  <p>M36611 -UN-12APR95</p>	<p>Disconnect red wire (A) from solenoid.</p> <p>Connect one end of a jumper wire to positive (+) battery terminal. Connect other end to solenoid terminal (B).</p>	<p>SOLENOID OPERATES: GO TO 4m</p> <p>SOLENOID DOESN'T OPERATE: Check black wire on solenoid for good ground. If solenoid has good ground, replace solenoid.</p>	

Electrical System Diagnosis/Fuel Shutoff Solenoid Circuit Tests

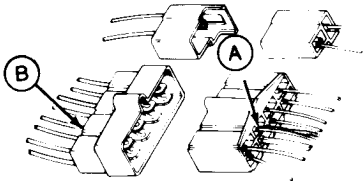
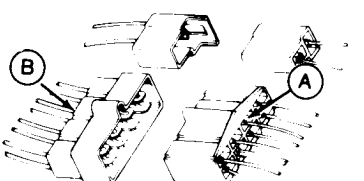
<p><b>4m Fuel Shutoff Solenoid Voltage Test At TDC Module 430 (SN —420468)</b></p>	 <p>M36638 -UN-12APR95</p>	<p>Install jumper wire across harness side of seat switch connector.</p> <p>Turn key switch to RUN position.</p> <p><i>NOTE: Do not disconnect the 8-pin connector for this test.</i></p> <p>Check for voltage at terminal with pink and orange wires (A).</p>	<p>VOLTAGE: Pink wire between TDC module connector and fuel shut-off solenoid is open. Repair or replace wire as needed.</p> <p>NO VOLTAGE: Check for voltage at single pink wire (B) (TDC module side of connector).</p> <p>VOLTAGE: Repair or replace connector, then GO TO A, Group 05.</p> <p>NO VOLTAGE: GO TO 4n</p>
<p><b>4n TDC Module Power Circuit Test 430 (SN —420468)</b></p>	 <p>M36639 -UN-12APR95</p>	<p>Turn key switch to RUN position.</p> <p><i>NOTE: Do not disconnect the 8-pin connector for this test.</i></p> <p>Check for voltage at terminal with large single pink wire (A).</p>	<p>NO VOLTAGE: Wire between TDC module connector and 25-amp fuse is open. Repair or replace wire as needed, then GO TO A, Group 05.</p> <p>VOLTAGE: Check for voltage at purple wire (B) (TDC module side of connector).</p> <p>NO VOLTAGE: Repair or replace connector as needed, then GO TO A, Group 05.</p> <p>VOLTAGE: GO TO 4o</p>
<p><b>4o Neutral Start Circuit Voltage Test At TDC Module 430 (SN —420468)</b></p>	<p>PTO switch OFF.</p> <p>Hydrostatic lever in N/STOP position.</p> <p>Turn key switch to RUN position.</p>		

MX,159124020,55-19-13JUL95

MX,159124020,56-19-13JUL95

240  
20  
34

Electrical System Diagnosis/Fuel Transfer Pump Circuit Tests

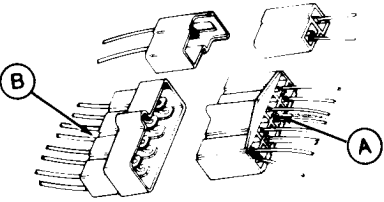

 <p>M36640 -UN-12APR95</p>	<p><b>NOTE:</b> Do not disconnect the 8-pin connector for this test.</p> <p>Check for voltage at terminal with two purple wires (A).</p>	<p><b>NO VOLTAGE:</b> GO TO 3d</p> <p><b>VOLTAGE:</b> Check for voltage at terminal with purple wire (B) (TDC module side of connector).</p> <p><b>NO VOLTAGE:</b> Repair or replace connector as needed, then GO TO <math>\dot{A}</math>, Group 05.</p> <p><b>VOLTAGE:</b> Replace TDC module, then GO TO <math>\dot{A}</math>, Group 05.</p> <p>MX,159124020,57-19-13JUL95</p>
---	--	--

<p>4p <b>Seat Switch Test</b></p>	 <p>M45187 -UN-08JAN90</p>	<p><b>NOTE:</b> Seat switch for 322 and 332/430 (S.N. 475001— ) shown.</p> <p>Key switch OFF.</p> <p>Disconnect seat switch connector.</p> <p>Connect ohmmeter or continuity tester across switch terminals.</p> <p>There should NOT be continuity.</p> <p>330 and 332/430 (S.N. —475000); Sit on or push down on surface of seat.</p> <p>322 and 332/430 (S.N. 475001— ); Push seat switch button down.</p> <p>There should be continuity.</p>	<p><b>OK:</b> Connect seat switch connector.</p> <p><b>NOT OK:</b> Replace switch, then GO TO <math>\dot{A}</math>, Group 05.</p> <p>MX,15912402055A-19-13JUL95</p>
-----------------------------------	---	---	---

<p><b>Ö FUEL TRANSFER PUMP CIRCUIT TESTS</b></p>	<p>322; GO TO 5a</p> <p>330, 332 and 430; GO TO 5b</p> <p>MX,159124020,38-19-13JUL95</p>
--	--

240  
20  
35

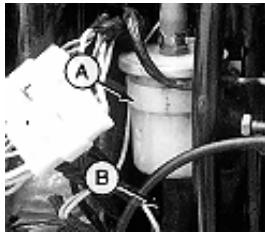
*Electrical System Diagnosis/Fuel Transfer Pump Circuit Tests*

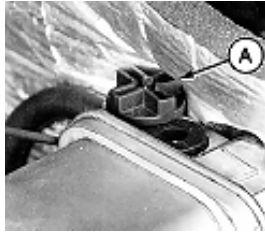
<p><b>5a Fuel Transfer Pump Test—322</b></p>	<p>Open hood.  Remove left engine side panel.</p>	 <p>M78859 -UN-12APR95</p>	<p>Disconnect fuel hose (B) from fuel filter (A).  Put end of hose in a container.  Turn key switch to RUN position.  <i>LOOK: Fuel must flow from end of hose.</i></p>	<p><b>OK:</b> Connect fuel hose.  <b>NOT OK:</b> Test pump circuit, GO TO 5c  <i>NOTE: If problem is poor engine performance, GO TO Section 220.</i></p> <p align="right">MX,159124020,39-19-13JUL95</p>
<p><b>5b Fuel Transfer Pump Test—330, 332 and 430</b></p>	<p>Open hood.  Remove left engine side panel.  Turn key switch to ON/RUN position.</p>	 <p>M55101 -UN-09DEC89</p>  <p>M36617 -UN-13APR95</p>	<p><i>NOTE: Top photo shows 330 and 332. Bottom photo shows 430.</i></p> <p>Loosen vent screw(s)/plug (A).  <i>LOOK: Fuel must flow from vent screw(s)/plug.</i></p>	<p><b>OK:</b> Tighten vent screw(s)/plug.  <b>NOT OK:</b> GO TO 5c</p> <p align="right">MX,159124020,40-19-13JUL95</p>
<p><b>5c Fuel Transfer Pump Circuit Test</b></p>	<p>Key switch OFF.  322, 330 and 332; Remove left engine side panel to access fuel transfer pump.  430; Remove fender deck to access fuel transfer pump.  Disconnect fuel pump wire connector.</p>	<p align="right"><b>Continued on next page</b></p>		

240  
20  
36

Electrical System Diagnosis/Glow Plug Controller Circuit Tests (330, 332 and 430)

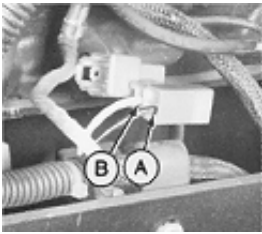
 <p>M45220 -UN-12JAN90</p>	<p><b>NOTE:</b> 322 (All) and 332/430 (S.N. 475001— ) use a 2-pin connector for the fuel pump. All other machines use a 1-pin connector and a ground wire. The ground wire connects directly to the machine frame.</p> <p>For machines equipped with 2-pin connector, check for continuity between terminal with black wire (A) (harness side of connector) and ground.</p> <p>For machines equipped with 1-pin connector, check fuel pump ground connection.</p> <p>Turn key switch to ON/RUN position.</p> <p>Check for voltage at yellow wire (B) at the connector.</p>	<p><b>CONTINUITY/GROUND AND VOLTAGE OK:</b> Replace fuel transfer pump.</p> <p><b>NO CONTINUITY OR POOR GROUND:</b> Repair or replace ground wire or clean ground connection.</p> <p><b>NO VOLTAGE:</b> Repair or replace yellow wire between connector and fuse.</p> <p>MX,159124020,41-19-13JUL95</p>
---	--	---

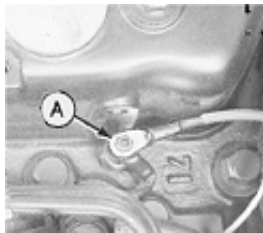
<p><b>0 GLOW PLUG CONTROLLER CIRCUIT TEST (330, 332, 430)</b></p> <p><b>NOTE:</b> Glow plug controller must be installed for this test.</p>	 <p>M36619 -UN-25JAN90</p> <p>Connect voltmeter or test light to glow plug power lead (A).</p> <p>Turn key switch to ON/RUN position.</p> <p><b>LOOK:</b> Voltmeter or test light should indicate voltage.</p> <p>After approximately 15 seconds, voltage to glow plugs should "switch off" (no voltage indicated).</p> <p><b>NOTE:</b> The 15 seconds elapsed time is when the engine compartment is at 20°C (68°F). Colder temperatures will increase length of time, warmer temperatures will decrease length of time.</p>	<p><b>VOLTAGE, THEN NO VOLTAGE AFTER SPECIFIED ELAPSED TIME:</b> Circuit OK.</p> <p><b>VOLTAGE, BUT CONTROLLER DOESN'T "SWITCH OFF" (NO VOLTAGE):</b> Replace controller.</p> <p><b>NO VOLTAGE AT ANY TIME:</b> GO TO 6a</p> <p>MX,159124020,58-19-13JUL95</p>
---	---	--

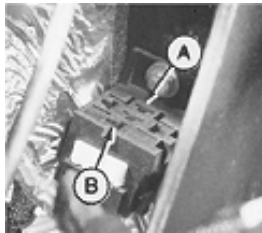
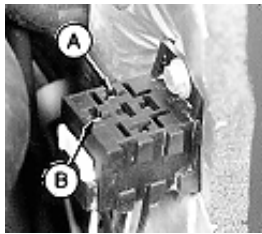
<p><b>6a Glow Plug Controller Circuit Test—Continued</b></p>	<p>Remove glow plug controller from socket.</p> <p>Turn key switch to ON/RUN position.</p>	 <p>M45232 -UN-12JAN90</p> <p><b>NOTE:</b> Top photo shows 330 and 332. Bottom photo shows 430.</p> <p>Check for voltage at terminal with red wire (A).</p>  <p>M36620 -UN-13APR95</p>	<p><b>VOLTAGE:</b> Verify good ground at terminal with black wire (B), if ground OK, replace glow plug controller, then GO TO 0, Group 05.</p> <p><b>NO VOLTAGE:</b> GO TO 6b</p> <p>MX,159124020,59-19-13JUL95</p>
--	--	--	---

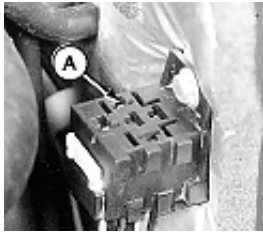
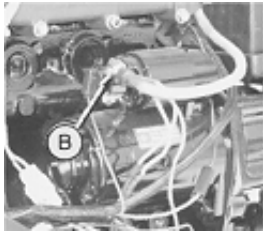
<p><b>6b Glow Plug Controller Fusible Link Test</b></p>	 <p>M36621 -UN-13APR95</p>  <p>M55114 -UN-09DEC89</p>	<p><i>NOTE: 330 and 332 shown.</i></p> <p>Turn key switch OFF.</p> <p>Check continuity between controller terminal with red wire (A) and starter terminal (B).</p>	<p><b>NO CONTINUITY:</b> Repair or replace the red wire or fusible link, then GO TO 0, Group 05.</p> <p style="text-align: right;">MX,159124020,60-19-13JUL95</p>
---	---	--	---

<p><b>0 IGNITION CIRCUIT TESTS (322)</b></p> <p>Listed at right are symptoms that may occur in a malfunctioning ignition circuit. Locate the symptom that applies, then proceed to the appropriate test or series of tests.</p>	<p><b>IMPORTANT: Test battery and verify grounds before testing ignition circuit. (See steps A and B at the beginning of this group.)</b></p>	<p><b>IGNITION CIRCUIT SYMPTOMS:</b></p> <p>Starter Cranks Engine Satisfactorily, But:</p> <ul style="list-style-type: none"> <li>—Engine Doesn't Start, Or Engine Starts, But Runs Rough; GO TO 7a</li> <li>—Engine Starts, But Misfires: GO TO 7q</li> <li>—Engine Stops With Operator On Seat When:             <ul style="list-style-type: none"> <li>PTO Switch Is Turned On, Or</li> <li>Hydrostatic Lever Is Moved To Forward Or Reverse Position, Or</li> </ul> </li> </ul>	<p>Brake Pedal Is Released On (S.N. 596006— ) Machines, GO TO 7n</p> <p style="text-align: right;">MX,159124020,75-19-13JUL95</p>
---	---	---	---

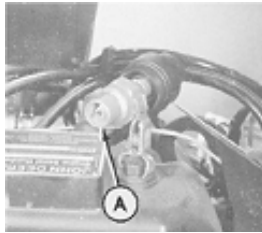
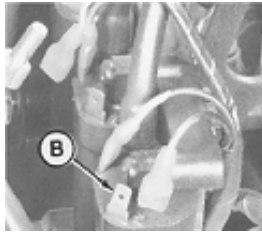
<p><b>7a Ignition Spark Test</b></p> <p>Check 10-amp and 25-amp fuses.</p>	<p>PTO switch OFF.</p> <p>Hydrostatic lever in N/STOP position.</p> <p>Later Models; Engage park brake.</p>	<p><i>NOTE: Perform spark test for all three spark plugs.</i></p>  <p>M45200 -UN-08JAN90</p> <p>Install a spark tester (A) on plug wire of cylinder to be tested.</p> <p>Disconnect orange wire from each ignition coil positive (+) terminal (B) of cylinders NOT being tested.</p> <p>Crank engine to check for spark.</p>  <p>M45201 -UN-08JAN90</p>	<p><b>NO SPARK FROM ALL CYLINDERS: GO TO 7b</b></p> <p><b>NO SPARK FROM ONE CYLINDER: GO TO 7f</b></p> <p><b>POOR, WEAK, OR YELLOW SPARK: GO TO 7j</b></p> <p><b>GOOD, SHARP BLUE SPARK: GO TO 4a</b></p> <p><b>GOOD, SHARP BLUE SPARK, BUT ENGINE MISFIRES: GO TO 7q</b></p> <p style="text-align: right;">MX,159124020,76-19-13JUL95</p>
--	---	---	--

240  
20  
38

Electrical System Diagnosis/Ignition Circuit Tests (322)

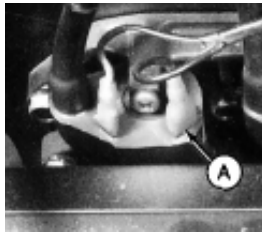
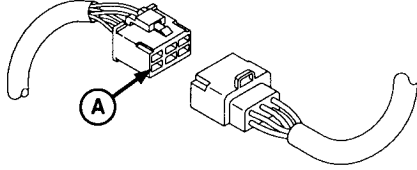
<p><b>7b Ignition Circuit Voltage Test At Ignition Coils</b></p>	<p>PTO switch OFF.</p> <p>Hydrostatic lever in N/STOP position.</p> <p>Later Models; Park brake engaged.</p> <p>Turn key switch to RUN position.</p>	 <p>M78962 -UN-27APR95</p>	<p>Check for voltage at orange wire (A) at positive (+) terminal of coils.</p>	<p>VOLTAGE: GO TO 7f</p> <p>NO VOLTAGE: GO TO 7c</p> <p>MX,159124020,77-19-13JUL95</p>
<p><b>7c Ignition Circuit Voltage Test At Ignition Coils 6-Pin Connector</b></p>	 <p>M78960 -UN-27APR95</p>	<p><i>NOTE: Do not disconnect the ignition coil 6-pin connector to perform this test .</i></p> <p>PTO switch OFF.</p> <p>Hydrostatic lever in N/STOP position.</p> <p>Later Models: Park brake engaged.</p> <p>Key switch to RUN position.</p> <p>Check for voltage at double pink/black wire terminal (A) at ignition coil 6-pin connector.</p> <p>Check for voltage on both sides of the connector.</p>	<p>VOLTAGE AT BOTH SIDES OF CONNECTOR: If testing ignition circuit, orange wire between 6-pin connector and coils is open. Repair or replace wire, then GO TO 0, Group 05.</p> <p>If testing fuel shutoff solenoid circuit, pink/black wire between 6-pin connector and solenoid is open. Repair or replace wire, then GO TO A, Group 05.</p> <p>VOLTAGE AT ONE SIDE OF CONNECTOR: Repair connector, then For fuel shutoff solenoid, GO TO E, Group 05. For ignition circuit, GO TO 0, Group 05.</p> <p>NO VOLTAGE: GO TO 7d</p> <p>MX,159124020,78-19-13JUL95</p>	

240  
20  
39

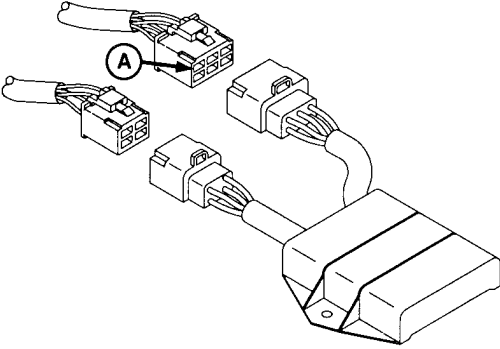
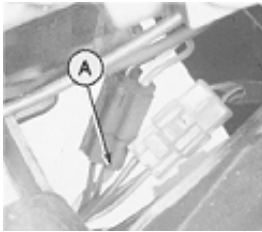
<p><b>7d Ignition Circuit Voltage Test At Transistor Module</b></p>	<p>PTO switch OFF.</p> <p>Hydrostatic lever in N/STOP position.</p> <p>Later Models; Park brake engaged.</p> <p>Key switch in RUN position.</p>	 <p>Check for voltage at double pink/black wire terminal (A) at transistor module 6-pin connector.</p>	<p>VOLTAGE: Pink/black wire between transistor module 6-pin connector and ignition coil 6-pin connector is open. Repair or replace wire as necessary, then GO TO 0, Group 05.</p> <p>NO VOLTAGE: GO TO 7e</p>
<p><b>7e Ignition Circuit Voltage Test At Engine Harness 2-Pin Connector</b></p>	<p>PTO switch OFF.</p> <p>Hydrostatic lever in N/STOP position.</p> <p>Later Models; Park brake engaged.</p> <p>Key switch in RUN position.</p>	 <p>Check for voltage at double pink/black wires (A) at engine harness 2-pin connector.</p>	<p>VOLTAGE: Pink/black wire between engine harness 2-pin connector and transistor module 6-pin connector is open. Repair or replace wire as necessary, then GO TO 0, Group 05.</p> <p>NO VOLTAGE: GO TO 7o</p>
<p><b>7f Ignition System Operational Test</b></p>	<p>PTO switch OFF.</p> <p>Hydrostatic lever in N/STOP position.</p> <p>Later Models; Park brake engaged.</p>	<p>Determine which pulsar unit operates with each ignition coil.</p> <p>Pulsars and coils are identified as follows:</p> <p>No. 1 Pulsar (A)— GRN/WHT (right side of engine)</p> <p>No. 2 Pulsar (B)— BRN (left side of engine)</p> <p>No. 3 Pulsar (C)— GRN (left side of engine)</p> <p><i>NOTE: Ignition coils are identified by position or color of wire at negative terminal.</i></p> <p>No. 1 coil is toward left side of engine.</p> <p>No. 1 Coil (D)— White wire</p> <p>No. 2 Coil (E)— Black/Yellow wire</p> <p>No. 3 Coil (F)— White/Blue wire</p>	<p>Continued on next page</p>

240  
20  
40



Electrical System Diagnosis/Ignition Circuit Tests (322)

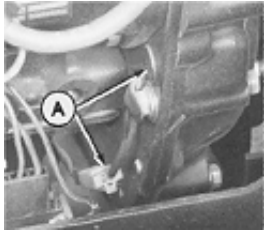

M45212 -UN-08JAN90

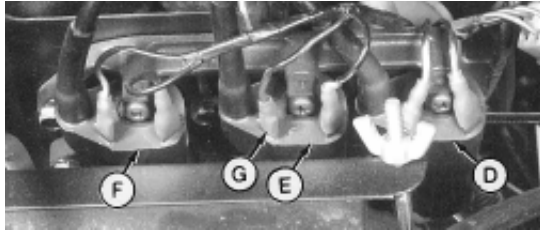

M45213 -UN-28APR95

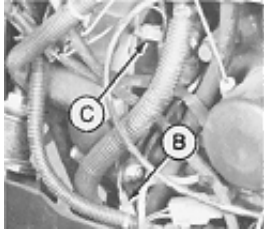

M45211 -UN-08JAN90

Put a test light on negative terminal (G) of coil being tested. DO NOT disconnect wires from coil.

Start engine and operate at slow idle.

*LOOK: Test light must blink rapidly.*

Perform test on each coil.

*NOTE: If the problem is not isolated by performing the tests indicated, then it will be necessary to perform tests on all the other related components in the circuit to determine the problem.*

**PROBLEM IS INTERMITTENT: GO TO 7g**

**ALL COIL CIRCUITS FAIL: Check transistor module first. GO TO 7m**

**ONE COIL CIRCUIT FAILS: Check pulsar for that coil first. GO TO 7h**

**COIL CIRCUIT PASSES TEST, BUT STILL NO SPARK AT RESPECTIVE CYLINDER: Check ignition coil first. GO TO 7j**

MX,159124020,81-19-13JUL95

**7g Ignition Circuit Wire Connections Test**

- PTO switch OFF.
- Hydrostatic lever in N/STOP position.
- Later Models; Park brake engaged.
- Turn key switch to RUN position.

Continued on next page

240  
20  
41

Electrical System Diagnosis/Ignition Circuit Tests (322)

Check for voltage difference between battery voltage and coil voltage as follows:

—Measure voltage between battery positive (+) and negative (—) terminals by touching voltmeter leads to top of battery posts, not to the battery cable clamps.

—Measure voltage at the positive (+) terminal of each ignition coil. Attach ground lead of voltmeter to the engine block. Do not attach ground lead to battery negative (—) terminal or machine frame.

**NO VOLTAGE DIFFERENCE:** (Voltage at battery and at each coil is the same or is less than 0.7 volts difference), GO TO 7h

**VOLTAGE DIFFERENCE IS 0.7 VOLTS OR MORE:** Check the following connections: Battery terminals.

Battery ground at engine block. Wire connections between battery (+) terminal and ignition coil (+) terminal.

Repair connections as necessary, then GO TO 0, Group 05.

MX,159124020,82-19-13JUL95

**7h Pulsar Coil Voltage Output Test**

PTO switch OFF.

Hydrostatic lever in N/STOP position.

Later Models; Park brake engaged.

*NOTE: Pulsar coils are identified by wire color at pulsar 4-pin connector.*

- No. 1 Pulsar—GRN/WHT
- No. 2 Pulsar—BRN
- No. 3 Pulsar—GRN



M45214 -UN-12JAN90

Disconnect pulsar 4-pin connector.

Attach black (ground) lead of voltmeter to terminal with black wire (A) (Pulsar side of connector).

Attach red lead of voltmeter to one of the three remaining terminals.

Crank engine to check for AC voltage from pulsar. Each pulsar should produce a minimum of 0.05 VAC.

Repeat voltage check at two remaining terminals.

**VOLTAGE 0.05 VAC OR MORE:** Pulsars OK. Check all circuit connections. If OK, GO TO 7m

**VOLTAGE LESS THAN 0.05 VAC:** GO TO 7i

MX,159124020,83-19-13JUL95

Electrical System Diagnosis/Ignition Circuit Tests (322)

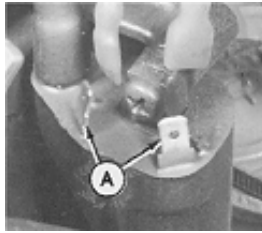
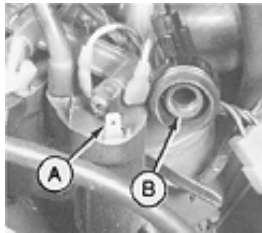
<p><b>7i Pulsar Coil Resistance Tests</b></p>	<p>Key switch OFF.</p> <p>Disconnect pulsar 4-pin connector located near fuel filter.</p> <p><i>NOTE: Pulsar coils are identified by wire color at pulsar 4-pin connector.</i></p> <p>No. 1 pulsar—GRN/ WHT No. 2 pulsar—BRN No. 3 pulsar—GRN</p>	 <p>M45214 -UN-12JAN90</p>	<p>Measure resistance between terminal with black ground wire (A) (pulsar side of connector) and each of the remaining three terminals.</p> <p>Resistance should be 15.5—23.3 ohms.</p>	<p><b>OK:</b> GO TO 7j</p> <p><b>NOT OK:</b> Replace pulsar coils as needed.</p> <p><b>NO CONTINUITY:</b> Wire between pulsar 4-pin connector and pulsar coil is open. Repair or replace wire as necessary, then GO TO 0, Group 05.</p> <p>MX,159124020,84-19-13JUL95</p>
<p><b>7j Ignition Coil Test (Primary Windings)</b></p>	<p>Key switch OFF.</p> <p>Disconnect wires from coil.</p>	 <p>M45215 -UN-12JAN90</p>	<p>Measure resistance of primary coil across terminals (A).</p> <p>Resistance should be 3.8—5.2 ohms.</p> <p>Repeat test for each coil.</p>	<p><b>OK:</b> Connect wires, then GO TO 7k</p> <p><b>NOT OK:</b> Replace coil, then GO TO 0, Group 05.</p> <p>MX,159124020,85-19-13JUL95</p>
<p><b>7k Ignition Coil Tests (Secondary Windings)</b></p>	<p>Key switch OFF.</p> <p>Disconnect plug wires from spark plugs.</p>	 <p>M45216 -UN-12JAN90</p>	<p>Measure resistance between coil positive (+) terminal (A) and terminal located at spark plug end of plug wire (B).</p> <p>Resistance should be 10.8—16.2 K-ohms.</p> <p>Repeat test for each coil.</p>	<p><b>OK:</b> GO TO 7l</p> <p><b>NOT OK:</b> Replace coil, then GO TO 0, Group 05.</p> <p>MX,159124020,86-19-13JUL95</p>

**7l Ignition Coil Tests  
(Core Insulation)**

Key switch OFF.

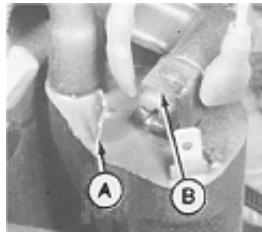

M45217 -UN-12JAN90

Check for continuity between negative terminal (A), and coil casing (B).

There should be no continuity (infinite resistance).

Repeat test for each coil.

**NO CONTINUITY:** Coil OK. Check wires and connections between coil and transistor module. If OK, GO TO 7m

**CONTINUITY:** Replace coil, then GO TO 0, Group 05.

MX,159124020,87-19-13JUL95

**7m Transistor Module Test**

Key switch OFF.

Transistor module connectors disconnected.

Use an ohmmeter to check resistance across terminals as indicated in the chart.

*NOTE: The resistance value shown is an approximation. The tested value may vary depending on ambient temperature and the condition of ohmmeter battery. What's most important is, either there is continuity or there isn't continuity.*

"O" = Continuity (resistance)

"X" = No Continuity (infinite resistance)

BLACK LEAD RED LEAD	BLACK	BROWN	GREEN WHITE	GREEN	BLACK YELLOW	WHITE	WHITE BLUE	ORANGE WHITE	BLACK WHITE
BLACK		O (2.2K)	O (2.2K)	O (2.2K)	O (2.4K)	O (2.4K)	O (2.4K)	X	O (0Ω)
BROWN	O (2.2K)		O (4.4K)	O (4.4K)	O (5.1K)	O (5.1K)	O (5.1K)	X	O (2.2K)
GREEN WHITE	O (2.2K)	O (4.4K)		O (4.4K)	O (5.1K)	O (5.1K)	O (5.1K)	X	O (2.2K)
GREEN	O (2.2K)	O (4.4K)	O (4.4K)		O (5.1K)	O (5.1K)	O (5.1K)	X	O (2.2K)
BLACK YELLOW	X	X	X	X		X	X	X	X
WHITE	X	X	X	X	X		X	X	X
WHITE BLUE	X	X	X	X	X	X		X	X
ORANGE WHITE	O (15K)	O (20K)	O (20K)	O (20K)	O (50K)	O (50K)	O (50K)		O (15K)
BLACK WHITE	O (0Ω)	O (2.2K)	O (2.2K)	O (2.2K)	O (2.4K)	O (2.4K)	O (2.4K)	X	

M45129 -19-03JAN89

MX,159124020,88-19-13JUL95

**OK:** Transistor module OK. Check circuit wires and ground connections.

**NOT OK:** Replace transistor module.

Electrical System Diagnosis/Ignition Circuit Tests (322)

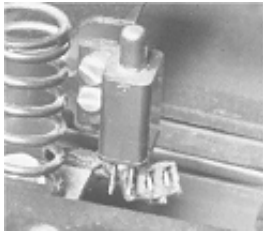
<p><b>7n Seat Switch Test for Ignition Circuit.</b></p>	 <p>M45187 -UN-08JAN90</p> <p><i>NOTE: Seat switch for 322 and 332/430 (S.N. 475001— ) shown in photo.</i></p> <p>Key switch OFF.</p> <p>Disconnect seat switch connector.</p> <p>Connect ohmmeter or continuity tester across switch terminals.</p> <p>There should NOT be continuity.</p> <p>330 and 332/430 (S.N. —475000); Sit on or push down on surface of seat.</p> <p>322 and 332/430 (S.N. 475001— ); Push seat switch button down.</p> <p>There should be continuity.</p>	<p><b>OK:</b> Connect seat switch connector, then GO TO 7o</p> <p><b>NOT OK:</b> Replace switch, then GO TO 0, Group 05.</p> <p>MX,159124020,89-19-13JUL95</p>
---	--	--

<p><b>7o TDC Module Test for Ignition Circuit</b></p> <p><i>NOTE: Perform all voltage and continuity tests before going to result column.</i></p> <p><i>Check both sides of connector when testing for voltage and continuity. If</i></p>	<p><i>test OK at only one side of connector, repair or replace connector as necessary.</i></p>	
---	--	--

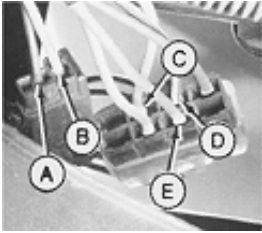
 <p>M45218 -UN-12JAN90</p>	<p>PTO switch OFF.</p> <p>Hydrostatic lever at N/STOP.</p> <p>Later Models; Park brake engaged.</p> <p>Key switch OFF.</p> <p>Install jumper wire across harness side of seat switch connector.</p> <p>At TDC module 2-pin connector:</p> <ul style="list-style-type: none"> <li>—Check for continuity between terminal with black wire (A) and ground.</li> <li>—Turn key switch to RUN position.</li> <li>—Check for voltage at pink wire (B).</li> </ul> <p>At TDC module 8-pin connector:</p> <ul style="list-style-type: none"> <li>—Check for voltage at: pink wire (C)</li> <li>yellow/blk wire (D)</li> <li>purple/blk wire (E)</li> </ul>	<p>CONTINUITY AND VOLTAGE OK: Pink wire between TDC 8-pin connector and engine connector is open. Repair or replace wire.</p> <p>NO CONTINUITY OF BLACK WIRE BETWEEN TERMINAL (A) AND GROUND: Repair or replace wire.</p> <p>NO VOLTAGE AT TERMINAL (B): Pink wire between seat switch and TDC 2-pin connector or wire between seat switch and 10-amp fuse is open. Repair or replace.</p> <p>NO VOLTAGE AT TERMINAL (C) (PINK WIRE) WHEN ALL OTHER TERMINALS TEST OK: Replace TDC module.</p> <p>NO VOLTAGE AT TERMINAL (D): Yellow/black wire between TDC 8-pin connector and 25-amp fuse is open. Repair or replace wire.</p> <p>NO VOLTAGE AT TERMINAL (E): Purple/black wire between TDC 8-pin connector and neutral start relay is open. Repair or replace wire.</p> <p>After the repair has been made; GO TO 0, Group 05.</p> <p>MX,159124020,90-19-13JUL95</p>
---	--	--

Electrical System Diagnosis/Ignition Circuit Tests (322)

**7q Ignition Timing Check**

*NOTE: Ignition timing is not adjustable, but can be checked for diagnostic purposes if a misfire condition exists.*

*Do not be concerned with alignment between BTDC mark (A) and*

*flywheel housing mark (B) because timing is determined by pulsars and flywheel notch.*

*What's important is that the timing light shows each cylinder timing mark (A) in the same position as the other cylinder timing marks.*

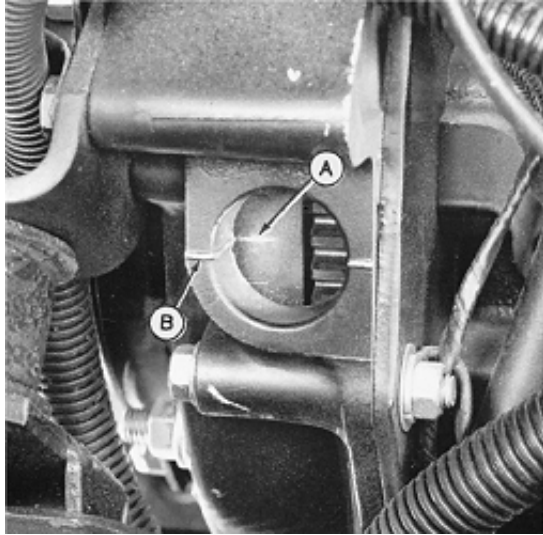

M45225 -UN-12JAN90

Connect timing light to ignition system following manufacturer's instructions.

*NOTE: Flywheel has three BTDC marks and one TDC mark for each cylinder.*

Remove rubber plug from flywheel housing.

Start engine and operate at slow idle.

Aim timing light at flywheel through flywheel housing hole. Check and compare center BTDC mark (A) with flywheel housing mark (B) for all three cylinders.

*LOOK: BTDC mark must be in same position for ALL cylinders.*

**OK:** GO TO SECTION 220.

**NOT OK:**  
ONE BTDC MARK  
NOT IN SAME  
POSITION: GO TO 7r

MX,159124020,91-19-13JUL95

**7r Transistor Module Input Voltage Test**

PTO switch OFF.  
Hydrostatic lever in N/STOP position.  
Later Models; Park brake engaged.



M45219 -UN-12JAN90

Start engine and operate at slow idle.

Measure voltage across black ground wire (A) in transistor 4-pin connector and each of the remaining three wires.

Voltage of all three wires must be the same.

**DIFFERENT VOLTAGES:** Wire from transistor module to pulsar is shorted to ground or pulsar is defective. If wire OK, GO TO 7h

MX,159124020,92-19-13JUL95

Electrical System Diagnosis/Hour Meter Circuit Test

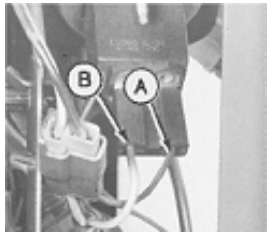
<p><b>Ú HOUR METER CIRCUIT TEST</b></p> <p>Check 10-amp and 25-amp fuses.</p>	<p>Key switch OFF.</p> <p>PTO switch OFF.</p> <p>Hydrostatic lever in N/STOP position.</p> <p>Later Models; Park brake engaged.</p>	 <p>M45221 -UN-12JAN90</p>	<p>Check for continuity between terminal with black wire (A) and ground.</p> <p>Turn key switch to ON/RUN position.</p> <p>Check for voltage at terminal with orange wire (B).</p> <p>CONTINUITY AND VOLTAGE OK: Replace hour meter.</p> <p>NO CONTINUITY: Black wire between hour meter and ground is open. Repair or replace wire, then GO TO Ú, Group 05.</p> <p>NO VOLTAGE: 322; Orange wire between hour meter and engine connector is open.</p> <p>330 and 430 (S.N. —420468); Orange wire between hour meter and TDC module 8-pin connector is open.</p> <p>332 (all) and 430 (S.N. 420469— ); Orange wire between hour meter and fuel shutoff solenoid is open.</p> <p>Repair or replace wire as necessary, then GO TO Ú, Group 05.</p> <p>MX,159124020105-19-13JUL95</p>
---	---	---	---

**Ü HEAD AND TAIL LIGHT CIRCUIT TESTS**

*NOTE: 322 (All) and 332/430 (S.N. 475001— ); 2-pin connectors are used on the headlight and tail light harnesses.*

*330; 1-pin connectors are used. The headlight ground wires connect directly to the machine frame.*

*332/430 (S.N. —475000); 1-pin connectors are used. The head and tail light ground wires connect directly to the machine frame.*

*The following procedure applies to either head or tail lights.*

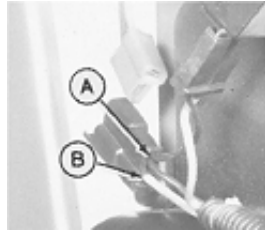

M45223 -UN-12JAN90

Key switch OFF.

Disconnect head and/or tail light connector(s).

For machines equipped with 2-pin connector, check for continuity between terminal with black wire (A) and ground on harness side of connection.

For machines equipped with 1-pin connector, check for good ground.

Turn key switch to ON/RUN position.

Pull light switch ON.

*NOTE: 430; A yellow wire is used between connector and light switch.*

Check for voltage at terminal with yellow/white wire (B).

**CONTINUITY AND VOLTAGE OK:** Replace headlight or tail light wiring harness.

**NO CONTINUITY:** Black wire between terminal (A) and ground is open. Repair or replace wire as necessary, then GO TO Ü, Group 05.

**NO VOLTAGE:** GO TO 9a

MX,159124020106-19-13JUL95

**9a Light Switch Test**

*NOTE: If either head or tail lamp comes on, light switch is OK.*

Check 25-amp fuse.

Check headlight and tail light bulbs.

Key switch ON/RUN position.

Light switch ON.



M77928 -UN-17JAN95

Check for voltage at terminal with double yellow wires.

**VOLTAGE:** Wire between head or tail light connector and light switch is open. Repair or replace wire as necessary, then GO TO Ü, Group 05.

**NO VOLTAGE:** Check for voltage at terminal (A).

**NO VOLTAGE:** Wire between light switch and 25-amp fuse is open. Repair or replace wire as necessary, then GO TO Ü, Group 05.

**VOLTAGE:** Replace switch, then GO TO Ü, Group 05.

MX,159124020107-19-13JUL95



# Electrical System Component Tests and Adjustments

## BEFORE YOU START

Always perform the system checkout procedures in Group 05 and the System Diagnosis in Group 20 before doing any tests in this group.

Always start with the first step and follow the sequence from left to right. Read each step completely before performing the test or adjustment.

The step-by-step procedures in this group provide the detailed information necessary for the component test or adjustment. These procedures include any special tooling required to identify a failure.

Make the the necessary repairs or adjustments, then perform the System Checkout in Group 05 to make certain the problem has been solved.

MX,159124025,1 -19-13JUL95

<p><b>DASH LAMPS SENSOR TESTS</b></p>	<p>Engine Coolant Temperature Switch Test, GO TO 1a</p> <p>Low Fuel Sensor Test: 322, 332, 430 (S.N. 475001— ), GO TO 1b 430 (S.N. —475000), GO TO 1c</p> <p>Water-In-Fuel Sensor Test (430),</p> <p>GO TO 1d</p> <p>Glow Plug Test (330, 332, 430), GO TO 1e</p>
---	---

MX,159124025,2 -19-13JUL95

<p><b>1a Engine Coolant Temperature Switch Test</b></p>	 <p>M36603 -UN-25JAN90</p>	<p>Remove engine coolant temperature switch from thermostat housing.</p>	<p>Put switch in a container filled with coolant.</p> <p>Heat the coolant to approximately 107°C (225°F).</p> <p>Remove switch from coolant and test for continuity between the switch wire terminal and switch body.</p>	<p>CONTINUITY: Switch OK.</p> <p>NO CONTINUITY: Replace switch.</p>
---	--	--	---	---

MX,159124025,3 -19-13JUL95

<p><b>1b Low Fuel Sensor Test—322, 332 and 430 (SN 475001— )</b></p>	<p>Remove fender deck to access low fuel sensor.</p>	<p>Continued on next page</p>
--	--	-------------------------------

240  
25  
1

Electrical System Component Tests and Adjustments/Dash Lamps Sensor Tests

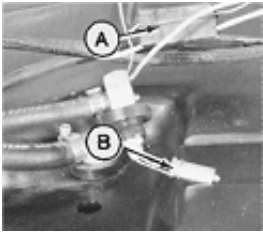
 <p>M49019 -UN-08JAN90</p>	<p>Disconnect low fuel sensor connector (A).</p> <p>Remove low fuel sensor from fuel tank.</p> <p>Connect low fuel sensor connector (A).</p> <p>Turn key switch to ON/RUN position.</p> <p><i>LOOK: Low fuel lamp should come on in approximately 30 seconds.</i></p> <p>Turn key switch OFF and allow sensor tip (B) to cool for about 10 seconds.</p> <p>Insert sensor into fuel tank and immerse in fuel.</p> <p>Turn key switch to ON/RUN position.</p> <p><i>LOOK: Low fuel lamp should NOT come on.</i></p>	<p><b>OK:</b> Install low fuel sensor.</p> <p><b>NOT OK:</b> Replace or repair sensor as necessary, then GO TO ; , Group 05.</p> <p>MX,159124025,4 -19-13JUL95</p>
---	---	--

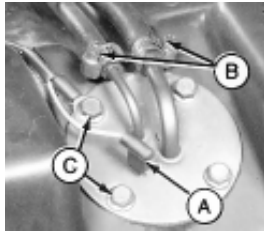
<p><b>1C Low Fuel Sensor Test</b> 430 (SN —475000)</p>	<p>Remove fender deck to access low fuel sensor.</p>	 <p>M36651 -UN-28APR95</p> <p>Disconnect wire (A) and fuel lines (B).</p> <p>Remove four cap screws (C).</p>	<p>Remove low fuel sensor from fuel tank.</p>
--	--	--	---

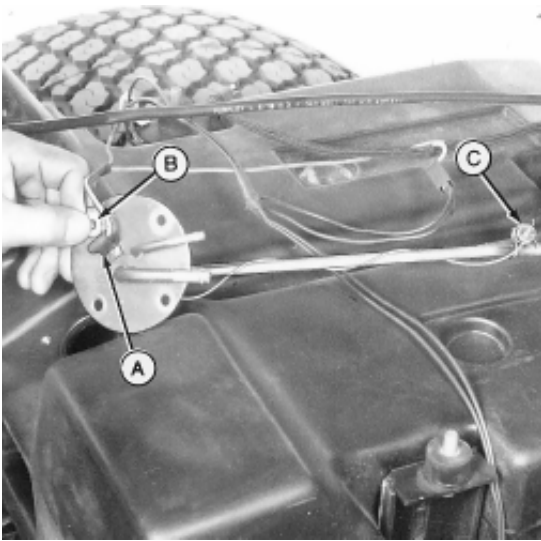
 <p>M36631 -UN-27APR95</p>	<p>Connect wire (A) to low fuel sensor.</p> <p>Hold ground wire ring terminal (B) to sensor base plate.</p> <p>Turn key switch to RUN position.</p> <p><i>LOOK: Low fuel lamp should come on in approximately 30 seconds.</i></p> <p>Turn key switch OFF and allow sensor tip (C) to cool for about 10 seconds.</p> <p>Insert sensor into fuel tank and immerse in fuel.</p> <p>Turn key switch to RUN position.</p> <p><i>LOOK: Low fuel lamp should NOT come on.</i></p> <p><i>NOTE: Make sure the plastic isolators are properly installed on both sides of the plate.</i></p>	<p><b>OK:</b> Install low fuel sensor.</p> <p><b>NOT OK:</b> Replace or repair sensor as necessary, then GO TO ; , Group 05.</p> <p>MX,159124025,5 -19-13JUL95</p>
---	---	--

240  
25  
2

**1d Water-In-Fuel Sensor Test (430)**

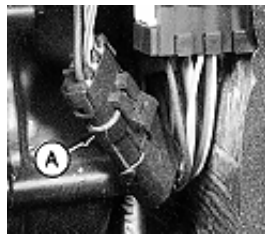

M36607 -UN-12APR95

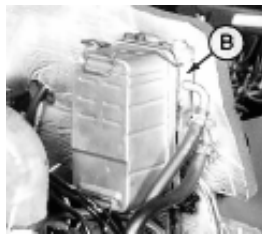

M78965 -UN-27APR95



M78966 -UN-27APR95

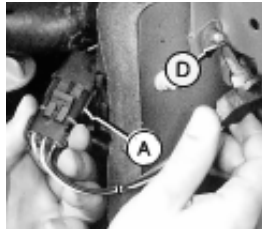

M78967 -UN-27APR95

Disconnect water-in-fuel sensor connector (A).

Remove fuel filter/base (B) from firewall.

Remove water-in-fuel sensor (C) from back of filter base.

Connect water-in-fuel sensor connector (A).

Turn key switch to RUN position.

Ground sensor tip (D) to machine frame.

*LOOK: Water-in-fuel lamp should come ON.*

**OK:** Install water-in-fuel sensor.

**NOT OK:** Replace sensor, then GO TO ; , Group 05.

MX,159124025,6 -19-13JUL95

**1e Glow Plug Test (330, 332, 430)**

Disconnect glow plug wire lead.

Remove glow plug(s).

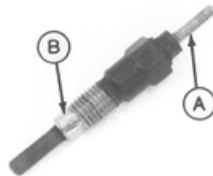

M78976 -UN-09JUN95

Measure resistance across terminal (A) and body (B).

Resistance should be a minimum of 1.00 ohms.

**OK:** Install glow plug(s) and connect wire lead.

**NOT OK:** Replace glow plug(s).

MX,159124025,32-19-13JUL95

**PTO CLUTCH ADJUSTMENT CHECK**

*NOTE: Front PTO clutch is shown. Use same procedure for rear PTO clutch if equipped.*

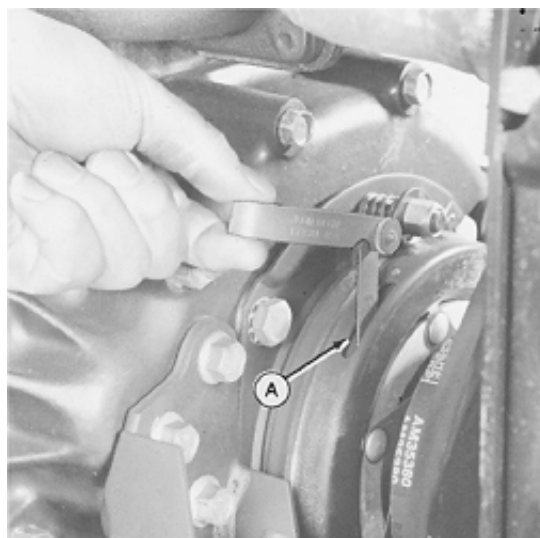

M36659 -UN-25JAN90

Key switch OFF.

*NOTE: There are three slots around the clutch for checking clearance.*

Using a feeler gauge, check armature-to-rotor clearance at each of the three slots (A) located around the clutch.

Clearance should be 0.46 mm (0.018 in.).

**OK:** Repair or replace clutch assembly as necessary. (See Section 40.)

**NOT OK:** Adjust clearance as necessary. (See Section 40.)

MX,159124025,7 -19-13JUL95

**Æ STARTING SYSTEM COMPONENT TESTS**

Key Switch Test:  
 —322, 330 and 332; GO TO 3a  
 —430; GO TO 3b

Neutral Start Relay Test; GO TO 3c

Starter Amp Draw Test; GO TO 3d

Starter No Load Running Test:  
 —322, 330 and 332; GO TO 3e  
 —430; GO TO 3h

Starter No Load RPM Test:  
 —322, 330 and 332; GO TO 3f  
 —430; GO TO 3i

Starter No Load Amp Draw Test:  
 —322, 330 and 332; GO TO 3g  
 —430; GO TO 3j

MX,159124025,8 -19-13JUL95

**3a Key Switch Test—322, 330 and 332**

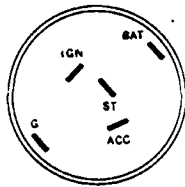

M55137 -UN-18APR89

Check for continuity between all key switch terminals at each of the key switch positions.

Refer to illustration and chart for switch position and continuity.

Key Position	Continuity
ACC	BAT + ACC
OFF	NONE
ON/RUN	BAT + ACC + IGN
START	BAT + IGN + ST, G + Switch Body

*NOTE: The labeling of the key switch positions for the 322 is "ACC", "OFF", "RUN" and START. The continuity checks are same for all machines.*

CONTINUITY ONLY BETWEEN DESIGNATED TERMINALS AT SPECIFIED SWITCH POSITION: Key switch OK.

CONTINUITY BETWEEN NONDESIGNATED TERMINALS AT SPECIFIED SWITCH POSITION: Replace key switch.

NO CONTINUITY BETWEEN DESIGNATED TERMINALS AT SPECIFIED SWITCH POSITION: Replace key switch.

MX,159124025,9 -19-13JUL95

**3b Key Switch Test—430**

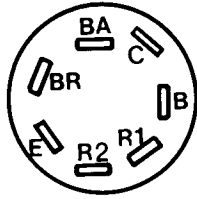

M36664 -UN-27APR95

Check for continuity between all key switch terminals at each of the key switch positions.

Refer to illustration and chart for switch position and continuity.

Key Position	Continuity
TEST	B + BR + R <sub>1</sub> , E + BA
OFF	E + BA
RUN	B + BA + BR
START	B + BA + BR + R <sub>2</sub> + C

CONTINUITY ONLY BETWEEN DESIGNATED TERMINALS AT SPECIFIED SWITCH POSITION: Key switch OK.

CONTINUITY BETWEEN NONDESIGNATED TERMINALS AT SPECIFIED SWITCH POSITION: Replace key switch.

NO CONTINUITY BETWEEN DESIGNATED TERMINALS AT SPECIFIED SWITCH POSITION: Replace key switch.

MX,159124025,10-19-13JUL95

**3c Neutral Start Relay Test**

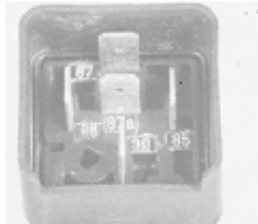

M36660 -UN-25JAN90

Remove neutral start relay.

Check for continuity between terminals.

There should be continuity between the following:  
 —Terminal 30 and 87a  
 —Terminal 85 and 86

There should NOT be continuity between terminals 30 and 87.

CONTINUITY NOT OK: Replace relay, then GO TO  $\bar{E}$ , Group 05.

CONTINUITY OK: Connect a jumper wire between terminal 86 and battery positive (+) terminal. Connect a jumper wire between terminal 85 and battery negative (—) terminal.

*LISTEN: Relay should “click” to engage.*

With relay engaged, check for continuity between terminals:  
 30 and 87,  
 30 and 87a.

There should be continuity between 30 and 87.

There should NOT be continuity between terminals 30 and 87a.

CONTINUITY OK: Relay OK.

CONTINUITY NOT OK: Replace relay, then GO TO  $\bar{E}$ , Group 05.

MX,159124025,11-19-13JUL95

**3d Starter Amp Draw Test**

Before performing starter draw test, test battery. (See Battery Tests B in Group 20 of this section.)

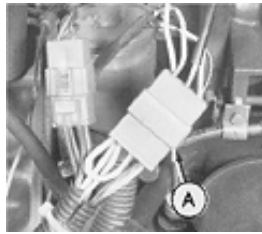

M45190 -UN-08JAN90



M55022 -UN-09DEC89

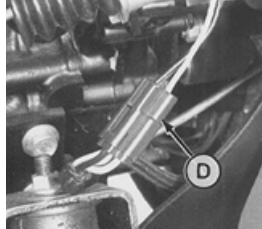

M45234 -UN-10JUL95

322; Disconnect ignition coils 6-pin connector (A).

330; Pull fuel stop knob all the way out.

332 and 430; Disconnect fuel shutoff connector.

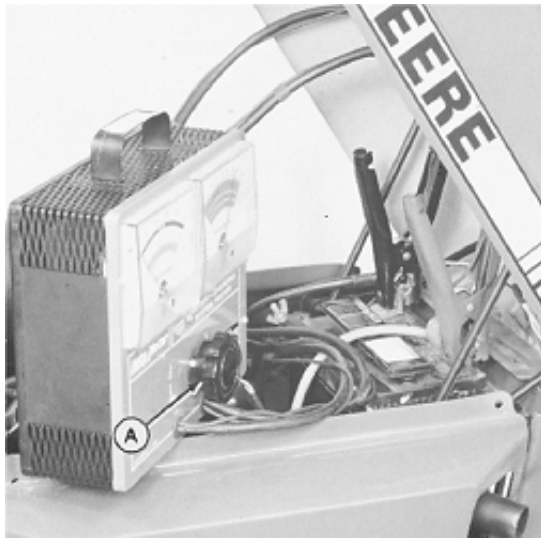

M45235 -UN-12JAN90

**IMPORTANT: Before connecting JT05685 Battery Tester to battery, turn load knob (A) fully counterclockwise.**

Connect JT05685 Battery Tester or equivalent to battery:

- Red lead to positive (+) battery terminal.
- Black lead to negative (—) battery terminal.

Crank engine with starter and read voltage on meter while cranking.

Check engine rpm while cranking using JT05719 Photo Tachometer or equivalent.

With key switch at OFF position, adjust load knob until battery voltage reads the same as when cranking.

Read amperage on meter. Amperage should read 230 amps or less.

Turn load knob fully counterclockwise.

230 AMPS OR LESS BUT RPM IS LESS THAN 300:

—322, 330 and 332; GO TO 3f

—430; GO TO 3i

230 AMPS OR LESS AT 300 RPM: Starter OK.

MORE THAN 230 AMPS:

—322, 330 and 332; GO TO 3e

—430; GO TO 3h

MX,159124025,12-19-13JUL95

**3e Starter No Load Running Test—322, 330 and 332**

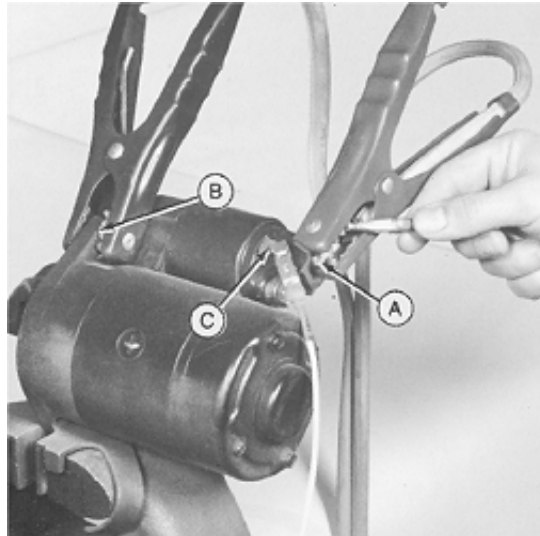

M45133 -UN-08JAN90

Disconnect battery ground cable.

Remove starter.

Mount starter in a vice.

Use jumper cables to connect starter to machine battery or one of similar capacity.

Connect positive clamp to starter common terminal (A).

Connect negative clamp to starter body (B).

Connect one end of a jumper wire to starter terminal (C) and connect other end to positive cable clamp as shown.

Starter should engage and run.

**SOLENOID "CLICKS" OR CHATTERS, MOTOR DOESN'T RUN:** Replace solenoid.

**PINION GEAR ENGAGED BUT MOTOR DOESN'T RUN:** Repair or replace starter motor. (See CTM3 or CTM12.)

**STARTER ENGAGES AND RUNS:** GO TO 3f

MX,159124025,13-19-13JUL95

**3f Starter No Load RPM Test—322, 330 and 332**

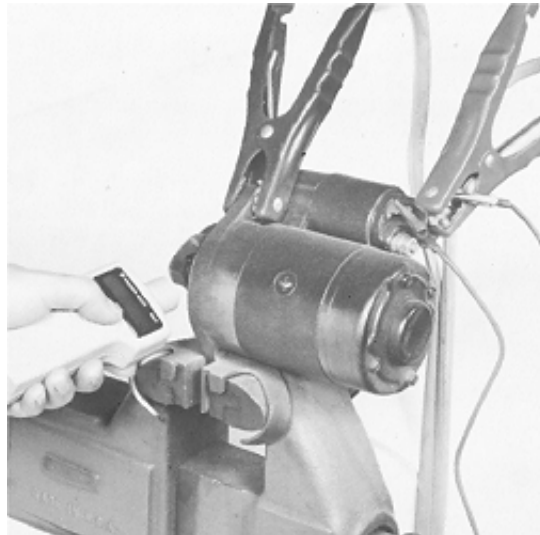

M45134 -UN-08JAN90

Mount starter in a vice and connect to a battery as instructed in step 3e.

With starter running, check no load rpm with a tachometer such as JT05719. Follow manufacturer instructions with the tachometer.

No load rpm should be about 7000.

**RPM 7000 OR MORE:** GO TO 3g

**RPM BELOW 7000:** Make sure battery is of proper rating size and fully charged.

Repeat test as needed with fully charged battery. If battery is OK, repair or replace starter (See CTM3 or CTM12.)

MX,159124025,14-19-13JUL95

240  
25  
7

**3g Starter No Load Amp Draw Test—322, 330 and 332**

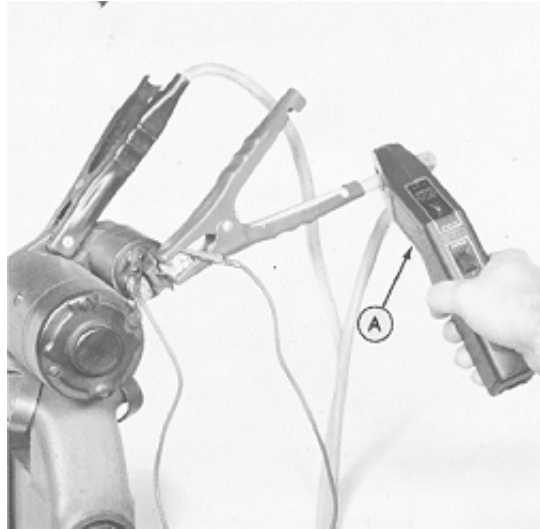

M45135 -UN-12JAN90

Mount starter in a vise and connect to a battery as instructed in step 3e.

With starter running, check amperage with JT05712 Current Gun (A).

Starter should draw 60 amps or less at 7000 rpm.

AMPERAGE 60 OR LESS: Starter OK. Malfunction is in wiring on machine. Check all connections and grounds.

AMPERAGE MORE THAN 60: Repair or replace starter. (See CTM3 or CTM12.)

MX,159124025,15-19-13JUL95

**3h Starter No Load Running Test—430**

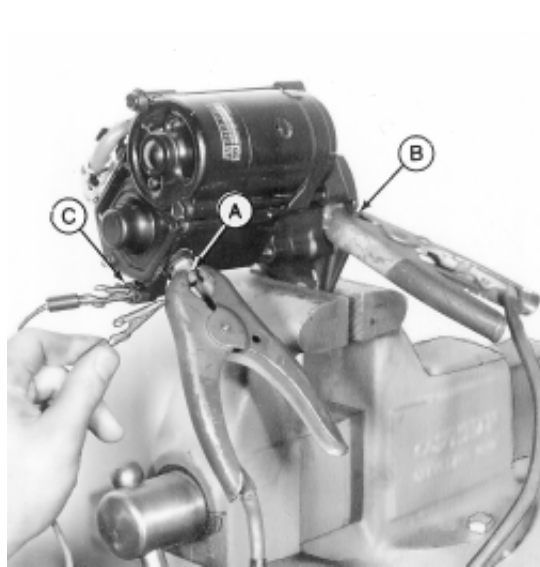

M36656 -UN-28APR95

Disconnect battery ground cable.

Remove starter.

Mount starter in a vise.

Use jumper cables to connect starter to machine battery or one of similar capacity.

Connect positive clamp to starter common terminal (A).

Connect negative clamp to starter body (B).

Connect one end of a jumper wire to starter terminal (C) and connect other end to positive cable clamp as shown.

Starter should engage and run.

SOLENOID "CLICKS" OR CHATTERS, MOTOR DOESN'T RUN: Replace solenoid.

PINION GEAR ENGAGED BUT MOTOR DOESN'T RUN: Repair or replace starter motor. (See CTM3.)

STARTER ENGAGES AND RUNS: GO TO 3i

MX,159124025,16-19-13JUL95



**3i Starter No Load RPM Test—430**

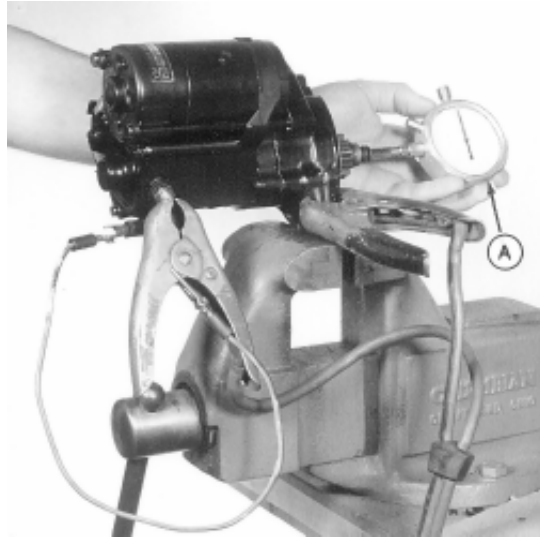

M36657 -UN-28APR95

Mount starter in a vise and connect to a battery as instructed in step 3h.

With starter running, check no load rpm with a tachometer (A). Follow manufacturer instructions with the tachometer.

No load rpm should be about 3000.

RPM 3000 OR MORE: GO TO 3j

RPM BELOW 3000: Make sure battery is of proper rating size and fully charged.

Repeat test as needed with fully charged battery. If battery is OK, repair or replace starter (See CTM3.)

MX,159124025,17-19-13JUL95

**3j Starter No Load Amp Draw Test—430**



M36658 -UN-28APR95

Mount starter in a vise and connect to a battery as instructed in step 3h.

With starter running, check amperage with JT05712 Current Gun (A).

Starter should draw 90 amps or less at 3000 rpm.

AMPERAGE 90 OR LESS: Starter OK. Malfunction is in wiring on machine. Check all connections and grounds.

AMPERAGE MORE THAN 90: Repair or replace starter. (See CTM3.)

MX,159124025,18-19-13JUL95

**Å FUEL SHUTOFF SOLENOID ADJUSTMENT**

332 (All) and 430 (S.N. 420469— ); GO TO 4a

430 (S.N. —420468); GO TO 4b

MX,159124025,19-19-13JUL95

Electrical System Component Tests and Adjustments/Charging System Tests

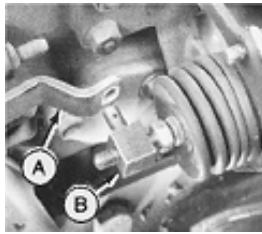
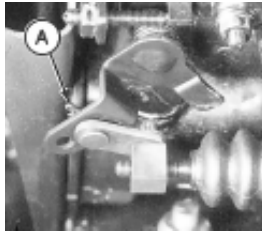
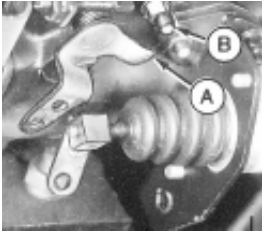
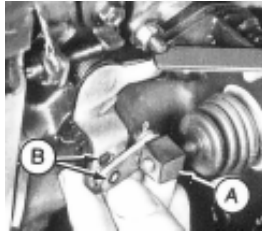
<p>4a <b>Fuel Shutoff Solenoid Adjustment—332 and 430 (SN 420469— )</b></p>	<p>Install jumper wire across harness side of seat switch connector.</p> <p>Disconnect fuel shutoff arm from solenoid plunger.</p> <p>Turn key switch to ON/RUN position.</p> <p>Push solenoid plunger in.</p>	 <p>M43343 -UN-15JAN90</p>	<p>Push fuel shutoff lever (A) toward solenoid until it stops.</p> <p>Turn adjustable link (B) until link aligns with lever hole.</p> <p>Turn link out 2 turns. Assemble linkage.</p>	<p>AFTER ADJUSTMENT: GO TO <math>\bar{A}</math>, Group 05.</p> <p>MX,159124025,20-19-13JUL95</p>
<p>4b <b>Fuel Shutoff Solenoid Adjustment 430 (SN —420468)</b></p>	<p>Install jumper wire across harness side of seat switch connector.</p>	 <p>M36612 -UN-27APR95</p>	<p>Remove cotter pin (A) to disconnect solenoid linkage from lever.</p>	
 <p>M36613 -UN-27APR95</p>	<p><i>NOTE: If 8-amp circuit breaker trips with linkage disconnected, replace solenoid.</i></p> <p>Turn key switch to RUN position.</p> <p>Insert feeler gauge blade thickness of approximately 2 mm (0.080 in.) between lever (A) and stop (B).</p>	 <p>M36614 -UN-27APR95</p>	<p>While holding lever tight against feeler gauge, rotate turnbuckle (A) until holes (B) are aligned.</p> <p>Install pin and cotter pin.</p>	<p>AFTER ADJUSTMENT: GO TO <math>\bar{A}</math>, Group 05.</p> <p>MX,159124025,21-19-13JUL95</p>
<p><b>CHARGING SYSTEM TESTS</b></p>				<p>322, 330 and 332; GO TO 5a</p> <p>430; GO TO 5d</p> <p>MX,159124025,22-19-13JUL95</p>

Electrical System Component Tests and Adjustments/Charging System Tests

**5a Regulated Voltage Output Test—322, 330 and 332**

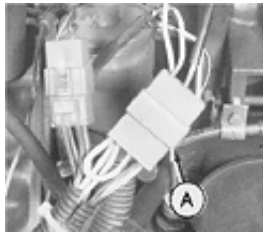

M45190 -UN-08JAN90



M55022 -UN-09DEC89

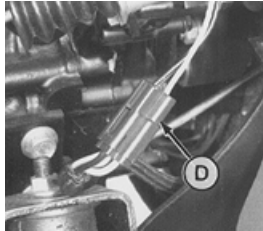

M45234 -UN-10JUL95

322; Disconnect ignition coils connector (A).

330; Pull fuel stop knob all the way out.

332; Disconnect fuel shutoff solenoid connector.

Crank engine for 10 seconds to remove battery surface charge.

322 and 332; Connect wire connector.

330; Push fuel stop knob in.

Measure and record battery voltage.

Start engine and let run at fast idle for 1—2 minutes.

After 1—2 minutes has elapsed, check battery voltage again while engine is still running.

VOLTAGE IS 13.5—15: Regulator is OK.

VOLTAGE ABOVE 15: Replace regulator.

VOLTAGE BELOW 13.5: GO TO 5b

MX,159124025,23-19-13JUL95

**5b Unregulated Voltage Output Test—322, 330 and 332**

PTO switch OFF.  
Hydrostatic lever in N/STOP position.  
Later Models; Engage park brake.

Continued on next page

240  
25  
11

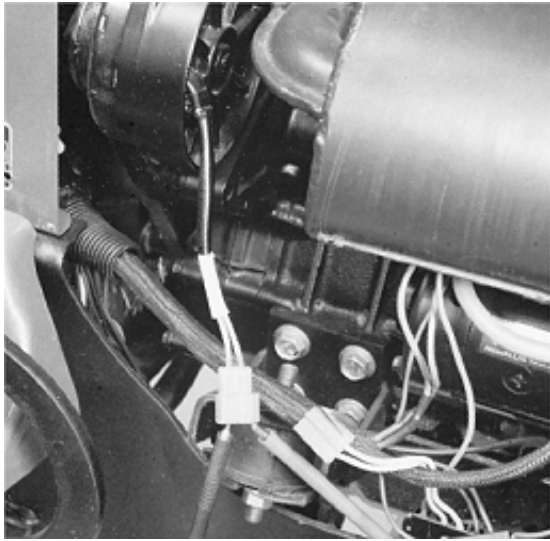

M45236 -UN-12JAN90

Disconnect alternator 2-pin connector.

Start engine and operate at fast idle.

Measure AC voltage across alternator terminal connector as shown.

OUTPUT 30 VOLTS OR MORE: Check current output, GO TO 5c.

OUTPUT LESS THAN 30 VOLTS: Low voltage may indicate weak magnets in alternator flywheel. Repair or replace alternator as necessary. (See CTM3 OR CTM12.)

MX,159124025,24-19-13JUL95

**5c Regulated Current Output Test—322, 330 and 332**

PTO switch OFF.

Hydrostatic lever in N/STOP position.

Later Models; Engage park brake.

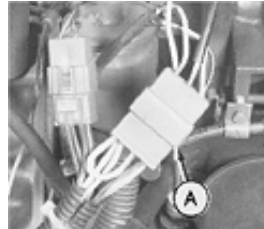

M45190 -UN-08JAN90



M55022 -UN-09DEC89

322; Disconnect ignition coils connector (A).

330; Pull fuel stop knob all the way out.

332; Disconnect fuel shutoff solenoid connector.

Crank engine for 10—15 seconds to remove battery surface charge.

322 and 332; Connect wire connector.

330; Push fuel stop knob in.

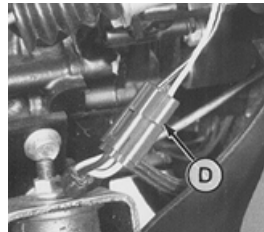

M45234 -UN-10JUL95

Continued on next page

240  
25  
12

Electrical System Component Tests and Adjustments/Charging System Tests

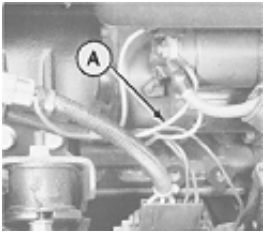
 <p>M45198 -UN-08JAN90</p>  <p>M45199 -UN-08JAN90</p>	<p>Clamp JT05712 Current Gun or equivalent around positive (+) battery cable. Set gun for DC current. Make sure arrow on gun points in direction of current flow.</p> <p>If current gun is not available, connect an ammeter in series to red wire (A) that runs between starter and voltage regulator/rectifier.</p> <p>Start engine and operate at fast idle.</p> <p><i>LOOK: Current output should start out high (approximately 18 amps or more), then decrease as battery voltage increases.</i></p>	<p>18 AMPS OR MORE: Alternator OK.</p> <p>LESS THAN 18 AMPS: Verify voltage regulator/rectifier has good ground. Verify voltage at green wire terminal of voltage regulator/rectifier.</p> <p>If voltage and ground OK, replace voltage regulator/rectifier.</p> <p>MX,159124025,25-19-13JUL95</p>
---	---	--

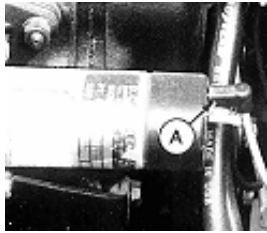
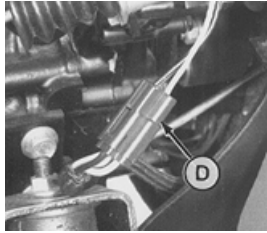
<p>5d <b>Regulated Volt/Amp Output Test—430</b></p>	<p>PTO switch OFF.</p> <p>Hydrostatic lever in N/STOP position.</p> <p>Later Models; Engage park brake.</p>	<p><i>NOTE: 430 (S.N. —420468) shown.</i></p> <p>Disconnect fuel shutoff solenoid connector.</p>  <p>M36602 -UN-12APR95</p>  <p>M45234 -UN-10JUL95</p>	<p>Crank engine for 10 seconds to remove battery surface charge, then connect wire connector.</p> <p><b>Continued on next page</b></p>
---	---	---	--

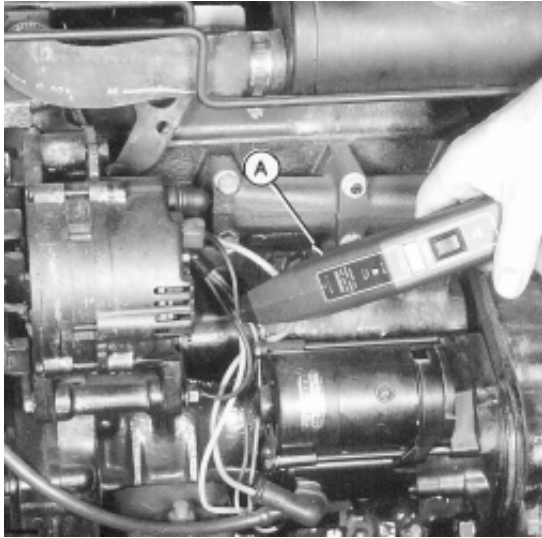

M36666 -UN-27APR95

Clamp JT05712 Current Gun or equivalent around large red wire at back of alternator. Set gun for DC current. Make sure arrow on gun points in direction of current flow.

Measure and record battery voltage (engine not running).

Start engine and operate at fast idle.

*LOOK: Current output should start out high (unregulated output is approximately 35 amps), then decrease as battery voltage increases.*

After 1—2 minutes has elapsed, check battery voltage again while engine is still running.

AMP OUTPUT HIGH, BUT BATTERY VOLTAGE DOESN'T INCREASE (VOLTAGE BELOW 13.8): Faulty battery or poor battery terminal connections or ground connections. Repair or replace as necessary, then perform voltage/current test again.

AMP OUTPUT HIGH, VOLTAGE INCREASES TO 13.8—14.7: Alternator/regulator OK.

AMP OUTPUT DOESN'T INCREASE, BATTERY VOLTAGE ABOVE 15: Replace regulator. (See CTM3.)

AMP OUTPUT IS LOW, BUT VOLTAGE EVENTUALLY INCREASES:

—430 (S.N. —420468); GO TO 5e

—430 (S.N. 420469— ); GO TO 5f

MX,159124025,26-19-13JUL95

**5e Unregulated Current Output Test**  
430 (SN —420468)

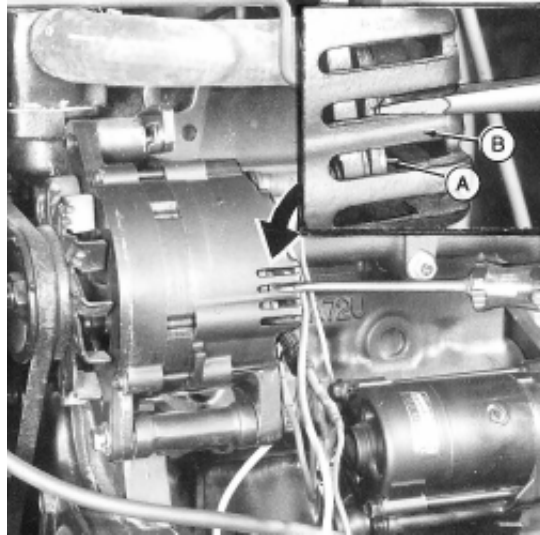

M36661 -UN-28APR95

Connect JT05712 Current Gun or equivalent as instructed in step 5d

Start engine and operate at fast idle.

**IMPORTANT: Complete the unregulated current output test in less than 10 seconds or battery will be damaged.**

Ground the regulator to alternator frame using a screwdriver. Insert screwdriver blade through cooling vent as shown. Touch side of blade against alternator frame while touching blade tip to base of regulator.

Read amp output on ammeter.

OUTPUT 35 AMPS OR MORE: Alternator OK. Check charging system wiring.

OUTPUT LESS THAN 35 AMPS: Repair or replace alternator. (See CTM3.)

MX,159124025,27-19-13JUL95

**5f Unregulated Current Output Test**  
430 (SN 420469— )

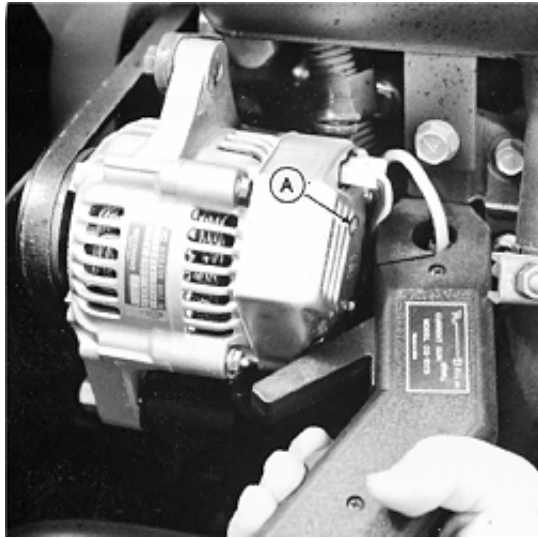

M48576 -UN-11DEC89

Connect JT05712 Current Gun or equivalent as instructed in step 5d

Start engine and operate at fast idle.

**IMPORTANT:**  
**Complete the unregulated current output test in less than 10 seconds or battery will be damaged.**

Insert a phillips screwdriver through small round hole (A) to ground terminal "F" to alternator rear cover.

Read current output on ammeter.

OUTPUT 40 AMPS OR MORE: Alternator OK. Check charging system wiring.

OUTPUT LESS THAN 35 AMPS: Repair or replace alternator. (See CTM3.)

MX,159124025,28-19-13JUL95

**0 SYSTEM SHORT CIRCUIT TESTS**

If the 10-amp fuse blows each time the key switch is turned ON/RUN or machine is operated, there is probably a short in the power circuit of a component protected by the 10-amp fuse.

If the 25-amp fuse blows each time the key switch is turned ON or machine is operated, there is probably a short in the power circuit of a component protected by the 25-amp fuse.

Short in the 10-Amp Fuse Circuits, GO TO 6a

Short in the 25-Amp Fuse Circuits, GO TO 6b

MX,159124025,29-19-13JUL95

<p><b>6a Short Circuit Tests For 10-Amp Fuse</b></p>	<p>The 10-AMP FUSE PROVIDES CURRENT TO:</p> <ul style="list-style-type: none"> <li>• ALL DASH PANEL INDICATOR LAMPS EXCEPT PTO LAMP: A short in the wires between the 10-amp fuse and dash lamps will cause the fuse to blow when the key switch is turned to ON/RUN position.</li> <li>• THE SEAT SAFETY SWITCH: A short in the pink wire between 10-amp fuse and the seat switch will cause the fuse to blow when the key switch is turned to ON/RUN position.</li> </ul> <p>A short in the pink wire between the seat switch and TDC module will cause the fuse to blow when the key switch is in the ON/RUN position and operator sits on seat. This will cause the engine to stop each time the PTO's are turned ON or when machine is shifted out of N/STOP position.</p> <ul style="list-style-type: none"> <li>• THE GLOW PLUG CONTROL MODULE—330, 332 AND 430: A short in the yellow wire running between the 10-amp fuse and the glow plug control module would blow the fuse when the key switch is turned to ON/RUN position.</li> </ul> <p>Because current from the 10-amp fuse is needed for the glow plug controller to operate, no current will flow to the glow plugs if fuse is blown.</p> <ul style="list-style-type: none"> <li>• CHARGING CIRCUIT:</li> </ul>	<p>A short in the green wire between the 10-amp fuse and the regulator/rectifier (322, 330 and 332) or alternator (430) will cause the fuse to blow when the key switch is turned to ON/RUN position.</p> <ul style="list-style-type: none"> <li>• THE FUEL TRANSFER PUMP—322, 330 and 332: A short in the yellow wire running between the 10-amp fuse and the pump will cause the fuse to blow when the key switch is turned to ON/RUN position.</li> </ul>	<p>THE MOST LIKELY AREAS TO CHECK IF THE 10-AMP FUSE BLOWS ARE:</p> <ul style="list-style-type: none"> <li>• The engine side of the fire wall where the main harness goes through the firewall. Check for proper installation of the firewall grommet.</li> <li>• The water pump belt or idler pulley. Check if wires are rubbing against belt or pulley.</li> <li>• The drive shaft flex coupling. Check if wires are rubbing against drive shaft.</li> </ul> <p>These are the wires for the fuel pump, low fuel sensor and seat safety switch.</p> <p>To check, remove the belly screen/pan from bottom of the machine.</p> <ul style="list-style-type: none"> <li>• Seat switch wiring through fender deck. Check for proper installation of grommet in fender deck.</li> </ul>
--	--	--	--

MX,159124025,30-19-13JUL95



<p><b>6b Short Circuit Tests For 25-Amp Fuse</b></p>	<p><b>THE 25-AMP FUSE PROVIDES CURRENT TO:</b></p> <ul style="list-style-type: none"> <li>• <b>THE STARTER SAFETY INTERLOCK CIRCUIT:</b> A short in this circuit will cause the 25-amp fuse to blow when the key switch is turned to the START position.</li> <li>• <b>THE HOUR METER/FUEL SHUTOFF SOLENOID/IGNITION CIRCUIT:</b> This circuit runs through the TDC module. If the fuse blows only when the key switch is in ON/RUN position, with PTO switch OFF, hydrostatic lever in N/STOP position and park brake engaged (later machines), the short is NOT in the TDC module. The short will be in the wires running between the TDC module and hour meter and/or fuel shutoff solenoid (322, 332 and 430) and/or ignition system (322).</li> <li>• <b>THE PTO CLUTCH:</b> This circuit runs through the TDC module. If the fuse blows only after the PTO is turned ON, the short is NOT in the TDC module. The short will be in the wires running to the PTO clutch or PTO lamp.</li> <li>• <b>THE HEAD LAMPS:</b> A short in the yellow wires between light switch and head or tail lights will cause the 25-amp fuse to blow when the key switch is in ON/RUN position and light switch is pulled ON.</li> <li>• <b>THE FUEL TRANSFER PUMP—430:</b> A short in the yellow wire between 25-amp fuse and fuel pump will cause the fuse to blow when the key switch is turned to the RUN position.</li> </ul>	<p><b>MOST LIKELY AREAS TO CHECK IF THE 25-AMP FUSE BLOWS ARE:</b></p> <ul style="list-style-type: none"> <li>• At engine side of the firewall where main harness goes through the firewall. Check for proper installation of the firewall grommet.</li> <li>• At front PTO clutch. Check if PTO clutch wire may be pinched against the engine block where it comes out from behind the coil mounting plate.</li> <li>• At engine exhaust manifold. Check if the insulation has burned off the blue wire for the PTO clutch.</li> <li>• At rear PTO clutch. Check if wires have gotten tangled in the drive shaft.</li> <li>• At PTO clutch connector. Check if the metal terminal of clutch connector is pushed into the insulation all the way.</li> <li>• At front of engine next to the exhaust manifold. Check if the insulation has burned off the yellow wire for the headlight.</li> <li>• At the hood hinge area. Check if yellow wire for the headlight is pinched.</li> <li>• At headlight harness connector. Check if the metal terminal of connector is pushed into the insulation all the way. If exposed, the bare terminal could ground against the engine shroud.</li> <li>• Under the fender deck. Check if the yellow wire to tail lamps (if equipped) is pinched between deck and frame.</li> <li>• 322; Check pulsar wires for shorts near engine mounts and flywheel.</li> </ul>
--	--	--

MX,159124025,31-19-13JUL95



# Section 250

# POWER TRAIN CHECKOUT, OPERATION AND DIAGNOSIS

## Contents

	Page	Page
<b>Group 05—Power Train Checkout</b>		
Before You Start . . . . .	250-05-1	
Transmission Oil Leak Check . . . . .	250-05-1	
Hydrostatic Lever Friction Check . . . . .	250-05-1	
Transmission Neutral Check . . . . .	250-05-1	
Neutral Return Check . . . . .	250-05-2	
Transmission Drive Check . . . . .	250-05-2	
Speed Reduction Check (322, 332 and 430) . . . . .	250-05-2	
Two-Speed Axle Lever Check (430) . . . . .	250-05-3	
Differential Lock Check (430) . . . . .	250-05-3	
Operator Complaint Not Identified . . . . .	250-05-3	
<b>Group 10—Theory of Operation</b>		
Hydrostatic Transmission Operation . . . . .	250-10-2	
<b>Group 15—Diagnosis, Tests and Adjustments</b>		
About This Group . . . . .	250-15-1	
Troubleshooting Guide . . . . .	250-15-1	
Check Valve Debris Check . . . . .	250-15-5	
Charge Pump		
Pressure Test . . . . .	250-15-5	
Suction Line Check . . . . .	250-15-6	
Charge Relief Valve		
Check . . . . .	250-15-6	
Adjustment . . . . .	250-15-6	
Implement Relief Valve		
Pressure Test . . . . .	250-15-7	
Check . . . . .	250-15-7	
Adjustment . . . . .	250-15-7	
Charge Pump Flow Test . . . . .	250-15-8	
Welch Plug Location Check . . . . .	250-15-8	
Hydraulic Oil Warm-Up Procedure . . . . .	250-15-9	
Steering Valve Neutral Check (322, 332 and 430) . . . . .	250-15-9	
Hydrostatic Lever Friction Adjustment . . . . .	250-15-10	
Neutral Return Linkage Adjustment (330, and Early 322, 332, 430) . . . . .	250-15-10	
Neutral Adjustment (330 and Early 322, 332, 430) . . . . .	250-15-13	
		Neutral and Neutral Return Linkage Adjustment (Later 322, 332, 430) . . . . . 250-15-14 Two-Speed Axle Lever Linkage Check (430) . . . . . 250-15-17 Differential Lock Linkage Check (430) . . . . . 250-15-17





## BEFORE YOU START

Always begin with this group to identify a failure in the power train. The step-by-step procedures will provide you with a quick check of the system. No tools are required to perform these checks. If a failure is indicated, you will be referred to a more detailed check, adjustment, or test.



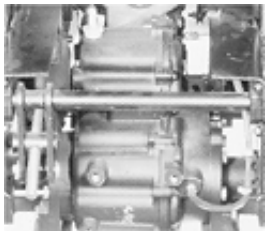

Always start with the first step and follow the sequence from left to right. Read each step completely before performing the check.

This procedure is designed as a quick check of the system. While performing the check, concentrate only on the check you are performing and disregard signals from unrelated components.



MX,159025005,1 -19-20APR95

<p><b>TRANSMISSION OIL LEAK CHECK</b></p>	 <p>M36695 -UN-25JAN90</p>	<p>Check transmission oil level and oil condition.</p> <p>Inspect for external transmission oil leakage from transmission filter, drain plug, lines, fittings, charge pump gasket, charge pump shaft seal and differential gasket.</p>	<p><b>OK:</b> GO TO ' </p> <p><b>NOT OK:</b> Repair or replace then GO TO ' </p> <p style="text-align: right;">MX,159025005,2 -19-20APR95</p>
<p><b>HYDROSTATIC LEVER FRICTION CHECK</b></p>	<p>Start and run engine at fast idle.</p>	 <p>M36669 -UN-25JAN90</p> <p>Move hydrostatic lever to slow forward position.</p> <p><i>LOOK: Hydrostatic lever must move freely and not move after released.</i></p>	<p><b>OK:</b> GO TO Æ</p> <p><b>NOT OK:</b> GO TO Ü, GROUP 15.</p> <p style="text-align: right;">MX,159025005,3 -19-20APR95</p>
<p><b>TRANSMISSION NEUTRAL CHECK</b></p>	 <p>M36668 -UN-25JAN90</p>	<p>Move hydrostatic lever to "STOP" position.</p> <p>Start and run engine at half throttle.</p> <p><i>LOOK: Machine must not creep in neutral.</i></p>	<p><b>OK:</b> GO TO Å</p> <p><b>NOT OK:</b> GO TO GROUP 15: 330, Early 322, 332 and 430: 1! Later 322, 332 and 430: 1@</p> <p style="text-align: right;">MX,159125005,1 -19-13JUL95</p>

Power Train Checkout/Speed Reduction Check (322, 332 and 430)

<p><b>Ä NEUTRAL RETURN CHECK</b></p>	<p>322, 332 and 430; Lock pedals together.</p>	 <p>M36667 -UN-25JAN90</p>  <p>M36668 -UN-25JAN90</p>	<p>Move hydrostatic lever to full forward or reverse position.</p> <p>Depress brake pedal(s).</p> <p><i>LOOK: Hydrostatic lever must move to "STOP" position from forward or reverse.</i></p>	<p><b>OK: GO TO 0</b></p> <p><b>NOT OK: GO TO 10, GROUP 15.</b></p> <p>MX,159125005,2 -19-13JUL95</p>
<p><b>0 TRANSMISSION DRIVE CHECK</b></p>	<p>Start and run engine at fast idle. Operate machine under no load and then under load conditions.</p>	 <p>M36669 -UN-25JAN90</p>	<p>Move hydrostatic lever from slow forward, to full forward, to full reverse.</p> <p><i>LOOK: Machine must move and increase speed, slow down, change direction and increase speed as lever is moved from full forward to full reverse.</i></p> <p><i>FEEL: Speed increase must be smooth. Transmission suction line must not be uncomfortable to touch.</i></p>	<p><b>OK: GO TO 0</b></p> <p><b>NOT OK: Check transmission oil level.</b></p> <p><b>OIL LEVEL OK: GO TO ;, GROUP 15.</b></p> <p>MX,159025005,6 -19-20APR95</p>
<p><b>0 SPEED REDUCTION CHECK (322, 332 and 430)</b></p>	<p>Start engine and run at half throttle.</p>	 <p>M36667 -UN-25JAN90</p>  <p>M36669 -UN-25JAN90</p>	<p>Move hydrostatic lever to full forward position.</p> <p>Depress right brake pedal.</p> <p><i>LOOK: Hydrostatic lever must move to slow forward position. Right wheel must stop; left wheel must continue to turn.</i></p> <p>Move hydrostatic lever to full forward position.</p>	<p><b>Continued on next page</b></p>

Power Train Checkout/Operator Complaint Not Identified

 <p>M36671 -UN-25JAN90</p>	<p>Depress left brake pedal.</p> <p><i>LOOK: Hydrostatic lever must move to slow forward position. Left wheel must stop; right wheel must continue to turn.</i></p>	<p><b>OK:</b> GO TO 0</p> <p><b>NOT OK:</b> GO TO Ü, GROUP 15.</p> <p>MX,159125005,3 -19-13JUL95</p>	
<p>0 <b>TWO-SPEED AXLE LEVER CHECK (430)</b></p>	<p>Start and run engine at half throttle.</p>	 <p>M36672 -UN-25JAN90</p> <p>Move two-speed axle lever to slow speed position. Move hydrostatic lever to full forward position.</p> <p><i>LOOK: Observe ground speed.</i></p> <p>Move two-speed axle lever to fast speed position. Move hydrostatic lever to full forward position.</p> <p><i>LOOK: Ground speed must be approximately twice as fast.</i></p>	<p><b>OK:</b> GO TO Ü</p> <p><b>NOT OK:</b> GO TO 1#, GROUP 15.</p> <p>MX,159125005,5 -19-13JUL95</p>
<p>Ü <b>DIFFERENTIAL LOCK CHECK (430)</b></p>	<p>Start and run engine at fast idle.</p> <p>Move hydrostatic lever to slow forward position.</p>	 <p>M36673 -UN-25JAN90</p> <p>Turn steering wheel left or right.</p> <p>Depress differential lock and turn left or right.</p> <p><i>LOOK: With differential lock depressed, machine must try to go straight forward when steering wheel is turned or rear tire must show scuffing on the ground.</i></p>	<p><b>OK:</b> System Normal.</p> <p><b>NOT OK:</b> GO TO 1\$, GROUP 15.</p> <p>MX,159125005,6 -19-13JUL95</p>
<p>Ü <b>OPERATOR COMPLAINT NOT IDENTIFIED</b></p>	<p>If you completed the checkout procedure and did not isolate a malfunction, the problem may be intermittent.</p> <p>Try to duplicate the conditions of the malfunction identified by the operator.</p>	<p>IF A MALFUNCTION IS NOT IDENTIFIED AFTER SYSTEM CHECKOUT PROCEDURE; FACTORY ASSISTANCE IS AVAILABLE THROUGH DEALER TECHNICAL ASSISTANCE CENTER (DTAC).</p> <p>MX,159025005,11-19-20APR95</p>	

*Power Train Checkout/Operator Complaint Not Identified*

250  
05  
4



250  
10  
1

## HYDROSTATIC TRANSMISSION OPERATION

### Function:

Transfers power from the input (pump) shaft to the gear drive components of the transmission. It also provides infinitely variable speed and torque within a range in forward and reverse directions.

Also supplies pressurized oil to the hydraulic lift and steering systems.

### Theory of Operation:

The transmission consists of a variable displacement, axial piston pump (B) connected in a closed loop to a fixed displacement, axial piston motor (I). A charge pump (C) and valve system is used to charge and lubricate the transmission.

The charge pump is a gerotor-type, fixed displacement pump. It continually pumps oil throughout the entire hydrostatic/hydraulic system whenever the engine is running.

As the input (pump) shaft (A) is turned by the engine drive shaft, the pump rotating group consisting of the variable hydrostatic pump and charge pump also turn. The charge pump draws pressure-free oil from the reservoir (F) through the filter (D) and pressurizes it to approximately 620—1240 kPa (90—180 psi). The charge oil pressure is enough to unseat the forward and/or reverse check valve (E and M), supplying charge pressure oil to pump (B).

The transmission also supplies pressurized oil to the lift and hydraulic steering systems. If pressure in this line becomes excessive, the implement relief valve (N) will open allowing the oil to flow into the reservoir.

### NEUTRAL:

With the transmission in the neutral position, springs in the pump cylinder bores force the pump pistons against the variable position swashplate, which is parallel to the pump body. With the swashplate parallel to the pump body, the pistons do not reciprocate in the cylinder block, they merely rotate, no oil is being drawn in or discharged from the pump. The pump is in a zero displacement position and the machine remains stationary.

### FORWARD:

As the swashplate control arm is moved to the forward position, the variable position swashplate is moved from the neutral position to a forward angle position. Springs inside the cylinder bores force the pistons against the swashplate. As the pump rotates

the pistons follow the contour of the swashplate they move outward, drawing oil into their bores. As the pistons continue to rotate, the swashplate angle forces the pistons back into the bores, forcing oil out of the bores through the valve plate.

High pressure oil from the pump forces the forward check valve (E) closed and supplies pressurized oil to the drive motor (I). The motor works in conjunction with a fixed position swashplate. Oil enters the piston bore through a port in the valve plate at a point where the piston is compressed in its bore.

As the oil fills the piston bore, the piston is forced out and follows the contour of the swashplate. This causes the motor to rotate. Oil pressure within these components is directly proportional to the load encountered. This is known as the high pressure side of the system.

As the motor continues to rotate, the piston is now compressed by the angle of the swashplate and oil is forced from the piston bore into the other port in the valve plate. This oil is directed back to the suction side of the pump. There is minimal oil pressure from the back to the motor and this is referred as the low pressure side of the system.

The reverse check (freewheel) valve (M) remains open to allow charge pressure oil to flow to the low pressure side of the system to make up for any oil lost due to internal lubrication/leakage.

### REVERSE:

The operation of the transmission in reverse is similar to forward operation, except that the reverse swashplate position causes the pressurized oil flow to be reversed. When oil flow is reversed, the reverse check (freewheel) valve (M) is forced closed supplying pressurized oil to the drive motor. The forward check valve (E) remains open to allow charge pressure oil to flow to the low pressure side of the system to make up for any oil lost due to internal lubrication/leakage.

### FREEWHEEL:

When the forward/reverse check (freewheel) valves are manually engaged, the valves are forced off their seats and allows oil to flow from both sides of the motor to the reservoir. Normally the motor would have excessive resistance to movement due to dynamic braking of the hydrostatic closed loop.

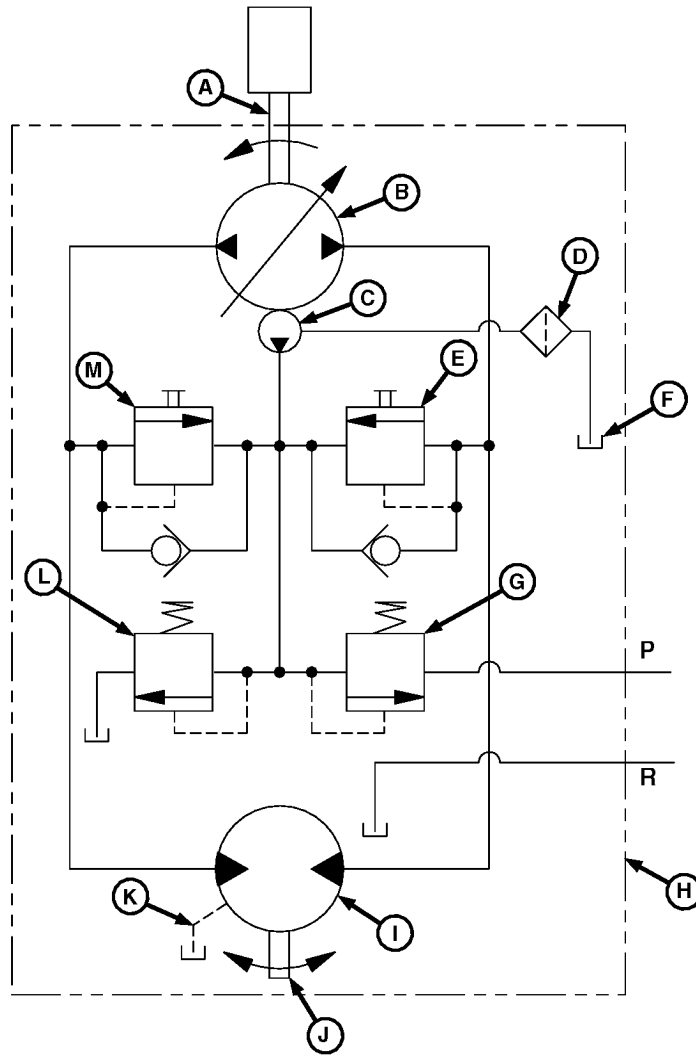

A—Input (Pump) Shaft  
 B—Variable Hydrostatic Pump  
 C—Charge Pump  
 D—Filter

E—Forward Check (Freewheel) Valve  
 F—Reservoir  
 G—Charge Relief Valve

H—Hydrostatic Transmission Housing  
 I—Hydrostatic Drive Motor  
 J—Output (Motor) Shaft

K—Transmission Case Drain  
 L—Implement Relief Valve  
 M—Reverse Check (Freewheel) Valve

M78856 -JUN-03/APR95

MX,159025010,2 -19-20APR95



## ABOUT THIS GROUP

Always perform the system checkout procedures in Group 05 BEFORE making any tests or adjustments in this group. The step-by-step procedures in this group provide you with the detailed diagnostic information you will need to isolate a malfunction. Basic diagnostic equipment is used.

It is assumed that you are familiar with the machine and its power train components. If you need additional information, read the theory of operation in Group 10 or refer to the overall hydraulic schematics in Section 270, Group 10.

Engine rpm and temperature are critical in most hydraulic tests. Be sure to follow test specifications carefully.

Always start with the first step and follow the sequence from left to right. Read each step completely before performing the test.

Upon completing a test or adjustment, check to see whether the problem is corrected by performing the checkout procedures in Group 05.

MX,159025015,1 -19-20APR95

## ; TROUBLESHOOTING GUIDE

If machine does not operate properly, select the appropriate symptom from the list below.

- MACHINE MOVES IN ONE DIRECTION ONLY: GO TO A
- MACHINE WILL NOT MOVE IN EITHER DIRECTION: GO TO B
- MACHINE CREEPS IN ONE DIRECTION CONSISTENTLY: GO TO 1! OR 1@
- HYDRO CONTROL LEVER DOES NOT RETURN TO NEUTRAL WHEN BOTH BRAKES ARE APPLIED: GO TO 10
- TRANSMISSION OPERATION HAS ERRATIC OR LOW POWER OR SPEED WILL NOT INCREASE: GO TO C
- MACHINE WILL NOT REACH FULL SPEED: GO TO D
- TRANSMISSION OPERATES HOT: GO TO E
- MACHINE FREEWHEELS: GO TO F
- HYDRAULIC SYSTEM IS NOISY: GO TO G
- NO HYDRAULICS AFTER BEING SERVICED: GO TO H
- CHARGE PUMP SEAL REPEATEDLY FAILS: GO TO I

MX,159025015,2 -19-20APR95

## **A MACHINE MOVES IN ONE DIRECTION ONLY**

- Inspect transmission control linkage for wear or damage. See Section 50.
- 322, 330 and 332; Test for debris in check valves: GO TO 1
- Inspect check valves for damaged valve seat, seals or stuck check ball. See Section 50.
- Inspect internal transmission components for wear or damage. See Section 50.

MX,159125015,1 -19-13JUL95

## **B MACHINE WILL NOT MOVE IN EITHER DIRECTION**

- Inspect transmission control linkage for wear or damage. See Section 50.
- Inspect transmission drive shaft and crankshaft pulley for loose cap screws or damage.
- Check for improper charge pump installation (180 degrees off). See Section 50.
- Test charge pump pressure: GO TO 2
- Inspect check valves for damaged valve seat, seals or stuck check ball. See Section 50.
- Inspect internal rotating group for scoring and wear (slippers, pistons and cylinder block, valve plate and cylinder block). If internal damage is found, check for missing welch plug: GO TO 3

MX,159025015,4 -19-20APR95

## **C TRANSMISSION OPERATION HAS ERRATIC OR LOW POWER OR SPEED WILL NOT INCREASE**

- Inspect brakes and brake linkage for wear or damage. See Section 60.
- Inspect transmission control linkage for wear or damage. See Section 50.
- Check for improper charge pump installation (180 degrees off). See Section 50.
- Test charge pump pressure: GO TO 2
- Inspect check valves for damaged valve seat, seals or stuck check ball. See Section 50.
- Inspect internal rotating group for scoring and wear (slippers, pistons and cylinder block, valve plate and cylinder block). If internal damage is found, check for missing welch plug: GO TO 3
- Check for dirt accumulation on transmission causing transmission oil to overheat: GO TO 4
- Check for high draft loads causing transmission oil to overheat: GO TO 5

MX,159025015,5 -19-20APR95

## D MACHINE WILL NOT REACH FULL SPEED

- Inspect transmission control linkage for wear or damage. See Section 50.
- Inspect transmission and differential mounting cap screws for loose condition.
- Check engine fast idle speed: See Section 220.
- Inspect check valves for damaged seat, seals or stuck check ball. See Section 50.
- Inspect internal rotating group for scoring and wear (slippers, pistons and cylinder block, valve plate and cylinder block). If internal damage is found check for missing welch plug: GO TO 0

MX,159025015,6 -19-20APR95

## E TRANSMISSION OPERATES HOT

- Check transmission temperature. GO TO 0
- Check all cooling components for plugged or restricted condition.
- 322, 332 and 430; Test steering valve for neutral return: GO TO U
- Test charge pump pressure: GO TO A
- Inspect internal transmission components for wear or damage. See Section 50.
- Check for dirt accumulation on transmission causing transmission oil to overheat: GO TO 0
- Check for high draft loads causing transmission oil to overheat: GO TO 0

MX,159125015,2 -19-13JUL95

## F MACHINE FREEWHEELS

- Inspect transmission control linkage for loose connections allowing swashplate movement under load. See Section 50.
- 322, 330 and 332; Test for debris in check valves: GO TO '
- Inspect check valves for damaged valve seat, seals or stuck check ball. See Section 50.
- Test charge pump pressure: GO TO A
- Inspect internal rotating group for scoring and wear (slippers, pistons and cylinder block, valve plate and cylinder block). If internal damage is found check for missing welch plug: GO TO 0

MX,159125015,3 -19-13JUL95

## **G HYDRAULIC SYSTEM IS NOISY**

- Check power steering valve, if equipped, or hydraulic control valve for overheating. If either valve is too hot to touch after 1/2 hour of operation, disassemble valve and repair internal leak. See Section 60 or 70.
- Adjust hydrostatic transmission linkage for positive neutral position: GO TO 10
- Check steel hydraulic lines for vibration. Especially the line that runs from the charge pump to the steering valve on 322, 332 and 430 models. Secure with clamps or replace with a rubber pressure hose rated at 8274 kPa (1200 psi).
- Adjust charge relief valve so that charge pressure is above 1379 kPa (200 psi). The increased charge pressure will not cause any problems and it may eliminate the noise, if it is caused by charge relief valve chattering: GO TO 3c
- Increase implement relief pressure to upper limit of specification: GO TO 4b

MX,159125015,4 -19-13JUL95

## **H NO HYDRAULICS AFTER BEING SERVICED**

- Check for improper charge pump installation (180 degrees off). See Section 50.
- Check for proper installation of transmission output shaft bearing into aluminum case. If installed too shallow, the motor rotating group will not contact the valve plate. See Section 50.

MX,159025015,10-19-20APR95

## **I CHARGE PUMP SEAL REPEATEDLY FAILS**

- Inspect the seal surface on the shaft.
- Inspect seal for cuts which may be caused by installing seal over shaft without covering sharp splines.
- Check for a loose or worn U-Joint on the drive shaft.
- Inspect charge pump for wear or damage. Charge pressure may be getting into the seal area because of internal pump leakage. See Section 50.

MX,159025015,11-19-20APR95



*Diagnosis, Tests and Adjustments/Charge Pump*

<p><b>CHECK VALVE DEBRIS CHECK</b></p>	<p>Engine OFF. Service park brake OFF.</p>	<div style="text-align: center;">  <p>M49216      -UN-20DEC89</p> </div> <p>322, 330 and 332; Engage Manual Push lever (A) and push machine forward to remove debris from check valves.</p> <p>Early 430; Remove fender deck. Remove and inspect check valves for debris. Repair or replace if necessary.</p> <p>Later 430; Remove fender deck. Manually depress check valve "buttons" and push machine forward to remove debris from check valves.</p>	<p>Repeat Transmission Drive Check in Group 05.</p> <p style="text-align: right; font-size: small;">MX,159125015.5 -19-13JUL95</p>
--	--	--	--

<p><b>Æ CHARGE PUMP PRESSURE TEST</b></p>	<p>Heat hydraulic oil to 43°C (110°F), See <math>\bar{O}</math> in this group.</p> <p><b>CAUTION: TO AVOID INJURY FROM ESCAPING HYDRAULIC OIL UNDER PRESSURE, RELIEVE THE PRESSURE IN THE SYSTEM BY STOPPING THE ENGINE AND OPERATING ALL HYDRAULIC CONTROL VALVES.</b></p> <p><i>NOTE: It is normal for charge pressure to increase as engine speed or implement pressure increases. Charge pressure up to 3448 kPa (500 psi) at fast idle is normal.</i></p>	<p style="text-align: right;">Continued on next page</p>
---	--	--

<p>M36682 -UN-25JAN90</p>	<p>A—JT03339 Connector                  B—JT03107 Adapter                  C—JT03017 Hose                  D—JT03344 Gauge, 2000 kPa (300 psi)</p>	<p><b>IMPORTANT:</b>                  Hydraulic control levers must remain in neutral position and engine must be run at slow idle.</p> <p>Pressure gauge will be damaged if a hydraulic function is actuated or test is run at fast idle.</p> <p>Make test connections from JT01765 Lawn and Grounds Care Products Hydraulic Fitting Kit.</p> <p>Run engine at slow idle.</p> <p><i>LOOK: Record pressure reading.</i></p> <p>Charge pressure must be 620—1240 kPa (90—180 psi).</p>	<p>CHARGE PRESSURE OK: Inspect check valves for wear or damage. See Section 50. Then repeat Æ</p> <p>CHARGE PRESSURE LOW: REPLACE FILTER, THEN...REPEAT Æ</p> <p>CHARGE PRESSURE STILL LOW: GO TO 3a</p> <p>MX,159025015,13-19-20APR95</p>
---------------------------	--	---	--

<p>3a Charge Pump Suction Line Check</p>	<p>M49217 -UN-20DEC89</p>	<p>Inspect suction line (A) for restriction, loose hose clamp, holes or damage that would cause air leakage.</p>	<p>SUCTION LINE OK: GO TO 3b</p> <p>SUCTION LINE DAMAGED: Repair or replace then bleed hydraulic system. See Section 270, Group 20.</p> <p>MX,159025015,14-19-20APR95</p>
--	---------------------------	--	---

<p>3b Charge Relief Valve Check</p>	<p>M36683 -UN-25JAN90</p>	<p>Remove charge relief valve and check for a broken spring or a stuck or damaged valve. Replace broken parts.</p>	<p>CHARGE RELIEF VALVE OR SPRING WORN: GO TO 3c</p> <p>CHARGE RELIEF VALVE NOT DAMAGED: GO TO Æ</p> <p>MX,159025015,15-19-20APR95</p>
-------------------------------------	---------------------------	--	---

<p>3c Charge Relief Valve Adjustment</p>	<p>M36684 -UN-25JAN90</p>	<p><i>NOTE: Only use shims to increase pressure when valve or spring are worn. Charge pressure will not increase by adding shims if another component is leaking.</i></p> <p>Add shims (A) in spring retainer to increase charge pressure to specification.</p> <p>Check charge pressure.</p>	<p>IF CHARGE PRESSURE IS STILL LOW: GO TO Æ</p> <p>MX,159025015,16-19-20APR95</p>
--	---------------------------	---	---

Diagnosis, Tests and Adjustments/Implement Relief Valve

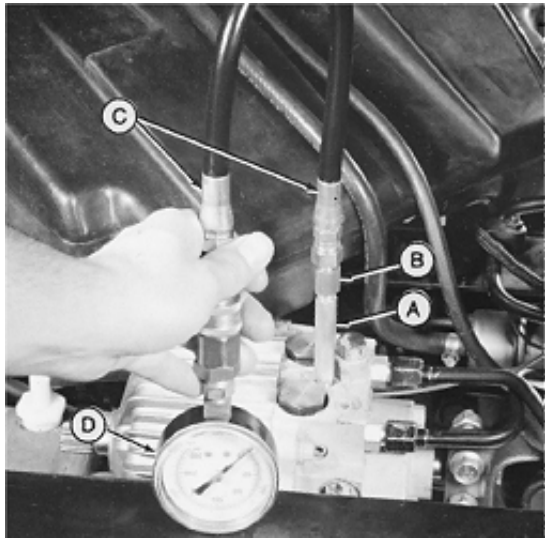
<p><b>IMPLEMENT RELIEF VALVE PRESSURE TEST</b></p>	<p><b>CAUTION: TO AVOID INJURY FROM ESCAPING HYDRAULIC OIL UNDER PRESSURE, RELIEVE THE PRESSURE IN THE SYSTEM BY STOPPING THE ENGINE AND OPERATING ALL HYDRAULIC CONTROL VALVES.</b></p>		<p>A—JT03339 Connector B—JT03107 Adaptor C—JT03017 Hose D—JT03345 Gauge, 20,000 kPa (3000 psi)</p>
--	--	--	--

<p>Make test connections from JT01765 Lawn and Grounds Care Products Hydraulic Fitting Kit.</p> <p>Heat hydraulic oil to 43°C (110°F), see 0 in this group.</p> <p>Run engine at fast idle.</p> <p>Move and hold control valve lever in</p>	<p>full raise position.</p> <p><i>LOOK: Record pressure reading.</i></p> <p>Implement pressure must be 5861—6722 kPa (850—975 psi).</p>	<p>IMPLEMENT PRESSURE OK: GO TO 0</p> <p>IMPLEMENT PRESSURE LOW: GO TO 4a</p> <p>MX,159025015,17-19-21APR95</p>
---	---	---

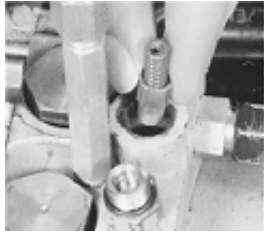
<p><b>4a Implement Relief Valve Check</b></p>	 <p>M36686 -UN-25JAN90</p> <p>Remove implement relief valve and check for a broken spring or a stuck or damaged valve.</p> <p><i>LOOK: Implement relief valve spring is a much heavier spring than the charge relief valve spring.</i></p>	<p>IMPLEMENT RELIEF VALVE NOT DAMAGED: GO TO 4b</p> <p>IMPLEMENT RELIEF VALVE DAMAGED: Replace damaged valve parts, then check implement pressure.</p> <p>IMPLEMENT PRESSURE STILL LOW: GO TO 4b</p> <p>MX,159025015,18-19-20APR95</p>
---	---	--

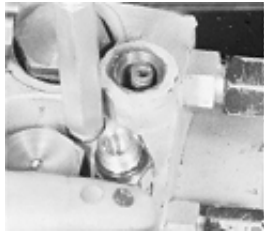
<p><b>4b Implement Relief Valve Adjustment</b></p>	 <p>M36687 -UN-25JAN90</p> <p><i>NOTE: Only use shims to increase pressure when valve or spring are worn. Implement pressure will not increase by adding shims if another component is leaking.</i></p> <p>Add shims in spring retainer to increase implement pressure to specification.</p> <p>Check implement pressure.</p>	<p>IF IMPLEMENT PRESSURE IS STILL LOW: GO TO 0</p> <p>MX,159025015,19-19-20APR95</p>
--	--	--

**0 CHARGE PUMP FLOW TEST**

**CAUTION: TO AVOID INJURY FROM ESCAPING HYDRAULIC OIL UNDER PRESSURE, RELIEVE THE PRESSURE IN THE SYSTEM BY STOPPING THE ENGINE AND OPERATING ALL HYDRAULIC CONTROL VALVES.**

Make front outlet connections from JT01765 Lawn and Grounds Care Products Hydraulic Fitting Kit and JT05469 Flowmeter Kit.

Heat hydraulic oil to 43°C (110°F), See 0 in this group.

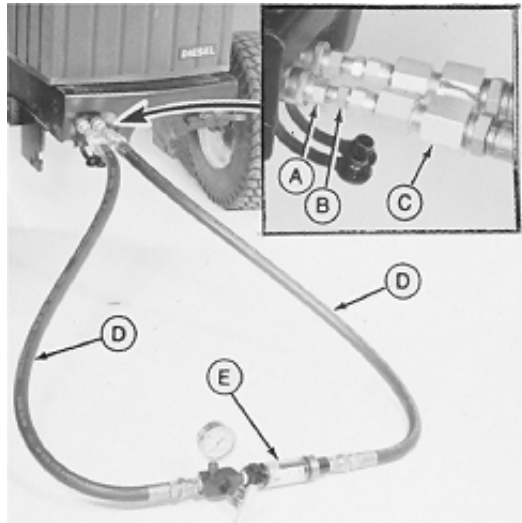

A—JT03340 Quick Coupler  
 B—JT03343 Connector  
 C—JT03342 Coupler  
 D—JT05531 Hose  
 E—STD12 Flowmeter

M36688 -UN-25JAN90

Run machine at fast idle.

Move and hold outside hydraulic control lever in implement lower position. Turn load valve until pressure reaches 3450 kPa (500 psi).

*LOOK: Pump flow must be a minimum of 11 L/min (3 gpm)*

**CHARGE PUMP FLOW OK:** Inspect transmission internal components for wear or damage. See Section 50.

**CHARGE PUMP FLOW NOT OK:** Inspect charge pump for sheared drive pin, wear or damage. Repair or replace, then test charge pump flow.

MX,159025015,20-19-20APR95

**0 WELCH PLUG LOCATION CHECK**

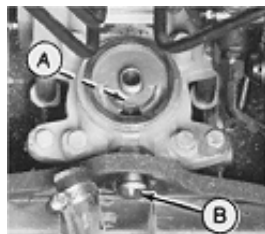

M49218 -UN-20DEC89

*NOTE: If welch plug is missing, unfiltered oil is flowing through the transmission possibly causing excessive wear of the rotating groups and charge pump.*

Remove transmission oil filter.

Check for welch plug at position (A). Put a piece of wire thru threaded fitting. It must hit welch plug and not come out kidney shaped port.

If welch plug is missing install a new one through suction hose fitting (B). Use LOCTITE thread sealant and stake into housing.

MX,159025015,21-19-20APR95

Diagnosis, Tests and Adjustments/Steering Valve Neutral Check (322, 332 and 430)

**0** HYDRAULIC OIL WARM-UP PROCEDURE

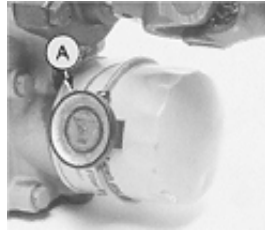

M43008 -UN-18JAN90

Remove belly screen/pan.

Install JDG282 Temperature Gauge (A) on transmission oil filter.

On 430; Partially cover the radiator. Be careful not to cover too much of the radiator causing engine to overheat.

Apply park brake.

Start engine and run at full throttle.

MX,159125015,17-19-13JUL95



M43629 -UN-12JAN90

Move and hold control lever in implement "raise" position.

Periodically cycle all hydraulic functions to distribute heated oil.

NOTE: 330 Shown

Heat oil to temperature specified in test.

NOTE: The hydrostatic transmission should not exceed 93°C (200°F) as a continuous operating temperature.

MX,159125015,6 -19-13JUL95

**U** STEERING VALVE NEUTRAL CHECK (322, 332 and 430)

**CAUTION: TO AVOID INJURY FROM ESCAPING HYDRAULIC OIL UNDER PRESSURE, RELIEVE THE PRESSURE IN THE SYSTEM BY STOPPING THE ENGINE AND OPERATING ALL HYDRAULIC CONTROL VALVES.**

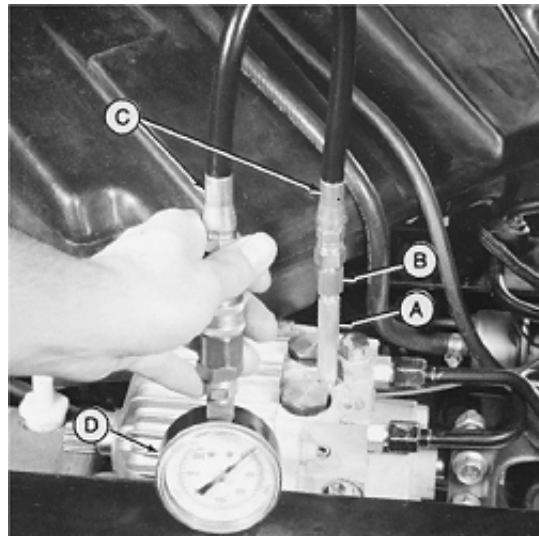

M36682 -UN-25JAN90

A—JT0339 Connector  
B—JT03107 Adaptor  
C—JT03017 Hose  
D—JT03345 Gauge, 20,000 kPa (3000 psi)

Make test connections from JT01765 Lawn and Grounds Care Products Hydraulic Fitting Kit.

Heat hydraulic oil to 43°C (110°F) see 0 in this group.

Run engine at slow idle.

Move steering wheel to left and right turn position.

LOOK: When steering wheel is being turned pressure should increase. When steering wheel is stopped (neutral position) pressure must drop to approximately 620—1240 kPa (90—180 psi).

Repeat several times to ensure neutral position.

**OK: STEERING VALVE RETURNS TO NEUTRAL.**

**STEERING VALVE DOES NOT RETURN TO NEUTRAL: Remove and repair steering valve. See Section 60.**

MX,159125015,7 -19-13JUL95

Diagnosis, Tests and Adjustments/Neutral Return Linkage Adjustment (330, and Early 322, 332, 430)

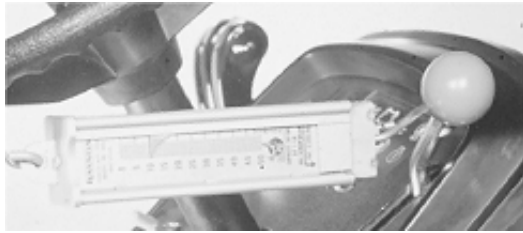
<p><b>Ü HYDROSTATIC LEVER FRICTION ADJUSTMENT</b></p>	<p>Early 430; Remove left and right engine side panels, battery and battery base.</p> <p>322, 330, 332 and Later 430; Remove right-hand pedestal screen/panel.</p>		<p>Connect a scale to hydrostatic control lever.</p>
---	--	--	--

M36674 -UN-25JAN90

MX,159125015,8 -19-13JUL95

		<p>Adjust friction disks by tightening or loosening lock nut (A) until 31—44.5 N (7—10 lb force) is required to move hydrostatic control lever.</p> <p><i>NOTE: Far left photo shows Version One—430.</i></p> <p><i>NOTE: Near left photo shows 330, Version One—322, 332 and Versions Two and Three—322, 332, 430.</i></p>
---	---	---

M36675 -UN-25JAN90

M49215 -UN-20DEC89

MX,159125015,9 -19-13JUL95

<p><b>10 NEUTRAL RETURN LINKAGE ADJUSTMENT</b></p>	<p>Hydrostatic lever friction must be adjusted previous to this adjustment: GO TO Ü</p>
--	---

MX,159125015,10-19-13JUL95

<p><b>1j a 330 and Version One—322 and 332 (Sliding Lever Linkage)</b></p> <p><i>NOTE: For Versions One—430, (J-Bolt Style Linkage): GO TO 1j b For later Versions of 322, 332 and 430 (Detented Neutral Style Linkage): GO TO 1@</i></p>	<p><b>IMPORTANT: This adjustment must be made with pedestal panels installed and hardware tightened.</b></p> <p>Remove belly screen from underneath machine.</p>	
---	--	--

<p>On 322 and 332; Lock both brake pedals together.</p> <p>Apply and lock park brake.</p> <p>Adjust cam plate (A) position by loosening lock nuts (B and C) and moving cam plate until neutral guide (D) just enters neutral slot (E) in</p>	<p>cam plate. Be sure neutral guide does not hit top of cam plate neutral slot.</p> <p>Tighten lock nuts.</p>	<p>Check position of hydrostatic control lever. Lever must be in STOP notch of dash panel. If necessary, loosen lock nut (C) and turn eccentric nut (F) until lever is in STOP notch of dash panel. Tighten lock nut.</p>
--	---	---

MX,159125015,11-19-13JUL95

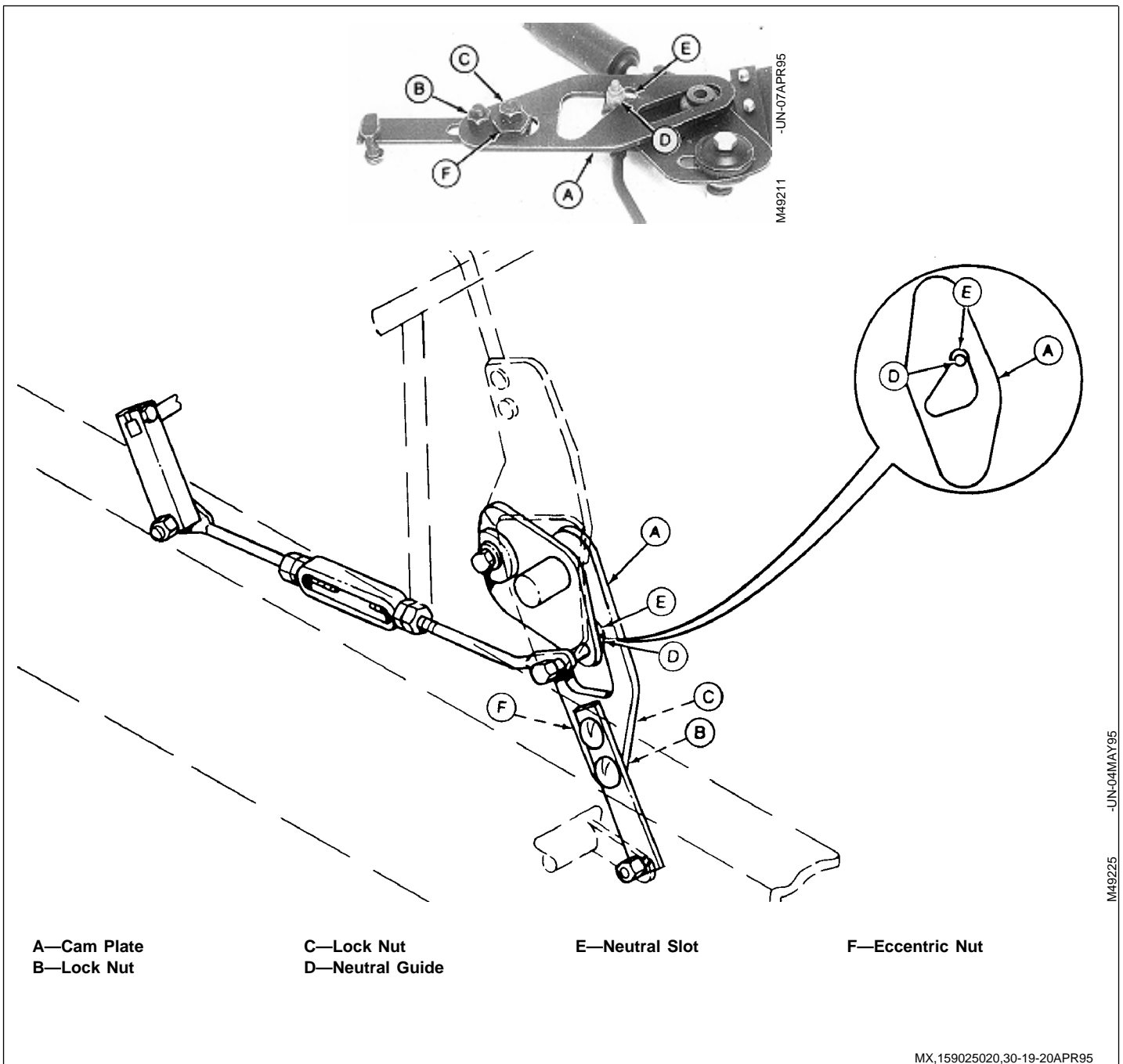

Diagnosis, Tests and Adjustments/Neutral Return Linkage Adjustment (330, and Early 322, 332, 430)

<p><b>1 j b Version One—430 (J-Bolt Style Linkage)</b></p> <p><i>NOTE: For 330 and Version One—322 and 332 (Sliding Lever Linkage): GO TO 1 j a For later Versions of 322, 332 and 430 (Detented Neutral Style Linkage): GO TO 1@</i></p>	<p><b>IMPORTANT: This adjustment must be made with pedestal panels installed and hardware tightened.</b></p> <p>Remove belly screen/pan from underneath machine.</p>	
<p>Lock both brake pedals together.</p> <p>Apply and lock park brake.</p> <p>Adjust cam plate (A) position by tightening or loosening J-Bolt lock nuts (B) until neutral guide (C) just enters neutral slot (D) in cam plate. Be sure neutral guide does not hit</p>	<p>top of cam plate neutral slot.</p> <p>Tighten lock nuts.</p>	<p>Check position of hydrostatic control lever. Lever must be in STOP notch of dash panel. If necessary, loosen lock nut (E) and turn eccentric nut (F) until lever is in STOP notch of dash panel. Tighten lock nut.</p> <p style="text-align: right;">MX,159125015,12-19-13JUL95</p>



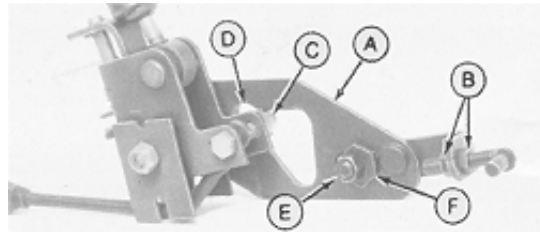

M49213 -UN-20DEC89

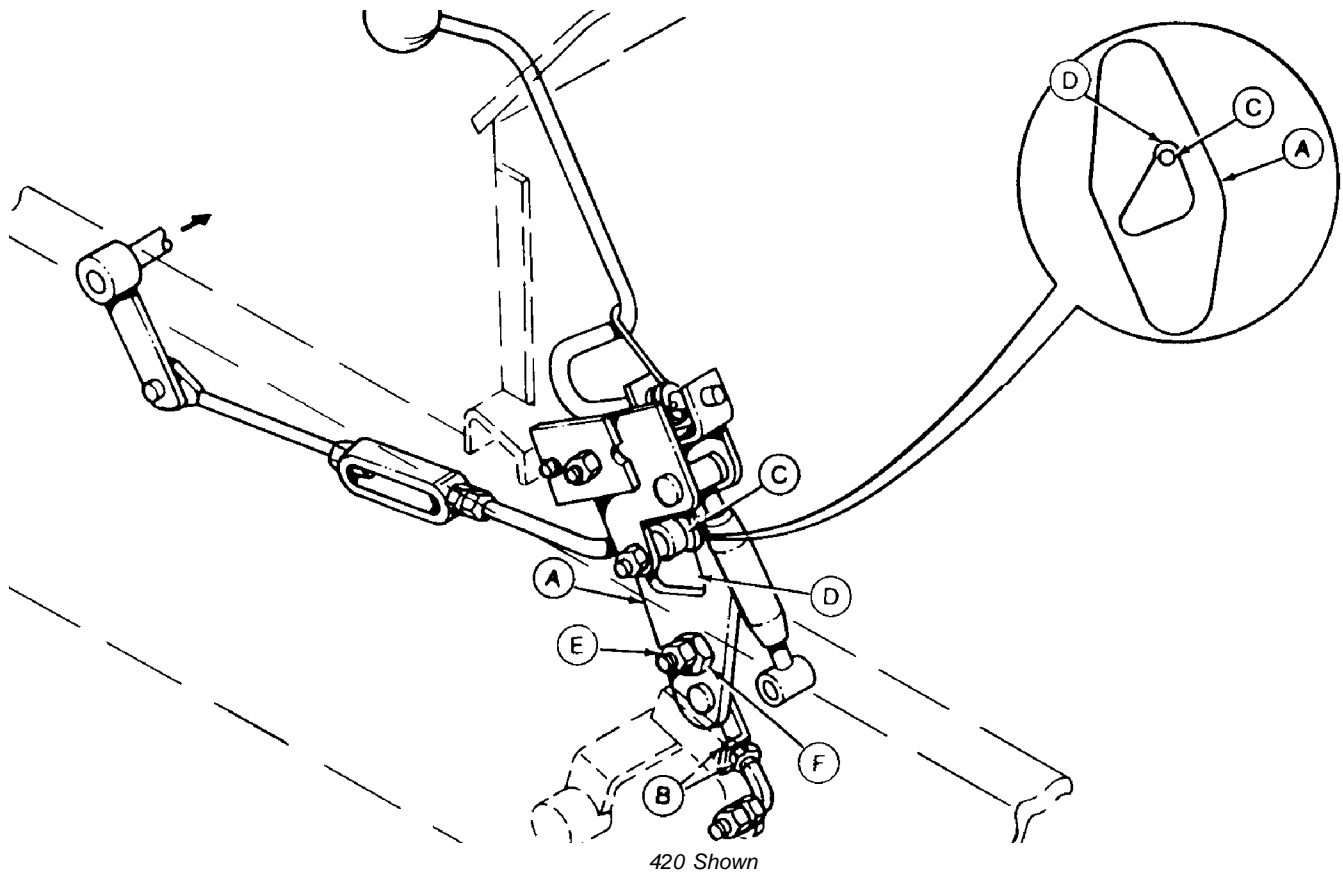

A—Cam Plate  
B—Lock Nuts

C—Neutral Guide  
D—Neutral Slot

E—Lock Nut

F—Eccentric Nut

M49226 -UN-04MAY95

MX,159025020,33-19-20APR95

**1!** NEUTRAL ADJUSTMENT (330 and Version One—322, 332 and 430)

**IMPORTANT:** This adjustment must be made with pedestal panels installed and hardware tightened.

Remove fender deck.

Raise rear of machine and put jack stands under frame.



M36668 -UN-25JAN90

Move hydrostatic control lever to STOP position.

On 430; Move Two-speed axle lever to low speed position.

Continued on next page



M36677 -UN-25JAN90

**CAUTION: USE EXTREME CAUTION WHEN PERFORMING THIS ADJUSTMENT BECAUSE DRIVE WHEELS ARE FREE TO SPIN AND DRIVE SHAFT IS CLOSE TO TURNBUCKLE.**

Loosen lock nuts.

Start and run engine at fast idle. Turn turnbuckle (A) as required until the drive wheels stop turning.

Turn engine OFF.

**IMPORTANT: Tighten lock nuts to proper torque to prevent loss of neutral.**

Hold turnbuckle and tighten lock nuts to 33 N-m (24 lb-ft).

Start engine and check for tire movement. Readjust if necessary.

MX,159125015,13-19-13JUL95

**1@ NEUTRAL AND NEUTRAL RETURN LINKAGE ADJUSTMENT (Later Versions—322, 332 and 430) (Detented Neutral Style Linkage)**

*NOTE: For 330 and Version One—322 and 332 (Sliding Lever Linkage): GO TO 1j a For Version One—430 (J-Bolt Style Linkage): GO TO 1j b*

Remove right-hand pedestal screen, belly screen/pan and fender deck.

Move and secure fuel tank off to the left side of machine to gain access to linkage.

*NOTE: Early machines with this style of linkage will have the torsional dampener behind the pedestal. Later machines will have the dampener attached to the frame behind the swashplate on the hydrostatic transmission. The hydrostatic control link may be different also. Both versions are covered by this adjustment.*

Raise rear wheels off the ground. Put jack stands under frame.

Continued on next page

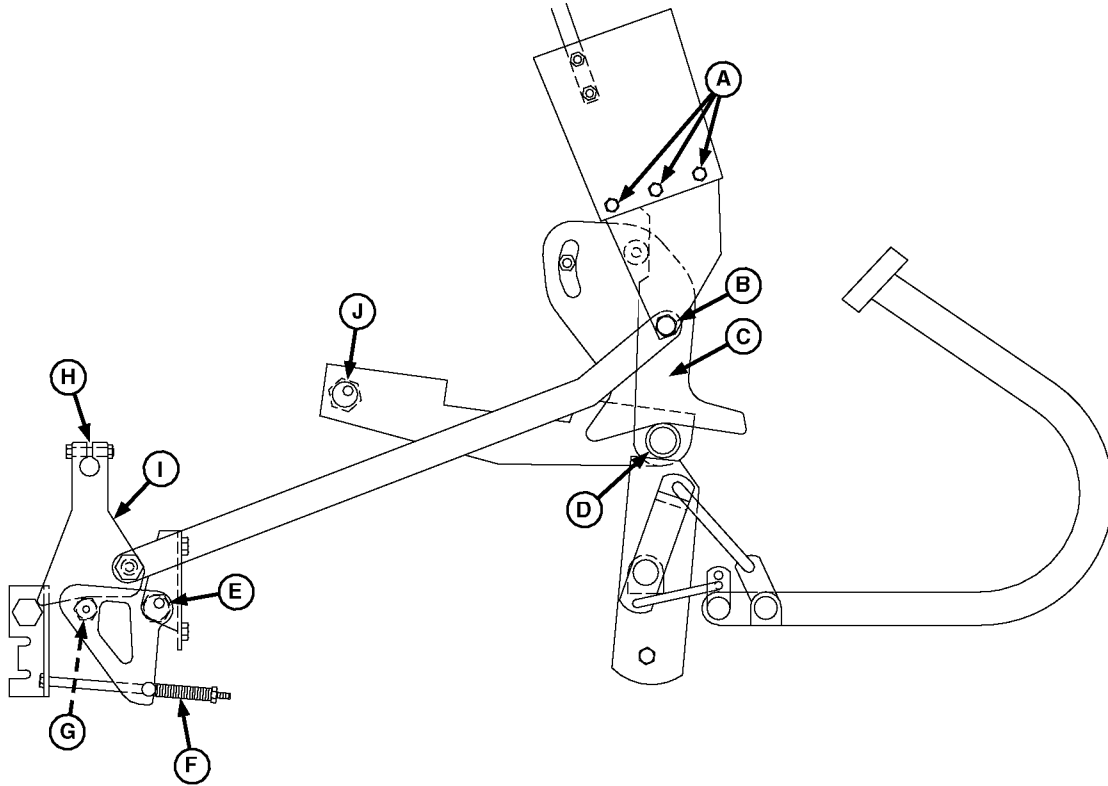

M51871 -UN-26APR95

A—Bolts  
B—Bolt  
C—Cam Plate

D—Roller  
E—Eccentric  
F—Detent Spring

G—Roller  
H—Slot

I—Swashplate Control Arm  
J—Eccentric

Loosen bolts (A and B).

Place a screwdriver in slot (H) and move swashplate control arm (I) until roller (G) is centered in detent notch.

Adjust length of detent spring (F) to 50 mm (1.970 in.).

**CAUTION: BE AWARE OF SPINNING DRIVE SHAFT AND WHEELS WHEN PERFORMING THE NEXT ADJUSTMENT.**

Start and run engine at fast idle.

Loosen bolt and adjust eccentric (E) until rear wheels stop turning, then tighten eccentric bolt.

Stop engine.

Loosen bolt and adjust eccentric (J) until bolt (B) is exactly centered in hole, while making sure roller (D) is centered in notch of cam plate (C).

Tighten bolt (B) and eccentric (J) bolt while holding eccentric in place.

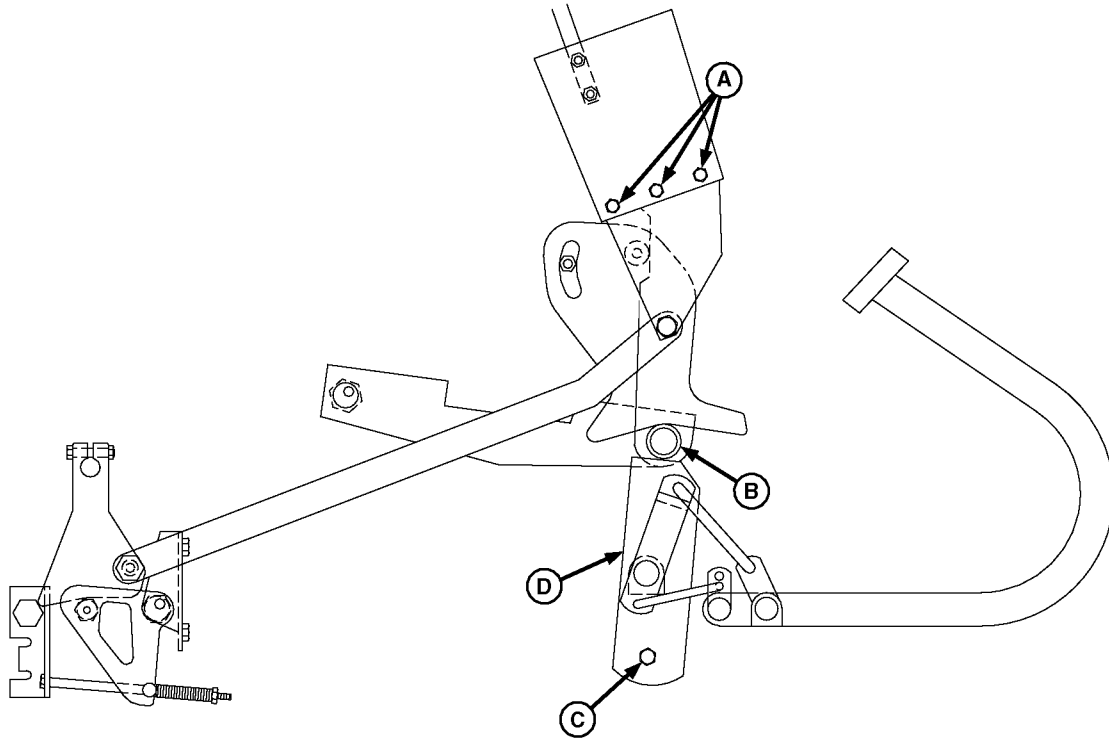

M51872 -UN-26APR95

**A—Bolts**

**B—Roller**

**C—Bolt(s)**

**D—Plate**

Lock park brake.

Loosen bolt(s) (C). (One bolt on 316 and 318, two bolts on 420).

Slide plate (D) upward until it firmly contacts roller (B).

Tighten bolt(s) (C).

Place the hydrostatic shift lever in the "STOP" position in the quadrant.

Tighten bolts (A).

Unlock park brake.

Adjust hydrostatic shift lever friction: GO TO Ü

Diagnosis, Tests and Adjustments/Differential Lock Linkage Check (430)

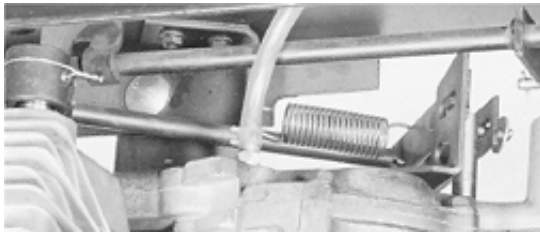
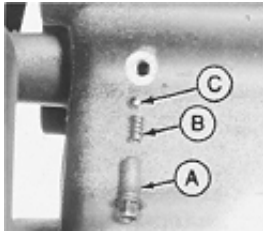
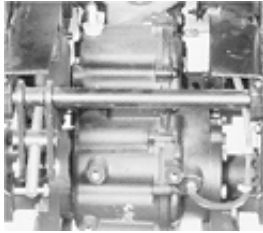
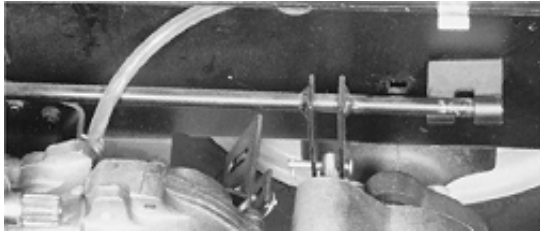
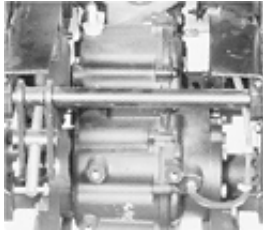
<p><b>1# TWO-SPEED AXLE LEVER LINKAGE CHECK (430)</b></p>	 <p>M36693 -UN-25JAN90</p>	<p>Remove belly pan.</p> <p>Inspect two-speed axle lever linkage for missing pin, broken spring, wear or damage. Plate notch must engage slots easily.</p>	<p>LINKAGE OK: GO TO 1fa</p> <p>LINKAGE DAMAGED: Repair or replace as necessary.</p> <p>MX,159125015,15-19-13JUL95</p>
<p><b>1fa Two-speed Axle Lever Detent Adjustment</b></p>	 <p>M36694 -UN-25JAN90</p>	<p>Remove fender deck and fuel tank.</p> <p>Remove detent screw (A), spring (B) and ball (C). Inspect parts for damage; replace as necessary. Install ball and spring.</p> <p>Apply thread lock and sealer (low strength) on detent screw threads. Install and tighten detent screw. If two-speed lever is hard to move, turn detent screw counterclockwise one turn.</p>	<p>DETENT OK: GO TO 1fb</p> <p>MX,159025020,40-19-20APR95</p>
<p><b>1fb Differential Inspection</b></p>	 <p>M36695 -UN-25JAN90</p>	<p>Remove and disassemble differential. (See procedures in Section 50.)</p> <p>Inspect shifter fork and two-speed gears for improper assembly, wear or damage.</p>	<p>MX,159025020,41-19-20APR95</p>
<p><b>1\$ DIFFERENTIAL LOCK LINKAGE CHECK (430)</b></p>	 <p>M36696 -UN-25JAN90</p>	<p>Remove belly pan.</p> <p>Inspect differential lock linkage for missing pin, bent rod, wear or damage. Differential lock shift rod must slide in and out easily.</p>	<p>LINKAGE OK: GO TO 1a</p> <p>MX,159125015,16-19-13JUL95</p>
<p><b>1a Differential Inspection</b></p>	 <p>M36695 -UN-25JAN90</p>	<p>Remove and disassemble differential. (See procedures in Section 50.)</p> <p>Inspect shifter fork, shift collar, pins, shift rod, and springs for improper assembly, wear or damage.</p>	<p>MX,159025020,43-19-20APR95</p>



# Section 260 STEERING AND BRAKES CHECKOUT, OPERATION AND DIAGNOSIS

260

## Contents

Page

### Group 05—Steering And Brakes System Checkout

Before You Start . . . . .	260-05-1
Steering System Oil Leak Check (322, 332 and 430) . . . . .	260-05-1
Hydrostatic Steering System Check (322, 332 and 430) . . . . .	260-05-2
Service Park Brake Check . . . . .	260-05-3
Turn Brake Check (322, 332 and 430) . . .	260-05-3
Operator Complaint Not Identified . . . . .	260-05-4

### Group 10—Theory of Operation

Steering Valve/System Operation . . . . .	260-10-2
---	----------

### Group 15—Diagnosis, Tests and Adjustments

About This Group . . . . .	260-15-1
Troubleshooting Guide . . . . .	260-15-1
Hydraulic Oil Warm-Up Procedure . . . . .	260-15-4
Steering System Leakage Test . . . . .	260-15-5
Steering Valve Leakage Test . . . . .	260-15-5





# Group 05

## Steering And Brakes System Checkout

### BEFORE YOU START

Always begin with this group to identify a failure in the steering system. The step-by-step procedures will provide you with a quick check of the system. No special tools are required to perform these checks. If a failure is indicated you will be referred to a more detailed check, adjustment, or test.

Always start with the first step and follow the sequence from left to right. Read each step completely before performing the check.

This procedure is designed as a quick check of the system. While performing the check, concentrate only on the check you are performing and disregard signals from unrelated components.

*NOTE: The 330 has manual steering (gearbox).*

*The 322, 332 and 430 have power steering (steering valve).*

MX,159126005,1 -19-13JUL95

### ; STEERING SYSTEM OIL LEAK CHECK (322, 332 AND 430)

MX,159126005,2 -19-13JUL95

Check hydraulic oil level, condition and viscosity.



M49199 -UN-07APR95

Inspect for external hydraulic oil leakage from steering valve, cylinder, lines and fittings.

*NOTE: 322/332 Shown*

**OK:** GO TO '

**NOT OK:** Repair or replace, then GO TO '

MX,159126005,4 -19-13JUL95

260  
05  
2

**HYDROSTATIC STEERING SYSTEM CHECK (322, 332 AND 430)**

MX,159126005,5 -19-13JUL95

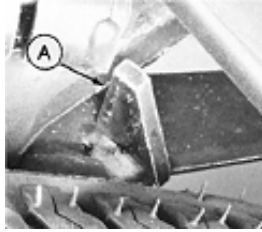
<p><b>2a Power Steering Check</b></p>	<p>Start engine and run at full throttle.</p>	 <p>M49195 -UN-02FEB90</p> <p>Turn steering wheel full left, then full right.</p> <p><i>FEEL: Smooth, constant effort should be felt.</i></p> <p><i>LOOK: Wheels must stop turning when steering wheel is stopped.</i></p> <p><i>LOOK: Wheels must move full left and full right. Stops (A) must contact axle.</i></p>	<p><b>OK: CONTINUE WITH TEST</b></p> <p>WHEELS CONTINUE TURNING AFTER STEERING WHEEL IS STOPPED: GO TO I , GROUP 15.</p> <p>STOPS DO NOT CONTACT AXLE: GO TO G, GROUP 15.</p> <p>MX,159026005,4 -19-24APR95</p>
---------------------------------------	---	---	---

 <p>M55027 -UN-09DEC89</p>	<p>Count the number of revolutions of the steering wheel from a full right turn to a full left turn then, from a full left turn to a full right turn.</p> <p>Approximate revolutions from right turn to left . . . . . 3                  Approximate revolutions from left turn to right . . . . . 2-1/2</p>	<p><b>OK: GO TO 2b</b></p> <p>INCORRECT NUMBER OF STEERING WHEEL REVOLUTIONS: GO TO Æ, GROUP 15.</p> <p>MX,159026005,5 -19-24APR95</p>
---	---	--

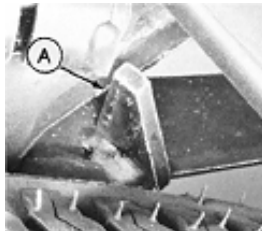
<p><b>2b Manual Steering Check</b></p>	<p>Engine OFF.</p>	 <p>M49195 -UN-02FEB90</p> <p>Turn steering wheel full left, then full right.</p> <p><i>LOOK: Wheels must move full left and full right.</i></p> <p><i>LOOK: Stops (A) must contact axle.</i></p>	<p><b>OK: GO TO Æ</b></p> <p>WHEELS DO NOT MOVE FULL LEFT AND FULL RIGHT: Remove and inspect steering valve check valve. See Section 60.</p> <p>STOPS DO NOT CONTACT AXLE: GO TO G, GROUP 15.</p> <p>MX,159026005,6 -19-24APR95</p>
--	--------------------	--	---

**Æ SERVICE PARK BRAKE CHECK**

MX,159026005,7 -19-24APR95

<p><b>3a Park Brake Lock Lever Check</b></p>	 <p>M49000 -UN-08JAN90</p>	<p>Depress brake pedal(s) and engage service park brake lock.</p> <p><i>LOOK: Service park brake must remain in park position.</i></p>	<p>Disengage service park brake.</p> <p>Move park brake knob up and down.</p> <p><i>FEEL: Slight spring pressure should be felt.</i></p>	<p><b>OK:</b> GO TO 3b</p> <p><b>NOT OK:</b> Adjust park brake linkage. See Section 60.</p> <p>MX,159026005,8 -19-24APR95</p>
--	---	--	--	---

<p><b>3b Brake Pedal(s) Check</b></p>	 <p>M49001 -UN-08JAN90</p>	<p>Latch brake pedals together, if equipped. Depress brake pedal(s) and engage service park brake lock.</p> <p><i>NOTE: 322 Shown</i></p>	<p>Try to move hydrostat lever forward or reverse.</p> <p><i>FEEL: Lever must NOT move from STOP position.</i></p>	<p><b>OK:</b> GO TO Å</p> <p><b>NOT OK:</b> Adjust park brake linkage and shoes. See Section 60.</p> <p>MX,159126005,6 -19-13JUL95</p>
---------------------------------------	---	---	--	--

**Å TURN BRAKE CHECK (322, 332 AND 430)**

MX,159126005,3 -19-13JUL95

<p>Drive machine forward at medium speed.</p>	 <p>M49002 -UN-08JAN90</p>	<p>Depress left, then right turn brake.</p> <p><i>LOOK: Left, then right wheel must stop and other must continue driving.</i></p>	<p><b>OK:</b> System normal.</p> <p><b>NOT OK:</b> Inspect and adjust brake shoes. See Section 60.</p> <p>MX,159126005,7 -19-13JUL95</p>
---	---	---	--

**Ö OPERATOR COMPLAINT NOT IDENTIFIED**

260  
05  
4

MX,159026005,11-19-24APR95

If you completed the checkout procedure and did not isolate a malfunction, the problem may be intermittent.

Try to duplicate the condition of the malfunction identified by the operator.

Repeat system checkout in this group.

IF A MALFUNCTION IS NOT IDENTIFIED AFTER REPEATING SYSTEM CHECKOUT PROCEDURE, FACTORY ASSISTANCE IS AVAILABLE THROUGH THE DEALER TECHNICAL ASSISTANCE CENTER (DTAC).

MX,159026005,14-19-24APR95

260  
10  
1

## STEERING VALVE/SYSTEM OPERATION

### Function:

Supply pressurized oil to the proper side of the steering cylinder to turn the wheels, when the engine is running.

### Theory of Operation:

*NOTE: Right-hand turn shown.*

All external oil flow from the transmission is routed through the steering valve. The steering valve is an open center type valve. The "five-port" design provides "power beyond" to the auxiliary hydraulic systems only after satisfying steering valve needs.

The steering valve consists of a self-centering fluid control valve section (E) and a fluid metering section (H). These are hydraulically and mechanically interconnected inside the valve (C).

### NEUTRAL:

Whenever the steering wheel (G) is released, the centering springs (D) return the control valve section to the center (neutral) position. In this position, charge pressure oil entering the steering valve through port "IN" is allowed to flow through the control valve section and out through port "AUX". When in neutral position, the control valve prevents charge pressure oil from entering the fluid metering section.

### POWER TURN:

As the steering wheel is turned to the right, the control valve section is shifted by the drive link assembly (B). This shifting opens the steering cylinder ports "RT" and "LT". Oil flow to auxiliary hydraulic systems through port "AUX" is reduced giving the steering valve priority over the auxiliary system components.

Oil flows from port "IN" directly to the inlet of the control valve section. As the steering wheel is turned,

charge pressure oil is routed through the control valve section to the fluid metering section. Metered oil is routed to port "RT" on the steering cylinder. Return oil from the other end of the steering cylinder is routed back to port "LT", through the control valve and "OUT" port, returning to the transmission.

When the rotation of the steering wheel stops, the centering springs (D) move the control valve section back to the center (neutral) position, and will remain there until the steering wheel is moved again.

### MANUAL TURN:

If hydraulic pressure is lost, the machine can still be steered without hydraulic assistance. All components still function the same with the exception of the fluid metering section (H). The fluid metering section now acts as a pump, moving oil from one side of the metering section to the other as the steering wheel is turned.

When the rotation of the steering wheel stops, the centering springs move the valve back to the center (neutral) position, and will remain there until the steering wheel is moved again.

### STEERING CYLINDER OPERATION:

The steering cylinder is a double-acting design.

One end of the cylinder is attached to the frame which prevents the cylinder from moving. The rod end is attached to the steering arm/spindle.

As pressurized oil enters the cylinder, the piston and rod move, moving the steering arm, causing the machine to turn.

To turn in the other direction, pressurized oil is applied to the other port, moving the cylinder in the opposite direction.

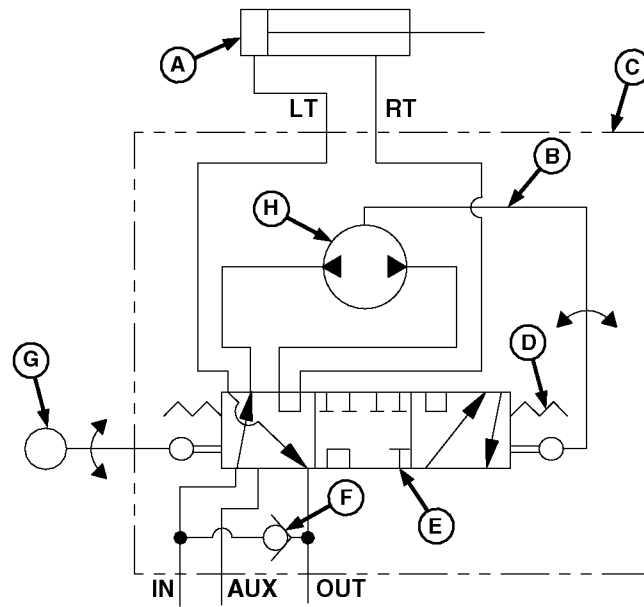

A—Steering Cylinder  
B—Drive Link Assembly

C—Steering Valve  
D—Centering Springs

E—Control Valve Section  
F—Check Valve

G—Steering Wheel  
H—Fluid Metering Section

MX,159026010,3 -19-24APR95

260  
10  
3

M78855 -JUN-26APR95

260  
10  
4



## ABOUT THIS GROUP

The step-by-step procedures in this group provide you with the detailed diagnostic information you will need to perform a test. Basic diagnostic equipment is used.

It is assumed that you are familiar with the machine and its steering system components. If you need additional information, read the theory of operation in Group 10 or refer to the overall hydraulic schematics in Section 270, Group 10.

Engine rpm and temperature are critical in most hydraulic tests. Be sure to follow test specifications carefully.

Always start with the first step and follow the sequence from left to right. Read each step completely before performing the test.

Upon completing a test or adjustment, check to see whether the problem is corrected.

*NOTE: The 330 has manual steering (gearbox).*

*The 322, 332 and 430 have power steering (steering valve).*

*Therefore, all solutions to the symptoms may not apply to your particular machine.*

MX,159126015,1 -19-13JUL95

## ; TROUBLESHOOTING GUIDE

If the steering system does not operate properly, select the appropriate symptom from the list below.

After selecting the appropriate symptom, go to that step and perform the following checks, tests, or adjustments in the order shown to isolate and repair the malfunction.

- STEERING WANDER: GO TO A
- STEERING SHIMMY: GO TO B
- SLUGGISH STEERING RESPONSE: GO TO C
- LOST MOTION AT THE STEERING WHEEL: GO TO D
- HIGH STEERING EFFORT IN ONE DIRECTION: GO TO E
- HIGH STEERING EFFORT IN BOTH DIRECTIONS: GO TO F
- WHEELS DO NOT HIT STOP: GO TO G
- STEERING EFFORT IS ERRATIC: GO TO H
- WHEELS CONTINUE TURNING AFTER STEERING WHEEL IS STOPPED: GO TO I

MX,159026015,2 -19-24APR95

## A STEERING WANDER

- Check for correct tire size.
- Check front tires for incorrect or unequal pressure.
- Check for loose or worn steering linkage parts.
- Check for worn wheel bearing or spindle bushings.
- Check Toe-In adjustment: See Section 80.

MX,159026015,3 -19-24APR95

## B STEERING SHIMMY

- Check for improperly mounted tire or wheel.
- Check for loose or worn steering linkage parts.
- Check for worn wheel bearings or spindle bushings.
- Bleed hydraulic system: See Section 270, Group 20.
- Check Toe-In adjustment: See Section 80.

MX,159026015,4 -19-24APR95

## C SLUGGISH STEERING RESPONSE

- Bleed hydraulic system: See Section 270, Group 20.
- Check for bent or restricted return line, oil cooler (if equipped) oil filter or steering linkage.
- Check for restricted oil filter or charge pump suction line.
- Check for cylinder rod binding in cylinder barrel.
- Check implement relief pressure. See Section 250.
- Test for steering system leakage. GO TO Æ
- Adjust engine rpm: See Section 220.

MX,159026015,5 -19-30MAR95

## **D LOST MOTION AT STEERING WHEEL**

- Check for loose or worn steering linkage.
- Check for steering valve loose at mounting.
- Bleed hydraulic system: See Section 270, Group 20.

MX,159026015,6 -19-30MAR95

260  
15  
3

## **E HIGH STEERING EFFORT IN ONE DIRECTION**

- Check for binding of linkage or cylinder rod binding in cylinder barrel.
- Check for bent or restricted return line.
- Test for steering system leakage: GO TO Æ
- Inspect plate valve for sticking: See Section 60.

MX,159026015,7 -19-30MAR95

## **F HIGH STEERING EFFORT IN BOTH DIRECTIONS**

- Check for improperly mounted tires or wheels.
- Check for binding of steering linkage and cylinder.
- Check for bent or restricted return line, oil cooler (if equipped) or oil filter.
- Check implement relief pressure. See Section 250.
- Check for steering valve check ball missing, damaged, or in "IN" port: See Section 60.
- Adjust engine rpm: See Section 220.
- Check for dirt accumulation on transmission causing transmission to overheat: GO TO '
- Check for high draft load causing transmission to overheat: GO TO '

MX,159026015,8 -19-30MAR95

**G WHEELS DO NOT HIT STOP**

- Check for bent steering linkage, cylinder or cylinder rod.

MX,159026015,9 -19-30MAR95

**H STEERING EFFORT IS ERRATIC**

- Bleed hydraulic system: See Section 270, Group 20.
- Test for steering system leakage. GO TO Æ

MX,159026015,10-19-30MAR95

**I WHEELS CONTINUE TURNING AFTER STEERING WHEEL IS STOPPED**

- Inspect valve plate for sticking: See Section 60.
- Inspect steering valve springs for wear or damage: See Section 60.

MX,159026015,11-19-30MAR95

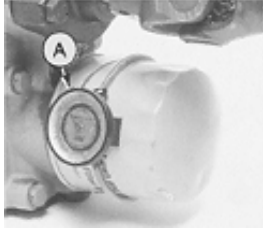
<p><b>HYDRAULIC OIL WARM-UP PROCEDURE</b></p>	 <p>M43008 -UN-18JAN90</p>	<p>Remove belly screen/pan.</p> <p>Install JDG282 Temperature Gauge (A) on transmission oil filter.</p> <p>On 430; Partially cover the radiator. Be careful not to cover too much of the radiator causing engine to overheat.</p>	<p>Apply park brake.</p> <p>Start engine and run at full throttle.</p> <p>MX,159126015,3 -19-13JUL95</p>
---	---	---	--

 <p>M43629 -UN-12JAN90</p>	<p>Move and hold control lever in implement "raise" position.</p> <p>Periodically cycle all hydraulic functions to distribute heated oil.</p> <p><i>NOTE: 330 Shown</i></p>	<p>Heat oil to temperature specified in test.</p> <p><i>NOTE: The hydrostatic transmission should not exceed 93°C (200°F) as a continuous operating temperature.</i></p> <p>MX,159125015,6 -19-13JUL95</p>
---	---	--



*Diagnosis, Tests and Adjustments/Steering Valve Leakage Test*

<p><b>Æ STEERING SYSTEM LEAKAGE TEST</b></p>	<p>Heat hydraulic oil to 43°C (110°F). See ' in this group.</p> <p>Start engine and run at slow idle.</p>	 <p>M49198 -UN-20DEC89</p>	<p>With wheels in a maximum right position, turn steering wheel with a constant torque of 6.8 N-m (60 lb-in.) for one minute.</p> <p><i>LOOK: Count the revolutions.</i></p> <p>RPM must not exceed 6.</p>
--	---	---	--

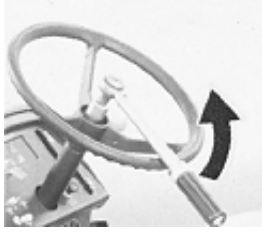
260  
15  
5

 <p>M49197 -UN-20DEC89</p>	<p>With wheels in a maximum left position, turn steering wheel with a constant torque of 6.8 N-m (60 lb-in.) for one minute.</p> <p><i>LOOK: Count the revolutions.</i></p> <p>Rpm must not exceed 6.</p>	<p><b>6 RPM OR LESS: STEERING SYSTEM OK.</b></p> <p><b>MORE THAN 6 RPM: GO TO Å</b></p> <p align="right">MX,159026015,13-19-27MAR95</p>
---	---	---

<p><b>Å STEERING VALVE LEAKAGE TEST</b></p>	<p><b>CAUTION: TO AVOID INJURY FROM ESCAPING HYDRAULIC OIL UNDER PRESSURE, RELIEVE THE PRESSURE IN THE SYSTEM BY STOPPING THE ENGINE AND OPERATING ALL HYDRAULIC CONTROL VALVES.</b></p>	 <p>M49196 -UN-20DEC89</p>	<p>Remove cap nut on left front side of fender deck and raise fender deck to access hydraulic lines. (Fender deck is removed in photo only for clarity of procedure.)</p> <p>Disconnect hydraulic lines at fittings (A) and plug fittings (A) with JT03391 Plugs.</p> <p>Start engine and run at slow idle.</p> <p align="right">MX,159126015,2 -19-13JUL95</p>
---	--	---	---

 <p>M49198 -UN-20DEC89</p>	<p>With wheels in a maximum right position, turn steering wheel with a constant torque of 6.8 N-m (60 lb-in.)</p> <p><i>LOOK: Count the revolutions.</i></p> <p>RPM must not exceed 6.</p>	 <p>M49197 -UN-20DEC89</p>	<p>With wheels in a maximum left position, turn steering wheel with a constant torque of 6.8 N-m (60 lb-in.)</p> <p><i>LOOK: Count the revolutions.</i></p> <p>RPM must not exceed 6.</p> <p><b>6 RPM OR LESS: STEERING VALVE OK: Replace steering cylinder.</b></p> <p><b>MORE THAN 6 RPM: Remove and repair steering valve. (See Section 60.)</b></p> <p align="right">MX,159026015,15-19-27MAR95</p>
---	--	---	---

260  
15  
6

Section 270

# HYDRAULIC SYSTEM CHECKOUT, OPERATION AND DIAGNOSIS

## Contents

Page

### Group 05—Hydraulic System Checkout

Before You Start . . . . .	270-05-1
Hydraulic System Oil Leak Check . . . . .	270-05-1
Hydraulic Control Valve Check . . . . .	270-05-2
Operator Complaint Not Identified . . . . .	270-05-2

### Group 10—Hydraulic Schematics

Hydraulic Circuit Symbols . . . . .	270-10-2
Hydraulic System Schematics	
330 . . . . .	270-10-5
322 and 332 . . . . .	270-10-6
430 . . . . .	270-10-9

### Group 15—Theory of Operation

Hydraulic Lift System Operation	
Three-Position Spool . . . . .	270-15-1
Four-Position Spool . . . . .	270-15-2

### Group 20—Diagnosis, Tests and Adjustments

About This Group . . . . .	270-20-1
Troubleshooting Guide . . . . .	270-20-2
Hydraulic Oil Warm-Up Procedure . . . . .	270-20-5
Rockshaft Cylinder Leakage Test . . . . .	270-20-5
Control Valve Leakage Test . . . . .	270-20-6
Bleed Hydraulic System . . . . .	270-20-8

270





## BEFORE YOU START

Always begin with this group to identify a failure in the hydraulic system. The step-by-step procedures will provide you with a quick check of the system. No special tools are required to perform these checks. If a failure is indicated, you will be referred to a more detailed check, adjustment, or test.

Always start with the first step and follow the sequence from left to right. Read each step completely before performing the check.

This procedure is designed as a quick check of the system. While performing the check, concentrate only on the check you are performing and disregard signals from unrelated components.

*NOTE: The 330 has manual steering (gearbox), single-spool control valve and rockshaft cylinder.*

*The 322 and 332 have power steering, steering cylinder, two-spool control valve, rockshaft cylinder and oil cooler (optional).*

*The 430 has power steering, steering cylinder, three-spool control valve, rockshaft cylinder and oil cooler.*

*For further information, refer to the overall hydraulic schematics in Group 10.*

MX,159127005,1 -19-13JUL95

<p><b>HYDRAULIC SYSTEM OIL LEAK CHECK</b></p>	<p>Check hydraulic oil level, condition and viscosity.</p>	 <p style="font-size: small;">M49199 -UN-07APR95</p>	<p>Inspect control valve, cylinders, lines, hoses and fittings for external hydraulic oil leakage.</p> <p style="text-align: center;"><i>NOTE: 330 Shown</i></p>	<p><b>OK:</b> GO TO ' '</p> <p><b>NOT OK:</b> Repair or replace, then GO TO ' '</p> <p style="text-align: right; font-size: small;">MX,159127005,2 -19-13JUL95</p>
---	--	--	--	--

270  
05  
1

Hydraulic System Checkout/Operator Complaint Not Identified

**HYDRAULIC CONTROL VALVE CHECK**

*NOTE: 330; Single lever controls rockshaft cylinder and right-hand front outlets.*

**322 and 332 Levers;**

- Inside lever controls right-hand front outlets “float” and optional rear outlets.
- Outside lever controls rockshaft cylinder and left-hand front outlets..

**430 Levers;**

- Inside lever controls right-hand front outlets “float”.
- Middle lever controls rockshaft cylinder.
- Outside lever controls left-hand front and optional rear outlets.



M36699 -UN-25JAN90

Run engine at full throttle.

Pull control valve lever rearward to raise implement. Release lever.

*LOOK: Implement must raise and hold position without dropping. Lever must return to neutral.*

*NOTE: 322/332 Shown*

270  
05  
2

*NOTE: With the exception of “float” position, all control valve levers should operate the same with an attachment correctly connected to the particular hydraulic system.*

- All control valve levers except “float” position:

Push control valve lever forward to lower implement. Release lever.

*LOOK: Implement must lower and hold position. Lever must return to neutral.*

Pull control valve lever rearward to raise implement. Release lever.

*LOOK: Implement must raise and hold position. Lever must return to neutral.*

- Control valve lever “float” position:

Push control valve lever forward to float position. Release lever.

*LOOK: Implement must lower to ground and lever must stay in float position.*

- All control valve levers:

Pull control valve lever rearward

and raise implement halfway.

Turn engine OFF.

Pull control valve rearward to raise implement.

*LOOK: Implement must not move down.*

**OK:** Procedure complete. System is normal.

**NOT OK:** GO TO ; in Group 20.

MX,159127005,3 -19-13JUL95

**Æ OPERATOR COMPLAINT NOT IDENTIFIED**

If you completed the checkout procedure and did not isolate a malfunction, the problem may be intermittent.

Try to duplicate the condition of the malfunction identified by the operator.

IF A MALFUNCTION IS NOT IDENTIFIED AFTER SYSTEM CHECKOUT PROCEDURE, FACTORY ASSISTANCE IS AVAILABLE THROUGH THE DEALER TECHNICAL ASSISTANCE CENTER (DTAC).

MX,159027005,4 -19-24APR95

**HYDRAULIC SYSTEM SCHEMATICS**

The hydraulic system schematics on the following pages can be folded out for use while diagnosing malfunctions or while repairing hydraulic components.

MX,159027010,1 -19-24APR95

270  
10  
1

HYDRAULIC CIRCUIT SYMBOLS

LINES

1		WORKING (MAIN) LINES
2		PILOT CONTROL LINES
3		DRAIN LINE
4		HYDRAULIC } FLOW PNEUMATIC } DIRECTION
5		CROSSING LINES
6		JOINING LINES
7		FLEXIBLE LINE

PUMPS

8		FIXED DISPLACEMENT
9		VARIABLE DISPLACEMENT

MOTORS

10		FIXED DISPLACEMENT
11		VARIABLE DISPLACEMENT

RESERVOIR

12		VENTED RESERVOIR
13		PRESSURIZED RESERVOIR
14		RESERVOIR RETURN - ABOVE FLUID LEVEL
15		RESERVOIR RETURN - BELOW FLUID LEVEL

VALVES

16		CHECK VALVE
17		MANUAL ON/OFF VALVE
19		PRESSURE RELIEF VALVE
20		PRESSURE REDUCTION VALVE
21		TWO POSITION, TWO CONNECTION VALVE
22		TWO POSITION, THREE CONNECTION VALVE
23		TWO POSITION, FOUR CONNECTION VALVE
24		THREE POSITION, FOUR CONNECTION VALVE
25		TWO POSITION, FOUR CONNECTION VALVE WITH TRANSMISSION
26		THREE POSITION, FOUR CONNECTION VALVE WITH INFINITE POSITIONING
27		ADJUSTABLE FLOW CONTROL VALVE (TEMPERATURE AND PRESSURE COMPENSATED)
18		FIXED } VARIABLE } ORIFICE

270  
10  
2

M81419AE -19-19NOV92

**VALVE OPERATORS**

<b>28</b>		SPRING
<b>29</b>		MANUAL
<b>30</b>		PUSH BUTTON
<b>31</b>		PUSH/PULL LEVER
<b>32</b>		PEDAL OR TREADLE
<b>33</b>		MECHANICAL
<b>34</b>		DETENTS
<b>35</b>		PRESSURE COMPENSATED
<b>36</b>		SOLENOID-SINGLE WINDING
<b>37</b>		REVERSING MOTOR
<b>38</b>		PILOT PRESSURE -REMOTE SUPPLY
<b>39</b>		PILOT PRESSURE -INTERNAL SUPPLY

**CYLINDERS**

<b>40</b>		SINGLE ACTING
<b>41</b>		DOUBLE ACTING, SINGLE ROD
<b>42</b>		DOUBLE ACTING, DOUBLE ROD
<b>43</b>		DOUBLE ACTING, ADJ. CUSHION, EXTEND ONLY
<b>44</b>		DOUBLE ACTING, DIFFERENTIAL PISTON

**MISCELLANEOUS**

<b>45</b>		COOLER
<b>46</b>		FILTER, STRAINER
<b>47</b>		HEATER
<b>48</b>		TEMPERATURE CONTROLLER
<b>49</b>		PRESSURE SWITCH
<b>50</b>		PRESSURE INDICATOR
<b>51</b>		TEMPERATURE INDICATOR
<b>52</b>		PRESSURE COMPENSATED VARIABLE COMPONENT (SYMBOL THRU COMPONENT)
<b>53</b>		VARIABLE COMPONENT (SYMBOL THRU COMPONENT)
<b>54</b>		PLUG, TEST PORT, PRESSURE SUPPLY TEST
<b>55</b>		GAS CHARGED ACCUMULATOR
<b>56</b>		SPRING LOADED ACCUMULATOR
<b>57</b>		ELECTRIC MOTOR
<b>58</b>		SHAFT ROTATION (ARROW ON NEAR SIDE OF SHAFT)
<b>59</b>		COMPONENT OUTLINE

270  
10  
3

M81440AE -19-19NOV92

## LEGEND FOR HYDRAULIC SYSTEM SCHEMATIC—330

1—Hydrostatic Transmission	6—Implement Relief Valve	11—Input (Pump) Shaft	14—Hydraulic Control Valve
2—Output (Motor) Shaft	7—Check (Freewheel) Valves	12—Control Valve Spool (Three-Position)	15—Rockshaft Cylinder
3—Hydrostatic Drive Motor	8—Charge Pump	13—Check Valve	16—Right Front Hydraulic Outlets
4—Transmission Case Drain	9—Filter		
5—Charge Relief Valve	10—Variable Hydrostatic Pump		

270  
10  
4

MX,159127010,1 -19-13JUL95

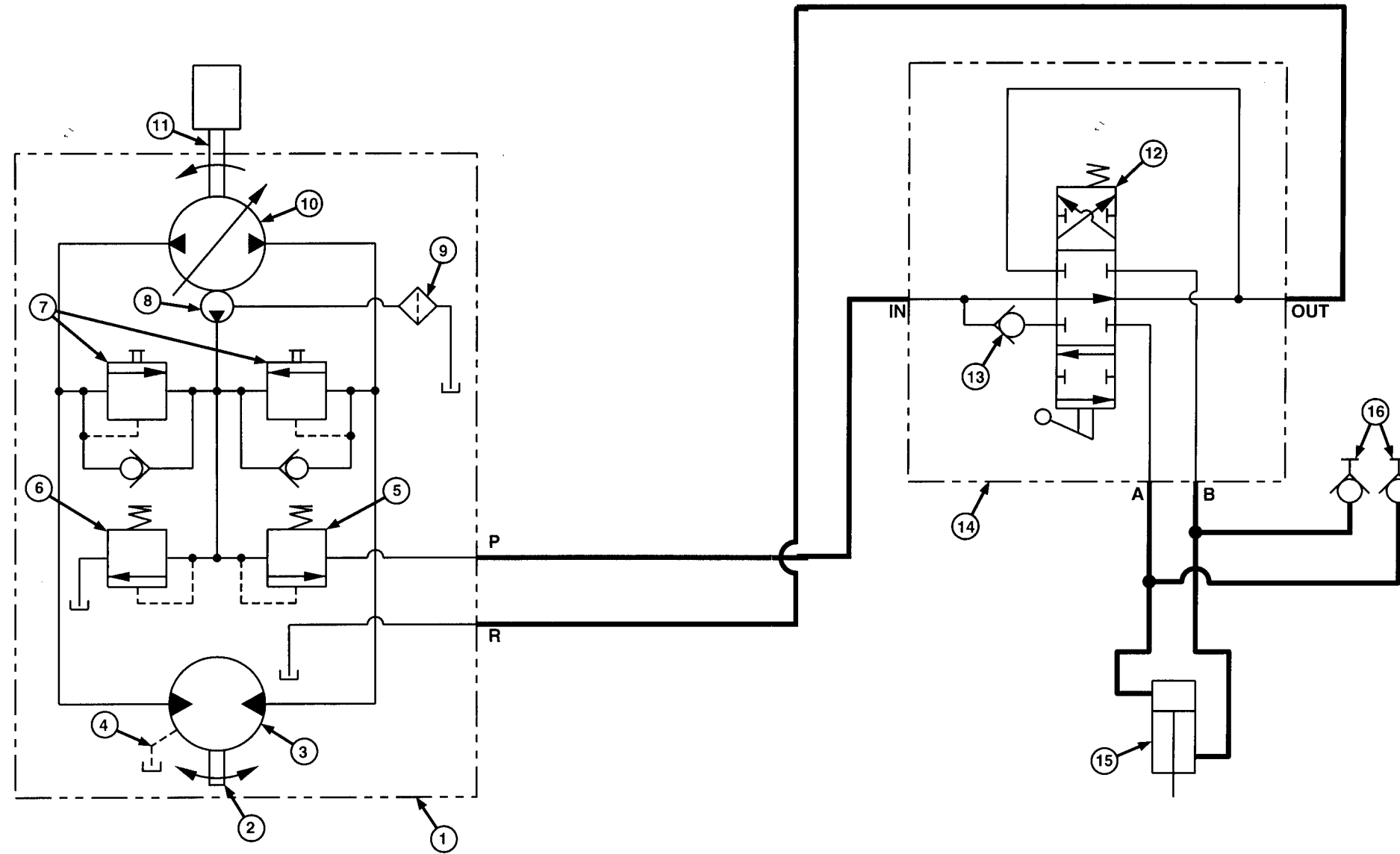

M78851

### HYDRAULIC SYSTEM SCHEMATIC — 330

1060X660

MX.159127010.2 -19-13JUL95

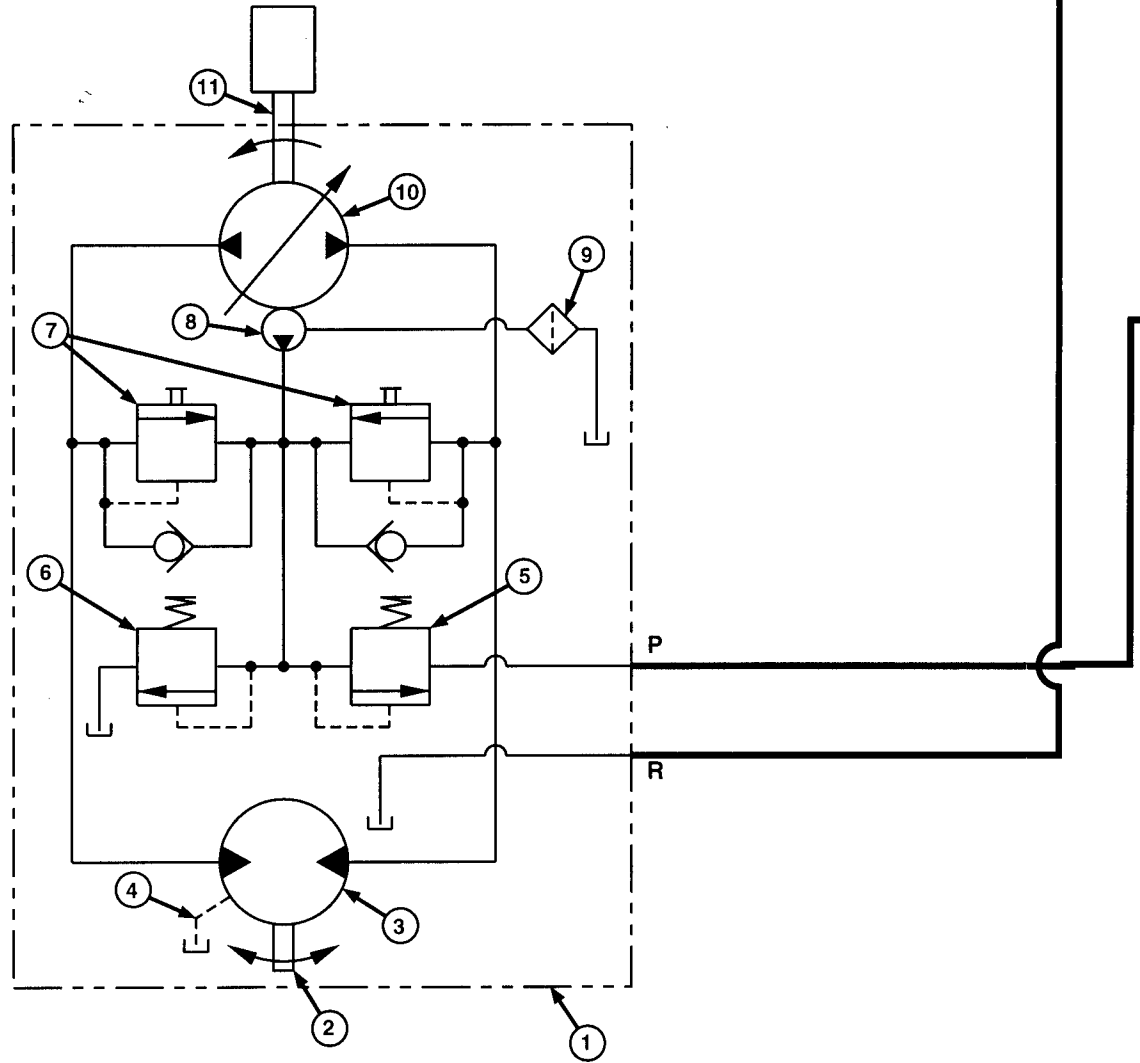

M78851

# HYDRAULIC SYSTEM SCHEMAT

1060X660

MX.159127010.2 -19-13JUL95



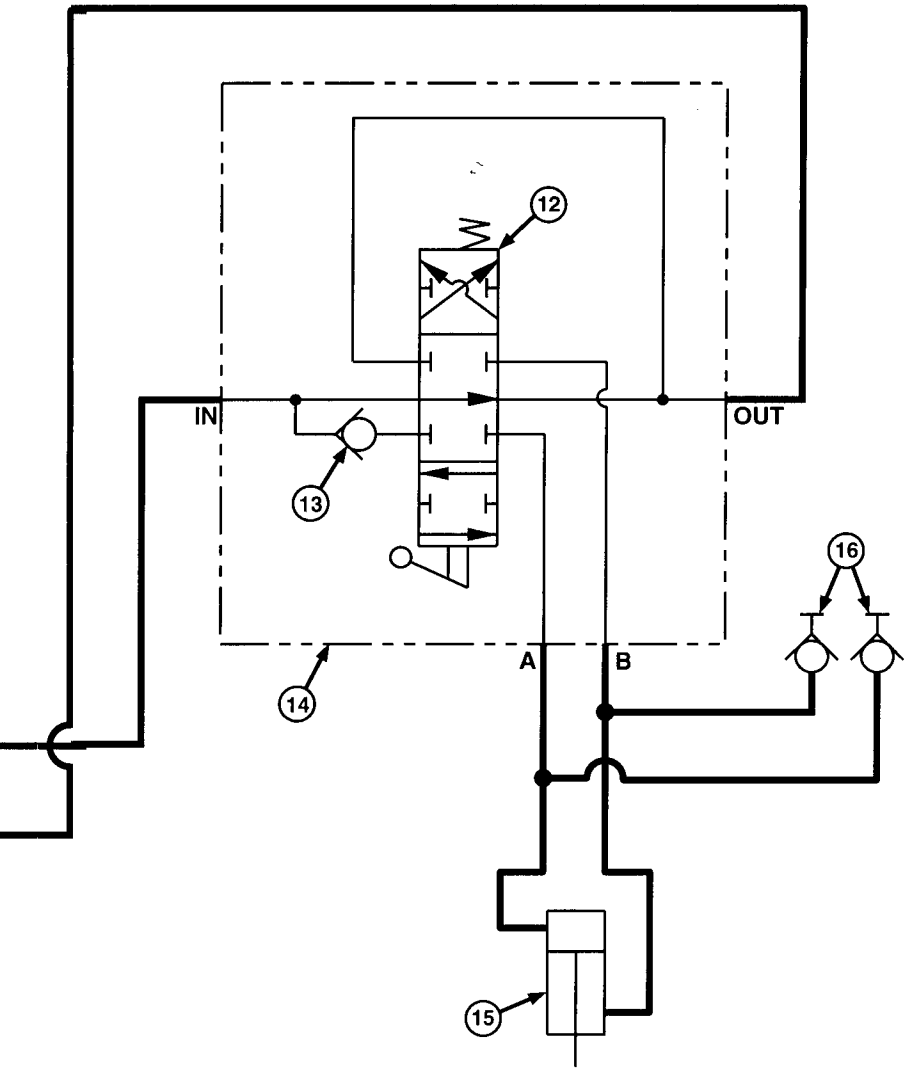

**SCHEMATIC — 330**

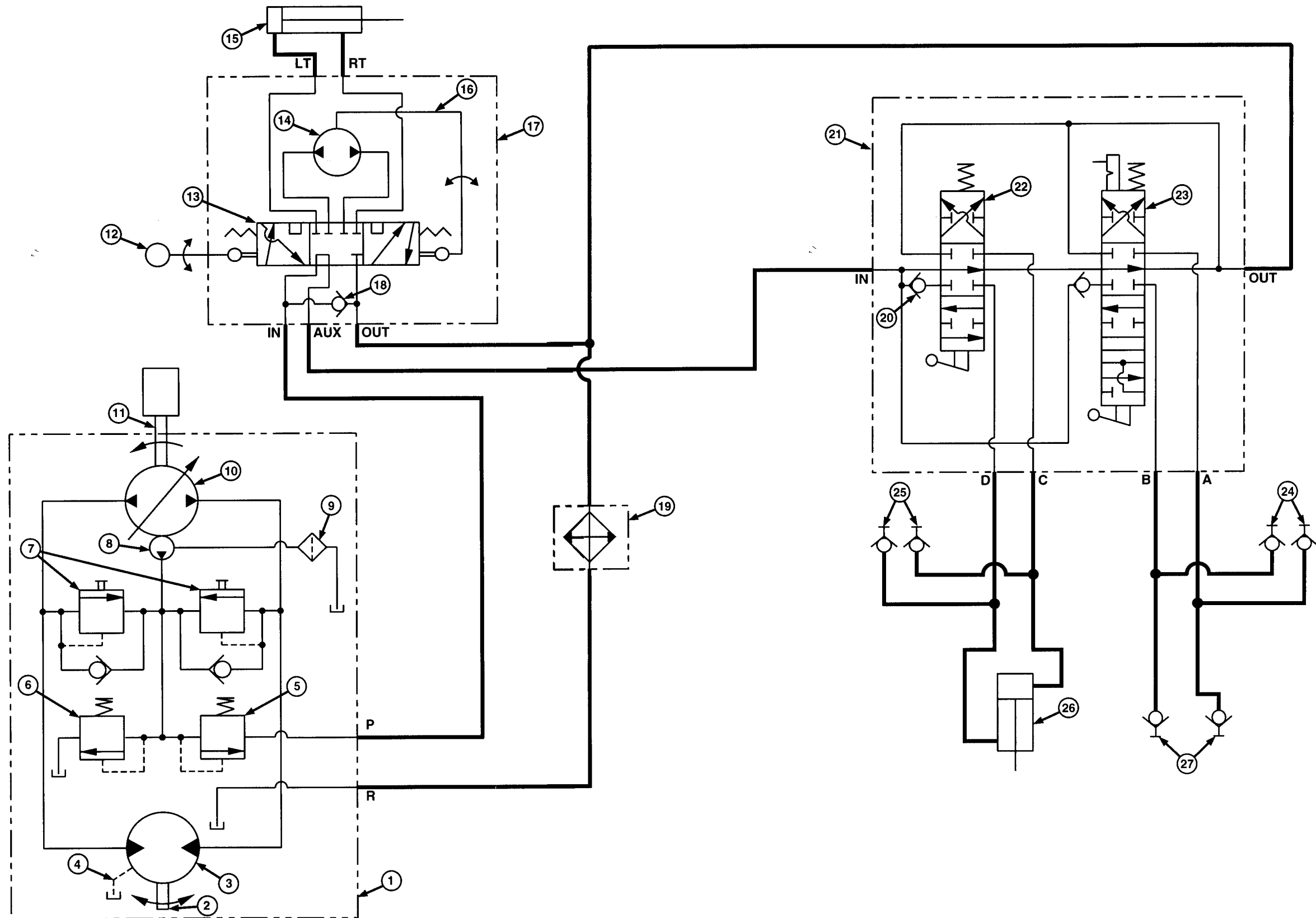

M78852

HYDRAULIC SYSTEM SCHEMATIC — 322 AND 332

1060X660

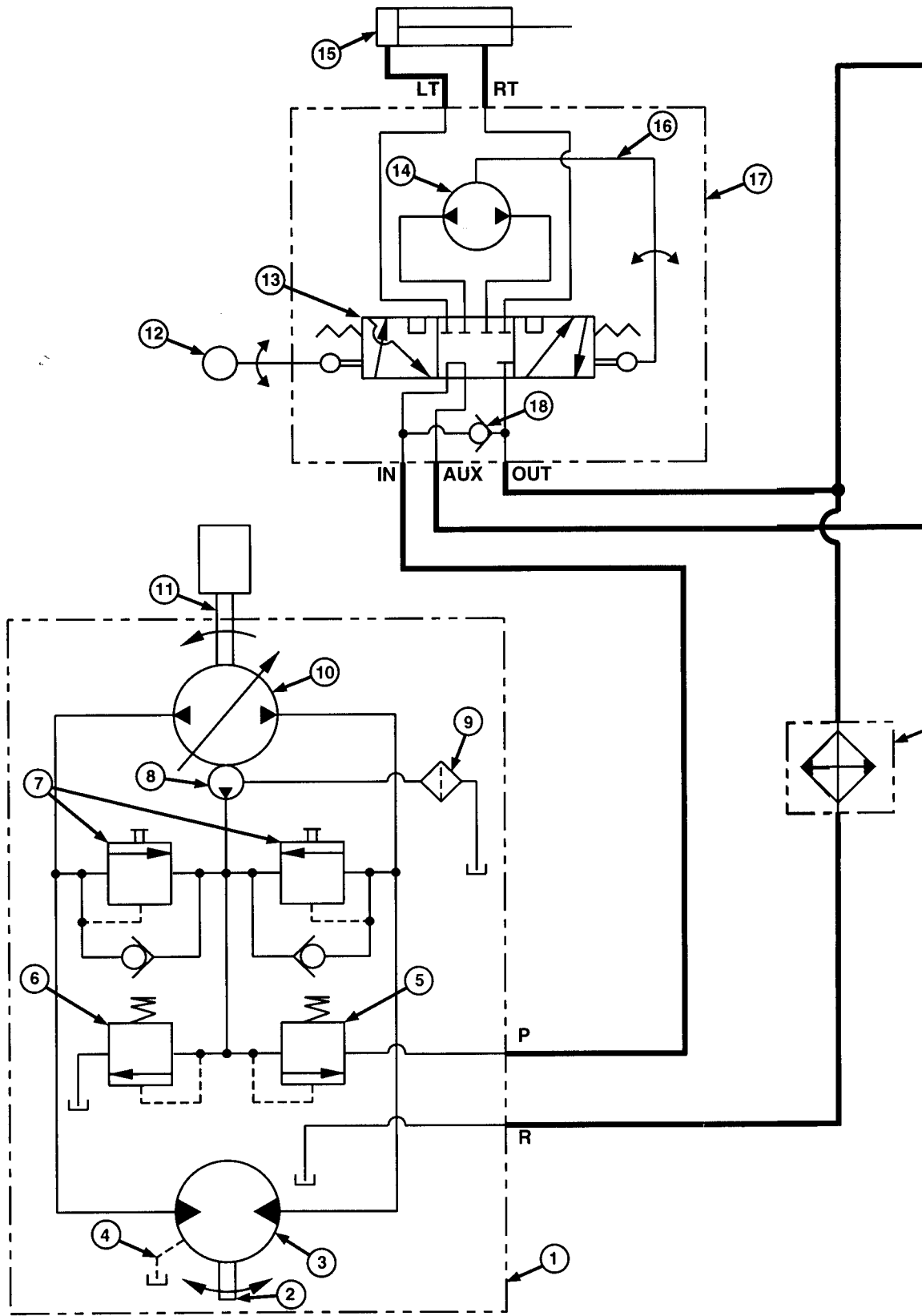

M78852

HYDRAULIC SYSTEM

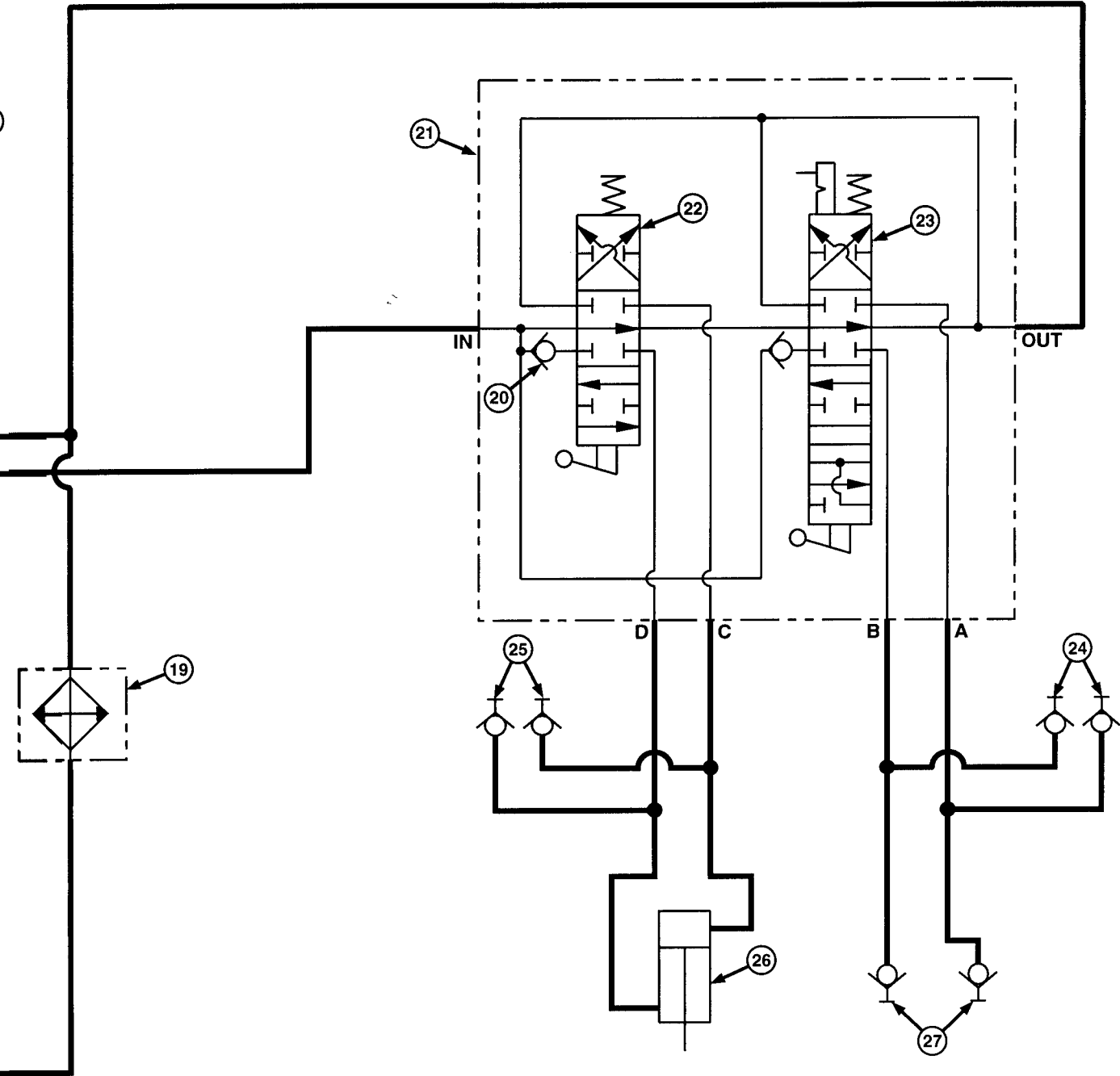

**C SYSTEM SCHEMATIC — 322 AND 332**

1060X660

MX.159127010.3 -19-13JUL95

## LEGEND FOR HYDRAULIC SYSTEM SCHEMATIC—322 AND 332

1—Hydrostatic Transmission	10—Variable Hydrostatic Pump	17—Steering Valve	24—Front Hydraulic Outlets—Right Side
2—Output (Motor) Shaft	11—Input (Pump) Shaft	18—Check Valve	25—Front Hydraulic Outlets—Left Side
3—Hydrostatic Drive Motor	12—Steering Wheel	19—Oil Cooler (Optional)	26—Rockshaft Cylinder
4—Transmission Case Drain	13—Control Valve Section	20—Check Valve (2 used)	27—Rear Hydraulic Outlets (Optional)
5—Charge Relief Valve	14—Fluid Metering Section	21—Hydraulic Control Valve	
6—Implement Relief Valve	15—Steering Cylinder	22—Control Valve Spool (Three-Position)	
7—Check (Freewheel) Valves	16—Drive Link Assembly	23—Control Valve Spool with “Float” (Four-Position)	
8—Charge Pump			
9—Filter			

MX,159127010,4 -19-13JUL95

270  
10  
7

## LEGEND FOR HYDRAULIC SYSTEM SCHEMATIC—430

1—Hydrostatic Transmission	10—Variable Hydrostatic Pump	17—Steering Valve	24—Front Hydraulic Outlets—Right Side
2—Output (Motor) Shaft	11—Input (Pump) Shaft	18—Check Valve	25—Front Hydraulic Outlets—Left Side
3—Hydrostatic Drive Motor	12—Steering Wheel	19—Oil Cooler	26—Rockshaft Cylinder
4—Transmission Case Drain	13—Control Valve Section	20—Check Valve (3 used)	27—Rear Hydraulic Outlets (Optional)
5—Charge Relief Valve	14—Fluid Metering Section	21—Hydraulic Control Valve	
6—Implement Relief Valve	15—Steering Cylinder	22—Control Valve Spool (Three-Position) (2 used)	
7—Check (Freewheel) Valves	16—Drive Link Assembly	23—Control Valve Spool with “Float” (Four-Position)	
8—Charge Pump			
9—Filter			

270  
10  
8

MX,159127010,5 -19-13JUL95



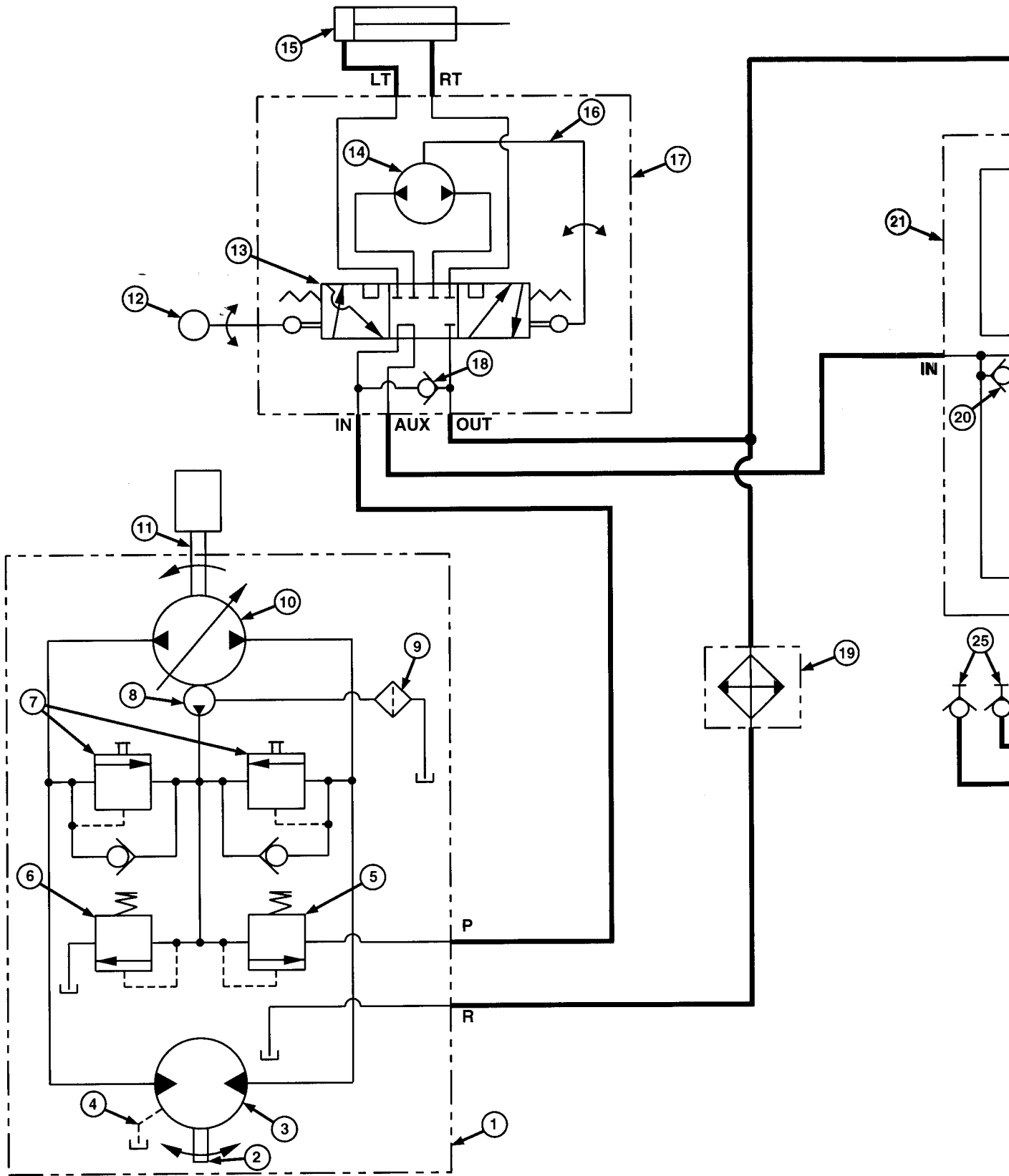

M78853

### HYDRAULIC SYSTEM SCHEMATIC

1060X660

MX.159127010.6 -19-13JUL95



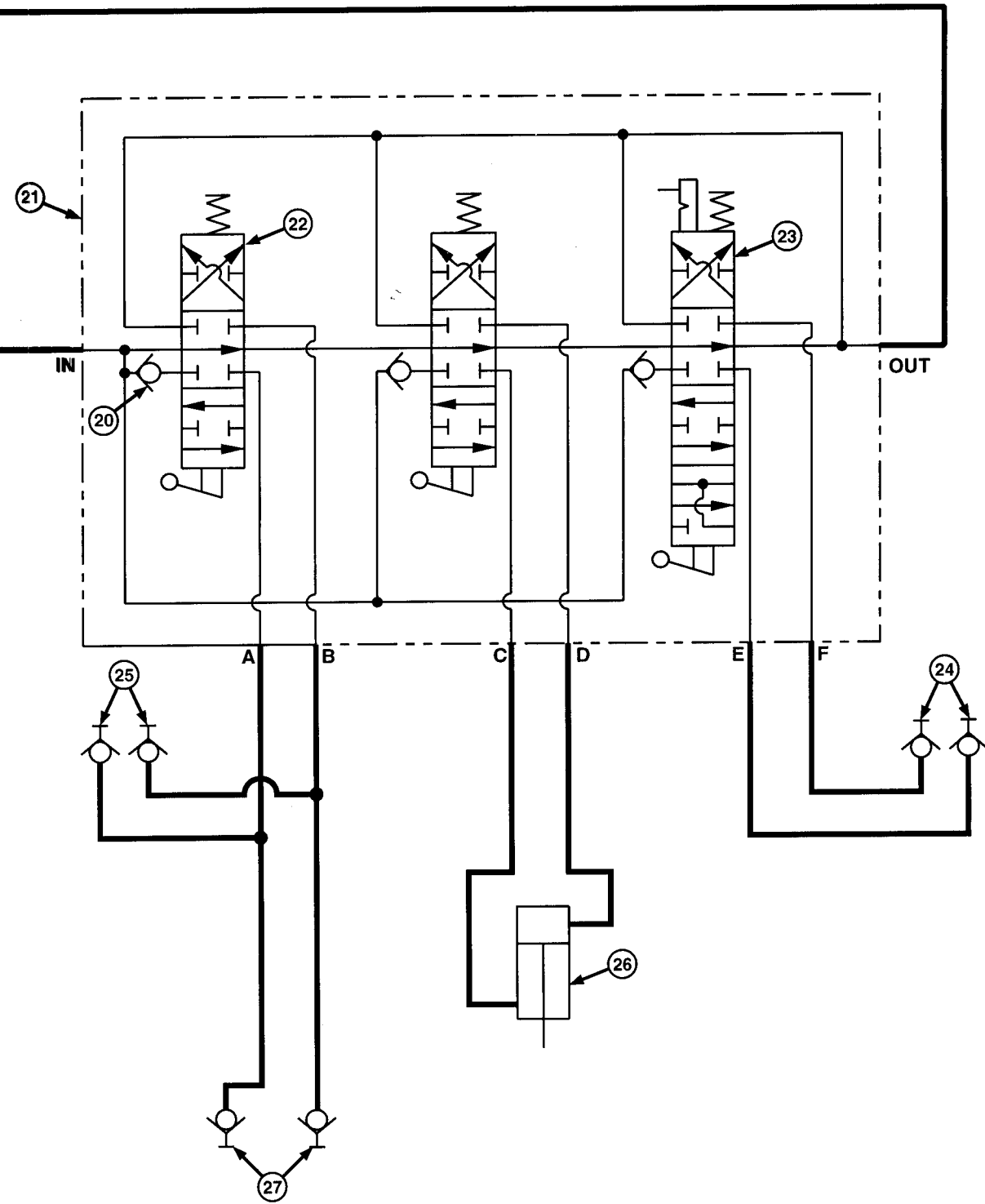

CHEMATIC — 430

270  
10  
10

## HYDRAULIC LIFT SYSTEM OPERATION—THREE-POSITION SPOOL

### Function:

To control the flow of pressurized oil to the rockshaft cylinder or implement.

### Theory of Operation:

*NOTE: Lower position shown.*

*On 322, 332 and 430 models, pressurized oil is routed through the steering valve before reaching the hydraulic control valve. This design provides "power beyond" to the auxiliary hydraulic systems only after satisfying steering valve needs. (See Section 260 for further information.)*

### LOWER:

As the handle is moved to the LOWER position, linkage connected to the actuator (F) causes the control valve spool (A) to change position. Pressurized oil entering the control valve inlet (H) forces the check valve (G) to open. Oil is then directed by the spool valve to the rockshaft cylinder (E) or hydraulic outlets (D).

Oil returning from the cylinder or implement is routed through the control valve spool and is returned to the transmission.

### RAISE:

Valve operation for RAISE is similar to LOWER, except that spool position reverses oil flow.

### NEUTRAL:

As the handle is released, the centering spring (B) returns the control valve spool (A) to the neutral position. Oil flow to/from the cylinder or implement is then blocked, holding the implement in either the raised or lowered position.

The valve spool position allows pressurized oil to flow through the valve to other valves in the system, or return to the transmission.

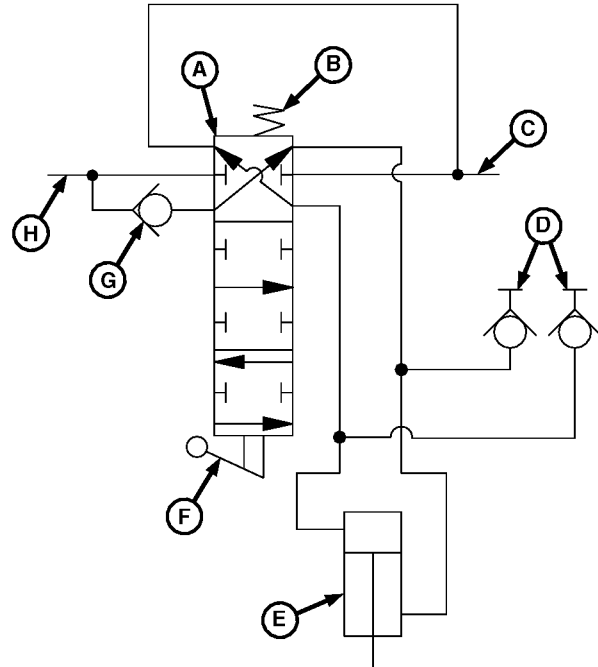

- A—Control Valve Spool
- B—Centering Spring
- C—Return Oil to Transmission
- D—Hydraulic Outlets
- E—Rockshaft Cylinder
- F—Actuator
- G—Check Valve
- H—Control Valve Inlet

M78849 -UN-03APR95

270  
15

## HYDRAULIC LIFT SYSTEM OPERATION—FOUR-POSITION SPOOL

### Function:

To control the flow of pressurized oil to the implement.

### Theory of Operation:

NOTE: Float position shown.

On 322, 332 and 430 models, pressurized oil is routed through the steering valve before reaching the hydraulic control valve. This design provides "power beyond" to the auxiliary hydraulic systems only after satisfying steering valve needs. (See Section 260 for further information.)

### RAISE:

As the handle is moved to the RAISE position, linkage connected to the actuator (F) causes the control valve spool (C) to change position. Pressurized oil entering the control valve inlet (H) forces the check valve (G) to open. Oil is then directed by the spool valve to the hydraulic outlets (E).

Oil returning from the implement is routed through the control valve spool and is returned to the transmission.

### LOWER:

Valve operation for LOWER is similar to RAISE, except that spool position reverses oil flow.

### NEUTRAL:

As the handle is released, the centering spring (B) returns the control valve spool (C) to the neutral position. Oil flow to/from the implement is then blocked, holding the implement in either the raised or lowered position.

The valve spool position allows pressurized oil to flow through the valve to other valves in the system, or return to the transmission.

### FLOAT:

As the handle is moved to the FLOAT position, linkage connected to the actuator (F) causes the control valve spool (C) to change position and engage the detent (A), locking the valve in position. In this position, both sides of the hydraulic outlets (E) are connected to the return line (D) to the transmission. This allows pressure to be released as the implement moves or "floats".

Valve spool position also allows pressurized oil entering from the valve stack inlet (I) to flow through the valve and return to the transmission.

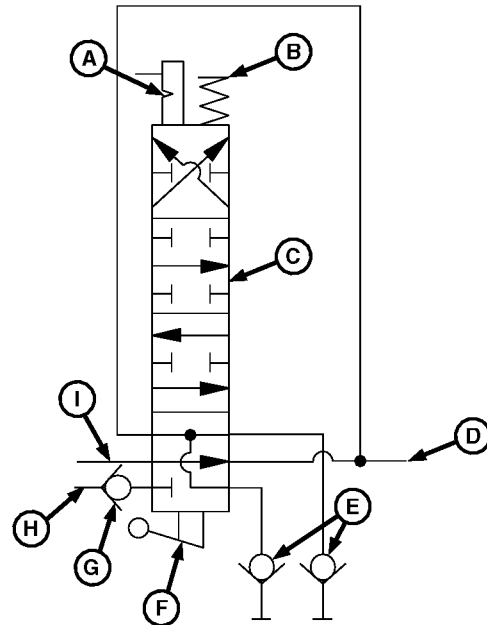

- A—Detent
- B—Centering Spring
- C—Control Valve Spool
- D—Return Oil to Transmission
- E—Hydraulic Outlets
- F—Actuator
- G—Check Valve
- H—Control Valve Inlet
- I—Inlet from Valve Stack

270  
15  
2

M78850  
-UN-03APR95

## ABOUT THIS GROUP

The step-by-step procedures in this group provide you with the detailed diagnostic information you will need to perform a test. Basic diagnostic equipment is used.

It is assumed that you are familiar with the machine and its hydraulic system components. If you need additional information, read the theory of operation in Group 15 or refer to the overall hydraulic schematics in Group 10.

Engine rpm and temperature are critical in most hydraulic tests. Be sure to follow test specifications carefully.

Always start with the first step and follow the sequence from left to right. Read each step completely before performing the test.

Upon completing a test or adjustment, check to see whether the problem is corrected.

*NOTE: The 330 has manual steering (gearbox), single-spool control valve and rockshaft cylinder.*

*The 322 and 332 have power steering, steering cylinder, two-spool control valve, rockshaft cylinder and oil cooler (optional).*

*The 430 has power steering, steering cylinder, three-spool control valve, rockshaft cylinder and oil cooler.*

MX,159127020,1 -19-13JUL95

270  
20  
1

270  
20  
2

## ; TROUBLESHOOTING GUIDE

If hydraulic system does not operate properly, select the appropriate symptom from the list below.

After selecting the appropriate symptom, go to that step and perform the following checks, tests, or adjustments in the order shown to isolate and repair malfunction.

- HYDRAULIC SYSTEM INOPERATIVE: GO TO A
- LOW OR SLOW HYDRAULIC POWER: GO TO B
- HYDRAULIC SYSTEM OPERATES ERRATICALLY: GO TO C
- LOAD DROPS WITH CONTROL VALVE IN NEUTRAL POSITION: GO TO D
- LOAD DROPS SLIGHTLY WHEN CONTROL VALVE IS SHIFTED TO RAISE POSITION: Check for damaged lift check in control valve. See Section 70.
- EXCESSIVE HYDRAULIC PUMP NOISE: GO TO E
- CONTROL VALVE STICKS OR HARD TO OPERATE: GO TO F
- FREQUENT FAILURE OF HYDRAULIC LINES AND O-RINGS: GO TO G
- HYDRAULIC OIL FOAMS: GO TO H
- HYDRAULIC OIL OVERHEATS: GO TO I
- 322, 332 AND 430; ATTACHMENT OR HYDRAULIC LEVER DOES NOT STAY IN FLOAT POSITION: Inspect control valve detent assembly for wear or damage. See Section 70.

MX,159127020,2 -19-13JUL95

## A HYDRAULIC SYSTEM INOPERATIVE

- Check for slipping or broken transmission drive shaft. See Section 50.
- Check for proper charge pump housing installation. See Section 50.
- Check hoses for proper attaching location.
- Check for dented or restricted lines.
- Test charge pump pressure. See Section 250.
- Check suction line for air leaks. See Section 250.
- Check for plugged oil filter.
- Test implement relief valve pressure. See Section 250.
- 322, 332 and 430; Check for steering valve check ball missing, damaged, or in "IN" port. See Section 60.

MX,159127020,3 -19-13JUL95

## **B LOW OR SLOW HYDRAULIC POWER**

- Check for dented or restricted lines.
- Check for proper engine speed. See Section 220.
- Test charge pump pressure. See Section 250.
- Check for plugged oil filter.
- Check suction line for air leaks. See Section 250.
- Test implement relief valve pressure. See Section 250.
- Test control valve for leakage. GO TO Å
- Inspect cylinder packings for excessive wear. GO TO Æ

MX,159027020,4 -19-24APR95

270  
20  
3

## **C HYDRAULIC SYSTEM OPERATES ERRATICALLY**

- Bleed hydraulic system. GO TO Ö
- Check for restricted lines.
- Test charge pump pressure. See Section 250.
- Check for plugged oil filter.
- Check suction line for air leaks. See Section 250.
- Check for dirt in implement relief valve. See Section 50.

MX,159027020,5 -19-24APR95

## **D LOAD DROPS WITH CONTROL VALVE IN NEUTRAL POSITION**

- Check lines from control valve to rockshaft cylinder for leakage.
- Check control valve for centering when released.
- Check implement relief valve for leakage. See Section 250.
- Test control valve for leakage. GO TO Å
- Check cylinder packings and O-rings for leakage. GO TO Æ

MX,159027020,6 -19-24APR95



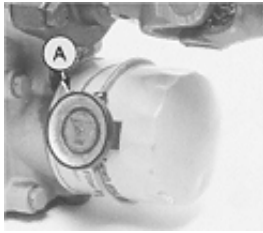

Diagnosis, Tests and Adjustments/Rockshaft Cylinder Leakage Test

<p><b>HYDRAULIC OIL WARM-UP PROCEDURE</b></p>	 <p>Remove belly screen/pan.</p> <p>Install JDG282 Temperature Gauge (A) on transmission oil filter.</p> <p>On 430; Partially cover the radiator. Be careful not to cover too much of the radiator causing engine to overheat.</p>	<p>Apply park brake.</p> <p>Start engine and run at full throttle.</p>
---	---	--

M43008 -UN-18JAN90

MX,159126015,3 -19-13JUL95

	<p>Move and hold control lever in implement "raise" position.</p> <p>Periodically cycle all hydraulic functions to distribute heated oil.</p> <p><i>NOTE: 330 Shown</i></p>	<p>Heat oil to temperature specified in test.</p> <p><i>NOTE: The hydrostatic transmission should not exceed 93°C (200°F) as a continuous operating temperature.</i></p>
---	---	--

M43629 -UN-12JAN90

MX,159125015,6 -19-13JUL95

<p><b>ROCKSHAFT CYLINDER LEAKAGE TEST</b></p>	<p>Heat hydraulic oil to 43°C (110°F).</p> <p>With implement linkage in the raised position (cylinder extended), shut off engine.</p> <p><b>CAUTION: TO AVOID INJURY FROM ESCAPING HYDRAULIC OIL UNDER PRESSURE, RELIEVE THE PRESSURE IN THE SYSTEM BY STOPPING THE ENGINE AND OPERATING ALL HYDRAULIC CONTROL VALVES.</b></p>	
---	--	--

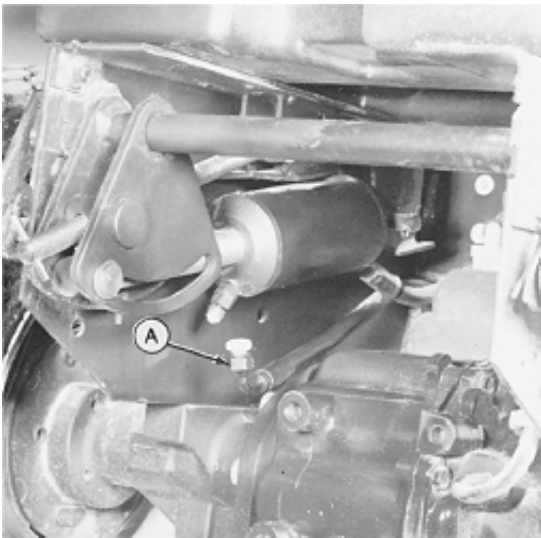
	<p>Disconnect hose (A) from rod-end of cylinder. There might be some initial dripping of hydraulic oil from the cylinder and hose. This is not leakage.</p> <p>Put JT03393 steel Plug in disconnected hose.</p> <p>Start engine and run at full throttle.</p> <p>Hold control valve lever in the "lift" position.</p> <p>Observe cylinder, hydraulic oil should not continually leak out of the rod-end fitting.</p>	<p><b>IF HYDRAULIC OIL CONTINUALLY LEAKS OUT OF THE ROD-END FITTING, REPLACE CYLINDER.</b></p>
---	--	--

M43631 -UN-12JAN90

MX,159027020,14-19-24APR95

Diagnosis, Tests and Adjustments/Control Valve Leakage Test

**Ä CONTROL VALVE LEAKAGE TEST**

**CAUTION: TO AVOID INJURY FROM ESCAPING HYDRAULIC OIL UNDER PRESSURE, RELIEVE THE PRESSURE IN THE SYSTEM BY STOPPING THE ENGINE AND OPERATING ALL HYDRAULIC CONTROL VALVES.**

**IMPORTANT: To avoid putting full pump flow into container, DO NOT return control valve lever to "neutral" or "float" (if equipped) position with engine running. If equipped with power steering, DO NOT move steering wheel.**

MX,159027020,15-19-03MAY95

270  
20  
6

**4a Model 330**

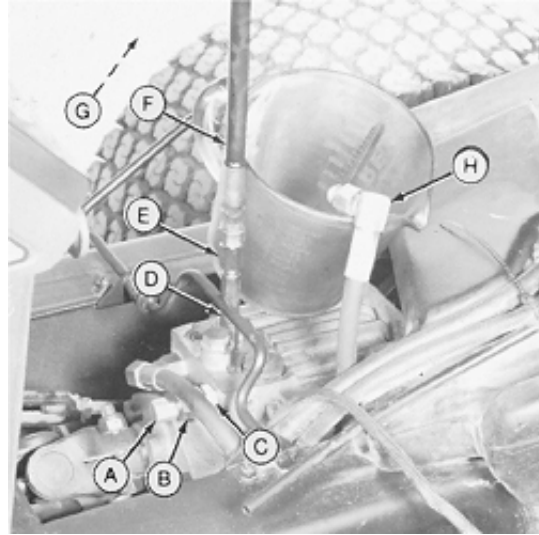

- A—JT05484 Cap
- B—JT03002 Adapter
- C—JT03036 Connector
- D—JT03339 Connector
- E—JT03107 Adapter
- F—JT03017 Hose
- G—JT03345 Gauge  
20,000 kPa (3,000 psi)(Not Shown)
- H—Return Line

M43632 -UN-12JAN90

MX,159127020,6 -19-13JUL95

Heat hydraulic oil to 43°C (110°F). See ' in this group.

Disconnect hydraulic hose (return line) (H). Put disconnected hose into a container.

Make test port connections from JT01765 Lawn and Grounds Care Products Hydraulic Fitting Kit.

Hold control valve lever in "raise" position.

Start engine and run at fast idle for one minute.

Stop engine. Record amount of oil in container. Amount must be less than 15 mL/min (1/2 fl oz/min). Pressure must be 5860—6550 kPa (850—950 psi).

Repeat test for "lower" position.

**IF PRESSURE IS NOT WITHIN SPECIFICATIONS: GO TO SECTION 250 AND TEST IMPLEMENT RELIEF PRESSURE.**

**IF LEAKAGE IS MORE THAN SPECIFICATION: REPLACE CONTROL VALVE.**

MX,159027020,17-19-24APR95

**4b Models 322, 332 and 430**

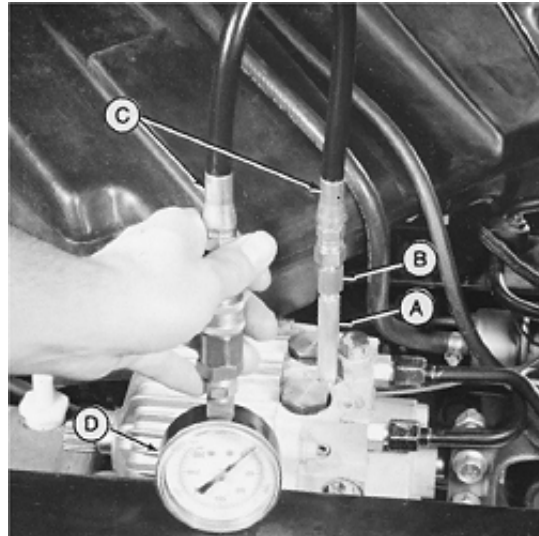

M36682 -UN-25JAN90

- A—JT03339 Connector
- B—JT03107 Adapter
- C—JT03017 Hose
- D—JT03345 Gauge  
20,000 kPa (3,000 psi)

MX,159127020,7 -19-13JUL95

Heat hydraulic oil to 43°C (110°F). See ' in this group.

Make test port connections from JT01765 Lawn and Grounds Care Products Hydraulic Fitting Kit.

Remove control valve return line from "OUT" port on control valve.

If steering valve return line is connected into control valve return line, it must be plugged in order to isolate only the control valve leakage.

Put container under control valve to catch leakage.

Hold a control valve lever in "raise" position.

Start engine and run at fast idle for

one minute.

Stop engine. Record amount of oil in container. Amount must be less than 15 mL/min (1/2 fl oz/min). Pressure must be 5860—6550 kPa (850—950 psi).

Repeat test for "lower" position.

Repeat test for remaining control lever(s).

IF PRESSURE IS NOT WITHIN SPECIFICATIONS: GO TO SECTION 250 AND TEST IMPLEMENT RELIEF PRESSURE.

IF LEAKAGE IS MORE THAN SPECIFICATION: REPLACE CONTROL VALVE.

MX,159027020,19-19-03MAY95

## Ö BLEED HYDRAULIC SYSTEM

After installing a repaired or replacement part, follow this run-in procedure to assure that air is purged from the hydraulic system.

1. Start engine and idle for 10 minutes.
2. Run engine at high idle for one minute.
3. Turn steering wheel full left and hold for five seconds.
4. Turn steering wheel to straight forward for 10 seconds.
5. Turn steering wheel full right and hold for five seconds.
6. Return steering wheel to straight forward. Travel vehicle forward about 20 feet and then make two hard left turns.
7. Then make two hard right turns.
8. Travel vehicle in reverse for 10 feet.
9. Cycle mower deck up and down three times.
10. Shut engine off and inspect hydraulic components for leaks.
11. Fill reservoir as required with John Deere Low Viscosity HY-GARD® oil.

270  
20  
8

MX,159027020,20-19-29MAR95

**Section 299**

# **DEALER FABRICATED TOOLS**

**Contents**

Page

**Group 00—Dealer Fabricated Tools**

DFMX1 Steering Valve Fixture . . . . .	299-00-1
DFMX2 Alignment Shims . . . . .	299-00-1

299



### DFMX1 STEERING VALVE FIXTURE

Steering valve fixture is used to hold steering valve during disassembly and assembly procedures.

Material required: One piece of 5 x 102 x 203 mm (3/16 x 4 x 8 in.) 1020 mild steel flat stock.

- A—203 mm (8.0 in.)
- B—9.5 mm (3/8 in.)\*
- C—51 mm (2.0 in.)
- D—102 mm (4.0 in.)
- E—51 mm (2.0 in.) Diameter Hole

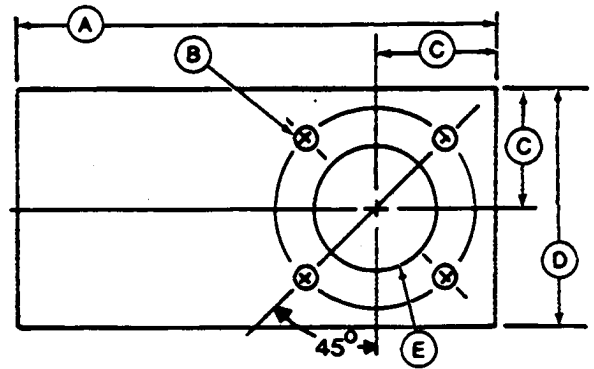

M36677 -UN-28APR89

\*Four diameter holes equally spaced on a 83 mm (3-1/4 in.) diameter circle.

MX,159129900,1 -19-13JUL95

299  
00  
1

### DFMX2 ALIGNMENT SHIMS

Alignment shims are used to align steering valve metering assembly with drive plates during assembly.

Material required: Six pieces of 13 x 38 mm (1/2 x 1-1/2 in.) long, 0.18 mm (0.007 in.) thick shim stock.

MX,159129900,2 -19-13JUL95

299  
00  
2



# Index

	Page		Page
<b>A</b>			
Air Cleaner and Radiator Screen Check . . .	220-05-2	Charging System Tests—430	
Alternator Tests—322, 330 and 332		Regulated Volt/Amp Output . . . . .	240-25-13
Regulated Current Output . . . . .	240-25-12	Unreg. Current Output (SN —420468) . . . . .	240-25-14
Regulated Voltage Output . . . . .	240-25-11	Unreg. Current Output (SN 420469— ) . . . . .	240-25-15
Unregulated Voltage Output . . . . .	240-25-11	Check Valve Debris Check . . . . .	250-15-5
Alternator Tests—430		Choke Adjustment (322) . . . . .	220-10-8
Regulated Volt/Amp Output . . . . .	240-25-13	Choke Lever Check (Early 322) . . . . .	220-05-6
Unreg. Current Output (SN —420468) . . . . .	240-25-14	Compression Pressure Test	
Unreg. Current Output (SN 420469— ) . . . . .	240-25-15	322 . . . . .	220-10-12
<b>B</b>			
Battery, Charge and Test . . . . .	240-20-4	330, 332 and 430 . . . . .	220-11-10
Bleed Fuel Injection System		Coolant conditioner . . . . .	10-25-6
330 and 332 . . . . .	220-11-8	Coolant, engine . . . . .	10-25-6
430 . . . . .	220-11-8	Cooling System	
Bleed Hydraulic System . . . . .	270-20-8	Leak Check . . . . .	220-05-2
Brake Pedal Linkage		Pressure Test—322 . . . . .	220-10-12
322 and 332 . . . . .	60-10-10	Pressure Test—330, 332 and 430 . . . . .	220-11-14
330 . . . . .	60-10-8	<b>D</b>	
430 . . . . .	60-10-14	Dash Lamp Circuit	
Brake Switch		Check . . . . .	240-05-2
Neutral Start, Check . . . . .	240-05-3	Tests . . . . .	240-20-6
Brakes		Dealer Fabricated Tools	
Adjust . . . . .	60-10-7	DFMX1 Steering Valve Fixture . . . . .	299-00-1
Install . . . . .	60-10-5	DFMX2 Alignment Shims . . . . .	299-00-1
Remove . . . . .	60-10-2	Diesel Engine Oil . . . . .	10-25-5
<b>C</b>			
Carburetor Idle Mixture Screw (322)		Diesel fuel . . . . .	10-25-2
Adjustment . . . . .	220-10-6	Differential	
Charge Pump		Assemble . . . . .	50-15-12
Assemble . . . . .	50-05-4	Disassemble and Inspect . . . . .	50-15-2
Disassemble and Inspect . . . . .	50-05-3	Remove and Install . . . . .	50-15-2
Flow Test . . . . .	250-15-8	Differential Lock (430)	
Pressure Test . . . . .	250-15-5	Check . . . . .	250-05-3
Remove and Install . . . . .	50-05-2	Linkage Check . . . . .	250-15-17
Suction Line Check . . . . .	250-15-6	Differential Lock Linkage (430) . . . . .	50-10-6
Charge Relief Valve		Drive Shaft	
Adjustment . . . . .	250-15-6	Assemble—322, 330 and 332 . . . . .	50-25-5
Check . . . . .	250-15-6	Assemble—430 . . . . .	50-26-7
Remove and Install . . . . .	50-05-5	Disassemble and Inspect—430 . . . . .	50-26-5
Charging System Tests—322, 330 and 332		Disassemble—322, 330 and 332 . . . . .	50-25-4
Regulated Current Output . . . . .	240-25-12	Inspect—322, 330 and 332 . . . . .	50-25-4
Regulated Voltage Output . . . . .	240-25-11	Remove and Install—322 and 332 . . . . .	50-25-2
Unregulated Voltage Output . . . . .	240-25-11	Remove and Install—330 . . . . .	50-25-3
<b>E</b>			
		Remove and Install—430 (Early) . . . . .	50-26-1
		Remove and Install—430 (Later) . . . . .	50-26-4

	Page		Page
Electrical Checkout		Electrical—Component Location—Continued	
Dash Lamps Circuit . . . . .	240-05-2	Voltage Regulator/Rectifier—330 . . . . .	240-15-6
Fuel Shutoff Solenoid Circuit . . . . .	240-05-4	Voltage Regulator/Rectifier—332 . . . . .	240-15-6
Fuel Transfer Pump Circuit . . . . .	240-05-5	Water-In-Fuel Sensor (430) . . . . .	240-15-6
Glow Plug Controller Circuit . . . . .	240-05-5	Electrical—Theory Of Operation	
Hour Meter . . . . .	240-05-6	Charging Circuit—322, 330 and 332 . . . . .	240-15-22
Ignition Circuit (322) . . . . .	240-05-5	Charging Circuit—430 . . . . .	240-15-24
Lighting Circuit . . . . .	240-05-6	Engine Preheat Circuit—330, 332 . . . . .	240-15-30
PTO Clutch and Lamp Circuits . . . . .	240-05-2	Engine Preheat Circuit—430 . . . . .	240-15-30
Starting Circuit . . . . .	240-05-3	Fuel Shutoff Circuit—322 . . . . .	240-15-10
Electrical Component Location . . . . .	240-15-1	Fuel Shutoff Circuit—332 . . . . .	240-15-28
Electrical Schematics		Fuel Shutoff Circuit—430 (Early) . . . . .	240-15-26
Light Circuit—All Machines . . . . .	240-10-14	Fuel Shutoff Circuit—430 (Later) . . . . .	240-15-28
322 . . . . .	240-10-3	Ignition Circuit (322) . . . . .	240-15-10
330 . . . . .	240-10-4	Low Fuel Level Circuit—322, 332 . . . . .	240-15-34
332 (S.N. 475001— ) . . . . .	240-10-8	Low Fuel Level Circuit—430 . . . . .	240-15-34
332 (S.N. —475000) . . . . .	240-10-7	PTO Circuit—322, 330, 430 (Early) . . . . .	240-15-14
430 (S.N. 420469— ) . . . . .	240-10-12	PTO Circuit—332 and 430 (Later) . . . . .	240-15-18
430 (S.N. —420468) . . . . .	240-10-11	Starting Circuit . . . . .	240-15-8
Electrical System Grounds, Verify		Water-In-Fuel Circuit (430) . . . . .	240-15-32
322 and 332 . . . . .	240-20-1	Engine coolant . . . . .	10-25-6
330 . . . . .	240-20-3	Engine coolant conditioner . . . . .	10-25-6
430 . . . . .	240-20-3	Engine Coolant Temperature Switch, Test . . . . .	240-25-1
Electrical—Component Location		Engine Oil	
Engine Coolant Temperature Switch . . . . .	240-15-4	322 . . . . .	10-25-4
Engine Oil Pressure Switch . . . . .	240-15-3	330, 332, 430 . . . . .	10-25-5
Fuel Shutoff Solenoid—322 . . . . .	240-15-5	Engine—322	
Fuel Shutoff Solenoid—332 and 430 . . . . .	240-15-5	Oil Leak Check . . . . .	220-05-1
Fuel Transfer Pump—322, 330 and		Oil Pressure Check . . . . .	220-05-7
332 . . . . .	240-15-5	Oil Pressure Test . . . . .	220-10-11
Fuel Transfer Pump—430 . . . . .	240-15-5	Performance Check . . . . .	220-05-7
Glow Plug Control Module—330, 332 . . . . .	240-15-1	Remove and install . . . . .	20-05-1
Glow Plug Control Module—430 . . . . .	240-15-1	Repair . . . . .	20-05-1
Ignition and Pulsar Coils (322) . . . . .	240-15-7	Start Check . . . . .	220-05-6
Neutral Start Relay—322, 330, 332 . . . . .	240-15-1	Troubleshooting . . . . .	220-10-1
Neutral Start Relay—430 . . . . .	240-15-2	Engine—330 and 332	
TDC Module—322, 330, 332 . . . . .	240-15-1	Oil Leak Check . . . . .	220-05-1
TDC Module—430 . . . . .	240-15-2	Oil Pressure Check . . . . .	220-05-7
TDC 2-Pin Connector—322 and 330 . . . . .	240-15-2	Oil Pressure Test . . . . .	220-11-11
TDC 2-Pin Connector—430 (Early) . . . . .	240-15-2	Performance Check . . . . .	220-05-7
TDC 3-Pin Connector—332 . . . . .	240-15-3	Remove and install . . . . .	20-06-1
TDC 3-Pin Connector—430 (Later) . . . . .	240-15-3	Repair . . . . .	20-06-1
TDC 6-Pin Connector—332 . . . . .	240-15-3	Start Check . . . . .	220-05-6
TDC 6-Pin Connector—430 (Later) . . . . .	240-15-3	Troubleshooting . . . . .	220-11-2
TDC 8-Pin Connector—322 and 330 . . . . .	240-15-2	Engine—430	
TDC 8-Pin Connector—430 (Early) . . . . .	240-15-2	Install . . . . .	20-06-8
Transistor Module (322) . . . . .	240-15-6	Oil Leak Check . . . . .	220-05-1
Transmission Neutral Start Switch . . . . .	240-15-4	Oil Pressure Check . . . . .	220-05-7
Voltage Regulator/Rectifier—322 . . . . .	240-15-6	Oil Pressure Test . . . . .	220-11-11
		Performance Check . . . . .	220-05-7

	Page		Page
Engine—430—Continued			
Remove . . . . .	20-06-4	Fuse	
Repair . . . . .	20-06-1	Short In 10-amp Circuit . . . . .	240-25-15
Start Check . . . . .	220-05-6	Short In 25-Amp Circuit . . . . .	240-25-15
Troubleshooting . . . . .	220-11-2		
		<b>G</b>	
<b>F</b>		Gasoline fuel . . . . .	10-25-1
Fan and Belt Check . . . . .	220-05-3	Glow Plug Controller Circuit	
Front Axle Spindles		Check (330, 332, 430) . . . . .	240-05-5
Inspect and Replace Bushings . . . . .	80-05-11	Test (330, 332, 430) . . . . .	240-20-37
Remove and Install . . . . .	80-05-9	Glow Plug Test (330, 332, 430) . . . . .	240-25-3
Front Axle—322, 330 and 332		Governor Linkage—322	
Inspect and Replace Pivot Bushings . . . . .	80-05-2	Adjustment . . . . .	220-10-6
Remove and Install . . . . .	80-05-1	Check . . . . .	220-05-4
Front Axle—430		Governor Linkage—330, 332 and 430	
Assemble Pivot Pin . . . . .	80-05-6	Check . . . . .	220-05-4
Disassemble and Inspect Pivot Pin . . . . .	80-05-5	Grease	
Install . . . . .	80-05-7	Extreme pressure and multipurpose . . . . .	10-25-8
Remove . . . . .	80-05-3		
Front PTO Clutch		<b>H</b>	
Disassemble, Inspect and Assemble . . . . .	40-05-4	Head and Tail Light, Circuit Test . . . . .	240-20-48
Install—322, 330 and 332 . . . . .	40-05-6	Hour Meter	
Install—430 . . . . .	40-05-7	Check . . . . .	240-05-6
Remove—322, 330 and 332 . . . . .	40-05-1	Circuit Test . . . . .	240-20-47
Remove—430 . . . . .	40-05-2	Hydraulic circuit symbols . . . . .	270-10-2
Fuel		Hydraulic Control Valve	
Diesel . . . . .	10-25-2	Assemble—Single-Spool . . . . .	70-05-9
Gasoline . . . . .	10-25-1	Assemble—Three-Spool . . . . .	70-05-12
Storage . . . . .	10-25-3	Assemble—Two-Spool . . . . .	70-05-10
Fuel Controller Adjustment		Disassemble & Inspect—Single-Spool . . . . .	70-05-9
330 and 332 . . . . .	220-11-15	Disassemble & Inspect—Three-Spool . . . . .	70-05-12
430 . . . . .	220-11-15	Disassemble & Inspect—Two-Spool . . . . .	70-05-10
Fuel Shutoff Lever Check (330) . . . . .	220-05-7	Leakage Test . . . . .	270-20-6
Fuel Shutoff Solenoid (322, 332, 430)		Remove and Install—322 and 332 . . . . .	70-05-2
Circuit Check . . . . .	240-05-4	Remove and Install—330 . . . . .	70-05-3
Circuit Test . . . . .	240-20-30	Remove and Install—430 . . . . .	70-05-6
Seat Switch, Check . . . . .	240-05-4	Hydraulic oil . . . . .	10-25-7
Fuel Shutoff Solenoid Adjustment		Hydraulic Oil Warm-Up Procedure . . . . .	250-15-9, 260-15-4, 270-20-5
332 and 430 (SN 420469— ) . . . . .	240-25-9	Hydraulic Schematics	
430 (SN —420468) . . . . .	240-25-9	322 and 332 . . . . .	270-10-6
Fuel System Check		330 . . . . .	270-10-5
322 . . . . .	220-05-5	430 . . . . .	270-10-9
330, 332 and 430 . . . . .	220-05-5	Hydraulic System	
Fuel Transfer Pump		Bleed Procedure . . . . .	270-20-8
Circuit Check . . . . .	240-05-5	Checkout . . . . .	270-05-1
Circuit Tests . . . . .	240-20-35	Control Valve Leakage Test . . . . .	270-20-6
Fuel Transfer Pump Test		Rockshaft Cylinder Leakage Test . . . . .	270-20-5
322 . . . . .	220-10-8	Troubleshooting . . . . .	270-20-2
330, 332 and 430 . . . . .	220-11-7		

	Page		Page
Hydraulics—Lift System Operation			
Four-Position Spool . . . . .	270-15-2		
Three-Position Spool . . . . .	270-15-1		
Hydrostatic Lever			
Friction Adjustment . . . . .	250-15-10		
Friction Check . . . . .	250-05-1		
		<b>I</b>	
Idle Speed Adjustment			
322 . . . . .	220-10-6		
330, 332 and 430 . . . . .	220-11-12		
Ignition Circuit (322)			
Check . . . . .	240-05-5		
Seat Switch, Check . . . . .	240-05-6		
Tests . . . . .	240-20-38		
Ignition Spark Test (322) . . . . .	220-10-11		
Implement Relief Valve			
Adjustment . . . . .	250-15-7		
Check . . . . .	250-15-7		
Pressure Test . . . . .	250-15-7		
Remove and Install . . . . .	50-05-6		
Inch torque values . . . . .	10-15-5		
		<b>K</b>	
Key Switch Test			
322, 330 and 332 . . . . .	240-25-4		
430 . . . . .	240-25-5		
		<b>L</b>	
Lamp Circuit, Dash			
Check . . . . .	240-05-2		
Tests . . . . .	240-20-6		
Leakage Test			
Hydraulic Control Valve . . . . .	270-20-6		
Rockshaft Cylinder . . . . .	270-20-5		
Lighting Circuit, Check . . . . .	240-05-6		
Low Fuel Sensor, Test			
322, 332 and 430 (SN 475001— ) . . . . .	240-25-1		
430 (SN —475000) . . . . .	240-25-2		
Lubricant			
Alternative . . . . .	10-25-9		
Mixing . . . . .	10-25-9		
Storage . . . . .	10-25-9		
Synthetic . . . . .	10-25-9		
		<b>M</b>	
Machine Specifications			
322 and 330 . . . . .	10-10-1		
332 and 430 . . . . .	10-10-4		
Metric torque values . . . . .	10-15-4		
Mixing lubricants . . . . .	10-25-9		
Mower Blade Jack Sheaves			
46 and 50-Inch Mower . . . . .	80-10-4		
Mower Blade Spindles			
Early 60-Inch and 260 Rotary Mower . . . . .	80-10-2		
Later 60-Inch and 260 Rotary Mower . . . . .	80-10-3		
38 (Early), 46 and 50-Inch Mower . . . . .	80-10-1		
38-Inch Mower (Later) . . . . .	80-10-1		
Mower Deck Gear Case Oil . . . . .	10-25-8		
Mower Gear Case—Early 60-Inch			
Assemble . . . . .	80-15-14		
Disassemble and Inspect . . . . .	80-15-10		
Mower Gear Case—Later 60-Inch			
Assemble . . . . .	80-15-23		
Disassemble and Inspect . . . . .	80-15-19		
Mower Gear Case—260 Rotary Mower			
Assemble . . . . .	80-15-32		
Disassemble and Inspect . . . . .	80-15-27		
Mower Gear Case—50-Inch			
Assemble . . . . .	80-15-6		
Disassemble and Inspect . . . . .	80-15-1		
		<b>N</b>	
Neutral Adjustment			
Later 322, 332 and 430 . . . . .	250-15-14		
330 and Early 322, 332, 430 . . . . .	250-15-13		
Neutral Return Check . . . . .	250-05-2		
Neutral Return Linkage			
322 and 332 . . . . .	60-10-10		
330 . . . . .	60-10-8		
430 . . . . .	60-10-14		
Neutral Return Linkage Adjustment			
Later 322, 332 and 430 . . . . .	250-15-14		
330, and Early 322, 332, 430 . . . . .	250-15-10		
Neutral Start Circuit, Check			
Brake Switch . . . . .	240-05-3		
PTO Switch . . . . .	240-05-4		
Transmission Switch . . . . .	240-05-4		
Neutral Start Relay, Test . . . . .	240-25-5		

	Page		Page
<b>O</b>			
O-ring boss fittings . . . . .	10-15-7		
Oil			
Engine . . . . .	10-25-4		
Hydraulic . . . . .	10-25-7		
Mower Deck Gear Case . . . . .	10-25-8		
Transmission . . . . .	10-25-7		
<b>P</b>			
Park Brake Lever, Inspect and Repair . . .	60-10-19		
PTO Clutch Adjustment, Check . . . . .	240-25-3		
PTO Clutch and Lamp Circuit			
Check . . . . .	240-05-2		
Seat Switch, Check . . . . .	240-05-3		
Tests . . . . .	240-20-18		
PTO Clutch, Front			
Disassemble, Inspect and Assemble . . .	40-05-4		
Install—322, 330 and 332 . . . . .	40-05-6		
Install—430 . . . . .	40-05-7		
Remove—322, 330 and 332 . . . . .	40-05-1		
Remove—430 . . . . .	40-05-2		
PTO Switch			
Neutral Start, Check . . . . .	240-05-4		
<b>R</b>			
Radiator Bubble Test			
322 . . . . .	220-10-5		
330, 332 and 430 . . . . .	220-11-6		
Rear Axle			
Install . . . . .	50-20-4		
Remove . . . . .	50-20-1		
Repair specifications . . . . .	10-15-1		
Rockshaft Cylinder Leakage Test . . . . .	270-20-5		
<b>S</b>			
Seat Switch			
Check For Fuel Shutoff Solenoid . . . . .	240-05-4		
Check For Ignition (322) . . . . .	240-05-6		
Check For PTO . . . . .	240-05-3		
Sensor Tests			
Glow Plug (330, 332, 430) . . . . .	240-25-3		
Low Fuel—322 and 332 . . . . .	240-25-1		
Low Fuel—430 (SN —475000) . . . . .	240-25-2		
Low Fuel—430 (SN 475001— ) . . . . .	240-25-1		
Water-In-Fuel (430) . . . . .	240-25-3		
		Serial Numbers	
		Control Valve . . . . .	10-30-2
		Differential . . . . .	10-30-2
		Engine . . . . .	10-30-1
		Product Identification . . . . .	10-30-1
		Transmission . . . . .	10-30-1
		Service Park Brake Check . . . . .	260-05-3
		Short Circuits	
		10-Amp Fuse . . . . .	240-25-15
		25-Amp Fuse . . . . .	240-25-15
		Shutoff Solenoid, Fuel (322, 332, 430)	
		Circuit Check . . . . .	240-05-4
		Seat Switch, Check . . . . .	240-05-4
		Specifications	
		Machine—322 and 330 . . . . .	10-10-1
		Machine—332 and 430 . . . . .	10-10-4
		Repair . . . . .	10-15-1
		Test and adjustment . . . . .	10-20-1
		Speed Reduction Check (322, 332 and 430) . . . . .	
			250-05-2
		Starter Tests	
		Amp Draw . . . . .	240-25-6
		No Load Amp Draw—322, 330 and 332 . . . . .	
			240-25-8
		No Load Amp Draw—430 . . . . .	
			240-25-9
		No Load RPM—322, 330 and 332 . . . . .	
			240-25-7
		No Load RPM—430 . . . . .	
			240-25-9
		No Load Running—322, 330 and 332 . . . . .	
			240-25-7
		No Load Running—430 . . . . .	
			240-25-8
		Starting Circuit	
		Brake Switch, Check . . . . .	240-05-3
		Circuit Test . . . . .	240-20-24
		PTO Switch, Check . . . . .	240-05-4
		Starting Circuit, Check . . . . .	240-05-3
		Transmission Switch, Check . . . . .	240-05-4
		Steering Column—322 and 332	
		Assemble . . . . .	60-06-15
		Disassemble and Inspect . . . . .	60-06-6
		Remove and Install . . . . .	60-06-2
		Steering Column—430	
		Assemble . . . . .	60-06-15
		Disassemble and Inspect . . . . .	60-06-6
		Remove and Install . . . . .	60-06-4
		Steering Cylinder (322, 332 and 430)	
		Remove and Install . . . . .	60-06-25
		Steering Gearbox—330	
		Assemble . . . . .	60-05-12
		Disassemble and Inspect . . . . .	60-05-5
		Remove and Install . . . . .	60-05-1

	Page		Page
Steering Shaft—330		Transmission—Continued	
Assemble . . . . .	60-05-12	Disassemble Pump and Motor Housing . . . . .	50-05-16
Disassemble and Inspect . . . . .	60-05-5	Drive Check . . . . .	250-05-2
Remove and Install . . . . .	60-05-1	Install . . . . .	50-05-25
Steering System		Neutral Check . . . . .	250-05-1
Check (322, 332 and 430) . . . . .	260-05-2	Oil Leak Check . . . . .	250-05-1
Leakage Test . . . . .	260-15-5	Remove . . . . .	50-05-6
Oil Leak Check (322, 332 and 430) . . . . .	260-05-1	Theory of Operation . . . . .	250-10-2
Troubleshooting . . . . .	260-15-1	Troubleshooting . . . . .	250-15-1
Steering Valve/System Operation . . . . .	260-10-2	Transmission Control Linkage—322, 332	
Steering Valve—322 and 332		Version 1 . . . . .	50-10-2
Assemble . . . . .	60-06-15	Version 2 . . . . .	50-10-4
Disassemble and Inspect . . . . .	60-06-6	Version 3 . . . . .	50-10-5
Leakage Test . . . . .	260-15-5	Transmission Control Linkage—330 . . . . .	50-10-1
Neutral Check . . . . .	250-15-9	Transmission Control Linkage—430	
Remove and Install . . . . .	60-06-2	Version 1 . . . . .	50-10-3
Steering Valve—430		Version 2 . . . . .	50-10-4
Assemble . . . . .	60-06-15	Version 3 . . . . .	50-10-5
Disassemble and Inspect . . . . .	60-06-6	Transmission oil . . . . .	10-25-7
Leakage Test . . . . .	260-15-5	Transmission Switch	
Neutral Check . . . . .	250-15-9	Neutral Start, Check . . . . .	240-05-4
Remove and Install . . . . .	60-06-4	Turn Brake Check (322, 332 and 430) . . . . .	260-05-3
Storing lubricants . . . . .	10-25-9	Two-Speed Axle (430)	
Synthetic Lubricants . . . . .	10-25-9	Lever Check . . . . .	250-05-3
		Lever Linkage Check . . . . .	250-15-17
		Two-Speed Control Linkage (430) . . . . .	50-10-6
		<b>W</b>	
		Water-In-Fuel Sensor, Test (430) . . . . .	240-25-3
		Welch Plug Location Check . . . . .	250-15-8
		Wheel Bearings, Inspect and Replace . . . . .	80-05-12
<b>T</b>			
Test and adjustment specifications . . . . .	10-20-1		
Throttle Cable Adjustment			
322 . . . . .	220-10-7		
330, 332 and 430 . . . . .	220-11-6		
Throttle Lever—322			
Adjustment . . . . .	220-10-5		
Check . . . . .	220-05-3		
Throttle Lever—330, 332 and 430			
Adjustment . . . . .	220-11-6		
Check . . . . .	220-05-3		
Toe-In, Adjust . . . . .	80-05-12		
Torque values			
Inch . . . . .	10-15-5		
Metric . . . . .	10-15-4		
Metric—Grade 7 . . . . .	10-15-6		
O-Ring boss fitting . . . . .	10-15-7		
Transmission			
Assemble Cover . . . . .	50-05-22		
Assemble Pump and Motor . . . . .	50-05-21		
Assemble Pump and Motor Housing . . . . .	50-05-19		
Disassemble Cover . . . . .	50-05-11		
Disassemble Pump and Motor . . . . .	50-05-14		