

TECHNICAL MANUAL

**OPERATOR, UNIT, INTERMEDIATE DIRECT SUPPORT
AND GENERAL SUPPORT MAINTENANCE MANUAL
(INCLUDING REPAIR PARTS AND SPECIAL TOOLS LISTS)**

POWER PLANT

AN/MJQ-18 (NSN 6115-00-033-1398)

(2) MEP-003A 10 KW 60 HZ

GENERATOR SETS

M103A3 2-WHEEL, 1 1/2 TON

MODIFIED TRAILER

This manual supersedes Chapter 15 of TM 5-6115-594-14&P dated 25 September 1984.

HEADQUARTERS, DEPARTMENT OF THE ARMY

13 JUNE 1988

TM 5-6115-633-14&P

C4

CHANGE

HEADQUARTERS
DEPARTMENT OF THE ARMY
WASHINGTON, D C., 30 May 1997

NO. 4

Operator, Unit, Intermediate Direct Support and
General Support Maintenance Manual
(Including Repair Parts and Special Tools Lists)

POWER PLANT
AN/MJO-18 (NSN 6115 1)33-1398)
(2) MEP003A 10 KW 60 HZ
GENERATOR SETS
M103A3 2-WHEEL, 1 1/2 TON
MODIFIED TRAILER

DISTRIBUTION STATEMENT A: Approved for public release; distribution is unlimited

TM 5-6115-633-14&P, 13 June 1988, is changed as follows:

1. Remove and insert pages as indicated below. New or changed text material is indicated by a vertical bar in the margin. An illustration change is indicated by a miniature pointing hand.

Remove pages

Insert pages

D-1 7 through D-22

D-17 through D-20

D-41/(D-42 blank)

D-41/(D-42 blank)

D-43 through D-45/D-46 blank)

D-43 through D-46

2. Retain this sheet in front of manual for reference purposes

By Order of the Secretary of the Army:

Official:



JOEL B. HUDSON
Administrative Assistant to the
Secretary of the Army
03274

DENNIS J. REIMER
General, United States Army
Chief of Staff

DISTRIBUTION:

To be distributed in accordance with DA Form 12-25-E, block no 3868, requirements for TM 5-6115-633-14&P.

CHANGE
NO. 3

HEADQUARTERS
DEPARTMENT OF THE ARMY
WASHINGTON, D.C, 4 September 1996

Operator, Unit, Intermediate Direct Support and
General Support Maintenance Manual
(Including Repair Parts and Special Tools Lists)

POWER PLANT
AN/MJQ-18 (NSN 6115-00-033-1398)
(2) MEP-003A 10 KW 60 HZ
GENERATOR SETS
M103A3 2-WHEEL, 1 1/2 TON
MODIFIED TRAILER

DISTRIBUTION STATEMENT A Approved for public release, distribution is unlimited

TM 5-6115-633-14&P, 13 June 1988, is changed as follows

1. Remove and insert pages as Indicated below. New or changed text material Is indicated by a vertical bar in the margin An Illustration change is indicated by a miniature pointing hand

Remove pages

i and ii
1-1 and 1-2
D- 17 through D-20

Insert pages

i and ii
1-1 and 1-2
D-17 through D-20

2. Retain this sheet In front of manual for reference purposes

By Order of the Secretary of the Army:

Official:

JOEL B HUDSON
*Administrative Assistant to the
Secretary of the Army*
02145

DENNIS J REIMER
*General, United States Army
Chief of Staff*

DISTRIBUTION

To be distributed In accordance with DA Form 12-25-E, block no 3868, requirements for TM 5-6115-633-14&P

CHANGE

NO. 2

HEADQUARTERS
DEPARTMENT OF THE ARMY
WASHINGTON, D. C., 11 June 1991

Operator, Unit, Intermediate Direct Support and
General Support Maintenance Manual
(Including Repair Parts and Special Tools Lists)

**POWER PLANT AN/MJQ-18
NSN 6115-00-033-1398
(2) MEP-003A, 10 kW, 60 HZ
GENERATOR SETS
M103A3, 2-WHEEL, 1 1/2 TON
MODIFIED TRAILER**

Approved for public release; distribution is unlimited

TM 5-6115-633-14&P, 13 June 1988 is changed as follows:

1. Remove and insert pages as indicated below. New or changed text material is indicated by a vertical bar in the margin. An illustration change is indicated by a miniature pointing hand.

Remove pages

iii and iv
1-1 through 1-4
3-7 and 3-8
3-19 through 3-22
4-1 through 4-6
4-15 and 4-16
C-3 and C-4

Insert pages

iii and iv
1-1 through 1-4
3-7 and 3-8
3-19 through 3-22
4-1 through 4-6
4-15 and 4-16
C-3 and C-4

2. Retain this sheet in front of manual for reference purposes.

By Order of the Secretary of the Army:

CARL E. VUONO
General, United States Army
Chief of Staff

Official:

PATRICIA P. HICKERSON
Brigadier General, United States Army
The Adjutant General

DISTRIBUTION:

To be distributed in accordance with DA Form 12-25E, (qty rqr block no. 3868).

CHANGE }
No. 1 }

HEADQUARTERS
DEPARTMENT OF THE ARMY
WASHINGTON, D.C. 25 October 1989

Operator, Unit, Intermediate Direct Support
And General Support Maintenance Manual
(Including Repair Parts And Special Tools Lists)

POWER PLANT
AN/MJQ-18 (NSN 6115-00-033-1398)
(2) MEP-003A 10 KW 60 HZ
GENERATOR SETS
M103A3 2-WHEEL, 1 1/2 TON
MODIFIED TRAILER

Approved for public release; distribution is unlimited.

TM 5-6115-633-14&P, 13 June 1988, is changed as follows:

1. Remove and insert pages as indicated below. New or changed text material is indicated by a vertical bar in the margin. An illustration change is indicated by a miniature pointing hand.

Remove pages

Insert pages

4-7 through 4-12

4-7 through 4-12

2. Retain this sheet in front of manual for reference purposes:

By Order of the Secretary of the Army:

CARL E. VUONO
General, United States Army
Chief of Staff

Official:

WILLIAM J. MEEHAN, II
Brigadier General, United States Army
The Adjutant General

DISTRIBUTION:

To be distributed in accordance with DA Form 12-25A, Operator, Unit, Direct Support and General Support Maintenance requirements for Generator Set, Diesel Engine Driven, Trailer Mounted.



**SAFETY STEPS TO FOLLOW IF SOMEONE IS THE
VICTIM OF ELECTRICAL SHOCK**

DO NOT TRY TO PULL OR GRAB THE INDIVIDUAL

IF POSSIBLE, TURN OFF THE ELECTRICAL POWER

**IF YOU CANNOT TURN OFF THE ELECTRICAL
POWER, PULL, PUSH, OR LIFT THE PERSON TO
SAFETY USING A WOODEN POLE OR A ROPE OR
SOME OTHER INSULATING MATERIAL**

SEND FOR HELP AS SOON AS POSSIBLE

**AFTER THE INJURED PERSON IS FREE OF
CONTACT WITH THE SOURCE OF ELECTRICAL
SHOCK, MOVE THE PERSON A SHORT DISTANCE
AWAY AND IMMEDIATELY START ARTIFICIAL
RESUSCITATION**

WARNING

All specific cautions and warnings contained in this manual shall be strictly adhered to. Otherwise, severe injury, death and/or damage to the equipment may result.

HIGH VOLTAGE

is produced when this power plant is in operation.

DEATH

or severe burns may result if personnel fail to observe safety precautions. Do not operate this power plant until the ground terminal stud has been connected to a suitable ground. Disconnect the battery ground cables on the generator sets before removing and installing components on the engine or in the electrical control panel system. Remove all rings, watches, and other jewelry when performing maintenance on this equipment. Loose fitting clothing should be secured to prevent it catching in moving parts. Do not attempt to service or otherwise make any adjustments, connections or reconnection of wires or cables until generator sets are shut down and completely de-energized.

DANGEROUS GASES

Batteries generate explosive gas during charging: therefore, utilize extreme caution. Do not smoke, or use open flame in the vicinity of the generator set when servicing batteries.

Exhaust discharge contains noxious and deadly fumes. Do not operate power plant generator sets in enclosed areas unless exhaust discharge is properly vented to the outside.

To avoid sparking between filler nozzle and fuel tank, always maintain metal to metal contact between filler nozzle and fuel tank when filling generator set fuel tanks.

Do not smoke or use open flame in the vicinity of the power plant while fueling generator sets.

LIQUIDS UNDER HIGH PRESSURE

are generated as a result of operation of the power plant generator sets. Do not expose any part of the body to a high pressure leak in the fuel injection system.

NOISE

Operating noise level of the generator sets can cause hearing damage. Ear protectors, as recommended by the medical or safety officer, must be worn when working near this power plant.

WARNING

Clean parts in a well-ventilated area. Avoid inhalation of solvent fumes and prolonged exposure of skin to cleaning solvent. Wash exposed skin thoroughly. Dry cleaning solvent (P-D-680) used to clean parts is potentially dangerous to personnel and property. Do not smoke or use near open flame or excessive heat. Flash point of solvent is 100°F. to 138°F.(38°C. to 59°C.).

TECHNICAL MANUAL
NO 5-6115-633-14&P

HEADQUARTERS
DEPARTMENT OF THE ARMY
WASHINGTON, D C, 13 June 1988

Operator, Unit, Intermediate Direct Support and
General Support Maintenance Manual
(Including Repair Parts and Special Tools Lists)

**POWER PLANT
AN/MJQ-18 (NSN 6115-00-033-1398)
(2) MEP-003A 10 KW 60 HZ
GENERATOR SETS
M103A3 2-WHEEL, 1 1/2 TON
MODIFIED TRAILER**

REPORTING ERRORS AND RECOMMENDING IMPROVEMENTS

You can help Improve this manual. If you find any mistakes, or if you know of a way to improve these procedures, please let us know Mali your letter or DA Form 2028 (Recommended Changes to Publications and Blank Forms), or DA Form 2028-2 located in the back of this manual directly to: Commander, US Army Aviation and Troop Command, ATTN. AMSAT-I-MP, 4300 Goodfellow Blvd., St Louis, MO 63120-1798. You may also submit your recommended changes by E-mail directly to <mpmt%/oavma28@st-louis-emh7 army.mil>. A reply will be furnished directly to you. Instructions for sending an electronic 2028 may be found at the back of this manual immediately preceding the hard copy 2028.

DISTRIBUTION STATEMENT A Approved for public release, distribution is unlimited

TABLE OF CONTENTS

| | PAGE |
|--|-------------|
| CHAPTER 1 INTRODUCTION | |
| Section I General | 1-1 |
| Section II Description and Data | 1-2 |
| CHAPTER 2 OPERATING INSTRUCTIONS | |
| Section I Operating Procedures | 2-1 |
| Section II Operation of Auxiliary Equipment | 2-2 |
| Section III Operation Under Unusual Conditions | 2-2 |
| CHAPTER 3 OPERATOR/CREW MAINTENANCE INSTRUCTIONS | |
| Section I Consumable Operating and Maintenance Supplies | 3-1 |
| Section II Lubrication Instructions | 3-1 |
| Section III Preventive Maintenance Checks and Services (PMCS)..... | 3-1 |
| Section IV Troubleshooting | 3-18 |
| Section V Operator/Crew Maintenance Instructions | 3-18 |

*This manual supersedes Chapter 15 of TM 5-6115-594-14&P dated 25 September 1984.

| | Page | |
|--------------|---|------|
| CHAPTER 5. | INTERMEDIATE (FIELD) DIRECT SUPPORT AND GENERAL SUPPORT MAINTENANCE INSTRUCTIONS | |
| Section I. | Introduction | 5-1 |
| Section II. | Maintenance of Power Plant Trailer | 5-1 |
| Section III. | Generator Set | 5-9 |
| Section IV. | Maintenance of Electrical System | 5-11 |
| CHAPTER 6. | TEST AND INSPECTION AFTER REPAIR | |
| Section I. | General Requirements | 6-1 |
| Section II. | Inspection | 6-1 |
| Section III. | Operational Tests | 6-1 |
| APPENDIX A. | REFERENCES | A-1 |
| APPENDIX B. | COMPONENTS OF END ITEM AND BASIC ISSUE ITEMS LISTS | B-1 |
| APPENDIX C. | MAINTENANCE ALLOCATION CHART | C-1 |
| APPENDIX D. | UNIT, INTERMEDIATE (FIELD) (DIRECT SUPPORT AND GENERAL GENERAL SUPPORT) AND DEPOT MAINTENANCE REPAIR PARTS AND SPECIAL TOOLS LIST | D-1 |

LIST OF ILLUSTRATIONS

| Figure | Title | Page |
|--------|---|------|
| 1-1 | Power Plant, Roadside Front, Three-Quarter View | 1-2 |
| 1-2 | Power Plant, Curbside Rear, Three-Quarter View | 1-3 |
| 3-1 | Fitted Cover Installed on Power Plant | 3-19 |
| 3-2 | Fitted Cover Rolled Up for Removal. | 3-20 |
| 3-3 | Bow Assembly Replacement.. | 3-21 |
| 4-1 | Unpacking Power Plant | 4-2 |
| 4-2 | Installing Power Plant | 4-4 |
| 4-3 | External Fuel Line Connection. | 4-6 |
| 4-4 | DELETED | |
| 4-5 | Accessory Box Replacement.. | 4-16 |
| 4-6 | Fire Extinguisher Bracket Replacement | 4-17 |
| 4-7 | Four-Wire Switch Box Schematic Diagram | 4-18 |
| 4-8 | Five-Wire Switch Box Schematic Diagram | 4-19 |
| 4-9 | Switch Box Replacement | 4-20 |
| 4-10 | Load Terminal and Terminal Board Replacement | 4-21 |
| 4-11 | Indicator Light and Wire Assembly Replacement | 4-23 |
| 4-12 | Switch to Load Terminal Wire Replacement | 4-24 |
| 4-13 | Power Cable Replacement | 4-25 |
| 4-14 | Ground Wire Replacement | 4-27 |
| 4-15 | Taillight Cable Assembly and Electrical Lead Repair | 4-29 |
| 5-1 | Leg Prop Assembly Replacement | 5-2 |
| 5-2 | Leg Prop Disassembly | 5-3 |
| 5-3 | Fender and Bed Replacement. | 5-4 |
| 5-4 | Accessory Box Repair | 5-8 |
| 5-5 | Power Plant Markings | 5-8 |
| 5-6 | Detaching Generator Set from Trailer | 5-9 |
| 5-7 | Lifting Generator Set | 5-10 |
| 5-8 | Switch Box Switch Replacement. | 5-12 |
| B-1 | Components of End Item | B-2 |
| B-2 | Basic Issue Items | B-3 |
| D-1 | Enclosure | D-10 |
| D-2 | Generator Set | D-12 |
| D-3 | Five-Wire Power Cable... | D-14 |
| D-4 | Four-Wire Power Cable | D-16 |
| D-5 | Five-Wire Switch Box | D-18 |
| D-6 | Four-Wire Distribution Box... | D-22 |
| D-7 | Distribution Box Electrical Leads | D-26 |
| D-8 | Trailer Body | D-28 |
| D-9 | Accessory Box | D-34 |
| D-10 | Data Plates and Reflectors | D-36 |
| D-11 | Leg Prop Assembly | D-38 |
| D-12 | Taillight Cable Assembly and Electrical Lead | D-40 |

LIST OF TABLES

| Number | Title | Page |
|--------|---|------|
| 3-1 | Consumable Operating and Maintenance Supplies | 3-1 |
| 3-2 | Operator/Crew Preventive Maintenance Checks and Services (PMCS). | 3-4 |
| 4-1 | Unit Preventive Maintenance Checks and Services (PMCS) | 4-9 |
| 4-2 | Troubleshooting. | 4-13 |

CHAPTER 1

INTRODUCTION

SECTION I. GENERAL

1-1. Scope. This manual is for your use in operating and maintaining the Power Plant, AN/MJQ-18. The AN/MJQ-18 is a mobile power plant used to supply power to any system or equipment requiring up to 10 kW of 60 Hz input operating power. In addition to operating instructions and operator, unit, and intermediate direct support and general support maintenance procedures, this manual contains a Repair Parts and Special Tools List for the power plant.

1-2. Limited Applicability. Some portions of this publication are not applicable to both services. These portions are prefixed to indicate the service to which they pertain (A) for Army, and (F) for Air Force. Portions not prefixed are applicable to both services.

1-3. Maintenance Forms and Records.

- a.* (A) Maintenance forms and records used by Army personnel are prescribed by DA Pam 738-750
- b.* (F) Maintenance forms and records used by Air Force personnel are prescribed in AFM66-1 and the applicable 00-20 Series Technical Orders

1-4. Reporting of Errors. Reporting of errors and omissions and recommendations for improvement of this publication by the individual user is encouraged. Reports should be submitted as follows:

- a.* (A) ARMY - DA Form 2028 directly to Commander, US Army Aviation and Troop Command, ATTN AMSAT-I-MT, 4300 Goodfellow Boulevard, St Louis, MO 63120-1798.
- b.* (F) Air Force - AFTO Form 22 directly to Commander, Sacramento Air Logistics Center, ATTN SM-ALC-MMEDTA, McClellan Air Force Base, CA, 95652-5609, in accordance with TO-00-5-1.

1-5. Reporting Equipment Improvement Recommendations (EIR). EIR's will be prepared using SF 368, Product Quality Deficiency Report Instructions for preparing EIR's are provided in DA PAM 738-750, The Army Maintenance Management System. EIR's should be mailed directly to Commander, US Army Aviation and Troop Support Command, ATTN AMSAT-I-MDO, 4300 Goodfellow Boulevard, St Louis, MO 63120-1798.

1-6. Levels of Maintenance Accomplishment.

- a.* (A) Army users shall refer to the Maintenance Allocation Chart (MAC) for tasks and levels of maintenance to be performed
- b.* (F) Air Force users shall accomplish maintenance at the user level consistent with their capability in accordance with policies established in AFM 66-1

1-7. Destruction of Army Materiel. Destruction of Army materiel to prevent enemy use shall be in accordance with TM 750-244-3.

1-8. Administrative Storage.

- a. Army equipment placed in administrative storage will have preventive maintenance performed in accordance with the PMCS tables before storage. When equipment is removed from storage, PMCS will be performed to ensure operational readiness.
- b. (F) For administrative storage procedures for Air Force equipment, refer to TO 35-1-4, Processing and Inspection of Aerospace Ground Equipment for Storage and Shipment.

1-9. Preparation for Shipment and Storage.

- a. (A) Army - Referto TB 740-97-2.
- b. (F) Air Force - Refer to TO 35-14 for component of end item generator sets and TO 38-1-5 for installed engine.

Section II. DESCRIPTION AND DATA

1-10. Description. Power Plant AN1MJQ-18 is made up of two Tactical Utility Generator Sets, DOD Model MEP-003A, mounted on a single modified M103A3 trailer. These generator sets are air-cooled, diesel engine-driven units, each with a load capacity of 10 KW at 60 Hz. The trailer is a two-wheeled unit with a 1-1/2-ton carrying capacity. The modifications to the basic trailer provide stowage for the accessories and all equipment necessary for mobile operation as well as providing a work platform for the operator and maintenance personnel. Output from the power plant is applied to the system or equipment being powered through a switch box. The AN/MJQ-18 is supplied with either a 4-wire or a 5-wire configuration switch box. Figures 1-1 and 1-2 illustrate the power plant with the fitted cover removed to show the generator sets.

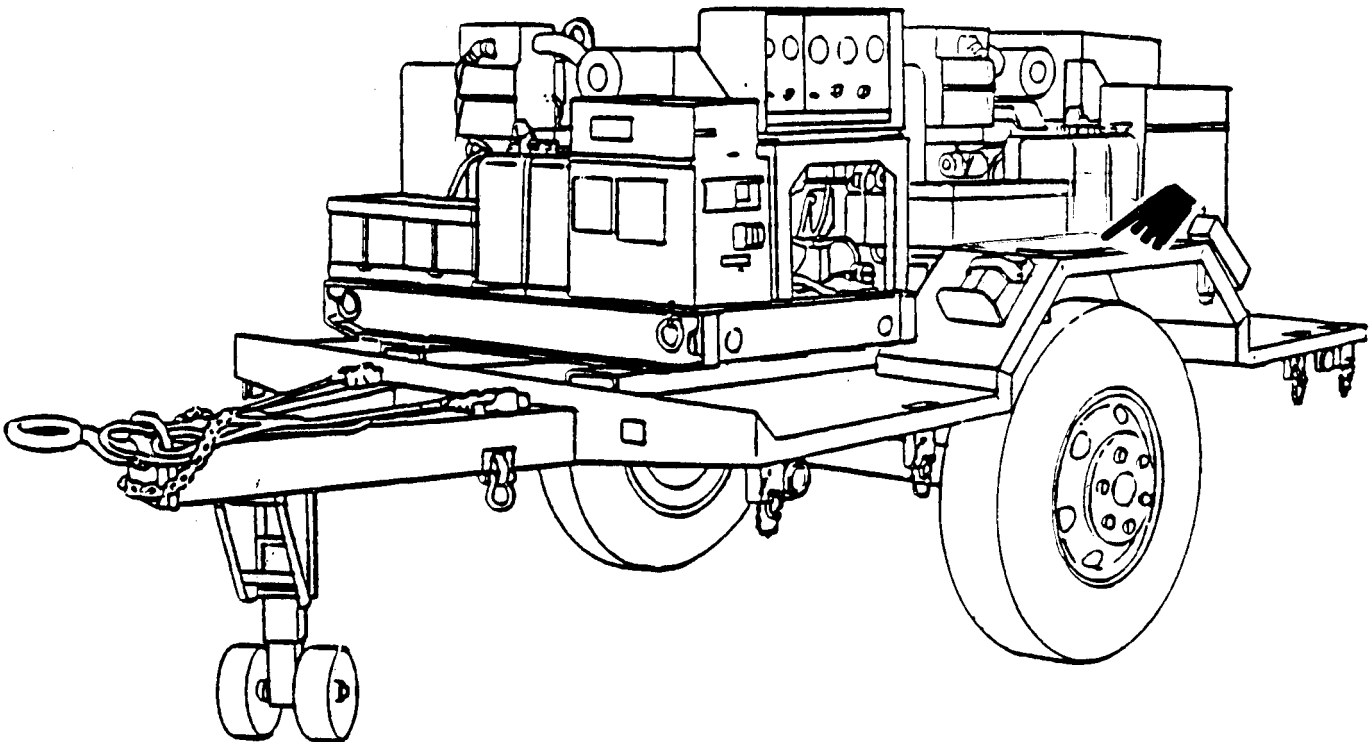

Figure 1-1. Power Plant, Roadside Front, Three-Quarter View.

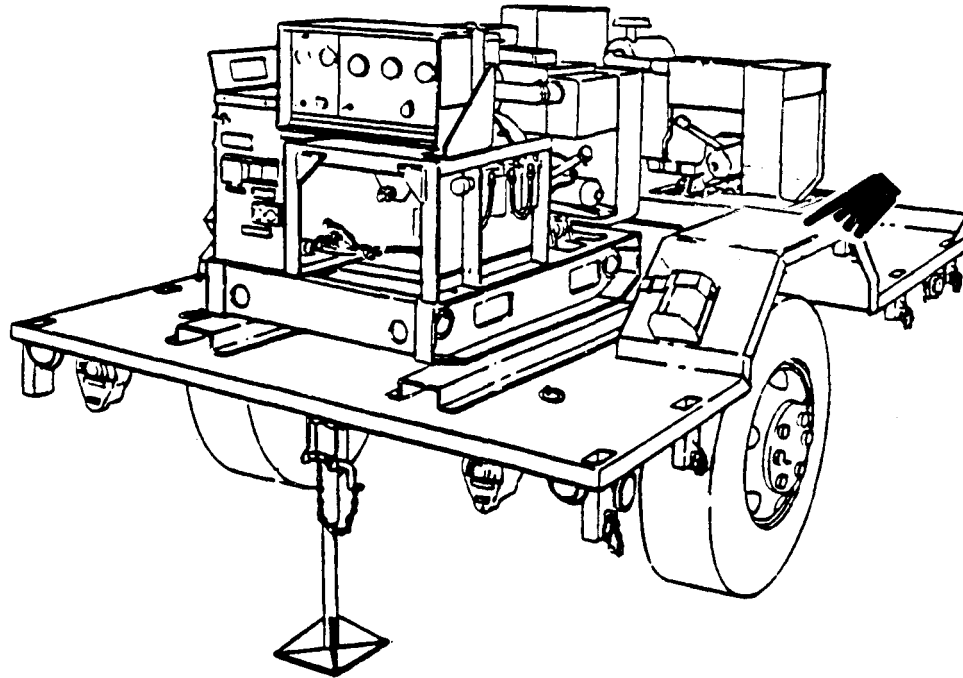

Figure 1-2. Power Plant, Curbside Rear Three-Quarter View.

1-11. Tabulated Data. The tabulated data provides operator and unit level personnel with the dimensions and weights for Power Plant, AN/MJQ-18. These specifications are computed from the combined dimensions and weights of the generator sets and trailer as modified for use with the power plant. Specifications of the individual components can be found in their respective technical publications. For additional information concerning Generator Set, DOD Model MEP-003A, refer to TM 5-6115-585-12 and -34. For additional information on the M103A3 trailer, refer to TM 9-2330-213-14&P. The tabulated data also includes the location and content of all data plates unique to the power plant.

a. Identification and Instruction Plates.

(1) Identification plate.

(a) Location. This plate is located on the front roadside frame between the trailer body and the drawbar ring.

(b) Content.

**US
POWER PLANT, ELECTRIC
AN/MJQ-18
KW10
HERTZ 60
NSN 6115-00-033-1398**

(2) *Identification plate.*

(a) *Location.* This plate is located next to the ground stud on the rear, roadside corner of the trailer bed.

(b) *Content.*

GROUND TERMINAL

(3) *Wiring diagram information plate.*

(a) *Location.* This plate is mounted inside the switch box.

(b) *Content* (see figure 4-7 or 4-8).

(4) *Warning plate.*

(a) *Location.* This plate is located on the switch box terminal board cover.

(b) *Content.*

DANGER
HIGH VOLTAGE

NOTE

The following two data plates are found only on the 5-wire configuration switch box.

(5) *Information plate.*

(a) *Location.* This plate is located on the outboard side of the switch box next to ground terminal E2.

(b) *Content.*

AC GROUND

(6) *Information plate.*

(a) *Location.* This plate is located next to ground terminal E1 on the rear of the switch box.

(b) *Content.*

EQUIPMENT
(FRAME)
GROUND

b. Tabulated Data for Power Plant.

| | |
|---------------------|-------------------------------------|
| Overall Length | 171.5 inches (435.6 centimeters) |
| Overall Width | 83 inches (210.8 centimeters) |
| Overall Height | 95 inches (241.3 centimeters) |
| Net Weight (empty) | 5150 pounds (2340.9 kilograms) |
| Net Weight (filled) | 5320 pounds (2418.1 kilograms) |
| Shipping Weight | 5700 pounds (2590.9 kilograms) |
| Cubage | 799 cubic feet (22.69 cubic meters) |

1.12. **Differences Between Models.** There are no differences between models, serial numbers, or serial number groups applicable to this equipment.

CHAPTER 2

OPERATING INSTRUCTIONS

Section I. OPERATING PROCEDURES

2-1. Operating Procedures. Before the power plant generators are started and operated, the power plant is towed to a worksite and installed. Installation instructions are provided in paragraph 4-2. Instructions for dismantling the power plant for movement are given in paragraph 4-3.

a. Generator Set Operating Procedures. Detailed prestarting, startup, operating and shutdown procedures for the generator sets can be found on the Operating Instructions data plate located on the right hand side of each generator set control cubicle, and in the generator set technical manual, TM 5-6115-585-12.

WARNING

Do not operate power plant until it is properly grounded (paragraph 4-2, b). Serious injury or death by electrocution can result from operating an ungrounded generator set.

Operating noise level of the generator sets can cause hearing damage. Ear protectors, as recommended by medical or safety officer, must be worn when working near power plant.

CAUTION

To avoid damage to equipment, make certain of voltage, frequency, and phase requirements of load connected to generator sets.

NOTE

Make sure generator set circuit breakers and switch box rotary switch are in OFF position before proceeding.

Before starting generator set, do your Before PMCS as described in table 3-2.

b. Switch Box Operating Procedures.

(1) *Single generator set operation.* Use the switch box to operate only one generator set as follows:

- (a) Make sure power and ground cables are connected to generator set and switch box.
- (b) Turn generator set on and bring it up to rated speed, voltage and frequency. (Refer to TM 5-6115-585-12.)
- (c) Close generator set circuit breaker (move to ON position).
- (d) Turn rotary switch on switch box to GEN 1 or GEN 2 position, as applicable.
- (e) To stop operation, move rotary switch and generator set circuit breaker to OFF position. Turn generator set off. (Refer to TM 5-6115-585-12.)

(2) *Dual generator set operation.* Use the switch box to alternately operate both generator sets as follows:

- (a) Make sure power and ground cables are connected to switch box and both generator sets.
- (b) Select first generator set to be used and bring it into operation in accordance with paragraph 2-1, b (1), steps (b) through (d).
- (c) Turn second generator set on and bring it up to rated speed, voltage and frequency. (Refer to TM 5-6115-585-12.) Close circuit breaker (move to ON position).
- (d) Move switch box rotary switch to GEN position corresponding to second generator set.
- (e) Open circuit breaker on first generator set (move to OFF position) and turn generator set off. (Refer to TM 5-6115-585-12.)
- (f) To stop operation, move rotary switch to OFF position and open circuit breaker on generator set still running. Turn generator set off. (Refer to TM 5-6115-585-12.)

c. Trailer Operating Procedures. Refer to TM 9-2330-213-14&P for specific operating procedures for the M103A3 trailer.

Section II. OPERATION OF AUXILIARY EQUIPMENT

2-2. Operation of Auxiliary Equipment. There is no auxiliary equipment supplied with the power plant.

Section III. OPERATION UNDER UNUSUAL CONDITIONS

2-3. Operation Under Unusual Conditions. When operating the power plant under unusual conditions such as extremes in temperature or difficult terrain, there are steps that must be taken to protect the equipment.

- a. Refer to TM 5-6115-585-12 for special procedures when operating the generator sets under unusual conditions.
- b. Refer to TM 9-2330-213-14&P for special procedures when operating the trailer under unusual conditions.

CHAPTER 3 OPERATOR/CREW MAINTENANCE INSTRUCTIONS

Section I. CONSUMABLE OPERATING AND MAINTENANCE SUPPLIES

3-1. Consumable Supplies. Consumable supplies used in the maintenance and operation of the power plant are listed in Table 3-1.

Table 3-1. Consumable Operating and Maintenance Supplies.

| (1) Component application | (2) National stock number | (3) Description | (4) Qty required for initial operation | (5) Qty required 8 hours operation | (6) Notes |
|------------------------------|------------------------------|---------------------------------------|---|---------------------------------------|--------------|
| General Cleaning | 6850-00-664-5685 | Solvent, Drycleaning, P-D-680 | 1 quart | As required | |
| Leg Prop Assembly | 9150-00-190-0904 | Grease, Automotive and Artillery, GAA | 1 pound | As required | |
| Leg Prop Assembly | 9150-00-186-6681 | Oil, Lubricating, OE/HDO-30 | 1 quart | As required | |
| | 9150-00-402-4478 | Oil, Lubricating, OEA | 1 quart | As required | |

Section II. LUBRICATION INSTRUCTIONS

3-2. General. Detailed instructions for the lubrication of the major components of the power plant are contained in the applicable Lubrication Orders (LO's). Refer to DA Pam 310-1 to ensure that the latest editions of the LO's are used.

3-3. Generator Lubrication. Refer to TM 5-6115-585-12 for generator set Lubrication Order.

3-4. Trailer Lubrication. There are no operator/crew lubrication requirements for the power plant trailer. However, the operator shall assist unit maintenance.

Section III. PREVENTIVE MAINTENANCE CHECKS AND SERVICES (PMCS)

NOTE

The PMCS chart in this section contains all necessary Operator/Crew preventive maintenance checks and services for this equipment.

3-5. General. The preventive maintenance checks and services listed in Table 3-2 are grouped according to stages of equipment operation or time intervals. Using the following as a guide, do the checks and services at the intervals shown.

- a. Before you operate, perform your before (B) PMCS. Observe all CAUTIONS and WARNINGS.

- b. While you operate, perform your during (D) PMCS. Observe all CAUTIONS and WARNINGS.
- c. After you operate, be sure to perform your after (A) PMCS.
- d. Do (W) PMCS weekly.
- e. Do (M) PMCS monthly.
- f. If equipment fails to operate, refer to Section IV Troubleshooting. If the problem cannot be corrected, see paragraph 3-8, Reporting Deficiencies.

3-6. Purpose of PMCS Table. The purpose of the PMCS table is to provide a systematic method of inspecting and servicing the equipment. In this way, small defects can be detected early before they become a major problem causing the equipment to fail to complete its mission. The PMCS table is arranged with the individual PMCS procedures listed in sequence under assigned intervals. The most logical time (before, during, or after operation) to perform each procedure determines the interval to which it is assigned. Make a habit of doing the checks and services in the same order each time and anything wrong will be seen quickly. See paragraph 3-7 for an explanation of the columns in table 3-2.

3-7. Explanation of Columns. The following is a list of the PMCS table column headings with a description of the information found in each column.

a. Item No. This column shows the sequence in which the checks and services are to be performed, and is used to identify the equipment area on the Equipment Inspection and Maintenance Worksheet, DA Form 2404.

b. Interval. This column shows when each check is to be done.

c. Item to be Inspected/Procedures. This column identifies the general area or specific part where the check or service is to be done, lists the checks or services to be done and explains how to do them.

d. Equipment is Not Ready/Available If. This column lists conditions that make the equipment unavailable for use because it is unable to perform its mission or because it would represent a safety hazard. Do not accept or operate equipment with a condition in the "Equipment is Not Ready/Available If" column.

3-8. Reporting Deficiencies. If you discover any problem with the equipment during PMCS or while operating it that you are unable to correct, it must be reported. Refer to DA Pam 738-750 and report the deficiency using the proper forms.

3-9. Special Instructions. Preventive maintenance is not limited to performing the checks and services listed in the PMCS table. Covering unused receptacles, stowing unused equipment and other routine procedures such as equipment inventory, cleaning components, and touch-up painting are not listed in the PMCS table. These are things you should do any time you see they need to be done. If a routine check is listed in the PMCS table it is because other operators have reported problems with this item. Take along tools and cleaning cloths needed to perform the required checks and services. Use the information in the following paragraphs to help you identify problems at any time.

a. Routine Inspections. Use the following information to help identify potential problems before and during checks and services.

WARNING

Drycleaning solvent P-D-680 is both toxic and flammable. Wear safety goggles and gloves and use in a well-ventilated area. Avoid prolonged breathing of vapors and avoid skin contact. Do not smoke or use near open flame or excessive heat. Flash point of solvent is 100°F to 138°F (38°C to 59°C). If you become dizzy while using P-D-680, get fresh air immediately and get medical aid. If P-D-680 contacts eyes, flush with water and get medical aid immediately.

- (1) Keep it clean. Dirt, grease, and oil get in the way and may cover up a serious problem. Use drycleaning solvent P-D-680, to clean metal surfaces. Use soap and water to clean rubber or plastic parts and material.
- (2) Bolts, nuts, and screws. Check them all to make sure they're not loose, missing, bent, or broken. Don't try to check them all with a tool, but look for chipped paint, bare metal, or rust around bolt heads. If you find one loose, tighten it or report it to unit maintenance.
- (3) Welds. Look for loose or chipped paint, rust, or gaps where parts are welded together. If a broken weld is found, report it to higher level of maintenance.
- (4) Electrical wires, connectors, terminals and receptacles. Look for cracked or broken insulation, bare wires, and loose or broken connectors. Tighten loose connectors and make sure the wires are in good condition. Examine terminals and receptacles for serviceability.
- (5) Hoses and fluid lines. Look for wear, damage, and leaks. Make sure clamps and fittings are tight. Wet spots and stains around a fitting or connector can mean a leak. If a leak comes from a loose connector, tighten it. If something is broken or worn out, report it to unit maintenance.

b. Leakage Definitions. It is necessary for you to know how fluid leakage affects the status of your equipment. The following are definitions of the types/classes of leakage you need to know to be able to determine the status of your equipment. Learn and be familiar with them. When in doubt, NOTIFY YOUR SUPERVISOR!

Leakage Definitions:

| | |
|-----------|--|
| Class I | Seepage of fluid (as indicated by wetness or discoloration) not great enough to form drops. |
| Class II | Leakage of fluid great enough to form drops but not enough to cause drops to drip from item being checked/inspected. |
| Class III | Leakage of fluid great enough to form drops that fall from the item being checked/inspected. |

CAUTION

Equipment operation is allowable with minor leakage (Class I or II) of any fluid except fuel. Of course, consideration must be given to the fluid capacity in the item being checked/inspected. When in doubt, notify your supervisor.

When operating with Class I or II leaks, continue to check fluid level more often than required in the PMCS. Parts without fluid will stop working and/or cause equipment damage.

Class III leaks should be reported to your supervisor or unit maintenance.

Table 3-2. Operator/Crew Preventive Maintenance Checks and Services (PMCS)

NOTE

If the equipment must be kept in continuous operation, check and service only those items that can be checked and serviced without disturbing operation. Make the complete checks and services when the equipment can be shut down.

Within designated interval, these checks are to be performed in the order listed.

B - Before

D - During

A - After

W - Weekly

M - Monthly

| Item no. | Interval | | | | | Item to be inspected. Procedure: check for and have repaired, filled, or adjusted as needed | Equipment is not ready/available if: |
|----------|----------|---|---|---|---|---|--------------------------------------|
| | B | D | A | W | M | | |
| | | | | | | <p><u>WARNING</u></p> <p>Before performing any maintenance that requires climbing on or under trailer, set trailer handbrakes, chock wheels, and lower rear leg prop. Injury to personnel could result from trailer suddenly rolling or tipping.</p> | |

Table 3-2. Operator/Crew Preventive Maintenance Checks and Services (PMCS) – CONT.

B - Before D – During A – After W – Weekly M – Monthly

| Item no. | Interval | | | | | Item to be inspected. Procedure: check for and have repaired, filled, or adjusted as needed | Equipment is not ready/available if: |
|----------|----------|---|---|---|---|--|--|
| | B | D | A | W | M | | |
| | | | | | | NOTE | |
| | | | | | | <p>Perform weekly as well as before PMCS if:</p> <p>You are the assigned operator but have not operated the equipment since the last weekly inspection.</p> <p>You are operating the equipment for the first time.</p> <p>Generator set checks and services in this table are described as performed on a single generator set. These procedures must be performed on each of the two generator sets that make up the AN/MJQ-18.</p> | |
| 1 | ● | | | | | <p>GENERATOR SET EXTERIOR</p> <p>a. Check on, around, and beneath the generator set (1) for fuel or oil leaks.</p> <p>b. Check that generator set (1) grounds are properly installed, and grounding connections are tight.</p> | <p>A Class III lubrication oil or any class fuel leak is detected.</p> <p>Not properly grounded.</p> |
| 2 | ● | | | | | <p>FUEL GAGE</p> <p>Check fuel gage (2) for sufficient fuel for continuous operation.</p> | |

Table 3-2. Operator/Crew Preventive Maintenance Checks and Services (PMCS) – CONT.

B - Before D – During A – After W – Weekly M – Monthly

| Item no. | Interval | | | | | Item to be inspected. Procedure: check for and have repaired, filled, or adjusted as needed | Equipment is not ready/available if: |
|----------|----------|---|---|---|---|--|--------------------------------------|
| | B | D | A | W | M | | |
| 2 | | | | | | <p>FUEL GAGE – CONT</p>  | |
| 3 | ● | | | | | <p>ENGINE OIL LEVEL</p> <p>Check oil filler dipstick (3) for proper oil level. Add oil as required.</p>  | |
| 4 | ● | ● | | | | <p>AIR CLEANER INDICATOR</p> <p>Check indicator (4) for a restricted air cleaner. If red warning indicator becomes visible, notify unit maintenance for cleaning or replacement.</p> | |

Table 3-2. Operator/Crew Preventive Maintenance Checks and Services (PMCS) – CONT.

| Item No. | Interval | | | | | Item to be inspected Procedure: check for and have repaired, filled, or adjusted as necessary | Equipment is Not Ready/ Available If: |
|----------|----------|---|---|---|---|--|--|
| | B | D | A | W | M | | |
| 4 | | | | | | <p>AIR CLEANER INDICATOR-CONT</p>  | |
| 5 | • | | | | | <p>ACCESSORIES</p> <p>Check that the following accessories are not missing.</p> <ol style="list-style-type: none"> Sledge hammer Fire extinguisher Driver/puller Ground rods | <p>Fire extinguisher is missing.</p> <p>Ground rods are missing.</p> |
| 6 | • | | | | | <p>BRACKETS</p> <p>Check fire extinguisher mounting bracket for loose hardware and broken fittings.</p> | |
| 7 | • | | | | | <p>TIRES</p> <ol style="list-style-type: none"> Check tires (5) for cuts, foreign objects, or unusual tread wear. Remove any stones from between the treads. | <p>One tire is flat, missing, or unserviceable.</p> |

Table 3-2. Operator/Crew Preventive Maintenance Checks and Services (PMCS) – CONT.

| Item No. | Interval | | | | | Item to be inspected Procedure: check for and have repaired, filled, or adjusted as necessary | Equipment is Not Ready/ Available If: |
|----------|----------|---|---|---|---|--|--|
| | B | D | A | W | M | | |
| 7 | | | | | | <p>TIRES-CONT</p> <p>a. Check that tire pressure is 50 psi (344.74 kPa) when tires are cool.</p> | |
| 8 | • | | | | | <p>WHEELS</p> <p>a. Check for damage and for missing or loose stud nuts (6).</p> <p style="text-align: center;">WARNING</p> <p>An improperly seated lockring can blow off. Never attempt to seat a lockring when tire is inflated. Serious injury or loss of life could result.</p> <p>b. Check for improperly mounted lockring assembly (7).</p>  | <p>One or more wheels are damaged. One or more stud nuts are loose or missing.</p> <p>Lockring is improperly seated.</p> |
| 9 | • | | | | | <p>DRAWBAR RING</p> <p>Check drawbar ring (8) for insecure mounting and obvious damage.</p> | <p>Ring is loose or bent.</p> |

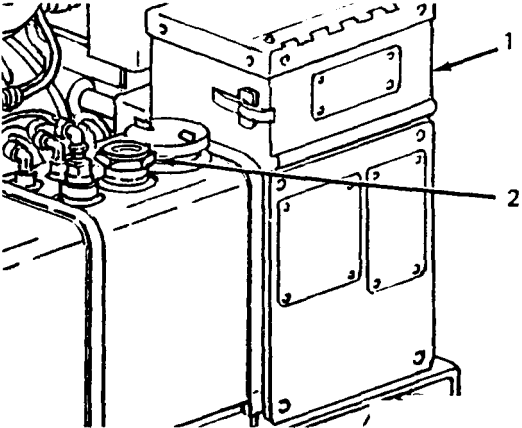
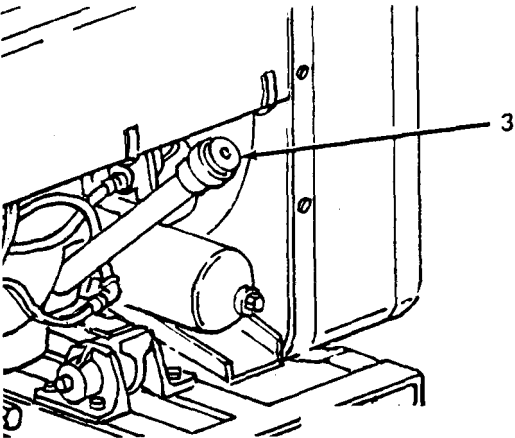
Table 3-2. Operator/Crew Preventive Maintenance Checks and Services (PMCS) – CONT.

| Item no. | Interval | | | | | Item to be inspected. Procedure: check for and have repaired, filled, or adjusted as needed | Equipment is not ready/available if: |
|----------|----------|---|---|---|---|--|--|
| | B | D | A | W | M | | |
| 10 | ● | | | | | <p>INTERVEHICULAR CABLE</p> <p>Check cable (9) and connector for cuts and breaks.</p> | <p>Intervehicular cable is broken or missing.</p> <p>Safety chains are missing or unsecured.</p> |
| 11 | ● | | | | | <p>SAFETY CHAINS</p> <p>Check safety chains (10) for insecure mounting and obvious damage.</p>  | |
| 12 | ● | | | | | <p>BOW ASSEMBLIES</p> <p>Inspect four long bow assemblies (11) and two short bow assemblies (12).</p> | |
| 13 | ● | | | | | <p>FITTED COVER</p> <ol style="list-style-type: none"> Check fitted cover (13) for missing and defective tiedown straps and snap fasteners (14). Check for missing and defective ropes (15). Check for missing and defective straps and buckles (16). Check for ripped seams and tears. | |

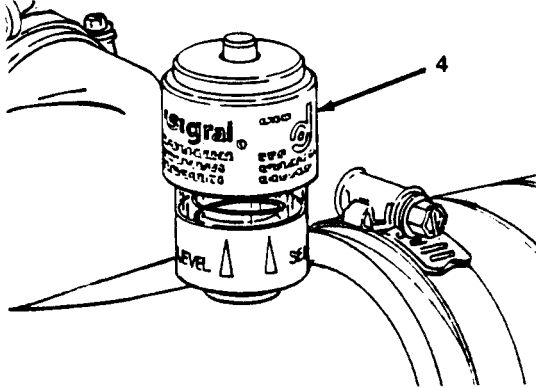
Table 3-2. Operator/Crew Preventive Maintenance Checks and Services (PMCS) – CONT.

B - Before D – During A – After W – Weekly M - Monthly

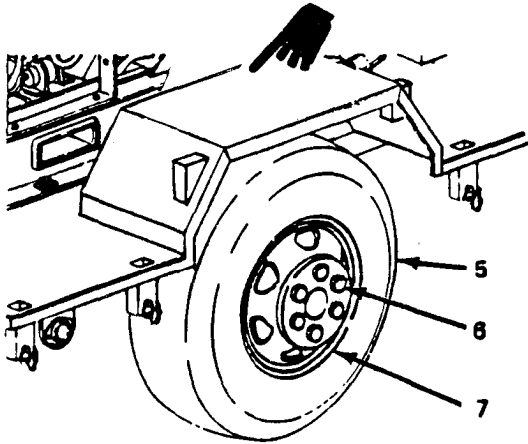
| Item no. | Interval | | | | | Item to be inspected. Procedure: check for and have repaired, filled, or adjusted as needed | Equipment is not ready/available if: |
|----------|----------|---|---|---|---|--|--------------------------------------|
| | B | D | A | W | M | | |
| 13 | | | | | | <p>FITTED COVER - CONT</p>  | |
| 14 | | ● | | | | <p>LIGHTS</p> <p>a. With intervehicular cable connected to towing vehicle, operate vehicle light switch through all settings and check lights.</p> <p style="text-align: center;">NOTE</p> <p style="text-align: center;">An assistant is required while checking brake lights.</p> <p>b. Step on brake pedal and check brake lights (17).</p>  | |

Table 3-2. Operator/Crew Preventive Maintenance Checks and Services (PMCS) – CONT.

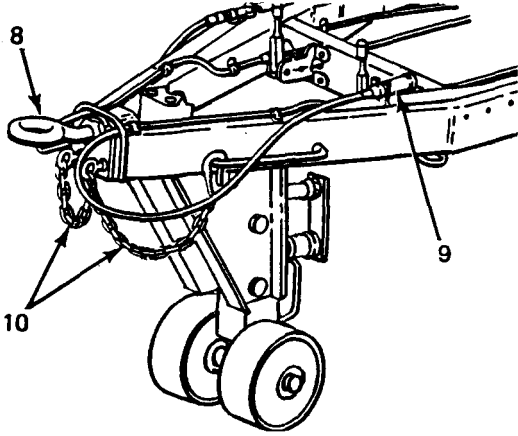
| Item no. | Interval | | | | | Item to be inspected. Procedure: check for and have repaired, filled, or adjusted as needed | Equipment is not ready/available if: |
|----------|----------|---|---|---|---|--|---|
| | B | D | A | W | M | | |
| 15 | ● | | | | | <p>AIR HOSES, FITTINGS AND BRAKE AIR CHAMBER</p> <p>Check air hoses (18), fittings (19) and brake air chamber (20) for signs of damage or leaks.</p>  | Damage or leaks are detected. |
| 16 | ● | | | | | <p>HYDRAULIC HOSES, FITTINGS AND MASTER CYLINDER</p> <p>Check brake system hoses (21) and fittings (22) and master cylinder (23), and check under vehicle for signs of brake fluid leaks.</p>  | A class III brake fluid leak is detected. |

Table 3-2. Operator/Crew Preventive Maintenance Checks and Services (PMCS) - CONT.

B - Before D - During A - After W - Weekly M - Monthly

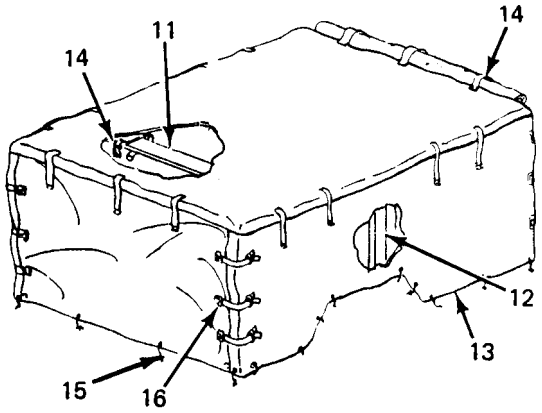
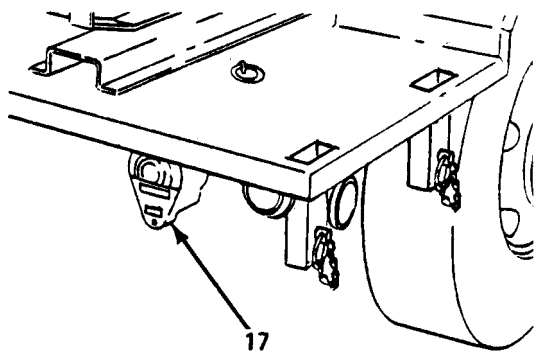
| Item no. | Interval | | | | | Item to be inspected. Procedure: check for and have repaired, filled, or adjusted as needed | Equipment is not ready/available if: |
|----------|----------|---|---|---|---|---|--------------------------------------|
| | B | D | A | W | M | | |
| 17 | | ● | | | | <p>SUPPORT LEG ASSEMBLY</p> <p>With trailer connected to towing vehicle, check support leg assembly (24) for ease of operation.</p>  | Support leg assembly is seized. |
| 18 | | ● | | | | <p>REAR LEG PROP ASSEMBLY</p> <p>Inspect leg prop assembly (25) for broken or missing parts.</p>  | Leg prop assembly is unserviceable. |

Table 3-2. Operator/Crew Preventive Maintenance Checks and Services (PMCS) - CONT.

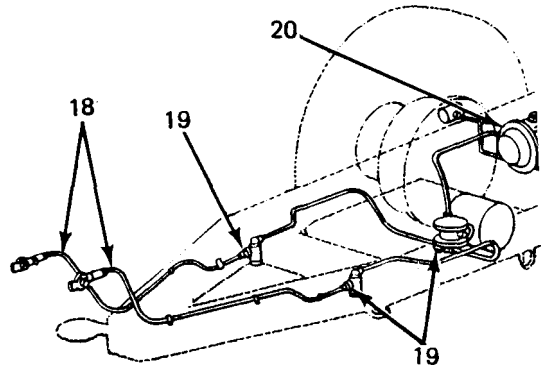
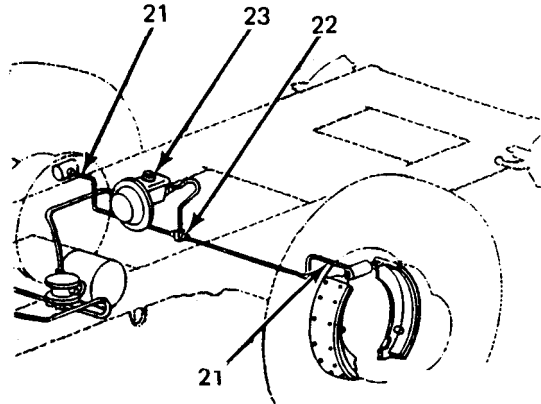
| Item no. | Interval | | | | | Item to be inspected. Procedure: check for and have repaired, filled, or adjusted as needed | Equipment is not ready/available if: |
|----------|----------|---|---|---|---|---|--------------------------------------|
| | B | D | A | W | M | | |
| 19 | | ● | | | | <p>BRAKE SYSTEM</p> <p>Test brake system by hooking trailer to towing vehicle and applying brakes.</p> | Service brakes fail to operate. |
| 20 | | ● | | | | <p>TRAILER OPERATION</p> <p>a. Be alert for any unusual noises while towing trailer. Stop and investigate any unusual noises.</p> <p>b. Ensure that trailer is tracking/following correctly behind towing vehicle with no side pull.</p> | |
| 21 | | ● | | | | <p>GENERATOR SET GAGES AND INSTRUMENTS</p> <p>a. Check that battery indicator (26) is in yellow area while batteries are charging and in green area when batteries are fully charged.</p> <p>b. Check that frequency meter (27) indicates 60 Hz (red line) when generator is operating under load.</p> | |
| | | | | | |  | |

Table 3-2. Operator/Crew Preventive Maintenance Checks and Services (PMCS) - CONT.

B - Before D – During A - After W – Weekly M - Monthly

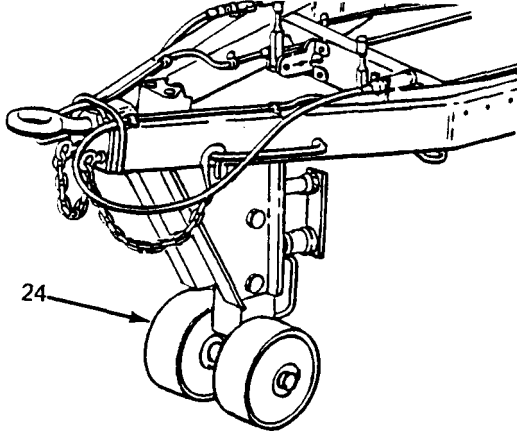
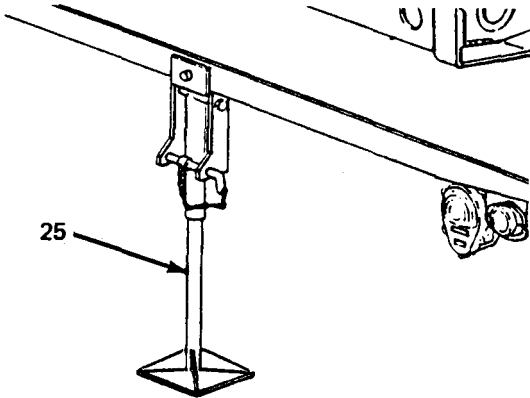
| Item no. | Interval | | | | | Item to be inspected. Procedure: check for and have repaired, filled, or adjusted as needed | Equipment is not ready/available if: |
|----------|----------|---|---|---|---|--|--|
| | B | D | A | W | M | | |
| 21 | | | | | | <p>GENERATOR SET GAGES AND INSTRUMENTS – CONT</p> <p>c. Check that current meter (28) reading does not exceed 100% or more than 5% load difference between phases.</p> <p>d. Check that voltmeter (29) indicates desired output voltage as determined by load connections and amps-volts transfer switch.</p> <div style="text-align: center;"> </div> <p>e. Check engine oil pressure gage (30) for 20 to 45 psig indication.</p> | <p>Desired voltage cannot be obtained and maintained.</p> <p>Oil pressure drops below 20 psig.</p> |

Table 3-2. Operator/Crew Preventive Maintenance Checks and Services(PMCS) - CONT.

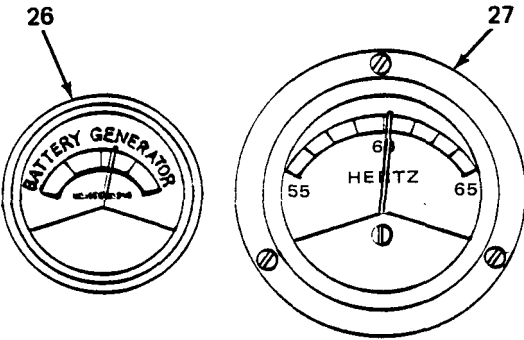
B – Before D– During A – After W – Weekly M – Monthly

| Item no. | Interval | | | | | Item to be inspected. Procedure: check for and have repaired, filled, or adjusted as needed | Equipment is not ready/available if: |
|----------|----------|---|---|---|---|---|--------------------------------------|
| | B | D | A | W | M | | |
| 21 | | | | | | <p>GENERATOR SET GAGES AND INSTRUMENTS – CONT</p>  | |
| 22 | ● | | | | | <p>FUEL TANK</p> <p>a. Fill fuel tank (31).</p> <p style="text-align: center;">NOTE</p> <p style="text-align: center;">Fuel system temperature must be above freezing when draining water and sediment.</p> <p>b. Open drain (32) and drain water and sediment from fuel tank. Allow to drain until fuel runs clean.</p> | |

Table 3-2. Operator/Crew Preventive Maintenance Checks and Services (PMCS) – CONT.

B - Before D - During A - After W - Weekly M - Monthly

| Item no. | Interval | | | | | Item to be inspected. Procedure: check for and have repaired, filled, or adjusted as needed | Equipment is not ready/available if: |
|----------|----------|---|---|---|---|--|--------------------------------------|
| | B | D | A | W | M | | |
| 22 | | | | | | <p>FUEL TANK – CONT</p>  | |
| 23 | ● | | | | | <p>FUEL STRAINER AND FILTERS</p> <p>Drain water and sediment from strainer (33), primary (34) and secondary (35) filters. Allow to drain until fuel runs clean.</p>  | |
| 24 | | | ● | | | <p>HANDBRAKES</p> <p>With trailer hooked to towing vehicle, set handbrakes (36). Move trailer slightly to see if handbrakes hold wheels.</p> | Handbrakes cannot be adjusted. |

Table 3-2. Operator/Crew Preventive Maintenance Checks and Services(PMCS) - CONT.

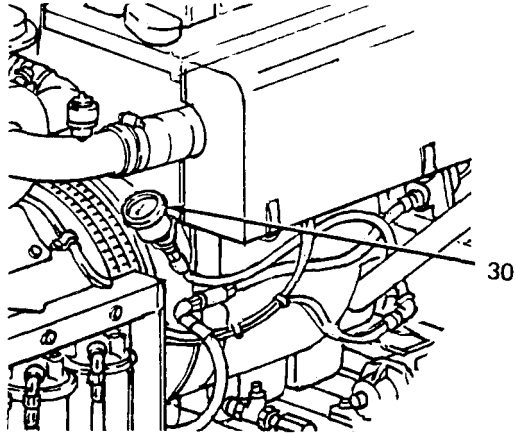
B - Before D- During A - After W - Weekly M - Monthly

| Item no. | Interval | | | | | Item to be inspected. Procedure: check for and have repaired, filled, or adjusted as needed | Equipment is not ready/available if: |
|----------|----------|---|---|---|---|--|--|
| | B | D | A | W | M | | |
| 24 | | | | | | <p>HANDBRAKES - CONT</p>  | |
| 25 | | | ● | | | <p>BRAKE DRUMS AND HUBS</p> <p><u>WARNING</u></p> <p>A defect in the operation of the brakes or hub can cause these parts to get hot enough to cause serious burns. Use extreme caution when attempting to detect heat in this area.</p> <p>Feel for overheating to detect dragging or binding.</p> | Brakes or hub are dragging or binding. |
| 26 | | | | ● | | <p>REFLECTORS</p> <p>Check for damaged or missing reflectors.</p> | |
| 27 | | | | | ● | <p>BATTERIES</p> <p>Check battery (37) electrolyte level. Level should be about 3/4 inch above top of plates. Add water if level is low. Use clean water (distilled water if available).</p> | |

Table 3-2. Operator/Crew Preventive Maintenance Checks and Services(PMCS) - CONT.

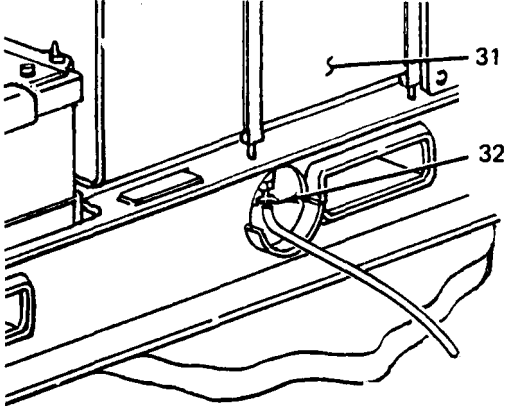
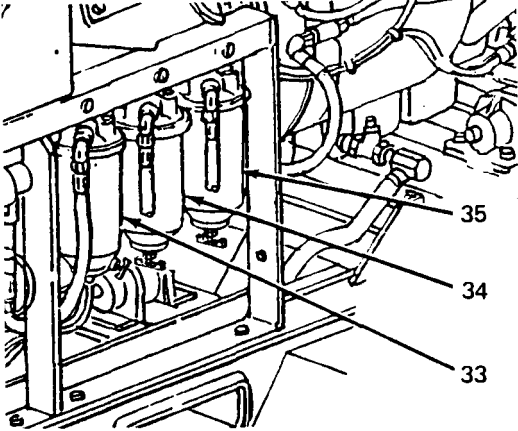
B - Before D - During A - After W - Weekly M - Monthly

| Item no. | Interval | | | | | Item to be inspected. Procedure: check for and have repaired, filled, or adjusted as needed | Equipment is not ready/available if: |
|----------|----------|---|---|---|---|---|---------------------------------------|
| | B | D | A | W | M | | |
| 27 | | | | | | <p>BATTERIES - CONT</p>  | |
| 28 | | | | | | <ul style="list-style-type: none"> ● FIRE EXTINGUISHER <p>Inspect and weigh fire extinguishers. (See paragraph 3-12.)</p> | |
| 29 | | | | | | <ul style="list-style-type: none"> ● TRAILER FRAME <p>Inspect entire chassis frame for damage, cracks, and broken welds.</p> | Frame is obviously broken or cracked. |

Section IV. TROUBLESHOOTING

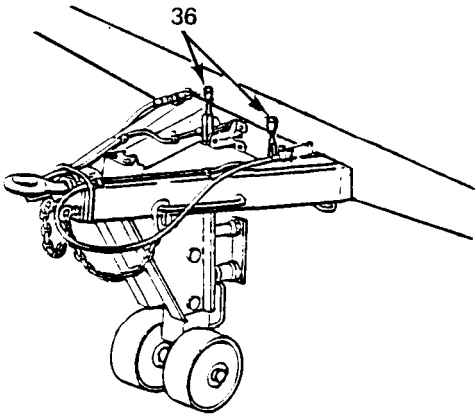
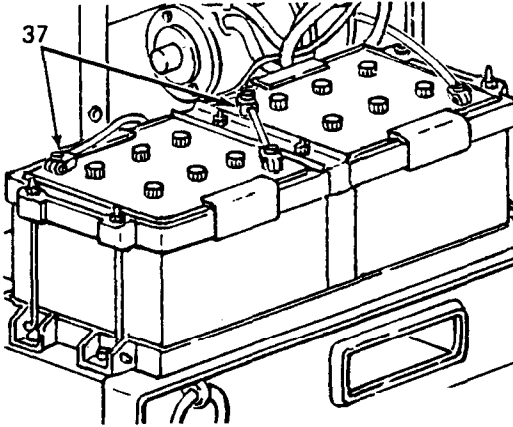
3-10. Power Unit Troubleshooting. There are no troubleshooting procedures authorized at operator level for the power plant end item. Troubleshooting procedures for the individual generator sets and trailer are contained in their respective technical manuals referenced below.

a. Generator Set Troubleshooting. Refer to TM 5-6115-585-12 for troubleshooting procedures.

b. Trailer Troubleshooting. Refer to TM 9-2330-213-14&P for troubleshooting procedures.

Section V. OPERATOR/CREW MAINTENANCE

3-11. Enclosure Maintenance. Maintenance of the enclosure at operator level is limited to replacement of the fitted cover and/or the bows.

a. Fitted Cover Replacement. (See figures 3-1 and 3-2.)

(1) *Removal.*

- (a) Untie 25 ropes (1, figure 3-1) fastening fitted cover to trailer body (2).
- (b) Unfasten six straps and buckles (3) securing rear curtain (4). Roll up curtain, and secure with three rollup straps (5) provided.
- (c) Unfasten six straps and buckles (3) securing front curtain (6). Roll up curtain, and secure with three rollup straps (5) provided.
- (d) Roll up each side (7) of fitted cover, in turn, and secure each side with six rollup straps (5) provided.
- (e) Working under fitted cover (1, figure 3-2), unfasten 12 straps (2) securing fitted cover to bow assemblies (3). Remove fitted cover.

(2) *Installation.*

NOTE

Front curtain is provided with three tie-down ropes. Rear curtain only has two ropes.

- (a) Position fitted cover (1, figure 3-2) on top of bows (3) making certain front of fitted cover is at front of trailer.

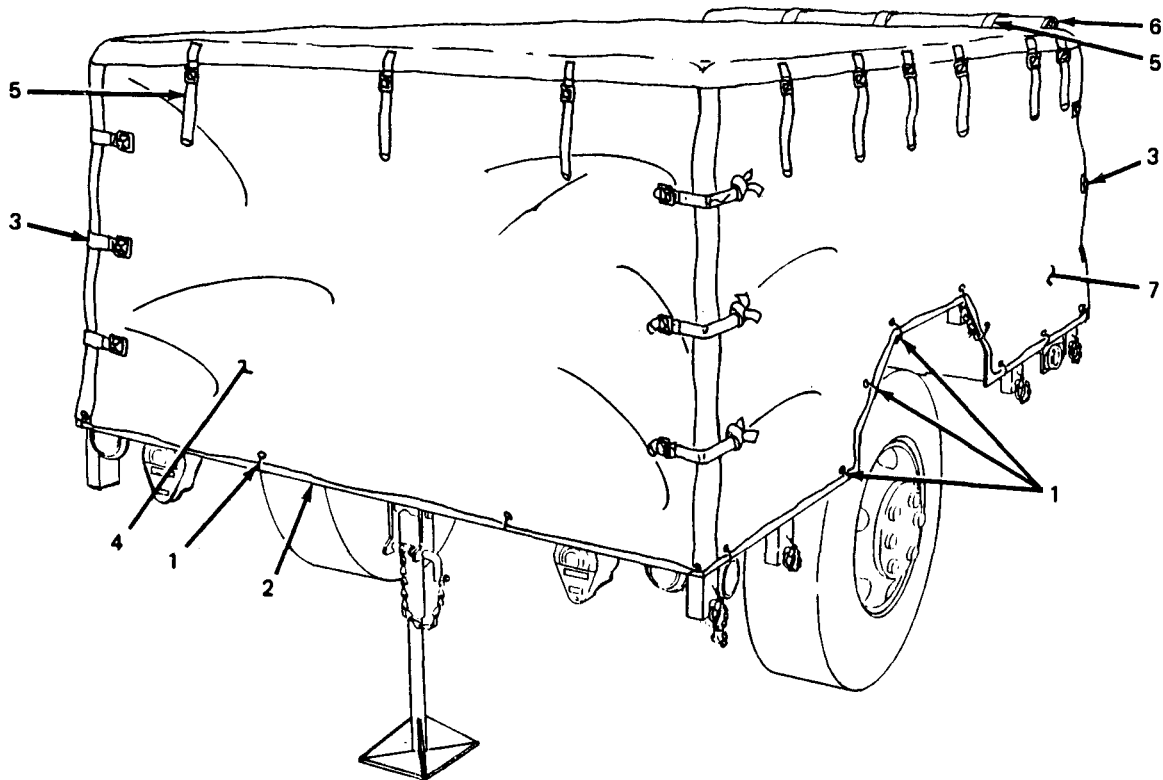

Figure 3-1. Fitted Cover Installed on Power Plant.

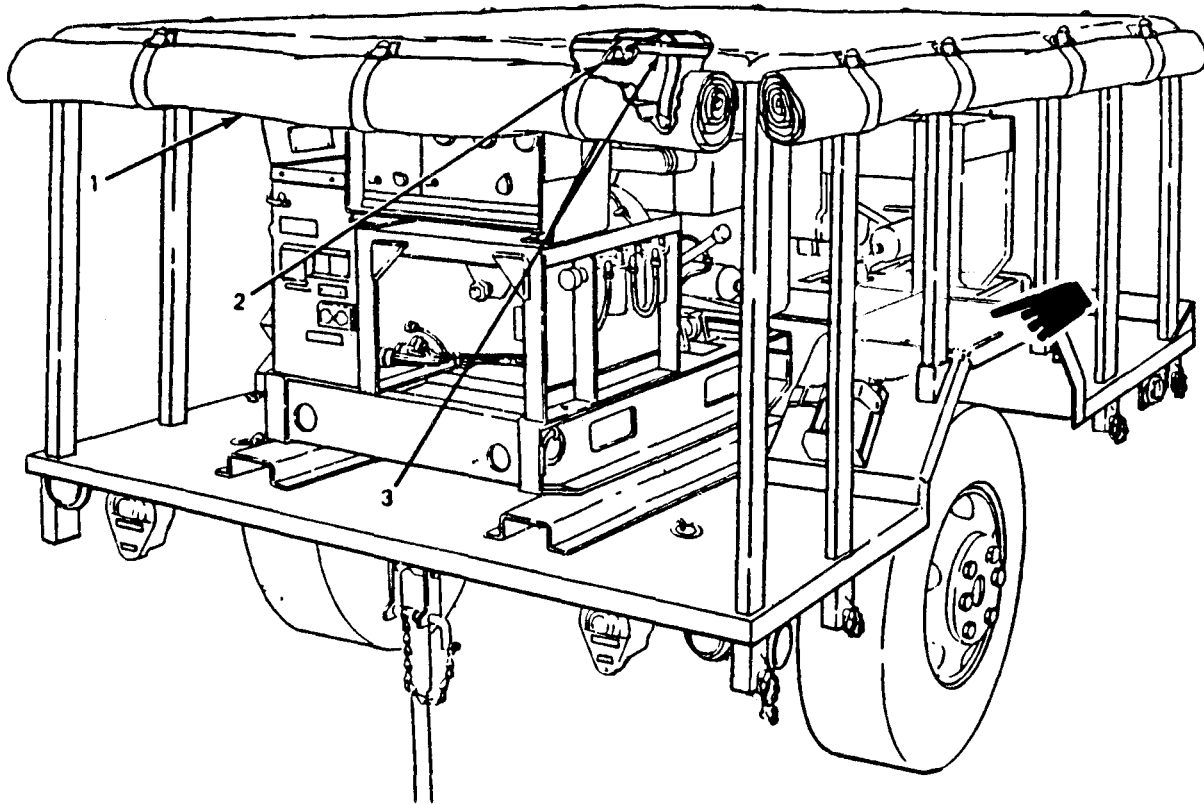

Figure 3-2. Fitted Cover Rolled Up for Removal.

(b) Secure fitted cover (1, figure 3-2) to bow assembly (3) with 12 straps (2) provided.

(c) Unfasten rollup straps (5, figure 3-1) securing sides of fitted cover and lower both sides (7).

(d) Unfasten rollup straps (5) securing front and rear curtains (4, 6) and lower both curtains.

(e) Secure front and rear curtains (4, 6) to sides (7) with six straps and buckles (3) provided on each curtain.

(f) Secure fitted cover to trailer body (2) with 25 ropes (1) provided.

b. Bow Assembly Replacement. (See figure 3-3.)

(1) *Removal.*

(a) Remove fitted cover (paragraph 3-11, a.(t)).

(b) Remove two quick release pins (1) securing each bow assembly (2) in pockets (3) on trailer body(4). Lift each bow out of pocket and off trailer body.

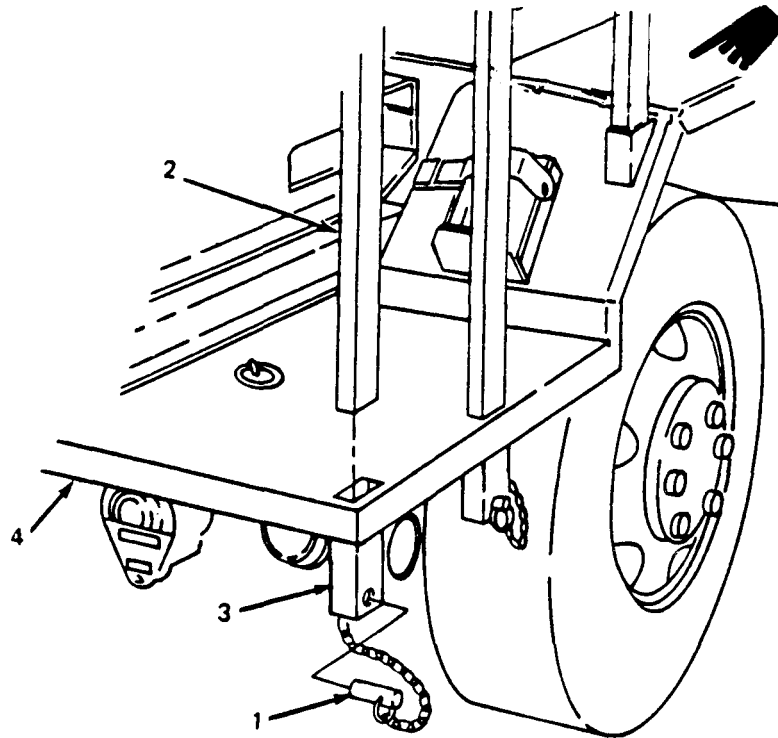

Figure 3-3. Bow Assembly Replacement.

(2) *Installation.*

- (a) Lift each bow (2) onto trailer, align ends with pockets (3) in trailer body (4) and drop bow in place. Secure each bow assembly with two quick release pins (1) provided.
- (b) Install fitted cover on trailer (paragraph 3-11, a.(2)).

3-12. Fire Extinguisher Maintenance. The AN/MJQ-18 Power Plant is equipped with two 2-3/4 lb Halon fire extinguishers. Maintenance is limited to weighing the fire extinguishers monthly to insure that they are sufficiently charged. Fully charged, each fire extinguisher (with head and horn attached) weighs 5 lb. Send the unit to specialized activity for recharging if it weighs 4 lb, 12 oz or less.

WARNING

Monobromotrifluoroethane liquid or gas (Halon 1301) can cause death or serious injury if personnel fail to observe safety precautions. Inhalation of monobromotrifluoroethane gas at concentrations of 5% to 6% for more than 4 or 5 minutes may result in serious cardiac or central nervous system effects. Liquid Halon 1301 (including the spray in the immediate vicinity of the discharge) may freeze the skin on contact. In the event of frostbite, warm the affected area quickly to body temperature. Immerse hands in warm water or place hands in armpits. Get medical attention promptly.

CAUTION

Do not attempt to verify readiness of fire extinguisher by partially discharging unit. Any discharge of contents will require refilling.

CHAPTER 4

UNIT MAINTENANCE

Section I. SERVICE UPON RECEIPT OF EQUIPMENT

4-1. Inspecting and Servicing Equipment. The power plant shall be unpacked, inspected, and serviced as described in the following paragraphs. Unpacked equipment must be checked against the Equipment Packing List to ensure completeness. Discrepancies must be reported in accordance with the instructions given in DA Pam 738-750.

a. Unpacking Power Plant. (See figure 4-1.) The generator sets are packed in place on the trailer body. Before beginning the unpacking procedure, locate, remove, and save the two Depreservation Guides.

WARNING

Steel strapping used in packaging of power plant has sharp edges. Care should be taken when cutting and handling strapping to avoid injury to personnel.

- (1) Remove lag screws securing plywood boxes over generator sets and lift boxes off generator sets. Remove wooden wedges and fiberboard pads positioned around base of generator sets.
- (2) Remove barrier material and corrugated paper surrounding generator sets.

NOTE

Inspection and servicing of equipment will be easier to perform before fitted cover is put in place on power plant.

- (3) Pry off end of plywood fitted cover box (strapped to one generator set box). Take out fitted cover. Remove plastic protective film and set fitted cover aside.
- (4) Remove ground wires and clamps taped to one generator set.
- (5) Take tape or covers off ends of power cables.
- (6) Remove two boxed fire extinguishers taped to generator sets. Unpack fire extinguishers and secure one in each fender-mounted bracket.
- (7) Take plywood box off switch box.
- (8) Remove strapping, framing and fiberboard edge protectors securing bows and remove bows from trailer.
- (9) Remove oil drain taped to generator set and install in place. (Refer to TM 5-6115-585-12.)
- (10) Remove package of technical publications from accessory box and save.
- (11) Unpack and inventory accessories in accessory box.

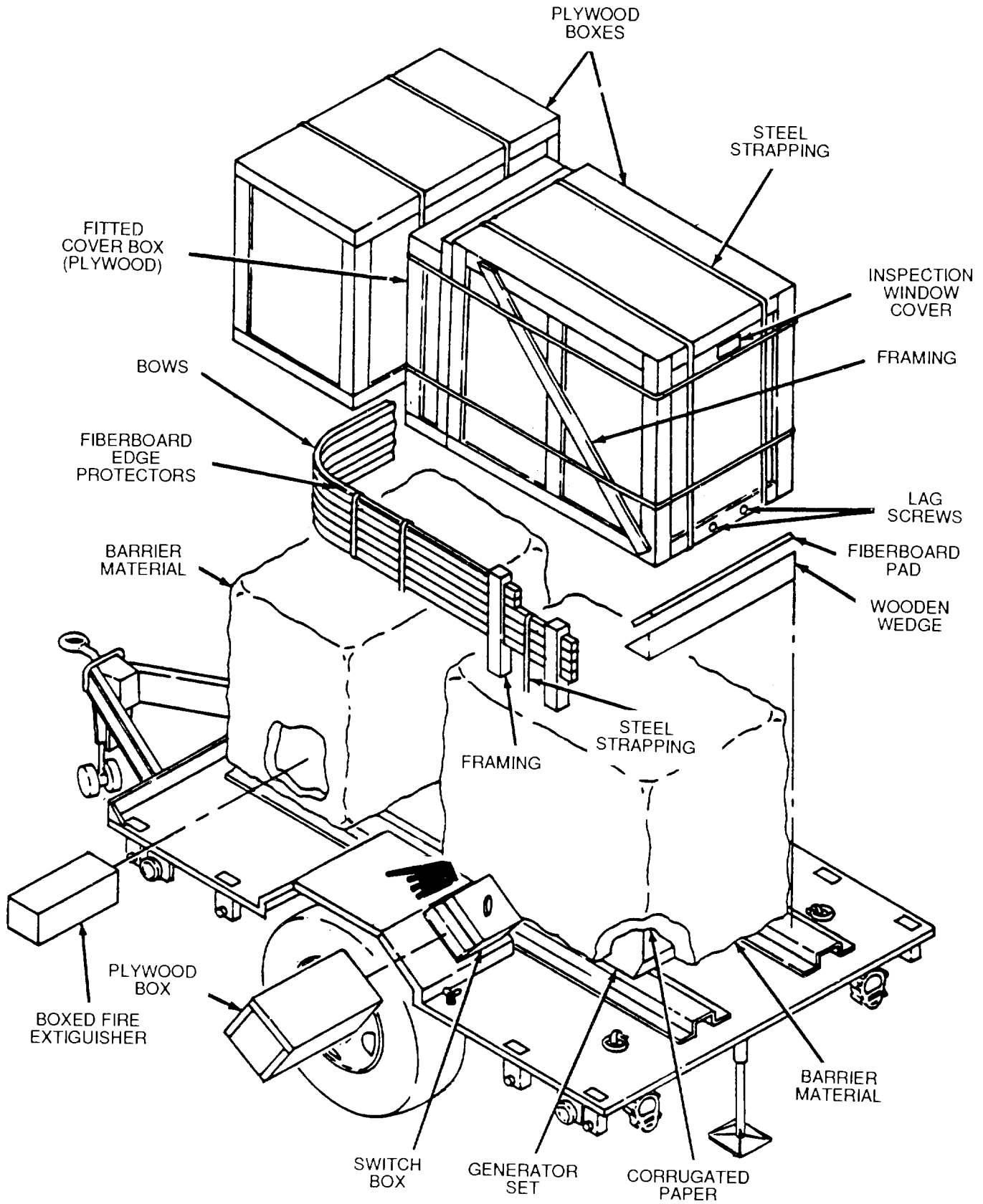

Figure 4-1. Unpacking Power Plant.

- (12) Connect power cables to each generator set load terminal board as follows and in accordance with identification on cables, wires and generator set terminals:
 - (a) White wire to load terminal L0;
 - (b) Black wire to load terminal L1;
 - (c) Red wire to load terminal L2;
 - (d) Blue wire to load terminal L3.
 - (e) Green wire to generator set ground terminal (5-wire switch box only).
- (13) Refer to DA Form 2258, Depreservation Guide for Vehicles and Equipment, packed with power plant and follow instructions given for putting power plant in service.
- (14) Stow all authorized accessories in accessory box.
- (15) Install bows on power plant (paragraph 3-11, b.(2)).
- (16) Install fitted cover on power plant (paragraph 3-11, a.(2)).

b. Inspection and Servicing of Generator Set. Refer to Service Upon Receipt of Materiel in TM 5-6115-585-12 for initial inspection and servicing procedures.

c. Inspection and Servicing of Trailer. Refer to Service Upon Receipt of Materiel in TM 9-2330-213-14&P for initial inspection and servicing procedures.

4-2. Installation. (See figure 4-2.) Installation of the power plant at a worksite involves positioning the trailer and grounding the power plant.

a. Positioning Power Plant. Position the power plant on the worksite as follows:

- (1) Select an area as level as possible to install power plant and position trailer.
- (2) Set trailer handbrakes and lower trailer support leg.
- (3) Chock both wheels and lower rear leg prop assembly. Adjust leg prop assembly by turning inner leg until leg base makes firm contact with ground.
- (4) Lift and secure fitted cover in raised position away from generator set exhaust.

WARNING

Remove fire extinguishers and fuel cans from power plant when generator sets are in operation. This will insure that, in the event of fire, extra fuel will not be involved and the extinguishers will remain accessible.

- (5) Locate fuel cans and fire extinguishers on ground away from power plant.

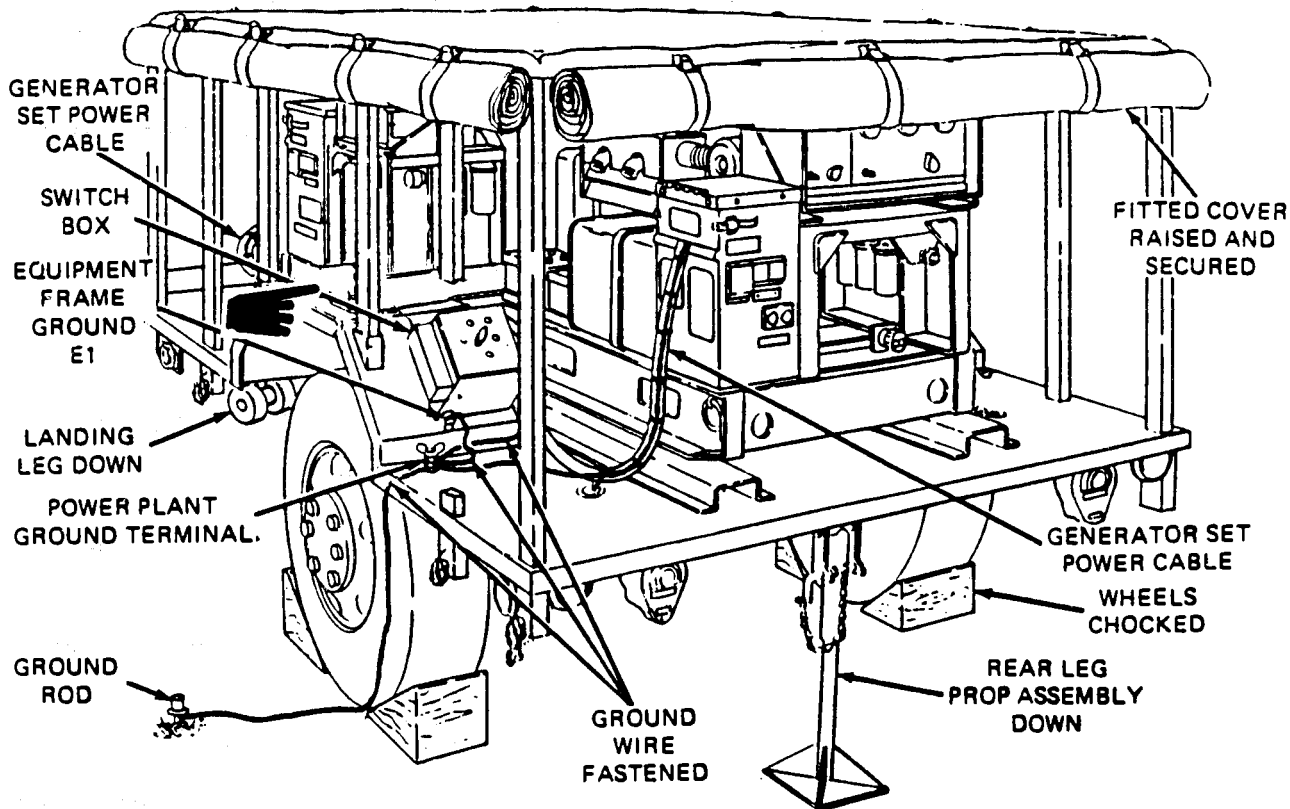

Figure 4-2. Installing Power Plant.

WARNING

Do not operate generator sets until power plant is properly grounded (paragraph 4-2, b.). Serious injury or death by electrocution can result from operating an ungrounded power plant.

CAUTION

To avoid damage to equipment, make certain of voltage, frequency, and phase requirements of load being connected to generator sets.

(6) Refer to data plate on load terminal board cover and to TM 5-6115-585-12. Connect power plant to system or equipment to be powered.

b. Grounding. Check that generator sets are grounded to GROUND TERMINAL stud on trailer body. Using ground wire supplied, connect power plant to a suitable ground as described below. The following sources of a good ground are listed in order of preference.

NOTE

As a substitute for the supplied ground wire, any copper wire of at least No. 6 AWG may be used.

- (1) *Underground water system.* Ground power plant to one of the accessible pipes in an underground water system. Make certain underground pipe is made of metal and there is no insulation, such as a water meter, between ground wire and earth.
- (2) *Ground rod.* Drive ground rod a minimum of eight feet into earth. A ground rod must have a minimum diameter of 5/8-inch, if solid, or 3/4-inch if pipe.

NOTE

It may be necessary to saturate the area around ground rod with water if soil conditions are dry.

- (3) *Ground plate.* Ground power plant to a metal plate buried four feet deep. Ground plate should cover a minimum area of nine square feet.

c. *External Fuel Line Connection.* (See figure 4-3.) The power plant generator sets can be fueled from an external source such as a five-gallon fuel can or 55 gallon drum. This eliminates the need for frequent refilling of each generator's fuel tank during long intervals of operation.

- (1) Remove fuel can adapter and fuel pickup tube from storage locations on generator set and assemble by threading pickup tube into adapter.
- (2) Thread one end of auxiliary fuel line onto fuel can adapter fitting and tighten.
- (3) Connect free end of auxiliary fuel line to AUXILIARY FUEL CONNECTION. This connection is located immediately below control cubicle on right-hand side of generator set.
- (4) Insert fuel can adapter in external fuel source and secure by pressing down on lever.
- (5) Set MASTER SWITCH on control panel to PRIME AND RUN AUX FUEL position.

NOTE

When generator set is run on auxiliary fuel, as described above, fuel is first pumped into generator set fuel tank by auxiliary fuel pump. Fuel is then fed to generator set engine from fuel tank.

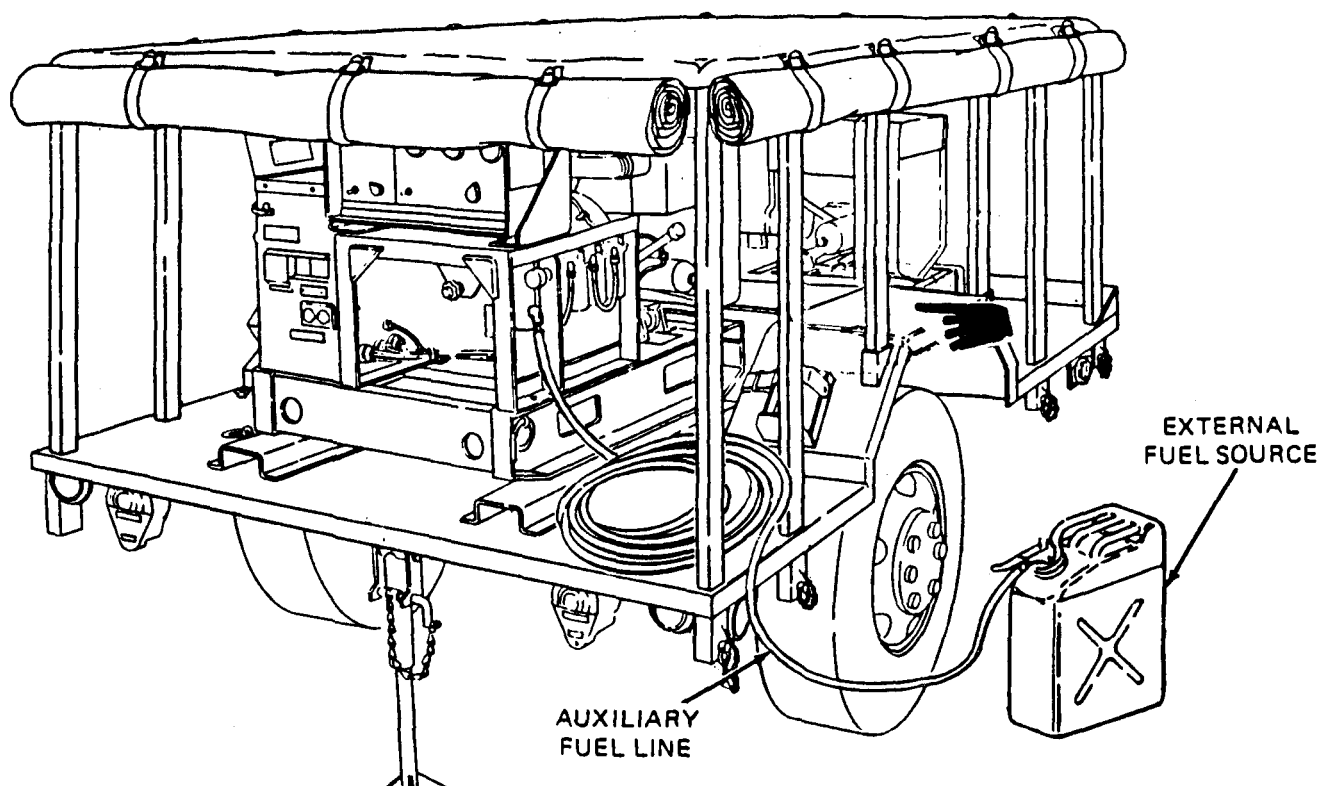

Figure 4-3. External Fuel Line Connection.

Section II. MOVEMENT TO A NEW WORKSITE

4-3 Dismantling for Movement. Because the power plant is designed to be mobile, a minimum amount of effort is required to relocate to a new worksite. Procedures are as follows:

- a. Disconnect power plant from system or equipment being powered.
- b. Disconnect ground cable from source of ground and from power plant GROUND TERMINAL stud. Roll up cable and store in accessory box.
- c. Using slide hammer, remove ground rod. Disassemble, clean, and stow ground rod in accessory box.
- d. Disconnect power plant from external fuel sources, if applicable.
- e. Stow any remaining authorized equipment in accessory box.
- f. Secure fire extinguishers and fuel cans in their respective mounting brackets.
- g. Lower and secure fitted cover in place on power plant.
- h. Remove locking pin from leg prop assembly on rear of trailer. Swing leg prop back and up into traveling position and secure with pin.

i. Attach power plant to towing vehicle. (Refer to TM 9-2330-213-14&P.)

4-4. Reinstallation After Movement. After movement to a new worksite, install power plant in accordance with paragraph 4-2.

Section III. REPAIR PARTS, SPECIAL TOOLS, SPECIAL TEST, MEASUREMENT AND DIAGNOSTIC EQUIPMENT (TMDE)

4-5. Tools and Equipment. There are no special tools or equipment required to maintain the AN/MJQ-18 power plant.

4-6. Maintenance Repair Parts. Repair parts and equipment for maintenance of this power plant are listed and illustrated in the repair parts and special tools list in Appendix D of this manual.

Section IV. LUBRICATION INSTRUCTIONS

4-7. General. Detailed instructions for the lubrication of the major components of the power plant are contained in the applicable Lubrication Orders (LO's). Refer to DA Pam 310-1 to ensure that the latest editions of the L.O.'S are used. This section contains lubrication instructions that are not included in the Lubrication Orders.

4-8. Generator Lubrication. Refer to TM 5-6115-585-12.

4.9. Trailer Assembly Lubrication.

a. Trailer Lubrication. Refer to TM 9-2330-213-14&P for trailer Lubrication Order.

b. Leg Prop Assembly Lubrication. The rear leg prop assembly is a modification to the standard M103A3 trailer and, as such, does not appear in the associated LO. Semiannually lubricate leg prop assembly as follows:

WARNING

Clean parts in a well-ventilated area. Avoid inhalation of solvent fumes and prolonged exposure of skin to cleaning solvent. Wash exposed skin thoroughly. Dry cleaning solvent (P-D-680) used to clean parts is potentially dangerous to personnel and property. Do not use near open flame or excessive heat. Flash point of solvent is 100°F. to 138°F. (38°C. to 59°C.).

- (1) Clean hydraulic lubrication fitting and area around lubrication points with P-D-680 or equivalent.
- (2) Inject sufficient GAA grease into hydraulic fitting to lubricate screw threads inside leg prop assembly.

NOTE

Refer to Lubrication Order in TM 9-2330-213-14&P for lubricating oils specified for use within different anticipated temperature ranges.

- (3) Apply OE lubricating oil to both ends of leg prop assembly pivot shaft.

Section V. PREVENTIVE MAINTENANCE CHECKS AND SERVICES

NOTE

The **PMCS** chart in this section contains all necessary unit preventive maintenance checks and services for this equipment.

4-10. General. The trailer assembly and generator sets must be inspected and serviced systematically to insure that the power plant is ready for operation at all times. Inspection will allow defects to be discovered and corrected before they result in serious damage or failure, Table 4-1 contains a tabulated list of preventive maintenance checks and services to be performed by unit maintenance personnel. All of the unit PMCS on the trailer is scheduled to be performed semiannually. Unit PMCS on the generator sets are scheduled weekly or on a per-hours-of-operation basis. The running time meter on the control panel is used to determine the generator set operating time. Using the following as a guide, do the checks and services at the intervals shown. Observe all **CAUTIONS** and **WARNINGS**.

- a. For PMCS performed on an operating time basis, perform your hourly (H) PMCS as close as possible to the time intervals indicated.

NOTE

For units in continuous operation, perform PMCS before starting operation if continuous operation will extend service interval past that which is shown.

- b. Perform your weekly (W) PMCS every week or 40 hours of generator set operating time.
- c. Perform your monthly (M) PMCS every month or 100 hours of generator set operating time.
- d. Do your semiannual (S) PMCS once every six months or 500 hours of generator set operating time.
- e. Do your annual (A) PMCS once every year or 1000 hours of generator set operating time.
- f. If you discover a problem with the equipment, refer to Section VI, Troubleshooting. If you cannot correct the problem, refer to paragraph 4-12, Reporting Deficiencies.

4-11. Explanation of Columns. The following is a list of the PMCS table column headings with a description of the information found in each column.

- a. **Item No.** This column shows the sequence in which to do the checks and services, and is used to identify the equipment area on the Equipment Inspection and Maintenance Worksheet, DA Form 2404.
- b. **Interval** This column shows when each check is to be done.
- c. **Item to be Inspected.** This column identifies the general area or specific part where the check or service is to be done.
- d. **Procedures.** This column lists the checks or service you have to do and explains how to do them.

4-12. Reporting Deficiencies. If you discover any problem with the equipment during PMCS that you are unable to correct, it must be reported, Refer to DA Pam 738-750 and report the deficiency using the proper forms.

Table 4-1. Unit Preventive Maintenance Checks and Services (PMCS). – CONT.

H – Hours of operation (As indicated) W – Weekly (40 hours) M - Monthly (100 hours) S – Semiannually (500 hours) A – Annually (1000 hours)

| Item no. | Interval | | | | | Item to be Inspected | Procedures |
|----------|----------|---|---|---|---|---------------------------|---|
| | H | W | M | S | A | | |
| 1 | | • | | | | Generator Set | <p style="text-align: center;"><u>WARNING</u></p> <p>Before performing any maintenance that requires climbing on or under trailer, set trailer handbrakes, chock wheels, and lower rear leg prop. Injury to personnel could result from trailer suddenly rolling or tipping.</p> <p style="text-align: center;">NOTE</p> <p>Generator set checks and services in this table are described as performed on a single generator set. These procedures must be performed on each of the two generator sets that make up the AN/MJQ-18.</p> <p>Inspect generator set for fuel and oil leaks, loose or missing components and hardware, and unusual wear or deterioration. Clean generator set.</p> <p style="text-align: center;">NOTE</p> <p>Fuel system must be above freezing temperature when draining water and sediment from strainer, filters, and tank.</p> |
| 2 | | | • | | | Fuel Strainer and Filters | <p>Open drains on fuel strainer, and primary and secondary filters. Drain water and sediment (para 3-20, TM 5-6115-585-12). Allow to drain until fuel runs clean.</p> |
| 3 | | | • | | | Fuel Tank | <p>Open drain on fuel tank and drain water and sediment (para 3-13, TM 5-6115-584-12). Allow to drain until fuels runs clean,</p> |

Table 4-1. Unit Preventive Maintenance Checks and Services (PMCS). – CONT.

H – Hours of operation (As indicated) **W – Weekly (40 hours)** **M – Monthly (100 hours)** **S – Semiannually (500 hours)** **A – Annually (1000 hours)**

| Item no. | Interval | | | | | Item to be Inspected | Procedures |
|----------|----------|---|---|---|---|----------------------------|--|
| | H | W | M | S | A | | |
| 4 | | | | ● | | Fuel Pumps | Clean or replace, as necessary, fuel strainer in bottom of fuel pump. |
| 5 | 100 | | | | | Lubricating Oil and Filter | Change lubricating oil and filter every 100 hours of operation (LO 5-6115-585-12). |
| 6 | 300 | | | | | Fuel Strainer | Clean fuel strainer every 300 hours of operation (para 4-10, TM 5-6115-585-12). |
| 7 | 500 | | | | | Primary Fuel Filter | Service primary filter every 500 hours of operation (para 4-20, TM 5-6115-585-12). |
| 8 | 1000 | | | | | Secondary Fuel Filter | Service secondary filter every 1000 hours (para 4-20, TM 5-6115-585-12). |
| 9 | 300 | | | | | Batteries | Perform a hydrometer test on batteries every 300 hours, or quarterly. Refer to para 4-25c, TM 5-6115-585-12 for test procedures. |
| 10 | 500 | | | | | Crankcase Breather | Inspect breather tube every 500 hours. Clean as necessary (para 4-45, TM 5-6115-585-12). |
| 11 | 100 | | | | | Dust Caps on Air Cleaner | Clean out dust caps on air cleaner assembly every 100 operating hours (more frequently under unusual conditions). |
| 12 | 1000 | | | | | Air Cleaner | Clean every 1000 operating hours or as conditions dictate. Replace air cleaner every 2000 operating hours. |
| 13 | | | | ● | | Taillights | Replace any broken or cracked lenses or defective bulbs. |
| 14 | | | | ● | | Intervehicular Cable | Check for cuts, breaks, frayed wires, or damaged plug. |
| 15 | | | | ● | | Drawbar Ring | Check security of mounting. Inspect ring for excessive wear. |

Table 4-1. Unit Preventive Maintenance Checks and Services (PMCS). - CONT.

H – Hours of operation
(As indicated)

W - Weekly
(40 hours)

M – Monthly
(100 hours)

S – Semiannually
(500 hours)

A – Annually
(1000 hours)

| Item no. | Interval | | | | | Item to be Inspected | Procedures |
|----------|----------|---|---|---|---|--------------------------|---|
| | H | W | M | S | A | | |
| 16 | | | | • | | Safety Chains | Inspect for broken links or missing chain(s). |
| 17 | | | | • | | Reflectors | Replace any cracked, broken, or missing reflectors. |
| 18 | | | | • | | Data Plates and Markings | Make sure data plates are legible and secure. Replace illegible data plates. |
| 19 | | | | • | | Support Leg Assembly | Inspect brackets and leg for bent or broken parts. |
| 20 | | | | • | | Rear Leg Prop Assembly | Inspect bracket and leg prop for bent or broken parts. |
| 21 | | | | • | | Suspension Assemblies | a. Inspect shackles, bearings, pins, leaf springs and spring eyes for damage or broken parts. b. Inspect mounting brackets for cracks or loose or missing hardware. c. Inspect shock absorbers for damage or leaks. |
| 22 | | | | • | | Axle | a. Check for damaged axle tube. b. Check for loose or missing U-bolts or nuts. |
| 23 | | | | • | | Wheels and Tires | a. Check serviceability of tires as indicated in TM 9-2610-200-24. b. Tighten wheel stud nuts. |

Table 4-1. Unit Preventive Maintenance Checks and Services (PMCS). – CONT.

H – Hours of operation (As indicated) W -- Weekly (40 hours) M – Monthly (100 hours) S – Semiannually (500 hours) A – Annually (1000 hours)

| Item no. | Interval | | | | | Item to be Inspected | Procedures |
|----------|----------|---|---|---|---|---------------------------------|--|
| | H | W | M | S | A | | |
| 24 | | | | ● | | Brakes | a. Inspect brake linings for wear. Replace if brake shoe lining is less than 1/8-inch (3.2 mm) thick. b. Inspect brake adjusting screw, retaining screw, retaining pins, springs, and clips for corrosion and wear. c. Inspect hydraulic wheel cylinders for leaks. d. Inspect master cylinder for leaks or low fluid level. Fill to within 1/2 inch from top, e. Adjust brakes (page 4-52, TM 9-2330-213-14&P). |
| 25 | | | | | ● | Wheel Bearings | Clean and repack (page 4-105, TM 9-2330-213-14&P). |
| 26 | | | | ● | | Hydraulic Brake Tubes and Hoses | Inspect for dents, cracks, loose connections and leaks. |
| 27 | | | | ● | | Trailer – Road Test | Perform road test paying special attention to items that were repaired or adjusted. |

Section VI. TROUBLESHOOTING

4-13. Troubleshooting. Troubleshooting procedures for components unique to the power plant end item are given in paragraph 4-14. Troubleshooting information for the individual generator sets and trailer are contained in their respective technical manuals referenced below.

a. Generator Set Troubleshooting. Refer to TM 5-6115-585-12 for troubleshooting procedures applicable to the generator set.

b. Trailer Troubleshooting. Refer to TM 9-2330-213-14&P for troubleshooting procedures applicable to the trailer.

4-14. Power Plant Troubleshooting. Table 4-2 contains troubleshooting information for locating and correcting operating troubles which may develop in components unique to the power plant end item. Each malfunction is followed by a list of tests or inspections which will help determine probable cause and corrective actions to take. Perform the tests/inspections and corrective actions in the order listed. This manual cannot list all malfunctions that may occur, nor all tests or inspections and corrective actions. If a malfunction is not listed or cannot be corrected by listed corrective actions, notify your supervisor.

Table 4-2. Troubleshooting.

| Malfunction | Test or inspection | Corrective action |
|---|---|--|
| <p>1. POWER IS ABSENT AT SWITCH BOX LOAD TERMINAL(S) WHEN ONE GENERATOR SET IS OPERATING.</p> | | |
| | <p>Step 1. Check that generator set circuit breaker is set to ON position.</p> | <p>If circuit breaker is in OFF position, set to ON position.</p> |
| | <p>Step 2. Check for power output at generator set load terminals.</p> | <p>If power is absent at generator set load terminals, troubleshoot generator set. (Refer to TM 5-6115-585-12).</p> |
| | <p>Step 3. Inspect power cable connections inside switch box for looseness or broken wire terminals.</p> | <p>Tighten loose connections. If any wire terminals are broken, replace cable (paragraph 4-25, d.) or refer to higher level of maintenance for repair.</p> |
| | <p>Step 4. Perform continuity check on associated generator set power cable (paragraph 4-23, a.).</p> | <p>If cable is defective, replace cable (paragraph 4-25, d.) or refer to higher level of maintenance for repair.</p> |
| | <p>Step 5. Perform continuity check on rotary switch (paragraph 4-23, c.).</p> | <p>If switch is defective, notify higher level of maintenance.</p> |
| <p>2. POWER IS ABSENT AT ONE OR MORE SWITCH BOX LOAD TERMINALS WHEN EITHER GENERATOR SET IS OPERATING.</p> | | |
| | <p>Step 1. Check wire associated with non-functioning load terminal(s) for looseness or broken terminals inside switch box.</p> | <p>Tighten loose connection(s). If any terminals are broken, replace wire (paragraph 4-25, c.).</p> |

Table 4-2. Troubleshooting – CONT.

| Malfunction | Test or inspection | Corrective action |
|--|--|--|
| 2. POWER IS ABSENT AT ONE OR MORE SWITCH BOX LOAD TERMINALS WHEN EITHER GENERATOR SET IS OPERATING – CONT. | | |
| | Step 2. Perform continuity check on wire from switch to non-functioning load terminal(s) (paragraph 4-23, b.(2)). | Replace defective wire(s) (paragraph 4-25, c.). |
| | Step 3. Perform continuity check on switch (paragraph 4-23, c.). | If switch is defective, notify higher level of maintenance. |
| 3. ONE OR BOTH INDICATOR LIGHTS FAIL TO LIGHT WHEN ASSOCIATED GENERATOR SET IS OPERATING AND ROTARY SWITCH IS SET TO "ON" POSITION FOR THAT GENERATOR. | | |
| | Step 1. Check if bulb is defective. | If bulb is defective, replace. |
| | Step 2. Check wires inside switch box associated with non-functioning light for looseness or broken wire terminals. | Tighten loose connections. If any terminals are broken, replace wire(s) (paragraph 4-25, c.) or refer to higher level of maintenance for repair. |
| | Step 3. Perform continuity check on wires associated with non-functioning indicator (paragraph 4-23, b.(3) or (4), as applicable). | If wires are defective, replace indicator light and wire assembly (paragraph 4-25, b.). |
| | Step 4. Perform continuity check on indicator housing (paragraph 4-23, b.(3) or (4), as applicable). | If housing is defective, replace indicator light and wire assembly (paragraph 4-25, b.). |

Section VII. RADIO INTERFERENCE SUPPRESSION

4-15. General Methods Used to Attain Proper Suppression. Essentially, suppression is attained by providing a low resistance path to ground for stray currents. The methods used include shielding ignition and high-frequency wires, grounding the frame with bonding straps, and using filtering systems.

4-16. Radio Interference Suppression Components. All component parts of the power plant end item, whose primary or secondary function is radio interference suppression, are on the generator sets. Refer to TM 5-6115-585-12 for location of radio interference suppression components.

Section VIII. MAINTENANCE OF POWER PLANT TRAILER

4-17. General. This section of the manual contains unit level maintenance procedures for components of the M103A3 trailer added when the trailer is used as part of the AN/MJQ-18 power plant. These components are not covered in the overall trailer maintenance manual. For all other unit maintenance procedures on the trailer, refer to TM 9-2330-213-14&P.

WARNING

Before performing any maintenance that requires climbing on or under trailer, set trailer handbrakes, chock both wheels, and lower rear leg prop. Injury to personnel could result from trailer suddenly rolling or tipping.

PARAGRAPH 4-18 AND FIGURE 4-4 HAVE BEEN DELETED.

4-19. Accessory Box Replacement. (See figure 4-5.) The power plant is equipped with an accessory box which is mounted to the trailer bed between the front and rear generator sets.

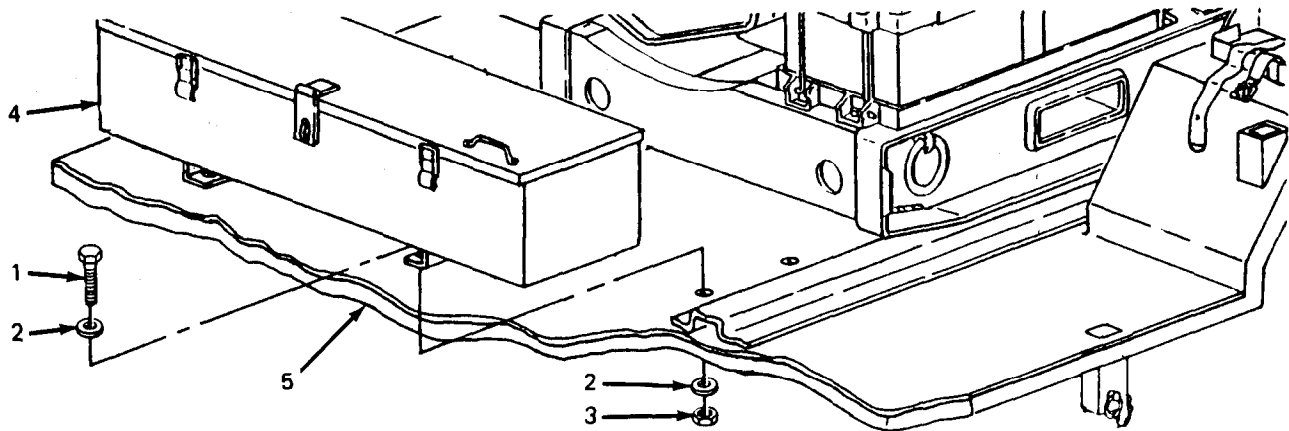

Figure 4-5. Accessory Box Replacement.

a. Removal.

- (1) Remove four screws (1), eight flat washers (2), and four nuts (3) securing accessory box (4) to trailer bed (5).
- (2) Lift accessory box (4) off trailer bed (5).

b. Installation.

- (1) Position accessory box (4) on trailer bed (5).
- (2) Insert four screws (1) with flat washers (2) through accessory box mounting brackets and trailer bed (5).
- (3) Working under trailer, install one flat washer (2) and one nut (3) on each screw (1). Tighten hardware to secure accessory box (4).

4-20. Fire Extinguisher Bracket Replacement. (See figure 4-6.) Each of the two fire extinguishers supplied with the power plant is carried in a bracket. One bracket is mounted on each fender. Replacement procedures described below are the same for both brackets.

a. Removal.

- (1) Remove four screws (1), four flat washers (2) and four nuts (3) securing bracket (4) to fender (5).
- (2) Remove bracket (4) from fender (5).

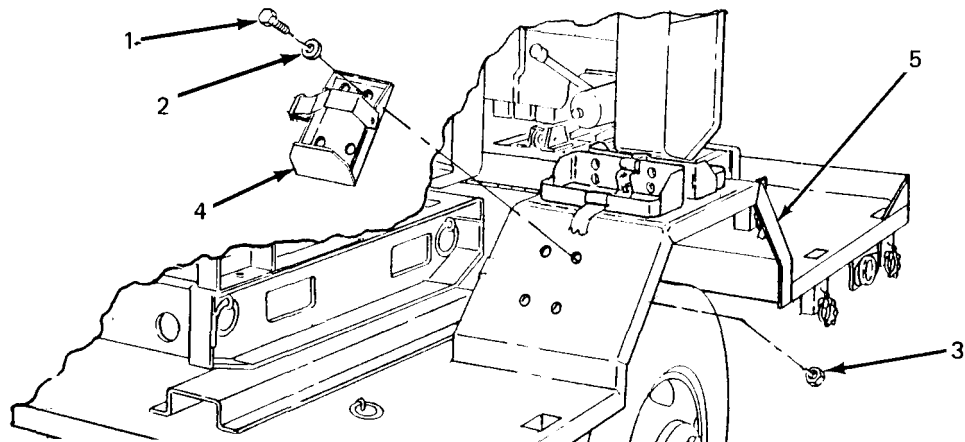

Figure 4-6. Fire Extinguisher Bracket Replacement.

b. Installation.

- (1) Position fire extinguisher bracket (4) on fender (5).
- (2) Insert four screws (1) with four washers (2) down through bracket (4) and through fender (5).
- (3) Install one nut (3) on each screw (1). Tighten hardware to secure bracket (4).

4-21. Leg Prop Assembly Servicing. Servicing of the leg prop assembly is limited to semiannual lubrication (paragraph 4-9, b.).

Section IX. MAINTENANCE OF ELECTRICAL SYSTEM

4-22. General. This section contains maintenance information on electrical components unique to the power plant end item. For all other electrical system maintenance, refer to the applicable generator set and trailer manuals as follows:

a. Generator Set Maintenance. For generator set maintenance procedures, refer to TM 5-6115-585-12.

b. Trailer Maintenance. For trailer maintenance procedures, refer to TM 9-2330-213-14&P.

4-23. Switch Box Testing. To isolate the source of an electrical system problem, perform continuity tests on the components of the switch box as described below. Refer to the schematic diagram inside the switch box (shown in figure 4-7 or 4-8, as applicable) to locate and identify the test points indicated in these procedures.

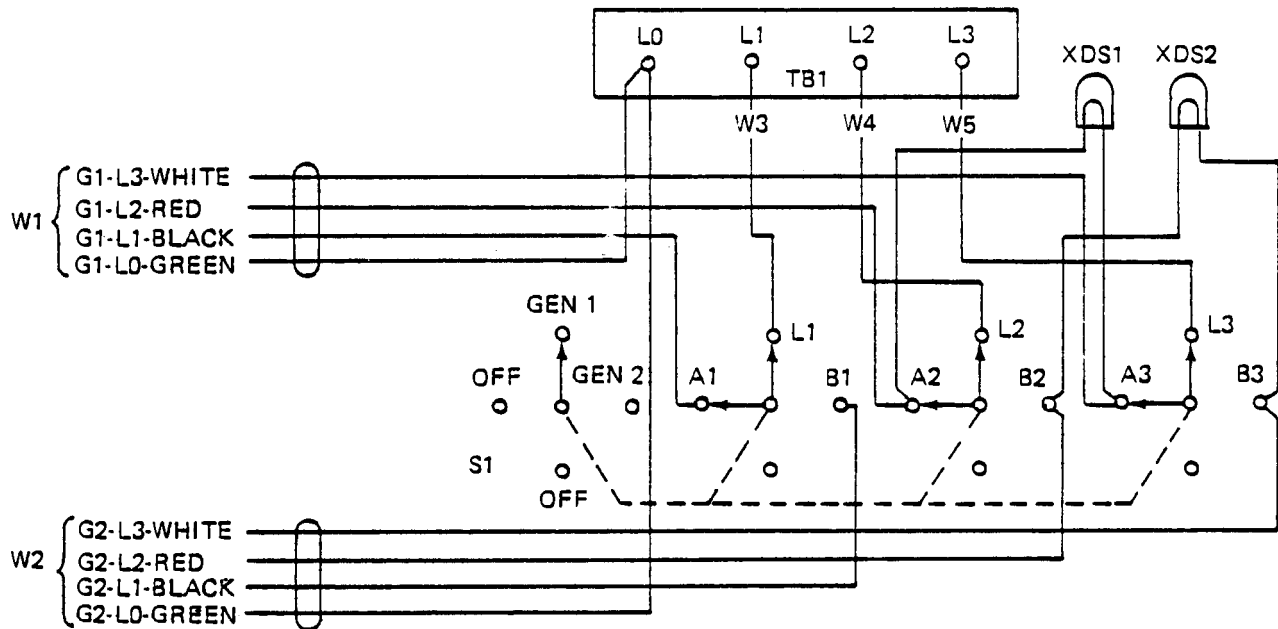

Figure 4-7. Four-Wire Switch Box Schematic Diagram.

a. Power Cable Assembly Test.

- (1) Set multimeter for continuity testing.
- (2) Set switch box rotary switch to GEN 1 position and locate power cable assembly associated with that switch position.
- (3) Test white wire by touching one probe of multimeter to load terminal L0 on generator set and touching other probe to load terminal L0 on switch box. Multimeter must indicate continuity between these points.
- (4) Repeat step (3) for black wire (between L1 on generator set and A1 on switch), red wire (between L2 on generator set and A2 on switch) and blue wire (between L3 on generator set and A3 on switch).
- (5) On power plants supplied with the 5-wire configuration switch box (figure 4-8), the green (ground) wire must also be tested. Disconnect wire from frame ground stud under generator set control panel. Test for continuity between free end of wire and ground stud E1 on switch box.
- (6) If multimeter does not indicate continuity exists on each wire in the cable, replace power cable assembly (paragraph 4-25, d.).
- (7) To test power cable assembly associated with GEN 2 switch position, perform steps (2) through (6) substituting switch terminals B1, B2 and B3 for terminals A1, A2 and A3, as test points. Generator set load terminal designations and wire color-coding is identical for both power cables.

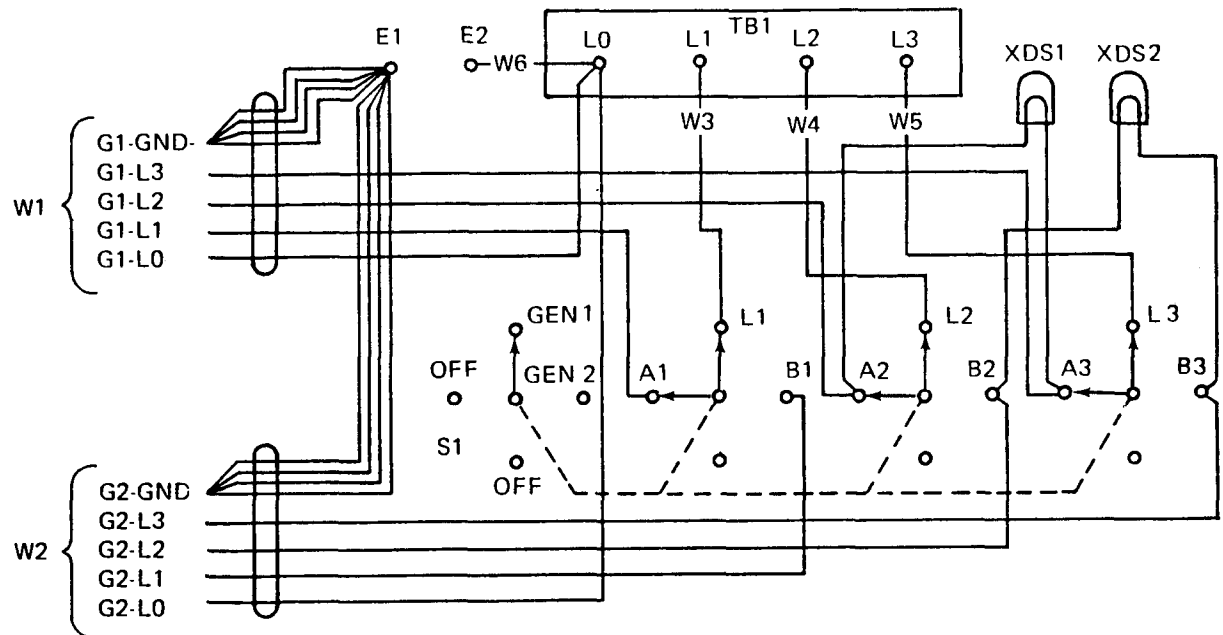

Figure 4-8. Five-Wire Switch Box Schematic Diagram.

b. Switch Box Internal Wiring Test.

- (1) Set multimeter for continuity testing.
- (2) Test wires between switch terminals and load terminals by touching probes to each of the following pairs of test points: L1 on switch to L1 load terminal, L2 to L2, and L3 to L3. If multimeter does not indicate continuity between each pair of test points replace associated wire (paragraph 4-25, c.).
- (3) Test wires and socket associated with GEN 1 indicator light by testing for continuity between switch terminal A2 and socket XDS1, and switch terminal A3 and socket XDS1. If multimeter does not indicate continuity exists on both of these wires, replace light and wire assembly (paragraph 4-25, b.).
- (4) Test wires and socket associated with GEN 2 indicator light by testing for continuity between switch terminal B2 and XDS2 socket, and switch terminal B3 and XDS2 socket. If multimeter does not indicate continuity exists on both of these wires, replace light and wire assembly (paragraph 4-25, b.).
- (5) On 5-wire switch box only, test ground wire by touching one probe to switch box load terminal L0 and touch remaining probe to AC GROUND terminal E2 on switch box. If multimeter does not indicate continuity, replace associated wire (paragraph 4-25, e.).

c. Switch Test.

- (1) Set multimeter for continuity testing.
- (2) Set switch lever to GEN 1 position.
- (3) Touch one probe to switch terminal A1 and remaining probe to switch terminal L1. Repeat test between terminals A2 and L2, and terminals A3 and L3. If multimeter does not indicate continuity exists between each pair of terminals, switch is defective. Notify higher level of maintenance.
- (4) Set switch lever to GEN 2 position and repeat step (3) above, substituting terminals B1, B2 and B3 for A1, A2 and A3.

4-24. Switch Box Replacement. (See figure 4-9.)

a. Removal.

- (1) Detach power cables (1) from load terminals on generator sets (2). (Refer to TM 5-6115-585-12.)
- (2) Working underneath roadside fender (3), remove four screws (4), four flat washers (5) and four lockwashers (6) securing switch box (7) to fender.
- (3) Lift switch box (7) off fender.

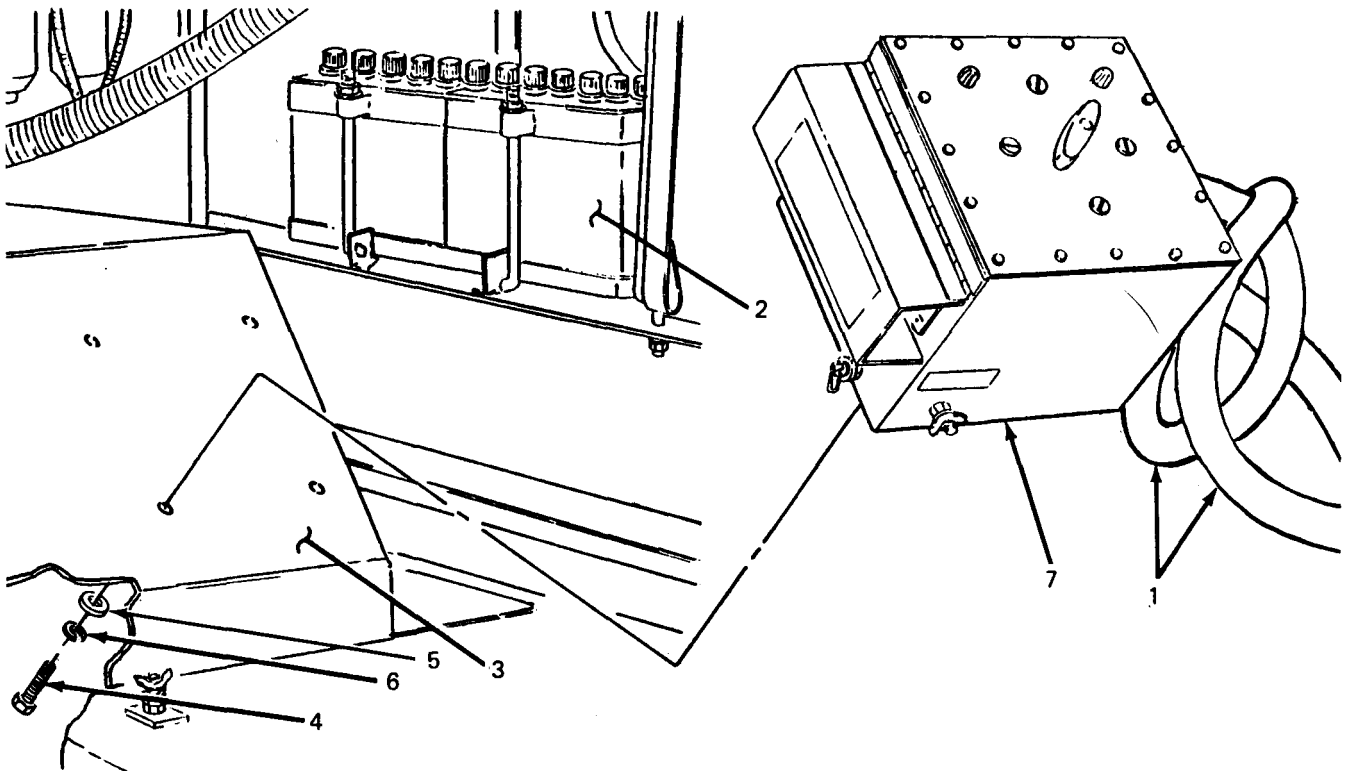

Figure 4-9. Switch Box Replacement.

b. Installation.

- (1) Position switch box (7) on fender (3).
- (2) Working underneath fender (3) insert four screws (4), four flat washers (5) and four lock-washers (6) through fender and into switch box (7) and tighten.
- (3) Connect power cables (1) to load terminals on generator sets (2). (Refer to TM 5-6115-585-12.)

4-25. **Switch Box Repair.**

WARNING

Make sure generator set circuit breakers are in OFF position before performing any repairs on switch box. Failure to observe this precaution may result in injury or death by electrocution.

a. Load Terminal and Terminal Board Replacement. (See figure 4-10.) There are four load terminals on the switch box terminal board. This procedure is typical for all four. When reconnecting wires, refer to the schematic inside the switch box (figure 4-7 or 4-8, as applicable) and to the identification bands on the wires.

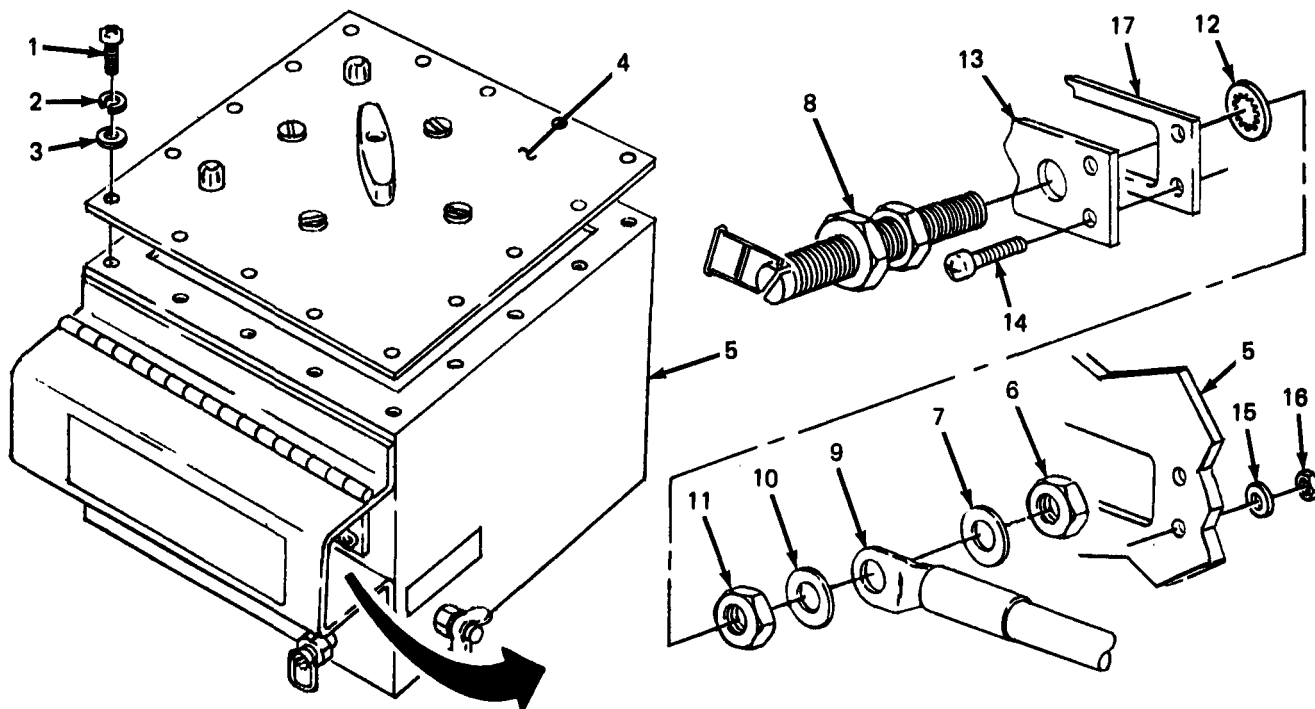

Figure 4-10. Load Terminal and Terminal Board Replacement.

(1) *Removal*

- (a) Remove 16 screws (1), 16 lockwashers (2) and 16 flat washers (3) securing cover(4) to switch box (5) and take cover off switch box.

NOTE

When disconnecting more than one wire, make sure wires are tagged to identify the load terminal to which they attach before disconnecting wires.

- (b) Working inside switch box (5), remove nut (6) and flat washer (7) from terminal (8). Detach wire(s) (9) by sliding terminal lug(s) off stud.
- (c) Remove flat washer (10), nut (11) and internal tooth lockwasher (12) and pull terminal (8) off terminal board (13).
- (d) Remove six screws (14), six flat washers (15) and six nuts (16) and take terminal board (13) and gasket (17) off switch box (5).

(2) *Installation.*

- (a) Position gasket (17) and terminal board (13) on switch box (5) and fasten with six screws (14), six flat washers (15) and six nuts (16).
- (b) Insert terminal (8) through terminal board (13) and into switch box (5).
- (c) Install internal tooth lockwasher (12) and nut(11) on terminal stud (8) and tighten against inside of terminal board (13).

NOTE

Observe identification tags when installing internal wires.

- (d) Slide flat washer (10) and terminal lug(s) of wire(s) (9) onto stud (8).
- (e) Install flat washer (7) and nut (6) on terminal (8) and tighten against wire terminal lug.
- (f) Position cover (4) on switch box (5) and secure with 16 screws (1), 16 lockwashers (2) and 16 flat washers (3).

b. Indicator Light and Wire Assembly Repair and Replacement. (See figure 4-11.) There are two indicator light and wire assemblies in the switch box. This procedure is typical for both. When attaching wires, refer to the schematic inside the switch box (figure 4-7 or 4-8, as applicable). The indicator light and wire assembly is repaired by replacing defective terminals or soldering broken wires. Soldering shall be done in accordance with TB SIG 222.

(1) *Removal.*

- (a) Remove 16 screws (1), 16 lockwashers (2) and 16 flat washers (3) securing cover (4) to switch box (5) and take cover off switch box.
- (b) Remove screw (6), nut (7) and star washer (8) attaching each indicator light wire terminal (9) to its respective switch terminal (10). Take power cable wire (11) and indicator light wire (12) off switch terminal.

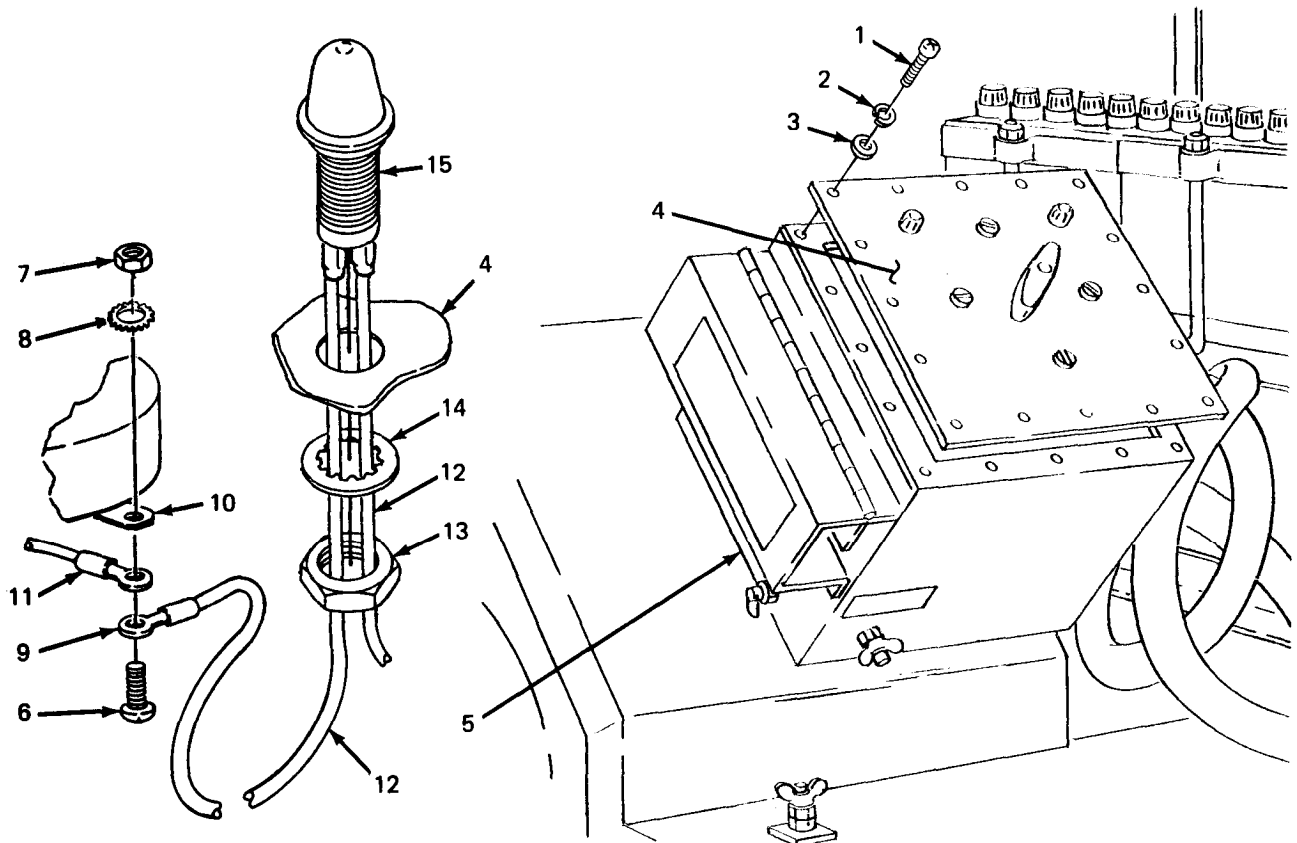

Figure 4-11. Indicator Light and Wire Assembly Replacement.

(c) Unscrew nut (13) and internal tooth lockwasher (14) securing indicator light housing (15) to cover (4) and slide nut and lockwasher off wires (12).

(d) Pull terminal (9) off each wire (12).

(3) Pull out light and wires through cover (4).

(2) *Installation.*

(a) Pull terminal (9) off each indicator light wire (12).

(b) Feed wires (12) through hole in cover (4) and fit light housing (15) in hole.

(c) Slide nut (13) and lockwasher (14) over both wires (12), thread onto housing (15) on inside of cover (4) and tighten.

(d) Crimp one terminal (9) onto each wire (12).

(e) Position terminal (9) of each indicator light wire (12) against underside of switch terminal (10). Position terminal of power cable wire (11) against terminal of indicator light wire. Insert screw (6) up through wire terminals and switch terminal. Install star washer (8) and nut (7) on screw and tighten against switch terminal.

(f) Position cover (4) on switch box (5) and secure with 16 screws (1), 16 lockwashers (2) and 16 flat washers (3).

c. Switch to Load Terminal Wire Replacement. (See figure 4-12.) There are three wires connecting the switch to the load terminals. When attaching wires, refer to the schematic inside the switch box (figure 4-7 or 4-8, as applicable) and to the identification bands on the wires.

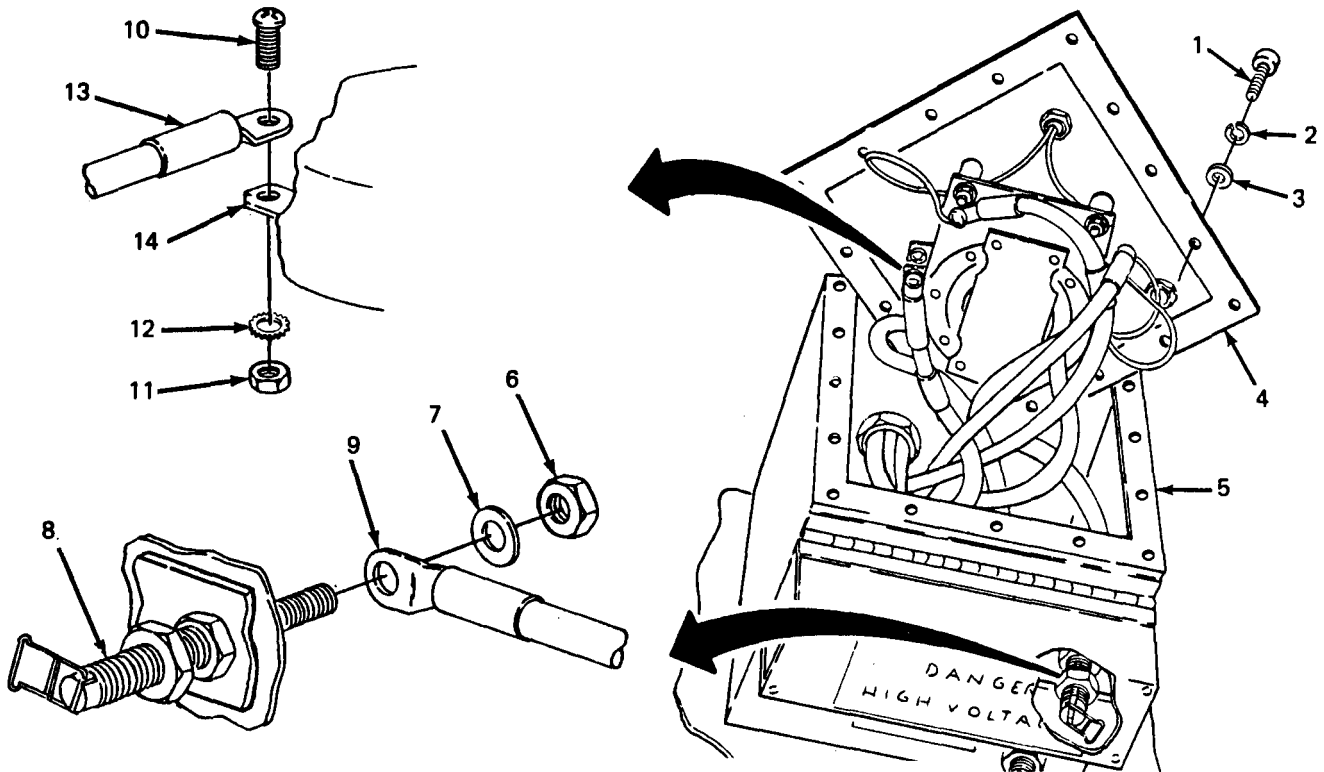

Figure 4-12. Switch to Load Terminal Wire Replacement.

(1) Removal.

- (a) Remove 16 screws (1), 16 lockwashers (2), and 16 flat washers (3) securing cover (4) to switch box (5) and take cover off switch box
- (b) Remove nut (6) and flat washer (7) from load terminal stud (8) inside switch box (5). Slide wire terminal (9) off stud.

NOTE

When removing more than one wire, tag switch terminals for identification.

- (c) Remove screw (10), nut (11) and star washer (12) securing wire terminal (13) to switch terminal (14). Take wire off switch.

(2) *Installation.***NOTE**

Observe identification tags on switch terminals when installing wires.

- (a) Position wire terminal (9) against underside of switch terminal (13). Insert screw (10) up through wire terminal and switch terminal. Install star washer (12) and nut (11) on screw and tighten against switch terminal.
- (b) Slide terminal (9) at free end of wire onto load terminal stud (8) and secure with flat washer (7) and nut (6).
- (c) Position cover (4) on switch box (5) and secure with 16 screws (1), 16 lockwashers (2) and 16 flat washers (3).

d. Power Cable Replacement. (See figure 4-13.) There are two power cables on the power plant - one for each generator set. This procedure is typical for both. When attaching wires, refer to the schematic inside the switch box (figure 4-7 or 4-8, as applicable) and to the identification bands on each of the five wires that make up each cable.

(1) *Removal.*

- (a) Disconnect power cable from load terminals on generator set. (Refer to TM 5-6115-585-12.)

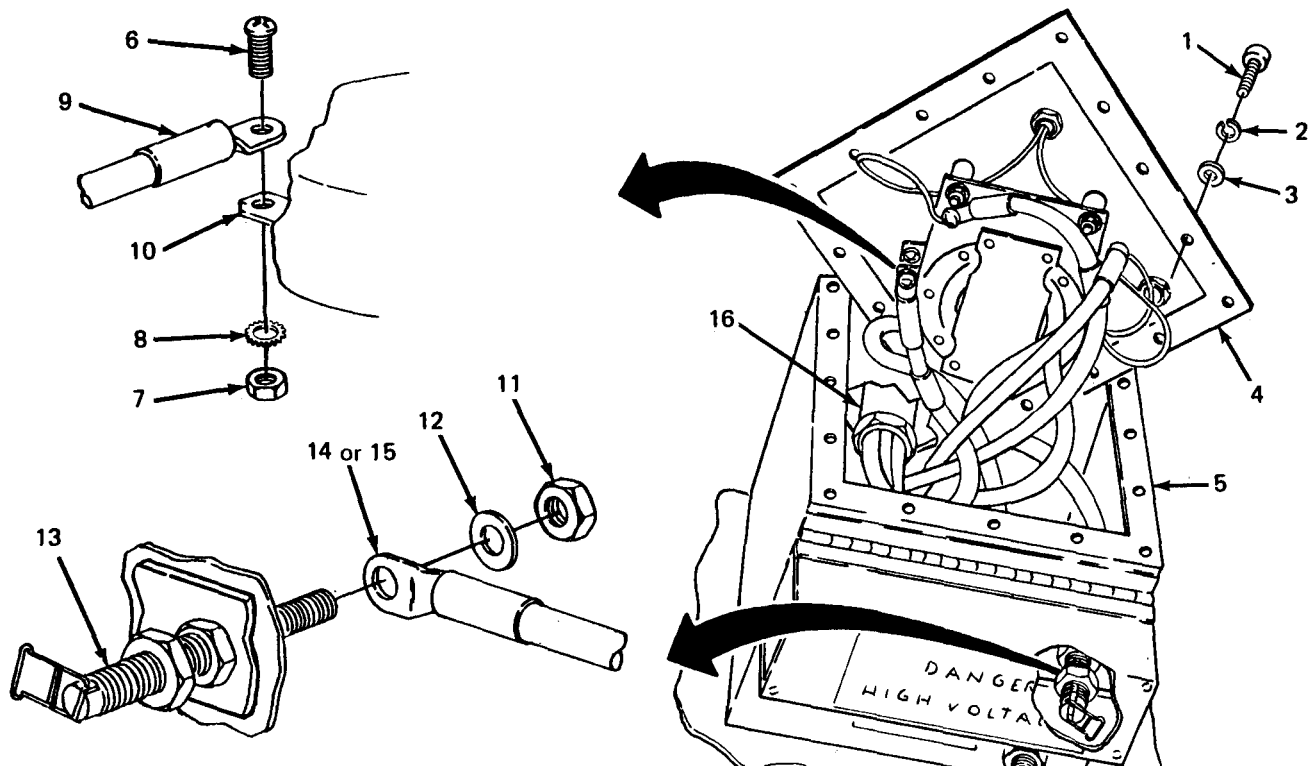

Figure 4-13. Power Cable Replacement.

- (b) Remove 16 screws (1), 16 lockwashers (2) and 16 flat washers (3) securing cover (4) to switch box (5) and take cover off switch box.

NOTE

Tag switch terminals for identification when removing wires. If identification bands on wires are illegible, tag wires.

- (c) Remove screw (6), nut (7) and star washer (8) attaching each of three wires (9) (black, red and blue) to its respective switch terminal (10). Take off wires.
- (d) Remove nut (11) and flat washer (12) from load terminal L0 (13) inside switch box (5). Take off white wire (14) associated with power cable being removed.
- (e) On 5-wire switch box only, repeat step (d) for ground terminal E1 and green wire (15).
- (f) Loosen power cable clamping nut (16) on outside of switch box (5) and pull cable through cable clamp and out of box.

(2) *Installation.*

- (a) Feed cable through cable clamping nut (16) and through hole into switch box (5).
- (b) Tighten clamping nut (16) on outside of switch box (5) to prevent cable from moving.
- (c) Slide terminal of white wire (14) onto load terminal L0 (13) and secure with flat washer (12) and nut (11).
- (d) On 5-wire switch box only, repeat step (c) for ground terminal E1 and green wire (15).

NOTE

Observe identification tags when installing wires.

- (e) Position each of three wires (9) (black, red and blue) against underside of its respective switch terminal (10). Insert screw (6) up through wire terminal and switch terminal. Install star washer (8) and nut (7) on screw and tighten against switch terminal. Where an indicator light wire is also mounted to the switch terminal, the indicator light wire shall be positioned against the underside of the switch terminal and the power cable wire shall be positioned against the indicator light wire.
- (f) Position cover (4) on switch box (5) and secure with 16 screws (1), 6 lockwashers (2) and 16 flat washers (3).
- (g) Connect power cable to load terminals on generator set. (Refer to TM 5-6115-585-12.)

e. Ground Wire Replacement (5-Wire Switch Box). (See figure 4-14.) In the 5-wire switch box only, a wire connects load terminal L0 to AC GROUND terminal E2 located on the side of the switch box below the terminal board.

(1) *Removal*

- (a) Remove 16 screws (1), 16 lockwashers (2) and 16 flat washers (3) securing cover (4) to switch box (5) and take cover off switch box.

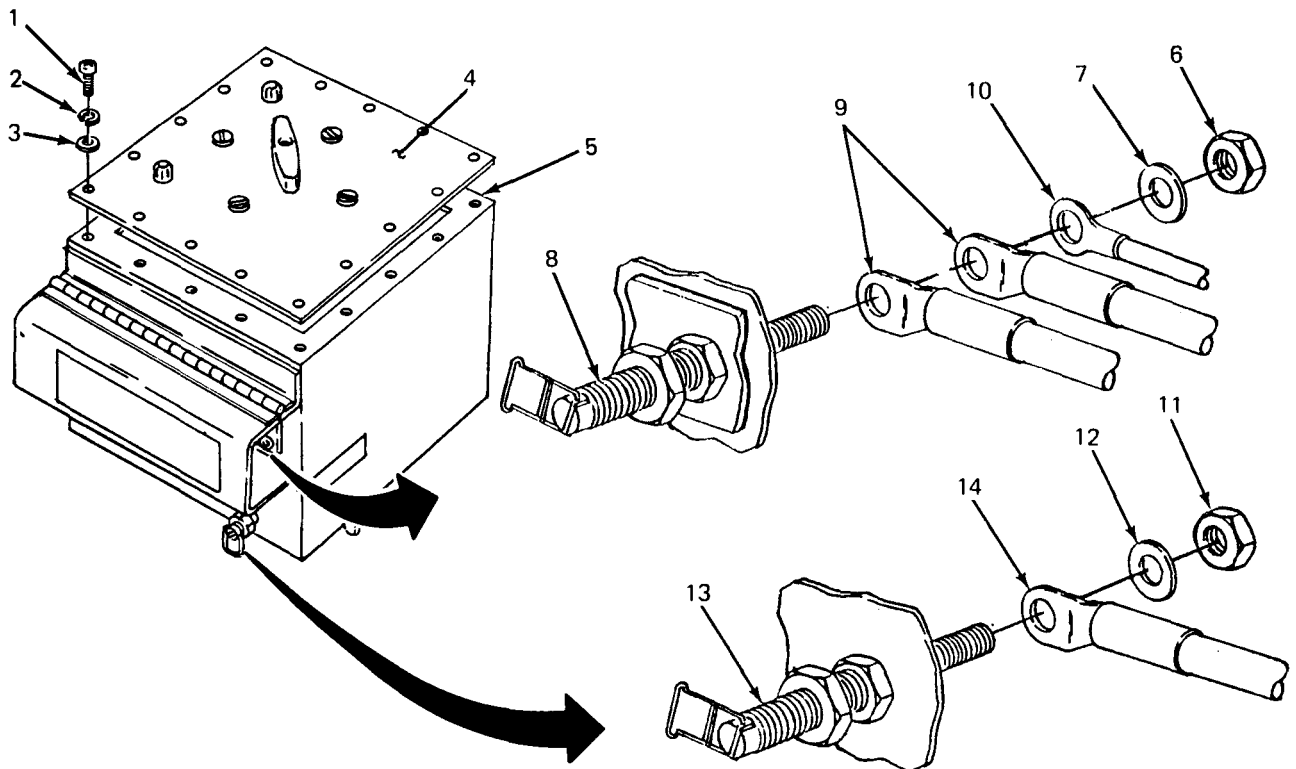

Figure 4-14. Ground Wire Replacement.

- (b) Remove nut (6) and flat washer (7) from load terminal L0 (8) inside switch box (5).
- (c) Slide power cable ground (white) wire terminals (9) and switch box ground wire terminal (10) off load terminal L0 (8).
- (d) Remove nut (11) and flat washer (12) from AC GROUND terminal E2 (13) inside switch box (5). Slide ground wire terminal (14) off terminal E2.

(2) *Installation.*

- (a) Install switch box ground wire terminal (14) on AC GROUND terminal E2 (13) and secure with flat washer (12) and nut (11).
- (b) Install other switch box ground wire terminal (10) on load terminal L0 (8). Install power cable ground (white) wire terminals (9) on terminal L0 and secure both wires with flat washer (7) and nut (6).
- (c) Position cover (4) on switch box (5) and secure with 16 screws (1), 16 lockwashers (2) and 16 flat washers (3).

4-26. Taillight Cable Assembly and Electrical Lead Repair and Replacement. One taillight cable assembly and one electrical lead connect each taillight to the trailer wiring harness. The taillight cable assembly and electrical lead are replaced by unplugging four connectors at each end. Repair is accomplished by replacing defective connectors. To manufacture a replacement cable assembly and electrical lead, install new connectors on suitable lengths of insulated wire using the procedure described for repair.

a. Male Connector Replacement. (See figure 4-15.)

- (1) Slide shell (1) back on wire lead (2).
- (2) Remove washer (3).
- (3) Slide shell (1) off over contact (4).
- (4) Cut off contact (4).

NOTE

Be careful not to strip too much insulation from wire. Connector contact must be crimped onto insulation to hold securely.

- (5) Strip insulation off wire lead (2) equal to depth of new contact (4).
- (6) Slide shell (1) and washer (3) of new connector onto wire lead (2).
- (7) Slide contact (4) onto stripped wire and solder in accordance with TB SIG 222.
- (8) Crimp contact onto wire.
- (9) Slide shell (1) forward over washer (3) and contact (4).

b. Female Connector Replacement. (See figure 4-15.)

- (1) Slide shell (5) and sleeve (6) back on wire lead (7).
- (2) Cut off contact (8).
- (3) Slide shell (5) and sleeve (6) off wire lead (7).

NOTE

Be careful not to strip too much insulation from wire. Connector contact must be crimped onto insulation to hold securely.

- (4) Strip insulation off wire lead (7) equal to depth of new contact (8).
- (5) Slide shell (5) and sleeve (6), onto wire lead (7).
- (6) Slide contact (8) onto stripped wire and solder in accordance with TB SIG 222.

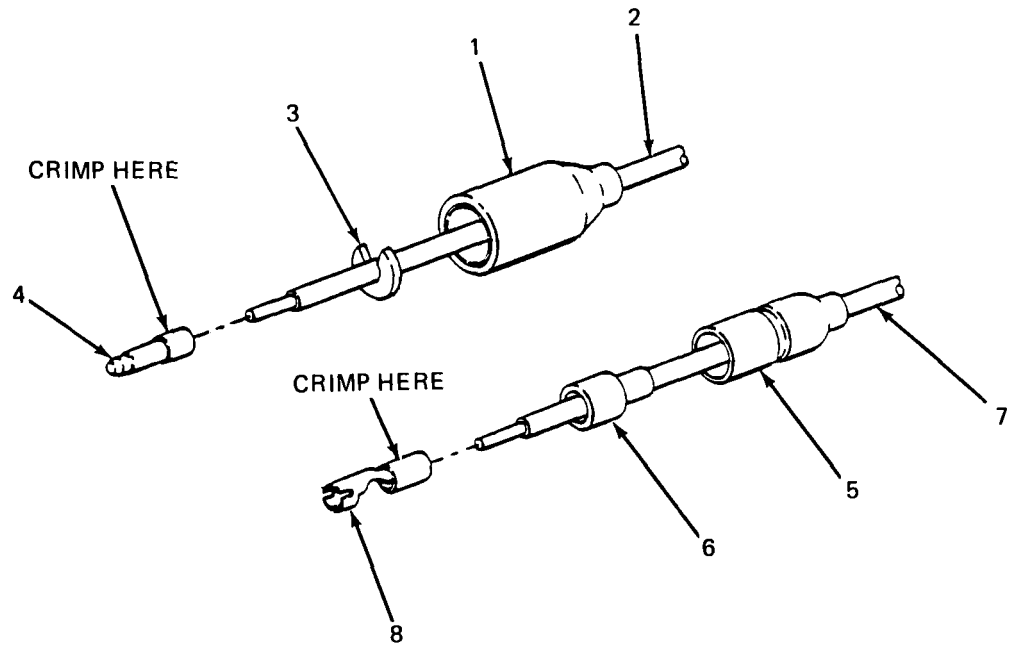

Figure 4-15. Taillight Cable Assembly and Electrical Lead Repair.

(7) Crimp contact onto wire.

(8) Slide shell (5) and sleeve (6) forward over contact (8).

CHAPTER 5

INTERMEDIATE (FIELD) DIRECT SUPPORT AND GENERAL SUPPORT MAINTENANCE INSTRUCTIONS

Section I. INTRODUCTION

5-1. General. This chapter contains Intermediate Direct Support and General Support level maintenance procedures for components of the AN/MJQ-18 Power Plant which are not part of the basic generator sets or trailer. For all other intermediate direct and general support maintenance procedures on the trailer, refer to TM 9-2330-213-14&P. For intermediate direct and general support maintenance procedures on the generator set, refer to TM 5-6115-585-34.

WARNING

Before performing any maintenance that requires climbing on or under trailer, set trailer handbrakes, chock wheels and lower rear leg prop. Injury to personnel could result from trailer suddenly rolling or tipping.

Section II. MAINTENANCE OF POWER PLANT TRAILER

5-2. Leg Prop Assembly Maintenance. Maintenance of the leg prop assembly at the Intermediate Direct Support and General Support level consists of repairing or replacing the assembly as required.

a. Leg Prop Assembly Replacement. (See figure 5-1.)

(1) *Removal.*

- (a) While supporting leg prop assembly, pull out angled bar (1) and lower leg from traveling position.
- (b) Line up boss (2) on upper leg (3) with holes in bracket (4) and insert angled bar (1) to lock leg in support position.
- (c) Remove either one of two cotter pins (5) from leg prop assembly pivot shaft (6).
- (d) While steadying leg prop assembly, remove shaft (6) with remaining cotter pin (5) in place.

WARNING

When angled bar is removed in step (e), leg prop assembly will fall from bracket if not supported. To prevent injury to personnel or damage to equipment, do not permit leg assembly to drop.

- (e) Lift leg assembly slightly to take weight off angled bar (1) and remove bar.
- (f) Lower leg assembly from bracket (4).
- (g) Remove three screws (7), three flat washers (8) and three nuts (9), and remove bracket (4) from trailer frame (10).

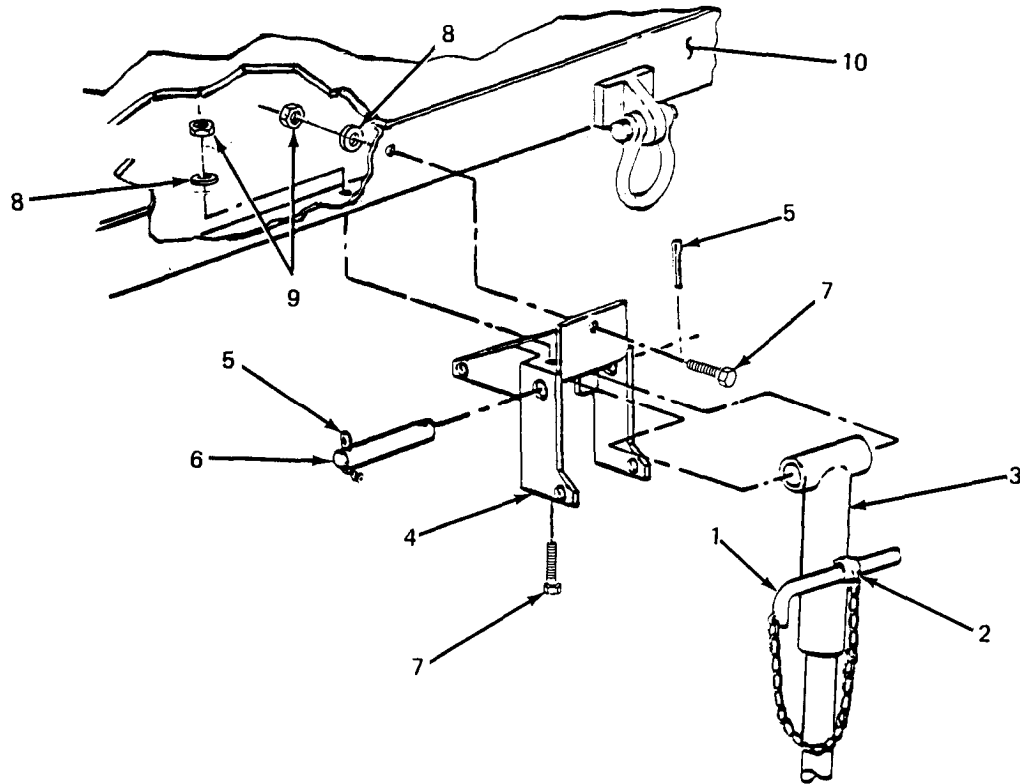

Figure 5-1. Leg Prop Assembly Replacement.

(2) *Installation.*

- (a) Position bracket (4) on trailer frame (10) and install three screws (7), three flat washers (8), and three nuts (9). Tighten hardware to secure bracket.
- (b) Lift leg assembly into bracket (4) and secure by inserting angled bar (1) through holes in bracket and boss (2) on upper leg (3).
- (c) Position leg assembly to line up boss (2) on top of leg with pivot holes in bracket (4). Insert pivot shaft (6).
- (d) Insert cotter pin (5) in pivot shaft (6) and bend cotter pin legs in opposite directions.
- (e) Pull out angled bar (1) to unlock leg prop assembly.
- (f) Swing leg prop assembly up into traveling position and secure by inserting angled bar (1) through holes in bracket (4) and boss (2) on upper leg (3).

b. Leg Prop Assembly Repair. (See figure 5-2.) Repair of the leg prop assembly is limited to welding and repainting. However, partial disassembly is possible to facilitate repair. If required, repaint in accordance with MIL-T-704, Type F, color Green No. 383 of MIL-C-46168.

(1) *Disassembly.*

- (a) Remove leg prop assembly from trailer (paragraph 5-2, a.(1)).
- (b) Clamp leg prop assembly in vise with spring pin (1) facing up.
- (c) Using suitable drift, drive spring pin (1) out of upper leg (2) and remove leg base (3).

(2) *Assembly.*

- (a) Clamp upper leg (2) in vise with spring pin hole facing up.
- (b) Insert leg base (3) into upper leg (2) and turn leg base until hole in screw lines up with hole in upper leg.
- (c) Install spring pin (1) to secure leg base (3) to upper leg (2).
- (d) Install leg prop assembly on trailer (paragraph 5-2, a. (2)).

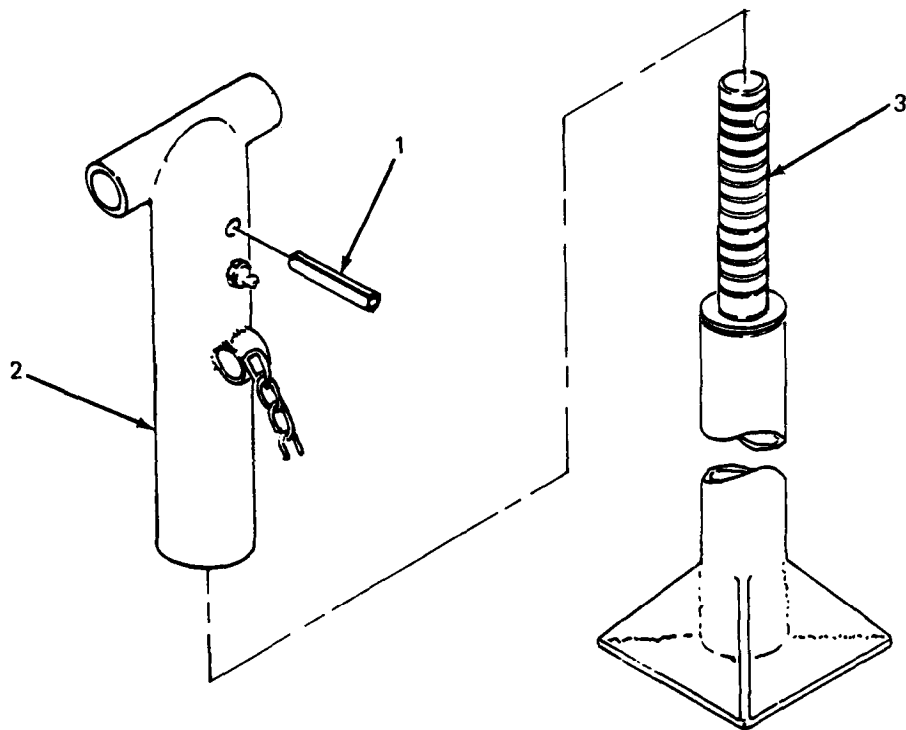

Figure 5-2. Leg Prop Disassembly.

5-3. Trailer Bed and Fenders Repair and Replacement. (See figure 5-3.) The body of the modified trailer consists of a single weldment that includes both fenders and the bed of the trailer.

a. *Removal.*

- (1) Remove fitted cover (paragraph 3-11, a.(1)).

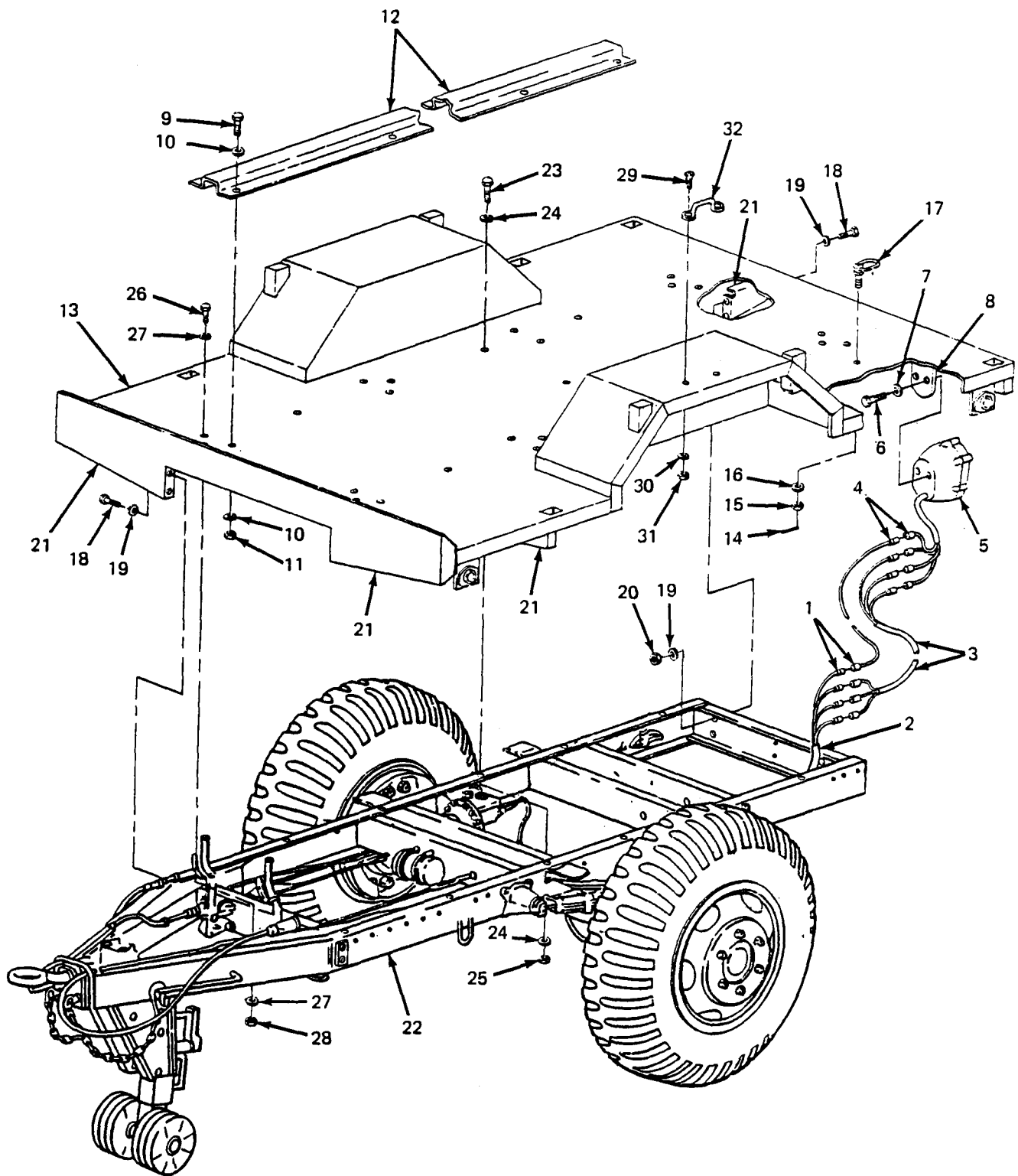

Figure 5-3. Fender and Bed Replacement.

- (2) Remove bow assemblies (paragraph 3-11, b.(1)).
- (3) Remove accessory box (paragraph 4-19, a.).
- (4) Remove switch box (paragraph 4-24, a.).
- (5) Remove both generator sets (paragraph 5-7, a.).
- (6) Working under trailer, unplug four connectors (1) joining trailer main wiring harness (2) to roadside composite light cable assembly (3), and four connectors (4) joining cable assembly to composite light (5).
- (7) Repeat step (6) for curbside composite light cable assembly.
- (8) Remove two screws (6) and two lockwashers (7) securing each composite light (5) to its bracket (8) and remove both composite lights.
- (9) Remove eight screws (9), 16 flat washers (10) and eight nuts(11) securing each generator mounting rail (12) to trailer body (13) and remove both rails.
- (10) Remove cotter pin (14), nut (15) and flat washer (16) from each of two trailer lifting rings (17) and remove lifting rings.

NOTE

The two trailer body support brackets located at the front of the trailer are secured with only two screws and two flat washers each.

- (11) Working under trailer, remove 16 screws (18), 28 flat washers (19) and 12 nuts (20) securing trailer body support brackets (21) to trailer frame (22).

NOTE

There are 18 short screws and four long screws securing trailer body to trailer frame. Since corner screws must extend through trailer frame rails, corner mounting locations require longer screws (step (13)).

- (12) Remove 18 screws (23), 36 flat washers (24) and 18 nuts (25) securing trailer body (13) to trailer frame (22).
- (13) Remove four long screws (26), eight flat washers (27) and four nuts (28) securing trailer body (13) to trailer frame (22) at corner mounting locations.

WARNING

When lifting trailer body, use lifting equipment with a minimum lifting capacity of 2000 lb. Do not stand under trailer body while it is being lifted. Failure to observe these precautions can cause injury to personnel or damage to equipment.

- (14) Using lifting equipment with a minimum lifting capacity of 2000 lb. lift trailer body (13) off trailer frame (22).

b. Repair. Repair of the trailer bed and fenders is limited to replacement of footmans loops and straightening welding, and repainting the bed and fender weldment. If required, repaint in accordance with MIL-T-704, Type F or G, as applicable, color Green, No. 383 of MIL-C-46168. There is one footmans loop mounted to the top of each fender. Replace footmans loop as follows:

- (1) Remove two screws (29), two flat washers (30) and two self-locking nuts (31) securing footmans loop (32) to fender and take off footmans loop.
- (2) Position new footmans loop (32) on fender and secure with two screws (29), two flat washers (30) and two self-locking nuts (31).

c. Installation.

WARNING

When lifting trailer body, use lifting equipment with a minimum lifting capacity of 2000 lb. Do not stand under trailer body while it is being lifted. Failure to observe these precautions can cause injury to personnel or damage to equipment.

- (1) Using lifting equipment with a minimum lifting capacity of 2000 lb. lift trailer body (13) onto trailer frame (22) and align mounting holes.

NOTE

There are 18 short screws and four long screws, securing trailer body to trailer frame. Since corner screws must extend through trailer chassis rails, corner mounting locations require longer screws (step (2)).

- (2) Working on top of trailer body, insert four long screws (26) with one flat washer (27) each through trailer body (13) and trailer frame (22) rails at corner mounting locations.
- (3) Insert 18 screws (23) with one flat washer (24) each through trailer body (13) and rails of trailer frame (22).
- (4) Working under trailer, install one flat washer (24 and 27) and one nut (25 and 28) on each of 22 screws installed in steps (2) and (3). Tighten hardware to secure trailer body (13) to trailer frame (22).
- (5) Install and tighten two screws (18) and two flat washers (19) securing each of two front trailer body support brackets (21) to trailer frame (22).
- (6) Install and tighten 12 screws (18), 24 flat washers (19) and 12 nuts (20) securing remaining trailer body support brackets (21) to trailer frame (22).
- (7) Insert one lifting ring (17) into each of two mounting holes in trailer body (13) and secure with one flat washer (16) and one nut (15). Install one cotter pin (14) in each nut and spread cotter pin ends.
- (8) Position two generator set mounting rails (12) on trailer body (13). Insert eight screws (9) with eight flat washers (10) through each mounting rail and through trailer bed and frame (22).

- (9) Working under trailer, install one flat washer (10) and one nut (11) on each of 16 mounting rail screws (9) and tighten.
- (10) Position one composite light (5) on each rear mounting bracket (8) and secure each light with two screws (6) and two lockwashers (7).
- (11) Working under trailer, connect one composite light cable assembly (3) to each composite light (5) by plugging four cable assembly connectors into four composite light connectors (4). Plug four connectors at opposite end of each cable assembly into four connectors (1) on trailer main wiring harness (2).
- (12) Install both generator sets (paragraph 5-7, b.).
- (13) Install switch box (paragraph 4-24, b.).
- (14) Install accessory box (paragraph 4-19, b.).
- (15) Install six bows (paragraph 3-11, b(2)).
- (16) Install fitted cover (paragraph 3-11, a(2)).

5-4. Fitted Cover Repair. Repairs to the fitted cover shall be made in accordance with FM 10-16, Fabric Repairing.

5-5. Accessory Box Repair. (See figure 5-4.) The accessory box is repaired by replacing the hasp, the catches and the footmans loops, as required. The box itself maybe straightened, welded, and repainted. If required, repaint in accordance with MIL-T-704, Type F, color Green, No. 383 of MIL-C-46168.

a. Catch and Hasp Replacement.

- (1) Grind off or drill out solid rivets (1) securing catch or hasp (2) to accessory box (3).
- (2) Position new catch or hasp (2) on accessory box and secure with solid rivets (1).
- (3) Touch up with paint as required.

b. Footmans Loop Replacement.

- (1) Remove two screws (4), two flat washers (5), and two self-locking nuts (6) securing footmans loop (7) to accessory box lid.
- (2) Position new footmans loop (7) on accessory box (3) and secure with two screws (4) two washers (5), and two self-locking nuts (6).

5-6. Marking. (See figure 5-5.) The power plant four-digit registration number, preceded by the prefix "VC" and the words "U.S. ARMY, " is marked in three places on the trailer. Marking is done in accordance with MIL-STD-642. On the fender, over each wheel, "T.P.50 PSI" is marked in 1.00± .12 inch high characters in accordance with MIL-STD-130. On the switch box, "GEN 1", "GEN 2" and "OFF" are marked on the cover at their respective switch lever positions. On the 5-wire switch box only, "E1" and "E2" are marked next to their respective ground terminal studs. Figure 5-5 shows the approximate location of markings on the power plant. If required, touch-up painting of the base color shall be done in accordance with MIL-T-704, Type F, color Green, No. 383 of MIL-C-46168.

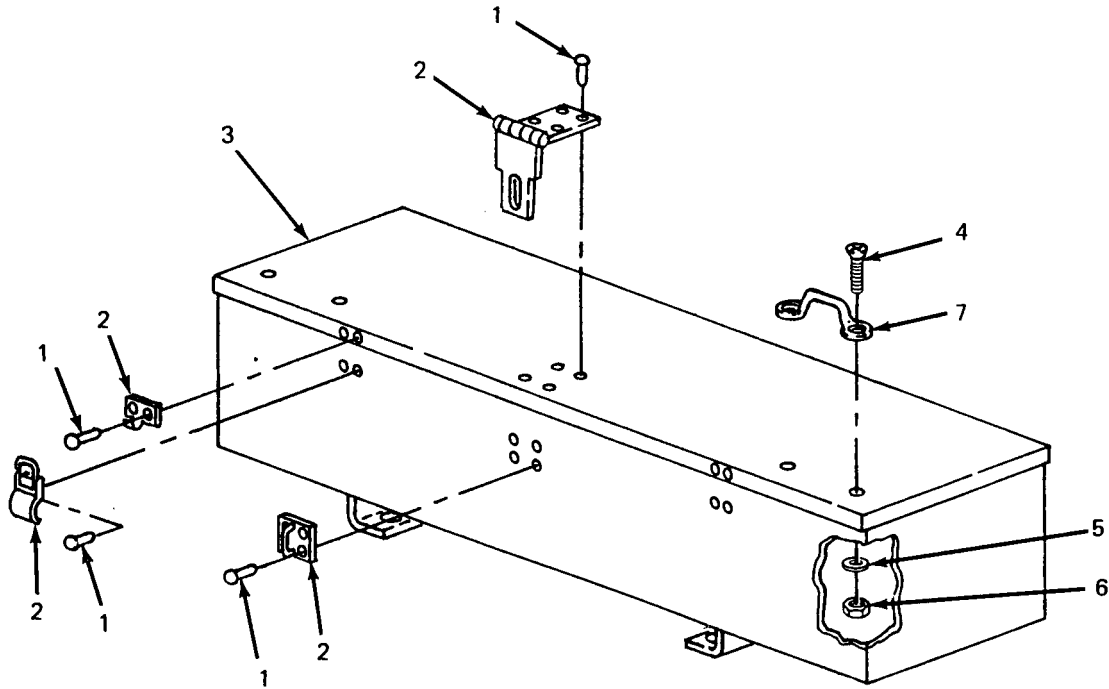

Figure 5-4. Accessory Box Repair.

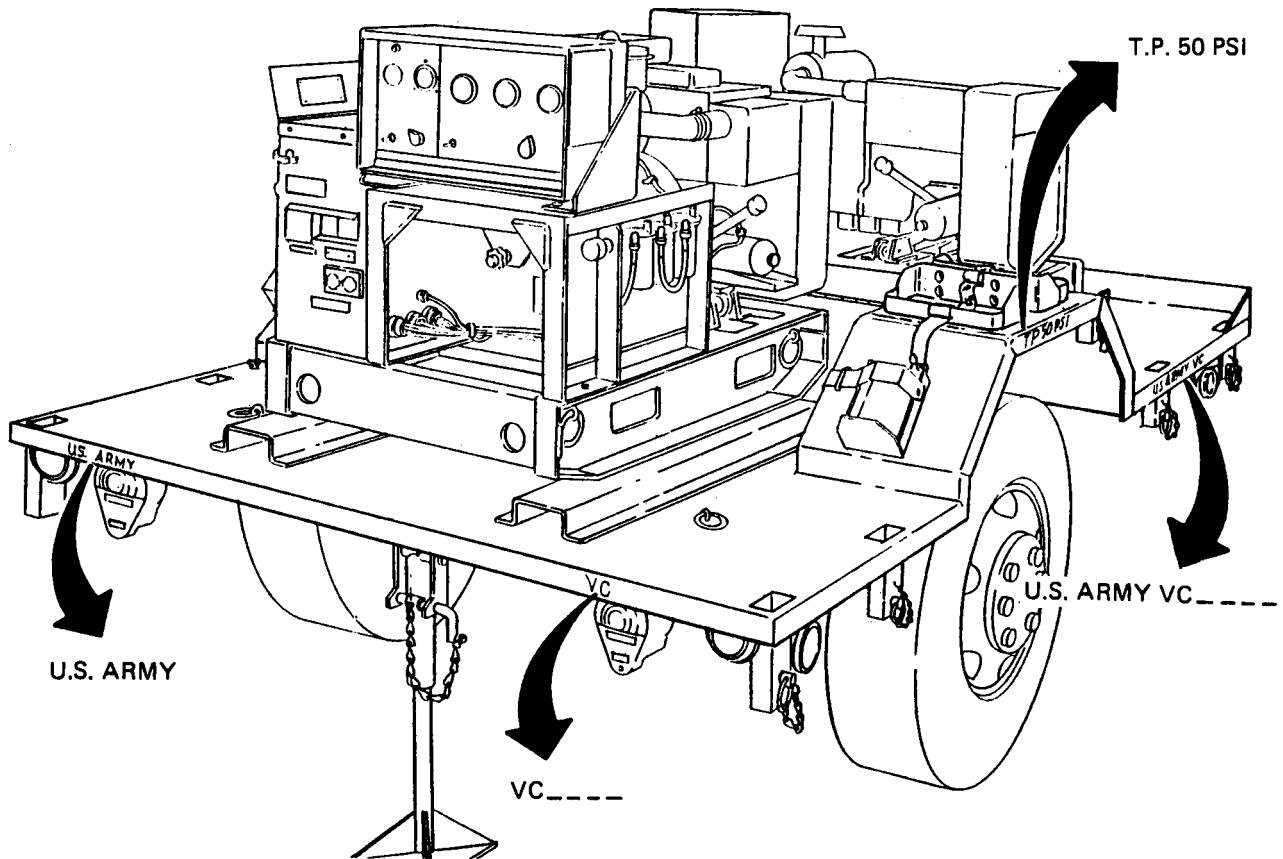

Figure 5-5. Power Plant Markings.

Section III. GENERATOR SET

5-7. Generator Set Replacement. (See figures 5-6 and 5-7.) Power Plant AN/MJQ-18 has two generator sets. Replacement procedures are identical for both.

a. Removal.

- (1) Remove fitted cover (paragraph 3-11, a.(1)).
- (2) Remove six bow assemblies (paragraph 3-11, b.(1)).
- (3) Disconnect all power cables and ground wires (1, figure 5-6) from generator set (2).

NOTE

The beveled washers (6) may have been welded in place.

- (4) Remove four screws (3), four lockwashers (4), four flat washers (5) and four beveled washers (6), securing generator set (2), to mounting rails (7) on trailer bed (8).
- (5) Remove engine oil drain hose (9) from grommet in trailer bed (8).
- (6) Disconnect external fuel line (10) if connected.

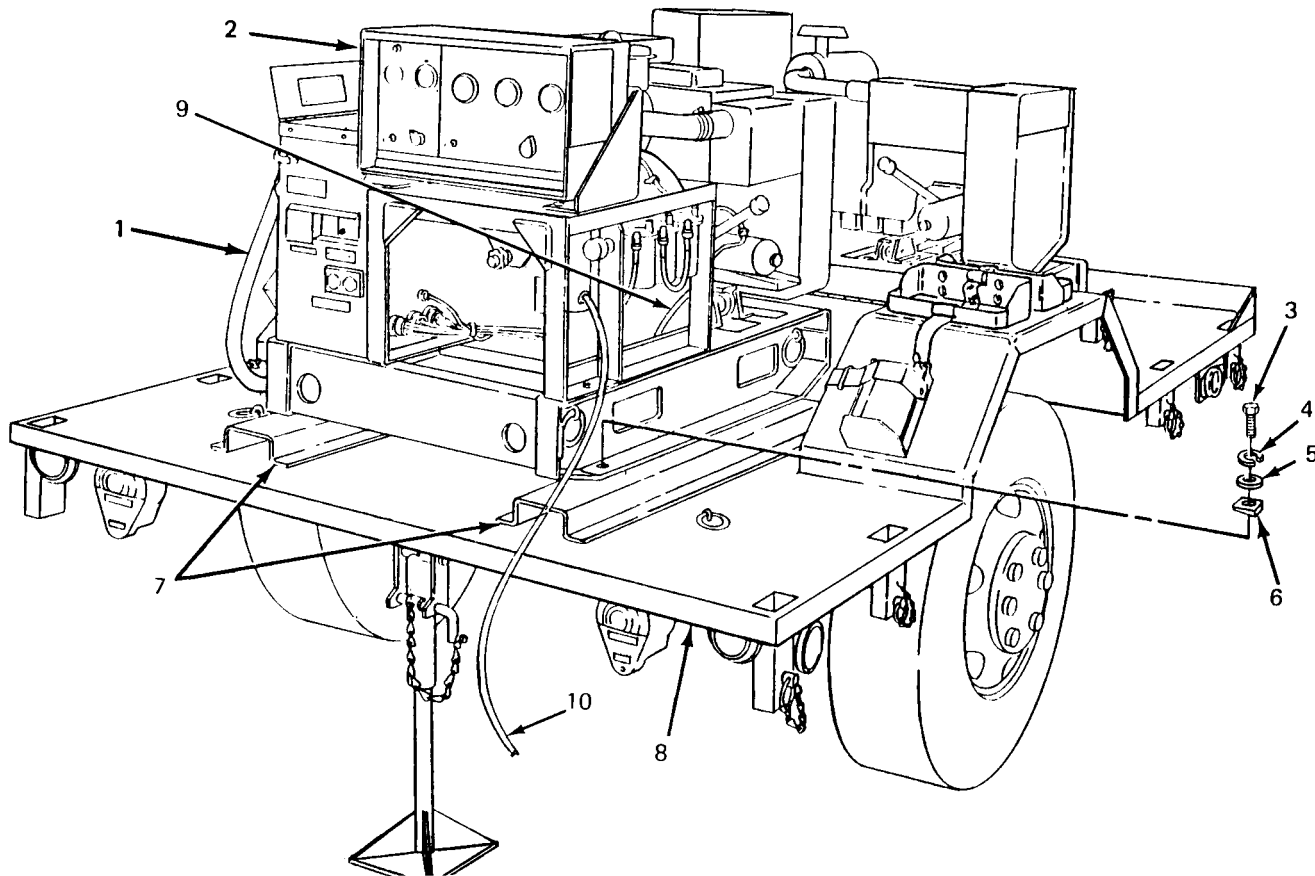

Figure 5-6. Detaching Generator Set from Trailer.

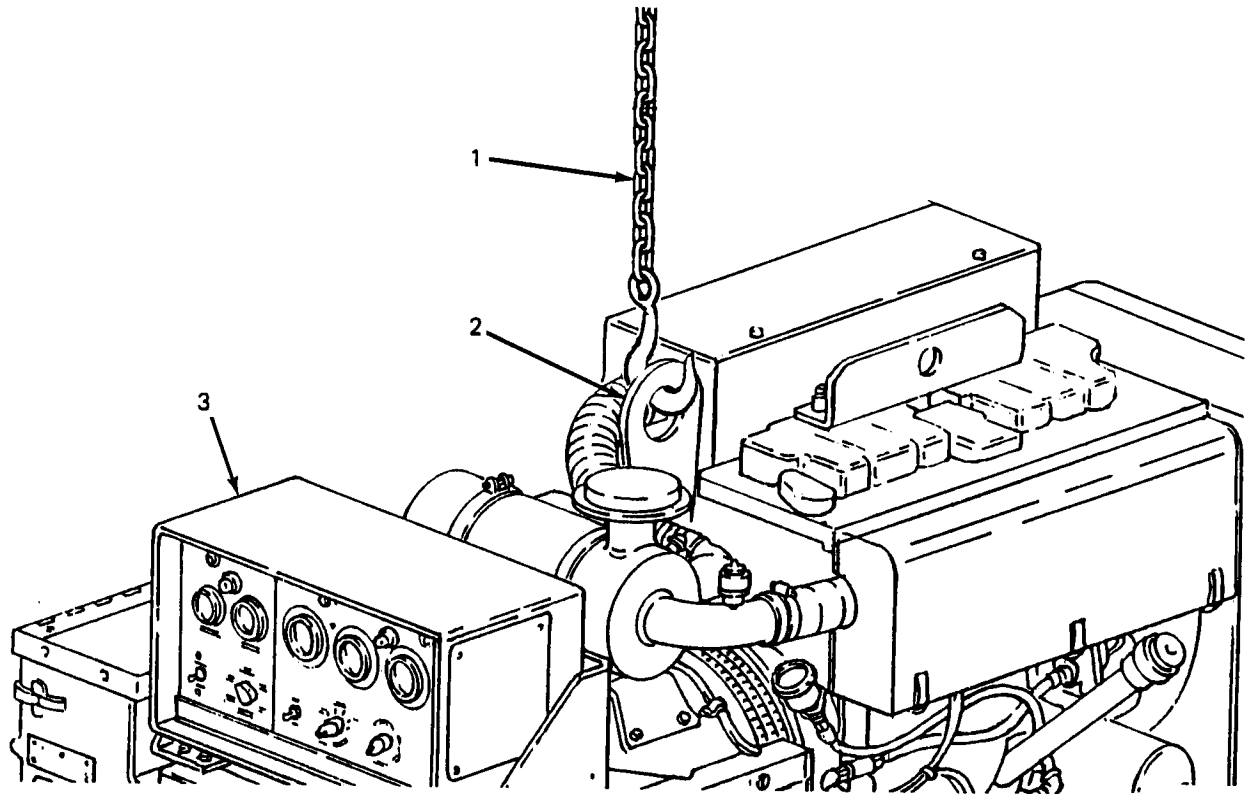

Figure 5-7. Lifting Generator Set.

WARNING

When lifting generator set, use lifting equipment with a minimum lifting capacity of 1500 lb. Do not stand under generator while it is being lifted. Failure to observe these precautions can cause injury to personnel or damage to equipment.

- (7) Attach lifting equipment with a minimum lifting capacity of 1500 lb (1, figure 5-7) to lifting eye (2) on top of generator set (3) and remove generator set from trailer.

b. Installation.

WARNING

When lifting generator set, use lifting equipment with a minimum lifting capacity of 1500 lb. Do not stand under generator while it is being lifted. Failure to observe these precautions can cause injury to personnel or damage to equipment.

- (1) Attach lifting equipment with a minimum lifting capacity of 1500 lb (1, figure 5-7) to lifting eye (2) on top of generator set (3) and lift generator.
- (2) Lower generator set (2, figure 5-6) onto mounting rails (5) on trailer bed (6) and aline mounting holes.

- (3) Insert four screws (3), four lockwashers (4), four flat washers (5) and four beveled washers (6) down through generator set skid into nuts welded to underside of mounting rails (7).
- (4) Position beveled washers (6) so that screw heads are parallel to tops of washers. While holding beveled washers in position, tighten hardware to secure generator set (2) to trailer (8).
- (5) Insert engine oil drain hose (9) through grommet in trailer bed (8).
- (6) Install six bow assemblies (paragraph 3-11, b.(2)).
- (7) Install fitted cover (paragraph 3-11, a.(2)).

Section IV. MAINTENANCE OF ELECTRICAL SYSTEM

5-6. Switch Box Repair. (See figure 5-8.) Repairs to the switch box require disconnecting wires. When reconnecting wires, refer to the schematic inside the switch box (figure 4-7 or 4-8, as applicable).

WARNING

Make sure generator set circuit breakers are in OFF position before performing any repairs on switch box. Failure to observe this precaution may result in injury or death by electrocution.

a. Switch Replacement.

NOTE

Replacement switch will have unmarked terminals and will have to be compared with original switch.

(1) *Removal.*

- (a) Remove 16 screws (1), 16 lockwashers (2) and 16 flat washers (3) securing cover (4) to switch box (5) and take cover, with switch (6) attached, off switch box.

NOTE

Make sure identification bands on wires are legible before disconnecting wires from switch. Tag switch terminals and all unmarked wires.

- (b) Disconnect all wires from switch (6) by removing one screw (7), one nut (8) and one star washer (9) from each switch terminal.
- (c) Remove screw (10) and lockwasher(11) securing knob (12) to switch (6) and take off knob.
- (d) Remove four screws (13), four nuts (14), eight flat washers (15) and preformed packing (16) securing switch (6) to cover(4) and take switch off cover.

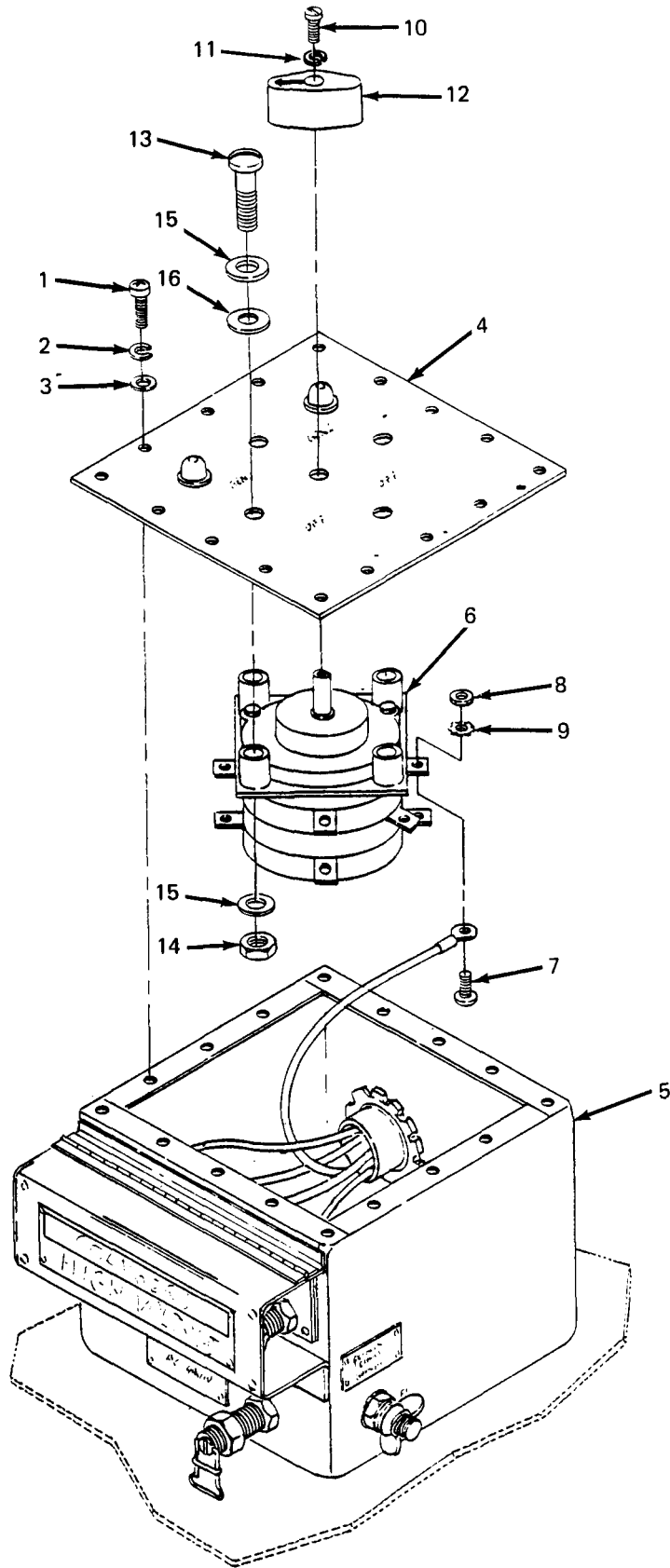

Figure 5-8. Switch Box Switch Replacement.

(2) *Installation.*

- (a) Position switch (6) on inside of cover (4). Insert four screws (13) with one flat washer (14) and one preformed packing (15) each through cover and switch standoffs.

NOTE

Install nut (14) so that flat side mates with washer (15).

- (b) Install one flat washer (15) and one nut (14) on end of each screw (13) and tighten.
- (c) Position knob (12) on switch (6) and install screw (10) and lockwasher (11).

NOTE

Observe identification bands on wires when reconnecting wires,

- (d) Connect indicator light wires to switch (paragraph 4-25, b.(2)).
- (e) Connect power cables to switch (paragraph 4-25, d.(2)).
- (f) Connect load terminal wires to switch (paragraph 4-25, c.(2)).
- (g) Position cover (4) on switch box (5) and secure with 16 screws (1), 16 lockwashers (2) and 16 flat washers (3).

b. Power Cable and Wiring Repair. The switch box wiring is repaired by tightening or replacing loose or damaged terminals. The power cables are repaired by replacing damaged terminals. The repair parts and special tools list in this manual lists part numbers for the terminals. The replacement terminals are soldered onto the wires in accordance with procedures given in TB SIG 222 (TO 31-3-64) and TM 55-1500-323-25 (TO 1-1A-14).

CHAPTER 6

TEST AND INSPECTION AFTER REPAIR

Section I. GENERAL REQUIREMENTS

6-4. General Requirements. The activity performing the repair is responsible for the performance of all applicable tests and inspections specified in the technical manuals referenced below. Activities performing maintenance on any component of the power plant must perform those tests and inspections required by the applicable component or system repair instruction.

Section II. INSPECTION

6-2. Generator Set Inspections. Refer to TM 5-6115-585-12 and -34 for inspections required following repair of the generator set.

6-3. Trailer Inspections. Refer to TM 9-2330-213-14&P for inspections required following repair of the trailer.

Section III. OPERATIONAL TESTS

6-4. Generator Set Operational Tests. Refer to TM 5-6115-585-12 and -34 for operational tests required to verify satisfactory performance of the generator set.

6-5. Trailer Operational Tests. Refer to TM 9-2330-213-14&P for operational tests required to verify satisfactory performance of the trailer.

APPENDIX A

REFERENCES

A-1. Scope. This appendix lists all pamphlets, forms, technical manuals, specifications and miscellaneous publications referenced in this manual.

A-2. Forms and Records.

| | |
|---|----------------|
| Air Force Maintenance Management Program | AFM 66-1 |
| Technical Order System Publication Improvement Report and Reply..... | AFTO Form 22 |
| Recommended Changes to Publications and Blank Forms..... | DA Form 2028 |
| Depreservation Guide for Vehicles and Equipment..... | DA Form 2258 |
| Equipment Inspection and Maintenance Worksheet | DA Form 2404 |
| Maintenance Request..... | DA Form 2407 |
| Consolidated Index of Army Publications | DA PAM 310-1 |
| The Army Maintenance Management System (TAMMS) | DA PAM 738-750 |
| Product Quality Deficiency Report | SF 388 |

A-3. Military Specifications.

| | |
|---|--------------|
| Chemical Agent Resistant Aliphatic Polyurethane Coating | MIL-C-46168 |
| Identification Marking of U.S. Military Property | MI L-STD-130 |
| Identification Marking of Combat and Tactical Transport | MIL-STD-642 |
| Treatment and Painting of Materiel | MIL-T-704 |

A-4. Technical Manuals.

| | |
|--|-------------------|
| Fabric Repairing, Tents, Canvas, Webbing | FM 10-16 |
| Operator and Organizational Maintenance Manual for Generator Set, Diesel Engine Driven, Tactical Skid Mounted, 10 KW, 1 Phase, 2 Wire; 1 Phase, 3 Wire and 3 Phase, 4 Wire; 120, 12/240 and 120/208 V (DOD Model MEP-003A) Utility Class 400 HZ (6115-00-465-1027)..... | TM 5-6115-585-12 |
| Organizational, Direct Support and General Support Maintenance Repair Parts and Special Tools List (Including Depot Maintenance Repair Parts and Special Tools) for Generator Sets, Diesel Engine Driven, Tactical Skid Mounted, 10 KW, 1 Phase, 2 Wire; 1 Phase, 3 Wire; 3 Phase, 4 Wire, 120, 120/240 and 120/208 V (DOD Model MEP-003A) Utility Class, 60 HZ (NSN 6115-00-465-1030) and (Model MEP-112A), Utility Class, 400 Hz (6115-00-485-1027) | TM 5-6115-585-24P |
| Intermediate (Field) (Direct and General Support) and Depot Level Maintenance Manual for Generator Set, Diesel Engine Driven, Tactical Skid Mounted, 10 KW, 1 Phase, 2 Wire; 1 Phase, 3 Wire; 3 Phase, 4 Wire, 120, 120/240 and 120/208 V (DOD Model MEP-003A), Utility Class, 60 HZ (NSN 6115-00-465-1030) and (Model MEP-112A), Utility Class, 400 HZ (6115-00-465-1027) | TM 5-6115-585-34 |
| Installation Practices for Aircraft Electric and Electronic Wiring [TO1-1A-14]..... | TM 55-1500-323-25 |

Procedures for Destruction of Equipment to Prevent
Enemy Use (Mobility Equipment Command) TM 750-244-3

Operator's, Organizational, Direct Support and General Support
Maintenance Manual (Including Repair Parts and Special Tools
List) for Chassis Trailer: 1-1/2-Ton, 2-Wheel, M103A1
(NSN 2330-00-835-8620), M103A2 (2330-00-049-8050), M103A3
(2330-00-141-8052), M103A3C (2330-00-542-2181), M103A4,
(2330-00-141-8051), M103A4C (233-00-542-2182); Trailer,
Cargo; M104 (2330-00-754-0509), M104A1 (2330-00-835-8630),
M105A1 (2330-00-835-8631), M105A2 (2330-00-141-8050)
M105A2C (2330-00-542-5689); Trailer Tank, Water, 400 Gallon,
M107A1 (2330-00-835-8633) M107A2 (2330-00-141-8049),
M107A2C (2330-00-542-5688) and Trailer, Van, Shop, Folding
Sides, M448 (2330-00-631-5692) TM 9-2330-213-14&P

Organizational, Direct Support, and General Support Care
Maintenance and Repair of Pneumatic Tires and Inner
Tubes TM 9-2610-200-24

Air Force Technical Order System TO-00-5-1

Painting and Marking of USAF Aerospace Ground Equipment TO 35-1-3

Processing and Inspection of Aerospace Ground Equipment
for Storage and Shipment TO 35-1-4

Processing and Inspection of Non-Mounted, Non-Aircraft
Gasoline and Diesel Engines for Storage and Shipment TO 38-1-5

A-5. Technical Bulletins.

Solder and Soldering [TO 31-3-64] TB SIG 222

Preservation of USAMECOM Mechanical Equipment for
Shipment and Storage TB 740-97-2

APPENDIX B

COMPONENTS OF END ITEM AND BASIC ISSUE ITEMS LISTS

Section I. INTRODUCTION

B-1. Scope. This appendix lists components of end item and basic issue items for the power plant to help you inventory items required for safe and efficient operation.

B-2. General. The Components of End Item and Basic Issue Items Lists are divided into the following sections:

a. Section II. Components of End Item. This listing is for informational purposes only, and is not authority to requisition replacements. These items are part of the end item, but are removed and separately packaged for transportation or shipment. As part of the end item, these items must be with the end item whenever it is issued or transferred between property accounts. Illustrations are furnished to assist you in identifying the items.

b. Section III. Basic Issue Items. These are the minimum essential items required to place the power plant in operation, to operate it, and to perform emergency repairs. Although shipped separately packaged, BII must be with the power plant during operation and whenever it is transferred between property accounts. The illustrations will assist you with hard-to-identify items. This manual is your authority to request/requisition replacement BII, based on TOE/MTOE authorization of the end item.

B-3. Explanation of Columns. The following provides an explanation of columns found in the tabular listings:

a. Column (1), Illustration Number (Illus No.). This column indicates the number assigned to the item.

b. Column (2), National Stock Number. Indicates the National stock number assigned to the item.

c. Column (3), Description. Indicates the federal item name and, if required, a minimum description to identify and locate the item. The last line for each item indicates the FSCM (in parentheses) followed by the part number.

If item needed differed for different models of this equipment, the model would be shown under the "Usable On Code" heading in this column. The Usable On Code is not applicable for this equipment.

d. Column (4), Unit of Measure (UIM). Indicates the measure used in performing the actual operational/maintenance function. This measure is expressed by a two-character alphabetical abbreviation (eg, ea, in, pr).

e. Column (5), Quantity Required (Qty Req'd). Indicates the quantity of the item authorized to be used with/on the equipment.

Section II. COMPONENTS OF END ITEM

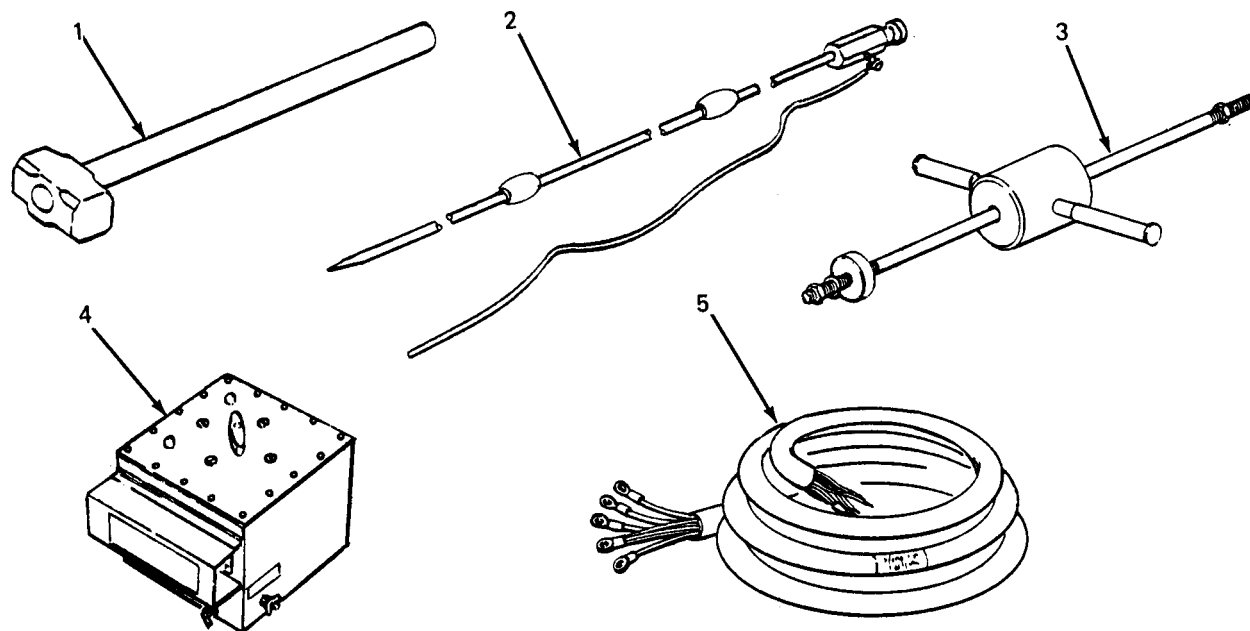

| (1) Illus no. | (2) National stock number | (3) Description FSCM and part number | Usable on code | (4) U/M | (5) Qty'd req'd |
|---------------------|---------------------------------|--|-------------------|----------------------|-----------------------|
| 1 | 5120-00-243-2957 | Hammer, Hand, Engineers 8 lb. (3.6 kg) (81348) GGG-H-86 | | EA | 1 |
| 2 | 5975-00-878-3791 | Rod, Ground, Driven, Sectional, 9 ft (2.7 m) (81349) MIL-R-11461 | | EA | 2 |
| 3 | 5120-01-013-1676 | Hammer, Slide (97403) 13226 E7741 | | EA | 1 |
| 4 | | Switch Box (97403) 13226 E5859-1 or Switch Box (97403) 13220 E4462 | | EA EA | 1 1 |
| 5 | | Cable Assembly (97403) 13226 E5888-1 and Cable Assembly (97403) 13226 E5888-2 or Cable Assembly (97403) 13212 E3584-4 and Cable Assembly (97403) 13212 E3585-4 | | EA EA EA EA | 1 1 1 1 |

Section III. BASIC ISSUE ITEMS

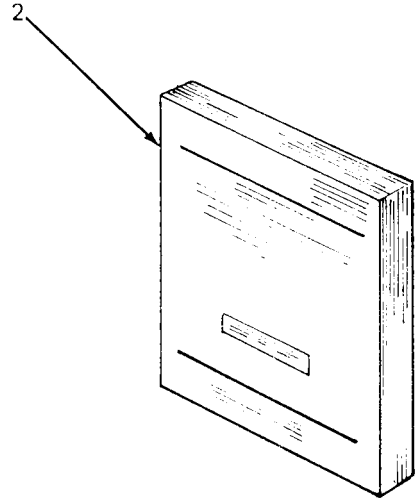
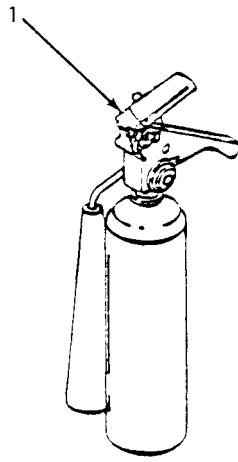

| (1) Illus no. | (2) National stock number | (3) Description FSCM and part number | (4) Usable on code | (5) Qty'd req'd |
|---------------------|---------------------------------|---|--------------------------|-----------------------|
| 1 | | Extinguisher, Fire, Hand, 2-3/4 lb. (1.25 kg) (81349) MIL-E-52031 | EA | 2 |
| 2 | | Manual, Technical, TM5-6115-633-14&P | EA | 1 |

APPENDIX C

MAINTENANCE ALLOCATION CHART

Section I. INTRODUCTION

C-1. General.

a. This section provides a general explanation of all maintenance and repair functions authorized at various maintenance levels.

b. Section II designates overall responsibility for the performance of maintenance functions on the identified end item or component. The implementation of the maintenance functions upon the end item or component will be consistent with the assigned maintenance functions.

c. Section III lists the tools and test equipment required for each maintenance function as referenced from Section II.

d. Section IV contains supplemental instructions, explanatory notes and/or illustrations required for a particular maintenance function.

C-2. Explanation of Columns in Section II.

a. Group Number. Column 1. The assembly group is a numerical group assigned to each assembly in a top down breakdown sequence. The applicable assembly groups are listed on the MAC in disassembly sequence beginning with the first assembly removed in a top down disassembly sequence.

b. Assembly Group. Column 2. This column contains a brief description of the components of each assembly group.

c. Maintenance Functions. Column 3. This column lists the various maintenance functions (A through K) and indicates the lowest maintenance category authorized to perform these functions. The symbol designations for the various maintenance categories are as follows:

- C - Operator or crew
- O - Unit maintenance
- F - Intermediate direct support maintenance
- H - Intermediate general support maintenance
- D - Depot maintenance

The maintenance functions are defined as follows:

A - Inspect. To determine serviceability of an item by comparing its physical, mechanical, and electrical characteristics with established standards.

B - Test. To verify serviceability and to detect electrical or mechanical failure by use of test equipment.

C - Service. To clean, to preserve, to charge, and to add fuel, lubricants, cooling agents, and air. If it is desired that elements, such as painting and lubricating, be defined separately, they may be so listed.

D - Adjust. To rectify to the extent necessary to bring into proper operating range.

E - Aline. To adjust specified variable elements of an item to bring to optimum performance.

F - Calibrate. To determine the corrections to be made in the readings of instruments or test equipment used in precise measurement. Consists of the comparison of two instruments, one of which is a certified standard of known accuracy, to detect and adjust any discrepancy in the accuracy of the instrument being compared with the certified standard.

G - Install. To set up for use in an operational environment such as an emplacement, site, or vehicle.

H - Replace. To replace unserviceable items with serviceable like items.

I - Repair. Those maintenance operations necessary to restore an item to serviceable condition through correction of material damage or a specific failure. Repair may be accomplished at each category of maintenance.

J - Overhaul. Normally, the highest degree of maintenance performed by the Army in order to minimize time work in process is consistent with quality and economy of operation. It consists of that maintenance necessary to restore an item to completely serviceable condition as prescribed by maintenance standard in technical publications for each item of equipment. Overhaul normally does not return an item to like new, zero mileage, or zero hour condition.

K - Rebuild. The highest degree of material maintenance. It consists of restoring equipment as nearly as possible to new conditions in accordance with original manufacturing standards. Rebuild is performed only when required by operational considerations or other paramount factors and then only at the depot maintenance category. Rebuild reduces to zero the hours or miles the equipment, or component thereof, has been in use.

d. Symbols. The uppercase letter placed in the appropriate column indicates the lowest level at which that particular maintenance function is to be performed.

e. Tools and Equipment. Column 4. This column is provided for referencing by code, the special tools and test equipment, (Section III) required to perform the maintenance functions (Section II).

f. Remarks. Column 5. This column is provided for referencing by code, the remarks (Section IV) pertinent to the maintenance functions.

C-3. Explanation of Columns in Section III. Section III, Tools, Test, and Support Equipment Requirements is not applicable.

C-4. Explanation of Columns in Section IV. Section IV, Remarks, is not applicable.

Section II. MAINTENANCE ALLOCATION CHART

| (1) Group no. | (2) Assembly group | (3) Maintenance functions | | | | | | | | | | (4) Tools and equipment | (5) Remarks | | | | |
|------------------|-------------------------|------------------------------|----------|----------|--------|-------|-----------|---------|----------|----------|----------|----------------------------|----------------|---------|--|--|--|
| | | A | B | C | D | E | F | G | H | I | J | | | K | | | |
| | | Inspect | Test | Service | Adjust | Align | Calibrate | Install | Replace | Repair | Overhaul | | | Rebuild | | | |
| 01 | ENCLOSURE | | | | | | | | | | | | | | | | |
| | Fitted Cover | C 0.1 | | | | | | | C 0.5 | F 1.0 | | | | | | | |
| | Bows | C 0.1 | | | | | | | C 0.1 | | | | | | | | |
| 02 | GENERATOR SET | C 0.2 | | C 2.0 | | | | | F 3.0 | | | | | | | | See TM 5-6115-585-12, -34 for generator set maintenance. |
| 03 | ELECTRICAL SYSTEM | | | | | | | | | | | | | | | | |
| 0301 | Cables | O 0.1 | O 0.2 | | | | | | O 0.2 | F 1.0 | | | | | | | |
| 0302 | Switch BOX | C 0.1 | O 0.5 | | | | | | O 0.5 | F 2.0 | | | | | | | |
| | Switch | | O 0.5 | | | | | | F 1.0 | | | | | | | | |
| | Load Terminals | | | | | | | | O 0.5 | | | | | | | | |
| | Wiring | O 0.2 | O 0.5 | | | | | | O 1.0 | F 1.0 | | | | | | | |
| | Light and Wire Assembly | | O 0.2 | | | | | | O 0.4 | O 0.4 | | | | | | | |

| (1) Group no. | (2) Assembly group | (3) Maintenance functions | | | | | | | | | | | (4) Tools and equipment | (5) Remarks | |
|------------------|----------------------------|---------------------------------|------------------|---------------------------------|----------------------------|-----------------------|---|---------------------------------|---------------------------------|----------------------------|--------------------------------------|---|----------------------------|----------------|--|
| | | A | B | C | D | E | F | G | H | I | J | K | | | |
| | | I n s p e c t | T e s t | S e r v i c e | A d j u s t | A l i g n | C a l i b r a t e | I n s t a l l | R e p l a c e | R e p a i r | O v e r h a u l | | | | |
| 04 | TRAILER ASSEMBLY | C 0.5 | O 1.0 | | | | | | | | | | | | |
| | Fire Extinguisher Bracket | C 0.1 | | | | | | | O 0.5 | | | | | | |
| | Bed/Fenders | | | | | | | | F 4.0 | F 4.0 | | | | | |
| 0401 | Accessory Box | | | | | | | | O 0.5 | F 2.0 | | | | | |
| 0402 | Reflectors and Data Plates | C 0.1 | | | | | | | O 0.5 | | | | | | |
| 0403 | Leg Prop Assembly | C 0.1 | | | | | | | F 0.5 | F 0.7 | | | | | |
| 0404 | Taillight Cable Assembly | C 0.1 | O 0.3 | | | | | | O 1.0 | O 0.5 | | | | | |
| | | | | | | | | | | | | | | | |

TM 9-2330-213-14 &P for trailer assembly maintenance.

APPENDIX D

UNIT, INTERMEDIATE, (FIELD) (DIRECT SUPPORT AND GENERAL SUPPORT) AND DEPOT MAINTENANCE REPAIR PARTS AND SPECIAL TOOLS LIST)

Section I. INTRODUCTION

D-1. Scope. This joint Army and Air Force manual lists repair parts and special tools required for the performance of unit, intermediate (field), (direct and general support) and depot maintenance of the power plant. The following paragraphs are keyed to applicable users. All users should read paragraph 4, Special Information, prior to using this manual.

D-2. General. Repair Parts and Special Tools List is divided into the following sections:

a. (ALL) Repair Parts - Section II. A list of repair parts authorized for the performance of maintenance at the unit, intermediate (field) (direct support and general support) and depot level in figure and item number sequence.

b. (ALL) Special Tools, Test and Support Equipment - Section III. A list of special tools, test and support equipment authorized for the performance of maintenance at the unit intermediate (field), (direct support and general support) and depot level.

c. National Stock Number and Reference Number Index - Section IV. A list of National stock numbers in numerical sequence, followed by a list of reference numbers appearing in all the listings, in alphanumeric sequence, cross-referenced to the illustration figure number and item number.

d. Reference Designator Index - Section V. The reference Designator Column includes all assigned reference designators arranged first in alphabetical order, second in numeric order. Opposite each symbol is listed the figure and item number of the part in Section II and the reference number.

D-3. Explanation of columns. The following provides an explanation of columns in the tabular lists in Sections II and III.

a. (ALL) Illustrations, (Column 1). This column is divided as follows:

(1) *Figure Number.* Indicates the figure number of the illustration on which the item is shown.

(2) *Item Number.* Indicates the number used to identify the item on the illustration.

b. (ALL) Source, Maintenance, and Recoverability Codes (SMR), (Column 2).

(1) *Uniform Source Codes applicable to all Military Services.*

GENERAL: Source Codes are assigned to support items to indicate the manner of acquiring support items for maintenance, repair, or overhaul of end items. Source codes are entered in the first and second positions of the Uniform SMR Code format as follows:

| Code | Definition |
|------|---|
| PA | Item procured and stocked for anticipated or known usage. |
| PB | Item procured and stocked for insurance purposes because essentiality dictates that a minimum quantity be available in the supply systems. |
| PC | Item procured and stocked and which otherwise would be coded PA except that it is deteriorative in nature. |
| PD | Support item, excluding support equipment, procured for initial issue or outfitting and stocked only for subsequent or additional initial issues or outfittings. Not subject to automatic replenishment. |
| PE | Support equipment procured and stocked for initial issue or outfittings to specified maintenance repair activities. |
| PF | Support equipment which will not be stocked but which will be centrally procured on demand. |
| PG | Item procured and stocked to provide for sustained support for the life of the equipment. It is applied to an item peculiar to the equipment which because of probable discontinuance or shutdown of production facilities would prove uneconomical to reproduce at a later time. |
| KD | An item of depot overhaul/repair kit and not purchased separately. Depot kit defined as a kit that provides items required at the time of overhaul or repair. |
| KF | An item of maintenance kit and not purchased separately. Maintenance kit defined as a kit that provides an item that can be replaced at unit or intermediate levels of maintenance. |
| KB | Item included in both a depot overhaul/repair kit and a maintenance kit. |
| MO | Item to be manufactured or fabricated at unit level. |
| MF | Item to be manufactured or fabricated at intermediate maintenance levels. |
| | Air Force - Intermediate (*) |
| | Army - General Support (*) |

| Code | Definition |
|------|---|
| MD | Item to be manufactured or fabricated at depot maintenance level. |
| AO | Item to be assembled at unit level. |
| AF | Item to be assembled at intermediate maintenance levels. Air Force – Intermediate (*) Army – Direct Support (*) |
| AH | Item to be assembled at intermediate maintenance levels. Air Force – Intermediate (*) Army – General Support (*) |
| AD | Item to be assembled at depot maintenance level. |
| XA | Item is not procured or stocked because the requirements for the item will result in the replacement of the next higher assembly. |
| XB | Item is not procured or stocked. If not available through salvage, requisition. |
| x c | Installation drawings, diagram, instruction sheet, field service drawing, that is identified by manufacturer's part number. |
| XD | A support item that is not stocked. When required, item will be procured through normal supply channels. |

(*)NOTE

For USAF and the USA Safeguard Program, only Code "F" will be used to denote intermediate maintenance. On joint programs, use of either code F or H by the jointing service will denote intermediate maintenance to USAF and USA Safeguard Program.

(2) *Uniform Maintenance Codes applicable to all Military Services:* GENERAL: Maintenance Codes are assigned to indicate the levels of maintenance authorized to USE and REPAIR support items. The Maintenance Codes are in the third and fourth position of the Uniform SMR Code Format.

(a) *Use (Third Position):* The Maintenance Code entered in the third position indicates the lowest level maintenance level authorized to remove, replace, and use the support item. The Maintenance Code entered in the third position indicates one of the following levels of maintenance.

| Code | Application/Explanation |
|------|---|
| o | Support item is removed, replaced, used at the unit level of maintenance. |

| Code | Application/Explanation |
|------|---|
| F | Support item is removed, replaced, used at the following intermediate levels: USAF - Intermediate (*) USA - Direct Support (*) |
| H | Support item is removed, replaced, used at the following intermediate levels: USAF - Intermediate (*) USA - General Support (*) |

| Code | Definition |
|------|--|
| D | Support items that are removed, replaced, used at Depot only: USAF – Depot, Mobile Depot and Specialized Repair Activity. USA – Depot, Mobile Depot and Specialized Repair Activity. |

(b) *Repair (Fourth Position)*: The maintenance code entered in the fourth position indicates whether the item is to be repaired and identifies the lowest maintenance level with the capability to perform complete repair (i.e., all authorized maintenance functions).

- o The lowest maintenance level capable of complete repair of the support item is the unit level.
- F The lowest maintenance level capable of complete repair of the support item is the following intermediate level:

USAF – Intermediate (*)
USA - General Support (*)
- H The lowest maintenance level capable of complete repair of the support item is the following intermediate level:

USAF – Intermediate (*)
USA - General Support (*)

(*) NOTE

For USAF programs and the USA Safeguard Program, Code F will be used to denote intermediate maintenance. On joint programs, use of either Code F or H by the joining Service will denote intermediate maintenance to USAF and the USA Safeguard Program.

| Code | Definition |
|------|--|
| D | The lowest maintenance level capable of complete repair of the support item is the depot level. USAF – Depot, Mobile Depot, and Specialized Repair Activity. USA – Depot, Mobile Depot, and Specialized Repair Activity. |

| Code | Application/Explanation |
|------|---|
| L | Repair restricted to designated Specialized Repair Activity. |
| Z | Nonreparable. No repair is authorized. |
| B | No repair is authorized. The item may be reconditioned by adjusting, lubricating, etc., at the user level. No parts or special tools are procured for the maintenance of this item. |

(3) *Uniform Recoverability Codes applicable to all Military Services:* GENERAL: Recoverability Codes are assigned to support items to indicate the disposition action on unserviceable items. The recoverability code is entered in the fifth position of the uniform SMR Code Format as follows:

| Recoverability Codes | Definition |
|----------------------|---|
| Z | Nonreparable item. When unserviceable, condemn and dispose at the level indicated in column 3. |
| O | Reparable item. When uneconomically reparable, condemn and dispose at unit level. |
| F | Reparable item. When uneconomically reparable, condemn and dispose at the following intermediate levels: USAF - Intermediate (*) USA - Direct Support (*) |
| H | Reparable item. When uneconomically reparable, condemn and dispose at the following levels: USAF - Intermediate (*) USA - General Support (*) |

(*) NOTE

For USAF programs and the USA Safeguard Program, Code F will be used to denote intermediate maintenance. On joint programs, use of either Code F or H by the joining Service will denote intermediate level of USAF and the USA Safeguard Program.

| Recoverability Codes | Definition |
|----------------------|---|
| D | Reparable item. When beyond lower level repair capability, return to depot. Condemnation and disposal not authorized below depot level. |
| L | Reparable item. Repair, condemnation and disposal not authorized below depot/Specialized Repair Activity level. |

Recoverability
Codes

Definition

| | |
|---|---|
| A | Item requires special handling or condemnation procedure because of specific reasons (i.e., precious metal content, high-dollar value, critical material or hazardous material). Refer to appropriate manuals/directives for specific instructions. |
|---|---|

c. (ALL) National Stock Number (Column 4). Indicates the National Stock Number assigned to the item and will be used for requisitioning purposes.

d. (ALL) Description (Column 5). Indicates the Federal item name and any additional descriptions of the item required. The abbreviation "w/e" when used as part of the nomenclature, indicates that the National Stock Number includes all armament, equipment, accessories and repair parts issued with the item. A part number or other reference number is followed by the applicable five digit Federal Supply Code for manufacturer in parentheses. If two reference numbers and Federal Supply Codes for manufacturer are listed, the first listing refers to the Department of Defense Drawing Number, the second listing refers to the actual part manufacturer. Items that are included in kits and sets are listed below the name of the kit or set with the quantity of each item in the kit or set indicated in the quantity incorporated in unit column.

e. (ALL) Unit of Measure (U/M) (Column 6). Indicates the standard of the basic quantity of the listed item as used in performing the actual maintenance function. This measure is expressed by a two-character alphabetical abbreviation (e.g., ea, in, pr, etc.). When the unit of measure differs from the unit of issue, the lowest unit of issue that will satisfy the required units of measure will be requisitioned.

f. (ALL) Quantity Incorporated in Unit (Column 7). Indicates the quantity of the item used in the assembly group. A "V" appearing in this column in lieu of a quantity indicates that a definite quantity cannot be indicated (e.g., shims, spacers, etc.).

D-4. Special Information.

a. (ALL) Identification of Usable On Codes for this Manual is not applicable.

b. Army unit maintenance personnel will extract the items which they require from Section II, 3rd or 4th position of column 2 of the intermediate direct and general support RPSTL. Parts which are manufactured or assembled at a higher level than that authorized to install the part are indicated by the use of higher level code in the source column.

c. Stockage Information.

(1) Air Force stockage information is contained in Initial Supply Support Lists issued separately from this publication by Sacramento Air Logistics Center in accordance with AFM 67-1, part 1, chapter 12.

- (2) Army stockage is demand based in accordance with AR 710-2. Repair parts listed in this publication represent those authorized for use at indicated maintenance levels and will be requisitioned on an as-required basis until stockage is justified in accordance with AR 710-2.

d. In the parts list, some items are indented to show that they are a component of the item under which they are indented.

D-5. How to Locate Repair Parts.

a. (ALL) When National Stock Number or reference number is unknown:

- (1) Using the table of contents, determine the functional group; i.e., batteries and related parts, exhaust and breather pipes, within which the repair part belongs. This is necessary since illustrations are prepared for functional groups.
- (2) Find the illustration covering the functional group to which the repair part belongs.
- (3) Identify the repair part on the illustration and note the illustration figure and item number of the repair part.
- (4) Using the Repair Parts Listing, find the figure and item number noted on the illustration.

b. (ALL) When national stock number or reference number is known:

- (1) Using the Index of National Stock Numbers and Reference Numbers, find the pertinent national stock number or reference number. This index is in ascending NSN sequence followed by a list of reference numbers in alphanumeric sequence, cross-referenced to the illustration figure number and item number.
- (2) After finding the figure and item number, locate the figure and item number in the repair parts list.

D-6. (F) Use of the Reference Designator Index Section. This Section (Section V) is used when the reference designator is known or identified by other technical manuals supporting this equipment. The reference number is given in this section. If description or location is desired, note the figure and item number. Turn to Section II to the noted figure and item number. The location of the part and description is given in this listing.

D-7. Abbreviations.

| Abbreviations | Explanation |
|----------------|-------------|
| Not Applicable | |

D-8. Federal Supply Codes for Manufacturers.

| C o d e | M a n u f a c t u r e r |
|----------------|-------------------------|
| Not Applicable | |

D-9. Recommendation for Maintenance Publication Improvements. Report of errors, omissions, and recommendations for improving this publication by the individual user is encouraged. Reports should be submitted as follows:

a. Air Force AFTO Form 22 in accordance with T.O. 00-5-1, directly to: Commander, Sacramento Air Logistics Center, ATTN: SM-ALC-MMEDTA, McClellan AFB, CA 95652-5609.

b. Army DA Form 2028, directly to: Commander, US Army Troop Support Command, ATTN: AMSTR-MCTS, 4300 Goodfellow Boulevard, St. Louis, MO 63120-1798.

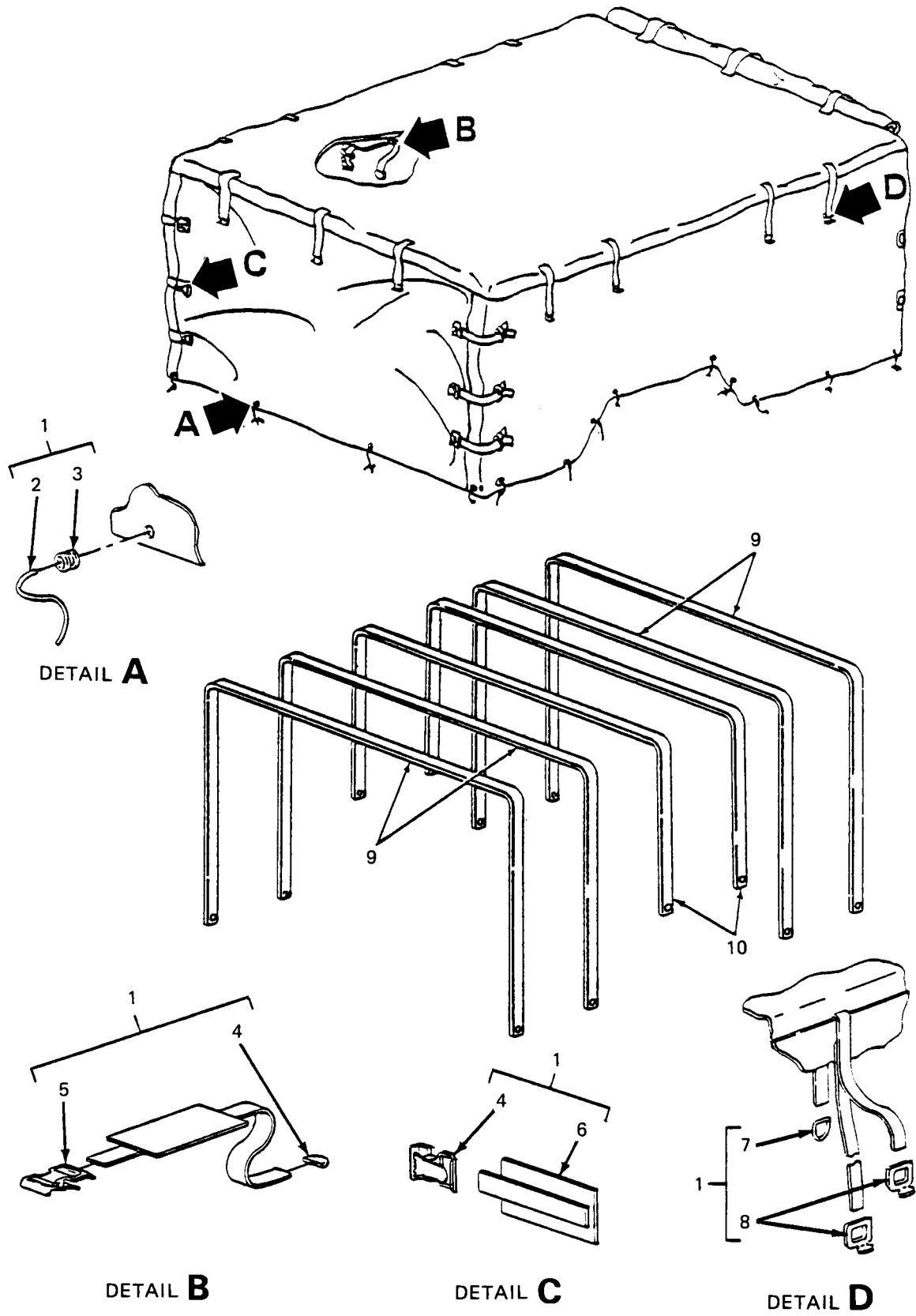

Figure D-1. Enclosure.

SECTION II

ARMY TMS-6115-633-14&P

| (1) ILLUS- TRATION | | (2) SMR CODE | | | | (3) USMC | | (4) | (5) DESCRIPTION | (6) | (7) | (8) |
|--------------------------|------|-----------------|-------|------|------|-------------|--------|------------------|---|--------|------|-------|
| A | B | A | B | C | D | A | B | NATIONAL | | USABLE | QTY | USMC |
| FIG | ITEM | ARMY | AIR | NAVY | USMC | SSI | REPL | STOCK | REF NUMBER | ON | INC | QTY |
| NO. | NO. | | FORCE | | | | FACTOR | NUMBER | & MFR CODE | CODE | IN | PER |
| | | | | | | | | | | U/M | UNIT | EQUIP |
| | | | | | | | | | GROUP 01 - ENCLOSURE | | | |
| D-1 | 1 | PAOFF | | | | | | 6115-01-206-1271 | FITTED COVER 13226E7740 97403 | EA | | 1 |
| D-1 | 2 | PAOZZ | | | | | | | ROPE, SISAL T-R-605B 81349 | EA | | 25 |
| D-1 | 3 | PAOZZ | | | | | | | GROMMET, METALLIC MIL-G-16491D 81349 | EA | | 25 |
| D-1 | 4 | PAOZZ | | | | | | 5340-00-078-7029 | CLIP, END STRAP MS51926-3 96906 | EA | | 24 |
| D-1 | 5 | PAOZZ | | | | | | 5340-00-057-6956 | BUCKLE, SPRING ACTION MS51929-2 96906 | EA | | 12 |
| D-1 | 6 | | | | | | | | CHAPE ASSEMBLY 13214E1392 97403 | EA | | 12 |
| D-1 | 7 | PAOZZ | | | | | | 5365-01-031-9674 | RING, DEE MS51925-1 96906 | EA | | 16 |
| D-1 | 8 | | | | | | | | HOOK, SNAP MIL-S-43770/1- 81349 SWZE3 | EA | | 26 |
| D-1 | 9 | PAOZZ | | | | | | 2540-00-924-8478 | BOW, VEHICULAR, TOP 13212E3597-1 97403 | EA | | 4 |
| D-1 | 10 | PAOZZ | | | | | | 2540-00-926-1003 | BOW, VEHICULAR TOP 13212E3597-2 97403 | EA | | 2 |

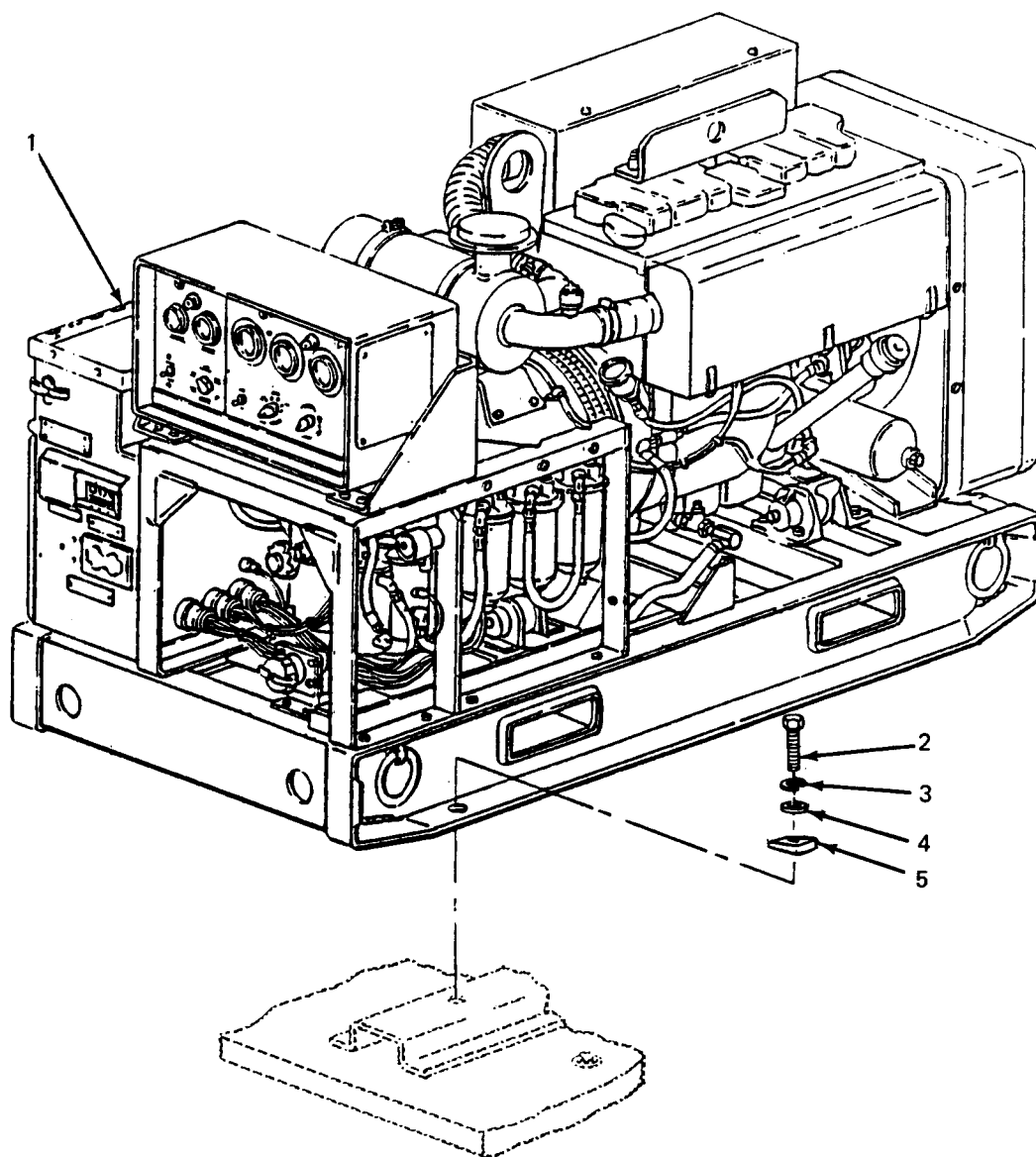

Figure D-2. Generator Set.

SECTION II

ARMY TMS-6115-633-14&P

| (1) ILLUS- TRATION | | (2) SMR CODE | | | | (3) | | (4) | (5) DESCRIPTION | (6) | (7) | (8) |
|--------------------------|-------------|-----------------|--------------|------|------|-----|----------------|-----------------------------|---|----------------------|--------------------------|-----------------------------|
| A | B | A | B | C | D | A | B | NATIONAL STOCK NUMBER | REF NUMBER & MFR CODE | USABLE ON CODE | QTY INC IN UNIT | USMC QTY PER EQUIP |
| FIG NO. | ITEM NO. | ARMY | AIR FORCE | NAVY | USMC | SSI | REPL FACTOR | | | U/M | | |
| | | | | | | | | | GROUP 02 - GENERATOR SET | | | |
| D-2 | 1 | PAOPH | | | | | | 6115-00-465-1030 | GENERATOR SET, DIESEL MEP-003A 30554 | EA | 2 | |
| D-2 | 2 | | | | | | | 5305-00-719-5235 | SCREW, CAP, HEX MS90727-114 96906 | EA | 8 | |
| D-2 | 3 | PAOZZ | | | | | | 5310-00-584-5272 | LOCKWASHER MS35338-48 96906 | EA | 8 | |
| D-2 | 4 | | | | | | | | WASHER, FLAT FN NOT AVAILABLE | EA | 8 | |
| D-2 | 5 | PAOZZ | | | | | | 5310-01-150-5922 | WASHER, BEVELED 13206E4482-2 97403 | EA | 8 | |

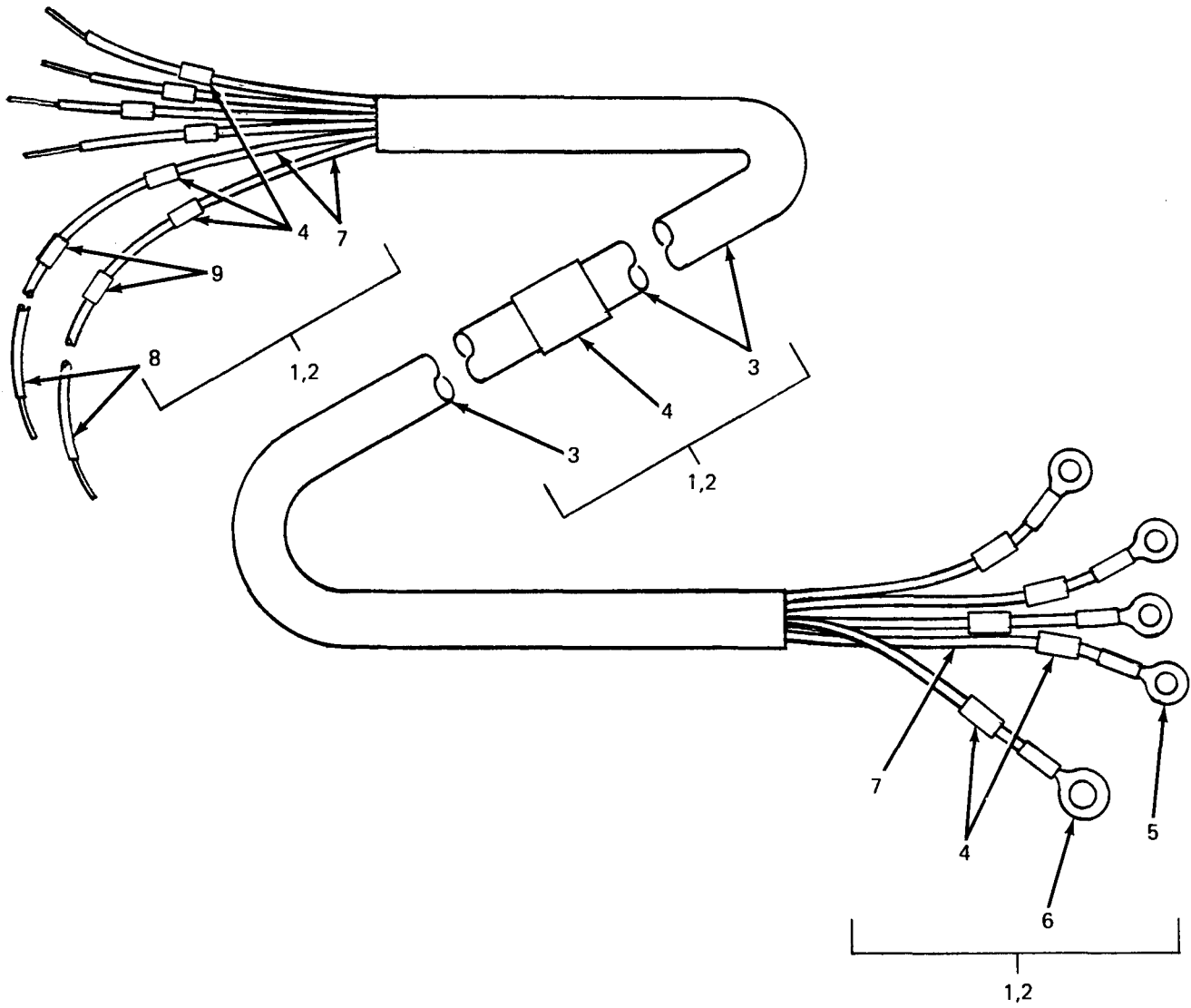

Figure D-3. Five-Wire Power Cable.

SECTION II

ARMY TMS-6115-633-14&P

| (1) ILLUS- TRATION | | (2) SMR CODE | | | | (3) | | | | (4) | (5) DESCRIPTION | (6) | (7) | (8) |
|--------------------------|------|-----------------|-------|------|------|-----|--------|------------------|--|-----|--------------------|------|-------|-----|
| A | B | A | B | C | D | A | B | NATIONAL | | | USABLE | QTY | USMC | |
| FIG | ITEM | ARMY | AIR | NAVY | USMC | SSI | REPL | STOCK | REF NUMBER | | ON | INC | QTY | |
| NO. | NO. | | FORCE | | | | FACTOR | NUMBER | & MFR CODE | | CODE | U/M | PER | |
| | | | | | | | | | | | | UNIT | EQUIP | |
| | | | | | | | | | GROUP 03 - ELECTRICAL SYSTEM 0301 - POWER CABLES | | | | | |
| D-3 | 1 | PAOFF | | | | | | | CABLE ASSY, POWER (FIVE-WIRE) (GEN 1) 13226E5888-1 97403 | | EA | 1 | | |
| D-3 | 2 | PAOFF | | | | | | 6150-01-B76-1221 | CABLE ASSY, POWER (FIVE-WIRE) (GEN 2) 13226E5888-2 97403 | | EA | 1 | | |
| D-3 | 3 | PAFZZ | | | | | | | CABLE CO-04-HDF- 81349 (4/1-4/8R) 1620 | | FT | AR | | |
| D-3 | 4 | PAOZZ | | | | | | | BAND, IDENTIFICATION MIL-P-15024/8 81349 TYPE K2 | | EA | 26 | | |
| D-3 | 5 | PAOZZ | | | | | | 5940-00-115-5007 | TERMINAL, LUG MS25036-130 96906 | | EA | 8 | | |
| D-3 | 6 | PAOZZ | | | | | | 5940-00-113-9833 | TERMINAL, LUG MS25036-131 96906 | | EA | 2 | | |
| D-3 | 7 | PAOZZ | | | | | | | SLEEVING, INSULATION MS23053/5-107-5 81349 | | EA | AR | | |
| D-3 | 8 | PAOZZ | | | | | | | WIRE, SIZE 6 AWG QQW343C06 B1B 81348 | | EA | 4 | | |
| D-3 | 9 | PAOZZ | | | | | | | SLEEVING, INSULATION MS23053/5-109-5 81349 | | EA | AR | | |

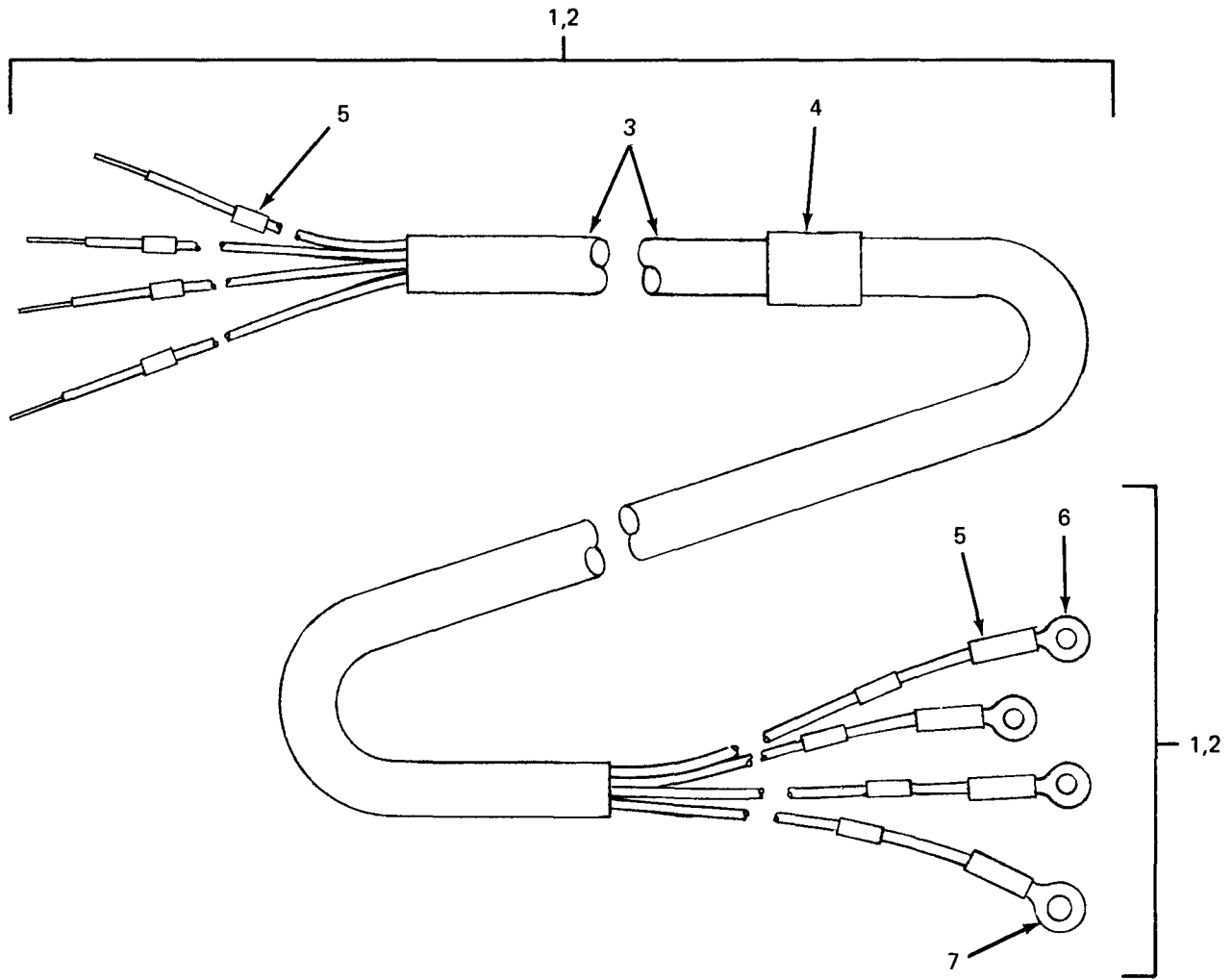

Figure D-4. Four- Wire Power Cable.

SECTION II

ARMY TMS-6115-633-14&P

| (1) ILLUS- TRATION | | (2) SMR CODE | | | | (3) | | | | (4) | (5) DESCRIPTION | (6) | (7) | (8) |
|--------------------------|------|-----------------|-------|------|------|-----|--------|------------------|---|-----|--------------------|------|-------|-----|
| A | B | A | B | C | D | A | B | NATIONAL | | | USABLE | QTY | USMC | |
| FIG | ITEM | ARMY | AIR | NAVY | USMC | SSI | REPL | STOCK | REF NUMBER | | ON | INC | QTY | |
| NO. | NO. | | FORCE | | | | FACTOR | NUMBER | & MFR CODE | | CODE | U/M | PER | |
| | | | | | | | | | | | | UNIT | EQUIP | |
| | | | | | | | | | 0301 - POWER CABLES | | | | | |
| D-4 | 1 | | | | | | | | CABLE ASSY, POWER (FOUR-WIRE) (GEN 1) 13212E3584-4 97403 | | EA | 1 | | |
| D-4 | 2 | | | | | | | | CABLE ASSY, POWER (FOUR-WIRE) (GEN 2) 13212E3585-4 97403 | | EA | 1 | | |
| D-4 | 3 | PAFZZ | | | | | | | CABLE CO-04HDE (4/2) 81349 1480 | | FT | AR | | |
| D-4 | 4 | PAOZZ | | | | | | | TUBING, INSULATION (2.000 ID X 0.045 NOM WALL) MIL-I-23053/5 81349 CLASS 1 | | EA | 1 | | |
| D-4 | 5 | PAOZZ | | | | | | | TUBING, INSULATION (0.500 ID X 0.025 NOM WALL) MIL-I-23053/5 81349 CLASS 1 | | EA | 8 | | |
| D-4 | 6 | PAOZZ | | | | | | 5490-00-113-8191 | TERMINAL, LUG MS25036-127 96906 | | EA | 3 | | |
| D-4 | 7 | PAOZZ | | | | | | 5490-00-113-9831 | TERMINAL, LUG MS25036-128 96906 | | EA | 1 | | |

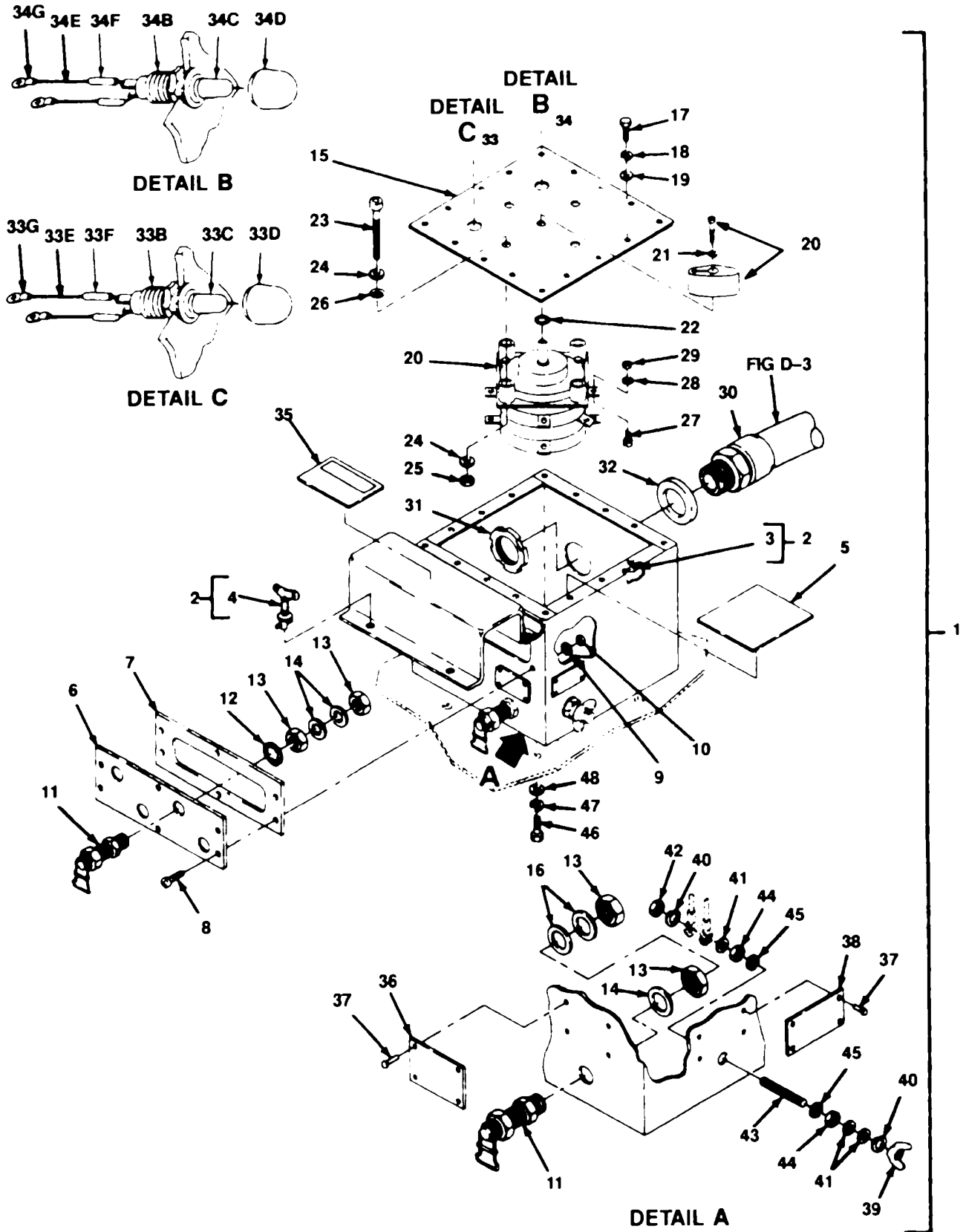

Figure D-5. Five Wire Switch Box.

SECTION II

| (1) ILLUS- TRATION | | (2) SMR CODE | | | | (3) USMC | | (4) | (5) DESCRIPTION | | (6) | (7) | (8) |
|--------------------------|-------------|-----------------|--------------|------|------|-------------|----------------|-----------------------------|--|----------------------|------|--------------------------|-----------------------------|
| a | b | a | b | c | d | a | b | NATIONAL STOCK NUMBER | REF NUMBER & MFR CODE | USABLE ON CODE | U/M | QTY INC IN UNIT | USMC QTY PER EQUIP |
| FIG NO. | ITEM NO. | ARMY | AIR FORCE | NAVY | USMC | SSI | REPL FACTOR | | | | | | |
| D-5 | 1 | PBOFF | | | | | | | 0302 - Switch Box BOX, SWITCH (FIVE-WIRE) 13226E5859-I | 97403 | EA | 1 | |
| D-5 | 2 | XBOFF | | | | | | 6115-01-B76-1197 | .BOX 13226E5B61 | 97403 | EA | 1 | |
| D-5 | 3 | | | | | | | | ..NUT, BLIND RIVET MS27130-S99 | 96906 | A EA | 16 | |
| D-5 | 4 | | | | | | | | ..FASTENER, PANEL | | EA | 2 | |
| D-5 | 5 | XBOZZ | | | | | | | .PLATE, INFORMATION 13212E3587 | 97403 | EA | 1 | |
| D-5 | 6 | PAOZZ | | | | | | 5940-01-B76-1201 | .BOARD TERMINAL 13211E4775 | 97403 | EA | 1 | |
| D-5 | 7 | PAFZZ | | | | | | 5330-00-178-9319 | .GASKET 13212E3583 | 97403 | EA | 1 | |
| D-5 | 8 | PAOZZ | | | | | | 5305-00-968-1727 | .SCREW, MACHNE MS35206- 23 | 96906 | EA | 6 | |
| D-5 | 9 | PAOZZ | | | | | | 5310-00-809-4058 | .WASHER, FLAT MS27183-10 | 96906 | EA | 6 | |
| D-5 | 10 | PAOZZ | | | | | | 5310-00-088-1251 | .NUT, SELF-LOCKING MS51922-1 | 96906 | EA | 6 | |
| D-5 | 11 | | | | | | | | .POST, TERMINAL MS39347-4 | 96006 | EA | 5 | |
| D-5 | 12 | PAOZZ | | | | | | 5310-00-042-4229 | .LOCKWASHER, INTERNAL TOOTH MS35333-113 | 96906 | EA | 4 | |
| D-5 | 13 | PAOZZ | | | | | | 5310-00-006-8286 | .NUT, PLAIN, HEX MS16203-41 | 96906 | EA | 10 | |
| D-5 | 14 | PAOZZ | | | | | | 5310-00-004-9129 | .WASHER, FLAT AN961-6168 | 81352 | EA | 11 | |
| | | PAOZZ | | | | | | 5310-0-187-2413 | .WASHER, FLAT AN961-616T | 88044 | EA | 11 | |
| D-5 | 15 | XBFZZ | | | | | | | .COVER 13212E3579 | 97403 | EA | 1 | |
| D-5 | 16 | | | | | | | | .WASHER, FLAT | | EA | 2 | |
| D-5 | 17 | PAOZZ | | | | | | 5305-00-989-7435 | .SCREW MACHINE MS35207-264 | 96906 | EA | 16 | |
| D-5 | 18 | PAOZZ | | | | | | 5310-00-045-3296 | .LOCKWASHER MS3533-3 | 96906 | EA | 16 | |
| D-5 | 19 | PAOZZ | | | | | | 5310-00-014-5850 | .WASHER, FLAT MS271342 | 96906 | EA | 16 | |
| D-5 | 20 | PAFZZ | | | | | | 5930-00-829-3238 | .SWITCH, ROTARY MIL-S-15291/12 | 81349 | EA | 1 | |
| D-5 | 20A | PAFZZ | | | | | | 5355-01-162-3704 | .KNOB 07000-1 | 82121 | EA | 1 | |
| D-5 | 21 | PAFZZ | | | | | | | .LOCKWASHER 02015-4 | 82121 | EA | 1 | |
| D-5 | 21A | PAFZZ | | | | | | | .SCREW 02016-28 | 82121 | EA | 1 | |
| D-5 | 22 | PAFZZ | | | | | | 5330-00-579-7916 | .PACKING, PREFORMED MS28775-115 | 96906 | EA | 1 | |
| D-5 | 23 | PAFZZ | | | | | | 5305-00-963-7467 | .SCREW, CAP, SOCKET HEAD MS16997-149 | 96906 | EA | 4 | |
| D-5 | 24 | PAFZZ | | | | | | 5310-00-809-5998 | .WASHER, FLAT kMS27183-18 | 96906 | EA | 8 | |
| D-5 | 25 | PAFZZ | | | | | | 5310-00-225-6993 | .NUT, SELF-LOCKING MS51922-33 | 96906 | EA | 4 | |
| D-5 | 26 | PAFZZ | | | | | | 5330-00-618-5361 | .PACKING, PREFORMED MS28775-015 | 96906 | EA | 4 | |
| D-5 | 27 | PAOZZ | | | | | | 5305-01-135-7528 | .SCREW, MACHINE MS35215-95 | 96906 | EA | 9 | |

| (1) ILLUS- TRATION | | (2) SMR CODE | | | | (3) USMC | | (4) | (5) DESCRIPTION | | (6) | (7) | (8) |
|--------------------------|------|-----------------|-------|------|------|-------------|--------|------------------|--------------------------------------|--------|-----|------|-------|
| a | b | a | b | c | d | a | b | NATIONAL | REF NUMBER | USABLE | | QTY | USMC |
| FIG | ITEM | ARMY | AIR | NAVY | USMC | SSI | REPL | STOCK | & MFR CODE | ON | U/M | INC | QTY |
| NO. | NO. | | FORCE | | | | FACTOR | NUMBER | | CODE | | IN | PER |
| | | | | | | | | | | | | UNIT | EQUIP |
| | | | | | | | | | 0302 - Switch Box - CONT | | | | |
| D-5 | 28 | PAOZZ | | | | | | | .WASHER, STAR | | EA | 9 | |
| D-5 | 29 | PAOZZ | | | | | | 5310-00-411-0687 | .NUT, PLAIN, HEX MS35650-3385T | 96906 | EA | 9 | |
| D-5 | 30 | | | | | | | | .TUBE STUFFING 13218E5149-10 | 97403 | EA | 2 | |
| D-5 | 31 | PAOZZ | | | | | | 5310-01-166-6154 | .WASHER 13218E5139- 5 | 97403 | EA | 2 | |
| D-5 | 32 | PAOZZ | | | | | | 5301-00-164-2351 | .GASKET 13218E5140-5 | 97403 | EA | 2 | |
| D-5 | 33 | PAOOO | | | | | | 6120-00-253-0688 | .LIGHT AND WIRE ASSY 13212E3581-2 | 97403 | EA | 1 | |
| D-5 | 33A | PAOOO | | | | | | 6210-00-900-9423 | ..LIGHT INDICATOR 13214E1391 | 97403 | EA | 1 | |
| D-5 | 33B | PAOZZ | | | | | | 6210-01-230 1851 | ...HOUSING 181-88309-553 | 72619 | EA | 1 | |
| D-5 | 33C | PAOZZ | | | | | | | ...LAMP GSB(OR) | 73070 | EA | 1 | |
| D-5 | 33D | PAOZZ | | | | | | 6210-00-941-6690 | ...LENS 181-0937-003 | 72619 | EA | 1 | |
| D-5 | 33E | MOOZZ | | | | | | | ..WIRE M5086/1-18 | 96908 | EA | 2 | |
| D-5 | 33F | PAOZZ | | | | | | | ..INSULATION TUBING M23053/5-106 | 81349 | EA | 2 | |
| D-5 | 33G | PAOZZ | | | | | | 5940-00-113-8184 | ..TERMINAL MS25036-150 | 96906 | EA | 2 | |
| D-5 | 34 | PAOOO | | | | | | 6120-00-406-1398 | .LIGHT AND WIRE ASSY 13212E3581-1 | 97403 | EA | 1 | |
| D-5 | 34A | PAOOO | | | | | | 6210-00-900-9423 | ..LIGHT, INDICATOR 13214E1391 | 97403 | EA | 1 | |
| D-5 | 34B | PAOZZ | | | | | | 6210-01-230-1851 | ...HOUSING 181-8836-09-553 | 72619 | EA | 1 | |
| D-5 | 34C | PAOZZ | | | | | | | ...LAMP G96(GR) | 73070 | EA | 1 | |
| D-5 | 34D | PAOZZ | | | | | | 6210-00-941-6690 | ...LENS 181-0937-003 | 72619 | EA | 1 | |
| D-5 | 34E | PAOZZ | | | | | | | ..WIRE M5086/1-18 | 96906 | EA | 2 | |
| D-5 | 34F | PAOZZ | | | | | | | ..INSULATION TUBING M230535-106 | 96906 | EA | 2 | |
| D-5 | 34G | PAOZZ | | | | | | | ..TERMINAL LUG MS25036-105 | 96906 | EA | 2 | |
| D-5 | 35 | XBFZZ | | | | | | | .PLATE, WARNING 13216E7603 | 97403 | EA | 1 | |
| D-5 | 36 | MDOZZ | | | | | | | .PLATE, INFORMATION 13226E5889-1 | 97403 | EA | 1 | |
| D-5 | 37 | PAOZZ | | | | | | 5320-00-721-5239 | .RIVET MS16535-153 | 96906 | EA | 8 | |
| D-5 | 38 | MDOZZ | | | | | | | .PLATE, INFORMATION 13226E5889-2 | 97403 | EA | 1 | |
| D-5 | 39 | PAOZZ | | | | | | 5310-01-078-5998 | .NUT, PLAIN, WING MS35425-75 | 96906 | EA | 1 | |
| D-5 | 40 | PAOZZ | | | | | | 5310-00-184-8971 | .LOCKWASHER MS35338-103 | 96906 | EA | 2 | |
| D-5 | 41 | PAOZZ | | | | | | 5310-00-187-2413 | .WASHER, FLAT AN961-616T | 81352 | EA | 3 | |
| D-5 | 42 | PAOZZ | | | | | | 5310-00-584-7995 | .NUT, PLAIN, HEX MS16203-27 | 96908 | EA | 1 | |

D-20 Change 4

| (1) ILLUS- TRATION | | (2) SMR CODE | | | | (3) USMC | | (4) | (5) DESCRIPTION | | (6) | (7) | (8) |
|--------------------------|-------------|-----------------|--------------|------|------|-------------|----------------|-----------------------------|--|----------------------|-----|--------------------------|-----------------------------|
| a | b | a | b | c | d | a | b | NATIONAL STOCK NUMBER | REF NUMBER & MFR CODE | USABLE ON CODE | U/M | QTY INC IN UNIT | USMC QTY PER EQUIP |
| FIG NO. | ITEM NO. | ARMY | AIR FORCE | NAVY | USMC | SSI | REPL FACTOR | | | | | | |
| D-5 | 43 | PAOZZ | | | | | | 5307-00-227-1741 | .SWITCH BOX - CONT | | | | |
| D-5 | 44 | PAOZZ | | | | | | 5310-01-026-5824 | .STUD 13214E1223 | 97403 | EA | 1 | |
| D-5 | 45 | | | | | | | | .NUT, PLAIN, HEX MS16203-39 | 96906 | EA | 2 | |
| D-5 | 46 | PAOZZ | | | | | | 5305-00-269-3211 | .WASHER, STAR .CREW, CAP, HEX MS90725-60 | 96906 | EA | 2 | |
| D-5 | 47 | PAOZZ | | | | | | 5310-00-637-9541 | .LOCKWASHER MS35338-46 | 96906 | EA | 4 | |
| D-5 | 48 | | | | | | | | .WASHER, FLAT | 96906 | EA | 4 | |

Change 4 D-21

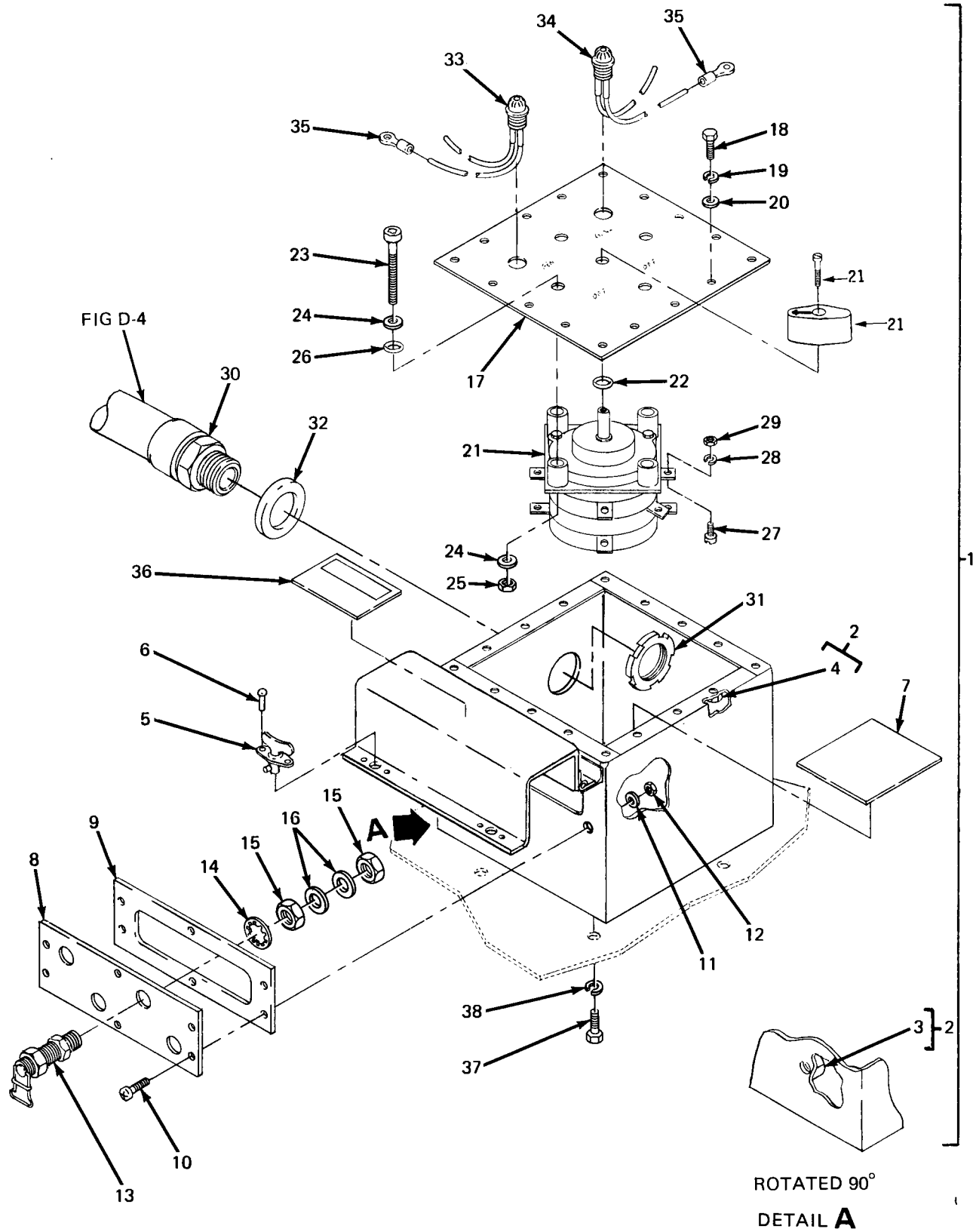

Figure D-6. Four-Wire Distribution Box.

SECTION II

ARMY TMS-6115-633-14&P

| (1) ILLUS- TRATION A FIG NO. | (2) SMR CODE B ITEM NO. | (3) A ARMY | (3) B AIR FORCE | (3) C NAVY | (3) D USMC | (3) A SSI | (3) B REPL FACTOR | (4) NATIONAL STOCK NUMBER | (5) DESCRIPTION REF NUMBER & MFR CODE | (6) USABLE ON CODE U/M | (7) QTY INC IN UNIT | (8) USMC QTY PER EQUIP |
|---|-------------------------------------|------------------|--------------------------|------------------|------------------|-----------------|----------------------------|------------------------------------|---|------------------------------------|---------------------------------|------------------------------------|
| | | | | | | | | | 0302 - DISTRIBUTION BOX | | | |
| D-6 | 1 | | | | | | | | BOX, DISTRIBUTION (FOUR-WIRE) 13220E4462 97403 | EA | 1 | |
| D-6 | 2 | | | | | | | | BOX 13220E4466 97403 | EA | 1 | |
| D-6 | 3 | PAOZZ | | | | | | | NUT, BLIND RIVET MS27130-557 96906 | EA | 4 | |
| D-6 | 4 | PAOZZ | | | | | | | NUT, BLIND RIVET MS27130-599 96906 | EA | 16 | |
| D-6 | 5 | PAOZZ | | | | | | | FASTENER, PANEL MIL-F-5591C 81349 TYPE 3A | EA | 2 | |
| D-6 | 6 | PAOZZ | | | | | | 5320-00-117-6963 | RIVET MS20426A4-6 96906 | EA | 4 | |
| D-6 | 7 | XBOZZ | | | | | | | PLATE, INFORMATION 13212E3587 97403 | EA | 1 | |
| D-6 | 8 | PAOZZ | | | | | | 5940-01-B76-1201 | BOARD, TERMINAL 13211E4775 97403 | EA | 1 | |
| D-6 | 9 | PAFZZ | | | | | | 5330-01-178-9319 | GASKET 13212E3583 97403 | EA | 1 | |
| D-6 | 10 | PAOZZ | | | | | | 5305-00-988-1727 | SCREW, MACHINE MS35206-283 96906 | EA | 6 | |
| D-6 | 11 | PAOZZ | | | | | | 5310-00-809-4058 | WASHER, FLAT MS27183-10 96906 | EA | 6 | |
| D-6 | 12 | PAOZZ | | | | | | 5310-00-088-1251 | NUT, SELF-LOCKING MS51922-1 96906 | EA | 6 | |
| D-6 | 13 | | | | | | | | POST, TERMINAL MS39347-4 96906 | EA | 4 | |
| D-6 | 14 | PAOZZ | | | | | | 5310-00-042-4229 | LOCKWASHER, INTERNAL TOOTH MS35333-113 96906 | EA | 5 | |
| D-6 | 15 | PAOZZ | | | | | | 5310-00-006-8286 | NUT, PLAIN, HEX MS16203-41 96906 | EA | 8 | |
| D-6 | 16 | PAOZZ | | | | | | 5310-01-004-9129 | WASHER, FLAT AN961-616S 81352 | EA | 11 | |
| D-6 | | PAOZZ | | | | | | 5310-00-187-2413 | WASHER, FLAT AN961-616T 81342 | EA | 11 | |
| D-6 | 17 | XBFZZ | | | | | | | COVER 13212E3579 97403 | EA | 1 | |
| D-6 | 18 | PAOZZ | | | | | | 5305-00-989-7435 | SCREW, MACHINE MS35207-264 96906 | EA | 16 | |
| D-6 | 19 | PAOZZ | | | | | | 5310-00-045-3296 | LOCKWASHER MS35338-43 96906 | EA | 16 | |
| D-6 | 20 | PAOZZ | | | | | | 5310-00-014-5850 | WASHER, FLAT MS27183-42 96906 | EA | 16 | |

D-23

SECTION II

ARMY TMS-6115-633-14&P

| (1) ILLUS- TRATION | | (2) SMR CODE | | | | (3) | | (4) | (5) DESCRIPTION | (6) | (7) | (8) |
|---------------------------------|-------------|-----------------|--------------|------|------|-----|----------------|-----------------------------|--|----------------------|--------------------------|-----------------------------|
| A | B | A | B | C | D | A | B | NATIONAL STOCK NUMBER | REF NUMBER & MFR CODE | USABLE ON CODE | QTY INC IN UNIT | USMC QTY PER EQUIP |
| FIG NO. | ITEM NO. | ARMY | AIR FORCE | NAVY | USMC | SSI | REPL FACTOR | | | U/M | | |
| 0302 - DISTRIBUTION BOX - CONT. | | | | | | | | | | | | |
| D-6 | 21 | PAFZZ | | | | | | | SWITCH, ROTARY 13205E5024 97403 | EA | 1 | |
| D-6 | 22 | PAFZZ | | | | | | 5330-00-579-7916 | PACKING, PREFORMED MS28775-115 96906 | EA | 1 | |
| D-6 | 23 | PAFZZ | | | | | | 5305-00-983-7467 | SCREW, CAP, SOCKET HEAD MS16997-149 96906 | EA | 4 | |
| D-6 | 24 | PAFZZ | | | | | | 5310-00-809-5998 | WASHER, FLAT MS27183-18 96906 | EA | 8 | |
| D-6 | 25 | PAFZZ | | | | | | 5310-00-225-6993 | NUT, SELF-LOCKING MS51922-33 96906 | EA | 4 | |
| D-6 | 26 | PAFZZ | | | | | | 5330-00-618-5361 | PACKING, PREFORMED MS28775-015 96906 | EA | 4 | |
| D-6 | 27 | PAOZZ | | | | | | 5305-01-135-7258 | SCREW, MACHINE MS35215-95 96906 | EA | 9 | |
| D-6 | 28 | PAOZZ | | | | | | 5310-00-913-9776 | LOCKWASHER MS35335-91 96906 | EA | 9 | |
| D-6 | 29 | PAOZZ | | | | | | 5310-00-411-0687 | NUT, PLAIN, HEX MS35650-3385T 96906 | EA | 9 | |
| D-6 | 30 | | | | | | | | TUBE, STUFFING 13218E5149-9 97403 | EA | 2 | |
| D-6 | 31 | PAOZZ | | | | | | 5310-01-166-6154 | WASHER 13218E5139-5 97403 | EA | 2 | |
| D-6 | 32 | PAOZZ | | | | | | 5330-01-164-2351 | GASKET 13218E5140-5 97403 | EA | 2 | |
| D-6 | 33 | PAOOO | | | | | | 6210-00-253-0688 | LIGHT AND WIRE ASSY 13212E3581-2 97403 | EA | 1 | |
| D-6 | 34 | PAOOO | | | | | | 6210-00-406-1398 | LIGHT AND WIRE ASSY 13212E3581-1 97403 | EA | 1 | |
| D-6 | 35 | PAFZZ | | | | | | | TERMINAL, LUG MS25036-105 96906 | EA | 4 | |
| D-6 | 36 | XBZZ | | | | | | | PLATE, WARNING 13216E7603 97403 | EA | 1 | |
| D-6 | 37 | PAOZZ | | | | | | 5305-00-269-3211 | SCREW, CAP, HEX MS90725-60 96906 | EA | 4 | |
| D-6 | 38 | PAOZZ | | | | | | 5310-00-637-9541 | LOCKWASHER MS35338-46 96906 | EA | 4 | |

D-24/(D-25 BLANK)

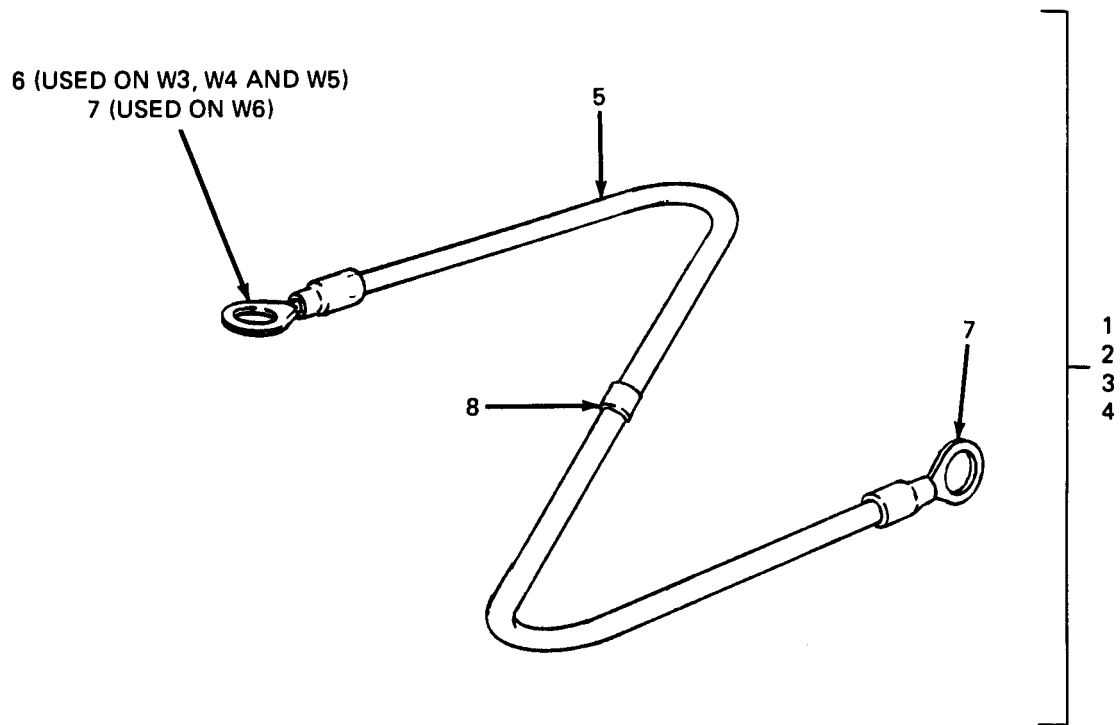

Figure D-7. Distribution Box Electrical Leads.

SECTION II

ARMY TMS-6115-633-14&P

| (1) ILLUS- TRATION | | (2) SMR CODE | | | | (3) | | | | (4) | (5) | (6) | (7) | (8) |
|--------------------------|------|-----------------|-------|------|------|-----|--------|------------------|---|--------|-----|------|-------|-----|
| A | B | A | B | C | D | A | B | NATIONAL | (5) | USABLE | | QTY | USMC | |
| FIG | ITEM | ARMY | AIR | NAVY | USMC | SSI | REPL | STOCK | DESCRIPTION | ON | U/M | INC | QTY | |
| NO. | NO. | | FORCE | | | | FACTOR | NUMBER | REF NUMBER & MFR CODE | CODE | | IN | PER | |
| | | | | | | | | | | | | UNIT | EQUIP | |
| | | | | | | | | | 0302- DISTRIBUTION BOX ELECTRICAL LEADS | | | | | |
| D-7 | 1 | MFFFF | | | | | | 6150-01-152-8315 | LEAD, ELECTRICAL (W3) 13212E3586-1 97403 | EA | | 1 | | |
| D-7 | 2 | MFFFF | | | | | | | LEAD, ELECTRICAL (W4) 13212E3586-2 97403 | EA | | 1 | | |
| D-7 | 3 | MFFFF | | | | | | | LEAD, ELECTRICAL (W5) 13212E3586-3 97403 | EA | | 1 | | |
| D-7 | 4 | MFFFF | | | | | | | LEAD, ELECTRICAL (W6) (USED ON SWITCH BOX) PN 13226E5859-1 ONLY 13212E3586-4 97403 | EA | | 1 | | |
| D-7 | 5 | PAOZZ | | | | | | | WIRE MS086/2-2 81349 | FT | | | AR | |
| D-7 | 6 | PAOZZ | | | | | | 5940-00-113-8191 | TERMINAL, LUG MS25036-127 96906 CL 1 SZ 2 | EA | | | 3 | |
| D-7 | 7 | PAFZZ | | | | | | 5940-00-113-9831 | TERMINAL, LUG MS25036-128 96906 CL 1 SZ 2 | EA | | | 5 | |
| D-7 | 8 | PAFZZ | | | | | | | TUBING, SHRINKABLE MS23053/5-108-5 81349 | EA | | | AR | |

D-27/(D-28 BLANK)

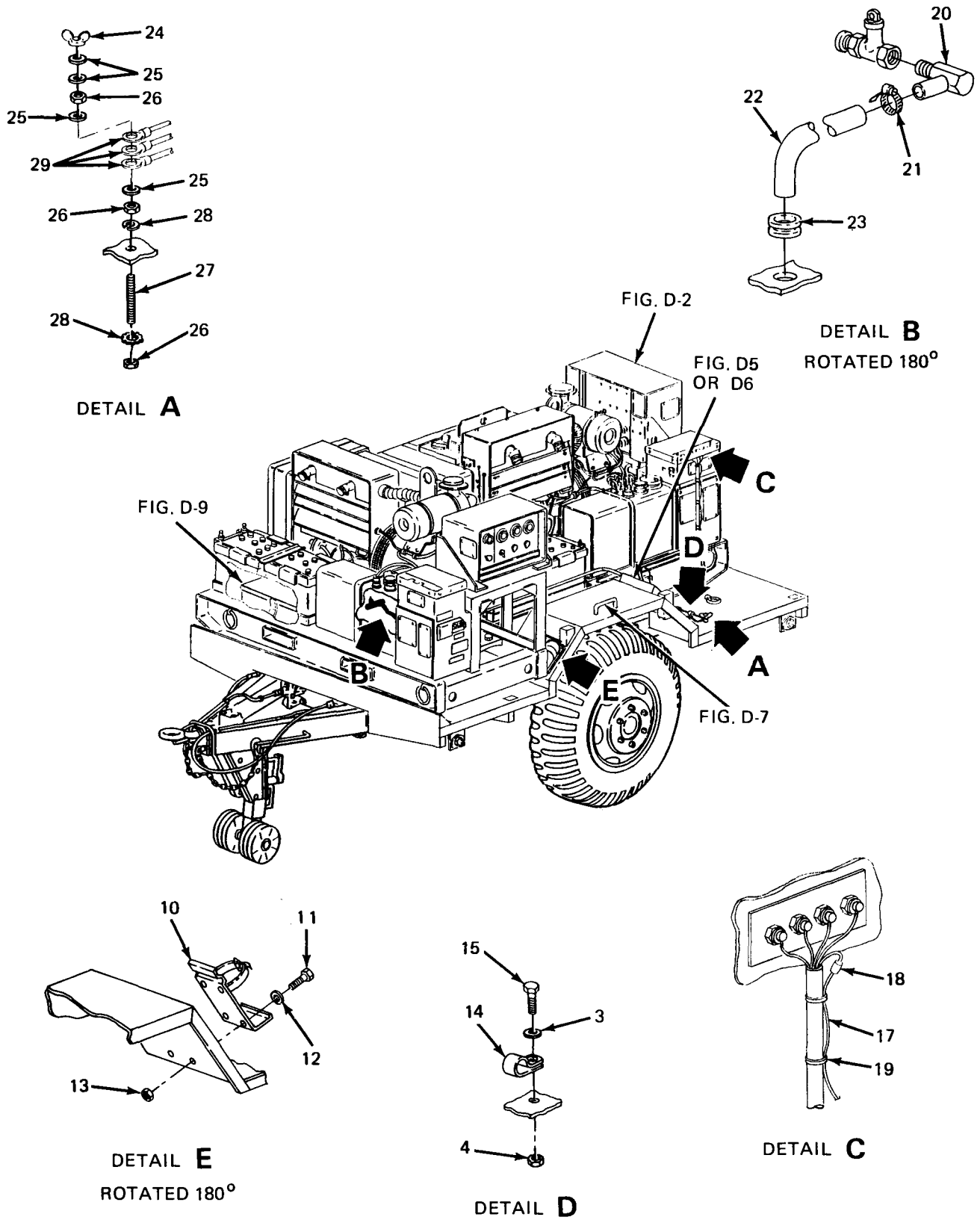

Figure D-8. Trailer Body (Sheet 1 of 2).

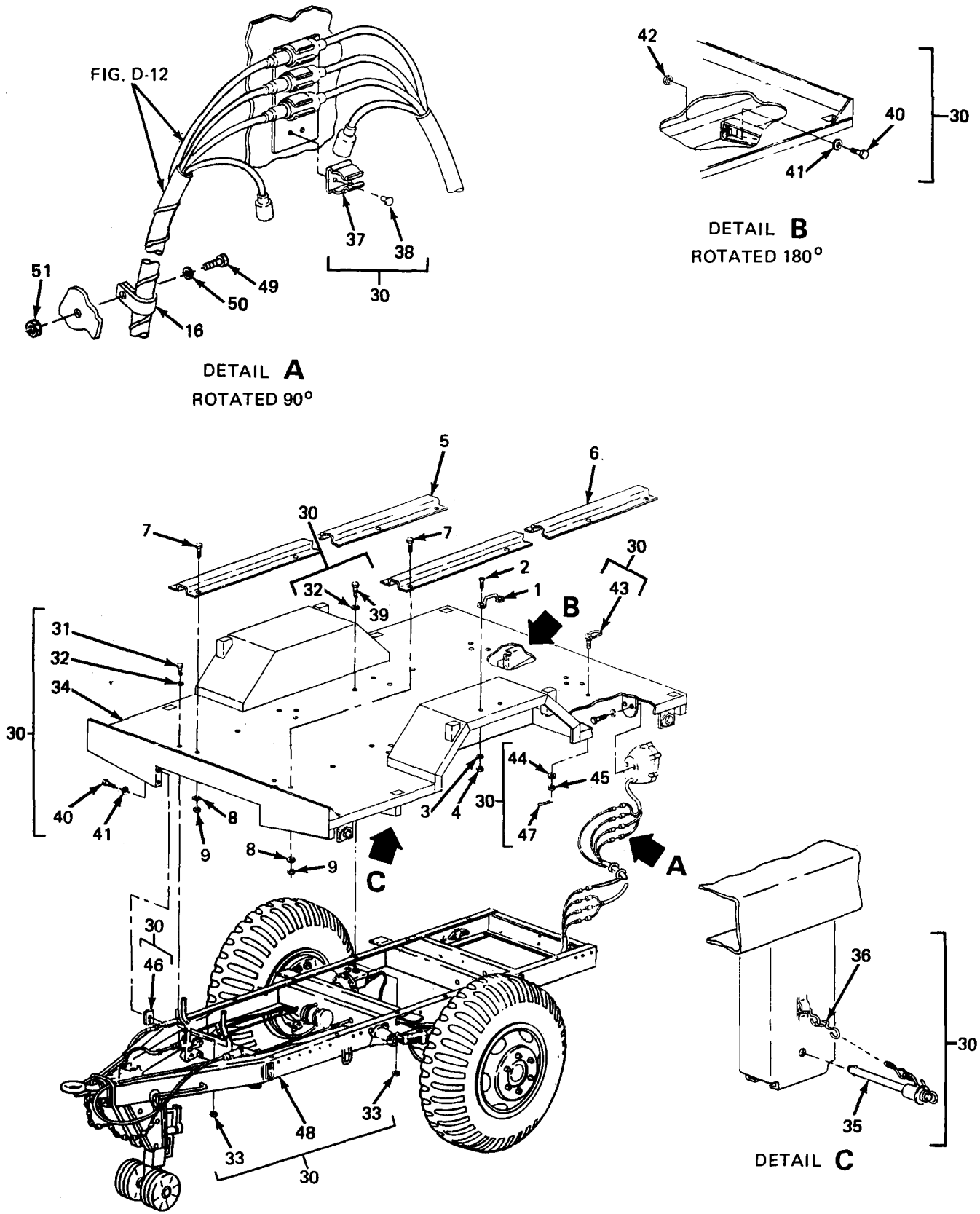

Figure D-8. Trailer Body (Sheet 2 of 2).

SECTION II

ARMY TMS-6115-633-14&P

| (1) ILLUS- TRATION A FIG NO. | B ITEM NO. | (2) SMR CODE | | | | (3) | | (4) NATIONAL STOCK NUMBER | (5) DESCRIPTION REF NUMBER & MFR CODE | (6) USABLE ON CODE U/M | (7) QTY INC IN UNIT | (8) USMC QTY PER EQUIP |
|---|------------------|-----------------|-------------------|-----------|-----------|----------|---------------------|---|--|--|---------------------------------|------------------------------------|
| | | A ARMY | B AIR FORCE | C NAVY | D USMC | A SSI | B REPL FACTOR | | | | | |
| | | | | | | | | 04 TRAILER | | | | |
| D-8 | 1 | PAOZZ | | | | | 5340-00-229-0340 | LOOP, STRAP FASTENER MS51939-3 96906 | EA | 4 | | |
| D-8 | 2 | PAOZZ | | | | | 5305-00-088-8332 | SCREW, MACHINE MS35190-272 96906 | EA | 8 | | |
| D-8 | 3 | PAOZZ | | | | | 5310-00-809-8546 | WASHER, FLAT MS27183-8 96906 | EA | 9 | | |
| D-8 | 4 | PAOZZ | | | | | | LOCK NUT FN NOT AVAILABLE | EA | 9 | | |
| D-8 | 5 | XBFZZ | | | | | | RAIL, MOUNTING, CURBSIDE 13220E4457-2 97403 | EA | 1 | | |
| D-8 | 6 | XBFFF | | | | | | RAIL, MOUNTING, ROADSIDE 13220E4458-2 97403 | EA | 1 | | |
| D-8 | 7 | XDOZZ | | | | | 5305-00-782-9495 | SCREW, CAP, HEX MS90725-111 96906 | EA | 16 | | |
| D-8 | 8 | PAFZZ | | | | | 5310-00-809-5998 | WASHER, FLAT MS27183-18 96906 | EA | 32 | | |
| D-8 | 9 | PAOZZ | | | | | 5310-00-225-6993 | NUT, SELF-LOCKING MS51922-33 96906 | EA | 16 | | |
| D-8 | 10 | XBOZZ | | | | | 4210-00-223-4857 | BRACKET, FIRE EXTINGUISHER 13214E1235 97403 | EA | 2 | | |
| D-8 | 11 | PAOZZ | | | | | 5305-00-068-0502 | SCREW, CAP, HEX MS90725-6 96906 | EA | 8 | | |
| D-8 | 12 | PAOZZ | | | | | 5310-00-809-4058 | WASHER, FLAT MS27183-10 96906 | EA | 8 | | |
| D-8 | 13 | PAOZZ | | | | | 5310-00-088-1251 | NUT, SELF-LOCKING MS51922-1 96906 | EA | 8 | | |
| D-8 | 14 | PAOZZ | | | | | 5340-00-930-1754 | CLAMP, LOOP MS21334-2 96906 | EA | 2 | | |
| D-8 | 15 | PAOZZ | | | | | 5305-00-984-6202 | SCREW, MACHINE MS35206-264 96906 | EA | 1 | | |
| D-8 | 16 | | | | | | | CLAMP, CABLE FN NOT AVAILABLE | EA | 2 | | |
| D-8 | 17 | PAOZZ | | | | | | WIRE, NO. 6 AWG QQ-W-343C06B1B 81348 | FT | AR | | |
| D-8 | 18 | PAOZZ | | | | | 5970-00-914-3118 | SLEEVING, INSULATION M23053/5-109-0 81349 | EA | AR | | |
| D-8 | 19 | PAOZZ | | | | | | STRAP, TIEDOWN MS3367-1-1 96906 TY 1 CL 1 | EA | AR | | |
| D-8 | 20 | PAOZZ | | | | | 4730-00-809-9703 | ELBOW, PIPE TO HOSE MS24519-9 96906 | EA | 2 | | |
| D-8 | 21 | PAOZZ | | | | | 4730-00-908-3194 | CLAMP, HOSE MS35842-11 96906 | EA | 2 | | |

SECTION II

ARMY TMS-6115-633-14&P

| (1) ILLUS- TRATION | | (2) SMR CODE | | | | (3) | | (4) | | (5) DESCRIPTION | | (6) | (7) | (8) |
|--------------------------|------|-----------------|-------|------|------|-----|--------|------------------|--|---|--------|------|-------|-----|
| A | B | A | B | C | D | A | B | NATIONAL | | REF NUMBER | USABLE | QTY | USMC | |
| FIG | ITEM | ARMY | AIR | NAVY | USMC | SSI | REPL | STOCK | | & MFR CODE | ON | INC | QTY | |
| NO. | NO. | | FORCE | | | | FACTOR | NUMBER | | | CODE | IN | PER | |
| | | | | | | | | | | | U/M | UNIT | EQUIP | |
| | | | | | | | | | | 04 TRAILER - CONT. | | | | |
| D-8 | 22 | | | | | | | | | HOSE, RUBBER MIL-H-6000 81349 | EA | 2 | | |
| D-8 | 23 | PAOZZ | | | | | | 5325-00-903-5909 | | GROMMET MS35489-112 96906 | EA | 2 | | |
| D-8 | 24 | PAOZZ | | | | | | 5310-00-543-4717 | | NUT, PLAIN WING MS35425-28 96906 | EA | 1 | | |
| D-8 | 25 | PAOZZ | | | | | | 5310-01-004-9129 | | WASHER, FLAT AN961-6165 81352 | EA | 4 | | |
| | | PAOZZ | | | | | | 5310-00-187-2413 | | WASHER, FLAT AN961-616T 88044 | EA | 4 | | |
| D-8 | 26 | PAOZZ | | | | | | 5310-01-026-5824 | | NUT, PLAIN, HEX MS16203-39 96906 | EA | 3 | | |
| D-8 | 27 | PAOZZ | | | | | | 5307-00-227-1741 | | STUD 13214E1223 97403 | EA | 1 | | |
| D-8 | 28 | PAOZZ | | | | | | | | WASHER, STAR PN NOT AVAILABLE | EA | 2 | | |
| D-8 | 29 | PAOZZ | | | | | | 5940-00-115-4992 | | TERMINAL, LUG MS20659-110 96906 TY 1 CL 1 | EA | 6 | | |
| D-8 | 30 | XBFHD | | | | | | | | TRAILER ASSY 13226E5858 97403 | EA | 1 | | |
| D-8 | 31 | PAOZZ | | | | | | 5805-01-186-7145 | | SCREW, CAP, HEX 13218E0021-41 97403 | EA | 4 | | |
| D-8 | 32 | PAOZZ | | | | | | 5310-00-823-8803 | | WASHER, FLAT MS27183-21 96906 | EA | 44 | | |
| D-8 | 33 | PAOZZ | | | | | | 5310-00-269-4040 | | NUT, SELF-LOCKING MS51922-49 96906 | EA | 22 | | |
| D-8 | 34 | XAFFF | | | | | | | | FLATBED, TRAILER 13226E5857 97403 | EA | 1 | | |
| D-8 | 35 | PAOZZ | | | | | | 5340-01-126-3826 | | PIN, QUICK-RELEASE MS17990C613 96906 | EA | 12 | | |
| D-8 | 36 | PAOZZ | | | | | | 4010-01-B75-1772 | | CHAIN, WELDLESS 13218E0025-4 97403 | EA | 12 | | |
| D-8 | 37 | PBFZZ | | | | | | | | CLIP, SPRING TENSION M24066/2-128 | EA | 8 | | |
| D-8 | 38 | PAFZZ | | | | | | 5320-00-637-6068 | | RIVET, SOLID MS20427-4C5 96906 | EA | 16 | | |
| D-8 | 39 | PAOZZ | | | | | | 5305-00-724-5911 | | SCREW, CAP, HEX MS90725-163 96906 | EA | 18 | | |
| D-8 | 40 | PAOZZ | | | | | | 5305-00-269-3211 | | SCREW, CAP, HEX MS90725-60 96906 | EA | 16 | | |
| D-8 | 41 | PAOZZ | | | | | | 5310-00-080-6004 | | WASHER, FLAT MS27183-14 96906 | EA | 28 | | |

SECTION II

ARMY TMS-6115-633-14&P

| (1) ILLUS- TRATION | | (2) SMR CODE | | | | (3) | | (4) | (5) DESCRIPTION | (6) | (7) | (8) |
|--------------------------|-------------|-----------------|--------------|------|------|-----|----------------|-----------------------------|---------------------------------------|----------------------|--------------------------|-----------------------------|
| A | B | A | B | C | D | A | B | NATIONAL STOCK NUMBER | REF NUMBER & MFR CODE | USABLE ON CODE | QTY INC IN UNIT | USMC QTY PER EQUIP |
| FIG NO. | ITEM NO. | ARMY | AIR FORCE | NAVY | USMC | SSI | REPL FACTOR | | | | U/M | |
| | | | | | | | | | 04 TRAILER - CONT. | | | |
| D-8 | 42 | PAOZZ | | | | | | 5310-00-087-4652 | NUT, SELF-LOCKING MS51922-17 96906 | EA | 12 | |
| D-8 | 43 | PAOZZ | | | | | | | RING, LIFTING 13226E7730-6 97403 | EA | 2 | |
| D-8 | 44 | PAOZZ | | | | | | 5310-00-584-7888 | WASHER MS35338-51 96906 | EA | 2 | |
| D-8 | 45 | PAOZZ | | | | | | 5310-00-832-9719 | NUT, SELF-LOCKING MS51922-61 96906 | EA | 2 | |
| D-8 | 46 | PAFZZ | | | | | | 5365-01-B75-1770 | SHIM 13212E3590-2 97403 | EA | AR | |
| D-8 | 47 | | | | | | | | PIN, COTTER PN NOT AVAILABLE | EA | 2 | |
| D-8 | 48 | XBFHH | | | | | | | CHASSIS, TRAILER 13226E7734 97403 | EA | 1 | |
| D-8 | 49 | | | | | | | | SCREW, DRIVE PN NOT AVAILABLE | EA | 2 | |
| D-8 | 50 | | | | | | | | WASHER, FLAT PN NOT AVAILABLE | EA | 2 | |
| D-8 | 51 | | | | | | | | NUT, SELF-LOCKING PN NOT AVAILABLE | EA | 2 | |

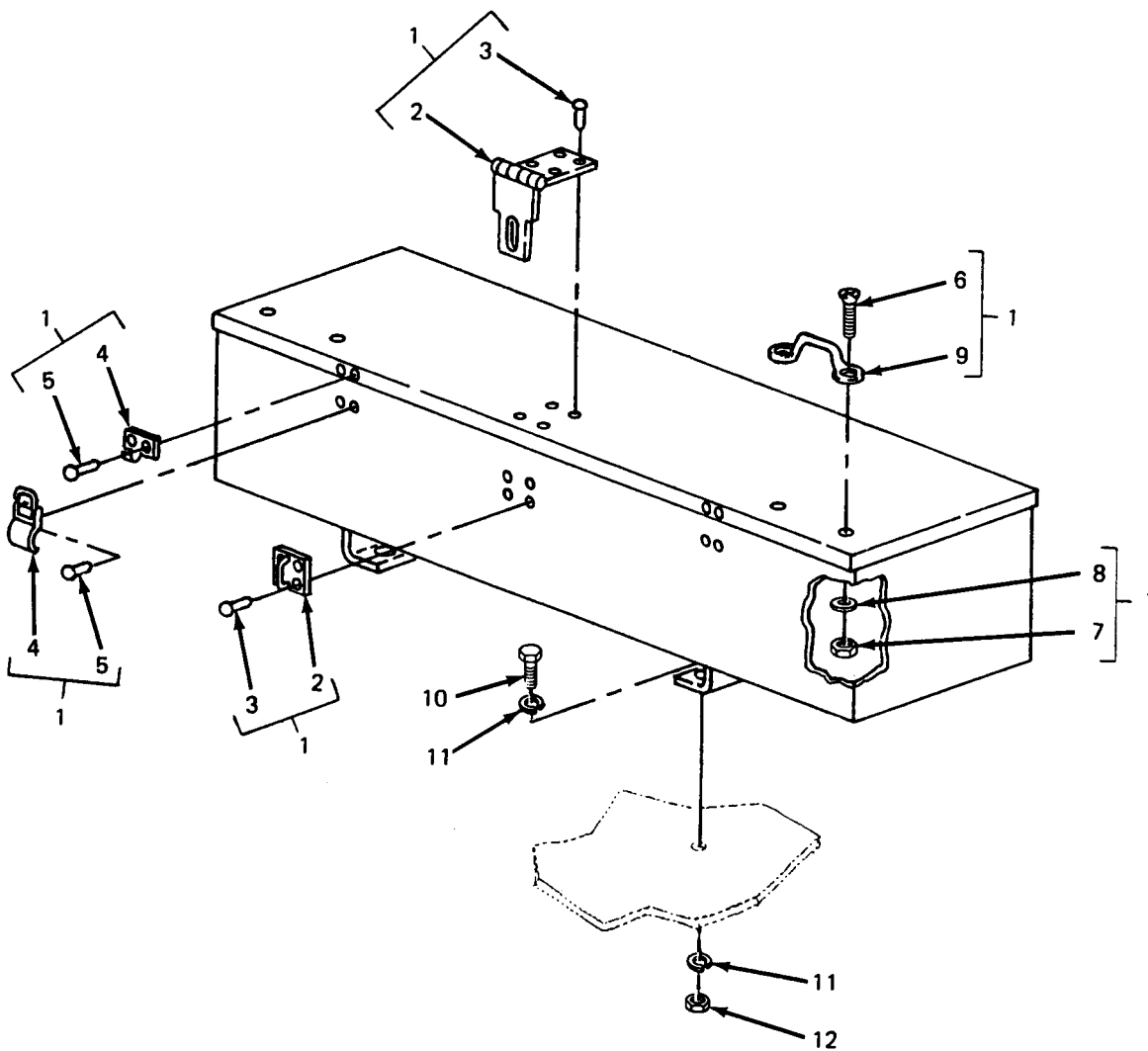

Figure D-9. Accessory Box.

SECTION II

ARMY TMS-6115-633-14&P

| (1) ILLUS- TRATION | | (2) SMR CODE | | | | (3) | | (4) | (5) DESCRIPTION | (6) | (7) | (8) |
|--------------------------|-------------|-----------------|--------------|------|------|-----|----------------|-----------------------------|---|----------------------|--------------------------|-----------------------------|
| A | B | A | B | C | D | A | B | NATIONAL STOCK NUMBER | REF NUMBER & MFR CODE | USABLE ON CODE | QTY INC IN UNIT | USMC QTY PER EQUIP |
| FIG NO. | ITEM NO. | ARMY | AIR FORCE | NAVY | USMC | SSI | REPL FACTOR | | | U/M | | |
| | | | | | | | | | 0401 - ACCESSORY BOX | | | |
| D-9 | 1 | PBOOO | | | | | | 6115-01-230-0677 | BOX, ACCESSORY 13226E7737 97403 | EA | 1 | |
| D-9 | 2 | PAOZZ | | | | | | 5340-00-234-8422 | HASP, HINGED MS27969-4 96906 | EA | 1 | |
| D-9 | 3 | PAOZZ | | | | | | 5320-01-168-3097 | RIVET, SOLID MS9460-102 96906 | EA | 8 | |
| D-9 | 4 | PAOZZ | | | | | | 5340-00-975-2126 | CATCH, CLAMPING AND STRIKE MS18015-1 96906 | EA | 2 | |
| D-9 | 5 | PAOZZ | | | | | | 5320-00-753-3830 | RIVET, SOLID MS20613-4P5 96906 | EA | 8 | |
| D-9 | 6 | PAOZZ | | | | | | 5305-00-957-7086 | SCREW, MACHINE MS24693-S273 96906 | EA | 4 | |
| D-9 | 7 | PAOZZ | | | | | | 5310-00-059-9263 | NUT, SELF-LOCKING MS21046C3 96906 | EA | 4 | |
| D-9 | 8 | PAOZZ | | | | | | 5310-00-014-5850 | WASHER, FLAT MS27183-42 96906 | EA | 4 | |
| D-9 | 9 | PAOZZ | | | | | | 5340-00-229-0340 | LOOP, STRAP FASTENER MS51939-3 96906 | EA | 2 | |
| D-9 | 10 | PAOZZ | | | | | | 5306-00-225-8496 | SCREW, CAP, HEX MS90725-31 96906 | EA | 4 | |
| D-9 | 11 | PAOZZ | | | | | | 5310-00-407-9566 | LOCKWASHER MS35338-45 96906 | EA | 8 | |
| D-9 | 12 | PAOZZ | | | | | | 5310-00-880-7744 | NUT, PLAIN, HEX MS51967-5 96906 | EA | 4 | |

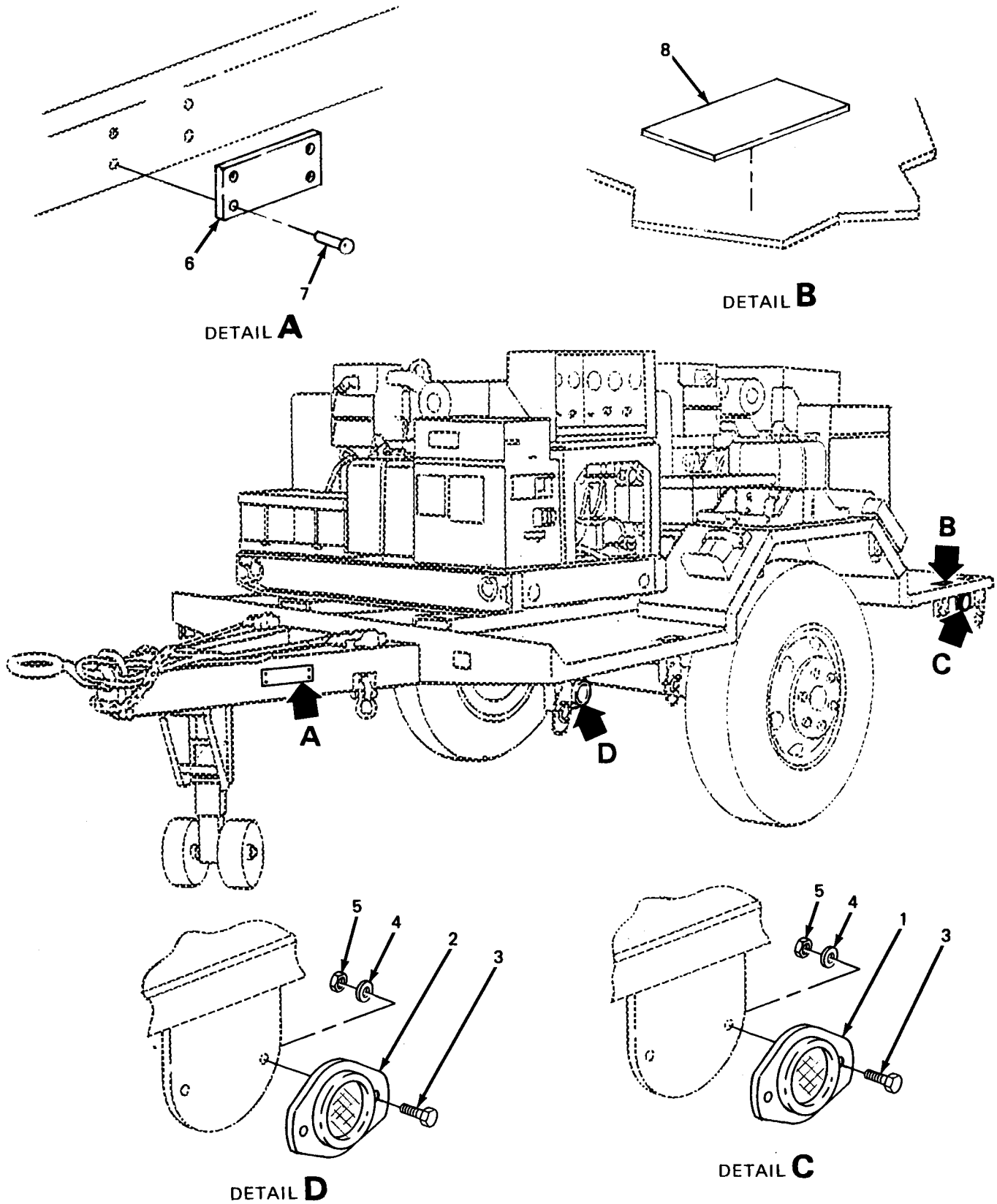

Figure D-10. Data Plates and Reflectors.

SECTION II

ARMY TMS-6115-633-14&P

| (1) ILLUS- TRATION | | (2) SMR CODE | | | | (3) | | (4) | (5) | (6) | (7) | (8) |
|--------------------------|------|-----------------|-------|------|------|-----|--------|------------------|---|--------|------|-------|
| A | B | A | B | C | D | A | B | NATIONAL | DESCRIPTION | USABLE | QTY | USMC |
| FIG | ITEM | ARMY | AIR | NAVY | USMC | SSI | REPL | STOCK | REF NUMBER | ON | INC | QTY |
| NO. | NO. | | FORCE | | | | FACTOR | NUMBER | & MFR CODE | CODE | IN | PER |
| | | | | | | | | | | U/M | UNIT | EQUIP |
| | | | | | | | | | 0402 - DATA PLATES AND REFLECTORS | | | |
| D-10 | 1 | PAOZZ | | | | | | 9905-00-205-2795 | REFLECTOR, RED MS35387-1 96906 | EA | | 4 |
| D-10 | 2 | PAOZZ | | | | | | 9905-00-202-3639 | REFLECTOR, AMBER MS35387-2 96906 | EA | | 2 |
| D-10 | 3 | PAOZZ | | | | | | 5305-00-068-0500 | SCREW, CAP, HEX MS90725-3 96906 | EA | | 12 |
| D-10 | 4 | PAOZZ | | | | | | 5310-00-809-4058 | WASHER, FLAT MS27183-10 96906 | EA | | 12 |
| D-10 | 5 | PAOZZ | | | | | | 5310-00-088-1251 | NUT, SELF-LOCKING MS51922-1 96906 | EA | | 12 |
| D-10 | 6 | XBOZZ | | | | | | | PLATE, IDENTIFICATION 13220E4463-2 97403 | EA | | 1 |
| D-10 | 7 | PAOZZ | | | | | | | RIVET FN NOT AVAILABLE | EA | | 4 |
| D-10 | 8 | PAOZZ | | | | | | 9905-01-085-7703 | PLATE, IDENTIFICATION 13205E4918 97403 | EA | | 1 |

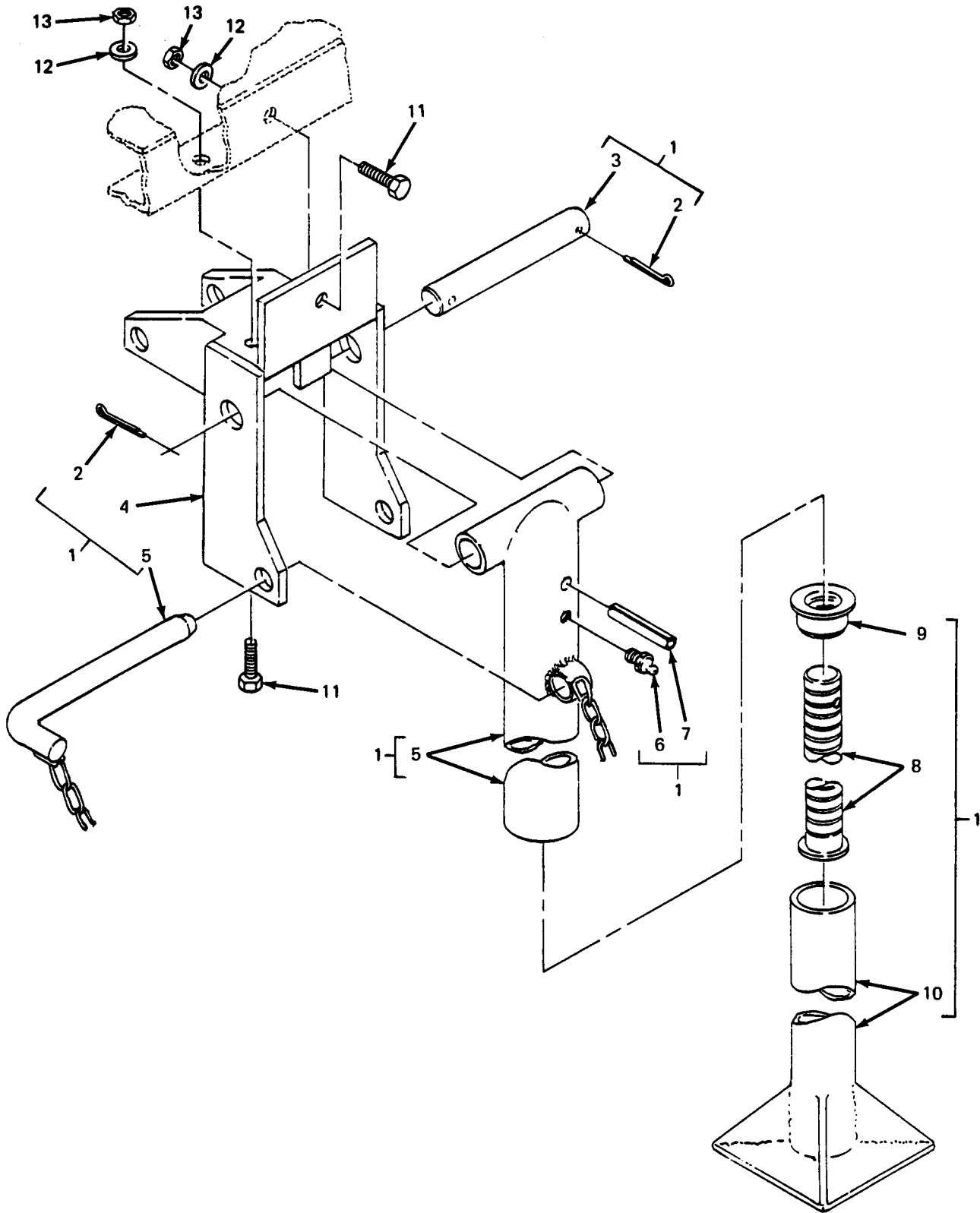

Figure D-11. Leg Prop Assembly.

SECTION II

ARMY TM5-6115-633-14&P

| (1) ILLUS- TRATION | | (2) SMR CODE | | | | (3) USMC | | (4) | (5) DESCRIPTION | (6) | (7) | (8) | |
|--------------------------|-------------|-----------------|--------------|------|------|-------------|----------------|-----------------------------|---|----------------------|-----|--------------------------|-----------------------------|
| A | B | A | B | C | D | A | B | NATIONAL STOCK NUMBER | REF NUMBER & MFR CODE | USABLE ON CODE | U/M | QTY INC IN UNIT | USMC QTY PER EQUIP |
| FIG NO. | ITEM NO. | ARMY | AIR FORCE | NAVY | USMC | SSI | REPL FACTOR | | | | | | |
| | | | | | | | | | 0403 LEG PROP | | | | |
| D-11 | 1 | XBFFZ | | | | | | 2950-00-420-8929 | LEG PROP ASSEMBLY 13214E1206 97403 | | EA | 1 | |
| D-11 | 2 | PAOZZ | | | | | | 5315-00-839-5822 | PIN, COTTER MS24665-353 96906 | | EA | 2 | |
| D-11 | 3 | XBOZZ | | | | | | 5315-01-162-0143 | SHAFT 13214E1209 97403 | | EA | 1 | |
| D-11 | 4 | XBOZZ | | | | | | 6115-01-220-1548 | BRACKET 13214E1207 97403 | | EA | 1 | |
| D-11 | 5 | XBOZZ | | | | | | 2590-00-453-8977 | LEG, UPPER 13214E1208 97403 | | EA | 1 | |
| D-11 | 6 | PAOZZ | | | | | | 4730-00-172-0049 | FITTING, LUBRICATION MS15006-1 96906 | | EA | 1 | |
| D-11 | 7 | XBOZZ | | | | | | 5315-00-838-4584 | PIN, SPRING MS16562-66 96906 | | EA | 1 | |
| D-11 | 8 | XBOZZ | | | | | | 5315-01-158-2144 | SCREW 13214E1210 | | EA | 1 | |
| D-11 | 9 | PAOZZ | | | | | | 5310-01-149-0869 | NUT 13214E1211 97403 | | EA | 1 | |
| D-11 | 10 | XBOZZ | | | | | | 2590-01-167-8596 | BASE, LEG 13214E1212 97403 | | EA | 1 | |
| D-11 | 11 | PAOZZ | | | | | | 5305-00-269-3213 | SCREW, CAP, HEX MS90725-62 96906 | | EA | 3 | |
| D-11 | 12 | PAOZZ | | | | | | 5310-00-080-6004 | WASHER, FLAT MS27183-14 96906 | | EA | 6 | |
| D-11 | 13 | PAOZZ | | | | | | 5310-00-087-4652 | NUT, SELF-LOCKING MS51922-17 | | EA | 3 | |

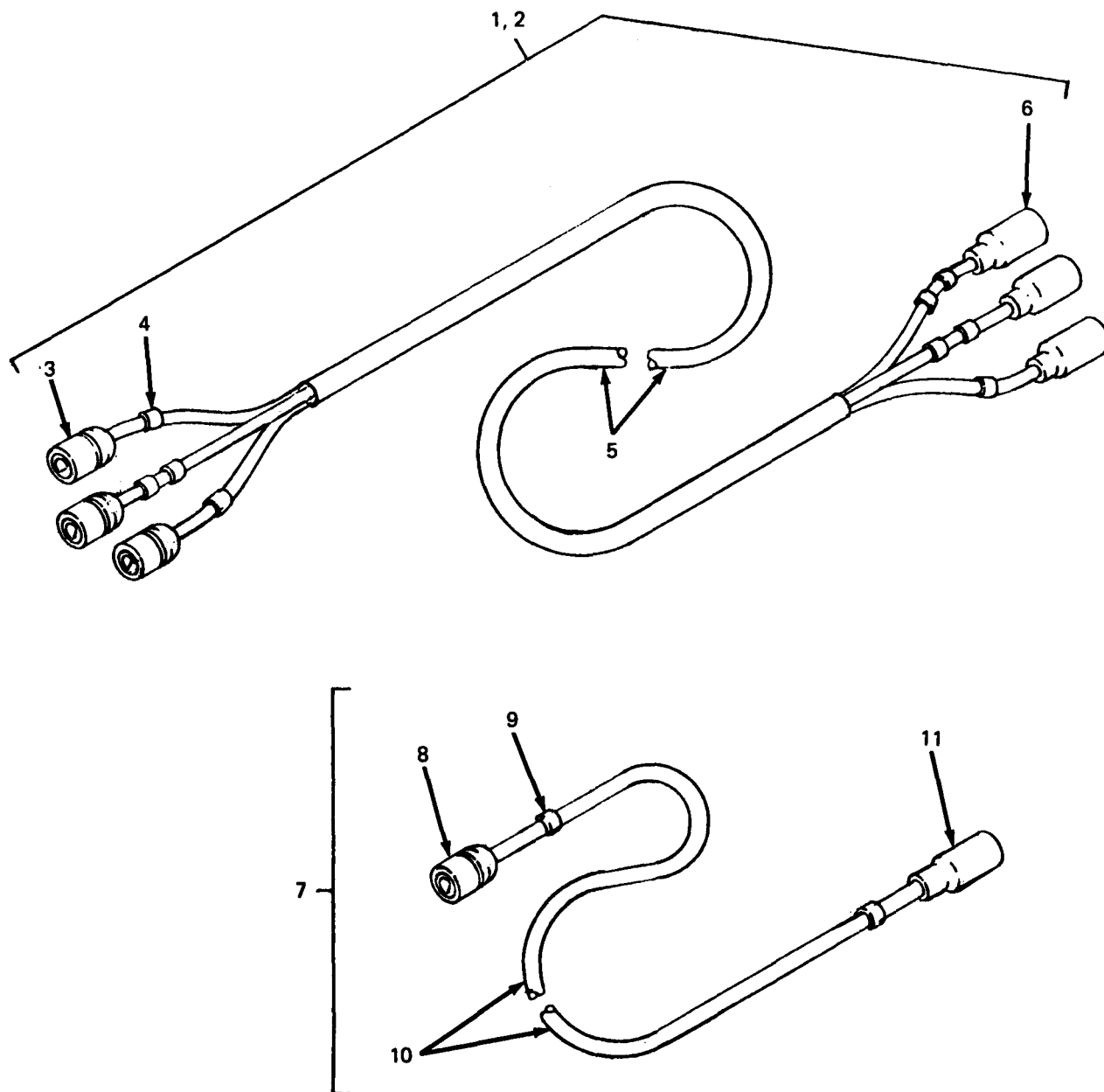

Figure D-12. Taillight Cable Assembly and Electrical Lead.

SECTION II

| (1) ILLUS- TRATION | | (2) SMR CODE | | | | (3) USMC | | (4) | (5) DESCRIPTION | (6) | (7) | (8) |
|--------------------------|-------------|-----------------|--------------|------|------|-------------|----------------|--|----------------------|-----|--------------------------|-----------------------------|
| a | b | a | b | c | d | a | b | NATIONAL STOCK NUMBER | USABLE ON CODE | U/M | QTY INC IN UNIT | USMC QTY PER EQUIP |
| FIG NO. | ITEM NO. | ARMY | AIR FORCE | NAVY | USMC | SSI | REPL FACTOR | REF NUMBER & MFR CODE | | | | |
| | | | | | | | | 0404 - Taillight Cable Assemblies and Electrical Lead | | | | |
| D-12 | 1 | PBOFF | | | | | | 6150-01-166-9112 CABLE ASSY ROADSIDE 13216E7479-1 | 97403 | EA | 1 | |
| D-12 | 2 | MOOFF | | | | | | 6150-01-166-9111 .CABLE ASSY, CURBSIDE 13216E7479-2 | 97403 | EA | 1 | |
| D-12 | 3 | PAOZZ | | | | | | 5935-00-167-7775 .CONNECTOR, PLUG MS2714- 1 | 96906 | EA | 6 | |
| D-12 | 4 | PAOZZ | | | | | | 9905-01-B75-1051 .BAND, MARKER M434361-66 | 81349 | EA | 20 | |
| D-12 | 5 | MFFZZ | | | | | | .CABLE M 13486/7-1 TYPE I CL B | 81349 | EA | 2 | |
| D-12 | 6 | PAOZZ | | | | | | 5935-00-462-6603 .CONNECTOR, PLUG M827142-2 | 96906 | EA | 6 | |
| D-12 | 7 | MOOFF | | | | | | 6150-01-166-9135 .LEAD, ELECTRICAL 13216E7476 | 97403 | EA | 2 | |
| D-12 | 8 | PAOZZ | | | | | | 5935-00-167-7775 .CONNECTOR, PLUG MS27144-1 STYLE 1 | 9690M | EA | 2 | |
| D-12 | 9 | PAOZZ | | | | | | 9905-01-B75-1051 .BAND, MARKER MA3436/1-6 | 81349 | EA | 4 | |
| D-12 | 10 | PAOZZ | | | | | | 6145-00-152-6499 .CABLE M13486/1-5 TYPE I CL A | 81349 | EA | 2 | |
| D-12 | 11 | PAOZZ | | | | | | 5935-00-462-6603 .CONNECTOR PLUG US27142-2 | 96906 | EA | 2 | |

Section III SPECIAL TOOLS, TEST AND SUPPORT EQUIPMENT
Not Applicable

Section IV. NATIONAL STOCK NUMBER AND REFERENCE NUMBER INDEX

| NSN | Figure No. | Item No. | | | |
|------------------|------------|----------|------------------|------|----|
| 2540-00-924-8478 | D-1 | 9 | 5310-00-411-0687 | D-5 | 29 |
| 2540-00-926-1003 | D-1 | 10 | | D-6 | 29 |
| 2590-00-420-8929 | D-11 | 1 | 5310-00-543-4717 | D-8 | 24 |
| 2590-00-453-8977 | D-11 | 5 | 5310-00-584-5272 | D-2 | 3 |
| 2590-01-167-8596 | D-11 | 10 | 5310-00-584-7888 | D-8 | 44 |
| 4010-00-875-1772 | D-8 | 36 | 5310-00-584-7995 | D-5 | 42 |
| 4210-00-223-4857 | D-8 | 10 | 5310-00-637-9541 | D-5 | 47 |
| 4730-00-172-0049 | D-11 | 6 | | D-6 | 38 |
| 4730-00-809 9703 | D-8 | 20 | 5310-00-809-4058 | D-5 | 9 |
| 4730-00-908-3194 | D-8 | 21 | | D-6 | 11 |
| 5305-00-068-0500 | D-10 | 3 | | D-8 | 12 |
| 5305-00-068-0502 | D-8 | 11 | 5310-00-809-5998 | D-10 | 4 |
| 5305-00-088-8332 | D-8 | 2 | | D-5 | 24 |
| 5305-00-269-3211 | D-5 | 46 | | D-6 | 24 |
| | D-6 | 37 | 5310-00-809-8546 | D-8 | 8 |
| 5305-00-269-3213 | D-11 | 11 | 5310-00-823-8803 | D-8 | 3 |
| 5305-00-719-5235 | D-2 | 2 | 5310-00-832-9719 | D-8 | 32 |
| 5305-00-724-5911 | D-8 | 39 | 5310-00-880-774 | D-8 | 45 |
| 5305-00-782-9495 | D-8 | 7 | 5310-00-913-9776 | D-9 | 12 |
| 5305-00-957-7086 | D-9 | 6 | 5310-01-004-9129 | D-6 | 28 |
| 5305-00-983-7467 | D-5 | 23 | | D-5 | 14 |
| | D-6 | 23 | 5310-01-026-5824 | D-6 | 16 |
| 5305-00-984-6202 | D-8 | 15 | | D-8 | 25 |
| 5305-00-988-1727 | D-5 | 8 | 5310-01-078-5996 | D-5 | 44 |
| | D-6 | 10 | 5310-01-149-0869 | D-8 | 26 |
| 5305-00-989-7435 | D-5 | 17 | 5310-01-150-5922 | D-5 | 39 |
| | D-6 | 18 | 5310 01-166-6154 | D-11 | 7 |
| 5305-01-135-7258 | D-5 | 27 | | D-2 | 5 |
| | D-6 | 27 | 5315-00-838-4584 | D-5 | 31 |
| 5306-00-225-8496 | D-9 | 10 | 5315-00-839-5822 | D-6 | 31 |
| 5307-00-227-1741 | D-5 | 43 | 5315-01-158-2144 | D-11 | 7 |
| | D-8 | 27 | 5315-01-162-0143 | D-11 | 2 |
| 5310-00-006-8288 | D-5 | 13 | 5320-00-117-6963 | D-11 | 8 |
| | D-6 | 15 | 5320-00-637-6068 | D-11 | 3 |
| 5310-00-014-5850 | D-5 | 19 | 5320-00-721-5239 | D-6 | 6 |
| | D-6 | 20 | 5320-00-753-3830 | D-8 | 38 |
| 5310-00-442-4229 | D-9 | 8 | 5320-01-168-3097 | D-5 | 37 |
| 5310-00-045-3296 | D-6 | 14 | 5325-00-903-5909 | D-9 | 5 |
| | D-5 | 18 | 5330-00-579-7916 | D-9 | 3 |
| | D-6 | 19 | | D-8 | 23 |
| 5310-00-059-9263 | D-9 | 7 | 5330-00-618-5361 | D-5 | 22 |
| 5310-00-080-6004 | D-8 | 41 | | D-6 | 22 |
| | D-11 | 12 | 5330-01-164-2351 | D-5 | 26 |
| 5310-00-087-4652 | D-8 | 42 | | D-6 | 26 |
| | D-11 | 12 | 5330-01-178-9319 | D-5 | 32 |
| 5310-00-088-1251 | D-5 | 10 | | D-6 | 32 |
| | D-6 | 12 | 5340-00-057-6958 | D-5 | 7 |
| | D-8 | 13 | 5340-00-078-7029 | D-6 | 9 |
| | D-10 | 5 | 5340-00-229-0340 | D-1 | 5 |
| 5310-00-184-8971 | D-5 | 40 | | D-1 | 4 |
| 5310-00-187-2413 | D-5 | 14 | 5340-00-234-8422 | D-8 | 1 |
| | D-5 | 41 | 5340-00-930-1754 | D-9 | 9 |
| | D-8 | 16 | 5340-00-975-2126 | D-9 | 2 |
| | D-8 | 25 | | D-8 | 14 |
| 5310-00-225-6993 | D-5 | 25 | | D-9 | 4 |
| | D-6 | 25 | | | |
| | D-8 | 9 | | | |

Change 4 D-43

| NSN | Figure No. | Item No. |
|------------------|------------|----------|
| 5310-00-269-4040 | D-8 | 33 |
| 5310-00-407-9566 | D-9 | 11 |

Section IV. NATIONAL STOCK NUMBER AND REFERENCE NUMBER INDEX

| NSN | Figure No. | Item No. | | | |
|------------------|------------|----------|------------------|------|-----|
| 5340-01-126-3826 | D-8 | 35 | 6120-00-253-0688 | D-5 | 33 |
| 5365-01-B75-1770 | D-8 | 46 | 6120-00-406-1398 | D-5 | 34 |
| 5365-01-031-9674 | D-1 | 7 | 6145-00-153-6499 | D-12 | 10 |
| 5490-00-113-8191 | D-4 | 6 | 6150-01-B76-1221 | D-3 | 2 |
| 5490-00-113-9831 | D-4 | 7 | 6150-01-152-8315 | D-7 | 1 |
| 5805-01-186-7145 | D-8 | 31 | 6150-01-166-9111 | D-12 | 2 |
| 5935-00-167-7775 | D-12 | 3 | 6150-01-166-9112 | D-12 | 1 |
| | D-12 | 8 | 6150-01-166-9135 | D-12 | 7 |
| 5935-00-462-6603 | D-12 | 6 | 6210-00-253-0688 | D-5 | 33 |
| | D-12 | 11 | | D-6 | 33 |
| 5940-00-113-8184 | D-5 | 33G | 6210-00-406-1398 | D-5 | 34 |
| 5940-00-113-8191 | D-7 | 6 | | D-6 | 34 |
| 5940-00-113-9831 | D-7 | 7 | 6210-00-900-9423 | D-5 | 33A |
| 5940-00-113-9833 | D-3 | 6 | | D-5 | 34A |
| 5940-00-115-4992 | D-8 | 29 | 6210-00-941-6690 | D-5 | 33D |
| 5940-00-115-5007 | D-3 | 5 | | D-5 | 34D |
| 5940-00-B76-1201 | D-5 | 6 | 6210-01-230-1851 | D-5 | 33B |
| | D-6 | 8 | | D-5 | 34B |
| 5970-00-914-3118 | D-8 | 18 | 9905-00-202-3639 | D-10 | 2 |
| 6115-00-465-1030 | D-2 | 1 | 9905-00-205-2795 | D-10 | 1 |
| 6115-01-B76-1197 | D-5 | 2 | 9905-01-B75-1051 | D-12 | 4 |
| 6115-01-206-1271 | D-1 | 1 | | D-12 | 9 |
| 6115-01-220-1548 | D-11 | 4 | 9905-01-085-7703 | D-10 | 8 |
| 6115-01-230-0677 | D-9 | 1 | | | |

D-44 Change 4

| NSN | Figure No. | Item No. |
|-----|------------|----------|
|-----|------------|----------|

Section IV. NATIONAL STOCK NUMBER AND REFERENCE - CONT

| Reference Number | FSCM | Fig. No. | Item No. | Number | FSCM | No. | No. |
|-------------------------|-------|----------|----------|------------------|-------|------|-----|
| AN961-616S | 81352 | D-5 | 14 | | | D-6 | 11 |
| | | D-6 | 16 | MS27183-14 | 96906 | D-8 | 12 |
| | | D-8 | 25 | | | D-10 | 4 |
| AN961-616S | 81352 | D-5 | 41 | MS27183-18 | 96906 | D-8 | 41 |
| AN961-616T | 81352 | D-5 | 16 | | | D-11 | 12 |
| | | D-6 | 14 | | | D-5 | 24 |
| | 88044 | D-5 | 14 | | | D-6 | 24 |
| | | D-8 | 25 | MS27183-21 | 96906 | D-8 | 8 |
| CO-04HDF-(4/1-4/8R)1620 | 81349 | D-3 | 3 | MS27183-42 | 96906 | D-5 | 32 |
| CO-04H E (42)1480 | 81349 | D-4 | 3 | | | D-6 | 19 |
| G9B(GR) | 73070 | D-5 | 33C | | | D-9 | 20 |
| | | D-5 | 34C | MS27969-4 | 96906 | D-9 | 8 |
| MEP-003A | 30554 | D-2 | 1 | MS28775-015 | 96906 | D-5 | 2 |
| MIL-G-16491D | 81349 | D-1 | 3 | | | D-6 | 26 |
| MIL-H-6000 | 81349 | D-7 | 22 | MS28775-115 | 96906 | D-5 | 26 |
| MIL-I-230535 CLASS 1 | 81349 | D-4 | 4 | | | D-6 | 22 |
| | | D-4 | 5 | MS3367-1 TY1 CL1 | 96906 | D-8 | 19 |
| MIL-P-15024/8 TYPE K2 | 81349 | D-3 | 4 | MS35190-272 | 96906 | D-8 | 2 |
| MIL-S-15291/12 | | D-5 | 20 | MS35206-264 | 96906 | D-8 | 15 |
| MIL-S-3770/1 -SWZE3 | 81349 | D - 1 | 8 | MS35206283 | 96906 | D-5 | 8 |
| MS15006-1 | 96906 | D-11 | 6 | | | D-6 | 10 |
| MS16203-27 | 96906 | D-5 | 42 | MS35207-264 | 96906 | D-5 | 17 |
| MS16203-39 | 96906 | D-5 | 44 | | | D-6 | 18 |
| | | D-8 | 26 | MS35215-95 | 96906 | D-5 | 27 |
| MS16203-41 | 96S06 | D-5 | 13 | | | D-6 | 27 |
| | | D-6 | 15 | MS35333-113 | 96906 | D-6 | 14 |
| MS16535-153 | 96006 | D-5 | 37 | MS35335-91 | 96906 | D-6 | 28 |
| MS16562-66 | 96906 | D-11 | 7 | MS35338-43 | 96906 | D-5 | 18 |
| MS16997-149 | 98906 | D-5 | 23 | | | D-6 | 19 |
| | | D-6 | 23 | MS35338-45 | 96906 | D-9 | 11 |
| MS17990C613 | 96906 | D-8 | 35 | MS35338-46 | 96906 | D-5 | 47 |
| MS18015-1 | 96906 | D-9 | 4 | | | D-6 | 38 |
| MS20426A4-6 | 96906 | D-6 | 6 | MS35338-48 | 96906 | D-2 | 3 |
| MS20427-4C5 | 96906 | D-8 | 38 | MS35338-51 | 96906 | D-8 | 44 |
| MS20613-4P5 | 98906 | D-9 | 5 | MS35338-103 | 96906 | D-5 | 40 |
| MS20659-110 TY1 CL1 | 96906 | D-8 | 29 | MS35387-1 | 96906 | D-10 | 1 |
| MS21046 | 96906 | D-9 | 7 | MS35387-2 | 96906 | D-10 | 2 |
| MS21334-2 | 96906 | D-8 | 14 | MS35425-28 | 96906 | D-8 | 24 |
| MS24519-9 | 96906 | D-8 | 20 | MS35425-75 | 96906 | D-5 | 39 |
| MS24665-353 | 96906 | D-11 | 2 | MS35489-112 | 96906 | D-8 | 23 |
| MS24693-S273 | 96906 | D-9 | 6 | MS35650-3385T | 96906 | D-5 | 29 |
| MS25036-105 | 96906 | D-6 | 35 | | | D-6 | 29 |
| | | D-5 | 34G | MS35842-11 | 96906 | D-8 | 21 |
| MS25036-127 | 96906 | D-4 | 6 | MS39347-4 | 96906 | D-5 | 11 |
| MS25036-127 CL1-5Z2 | 96906 | D-7 | 6 | MS39347-4 | 96906 | D-6 | 13 |
| MS25036-128 | 96906 | D-4 | 7 | MS51922-1 | 96906 | D-5 | 10 |
| MS25036-129CL1-5Z2 | 96906 | D-7 | 7 | | | D-6 | 12 |
| MS25036-130 | 96906 | D-3 | 5 | | | D-8 | 13 |
| MS25036-131 | 96906 | D-3 | 6 | | | D-10 | 5 |
| MS25036-150 | 96906 | D-5 | 33G | MS51922-17 | 96906 | D-8 | 42 |
| MS27130-S57 | 96906 | D-6 | 3 | | | D-11 | 12 |
| MS27130-S99 | 96906 | D-5 | 3 | MS51922-33 | 96906 | D-5 | 25 |
| MS27142-2 | 96906 | D-12 | 6 | | | D-6 | 25 |
| | | D-12 | 11 | | | D-8 | 9 |
| MS27144-1 | 96906 | D-12 | 3 | MS51922-49 | 96906 | D-8 | 33 |
| MS27144-1 STYLE 1 | 96906 | D-12 | 8 | MS51922-61 | 96906 | D-8 | 45 |
| MS27183-8 | 96906 | D-8 | 3 | | | | |
| MS27183-10 | 96906 | D-5 | 9 | | | | |

Change 4 D-45

Reference Fig. Item

Section IV. NATIONAL STOCK NUMBER AND REFERENCE - CONT

| Reference Number | FSCM | Fig. No. | Item No. | Reference Number | FSCM | Fig. No. | Item No. |
|------------------------|-------|----------|----------|------------------|-------|----------|----------|
| MS51925-1 | 96906 | D-1 | 7 | | | D-6 | 7 |
| MS51926-3 | 96906 | D-1 | 4 | 13212E3590-2 | 97403 | D-8 | 46 |
| MS51929-2 | 96906 | D-1 | 5 | 13212E3597-1 | 97403 | D-1 | 9 |
| MS51939-3 | 96906 | D-8 | 1 | 13212E3597-2 | 97403 | D-1 | 10 |
| | | D-9 | 9 | 13214E1206 | 97403 | D-11 | 1 |
| MS51967-5 | 96906 | D-9 | 12 | 13214E1207 | 97403 | D-11 | 4 |
| MS90725-3 | 96906 | D-10 | 3 | 13214E1208 | 97403 | D-11 | 5 |
| MS90725-6 | 96906 | D-8 | 11 | 13214E1209 | 97403 | D-11 | 3 |
| MS90725-31 | 96906 | D-9 | 10 | 13214E1210 | 97403 | D-11 | 8 |
| MS90725-60 | 96906 | D-5 | 46 | 13214E1211 | 97403 | D-11 | 9 |
| | | D6 | 37 | 13214E1212 | 97403 | D-11 | 10 |
| MS90725-62 | 96906 | D-11 | 11 | 13214E1223 | 97403 | D-5 | 43 |
| MS90725-111 | 96906 | D-8 | 7 | | | D-8 | 27 |
| MS90725 114 | 96906 | D-2 | 2 | 13214E1235 | 97403 | D-8 | 10 |
| MS9460-102 | 96906 | D-9 | 3 | 13214E1391 | 97403 | D-5 | 33A |
| M13486/1-5 TYPE 1, CLA | 81349 | D-12 | 10 | | | D-5 | 34A |
| M13486/7-1 TYPE 1, CLB | 81349 | D-12 | 5 | 13214E1392 | 97403 | D-1 | 6 |
| M23053/5-106 | 96906 | D-5 | 33F | 13216E7476 | 97403 | D-12 | 7 |
| | | D-5 | 34F | 13216E7479-1 | 97403 | D-12 | 1 |
| M23053/5-107-5 | 81349 | D-3 | 7 | 13216E7479-2 | 97403 | D-12 | 2 |
| M23053/5-108-5 | 81349 | D-7 | 8 | 13216E7603 | 97403 | D-5 | 35 |
| M23053/5-1 09-0 | 81349 | D-8 | 18 | | | D-6 | 36 |
| M23053/5-109-5 | 81349 | D-3 | 9 | 13218E0021-41 | 97403 | D-8 | 31 |
| M24066/2-128 | | D-8 | 37 | 13218E0025-4 | 97403 | D-8 | 36 |
| M43436/1-6 | 81349 | D-12 | 9 | 13218E5139-5 | 97403 | D-5 | 31 |
| | 91349 | D-12 | 4 | | | D-6 | 31 |
| M5086/1-18 | 96906 | D-5 | 33E | 13218E5140-5 | 97403 | D-5 | 32 |
| | | D-5 | 34E | | | D-6 | 32 |
| M5086/2-2 | 81349 | D-7 | 5 | 13218E5149-9 | 97403 | D-6 | 30 |
| QQW343C06B1B | 81348 | D-3 | 8 | 13218E5149-10 | 97403 | D-5 | 30 |
| QQ-W-343C06B1B | 81348 | D-8 | 17 | 13220E4457-2 | 97403 | D-8 | 5 |
| T-R-6053 | 81349 | D-1 | 2 | 13220E4458-2 | 97403 | D-8 | 6 |
| 13205E4918 | 97403 | D-10 | 8 | 13220E4462 | 97403 | D-6 | 1 |
| 13205E5024 | 97403 | D-6 | 21 | 13220E4463-2 | 97403 | D-10 | 6 |
| 13206E4482-2 | 97403 | D-2 | 5 | 13220E4486 | 97403 | D-6 | 2 |
| 13211E4775 | 97403 | D-5 | 6 | 13226E5857 | 97403 | D-8 | 34 |
| | | D-6 | 8 | 13226E5858 | 97403 | D-8 | 30 |
| 13212E3579 | 97403 | D-5 | 15 | 13226E5859-1 | 97403 | D-5 | 1 |
| | | D-6 | 17 | 13226E5861 | 97403 | D-5 | 2 |
| 13212E3581-1 | 97403 | D-5 | 34 | 13226E5888-1 | 97403 | D-3 | 1 |
| | | D-6 | 34 | 13226E5888-2 | 97403 | D-3 | 2 |
| 13212E3581-2 | 97403 | D-5 | 33 | 13226E5889-1 | 97403 | D-5 | 36 |
| | | D-6 | 33 | 13226E5889-2 | 97403 | D-5 | 38 |
| 13212E3583 | 97403 | D-5 | 7 | 13226E7734 | 97403 | D-8 | 48 |
| | | D-6 | 9 | 13226E7737 | 97403 | D-9 | 1 |
| 13212E3584-4 | 97403 | D-4 | 1 | 13226E7740 | 97403 | D-1 | 1 |
| 13212E3585-4 | 97403 | D-4 | 2 | 13226E-7730-6 | 97403 | D-8 | 43 |
| 13212E3586-1 | 97403 | D-7 | 1 | 181-0937-003 | 72619 | D-5 | 33D |
| 13212E3586-2 | 97403 | D-7 | 2 | | | D-5 | 34D |
| 13212E3586-3 | 97403 | D-7 | 3 | 181-8836-09-553 | 72619 | D-5 | 33C |
| 13212E3586-4 | 97403 | D-7 | 4 | | | D-5 | 34C |
| 13212E587 | 97403 | D-5 | 5 | | | | |

Section V. REFERENCE DESIGNATOR INDEX

Not Applicable

TM 5-6115-633-14&P

By Order of the Secretary of the Army:

CARL E. VUONO
General, United States Army
Chief of Staff

Official:

R. L. DILWORTH
Brigadier General, United States Army
The Adjutant General

DISTRIBUTION:

To be distributed in accordance with DA Form 12-25A, Operator, Unit, Intermediate Direct Support and General Support Maintenance Manual requirements for Generator Sets, Gas/Diesel Engine, Trailer Mounted (PU Series)

*U.S. GOVERNMENT PRINTING OFFICE: 1988 554-169/87031

RECOMMENDED CHANGES TO EQUIPMENT TECHNICAL PUBLICATIONS



SOMETHING WRONG WITH THIS PUBLICATION?

THEN... JOT DOWN THE DOPE ABOUT IT ON THIS FORM. CAREFULLY TEAR IT OUT, FOLD IT AND DROP IT IN THE MAIL!

FROM: (PRINT YOUR UNIT'S COMPLETE ADDRESS)
PFC JOHN DOE
COA, 3d ENGINEER BN
FT. LEONARDWOOD, MA 63108
 DATE SENT

| | | |
|---|---------------------------------------|---|
| PUBLICATION NUMBER TM 5-6115-633-14&P | PUBLICATION DATE 13 June 88 | PUBLICATION TITLE POWER PLANT AN/MJQ-18 |
|---|---------------------------------------|---|

| BE EXACT. PIN-POINT WHERE IT IS | | | | IN THIS SPACE TELL WHAT IS WRONG AND WHAT SHOULD BE DONE ABOUT IT: |
|---------------------------------|------------------|------------|----------|---|
| PAGE NO | PARA-GRAPH | FIGURE NO | TABLE NO | |
| 6 | 2-1 a | | | <i>In line 6 of paragraph 2-1a the manual states the engine has <u>6</u> cylinders. The engine on my set only has <u>4</u> cylinders. Change the manual to show <u>4</u> cylinders.</i> |
| B1 | | 4-3 | | <i>Callout 16 on figure 4-3 is pointing at a <u>bolt</u>. In key to figure 4-3, item 16 is called a <u>shim</u> - Please correct one or the other.</i> |
| 125 | line 20 | | | <i>I ordered a gasket, item 19 on figure B-16 by NSN 2 910-00-762-3001. I got a gasket but it doesn't fit. Supply says I got what I ordered, so the NSN is wrong. Please give me a good NSN</i> |

| | |
|---|---|
| PRINTED NAME, GRADE OR TITLE, AND TELEPHONE NUMBER JOHN DOE, PFC (268) 317-7111 | SIGN HERE <i>John Doe</i> JOHN DOE |
|---|---|

DA FORM 2028-2
1 JUL 79

PREVIOUS EDITIONS ARE OBSOLETE.
DRSTS-M Overprint 1, 1 Nov 80

P.S.--IF YOUR OUTFIT WANTS TO KNOW ABOUT YOUR RECOMMENDATION MAKE A CARBON COPY OF THIS AND GIVE IT TO YOUR HEADQUARTERS.

TEAR ALONG PERFORATED LINE

FILL IN YOUR
UNIT'S ADDRESS

FOLD BACK

DEPARTMENT OF THE ARMY

OFFICIAL BUSINESS
PENALTY FOR PRIVATE USE \$300

POSTAGE AND FEES PAID
DEPARTMENT OF THE ARMY
DOD 314



TEAM ALONG PERFORATED LINE

COMMANDER
U S ARMY TROOP SUPPORT COMMAND
ATTN: AMSTR-MCTS
4300 GOODFELLOW BOULEVARD
ST. LOUIS, MO 63120-1798

RECOMMENDED CHANGES TO EQUIPMENT TECHNICAL PUBLICATIONS

SOMETHING WRONG WITH THIS PUBLICATION?



THEN... JOT DOWN THE DOPE ABOUT IT ON THIS FORM. CAREFULLY TEAR IT OUT. FOLD IT AND DROP IT IN THE MAIL!

FROM: (PRINT YOUR UNIT'S COMPLETE ADDRESS)

DATE SENT

PUBLICATION NUMBER

TM 5-6115-633-14&P

PUBLICATION DATE

13 June 1988

PUBLICATION TITLE

POWER PLANT AN/MJO-18

BE EXACT... PIN-POINT WHERE IT IS

PAGE NO

PARA-GRAPH

FIGURE NO

TABLE NO

IN THIS SPACE TELL WHAT IS WRONG AND WHAT SHOULD BE DONE ABOUT IT:

TEAR ALONG PERFORATED LINE

PRINTED NAME, GRADE OR TITLE, AND TELEPHONE NUMBER

SIGN HERE

DA FORM 2028-2
1 JUL 79

PREVIOUS EDITIONS ARE OBSOLETE.
DRSTS-M Overprint 2, 1 Nov 80.

P.S.--IF YOUR OUTFIT WANTS TO KNOW ABOUT YOUR RECOMMENDATION MAKE A CARBON COPY OF THIS AND GIVE IT TO YOUR HEADQUARTERS.

FILL IN YOUR
UNIT'S ADDRESS

FOLD BACK

DEPARTMENT OF THE ARMY

OFFICIAL BUSINESS
PENALTY FOR PRIVATE USE \$300

POSTAGE AND FEES PAID
DEPARTMENT OF THE ARMY
DOD 314



TEAR ALONG PERFORATED LINE

COMMANDER
U S ARMY TROOP SUPPORT COMMAND
ATTN: AMSTR-MCTS
4300 GOODFELLOW BOULEVARD
ST. LOUIS, MO 63120-1798

FILL IN YOUR
UNIT'S ADDRESS

FOLD BACK

DEPARTMENT OF THE ARMY

OFFICIAL BUSINESS
PENALTY FOR PRIVATE USE \$300

POSTAGE AND FEES PAID
DEPARTMENT OF THE ARMY
DOD 314



COMMANDER
U S ARMY TROOP SUPPORT COMMAND
ATTN: AMSTR-MCTS
4300 GOODFELLOW BOULEVARD
ST. LOUIS, MO 63120-1798

TEAR ALONG PERFORATED LINE

RECOMMENDED CHANGES TO EQUIPMENT TECHNICAL PUBLICATIONS

SOMETHING WRONG WITH THIS PUBLICATION?



THEN... JOT DOWN THE DOPE ABOUT IT ON THIS FORM. CAREFULLY TEAR IT OUT. FOLD IT AND DROP IT IN THE MAIL!

FROM: (PRINT YOUR UNIT'S COMPLETE ADDRESS)

DATE SENT

PUBLICATION NUMBER

TM 5-6115-633-14&P

PUBLICATION DATE

13 June 1988

PUBLICATION TITLE

POWER PLANT AN/MJQ-18

BE EXACT... PIN-POINT WHERE IT IS

| PAGE NO | PARA-GRAPH | FIGURE NO | TABLE NO |
|---------|------------|-----------|----------|
|---------|------------|-----------|----------|

IN THIS SPACE TELL WHAT IS WRONG AND WHAT SHOULD BE DONE ABOUT IT:

TEAR ALONG PERFORATED LINE

PRINTED NAME, GRADE OR TITLE, AND TELEPHONE NUMBER

SIGN HERE:

DA FORM 2028-2
1 JUL 79

PREVIOUS EDITIONS ARE OBSOLETE.
DRSTS-M Overprint 2, 1 Nov 80.

P.S.--IF YOUR OUTFIT WANTS TO KNOW ABOUT YOUR RECOMMENDATION MAKE A CARBON COPY OF THIS AND GIVE IT TO YOUR HEADQUARTERS.

FILL IN YOUR
UNIT'S ADDRESS

FOLD BACK

DEPARTMENT OF THE ARMY

OFFICIAL BUSINESS
PENALTY FOR PRIVATE USE \$300

POSTAGE AND FEES PAID
DEPARTMENT OF THE ARMY
DOD 314



TEAR ALONG PERFORATED LINE

COMMANDER
U S ARMY TROOP SUPPORT COMMAND
ATTN: AMSTR-MCTS
4300 GOODFELLOW BOULEVARD
ST. LOUIS, MO 63120-1798

The Metric System and Equivalents

Linear Measure

1 centimeter = 10 millimeters = .39 inch
 1 decimeter = 10 centimeters = 3.94 inches
 1 meter = 10 decimeters = 39.37 inches
 1 dekameter = 10 meters = 32.8 feet
 1 hectometer = 10 dekameters = 328.08 feet
 1 kilometer = 10 hectometers = 3,280.8 feet

Weights

1 centigram = 10 milligrams = .15 grain
 1 decigram = 10 centigrams = 1.54 grains
 1 gram = 10 decigrams = .035 ounce
 1 dekagram = 10 grams = .35 ounce
 1 hectogram = 10 dekagrams = 3.52 ounces
 1 kilogram = 10 hectograms = 2.2 pounds
 1 quintal = 100 kilograms = 220.46 pounds
 1 metric ton = 10 quintals = 1.1 short tons

Liquid Measure

1 centiliter = 10 milliliters = .34 fl. ounce
 1 deciliter = 10 centiliters = 3.38 fl. ounces
 1 liter = 10 deciliters = 33.81 fl. ounces
 1 dekaliter = 10 liters = 2.64 gallons
 1 hectoliter = 10 dekaliters = 26.42 gallons
 1 kiloliter = 10 hectoliters = 264.18 gallons

Square Measure

1 sq. centimeter = 100 sq. millimeters = .155 sq. inch
 1 sq. decimeter = 100 sq. centimeters = 15.5 sq. inches
 1 sq. meter (centare) = 100 sq. decimeters = 10.76 sq. feet
 1 sq. dekameter (are) = 100 sq. meters = 1,076.4 sq. feet
 1 sq. hectometer (hectare) = 100 sq. dekameters = 2.47 acres
 1 sq. kilometer = 100 sq. hectometers = .386 sq. mile

Cubic Measure

1 cu. centimeter = 1000 cu. millimeters = .06 cu. inch
 1 cu. decimeter = 1000 cu. centimeters = 61.02 cu. inches
 1 cu. meter = 1000 cu. decimeters = 35.31 cu. feet

Approximate Conversion Factors

| To change | To | Multiply by | To change | To | Multiply by |
|---------------|--------------------|-------------|--------------------|---------------|-------------|
| inches | centimeters | 2.540 | ounce-inches | newton-meters | .007062 |
| feet | meters | .305 | centimeters | inches | .394 |
| yards | meters | .914 | meters | feet | 3.280 |
| miles | kilometers | 1.609 | meters | yards | 1.094 |
| square inches | square centimeters | 6.451 | kilometers | miles | .621 |
| square feet | square meters | .093 | square centimeters | square inches | .155 |
| square yards | square meters | .836 | square meters | square feet | 10.764 |
| square miles | square kilometers | 2.590 | square meters | square yards | 1.196 |
| acres | square hectometers | .405 | square kilometers | square miles | .386 |
| cubic feet | cubic meters | .028 | square hectometers | acres | 2.471 |
| cubic yards | cubic meters | .765 | cubic meters | cubic feet | 35.315 |
| fluid ounces | milliliters | 29.573 | cubic meters | cubic yards | 1.308 |
| pints | liters | .473 | milliliters | fluid ounces | .034 |
| quarts | liters | .946 | liters | pints | 2.113 |
| gallons | liters | 3.785 | liters | quarts | 1.057 |
| ounces | grams | 28.349 | liters | gallons | .264 |
| pounds | kilograms | .454 | grams | ounces | .035 |
| short tons | metric tons | .907 | kilograms | pounds | 2.205 |
| pound-feet | newton-meters | 1.356 | metric tons | short tons | 1.102 |
| pound-inches | newton-meters | .11296 | | | |

Temperature (Exact)

| | | | | |
|----|-------------|-----------------|-------------|----|
| °F | Fahrenheit | 5/9 (after | Celsius | °C |
| | temperature | subtracting 32) | temperature | |

